

A/C COMPRESSOR SERVICING

1991 Mitsubishi Montero

1991 GENERAL SERVICING
Compressor Service

* PLEASE READ THIS FIRST *

CAUTION: When discharging air conditioning system, use only approved refrigerant recovery/recycling equipment. Make every attempt to avoid discharging refrigerant into the atmosphere.

ISOLATING COMPRESSOR

NOTE: Only compressors with stem-type service valves can be isolated.

1) Connect service gauge set to the compressor service valves and open compressor valves slightly (turn in clockwise). Start engine and operate air conditioning. Slowly turn compressor suction valve clockwise toward closed (front-seated) position.

2) When suction pressure is reduced to zero or less, turn off engine and compressor and quickly turn suction valve stem in to full front-seated position. Suction pressure should be slightly above zero. Turn discharge valve into front-seated position.

3) To check oil level, slowly open compressor crankcase plug to relieve any remaining pressure. After oil level is corrected, cap service gauge ports on both valves. Back-seat suction service valve to allow refrigerant to enter compressor. Open discharge valve halfway.

4) Loosen discharge service valve cap, allowing refrigerant pressure to force air out of compressor. Back-seat service valve and tighten cap. Compressor is now ready for operation.

REFRIGERANT OIL

Only new, pure, moisture-free refrigerant oil should be used in the air conditioning system. This oil is highly refined and dehydrated to a point where moisture content is less than 10 parts per million. The oil container must be tightly closed at all times when not in use, or moisture will be absorbed into the refrigerant oil from the air.

DISCHARGING SYSTEM PRECAUTIONS

CAUTION: When discharging air conditioning system, use only approved refrigerant recovery/recycling equipment. Make every attempt to avoid discharging refrigerant into the atmosphere.

If compressor has stem-type service valves, it can be isolated and removed without discharging entire system. Otherwise, discharge system completely using approved refrigerant recovery/recycling equipment before loosening any fittings.

DISCONNECTING LINES & FITTINGS TEST

After system is discharged, carefully clean area around all fittings to be opened. Always use 2 wrenches when tightening or loosening fittings to avoid twisting or distorting lines. Cap or plug all openings as soon as lines are removed. Do not remove caps until

immediately before connections are made. This will keep entry of air and moisture to a minimum.

CONNECTING LINES AND FITTINGS

A new gasket or "O" ring should be used in all instances when connecting lines or fittings. Dip "O" ring in new refrigerant oil and ensure it is not twisted during installation. Always use 2 wrenches to prevent damage to lines and fittings.

PLACING SYSTEM IN OPERATION

After component service or replacement has been completed and all connections have been made, evacuate system thoroughly with a vacuum pump. Charge system with proper amount of refrigerant and perform a leak test. See REFRIGERANT OIL & R-12 SPECIFICATIONS chart in this section for system capacities. Be sure to check all fittings that have been opened. After system has been leak tested, make a system performance check.

NOTE: Air conditioning systems will not normally need addition of refrigerant oil unless definite oil loss has occurred due to ruptured lines, leaking compressor seals, compressor overhaul or component replacement.

ATSUGI ROTARY VANE CLUTCH R & I

Removal

When replacing compressor clutch, be careful not to scratch shaft or bend pulley. When removing center bolt, hold clutch disc with Clutch Holder (KV99231010). Using Hub Puller (KV998VR001 & KV99231010), remove clutch disc. When removing pulley, remove lock nut with Hub Socket (KV99235160).

Installation

Wipe oil off clutch surface. Adjust disc pulley clearance to .012-.024" (.3-.6 mm). Tighten center bolt to 80-104 INCH lbs. (9.1-11.8 N.m). Tighten clutch lock nut to 22-29 ft. lbs. (29-39 N.m). See Fig. 1.

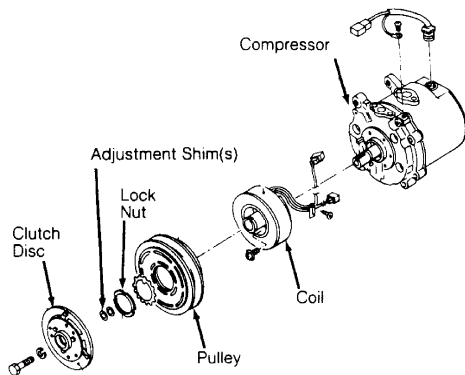

103223

Fig. 1: Atsugi Rotary Vane Compressor
Courtesy of Nissan Motor Co., U.S.A.

BOSCH 6-CYL CLUTCH R & I

Removal

1) Hold clutch plate and remove shaft nut. Using Clutch Plate Remover (64 5 00), remove clutch plate. Using snap ring pliers, remove circlip and remove pulley assembly.

2) If pulley bearing is being replaced, remove circlip at rear of pulley. Press bearing and spacer from pulley. Press in new bearing with spacer and replace circlip.

Installation

1) Clean all surfaces. Install pulley assembly on compressor and install circlip. Ensure clutch plate shim is in place on shaft. Install clutch plate and nut. Tighten nut to 13-14 ft. lbs. (18-20 N. m).

2) Using a feeler gauge, check clutch plate-to-pulley clearance. Clearance should be .028-.051" (.7-1.3 mm). If clearance is not correct, remove clutch plate and replace clutch plate shim. See Fig. 2.

BOSCH 6-CYL SHAFT SEAL R & I

Removal & Installation

1) Remove clutch plate. Remove shaft key and circlip. Using Seal Seat Remover/Installer (64 5 030), remove seal seat.

2) Using Seal Remover/Installer (64 5 040), remove shaft seal by turning seal slightly clockwise to disengage tangs and pull out shaft seal. Remove "O" ring seal.

3) Coat new "O" ring seal with refrigerant oil and install. Coat new shaft seal with refrigerant oil and install shaft seal on Seal Remover/Installer (64 5 040). Ensure alignment of shaft seal and shaft machine surfaces. Insert shaft seal and turn slightly counterclockwise to secure on shaft.

4) Using sleeve from Seal Seat Remover/Installer (64 5 030), push seal seat into compressor and install circlip. Install shaft key and clutch plate. Check compressor oil level before charging system.

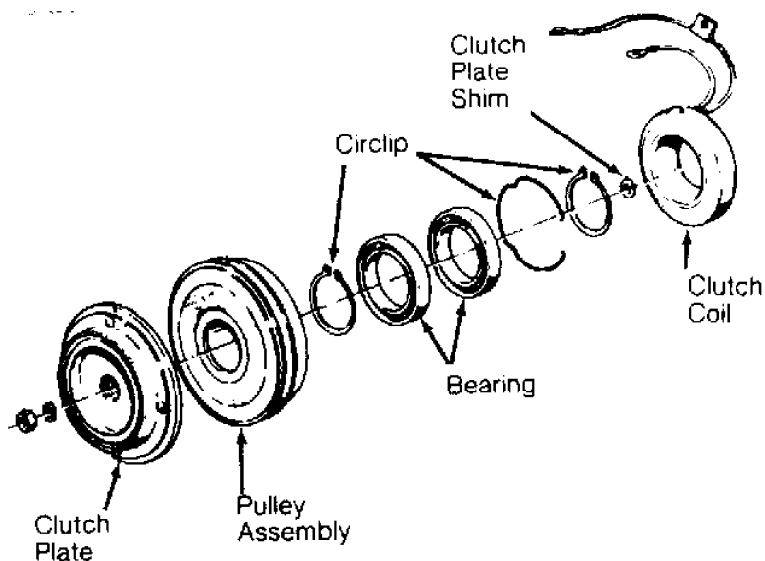

Fig. 2: Bosch 6-Cylinder Compressor Clutch
Courtesy of BMW of North America, Inc.

CALSONIC V5 CLUTCH R & I

Removal

1) Remove shaft nut while holding armature plate with clutch disk wrench. Install clutch disk puller and remove clutch plate. Remove snap ring from center of clutch pulley.

2) Use a universal gear puller to remove clutch pulley. See Fig. 3. Remove screw securing clutch coil ground lead. Use puller to remove clutch coil.

Installation

1) To install clutch coil, reverse removal procedure.

Carefully press clutch coil into place. Ensure that coil lead and connector are positioned on same side as removed coil.

2) Install a NEW clutch pulley snap ring, being careful not to damage shaft seal. Press clutch plate into place. Install shaft nut and torque to 0.9-1.4 INCH lbs. (0.10-.12 N.m).

3) Use a feeler gauge to check clutch plate-to-pulley clearance. Clearance should be .012-.024" (0.3-0.6 mm). If clearance is too large, remove shaft nut and again press in clutch plate. If clearance is too small, increase gap by pulling up clutch plate. Do not remove shaft nut.

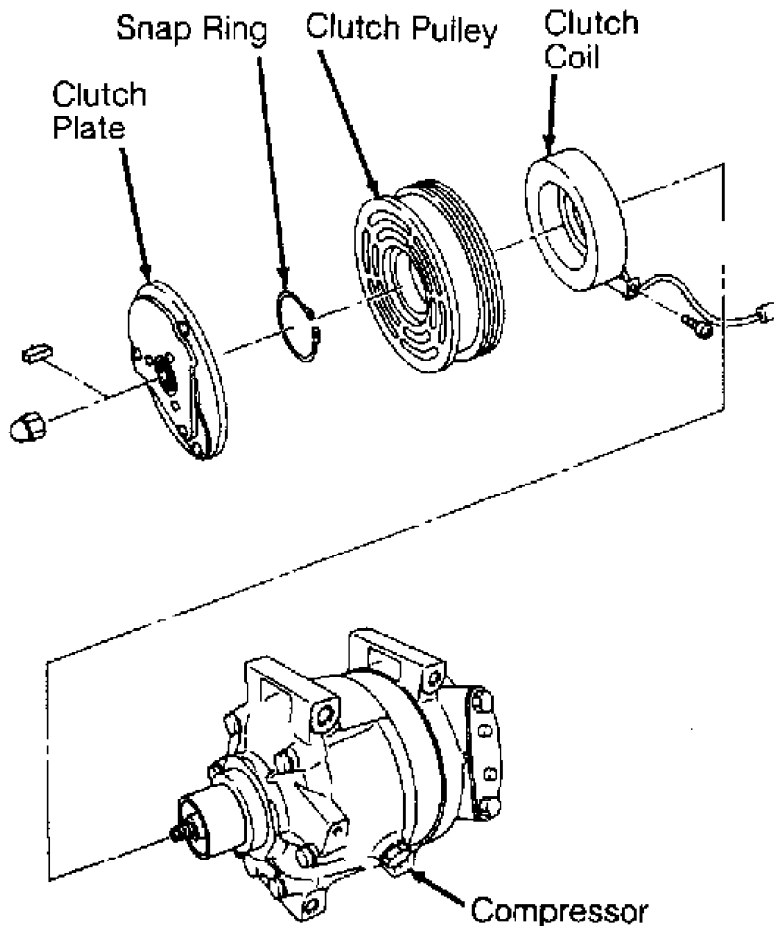

92C02496

Fig. 3: Explode View of Compressor Clutch (Calsonic V5)
Courtesy of Nissan Motor Co. U.S.A.

Removal

1) Using Clutch Holder (KV99231010), hold clutch disc. Remove center bolt retaining clutch assembly to shaft. Thread Hub Remover (KV99232232) into bore of clutch hub. Hold hub remover with wrench and thread center bolt inward until clutch disc is removed.

2) Remove clutch disc, collar and adjusting shims. Remove snap ring and plate. Remove pulley and bearing assembly. If assembly cannot be removed by hand, use a puller and adapter.

3) Be careful not to scratch shaft or bend pulley. Using an impact driver, loosen 6 coil mounting screws. Remove key and clutch coil. See Fig. 4.

Installation

1) Install key. Position coil assembly on compressor body. Be sure that electrical terminals are installed in original position. Install and tighten coil mounting screws to 35-52 INCH lbs. (4-6 N.m).

2) Press pulley assembly onto neck of coil assembly using Pulley Installer (KV99234160). Wipe oil thoroughly off clutch surface. Select adjusting shims which give correct clearance between pulley and clutch disc.

3) Using a plastic mallet, tap clutch disc in place on drive shaft. Do not use excessive force with plastic mallet or press. Place spring washer and center bolt onto drive shaft. Tighten center bolt to drive clutch wheel onto drive shaft. Tighten center bolt to 11-13 ft. lbs. (15-18 N.m).

4) Hold clutch with Clutch Holder (KV99231010). Check clearance around entire outer edge of clutch disc. Clearance should be .012-.024" (.3-.6 mm). If specified clearance is not obtained, replace adjusting shims as required.

5) When replacing compressor clutch assembly, break-in procedure must be performed. This is accomplished by engaging and disengaging clutch 30 times.

DIESEL KIKI 6-CYL CLUTCH COIL R & I

Removal & Installation

Using clutch holder to prevent clutch disc rotation, remove bolt. Using clutch holder and puller, remove clutch disc. Remove shims from compressor drive shaft or clutch disc. Remove snap ring with external snap ring pliers and then remove pulley. Using a gear puller, remove pulley. Remove coil lead wire and 6 screws. Remove coil. To install, reverse removal procedure. Adjust clutch disc-to-pulley clearance to .010-.020" (.3-.6 mm). See Fig. 4.

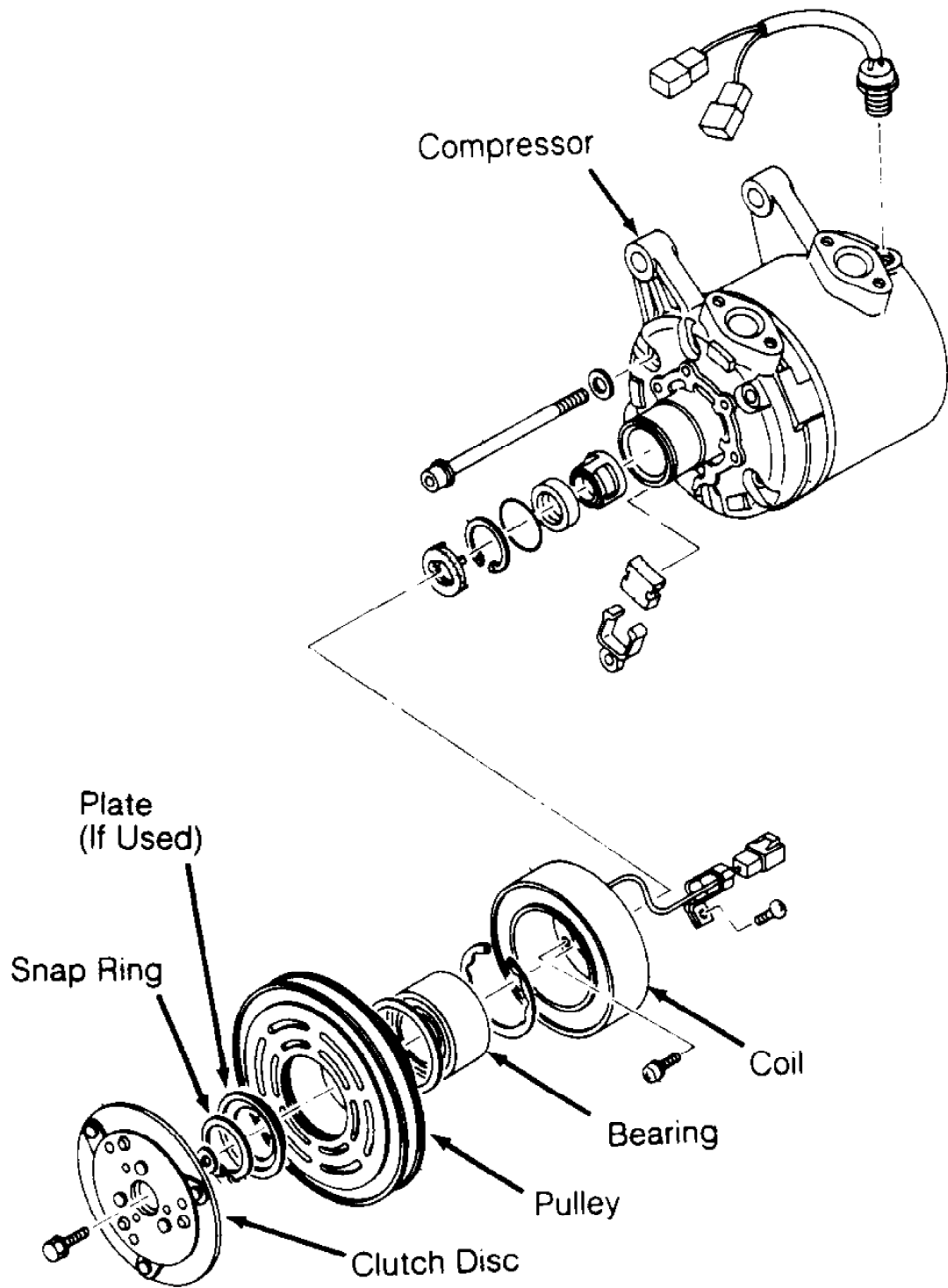

103225

Fig. 4: Diesel Kiki Rotary Vane Compressor
 Courtesy of Nissan Motor Co., U.S.A.

DIESEL KIKI 6-CYL SHAFT SEAL R & I

Removal & Installation

1) Remove clutch coil assembly. Remove retainer and felt. Discard retainer and felt. Using internal snap ring pliers, remove seal seat snap ring. Remove seal seat and discard. Using a seal pick, remove "O" ring from inside groove of shaft seal housing. Discard "O" ring.

2) To remove shaft seal, push down and turn clockwise on seal remover to engage tangs. Slowly draw seal from bore. Discard seal. Check shaft and inside of compressor neck for dirt or foreign material and ensure these areas are perfectly clean before installing new seal.

3) To install, reverse removal procedure. Coat "O" ring, shaft seal, and seal seat with new refrigerant oil.

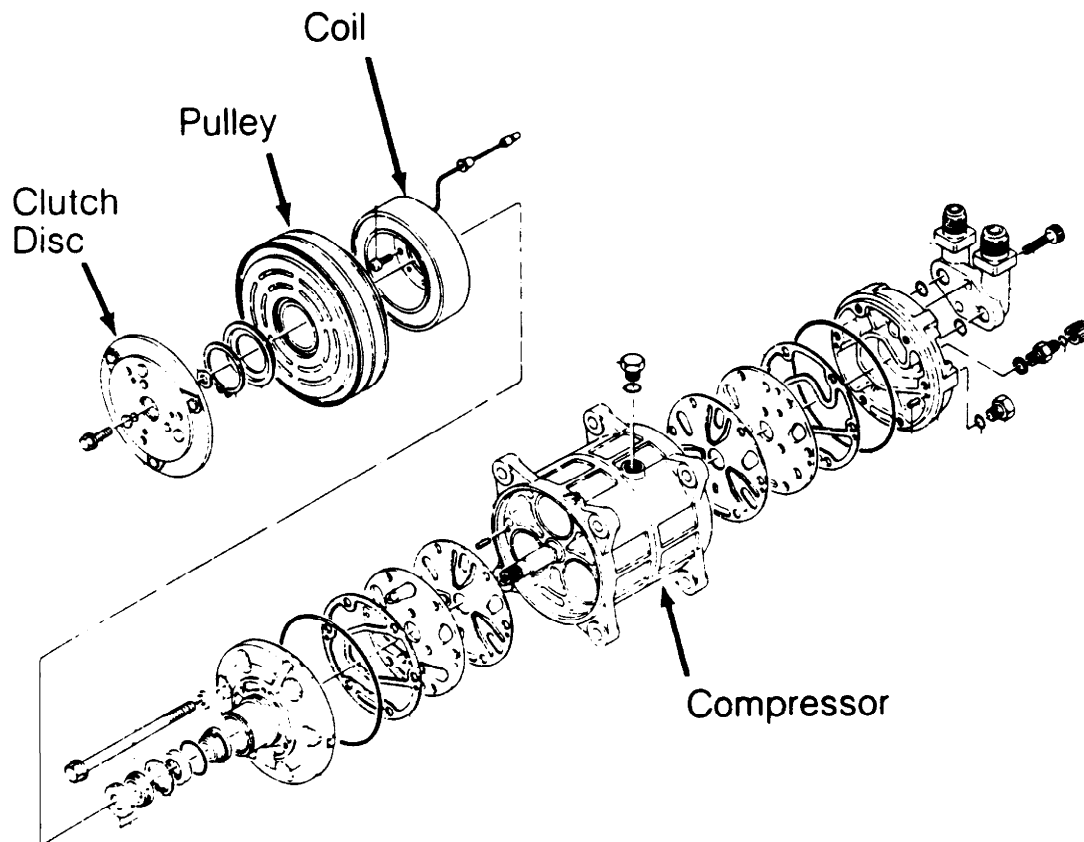

200339

Fig. 5: Diesel Kiki 6-Cylinder Compressor
Courtesy of Mitsubishi Motor Sales of America.

FORD FX-15 CLUTCH R & I

Removal

1) Using Clutch Holder (00 41 0812 05), remove clutch plate retaining bolt and discard. Using an 8 mm bolt threaded into clutch plate, remove clutch plate and shim(s). See Fig. 6.

2) Remove snap ring and pulley assembly. Install Shaft Protector (49 UN01 47) over shaft seal opening. Use a 2-jaw puller to remove clutch coil from compressor.

Installation

1) Ensure clutch coil mounting surface is clean. Use Coil

Installer (49 UN01 046) and 2-jaw puller engaged to rear side of compressor front mounts to press coil into place.

2) Install pulley assembly. Install pulley assembly snap ring with bevel side of snap ring facing out. Install shim(s) and clutch plate. Install a NEW clutch plate retaining bolt and tighten to 96-120 INCH lbs. (11-14 N.m).

3) Use a feeler gauge to check clearance between clutch plate and pulley assembly. Clearance should be .018-.033" (.46-.84 mm). If clearance is incorrect, add or remove shims as necessary.

FORD FX-15 SHAFT SEAL R & I

Removal

1) Using Clutch Holder (000 41 0812 05), remove clutch plate retaining bolt and discard. Using an 8 mm bolt threaded into clutch plate, remove clutch plate and shim(s). See Fig. 6.

2) Remove shaft felt seal. Thoroughly clean seal area of compressor. Remove shaft seal retaining snap ring. Position Shaft Seal Remover (49 UN01 044) over compressor shaft.

3) Push shaft seal remover downward against seal. Ensure end of shaft seal remover is engaged with inside of seal. Rotate shaft seal remover clockwise to expand remover tip inside seal. Pull shaft seal from compressor.

Installation

1) Lubricate shaft seal protector and shaft seal with refrigerant oil. Install shaft seal on shaft seal protector so lip seal is toward compressor (large end of shaft seal protector).

2) Install shaft seal protector on compressor shaft. Using shaft seal installer (49 UN01 043), push shaft seal down seal protector until seal is seated.

3) Remove shaft seal installer and protector. Install a NEW shaft seal retaining snap ring and shaft seal felt. Install shim(s) and clutch plate. Install a NEW clutch plate retaining bolt and tighten to 91-120 INCH lbs. (11-14 N.m).

4) Use a feeler gauge to check clearance between clutch plate and pulley assembly. Clearance should be .018-.033" (.46-.84 mm). If clearance is incorrect, add or remove shims as necessary.

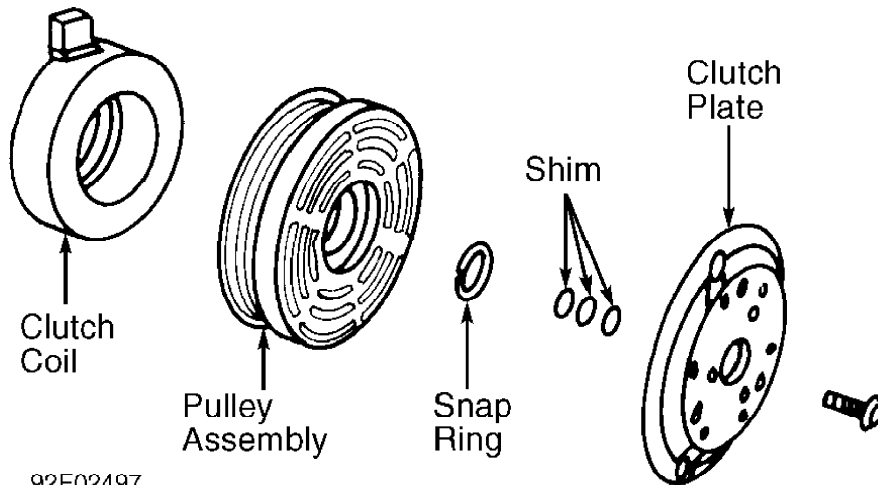

92E02497

Fig. 6: Exploded View of Compressor Clutch (Ford FX-15)
Courtesy of Mazda Motors Corp.

HARRISON R4 4-CYL CLUTCH R & I

Removal

1) Clamp Holding Fixture (J-25008-A) in a vise and attach compressor to holding fixture with thumb screws. Use Clutch Hub Holder (J-33027) to hold clutch. Remove shaft nut using Shaft Nut Socket (J-9399).

2) Thread Clutch Plate and Hub Assembly Remover (J-33013-B) into hub. Hold body of remover with a wrench and turn center screw into remover body to remove clutch plate and hub assembly. Remove shaft key and retain for assembly. See Fig. 5.

NOTE: DO NOT drive or pound on clutch hub or shaft.

Installation

1) Install shaft key into hub key groove. Allow key to project approximately 1/8" out of key way. Shaft key is curved slightly to provide an interference fit in hub key groove.

2) Ensure frictional surface of clutch plate and clutch rotor are clean before installing clutch plate and hub assembly. Align shaft key with shaft key way and place clutch plate and hub assembly onto compressor shaft.

3) Hold hex portion of Installer (J-9480-B) with a wrench. Tighten center screw to press hub into shaft until there is .020-.040" (.5-1.0 mm) air gap between frictional plate and clutch rotor.

4) Install new shaft nut with small diameter boss of nut against crankshaft shoulder. Use Thin Wall Socket (J-9399) and Clutch Hub Holder (J-25030). Tighten shaft nut to 10 ft. lbs. (14 N.m). Spin pulley rotor by hand to ensure rotor is not rubbing on clutch drive plate.

HARRISON R4 4-CYL SHAFT SEAL R & I

Removal

1) Clamp Holding Fixture (J-25008-A) in a vise and attach compressor to holding fixture with thumb screws. Use Clutch Hub Holder (J-33027) to hold clutch. Remove shaft nut using Shaft Nut Socket (J-9399).

2) Thread Clutch Plate and Hub Assembly Remover (J-33013-B) into hub. Hold body of remover with a wrench and turn center screw into remover body to remove clutch plate and hub assembly. Remove clutch plate and shaft key. Pry out dust seal (if equipped). Remove seal seat snap ring. Thoroughly clean compressor neck area and "O" ring groove surrounding shaft. Any dirt or foreign material may cause compressor damage.

3) Use Seal Remover/Installer (J23128-A), remove seal with a twisting motion. Use "O" Ring Remover (J-9553-01) to remove "O" ring.

Installation

1) Coat new shaft seal with refrigerant oil and install shaft seal on remover/installer. Align compressor shaft machined surface with shaft seal and install. Turn remover/installer slightly counterclockwise to secure shaft seal tangs.

2) Using Seal Installer (J-33011), install "O" ring and coat with refrigerant oil. Coat seal seat with refrigerant oil and install using seal seat remover/installer. Install snap ring. Install dust seal (if supplied in seal kit). See Fig. 7.

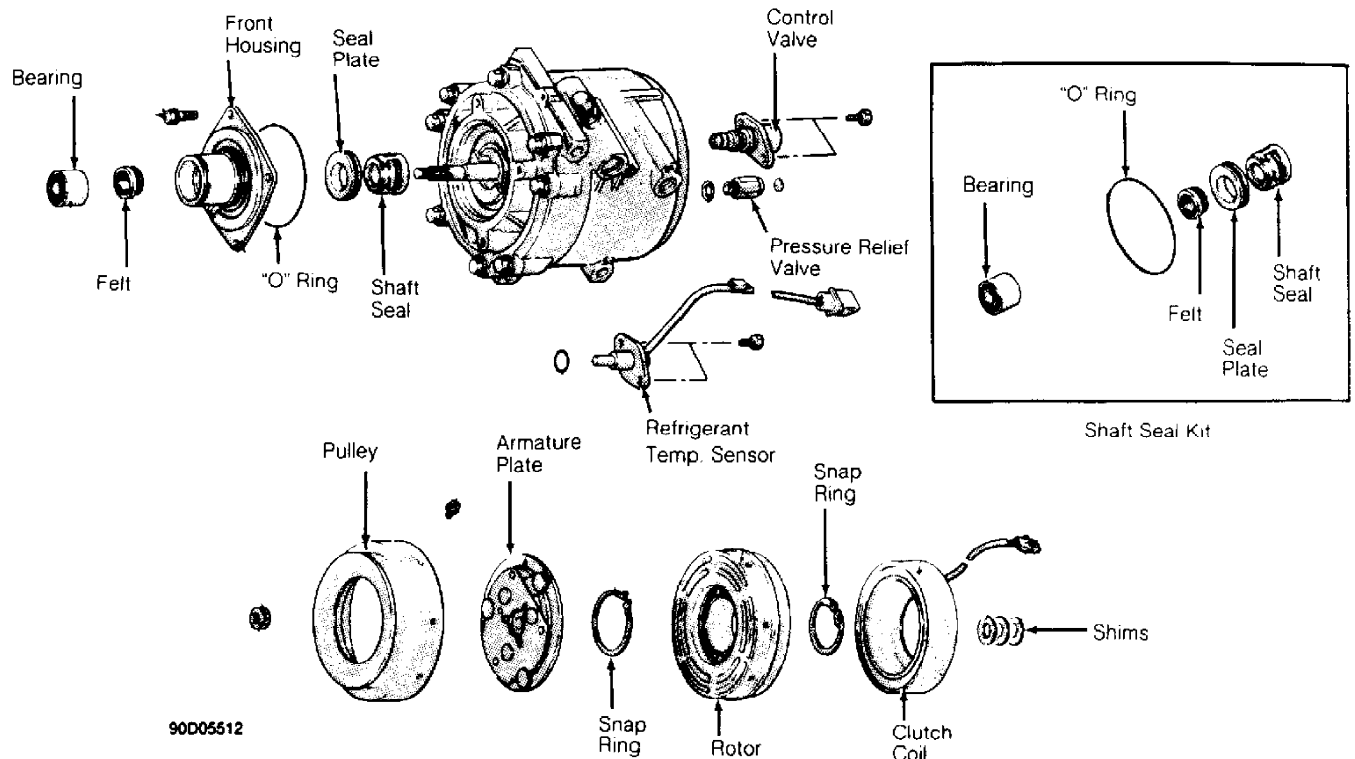

Fig. 7: Harrison R-4 Radial Compressor
 Courtesy of Isuzu Motor Co.

HARRISON V5 5-CYLINDER CLUTCH R & I

Removal

1) Clamp Holding Fixture (J-34992) in vise and attach compressor to holding fixture with thumb screws. Use Clutch Hub Holder (J-33027) to hold clutch. Remove shaft nut using Shaft Nut Socket (J-33022).

2) Thread Clutch Plate and Hub Assembly Remover (J-33013-B) into hub. Hold body of remover with a wrench and turn center screw into remover body to remove clutch plate and hub assembly. Remove shaft key and retain for installation.

Installation

1) Install shaft key into hub key groove. Allow key to project approximately 1/8" (3.2 mm) out of key way. Shaft key is curved slightly to provide an interference fit in hub key groove.

2) Ensure frictional surface of clutch plate and clutch rotor are clean before installing clutch plate and hub assembly. Align shaft key with shaft key way and place clutch plate and hub assembly onto compressor shaft.

NOTE: DO NOT drive or pound on clutch hub or compressor shaft, as compressor could be damaged internally.

3) Hold hex portion of installer (J-33013) with a wrench. Tighten center screw to press hub into shaft until there is .015-.025" (.38-.64 mm) air gap between frictional plate and clutch rotor.

4) Install new shaft nut with a small diameter boss of nut

against crankshaft shoulder. Use Thin Wall Socket (J-9399) and Clutch Hub Holder (J-25030). Tighten shaft nut to 96-192 INCH lbs. (11-22 N.m). Spin pulley rotor by hand to ensure rotor is not rubbing on clutch drive plate. See Fig. 8.

HARRISON V5 5-CYLINDER SHAFT SEAL R & I

Removal

Discharge refrigerant from system using approved refrigerant recovery/recycling equipment. See SERVICING PRECAUTIONS at beginning of article. Remove clutch plate assembly. Remove shaft seal snap ring. Thoroughly clean inside of compressor neck area around shaft and seal. Engage tangs of Seal Remover/Installer (J-23128-A) into recessed portion of seal and remove seal. Remove and discard seal "O" ring from compressor neck. Thoroughly clean inside of compressor neck and "O" ring groove.

Installation

1) Coat new "O" ring with refrigerant oil and install on "O" ring installer (J-33011). Install "O" ring into groove in compressor neck. Attach new seal to Seal Remover/Installer (J-23128-A). Dip seal in clean refrigerant oil.

2) Place Seal Protector (J-34614) over compressor shaft. Push new seal over shaft protector. Install new snap ring with flat side against seal. Install clutch plate assembly.

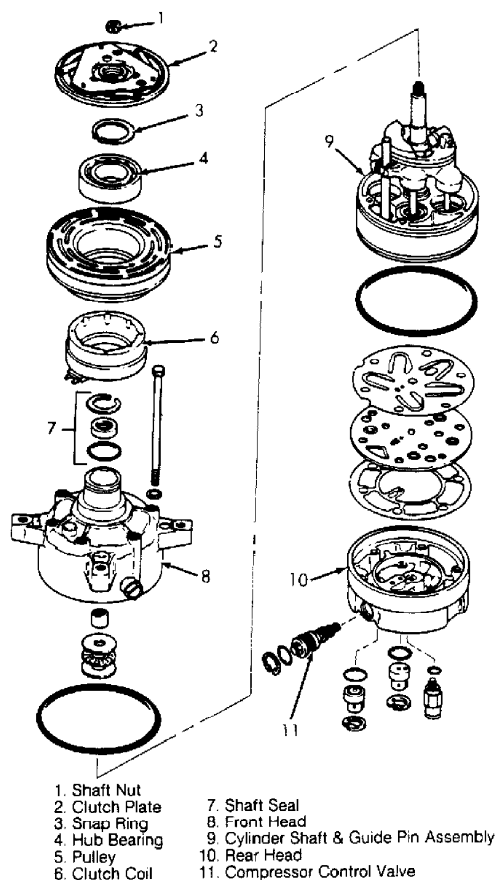

91H04346

Fig. 8: Exploded View of Harrison V5 5-Cylinder Compressor
Courtesy of General Motors Co.

HITACHI 5 & 6-CYL CLUTCH R & I

Removal

1) Using Clutch Holder (KV99412302), hold clutch hub. Remove shaft nut from shaft. Using Clutch Hub Remover (KV994C5780), remove clutch hub.

2) Pry inner snap ring off. Remove pulley and bearing assembly. If assembly cannot be removed by hand, use Pulley and Bearing Removers (KV994C5781 and KV994C5782).

3) Remove clamping screws that secure coil assembly leads. Remove inner snap ring from coil assembly. Remove coil assembly from front cover. See Fig. 9.

Inspection

Check friction surfaces of clutch for damage due to excessive heat, or excessive grooving due to slippage. Replace compressor components as necessary. Oil or dirt on friction surfaces should be cleaned with a solvent and a dry rag. Check coil for binding, shorted or open leads.

Installation

1) Install coil assembly on compressor. Properly position terminals. Using snap ring pliers, install snap ring. Using a plastic mallet, drive pulley and bearing assembly onto neck of front cover. Turn pulley, making sure that there is no noise and that rotation is free. Ensure there is no pulley play.

2) Using snap ring pliers, install inner snap ring. Remove all oil from clutch pulley. Fit key and clutch hub to shaft. Select adjusting spacer which gives the correct clearance between pulley and clutch hub.

3) Coat shaft nut with Loctite and install. Using a feeler gauge, measure clutch hub-to-pulley clearance. Clearance should be .020-.031" (.5-.8 mm). If specified clearance is not obtained, replace adjusting spacer and readjust.

4) When replacing compressor clutch assembly, DO NOT forget break-in operation. This is accomplished by engaging and disengaging clutch 30 times.

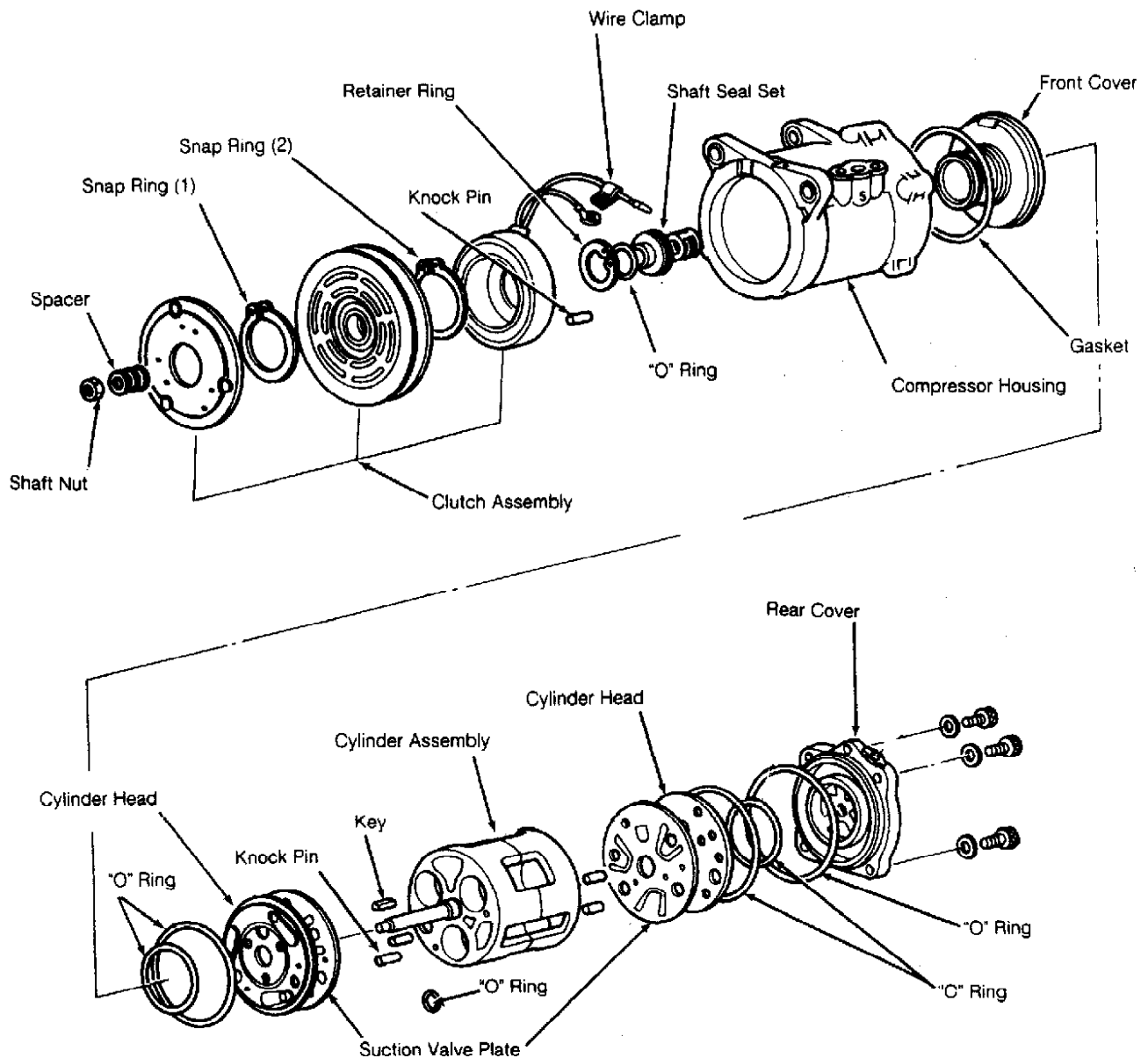

Fig. 9: Hitachi 6-Cylinder Compressor (5-Cylinder Similar)
 Courtesy of Nissan Motor Co., U.S.A.

HITACHI 5 & 6-CYL SHAFT SEAL R & I

NOTE: Check compressor refrigerant oil level when replacing seals.
 See COMPRESSOR REFRIGERANT OIL CHECKING article in this section.

Removal

- 1) Drain oil from suction port, measure oil drained and discard oil. Remove clutch hub, pulley, bearing assembly and coil assembly. See HITACHI 5 & 6-CYLINDER CLUTCH R & I in this article.
- 2) Using snap ring pliers, remove retainer ring. Remove key and plug low and high pressure openings of compressor with Plugs (KV994C4531, KV994C4532 and KV994C4559).
- 3) Insert Adapter (KV994C1552) into hole in middle of blind

cover at low pressure side of compressor. Connect Pressurizer (KV994C1552) to can of R-12 refrigerant. Wrap a rag around compressor shaft. Apply pressure of 28-71 psi (2-5 kg/cm²) at low pressure (suction) service valve of compressor. Catch shaft seal seat in rag. See Fig. 11.

NOTE: If shaft seal cannot be pulled out, reset to its original position, and pressurize again.

4) Insert shaft seal Remover/Installer (KV994C1143) through the open end of front cover. Depress carbon seal and hook tool at case projection of shaft seal. Slowly pull out to remove shaft seal. See Fig. 11.

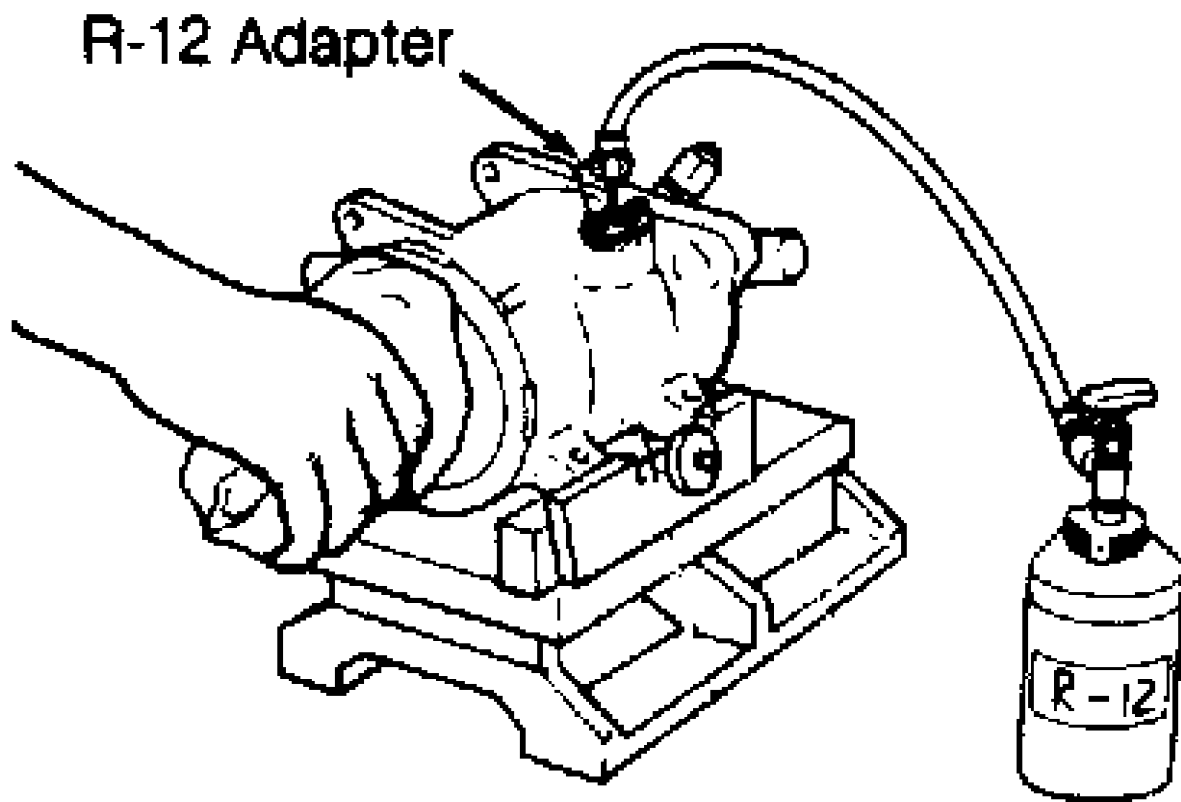

Fig. 10: Hitachi 6-Cylinder Compressor Shaft Seal Seat Removal
Courtesy of Nissan Motor Co., U.S.A.

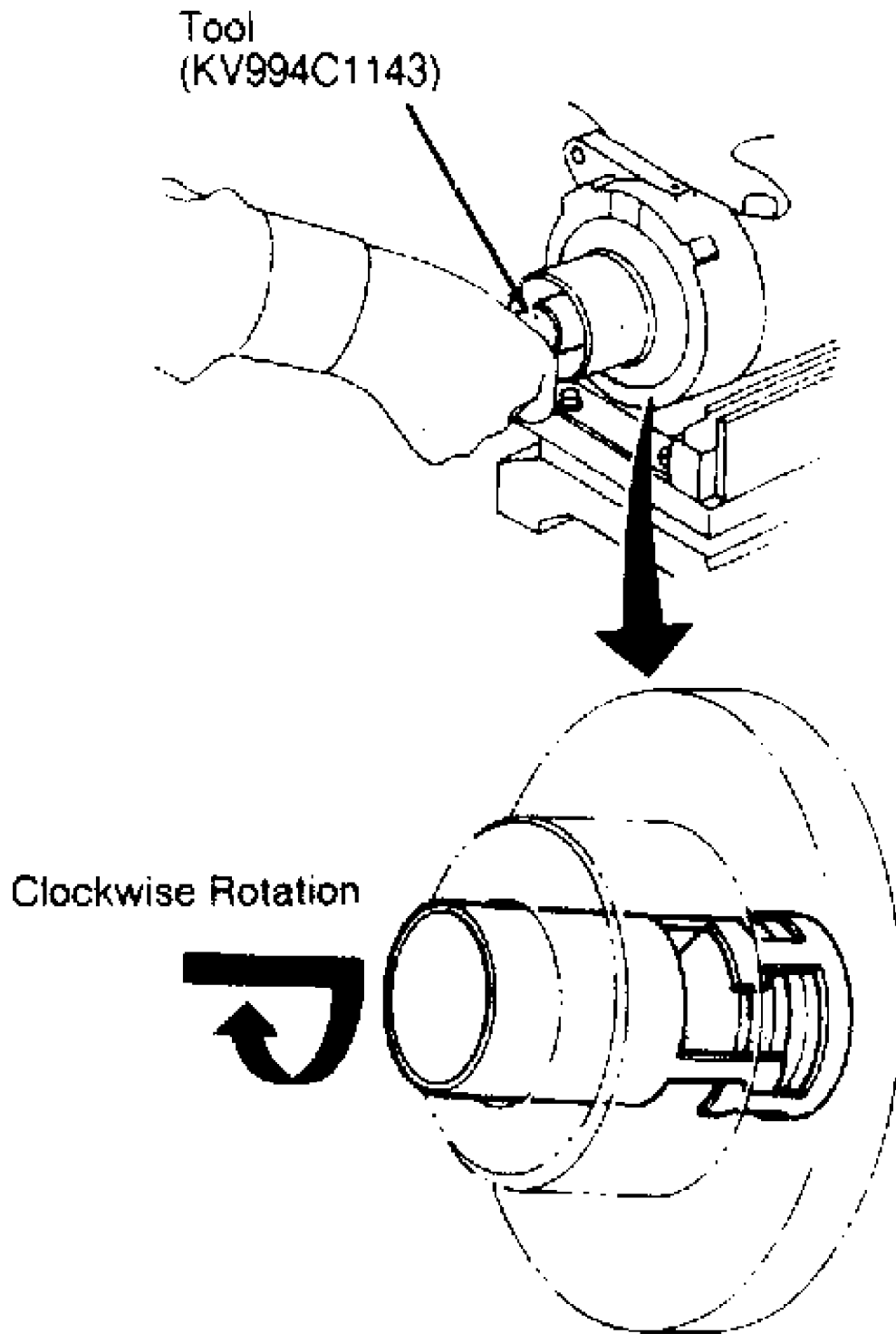

Fig. 11: Hitachi 6-Cylinder Compressor Shaft Seal Removal
Courtesy of Nissan Motor Co., U.S.A.

Inspection
Check carbon seal surface of shaft seal for damage. Check "O"

ring and carbon seal contact surface of shaft seal seat for damage. Make sure that "O" ring contact surface on front cover is not damaged. Make sure refrigerant oil is applied to oil seal in shaft seal seat.

Installation

1) To install, reverse removal procedure. Ensure shaft seal contact surface is free of dirt. Lubricate with refrigerant oil. Cap end of compressor shaft.

2) Using Guard (KV994C1143), insert shaft seal. Be sure shaft seal case is aligned with shaft. Apply force to turn seal to left and right. Ensure shaft seal seats properly in shaft cut-out.

3) Fit "O" ring to outside groove of shaft seal seat. Ensure "O" ring seats properly. Apply refrigerant oil on contact surfaces and around shaft seal seat. Lightly coat surface of shaft with refrigerant oil.

4) Install key on compressor shaft. Using snap ring pliers, compress retainer ring and fit retainer ring into front cover. Seat retainer ring firmly in groove. Thoroughly wipe grease or oil from shaft surface.

5) Connect Installer (KV99412329) to shaft of compressor, and turn shaft 5 or 6 times in a clockwise direction to seat seal. See REFRIGERANT OIL & R-12 SPECIFICATIONS chart in this section for system capacities.

MATSUSHITA ROTARY VANE CLUTCH R & I

Removal & Installation

1) Insert two 5 mm bolts into threaded holes in armature. Using a screwdriver as lever in between bolts, remove center bolt. remove armature and shim from shaft.

2) Remove snap ring. Using a puller, remove pulley. Disconnect electrical leads from field coil. Remove 3 field coil mounting bolts. Remove field coil. See Fig. 12. To install, reverse removal procedure.

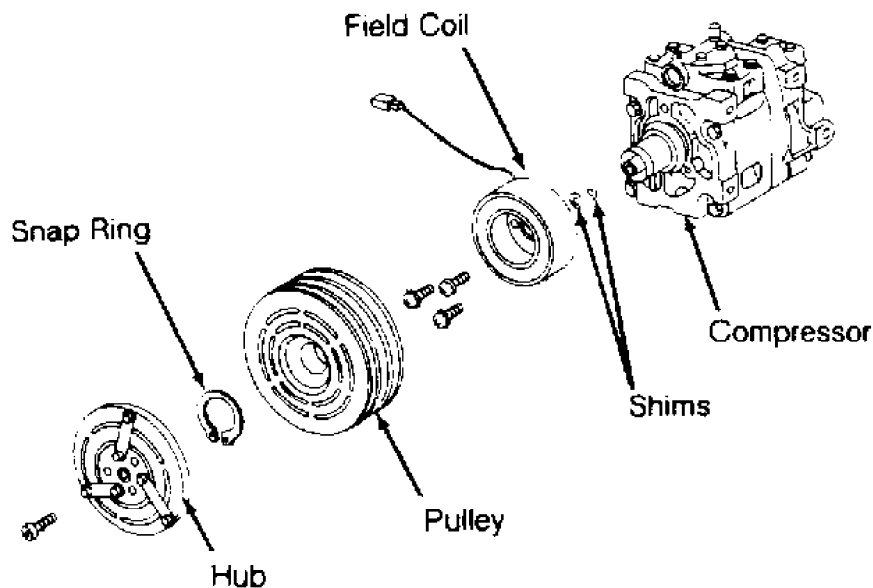

Fig. 12: Exploded View of Rotary Vane Compressor (Matsushita)
Courtesy of Subaru of America, Inc.

NIPPONDENSO TV12 ROTARY VANE CLUTCH R & I

Removal

Remove compressor from vehicle and place on work bench. Holding clutch with Clutch Holder (00007-10331), remove shaft nut. Install Clutch Disc Remover (4992-02-020) and remove clutch disk and shims. Remove pulley snap ring and tap pulley (with bearing) off of compressor with plastic hammer. See Fig. 13.

Installation

To install, reverse removal procedure. Ensure pulley-to-clutch disc clearance is .016-.024" (.4-.6 mm). Adjust (if necessary) by adding or subtracting shims.

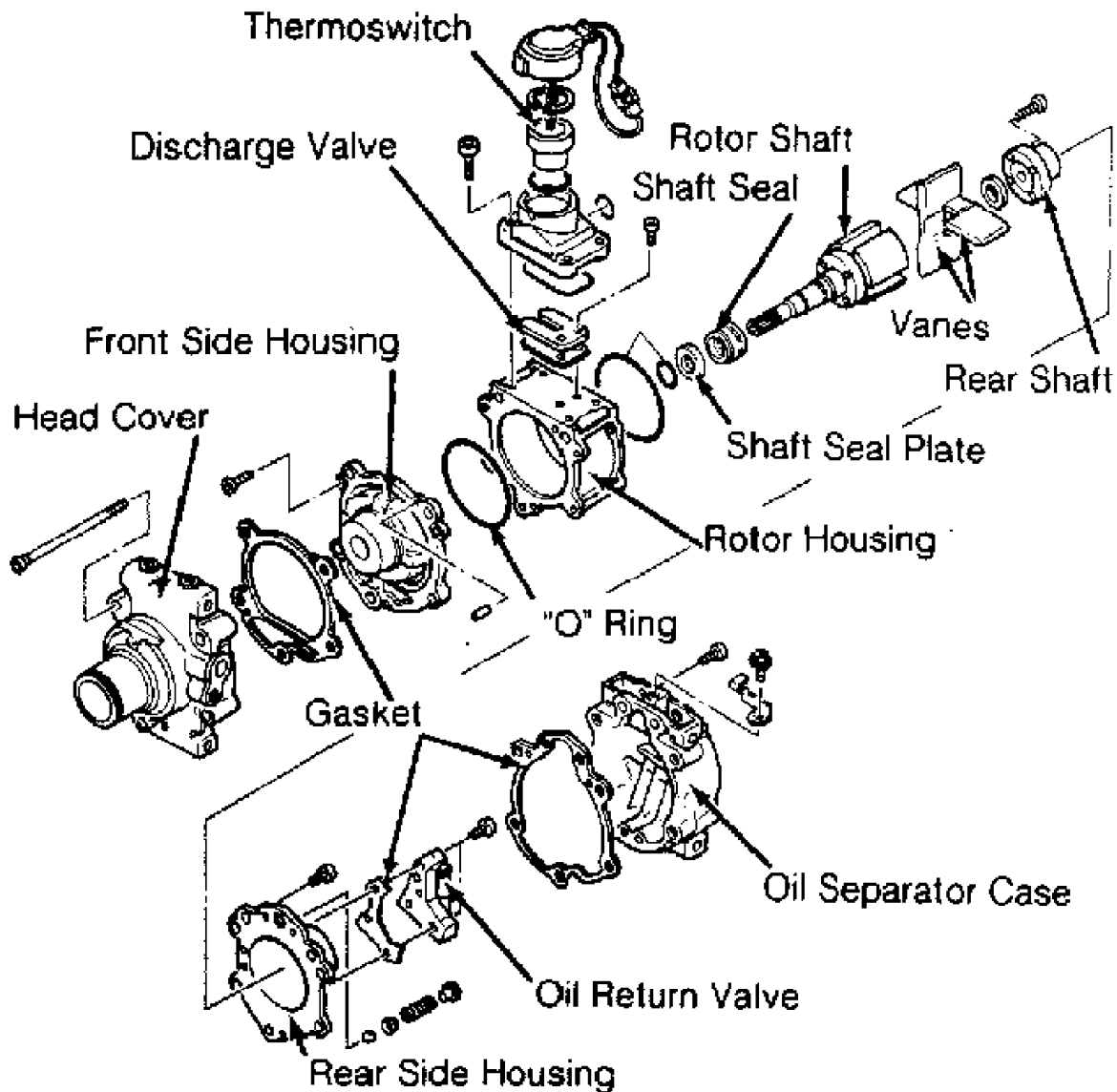

91J04347

Fig. 13: Exploded View of Rotary Vane Compressor (Nippondenso TV12)
Courtesy of Mazda Motors Co., U.S.A.

Removal

1) Remove A/C compressor. Remove pressure plate shaft bolt using socket wrench and Clutch Stopper (07112-76060). Install Clutch Remover (07112-66040) on pressure plate. Using clutch stopper and socket wrench, rotate clutch remover to remove pressure plate.

2) Remove shims from pressure plate. Remove snap ring from compressor. Tap rotor off shaft with plastic hammer. Disconnect stator wire from housing. Remove snap ring from inside stator. Remove stator. See Fig. 12.

CAUTION: DO NOT damage pulley when tapping on rotor.

Installation

To install, reverse removal procedure. Ensure snap rings are installed with beveled side up. Tighten shaft bolt to 10 ft. lbs. (14 N.m). Ensure clutch clearance is .014-.026" (.36-66 mm). Adjust clearance by adding or subtracting shims as necessary.

NIPPONDENSO 6 & 10-CYL SHAFT SEAL R & I

NOTE: Check compressor refrigerant oil level when replacing seals. See COMPRESSOR OIL CHECKING article in the AIR CONDITIONING & HEAT section.

Removal

1) Hold clutch hub stationary and remove center nut. Screw remover into center of hub. Turn center bolt to remove pressure plate.

2) Remove shims from shaft. Remove snap ring from inside of pulley. Tap pulley off of shaft with plastic mallet. Be careful not to distort pulley while removing.

3) Disconnect clutch coil wires from compressor housing. Remove snap ring inside coil and lift coil off compressor. Pry dust seal out from around compressor shaft (if equipped).

4) Place shaft key remover on shaft and turn to remove key. Remove drain plug (if equipped). Remove service valves-to-compressor body bolts. Remove valves. Discard "O" rings. Drain oil out of compressor.

5) Remove 6 through bolts from front head of compressor and discard washers. Tap head loose from compressor; be careful not to scratch sealing surfaces. Remove snap ring (if equipped) from front housing. Press seal plate out. Remove seal from shaft. See Fig. 14.

Installation

1) Lubricate shaft seal with clean refrigerant oil and place on compressor shaft. Lubricate seal plate and "O" ring (if equipped) and install in front housing. Install snap ring (if equipped).

2) Place front housing on compressor body. Install through bolts with new washers. Tighten bolts evenly and alternately to 18 ft. lbs. (24 N.m). Install shaft key using installer and plastic mallet. Insert dust seal into front of compressor.

3) Install drain plug with new gasket. Add correct amount of refrigerant oil to compressor. If service valves were removed, coat new "O" rings with refrigerant oil and install service valves.

4) Place clutch coil on compressor and install snap ring. Install shims on shaft to adjust pressure plate-to-rotor clearance to .016-.028" (.41-.71 mm). Tighten shaft nut to 12 ft. lbs. (16 N.m).

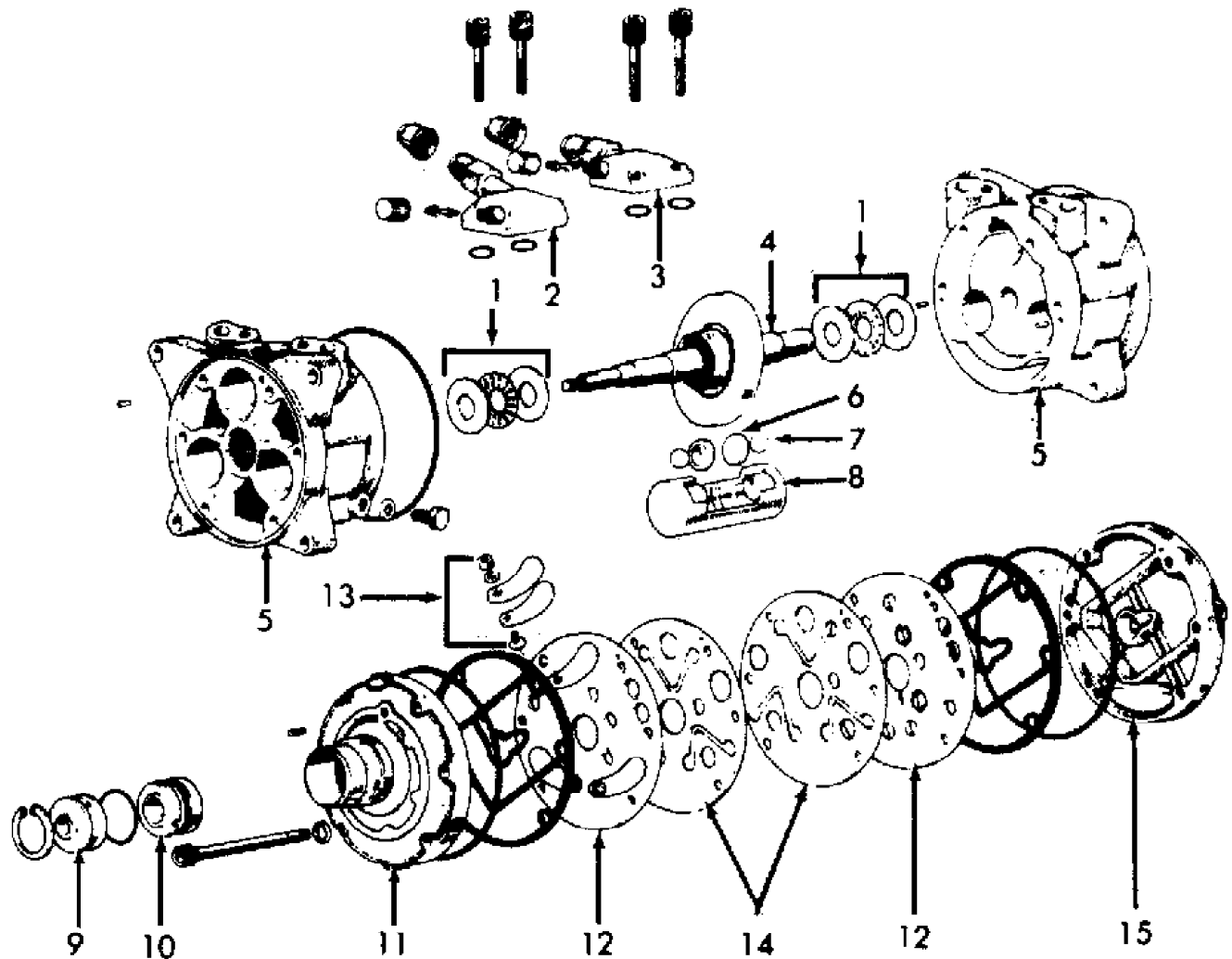

- | | |
|----------------------------|--------------------------|
| 1. Thrust Bearing | 9. Seal Plate |
| 2. Discharge Service Valve | 10. Shaft Seal |
| 3. Suction Service Valve | 11. Front Housing |
| 4. Crankshaft | 12. Valve Plate |
| 5. Cylinder Block | 13. Discharge Reed Valve |
| 6. Shoe | 14. Suction Reed Valve |
| 7. Ball | 15. Rear Housing |
| 8. Piston | |

Fig. 14: Nippondenso 6-Cylinder Compressor
 Courtesy of Chrysler Motors.

PANASONIC ROTARY VANE CLUTCH R & I

Removal

1) Insert two 5 mm bolts into threaded holes in armature. Using screwdriver as a lever in between bolts, remove center bolt. Remove armature and shims from shaft.

2) remove snap ring. Using puller, remove pulley. Disconnect

electrical leads from field coil. Remove 3 field coil mounting bolts. Remove field coil.

Inspection

Check friction surfaces for damage from excessive heat or grooving caused by slippage. Replace parts as necessary. Check coil winding for shorted or open winding. Clean surfaces with solvent and dry rag.

Installation

To install, reverse removal procedure. Tighten field coil retaining screws to 30-56 INCH lbs. (3.4-6.4 N.m). Ensure pulley-to-armature gap is .016-.024" (.4-.6 mm). If gap is not as specified, adjust by adding or removing shims. Tighten center bolt to 96-108 INCH lbs. (11-13 N.m). See Fig. 15.

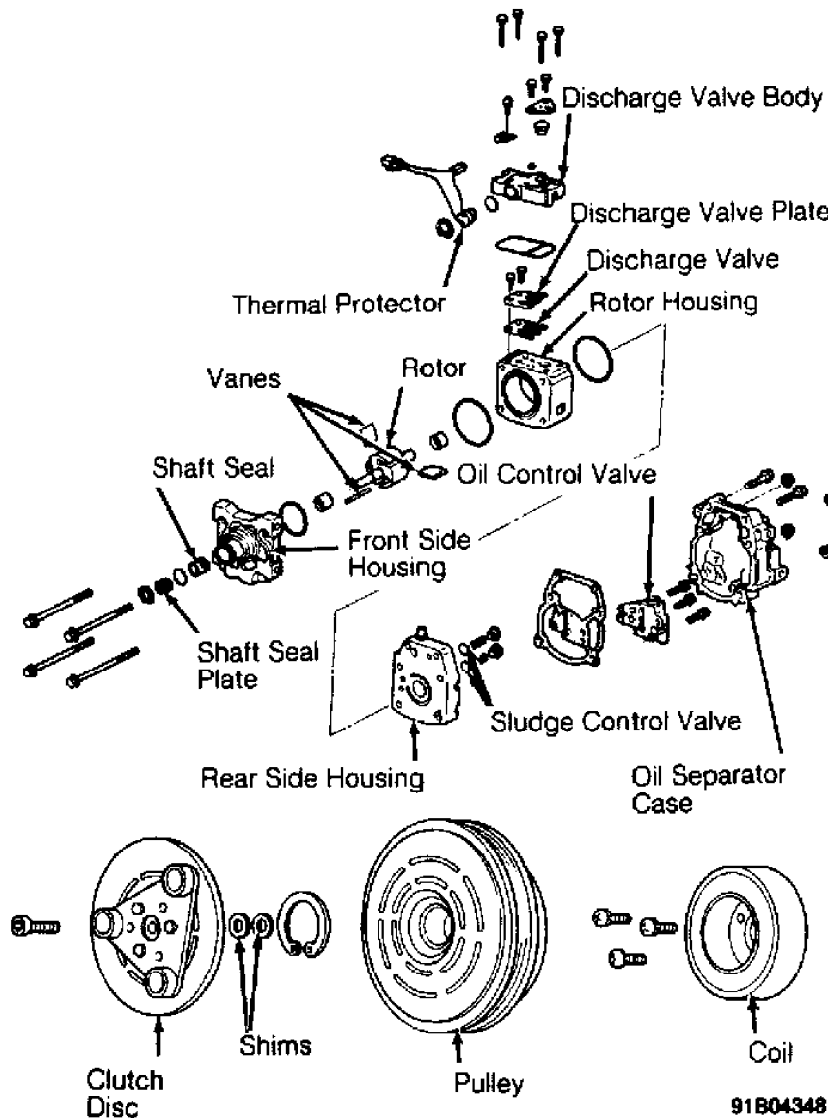
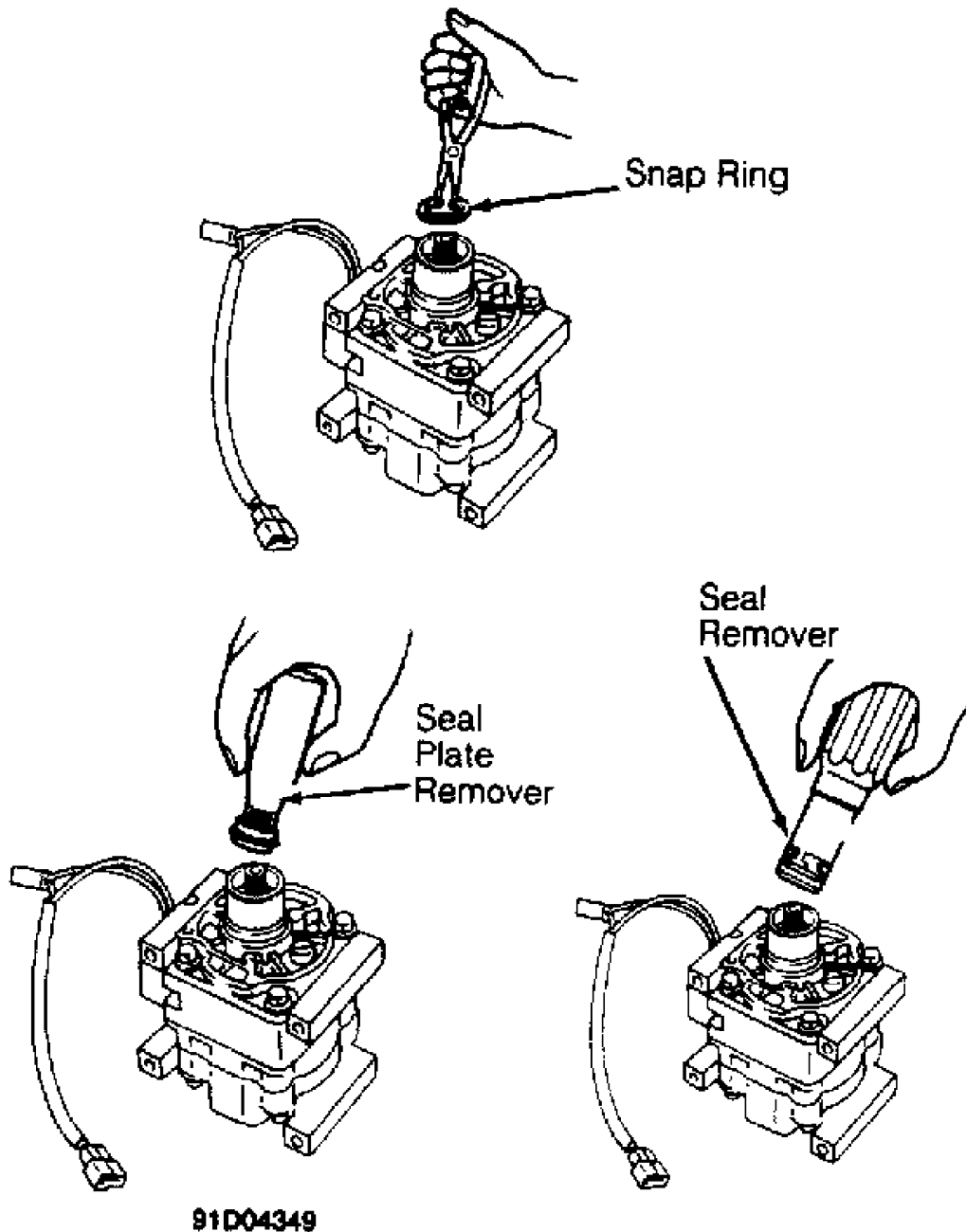

Fig. 15: Exploded View of Rotary Vane Compressor (Panasonic)
 Courtesy of Chrysler Motors.

PANASONIC ROTARY VANE SHAFT SEAL R & I

Removal & Installation

Remove clutch and coil. Remove seal plate snap ring. Using seal plate remover, engage seal and remove seal plate. Using seal remover, engage seal ears and remove seal. See Fig. 16. To install, reverse removal procedure. Coat new seal plate and seal with clean refrigerant oil before installing. DO NOT touch seal surfaces with fingers.



91D04349

Fig. 16: Removing Rotary Vane Compressor Shaft Seal (Panasonic)
Courtesy of Chrysler Motors.

NOTE: Check compressor refrigerant oil level when replacing seals.

Removal

1) Secure 2 box-end wrenches, to hold armature plate, using two 6 mm bolts 1 in. (25 mm) or longer. Holding box-end wrenches, use a socket and ratchet to remove clutch hub nut.

2) Remove armature plate. See Fig. 17. Remove snap ring with internal snap ring pliers. Remove clutch hub. Remove snap ring and clutch coil.

3) Remove bolts retaining front housing. Remove front housing and "O" ring from compressor. Remove shaft seal from shaft. Remove snap ring from back side of front housing. Remove seal plate.

4) Use brass drift and hammer to lightly tap shaft bearing from front housing. Remove felt seal.

NOTE: Do not touch the sealing surfaces of the shaft seal carbon ring and shaft seal plate.

Installation

1) Lubricate shaft seal with compressor oil. Align notches on shaft seal with notches on crank shaft. Install shaft seal plate on the front housing. Install front seal housing to compressor.

2) Use Press Tool (MB991301) to install felt into front housing. Make sure felt metal section faces up. Use Press Tool (MB991301) to press bearing into front housing.

3) Align and install clutch coil. Install snap ring so that the tapered surface is facing outward. Install clutch hub. Install snap ring. Install armature plate, aligning raised area to notch.

4) Secure 2 box-end wrenches, to hold armature plate, using two 6 mm bolts 1 in. (25 mm) or longer. Holding box-end wrenches, use a socket and ratchet to tighten clutch hub nut to 12 ft. lbs. (16 N. m).

5) Use feeler gauge to measure distance between armature and clutch hub. If gap is not .01-.02" (.25-.51 mm), remove clutch assembly and add or remove shims accordingly.

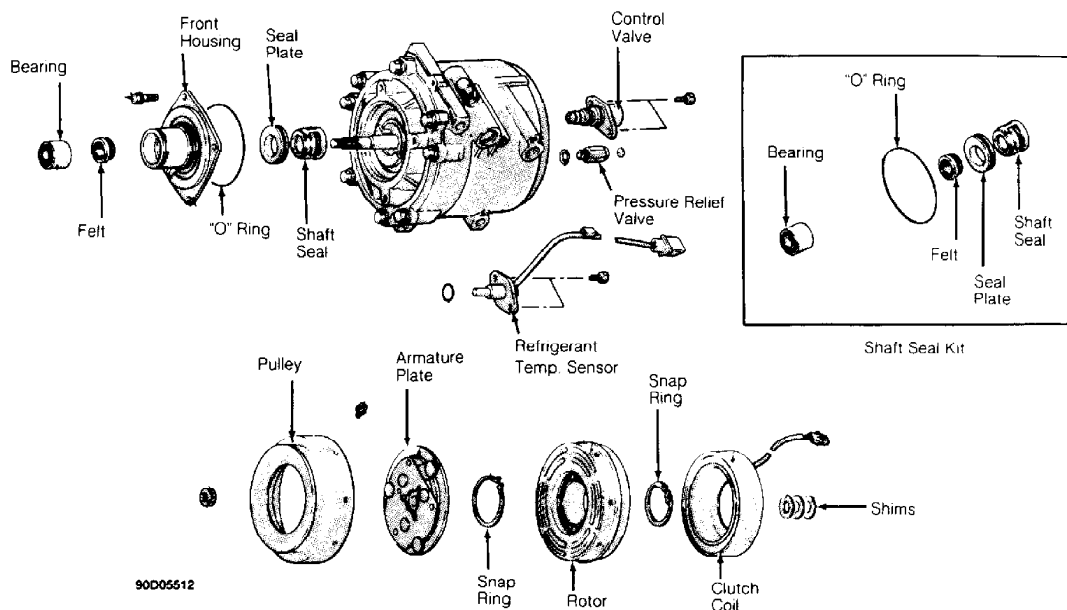

Fig. 17: Sanden Scroll Compressor
Courtesy of Chrysler Motors.

SANDEN 5-CYL CLUTCH R & I

Removal

1) Hold clutch hub stationary and remove shaft nut. Remove clutch plate using puller. Remove external front housing snap ring and internal bearing snap ring. See Fig. 16.

2) Install puller and pull rotor assembly off. remove 3 screws and clutch coil. Use driver and hammer to drive bearing out from hub.

Installation

1) Install new bearing; ensure installer contacts outer race of bearing. Install snap ring and ensure bearing turns freely. Install clutch coil on compressor.

2) Support compressor on rear mounting ears. Align rotor on front housing hub. Use adapter and press to install rotor (or drive into place with soft mallet). After rotor is seated, install front snap ring.

SANDEN 5-CYL SHAFT SEAL R & I

NOTE: Check compressor refrigerant oil level when replacing seals.

Removal

1) Hold clutch hub stationary and remove shaft nut with thin wall socket. Use clutch plate puller to remove clutch plate. Tap key out of slot in crankshaft.

2) Remove seal retainer with seal remover and 3/4" socket wrench. Use seal seat remover tongs to pull seal seat off compressor shaft. Insert seal remover into front housing and turn to engage tangs on seal. Lift seal out. Remove seal "O" ring from front housing, being careful not to scratch shaft.

Installation

1) Coat "O" ring with refrigerant oil and install into groove. Load a new seal onto installer, being careful not to touch carbon sealing surface with fingers. Install shaft protector. Dip seal in refrigerant oil and install on shaft. Rotate seal clockwise until seal fits into flats on shaft. Remove seal installer by turning counterclockwise.

2) Coat seal seat with refrigerant oil and install with tongs. Reinstall seal seat retainer (with flat side down). Install shims and shaft key. Rotate shaft several times to help break in seal.

3) Use a press to install clutch plate. Make sure that air gap is .016-.031" (.41-.79 mm). Hold plate stationary and install shaft nut.

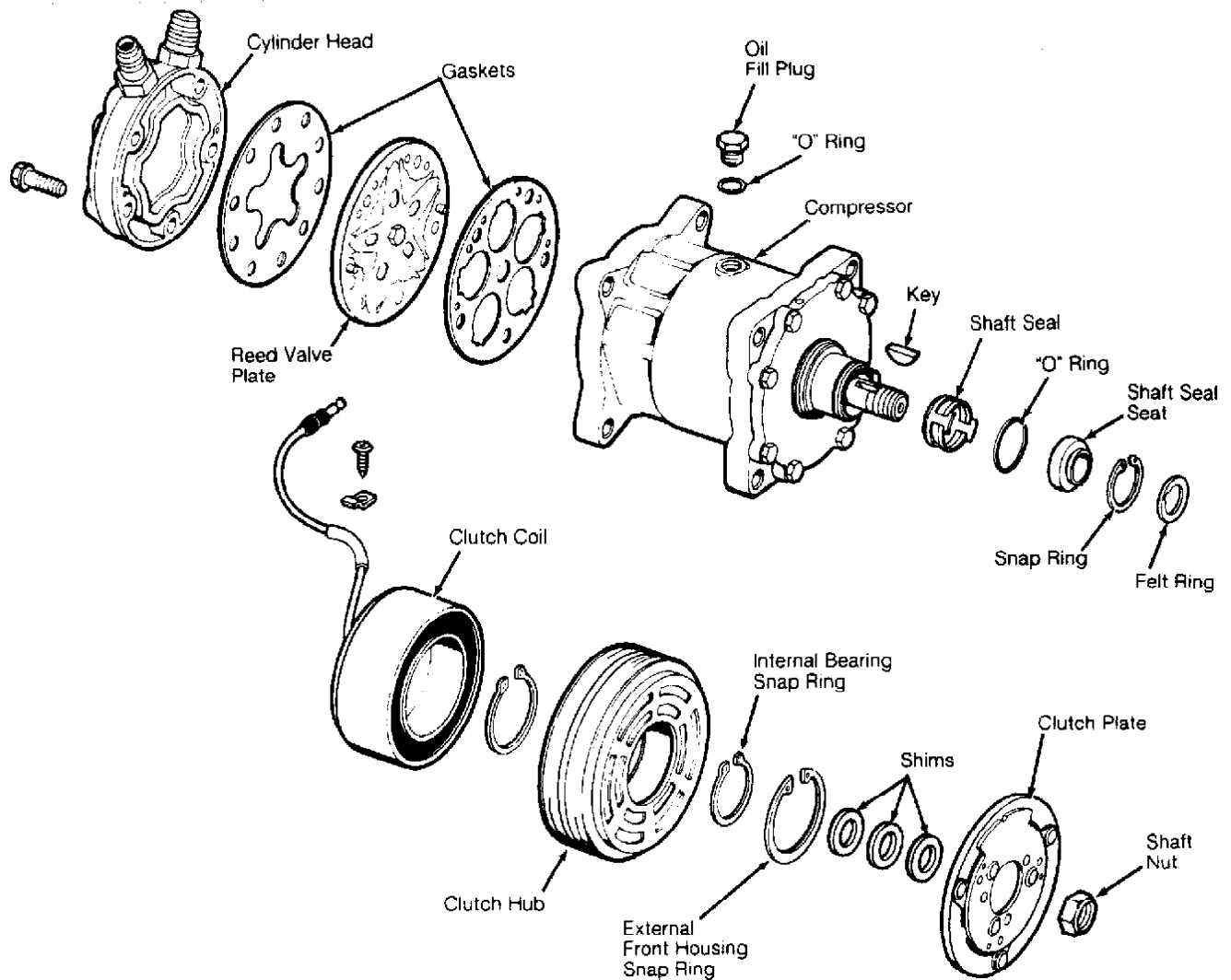

Fig. 18: Sanden 5-Cylinder Compressor
 Courtesy of Chrysler Motors.

SANDEN 7-CYL CLUTCH COIL & BEARING R & I

Removal

- 1) Hold clutch hub stationary and remove shaft nut. Remove clutch plate using Clutch Plate Puller (09977-21110). Remove clutch shims and bearing dust cover. Remove external front housing snap ring.
- 2) Install puller, and pull drive pulley assembly off. Detach clutch coil lead from compressor housing. Remove clutch coil snap ring and clutch coil. If necessary, invert drive pulley assembly and remove snap ring and bearing.

Installation

- 1) Ensure clutch coil protrusion aligns with hole in compressor housing, and install clutch coil snap ring. Install drive pulley assembly using Drive Pulley Installer (09977-21811).
- 2) install external bearing snap ring. Using Seal Installer (09977-21800), install bearing dust cover. After dust cover

installation, ensure there is no contact between cover and front housing.

3) Install clutch shims and clutch plate. Tighten shaft nut to 12-14 ft. lbs. (17-19 N.m). Using a dial indicator, apply voltage to clutch coil to check air gap between clutch plate and drive pulley assembly. Ensure air gap is .016-.032" (.41-.80 mm).

SANDEN 7-CYL SHAFT SEAL R & I

NOTE: Check compressor refrigerant oil level when replacing seals.

Removal

1) Hold clutch hub stationary and remove shaft nut. Remove clutch plate using Clutch Plate Puller (09977-21110). Tap shaft key out of slot in compressor shaft. Remove clutch shims.

2) Remove seal retainer felt ring. Remove shaft seal seat snap ring with snap ring pliers. Insert Seal Seat Remover/Installer (09977-21400) into front housing and turn to engage tangs on seat. Lift seal seat out.

3) Insert seal Remover/Installer (09977-21510) into front housing and turn to engage tangs on seal. Carefully lift seal seat out without scratching compressor shaft.

Installation

1) Install Shaft Seal Guide Sleeve (09977-21700) over compressor shaft. Dip seal in refrigerant oil and install seal on sleeve. Using seal remover/installer, rotate seal clockwise until seal is engaged. Remove seal remover/installer by turning it counterclockwise.

2) Coat seal seat with refrigerant oil and install seal with seal seat remover/installer. Remove shaft seal guide sleeve. Install snap ring. Install seal retainer felt ring using seal seat remover/installer. Install clutch shims and shaft key.

3) Install clutch plate. Tighten shaft nut to 12-14 ft. lbs. (17-19 N.m). Using dial indicator, apply voltage to clutch coil to check air gap between clutch plate and drive pulley assembly. Ensure air gap is .016-.032" (.41-.80 mm).