

HEATER SYSTEM

1991 Mitsubishi Montero

1991-92 HEATER SYSTEMS
Chrysler Motors, Mitsubishi

Chrysler Motors: Ram-50
Mitsubishi: Montero, Pickup

DESCRIPTION

Heater assembly on all models is located in passenger compartment. A heater control valve is used to regulate coolant flow and heat output. Heater assembly contains heater core, heater control valve, air ducts, blower motor and intake ducts. See Fig. 1 or 2. Heater systems are blend-air type.

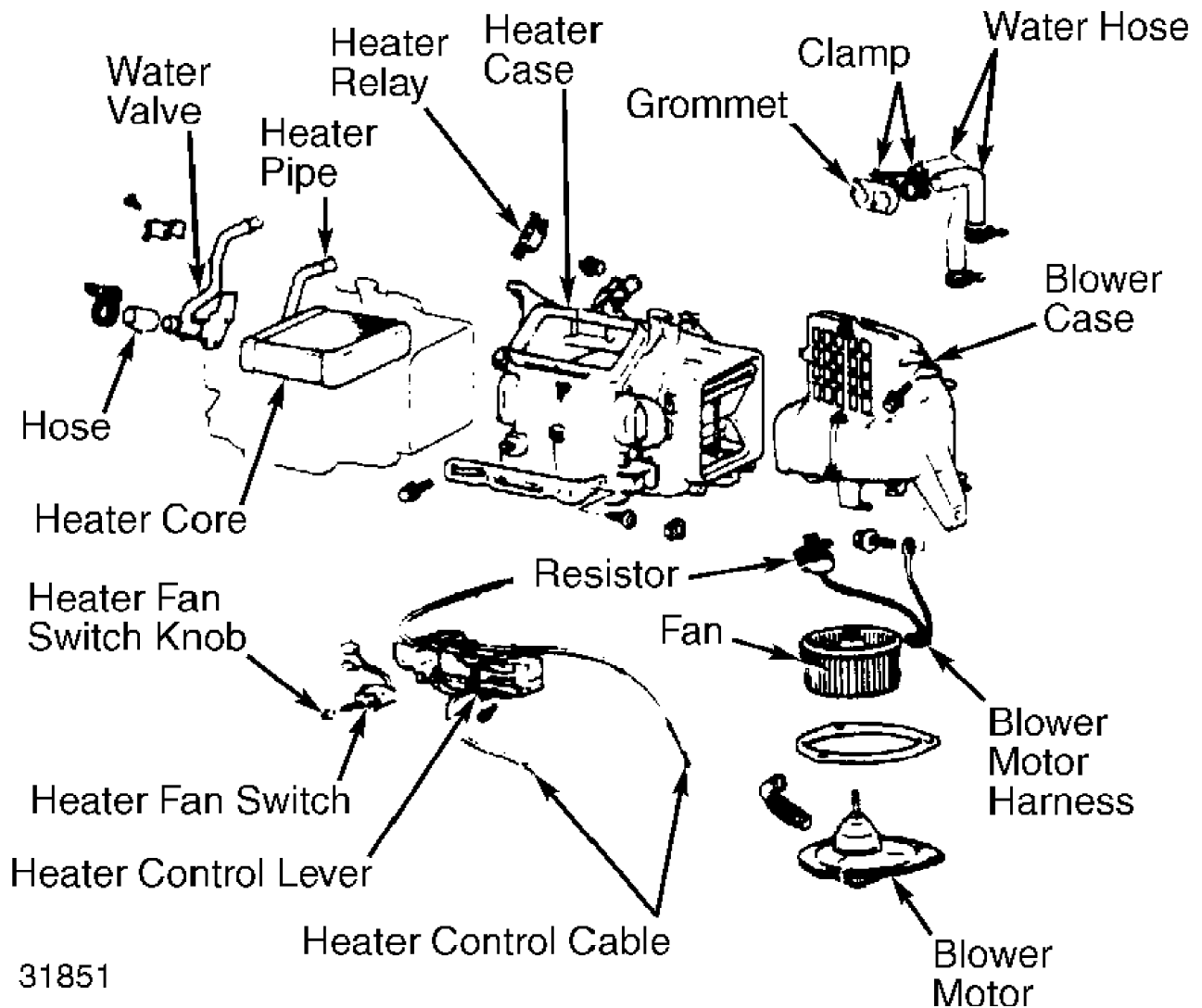

Fig. 1: Identifying Heater System Components (Montero)
Courtesy of Mitsubishi Motor Sales of America.

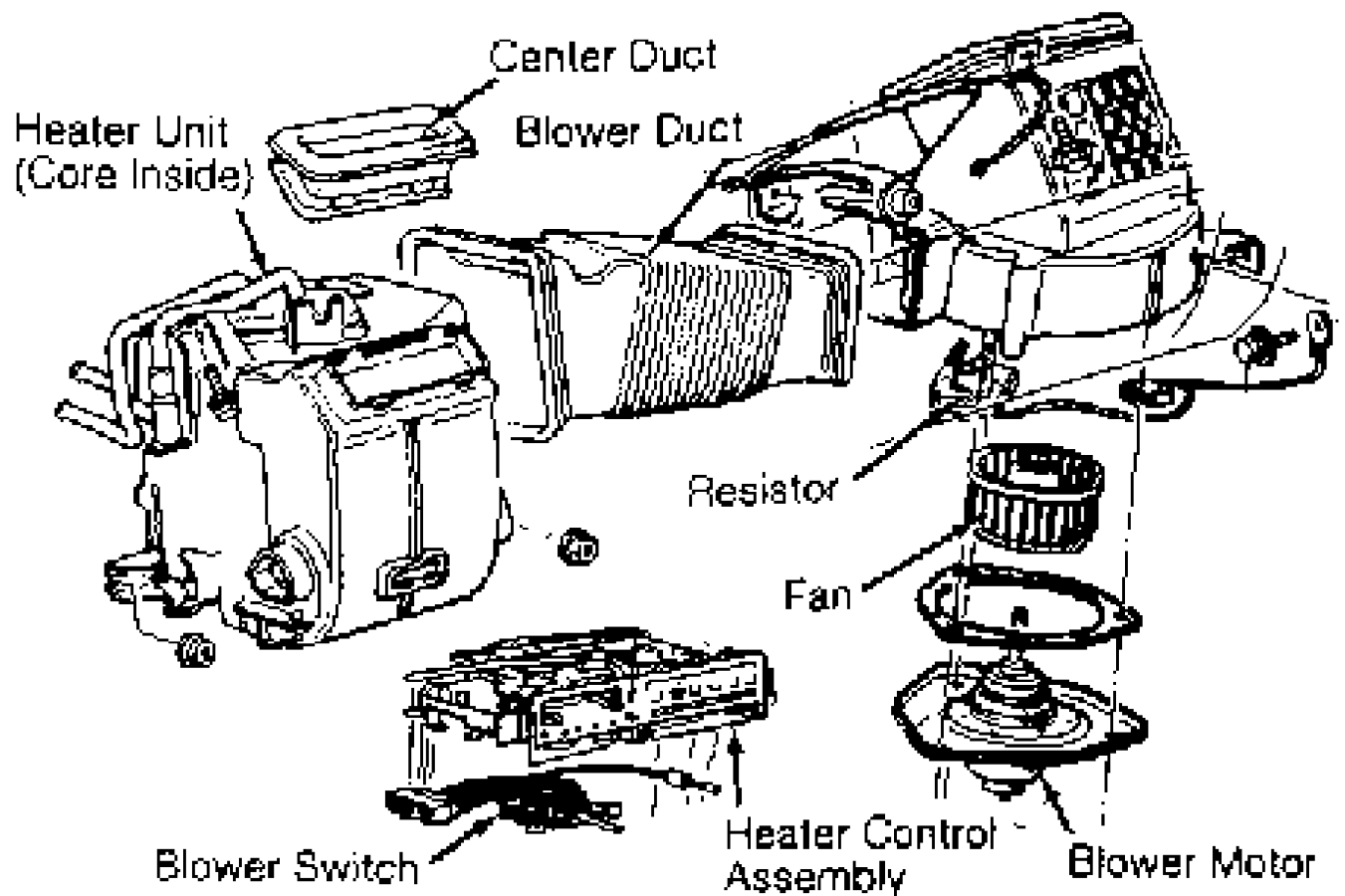

Fig. 2: Identifying Heater System Components (Pickup & Ram-50)
 Courtesy of Mitsubishi Motor Sales of America.

OPERATION

Heater and fresh air operations are controlled by knobs on some models and control levers on others. The control panel of models equipped with control levers consists of mode control levers for inside/outside air, temperature control, air selector and multi-speed blower switch.

The temperature control opens and closes heater control valve, which determines heat output. Heater mode control directs heated air to windshield when in DEF position, to floor when in HEAT position, or to center ventilation ducts when in VENT position. Bi-level output is possible by positioning lever between VENT and HEAT positions.

TEMPERATURE CONTROL LEVER

Temperature level is selected by sliding lever left or right. Highest heat setting is when selector lever is in WARM position. With temperature lever set at COOL position, ambient air is used for ventilating.

AIR SELECTOR LEVER

This lever is used to select source of air flow into vehicle.

With lever set at OUTSIDE position, outside air is allowed to enter and/or pass through heater. With lever set at INSIDE position, air is recirculated inside passenger compartment.

BLOWER SWITCH

The blower can be operated at different fan speeds to regulate amount of air forced through vehicle. Fan speed will increase as switch is turned or moved right.

AIR CONTROL INDICATION SYSTEM

This system consists of indication lights built into instrument cluster and 4 switches connected to various control levers. An indication light glows when heater blower is on. Lights also indicate choice of outlets and whether air source is inside or outside vehicle. In addition, temperature of air directed from outlets is indicated for each air outlet by light colors of green (cool air) and orange (warm air).

ADJUSTMENTS

HEATER (TEMPERATURE) CONTROL VALVE

Place control lever to indicated position. See TEMPERATURE CONTROL CABLE ADJUSTMENT table. See Fig. 3. Connect cable to heater control valve and/or air damper lever according to table. Secure cable sleeve using clips. With engine running, check for coolant leaks and check operation of heater control valve. If heater control valve does not operate properly, adjust by moving cable sleeve forward or backward at retaining clip.

TEMPERATURE CONTROL CABLE ADJUSTMENT TABLE

Application	Control Lever Position	Water Valve Lever Position
Montero	Far Left	Toward cable
Pickup & Ram-50	Far Left	(2) Away from cable

(2) - Disconnect link between air damper lever and water valve lever. Close water valve. Close air damper. Reconnect link. Attach cable to clip.

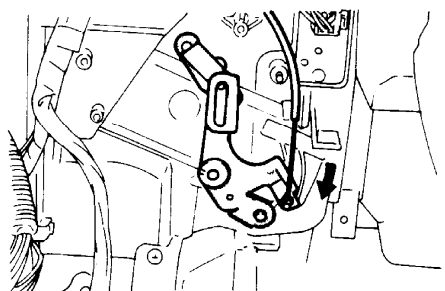

91H05044
Fig. 3: Adjusting Temperature Control Cable (Typical)
Courtesy of Mitsubishi Motor Sales of America.

INSIDE/OUTSIDE AIR SELECTION CABLE

Move control lever to INSIDE position. Connect cable to damper lever with outside air intake to heater closed. Apply multipurpose grease to rotating portions of sliding lever. Check for proper damper operation by moving control lever. To adjust, press air control lever toward cable and move outer wire at retaining clip. See Fig. 4.

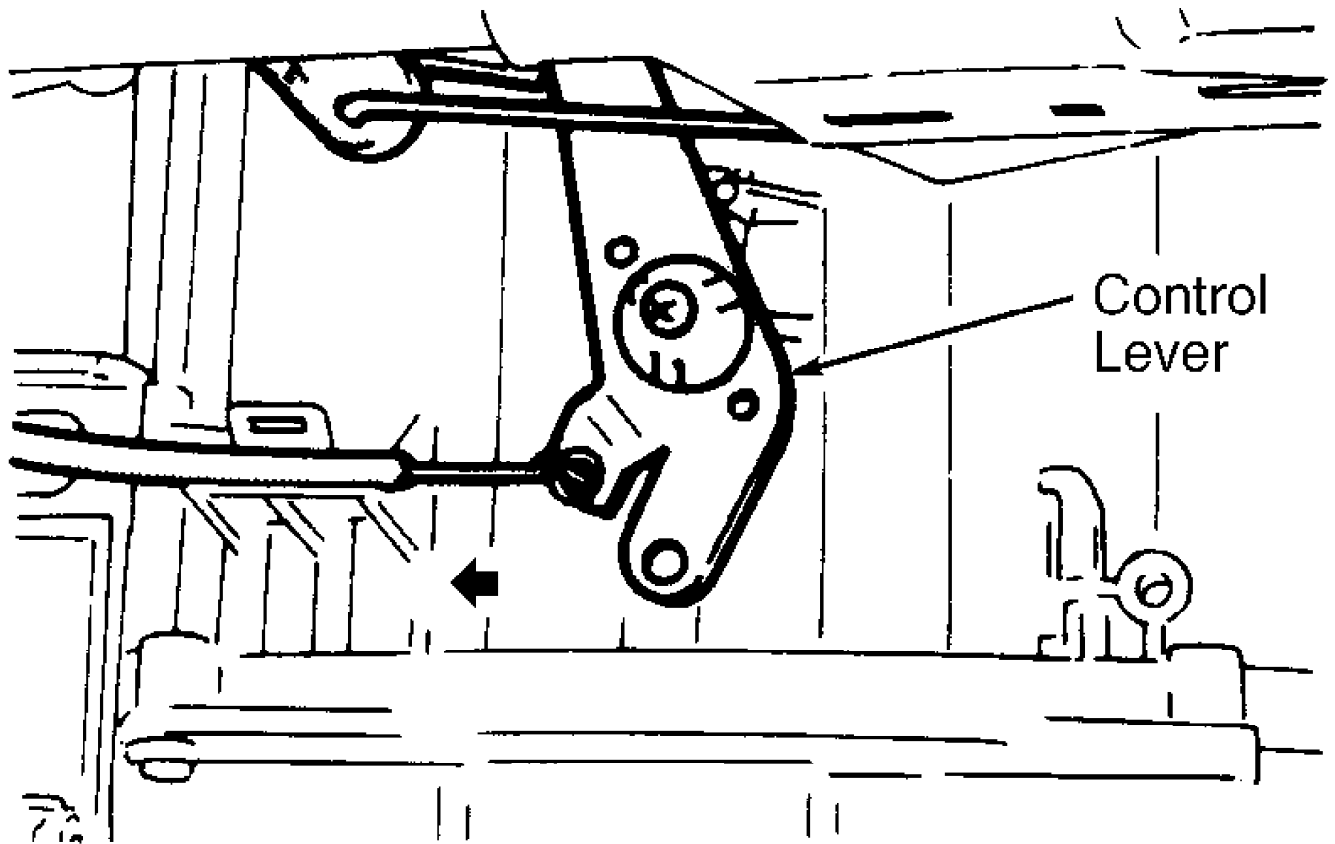

91C05046

Fig. 4: Adjusting Air Selection Cable (Typical)
Courtesy of Mitsubishi Motor Sales of America.

MODE SELECTOR LEVER

Place selection lever in DEF position, and remove cable clip. Ensure defroster door is fully open. Secure cable sleeve using clips. Move lever to other positions to check for correct operation. Adjust cable, if necessary, by moving sleeve forward or backward at retaining clip.

TROUBLE SHOOTING

BLOWER MOTOR INOPERATIVE

Blown blower fuse. Blower motor improperly grounded. Defective switch or faulty blower motor wiring connections. Foreign object in fan.

INSUFFICIENT HEAT

Incorrect thermostat in cooling system. Improperly adjusted temperature control cable. Clogged heater core fins. Faulty heater control valve.

NO TEMPERATURE REGULATION

Clogged or stuck heater control valve. Incorrect installation of heater control valve control cable. Incorrect adjustment of heater control valve link.

NO VENTILATION

Incorrect adjustment of change-over dampers. Duct connection loose.

TESTING

BLOWER MOTOR SWITCH TEST

Blower motor switch can be tested using an ohmmeter. Insert test leads into appropriate connector terminals, and check continuity. See BLOWER SWITCH CONTINUITY table. See Fig. 5 or 6.

BLOWER MOTOR SWITCH CONTINUITY TABLE

Switch Position	Continuity Between Terminal Nos.
Montero	
Low	1-2 & 1-7
Medium 1	2-4 & 4-7
Medium 2	2-5 & 5-7
High	2-6 & 6-7
1992 Montero	
Low	1-8 & 3-5
Medium 1	1-8 & 5-6
Medium 2	1-4, 1-8 & 2-5
High	1-4, 1-8 & 5-7
Pickup & Ram-50	
Low	1-2, 2-6 & 7-8
Medium 1	1-3, 3-6 & 7-8
Medium 2	1-4, 4-6 & 7-8
High	1-5, 5-6 & 7-8

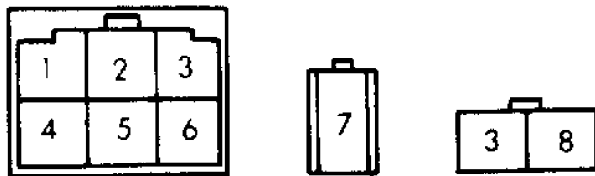

CORDIA & TREDIA

Fig. 5: Blower Motor Switch Connector Terminal ID (Pickup & Ram-50)
 Courtesy of Mitsubishi Motor Sales of America.

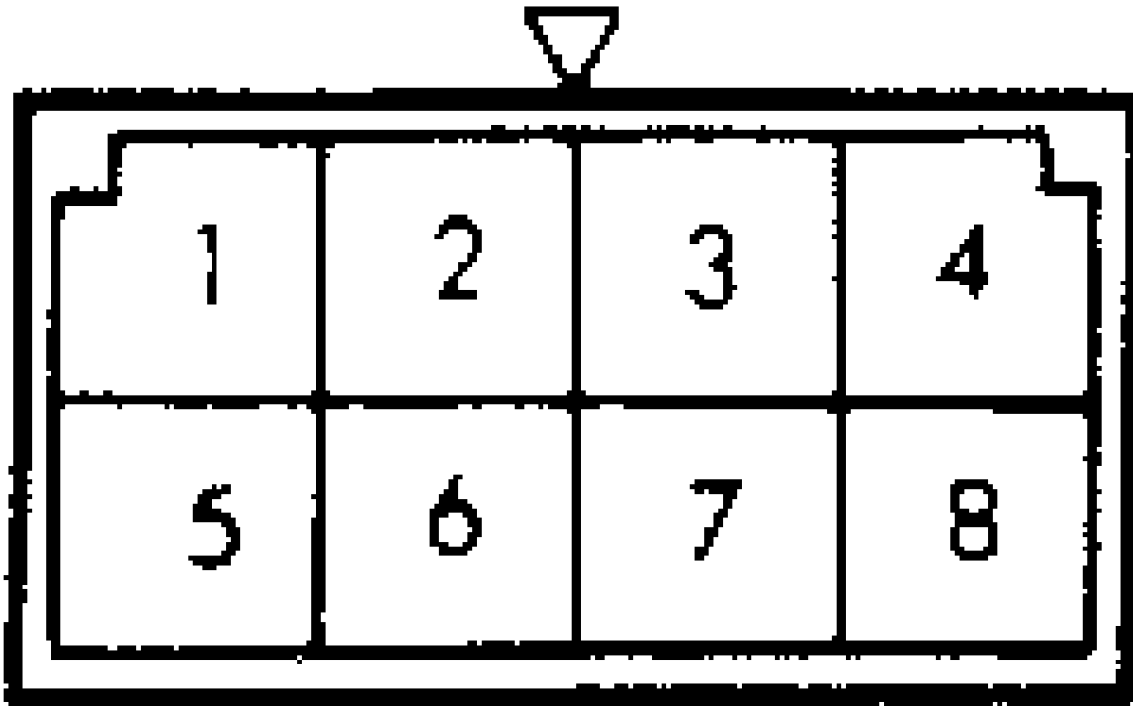

COLT, MIRAGE, PICKUP & VAN/WAGON (FRONT)

Fig. 6: Blower Motor Switch Connector Terminal ID (Montero)
Courtesy of Mitsubishi Motor Sales of America.

BLOWER MOTOR TEST

1) Turn ignition on. Check fuses. If fuses are bad, check wiring harness for short circuits. If fuses are okay, check voltage between heater relay and ground circuit. If voltage does not exist at heater relay, check for broken wire between fuse block and heater relay.

2) If voltage exists at heater relay, check relay, and replace if necessary. See BLOWER MOTOR RELAY TEST under TESTING. If relay is okay, disconnect blower motor connector. Set heater switch to either LO, MED or HI setting.

3) Check voltage between harness side of connector and vehicle ground. Battery voltage should be present. If battery voltage is present, go to next step. If battery voltage is not present, check continuity between resistor terminals. See BLOWER MOTOR RESISTOR TEST under TESTING. If continuity is not present, replace resistor.

4) If continuity is present between motor terminals at blower connector, check ground circuit. If ground circuit is okay, check for blower motor malfunction. Disconnect blower motor terminals. Connect blower motor terminals directly to battery. Blower motor should operate smoothly.

5) Reverse blower motor terminal polarity to battery. Blower motor should operate smoothly in reverse direction. If blower motor does not operate as specified, replace blower motor.

BLOWER MOTOR RELAY TEST

NOTE: Pickup and Ram-50 blower motors do not have blower motor relays.

1) Remove blower motor relay from fuse/relay block. Connect an ohmmeter between terminals No. 1 and 3. See Fig. 7. Continuity should not be present.

2) Connect an ohmmeter between terminals No. 2 and 4. Continuity should be present. Connect 12-volt battery positive lead to terminal No. 2 and negative lead to terminal No. 4. See Fig. 7.

3) Connect an ohmmeter between terminals No. 1 and 3. Continuity should be present. If continuity is not as specified in any step, replace relay.

Blower Motor Relay

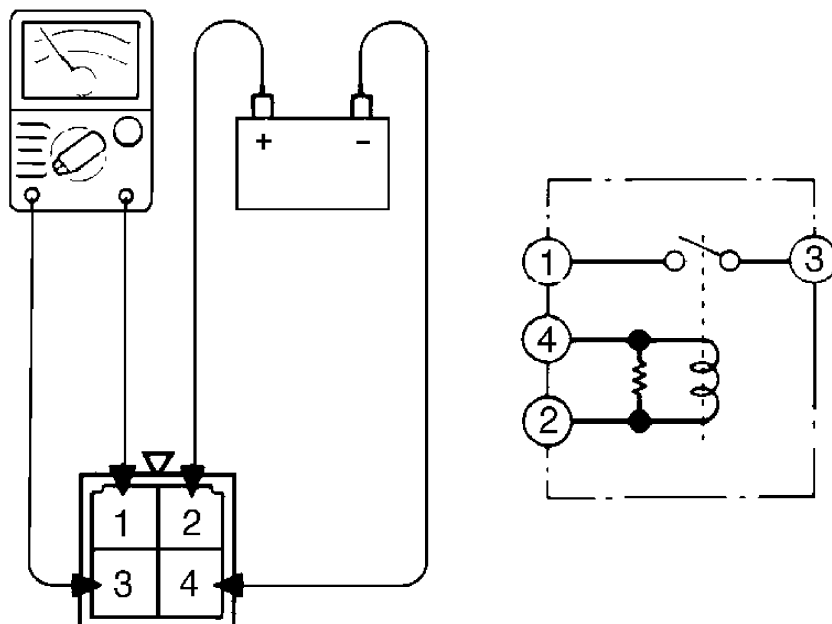
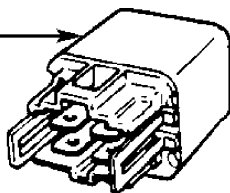

92H02658

Fig. 7: Identifying Blower Relay Terminals
Courtesy of Mitsubishi Motor Sales of America.

BLOWER MOTOR RESISTOR TEST

Disconnect harness connector from resistor terminals. Using an ohmmeter, check resistance between terminals indicated in BLOWER MOTOR RESISTOR RESISTANCE table. See Fig. 8. If resistance is not as shown, replace resistor.

BLOWER MOTOR RESISTOR RESISTANCE TABLE

Terminal Nos.	Ohms
Montero	
1-2	1.22
1-341
1-4	2.25
1-5	0
Pickup & Ram-50	
1-2	1.19
1-350
1-4	2.33
1-5	0

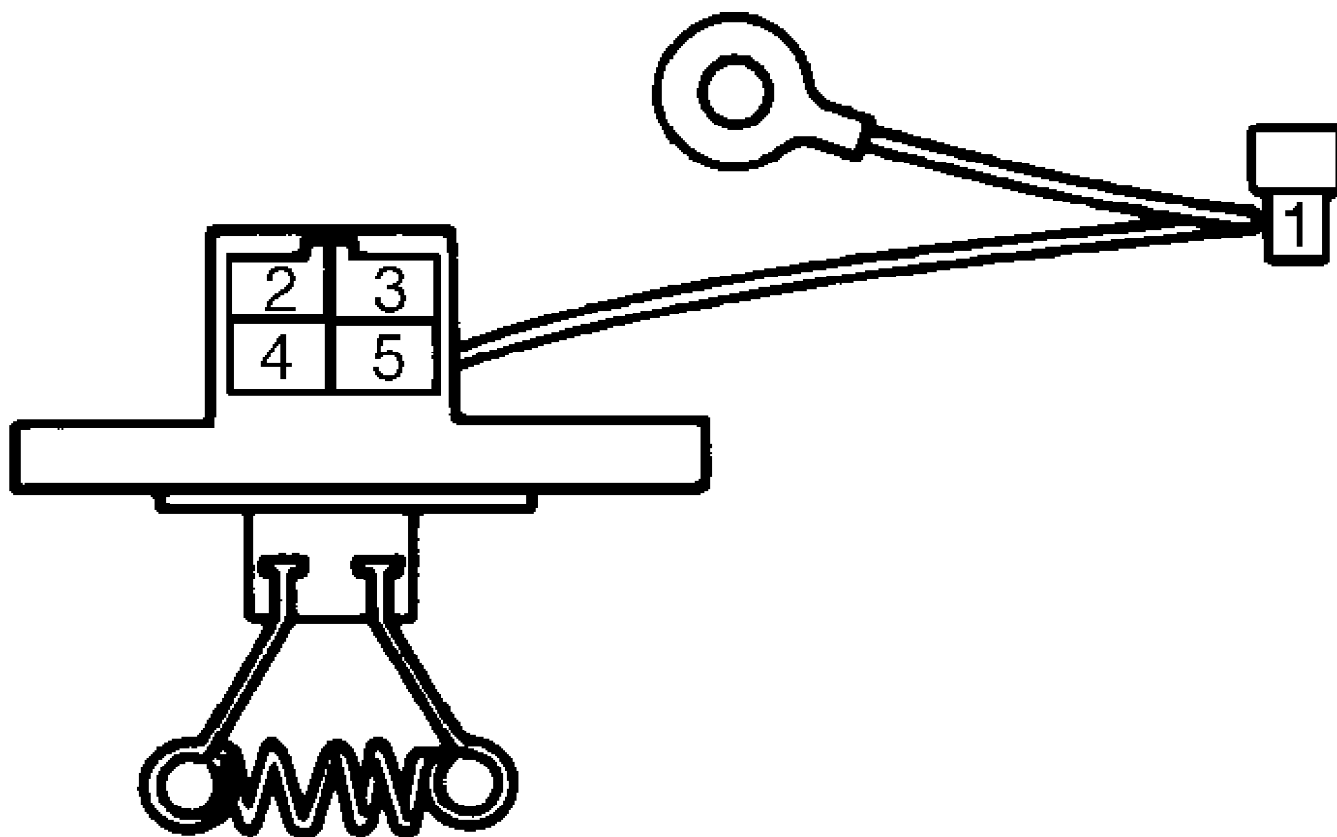

91D04783

Fig. 8: Identifying Blower Resistor Terminals
 Courtesy of Mitsubishi Motor Sales of America.

REMOVAL & INSTALLATION

HEATER CORE

Removal (Montero)

1) Move temperature control lever to WARM position. Drain coolant from vehicle. Disconnect heater hoses from heater unit. See Fig. 1.

2) Remove lap heater ducts. Remove hood release bracket. Using screwdriver, release tabs and remove left and right demister grilles. Remove glove box frame attaching screws, and remove glove box. Remove passenger lap heater duct.

3) Using screwdriver and shop towel, carefully pry at top center of instrument cluster cover, and remove cover. Remove 2 screws at bottom of instrument panel and one bolt at top of instrument panel. Gently pull instrument cluster out, and disconnect speedometer cable and electrical connections. Remove instrument cluster.

4) Remove 4 screws, and disconnect electrical connections on back of instrument cluster. Remove instrument cluster. Handle instrument cluster carefully. Instrument cluster can be damaged if dropped.

5) Remove center console knobs and side screw plugs. Remove screws, disconnect electrical connections and remove console. Remove 6 bolts and console bracket (center dash reinforcement). Disconnect radio connections while removing console bracket.

6) Remove horn pad and steering wheel retaining nut. Mark steering wheel and steering shaft for reassembly reference. Using steering wheel puller, remove steering wheel.

7) Using screwdriver, carefully pry out dash plug at upper center of dash panel. Remove 3 upper dash mounting nuts, one upper screw above steering column, and 2 lower mounting screws. Remove dash panel.

8) Remove control cables at heater unit. Remove heater unit attaching screws. Remove heater ducts. Remove heater unit. Remove heater control lever arm.

9) Remove heater control valve cover. Remove heater pipe and heater control valve. Disconnect control arm linkage. Remove control arm. Remove heater core by moving it sideways.

Installation

1) To install, reverse removal procedure. Insert heater hoses fully into pipes, and clamp securely to prevent leaks. Connect heater hoses with 1-1.2" (25-30 mm) overlap on outlet.

2) When filling radiator with coolant, first open heater control valve fully and run engine to circulate coolant and discharge air from inside heater and engine cooling system. Stop engine, and add coolant.

3) Adjust all control cables. When installing heater hose grommets, apply sealer. After installing heater control assembly, ensure each lever operates smoothly.

Removal (Pickup & Ram-50)

1) Disconnect battery ground cable. Place heater control lever to far right. Drain coolant. Using trim stick, pry out hazard switch and remove electrical connection. Remove 4 instrument cluster cover screws, and remove cover. Remove 4 instrument cluster screws. Tilt instrument cluster out, and disconnect speedometer cable and electrical connections. Remove cluster.

2) Remove fuse box cover and fuse box assembly. Remove glove box. Remove defroster air ducts. Disconnect heater control cables. Using trim stick, pry under and remove speaker grilles. Remove clock or coin box in center of dash. Remove center dash hole cover (located above clock).

3) Remove 2 center support cover screws, and remove cover. Remove shift knob and 6 console attaching screws. Remove console. Ensure all electrical connections are free of dash panel. Remove 3 top nuts, one bolt above steering column, and side and lower attaching

screws. Remove dash panel.

4) Remove blower duct, center duct and defroster ducts. See Fig. 2. Disconnect heater wiring harness from heater unit. Remove heater center support brackets. Remove heater unit. Remove heater core cover plate and joint hose. Remove heater core from heater unit.

Installation

1) To install, reverse removal procedure. Insert heater hoses fully into pipes, and clamp securely to prevent leaks.

2) When filling radiator with coolant, first open heater control valve fully and run engine to circulate coolant and discharge air from inside heater and engine cooling system. Stop engine, and add coolant.

3) Adjust all control cables. When installing heater hose grommets, apply sealer. After installing heater control assembly, ensure each lever operates smoothly.

HEATER CONTROL PANEL

Removal (Montero)

1) Remove heater control knob and heater fan switch knob. Remove center console. Remove defroster nozzle at temperature control cable side.

2) Remove lap heater duct and glove box stopper, and push glove box forward and down. Disconnect inside/outside control cable from blower assembly.

3) Disconnect control cables from heater unit. Remove heater control panel mounting screws, and pull out panel slightly. Disconnect heater fan switch harness connectors. Remove heater control panel. Remove heater fan switch from heater control panel.

Installation

1) Place air outlet change-over lever at closed position. With heater side air outlet change-over damper lever in position, connect inner cable to lever, and secure cable casing using clips.

2) Place heater control lever at OFF position. With heater control lever in position, connect inner cable to lever, and secure cable casing using clips.

3) Place inside/outside air change-over lever at INSIDE position. With heater side inside/outside air change-over damper lever in position, connect inner cable to lever, and secure cable casing using clips.

4) Set control lever to each position to check for correct operation. If lever does not operate correctly, adjust by moving outer wire at clipped point. Ensure each control lever moves smoothly. If any noise or stiff movement exists, apply multipurpose grease to all moving parts.

NOTE: When mounting heater control panel to instrument panel, tighten upper bolts to instrument panel so they also secure center panel.

Removal & Installation (Pickup & Ram-50)

Remove cluster panel. Remove all control cables at heater. Remove heater control panel. To install, reverse removal procedure. Adjust cables as necessary.

WIRING DIAGRAMS

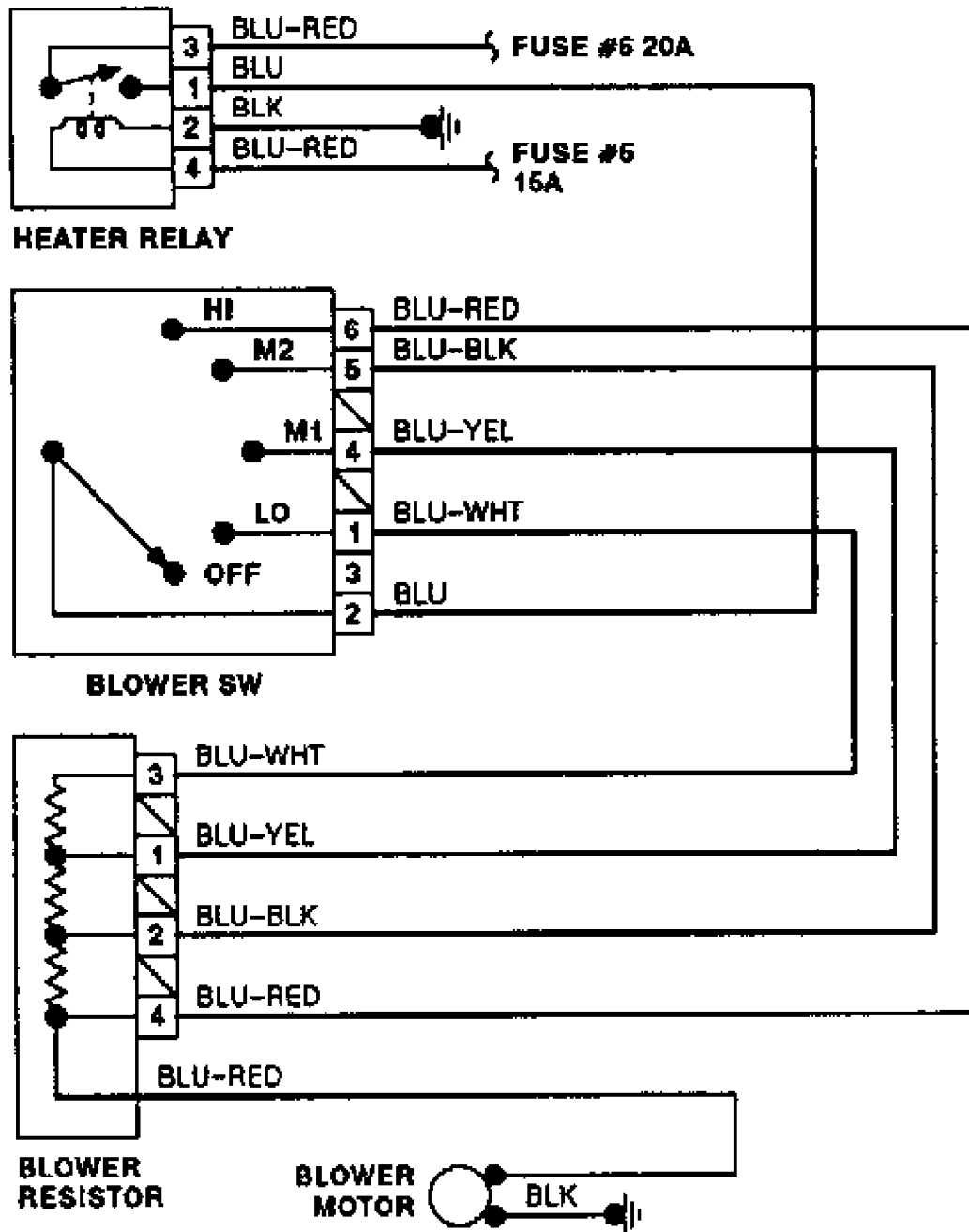

Fig. 9: Heater System Wiring Diagram (Montero)

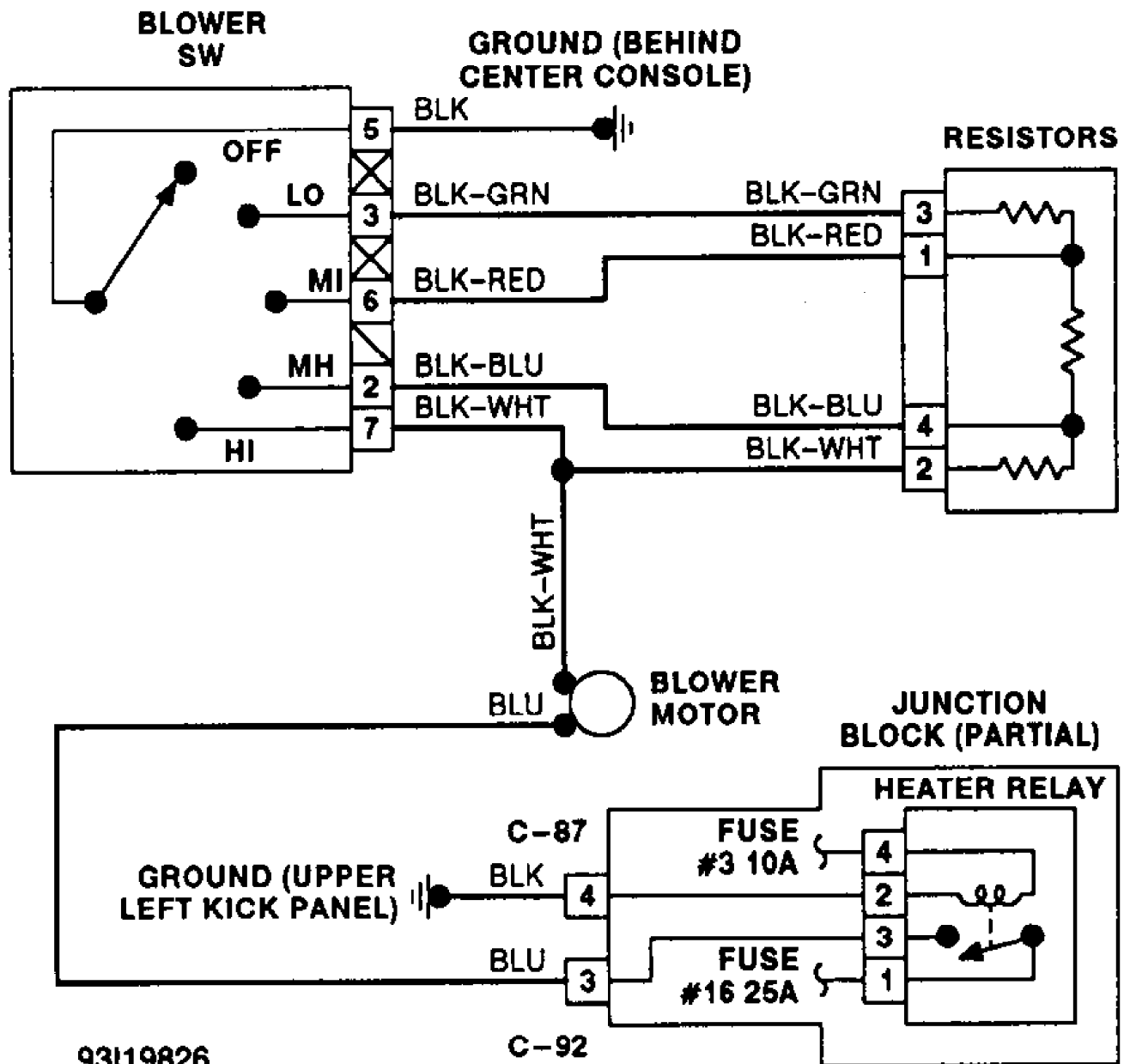

Fig. 10: Heater System Wiring Diagram (1992 Montero)

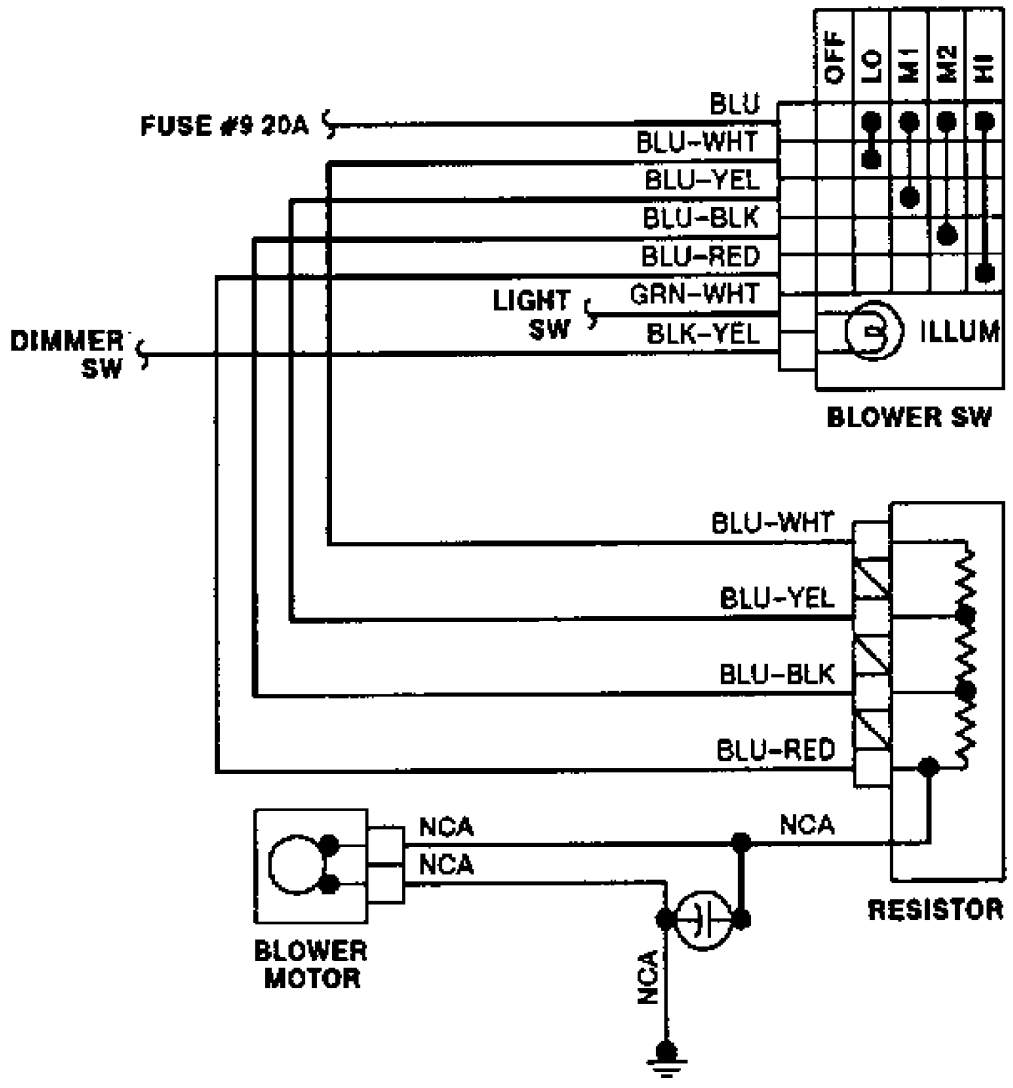

Fig. 11: Heater System Wiring Diagram (Pickup & Ram-50)

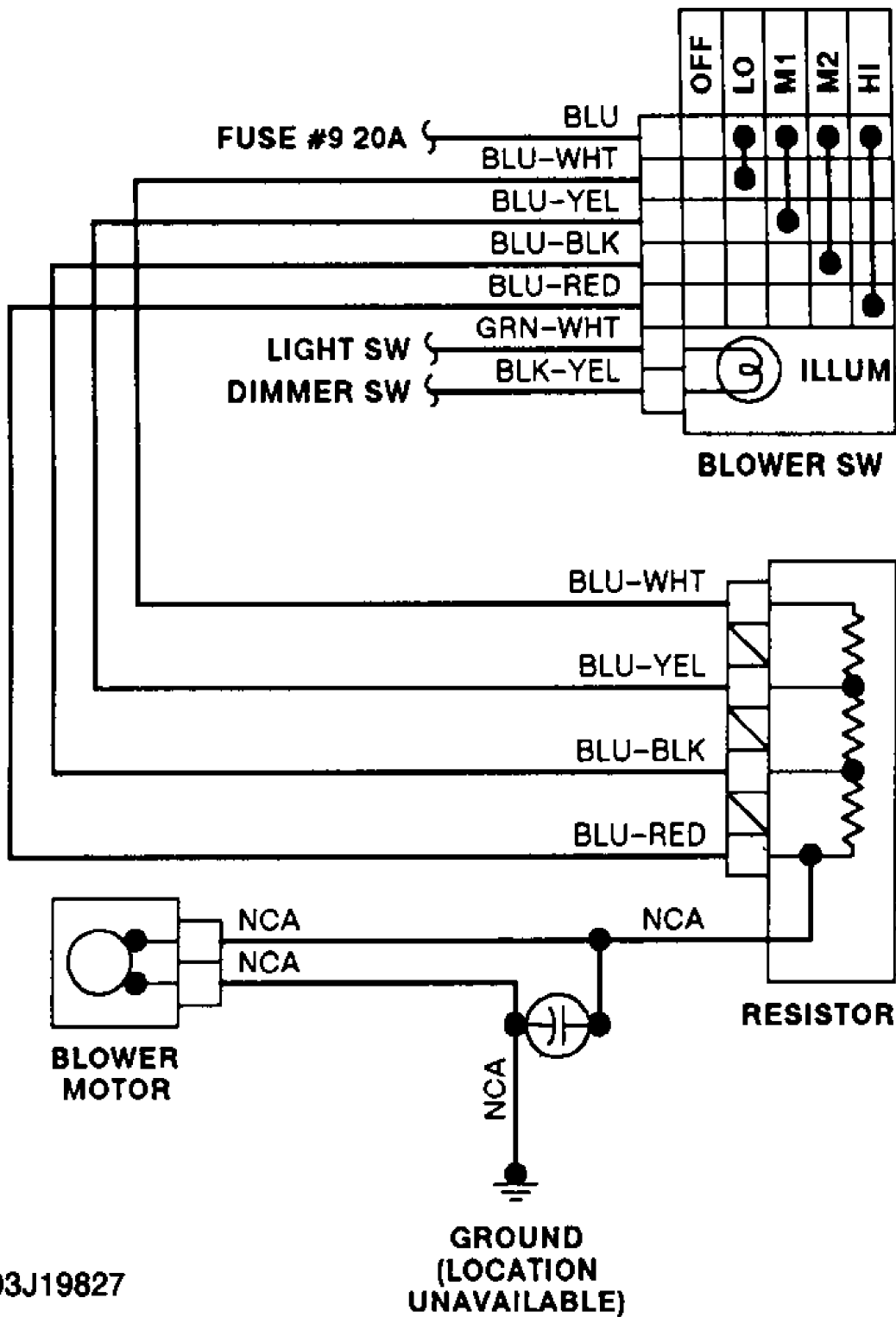

Fig. 12: Heater System Wiring Diagram (1992 Pickup & Ram-50)