

JACKING & HOISTING

1991 Mitsubishi Montero

1991 WHEEL ALIGNMENT
Jacking & Hoisting

Chrysler Motors: Ram-50
Mitsubishi: Montero, Pickup

JACKING & HOISTING

NOTE: The following illustrations DO NOT represent the exact structure of vehicle's frame, underbody or body outline. Illustrations are given to provide reference points for the mechanic.

FRAME & UNDERBODY

The following illustrations indicate points for jacking and hoisting vehicle. These points are indicated by shaded areas on the frame and underbody. See Fig. 1.

OUTERBODY

Points on the outline of body were designated to be used specifically with vehicle's own jack. See Fig. 2. If floor jack or hoist is used at these points, use extreme care to avoid damaging outer body shell. See Fig. 2 or 3.

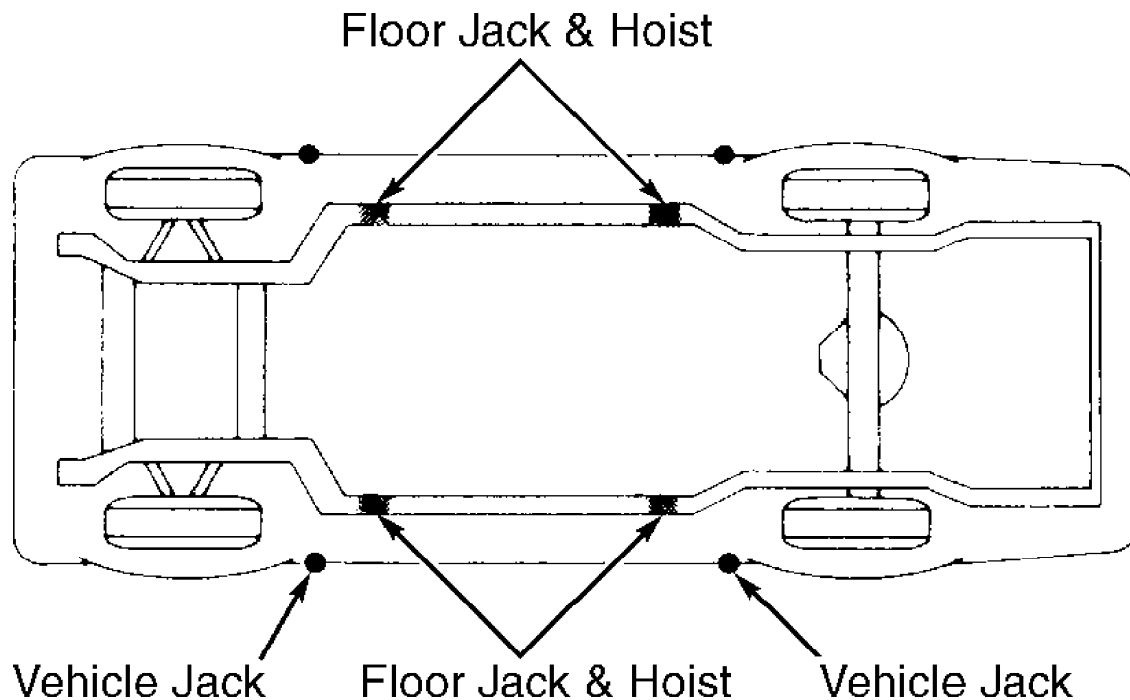

90C00325

Fig. 1: Jacking & Hoisting Points (Typical)

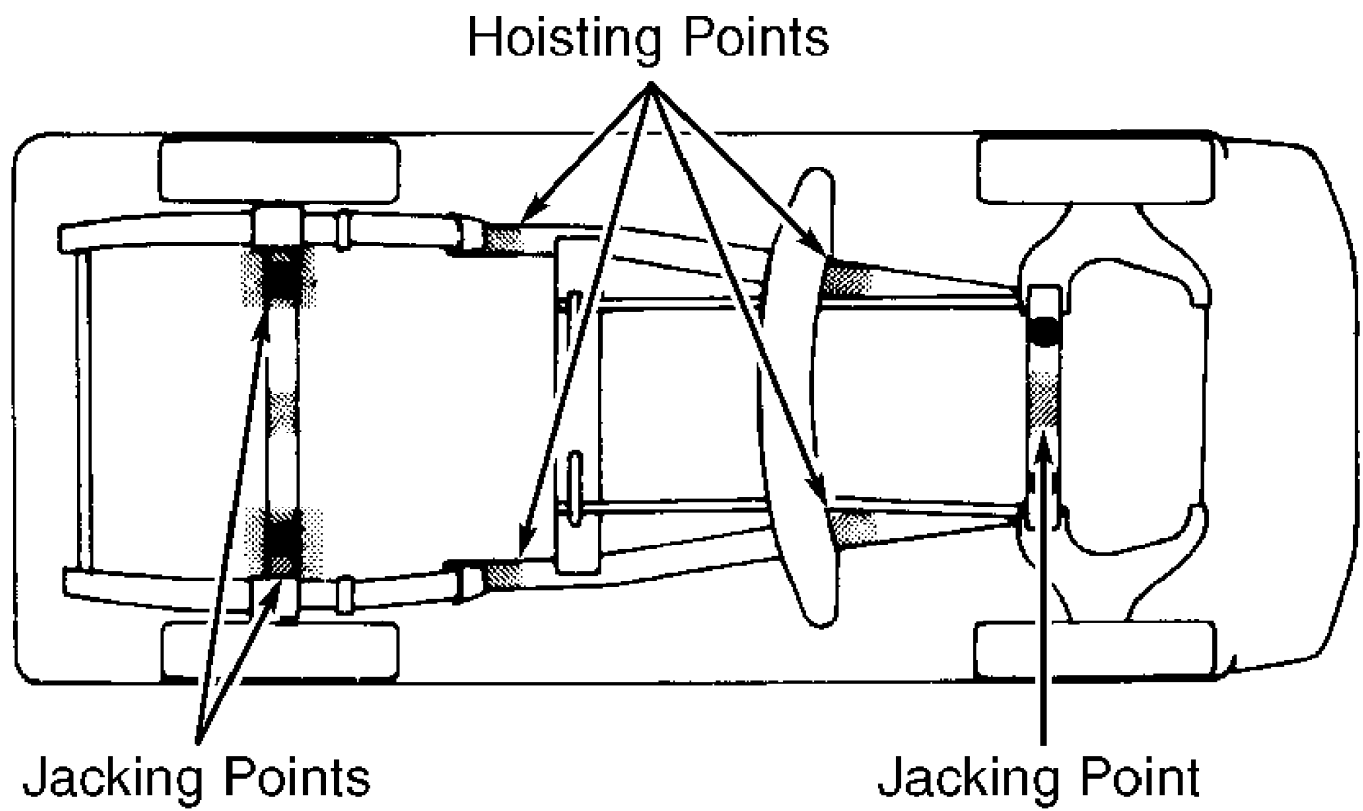

90G00329

Fig. 2: Jacking & Hoisting Points (Montero)
 Courtesy of Mitsubishi Motor Sales of America.

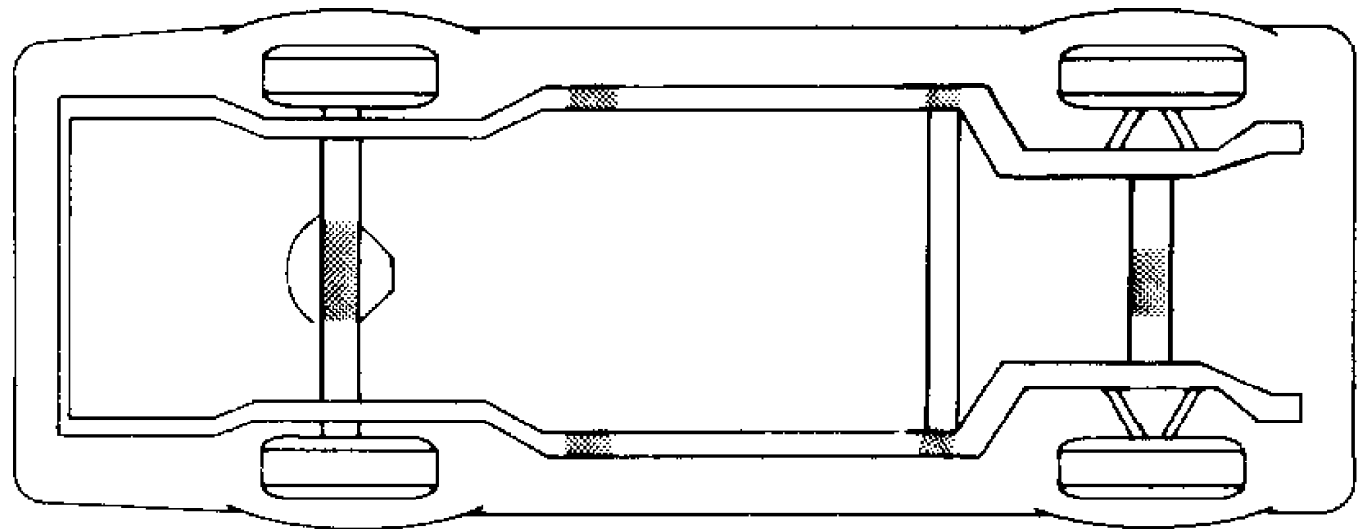

90F00328

Fig. 3: Jacking & Hoisting Points (Pickup & Ram-50)
 Courtesy of Mitsubishi Motor Sales of America.