

MAINTENANCE REMINDER LIGHT RESET PROCEDURES

1991 Mitsubishi Montero

1983-96 MAINTENANCE

Chrysler Motors/Mitsubishi Maintenance Reminder Lights

Dodge; Challenger, Colt, Colt Vista, Conquest, Raider, Ram-50

Eagle; Summit, Summit Wagon

Plymouth; Colt, Colt Vista, Sapporo

Mitsubishi; 3000GT, Cordia, Diamante, Eclipse, Expo/Expo LRV, Galant, Mirage, Montero, Pickup, Precis, Sigma, Starion, Tredia, Van/Wagon

EGR/MAINTENANCE REQUIRED WARNING LIGHT

1) On some models, an EGR or MAINTENANCE REQUIRED warning light in dash will come on as a reminder to have EGR system serviced (each 50,000 miles), oxygen sensor replaced (each 80,000 miles) or evaporative carbon canister replaced (100,000 miles).

2) After servicing or replacing components, reset mileage counter. On all models except 1987-95 Pickup and 1987-93 Ram-50, reset switch is located on back of instrument cluster.

3) On 1987-95 Pickup and 1987-93 Ram-50, reset switch is on lower right corner of instrument cluster, behind instrument cluster face trim. Slide switch to other side to reset indicator light.

4) Remove warning light bulb after 150,000 mile servicing on Colt Vista and Wagon. Remove bulb after 120,000 mile servicing on Ram-50.

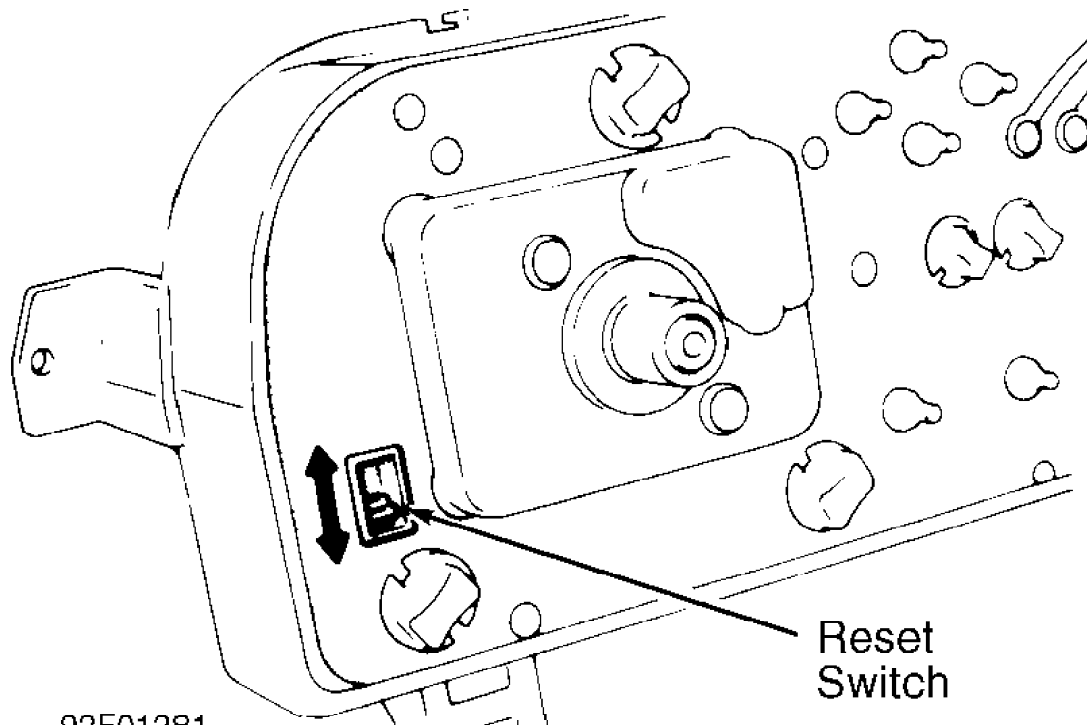

92F01281

Fig. 1: Locating Warning Light Reset Switch (Colt Vista; Colt Wagon is Similar)
Courtesy of Chrysler Motors.

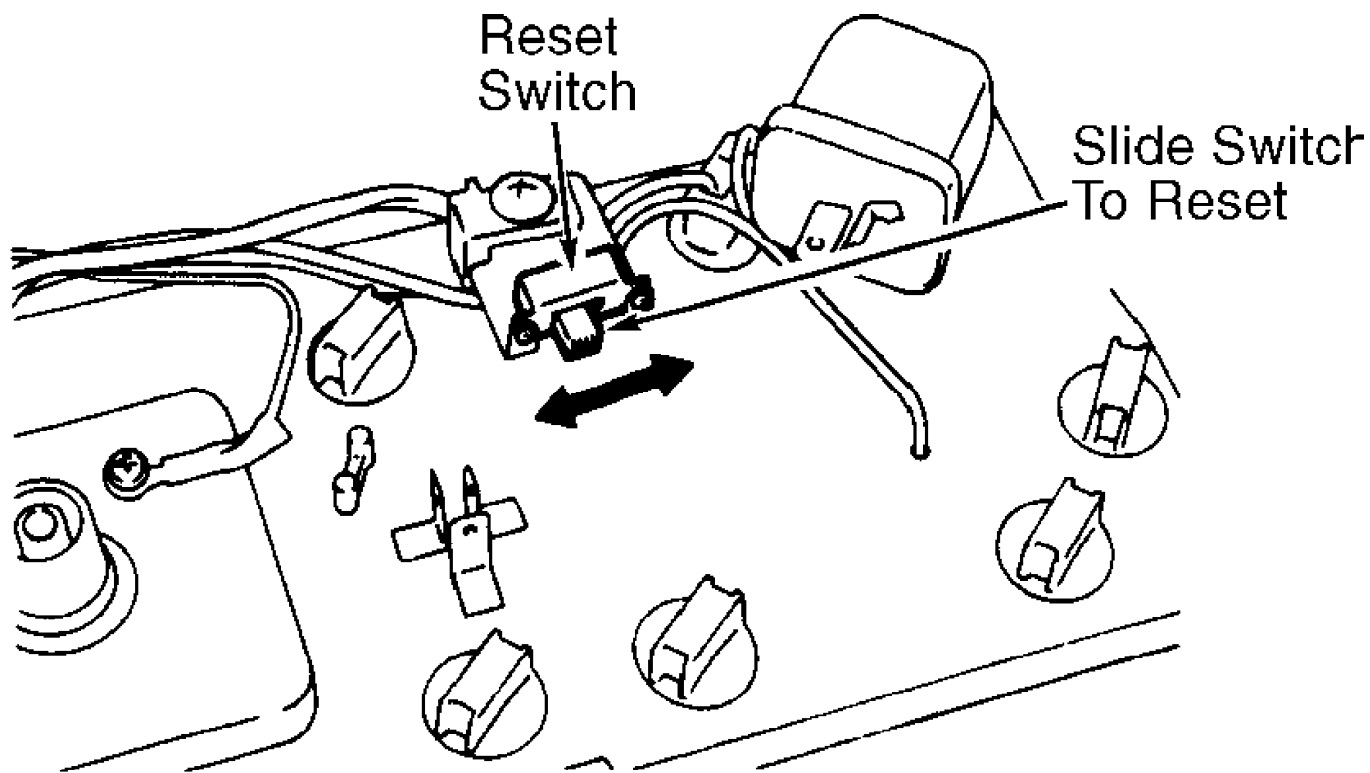

92H01282

Fig. 2: Locating Warning Light Reset Switch (1985-86 Pickup & Ram-50)
 Courtesy of Chrysler Motors.

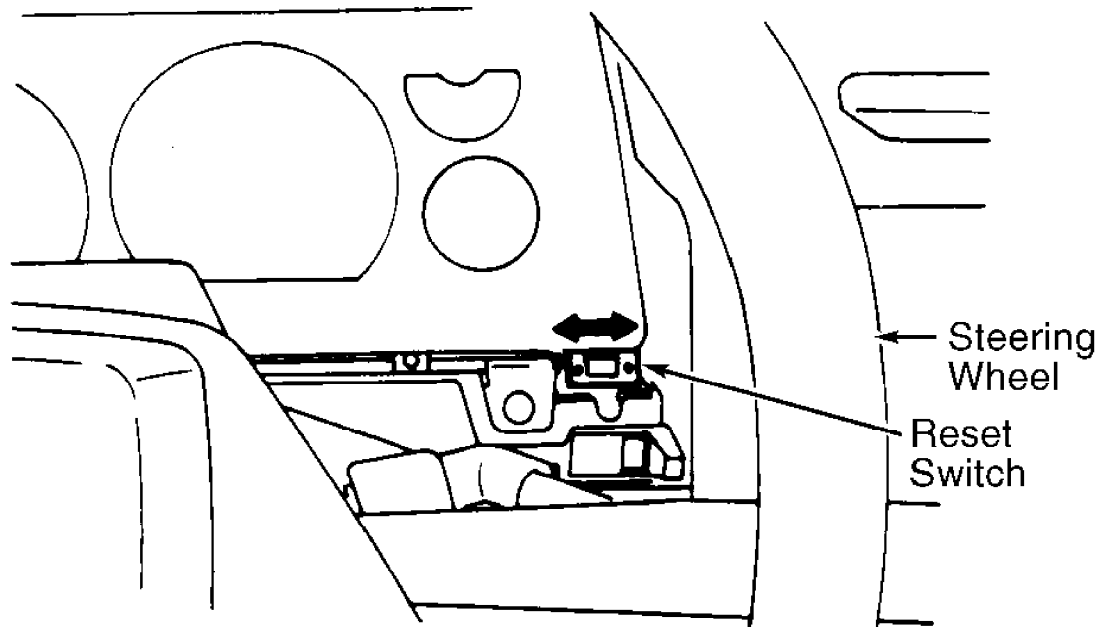

92J01283

Fig. 3: Locating Warning Light Reset Switch (1987-92 Pickup & Ram-50)
 Courtesy of Chrysler Motors.

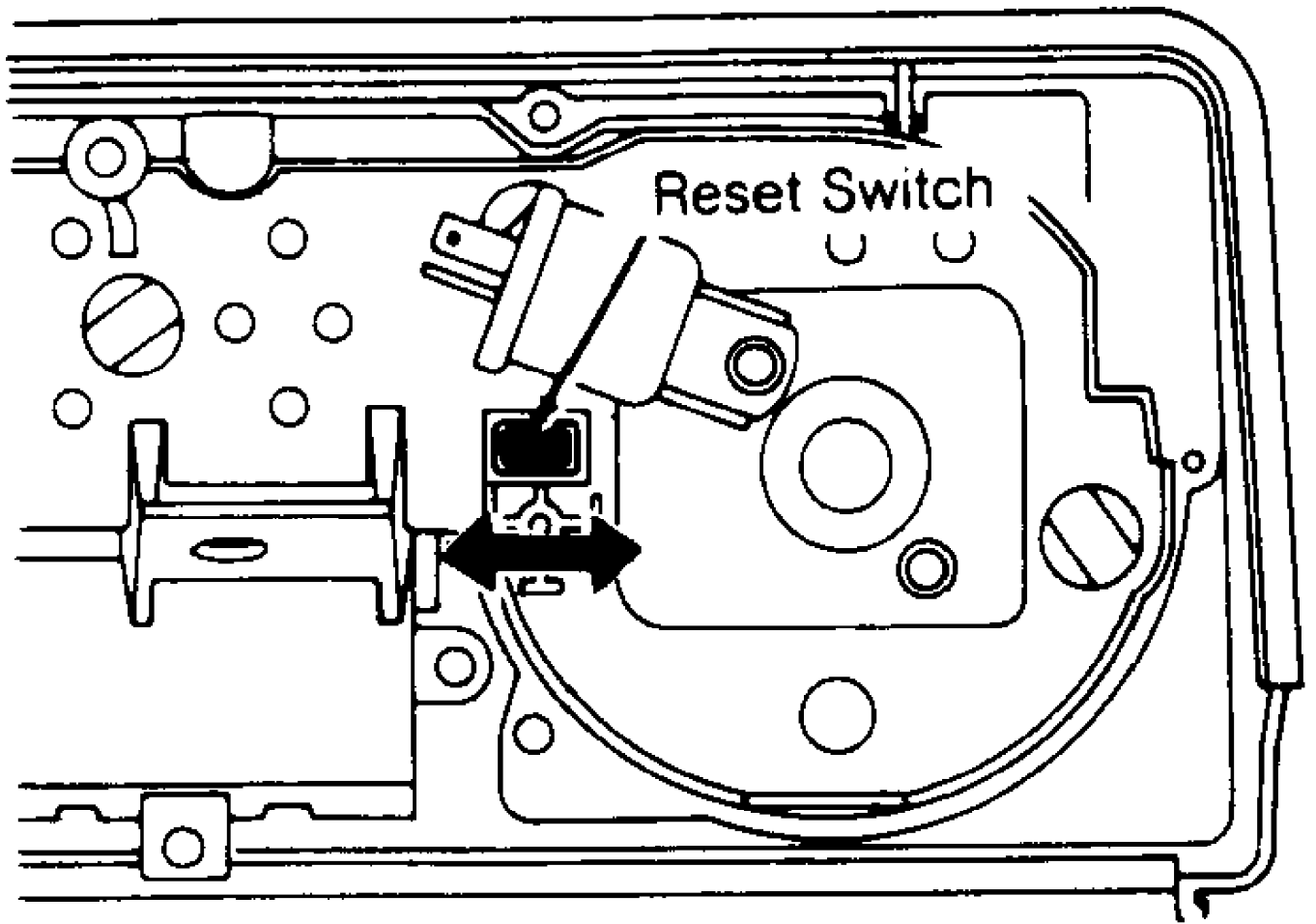

92B01284

Fig. 4: Locating Warning Light Reset Switch (Raider)
 Courtesy of Chrysler Motors.

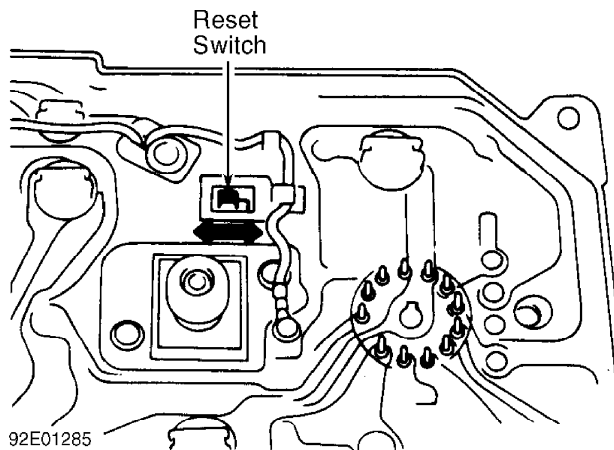

92E01285

Fig. 5: Locating Warning Light Reset Switch (Van & Wagon)
 Courtesy of Chrysler Motors.

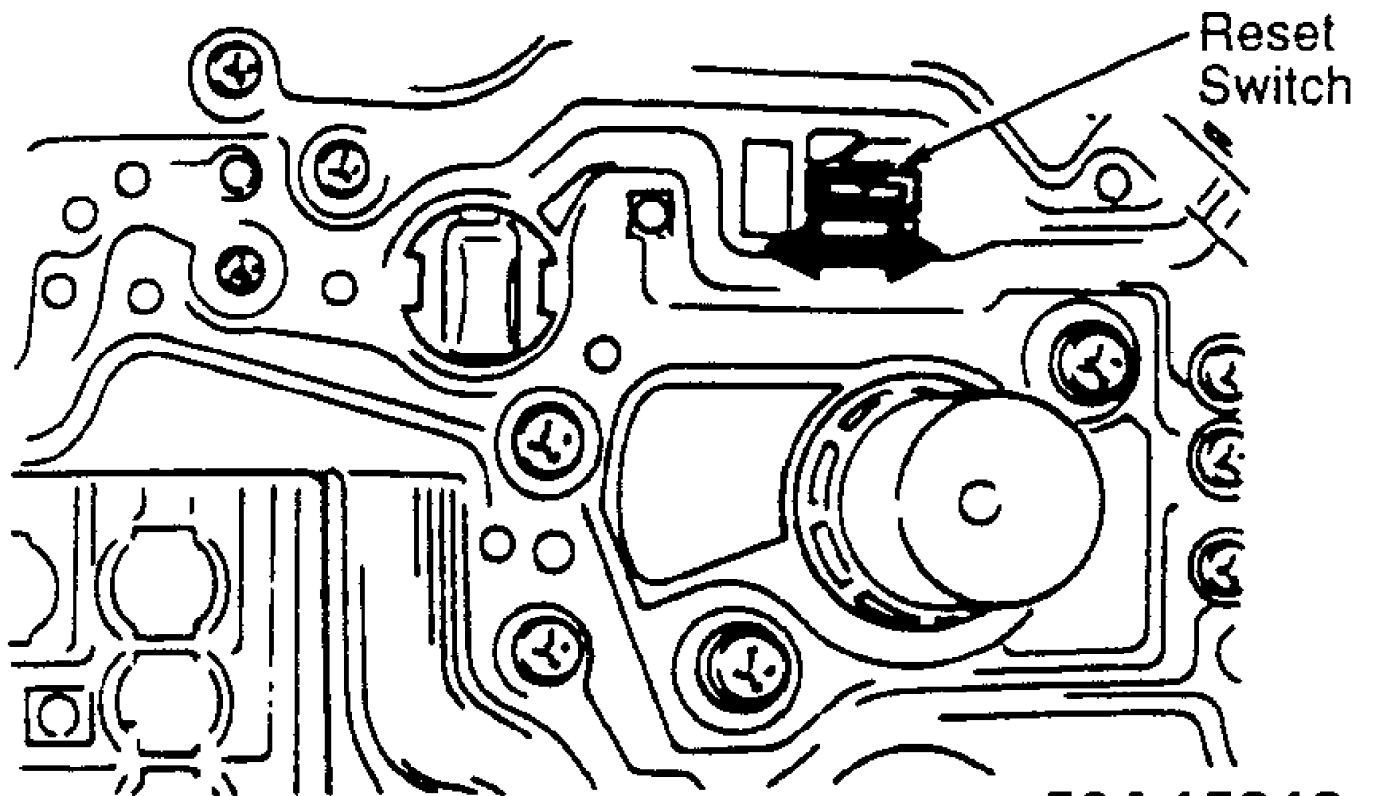

50A15818

Fig. 6: Locating Warning Light Reset Switch (1983-93 Montero)
Courtesy of Chrysler Motors.

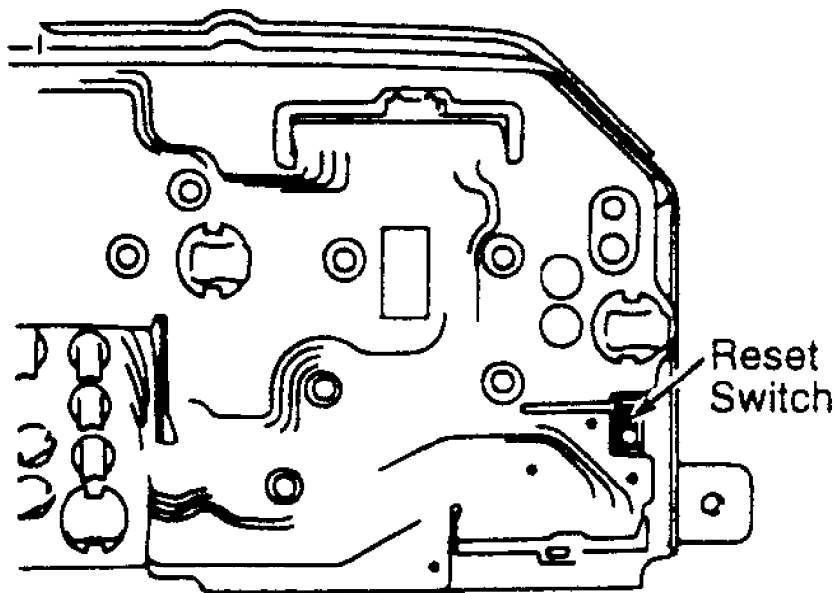

50B15819

Fig. 7: Locating Warning Light Reset Switch (1994-96 Montero)
Courtesy of Chrysler Motors.