

# TRANSFER CASE

## 1991 Mitsubishi Montero

1991-94 TRANSFER CASES  
Mitsubishi

Dodge; Ram-50  
Mitsubishi; Pickup, Montero

### APPLICATION

#### TRANSFER CASE APPLICATIONS TABLE

Application	(1) Transmission Model
Dodge	
1991-93 Ram-50 (2.4L)	V5M21-1
1991-93 Ram-50 (3.0L M/T)	V5MT1-2
1991-93 Ram-50 (3.0L A/T)	V4AC1-2
Mitsubishi	
1991-92 Pickup	V5MT1-2
1991 Montero (M/T)	V5MT1-2
1991 Montero (A/T)	V4AW2-2
1992 Montero (M/T)	(2) V5MT1-3
1992 Montero (A/T)	(2) V4AW2-3
1993-94 Montero (M/T)	(2) V5MT1-2
1993-94 Montero (A/T)	(2) R4AC1

(1) - Transfer case is indicated by a -2 or -3 following the transmission model number.

(2) - Transfer cases for Montero are identical for automatic and manual transmission models.

### DESCRIPTION

Transfer case is a part-time, 2-speed unit with a 3-piece aluminum case. Transfer case has a floor-mounted shifter and integral speedometer gear. In Montero a Viscous Coupling Unit (VCU) and center differential allows 2WD-to-4WD shifting at speeds under 62 MPH and full-time 4WD operation.

**WARNING:** When battery is disconnected, vehicles equipped with computers may lose memory data. When battery power is restored, driveability problems may exist on some vehicles. These vehicles may require a relearn procedure. See the COMPUTER RELEARN PROCEDURES article in the GENERAL INFORMATION section.

### TESTING

#### 4WD INDICATOR CONTROL UNIT (MONTERO)

The 4WD indicator control unit is located behind radio or CD player. Remove 4WD indicator control unit and disconnect harness. Backprobe harness connector and measure voltage between terminal No. 8 (ground) and each respective terminal. Compare test results with chart. See Fig. 1.

#### DETECTION SWITCH

NOTE: With switch removed, check continuity between switch connector terminal and switch body. With switch installed, check continuity between switch connector terminal and transfer case.

4WD Indicator Light Switch (RAM-50)

With switch removed, check continuity between connector terminal and switch body. With switch end pressed, there should be no continuity. With switch end released, there should be continuity.

Center Differential Lock Operation Detection Switch (Montero)

Check continuity between terminals at Brown wire connector terminal on top of transfer case. With transfer control lever in "4H" position, there should be no continuity. With transfer control lever in "4HLc" position, there should be continuity. See Fig. 2.

4WD Operation Detection Switch (Montero)

Check continuity between terminals at Black wire connector terminal on top of transfer case. With transfer control lever in "2H" position, there should be no continuity. With transfer control lever in "4H" position, there should be continuity. See Fig. 2.

Center Differential Lock Detection Switch (Montero)

Check continuity between terminals at Brown wire connector terminal on side of transfer case. With transfer control lever in "4H" position, there should be no continuity. With transfer control lever in "4HLc" position, there should be continuity. See Fig. 2.

2WD-4WD Detection Switch (Montero)

Check continuity between terminals at Black wire connector terminal on side of transfer case. With transfer control lever in "4H" position, there should be no continuity. With transfer control lever in "2H" position, there should be continuity. See Fig. 2.

HI/LO Detection Switch (Montero)

Check continuity between terminals at White wire connector terminal on side of transfer case. With transfer control lever in "N" (between "4HLc" and "4LLc") position, there should be no continuity. With transfer control lever in "4HLc" position, there should be continuity. With transfer control lever in "4LLc" position, there should be continuity. See Fig. 2.



CONTROL UNIT SIDE

NOTE: Battery positive voltage marked with (\*) is 1-2 volts lower than actual battery positive voltage.

Terminal No.	Inspection item		Inspection condition		Terminal voltage	
3	Ignition switch (IG2)		Ignition switch (IG2)		OFF	0 V
					ON	Battery positive voltage
4	Combination meter	Center differential lock indicator lamp	Ignition switch: ON	Transfer lever position	4H	Battery positive voltage
					4HLc	Less than 1.5V
10	(4WD indicator lamp)	Front wheel lamp	Ignition switch: ON		In 2WD	0 V
					In 4WD	Battery positive voltage*
9		Rear wheel lamp	Ignition switch: ON	Transfer lever position	N	0 V
					4HLc, 4LLc	Battery positive voltage*
6	Free-wheel engage switch		Ignition switch: ON		In 2WD	Battery positive voltage*
					In 4WD	0 V
1	HI/LOW detection switch		Ignition switch: ON	Transfer lever position	N	Battery positive voltage*
					4HLc, 4LLc	0 V
2	4WD operation detection switch		Ignition switch: ON	Transfer lever position	2H	Battery positive voltage*
					4H	0 V
5	Center differential lock detection switch		Ignition switch: ON	Transfer lever position	4H	Battery positive voltage*
					4HLc	0 V
7	Center differential lock operation detection switch		Ignition switch: ON	Transfer lever position	4H	Battery positive voltage*
					4HLc	0 V

93J25576

Fig. 1: 4WD Indicator Control Unit Testing (Montero)  
 Courtesy of Mitsubishi Motor Sales of America.

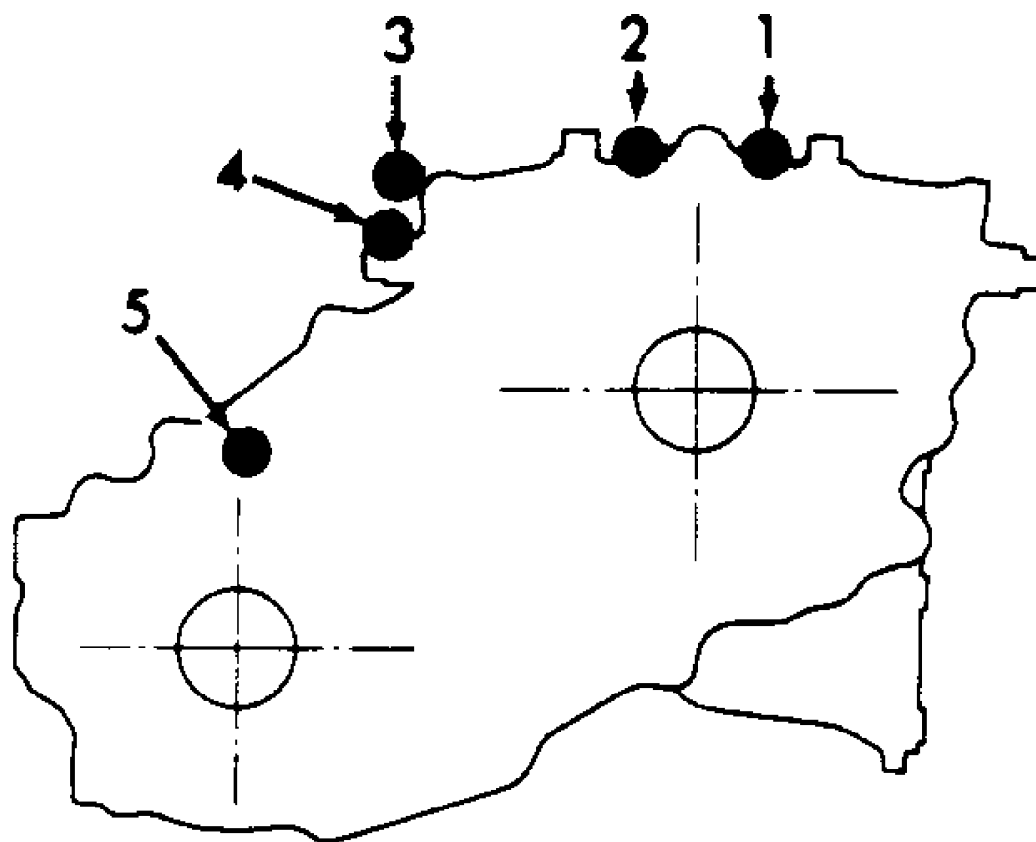

1. Center Differential Lock Operation Detection Switch.
2. 4WD Operation Detection Switch.
3. Center Differential Lock Detection Switch.
4. 2WD-4WD Detection Switch.
5. HI/LO Detection Switch.

**93A25577**

Fig. 2: Detection Switch Testing Locations (Montero)  
 Courtesy of Mitsubishi Motor Sales of America.

## REMOVAL & INSTALLATION

### Removal

1) Remove negative battery cable. Remove transfer case skid plate (if equipped). Scribe alignment marks and remove both drive shafts. Drain oil from transfer case. Disconnect wiring harness from back-up light switch, all 4WD switches and any other electrical connectors (if equipped).

2) Disconnect speedometer cable from drive. Unclip cable from case. Place transfer case shifter in "2H" position and transmission in Neutral. Remove 6 bolts holding control lever assembly. Remove control lever assembly and gasket.

3) Remove select plunger bore plug at right side of case. Remove select spring and plunger. Remove change shifter spring pin. Remove change shifter. Remove transfer case mount. Remove 4 bolts and 2 nuts holding transfer case to adapter. Remove transfer case from vehicle.

### Installation

1) Position transmission shifter in Neutral and transfer case lever in "2H" position. Install neutral return plungers and springs in holes on top of adapter. Tighten plug until it is flush with adapter surface. Cover plug threads with sealant.

2) Coat inside of change shifter with grease. Ensure change shifter pin protrudes 1/8" above change shifter when installed. Mount detent plunger spring and install plug (if equipped). To complete installation, reverse removal procedure. Fill transfer case with API GL-4 or higher 75W-90 or 75W-85W gear oil.

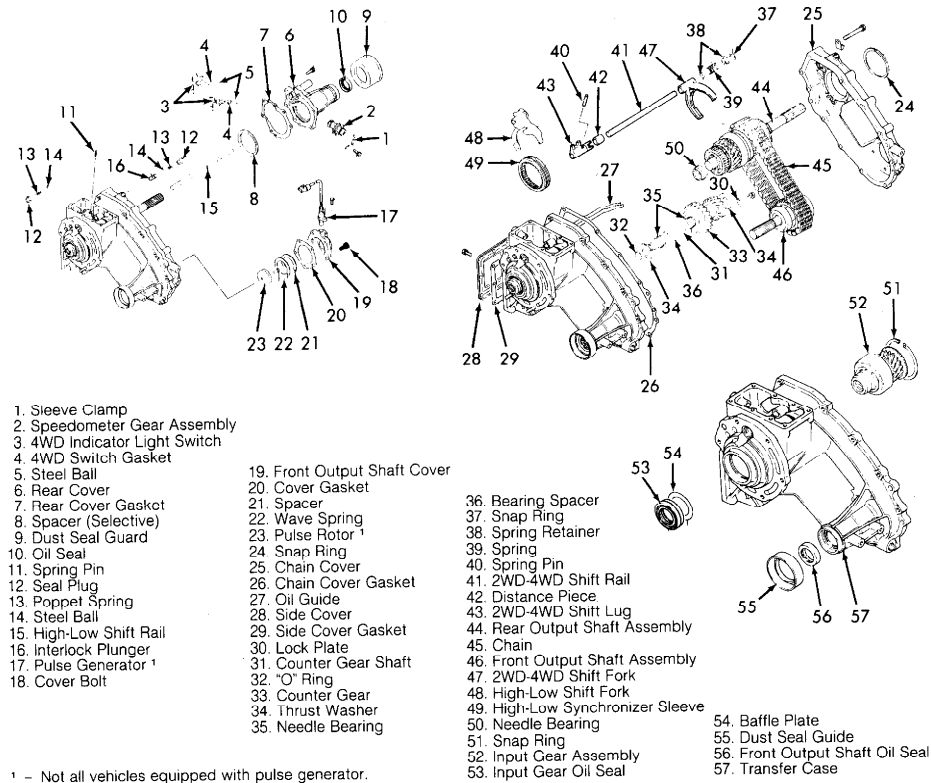
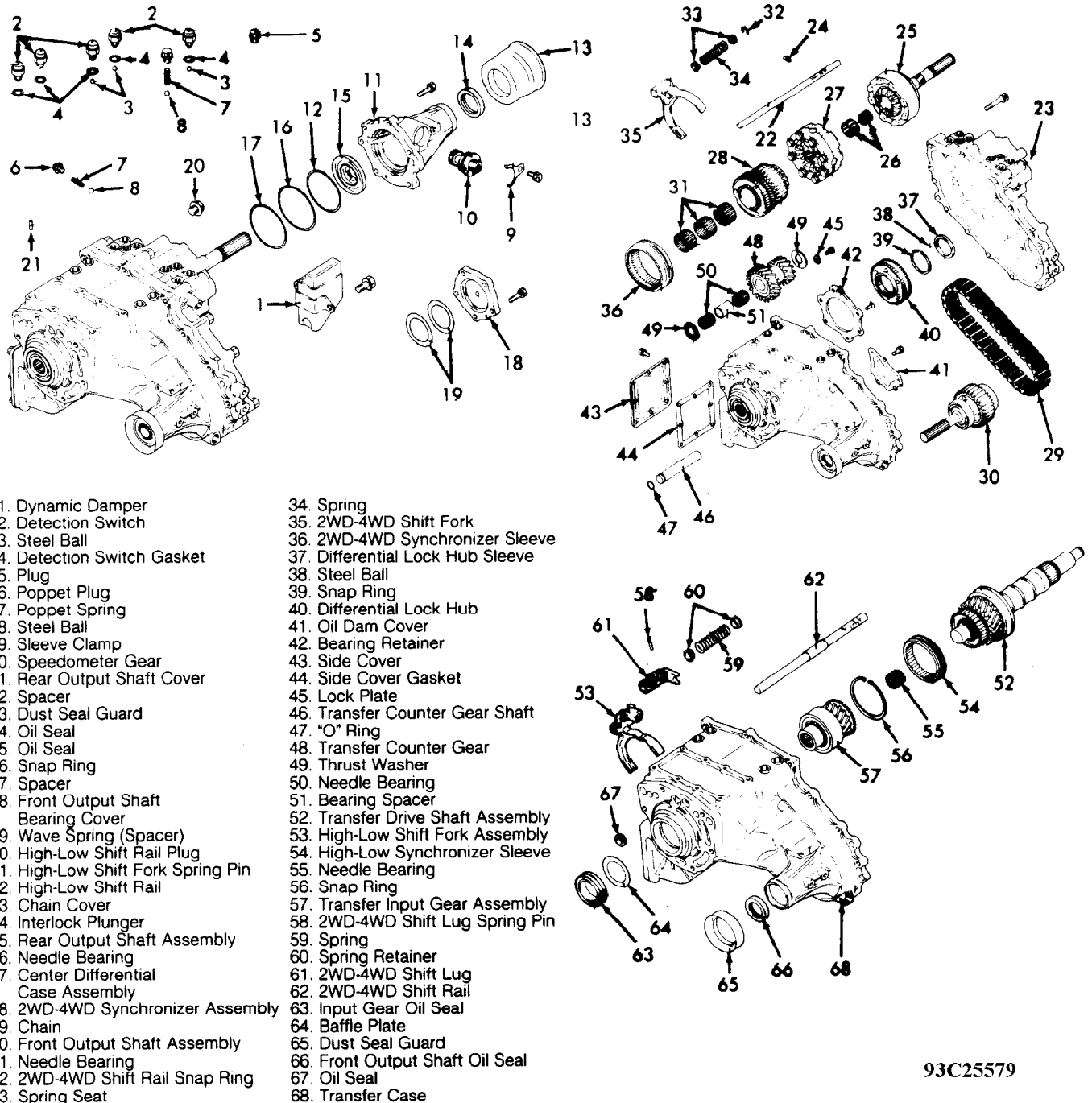

Fig. 3: Exploded View Of Transfer Case (Ram-50)  
 Courtesy of Mitsubishi Motor Sales of America.



- |                                       |                                   |
|---------------------------------------|-----------------------------------|
| 1. Dynamic Damper                     | 34. Spring                        |
| 2. Detection Switch                   | 35. 2WD-4WD Shift Fork            |
| 3. Steel Ball                         | 36. 2WD-4WD Synchronizer Sleeve   |
| 4. Detection Switch Gasket            | 37. Differential Lock Hub Sleeve  |
| 5. Plug                               | 38. Steel Ball                    |
| 6. Poppet Plug                        | 39. Snap Ring                     |
| 7. Poppet Spring                      | 40. Differential Lock Hub         |
| 8. Steel Ball                         | 41. Oil Dam Cover                 |
| 9. Sleeve Clamp                       | 42. Bearing Retainer              |
| 10. Speedometer Gear                  | 43. Side Cover                    |
| 11. Rear Output Shaft Cover           | 44. Side Cover Gasket             |
| 12. Spacer                            | 45. Lock Plate                    |
| 13. Dust Seal Guard                   | 46. Transfer Counter Gear Shaft   |
| 14. Oil Seal                          | 47. "O" Ring                      |
| 15. Oil Seal                          | 48. Transfer Counter Gear         |
| 16. Snap Ring                         | 49. Thrust Washer                 |
| 17. Spacer                            | 50. Needle Bearing                |
| 18. Front Output Shaft Bearing Cover  | 51. Bearing Spacer                |
| 19. Wave Spring (Spacer)              | 52. Transfer Drive Shaft Assembly |
| 20. High-Low Shift Rail Plug          | 53. High-Low Shift Fork Assembly  |
| 21. High-Low Shift Fork Spring Pin    | 54. High-Low Synchronizer Sleeve  |
| 22. High-Low Shift Rail               | 55. Needle Bearing                |
| 23. Chain Cover                       | 56. Snap Ring                     |
| 24. Interlock Plunger                 | 57. Transfer Input Gear Assembly  |
| 25. Rear Output Shaft Assembly        | 58. 2WD-4WD Shift Lug Spring Pin  |
| 26. Needle Bearing                    | 59. Spring                        |
| 27. Center Differential Case Assembly | 60. Spring Retainer               |
| 28. 2WD-4WD Synchronizer Assembly     | 61. 2WD-4WD Shift Lug             |
| 29. Chain                             | 62. 2WD-4WD Shift Rail            |
| 30. Front Output Shaft Assembly       | 63. Input Gear Oil Seal           |
| 31. Needle Bearing                    | 64. Baffle Plate                  |
| 32. 2WD-4WD Shift Rail Snap Ring      | 65. Dust Seal Guard               |
| 33. Spring Seat                       | 66. Front Output Shaft Oil Seal   |
|                                       | 67. Oil Seal                      |
|                                       | 68. Transfer Case                 |

93C25579

Fig. 4: Exploded View Of Transfer Case (Montero)  
 Courtesy of Mitsubishi Motor Sales of America.

## TRANSFER CASE DISASSEMBLY

Disassembly (Ram-50)

1) Remove both 4WD indicator switches and steel balls. Remove speedometer gear assembly. Remove output shaft cover, gasket, wave spring and spacer. See Fig. 3. Remove rear cover, rear cover gasket and spacer from chain cover. Drive roll pin out of high-low shift fork.

2) Remove 2 seal plugs. Remove 2 poppet springs and steel balls. Shift transfer case to "4WD" and pull high-low shift rail out, in rear cover direction. Remove interlock plunger. Remove pulse generator (if equipped), front output shaft cover and pulse rotor (if equipped). Remove snap ring from rear bearing on output shaft. Remove chain cover, oil guide and side cover. Remove countershaft locking plate. Remove countershaft.

3) Remove countergear, 2 thrust washers, 2 needle bearings and spacer through side cover opening. Remove snap ring, spring retainers and spring from 2WD-4WD shift rail. Remove front output shaft, rear output shaft and chain as assembly.

4) Remove 2WD-4WD shift fork and distance piece. Drive out 2WD-4WD shift rail spring pin. Remove 2WD-4WD shift rail and lug. Remove high-low shift fork and high-low synchronizer sleeve. Remove needle bearing and snap ring from input gear. Remove input gear assembly.

5) If either control shaft or input gear oil seals are to be replaced, drive out roll pin from transmission control change shifter. Separate transfer case from adapter. See Fig. 3.

#### Disassembly (Montero)

1) Remove dynamic damper, 5 detection switches and 3 steel balls. Remove poppet plug, spring and steel ball. Remove speedometer gear assembly. Remove output shaft rear cover, spacers, dust seal guard and oil seals. Front output shaft cover, wave spring and spacer (if equipped).

2) Remove high-low shift rail plug and high-low shift fork spring pin. Shift transfer case to "4WD". Remove rear cover and high-low shift rail. Remove interlock plunger. Remove rear output shaft (viscous coupling) assembly and center differential assembly. Remove 2WD-4WD synchronizer assembly, chain and front output shaft from transmission as a unit. With White paint make match marks in grooves of 2WD-4WD synchronizer in 3 places. With White paint make match marks on spline projections of 2WD-4WD synchronizer sleeve in 3 places. Refer to match marks reassembly.

3) Remove snap ring, spring seat, spring, 2WD-4WD shift fork and 2WD-4WD synchronizer sleeve. Remove differential lock hub, oil dam cover and bearing retainer. Remove side cover and gasket. Remove transfer counter gear shaft, transfer counter gear, thrust washer, needle bearings and spacer. Remove transfer drive shaft assembly. Remove high-low shift fork assembly and clutch sleeve. Remove transfer input gear assembly.

4) Remove 2WD-4WD shift lug spring pin, spring, spring retainer 2WD-4WD shift lug and shift rail. Remove input gear oil seal, baffle plate, dust seal guard and front output shaft oil seal. See Fig. 4.

## COMPONENT DISASSEMBLY & REASSEMBLY

### OUTPUT SHAFT ASSEMBLY (MONTERO)

#### Disassembly & Reassembly (Rear Shaft)

Remove snap ring and press ball bearing off without putting pressure on viscous coupling. Remove viscous coupling. To install, reverse removal procedure. When installing new snap ring, select thickest ring that will fit into groove. Acceptable clearance is 0-.003" (0-.08 mm).

#### Disassembly & Reassembly (Front Shaft)

Remove front bearing. Remove rear bearing. To install reverse removal procedure.

## OUTPUT SHAFT ASSEMBLY (RAM-50)

### Disassembly

1) Remove snap ring from rear of output shaft. Remove high-low synchronizer hub by hand or when low speed gear is pressed off. Remove bearing spacer and needle bearing. Remove staking from lock nut on rear output shaft. See Fig. 5. Remove lock nut. Remove ball bearing from below lock nut. Remove sprocket spacer and steel ball.

2) Remove drive sprocket, 2 needle bearings, sprocket sleeve and steel ball. Remove 2WD-4WD synchronizer sleeve, hub, stopper plate and ball bearing.

### Reassembly

1) Press ball bearing and stopper plate on front output shaft, pushing against inner race. After fitting, ensure bearing rotates smoothly. Install 2WD-4WD synchronizer hub and sleeve. Ensure hub and sleeve face correct direction. Install steel ball (for sprocket sleeve positioning) on rear output shaft. Install sprocket sleeve.

2) Install 2 needle bearings on outer circumference of sprocket sleeve. Install drive sprocket. Install steel ball and sprocket spacer. Install ball bearing (press may not be needed as bearing may be loose). Check for smooth rotation.

3) Tighten sprocket retaining lock nut to specification. See the TORQUE SPECIFICATIONS table. Stake lock nut with punch. After lock nut is tightened, ensure drive sprocket rotates smoothly. Install needle bearing, thrust washer and low speed gear on rear of rear output shaft.

4) Install needle bearing, thrust washer and low speed gear on rear output shaft. Mount high-low synchronizer hub. Ensure hub faces correct direction.

5) Mount high-low synchronizer hub snap ring on front end of rear output shaft. Selective fit snap rings are available in 5 thicknesses. Use thickest snap ring that will fit into output shaft groove. Acceptable clearance is 0-.003" (0-.08 mm). See Fig. 5.

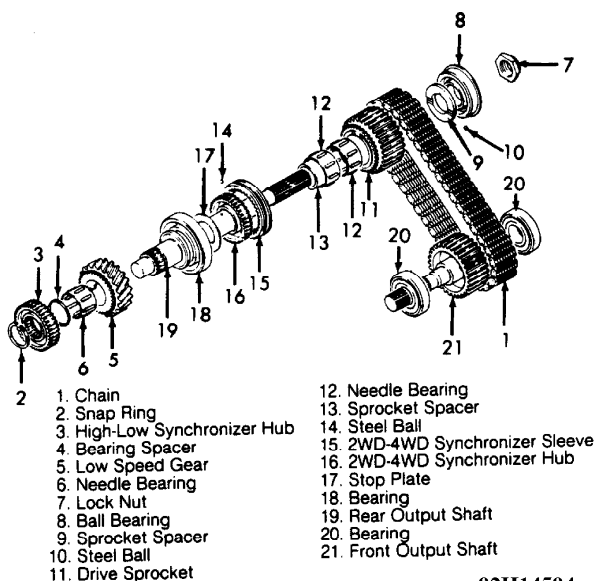

92H14594

Fig. 5: Exploded View Of Output Shaft Assembly (Ram-50)  
Courtesy of Mitsubishi Motor Sales of America.

## TRANSFER DRIVE SHAFT (MONTERO)



Disassembly & Reassembly

Remove snap ring, high-low synchronizer hub and low speed gear. Remove bearing spacer, needle bearing and ball bearing. To assemble, reverse disassembly procedure. Use thickest snap ring that will fit into output shaft groove. Acceptable clearance is 0-.003" (0-.08 mm). See Fig. 4.

**INPUT SHAFT ASSEMBLY (RAM-50)**

Disassembly & Reassembly

1) Remove snap ring from input shaft. Support bearing in press. Press input shaft out to remove bearing.

2) On manual transmission models, remove spacer and snap ring from below bearing. Remove cone spring and sub gear. See Fig. 6. For reassembly, reverse disassembly procedures.

3) Press bearing into input shaft, pushing against inner race. After fitting, ensure bearing rotates smoothly. Fit snap ring over front end of input shaft. Snap rings are available in selective thicknesses. Select thickest snap ring that will fit in groove.

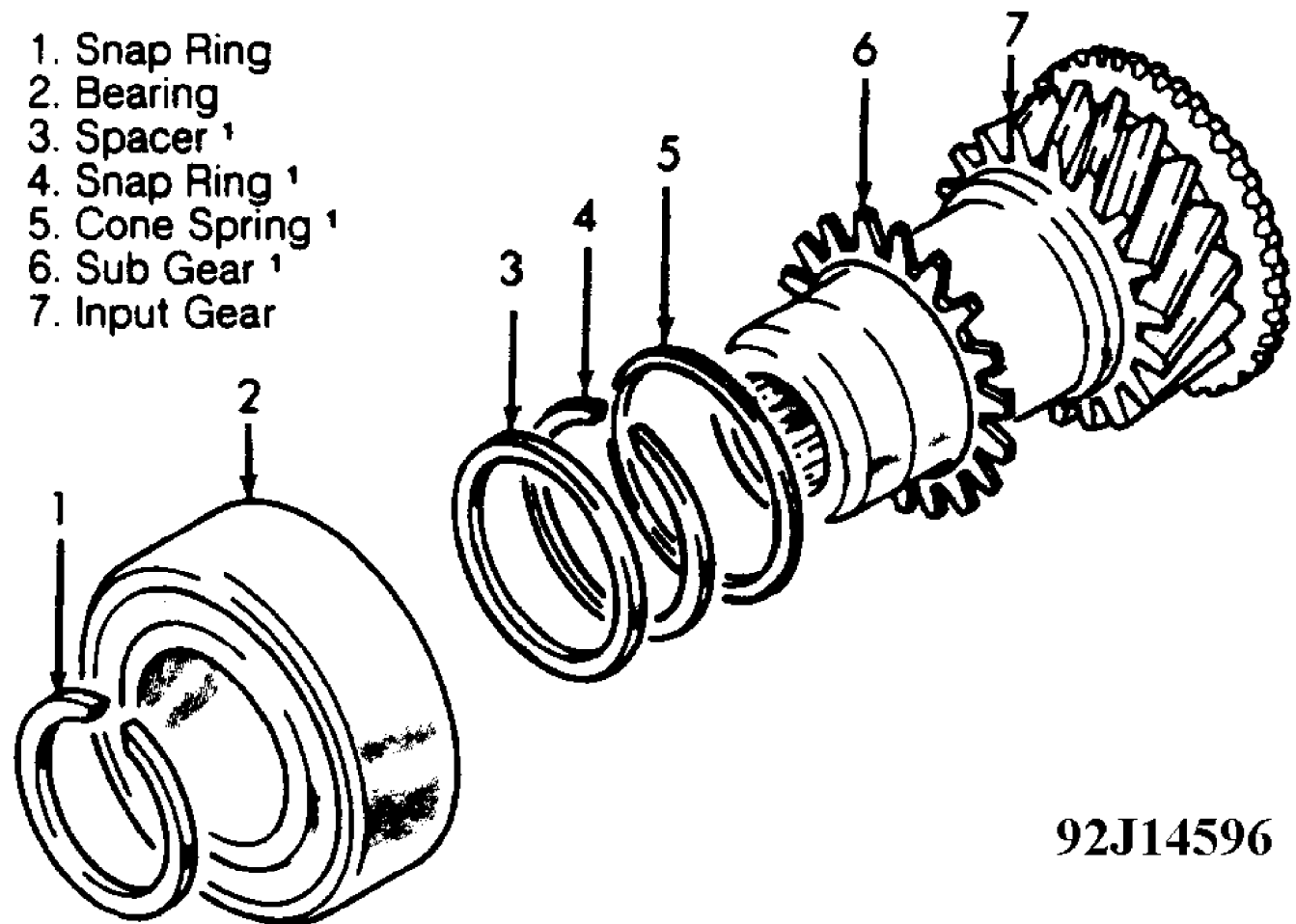

92J14596

**1 - Transfer cases used with manual transmission only.**

Fig. 6: Exploded View Of Input Shaft Assembly (Ram-50 - Manual Shown, Automatic Similar)  
Courtesy of Mitsubishi Motor Sales of America.

**CENTER DIFFERENTIAL CASE (MONTERO)**

Disassembly & Reassembly

Separate center differential case front from rear case.

Remove pinion shaft, pinions, thrust washers and dowel pins. Inspect for excessive wear and replace parts as needed. Align dowel pins and match marks on outer case circumferences. Assemble front and rear center differential cases. See the TORQUE SPECIFICATIONS table. Also, see Fig. 7.

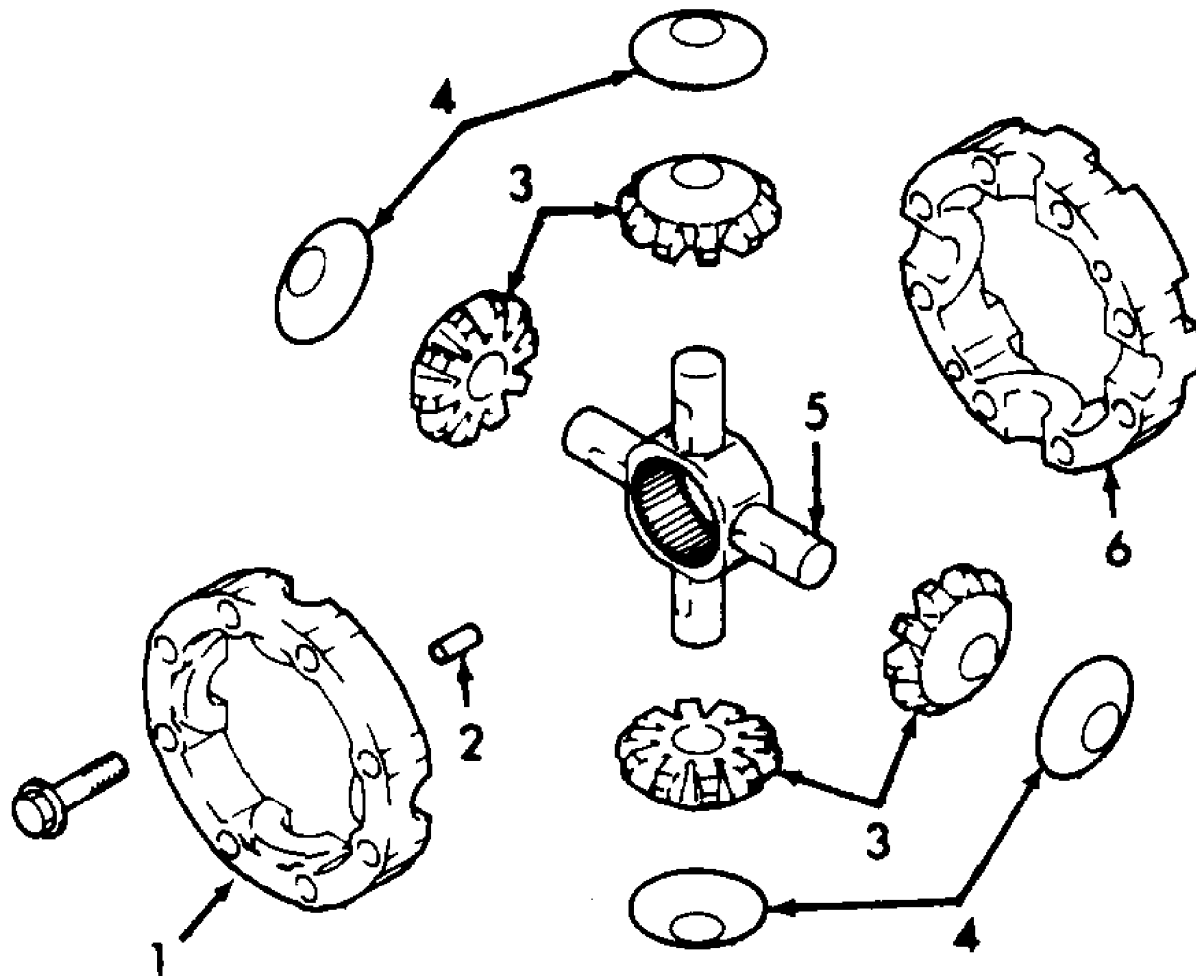

1. Center Differential Case Front
2. Dowel Pin
3. Pinion
4. Thrust Washer
5. Pinion Shaft
6. Center Differential Case Rear

**93J25584**

Fig. 7: Exploded View Of Center Differential (Montero)  
Courtesy of Mitsubishi Motor Sales of America.

#### Disassembly

Remove snap ring, 2WD-4WD synchronizer hub and synchronizer spring. Remove outer synchronizer ring, synchronizer cone and inner synchronizer ring. Remove drive sprocket and needle bearing from front drive pinion. Inspect inner and outer synchronizer rings and cone for excessive wear. Install inner and outer synchronizer rings and cone onto drive sprocket. Measure distance between drive sprocket and outer synchronizer. If distance is less than .0118" (.300 mm) replace synchronizer parts as a set.

#### Reassembly

Install drive sprocket and needle bearing onto front drive pinion. Apply transfer case gear oil to contacting surfaces of inner and outer synchronizer rings and synchronizer cone. Install inner and outer synchronizer rings and synchronizer cone. Install synchronizer spring, 2WD-4WD synchronizer hub and snap ring to complete assembly. When installing new snap ring, select thickest ring that will fit into groove. Acceptable snap ring clearance is 0-.003" (0-.080 mm).

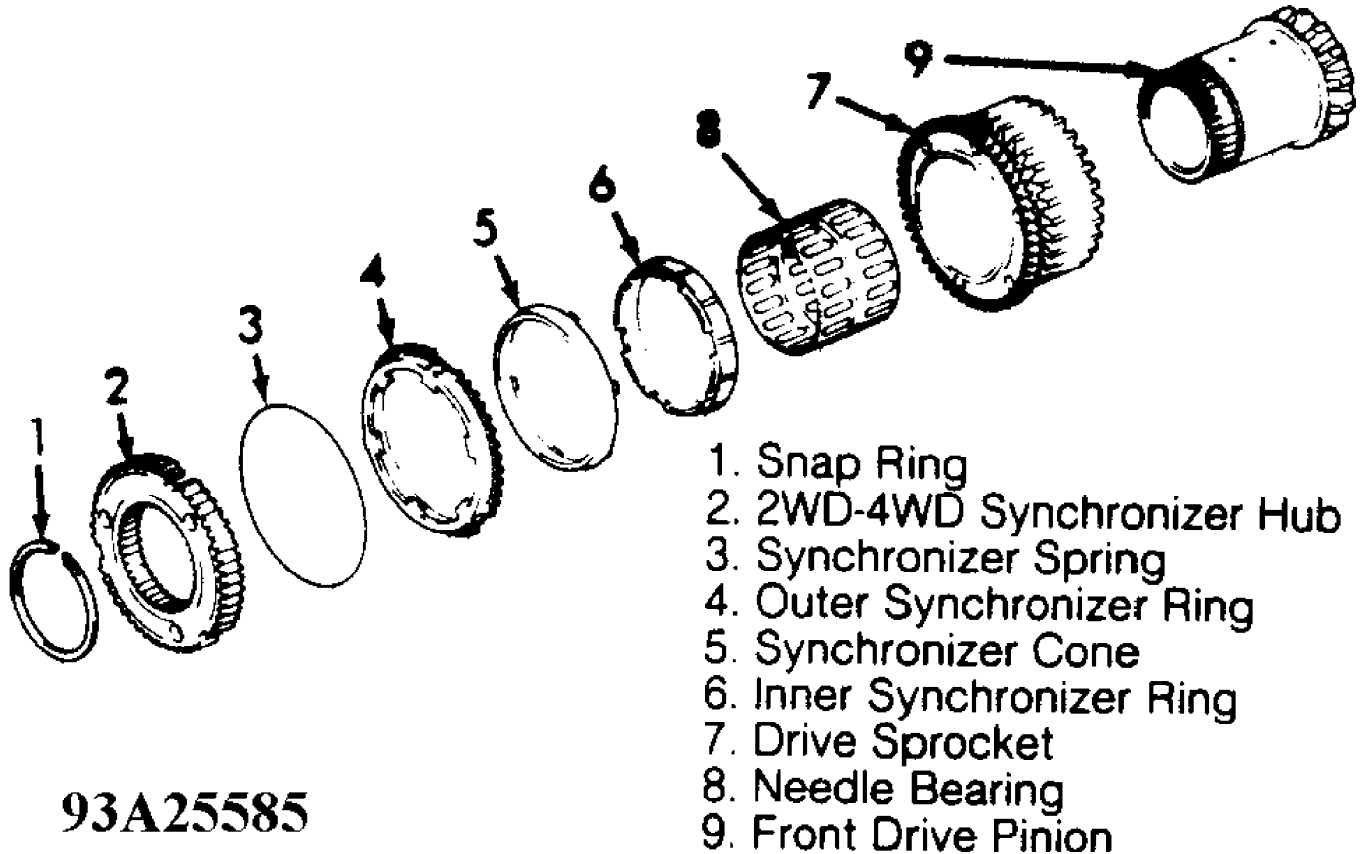

**93A25585**

Fig. 8: Exploded View Of 2WD-4WD Synchronizer (Montero)  
Courtesy of Mitsubishi Motor Sales of America.

#### TRANSFER CASE REASSEMBLY

NOTE: ALWAYS replace all gaskets, oil seals, snap rings and spring pins with new parts. Coat both sides of gaskets and bolt threads with sealant. Lubricate all sliding and rotating parts with transfer case gear oil before assembling.

Reassembly (Ram-50)

1) Install input gear and front output shaft oil seals into transfer case housing. Pack grease between lips of seals and press seal circumference uniformly.

2) Install input gear assembly in transfer case. See Figs. 3 and 6. Input gear assembly snap ring is available in selective thicknesses. Use thickest snap ring that will fit into input shaft groove. Allowed snap ring clearance is 0-.0024" (0-.060 mm).

3) Insert needle bearing onto rear output shaft assembly. Install high-low synchronizer sleeve and shift fork. Install 2WD-4WD shift fork. Engage chain securely on front and rear output shaft sprockets. Assemble 2WD-4WD synchronizer sleeve with 2WD-4WD shift fork. Install assembly over 2WD-4WD shift rail. Install front and rear output shafts with chain as an assembly.

4) Install 2WD-4WD shift lug, distance piece, 2WD-4WD shift rail and spring pin. Ensure slit in spring pin is in line with 2WD-4WD shift rail. Install 2 spring retainers with spring on 2WD-4WD shift rail. Install snap ring to end of 2WD-4WD shift rail. See Fig. 3.

5) Insert 2 needle bearings and spacer into countergear. Install one thrust washer at each end of countergear. Ensure tab on thrust washers fits into groove of transfer case. Install countergear shaft assembly with "O" ring.

6) Install side cover and gasket. Install oil guide. Apply sealant to both sides of gasket and install gasket and chain cover. Ensure oil guide end fits into chain cover opening. Fit snap ring into groove of rear bearing on rear output shaft. Tighten bolts to specification. See TORQUE SPECIFICATIONS.

7) Install interlock plunger. Shift 2WD-4WD shift rail to 4WD position. Install high-low shift rail through high-low shift fork in case. Install 2 poppet balls and springs. Install seal plugs. When installing poppet springs, smaller end must be toward ball.

8) On models with pulse generator, install pulse rotor, wave spring and spacer. Measure protrusion "A" of front output shaft rear bearing and recess "B" of cover and calculate clearance. See Fig. 9. If clearance is greater than .079" (2.0 mm), select and install spacer to bring clearance within specification. If clearance is less than .079" (2.0 mm), use wave spring alone. Apply sealant to both sides of gasket and install gasket and cover. Install pulse generator (if equipped).

9) On all models, align high-low shift fork and shift rail spring holes and drive in roll pin with punch. Roll pin should be installed with slit on center line of shift rail. Install wave spring on rear of rear output shaft bearing. Apply sealant to both sides of rear cover gasket. Install gasket and cover.

10) Check output shaft end play. Measure protrusion "A" of rear output shaft rear bearing and recess "B" of cover and calculate clearance. Ensure end play is 0-.004" (0-.10 mm). Apply sealant to both sides of gasket and install gasket and cover. See Fig. 9.

11) Install speedometer sleeve assembly in rear cover. Align match mark on speedometer sleeve assembly in rear cover. See Fig. 10. Align match mark on speedometer sleeve with mark on case according to number of teeth on speedometer driven gear. Install speedometer driven gear sleeve clamp and tighten bolt to specification. Install both 4WD indicator light switches with steel balls. See TORQUE SPECIFICATIONS.

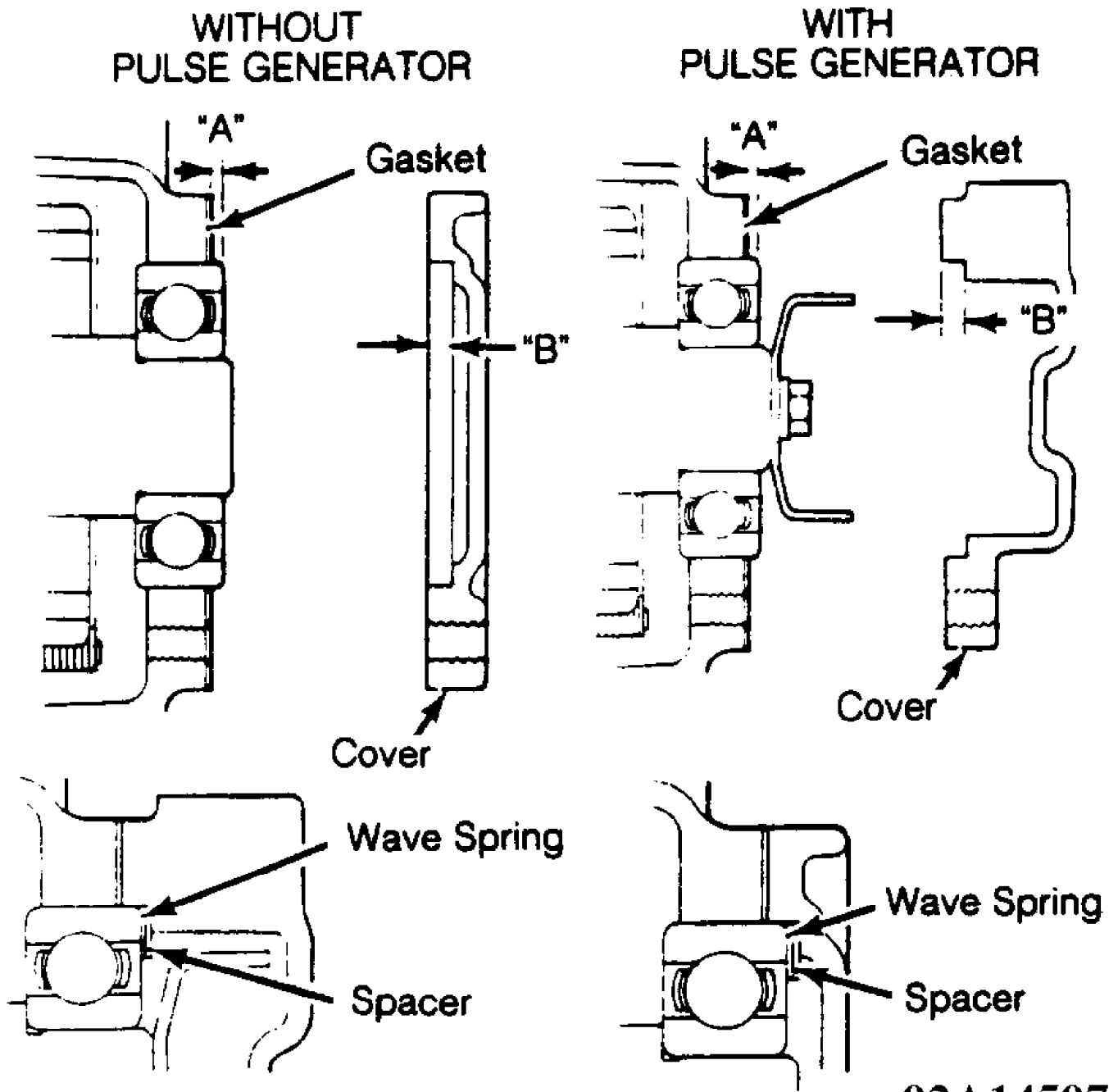

92A14597

Fig. 9: Measuring Rear Output Shaft Bearing Clearance (Ram-50)  
 Courtesy of Mitsubishi Motor Sales of America.

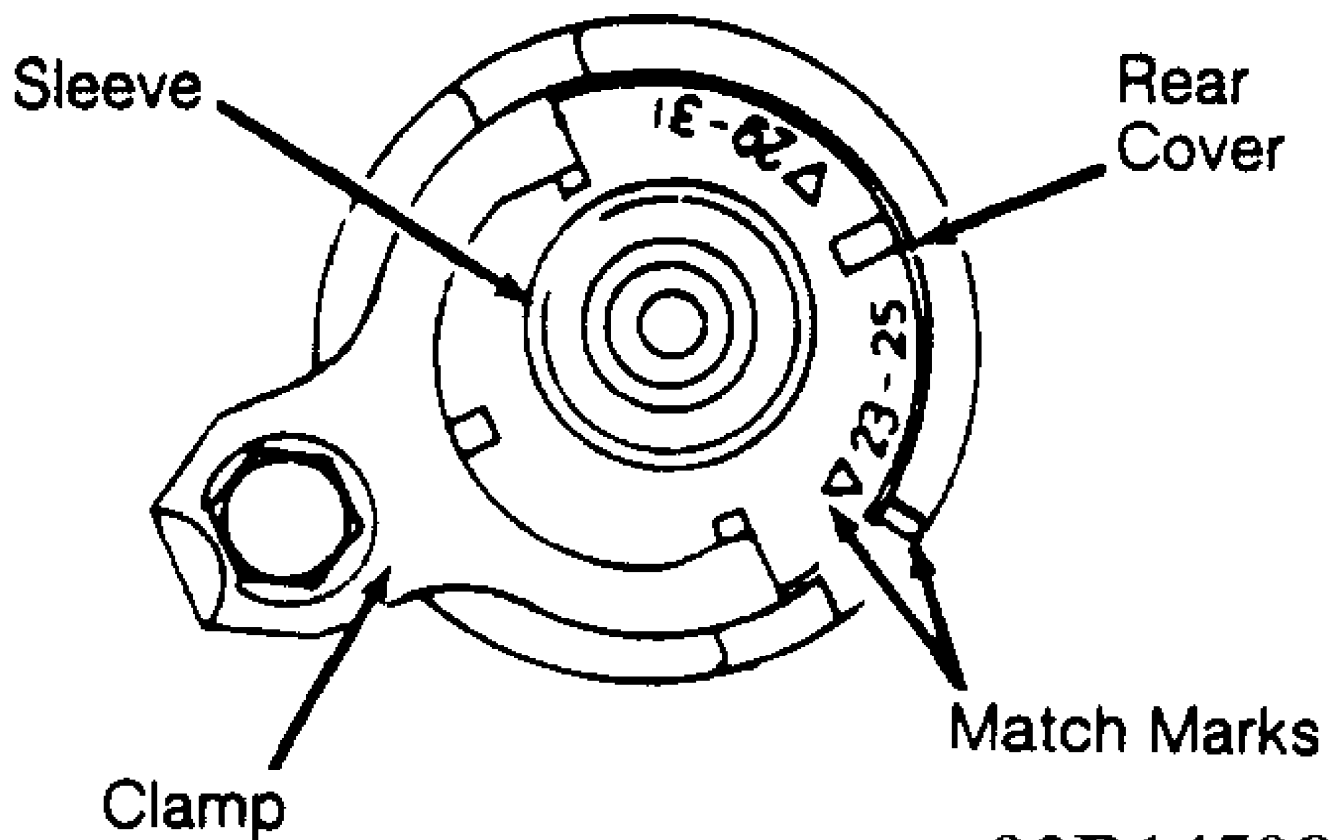

**92B14598**

Fig. 10: Aligning Speedometer Sleeve  
 Courtesy of Mitsubishi Motor Sales of America.

Reassembly (Montero)

1) Install input gear and front output shaft oil seals into transfer case housing. Install transfer input gear assembly baffle plate and input gear seal. Pack grease between lips of seals and press seal circumference uniformly.

2) Install 2WD-4WD shift lug into transfer case. Install spring retainer and spring to shift rail and install into shift lug. Press on shift rail to align spring pin holes in shift rail and shift lug. While holding shift rail, tap spring pin into place with slit facing center of shift rail.

3) Install transfer input gear assembly and snap ring. Select thickest snap ring that will fit into groove. Allowed snap ring clearance is 0-.0024" (0-.060 mm). Insert needle bearing onto transfer drive shaft assembly. Install high-low synchronizer sleeve and shift fork assembly. Install transfer drive shaft assembly.

4) Install transfer countergear shaft thrust washers, needle bearings, bearing spacer and transfer countergear. Install one thrust washer at each end of transfer countergear. Ensure tab on thrust washers fits into groove of transfer case. Install counter gear shaft from transmission case side so lock plate groove is aligned with lock plate. Install lock plate. Install side cover and gasket.

5) Install bearing retainer. If reusing bearing retainer bolts, apply Locking Adhesive (3M 4170 Stud Lock) to threads. Install oil dam cover. Install differential lock hub, snap ring, steel ball and sleeve. Select thickest snap ring that will fit into groove. Allowed snap ring clearance is 0-.003" (0-.08 mm). Install 2WD-4WD synchronizer sleeve, 2WD-4WD shift fork, spring, spring seat and 2WD-

4WD shift rail snap ring.

6) Assemble front output shaft assembly, chain and 2WD-4WD synchronizer assembly. Align match marks made during disassembly. Link chain tightly onto 2WD-4WD synchronizer and front output shaft sprockets. Install both sprockets and chain to transfer case at same time, while keeping them as far apart as possible.

7) Install center differential case assembly, rear output shaft assembly needle bearings and rear output shaft assembly. Install interlock plunger so it does not interfere with 2WD-4WD shift rail. Evenly apply sealant to chain cover and install chain cover.

8) Install high-low shift rail through high-low shift rail hole into shift fork. Align spring pin holes in high-low shift rail and shift fork. Tap in spring pin so slit is facing shift rail shaft center. Install and tighten high-low shift rail plug to specification. See TORQUE SPECIFICATIONS.

9) Before installing front output shaft cover, measure protrusion "A" of front output shaft rear bearing and recess "B" of cover and calculate clearance. See Fig. 11. If clearance is greater than .079" (2.00 mm), select and install spacer to bring clearance within specification. If clearance is less than .079" (2.00 mm), use wave spring alone. Apply sealant to both sides of gasket and install gasket and cover. Apply Locking Adhesive (3M 4170 Stud Lock) to bolts and tighten to specification. See TORQUE SPECIFICATIONS.

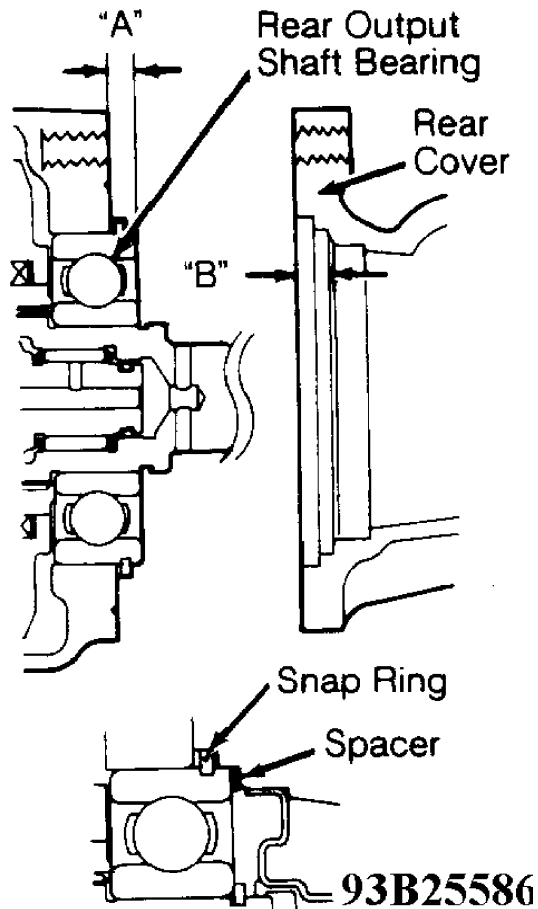

Fig. 11: Measuring Rear Output Shaft Bearing Clearance (Montero)  
Courtesy of Mitsubishi Motor Sales of America.

10) Install rear output shaft ball bearing snap ring. Measure clearance between chain cover and snap ring. Add .0008-.0039" (.02-.10

mm) to clearance measured and install spacer of similar thickness. Install rear output shaft oil seal (apply grease to lip of seal). Install rear cover oil seal (apply grease to lip of seal).

11) Before installing rear cover, snap ring and spacer thicknesses must be determined. Measure protrusion of rear output shaft bearing. Measure inset of both stages of cover. Subtract inset recess from rear bearing protrusion. Select a snap ring which adjusts difference between inset recess and rear bearing protrusion, and spacer thickness to 0-.004" (0-0.10 mm). Evenly apply sealant to rear cover and install cover. Tighten bolts to specification. Refer to the TORQUE SPECIFICATIONS table.

12) Install speedometer gear, ensuring mating marks match according to number of gear teeth. Install speedometer gear sleeve clamp and tighten bolt to specification. See Fig. 10.

13) Apply sealant to poppet plug threads. Install poppet steel balls, springs and poppet plugs and tighten to specification. Install detection switches, steel balls and gaskets. See Fig. 12. Install dynamic damper and tighten bolts to specification.

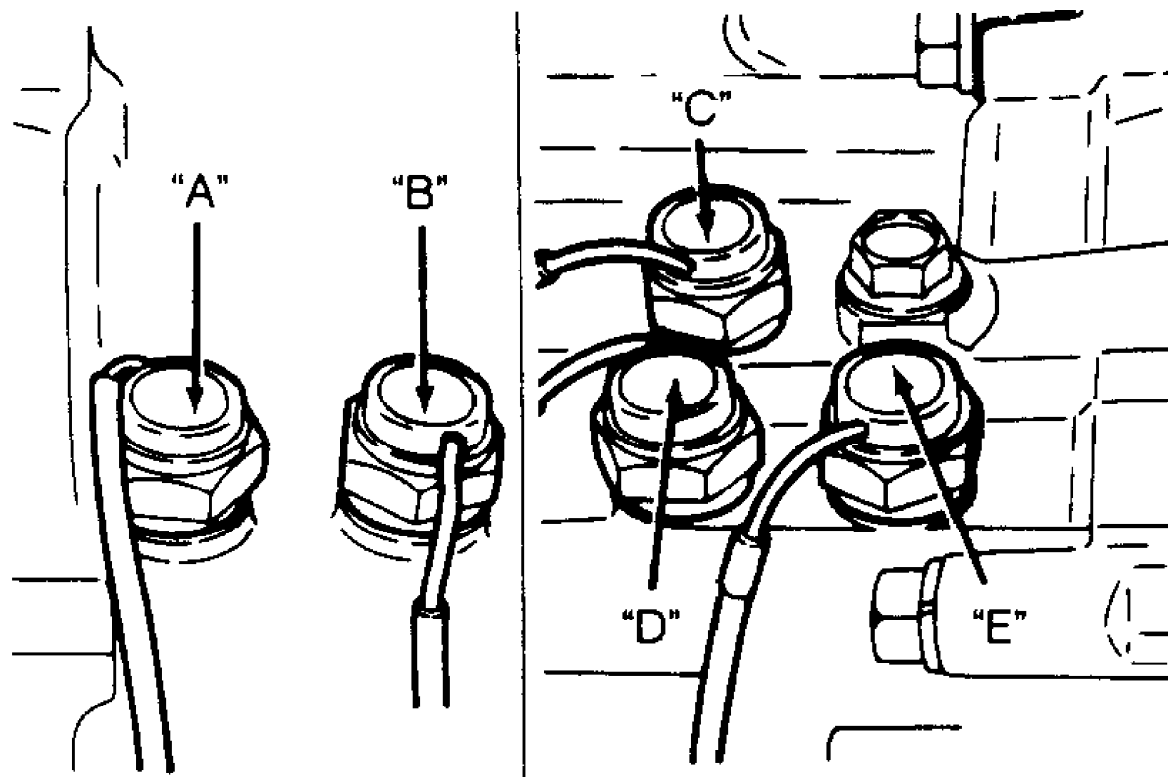

- "A" - Ball Built-In, Brown Connector
- "B" - Ball Built-In, Black Connector
- "C" - Ball Separate, Brown Connector
- "D" - Ball Separate, Black Connector
- "E" - Ball Separate, White Connector

**93C25587**

Fig. 12: Installation Of Detection Switches (Montero)  
Courtesy of Mitsubishi Motor Sales of America.

## TORQUE SPECIFICATIONS



TORQUE SPECIFICATIONS TABLE

Application		Ft. Lbs. (N.m)
Adapter-To-Transfer Bearing Retainer	(1)	14 (19)
Case Nuts & Bolts	22-31	(30-42)
Center Differential Case Bolts		48 (65)
Chain Cover Bolt	22-31	(30-42)
Detection Switch	(1)	27 (36)
Drain Plug	22-26	(30-35)
Dynamic Damper		52 (70)
High-Low Shift Rail Plug	(1)	24 (33)
Interlock Plunger Plug	(1)	22-26 (30-35)
Lock Plate Bolts	11-16	(15-22)
Oil Dam Cover	(1)	14 (19)
Oil Filler Plug	22-26	(30-35)
Output Shaft Cover Bolt	11-16	(15-22)
Poppet Plug	(1)	27 (36)
Pulse Rotor Bolt	(2)	11-16 (15-22)
Rear Cover Bolt	11-16	(15-22)
Rear Output Shaft Lock Nut	74-96	(100-130)
Seal Plug	(2)	22-31 (30-42)
Speedometer Sleeve Clamp Bolt	11-16	(15-22)
4WD Indicator Light Switch	(2)	22 (33)
		INCH Lbs. (N.m)
Pulse Generator Bolt	(2)	89-106 (10-12)
Side Cover Bolt		71-89 (8-10)

- (1) - Montero.  
(2) - Ram-50.

**WIRING DIAGRAMS**

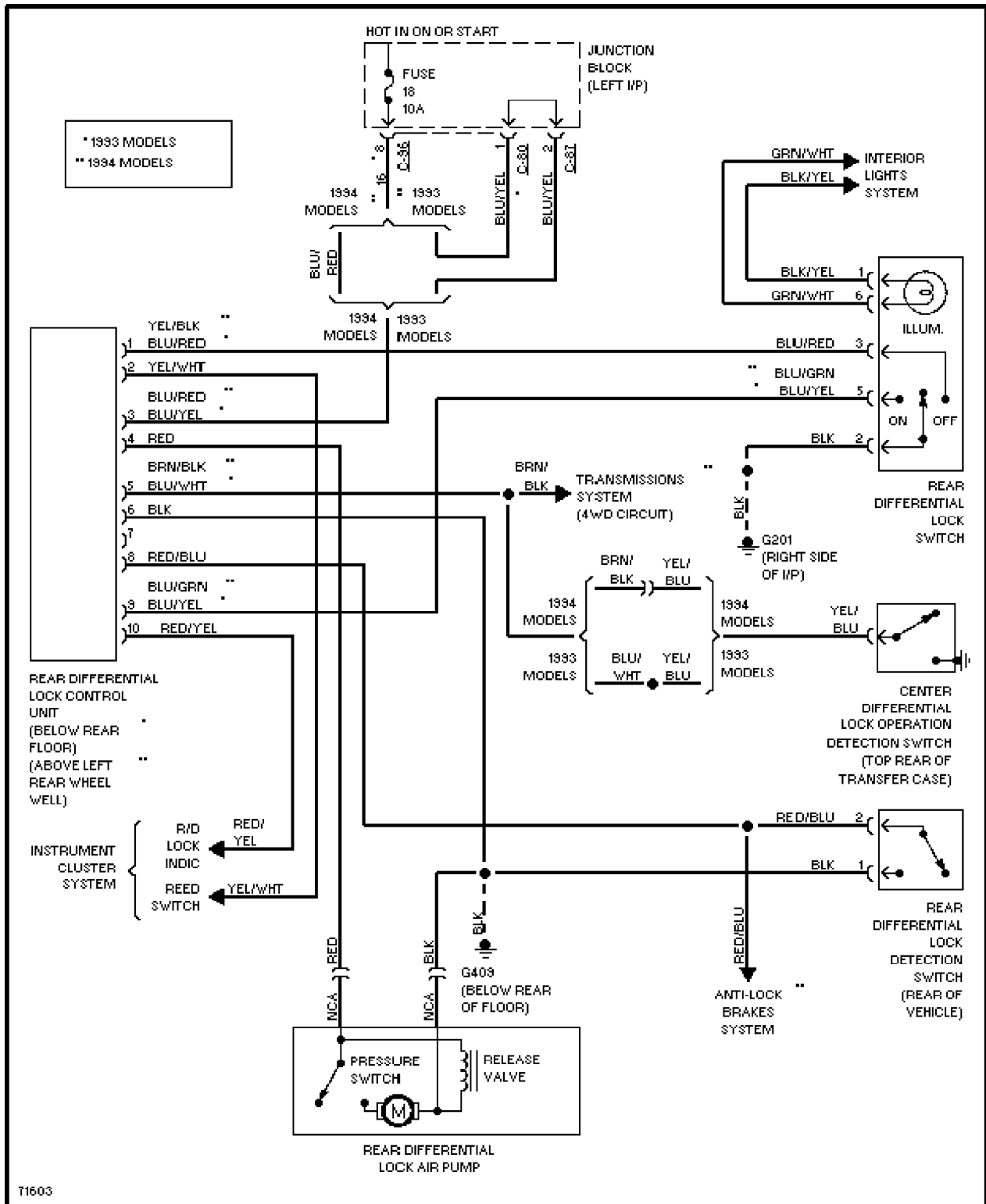

Fig. 13: Rear Differential Lock Circuit (Montero)

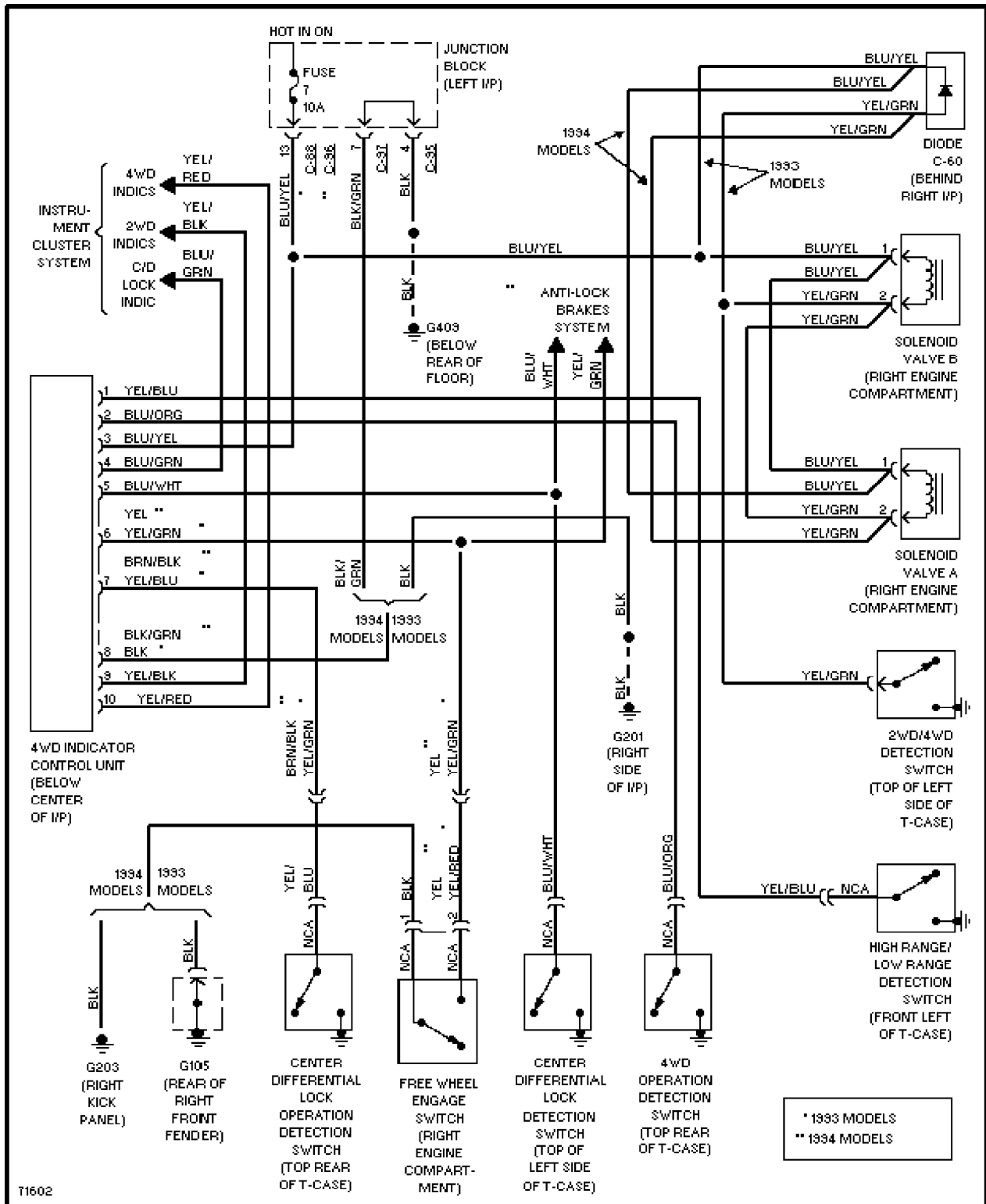

Fig. 14: Active Trac 4WD Circuit (Montero)