

MITSUBISHI PAJERO'94

WORKSHOP MANUAL ELECTRICAL WIRING

FILING INSTRUCTION

Please keep these manual pages in the binder
No.BN890001 to be send under separate cover.

Missing sheets will be supplied upon request.

Pub. No. PHJE9026-C



ADDED

MITSUBISHI PAJERO

ELECTRICAL WIRING

FOREWORD

This Electrical Wiring Manual contains information necessary for inspection and servicing of electrical wiring in the Mitsubishi PAJERO edited in the form of wiring harness configuration diagrams and function-separated circuit diagrams.

It is recommended that all service mechanics engaged in the servicing of the vehicle refer to the following publications as well as this manual.

TECHNICAL INFORMATION PYJE9002
MANUAL

WORKSHOP MANUAL PWJE9086
(Loose-leaf edition)

WORKSHOP MANUAL PWEE□□□□
Engine Group (Loose-leaf edition)

PARTS CATALOGUE B6035604A□

All information, illustrations and product descriptions contained in this manual are current as of time of publication. We, however, reserve the right to make changes at any time without prior notice or obligation.

GROUP INDEX

HOW TO READ THE WIRING DIAGRAMS	1A
WIRING HARNESS CONFIGURATION DIAGRAMS	2A
SINGLE PART INSTALLATION POSITION	3A
CIRCUIT DIAGRAM	4A
INDEX	



HOW TO USE THIS MANUAL

CONTENTS

The preceding page contains GROUP INDEX which lists the group title and group number.

PAGE NUMBERS

All page numbers consist of two sets of digits separated by a dash. The digits preceding the dash identify the number of the group. The digits following the dash represent the consecutive page number within the group. The page numbers can be found on the top left or right of each page.

OPERATION AND TROUBLESHOOTING HINTS

In the GROUP 4A circuit diagrams, the operation and troubleshooting hints are given on the previous page or following page for each circuit where necessary.

1A HOW TO READ THE WIRING DIAGRAMS

MODEL	1A-3
COMPOSITION AND CONTENTS OF WIRING DIAGRAMS	1A-4
HOW TO READ CONFIGURATION DIAGRAMS	1A-5
HOW TO READ CIRCUIT DIAGRAMS	1A-6
MARKINGS FOR CONNECTOR EARTHING	1A-8
SYMBOLIC MARKS	1A-10
WIRE COLOUR CODES	1A-10
CONNECTOR COLOUR CODES	1A-11
ABBREVIATION SYMBOLS	1A-11

1A-2

NOTES

MODEL

<2-DOOR MODELS>

Model code		Body style	Engine model	Transmission model	Fuel supply system	
V24C	NSFL6	Canvas top	4D56 [2477 cm ³ , (151.2 cu.in.)] with turbocharger and intercooler	V5MT1 (5M/T)	Injection	
V23C	GNHEL6	Canvas top with wide fender	6G72 [2972 cm ³ , (181.3 cu.in.)]	V4AW2 (4A/T)	MPI	
	GRHEL6					
V21W	NHEL6	Wagon	4G64 [2351 cm ³ , (143.5 cu.in.)]	V5M21 (5M/T)	Injection	
V24W	NDFL6		4D56 [2477 cm ³ , (151.2 cu.in.)] with turbocharger and intercooler	V5MT1 (5M/T)		
	NHFL6/R6					
	NAFL6					
	NBFL6					
V24WG	NXFL6/R6		Wagon with wide fender	6G72 [2972 cm ³ , (181.3 cu.in.)]	V4AW2 (4A/T)	MPI
	NCFL6					
V23W	GNXEL6/R6			6G74 [3497 cm ³ , (213.3 cu.in.)]	V5M31 (5M/T)	
	GRXEL6/R6					
V25W	GNXML6/R6			V4AW3 (4A/T)		
	GRXML6/R6					

<4-DOOR MODELS>

Model code		Body style	Engine model	Transmission model	Fuel supply system
V46W	NDFL6	Wagon	4M40 [2835 cm ³ , (173.0 cu.in.)] with turbocharger and intercooler	V5M31 (5M/T)	Injection
	NDFCL6			V4AW3 (4A/T)	
	NHFL6/R6			V5M31 (5M/T)	
	RHFL6/R6				
	NAFL6			V4AW3 (4A/T)	
	NAFCL6			V5M31 (5M/T)	
	NBFL6				
	RBFL6			V4AW3 (4A/T)	
V46WG	NXFL6/R6	Wagon with wide fender	6G72 [2972 cm ³ , (181.3 cu.in.)]	V5MT1 (5M/T)	MPI
	RXFL6/R6			V4AW2 (4A/T)	
	NCFL6			V5M31 (5M/T)	
	RCFL6				
V43W	GNXEL6/R6		6G74 [3497 cm ³ , (213.3 cu.in.)]	V5M31 (5M/T)	
	GRXEL6/R6				V4AW3 (4A/T)
V45W	GNXML6/R6		V4AW3 (4A/T)		
	GRXML6/R6				

COMPOSITION AND CONTENTS OF WIRING DIAGRAMS

- (1) This manual consists of wiring harness diagrams, installation locations of individual parts, circuit diagrams and index.
- (2) In each of the sections, all specifications are listed, including optional specifications. Accordingly, some specifications may not be applicable for individual vehicles.

Section	Basic contents
Wiring harness configuration diagrams	Connector locations and harness wiring configurations on actual vehicles are illustrated.
Single part installation position	Locations are shown for earth points of relays, control units, sensors, diodes, check terminals, spare terminals, fusible links, fuses, etc. In the parts lists, parts are listed in alphabetical order.
Circuit diagrams	<p>Circuits from power supply to earth are shown completely, classified according to system. There is a main division into power circuits, and circuits classified by system. The circuits classified by system also include operation and troubleshooting hints.</p> <ul style="list-style-type: none"> • Junction block Here is the circuit for the entire junction block since only the part of the junction block needed is normally show in each circuit diagram. • Power supply circuits Circuits from the battery to fusible link, dedicated fuses, ignition switch, general purpose fuses, etc. • Circuits classified by system For each system, the circuits are shown from fuse to earth, excluding the power supply sections. • Operation The normal operation of each system is briefly described, following the route of current flow. • Troubleshooting hints This is a brief explanation of the inspection points that serve as hints when troubleshooting. Explanations of the circuits controlled by the electronic control unit are omitted. Refer to the related publications as required.
Index	All components used are listed by connector number and component name.

HOW TO READ CONFIGURATION DIAGRAMS

The wiring harness diagrams clearly show the connector locations and harness routings at each site in actual vehicles.

Denotes connector No.
 The same connector No. is used throughout the circuit diagrams to facilitate connector location searches.
 The first alphabetical symbol indicates the location site of the connector and a number that follows is the unique number. Numbers are assigned to parts in clockwise order on the diagram.
 Furthermore, to make searching easier, number of connector pins and connector colours (except in the case of milky white) are listed.

Example: A-12

- (6-B) — Number of connector pins and connector colour (Connectors with no colour listed are milky white.)
- A-12 — Number specific to connector (serial number)
- A — Connector location site symbol
 - A: Engine compartment
 - B: Transmission
 - C: Dash panel
 - D: Instrument panel and floor console
 - E: Floor, roof
 - F: Door
 - G: Back door and rear under floor

The mark ★ shows the standard mounting position of wiring harness.

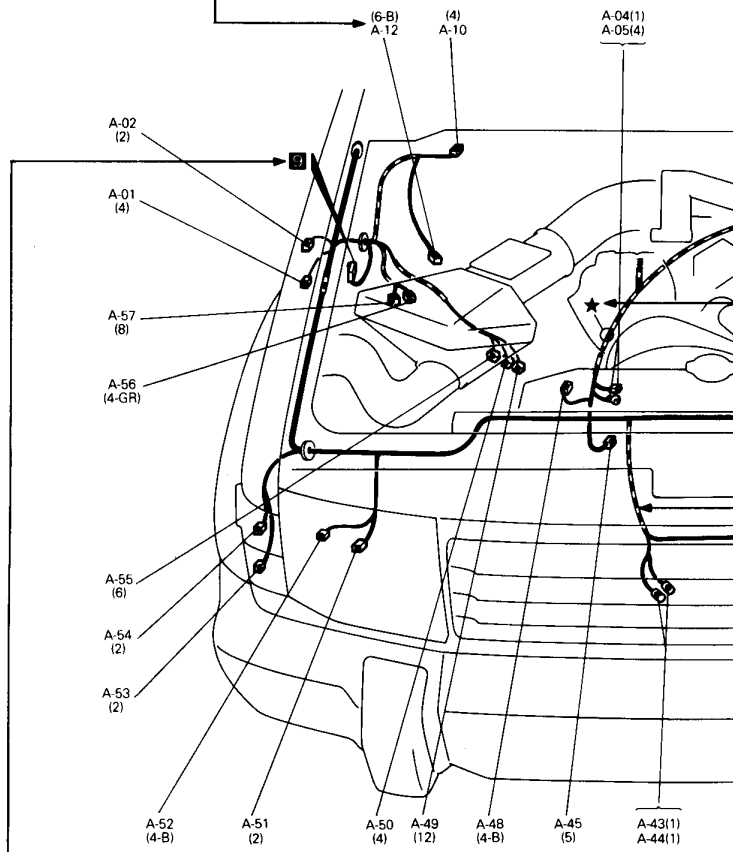

Denotes earth point.
 Same earth number is used throughout circuit diagrams to facilitate search of earth point. Refer to GROUP 3A SINGLE PART INSTALLATION POSITION-EARTH MOUNTING LOCATIONS for details of earth points.

Denotes a section covered by a corrugated tube.

1A-6 HOW TO READ THE WIRING DIAGRAMS — How to Read Circuit Diagrams

HOW TO READ CIRCUIT DIAGRAMS

The circuit of each system from fuse (or fusible link) to earth is shown. The power supply is shown at the top and the earth at the bottom to facilitate understanding of the current flow.

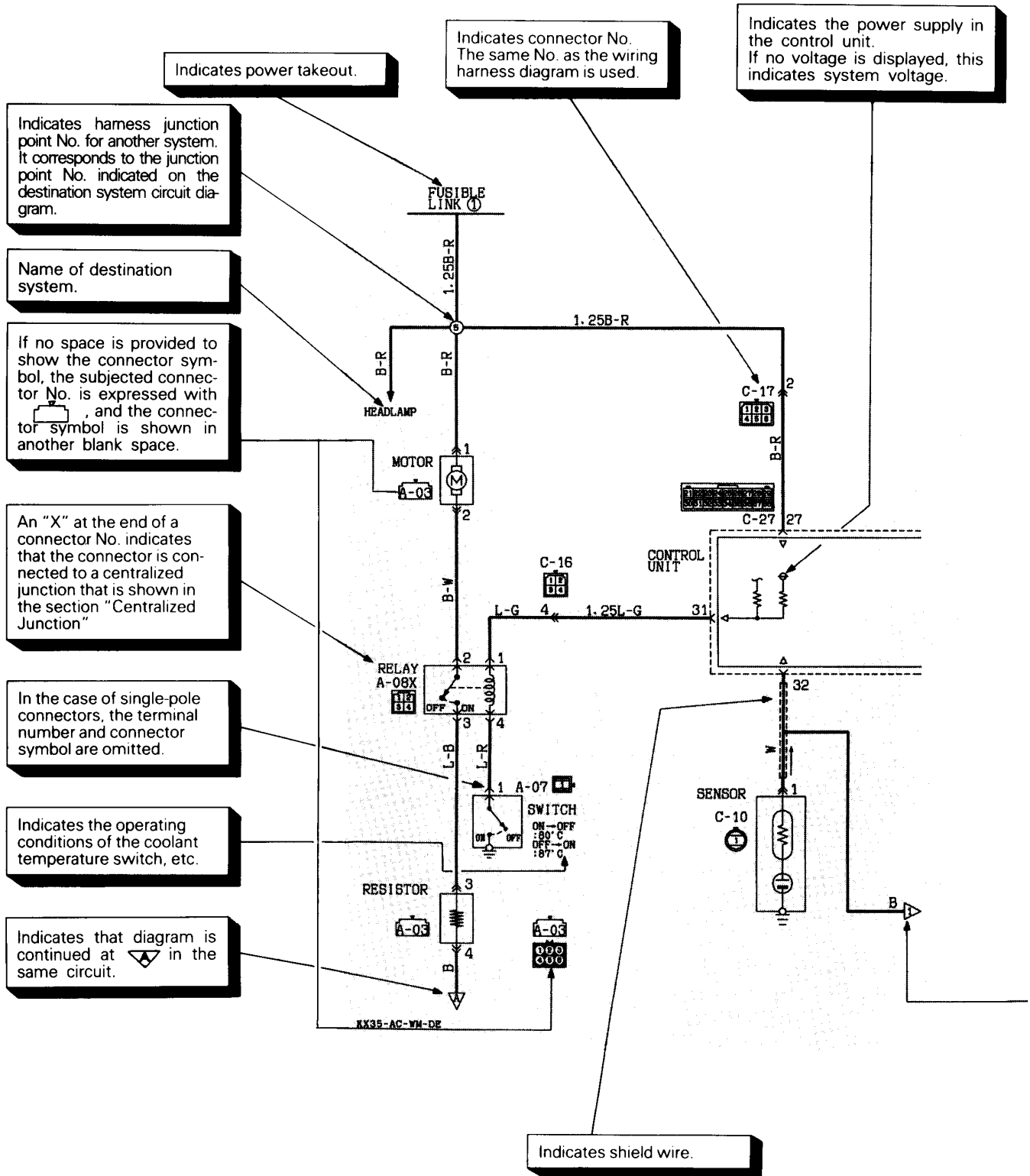

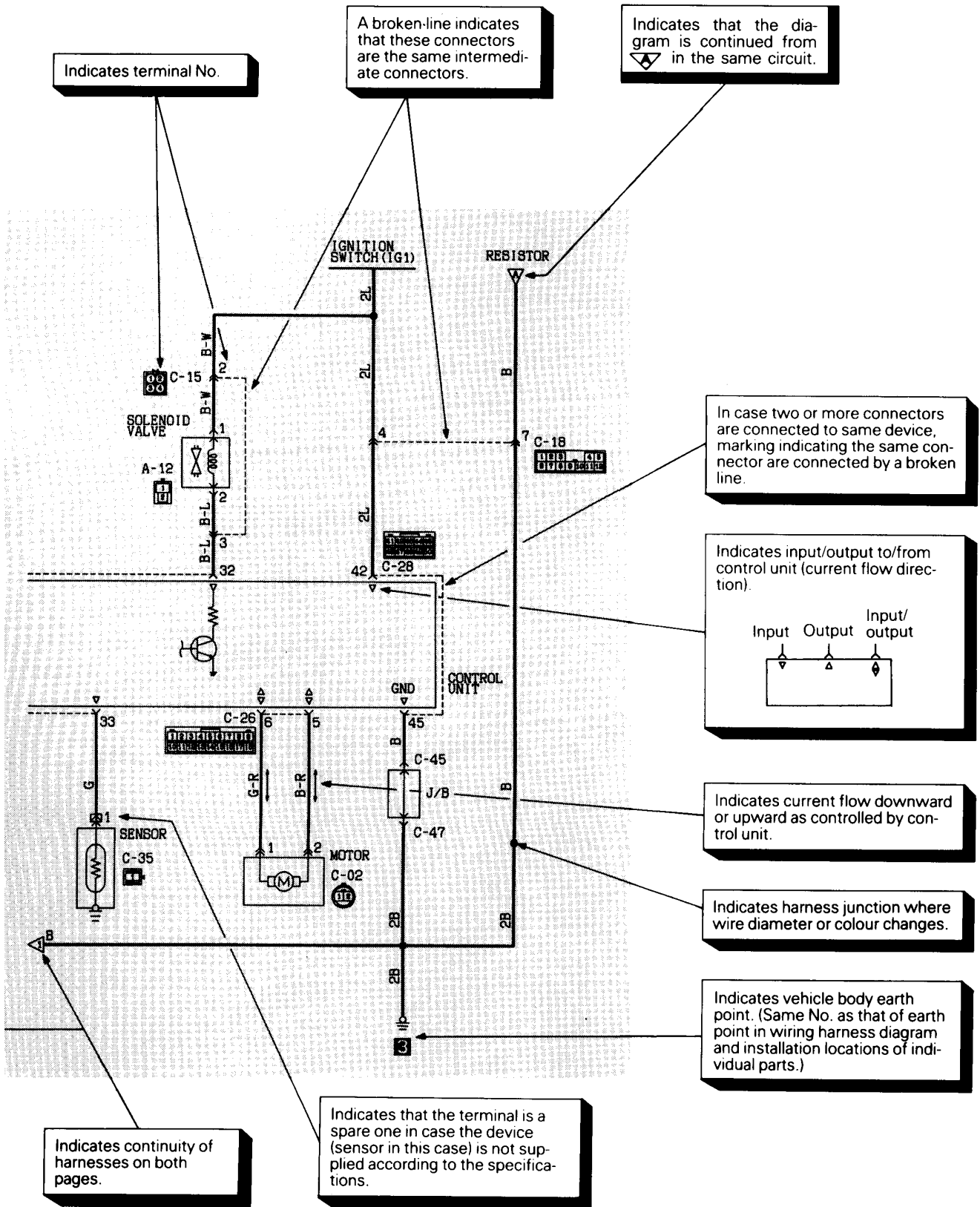





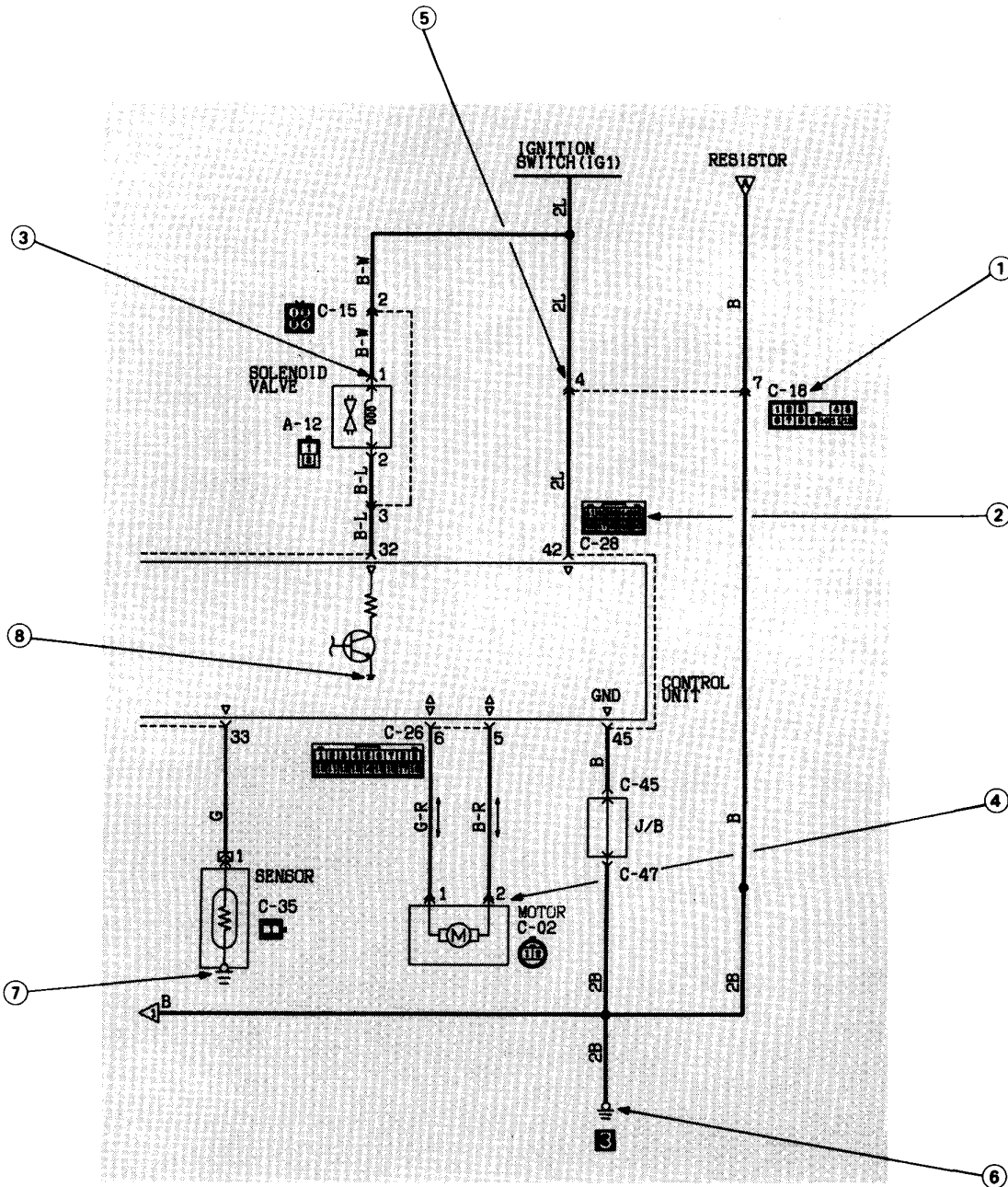

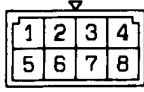
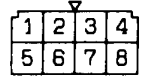
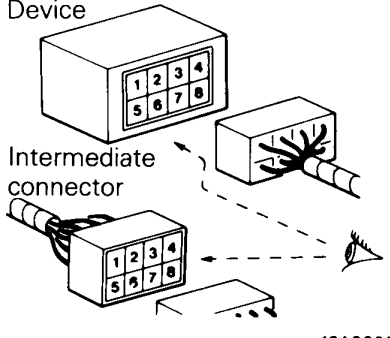
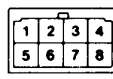
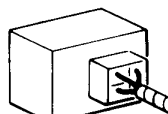
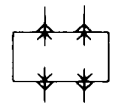
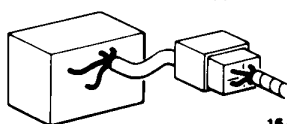
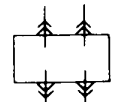
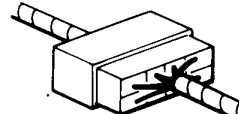

1A-8 HOW TO READ THE WIRING DIAGRAMS — Markings for Connector Earthing

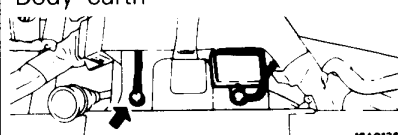
MARKINGS FOR CONNECTOR EARTHING

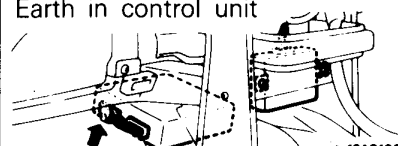

HOW TO READ THE WIRING DIAGRAMS — Markings for Connector Earthing 1A-9

	No	Item	Symbol	Contents
Connector marking	①	Male 	↓	Double connector contour lines indicate male connector terminals and single contour line indicates female terminals as illustrated here.
	—	Female 	Y	
Connector symbol marking	②	Device 		The symbol indicates the connector as viewed from illustrated direction. At the connection with a device, the connector symbol on the device side is shown, and for an intermediate connector, male connector symbol is shown. For the data link connector, its contents differ from the previous description. Refer to "MUT-II operation instruction" in detail.
Connector connection marking	③	Direct connection type 		A connection between a device and connector on the harness side is either by direct insertion in the device (direct connection type) or by connection with a harness connector on the device side furnished. (harness connection type). The two types are indicated as illustrated.
	④	Harness connection type 		
	⑤	Intermediate connector 		
Earth markings	⑥	Body earth 		Earth is either by body earth, device earth or control unit interior earth. These are indicated as illustrated.
	⑦	Device earth 		
	⑧	Earth in control unit 		

1A-10 HOW TO READ THE WIRING DIAGRAMS — Symbolic Marks/Wire Colour Codes

SYMBOLIC MARKS

Devices appearing in circuit diagrams are indicated by the following symbols.

Battery 	Body earth 	Single bulb 	Resistor 	Diode 	Capacitor
Fuse 	Equipment earth 	Dual bulb 	Variable resistor 	Zener diode 	Crossing of wires without connection
Fusible link 	ECU interior earth 	Speaker 	Coil 	Transistor 	Crossing of wires with connection
Connector Female side Male side 	Motor 	Horn 	Pulse generator 	Buzzer 	Chime
Thyristor 	Piezoelectric device 	Thermistor 	Light emitting diode 	Photo diode 	Photo transistor

WIRE COLOUR CODES

Wire colours are identified by the following colour codes.

Code	Wire colour	Code	Wire colour
B	Black	P	Pink
BR	Brown	R	Red
G	Green	SB	Sky blue
GR	Gray	V	Violet
L	Blue	W	White
LG	Light green	Y	Yellow
O	Orange		

NOTE

If a cable has two colours, the first of the two colour code characters indicates the basic colour (colour of the cable coating) and the second indicates marking colour.

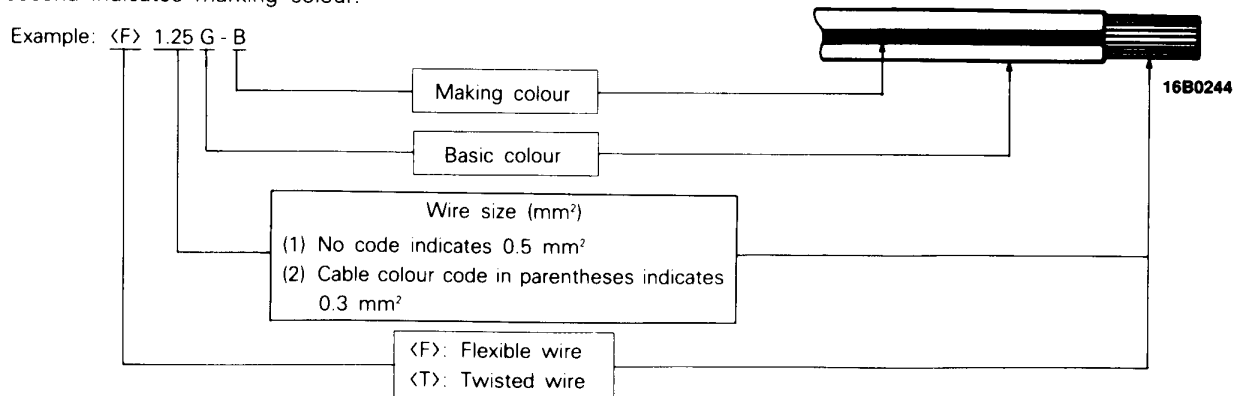

CONNECTOR COLOUR CODES

Connector colours are identified by the following colour codes.

Code	Connector colour	Code	Connector colour
B	Black	L	Blue
BR	Brown	R	Red
G	Green	Y	Yellow
GR	Gray		

ABBREVIATION SYMBOLS

The abbreviation symbols used in wiring diagrams are defined below.

Abbreviation symbol	Meaning	Abbreviation symbol	Meaning
4D56	4D56 engine	GND	Earth
4G64	4G64 engine	ILL	Illumination lamp
4M40	4M40 engine	IND	Indication lamp
6G72	6G72 engine	J/B	Junction block
6G74	6G74 engine	J/C	Joint connector
ABS	Anti-lock brake system	LHD	L.H. drive vehicles
A/C	Air conditioner	MPI	Multi-point injection
A/T	Automatic transmission	M/T	Manual transmission
DIESEL	Diesel-powered vehicles	PETROL	Petrol-powered vehicles
DRL	Daytime running lamp	RHD	R.H. drive vehicles
EGR	Exhaust gas recirculation	SRS	Supplemental restraint system
ELC-4A/T	Electronic control 4-speed automatic transmission		

Abbreviation symbols used for combination meters

Abbreviation symbol	Meaning	Abbreviation symbol	Meaning
2WD	2WD indicator lamp	H	Hard mode indicator lamp <Remote controlled variable shock absorber>
4WD	4WD indicator lamp		
ABS	Anti-lock brake system warning lamp		
A/T TEMP	Automatic transmission fluid temperature warning lamp	HAZARD	Hazard warning indicator lamp
BEAM	Upper beam indicator lamp	HOLD	Hold mode indicator lamp <ELC-4A/T>
BRAKE	Brake warning lamp	M	Medium mode indicator lamp <Remote controlled variable shock absorber>
C/D LOCK	Center differential lock indicator lamp		
CHECK ENGINE	Check engine warning lamp		
CHG	Charging warning lamp	O/GA	Oil pressure gauge
CRUISE	Auto-cruise control indicator lamp	OIL	Oil pressure warning lamp
DOOR	Door-ajar warning lamp	OIL LEVEL	Low engine oil warning lamp
F/GA	Fuel gauge	POWER	Power mode indicator lamp <ELC-4A/T>
FILTER	Fuel filter warning lamp		
FUEL	Low fuel warning lamp	R/D LOCK	Rear differential lock indicator lamp
GLOW	Diesel preheat indicator lamp	REED	Reed switch

1A-12 HOW TO READ THE WIRING DIAGRAMS — Abbreviation Symbols

Abbreviation symbol	Meaning	Abbreviation symbol	Meaning
S	Soft mode indicator lamp <Remote controlled variable shock absorber>	TACHO	Tachometer
		T/GA	Engine coolant temperature gauge
		TURN (LH)	Turn signal indicator lamp (L.H.)
SPEED	Speedometer	TURN (RH)	Turn signal indicator lamp (R.H.)
		WASHER	Low washer fluid warning lamp

Abbreviation symbols used for switches and relays

Name of switches and relays	Abbreviation symbol	Operation	Name of switches and relays	Abbreviation symbol	Operation
Ignition switch	ACC	When turned to the ACC (ACCESSORY) or ON position, the power circuit starts functions	Rear heater control switch or Rear A/C control switch	LO	Rear blower operates at low speed
	IG1	Even when at the ST (START) position, the power circuit start functioning		M	Rear blower operates at medium speed
	IG2	When at the ST (START) position, the power circuit dose not start functioning		HI	Rear blower operates at high speed
	Dimmer passing switch	LO	Low beams ON	Air conditioner switch	ECONO
HI		High beams ON	A/C		2nd position (full load operation)
Lighting switch		TAIL	Position, tail, license-plate and instrument panel lamps ON		Windshield wiper switch
	HEAD	Headlamps ON	HI	Wipers operate at high speed	
			INT	Wipers operate intermittently	
Room lamp switch	DOOR	Room lamp ON when a door is open	Rear wiper switch	LO	Wipers operate at low speed
				INT	Wiper operate intermittently
Turn signal switch	LH	L.H. turn signal lamps ON	Remote control mirror switch	LH	L.H. mirror operates
	RH	R.H. turn signal lamps ON		RH	R.H. mirror operates
Power window switch	UP	Window closed	Sunroof switch	OPEN	Sunroof slides open
	DOWN	Window opened		CLOSE	Sunroof slides to close
Door lock actuator	LOCK	Door locked	Variable shock absorber control switch	S	Sets the shock absorbers to SOFT mode
	UNLOCK	Door unlocked		M	Sets the shock absorbers to MEDIUM mode
Door key cylinder switch	LOCK	Door locked		H	Sets the shock absorbers to HARD mode
	UNLOCK	Door unlocked	Rear differential lock switch	LOCK	Rear differential locked
Blower switch	LO	Blower operates at low speed		Heated seat switch	LO
	ML	Blower operates at medium speed	HI		Rapid heating
	MH	Blower operates at medium high speed	Others	ON	Switched on
	HI	Blower operates at high speed		OFF	Switched off

2A WIRING HARNESS CONFIGURATION DIAGRAMS

OVERALL WIRING DIAGRAM

2-door models <L.H. drive vehicles>	2A-2
2-door models <R.H. drive vehicles>	2A-2
4-door models <L.H. drive vehicles>	2A-3
4-door models <R.H. drive vehicles>	2A-3

ENGINE COMPARTMENT **A**

Vehicles with 4G64 engine	2A-4
L.H. drive vehicles with 6G72 engine	2A-8
R.H. drive vehicles with 6G72 engine	2A-12
L.H. drive vehicles with 6G74 engine	2A-16
R.H. drive vehicles with 6G74 engine	2A-20
L.H. drive vehicles with 4D56 engine	2A-24
R.H. drive vehicles with 4D56 engine	2A-28
L.H. drive vehicles with 4M40 engine	2A-32
R.H. drive vehicles with 4M40 engine	2A-36

TRANSMISSION **B**

Part time 4WD	2A-40
Super select 4WD	2A-41

DASH PANEL **C**

L.H. drive vehicles	2A-42
R.H. drive vehicles	2A-44

INSTRUMENT PANEL AND FLOOR CONSOLE **D**

L.H. drive vehicles <M/T>	2A-46
R.H. drive vehicles <M/T>	2A-47
L.H. drive vehicles <A/T>	2A-48
R.H. drive vehicles <A/T>	2A-49

FLOOR AND ROOF **E**

2-door models <L.H. drive vehicles>	2A-50
2-door models <R.H. drive vehicles>	2A-51
4-door models <L.H. drive vehicles>	2A-52
4-door models <R.H. drive vehicles>	2A-53

DOOR **F**

2-door models <L.H. drive vehicles>	2A-54
2-door models <R.H. drive vehicles>	2A-55
4-door models <L.H. drive vehicles>	2A-56
4-door models <R.H. drive vehicles>	2A-57

BACK DOOR AND REAR UNDER FLOOR **G** 2A-58

OVERALL WIRING DIAGRAM

2-door models <L.H. drive vehicles>

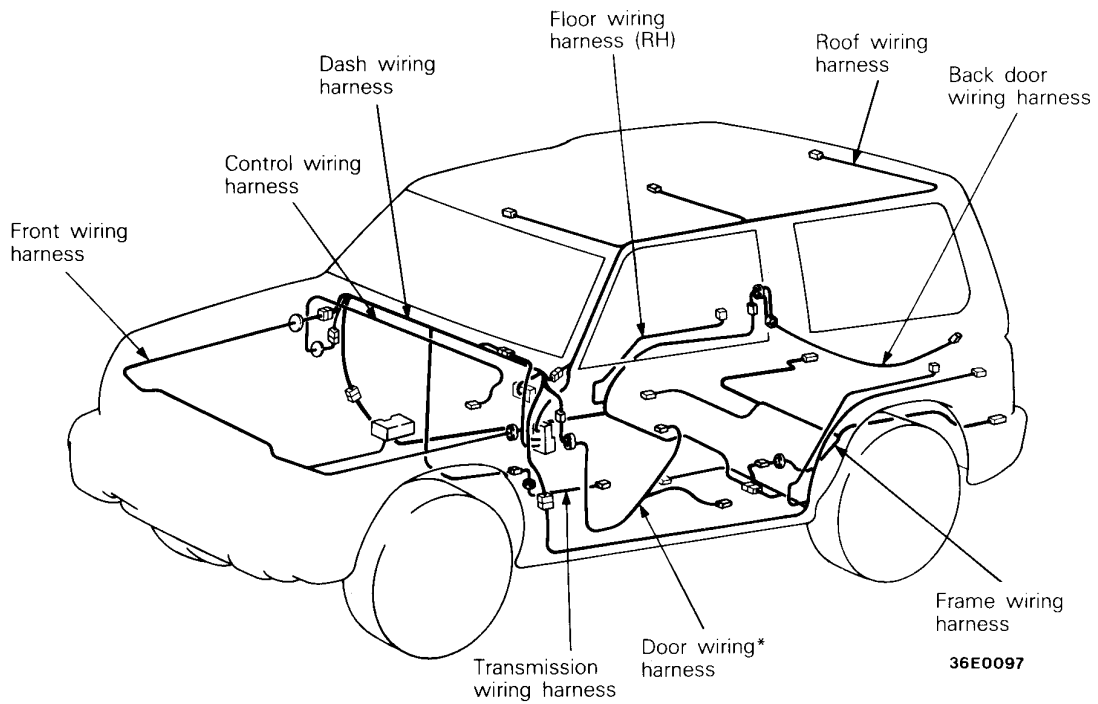

2-door models <R.H. drive vehicles>

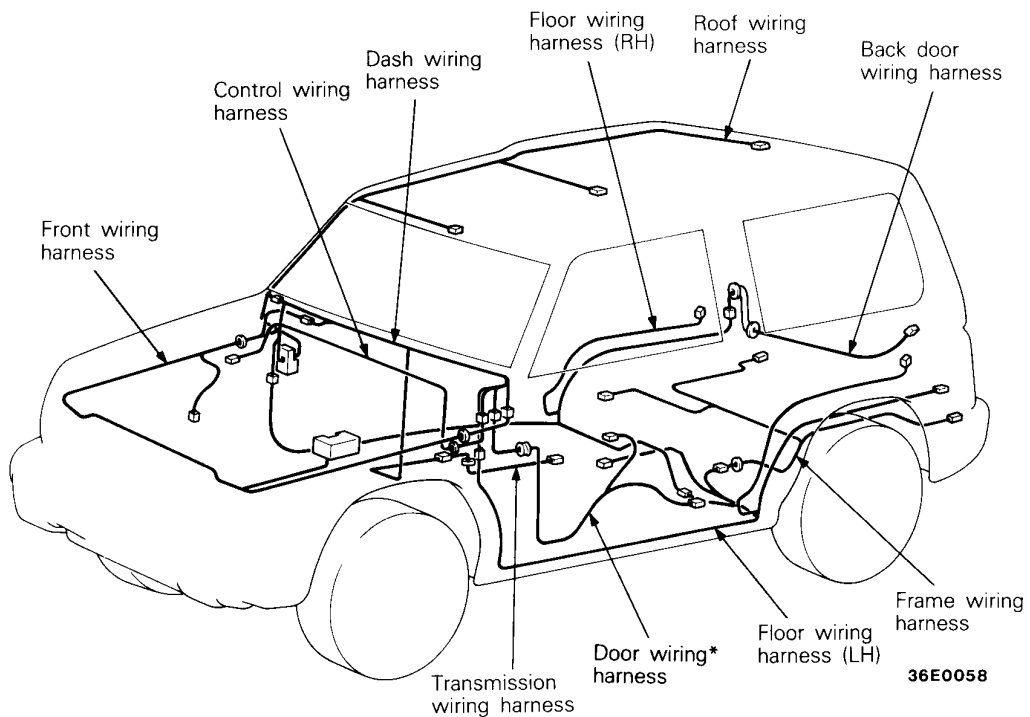

NOTE

- (1) This illustration shows only the major wiring harness.
- (2) *indicates also equipped at the right side.

4-door models <L.H. drive vehicles>

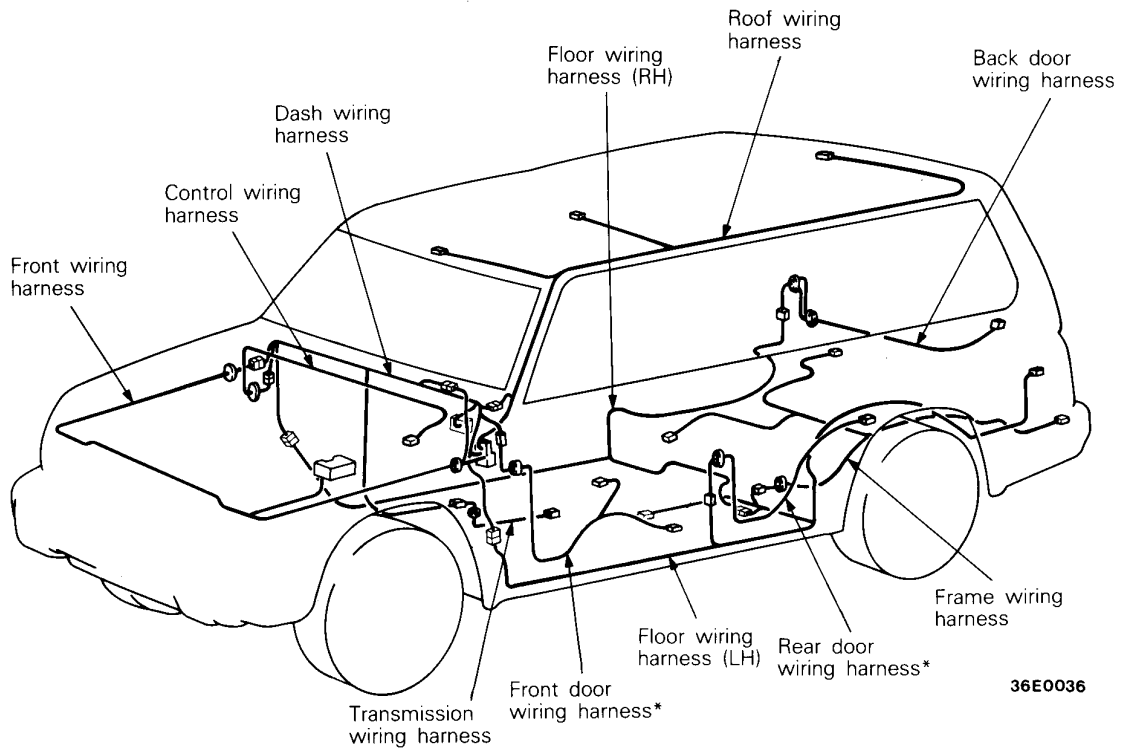

4-door models <R.H. drive vehicles>

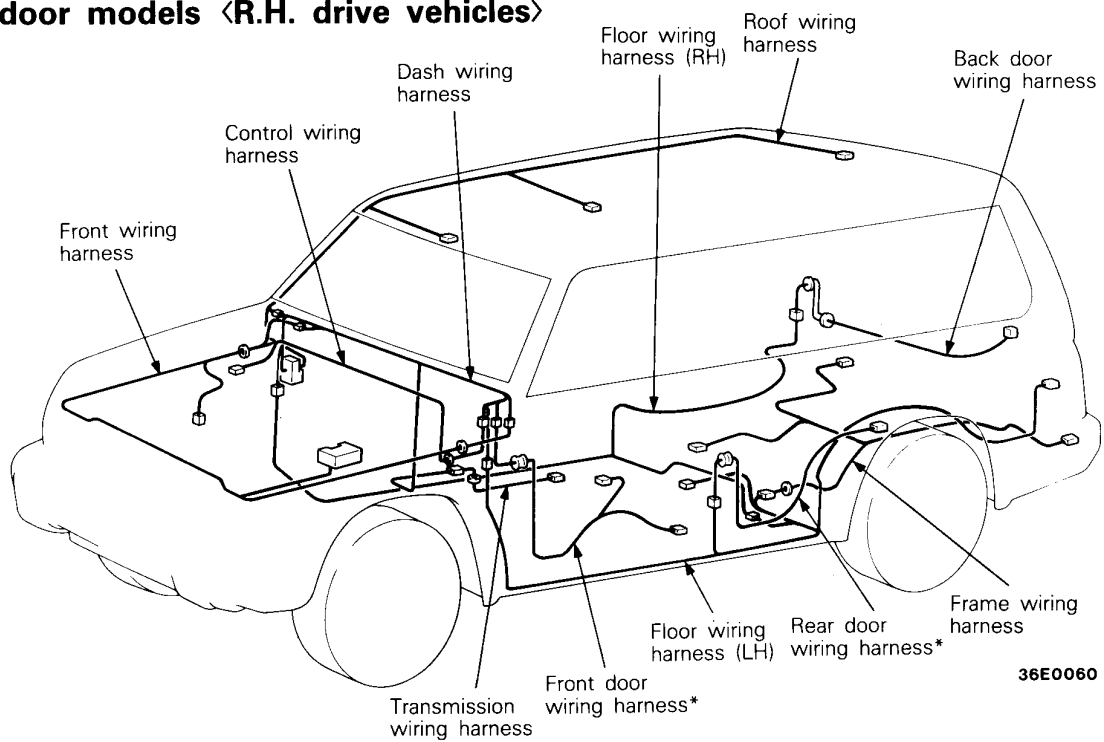

NOTE

- (1) This illustration shows only the major wiring harness.
- (2) *indicates also equipped at the right side.

ENGINE COMPARTMENT

Vehicles with 4G64 engine

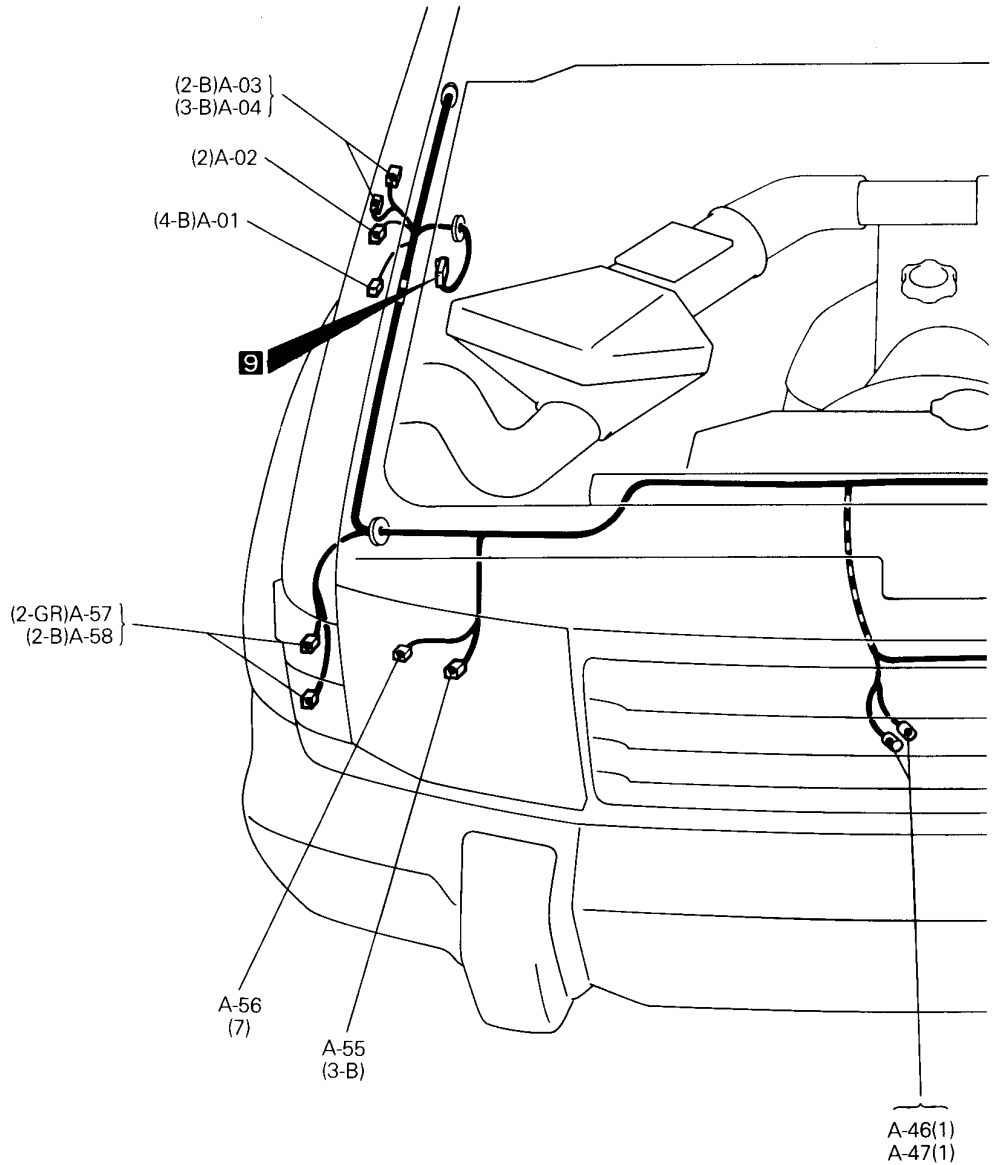
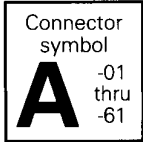

- | | | | |
|------------------|--------------------------------------------------------------|--------------------|-----------------------------------------------------------------------------------------------------------|
| A-01 | Headlamp washer motor and headlamp washer fluid level sensor | A-14 | — |
| A-02 | Side turn signal lamp (RH) | A-15 | — |
| A-03 }
A-04 } | Motor antenna | A-16 | Control wiring harness and front wiring harness combination |
| A-05 }
A-06 } | Starter | A-17 | Side turn signal lamp (LH) |
| A-07 | Daytime running lamp relay 2 | A-18 | Windshield washer motor |
| A-08 | Daytime running lamp relay 1 | A-19X }
A-26X } | Refer to centralized junction |
| A-09 | Daytime running lamp control unit | A-27 | Battery cable and front wiring harness combination |
| A-10 | — | A-28 | — |
| A-11 | Windshield wiper motor | A-29 }
A-30 } | Daytime running lamp harness and front wiring harness combination or front wiring harness joint connector |
| A-12 | — | | |
| A-13 | Brake fluid level switch | | |

WIRING HARNESS CONFIGURATION DIAGRAMS — Engine Compartment 2A-5

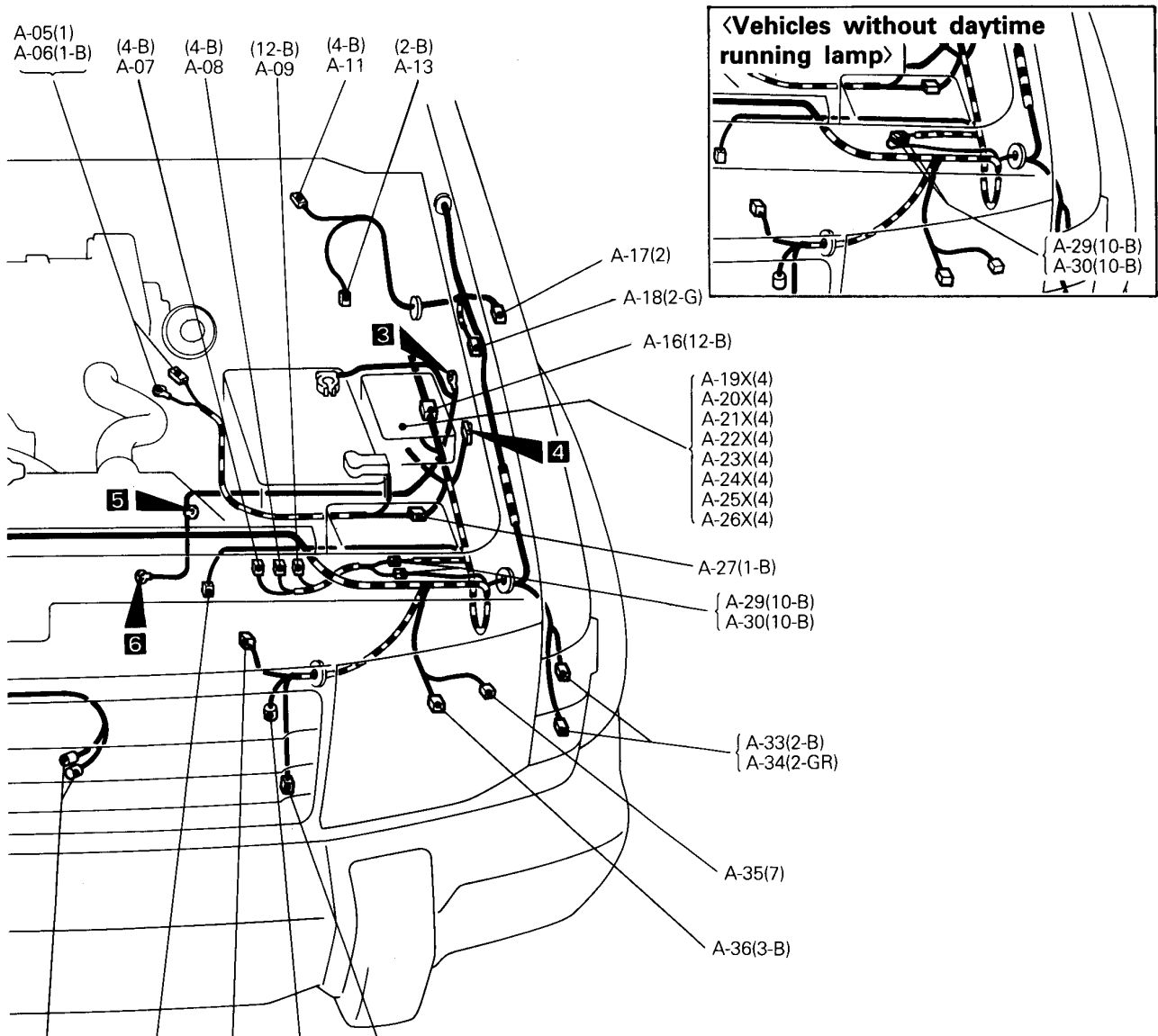

36E0113

- | | | |
|--------------------------------------------------------------------------------------------------------------------------------------------------------------------------------------------------------------------------------------------------------------------------------------------------------------------------------------------------------------------------------------------------------------------------------------------------------------------------------------------------------------------------------------------------------------|------------------------------------------------------------------------------------------------------------------------------------------------------------------------------------------------------------------------------------------------------------------------------------------------------------------------------------------------------------------------------------------------------------|----------------------------------------------------------------------------------------------------------------------------------------------------------------------------------------------------------------------------------------------------------------------------------------------------------------------------------------------------------------|
| <p>A-05(1)
A-06(1-B)</p> <p>(4-B)
A-07</p> <p>(4-B)
A-08</p> <p>(12-B)
A-09</p> <p>(4-B)
A-11</p> <p>(2-B)
A-13</p> <p>A-17(2)</p> <p>A-18(2-G)</p> <p>A-16(12-B)</p> <p>A-19X(4)</p> <p>A-20X(4)</p> <p>A-21X(4)</p> <p>A-22X(4)</p> <p>A-23X(4)</p> <p>A-24X(4)</p> <p>A-25X(4)</p> <p>A-26X(4)</p> <p>A-27(1-B)</p> <p>A-29(10-B)</p> <p>A-30(10-B)</p> <p>A-33(2-B)</p> <p>A-34(2-GR)</p> <p>A-35(7)</p> <p>A-36(3-B)</p> <p>A-40 (1-B)</p> <p>A-43 (2-B)</p> <p>A-42 (2-BR)</p> <p>A-41 (2-B)</p> <p>A-44(1)</p> <p>A-45(1)</p> | <p>A-31 —</p> <p>A-32 —</p> <p>A-33 } Front combination lamp (LH)</p> <p>A-34 }</p> <p>A-35 Headlamp leveling unit (LH)</p> <p>A-36 Headlamp (LH)</p> <p>A-37 —</p> <p>A-38 —</p> <p>A-39 —</p> <p>A-40 Magnetic clutch <A/C></p> <p>A-41 Thermo sensor (outside air) <Multi-meter></p> <p>A-42 Dual pressure switch</p> <p>A-43 Condenser fan motor</p> <p>A-44 } Horn (LO)</p> <p>A-45 }</p> | <p>A-46 } Horn (HI)</p> <p>A-47 }</p> <p>A-48 Oil pressure switch</p> <p>A-49 } Alternator</p> <p>A-50 }</p> <p>A-51 Engine oil level sensor</p> <p>A-52 —</p> <p>A-53 —</p> <p>A-54 —</p> <p>A-55 Headlamp (RH)</p> <p>A-56 Headlamp leveling unit (RH)</p> <p>A-57 } Front combination lamp (RH)</p> <p>A-58 }</p> <p>A-59 —</p> <p>A-60 —</p> <p>A-61 —</p> |
|--------------------------------------------------------------------------------------------------------------------------------------------------------------------------------------------------------------------------------------------------------------------------------------------------------------------------------------------------------------------------------------------------------------------------------------------------------------------------------------------------------------------------------------------------------------|------------------------------------------------------------------------------------------------------------------------------------------------------------------------------------------------------------------------------------------------------------------------------------------------------------------------------------------------------------------------------------------------------------|----------------------------------------------------------------------------------------------------------------------------------------------------------------------------------------------------------------------------------------------------------------------------------------------------------------------------------------------------------------|

2A-6 WIRING HARNESS CONFIGURATION DIAGRAMS — Engine Compartment

Vehicles with 4G64 engine

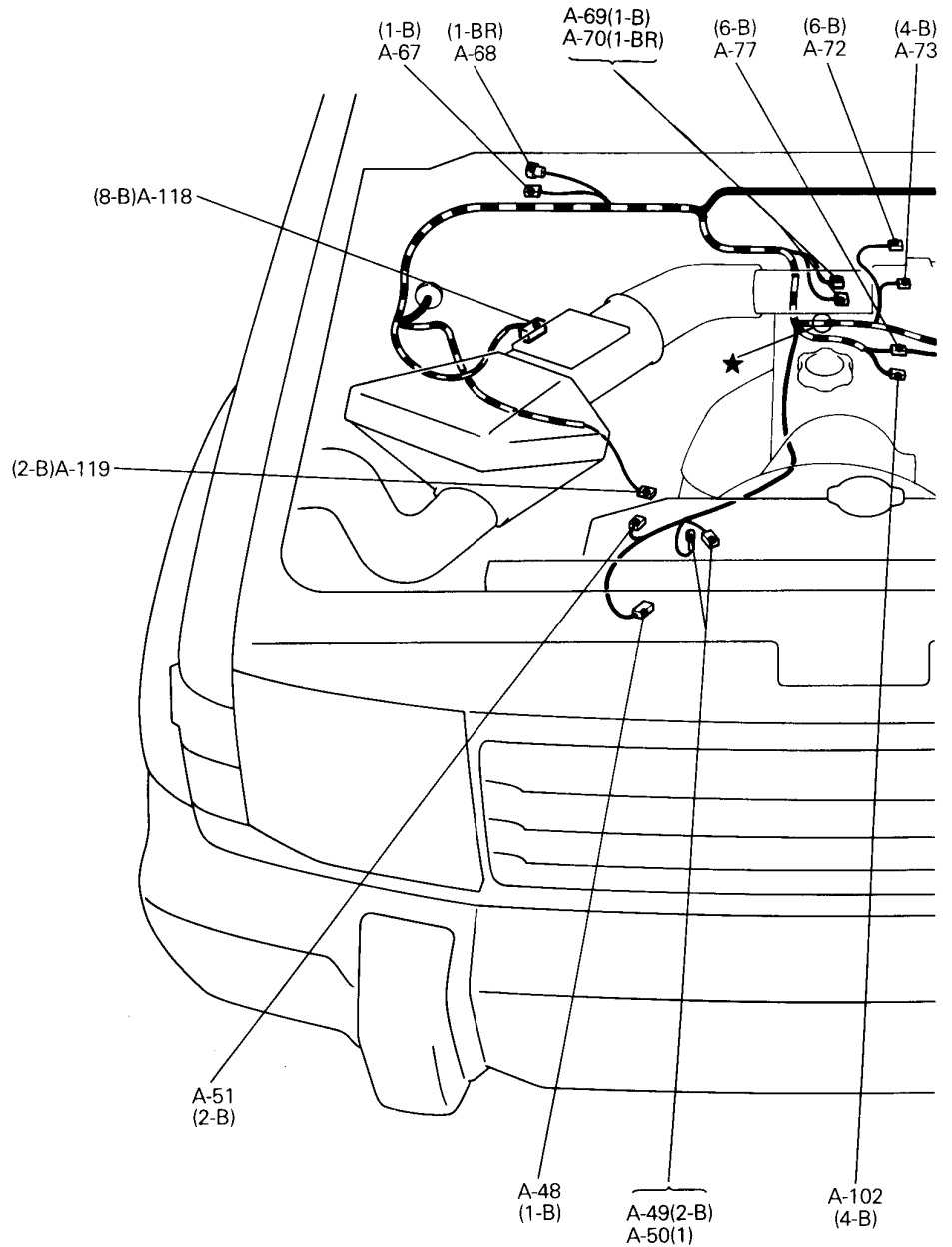
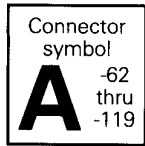

A-62 } thru } A-66 }	—
A-67	Fuel pump check connector
A-68	Ignition timing adjustment connector
A-69 } A-70 }	Noise filter
A-71	—
A-72	Idle speed control servo
A-73	Throttle position sensor
A-74	Injector No.1
A-75	Injector No.3

A-76	—
A-77	Injector wiring harness and control wiring harness combination
A-78	—
A-79	—
A-80	—
A-81	Power transistor
A-82	—
A-83	—
A-84	Injector No.4
A-85	Injector No.2

WIRING HARNESS CONFIGURATION DIAGRAMS — Engine Compartment 2A-7

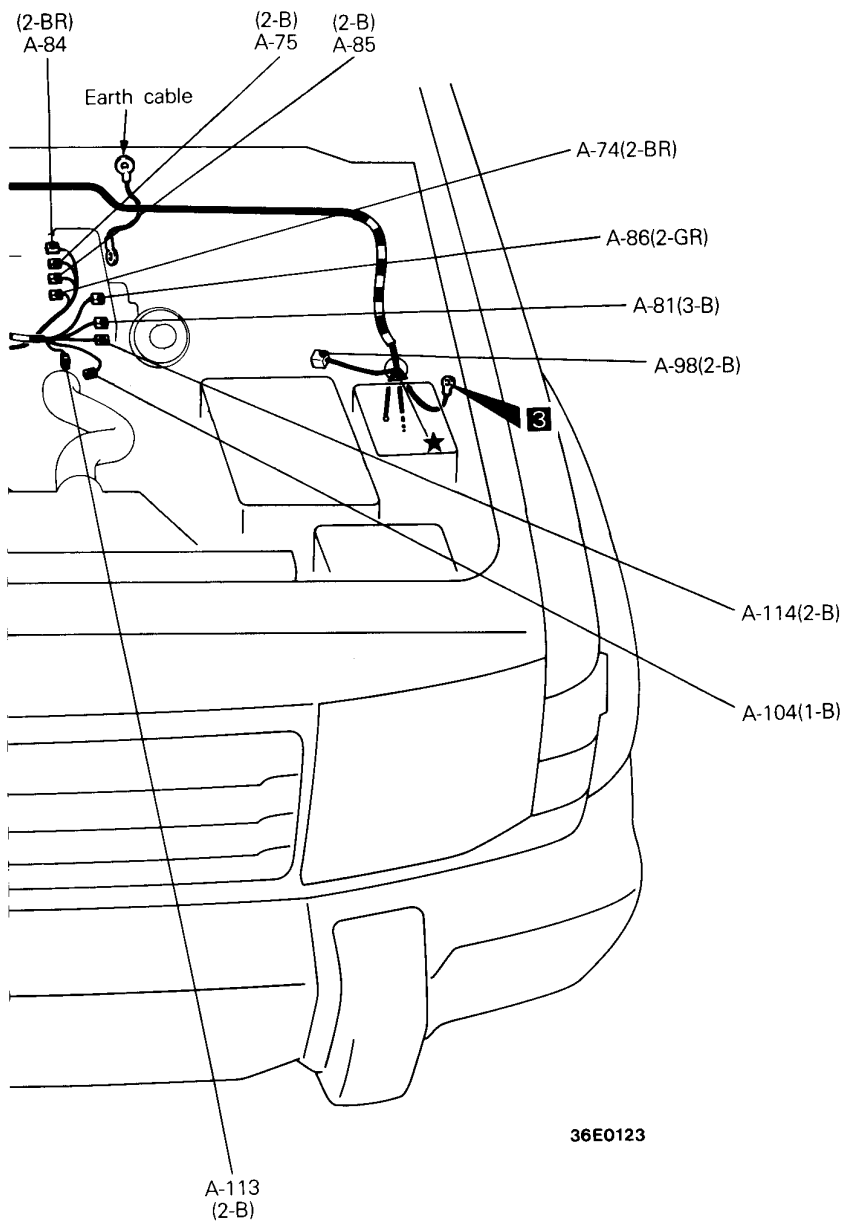

36E0123

A-86	Ignition coil	A-105	} —
A-87	} —	thru	
A-97		A-112	
A-98	Purge control solenoid valve	A-113	Engine coolant temperature sensor
A-99	—	A-114	Engine coolant temperature switch (for A/C compressor control)
A-100	—	A-115	—
A-101	—	A-116	—
A-102	Distributor signal generator	A-117	—
A-103	—	A-118	Air flow sensor
A-104	Engine coolant temperature gauge unit	A-119	Oxygen sensor

2A-8 WIRING HARNESS CONFIGURATION DIAGRAMS — Engine Compartment

L.H. drive vehicles with 6G72 engine

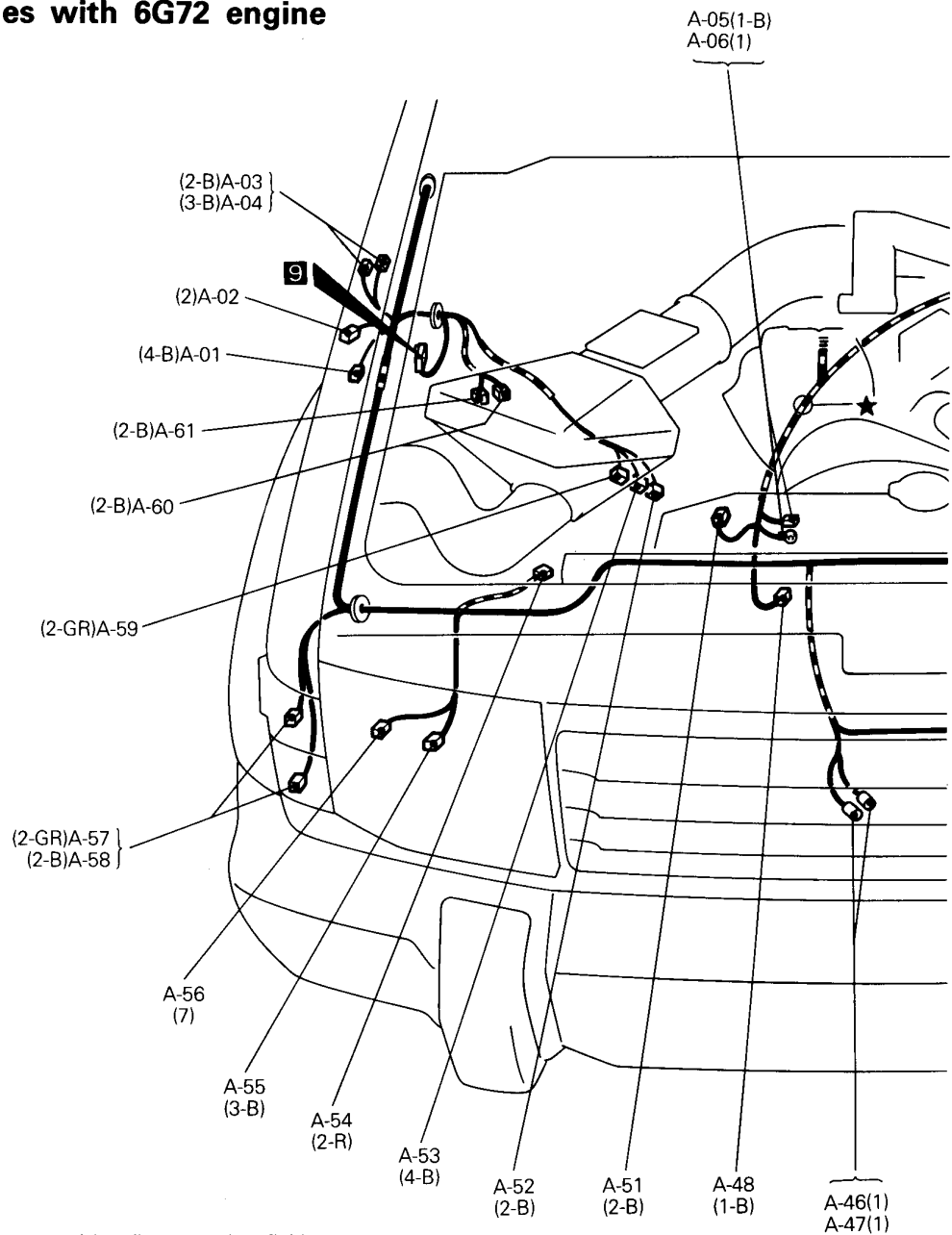
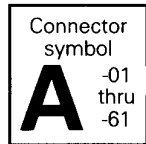

A-01	Headlamp washer motor and headlamp washer fluid level sensor	A-15	—
A-02	Side turn signal lamp (RH)	A-16	Control wiring harness and front wiring harness combination
A-03 } A-04 }	Motor antenna	A-17	Side turn signal lamp (LH)
A-05 } A-06 }	Starter	A-18	Windshield washer motor
A-07	Daytime running lamp relay 2	A-19X } thru } A-26X }	Refer to centralized junction
A-08	Daytime running lamp relay 1	A-27	Battery cable and front wiring harness combination
A-09	Daytime running lamp control unit	A-28	Front impact sensor (LH) <SRS>
A-10	—	A-29 } A-30 }	Daytime running lamp harness and front wiring harness combination or front wiring harness joint connector
A-11	Windshield wiper motor	A-31	Horn relay <Vehicles with SRS>
A-12	—	A-32	—
A-13	Brake fluid level switch		
A-14	—		

WIRING HARNESS CONFIGURATION DIAGRAMS — Engine Compartment 2A-9

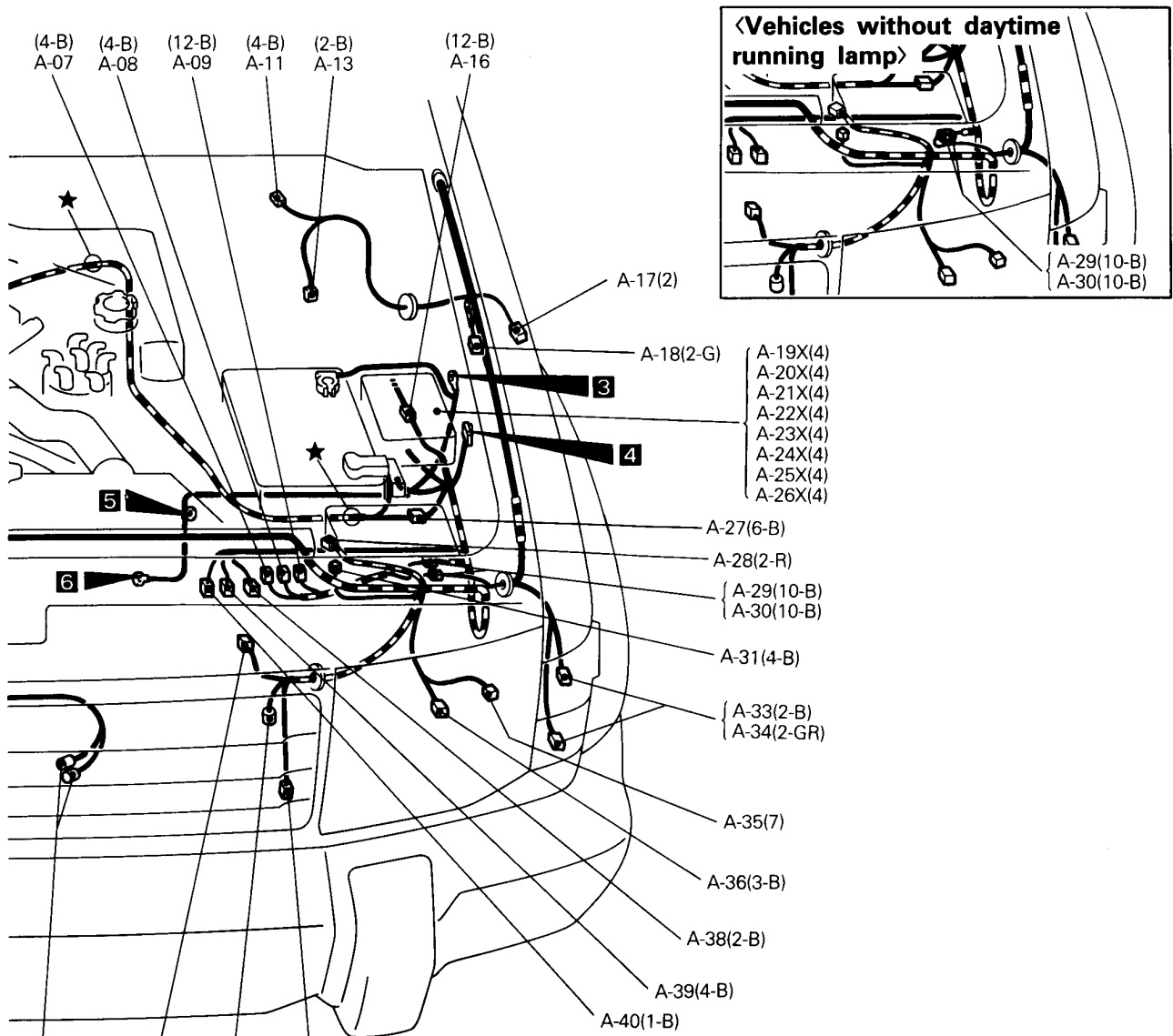

36E0116

- | | | |
|------------------------------------------------------------------------------------------------------------------------------------------------------------------------------------------------------------------------------------------------------------------------------------------------------------------------------------------------------------------------------------------------------------------------------------------------------------------------------------------------------------------------------------------------------------------------|-------------------------------------------------------------------------------------------------------------------------------------------------------------------------------------------------------------------------------------------------------------------------------------------------------------------------------------------------------------------------------------------------------------------------------------------------------------------------------------------------------------------------------------------------------------------------------------------------------------|------------------------------------------------------------------------------------------------------------------------------------------------------------------------------------------------------------------------------------------------------------------------------------------------------------------------------------------------------------------------------------------------------------------------------------------------------------------------------------------|
| <p>A-44(1)
A-45(1)</p> <p>A-43 (2-B)</p> <p>A-42 (2-BR)</p> <p>A-41 (2-B)</p> <p>A-33 }
A-34 } Front combination lamp (LH)</p> <p>A-35 Headlamp leveling unit (LH)</p> <p>A-36 Headlamp (LH)</p> <p>A-37 —</p> <p>A-38 Speed sensor (Front:LH) <ABS></p> <p>A-39 Shock absorber (Front:LH) <Remote controlled variable shock absorber></p> <p>A-40 Magnetic clutch <A/C></p> <p>A-41 Thermo sensor (outside air) <Multi-meter></p> <p>A-42 Dual pressure switch</p> <p>A-43 Condenser fan motor</p> <p>A-44 }
A-45 } Horn (LO)</p> | <p>A-46 }
A-47 } Horn (HI)</p> <p>A-48 Oil pressure switch</p> <p>A-49 }
A-50 } Alternator</p> <p>A-51 Engine oil level sensor</p> <p>A-52 Speed sensor (Front:RH) <ABS></p> <p>A-53 Shock absorber (Front:RH) <Remote controlled variable shock absorber></p> <p>A-54 Front impact sensor (RH) <SRS></p> <p>A-55 Headlamp (RH)</p> <p>A-56 Headlamp leveling unit (RH)</p> <p>A-57 }
A-58 } Front combination lamp (RH)</p> <p>A-59 Free wheel engage switch</p> <p>A-60 Solenoid valve A <Super select 4WD></p> <p>A-61 Solenoid valve B <Super select 4WD></p> | <p>(4-B) A-07</p> <p>(4-B) A-08</p> <p>(12-B) A-09</p> <p>(4-B) A-11</p> <p>(2-B) A-13</p> <p>(12-B) A-16</p> <p>A-17(2)</p> <p>A-18(2-G)</p> <p>A-19X(4)</p> <p>A-20X(4)</p> <p>A-21X(4)</p> <p>A-22X(4)</p> <p>A-23X(4)</p> <p>A-24X(4)</p> <p>A-25X(4)</p> <p>A-26X(4)</p> <p>A-27(6-B)</p> <p>A-28(2-R)</p> <p>{ A-29(10-B)
A-30(10-B)</p> <p>A-31(4-B)</p> <p>{ A-33(2-B)
A-34(2-GR)</p> <p>A-35(7)</p> <p>A-36(3-B)</p> <p>A-38(2-B)</p> <p>A-39(4-B)</p> <p>A-40(1-B)</p> |
|------------------------------------------------------------------------------------------------------------------------------------------------------------------------------------------------------------------------------------------------------------------------------------------------------------------------------------------------------------------------------------------------------------------------------------------------------------------------------------------------------------------------------------------------------------------------|-------------------------------------------------------------------------------------------------------------------------------------------------------------------------------------------------------------------------------------------------------------------------------------------------------------------------------------------------------------------------------------------------------------------------------------------------------------------------------------------------------------------------------------------------------------------------------------------------------------|------------------------------------------------------------------------------------------------------------------------------------------------------------------------------------------------------------------------------------------------------------------------------------------------------------------------------------------------------------------------------------------------------------------------------------------------------------------------------------------|

2A-10 WIRING HARNESS CONFIGURATION DIAGRAMS — Engine Compartment

L.H. drive vehicles with 6G72 engine

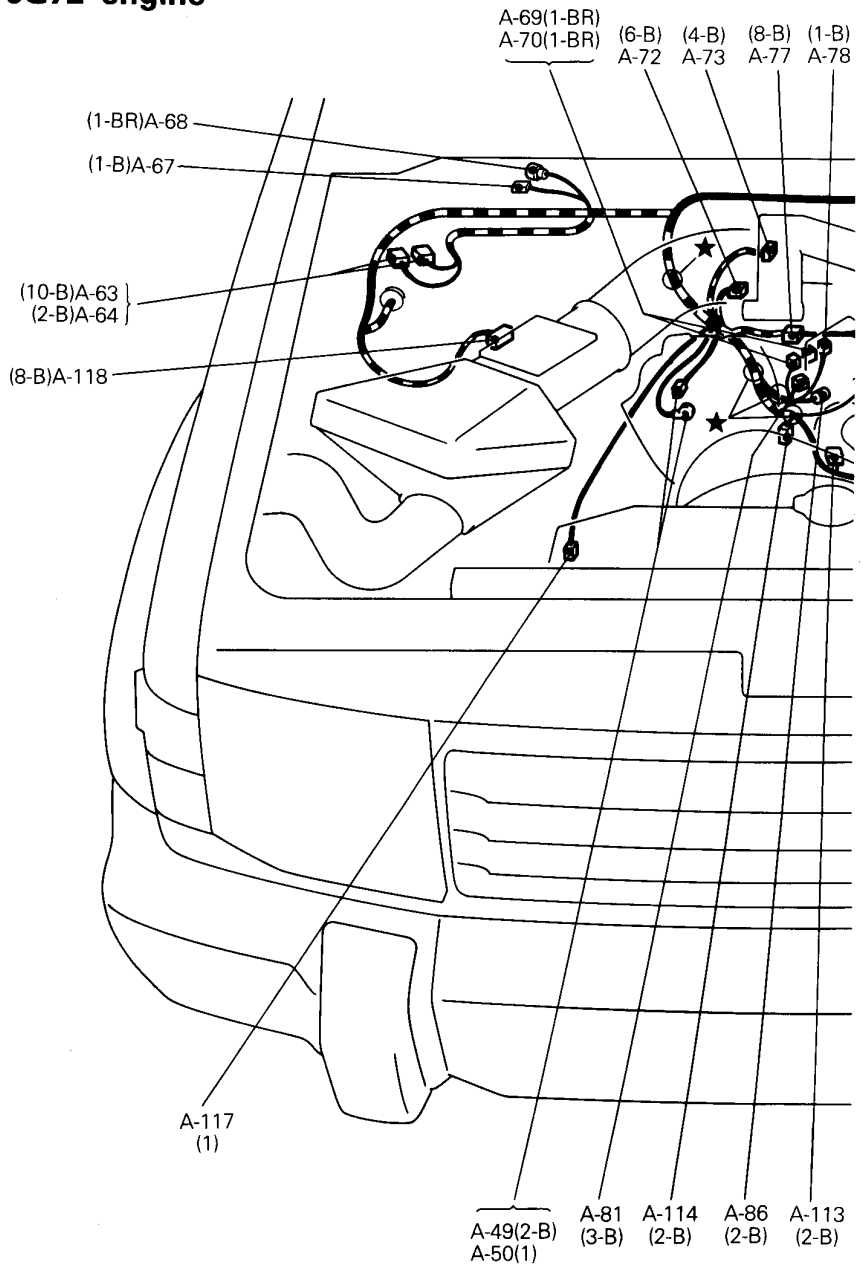
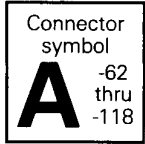

- A-62 Auto-cruise control actuator
- A-63 } Hydraulic unit
- A-64 }
- A-65 —
- A-66 —
- A-67 Fuel pump check connector
- A-68 Ignition timing adjustment connector
- A-69 } Noise filter
- A-70 }
- A-71 —
- A-72 Idle speed control servo
- A-73 Throttle position sensor
- A-74 Injector No.1

- A-75 Injector No.3
- A-76 Injector No.5
- A-77 Injector wiring harness and control wiring harness combination
- A-78 Capacitor
- A-79 —
- A-80 —
- A-81 Power transistor
- A-82 —
- A-83 Injector No.6
- A-84 Injector No.4
- A-85 Injector No.2

WIRING HARNESS CONFIGURATION DIAGRAMS — Engine Compartment 2A-11

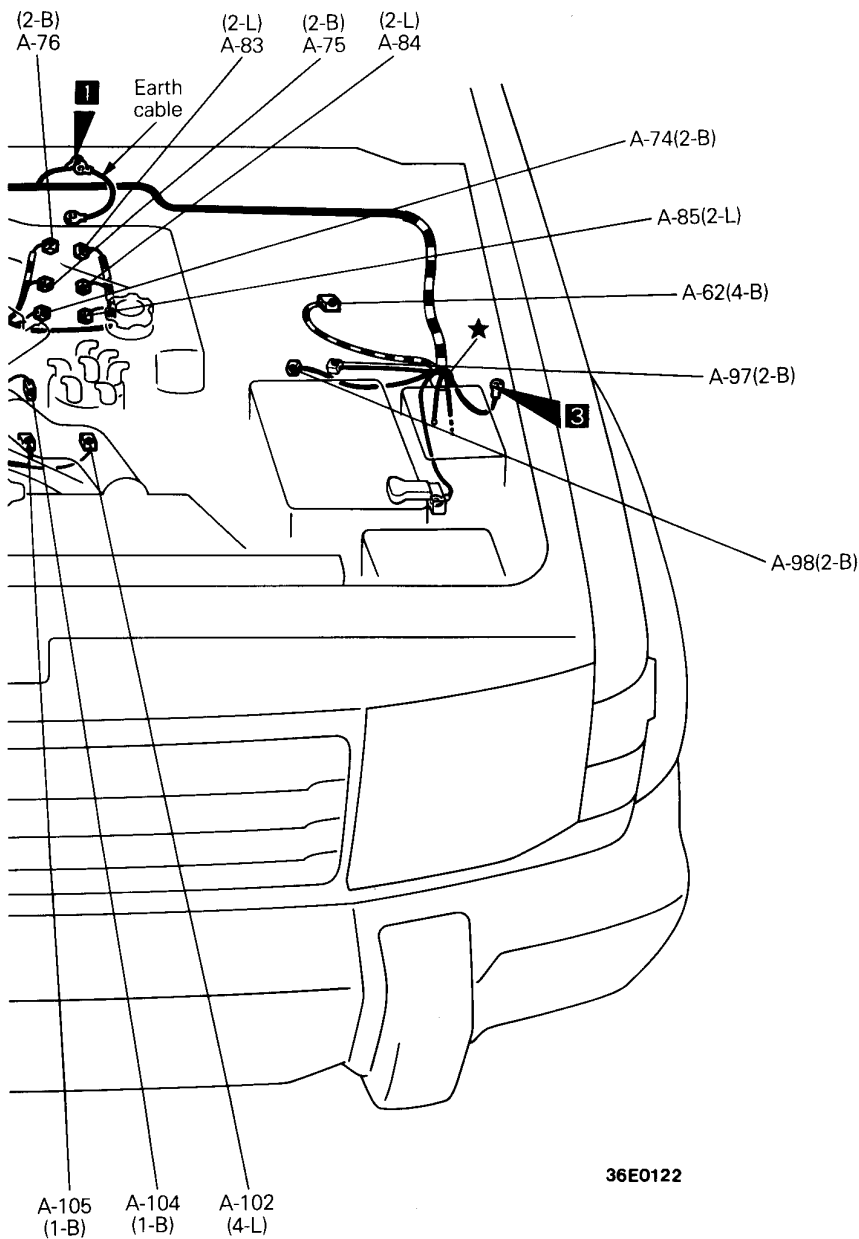

36E0122

A-86 Ignition coil
 A-87 } —
 thru }
 A-96 }
 A-97 No connection
 A-98 Purge control solenoid valve
 A-99 —
 A-100 —
 A-101 —
 A-102 Distributor signal generator
 A-103 —
 A-104 Engine coolant temperature gauge unit

A-105 Engine coolant temperature switch <A/T>
 A-106 } —
 thru }
 A-112 }
 A-113 Engine coolant temperature sensor
 A-114 Engine coolant temperature switch (for A/C compressor control)
 A-115 —
 A-116 —
 A-117 Power steering oil pressure switch <A/T> or No connection
 A-118 Air flow sensor

2A-12 WIRING HARNESS CONFIGURATION DIAGRAMS — Engine Compartment

R.H. drive vehicles with 6G72 engine

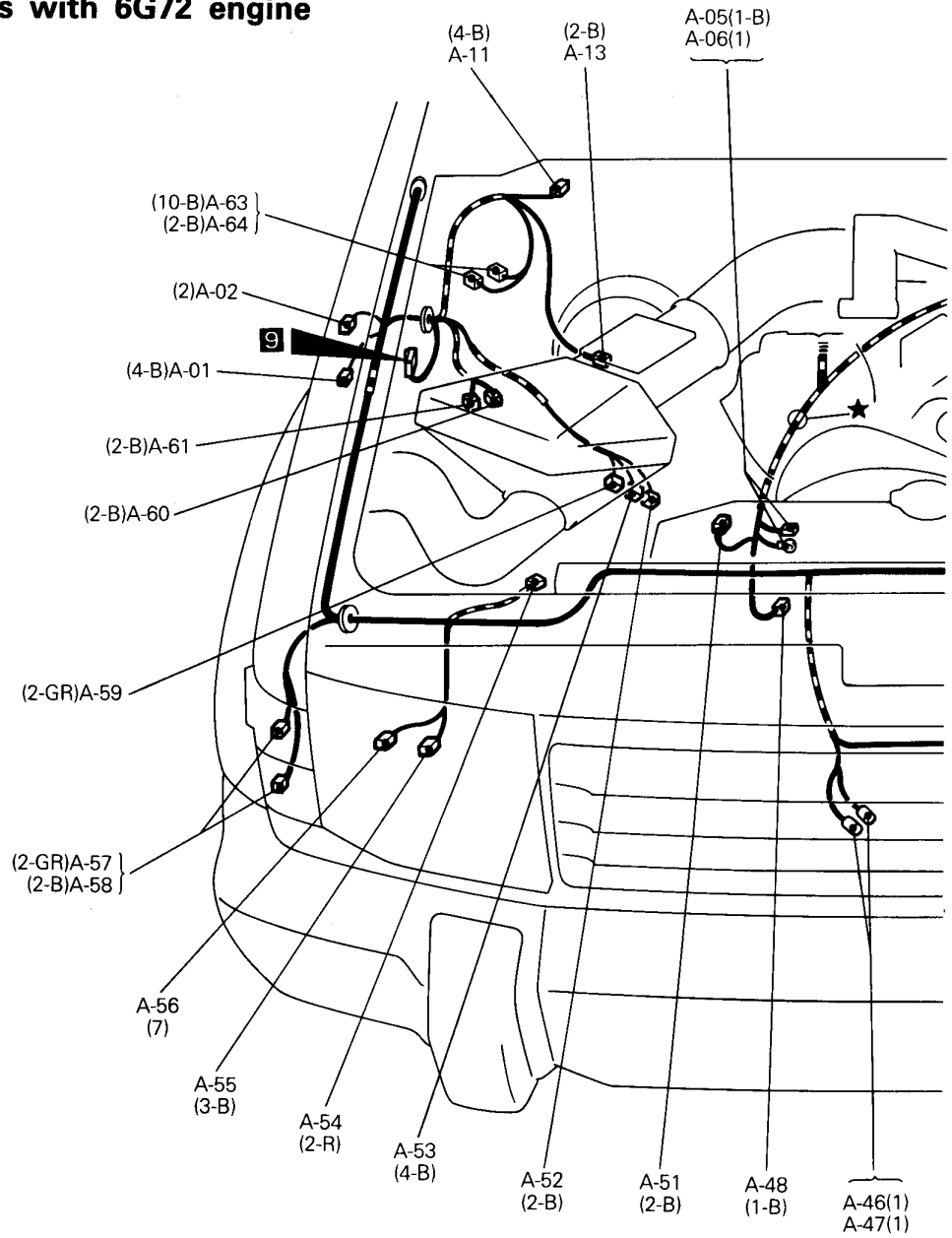
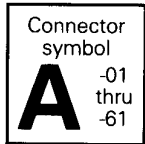

A-01	Headlamp washer motor and headlamp washer fluid level sensor	A-15	—
A-02	Side turn signal lamp (RH)	A-16	Control wiring harness and front wiring harness combination
A-03 } A-04 }	Motor antenna	A-17	Side turn signal lamp (LH)
A-05 } A-06 }	Starter	A-18	Windshield washer motor
A-07 } thru }	—	A-19X } thru }	Refer to centralized junction
A-10 }	—	A-26X }	—
A-11	Windshield wiper motor	A-27	Battery cable and front wiring harness combination
A-12	—	A-28	Front impact sensor (LH) <SRS>
A-13	Brake fluid level switch	A-29	—
A-14	—	A-30	—
		A-31	Horn relay <Vehicles with SRS>
		A-32	Resistor <for dim-dip lamp circuit>

WIRING HARNESS CONFIGURATION DIAGRAMS — Engine Compartment 2A-13

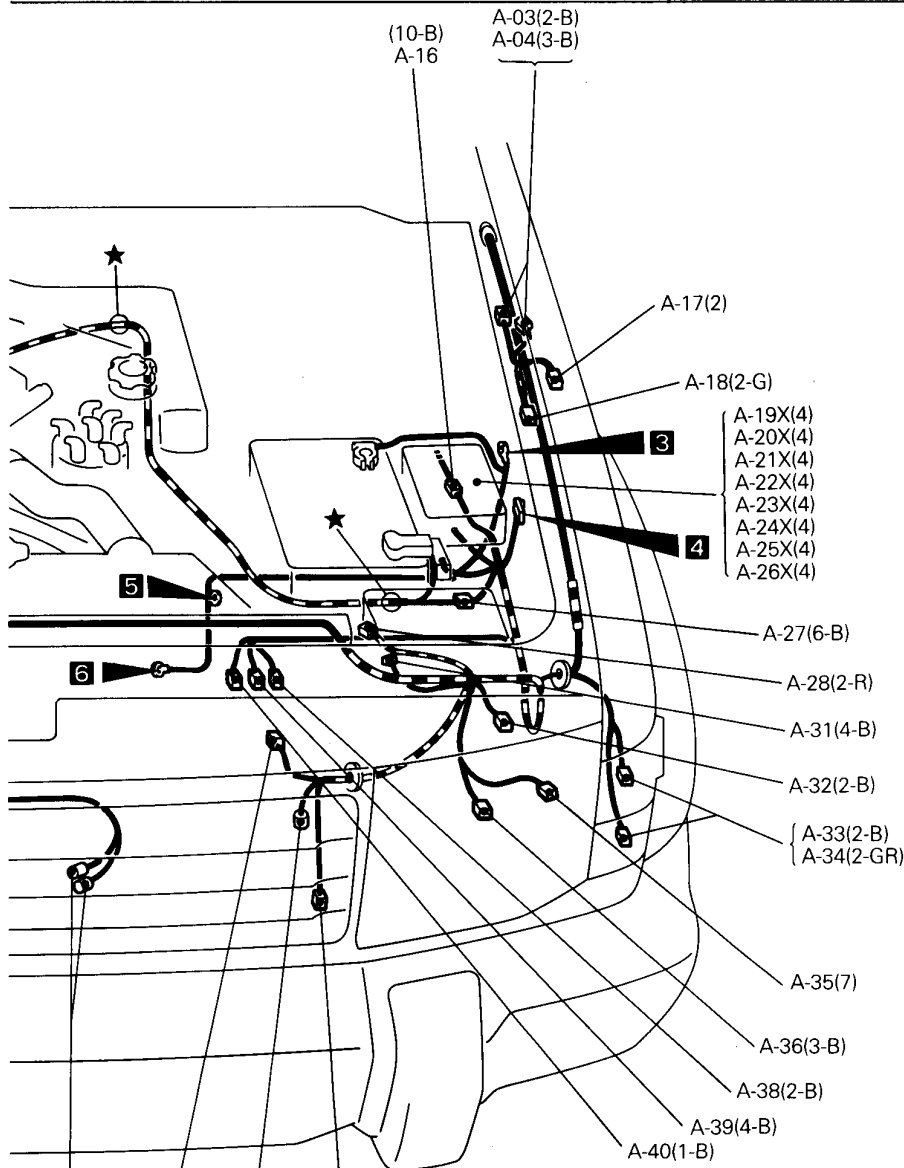

36E0120

A-44(1)
A-45(1)

A-43
(2-B)

A-42
(2-BR)

A-41
(2-B)

- A-33 } Front combination lamp (LH)
- A-34 }
- A-35 Headlamp leveling unit (LH)
- A-36 Headlamp (LH)
- A-37 —
- A-38 Speed sensor (Front:LH) <ABS>
- A-39 Shock absorber (Front:LH) <Remote controlled variable shock absorber>
- A-40 Magnetic clutch <A/C>
- A-41 Thermo sensor (outside air) <Multi-meter>
- A-42 Dual pressure switch
- A-43 Condenser fan motor
- A-44 } Horn (LO)
- A-45 }

- A-46 } Horn (HI)
- A-47 }
- A-48 Oil pressure switch
- A-49 } Alternator
- A-50 }
- A-51 Engine oil level sensor
- A-52 Speed sensor (Front:RH) <ABS>
- A-53 Shock absorber (Front:RH) <Remote controlled variable shock absorber>
- A-54 Front impact sensor (RH) <SRS>
- A-55 Headlamp (RH)
- A-56 Headlamp leveling unit (RH)
- A-57 } Front combination lamp (RH)
- A-58 }
- A-59 Free wheel engage switch
- A-60 Solenoid valve A <Super select 4WD>
- A-61 Solenoid valve B <Super select 4WD>

2A-14 WIRING HARNESS CONFIGURATION DIAGRAMS — Engine Compartment

R.H. drive vehicles with 6G72 engine

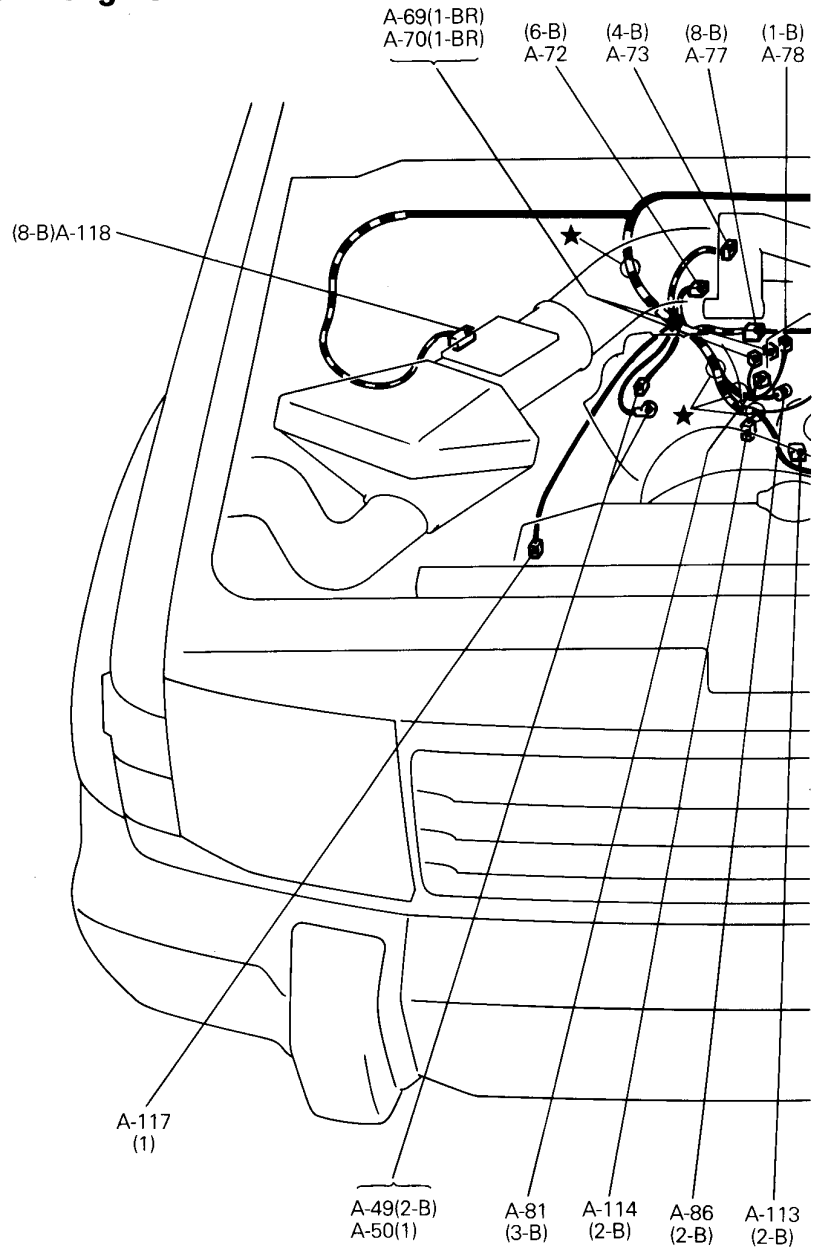
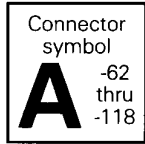

A-62 Auto-cruise control actuator

A-63 } Hydraulic unit

A-64 } —

A-65 —

A-66 —

A-67 Fuel pump check connector

A-68 Ignition timing adjustment connector

A-69 } Noise filter

A-70 } —

A-71 —

A-72 Idle speed control servo

A-73 Throttle position sensor

A-74 Injector No.1

A-75 Injector No.3

A-76 Injector No.5

A-77 Injector wiring harness and control wiring harness combination

A-78 Capacitor

A-79 —

A-80 —

A-81 Power transistor

A-82 —

A-83 Injector No.6

A-84 Injector No.4

A-85 Injector No.2

WIRING HARNESS CONFIGURATION DIAGRAMS — Engine Compartment 2A-15

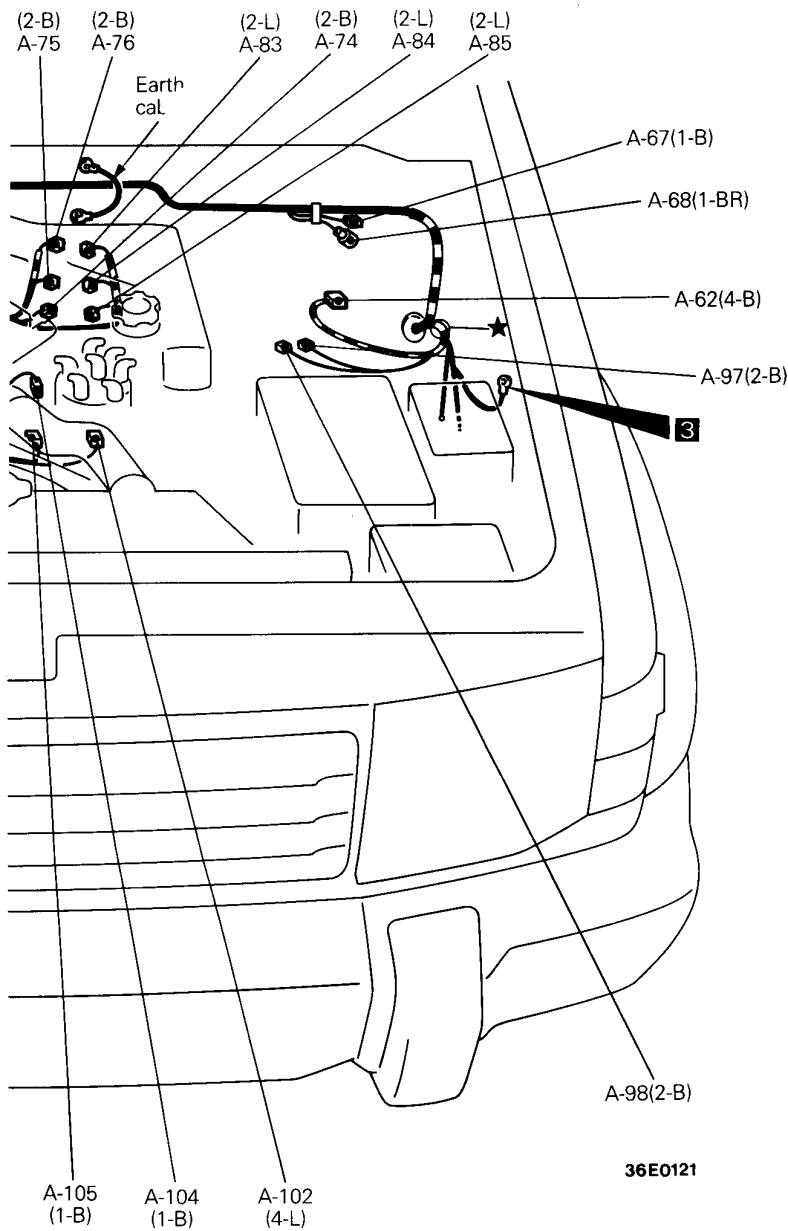

36E0121

- A-86 Ignition coil
- A-87 } —
- thru } —
- A-96 } —
- A-97 No connection
- A-98 Purge control solenoid valve
- A-99 —
- A-100 —
- A-101 —
- A-102 Distributor signal generator
- A-103 —
- A-104 Engine coolant temperature gauge unit

- A-105 Engine coolant temperature switch <A/T>
- A-106 } —
- thru } —
- A-112 } —
- A-113 Engine coolant temperature sensor
- A-114 Engine coolant temperature switch (for A/C compressor control)
- A-115 —
- A-116 —
- A-117 Power steering oil pressure switch <A/T> or No connection
- A-118 Air flow sensor

2A-16 WIRING HARNESS CONFIGURATION DIAGRAMS — Engine Compartment

L.H. drive vehicles with 6G74 engine

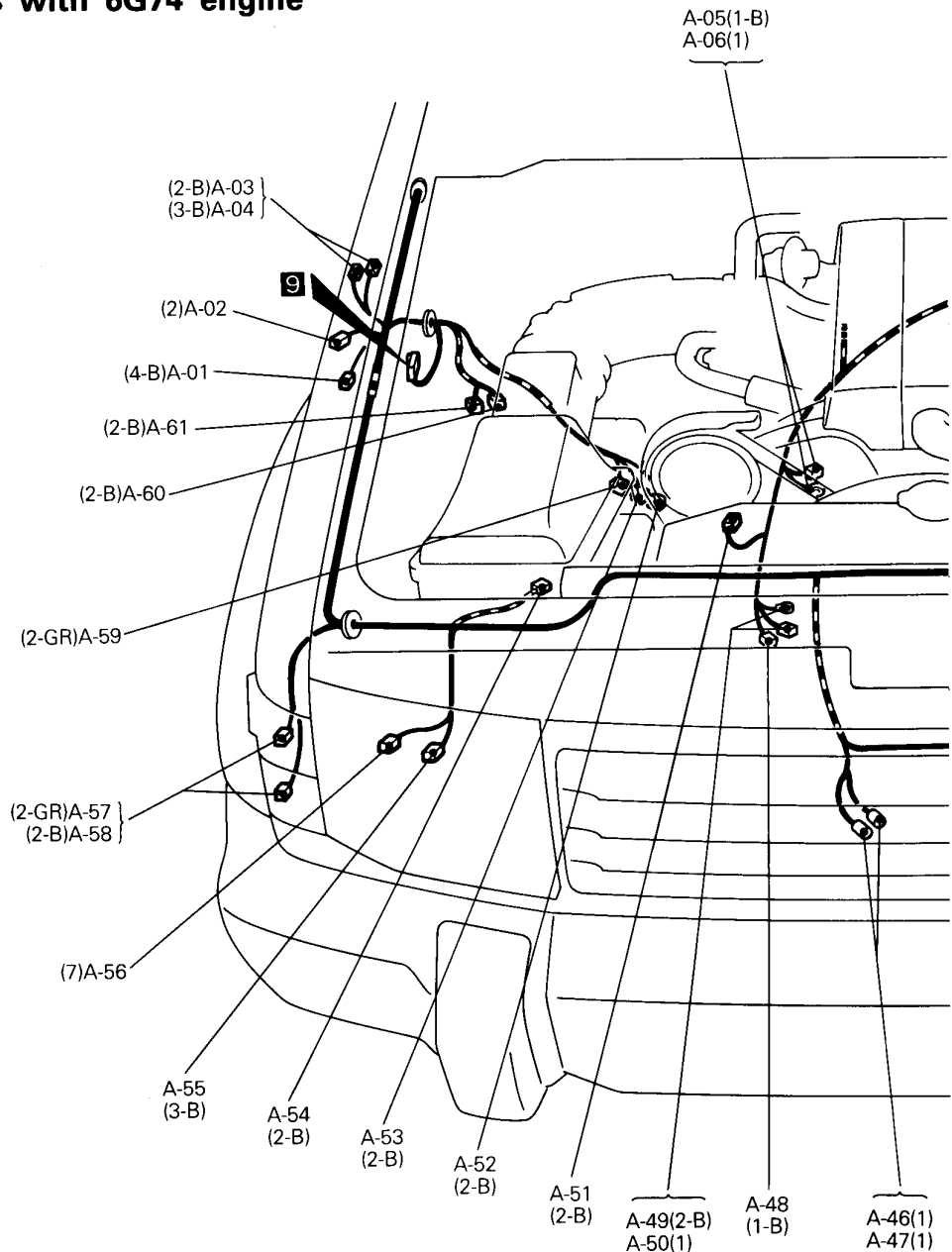
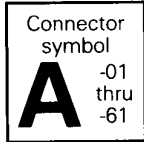

A-01	Headlamp washer motor and headlamp washer fluid level sensor	A-15	—
A-02	Side turn signal lamp (RH)	A-16	Control wiring harness and front wiring harness combination
A-03 } A-04 }	Motor antenna	A-17	Side turn signal lamp (LH)
A-05 } A-06 }	Starter	A-18	Windshield washer motor
A-07	Daytime running lamp relay 2	A-19X } thru }	Refer to centralized junction
A-08	Daytime running lamp relay 1	A-26X }	
A-09	Daytime running lamp control unit	A-27	Battery cable and front wiring harness combination
A-10	—	A-28	Front impact sensor (LH) <SRS>
A-11	Windshield wiper motor	A-29	Daytime running lamp harness and front wiring harness combination or front wiring harness joint connector
A-12	—	A-30	—
A-13	Brake fluid level switch	A-31	Horn relay <Vehicles with SRS>
A-14	—	A-32	—

WIRING HARNESS CONFIGURATION DIAGRAMS — Engine Compartment 2A-17

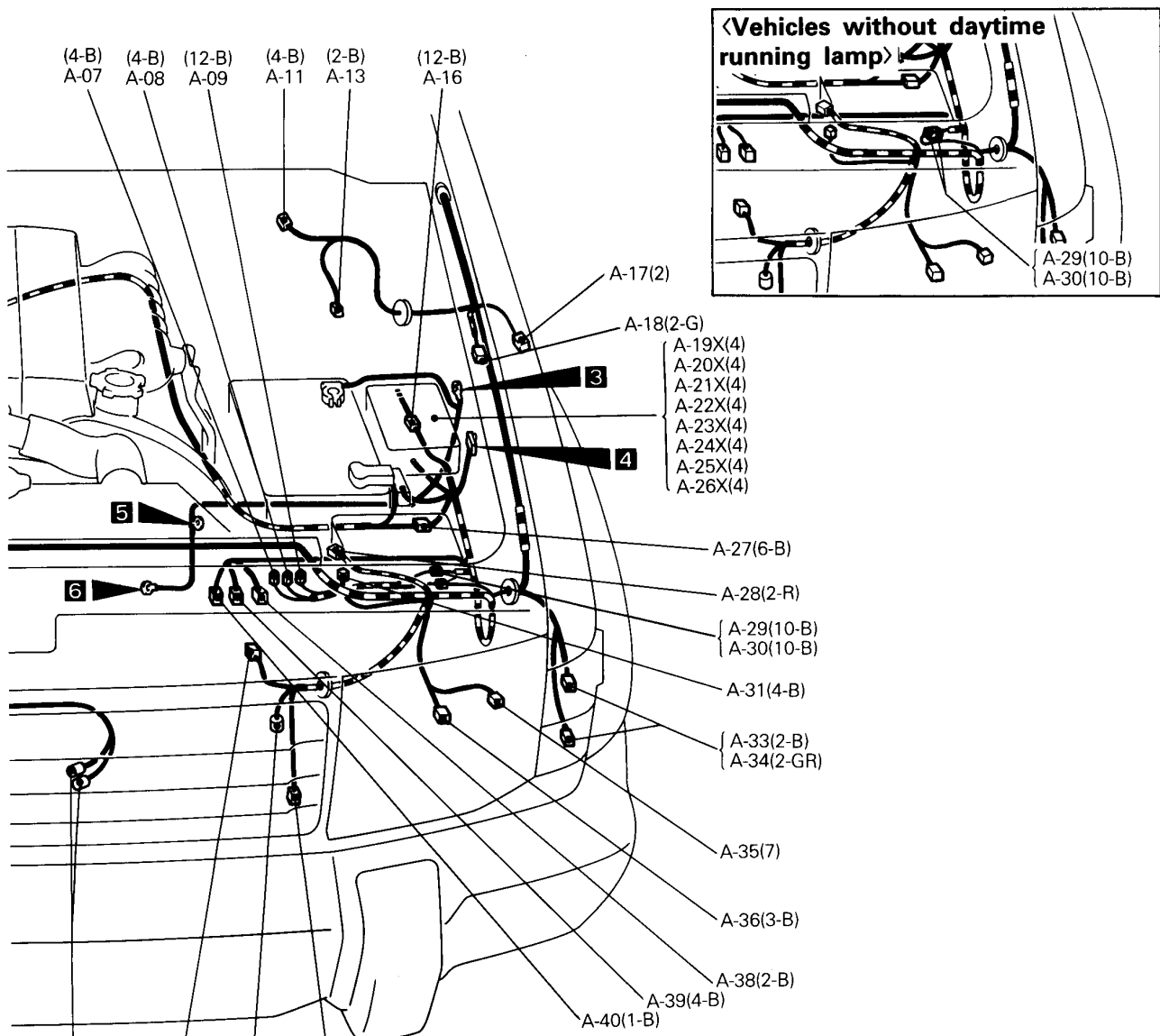

36E0112

- | | | |
|-----------------------------------------------------------------------------------------------------------------------------------------------------------------------------------------------------------------------------------------------------------------------------------------------------------------------------------------------------------------------------------------------------------------------------------------------------------------------------------------------------------------|-------------------------------------------------------------------------------------------------------------------------------------------------------------------------------------------------------------------------------------------------------------------------------------------------------------------------------------------------------------------------------------------------------------------------------------------------------------------------------------------------------------------------------------------------------------------------------------------------------------|--|
| <p>A-44(1)
A-45(1)</p> <p>A-33 }
A-34 } Front combination lamp (LH)</p> <p>A-35 Headlamp leveling unit (LH)</p> <p>A-36 Headlamp (LH)</p> <p>A-37 —</p> <p>A-38 Speed sensor (Front:LH) <ABS></p> <p>A-39 Shock absorber (Front:LH) <Remote controlled variable shock absorber></p> <p>A-40 Magnetic clutch <A/C></p> <p>A-41 Thermo sensor (outside air) <Multi-meter></p> <p>A-42 Dual pressure switch</p> <p>A-43 Condenser fan motor</p> <p>A-44 }
A-45 } Horn (LO)</p> | <p>A-46 }
A-47 } Horn (HI)</p> <p>A-48 Oil pressure switch</p> <p>A-49 }
A-50 } Alternator</p> <p>A-51 Engine oil level sensor</p> <p>A-52 Speed sensor (Front:RH) <ABS></p> <p>A-53 Shock absorber (Front:RH) <Remote controlled variable shock absorber></p> <p>A-54 Front impact sensor (RH) <SRS></p> <p>A-55 Headlamp (RH)</p> <p>A-56 Headlamp leveling unit (RH)</p> <p>A-57 }
A-58 } Front combination lamp (RH)</p> <p>A-59 Free wheel engage switch</p> <p>A-60 Solenoid valve A <Super select 4WD></p> <p>A-61 Solenoid valve B <Super select 4WD></p> | |
|-----------------------------------------------------------------------------------------------------------------------------------------------------------------------------------------------------------------------------------------------------------------------------------------------------------------------------------------------------------------------------------------------------------------------------------------------------------------------------------------------------------------|-------------------------------------------------------------------------------------------------------------------------------------------------------------------------------------------------------------------------------------------------------------------------------------------------------------------------------------------------------------------------------------------------------------------------------------------------------------------------------------------------------------------------------------------------------------------------------------------------------------|--|

2A-18 WIRING HARNESS CONFIGURATION DIAGRAMS — Engine Compartment

L.H. drive vehicles with 6G74 engine

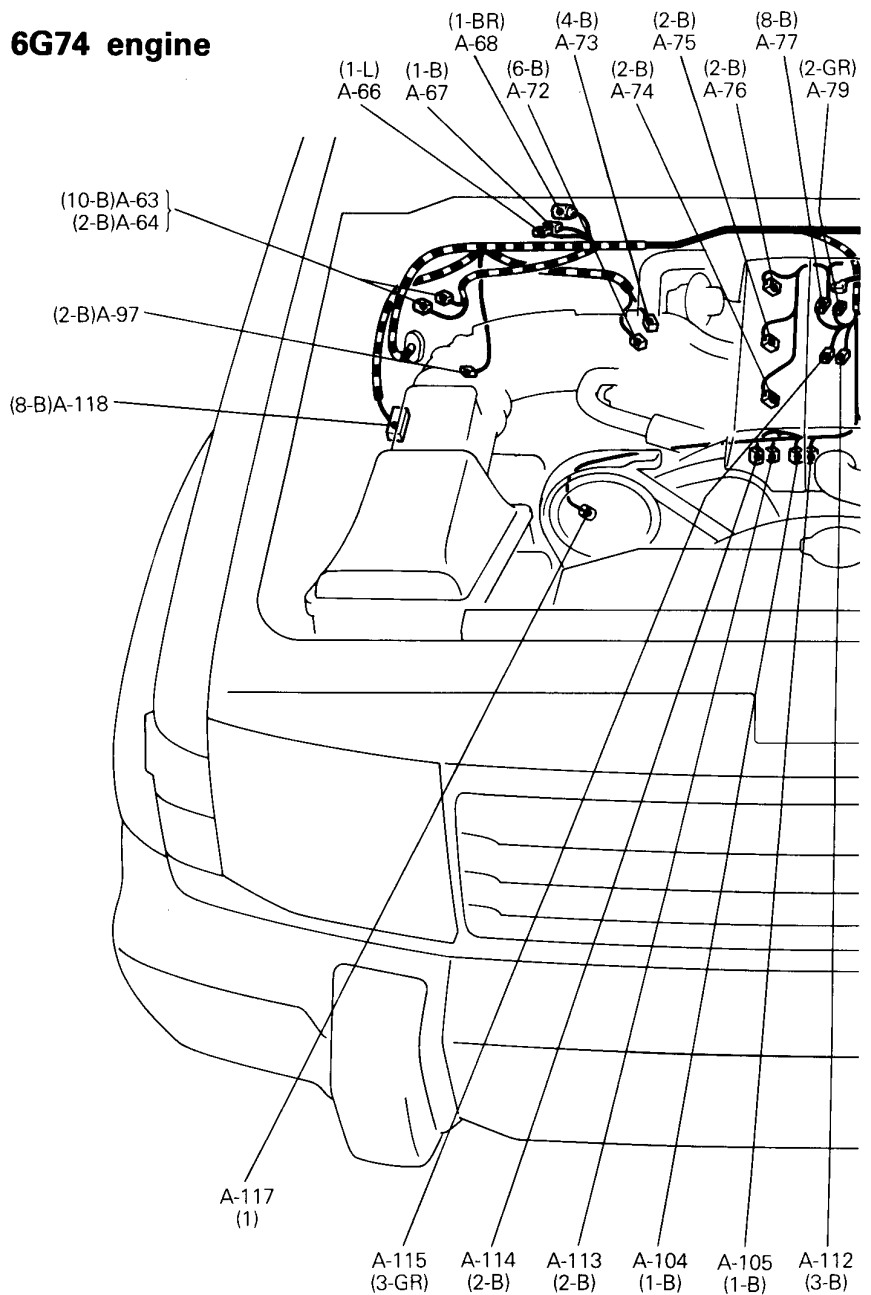
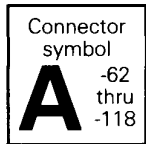

- A-62 Auto-cruise control actuator
- A-63 } Hydraulic unit
- A-64 }
- A-65 —
- A-66 Engine speed detection connector
- A-67 Fuel pump check connector
- A-68 Ignition timing adjustment connector
- A-69 —
- A-70 —
- A-71 —
- A-72 Idle speed control servo
- A-73 Throttle position sensor
- A-74 Injector No.1

- A-75 Injector No.3
- A-76 Injector No.5
- A-77 Injector wiring harness and control wiring harness combination
- A-78 —
- A-79 Detonation sensor
- A-80 Ignition wiring harness and control wiring harness combination
- A-81 } Power transistor
- A-82 }
- A-83 Injector No.6
- A-84 Injector No.4
- A-85 Injector No.2

WIRING HARNESS CONFIGURATION DIAGRAMS — Engine Compartment 2A-19

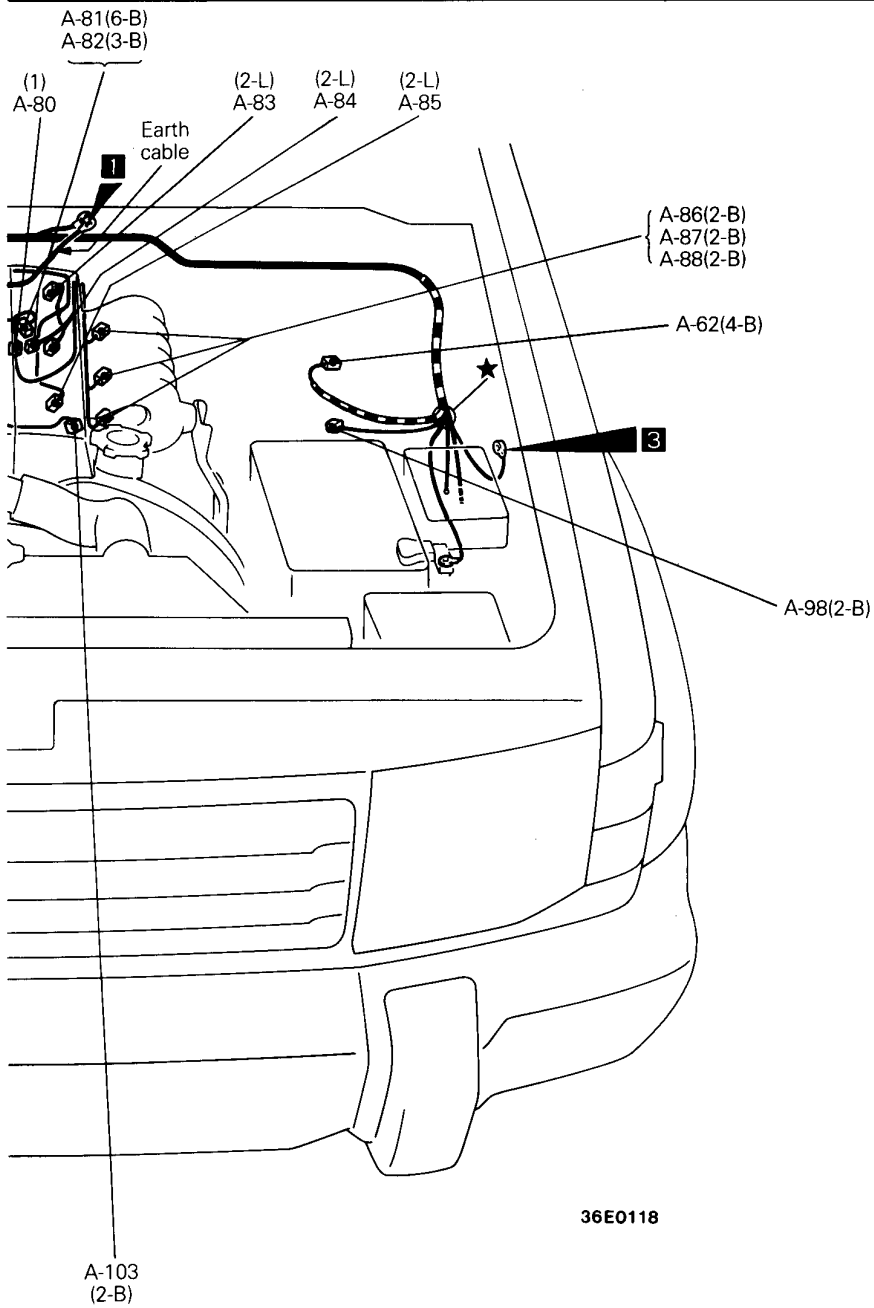

36E0118

A-86 }
 A-87 } Ignition coil
 A-88 }
 A-89 }
 thru } —
 A-96 }

A-97 EGR solenoid valve
 A-98 Purge control solenoid valve

A-99 }
 thru } —
 A-102 }

A-103 Variable induction control solenoid valve
 A-104 Engine coolant temperature gauge unit

A-105 Engine coolant temperature switch <A/T>

A-106 }
 thru } —
 A-111 }

A-112 Crank angle sensor
 A-113 Engine coolant temperature sensor
 A-114 Engine coolant temperature switch (for A/C compressor control)

A-115 Camshaft position sensor

A-116 —

A-117 Power steering oil pressure switch <A/T> or No connection

A-118 Air flow sensor

2A-20 WIRING HARNESS CONFIGURATION DIAGRAMS — Engine Compartment

R.H. drive vehicles with 6G74 engine

Connector symbol
A -01 thru -61

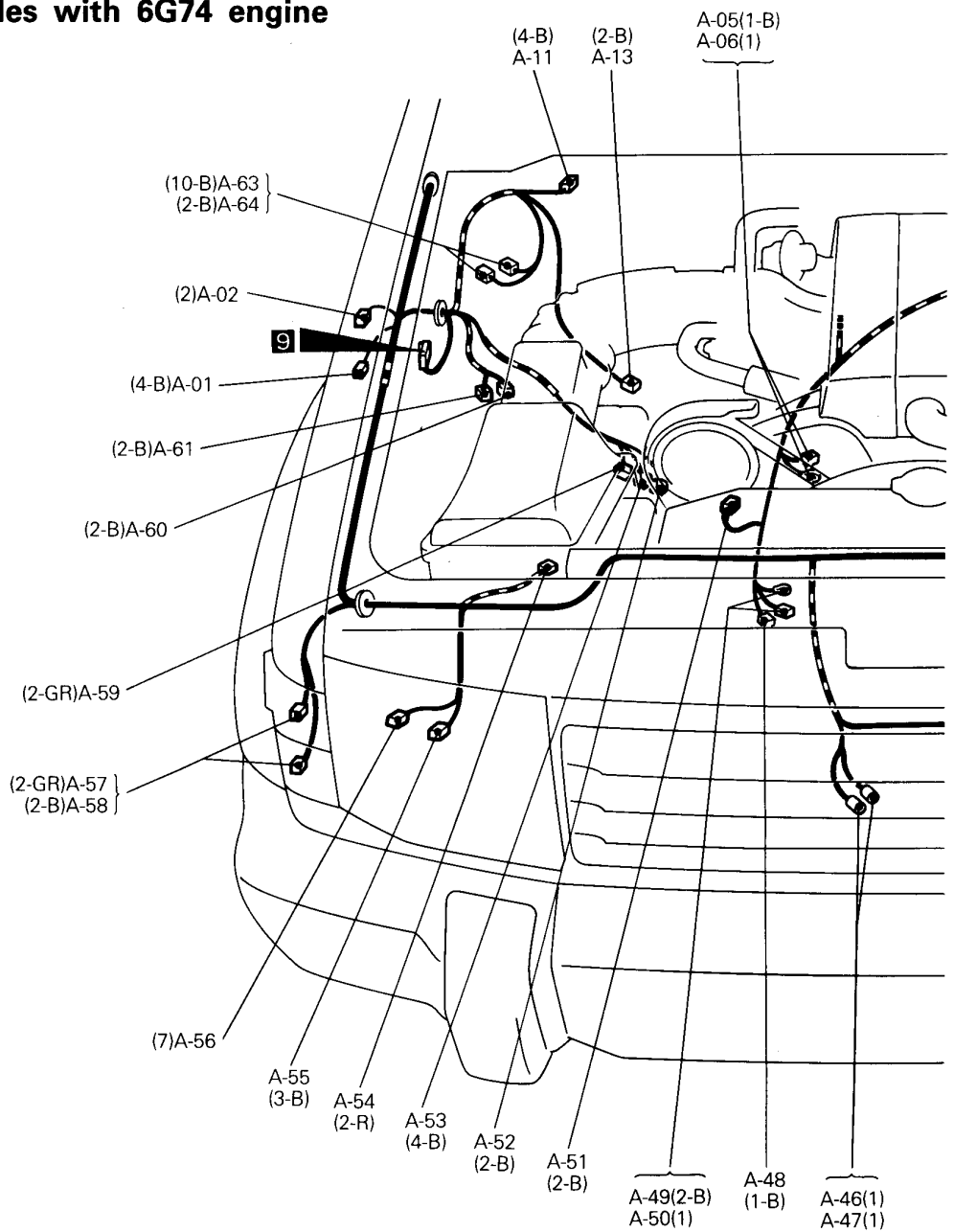

A-01	Headlamp washer motor and headlamp washer fluid level sensor	A-15	—
A-02	Side turn signal lamp (RH)	A-16	Control wiring harness and front wiring harness combination
A-03 } A-04 }	Motor antenna	A-17	Side turn signal lamp (LH)
A-05 } A-06 }	Starter	A-18	Windshield washer motor
A-07 } thru }	—	A-19X } thru }	Refer to centralized junction
A-10	—	A-26X }	—
A-11	Windshield wiper motor	A-27	Battery cable and front wiring harness combination
A-12	—	A-28	Front impact sensor (LH) <SRS>
A-13	Brake fluid level switch	A-29	—
A-14	—	A-30	—
		A-31	Horn relay <Vehicles with SRS>
		A-32	Resistor <for dim-dip lamp circuit>

WIRING HARNESS CONFIGURATION DIAGRAMS — Engine Compartment 2A-21

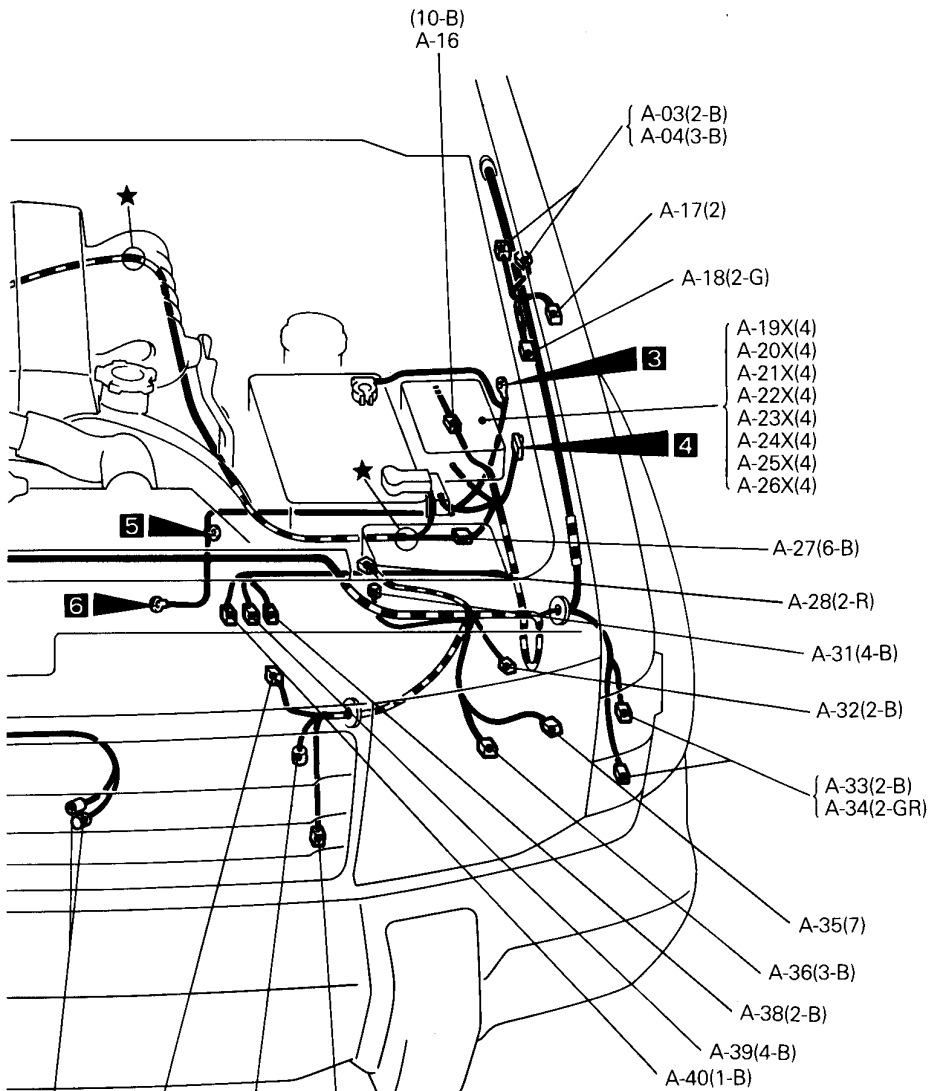

36E0119

A-44(1)
A-45(1)

A-43 (2-B)

A-42 (2-BR)

A-41 (2-B)

A-33 }
A-34 } Front combination lamp (LH)

A-35 Headlamp leveling unit (LH)

A-36 Headlamp (LH)

A-37 —

A-38 Speed sensor (Front:LH) <ABS>

A-39 Shock absorber (Front:LH) <Remote controlled variable shock absorber>

A-40 Magnetic clutch <A/C>

A-41 Thermo sensor (outside air) <Multi-meter>

A-42 Dual pressure switch

A-43 Condenser fan motor

A-44 }
A-45 } Horn (LO)

A-46 }
A-47 } Horn (HI)

A-48 Oil pressure switch

A-49 }
A-50 } Alternator

A-51 Engine oil level sensor

A-52 Speed sensor (Front:RH) <ABS>

A-53 Shock absorber (Front:RH) <Remote controlled variable shock absorber>

A-54 Front impact sensor (RH) <SRS>

A-55 Headlamp (RH)

A-56 Headlamp leveling unit (RH)

A-57 }
A-58 } Front combination lamp (RH)

A-59 Free wheel engage switch

A-60 Solenoid valve A <Super select 4WD>

A-61 Solenoid valve B <Super select 4WD>

2A-22 WIRING HARNESS CONFIGURATION DIAGRAMS — Engine Compartment

R.H. drive vehicles with 6G74 engine

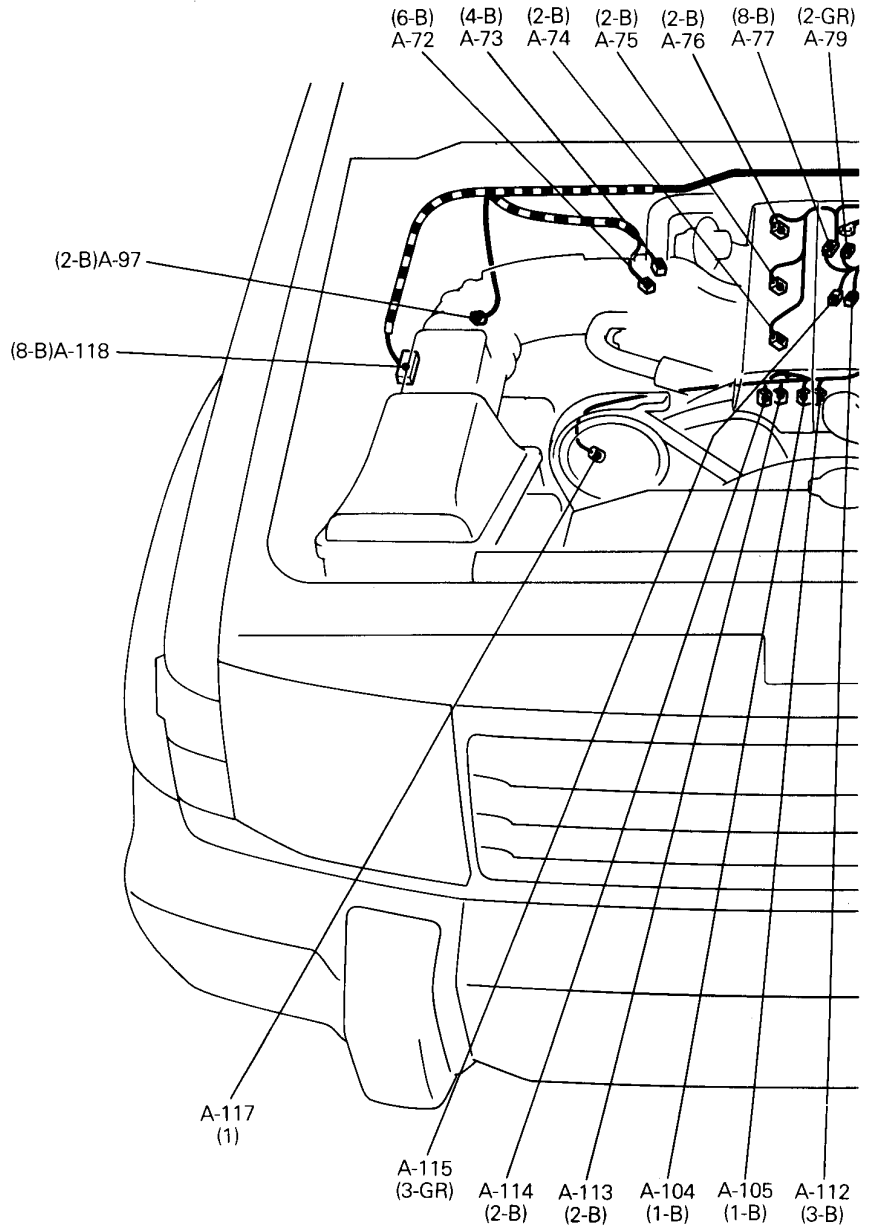
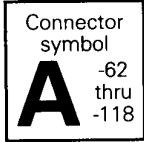

- A-62 Auto-cruise control actuator
- A-63 } Hydraulic unit
- A-64 }
- A-65 —
- A-66 Engine speed detection connector
- A-67 Fuel pump check connector
- A-68 Ignition timing adjustment connector
- A-69 —
- A-70 —
- A-71 —
- A-72 Idle speed control servo
- A-73 Throttle position sensor
- A-74 Injector No.1

- A-75 Injector No.3
- A-76 Injector No.5
- A-77 Injector wiring harness and control wiring harness combination
- A-78 —
- A-79 Detonation sensor
- A-80 Ignition wiring harness and control wiring harness combination
- A-81 } Power transistor
- A-82 }
- A-83 Injector No.6
- A-84 Injector No.4
- A-85 Injector No.2

WIRING HARNESS CONFIGURATION DIAGRAMS — Engine Compartment 2A-23

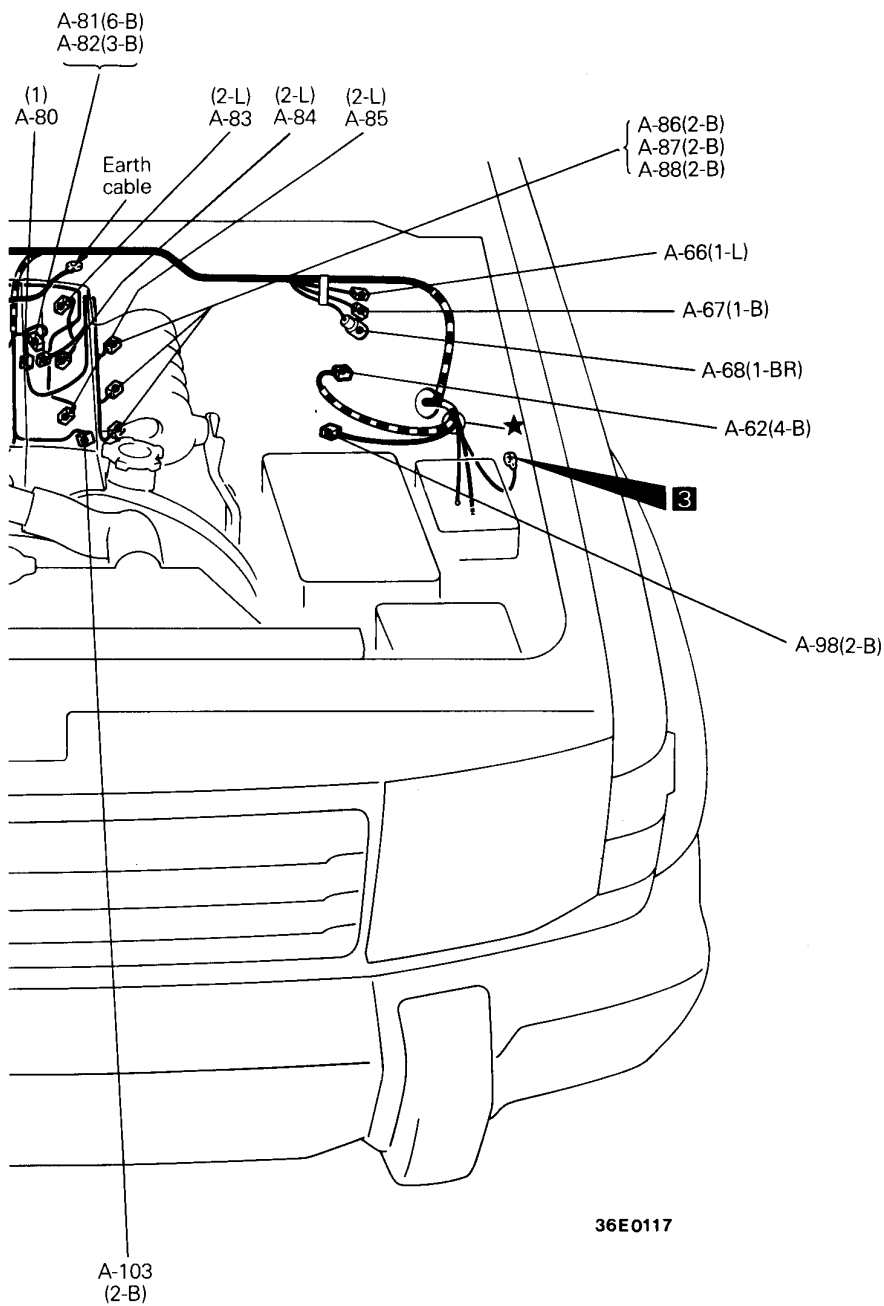

36E0117

<p>A-86 } A-87 } Ignition coil A-88 } A-89 } — thru } A-96 } A-97 EGR solenoid valve A-98 Purge control solenoid valve A-99 } thru } — A-102 } A-103 Variable induction control solenoid valve A-104 Engine coolant temperature gauge unit</p>	<p>A-105 Engine coolant temperature switch <A/T> A-106 } thru } — A-111 } A-112 Crank angle sensor A-113 Engine coolant temperature sensor A-114 Engine coolant temperature switch (for A/C compressor control) A-115 Camshaft position sensor A-116 — A-117 Power steering oil pressure switch <A/T> or No connection A-118 Air flow sensor</p>
------------------------------------------------------------------------------------------------------------------------------------------------------------------------------------------------------------------------------------------------------------------------------------------------------------------------------------------------------------------------------------------------------------------------------------------------------------------------------------------------------------------------------------------------------------	------------------------------------------------------------------------------------------------------------------------------------------------------------------------------------------------------------------------------------------------------------------------------------------------------------------------------------------------------------------------------------------------------------------------------------------------------------------------------------------------------------------------------------------------------------------------------------------------------------------------

2A-24 WIRING HARNESS CONFIGURATION DIAGRAMS — Engine Compartment

L.H. drive vehicles with 4D56 engine

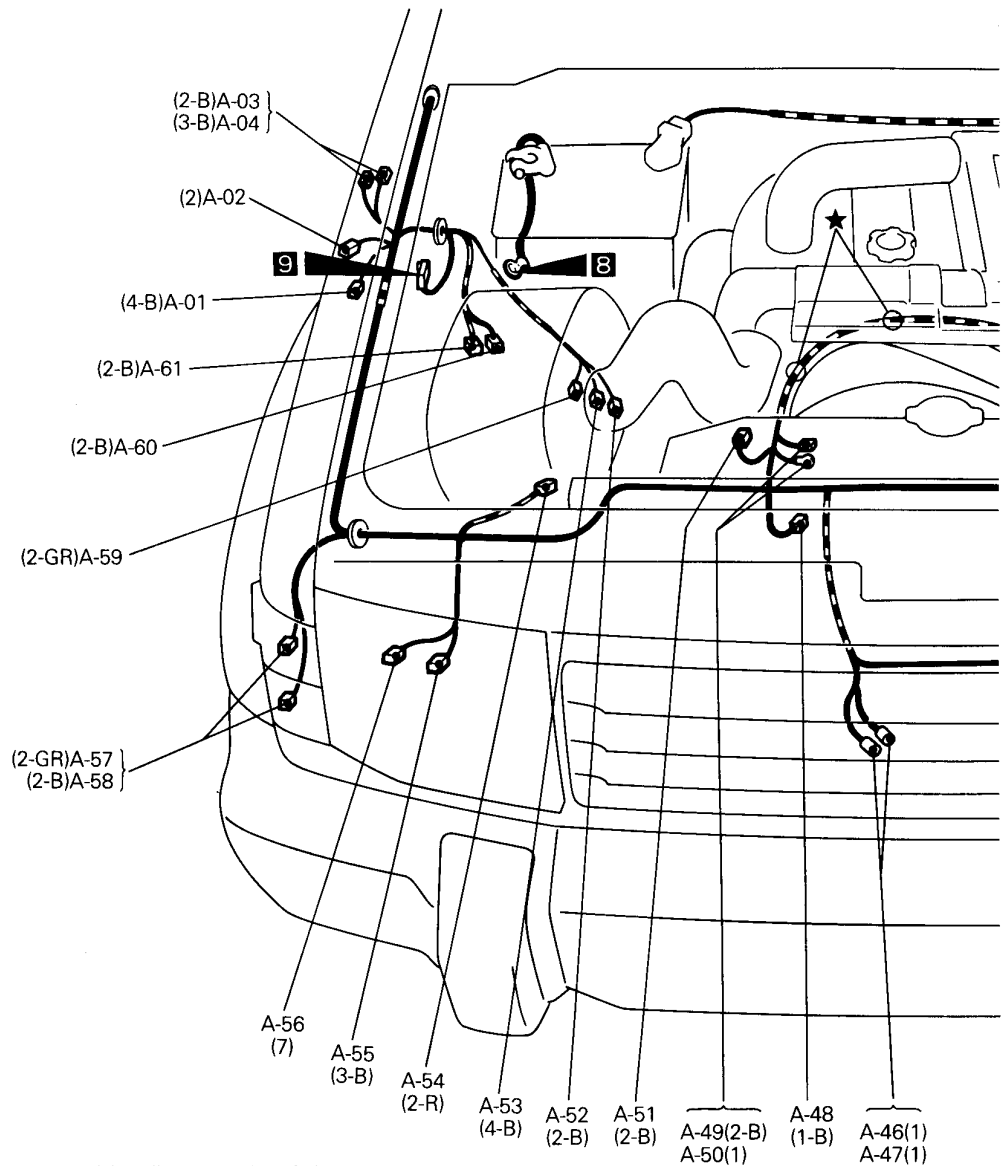
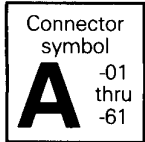

- | | | | |
|------------------|--------------------------------------------------------------|--------------------|-----------------------------------------------------------------------------------------------------------|
| A-01 | Headlamp washer motor and headlamp washer fluid level sensor | A-16 | Control wiring harness and front wiring harness combination |
| A-02 | Side turn signal lamp (RH) | A-17 | Side turn signal lamp (LH) |
| A-03 }
A-04 } | Motor antenna | A-18 | Windshield washer motor |
| A-05 }
A-06 } | Starter | A-19X }
A-26X } | Refer to centralized junction |
| A-07 | Daytime running lamp relay 2 | A-27 | Battery cable and front wiring harness combination |
| A-08 | Daytime running lamp relay 1 | A-28 | Front impact sensor (LH) <SRS> |
| A-09 | Daytime running lamp control unit | A-29 }
A-30 } | Daytime running lamp harness and front wiring harness combination or front wiring harness joint connector |
| A-10 | Starter relay | A-31 | Horn relay <Vehicles with SRS> |
| A-11 | Windshield wiper motor | A-32 | — |
| A-12 | Vacuum switch | A-33 } | |
| A-13 | Brake fluid level switch | A-34 } | Front combination lamp (LH) |
| A-14 | No connection | | |
| A-15 | Condenser fan motor control relay | | |

WIRING HARNESS CONFIGURATION DIAGRAMS — Engine Compartment 2A-25

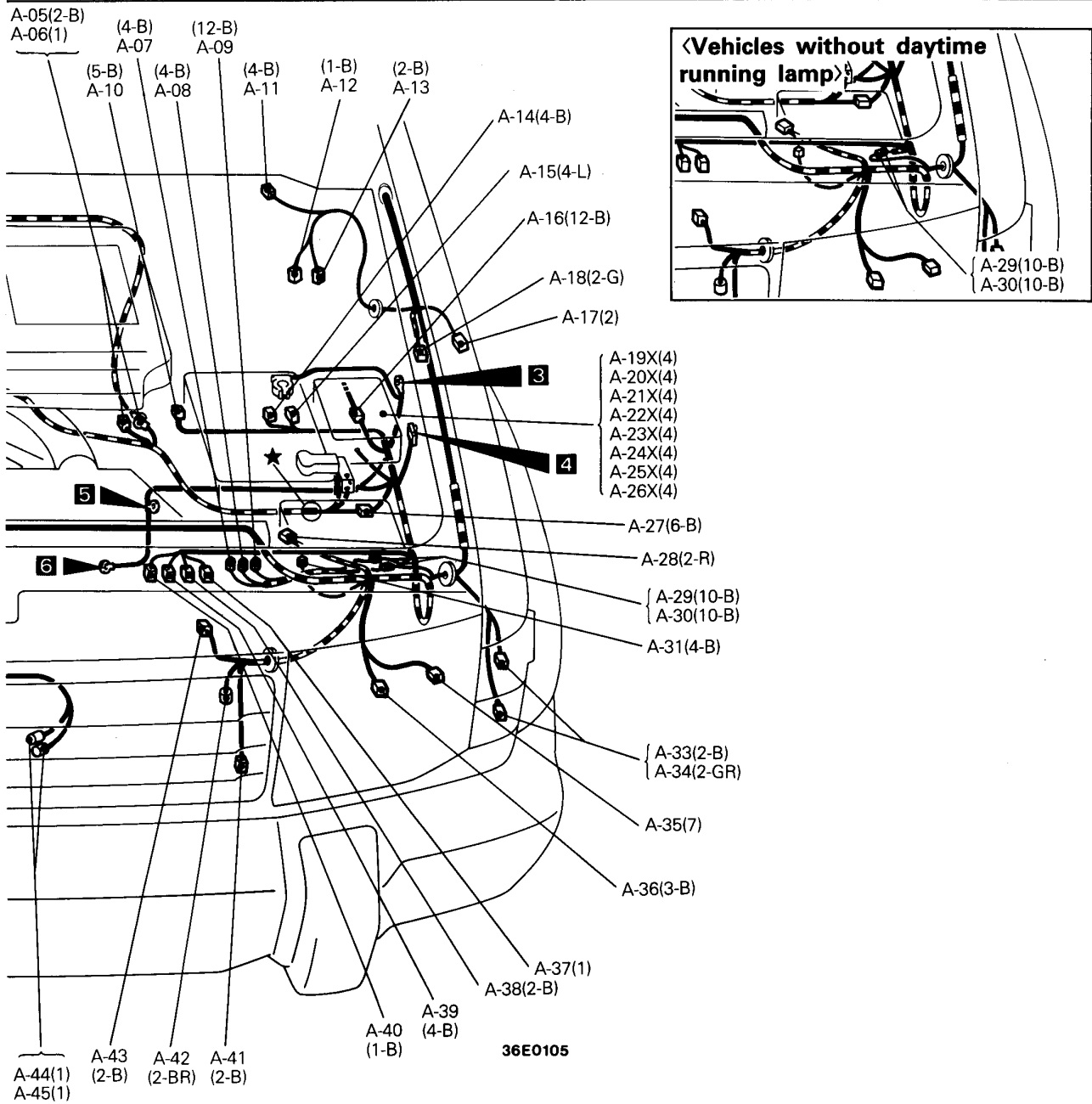

36E0105

- | | |
|---------------------------------------------------------------------------------------------------------------------------------------------------------------------------------------------------------------------------------------------------------------------------------------------------------------------------------------------------------------------------------------------------------------------------------------------------------------------------------------------------------------------------------------------------------|-----------------------------------------------------------------------------------------------------------------------------------------------------------------------------------------------------------------------------------------------------------------------------------------------------------------------------------------------------------------------------------------------------------------------------------------------------------------------------------------------------------------------------------------------------------------------------------------------------------------------------------------------------|
| <ul style="list-style-type: none"> A-35 Headlamp leveling unit (LH) A-36 Headlamp (LH) A-37 No connection A-38 Speed sensor (Front:LH) <ABS> A-39 Shock absorber (Front:LH) <Remote controlled variable shock absorber> A-40 Magnetic clutch <A/C> A-41 Thermo sensor (outside air) <Multi-meter> A-42 Dual pressure switch A-43 Condenser fan motor A-44 } Horn (LO) A-45 } A-46 } Horn (HI) A-47 } | <ul style="list-style-type: none"> A-48 Oil pressure switch A-49 } Alternator A-50 } A-51 Engine oil level sensor A-52 Speed sensor (Front:RH) <ABS> A-53 Shock absorber (Front:RH) <Remote controlled variable shock absorber> A-54 Front impact sensor (RH) <SRS> A-55 Headlamp (RH) A-56 Headlamp leveling unit (RH) A-57 } Front combination lamp (RH) A-58 } A-59 Free wheel engage switch A-60 Solenoid valve A <Super select 4WD> A-61 Solenoid valve B <Super select 4WD> |
|---------------------------------------------------------------------------------------------------------------------------------------------------------------------------------------------------------------------------------------------------------------------------------------------------------------------------------------------------------------------------------------------------------------------------------------------------------------------------------------------------------------------------------------------------------|-----------------------------------------------------------------------------------------------------------------------------------------------------------------------------------------------------------------------------------------------------------------------------------------------------------------------------------------------------------------------------------------------------------------------------------------------------------------------------------------------------------------------------------------------------------------------------------------------------------------------------------------------------|

2A-26 WIRING HARNESS CONFIGURATION DIAGRAMS — Engine Compartment

L.H. drive vehicles with 4D56 engine

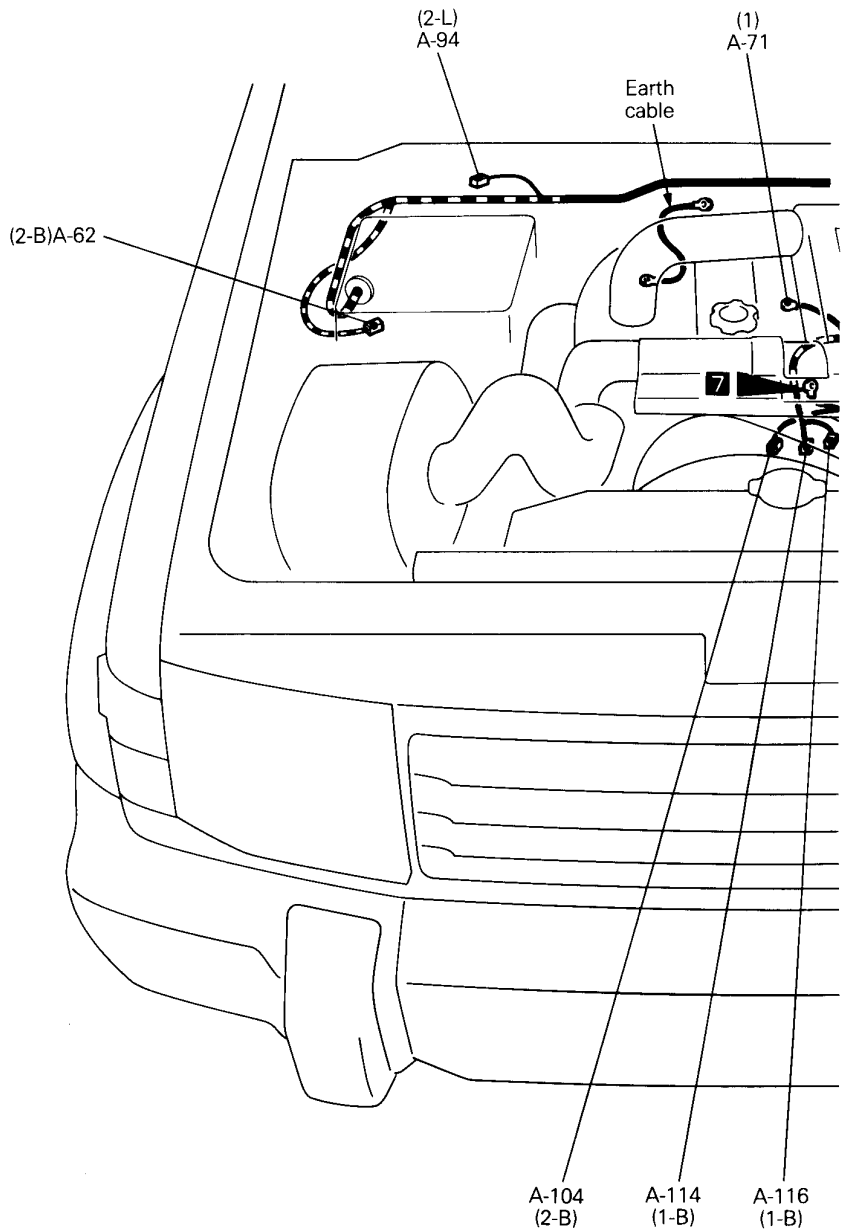
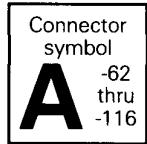

A-62 Auto-cruise control actuator
 A-63 } Hydraulic unit
 A-64 }
 A-65 Idle up solenoid valve <ABS>
 A-66 }
 thru } —
 A-70 }
 A-71 Glow plug
 A-72 }
 thru } —
 A-88 }

A-89 EGR solenoid valve I
 A-90 EGR solenoid valve II
 A-91 Supercharging pressure relief solenoid valve
 A-92 Water level switch
 A-93 Fuel line heater or no connection
 A-94 Idle up solenoid valve <A/C>
 A-95 Intake air temperature switch
 A-96 Intercooler fan motor
 A-97 —
 A-98 —

WIRING HARNESS CONFIGURATION DIAGRAMS — Engine Compartment 2A-27

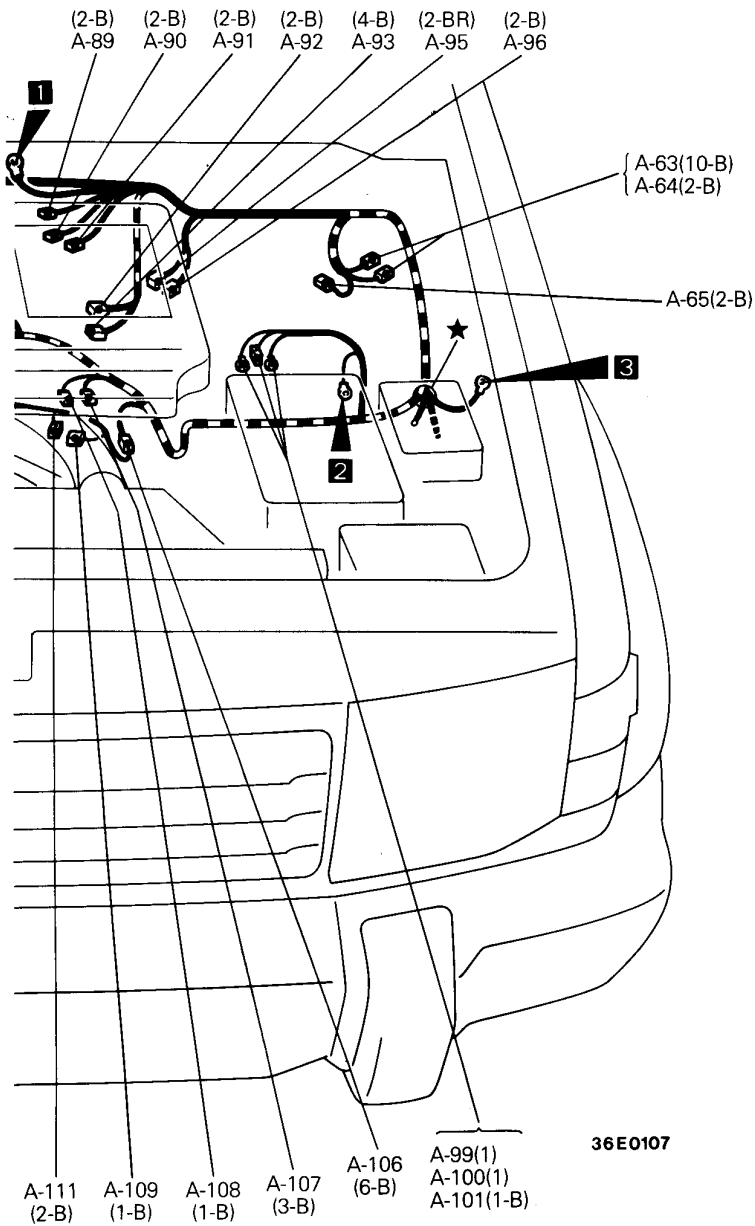

A-99	} Glow plug relay	A-108	Lever position switch <A/T> or short connector <M/T>
A-100		A-109	Fuel cut solenoid valve
A-101		A-110	—
A-102	—	A-111	Rotation sensor
A-103	—	A-112	—
A-104	Engine coolant temperature gauge unit	A-113	—
A-105	—	A-114	Engine coolant temperature switch (for A/C compressor control)
A-106	Fuel injection pump wiring harness and control wiring harness combination	A-115	—
A-107	Lever position sensor	A-116	Engine coolant temperature switch (for condenser fan motor control)

2A-28 WIRING HARNESS CONFIGURATION DIAGRAMS — Engine Compartment

R.H. drive vehicles with 4D56 engine

Connector symbol
A -01 thru -61

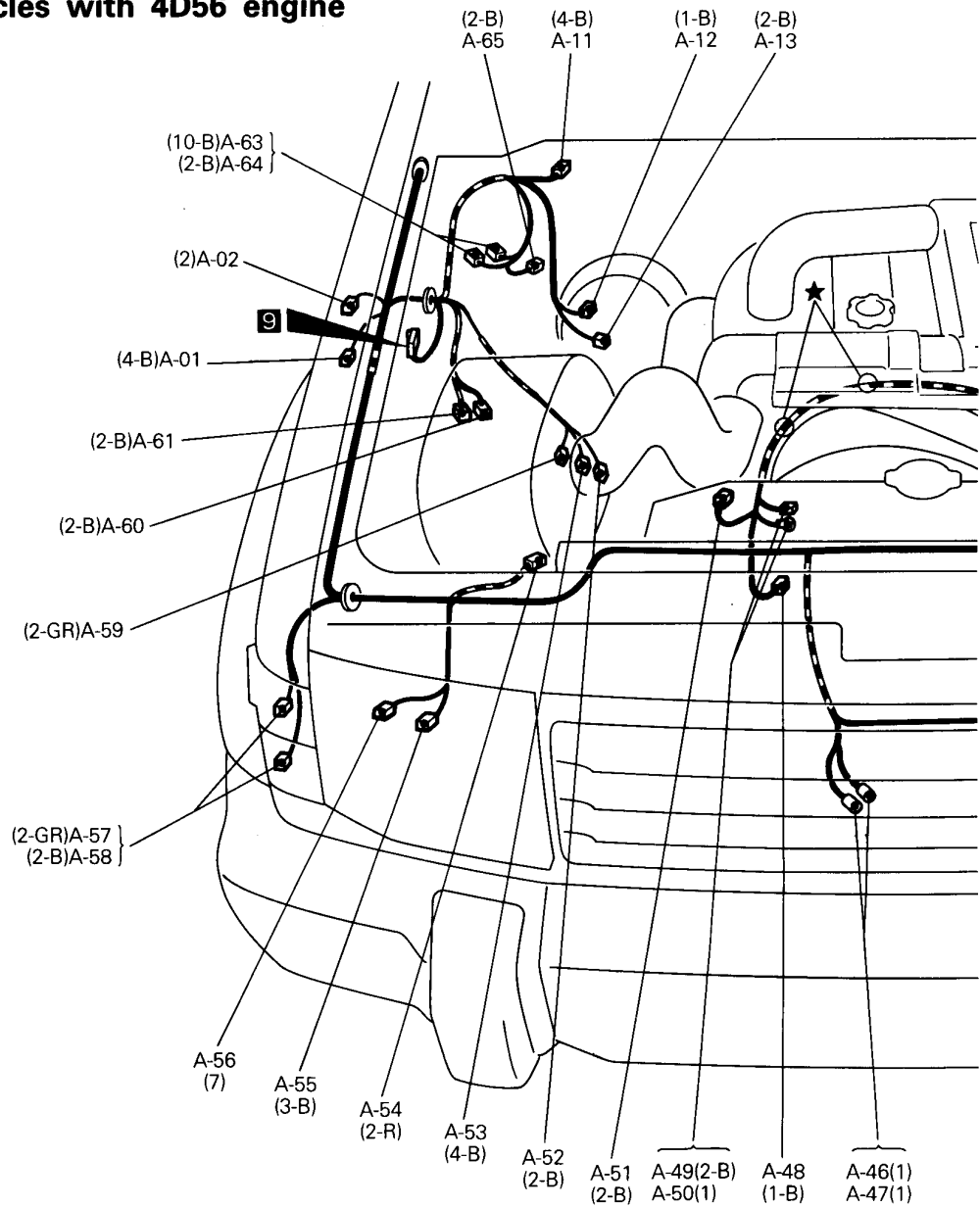

- | | | | |
|------------------|--------------------------------------------------------------|--------------------|-------------------------------------------------------------|
| A-01 | Headlamp washer motor and headlamp washer fluid level sensor | A-16 | Control wiring harness and front wiring harness combination |
| A-02 | Side turn signal lamp (RH) | A-17 | Side turn signal lamp (LH) |
| A-03 }
A-04 } | Motor antenna | A-18 | Windshield washer motor |
| A-05 }
A-06 } | Starter | A-19X }
A-26X } | Refer to centralized junction |
| A-07 | — | A-27 | Battery cable and front wiring harness combination |
| A-08 | — | A-28 | Front impact sensor (LH) <SRS> |
| A-09 | — | A-29 | — |
| A-10 | Starter relay | A-30 | — |
| A-11 | Windshield wiper motor | A-31 | Horn relay <Vehicles with SRS> |
| A-12 | Vacuum switch | A-32 | Resistor <for dim-dip lamp circuit> |
| A-13 | Brake fluid level switch | A-33 } | Front combination lamp (LH) |
| A-14 | No connection | A-34 } | |
| A-15 | Condenser fan motor control relay | | |

WIRING HARNESS CONFIGURATION DIAGRAMS — Engine Compartment 2A-29

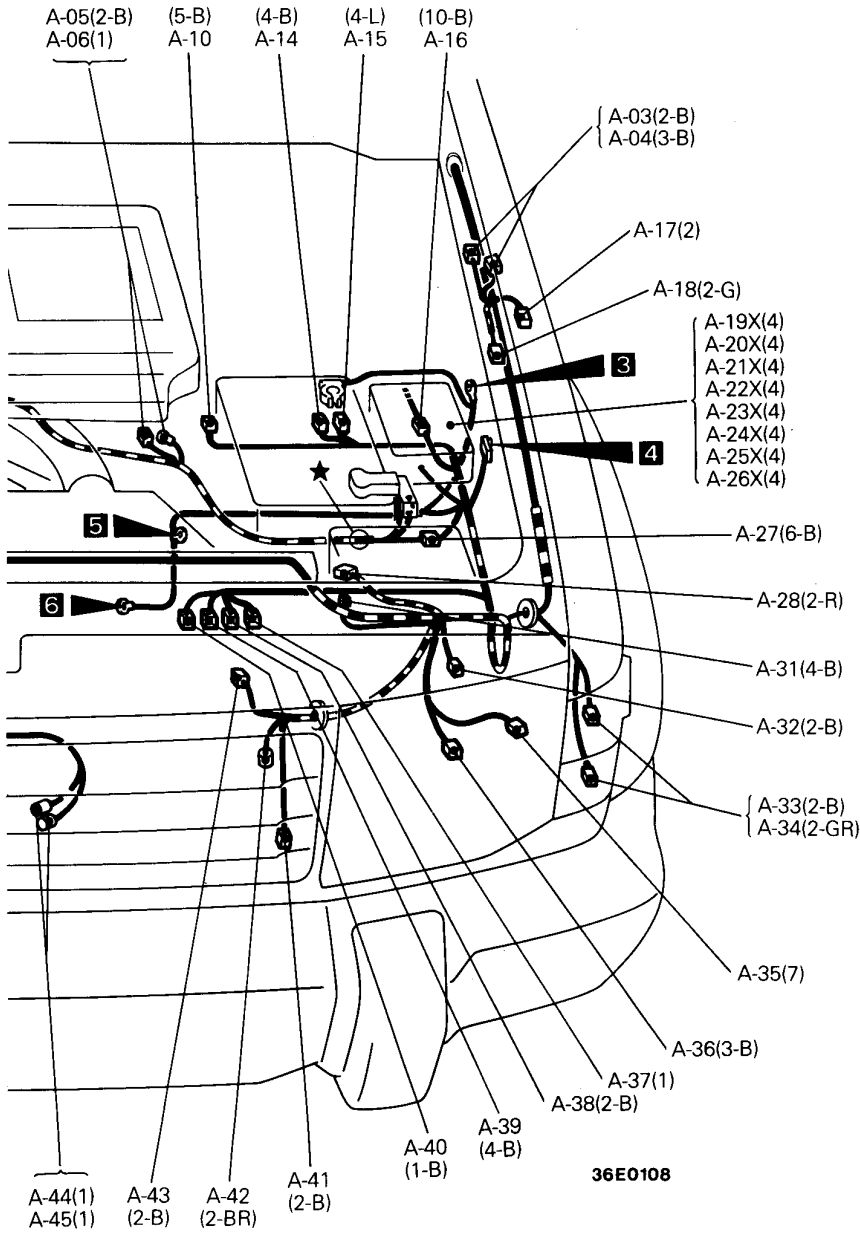

A-35	Headlamp leveling unit (LH)	A-48	Oil pressure switch
A-36	Headlamp (LH)	A-49 } A-50 }	Alternator
A-37	No connection	A-51	Engine oil level sensor
A-38	Speed sensor (Front:LH) <ABS>	A-52	Speed sensor (Front:RH) <ABS>
A-39	Shock absorber (Front:LH) <Remote controlled variable shock absorber>	A-53	Shock absorber (Front:RH) <Remote controlled variable shock absorber>
A-40	Magnetic clutch <A/C>	A-54	Front impact sensor (RH) <SRS>
A-41	Thermo sensor (outside air) <Multi-meter>	A-55	Headlamp (RH)
A-42	Dual pressure switch	A-56	Headlamp leveling unit (RH)
A-43	Condenser fan motor	A-57 } A-58 }	Front combination lamp (RH)
A-44 } A-45 }	Horn (LO)	A-59	Free wheel engage switch
A-46 } A-47 }	Horn (HI)	A-60	Solenoid valve A <Super select 4WD>
		A-61	Solenoid valve B <Super select 4WD>

2A-30 WIRING HARNESS CONFIGURATION DIAGRAMS — Engine Compartment

R.H. drive vehicles with 4D56 engine

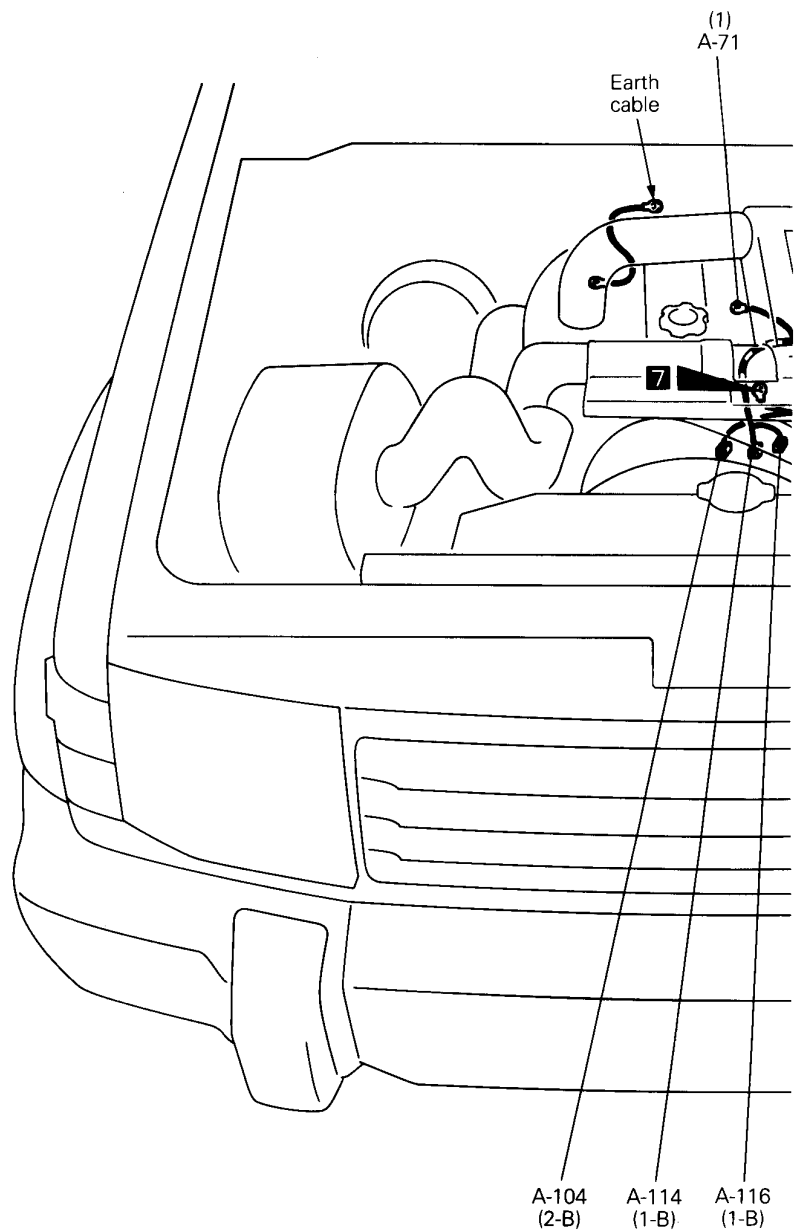
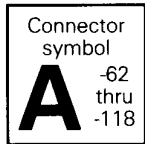

A-62 Auto-cruise control actuator
 A-63 } Hydraulic unit
 A-64 }
 A-65 Idle up solenoid valve <ABS>
 A-66 }
 thru } —
 A-70 }
 A-71 Glow plug
 A-72 }
 thru } —
 A-88 }

A-89 EGR solenoid valve I
 A-90 EGR solenoid valve II
 A-91 —
 A-92 Water level switch
 A-93 —
 A-94 Idle up solenoid valve <A/C>
 A-95 Intake air temperature switch
 A-96 Intercooler fan motor
 A-97 —
 A-98 —

WIRING HARNESS CONFIGURATION DIAGRAMS — Engine Compartment 2A-31

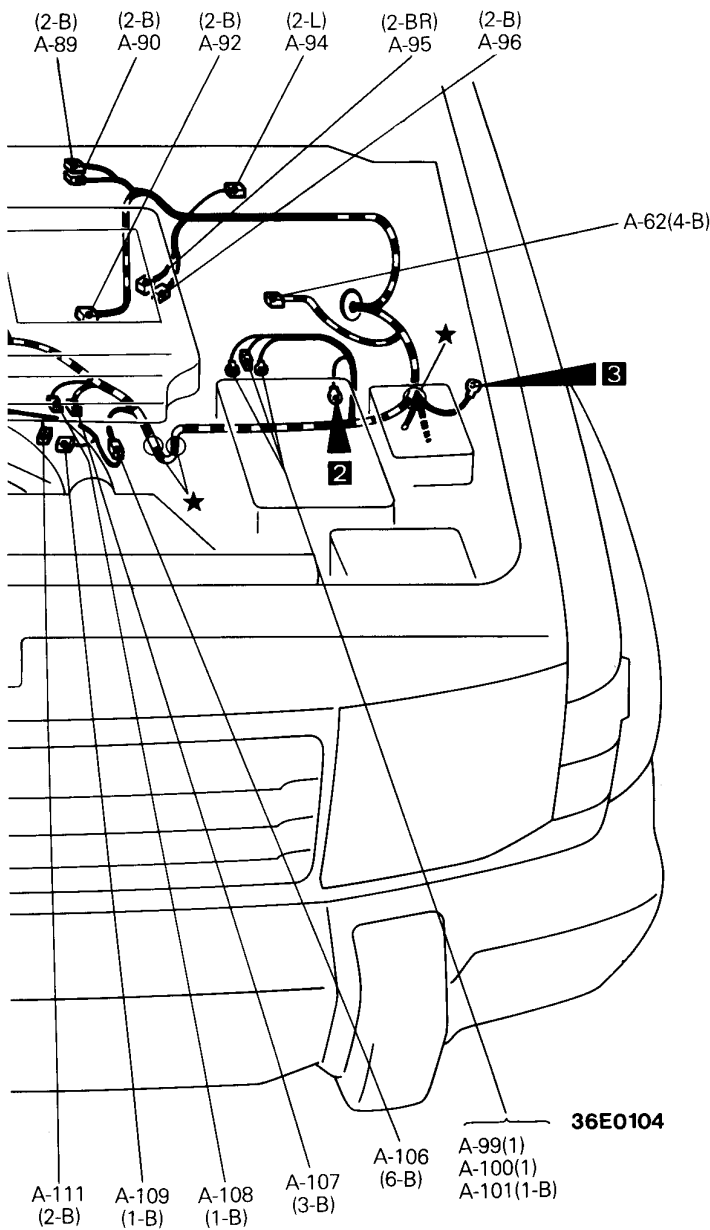

A-99	} Glow plug relay	A-108	Lever position switch <A/T> or short connector <M/T>
A-100		A-109	Fuel cut solenoid valve
A-101		A-110	—
A-102	—	A-111	Rotation sensor
A-103	—	A-112	—
A-104	Engine coolant temperature gauge unit	A-113	—
A-105	—	A-114	Engine coolant temperature switch (for A/C compressor control)
A-106	Fuel injection pump wiring harness and control wiring harness combination	A-115	—
A-107	Lever position sensor	A-116	Engine coolant temperature switch (for condenser fan motor control)

2A-32 WIRING HARNESS CONFIGURATION DIAGRAMS — Engine Compartment

L.H. drive vehicles with 4M40 engine

Connector symbol
A -01 thru -61

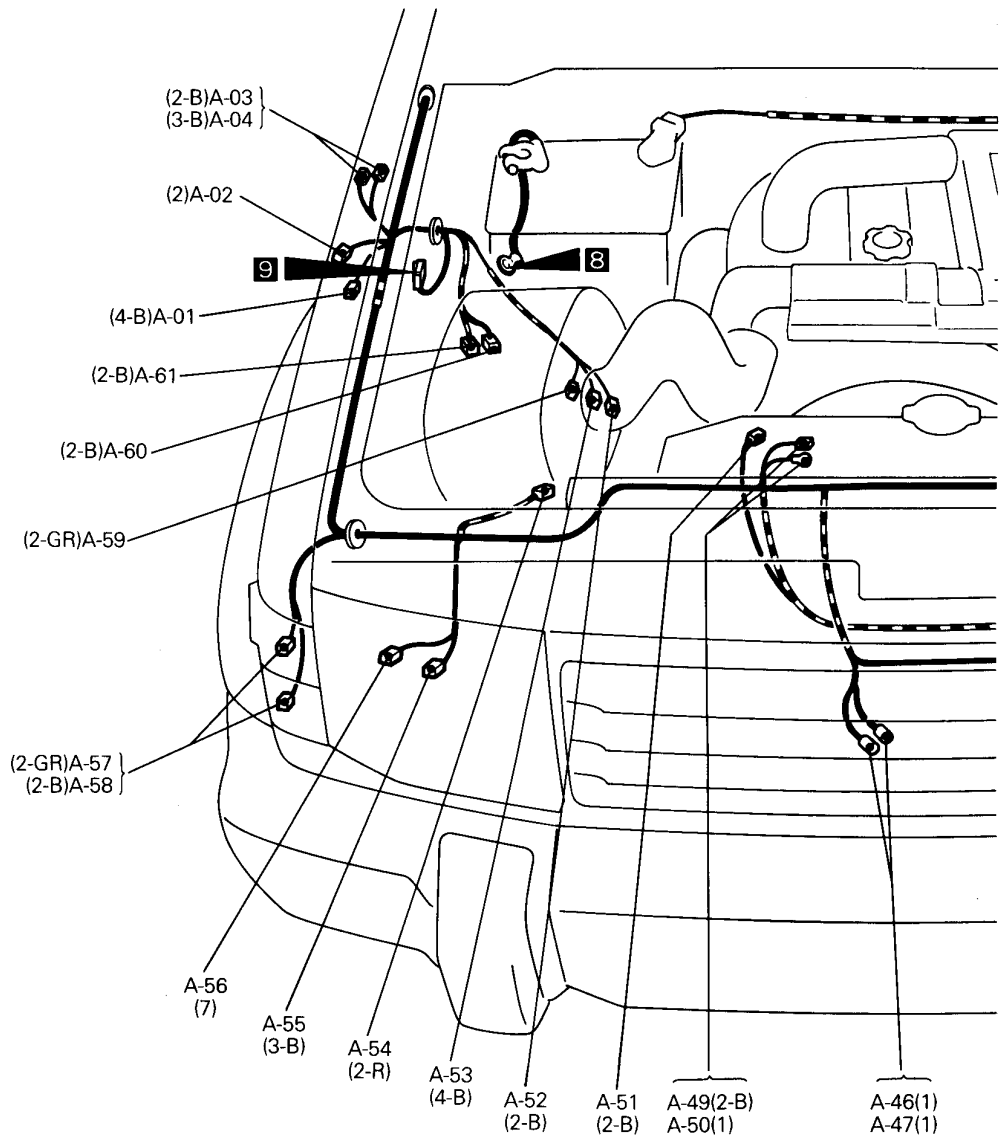

- | | | | |
|------------------|--------------------------------------------------------------|-----------------|-----------------------------------------------------------------------------------------------------------|
| A-01 | Headlamp washer motor and headlamp washer fluid level sensor | A-16 | Control wiring harness and front wiring harness combination |
| A-02 | Side turn signal lamp (RH) | A-17 | Side turn signal lamp (LH) |
| A-03 }
A-04 } | Motor antenna | A-18 | Windshield washer motor |
| A-05 }
A-06 } | Starter | A-19X }
thru | Refer to centralized junction |
| A-07 | Daytime running lamp relay 2 | A-26X } | |
| A-08 | Daytime running lamp relay 1 | A-27 | Battery cable and front wiring harness combination |
| A-09 | Daytime running lamp control unit | A-28 | Front impact sensor (LH) <SRS> |
| A-10 | Starter relay | A-29 } | Daytime running lamp harness and front wiring harness combination or front wiring harness joint connector |
| A-11 | Windshield wiper motor | A-30 } | |
| A-12 | Vacuum switch | A-31 | Horn relay <Vehicles with SRS> |
| A-13 | Brake fluid level switch | A-32 | — |
| A-14 | A/C compressor capacity control relay | A-33 } | Front combination lamp (LH) |
| A-15 | Condenser fan motor control relay | A-34 } | |

WIRING HARNESS CONFIGURATION DIAGRAMS — Engine Compartment 2A-33

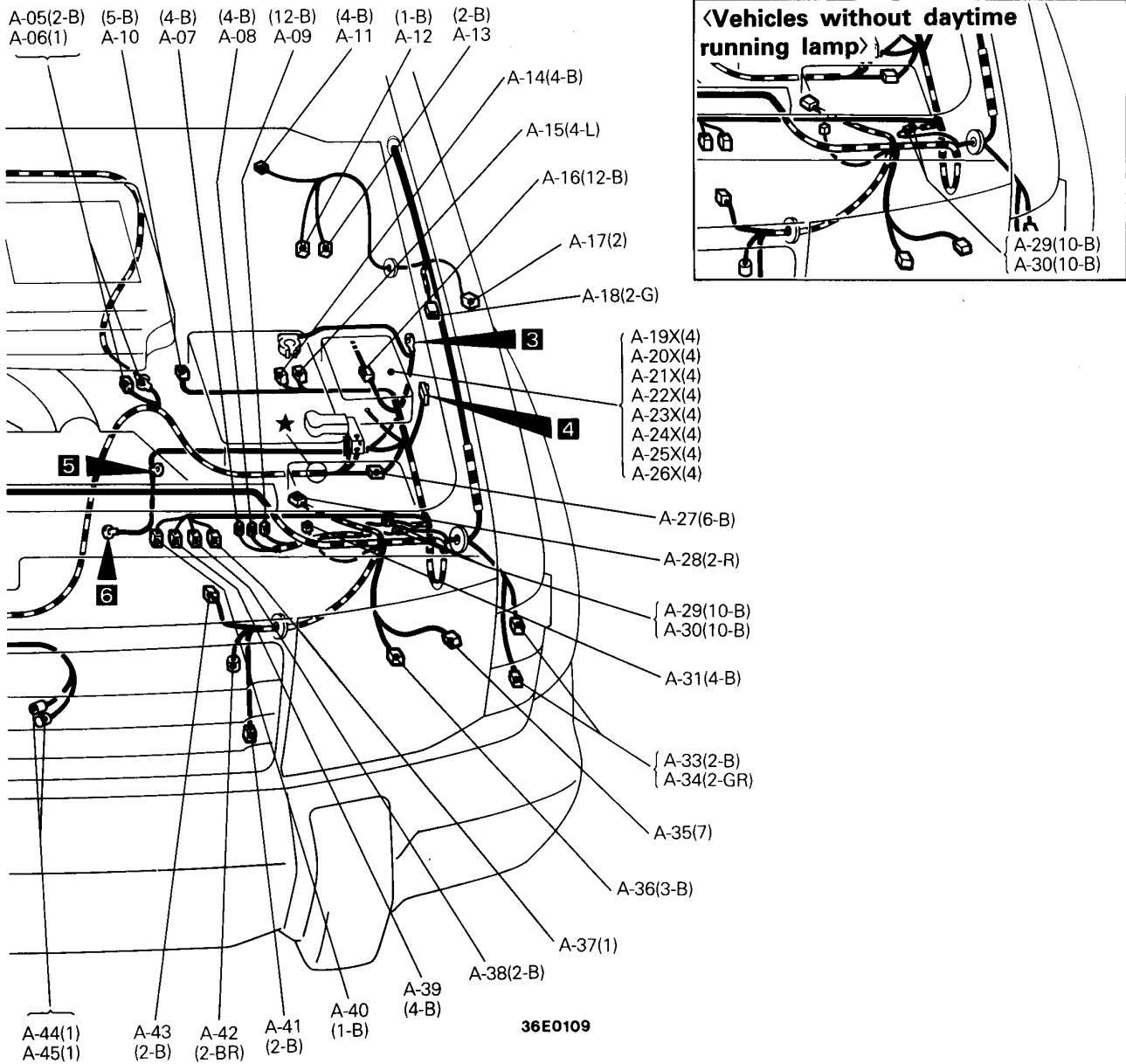

- | | | | |
|------------------|-----------------------------------------------------------------------|------------------|-----------------------------------------------------------------------|
| A-35 | Headlamp leveling unit (LH) | A-48 | Oil pressure switch |
| A-36 | Headlamp (LH) | A-49 }
A-50 } | Alternator |
| A-37 | A/C compressor capacity control solenoid valve | A-51 | Engine oil level sensor |
| A-38 | Speed sensor (Front:LH) <ABS> | A-52 | Speed sensor (Front:RH) <ABS> |
| A-39 | Shock absorber (Front:LH) <Remote controlled variable shock absorber> | A-53 | Shock absorber (Front:RH) <Remote controlled variable shock absorber> |
| A-40 | Magnetic clutch <A/C> | A-54 | Front impact sensor (RH) <SRS> |
| A-41 | Thermo sensor (outside air) <Multi-meter> | A-55 | Headlamp (RH) |
| A-42 | Dual pressure switch | A-56 | Headlamp leveling unit (RH) |
| A-43 | Condenser fan motor | A-57 }
A-58 } | Front combination lamp (RH) |
| A-44 }
A-45 } | Horn (LO) | A-59 | Free wheel engage switch |
| A-46 }
A-47 } | Horn (HI) | A-60 | Solenoid valve A <Super select 4WD> |
| | | A-61 | Solenoid valve B <Super select 4WD> |

2A-34 WIRING HARNESS CONFIGURATION DIAGRAMS — Engine Compartment

L.H. drive vehicles with 4M40 engine

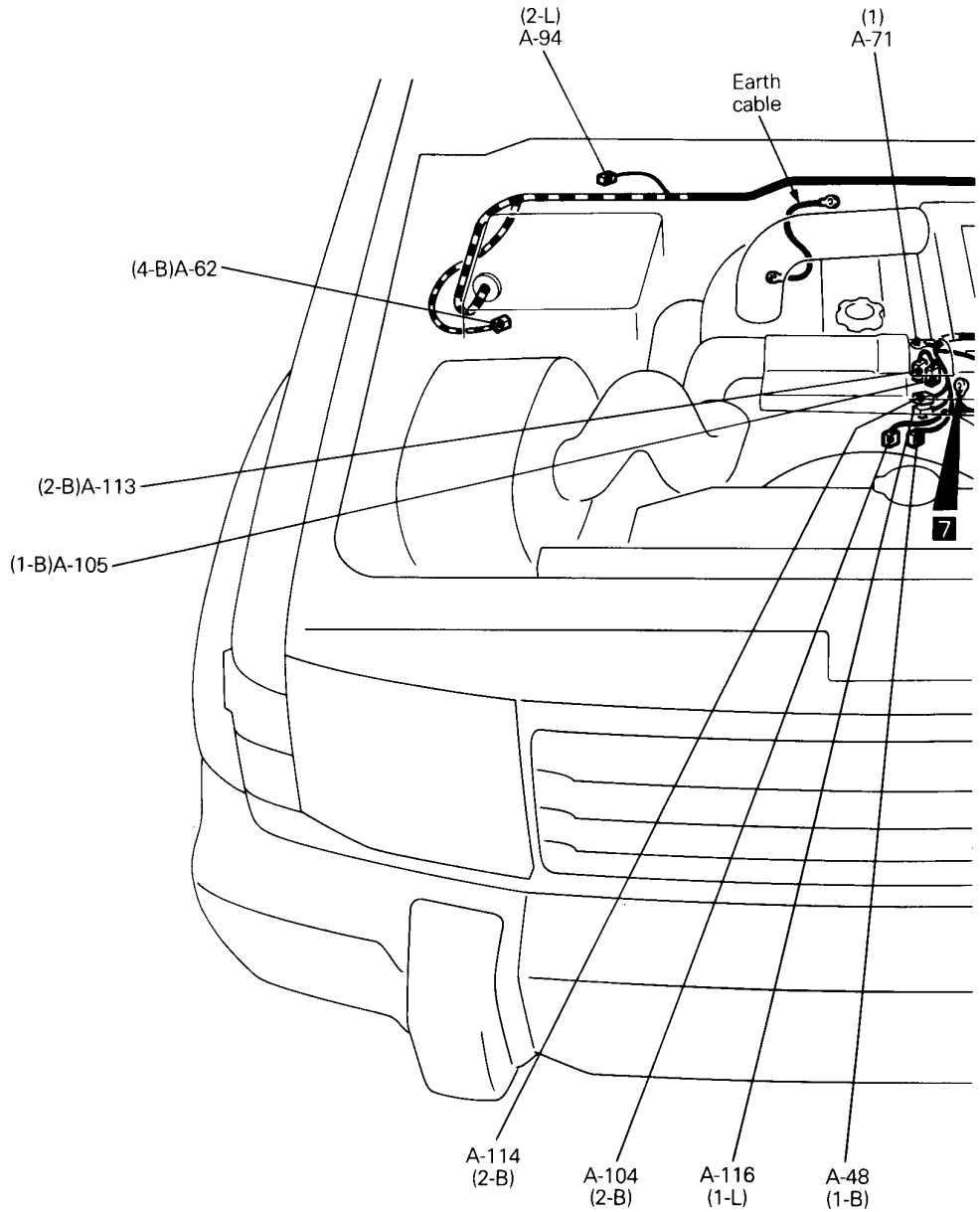
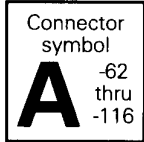

- A-62 Auto-cruise control actuator
- A-63 } Hydraulic unit
- A-64 }
- A-65 Idle up solenoid valve <ABS>
- A-66 } —
- thru }
- A-70 }
- A-71 Glow plug
- A-72 } —
- thru }
- A-88 }

- A-89 EGR solenoid valve I
- A-90 EGR solenoid valve II
- A-91 Supercharging pressure relief solenoid valve
- A-92 Water level switch
- A-93 Fuel line heater or no connection
- A-94 Idle up solenoid valve <A/C>
- A-95 Intake air temperature switch
- A-96 Intercooler fan motor
- A-97 —
- A-98 —

WIRING HARNESS CONFIGURATION DIAGRAMS — Engine Compartment 2A-35

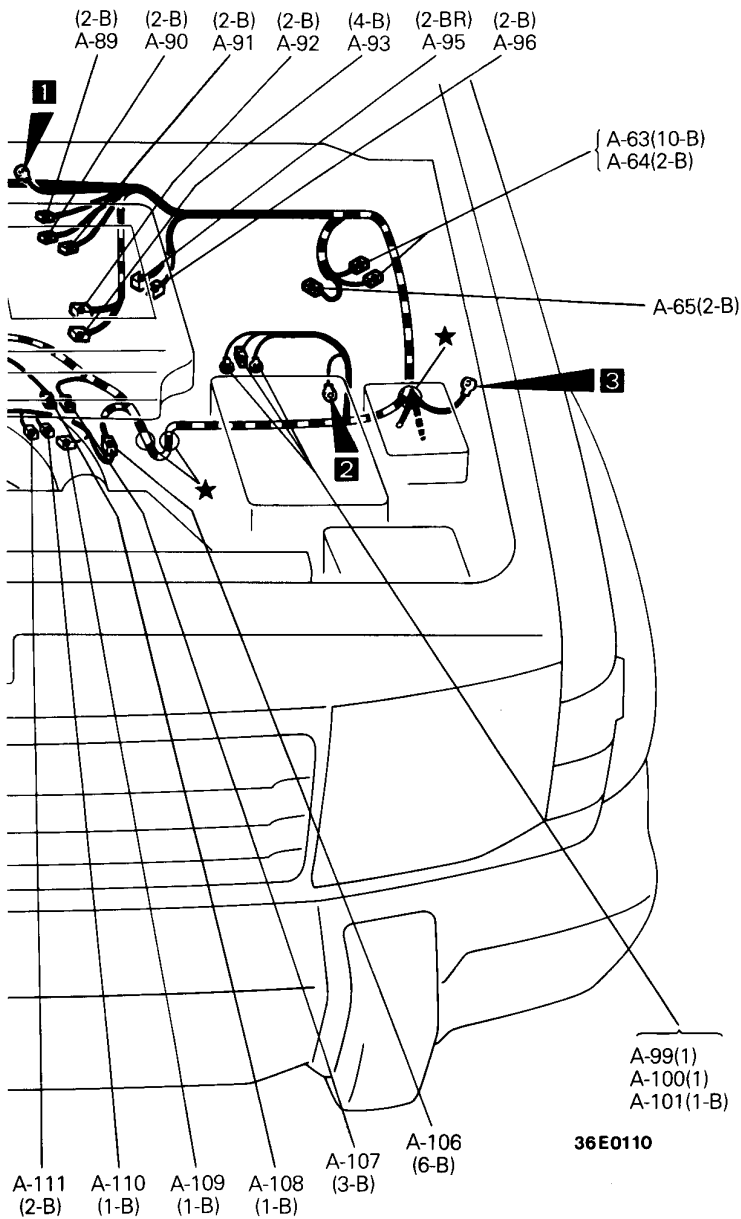

A-99 }
 A-100 } Glow plug relay
 A-101 }
 A-102 —
 A-103 —
 A-104 Engine coolant temperature gauge unit
 A-105 Engine coolant temperature switch <A/T>
 A-106 Fuel injection pump wiring harness and control wiring
 harness combination
 A-107 Lever position sensor

A-108 Lever position switch <A/T> or short connector <M/T>
 A-109 Fuel cut solenoid valve
 A-110 Timer solenoid valve
 A-111 Rotation sensor
 A-112 —
 A-113 Engine coolant temperature sensor
 A-114 Engine coolant temperature switch (for A/C compressor control)
 A-115 —
 A-116 Engine coolant temperature switch (for condenser fan motor control)

2A-36 WIRING HARNESS CONFIGURATION DIAGRAMS — Engine compartment

R.H. drive vehicles with 4M40 engine

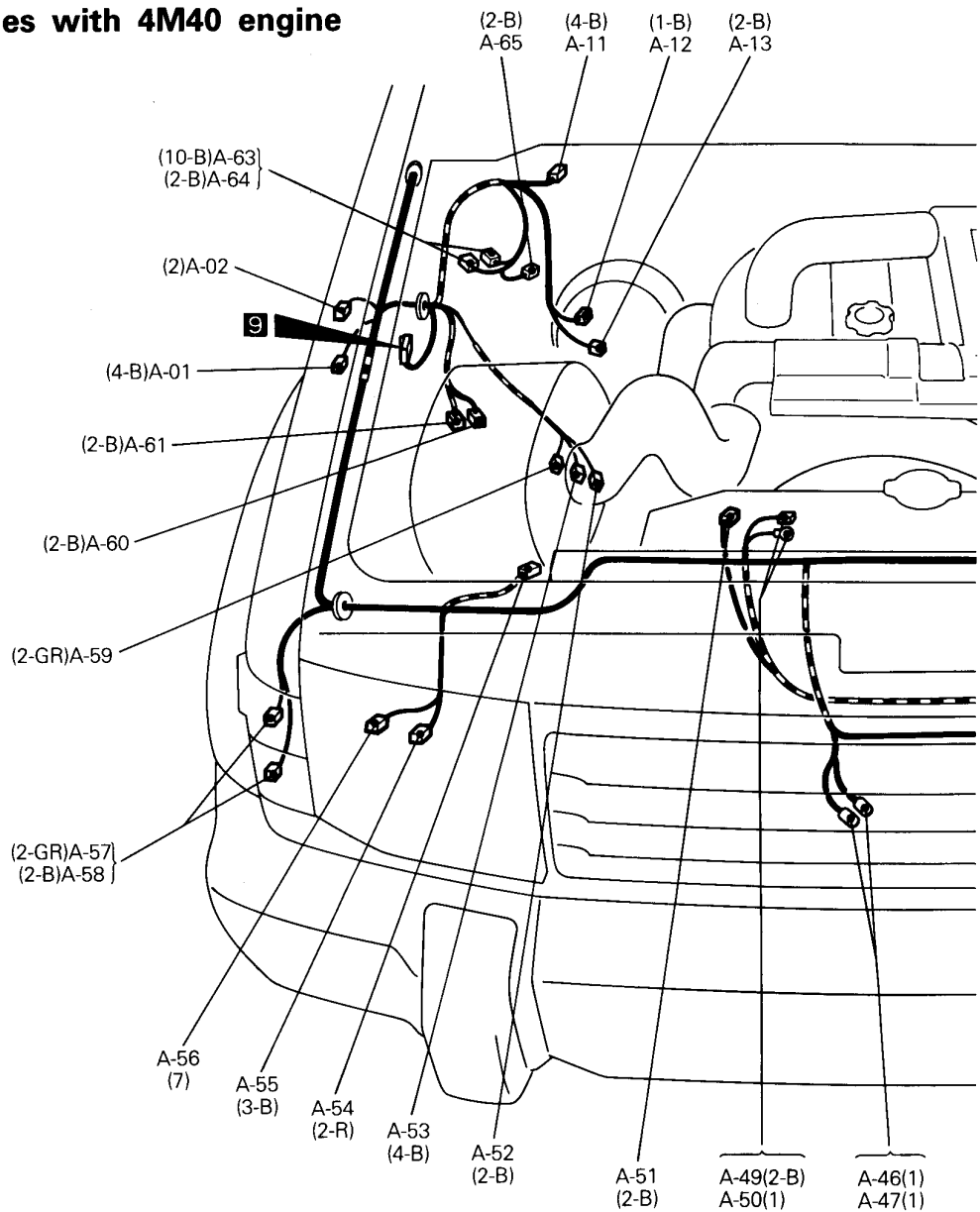
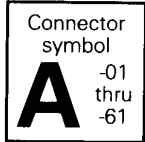

A-01	Headlamp washer motor and headlamp washer fluid level sensor	A-16	Control wiring harness and front wiring harness combination
A-02	Side turn signal lamp (RH)	A-17	Side turn signal lamp (LH)
A-03 } A-04 }	Motor antenna	A-18	Windshield washer motor
A-05 } A-06 }	Starter	A-19X } thru } A-26X }	Refer to centralized junction
A-07	—	A-27	Battery cable and front wiring harness combination
A-08	—	A-28	Front impact sensor (LH) <SRS>
A-09	—	A-29	—
A-10	Starter relay	A-30	—
A-11	Windshield wiper motor	A-31	Horn relay <Vehicles with SRS>
A-12	Vacuum switch	A-32	Resistor <for dim-dip lamp circuit>
A-13	Brake fluid level switch	A-33 }	Front combination lamp (LH)
A-14	A/C compressor capacity control relay	A-34 }	
A-15	Condenser fan motor control relay		

WIRING HARNESS CONFIGURATION DIAGRAMS — Engine compartment 2A-37

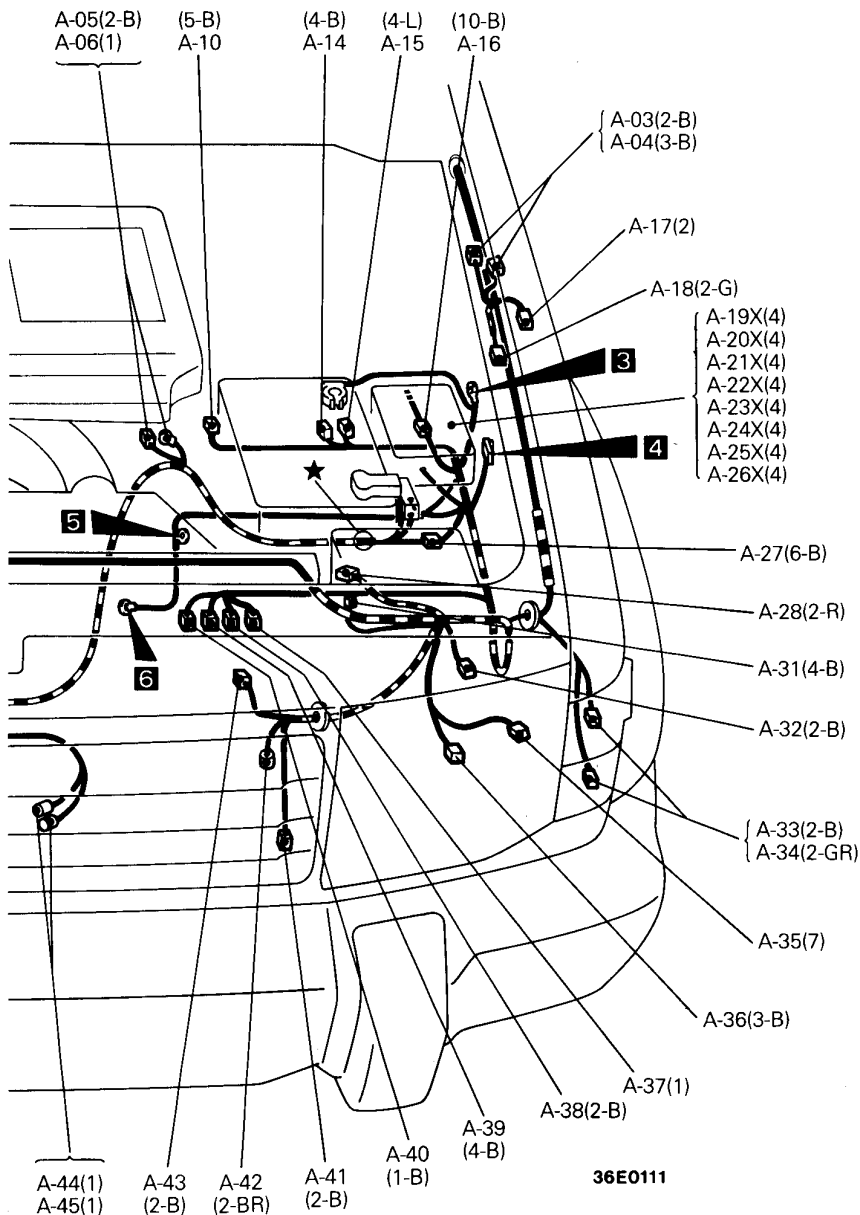

A-35	Headlamp leveling unit (LH)	A-48	Oil pressure switch
A-36	Headlamp (LH)	A-49 } Alternator	
A-37	A/C compressor capacity control solenoid valve	A-50 }	
A-38	Speed sensor (Front: LH) <ABS>	A-51	Engine oil level sensor
A-39	Shock absorber (Front: LH) <Remote controlled variable shock absorber>	A-52	Speed sensor (Front: RH) <ABS>
A-40	Magnetic clutch <A/C>	A-53	Shock absorber (Front: RH) <Remote controlled variable shock absorber>
A-41	Thermo sensor (outside air) <Multi-meter>	A-54	Front impact sensor (RH) <SRS>
A-42	Dual pressure switch	A-55	Headlamp (RH)
A-43	Condenser fan motor	A-56	Headlamp leveling unit (RH)
A-44 } Horn (LO)		A-57 }	Front combination lamp (RH)
A-45 }		A-58 }	
A-46 } Horn (HI)		A-59	Free wheel engage switch
A-47 }		A-60	Solenoid valve A <Super select 4WD>
		A-61	Solenoid valve B <Super select 4WD>

2A-38 WIRING HARNESS CONFIGURATION DIAGRAMS — Engine compartment

R.H. drive vehicles with 4M40 engine

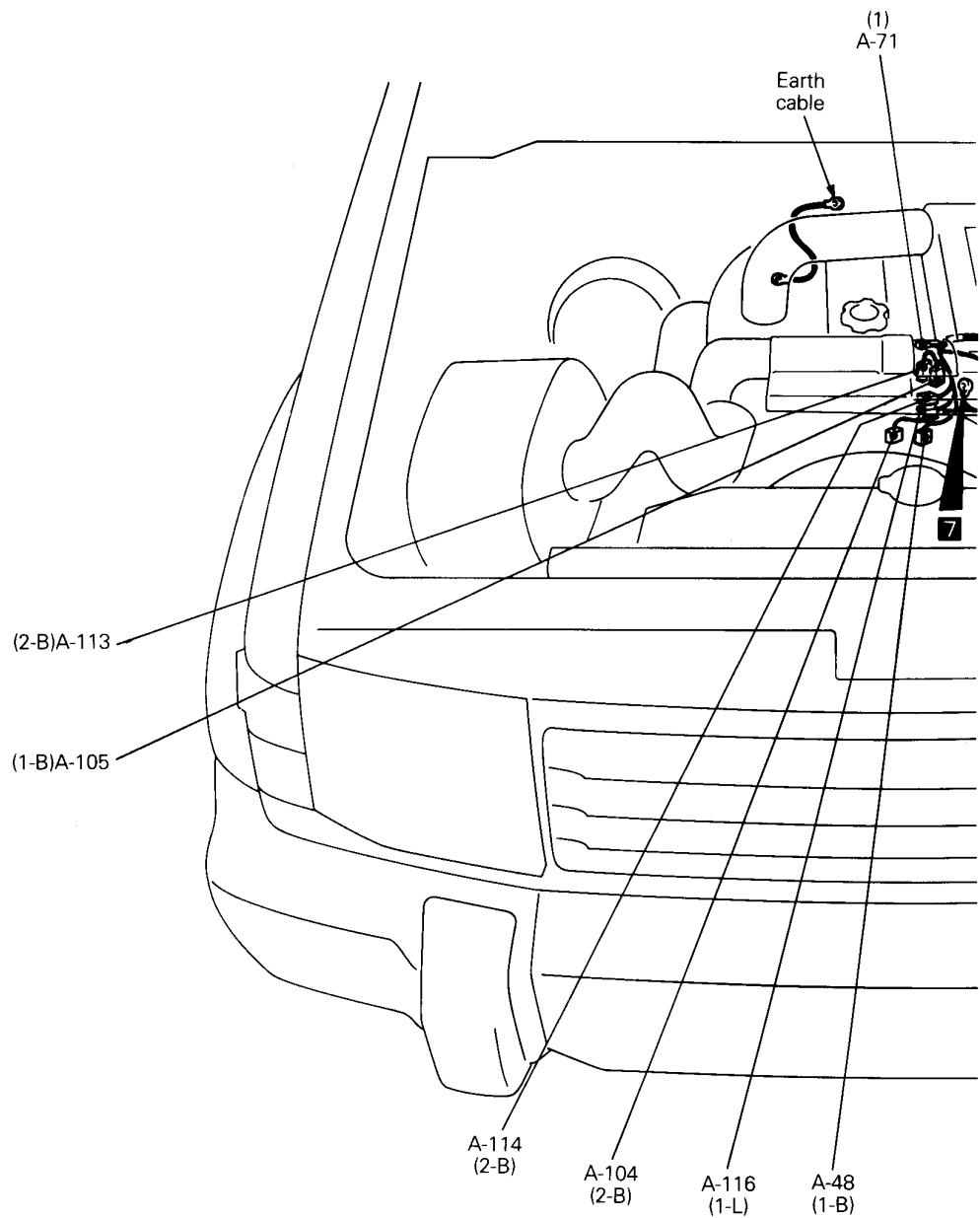
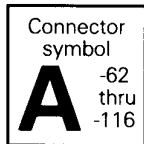

A-62 Auto-cruise control actuator
 A-63 } Hydraulic unit
 A-64 }
 A-65 Idle up solenoid valve <ABS>
 A-66 }
 thru } —
 A-70 }
 A-71 Glow plug
 A-72 }
 thru } —
 A-88 }

A-89 EGR solenoid valve I
 A-90 EGR solenoid valve II
 A-91 —
 A-92 Water level switch
 A-93 Fuel line heater or no connection
 A-94 Idle up solenoid valve <A/C>
 A-95 Intake air temperature switch
 A-96 Intercooler fan motor
 A-97 —
 A-98 —

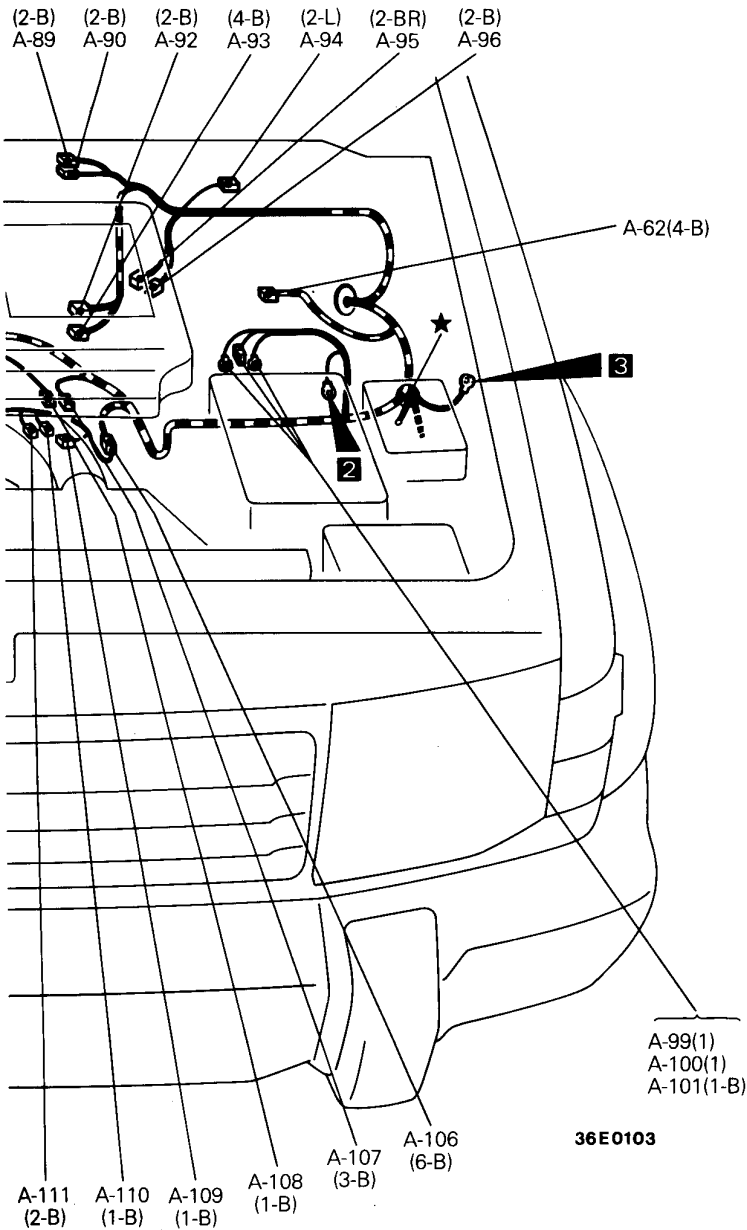

A-99 }
 A-100 } Glow plug relay
 A-101 }

A-102 —
 A-103 —
 A-104 Engine coolant temperature gauge unit
 A-105 Engine coolant temperature switch <A/T>
 A-106 Fuel injection pump wiring harness and control wiring harness combination
 A-107 Lever position sensor
 A-108 Lever position switch <A/T> or short connector <M/T>

A-109 Fuel cut solenoid valve
 A-110 Timer solenoid valve
 A-111 Rotation sensor
 A-112 —
 A-113 Engine coolant temperature sensor
 A-114 Engine coolant temperature switch (for A/C compressor control)
 A-115 —
 A-116 Engine coolant temperature switch (for condenser fan motor control)

TRANSMISSION
PART TIME 4WD

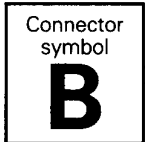

<V5MT1, V5M21>

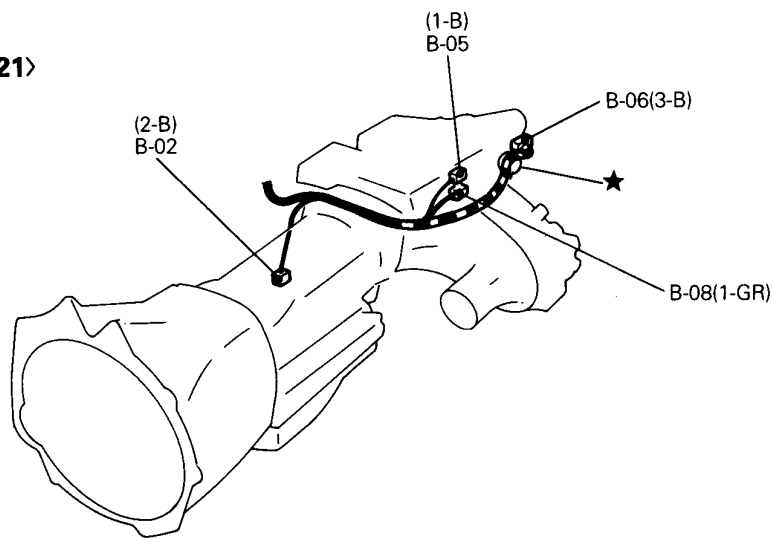

36E0096

<V5M31>

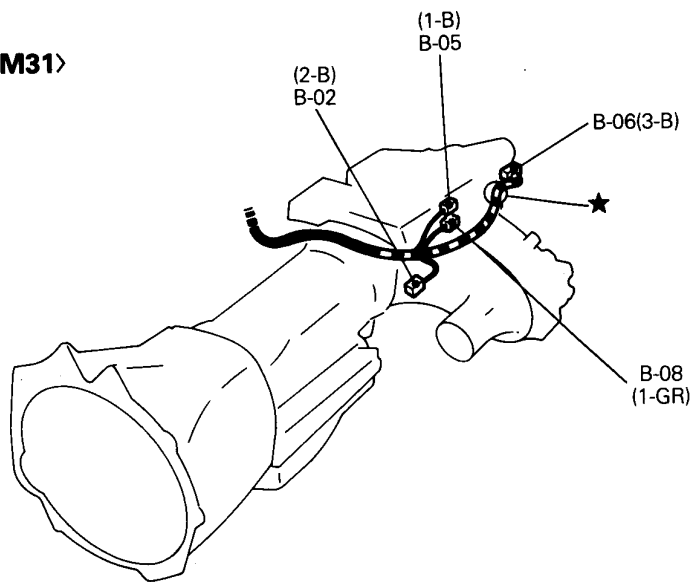

36E0095

B-01 —
B-02 Back-up lamp switch <M/T>
B-03 —
B-04 —

B-05 4WD operation detection switch
B-06 Vehicle speed sensor
B-07 —
B-08 High range/low range detection switch

SUPER SELECT 4WD

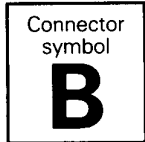

<V5MT1, V4AW2>

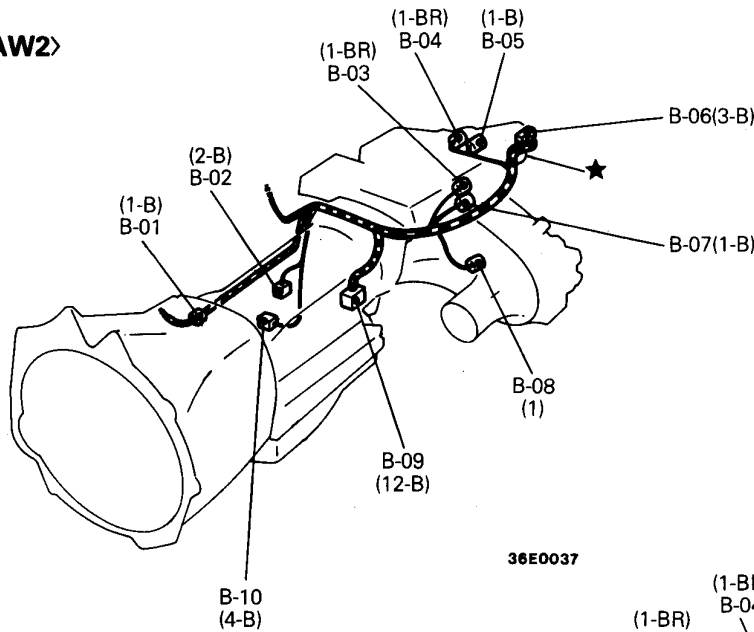

36E0037

<V5M31, V4AW3>

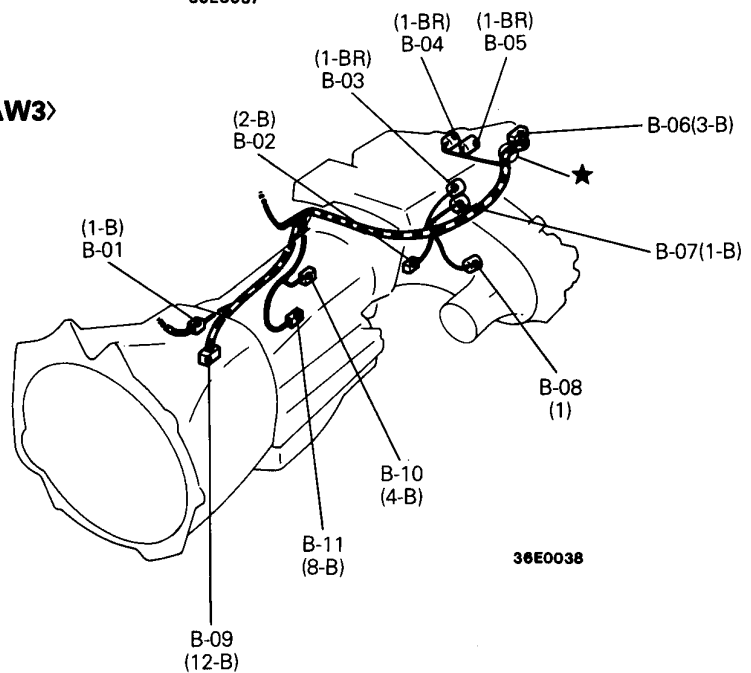

36E0038

- | | | | |
|------|-------------------------------------------------------------------------------------|------|-----------------------------------------|
| B-01 | Battery cable and transmission wiring harness combination <Petrol-powered vehicles> | B-06 | Vehicle speed sensor |
| B-02 | Back-up lamp switch <M/T> | B-07 | 2WD/4WD detection switch |
| B-03 | Center differential lock detection switch | B-08 | High range/low range detection switch |
| B-04 | Center differential lock operation detection switch | B-09 | Inhibitor switch <A/T> |
| B-05 | 4WD operation detection switch | B-10 | Oxygen sensor <Petrol-powered vehicles> |
| | | B-11 | Solenoid assembly <V4AW3> |

DASH PANEL

L.H. drive vehicles

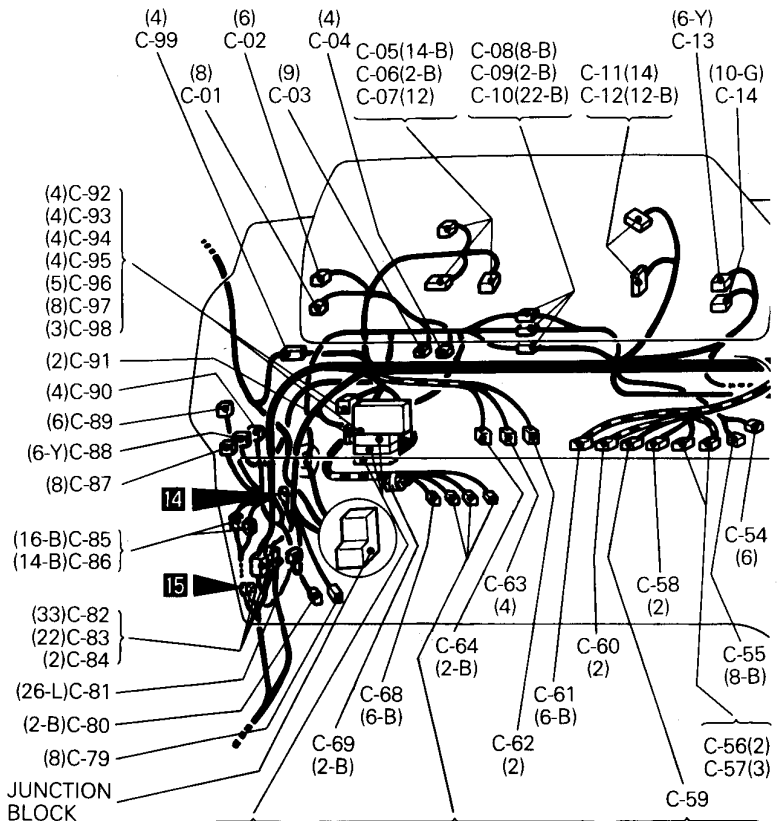
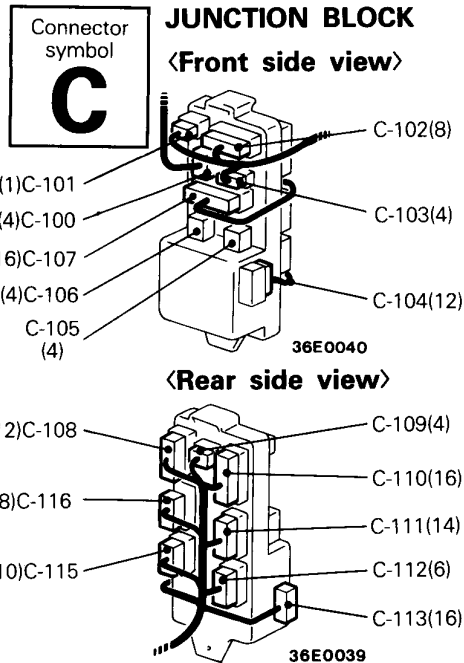

- | | | | |
|------|---------------------------------------------------------------------------------------------------------------------------|------|------------------------------------------------------------------|
| C-01 | Auto-cruise control main switch | C-31 | Engine oil level relay |
| C-02 | Rear fog lamp switch | C-32 | Door wiring harness (passenger's side) and dash wiring |
| C-03 | Remote controlled mirror switch | C-33 | harness combination |
| C-04 | Rheostat or jumper connector | C-34 | Control wiring harness and floor wiring harness (RH) combination |
| C-05 | } Combination meter | C-35 | Dash wiring harness and floor wiring harness (RH) combination |
| C-06 | | C-36 | — |
| C-07 | | C-37 | Front speaker (RH) |
| C-08 | } Front wiring harness and dash wiring harness combination | C-38 | Resistor (for blower motor control circuit) |
| C-09 | | C-39 | Blower motor |
| C-10 | | C-40 | Intercooler fan control unit <Vehicles with fuel line heater> |
| C-11 | } Combination meter | C-41 | Engine control unit or glow control unit |
| C-12 | | C-42 | Engine control unit |
| C-13 | Defogger switch | C-43 | Engine control unit |
| C-14 | Hazard switch | C-44 | Key cylinder illumination lamp timer |
| C-15 | Auto-cruise control unit or spare connector | C-45 | Diode (for ABS circuit) |
| C-16 | Kickdown switch | C-46 | Diode (for MPI circuit) |
| C-17 | A/C switch | C-47 | 4WD indicator relay |
| C-18 | Blower switch | C-48 | } SRS diagnosis unit |
| C-19 | Blower control illumination lamp | C-49 | |
| C-20 | Dash wiring harness and radio sub wiring harness combination | C-50 | Transmission wiring harness and dash wiring harness combination |
| C-21 | } Radio | C-51 | 4WD indicator control unit |
| C-22 | | C-52 | Motor antenna control unit |
| C-23 | A/C unit | C-53 | Lighting monitor buzzer |
| C-24 | } Control wiring harness and dash wiring harness combination | C-54 | Wiper deicer switch |
| C-25 | | C-55 | Motor antenna switch |
| C-26 | | | |
| C-27 | Diode (for super select 4WD circuit) | | |
| C-28 | } Front wiring harness and dash wiring harness combination | | |
| C-29 | | | |
| C-30 | Engine control relay or fuel line heater control unit or intercooler fan control unit <Vehicles without fuel line heater> | | |

WIRING HARNESS CONFIGURATION DIAGRAMS — Dash panel 2A-43

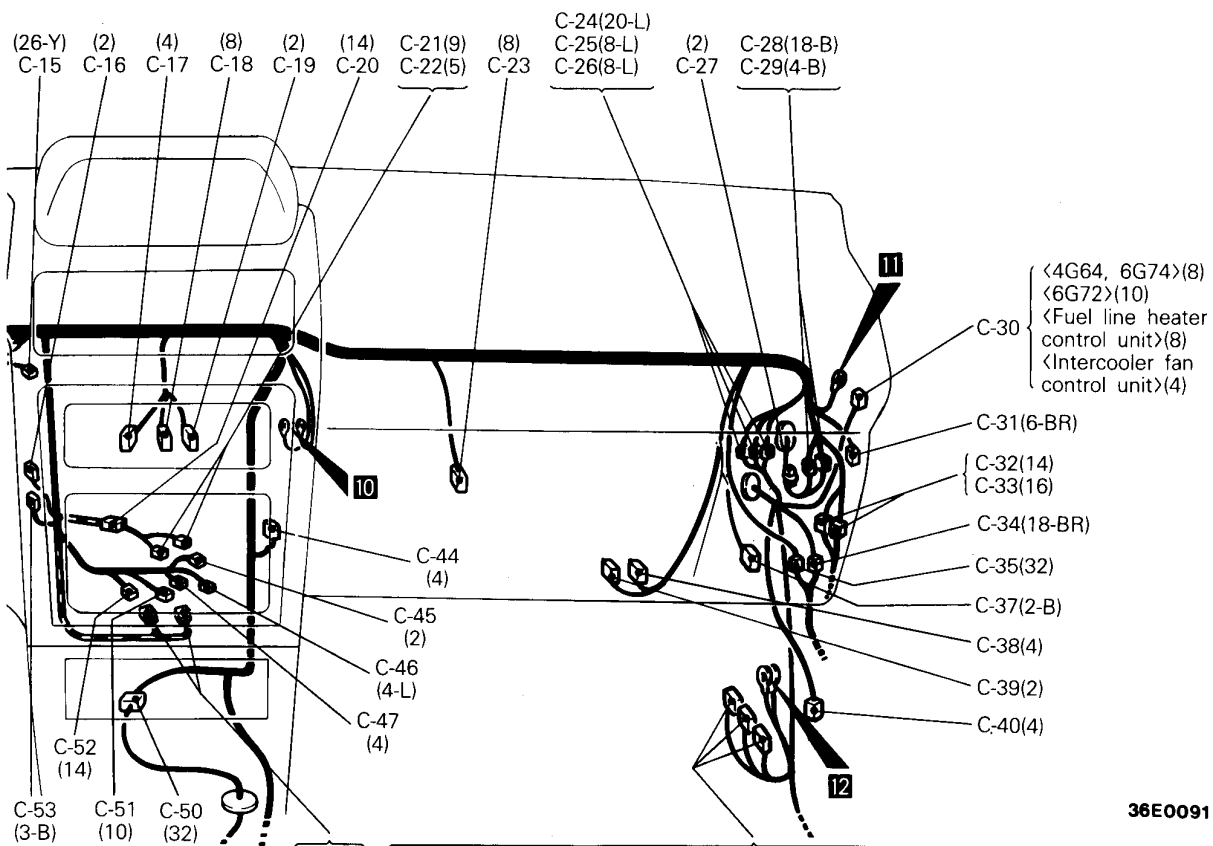

36E0091

- | | |
|----------------------------------------------------------------------------------------------------------------------------------------------------------------------------------------------------------------------------------------------------------------------------------------------------------------------------------------------------------------------------------------------------------------------------------------------------------------------------------------------------------------------------------------------------------------------------------------------------------------------------------------------------------------------------------------------------------------------------------------------------------------------------------------------------------------------------------------------------------------------------------------------------|---------------------------------------------------------------------------------------------------------------------------------------------------------------------------------------------------------------------------------------------------------------------------------------------------------------------------------------------------------------------------------------------------------------------------------------------------------------------------------------------------------------------------------------------------------------------------------------------------------------------------------------------------------------------------------------------------------------------------------------------------------------------------------------------------------------------------------------------------------------------------------------------------------------------------------------------------------------------------------------------------------------------------------------------------------------------------------------------------------------------------------------------------------------------------------------------------------------------------------------------------------------------------------------------------------------------------------------------------------------------------------------------------------------------------------------------------------------------------------------------------------------------------------------------------------------------------------------------------------------------------------------------------------------------------------------------------------------------------------------------------------------|
| <p>C-56 }
C-57 } Clock spring <SRS></p> <p>C-58 Thermo sensor (inside air) <Multi-meter></p> <p>C-59 Steering lock switch</p> <p>C-60 Auto-cruise control switch <Vehicles without SRS></p> <p>C-61 Ignition switch</p> <p>C-62 Stop lamp switch (2-pin) or no connection <Auto-cruise control></p> <p>C-63 Stop lamp switch (4-pin) <Auto-cruise control> or no connection</p> <p>C-64 Clutch switch</p> <p>C-65 }
C-66 } Column switch
C-67 }</p> <p>C-68 Headlamp leveling switch</p> <p>C-69 Diode (for Headlamp circuit)</p> <p>C-70 }
thru } —
C-74 }</p> <p>C-75 J/C (1)</p> <p>C-76 J/C (2)</p> <p>C-77 J/C (3)</p> <p>C-78 —</p> <p>C-79 Overdrive control relay</p> <p>C-80 Front speaker (LH)</p> <p>C-81 ELC-4A/T control unit</p> <p>C-82 }
C-83 } Dash wiring harness and floor wiring harness (LH)
C-84 } combination</p> | <p>C-48(14) <4G64, 6G72></p> <p>C-49(2) C-41(24-Y) C-41(26-Y)</p> <p>C-42(18-Y) C-42(16-Y)</p> <p>C-43(10-Y) C-43(22-Y)</p> <p><4G64, 6G74>(8)</p> <p><6G72>(10)</p> <p><Fuel line heater control unit>(8)</p> <p><Intercooler fan control unit>(4)</p> <p>C-30</p> <p>C-31(6-BR)</p> <p>C-32(14)</p> <p>C-33(16)</p> <p>C-34(18-BR)</p> <p>C-35(32)</p> <p>C-37(2-B)</p> <p>C-38(4)</p> <p>C-39(2)</p> <p>C-40(4)</p> <p>C-44(4)</p> <p>C-45(2)</p> <p>C-46(4-L)</p> <p>C-47(4)</p> <p>C-50(32)</p> <p>C-51(10)</p> <p>C-52(14)</p> <p>C-53(3-B)</p> <p>C-48(14) <4G64, 6G72></p> <p>C-49(2) C-41(24-Y) C-41(26-Y)</p> <p>C-42(18-Y) C-42(16-Y)</p> <p>C-43(10-Y) C-43(22-Y)</p> <p><Diesel-powered vehicles without EGR> C-41(13)</p> <p><Diesel-powered vehicles with EGR> C-41(26-Y)</p> <p>C-85 }
C-86 } Door wiring harness (driver's side) and dash wiring
harness combination</p> <p>C-87 Door lock control unit</p> <p>C-88 Headlamp washer relay</p> <p>C-89 Wiper deicer timer</p> <p>C-90 Wiper deicer relay</p> <p>C-91 Dedicated fuse No. ⑨</p> <p>C-92X }
thru } Refer to centralized junction
C-98X }</p> <p>C-99 Roof wiring harness and dash wiring harness combination</p> <p>C-100 Roof wiring harness and junction block combination</p> <p>C-101 }
C-102 } Front wiring harness and junction block combination
C-103 }</p> <p>C-104 Diagnosis connector</p> <p>C-105 Blower relay</p> <p>C-106 Accessory socket relay</p> <p>C-107 }
thru } Dash wiring harness and junction block combination
C-112 }</p> <p>C-113 Diagnosis connector</p> <p>C-114 Jumper connector</p> <p>C-115 }
C-116 } Dash wiring harness and junction block combination</p> |
|----------------------------------------------------------------------------------------------------------------------------------------------------------------------------------------------------------------------------------------------------------------------------------------------------------------------------------------------------------------------------------------------------------------------------------------------------------------------------------------------------------------------------------------------------------------------------------------------------------------------------------------------------------------------------------------------------------------------------------------------------------------------------------------------------------------------------------------------------------------------------------------------------|---------------------------------------------------------------------------------------------------------------------------------------------------------------------------------------------------------------------------------------------------------------------------------------------------------------------------------------------------------------------------------------------------------------------------------------------------------------------------------------------------------------------------------------------------------------------------------------------------------------------------------------------------------------------------------------------------------------------------------------------------------------------------------------------------------------------------------------------------------------------------------------------------------------------------------------------------------------------------------------------------------------------------------------------------------------------------------------------------------------------------------------------------------------------------------------------------------------------------------------------------------------------------------------------------------------------------------------------------------------------------------------------------------------------------------------------------------------------------------------------------------------------------------------------------------------------------------------------------------------------------------------------------------------------------------------------------------------------------------------------------------------|

2A-44 WIRING HARNESS CONFIGURATION DIAGRAMS — Dash panel

R.H. drive vehicles

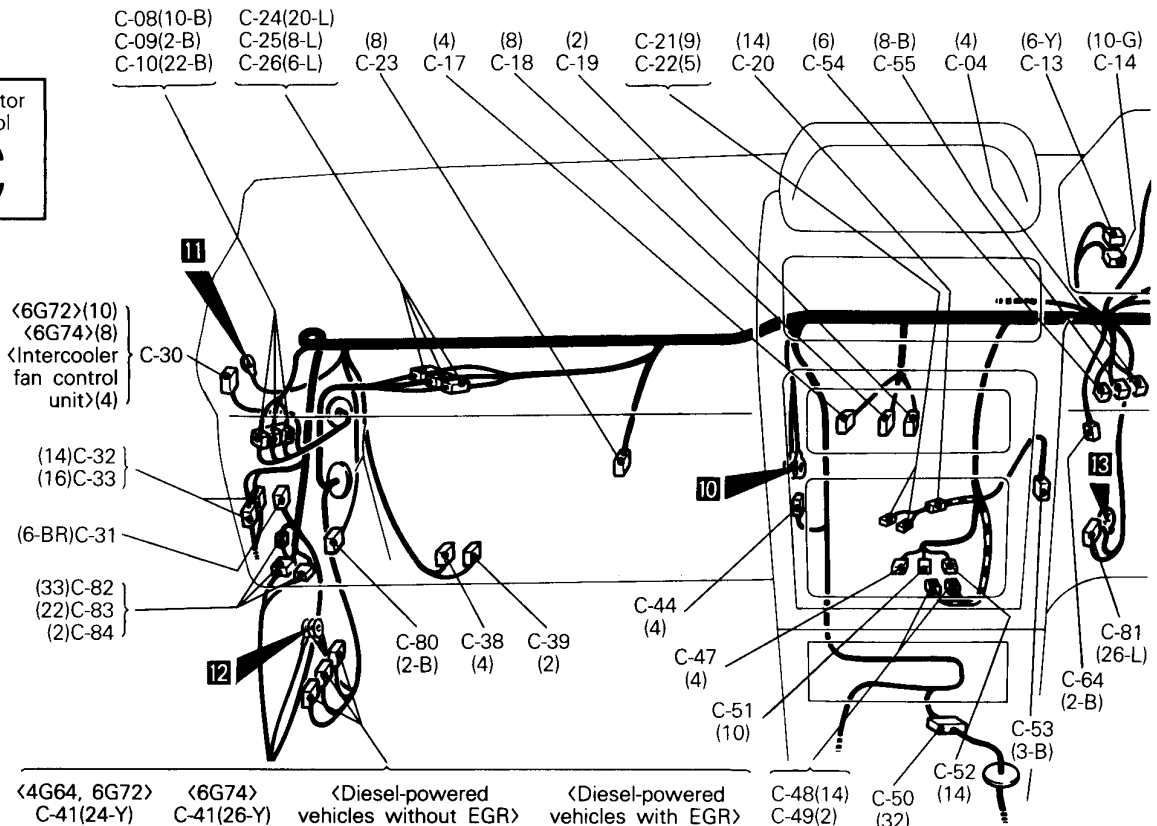
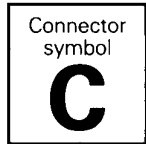

	<4G64, 6G72>	<6G74>	<Diesel-powered vehicles without EGR>	<Diesel-powered vehicles with EGR>	C-48(14)	C-50(32)	
	C-41(24-Y)	C-41(26-Y)	C-41(13)	C-41(26-Y)	C-49(2)		
	C-42(18-Y)	C-42(16-Y)					
	C-43(10-Y)	C-43(22-Y)					
C-01	Auto-cruise control main switch			C-28	Front wiring harness and dash wiring harness combination		
C-02	Rear fog lamp switch			C-29	Front wiring harness and dash wiring harness combination		
C-03	Remote controlled mirror switch			C-30	Engine control relay or intercooler fan control unit		
C-04	Rheostat or jumper connector			C-31	Engine oil level relay		
C-05	Combination meter			C-32	Door wiring harness (passenger's side) and dash wiring harness combination		
C-06				C-33	Door wiring harness (passenger's side) and dash wiring harness combination		
C-07				C-34	—		
C-08	Front wiring harness and dash wiring harness combination			C-35	Dash wiring harness and floor wiring harness (RH) combination		
C-09				C-36	Front wiring harness and floor wiring harness (RH) combination		
C-10				C-37	Front speaker (RH)		
C-11	Combination meter			C-38	Resistor (for blower motor control circuit)		
C-12				C-39	Blower motor		
C-13	Defogger switch			C-40	Intercooler control unit <Vehicles with fuel line heater>		
C-14	Hazard switch			C-41	Engine control unit or glow control unit		
C-15	Auto-cruise control unit or spare connector			C-42	Engine control unit		
C-16	Kickdown switch			C-43	Engine control unit		
C-17	A/C switch			C-44	Key cylinder illumination lamp timer		
C-18	Blower switch			C-45	Diode (for ABS circuit)		
C-19	Blower control illumination lamp			C-46	Diode (for MPI circuit)		
C-20	Dash wiring harness and radio sub wiring harness combination			C-47	4WD indicator relay		
C-21	Radio			C-48	SRS diagnosis unit		
C-22				C-49			
C-23	A/C unit			C-50	Transmission wiring harness and dash wiring harness combination		
C-24	Control wiring harness and dash wiring harness combination			C-51	4WD indicator control unit		
C-25				C-52	Motor antenna control unit		
C-26				C-53	Lighting monitor buzzer		
C-27	Diode (for super select 4WD circuit)						

WIRING HARNESS CONFIGURATION DIAGRAMS — Dash panel 2A-45

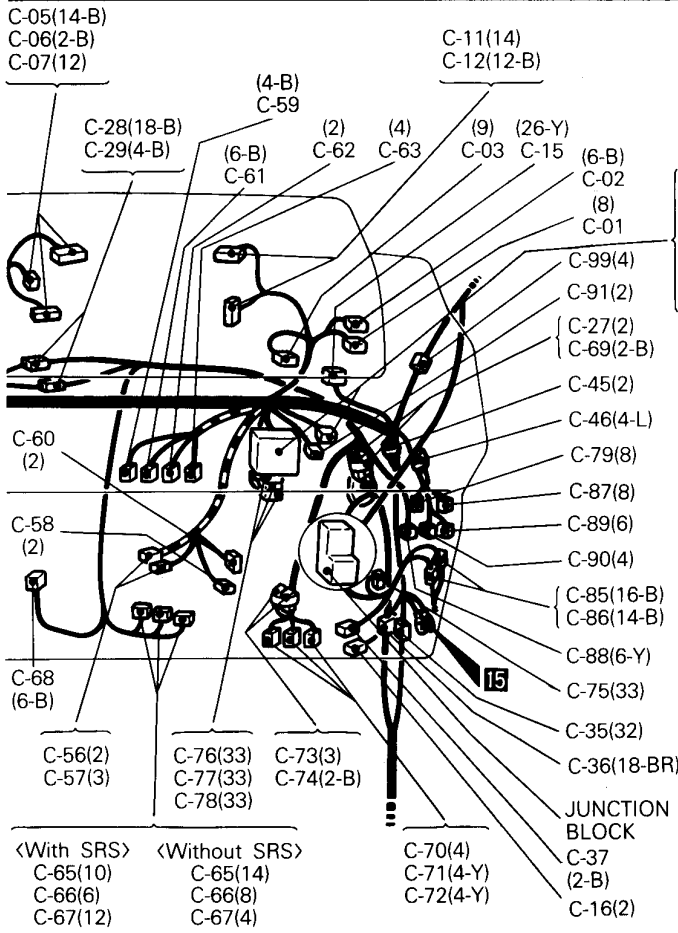

JUNCTION BLOCK

<Front side view>

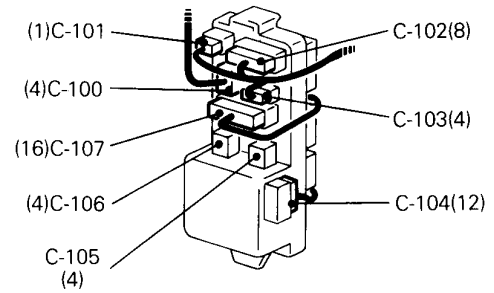

36E0040

<Rear side view>

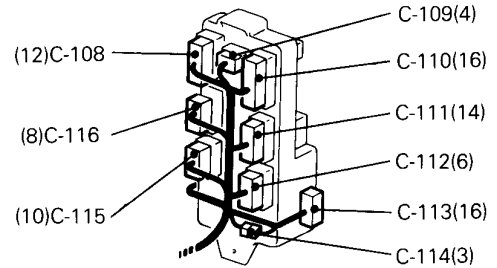

36E0050

36E0090

- | | | |
|----------------------------|-----------------------------------------------------------------|-----------|
| <With SRS> | <Without SRS> | |
| C-65(10) | C-65(14) | C-70(4) |
| C-66(6) | C-66(8) | C-71(4-Y) |
| C-67(12) | C-67(4) | C-72(4-Y) |
| C-54 | Wiper deicer switch | |
| C-55 | Motor antenna switch | |
| C-56 }
C-57 } | Clock spring <SRS> | |
| C-58 | Thermo sensor (inside air) <Multi-meter> | |
| C-59 | Steering lock switch | |
| C-60 | Auto-cruise control switch <Vehicles without SRS> | |
| C-61 | Ignition switch | |
| C-62 | Stop lamp switch (2-pin) or no connection <Auto-cruise control> | |
| C-63 | Stop lamp switch (4-pin) <Auto-cruise control> or no connection | |
| C-64 | Clutch switch | |
| C-65 }
C-66 }
C-67 } | Column switch | |
| C-68 | Headlamp leveling switch | |
| C-69 | Diode (for Headlamp circuit) | |
| C-70 | Dim-dip lamp relay 1 | |
| C-71 | Dim-dip lamp relay 2 | |
| C-72 | Dim-dip lamp relay 3 | |
| C-73 }
C-74 } | Diode (for dim-dip lamp circuit) | |
| C-75 | J/C (1) | |
| C-76 | J/C (2) | |
| C-77 | J/C (3) | |
| C-78 | J/C (4) | |
| C-79 | Overdrive control relay | |
| C-80 | Front speaker (LH) | |

- | | |
|------------------------------|-------------------------------------------------------------------------|
| C-81 | ELC-4A/T control unit |
| C-82 }
C-83 }
C-84 } | Dash wiring harness and floor wiring harness (LH) combination |
| C-85 }
C-86 } | Door wiring harness (driver's side) and dash wiring harness combination |
| C-87 | Door lock control unit |
| C-88 | Headlamp washer relay |
| C-89 | Wiper deicer timer |
| C-90 | Wiper deicer relay |
| C-91 | Dedicated fuse No. ⑨ |
| C-92X }
thru }
C-98X } | Refer to centralized junction |
| C-99 | Roof wiring harness and dash wiring harness combination |
| C-100 | Roof wiring harness and junction block combination |
| C-101 }
C-102 } | Front wiring harness and junction block combination |
| C-103 | Diagnosis connector |
| C-104 | Diagnosis connector |
| C-105 | Blower relay |
| C-106 | Accessory socket relay |
| C-107 }
thru } | Dash wiring harness and junction block combination |
| C-112 | Diagnosis connector |
| C-113 | Diagnosis connector |
| C-114 | Jumper connector |
| C-115 }
C-116 } | Dash wiring harness and junction block combination |

INSTRUMENT PANEL AND FLOOR CONSOLE

L.H. drive vehicles <M/T>

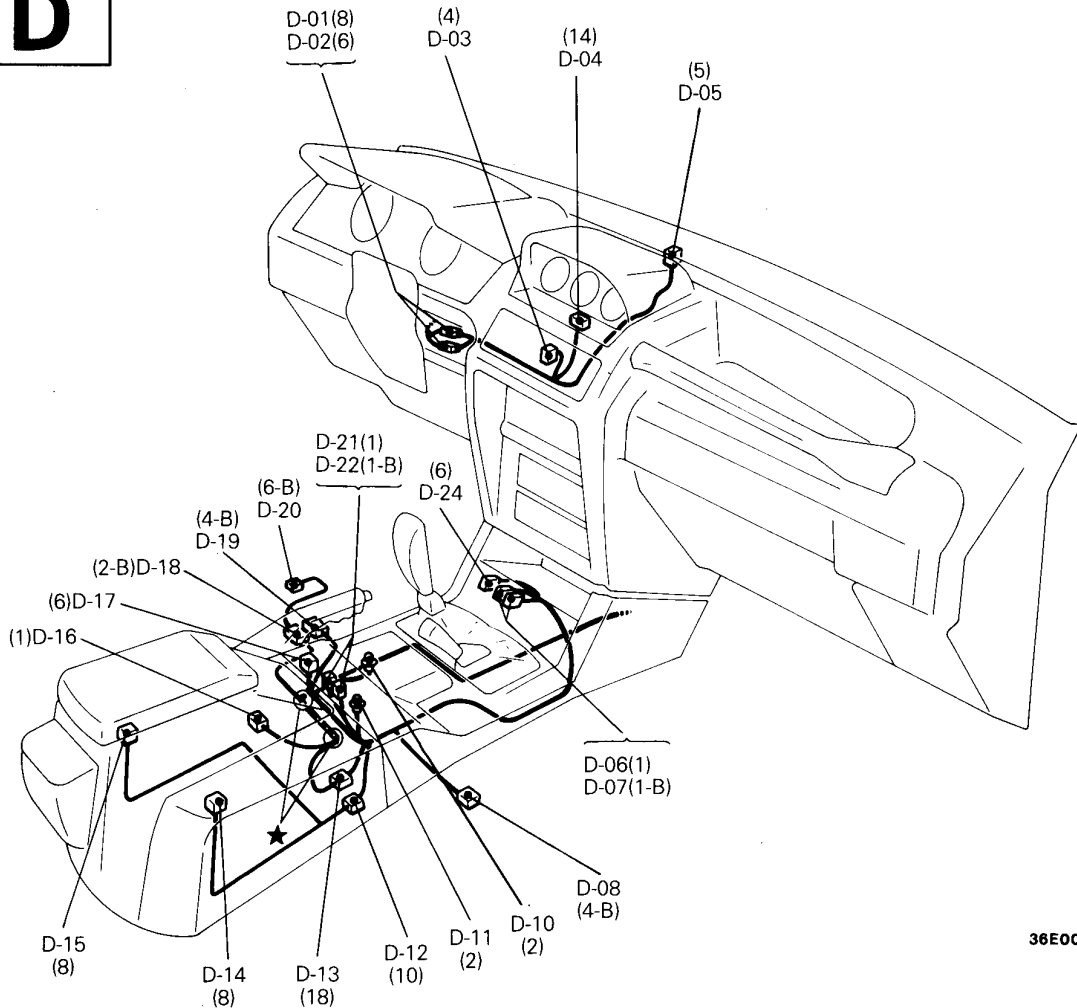
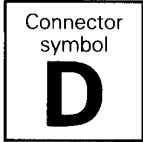

36E0093

- | | | |
|--------------------------------------------------------|--------|-----------------------------------------------------------------------------------------------------------------------|
| D-01 } Instrument panel wiring harness and dash wiring | D-14 | Heated seat switch (Passenger's side) |
| D-02 } harness combination | D-15 | Heated seat switch (Driver's side) |
| D-03 | D-16 | Parking brake switch |
| D-04 | D-17 | Rear blower main switch |
| D-05 | D-18 | Power seat wiring harness and dash wiring harness combination |
| D-06 } Accessory socket | D-19 | Front seat assembly (Driver's side) <Heated seat> or power seat wiring harness and console wiring harness combination |
| D-07 } | D-20 | Front seat assembly <Power seat> |
| D-08 | D-21 } | Cigarette lighter |
| D-09 | D-22 } | — |
| D-10 | D-23 | — |
| D-11 | D-24 | Rear differential lock switch |
| D-12 | | |
| D-13 | | |

R.H. drive vehicles <M/T>

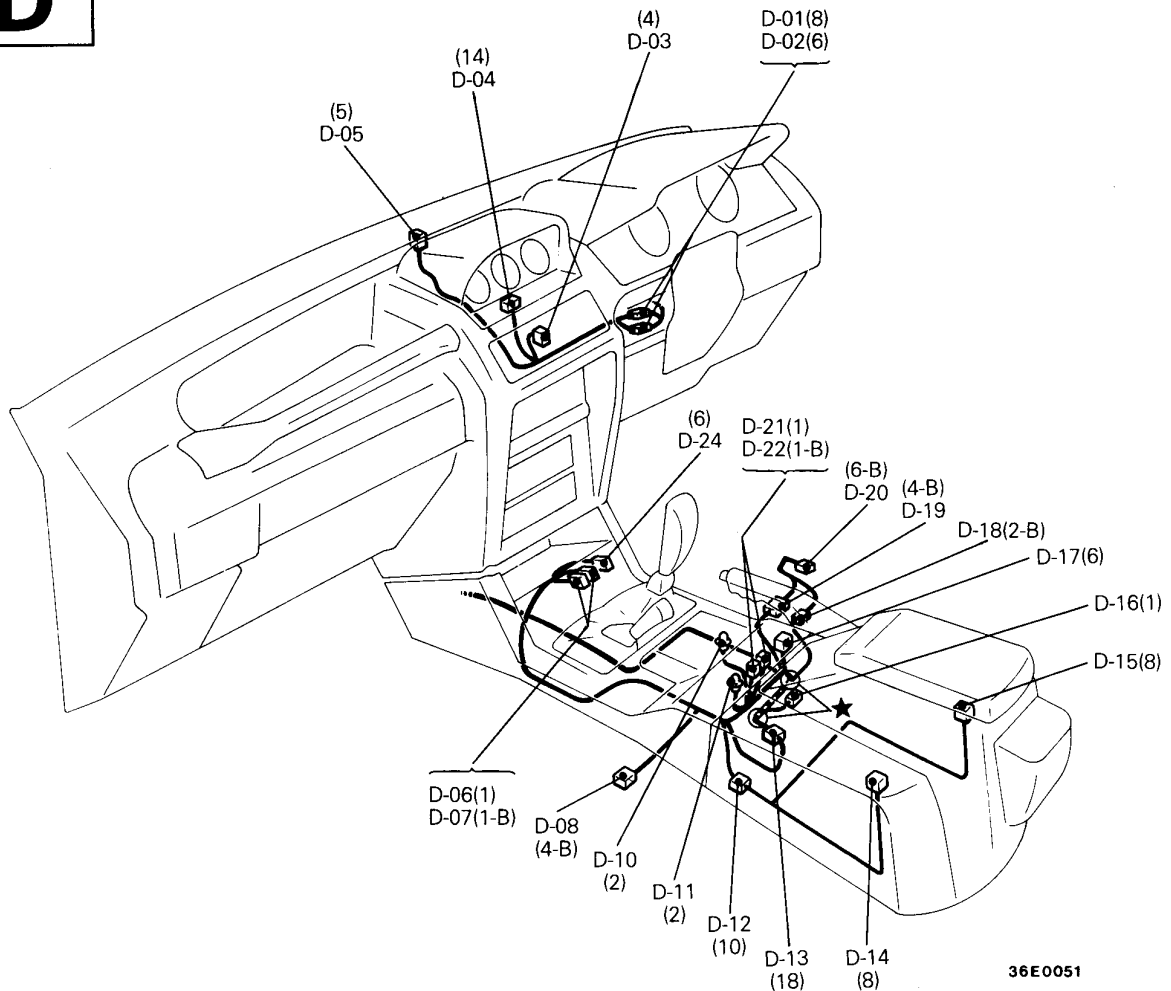
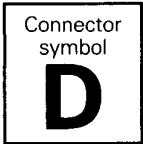

36E0051

- | | | | |
|--------|--------------------------------------------------------------------|--------|-----------------------------------------------------------------------------------------------------------------------|
| D-01 } | Instrument panel wiring harness and dash wiring | D-14 | Heated seat switch (Passenger's side) |
| D-02 } | harness combination | D-15 | Heated seat switch (Driver's side) |
| D-03 | Clock | D-16 | Parking brake switch |
| D-04 | Multi-meter | D-17 | Rear blower main switch |
| D-05 | Geomagnetic sensor | D-18 | Power seat wiring harness and dash wiring harness combination |
| D-06 } | Accessory socket | D-19 | Front seat assembly (Driver's side) <Heated seat> or power seat wiring harness and console wiring harness combination |
| D-07 } | | | |
| D-08 | Front seat assembly (Passenger's side) <Heated seat> | D-20 | Front seat assembly <Power seat> |
| D-09 | — | D-21 } | Cigarette lighter |
| D-10 | Ashtray illumination lamp | D-22 } | |
| D-11 | Cigarette lighter illumination lamp | D-23 | — |
| D-12 | Rear console wiring harness and console wiring harness combination | D-24 | Rear differential lock switch |
| D-13 | Console wiring harness and dash wiring harness combination | | |

L.H. drive vehicles <A/T>

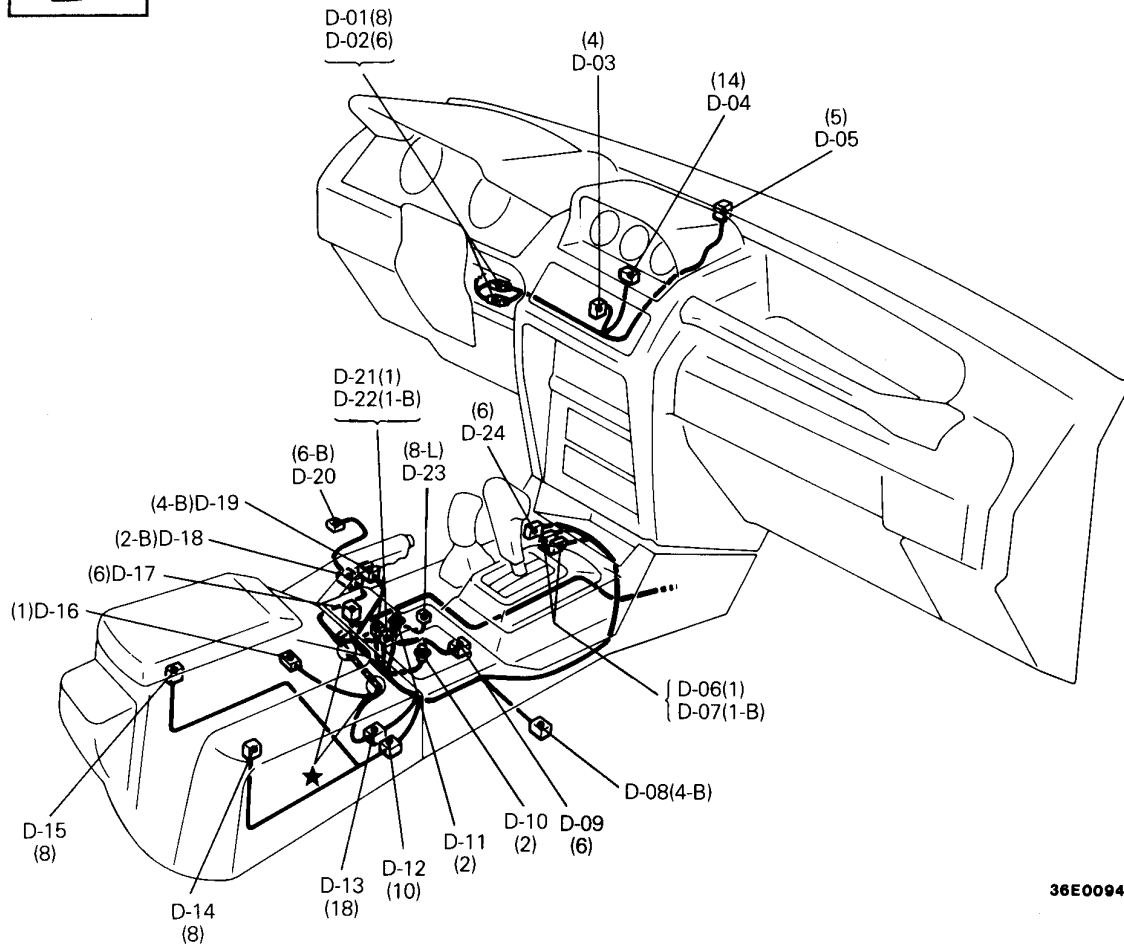
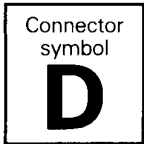

36E0094

- | | | |
|--------------------------------------------------------|--------------------------|-----------------------------------------------------------------------------------------------------------------------|
| D-01 } Instrument panel wiring harness and dash wiring | D-14 | Heated seat switch (Passenger's side) |
| D-02 } harness combination | D-15 | Heated seat switch (Driver's side) |
| D-03 | D-16 | Parking brake switch |
| D-04 | D-17 | Rear blower main switch |
| D-05 | D-18 | Power seat wiring harness and dash wiring harness combination |
| D-06 } Accessory socket | D-19 | Front seat assembly (Driver's side) <Heated seat> or power seat wiring harness and console wiring harness combination |
| D-07 } | D-20 | Front seat assembly <Power seat> |
| D-08 | D-21 } Cigarette lighter | |
| D-09 | D-22 } | |
| D-10 | D-23 | Power/Hold changeover switch <ELC-4A/T> |
| D-11 | D-24 | Rear differential lock switch |
| D-12 | | |
| D-13 | | |

R.H. drive vehicles <A/T>

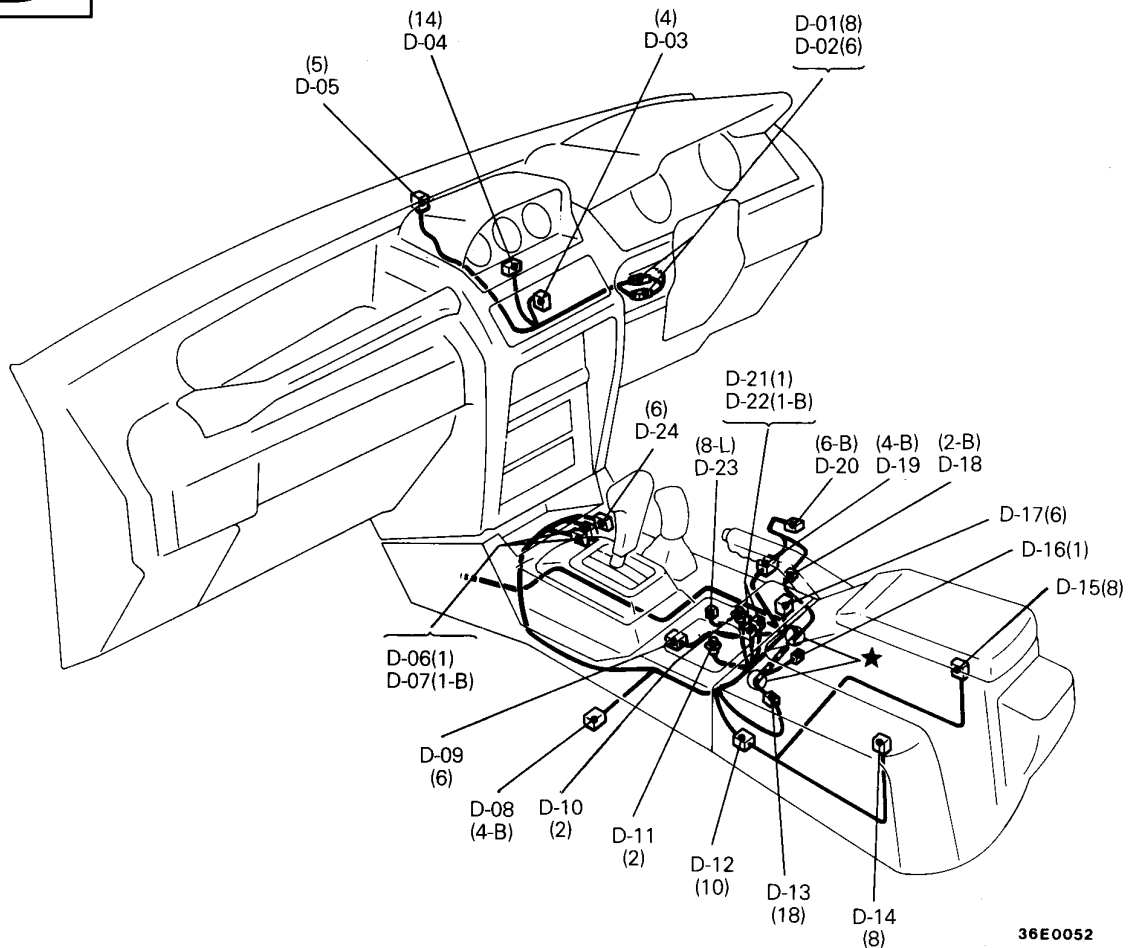
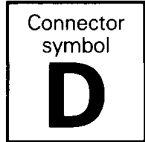

36E0052

- | | | | |
|--------|--------------------------------------------------------------------|--------|-----------------------------------------------------------------------------------------------------------------------|
| D-01 } | Instrument panel wiring harness and dash wiring | D-14 | Heated seat switch (Passenger's side) |
| D-02 } | harness combination | D-15 | Heated seat switch (Driver's side) |
| D-03 | Clock | D-16 | Parking brake switch |
| D-04 | Multi-meter | D-17 | Rear blower main switch |
| D-05 | Geomagnetic sensor | D-18 | Power seat wiring harness and dash wiring harness combination |
| D-06 } | Accessory socket | D-19 | Front seat assembly (Driver's side) <Heated seat> or power seat wiring harness and console wiring harness combination |
| D-07 } | | D-20 | Front seat assembly <Power seat> |
| D-08 | Front seat assembly (Passenger's side) <Heated seat> | D-21 } | Cigarette lighter |
| D-09 | Overdrive switch | D-22 } | |
| D-10 | Ashtray illumination lamp | D-23 | Power/Hold changeover switch <ELC-4A/T> |
| D-11 | Cigarette lighter illumination lamp | D-24 | Rear differential lock switch |
| D-12 | Rear console wiring harness and console wiring harness combination | | |
| D-13 | Console wiring harness and dash wiring harness combination | | |

2-door models <R.H. drive vehicles>

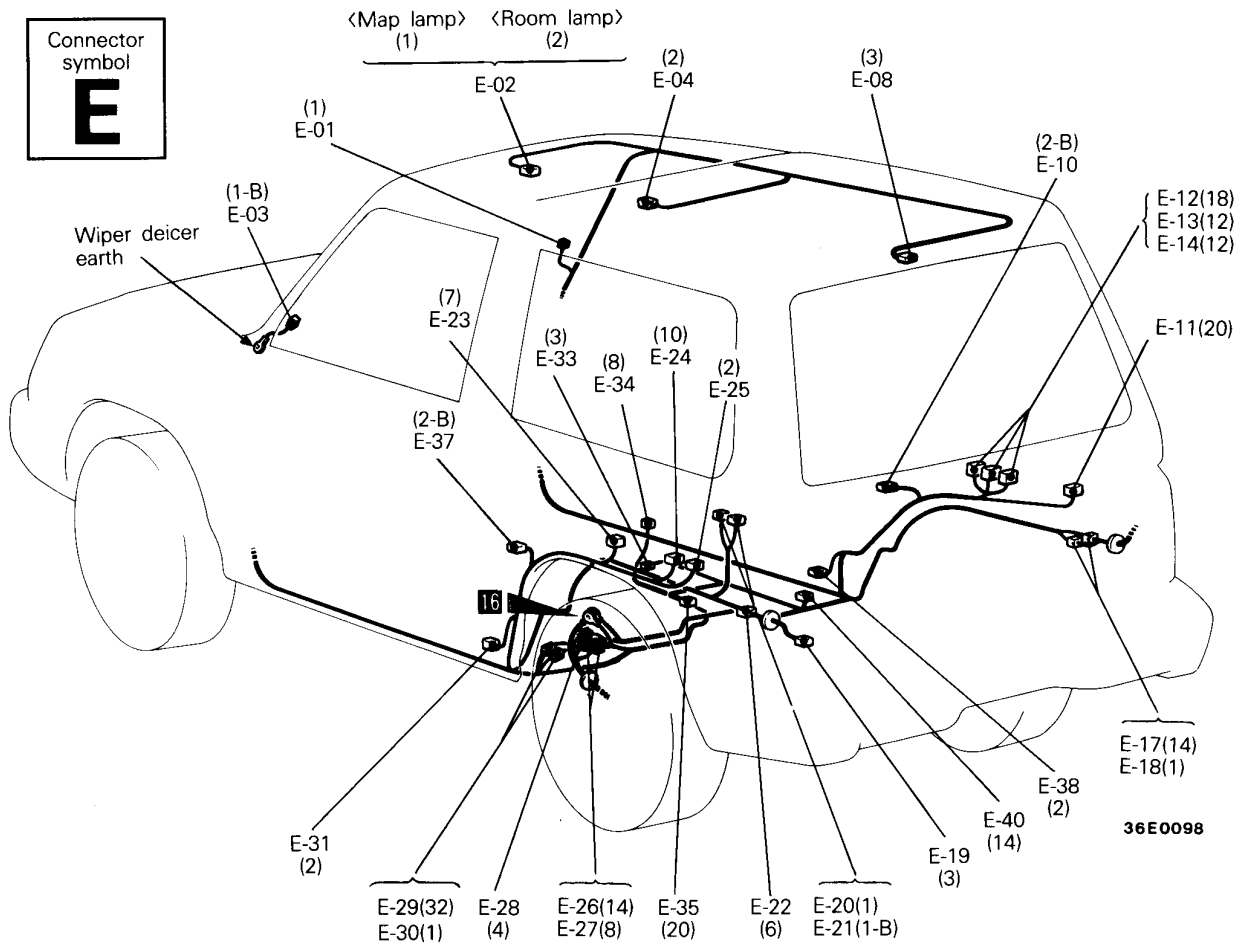

- | | | | |
|------|--------------------------------------------------------------------|------|-------------------------------------------------------------------------|
| E-01 | Wiper deicer (+) | E-22 | Rear combination lamp harness and floor wiring harness (LH) combination |
| E-02 | Map lamp or room | E-23 | Variable shock absorber control unit |
| E-03 | Wiper deicer (-) | E-24 | Rear differential lock control unit |
| E-04 | Room lamp | E-25 | Rear differential lock air pump |
| E-05 | - | E-26 | Frame wiring harness and floor wiring harness (LH) combination |
| E-06 | - | E-27 | |
| E-07 | - | E-28 | Frame wiring harness and floor wiring harness (RH) combination |
| E-08 | Cargo space lamp | E-29 | Floor wiring harness (LH) and floor wiring harness (RH) combination |
| E-09 | - | E-30 | |
| E-10 | Rear speaker (RH) | E-31 | Front door switch (LH) |
| E-11 | No connection | E-32 | - |
| E-12 | ABS control unit | E-33 | G sensor |
| E-13 | | E-34 | Variable shock absorber control switch |
| E-14 | | E-35 | Rear heater control switch or rear A/C control switch <Dual A/C> |
| E-15 | - | E-36 | - |
| E-16 | - | E-37 | Rear speaker (LH) |
| E-17 | Back door wiring harness and floor wiring harness (RH) combination | E-38 | Front door switch (RH) |
| E-18 | | E-39 | - |
| E-19 | Rear combination lamp (LH) | E-40 | Rear heater assembly |
| E-20 | Accessory socket | | |
| E-21 | | | |

2A-52 WIRING HARNESS CONFIGURATION DIAGRAMS — Floor and Roof

4-door models <L.H. drive vehicles>

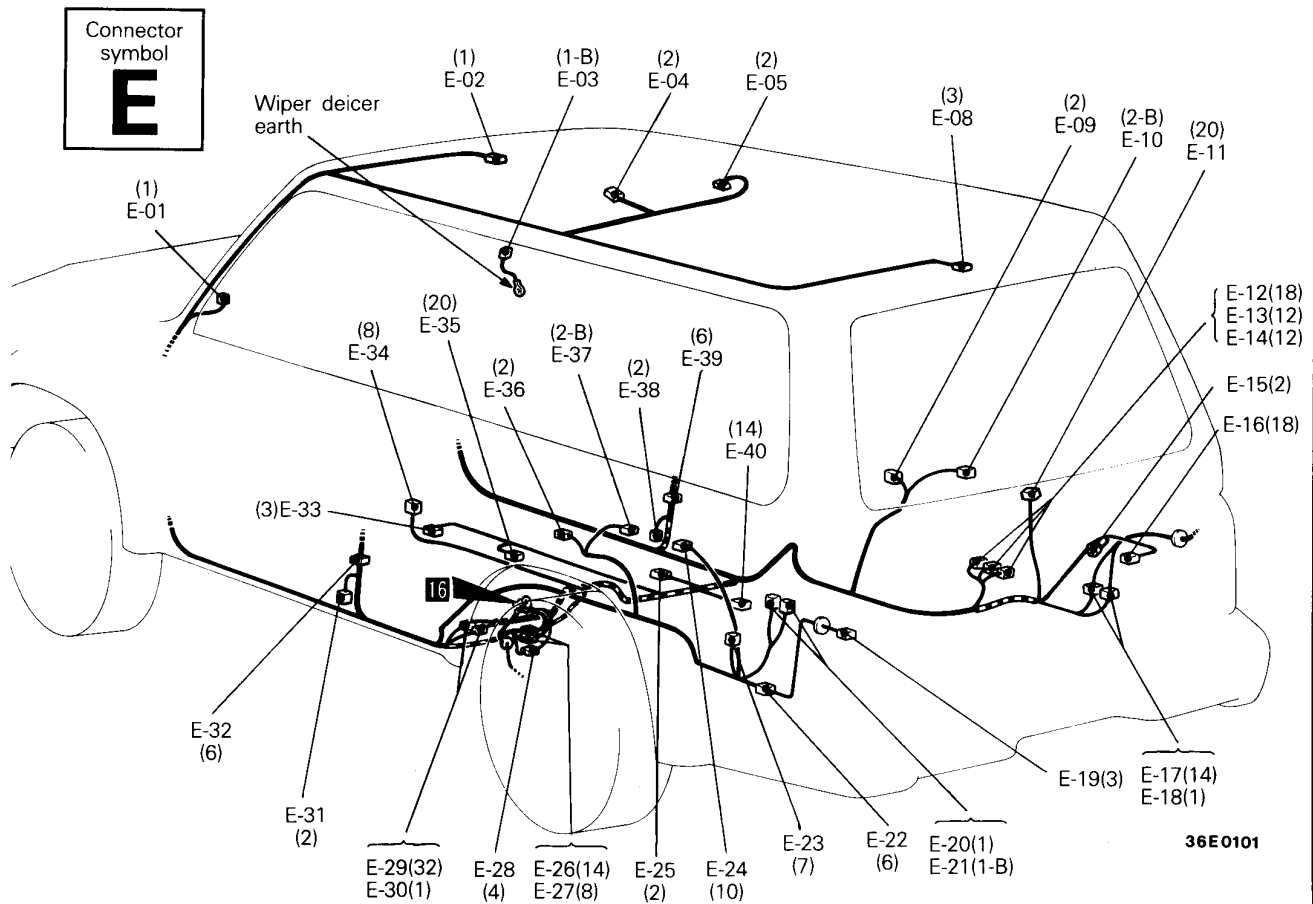

- | | | | |
|--------|-------------------------------------------------------------------------|-------------|-------------------------------------------------------------------------|
| E-01 | Wiper deicer (+) | E-23 | Variable shock absorber control unit |
| E-02 | Map lamp or room lamp | E-24 | Rear differential lock control unit |
| E-03 | Wiper deicer (-) | E-25 | Rear differential lock air pump |
| E-04 | Room lamp | E-26 } | Frame wiring harness and floor wiring harness (LH) |
| E-05 | Sunroof assembly | E-27 } | combination |
| E-06 | — | E-28 | Frame wiring harness and floor wiring harness (RH) |
| E-07 | — | | combination |
| E-08 | Cargo space lamp | E-29 } | Floor wiring harness (LH) and floor wiring harness (RH) |
| E-09 | Rear door switch (RH) | E-30 } | combination |
| E-10 | Rear speaker (RH) | E-31 | Front door switch (LH) |
| E-11 | No connection | E-32 | Rear door wiring harness (LH) and floor wiring harness (LH) combination |
| E-12 } | ABS control unit | E-33 | G sensor |
| E-13 } | | | |
| E-14 } | | | |
| E-15 | No connection | E-34 | Variable shock absorber control switch |
| E-16 | Rear A/C control unit | E-35 | Rear heater control switch or rear A/C control switch <Dual A/C> |
| E-17 } | Back door wiring harness and floor wiring harness (RH) | E-36 | Rear door switch (LH) |
| E-18 } | | combination | E-37 |
| E-19 | Rear combination lamp (LH) | E-38 | Front door switch (RH) |
| E-20 } | Accessory socket | E-39 | Rear door wiring harness (RH) and floor wiring harness (RH) combination |
| E-21 } | | | E-40 |
| E-22 | Rear combination lamp harness and floor wiring harness (LH) combination | | |

4-door models <R.H. drive vehicles>

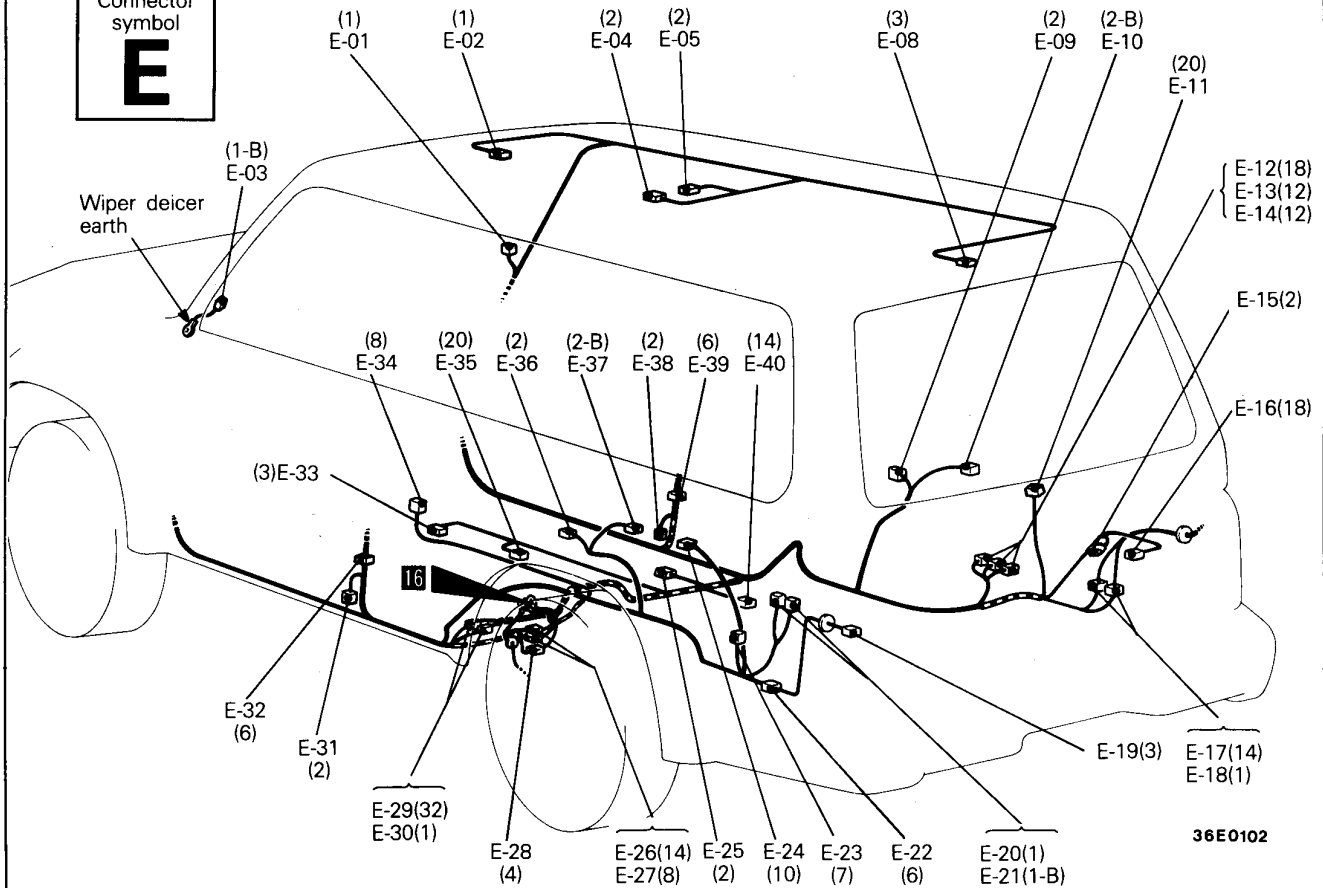
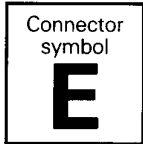

36E0102

- | | | | |
|--------|-------------------------------------------------------------------------|-------------|-------------------------------------------------------------------------|
| E-01 | Wiper deicer (+) | E-23 | Variable shock absorber control unit |
| E-02 | Map lamp or room lamp | E-24 | Rear differential lock control unit |
| E-03 | Wiper deicer (-) | E-25 | Rear differential lock air pump |
| E-04 | Room lamp | E-26 } | Frame wiring harness and floor wiring harness (LH) |
| E-05 | Sunroof assembly | E-27 } | combination |
| E-06 | — | E-28 | Frame wiring harness and floor wiring harness (RH) |
| E-07 | — | | combination |
| E-08 | Cargo space lamp | E-29 } | Floor wiring harness (LH) and floor wiring harness (RH) |
| E-09 | Rear door switch (RH) | E-30 } | combination |
| E-10 | Rear speaker (RH) | E-31 | Front door switch (LH) |
| E-11 | No connection | E-32 | Rear door wiring harness (LH) and floor wiring harness (LH) combination |
| E-12 } | ABS control unit | E-33 | G sensor |
| E-13 } | | | |
| E-14 } | | | |
| E-15 | No connection | E-34 | Variable shock absorber control switch |
| E-16 | Rear A/C control unit | E-35 | Rear heater control switch or rear A/C control switch <Dual A/C> |
| E-17 } | Back door wiring harness and floor wiring harness (RH) | E-36 | Rear door switch (LH) |
| E-18 } | | combination | E-37 |
| E-19 | Rear combination lamp (LH) | E-38 | Front door switch (RH) |
| E-20 } | Accessory socket | E-39 | Rear door wiring harness (RH) and floor wiring harness (RH) combination |
| E-21 } | | | |
| E-22 | Rear combination lamp harness and floor wiring harness (LH) combination | E-40 | Rear heater assembly |

DOOR

2-door models <L.H. drive vehicles>

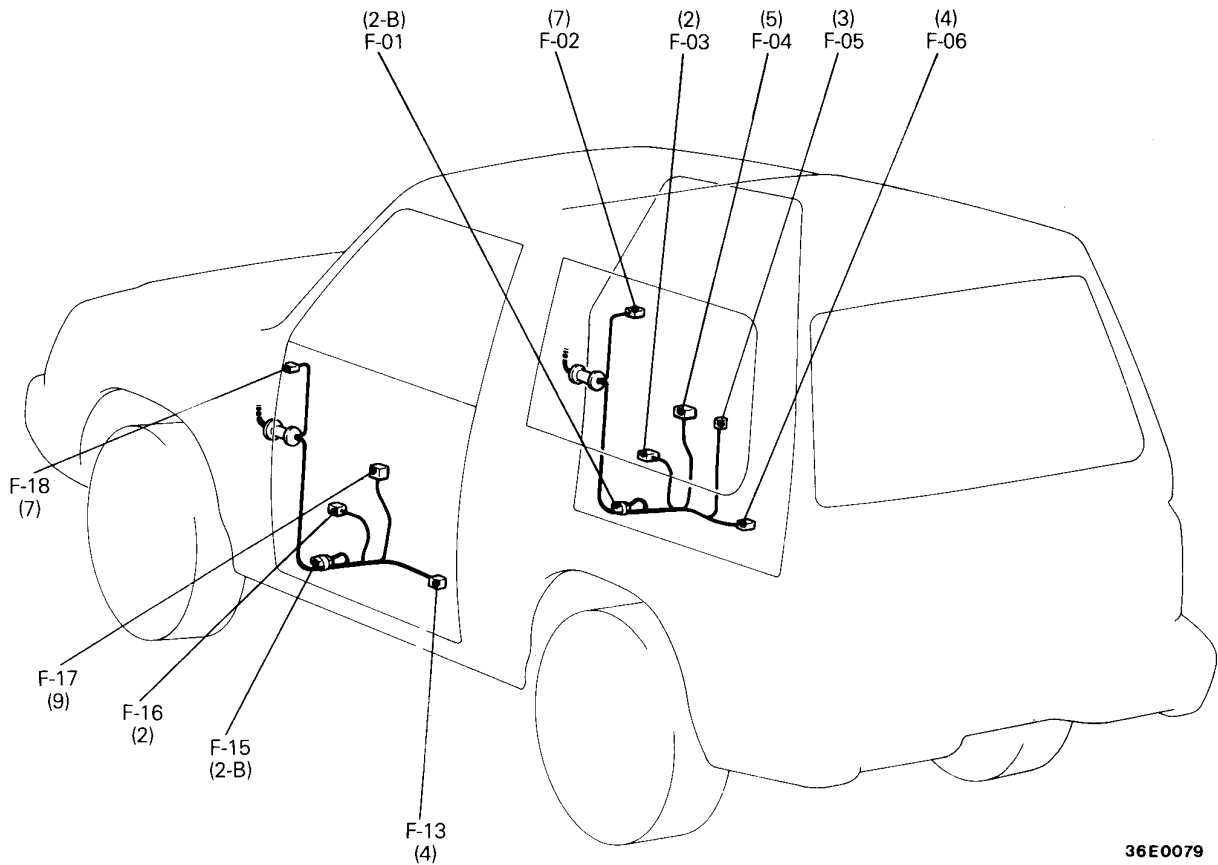
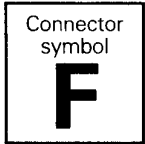

36E0079

- | | | | |
|------|---------------------------------------------------------------|------|------------------------------------------|
| F-01 | No connection | F-07 | } — |
| F-02 | Remote controlled mirror (RH) | thru | |
| F-03 | Power window motor (Front: RH) | F-12 | |
| F-04 | Power window sub switch (Passenger's side) | F-13 | Door lock actuator (Front: LH) |
| F-05 | Door key cylinder switch <Vehicles with central door locking> | F-14 | — |
| F-06 | Door lock actuator (Front: RH) | F-15 | No connection |
| | | F-16 | Power window motor (Front: LH) |
| | | F-17 | Power window main switch (Driver's side) |
| | | F-18 | Remote controlled mirror (LH) |

2-door models <R.H. drive vehicles>

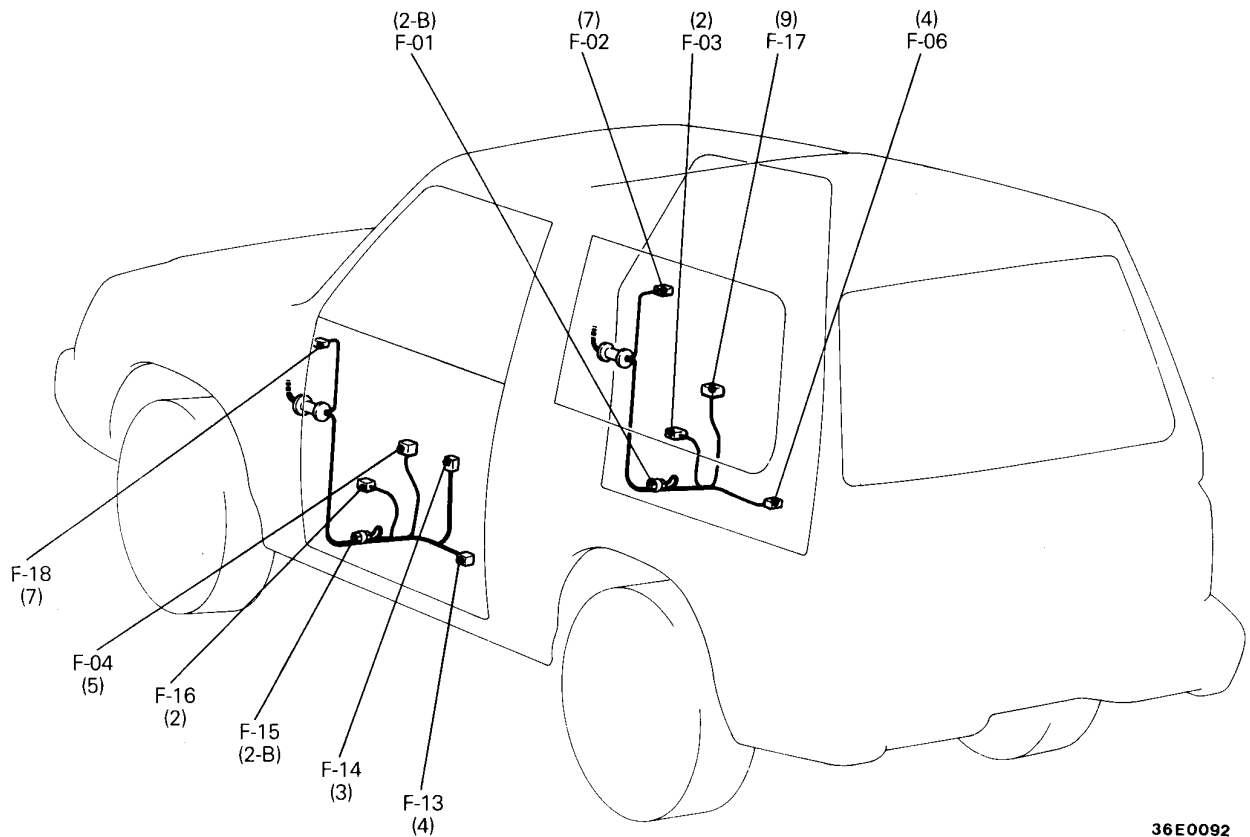
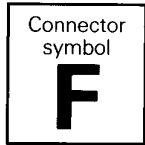

36E0092

- | | | | |
|----------|--------------------------------------------|------|------------------------------------------|
| F-01 | No connection | F-13 | Door lock actuator (Front: LH) |
| F-02 | Remote controlled mirror (RH) | F-14 | Door key cylinder switch |
| F-03 | Power window motor (Front: RH) | | <Vehicles with central door locking> |
| F-04 | Power window sub switch (Passenger's side) | F-15 | No connection |
| F-05 | — | F-16 | Power window motor (Front: LH) |
| F-06 | Door lock actuator (Front: RH) | F-17 | Power window main switch (Driver's side) |
| F-07 } — | | F-18 | Remote controlled mirror (LH) |
| thru } | | | |
| F-12 } | | | |

4-door models <L.H. drive vehicles>

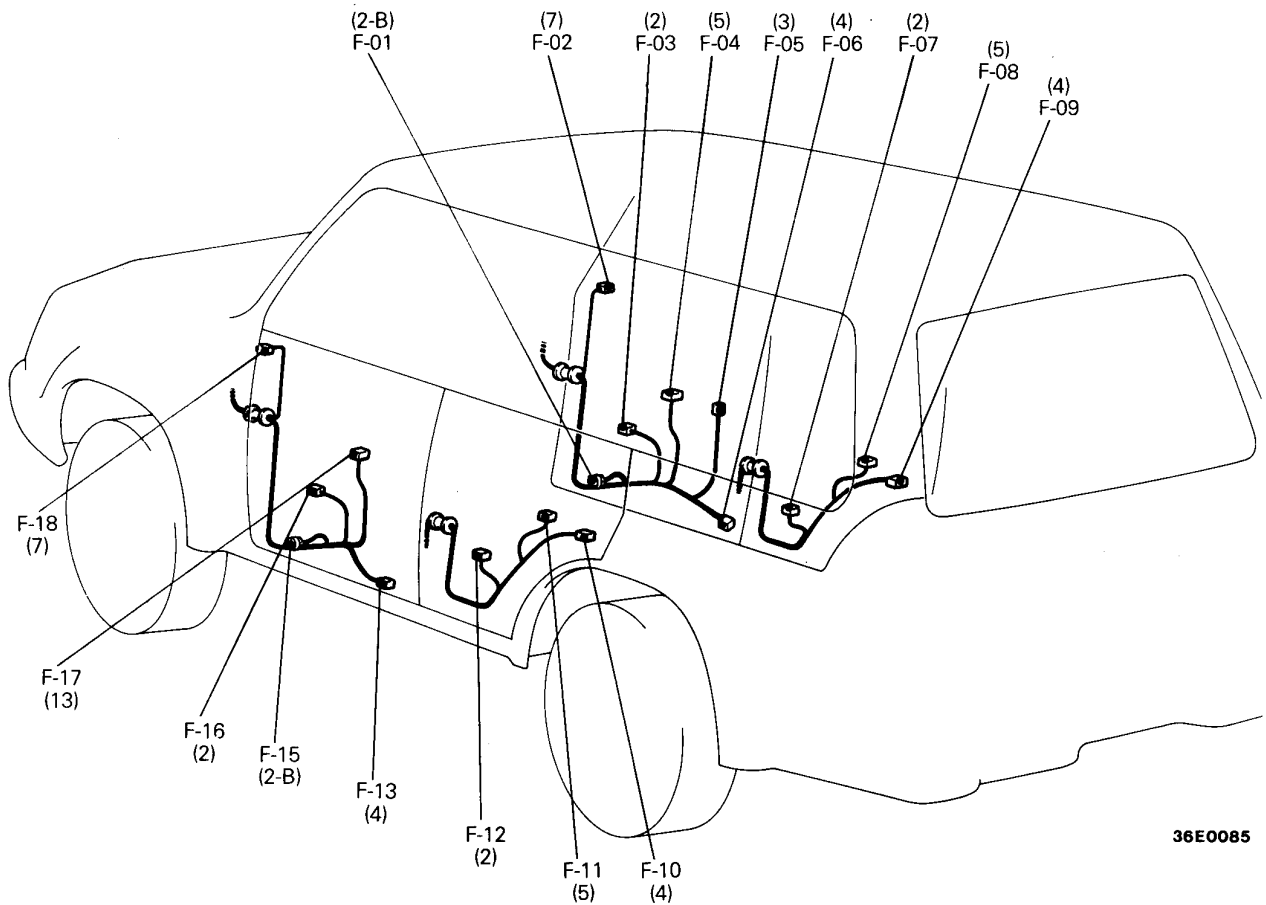
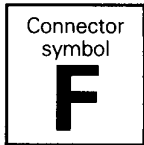

36E0085

- | | | | |
|------|--------------------------------------------|------|------------------------------------------|
| F-01 | No connection | F-10 | Door lock actuator (Rear: LH) |
| F-02 | Remote controlled mirror (RH) | F-11 | Power window sub switch (Rear: LH) |
| F-03 | Power window motor (Front: RH) | F-12 | Power window motor (Rear: LH) |
| F-04 | Power window sub switch (Passenger's side) | F-13 | Door lock actuator (Front: LH) |
| F-05 | Door key cylinder switch | F-14 | Door key cylinder switch |
| F-06 | Door lock actuator (Front: RH) | | <Vehicles with central door locking> |
| F-07 | Power window motor (Rear: RH) | F-15 | No connection |
| F-08 | Power window sub switch (Rear: RH) | F-16 | Power window motor (Front: LH) |
| F-09 | Door lock actuator (Rear: RH) | F-17 | Power window main switch (Driver's side) |
| | | F-18 | Remote controlled mirror (LH) |

4-door models <R.H. drive vehicles>

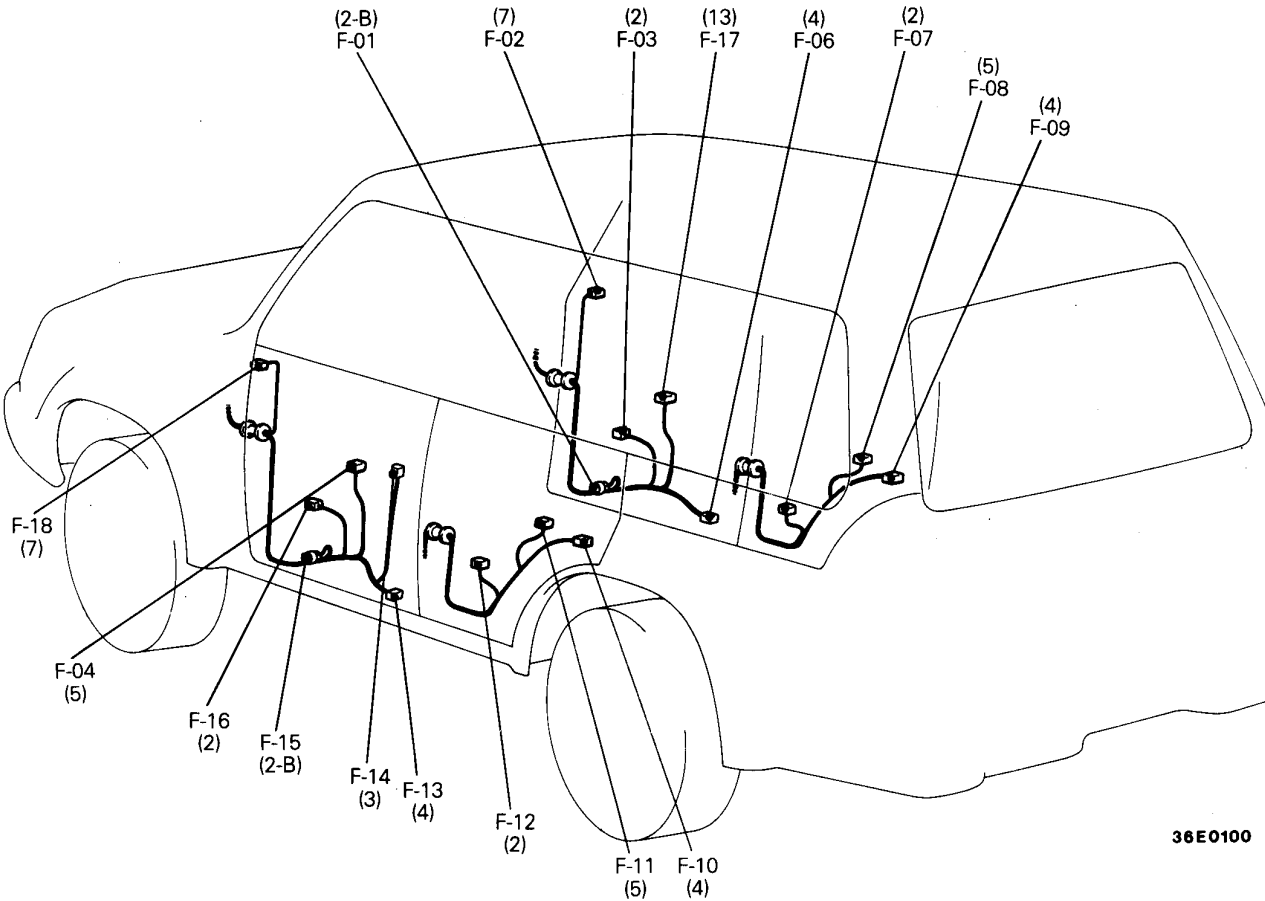
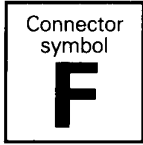

36E0100

- | | | | |
|------|--------------------------------------------|------|------------------------------------------------------------------|
| F-01 | No connection | F-10 | Door lock actuator (Rear: LH) |
| F-02 | Remote controlled mirror (RH) | F-11 | Power window sub switch (Rear: LH) |
| F-03 | Power window motor (Front: RH) | F-12 | Power window motor (Rear: LH) |
| F-04 | Power window sub switch (Passenger's side) | F-13 | Door lock actuator (Front: LH) |
| F-05 | — | F-14 | Door key cylinder switch
<Vehicles with central door locking> |
| F-06 | Door lock actuator (Front: RH) | F-15 | No connection |
| F-07 | Power window motor (Rear: RH) | F-16 | Power window motor (Front: LH) |
| F-08 | Power window sub switch (Rear: RH) | F-17 | Power window main switch (Driver's side) |
| F-09 | Door lock actuator (Rear: RH) | F-18 | Remote controlled mirror (LH) |

BACK DOOR AND REAR UNDER FLOOR

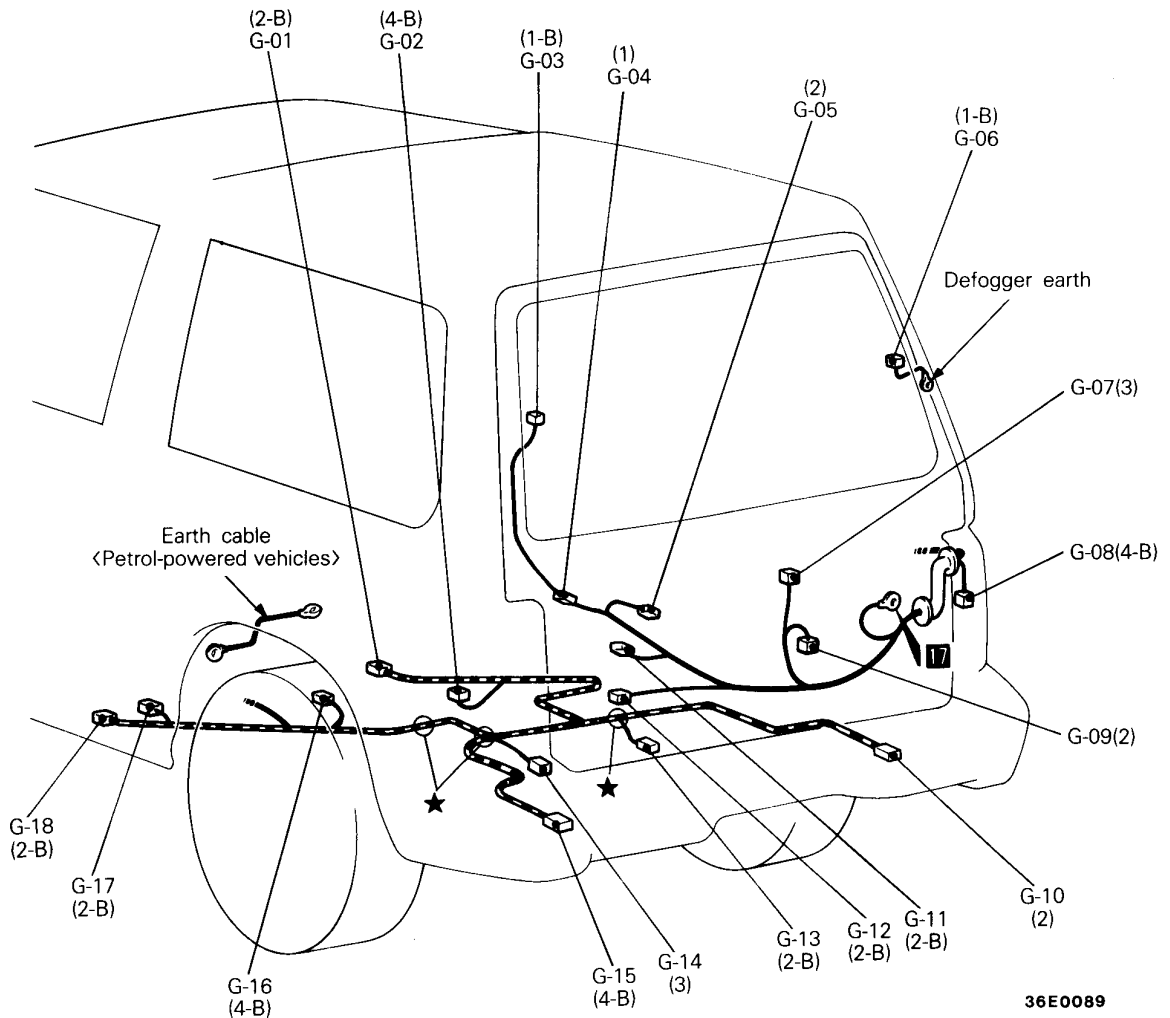
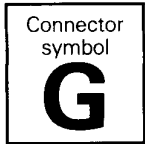

36E0089

- | | | | |
|------|-----------------------------------------------------------------------|------|-----------------------------------------------------------------------|
| G-01 | Speed sensor (Rear: RH) <ABS> | G-10 | Rear combination lamp (In bumper: RH) |
| G-02 | Shock absorber (Rear: RH) <Remote controlled variable shock absorber> | G-11 | Licence plate lamp |
| G-03 | Defogger (+) | G-12 | Door lock actuator (Back door) |
| G-04 | Defogger cable and back door wiring harness combination | G-13 | Fuel pump <MPI> |
| G-05 | Back door switch | G-14 | Fuel gauge unit |
| G-06 | Defogger (-) | G-15 | Rear combination lamp (In bumper: LH) |
| G-07 | Rear wiper motor | G-16 | Shock absorber (Rear: LH) <Remote controlled variable shock absorber> |
| G-08 | Rear combination lamp (RH) | G-17 | Speed sensor (Rear: LH) <ABS> |
| G-09 | Rear washer motor | G-18 | Rear differential lock detection switch |

3A SINGLE PART INSTALLATION POSITION

RELAY	3A-2
CONTROL UNIT	3A-5
SENSOR	3A-8
SOLENOID VALVE	3A-14
DIODE	3A-17
INSPECTION TERMINAL	3A-18
FUSIBLE LINK AND FUSE	3A-19
EARTH CABLE	3A-20
EARTH	3A-21

RELAY

Name	Symbol	Name	Symbol
ABS motor relay	A	Headlamp relay	C
ABS valve relay	A	Headlamp washer relay	LHD L
A/C compressor capacity control relay	B		RHD M
A/C compressor relay	C	Horn relay<Vehicles with SRS>	D
Accessory socket relay	J	Intercooler fan motor relay	C
Alternator relay	C	Intermittent wiper relay (rear wiper)	K
Blower relay	J	Intermittent wiper relay (windshield wiper)	E
Condensor fan motor control relay <Diesel-powered vehicles>	B	Overdrive control relay	LHD I
			RHD H
Condenser fan motor relay	C	Power seat relay box	N
Daytime running lamp relay 1	D	Power window relay	K
Daytime running lamp relay 2	D	Rear fog lamp relay	C
Dim-dip lamp relay 1	M	Rear heater relay	K
Dim-dip lamp relay 2	M	Starter relay	B
Dim-dip lamp relay 3	M	Tail lamp relay	C
Defogger relay	K	Turn and hazard flasher unit	K
Engine control relay	G	Wiper deicer relay	LHD L
Engine oil level relay	G		RHD M
Glow plug relay	B	4WD indicator relay <Part time 4WD>	F

NOTE
Names are listed in alphabetical order.

Engine compartment

<Petrol-powered vehicles>

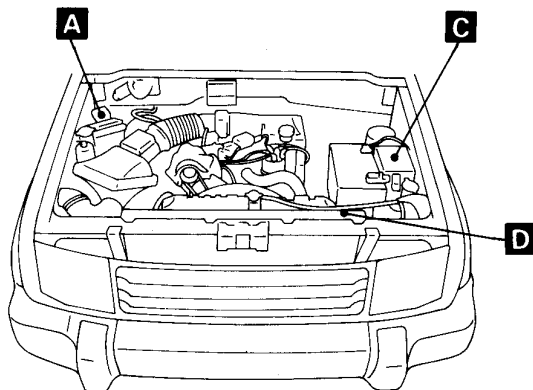

16E0128

<Diesel-powered vehicles>

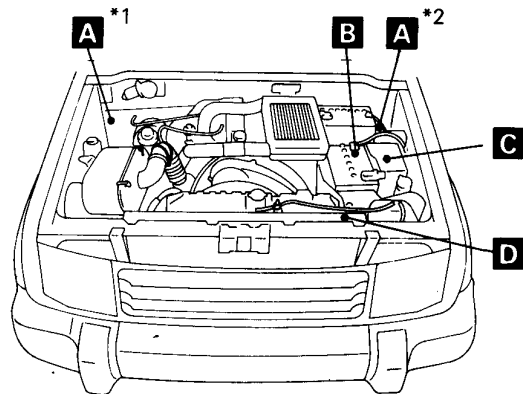

16E0129

Remarks

- *1: R.H. drive vehicles
- *2: L.H. drive vehicles

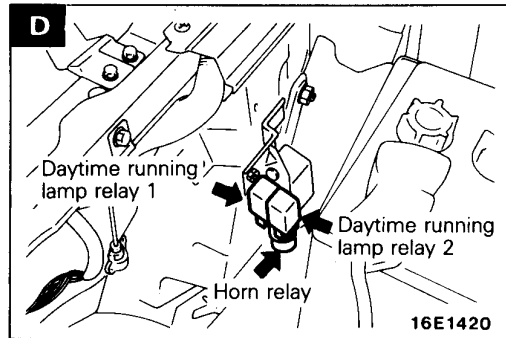
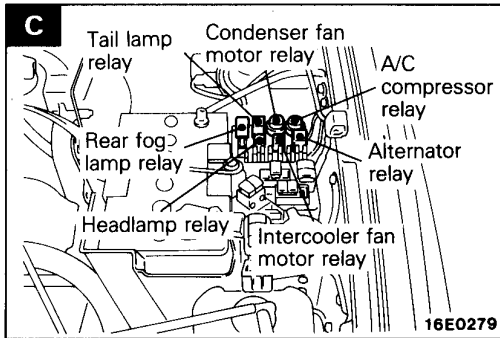
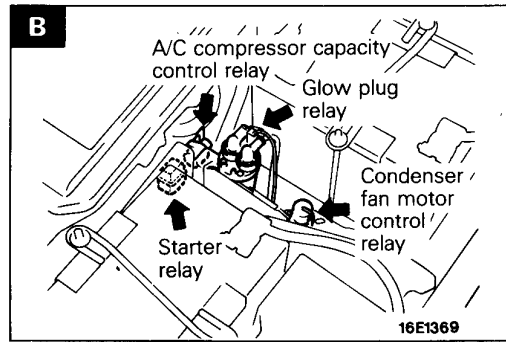
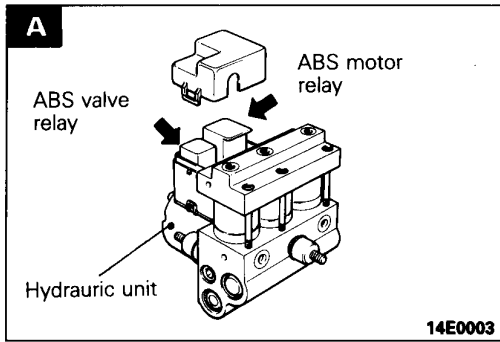

Interior

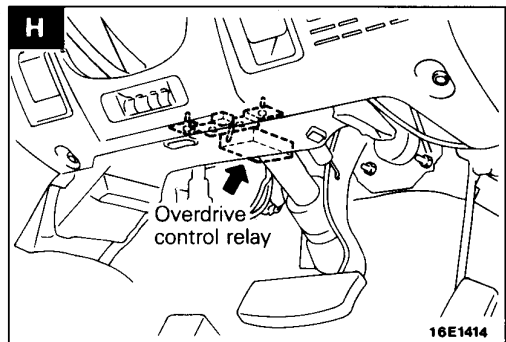
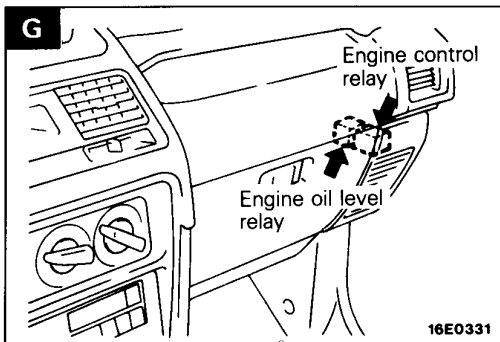
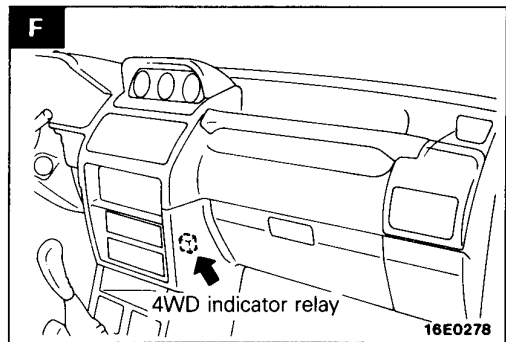
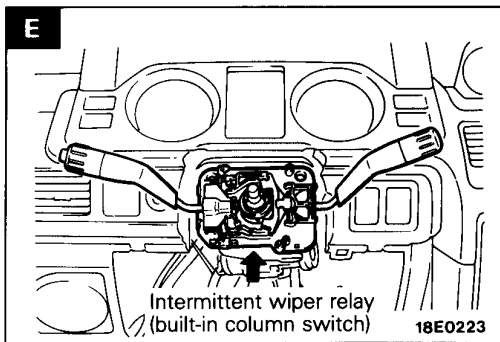
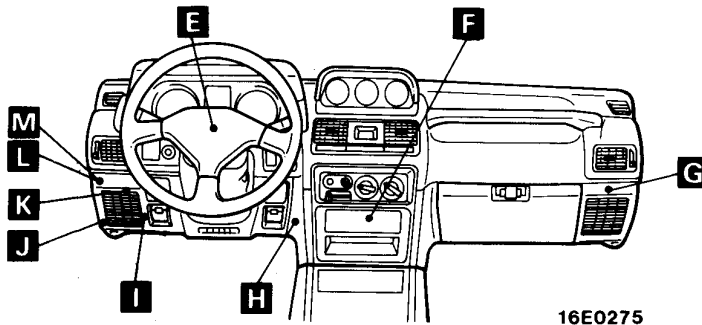

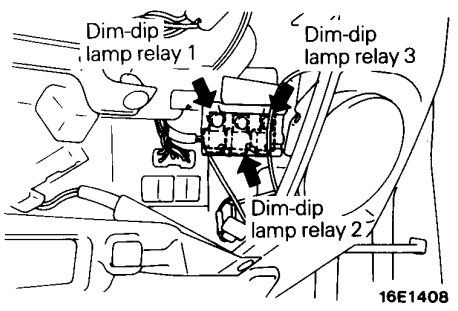
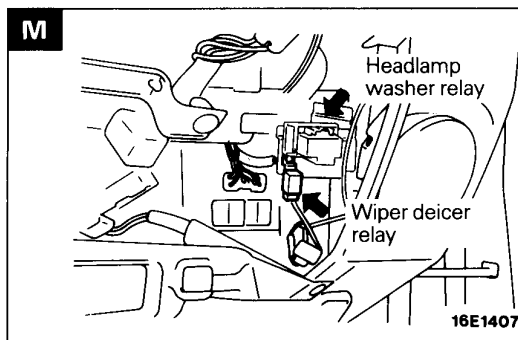
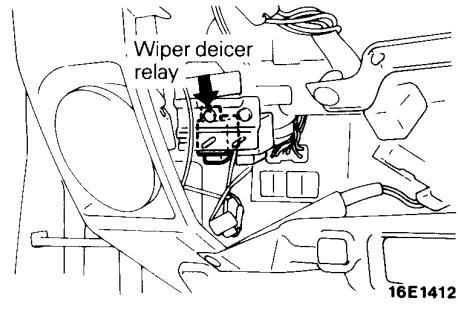
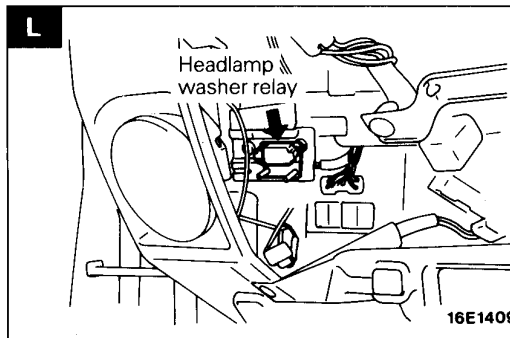
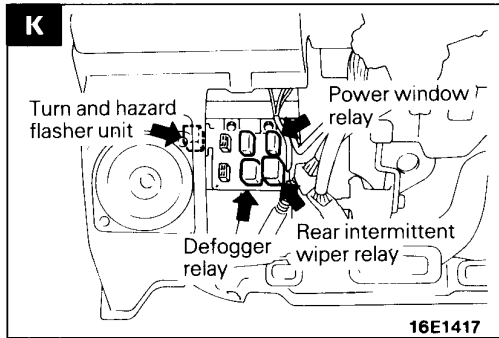
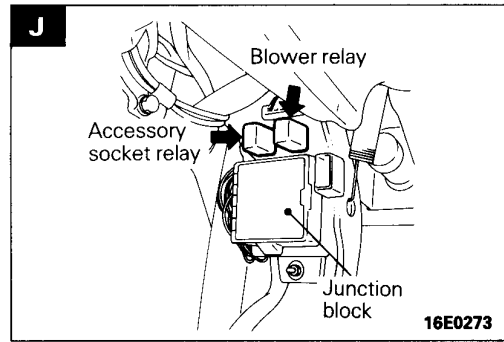
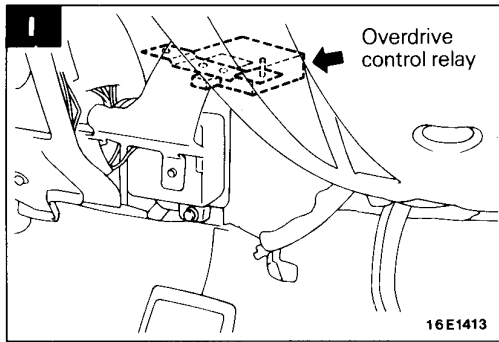

Floor

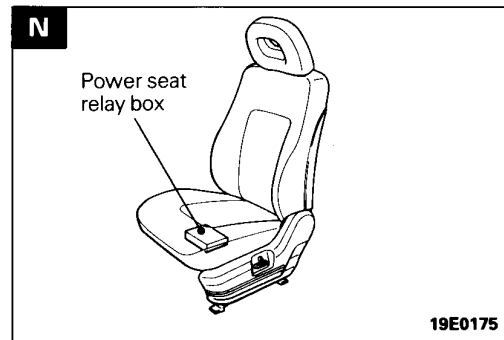
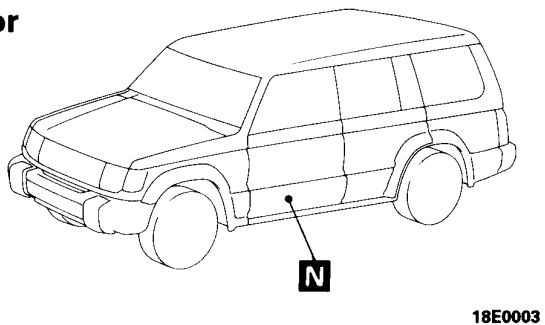

CONTROL UNIT

Name		Symbol	Name	Symbol
ABS control unit		M	Ignition key cylinder illumination lamp timer	G
A/C control unit (front)		D	Intercooler fan control unit <Vehicles with fuel line heater>	F
A/C control unit (rear)		N		
Auto-cruise control unit	LHD	C	Intercooler fan control unit <Vehicles without fuel line heater>	E
	RHD	B		
Daytime running lamp control unit		A	Motor antenna control unit	G
Door lock control unit	LHD	J	Rear differential lock control unit	O
	RHD	K	SRS diagnosis unit	G
ELC-4A/T control unit	LHD	I	Sunroof control unit	L
	RHD	H	Variable shock absorber control unit	O
Engine control unit	F	Wiper deicer timer		
Fuel line heater control unit	E			RHD
Glow control unit	F	4WD indicator control unit		G

NOTE
Names are listed in alphabetical order.

Engine compartment

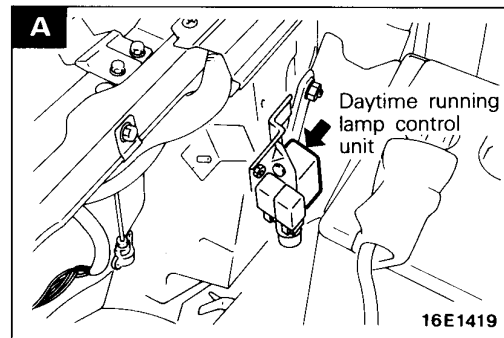
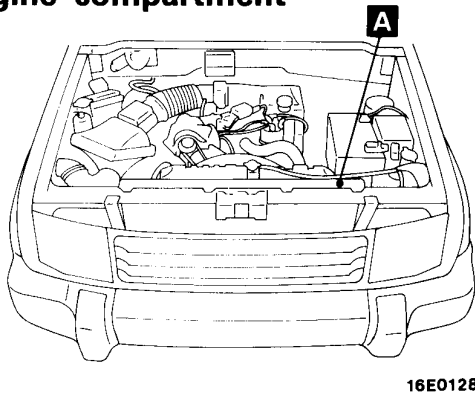

Interior

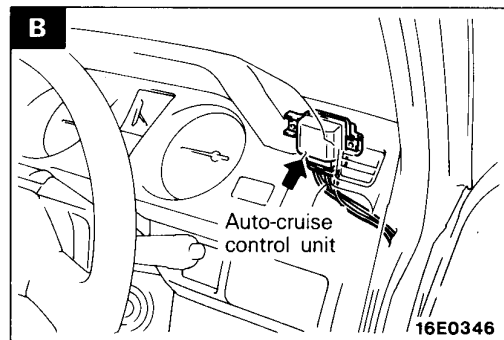
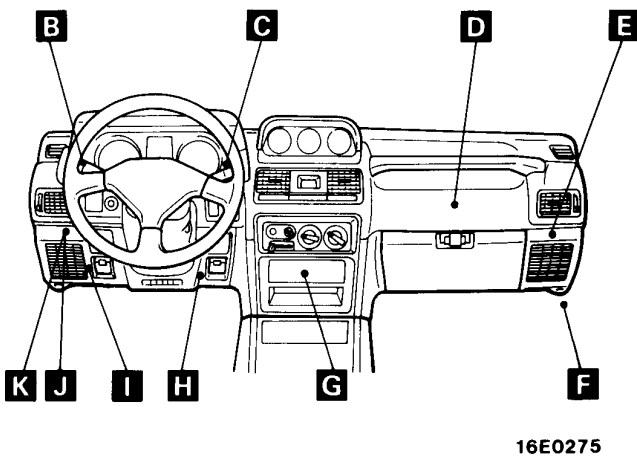

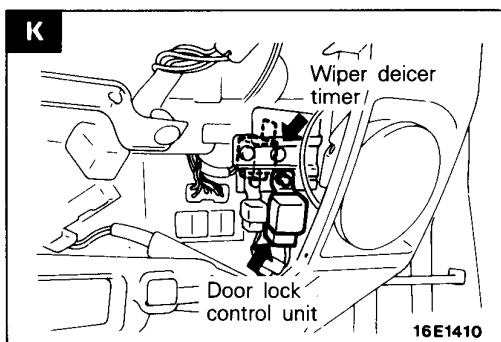
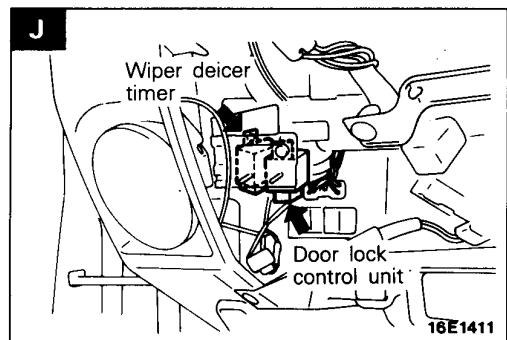
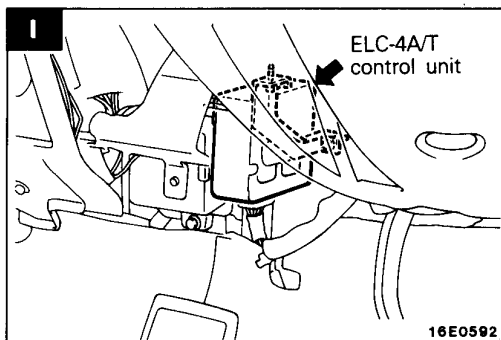
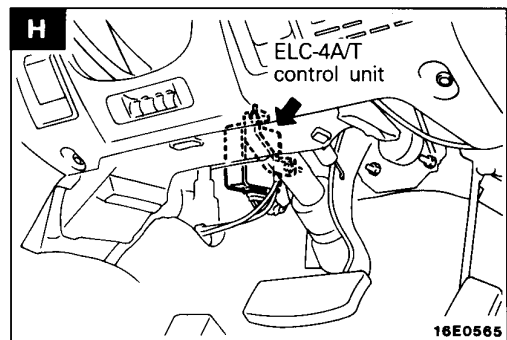
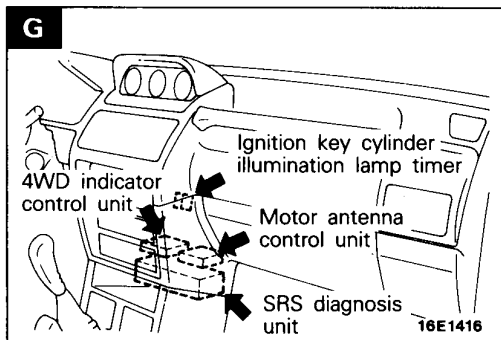
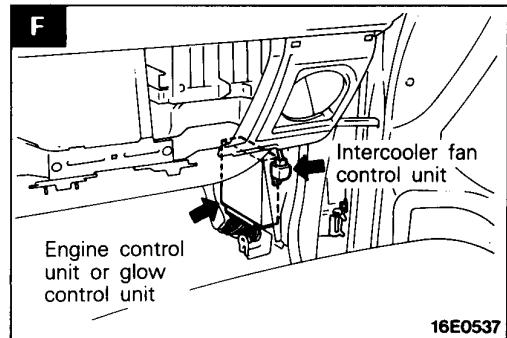
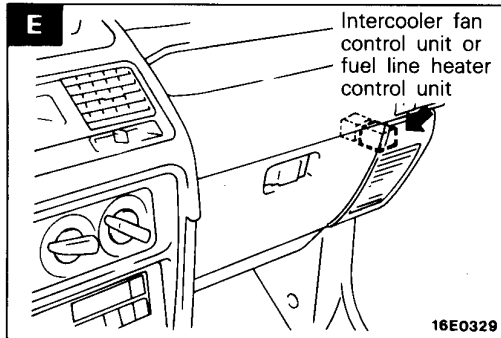
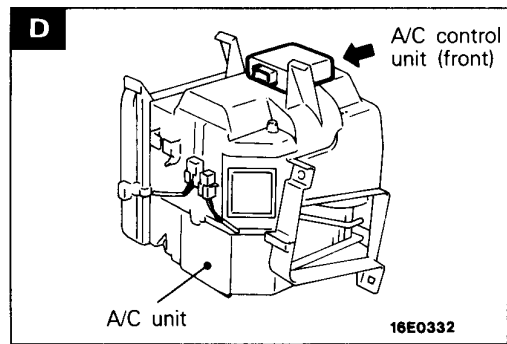
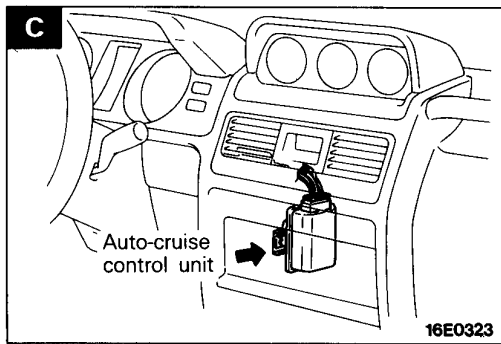

Roof, Luggage compartment, Floor

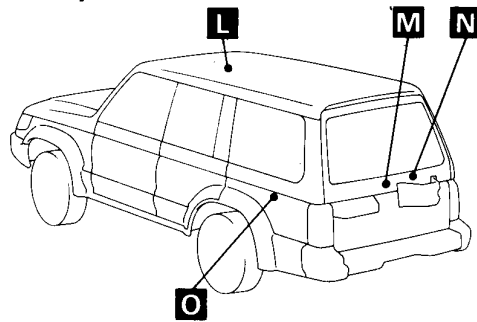

18E0004

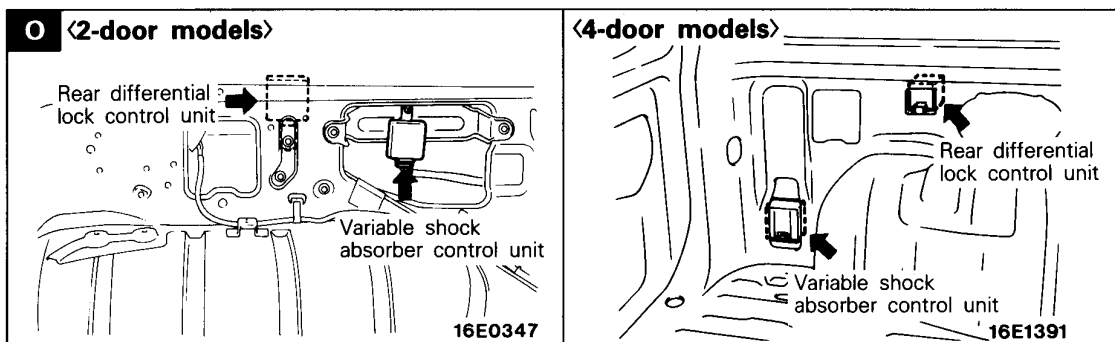
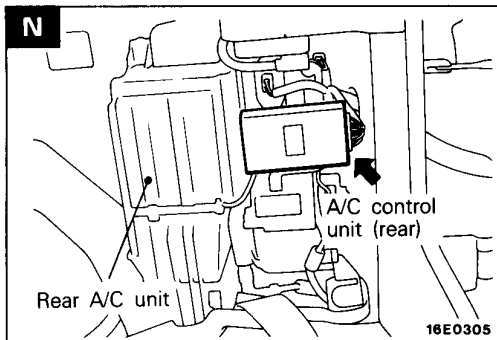
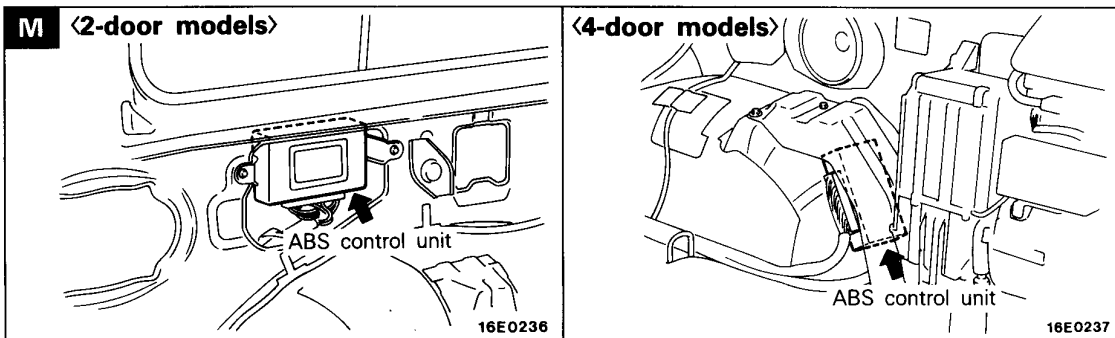
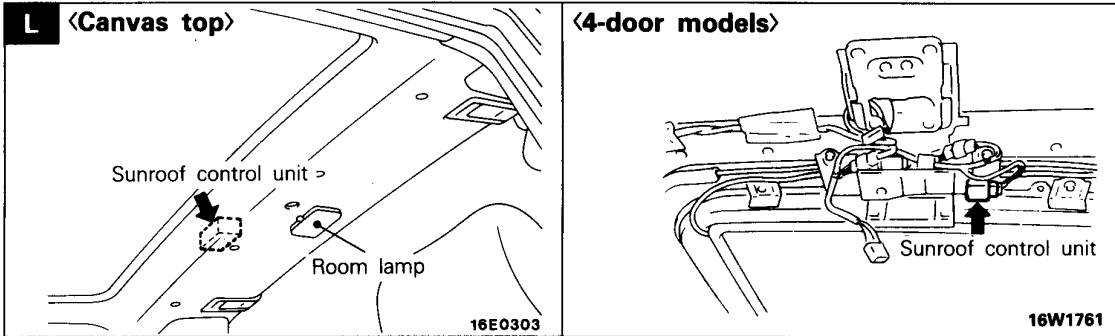

SENSOR

Name	Symbol	Name	Symbol	
Air-flow sensor (with built-in atmospheric sensor, intake air temperature sensor)	B	Front impact sensor	L	
Air inlet sensor	O	Fuel thermo sensor	I	
Air thermo sensor (front)	O	G sensor	Q	
Air thermo sensor (rear)	R	Geomagnetic sensor	N	
A/T fluid temperature switch	T	Idle speed control actuator <4G64 engine>	C	
Cam position sensor <6G74 engine>	G	Lever position sensor	J	
Crank angle sensor <6G74 engine>	G	Oxygen sensor	4G64 engine	A
Crank angle sensor and top dead center sensor <4G64, 6G72 engine>	E		6G72, 6G74 engine	W
Detonation sensor <6G74 engine>	F	Reed switch	M	
Engine coolant temperature gauge unit <Diesel-powered vehicles>	H	Rotation sensor	J	
Engine coolant temperature sensor (for A/C) <Petrol-powered vehicles>	D	Speed sensor (front)	S	
		Speed sensor (rear)	U	
Engine coolant temperature sensor (for engine control)	D	Thermo sensor (inside air)	P	
		Thermo sensor (outside air)	K	
		Throttle position sensor	C	
		Vehicle speed sensor	V	

NOTE
Names are listed in alphabetical order.

Engine compartment

<4G64, 6G72 engine>

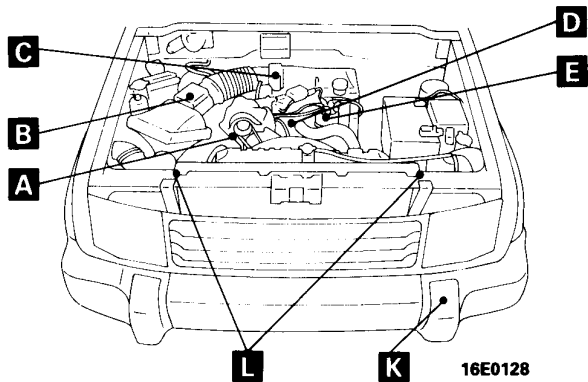

<6G74 engine>

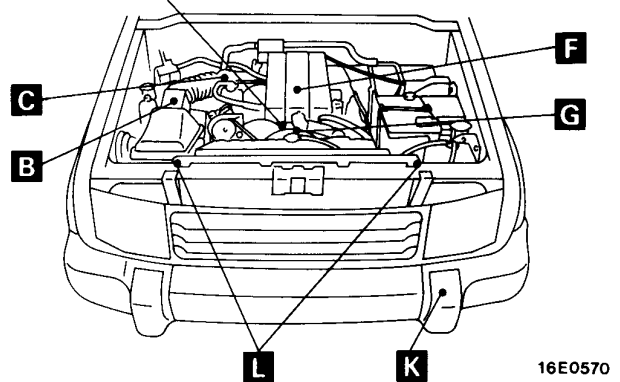

<Diesel-powered vehicles>

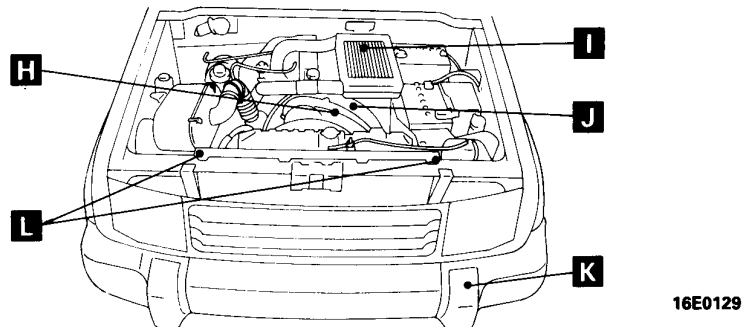

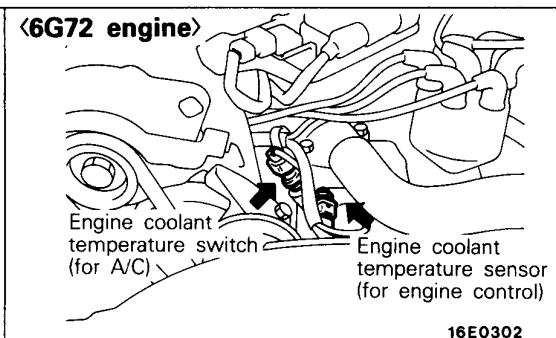
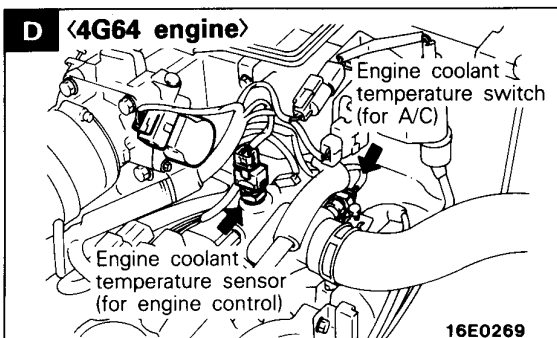
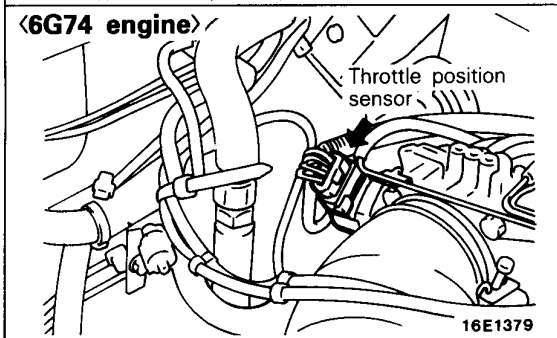
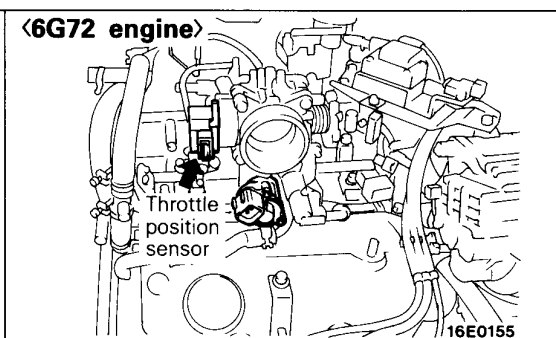
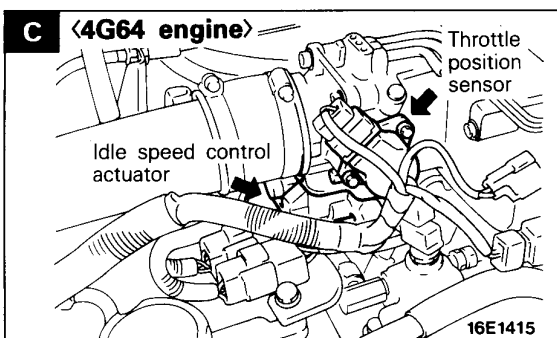
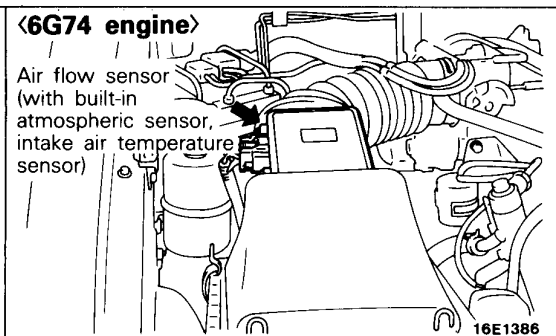
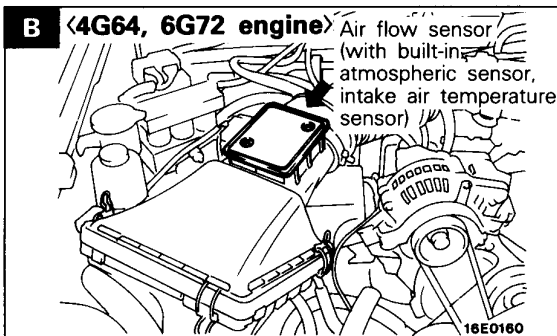
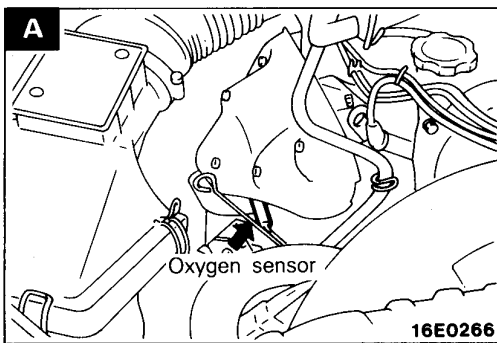

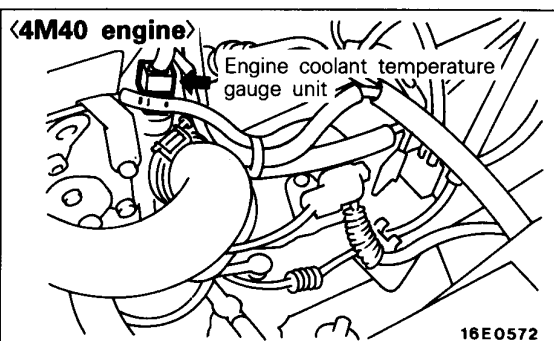
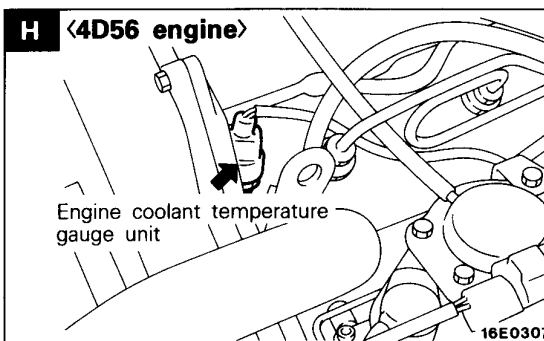
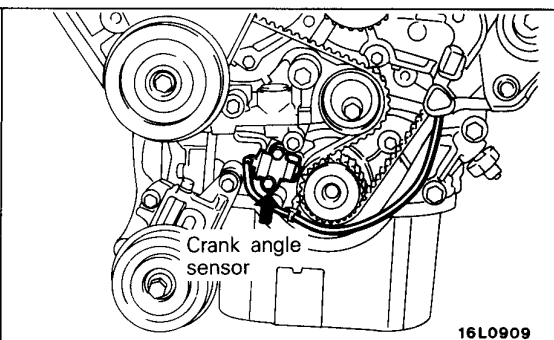
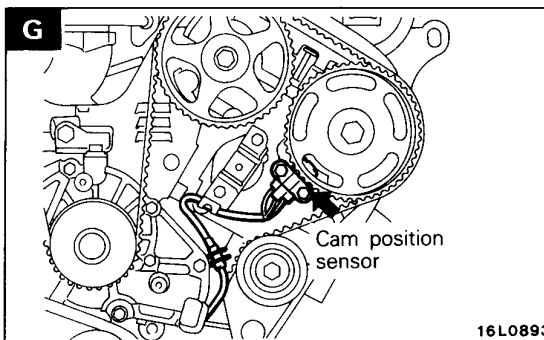
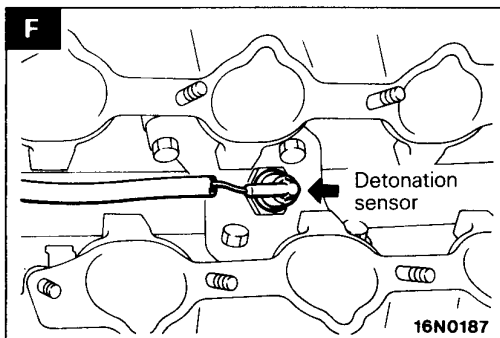
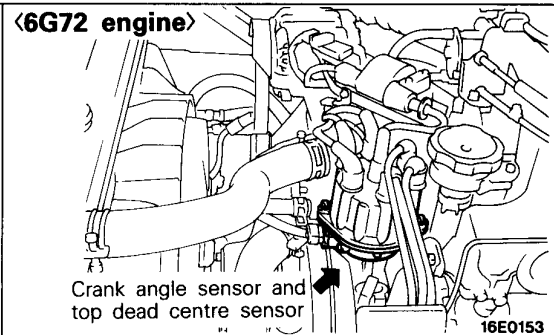
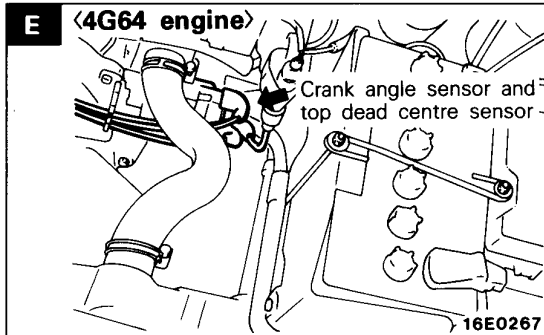
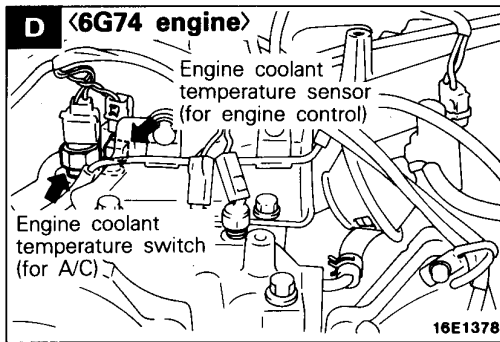

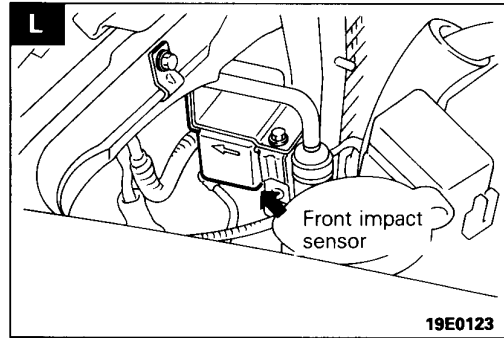
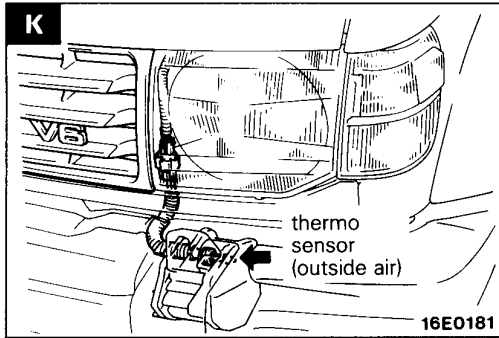
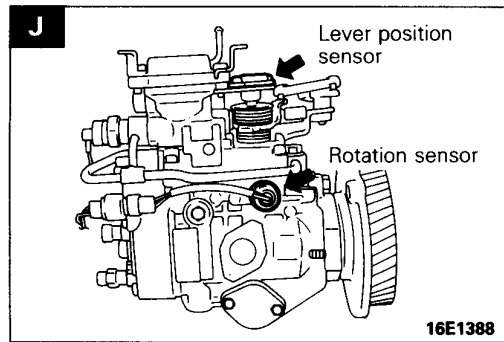
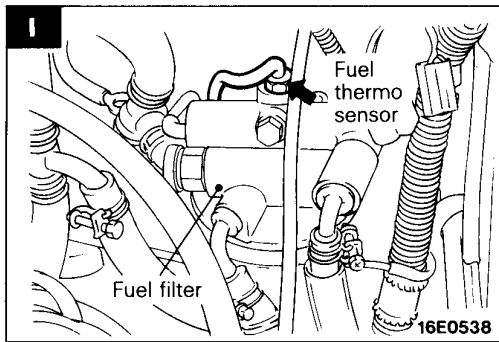

Interior

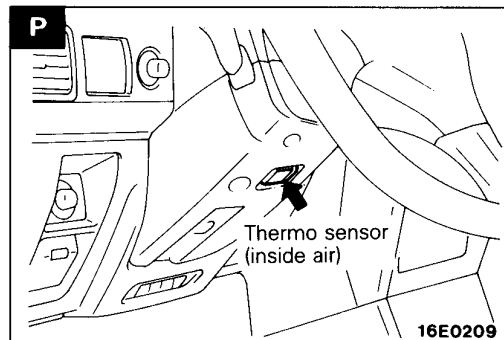
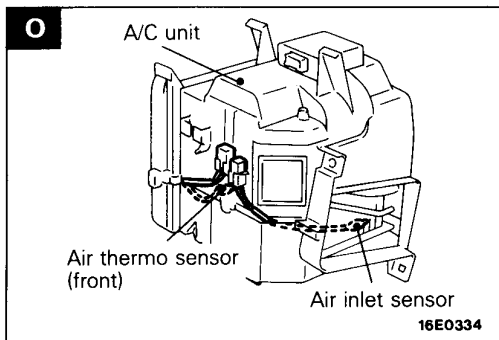
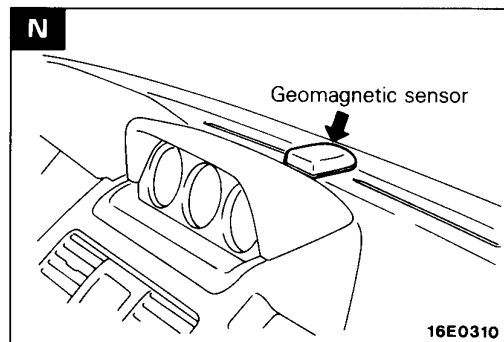
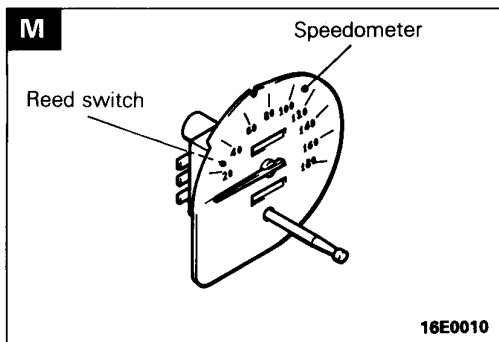
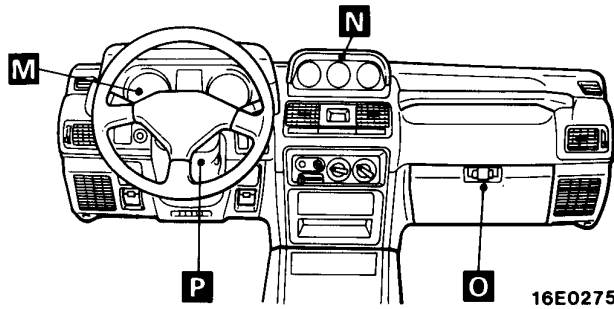

Floor

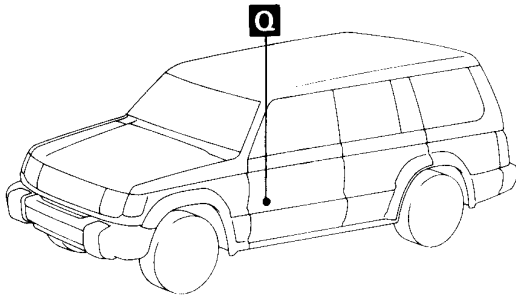

18E0003

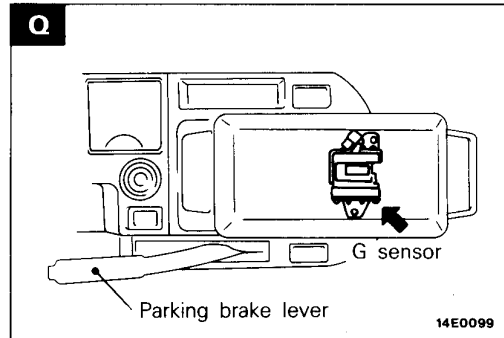

14E0099

Luggage compartment

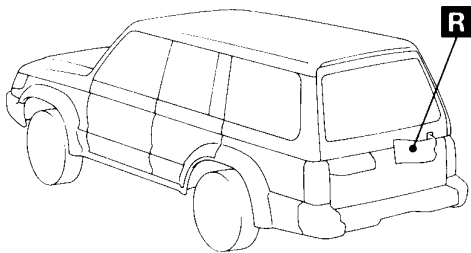

18E0004

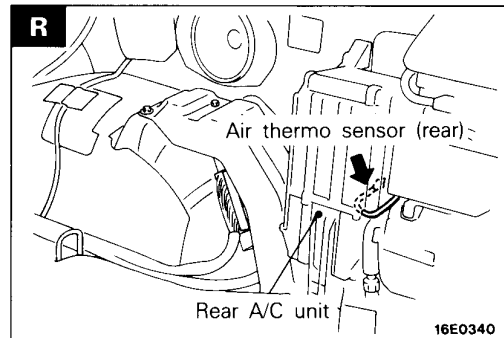

16E0340

Under floor

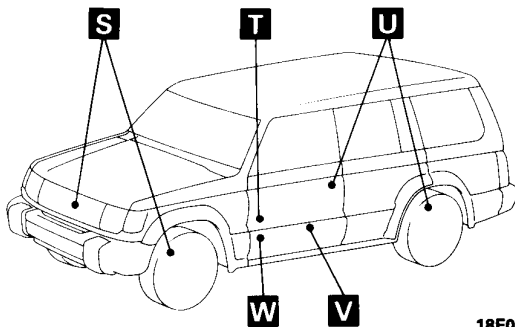

18E0003

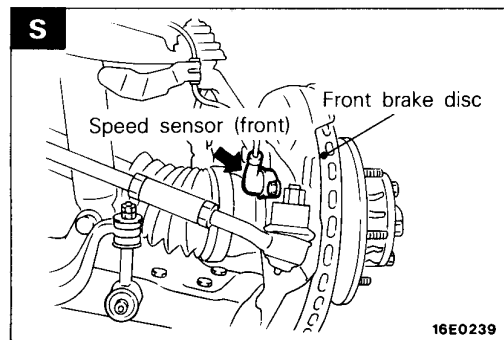

16E0239

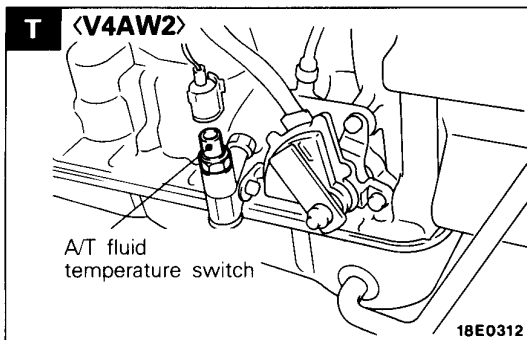

18E0312

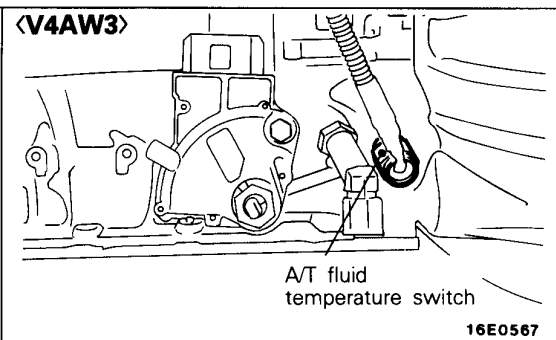

16E0567

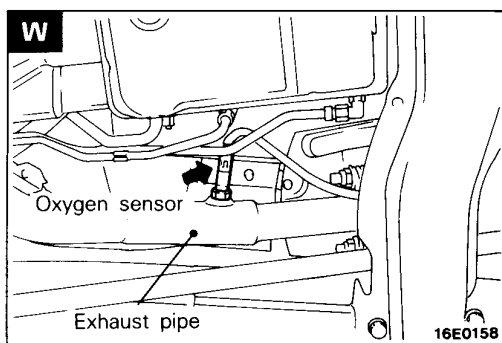
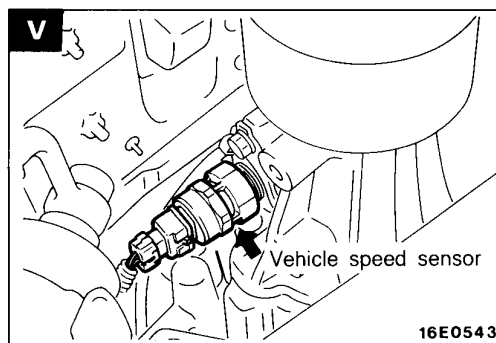
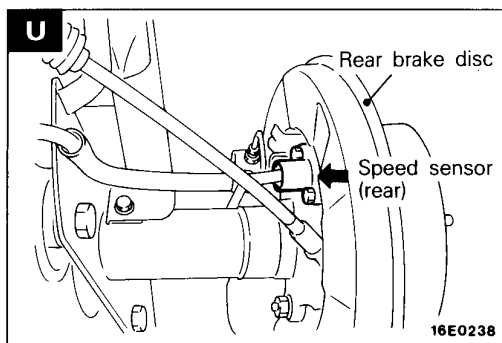

SOLENOID VALVE

Name		Symbol	Name	Symbol
Auto-cruise control actuator (with built-in solenoid valve)		I	Overdrive solenoid valve <V4AW2>	N
EGR solenoid valve <6G74 engine>		C	Purge control solenoid valve <Petrol-powered vehicles>	F
EGR solenoid valve I, II <Diesel-powered vehicles with EGR system>		E	Solenoid assembly <V4AW3>	M
Hydraulic unit (with build-in solenoid valve)		A	Solenoid valve (super select 4WD)	L
Idle up solenoid valve(ABS)	LHD	H	Supercharging pressure relief solenoid valve	E
	RHD	B	Timer solenoid valve <4M40 engine>	K
Idle up solenoid valve(A/C)	LHD	D	Variable induction control solenoid valve <6G74 engine>	J
	RHD	G		

NOTE
Names are listed in alphabetical order.

Engine compartment

<Petrol-powered vehicles>

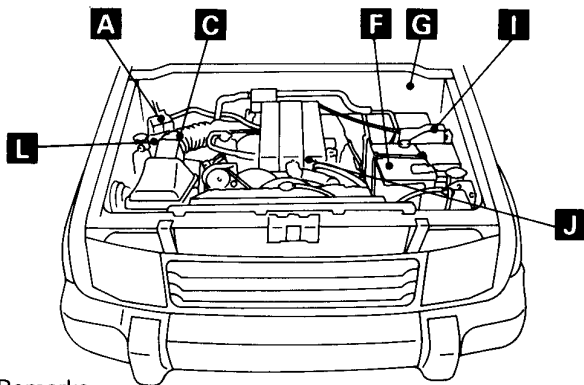

16E0570

<Diesel-powered vehicles>

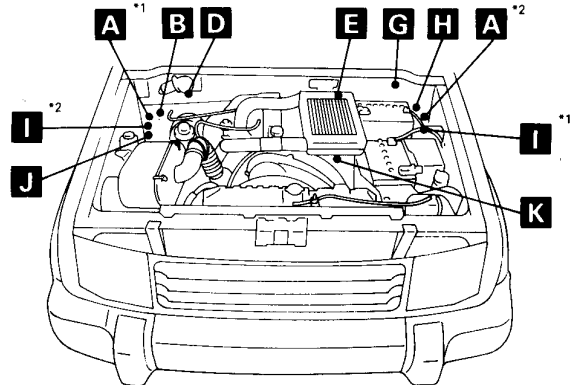

16E0129

Remarks
*1: R.H.drive vehicles
*2: L.H.drive vehicles

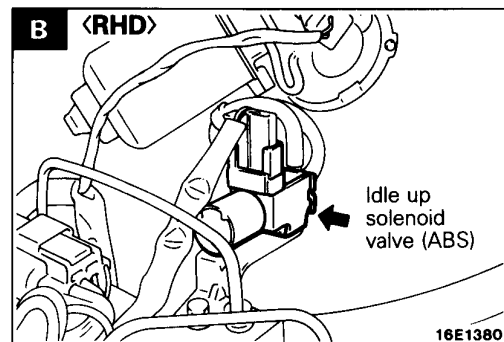
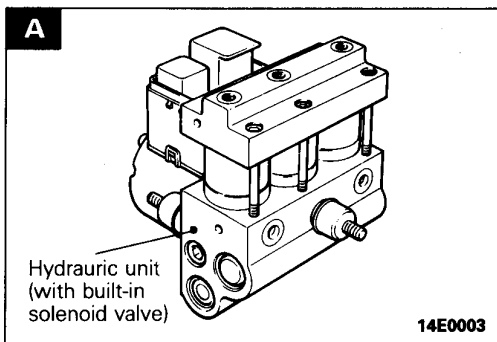

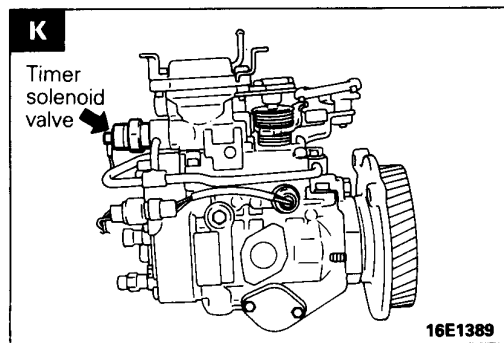
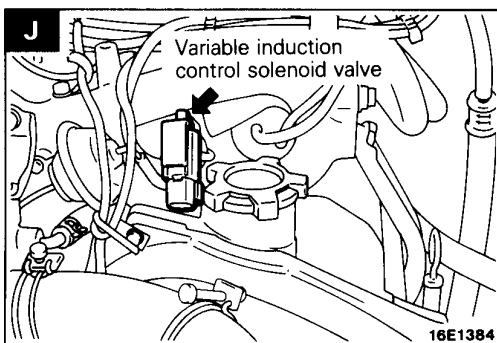
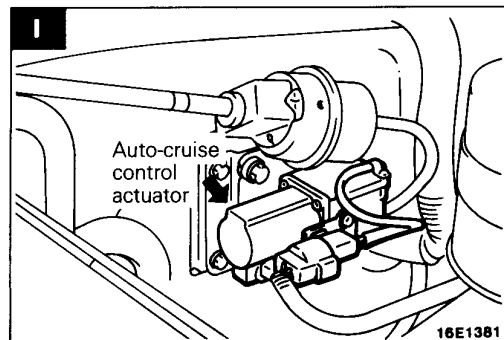
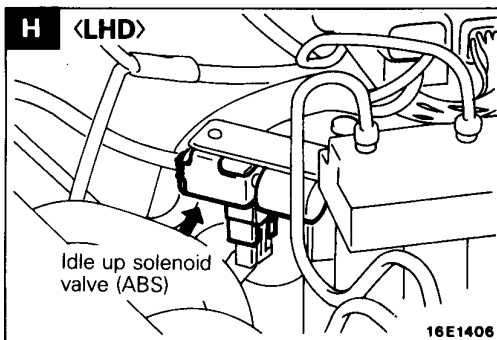
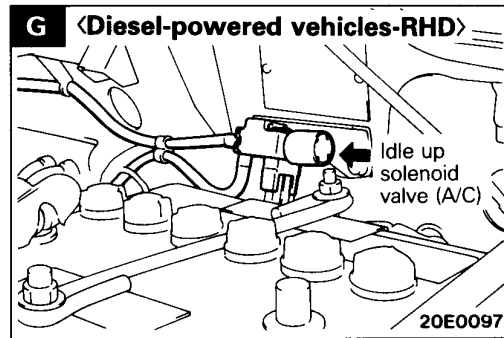
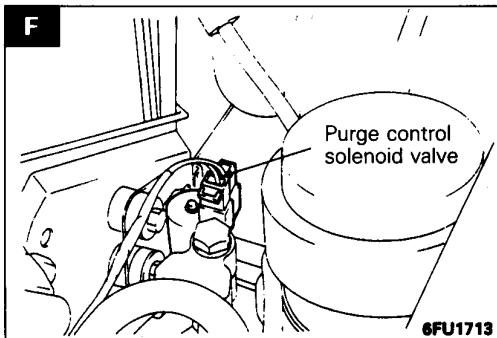
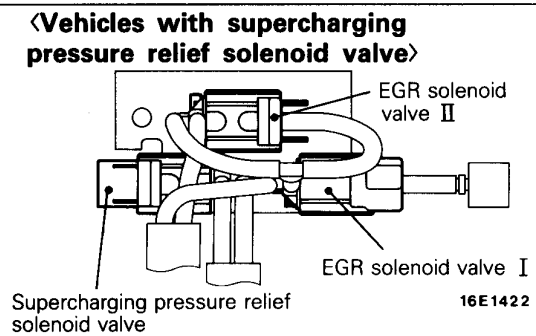
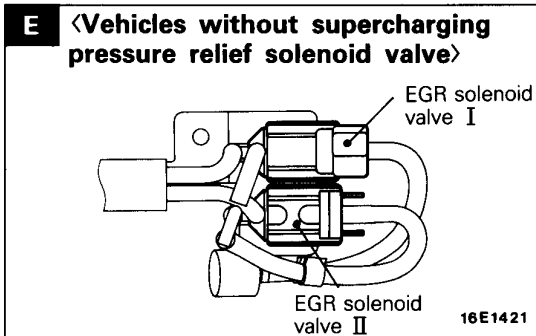
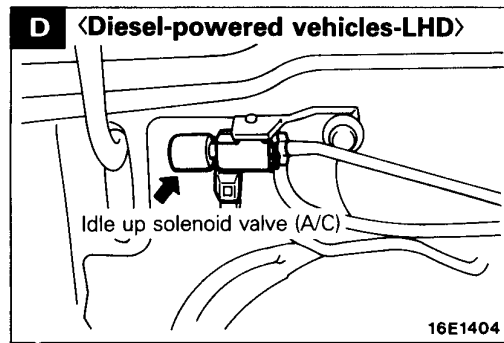
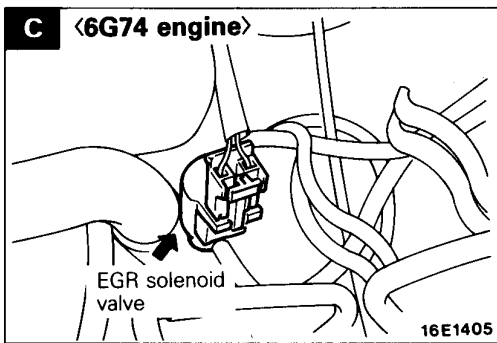

3A-16 SINGLE PART INSTALLATION POSITION — Solenoid Valve

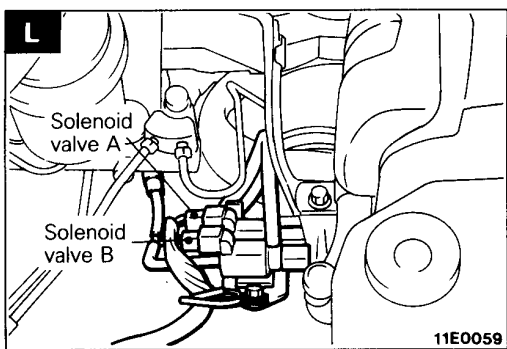

Under floor

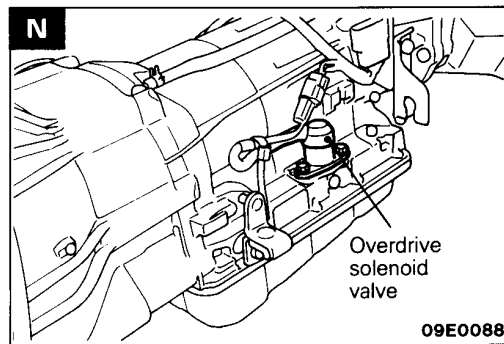
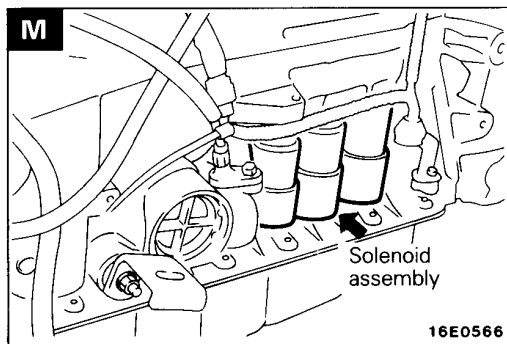
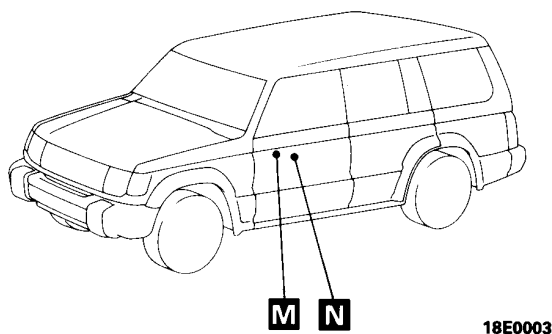

DIODE

Name		Symbol	Name		Symbol
Diode (for ABS circuit)	LHD	B	Diode (for headlamp circuit)		A
	RHD	A	Diode (for MPI circuit) <6G74 engine>	LHD	B
Diode (for dim-dip lamp circuit)		A		RHD	A
Diode (for dim-dip lamp circuit)		A	Diode (for super select 4WD circuit)	LHD	C
				RHD	A

NOTE
Names are listed in alphabetical order.

Interior

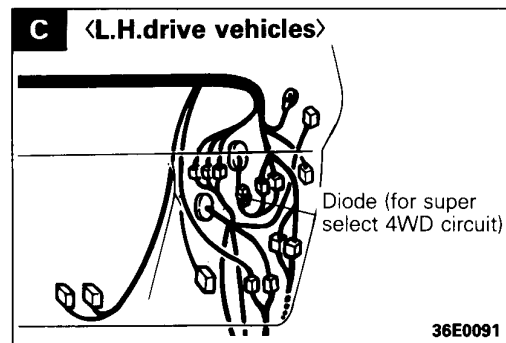
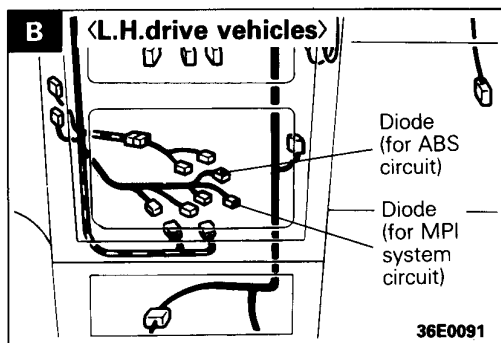
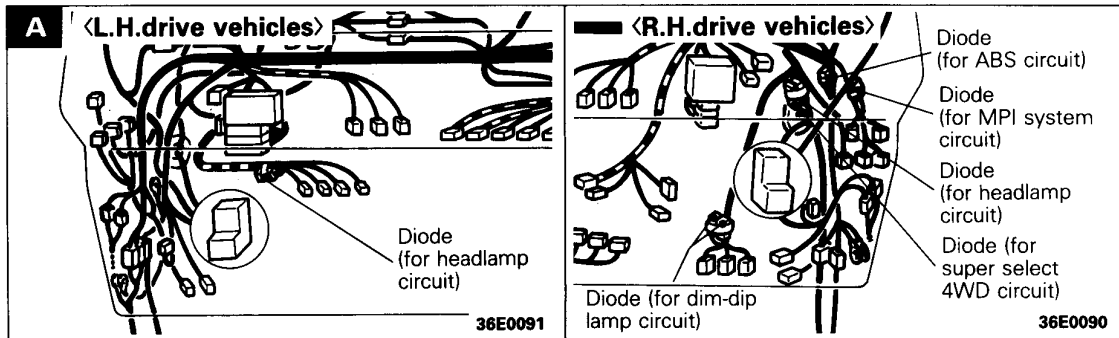
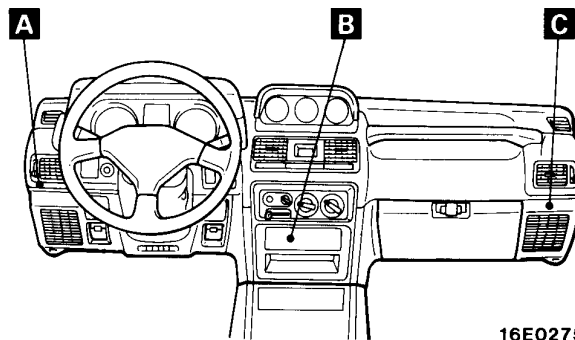

3A-18 SINGLE PART INSTALLATION POSITION — Inspection Terminal

INSPECTION TERMINAL

Name		Symbol	Name		Symbol
Diagnosis connector		C	Fuel pump check connector	LHD	A
				RHD	B
Engine speed detection connector (6G74 engine)	LHD	A	Ignition timing adjustment connector	LHD	A
	RHD	B		RHD	B

NOTE
Names are listed in alphabetical order.

Engine compartment

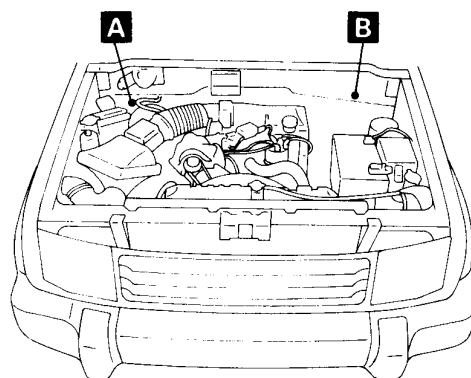

16E0128

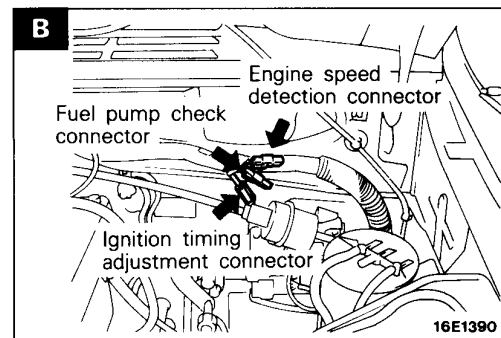
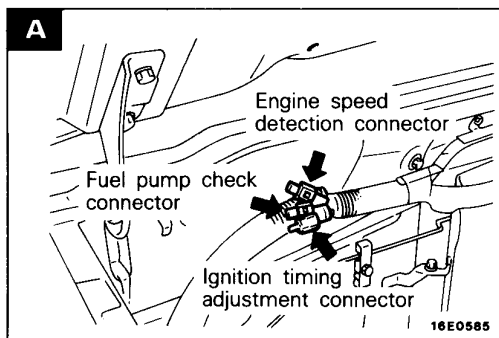

Interior

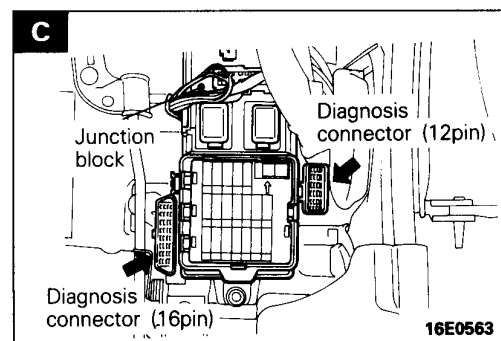
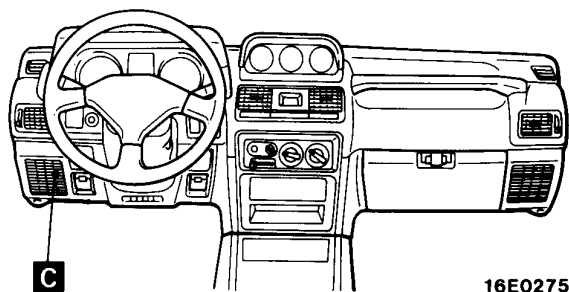

FUSIBLE LINK AND FUSE

Name	Symbol	Name	Symbol
Dedicated fuse	A, B	Multi-purpose fuse	B
Fusible link	A		

NOTE
Names are listed in alphabetical order.

Engine compartment

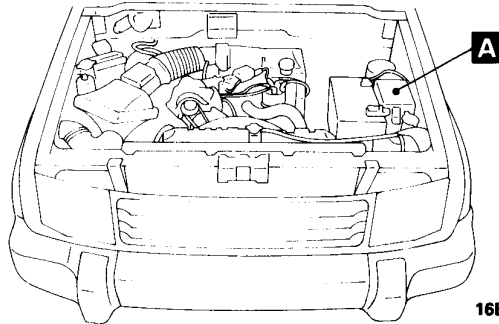

Fusible link

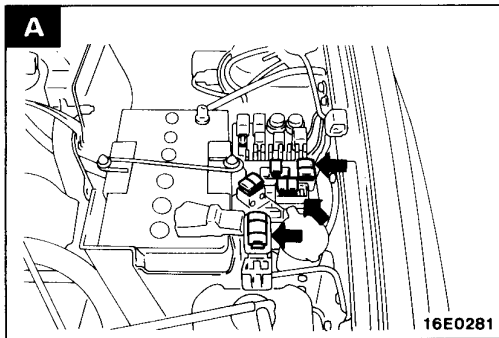

Dedicated fuse

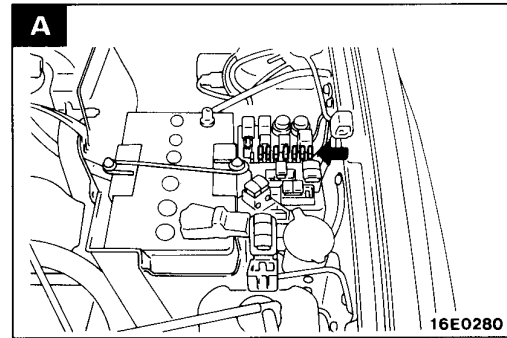

Interior

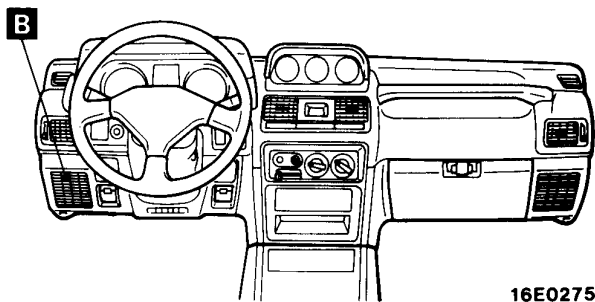

Multi-purpose fuse

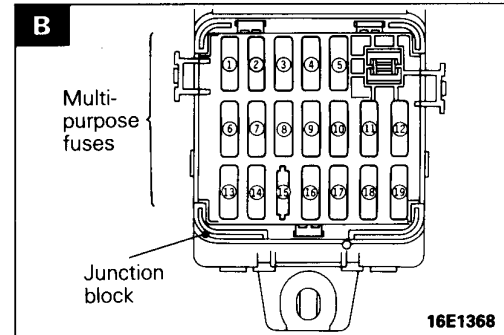

Dedicated fuse

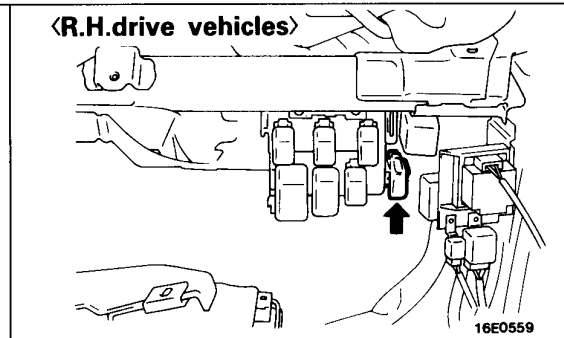
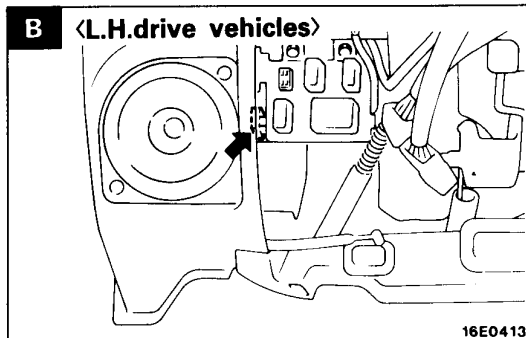

EARTH CABLE

Engine compartment 1

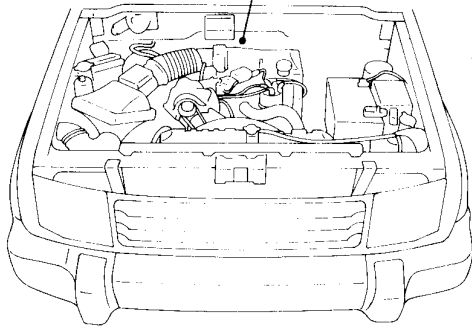

16E0128

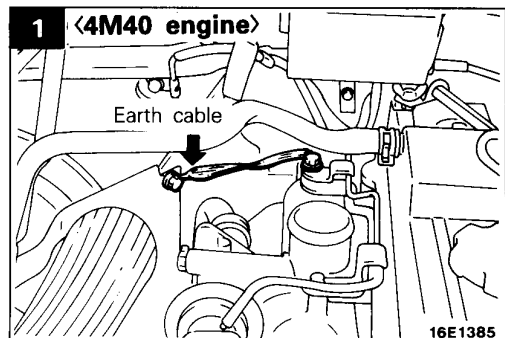
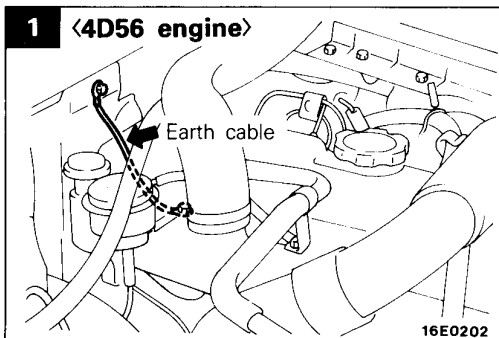
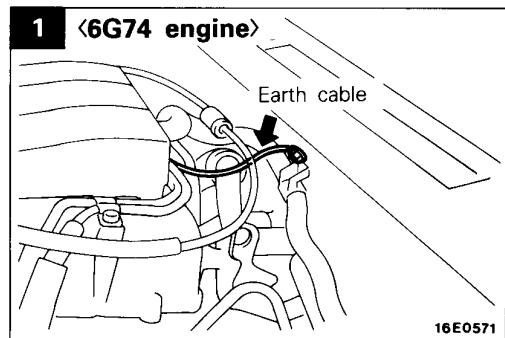
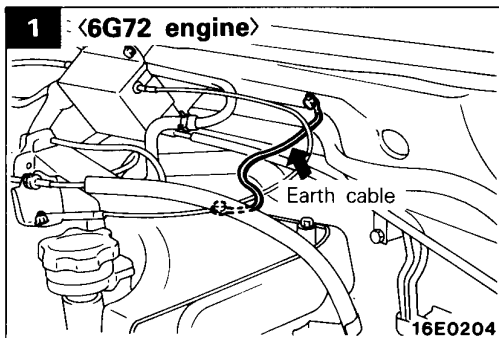
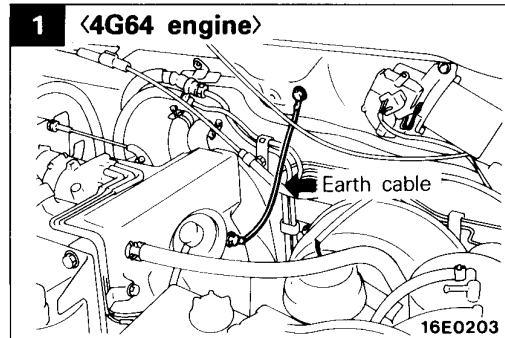

Under floor

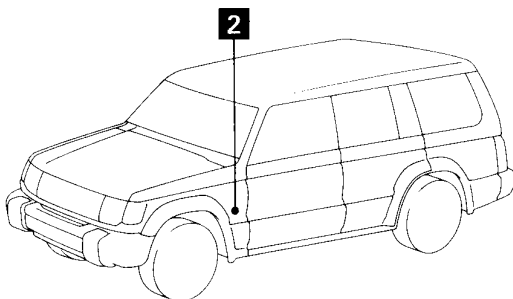

18E0003

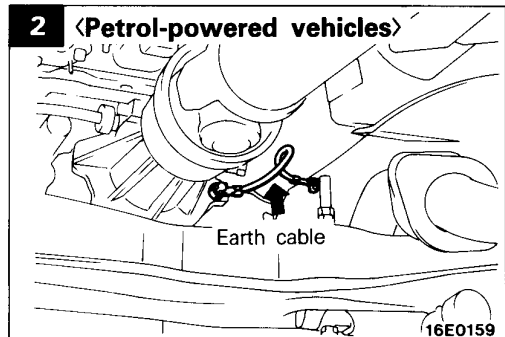

EARTH

Engine compartment

<Petrol-powered vehicles>

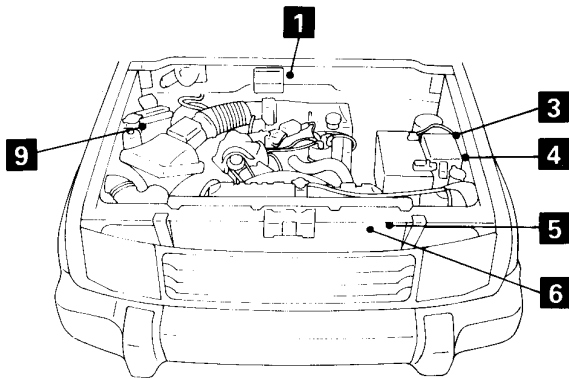

16E0128

<Diesel-powered vehicles>

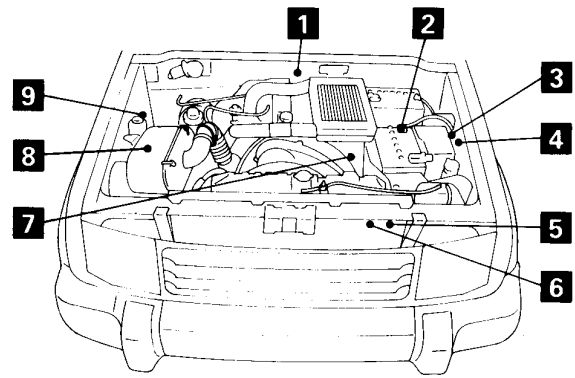

16E0129

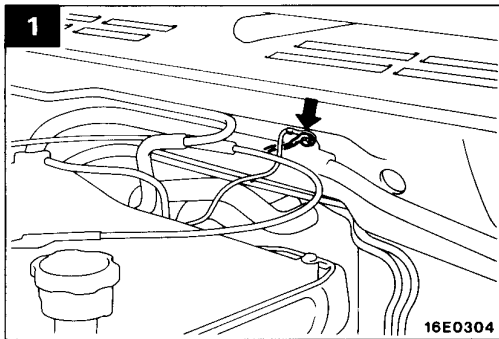

16E0304

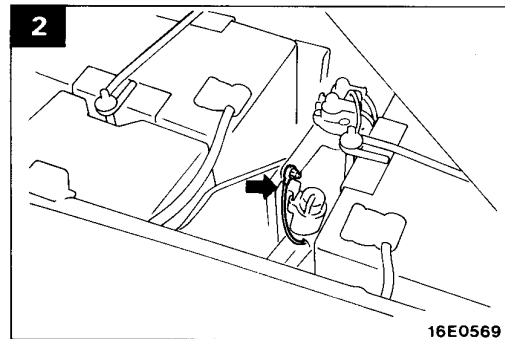

16E0569

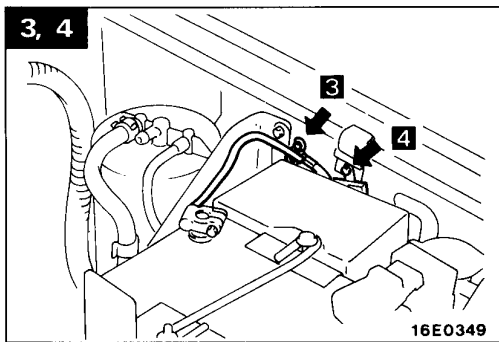

16E0349

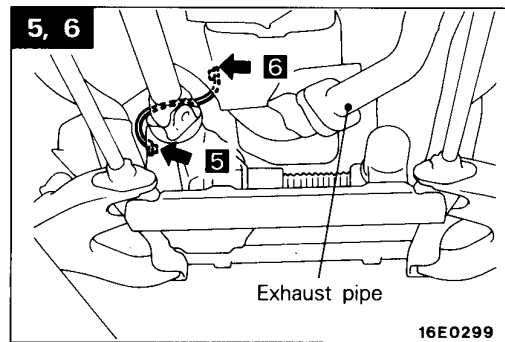

16E0299

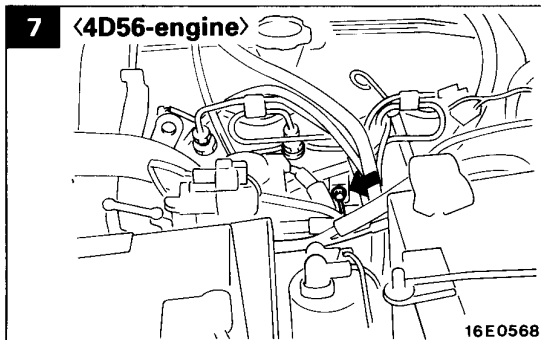

16E0568

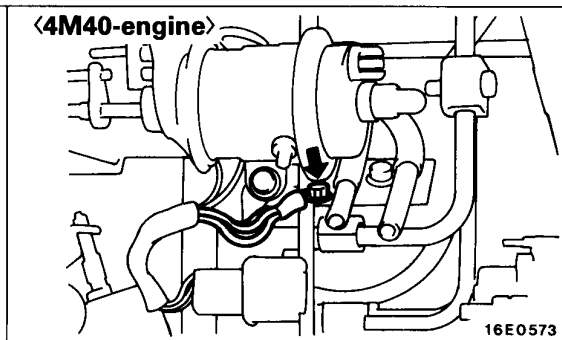

16E0573

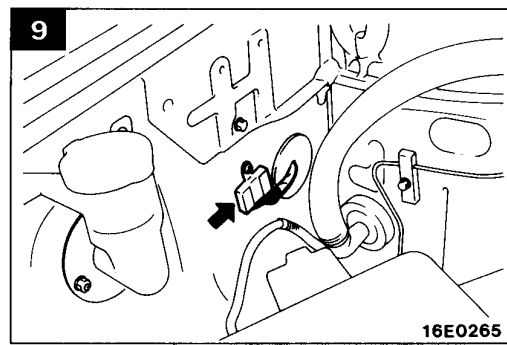
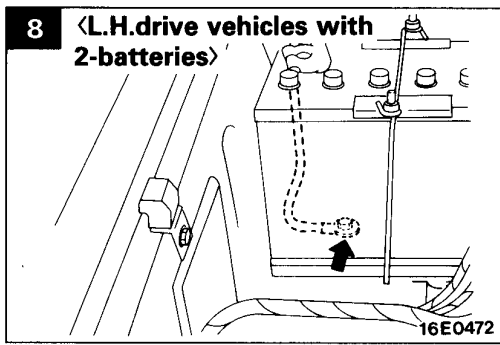

Interior

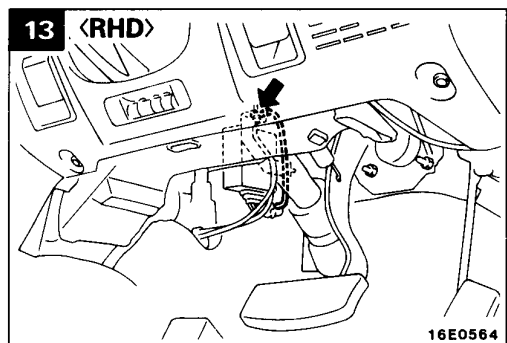
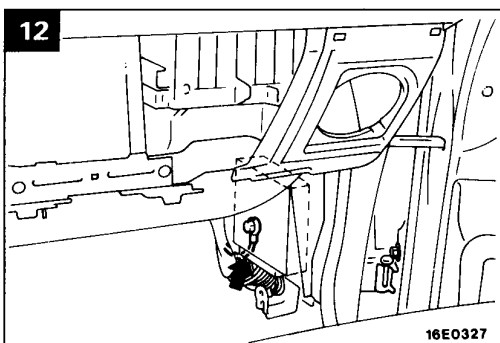
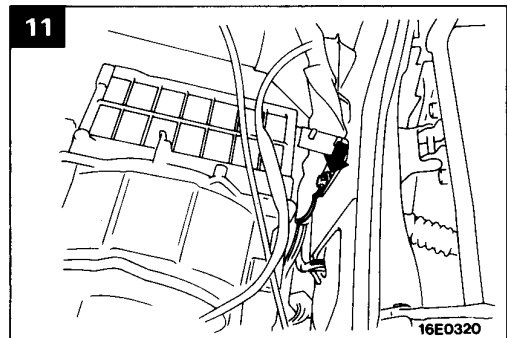
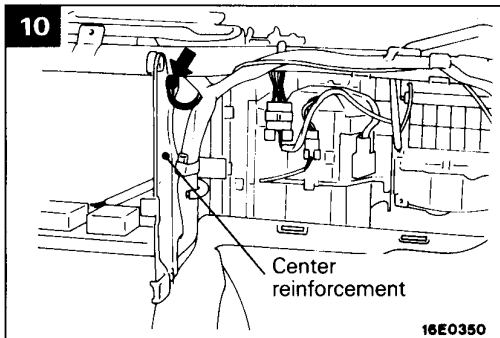
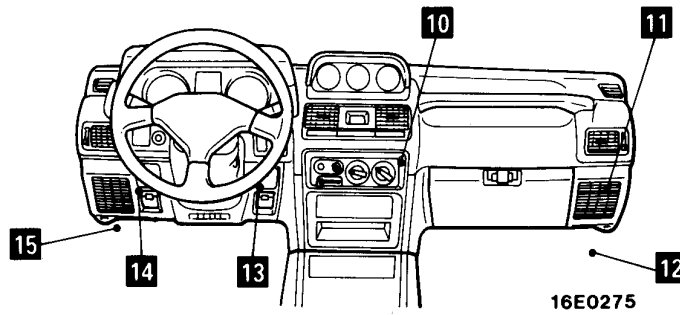

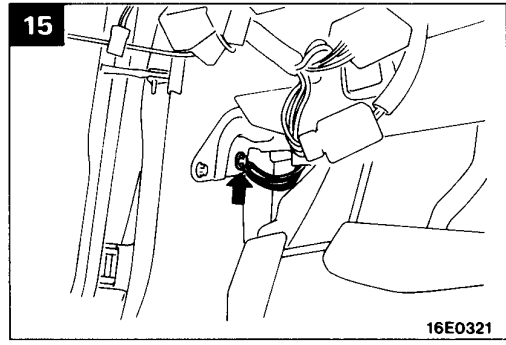
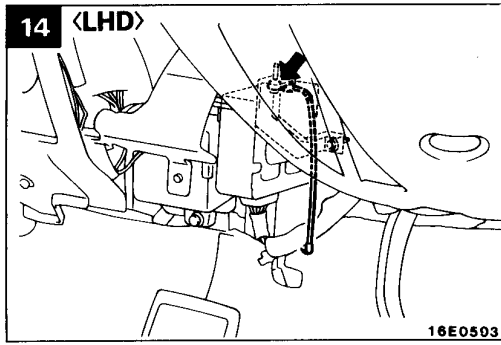

Floor, Back door

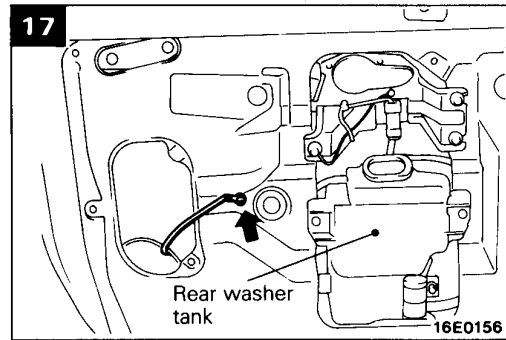
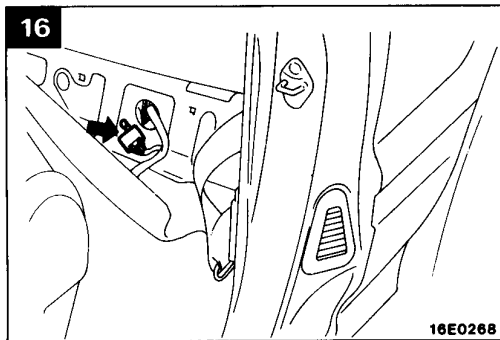
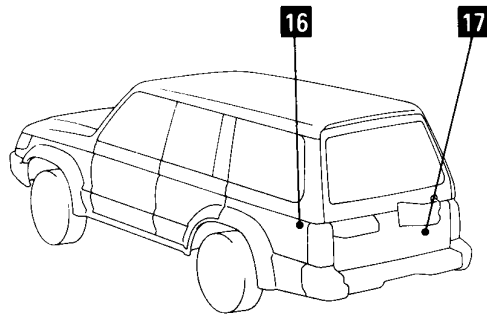

4A CIRCUIT DIAGRAM

JUNCTION BLOCK	4A-4	REAR FOG LAMP	
CENTRALIZED JUNCTION	4A-6	L.H. drive vehicles <without SRS>	4A-120
POWER DISTRIBUTION		L.H. drive vehicles <with SRS>	4A-122
Petrol-powered vehicles	4A-10	R.H. drive vehicles <without SRS>	4A-124
Diesel-powered vehicles	4A-16	R.H. drive vehicles <with SRS>	4A-126
STARTING SYSTEM		ROOM LAMP	
4G64 engine	4A-22	Canvas top	4A-128
6G72, 6G74 engine	4A-23	2-door models without sunroof	4A-129
4D56, 4M40 engine	4A-24	2-door models with sunroof	4A-130
IGNITION SYSTEM		4-door models	4A-131
4G64 engine	4A-26	IGNITION KEY ILLUMINATION LAMP	
6G72 engine	4A-27	L.H. drive vehicles	4A-134
6G74 engine	4A-28	R.H. drive vehicles	4A-135
CHARGING SYSTEM		TURN-SIGNAL LAMP AND HAZARD LAMP	4A-136
4G64, 6G72 engine	4A-30	STOP LAMP	4A-139
6G74 engine	4A-31	BACK-UP LAMP	
4D56, 4M40 engine	4A-32	M/T	4A-140
GLOW SYSTEM		A/T	4A-141
4D56 engine <without supercharging		HORN	
pressure relief solenoid valve>	4A-34	Vehicles without SRS	4A-142
4D56 engine <with supercharging		Vehicles with SRS	4A-143
pressure relief solenoid valve>	4A-36	METER AND GAUGE	
4M40 engine <without supercharging		4G64 engine	4A-144
pressure relief solenoid valve>	4A-38	6G72, 6G74 engine	4A-146
4M40 engine <with supercharging		4D56, 4M40 engine	4A-150
pressure relief solenoid valve>	4A-40	LOW FUEL WARNING LAMP	4A-154
MPI SYSTEM		FUEL FILTER WARNING LAMP	4A-154
4G64 engine-M/T	4A-42	OIL PRESSURE WARNING LAMP	4A-155
6G72 engine-M/T	4A-46	LOW ENGINE OIL LEVEL WARNING LAMP	4A-156
6G72 engine-A/T	4A-54	BRAKE WARNING LAMP	4A-156
6G74 engine-M/T	4A-62	MULTI-METER	
6G74 engine-A/T	4A-72	Vehicles without electronic compass	4A-158
OVERDRIVE CONTROL SYSTEM		Vehicles with electronic compass	4A-160
6G72 engine	4A-82	POWER WINDOW	
ELC-4A/T		L.H. drive vehicles <2-door models>	4A-162
6G74 engine	4A-86	L.H. drive vehicles <4-door models>	4A-163
4M40 engine	4A-94	R.H. drive vehicles <2-door models>	4A-166
HEADLAMP		R.H. drive vehicles <4-door models>	4A-167
L.H. drive vehicles without daytime		CENTRAL DOOR LOCKING SYSTEM	
running lamp <without SRS>	4A-101	L.H. drive vehicles	4A-172
L.H. drive vehicles without daytime		R.H. drive vehicles	4A-174
running lamp <with SRS>	4A-102	HEATER	
L.H. drive vehicles with daytime		L.H. drive vehicles without rear heater	4A-176
running lamp <without SRS>	4A-104	L.H. drive vehicles with rear heater	
L.H. drive vehicles with daytime		<without dual air conditioner>	4A-177
running lamp <with SRS>	4A-106	L.H. drive vehicles with rear heater	
R.H. drive vehicles without SRS	4A-110	<with dual air conditioner>	4A-180
R.H. drive vehicles with SRS	4A-112	R.H. drive vehicles without rear heater	4A-183
HEADLAMP LEVELING SYSTEM	4A-114	R.H. drive vehicles with rear heater	
TAIL LAMP, CLEARANCE LAMP,		<without dual air conditioner>	4A-184
LICENCE PLATE LAMP	4A-116	R.H. drive vehicles with rear heater	
		<with dual air conditioner>	4A-187

HEATER

L.H. drive vehicles without rear heater	4A-176
L.H. drive vehicles with rear heater <without dual air conditioner>	4A-177
L.H. drive vehicles with rear heater <with dual air conditioner>	4A-180
R.H. drive vehicles without rear heater	4A-183
R.H. drive vehicles with rear heater <without dual air conditioner>	4A-184
R.H. drive vehicles with rear heater <with dual air conditioner>	4A-187

SINGLE AIR CONDITIONER

L.H. drive vehicles <4G64, 6G72 engine>	4A-191
L.H. drive vehicles <6G74 engine>	4A-194
L.H. drive vehicles <diesel-powered vehicles>	4A-197
R.H. drive vehicles <petrol-powered vehicles>	4A-201
R.H. drive vehicles <diesel-powered vehicles>	4A-204

DUAL AIR CONDITIONER

L.H. drive vehicles without rear heater <petrol-powered vehicles>	4A-208
L.H. drive vehicles without rear heater <diesel-powered vehicles>	4A-213
L.H. drive vehicles with rear heater <petrol-powered vehicles>	4A-219
L.H. drive vehicles with rear heater <diesel-powered vehicles>	4A-226
R.H. drive vehicles without rear heater <petrol-powered vehicles>	4A-234
R.H. drive vehicles without rear heater <diesel-powered vehicles>	4A-239
R.H. drive vehicles with rear heater <petrol-powered vehicles>	4A-245
R.H. drive vehicles with rear heater <diesel-powered vehicles>	4A-252

WINDSHIELD WIPER AND WASHER

Vehicles without SRS	4A-260
Vehicles with SRS	4A-261

REAR WIPER AND WASHER

Vehicles without SRS	4A-264
Vehicles with SRS	4A-266

HEADLAMP WASHER 4A-268

DEFOGGER AND DOOR MIRROR HEATER 4A-270

WIPER DEICER 4A-272

REMOTE CONTROLLED MIRROR 4A-274

RADIO AND TAPE PLAYER

L.H. drive vehicles <AM/FM radio>	4A-276
L.H. drive vehicles <LW/MW/FM radio and tape player>	4A-278
L.H. drive vehicles <AM/FM radio and tape player>	4A-281
R.H. drive vehicles <AM/FM radio>	4A-285
R.H. drive vehicles <LW/MW/FM radio and tape player>	4A-286
R.H. drive vehicles <AM/FM radio and tape player>	4A-288

CLOCK

L.H. drive vehicles	4A-291
R.H. drive vehicles	4A-292

CIGARETTE LIGHTER 4A-293

ACCESSORY SOCKET 4A-294

SUNROOF

Canvas top	4A-295
4-door models	4A-296

INTERCOOLER FAN 4A-297

REAR DIFFERENTIAL LOCK SYSTEM

L.H. drive vehicles	4A-298
R.H. drive vehicles	4A-300

PART TIME 4WD SYSTEM 4A-302

SUPER SELECT 4WD SYSTEM 4A-304

REMOTE CONTROLLED VARIABLE SHOCK ABSORBERS SYSTEM 4A-306

ANTI-LOCK BRAKE SYSTEM 4A-308

AUTO-CRUISE CONTROL SYSTEM

L.H. drive vehicles <Petrol-powered vehicles>	4A-312
L.H. drive vehicles <Diesel-powered vehicles>	4A-316
R.H. drive vehicles <Petrol-powered vehicles>	4A-320
R.H. drive vehicles <Diesel-powered vehicles>	4A-324

HEATED SEAT

Vehicles without power seat	4A-328
Vehicles with power seat	4A-330

POWER SEAT 4A-333

LIGHTING MONITOR BUZZER 4A-336

FUEL LINE HEATER 4A-338

SUPPLEMENTAL RESTRAINT SYSTEM

Petrol-powered vehicles	4A-340
Diesel-powered vehicles	4A-342

NOTES

JUNCTION BLOCK

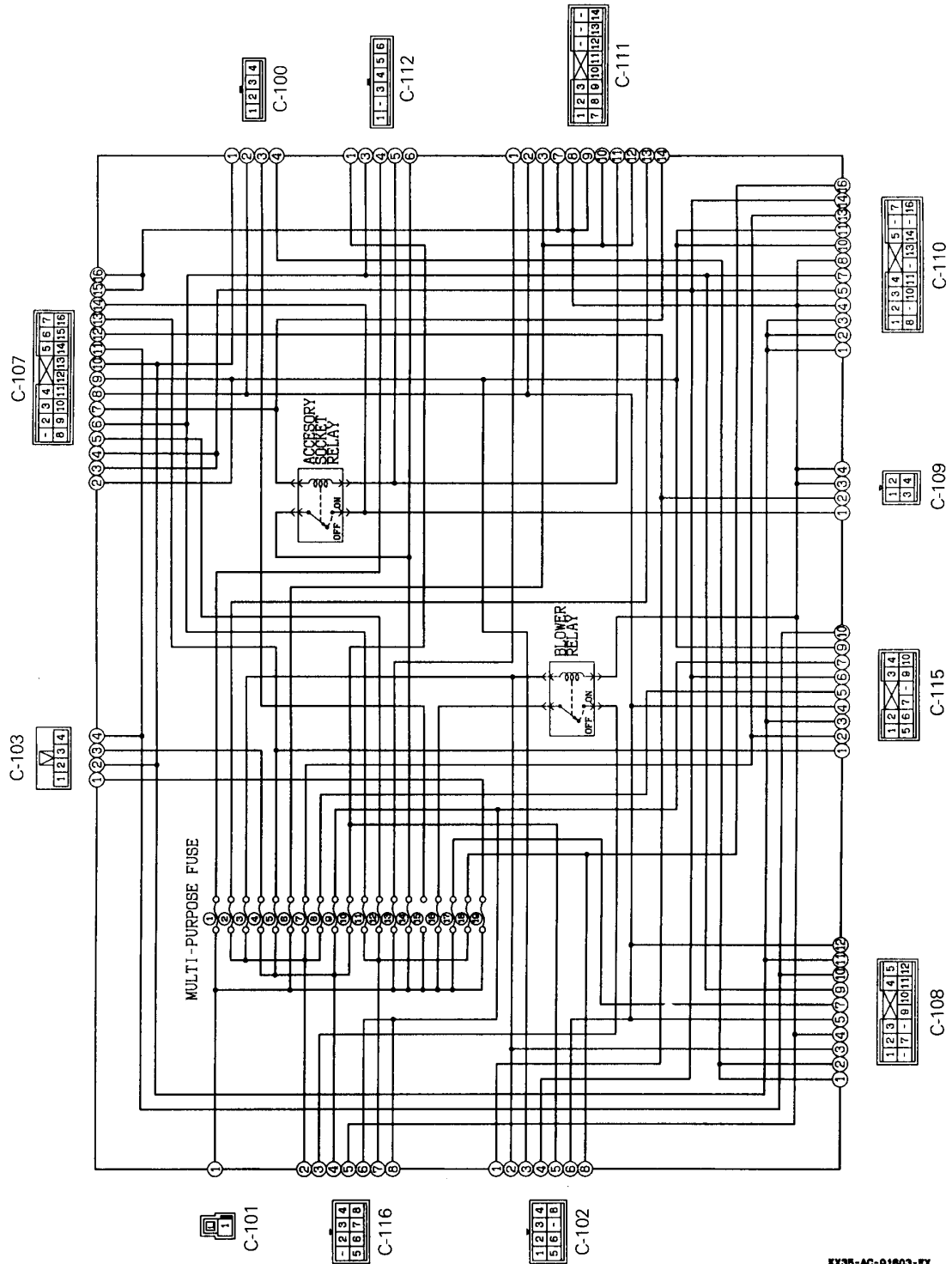

KX35-AC-01603-EX

Remark

- Connector numbers are keyed to the configuration diagram (dashboard panel) and each circuit diagram.

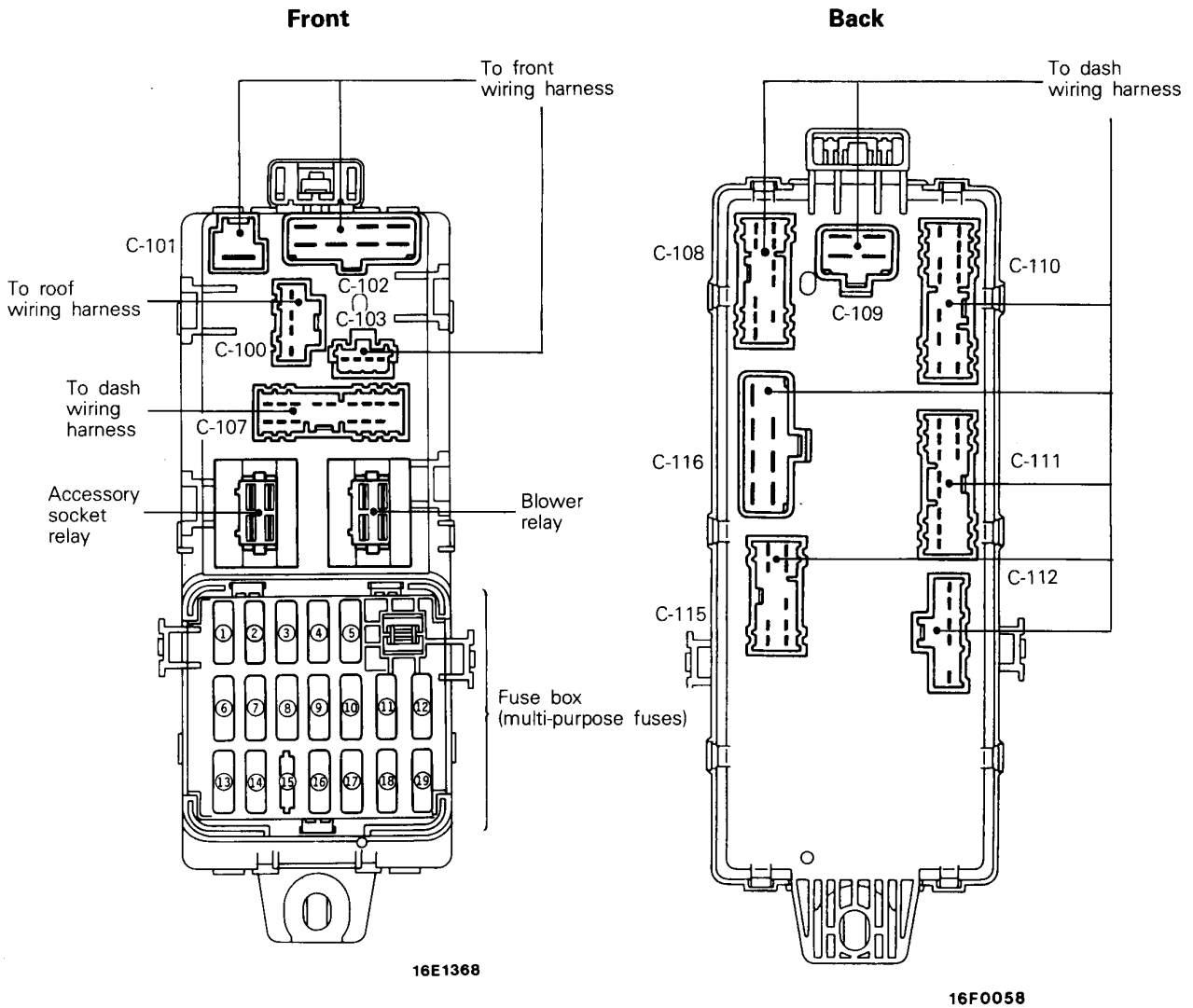

CENTRALIZED JUNCTION

FUSIBLE LINK

No.	Circuit	Housing colour	Rated capacity (A)
1	ABS circuit (hydraulic unit power source)	Yellow	60
2	—	—	—
3	Glow control circuit	Black	80
4	Junction block (Multi-purpose fuse ①, ⑥, ⑬, ⑭, ⑯, ⑰, ⑱ A/C circuit)	Yellow	60
5	Alternator circuit	Blue	100
6	MPI or intercooler fan circuit	Light blue	20
7	Ignition switch and starting circuit	Green	40
8	—	—	—
9	Defogger circuit	Pink	30
10	Power window circuit	Pink	30
11	—	—	—
12	Condenser fan motor circuit	Pink	30
13	Alternator, headlamp and tail lamp circuit	Green	40

(Connected directly to battery positive terminal)

<Vehicles with ABS>

<Diesel-powered vehicles without ABS>

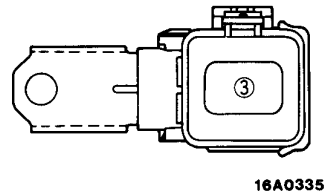
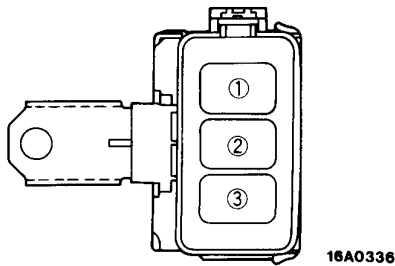

(Relay box in engine compartment)

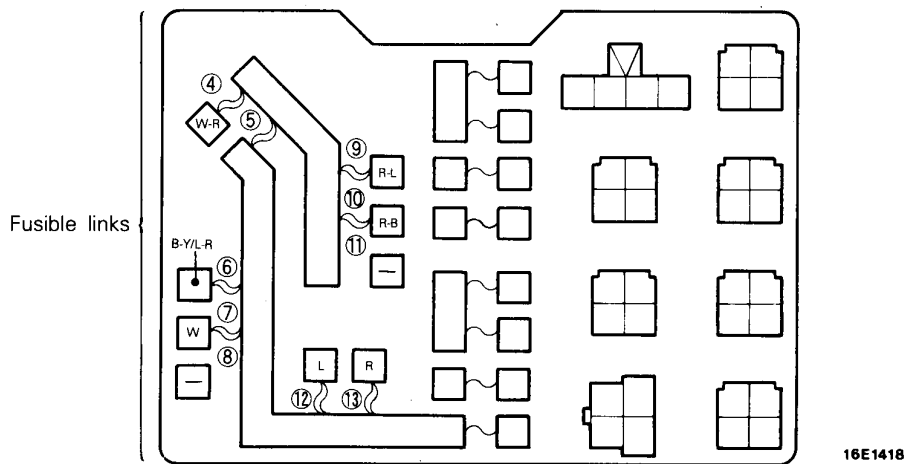

DEDICATED FUSE

Power supply circuit	No.	Rated capacity (A)	Housing Colour	Circuit
Battery/Alternator	1	15	Blue	Fuel line heater
	2	10	Red	A/C compressor circuit
	3	25	Transparent	Condenser fan motor circuit
		30*	Green	
Headlamp relay (Battery)	4	10	Red	Rear fog lamp circuit
Tail lamp relay (Battery)	5	10	Red	Tail lamp circuit
Tail lamp relay (Battery)	6	10	Red	Tail lamp circuit
Headlamp relay (Battery)	7	10	Red	Upper beam indicator circuit
Battery/Alternator	8	10	Red	Hazard lamp circuit
Ignition switch (ACC)	9	15	Blue	Sunroof circuit

NOTE

(1)*: Diesel-powered vehicles with dual air conditioner.

(Relay box in engine compartment)

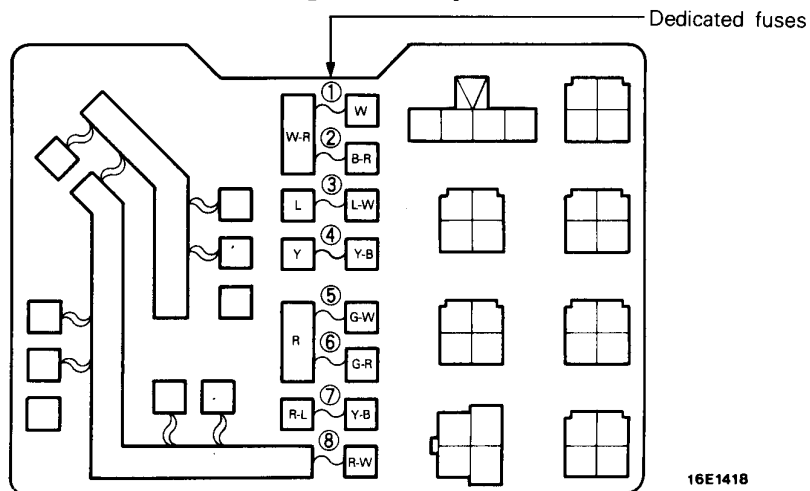

(Relay box in passenger compartment)

<L.H. drive vehicles>

<R.H. drive vehicles>

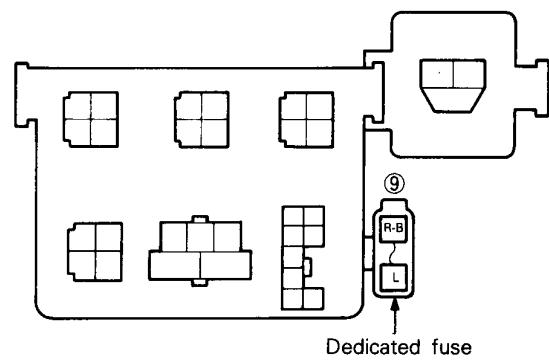
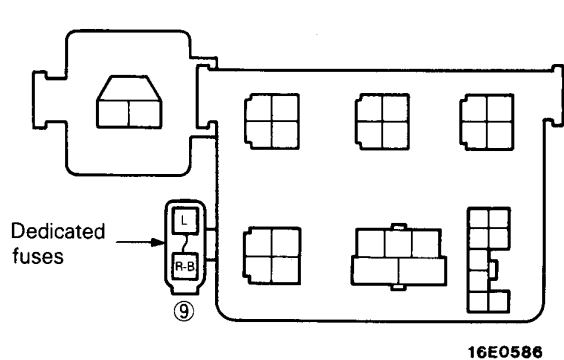

MULTI-PURPOSE FUSES (In junction block)

Power supply circuit		No.	Rated capacity (A)	Load circuit
Battery		1	20	Rear A/C control unit
Ignition switch	(IG2)	2	10	Overdrive control relay, ELC-4A/T control unit and auto-cruise control unit
		3	10	DRL control unit, blower relay, rear heater relay, headlamp washer relay, defogger relay, and wiper deicer timer
	(ACC)	4	10	Radio, clock, accessory socket relay and auto-cruise control unit
		5	15	Remote control mirror, cigarette lighter
	Battery		6	15
Ignition switch	(IG2)	7	10	Variable shock absorber control unit, ABS control unit, 4WD indicator control unit, 4WD indicator relay
		8	10	Power window relay and heated seat
	(ACC)	9	15	Wiper and washer
		10	10	Horn
	(IG1)	11	10	Combination meter and motor antenna control unit
		12	10	Turn-signal lamp and hazard lamp and SRS diagnosis unit
Battery		13	10	Rear heater blower motor
		14	15	Accessory socket relay
		15	—	—
		16	25	Blower motor
		17	15	Stop lamp
Ignition switch	(IG1)	18	15	Back-up lamp and rear differential lock control unit, SRS diagnosis unit
Battery		19	10	Engine control unit, ELC-4A/T control unit, room lamp, map lamp, cargo space lamp, combination meter, radio, clock, door lock control unit, auto-cruise control unit and ABS control unit and SRS diagnosis unit

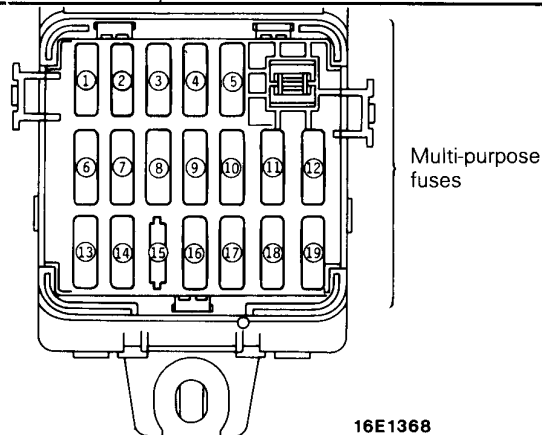

16E1368

CENTRALIZED RELAY

Classification		Name	Classification		Name
Relay box in engine compartment	A-19X	Jumper connector	Relay box in passenger compartment	C-92X	—
	A-20X	Headlamp relay		C-93X	Rear heater relay
	A-21X	Intercooler fan motor relay		C-94X	Power window relay
	A-22X	Alternator relay		C-95X	Door lock control unit
	A-23X	Rear fog lamp relay		C-96X	Defogger relay
	A-24X	Tail lamp relay		C-97X	Rear intermittent wiper relay
	A-25X	Condenser fan motor relay		C-98X	Turn and hazard flasher unit
	A-26X	A/C compressor relay			

(Relay box in engine compartment)

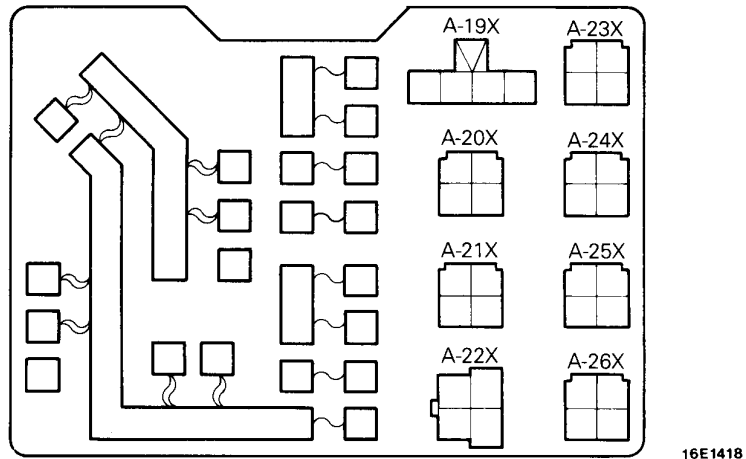

(Relay box in passenger compartment)

〈L.H. drive vehicles〉

〈R.H. drive vehicles〉

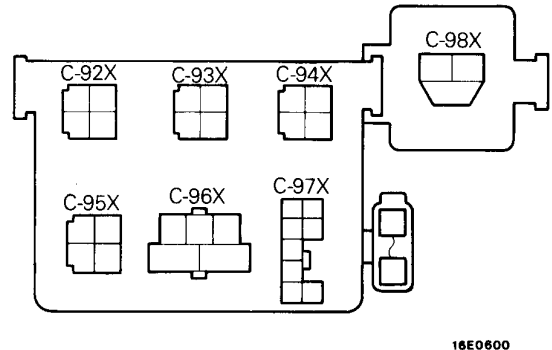
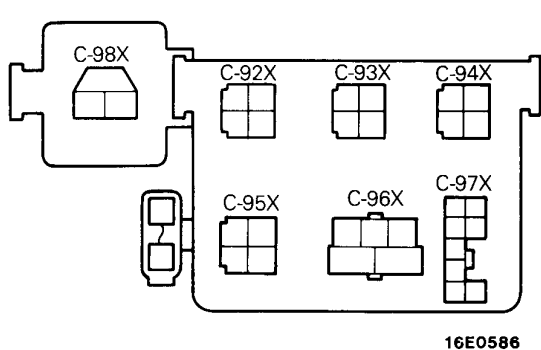

POWER DISTRIBUTION SYSTEM
(Petrol-powered vehicles)

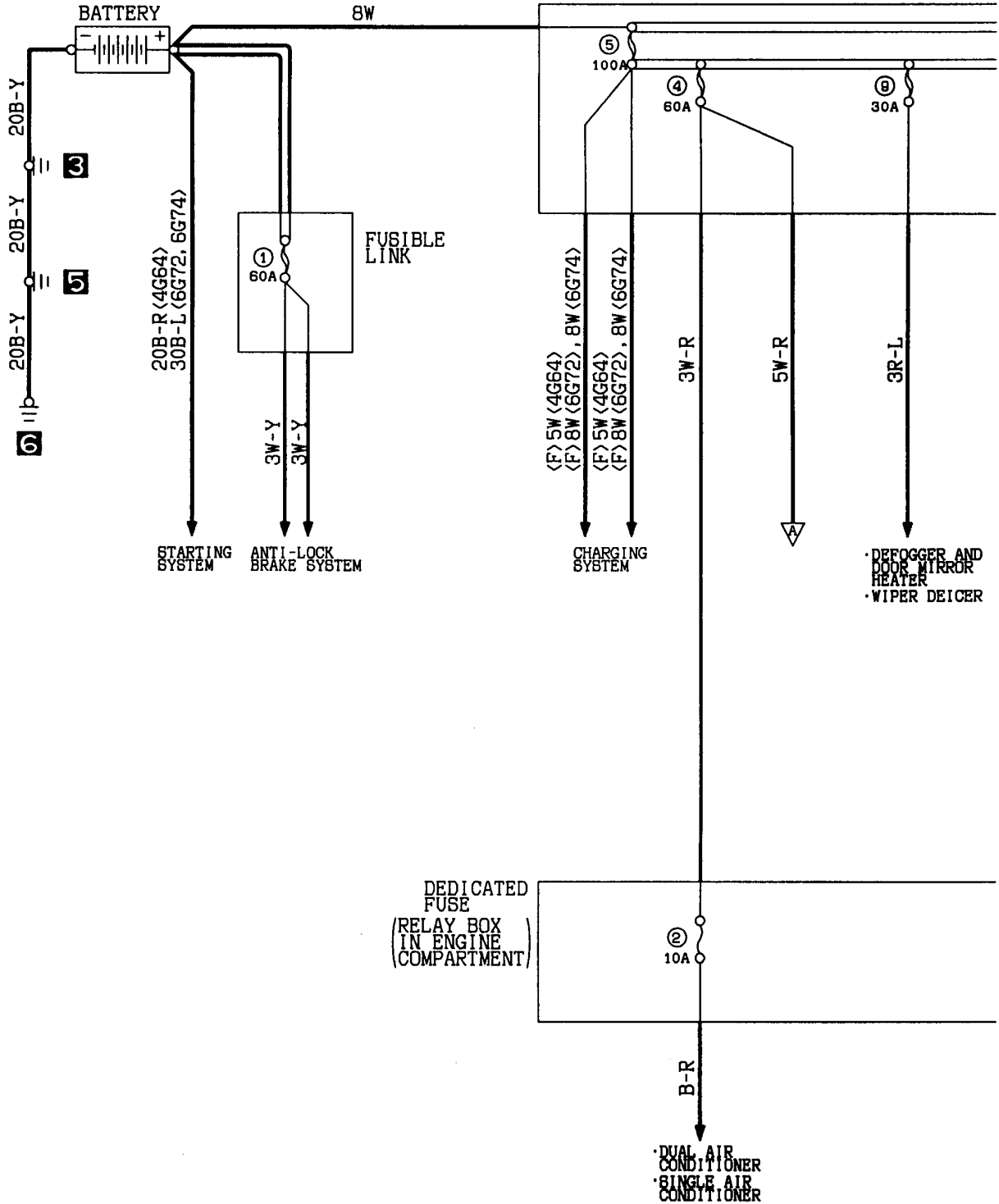

Wire colour code
 B:Black LG:Light green G:Green L:Blue W:White Y:Yellow SB:Sky blue
 BR:Brown O:Orange GR:Gray R:Red P:Pink V:Violet

FUSIBLE LINK

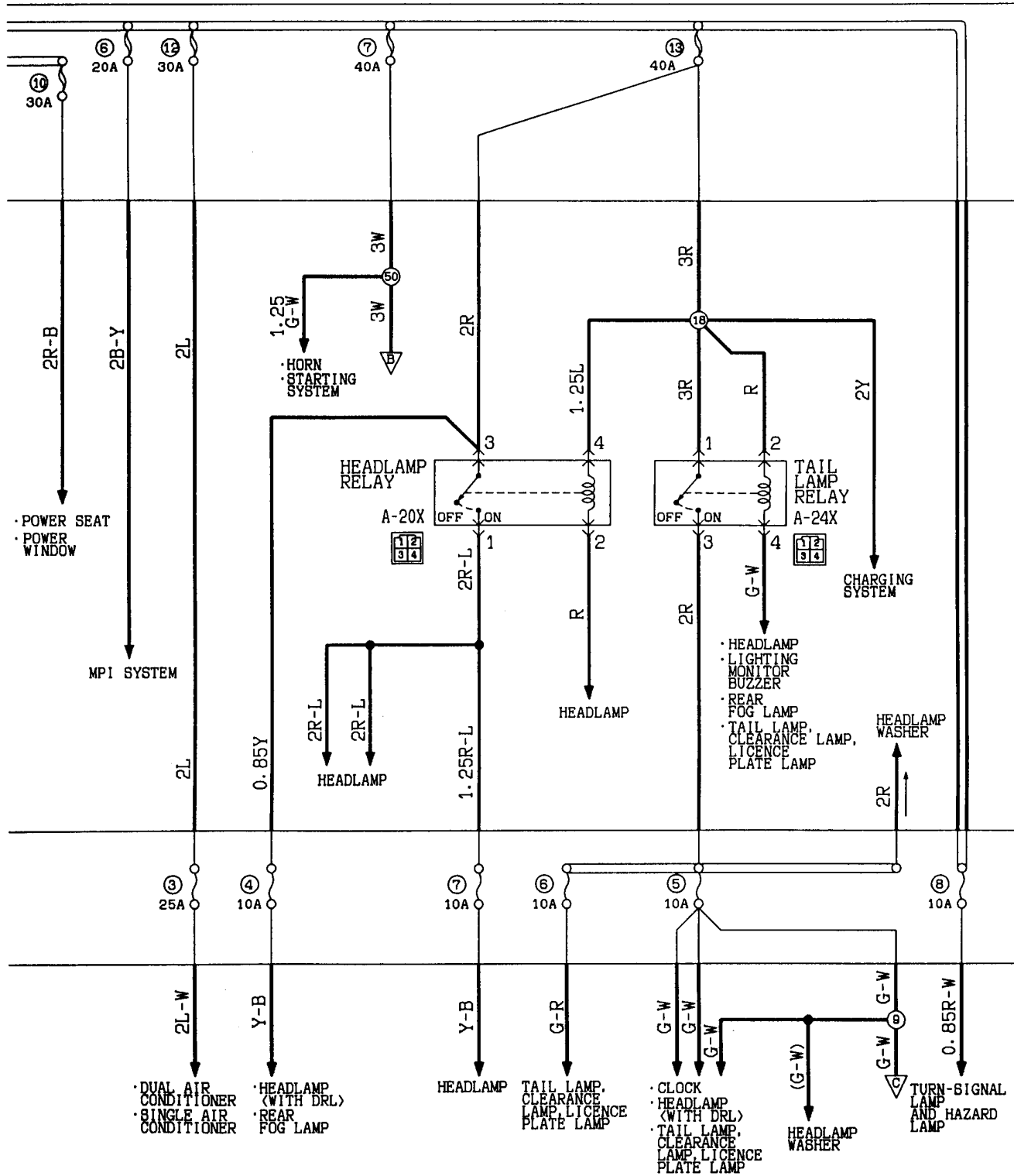

POWER DISTRIBUTION SYSTEM (Petrol-powered vehicles)
(CONTINUED)

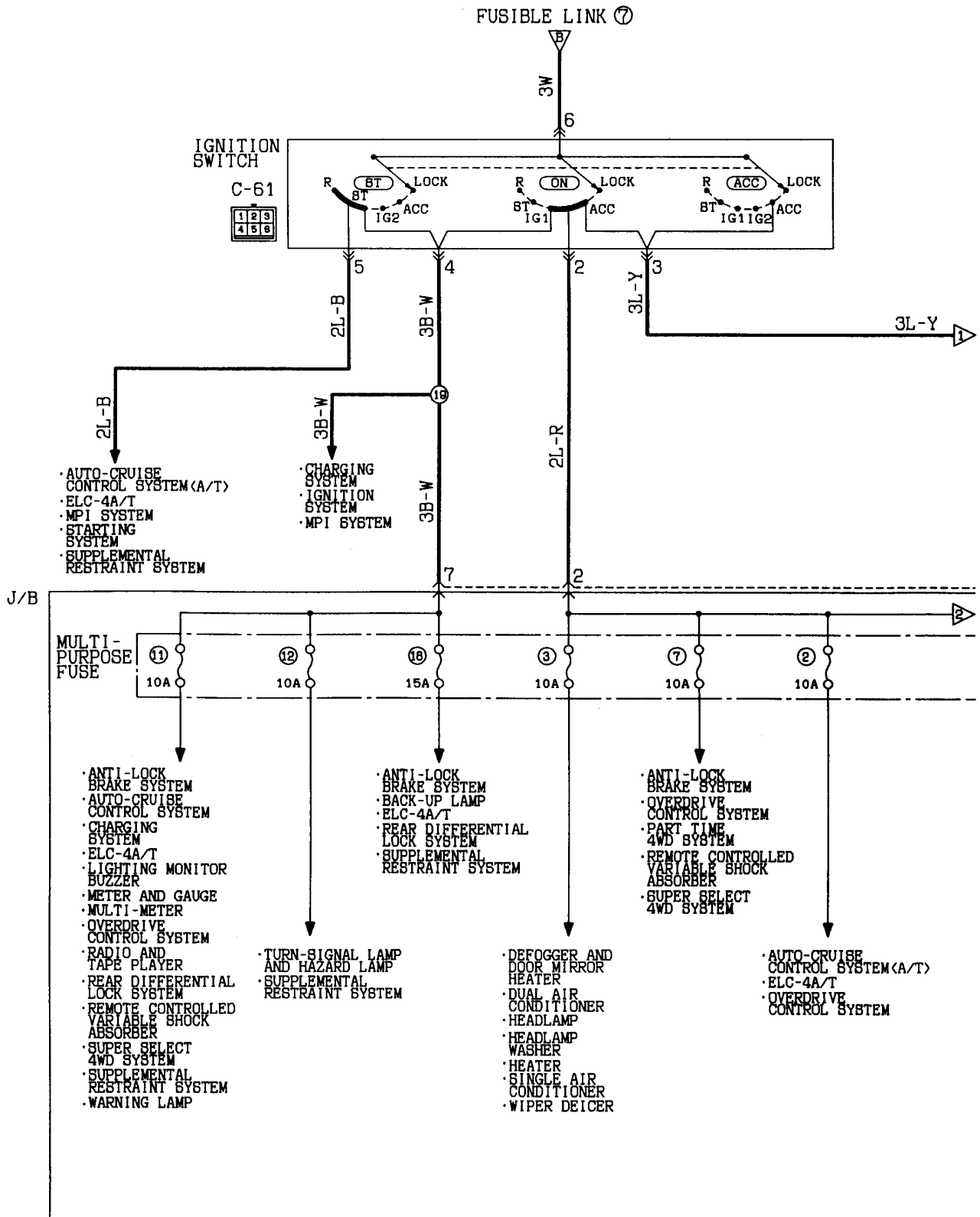

Remark

The above circuit diagram shows the current flow at the ignition key position "ACC", "ON" and "BT" combined. Be sure trace the appropriate circuit depending on the ignition key position.

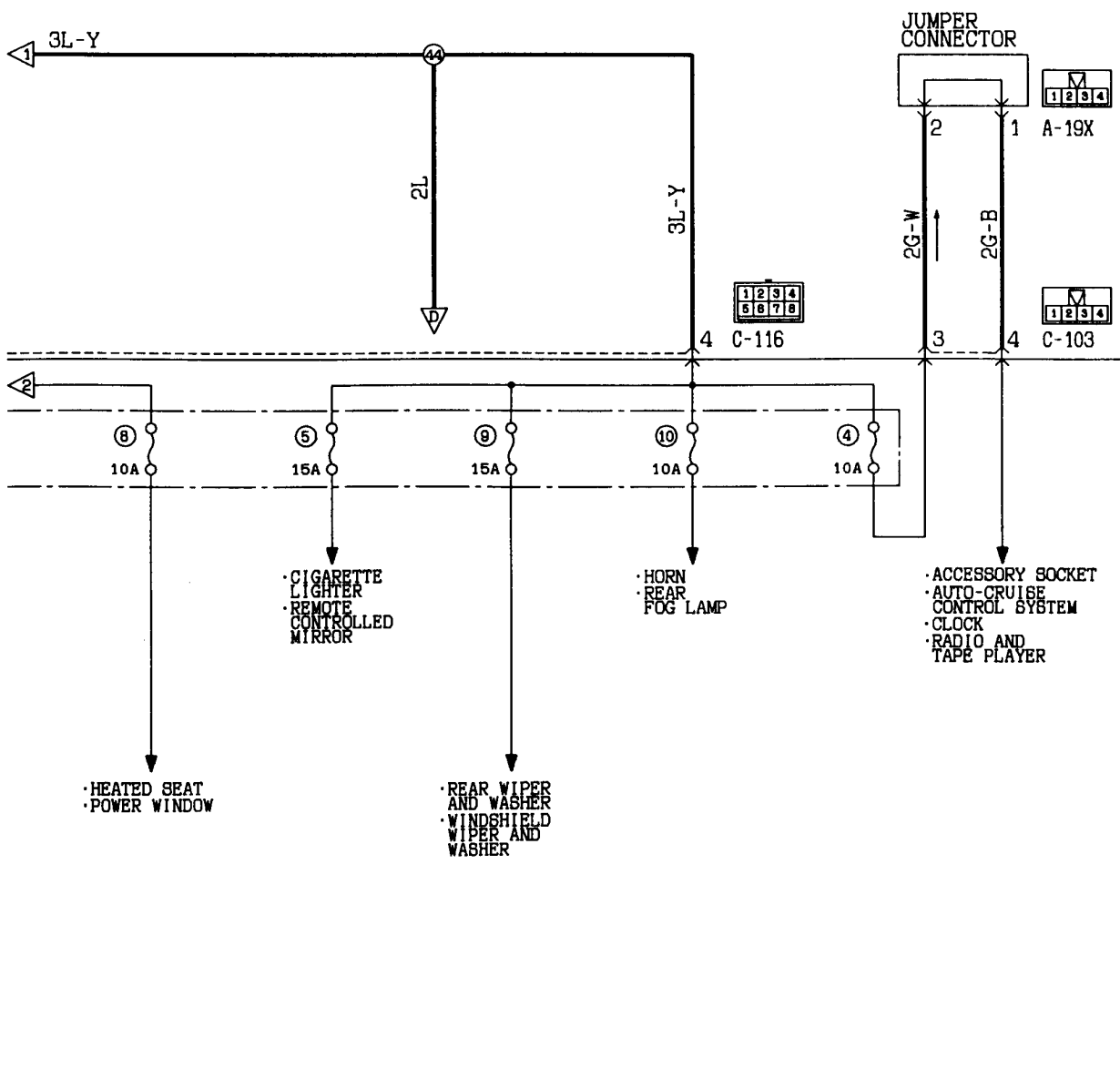

Wire colour code
 B:Black LG:Light green G:Green L:Blue W:White Y:Yellow SB:Sky blue
 BR:Brown O:Orange GR:Gray R:Red P:Pink V:Violet

POWER DISTRIBUTION SYSTEM <Petrol-powered vehicles>
(CONTINUED)

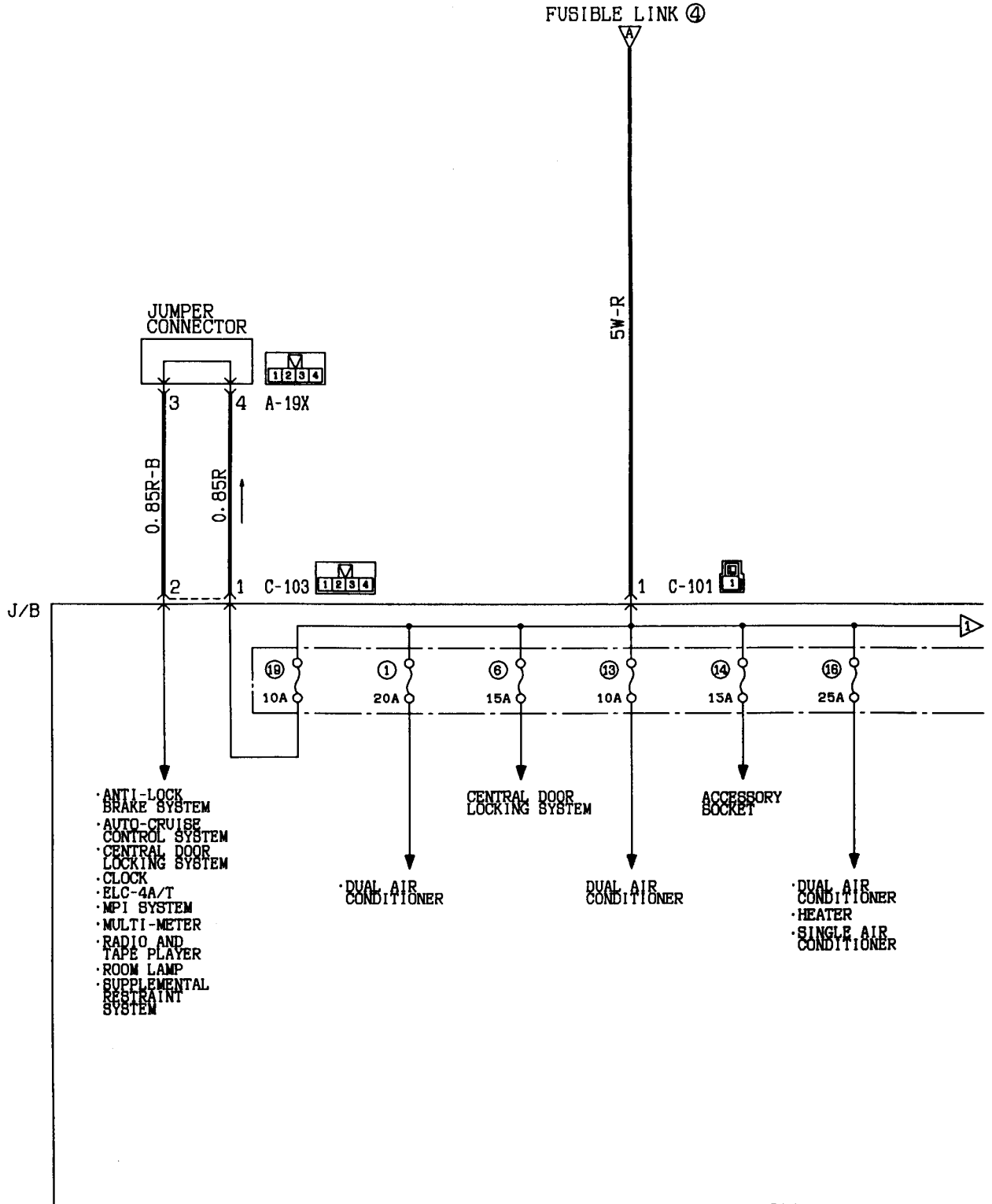

Wire colour code
 B:Black LG:Light green G:Green L:Blue W:White Y:Yellow SB:Sky blue
 BR:Brown O:Orange GR:Gray R:Red P:Pink V:Violet

KX35-AC-00105B-EC

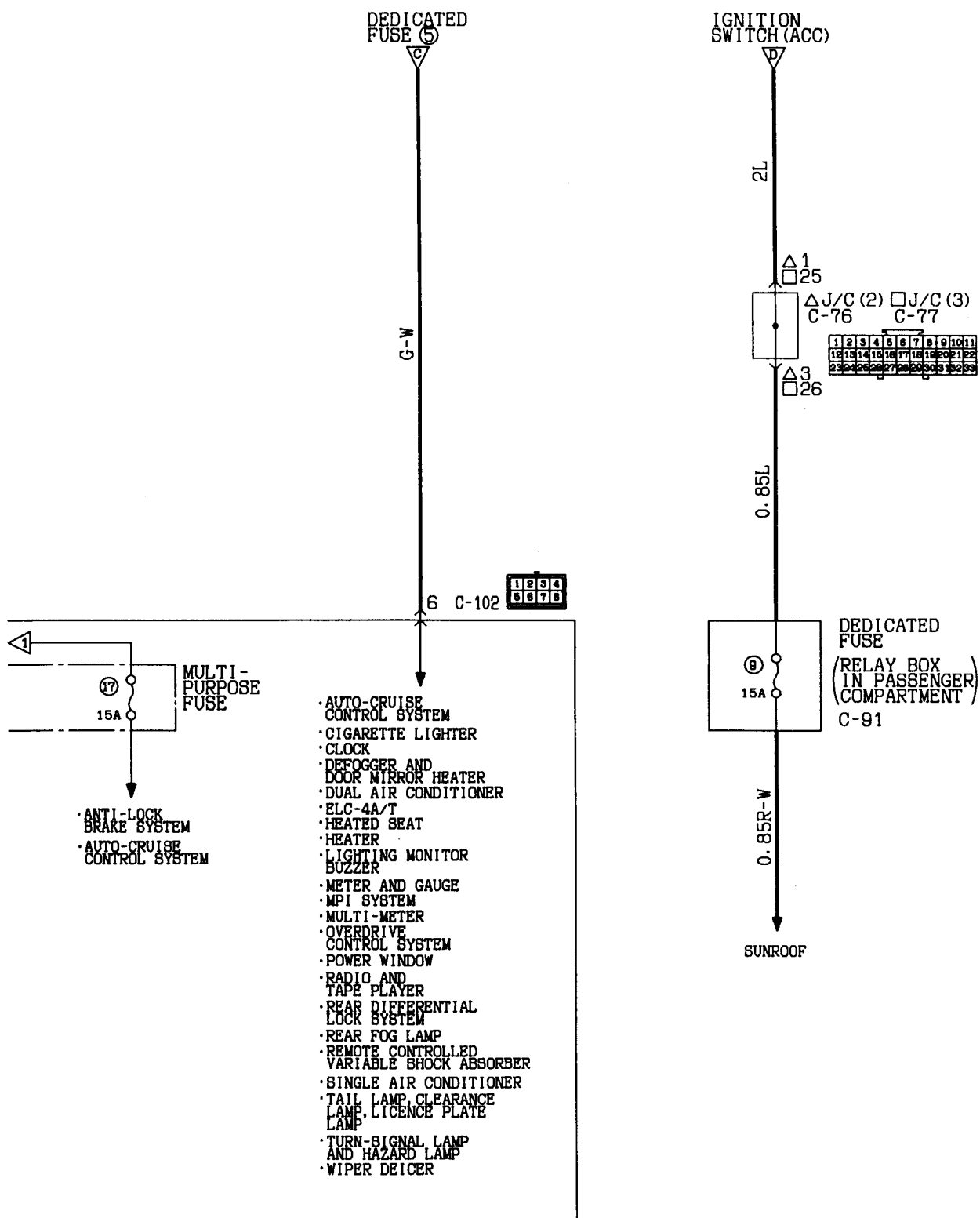

Remarks
 (1) □ : L. H. drive vehicles.
 (2) △ : R. H. drive vehicles.

POWER DISTRIBUTION SYSTEM
(Diesel-powered vehicles)

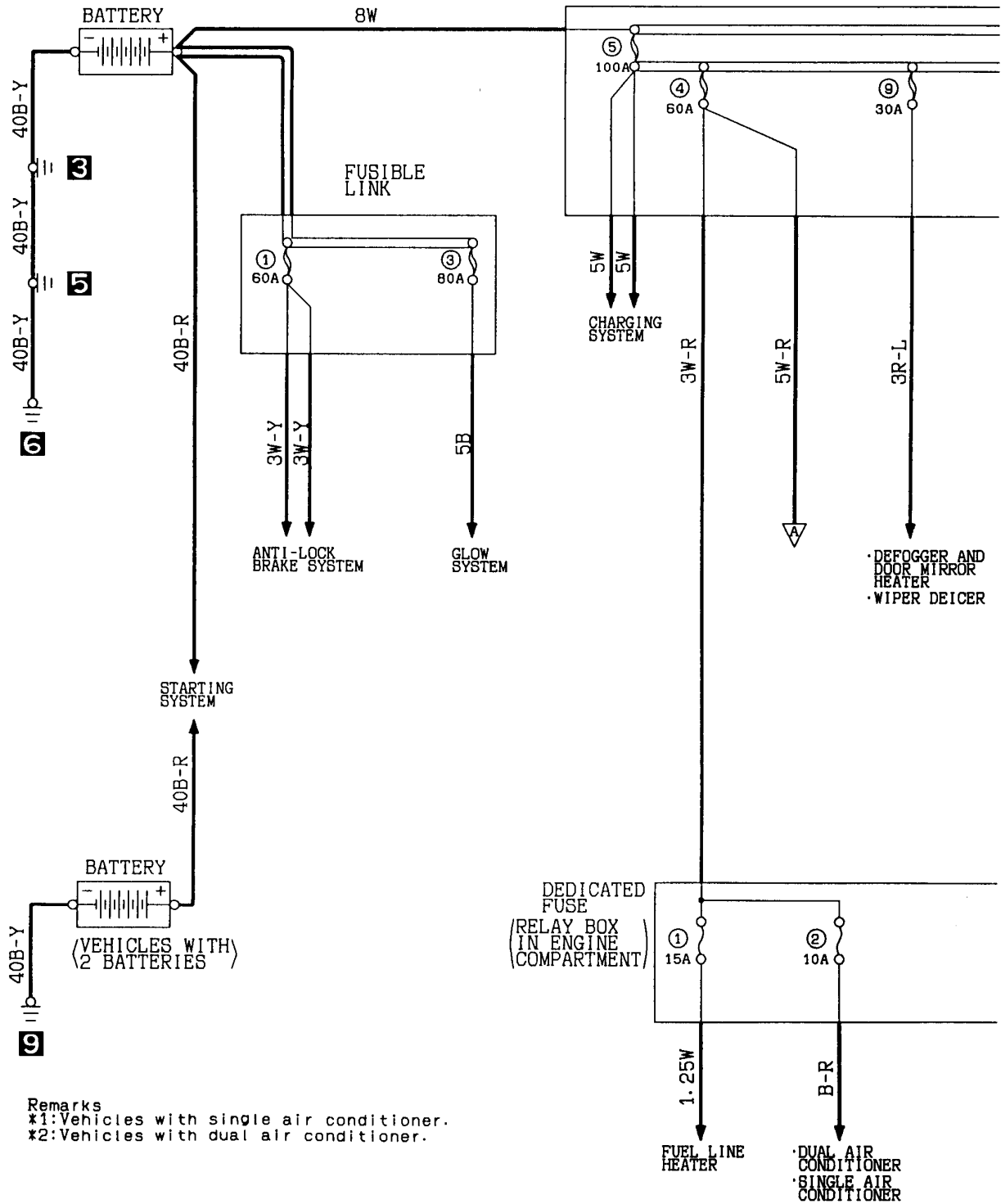

Remarks
 *1: Vehicles with single air conditioner.
 *2: Vehicles with dual air conditioner.

Wire colour code
 B:Black LG:Light green G:Green L:Blue W:White Y:Yellow SB:Sky blue
 BR:Brown O:Orange GR:Gray R:Red P:Pink V:Violet

POWER DISTRIBUTION SYSTEM (Diesel-powered vehicles)
(CONTINUED)

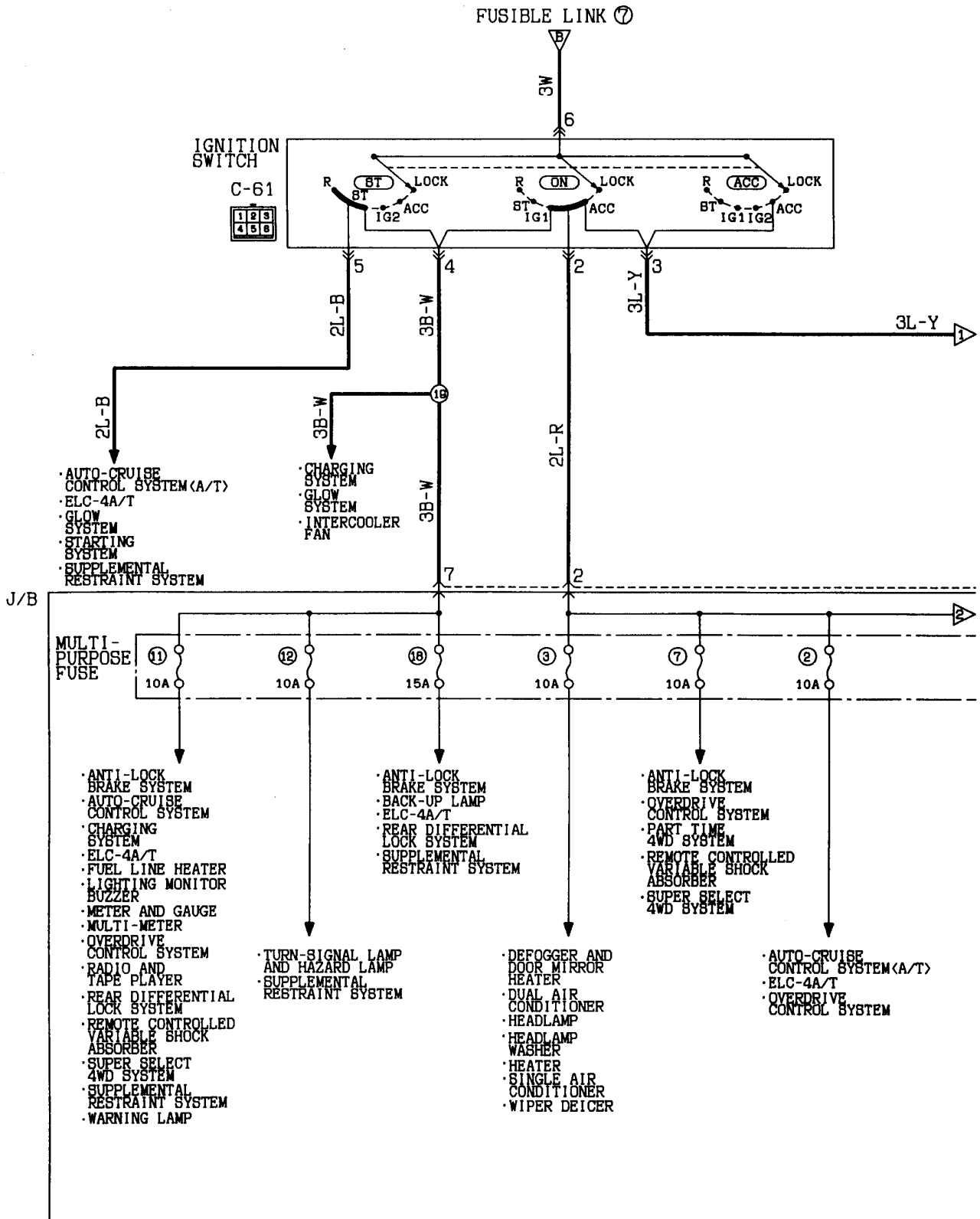

Remark
 The above circuit diagram shows the current flow at the ignition key position "ACC", "ON" and "BT" combined. Be sure trace the appropriate circuit depending on the ignition key position.

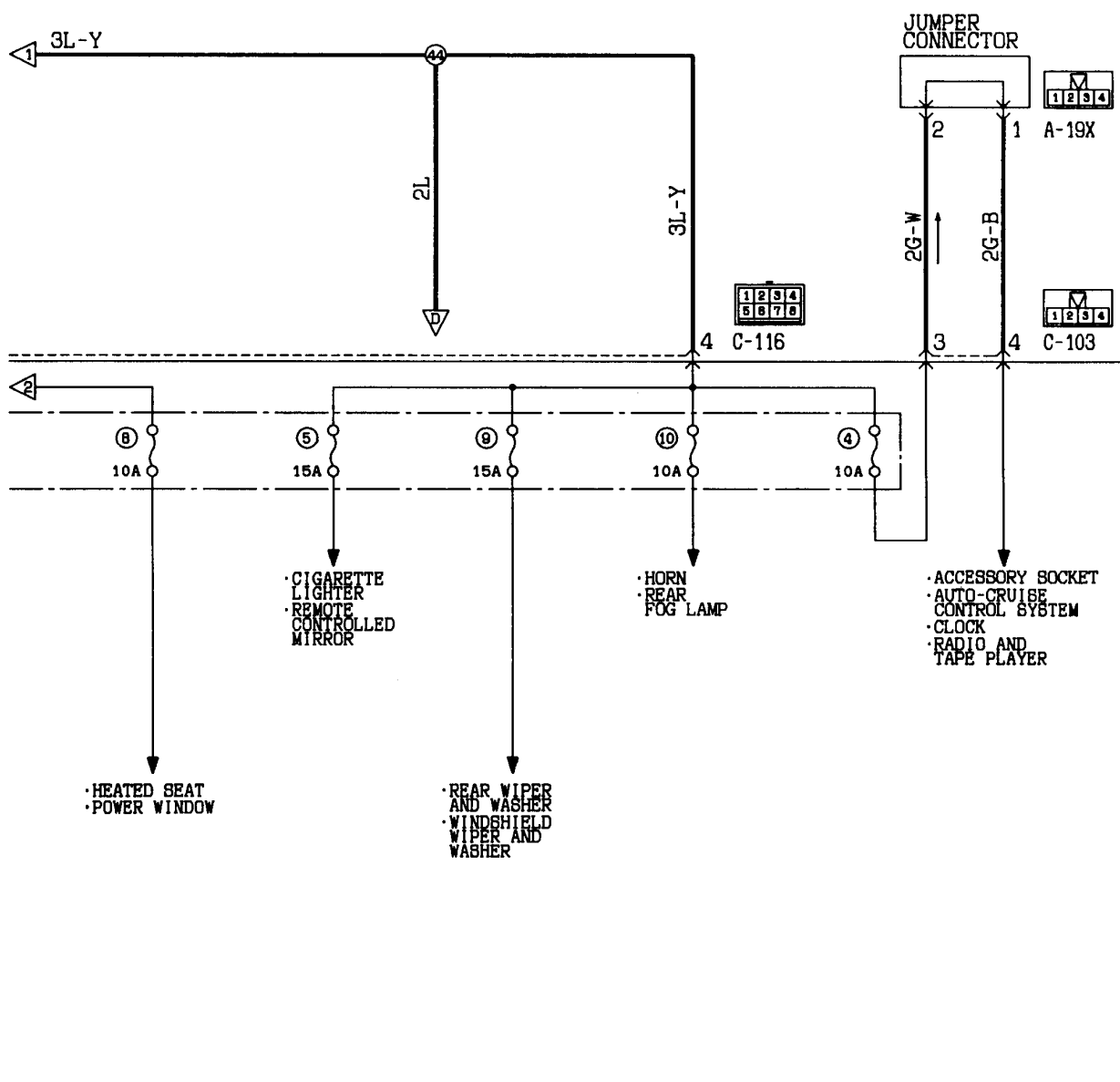

Wire colour code
 B:Black LG:Light green G:Green L:Blue W:White Y:Yellow SB:Sky blue
 BR:Brown O:Orange GR:Gray R:Red P:Pink V:Violet

POWER DISTRIBUTION SYSTEM (Diesel-powered vehicles)
(CONTINUED)

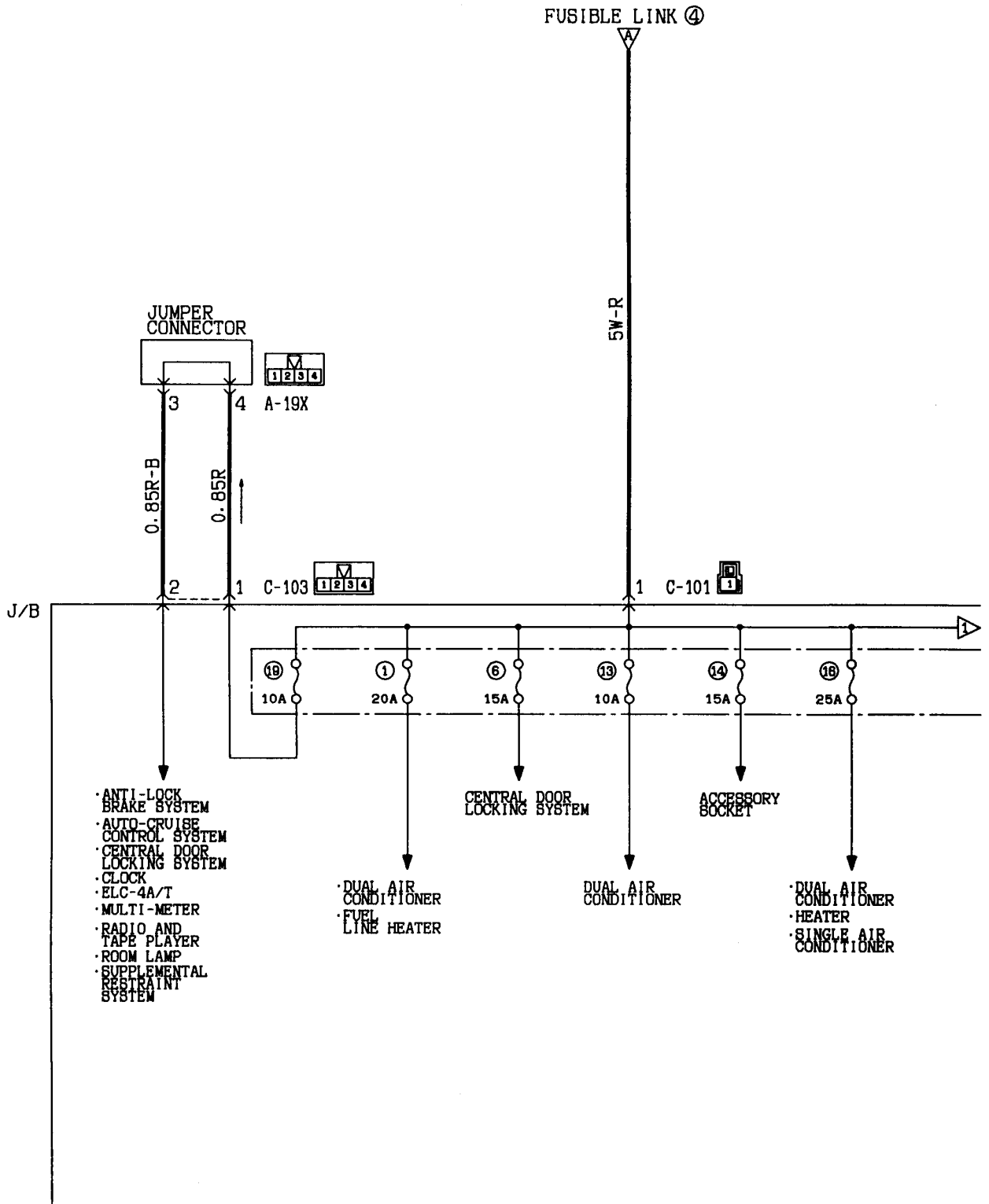

Wire colour code
 B:Black LG:Light green G:Green L:Blue W:White Y:Yellow SB:Sky blue
 BR:Brown O:Orange GR:Gray R:Red P:Pink V:Violet

KX35-AC-00104B-EC

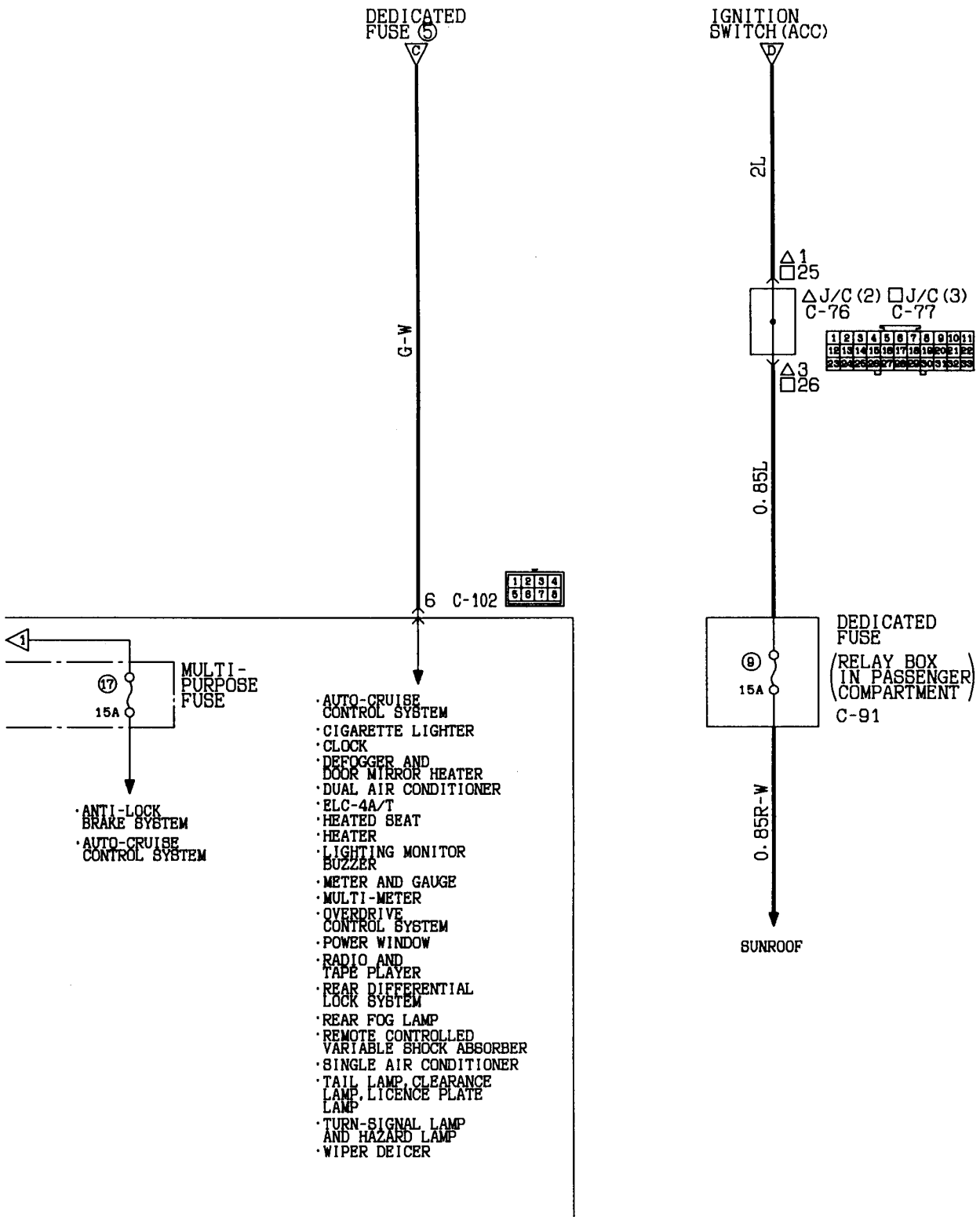

Remarks
 (1) □ : L. H. drive vehicles.
 (2) △ : R. H. drive vehicles.

STARTING SYSTEM
4G64 engine

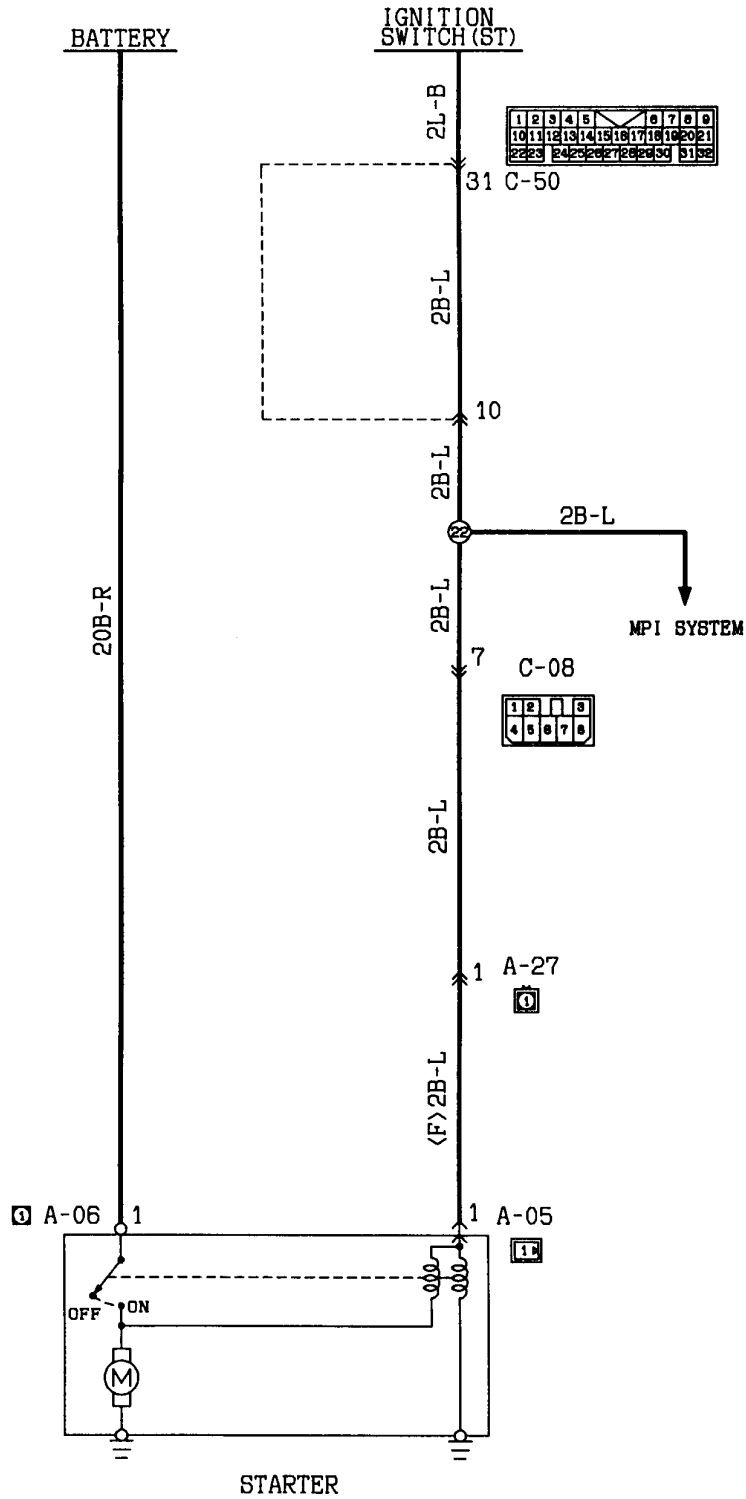

KX35-AC-00206-EC

Wire colour code
 B:Black LG:Light green G:Green L:Blue W:White Y:Yellow SB:Sky blue
 BR:Brown O:Orange GR:Gray R:Red P:Pink V:Violet

STARTING SYSTEM
6G72, 6G74 engine

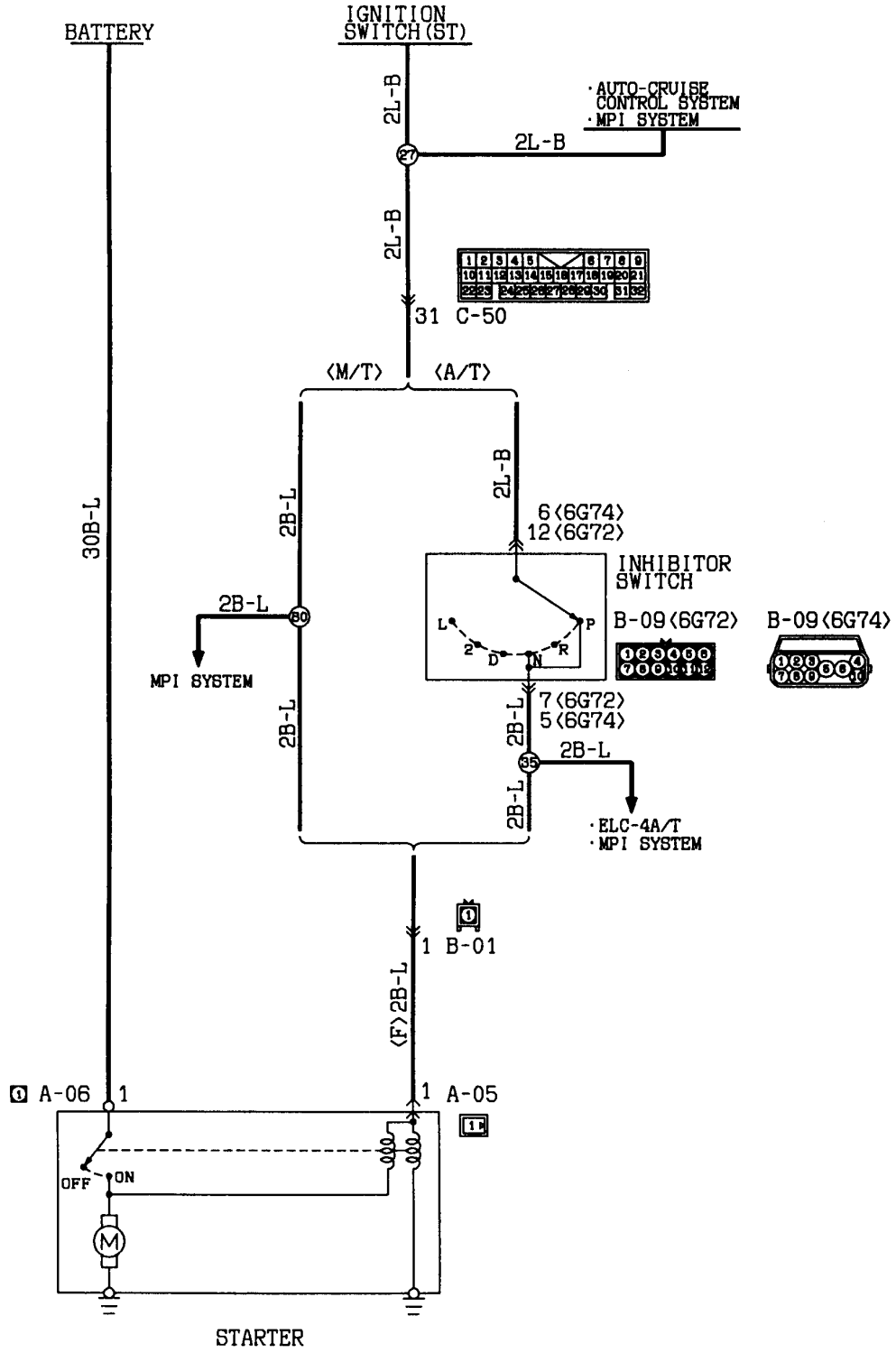

Wire colour code
 B:Black LG:Light green G:Green L:Blue W:White Y:Yellow BB:Sky blue
 BR:Brown O:Orange GR:Gray R:Red P:Pink V:Violet

KX35-AC-00204-EC

© Mitsubishi Motors Corporation Dec. 1993

PHJE9026-C

ADDED

STARTING SYSTEM
4D56, 4M40 engine

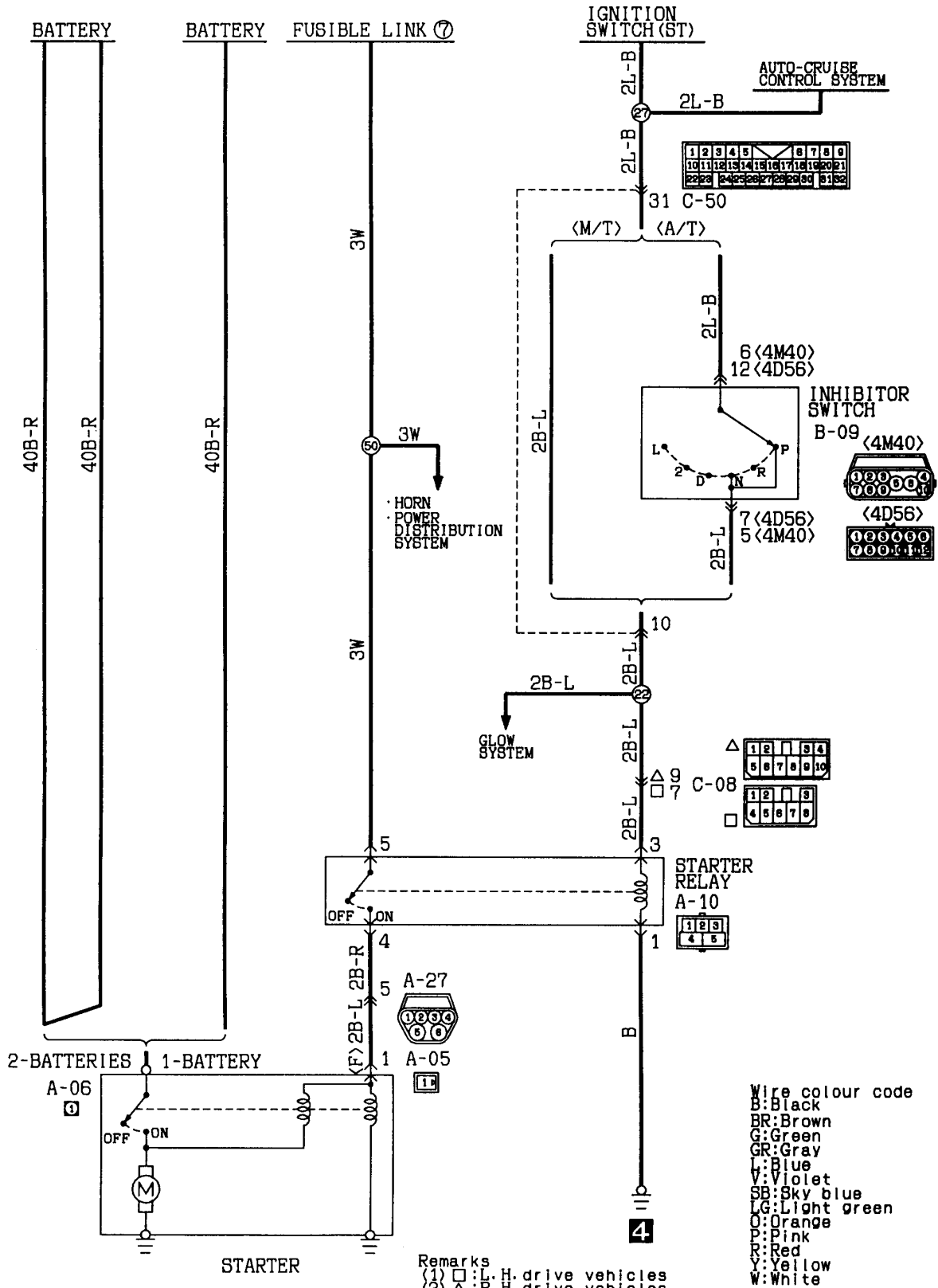

KX35-AC-00205-EC

STARTING SYSTEM (See P. 4A-22, 23, 24.)**OPERATION****<Petrol-powered vehicles>**

- On vehicles with automatic transmission, placing the ignition switch in the ST position with the selector lever in P or N position causes the starter contacts (magnet switch) to close energizing the starter motor.

<Diesel-powered vehicles>

- On vehicles with automatic transmission, placing the ignition switch in the ST position with the selector lever in P or N position, the starter relay becomes on. This will turn on the contacts of the starter (magnetic switch) to revolve the starter motor.

TROUBLESHOOTING HINTS

1. Starter motor does not turn over at all.
 - Check starter (coil).
 - Check battery terminals for proper contact.
2. Starter motor does not stop rotating.
 - Check starter (magnet switch).

IGNITION SYSTEM
4G64 engine

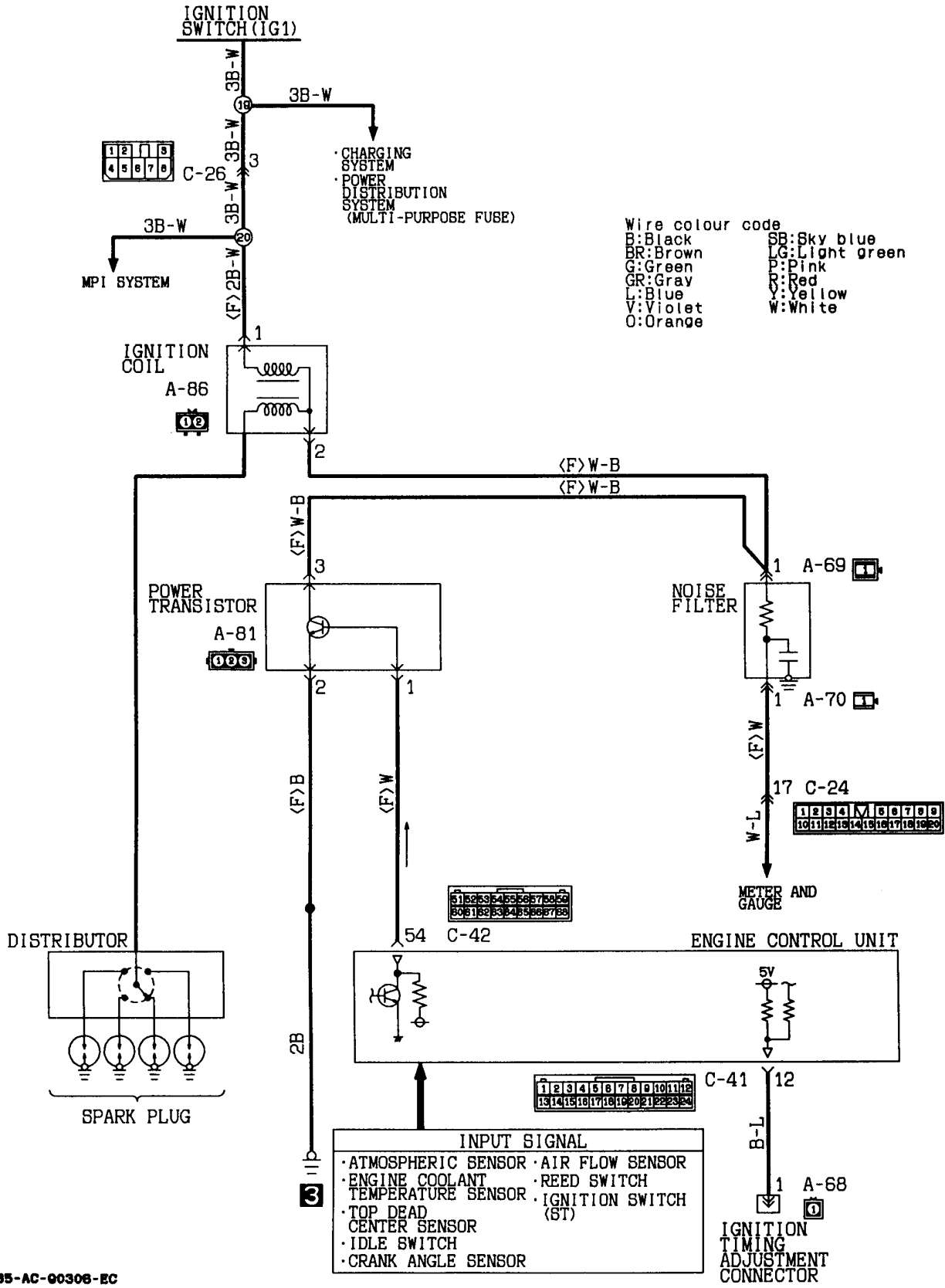

KX35-AC-00306-EC

IGNITION SYSTEM
6G72 engine

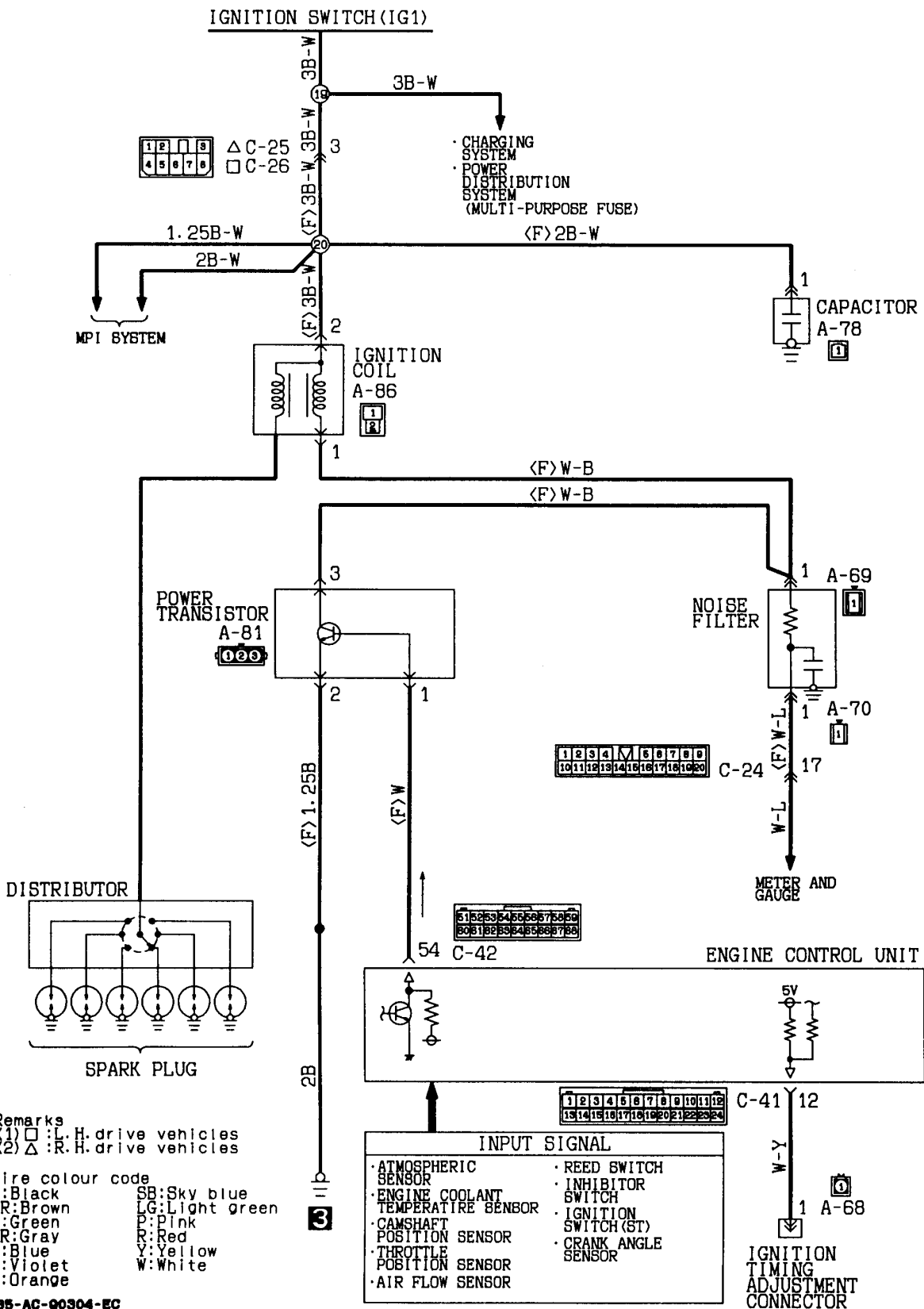

KX35-AC-00304-EC

IGNITION SYSTEM
6G74 engine

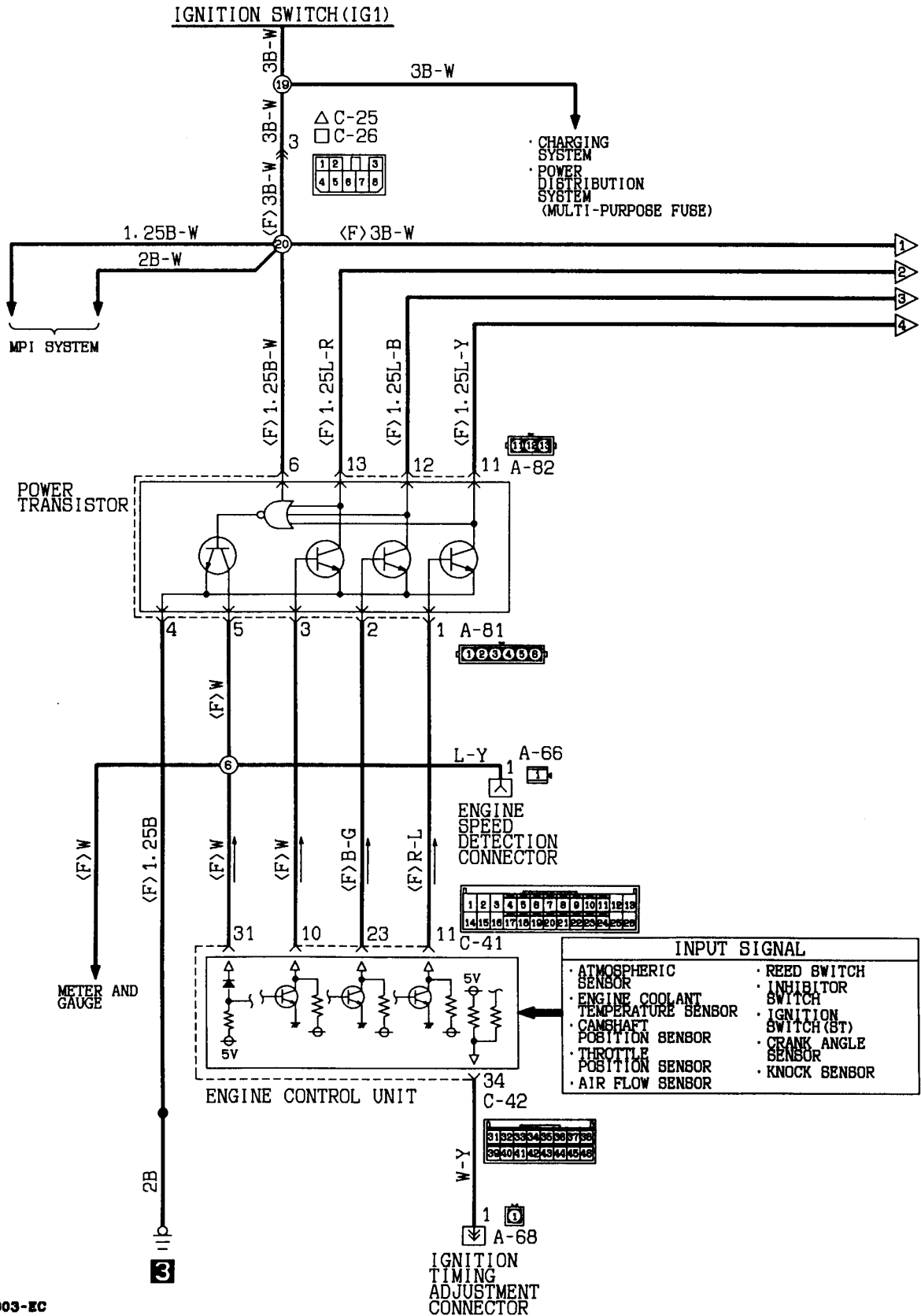

KX35-AC-00303-EC

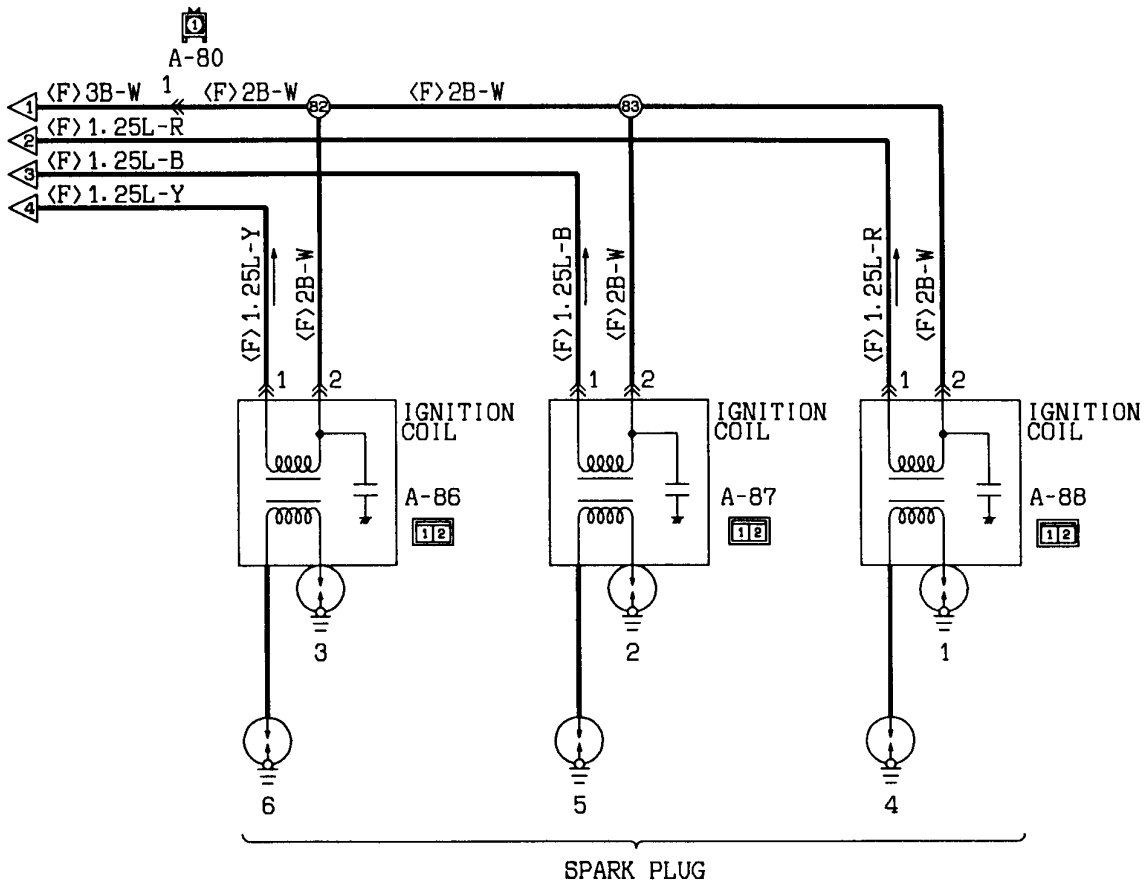

Remarks
 (1) □: L.H. drive vehicles.
 (2) △: R.H. drive vehicles.

Wire colour code
 B:Black LG:Light green G:Green L:Blue W:White Y:Yellow SB:Sky blue
 BR:Brown O:Orange GR:Gray R:Red P:Pink V:Violet

CHARGING SYSTEM
4G64, 6G72 engine

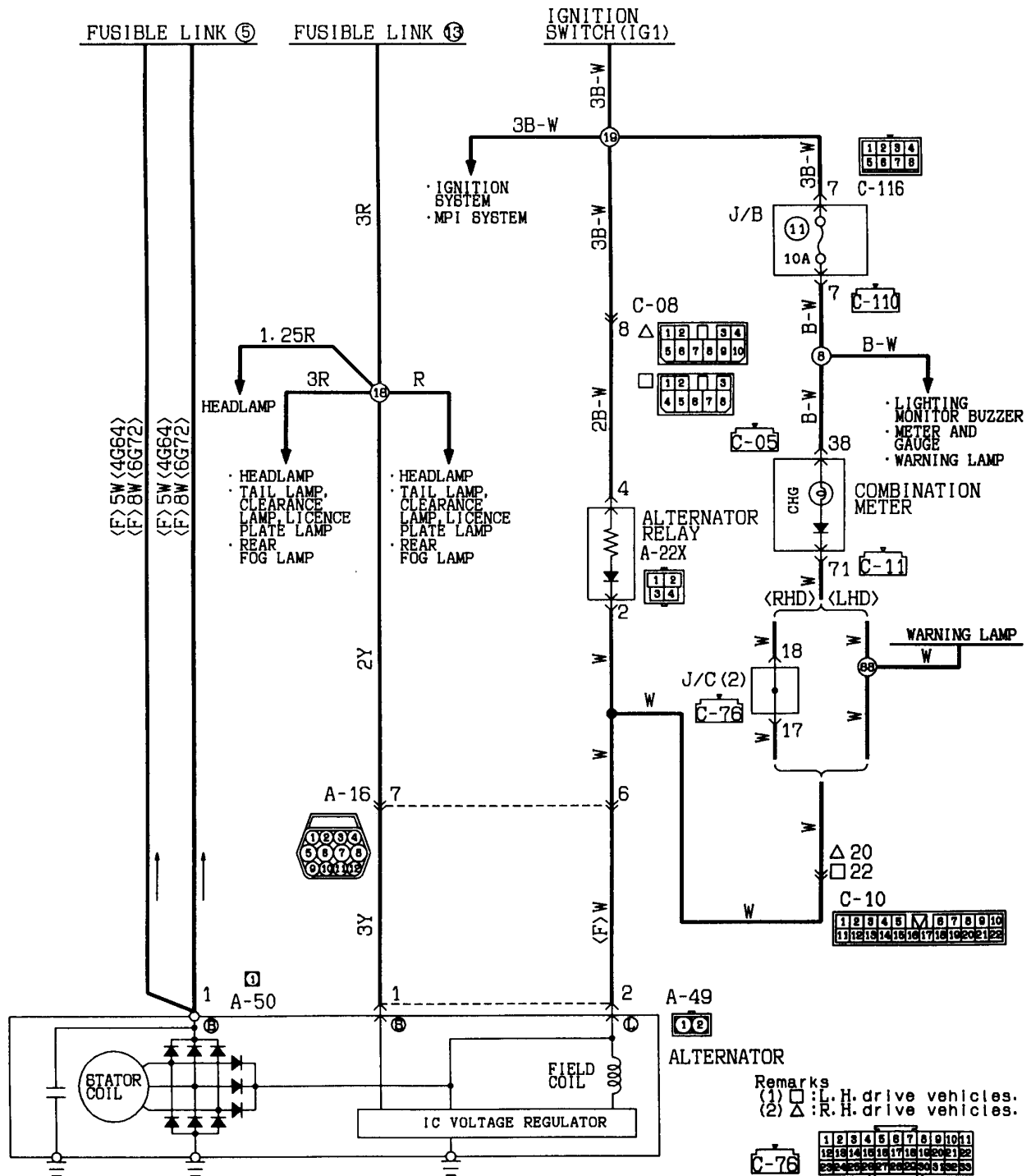

Wire colour code
 B:Black LG:Light green G:Green L:Blue
 BR:Brown O:Orange GR:Gray R:Red
 W:White SB:Sky blue P:Pink Y:Yellow
 V:Violet

Remarks
 (1) □ : L. H. drive vehicles.
 (2) △ : R. H. drive vehicles.

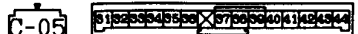

CHARGING SYSTEM
6G74 engine

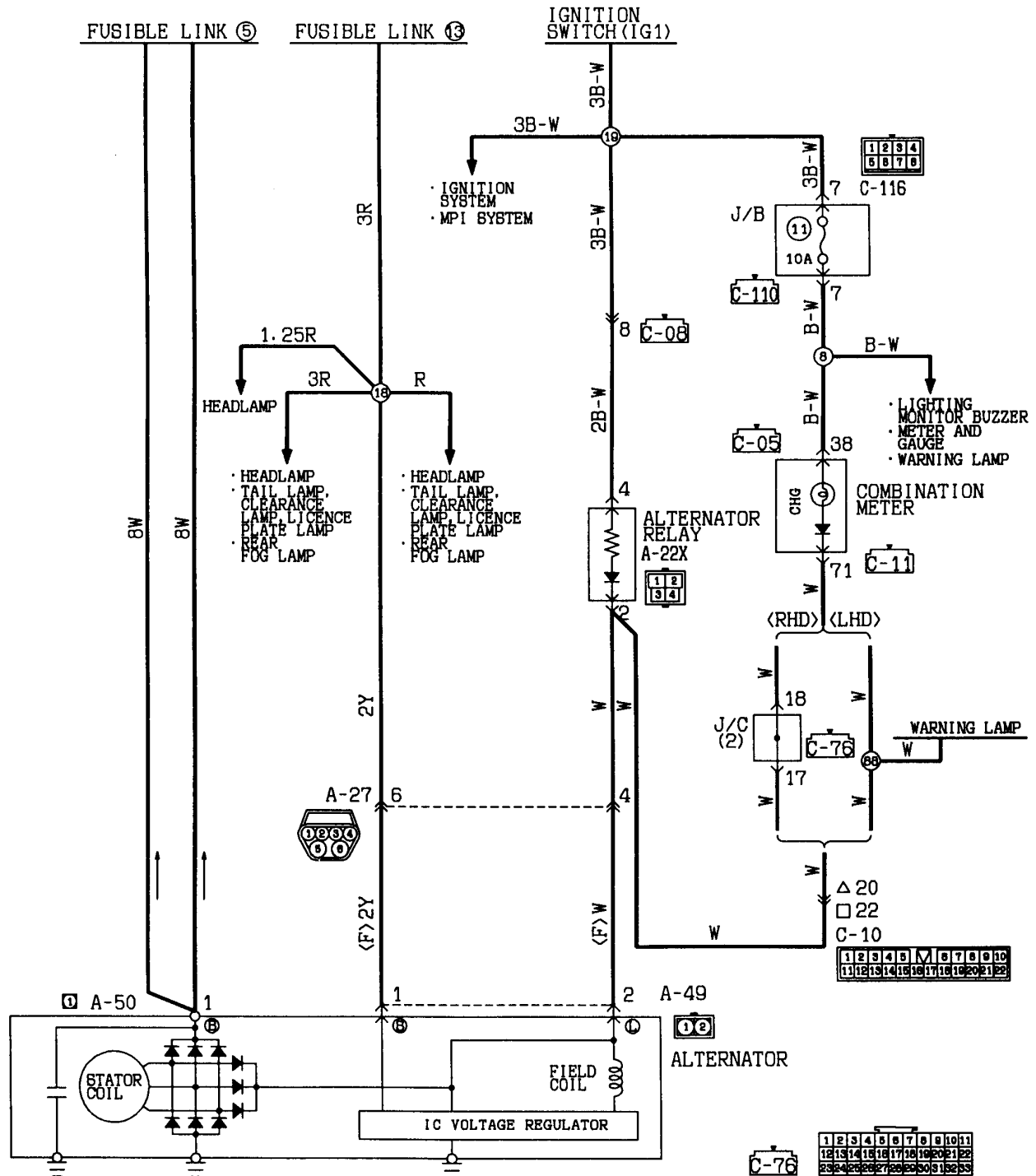

Wire colour code
 B:Black LG:Light green G:Green L:Blue
 BR:Brown O:Orange GR:Gray R:Red
 W:White SB:Sky blue P:Pink Y:Yellow
 V:Violet

Remarks
 (1) □ : L. H. drive vehicles
 (2) △ : R. H. drive vehicles

KX35-AC-00404-EC

C-08	(RHD)	C-110
	(LHD)	
C-11	(RHD)	C-05
	(LHD)	

CHARGING SYSTEM
4D56, 4M40 engine

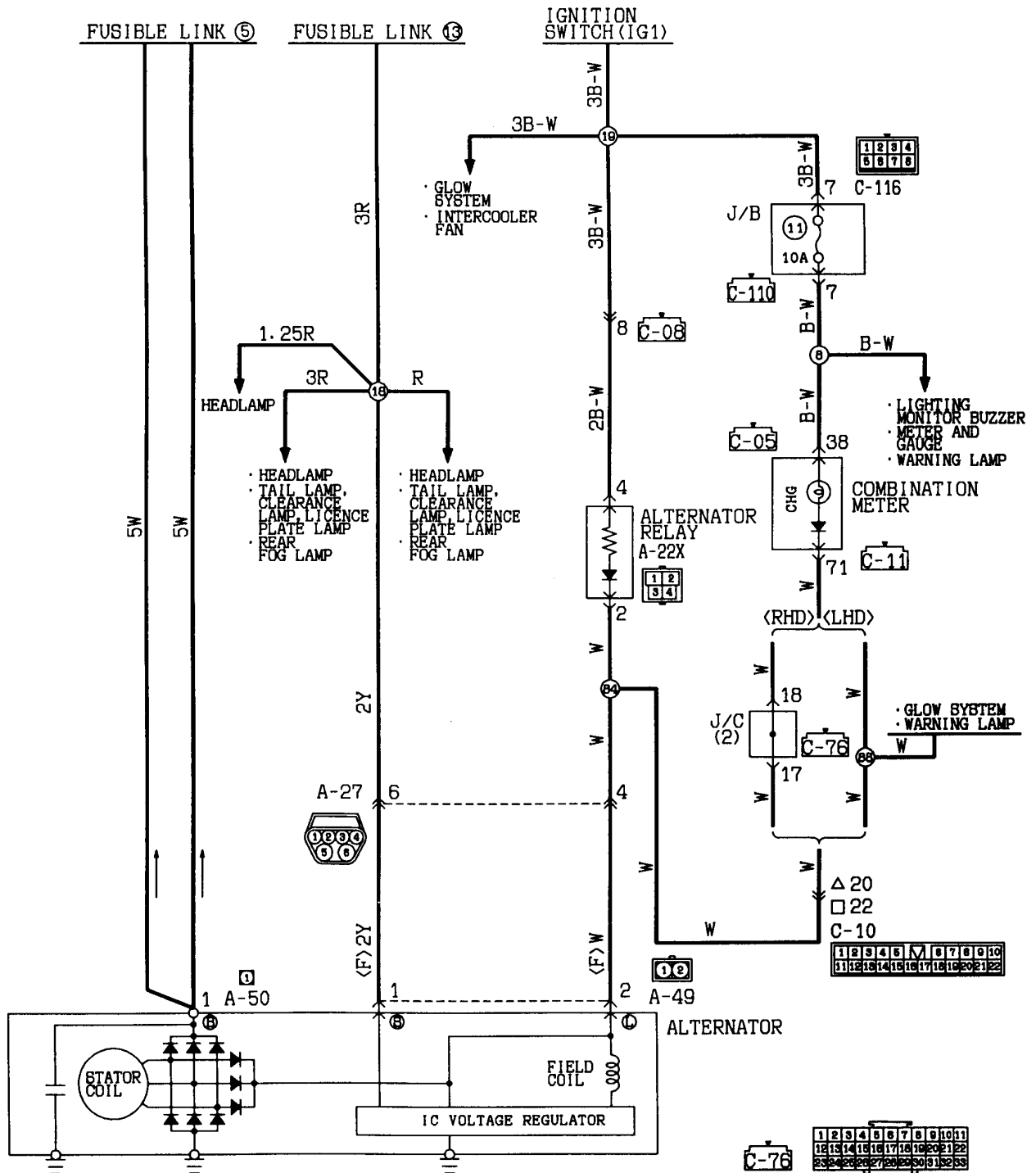

Wire colour code
 B:Black LG:Light green G:Green L:Blue
 BR:Brown O:Orange GR:Gray R:Red
 W:White SB:Sky blue P:Pink Y:Yellow
 V:Violet

Remarks
 (1) □ : L. H. drive vehicles
 (2) △ : R. H. drive vehicles

KX35-AC-00407-EC

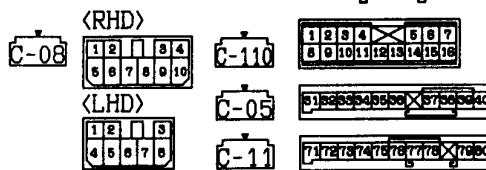

CHARGING SYSTEM (See P. 4A-30, 31, 32.)**OPERATION****When engine is stationary**

- When the ignition switch is turned to the ON position, current flows the alternator L terminal to the field coil and, at the same time, the charge warning lamp lights up.

When engine is started and after engine has started

- When the engine is started, the charge warning lamp goes out because of the charging voltage being applied to the alternator L terminal.
- The battery voltage being applied to the alternator S terminal is monitored by the voltage regulator. Hence, the amount of electricity produced by the alternator is controlled by allowing and cutting off the current flowing to the field coil.
- The alternator B terminal supplies power to each load.

Remark

- The alternator relay is provided to back up the flow of current to the field coil when the charge warning lamp is open.

TROUBLESHOOTING HINTS

1. Charging indicator lamp does not go on when the ignition switch is turned to "ON", before the engine starts.
 - Check multi-porpose fuse No. ①.
 - Check the bulb.
2. Charging indicator lamp fails to go off once the engine starts.
 - Check voltage regulator of alternator.
3. Discharged or overcharged battery.
 - Check voltage regulator of alternator.
4. Charge warning lamp lights up dimly.
 - Check combination meter diode (for short).

GLOW SYSTEM

4D56 engine <Without supercharging pressure relief solenoid valve>

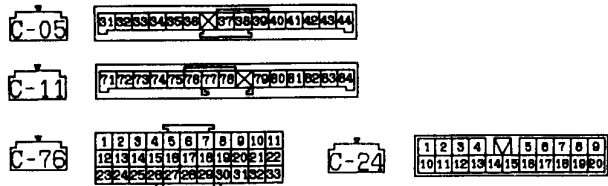
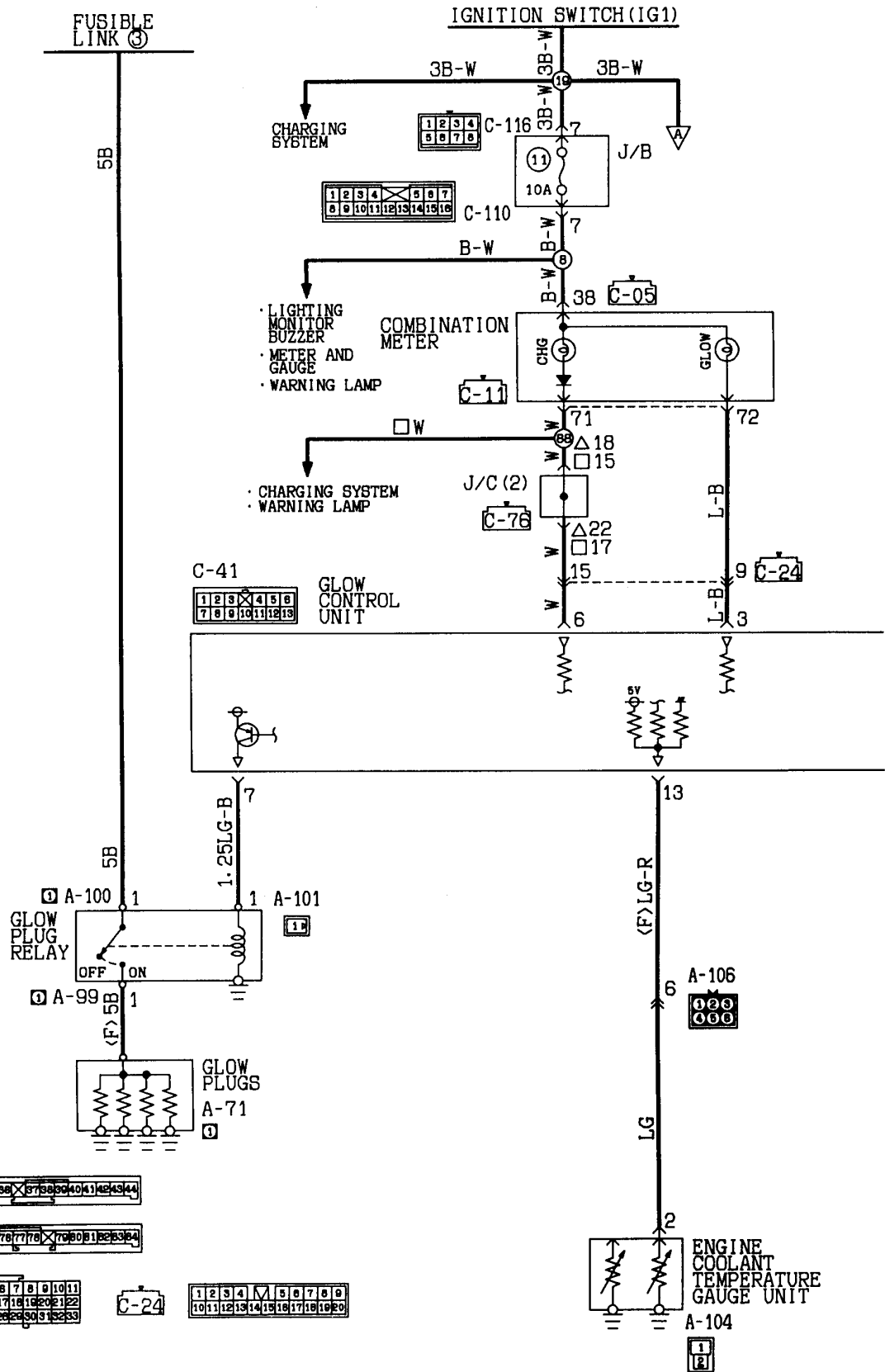

KX35-AC-00515-EC

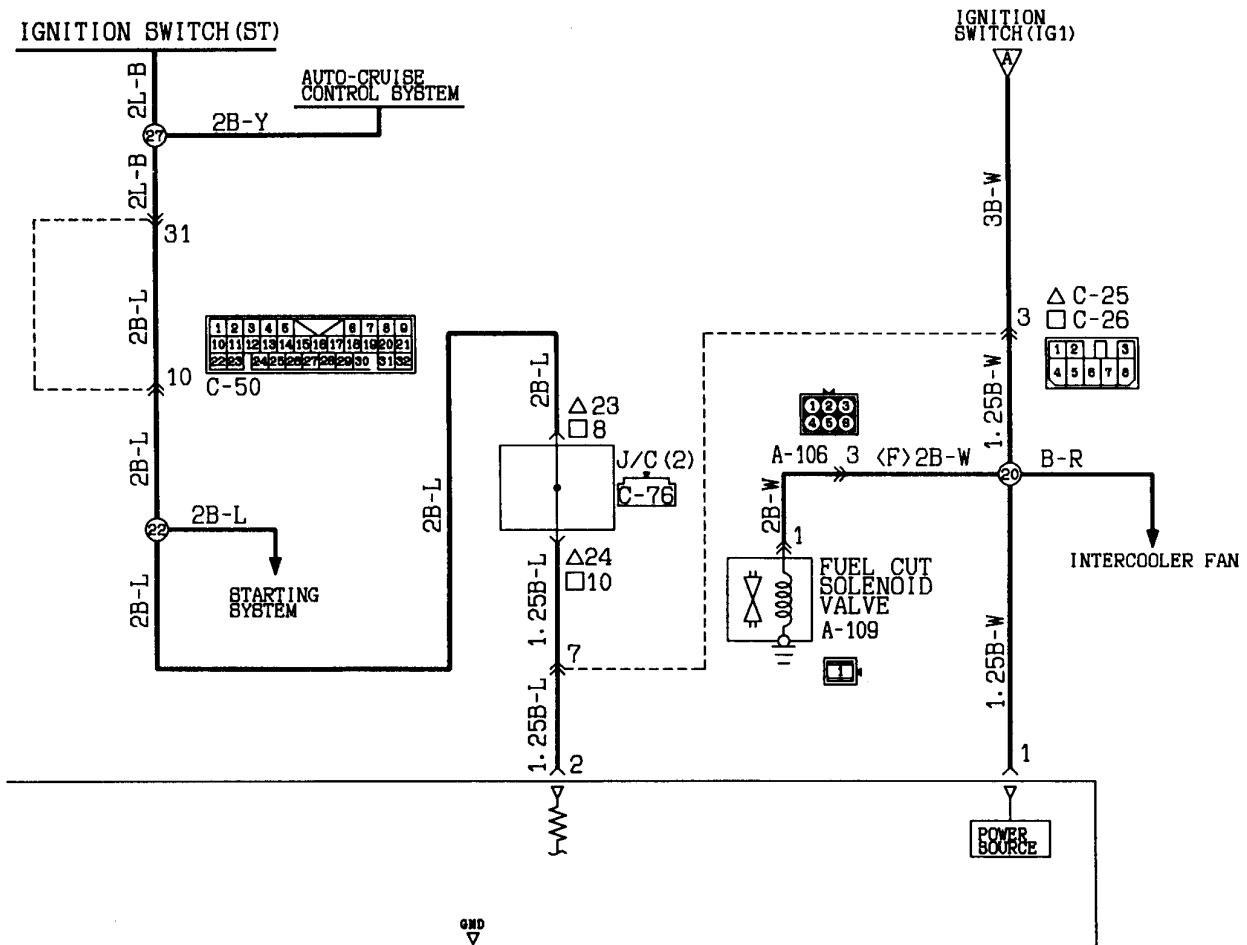

GND
10

<F> 1. 25B

A-106
1 2 3
4 5 6

2B

7

Remarks
(1) □ : L. H. drive vehicles.
(2) △ : R. H. drive vehicles.

Wire colour code
B:Black LG:Light green G:Green L:Blue
BR:Brown O:Orange GR:Gray R:Red
W:White SB:Sky blue P:Pink Y:Yellow
V:Violet

C-76
1 2 3 4 5 6 7 8 9 10 11
12 13 14 15 16 17 18 19 20 21 22
23 24 25 26 27 28 29 30 31 32 33

GLOW SYSTEM

4D56 engine (With supercharging pressure relief solenoid valve)

FUSIBLE LINK ③

IGNITION SWITCH (IG1)

IGNITION SWITCH (ST)

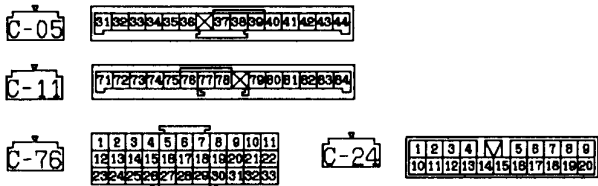
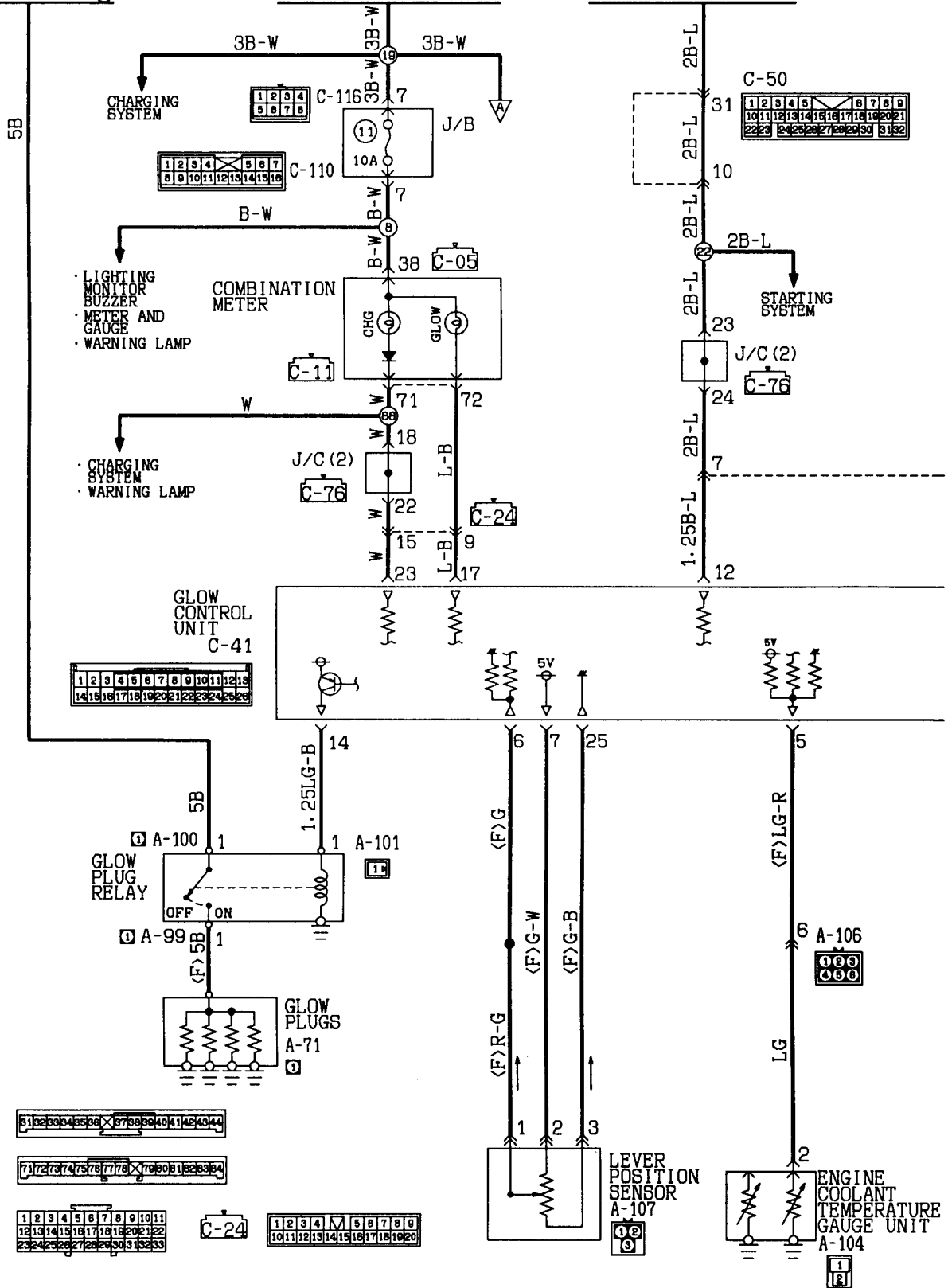

KX35-AC-00519-EC

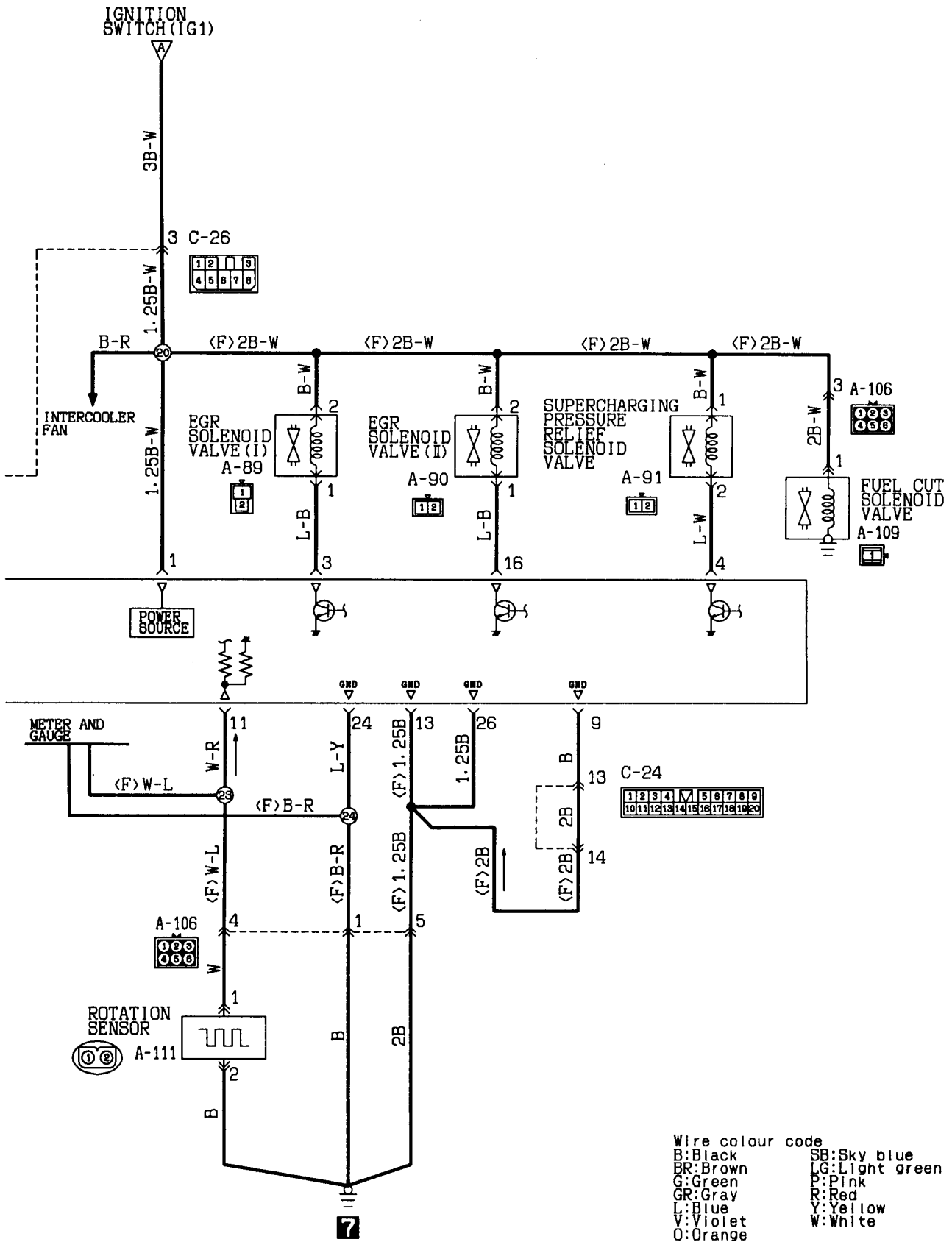

GLOW SYSTEM

4M40 engine (Without supercharging pressure relief solenoid valve)

FUSIBLE LINK ③

IGNITION SWITCH (IG1)

IGNITION SWITCH (ST)

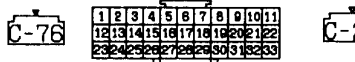
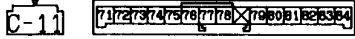
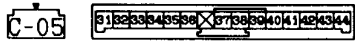
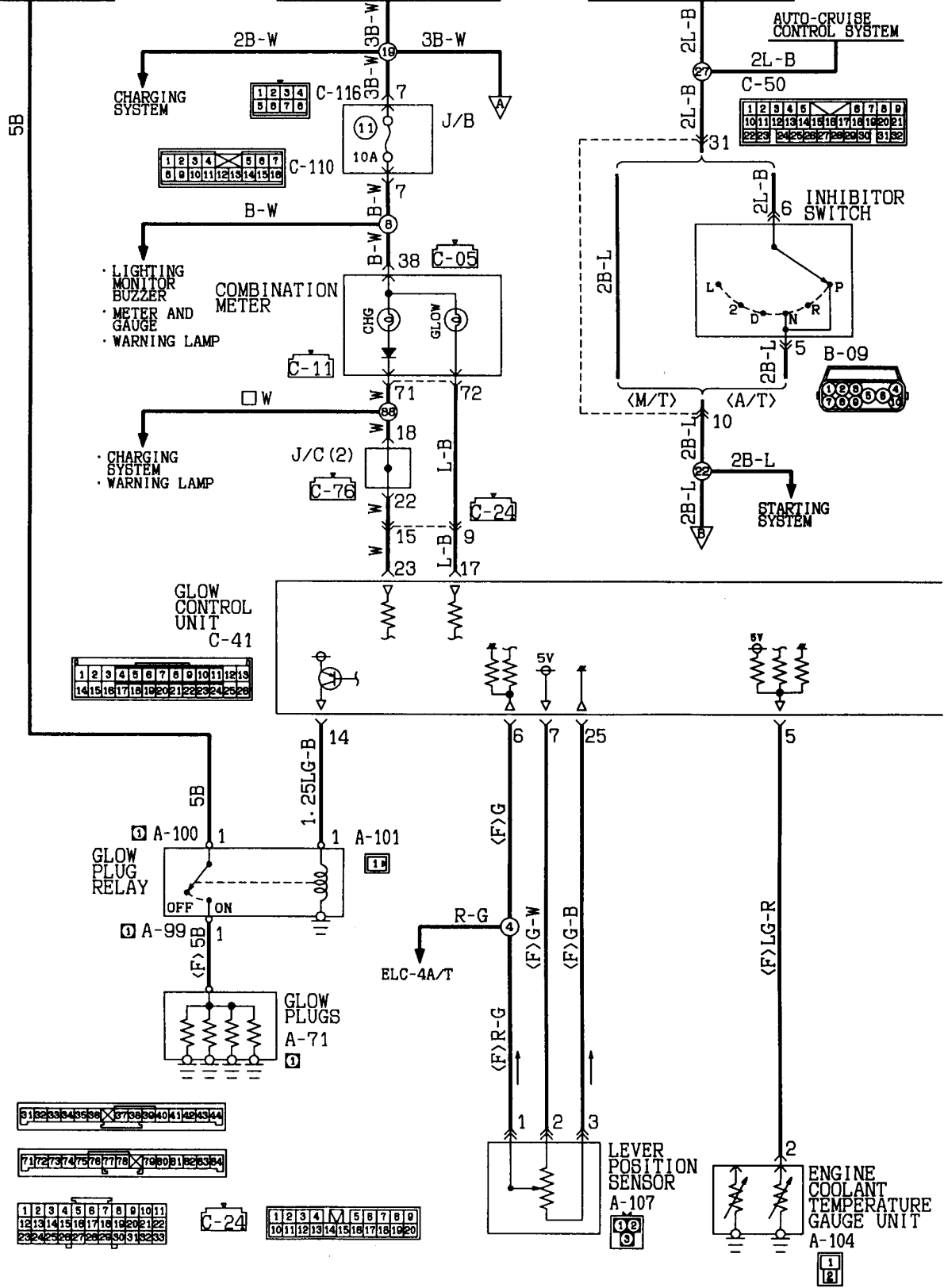

KX35-AC-00512-EC

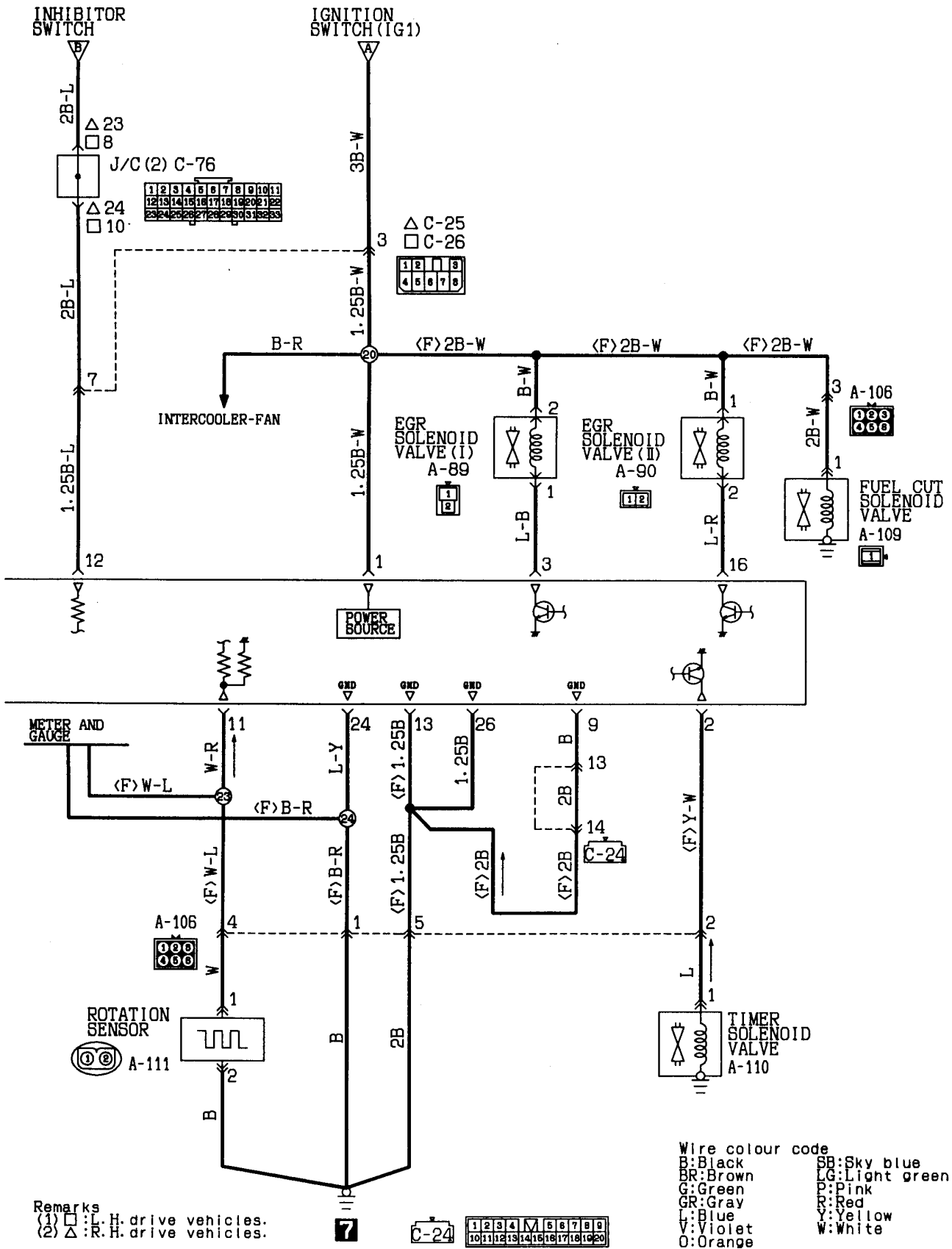

GLOW SYSTEM

4M40 engine (With supercharging pressure relief solenoid valve)

FUSIBLE LINK ③

IGNITION SWITCH (IG1)

IGNITION SWITCH (ST)

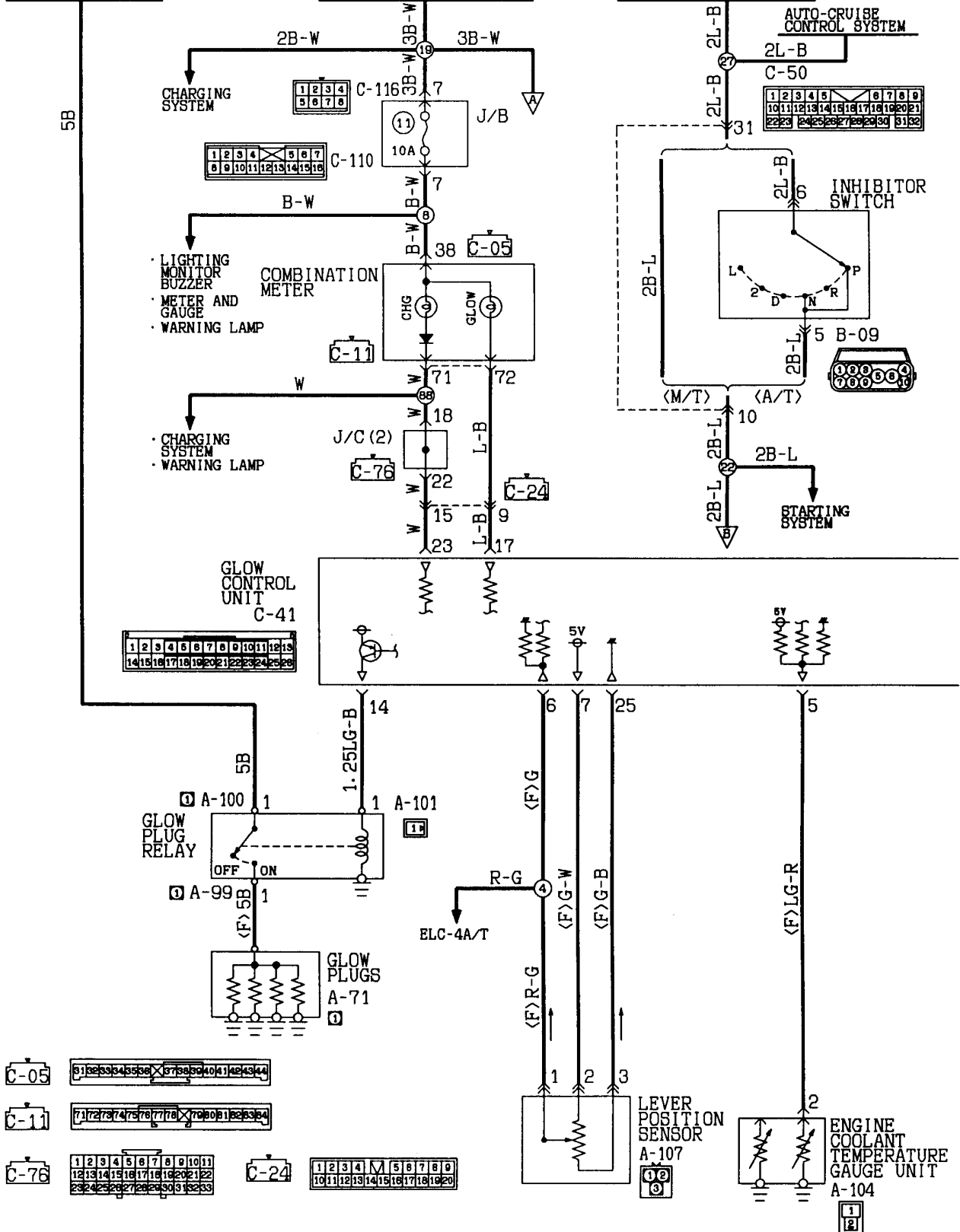

KX35-AC-00520-EC

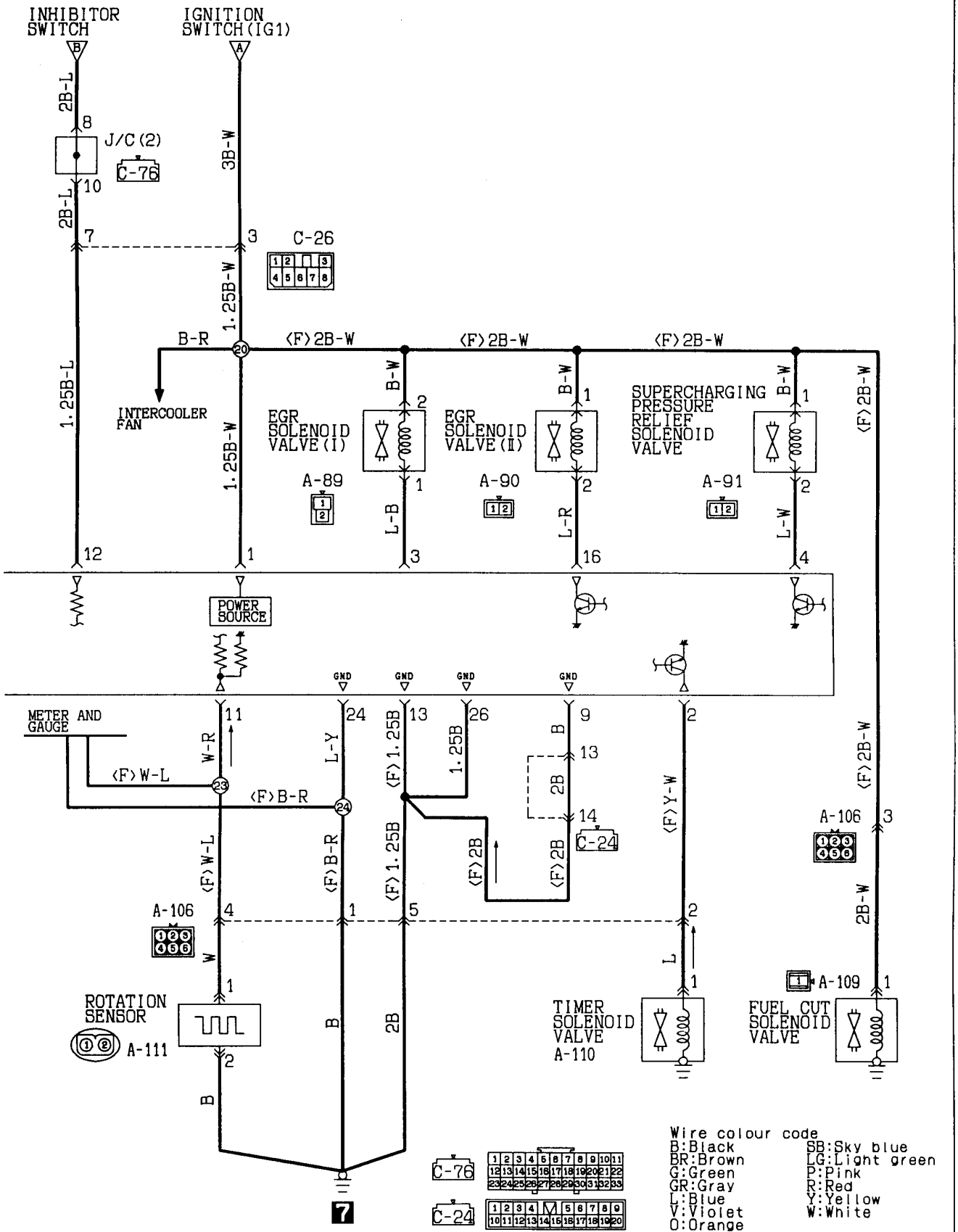

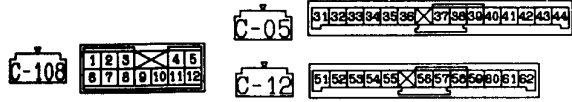
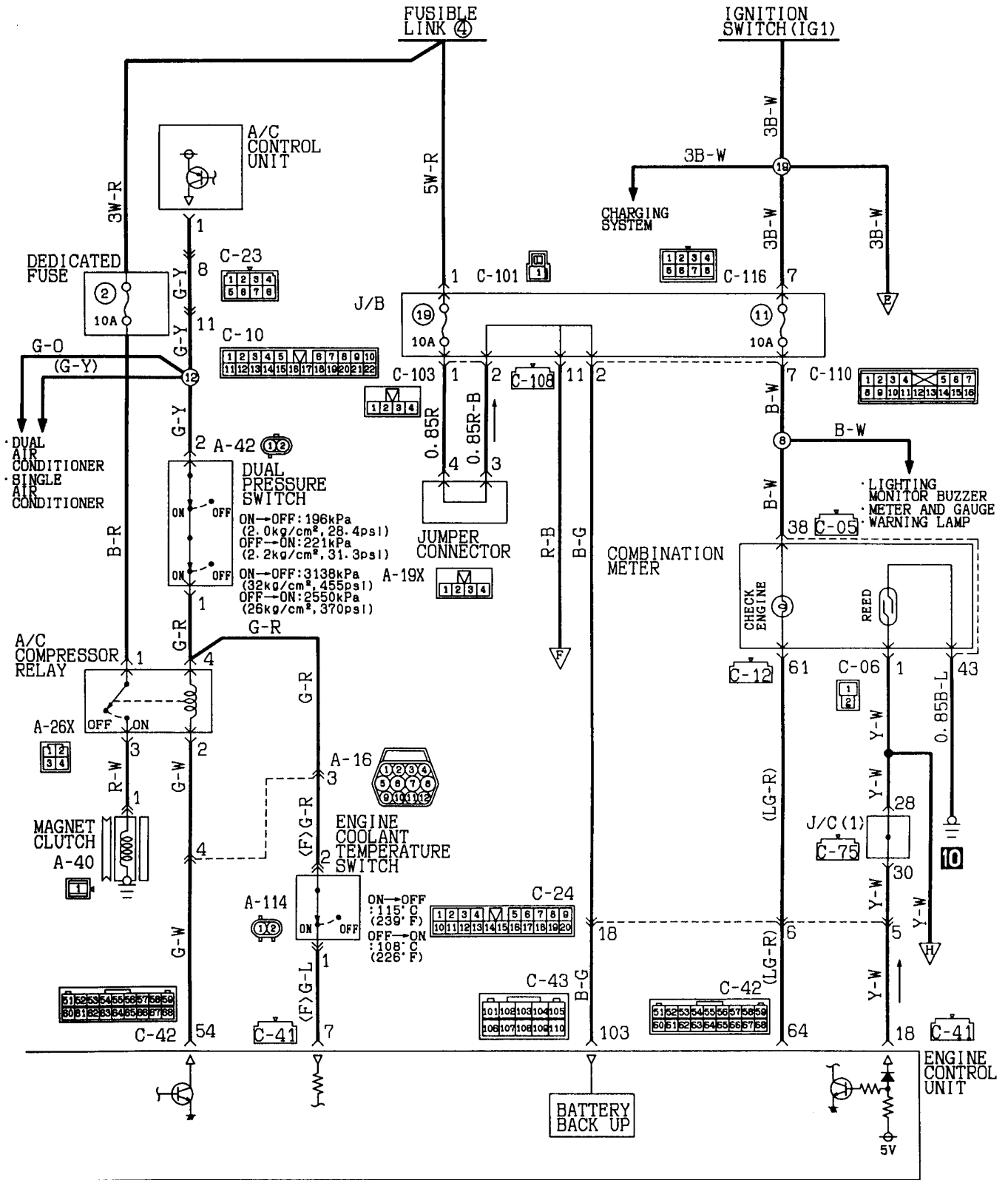

Wire colour code
 B:Black LG:Light green G:Green L:Blue
 BR:Brown O:Orange GR:Gray R:Red
 W:White SB:Sky blue P:Pink Y:Yellow
 V:Violet

MPI SYSTEM (4G64 engine)
(CONTINUED)

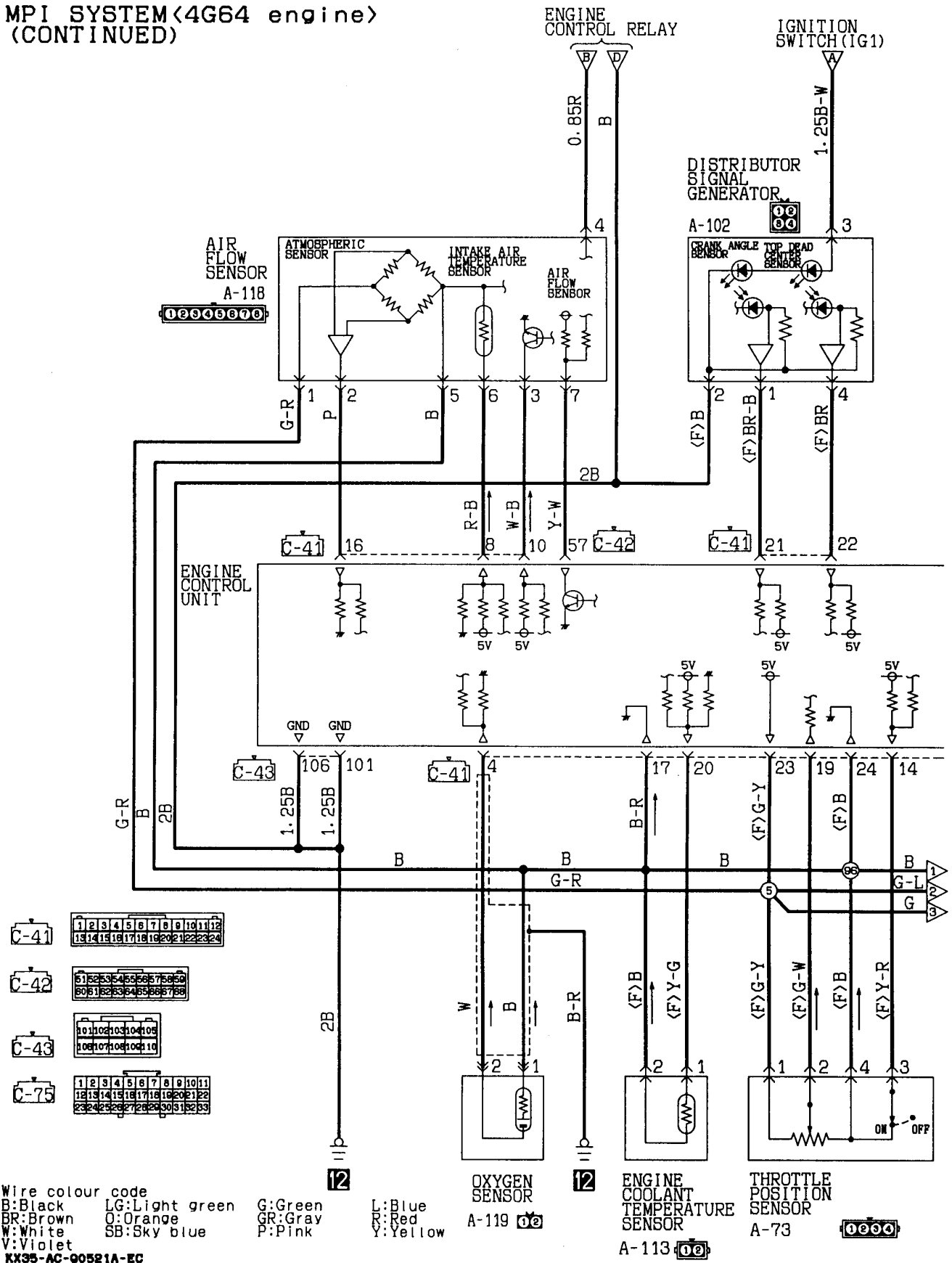

Wire colour code
 B:Black LG:Light green G:Green L:Blue
 BR:Brown O:Orange GR:Gray R:Red
 W:White SB:Sky blue P:Pink Y:Yellow
 V:Violet

KX35-AC-00521A-EC

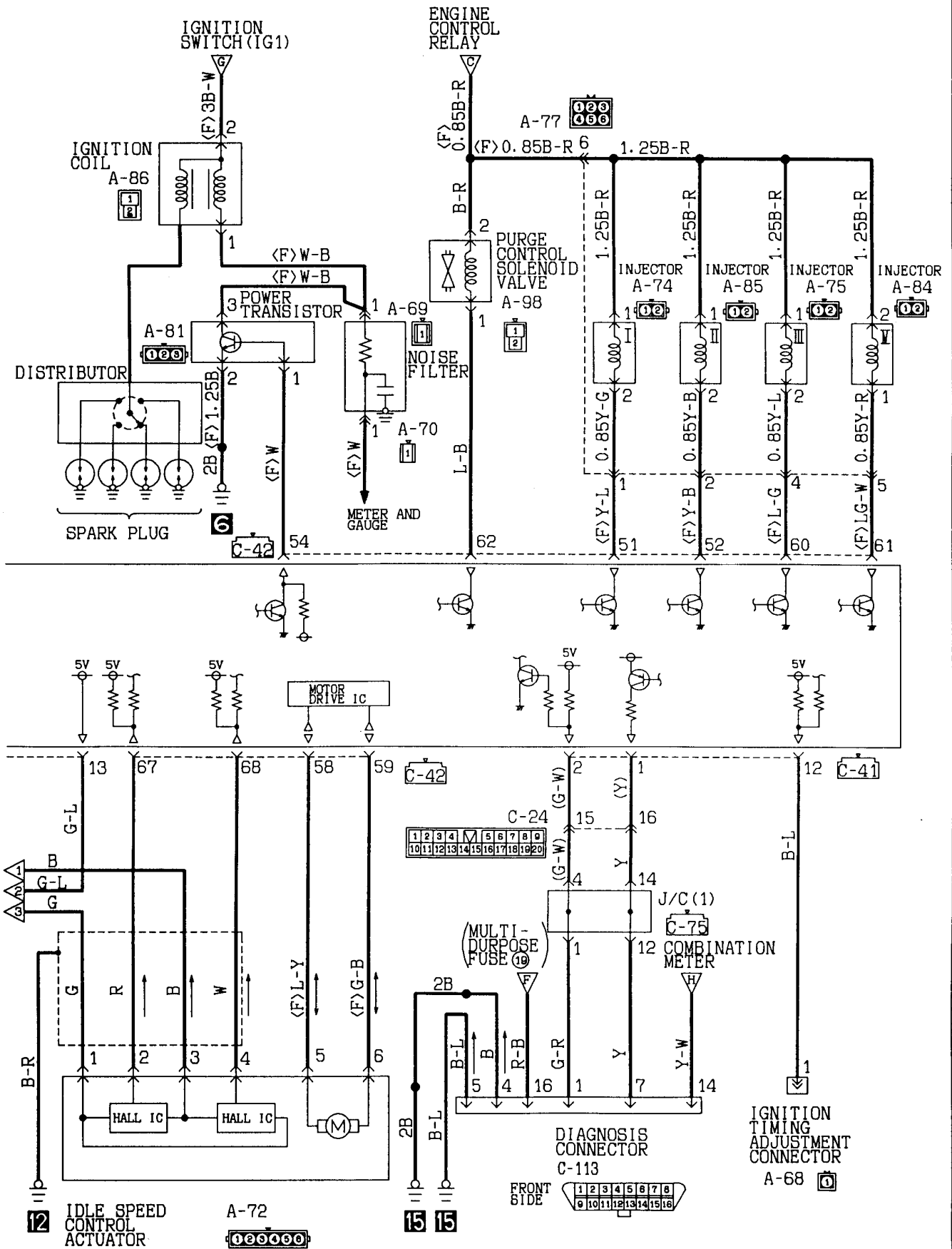

MPI SYSTEM
6G72-M/T

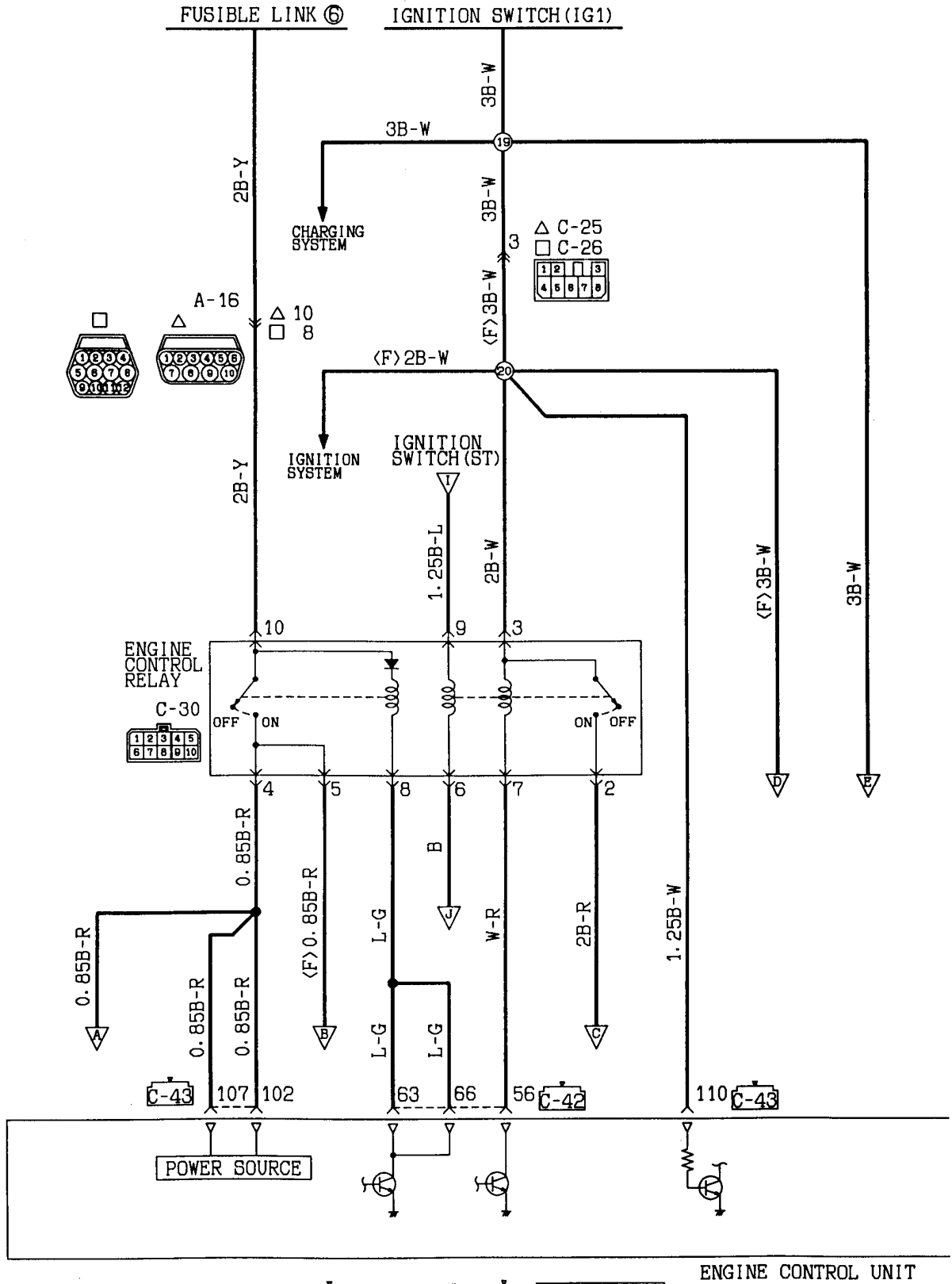

Remarks
(1) □ : L. H. drive vehicles.
(2) △ : R. H. drive vehicles.

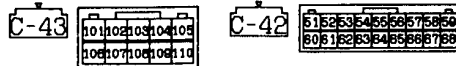

ENGINE CONTROL UNIT

KX35-AC-90518-EC

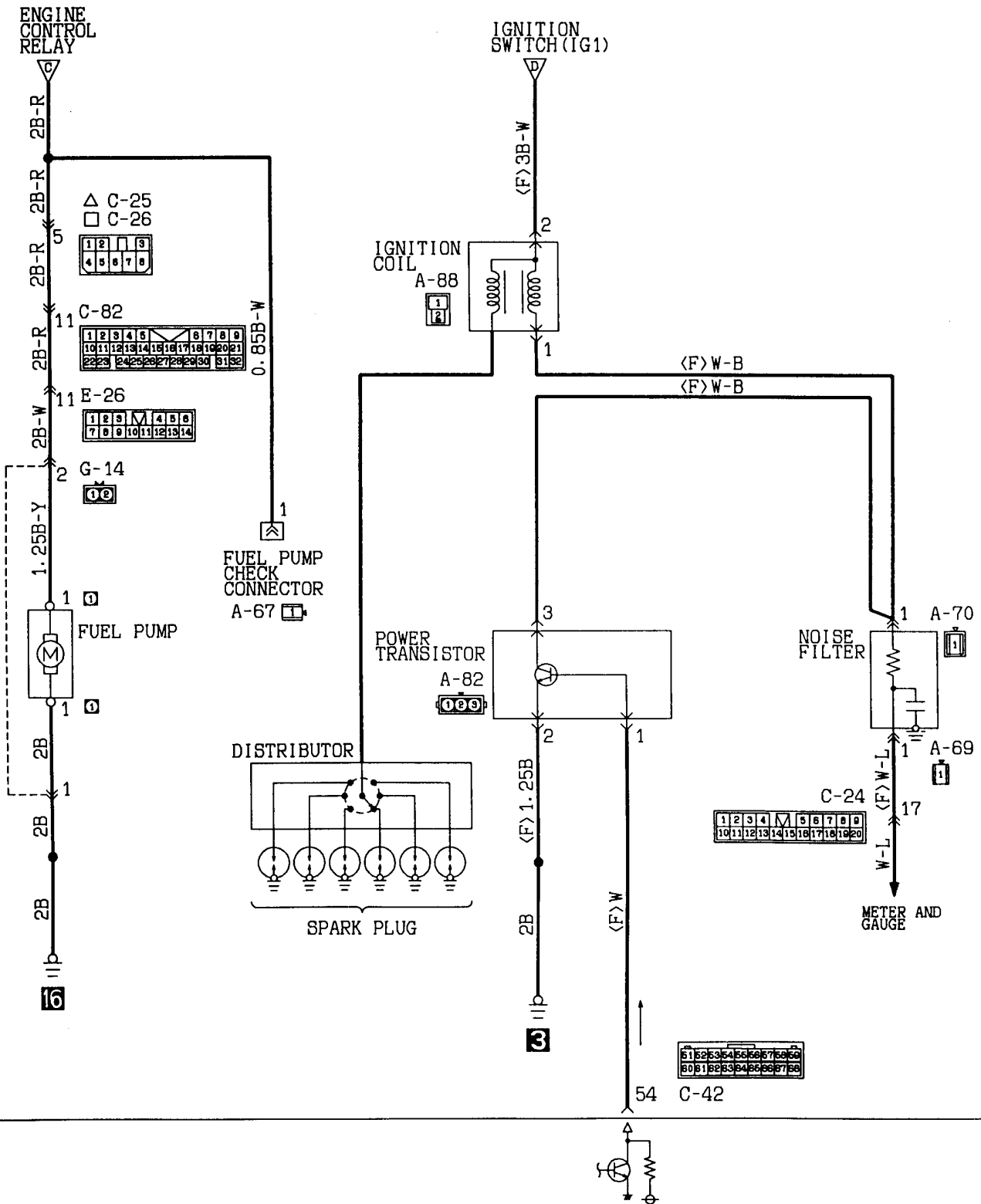

ENGINE CONTROL UNIT

Wire colour code
 B:Black LG:Light green G:Green L:Blue W:White Y:Yellow SB:Sky blue
 BR:Brown O:Orange GR:Gray R:Red P:Pink V:Violet

MPI SYSTEM <6G72-M/T> (CONTINUED)

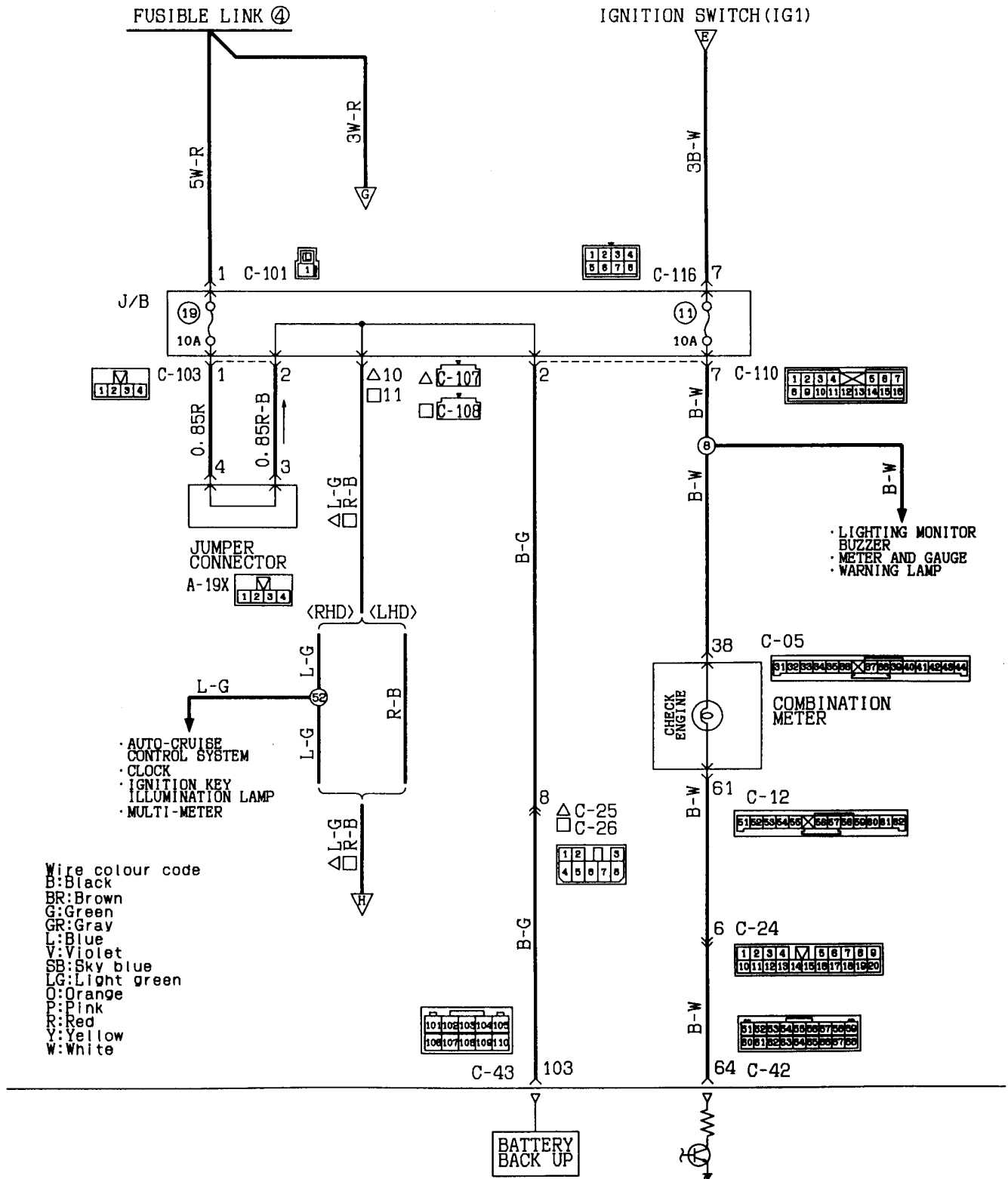

Remarks
 (1) □: L.H. drive vehicles.
 (2) △: R.H. drive vehicles.

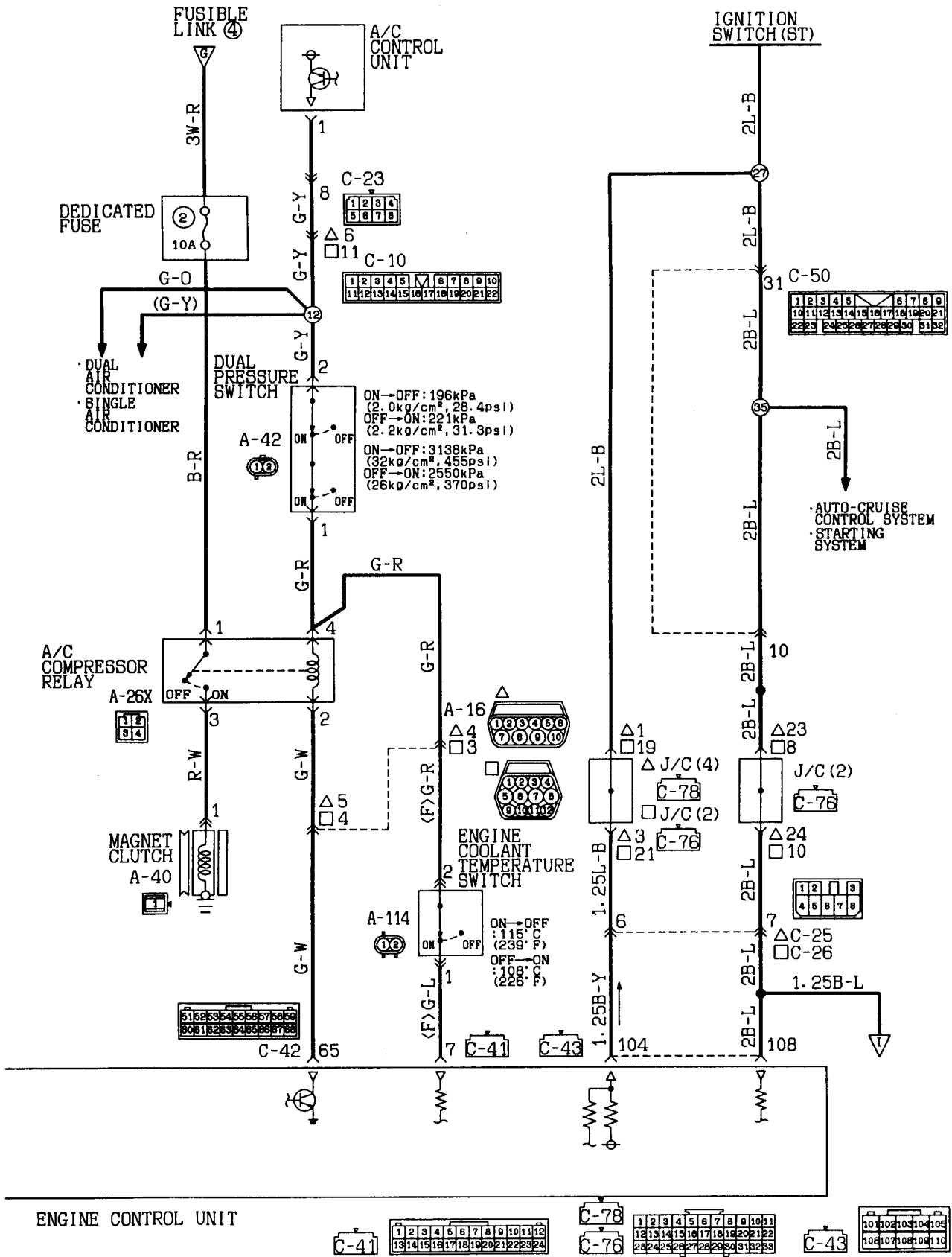

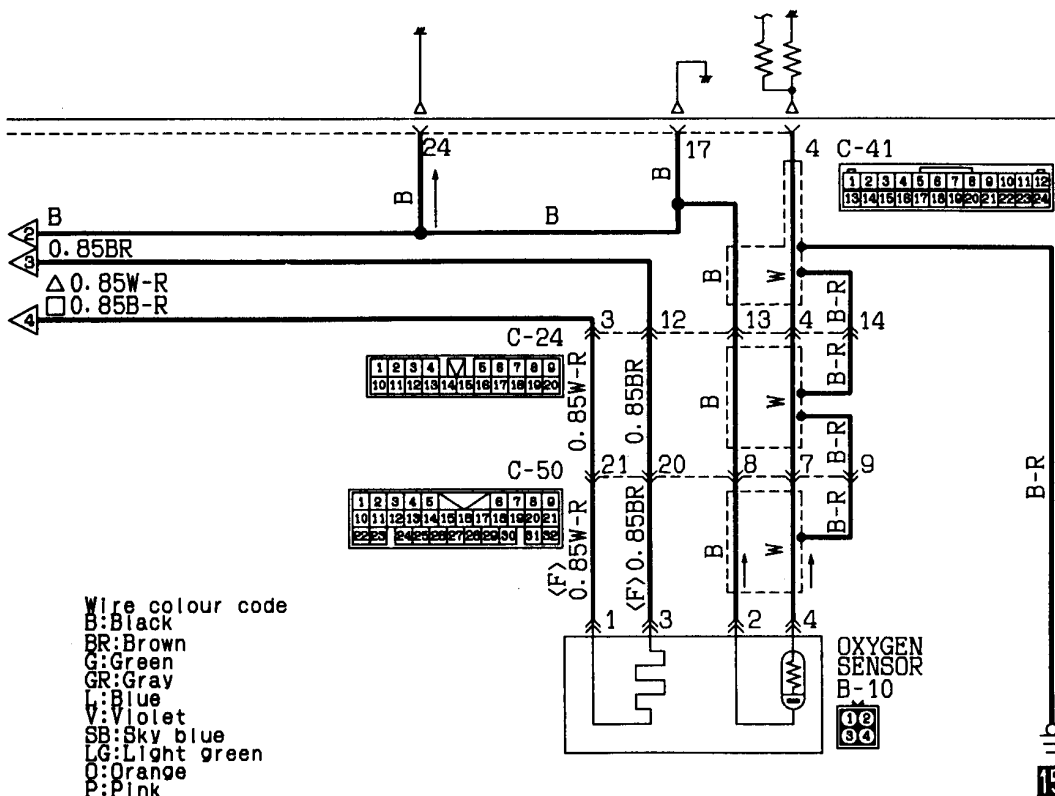
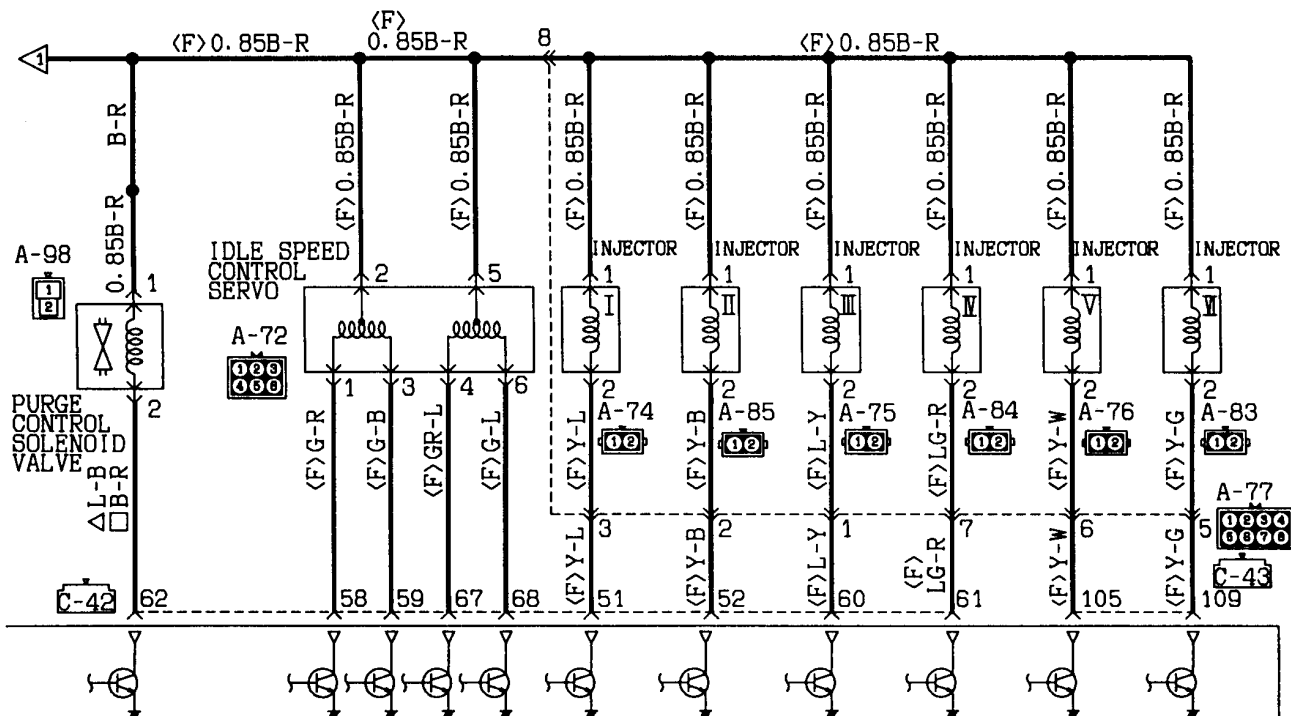

Wire colour code
 B: Black
 BR: Brown
 G: Green
 GR: Gray
 L: Blue
 V: Violet
 SB: Sky blue
 LG: Light green
 O: Orange
 P: Pink
 R: Red
 Y: Yellow
 W: White

Remarks
 (1) □: L. H. drive vehicles.
 (2) △: R. H. drive vehicles.

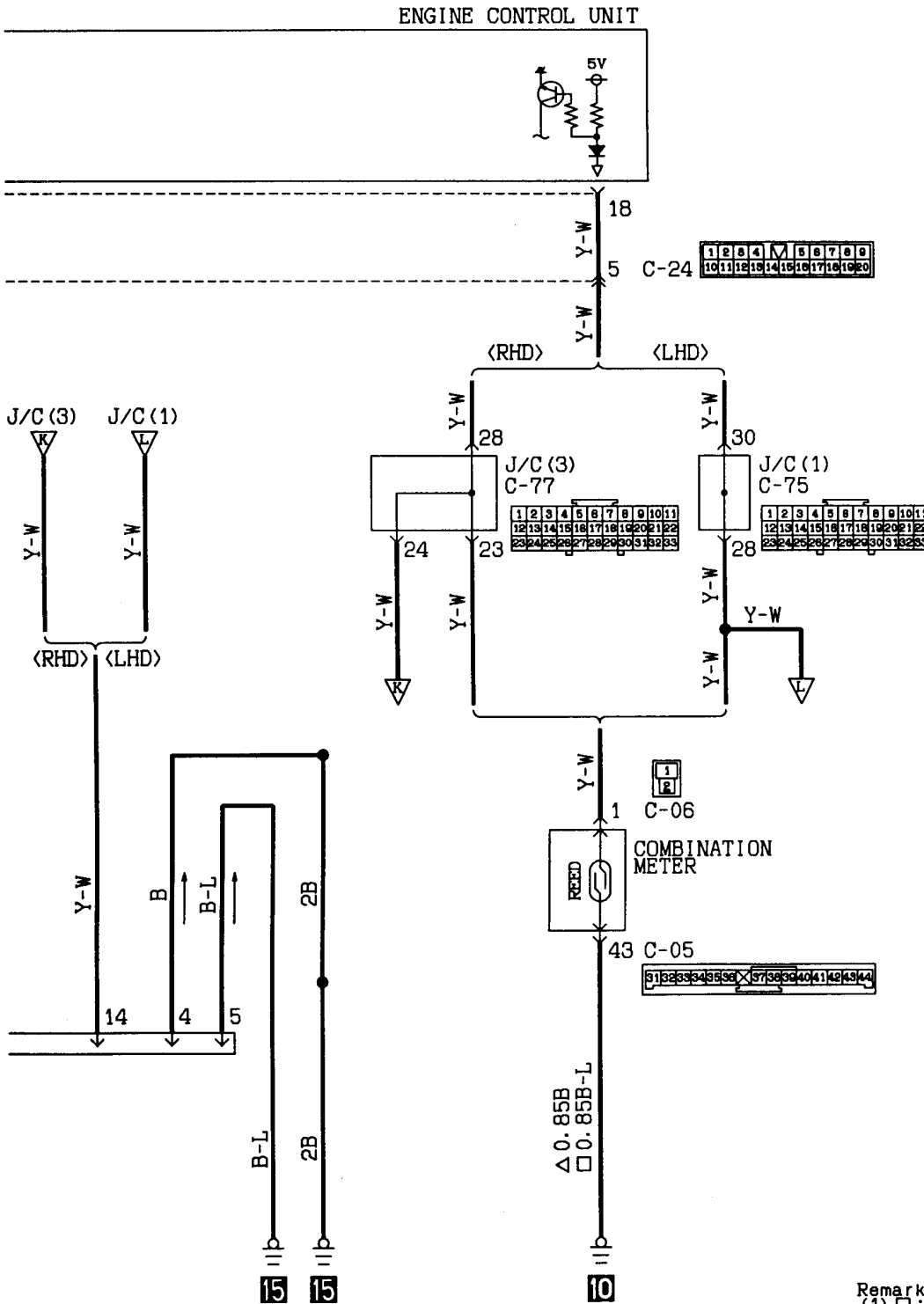

Remarks
 (1) □ : L. H. drive vehicles
 (2) Δ : R. H. drive vehicles

Wire colour code
 B:Black LG:Light green G:Green L:Blue W:White Y:Yellow SB:Sky blue
 BR:Brown O:Orange GR:Gray R:Red P:Pink V:Violet

MPI SYSTEM
6G72-A/T

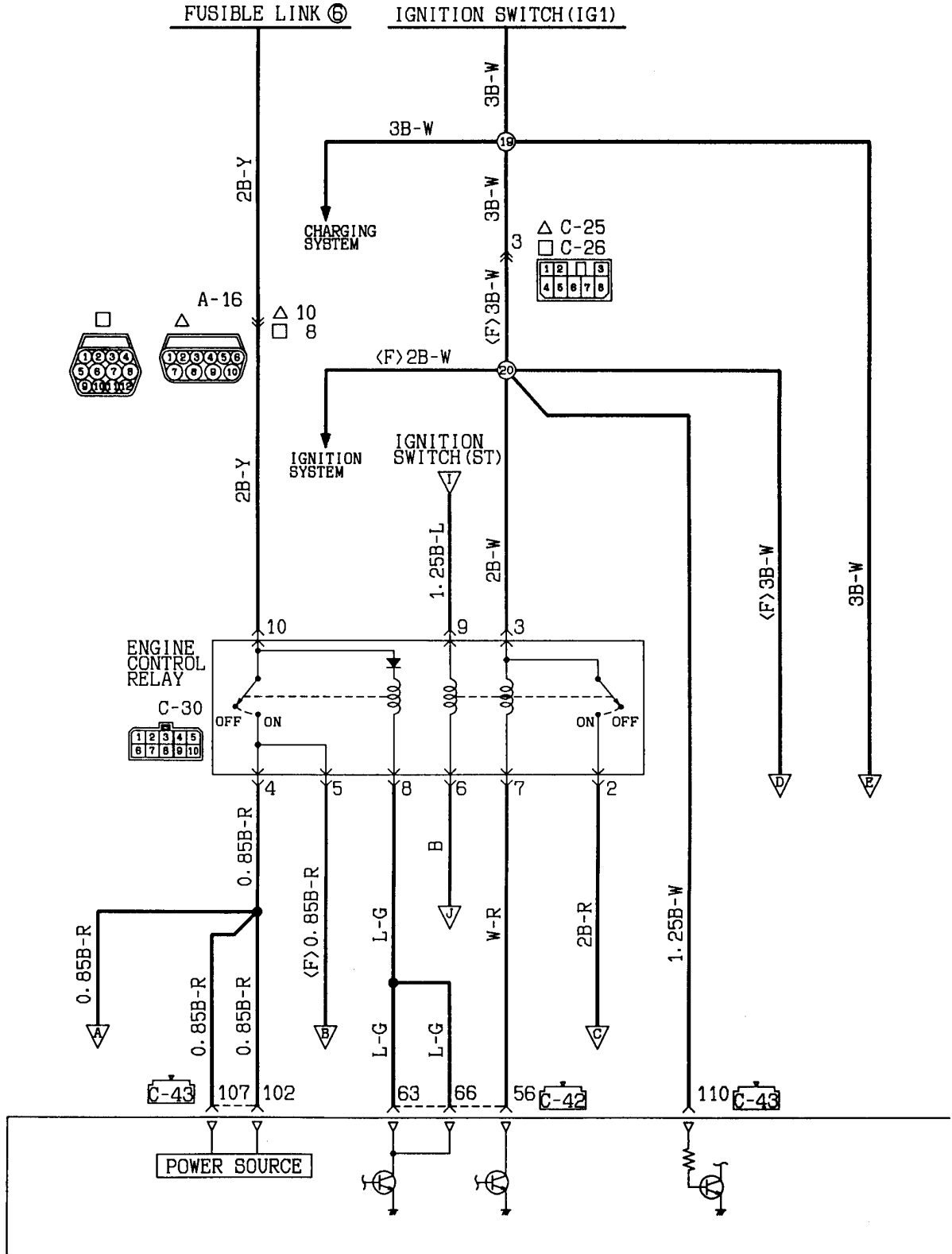

Remarks
 (1) □: L. H. drive vehicles.
 (2) △: R. H. drive vehicles.

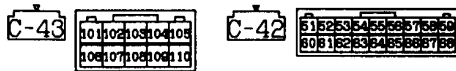

ENGINE CONTROL UNIT

KX35-AC-90517-EC

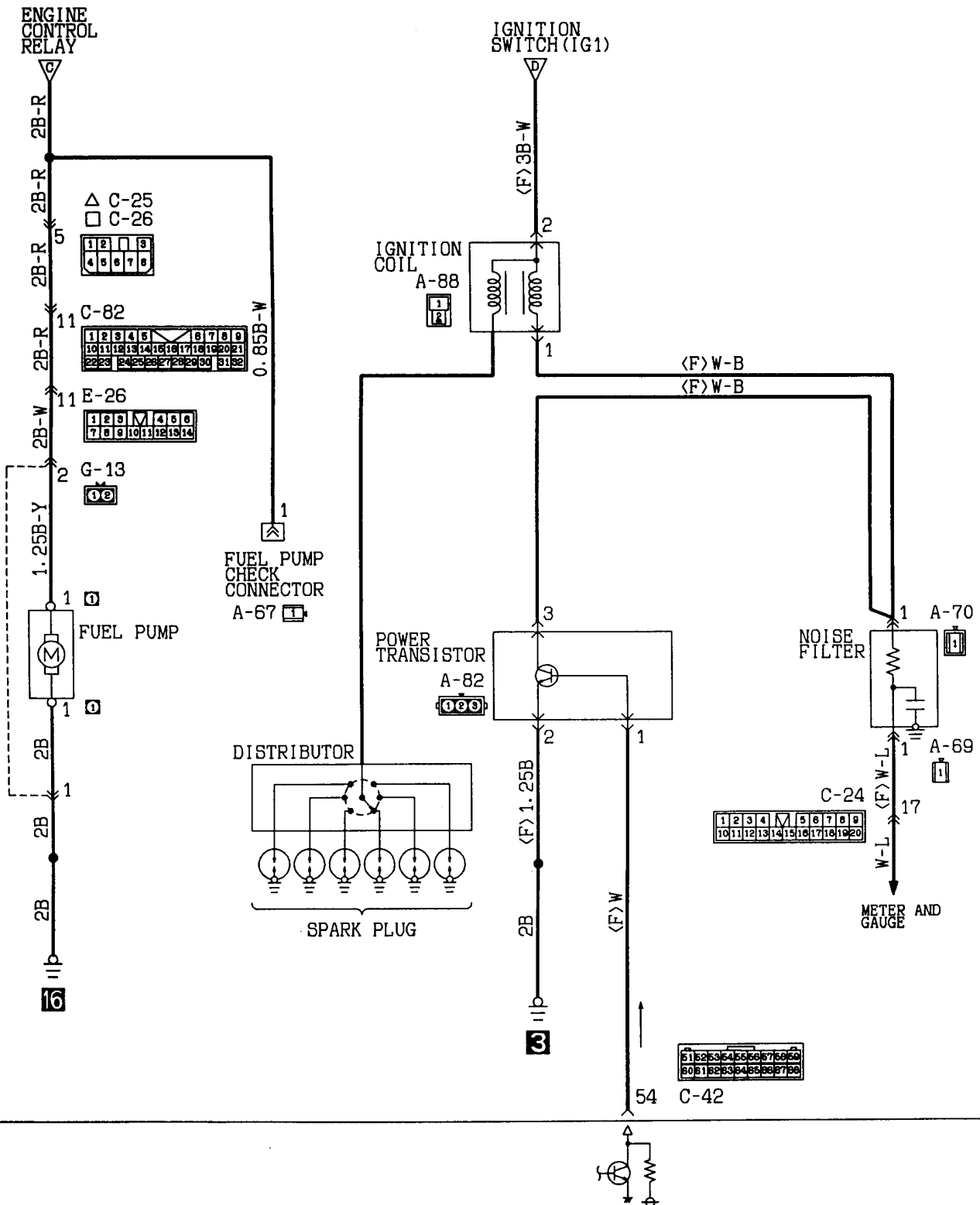

ENGINE CONTROL UNIT

Wire colour code
 B:Black LG:Light green G:Green L:Blue W:White Y:Yellow SB:Sky blue
 BR:Brown O:Orange GR:Gray R:Red P:Pink V:Violet

MPI SYSTEM <6G72-A/T> (CONTINUED)

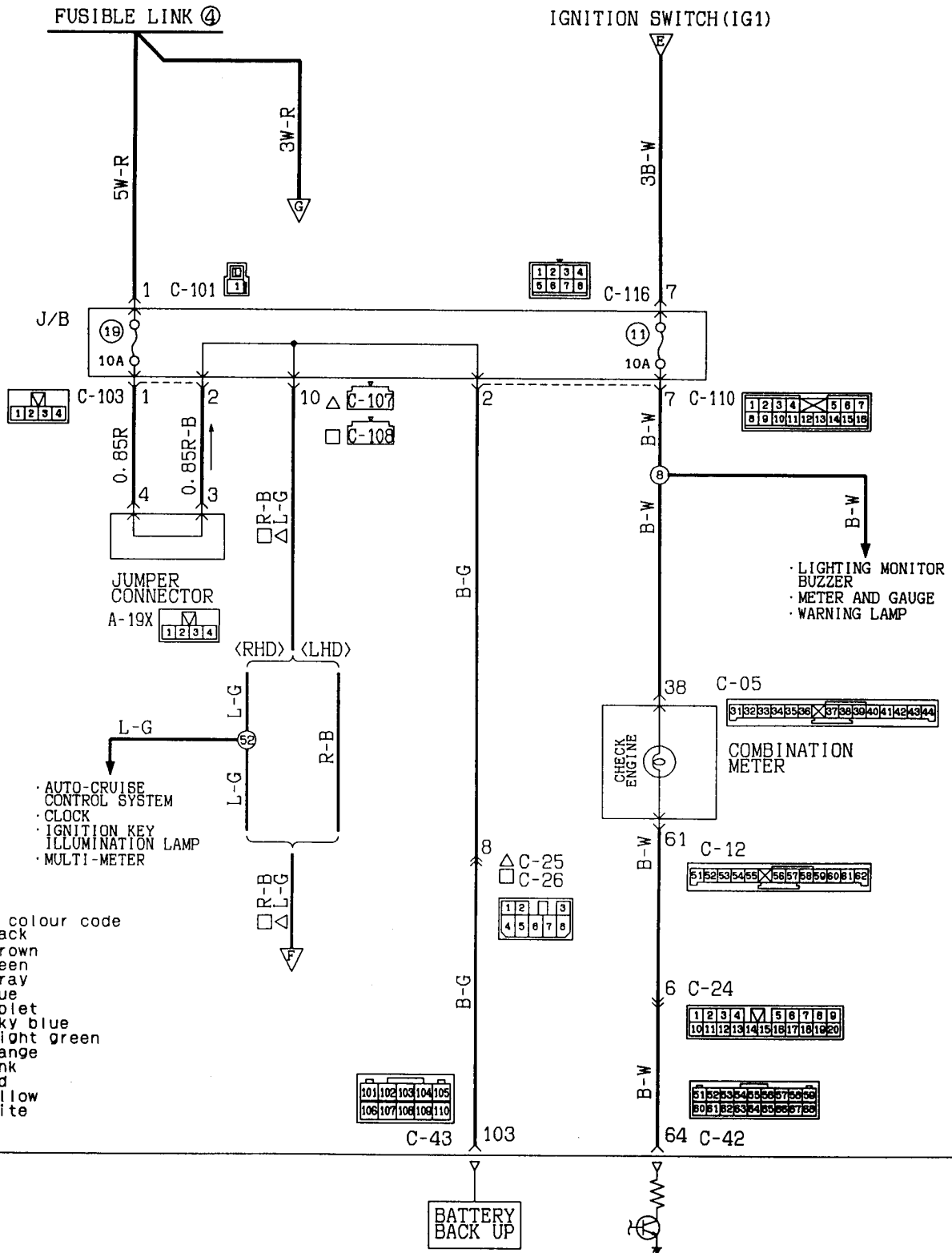

Remarks
 (1) □ : L.H. drive vehicles.
 (2) △ : R.H. drive vehicles.

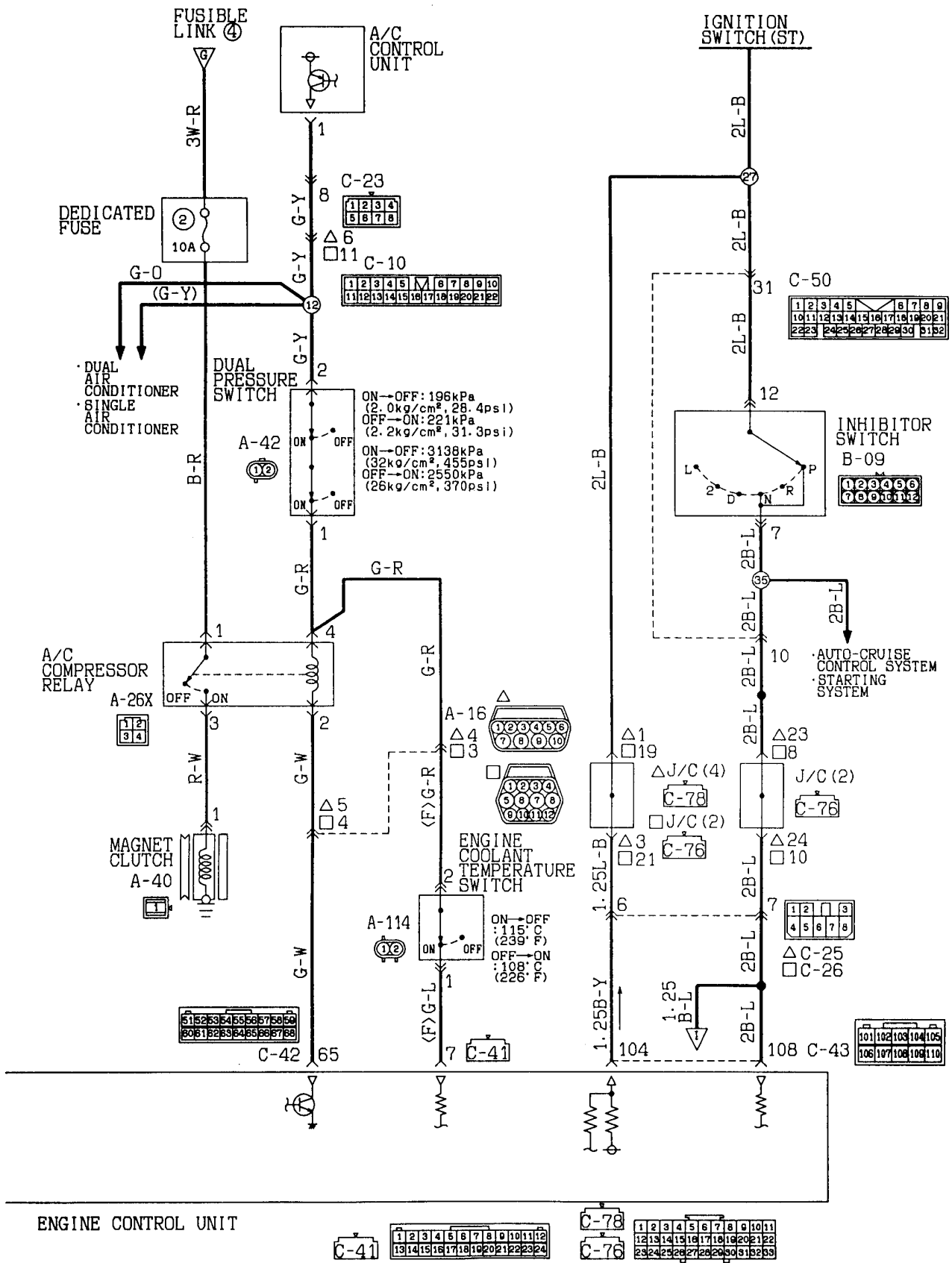

MPI SYSTEM <6G72-A/T> (CONTINUED)

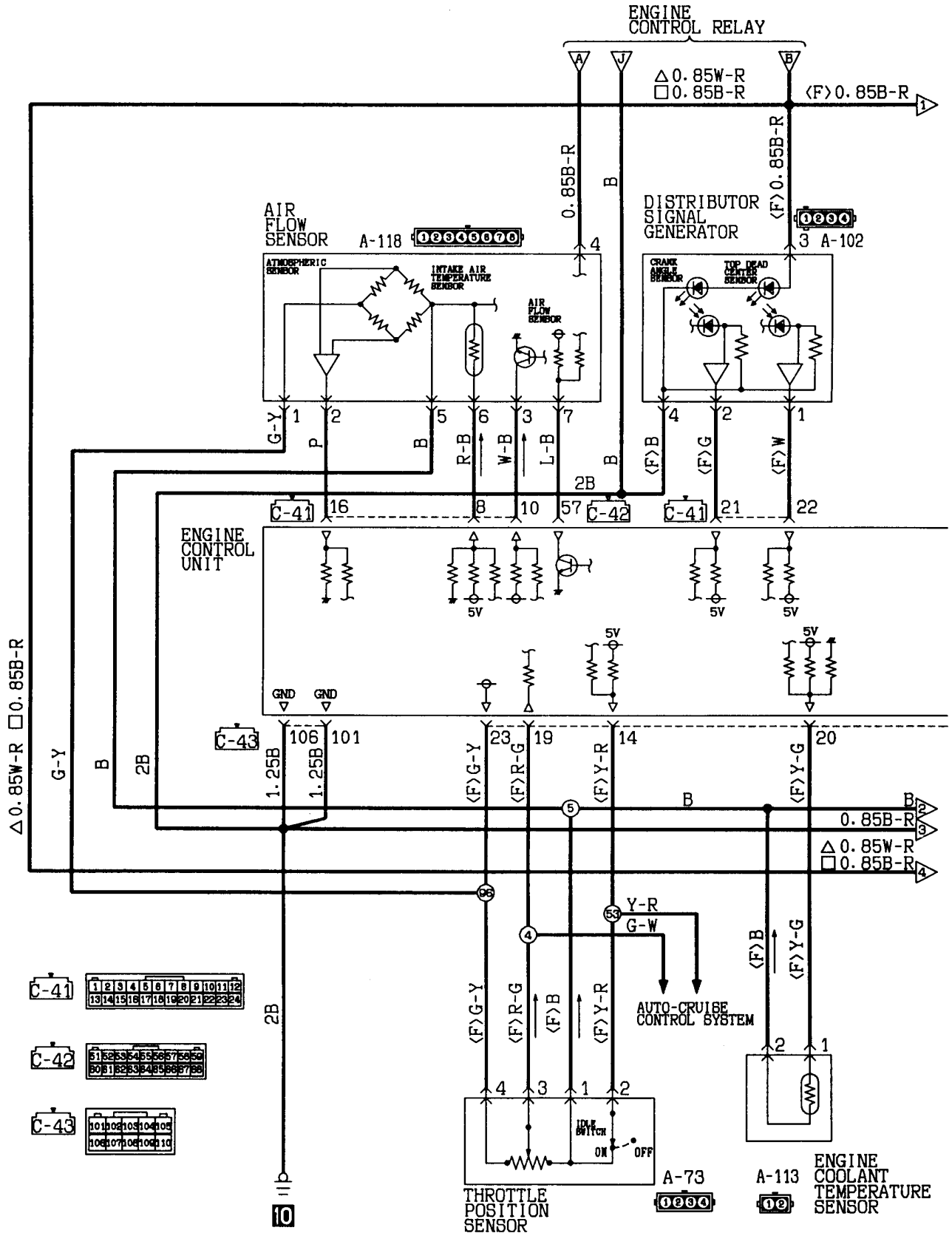

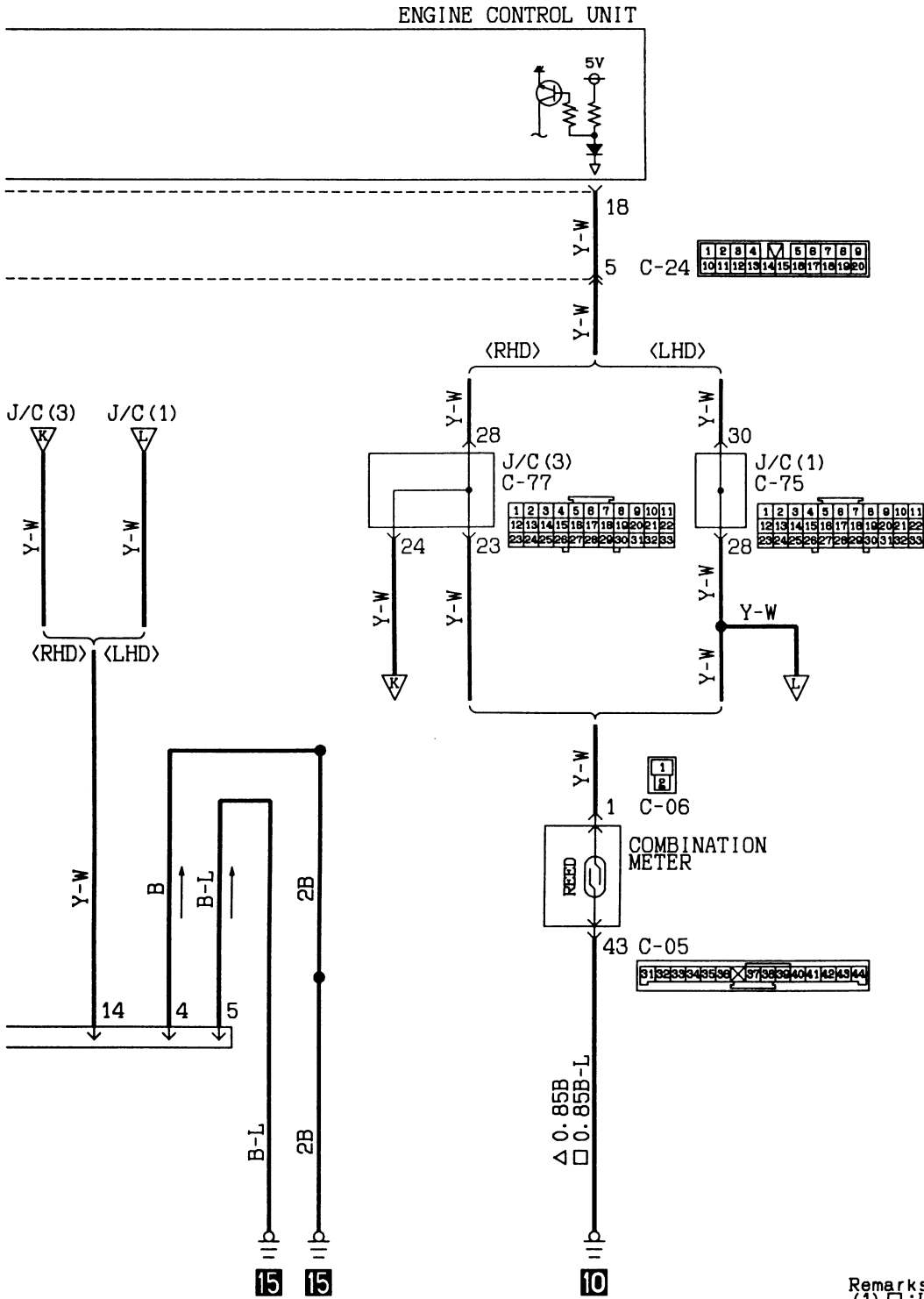

Remarks
 (1) □ : L. H. drive vehicles
 (2) △ : R. H. drive vehicles

Wire colour code
 B:Black LG:Light green G:Green L:Blue W:White Y:Yellow SB:Sky blue
 BR:Brown O:Orange GR:Gray R:Red P:Pink V:Violet

MPI SYSTEM
6G74-M/T

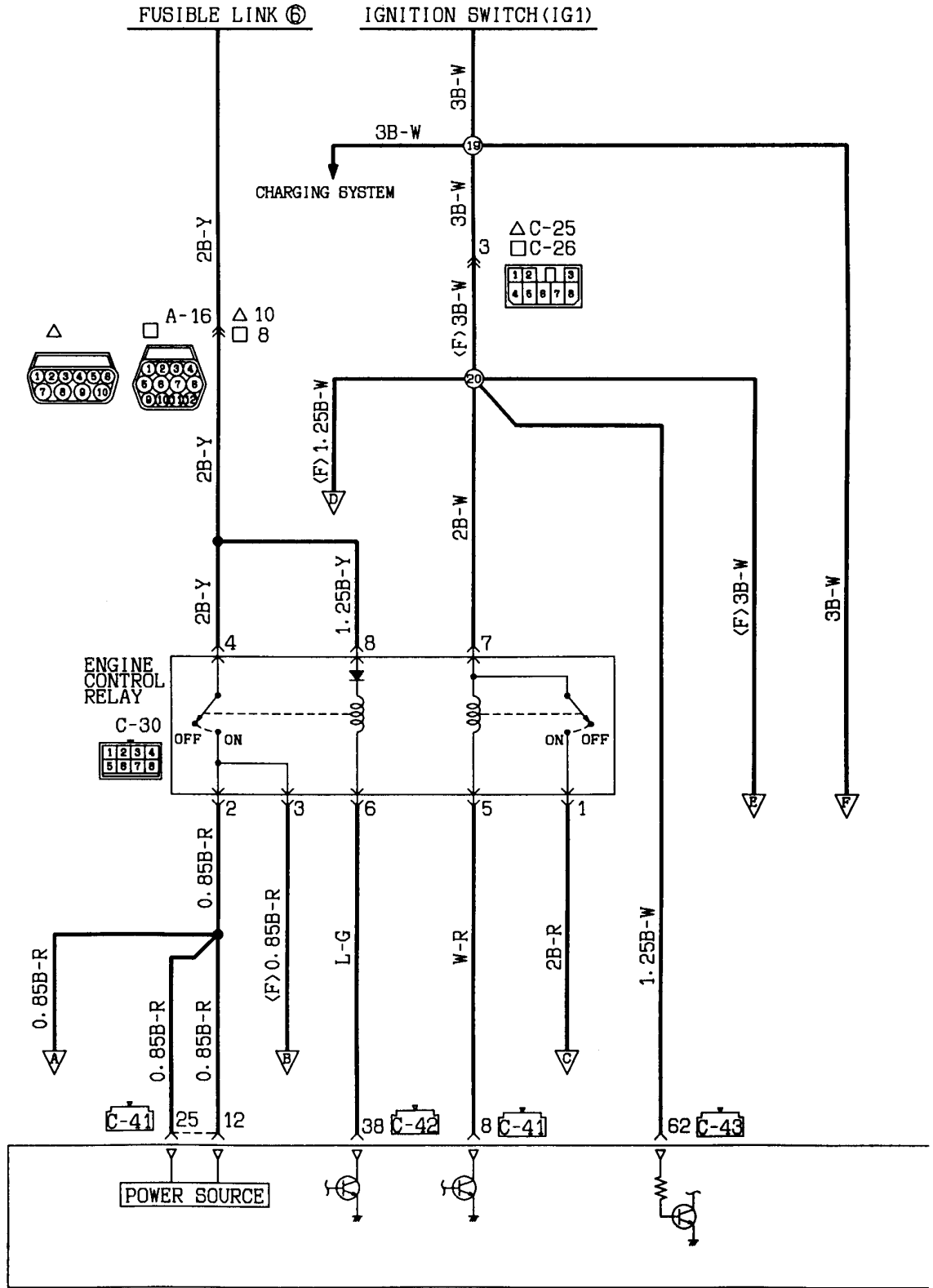

C-42	31 32 33 34 35 36 37 38	C-41	1 2 3 4 5 6 7 8 9 10 11 12 13	C-43	51 52 53 54 55 56 57 58 59 60 61
	39 40 41 42 43 44 45 46		14 15 16 17 18 19 20 21 22 23 24 25 26		62 63 64 65 66 67 68 69 70 71 72

ENGINE CONTROL UNIT
Remarks
(1) □ : L.H. drive vehicles.
(2) △ : R.H. drive vehicles.

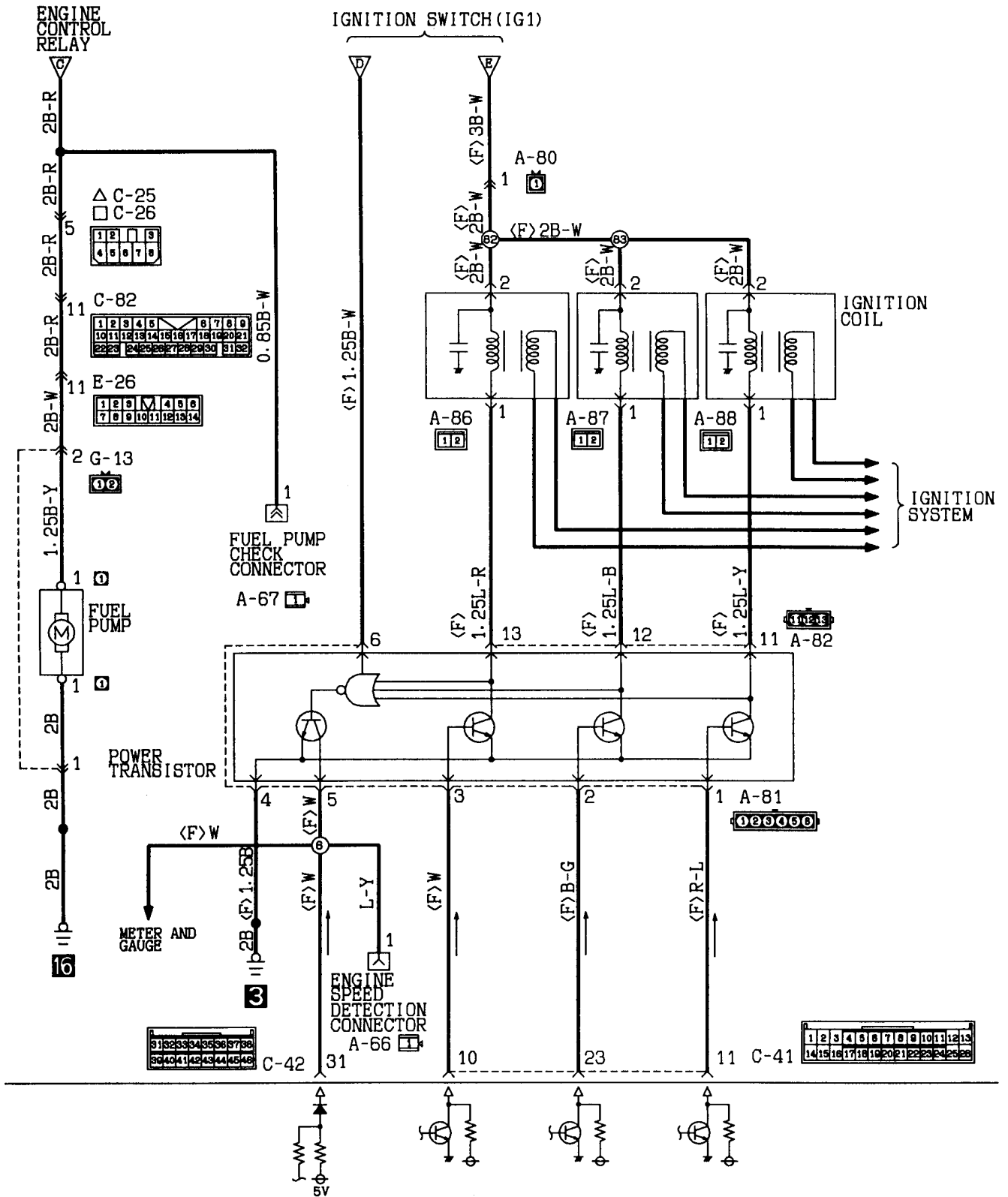

ENGINE CONTROL UNIT

Wire colour code
 B:Black LG:Light green G:Green L:Blue W:White Y:Yellow SB:Sky blue
 BR:Brown O:Orange GR:Gray R:Red P:Pink V:Violet

MPI SYSTEM <6G74-M/T> (CONTINUED)

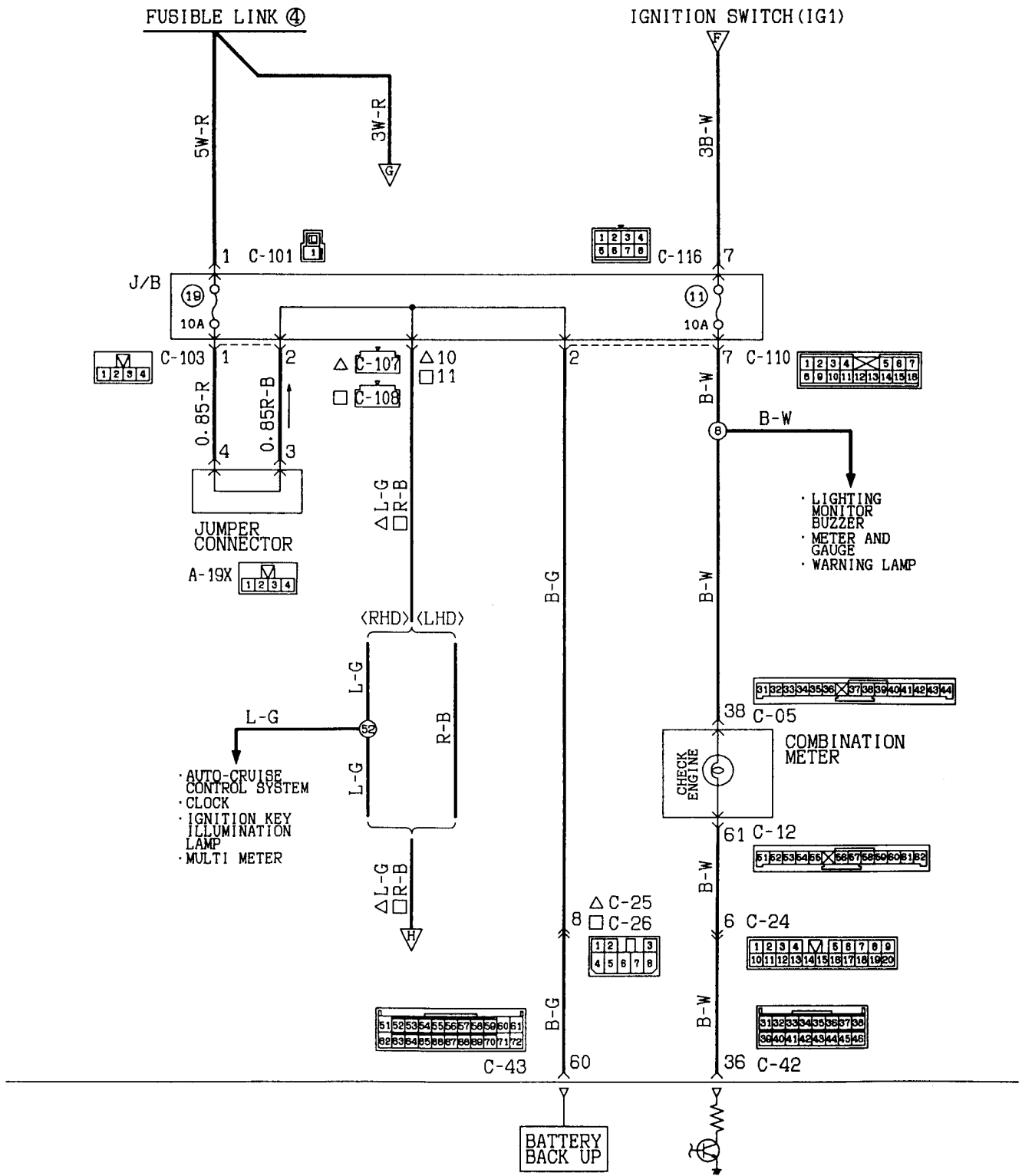

ENGINE CONTROL UNIT

KX35-AC-00509A-EC



Remarks
 (1) □ : L.H. drive vehicles.
 (2) △ : R.H. drive vehicles.

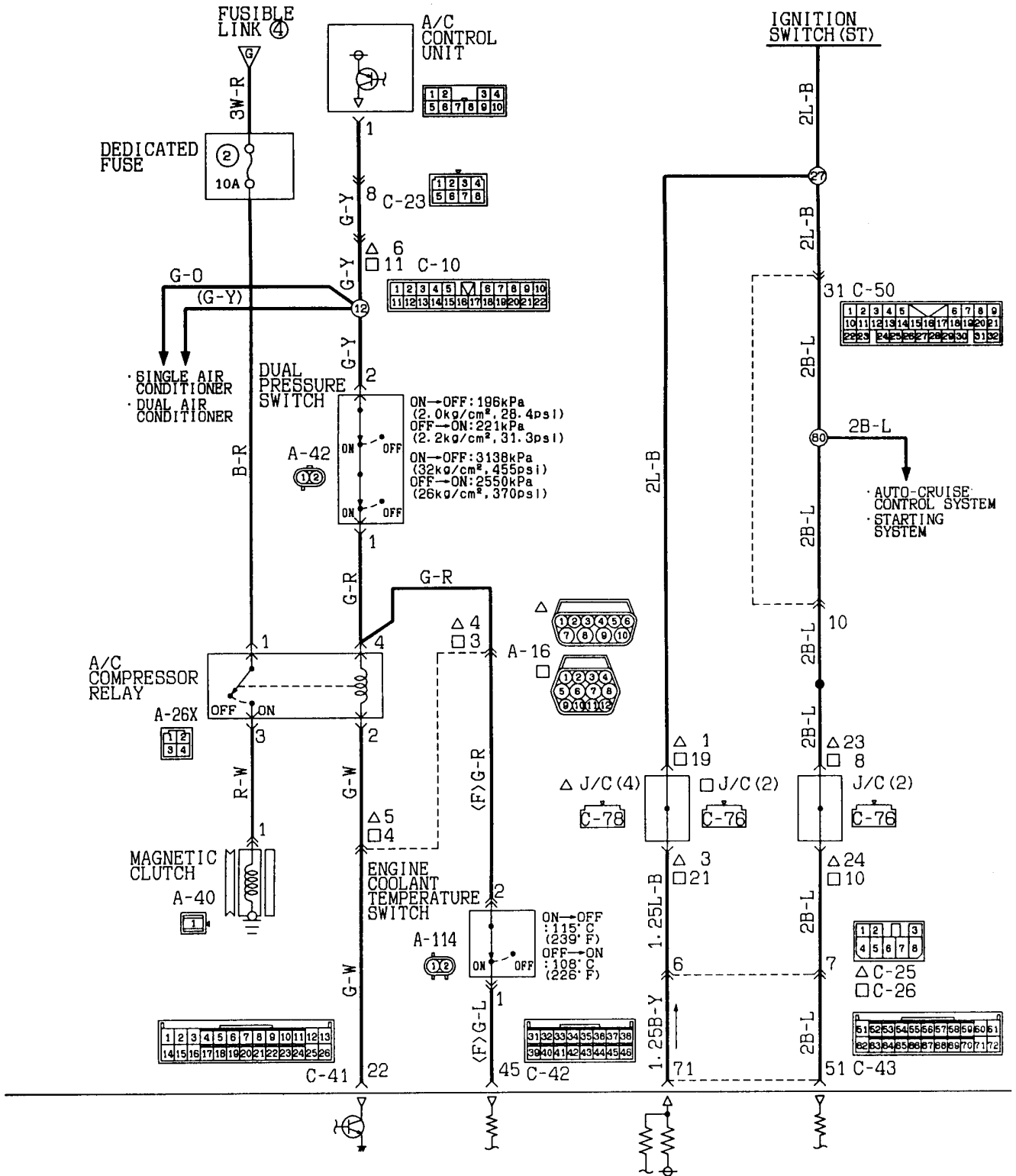

C-76	1 2 3 4 5 6 7 8 9 10 11	Wire colour code B:Black LG:Light green G:Green L:Blue W:White Y:Yellow SB:Sky blue BR:Brown O:Orange GR:Gray R:Red P:Pink V:Violet	ENGINE CONTROL UNIT					
C-78	12 13 14 15 16 17 18 19 20 21 22							
C-78	23 24 25 26 27 28 29 30 31 32 33							

MPI SYSTEM <6G74-M/T> (CONTINUED)

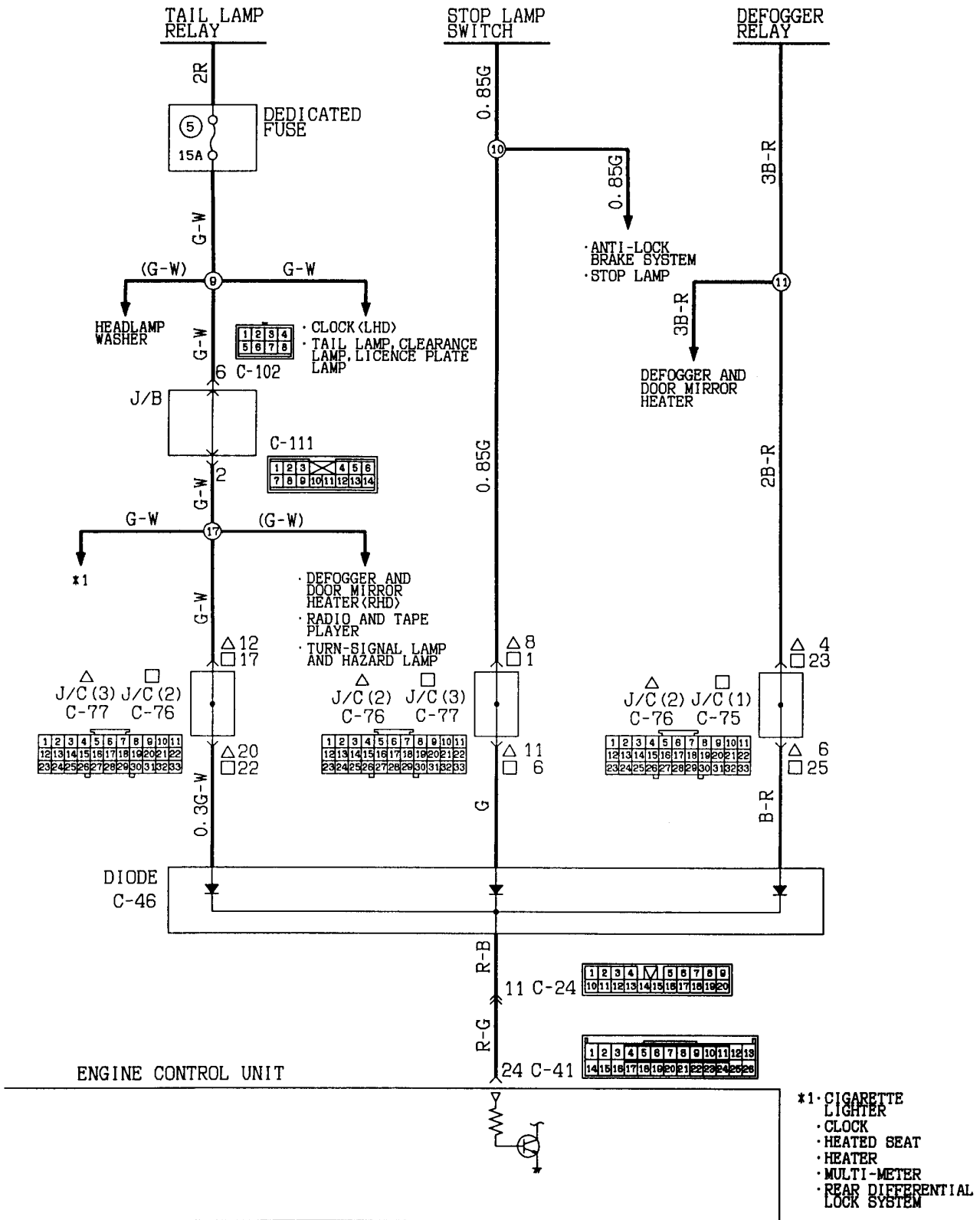

MPI SYSTEM <6G74-M/T> (CONTINUED)

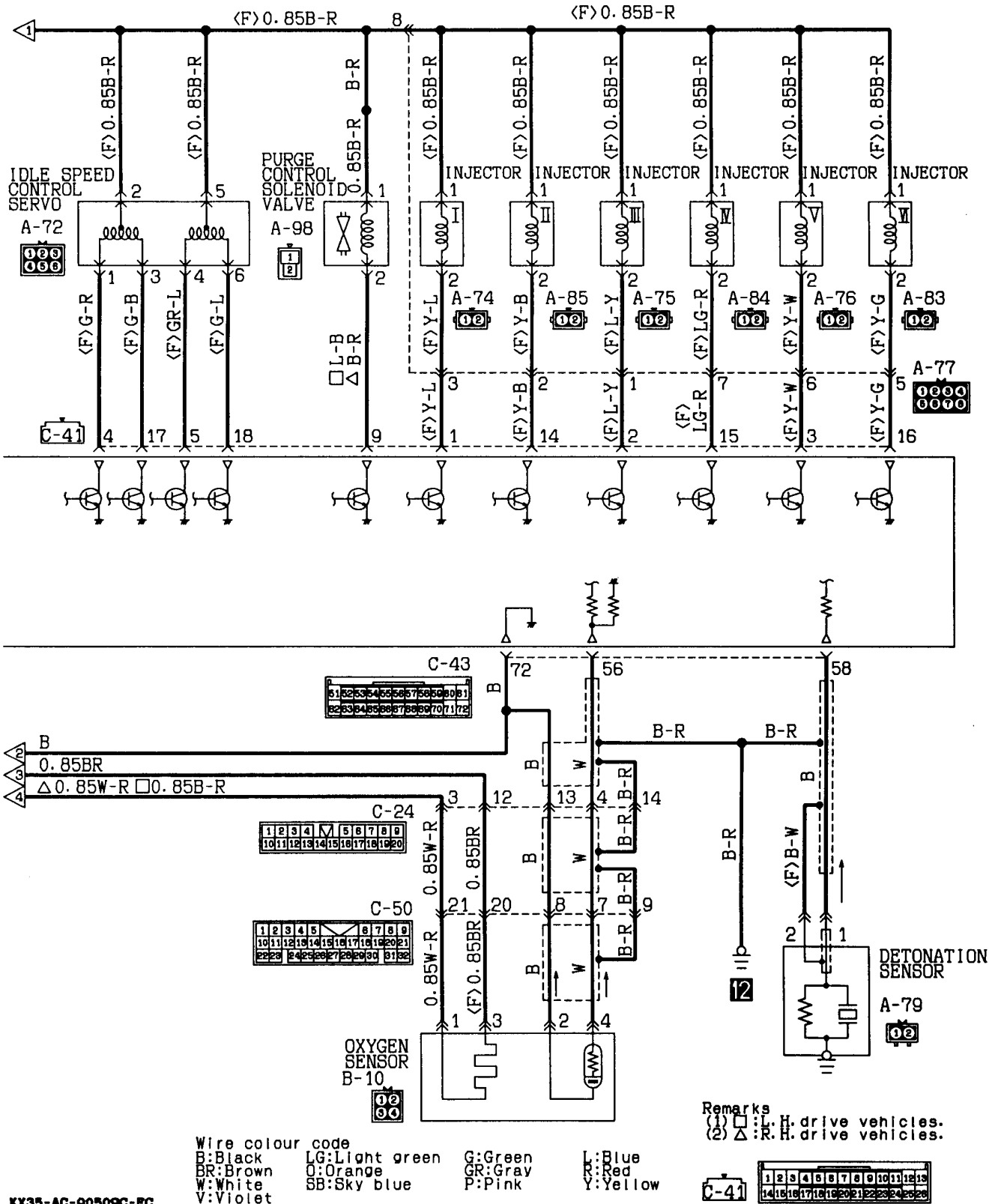

KX35-AC-00509C-EC

MPI SYSTEM <6G74-M/T> (CONTINUED)

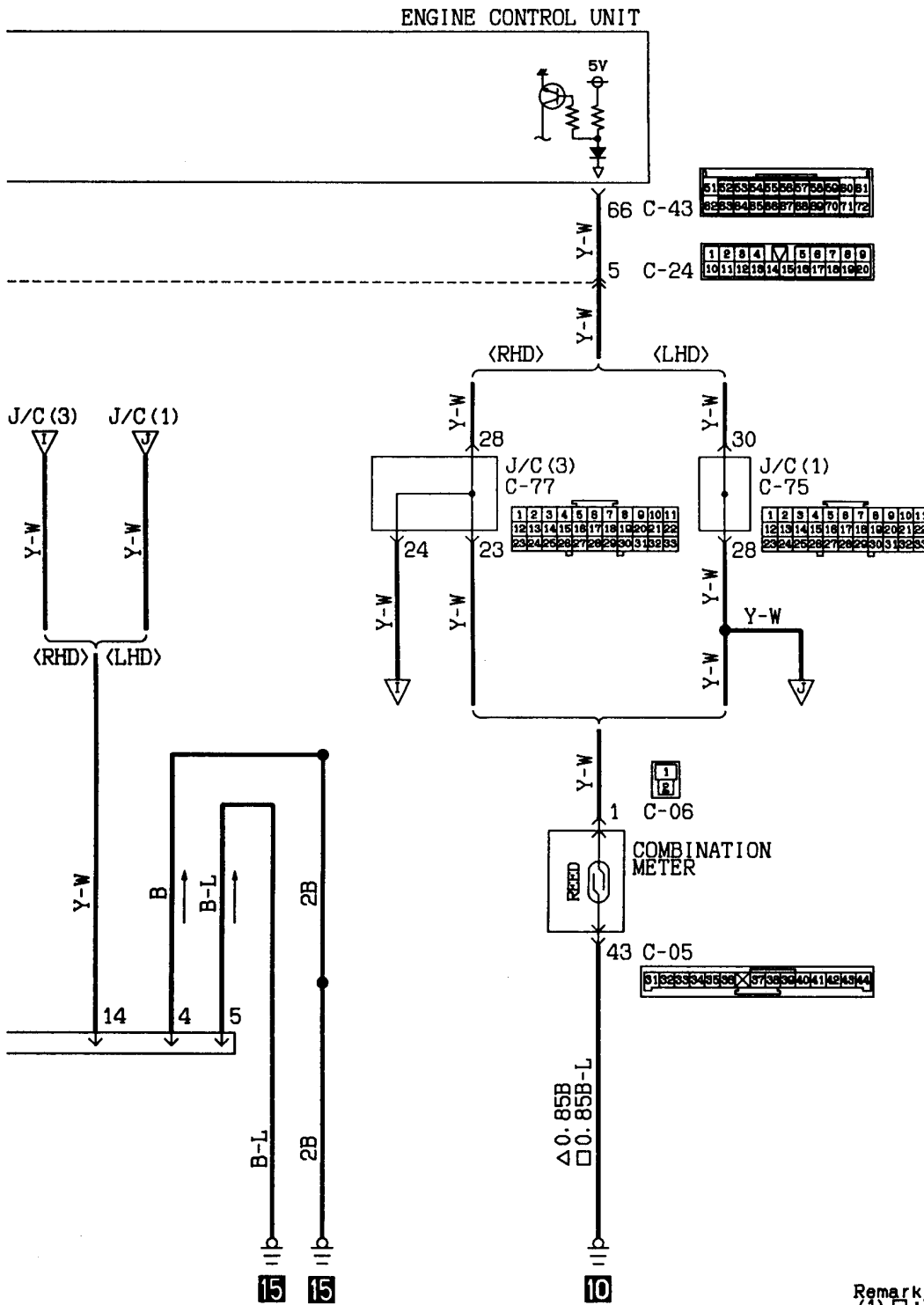

Remarks
 (1) □: L.H. drive vehicles
 (2) △: R.H. drive vehicles

Wire colour code
 B:Black LG:Light green G:Green L:Blue Y:Yellow SB:Sky blue
 BR:Brown O:Orange GR:Gray R:Red P:Pink V:Violet

NOTES

MPI SYSTEM
6G74-A/T

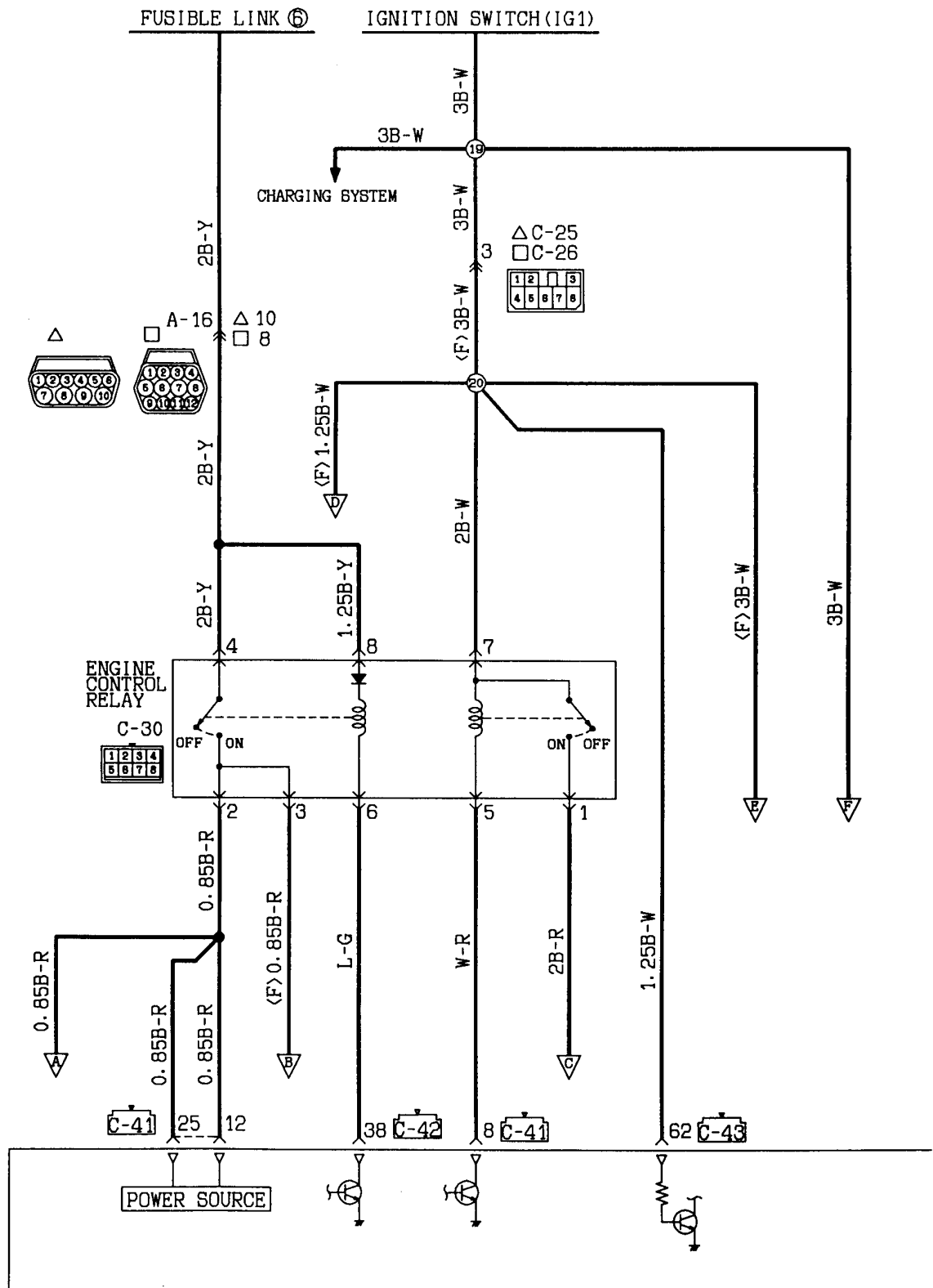

ENGINE CONTROL UNIT

Remarks
(1) □ : L.H. drive vehicles.
(2) △ : R.H. drive vehicles.

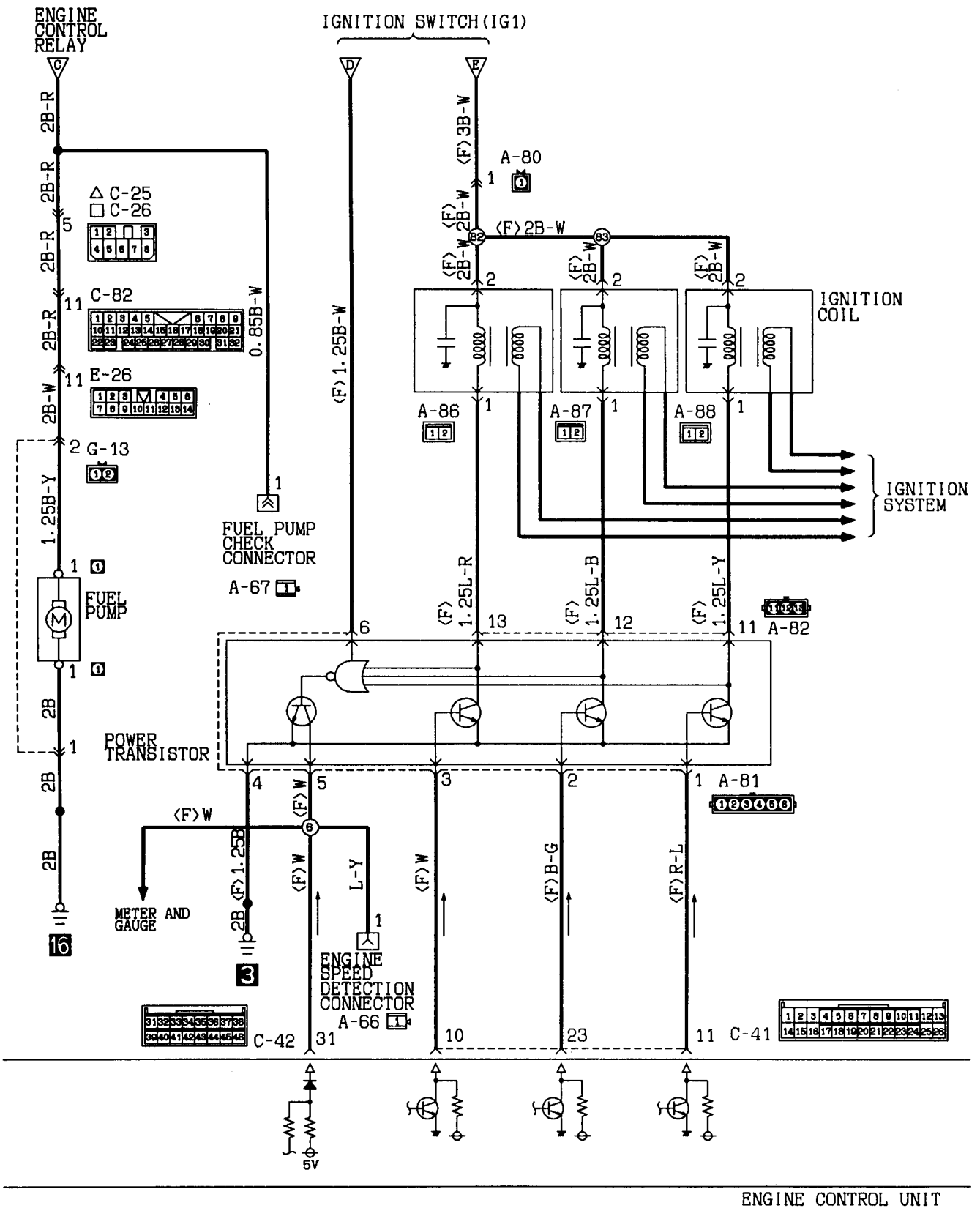

ENGINE CONTROL UNIT

Wire colour code
 B:Black LG:Light green G:Green L:Blue W:White Y:Yellow SB:Sky blue
 BR:Brown O:Orange GR:Gray R:Red P:Pink V:Violet

MPI SYSTEM <6G74-A/T> (CONTINUED)

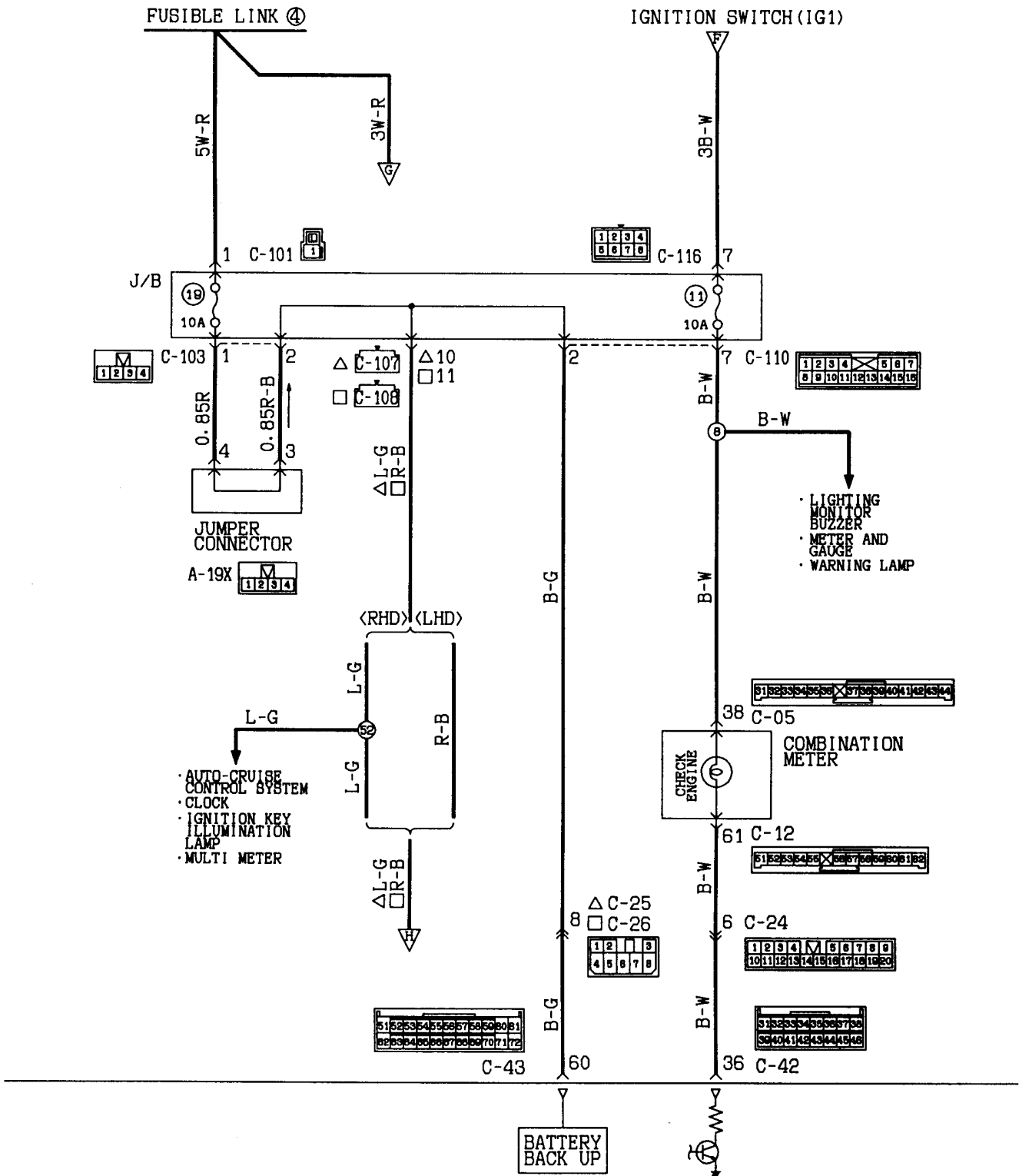

ENGINE CONTROL UNIT

KX35-AC-00508A-EC

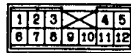

Remarks
 (1) □ : L. H. drive vehicles.
 (2) △ : R. H. drive vehicles.

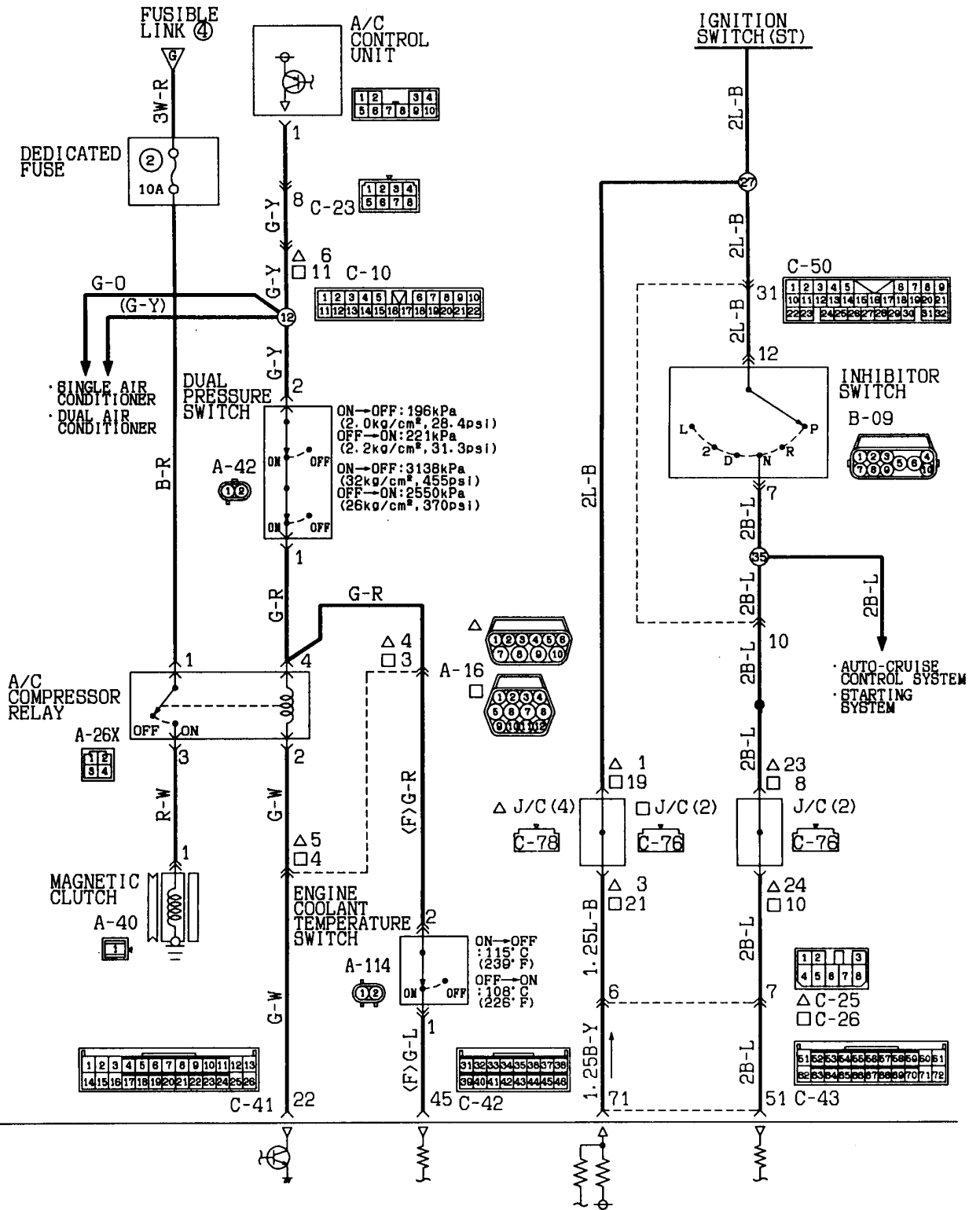

Wire colour code
 B:Black LG:Light green G:Green L:Blue W:White Y:Yellow SB:Sky blue
 BR:Brown O:Orange GR:Gray R:Red P:Pink V:Violet

ENGINE CONTROL UNIT

MPI SYSTEM <6G74-A/T> (CONTINUED)

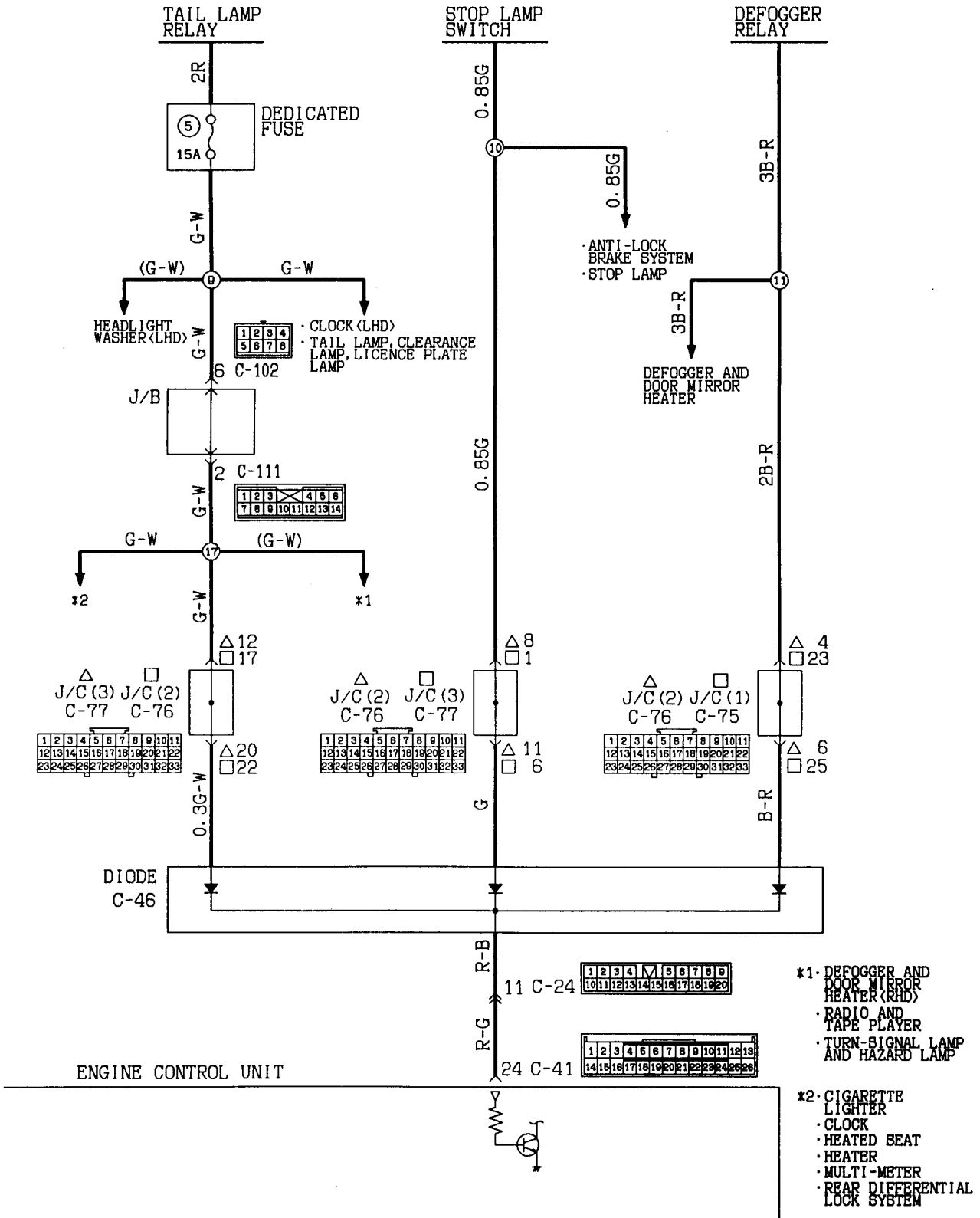

Wire colour code
 B:Black LG:Light green G:Green L:Blue W:White Y:Yellow SB:Sky blue
 BR:Brown O:Orange GR:Gray R:Red P:Pink V:Violet

MPI SYSTEM <6G74-A/T> (CONTINUED)

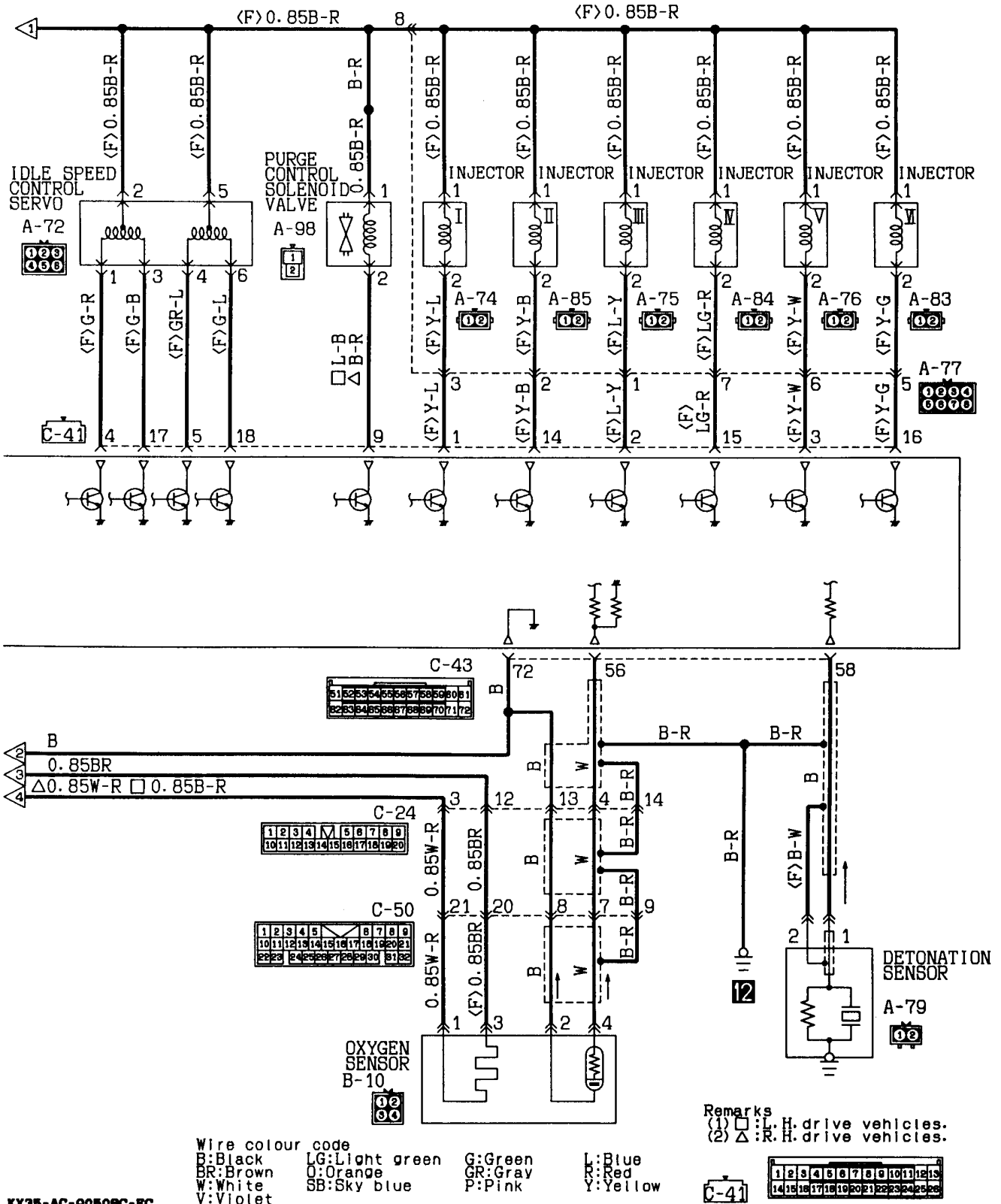

MPI SYSTEM <6G74-A/T> (CONTINUED)

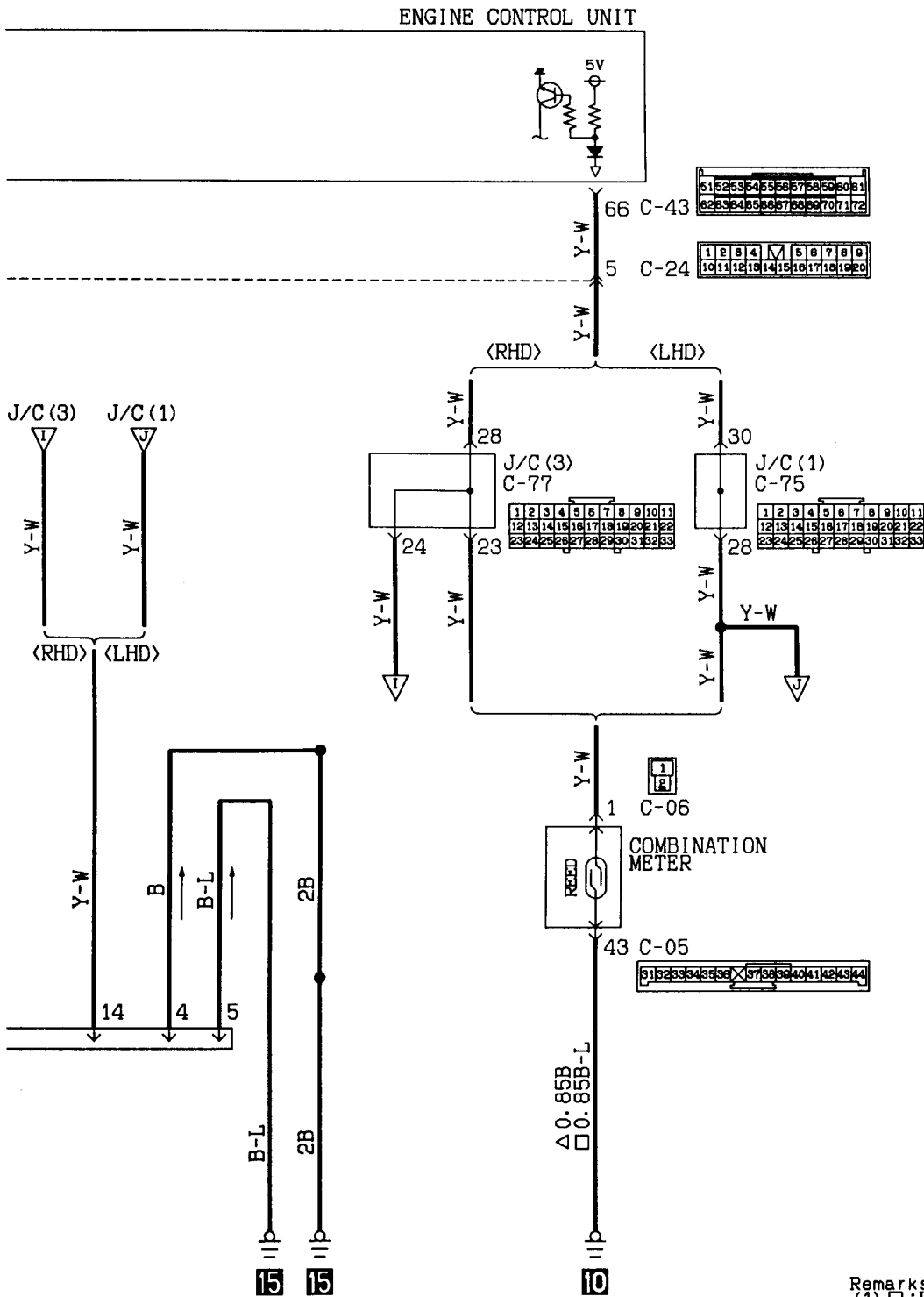

Remarks
 (1) □: L.H. drive vehicles
 (2) Δ: R.H. drive vehicles

Wire colour code
 B:Black LG:Light green G:Green L:Blue W:White Y:Yellow SB:Sky blue
 BR:Brown O:Orange GR:Gray R:Red P:Pink V:Violet

NOTES

OVERDRIVE CONTROL SYSTEM
6G72 engine

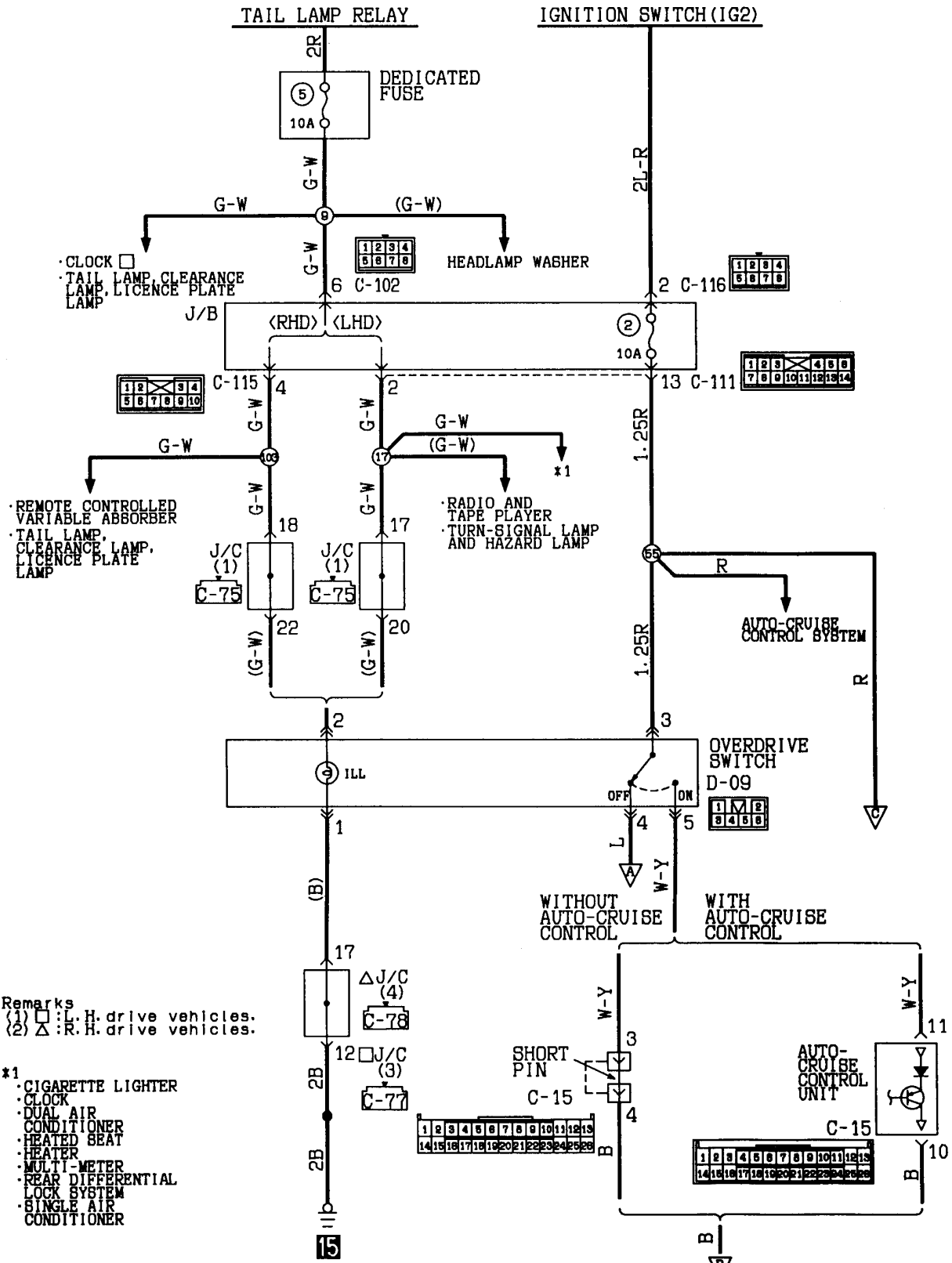

Remarks
(1) □ : L.H. drive vehicles.
(2) △ : R.H. drive vehicles.

- *1
- CIGARETTE LIGHTER
 - CLOCK
 - DUAL AIR CONDITIONER
 - HEATED SEAT HEATER
 - MULTI-METER
 - REAR DIFFERENTIAL LOCK SYSTEM
 - SINGLE AIR CONDITIONER

Wire colour code
B:Black LG:Light green G:Green L:Blue W:White Y:Yellow SB:Sky blue
BR:Brown O:Orange GR:Gray R:Red P:Pink V:Violet

OVERDRIVE CONTROL SYSTEM (6G72 engine)
(CONTINUED)

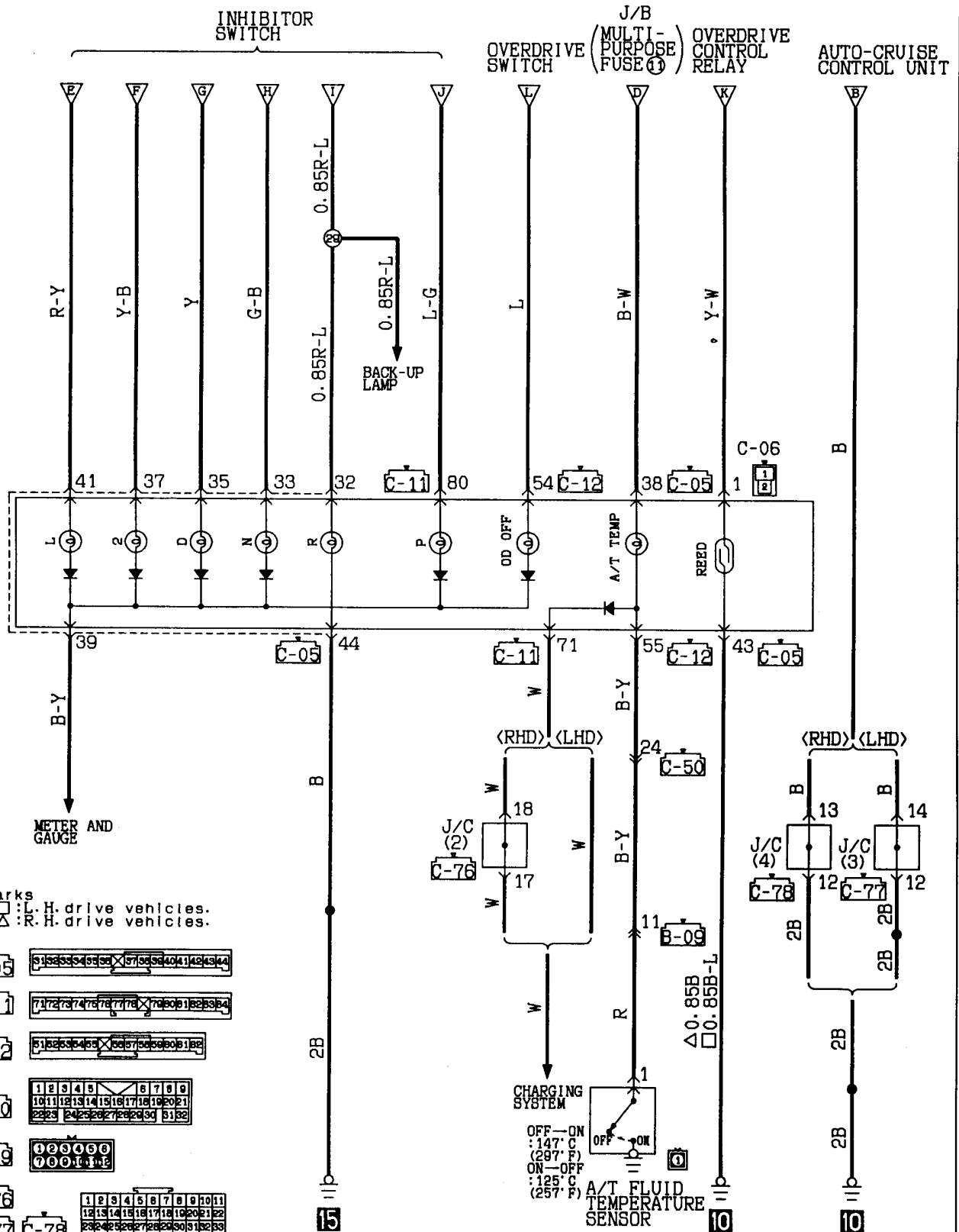

Remarks

- (1) □: L.H. drive vehicles.
- (2) Δ: R.H. drive vehicles.

C-05	1 2 3 4 5 6 7 8 9 10 11 12 13 14 15 16 17 18 19 20 21 22 23 24 25 26 27 28 29 30 31 32
C-11	1 2 3 4 5 6 7 8 9 10 11 12 13 14 15 16 17 18 19 20 21 22 23 24 25 26 27 28 29 30 31 32
C-12	1 2 3 4 5 6 7 8 9 10 11 12 13 14 15 16 17 18 19 20 21 22 23 24 25 26 27 28 29 30 31 32
C-50	1 2 3 4 5 6 7 8 9 10 11 12 13 14 15 16 17 18 19 20 21 22 23 24 25 26 27 28 29 30 31 32
B-09	1 2 3 4 5 6 7 8 9 10 11 12
C-76	1 2 3 4 5 6 7 8 9 10 11 12 13 14 15 16 17 18 19 20 21 22 23 24 25 26 27 28 29 30 31 32
C-77	1 2 3 4 5 6 7 8 9 10 11 12 13 14 15 16 17 18 19 20 21 22 23 24 25 26 27 28 29 30 31 32
C-78	1 2 3 4 5 6 7 8 9 10 11 12 13 14 15 16 17 18 19 20 21 22 23 24 25 26 27 28 29 30 31 32

Wire colour code
 B:Black LG:Light green G:Green L:Blue W:White Y:Yellow SB:Sky blue
 BR:Brown O:Orange GR:Gray R:Red P:Pink V:Violet

OVERDRIVE CONTROL SYSTEM (See P. 4A-82.)**OPERATION****<Overdrive solenoid valve>**

- When the overdrive switch is switched OFF (with the ignition switch at the ON position), battery voltage is applied, through fuse No. ② and the overdrive relay, to the engine coolant temperature switch.
- When the engine coolant temperature becomes 50°C (122°F) or higher, the engine coolant temperature switch is switched ON.
- When the engine coolant temperature switch is switched ON, current flows to the ignition switch, fuse No. ②, the overdrive switch, the overdrive relay, the engine coolant temperature switch, and earth, and the relay is switched ON.
- When the overdrive relay is switched OFF, current flows to the ignition switch, fuse No. ②, the overdrive switch, the overdrive relay, the overdrive solenoid, and earth, and the solenoid valve is activated.

<Overdrive off indicator lamp>

- When the overdrive switch is switched OFF (with the ignition switch at the ON position), current flows to the ignition switch, fuse No. ②, the overdrive switch, the overdrive off indicator, and earth, and the indicator illuminates.

<Automatic transmission oil temperature warning lamp>

- When the ignition switch is turned to the "ON" position (with the engine stopped), the automatic transmission oil temperature warning lamp comes on and the lamp switches OFF when the engine is started. This feature can be used to check for a failure of the lamp's bulb.
- When the automatic transmission oil temperature becomes abnormally high, the automatic transmission oil temperature switch turns ON causing the automatic transmission oil temperature warning lamp to light up.

ELC 4-SPEED AUTOMATIC TRANSMISSION
6G74 engine

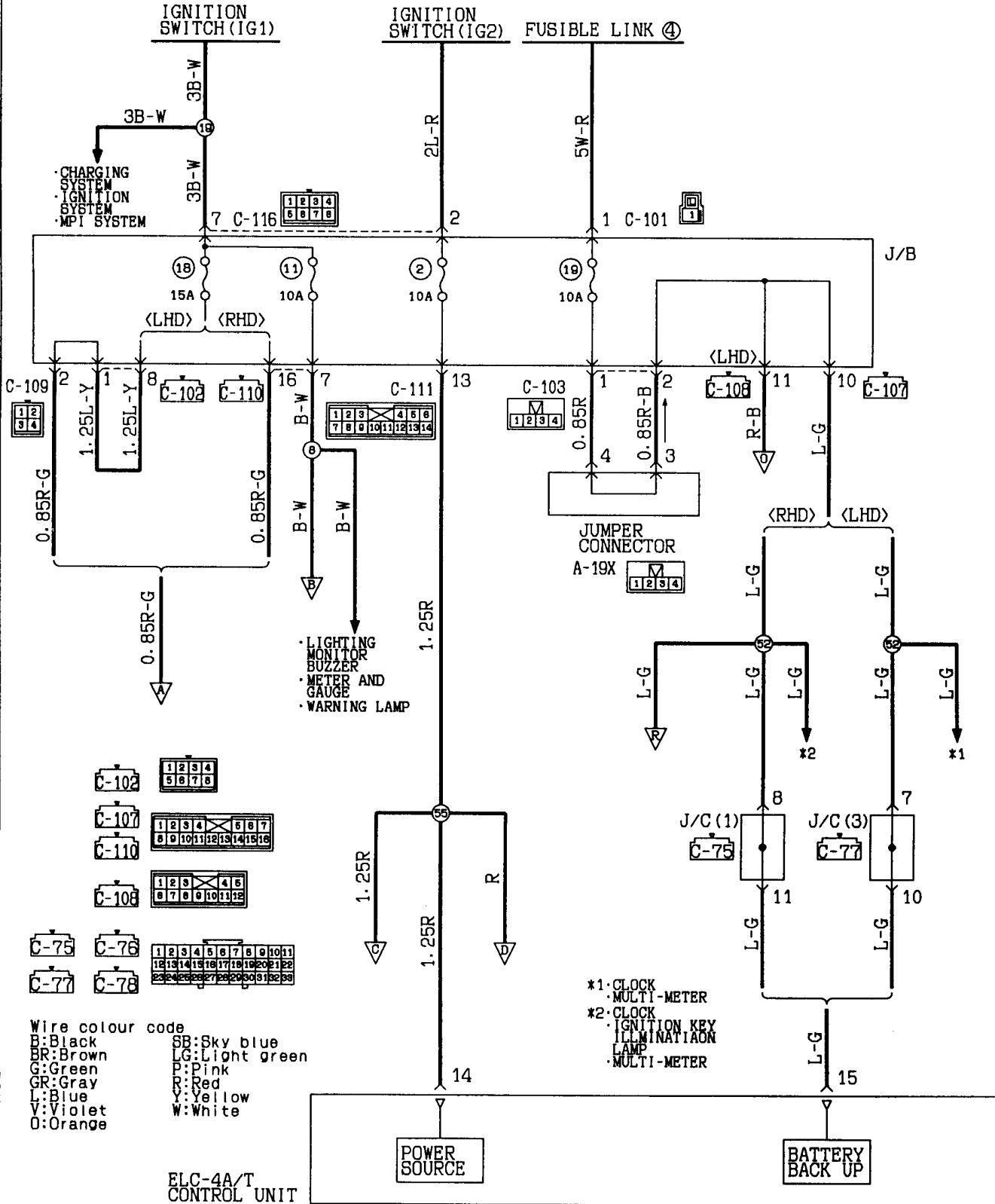

KX35-AC-00705-EC

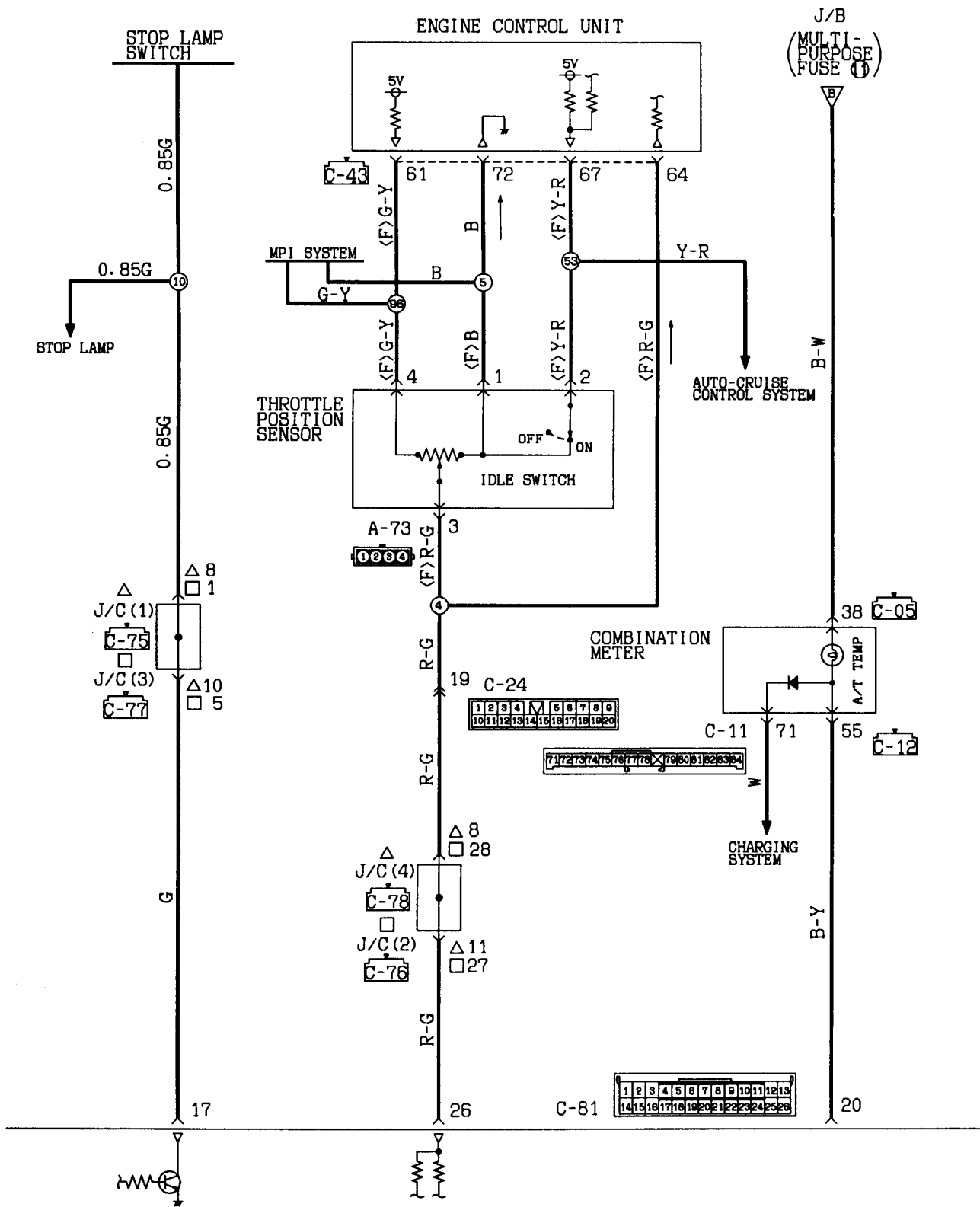

ELC-4A/T CONTROL UNIT



ELC 4-SPEED AUTOMATIC TRANSMISSION
(6G74 engine) (CONTINUED)

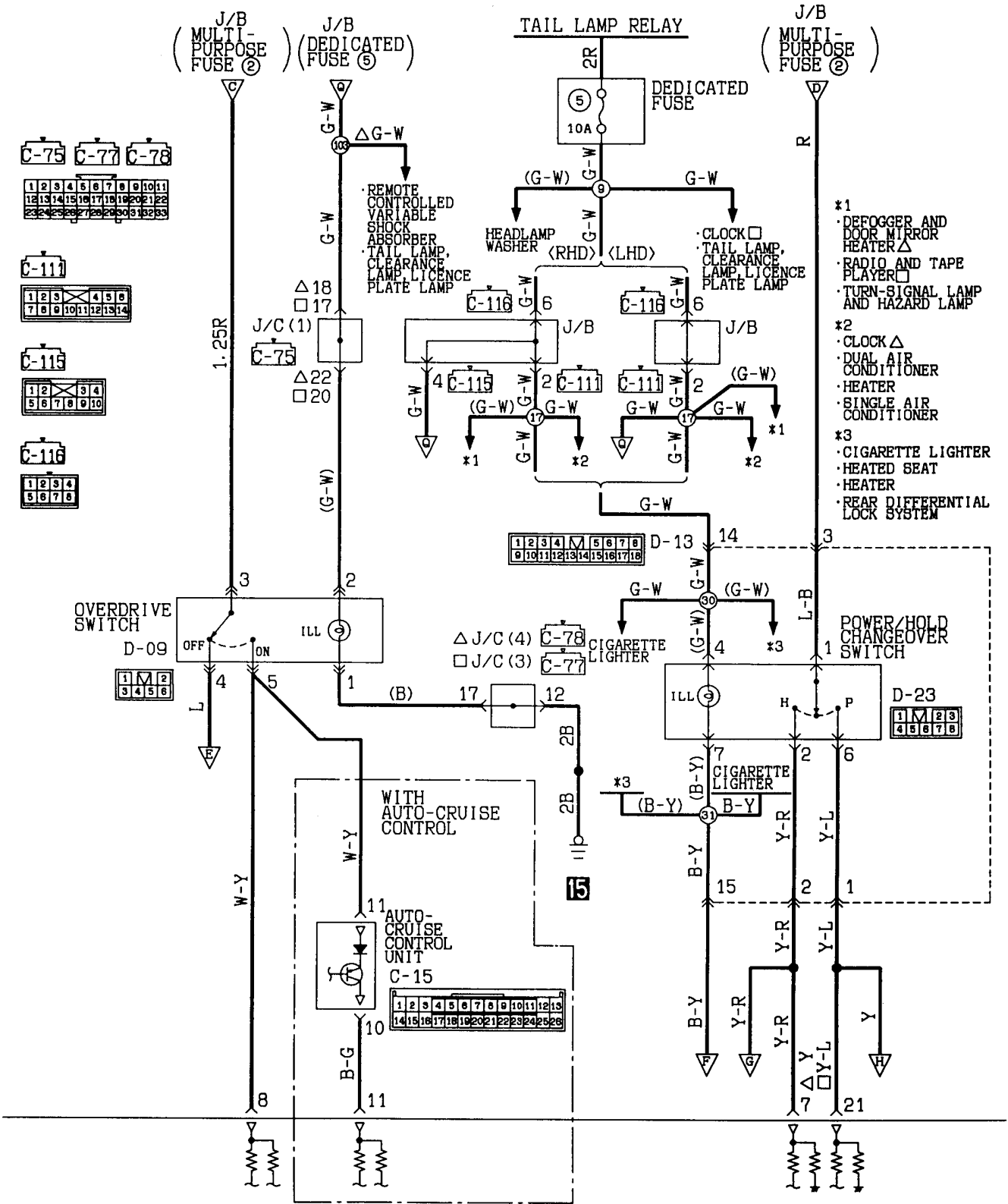

ELC-4A/T CONTROL UNIT

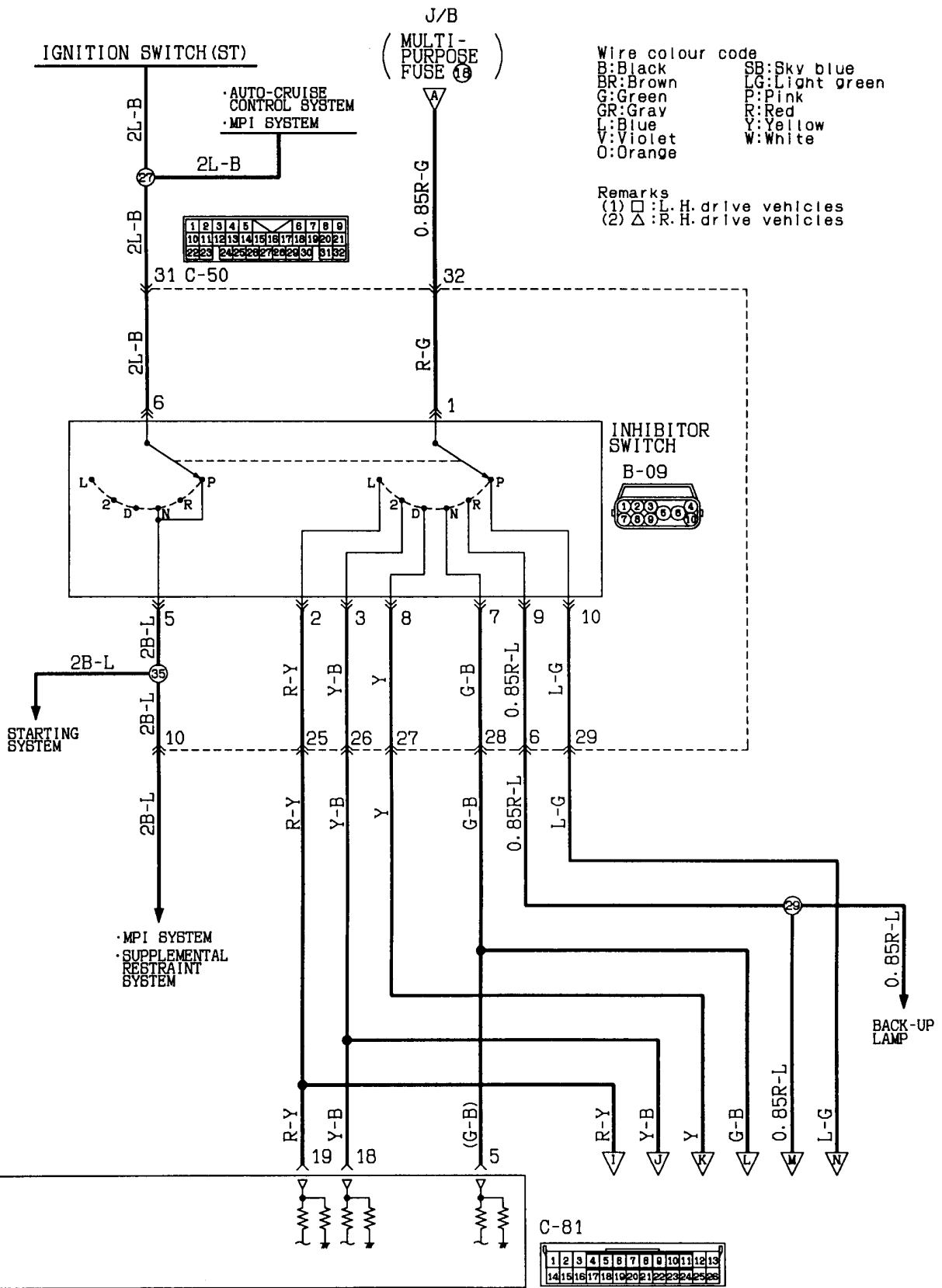

ELC 4-SPEED AUTOMATIC TRANSMISSION
(6G74 engine) (CONTINUED)

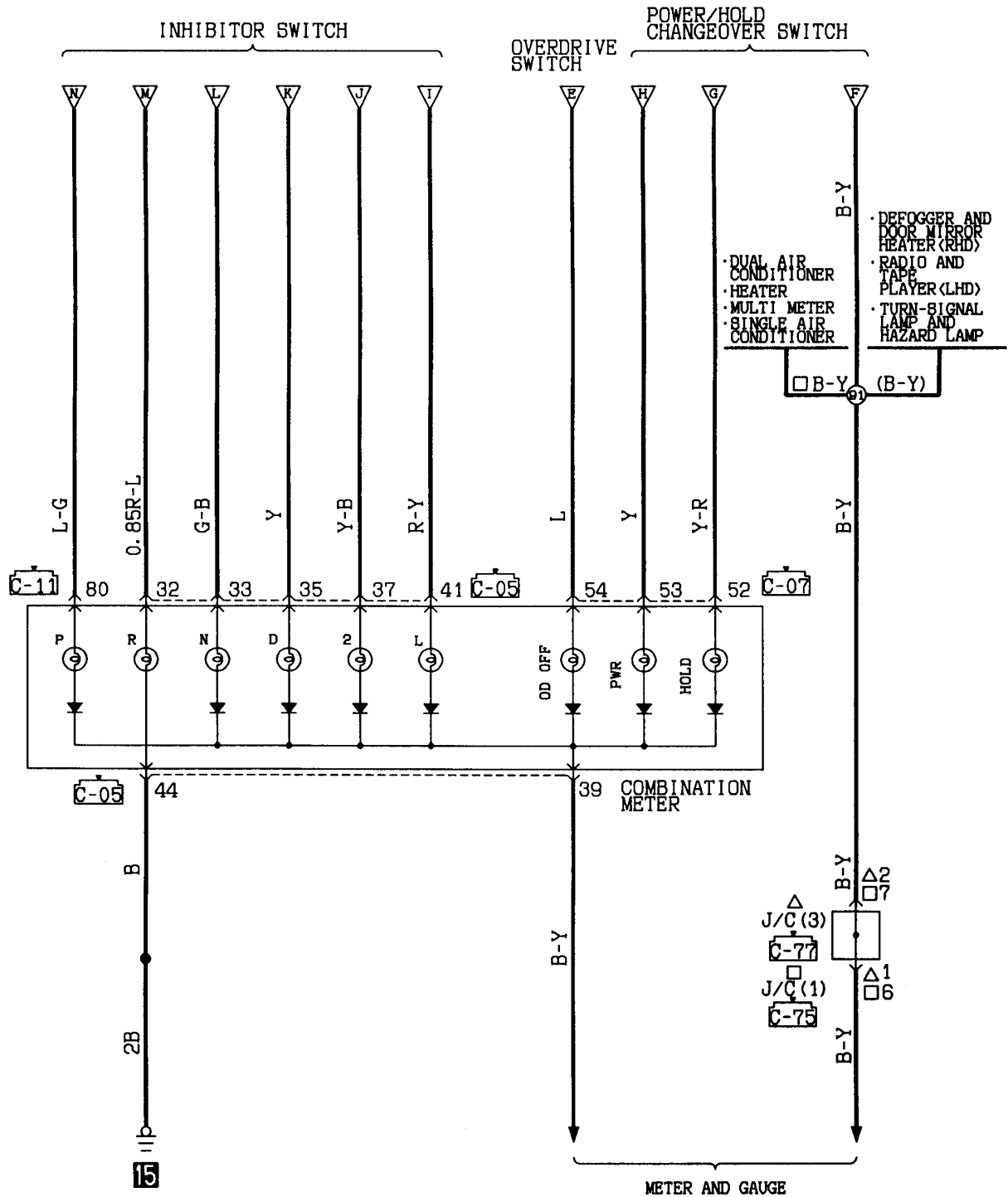

Wire colour code
 B:Black
 BR:Brown
 G:Green
 GR:Gray
 L:Blue
 V:Violet
 O:Orange
 SB:Sky blue
 LG:Light green
 P:Pink
 R:Red
 Y:Yellow
 W:White

Remarks
 (1) □: L.H. drive vehicles.
 (2) △: R.H. drive vehicles.

C-11	7172737475767778798081828384
------	------------------------------

C-05	8182838485868788899091929394
------	------------------------------

C-75	11213141516171819202122
C-77	2324252627282930313233

C-07	515253545556575859606162
------	--------------------------

KX35-AC-00705B-EC

ELC-4A/T CONTROL UNIT

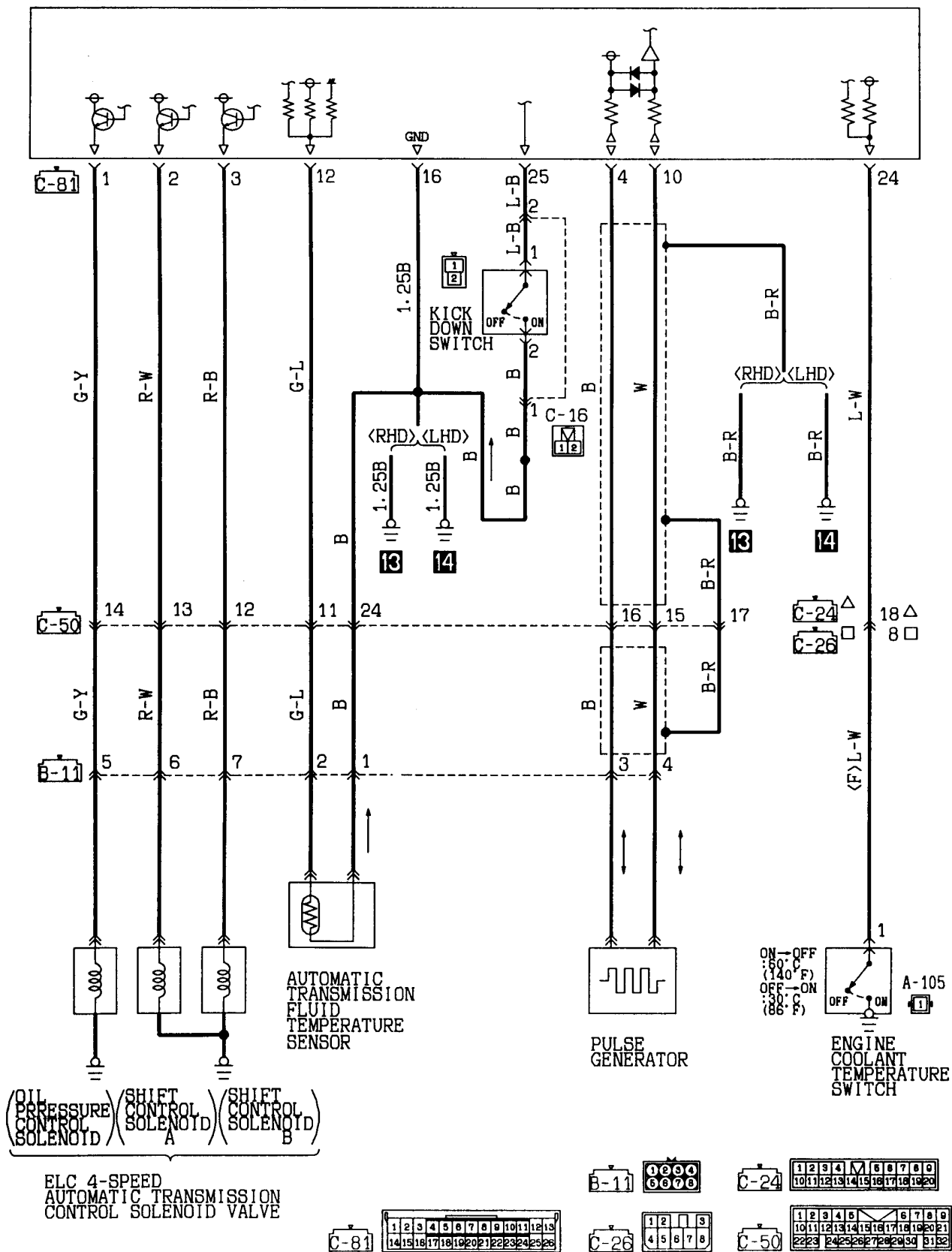

ELC 4-SPEED AUTOMATIC TRANSMISSION
(6G74 engine) (CONTINUED)

ELC-4A/T CONTROL UNIT

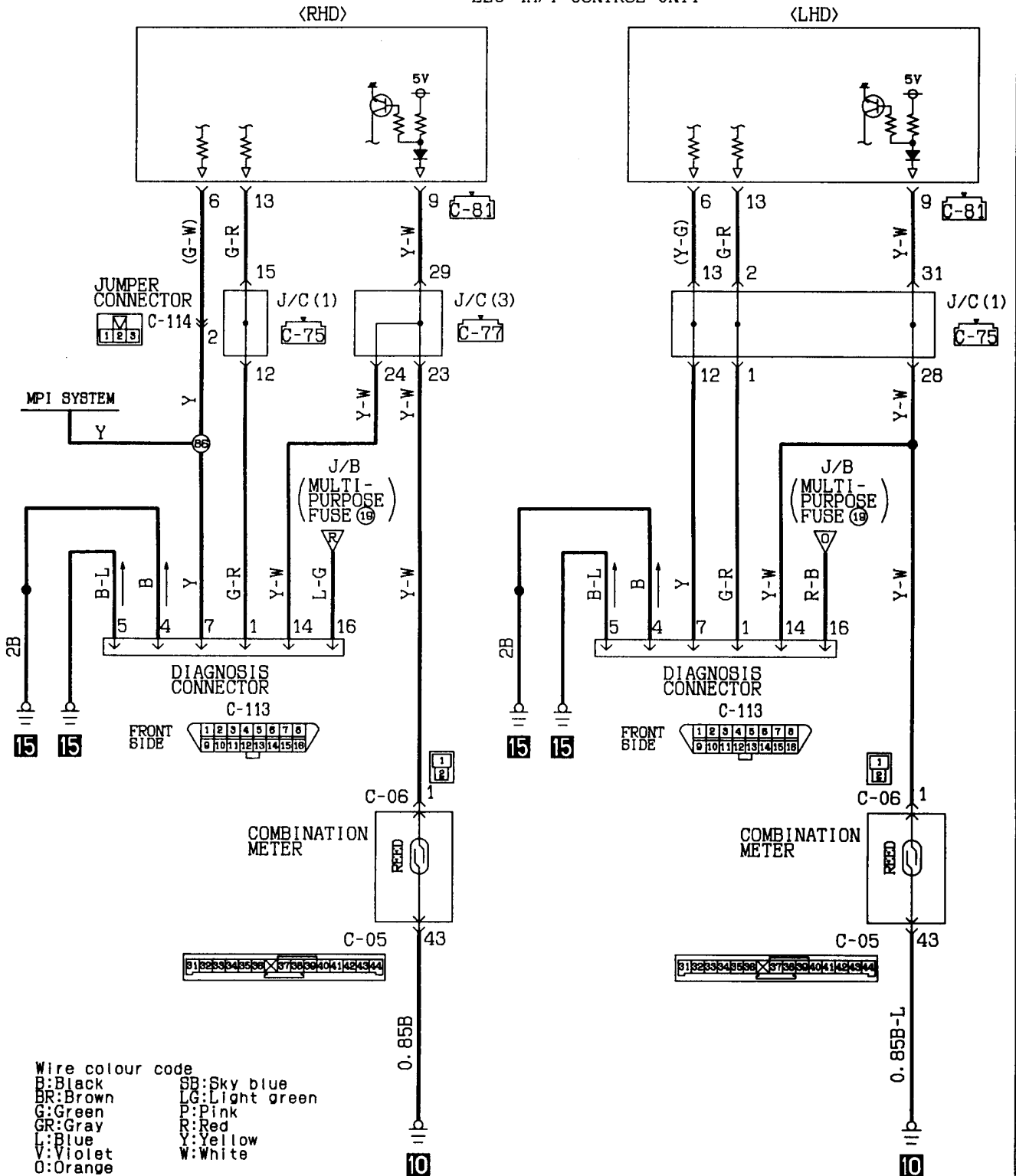

KX35-AC-90705C-EC

NOTES

ELC 4-SPEED AUTOMATIC TRANSMISSION 4M40 engine

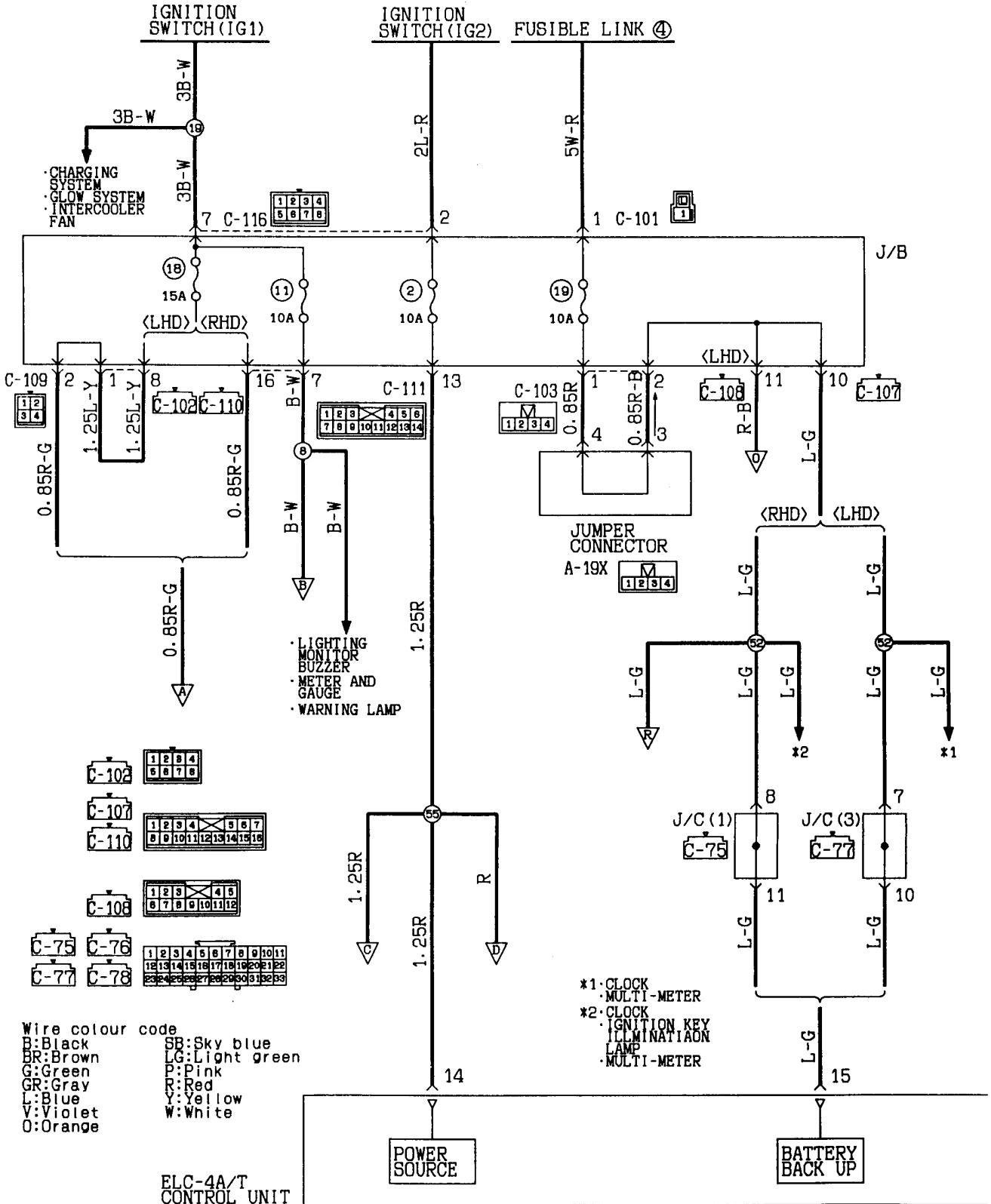

KX35-AC-00708-EC

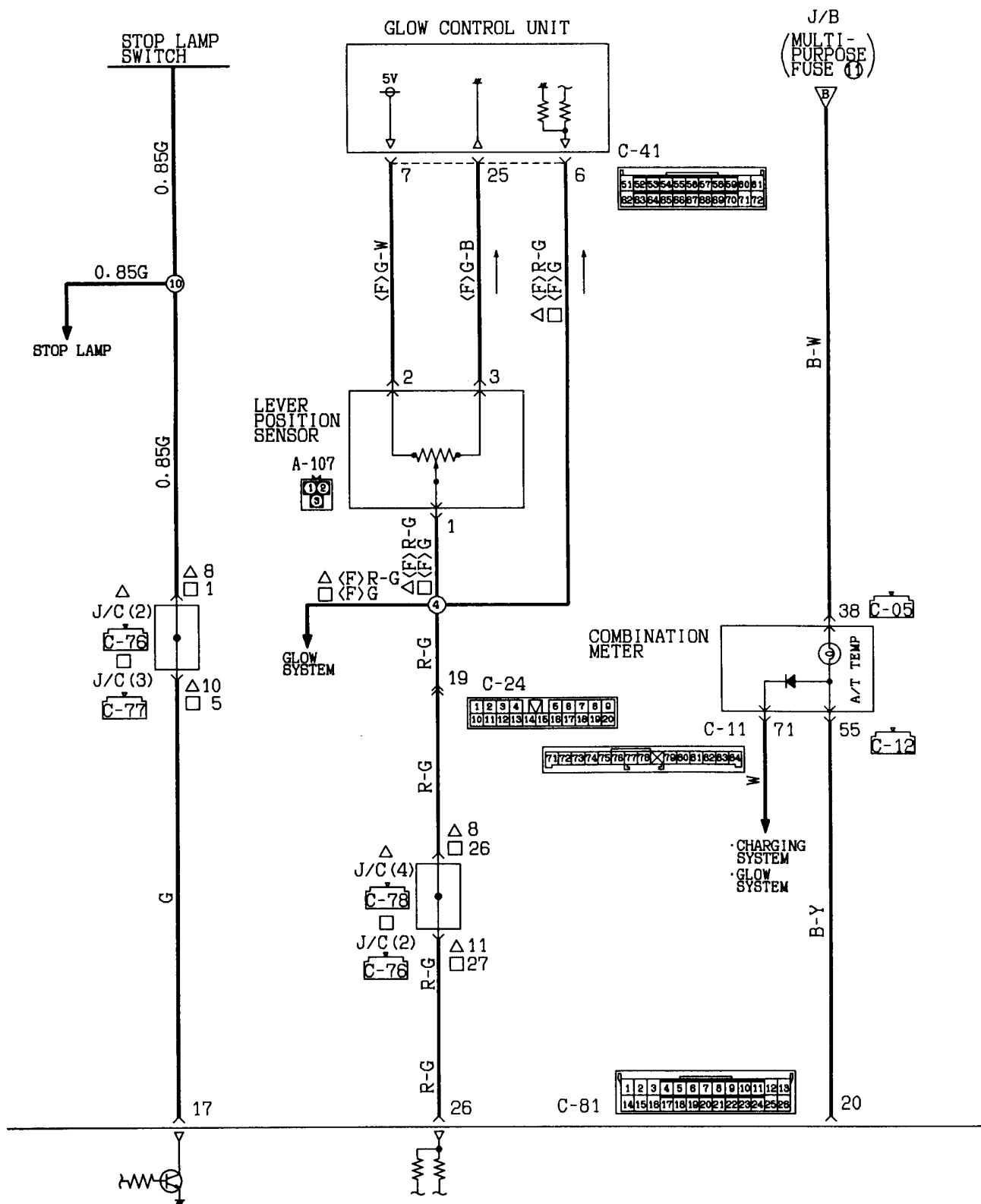

ELC-4A/T CONTROL UNIT



ELC 4-SPEED AUTOMATIC TRANSMISSION
(4M40 engine) (CONTINUED)

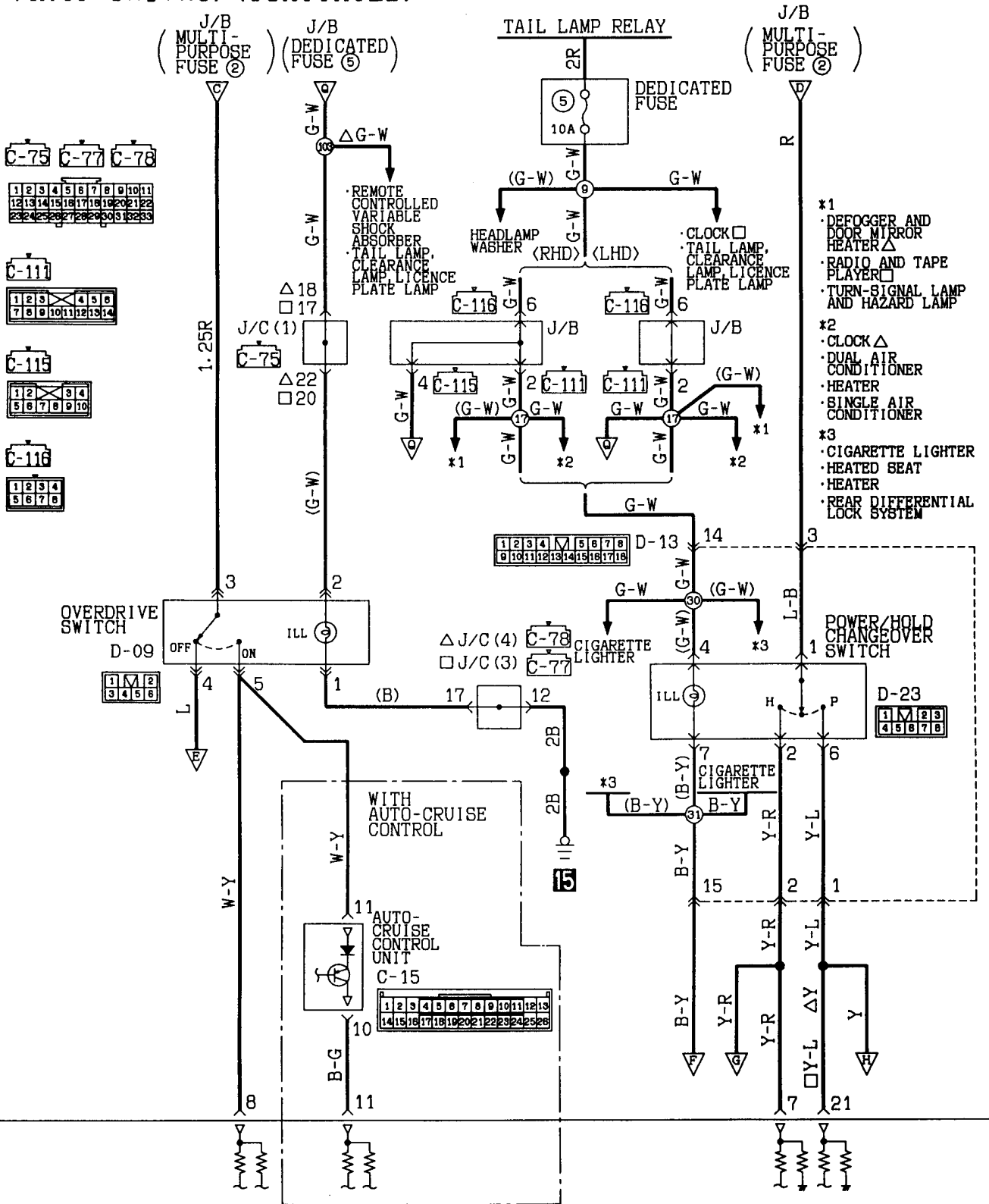

ELC-4A/T CONTROL UNIT

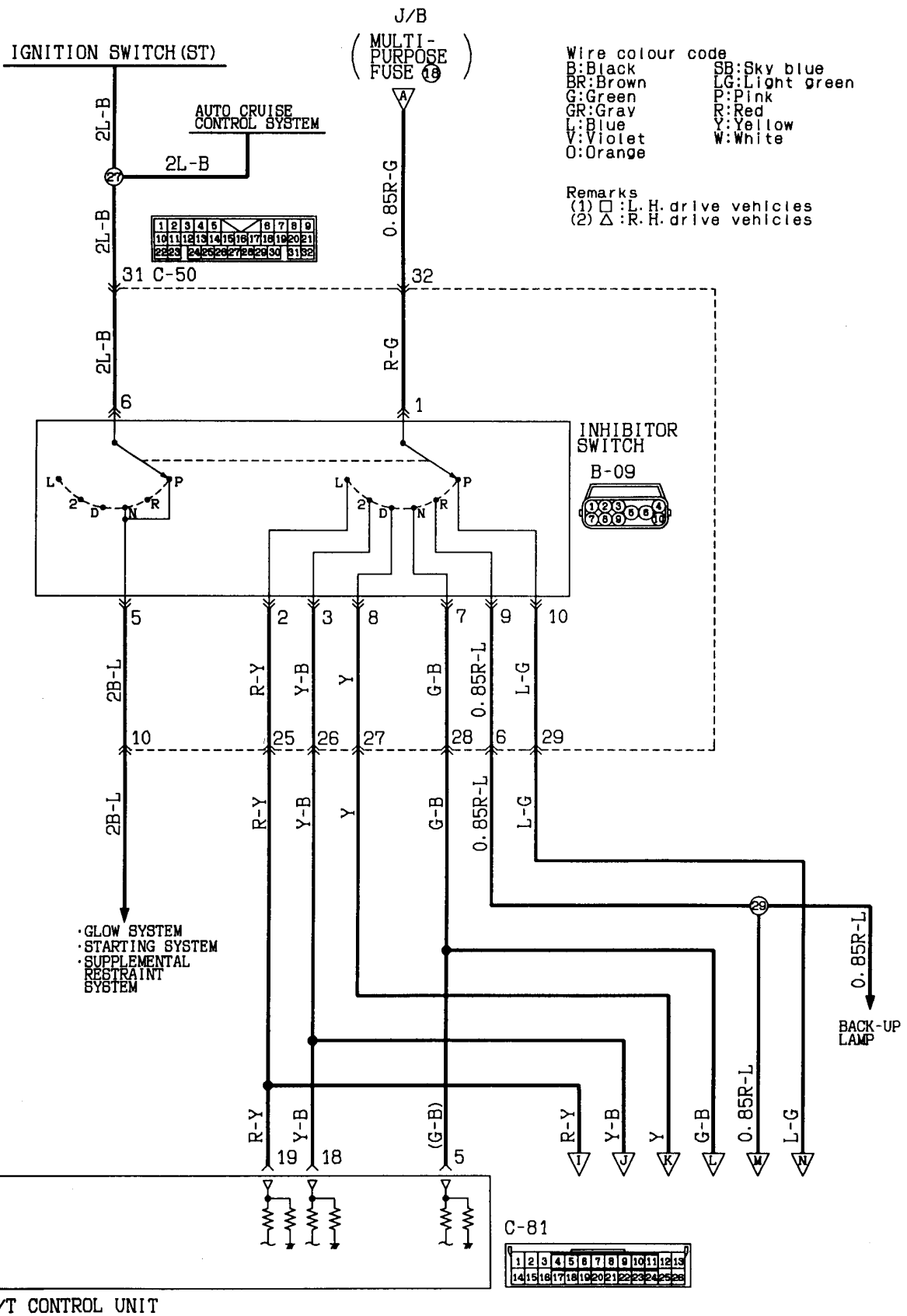

ELC 4-SPEED AUTOMATIC TRANSMISSION
(4M40 engine) (CONTINUED)

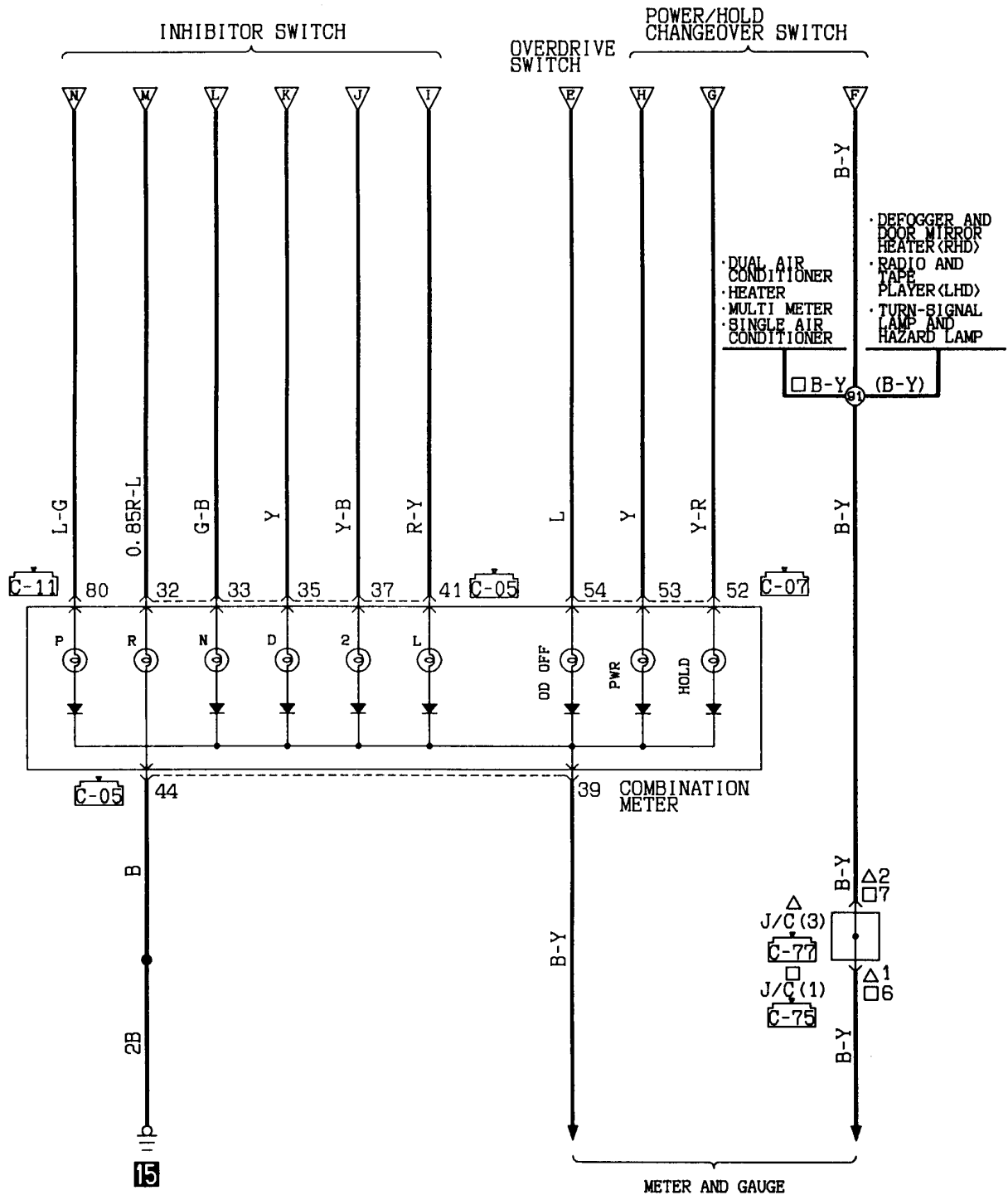

Wire colour code
 B:Black
 BR:Brown
 G:Green
 GR:Gray
 L:Blue
 V:Violet
 O:Orange
 SB:Sky blue
 LG:Light green
 P:Pink
 R:Red
 Y:Yellow
 W:White

Remarks
 (1) □: L.H. drive vehicles.
 (2) △: R.H. drive vehicles.

C-11	7 1 7 2 7 3 7 4 7 5 7 6 7 7 7 8 X 7 9 8 0 8 1 8 2 8 3 8 4
------	-----------------------------------------------------------

C-05	3 1 3 2 3 3 3 4 3 5 3 6 X 3 7 3 8 3 9 4 0 4 1 4 2 4 3 4 4
------	-----------------------------------------------------------

C-75	1 2 3 4 5 6 7 8 9 10 11
C-77	12 13 14 15 16 17 18 19 20 21 22
	23 24 25 26 27 28 29 30 31 32 33

C-07	5 1 5 2 5 3 5 4 5 5 X 5 6 5 7 5 8 5 9 6 1 6 2
------	-----------------------------------------------

KX35-AC-00708B-EC

ELC-4A/T CONTROL UNIT

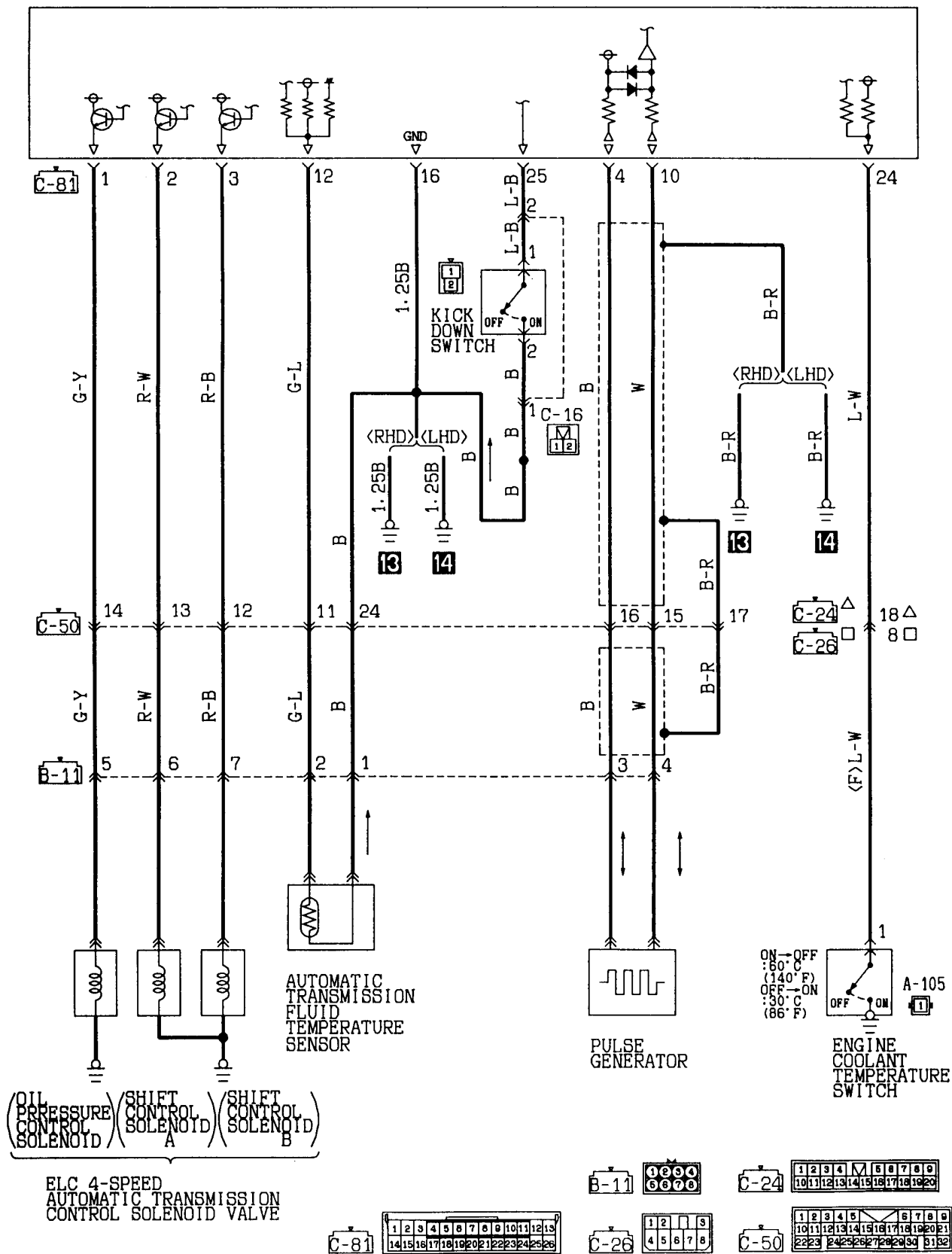

ELC 4-SPEED AUTOMATIC TRANSMISSION
(4M40 engine) (CONTINUED)

ELC-4A/T CONTROL UNIT

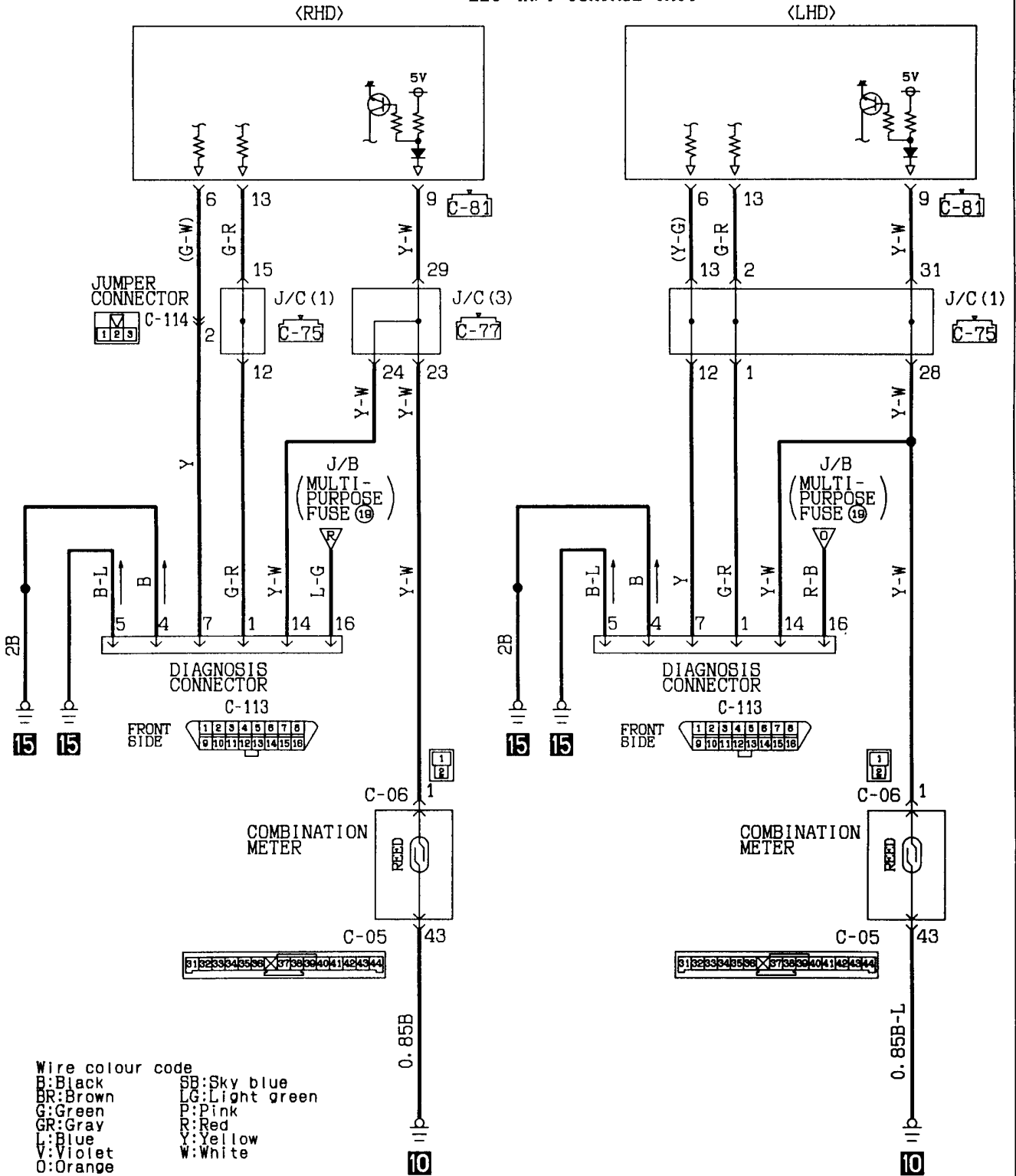

HEADLAMP

L.H. drive vehicles without daytime running lamp
(without SR5)

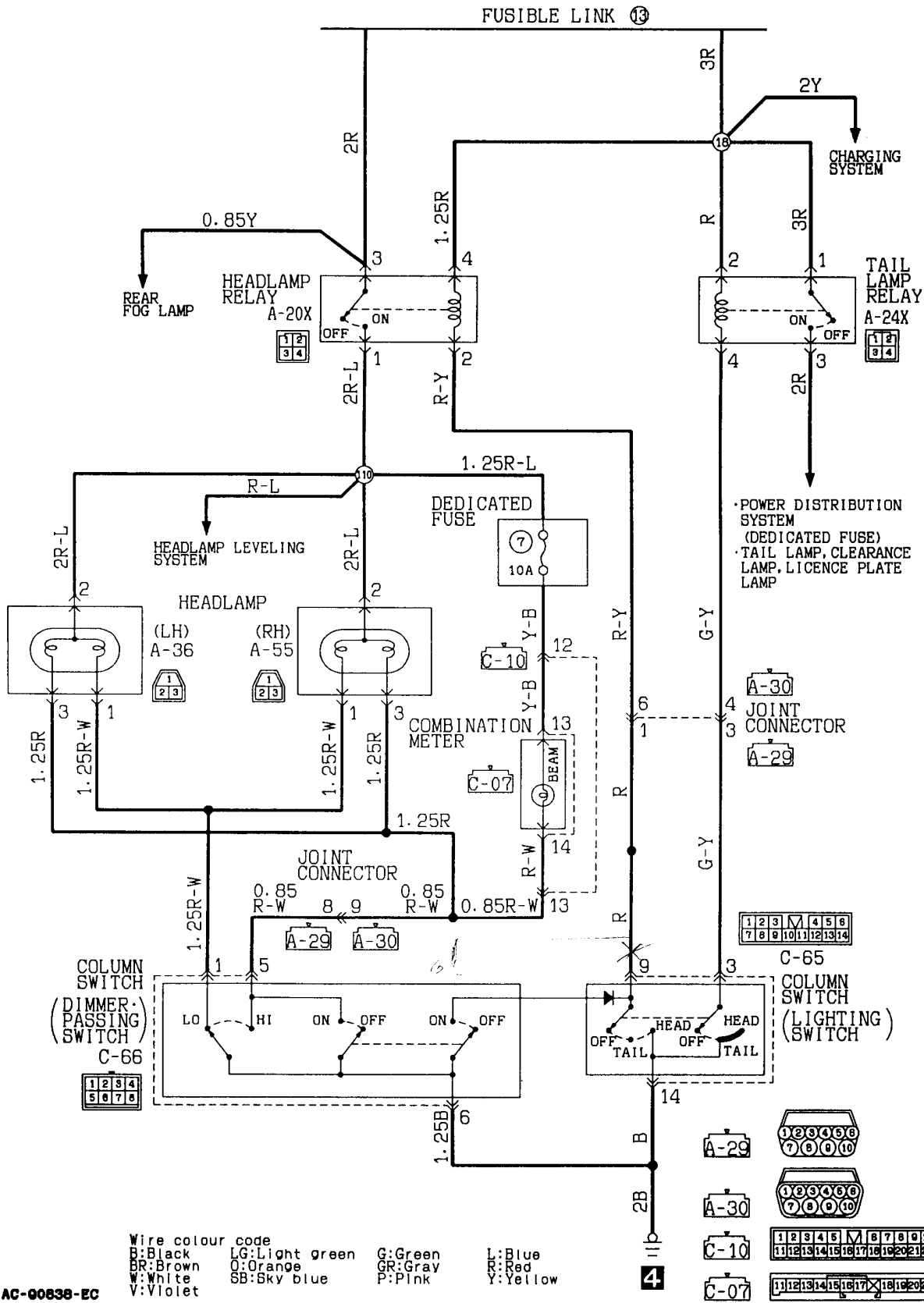

KX35-AC-00638-EC

HEADLAMP

L.H. drive vehicles without daytime running lamp
(with SRS)

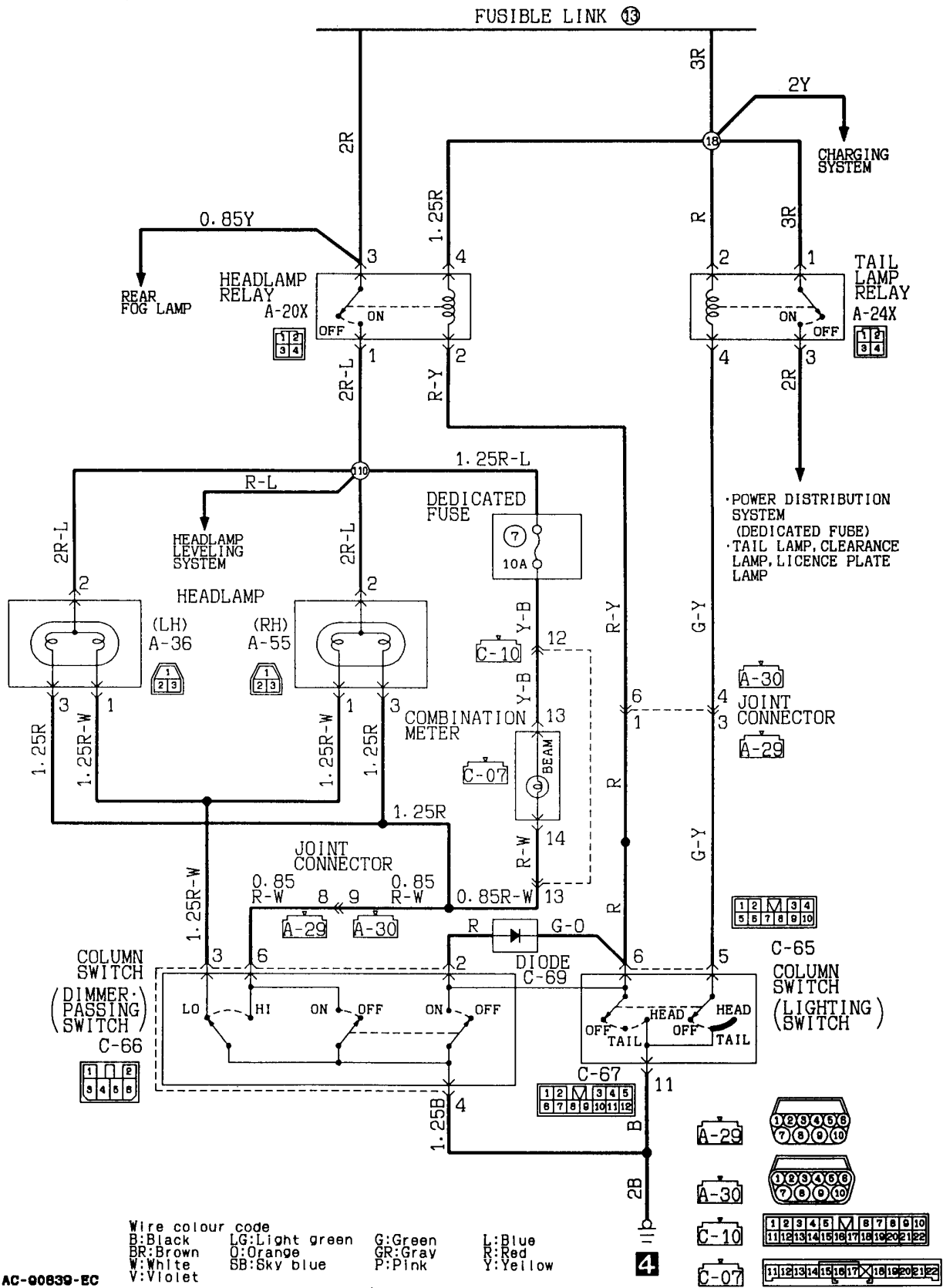

KX35-AC-00839-EC

HEADLAMP <L.H.drive vehicles without daytime running lamp> (See P. 4A-101, 102.)**OPERATION****Headlamp Relay ON Conditions**

Ignition switch	Lighting switch	Dimmer/passing switch	Headlamp relay
—	"HEAD"	—	ON
—	—	ON	ON

<Low-beam operation>

- Placing the lighting switch in the HEAD position causes the headlamp relay to be energized.
- If the dimmer/passing switch is placed in the LO position at this time, then the headlamps light up in low beam.

<Upper-beam operation>

- Placing the lighting switch in the HEAD position causes the headlamp relay to be energized.
- If the dimmer/passing switch is placed in the HI position at this time, the headlamps light up in upper beam.

<Upper-beam indicator lamp>

- This lamp lights up when the upper/passing beams are on, indicating that the headlamps are on in upper beam.

<Passing operation>

- When the dimmer/passing switch is set to the "ON" position, the headlamp relay is switched ON and the upper beam of the headlamps illuminates.

TROUBLESHOOTING HINTS

1. Headlamps don't come on.
 - 1) But the tail lamps do illuminate.
 - Check the headlamp relay.
 - Check the lighting switch.
 - 2) The tail lamps also don't illuminate.
 - Check the fusible link No. ⑬.
2. The low beam at both sides doesn't illuminate.
 - Check the dimmer switch LO contacts.
3. The upper beam at both sides doesn't illuminate.
 - 1) The passing signal functions OK.
 - Check the dimmer switch HI contacts.
 - 2) The passing signal doesn't function.
 - Check the dimmer switch.
4. One headlamp doesn't illuminate.
 - Check the bulb.
5. Can't switch from low to upper beam or vice-versa.
 - Check the dimmer switch.
6. Upper-beam indicator lamp does not come on.
 - 1) Headlamp upper beams are operational.
 - Check dedicated fuse No. ⑦.
 - Check the indicator lamp bulb.

HEADLAMP

L.H. drive vehicles with daytime running lamp
(without SRS)

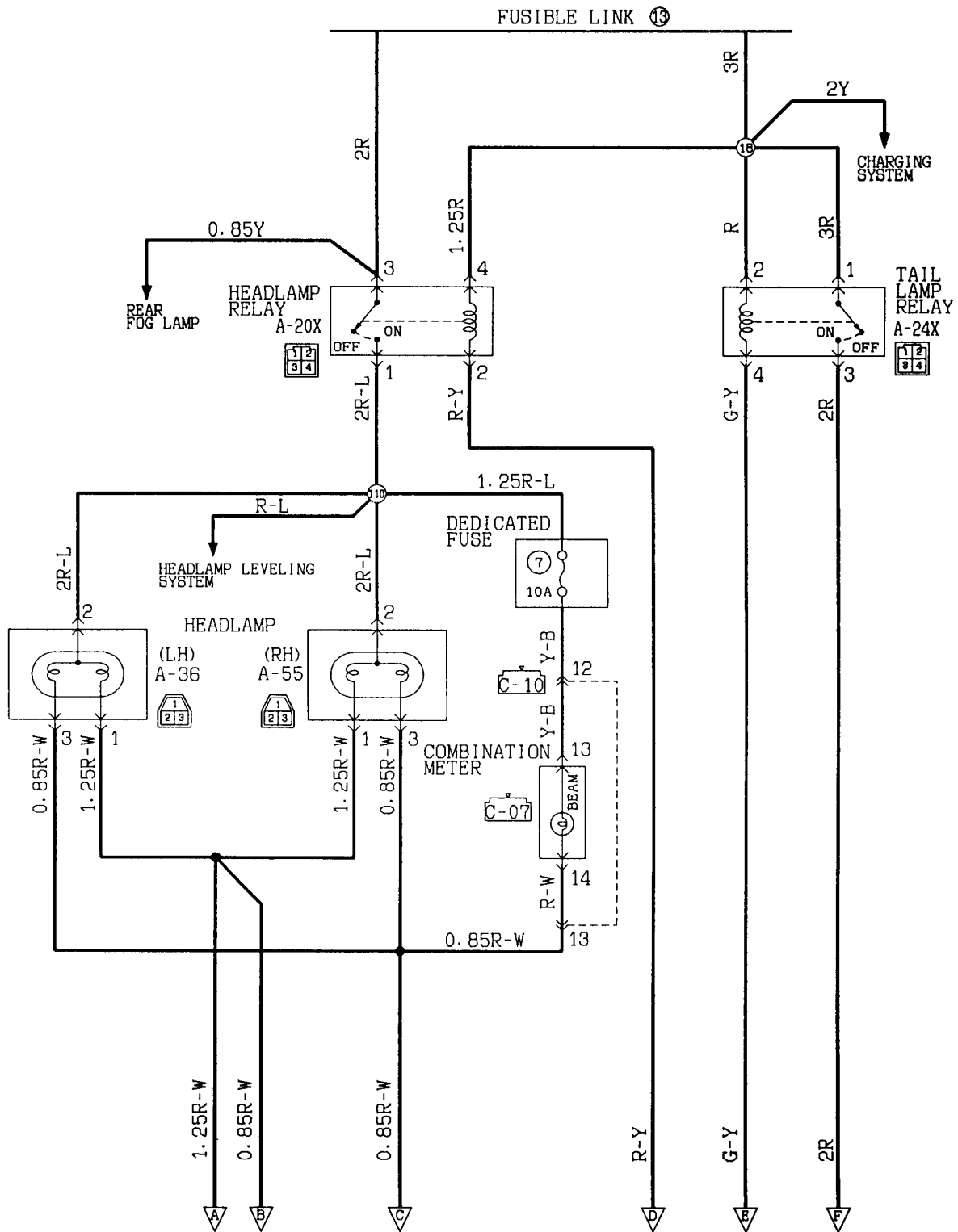

KX35-AC-00840-EC



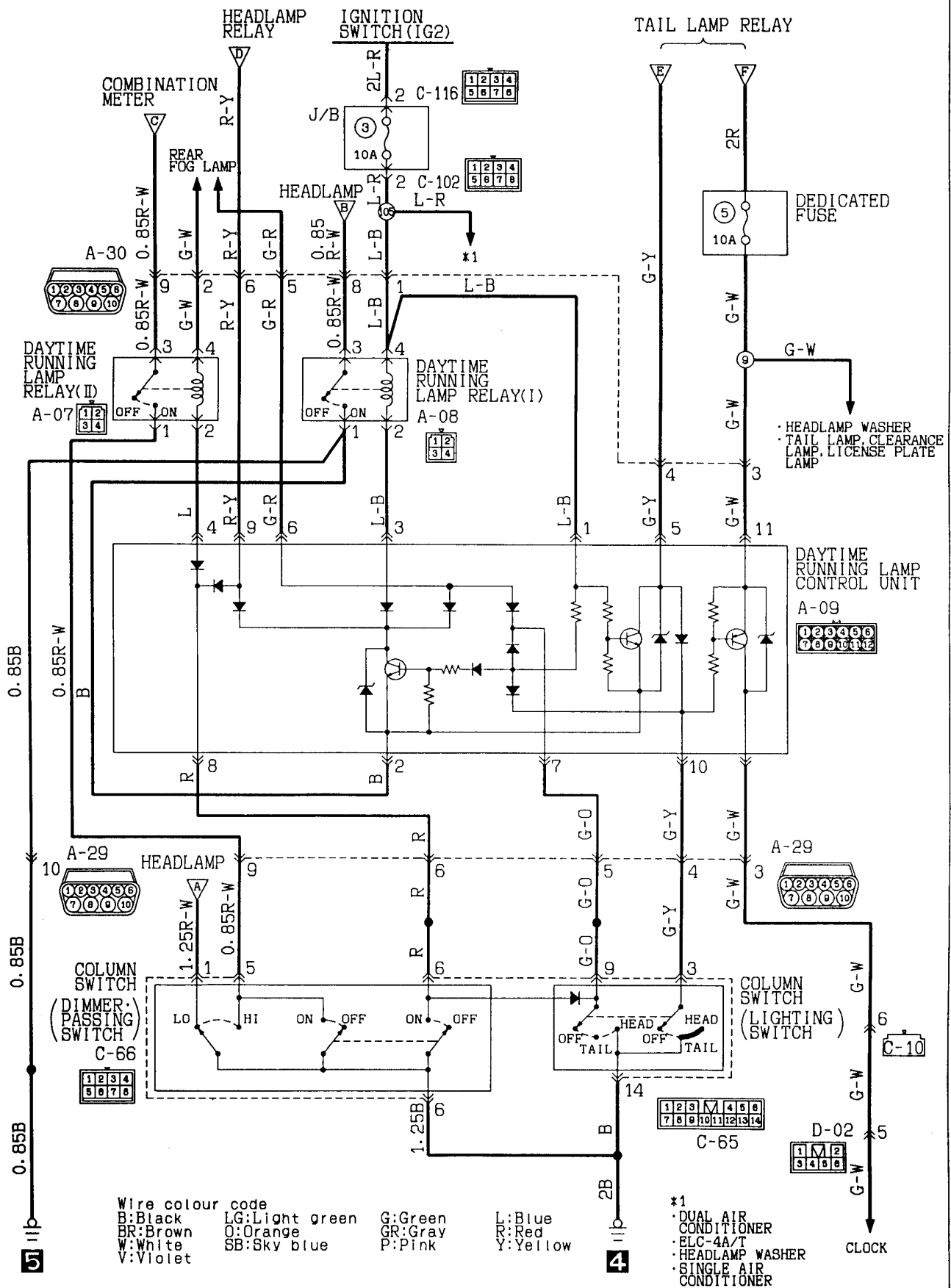

Wire colour code
 B:Black LG:Light green G:Green L:Blue
 BR:Brown O:Orange GR:Gray R:Red
 W:White SB:Sky blue P:Pink Y:Yellow
 V:Violet

*1
 • DUAL AIR
 CONDITIONER
 • ELC-4A/T
 • HEADLAMP WASHER
 • SINGLE AIR
 CONDITIONER

HEADLAMP

L.H. drive vehicles with daytime running lamp
(with SRS)

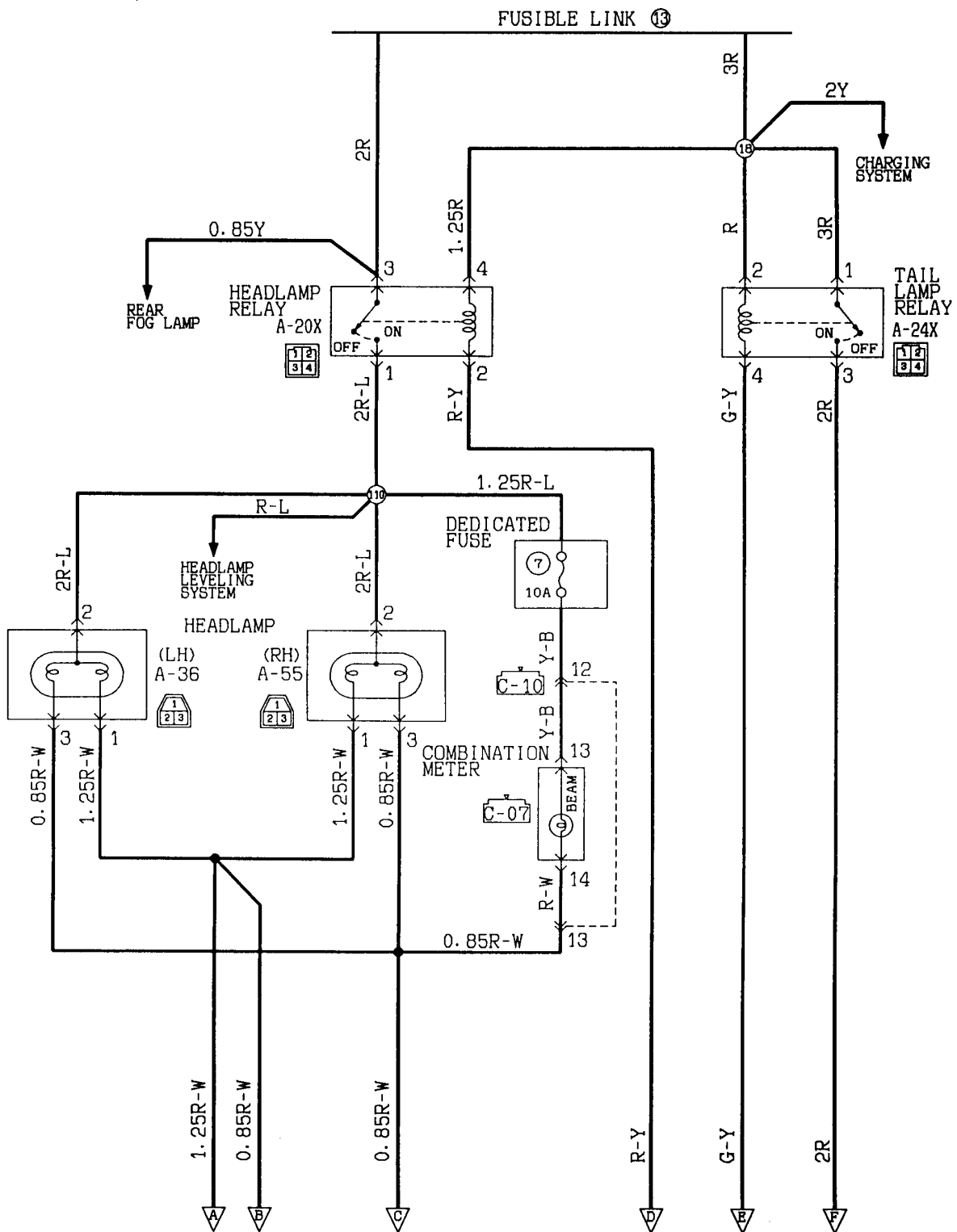

KX35-AC-00841-EC

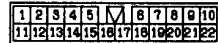

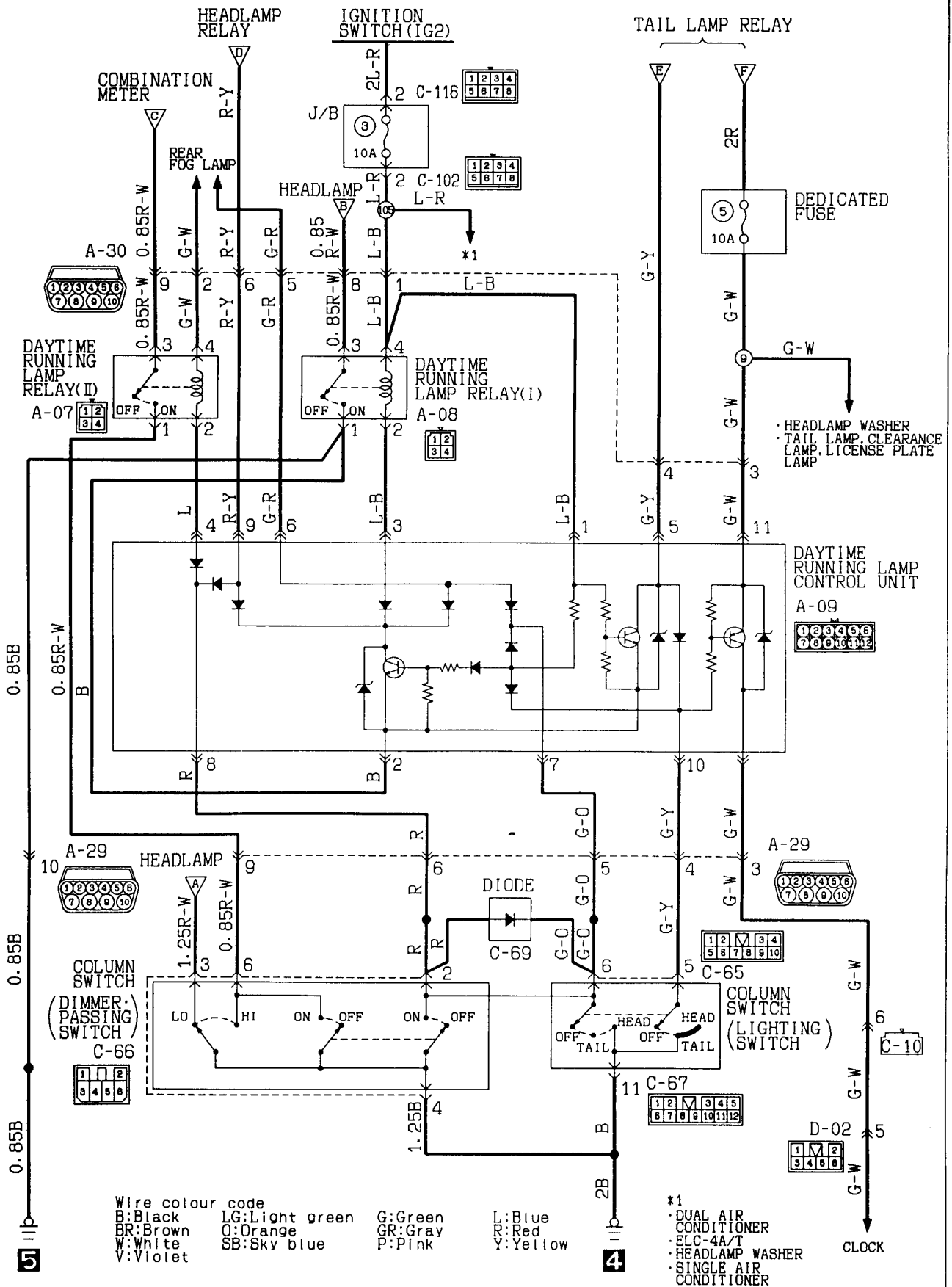

HEADLAMP <L.H.drive vehicles with daytime running lamp> (See P. 4A-104, 106.)**OPERATION**

Headlamp Relay ON Conditions

Ignition switch	Lighting switch	Dimmer/passing switch	Headlamp relay
"ON"	—	—	ON
—	"HEAD"	—	ON
—	—	ON	ON

<Daytime running lamp operation>

- Turning the ignition switch to the ON position causes the headlamp relay, daytime running lamp relay (I), and tail lamp relay to be energized, which causes the headlamps, tail lamps, etc. to come on.

<Low-beam operation>

- Placing the lighting switch in the HEAD position causes the headlamp relay and daytime running lamp relay (II) to be energized.
- If the dimmer/passing switch is placed in the LO position at this time, the headlamps light up in low beam.

<Upper-beam operation>

- Placing the lighting switch in the HEAD position causes the headlamp relay and daytime running lamp relay (II) to be energized.
- If the dimmer/passing switch is placed in the HI position at this time, the headlamps light up in upper beam.

<Upper-beam indicator lamp>

- This lamp lights up when the upper/passing beams are on, indicating that the headlamps are on in upper beam.

TROUBLESHOOTING HINTS

1. Headlamps don't come on.
 - 1) But the tail lamps do illuminate.
 - Check the headlamp relay.
 - Check the lighting switch.
 - 2) The tail lamps also don't illuminate.
 - Check the fusible link No. ⑬.
2. The low beam at both sides doesn't illuminate.
 - Check the dimmer switch LO contacts.
3. The upper beam at both sides doesn't illuminate.
 - 1) The passing signal functions OK.
 - Check the dimmer switch HI contacts.
 - 2) The passing signal doesn't function.
 - Check the dimmer switch.
 - Check the daytime running lamp relay (II).
 - Check the daytime running lamp control unit.
4. One headlamp doesn't illuminate.
 - Check the bulb.
5. Can't switch from low to upper beam or vice-versa.
 - Check the dimmer switch.
6. With the ignition switch at the "ON" position, the headlamps' low beam does not illuminate.
 - Check the daytime running lamp relay (I).
 - Check the daytime running lamp control unit.
7. Upper-beam indicator lamp does not come on.
 - 1) Headlamp upper beams are operational.
 - Check dedicated fuse No. ⑦.
 - Check the indicator lamp bulb.

HEADLAMP <R.H.drive vehicles> (See P. 4A-110, 112.)**OPERATION**

Headlamp Relay ON Conditions

Ignition switch	Lighting switch	Dimmer/passing switch	Headlamp relay
"ON"	"TAIL"	—	ON
—	"HEAD"	—	ON
—	—	ON	ON

<Dim-dip lamp operation>

- Placing the lighting switch in the TAIL position causes dim-dip lamp relay (I) to be energized.
- This causes the headlamp relay to be also energized resulting in the headlamps being lit up dimly through the circuit by way of resistor.

<Low-beam operation>

- Placing the lighting switch in the HEAD position causes the headlamp relay, dim-dip lamp relay (II), and dim-dip lamp relay (III) to be energized.
- If the dimmer/passing switch is placed in the LO position at this time, the headlamps light up in low beam.

<Upper-beam operation>

- Placing the lighting switch in the HEAD position causes the headlamp relay, dim-dip lamp relay (II) and dim-dip lamp relay (III) to be energized.
- If the dimmer/passing switch is placed in the HI position at this time, the headlamps light up in upper beam.

<Upper-beam indicator lamp>

- This lamp lights up when the upper/passing beams are on, indicating that the headlamps are on in upper beam.

TROUBLESHOOTING HINTS

1. Headlamps don't come on.
 - 1) But the tail lamps do illuminate.
 - Check the headlamp relay.
 - Check the lighting switch.
 - Check the dim-dip lamp relays (II) and (III).
 - 2) The tail lamps also don't illuminate.
 - Check the fusible link No. ⑬.
2. The low beam at both sides doesn't illuminate.
 - Check the dimmer switch LO contacts.
3. The upper beam at both sides doesn't illuminate.
 - 1) The passing signal functions OK.
 - Check the dimmer switch HI contacts.
 - 2) The passing signal doesn't function.
 - Check the dimmer switch.
4. One headlamp doesn't illuminate.
 - Check the bulb.
5. Can't switch from low to upper beam or vice-versa.
 - Check the dimmer switch.
6. The headlamps' low beam does not illuminate at the "TAIL" position of the lighting switch.
 - 1) The low beam does illuminate, however, when, with lighting switch at the "HEAD" position, the dimmer switch is set to "LO".
 - Check the dim-dip lamp relay (I).
 - Check the resistor.
 - Check the diode.
7. Upper-beam indicator lamp does not come on.
 - 1) Headlamp upper beams are operational.
 - Check dedicated fuse No. ⑦.
 - Check the indicator lamp bulb.

HEADLAMP
R. H. drive vehicles (without SRS)

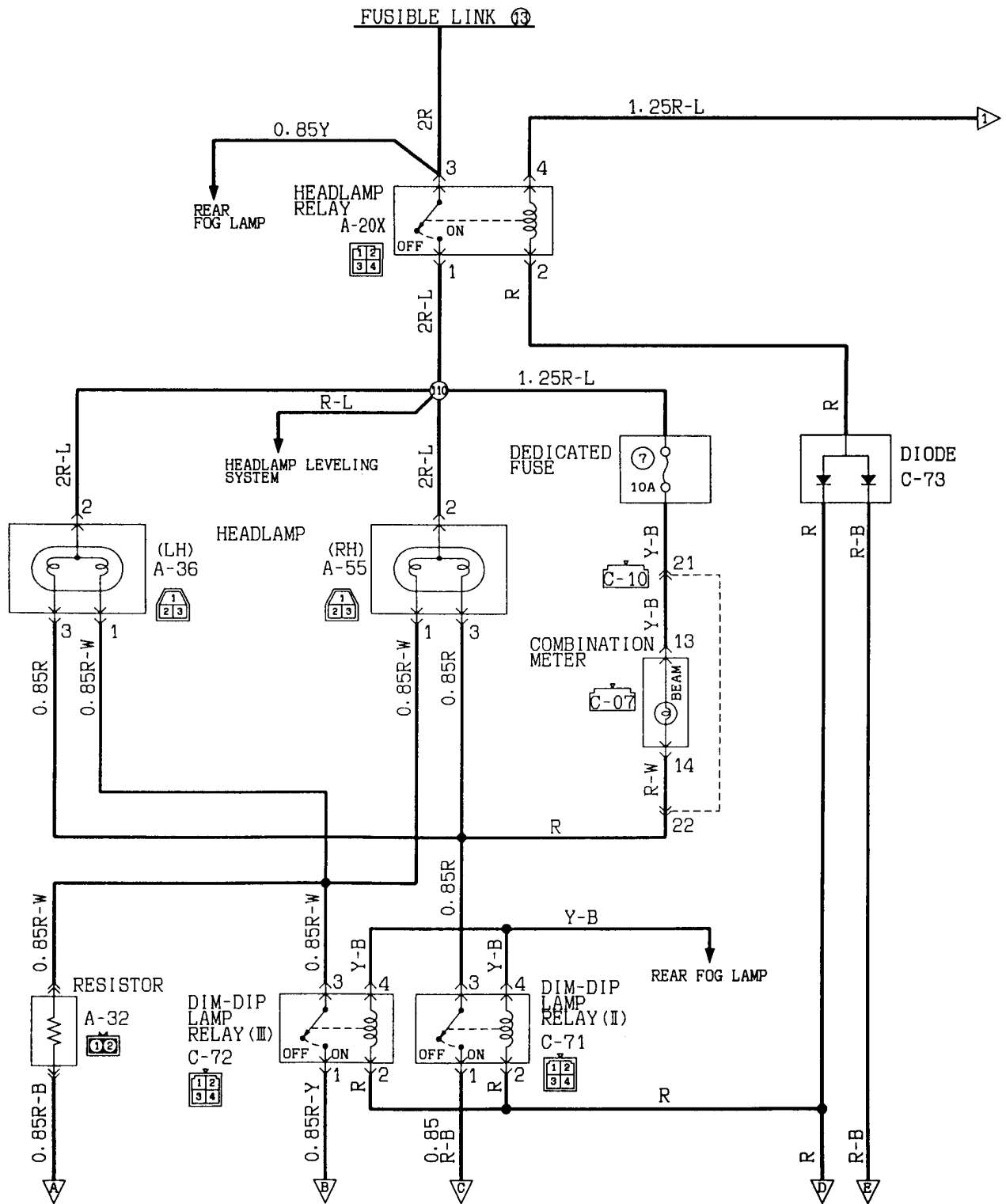

KX35-AC-00845-EC

C-07

1 1 2 3 4 5 6 7 8 9 10 11 12 13 14 15 16 17 18 19 20 21 22

C-10

1 2 3 4 5 6 7 8 9 10 11 12 13 14 15 16 17 18 19 20 21 22

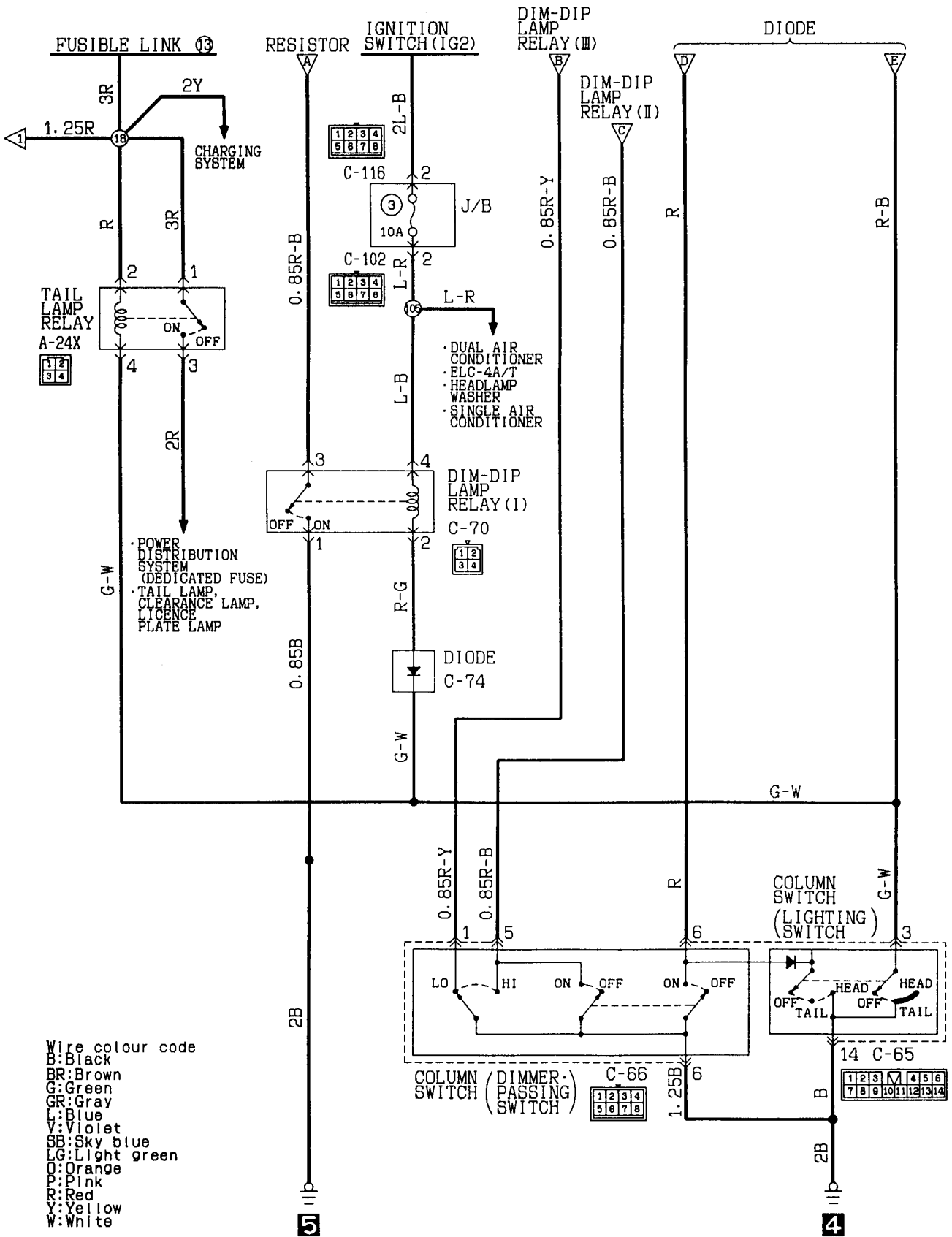

HEADLAMP

R. H. drive vehicles (with SRS)

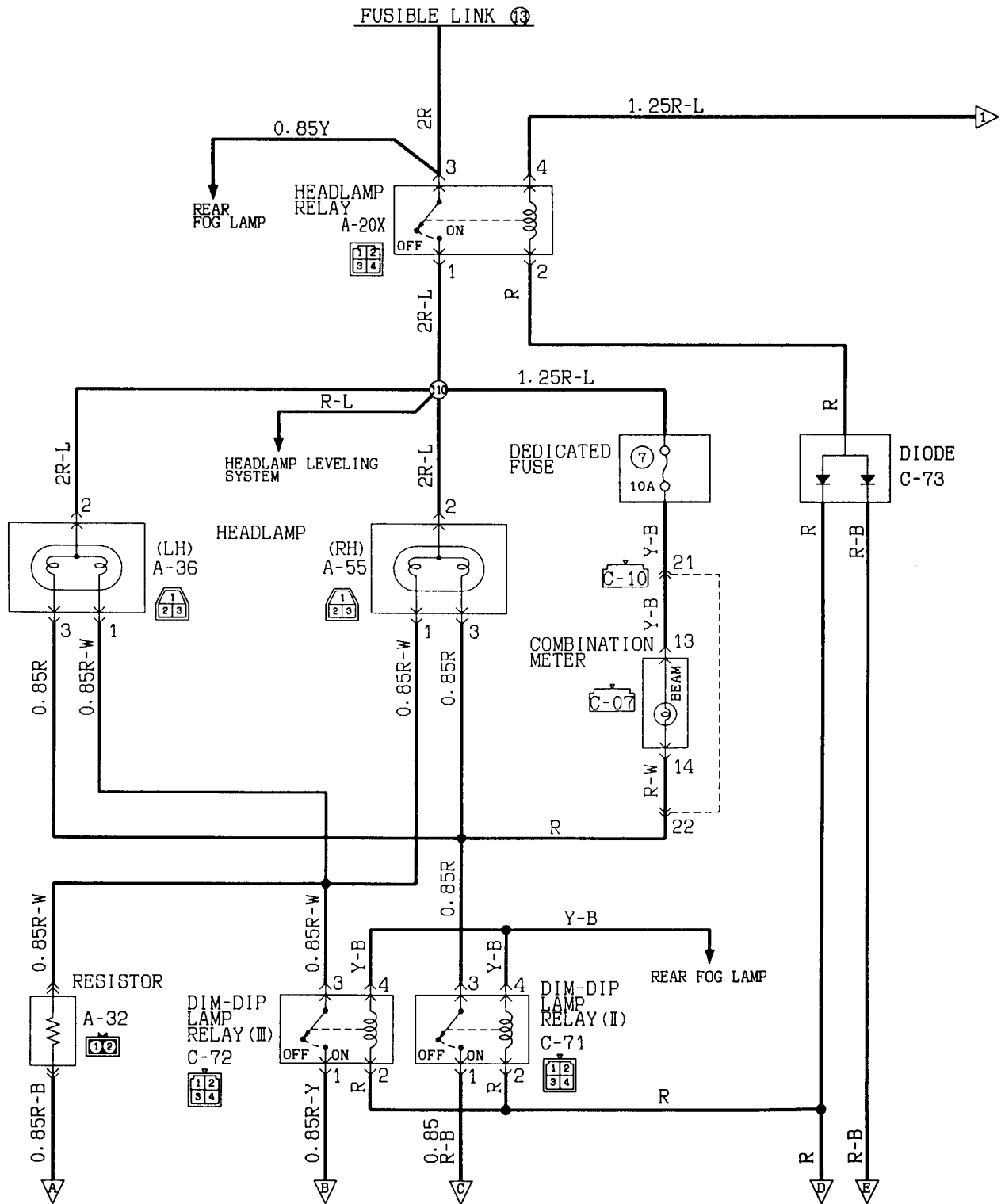

KX35-AC-Q0846-EC

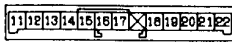

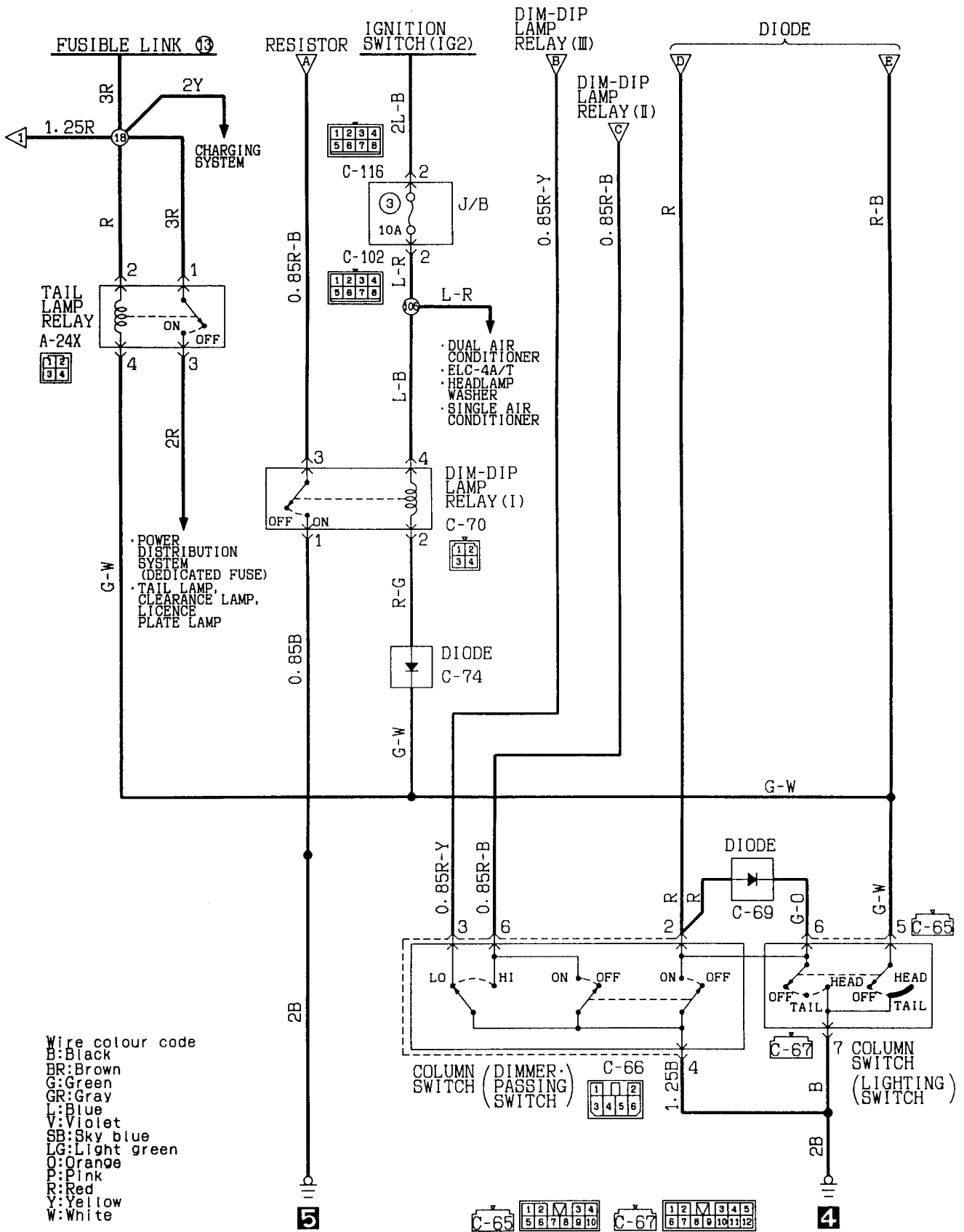

HEADLAMP LEVELING SYSTEM

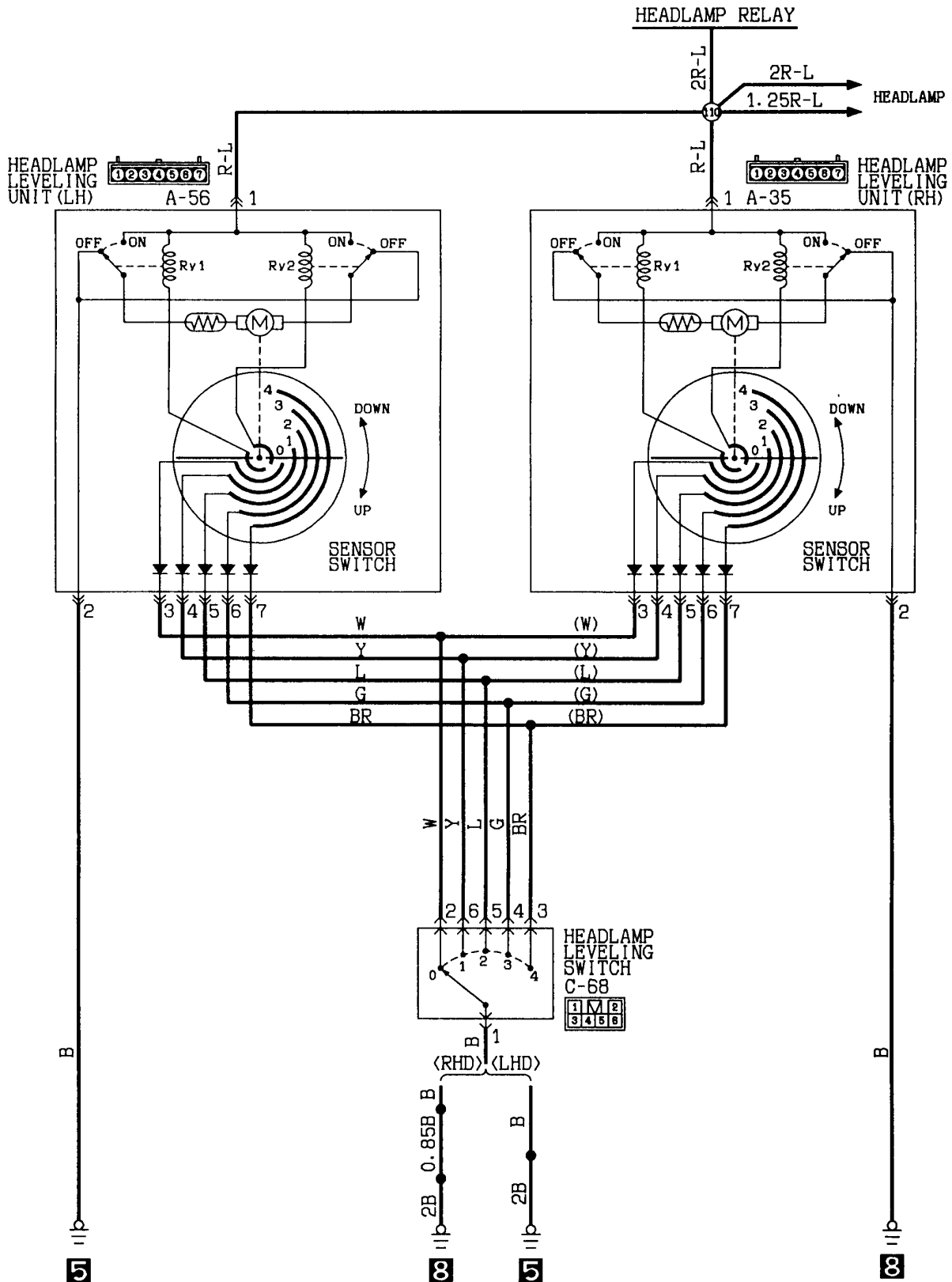

Wire colour code
 B:Black LG:Light green G:Green L:Blue W:White Y:Yellow SB:Sky blue
 BR:Brown O:Orange GR:Gray R:Red P:Pink V:Violet

KX35-AC-00836-EC

HEADLAMP LEVELING SYSTEM (See P. 4A-114.)**OPERATION****Downtilt operation**

- When the headlamps are switched ON, battery voltage is applied, from the headlamp relay to the headlamp leveling unit.
- When the headlamp leveling switch setting is changed from the "0" position to the "1" position, electricity flows from Relay 2 to print base 1 to the headlamp leveling switch and to earth; the Relay 2 contacts are thus switched ON and the motor is activated. As a result, the headlamp leveling unit's shaft is pushed outward, the reflector tilts downward, and the optical axis of the headlamps is tilted in the downward direction.
- At the same time, the contacts of the sensor switch, which are interlocked with the movement of the motor, also turn in the "DOWN" direction, and, at the position where there is no longer contact of print base 1 and the brush contact, Relay 2 is switched OFF and the motor stops.
- In the same way as described above, when the headlamp leveling switch setting is changed from the "1" position to the "2" position and further to the "3" position and the "4" position, the motor continues to rotate so that the headlamp leveling unit's shaft is pushed outward, tilting the reflector further downward; the optical axis of the headlamps is at the maximum downward tilt at the "4" position of the headlamp leveling switch.

Return operation

- When the setting of the headlamp leveling switch is changed from the "4" position to the "3" position, electricity flows from Relay 1 to print base 3 to the headlamp leveling switch and to earth; the Relay 1 contacts are thus switched ON, and the motor rotates in the direction opposite to that for downtilt.
As a result, the headlamp leveling unit's shaft is drawn inward, the tilt of the reflector is reduced, and the optical axis of the headlamps is changed in the upward direction.
- At the same time, the contacts of the sensor switch turn in the "UP" direction, and, at the position where there is no longer contact of print base 3 and the brush contact, Relay 1 is switched OFF and the motor stops.
- When the setting of the headlamp leveling switch is further changed from the "3" position to the "2" position and to the "1" position, the motor continues to rotate, and the optical axis of the headlamps returns to the minimum tilt position at the "0" setting of the switch.
- In order to prevent overheat damage to the motor as a result of frequent operation of the headlamp leveling system, a thermistor is provided in the circuitry within the headlamp leveling unit.

TROUBLESHOOTING HINTS

1. No operation of the headlamp leveling system.
 - Check the headlamp leveling switch.
 - Check the headlamp leveling unit.
2. Either the left or right part of the headlamp leveling system does not operate.
 - Check the headlamp leveling unit for the side that does not operate.
3. Either the downtilt operation or the return operation does not function.
 - Check the headlamp leveling unit.

TAIL LAMP, CLEARANCE LAMP, LICENCE PLATE LAMP

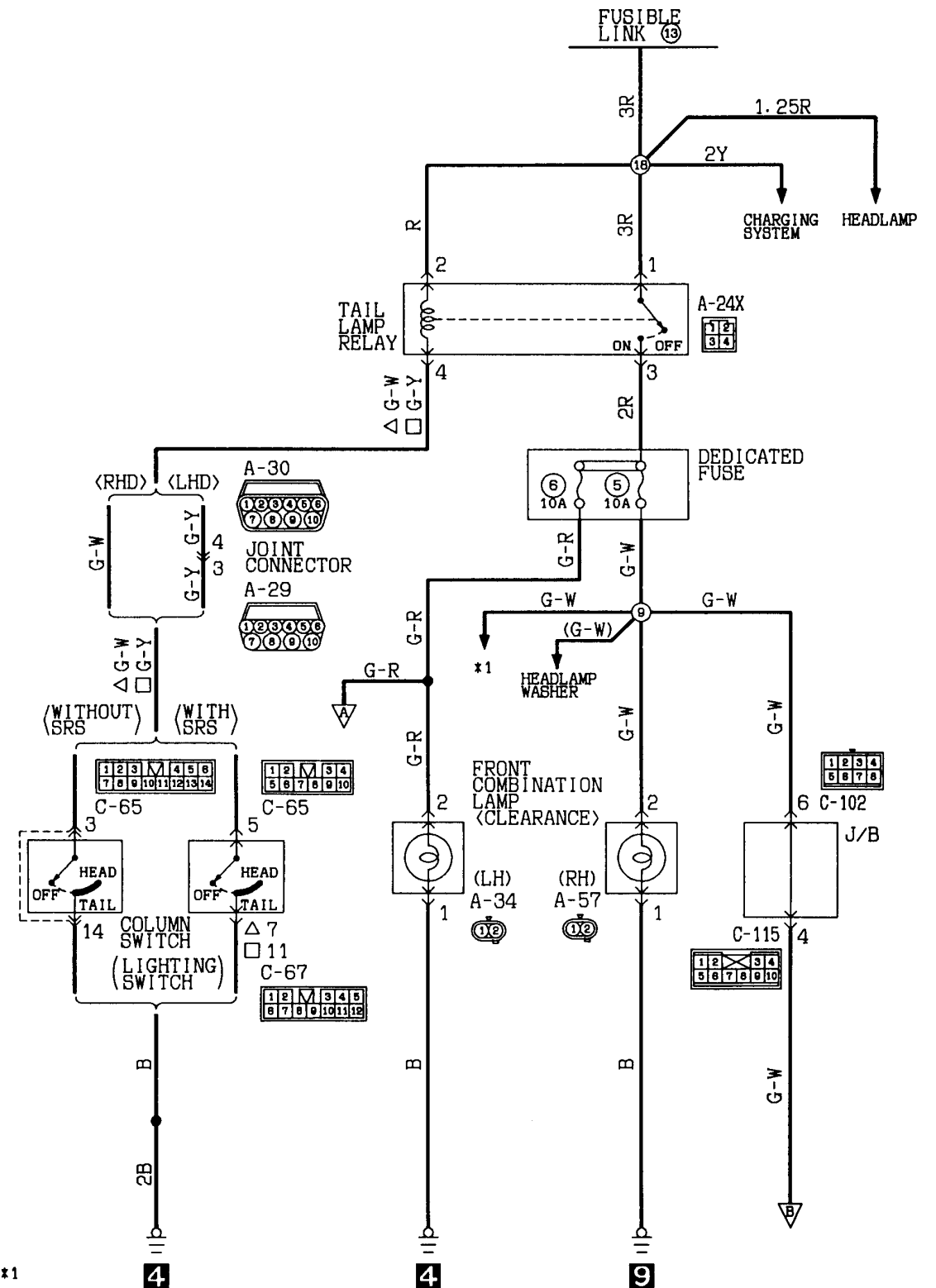

*1
 ·CLOCK
 ·TURN-SIGNAL LAMP
 AND HAZARD LAMP

Wire colour code
 B:Black LG:Light green G:Green L:Blue W:White Y:Yellow SB:Sky blue
 BR:Brown O:Orange GR:Gray R:Red P:Pink V:Violet

KX35-AC-00842-EC

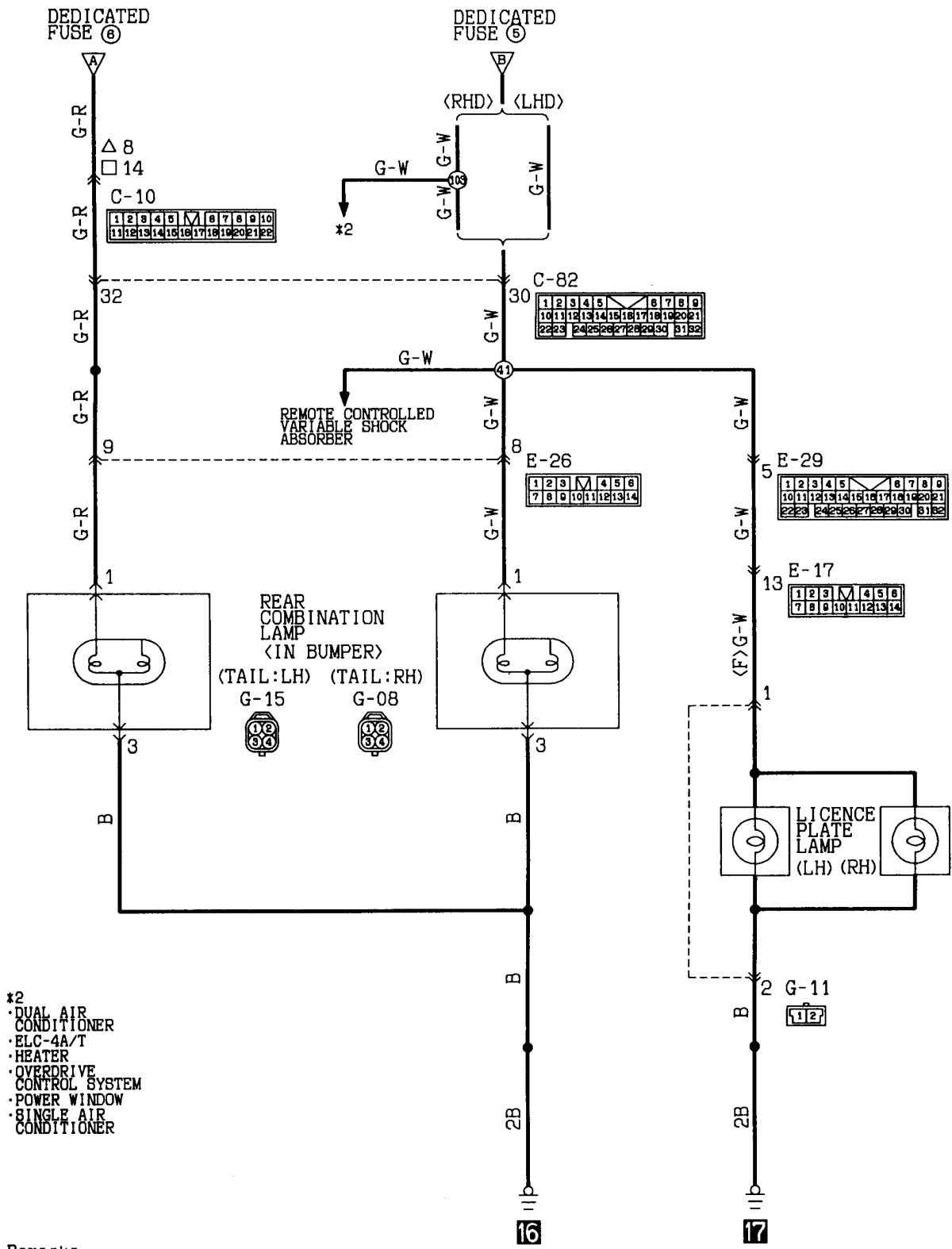

TAIL LAMP, CLEARANCE LAMP AND LICENCE PLATE LAMP (See P. 4A-116.)**OPERATION**

- Placing the lighting switch in the TAIL or HEAD position causes the tail lamp relay to be energized.
- As a result, current flows by way of dedicated fuse No. ⑤ and No. ⑥ to each lamp, causing the lamp to come on.

TROUBLESHOOTING HINTS

1. No lamp come on.
 - 1) Headlamps do not come on, either.
 - Check fusible link No. ⑬.
 - 2) Headlamps do come on.
 - Check tail lamp relay.
 - Check dedicated fuse No. ⑤ and No. ⑥.

REAR FOG LAMP (See P. 4A-120, 122, 124, 126.)**OPERATION**

- Placing the lighting switch in the HEAD position causes the rear fog lamp relay to be energized.
- When the rear fog lamp switch is turned ON in this condition, the rear fog lamp comes on.

TROUBLESHOOTING HINTS

1. The rear fog lamp doesn't illuminate.
 - 1) Headlamps come on.
 - Check the rear fog lamp relay.
 - Check the rear fog lamp switch.
 - Check the dedicated fuse No. ④.
 - 2) Headlamps do not come on, either.
 - Check the headlamp relay.
 - Check the lighting switch.
 - Check the fusible link No. ⑬.
2. The rear fog lamp at the one side doesn't illuminate.
 - Check the bulb.

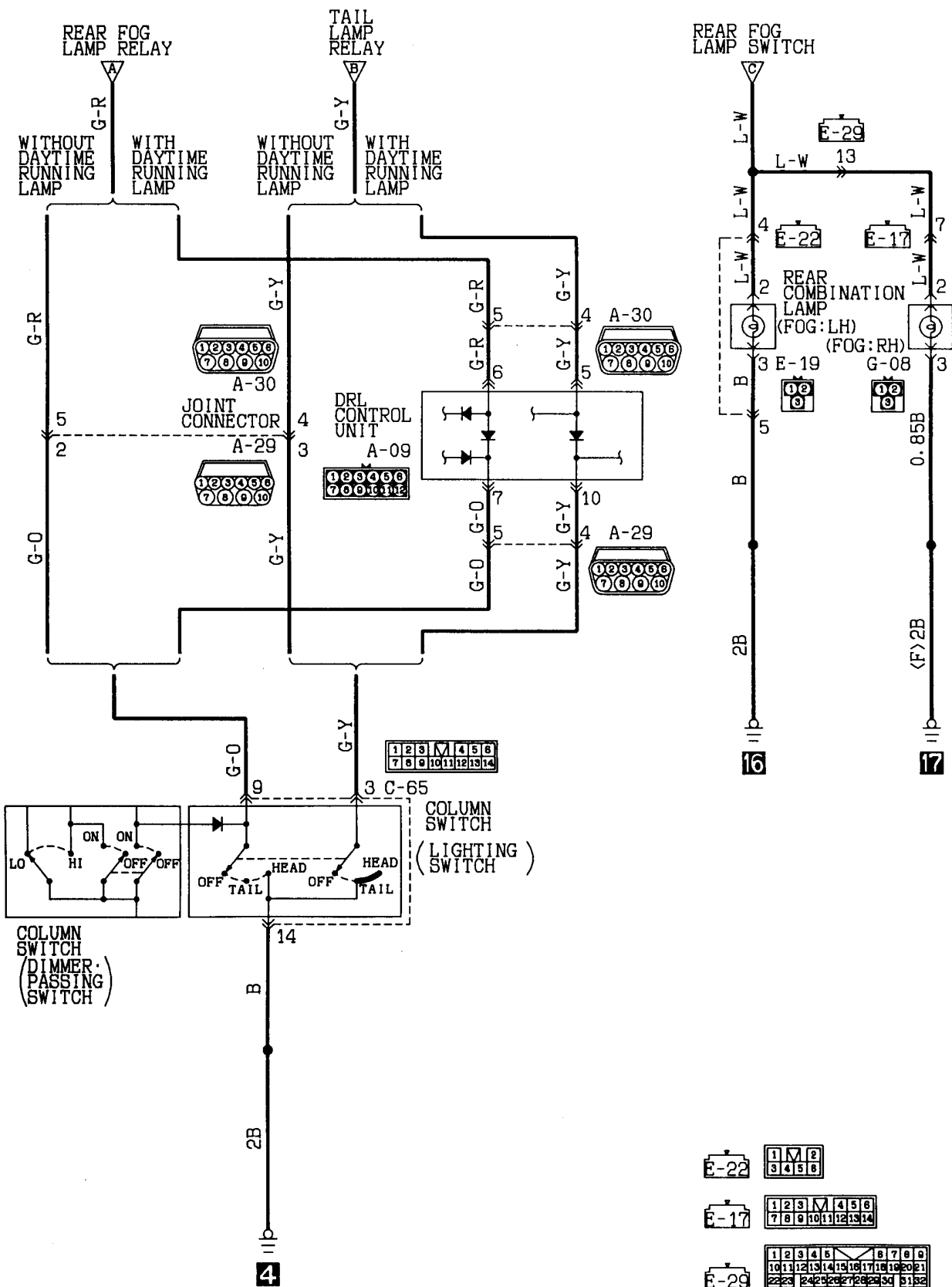

Wire colour code
 B:Black LG:Light green G:Green L:Blue W:White Y:Yellow
 BR:Brown O:Orange GR:Gray R:Red P:Pink V:Violet

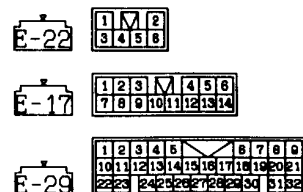

REAR FOG LAMP
L.H. drive vehicles (with SRS)

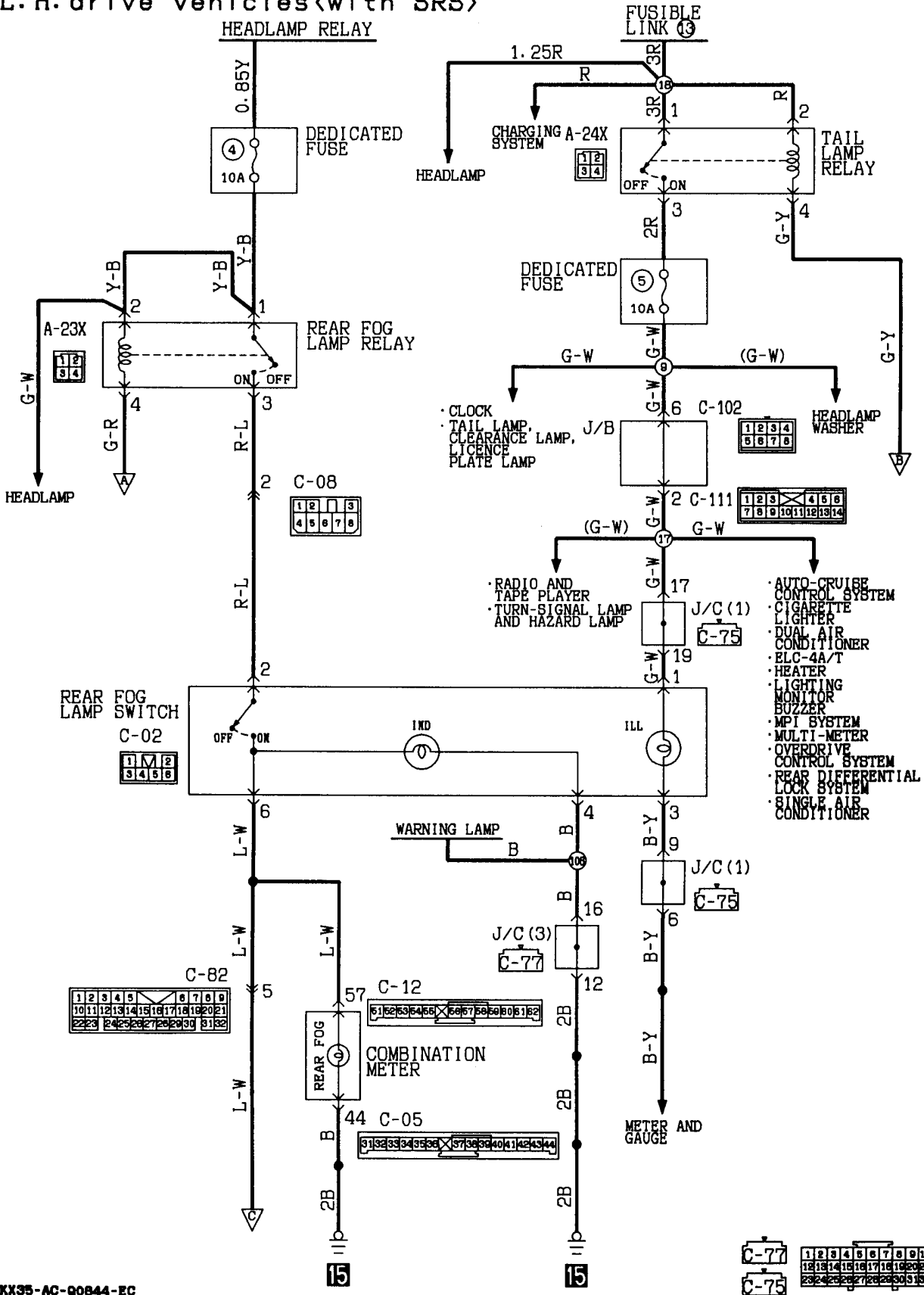

KX35-AC-00844-EC

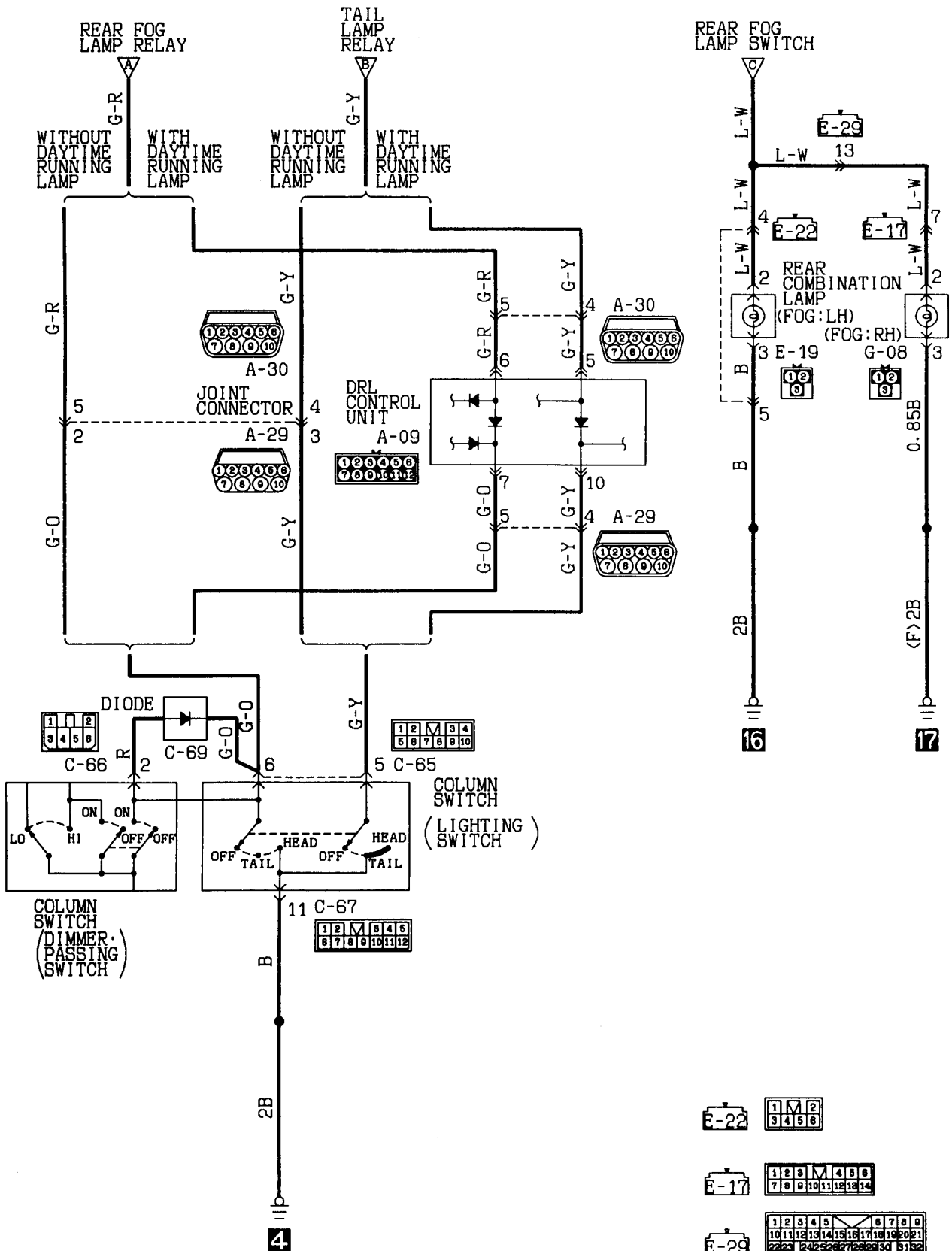

Wire colour code
 B:Black LG:Light green G:Green L:Blue W:White Y:Yellow
 BR:Brown O:Orange GR:Gray R:Red P:Pink V:Violet

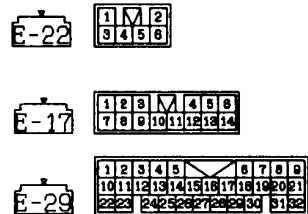

REAR FOG LAMP
R. H. drive vehicles (Without SRS)

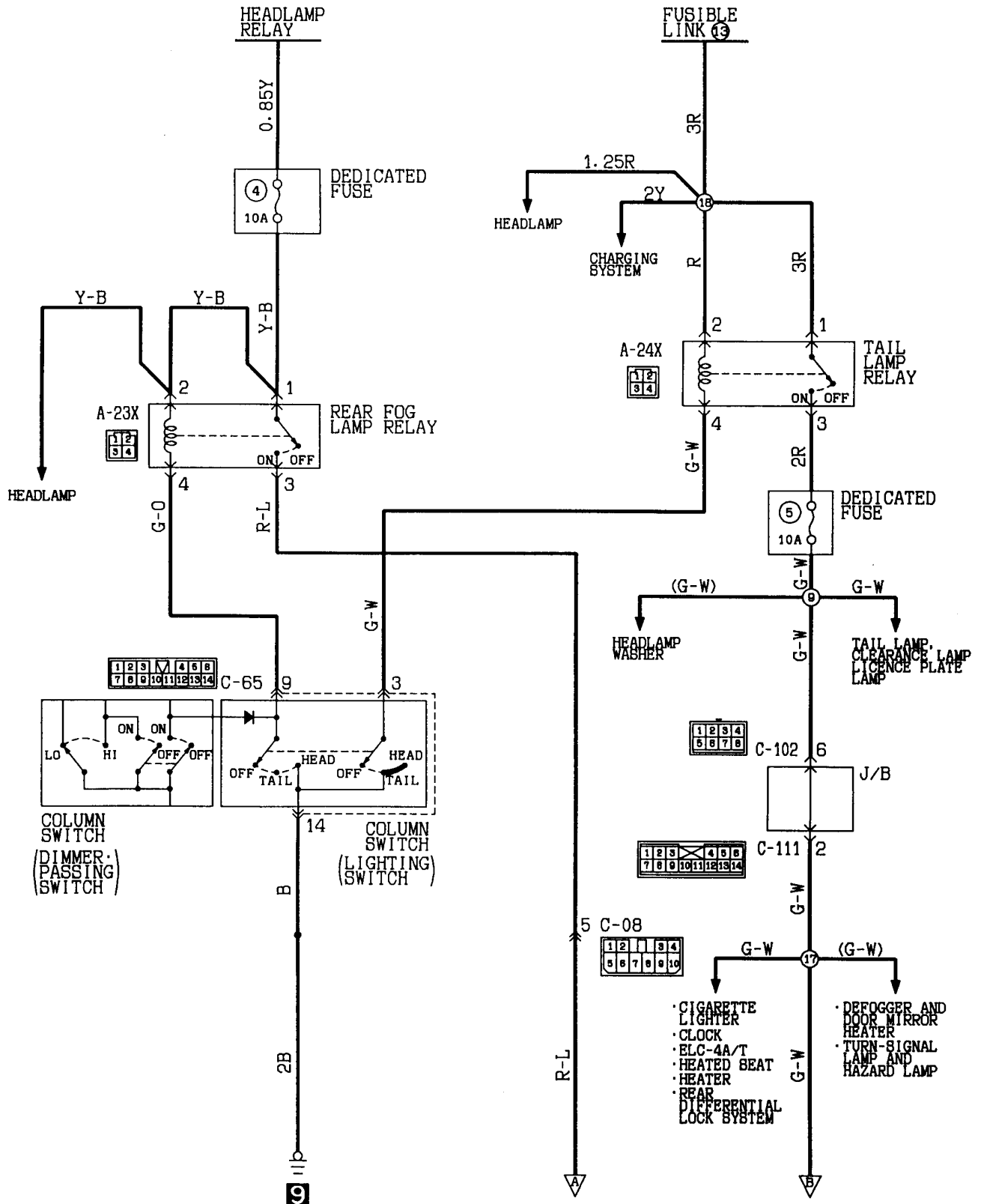

Wire colour code
 B:Black LG:Light green G:Green L:Blue Y:White Y:Yellow BB:Sky blue
 BR:Brown O:Orange GR:Gray R:Red P:Pink V:Violet

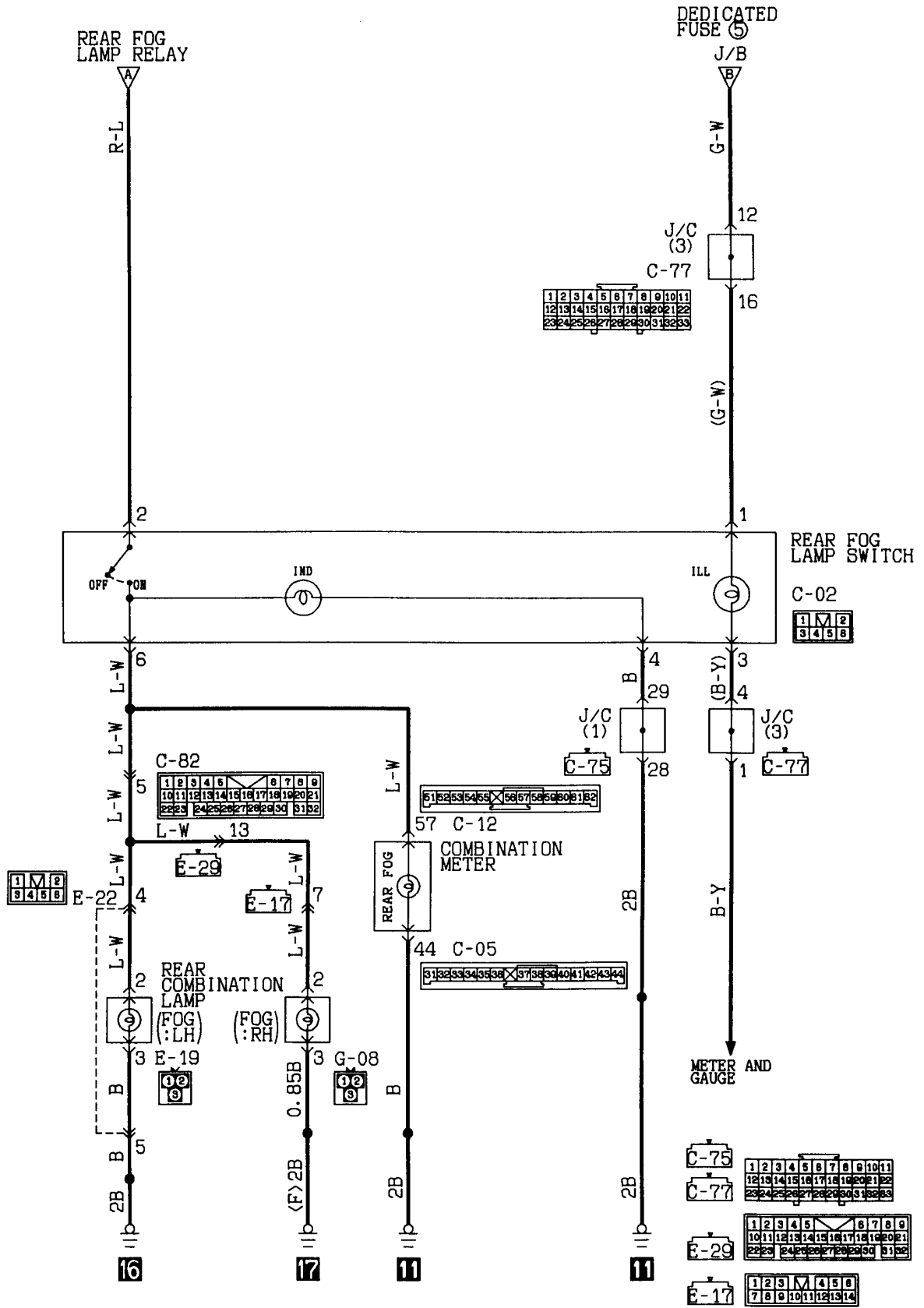

REAR FOG LAMP
R. H. drive vehicles <With SRS>

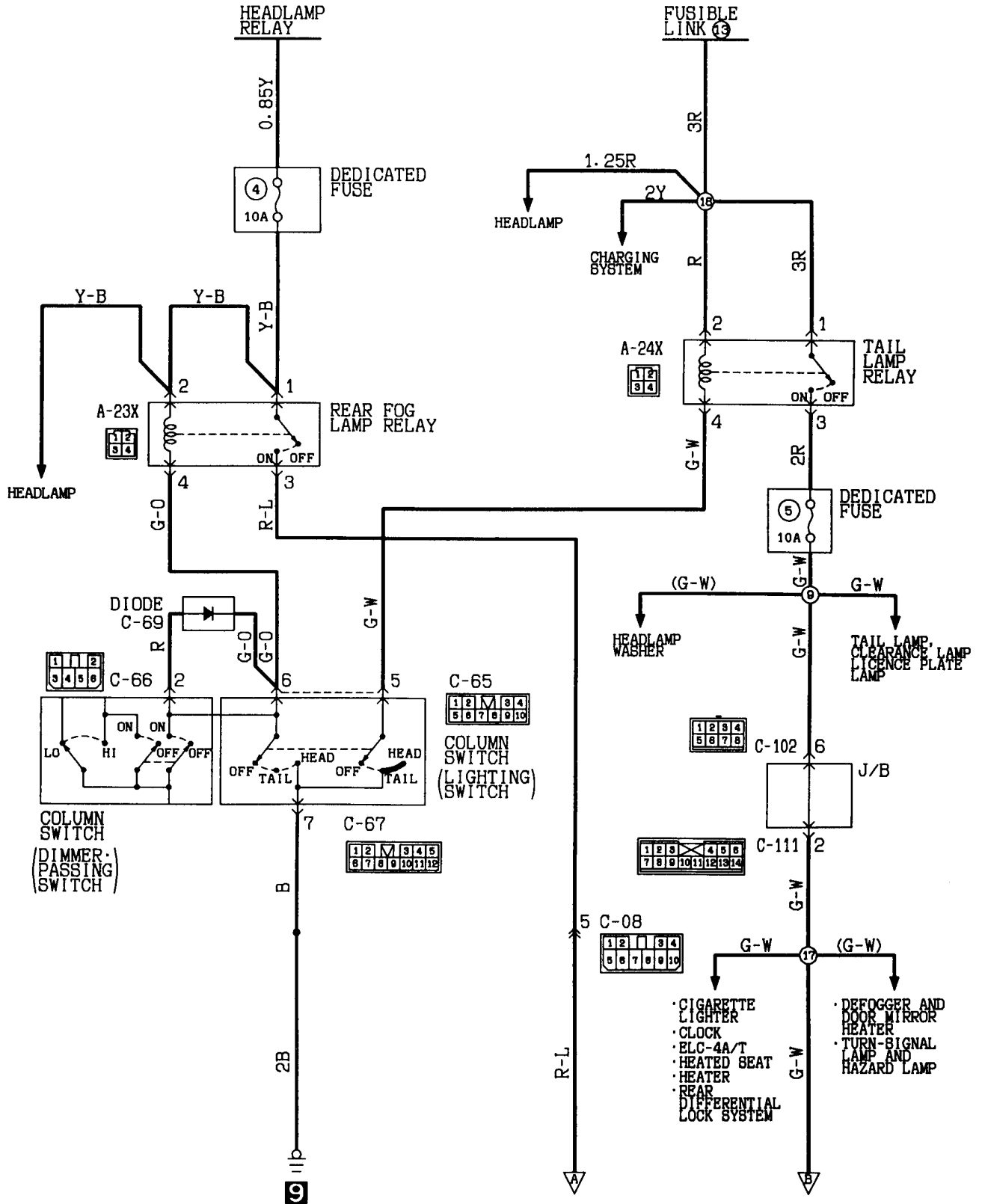

Wire colour code

B:Black LG:Light green G:Green L:Blue W:White Y:Yellow SB:Sky blue
BR:Brown O:Orange GR:Gray R:Red P:Pink V:Violet

ROOM LAMP
Canvas top

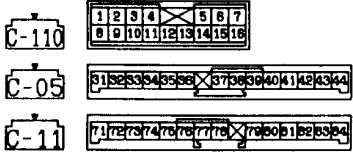
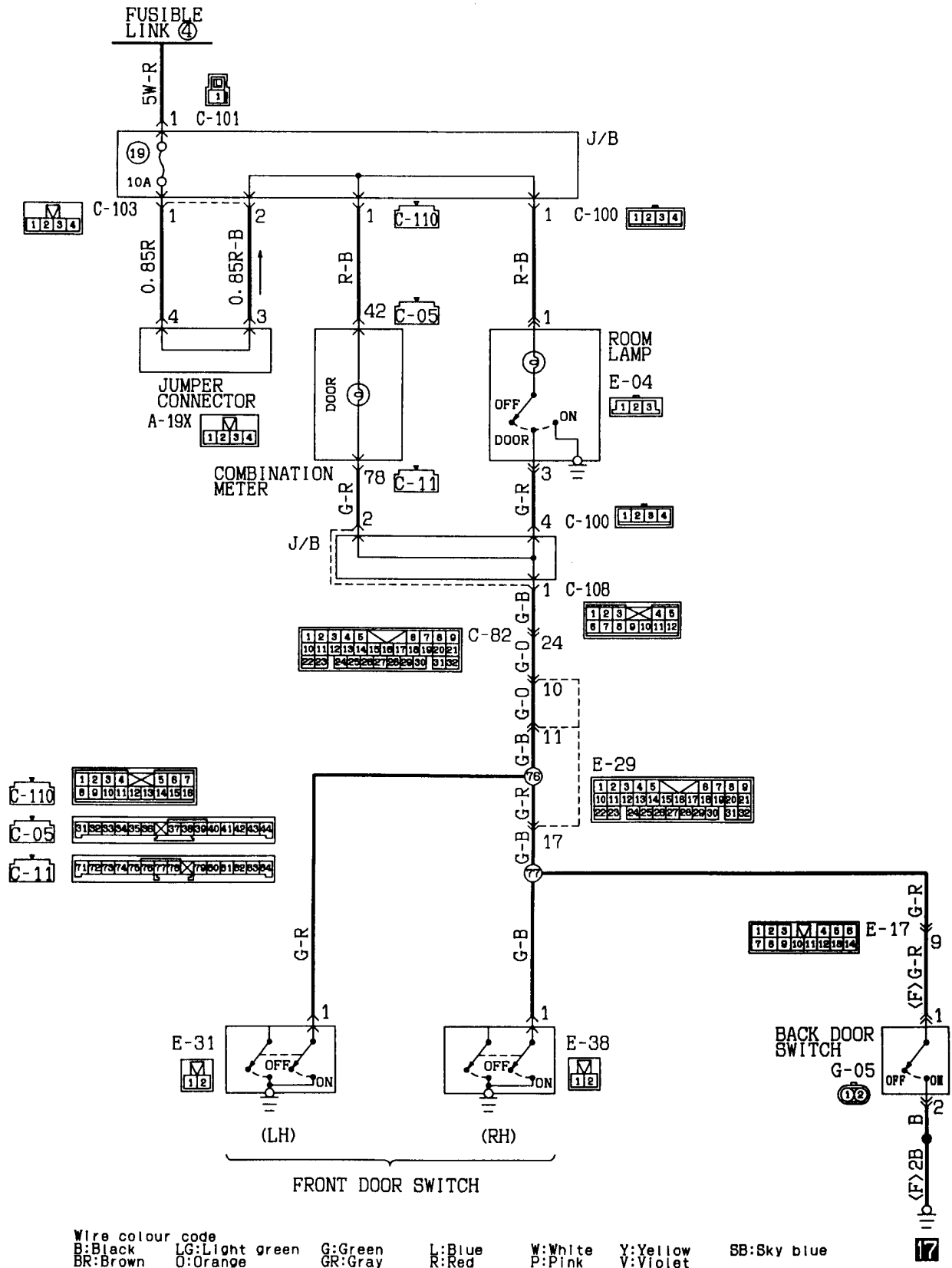

Wire colour code
 B:Black LG:Light green G:Green L:Blue W:White Y:Yellow SB:Sky blue
 BR:Brown O:Orange GR:Gray R:Red P:Pink V:Violet

KX35-AC-00829-EC

ROOM LAMP
2-door models without sunroof

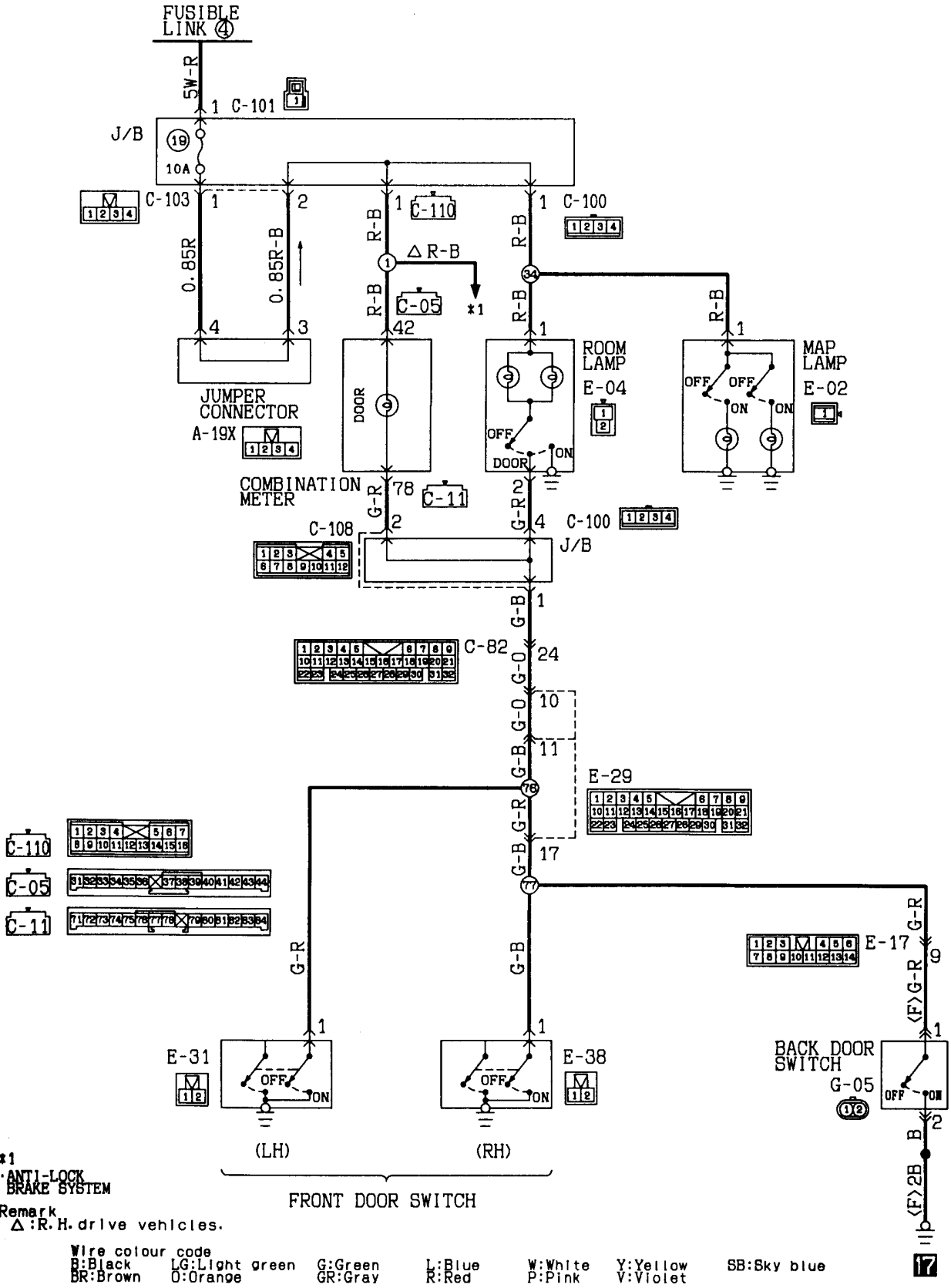

*1
ANTI-LOCK
BRAKE SYSTEM

Remark
Δ: R. H. drive vehicles.

Wire colour code
 B: Black LG: Light green G: Green L: Blue W: White Y: Yellow SB: Sky blue
 BR: Brown O: Orange GR: Gray R: Red P: Pink V: Violet

KX35-AC-00630-EC

ROOM LAMP
2-door models with sunroof

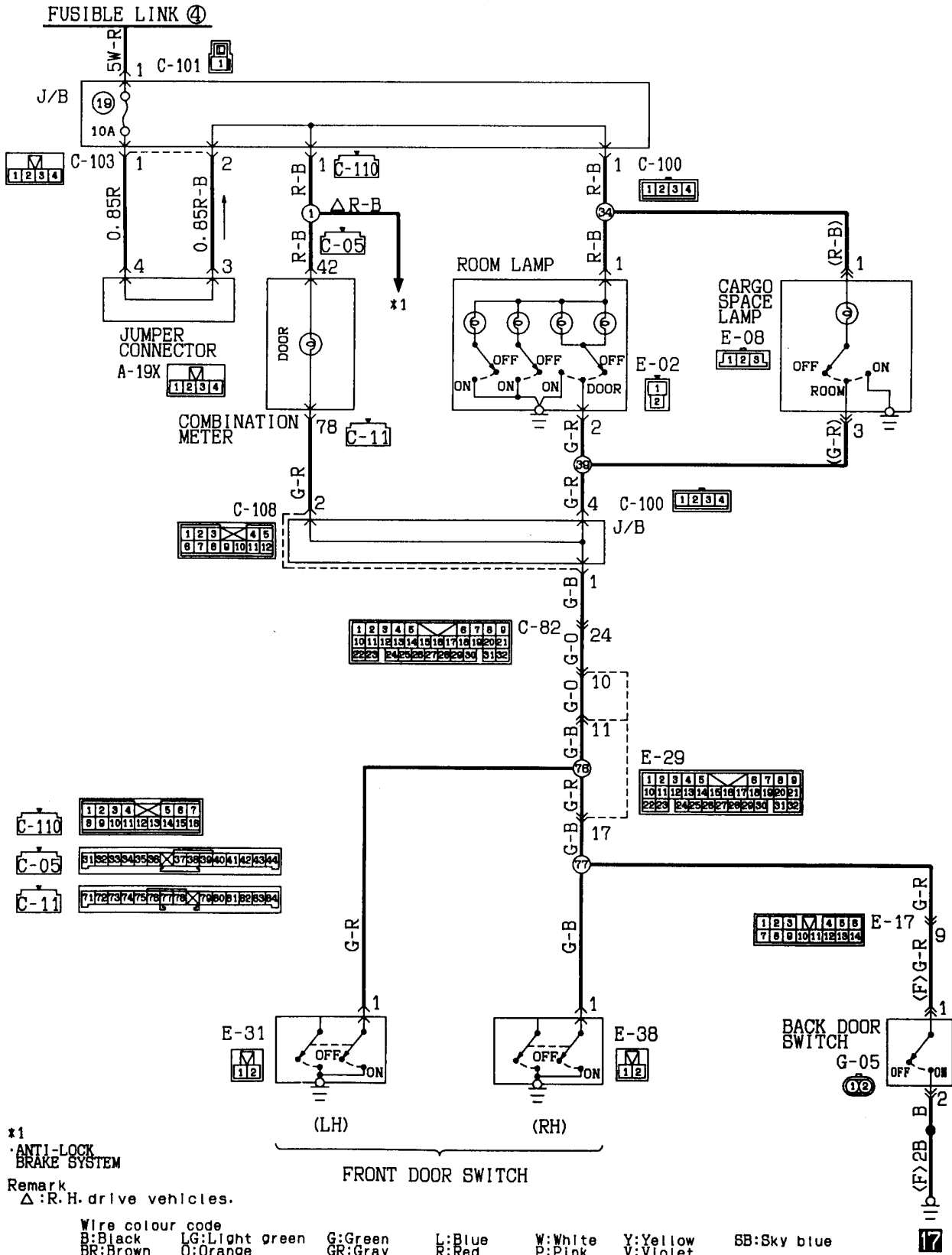

*1
ANTI-LOCK
BRAKE SYSTEM

Remark
△: R.H. drive vehicles.

Wire colour code
B:Black LG:Light green G:Green L:Blue W:White Y:Yellow SB:Sky blue
BR:Brown O:Orange GR:Gray R:Red P:Pink V:Violet

KX35-AC-00831-EC

ROOM LAMP
4-door models

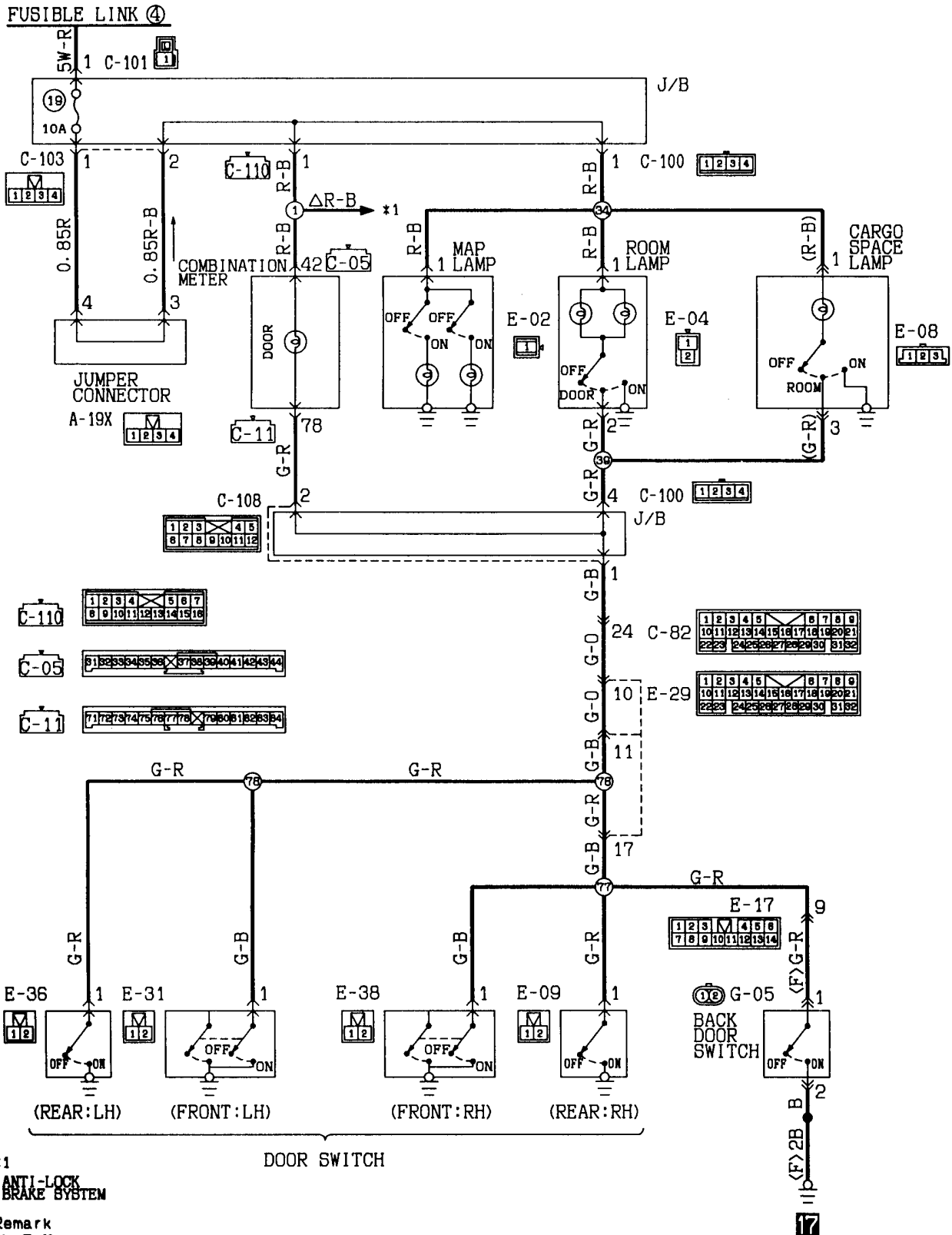

ROOM LAMP (See P. 4A-128, 129, 130, 131.)**OPERATION**

- Placing the room lamp switch in the ON position causes the room lamp to come on at all times.
- Opening any one of the doors with the room lamp switch in the DOOR position causes the room lamp to come on.
- Closing all doors causes the room lamp to go out.

TROUBLESHOOTING HINTS

1. Room lamp does not come on.
 - 1) Clock is not operating, either.
 - Check multi-purpose fuse No. ⑱.
 - 2) Room lamp does not come on when any door is opened with the room lamp switch in the DOOR position.
 - Check bulb.
 - Check room lamp switch.
 - 3) Room lamp does not come on when a door is opened with the room lamp switch in the DOOR position.
 - Check door switch (of the suspected door).

IGNITION KEY ILLUMINATION LAMP (See P. 4A-134, 135.)**OPERATION**

- When the driver's door is opened, the driver's front door switch turns on and the ignition key illumination lamp illuminates.
- When the driver's door is closed, the driver's front door switch turns off and the discharge from the condenser inside the ignition key illumination lamp timer causes the ignition key illumination lamp to illuminate for 8-16 seconds, after which the lamp switches off.

TROUBLESHOOTING HINTS

1. The ignition key illumination lamp does not illuminate.
 - 1) The room lamp also doesn't illuminate when the room lamp switch is at the door position.
 - Check multi-purpose fuse No. ⑱.
 - Check the driver's door switch.
 - Check the ignition key illumination lamp timer.
2. The ignition key illumination lamp switches off immediately after the driver's door is closed.
 - Check the ignition key illumination lamp timer.

IGNITION KEY ILLUMINATION LAMP

L.H. drive vehicles

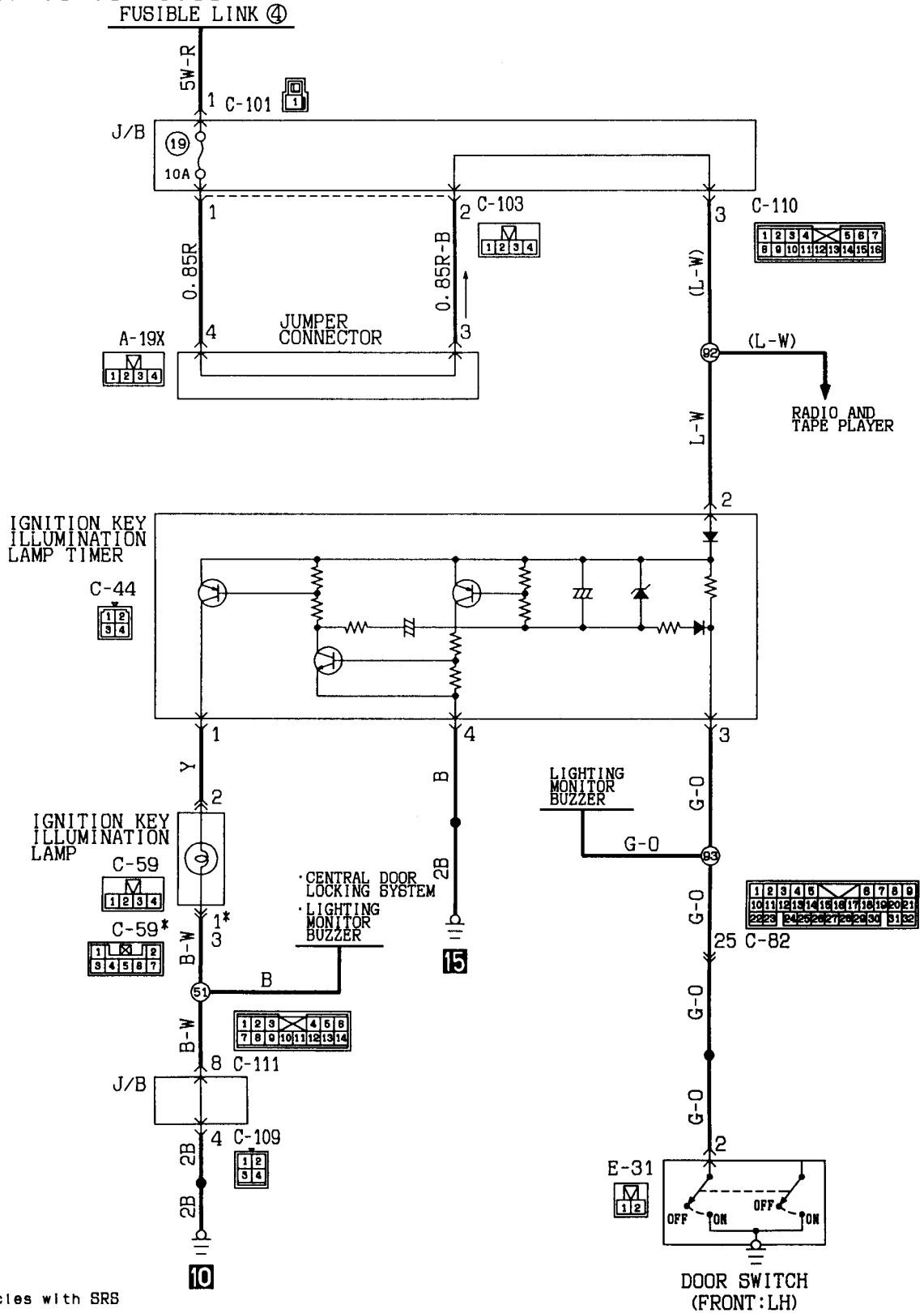

Remark
*: Vehicles with SRS

Wire colour code
 B:Black LG:Light green G:Green L:Blue W:White Y:Yellow BB:Sky blue
 BR:Brown O:Orange GR:Gray R:Red P:Pink V:Violet

KX35-AC-00833-EC

IGNITION KEY ILLUMINATION LAMP
R.H. drive vehicles

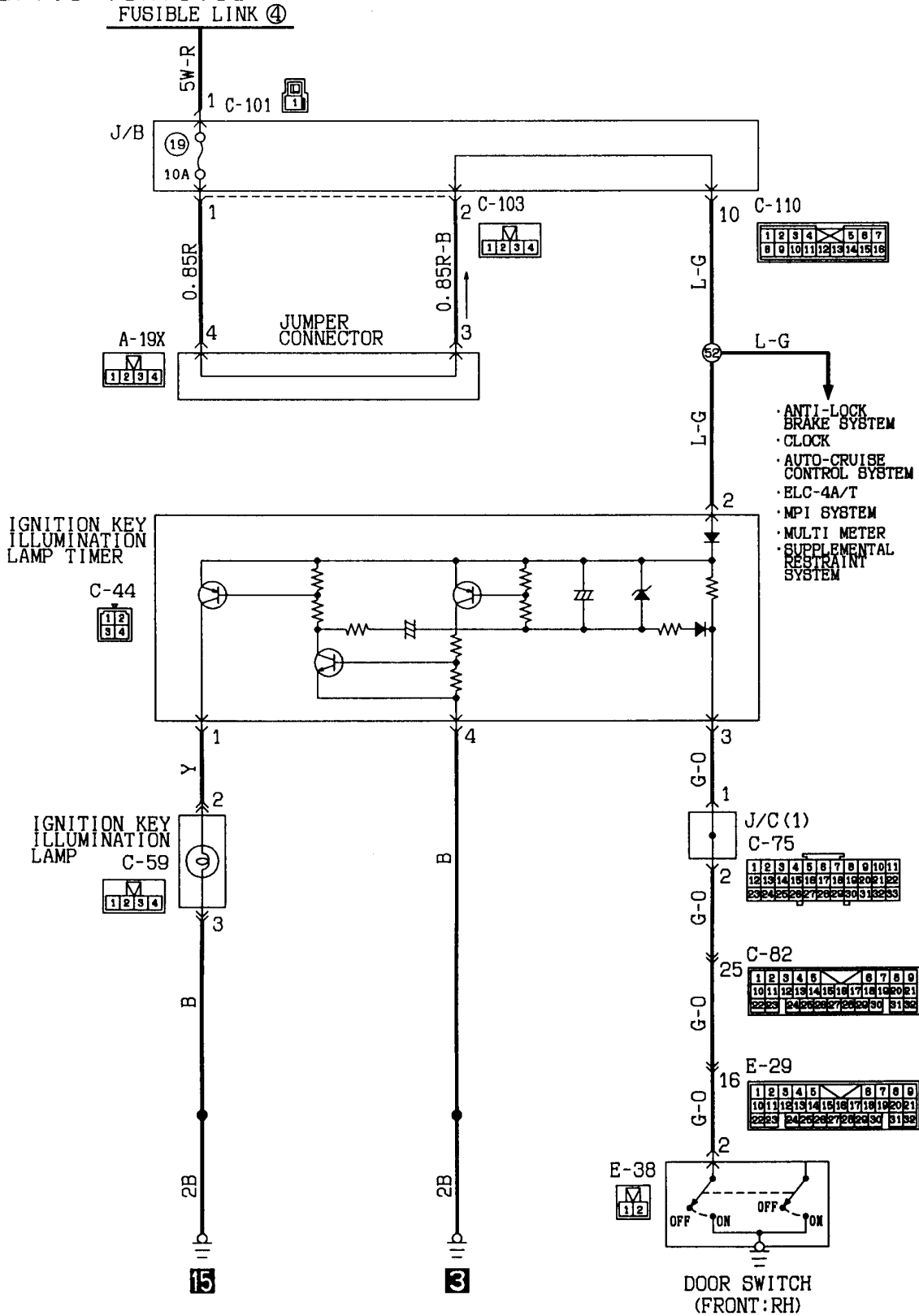

Wire colour code
 B:Black LG:Light green G:Green L:Blue W:White Y:Yellow BB:Sky blue
 BR:Brown O:Orange GR:Gray R:Red P:Pink V:Violet

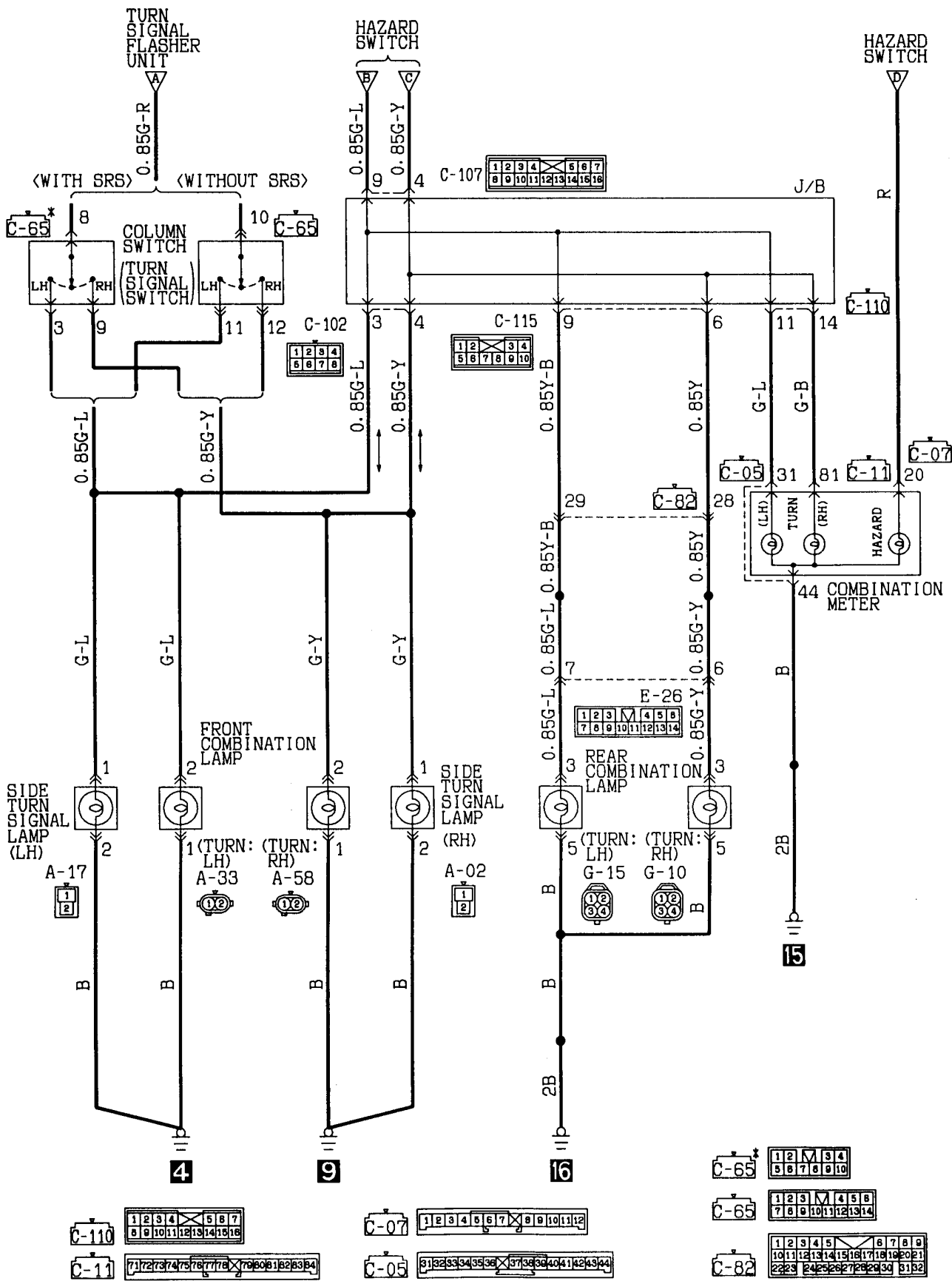

TURN-SIGNAL LAMP AND HAZARD LAMP (See P. 4A-136.)**OPERATION****<Turn-signal lamp>****1. In normal operating condition**

- When the ignition switch is placed in the ON position, battery voltage is applied through the hazard switch to the turn-signal and hazard flasher unit.
- When the turn-signal switch is placed in the LH (or RH) position, Tr₁ in the flasher unit turns ON, causing the relay contacts in the flasher unit to close. This results in the LH (or RH) turn-signal lamp and turn-signal indicator lamp lighting up.
- At the same time, the capacitor is charged through R² up to the lower limit as set by COM3.
- As soon as the capacitor is fully charged, the output from COM3 is inverted, turning OFF Tr₁. This opens the relay contacts and, as a result, the LH (or RH) turn-signal lamp and turn-signal indicator lamp go out.
- At the same time when Tr₁ turns OFF, the capacitor starts discharging. As soon as the capacitor completes discharging, the COM3 output is inverted again causing Tr₁ to turn ON. This results in the LH (or RH) turn-signal lamp and turn-signal indicator lamp coming on.
- These sequences of operation repeat, which results in the LH (or RH) turn-signal lamp and turn-signal indicator lamp flashing off and on.

2. When one bulb is burnt

- When either one of the turn-signal lamp bulbs goes out, it causes the resistance of the entire lamp circuit to increase; hence a smaller voltage drop at R1 in the flasher unit.
- This smaller voltage drop is sensed and the lower voltage limit set by COM3 is raised, thus shortening the time required by the capacitor before it is fully charged.
- As a result, the on-off cycle of Tr₁ becomes shorter with the resultant greater number of times the lamp flashes on and off.

<Hazard lamp>

- When the hazard switch is placed in the ON position, the flasher unit relay contacts repeatedly close and open, which results in the RH and LH turn-signal lamps, turn-signal indicator lamps, and hazard warning indicator lamps flashing on and off at the same time.

Remark

- The number of times the hazard lamps flash on and off does not change even when one bulb is out.

TROUBLESHOOTING HINTS

1. Neither the turn-signal lamps nor hazard lamps operate.
 - Check hazard switch contacts (on power source end).
 - Check flasher unit.
2. All LH or RH turn-signal lamps do not operate.
 - 1) Hazard lamp is fully operational.
 - Check hazard switch contacts (on turn-signal end).
 - Check turn-signal switch.
3. Flashing cycle of turn signal lamps is shorter.
 - Check bulb.
4. Hazard lamp does not operate.
 - 1) Turn-signal lamps are operational.
 - Check hazard switch contacts (on hazard lamp end).

STOP LAMP

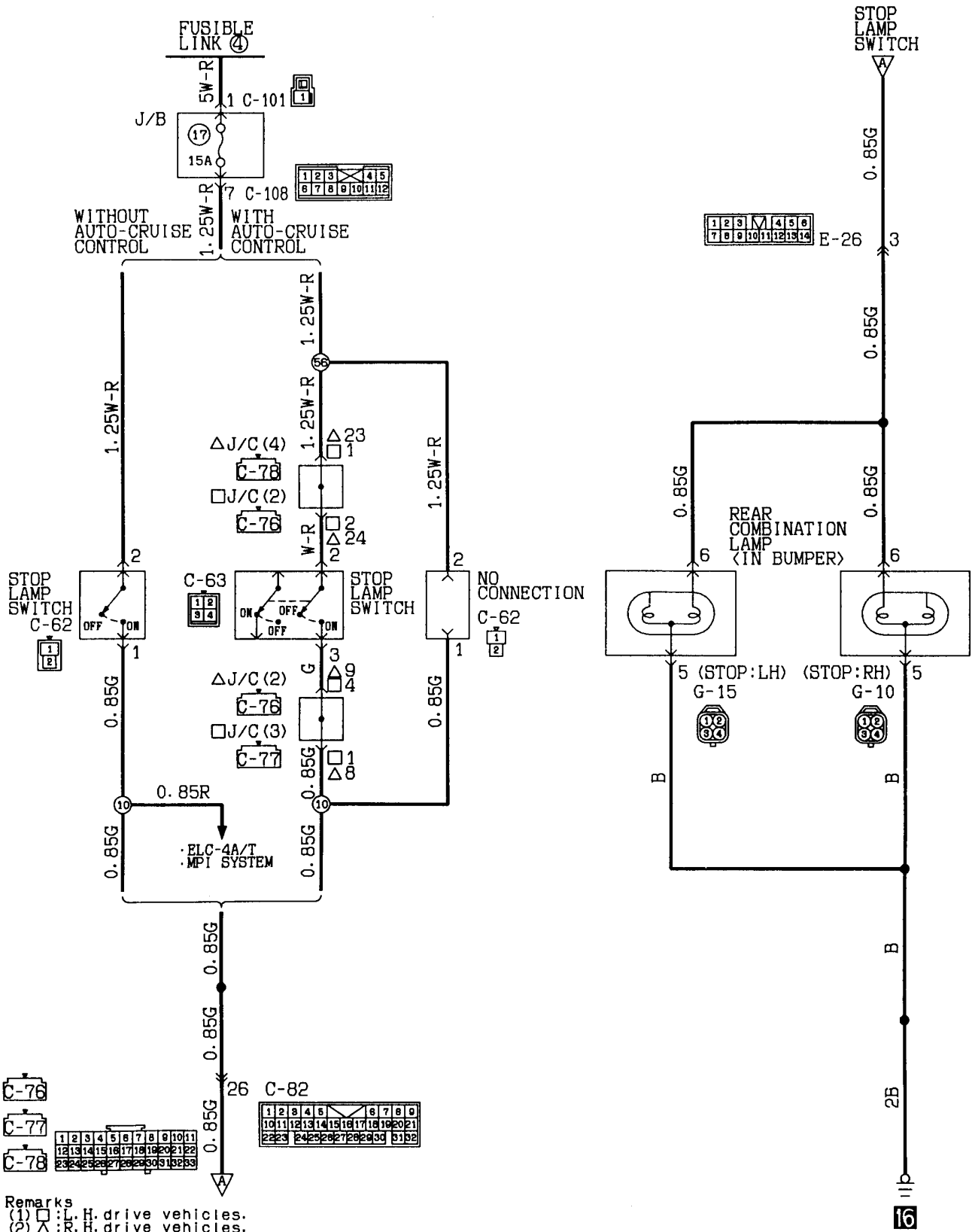

Remarks
 (1) □ : L. H. drive vehicles.
 (2) △ : R. H. drive vehicles.

Wire colour code

B:Black LG:Light green G:Green L:Blue W:White Y:Yellow SB:Sky blue
 BR:Brown O:Orange GR:Gray R:Red P:Pink V:Violet

KX35-AC-00915-EC

BACK-UP LAMP
M/T

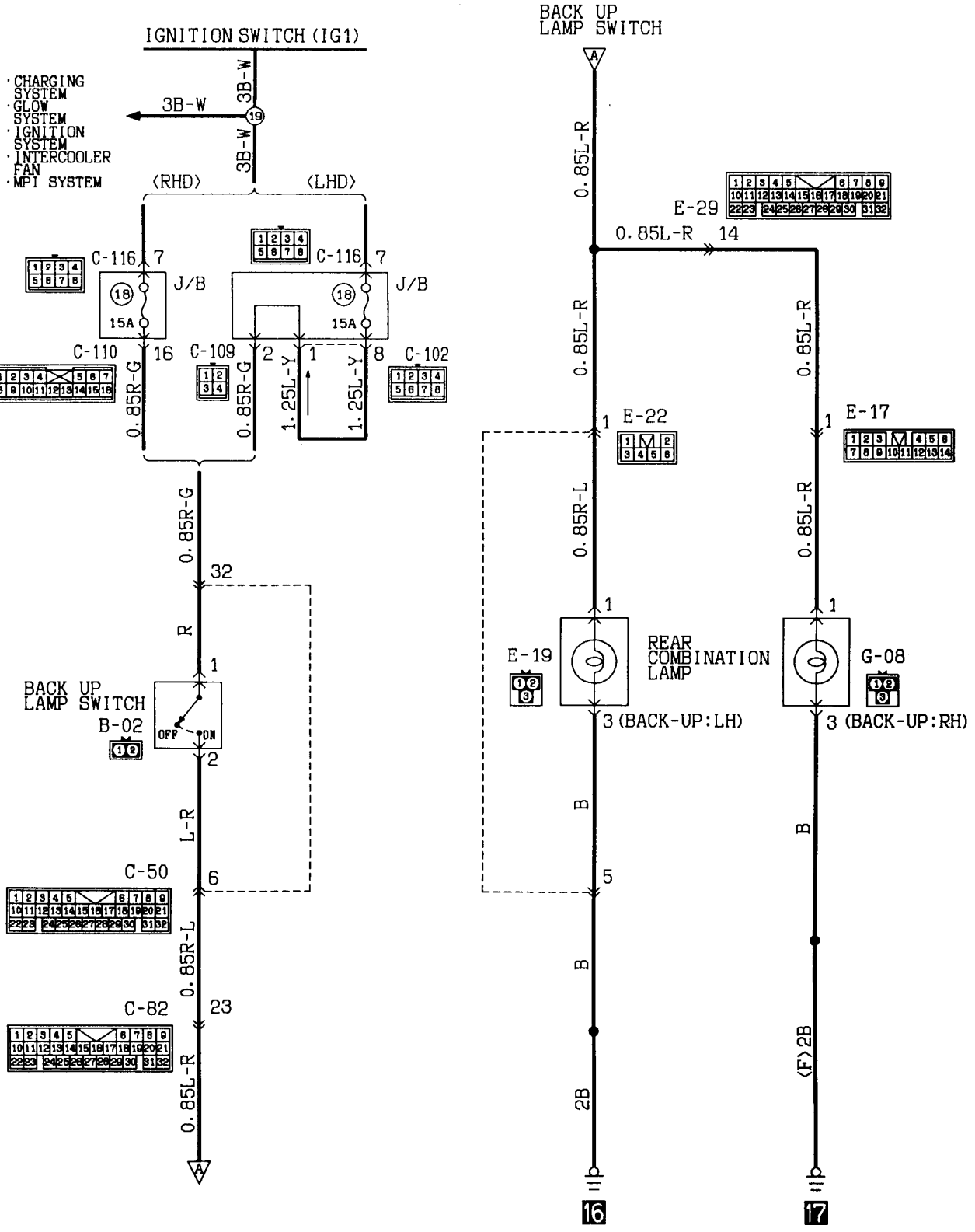

Wire colour code

B:Black LG:Light green G:Green L:Blue W:White Y:Yellow SB:Sky blue
BR:Brown O:Orange GR:Gray R:Red P:Pink V:Violet

BACK-UP LAMP
A/T

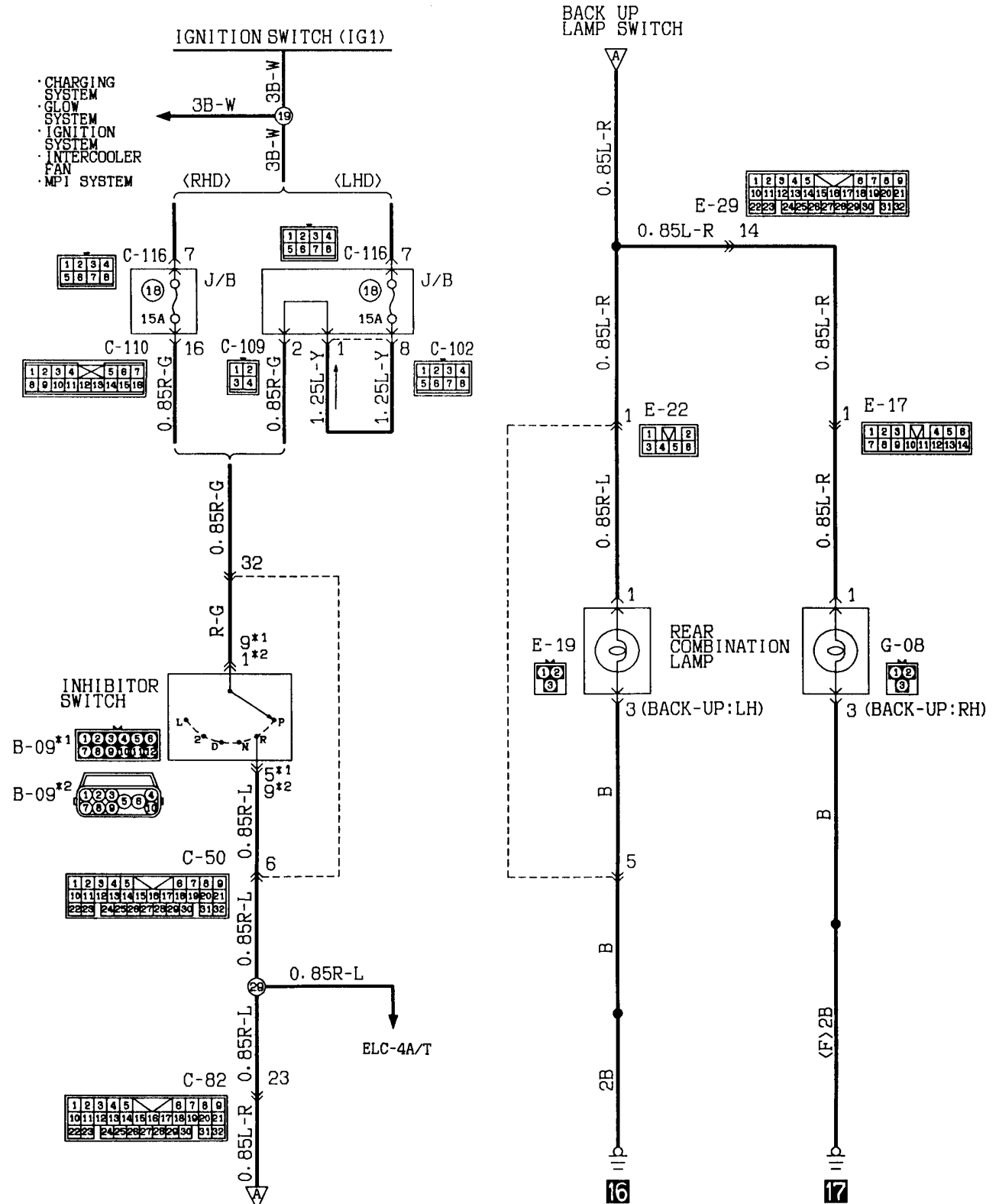

Remarks

- (1) *1: 6G72 engine
- (2) *2: 6G74, 4M40 engine

Wire colour code

B: Black LG: Light green G: Green L: Blue W: White Y: Yellow SB: Sky blue
 BR: Brown O: Orange GR: Gray R: Red P: Pink V: Violet

KX35-AC-00912-EC

HORN
Vehicles without SRS

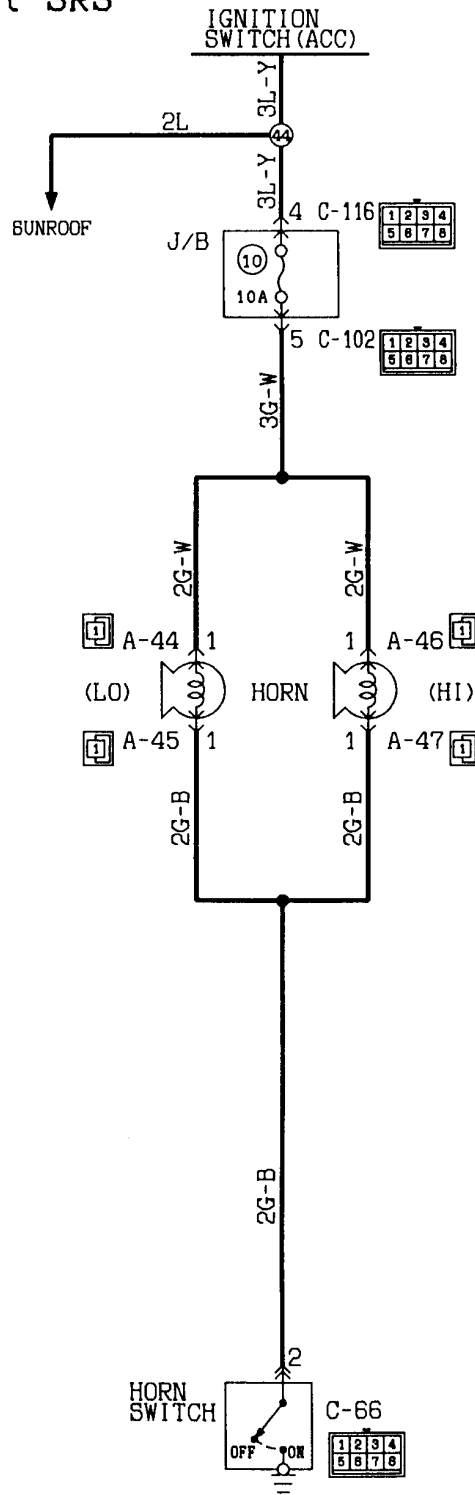

Wire colour code
 B:Black LG:Light green G:Green L:Blue W:White Y:Yellow SB:Sky blue
 BR:Brown O:Orange GR:Gray R:Red P:Pink V:Violet

HORN
Vehicles with SRS

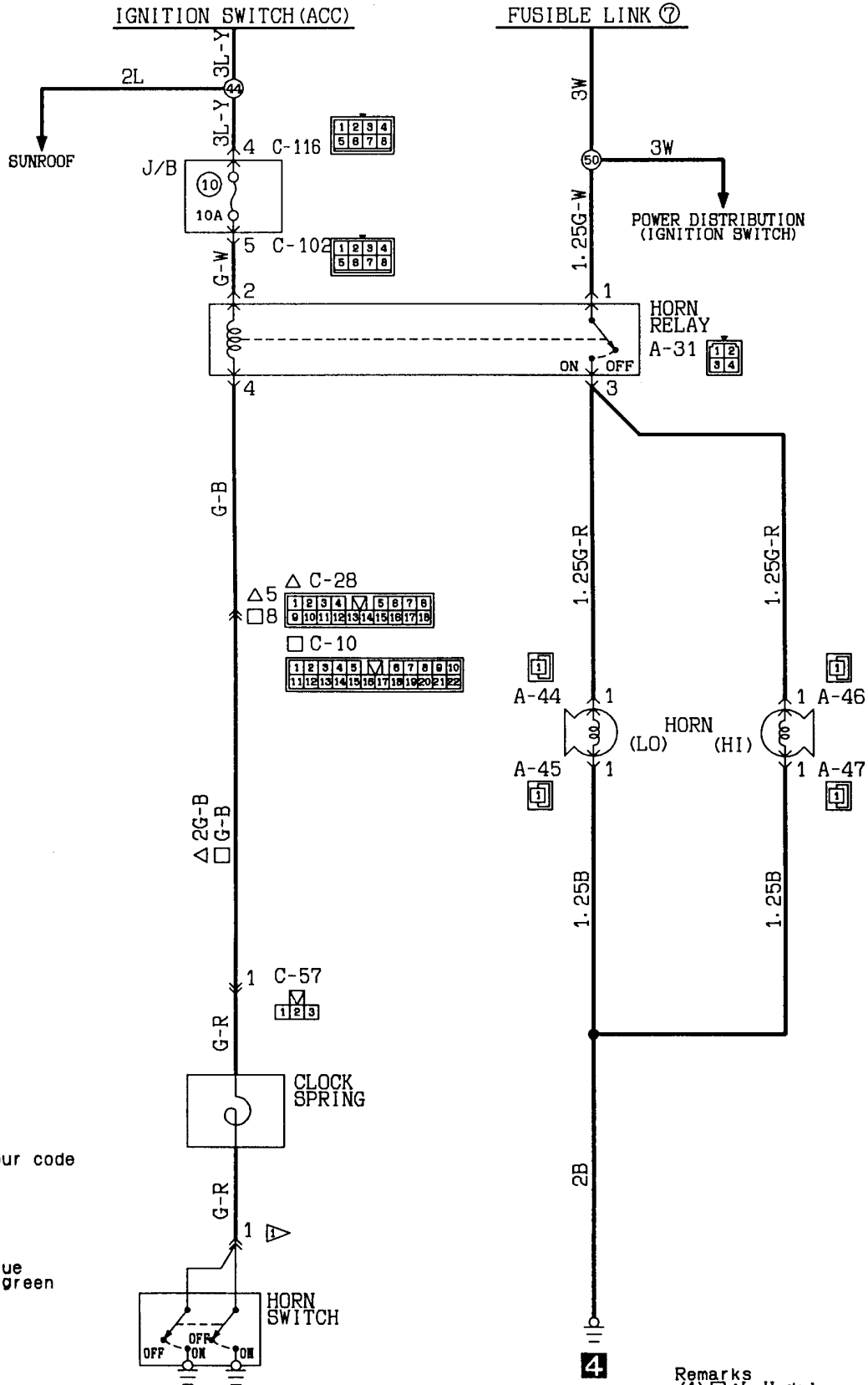

Wire colour code
 B: Black
 BR: Brown
 G: Green
 GR: Gray
 L: Blue
 V: Violet
 SB: Sky blue
 LG: Light green
 O: Orange
 P: Pink
 R: Red
 Y: Yellow
 W: White

Remarks
 (1) □: L. H. drive vehicles.
 (2) △: R. H. drive vehicles.

KX35-AC-00914-EC

METER AND GAUGE
4G64 engine

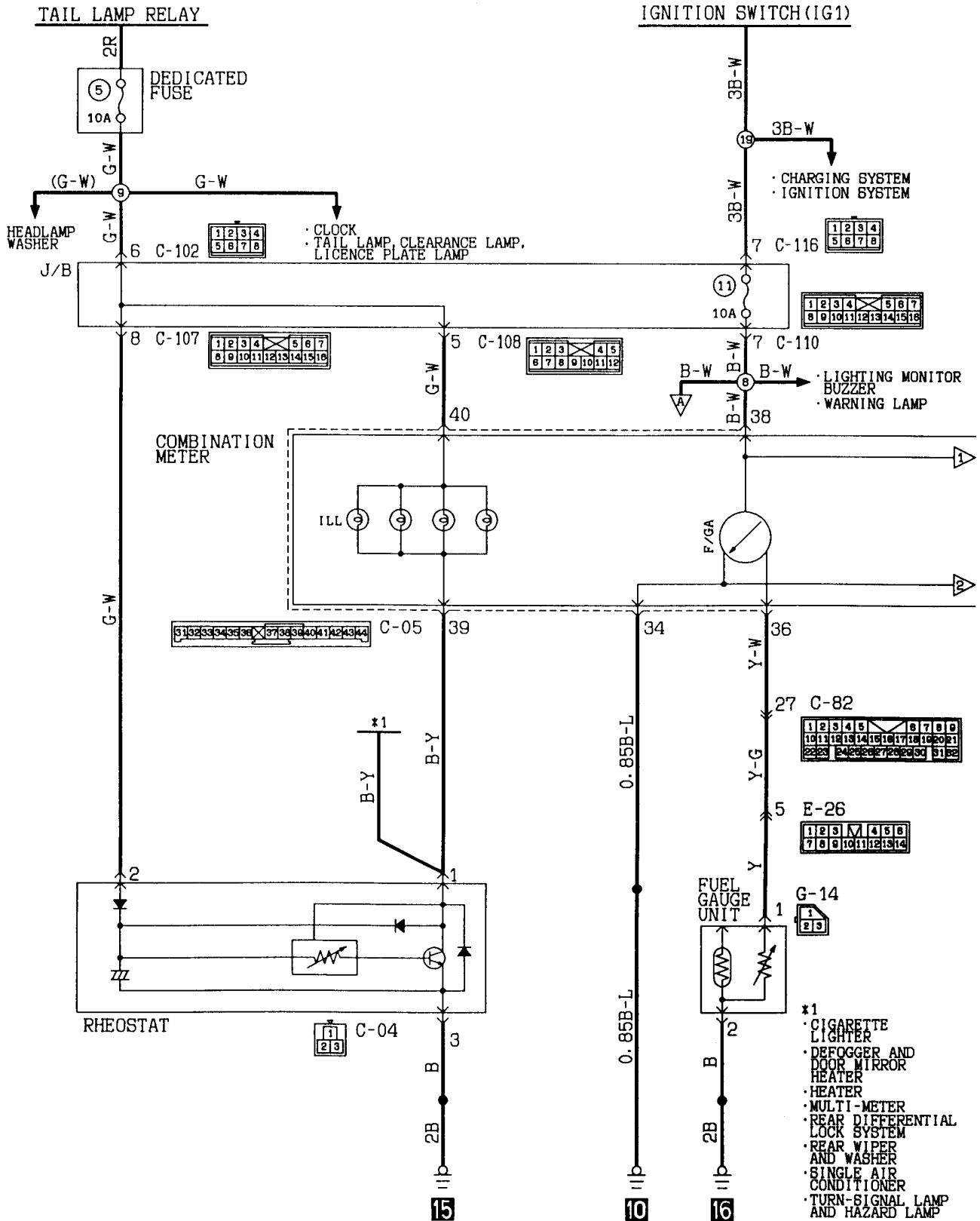

Wire colour code
 B:Black LG:Light green G:Green L:Blue W:White Y:Yellow
 BR:Brown O:Orange GR:Gray R:Red P:Pink V:Violet SB:Sky blue

KX35-AC-Q100B-EC

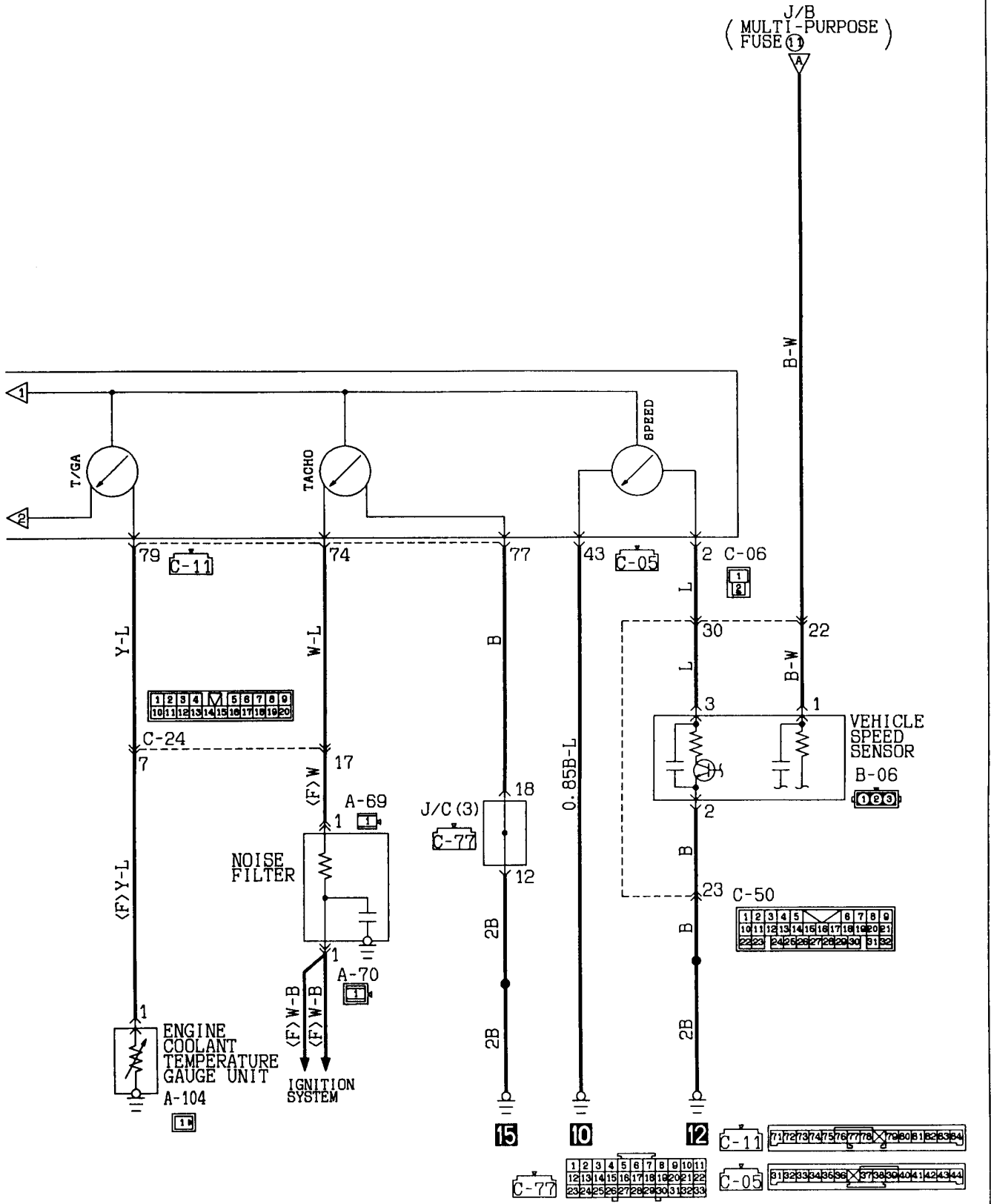

METER AND GAUGE
6G72, 6G74 engine

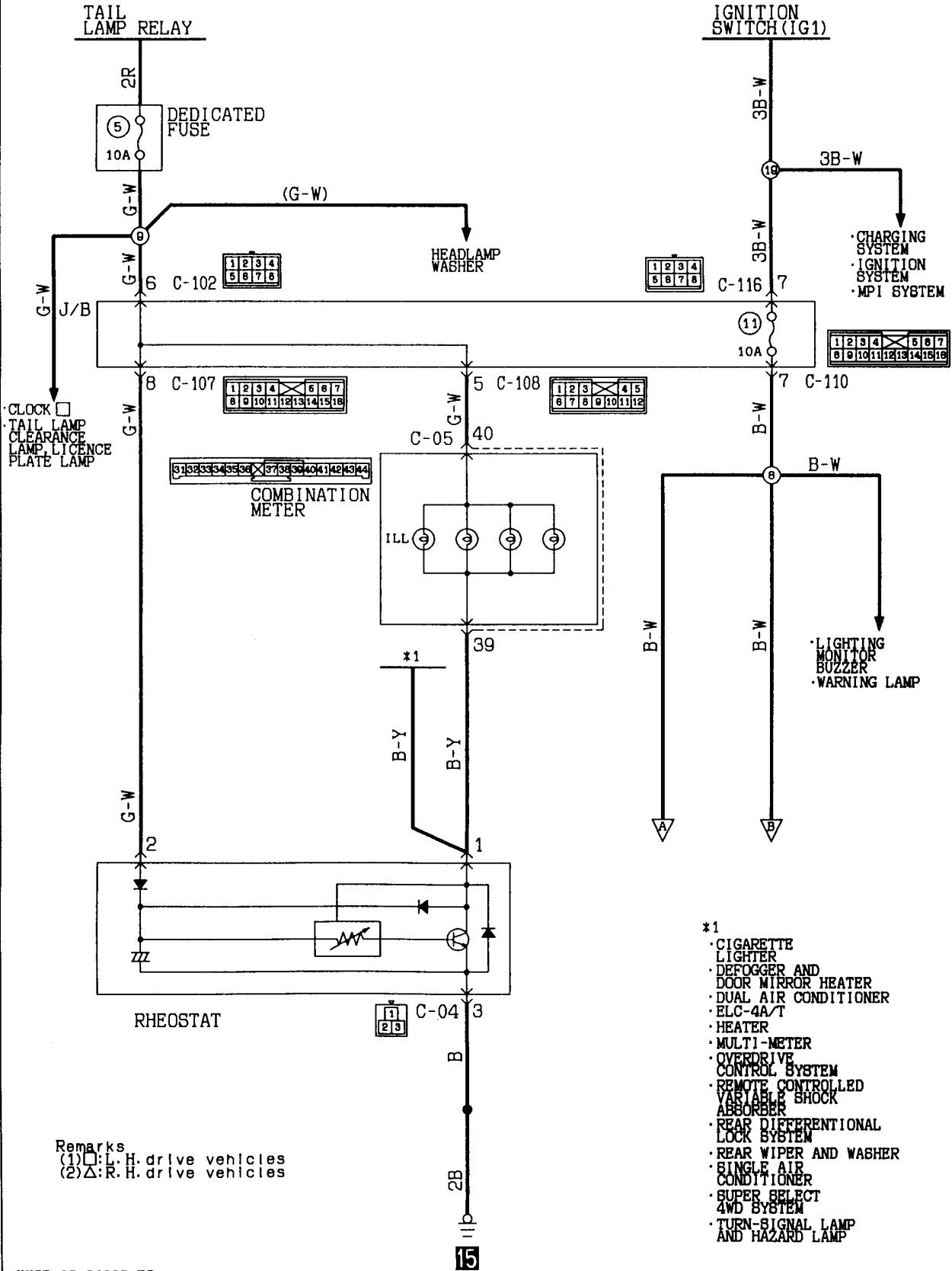

Remarks
(1) □: L.H. drive vehicles
(2) △: R.H. drive vehicles

- *1
- CIGARETTE LIGHTER
 - DEFOGGER AND DOOR MIRROR HEATER
 - DUAL AIR CONDITIONER
 - ELC-4A/T
 - HEATER
 - MULTI-METER
 - OVERDRIVE CONTROL SYSTEM
 - REMOTE CONTROLLED VARIABLE SHOCK ABSORBER
 - REAR DIFFERENTIAL LOCK SYSTEM
 - REAR WIPER AND WASHER
 - SINGLE AIR CONDITIONER
 - SUPER SELECT 4WD SYSTEM
 - TURN-SIGNAL LAMP AND HAZARD LAMP

KX35-AC-01009-EC

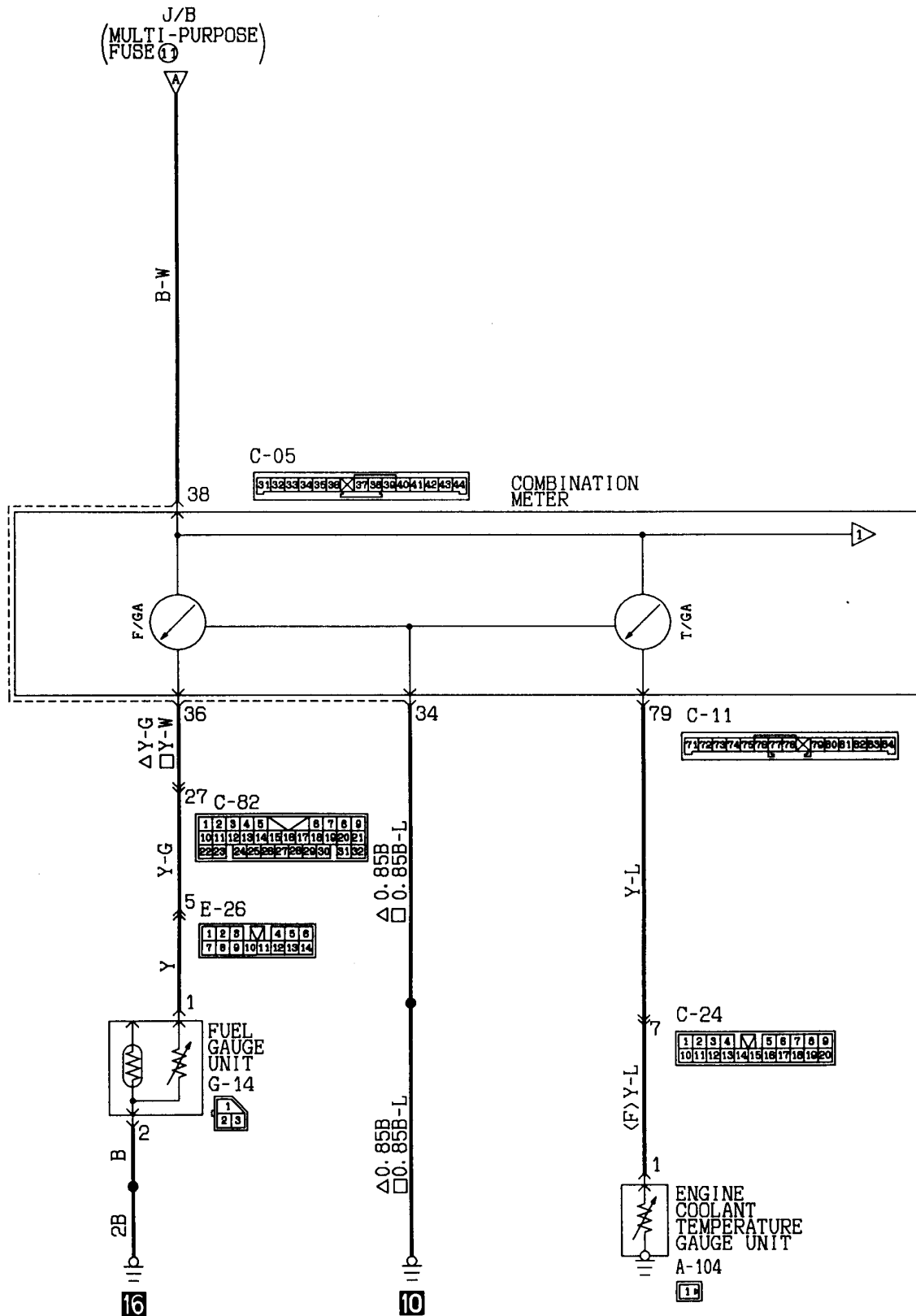

Wire colour code
 B:Black LG:Light green G:Green L:Blue W:White Y:Yellow BB:Sky blue
 BR:Brown O:Orange GR:Gray R:Red P:Pink V:Violet

METER AND GAUGE (6G72, 6G74 engine) (CONTINUED)

Remarks
 (1) □ : L.H. drive vehicles
 (2) △ : R.H. drive vehicles

Wire colour code
 B:Black SB:Sky blue
 BR:Brown LG:Light green
 G:Green P:Pink
 GR:Gray R:Red
 L:Blue Y:Yellow
 V:Violet W:White
 O:Orange

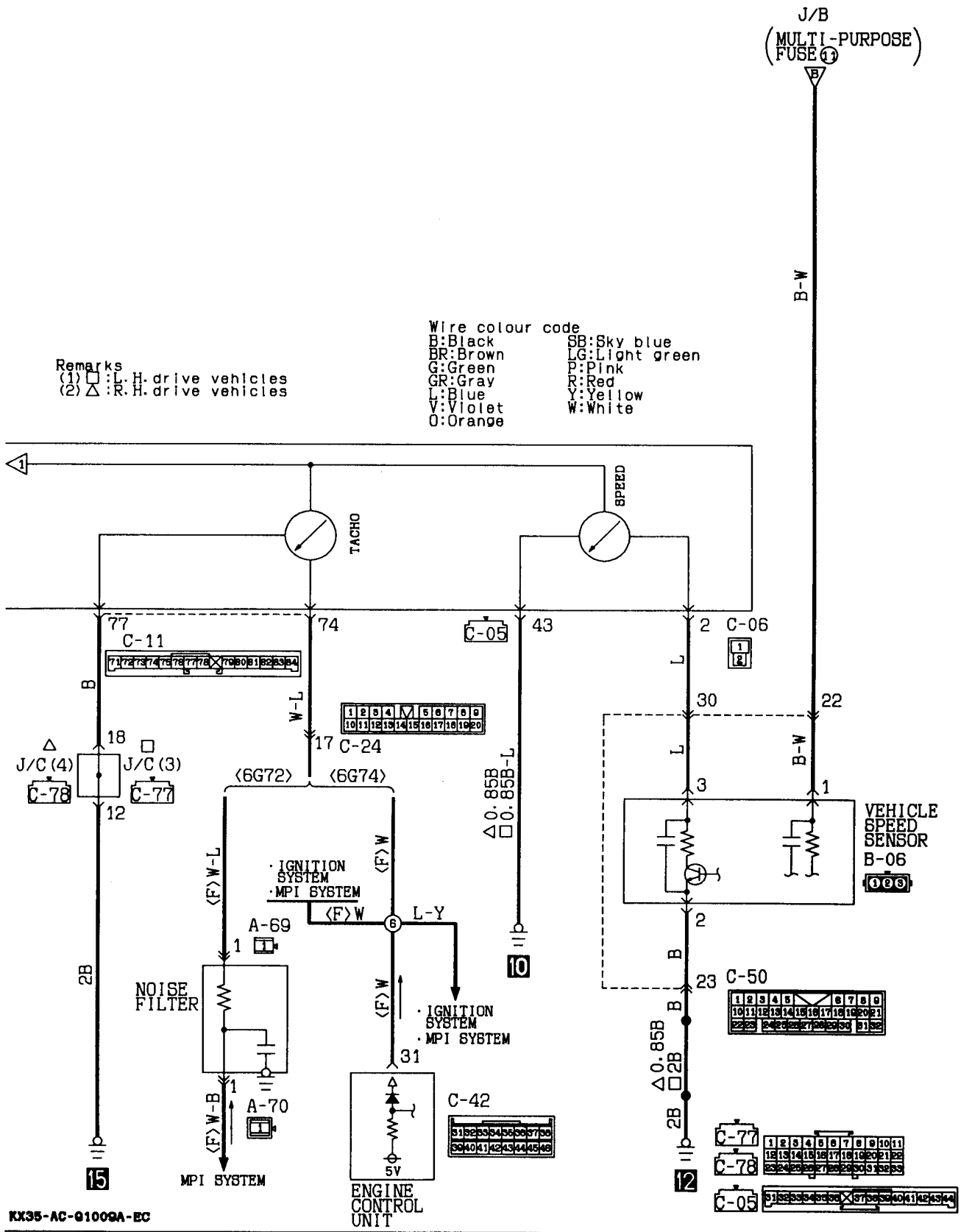

NOTES

METER AND GAUGE
4D56, 4M40 engine

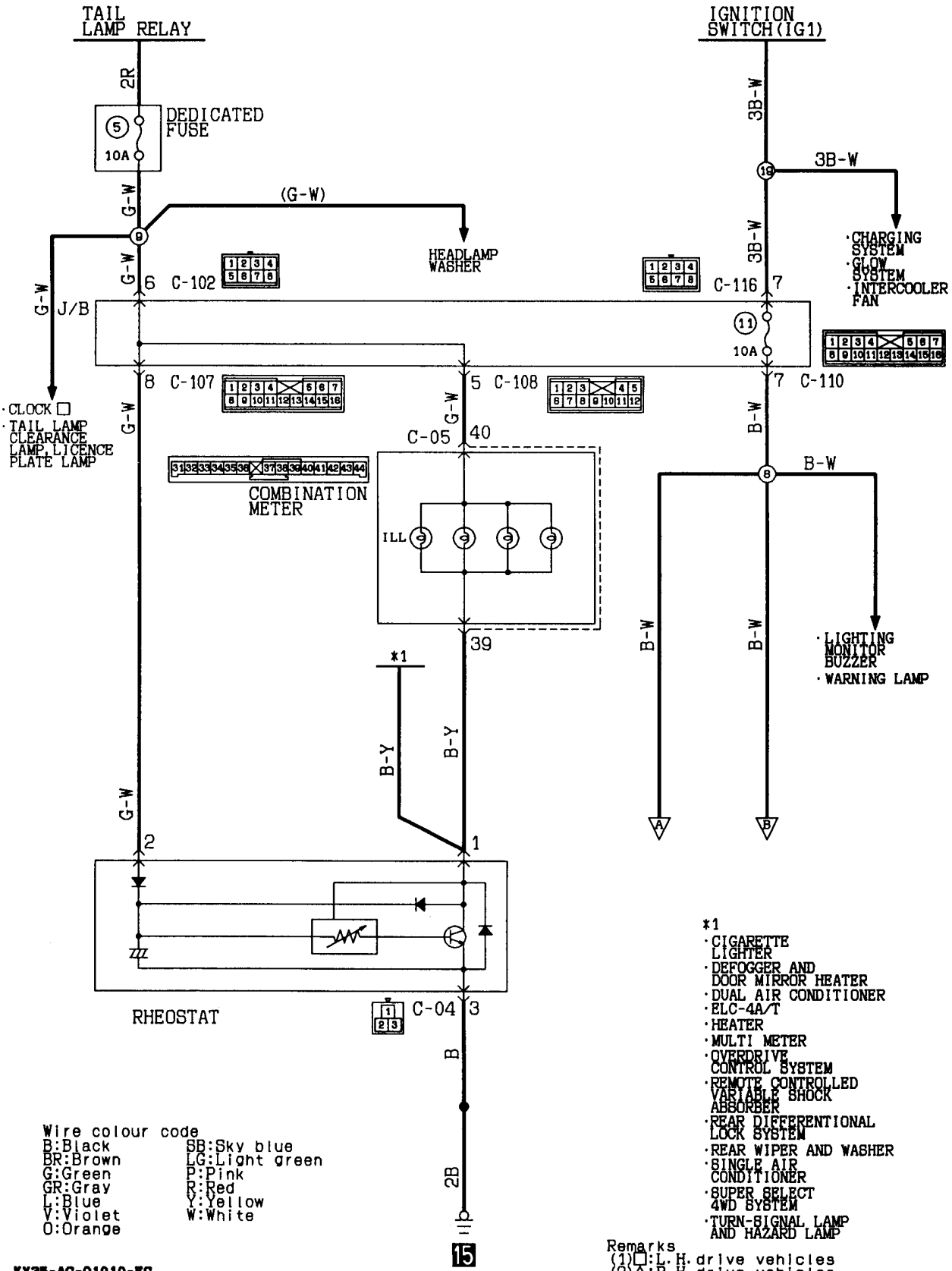

Wire colour code
 B:Black SB:Sky blue
 BR:Brown LG:Light green
 G:Green P:Pink
 GR:Gray R:Red
 L:Blue Y:Yellow
 V:Violet W:White
 O:Orange

- *1
- CIGARETTE LIGHTER
 - DEFOGGER AND DOOR MIRROR HEATER
 - DUAL AIR CONDITIONER
 - ELC-4A/T
 - HEATER
 - MULTI METER
 - OVERDRIVE CONTROL SYSTEM
 - REMOTE CONTROLLED VARIABLE SHOCK ABSORBER
 - REAR DIFFERENTIAL LOCK SYSTEM
 - REAR WIPER AND WASHER
 - SINGLE AIR CONDITIONER
 - SUPER SELECT 4WD SYSTEM
 - TURN-SIGNAL LAMP AND HAZARD LAMP

Remarks
 (1) □: L. H. drive vehicles
 (2) △: R. H. drive vehicles

KX35-AC-01010-EC

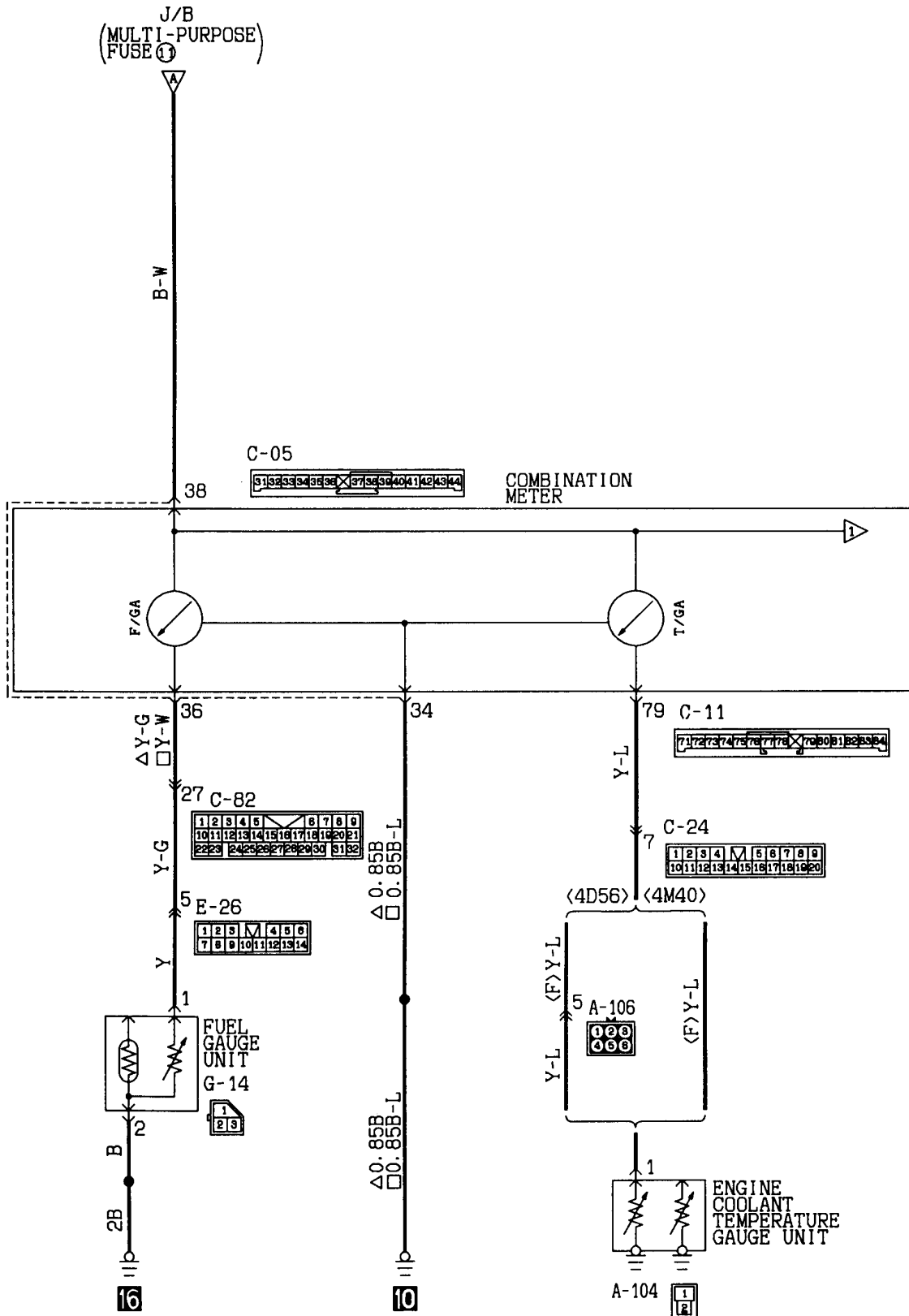

Remarks
 (1) □: L. H. drive vehicles
 (2) △: R. H. drive vehicles

Wire colour code
 B: Black
 BR: Brown
 G: Green
 GR: Gray
 L: Blue
 V: Violet
 O: Orange
 SB: Sky blue
 LG: Light green
 P: Pink
 R: Red
 Y: Yellow
 W: White

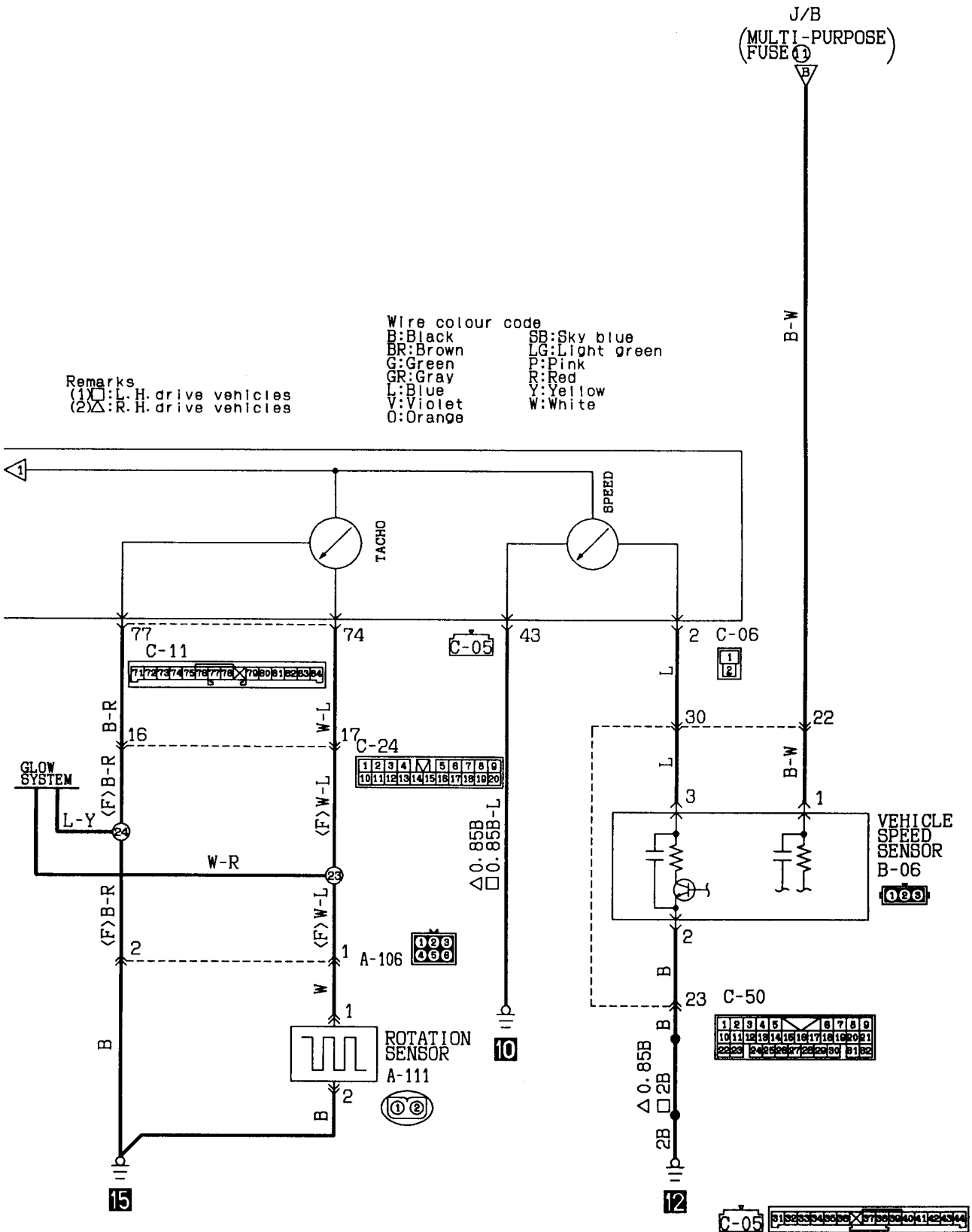

KX35-AC-01010A-EC

METER AND GAUGE (See P. 4A-144, 146, 150.)**OPERATION****<Fuel gauge>**

- When the ignition switch is at the "ON" position, the fuel gauge is activated.
- When there is much fuel, the unit's resistance is small and the current flowing in the circuit is great, so the gauge's indicator indicates in the "F" area.
- When there is little fuel, the unit's resistance is high and the current flowing in the circuit is small, so the gauge's indicator indicates in the "E" area.

<Engine coolant temperature gauge>

- When the ignition switch is at the "ON" position, the engine coolant temperature gauge is activated.
- When the engine coolant temperature is high, the unit's resistance is low and there is a great flow of current in the circuit, so the gauge's indicator indicates in the "H" area.
- When the engine coolant temperature is low, the unit's resistance is high and there is a small flow of current in the circuit, so the gauge's indicator indicates in the "C" area.

TROUBLESHOOTING HINTS

1. Fuel gauge does not operate, or registers incorrectly.
 - 1) The fuel gauge indicates "F" when the fuel gauge unit connector is disconnected and the "1" terminal is earthed.
 - Check fuel gauge.
2. Engine coolant temperature gauge does not operate, or registers incorrectly.
 - 1) When the engine coolant temperature gauge is earthed with its connector unplugged, it registers "H".
 - Check engine coolant temperature gauge unit.
3. Meter illumination lamp does not come on.
 - 1) Tail lamps do come on.
 - Check rheostat.

LOW FUEL WARNING LAMP

FUEL FILTER WARNING LAMP
(Diesel-powered vehicles)

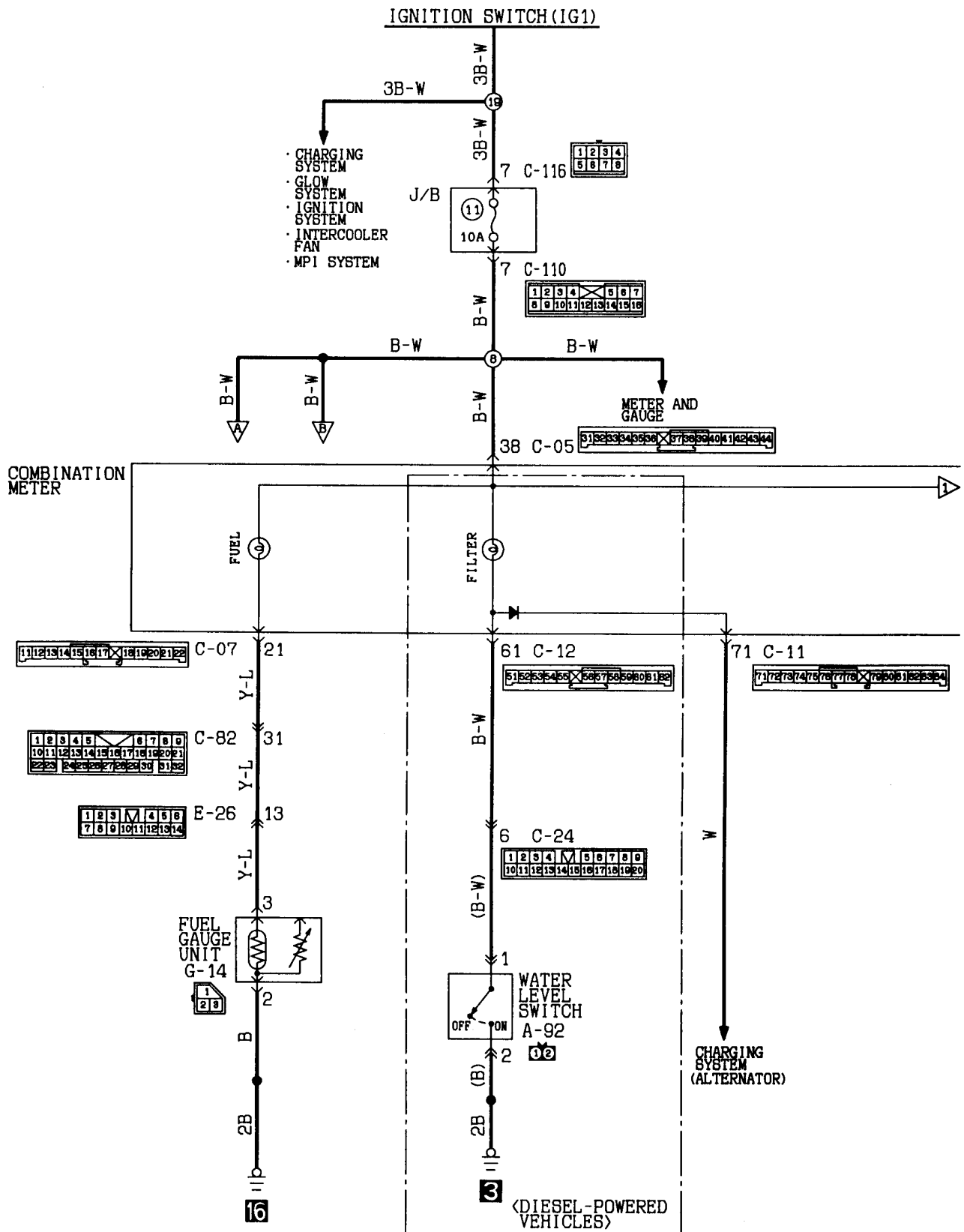

KX35-AC-01014-EC

OIL PRESSURE WARNING LAMP

Remarks
 (1) □ : L. H. drive vehicles
 (2) △ : R. H. drive vehicles

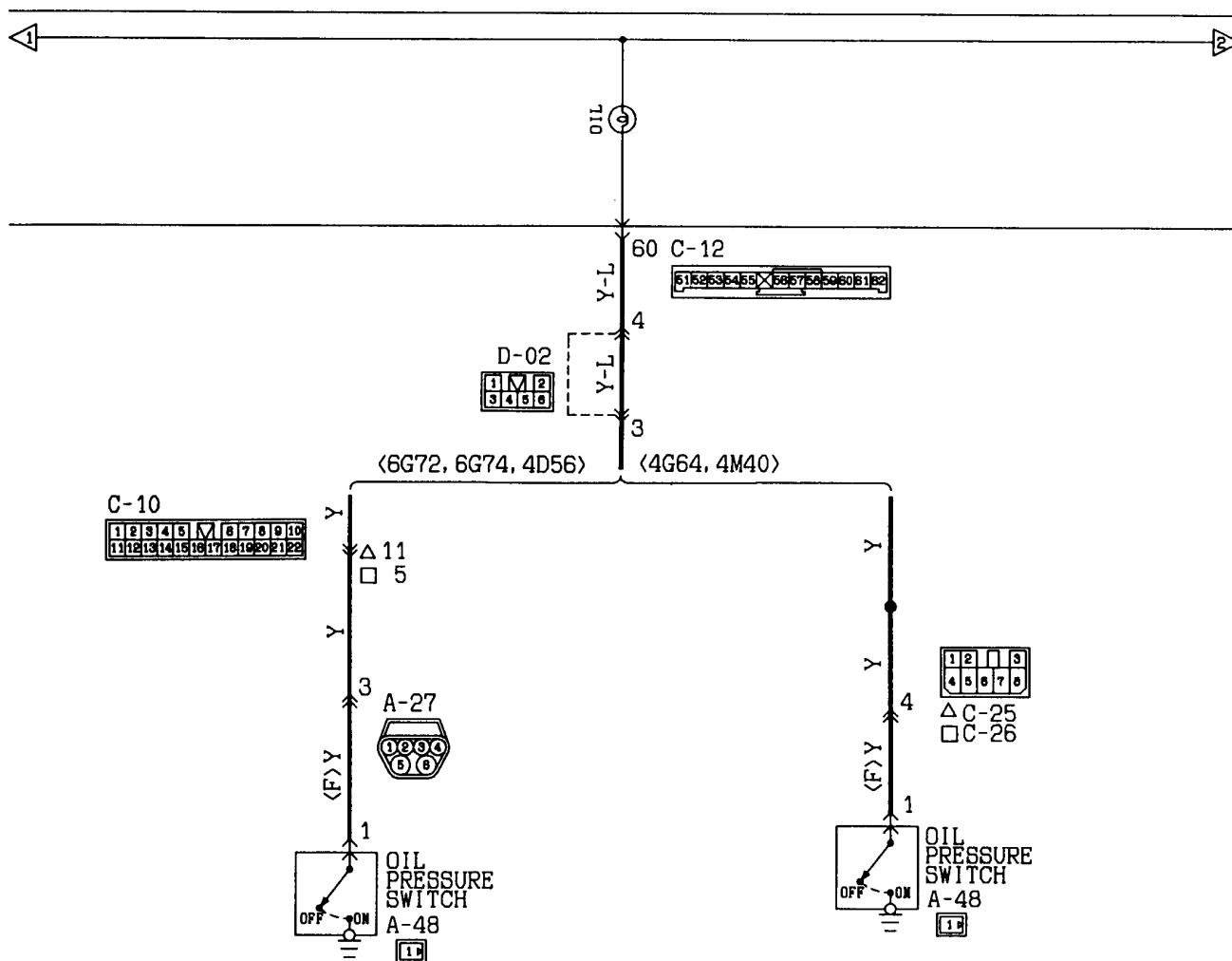

Wire colour code
 B:Black LG:Light green G:Green L:Blue W:White Y:Yellow SB:Sky blue
 BR:Brown O:Orange GR:Gray R:Red P:Pink V:Violet

LOW ENGINE OIL LEVEL WARNING LAMP

BRAKE WARNING LAMP

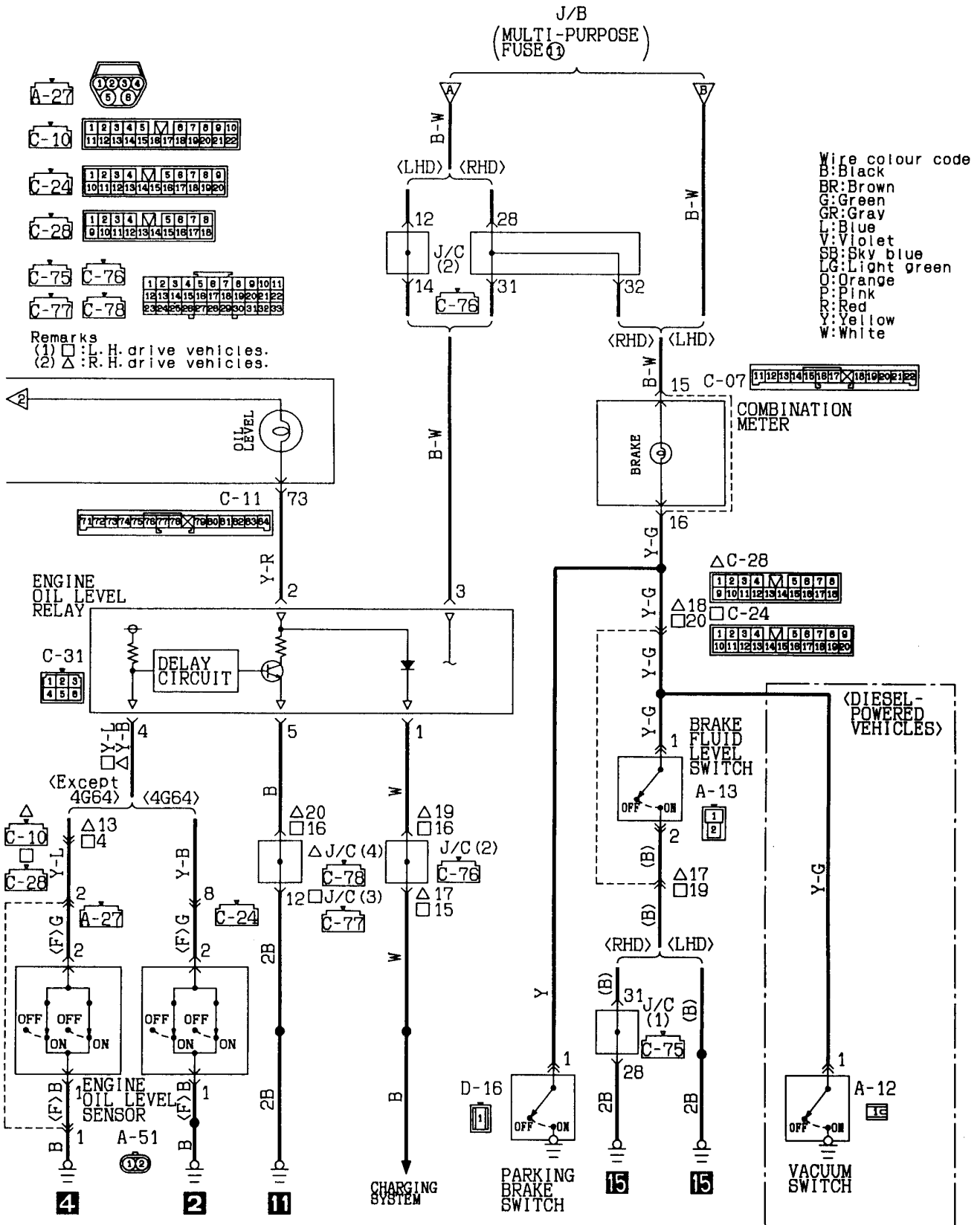

KX35-AC-Q1014A-EC

LOW FUEL WARNING LAMP
FUEL FILTER WARNING LAMP (Diesel-powered vehicles)
OIL PRESSURE WARNING LAMP
BRAKE WARNING LAMP
LOW ENGINE OIL WARNING LAMP (See P. 4A-154.)

OPERATION

<Low fuel warning lamp>

- When the fuel level goes down causing the level sensor to be exposed, with the ignition switch in the ON position, the resistance of level sensor becomes small. When this resistance goes down below the predetermined level, the fuel warning lamp lights up to warn the driver that the amount of fuel still available for use is small.

<Fuel filter warning lamp (Diesel-powered vehicles)>

- When the ignition switch is turned to the "ON" position (with the engine stopped), the fuel filter warning lamp comes on and the lamp switches OFF when the engine is started. This feature can be used to check for a failure of the lamp's bulb.
- When condensate has accumulated in the fuel filter, the water level switch turns ON causing the fuel filter warning lamp to light up.

<Oil pressure warning lamp>

- When the lubrication system fails after engine starting, resulting in the oil pressure failing to build up, the oil pressure switch turns ON causing the oil pressure warning lamp to light up.

<Brake warning lamp>

- When the brake fluid level goes down below a predetermined level or parking brake lever pulled, with the ignition switch in the ON position, the brake fluid level sensor is activated or the parking brake switch is turned ON, causing the brake warning lamp to light up.
- On diesel-powered vehicles, when the brake booster vacuum line fails, the vacuum switch is turned ON causing the brake warning lamp to light up.

<Low engine oil warning lamp>

- When the ignition switch is turned to the "ON" position (in the state where the engine is stopped), electric current will flow to terminal "L" of the alternator through the multi-purpose fuse No. ①, low engine oil warning lamp and engine oil level relay and the low engine oil warning lamp will also light up.
- When the engine starts, the charging voltage will be applied to the terminal "L" of the alternator. Therefore, the low engine oil warning lamp will go out.
- When the engine oil temperature rises to approx. 55°C (131°F), the engine oil level sensor (TEMP) provided in the oil pan will be turned off.
- When the engine oil amount in the oil pan drops below the set level in this state, the engine oil level sensor (LEVEL) will be turned off to apply the voltage to the delay circuit.
- If the "OFF" state continues for approx. 20 seconds or more, the power transistor will be turned on to light the low engine oil warning lamp to indicate a shortage of engine oil.

Remark

The delay circuit is provided to prevent the low engine oil warning lamp from going on even if the engine oil level sensor is temporarily turned off due to cornering or other running conditions of the vehicle.

MULTI-METER
Without electronic compass

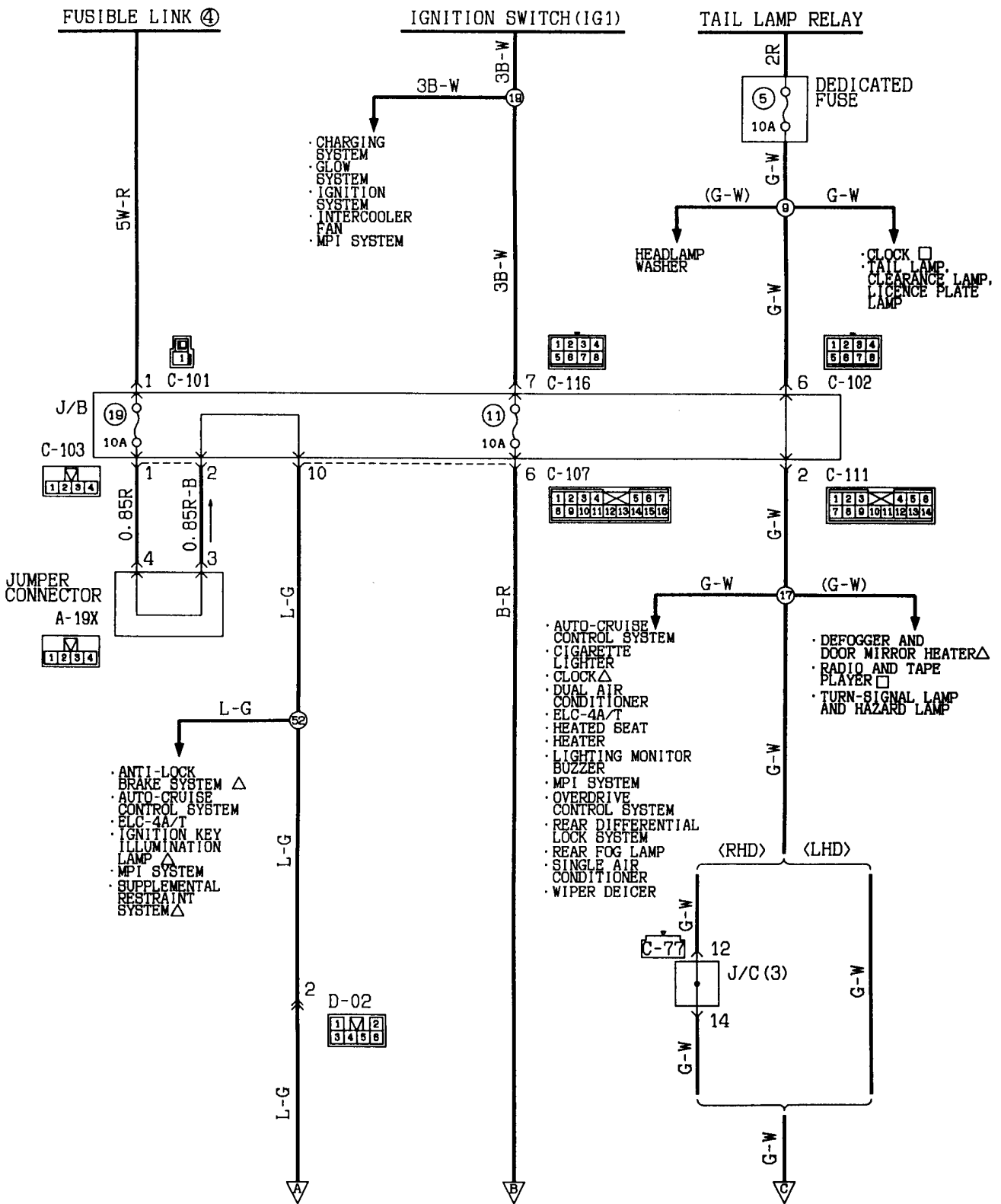

Wire colour code
 B:Black LG:Light green G:Green L:Blue W:White Y:Yellow SB:Sky blue
 BR:Brown O:Orange GR:Gray R:Red P:Pink V:Violet

KX35-AC-01011-EC

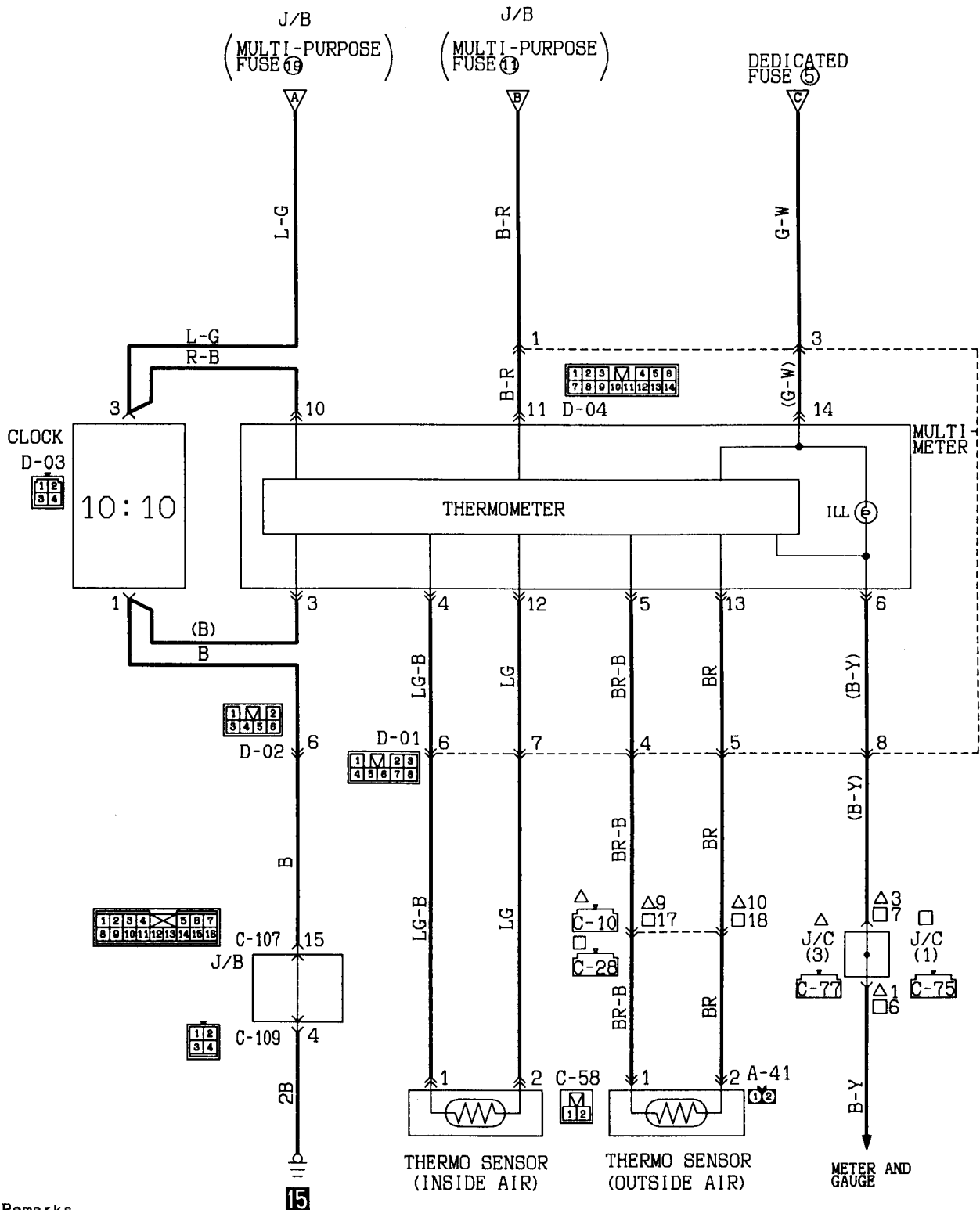

Remarks
 (1) □: L. H. drive vehicles
 (2) △: R. H. drive vehicles

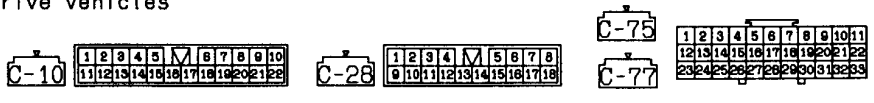

MULTI-METER
With electronic compass

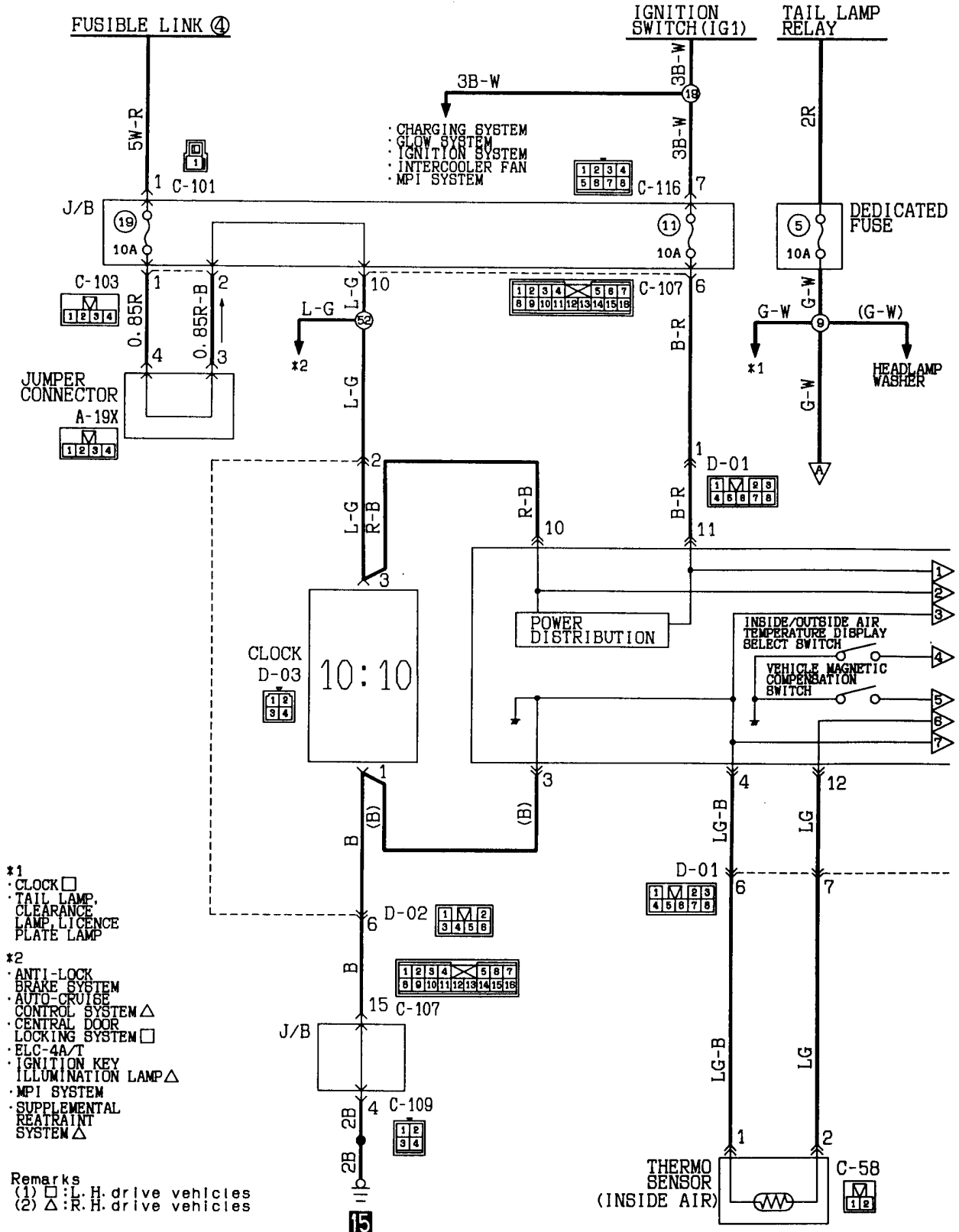

- *1 CLOCK
- TAIL LAMP
- CLEARANCE LAMP, LICENCE PLATE LAMP
- *2 ANTI-LOCK BRAKE SYSTEM
- BRAKE SYSTEM
- AUTO-CRUISE CONTROL SYSTEM
- CENTRAL DOOR LOCKING SYSTEM
- ELC-4A/T
- IGNITION KEY ILLUMINATION LAMP
- MPI SYSTEM
- SUPPLEMENTAL RESTRAINT SYSTEM

Remarks
(1) : L.H. drive vehicles
(2) : R.H. drive vehicles

Wire colour code

B:Black	LG:Light green	G:Green	L:Blue	W:White	Y:Yellow	SB:Sky blue
BR:Brown	O:Orange	GR:Gray	R:Red	P:Pink	V:Violet	

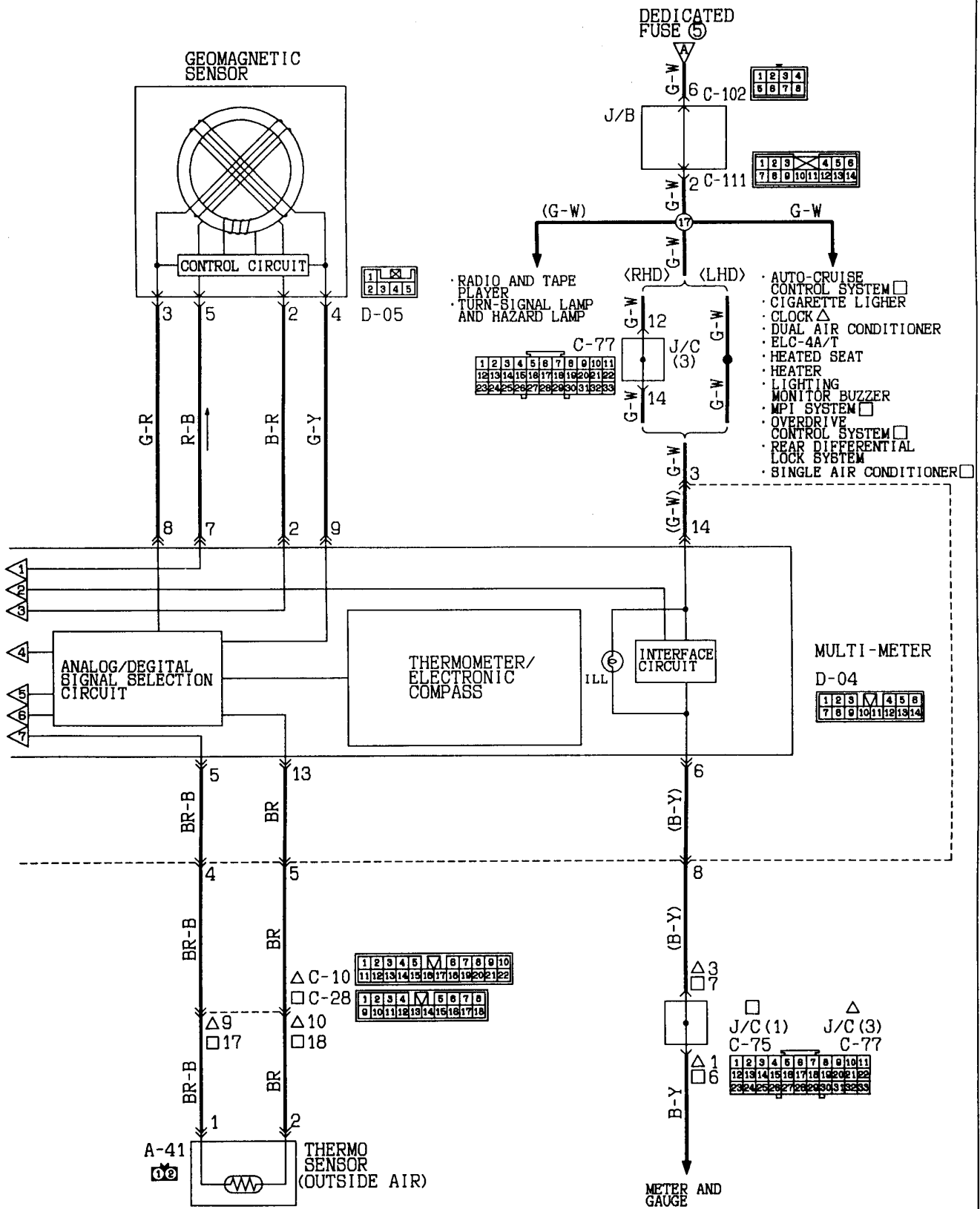

POWER WINDOW

L.H. drive vehicles (2-door models)

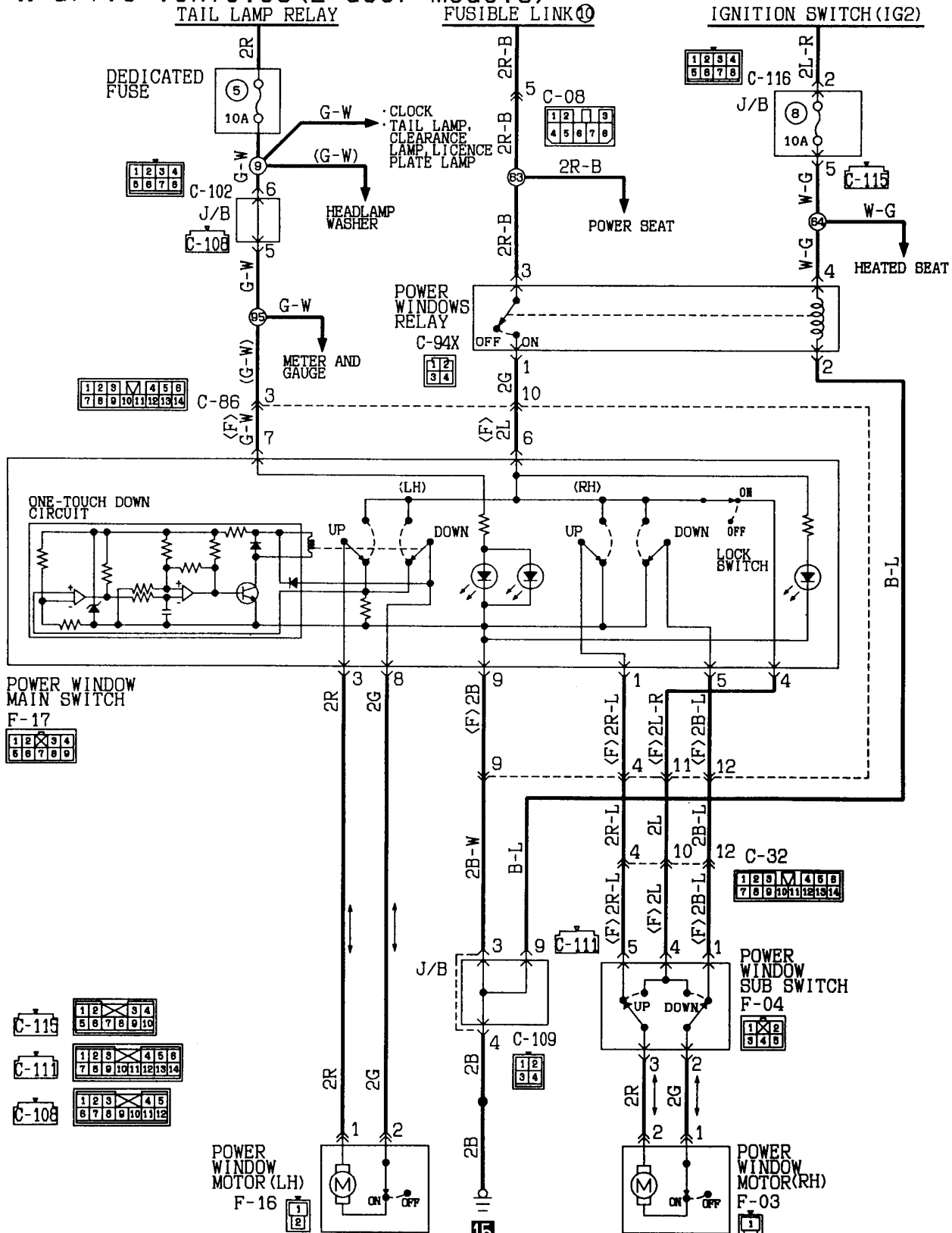

Wire colour code
 B:Black LG:Light green G:Green L:Blue W:White Y:Yellow
 BR:Brown O:Orange GR:Gray R:Red P:Pink V:Violet
 8B:Sky blue

POWER WINDOW

L.H. drive vehicles <4-door models>

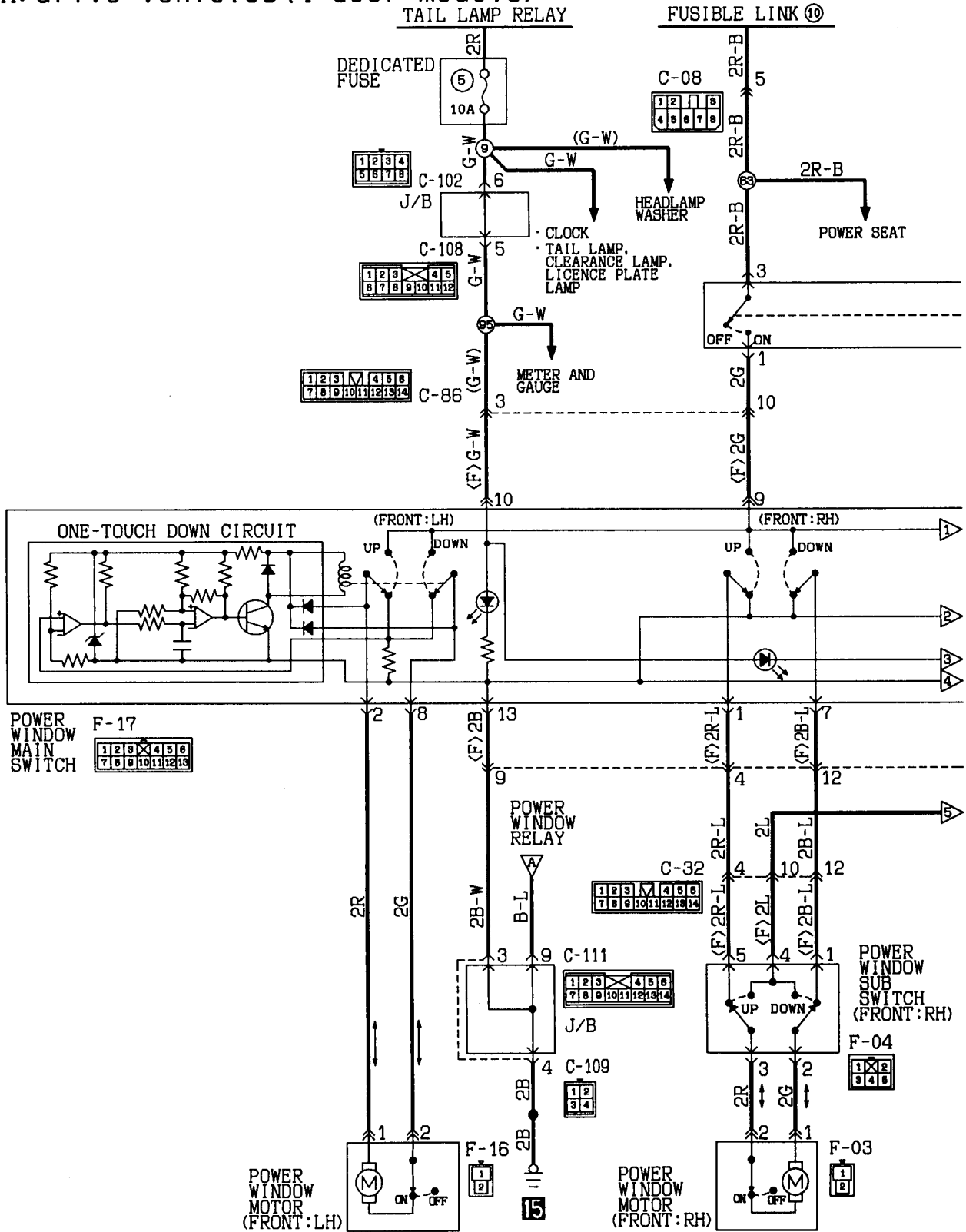

Wire colour code
 B:Black LG:Light green G:Green L:Blue W:White Y:Yellow SB:Sky blue
 BR:Brown O:Orange GR:Gray R:Red P:Pink V:Violet

POWER WINDOW (L. H. drive vehicles (4-door models))
(CONTINUED)

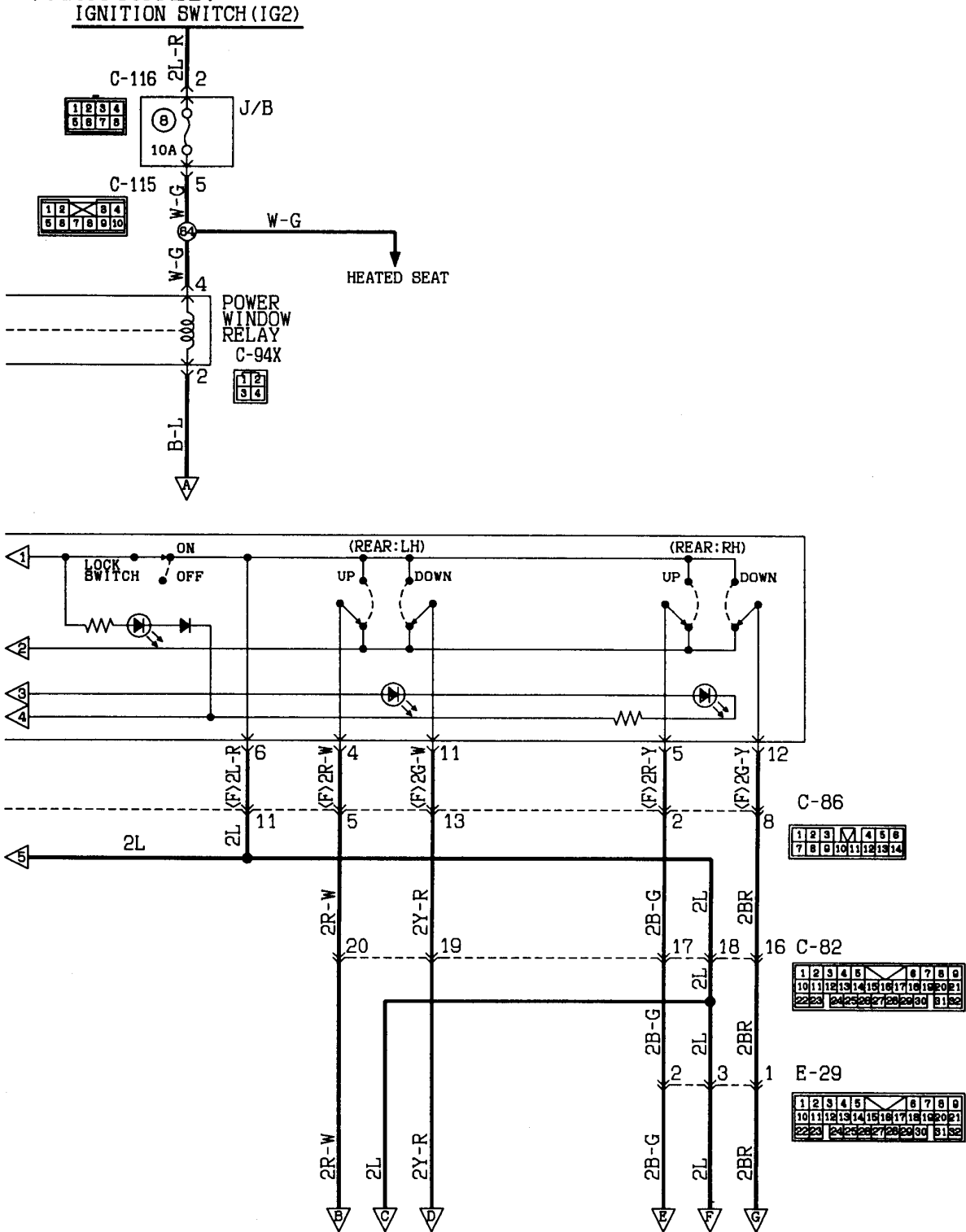

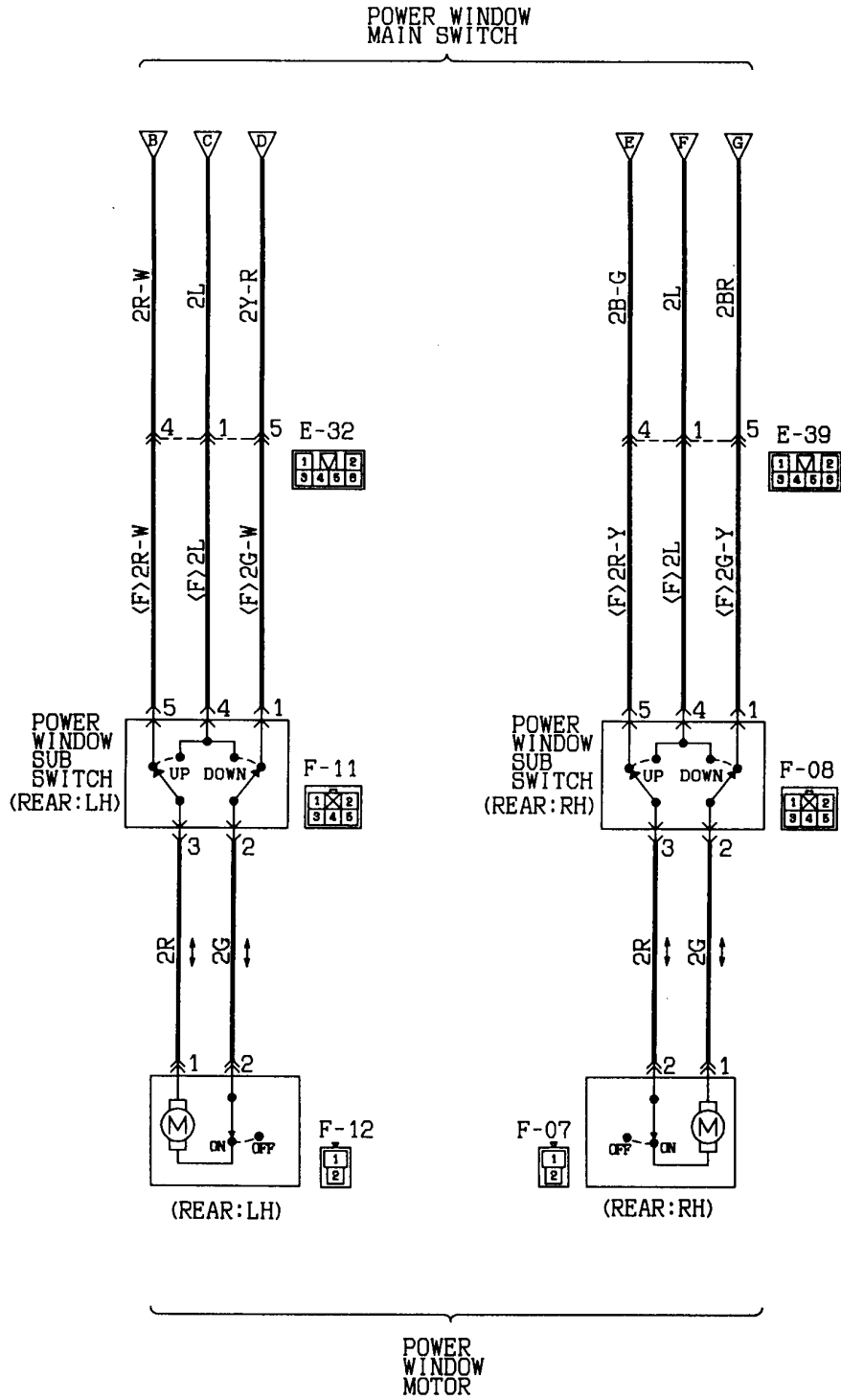

Wire colour code
 B:Black LG:Light green G:Green L:Blue W:White Y:Yellow SB:Sky blue
 BR:Brown O:Orange GR:Gray R:Red P:Pink V:Violet

POWER WINDOW

R. H. drive vehicles (2-door models)

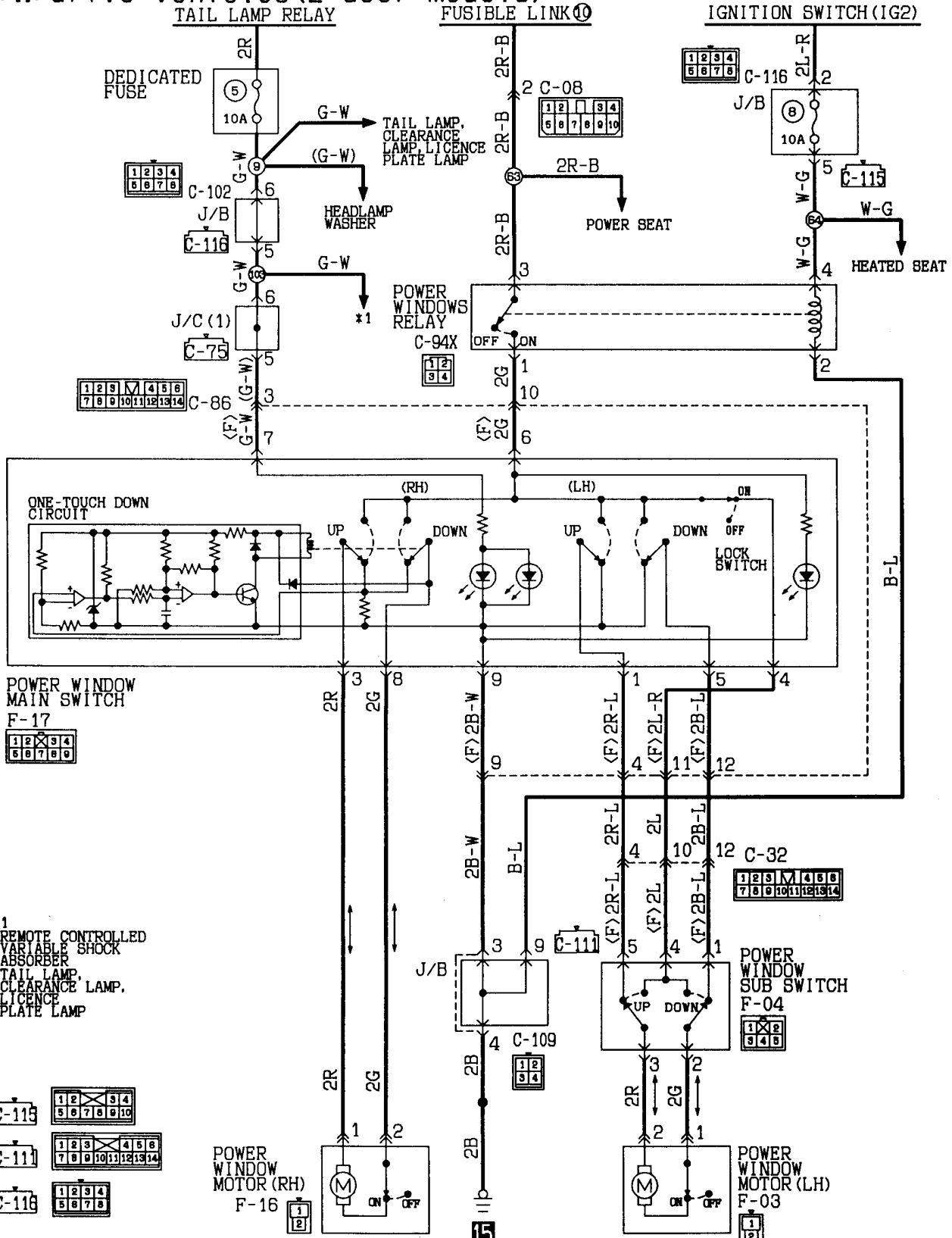

*1
 REMOTE CONTROLLED
 VARIABLE SHOCK
 ABSORBER
 TAIL LAMP,
 CLEARANCE LAMP,
 LICENCE
 PLATE LAMP

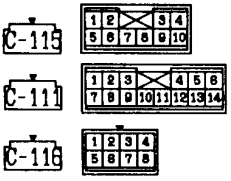

Wire colour code
 B:Black LG:Light green G:Green L:Blue W:White Y:Yellow SB:Sky blue
 BR:Brown O:Orange GR:Gray R:Red P:Pink V:Violet

POWER WINDOW

R. H. drive vehicles <4-door models>

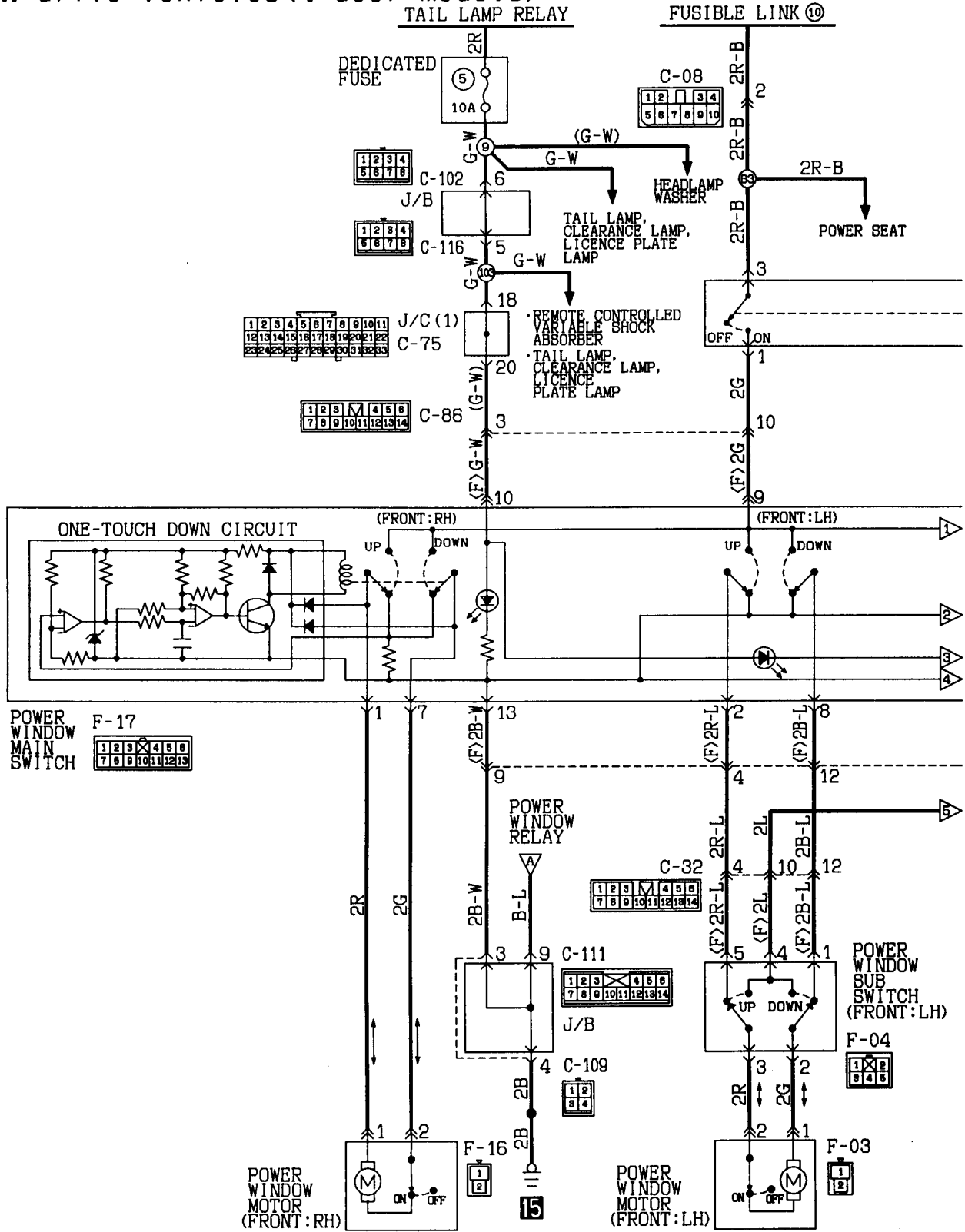

Wire colour code
 B:Black LG:Light green G:Green L:Blue W:White Y:Yellow SB:Sky blue
 BR:Brown O:Orange GR:Gray R:Red P:Pink V:Violet

KX35-AC-01113-EC

POWER WINDOW (R. H. drive vehicles (4-door models))
(CONTINUED)

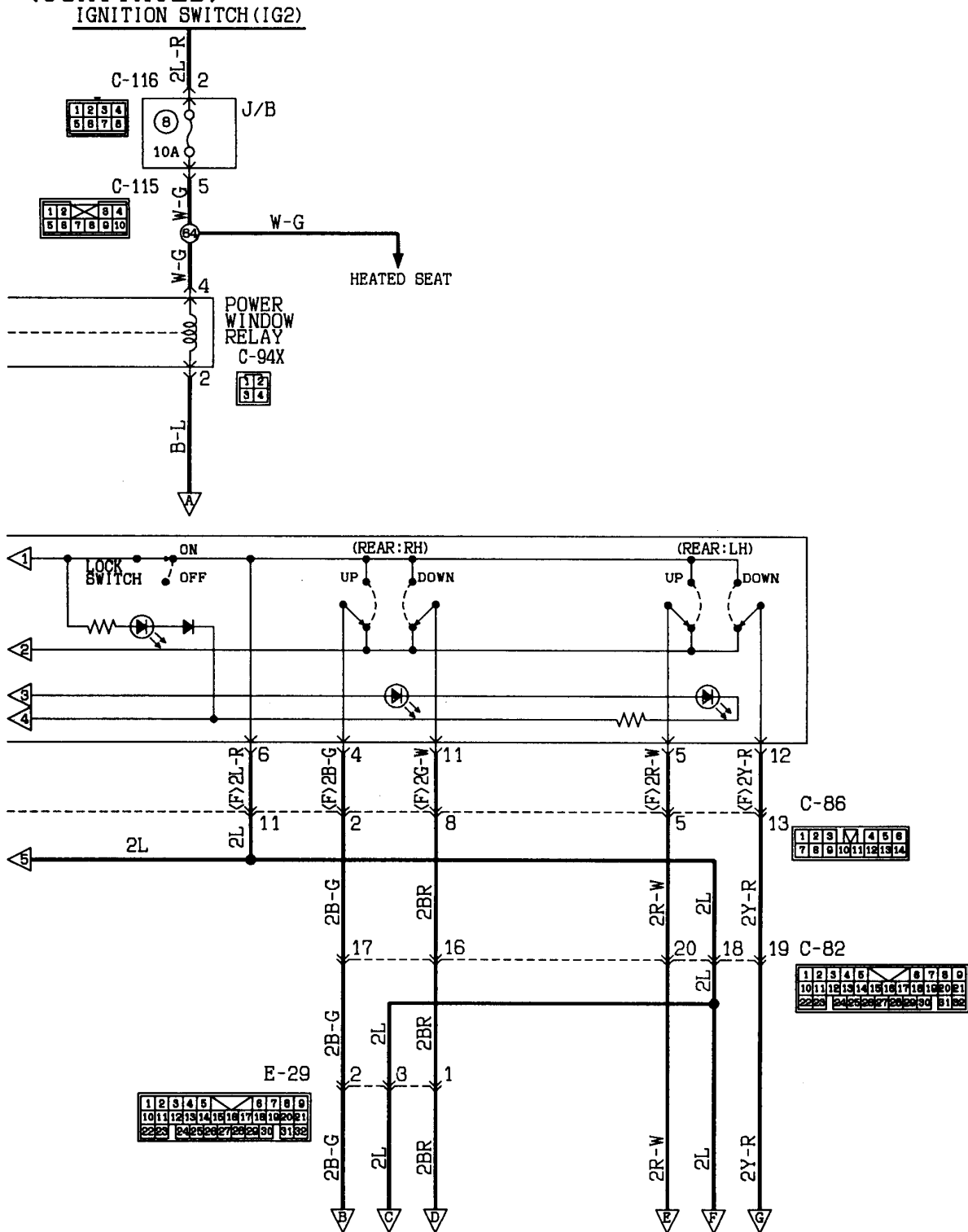

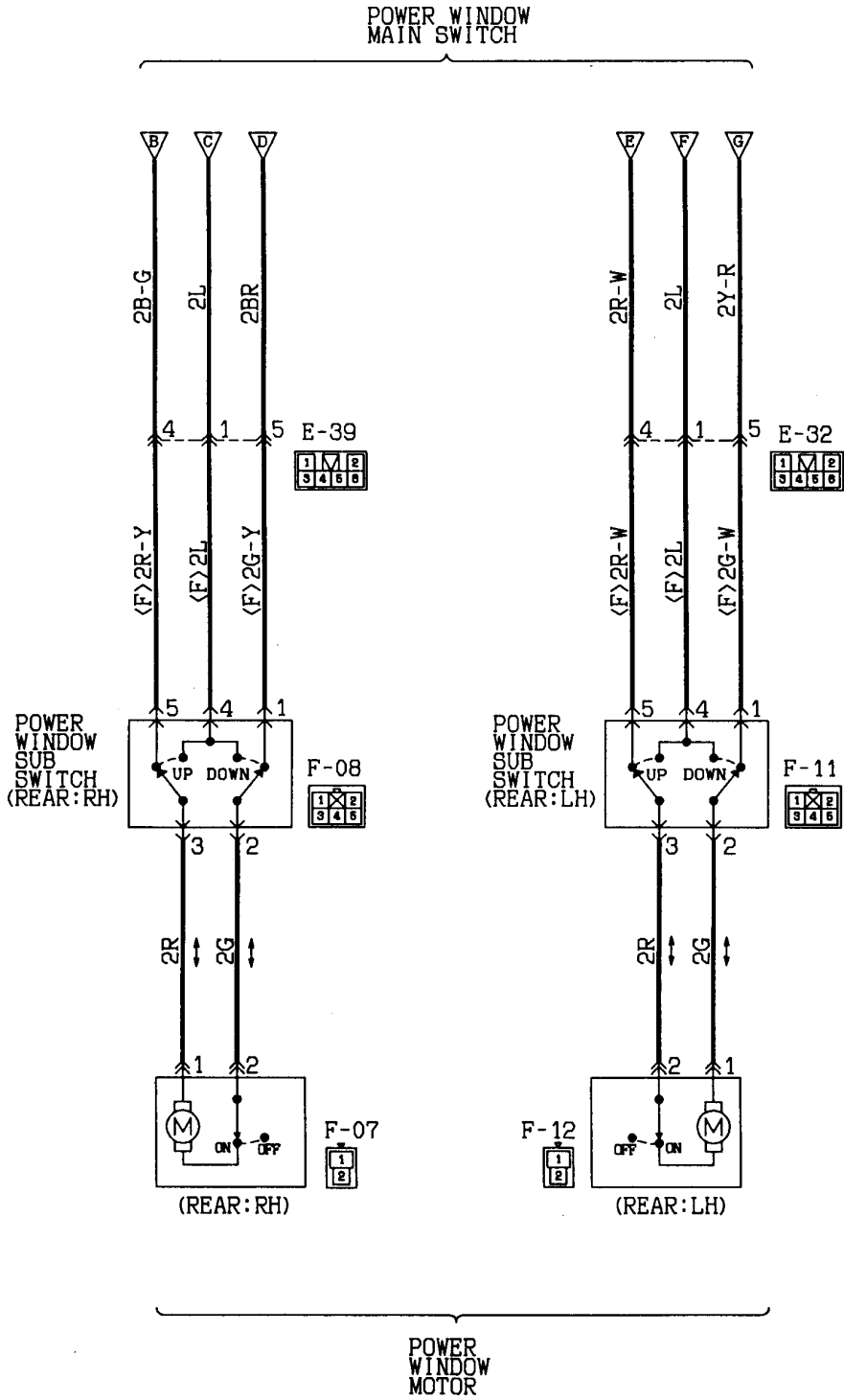

Wire colour code
 B:Black LG:Light green G:Green L:Blue W:White Y:Yellow BB:Sky blue
 BR:Brown O:Orange GR:Gray R:Red P:Pink V:Violet

POWER WINDOW (See P. 4A-162, 163, 166, 167.)**OPERATION**

- When the power window (main or sub) switch is depressed (UP or DOWN) with the ignition switch in the ON position, current flows through fusible link No. ⑩ to the power window motor. This energizes the power window motor causing the door window glass to open or close.
- When the DOWN side of the power window main switch (driver's seat side switch) is depressed all the way, it is locked in the depressed position and the power window motor is operated until the door glass is fully opened.
- When the power window lock switch is placed in the LOCK (OFF) position, operating a switch other than the ones for the driver's side and front passenger's side window (main) does not cause the power window motor to be operated.
- The power window motor is provided with a circuit breaker that protects the motor from damage caused by overcurrent.

Reference: Circuit breaker characteristics

Restricts the motor at room temperature [20 to 25°C (68 to 77°F)];

Opens following 4-to-40-sec. initial energization time;

Resets within 60 seconds if left open thereafter.

TROUBLESHOOTING HINTS

1. All door glasses cannot be opened or closed.
 - Check fusible link No. ⑩.
 - Check multi-purpose fuse No. ⑧.
 - Check power window relay.
 - Check power window main switch.
2. Some door glass cannot be opened or closed.
 - 1) Neither power window main nor sub switch is activated.
 - Check power window main switch.
 - Check defective power window motor.
 - 2) Either power window main or sub switch is inoperative.
 - Check inoperative power window switch.
3. One-touch switch function is not operational.
 - Replace power window main switch.

CENTRAL DOOR LOCKING SYSTEM (See P. 4A-172, 174.)**OPERATION****1. Operation with the inside lock knob on the driver's side (including door lock key operation).**

- If the inside lock knob on the driver's side is locked (or unlocked), the switch in the front door lock actuator (driver's side) goes off (or on) and the lock side (or unlock side) relay in the door lock control unit goes on for 0.5 second and the actuators for all doors function.

2. Operation with the door lock key.

- If the door lock key (passenger's side) is turned to the lock side (or unlock side), the lock side (or unlock side) relay in the door lock control unit goes on for 0.5 second and the actuators for all doors function.

TROUBLESHOOTING HINTS

1. Any one of the door lock actuators is inoperative.
 - Check the defective door actuator.
2. Locking (or unlocking) is possible with the door lock key (passenger's side) but locking (or unlocking) is not possible with the inside lock knob on the driver's side (including door lock key operation).
 - Inspect the front door lock actuator (driver's side)
 - Inspect the door lock control unit.
3. Locking (or unlocking) is possible with the inside lock knob (including door lock key operation) on the driver's side but locking (or unlocking) is not possible with the door lock key (passenger's side).
 - Inspect the door lock key cylinder (passenger's side).
 - Inspect the door lock control unit.

CENTRAL DOOR LOCKING SYSTEM

L.H. drive vehicles

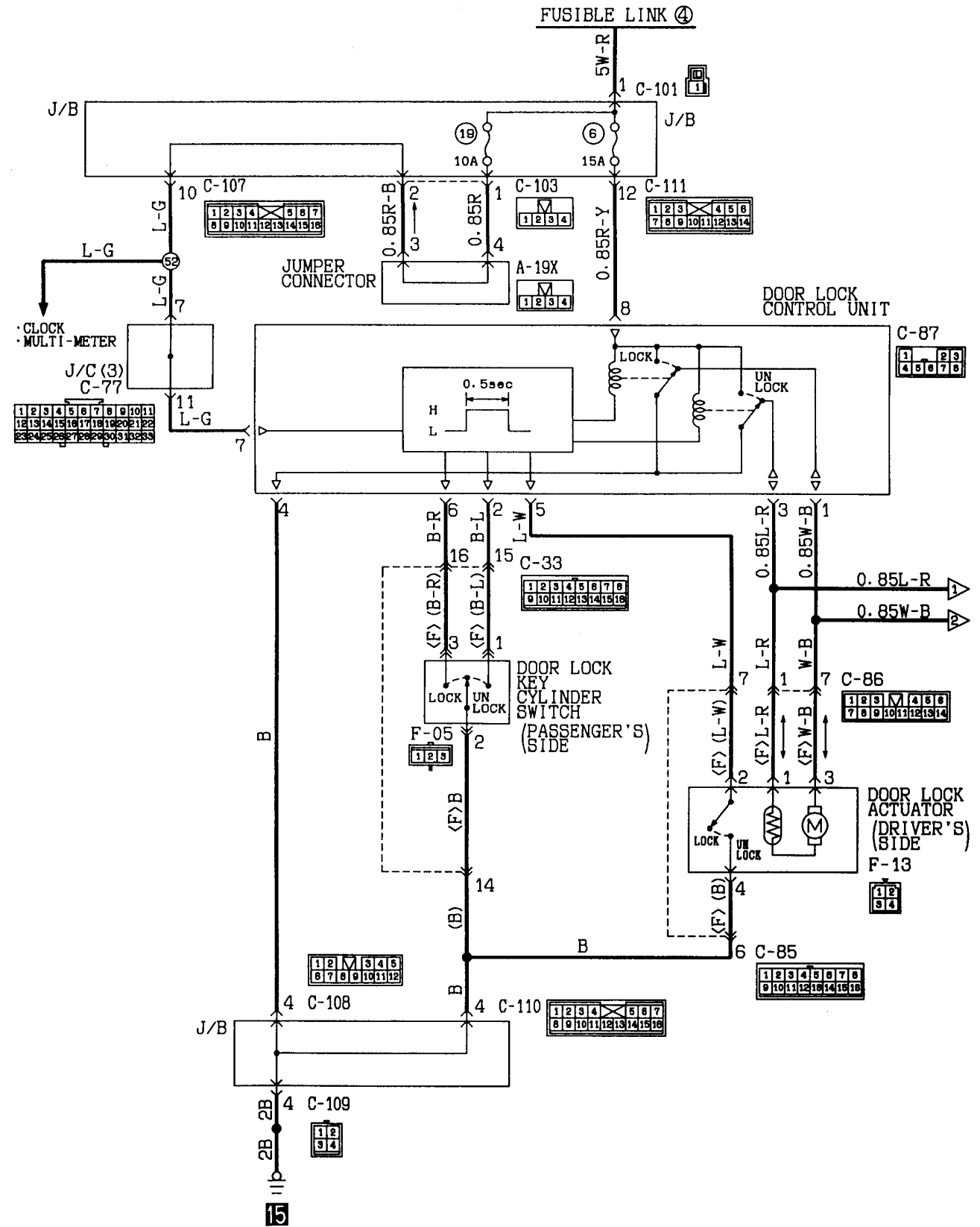

KX35-AC-01107-EC

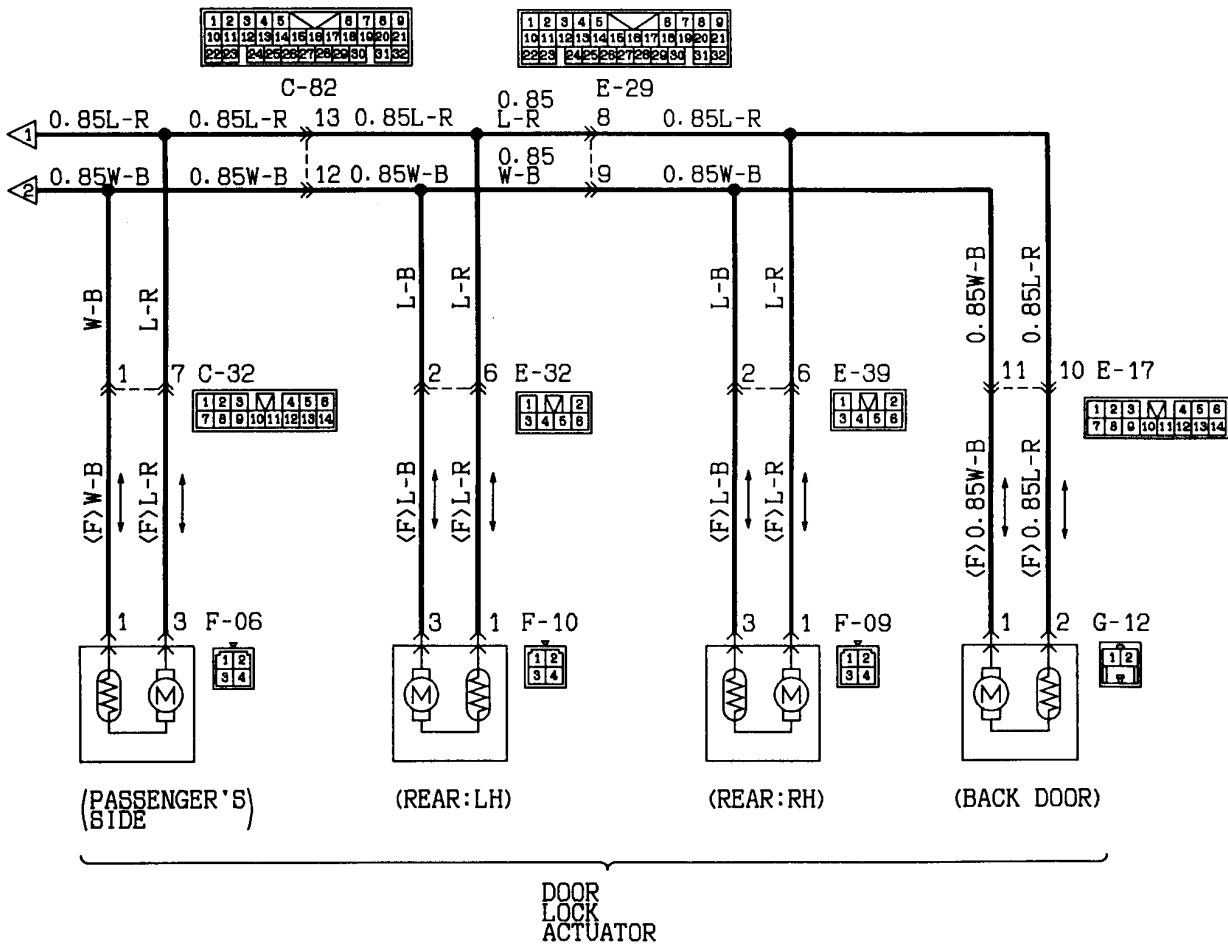

Wire colour code
 B:Black LG:Light green G:Green L:Blue W:White Y:Yellow SB:Sky blue
 BR:Brown O:Orange GR:Gray R:Red P:Pink V:Violet

CENTRAL DOOR LOCKING SYSTEM
R. H. drive vehicles

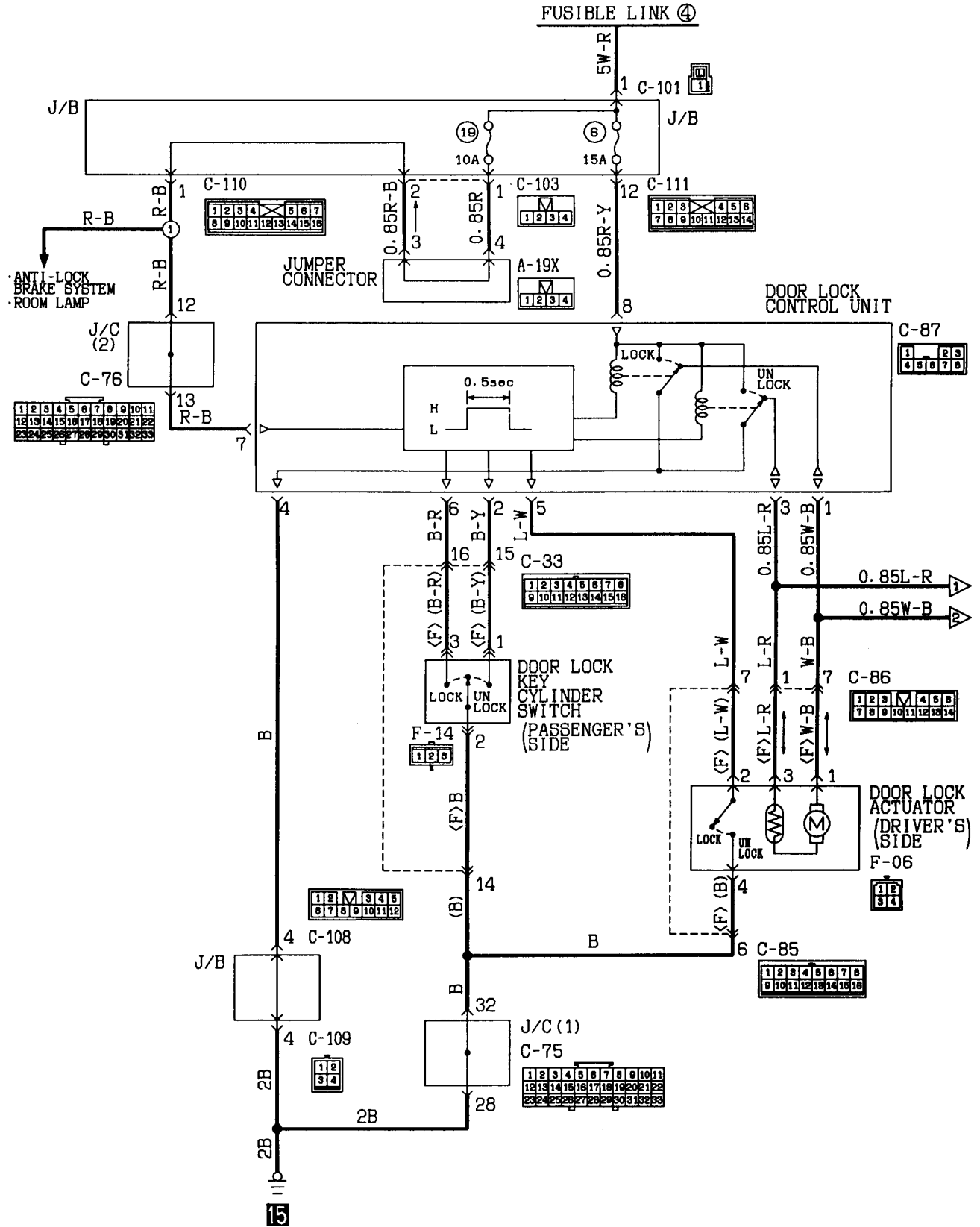

KX35-AC-01106-EC

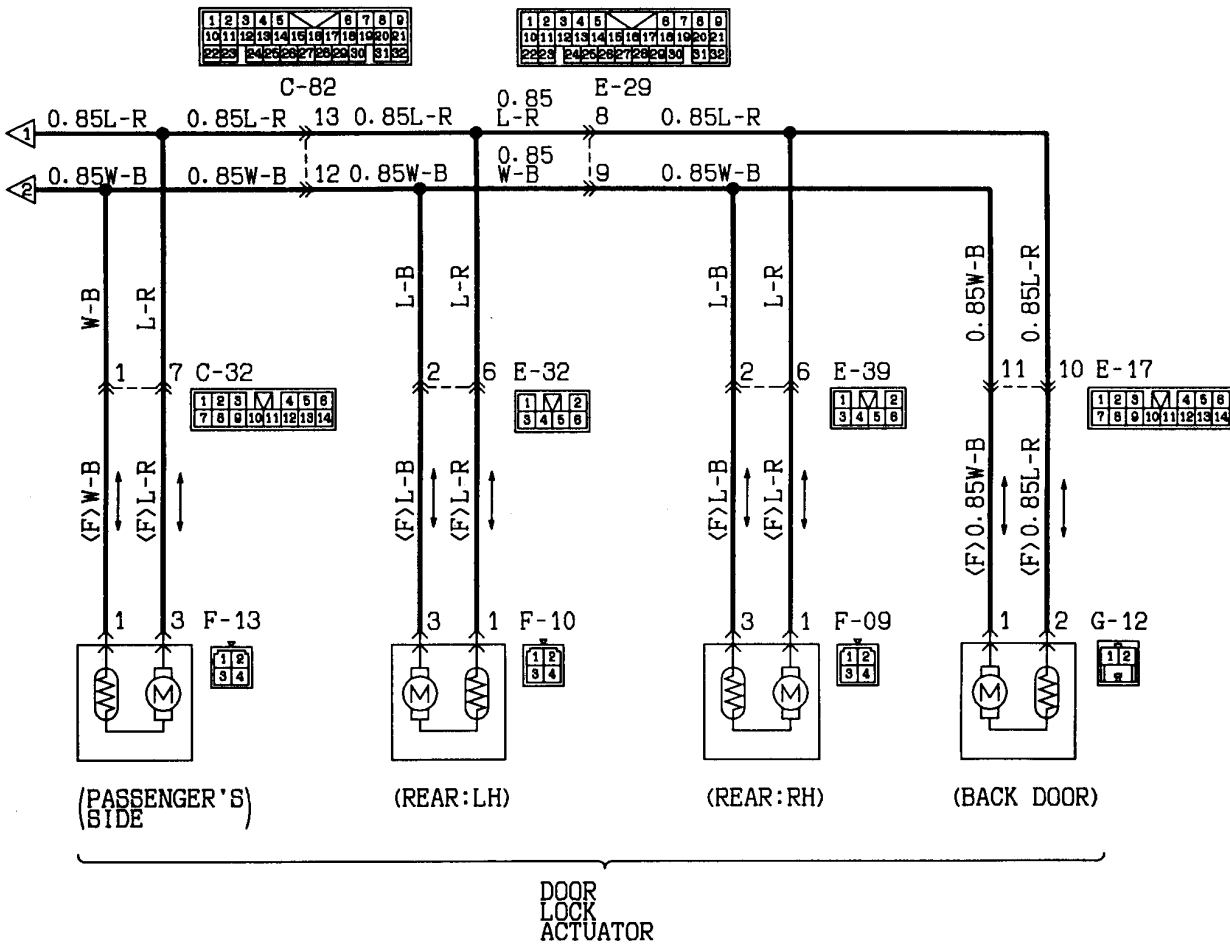

Wire colour code
 B:Black LG:Light green G:Green L:Blue Y:Yellow BB:Bky blue
 BR:Brown O:Orange GR:Gray R:Red P:Pink V:Violet

HEATER

L.H. drive vehicles with rear heater (without dual air conditioner)

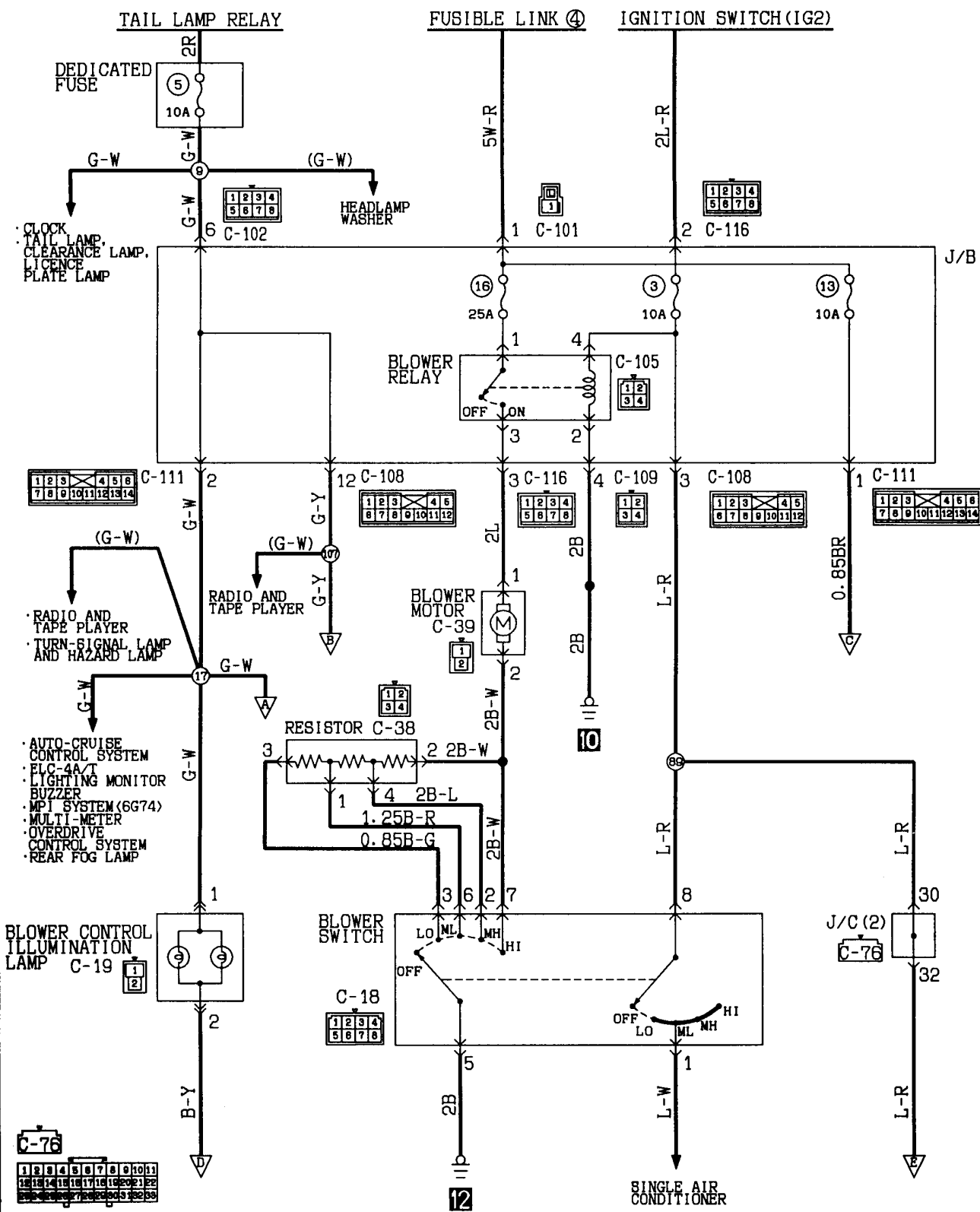

Wire colour code
 B:Black LG:Light green G:Green L:Blue W:White Y:Yellow SB:Sky blue
 BR:Brown O:Orange GR:Gray R:Red P:Pink V:Violet

KX35-AC-01220-EC

PHJE9026-C

ADDED

HEATER (L.H. drive vehicles with rear heater (without dual air conditioner)) (CONTINUED)

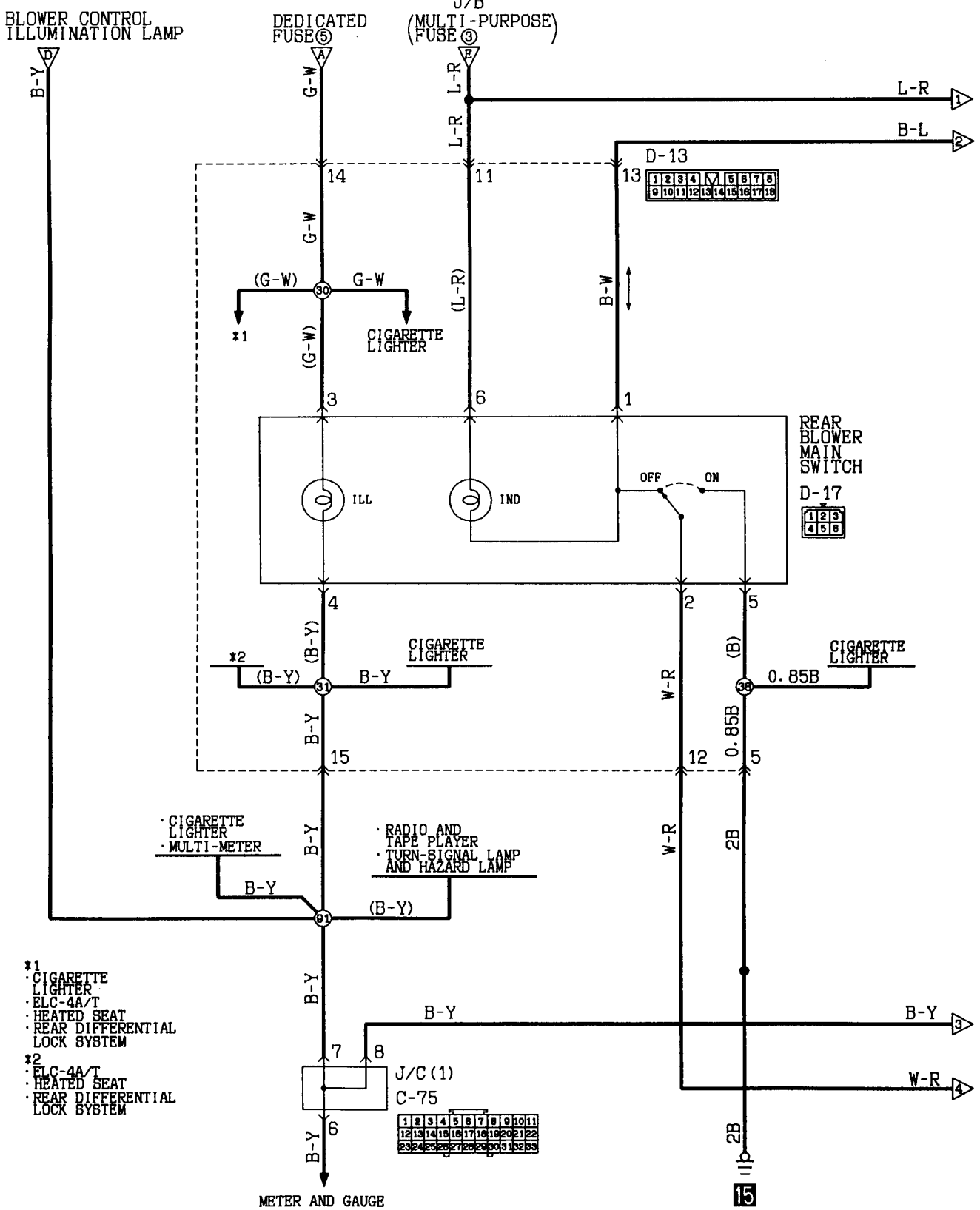

KX35-AC-01226A-EC

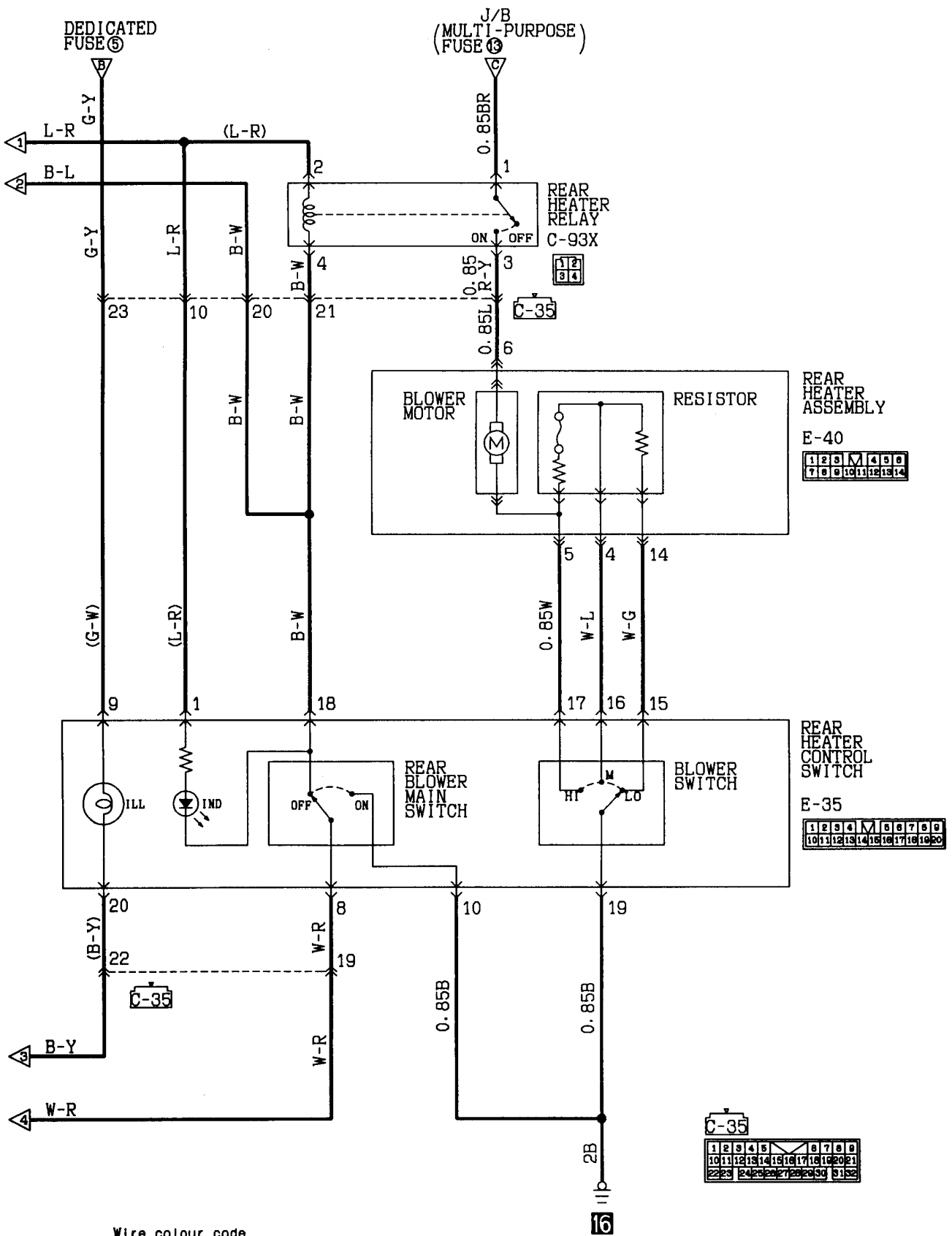

Wire colour code
 B:Black LG:Light green G:Green L:Blue W:White Y:Yellow SB:Sky blue
 BR:Brown O:Orange GR:Gray R:Red P:Pink V:Violet

HEATER

L.H. drive vehicles with rear heater (with dual air conditioner)

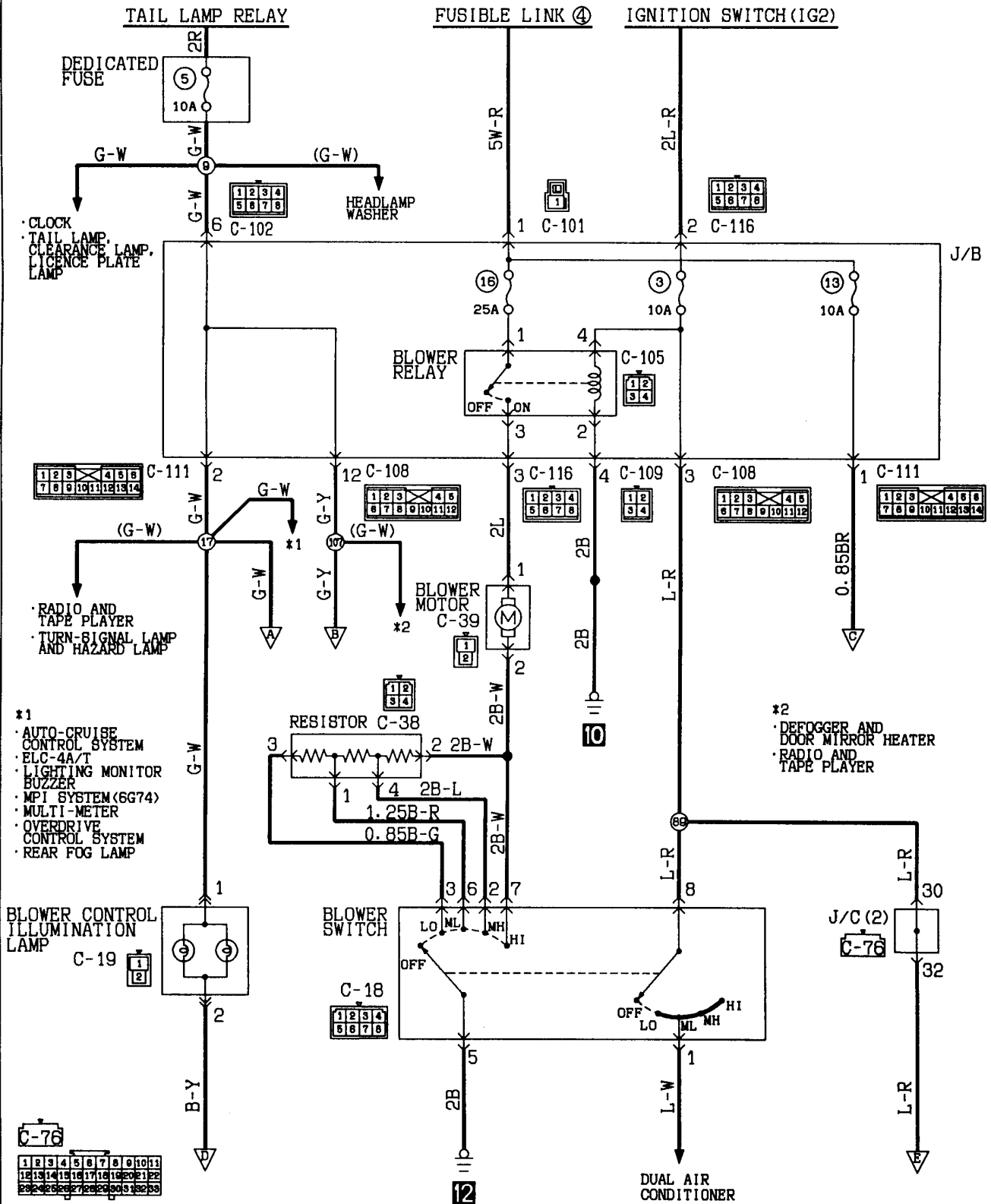

- *1
- AUTO-CRUISE CONTROL SYSTEM
 - ELC-4A/T
 - LIGHTING MONITOR BUZZER
 - MPI SYSTEM (6G74)
 - MULTI-METER
 - OVERDRIVE CONTROL SYSTEM
 - REAR FOG LAMP

- *2
- DEFOGGER AND DOOR MIRROR HEATER
 - RADIO AND TAPE PLAYER

Wire colour code

B:Black LG:Light green G:Green L:Blue W:White Y:Yellow
 BR:Brown O:Orange GR:Gray R:Red P:Pink V:Violet

KX35-AC-01226-EC

PHJE9026-C

ADDED

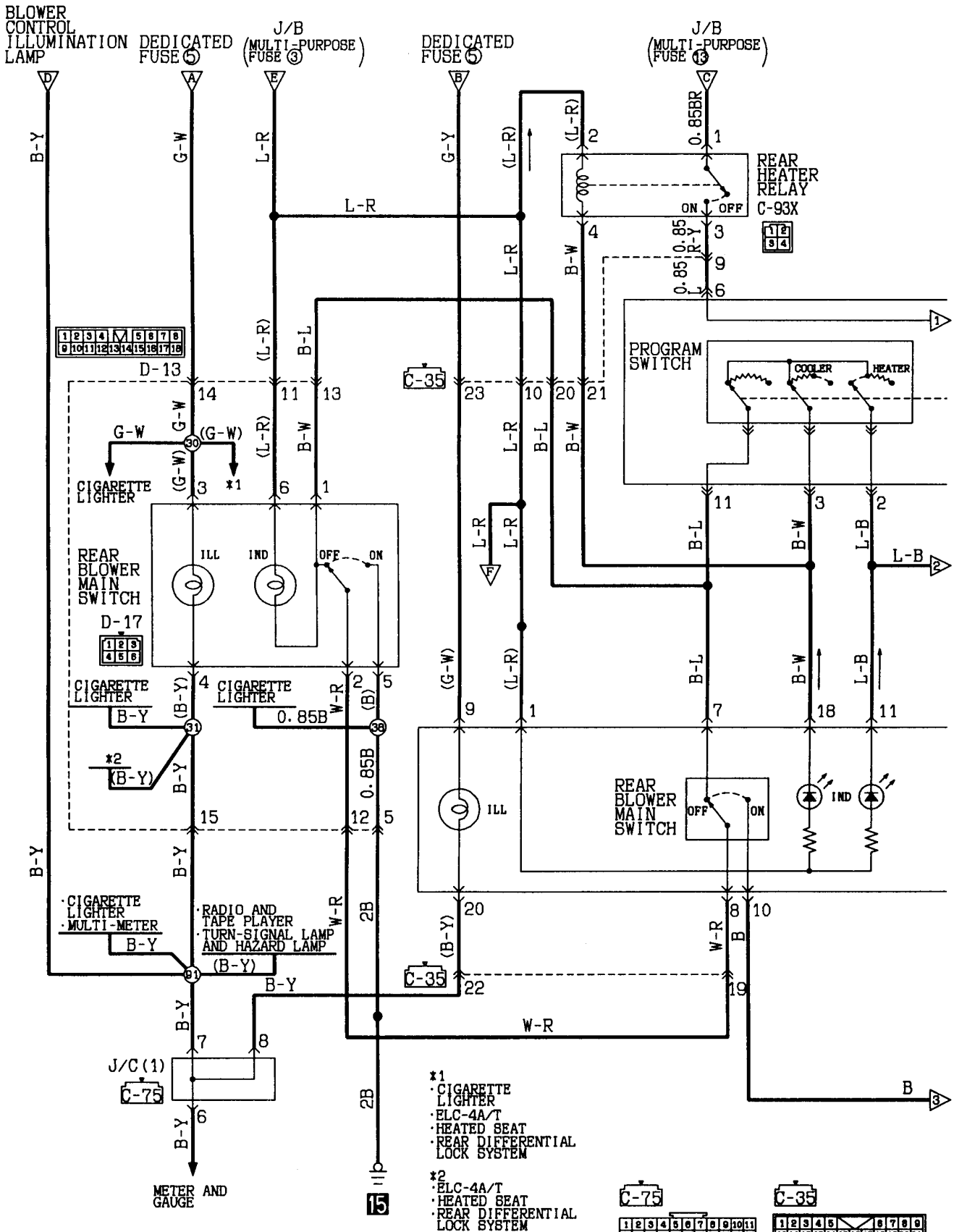

KX35-AC-01226A-EC

HEATER (L.H. drive vehicles with rear heater
(with dual air conditioner)) (CONTINUED)

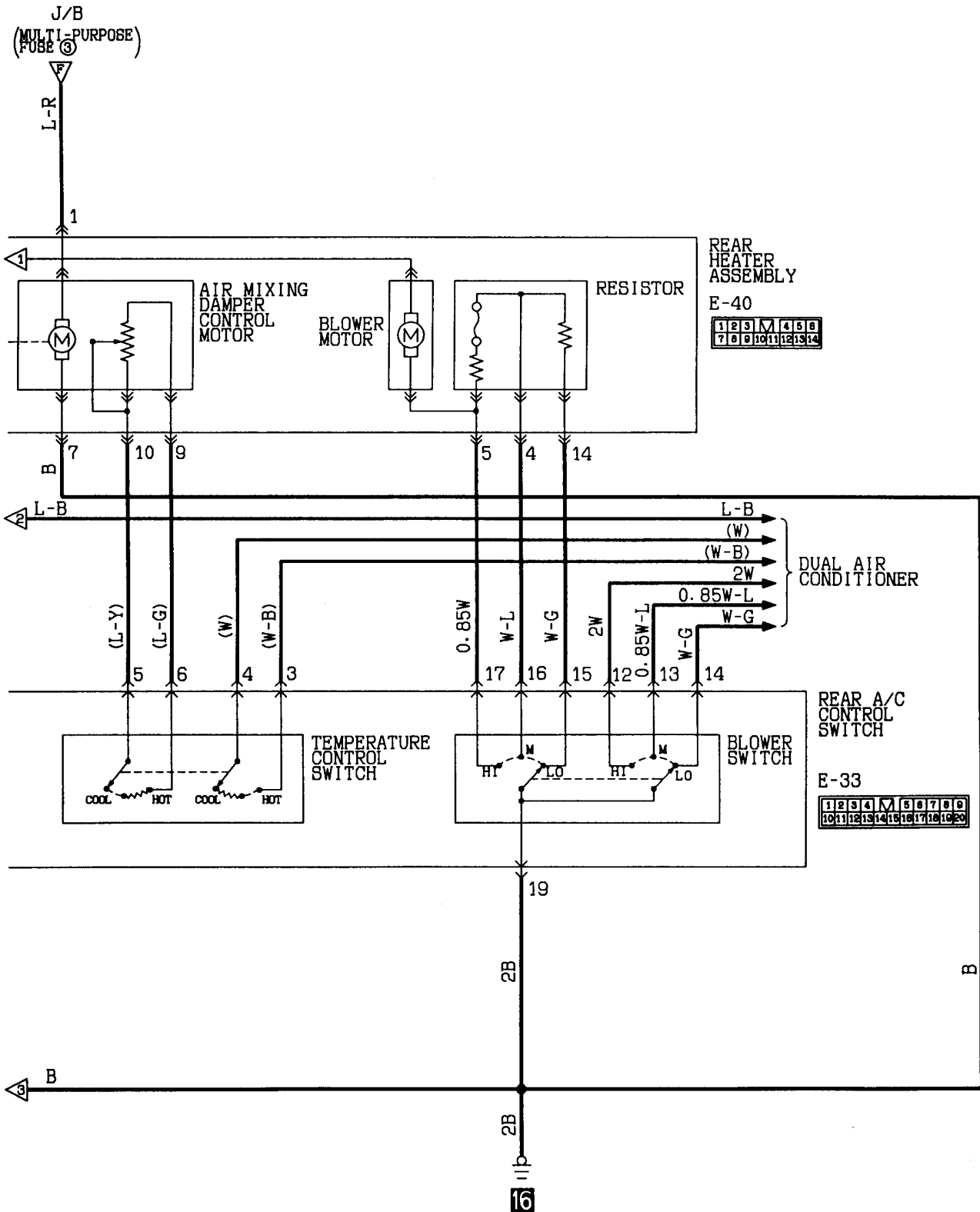

Wire colour code
 B:Black LG:Light green G:Green L:Blue W:White Y:Yellow SB:Sky blue
 BR:Brown O:Orange GR:Gray R:Red P:Pink V:Violet

HEATER

R.H. drive vehicles without rear heater

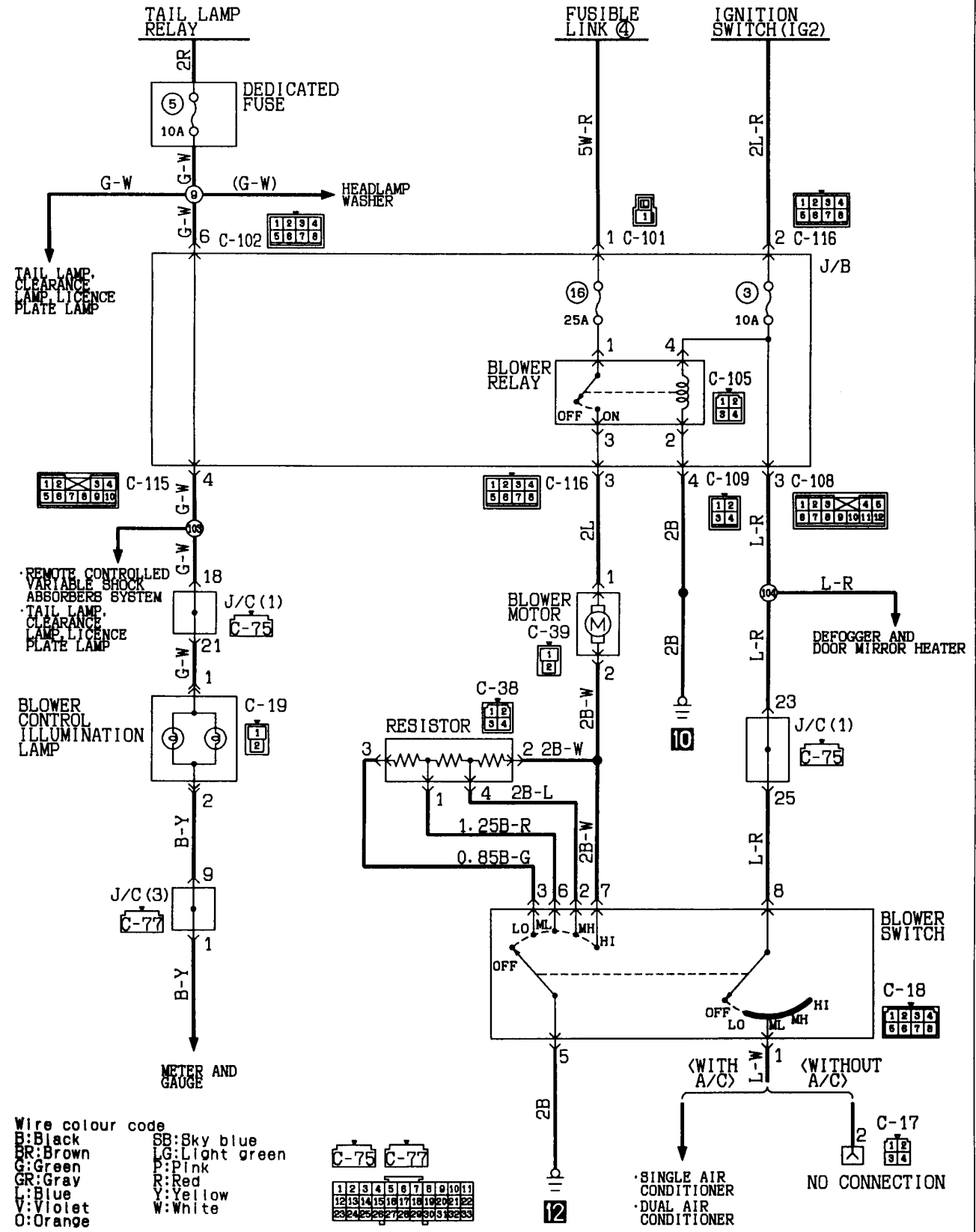

KX35-AC-01214-BC

HEATER

R. H. drive vehicles with rear heater (without dual air conditioner)

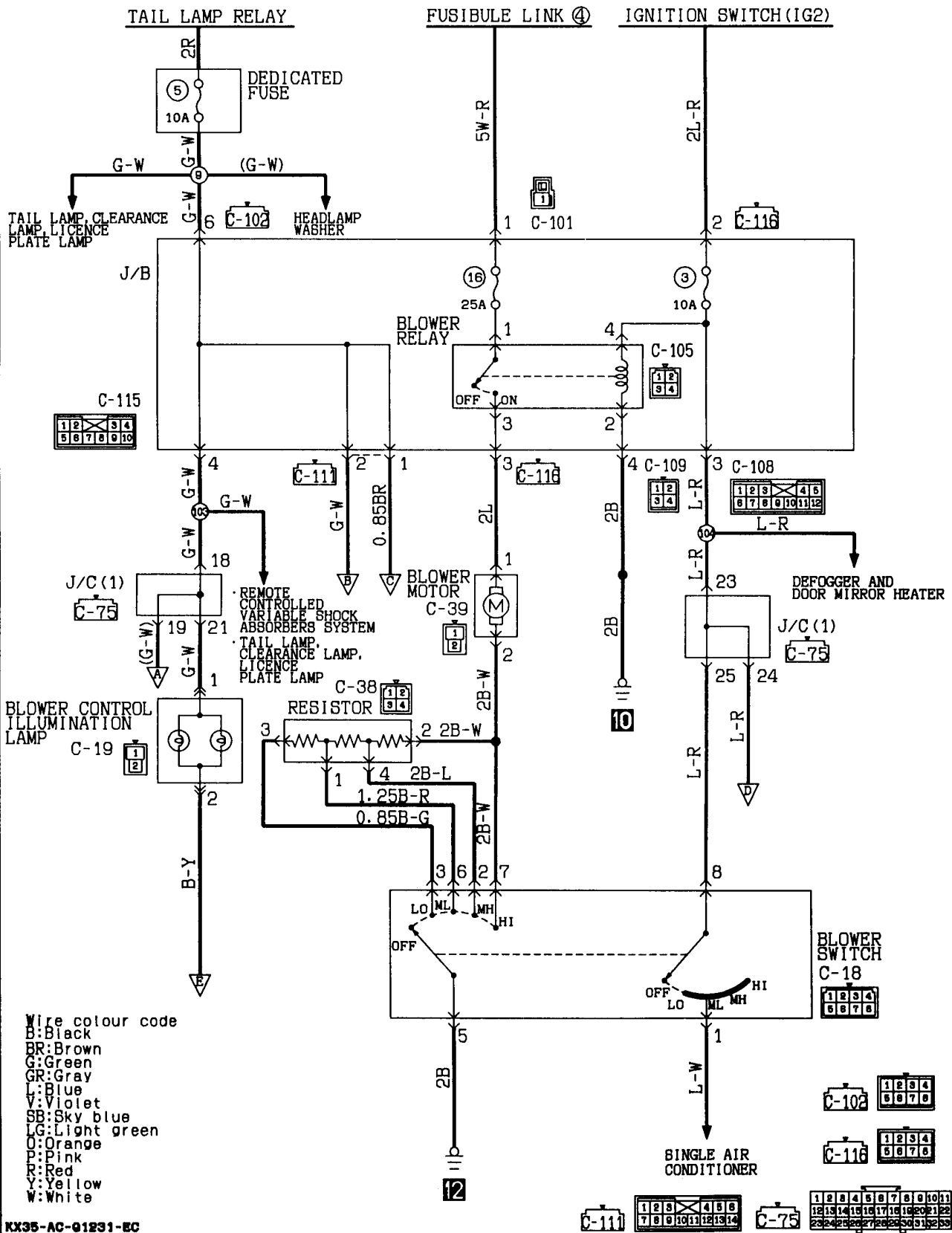

KX35-AC-01231-EC

HEATER (R. H. drive vehicles with rear heater
(without dual air conditioner)) (CONTINUED)

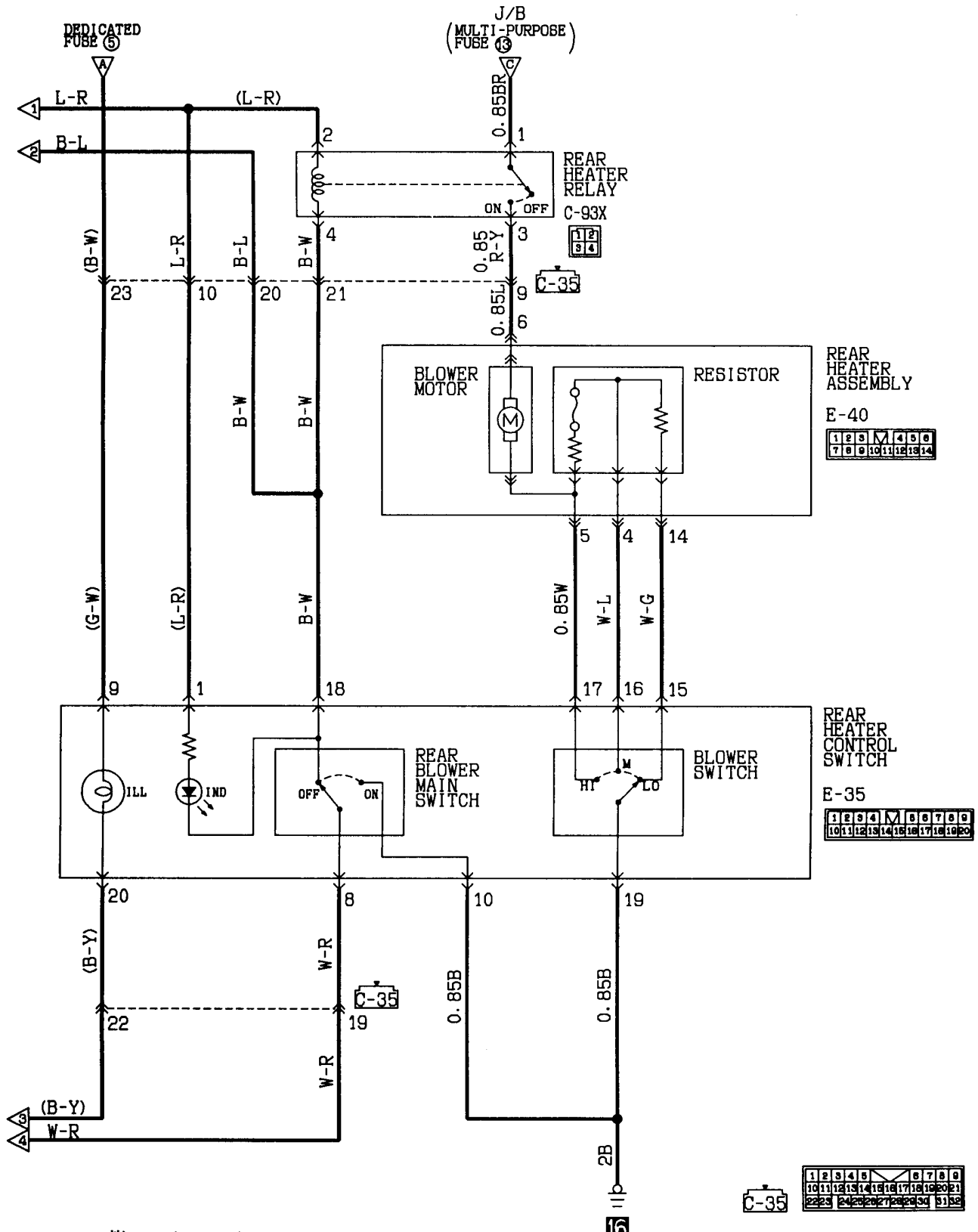

Wire colour code
 B:Black LG:Light green G:Green L:Blue W:White Y:Yellow SB:Sky blue
 BR:Brown O:Orange GR:Gray R:Red P:Pink V:Violet

HEATER

R.H. drive vehicles with rear heater (with dual air conditioner)

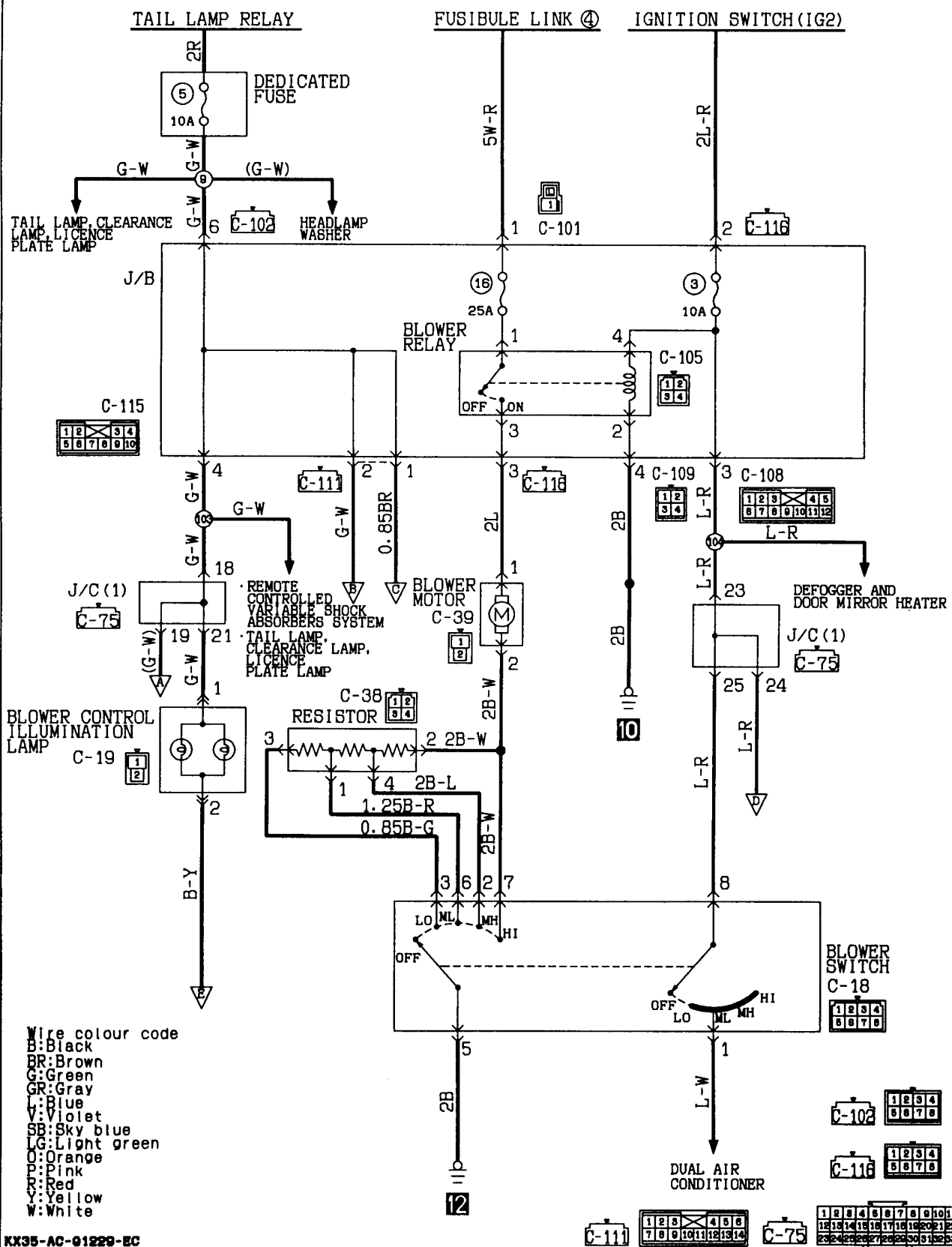

KX35-AC-01229-EC

HEATER (R.H. drive vehicles with rear heater (with dual air conditioner)) (CONTINUED)

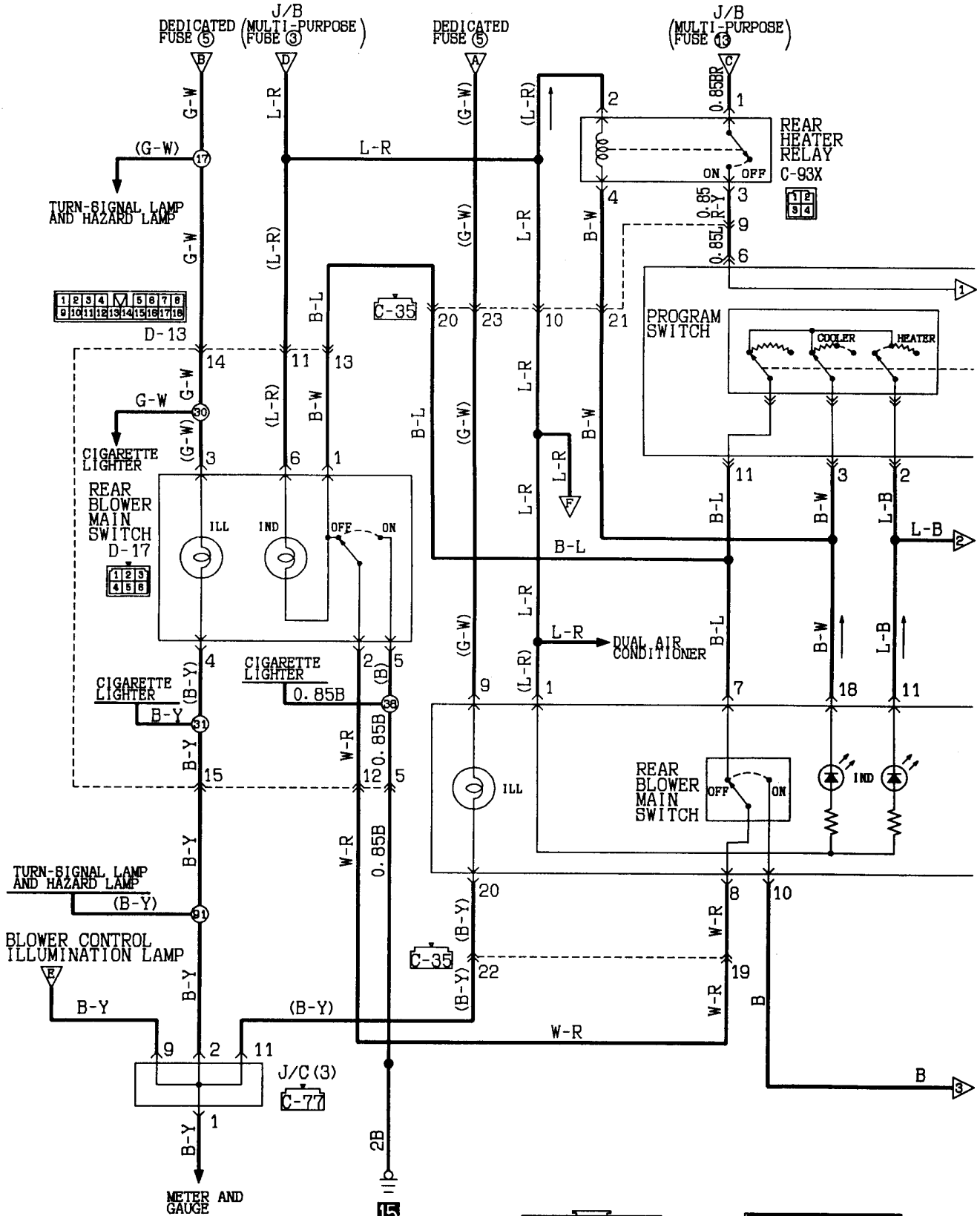

KX35-AC-01229A-EC



HEATER (See P. 4A-176, 177, 180, 183, 184, 187.)**OPERATION****<Front heater operation>**

- When the ignition switch is turned ON, the blower relay is energized. If the blower switch is turned ON (LO, ML, MH, or HI position) in this condition, the blower is activated through the circuit via resistor at a speed corresponding to the blower switch position.

<Rear heater operation>

- When the ignition switch is in the ON position and the rear heater control switch is turned to ON, the rear heater relay turns ON and the blower motor is activated via the resistor at a speed corresponding to the blower switch position (LO, M, HI).

TROUBLESHOOTING HINTS

1. Blower motor is energized at one switch position and not energized at another.
 - Check harness and connectors between defective switch position and resistor (or blower motor in HI position).
2. Blower motor is energized only when switch is positioned in HI.
 - Check resistor.
3. Blower motor speed does not represent the switch position.
 - Check blower switch.

SINGLE AIR CONDITIONER
L.H. drive vehicles <4G64, 6G72 engine>

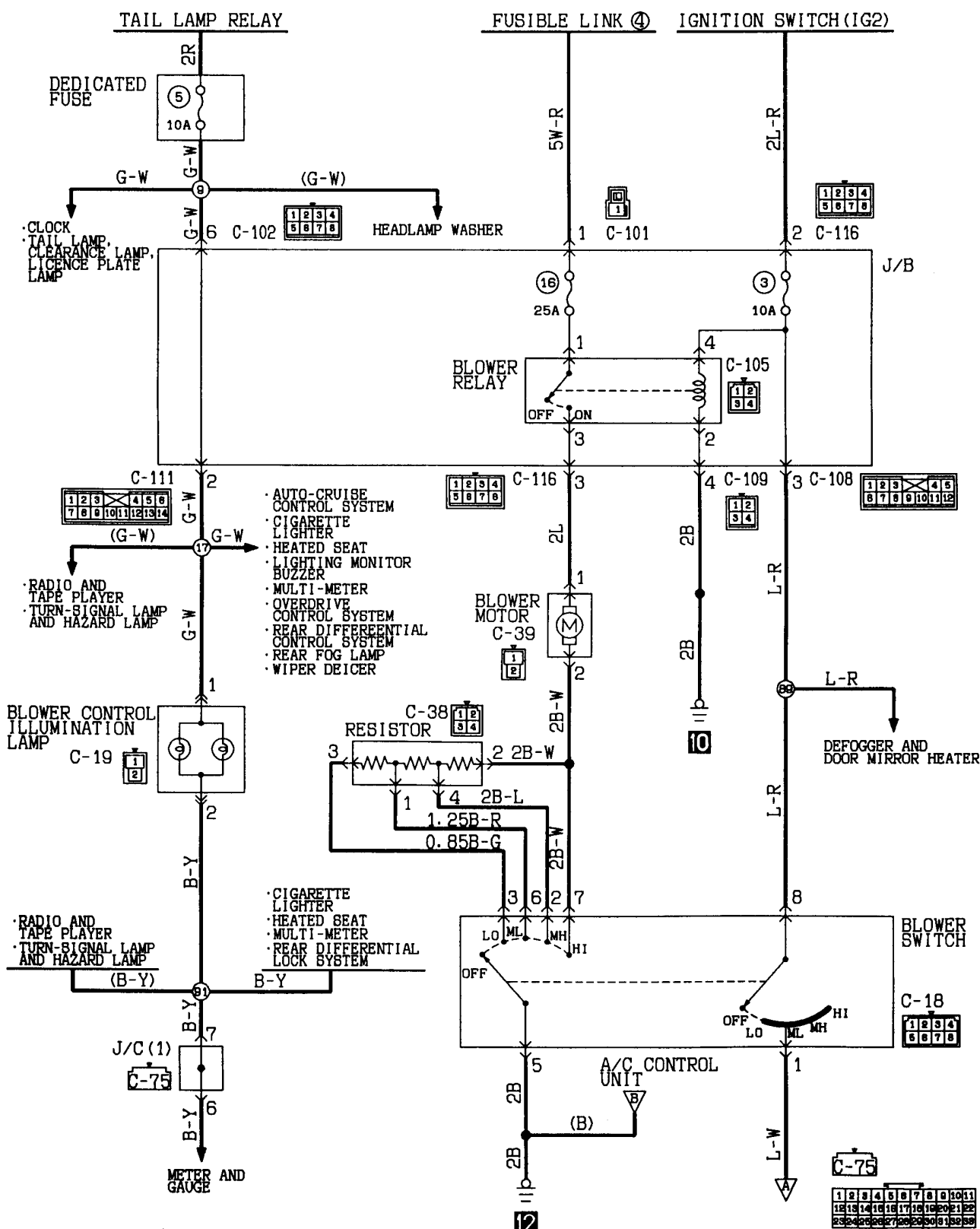

Wire colour code
 B:Black LG:Light green G:Green L:Blue W:White Y:Yellow BB:Sky blue
 BR:Brown O:Orange GR:Gray R:Red P:Pink V:Violet

SINGLE AIR CONDITIONER
 (L. H. drive vehicles (4G64, 6G72 engine)) (CONTINUED)

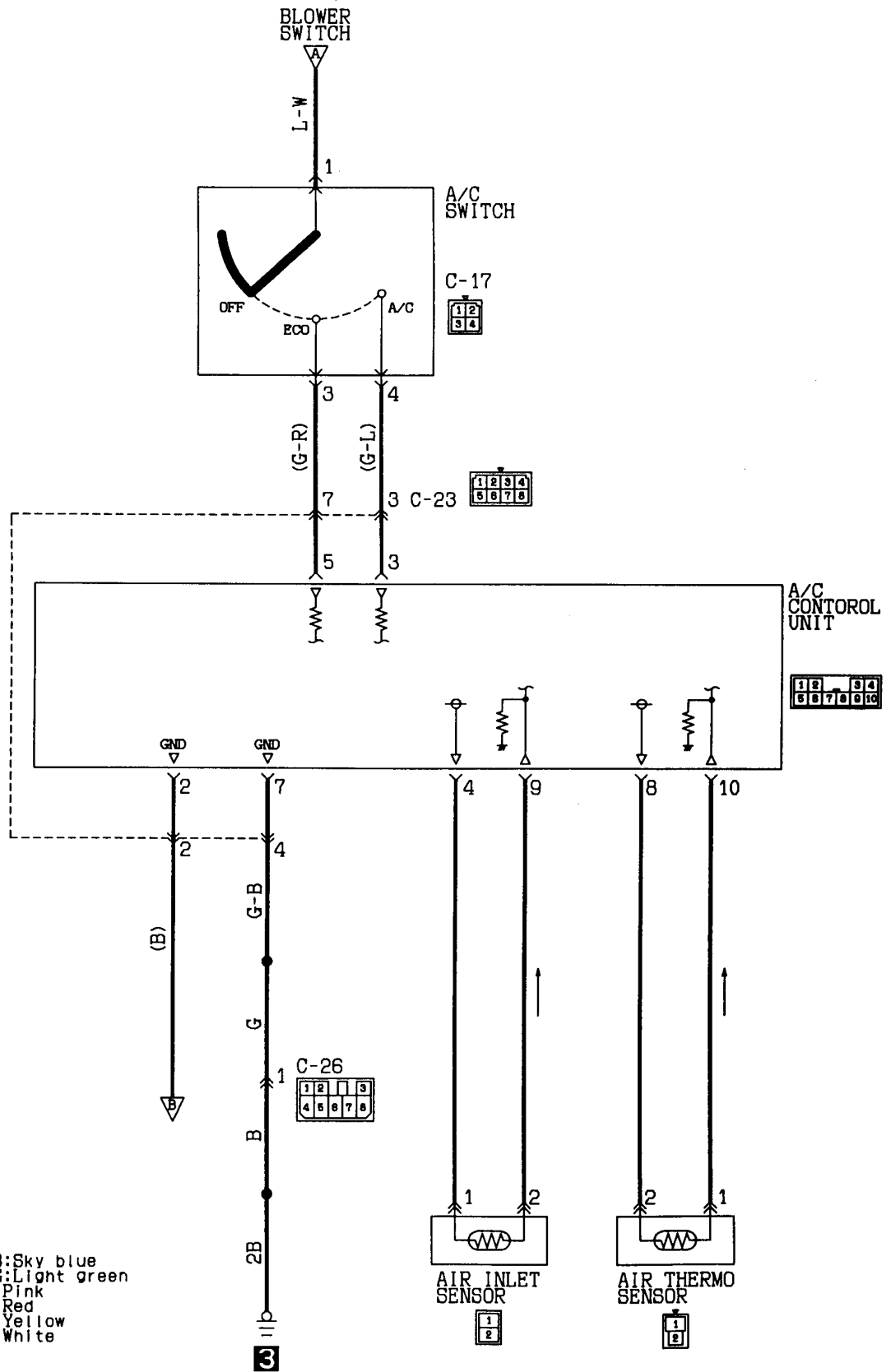

Wire colour code
 B:Black SB:Sky blue
 BR:Brown LG:Light green
 G:Green P:Pink
 GR:Gray R:Red
 L:Blue Y:Yellow
 V:Violet W:White
 O:Orange

KX35-AC-Q1217A-EC

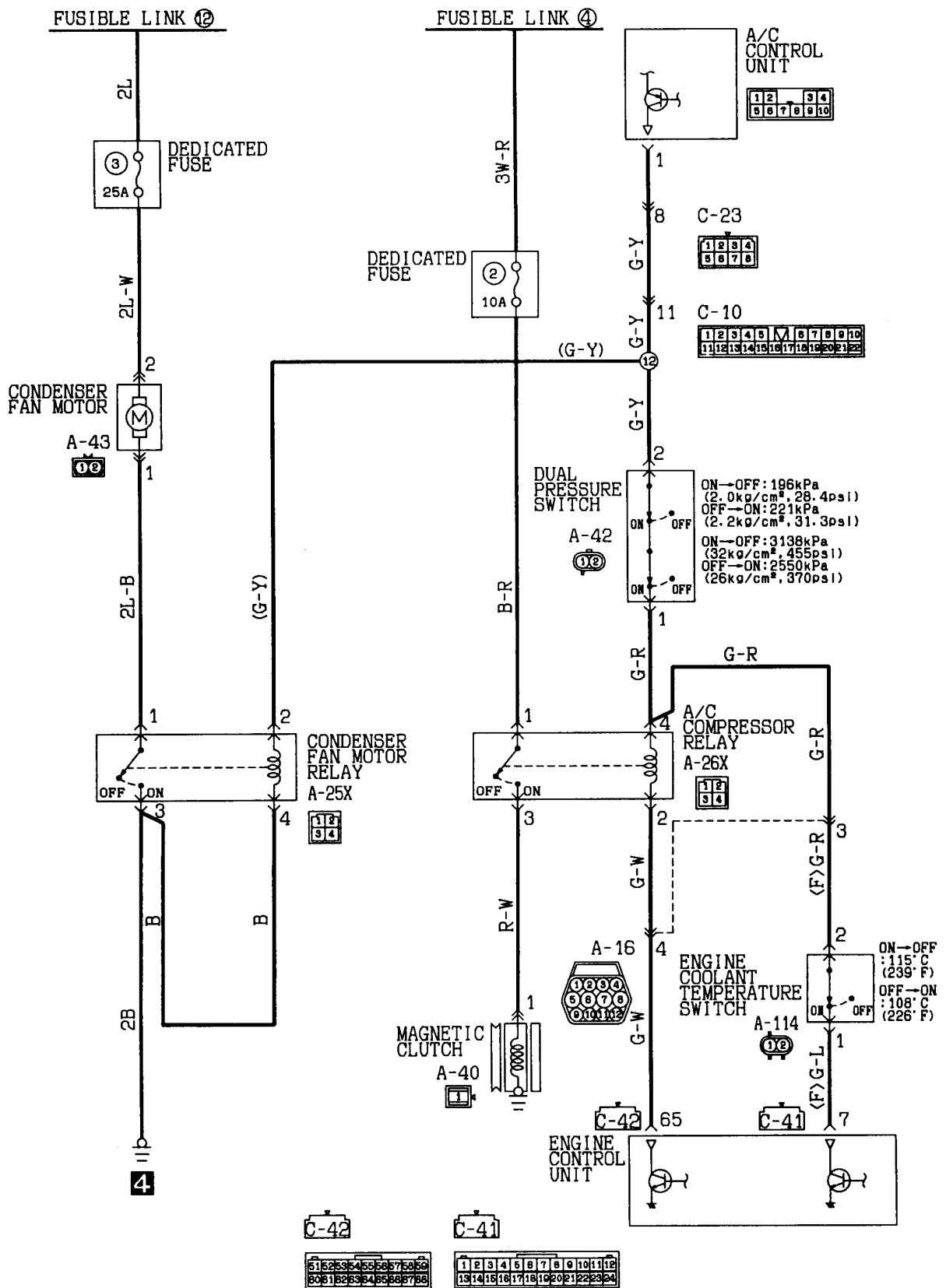

SINGLE AIR CONDITIONER

L.H. drive vehicles (6G74 engine)

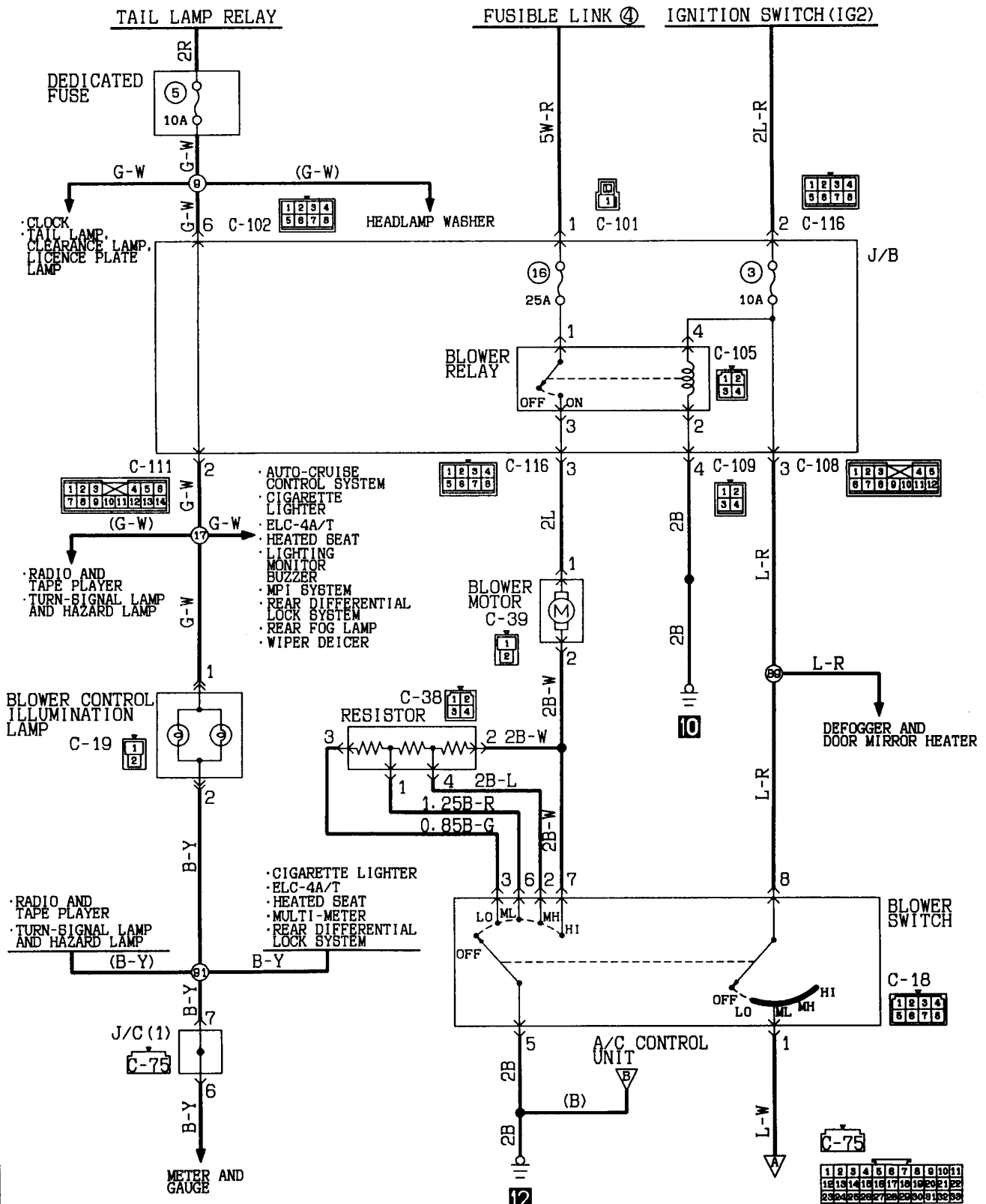

Wire colour code
 B:Black LG:Light green G:Green L:Blue W:White Y:Yellow
 BR:Brown O:Orange GR:Gray R:Red P:Pink V:Violet
 SB:Sky blue

SINGLE AIR CONDITIONER
 (L.H. drive vehicles (6G74 engine)) (CONTINUED)

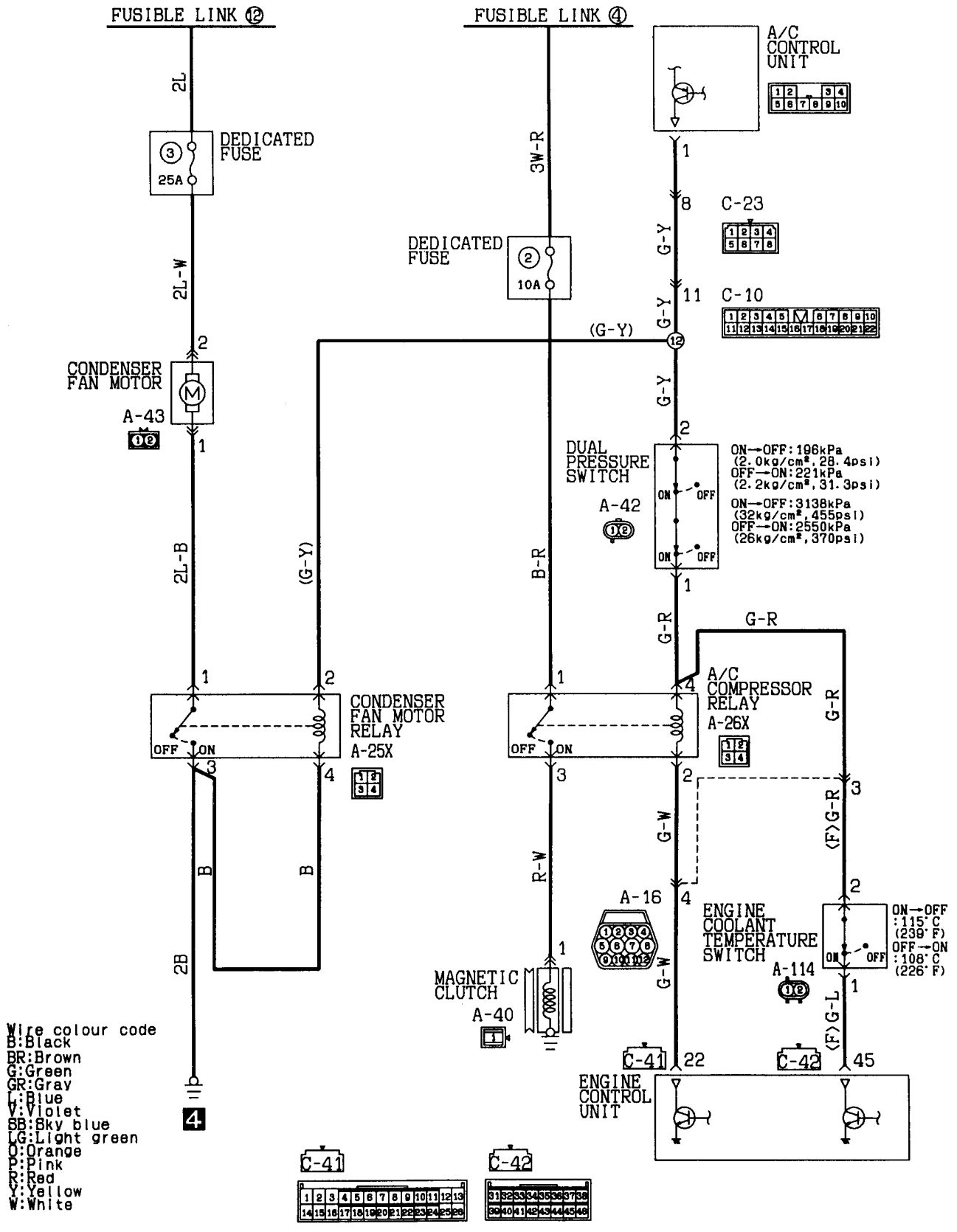

SINGLE AIR CONDITIONER
L.H. drive vehicles <diesel-powered vehicles>

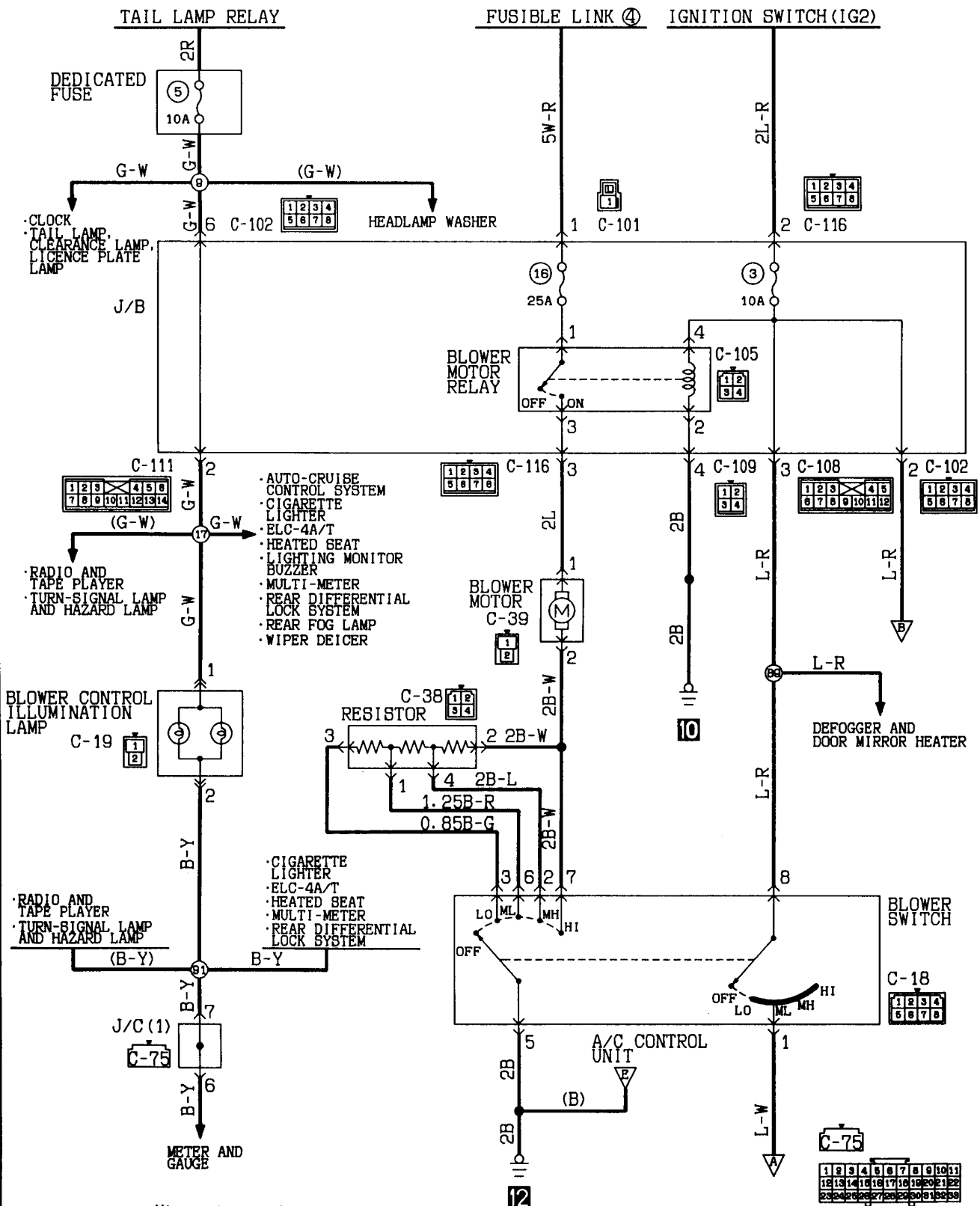

Wire colour code
B:Black LG:Light green G:Green L:Blue W:White Y:Yellow
BR:Brown O:Orange GR:Gray R:Red P:Pink V:Violet

KX35-AC-01210-EC

PHJE9026-C

ADDED

SINGLE AIR CONDITIONER

(L.H. drive vehicles (diesel-powered vehicles)) (CONTINUED)

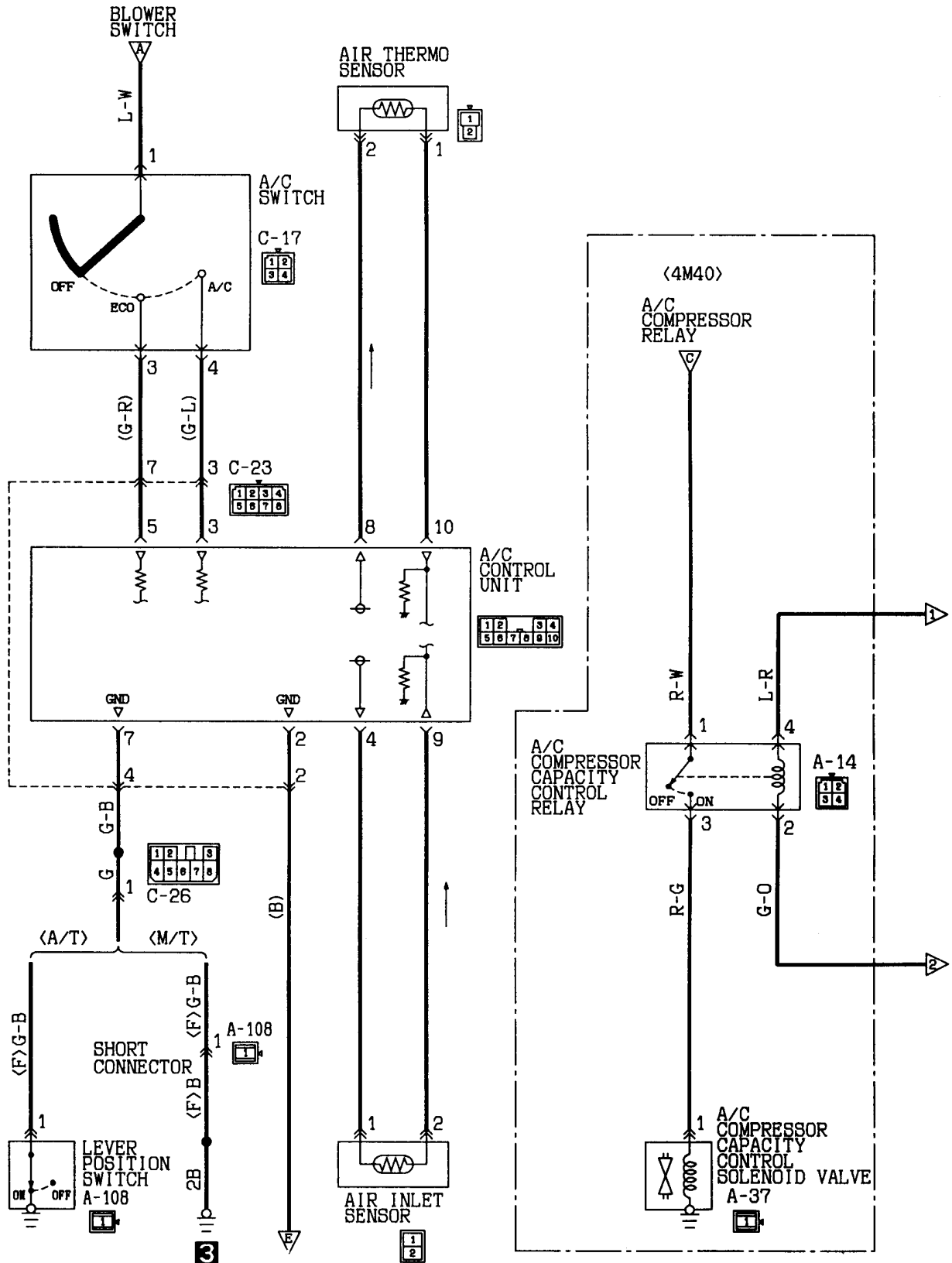

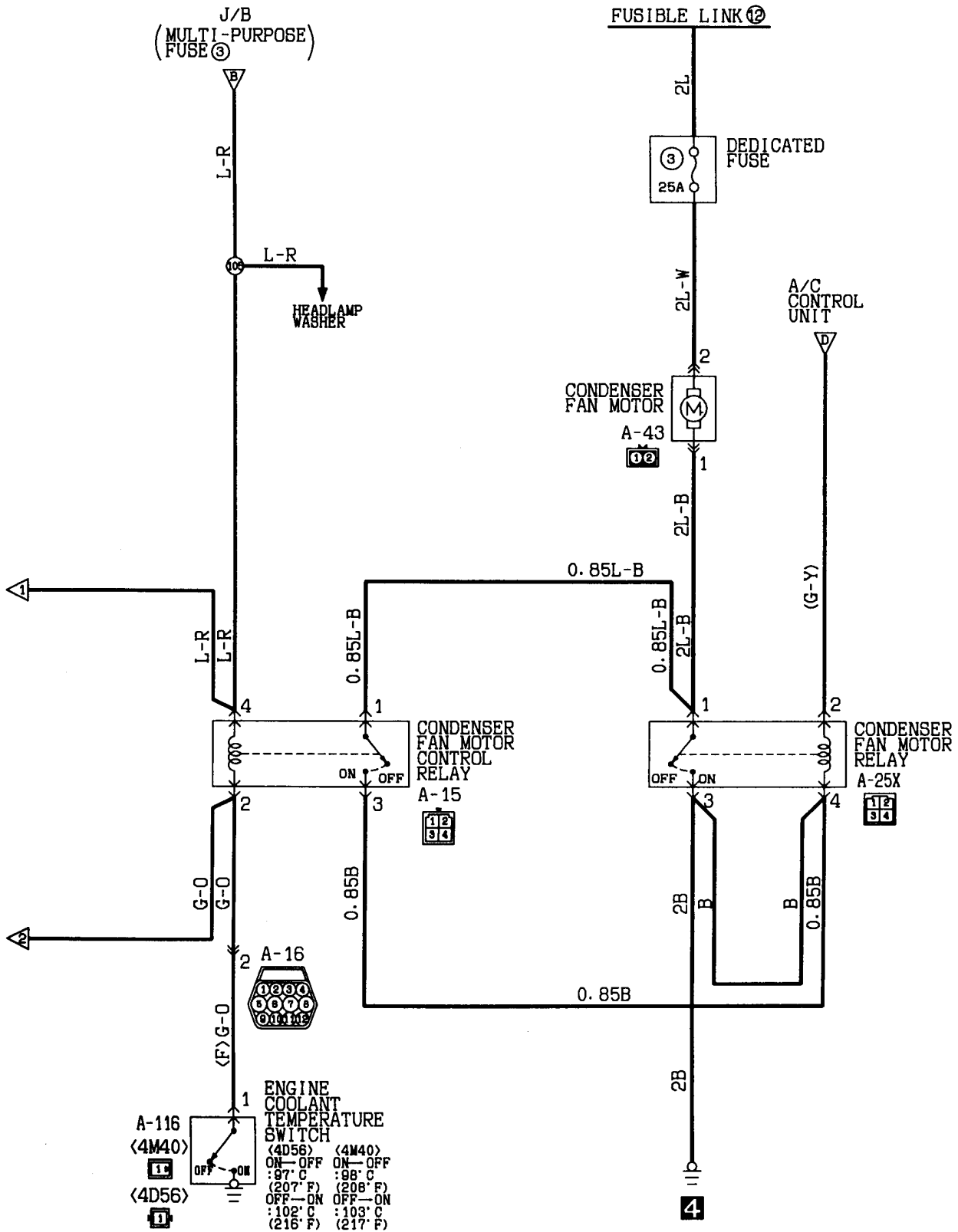

Wire colour code
 B:Black LG:Light green G:Green L:Blue W:White Y:Yellow SB:Sky blue
 BR:Brown O:Orange GR:Gray R:Red P:Pink V:Violet

SINGLE AIR CONDITIONER
R. H. drive vehicles (petrol-powered vehicles)

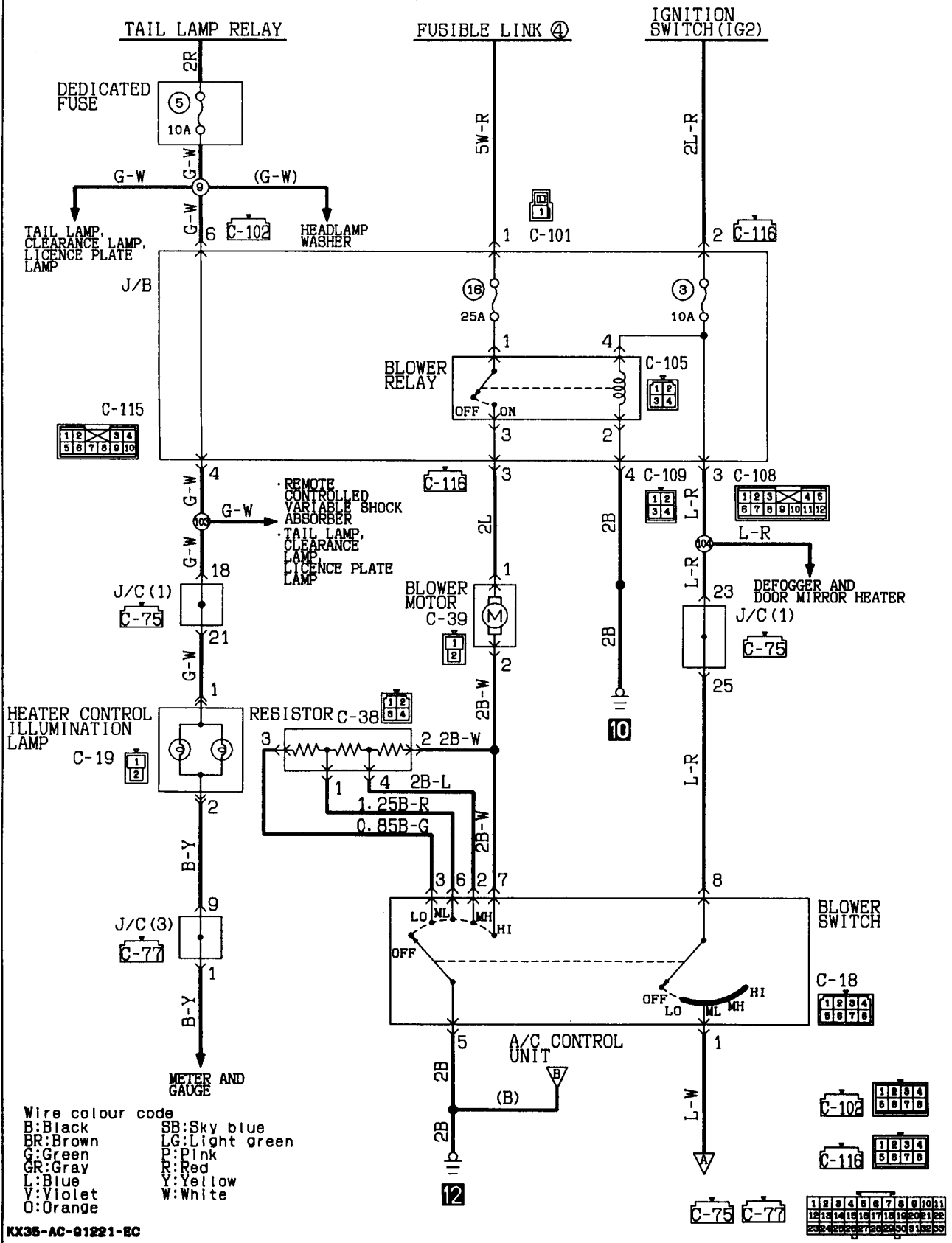

KX35-AC-01221-EC

SINGLE AIR CONDITIONER

(R. H. drive vehicles (petrol-powered vehicles)) (CONTINUED)

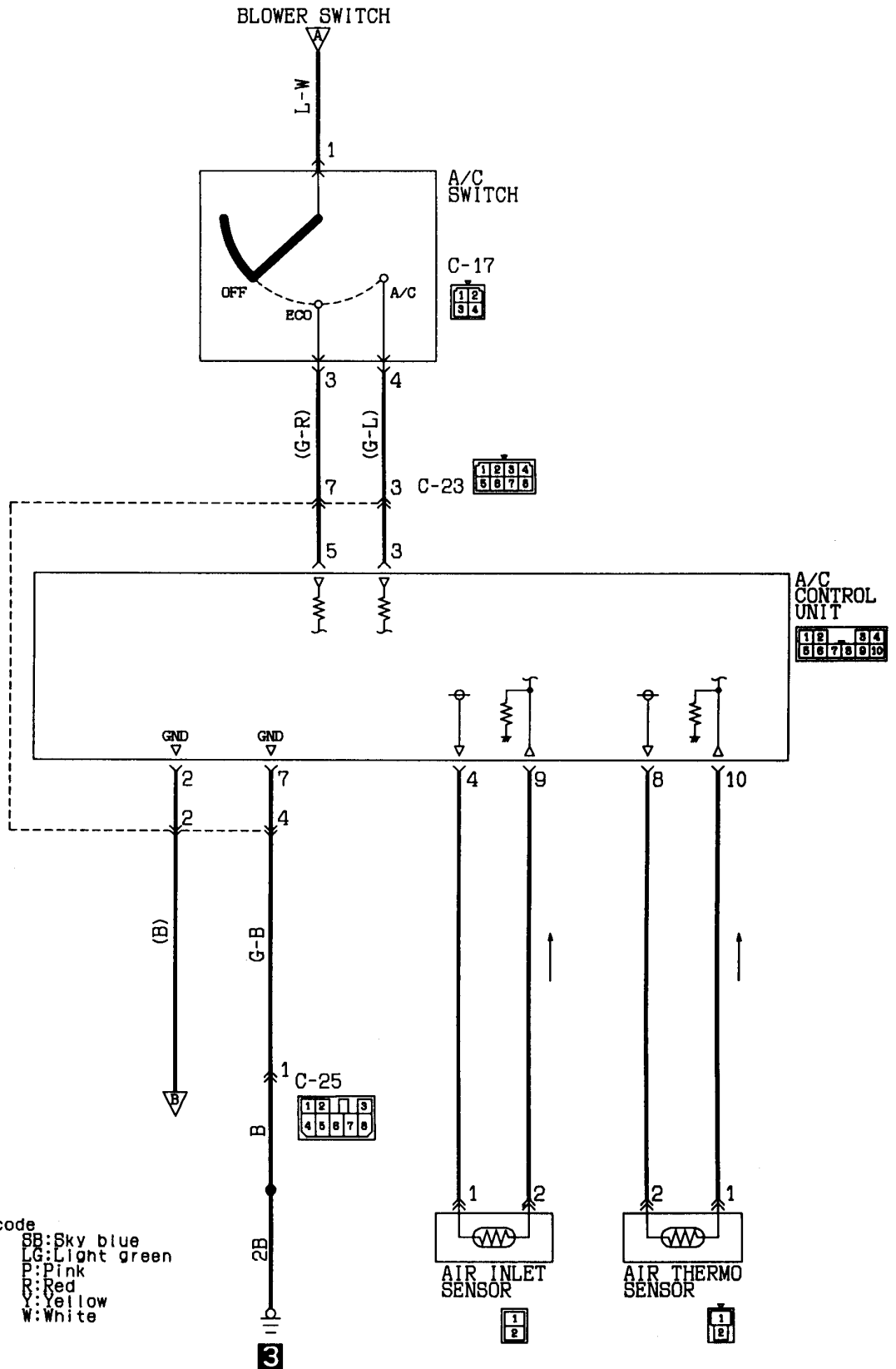

KX35-AC-01221A-EC

SINGLE AIR CONDITIONER
R. H. drive vehicles <diesel-powered vehicles>

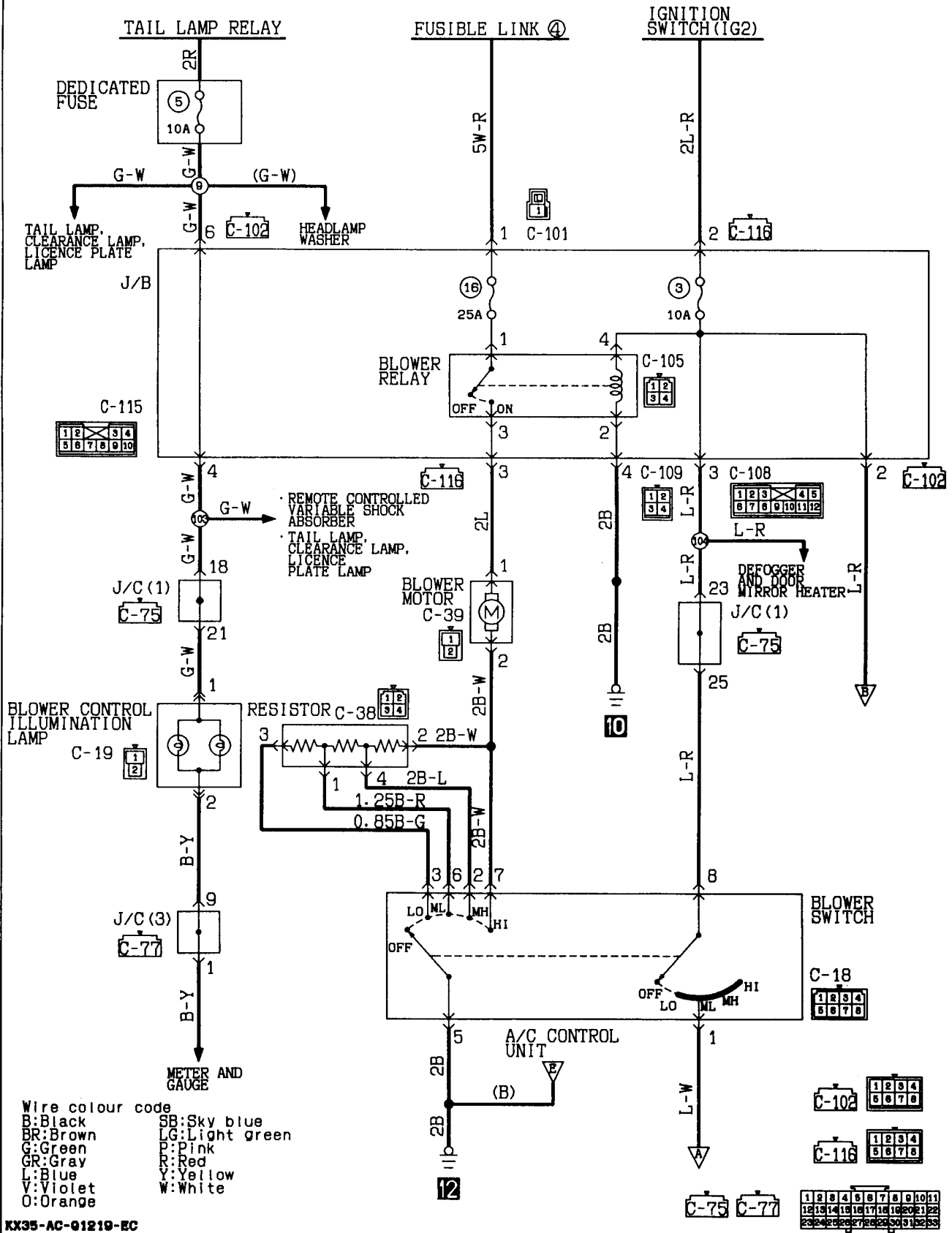

KX35-AC-01219-EC

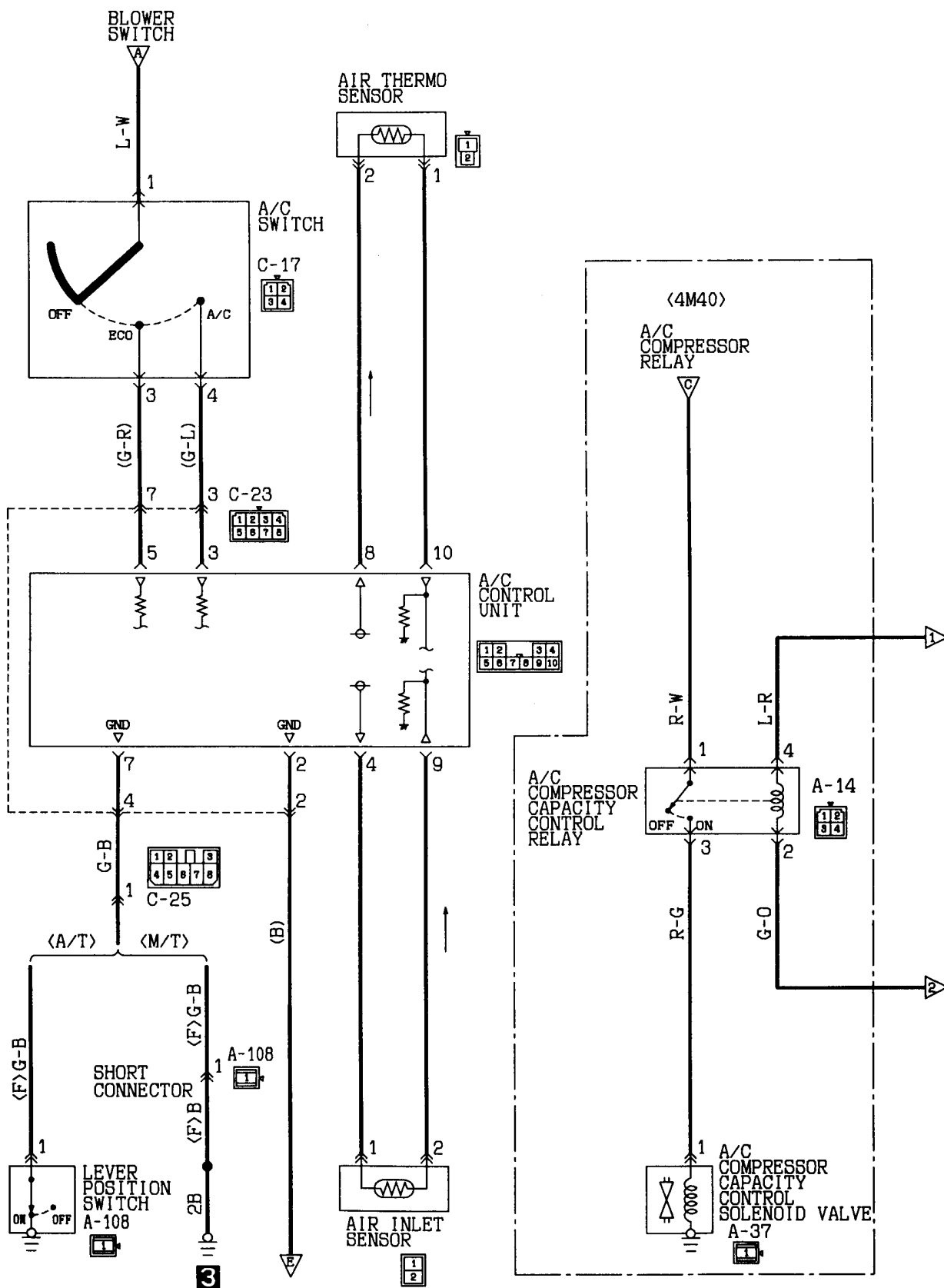

KX35-AC-01219A-EC

SINGLE AIR CONDITIONER

<R. H. drive vehicles (diesel-powered vehicles)> (CONTINUED)

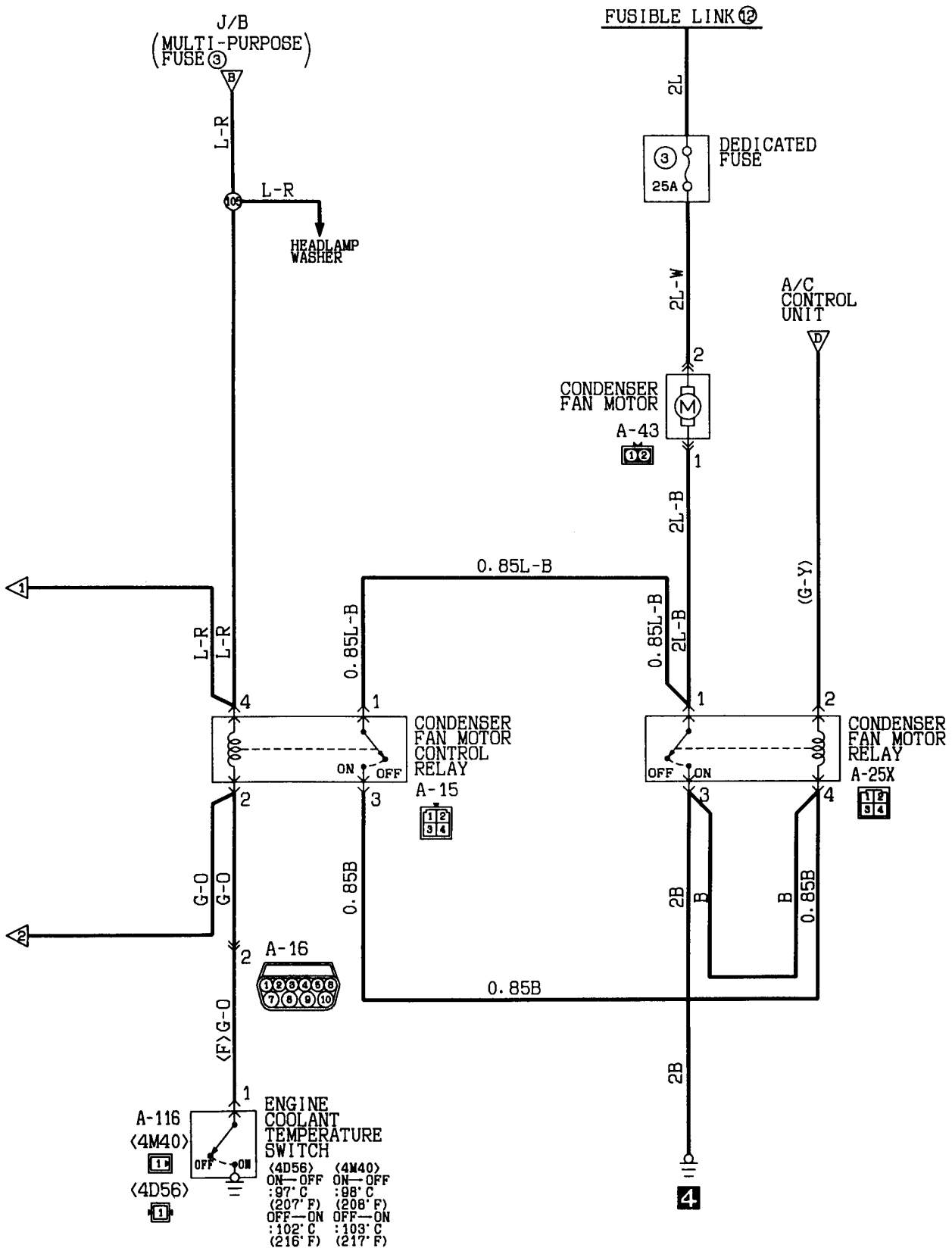

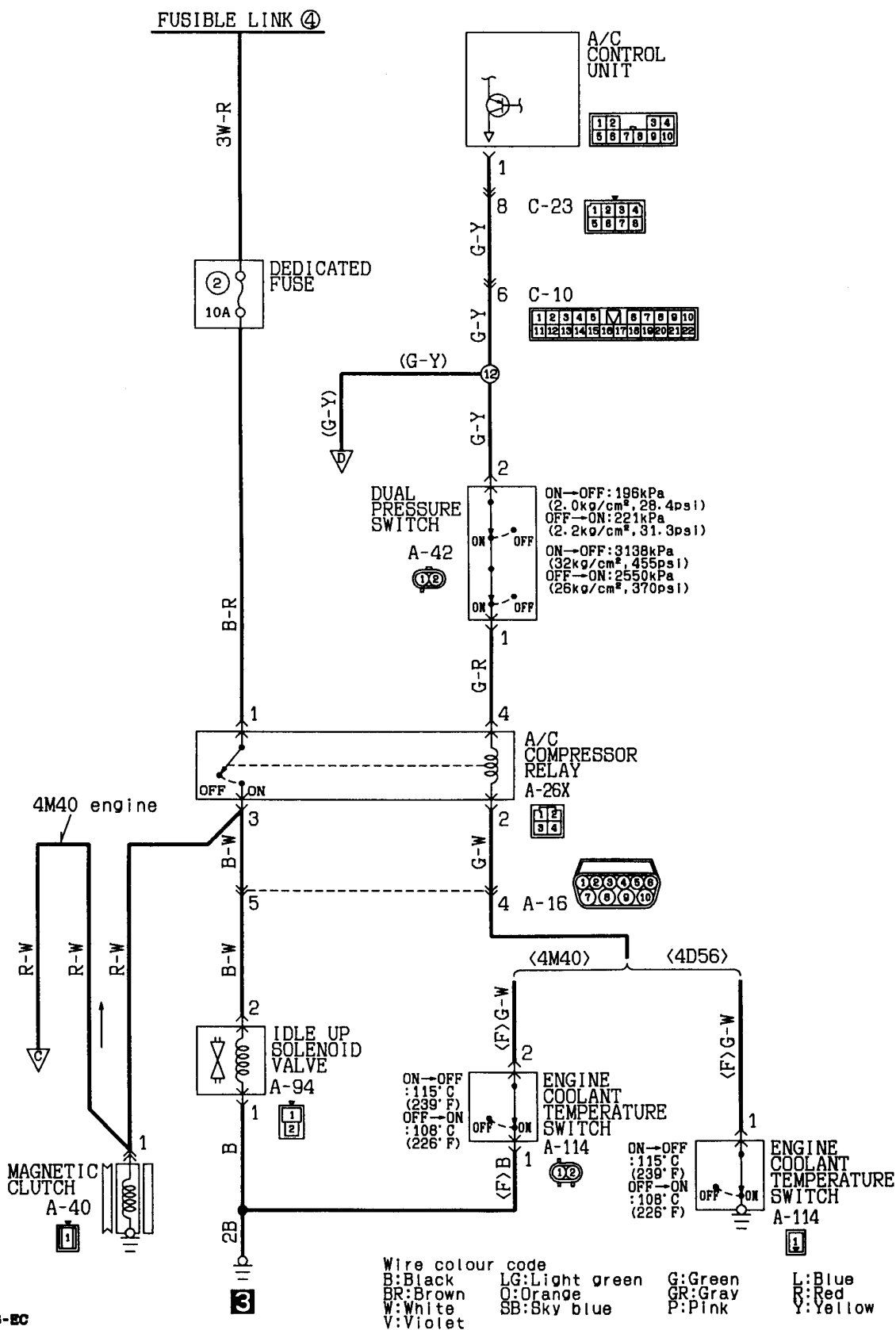

DUAL AIR CONDITIONER
L.H. drive vehicles without rear heater
(petrol-powered vehicles)

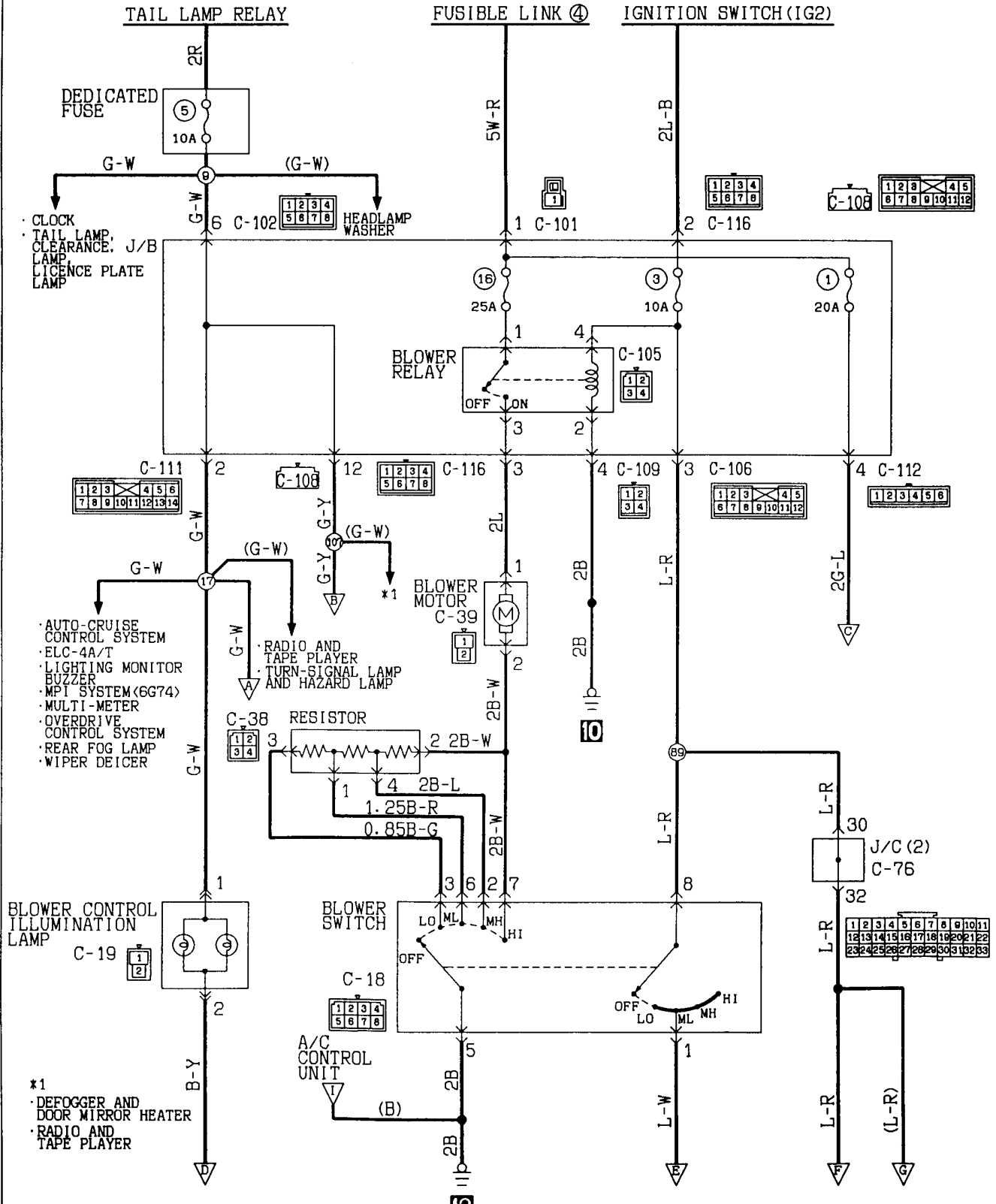

- CLOCK
- TAIL LAMP, CLEARANCE, J/B LAMP, LICENCE PLATE LAMP

- AUTO-CRUISE CONTROL SYSTEM
- ELC-4A/T
- LIGHTING MONITOR BUZZER
- MPI SYSTEM (6G74)
- MULTI-METER
- OVERDRIVE CONTROL SYSTEM
- REAR FOG LAMP
- WIPER DEICER

- *1
- DEFOGGER AND DOOR MIRROR HEATER
- RADIO AND TAPE PLAYER

Wire colour code
 B:Black LG:Light green G:Green L:Blue W:White Y:Yellow
 BR:Brown O:Orange GR:Gray R:Red P:Pink V:Violet
 SB:Sky blue

KX35-AC-01232-EC

PHJE9026-C

ADDED

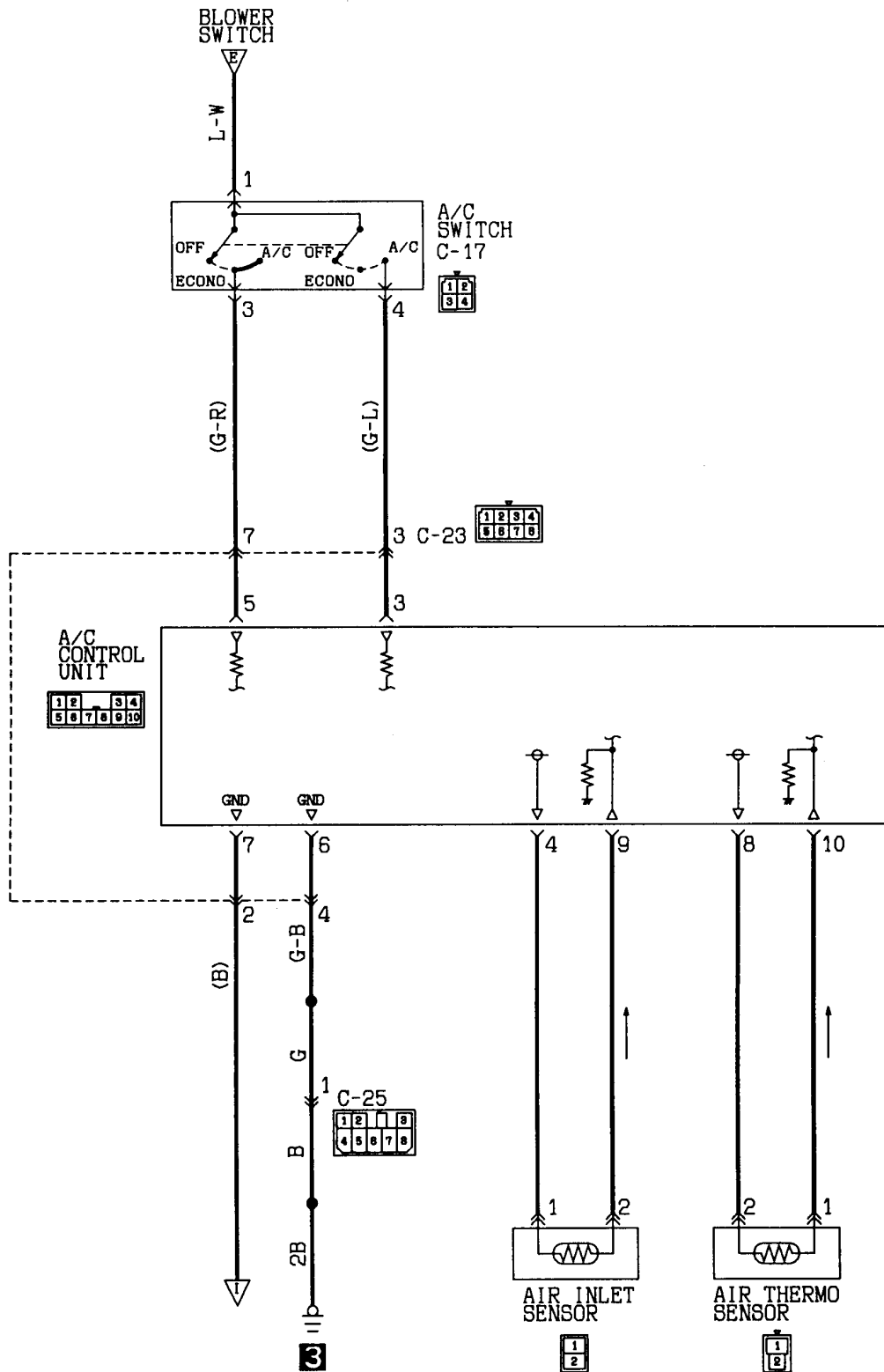

DUAL AIR CONDITIONER
 (L.H. drive vehicles without rear heater
 (petrol-powered vehicles)) (CONTINUED)

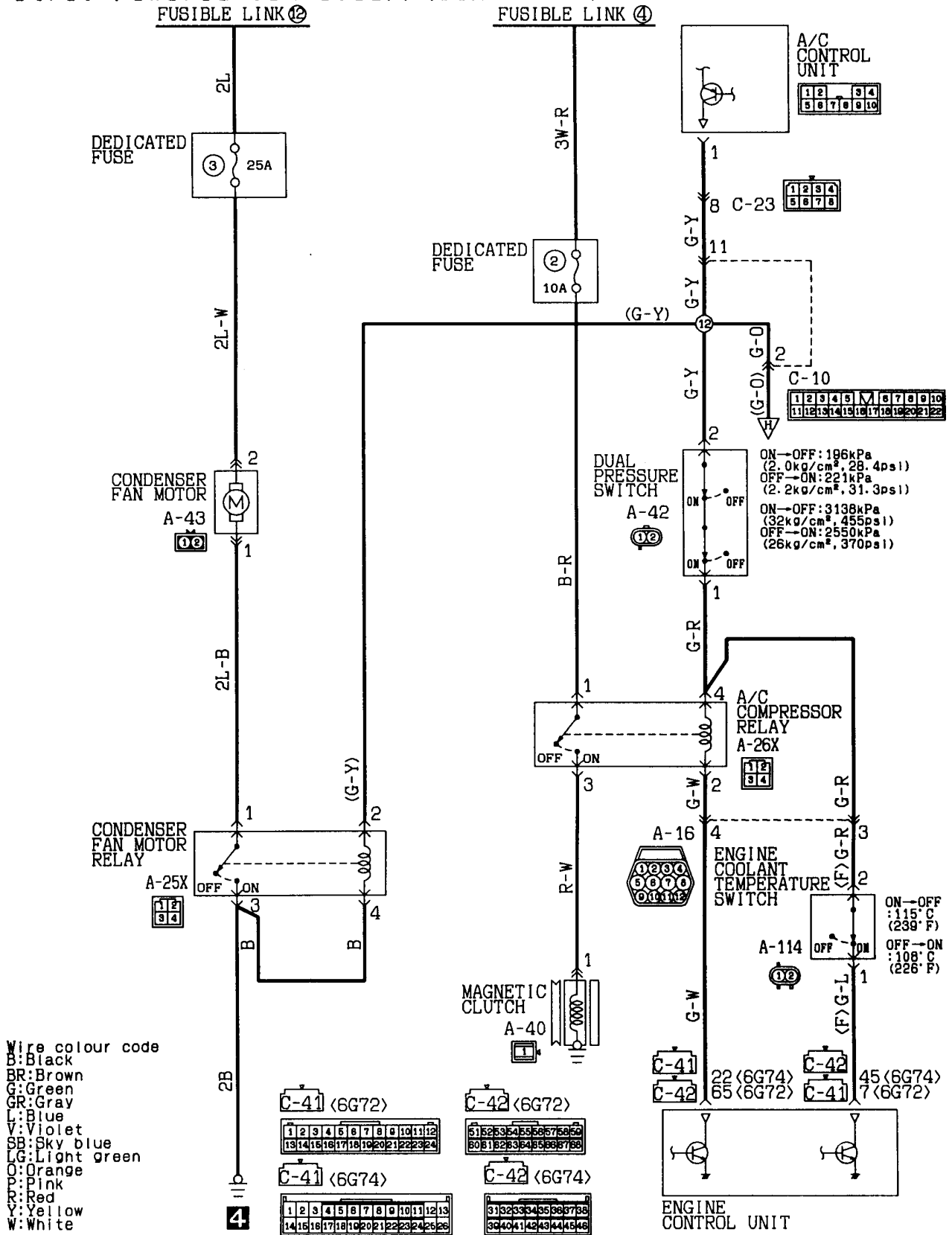

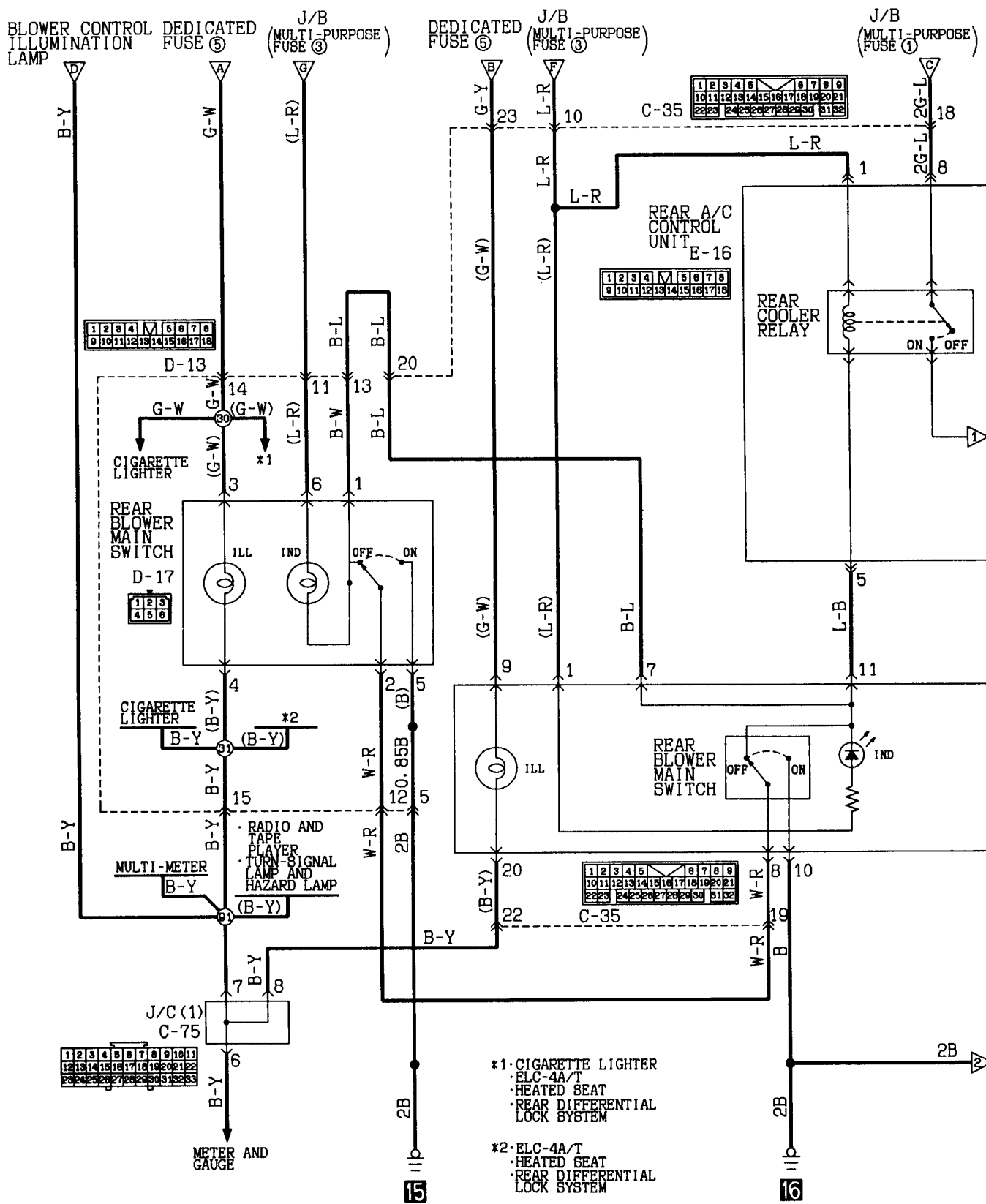

- *1 CIGARETTE LIGHTER
· ELC-4A/T
· HEATED SEAT
· REAR DIFFERENTIAL LOCK SYSTEM
- *2 ELC-4A/T
· HEATED SEAT
· REAR DIFFERENTIAL LOCK SYSTEM

KX35-AC-01232B-EC

DUAL AIR CONDITIONER
 (L.H. drive vehicles without rear heater
 (petrol-powered vehicles)) (CONTINUED)

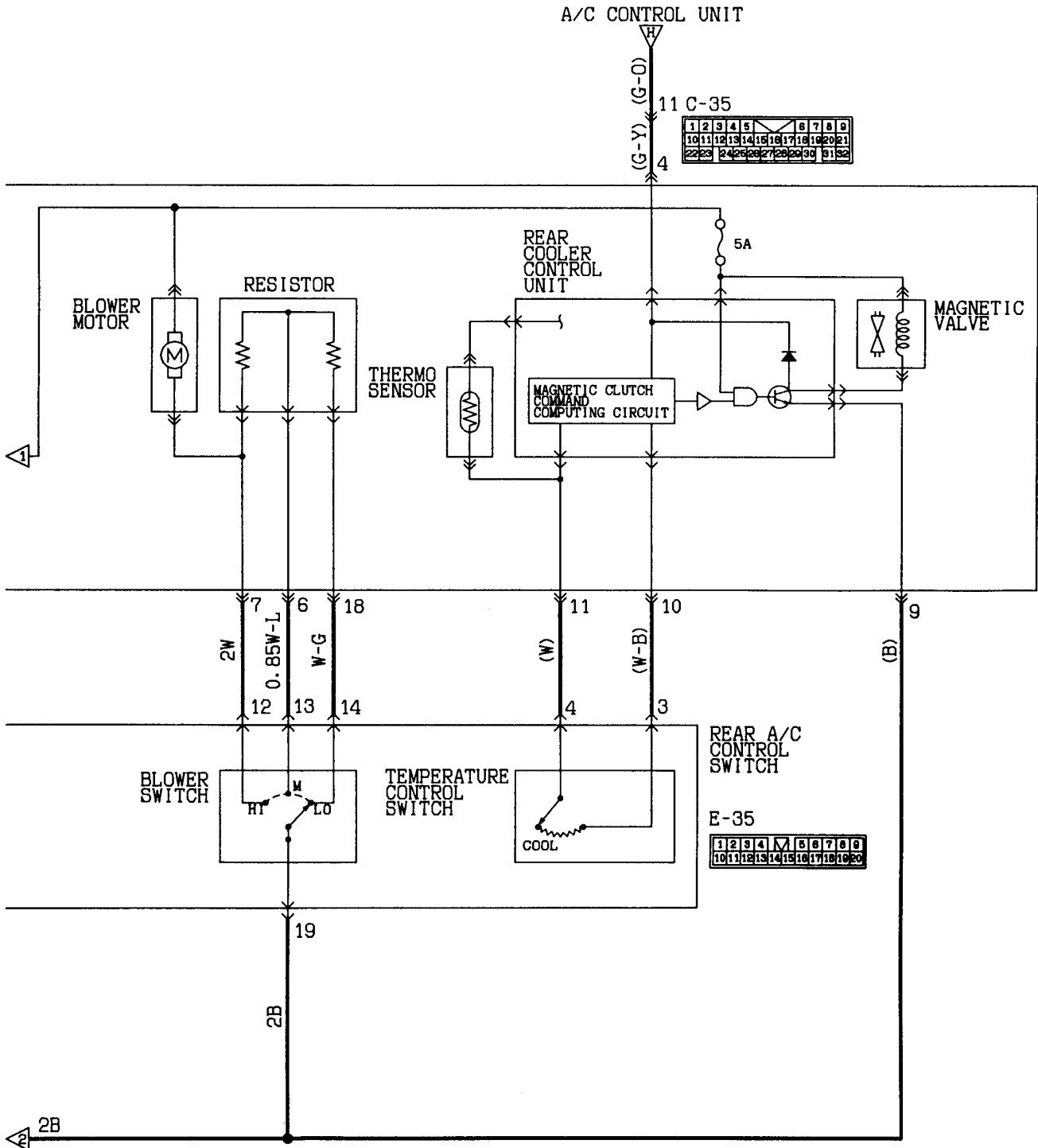

Wire colour code
 B:Black LG:Light green G:Green L:Blue W:White Y:Yellow SB:Sky blue
 BR:Brown O:Orange GR:Gray R:Red P:Pink V:Violet

DUAL AIR CONDITIONER

<L.H. drive vehicles without rear heater
(diesel-powered vehicles)> (CONTINUED)

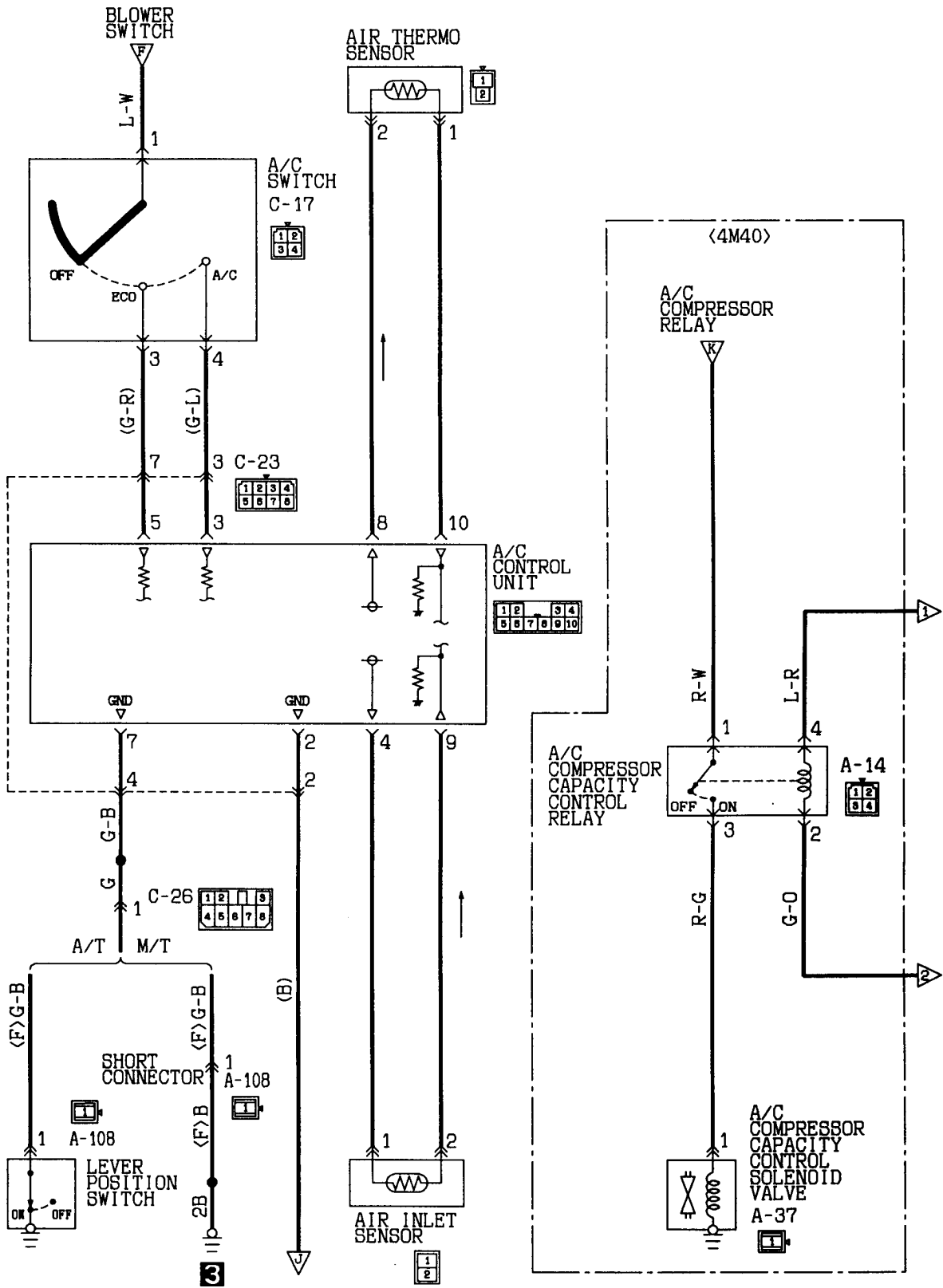

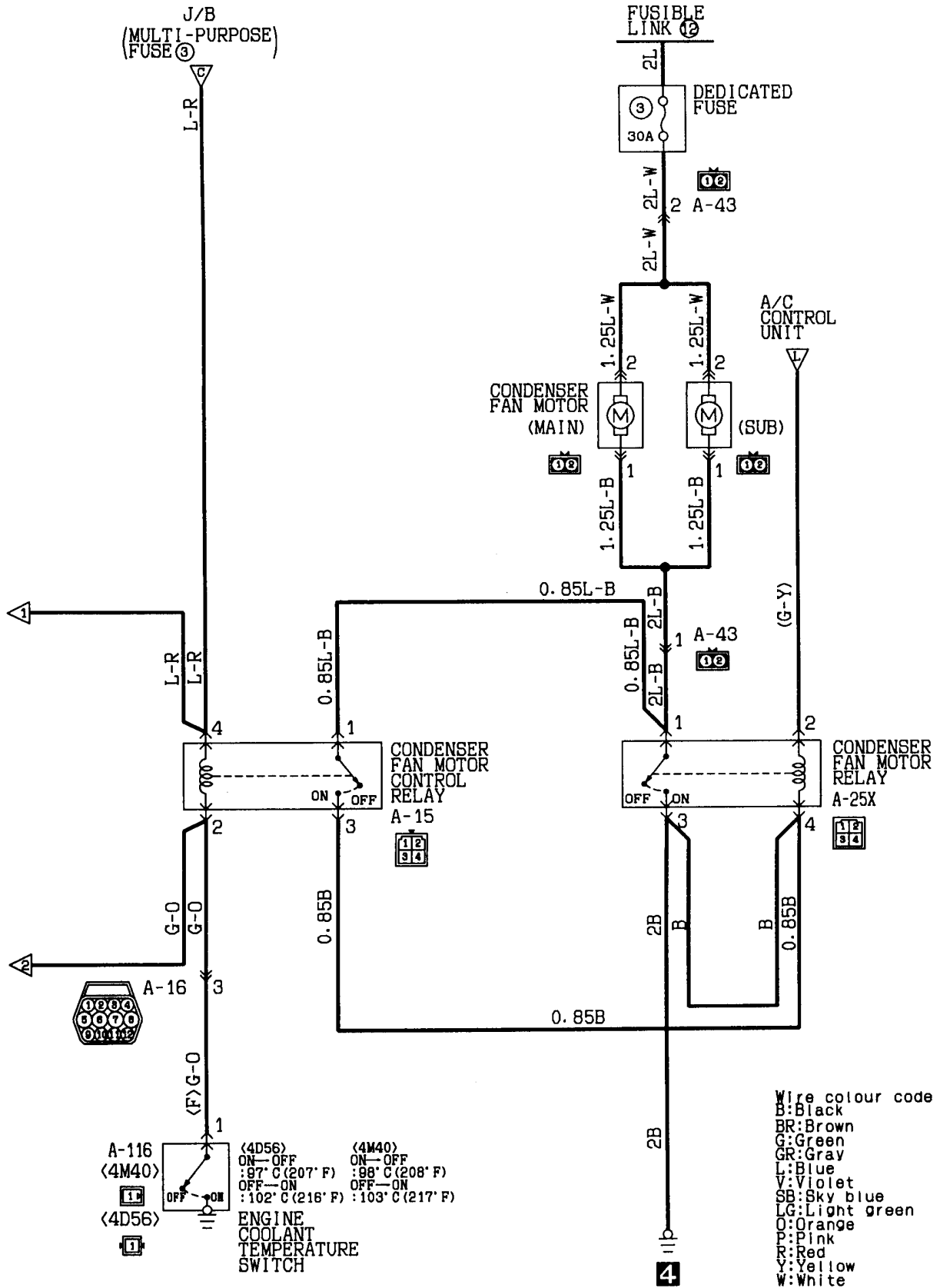

DUAL AIR CONDITIONER

(L.H. drive vehicles without rear heater (diesel-powered vehicles)) (CONTINUED)

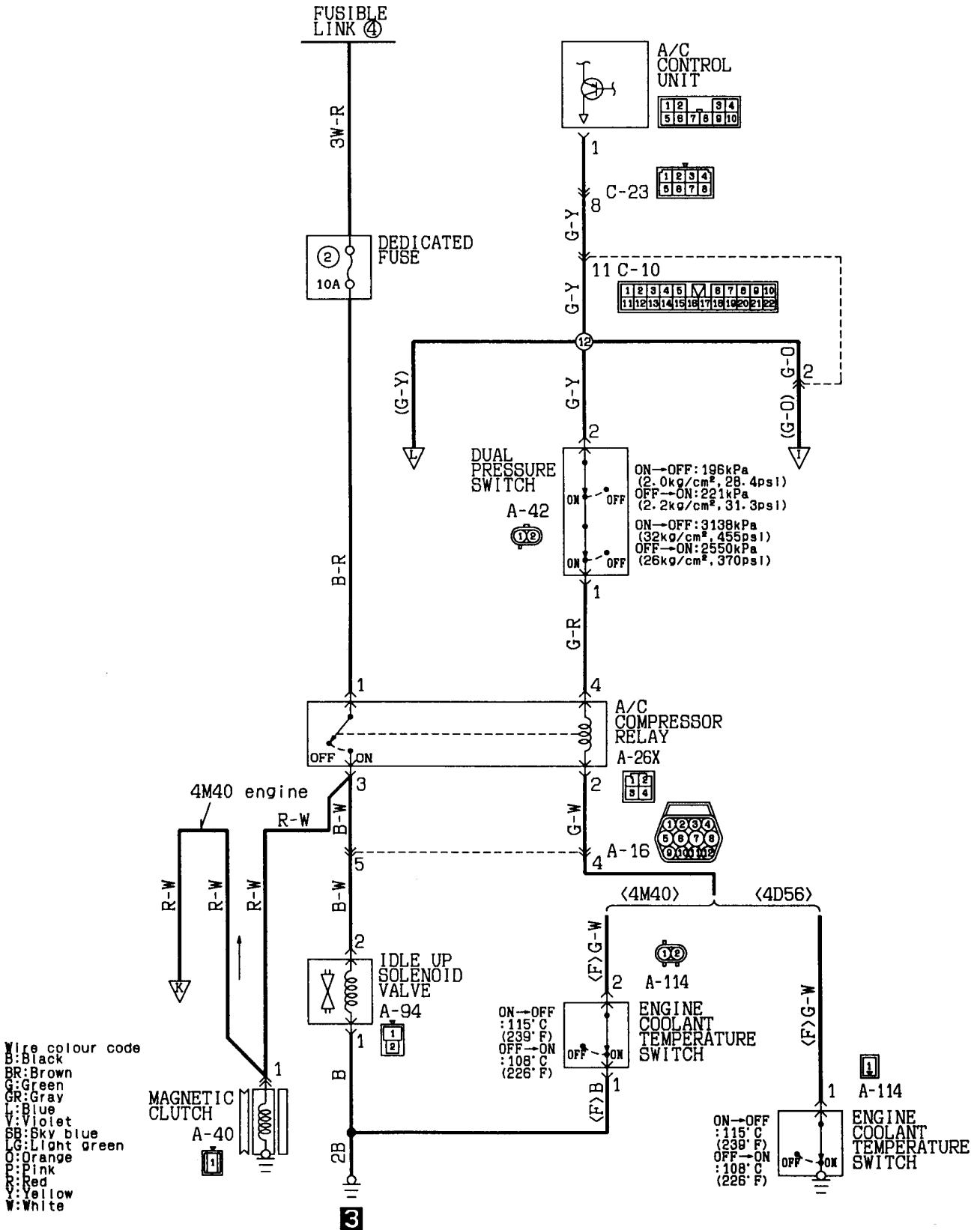

KX35-AC-012368-EC

CIRCUIT DIAGRAM

4A-217

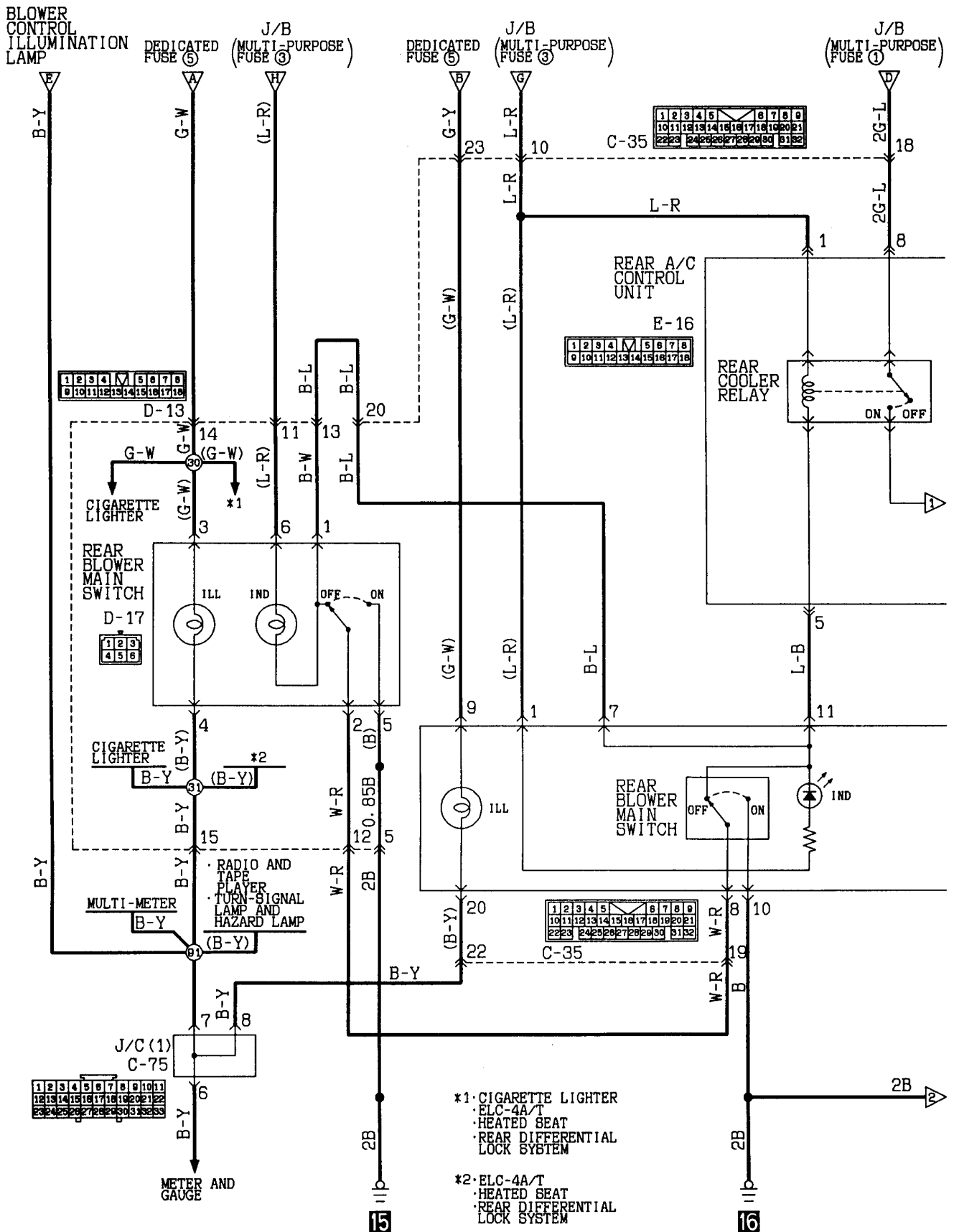

KX35-AC-01238C-EC

DUAL AIR CONDITIONER
 (L.H. drive vehicles without rear heater
 (diesel-powered vehicles)) (CONTINUED)

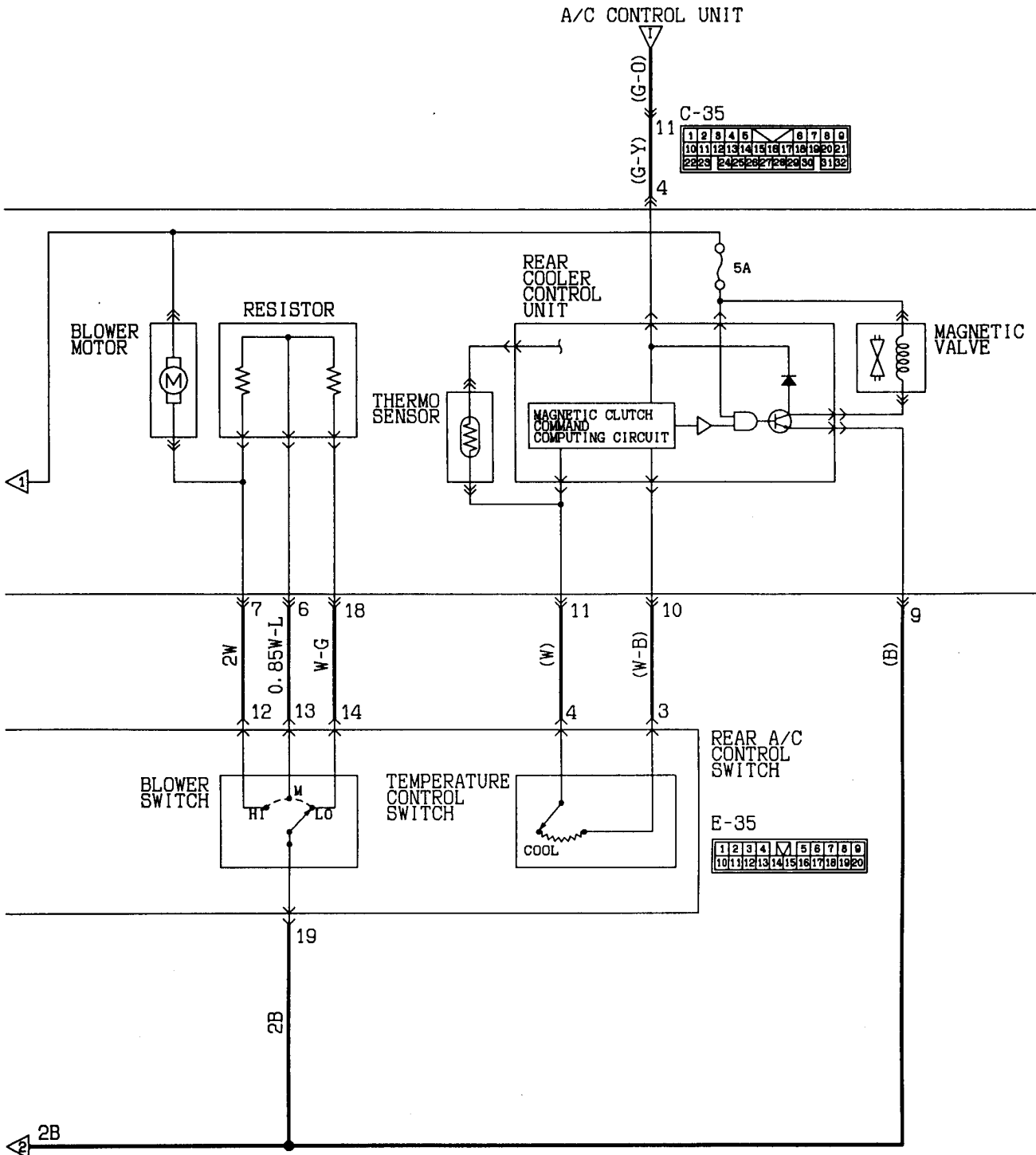

Wire colour code
 B:Black LG:Light green G:Green L:Blue W:White Y:Yellow SB:Sky blue
 BR:Brown O:Orange GR:Gray R:Red P:Pink V:Violet

DUAL AIR CONDITIONER
L.H. drive vehicles with rear heater
(petrol-powered vehicles)

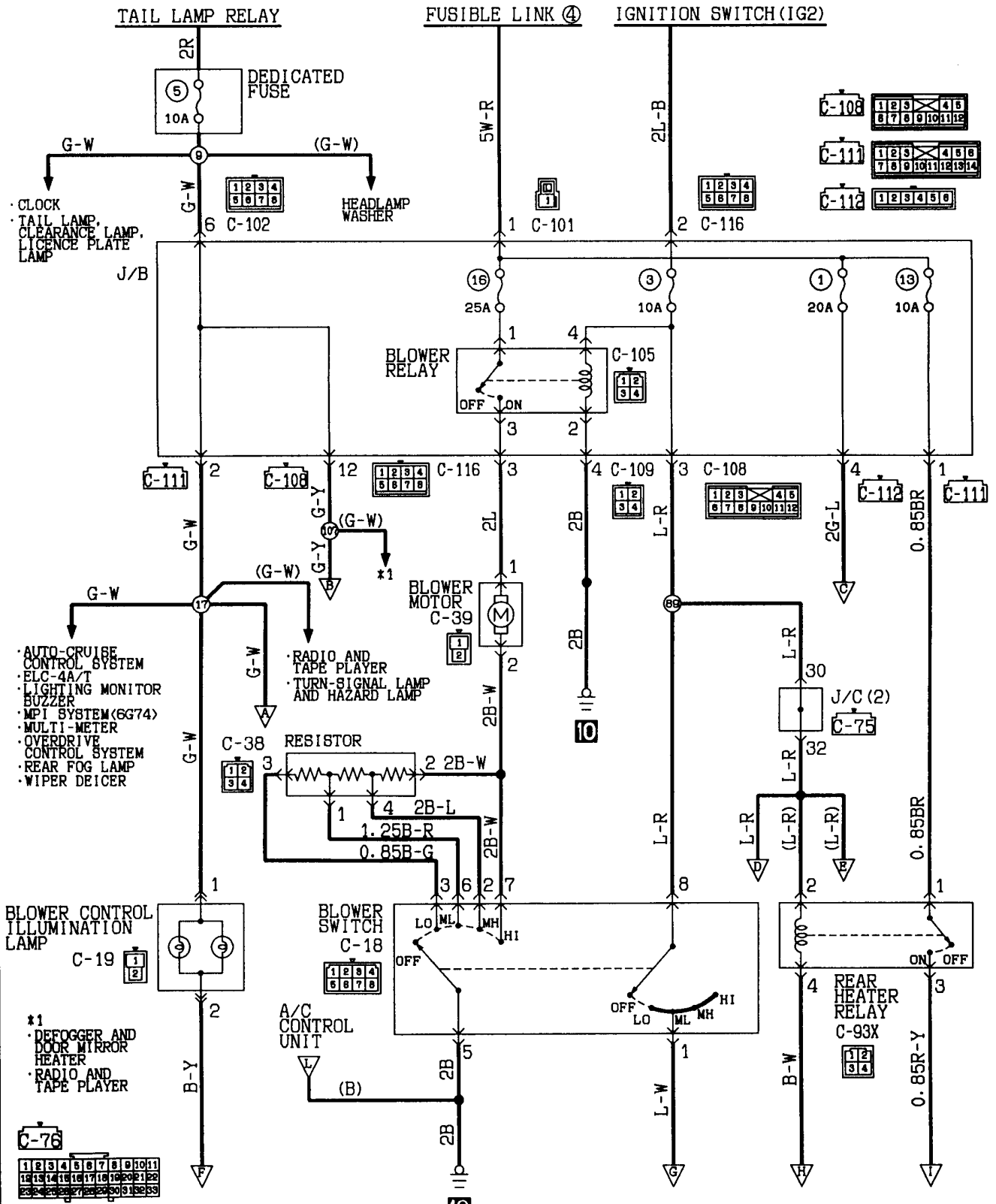

Wire colour code
 B:Black LG:Light green G:Green L:Blue W:White Y:Yellow
 BR:Brown O:Orange GR:Gray R:Red P:Pink V:Violet SB:Sky blue

KX35-AC-01234-EC

PHJE9026-C

ADDED

DUAL AIR CONDITIONER
 (L.H. drive vehicles with rear heater
 (petrol-powered vehicles)) (CONTINUED)

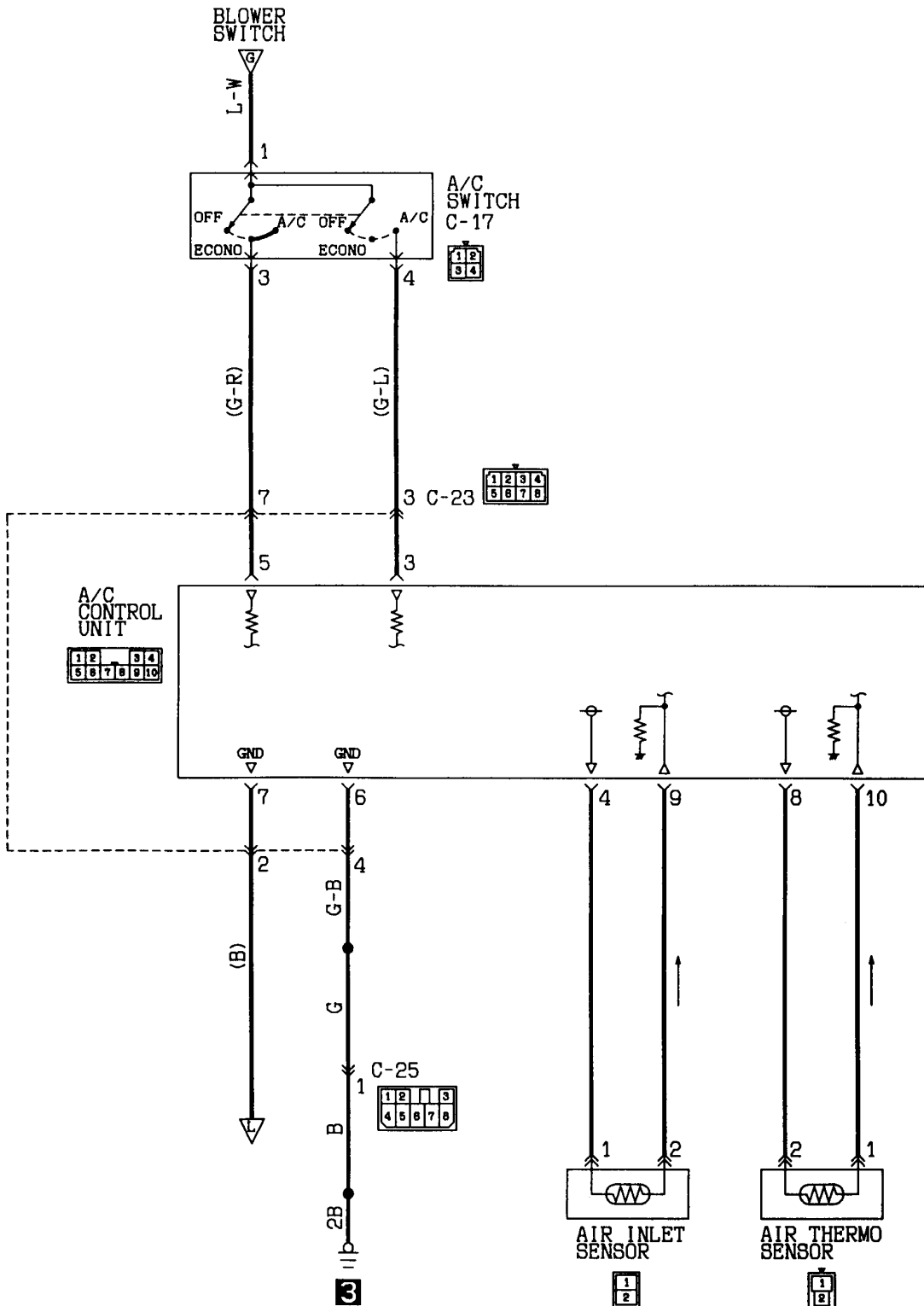

Wire colour code

B:Black LG:Light green G:Green L:Blue W:White Y:Yellow SB:Sky blue
 BR:Brown O:Orange GR:Gray R:Red P:Pink V:Violet

DUAL AIR CONDITIONER
 (L.H. drive vehicles with rear heater
 (petrol-powered vehicles)) (CONTINUED)

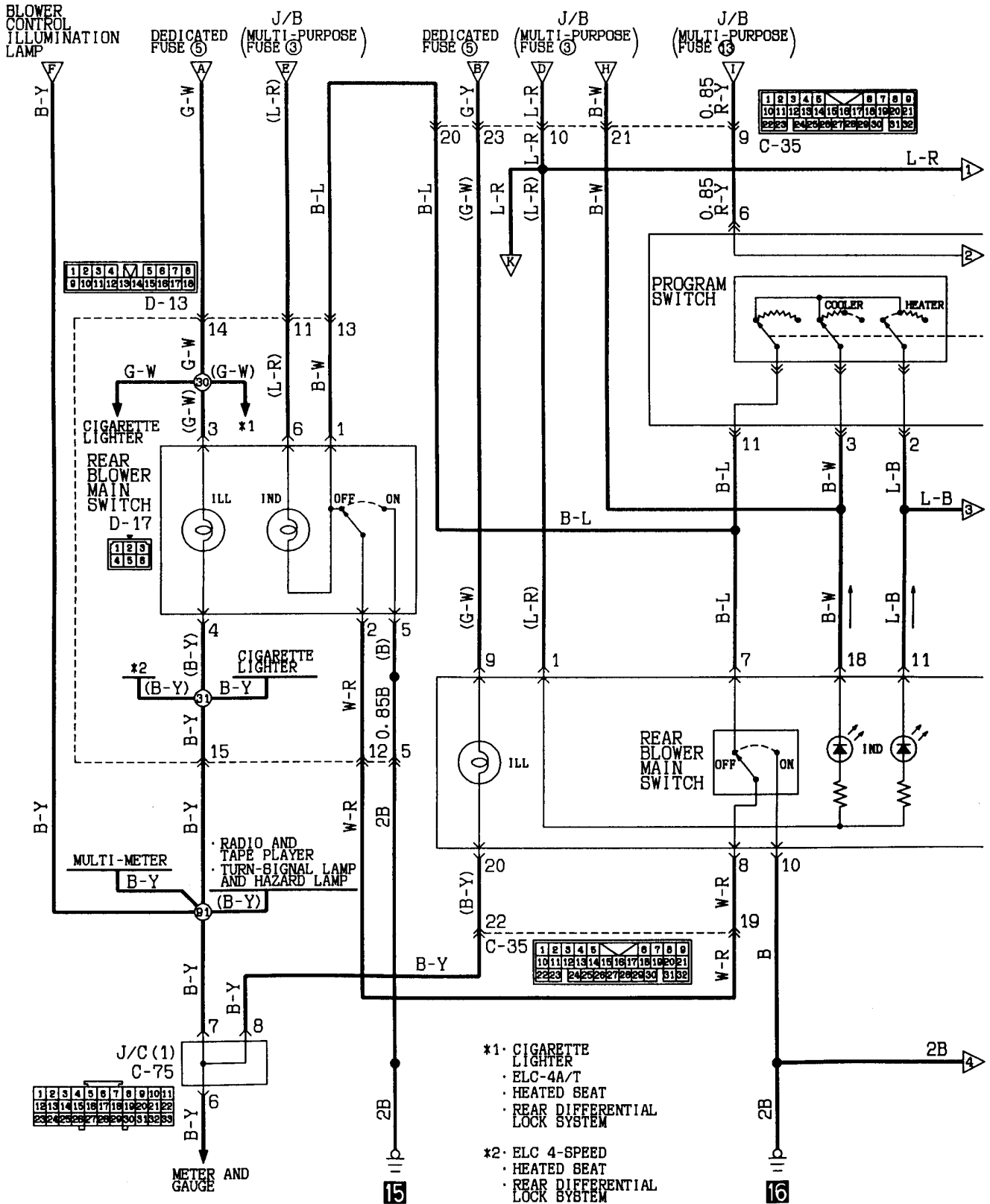

- *1. CIGARETTE LIGHTER
- ELC-4A/T
- HEATED SEAT
- REAR DIFFERENTIAL LOCK SYSTEM
- *2. ELC 4-SPEED
- HEATED SEAT
- REAR DIFFERENTIAL LOCK SYSTEM

KX35-AC-012348-EC

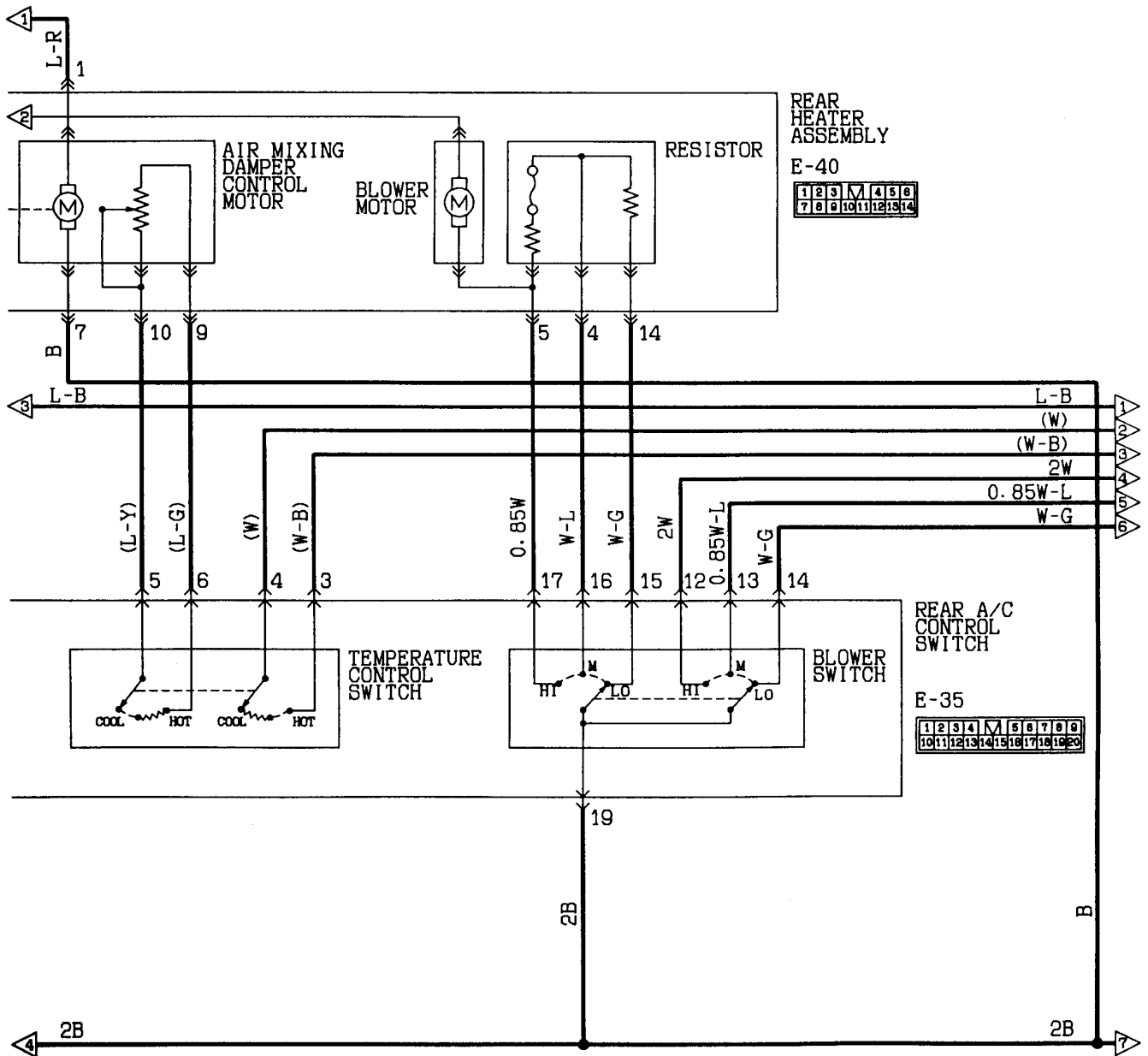

Wire colour code
 B:Black LG:Light green G:Green L:Blue W:White Y:Yellow SB:Sky blue
 BR:Brown O:Orange GR:Gray R:Red P:Pink V:Violet

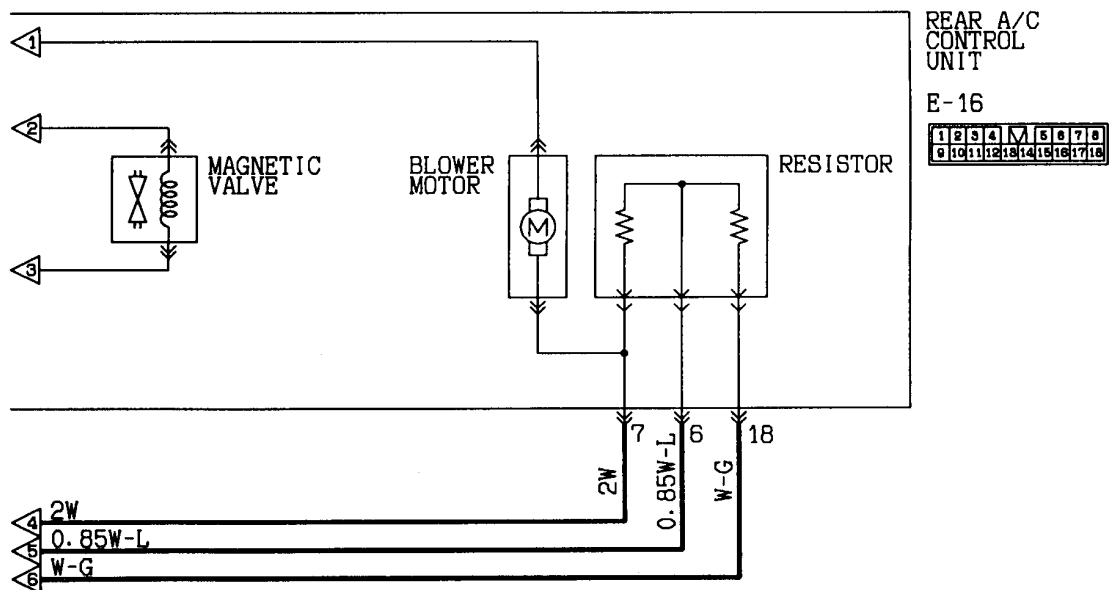

Wire colour code
 B:Black LG:Light green G:Green L:Blue W:White Y:Yellow SB:Sky blue
 BR:Brown O:Orange GR:Gray R:Red P:Pink V:Violet

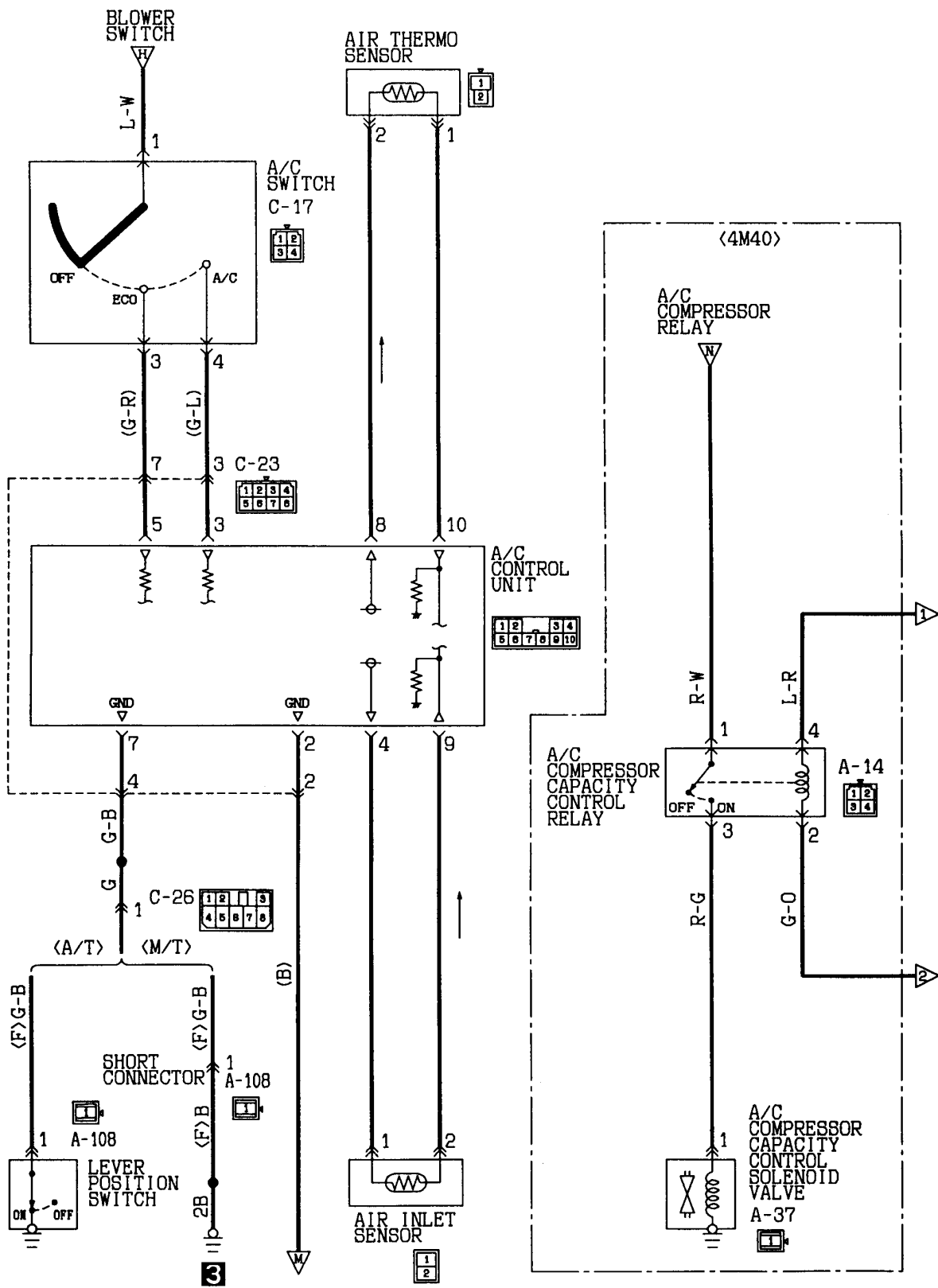

DUAL AIR CONDITIONER
 (L.H. drive vehicles with rear heater
 (diesel-powered vehicles)) (CONTINUED)

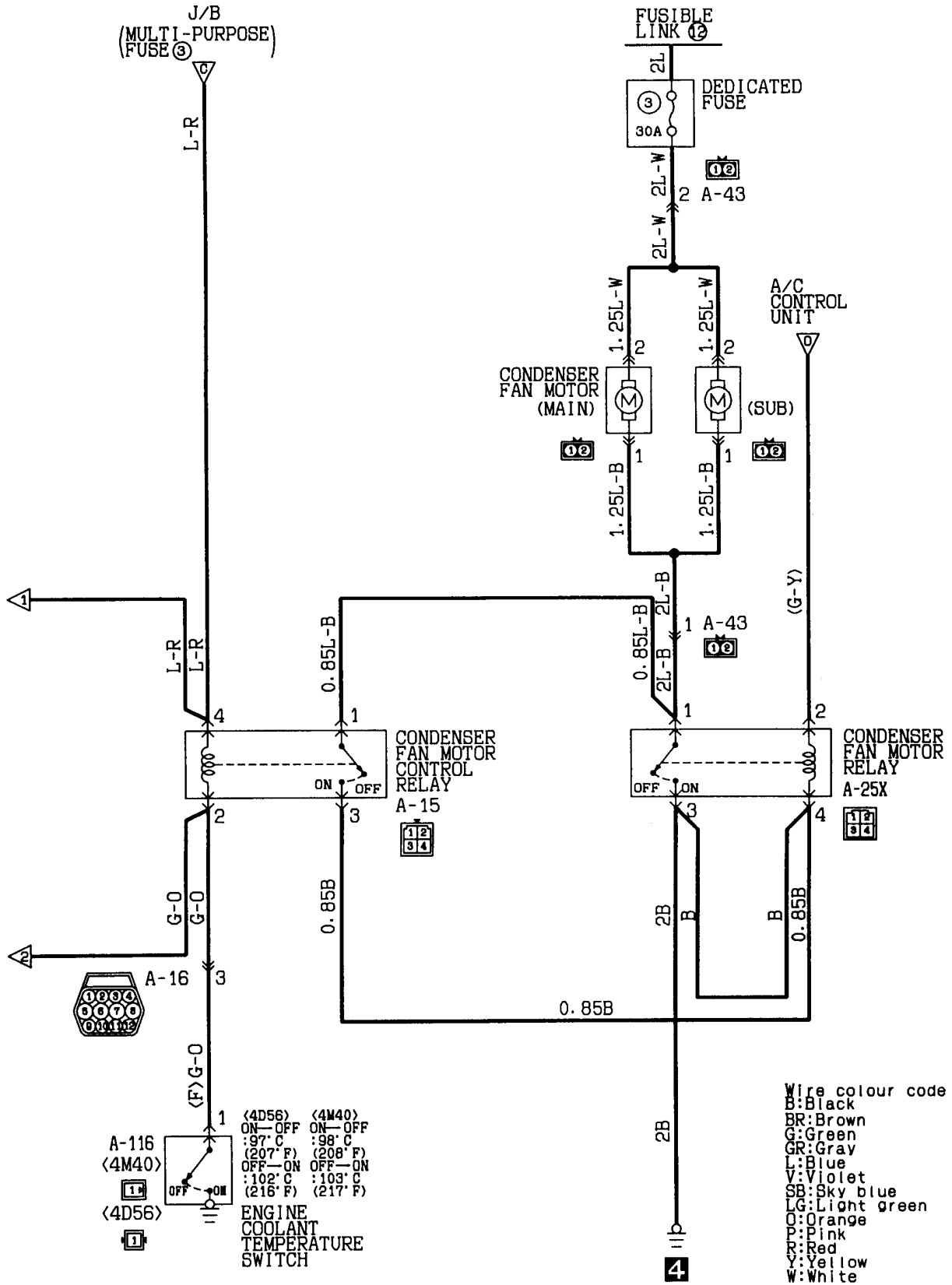

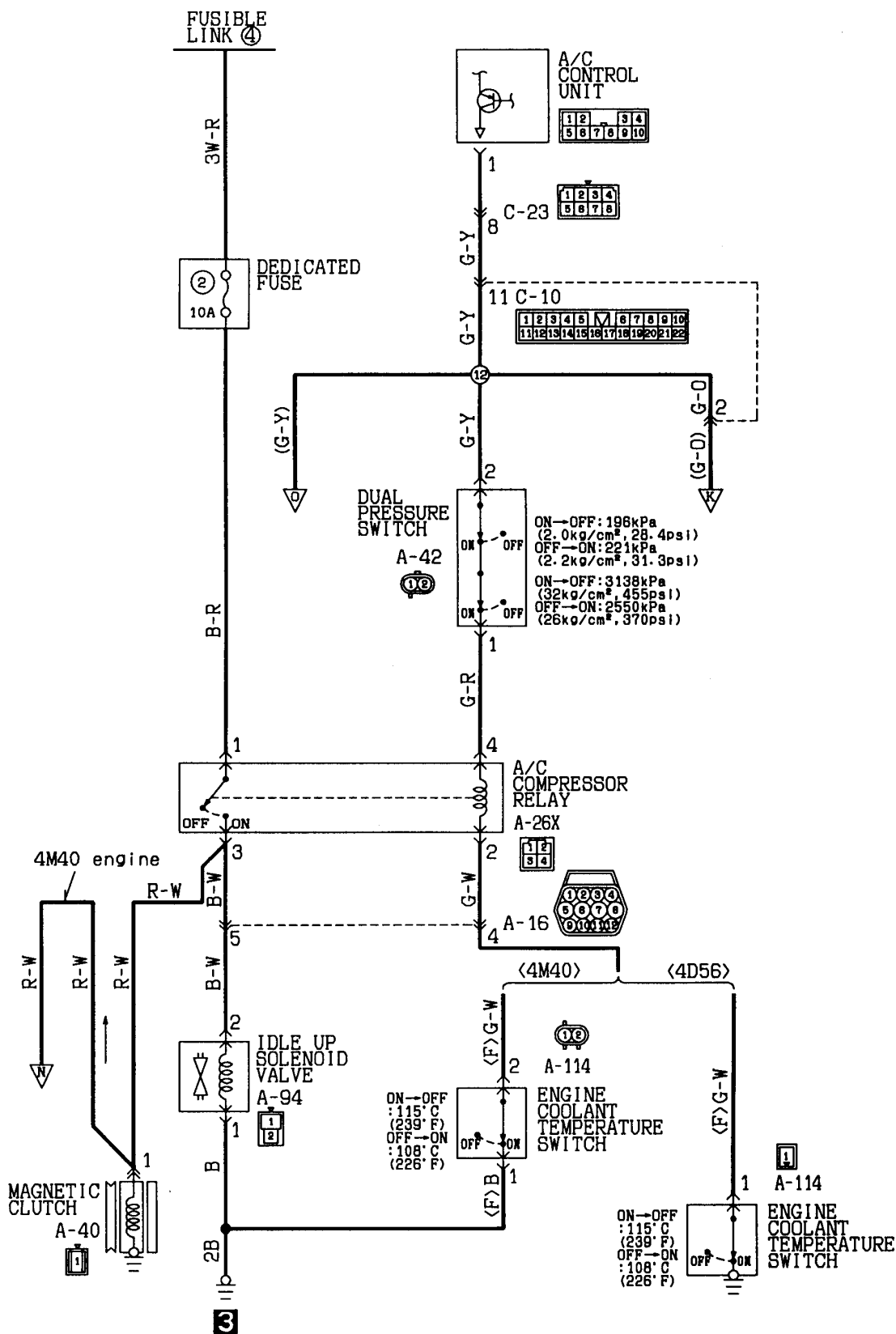

KX35-AC-01238B-EC

DUAL AIR CONDITIONER
 (L.H. drive vehicles without rear heater
 (diesel-powered vehicles))

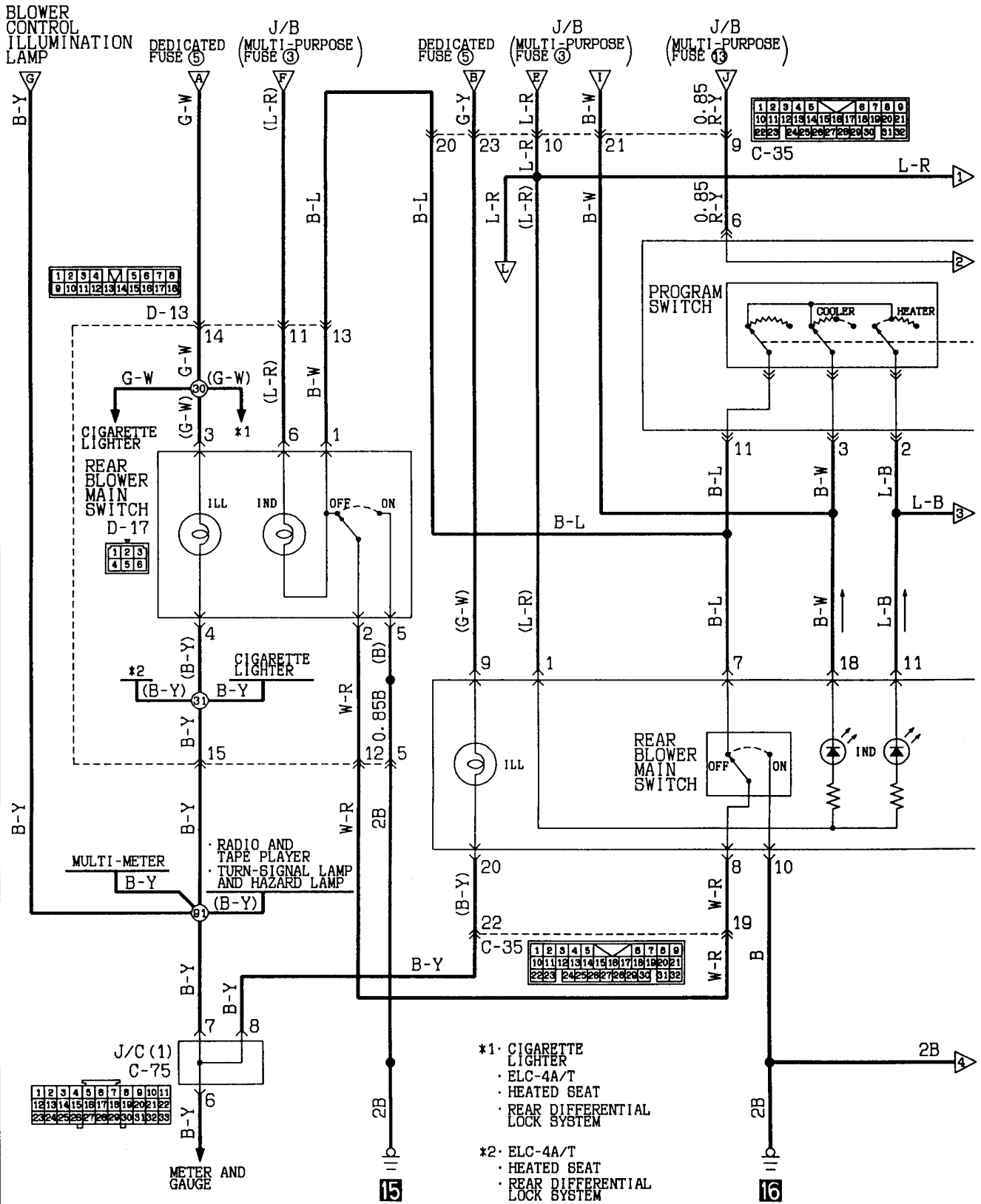

KX35-AC-01238C-EC

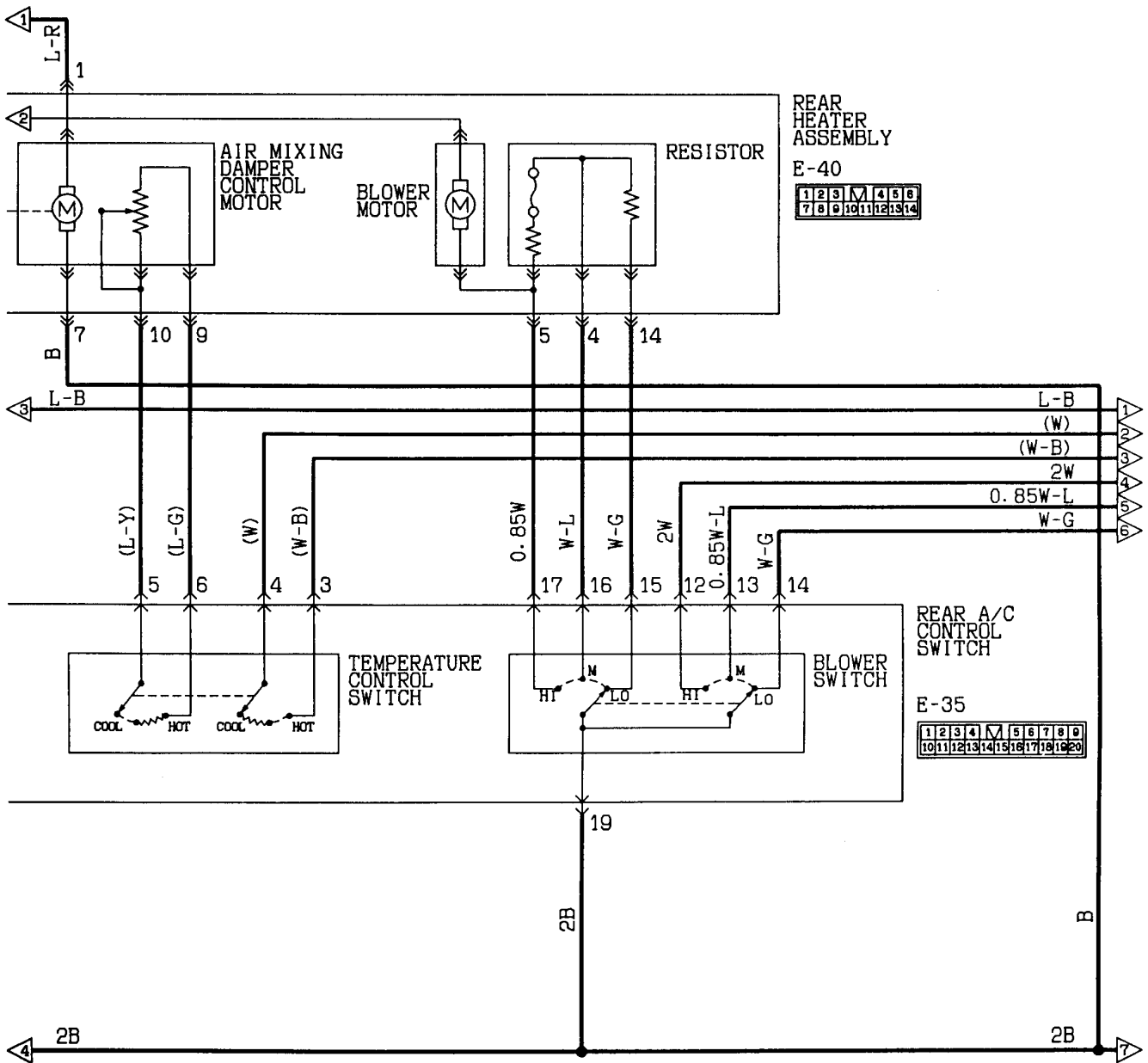

Wire colour code
 B:Black LG:Light green G:Green L:Blue W:White Y:Yellow SB:Sky blue
 BR:Brown O:Orange GR:Gray R:Red P:Pink V:Violet

DUAL AIR CONDITIONER
 (L.H. drive vehicles with rear heater
 (diesel-powered vehicles)) (CONTINUED)

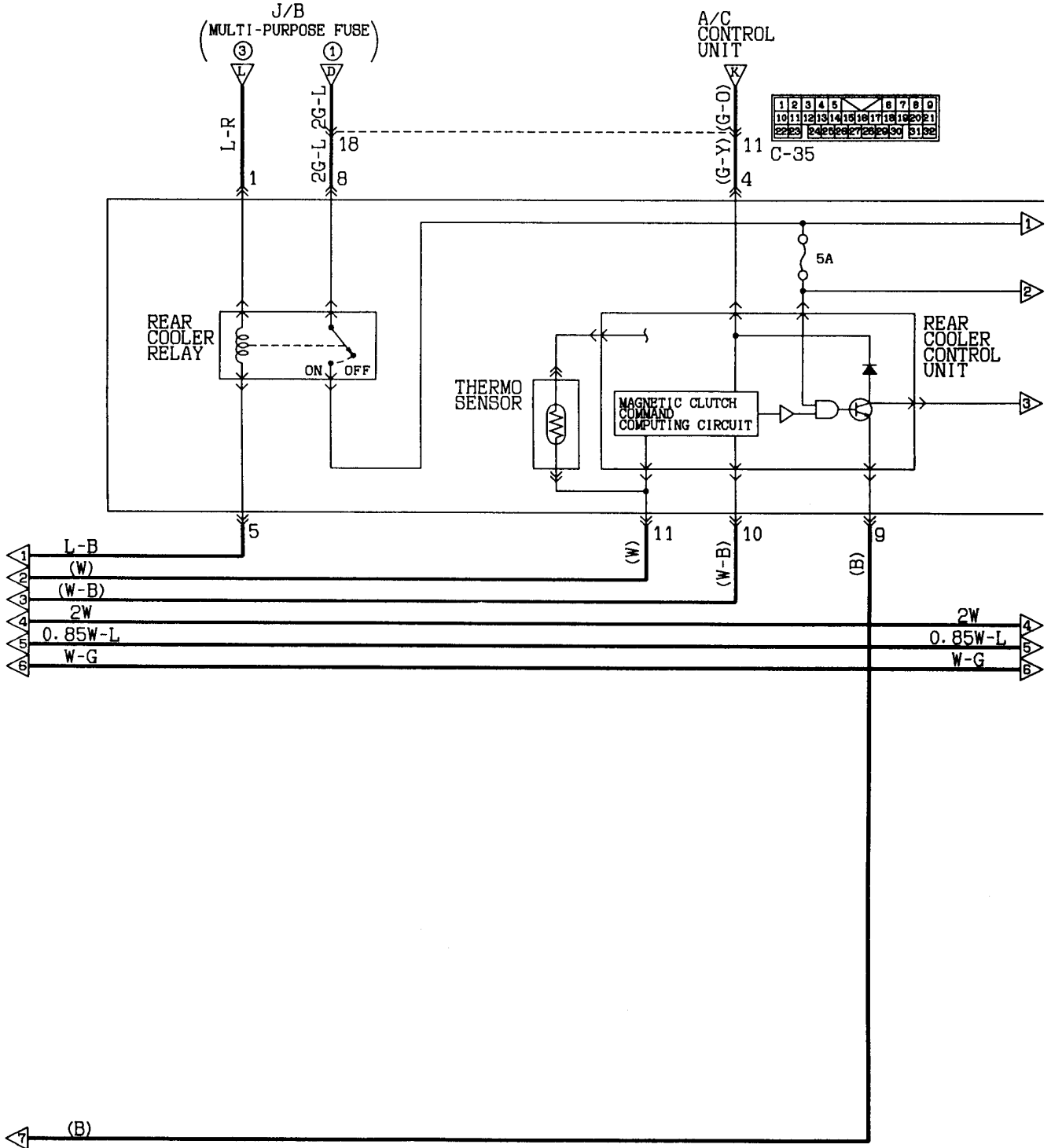

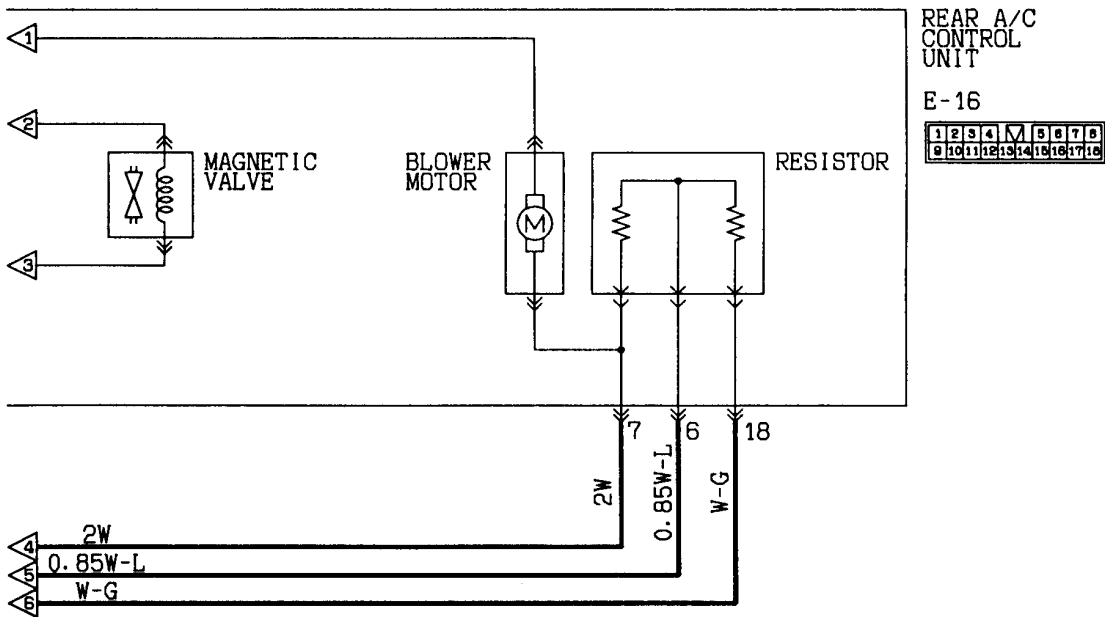

Wire colour code

B:Black LG:Light green G:Green L:Blue W:White Y:Yellow SB:Sky blue
BR:Brown O:Orange GR:Gray R:Red P:Pink V:Violet

DUAL AIR CONDITIONER
R.H. drive vehicles without rear heater
(petrol-powered vehicles)

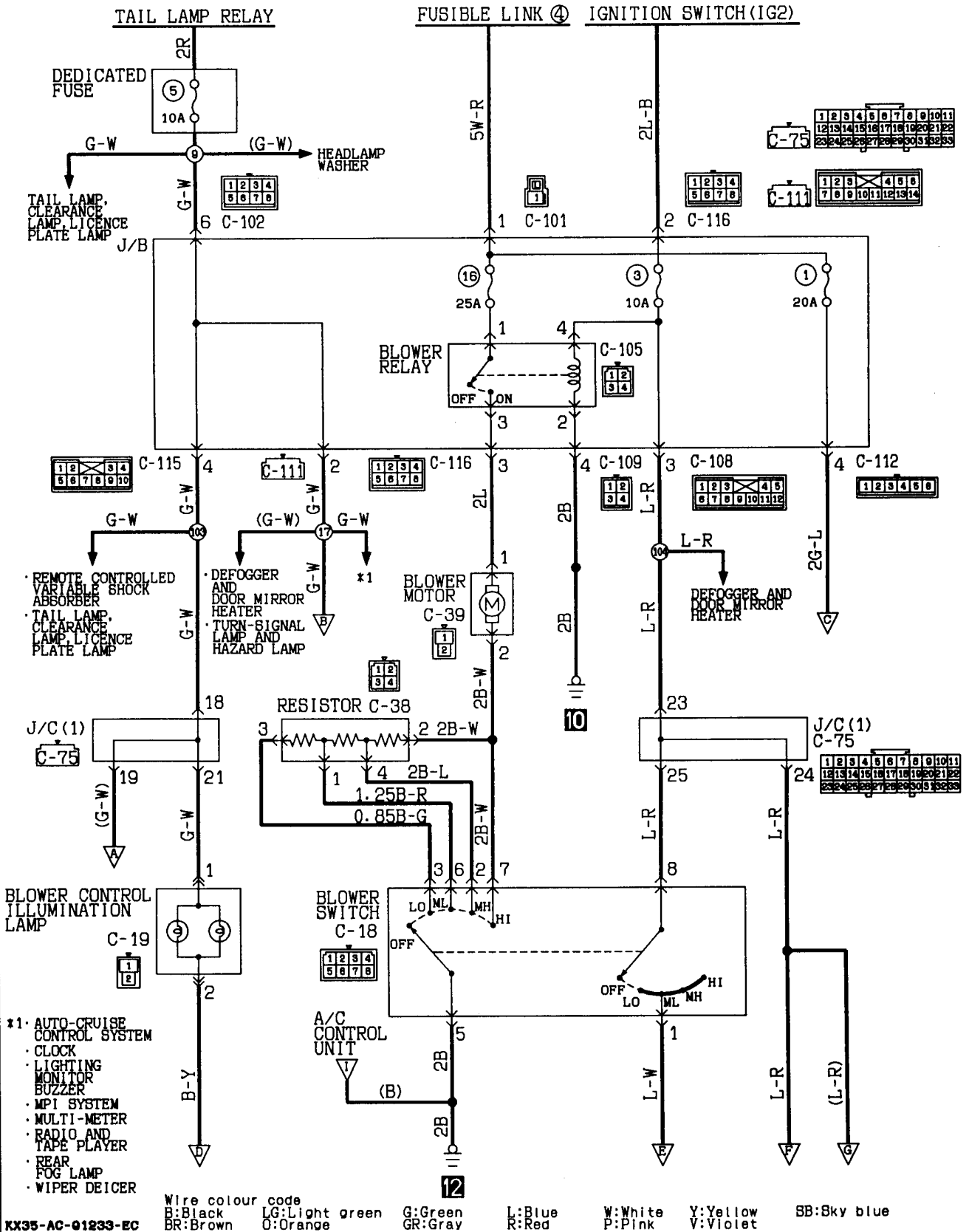

KX35-AC-01233-EC

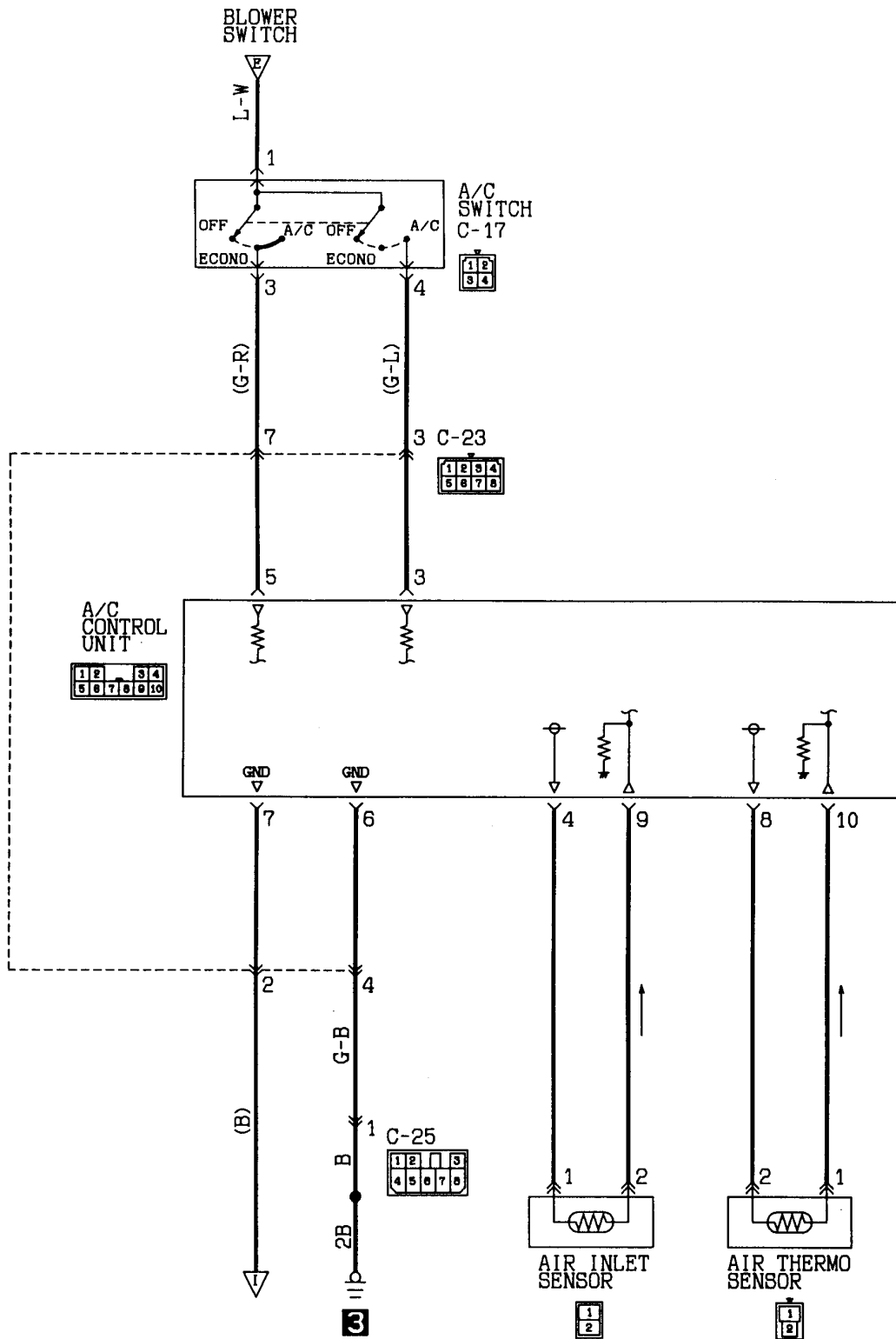

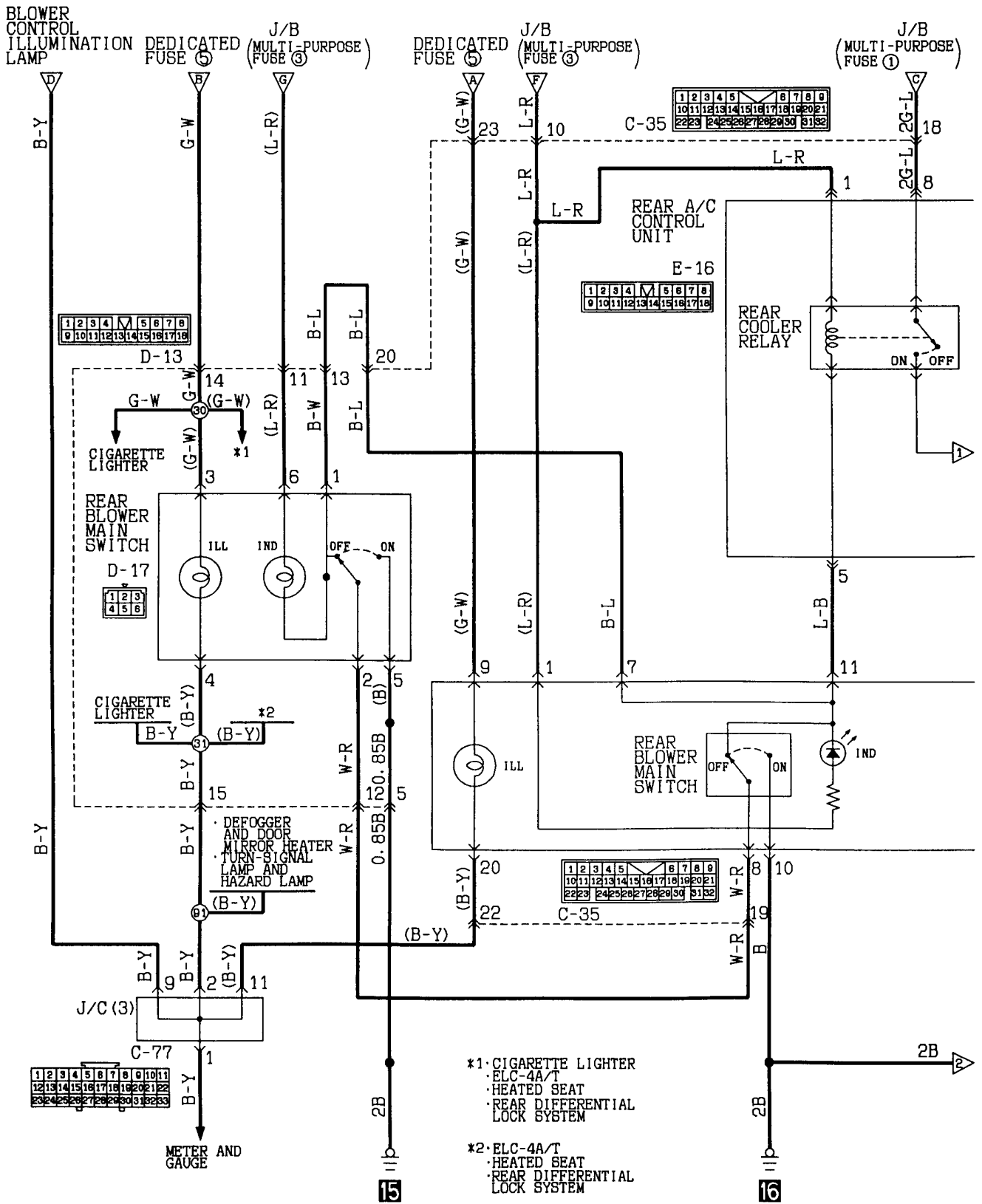

KX35-AC-Q1233B-EC

DUAL AIR CONDITIONER
 (R.H. drive vehicles without rear heater
 (petrol-powered vehicles)) (CONTINUED)

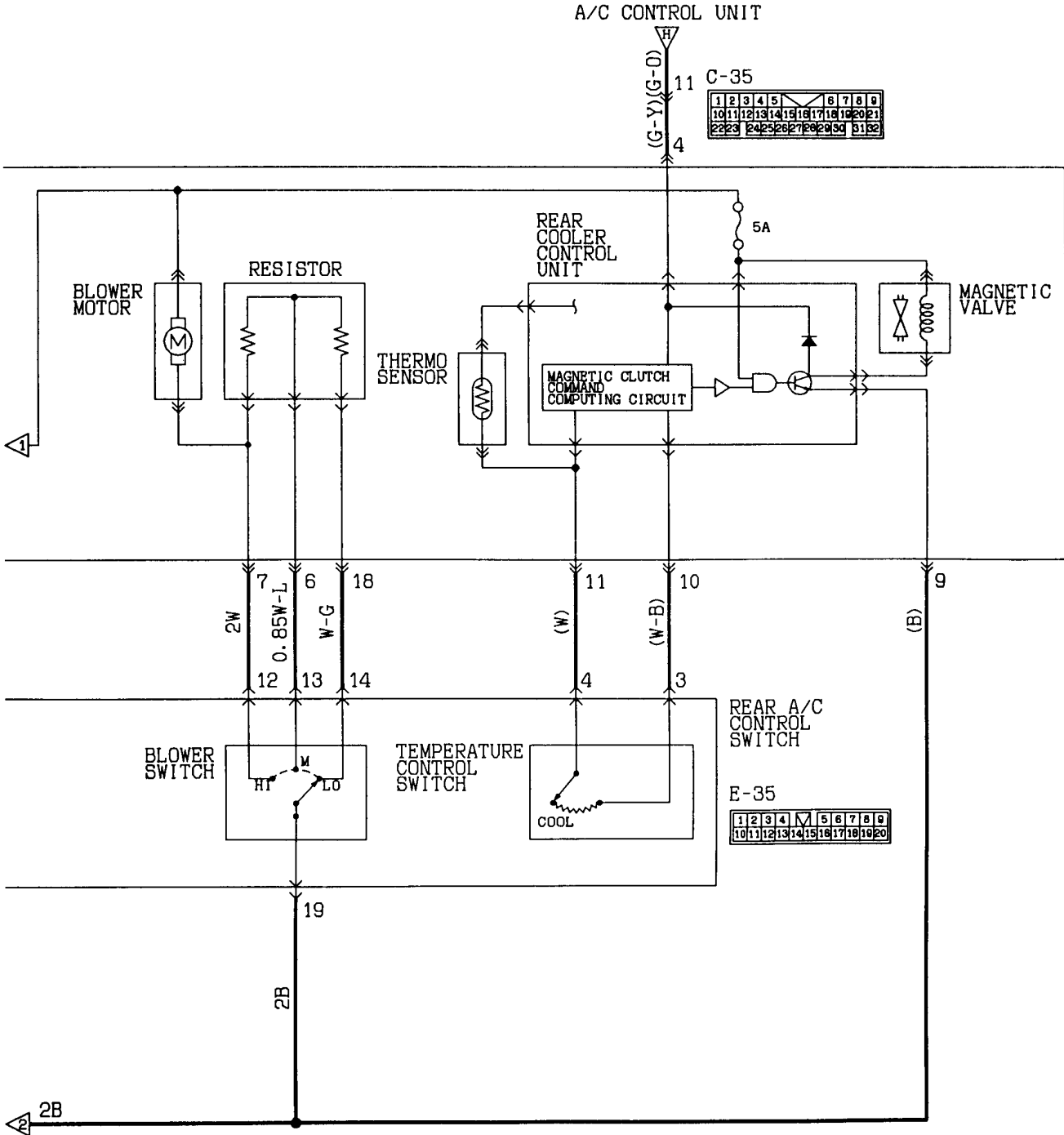

Wire colour code
 B:Black LG:Light green G:Green L:Blue W:White Y:Yellow SB:Sky blue
 BR:Brown O:Orange GR:Gray R:Red P:Pink V:Violet

DUAL AIR CONDITIONER
R.H. drive vehicles without rear heater
(diesel-powered vehicles)

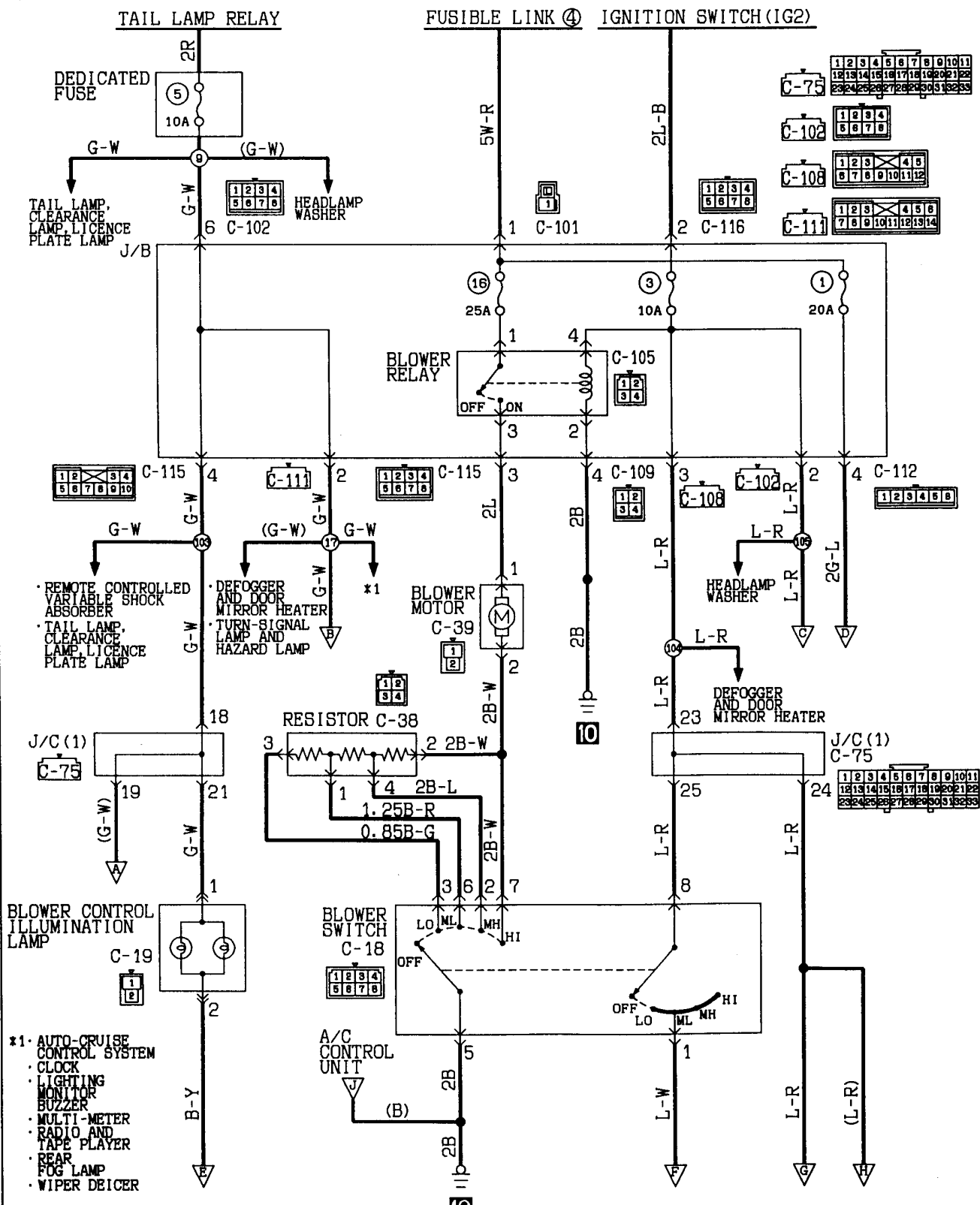

Wire colour code
 B:Black LG:Light green G:Green L:Blue W:White Y:Yellow
 BR:Brown O:Orange GR:Gray R:Red P:Pink V:Violet SB:Sky blue

DUAL AIR CONDITONER
 (R.H. drive vehicles without rear heater
 (diesel-powered vehicles)) (CONTINUED)

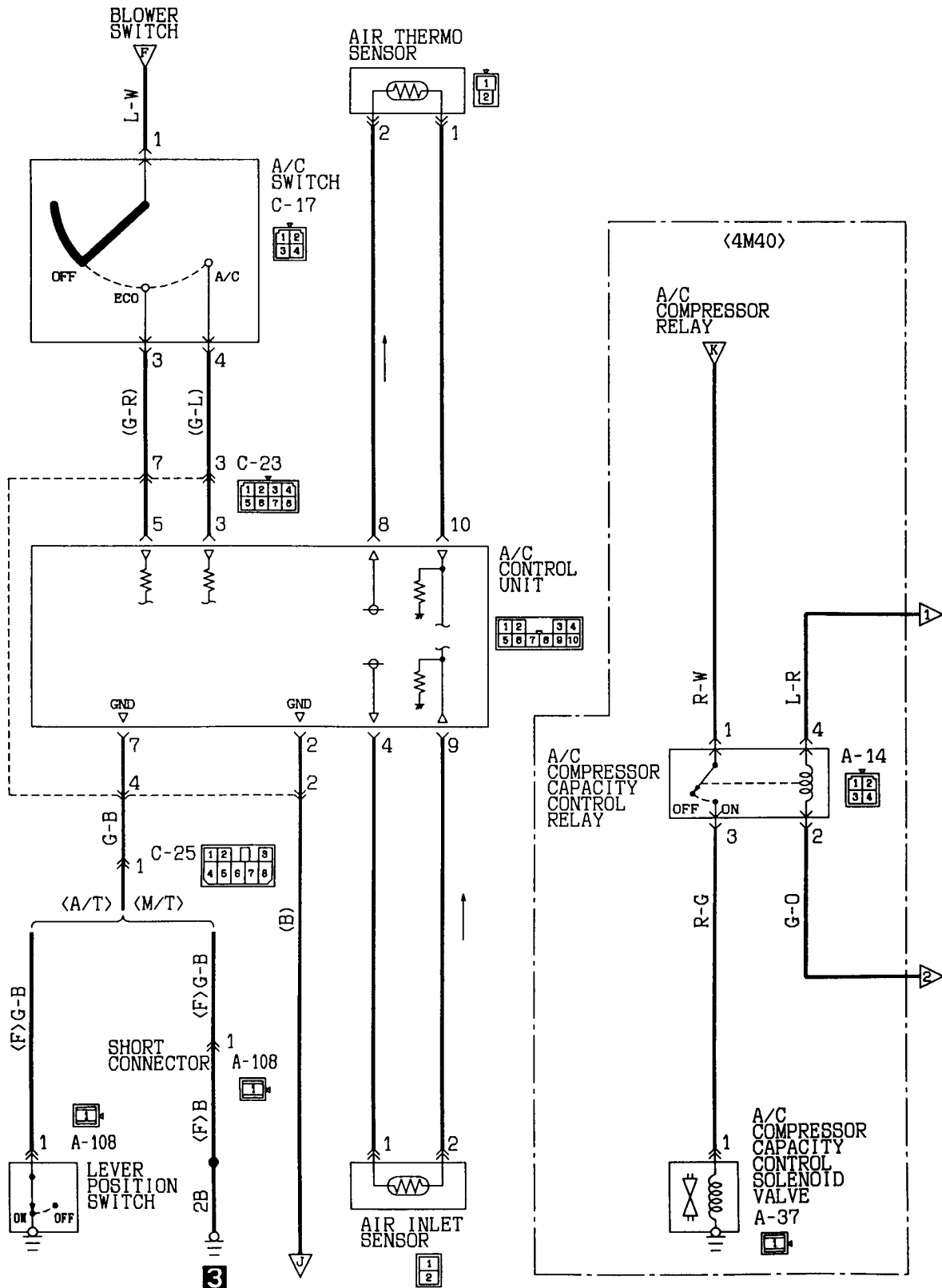

KX35-AC-Q1237A-EC

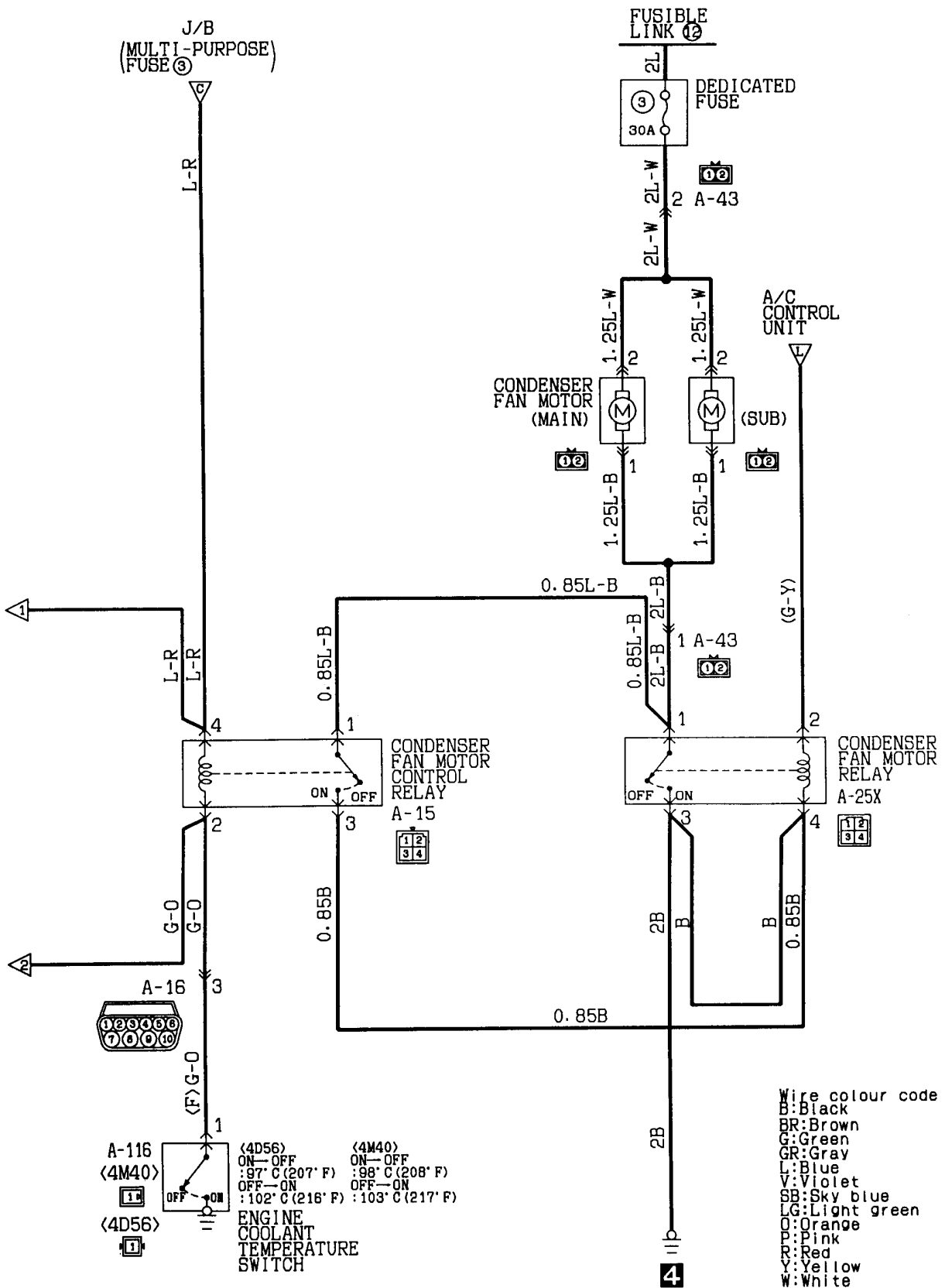

DUAL AIR CONDITIONER
 (R.H. drive vehicles without rear heater
 (diesel-powered vehicles)) (CONTINUED)

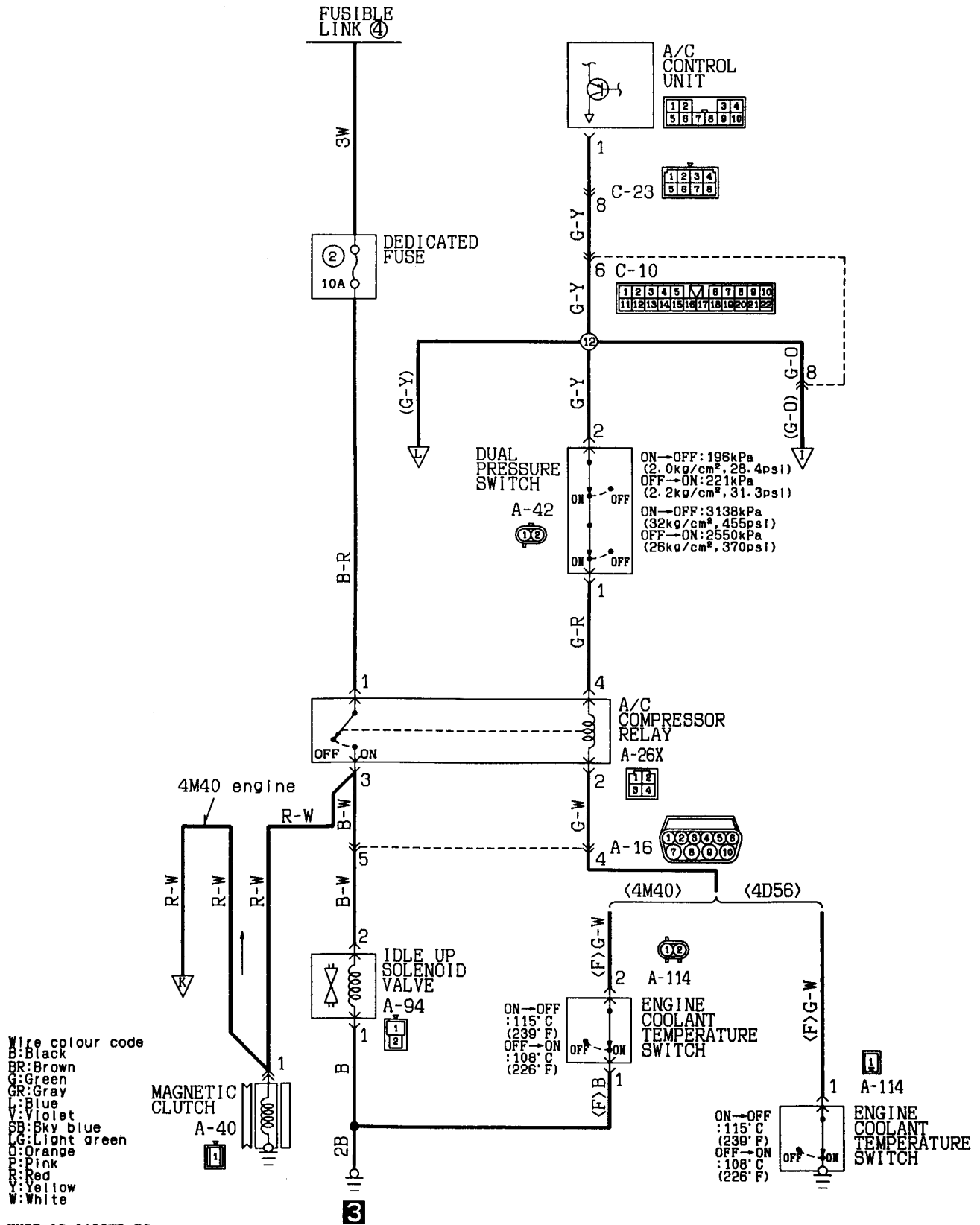

KX35-AC-01237B-EC

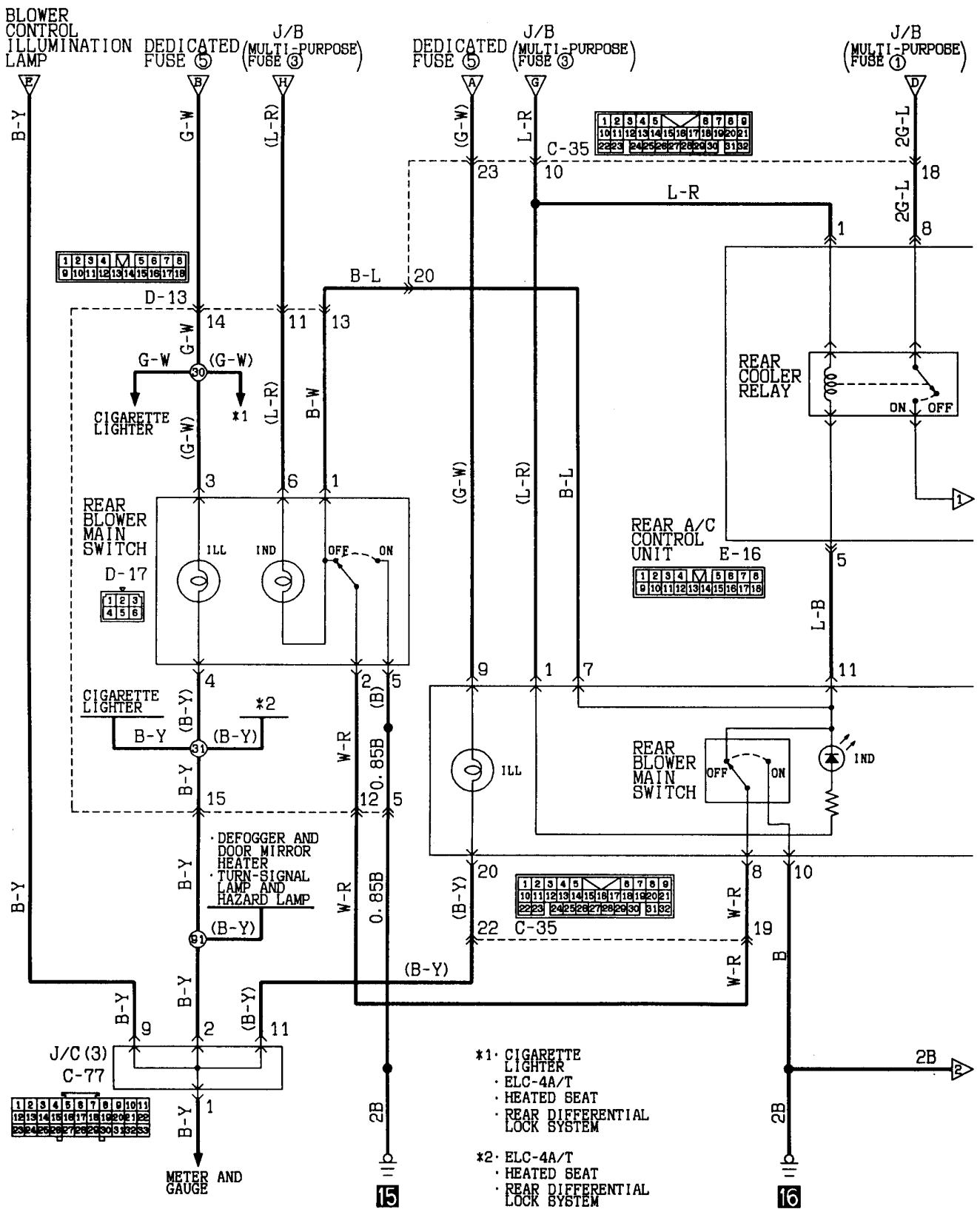

KX35-AC-01237C-EC

DUAL AIR CONDITIONER
 (R. H. drive vehicles without rear heater
 (diesel-powered vehicles)) (CONTINUED)

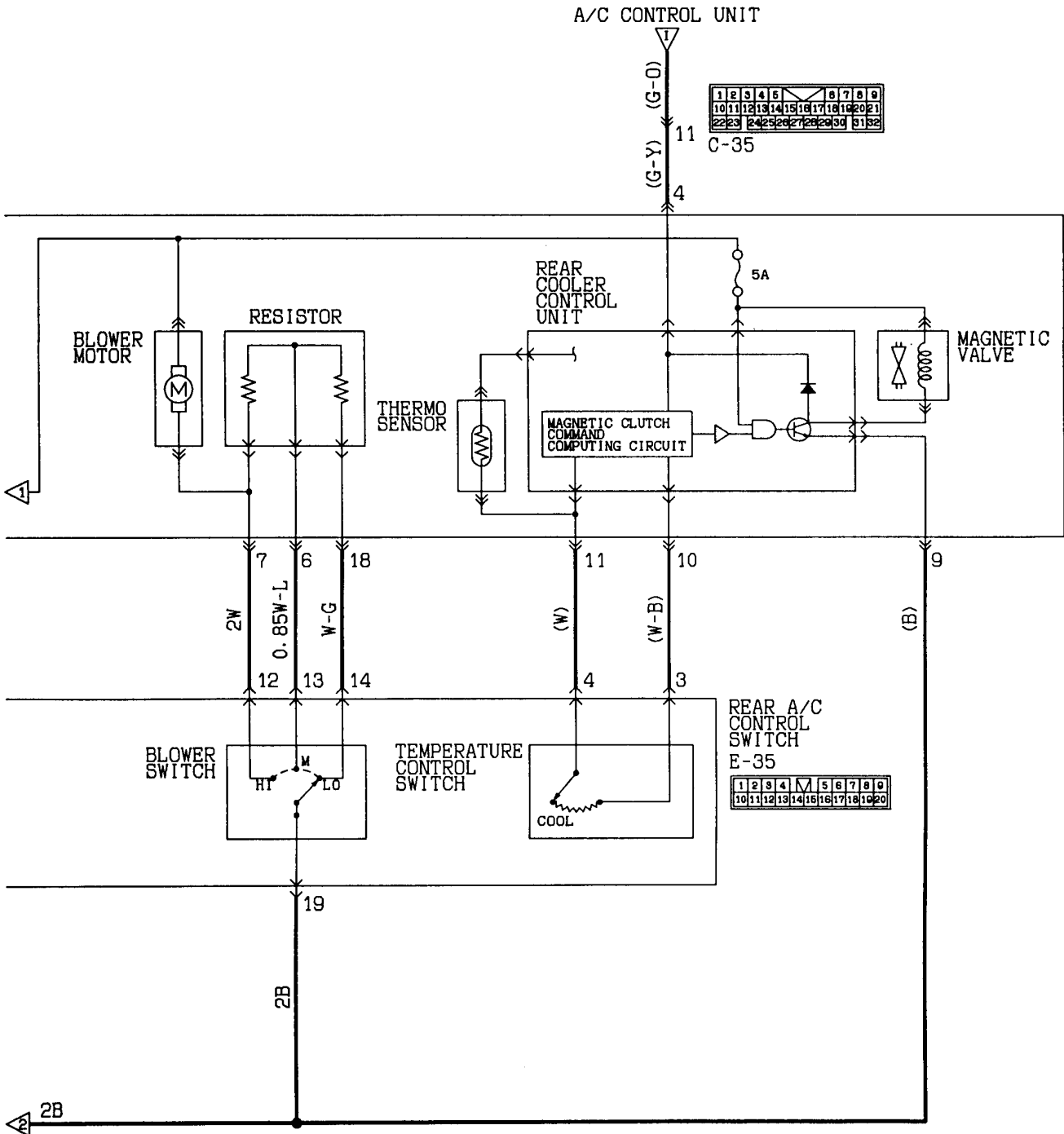

Wire colour code
 B:Black LG:Light green G:Green L:Blue W:White Y:Yellow SB:Sky blue
 BR:Brown O:Orange GR:Gray R:Red P:Pink V:Violet

DUAL AIR CONDITIONER
 (R.H. drive vehicles with rear heater
 (petrol-powered vehicles)) (CONTINUED)

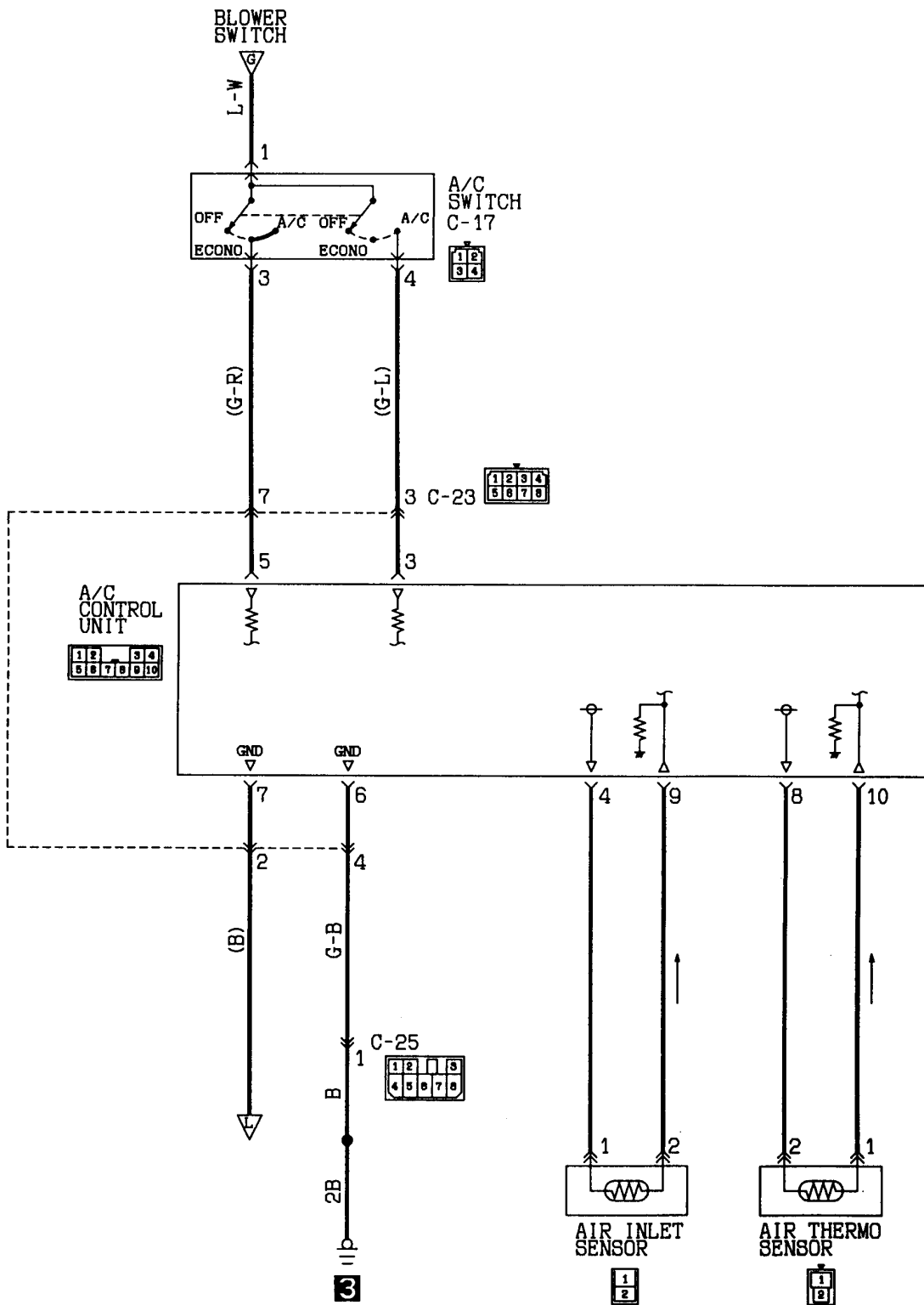

Wire colour code
 B:Black LG:Light green G:Green L:Blue W:White Y:Yellow SB:Sky blue
 BR:Brown O:Orange GR:Gray R:Red P:Pink V:Violet

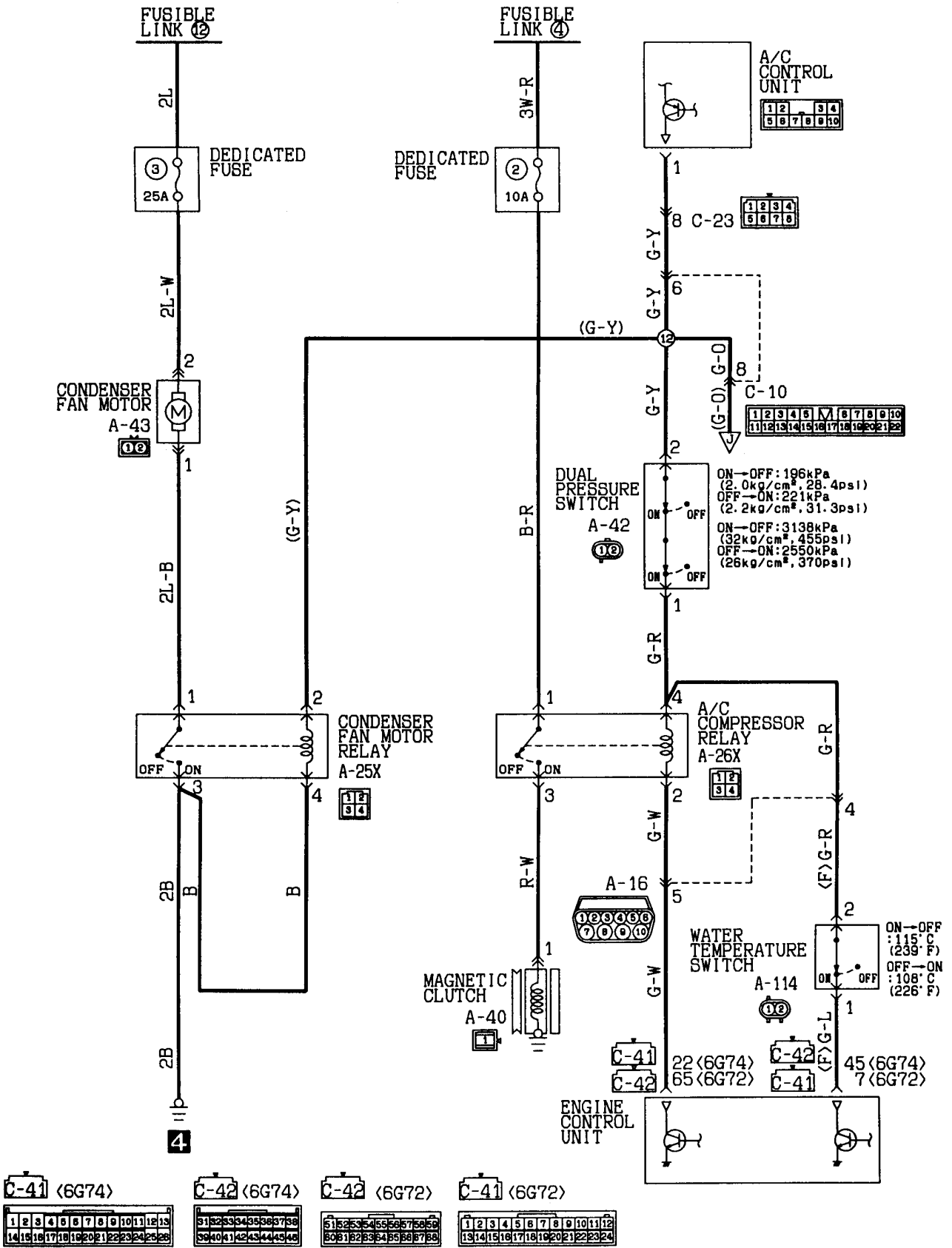

DUAL AIR CONDITIONER
 (R.H. drive vehicles with rear heater
 (petrol-powered vehicles)) (CONTINUED)

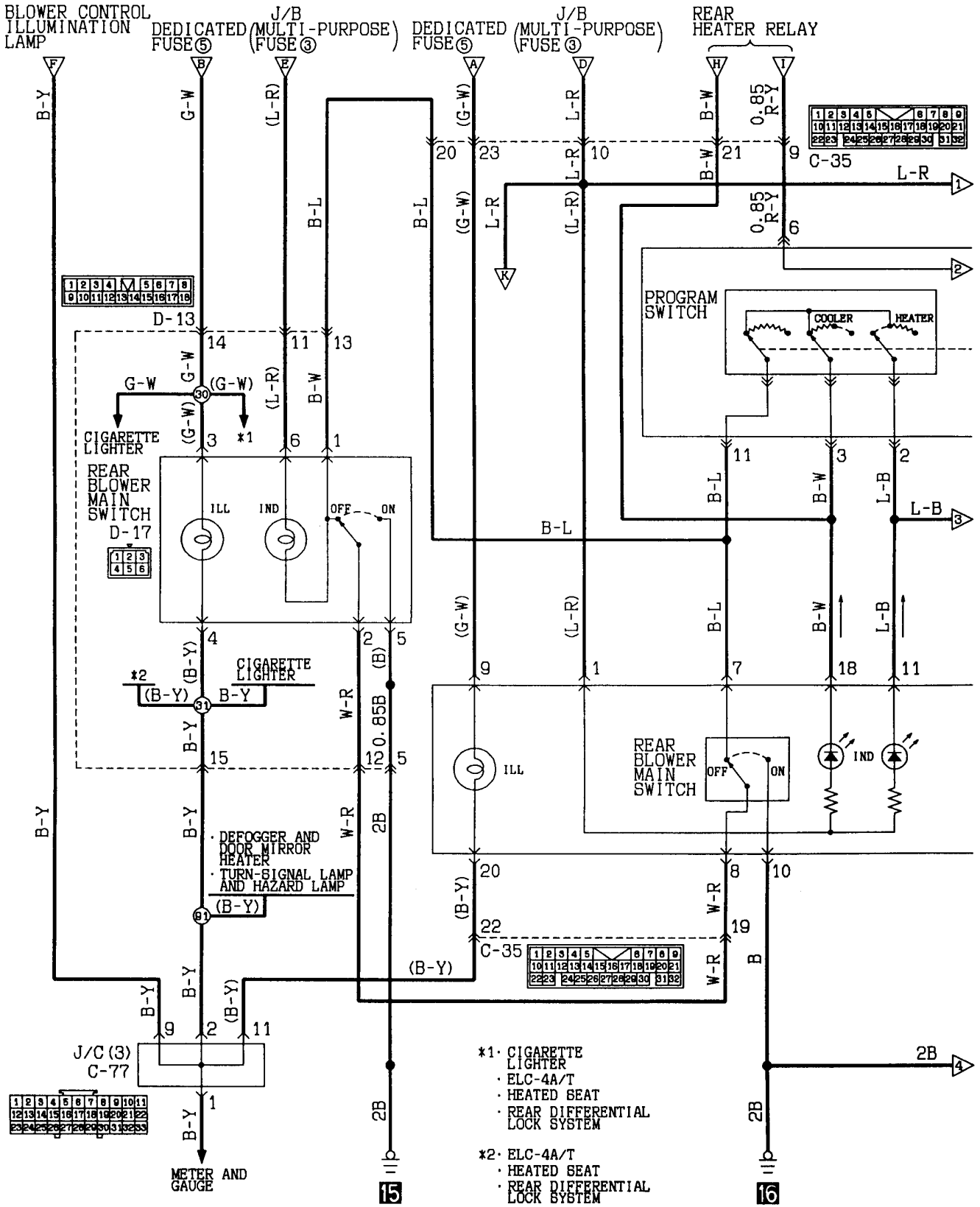

KX35-AC-01235B-EC

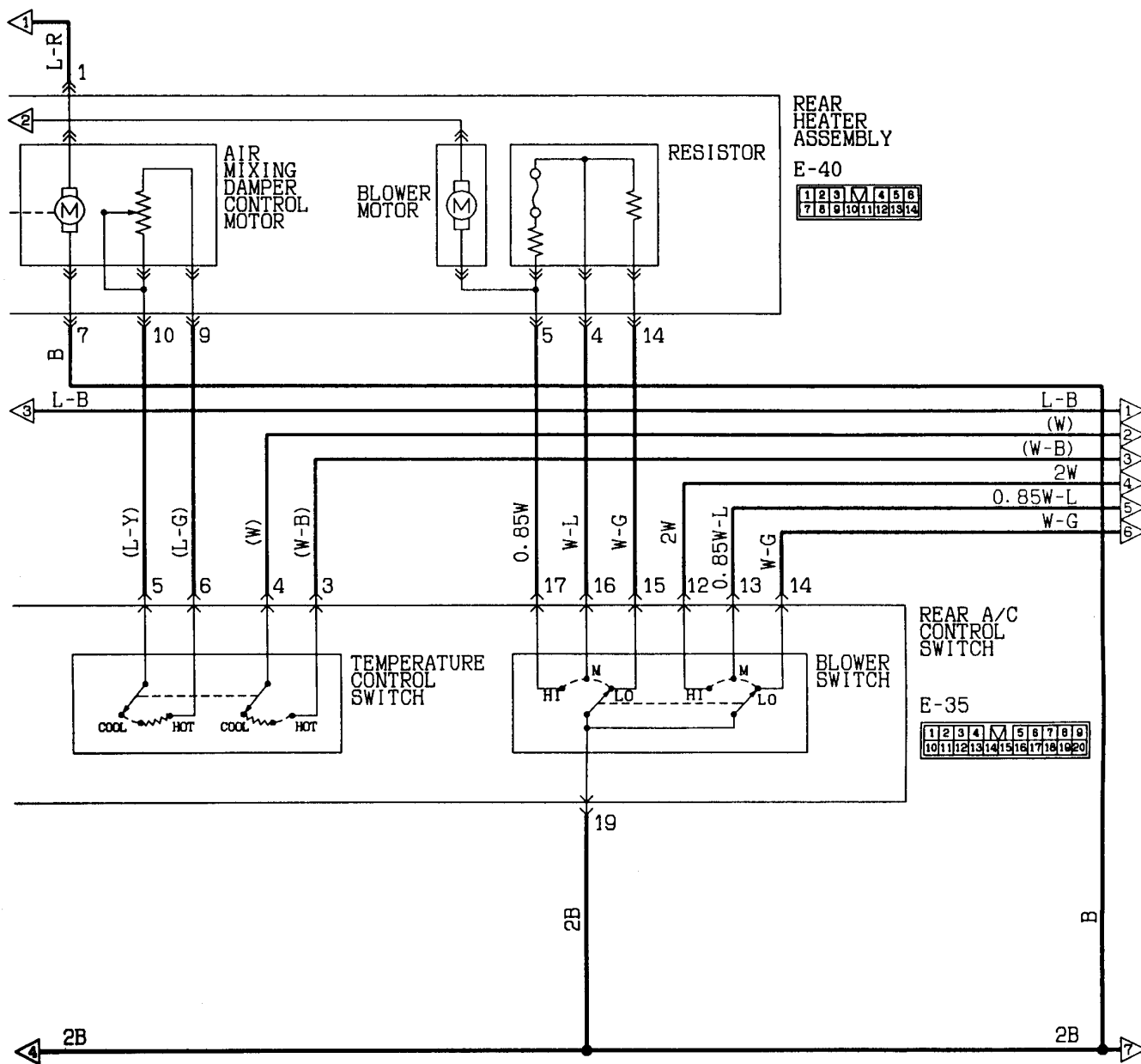

Wire colour code
 B:Black LG:Light green G:Green L:Blue W:White Y:Yellow SB:Sky blue
 BR:Brown O:Orange GR:Gray R:Red P:Pink V:Violet

DUAL AIR CONDITIONER
 (R.H. drive vehicles with rear heater
 (petrol-powered vehicles)) (CONTINUED)

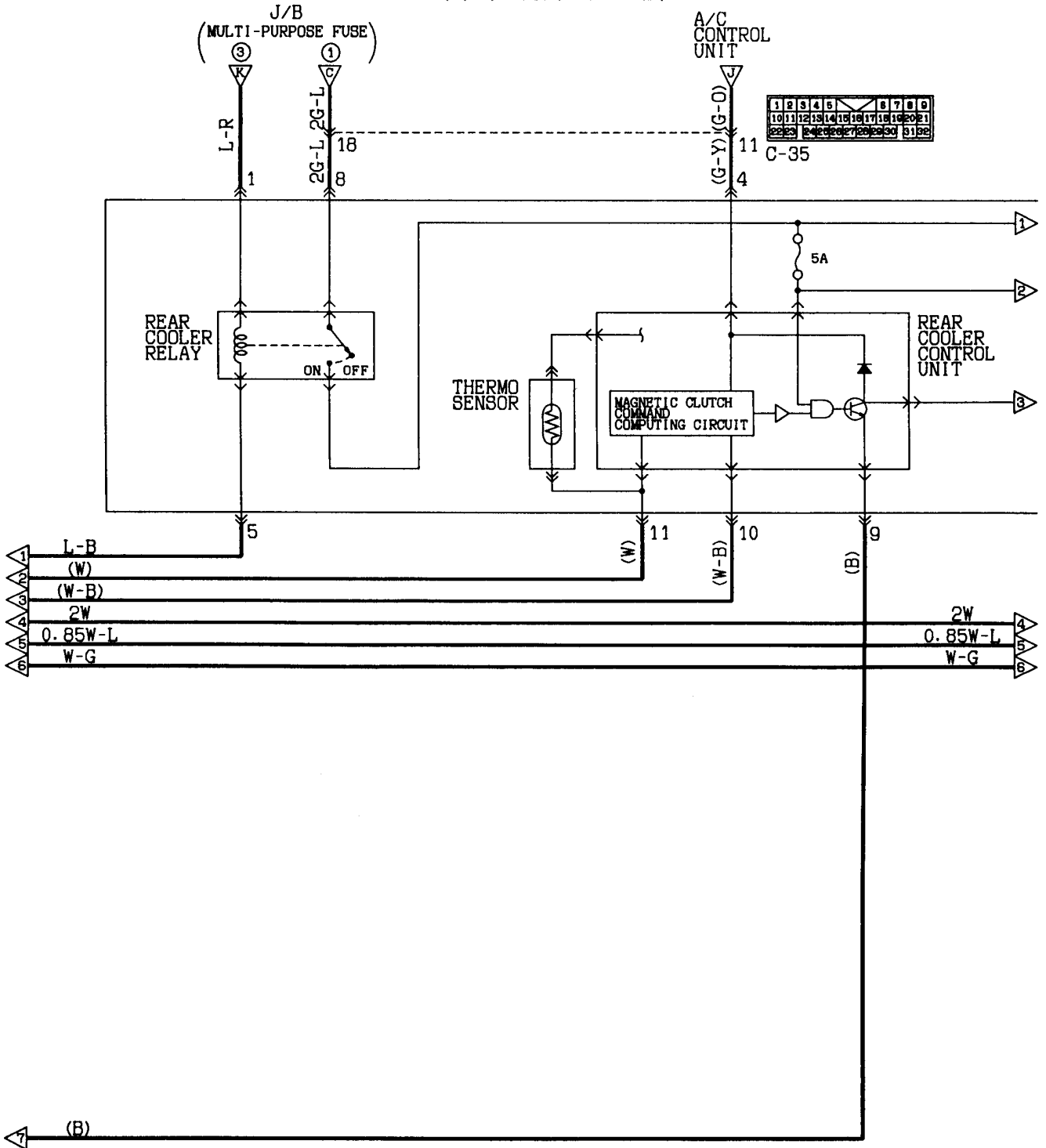

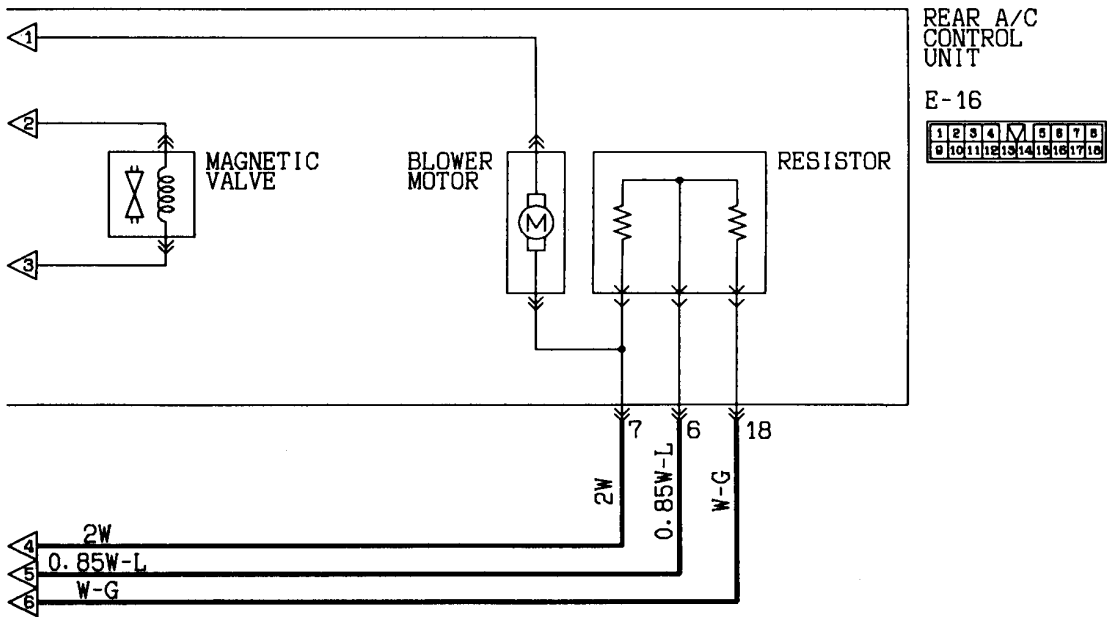

Wire colour code
 B:Black LG:Light green G:Green L:Blue W:White Y:Yellow SB:Sky blue
 BR:Brown O:Orange GR:Gray R:Red P:Pink V:Violet

DUAL AIR CONDITIONER
R.H. drive vehicles with rear heater
(diesel-powered vehicles)

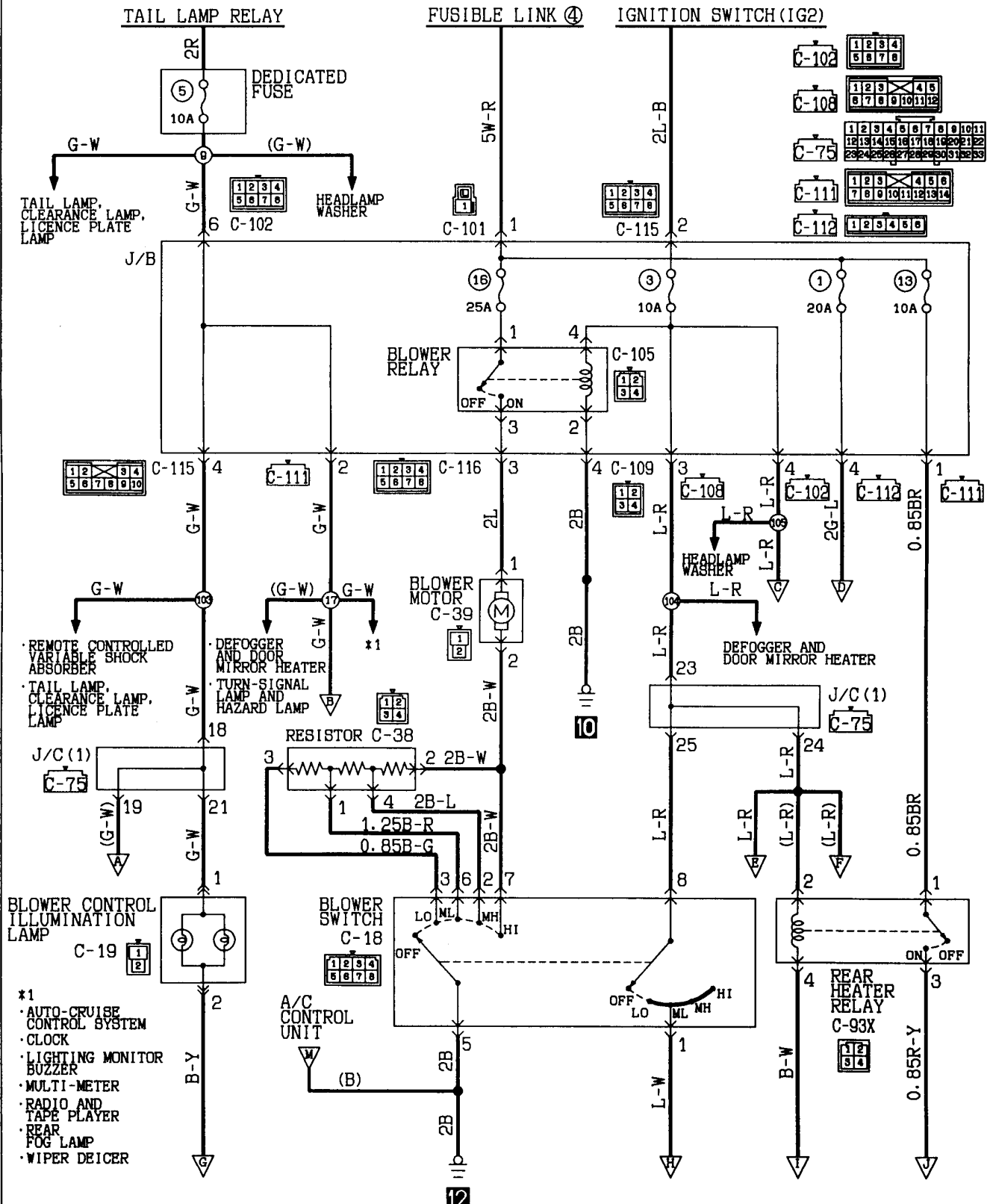

Wire colour code
 B:Black LG:Light green G:Green L:Blue W:White Y:Yellow BB:Sky blue
 BR:Brown O:Orange GR:Gray R:Red P:Pink V:Violet

KX35-AC-01239-EC

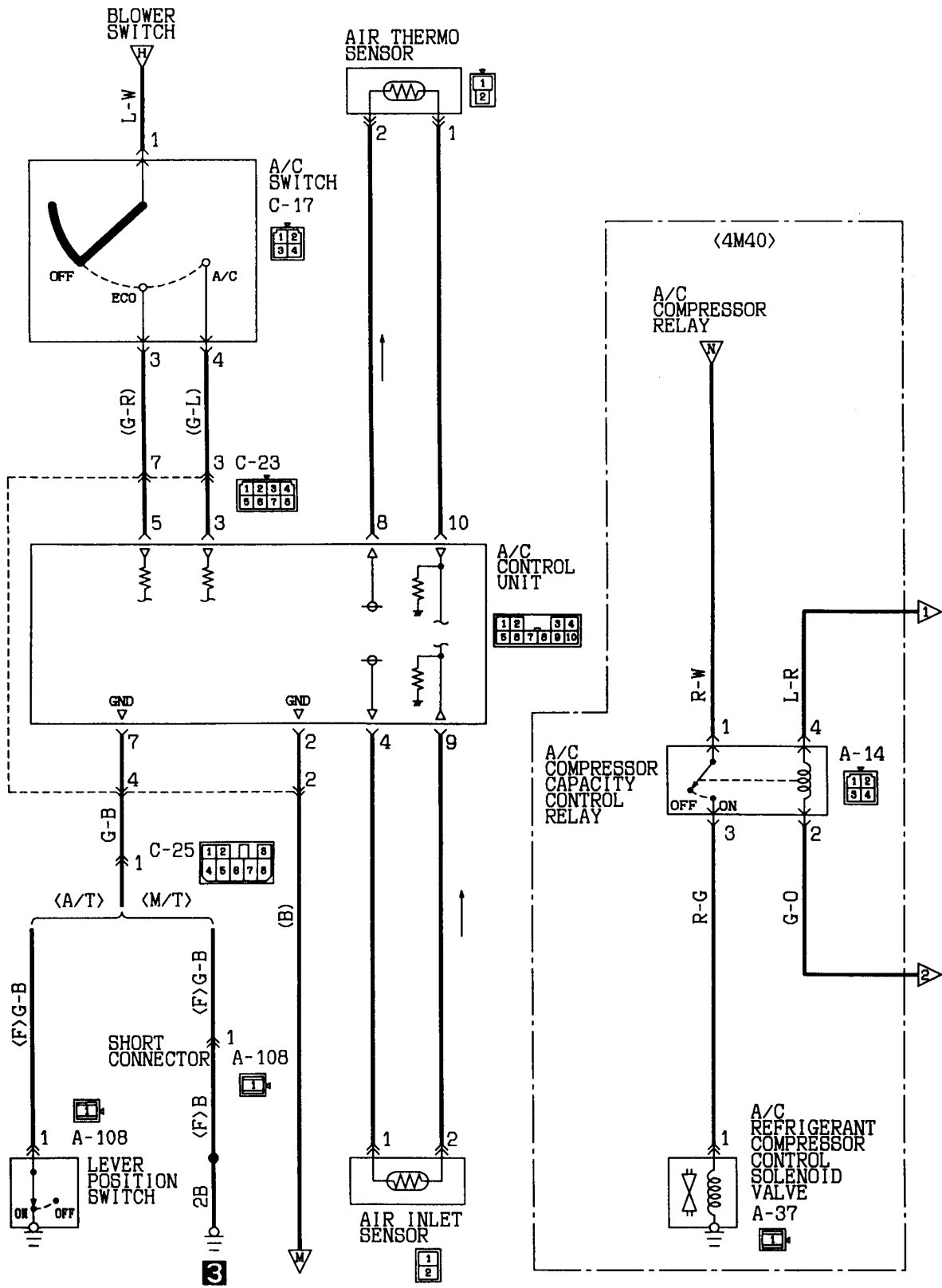

KX35-AC-01230A-EC

DUAL AIR CONDITONER
 (R. H. drive vehicles with rear heater
 (diesel-powered vehicles)) (CONTINUED)

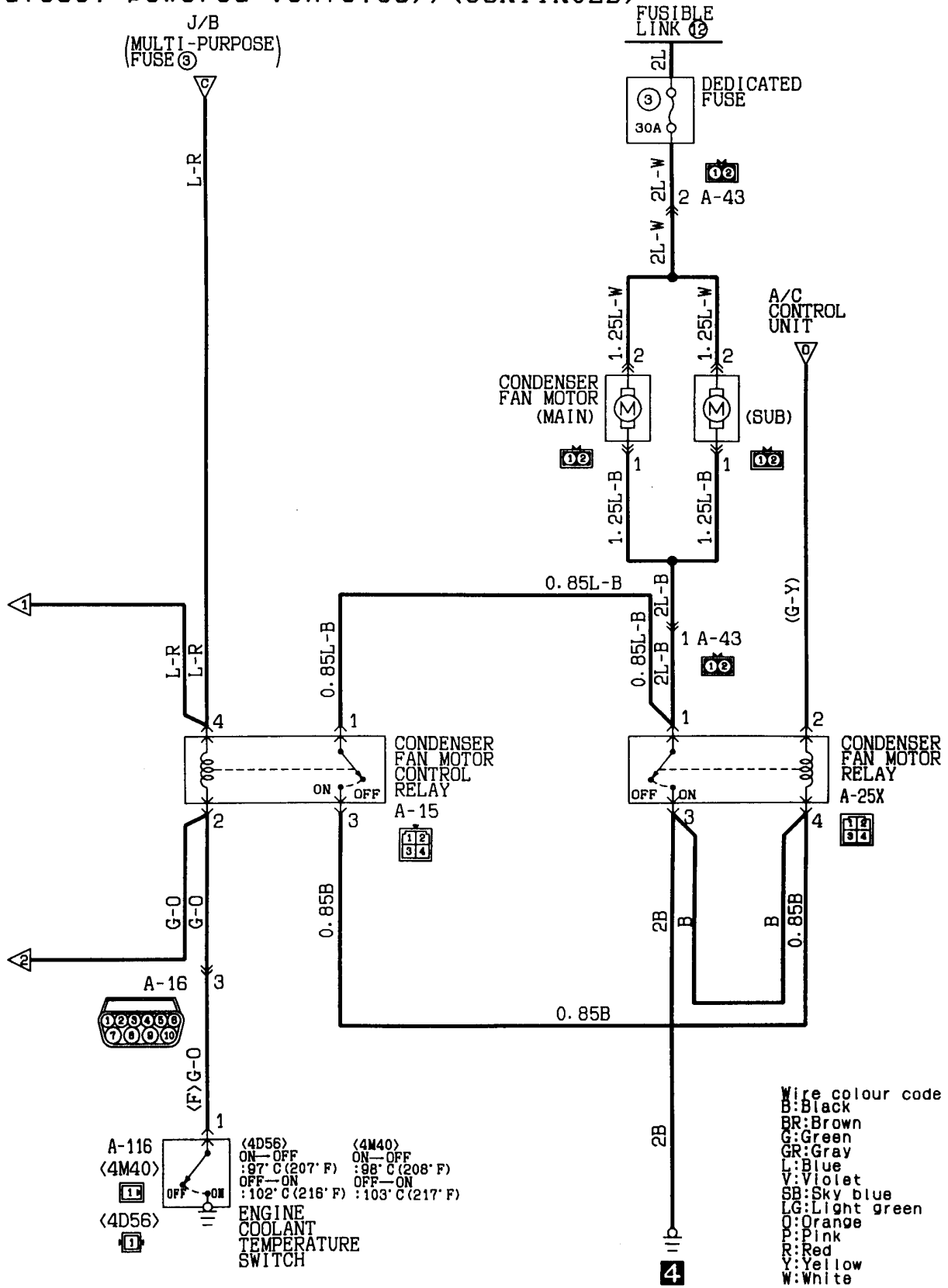

DUAL AIR CONDITIONER
 (R.H. drive vehicles with rear heater
 (diesel-powered vehicles)) (CONTINUED)

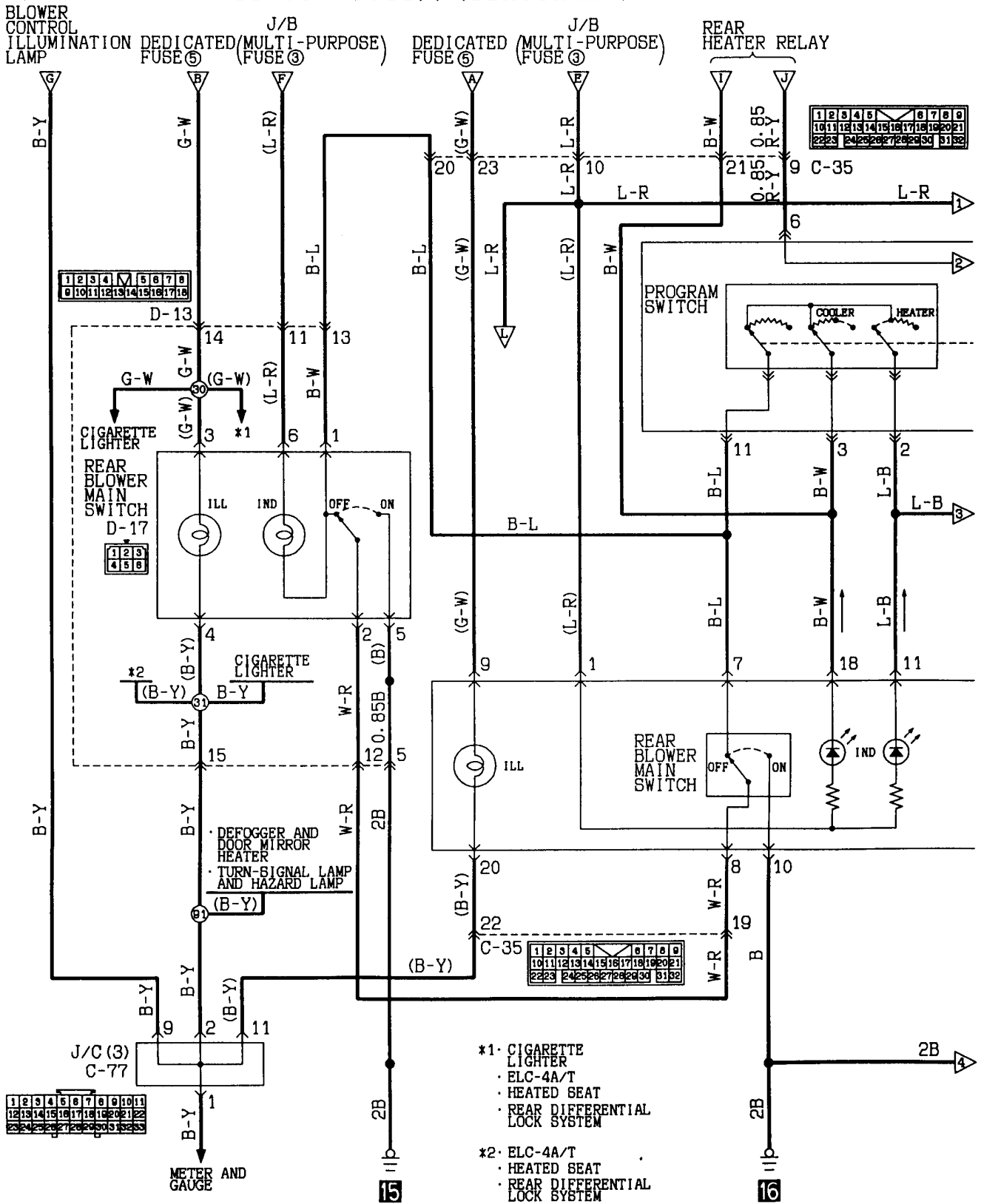

KX35-AC-01239C-EC

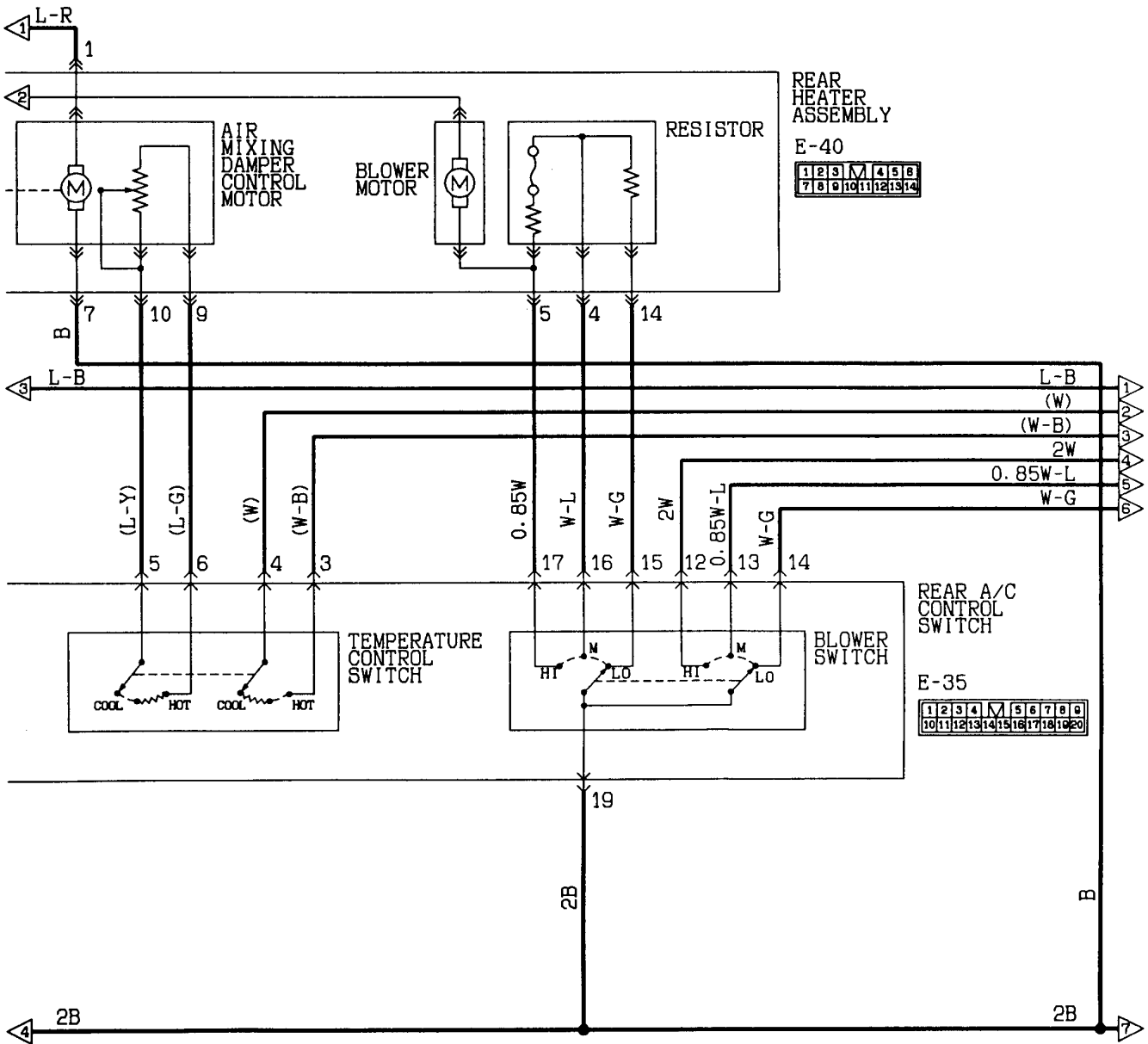

Wire colour code
 B:Black LG:Light green G:Green L:Blue W:White Y:Yellow SB:Sky blue
 BR:Brown O:Orange GR:Gray R:Red P:Pink V:Violet

DUAL AIR CONDITIONER
 (R.H. drive vehicles with rear heater
 (diesel-powered vehicles)) (CONTINUED)

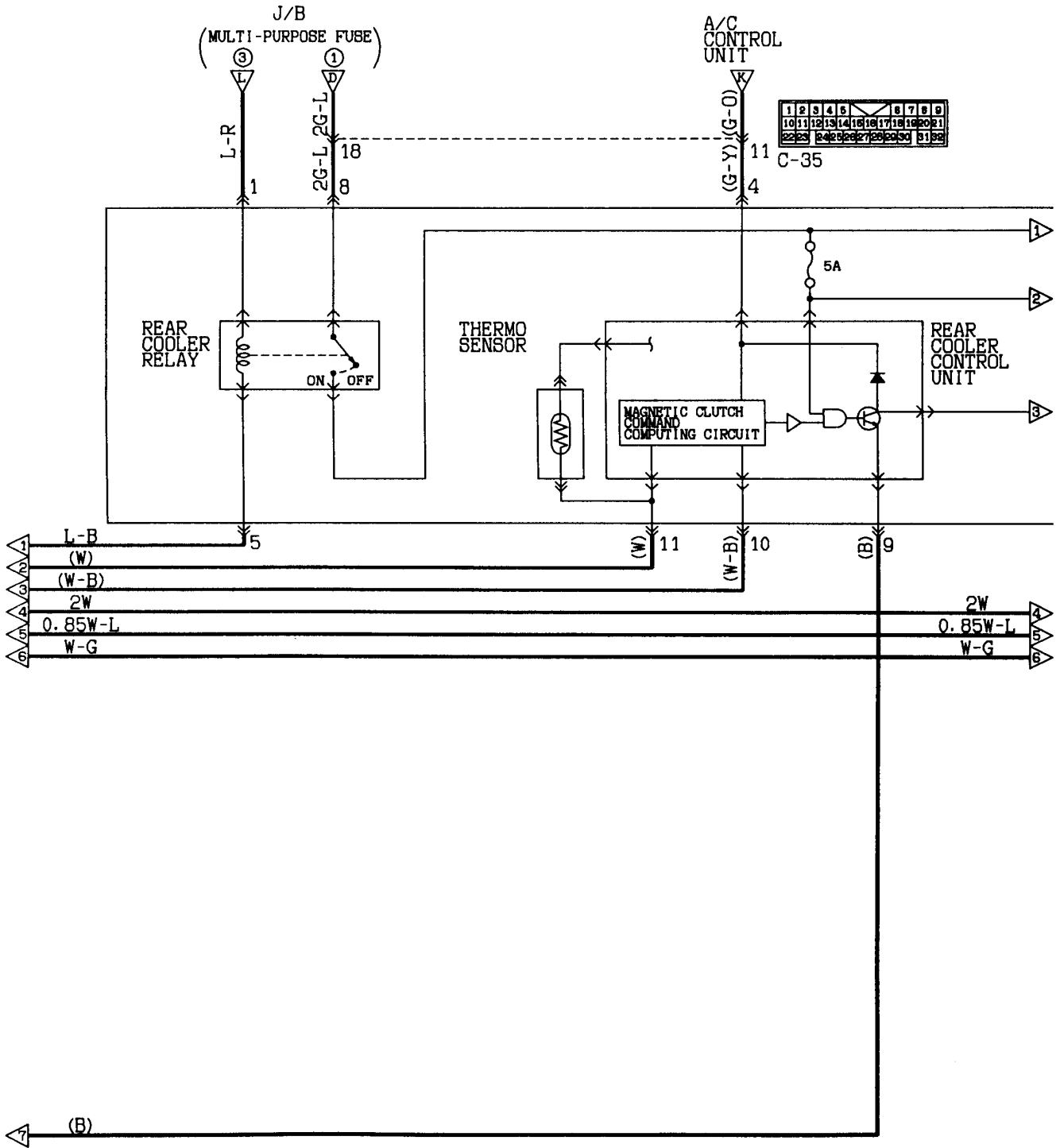

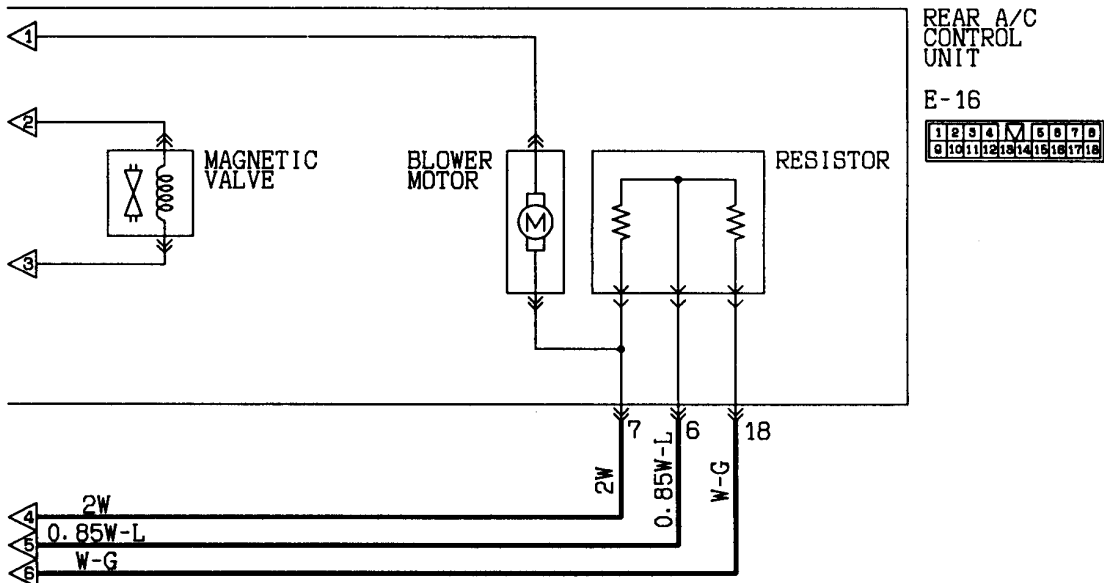

Wire colour code
 B:Black LG:Light green G:Green L:Blue W:White Y:Yellow SB:Sky blue
 BR:Brown O:Orange GR:Gray R:Red P:Pink V:Violet

WINDSHIELD WIPER AND WASHER
Vehicles without SRS

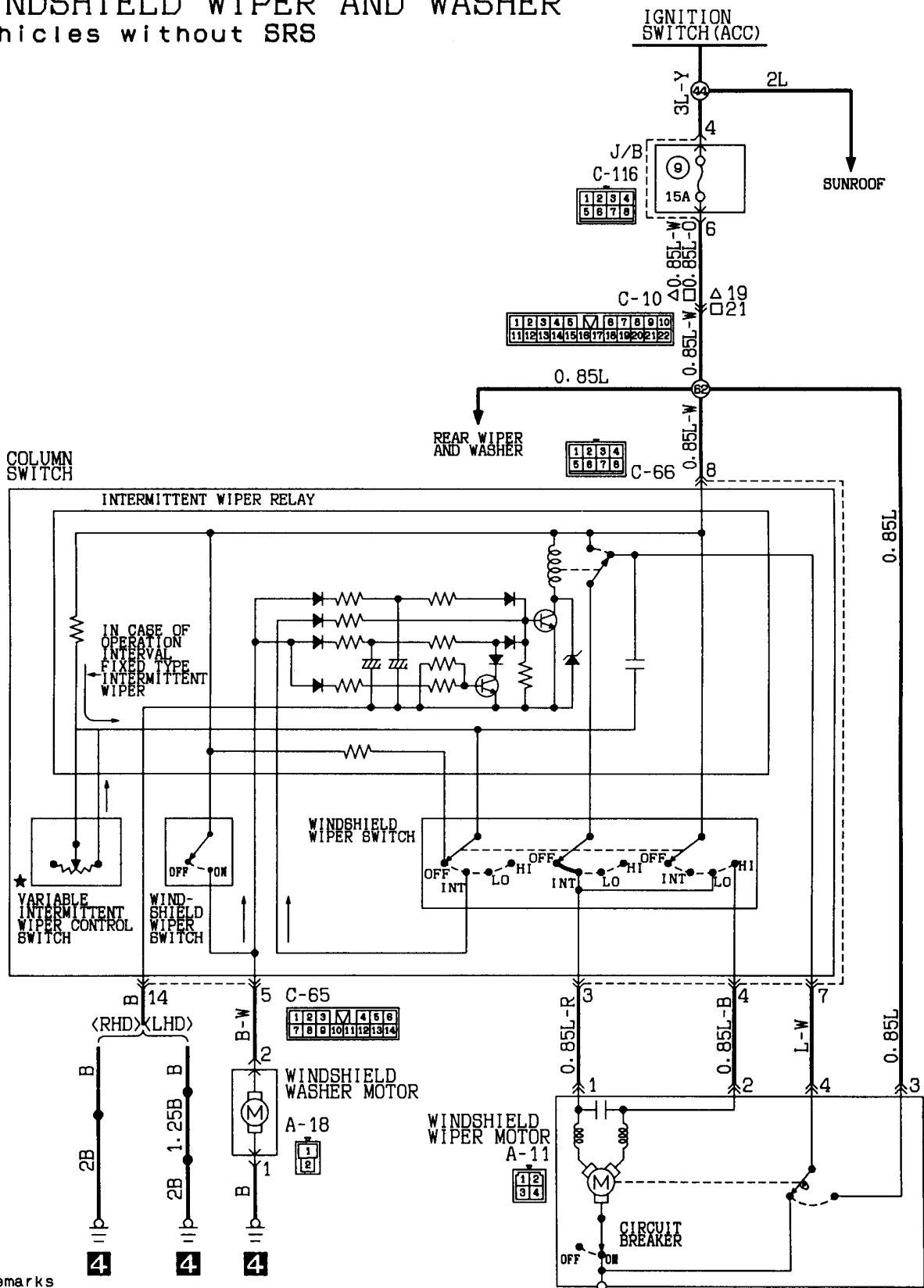

Remarks
 (1) □: L.H. drive vehicles.
 (2) △: R.H. drive vehicles.
 (3) ★: Vehicles with variable intermittent wiper.

Wire colour code
 B: Black LG: Light green G: Green L: Blue
 BR: Brown O: Orange GR: Gray R: Red
 W: White SB: Sky blue P: Pink Y: Yellow
 V: Violet

KX35-AC-01306-EC

WINDSHIELD WIPER AND WASHER

Vehicles with SRS

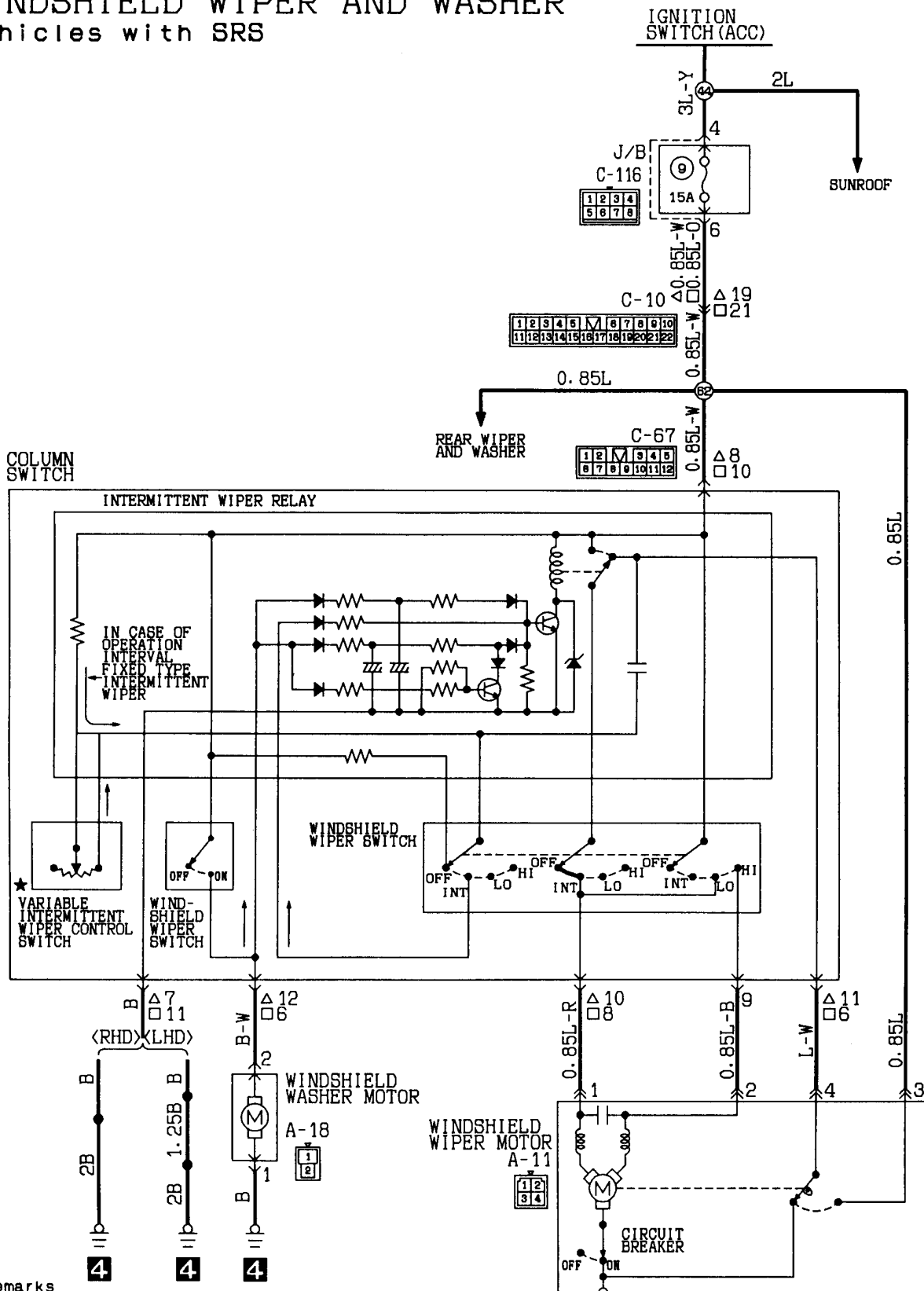

Remarks
 (1) □: L. H. drive vehicles.
 (2) △: R. H. drive vehicles.
 (3) ★: Vehicles with variable intermittent wiper.

Wire colour code
 B: Black LG: Light green G: Green L: Blue
 BR: Brown O: Orange GR: Gray R: Red
 W: White SB: Sky blue P: Pink Y: Yellow
 V: Violet

KX35-AC-01316-EC

WINDSHIELD WIPER AND WASHER (See P. 4A-260, 261.)**OPERATION****⟨Low-speed (and high-speed) wiper operation⟩**

- When the wiper switch is placed in the LO position with the ignition switch in the ACC or ON position, wipers operate continuously at low speed.
- Placing the wiper switch in the HI position causes the wipers to operate at high speed.

⟨Auto wiper stop operation⟩

- When the wiper switch is placed in the OFF position, the cam contacts of wiper motor caused current to flow through the auto wiper stop circuit, allowing the wiper blades to cycle before they reach to the stop positions.

⟨Intermittent wiper operation⟩

- When the wiper switch is placed in the INT position with the ignition switch in ACC or ON position, the intermittent wiper relay is energized causing the intermittent wiper relay contacts to close and open repeatedly.
- When the contacts are closed, the wiper motor is energized.
- When the wiper motor is energized, the relay contacts open; however, the cam contacts keep the wiper motor energized until the wiper blades return to their stop position.

⟨Washer-Wiper operation⟩

- When the washer switch is turned ON, the intermittent wiper relay contacts close causing wipers to cycle two to three times.

TROUBLESHOOTING HINTS

1. Wipers do not operate.
 - 1) Washer is not operative, either.
 - Check multi-purpose fuse No. ⑨.
 - Check earth.
2. Low-speed (or high-speed) wiper operation only is inoperative.
 - Check wiper switch.
3. Wipers do not stop.
 - Check wiper motor.
 - Check intermittent wiper relay.
 - Check wiper switch.
4. Intermittent wiper operation is inoperative.
 - Check terminal voltage of steering-column switch (with a built-in intermittent wiper relay) with the intermittent wiper relay energized.

Terminal No.	Voltage	Check
3	0V	Intermittent wiper relay or wiper switch
	System voltage	Intermittent wiper relay
	0V ↔ System voltage (alternating)	— (Normal)

5. The length of pause for intermittent operation cannot be varied.
 - Check variable intermittent wiper control switch.
 - Check intermittent wiper relay.
6. Washer is inoperative.
 - 1) Wiper is operative on washer-wiper operation.
 - Check washer motor.
 - 2) Washer-wiper operation is inoperative also.
 - Check washer switch.
7. Washer-wiper operation is inoperative.
 - Check intermittent wiper relay.

REAR WIPER AND WASHER (See P. 4A-264, 266.)**OPERATION****<Low-speed wiper operation>**

- When the wiper switch is placed in the LO (or ON) position with the ignition switch in the ACC or ON position, wipers operate continuously at low speed.

<Auto wiper stop operation>

- When the wiper switch is placed in the OFF position, the cam contacts of wiper motor causes current to flow through the auto wiper stop circuit, allowing the wiper blades to cycle before they reach to the stop positions.

<Intermittent wiper operation>

- When the wiper switch is placed in the INT position with the ignition switch in ACC or ON position, the intermittent wiper relay is energized causing the intermittent wiper relay contacts to close and open repeatedly.
- When the contacts are closed, the wiper motor is energized.
- When the wiper motor is energized, the relay contacts open; however, the cam contacts keep the wiper motor energized until the wiper blades return to their stop position.

<Washer-Wiper operation>

- When the washer switch is turned ON, the intermittent wiper relay contacts close causing wipers to cycle two to three times.

TROUBLESHOOTING HINTS

1. Wipers do not operate.
 - 1) Washer is not operative, either.
 - Check multi-purpose fuse No. ⑨.
 - Check earth.
 - Check wiper switch.
2. Wipers do not stop.
 - Check wiper motor.
 - Check intermittent wiper relay.
 - Check wiper switch.
3. Intermittent wiper operation is inoperative.
 - Check terminal voltage of the intermittent wiper relay energized.

Terminal No.	Voltage	Check
1	0 V	Intermittent wiper relay or wiper switch
	System voltage	Intermittent wiper relay
	0 V ↔ System voltage (alternating)	— (Normal)

4. Washer is inoperative.
 - Check washer motor.
 - Check washer switch.
5. Washer-wiper operation is inoperative.
 - Check intermittent wiper relay.

REAR WIPER AND WASHER

Vehicles without SRS IGNITION SWITCH (ACC)

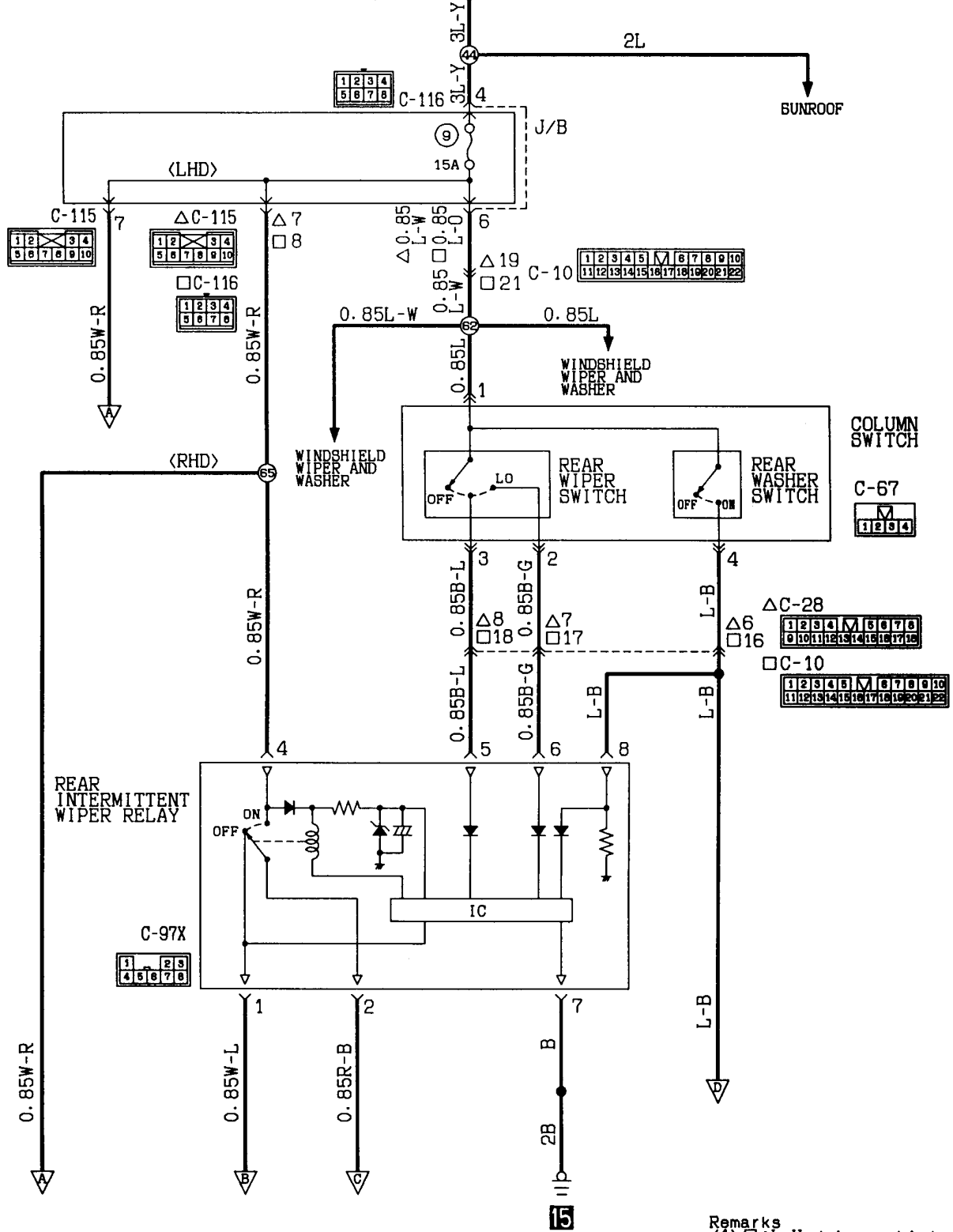

Remarks
 (1) □: L.H. drive vehicles
 (2) △: R.H. drive vehicles

Wire colour code
 B:Black LG:Light green G:Green L:Blue W:White Y:Yellow SB:Sky blue
 BR:Brown O:Orange GR:Gray R:Red P:Pink V:Violet

KX35-AC-01307-EC

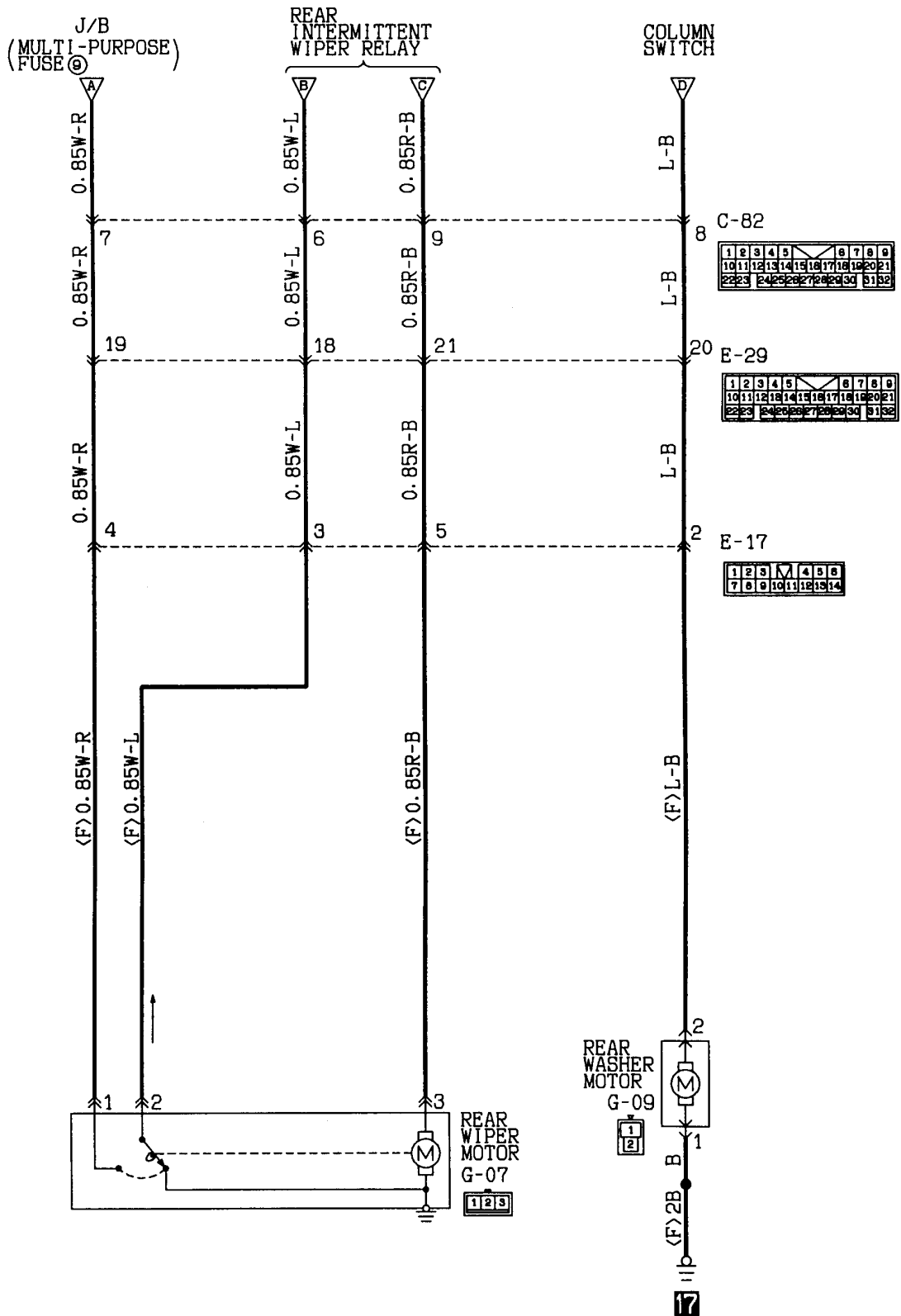

REAR WIPER AND WASHER
Vehicles with SRS

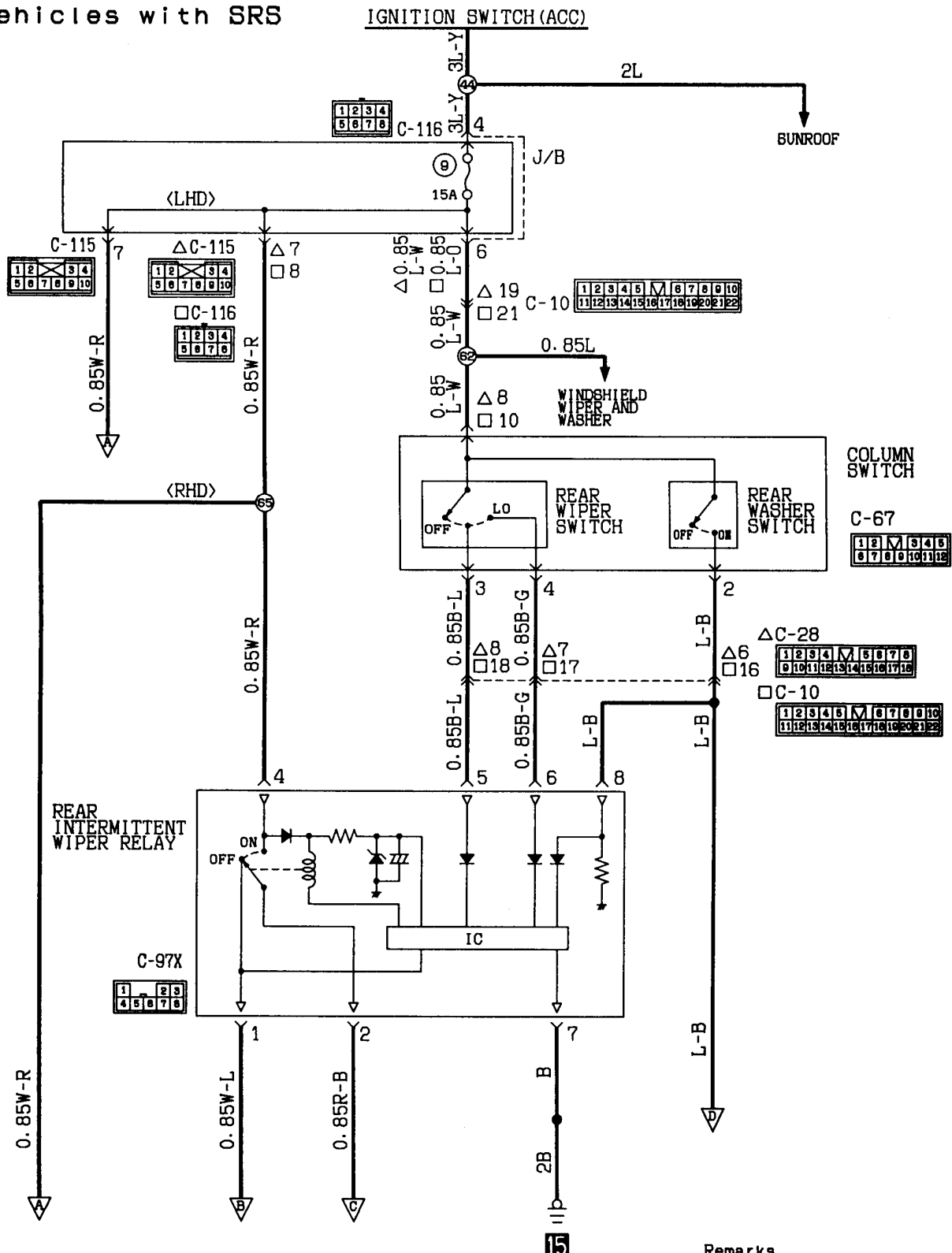

Remarks
(1) □: L.H. drive vehicles
(2) △: R.H. drive vehicles

KX35-AC-01317-EC
Wire colour code
B:Black LG:Light green G:Green L:Blue W:White Y:Yellow SB:Sky blue
BR:Brown O:Orange GR:Gray R:Red P:Pink V:Violet

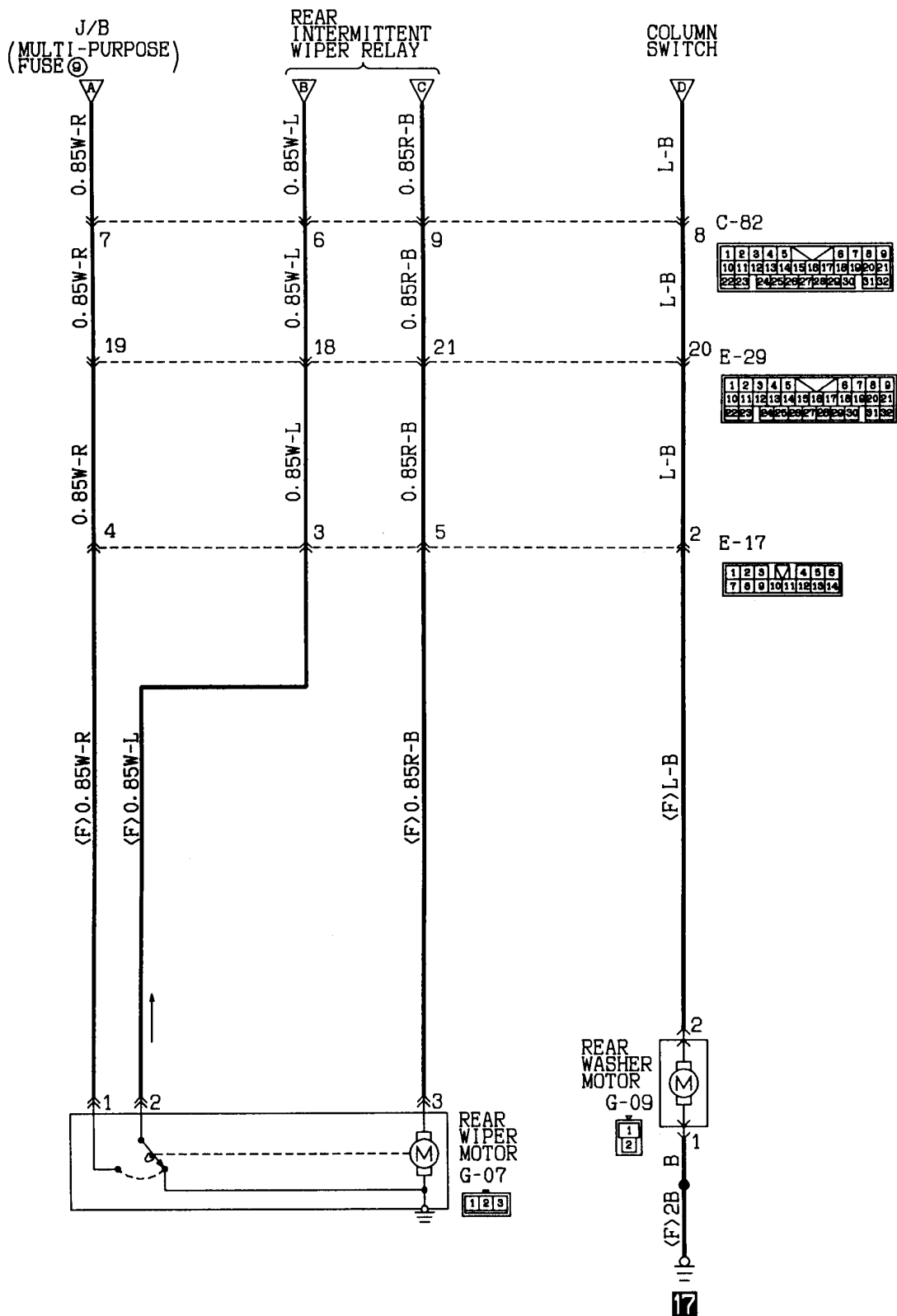

HEADLAMP WASHER

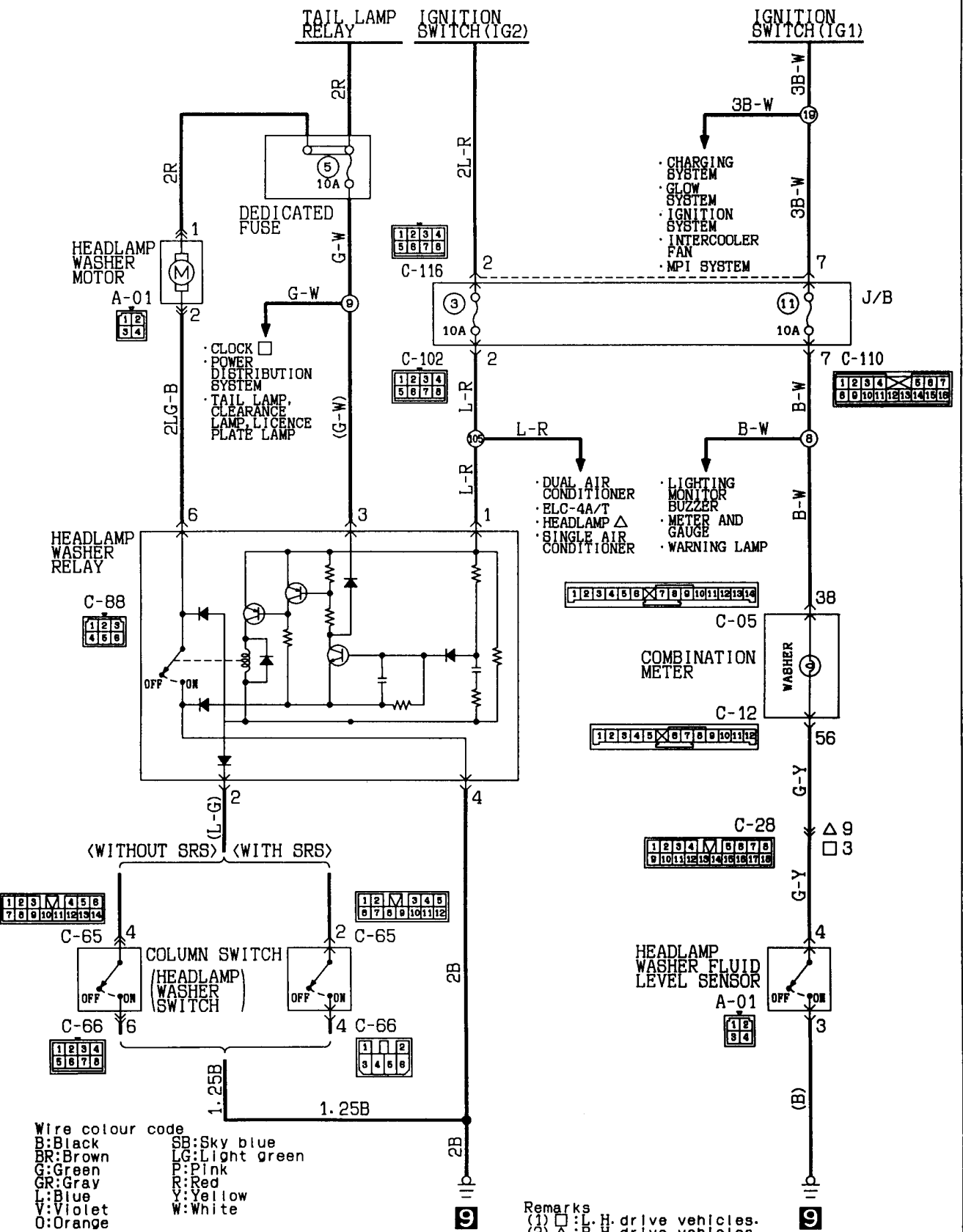

Wire colour code
 B:Black
 BR:Brown
 G:Green
 GR:Gray
 L:Blue
 V:Violet
 O:Orange
 SB:Sky blue
 LG:Light green
 P:Pink
 R:Red
 Y:Yellow
 W:White

Remarks
 (1) □ : L.H. drive vehicles.
 (2) △ : R.H. drive vehicles.

KX35-AC-01309-EC

HEADLAMP WASHER (See P. 4A-268.)**OPERATION**

- When the headlamp washer switch is turned ON with ignition switch in ON and lighting switch in TAIL or HEAD position, the headlamp washer relay is energized causing the headlamp washer motor to start.

TROUBLESHOOTING HINTS

1. Headlamp washer motor does not start.
 - 1) Blower motor does not start, either.
 - Check multi-purpose fuse No. ③.
 - 2) Blower motor does start.
 - Check headlamp washer motor.
 - Check headlamp washer relay.
 - Check headlamp washer switch.

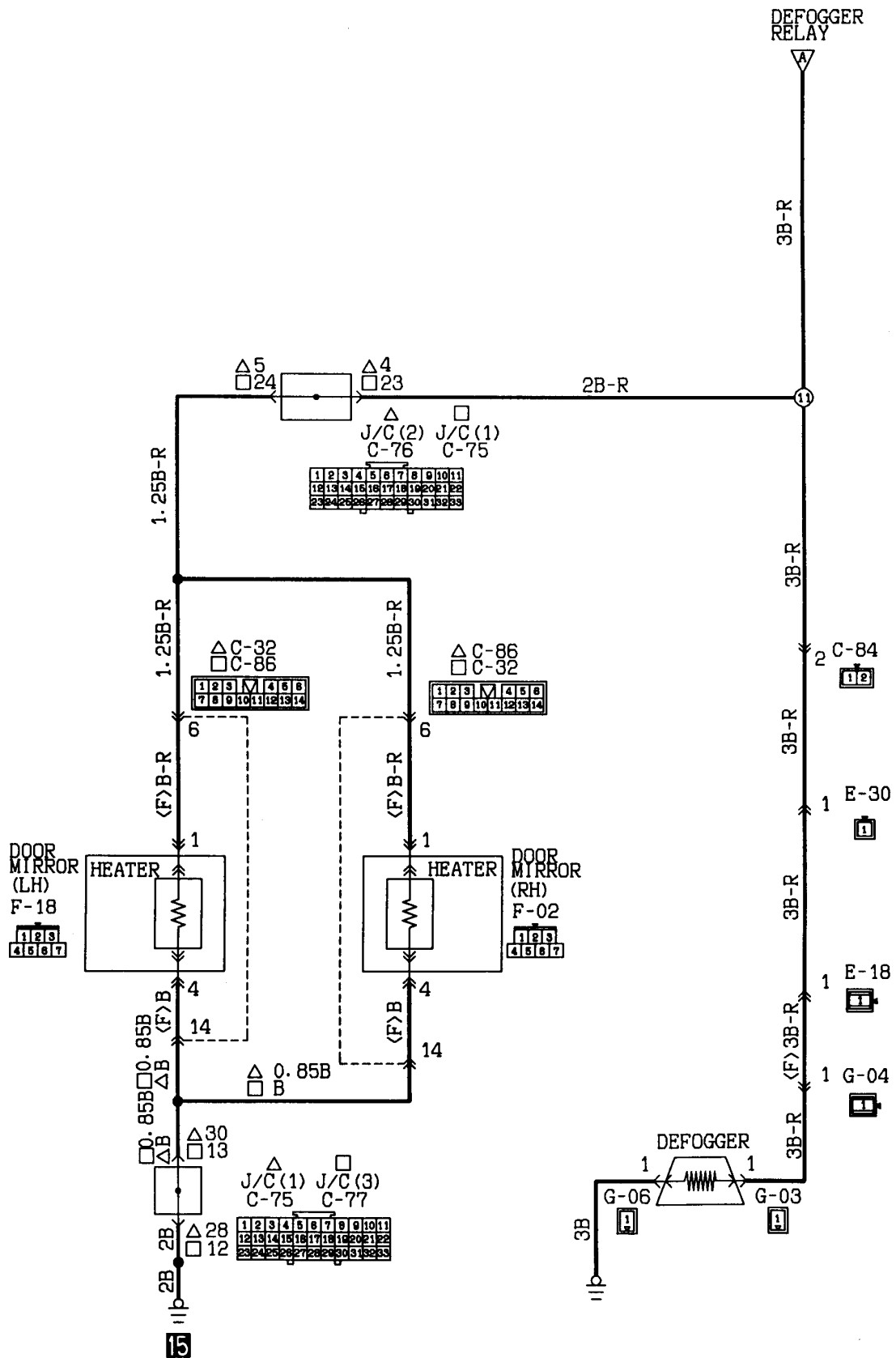

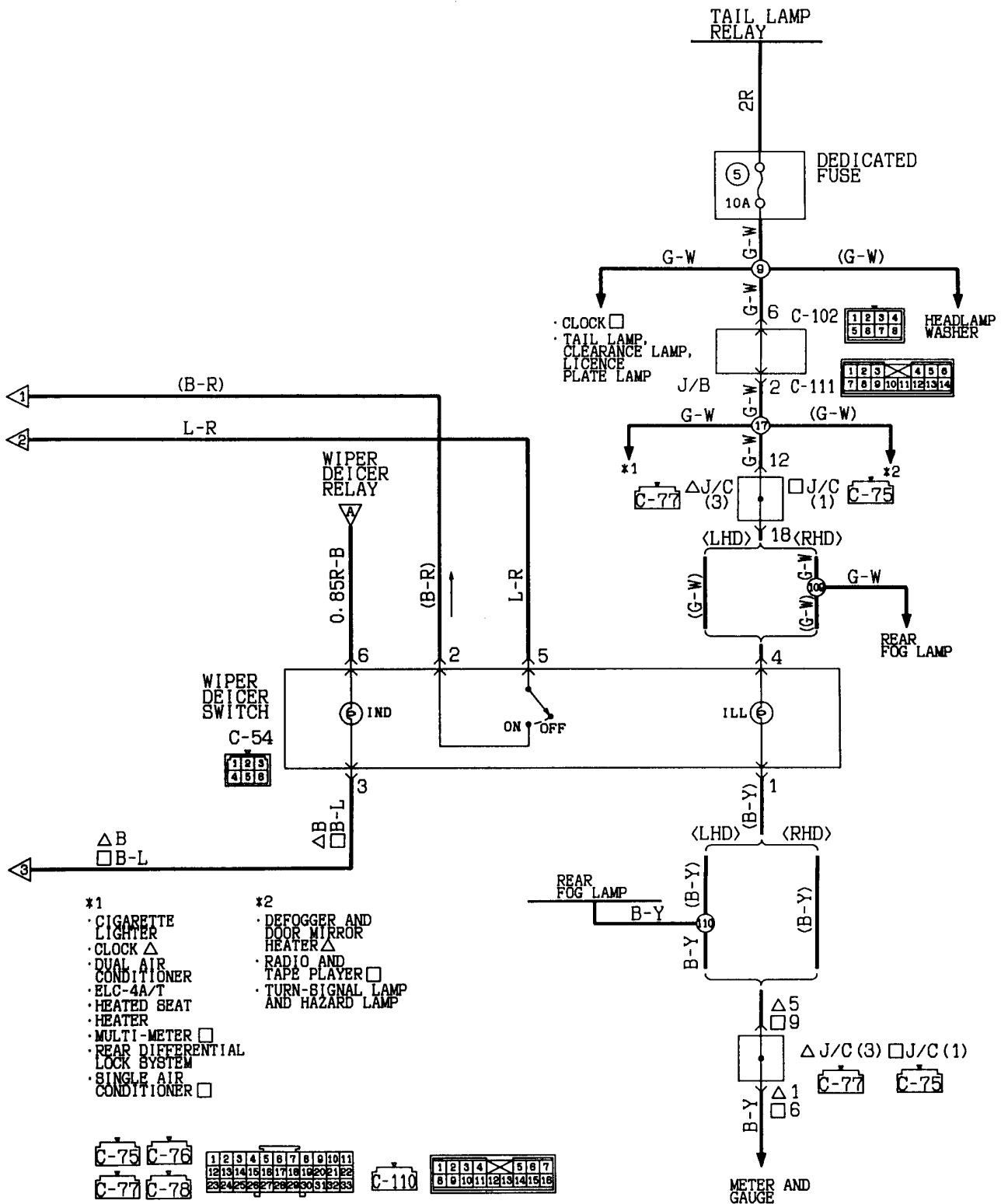

- *1
 - CIGARETTE LIGHTER
 - CLOCK Δ
 - DUAL AIR CONDITIONER
 - ELC-4A/T
 - HEATED SEAT HEATER
 - MULTI-METER \square
 - REAR DIFFERENTIAL LOCK SYSTEM
 - SINGLE AIR CONDITIONER \square
- *2
 - DEFOGGER AND DOOR MIRROR HEATER Δ
 - RADIO AND TAPE PLAYER \square
 - TURN-SIGNAL LAMP AND HAZARD LAMP

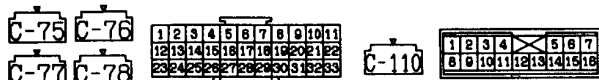

Remarks
 (1) \square : L. H. drive vehicles.
 (2) Δ : R. H. drive vehicles.

Wire colour code
 B:Black LG:Light green G:Green L:Blue W:White Y:Yellow SB:Sky blue
 BR:Brown O:Orange GR:Gray R:Red P:Pink V:Violet

REMOTE CONTROLLED MIRROR

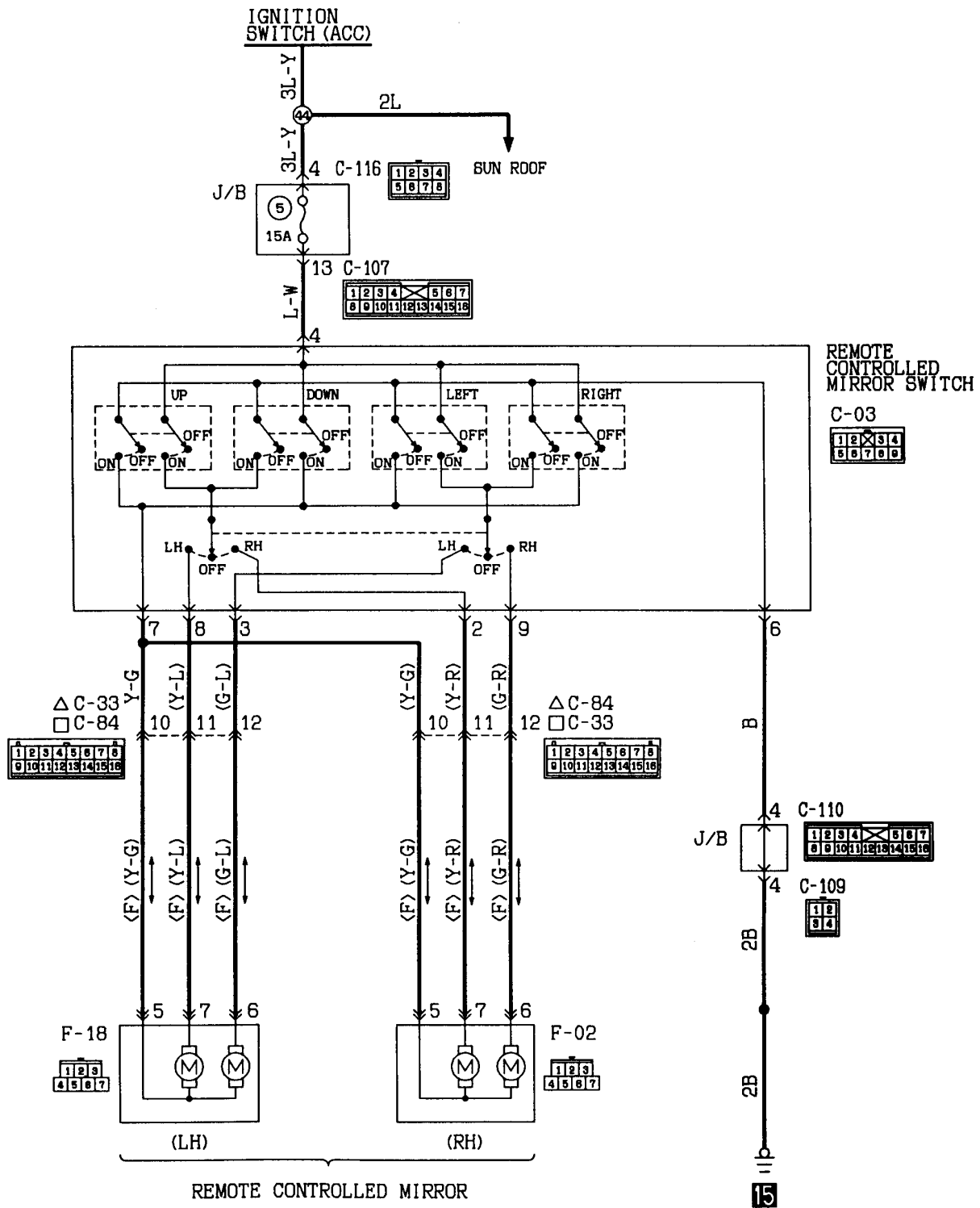

Remarks
 (1) Δ: L.H. drive vehicles
 (2) □: R.H. drive vehicles

Wire colour code
 B:Black LG:Light green G:Green L:Blue W:White Y:Yellow 8B:8kv blue
 BR:Brown O:Orange GR:Gray R:Red P:Pink V:Violet

REMOTE CONTROLLED MIRROR (See P. 4A-274.)**OPERATION**

- When the remote controlled mirror switch is operated with the ignition switch in ACC or ON position, the motor is started allowing the driver to adjust the orientation of the mirror surface.

TROUBLESHOOTING HINTS

1. LH and RH mirrors do not move.
 - 1) Cigarette lighter is also inoperative.
 - Check multi-purpose fuse No. ⑤.
 - 2) Cigarette lighter is operative.
 - Check remote controlled mirror switch.

RADIO AND TAPE PLAYER
L.H. drive vehicles (AM/FM radio)

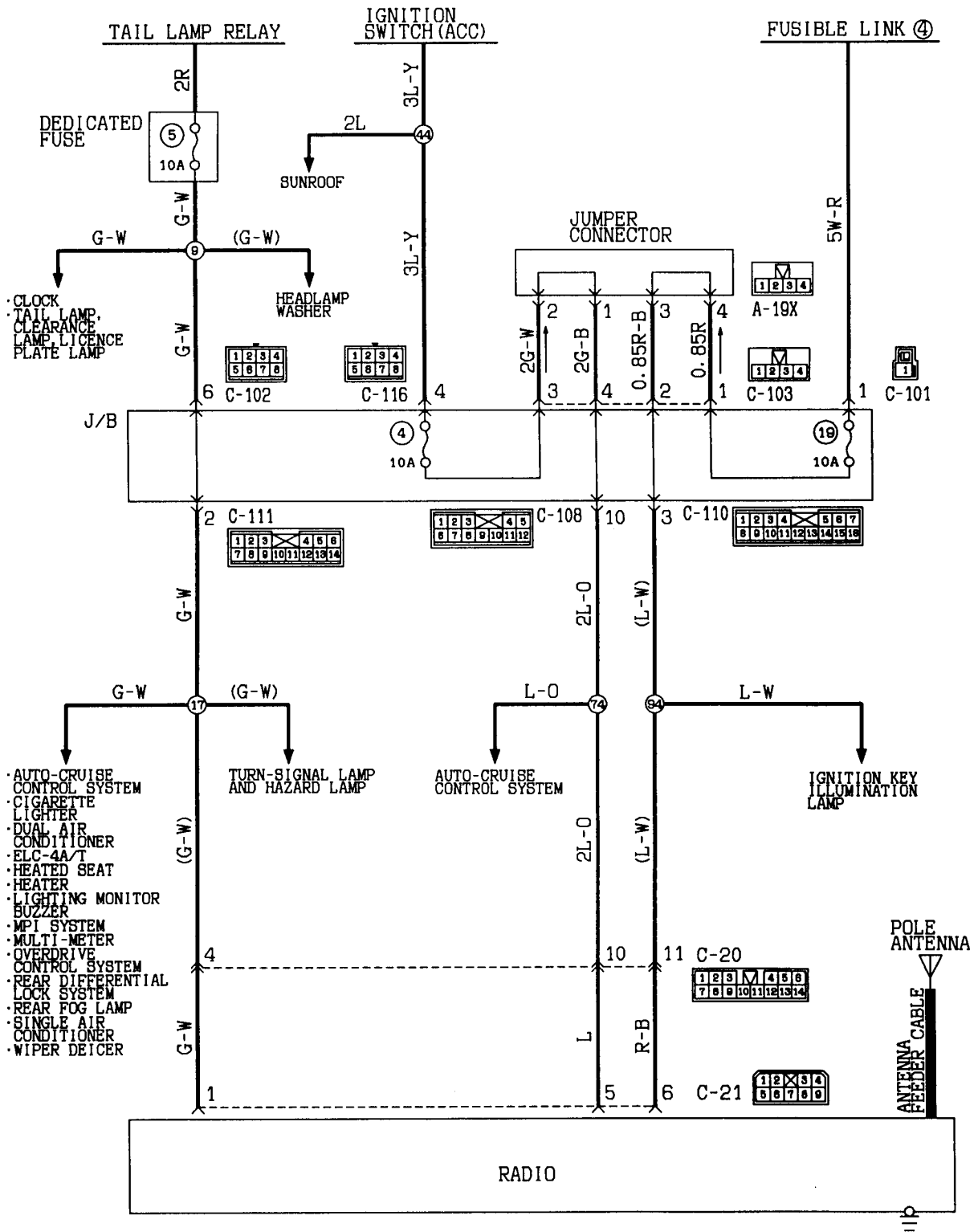

CLOCK
TAIL LAMP
CLEARANCE
LAMP LICENCE
PLATE LAMP

AUTO-CRUISE
CONTROL SYSTEM
CIGARETTE
LIGHTER
DUAL AIR
CONDITIONER
ELC-4A/T
HEATED SEAT
HEATER
LIGHTING MONITOR
BUZZER
MPI SYSTEM
MULTI-METER
OVERDRIVE
CONTROL SYSTEM
REAR DIFFERENTIAL
LOCK SYSTEM
REAR FOG LAMP
SINGLE AIR
CONDITIONER
WIPER DEICER

Wire colour code
B:Black LG:Light green G:Green L:Blue W:White Y:Yellow BB:Sky blue
BR:Brown O:Orange GR:Gray R:Red P:Pink V:Violet

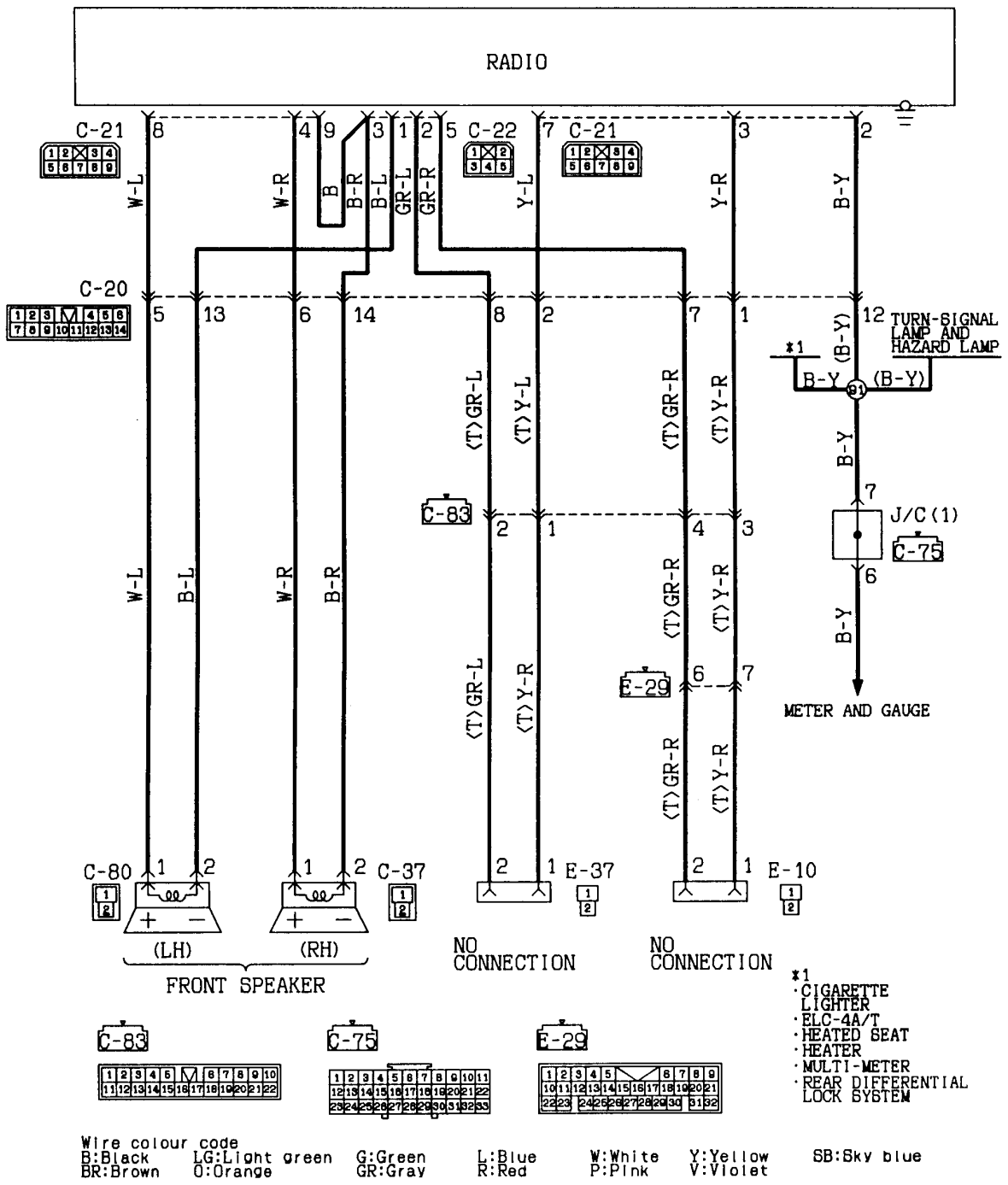

RADIO AND TAPE PLAYER

L.H. drive vehicles <LW/MW/FM radio and tape player>

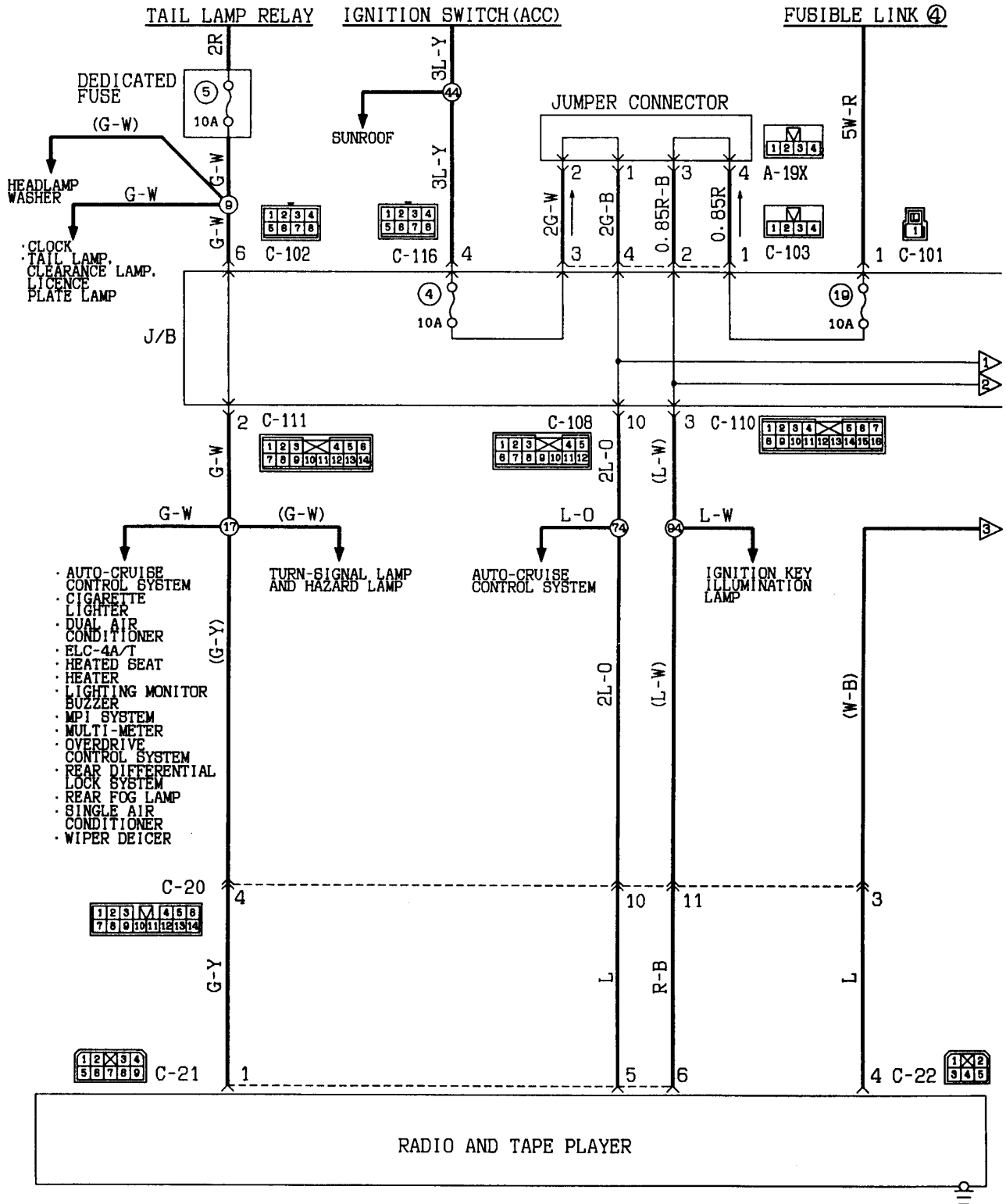

- AUTO-CRUISE CONTROL SYSTEM
- CIGARETTE LIGHTER
- DUAL AIR CONDITIONER
- ELC-4A/T
- HEATED SEAT
- HEATER
- LIGHTING MONITOR BUZZER
- MPI SYSTEM
- MULTI-METER
- OVERDRIVE CONTROL SYSTEM
- REAR DIFFERENTIAL LOCK SYSTEM
- REAR FOG LAMP
- SINGLE AIR CONDITIONER
- WIPER DEICER

Wire colour code
 B:Black LG:Light green G:Green L:Blue W:White Y:Yellow SB:Sky blue
 BR:Brown O:Orange GR:Gray R:Red P:Pink V:Violet

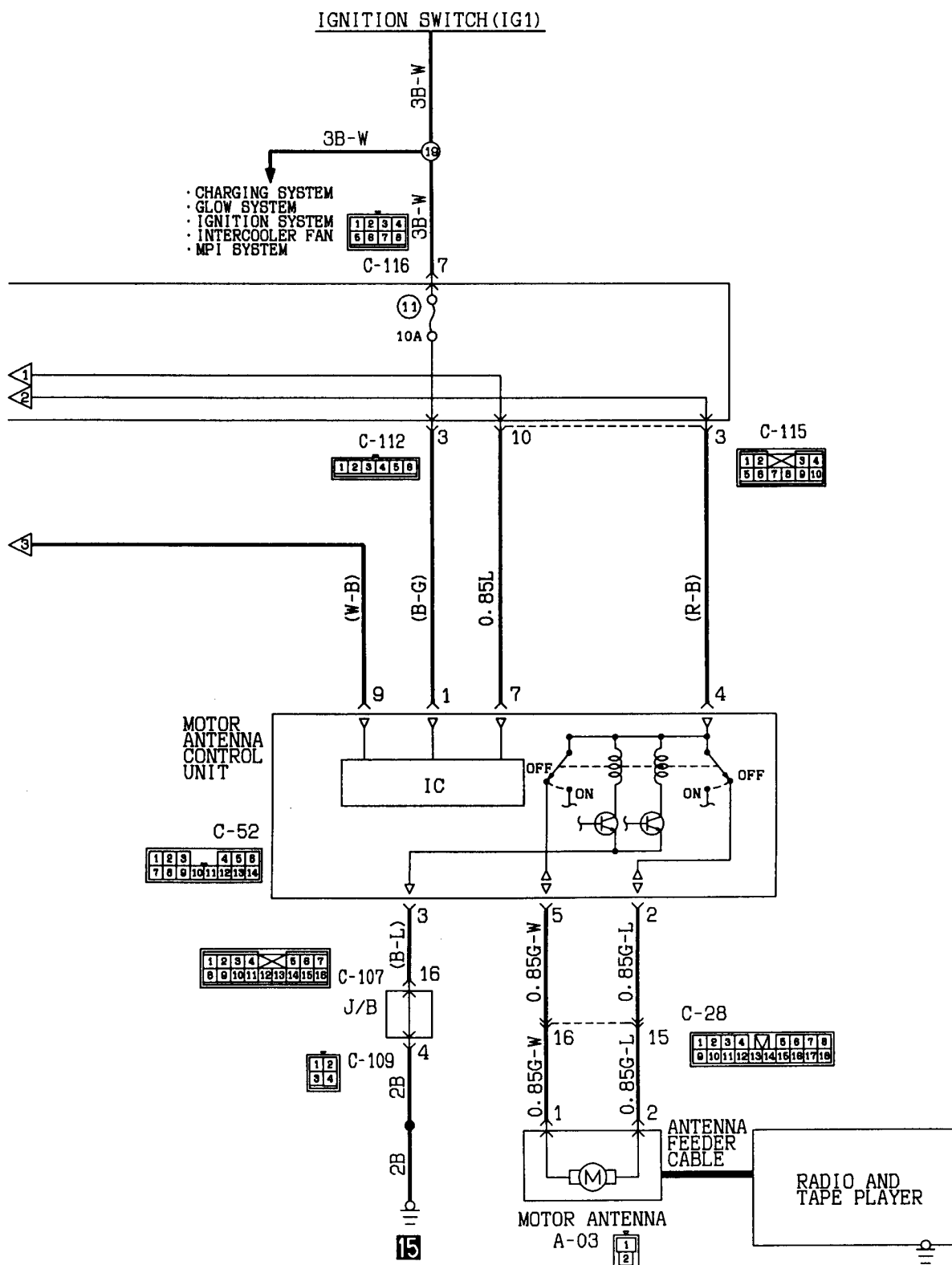

RADIO AND TAPE PLAYER
 (L.H. drive vehicles (LW/MW/FM radio and tape player))
 (CONTINUED)

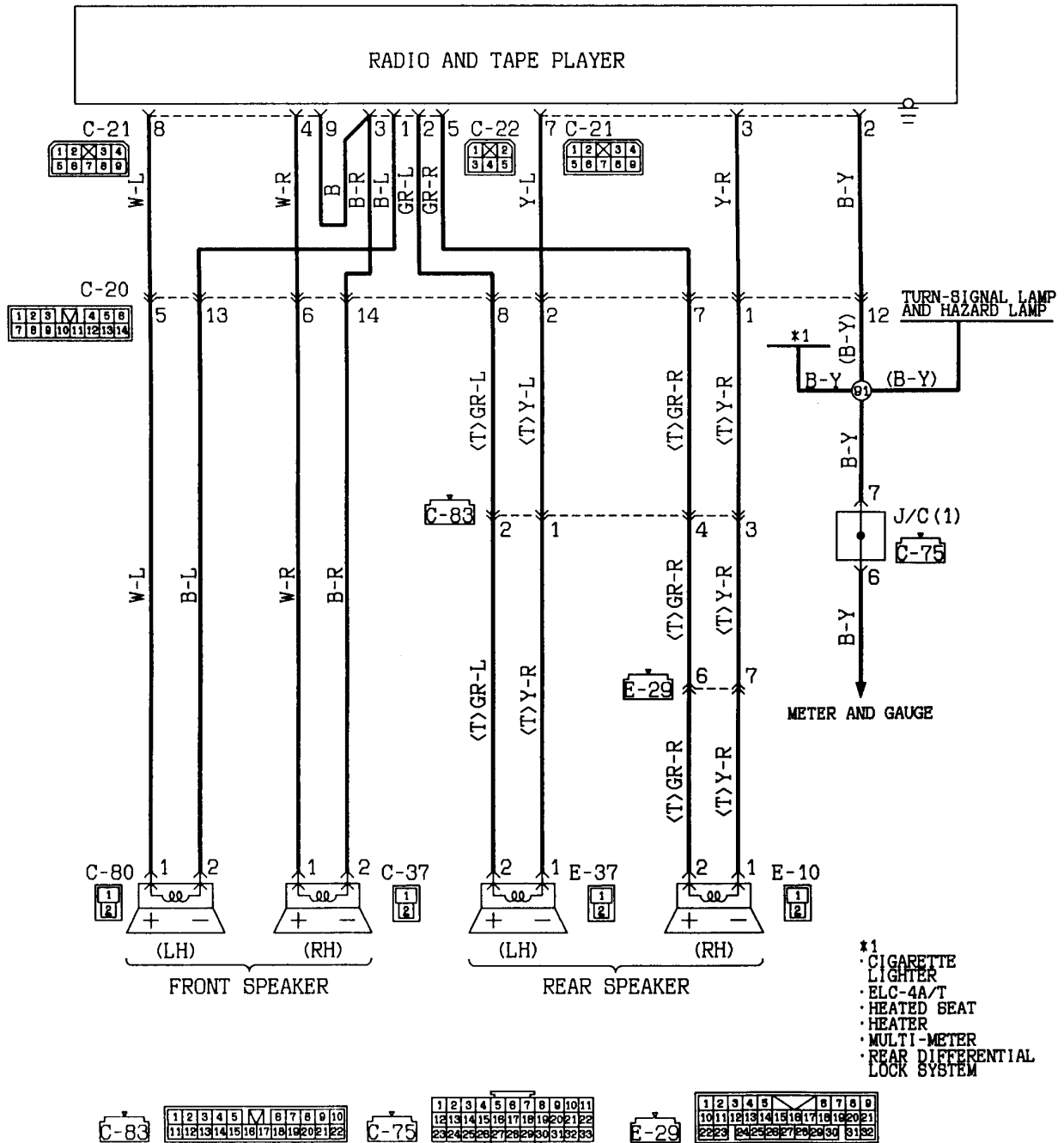

- *1
- CIGARETTE LIGHTER
- ELC-4A/T
- HEATED SEAT
- HEATER
- MULTI-METER
- REAR DIFFERENTIAL LOCK SYSTEM



Wire colour code
 B:Black LG:Light green G:Green L:Blue W:White Y:Yellow SB:Sky blue
 BR:Brown O:Orange GR:Gray R:Red P:Pink V:Violet

RADIO AND TAPE PLAYER

L.H. drive vehicles (AM/FM radio and tape player)

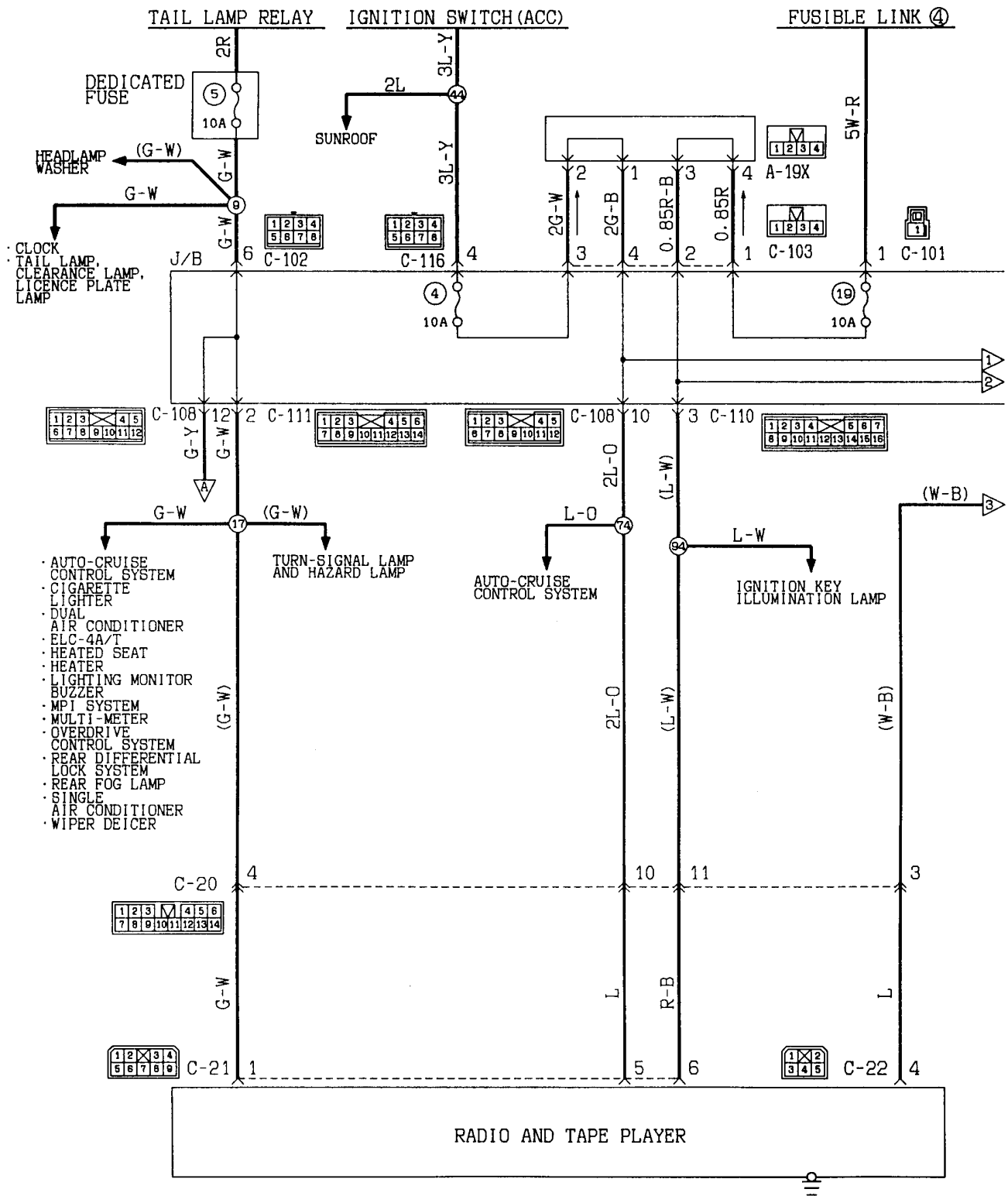

Wire colour code
 B:Black LG:Light green G:Green L:Blue W:White Y:Yellow SB:Sky blue
 BR:Brown O:Orange GR:Gray R:Red P:Pink V:Violet

KX35-AC-01427-EC

RADIO AND TAPE PLAYER
 L.H. drive vehicles (AM/FM radio and tape player)
 (CONTINUED)

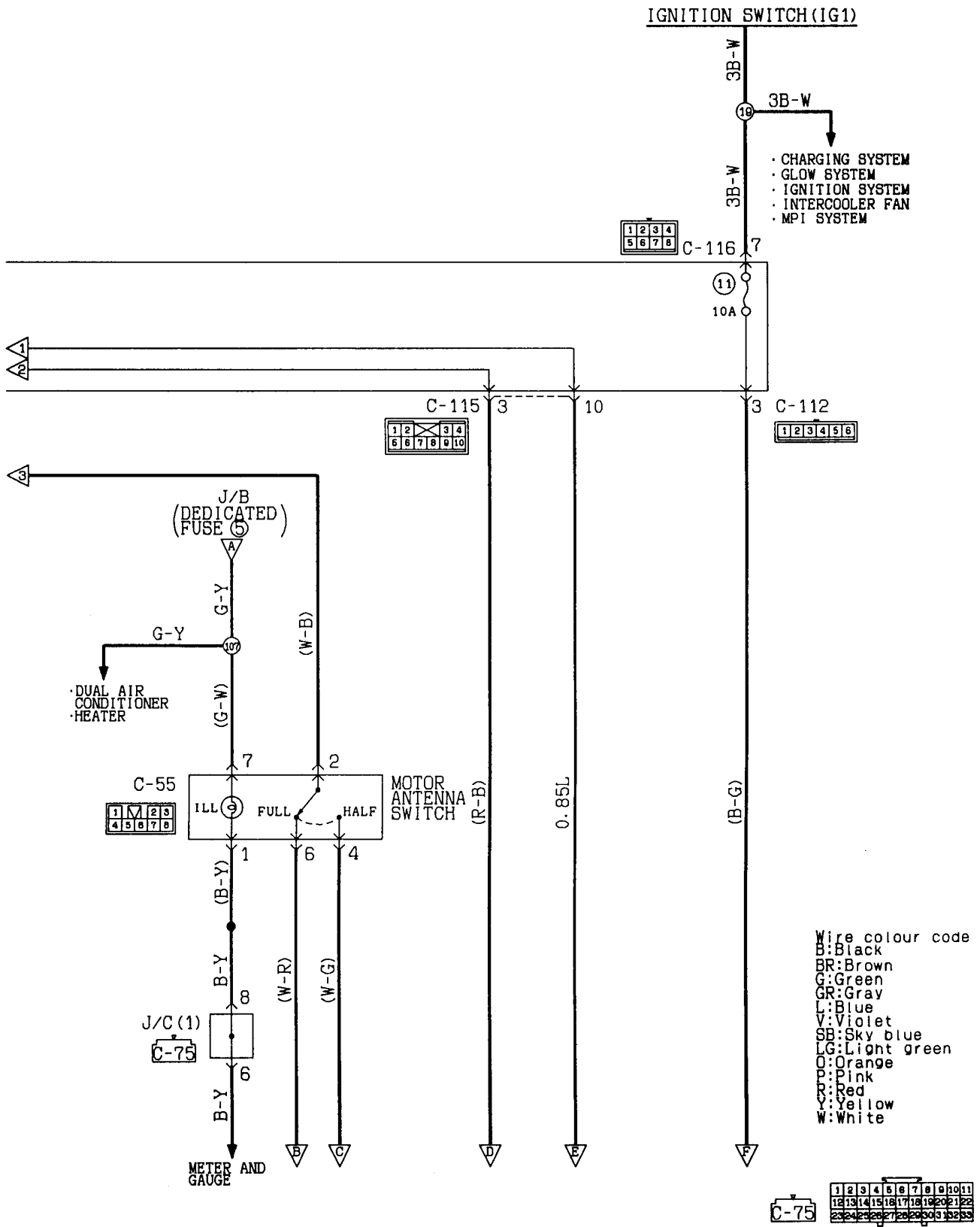

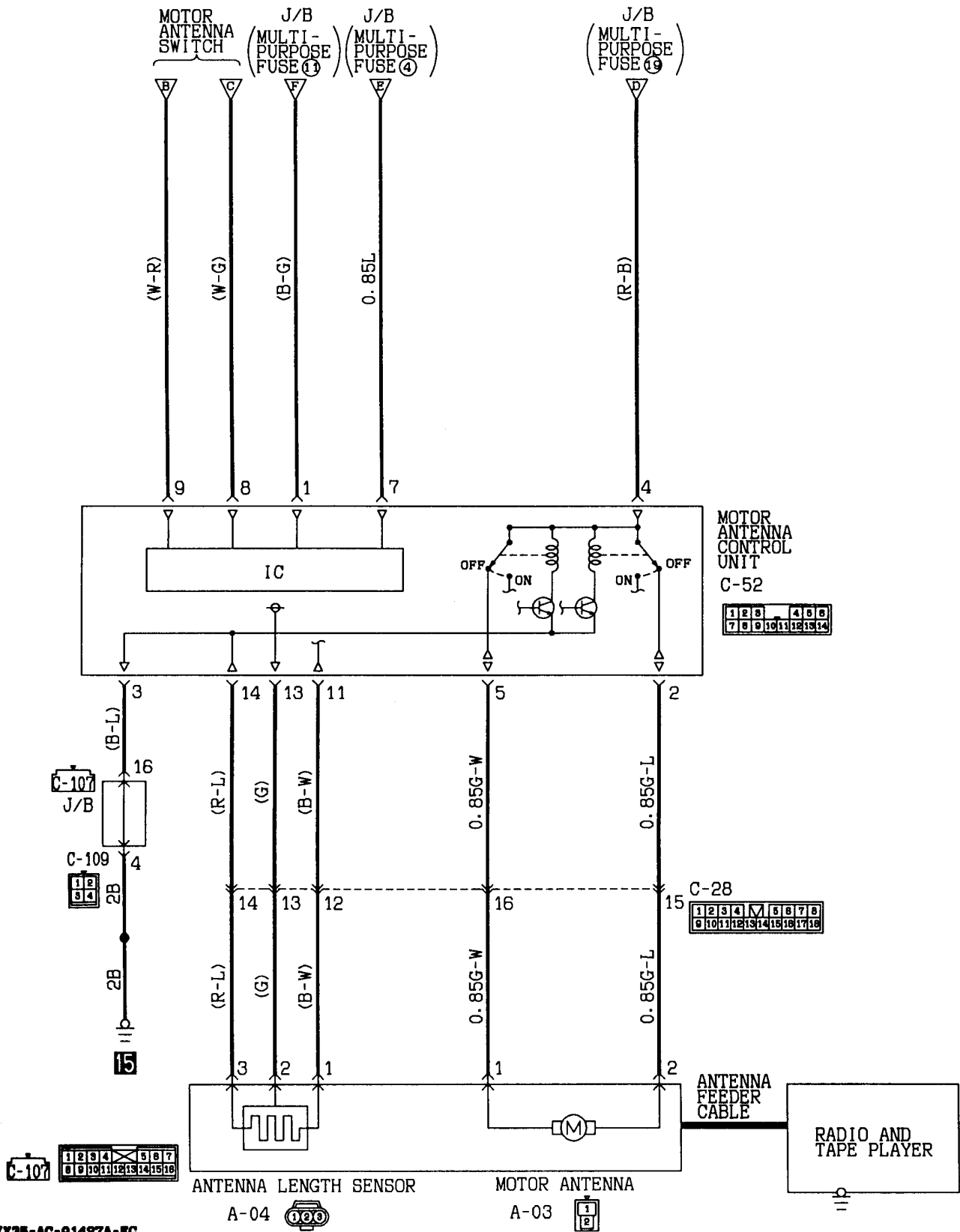

KX35-AC-01427A-EC

RADIO AND TAPE PLAYER
 (L.H. drive vehicles (AM/FM radio and tape player))
 (CONTINUED)

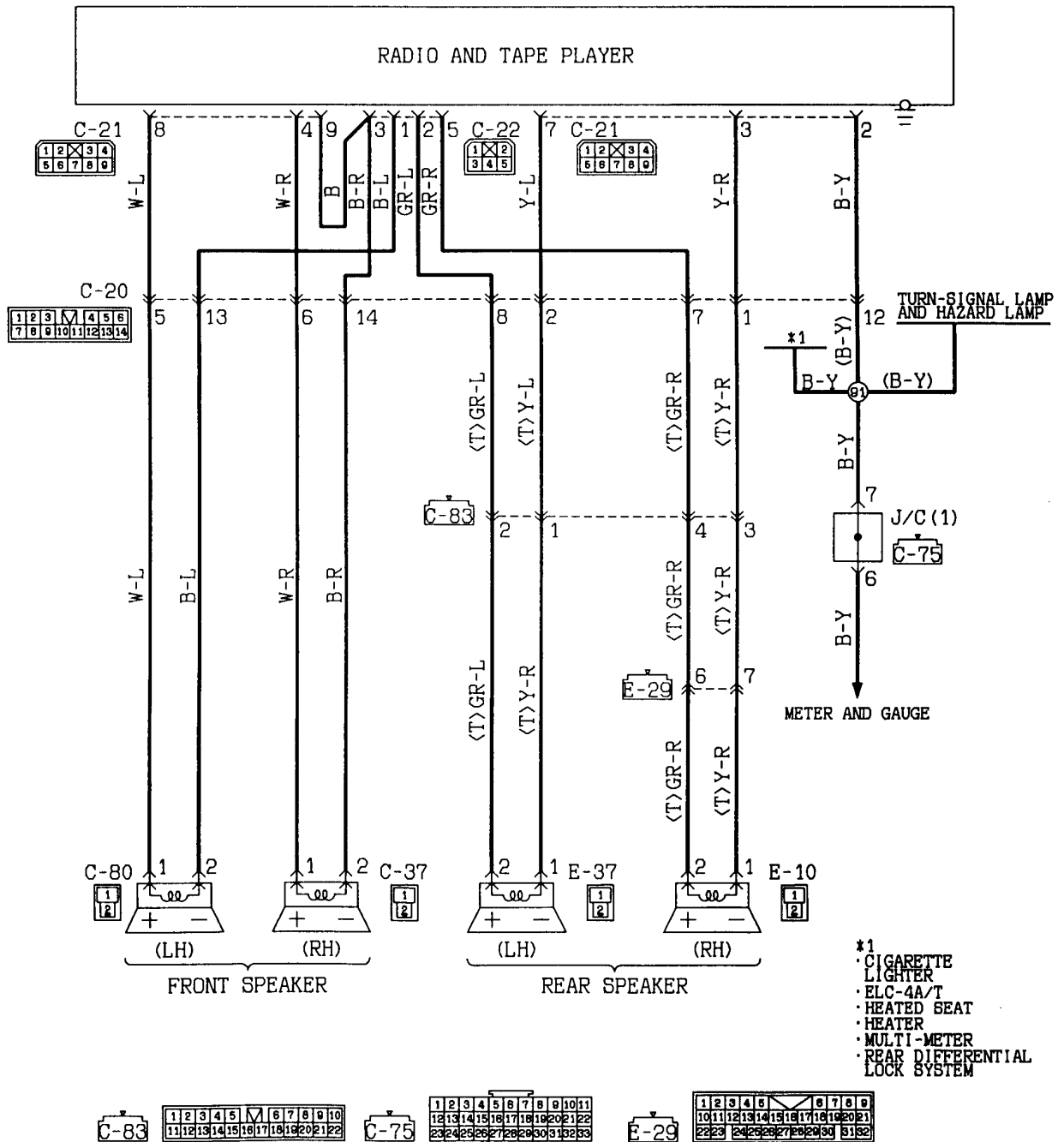

Wire colour code
 B:Black LG:Light green G:Green L:Blue W:White Y:Yellow SB:Sky blue
 BR:Brown O:Orange GR:Gray R:Red P:Pink V:Violet

RADIO AND TAPE PLAYER
R.H. drive vehicles (AM/FM radio)

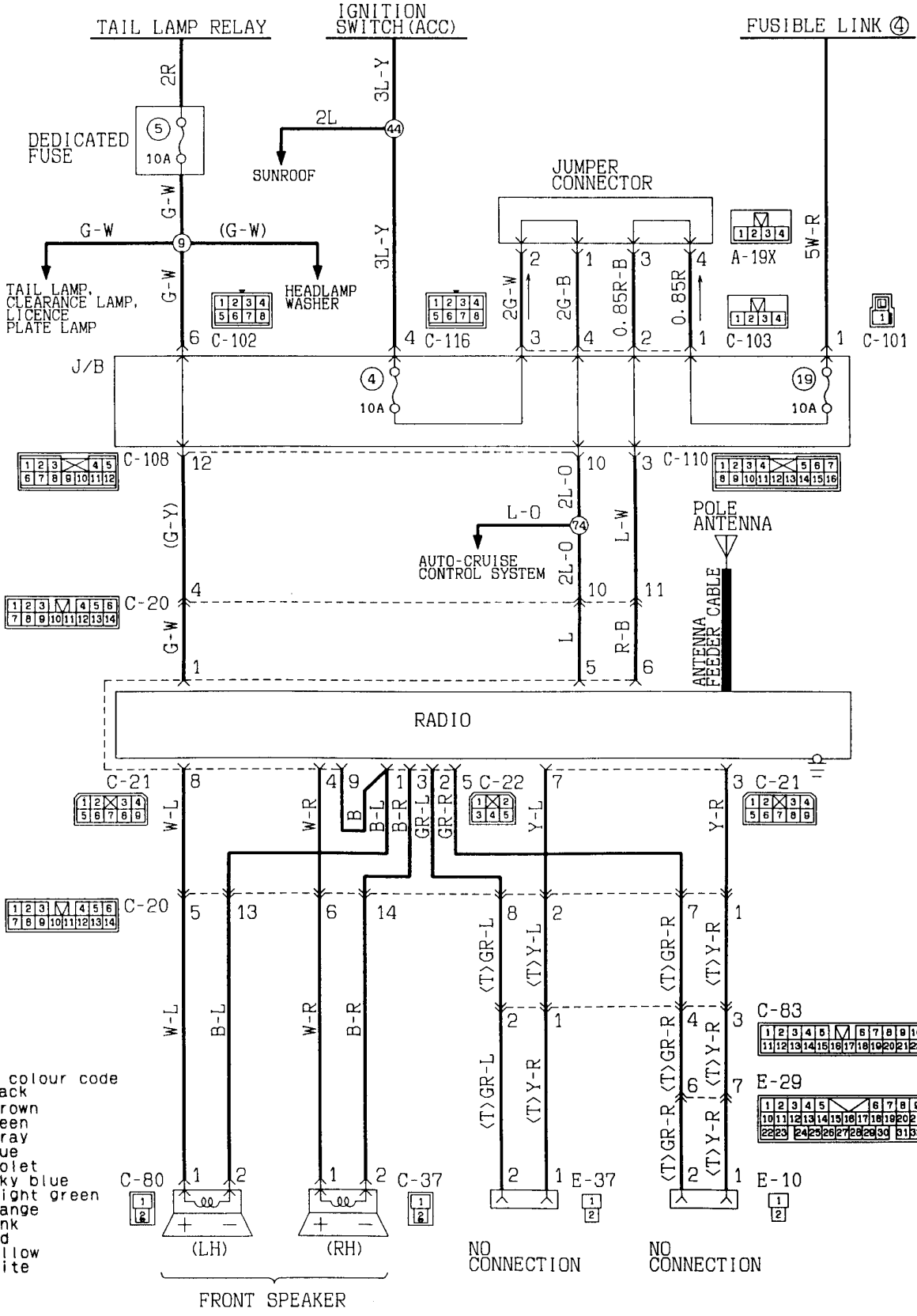

- Wire colour code
 B: Black
 BR: Brown
 G: Green
 GR: Gray
 L: Blue
 V: Violet
 SB: Sky blue
 LG: Light green
 O: Orange
 P: Pink
 R: Red
 Y: Yellow
 W: White

KX35-AC-01422-EC

RADIO AND TAPE PLAYER

R. H. drive vehicles <LW/MW/FM radio and tape player>

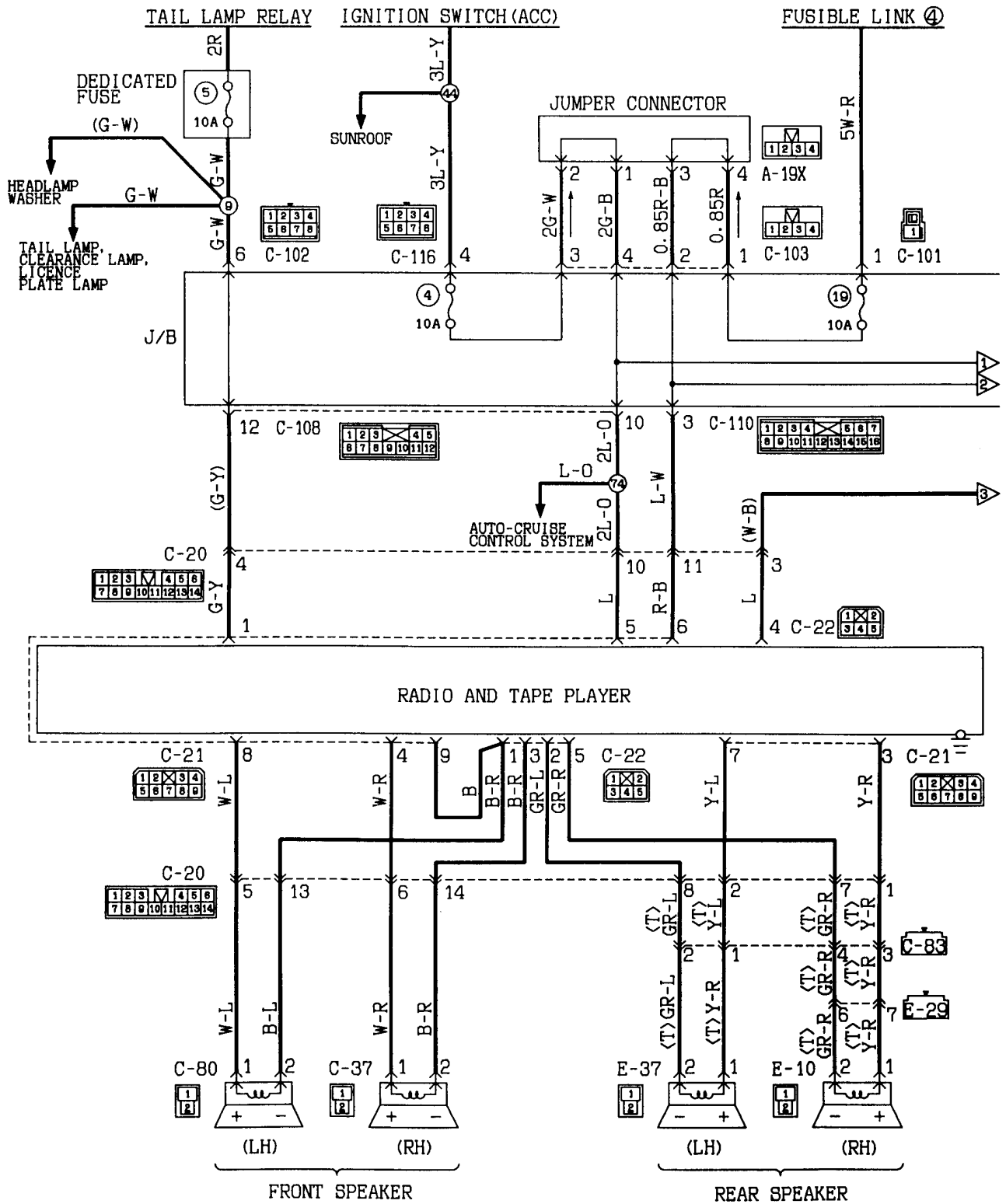

KX35-AC-01408-EC



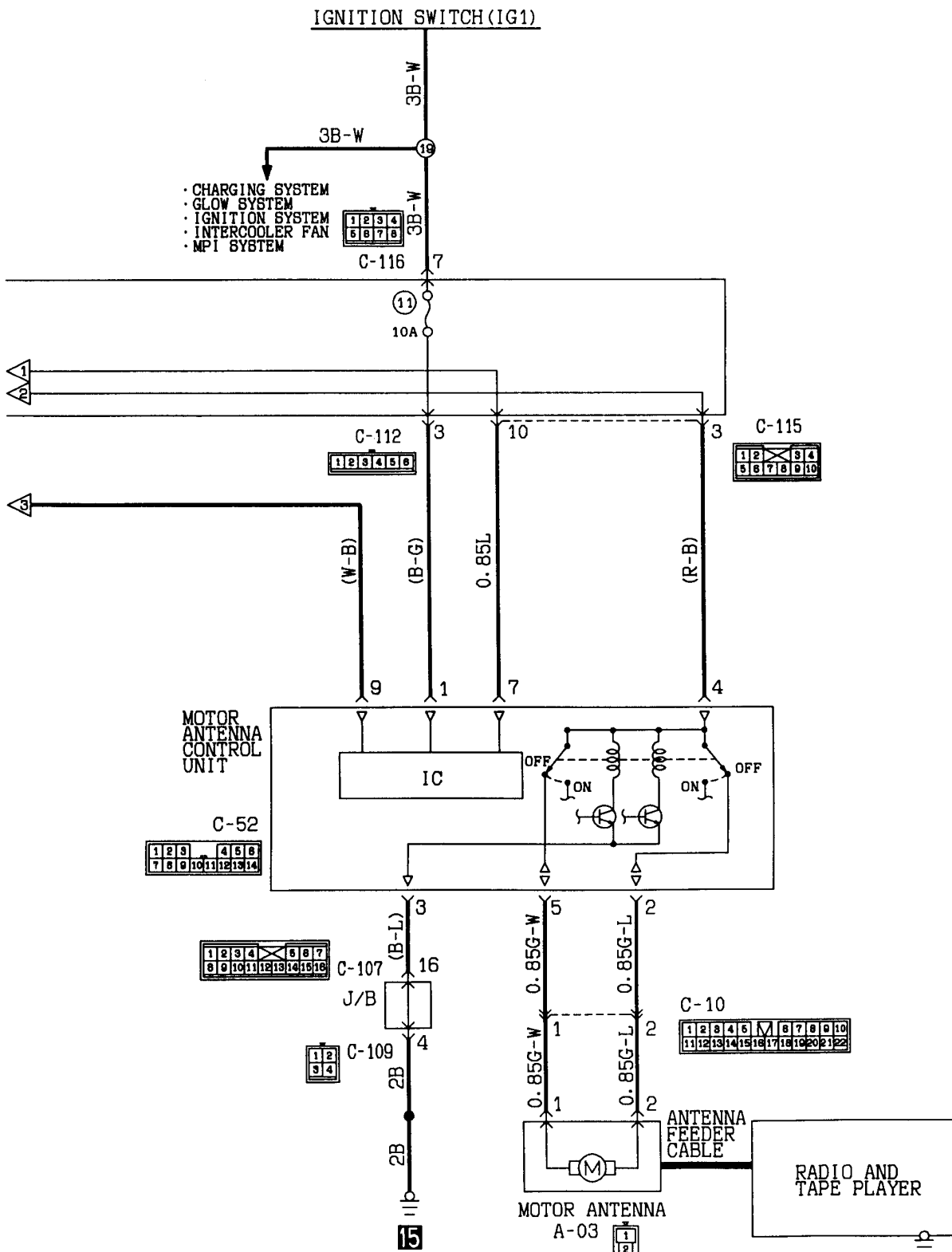

Wire colour code
 B:Black LG:Light green G:Green L:Blue W:White Y:Yellow SB:Sky blue
 BR:Brown O:Orange GR:Gray R:Red P:Pink V:Violet

RADIO AND TAPE PLAYER

R. H. drive vehicles (AM/FM radio and tape player)

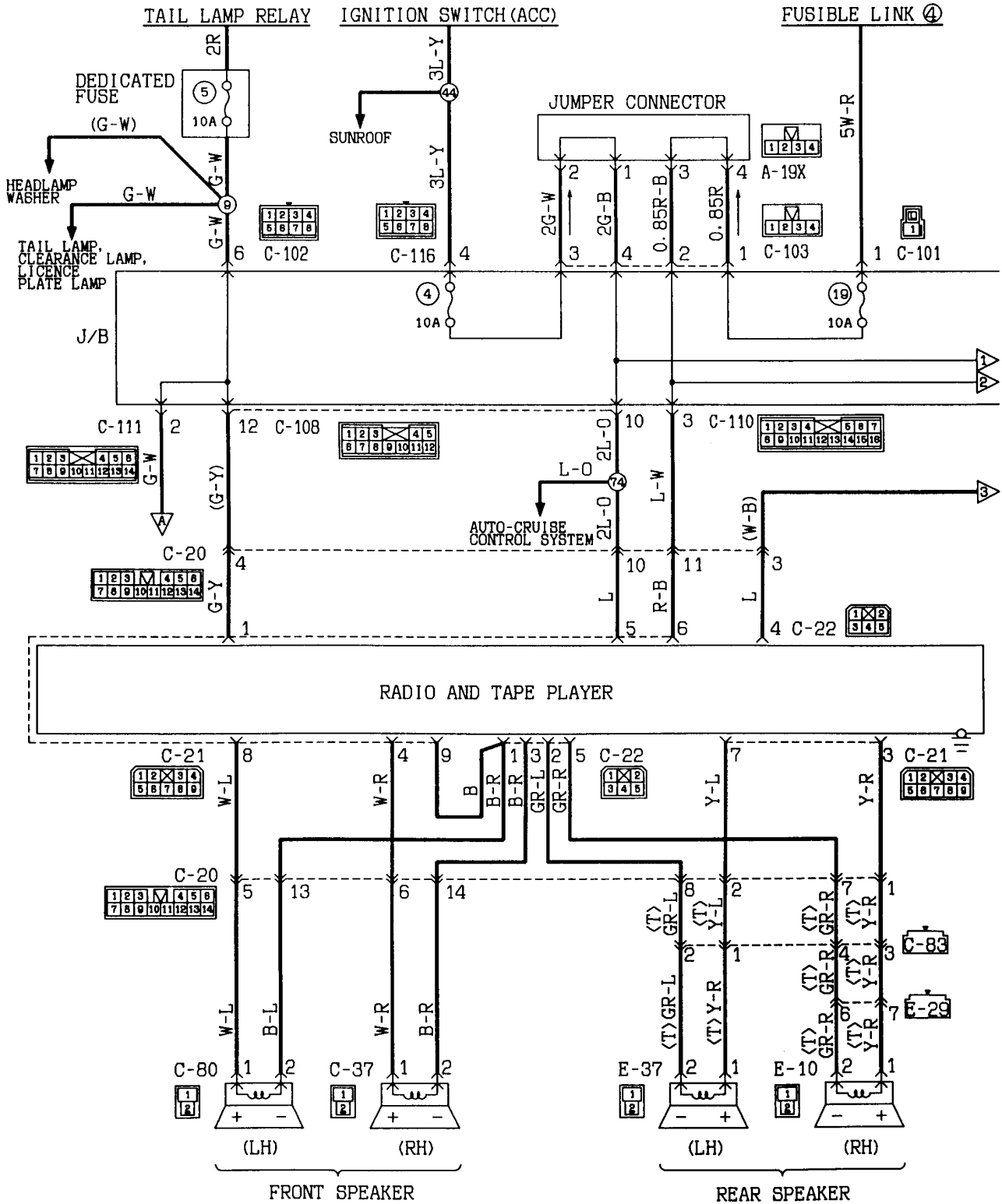

KX35-AC-01426-EC



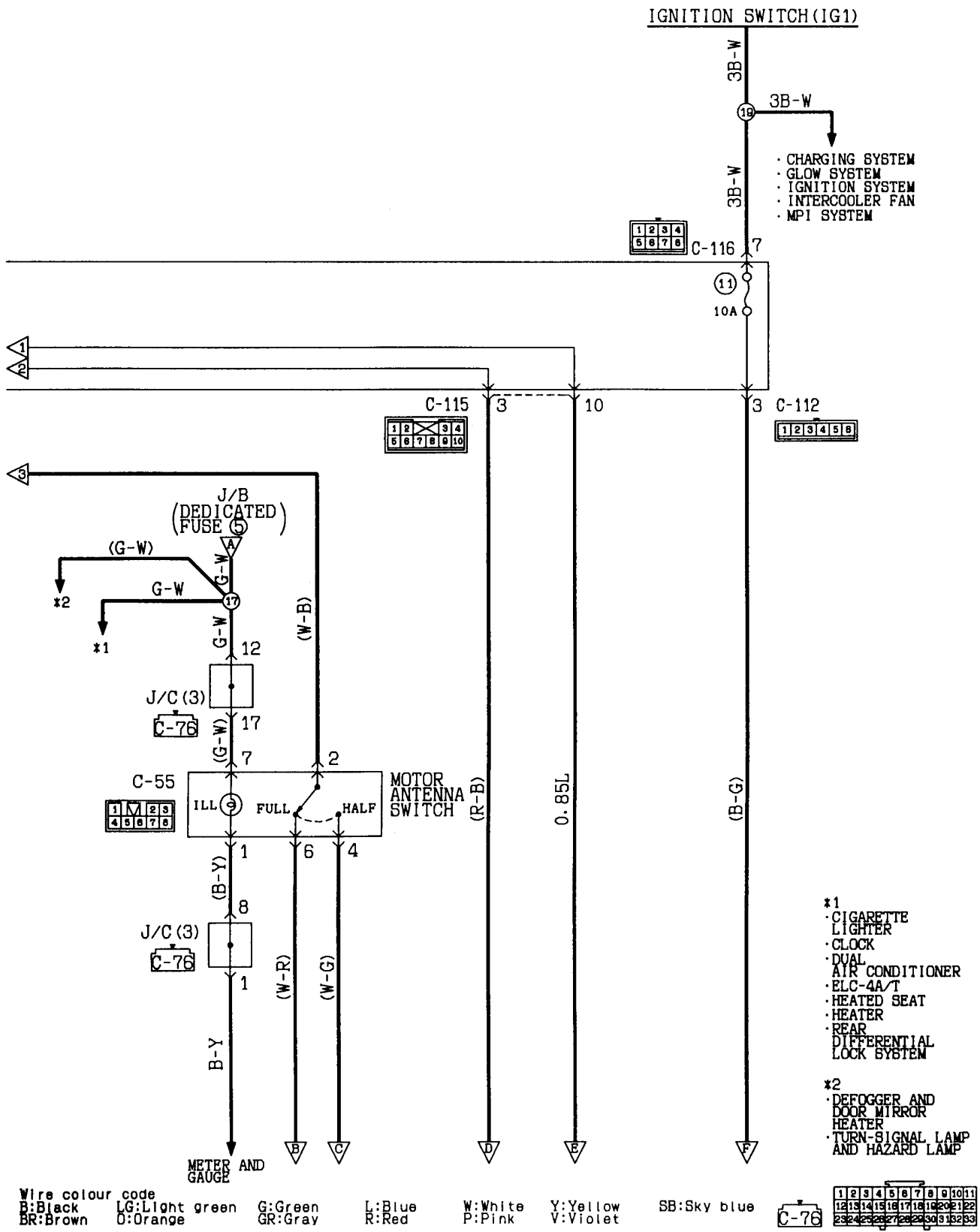

RADIO AND TAPE PLAYER

<R. H. drive vehicles (AM/FM radio and tape player)>
(CONTINUED)

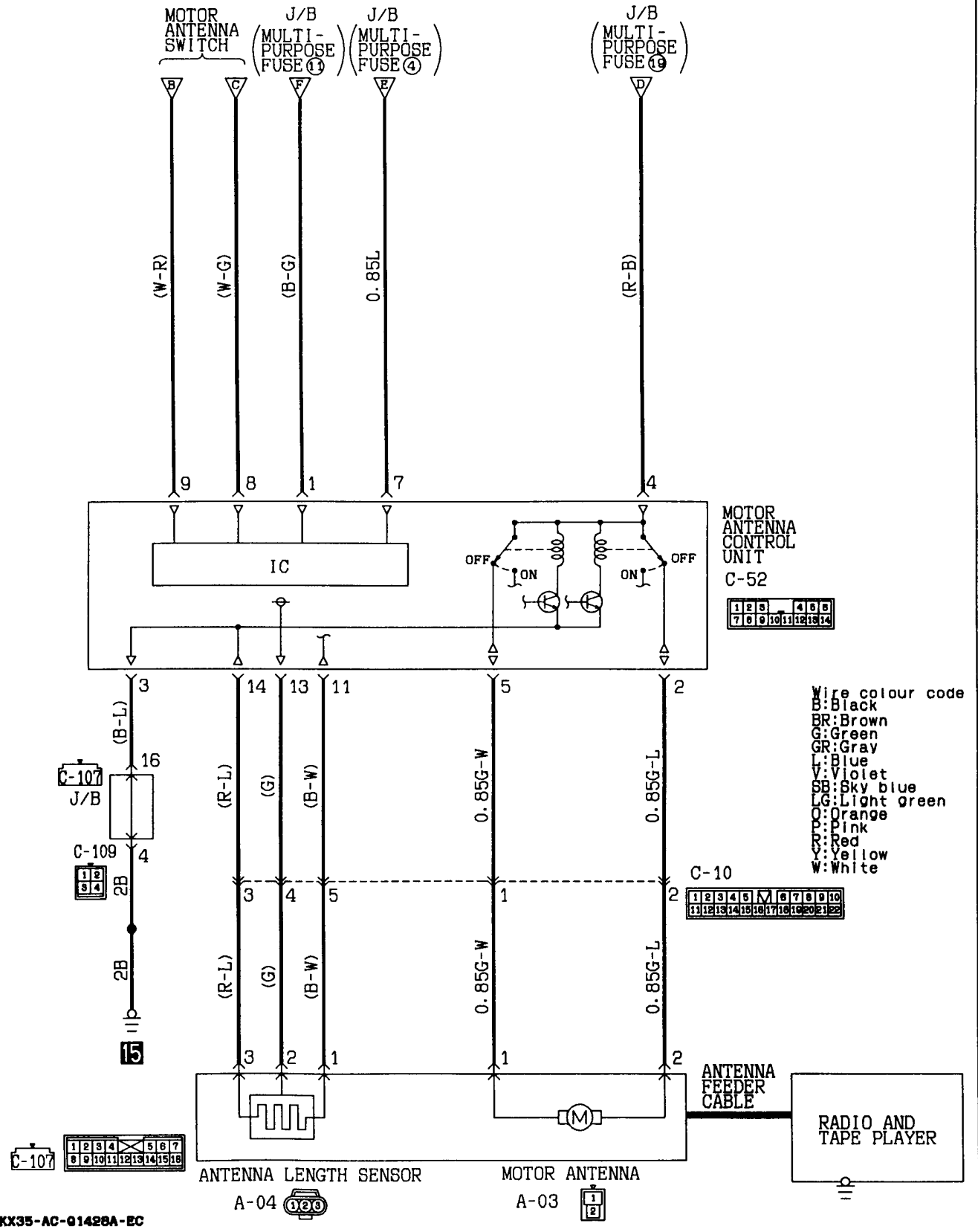

CLOCK
L.H. drive vehicles

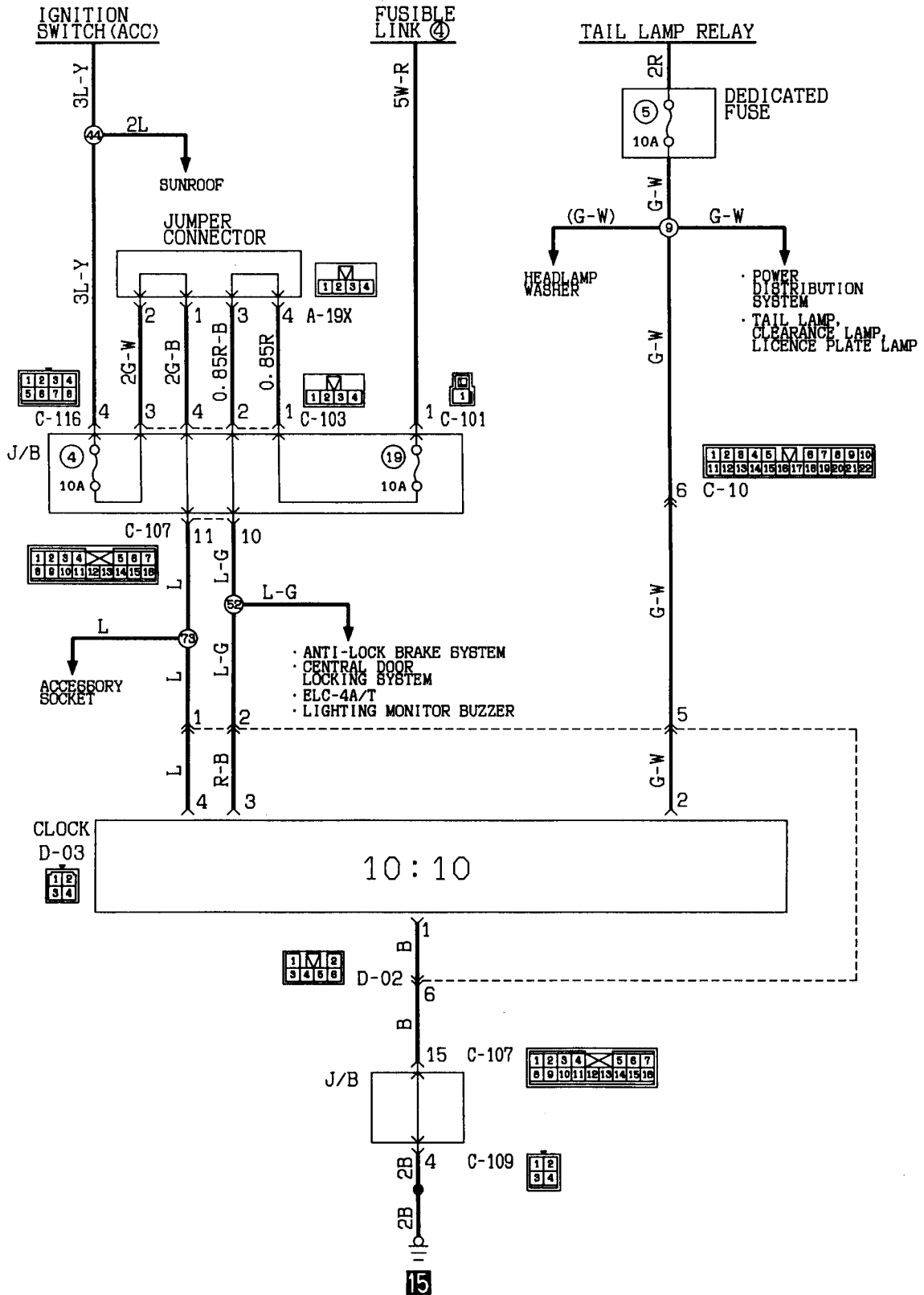

Wire colour code
 B:Black LG:Light green G:Green L:Blue W:White Y:Yellow BB:Sky blue
 BR:Brown O:Orange GR:Gray R:Red P:Pink V:Violet

CLOCK
R.H. drive vehicles

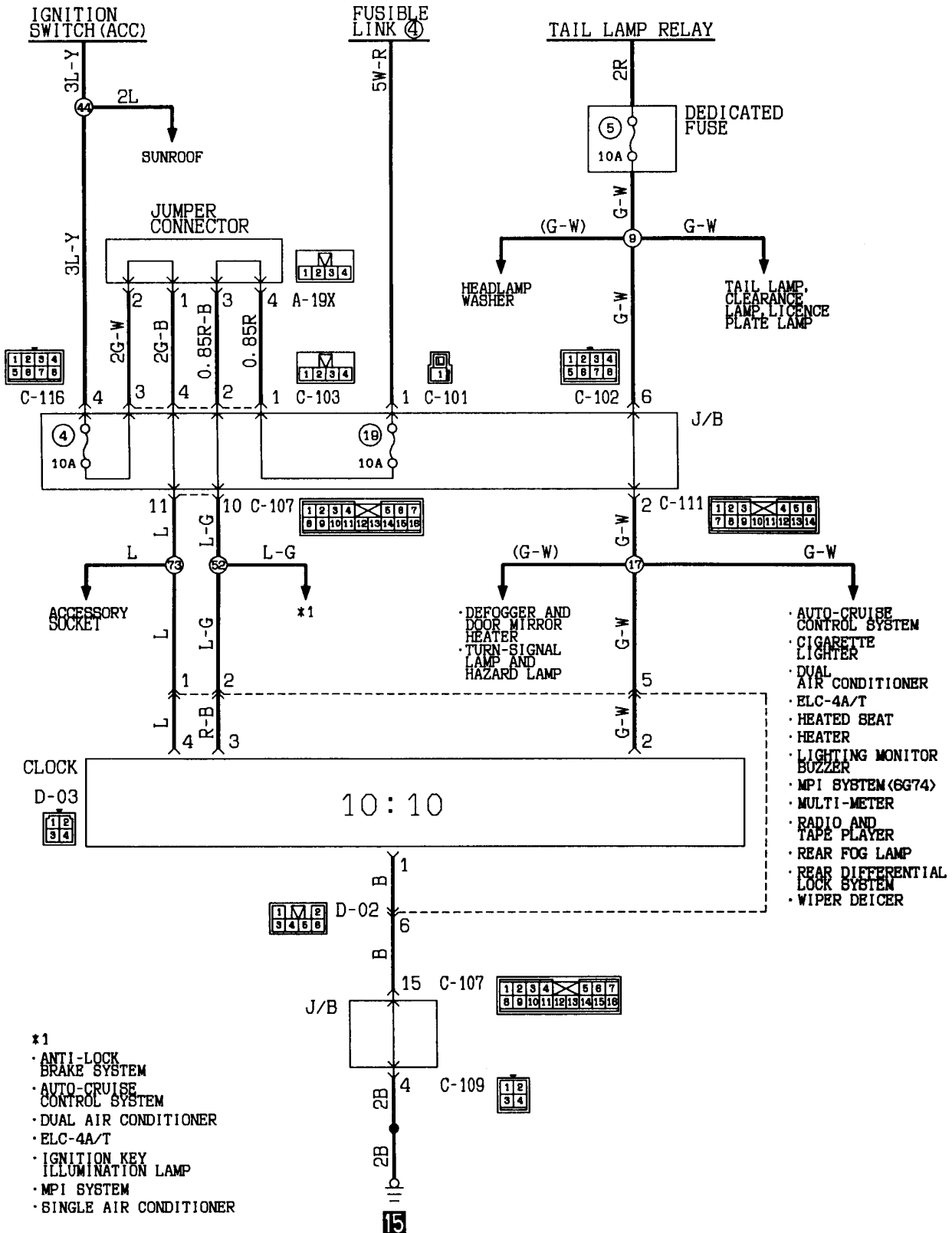

- *1
- ANTI-LOCK BRAKE SYSTEM
 - AUTO-CRUISE CONTROL SYSTEM
 - DUAL AIR CONDITIONER
 - ELC-4A/T
 - IGNITION KEY ILLUMINATION LAMP
 - MPI SYSTEM
 - SINGLE AIR CONDITIONER

Wire colour code
 B:Black LG:Light green G:Green L:Blue W:White Y:Yellow BB:Sky blue
 BR:Brown O:Orange GR:Gray R:Red P:Pink V:Violet

ACCESSORY SOCKET

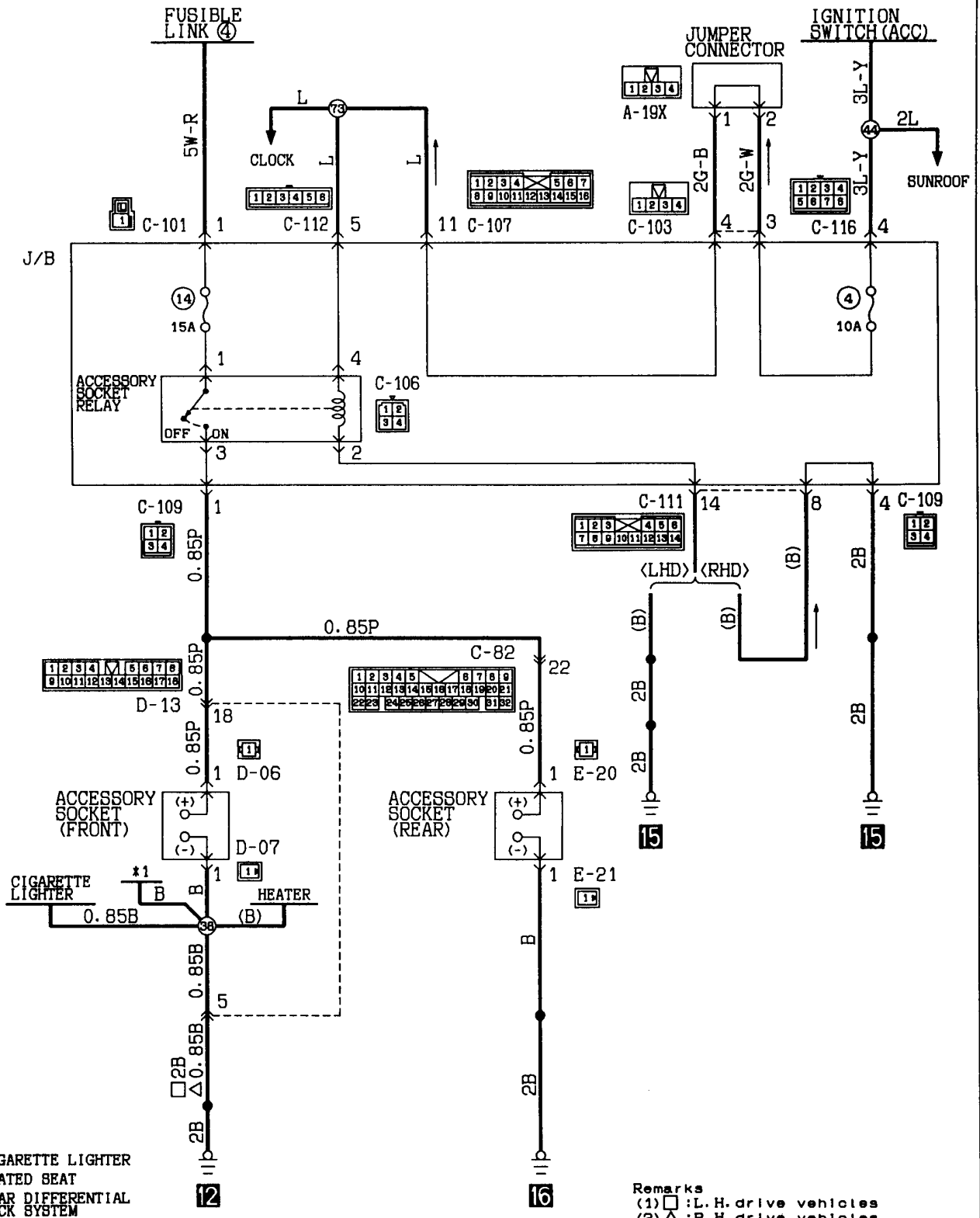

Wire colour code
 B:Black LG:Light green G:Green L:Blue W:White Y:Yellow SB:Sky blue
 BR:Brown O:Orange GR:Gray R:Red P:Pink V:Violet

SUNROOF
4-door models

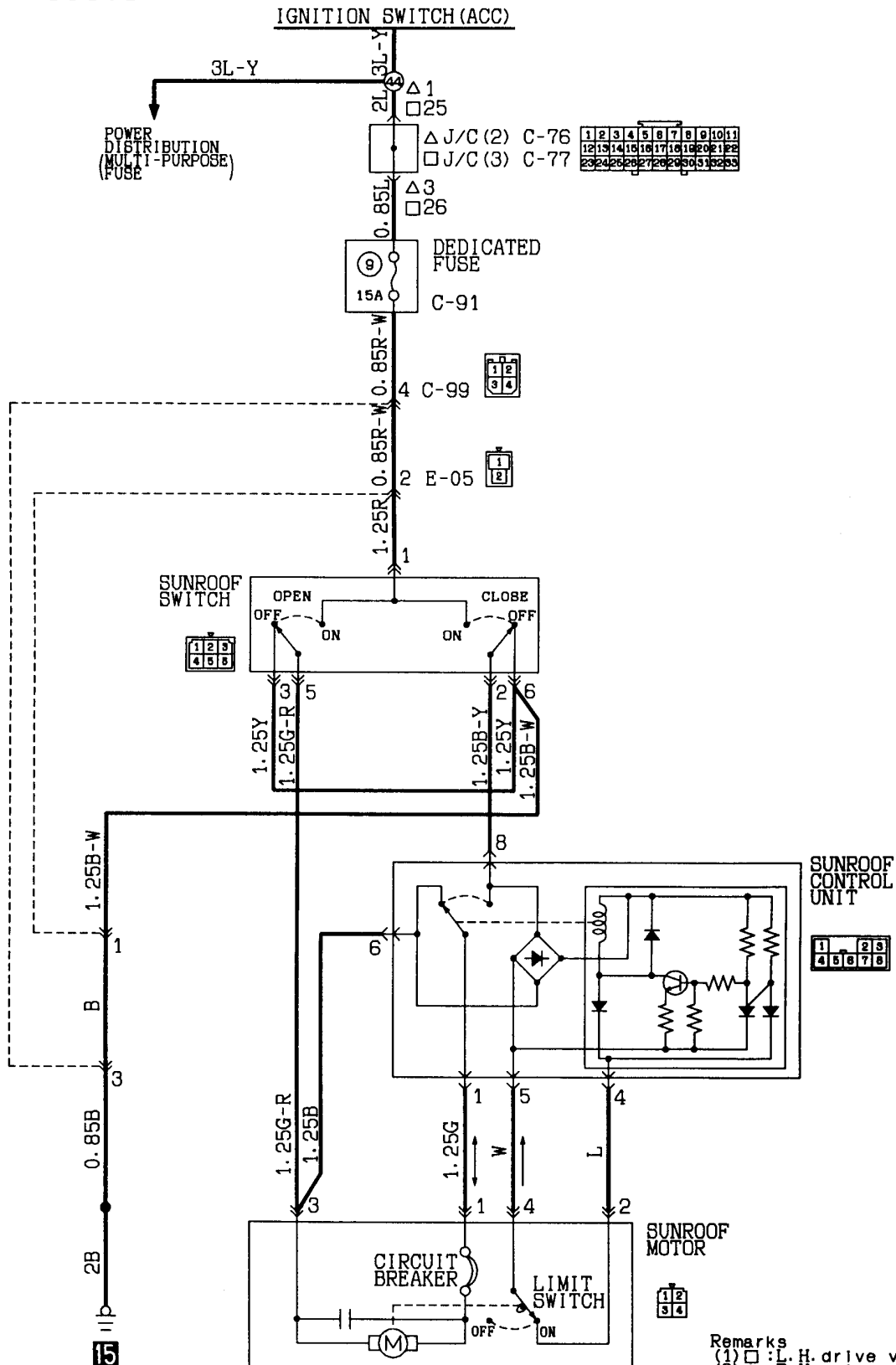

1	2	3	4	5	6	7	8	9	10	11
12	13	14	15	16	17	18	19	20	21	22
23	24	25	26	27	28	29	30	31	32	33

1	2
3	4

1	2
---	---

1	2	3
4	5	6

1	2	3		
4	5	6	7	8

1	2
3	4

Remarks
(1) □ : L.H. drive vehicles
(2) △ : R.H. drive vehicles

Wire colour code
B:Black LG:Light green G:Green L:Blue W:White Y:Yellow BB:Sky blue
BR:Brown O:Orange GR:Gray R:Red P:Pink V:Violet

INTERCOOLER FAN

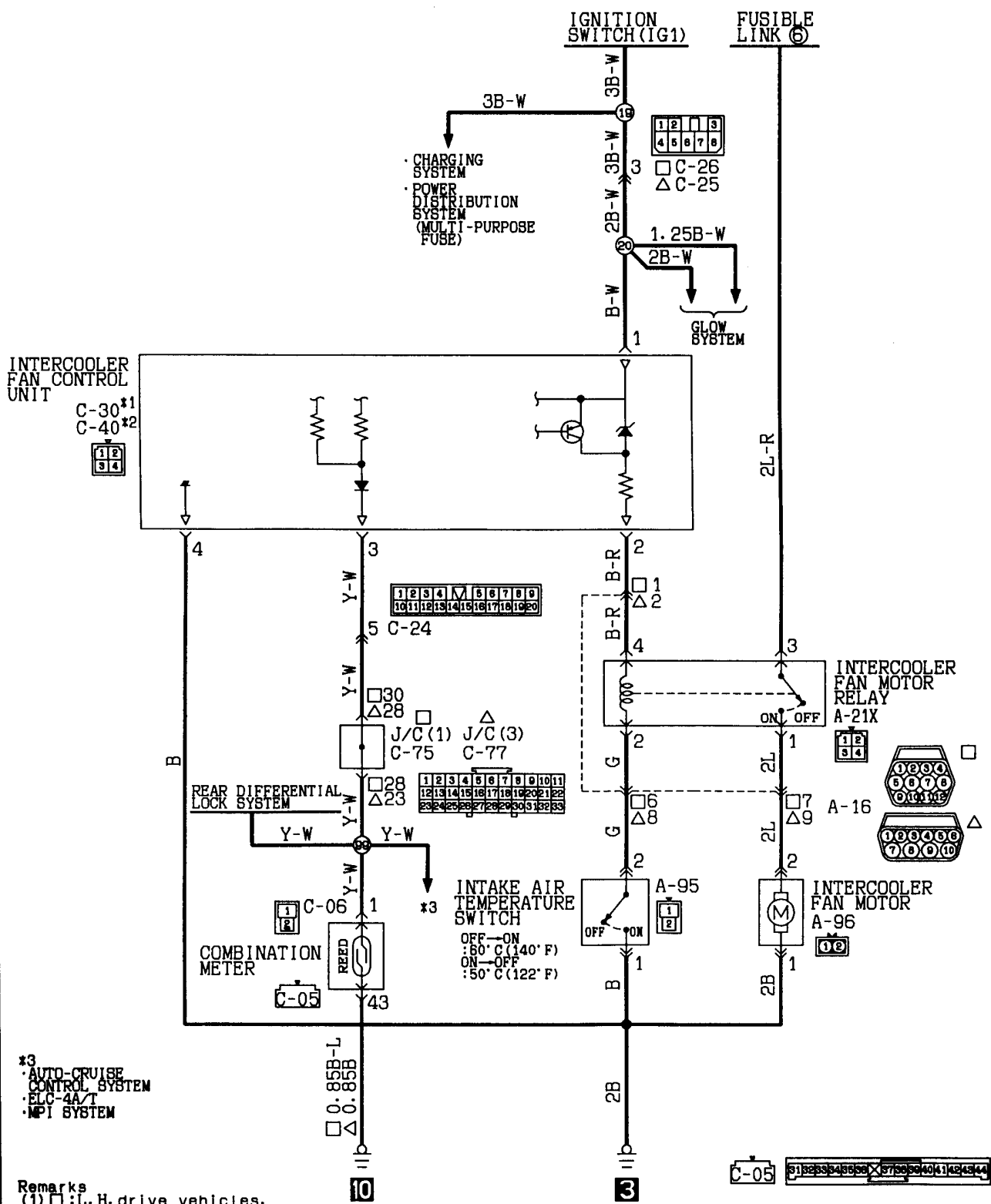

*3
 AUTO-CRUISE CONTROL SYSTEM
 ELC-4A/T
 MPI SYSTEM

Remarks
 (1) □: L. H. drive vehicles.
 (2) △: R. H. drive vehicles.
 (3) *1: Vehicles without fuel line heater
 (4) *2: Vehicles with fuel line heater

Wire colour code
 B:Black LG:Light green G:Green L:Blue W:White Y:Yellow BB:Sky blue
 BR:Brown O:Orange GR:Gray R:Red P:Pink V:Violet

KX35-AC-01514-EC

REAR DIFFERENTIAL LOCK SYSTEM L.H. drive vehicles

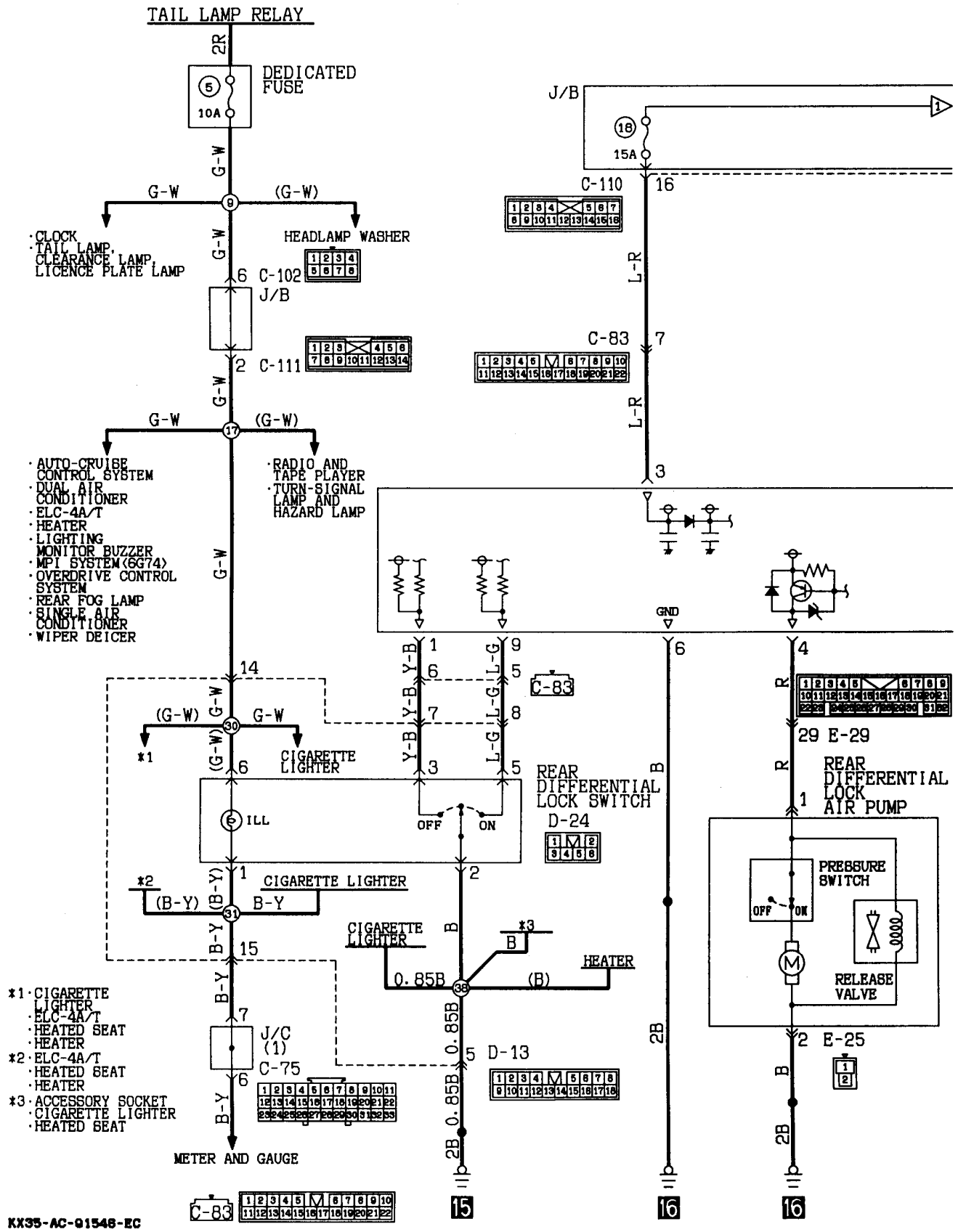

KX35-AC-01548-ZC

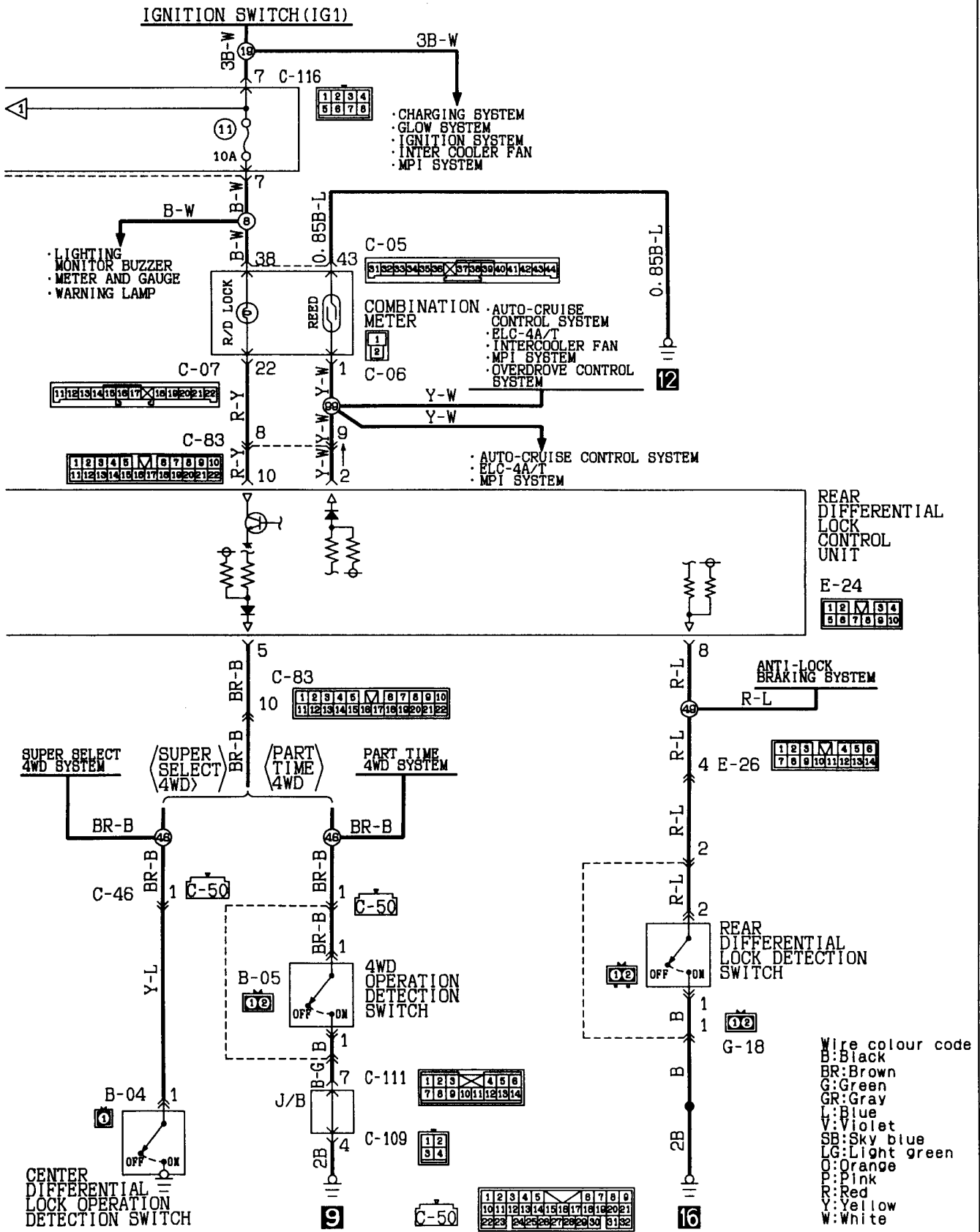

REAR DIFFERENTIAL LOCK SYSTEM

R. H. drive vehicles

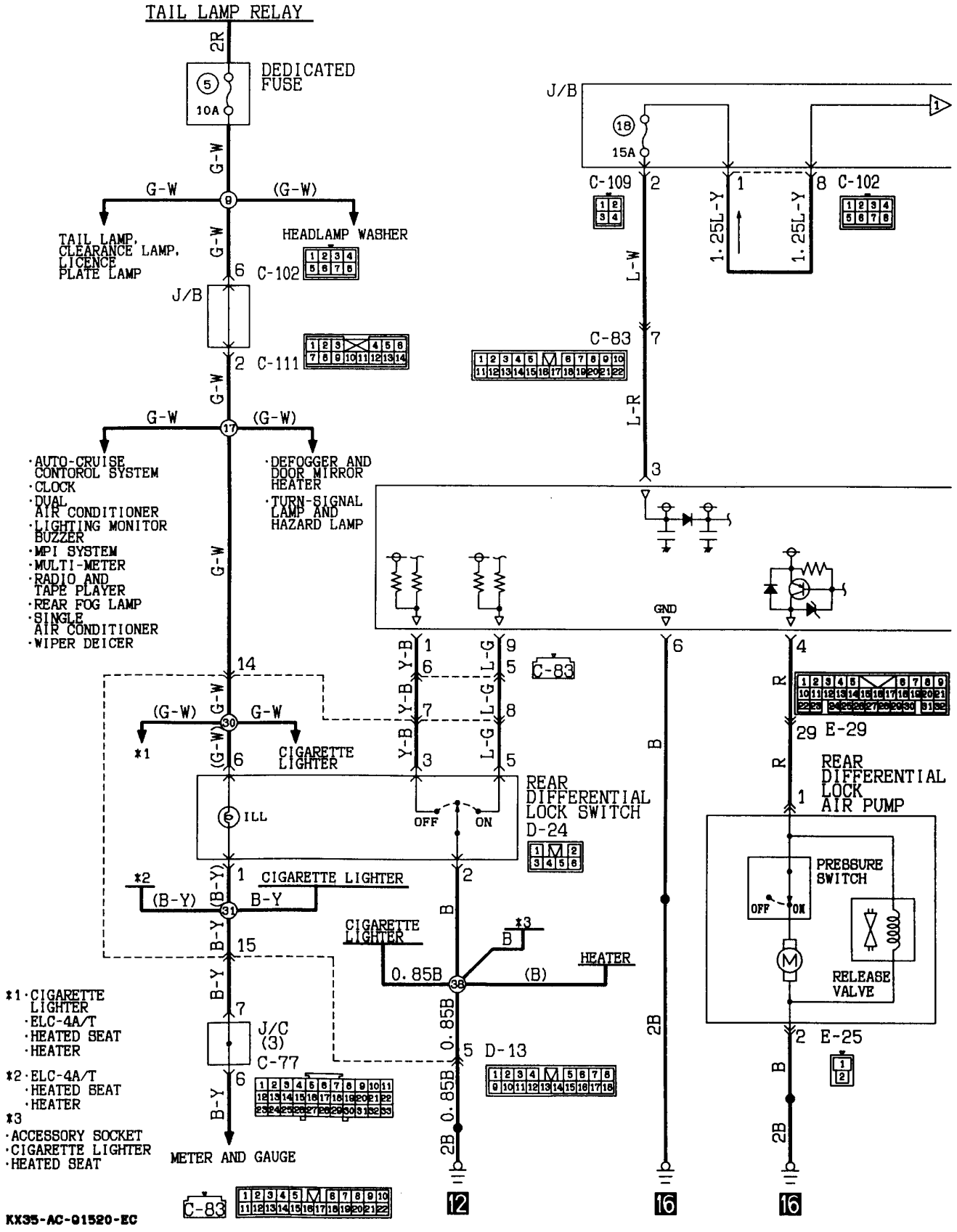

KX35-AC-01520-EC

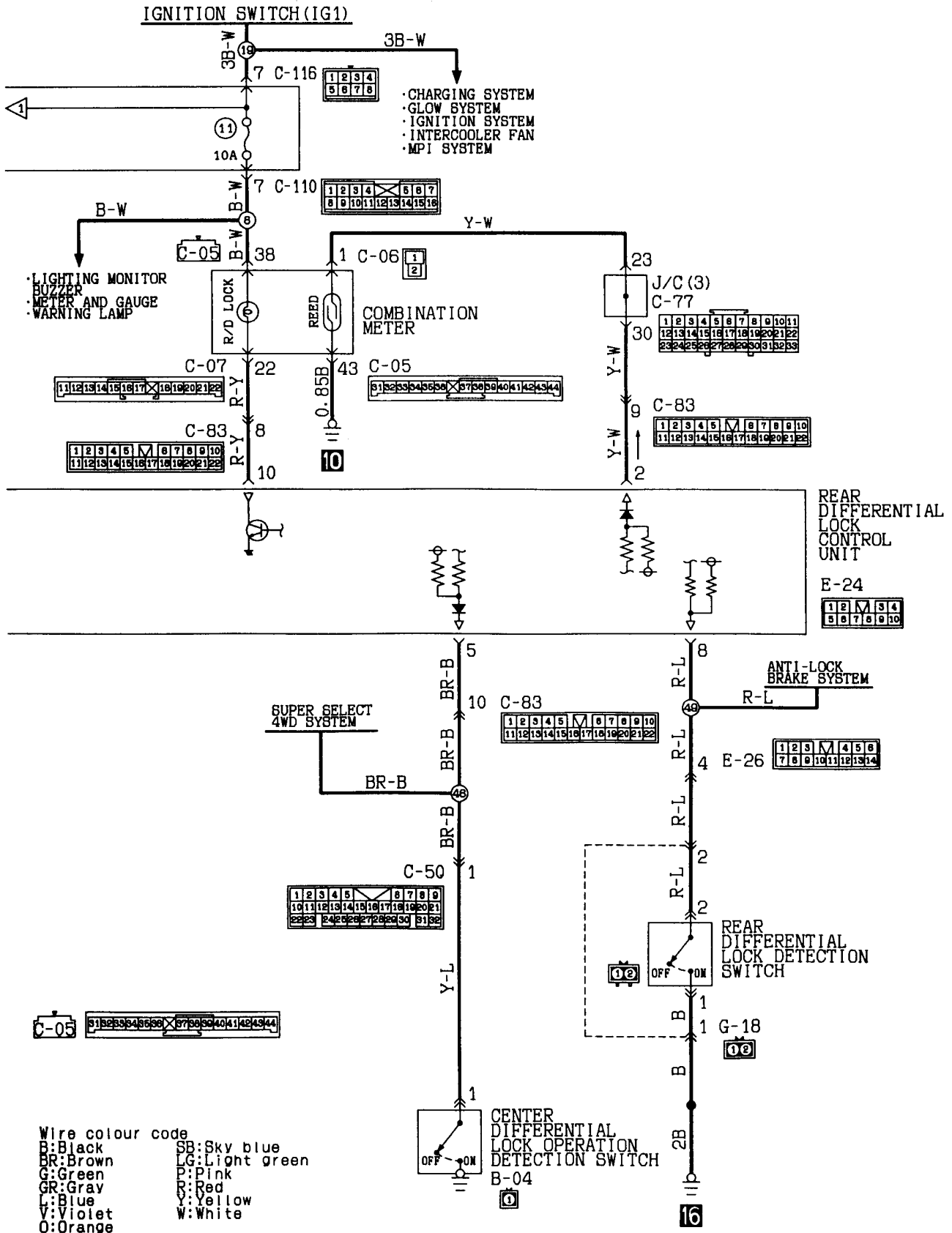

Wire colour code
 B:Black SB:Sky blue
 BR:Brown LG:Light green
 G:Green P:Pink
 GR:Gray R:Red
 L:Blue Y:Yellow
 V:Violet W:White
 O:Orange

PART TIME 4WD SYSTEM

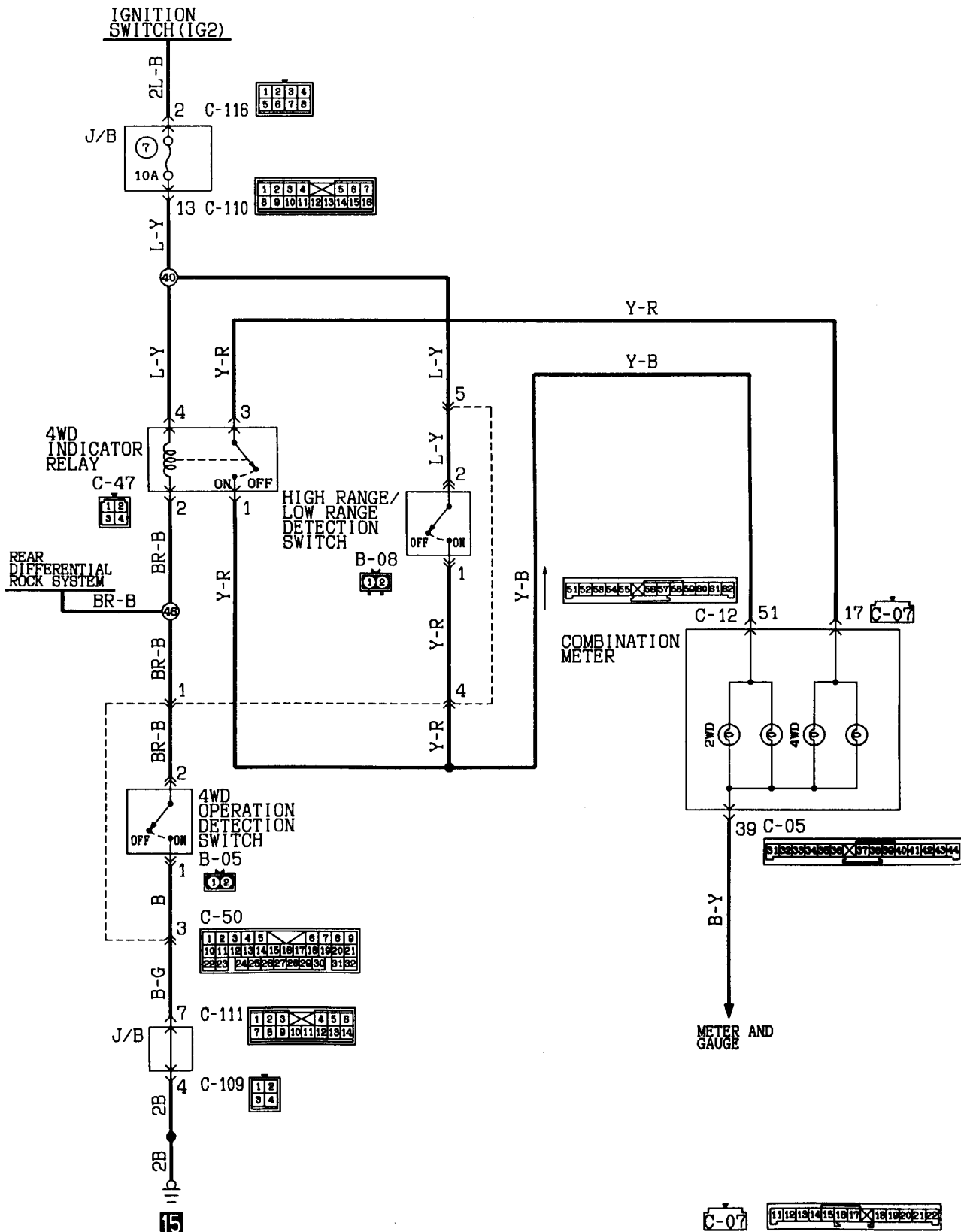

Wire colour code
 B:Black LG:Light green G:Green L:Blue W:White Y:Yellow BB:Sky blue
 BR:Brown O:Orange GR:Gray R:Red P:Pink V:Violet

NOTES

SUPER SELECT 4WD SYSTEM

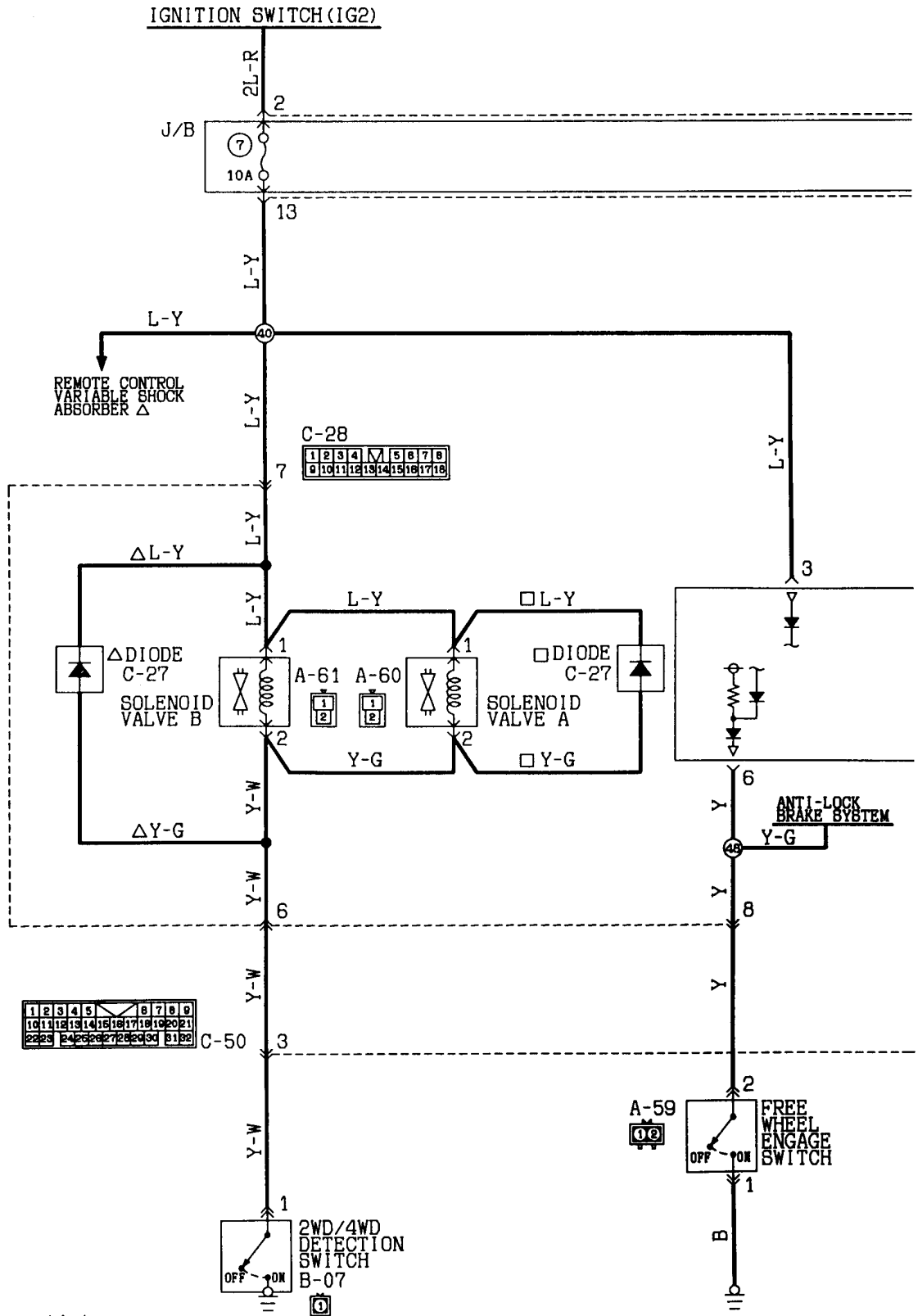

Remarks

- (1) □ : L.H. drive vehicles
- (2) △ : R.H. drive vehicles

Wire colour code

B:Black LG:Light green G:Green L:Blue W:White Y:Yellow
 BR:Brown O:Orange GR:Gray R:Red P:Pink V:Violet

KX35-AC-01517-EC

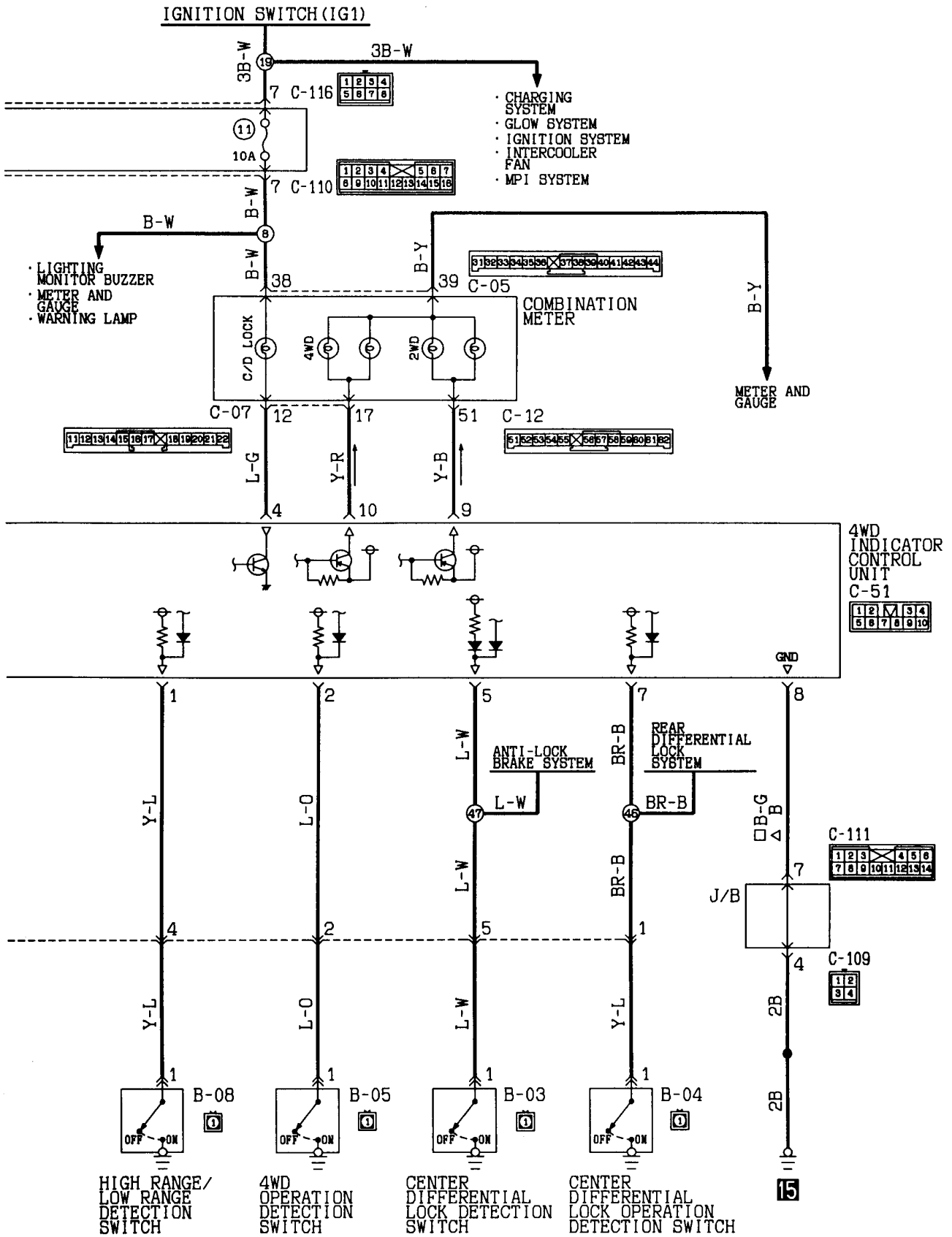

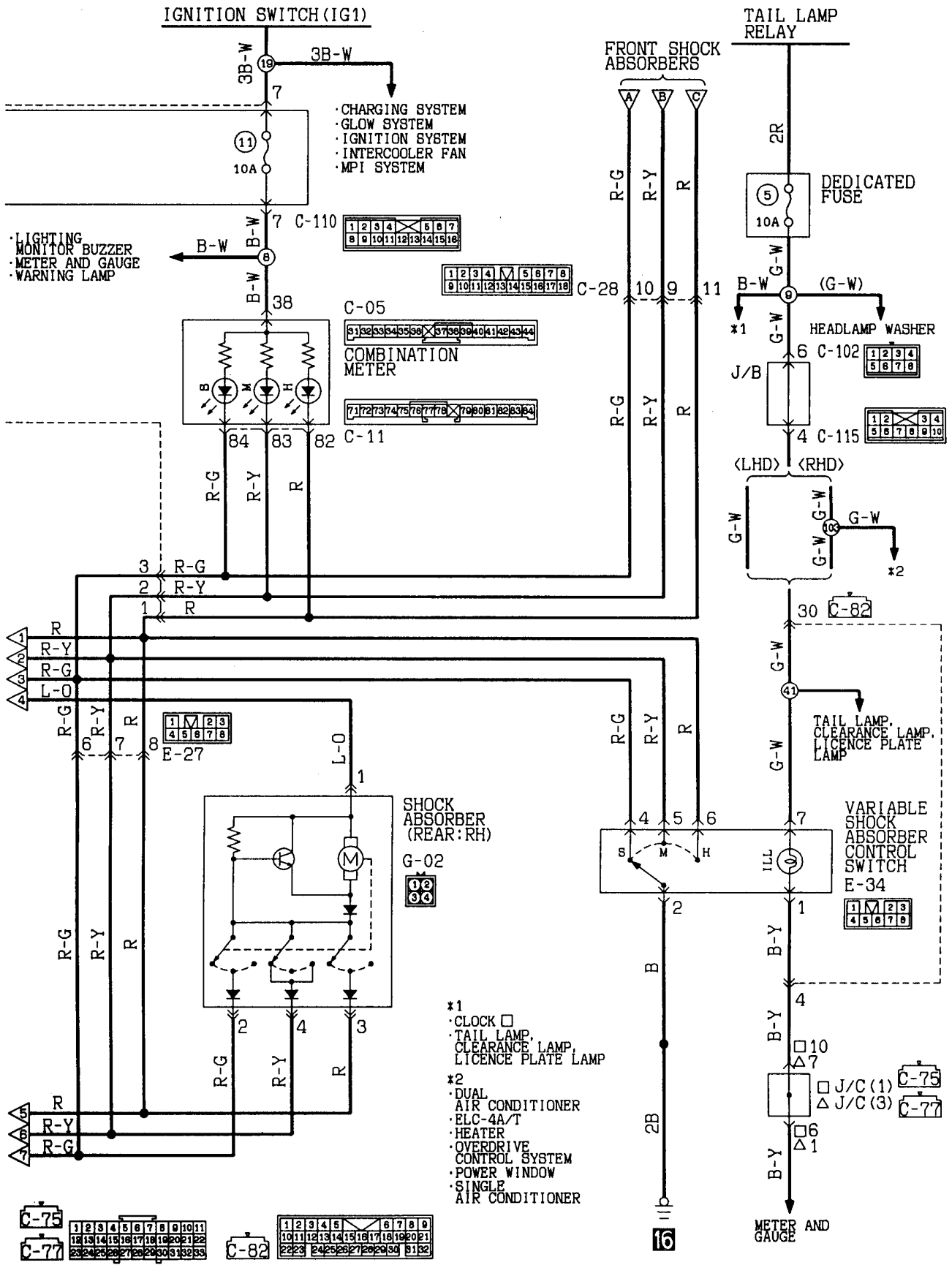

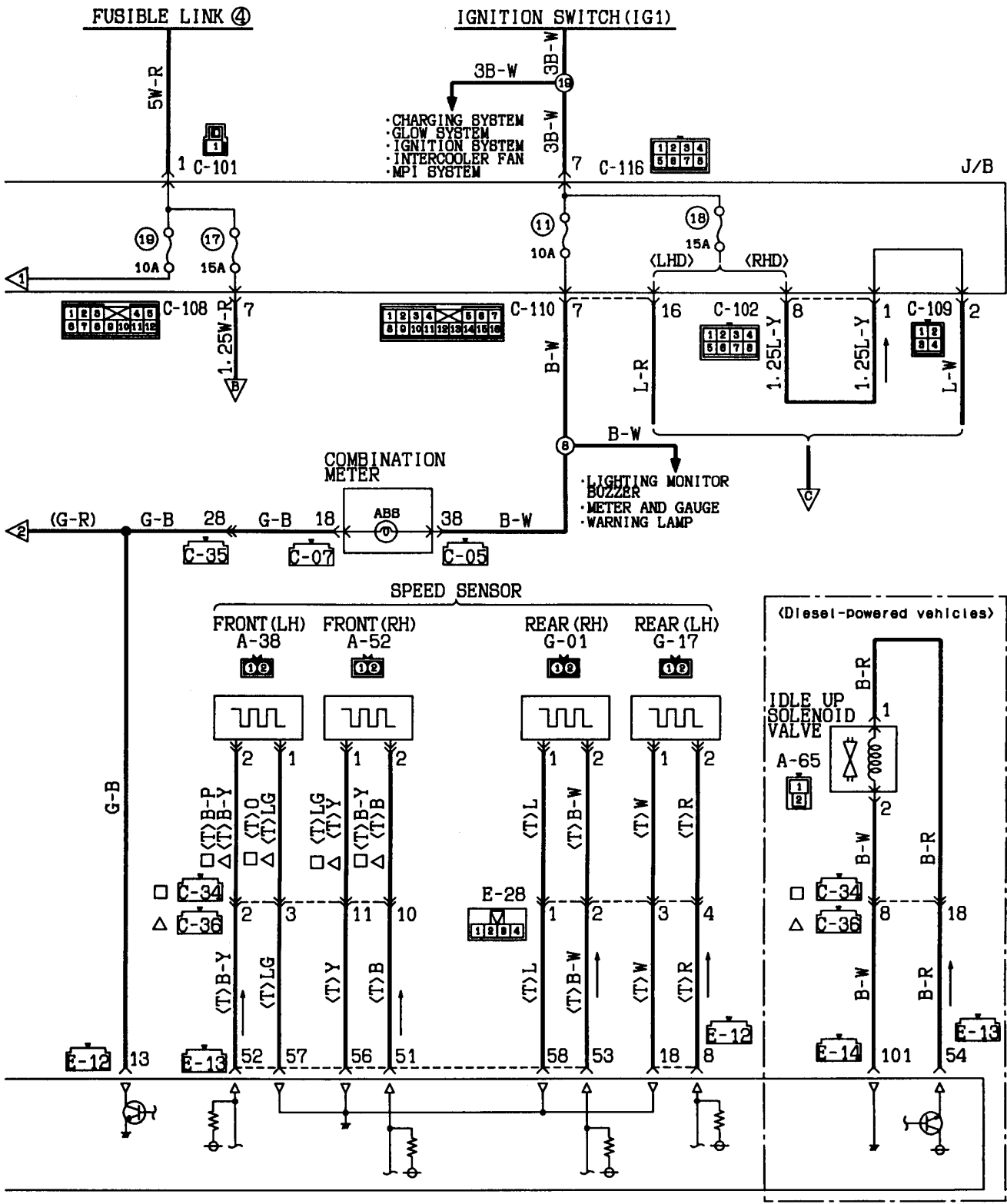

Remarks
 (1) □ : L. H. drive vehicles
 (2) △ : R. H. drive vehicles

ANTI-LOCK BRAKE SYSTEM (CONTINUED)

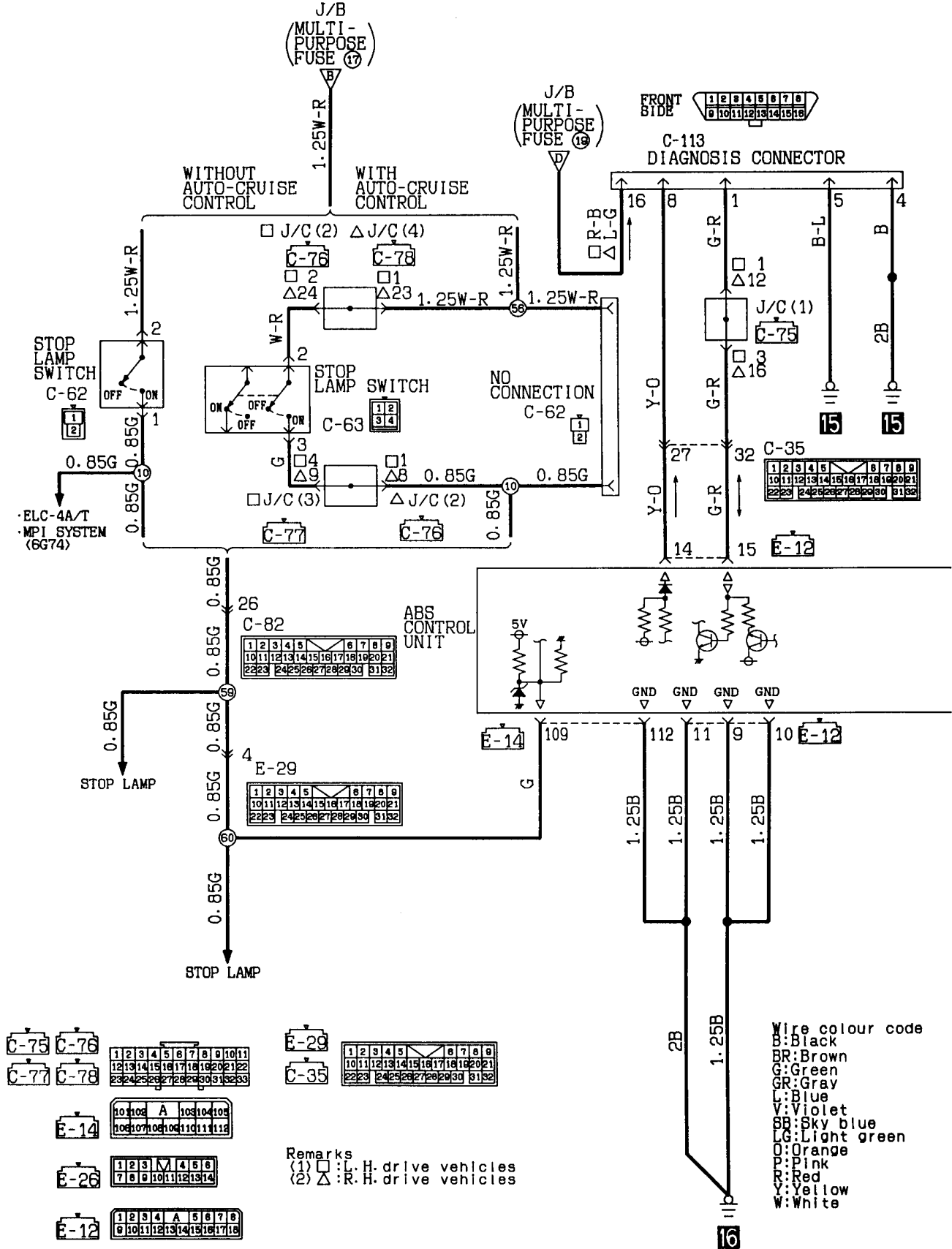

Wire colour code
 B:Black
 BR:Brown
 G:Green
 GR:Gray
 L:Blue
 V:Violet
 SB:Sky blue
 LG:Light green
 O:Orange
 P:Pink
 R:Red
 Y:Yellow
 W:White

Remarks
 (1) □ : L.H. drive vehicles
 (2) △ : R.H. drive vehicles

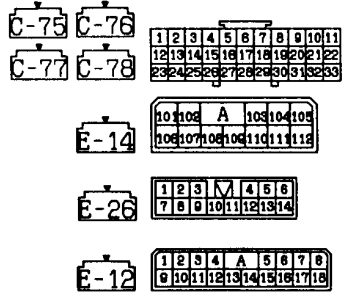

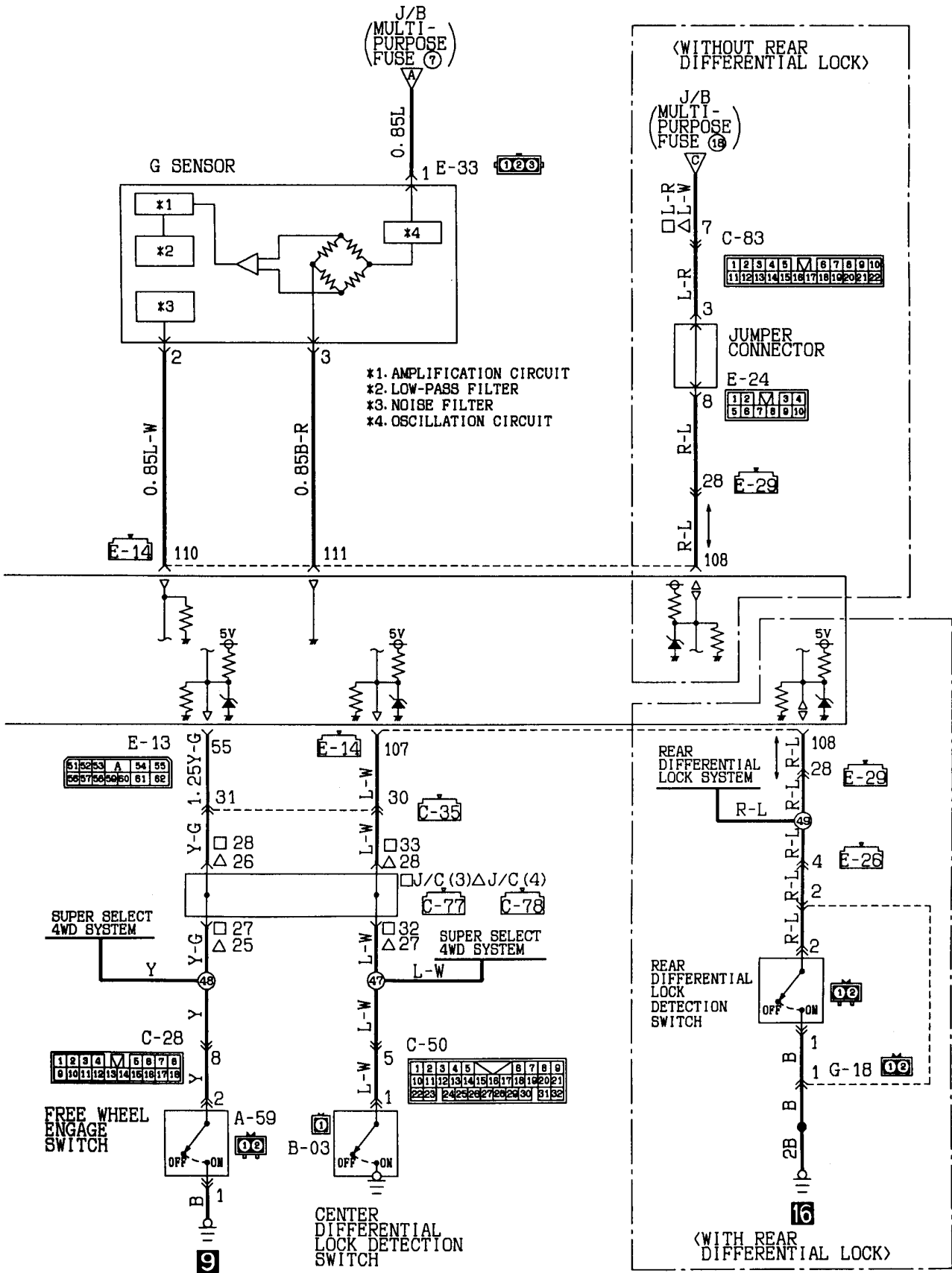

AUTO-CRUISE CONTROL SYSTEM

L.H. drive vehicles (Petrol-powered vehicles)

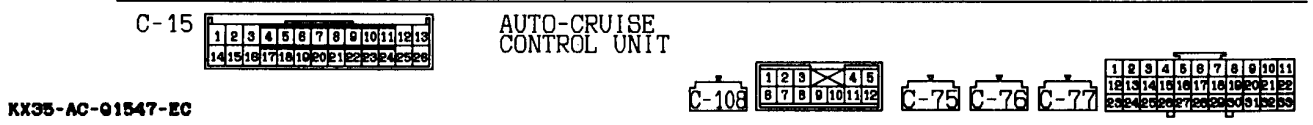
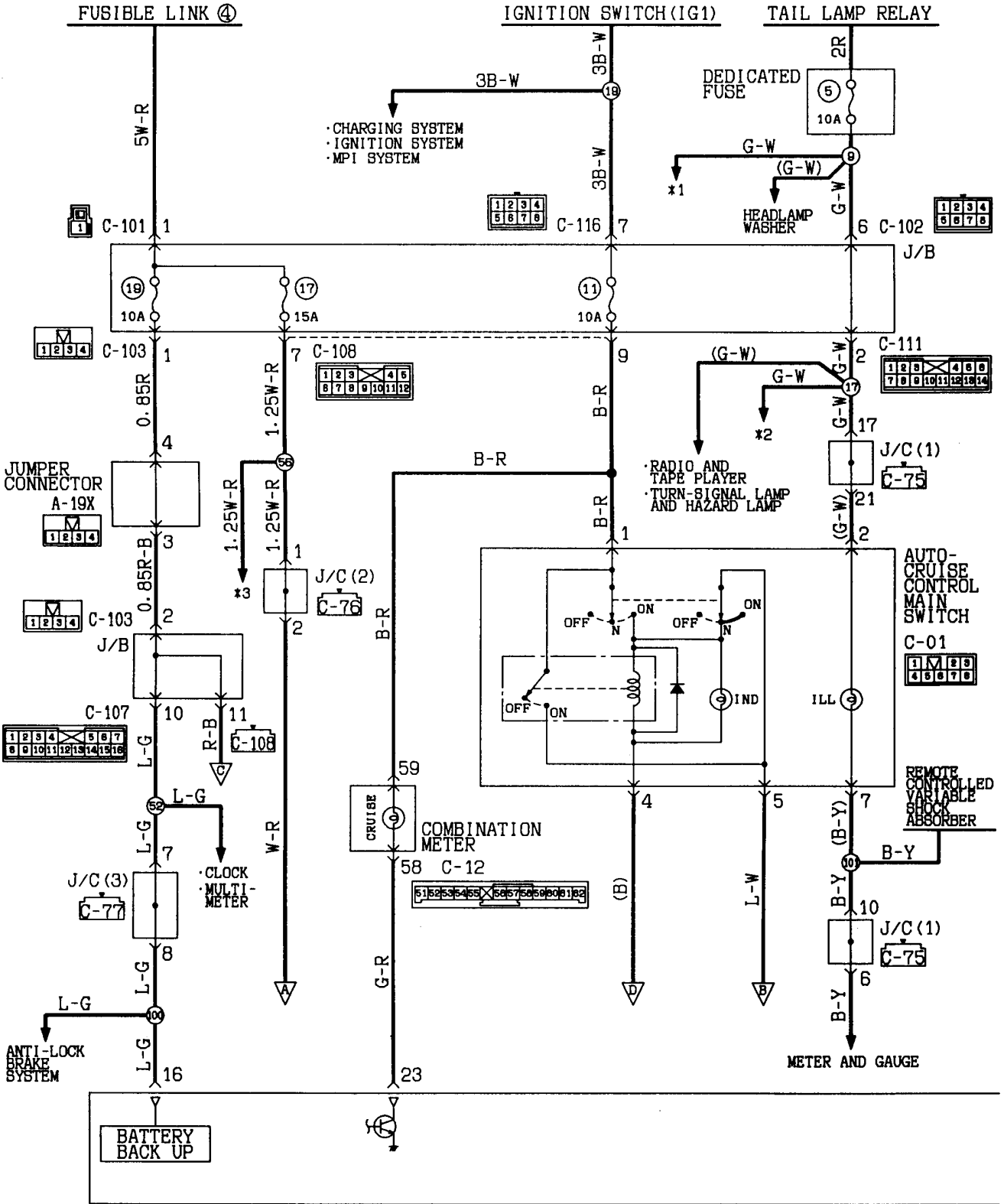

KX35-AC-01547-EC

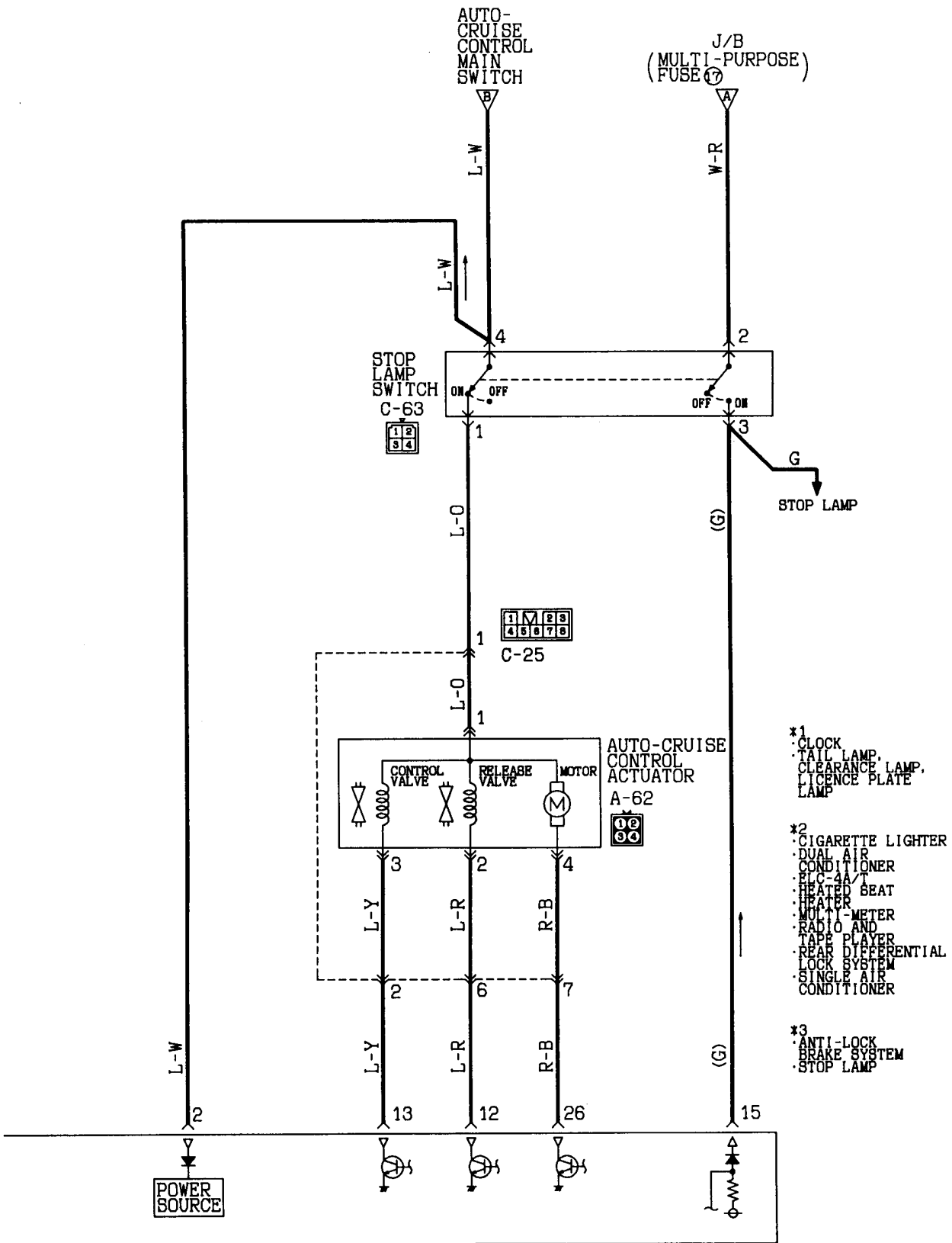

Wire colour code
 B:Black LG:Light green G:Green L:Blue W:White Y:Yellow SB:Sky blue
 BR:Brown O:Orange GR:Gray R:Red P:Pink V:Violet

AUTO-CRUISE CONTROL SYSTEM

<L.H. drive vehicles (Petrol-powered vehicles)> (CONTINUED)

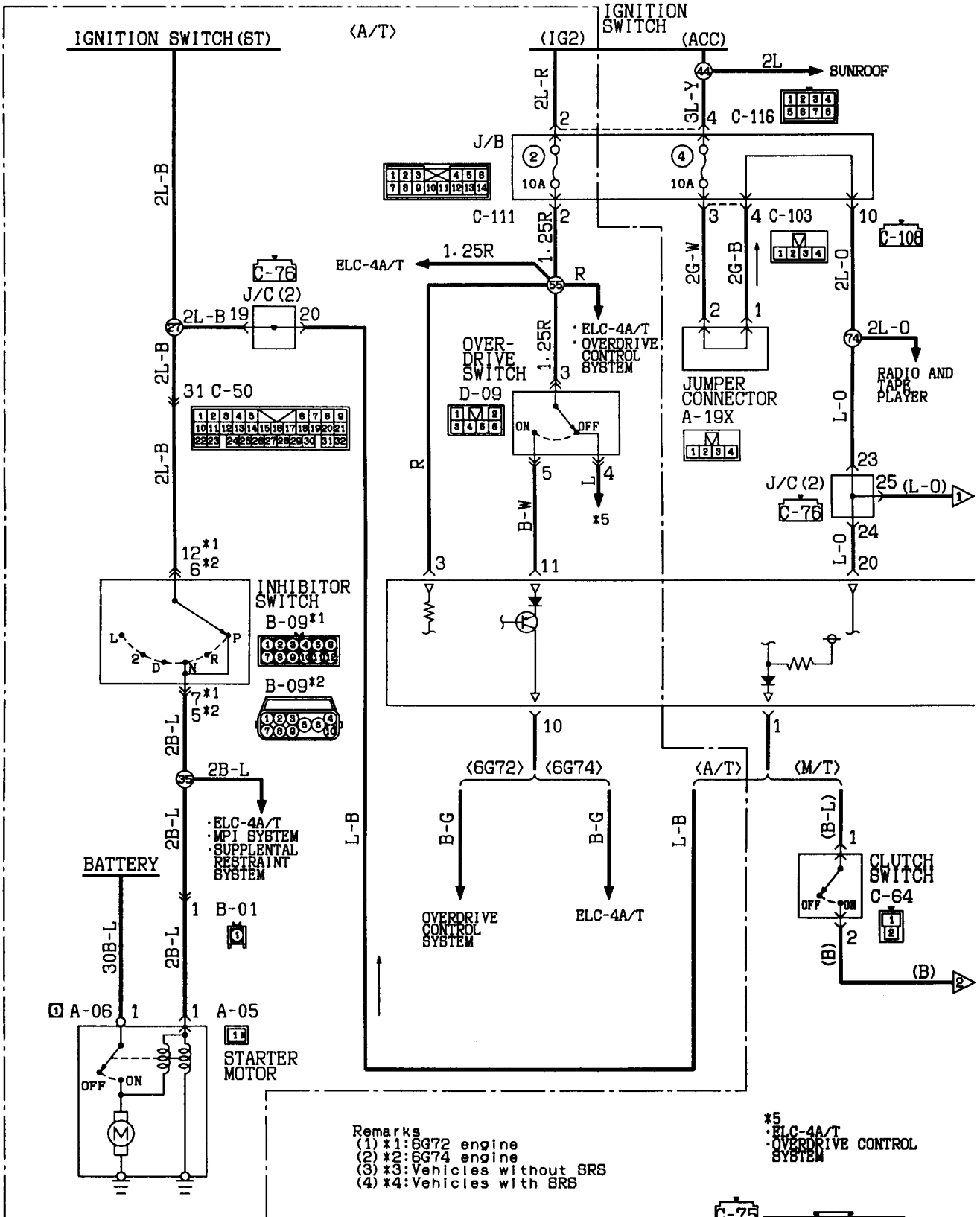

Remarks
 (1) *1: 6G72 engine
 (2) *2: 6G74 engine
 (3) *3: Vehicles without SRS
 (4) *4: Vehicles with SRS

*5
 : ELC-4A/T
 : OVERDRIVE CONTROL SYSTEM

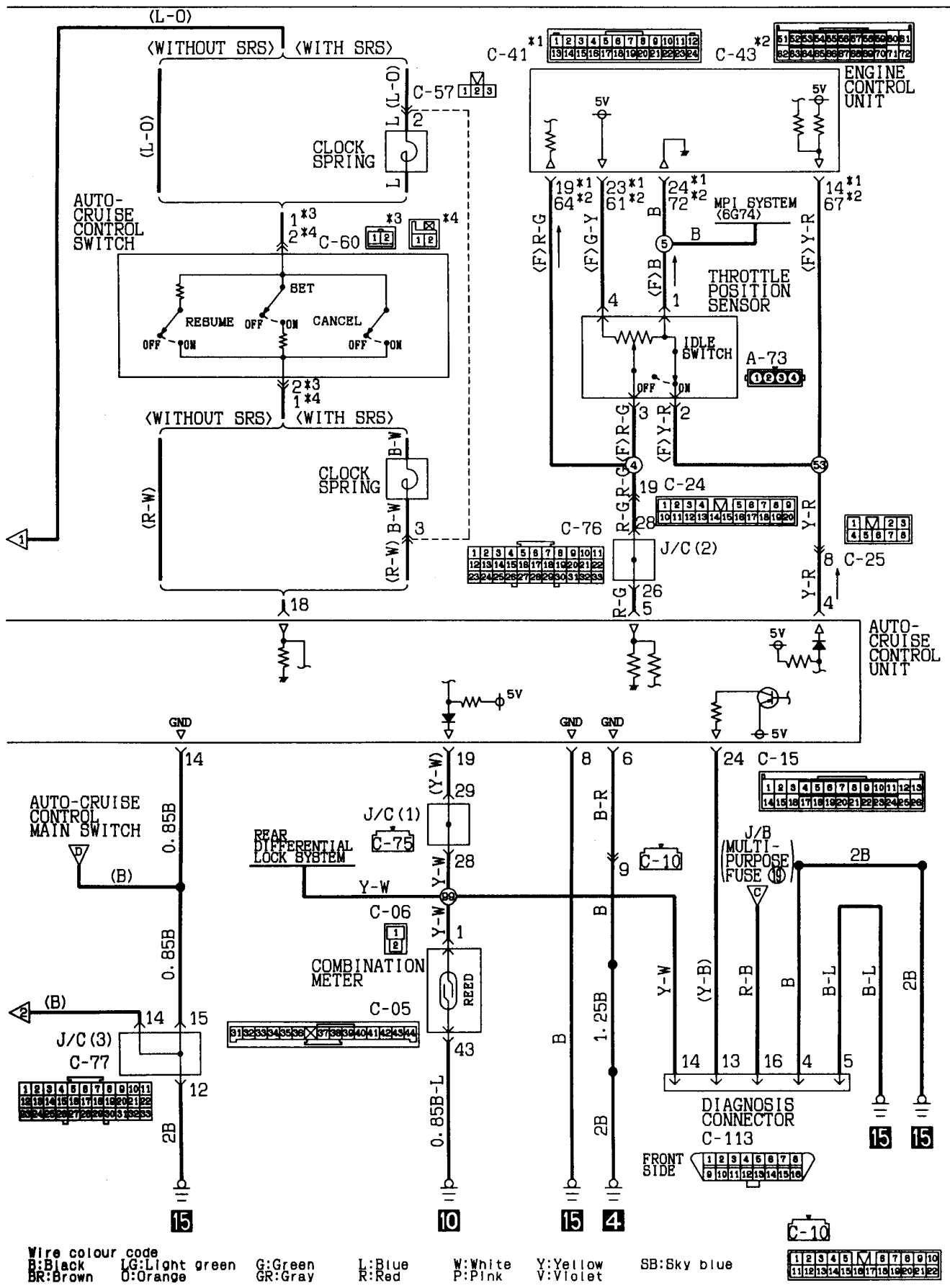

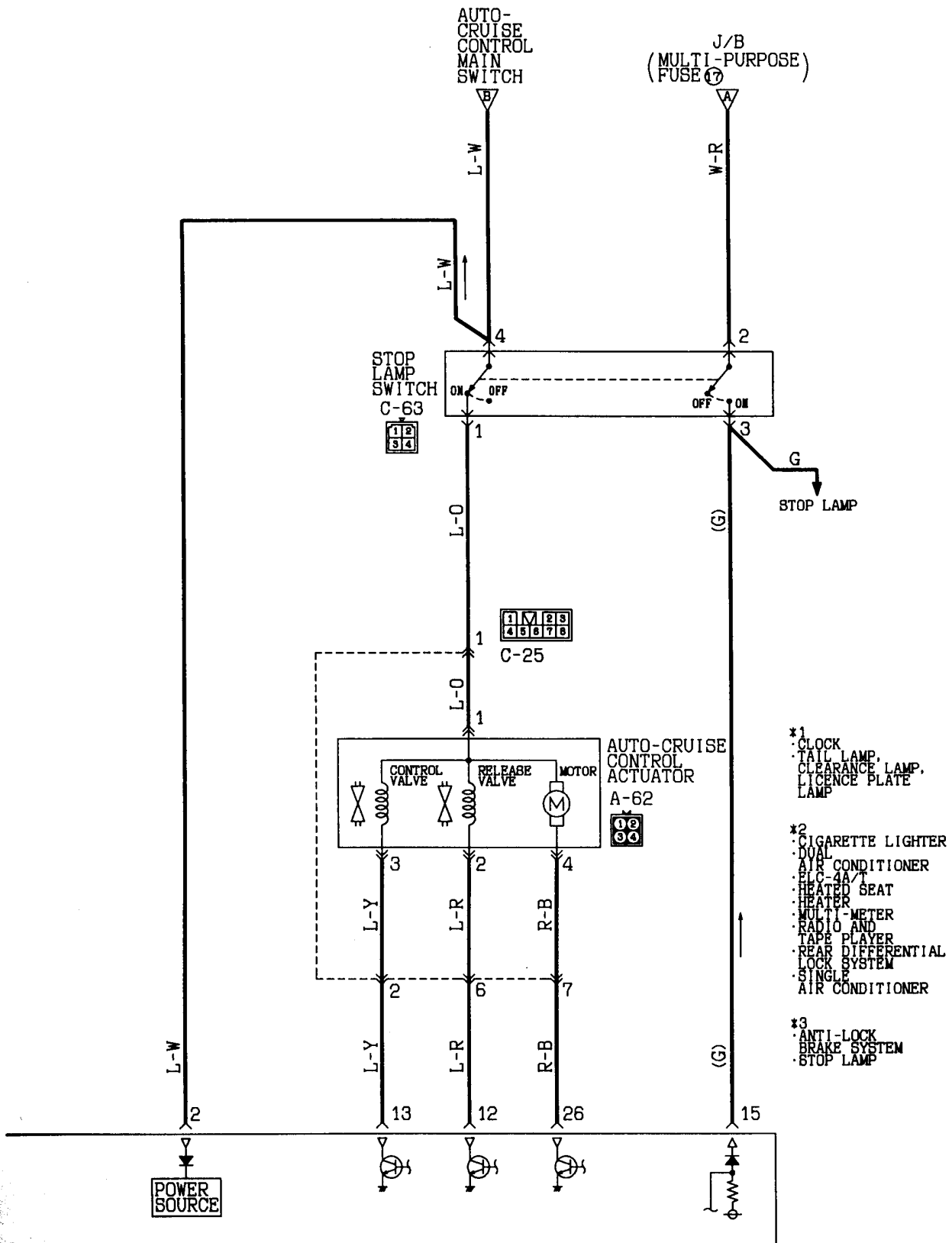

Wire colour code
 B:Black LG:Light green G:Green L:Blue W:White Y:Yellow SB:Sky blue
 BR:Brown O:Orange GR:Gray R:Red P:Pink V:Violet

AUTO-CRUISE CONTROL SYSTEM
(L.H. drive vehicles (Diesel-powered vehicles)) (CONTINUED)

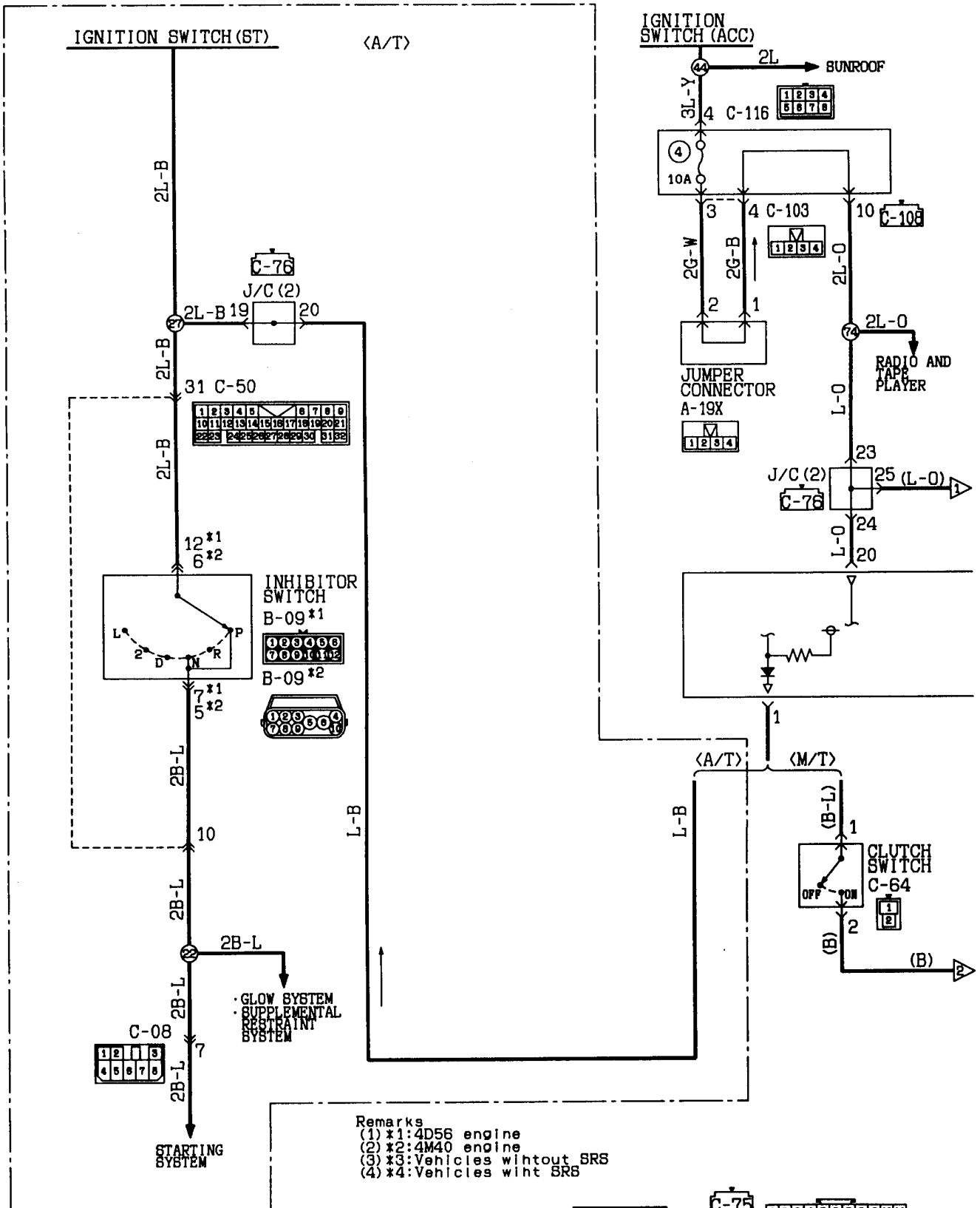

KX35-AC-01548A-EC



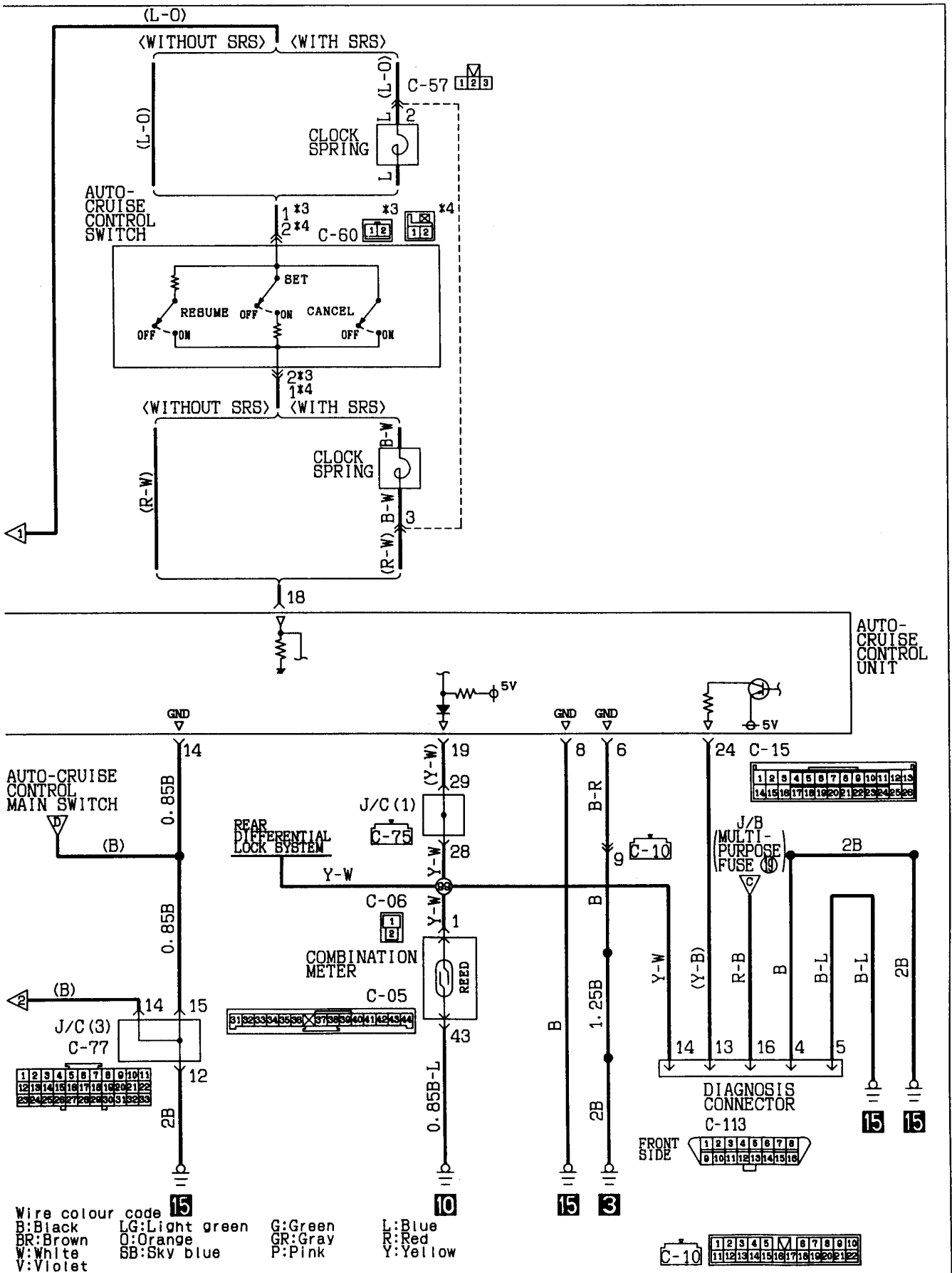

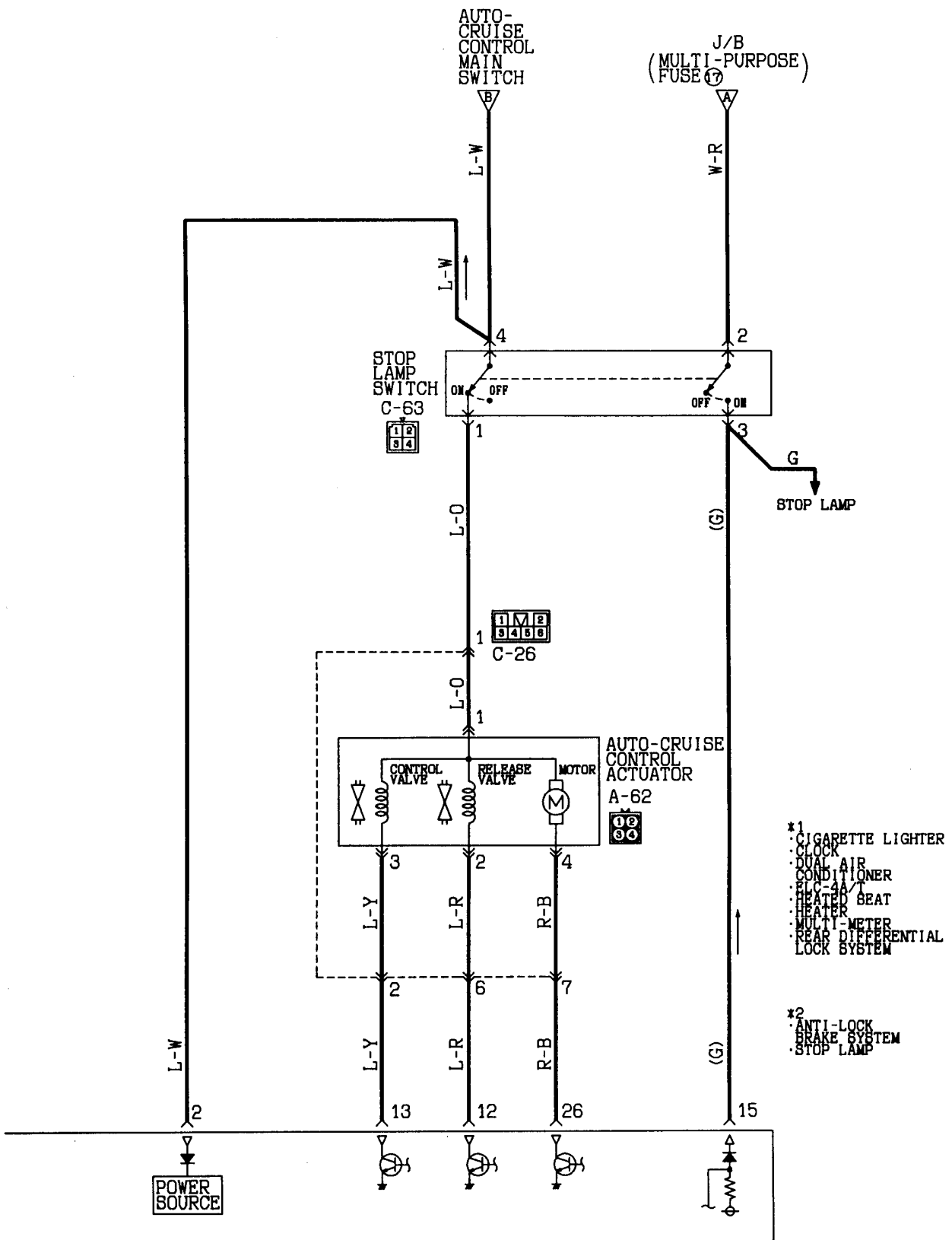

- *1
- CIGARETTE LIGHTER
- CLOCK
- DUAL AIR CONDITIONER
- PLC-4A/T
- HEATED BEAT
- HEATER
- MULTI-METER
- REAR DIFFERENTIAL LOCK SYSTEM
- *2
- ANTI-LOCK BRAKE SYSTEM
- STOP LAMP

Wire colour code
 B:Black LG:Light green G:Green L:Blue W:White Y:Yellow SB:Sky blue
 BR:Brown O:Orange GR:Gray R:Red P:Pink V:Violet

AUTO-CRUISE CONTROL SYSTEM

<R. H. drive vehicles (Petrol-powered vehicles)> (CONTINUED)

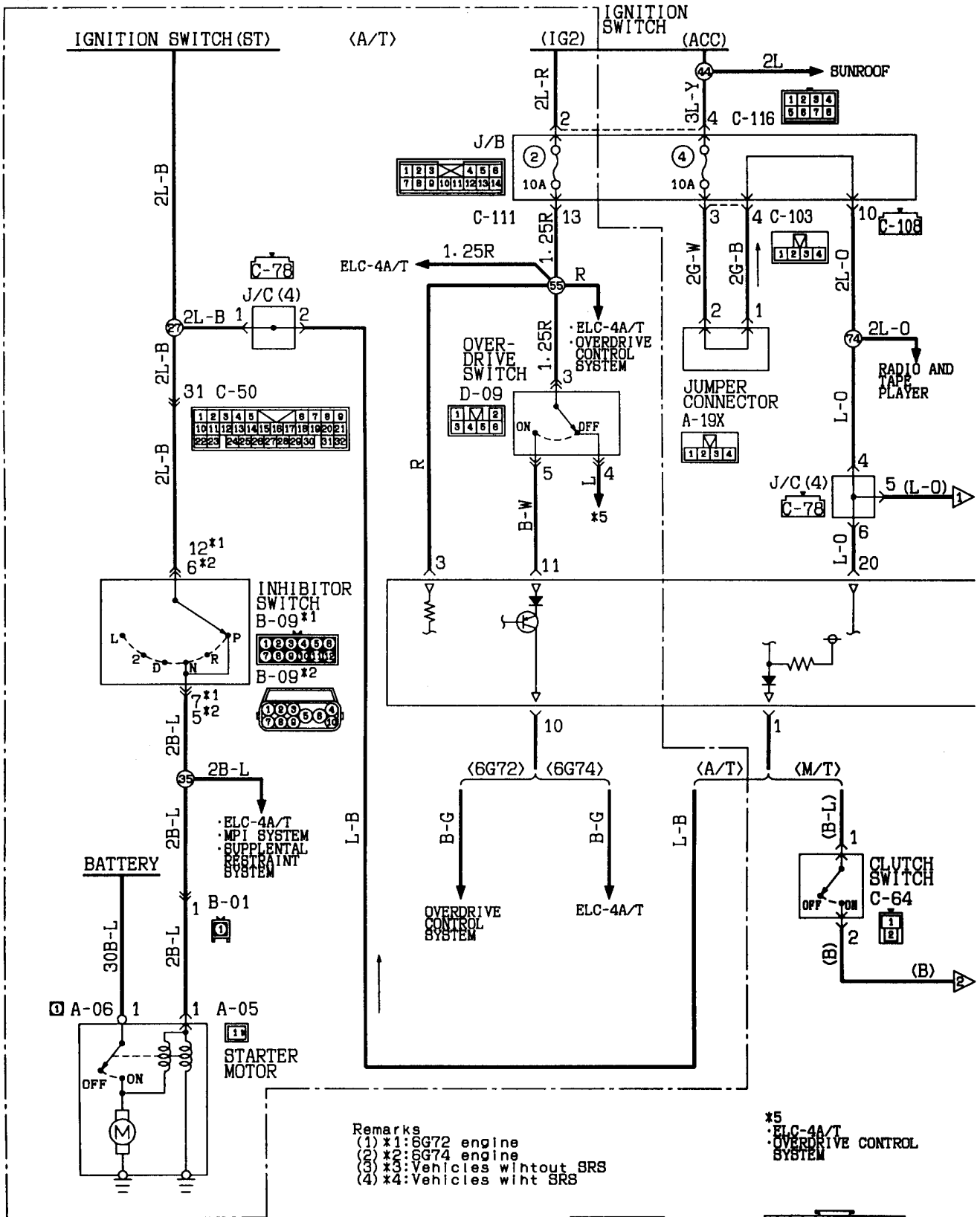

Remarks
 (1) *1: 6G72 engine
 (2) *2: 6G74 engine
 (3) *3: Vehicles without SRS
 (4) *4: Vehicles with SRS

*5
 ELC-4A/T
 OVERDRIVE CONTROL SYSTEM



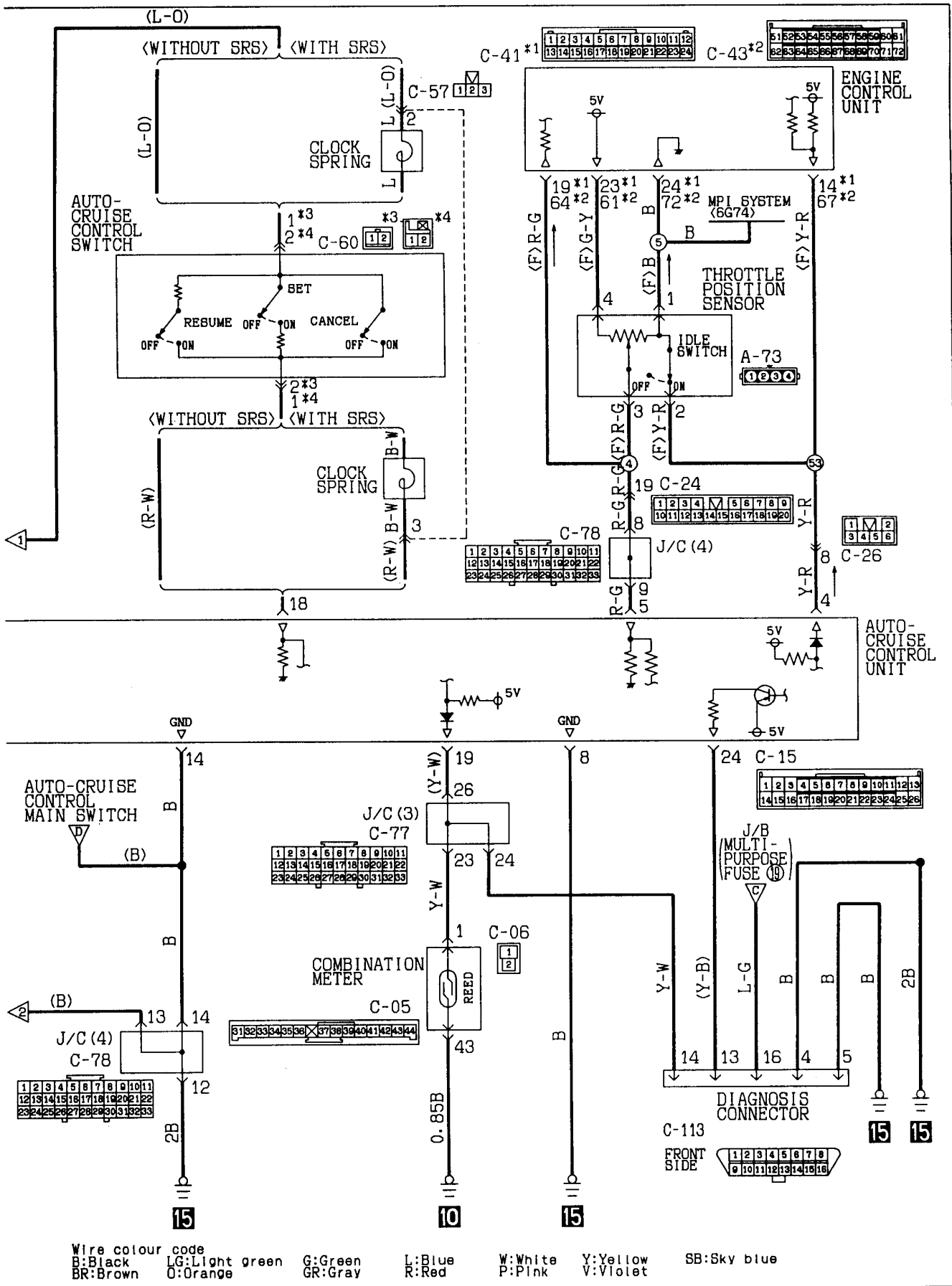

AUTO-CRUISE CONTROL SYSTEM

R. H. drive vehicles (Diesel-powered vehicles)

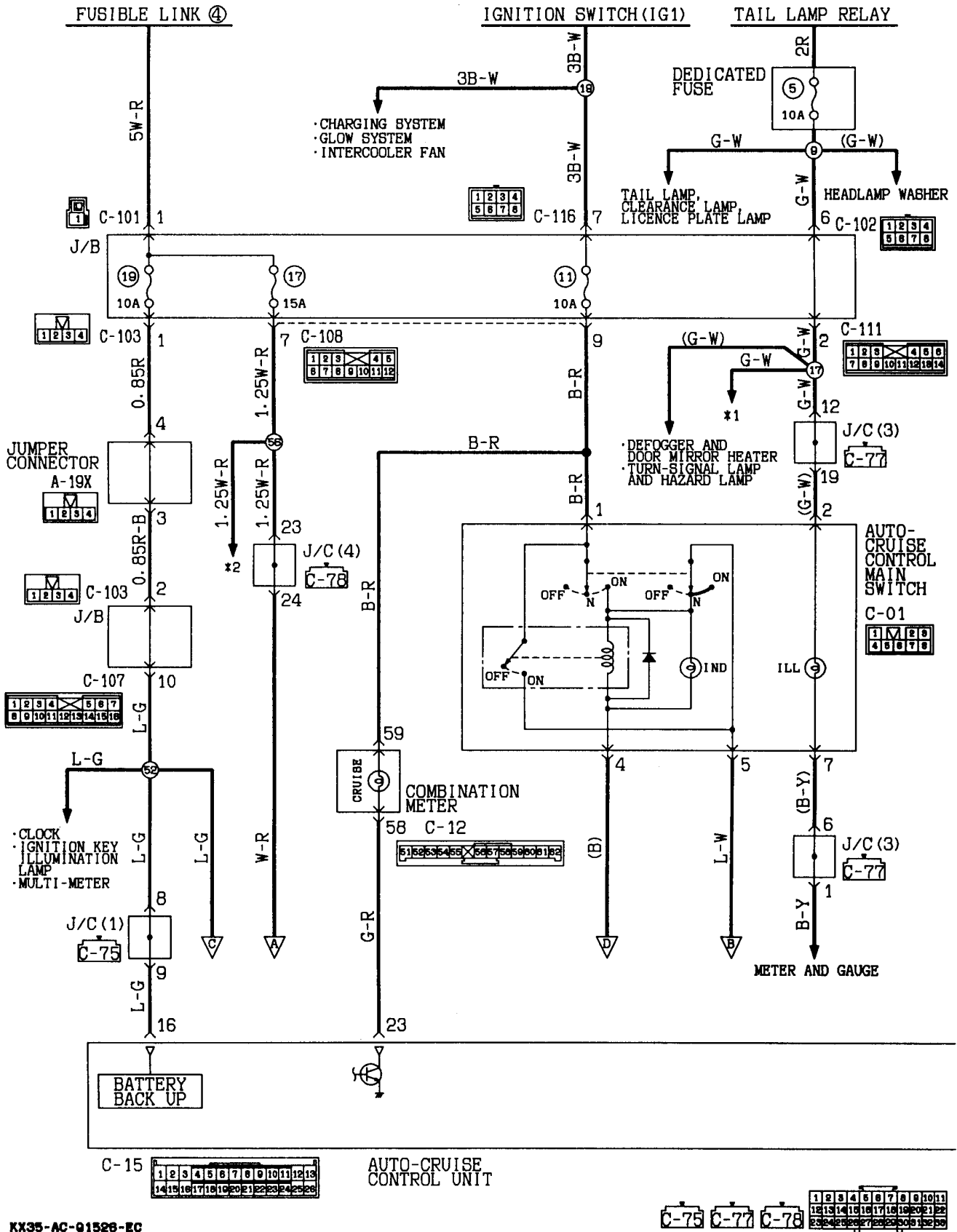

KX35-AC-Q1526-EC

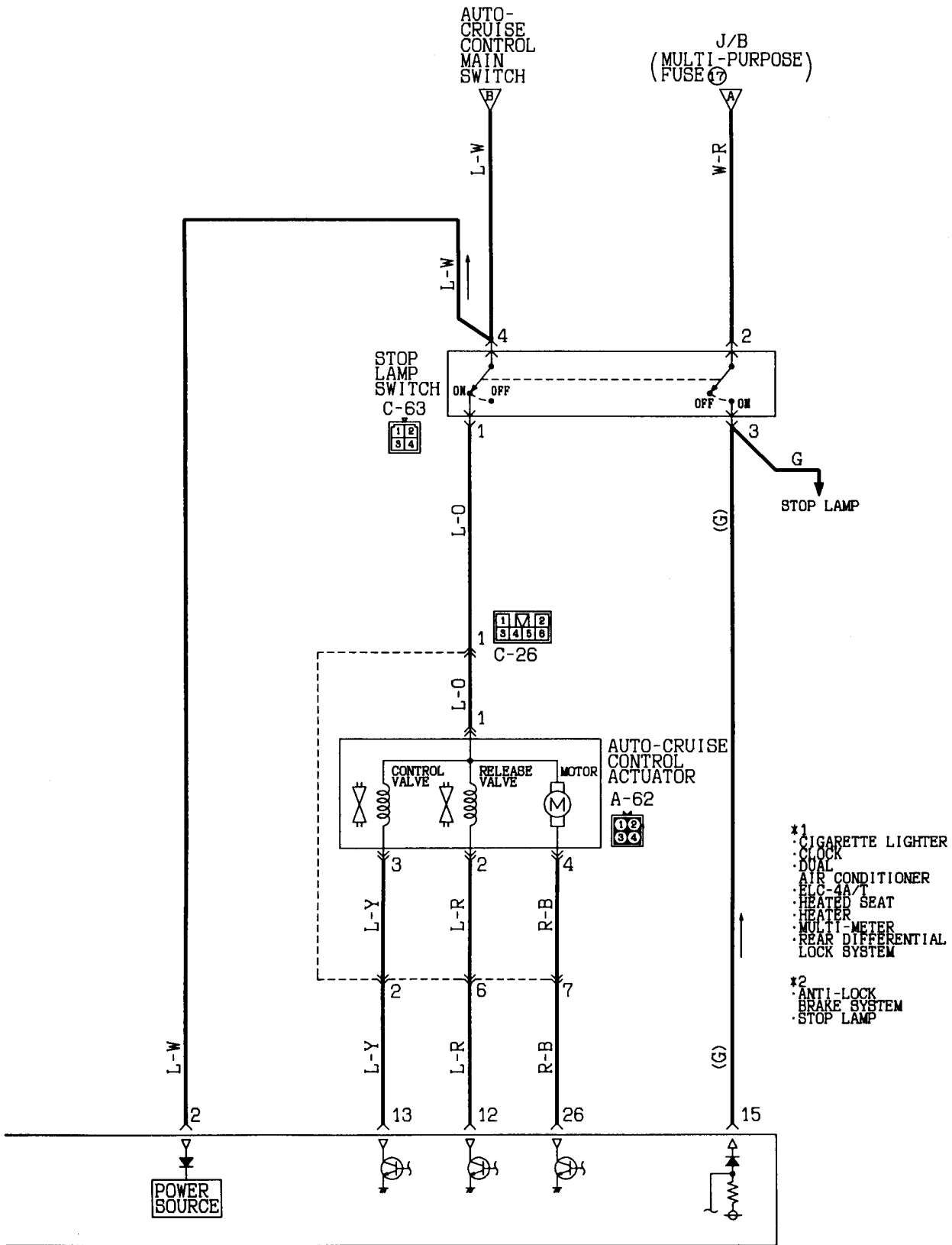

- *1
- CIGARETTE LIGHTER
- CLOCK
- DUAL
- A/C
- A/C-4A/T
- HEATED SEAT
- HEATER
- MULTI-METER
- REAR DIFFERENTIAL LOCK SYSTEM
- *2
- ANTI-LOCK BRAKE SYSTEM
- STOP LAMP

Wire colour code
 B:Black LG:Light green G:Green L:Blue W:White Y:Yellow SB:Sky blue
 BR:Brown O:Orange GR:Gray R:Red P:Pink V:Violet

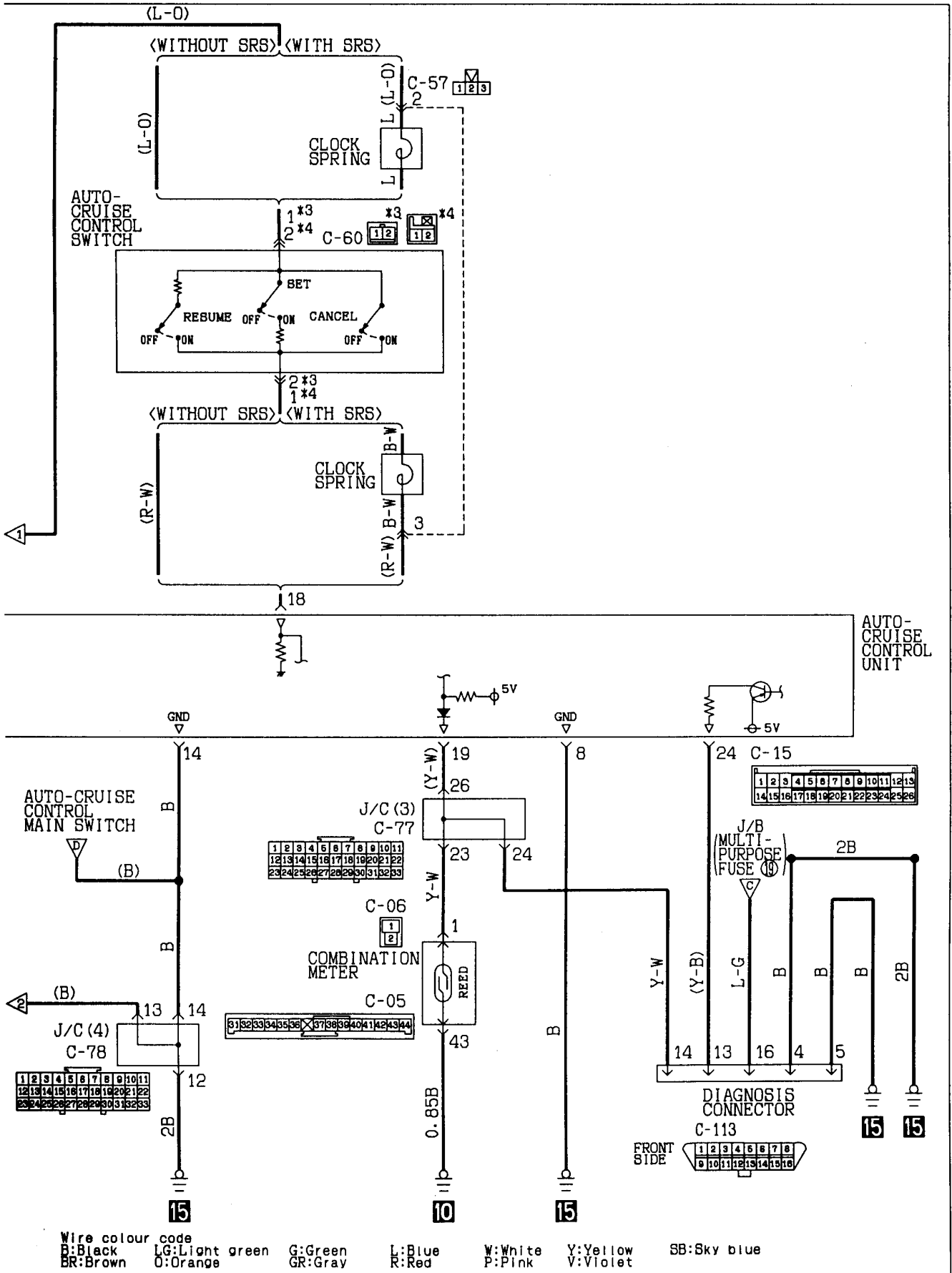

HEATED SEAT

Vehicles without power seat

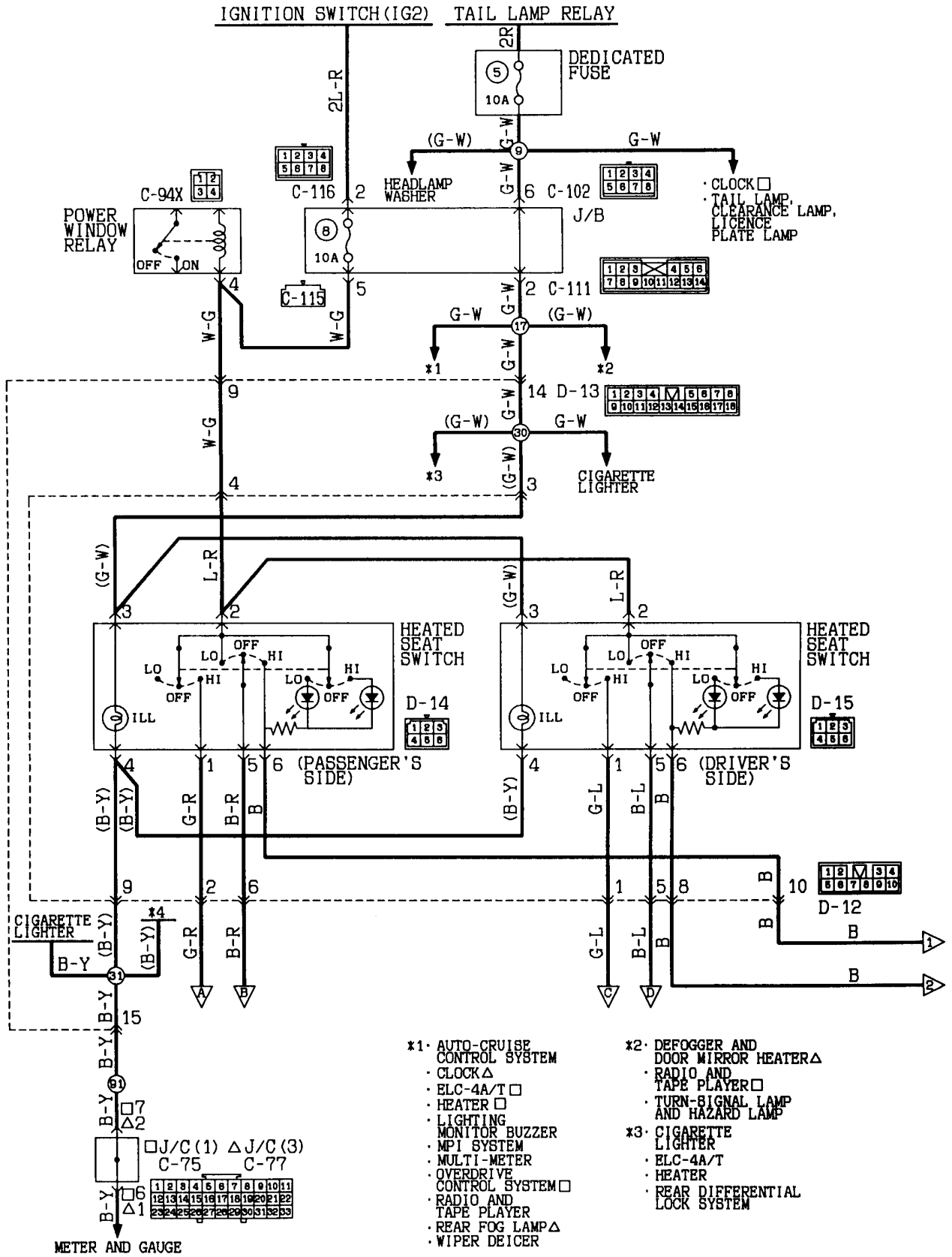

KX35-AC-01528-EC

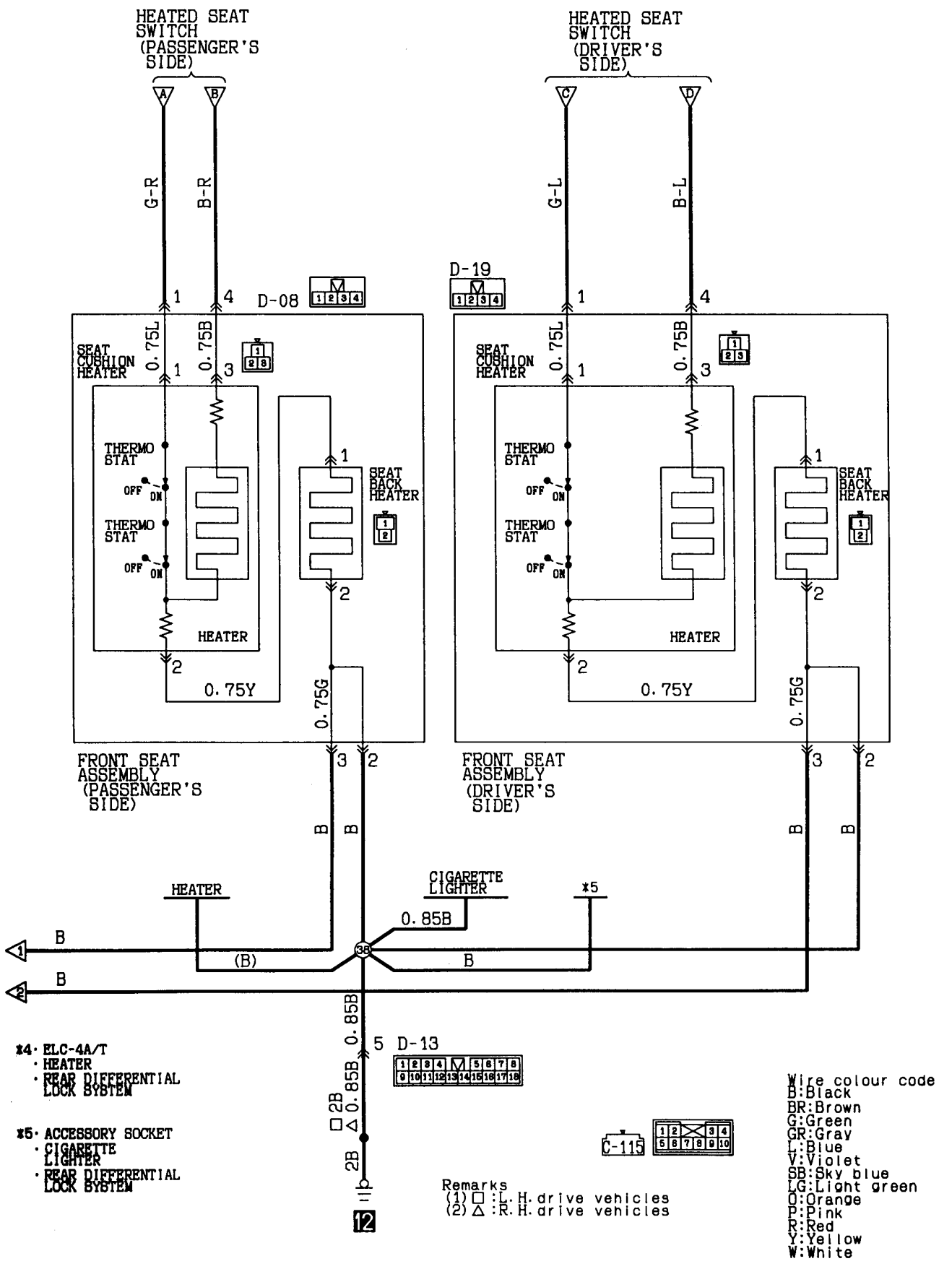

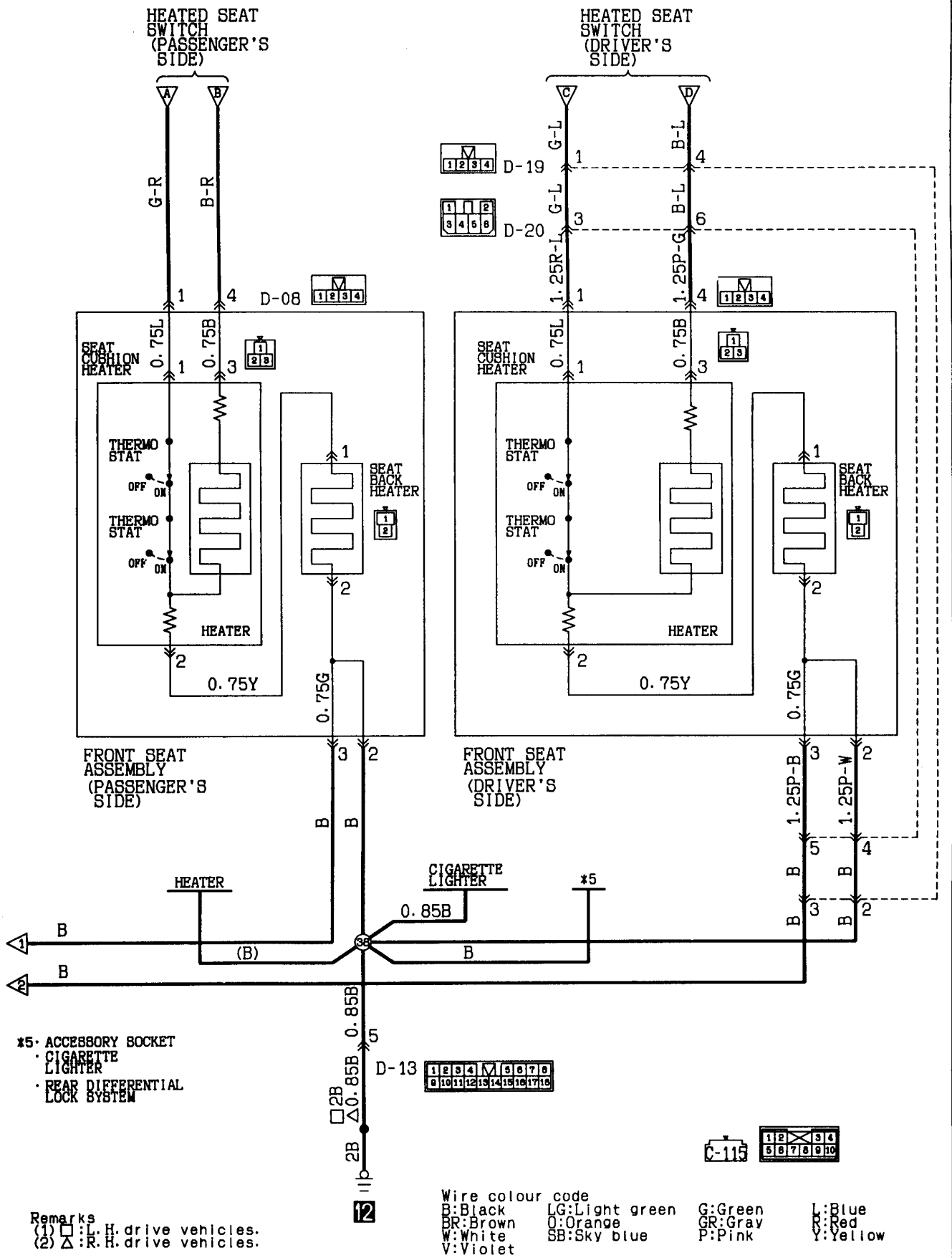

HEATED SEAT (See P. 4A-328, 330)**OPERATION**

- When the heated seat switch is turned ON (either in LO or HI) with the ignition switch in ON position, the heated seat is activated with operation corresponding to the switch position.

TROUBLESHOOTING HINTS

1. The heated seat warms at one place only.
 - Check the heated seat.
2. The heated seat doesn't become warm.
 - Check the multi-purpose fuse No. ⑧.
 - Check the heated seat switch.

POWER SEAT

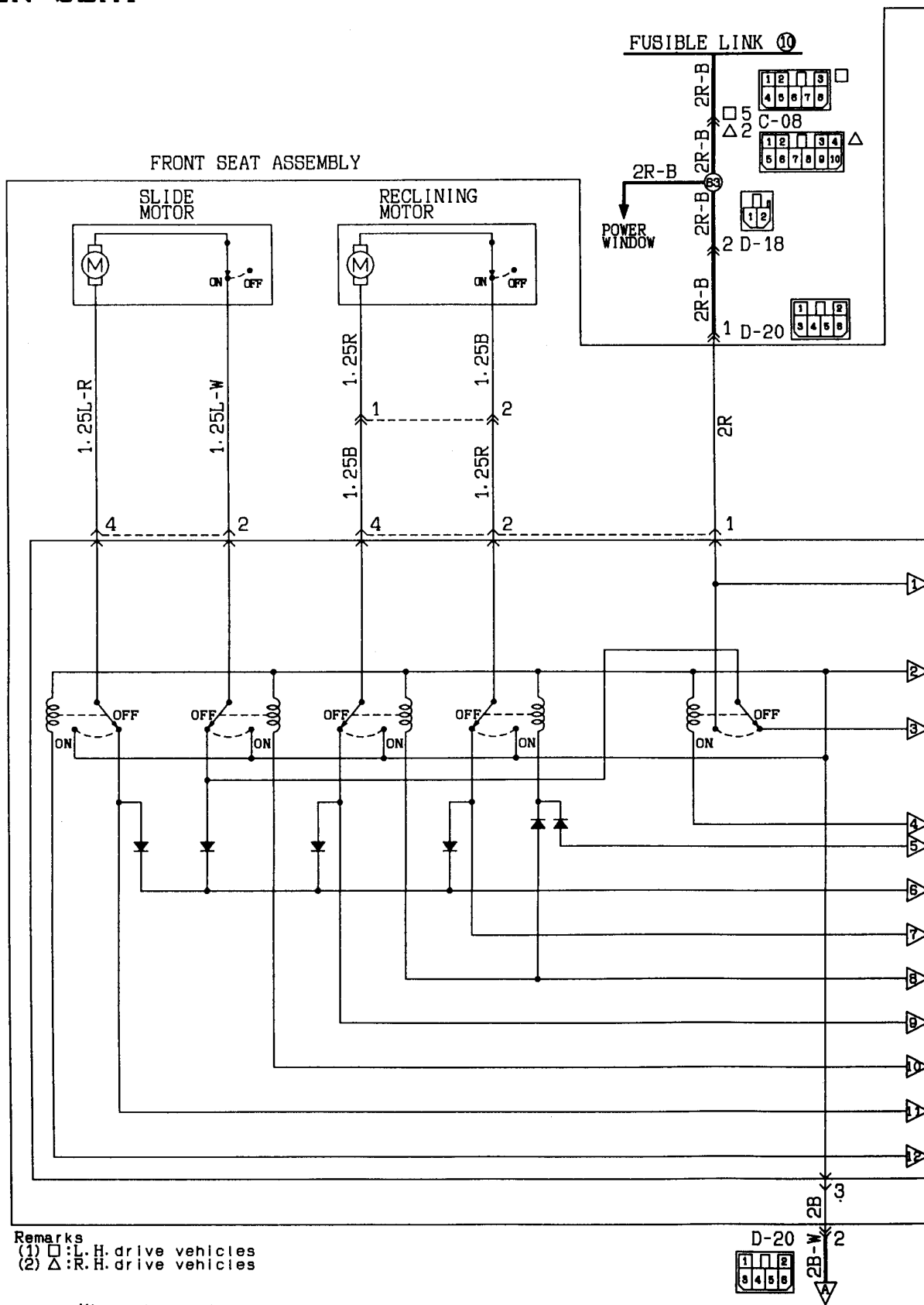

Remarks
 (1) □ : L.H. drive vehicles
 (2) △ : R.H. drive vehicles

Wire colour code
 B:Black LG:Light green G:Green L:Blue W:White Y:Yellow SB:Sky blue
 BR:Brown O:Orange GR:Gray R:Red P:Pink V:Violet

POWER SEAT (CONTINUED)

FRONT SEAT ASSEMBLY

MANUAL SWITCH

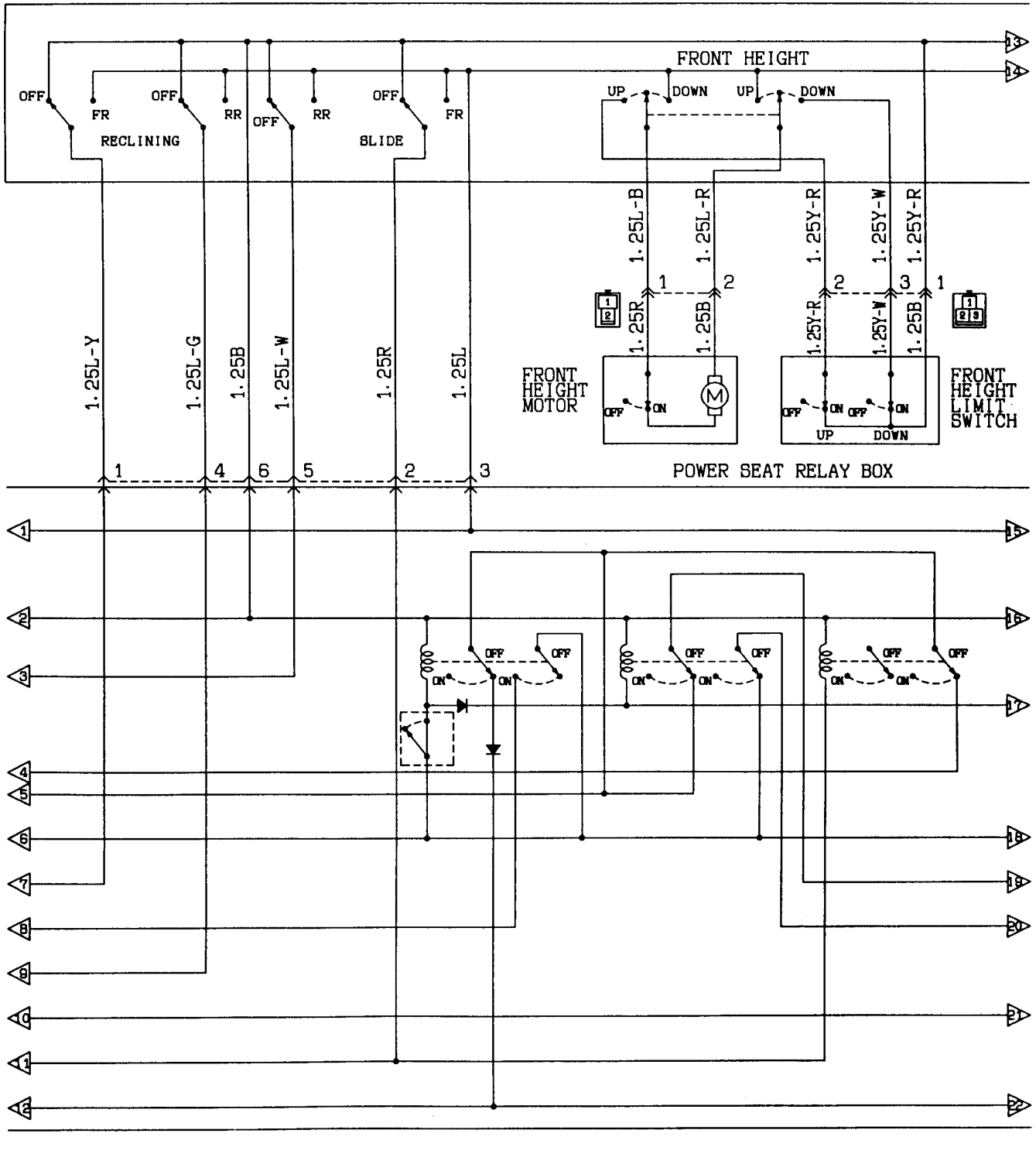

LIGHTING MONITOR BUZZER

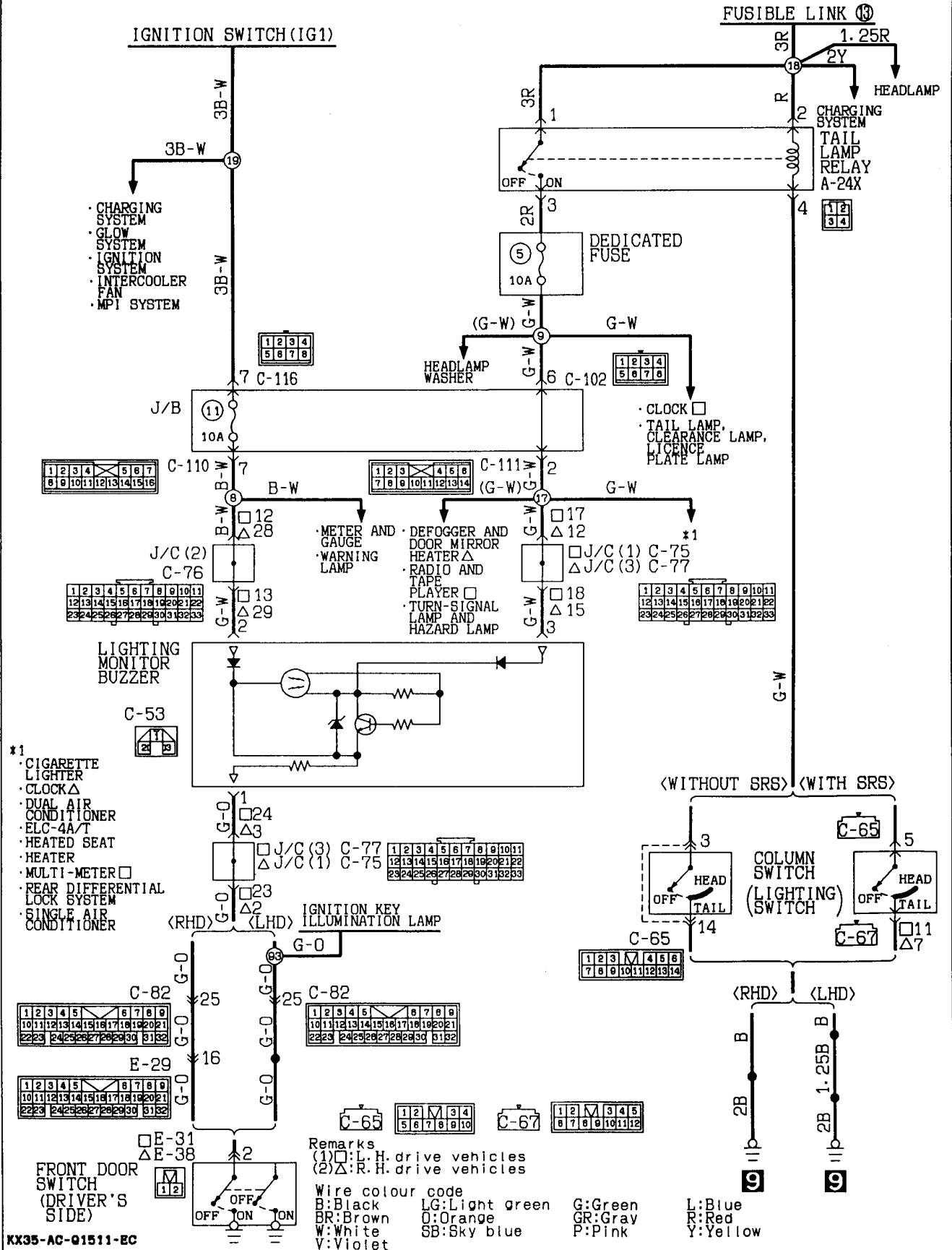

LIGHTING MONITOR BUZZER (See P. 4A-336.)**OPERATION**

- Placing the lighting switch in the TAIL or HEAD position causes the tail lamp relay to be energized.
- When the ignition switch is in the "OFF" position in this condition, if the driver's side door is opened and the front door switch turns "ON", the buzzer sounds to indicate that the lamps are not switched off.

TROUBLESHOOTING HINTS

1. Lighting monitor buzzer doesn't sound
 - (1) But the tail lamps do illuminate.
 - Check the lightning monitor buzzer.
 - Check the front door switch (driver's side).
 - (2) The tail lamps also don't illuminate.
 - Check the fusible link No. ⑬.
 - Check the dedicated fuse No. ⑤.

FUEL LINE HEATER

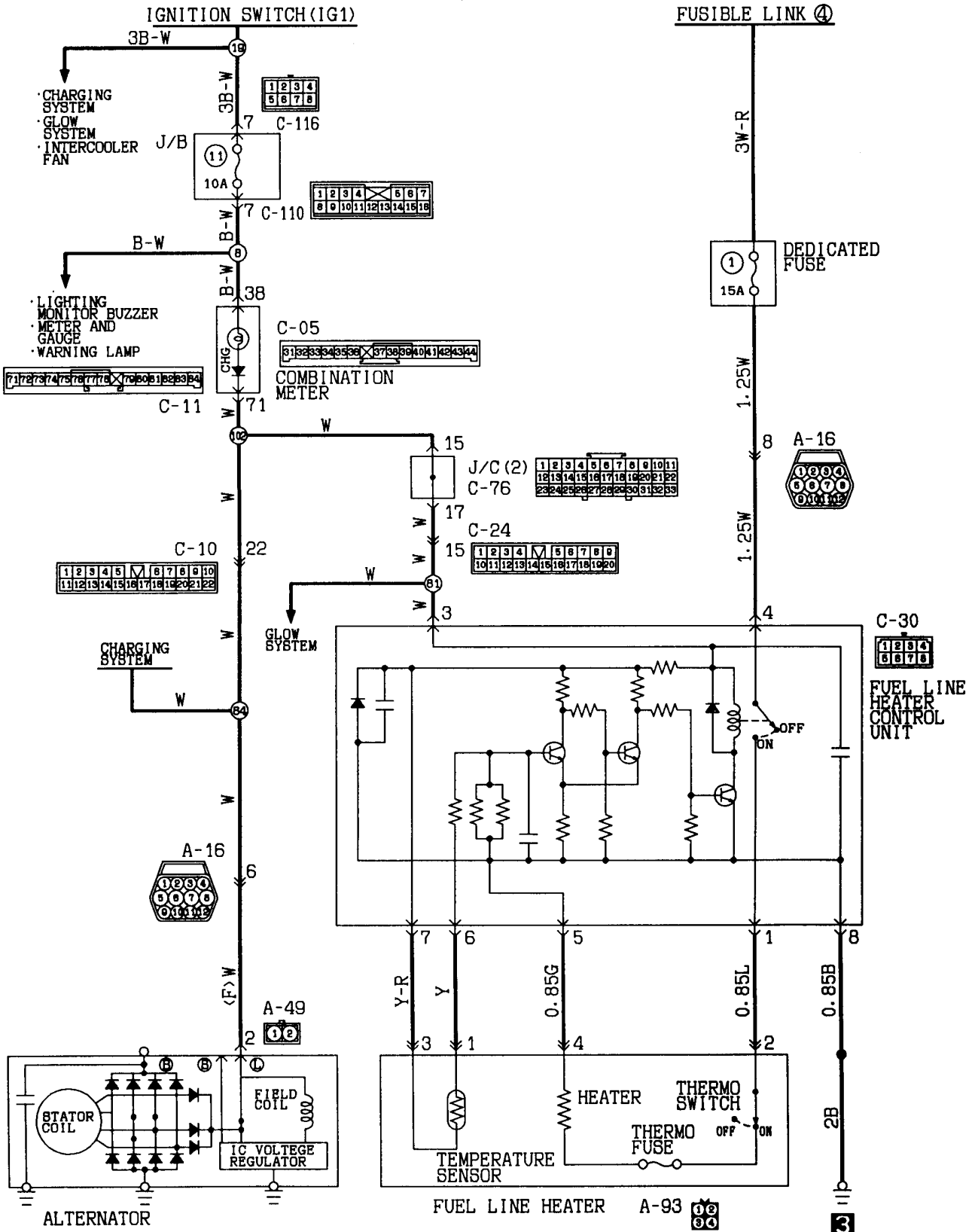

Wire colour code
 B:Black LG:Light green G:Green L:Blue W:White Y:Yellow
 BR:Brown O:Orange GR:Gray R:Red P:Pink V:Violet
 BB:Sky blue

FUEL LINE HEATER (See P. 4A-338.)**OPERATION**

- When the engine is started, the fuel thermo sensor operates to detect the fuel temperature. If the fuel temperature drops below 0~6°C (32~43°F), the fuel line heater control unit operates to turn the heater on in order to warm the fuel. When the fuel temperature is between 1.5~7.5°C (34.5~45.5°F), the heater turns off.
- If there is a malfunction of the fuel thermo sensor and the heater becomes too warm, the thermo switch operates when the temperature becomes 36~46°C (97~115°F) to turn the heater circuit off. If there is a malfunction of the thermo switch, the thermo fuse will burn out at 114~124°C (237~255°F) to fully isolate the heater circuit.

SUPPLEMENTAL RESTRAINT SYSTEM
Petrol-powered vehicles

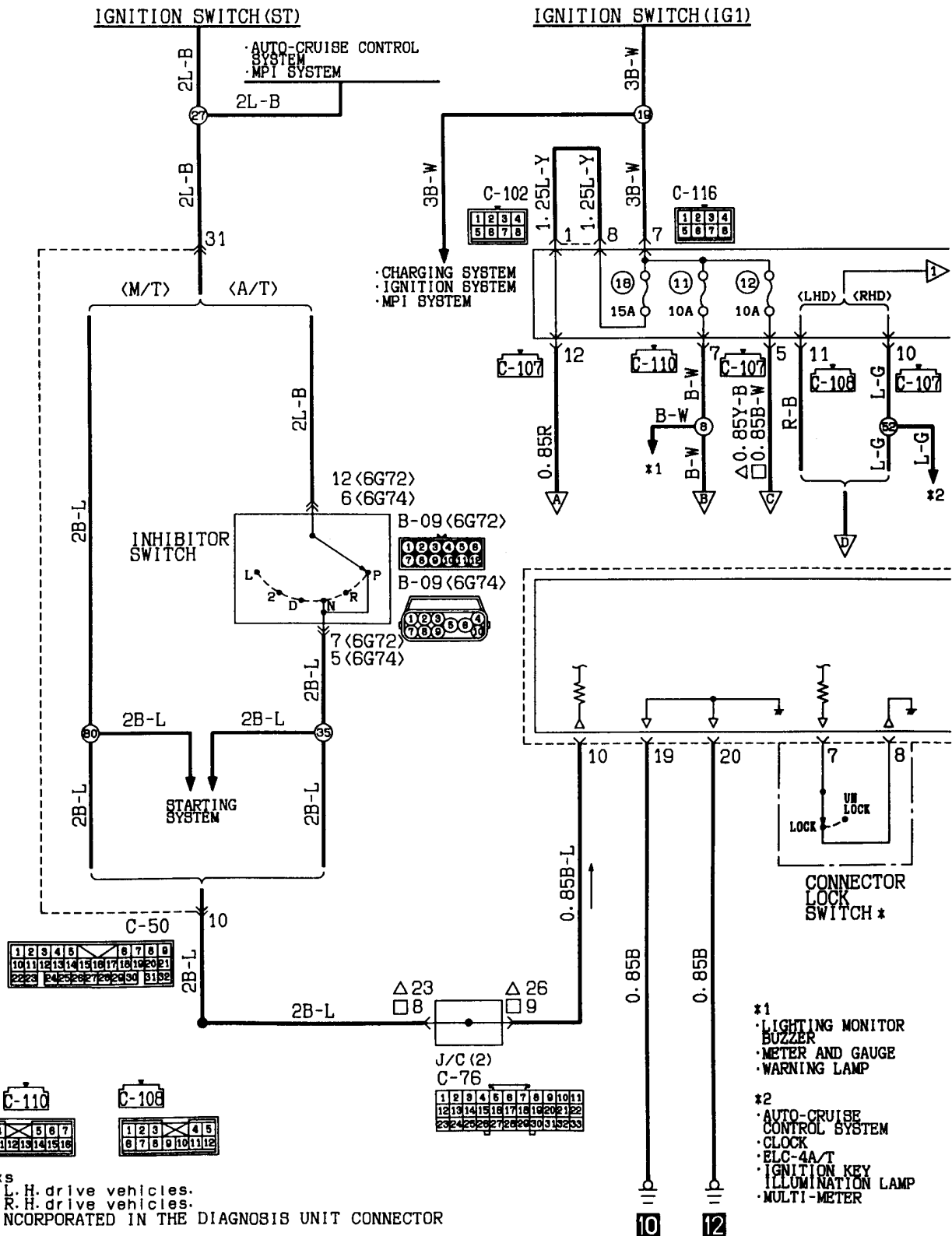

- *1
- LIGHTING MONITOR BUZZER
- METER AND GAUGE
- WARNING LAMP
- *2
- AUTO-CRUISE CONTROL SYSTEM
- CLOCK
- ELC-4A/T
- IGNITION KEY ILLUMINATION LAMP
- MULTI-METER

Remarks
 (1) □ : L. H. drive vehicles.
 (2) △ : R. H. drive vehicles.
 (3) * : INCORPORATED IN THE DIAGNOSIS UNIT CONNECTOR

Wire colour code
 B:Black LG:Light green G:Green L:Blue W:White Y:Yellow SB:Sky blue
 BR:Brown O:Orange GR:Gray R:Red P:Pink V:Violet

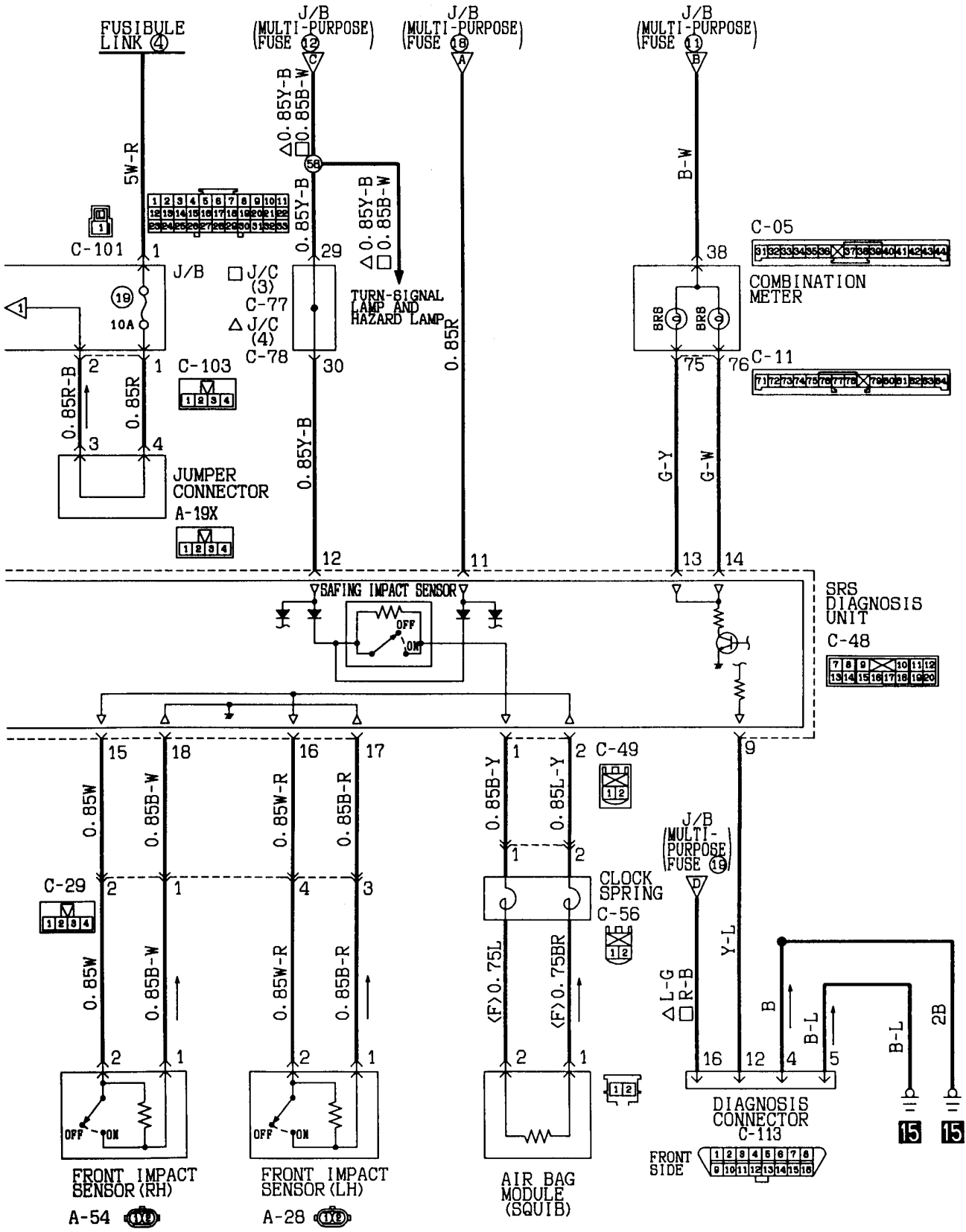

SUPPLEMENTAL RESTRAINT SYSTEM
Diesel-powered vehicles

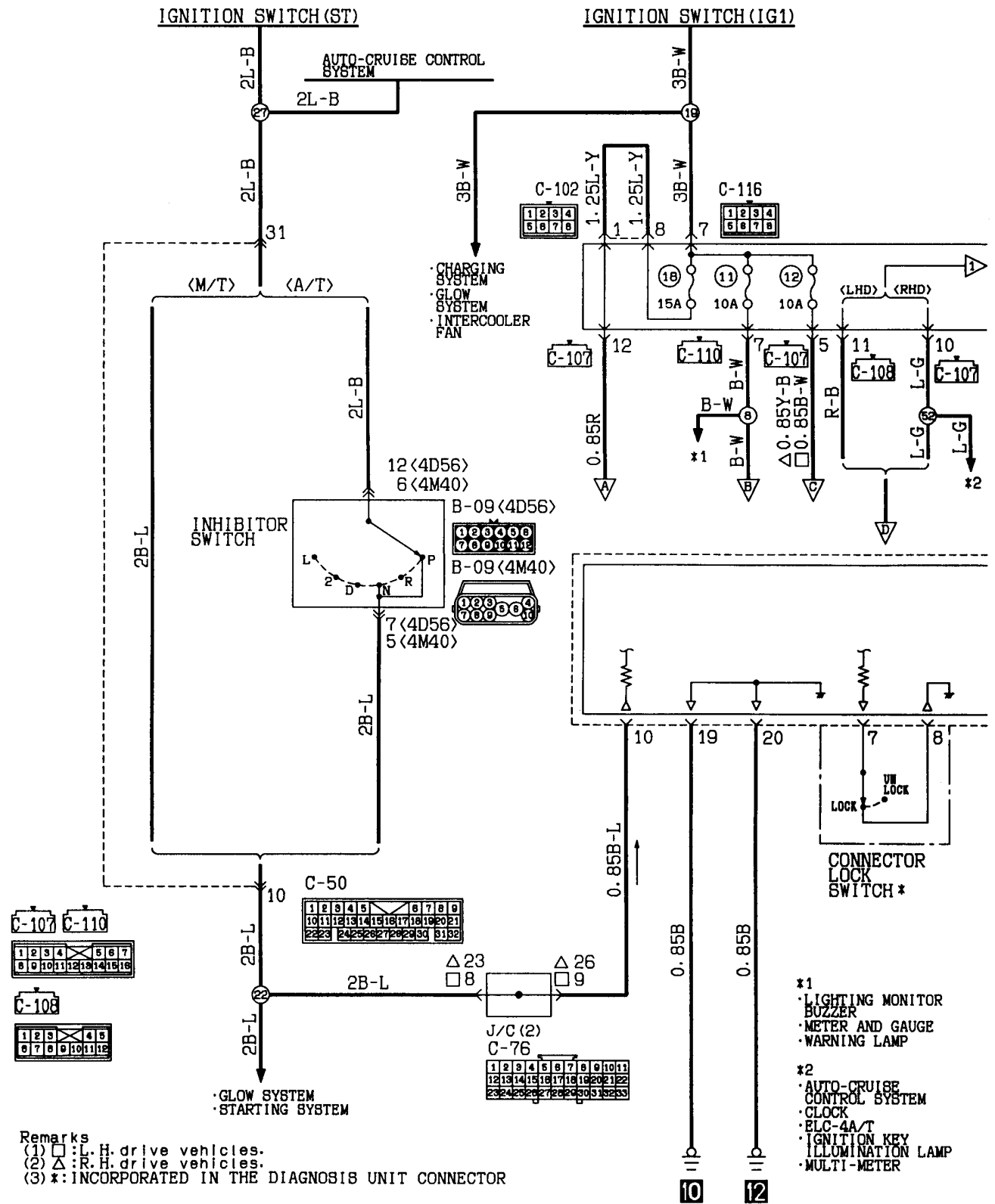

Wire colour code
 B:Black LG:Light green G:Green L:Blue W:White Y:Yellow SB:Sky blue
 BR:Brown O:Orange GR:Gray R:Red P:Pink V:Violet

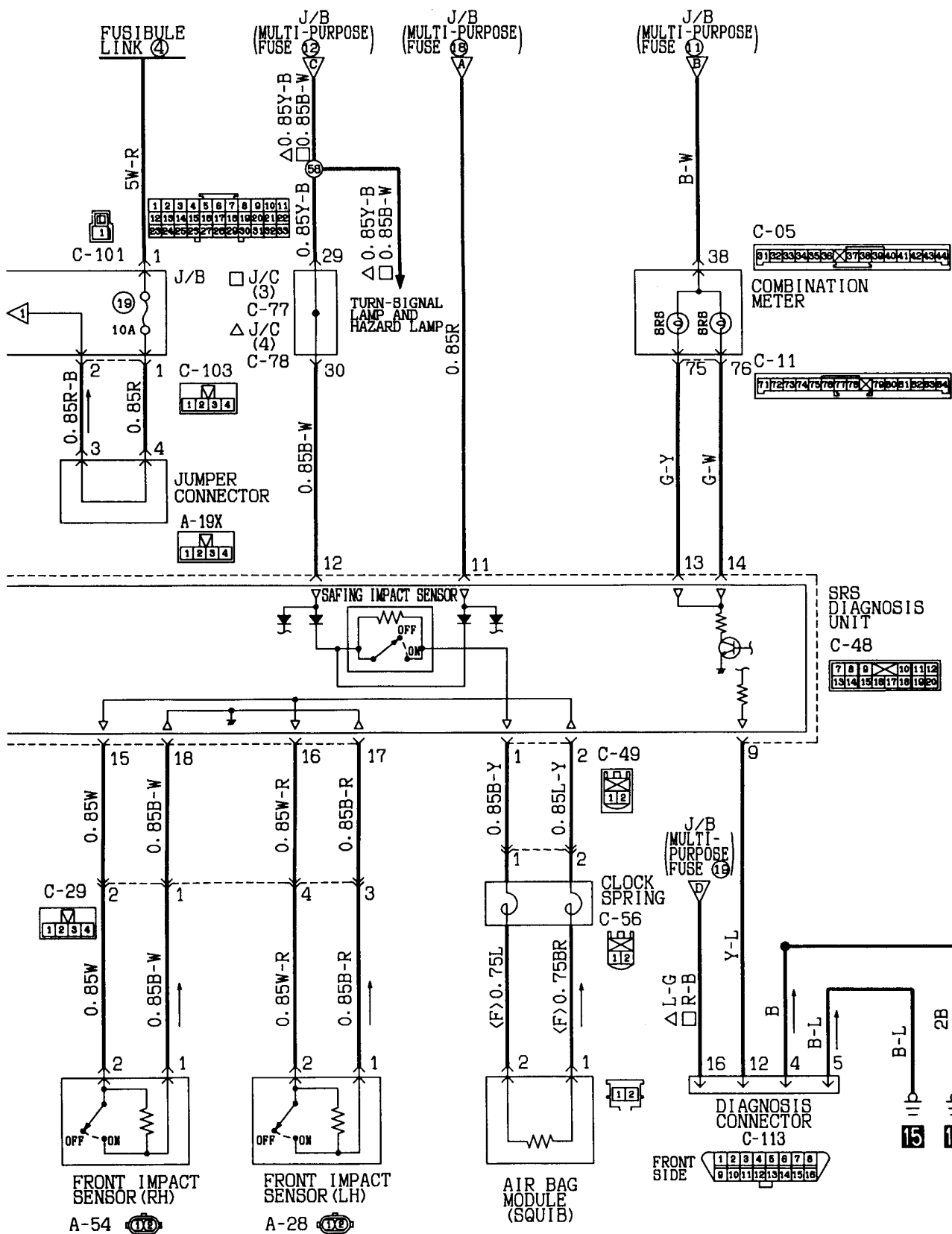

INDEX (In order of connector No.)

Connector No.	Parts name	Circuit diagram page	Wiring diagram page	
A	A-01	Headlamp washer motor and headlamp washer fluid level sensor	4A-268	2A-4, 8, 12, 16, 20, 24, 28, 32, 36
	A-02	Side turn signal lamp (RH)	4A-137	2A-4, 8, 12, 16, 20, 24, 28, 32, 36
	A-03	} Motor antenna	4A-279, 283, 287	2A-4, 8, 13, 16, 21, 24, 29, 32, 37
	A-04		4A-283, 290	2A-4, 8, 13, 16, 21, 24, 29, 32, 37
	A-05	} Starter	4A-22, 23, 24, 290, 314, 322	2A-5, 8, 12, 16, 20, 25, 29, 33, 37
	A-06		4A-22, 23, 24, 314, 322	2A-5, 8, 12, 16, 20, 25, 29, 33, 37
	A-07	Daytime running lamp relay 2	4A-105, 107	2A-5, 9, 17, 25, 33
	A-08	Daytime running lamp relay 1	4A-105, 107	2A-5, 9, 17, 25, 33
	A-09	Daytime running lamp control unit	4A-105, 107, 121, 123	2A-5, 9, 17, 25, 33
	A-10	Starter relay	4A-24	2A-25, 29, 33, 37
	A-11	Windshield wiper motor	4A-260, 261	2A-5, 9, 12, 17, 20, 25, 28, 33, 36
	A-12	Vacuum switch	4A-156	2A-25, 28, 33, 36
	A-13	Brake fluid level switch	4A-156	2A-5, 9, 12, 17, 20, 25, 28, 33, 36
	A-14	A/C compressor capacity control relay or no connection	4A-198, 205, 214, 227, 240, 253	2A-25, 29, 33, 37
	A-15	Condenser fan motor control relay	4A-199, 206, 215, 228, 241, 254	2A-25, 29, 33, 37
	A-16	Control wiring harness and front wiring harness combination	4A-30, 42, 43, 46, 49, 52, 54, 57, 60, 62, 65, 69, 72, 75, 79, 193, 196, 199, 200, 203, 206, 207, 210, 215, 216, 221, 228, 229, 236, 241, 242, 247, 254, 255, 297, 338	2A-5, 9, 13, 17, 21, 25, 29, 33, 37
	A-17	Side turn signal lamp (LH)	4A-137	2A-5, 9, 13, 17, 21, 25, 29, 33, 37
	A-18	Windshield washer motor	4A-260, 261	2A-5, 9, 13, 17, 21, 25, 29, 33, 37
	A-19X	} Refer to centralized junction	4A-13, 14, 19, 20, 43, 48, 56, 64, 74, 86, 94, 128, 129, 130, 131, 134, 135, 158, 160, 172, 174, 276, 278, 281, 285, 286, 288, 291, 294, 308, 312, 314, 316, 318, 322, 324, 326, 341, 343	2A-5, 9, 13, 17, 21, 25, 29, 33, 37
	A-20X		4A-11, 17, 101, 102, 104, 106, 110, 112	2A-5, 9, 13, 17, 21, 25, 29, 33, 37
	A-21X		4A-297	2A-5, 9, 13, 17, 21, 25, 29, 33, 37
	A-22X		4A-30, 31, 32	2A-5, 9, 13, 17, 21, 25, 29, 33, 37
	A-23X		4A-120, 122, 124, 126	2A-5, 9, 13, 17, 21, 25, 29, 33, 37
	A-24X		4A-11, 17, 101, 102, 104, 106, 111, 113, 116, 120, 122, 124, 126, 336	2A-5, 9, 13, 17, 21, 25, 29, 33, 37
	A-25X		4A-193, 196, 199, 203, 206, 210, 215, 221, 228, 236, 241, 247, 254	2A-5, 9, 13, 17, 21, 25, 29, 33, 37
	A-26X		4A-43, 49, 57, 65, 75, 193, 196, 200, 203, 207, 210, 216, 221, 229, 236, 242, 247, 255	2A-5, 9, 13, 17, 21, 25, 29, 33, 37
	A-27	Battery cable and front wiring harness combination	4A-22, 24, 31, 32, 155, 156	2A-5, 9, 13, 17, 21, 25, 29, 33, 37
	A-28	Front impact sensor (LH) <SRS>	4A-341, 343	2A-9, 13, 17, 21, 25, 29, 33, 37
	A-29	} Daytime running lamp harness and front wiring harness combination or front wiring harness joint connector	4A-101, 102, 105, 107, 116, 121, 123	2A-5, 9, 17, 25, 33
	A-30		4A-101, 102, 105, 107, 116, 121, 123	2A-5, 9, 17, 25, 33
	A-31	Horn relay <Vehicles with SRS>	4A-143	2A-9, 13, 17, 21, 25, 29, 33, 37

	Connector No.	Parts name	Circuit diagram page	Wiring diagram page
A	A-32	Resistor <for dim-dip lamp circuit>	4A-110, 112	2A-13, 21, 29, 37
	A-33	} Front combination lamp (LH)	4A-137	2A-5, 9, 13, 17, 21, 25, 29, 33, 37
	A-34		4A-116	2A-5, 9, 13, 17, 21, 25, 29, 33, 37
	A-35	Headlamp leveling unit (LH)	4A-114	2A-5, 9, 13, 17, 21, 25, 29, 33, 37
	A-36	Headlamp (LH)	4A-101, 102, 104, 106, 110, 112	2A-5, 9, 13, 17, 21, 25, 29, 33, 37
	A-37	A/C compressor capacity control solenoid valve or no connection	4A-198, 205, 214, 227, 240, 253	2A-25, 29, 33, 37
	A-38	Speed sensor (Front:LH) <ABS>	4A-309	2A-9, 13, 17, 21, 25, 29, 33, 37
	A-39	Shock absorber (Front:LH) <Remote controlled variable shock absorber>	4A-306	2A-9, 13, 17, 21, 25, 29, 33, 37
	A-40	Magnetic clutch <A/C>	4A-43, 49, 57, 65, 75, 193, 196, 200, 203, 207, 210, 216, 221, 229, 236, 242, 247, 255	2A-5, 9, 13, 17, 21, 25, 29, 33, 37
	A-41	Thermo sensor (outside air) <Multi-meter>	4A-159, 161	2A-5, 9, 13, 17, 21, 25, 29, 33, 37
	A-42	Dual pressure switch	4A-43, 49, 57, 65, 75, 193, 196, 200, 203, 207, 210, 216, 221, 229, 247, 255	2A-5, 9, 13, 17, 21, 25, 29, 33, 37
	A-43	Condenser fan motor	4A-193, 196, 199, 203, 206, 210, 215, 221, 228, 236, 241, 247, 254	2A-5, 9, 13, 17, 21, 25, 29, 33, 37
	A-44	} Horn (LO)	4A-142, 143	2A-5, 9, 13, 17, 21, 25, 29, 33, 37
	A-45		4A-142, 143	2A-5, 9, 13, 17, 21, 25, 29, 33, 37
	A-46	} Horn (HI)	4A-142, 143	2A-4, 8, 12, 16, 20, 24, 28, 32, 36
	A-47		4A-142, 143	2A-4, 8, 12, 16, 20, 24, 28, 32, 36
	A-48	Oil pressure switch	4A-155	2A-6, 8, 12, 16, 20, 24, 28, 34, 38
	A-49	} Alternator	4A-30, 31, 32, 338	2A-6, 10, 14, 16, 20, 24, 28, 32, 36
	A-50		4A-30, 31, 32	2A-6, 10, 14, 16, 20, 24, 28, 32, 36
	A-51	Engine oil level sensor	4A-156	2A-6, 8, 12, 16, 20, 24, 28, 32, 36
	A-52	Speed sensor (Front:RH) <ABS>	4A-309	2A-8, 12, 16, 20, 24, 28, 32, 36
	A-53	Shock absorber (Front:RH) <Remote controlled variable shock absorber>	4A-306	2A-8, 12, 16, 20, 24, 28, 32, 36
	A-54	Front impact sensor (RH) <SRS>	4A-341, 343	2A-8, 12, 16, 20, 24, 28, 32, 36
	A-55	Headlamp (RH)	4A-101, 102, 104, 106, 110, 112	2A-4, 8, 12, 16, 20, 24, 28, 32, 36
	A-56	Headlamp leveling unit (RH)	4A-114	2A-4, 8, 12, 16, 20, 24, 28, 32, 36
	A-57	} Front combination lamp (RH)	4A-116	2A-4, 8, 12, 16, 20, 24, 28, 32, 36
	A-58		4A-137	2A-4, 8, 12, 16, 20, 24, 28, 32, 36
	A-59	Free wheel engage switch	4A-304, 311	2A-8, 12, 16, 20, 24, 28, 32, 36
	A-60	Solenoid valve A <Super select 4WD>	4A-304	2A-8, 12, 16, 20, 24, 28, 32, 36
	A-61	Solenoid valve B <Super select 4WD>	4A-304	2A-8, 12, 16, 20, 24, 28, 32, 36
	A-62	Auto-cruise control actuator	4A-313, 317, 321, 325	2A-11, 15, 19, 23, 26, 31, 34, 39

Connector No.	Parts name	Circuit diagram page	Wiring diagram page	
A	A-63	} Hydraulic unit	4A-308	2A-10, 12, 18, 20, 27, 28, 35, 36
	A-64		4A-308	2A-10, 12, 18, 20, 27, 28, 35, 36
	A-65	Idle up solenoid valve <ABS>	4A-309	2A-27, 28, 35, 36
	A-66	Engine speed detection connector	4A-28, 63, 73	2A-18, 23
	A-67	Fuel pump check connector	4A-42, 47, 55, 63, 73	2A-6, 10, 15, 18, 23
	A-68	Ignition timing adjustment connector	4A-26, 27, 28, 45, 52, 60, 69, 79	2A-6, 10, 15, 18, 23
	A-69	} Noise filter	4A-26, 27, 45, 47, 55, 145, 148	2A-6, 10, 14
	A-70		4A-26, 27, 45, 47, 55, 145, 148	2A-6, 10, 14
	A-71	Glow plug	4A-34, 36, 38, 40	2A-26, 30, 34, 38
	A-72	Idle speed control servo	4A-45, 51, 59, 68, 78	2A-6, 10, 14, 18, 22
	A-73	Throttle position sensor	4A-44, 50, 58, 67, 77, 87, 315, 323	2A-6, 10, 14, 18, 22
	A-74	Injector No.1	4A-45, 51, 59, 68, 78	2A-7, 11, 15, 18, 22
	A-75	Injector No.3	4A-45, 51, 59, 68, 78	2A-7, 11, 15, 18, 22
	A-76	Injector No.5	4A-51, 59, 68, 78	2A-11, 15, 18, 22
	A-77	Injector wiring harness and control wiring harness combination	4A-45, 51, 59, 68, 78	2A-6, 10, 14, 18, 22
	A-78	Capacitor	4A-27	2A-10, 14
	A-79	Detonation sensor	4A-68, 78	2A-18, 22
	A-80	Ignition wiring harness and control wiring harness combination	4A-29, 63, 73	2A-19, 23
	A-81	} Power transistor	4A-26, 27, 28, 45, 63, 73	2A-7, 10, 14, 19, 23
	A-82		4A-28, 47, 55, 63, 73	2A-19, 23
	A-83	Injector No.6	4A-51, 59, 68, 78	2A-11, 15, 19, 23
	A-84	Injector No.4	4A-45, 51, 59, 68, 78	2A-7, 11, 15, 19, 23
	A-85	Injector No.2	4A-45, 51, 59, 68, 78	2A-7, 11, 15, 19, 23
	A-86	} Ignition coil	4A-26, 27, 29, 45, 63, 73	2A-7, 10, 14, 19, 23
	A-87		4A-29, 63, 73	2A-19, 23
	A-88		4A-29, 47, 55, 63, 73	2A-19, 23
	A-89	EGR solenoid valve I	4A-37, 39, 41	2A-27, 31, 35, 39
	A-90	EGR solenoid valve II	4A-37, 39, 41	2A-27, 31, 35, 39
	A-91	Supercharging pressure relief solenoid valve	4A-37, 41	2A-27, 35
	A-92	Water level switch	4A-154	2A-27, 31, 35, 39
	A-93	Fuel line heater or no connection	4A-338	2A-27, 35, 39
	A-94	Idle up solenoid valve <A/C>	4A-200, 207, 216, 229, 242, 255	2A-26, 31, 34, 39
	A-95	Intake air temperature switch	4A-297	2A-27, 31, 35, 39
	A-96	Intercooler fan motor	4A-297	2A-27, 31, 35, 39
	A-97	} EGR solenoid valve	4A-67, 77	2A-11, 15, 18, 22
	A-98		4A-45, 59, 68, 78	2A-7, 11, 15, 19, 23
	A-99	} Glow plug relay	4A-34, 36, 38, 40, 51	2A-27, 31, 35, 39
	A-100		4A-34, 36, 38, 40	2A-27, 31, 35, 39
	A-101		4A-34, 36, 38, 40	2A-27, 31, 35, 39
	A-102	Distributor signal generator	4A-44, 50, 53	2A-6, 11, 15
	A-103	Variable induction control solenoid valve	4A-67, 77	2A-19, 23
	A-104	Engine coolant temperature gauge unit	4A-34, 36, 38, 40, 145, 151	2A-7, 11, 15, 18, 22, 26, 30, 34, 38
A-105	Engine coolant temperature switch <A/T>	4A-83, 91, 99	2A-11, 15, 18, 22, 34, 38	
A-106	Fuel injection pump wiring harness and control wiring harness combination	4A-34, 35, 36, 37, 39, 41, 151, 152	2A-27, 31, 35, 39	
A-107	Lever position sensor	4A-36, 38, 40, 95	2A-27, 31, 35, 39	
A-108	Lever position switch <A/T>or short connector <M/T>	4A-198, 205, 214, 227, 240, 253	2A-27, 31, 35, 39	
A-109	Fuel cut solenoid valve	4A-35, 37, 39, 41	2A-27, 31, 35, 39	
A-110	Timer solenoid valve	4A-39, 41	2A-35, 39	
A-111	Rotation sensor	4A-37, 39, 41, 152	2A-27, 31, 35, 39	
A-112	Crank angle sensor	4A-67, 77	2A-18, 22	

	Connector No.	Parts name	Circuit diagram page	Wiring diagram page
A	A-113	Engine coolant temperature sensor	4A-44, 50, 58, 67, 77	2A-7, 10, 14, 18, 22, 34, 38
	A-114	Engine coolant temperature switch (for A/C compressor control)	4A-43, 49, 57, 65, 75, 193, 196, 200, 203, 207, 210, 216, 221, 229, 242, 247, 255	2A-7, 10, 14, 18, 22, 26, 30, 34, 38
	A-115	Camshaft position sensor	4A-67, 77	2A-18, 22
	A-116	Engine coolant temperature switch (for condenser fan motor control)	4A-199, 206, 215, 228, 241, 254	2A-26, 30, 34, 38
	A-117	Power steering oil pressure switch <A/T> or No connection	4A-52, 60, 69, 79	2A-10, 14, 18, 22
	A-118	Air flow sensor	4A-44, 50, 58, 67, 77	2A-6, 10, 14, 18, 22
	A-119	Oxygen sensor <4G64 engine>	4A-44	2A-6
B	B-01	Battery cable and transmission wiring harness combination <Petrol-powered vehicles>	4A-23, 314, 322	2A-41
	B-02	Back-up lamp switch <M/T>	4A-140	2A-40, 41
	B-03	Center differential lock detection switch	4A-305, 311	2A-41
	B-04	Center differential lock operation detection switch	4A-299, 301, 305	2A-41
	B-05	4WD operation detection switch	4A-299, 302, 305	2A-40, 41
	B-06	Vehicle speed sensor	4A-145, 148, 152	2A-40, 41
	B-07	2WD/4WD detection switch	4A-304	2A-41
	B-08	High range/low range detection switch	4A-302, 305	2A-40, 41
	B-09	Inhibitor switch <A/T>	4A-23, 24, 38, 40, 57, 75, 83, 84, 89, 97, 141, 314, 318, 322, 326, 340, 342	2A-41
	B-10	Oxygen sensor <6G72,6G74 engine>	4A-51, 59, 68, 78	2A-41
	B-11	Solenoid assembly <V4AW3>	4A-9, 99	2A-41
C	C-01	Auto-cruise control main switch	4A-312, 316, 320, 324	2A-42, 45
	C-02	Rear fog lamp switch	4A-120, 122, 125, 127	2A-42, 45
	C-03	Remote controlled mirror switch	4A-274	2A-42, 45
	C-04	Rheostat or jumper connector	4A-144, 146, 150	2A-42, 44
	C-05	} Combination meter	4A-30, 31, 32, 34, 36, 38, 40, 43, 48, 53, 56, 61, 64, 70, 74, 80, 84, 87, 90, 92, 95, 98, 100, 120, 122, 125, 127, 128, 129, 130, 131, 137, 144, 145, 146, 147, 148, 150, 151, 152, 154, 268, 297, 299, 301, 302, 305, 307, 309, 315, 319, 323, 327, 338, 341, 343	2A-42, 45
	C-06		4A-43, 53, 61, 70, 80, 84, 92, 100, 145, 148, 152, 297, 299, 301, 302, 305, 307, 309, 315, 319, 323, 327, 338, 341, 343	2A-42, 45
	C-07		4A-90, 98, 101, 102, 104, 106, 110, 112, 137, 154, 156, 299, 301, 302, 305, 309	2A-42, 45
	C-08		} Front wiring harness and dash wiring harness combination	4A-22, 24, 30, 31, 32, 120, 122, 124, 126, 136, 162, 163, 166, 167, 272, 318, 326, 333
	C-09	4A-270		2A-42, 44
	C-10	4A-30, 31, 32, 43, 49, 57, 65, 75, 101, 102, 104, 105, 106, 107, 110, 112, 117, 136, 143, 155, 156, 159, 161, 193, 196, 200, 203, 207, 210, 216, 221, 229, 236, 242, 247, 255, 260, 261, 264, 266, 287, 290, 291, 315, 319, 330		2A-42, 44
	C-11	} Combination meter	4A-30, 31, 32, 34, 36, 38, 40, 84, 87, 90, 95, 98, 128, 129, 130, 131, 137, 145, 147, 148, 151, 152, 154, 156, 307, 338, 341, 343	2A-42, 45
	C-12		4A-43, 48, 56, 64, 74, 84, 87, 95, 120, 122, 125, 127, 154, 155, 268, 302, 305, 312, 316, 320, 324	2A-42, 45
	C-13	Defogger switch	4A-270	2A-42, 44
	C-14	Hazard switch	4A-136	2A-42, 44
	C-15	Auto-cruise control unit or spare connector	4A-82, 88, 96, 312, 315, 316, 319, 320, 323, 324, 327	2A-43, 45
	C-16	Kickdown switch	4A-91, 99	2A-43, 45
	C-17	A/C switch	4A-176, 183, 192, 195, 198, 202, 205, 209, 214, 220, 227, 235, 240, 246, 253	2A-43, 44

Connector No.	Parts name	Circuit diagram page	Wiring diagram page
C-18	Blower switch	4A-176, 177, 180, 183, 184, 187, 191, 194, 197, 201, 204, 208, 219, 226, 234, 239, 245, 252	2A-43, 44
C-19	Blower control illumination lamp	4A-176, 177, 180, 183, 184, 187, 191, 194, 197, 201, 204, 208, 213, 219, 226, 234, 239, 245, 252	2A-43,44
C-20	Dash wiring harness and radio sub wiring harness combination	4A-276, 277, 278, 280, 281, 284, 285, 286, 288	2A-43, 44
C-21	} Radio	4A-213, 276, 277, 278, 280, 281, 284, 285, 286, 288	2A-43, 44
C-22		4A-277, 278, 280, 281, 284, 285, 286, 288	2A-43, 44
C-23	A/C unit	4A-43, 49, 57, 65, 75, 192, 193, 195, 196, 198, 200, 202, 203, 205, 207	2A-43, 44
C-24	} Control wiring harness and dash wiring harness combination	4A-26, 27, 34, 36, 37, 38, 39, 40, 41, 43, 45, 47, 48, 51, 53, 55, 56, 59, 61, 64, 66, 68, 70, 74, 76, 78, 80, 83, 87, 91, 95, 99, 145, 147, 148, 151, 152, 154, 156, 297, 315, 323, 338	2A-43, 44
C-25		4A-27, 28, 35, 39, 46, 47, 48, 49, 54, 55, 56, 57, 62, 63, 64, 65, 72, 73, 74, 75, 83, 155, 202, 205, 209, 220, 235, 240, 246, 252, 297, 313, 315, 317	2A-43, 44
C-26		4A-26, 27, 28, 35, 37, 39, 41, 42, 46, 47, 48, 49, 54, 55, 56, 57, 62, 63, 64, 65, 72, 73, 74, 75, 91, 99, 155, 192, 195, 198, 214, 227, 297, 321, 323, 325	2A-43, 44
C-27	Diode (for super select 4WD circuit)	4A-304	2A-43, 45
C-28	} Front wiring harness and dash wiring harness combination	4A-136, 143, 156, 159, 161, 264, 266, 268, 279, 283, 304, 306, 307, 311	2A-43, 45
C-29		4A-341, 343	2A-43, 45
C-30	Engine control relay or fuel line heater control unit or intercooler fan control unit (Vehicles without fuel line heater)	4A-42, 46, 54, 62, 72, 297, 338	2A-43, 44
C-31	Engine oil level relay	4A-156	2A-43, 44
C-32	} Door wiring harness (passenger's side) and dash wiring harness combination	4A-162, 163, 166, 167, 173, 175, 271	2A-43, 44
C-33		4A-172, 174, 274	2A-43, 44
C-34	Control wiring harness and floor wiring harness (RH) combination	4A-52, 60, 69, 79, 308, 309	2A-43
C-35	Dash wiring harness and floor wiring harness (RH) combination	4A-179, 181, 186, 188, 211, 212, 217, 218, 222, 224, 230, 232, 237, 238, 243, 244, 248, 250, 256, 258, 308, 309, 310, 311	2A-43, 45
C-36	Front wiring harness and floor wiring harness (RH) combination	4A-52, 60, 69, 79, 308, 309	2A-45
C-37	Front speaker (RH)	4A-277, 280, 284, 285, 286, 288	2A-43, 45
C-38	Resistor (for blower motor control circuit)	4A-176, 177, 180, 183, 184, 187, 191, 194, 197, 201, 204, 208, 213, 219, 226, 234, 239, 245, 252	2A-43, 44
C-39	Blower motor	4A-176, 177, 180, 183, 184, 187, 191, 194, 197, 201, 204, 208, 213, 219, 226, 234, 239, 245, 252	2A-43, 44
C-40	Intercooler fan control unit (Vehicles with fuel line heater)	4A-297	2A-43
C-41	Engine control unit or glow control unit	4A-26, 27, 28, 34, 36, 38, 40, 43, 44, 45, 49, 50, 51, 52, 57, 58, 59, 60, 62, 63, 65, 66, 67, 68, 72, 73, 75, 76, 77, 78, 95, 193, 196, 203, 210, 221, 236, 247, 315, 323	2A-43, 44
C-42	} Engine control unit	4A-26, 27, 28, 42, 43, 44, 45, 46, 47, 48, 49, 50, 51, 54, 55, 56, 57, 58, 59, 62, 63, 64, 65, 69, 72, 73, 74, 75, 79, 148, 193, 196, 203, 210, 221, 236, 247	2A-43, 44
C-43		4A-42, 43, 44, 46, 48, 49, 50, 51, 54, 56, 57, 58, 59, 62, 64, 65, 67, 68, 70, 72, 74, 75, 77, 78, 80, 87, 315, 323	2A-43, 44
C-44	Key cylinder illumination lamp timer	4A-134, 135	2A-43, 44

	Connector No.	Parts name	Circuit diagram page	Wiring diagram page
C	C-45	Diode (for ABS circuit)	4A-308	2A-43, 45
	C-46	Diode (for MPI circuit)	4A-66, 76, 299	2A-43, 45
	C-47	4WD indicator relay	4A-302	2A-43, 44
	C-48	} SRS diagnosis unit	4A-341, 343	2A-43, 44
	C-49		4A-341, 343	2A-43, 44
	C-50	Transmission wiring harness and dash wiring harness combination	4A-22, 23, 24, 35, 36, 38, 40, 42, 49, 51, 57, 59, 65, 68, 75, 78, 83, 84, 89, 91, 97, 99, 140, 141, 145, 148, 152, 299, 301, 302, 304, 311, 314, 318, 322, 326, 340, 342	2A-43, 44
	C-51	4WD indicator control unit	4A-305	2A-43, 44
	C-52	Motor antenna control unit	4A-279, 283, 287, 290	2A-43, 44
	C-53	Lighting monitor buzzer	4A-336	2A-43, 44
	C-54	Wiper deicer switch	4A-273	2A-42, 44
	C-55	Motor antenna switch	4A-282, 289	2A-42, 44
	C-56	} Clock spring <SRS>	4A-341	2A-42, 45
	C-57		4A-143, 315, 319, 323, 327	2A-42, 45
	C-58	Thermo sensor (inside air) <Multi-meter>	4A-159, 160	2A-42, 45
	C-59	Steering lock switch	4A-134, 135	2A-42, 45
	C-60	Auto-cruise control switch <Vehicles without SRS>	4A-315, 319, 323, 327	2A-42, 45
	C-61	Ignition switch	4A-12, 18	2A-42, 45
	C-62	Stop lamp switch (2-pin) or no connection <Auto-cruise control>	4A-139, 310	2A-42, 45
	C-63	Stop lamp switch (4-pin) <Auto-cruise control> or no connection	4A-139, 310, 313, 317, 321, 325	2A-42, 45
	C-64	Clutch switch	4A-314, 318, 322, 326	2A-42, 44
	C-65	} Column switch	4A-101, 102, 105, 107, 111, 113, 116, 121, 123, 124, 126, 137, 260, 268, 336	2A-42, 45
	C-66		4A-101, 102, 105, 107, 111, 113, 123, 126, 142, 260, 268	2A-42, 45
	C-67		4A-102, 107, 113, 116, 123, 126	2A-42, 45
	C-68	Headlamp leveling switch	4A-114	2A-42, 45
	C-69	Diode (for Headlamp circuit)	4A-102, 107, 113, 123, 126	2A-42, 45
	C-70	Dim-dip lamp relay 1	4A-111, 113	2A-45
	C-71	Dim-dip lamp relay 2	4A-110, 112	2A-45
	C-72	Dim-dip lamp relay 3	4A-110, 112	2A-45
	C-73	} Diode (for dim-dip lamp circuit)	4A-110, 112	2A-45
	C-74		4A-111, 113	2A-45
	C-75	J/C (1)	4A-43, 45, 52, 53, 60, 61, 66, 69, 70, 76, 79, 80, 82, 83, 86, 87, 88, 90, 92, 94, 96, 98, 100, 120, 122, 125, 127, 135, 156, 159, 161, 166, 167, 174, 176, 178, 181, 183, 184, 187, 191, 194, 197, 201, 204, 211, 217, 219, 222, 230, 234, 239, 245, 252, 270, 271, 272, 273, 277, 280, 282, 284, 293, 297, 298, 306, 307, 310, 312, 315, 316, 319, 320, 324, 328, 330, 336	2A-42, 45
	C-76	J/C (2)	4A-15, 21, 30, 31, 32, 34, 35, 36, 38, 39, 40, 41, 42, 49, 57, 65, 66, 75, 76, 84, 87, 95, 139, 156, 174, 177, 180, 208, 213, 219, 226, 270, 272, 289, 296, 308, 310, 312, 314, 315, 316, 318, 320, 336, 338, 340, 342	2A-42, 45
C-77	J/C (3)	4A-15, 21, 42, 53, 61, 66, 70, 76, 80, 82, 83, 84, 87, 88, 90, 92, 94, 95, 96, 98, 100, 120, 122, 125, 127, 139, 145, 148, 156, 158, 159, 161, 172, 183, 185, 188, 201, 204, 237, 243, 248, 256, 270, 271, 273, 293, 295, 296, 297, 300, 301, 307, 308, 310, 311, 312, 315, 316, 319, 320, 323, 324, 327, 328, 330, 336, 341, 343	2A-42, 45	
C-78	J/C (4)	4A-49, 57, 65, 75, 82, 83, 84, 87, 88, 95, 96, 139, 148, 156, 272, 310, 311, 320, 321, 322, 323, 324, 326, 327, 341, 343	2A-45	

Connector No.	Parts name	Circuit diagram page	Wiring diagram page		
C	C-79	Overdrive control relay	4A-83	2A-42, 45	
	C-80	Front speaker (LH)	4A-277, 280, 284, 285, 286, 288	2A-42, 44	
	C-81	ELC-4A/T control unit	4A-87, 89, 91, 92, 95, 97, 99, 100	2A-42, 44	
	C-82	Dash wiring harness and floor wiring harness (LH) combination	4A-42, 47, 55, 63, 73, 117, 120, 122, 125, 127, 128, 129, 130, 131, 134, 135, 137, 139, 140, 141, 144, 147, 154, 164, 168, 173, 175, 265, 267, 294, 306, 307, 310, 336	2A-42, 44	
	C-83		4A-277, 280, 284, 285, 286, 288, 298, 299, 300, 301, 311	2A-42, 44	
	C-84		4A-271, 274	2A-42, 44	
	C-85		Door wiring harness (driver's side) and dash wiring harness combination	4A-172, 174	2A-42, 45
	C-86		4A-162, 163, 166, 164, 166, 167, 168, 172, 174, 271	2A-42, 45	
	C-87	Door lock control unit	4A-172, 174	2A-42, 45	
	C-88	Headlamp washer relay	4A-268	2A-42, 45	
	C-89	Wiper deicer timer	4A-272	2A-42, 45	
	C-90	Wiper deicer relay	4A-272	2A-42, 45	
	C-91	Dedicated fuse No. ⑨	4A-15, 21, 295, 296	2A-42, 45	
	C-92X	Refer to centralized junction	—	2A-42, 45	
	C-93X		4A-179, 181, 186, 219, 226, 245, 252	2A-42, 45	
	C-94X		4A-162, 164, 166, 168, 328, 330	2A-42, 45	
	C-95X		—	2A-42, 45	
	C-96X		4A-270	2A-42, 45	
	C-97X		4A-264, 266	2A-42, 45	
	C-98X		4A-136	2A-42, 45	
	C-99	Roof wiring harness and dash wiring harness combination	4A-272, 295, 296	2A-42, 45	
	C-100	Front wiring harness and junction block combination	4A-128, 129, 130, 131	2A-42, 45	
	C-101		4A-14, 20, 43, 48, 64, 74, 86, 94, 128, 129, 130, 131, 134, 135, 139, 158, 160, 172, 174, 176, 177, 180, 183, 184, 187, 191, 194, 197, 201, 204, 208, 213, 219, 226, 234, 239, 245, 252, 276, 278, 281, 285, 286, 288, 291, 292, 294, 309, 312, 316, 320, 324, 341, 343	2A-42, 45	
	C-102		4A-15, 21, 66, 76, 82, 83, 86, 94, 105, 107, 111, 113, 116, 120, 122, 124, 126, 136, 137, 140, 141, 142, 143, 144, 146, 150, 158, 161, 163, 166, 167, 176, 177, 180, 183, 184, 187, 191, 194, 197, 201, 204, 208, 213, 219, 226, 234, 239, 245, 252, 268, 270, 273, 276, 278, 281, 285, 286, 288, 292, 293, 298, 300, 307, 309, 312, 316, 320, 324, 328, 330, 336, 340, 342	2A-42, 45	
	C-103		4A-13, 14, 19, 20, 43, 48, 64, 74, 86, 94, 128, 129, 130, 131, 134, 135, 158, 160, 172, 174, 276, 278, 281, 285, 286, 288, 291, 292, 294, 308, 312, 314, 316, 318, 320, 322, 324, 326, 341, 343	2A-42, 45	
	C-104		Diagnosis connector	4A-52, 60	2A-42, 45
	C-105		Blower relay	4A-176, 177, 180, 183, 184, 187, 191, 194, 197, 201, 204, 208, 213, 219, 226, 234, 239, 245, 252	2A-42, 45
	C-106		Accessory socket relay	4A-208, 294	2A-42, 45
	C-107		Dash wiring harness and junction block combination	4A-48, 64, 74, 86, 94, 136, 137, 144, 146, 150, 158, 159, 160, 172, 274, 279, 283, 287, 290, 291, 292, 294, 308, 312, 316, 320, 324, 340, 342	2A-42, 45

	Connector No.	Parts name	Circuit diagram page	Wiring diagram page	
C	C-108	Dash wiring harness and junction block combination	4A-43, 48, 64, 74, 86, 94, 128, 129, 130, 131, 139, 144, 146, 150, 162, 163, 172, 174, 176, 177, 180, 183, 184, 187, 191, 194, 197, 201, 204, 208, 213, 219, 226, 234, 239, 245, 252, 270, 272, 276, 278, 281, 285, 286, 288, 308, 309, 312, 314, 316, 318, 320, 322, 324, 326, 340, 342	2A-42, 45	
	C-109		4A-83, 86, 94, 134, 136, 140, 141, 159, 160, 162, 163, 166, 167, 172, 174, 176, 177, 180, 183, 184, 187, 191, 194, 197, 201, 204, 208, 213, 219, 226, 234, 239, 245, 252, 272, 274, 279, 283, 287, 290, 291, 292, 294, 299, 300, 302, 305, 309, 335	2A-42, 45	
	C-110		4A-30, 31, 32, 35, 36, 38, 40, 43, 48, 64, 74, 83, 86, 94, 128, 129, 130, 131, 134, 135, 136, 137, 140, 141, 144, 150, 154, 172, 174, 268, 272, 274, 276, 278, 281, 285, 286, 288, 298, 301, 302, 305, 306, 307, 308, 309, 336, 338, 340, 342	2A-42, 45	
	C-111		4A-66, 76, 82, 88, 94, 96, 120, 122, 124, 126, 134, 136, 158, 161, 162, 163, 166, 167, 172, 174, 176, 177, 180, 184, 187, 191, 194, 197, 208, 213, 219, 226, 234, 239, 245, 252, 270, 273, 276, 278, 281, 288, 292, 293, 294, 298, 299, 300, 302, 305, 312, 314, 316, 320, 322, 324, 328, 330, 336	2A-42, 45	
	C-112		4A-208, 213, 219, 226, 234, 239, 245, 252, 279, 282, 287, 289, 294	2A-42, 45	
	C-113		Diagnosis connector	4A-45, 52, 60, 69, 79, 91, 100, 310, 315, 319, 323, 327, 341, 343	2A-42, 45
	C-114		Jumper connector	4A-52, 60, 69, 79, 91, 100	2A-45
	C-115		Dash wiring harness and junction block combination	4A-82, 88, 96, 116, 137, 162, 164, 166, 168, 183, 184, 187, 201, 204, 234, 239, 245, 252, 264, 266, 279, 282, 287, 289, 293, 306, 307, 308, 328, 330	2A-42, 45
	C-116			4A-13, 19, 30, 31, 32, 35, 36, 38, 40, 43, 48, 64, 74, 82, 83, 86, 88, 94, 96, 105, 107, 111, 113, 136, 140, 141, 142, 143, 144, 146, 150, 154, 158, 160, 162, 164, 166, 167, 168, 176, 177, 180, 183, 184, 187, 191, 194, 197, 201, 204, 208, 213, 219, 226, 234, 239, 245, 260, 261, 264, 266, 268, 270, 272, 274, 276, 278, 279, 281, 282, 285, 286, 287, 288, 289, 291, 292, 293, 294, 299, 301, 305, 306, 308, 309, 312, 314, 316, 318, 320, 322, 324, 326, 328, 330, 336, 338, 340, 342	2A-42, 45
	D		D-01	Instrument panel wiring harness and dash wiring harness combination	4A-159, 160
D-02		4A-105, 107, 155, 158, 159, 160, 291, 292	2A-46, 47, 48, 49		
D-03		Clock	4A-159, 160, 291, 292	2A-46, 47, 48, 49	
D-04		Multi-meter	4A-159, 160	2A-46, 47, 48, 49	
D-05		Geomagnetic sensor	4A-161	2A-46, 47, 48, 49	
D-06		Accessory socket	4A-294	2A-46, 47, 48, 49	
D-07			4A-294	2A-46, 47, 48, 49	
D-08		Front seat assembly (Passenger's side) (Heated seat)	4A-329, 331	2A-46, 47, 48, 49	
D-09		Overdrive switch	4A-82, 88, 96, 312, 322	2A-48, 49	
D-10		Ashtray illumination lamp	4A-293	2A-46, 47, 48, 49	
D-11		Cigarette lighter illumination lamp	4A-293	2A-46, 47, 48, 49	
D-12		Rear console wiring harness and console wiring harness combination	4A-328, 330	2A-46, 47, 48, 49	
D-13		Console wiring harness and dash wiring harness combination	4A-88, 96, 178, 181, 185, 188, 211, 217, 222, 230, 237, 243, 248, 256, 293, 294, 298, 300, 328, 329, 330, 331	2A-46, 47, 48, 49	
D-14		Heated seat switch (Passenger's side)	4A-328, 330	2A-46, 47, 48, 49	

	Connector No.	Parts name	Circuit diagram page	Wiring diagram page
D	D-15	Heated seat switch (Driver's side)	4A-328, 330	2A-46, 47, 48, 49
	D-16	Parking brake switch	4A-156	2A-46, 47, 48, 49
	D-17	Rear blower main switch	4A-178, 181, 185, 188, 211, 217, 222, 230, 237, 243, 248, 256	2A-46, 47, 48, 49
	D-18	Power seat wiring harness and dash wiring harness combination	4A-333, 335	2A-46, 47, 48, 49
	D-19	Front seat assembly (Driver's side) <Heated seat> or power seat wiring harness and console wiring harness	4A-329, 331	2A-46, 47, 48, 49
	D-20	Front seat assembly <Power seat>	4A-331, 333	2A-46, 47, 48, 49
	D-21	} Cigarette lighter	4A-293	2A-46, 47, 48, 49
	D-22		4A-293	2A-46, 47, 48, 49
	D-23	Power/Hold changeover switch <ELC-4A/T>	4A-88, 96	2A-48, 49
	D-24	Rear differential lock switch	4A-298, 300	2A-46, 47, 48, 49
E	E-01	Wiper deicer (+)	4A-272	2A-50, 51, 52, 53
	E-02	Map lamp or room lamp or canvas roof switch	4A-129, 130, 131	2A-50, 51, 52, 53
	E-03	Wiper deicer (-)	4A-272	2A-50, 51, 52, 53
	E-04	Room lamp	4A-128, 129, 131, 295	2A-50, 51, 52, 53
	E-05	Sunroof assembly	4A-296	2A-52, 53
	E-06	} Folding top assembly <Canvas top>	4A-295	2A-50, 51, 52, 53
	E-07		4A-295	2A-50, 51, 52, 53
	E-08	Cargo space lamp	4A-130, 131	2A-50, 51, 52, 53
	E-09	Rear door switch (RH)	4A-131	2A-50, 51, 52, 53
	E-10	Rear speaker (RH)	4A-277, 280, 284, 285, 286, 288	2A-50, 51, 52, 53
	E-11	No connection	—	2A-50, 51, 52, 53
	E-12	} ABS control unit	4A-52, 60, 69, 79, 308, 309, 310	2A-50, 51, 52, 53
	E-13		4A-308, 309, 311	2A-50, 51, 52, 53
	E-14		4A-308, 309, 310, 311	2A-50, 51, 52, 53
	E-15	No connection	—	2A-52, 53
	E-16	Rear A/C control unit	4A-211, 217, 225, 233, 237, 243, 251, 259	2A-52, 53
	E-17	} Back door wiring harness and floor wiring harness (RH) combination	4A-117, 121, 123, 125, 127, 128, 129, 130, 131, 140, 141, 175, 265, 267	2A-50, 51, 52, 53
	E-18		4A-271	2A-50, 51, 52, 53
	E-19	Rear combination lamp (LH)	4A-121, 123, 125, 127, 140, 141	2A-50, 51, 52, 53
	E-20	} Accessory socket	4A-294	2A-50, 51, 52, 53
	E-21		4A-294	2A-50, 51, 52, 53
	E-22	Rear combination lamp harness and floor wiring harness (LH) combination	4A-121, 123, 125, 127, 140, 141	2A-50, 51, 52, 53
	E-23	Variable shock absorber control unit	4A-306	2A-50, 51, 52, 53
	E-24	Rear differential lock control unit	4A-299, 301, 311	2A-50, 51, 52, 53
	E-25	Rear differential lock air pump	4A-298, 300	2A-50, 51, 52, 53
	E-26	} Frame wiring harness and floor wiring harness (RH) combination	4A-47, 55, 63, 73, 117, 137, 139, 144, 146, 151, 154, 299, 301, 311	2A-50, 51, 52, 53
	E-27		4A-306, 307	2A-50, 51, 52, 53
	E-28		4A-309	2A-50, 51, 52, 53
	E-29	} Floor wiring harness (LH) and floor wiring harness (RH) combination	4A-117, 121, 123, 125, 127, 128, 129, 130, 131, 135, 140, 141, 164, 168, 173, 175, 265, 267, 277, 280, 284, 285, 286, 288, 298, 300, 310, 311, 336	2A-50, 51, 52, 53
	E-30		4A-271	2A-50, 51, 52, 53
	E-31	Front door switch (LH)	4A-128, 129, 130, 131, 134, 336	2A-50, 51, 52, 53
	E-32	Rear door wiring harness (LH) and floor wiring harness (LH) combination	4A-165, 169, 173, 175	2A-52, 53
	E-33	G sensor	4A-182, 311	2A-50, 51, 52, 53
	E-34	Variable shock absorber control switch	4A-307	2A-50, 51, 52, 53
	E-35	Rear heater control switch or rear A/C control switch <Dual A/C>	4A-179, 186, 189, 212, 217, 223, 231, 238, 244, 249, 257	2A-50, 51, 52, 53
	E-36	Rear door switch (LH)	4A-131	2A-52, 53
	E-37	Rear speaker (LH)	4A-277, 280, 284, 285, 286, 288	2A-52, 53

	Connector No.	Parts name	Circuit diagram page	Wiring diagram page
E	E-38	Front door switch (RH)	4A-128, 129, 130, 131, 135, 336	2A-50, 51, 52, 53
	E-39	Rear door wiring harness (RH) and floor wiring harness (RH) combination	4A-165, 169, 173, 175	2A-52, 53
	E-40	Rear heater assembly	4A-179, 182, 186, 189, 223, 231, 249, 257	2A-52, 53
F	F-01	No connection	—	2A-54, 55, 56, 57
	F-02	Remote controlled mirror (RH)	4A-271, 274	2A-54, 55, 56, 57
	F-03	Power window motor (Front:RH)	4A-162, 163, 166, 167	2A-54, 55, 56, 57
	F-04	Power window sub switch (Passenger's side)	4A-162, 163, 166, 167	2A-54, 55, 56, 57
	F-05	Door key cylinder switch <Vehicles with central door locking>	4A-172	2A-54, 56
	F-06	Door lock actuator (Front:RH)	4A-173, 174	2A-54, 55, 56, 57
	F-07	Power window motor (Rear:RH)	4A-165, 169	2A-56, 57
	F-08	Power window sub switch (Rear:RH)	4A-165, 169	2A-56, 57
	F-09	Door lock actuator (Rear:RH)	4A-173, 175	2A-56, 57
	F-10	Door lock actuator (Rear:LH)	4A-173, 175	2A-56, 57
	F-11	Power window sub switch (Rear:LH)	4A-165, 169	2A-56, 57
	F-12	Power window motor (Rear:LH)	4A-165, 169	2A-56, 57
	F-13	Door lock actuator (Front:LH)	4A-172, 175	2A-54, 55, 56, 57
	F-14	Door key cylinder switch <Vehicles with central door locking>	4A-174	2A-55, 57
	F-15	No connection	—	2A-54, 55, 56, 57
	F-16	Power window motor (Front:LH)	4A-162, 163, 166, 167	2A-54, 55, 56, 57
	F-17	Power window main switch (Driver's side)	4A-162, 163, 166, 167	2A-54, 55, 56, 57
	F-18	Remote controlled mirror (LH)	4A-271, 274	2A-54, 55, 56, 57
G	G-01	Speed sensor (Rear:RH) <ABS>	4A-309	2A-58
	G-02	Shock absorber (Rear:RH) <Remote controlled variable shock absorber>	4A-307	2A-58
	G-03	Defogger (+)	4A-271	2A-58
	G-04	Defogger cable and back door wiring harness combination	4A-271	2A-58
	G-05	Back door switch	4A-128, 129, 130, 131	2A-58
	G-06	Defogger (—)	4A-271	2A-58
	G-07	Rear wiper motor	4A-265, 267	2A-58
	G-08	Rear combination lamp (RH)	4A-117, 121, 123, 125, 127, 140, 141	2A-58
	G-09	Rear washer motor	4A-265, 267	2A-58
	G-10	Rear combination lamp (In bumper:RH)	4A-137, 139	2A-58
	G-11	Licence plate lamp	4A-117	2A-58
	G-12	Door lock actuator (Back door)	4A-173, 175	2A-58
	G-13	Fuel pump <MPI>	4A-42, 47, 55, 63, 73	2A-58
	G-14	Fuel gauge unit	4A-144, 147, 151, 154	2A-58
	G-15	Rear combination lamp (In bumper:LH)	4A-117, 137, 139	2A-58
	G-16	Shock absorber (Rear:LH) <Remote controlled variable shock absorber>	4A-306	2A-58
	G-17	Speed sensor (Rear:LH) <ABS>	4A-309	2A-58
	G-18	Rear differential lock detection switch	4A-299, 301, 311	2A-58

INDEX (In order of parts name)

	Parts name	Connector No.	Circuit diagram page	Wiring diagram page
2	2WD/4WD detection switch	B-07	4A-304	2A-41
4	4WD indicator control unit	C-51	4A-305	2A-43, 44
	4WD indicator relay	C-47	4A-302	2A-43, 44
	4WD operation detection switch	B-05	4A-299, 302, 305	2A-40, 41
A	ABS control unit	E-12	4A-52, 60, 69, 79, 308, 309, 310	2A-50, 51, 52, 53
		E-13	4A-308, 309, 311	2A-50, 51, 52, 53
		E-14	4A-308, 309, 310, 311	2A-50, 51, 52, 53
	A/C compressor capacity control relay or no connection	A-14	4A-198, 205, 214, 227, 240, 253	2A-25, 29, 33, 37
	A/C compressor capacity control solenoid valve or no connection	A-37	4A-198, 205, 214, 227, 240, 253	2A-25, 29, 33, 37
	A/C switch	C-17	4A-176, 183, 192, 195, 198, 202, 205, 209, 214, 220, 227, 235, 240, 246, 253	2A-43, 44
	A/C unit	C-23	4A-43, 49, 57, 65, 75, 192, 193, 195, 196, 198, 200, 202, 203, 205, 207	2A-43, 44
	Accessory socket	D-06	4A-294	2A-46, 47, 48, 49
		D-07	4A-294	2A-46, 47, 48, 49
		E-20	4A-294	2A-50, 51, 52, 53
		E-21	4A-294	2A-50, 51, 52, 53
	Accessory socket relay	C-106	4A-208, 294	2A-42, 45
	Air flow sensor	A-118	4A-44, 50, 58, 67, 77	2A-6, 10, 14, 18, 22
	Alternator	A-49	4A-30, 31, 32, 338	2A-6, 10, 14, 16, 20, 24, 28, 32, 36
		A-50	4A-30, 31, 32	2A-6, 10, 14, 16, 20, 24, 28, 32, 36
	Ashtray illumination lamp	D-10	4A-293	2A-46, 47, 48, 49
	Auto-cruise control actuator	A-62	4A-313, 317, 321, 325	2A-11, 15, 19, 23, 26, 31, 34, 39
	Auto-cruise control main switch	C-01	4A-312, 316, 320, 324	2A-42, 45
	Auto-cruise control switch <Vehicles without SRS>	C-60	4A-315, 319, 323, 327	2A-42, 45
	Auto-cruise control unit or spare connector	C-15	4A-82, 88, 96, 312, 315, 316, 319, 320, 323, 324, 327	2A-43, 45
B	Back door switch	G-05	4A-128, 129, 130, 131	2A-58
	Back door wiring harness and floor wiring harness (RH) combination	E-17	4A-117, 121, 123, 125, 127, 128, 129, 130, 131, 140, 141, 175, 265, 267	2A-50, 51, 52, 53
		E-18	4A-271	2A-50, 51, 52, 53
	Back-up lamp switch <M/T>	B-02	4A-140	2A-40, 41
	Battery cable and front wiring harness combination	A-27	4A-22, 24, 31, 32, 155, 156	2A-5, 9, 13, 17, 21, 25, 29, 33, 37
	Battery cable and transmission wiring harness combination <Petrol-powered vehicles>	B-01	4A-23, 314, 322	2A-41
	Blower control illumination lamp	C-19	4A-176, 177, 180, 183, 184, 187, 191, 194, 197, 201, 204, 208, 213, 219, 226, 234, 239, 245, 252	2A-43, 44
	Blower motor	C-39	4A-176, 177, 180, 183, 184, 187, 191, 194, 197, 201, 204, 208, 213, 219, 226, 234, 239, 245, 252	2A-43, 44
	Blower relay	C-105	4A-176, 177, 180, 183, 184, 187, 191, 194, 197, 201, 204, 208, 213, 219, 226, 234, 239, 245, 252	2A-42, 45
	Blower switch	C-18	4A-176, 177, 180, 183, 184, 187, 191, 194, 197, 201, 204, 208, 219, 226, 234, 239, 245, 252	2A-43, 44
	Brake fluid level switch	A-13	4A-156	2A-5, 9, 12, 17, 20, 25, 28, 33, 36
C	Camshaft position sensor	A-115	4A-67, 77	2A-18, 22
	Capacitor	A-78	4A-27	2A-10, 14
	Cargo space lamp	E-08	4A-130, 131	2A-50, 51, 52, 53

	Parts name	Connector No.	Circuit diagram page	Wiring diagram page
C	Center differential lock detection switch	B-03	4A-305, 311	2A-41
	Center differential lock operation detection switch	B-04	4A-299, 301, 305	2A-41
	Cigarette lighter	D-21	4A-293	2A-46, 47, 48, 49
		D-22	4A-293	2A-46, 47, 48, 49
	Cigarette lighter illumination lamp	D-11	4A-293	2A-46, 47, 48, 49
	Clock	D-03	4A-159, 160, 291, 292	2A-46, 47, 48, 49
	Clock spring <SRS>	C-56	4A-341	2A-42, 45
		C-57	4A-143, 315, 319, 323, 327	2A-42, 45
	Clutch switch	C-64	4A-314, 318, 322, 326	2A-42, 44
	Column switch	C-65	4A-101, 102, 105, 107, 111, 113, 116, 121, 123, 124, 126, 137, 260, 268, 336	2A-42, 45
		C-66	4A-101, 102, 105, 107, 111, 113, 123, 126, 142, 260, 268	2A-42, 45
		C-67	4A-102, 107, 113, 116, 123, 126	2A-42, 45
	Combination meter	C-05	4A-30, 31, 32, 34, 36, 38, 40, 43, 48, 53, 56, 61, 64, 70, 74, 80, 84, 87, 90, 92, 95, 98, 100, 120, 122, 125, 127, 128, 129, 130, 131, 137, 144, 145, 146, 147, 148, 150, 151, 152, 154, 268, 297, 299, 301, 302, 305, 307, 309, 315, 319, 323, 327, 338, 341, 343	2A-42, 45
		C-06	4A-43, 53, 61, 70, 80, 84, 92, 100, 145, 148, 152, 297, 299, 301, 302, 305, 307, 309, 315, 319, 323, 327, 338, 341, 343	2A-42, 45
		C-07	4A-90, 98, 101, 102, 104, 106, 110, 112, 137, 154, 156, 299, 301, 302, 305, 309	2A-42, 45
		C-11	4A-30, 31, 32, 34, 36, 38, 40, 84, 87, 90, 95, 98, 128, 129, 130, 131, 137, 145, 147, 148, 151, 152, 154, 156, 307, 338, 341, 343	2A-42, 45
		C-12	4A-43, 48, 56, 64, 74, 84, 87, 95, 120, 122, 125, 127, 154, 155, 268, 302, 305, 312, 316, 320, 324	2A-42, 45
	Condenser fan motor	A-43	4A-193, 196, 199, 203, 206, 210, 215, 221, 228, 236, 241, 247, 254	2A-5, 9, 13, 17, 21, 25, 29, 33, 37
	Condenser fan motor control relay	A-15	4A-199, 206, 215, 228, 241, 254	2A-25, 29, 33, 37
	Console wiring harness and dash wiring harness combination	D-13	4A-88, 96, 178, 181, 185, 188, 211, 217, 222, 230, 237, 243, 248, 256, 293, 294, 298, 300, 328, 329, 330, 331	2A-46, 47, 48, 49
		C-24	4A-26, 27, 34, 36, 37, 38, 39, 40, 41, 43, 45, 47, 48, 51, 53, 55, 56, 59, 61, 64, 66, 68, 70, 74, 76, 78, 80, 83, 87, 91, 95, 99, 145, 147, 148, 151, 152, 154, 156, 297, 315, 323, 338	2A-43, 44
		C-25	4A-27, 28, 35, 39, 46, 47, 48, 49, 54, 55, 56, 57, 62, 63, 64, 65, 72, 73, 74, 75, 83, 155, 202, 205, 209, 220, 235, 240, 246, 252, 297, 313, 315, 317	2A-43, 44
		C-26	4A-26, 27, 28, 35, 37, 39, 41, 42, 46, 47, 48, 49, 54, 55, 56, 57, 62, 63, 64, 65, 72, 73, 74, 75, 91, 99, 155, 192, 195, 198, 214, 227, 297, 321, 323, 325	2A-43, 44
Control wiring harness and floor wiring harness (RH) combination	C-34	4A-52, 60, 69, 79, 308, 309	2A-43	
Control wiring harness and front wiring harness combination	A-16	4A-30, 42, 43, 46, 49, 52, 54, 57, 60, 62, 65, 69, 72, 75, 79, 193, 196, 199, 200, 203, 206, 207, 210, 215, 216, 221, 228, 229, 236, 241, 242, 247, 254, 255, 297, 338	2A-5, 9, 13, 17, 21, 25, 29, 33, 37	
Crank angle sensor	A-112	4A-67, 77	2A-18, 22	
D	Dash wiring harness and floor wiring harness (LH) combination	C-82	4A-42, 47, 55, 63, 73, 117, 120, 122, 125, 127, 128, 129, 130, 131, 134, 135, 137, 139, 140, 141, 144, 147, 154, 164, 168, 173, 175, 265, 267, 294, 306, 307, 310, 336	2A-42, 44
		C-83	4A-277, 280, 284, 285, 286, 288, 298, 299, 300, 301, 311	2A-42, 44

	Parts name	Connector No.	Circuit diagram page	Wiring diagram page	
D	Dash wiring harness and floor wiring harness (LH) combination	C-84	4A-271, 274	2A-42, 44	
	Dash wiring harness and floor wiring harness (RH) combination	C-35	4A-179, 181, 186, 188, 211, 212, 217, 218, 222, 224, 230, 232, 237, 238, 243, 244, 248, 250, 256, 258, 308, 309, 310, 311	2A-43, 45	
	Dash wiring harness and junction block combination	C-107	4A-48, 64, 74, 86, 94, 136, 137, 144, 146, 150, 158, 159, 160, 172, 274, 279, 283, 287, 290, 291, 292, 294, 308, 312, 316, 320, 324, 340, 342	2A-42, 45	
		C-108	4A-43, 48, 64, 74, 86, 94, 128, 129, 130, 131, 139, 144, 146, 150, 162, 163, 172, 174, 176, 177, 180, 183, 184, 187, 191, 194, 197, 201, 204, 208, 213, 219, 226, 234, 239, 245, 252, 270, 272, 276, 278, 281, 285, 286, 288, 308, 309, 312, 314, 316, 318, 320, 322, 324, 326, 340, 342	2A-42, 45	
		C-109	4A-83, 86, 94, 134, 136, 140, 141, 159, 160, 162, 163, 166, 167, 172, 174, 176, 177, 180, 183, 184, 187, 191, 194, 197, 201, 204, 208, 213, 219, 226, 234, 239, 245, 252, 272, 274, 279, 283, 287, 290, 291, 292, 294, 299, 300, 302, 305, 309, 335	2A-42, 45	
		C-110	4A-30, 31, 32, 35, 36, 38, 40, 43, 48, 64, 74, 83, 86, 94, 128, 129, 130, 131, 134, 135, 136, 137, 140, 141, 144, 150, 154, 172, 174, 268, 272, 274, 276, 278, 281, 285, 286, 288, 298, 301, 302, 305, 306, 307, 308, 309, 336, 338, 340, 342	2A-42, 45	
		C-111	4A-66, 76, 82, 88, 94, 96, 120, 122, 124, 126, 134, 136, 158, 161, 162, 163, 166, 167, 172, 174, 176, 177, 180, 184, 187, 191, 194, 197, 208, 213, 219, 226, 234, 239, 245, 252, 270, 273, 276, 278, 281, 288, 292, 293, 294, 298, 299, 300, 302, 305, 312, 314, 316, 320, 322, 324, 328, 330, 336	2A-42, 45	
		C-112	4A-208, 213, 219, 226, 234, 239, 245, 252, 279, 282, 287, 289, 294	2A-42, 45	
		C-115	4A-82, 88, 96, 116, 137, 162, 164, 166, 168, 183, 184, 187, 201, 204, 234, 239, 245, 252, 264, 266, 279, 282, 287, 289, 293, 306, 307, 308, 328, 330	2A-42, 45	
		C-116	4A-13, 19, 30, 31, 32, 35, 36, 38, 40, 43, 48, 64, 74, 82, 83, 86, 88, 94, 96, 105, 107, 111, 113, 136, 140, 141, 142, 143, 144, 146, 150, 154, 158, 160, 162, 164, 166, 167, 168, 176, 177, 180, 183, 184, 187, 191, 194, 197, 201, 204, 208, 213, 219, 226, 234, 239, 245, 260, 261, 264, 266, 268, 270, 272, 274, 276, 278, 279, 281, 282, 285, 286, 287, 288, 289, 291, 292, 293, 294, 299, 301, 305, 306, 308, 309, 312, 314, 316, 318, 320, 322, 324, 326, 328, 330, 336, 338, 340, 342	2A-42,45	
		Dash wiring harness and radio sub wiring harness combination	C-20	4A-276, 277, 278, 280, 281, 284, 285, 286, 288	2A-43, 44
		Daytime running lamp control unit	A-09	4A-105, 107, 121, 123	2A-5, 9, 17, 25, 33
	Daytime running lamp harness and front wiring harness combination or front wiring harness joint connector	A-29	4A-101, 102, 105, 107, 116, 121, 123	2A-5, 9, 17, 25, 33	
		A-30	4A-101, 102, 105, 107, 116, 121, 123	2A-5, 9, 17, 25, 33	
	Daytime running lamp relay 1	A-08	4A-105, 107	2A-5, 9, 17, 25, 33	
Daytime running lamp relay 2	A-07	4A-105, 107	2A-5, 9, 17, 25, 33		
Dedicated fuse No. ⑨	C-91	4A-15, 21, 295, 296	2A-42, 45		
Defogger (+)	G-03	4A-271	2A-58		
Defogger (-)	G-06	4A-271	2A-58		

	Parts name	Connector No.	Circuit diagram page	Wiring diagram page
D	Defogger cable and back door wiring harness combination	G-04	4A-271	2A-58
	Defogger switch	C-13	4A-270	2A-42, 44
	Detonation sensor	A-79	4A-68, 78	2A-18, 22
	Diagnosis connector	C-104	4A-52, 60	2A-42, 45
		C-113	4A-45, 52, 60, 69, 79, 91, 100, 310, 315, 319, 323, 327, 341, 343	2A-42, 45
	Dim-dip lamp relay 1	C-70	4A-111, 113	2A-45
	Dim-dip lamp relay 2	C-71	4A-110, 112	2A-45
	Dim-dip lamp relay 3	C-72	4A-110, 112	2A-45
	Diode (for ABS circuit)	C-45	4A-308	2A-43, 45
	Diode (for dim-dip lamp circuit)	C-73	4A-110, 112	2A-45
		C-74	4A-111, 113	2A-45
	Diode (for Headlamp circuit)	C-69	4A-102, 107, 113, 123, 126	2A-42, 45
	Diode (for MPI circuit)	C-46	4A-66, 76, 299	2A-43, 45
	Diode (for super select 4WD circuit)	C-27	4A-304	2A-43, 45
	Distributor signal generator	A-102	4A-44, 50, 53	2A-6, 11, 15
	Door key cylinder switch <Vehicles with central door locking>	F-05	4A-172	2A-54, 56
		F-14	4A-174	2A-55, 57
	Door lock actuator (Back door)	G-12	4A-173, 175	2A-58
	Door lock actuator (Front:LH)	F-13	4A-172, 175	2A-54, 55, 56, 57
	Door lock actuator (Front:RH)	F-06	4A-173, 174	2A-54, 55, 56, 57
	Door lock actuator (Rear:LH)	F-10	4A-173, 175	2A-56, 57
	Door lock actuator (Rear:RH)	F-09	4A-173, 175	2A-56, 57
	Door lock control unit	C-87	4A-172, 174	2A-42, 45
	Door wiring harness (driver's side) and dash wiring harness combination	C-85	4A-172, 174	2A-42, 45
		C-86	4A-162, 163, 166, 164, 166, 167, 168, 172, 174, 271	2A-42, 45
	Door wiring harness (passenger's side) and dash wiring harness combination	C-32	4A-162, 163, 166, 167, 173, 175, 271	2A-43, 44
		C-33	4A-172, 174, 274	2A-43, 44
Dual pressure switch	A-42	4A-43, 49, 57, 65, 75, 193, 196, 200, 203, 207, 210, 216, 221, 229, 247, 255	2A-5, 9, 13, 17, 21, 25, 29, 33, 37	
E	EGR solenoid valve	A-97	4A-67, 77	2A-11, 15, 18, 22
		A-98	4A-45, 59, 68, 78	2A-7, 11, 15, 19, 23
	EGR solenoid valve I	A-89	4A-37, 39, 41	2A-27, 31, 35, 39
	EGR solenoid valve II	A-90	4A-37, 39, 41	2A-27, 31, 35, 39
	ELC-4A/T control unit	C-81	4A-87, 89, 91, 92, 95, 97, 99, 100	2A-42, 44
	Engine control relay or fuel line heater control unit or intercooler fan control unit <Vehicles without fuel line heater>	C-30	4A-42, 46, 54, 62, 72, 297, 338	2A-43, 44
	Engine control unit	C-42	4A-26, 27, 28, 42, 43, 44, 45, 46, 47, 48, 49, 50, 51, 54, 55, 56, 57, 58, 59, 62, 63, 64, 65, 69, 72, 73, 74, 75, 79, 148, 193, 196, 203, 210, 221, 236, 247	2A-43, 44
		C-43	4A-42, 43, 44, 46, 48, 49, 50, 51, 54, 56, 57, 58, 59, 62, 64, 65, 67, 68, 70, 72, 74, 75, 77, 78, 80, 87, 315, 323	2A-43, 44
	Engine control unit or glow control unit	C-41	4A-26, 27, 28, 34, 36, 38, 40, 43, 44, 45, 49, 50, 51, 52, 57, 58, 59, 60, 62, 63, 65, 66, 67, 68, 72, 73, 75, 76, 77, 78, 95, 193, 196, 203, 210, 221, 236, 247, 315, 323	2A-43, 44
	Engine coolant temperature gauge unit	A-104	4A-34, 36, 38, 40, 145, 151	2A-7, 11, 15, 18, 22, 26, 30, 34, 38
	Engine coolant temperature sensor	A-113	4A-44, 50, 58, 67, 77	2A-7, 10, 14, 18, 22, 34, 38
	Engine coolant temperature switch <A/T>	A-105	4A-83, 91, 99	2A-11, 15, 18, 22, 34, 38

	Parts name	Connector No.	Circuit diagram page	Wiring diagram page
E	Engine coolant temperature switch (for A/C compressor control)	A-114	4A-43, 49, 57, 65, 75, 193, 196, 200, 203, 207, 210, 216, 221, 229, 242, 247, 255	2A-7, 10, 14, 18, 22, 26, 30, 34, 38
	Engine coolant temperature switch (for condenser fan motor control)	A-116	4A-199, 206, 215, 228, 241, 254	2A-26, 30, 34, 38
	Engine oil level relay	C-31	4A-156	2A-43, 44
	Engine oil level sensor	A-51	4A-156	2A-6, 8, 12, 16, 20, 24, 28, 32, 36
	Engine speed detection connector	A-66	4A-28, 63, 73	2A-18, 23
F	Floor wiring harness (LH) and floor wiring harness (RH) combination	E-29	4A-117, 121, 123, 125, 127, 128, 129, 130, 131, 135, 140, 141, 164, 168, 173, 175, 265, 267, 277, 280, 284, 285, 286, 288, 298, 300, 310, 311, 336	2A-50, 51, 52, 53
	Folding top assembly <Canvas top>	E-30	4A-271	2A-50, 51, 52, 53
		E-06	4A-295	2A-50, 51, 52, 53
		E-07	4A-295	2A-50, 51, 52, 53
	Frame wiring harness and floor wiring harness (RH) combination	E-26	4A-47, 55, 63, 73, 117, 137, 139, 144, 146, 151, 154, 299, 301, 311	2A-50, 51, 52, 53
		E-27	4A-306, 307	2A-50, 51, 52, 53
		E-28	4A-309	2A-50, 51, 52, 53
	Free wheel engage switch	A-59	4A-304, 311	2A-8, 12, 16, 20, 24, 28, 32, 36
	Front combination lamp (LH)	A-33	4A-137	2A-5, 9, 13, 17, 21, 25, 29, 33, 37
		A-34	4A-116	2A-5, 9, 13, 17, 21, 25, 29, 33, 37
	Front combination lamp (RH)	A-57	4A-116	2A-4, 8, 12, 16, 20, 24, 28, 32, 36
		A-58	4A-137	2A-4, 8, 12, 16, 20, 24, 28, 32, 36
	Front door switch (LH)	E-31	4A-128, 129, 130, 131, 134, 336	2A-50, 51, 52, 53
	Front door switch (RH)	E-38	4A-128, 129, 130, 131, 135, 336	2A-50, 51, 52, 53
	Front impact sensor (LH) <SRS>	A-28	4A-341, 343	2A-9, 13, 17, 21, 25, 29, 33, 37
	Front impact sensor (RH) <SRS>	A-54	4A-341, 343	2A-8, 12, 16, 20, 24, 28, 32, 36
	Front seat assembly (Driver's side) <Heated seat> or power seat wiring harness and console wiring harness	D-19	4A-329, 331	2A-46, 47, 48, 49
	Front seat assembly (Passenger's side) <Heated seat>	D-08	4A-329, 331	2A-46, 47, 48, 49
	Front seat assembly <Power seat>	D-20	4A-331, 333	2A-46, 47, 48, 49
	Front speaker (LH)	C-80	4A-277, 280, 284, 285, 286, 288	2A-42, 44
	Front speaker (RH)	C-37	4A-277, 280, 284, 285, 286, 288	2A-43, 45
	Front wiring harness and dash wiring harness combination	C-08	4A-22, 24, 30, 31, 32, 120, 122, 124, 126, 136, 162, 163, 166, 167, 272, 318, 326, 333	2A-42, 44
		C-09	4A-270	2A-42, 44
		C-10	4A-30, 31, 32, 43, 49, 57, 65, 75, 101, 102, 104, 105, 106, 107, 110, 112, 117, 136, 143, 155, 156, 159, 161, 193, 196, 200, 203, 207, 210, 216, 221, 229, 236, 242, 247, 255, 260, 261, 264, 266, 287, 290, 291, 315, 319, 330	2A-42, 44
		C-28	4A-136, 143, 156, 159, 161, 264, 266, 268, 279, 283, 304, 306, 307, 311	2A-43, 45
		C-29	4A-341, 343	2A-43, 45
	Front wiring harness and floor wiring harness (RH) combination	C-36	4A-52, 60, 69, 79, 308, 309	2A-45
	Front wiring harness and junction block combination	C-100	4A-128, 129, 130, 131	2A-42, 45
		C-101	4A-14, 20, 43, 48, 64, 74, 86, 94, 128, 129, 130, 131, 134, 135, 139, 158, 160, 172, 174, 176, 177, 180, 183, 184, 187, 191, 194, 197, 201, 204, 208, 213, 219, 226, 234, 239, 245, 252, 276, 278, 281, 285, 286, 288, 291, 292, 294, 309, 312, 316, 320, 324, 341, 343	2A-42, 45

	Parts name	Connector No.	Circuit diagram page	Wiring diagram page
F	Front wiring harness and junction block combination	C-102	4A-15, 21, 66, 76, 82, 83, 86, 94, 105, 107, 111, 113, 116, 120, 122, 124, 126, 136, 137, 140, 141, 142, 143, 144, 146, 150, 158, 161, 163, 166, 167, 176, 177, 180, 183, 184, 187, 191, 194, 197, 201, 204, 208, 213, 219, 226, 234, 239, 245, 252, 268, 270, 273, 276, 278, 281, 285, 286, 288, 292, 293, 298, 300, 307, 309, 312, 316, 320, 324, 328, 330, 336, 340, 342	2A-42, 45
		C-103	4A-13, 14, 19, 20, 43, 48, 64, 74, 86, 94, 128, 129, 130, 131, 134, 135, 158, 160, 172, 174, 276, 278, 281, 285, 286, 288, 291, 292, 294, 308, 312, 314, 316, 318, 320, 322, 324, 326, 341, 343	2A-42, 45
	Fuel cut solenoid valve	A-109	4A-35, 37, 39, 41	2A-27, 31, 35, 39
	Fuel gauge unit	G-14	4A-144, 147, 151, 154	2A-58
	Fuel injection pump wiring harness and control wiring harness combination	A-106	4A-34, 35, 36, 37, 39, 41, 151, 152	2A-27, 31, 35, 39
	Fuel line heater or no connection	A-93	4A-338	2A-27, 35, 39
	Fuel pump check connector	A-67	4A-42, 47, 55, 63, 73	2A-6, 10, 15, 18, 23
	Fuel pump <MPI>	G-13	4A-42, 47, 55, 63, 73	2A-58
G	Geomagnetic sensor	D-05	4A-161	2A-46, 47, 48, 49
	Glow plug	A-71	4A-34, 36, 38, 40	2A-26, 30, 34, 38
	Glow plug relay	A-100	4A-34, 36, 38, 40	2A-27, 31, 35, 39
		A-101	4A-34, 36, 38, 40	2A-27, 31, 35, 39
	G sensor	A-99	4A-34, 36, 38, 40, 51	2A-27, 31, 35, 39
		E-33	4A-182, 311	2A-50, 51, 52, 53
H	Hazard switch	C-14	4A-136	2A-42, 44
	Headlamp (LH)	A-36	4A-101, 102, 104, 106, 110, 112	2A-5, 9, 13, 17, 21, 25, 29, 33, 37
		C-68	4A-114	2A-42, 45
	Headlamp leveling switch	A-35	4A-114	2A-5, 9, 13, 17, 21, 25, 29, 33, 37
	Headlamp leveling unit (LH)	A-56	4A-114	2A-4, 8, 12, 16, 20, 24, 28, 32, 36
		A-55	4A-101, 102, 104, 106, 110, 112	2A-4, 8, 12, 16, 20, 24, 28, 32, 36
	Headlamp leveling unit (RH)	A-01	4A-268	2A-4, 8, 12, 16, 20, 24, 28, 32, 36
	Headlamp (RH)	C-88	4A-268	2A-42, 45
	Headlamp washer motor and headlamp washer fluid level sensor	D-15	4A-328, 330	2A-46, 47, 48, 49
	Headlamp washer relay	D-14	4A-328, 330	2A-46, 47, 48, 49
	Heated seat switch (Driver's side)	B-08	4A-302, 305	2A-40, 41
	Heated seat switch (Passenger's side)	A-46	4A-142, 143	2A-4, 8, 12, 16, 20, 24, 28, 32, 36
	High range/low range detection switch			2A-4, 8, 12, 16, 20, 24, 28, 32, 36
	Horn (HI)	A-47	4A-142, 143	2A-4, 8, 12, 16, 20, 24, 28, 32, 36
		A-44	4A-142, 143	2A-5, 9, 13, 17, 21, 25, 29, 33, 37
	Horn (LO)	A-45	4A-142, 143	2A-5, 9, 13, 17, 21, 25, 29, 33, 37
		A-31	4A-143	2A-9, 13, 17, 21, 25, 29, 33, 37
	Horn relay <Vehicles with SRS>	A-63	4A-308	2A-10, 12, 18, 20, 27, 28, 35, 36
	Hydraulic unit	A-64	4A-308	2A-10, 12, 18, 20, 27, 28, 35, 36
		A-72	4A-45, 51, 59, 68, 78	2A-6, 10, 14, 18, 22
I	Idle speed control servo	A-65	4A-309	2A-27, 28, 35, 36
	Idle up solenoid valve <ABS>	A-94	4A-200, 207, 216, 229, 242, 255	2A-26, 31, 34, 39
	Idle up solenoid valve <A/C>			

	Parts name	Connector No.	Circuit diagram page	Wiring diagram page
I	Ignition coil	A-86	4A-26, 27, 29, 45, 63, 73	2A-7, 10, 14, 19, 23
		A-87	4A-29, 63, 73	2A-19, 23
		A-88	4A-29, 47, 55, 63, 73	2A-19, 23
	Ignition switch	C-61	4A-12, 18	2A-42, 45
	Ignition timing adjustment connector	A-68	4A-26, 27, 28, 45, 52, 60, 69, 79	2A-6, 10, 15, 18, 23
	Ignition wiring harness and control wiring harness combination	A-80	4A-29, 63, 73	2A-19, 23
	Inhibitor switch <A/T>	B-09	4A-23, 24, 38, 40, 57, 75, 83, 84, 89, 97, 141, 314, 318, 322, 326, 340, 342	2A-41
	Injector No.1	A-74	4A-45, 51, 59, 68, 78	2A-7, 11, 15, 18, 22
	Injector No.2	A-85	4A-45, 51, 59, 68, 78	2A-7, 11, 15, 19, 23
	Injector No.3	A-75	4A-45, 51, 59, 68, 78	2A-7, 11, 15, 18, 22
	Injector No.4	A-84	4A-45, 51, 59, 68, 78	2A-7, 11, 15, 19, 23
	Injector No.5	A-76	4A-51, 59, 68, 78	2A-11, 15, 18, 22
	Injector No.6	A-83	4A-51, 59, 68, 78	2A-11, 15, 19, 23
	Injector wiring harness and control wiring harness combination	A-77	4A-45, 51, 59, 68, 78	2A-6, 10, 14, 18, 22
	Instrument panel wiring harness and dash wiring harness combination	D-01	4A-159, 160	2A-46, 47, 48, 49
		D-02	4A-105, 107, 155, 158, 159, 160, 291, 292	2A-46, 47, 48, 49
Intake air temperature switch	A-95	4A-297	2A-27, 31, 35, 39	
Intercooler fan control unit <Vehicles with fuel line heater>	C-40	4A-297	2A-43	
Intercooler fan motor	A-96	4A-297	2A-27, 31, 35, 39	
J	J/C (1)	C-75	4A-43, 45, 52, 53, 60, 61, 66, 69, 70, 76, 79, 80, 82, 83, 86, 87, 88, 90, 92, 94, 96, 98, 100, 120, 122, 125, 127, 135, 156, 159, 161, 166, 167, 174, 176, 178, 181, 183, 184, 187, 191, 194, 197, 201, 204, 211, 217, 219, 222, 230, 234, 239, 245, 252, 270, 271, 272, 273, 277, 280, 282, 284, 293, 297, 298, 306, 307, 310, 312, 315, 316, 319, 320, 324, 328, 330, 336	2A-42, 45
	J/C (2)	C-76	4A-15, 21, 30, 31, 32, 34, 35, 36, 38, 39, 40, 41, 42, 49, 57, 65, 66, 75, 76, 84, 87, 95, 139, 156, 174, 177, 180, 208, 213, 219, 226, 270, 272, 289, 296, 308, 310, 312, 314, 315, 316, 318, 320, 336, 338, 340, 342	2A-42, 45
	J/C (3)	C-77	4A-15, 21, 42, 53, 61, 66, 70, 76, 80, 82, 83, 84, 87, 88, 90, 92, 94, 95, 96, 98, 100, 120, 122, 125, 127, 139, 145, 148, 156, 158, 159, 161, 172, 183, 185, 188, 201, 204, 237, 243, 248, 256, 270, 271, 273, 293, 295, 296, 297, 300, 301, 307, 308, 310, 311, 312, 315, 316, 319, 320, 323, 324, 327, 328, 330, 336, 341, 343	2A-42, 45
	J/C (4)	C-78	4A-49, 57, 65, 75, 82, 83, 84, 87, 88, 95, 96, 139, 148, 156, 272, 310, 311, 320, 321, 322, 323, 324, 326, 327, 341, 343	2A-45
	Jumper connector	C-114	4A-52, 60, 69, 79, 91, 100	2A-45
K	Key cylinder illumination lamp timer	C-44	4A-134, 135	2A-43, 44
	Kickdown switch	C-16	4A-91, 99	2A-43, 45
L	Lever position sensor	A-107	4A-36, 38, 40, 95	2A-27, 31, 35, 39
	Lever position switch <A/T> or short connector <M/T>	A-108	4A-198, 205, 214, 227, 240, 253	2A-27, 31, 35, 39
	Licence plate lamp	G-11	4A-117	2A-58
	Lighting monitor buzzer	C-53	4A-336	2A-43, 44
M	Magnetic clutch <A/C>	A-40	4A-43, 49, 57, 65, 75, 193, 196, 200, 203, 207, 210, 216, 221, 229, 236, 242, 247, 255	2A-5, 9, 13, 17, 21, 25, 29, 33, 37
	Map lamp or room lamp or canvas roof switch	E-02	4A-129, 130, 131	2A-50, 51, 52, 53
	Motor antenna	A-03	4A-279, 283, 287	2A-4, 8, 13, 16, 21, 24, 29, 32, 37

	Parts name	Connector No.	Circuit diagram page	Wiring diagram page
M	Motor antenna	A-04	4A-283, 290	2A-4, 8, 13, 16, 21, 24, 29, 32, 37
	Motor antenna control unit	C-52	4A-279, 283, 287, 290	2A-43, 44
	Motor antenna switch	C-55	4A-282, 289	2A-42, 44
	Multi-meter	D-04	4A-159, 160	2A-46, 47, 48, 49
N	No connection	E-11	—	2A-50, 51, 52, 53
		E-15	—	2A-52, 53
		F-01	—	2A-54, 55, 56, 57
		F-15	—	2A-54, 55, 56, 57
	Noise filter	A-69	4A-26, 27, 45, 47, 55, 145, 148	2A-6, 10, 14
		A-70	4A-26, 27, 45, 47, 55, 145, 148	2A-6, 10, 14
O	Oil pressure switch	A-48	4A-155	2A-6, 8, 12, 16, 20, 24, 28, 34, 38
	Overdrive control relay	C-79	4A-83	2A-42, 45
	Overdrive switch	D-09	4A-82, 88, 96, 312, 322	2A-48, 49
	Oxygen sensor <4G64 engine>	A-119	4A-44	2A-6
	Oxygen sensor <6G72,6G74 engine>	B-10	4A-51, 59, 68, 78	2A-41
P	Parking brake switch	D-16	4A-156	2A-46, 47, 48, 49
	Power/Hold changeover switch <ELC-4A/T>	D-23	4A-88, 96	2A-48, 49
	Power seat wiring harness and dash wiring harness combination	D-18	4A-333, 335	2A-46, 47, 48, 49
	Power steering oil pressure switch <A/T> or No connection	A-117	4A-52, 60, 69, 79	2A-10, 14, 18, 22
	Power transistor	A-81	4A-26, 27, 28, 45, 63, 73	2A-7, 10, 14, 19, 23
		A-82	4A-28, 47, 55, 63, 73	2A-19, 23
	Power window main switch (Driver's side)	F-17	4A-162, 163, 166, 167	2A-54, 55, 56, 57
	Power window motor (Front:LH)	F-16	4A-162, 163, 166, 167	2A-54, 55, 56, 57
	Power window motor (Front:RH)	F-03	4A-162, 163, 166, 167	2A-54, 55, 56, 57
	Power window motor (Rear:LH)	F-12	4A-165, 169	2A-56, 57
	Power window motor (Rear:RH)	F-07	4A-165, 169	2A-56, 57
	Power window sub switch (Passenger's side)	F-04	4A-162, 163, 166, 167	2A-54, 55, 56, 57
	Power window sub switch (Rear:LH)	F-11	4A-165, 169	2A-56, 57
	Power window sub switch (Rear:RH)	F-08	4A-165, 169	2A-56, 57
	R	Radio	C-21	4A-213, 276, 277, 278, 280, 281, 284, 285, 286, 288
C-22			4A-277, 278, 280, 281, 284, 285, 286, 288	2A-43, 44
Rear A/C control unit		E-16	4A-211, 217, 225, 233, 237, 243, 251, 259	2A-52, 53
Rear blower main switch		D-17	4A-178, 181, 185, 188, 211, 217, 222, 230, 237, 243, 248, 256	2A-46, 47, 48, 49
Rear combination lamp harness and floor wiring harness (LH) combination		E-22	4A-121, 123, 125, 127, 140, 141	2A-50, 51, 52, 53
Rear combination lamp (In bumper:LH)		G-15	4A-117, 137, 139	2A-58
Rear combination lamp (In bumper:RH)		G-10	4A-137, 139	2A-58
Rear combination lamp (LH)		E-19	4A-121, 123, 125, 127, 140, 141	2A-50, 51, 52, 53
Rear combination lamp (RH)		G-08	4A-117, 121, 123, 125, 127, 140, 141	2A-58
Rear console wiring harness and console wiring harness combination		D-12	4A-328, 330	2A-46, 47, 48, 49
Rear differential lock air pump		E-25	4A-298, 300	2A-50, 51, 52, 53
Rear differential lock control unit		E-24	4A-299, 301, 311	2A-50, 51, 52, 53
Rear differential lock detection switch		G-18	4A-299, 301, 311	2A-58
Rear differential lock switch		D-24	4A-298, 300	2A-46, 47, 48, 49
Rear door switch (LH)		E-36	4A-131	2A-52, 53
Rear door switch (RH)		E-09	4A-131	2A-50, 51, 52, 53
Rear door wiring harness (LH) and floor wiring harness (LH) combination		E-32	4A-165, 169, 173, 175	2A-52, 53
Rear door wiring harness (RH) and floor wiring harness (RH) combination		E-39	4A-165, 169, 173, 175	2A-52, 53
Rear fog lamp switch		C-02	4A-120, 122, 125, 127	2A-42, 45

	Parts name	Connector No.	Circuit diagram page	Wiring diagram page
R	Rear heater assembly	E-40	4A-179, 182, 186, 189, 223, 231, 249, 257	2A-52, 53
	Rear heater control switch or rear A/C control switch <Dual A/C>	E-35	4A-179, 186, 189, 212, 217, 223, 231, 238, 244, 249, 257	2A-50, 51, 52, 53
	Rear speaker (LH)	E-37	4A-277, 280, 284, 285, 286, 288	2A-52, 53
	Rear speaker (RH)	E-10	4A-277, 280, 284, 285, 286, 288	2A-50, 51, 52, 53
	Rear washer motor	G-09	4A-265, 267	2A-58
	Rear wiper motor	G-07	4A-265, 267	2A-58
	Refer to centralized junction	A-19X	4A-13, 14, 19, 20, 43, 48, 56, 64, 74, 86, 94, 128, 129, 130, 131, 134, 135, 158, 160, 172, 174, 276, 278, 281, 285, 286, 288, 291, 294, 308, 312, 314, 316, 318, 322, 324, 326, 341, 343	2A-5, 9, 13, 17, 21, 25, 29, 33, 37
		A-20X	4A-11, 17, 101, 102, 104, 106, 110, 112	2A-5, 9, 13, 17, 21, 25, 29, 33, 37
		A-21X	4A-297	2A-5, 9, 13, 17, 21, 25, 29, 33, 37
		A-22X	4A-30, 31, 32	2A-5, 9, 13, 17, 21, 25, 29, 33, 37
		A-23X	4A-120, 122, 124, 126	2A-5, 9, 13, 17, 21, 25, 29, 33, 37
		A-24X	4A-11, 17, 101, 102, 104, 106, 111, 113, 116, 120, 122, 124, 126, 336	2A-5, 9, 13, 17, 21, 25, 29, 33, 37
		A-25X	4A-193, 196, 199, 203, 206, 210, 215, 221, 228, 236, 241, 247, 254	2A-5, 9, 13, 17, 21, 25, 29, 33, 37
		A-26X	4A-43, 49, 57, 65, 75, 193, 196, 200, 203, 207, 210, 216, 221, 229, 236, 242, 247, 255	2A-5, 9, 13, 17, 21, 25, 29, 33, 37
		C-92X	—	2A-42, 45
		C-93X	4A-179, 181, 186, 219, 226, 245, 252	2A-42, 45
		C-94X	4A-162, 164, 166, 168, 328, 330	2A-42, 45
		C-95X	—	2A-42, 45
		C-96X	4A-270	2A-42, 45
		C-97X	4A-264, 266	2A-42, 45
		C-98X	4A-136	2A-42, 45
	Remote controlled mirror (LH)	F-18	4A-271, 274	2A-54, 55, 56, 57
	Remote controlled mirror (RH)	F-02	4A-271, 274	2A-54, 55, 56, 57
	Remote controlled mirror switch	C-03	4A-274	2A-42, 45
	Resistor (for blower motor control circuit)	C-38	4A-176, 177, 180, 183, 184, 187, 191, 194, 197, 201, 204, 208, 213, 219, 226, 234, 239, 245, 252	2A-43, 44
	Resistor <for dim-dip lamp circuit>	A-32	4A-110, 112	2A-13, 21, 29, 37
	Rheostat or jumper connector	C-04	4A-144, 146, 150	2A-42, 44
Roof wiring harness and dash wiring harness combination	C-99	4A-272, 295, 296	2A-42, 45	
Room lamp	E-04	4A-128, 129, 131, 295	2A-50, 51, 52, 53	
Rotation sensor	A-111	4A-37, 39, 41, 152	2A-27, 31, 35, 39	
S	Shock absorber (Front:LH) <Remote controlled variable shock absorber>	A-39	4A-306	2A-9, 13, 17, 21, 25, 29, 33, 37
	Shock absorber (Front:RH) <Remote controlled variable shock absorber>	A-53	4A-306	2A-8, 12, 16, 20, 24, 28, 32, 36
	Shock absorber (Rear:LH) <Remote controlled variable shock absorber>	G-16	4A-306	2A-58
	Shock absorber (Rear:RH) <Remote controlled variable shock absorber>	G-02	4A-307	2A-58
	Side turn signal lamp (LH)	A-17	4A-137	2A-5, 9, 13, 17, 21, 25, 29, 33, 37
	Side turn signal lamp (RH)	A-02	4A-137	2A-4, 8, 12, 16, 20, 24, 28, 32, 36
	Solenoid assembly <V4AW3>	B-11	4A-9, 99	2A-41
	Solenoid valve A <Super select 4WD>	A-60	4A-304	2A-8, 12, 16, 20, 24, 28, 32, 36

	Parts name	Connector No.	Circuit diagram page	Wiring diagram page
S	Solenoid valve B <Super select 4WD>	A-61	4A-304	2A-8, 12, 16, 20, 24, 28, 32, 36
	Speed sensor (Front:LH) <ABS>	A-38	4A-309	2A-9, 13, 17, 21, 25, 29, 33, 37
	Speed sensor (Front:RH) <ABS>	A-52	4A-309	2A-8, 12, 16, 20, 24, 28, 32, 36
	Speed sensor (Rear:LH) <ABS>	G-17	4A-309	2A-58
	Speed sensor (Rear:RH) <ABS>	G-01	4A-309	2A-58
	SRS diagnosis unit	C-48	4A-341, 343	2A-43, 44
		C-49	4A-341, 343	2A-43, 44
	Starter	A-05	4A-22, 23, 24, 290, 314, 322	2A-5, 8, 12, 16, 20, 25, 29, 33, 37
		A-06	4A-22, 23, 24, 314, 322	2A-5, 8, 12, 16, 20, 25, 29, 33, 37
	Starter relay	A-10	4A-24	2A-25, 29, 33, 37
	Steering lock switch	C-59	4A-134, 135	2A-42, 45
	Stop lamp switch (2-pin) or no connection <Auto-cruise control>	C-62	4A-139, 310	2A-42, 45
	Stop lamp switch (4-pin) <Auto-cruise control> or no connection	C-63	4A-139, 310, 313, 317, 321, 325	2A-42, 45
	Sunroof assembly	E-05	4A-296	2A-52, 53
	Supercharging pressure relief solenoid valve	A-91	4A-37, 41	2A-27, 35
T	Thermo sensor (inside air) <Multi-meter>	C-58	4A-159, 160	2A-42, 45
	Thermo sensor (outside air) <Multi-meter>	A-41	4A-159, 161	2A-5, 9, 13, 17, 21, 25, 29, 33, 37
	Throttle position sensor	A-73	4A-44, 50, 58, 67, 77, 87, 315, 323	2A-6, 10, 14, 18, 22
	Timer solenoid valve	A-110	4A-39, 41	2A-35, 39
	Transmission wiring harness and dash wiring harness combination	C-50	4A-22, 23, 24, 35, 36, 38, 40, 42, 49, 51, 57, 59, 65, 68, 75, 78, 83, 84, 89, 91, 97, 99, 140, 141, 145, 148, 152, 299, 301, 302, 304, 311, 314, 318, 322, 326, 340, 342	2A-43, 44
V	Vacuum switch	A-12	4A-156	2A-25, 28, 33, 36
	Variable induction control solenoid valve	A-103	4A-67, 77	2A-19, 23
	Variable shock absorber control switch	E-34	4A-307	2A-50, 51, 52, 53
	Variable shock absorber control unit	E-23	4A-306	2A-50, 51, 52, 53
	Vehicle speed sensor	B-06	4A-145, 148, 152	2A-40, 41
W	Water level switch	A-92	4A-154	2A-27, 31, 35, 39
	Windshield washer motor	A-18	4A-260, 261	2A-5, 9, 13, 17, 21, 25, 29, 33, 37
	Windshield wiper motor	A-11	4A-260, 261	2A-5, 9, 12, 17, 20, 25, 28, 33, 36
	Wiper deicer (+)	E-01	4A-272	2A-50, 51, 52, 53
	Wiper deicer (-)	E-03	4A-272	2A-50, 51, 52, 53
	Wiper deicer relay	C-90	4A-272	2A-42, 45
	Wiper deicer switch	C-54	4A-273	2A-42, 44
	Wiper deicer timer	C-89	4A-272	2A-42, 45

mitsubishi PAJERO

WORKSHOP MANUAL ELECTRICAL WIRING

FILING INSTRUCTION

Please keep these manual pages in the binder which is keeping the manual PHJE9026.

File these pages according to the signs "ADDED" and "REVISED" on the "List of effective pages" which are interpreted below.

ADDED: File the pages with this sign additionally in your manual.

REVISED: Replace the existing pages with the corresponding pages with this sign.

Missing sheets will be supplied upon request.

Group/ Page	Revision code	Date	Remarks	Group/ Page	Revision code	Date	Remarks
LIST OF EFFECTIVE PAGES				29 thru 42		Feb. 1991	
1	C	Dec. 1993	REVISED	43 thru 44	A	Jan. 1993	
2	C	Dec. 1993	ADDED	45		Feb. 1991	
<Up to 1993 models>				45-1 thru 45-2	A	Jan. 1993	
Foreword	C	Dec. 1993	REVISED	46	A	Jan. 1993	
HOW TO USE THIS MANUAL				47 thru 48		Feb. 1991	
		Feb. 1991		48-1 thru 48-4	A	Jan. 1993	
1-HOW TO READ THE WIRING DIAGRAMS				49 thru 50	A	Jan. 1993	
1	B	July 1993		51 thru 52		Feb. 1991	
2		Feb. 1991		52-1 thru 52-4	A	Jan. 1993	
3	B	July 1993		53	A	Jan. 1993	
4 thru 5		Feb. 1991		54 thru 59		Feb. 1991	
6 thru 7	B	July 1993		60	A	Jan. 1993	
8 thru 10		Feb. 1991		61		Feb. 1991	
11 thru 12	B	July 1993		61-1 thru 61-2	A	Jan. 1993	
2-WIRING HARNESS CONFIGURATION				62	A	Jan. 1993	
1 thru 17		Feb. 1991		63		Feb. 1991	
18	C	Dec. 1993	REVISED	63-1 thru 63-2	A	Jan. 1993	
19	B	July 1993		64 thru 119		Feb. 1991	
20 thru 25		Feb. 1991		120	B	July 1993	
26 thru 29	A	Jan. 1993		121 thru 160		Feb. 1991	
30 thru 42		Feb. 1991		161 thru 163	A	Jan. 1993	
3-SINGLE PART INSTALLATION POSITION				163-1 thru 163-2	A	Jan. 1993	
1 thru 4		Feb. 1991		164 thru 169		Feb. 1991	
5 thru 6	A	Jan. 1993		170 thru 173	B	July 1993	
7		Feb. 1991		174 thru 184		Feb. 1991	
8 thru 9	A	Jan. 1993		185	A	Jan. 1993	
10 thru 16		Feb. 1991		186 thru 187		Feb. 1991	
4-CIRCUIT DIAGRAM				188 thru 190	A	Jan. 1993	
1 thru 2	B	July 1993		Wiring Diagram			
3 thru 9		Feb. 1991		A and C		Feb. 1991	
10	A	Jan. 1993		B and D		Feb. 1991	
11 thru 26		Feb. 1991		E and F		Feb. 1991	
27	A	Jan. 1993		G and I		Feb. 1991	
27-1 thru 27-2	A	Jan. 1993		H and J		Feb. 1991	
27-3	B	July 1993		K and L		Feb. 1991	
27-4	C	Dec. 1993	REVISED				
28	A	Jan. 1993					

LIST OF EFFECTIVE PAGES

Group/ Page	Revision code	Date	Remarks	Group/ Page	Revision code	Date	Remarks
<1994 models>							
Foreword	C	Dec. 1993	ADDED				
HOW TO USE THIS MANUAL							
		Dec. 1993	ADDED				
1A-HOW TO READ THE WIRING DIAGRAMS							
1 thru 12	C	Dec. 1993	ADDED				
2A-WIRING HARNESS CONFIGURATION DIAGRAMS							
1 thru 58	C	Dec. 1993	ADDED				
3A-SINGLE PART INSTALLATION POSITION							
1 thru 23	C	Dec. 1993	ADDED				
4A-CIRCUIT DIAGRAM							
1 thru 343	C	Dec. 1993	ADDED				
INDEX							
1 thru 20	C	Dec. 1993	ADDED				

RJCR312009-474
 RJCR306009-32
 RJCR301006-66
 RJCR102008-262
ADDED

mitsubishi PAJERO '91, '93

WORKSHOP MANUAL ELECTRICAL WIRING

FILING INSTRUCTION

Please keep these manual pages in the binder which is keeping the manual PHJE9026.

File these pages according to the signs "ADDED" and "REVISED" on the "List of effective pages" which are interpreted below.

ADDED: File the pages with this sign additionally in your manual.

REVISED: Replace the existing pages with the corresponding pages with this sign.

Missing sheets will be supplied upon request.

MITSUBISHI PAJERO

ELECTRICAL WIRING

GROUP INDEX

HOW TO READ THE WIRING DIAGRAMS	1
WIRING HARNESS CONFIGURATION DIAGRAMS	2
SINGLE PART INSTALLATION POSITION	3
CIRCUIT DIAGRAM	4

FOREWORD

This Electrical Wiring Manual contains information necessary for inspection and servicing of electrical wiring in the Mitsubishi PAJERO edited in the form of wiring harness configuration diagrams and function-separated circuit diagrams.

It is recommended that all service mechanics engaged in the servicing of the vehicle refer to the following publications as well as this manual.

TECHNICAL INFORMATION PYJE9002
MANUAL

WORKSHOP MANUAL PWJE9086
(Loose-leaf edition)

WORKSHOP MANUAL
Engine Group PWEE□□□□
(Loose-leaf edition)

PARTS CATALOGUE B6035604A□

All information, illustrations and product descriptions contained in this manual are current as of time of publication. We, however, reserve the right to make changes at any time without prior notice or obligation.



HOW TO USE THIS MANUAL

CONTENTS

The preceding page contains GROUP INDEX which lists the group title and group number.

PAGE NUMBERS

All page numbers consist of two sets of digits separated by a dash. The digits preceding the dash identify the number of the group. The digits following the dash represent the consecutive page number within the group. The page numbers can be found on the top left or right of each page.

OPERATION AND TROUBLESHOOTING HINTS

In the GROUP 4 circuit diagrams, the operation and troubleshooting hints are given on the previous page or following page for each circuit where necessary.

1 HOW TO READ THE WIRING DIAGRAMS

MODEL	1- 3
COMPOSITION AND CONTENTS OF WIRING DIAGRAMS	1- 4
HOW TO READ CONFIGURATION DIAGRAMS	1- 5
HOW TO READ CIRCUIT DIAGRAMS	1- 6
MARKINGS FOR CONNECTOR EARTHING	1- 8
SYMBOLIC MARKS	1-10
WIRE COLOUR CODES	1-10
ABBREVIATION SYMBOLS	1-11

NOTES

MODEL
<2-DOOR MODELS>

Model code		Body style	Engine model	Transmission model	Fuel supply system
V21C	NSEL6	Canvas top	4G64 [2351 cm ³ , (143.5 cu.in.)]	V5M21 (5M/T)	MPI
V24C	NSFL6		4D56 [2477 cm ³ , (151.2 cu.in.)] with turbocharger and intercooler	V5MT1 (5M/T)	Injection
V23C	GRHEL6	Canvas top with wide fender	6G72 [2972 cm ³ , (181.3 cu.in.)]	V4AW2 (4A/T)	MPI
V21W	NHEL6	Wagon	4G64 [2351 cm ³ , (143.5 cu.in.)]	V5M21 (5M/T)	MPI
V24W	NAFL6	Wagon	4D56 [2477 cm ³ , (151.2 cu.in.)] with turbocharger and intercooler	V5MT1 (5M/T)	Injection
	NBFL6				
	NDFL6				
	NHFL6/R6				
V24WG	NCFL6	Wagon with wide fender	6G72 [2972 cm ³ , (181.3 cu.in.)]	V4AW2 (4A/T)	MPI
	NXFL6/R6				
V23W	GNXEL6/R6				
	GRXEL6/R6				

<4-DOOR MODELS>

Model code		Body style	Engine model	Transmission model	Fuel supply system
V41W	NHEL6	Wagon	4G64 [2351 cm ³ , (143.5 cu.in.)]	V5M21 (5M/T)	MPI
V44W	NDFL6			Wagon without 3rd seat row	4D56 [2477 cm ³ , (151.2 cu.in.)] with turbocharger and intercooler
	NDFCL6				
	NHFL6/R6	Wagon	V4AW2 (4A/T)		
	RHFL6/R6				
V44WG	NXFL6/R6	Wagon with wide fender		V5MT1 (5M/T)	
	RXFL6/R6				
	NXFCL6	Wagon with wide fender, without 3rd seat row		V4AW2 (4A/T)	
	RXFCL6				
V43W	GNXEL6/R6	Wagon with wide fender	6G72 [2972 cm ³ , (181.3 cu.in.)]	V5MT1 (5M/T)	MPI
	GRXEL6/R6				
	GNXECL6	Wagon with wide fender, without 3rd seat row		V4AW2 (4A/T)	
	GRXECL6				

COMPOSITION AND CONTENTS OF WIRING DIAGRAMS

This manual consists of wiring harness diagrams, installation locations of individual parts, circuit diagrams and wiring diagram.

Section	Basic contents
Wiring harness configuration diagrams	Connector locations and harness wiring configurations on actual vehicles are illustrated.
Single part installation position	Locations are shown for earth points of relays, control units, sensors, diodes, check terminals, spare terminals, fusible links, fuses, etc. In the parts lists, parts are listed in alphabetical order.
Circuit diagrams	<p>Circuits from power supply to earth are shown completely, classified according to system. There is a main division into power circuits, and circuits classified by system. The circuits classified by system also include operation and troubleshooting hints.</p> <ul style="list-style-type: none"> • Power supply circuits Circuits from the battery to fusible link, dedicated fuses, ignition switch, general purpose fuses, etc. • Circuits classified by system For each system, the circuits are shown from fuse to earth, excluding the power supply sections. • Operation The normal operation of each system is briefly described, following the route of current flow. • Troubleshooting hints This is a brief explanation of the inspection points that serve as hints when troubleshooting. Explanations of the circuits controlled by the electronic control unit are omitted. Refer to the related publications as required. • Junction block Here is the circuit for the entire junction block since only the part of the junction block needed is normally shown in each circuit diagram.
Wiring diagram	All the harnesses and connectors are shown together so that the circuit diagrams and wiring harnesses of the entire vehicle can be seen at a glance.

HOW TO READ CONFIGURATION DIAGRAMS

The wiring harness diagrams clearly show the connector locations and harness routings at each site in actual vehicles.

Denotes connector No.
 The same connector No. is used throughout the circuit diagrams to facilitate connector location searches.
 The first alphabetical symbol indicates the location site of the connector and a number that follows is the unique number. Numbers are assigned to parts in clockwise order on the diagram.
 When the connectors are centralized in one place, the connector colors are shown for easy identification.

Example: A-12 (black)

- Connector colour
- Number specific to connector (serial number)
- Connector location site symbol
- A: Engine compartment
- B: Transmission
- C: Dash panel
- D: Instrument panel and floor console
- E: Floor and roof
- F: Door
- G: Back door and rear under floor

The mark ★ shows the standard mounting position of wiring harness.

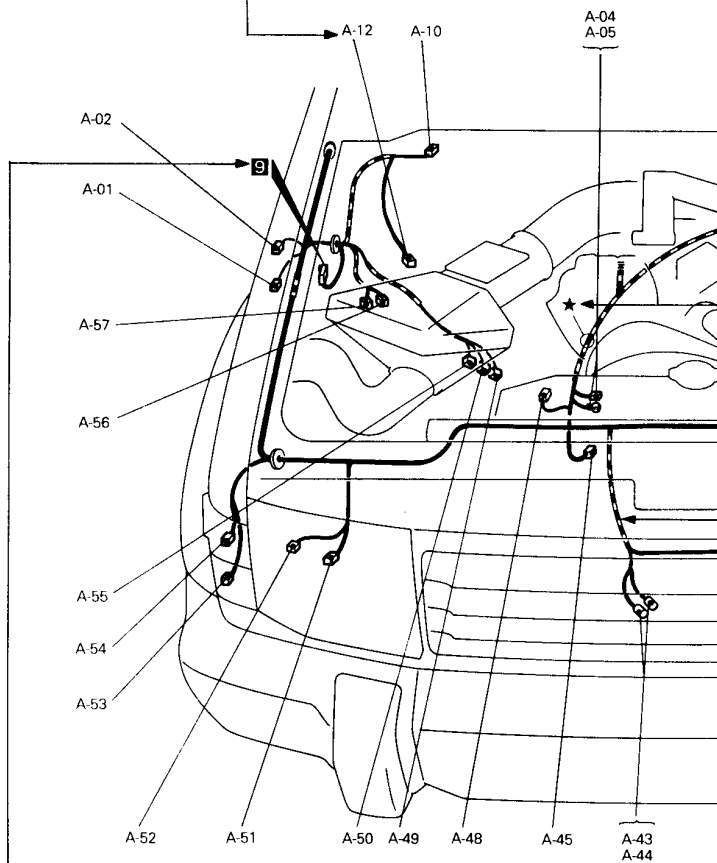

Denotes earth point.
 Same earth number is used throughout circuit diagrams to facilitate search of earth point. Refer to GROUP 3 SINGLE PART INSTALLATION POSITION-EARTH MOUNTING LOCATIONS for details of earth points.

Denotes a section covered by a corrugated tube.

1-6 HOW TO READ THE WIRING DIAGRAMS — How to Read Circuit Diagrams

HOW TO READ CIRCUIT DIAGRAMS

The circuit of each system from fuse (or fusible link) to earth is shown. The power supply is shown at the top and the earth at the bottom to facilitate understanding of the current flow.

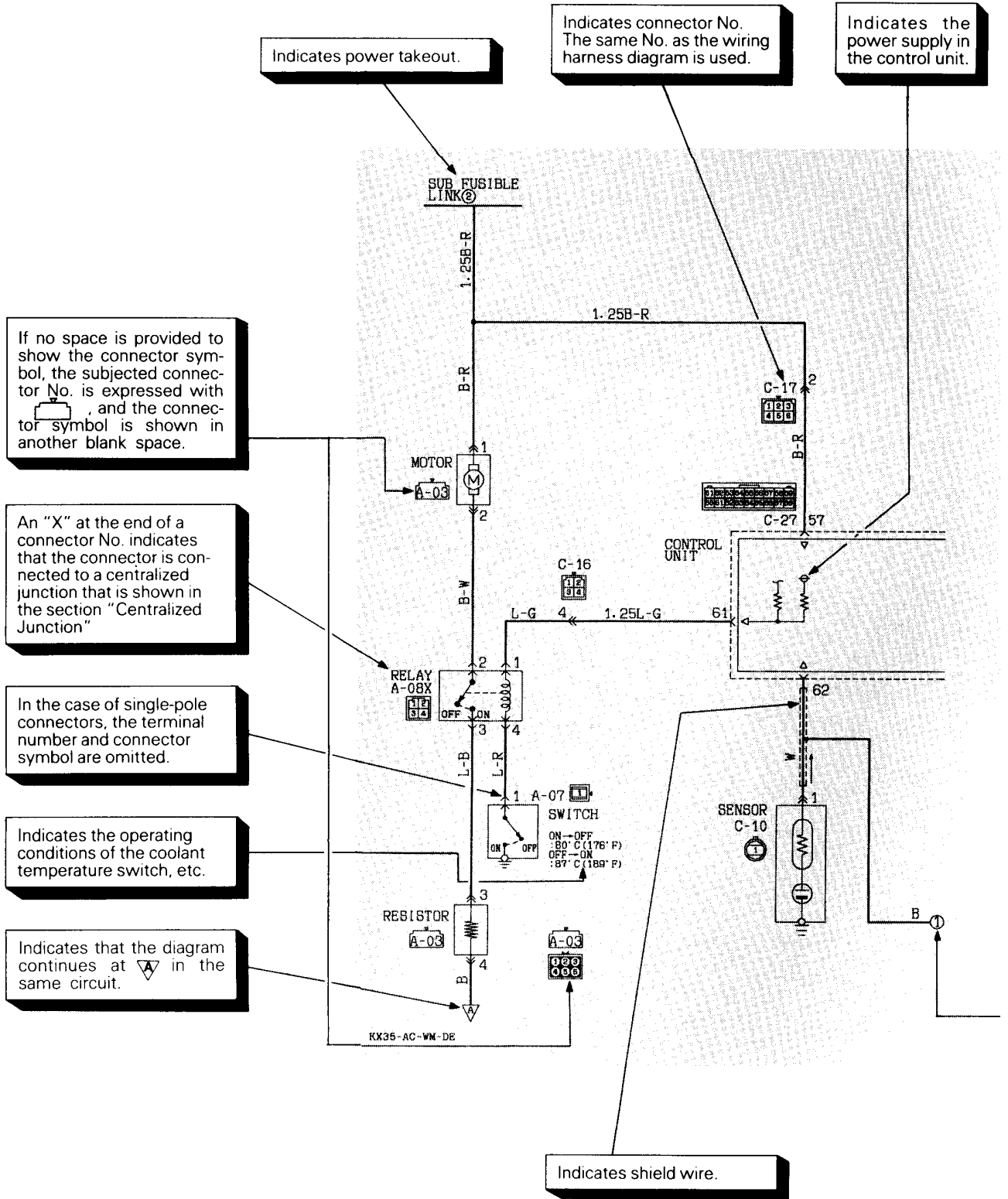

Indicates power takeout.

Indicates connector No. The same No. as the wiring harness diagram is used.

Indicates the power supply in the control unit.

If no space is provided to show the connector symbol, the subjected connector No. is expressed with , and the connector symbol is shown in another blank space.

An "X" at the end of a connector No. indicates that the connector is connected to a centralized junction that is shown in the section "Centralized Junction"

In the case of single-pole connectors, the terminal number and connector symbol are omitted.

Indicates the operating conditions of the coolant temperature switch, etc.

Indicates that the diagram continues at in the same circuit.

Indicates shield wire.

HOW TO READ THE WIRING DIAGRAMS — How to Read Circuit Diagrams 1-7

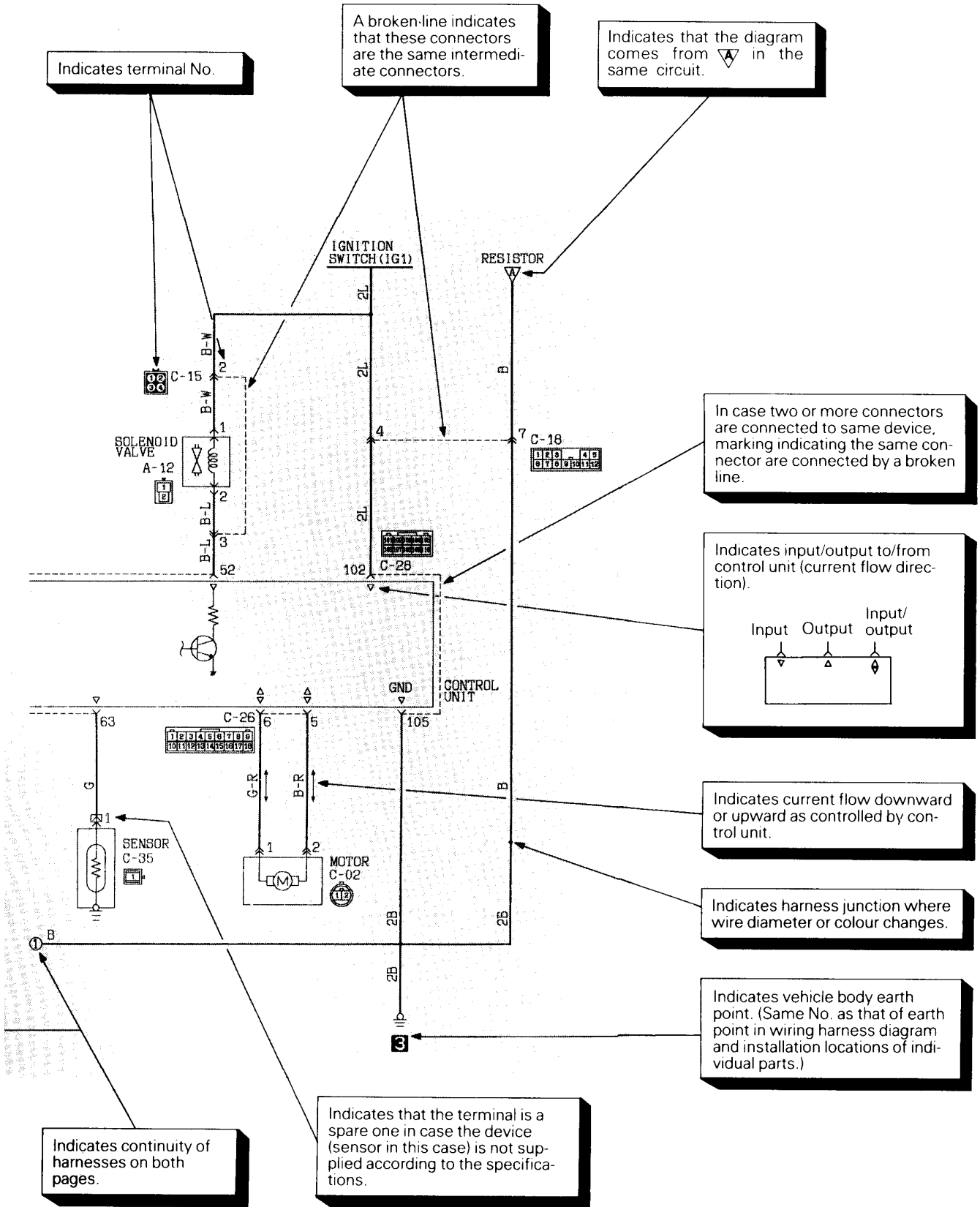





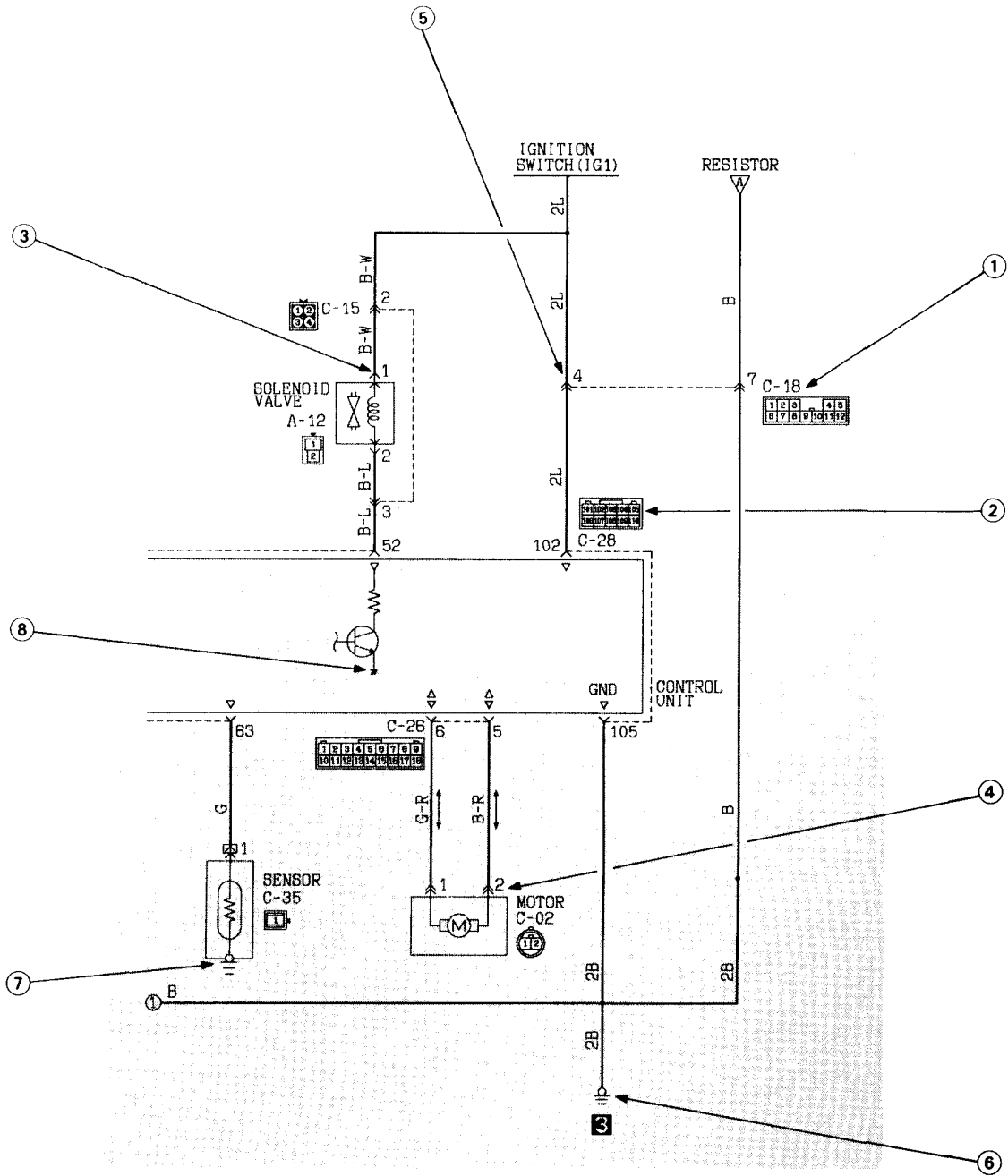



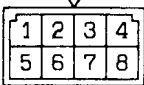
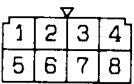
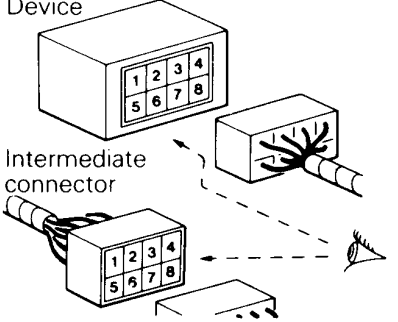
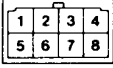
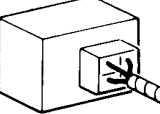

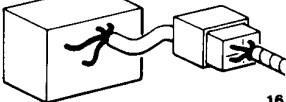
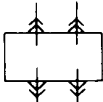
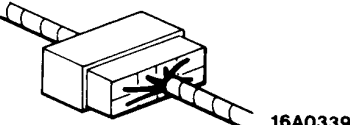
1-8 HOW TO READ THE WIRING DIAGRAMS — Markings for Connector Earthing

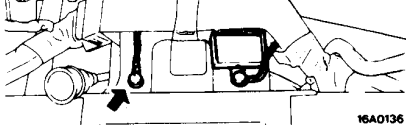
MARKINGS FOR CONNECTOR EARTHING

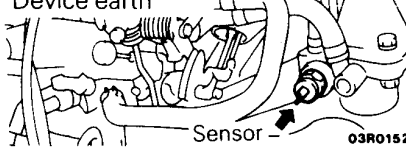

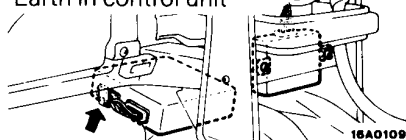
HOW TO READ THE WIRING DIAGRAMS — Markings for Connector Earthing 1-9

No	Item	Symbol	Contents
Connector marking	① Male 	↓	Double connector contour lines indicate male connector terminals and single contour line indicates female terminals as illustrated here.
	Female 	Y	
Connector symbol marking	② Device 		The symbol indicates the connector as viewed from illustrated direction. At the connection with a device, the connector symbol on the device side is shown, and for an intermediate connector, male connector symbol is shown.
Connector connection marking	③ Direct connection type 		A connection between a device and connector on the harness side is either by direct insertion in the device (direct connection type) or by connection with a harness connector on the device side furnished (harness connection type). The two types are indicated as illustrated.
	④ Harness connection type 		
	⑤ Intermediate connector 		
Earth markings	⑥ Body earth 		Earth is either by body earth, device earth or control unit interior earth. These are indicated as illustrated.
	⑦ Device earth 		
	⑧ Earth in control unit 		

1-10 HOW TO READ THE WIRING DIAGRAMS — Symbolic Marks/Wire Colour Codes

SYMBOLIC MARKS

Devices appearing in circuit diagrams are indicated by the following symbols.

Battery 	Body earth 	Single bulb 	Resistor 	Diode 	Capacitor
Fuse 	Equipment earth 	Dual bulb 	Variable resistor 	Zener diode 	Crossing of wires without connection
Fusible link 	ECU interior earth 	Speaker 	Coil 	Transistor 	Crossing of wires with connection
Connector Female side Male side 	Motor 	Horn 	Pulse generator 	Buzzer 	Chime
Thyristor 	Piezoelectric device 	Thermistor 	Light emitting diode 	Photo diode 	Photo transistor

WIRE COLOUR CODES

Wire colours are identified by the following colour codes.

Code	Wire colour	Code	Wire colour
B	Black	P	Pink
BR	Brown	R	Red
G	Green	SB	Sky blue
GR	Gray	V	Violet
L	Blue	W	White
LG	Light green	Y	Yellow
O	Orange		

NOTE

If a cable has two colours, the first of the two colour code characters indicates the basic colour (colour of the cable coating) and the second indicates marking colour.

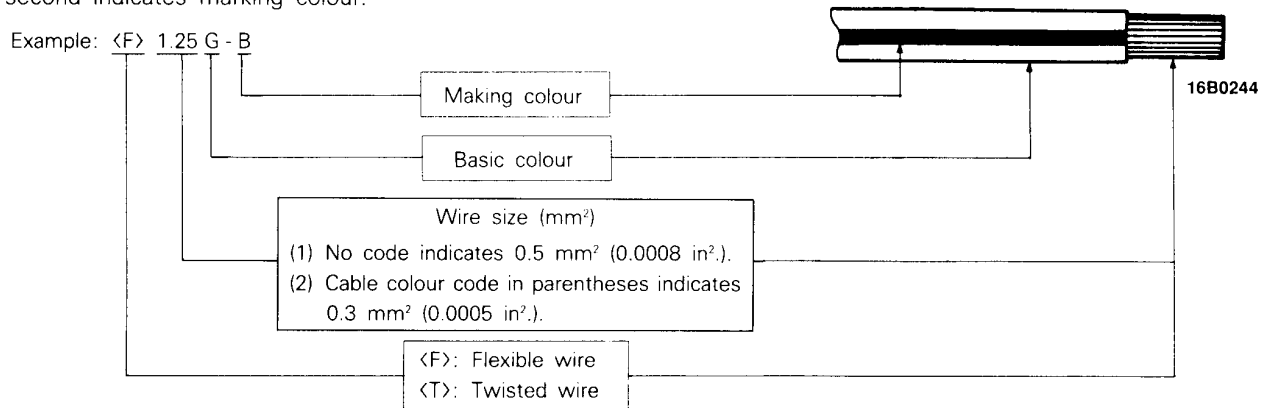

ABBREVIATION SYMBOLS

The abbreviation symbols used in wiring diagrams are defined below.

Abbreviation symbol	Meaning	Abbreviation symbol	Meaning
PETROL	Petrol-powered vehicles	M/T	Manual transmission
DIESEL	Diesel-powered vehicles	LHD	L.H. drive vehicles
MPI	Multi-point injection	RHD	R.H. drive vehicles
4G64	4G64 engine	ABS	Anti-skid brake system
6G72	6G72 engine	DRL	Daytime running lamp
4D56	4D56 engine	GND	Earth
A/C	Air conditioner	ILL	Illumination lamp
A/T	Automatic transmission	IND	Indicator lamp
		J/B	Junction block

Abbreviation symbols used for combination meters

Abbreviation symbol	Meaning	Abbreviation symbol	Meaning
ABS	Anti-skid brake system warning lamp	HAZARD	Hazard warning indicator lamp
BEAM	Upper beam indicator lamp	OIL	Oil pressure warning lamp
BRAKE	Brake warning lamp	OIL LEVEL	Low engine oil warning lamp
C/D LOCK	Center differential lock indicator lamp	R/D LOCK	Rear differential lock indicator lamp
CHECK ENGINE	Check engine warning lamp	REED	Reed switch
CHG	Charging warning lamp	TACHO	Tachometer
DOOR	Door-ajar warning lamp	T/GA	Engine coolant temperature gauge
F/GA	Fuel gauge	TURN (LH)	Turn signal indicator lamp (L.H.)
FILTER	Fuel filter warning lamp	TURN (RH)	Turn signal indicator lamp (R.H.)
FUEL	Low fuel warning lamp	WASHER	Low washer fluid warning lamp

1-12 HOW TO READ THE WIRING DIAGRAMS — Abbreviation Symbols

Abbreviation symbols used for switches and relays

Name of switches and relays	Abbreviation symbol	Operation	Name of switches and relays	Abbreviation symbol	Operation	
Ignition switch	ACC	When turned to the ACC (ACCESSORY) or ON position, the power circuit starts functioning.	Rear heater control switch or Rear A/C control switch	LO	Rear blower operates at low speed	
	IG1	Even when at the ST (START) position, the power circuit starts functioning.		M	Rear blower operates at medium speed	
	IG2	When at the ST (START) position, the power circuit does not start functioning.		HI	Rear blower operates at high speed	
			Air conditioner switch	ECONO	1st position (economical operation)	
				A/C	2nd position (full load operation)	
Dimmer passing switch	LO	Low beams ON	Wiper switch	LO	Wipers operate at low speed	
	HI	High beams ON		HI	Wipers operate at high speed	
					INT	Wipers operate intermittently
Lighting switch	TAIL	Position, tail, licence-plate and instrument panel lamps ON	RH/LH CHANGE-OVER SWITCH	LH	L.H. mirror operates	
	HEAD	Headlamps ON		RH	R.H. mirror operates	
Room lamp switch	DOOR	Room lamp ON when a door is open	Sunroof switch	OPEN	Sunroof slides open	
				CLOSE	Sunroof slides to close	
Turn signal switch	LH	L.H. turn signal lamps ON	Variable shock absorber control switch	S	Sets the shock absorbers to SOFT mode	
	RH	R.H. turn signal lamps ON		M	Sets the shock absorbers to MEDIUM mode	
Power window switch	UP	Window closed			H	Sets the shock absorbers to HARD mode
	DOWN	Window opened				
Door lock actuator	LOCK	Door locked	Rear differential lock switch	LOCK	Rear differential locked	
	UNLOCK	Door unlocked		UNLOCK	Rear differential unlocked	
Door key cylinder switch	LOCK	Door locked	Heated seat switch	LO	Normal heating	
	UNLOCK	Door unlocked		HI	Rapid heating	
Blower switch	LO	Blower operates at low speed		Others	ON	Switched on
	ML	Blower operates at medium speed			OFF	Switched off
	MH	Blower operates at medium high speed				
	HI	Blower operates at high speed				

2 WIRING HARNESS CONFIGURATION DIAGRAMS

1 OVERALL WIRING DIAGRAM

1-1	2-door models <L.H. drive vehicles>	2- 2
1-2	2-door models <R.H. drive vehicles>	2- 2
1-3	4-door models <L.H. drive vehicles>	2- 3
1-4	4-door models <R.H. drive vehicles>	2- 3

2 ENGINE COMPARTMENT **A**

2-1	Vehicles with 4G64 engine	2- 4
2-2	L.H. drive vehicles with 6G72 engine	2- 8
2-3	R.H. drive vehicles with 6G72 engine	2-12
2-4	L.H. drive vehicles with 4D56 engine	2-16
2-5	R.H. drive vehicles with 4D56 engine	2-20

3 TRANSMISSION **B**

3-1	Part time 4WD	2-24
3-2	Super select 4WD	2-25

4 DASH PANEL **C**

4-1	L.H. drive vehicles	2-26
4-2	R.H. drive vehicles	2-28

5 INSTRUMENT PANEL AND FLOOR CONSOLE **D**

5-1	L.H. drive vehicles <M/T>	2-30
5-2	R.H. drive vehicles <M/T>	2-31
5-3	L.H. drive vehicles <A/T>	2-32
5-4	R.H. drive vehicles <A/T>	2-33

6 FLOOR AND ROOF **E**

6-1	2-door models <L.H. drive vehicles>	2-34
6-2	2-door models <R.H. drive vehicles>	2-35
6-3	4-door models <L.H. drive vehicles>	2-36
6-4	4-door models <R.H. drive vehicles>	2-37

7 DOOR **F**

7-1	2-door models <L.H. drive vehicles>	2-38
7-2	2-door models <R.H. drive vehicles>	2-39
7-3	4-door models <L.H. drive vehicles>	2-40
7-4	4-door models <R.H. drive vehicles>	2-41

8 BACK DOOR AND REAR UNDER FLOOR **G** 2-42

1 OVERALL WIRING DIAGRAM

1-1 2-door models <L.H. drive vehicles>

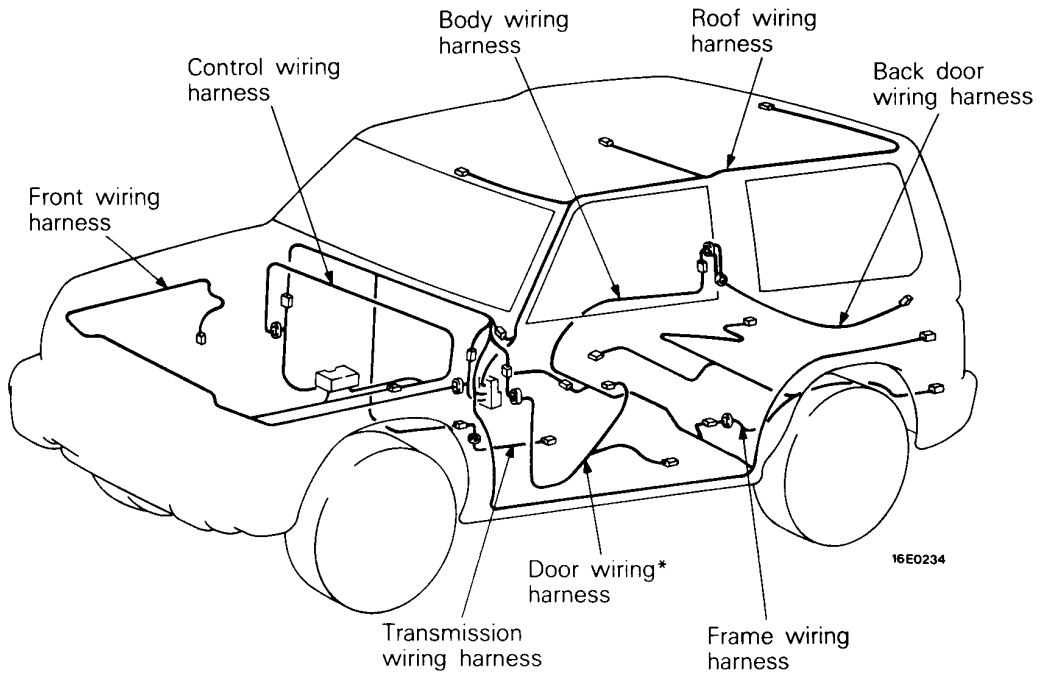

1-2 2-door models <R.H. drive vehicles>

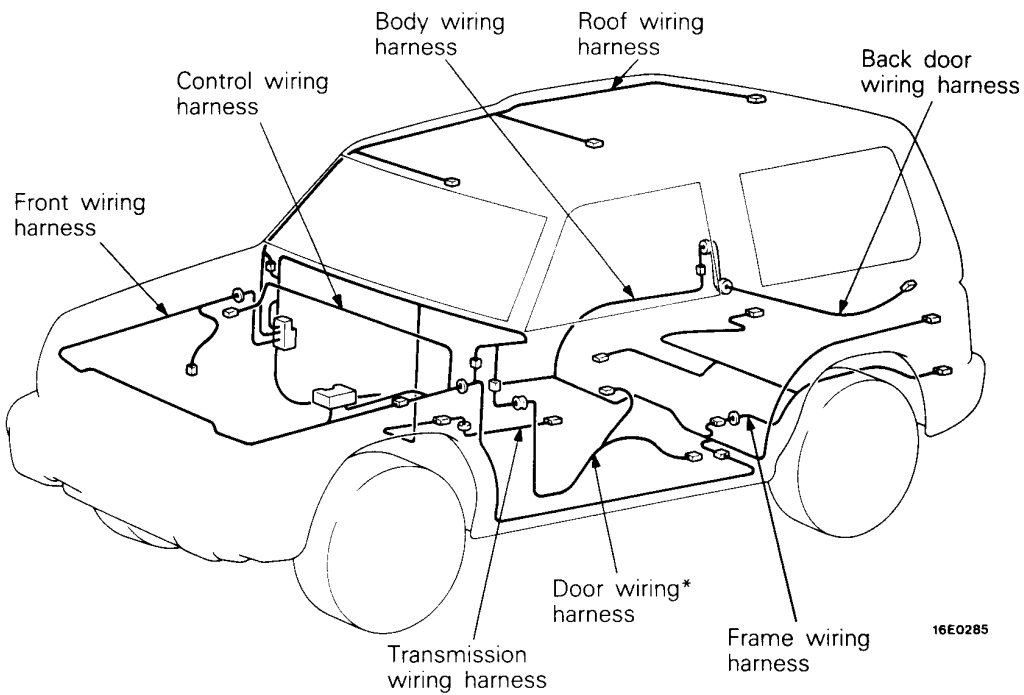

NOTE

- (1) This illustration shows only the major wiring harness.
- (2) * indicates also equipped at the right side.

1-3 4-door models <L.H. drive vehicles>

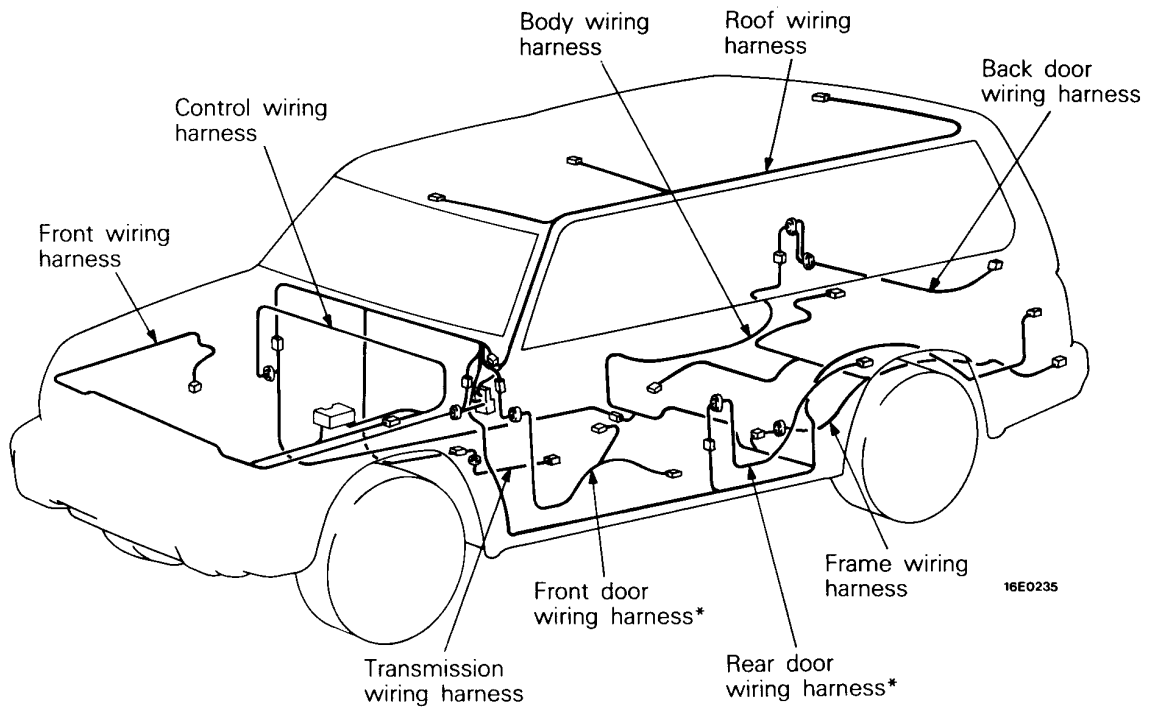

1-4 4-door models <R.H. drive vehicles>

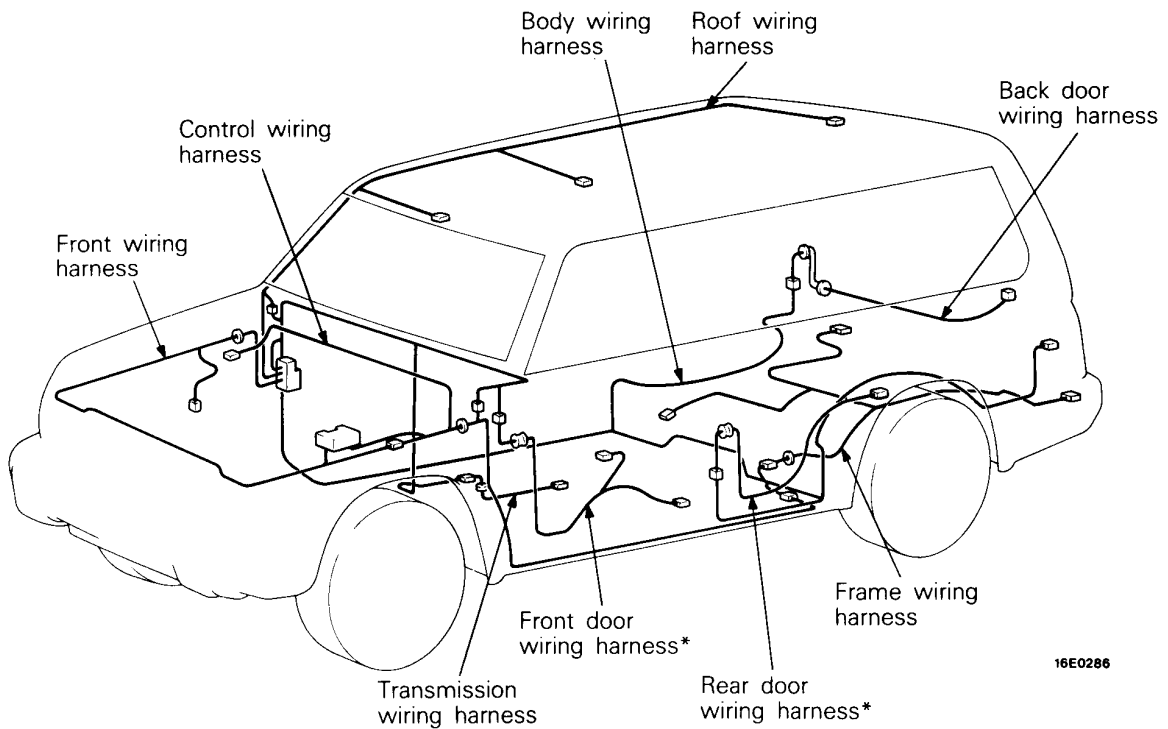

NOTE

- (1) This illustration shows only the major wiring harness.
- (2) * indicates also equipped at the right side.

2 ENGINE COMPARTMENT

2-1 Vehicles with 4G64 engine

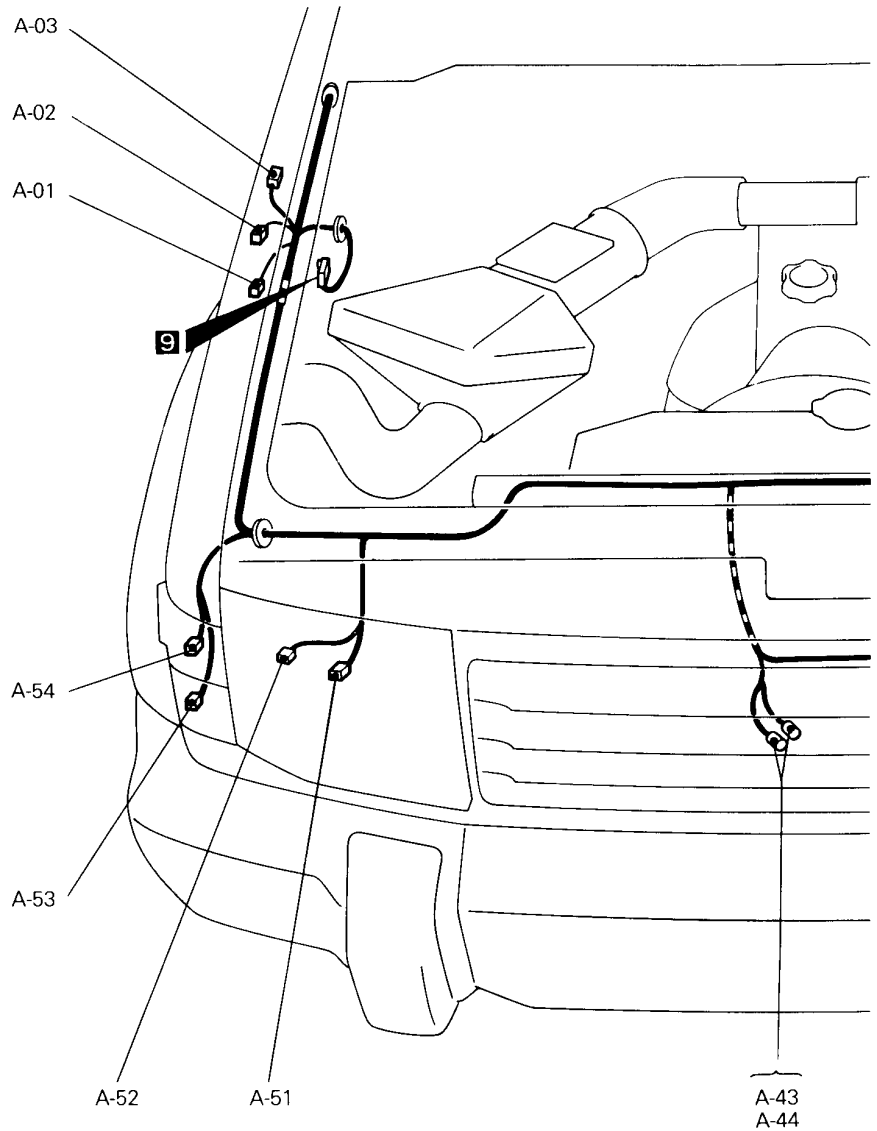
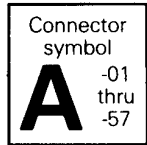

- A-01 Headlamp washer tank assembly
- A-02 Side turn signal lamp (RH)
- A-03 Motor antenna
- A-04 } Starter
- A-05 }
- A-06 Daytime running lamp relay 2
- A-07 Daytime running lamp relay 1
- A-08 Daytime running lamp control unit
- A-09 —
- A-10 Windshield wiper motor
- A-11 —
- A-12 Brake fluid level switch
- A-13 —

- A-14 Side turn signal lamp (LH)
- A-15 Windshield washer motor
- A-16 No connection
- A-17 Control wiring harness and front wiring harness combination
- A-18X } Refer to centralized junction
- thru }
- A-25X }
- A-26 Battery cable and front wiring harness combination
- A-27 } Daytime running lamp harness and front wiring harness combination
- A-28 }
- A-29 Jumper connector

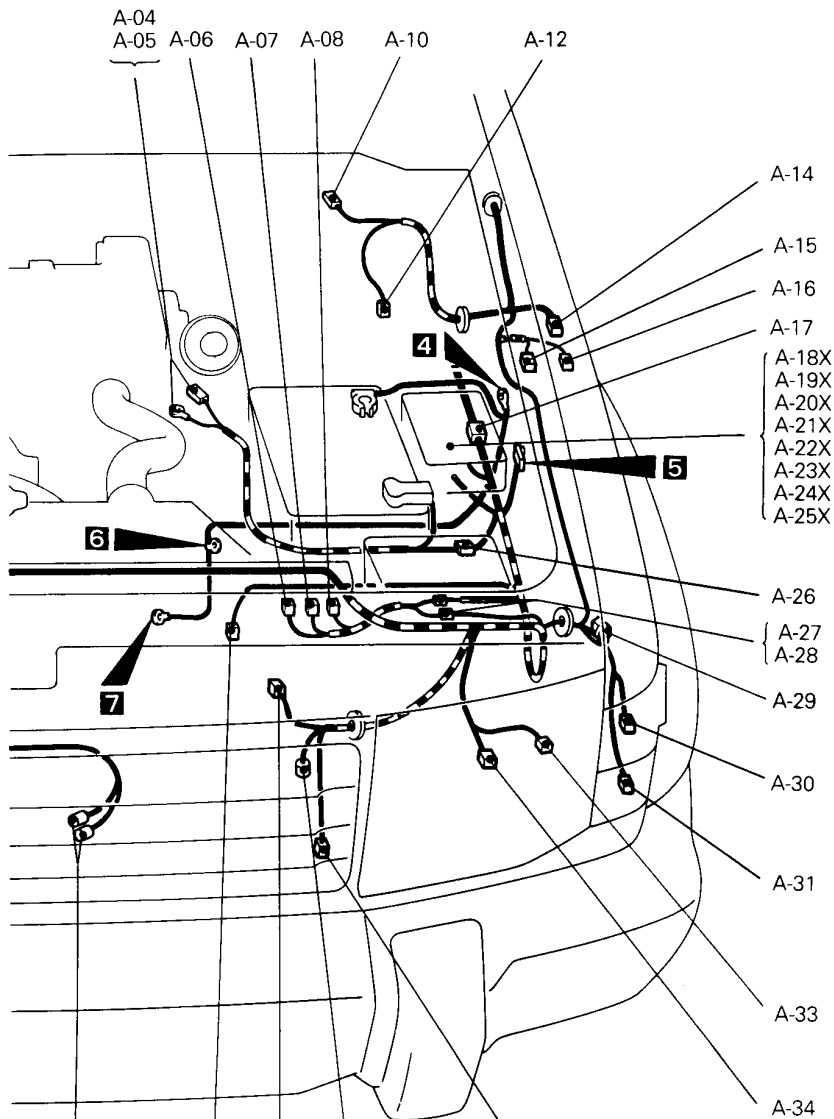

A-41 A-42 A-37 A-40 A-39 A-38 16E0376

- | | | | |
|------------------|--------------------------------------------|------------------|-----------------------------|
| A-30 }
A-31 } | Front combination lamp (LH) | A-43 }
A-44 } | Horn (HI) |
| A-32 | — | A-45 }
A-50 } | — |
| A-33 | Headlamp leveling unit (LH) | A-51 | Headlamp (RH) |
| A-34 | Headlamp (LH) | A-52 | Headlamp leveling unit (RH) |
| A-35 | — | A-53 }
A-54 } | Front combination lamp (RH) |
| A-36 | — | A-55 | — |
| A-37 | Magnetic clutch <A/C> | A-56 | — |
| A-38 | Thermo sensor (Out side air) <Multi-meter> | A-57 | — |
| A-39 | Dual pressure switch | | |
| A-40 | Condenser fan motor | | |
| A-41 }
A-42 } | Horn (LO) | | |

2-1 Vehicles with 4G64 engine

Connector symbol
A -58 thru -111

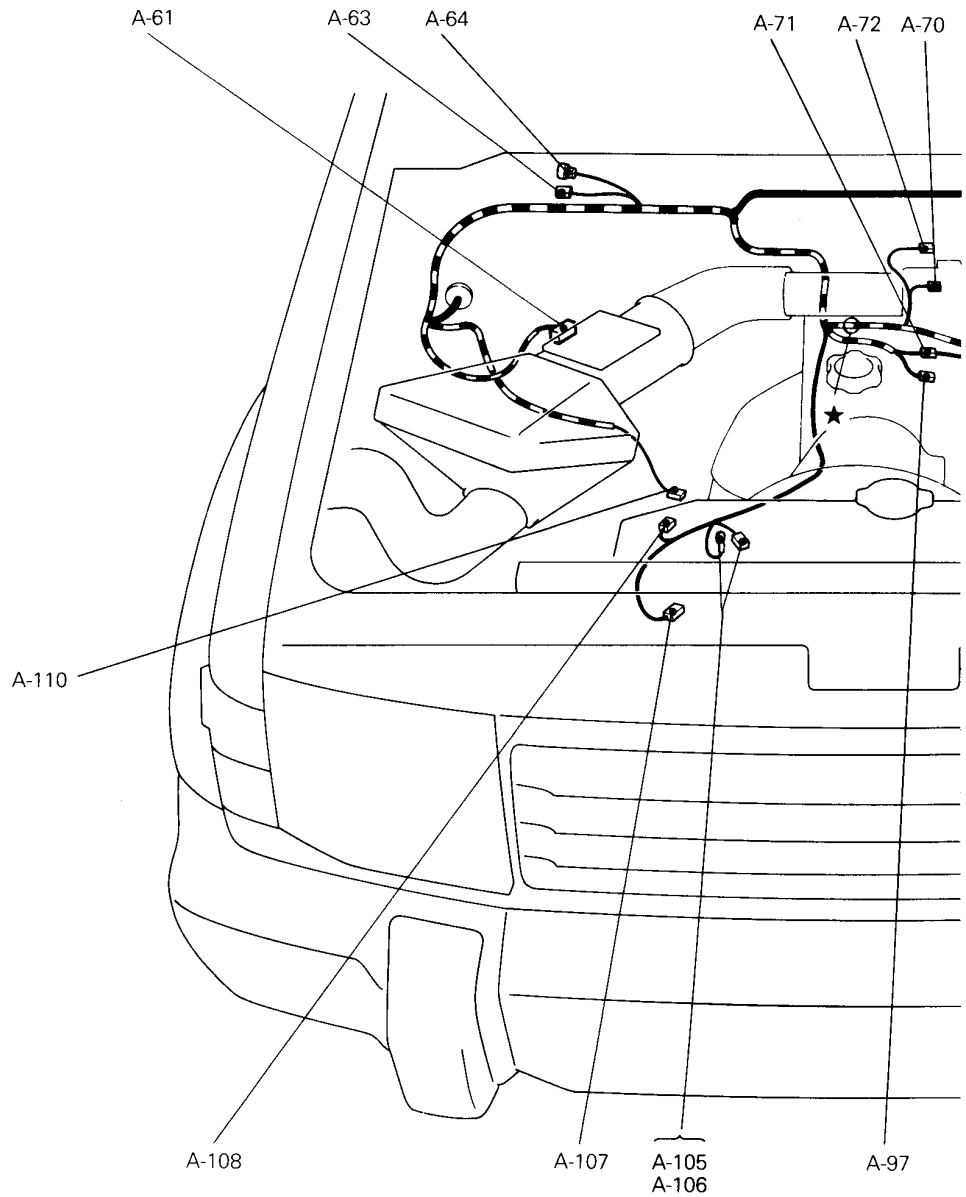

- | | | | |
|---------------------|--------------------------------------|------|----------------------------------------------------------------|
| A-58 | — | A-70 | Throttle position sensor |
| A-59 | — | A-71 | Injector wiring harness and control wiring harness combination |
| A-60 | — | A-72 | Idle speed control actuator |
| A-61 | Air flow sensor | A-73 | — |
| A-62 | Power transistor | A-74 | — |
| A-63 | Fuel pump check connector | A-75 | — |
| A-64 | Ignition timing adjustment connector | A-76 | Injector No. 3 |
| A-65 | — | A-77 | Injector No. 4 |
| A-66 | — | A-78 | Injector No. 1 |
| A-67 } Noise filter | | A-79 | Injector No. 2 |
| A-68 } | | | |
| A-69 | — | | |

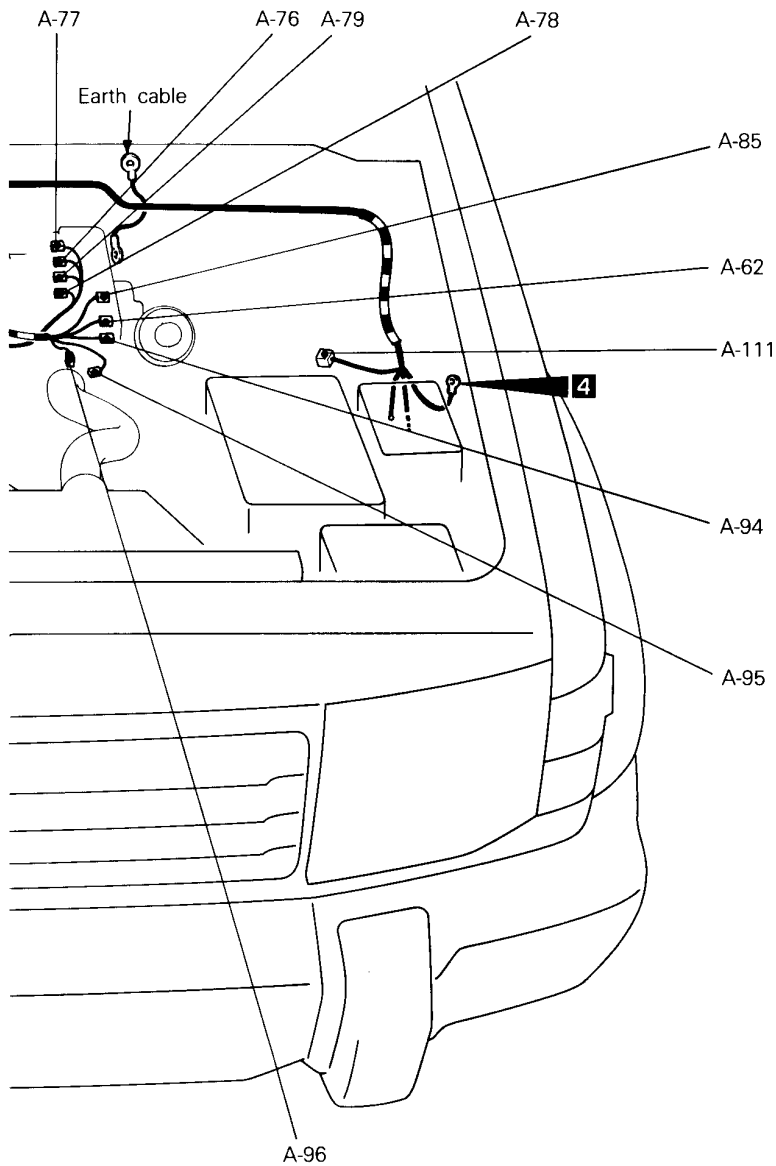

16E0377

A-80 } —	A-97	Distributor signal generator
thru } —	A-98 } —	
A-84 } —	thru } —	
A-85	A-104 }	
Ignition coil	A-105 }	Alternator
A-86 } —	A-106 }	
thru } —	A-107	Oil pressure switch
A-93 }	A-108	Engine oil level sensor
A-94	A-109	—
Engine coolant temperature switch (for A/C compress- or control)	A-110	Oxygen sensor
A-95	A-111	Purge control solenoid valve
Engine coolant temperature gauge unit		
A-96		
Engine coolant temperature sensor		

2-2 L.H. drive vehicles with 6G72 engine

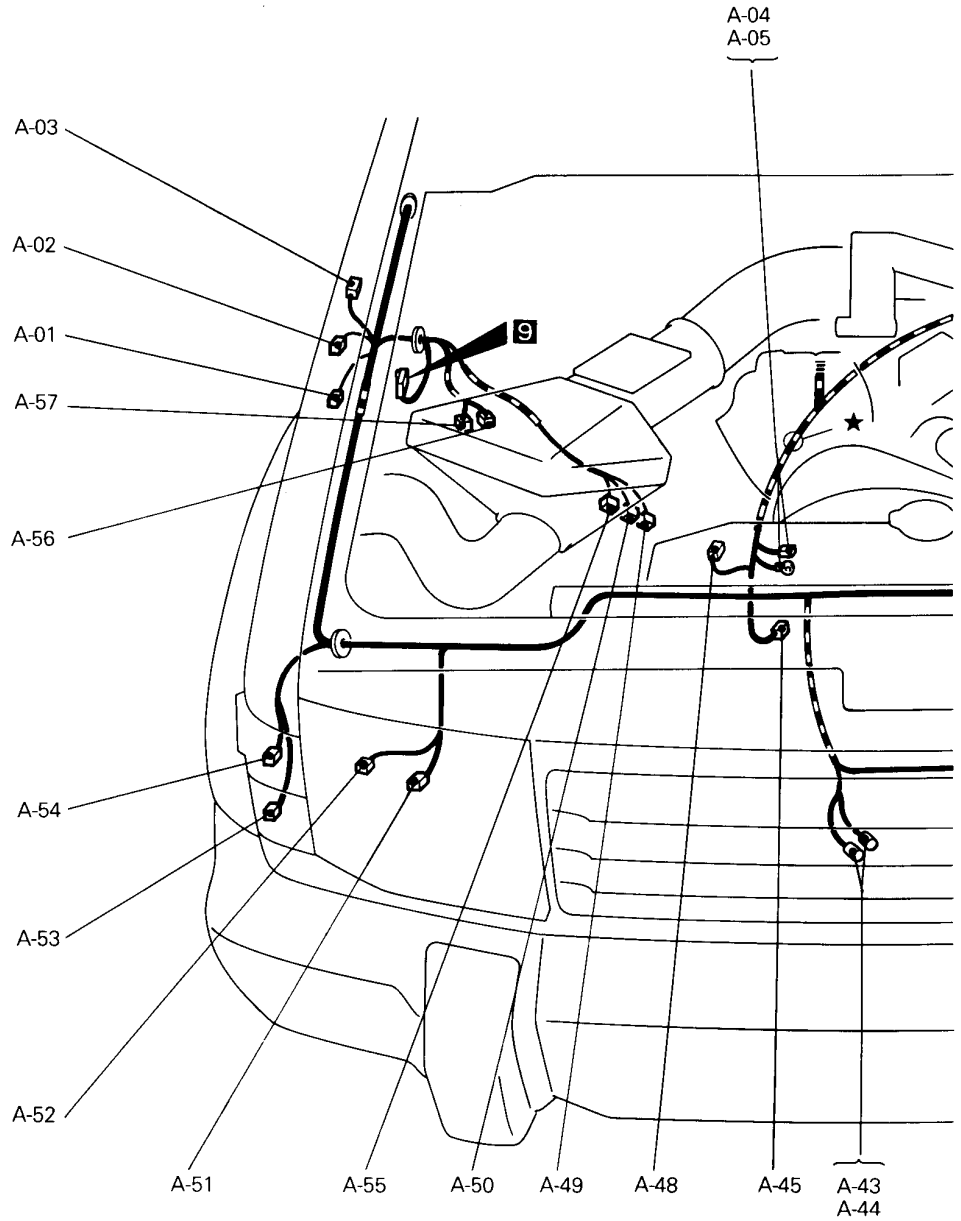
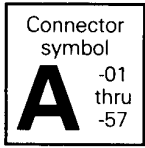

- A-01 Headlamp washer tank assembly
- A-02 Side turn signal lamp (RH)
- A-03 Motor antenna
- A-04 } Starter
- A-05 }
- A-06 Daytime running lamp relay 2
- A-07 Daytime running lamp relay 1
- A-08 Daytime running lamp control unit
- A-09 —
- A-10 Windshield wiper motor
- A-11 —
- A-12 Brake fluid level switch
- A-13 —
- A-14 Side turn signal lamp (LH)

- A-15 Windshield washer motor
- A-16 No connection
- A-17 Control wiring harness and front wiring harness combination
- A-18X } Refer to centralized junction
- A-19X }
- A-20X }
- A-21X }
- A-22X }
- A-23X }
- A-24X }
- A-25X }
- A-26 Battery cable and front wiring harness combination
- A-27 } Daytime running lamp harness and front wiring harness combination
- A-28 }
- A-29 Jumper connector
- A-30 } Front combination lamp (LH)
- A-31 }
- A-32 —

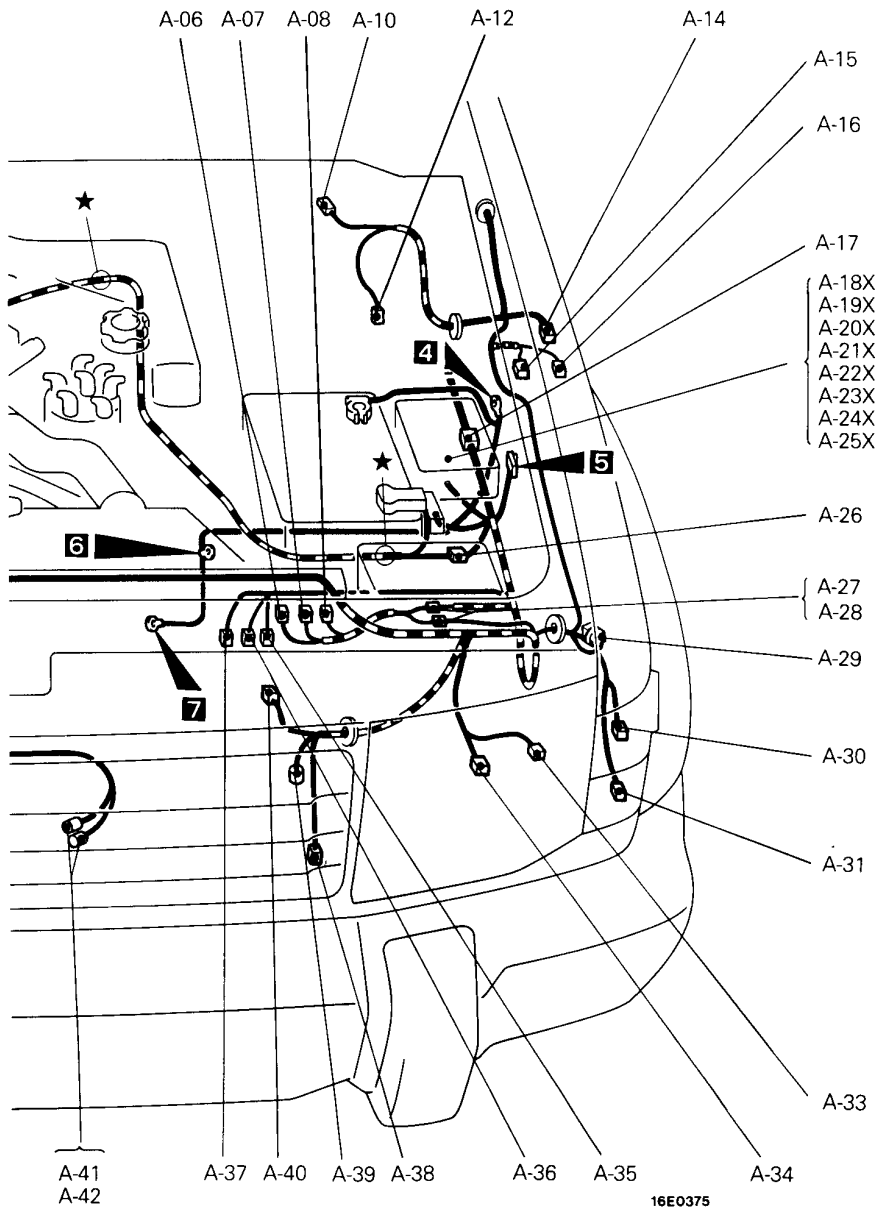

16E0375

- | | | | |
|------------------|------------------------------------------------------------------------|------------------------------------|------------------------------------------------------------------------|
| A-33 | Headlamp leveling unit (LH) | A-46 | — |
| A-34 | Headlamp (LH) | A-47 | — |
| A-35 | Speed sensor (Front: LH) <ABS> | A-48 | Engine oil level sensor |
| A-36 | Shock absorber (Front: LH) <Remote controlled variable shock absorber> | A-49 | Speed sensor (Front: RH) <ABS> |
| A-37 | Magnetic clutch <A/C> | A-50 | Shock absorber (Front: RH) <Remote controlled variable shock absorber> |
| A-38 | Thermo sensor (Out side air) <Multi-meter> | A-51 | Headlamp (RH) |
| A-39 | Dual pressure switch | A-52 | Headlamp leveling unit (RH) |
| A-40 | Condenser fan motor | A-53 } Front combination lamp (RH) | |
| A-41 } Horn (LO) | | A-54 } | |
| A-42 } | | A-55 | Free wheel engage switch |
| A-43 } Horn (HI) | | A-56 | Solenoid valve A <Super select 4WD> |
| A-44 } | | A-57 | Solenoid valve B <Super select 4WD> |
| A-45 | Oil pressure switch | | |

2-2 L.H. drive vehicles with 6G72 engine

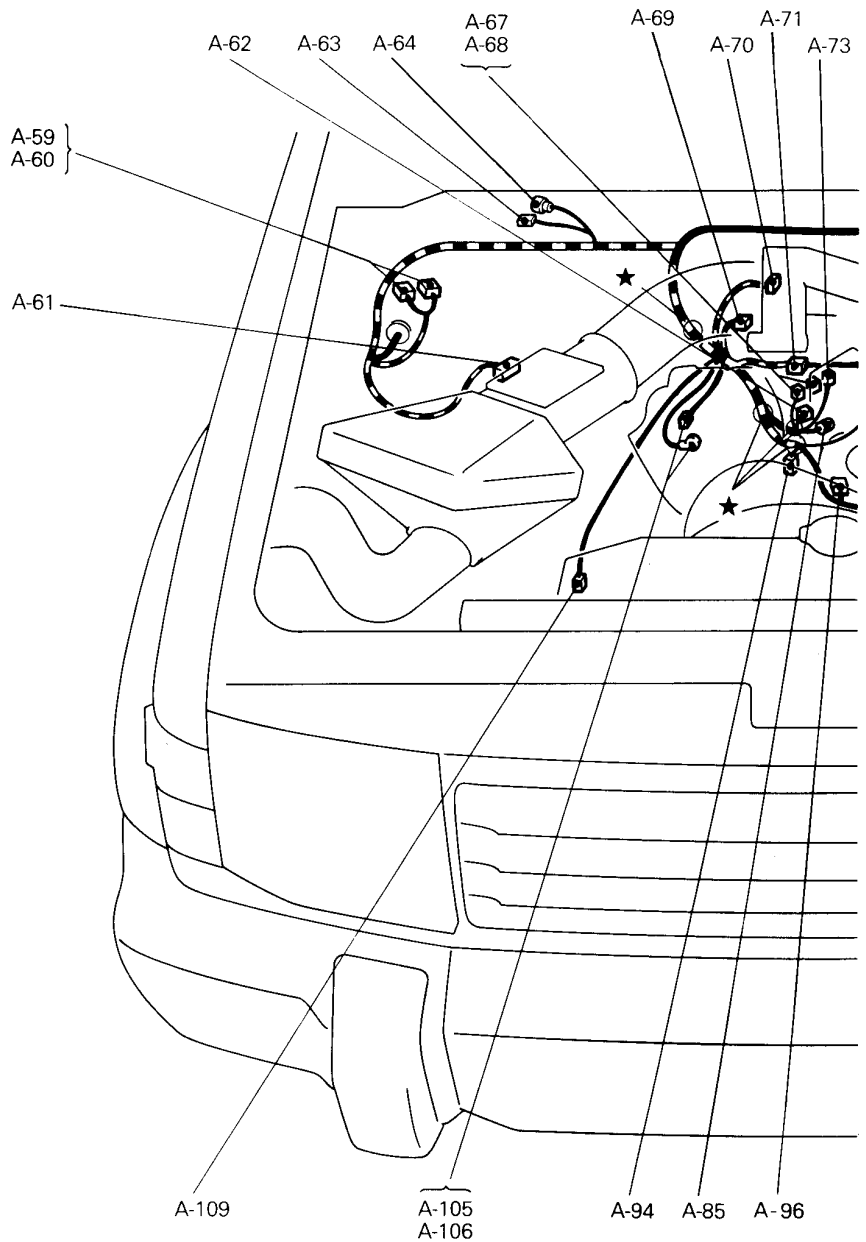
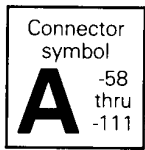

- A-58 Auto-cruise control actuator
- A-59 } Hydraulic unit
- A-60 }
- A-61 Air flow sensor
- A-62 Power transistor
- A-63 Fuel pump check connector
- A-64 Ignition timing adjustment connector
- A-65 —
- A-66 —
- A-67 } Noise filter
- A-68 }

- A-69 Idle speed control servo
- A-70 Throttle position sensor
- A-71 Injector wiring harness and control wiring harness combination
- A-72 —
- A-73 Capacitor
- A-74 Injector No. 5
- A-75 Injector No. 6
- A-76 Injector No. 3
- A-77 Injector No. 4
- A-78 Injector No. 1

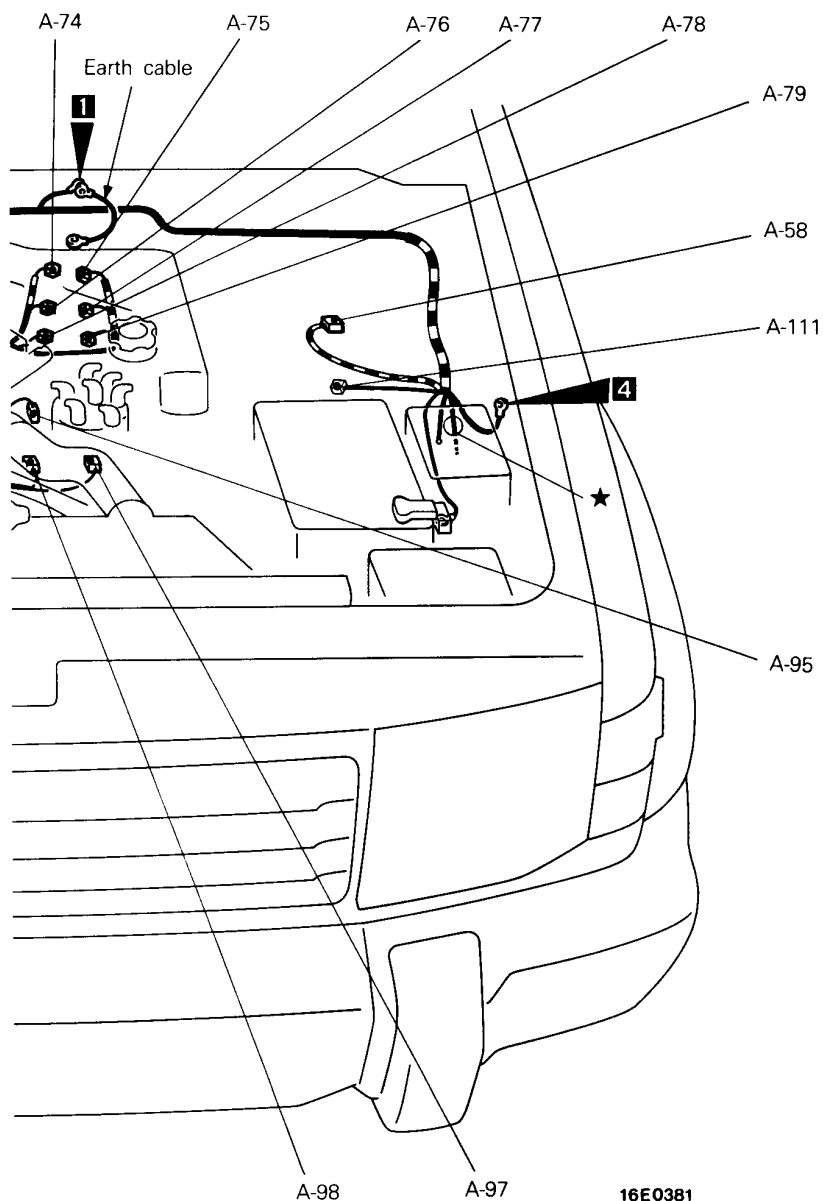

16E0381

A-79	Injector No. 2	A-97	Distributor signal generator	
A-80	}	A-98	Engine coolant temperature switch <AT>	
thru		A-99	}	
A-84		thru		
A-85	Ignition coil	A-104	}	
A-86	}	A-105		} Alternator
thru		A-106		
A-93		—	A-107	—
A-94	Engine coolant temperature switch (for A/C compressor control)	A-108	—	
A-95	Engine coolant temperature gauge unit	A-109	Power steering oil pressure switch <AT>	
A-96	Engine coolant temperature sensor	A-110	—	
		A-111	Purge control solenoid valve	

2-3 R.H. drive vehicles with 6G72 engine

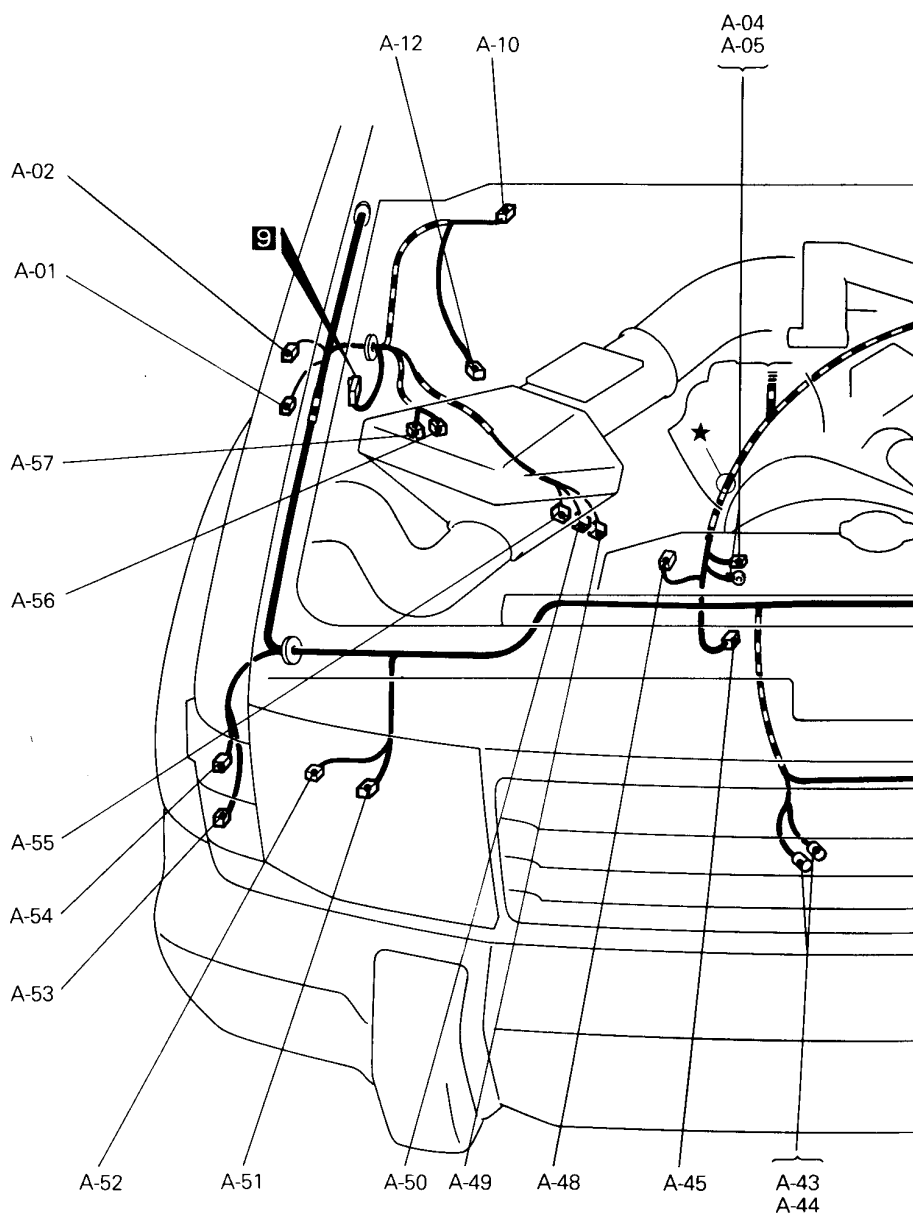
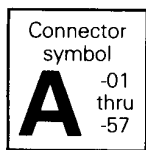

- A-01 Headlamp washer tank assembly
- A-02 Side turn signal lamp (RH)
- A-03 Motor antenna
- A-04 } Starter
- A-05 }
- A-06 } —
- thru }
- A-09 }
- A-10 Windshield wiper motor
- A-11 —
- A-12 Brake fluid level switch
- A-13 —
- A-14 Side turn signal lamp (LH)
- A-15 Windshield washer motor

- A-16 No connection
- A-17 Control wiring harness and front wiring harness combination
- A-18X } Refer to centralized junction
- thru }
- A-25X }
- A-26 Battery cable and front wiring harness combination
- A-27 —
- A-28 —
- A-29 Jumper connector
- A-30 } Front combination lamp (LH)
- A-31 }
- A-32 Resistor <DIM-DIP lamp>

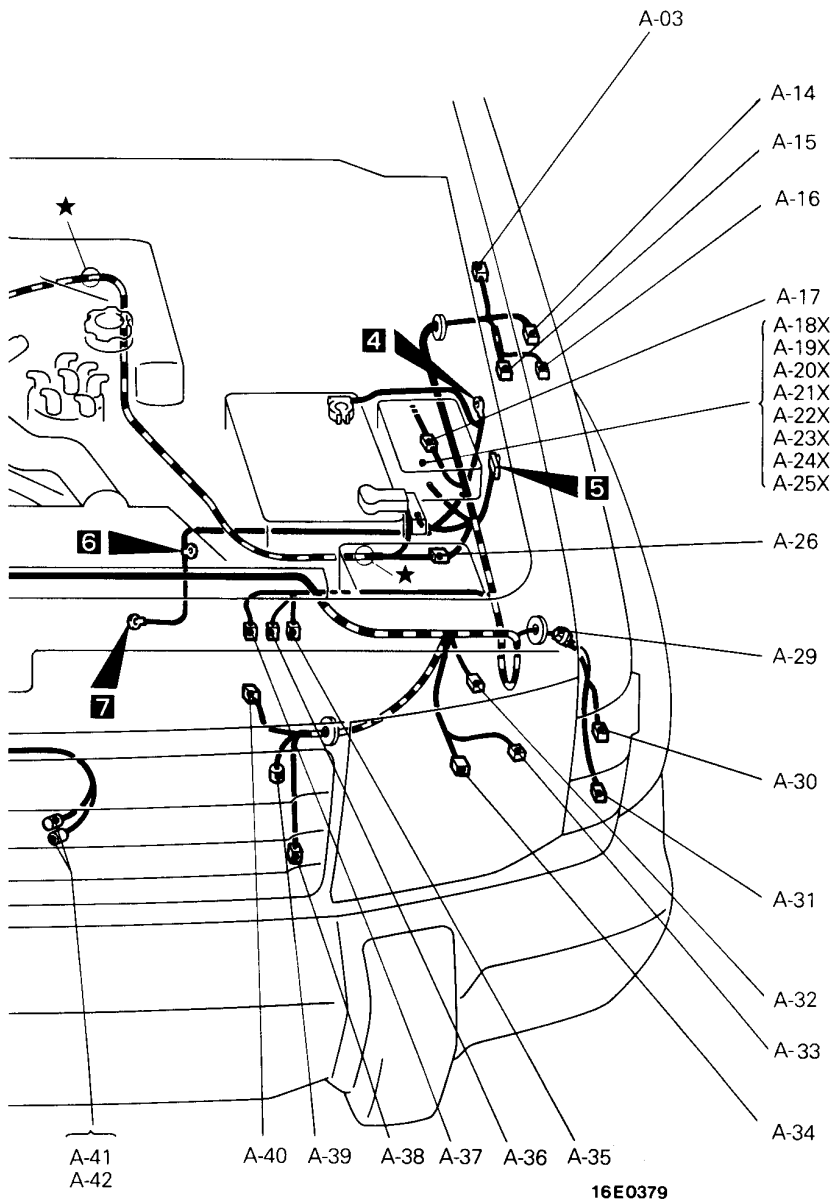

- | | | | |
|------------------|------------------------------------------------------------------------|------------------|------------------------------------------------------------------------|
| A-33 | Headlamp leveling unit (LH) | A-46 | — |
| A-34 | Headlamp (LH) | A-47 | — |
| A-35 | Speed sensor (Front: LH) <ABS> | A-48 | Engine oil level sensor |
| A-36 | Shock absorber (Front: LH) <Remote controlled variable shock absorber> | A-49 | Speed sensor (Front: RH) <ABS> |
| A-37 | Magnetic clutch <A/C> | A-50 | Shock absorber (Front: RH) <Remote controlled variable shock absorber> |
| A-38 | Thermo sensor (Out side air) <Multi-meter> | A-51 | Headlamp (RH) |
| A-39 | Dual pressure switch | A-52 | Headlamp leveling unit (RH) |
| A-40 | Condenser fan motor | A-53 }
A-54 } | Front combination lamp (RH) |
| A-41 }
A-42 } | Horn (LO) | A-55 | Free wheel engage switch |
| A-43 }
A-44 } | Horn (HI) | A-56 | Solenoid valve A <Super select 4WD> |
| A-45 | Oil pressure switch | A-57 | Solenoid valve B <Super select 4WD> |

2-3 R.H. drive vehicles with 6G72 engine

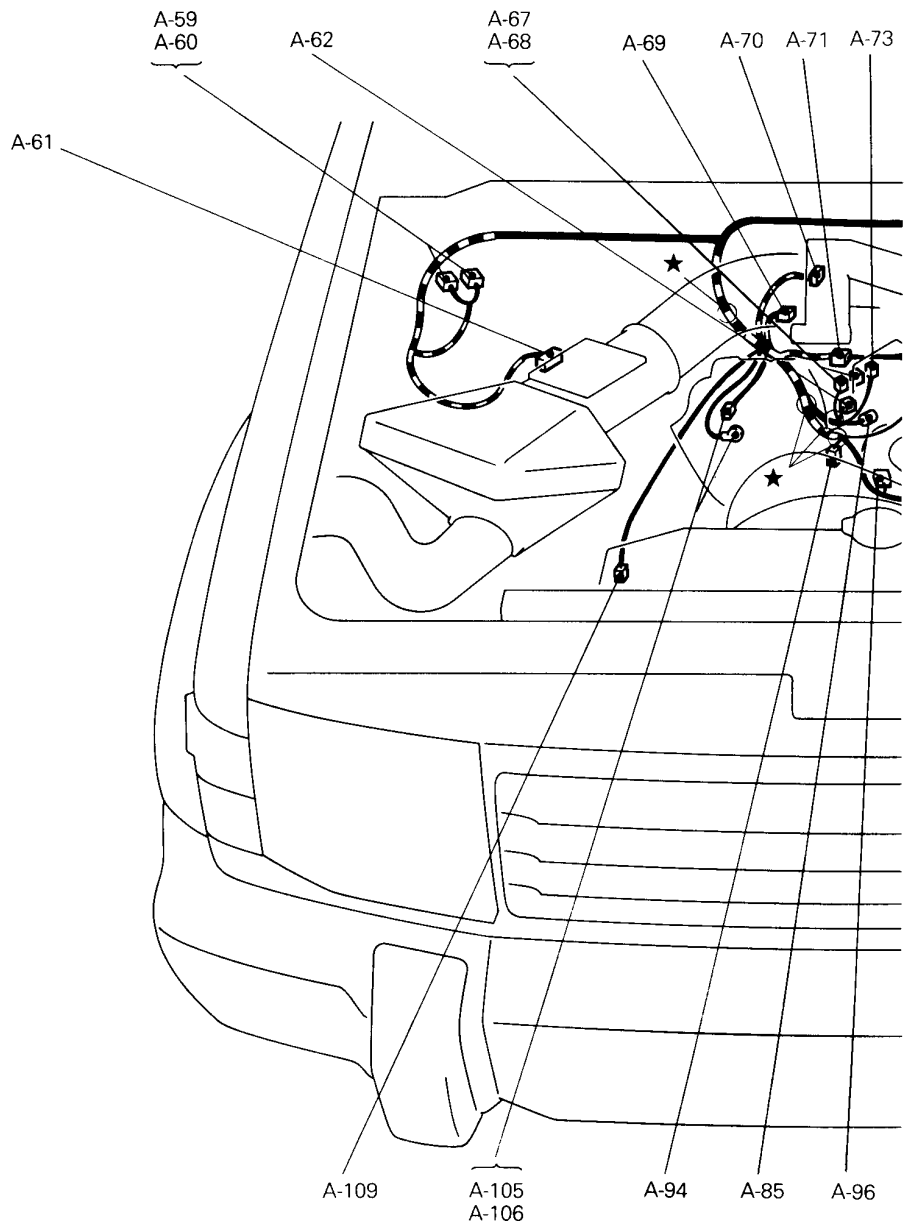
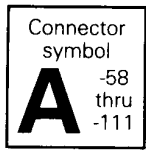

- A-58 Auto-cruise control actuator
- A-59 } Hydraulic unit
- A-60 }
- A-61 Air flow sensor
- A-62 Power transistor
- A-63 Fuel pump check connector
- A-64 Ignition timing adjustment connector
- A-65 —
- A-66 —
- A-67 } Noise filter
- A-68 }

- A-69 Idle speed control servo
- A-70 Throttle position sensor
- A-71 Injector wiring harness and control wiring harness combination
- A-72 —
- A-73 Capacitor
- A-74 Injector No. 5
- A-75 Injector No. 6
- A-76 Injector No. 3
- A-77 Injector No. 4
- A-78 Injector No. 1

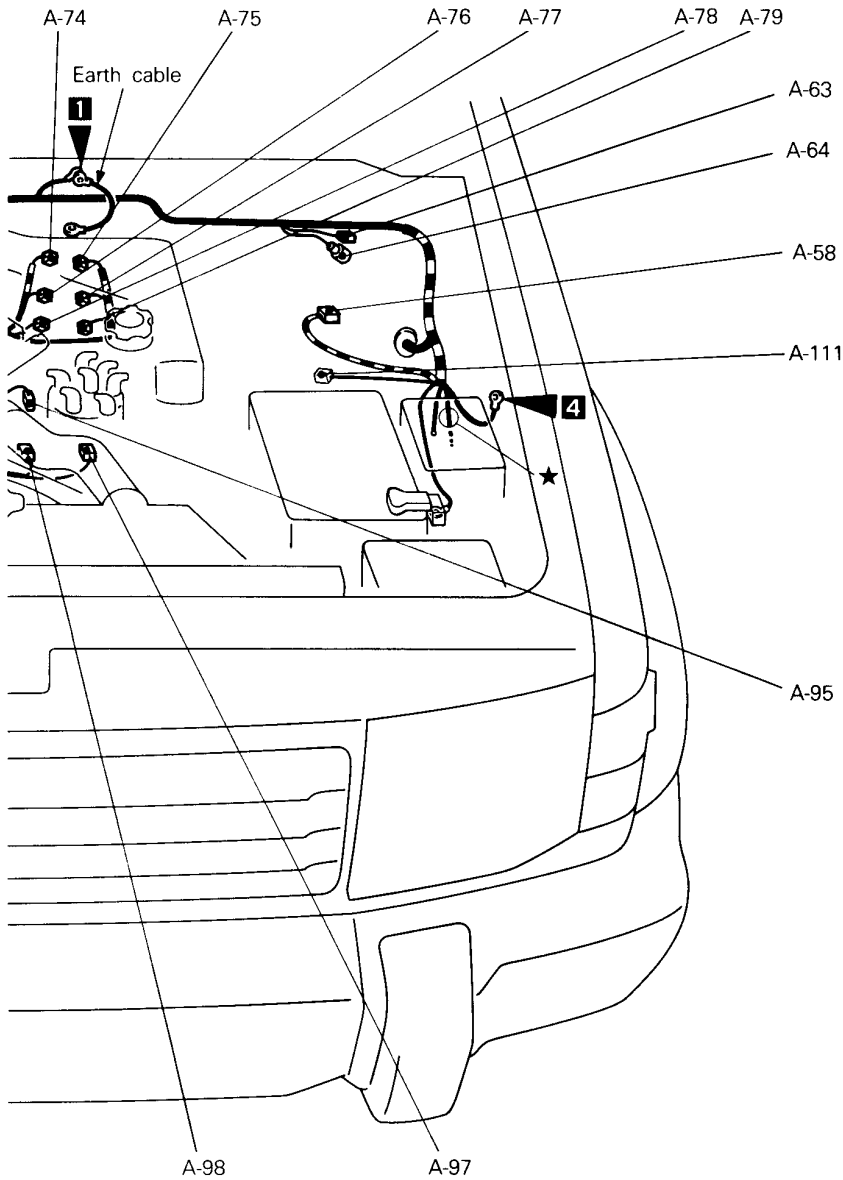

16E0382

- | | | | | |
|------|----------------------------------------------------------------|-------|-----------------------------------------|------------|
| A-79 | Injector No. 2 | A-97 | Distributor signal generator | |
| A-80 | — | A-98 | Engine coolant temperature switch <AT> | |
| thru | | A-99 | — | |
| A-84 | | thru | | |
| A-85 | Ignition coil | A-104 | — | |
| A-86 | — | A-105 | | Alternator |
| thru | | A-106 | | |
| A-93 | | | A-107 | |
| A-94 | Engine coolant temperature switch (for A/C compressor control) | A-108 | — | |
| A-95 | Engine coolant temperature gauge unit | A-109 | Power steering oil pressure switch <AT> | |
| A-96 | Engine coolant temperature sensor | A-110 | — | |
| | | A-111 | Purge control solenoid valve | |

2-4 L.H. drive vehicles with 4D56 engine

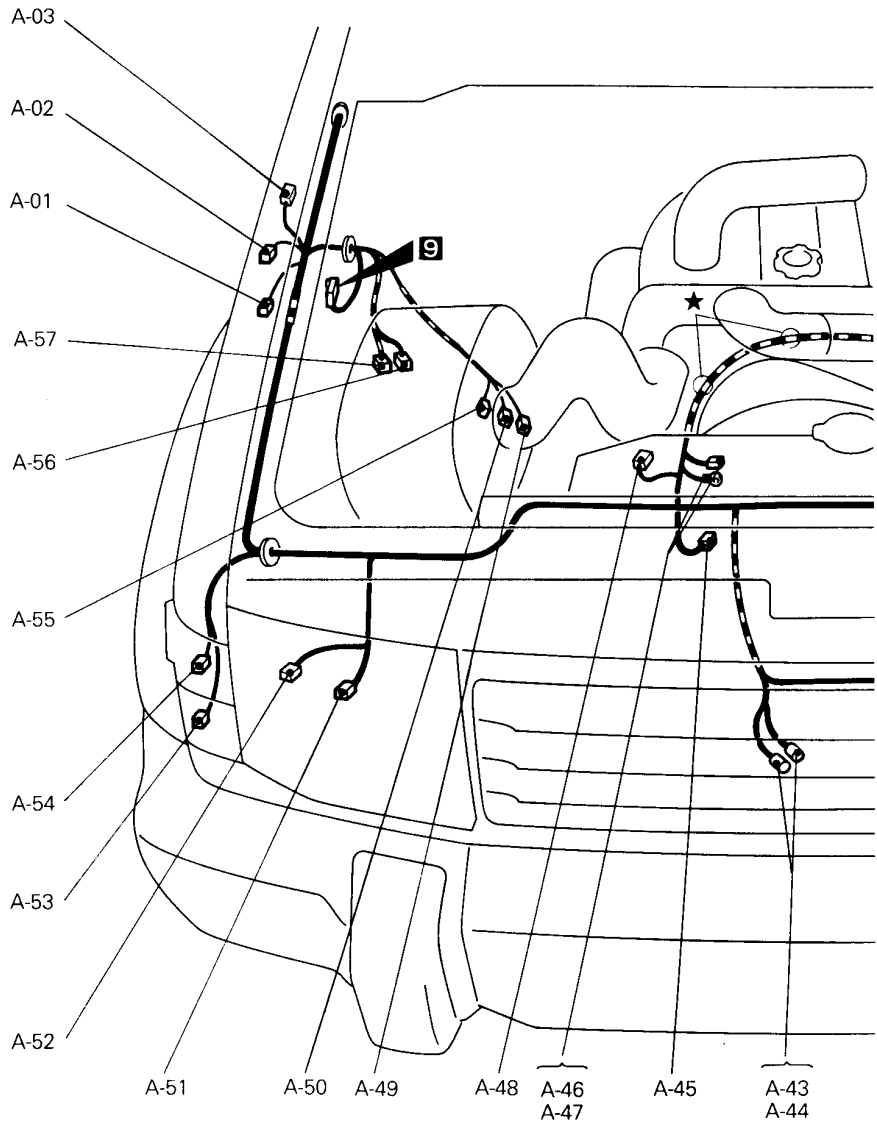
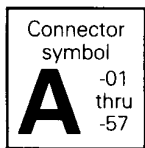

- A-01 Headlamp washer tank assembly
- A-02 Side turn signal lamp (RH)
- A-03 Motor antenna
- A-04 } Starter
- A-05 }
- A-06 Daytime running lamp relay 2
- A-07 Daytime running lamp relay 1
- A-08 Daytime running lamp control unit
- A-09 Starter relay
- A-10 Windshield wiper motor
- A-11 Vacuum switch
- A-12 Brake fluid level switch
- A-13 Condenser fan motor control relay
- A-14 Side turn signal lamp (LH)

- A-15 Windshield washer motor
- A-16 No connection
- A-17 Control wiring harness and front wiring harness combination
- A-18X } Refer to centralized junction
- A-25X }
- A-26 Battery cable and front wiring harness combination
- A-27 } Daytime running lamp harness and front wiring harness combination
- A-28 }
- A-29 Jumper connector
- A-30 } Front combination lamp (LH)
- A-31 }
- A-32 —

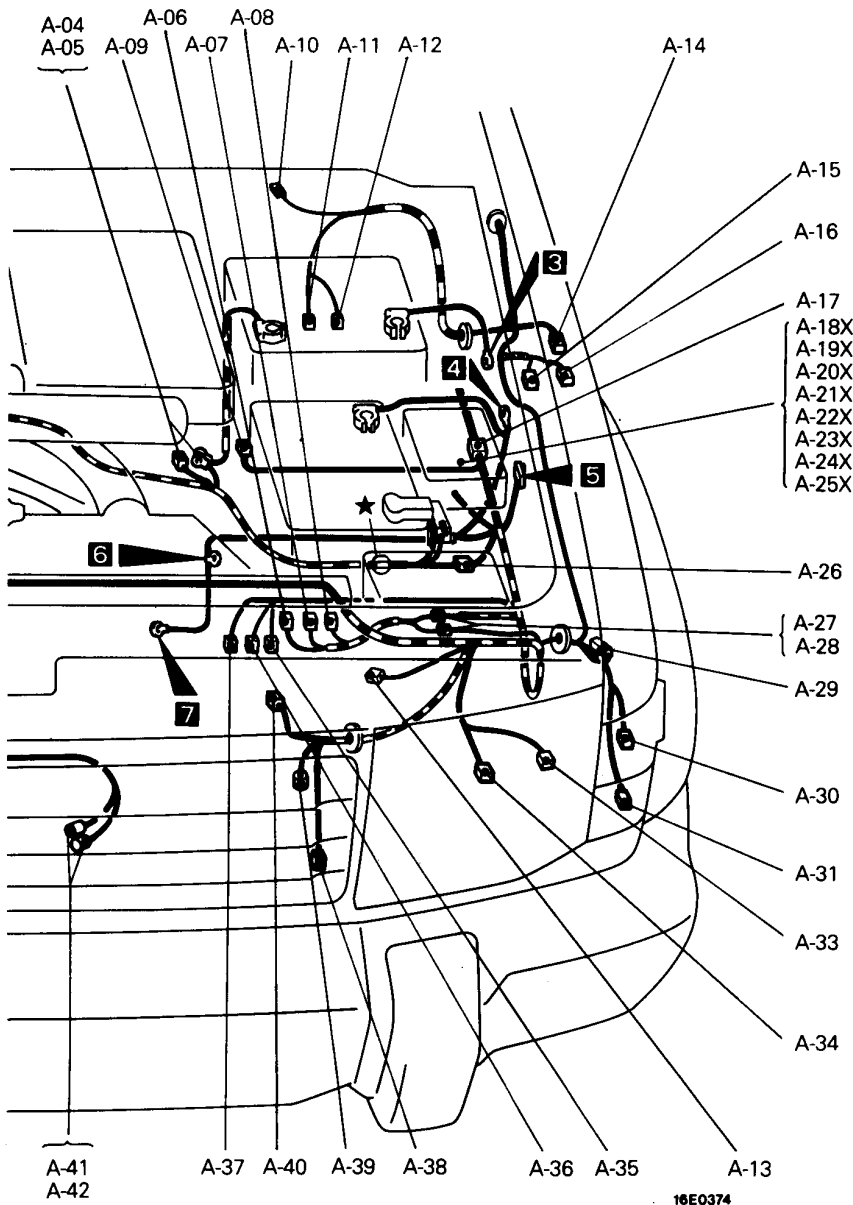

16E0374

- | | | | |
|------|------------------------------------------------------------------------|------|------------------------------------------------------------------------|
| A-33 | Headlamp leveling unit (LH) | A-46 | } Alternator |
| A-34 | Headlamp (LH) | A-47 | |
| A-35 | Speed sensor (Front: LH) <ABS> | A-48 | Engine oil level sensor |
| A-36 | Shock absorber (Front: LH) <Remote controlled variable shock absorber> | A-49 | Speed sensor (Front: RH) <ABS> |
| A-37 | Magnetic clutch <A/C> | A-50 | Shock absorber (Front: RH) <Remote controlled variable shock absorber> |
| A-38 | Thermo sensor (Out side air) <Multi-meter> | A-51 | Headlamp (RH) |
| A-39 | Dual pressure switch | A-52 | Headlamp leveling unit (RH) |
| A-40 | Condenser fan motor | A-53 | } Front combination lamp (RH) |
| A-41 | } Horn (LO) | A-54 | |
| A-42 | | A-55 | Free wheel engage switch |
| A-43 | } Horn (HI) | A-56 | Solenoid valve A <Super select 4WD> |
| A-44 | | A-57 | Solenoid valve B <Super select 4WD> |
| A-45 | Oil pressure switch | | |

2-4 L.H. drive vehicles with 4D56 engine

Connector symbol
A -58 thru -118

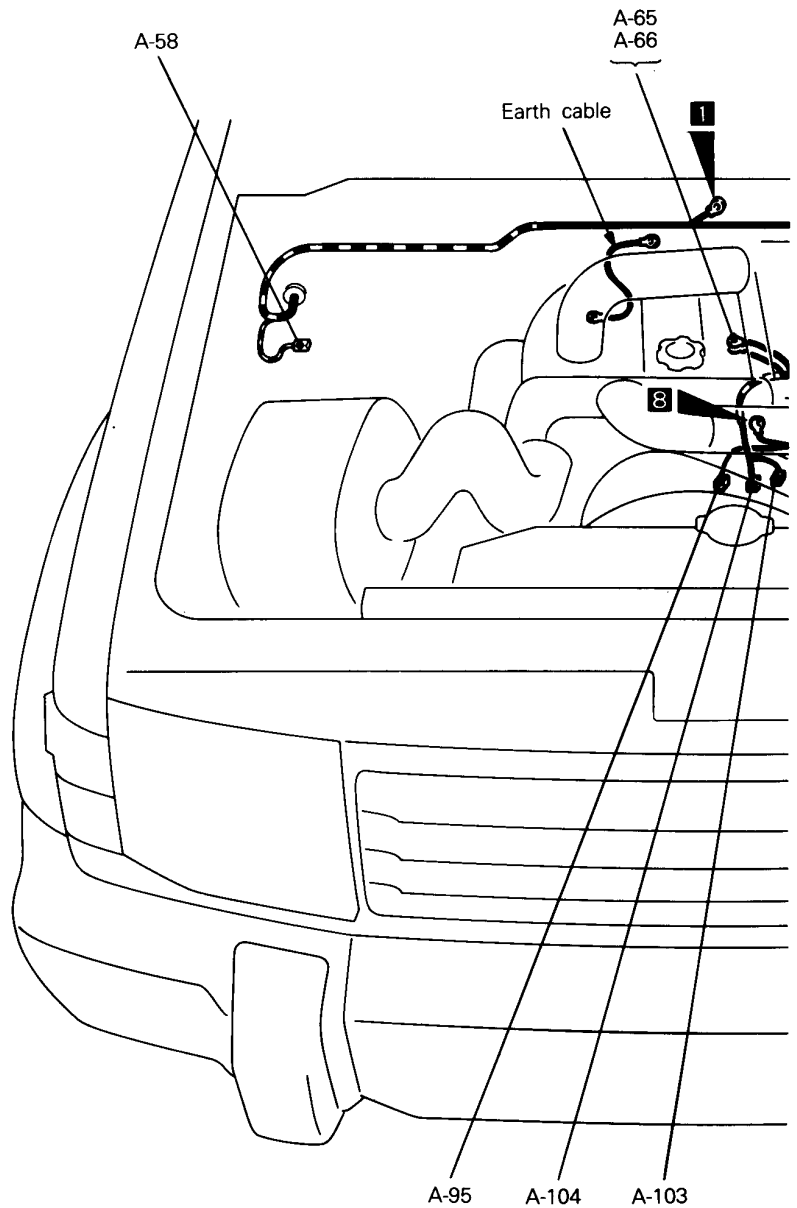

- A-58 Auto-cruise control actuator
- A-59 } Hydraulic unit
- A-60 }
- A-61 } —
- thru }
- A-64 }
- A-65 Glow plug
- A-66 Glow plug <Super quick glow>
- A-67 } —
- thru }
- A-79 }
- A-79-1 } EGR solenoid valve <Vehicles with EGR system>
- A-79-2 }

- *A-79-3 Supercharging pressure relief solenoid valve
- A-80 Idle up solenoid valve <A/C>
- A-81 Water level switch
- A-81-1 Fuel line heater
- A-82 Intake air temperature switch
- A-83 Intercooler fan motor
- A-84 Idle up solenoid valve <ABS>
- A-85 —
- A-86 } Glow plug relay <Auto glow>
- A-87 }
- A-88 }
- A-89 } Glow plug relay 2 <Super quick glow>
- A-90 }

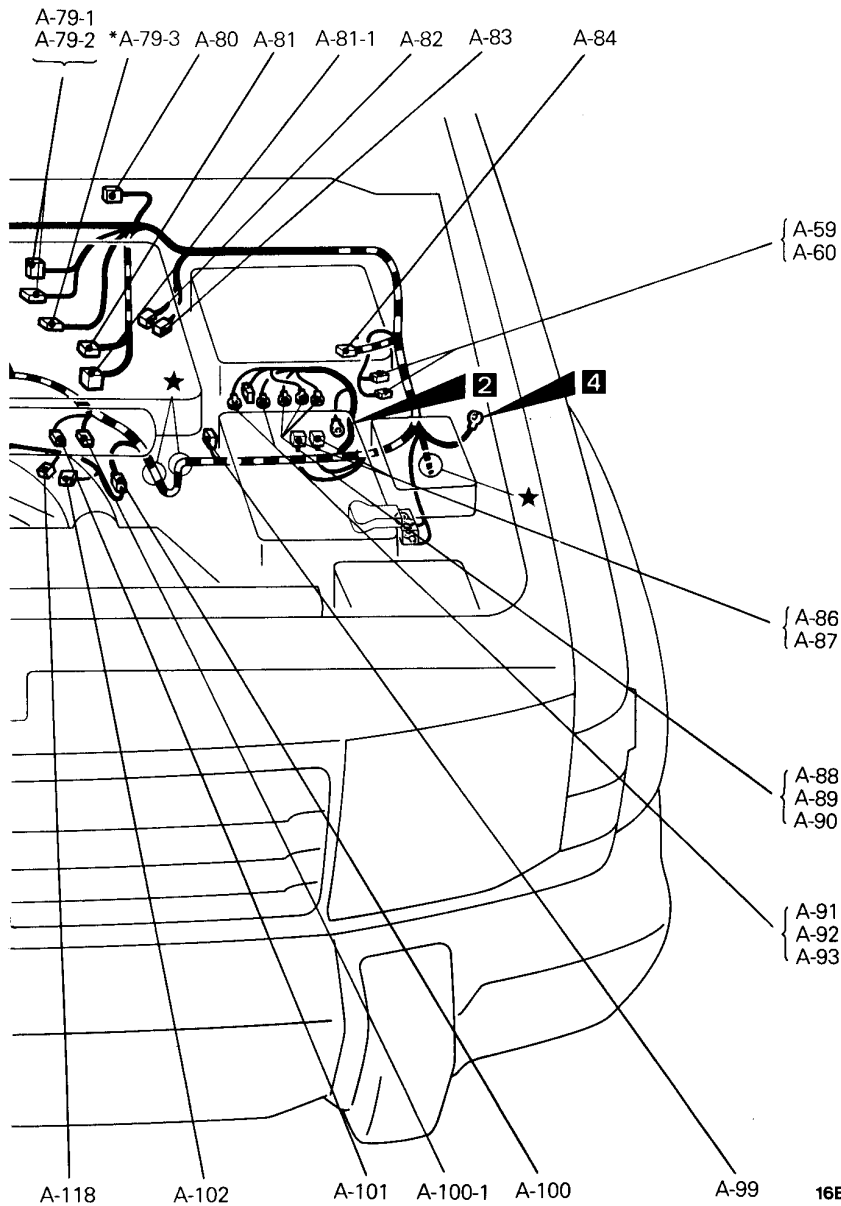

- A-91 } Glow plug relay 1 <Super quick glow>
- A-92 }
- A-93 }
- A-94 —
- A-95 Engine coolant temperature gauge unit
- A-96 —
- A-97 —
- A-98 —
- A-99 Dropping resistor <Super quick glow>
- A-100 Fuel injection pump wiring harness and control wiring harness combination

- A-100-1 Lever position sensor <Vehicles with EGR system>
- A-101 Lever position switch <A/T>
- A-102 Fuel cut solenoid valve
- A-103 Engine coolant temperature switch (for condenser fan motor control)
- A-104 Engine coolant temperature switch (for A/C compressor control)
- A-105 } —
- thru }
- A-117 }
- A-118 Rotation sensor

NOTE

*: 2-door models for Switzerland or Finland
<Vehicles built from July 1993>

2-5 R.H. drive vehicles with 4D56 engine

Connector symbol
A -01 thru -57

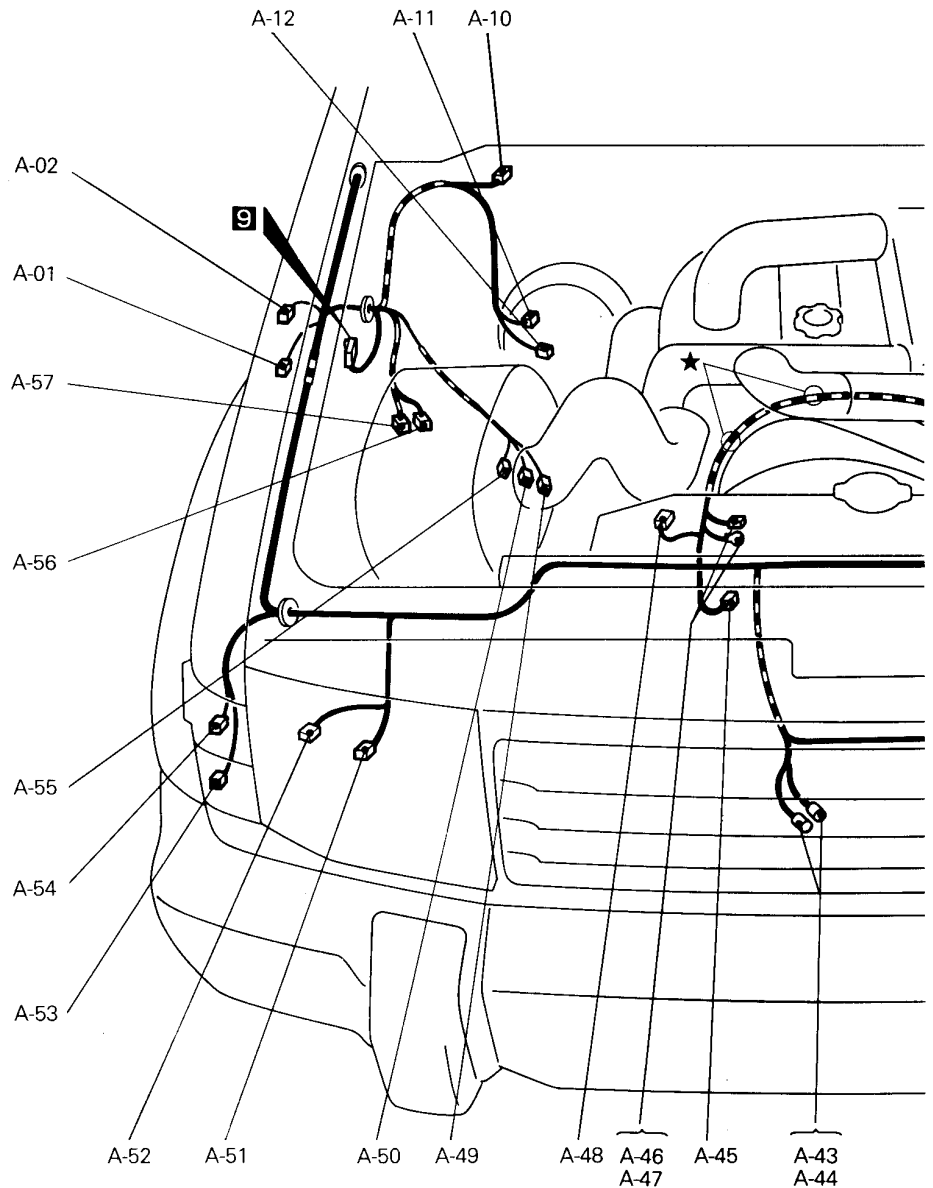

- A-01 Headlamp washer tank assembly
- A-02 Side turn signal lamp (RH)
- A-03 Motor antenna
- A-04 } Starter
- A-05 }
- A-06 —
- A-07 —
- A-08 —
- A-09 Starter relay
- A-10 Windshield wiper motor
- A-11 Vacuum switch
- A-12 Brake fluid level switch
- A-13 Condenser fan motor control relay
- A-14 Side turn signal lamp (LH)

- A-15 Windshield washer motor
- A-16 No connection
- A-17 Control wiring harness and front wiring harness combination
- A-18X } Refer to centralized junction
- A-19X }
- A-20X }
- A-21X }
- A-22X }
- A-23X }
- A-24X }
- A-25X }
- A-26 Battery cable and front wiring harness combination
- A-27 —
- A-28 —
- A-29 Jumper connector
- A-30 } Front combination lamp (LH)
- A-31 }
- A-32 Resistor <DIM-DIP lamp>

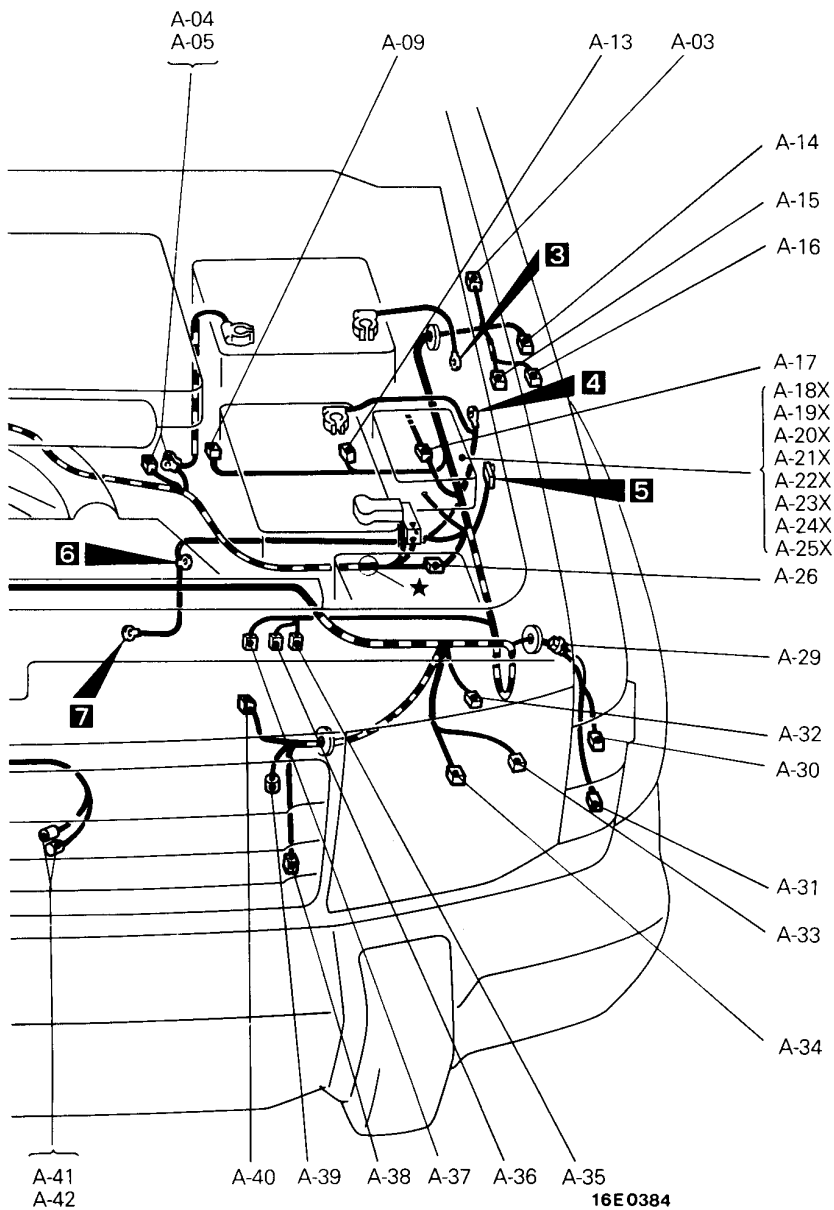

- | | | | |
|--------|------------------------------------------------------------------------|--------|------------------------------------------------------------------------|
| A-33 | Headlamp leveling unit (LH) | A-46 } | Alternator |
| A-34 | Headlamp (LH) | A-47 } | |
| A-35 | Speed sensor (Front: LH) <ABS> | A-48 | Engine oil level sensor |
| A-36 | Shock absorber (Front: LH) <Remote controlled variable shock absorber> | A-49 | Speed sensor (Front: RH) <ABS> |
| A-37 | Magnetic clutch <A/C> | A-50 | Shock absorber (Front: RH) <Remote controlled variable shock absorber> |
| A-38 | Thermo sensor (Out side air) <Multi-meter> | A-51 | Headlamp (RH) |
| A-39 | Dual pressure switch | A-52 | Headlamp leveling unit (RH) |
| A-40 | Condenser fan motor | A-53 } | Front combination lamp (RH) |
| A-41 } | Horn (LO) | A-54 } | |
| A-42 } | | A-55 | Free wheel engage switch |
| A-43 } | Horn (HI) | A-56 | Solenoid valve A <Super select 4WD> |
| A-44 } | | A-57 | Solenoid valve B <Super select 4WD> |
| A-45 | Oil pressure switch | | |

2-5 R.H. drive vehicles with 4D56 engine

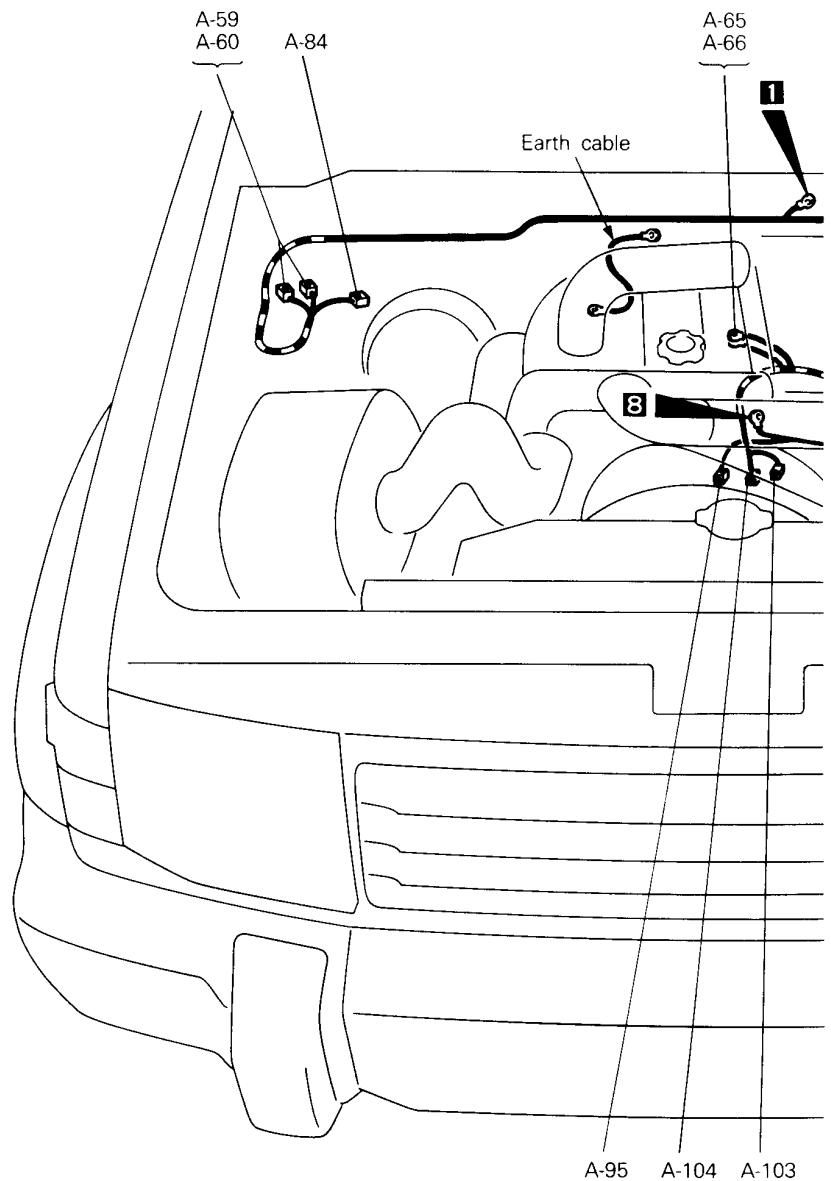
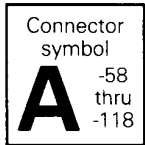

- A-58 Auto-cruise control actuator
- A-59 } Hydraulic unit
- A-60 }
- A-61 } —
- thru }
- A-64 }
- A-65 Glow plug
- A-66 Glow plug <Super quick glow>
- A-67 } —
- thru }
- A-79 }

- A-80 Idle up solenoid valve <A/C>
- A-81 Water level switch
- A-82 Intake air temperature switch
- A-83 Intercooler fan motor
- A-84 Idle up solenoid valve <ABS>
- A-85 —
- A-86 } Glow plug relay <Auto glow>
- A-87 }
- A-88 } Glow plug relay 2 <Super quick glow>
- A-89 }
- A-90 }

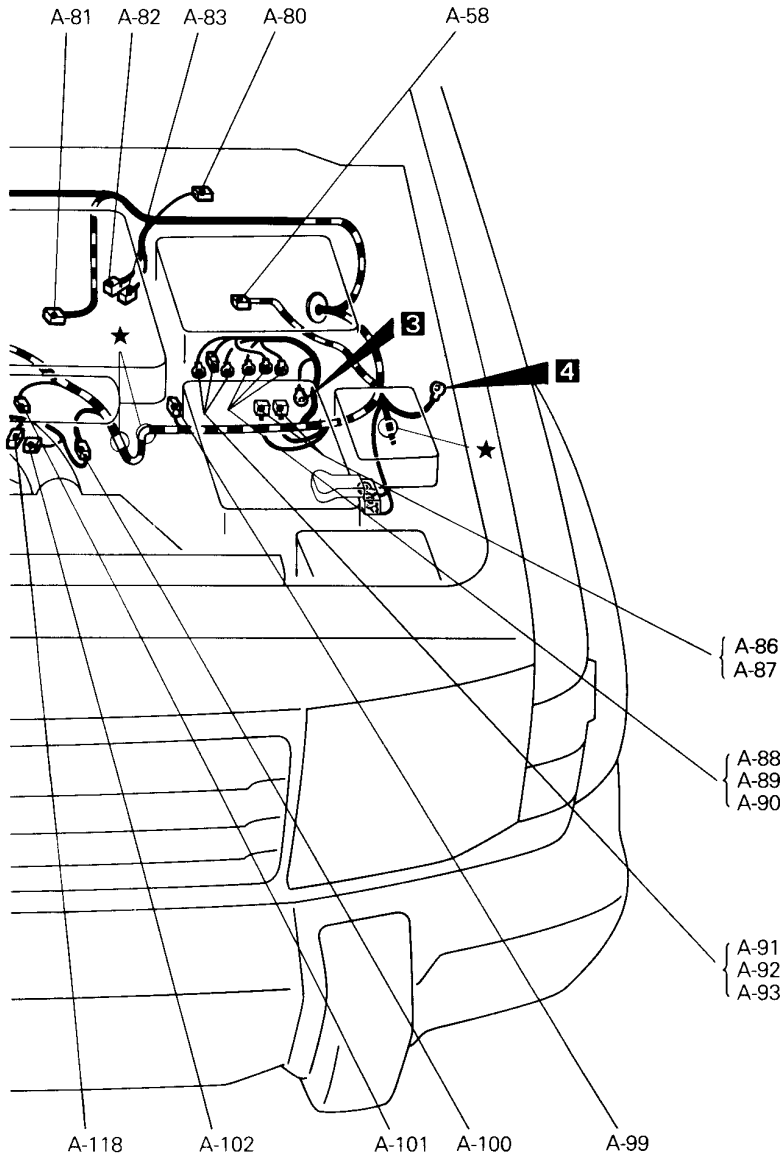

16E0383

- | | | | |
|----------------------------|---------------------------------------------------------------------------|-------------------|---------------------------------------------------------------------|
| A-91 }
A-92 }
A-93 } | Glow plug relay 1 <Super quick glow> | A-101 | Lever position switch <A/T> |
| A-94 | — | A-102 | Fuel cut solenoid valve |
| A-95 | Engine coolant temperature gauge unit | A-103 | Engine coolant temperature switch (for condenser fan motor control) |
| A-96 | — | A-104 | Engine coolant temperature switch (for A/C compressor control) |
| A-97 | — | A-105 }
thru } | — |
| A-98 | — | A-117 } | |
| A-99 | Dropping resistor <Super quick glow> | A-118 | Rotation Sensor |
| A-100 | Fuel injection pump wiring harness and control wiring harness combination | | |

3 TRANSMISSION

3-1 PART TIME 4WD

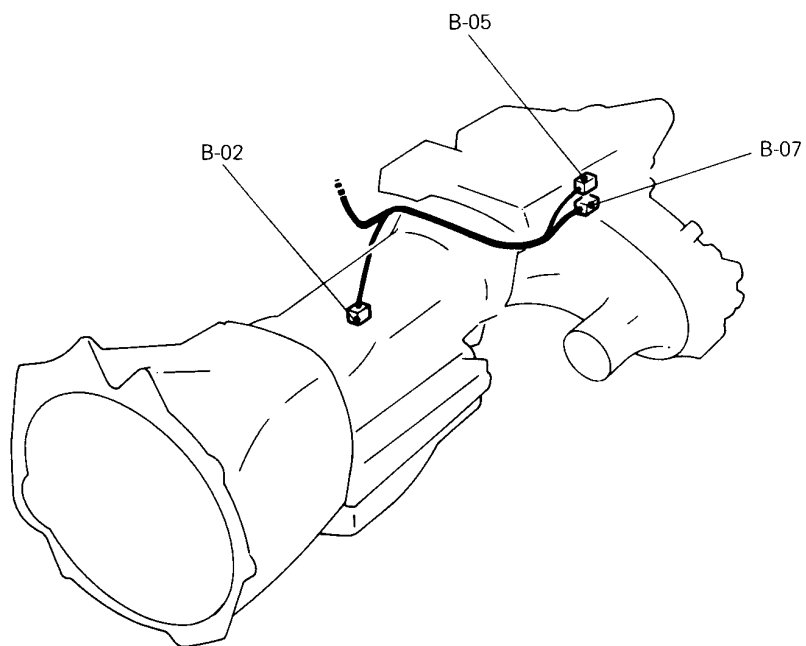
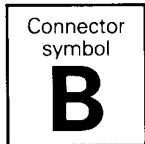

16E0369

B-01	—	B-05	4WD operation detection switch
B-02	Back-up lamp switch	B-06	—
B-03	—	B-07	High range/low range detection switch
B-04	—		

3-2 SUPER SELECT 4WD

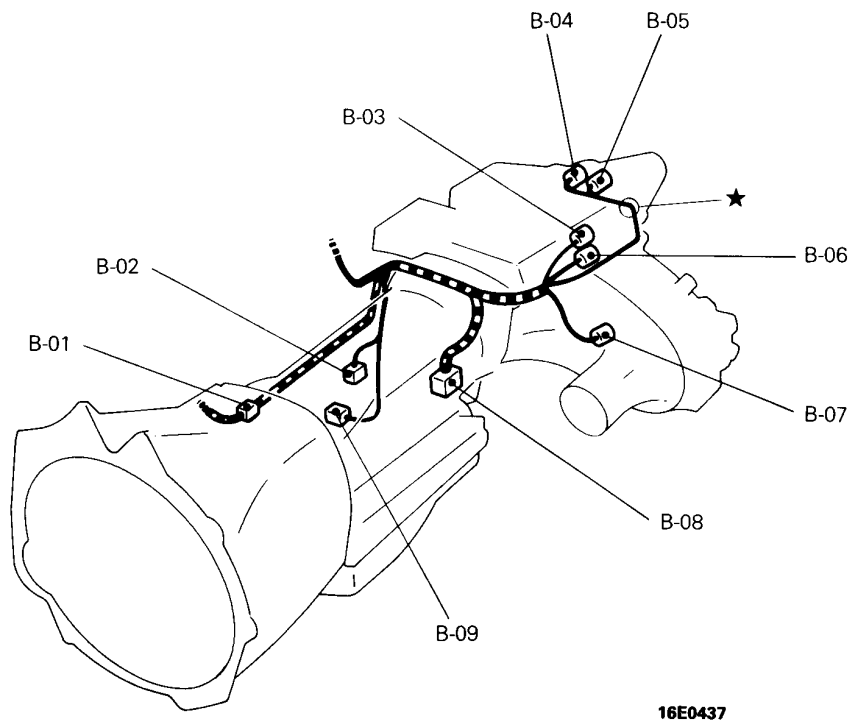
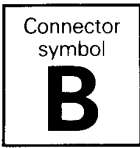

- | | | | |
|------|-------------------------------------------------------------------------------------|------|-----------------------------------------|
| B-01 | Battery cable and transmission wiring harness combination <Petrol-powered vehicles> | B-06 | 2WD/4WD detection switch |
| B-02 | Back-up lamp switch <M/T> | B-07 | High range/low range detection switch |
| B-03 | Center differential lock detection switch | B-08 | Inhibitor switch <A/T> |
| B-04 | Center differential lock operation detection switch | B-09 | Oxygen sensor <Petrol-powered vehicles> |
| B-05 | 4WD operation detection switch | | |

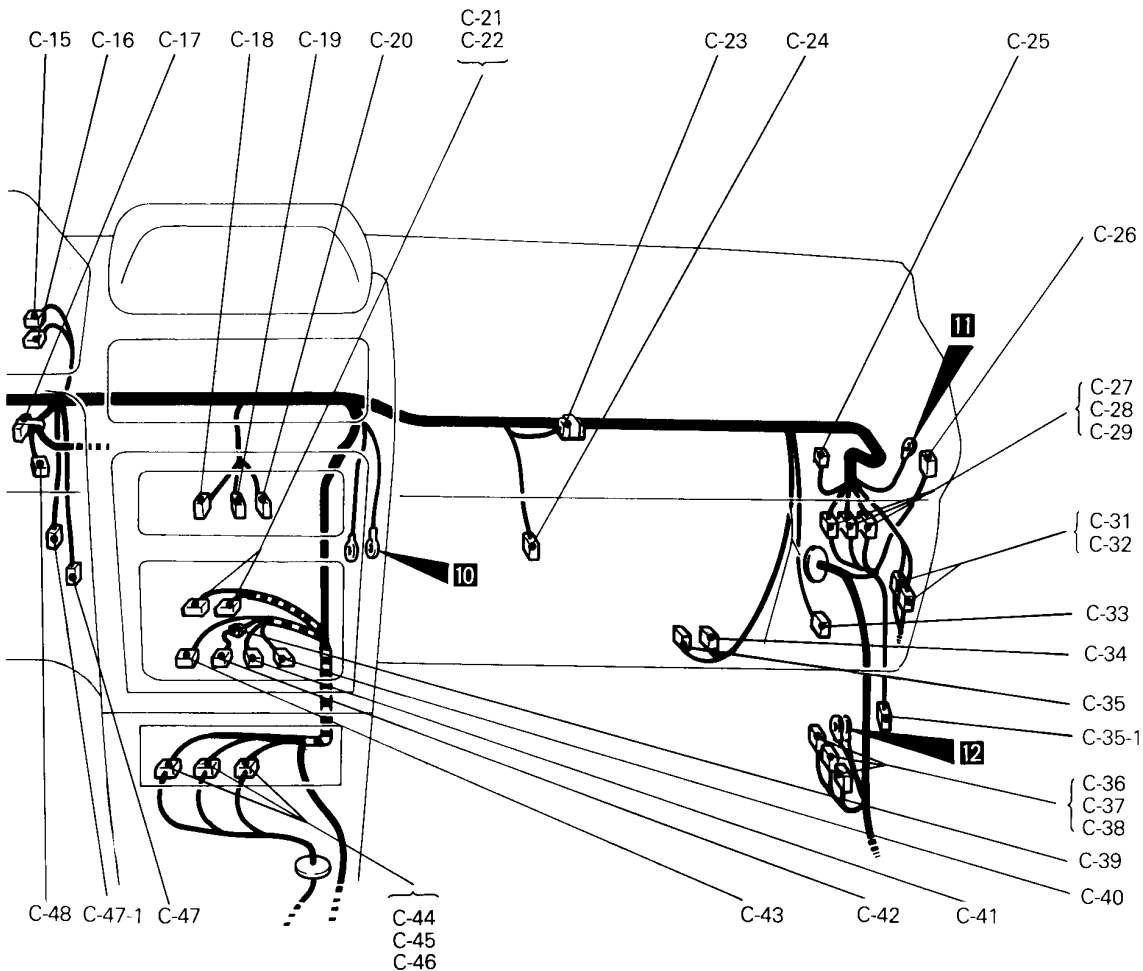

16E0539

- | | |
|------------------------------------------------------------------------|----------------------------------------------------------------|
| C-44 } Transmission wiring harness and body wiring harness | C-65 } Door wiring harness (LH) and body wiring harness |
| C-45 } combination | C-66 } combination |
| C-46 } combination | C-67 } Overdrive control relay |
| C-47 } Vehicle speed relay <ABS> | C-68 } Headlamp washer relay |
| C-47-1 } Lighting monitor buzzer <1993 MODELS> | C-69 } — |
| C-48 } Rear wiper and washer switch | C-70 } Dedicated fuse No. ⑩ |
| C-49 } Auto-cruise control unit or spare connector | C-71 } Dedicated fuse No. ⑨ |
| C-50 } Auto-cruise control switch | C-72X } Refer to centralized junction |
| C-51 } Thermo sensor (inside air) | C-77X } — |
| C-52 } Stop lamp switch (2-pin) or no connection <Auto-cruise control> | C-78 } Roof wiring harness and body wiring harness combination |
| C-53 } Stop lamp switch (4-pin) <Auto-cruise control> or no connection | C-79 } — |
| C-54 } Headlamp leveling switch | C-80 } Roof wiring harness and junction block combination |
| C-55 } Ignition switch | C-81 } — |
| C-56 } Column switch | C-82 } Front wiring harness and junction block combination |
| C-57 } — | C-83 } — |
| C-58 } Clutch switch | C-84 } Diagnosis connector |
| C-59 } Front speaker (LH) | C-85 } Blower relay |
| C-60 } — | C-86 } Accessory socket relay |
| thru } — | C-87 } — |
| C-64 } — | thru } Body wiring harness and junction block combination |
| | C-93 } — |
| | C-94 } Front wiring harness and junction block combination |

4-2 R.H. drive vehicles

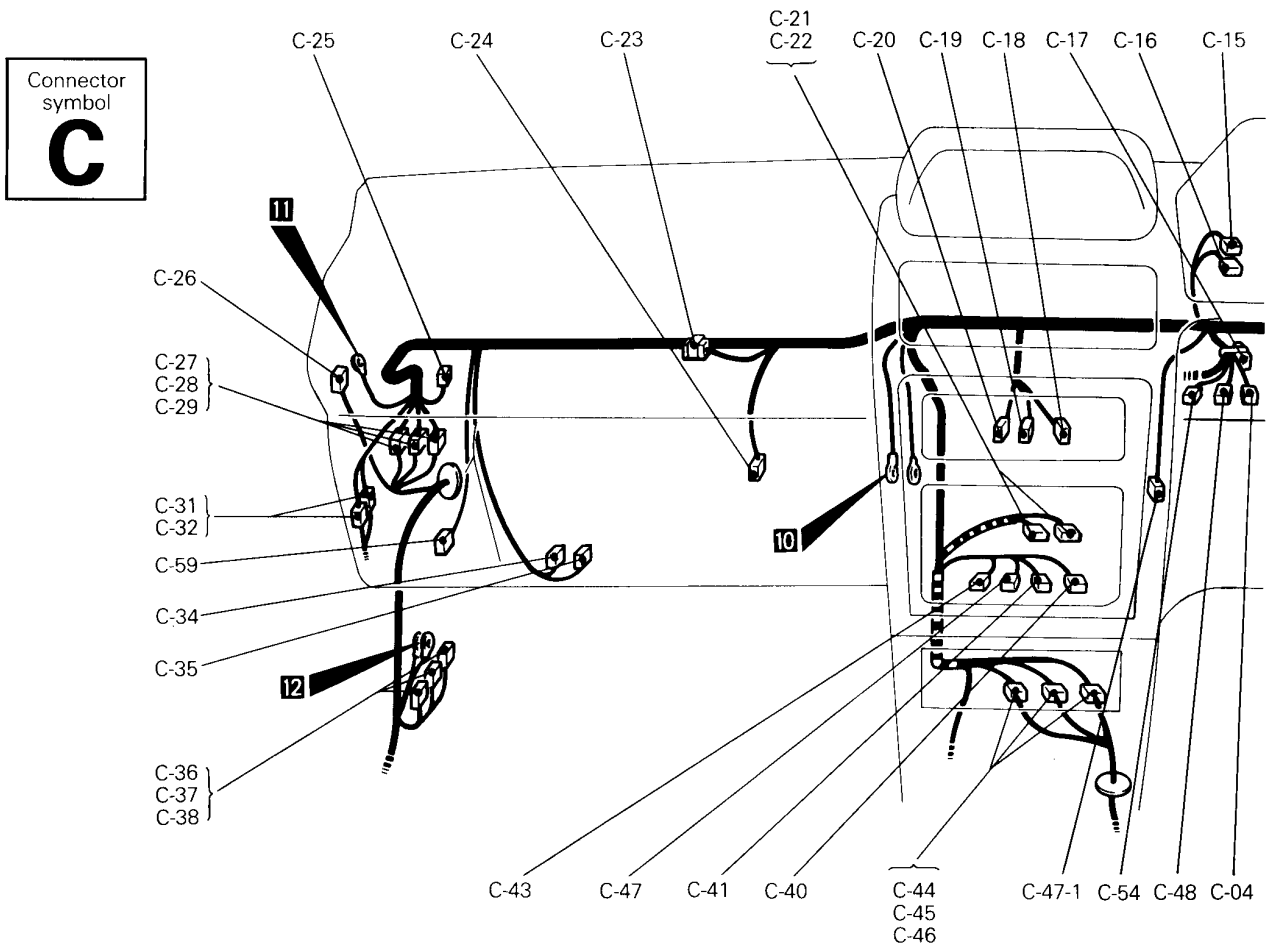

- C-01 Auto-cruise control main switch
- C-02 Rear fog lamp switch
- C-03 Remote controlled mirror switch
- C-04 Rheostat
- C-05 } Combination meter
- C-06 }
- C-07 }
- C-08 } Front wiring harness and body wiring harness combination thru
- C-11 }
- C-12 }
- C-13 } Combination meter
- C-14 }
- C-15 Defogger switch
- C-16 Hazard switch
- C-17 No connection
- C-18 A/C switch
- C-19 Blower switch
- C-20 Blower control illumination lamp
- C-21 } Radio
- C-22 }

- C-23 No connection
- C-24 A/C unit
- C-25 Engine oil level relay
- C-26 Engine control relay or intercooler fan control unit
- C-27 } Control wiring harness and body wiring harness combination
- C-28 }
- C-29 }
- C-30 —
- C-31 } Door wiring harness (LH) and body wiring harness combination
- C-32 }
- C-33 Front speaker (RH)
- C-34 Resistor (for blower motor control circuit)
- C-35 Blower motor
- C-36 Engine control unit
- C-37 Engine control unit
- C-38 Engine control unit or glow control unit
- C-39 Diode (for ABS circuit)
- C-40 Motor antenna control unit
- C-41 4WD indicator relay
- C-42 ABS power relay
- C-43 4WD indicator control unit

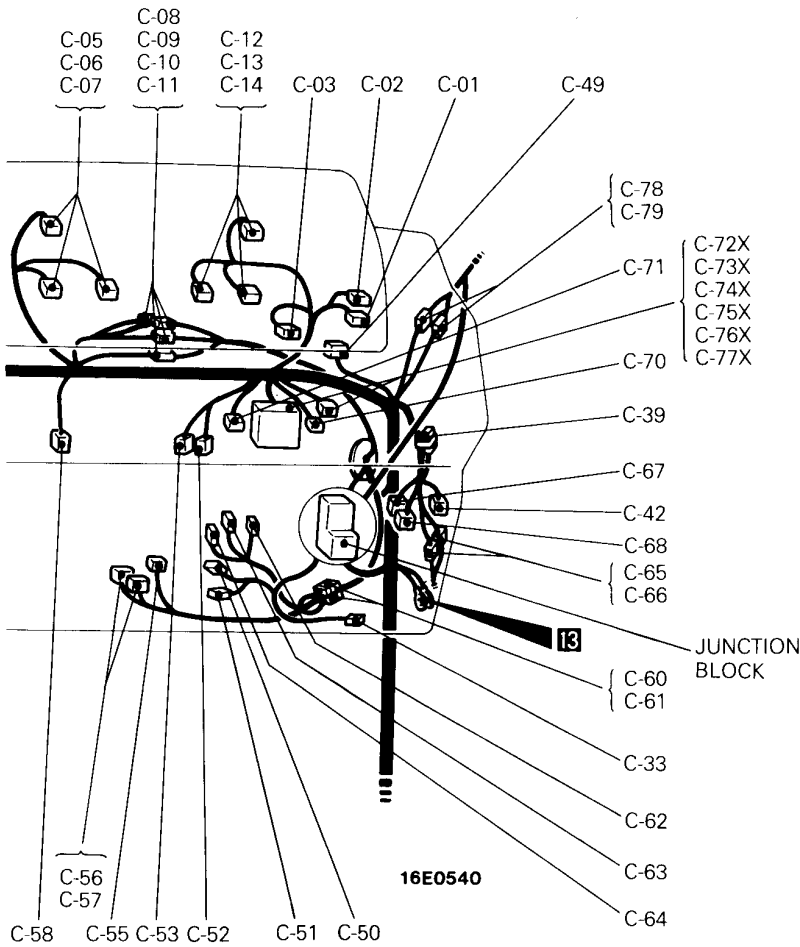

JUNCTION BLOCK

⟨Front side view⟩

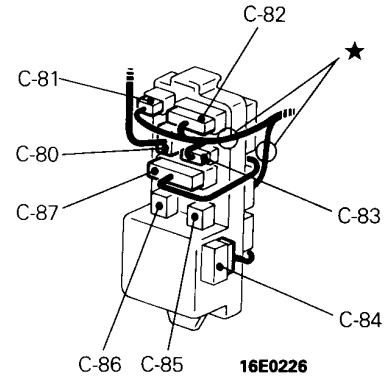

⟨Rear side view⟩

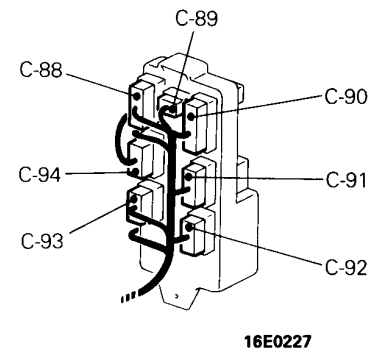

- C-44 } Transmission wiring harness and body wiring harness combination
- C-45 }
- C-46 }
- C-47 Vehicle speed relay ⟨ABS⟩
- C-47-1 Lighting monitor buzzer ⟨1993 MODELS⟩
- C-48 Rear wiper and washer switch
- C-49 Auto-cruise control unit or spare connector
- C-50 Auto-cruise control switch
- C-51 Thermo sensor (inside air)
- C-52 Stop lamp switch (2-pin) or no connection ⟨Auto-cruise control⟩
- C-53 Stop lamp switch (4-pin) ⟨Auto-cruise control⟩ or no connection
- C-54 Headlamp leveling switch
- C-55 Ignition switch
- C-56 } Column switch
- C-57 }
- C-58 Clutch switch
- C-59 Front speaker (LH)
- C-60 } Diode (for dim-dip lamp circuit)
- C-61 }
- C-62 Dim-dip lamp relay 1
- C-63 Dim-dip lamp relay 2
- C-64 Dim-dip lamp relay 3

- C-65 } Door wiring harness (RH) and body wiring harness combination
- C-66 }
- C-67 Overdrive control relay
- C-68 Headlamp washer relay
- C-69 —
- C-70 Dedicated fuse No. ⑩
- C-71 Dedicated fuse No. ⑨
- C-72X } Refer to centralized junction
- C-73X }
- C-74X }
- C-75X }
- C-76X }
- C-77X }
- C-78 } Roof wiring harness and body wiring harness combination
- C-79 }
- C-80 Roof wiring harness and junction block combination
- C-81 } Front wiring harness and junction block combination
- C-82 }
- C-83 }
- C-84 Diagnosis connector
- C-85 Blower relay
- C-86 Accessory socket relay
- C-87 } Body wiring harness and junction block combination
- C-88 }
- C-89 }
- C-90 }
- C-91 }
- C-92 }
- C-93 }
- C-94 Front wiring harness and junction block combination

5 INSTRUMENT PANEL AND FLOOR CONSOLE

5-1 L.H. drive vehicles <M/T>

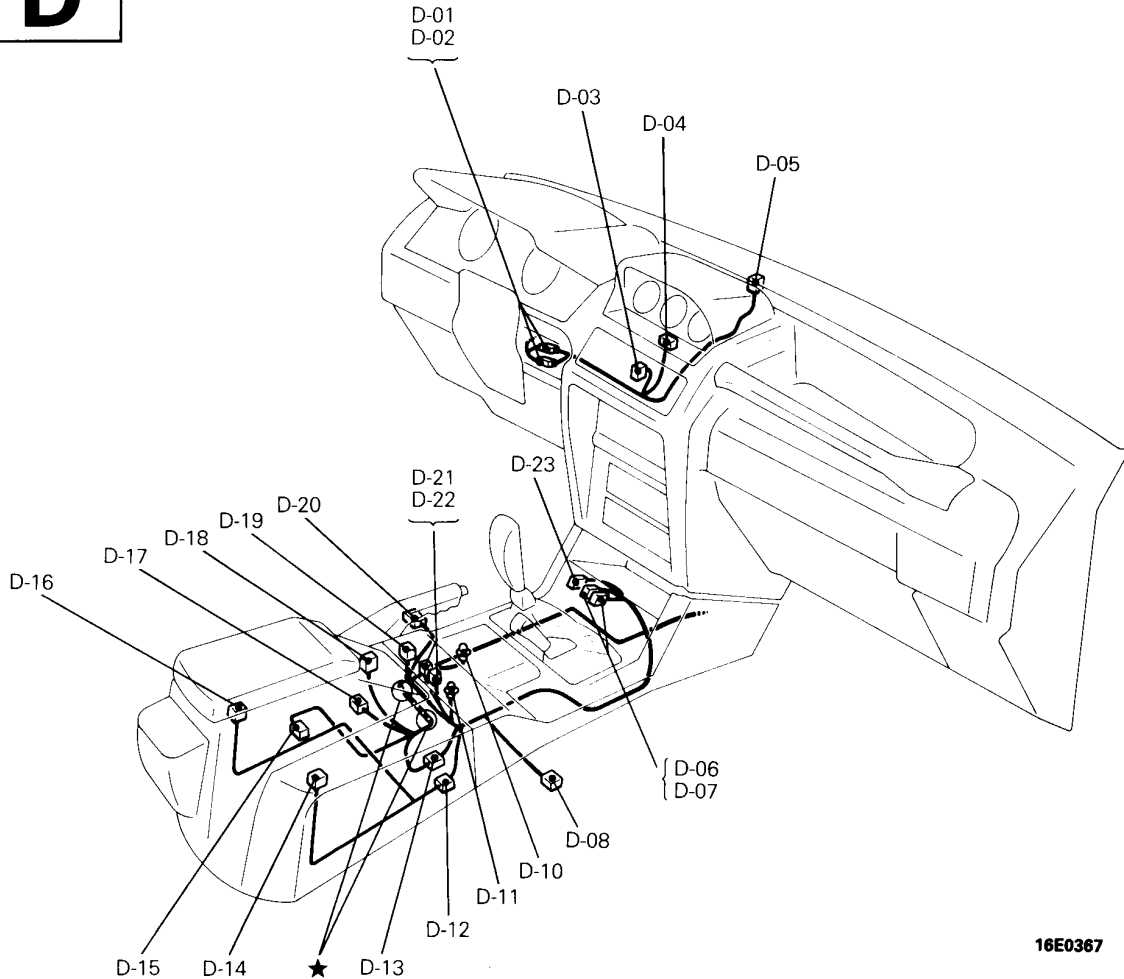
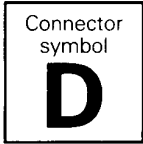

16E0367

D-01 } Instrument panel wiring harness and body wiring	D-13 } Console wiring harness and body wiring harness combination
D-02 } harness combination	D-14 Heated seat switch (RH)
D-03 Clock	D-15 G sensor <ABS>
D-04 Multi-meter	D-16 Heated seat switch (LH)
D-05 Geomagnetic sensor	D-17 Parking brake switch
D-06 } Accessory socket	D-18 Variable shock absorber control switch
D-07 }	D-19 Rear blower main switch
D-08 Seat heater (RH)	D-20 Seat heater (LH)
D-09 —	D-21 } Cigarette lighter
D-10 Ashtray illumination lamp	D-22 }
D-11 Cigarette lighter illumination lamp	D-23 Rear differential lock switch
D-12 Rear console wiring harness and console wiring harness combination	

5-2 R.H. drive vehicles <M/T>

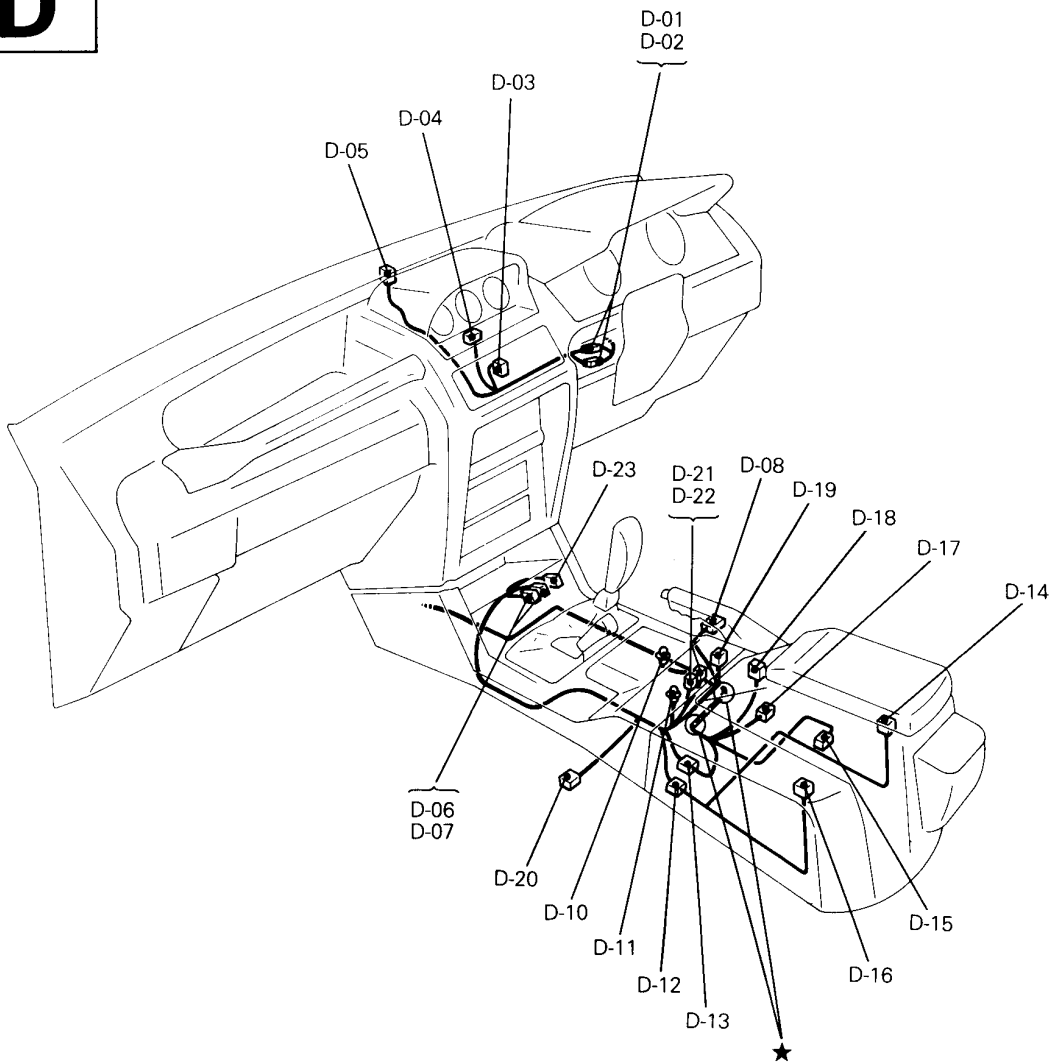
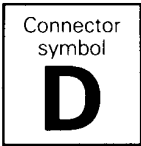

16E0366

- | | |
|---------------------------------------------------------------------------|-------------------------------------------------------------------|
| D-01 } Instrument panel wiring harness and body wiring | D-13 } Console wiring harness and body wiring harness combination |
| D-02 } harness combination | D-14 } Heated seat switch (RH) |
| D-03 } Clock | D-15 } G sensor <ABS> |
| D-04 } Multi-meter | D-16 } Heated seat switch (LH) |
| D-05 } Geomagnetic sensor | D-17 } Parking brake switch |
| D-06 } Accessory socket | D-18 } Variable shock absorber control switch |
| D-07 } Accessory socket | D-19 } Rear blower main switch |
| D-08 } Seat heater (RH) | D-20 } Seat heater (LH) |
| D-09 } — | D-21 } Cigarette lighter |
| D-10 } Ashtray illumination lamp | D-22 } Cigarette lighter |
| D-11 } Cigarette lighter illumination lamp | D-23 } Rear differential lock switch |
| D-12 } Rear console wiring harness and console wiring harness combination | |

5-3 L.H. drive vehicles <A/T>

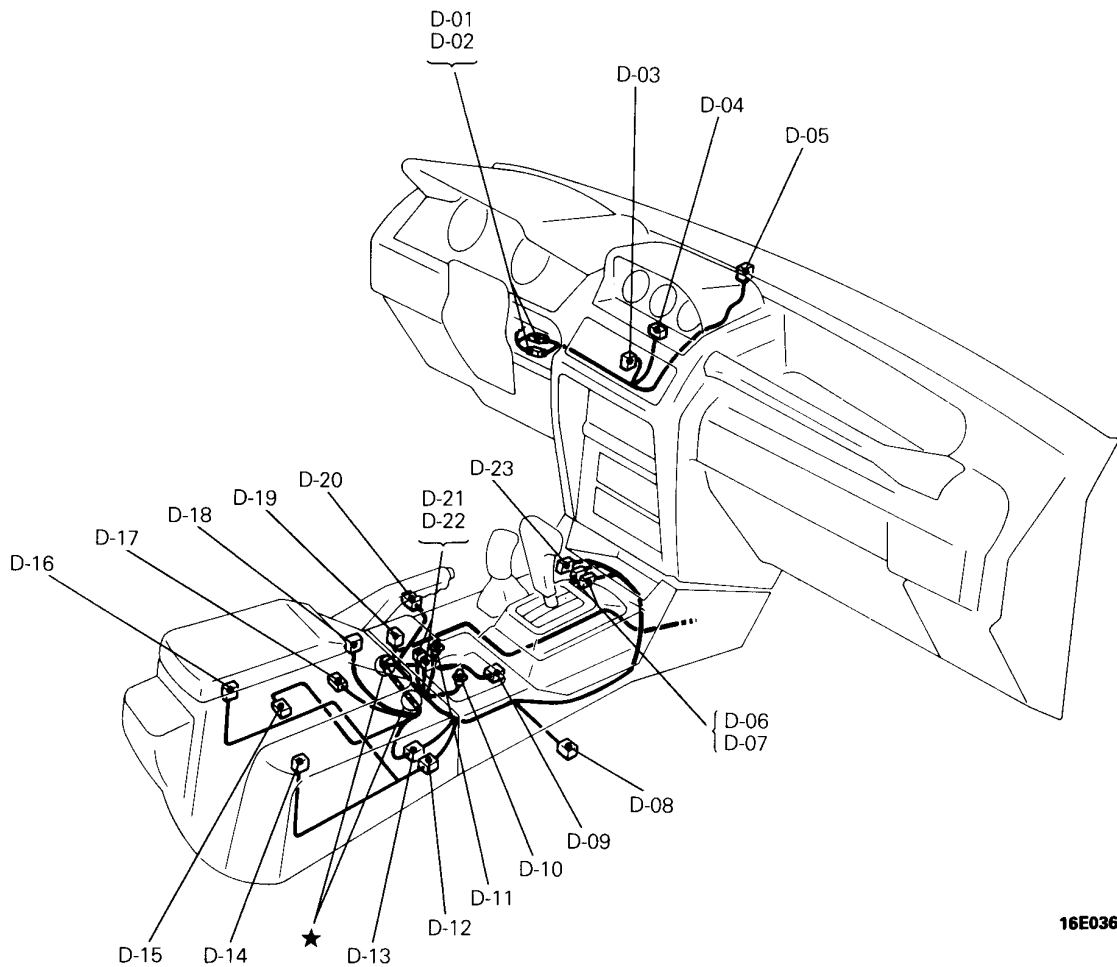
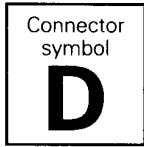

16E0364

- | | |
|-------------------------------------------------------------------------|-------------------------------------------------------------------|
| D-01 } Instrument panel wiring harness and body wiring | D-13 } Console wiring harness and body wiring harness combination |
| D-02 } harness combination | D-14 Heated seat switch (RH) |
| D-03 Clock | D-15 G sensor <ABS> |
| D-04 Multi-meter | D-16 Heated seat switch (LH) |
| D-05 Geomagnetic sensor | D-17 Parking brake switch |
| D-06 } Accessory socket | D-18 Variable shock absorber control switch |
| D-07 } | D-19 Rear blower main switch |
| D-08 Seat heater (RH) | D-20 Seat heater (LH) |
| D-09 Overdrive switch | D-21 } Cigarette lighter |
| D-10 Ashtray illumination lamp | D-22 } |
| D-11 Cigarette lighter illumination lamp | D-23 Rear differential lock switch |
| D-12 Rear console wiring harness and console wiring harness combination | |

5-4 R.H. drive vehicles <A/T>

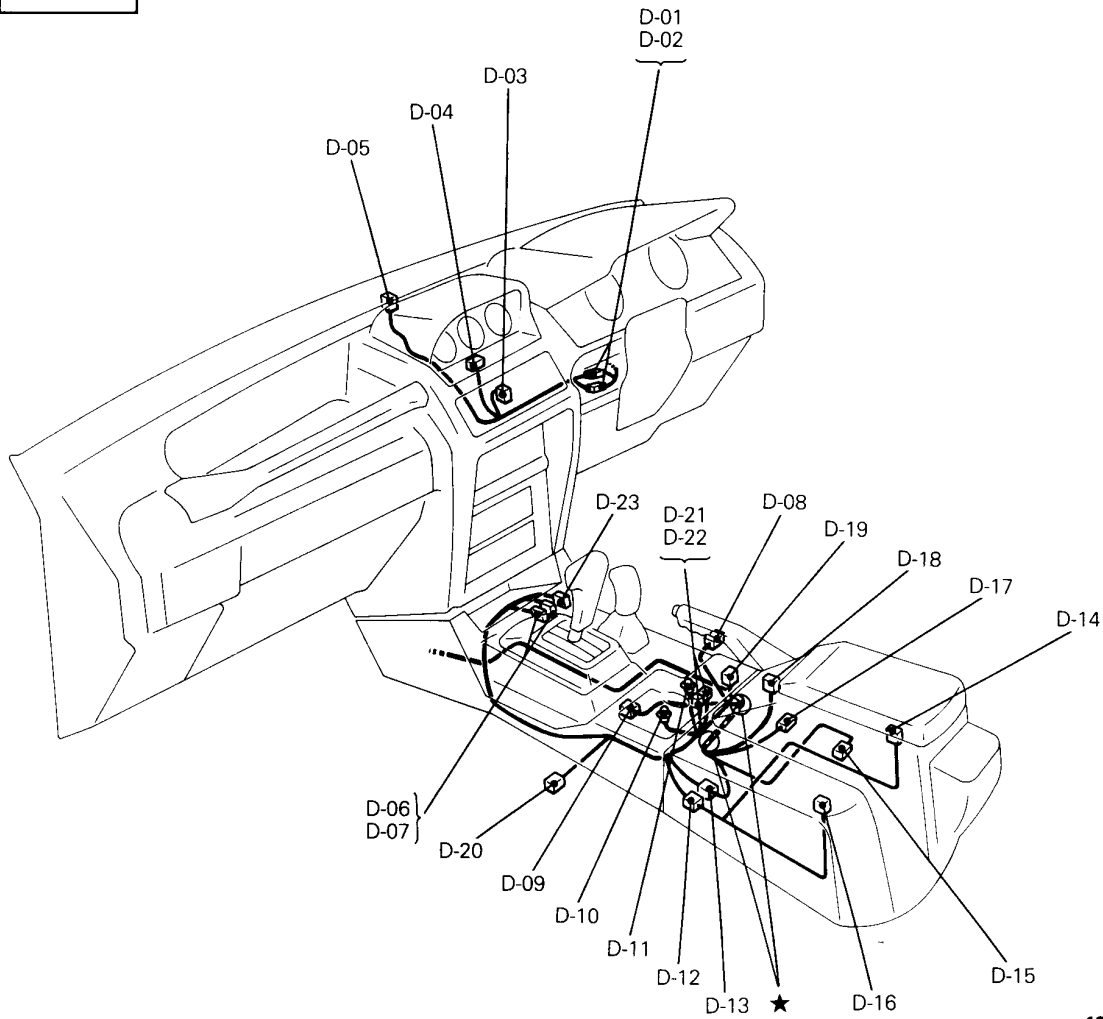
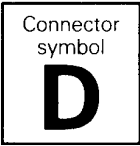

16E0363

- | | |
|---------------------------------------------------------------------------|-------------------------------------------------------------------|
| D-01 } Instrument panel wiring harness and body wiring | D-13 } Console wiring harness and body wiring harness combination |
| D-02 } harness combination | D-14 } Heated seat switch (RH) |
| D-03 } Clock | D-15 } G sensor <ABS> |
| D-04 } Multi-meter | D-16 } Heated seat switch (LH) |
| D-05 } Geomagnetic sensor | D-17 } Parking brake switch |
| D-06 } Accessory socket | D-18 } Variable shock absorber control switch |
| D-07 } Accessory socket | D-19 } Rear blower main switch |
| D-08 } Seat heater (RH) | D-20 } Seat heater (LH) |
| D-09 } Overdrive switch | D-21 } Cigarette lighter |
| D-10 } Ashtray illumination lamp | D-22 } Cigarette lighter |
| D-11 } Cigarette lighter illumination lamp | D-23 } Rear differential lock switch |
| D-12 } Rear console wiring harness and console wiring harness combination | |

6 FLOOR AND ROOF

6-1 2-door models <L.H. drive vehicles>

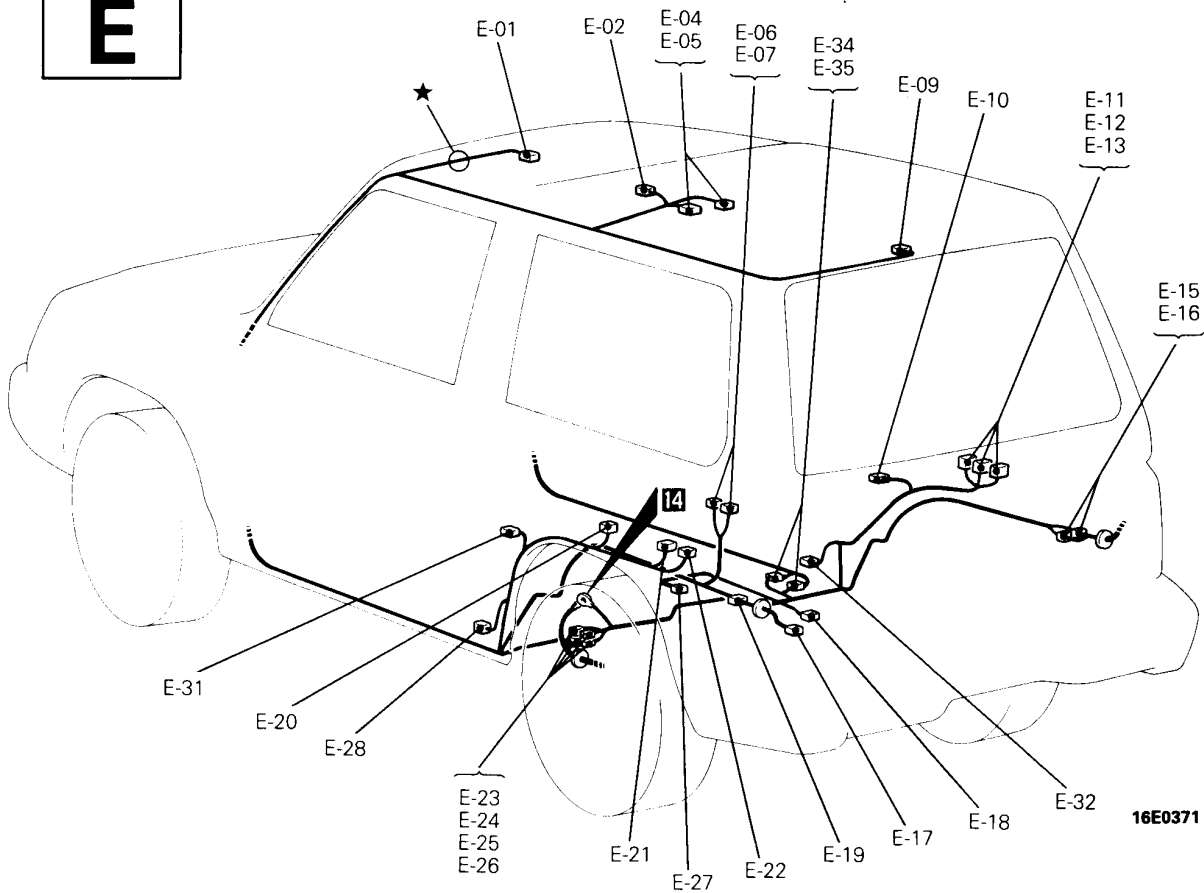
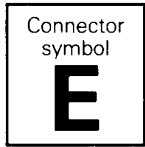

E-01	Map lamp, room lamp or canvas roof switch	E-19	Rear combination lamp harness and body wiring harness combination
E-02	Room lamp	E-20	Variable shock absorber control unit
E-03	—	E-21	Rear differential lock air pump
E-04 } E-05 }	Folding top assembly <Canvas top>	E-22	Rear differential lock control unit
E-06 } E-07 }	Accessory socket	E-23 } E-24 } E-25 } E-26 }	Frame wiring harness and body wiring harness combination
E-08	—	E-27	Rear heater control switch
E-09	Cargo space lamp	E-28	Front door switch (LH)
E-10	Rear speaker (RH)	E-29	—
E-11 } E-12 } E-13 }	ABS control unit	E-30	—
E-14	—	E-31	Rear speaker (LH)
E-15 } E-16 }	Back door wiring harness and body wiring harness combination	E-32	Front door switch (RH)
E-17	Rear combination lamp (LH)	E-33	—
E-18	Rear heater assembly	E-34 } E-35 }	Control wiring harness and body wiring harness combination

6-2 2-door models <R.H. drive vehicles>

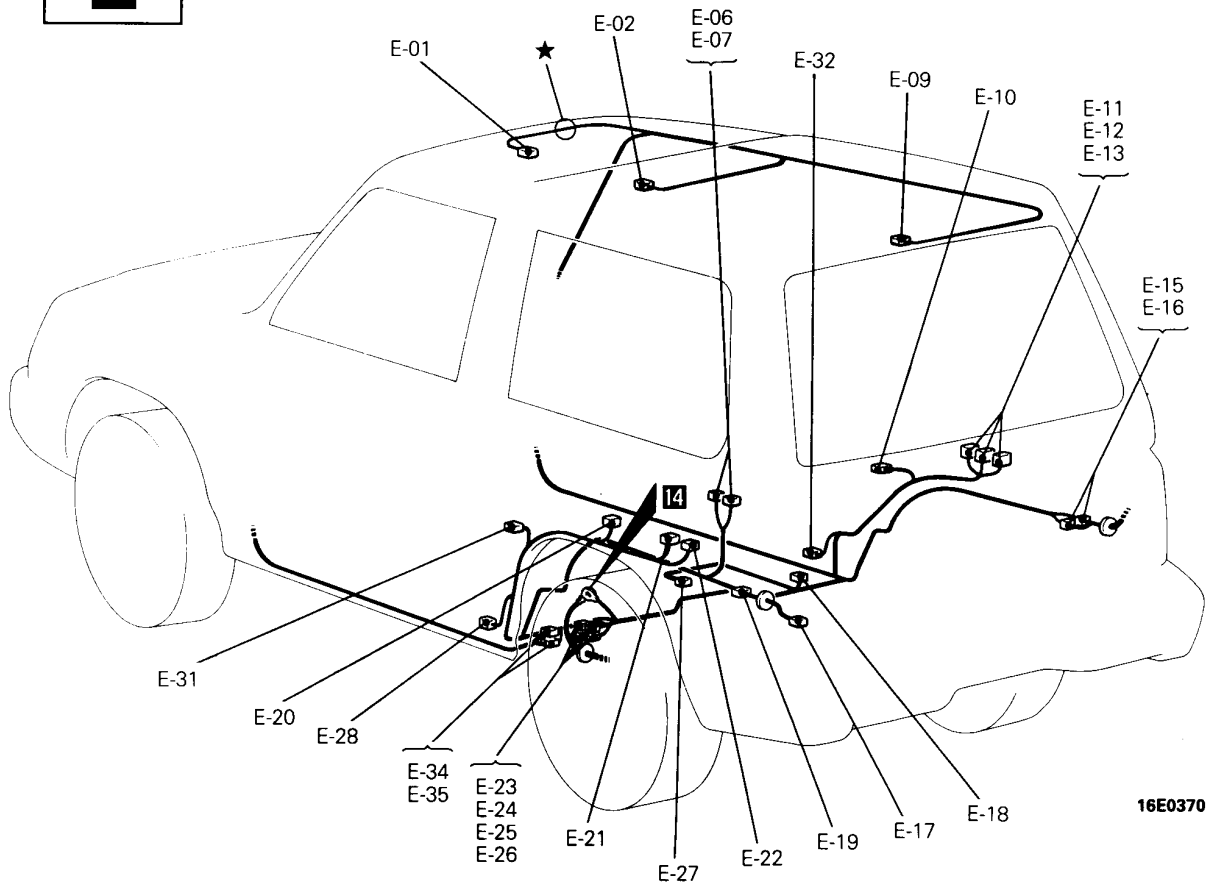
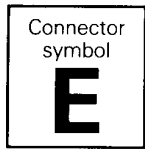

E-01	Map lamp or room lamp	E-19	Rear combination lamp harness and body wiring harness combination
E-02	Room lamp	E-20	Variable shock absorber control unit
E-03	—	E-21	Rear differential lock air pump
E-04	—	E-22	Rear differential lock control unit
E-05	—	E-23	Frame wiring harness and body wiring harness combination
E-06 } E-07 }	Accessory socket	thru	
E-08	—	E-26	
E-09	Cargo space lamp	E-27	
E-10	Rear speaker (RH)	E-28	Front door switch (LH)
E-11 } E-12 } E-13 }	ABS control unit	E-29	—
E-14	—	E-30	—
E-15 } E-16 }	Back door wiring harness and body wiring harness combination	E-31	Rear speaker (LH)
E-17	Rear combination lamp (LH)	E-32	Front door switch (RH)
E-18	Rear heater assembly	E-33	—
		E-34 } E-35 }	Control wiring harness and body wiring harness combination

6-3 4-door models <L.H. drive vehicles>

Connector symbol
E

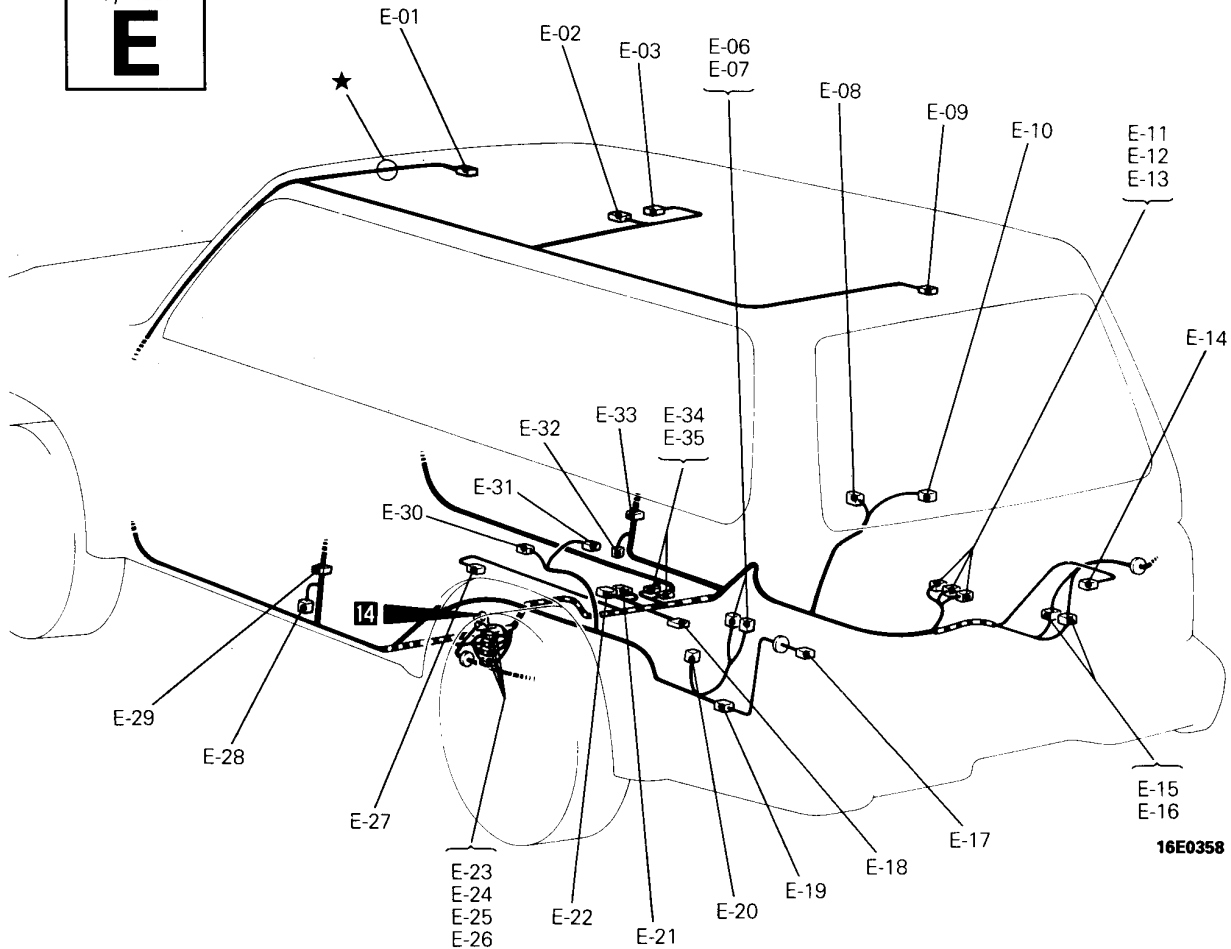

16E0358

- | | | | |
|----------------------------|-------------------------------------------------------------------|------------------|-------------------------------------------------------------------|
| E-01 | Map lamp | E-20 | Variable shock absorber control unit |
| E-02 | Room lamp | E-21 | Rear differential lock air pump |
| E-03 | Sunroof assembly | E-22 | Rear differential lock control unit |
| E-04 }
E-05 } | — | E-23 }
E-26 } | Frame wiring harness and body wiring harness combination thru |
| E-06 }
E-07 } | Accessory socket | E-27 | Rear heater control switch or rear A/C control switch <Dual A/C> |
| E-08 | Rear door switch (RH) | E-28 | Front door switch (LH) |
| E-09 | Cargo space lamp | E-29 | Rear door wiring harness (LH) and body wiring harness combination |
| E-10 | Rear speaker (RH) | E-30 | Rear door switch (LH) |
| E-11 }
E-12 }
E-13 } | ABS control unit | E-31 | Rear speaker (LH) |
| E-14 | Rear A/C control unit | E-32 | Front door switch (RH) |
| E-15 }
E-16 } | Back door wiring harness and body wiring harness combination | E-33 | Rear door wiring harness (RH) and body wiring harness combination |
| E-17 | Rear combination lamp (LH) | E-34 }
E-35 } | Control wiring harness and body wiring harness combination |
| E-18 | Rear heater assembly | | |
| E-19 | Rear combination lamp harness and body wiring harness combination | | |

6-4 4-door models <R.H. drive vehicles>

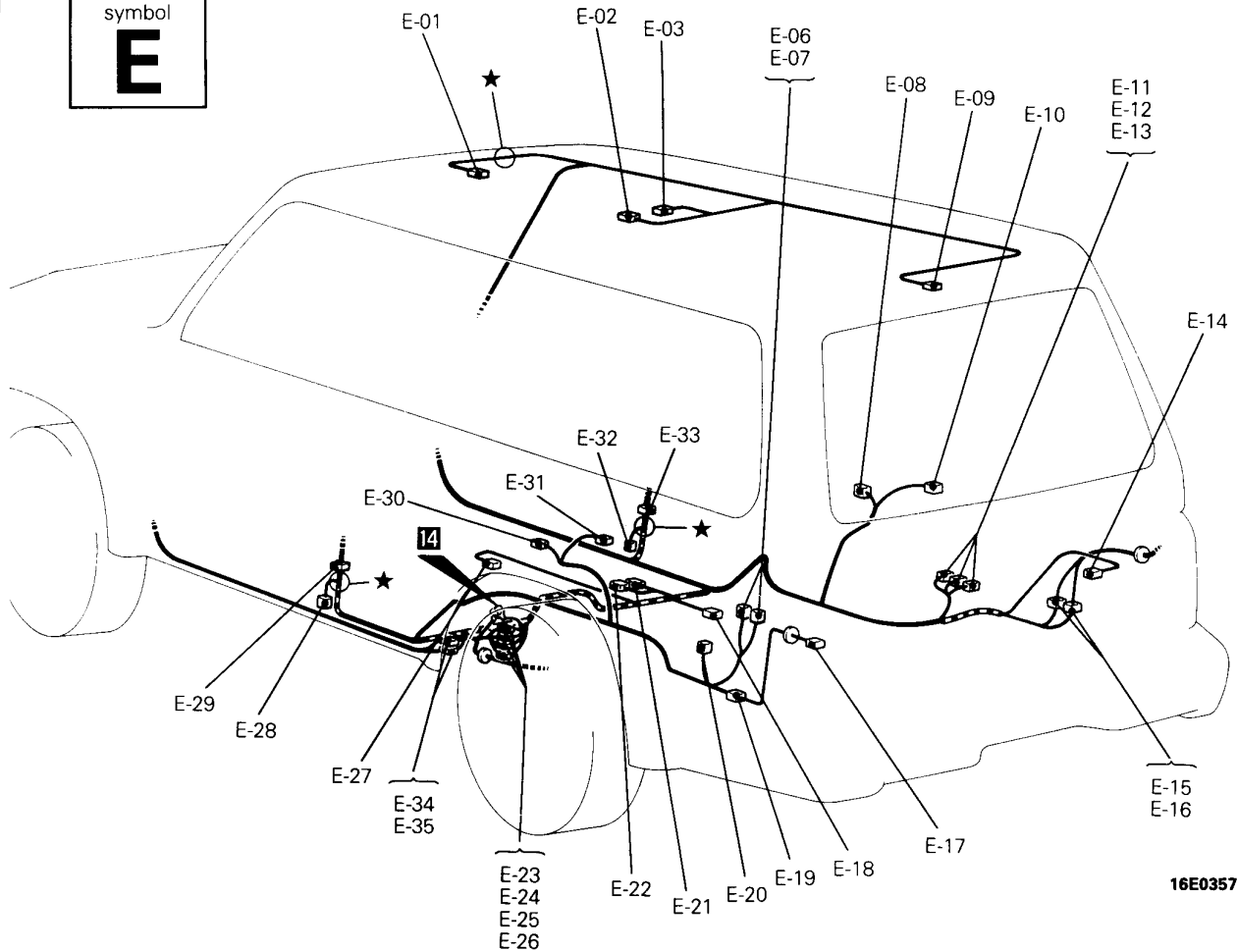
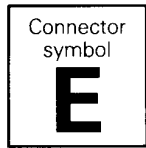

- | | | | |
|--------|-------------------------------------------------------------------|--------|-------------------------------------------------------------------|
| E-01 | Map lamp | E-20 | Variable shock absorber control unit |
| E-02 | Room lamp | E-21 | Rear differential lock air pump |
| E-03 | Sunroof assembly | E-22 | Rear differential lock control unit |
| E-04 } | — | E-23 } | Frame wiring harness and body wiring harness combination |
| E-05 } | | E-24 } | |
| E-06 } | | E-25 } | |
| E-07 } | Accessory socket | E-26 } | |
| E-08 | Rear door switch (RH) | E-27 | Rear heater control switch or rear A/C control switch <Dual A/C> |
| E-09 | Cargo space lamp | E-28 | Front door switch (LH) |
| E-10 | Rear speaker (RH) | E-29 | Rear door wiring harness (LH) and body wiring harness combination |
| E-11 } | ABS control unit | E-30 | Rear door switch (LH) |
| E-12 } | | E-31 | Rear speaker (LH) |
| E-13 } | | E-32 | Front door switch (RH) |
| E-14 | Rear A/C control unit | E-33 | Rear door wiring harness (RH) and body wiring harness combination |
| E-15 } | Back door wiring harness and body wiring harness combination | E-34 } | Control wiring harness and body wiring harness combination |
| E-16 } | | E-35 } | |
| E-17 | Rear combination lamp (LH) | | |
| E-18 | Rear heater assembly | | |
| E-19 | Rear combination lamp harness and body wiring harness combination | | |

7 DOOR

7-1 2-door models <L.H. drive vehicles>

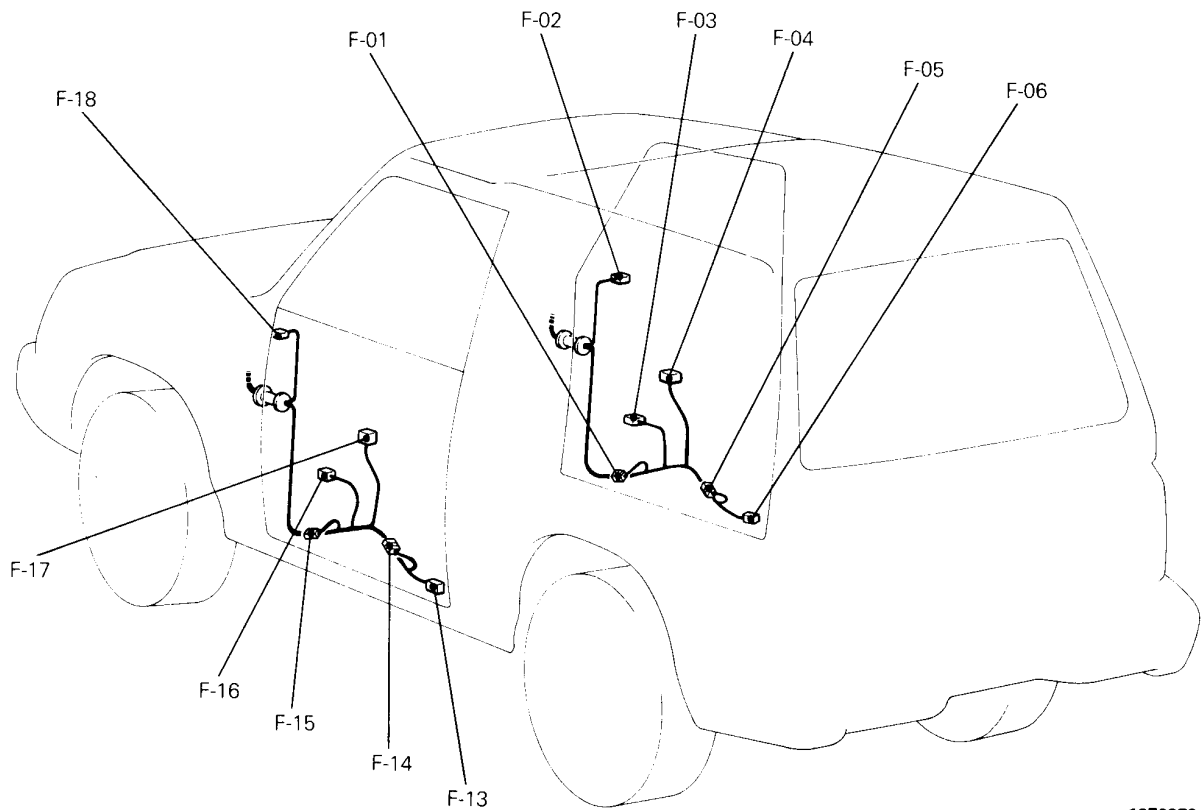
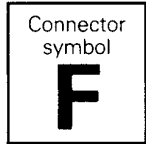

16E0372

- | | | | |
|----------------------------|------------------------------------------------------------------|------|-------------------------------------------------------|
| F-01 | No connection * | F-14 | No connection
<Vehicles with central door locking> |
| F-02 | Remote controlled mirror (RH) | F-15 | No connection * |
| F-03 | Power window motor (Front: RH) | F-16 | Power window motor (Front: LH) |
| F-04 | Power window sub switch (Front: RH) | F-17 | Power window main switch (Front: LH) |
| F-05 | Door key cylinder switch
<Vehicles with central door locking> | F-18 | Remote controlled mirror (LH) |
| F-06 | Door lock actuator (Front: RH) | | |
| F-07 }
thru }
F-12 } | — | | |
| F-13 | Door lock actuator (Front: LH) | | |

Note

* is applicable only to vehicles with remote controlled mirror as an option.

7-2 2-door models <R.H. drive vehicles>

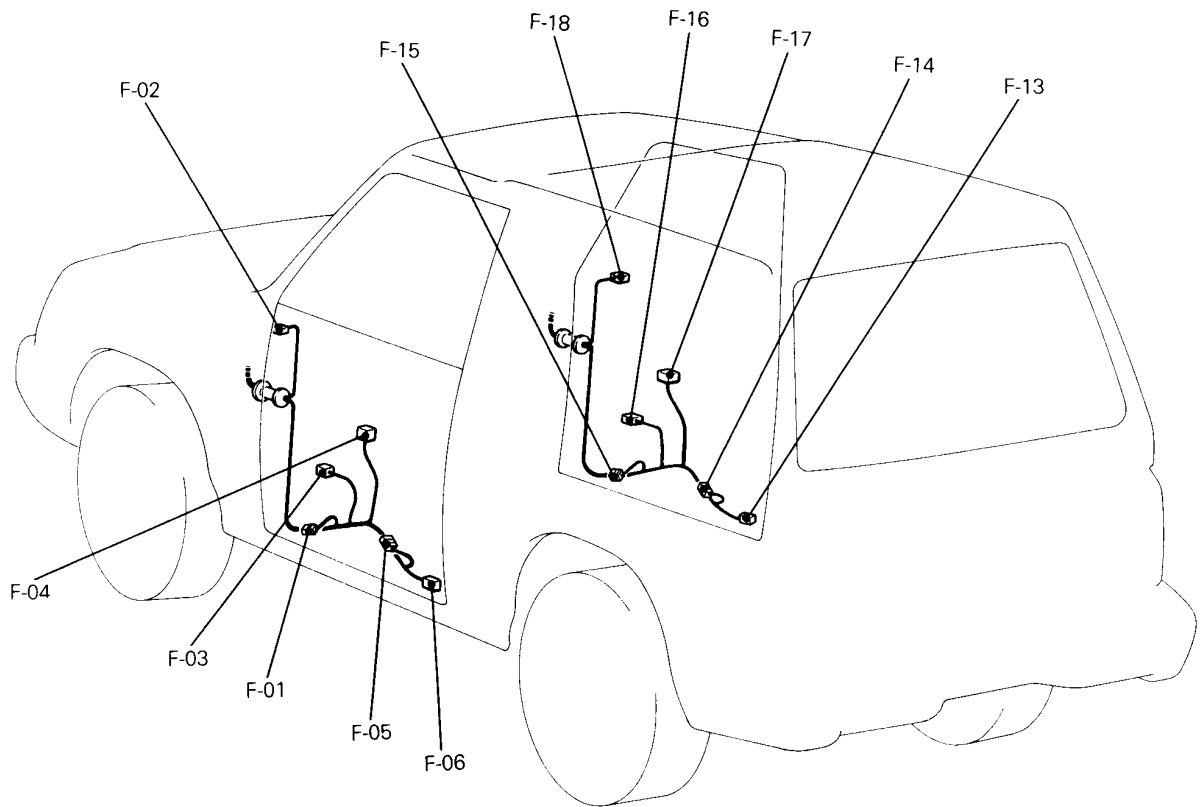
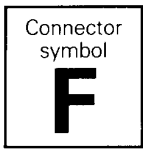

16E0372

- F-01 No connection *
- F-02 Remote controlled mirror (LH)
- F-03 Power window motor (Front: LH)
- F-04 Power window sub switch (Front: LH)
- F-05 Door key cylinder switch
<Vehicles with central door locking>
- F-06 Door lock actuator (Front: LH)
- F-07 } —
- thru } —
- F-12 } —
- F-13 Door lock actuator (Front: RH)

- F-14 No connection
<Vehicles with central door locking>
- F-15 No connection *
- F-16 Power window motor (Front: RH)
- F-17 Power window main switch (Front: RH)
- F-18 Remote controlled mirror (RH)

Note

* is applicable only to vehicles with remote controlled mirror as an option.

7-3 4-door models <L.H. drive vehicles>

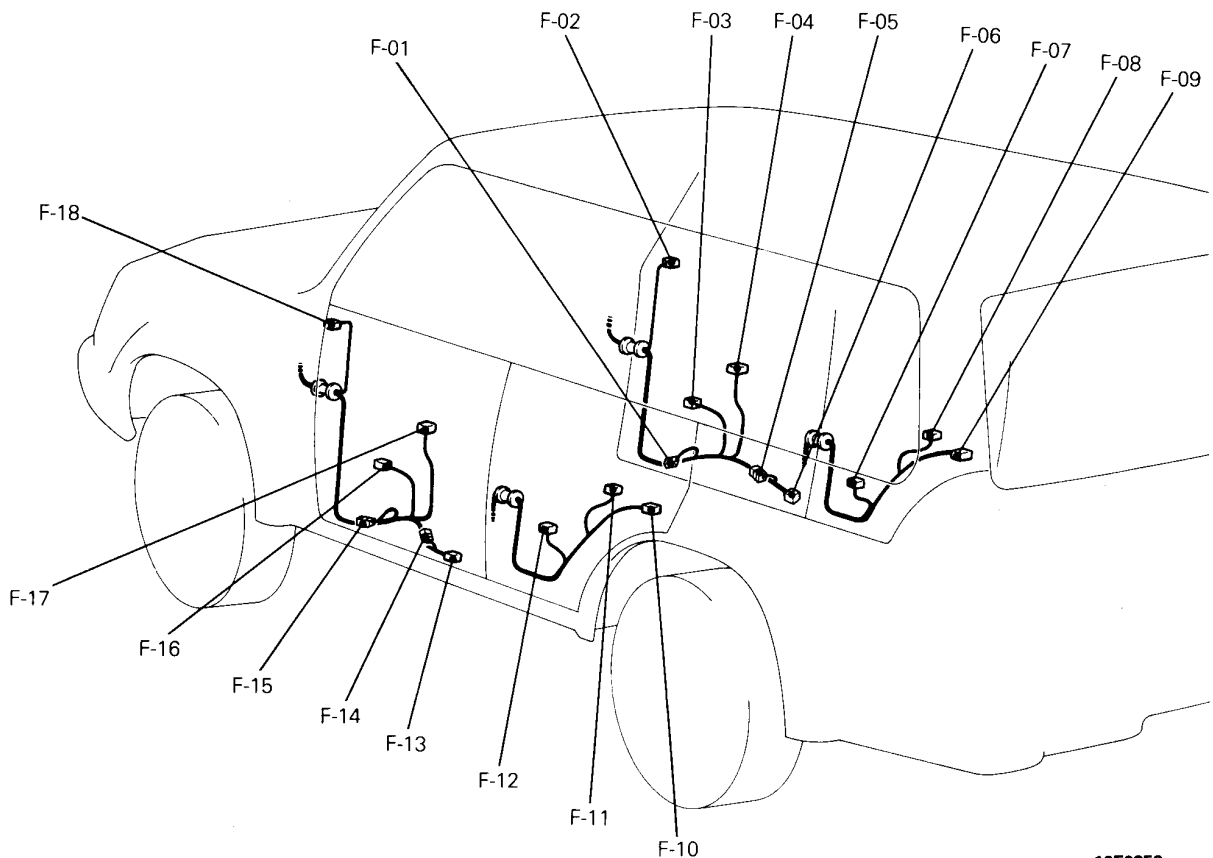
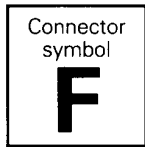

16E0359

F-01	No connection *	F-12	Power window motor (Rear: LH)
F-02	Remote controlled mirror (RH)	F-13	Door lock actuator (Front: LH)
F-03	Power window motor (Front: RH)	F-14	No connection
F-04	Power window sub switch (Front: RH)		<Vehicles with central door locking>
F-05	Door key cylinder switch	F-15	No connection *
	<Vehicles with central door locking>	F-16	Power window motor (Front: LH)
F-06	Door lock actuator (Front: RH)	F-17	Power window main switch (Front: LH)
F-07	Power window motor (Rear: RH)	F-18	Remote controlled mirror (LH)
F-08	Power window sub switch (Rear: RH)		
F-09	Door lock actuator (Rear: RH)		
F-10	Door lock actuator (Rear: LH)		
F-11	Power window sub switch (Rear: LH)		

Note

* is applicable only to vehicles with remote controlled mirror as an option.

7-4 4-door models <R.H. drive vehicles>

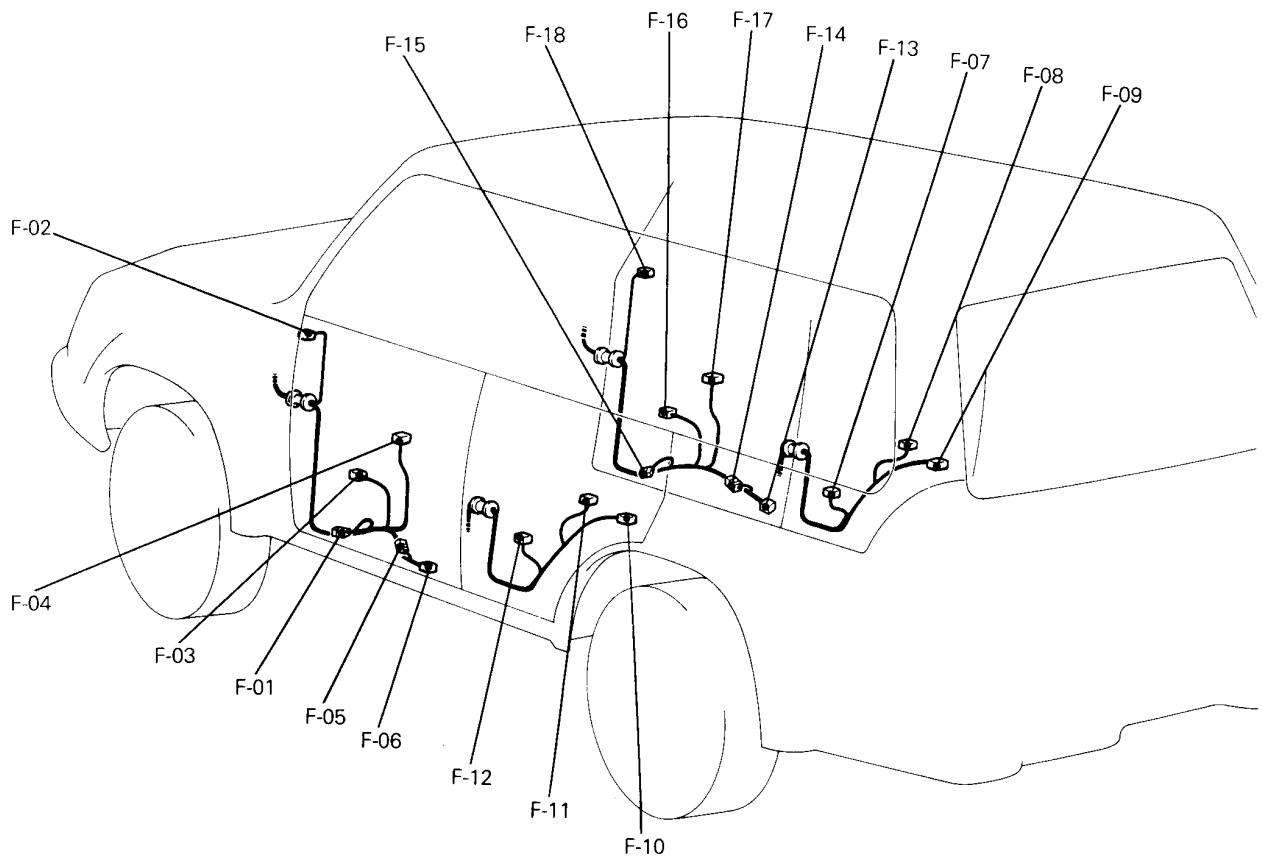
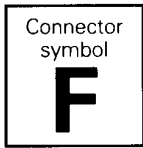

16E0359

- F-01 No connection *
- F-02 Remote controlled mirror (LH)
- F-03 Power window motor (Front: LH)
- F-04 Power window sub switch (Front: LH)
- F-05 Door key cylinder switch
<Vehicles with central door locking>
- F-06 Door lock actuator (Front: LH)
- F-07 Power window motor (Rear: RH)
- F-08 Power window sub switch (Rear: RH)
- F-09 Door lock actuator (Rear: RH)
- F-10 Door lock actuator (Rear: LH)
- F-11 Power window sub switch (Rear: LH)

- F-12 Power window motor (Rear: LH)
- F-13 Door lock actuator (Front: RH)
- F-14 No connection
<Vehicles with central door locking>
- F-15 No connection *
- F-16 Power window motor (Front: RH)
- F-17 Power window main switch (Front: RH)
- F-18 Remote controlled mirror (RH)

Note

* is applicable only to vehicles with remote controlled mirror as an option.

8 BACK DOOR AND REAR UNDER FLOOR

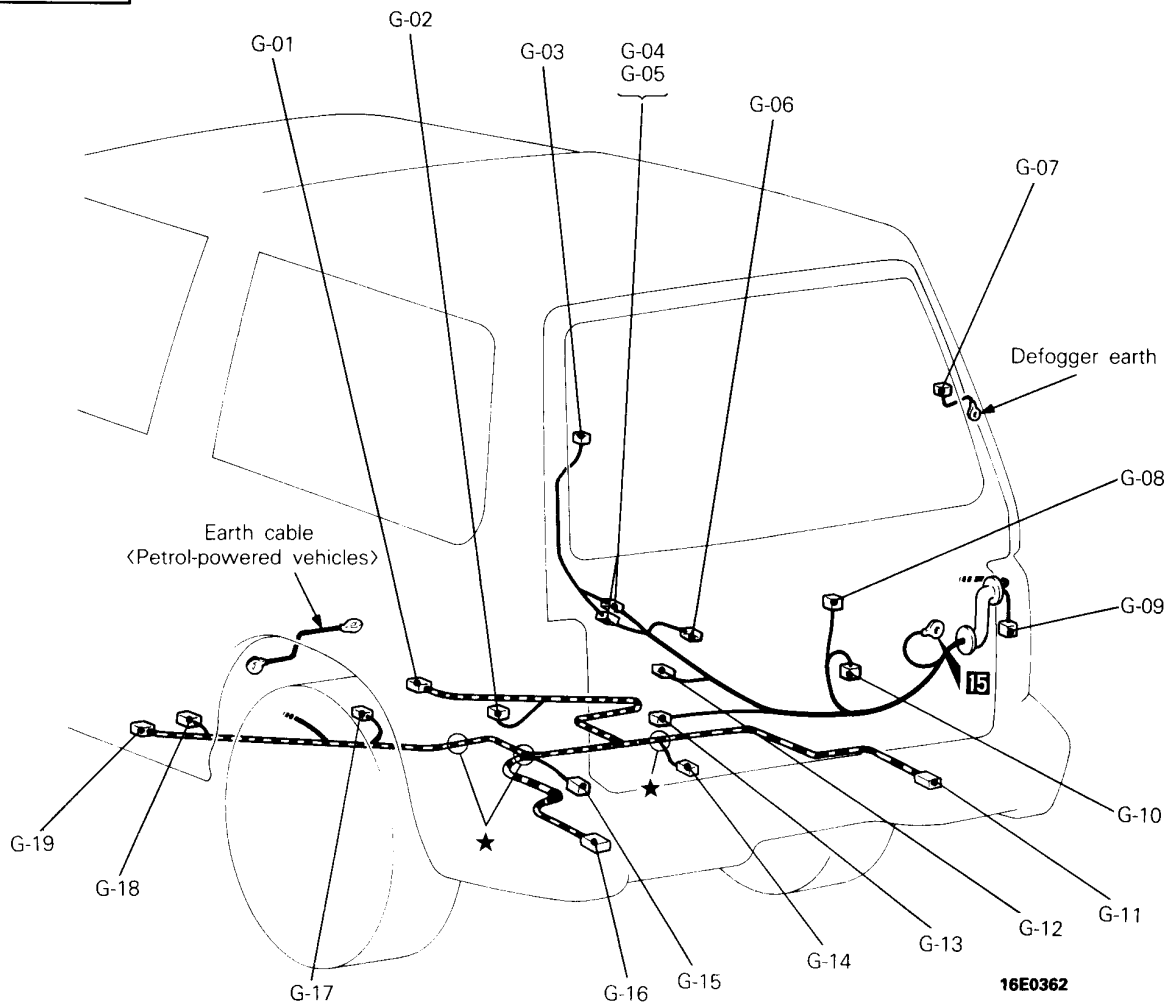
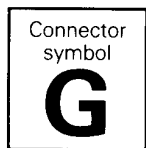

- | | | | |
|------------------|-----------------------------------------------------------------------|------------------|-----------------------------------------------------------------------|
| G-01 | Speed sensor (Rear: RH) <ABS> | G-11 | Rear combination lamp (In bumper: RH) |
| G-02 | Shock absorber (Rear: RH) <Remote controlled variable shock absorber> | G-12 | License plate lamp |
| G-03 | Defogger (+) | G-13 | Door lock actuator (Back door) |
| G-04 }
G-05 } | Defogger cable and back door wiring harness combination | G-14 | Fuel pump <MPI> |
| G-06 | | Back door switch | G-15 |
| G-07 | Defogger (-) | G-16 | Rear combination lamp (In bumper: LH) |
| G-08 | Rear wiper motor | G-17 | Shock absorber (Rear: LH) <Remote controlled variable shock absorber> |
| G-09 | Rear combination lamp (RH) | G-18 | Speed sensor (Rear: LH) <ABS> |
| G-10 | Rear washer motor | G-19 | Rear differential lock detection switch |

3 SINGLE PART INSTALLATION POSITION

RELAY	3- 2
CONTROL UNIT	3- 5
SENSOR	3- 8
DIODE	3-11
INSPECTION TERMINAL	3-12
FUSIBLE LINK AND FUSE	3-13
EARTH CABLE	3-14
EARTH	3-15

RELAY

Name		Symbol	Name		Symbol
ABS motor relay		A	Glow plug relay 2 <Super quick glow>		B
ABS power relay	LHD	G	Headlamp relay		C
	RHD	L	Headlamp washer relay	LHD	K
ABS valve relay		A		RHD	
A/C compressor relay		C	Intercooler fan motor relay		C
Accessory socket relay		I	Intermittent wiper relay (windshield wiper)		E
Alternator relay		C	Intermittent wiper relay (rear wiper)		J
Blower relay		I	Overdrive control relay	LHD	K
Condenser fan motor control relay <Diesel-powered vehicles>		D		RHD	
Condenser fan motor relay		C	Power window relay		J
Daytime running lamp relay 1		D	Rear fog lamp relay		C
Daytime running lamp relay 2		D	Rear heater relay		J
Dim-dip lamp relay 1		L	Starter relay		B
Dim-dip lamp relay 2		L	Tail lamp relay		C
Dim-dip lamp relay 3		L	Turn and hazard flasher unit		J
Engine control relay		H	Vehicle speed relay	LHD	F
Engine oil level relay		H		RHD	
Glow plug relay <Auto glow>		B	4WD indicator relay <Part time 4WD>		G
Glow plug relay 1 <Super quick glow>		B			

NOTE

Names are listed in alphabetical order.

Engine compartment

<Petrol-powered vehicles>

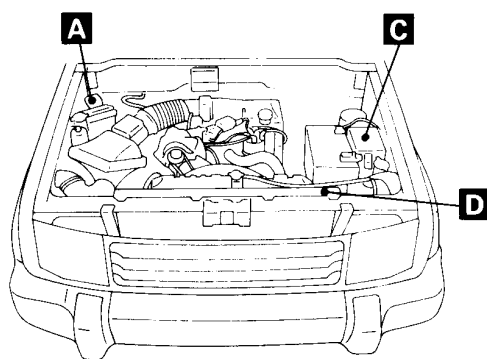

16E0128

<Diesel-powered vehicles>

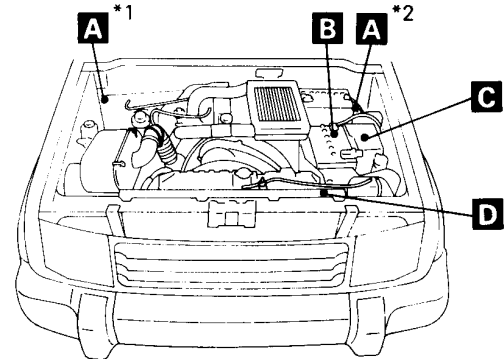

16E0129

Remark

*1: R.H. drive vehicles

*2: L.H. drive vehicles

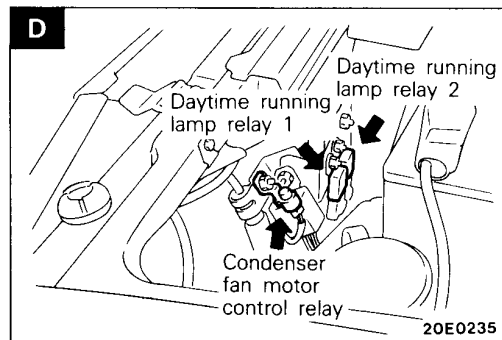
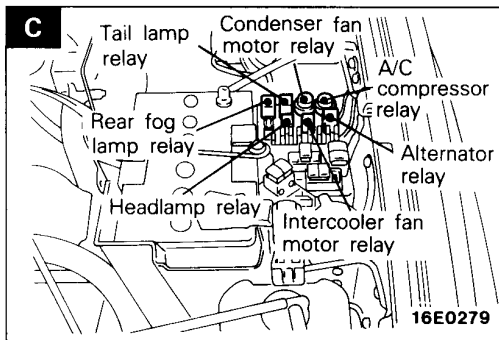
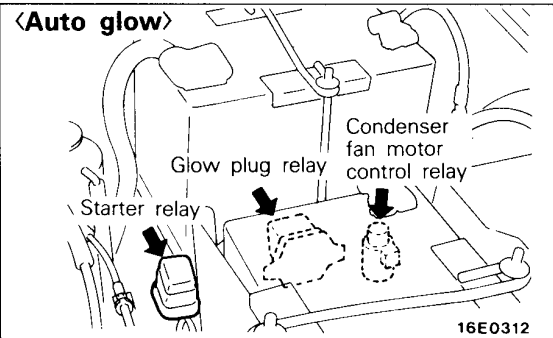
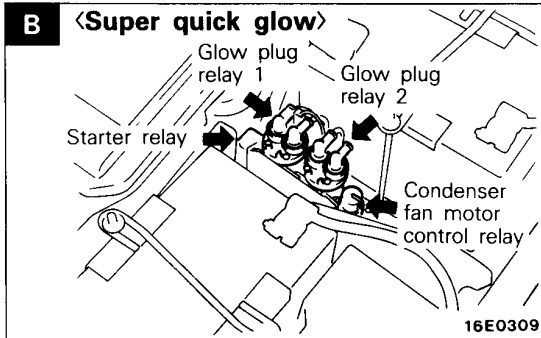
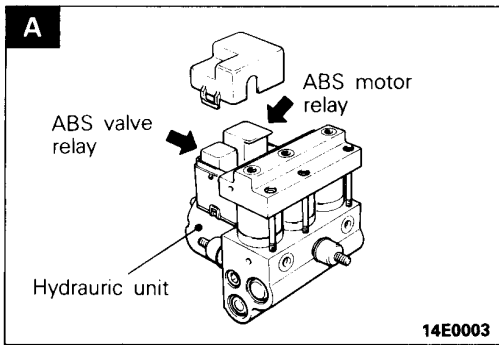

Interior

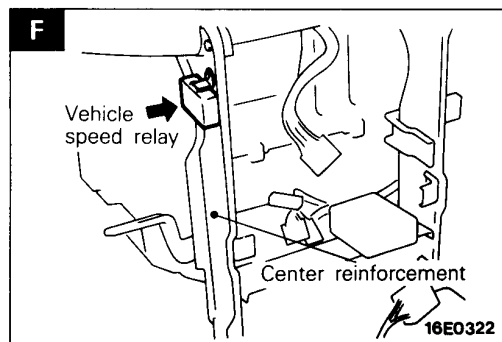
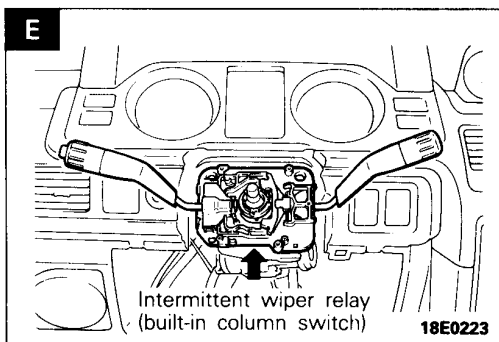
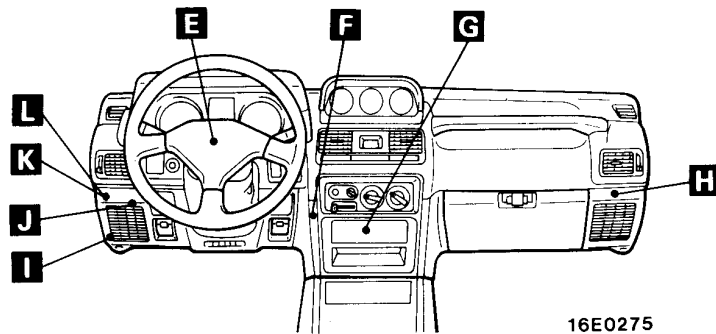

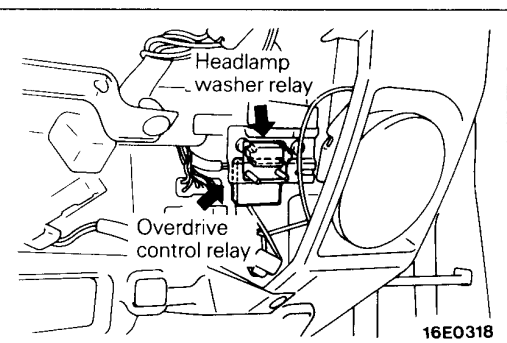
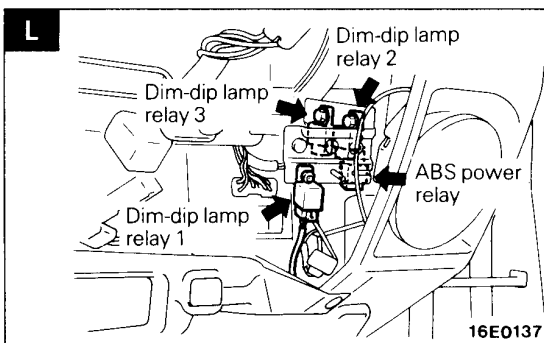
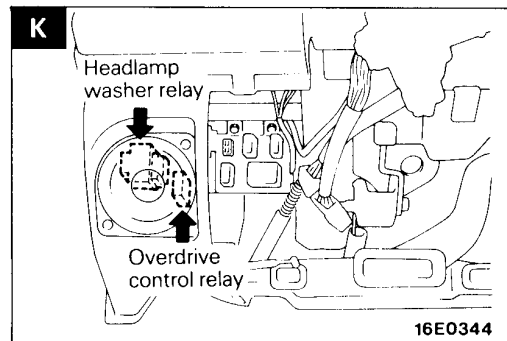
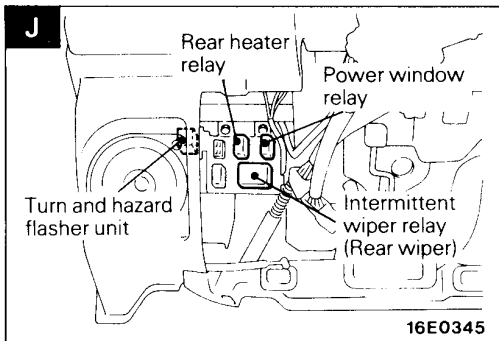
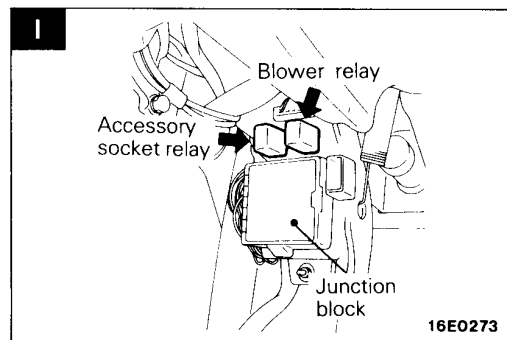
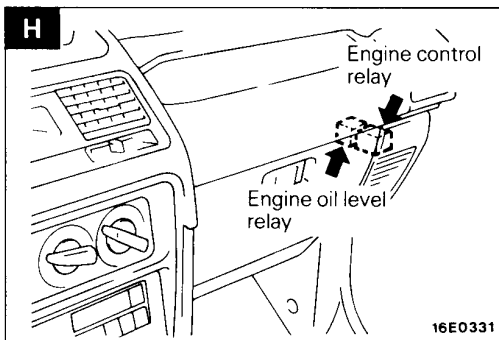
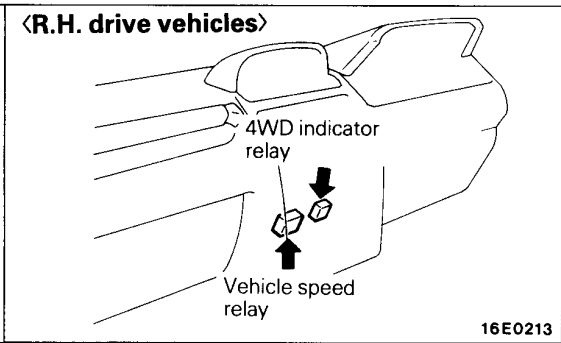
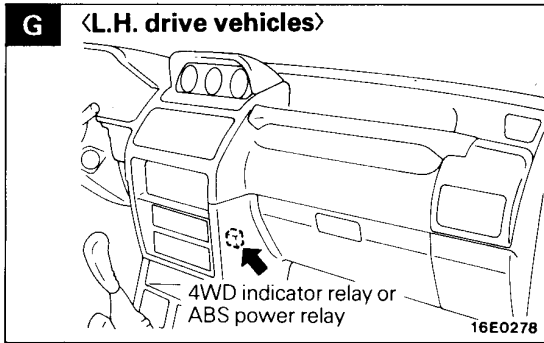

CONTROL UNIT

Name		Symbol	Name	Symbol
ABS control unit		L	Intercooler fan control unit <Vehicles with fuel line heater>	F
A/C control unit (front)		D		Intercooler fan control unit <Vehicles without fuel line heater>
A/C control unit (rear)		K	Motor antenna control unit	
Auto-cruise control unit	LHD	C		Rear differential lock control unit
	RHD	B	2-door models J	
Daytime running lamp control unit		A	Sunroof control unit	I
Door lock control unit		H	Variable shock absorber control unit	M
Engine control unit		F	4WD indicator control unit	G
Fuel line heater control unit		E		
Glow control unit		F		

NOTE
Names are listed in alphabetical order.

Engine compartment

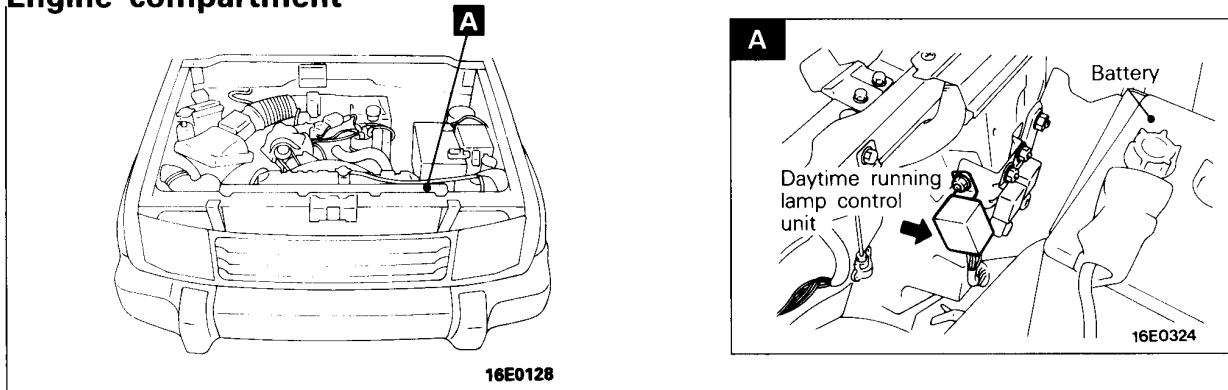

Interior

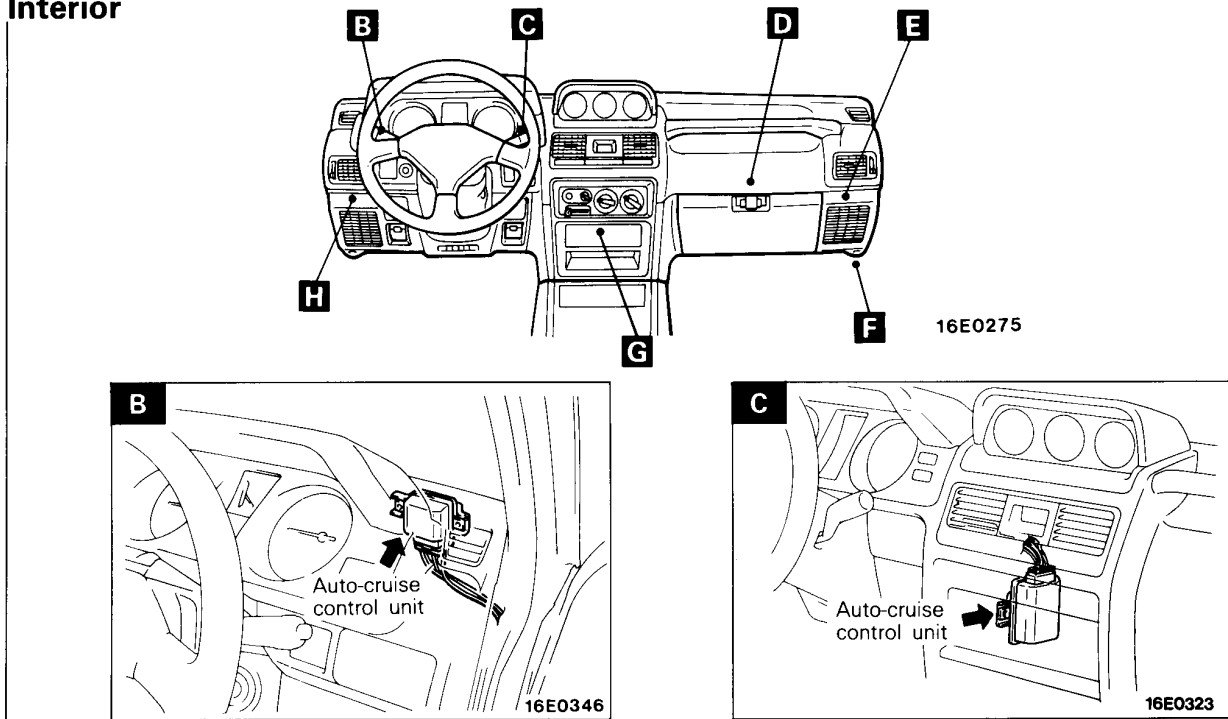

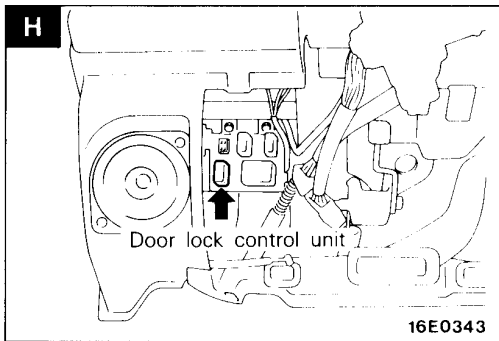
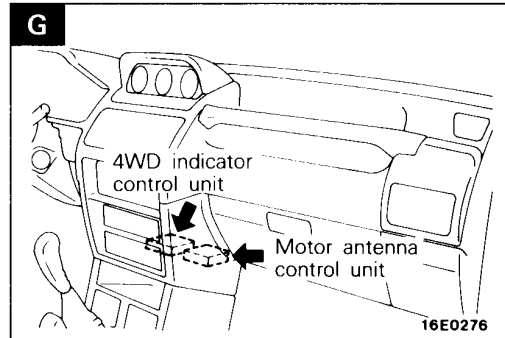
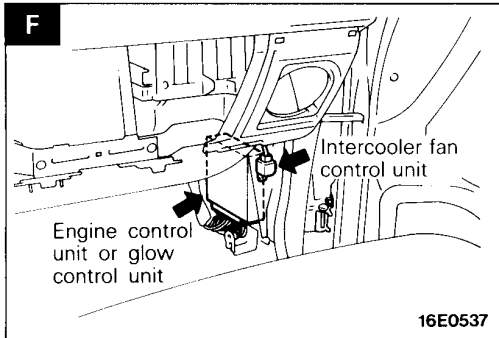
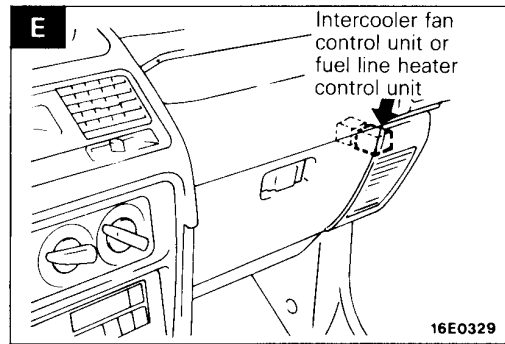
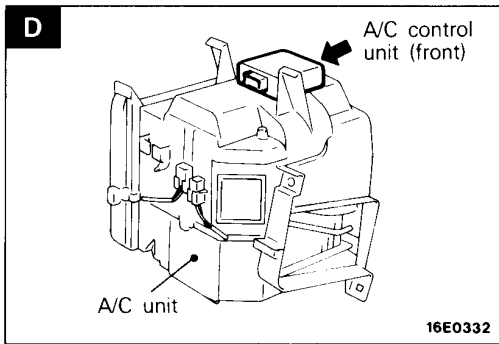

Roof, Luggage compartment, Floor

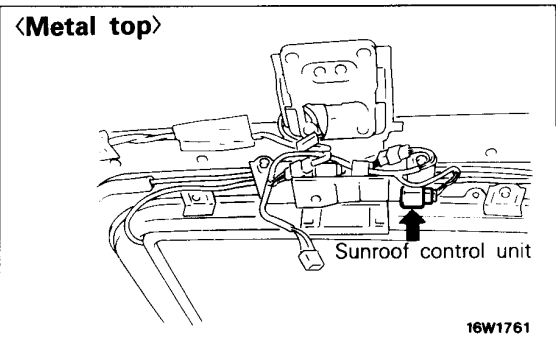
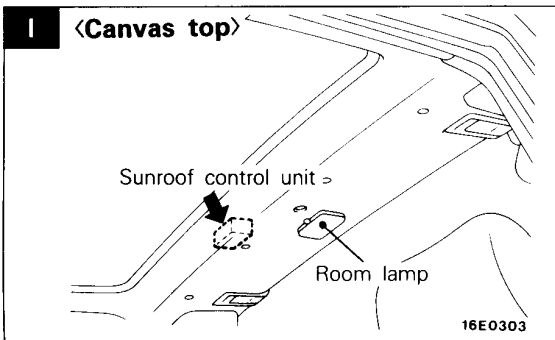
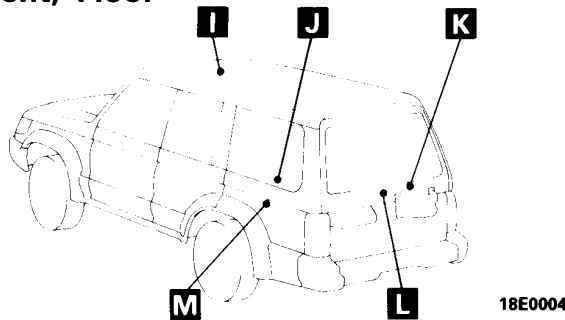

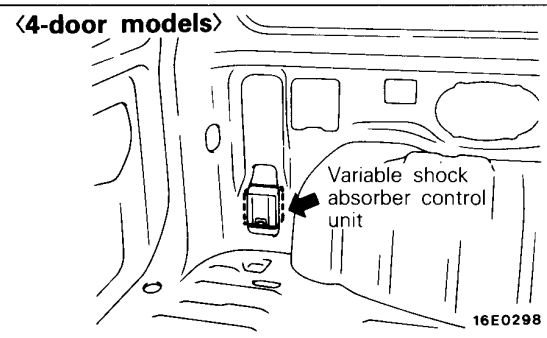
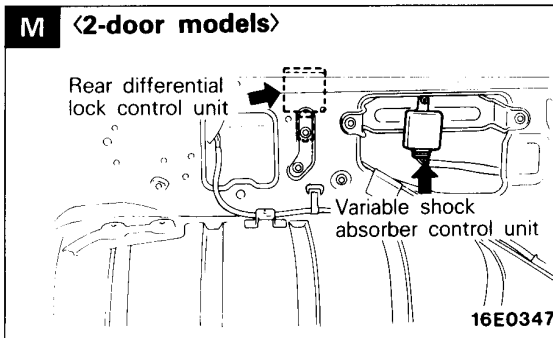
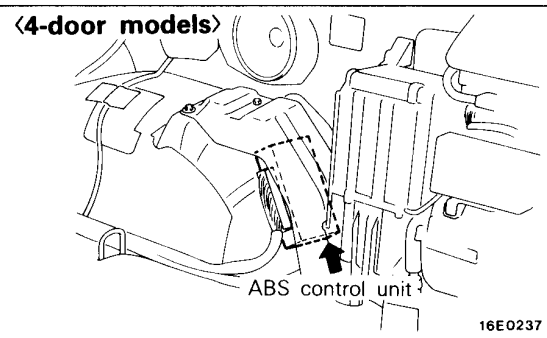
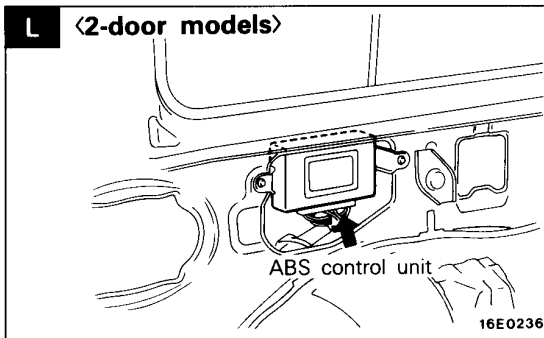
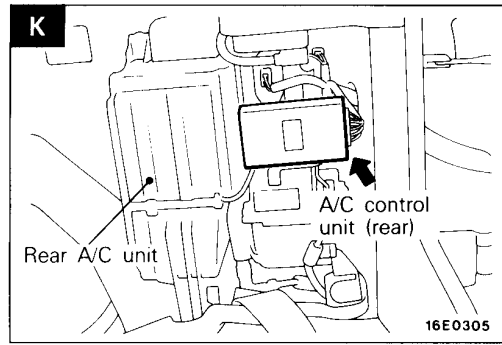
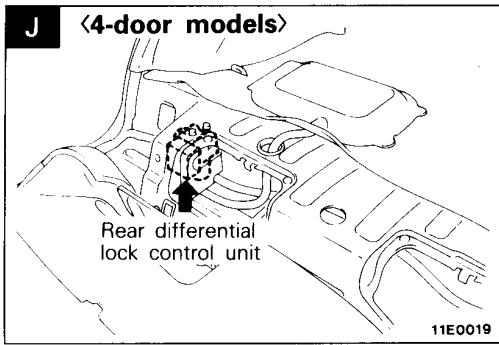

SENSOR

Name	Symbol	Name	Symbol
Air-flow sensor (with built-in atmospheric sensor, intake air temperature sensor)	B	Geomagnetic sensor	H
Air inlet sensor	I	G sensor	K
Air thermo sensor (front)	I	Idle speed control actuator <4G64 engine>	D
Air thermo sensor (rear)	L	Oxygen sensor	A
Crank angle sensor and top dead center sensor	E	Reed switch	G
Engine coolant temperature gauge unit <Diesel-powered vehicles>	C	Speed sensor (front)	M
Engine coolant temperature sensor (for engine control)	D	Speed sensor (rear)	N
Engine coolant temperature switch (for A/C <MPI>)	D	Throttle position sensor	D
Fuel thermo sensor	O	Thermo sensor (inside air)	J
		Thermo sensor (outside air)	F

NOTE

Names are listed in alphabetical order.

Engine compartment

<Petrol-powered vehicles>

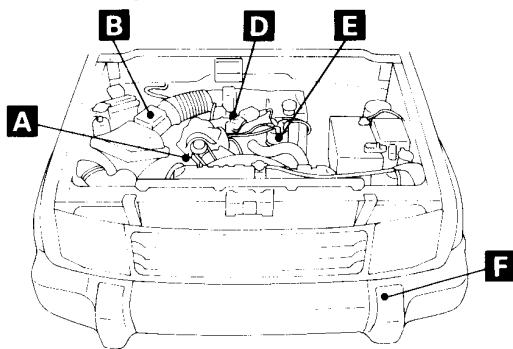

16E0128

<Diesel-powered vehicles>

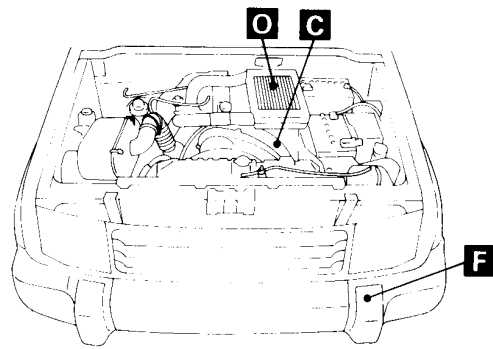

16E0129

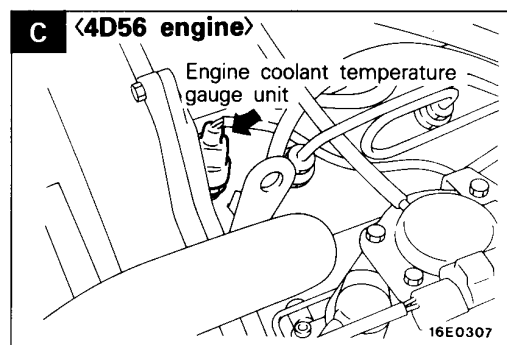
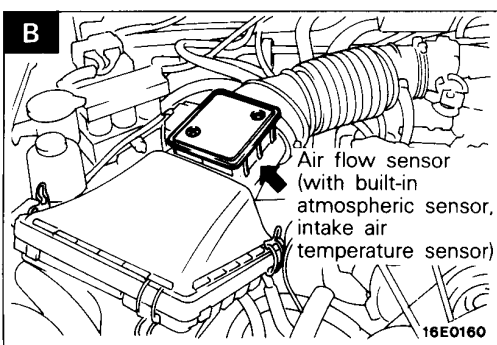
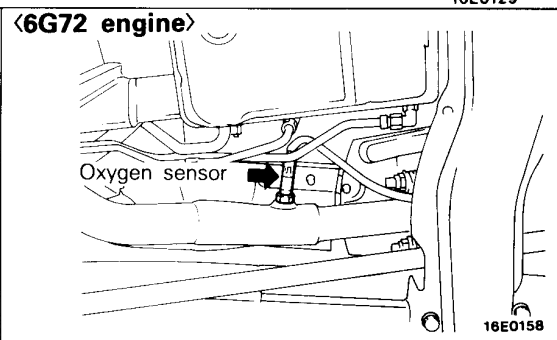
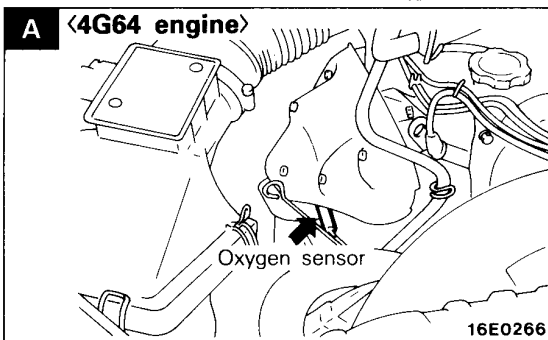

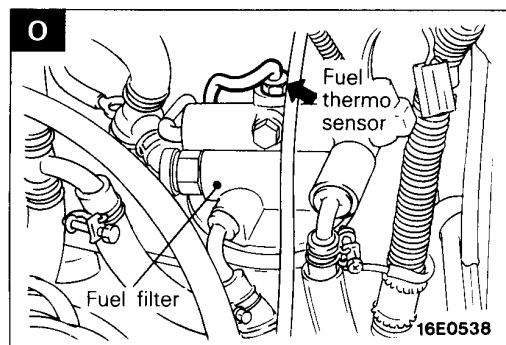
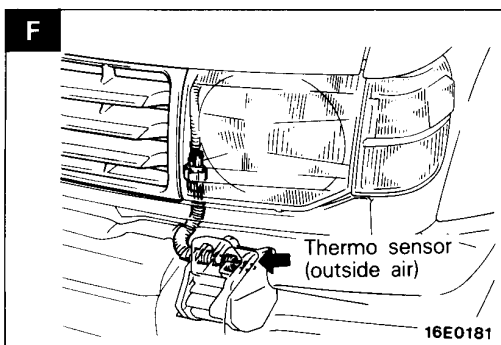
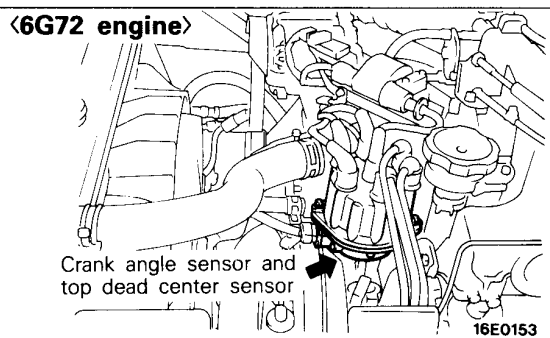
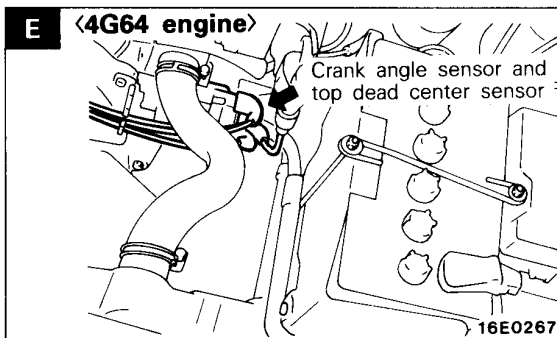
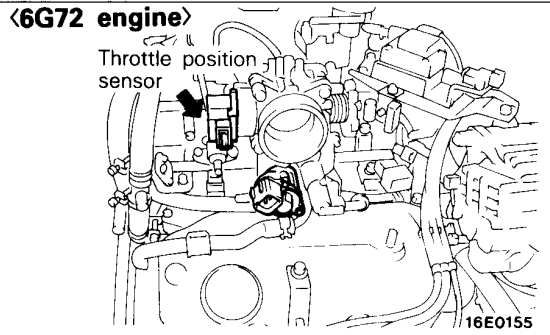
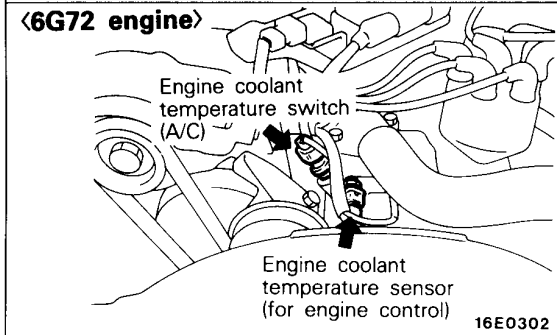
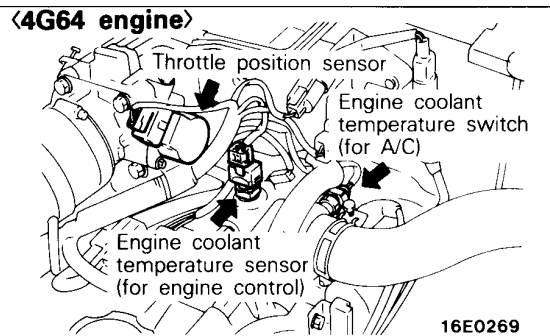
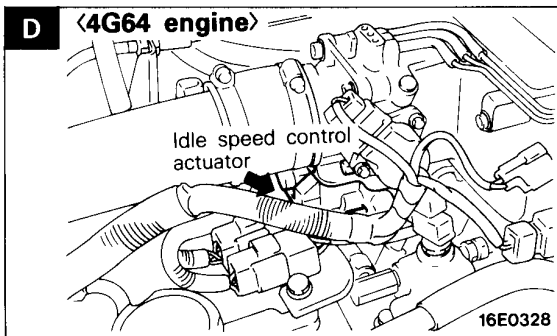

Interior

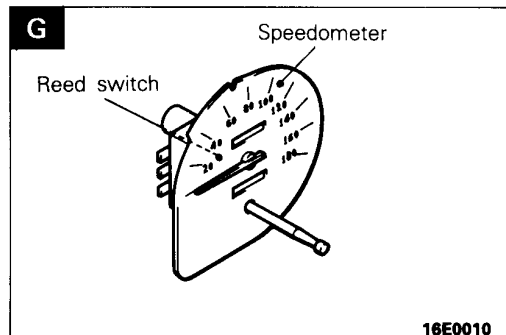
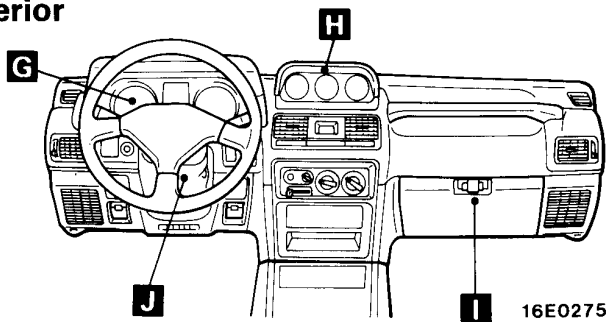

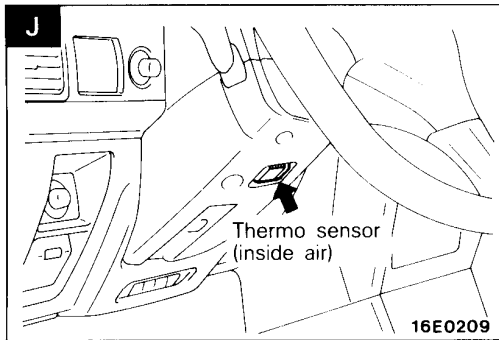
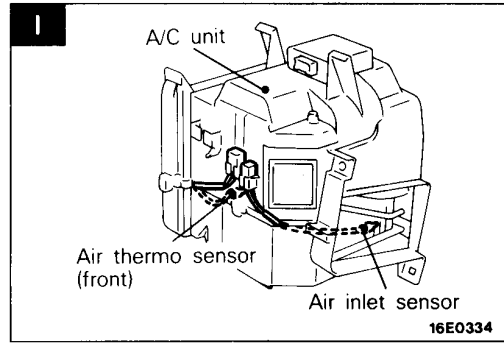
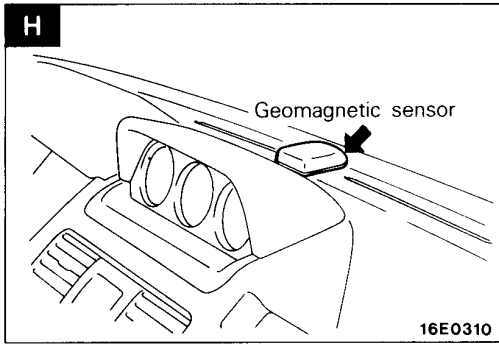

Floor

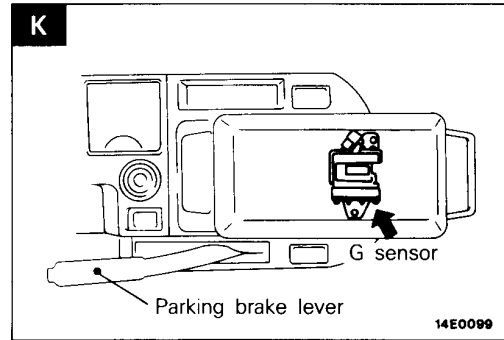
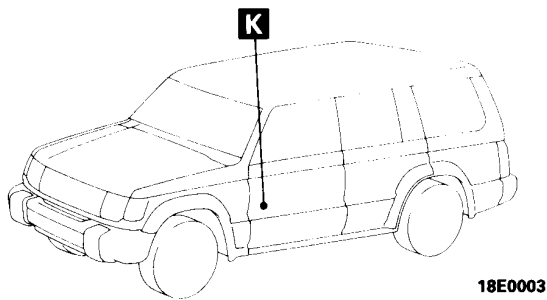

Luggage compartment

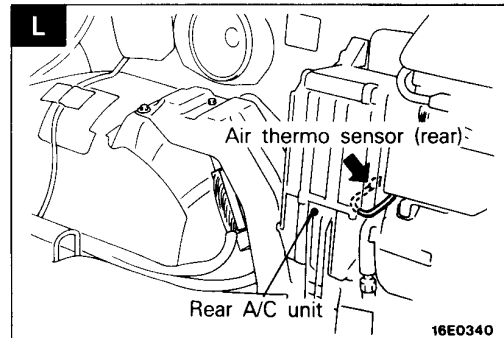
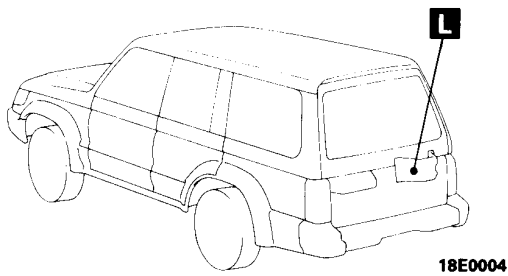

Under floor

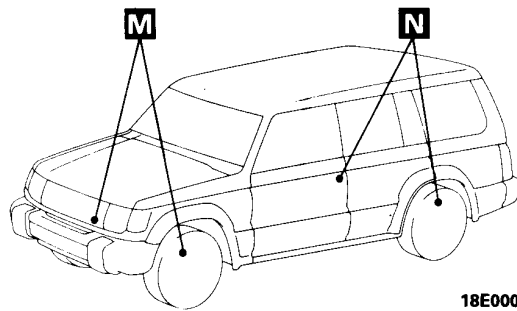

18E0003

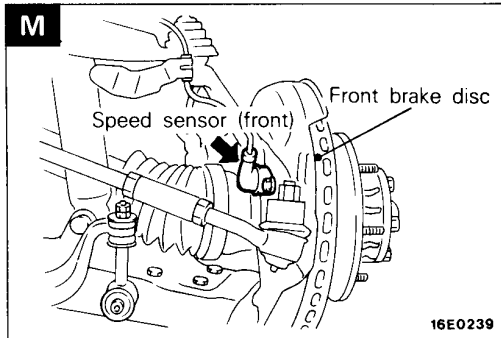

16E0239

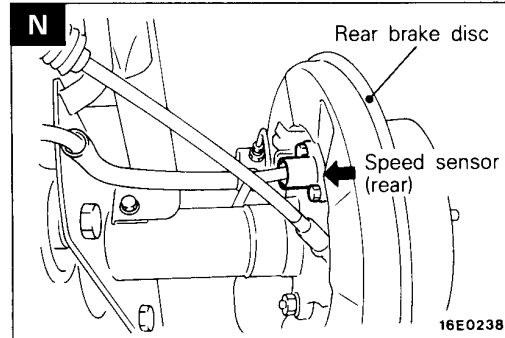

16E0238

DIODE

Name		Symbol	Name		Symbol
Diode (for ABS circuit)	LHD	B	Diode (for dim-dip lamp circuit)		A
	RHD	A	Diode (for dim-dip lamp circuit)		A

NOTE
Names are listed in alphabetical order.

Interior

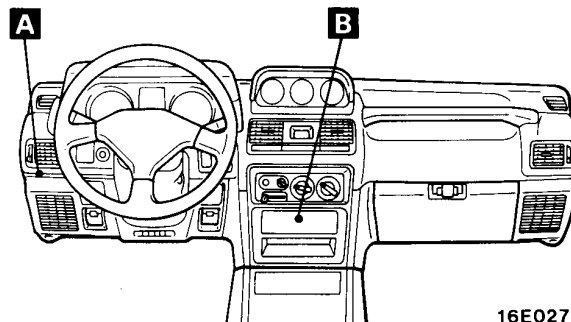

16E0275

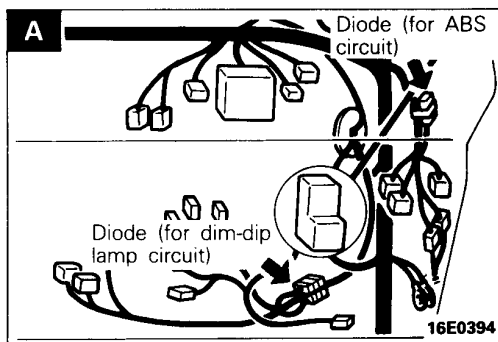

16E0394

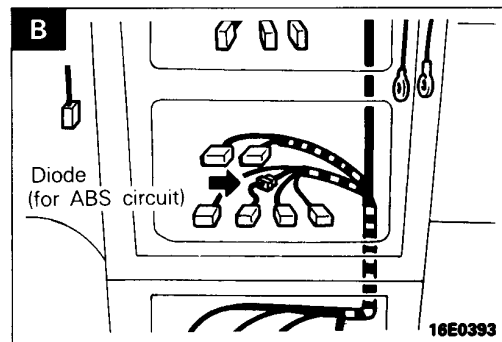

16E0393

3-12 SINGLE PART INSTALLATION POSITION — Inspection Terminal

INSPECTION TERMINAL

Name	Symbol	Name	Symbol
Fuel pump check connector	A	Diagnosis connector	B
Ignition timing adjustment connector	A		

NOTE

Names are listed in alphabetical order.

Engine compartment

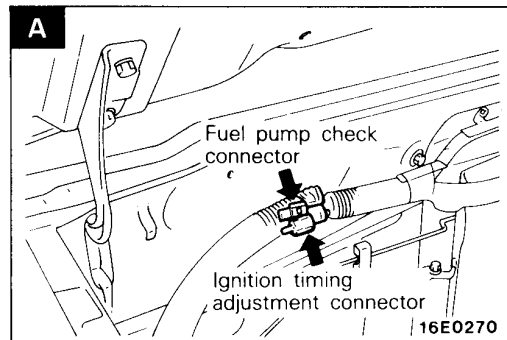
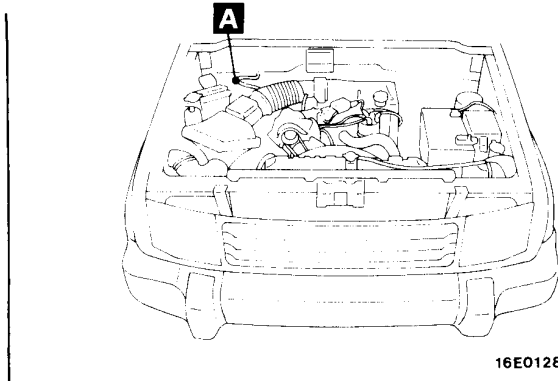

Interior

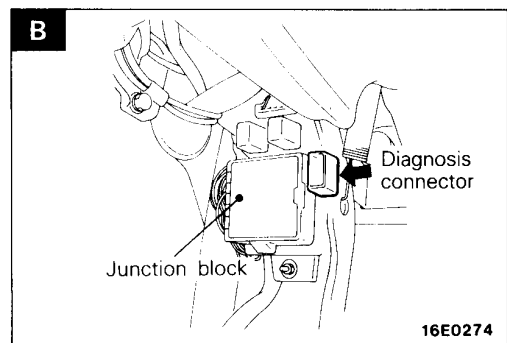
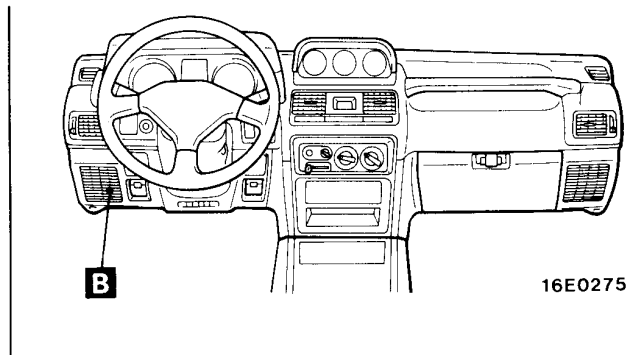

FUSIBLE LINK AND FUSE

Name	Symbol	Name	Symbol
Dedicated fuse	A, B	Multi-purpose fuse	B
Fusible link	A		

NOTE
Names are listed in alphabetical order.

Engine compartment

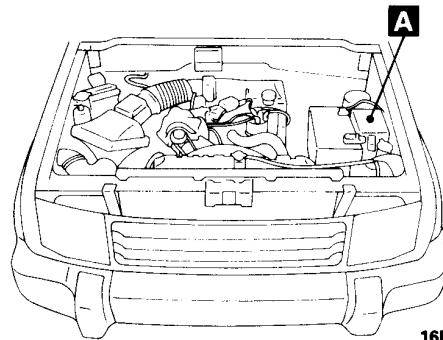

16E0128

Fusible link

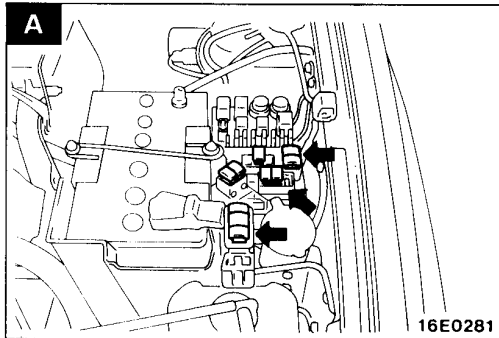

16E0281

Dedicated fuse

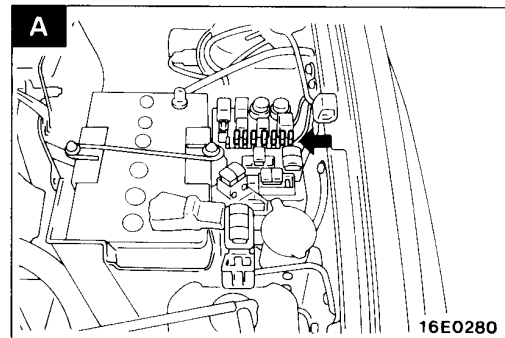

16E0280

Interior

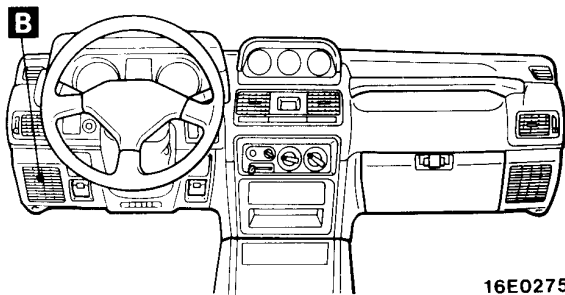

16E0275

Multi-purpose fuse

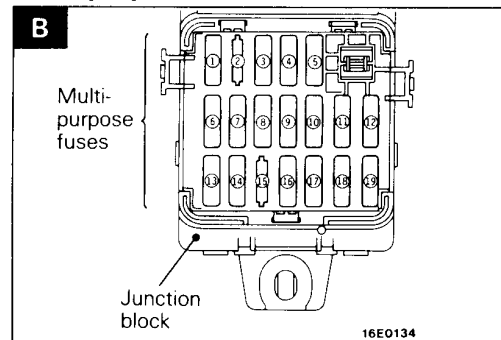

16E0134

Dedicated fuse

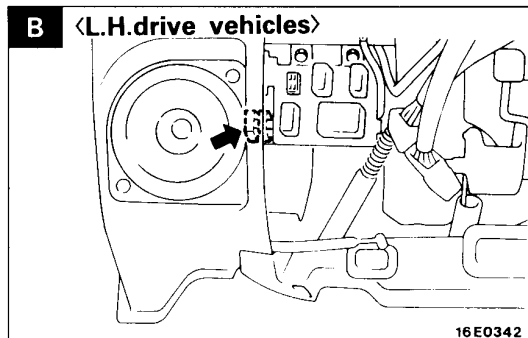

16E0342

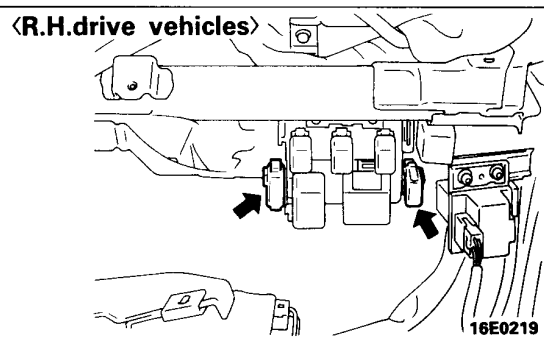

16E0219

EARTH CABLE

Engine compartment

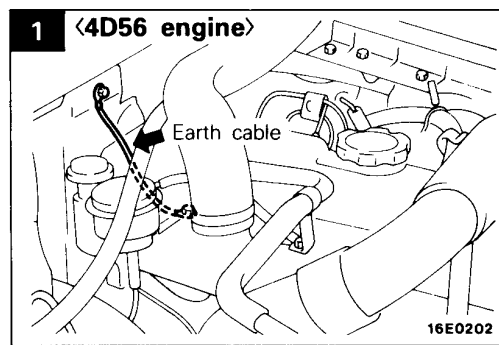
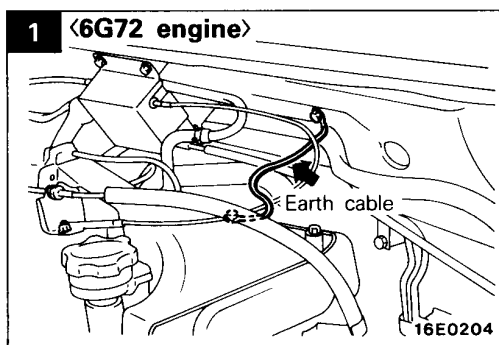
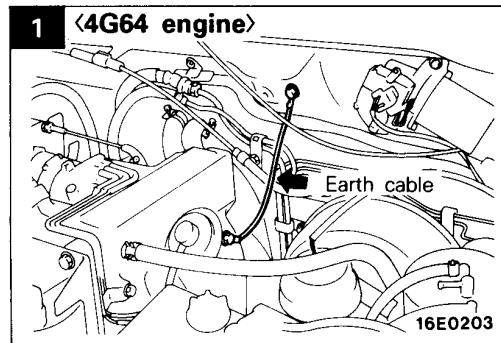
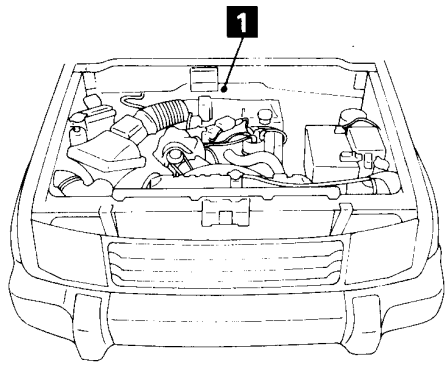

Under floor

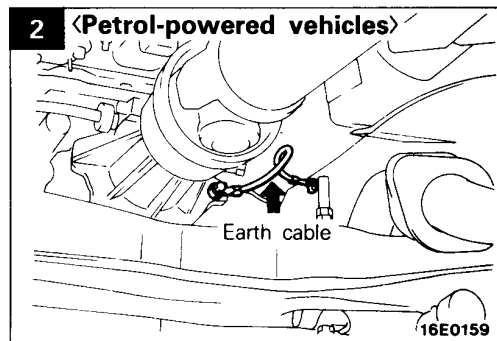
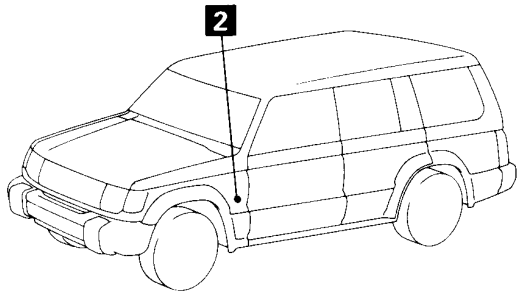

EARTH

Engine compartment

<Petrol-powered vehicles>

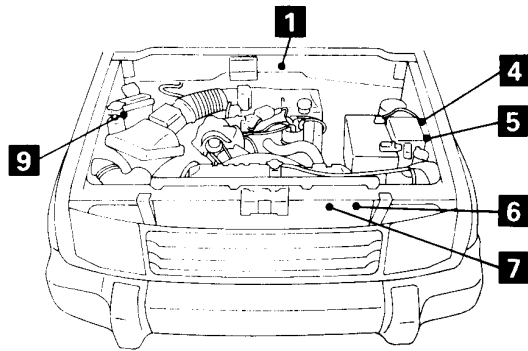

16E0128

<Diesel-powered vehicles>

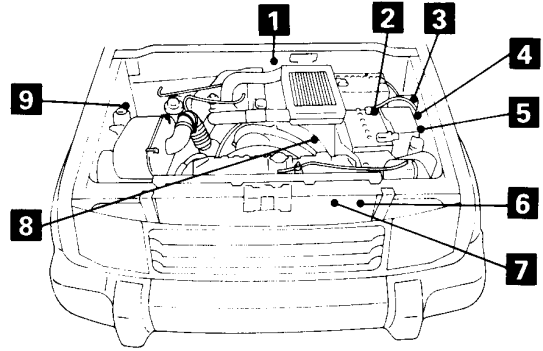

16E0129

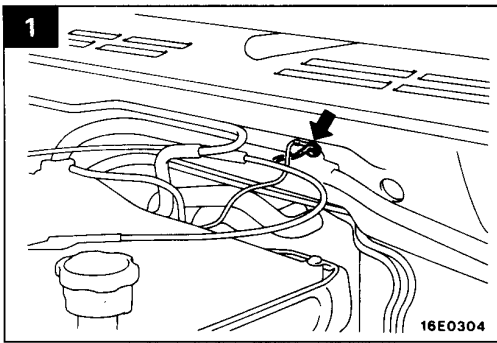

16E0304

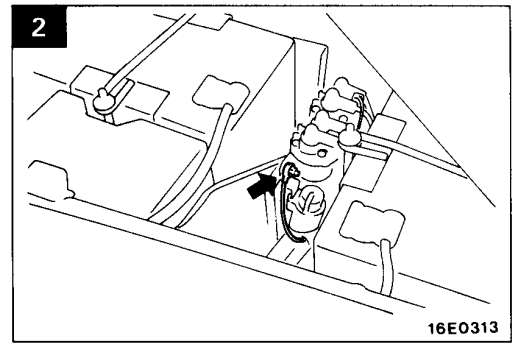

16E0313

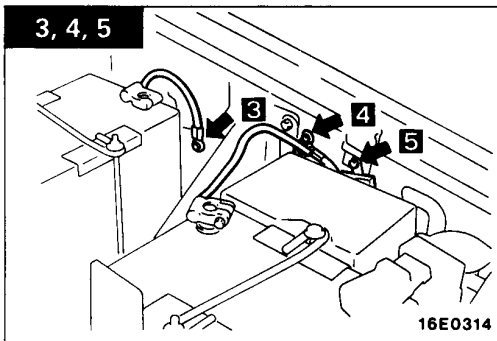

16E0314

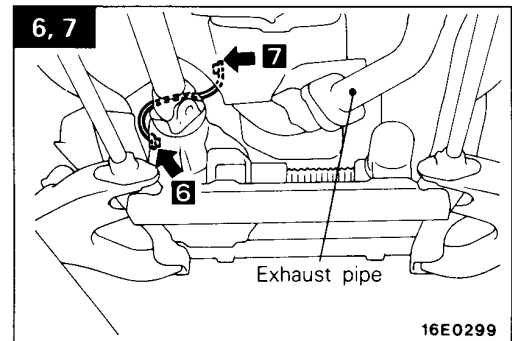

16E0299

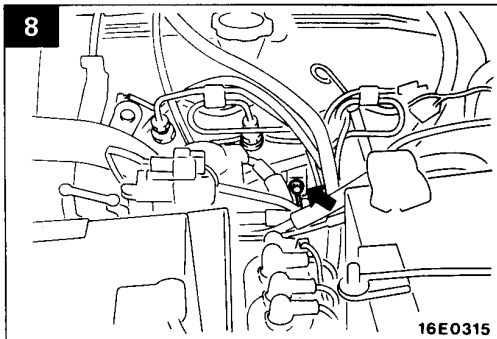

16E0315

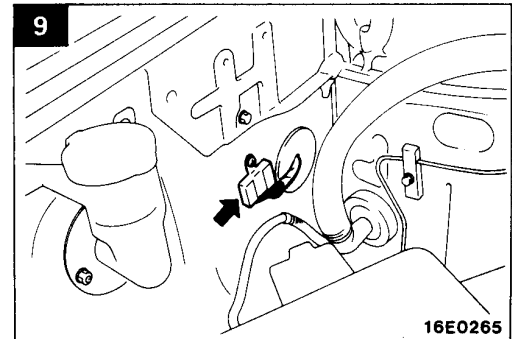

16E0265

Interior

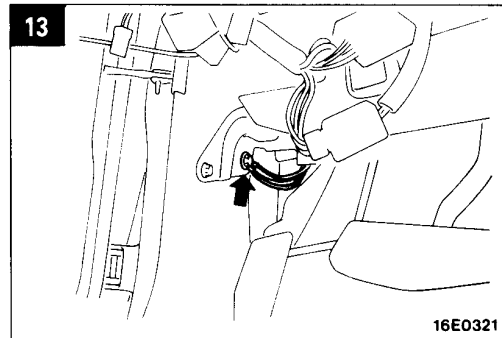
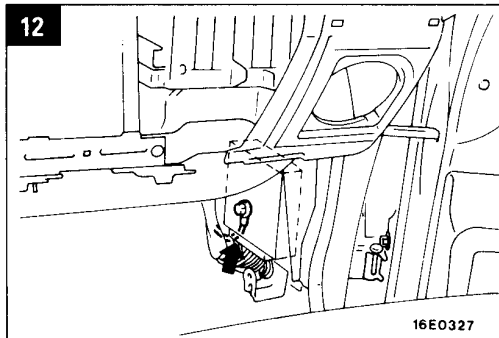
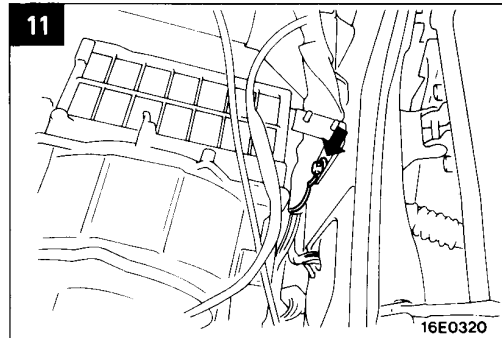
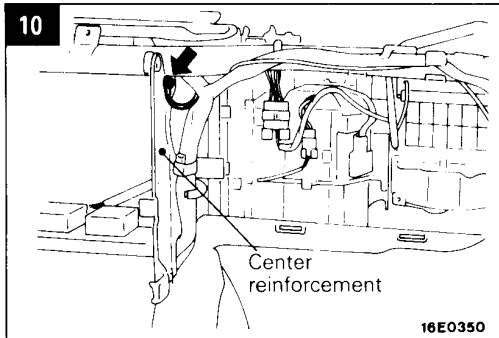
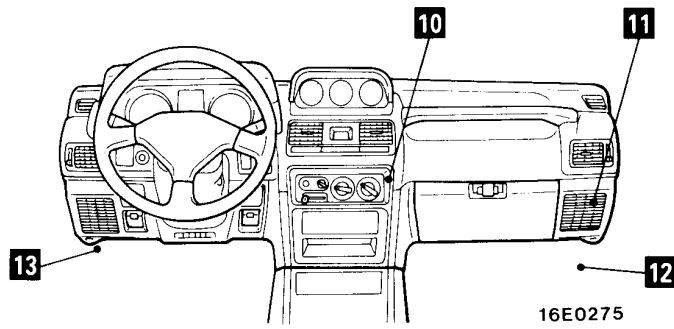

Floor, Rear door

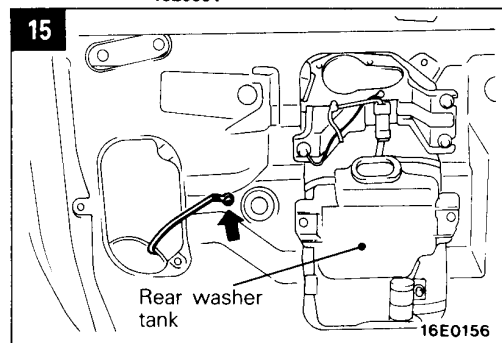
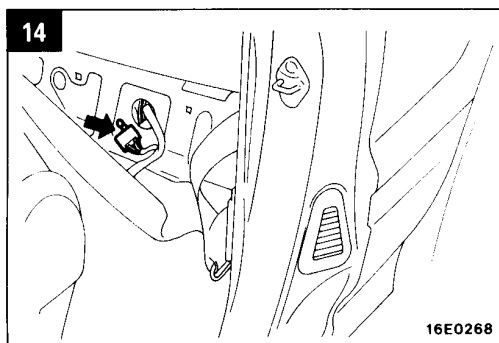
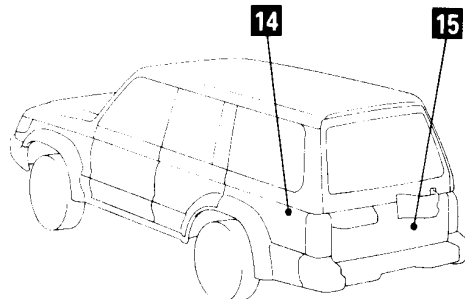

4 CIRCUIT DIAGRAM

1 POWER DISTRIBUTION SYSTEM	
1-1 Petrol-powered vehicles	4-4
1-2 Diesel-powered vehicles	4-10
2 STARTING SYSTEM	
2-1 Petrol-powered vehicles	4-16
2-2 Diesel-powered vehicles	4-17
3 IGNITION SYSTEM	
3-1 4G64 engine	4-19
3-2 6G72 engine	4-20
4 CHARGING SYSTEM	
4-1 Petrol-powered vehicles	4-21
4-2 Diesel-powered vehicles <2-door models>	4-22
4-3 Diesel-powered vehicles <4-door models>	4-23
5 GLOW SYSTEM	
5-1 Auto glow	4-26
5-2 Super quick glow	4-27
5-3 Super quick glow <with EGR system>	4-27-1
5-4 Super quick glow <2-door models with EGR system>	4-27-3
6 MPI SYSTEM	
6-1 4G64 engine	4-28
6-2 6G72 engine <M/T>	4-32
6-3 6G72 engine <A/T>	4-36
7 OVERDRIVE CONTROL SYSTEM	4-40
8 HEADLAMP	
8-1 L.H. drive vehicles without daytime running lamp <1991 MODELS>	4-44
8-1 L.H. drive vehicles without daytime running lamp <1993 MODELS>	4-45-1
8-2 L.H. drive vehicles with daytime running lamp <1991 MODELS>	4-46
8-2 L.H. drive vehicles with daytime running lamp <1993 MODELS>	4-48-2
8-3 R.H. drive vehicles <1991 MODELS>	4-50
8-3 R.H. drive vehicles <1993 MODELS>	4-52-2
9 HEADLAMP LEVELING SYSTEM	
9-1 L.H. drive vehicles	4-54
9-2 R.H. drive vehicles	4-55
10 TAIL LAMP, CLEARANCE LAMP, LICENSE PLATE LAMP	4-58
11 REAR FOG LAMP	
11-1 L.H. drive vehicles <1991 MODELS>	4-60
11-1 L.H. drive vehicles <1993 MODELS>	4-61-1
11-2 R.H. drive vehicles <1991 MODELS>	4-62
11-2 R.H. drive vehicles <1993 MODELS>	4-63-1
12 ROOM LAMP	
12-1 Canvas top	4-66
12-2 2-door models without sunroof	4-67
12-3 2-door models with sunroof	4-68
12-4 4-door models	4-69
13 TURN-SIGNAL LAMP AND HAZARD LAMP	4-70
14 STOP LAMP	4-73
15 BACK-UP LAMP	
15-1 M/T	4-74
15-2 A/T	4-75
16 HORN	4-76
17 METER AND GAUGE	
17-1 4G64 engine	4-78
17-2 6G72, 4D56 engine	4-80
18 WARNING LAMP	
18-1 4G64 engine	4-83
18-2 6G72, 4D56 engine	4-86
19 INDICATOR LAMP	4-91
20 MULTI-METER	
20-1 Vehicles without electronic compass	4-95
20-2 Vehicles with electronic compass	4-96
21 POWER WINDOW	
21-1 L.H. drive vehicles <2-door models>	4-98
21-2 R.H. drive vehicles <2-door models>	4-99
21-3 L.H. drive vehicles <4-door models>	4-100
21-4 R.H. drive vehicles <4-door models>	4-102
22 CENTRAL DOOR LOCKING SYSTEM	4-106
23 HEATER	
23-1 Vehicles with rear heater <with dual air conditioner>	4-108
23-2 Vehicles with rear heater <without dual air conditioner>	4-111
23-3 Vehicles without rear heater	4-114
24 SINGLE AIR CONDITIONER	
24-1 Petrol-powered vehicles	4-116
24-2 Diesel-powered vehicles	4-118
25 DUAL AIR CONDITIONER	
25-1 Petrol-powered vehicles with rear heater	4-121
25-2 Petrol-powered vehicles without rear heater	4-127
25-3 Diesel-powered vehicles with rear heater	4-131
25-4 Diesel-powered vehicles without rear heater	4-138
26 WINDSHIELD WIPER AND WASHER	4-144
27 REAR WIPER AND WASHER	4-146
28 HEADLAMP WASHER	4-148
29 DEFOGGER	4-150
30 REMOTE CONTROLLED MIRROR	4-151
31 AUDIO	
31-1 AM/FM radio without cassette player	4-153
31-2 AM/FM, LW/MW/FM radio with cassette player	4-154
32 CLOCK	4-156

33 CIGARETTE LIGHTER	4-157	40 HEATED SEAT	4-168
34 SUNROOF		41 ANTI-SKID BRAKE SYSTEM	4-170
34-1 Metal top	4-158	42 AUTO-CRUISE CONTROL	
34-2 Canvas top	4-159	42-1 Petrol-powered vehicles	4-174
35 ACCESSORY SOCKET	4-160	42-2 Diesel-powered vehicles	4-178
36 INTERCOOLER FAN	4-161	43 JUNCTION BLOCK	4-182
37 REAR DIFFERENTIAL LOCK SYSTEM	4-162	44 CENTRALIZED JUNCTION	4-184
38 SUPER SELECT 4WD SYSTEM	4-164	45 LIGHTING MONITOR BUZZER	4-188
39 REMOTE CONTROLLED VARIABLE		46 FUEL LINE HEATER	4-190
SHOCK ABSORBER SYSTEM	4-166		

NOTES

1 POWER DISTRIBUTION SYSTEM
1-1 Petrol-powered vehicles

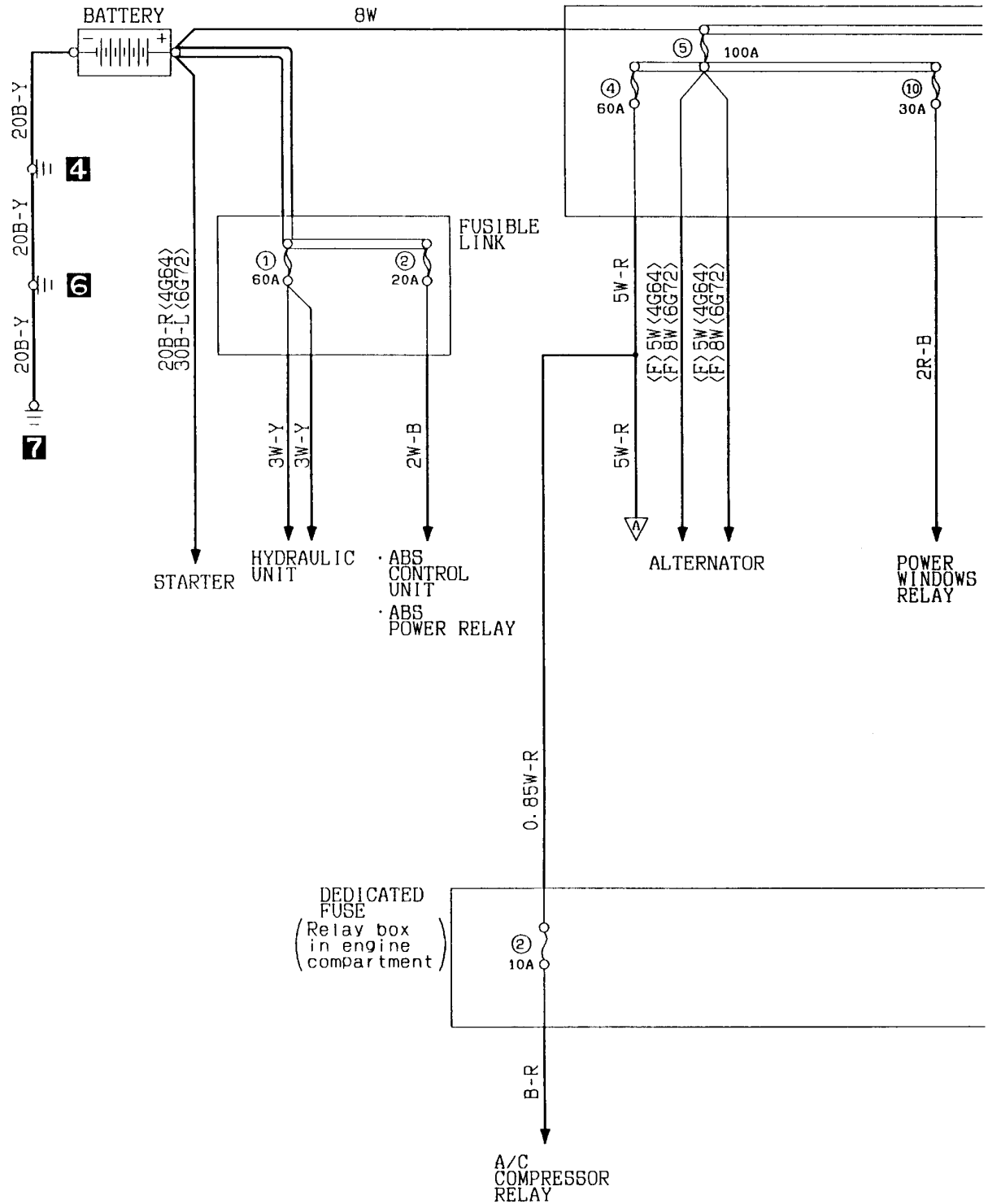

Wire colour code
 B:Black LG:Light green G:Green L:Blue W:White Y:Yellow SB:Sky blue
 BR:Brown O:Orange GR:Gray R:Red P:Pink V:Violet

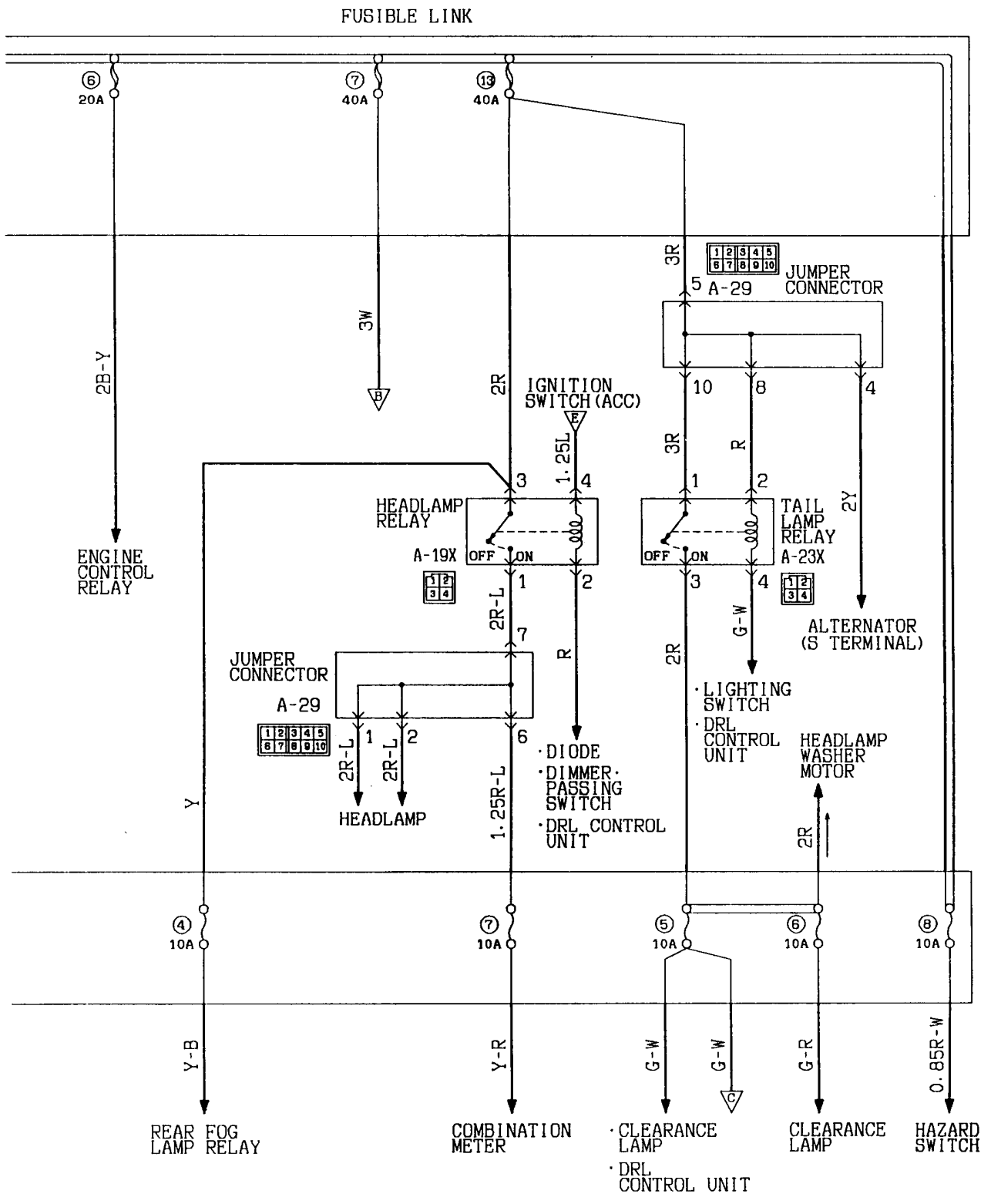

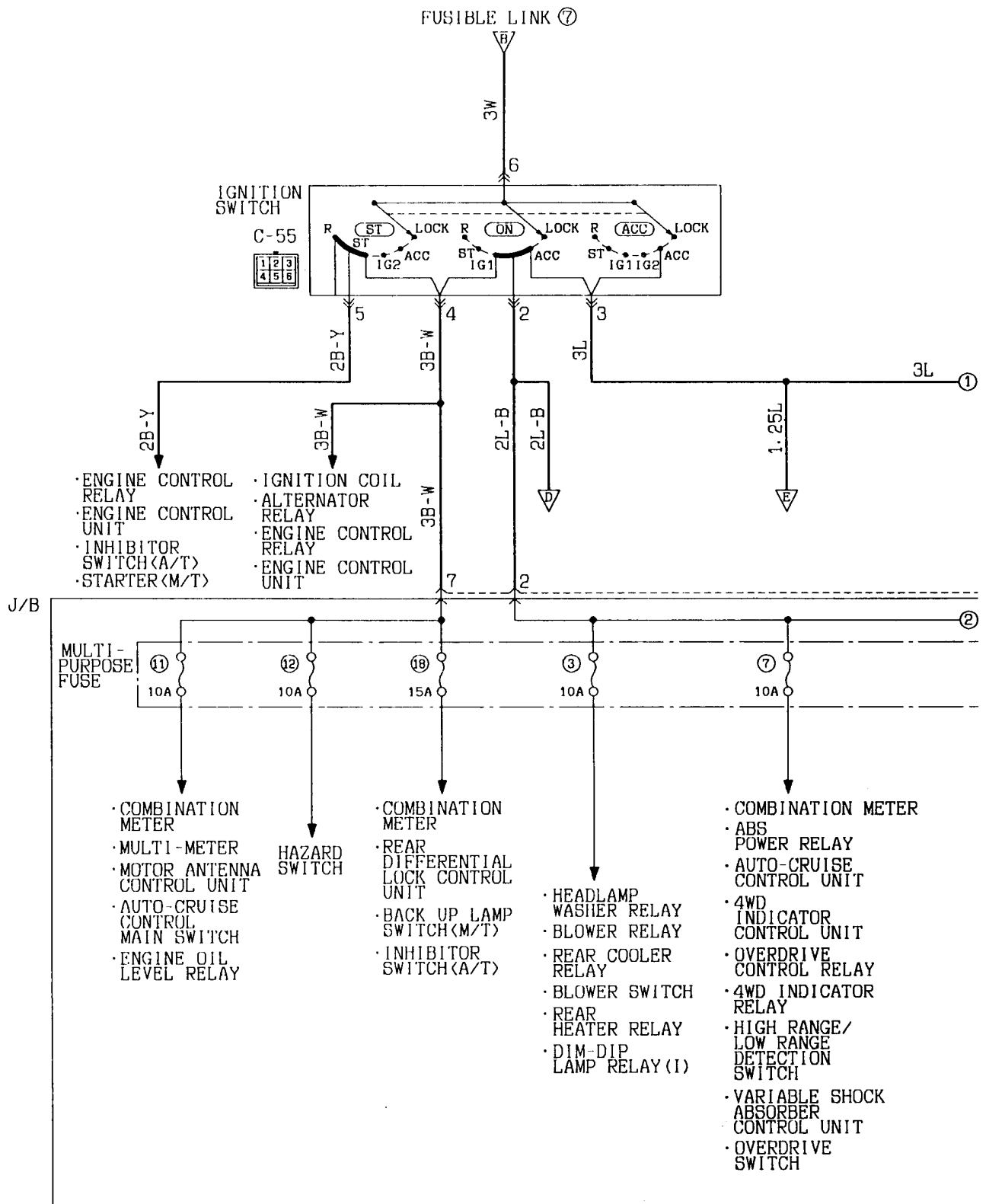

Remark

The above circuit diagram shows the current flow at the ignition key position "ACC", "ON" and "ST" combined. Be sure trace the appropriate circuit depending on the ignition key position.

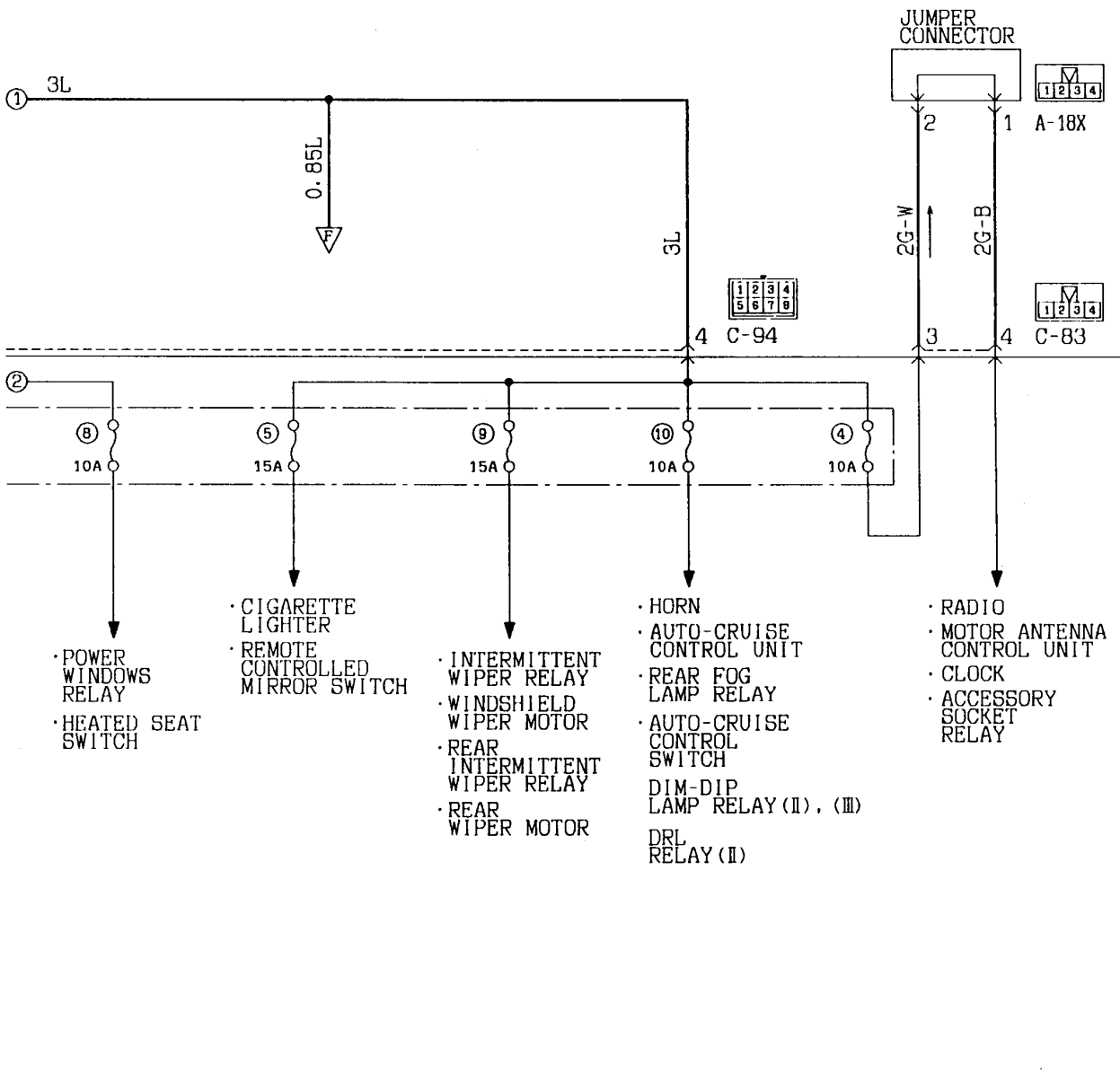

Wire colour code
 B:Black I,G:Light green G:Green L:Blue W:White Y:Yellow SB:Sky blue
 BR:Brown O:Orange GR:Gray R:Red P:Pink V:Violet

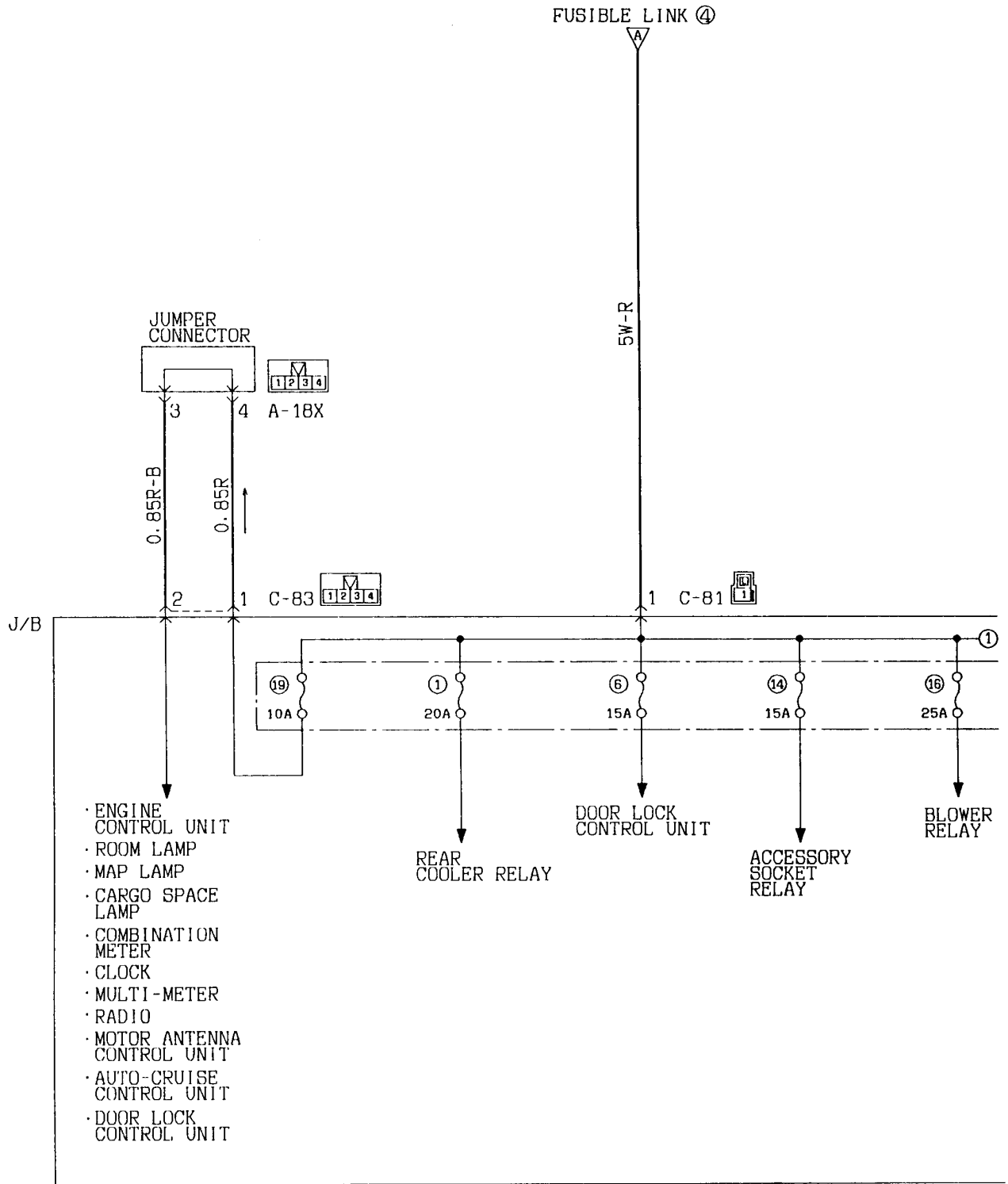

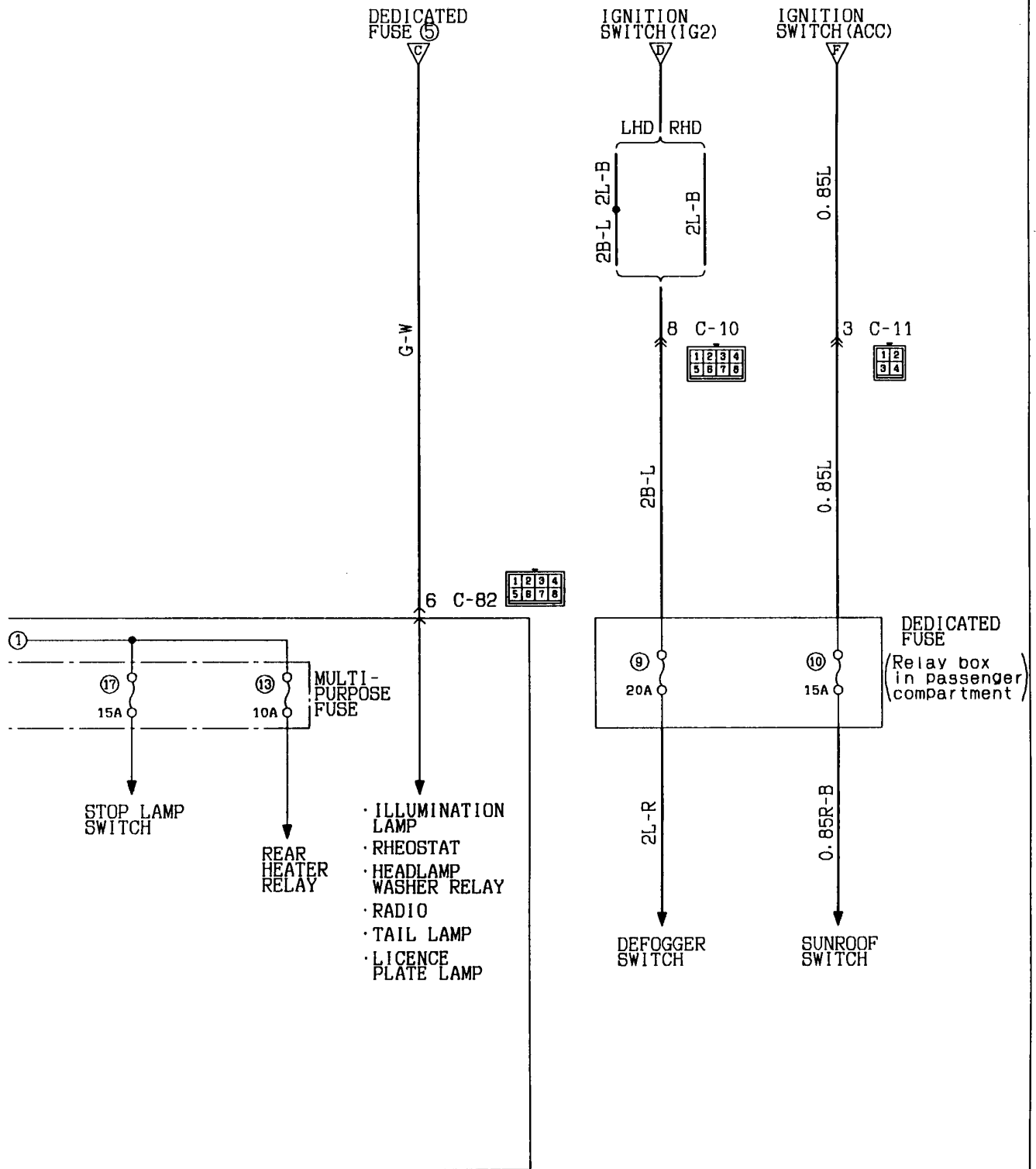

1-2 Diesel-powered vehicles

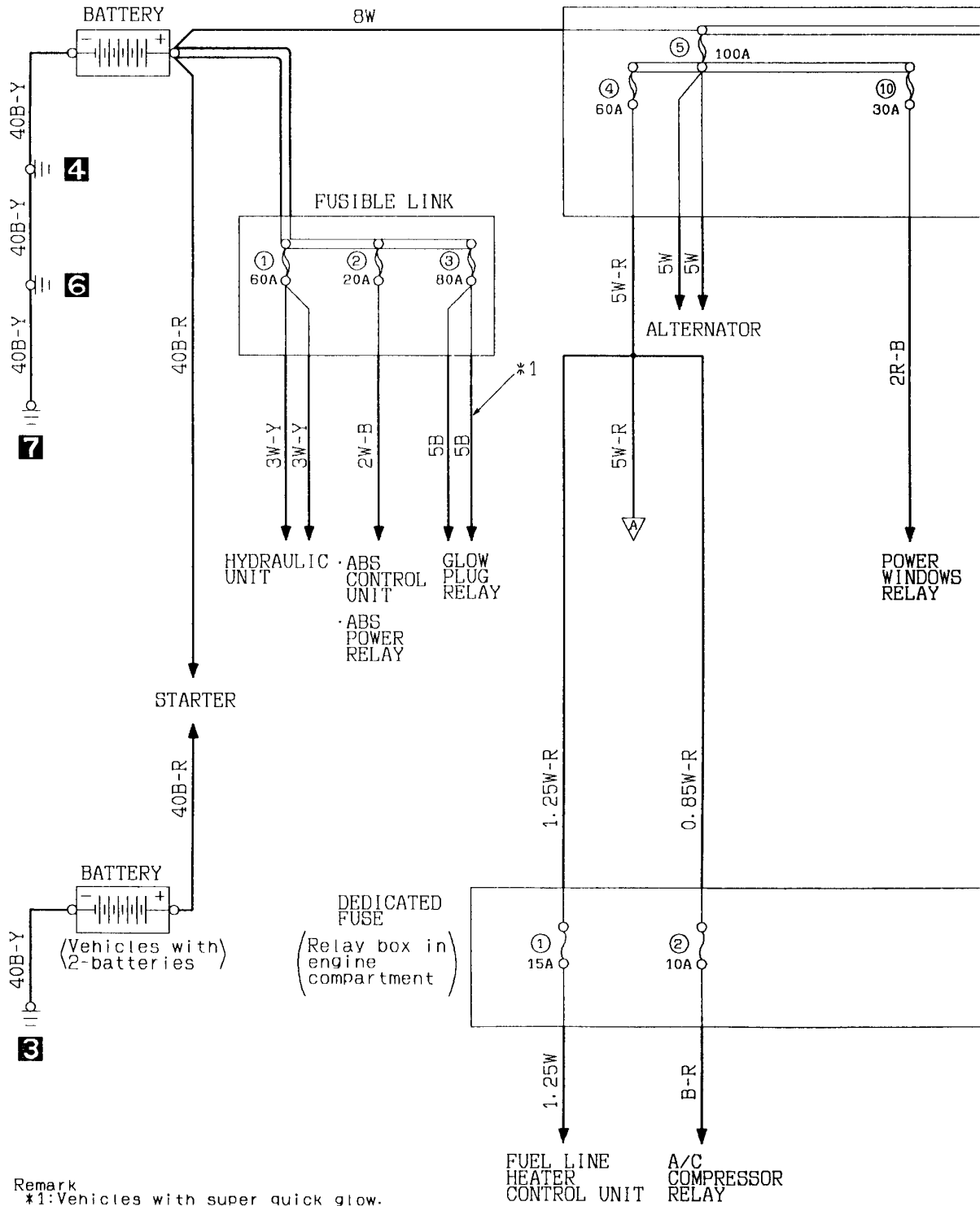

Remark
 *1: Vehicles with super quick glow.
 *2: Vehicles with dual air conditioner.

KX35-AC-00103-EC

Wire colour code						
B:Black	LG:Light green	G:Green	L:Blue	W:White	Y:Yellow	SB:Sky blue
BR:Brown	O:Orange	GR:Gray	R:Red	P:Pink	V:Violet	

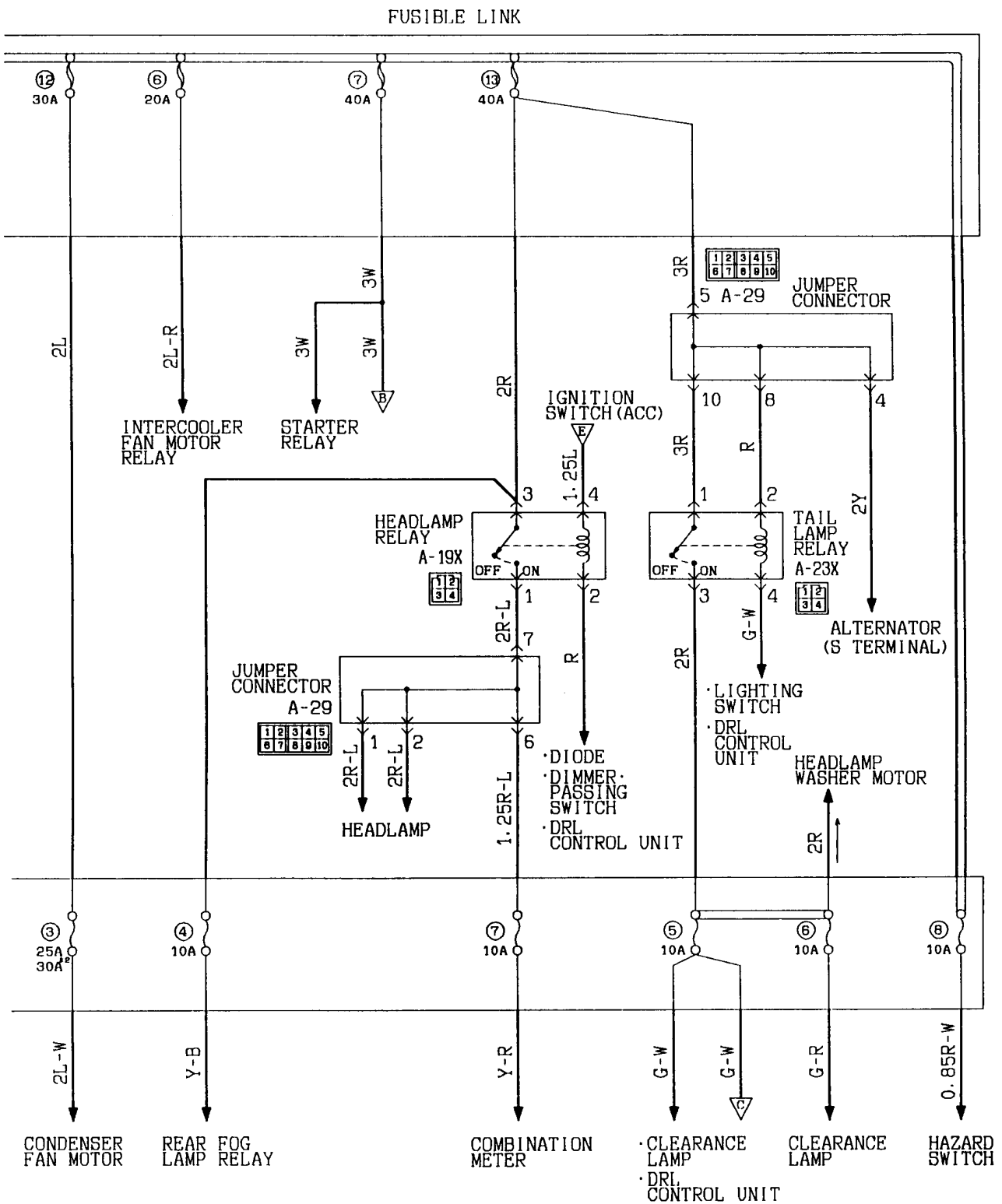

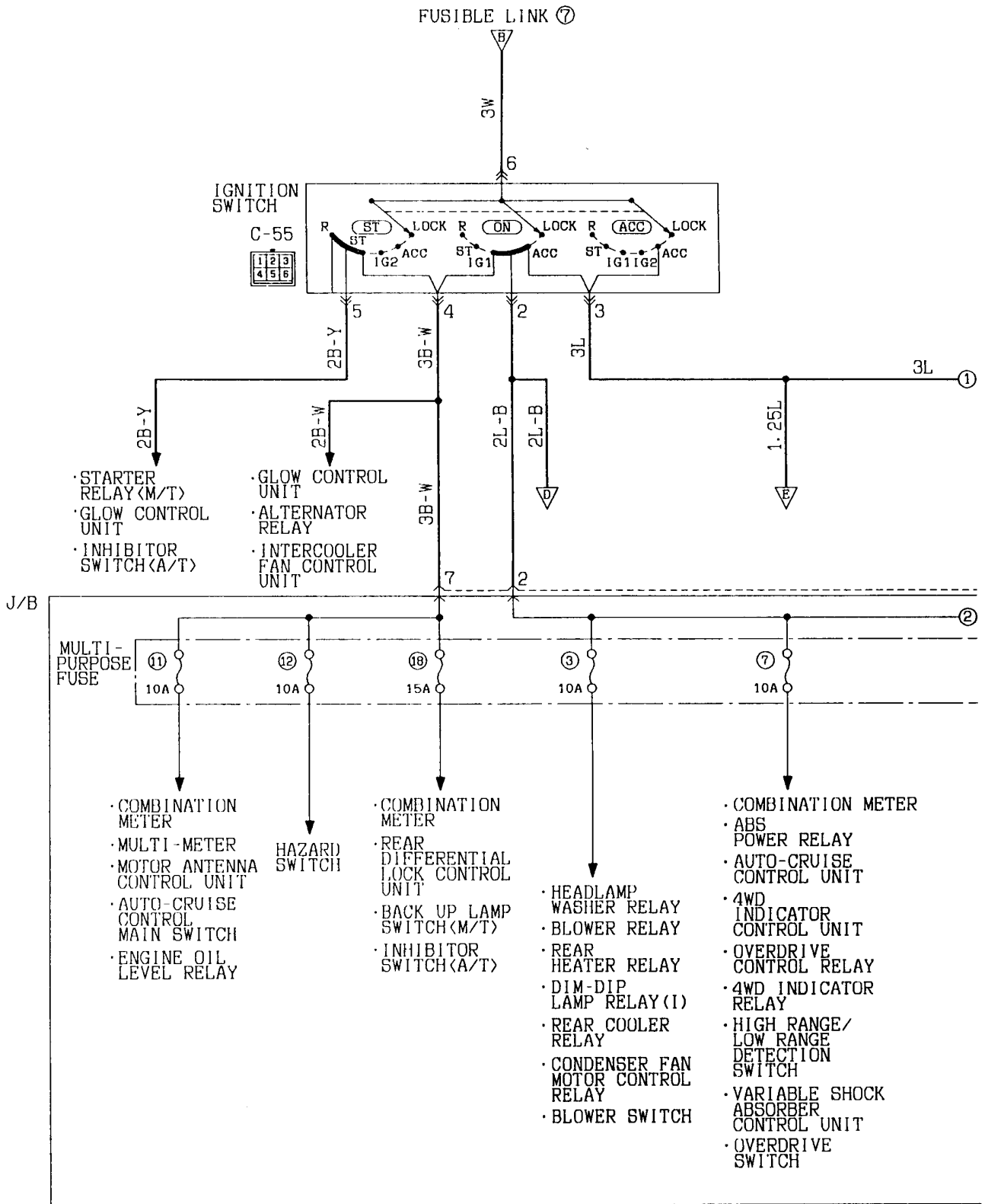

Remark

The above circuit diagram shows the current flow at the ignition key position "ACC", "ON" and "ST" combined. Be sure trace the appropriate circuit depending on the ignition key position.

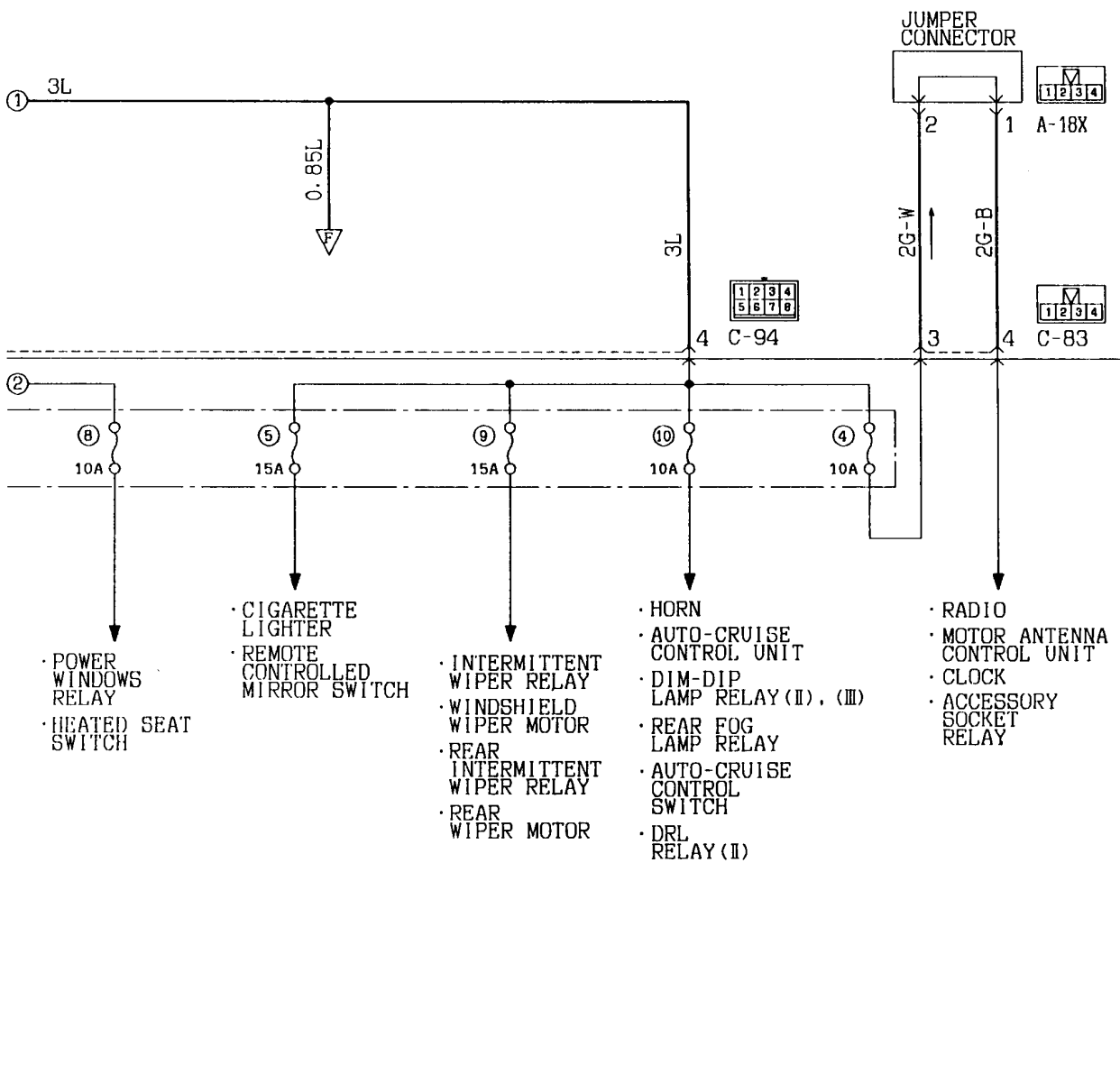

Wire colour code
 B:Black LG:Light green G:Green L:Blue W:White Y:Yellow SB:Sky blue
 BR:Brown O:Orange GR:Gray R:Red P:Pink V:Violet

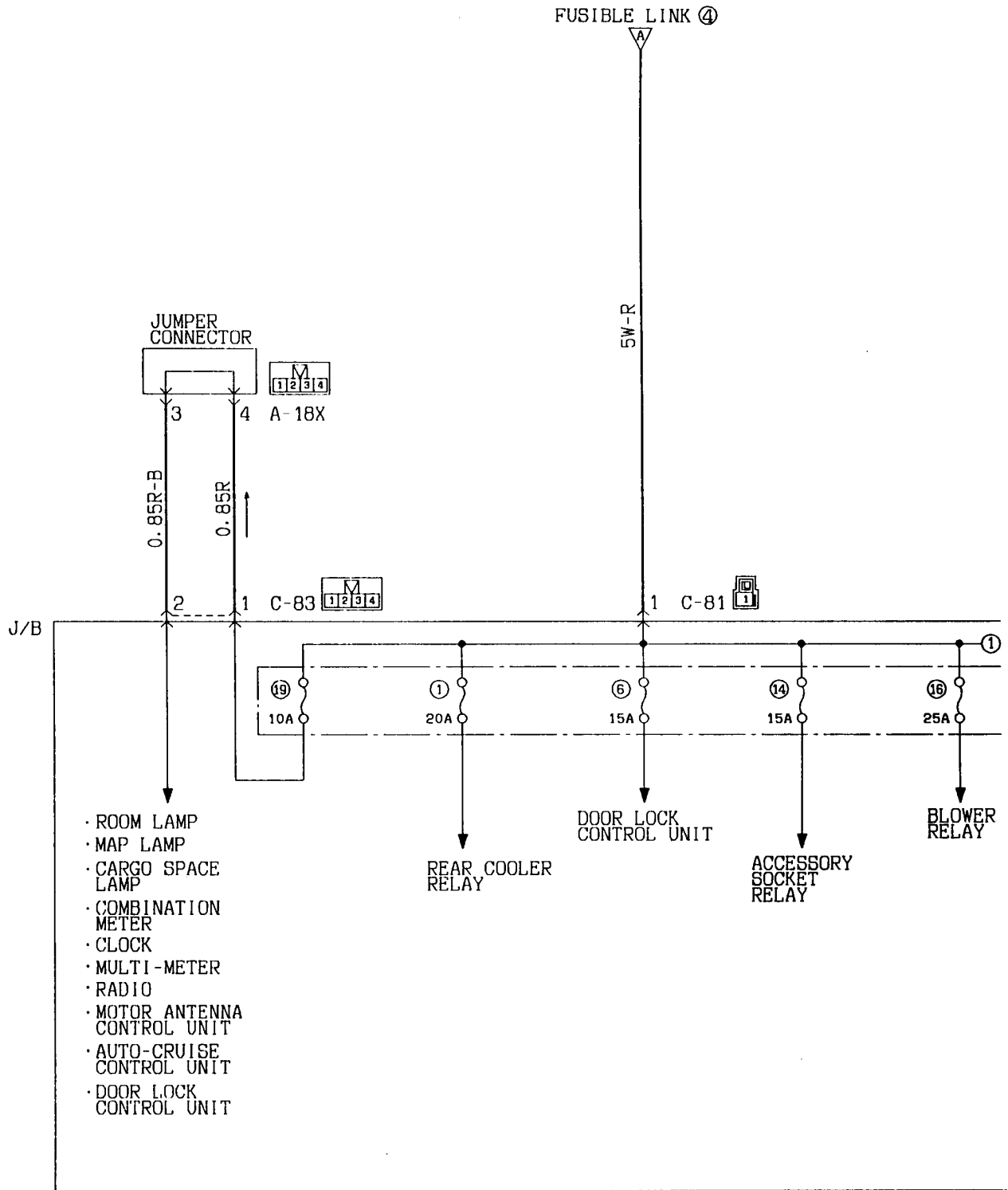

Wire colour code
 B:Black LG:Light green G:Green L:Blue W:White Y:Yellow SB:Sky blue
 BR:Brown O:Orange GR:Gray R:Red P:Pink V:Violet

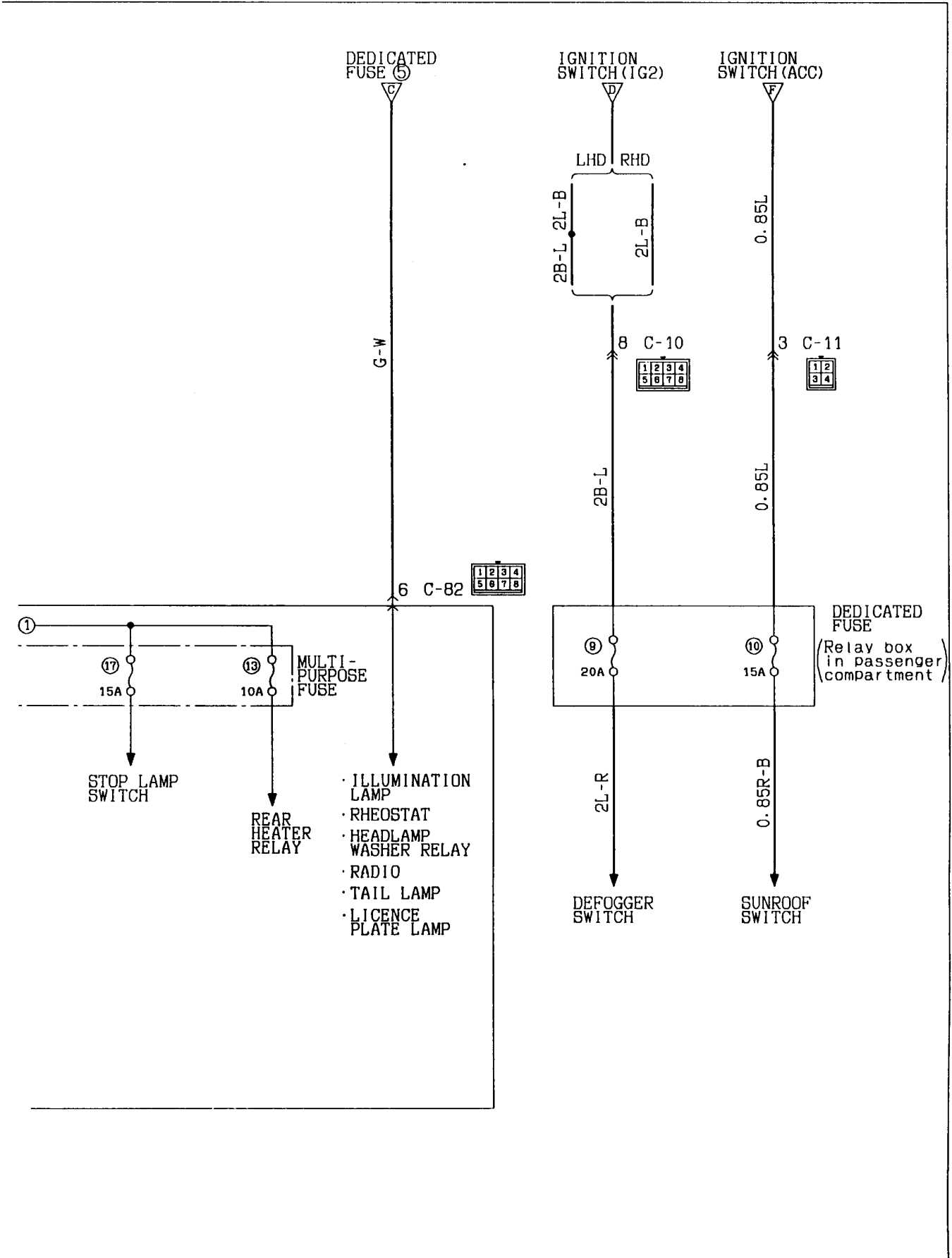

2 STARTING SYSTEM
2-1 Petrol-powered vehicles

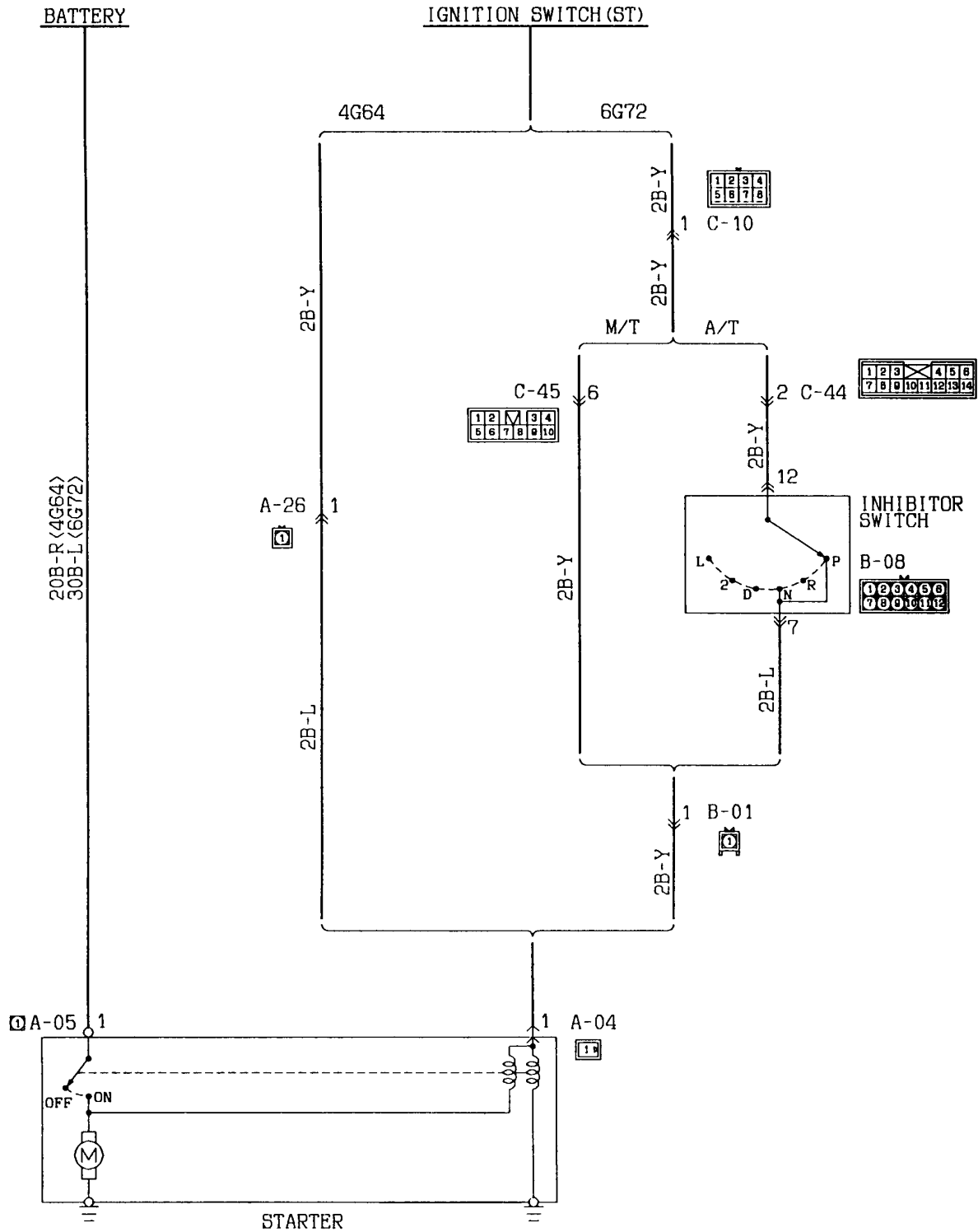

KX35-AC-00201-EC

Wire colour code	B:Black	LG:Light green	G:Green	L:Blue	W:White	Y:Yellow	SB:Sky blue
	BR:Brown	O:Orange	GR:Gray	R:Red	P:Pink	V:Violet	

2-2 Diesel-powered vehicles

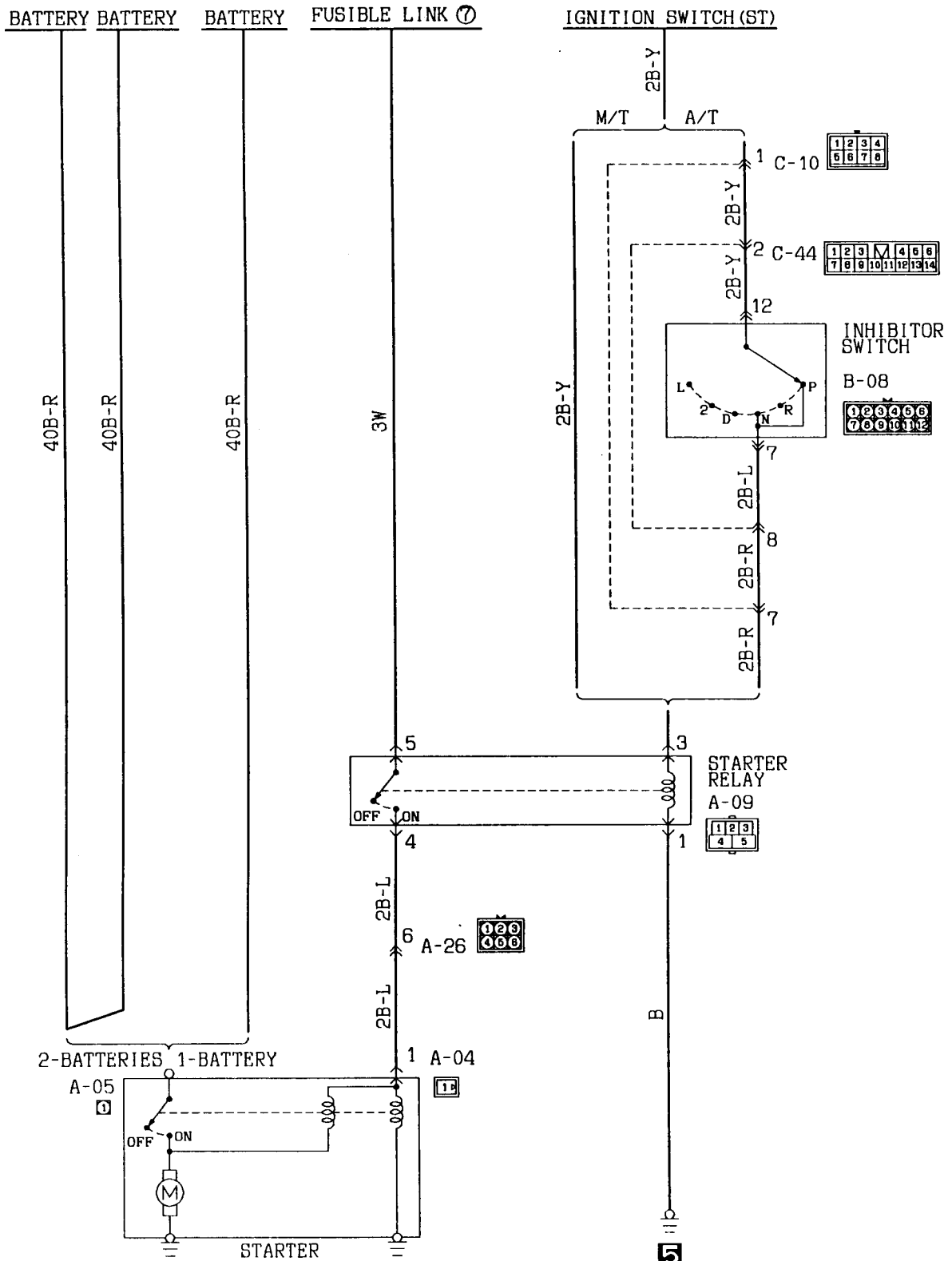

Wire colour code
 B:Black LG:Light green G:Green L:Blue W:White Y:Yellow SB:Sky blue
 BR:Brown O:Orange GR:Gray R:Red P:Pink V:Violet

STARTING SYSTEM (See P. 4-16, 17.)**OPERATION****⟨Petrol-powered vehicles⟩**

- On vehicles with automatic transmission, placing the ignition switch in the ST position with the selector lever in P or N position causes the starter contacts (magnet switch) to close energizing the starter motor.

⟨Diesel-powered vehicles⟩

- On vehicles with automatic transmission, placing the ignition switch in the ST position with the selector lever in P or N position, the starter relay becomes on. This will turn on the contacts of the starter (magnetic switch) to revolve the starter motor.

TROUBLESHOOTING HINTS

1. Starter motor does not turn over at all.
 - Check starter (coil).
 - Check battery terminals for proper contact.
2. Starter motor does not stop rotating.
 - Check starter (magnet switch).

3 IGNITION SYSTEM
3-1 4G64 engine

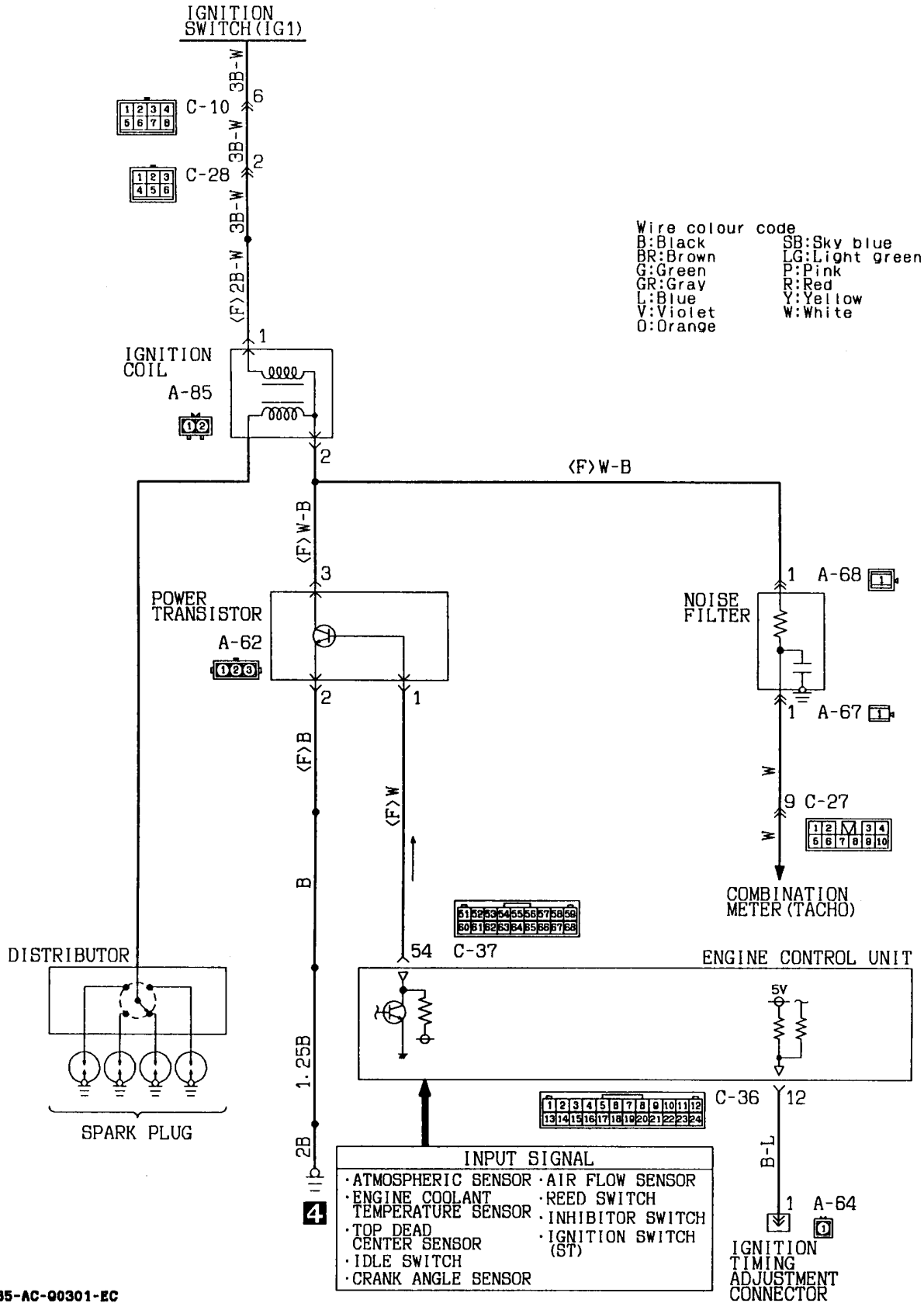

KX35-AC-00301-EC

4 CHARGING SYSTEM
4-1 Petrol-powered vehicles

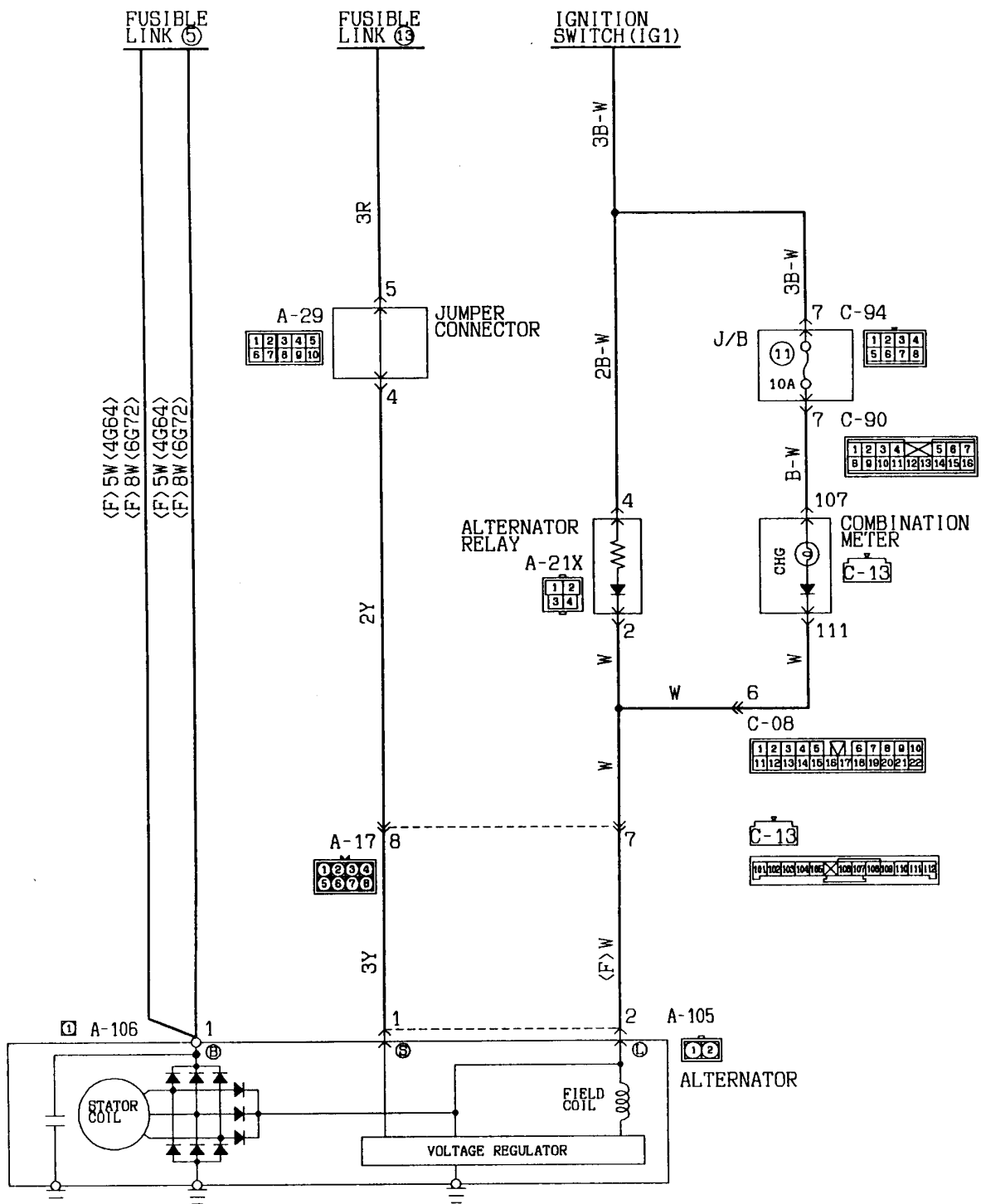

Wire colour code
 B:Black LG:Light green G:Green L:Blue W:White Y:Yellow SB:Sky blue
 BR:Brown O:Orange GR:Gray R:Red P:Pink V:Violet

KX35-AC-00401-EC

4-3 Diesel-powered vehicles (4-door models)

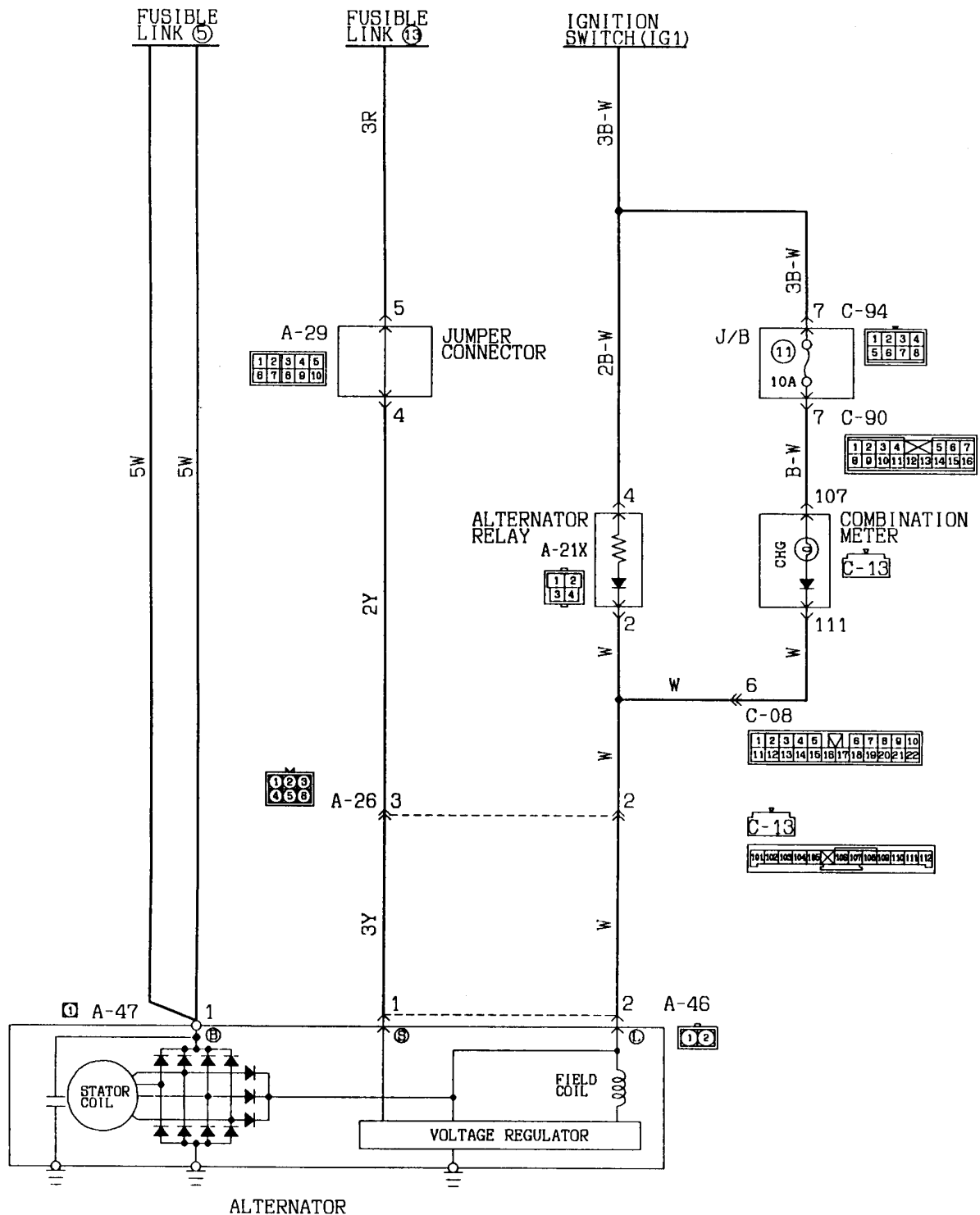

Wire colour code
 B:Black LG:Light green G:Green L:Blue W:White Y:Yellow SB:Sky blue
 BR:Brown O:Orange GR:Gray R:Red P:Pink V:Violet

CHARGING SYSTEM (See P. 4-21, 22, 23.)**OPERATION****When engine is stationary**

- When the ignition switch is turned to the ON position, current flows the alternator L terminal to the field coil and, at the same time, the charge warning lamp lights up.

When engine is started and after engine has started

- When the engine is started, the charge warning lamp goes out because of the charging voltage being applied to the alternator L terminal.
- The battery voltage being applied to the alternator S terminal is monitored by the voltage regulator. Hence, the amount of electricity produced by the alternator is controlled by allowing and cutting off the current flowing to the field coil.
- The alternator B terminal supplies power to each load.

Remark

- The alternator relay is provided to back up the flow of current to the field coil when the charge warning lamp is open.

TROUBLESHOOTING HINTS

1. Charging indicator lamp does not go on when the ignition switch is turned to "ON", before the engine starts.
 - Check the bulb.
2. Charging indicator lamp fails to go off once the engine starts.
 - Check voltage regulator of alternator.
3. Discharged or overcharged battery.
 - Check voltage regulator of alternator.
4. Charge warning lamp lights up dimly.
 - Check combination meter diode (for short).

NOTES

5 GLOW SYSTEM

5-1 Auto glow
FUSIBLE LINK ③

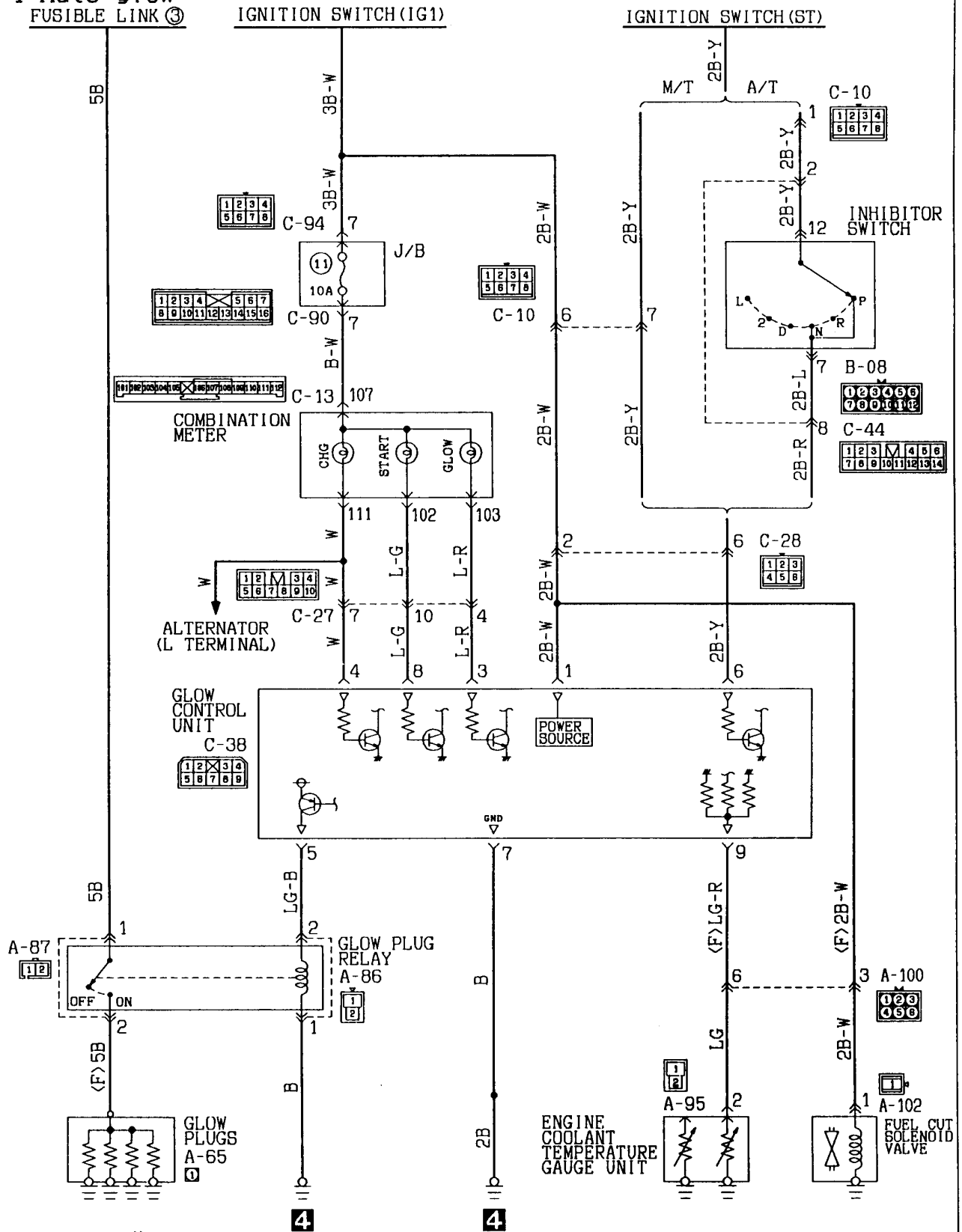

Wire colour code
 B:Black LG:Light green G:Green L:Blue W:White Y:Yellow SB:Sky blue
 BR:Brown O:Orange GR:Gray R:Red P:Pink V:Violet

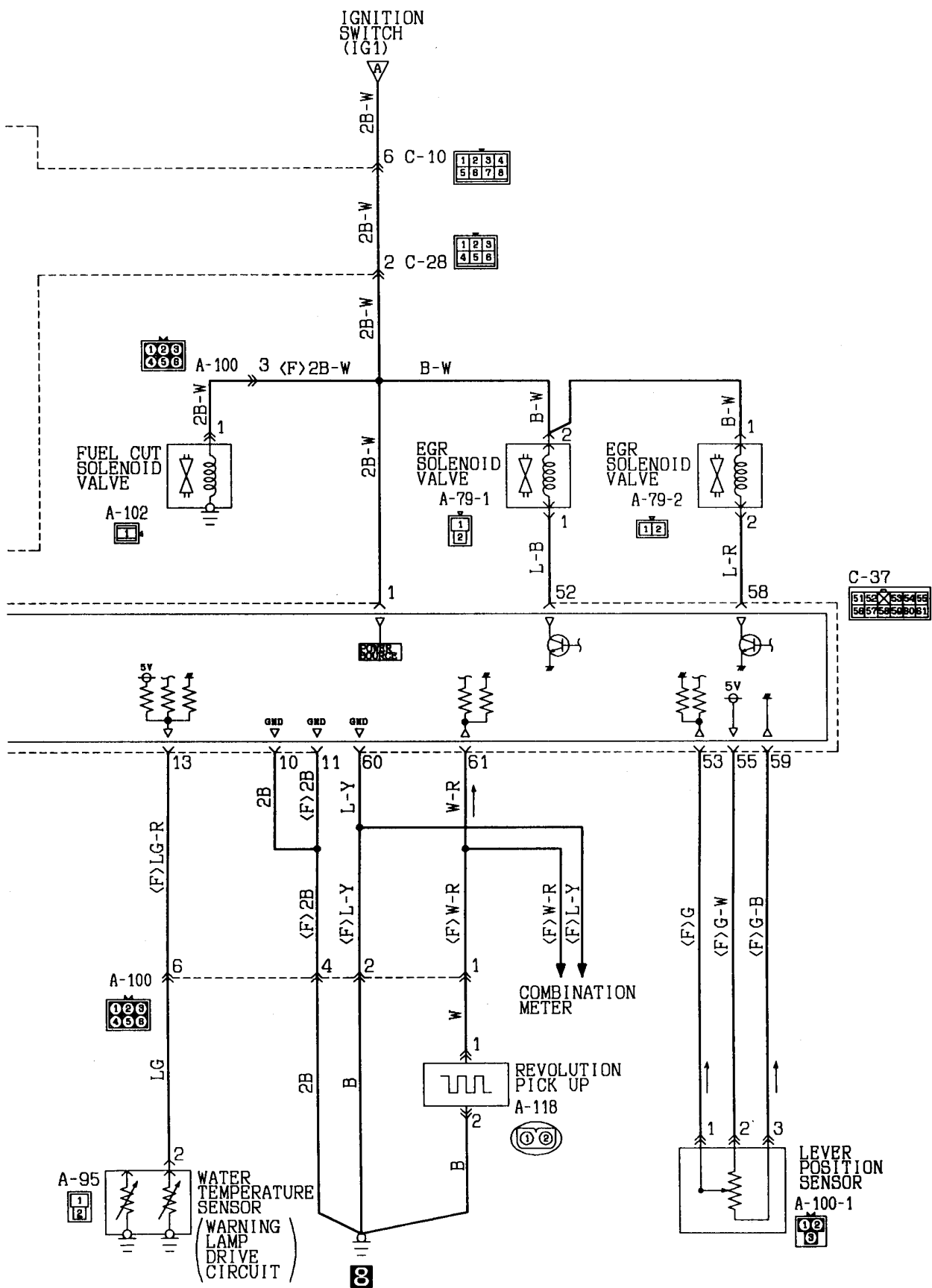

5-4 Super quick glow (2-door models with EGR system)
(Vehicles built from July 1993)

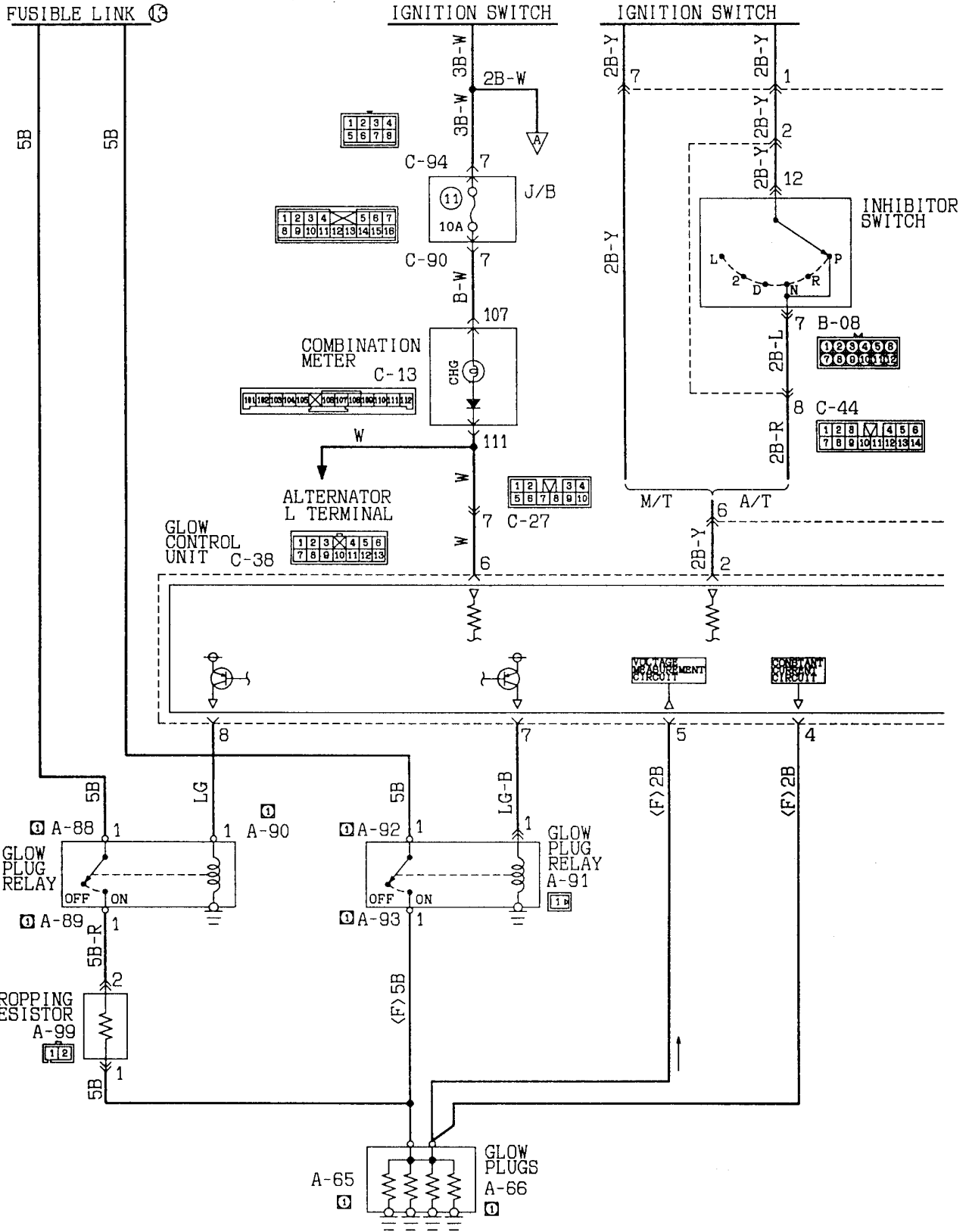

KX35-AC-00513-EC

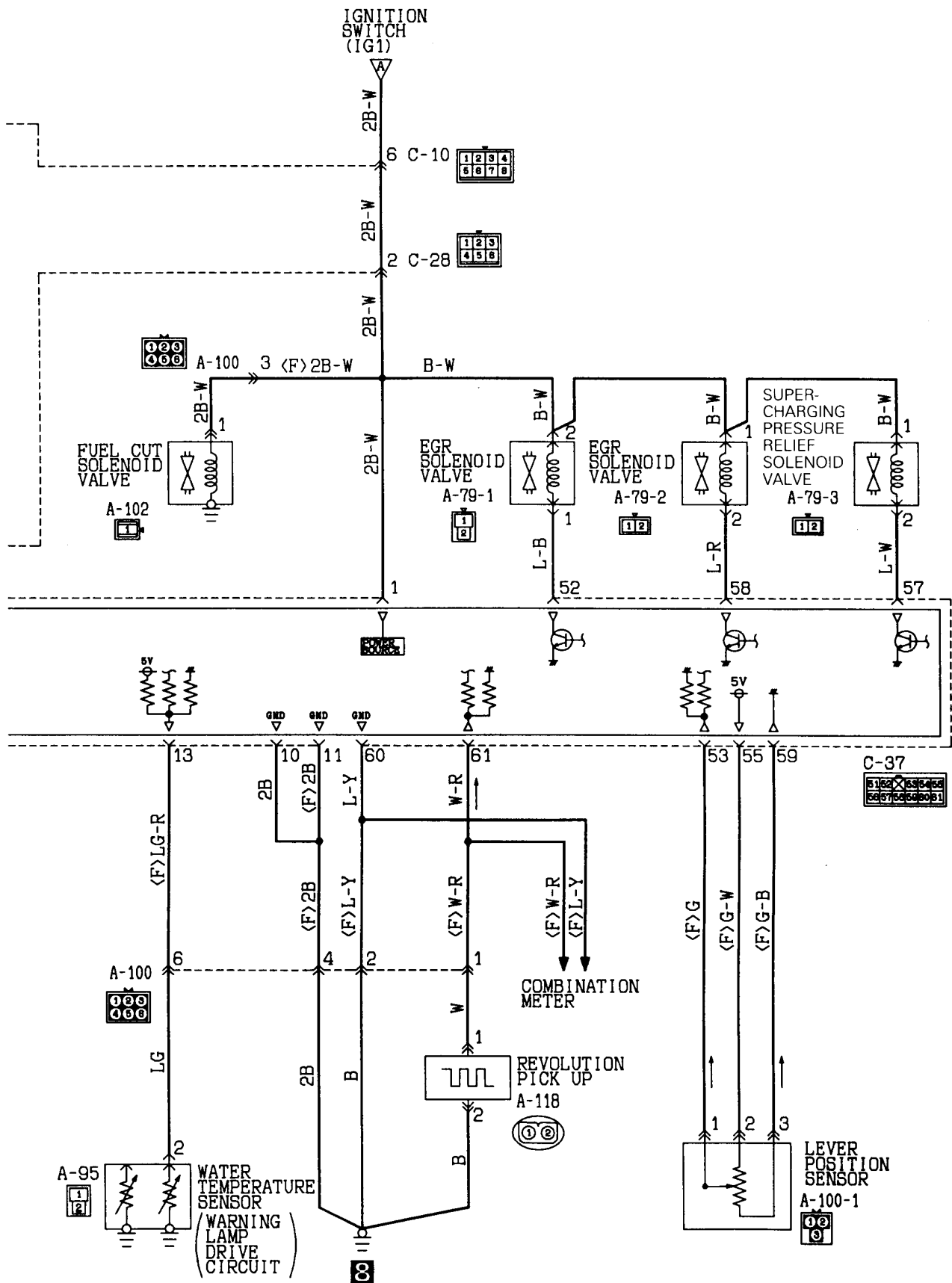

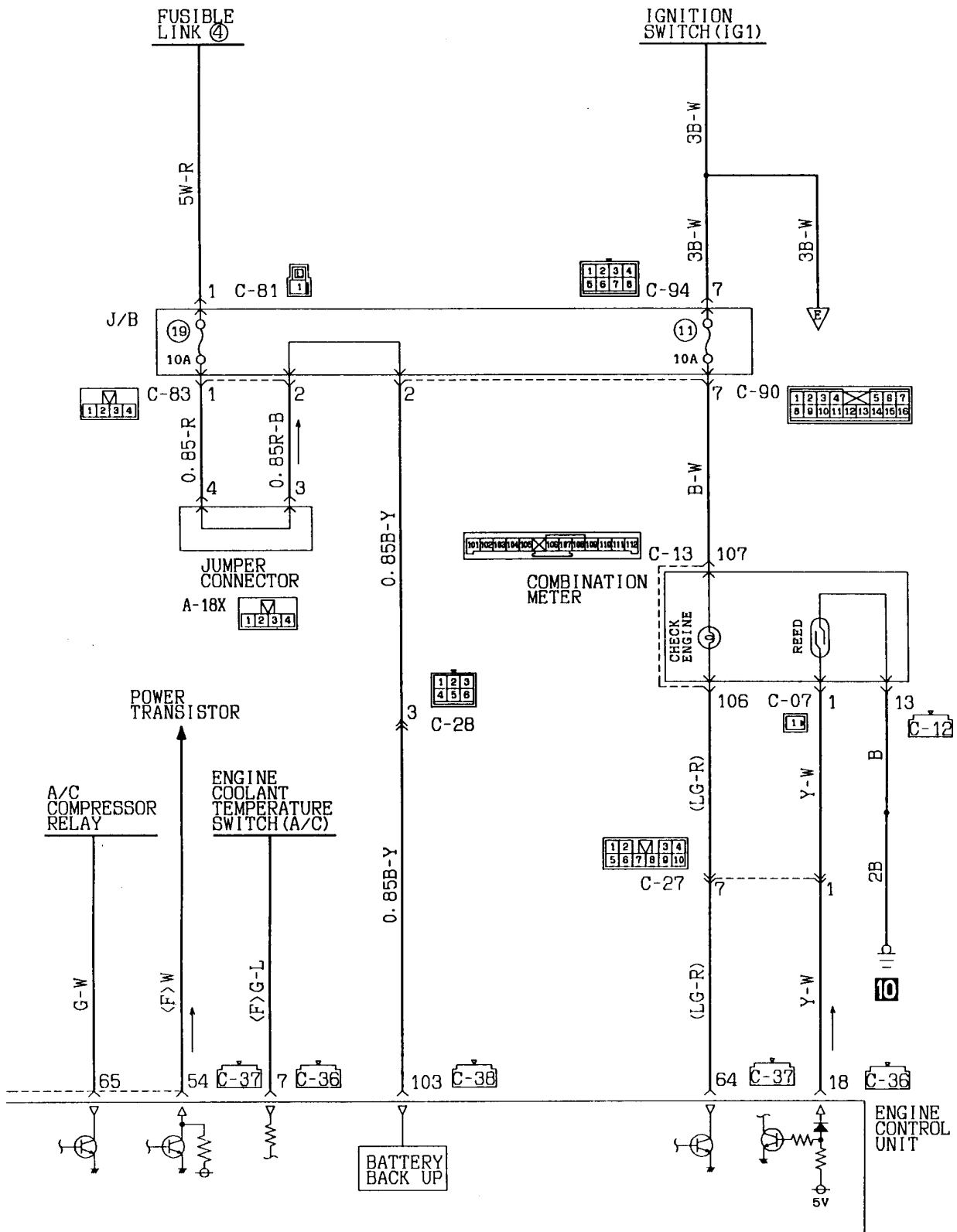

Wire colour code
 B:Black LG:Light green G:Green L:Blue
 BR:Brown O:Orange GR:Gray R:Red
 W:White SB:Sky blue P:Pink Y:Yellow
 V:Violet

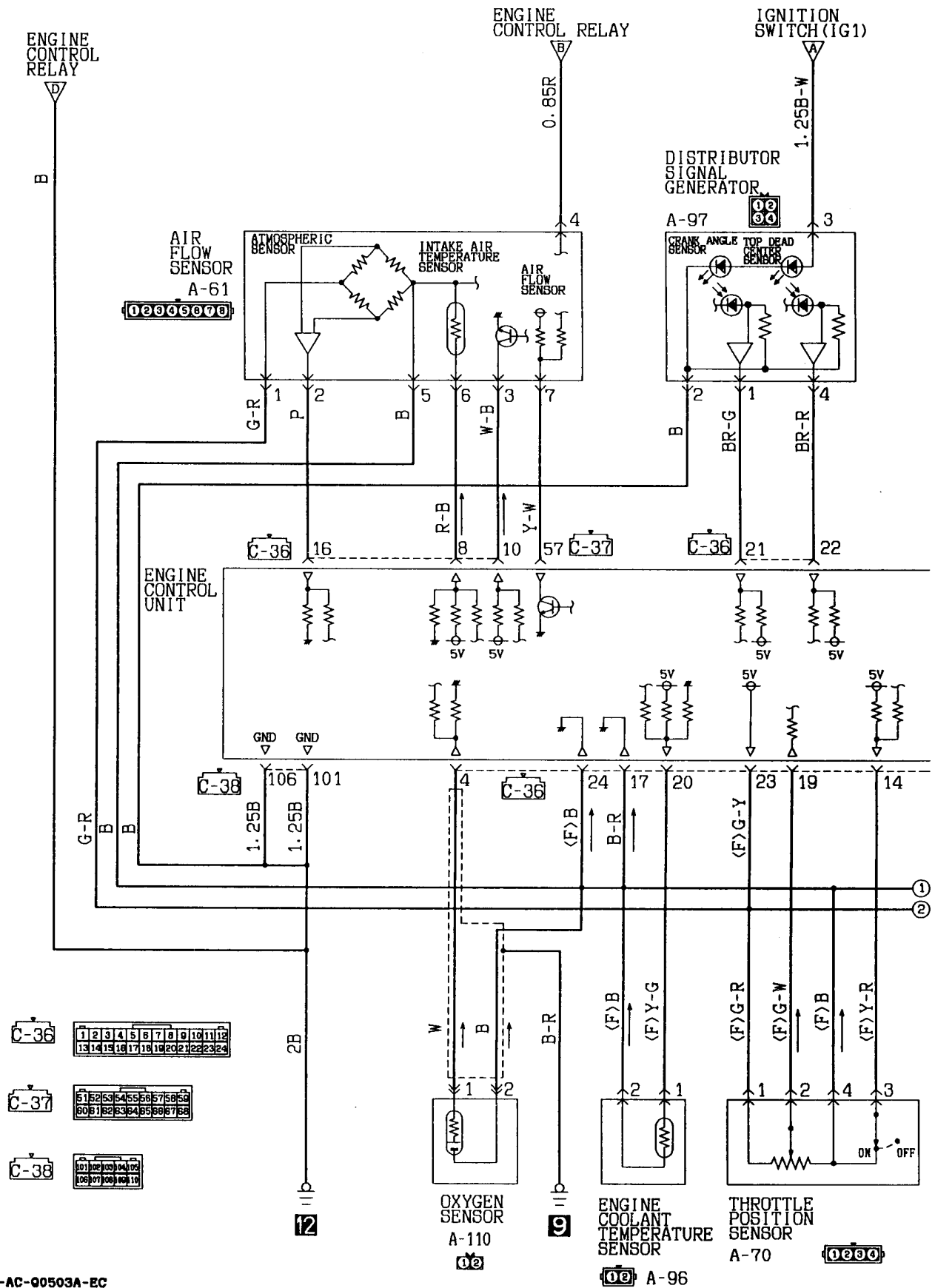

KX35-AC-Q0503A-EC

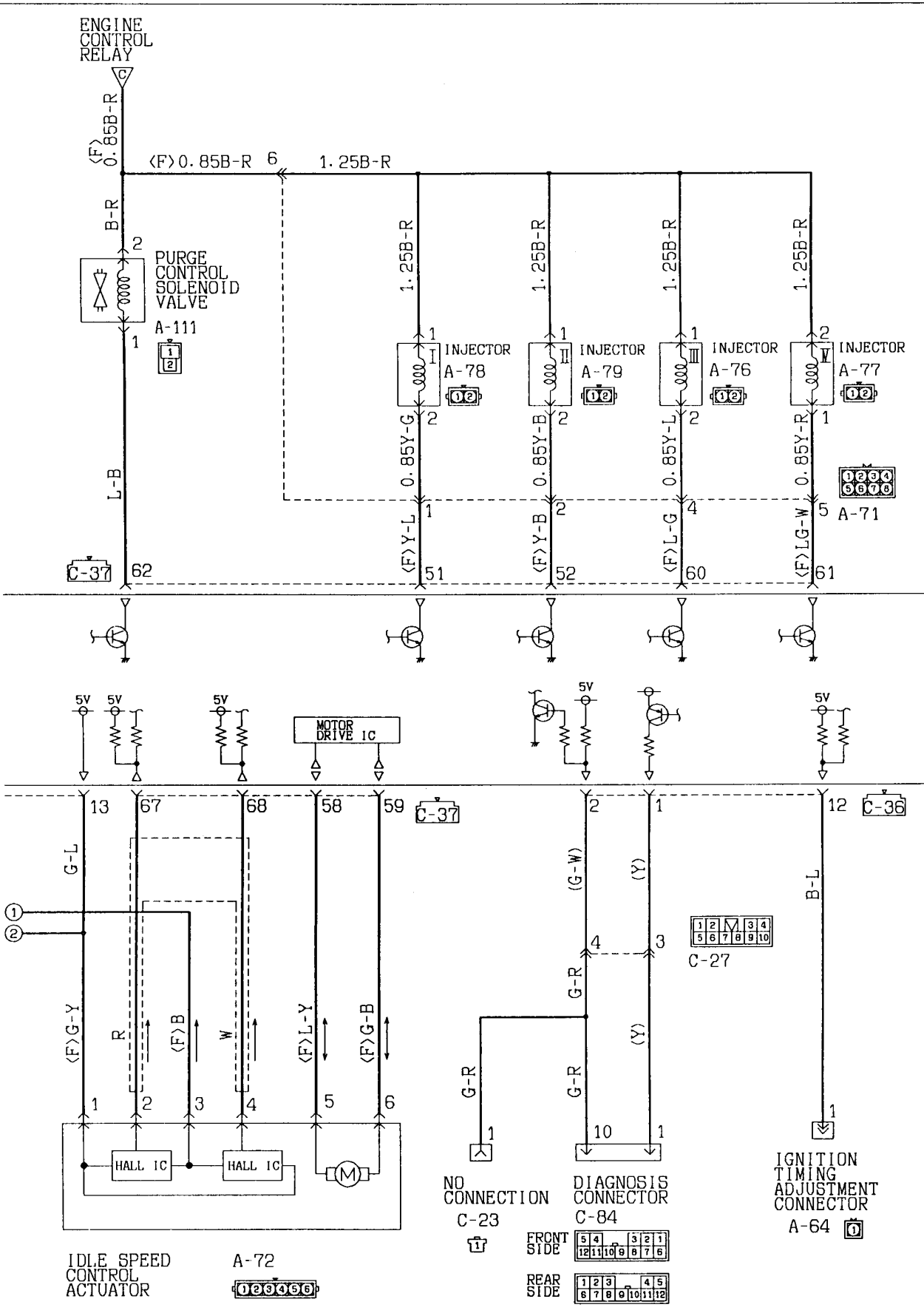

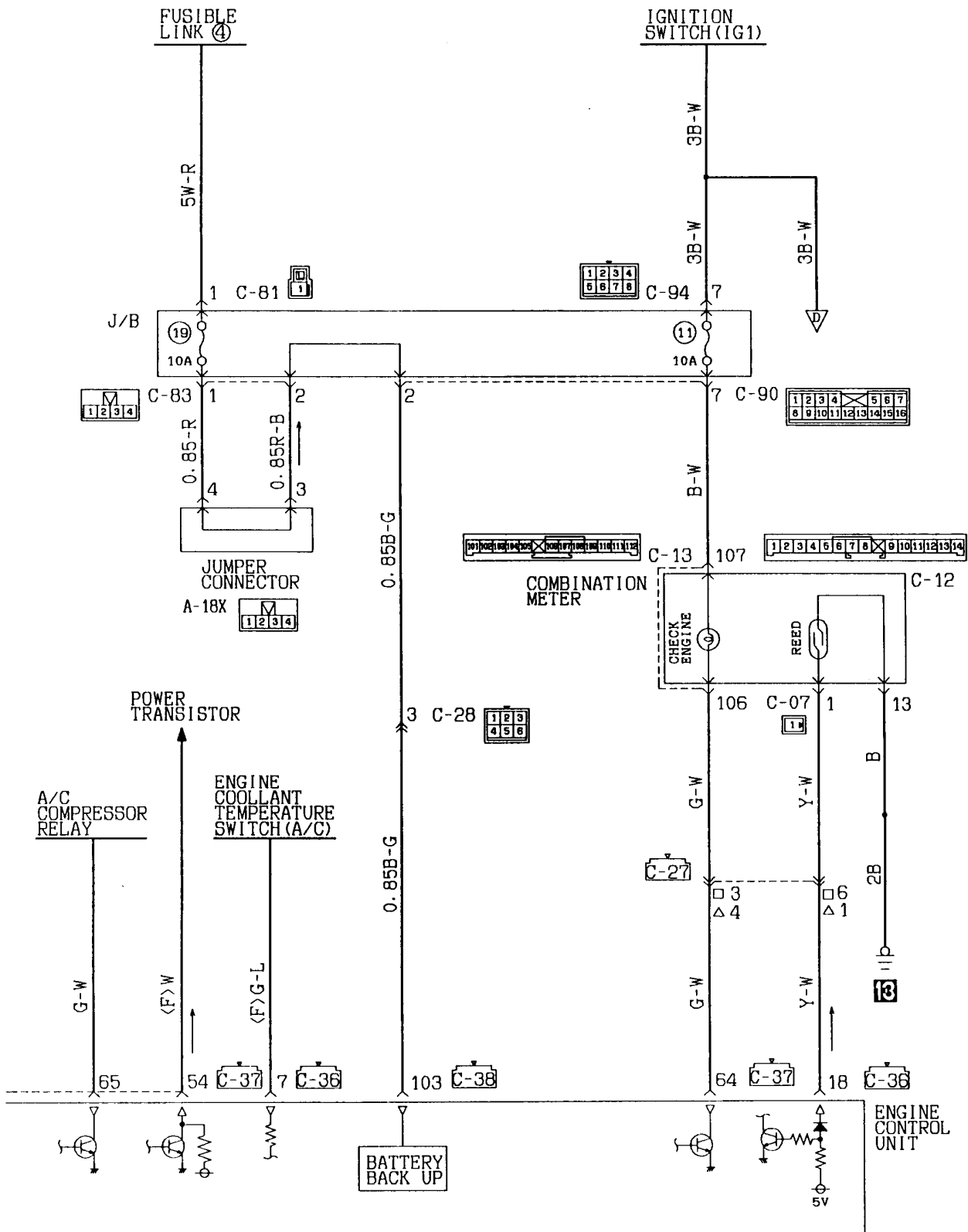

	<RHD>	<LHD>																																
C-27	<table border="1"> <tr><td>1</td><td>2</td><td>3</td><td>4</td><td>5</td><td>6</td><td>7</td><td>8</td></tr> <tr><td>9</td><td>10</td><td>11</td><td>12</td><td>13</td><td>14</td><td>15</td><td>16</td><td>17</td><td>18</td></tr> </table>	1	2	3	4	5	6	7	8	9	10	11	12	13	14	15	16	17	18	<table border="1"> <tr><td>1</td><td>2</td><td>3</td><td>4</td><td>5</td><td>6</td></tr> <tr><td>7</td><td>8</td><td>9</td><td>10</td><td>11</td><td>12</td><td>13</td><td>14</td></tr> </table>	1	2	3	4	5	6	7	8	9	10	11	12	13	14
1	2	3	4	5	6	7	8																											
9	10	11	12	13	14	15	16	17	18																									
1	2	3	4	5	6																													
7	8	9	10	11	12	13	14																											

Remark
 □: L. H. drive vehicles
 △: R. H. drive vehicles

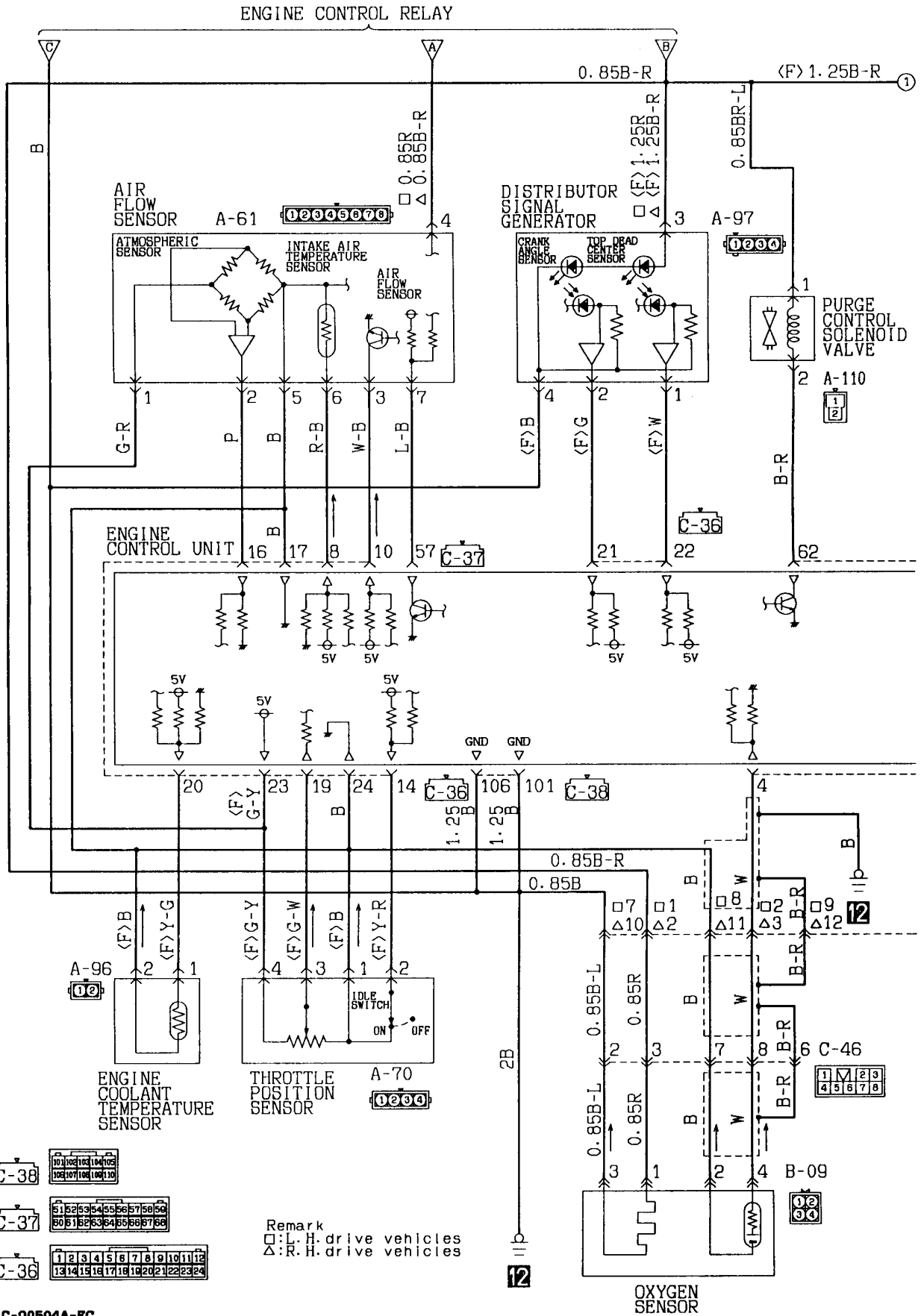

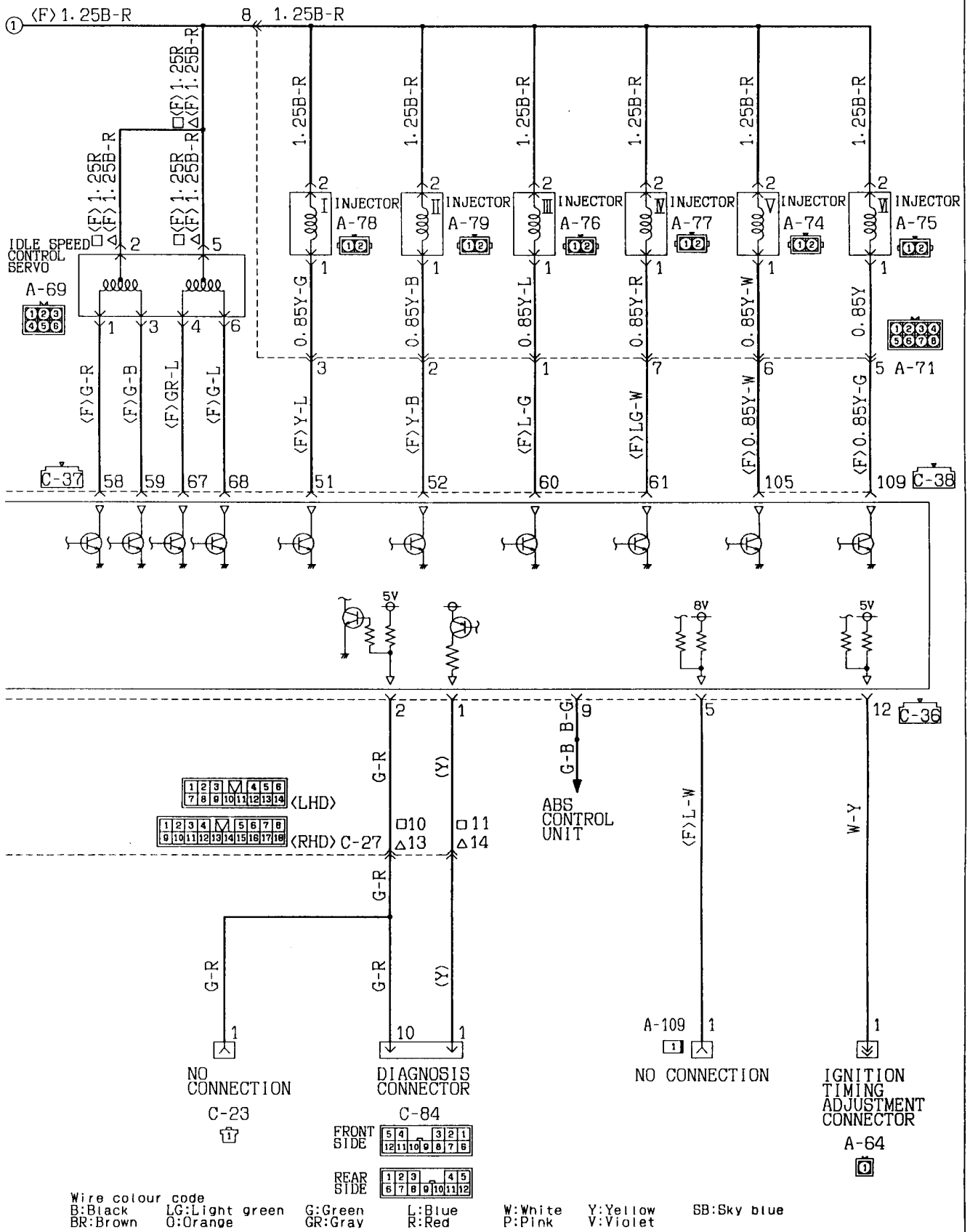

6-3 6G72 engine (A/T)

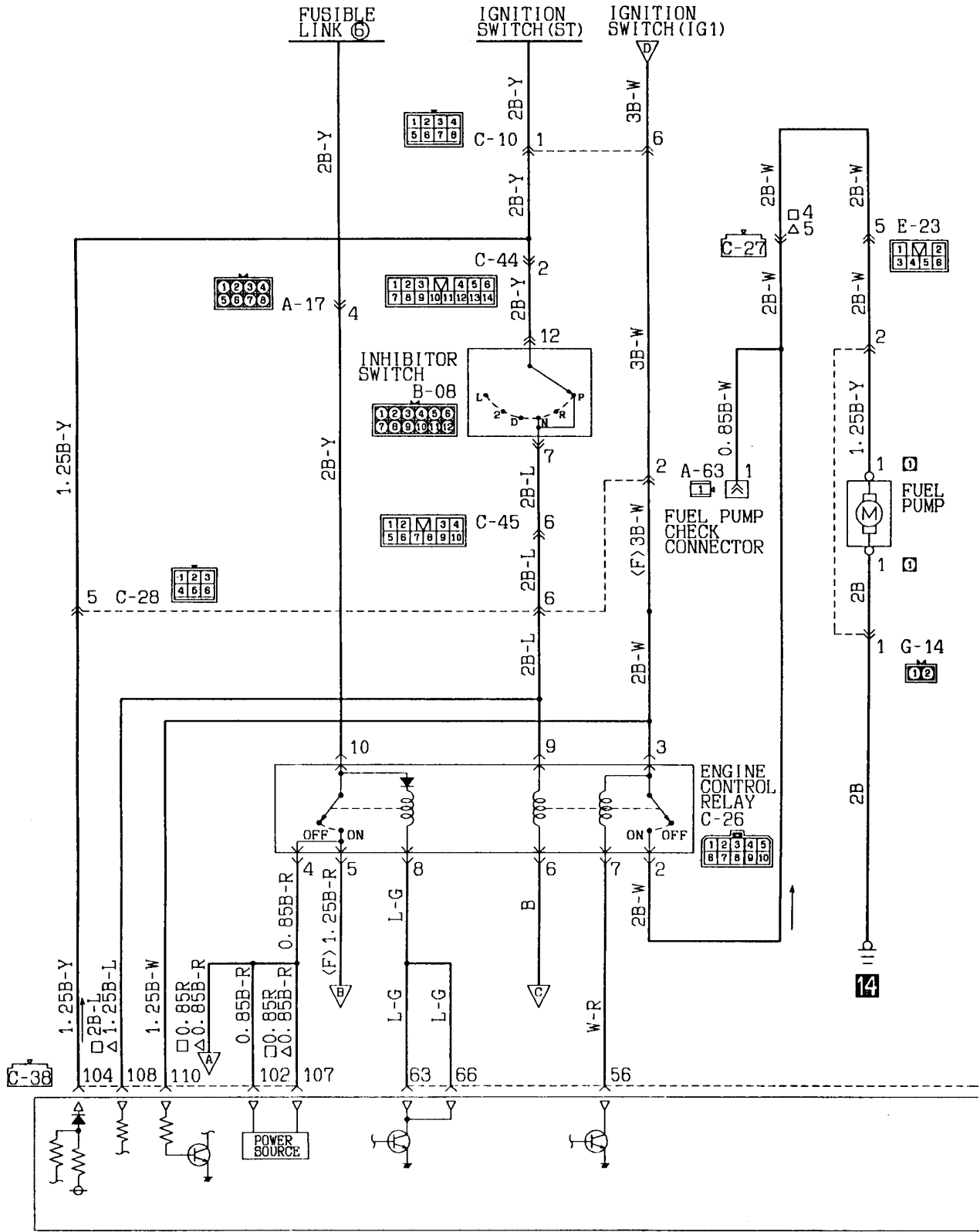

C-38
101 102 103 104 105
106 107 108 109 110
C-37
51 52 53 54 55 56 57 58 59
60 61 62 63 64 65 66 67 68
C-36
1 2 3 4 5 6 7 8 9 10 11 12
13 14 15 16 17 18 19 20 21 22 23 24

Wire colour code
 B:Black LG:Light green G:Green L:Blue W:White Y:Yellow SB:Sky blue
 BR:Brown O:Orange GR:Gray R:Red P:Pink V:Violet

KX35-AC-00505-EC

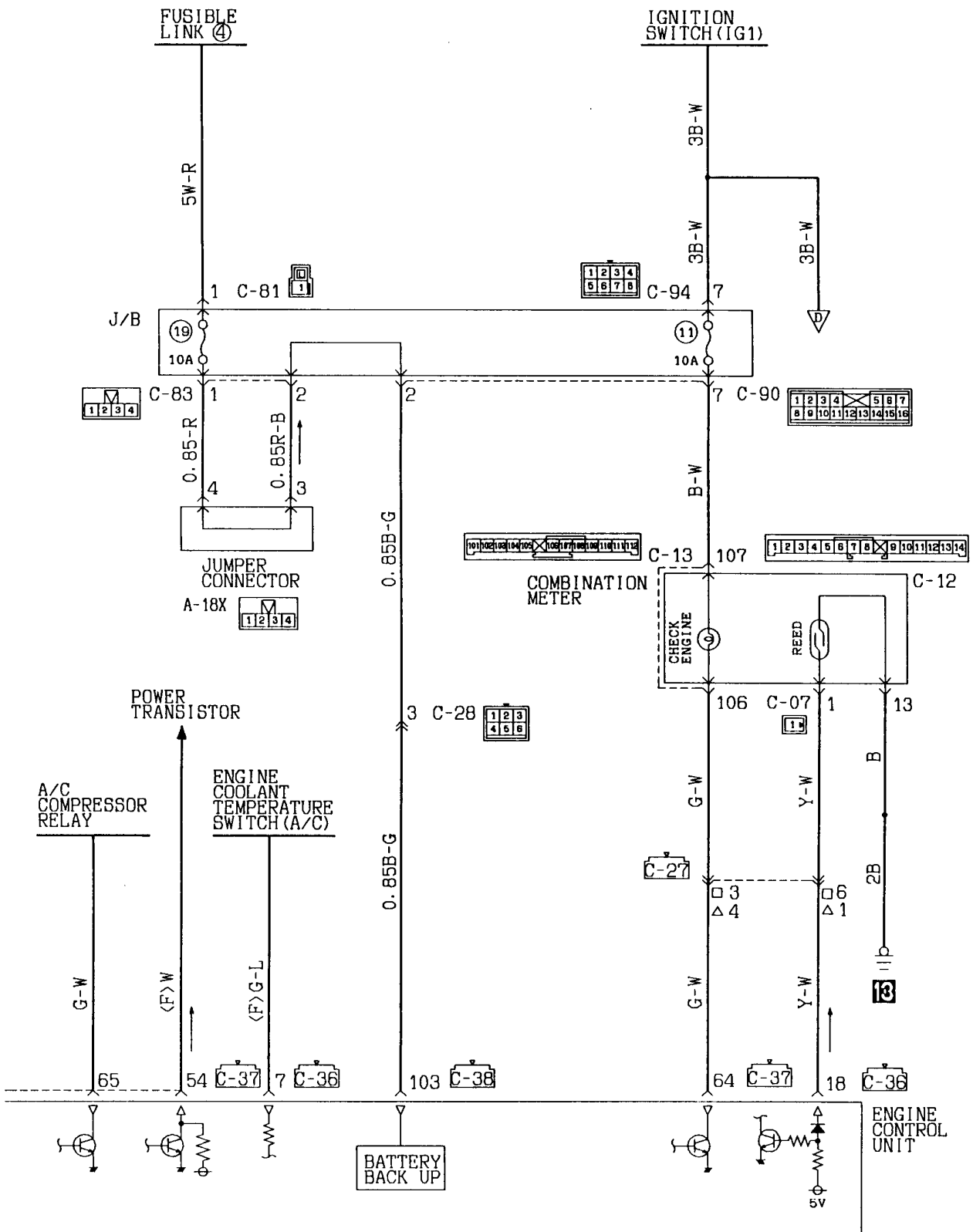

	(RHD)	(LHD)																																		
C-27	<table border="1"> <tr><td>1</td><td>2</td><td>3</td><td>4</td><td>M</td><td>5</td><td>6</td><td>7</td><td>8</td></tr> <tr><td>9</td><td>10</td><td>11</td><td>12</td><td>13</td><td>14</td><td>15</td><td>16</td><td>17</td><td>18</td></tr> </table>	1	2	3	4	M	5	6	7	8	9	10	11	12	13	14	15	16	17	18	<table border="1"> <tr><td>1</td><td>2</td><td>3</td><td>M</td><td>4</td><td>5</td><td>6</td></tr> <tr><td>7</td><td>8</td><td>9</td><td>10</td><td>11</td><td>12</td><td>13</td><td>14</td></tr> </table>	1	2	3	M	4	5	6	7	8	9	10	11	12	13	14
1	2	3	4	M	5	6	7	8																												
9	10	11	12	13	14	15	16	17	18																											
1	2	3	M	4	5	6																														
7	8	9	10	11	12	13	14																													

Remark
 □: L.H. drive vehicles
 △: R.H. drive vehicles

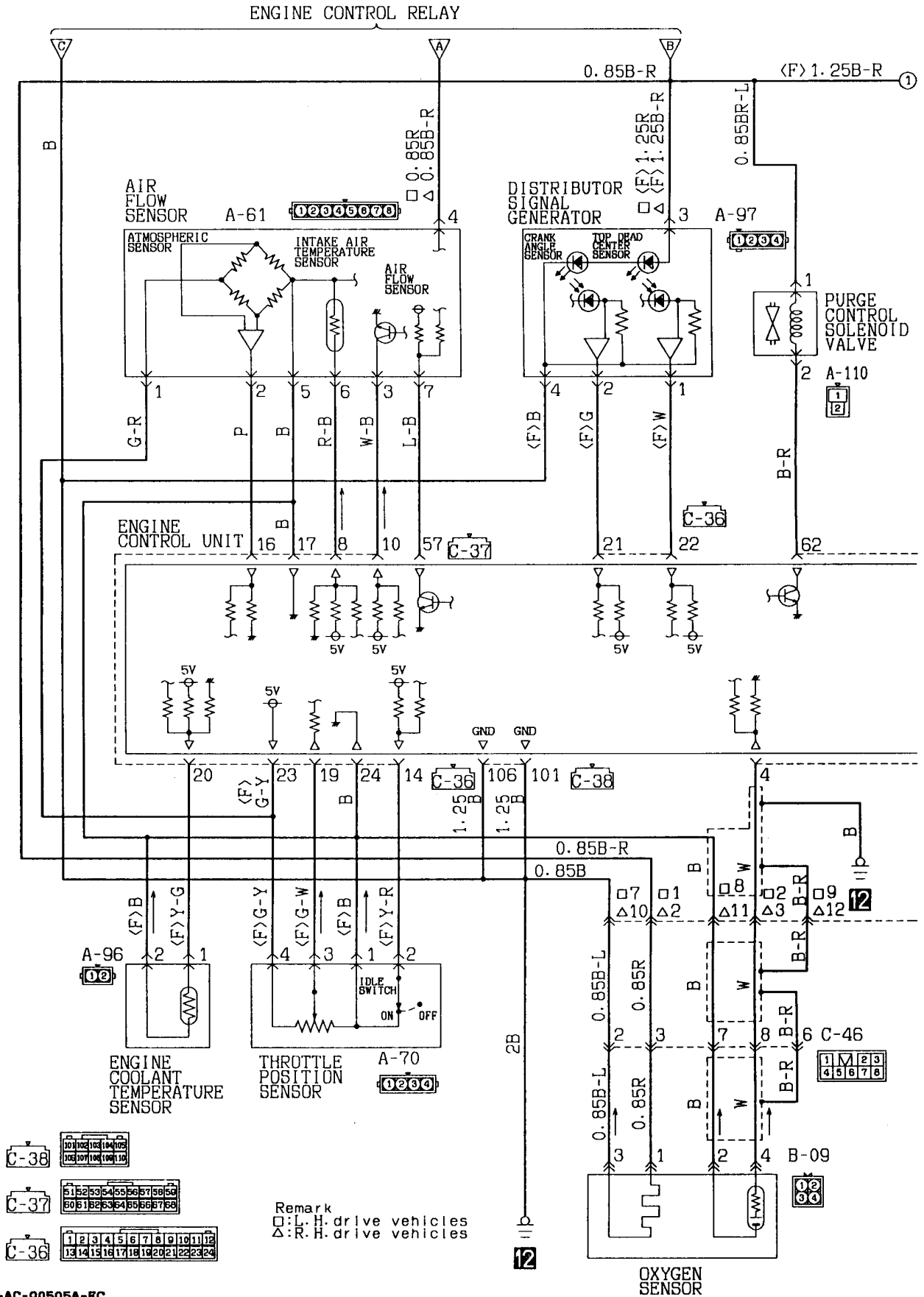

Remark
 □: L. H. drive vehicles
 △: R. H. drive vehicles

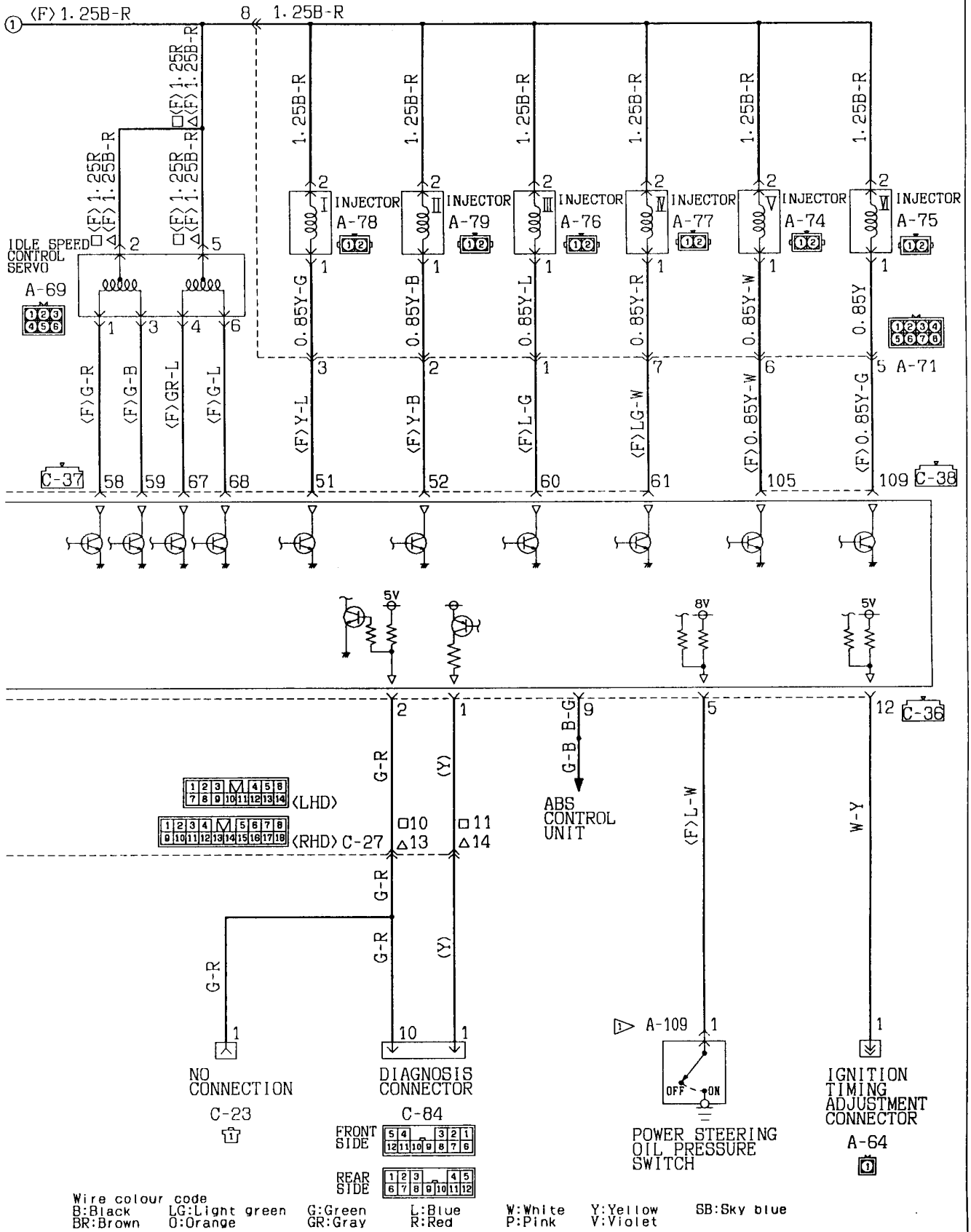

7 OVERDRIVE CONTROL SYSTEM

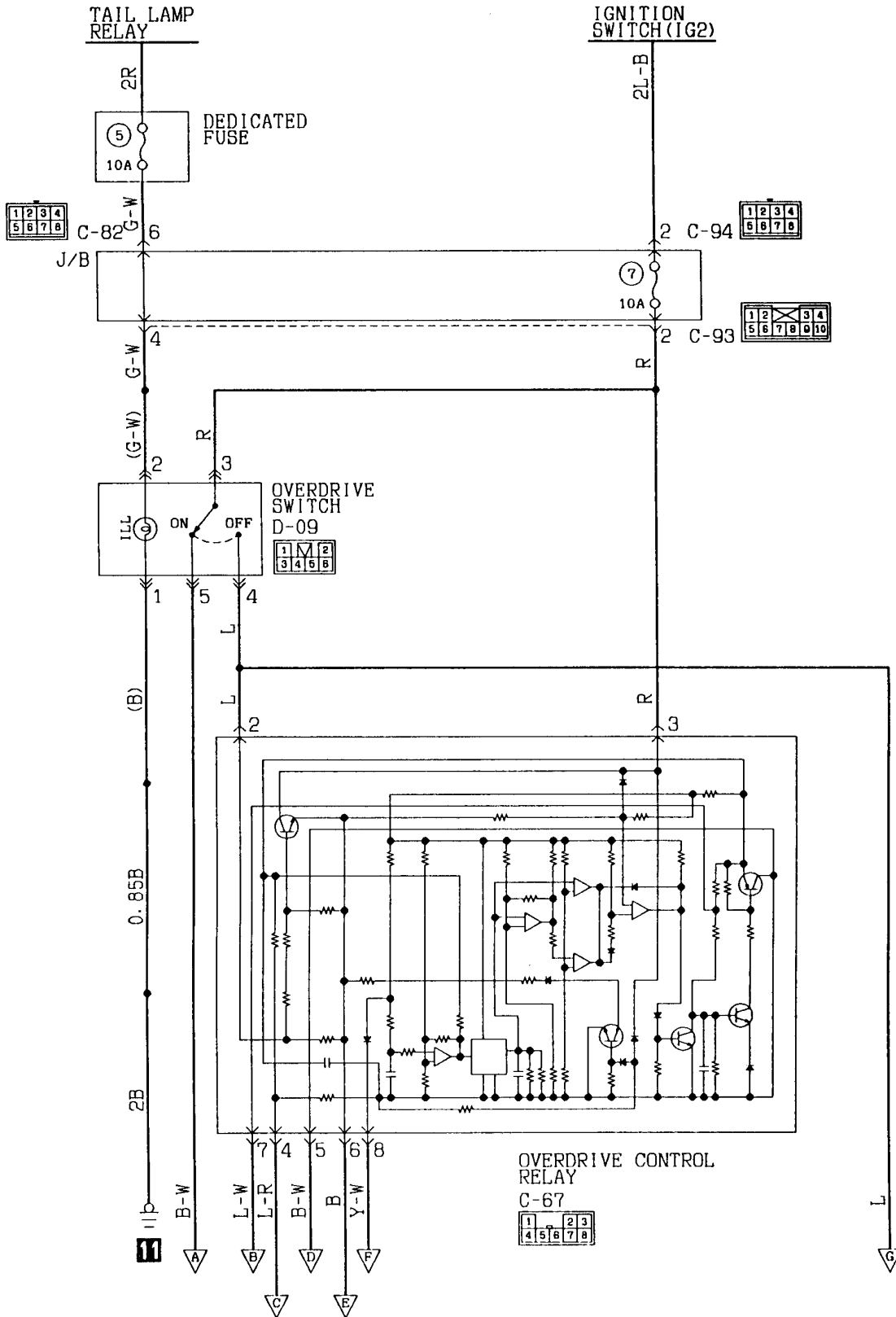

Wire colour code
 B:Black LG:Light green G:Green L:Blue W:White Y:Yellow SB:Sky blue
 BR:Brown O:Orange GR:Gray R:Red P:Pink V:Violet

KX35-AC-00701-EC

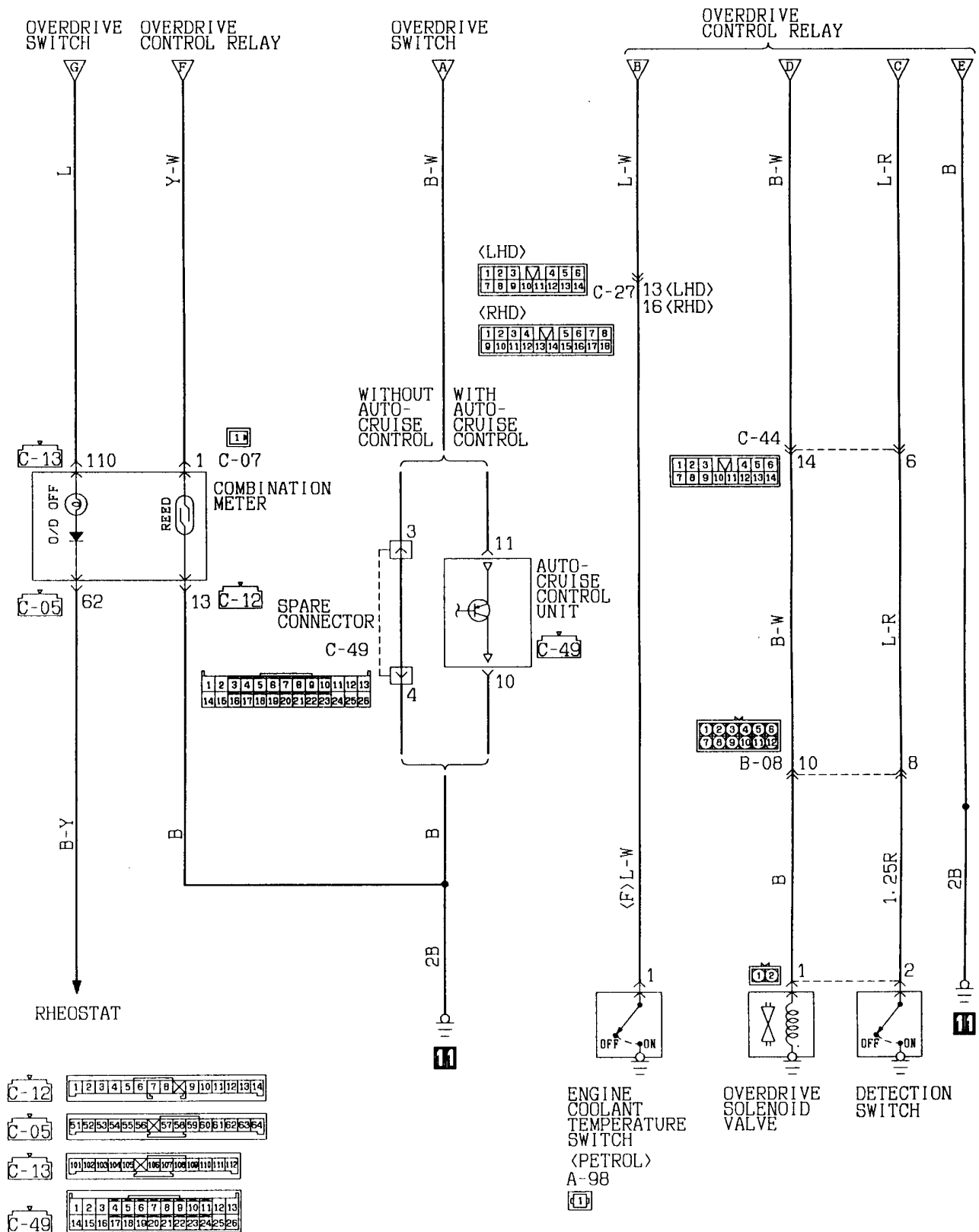

OVERDRIVE CONTROL SYSTEM (See P. 4-40.)**OPERATION****<Overdrive solenoid valve>**

- When the overdrive switch is switched OFF (with the ignition switch at the ON position), battery voltage is applied, through fuse No. ⑦ and the overdrive relay, to the engine coolant temperature switch.
- When the engine coolant temperature becomes 50°C (122°F) or higher, the engine coolant temperature switch is switched ON.
- When the engine coolant temperature switch is switched ON, current flows to the ignition switch, fuse No. ⑦, the overdrive switch, the overdrive relay, the engine coolant temperature switch, and earth, and the relay is switched ON.
- When the overdrive relay is switched OFF, current flows to the ignition switch, fuse No. ⑦, the overdrive switch, the overdrive relay, the overdrive solenoid, and earth, and the solenoid valve is activated.

<Overdrive off indicator lamp>

- When the overdrive switch is switched OFF (with the ignition switch at the ON position), current flows to the ignition switch, fuse No. ⑦, the overdrive switch, the overdrive off indicator, and earth, and the indicator illuminates.

HEADLAMP <L.H.drive vehicles without daytime running lamp> (See P. 4-44.)**OPERATION**

Headlamp Relay ON Conditions
<1991 Models>

Ignition switch	Lighting switch	Dimmer/passing switch	Headlamp relay
"ACC" or "ON"	"HEAD"	—	ON
"ACC" or "ON"	—	ON	ON

<1993 Models>

Ignition switch	Lighting switch	Dimmer/passing switch	Headlamp relay
—	"HEAD"	—	ON
—	—	ON	ON

<Low-beam operation>

- Placing the lighting switch in the HEAD position causes the headlamp relay to be energized.
- If the dimmer/passing switch is placed in the LO position at this time, then the headlamps light up in low beam.

<Upper-beam operation>

- Placing the lighting switch in the HEAD position causes the headlamp relay to be energized.
- If the dimmer/passing switch is placed in the HI position at this time, the headlamps light up in upper beam.

<Upper-beam indicator lamp>

- This lamp lights up when the upper/passing beams are on, indicating that the headlamps are on in upper beam.

<Passing operation>

- When the dimmer/passing switch is set to the "ON" position, the headlamp relay is switched ON and the upper beam of the headlamps illuminates.

TROUBLESHOOTING HINTS

1. Headlamps don't come on.
 - 1) But the tail lamps do illuminate.
 - Check the headlamp relay.
 - Check the lighting switch.
 - 2) The tail lamps also don't illuminate.
 - Check the fusible link No. ⑬.
2. The low beam at both sides doesn't illuminate.
 - Check the dimmer switch LO contacts.
3. The upper beam at both sides doesn't illuminate.
 - 1) The passing signal functions OK.
 - Check the dimmer switch HI contacts.
 - 2) The passing signal doesn't function.
 - Check the dimmer switch.
4. One headlamp doesn't illuminate.
 - Check the bulb.
5. Can't switch from low to upper beam or vice-versa.
 - Check the dimmer switch.
6. Upper-beam indicator lamp does not come on.
 - 1) Headlamp upper beams are operational.
 - Check dedicated fuse No. ⑦.
 - Check the indicator lamp bulb.

8 HEADLAMP

8-1 L.H.drive vehicles without daytime running lamp
(1991 MODELS)

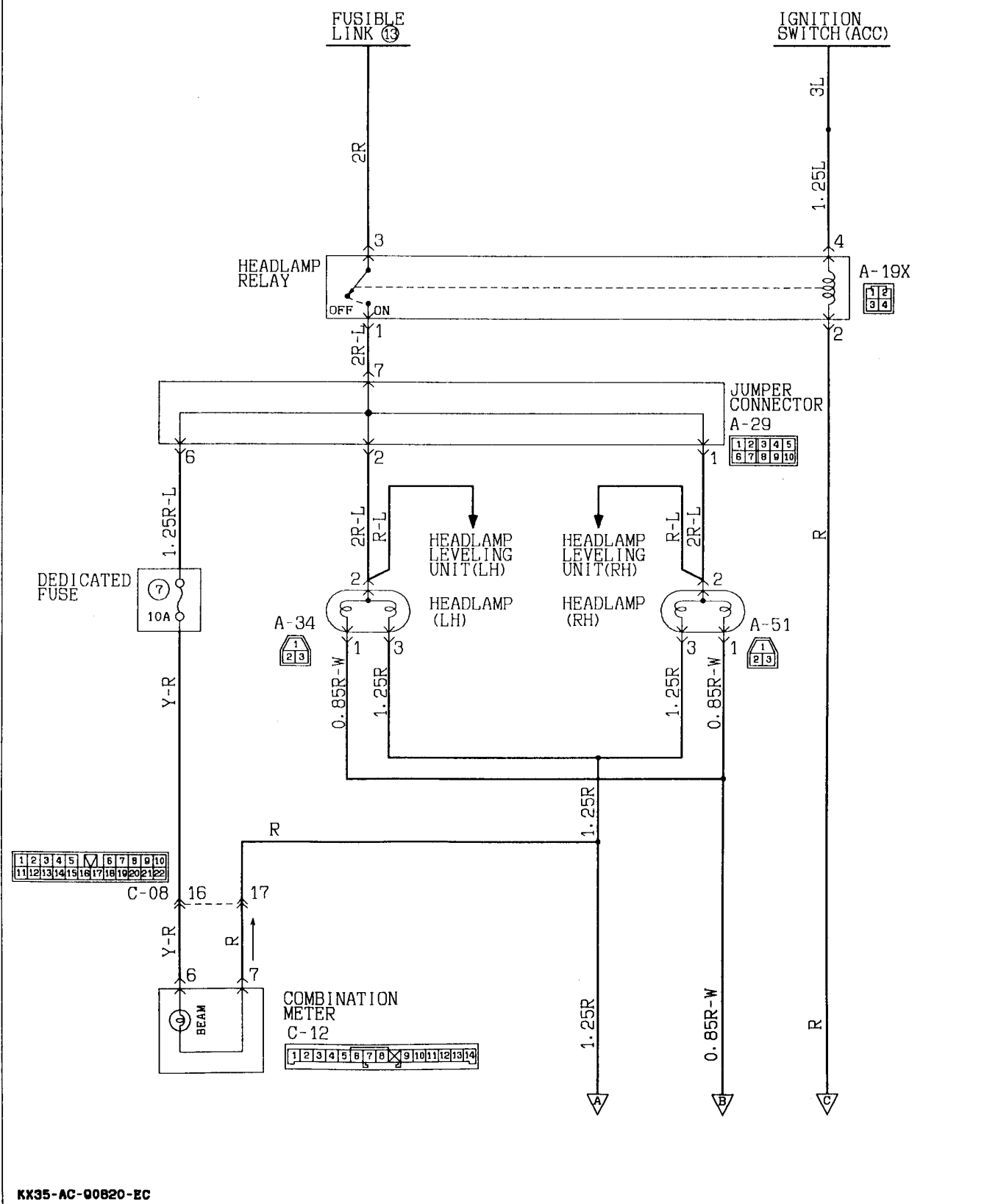

KX35-AC-00820-EC

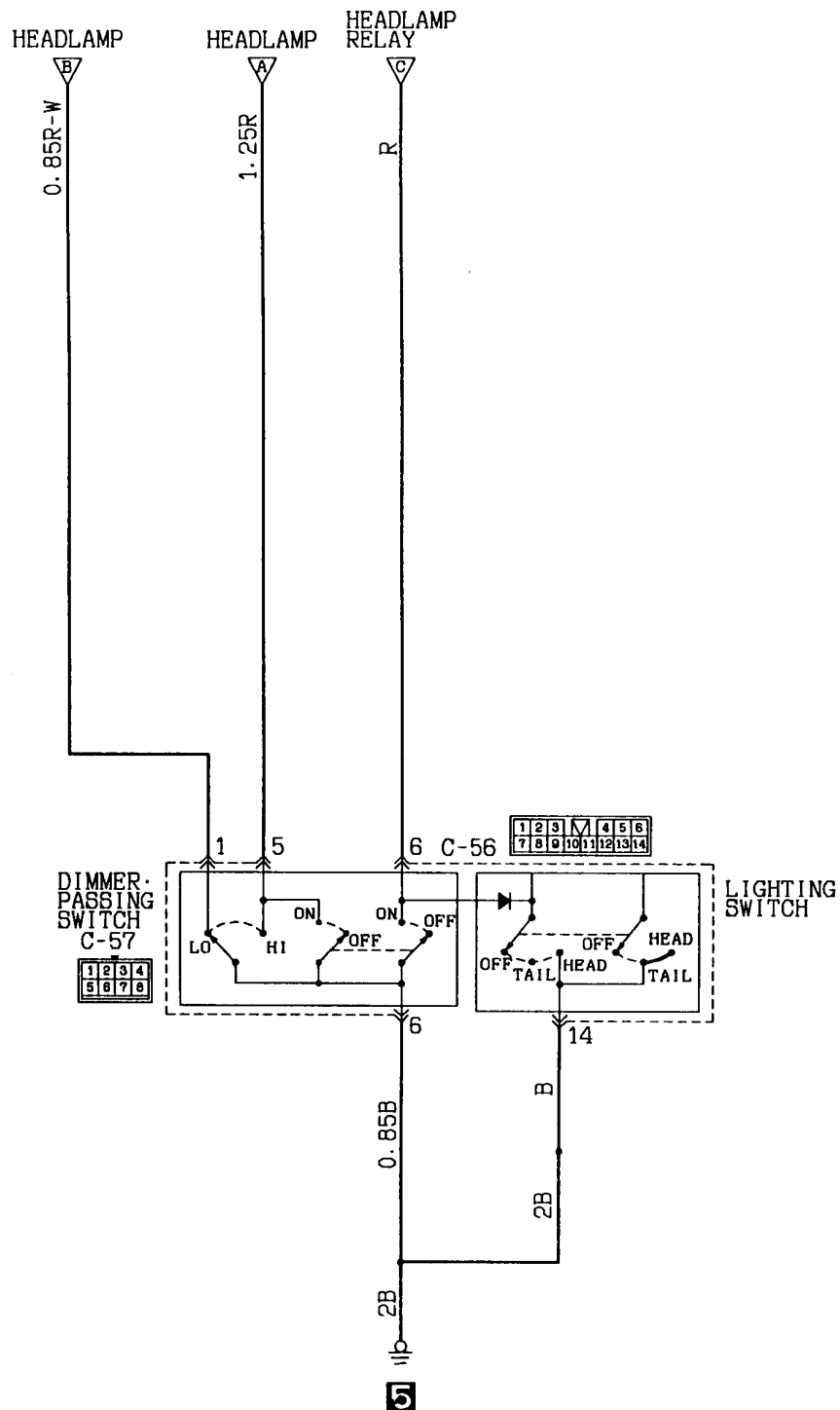

Wire colour code
 B:Black LG:Light green G:Green L:Blue W:White Y:Yellow SB:Sky blue
 BR:Brown O:Orange GR:Gray R:Red P:Pink V:Violet

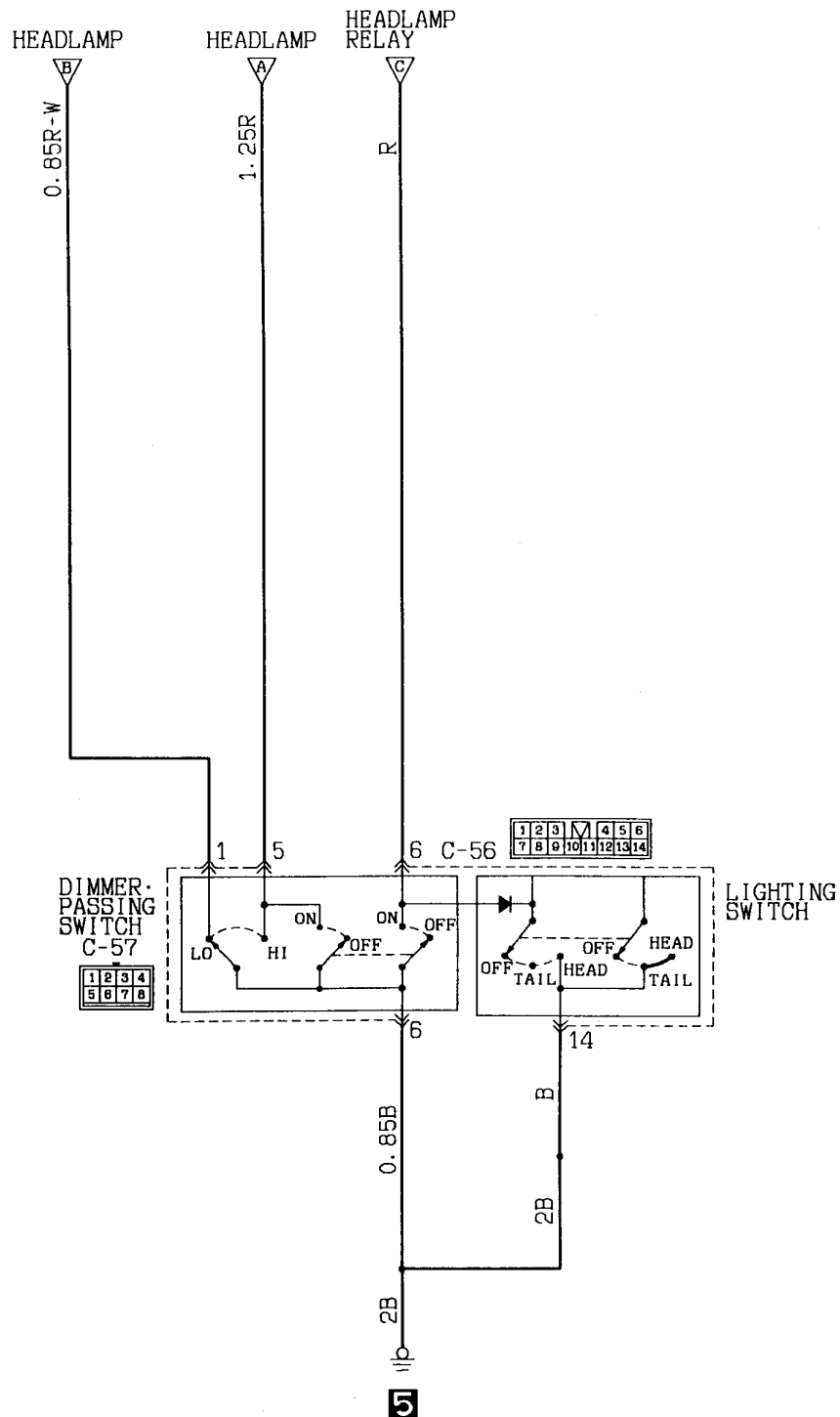

Wire colour code
 B:Black LG:Light green G:Green L:Blue W:White Y:Yellow SB:Sky blue
 BR:Brown O:Orange GR:Gray R:Red P:Pink V:Violet

8-2 L.H. drive vehicles with daytime running lamp
(1991 MODELS)

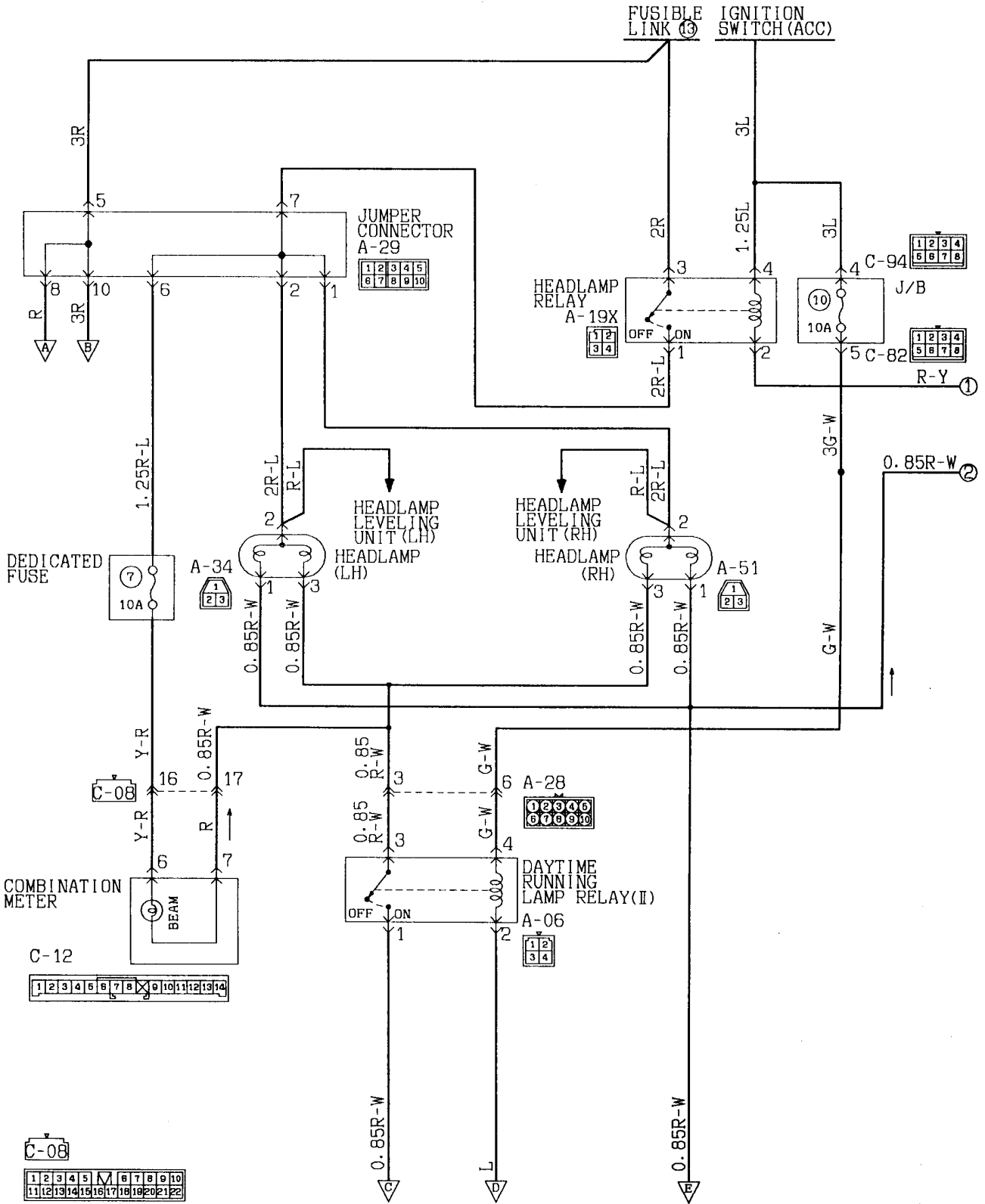

Wire colour code
 B:Black LG:Light green G:Green L:Blue W:White Y:Yellow SB:Sky blue
 BR:Brown O:Orange GR:Gray R:Red P:Pink V:Violet

KX35-AC-00821-EC

PHJE9026-A

REVISED

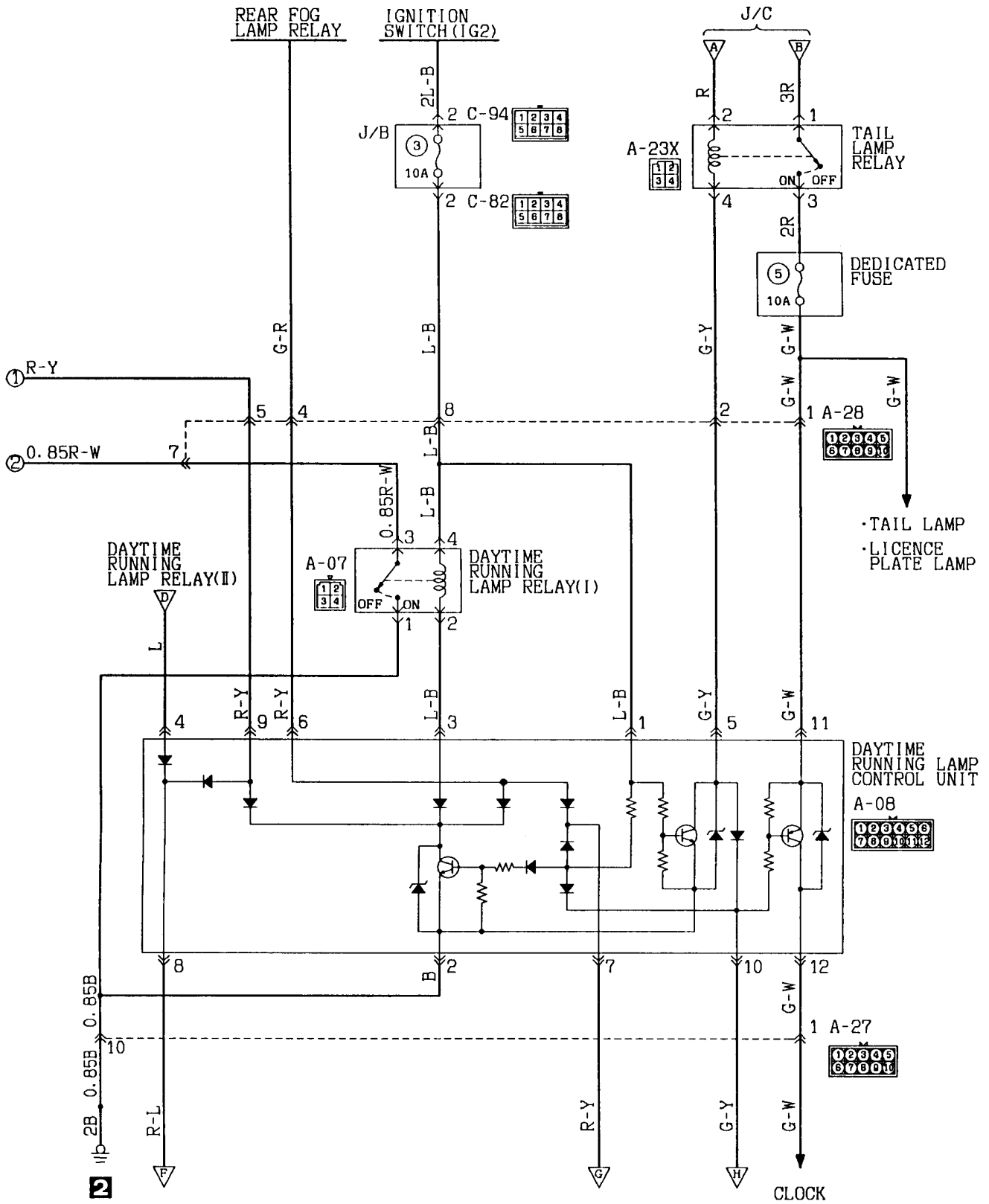

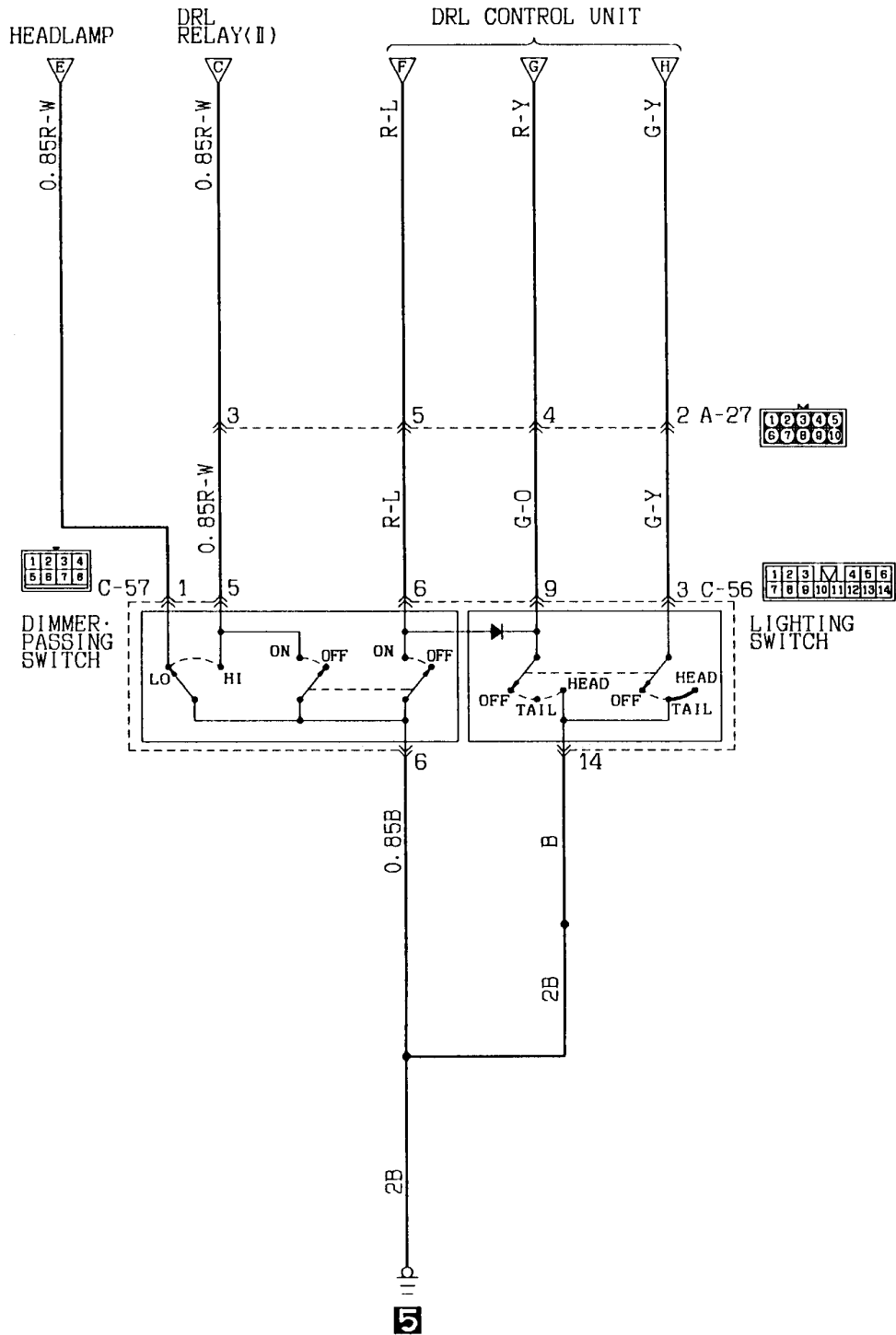

Wire colour code
 B:Black LG:Light green G:Green L:Blue W:White Y:Yellow SB:Sky blue
 BR:Brown O:Orange GR:Gray R:Red P:Pink V:Violet

KX35-AC-Q0802A-EC

NOTES

8-2 L.H. drive vehicles with daytime running lamp
(1993 MODELS)

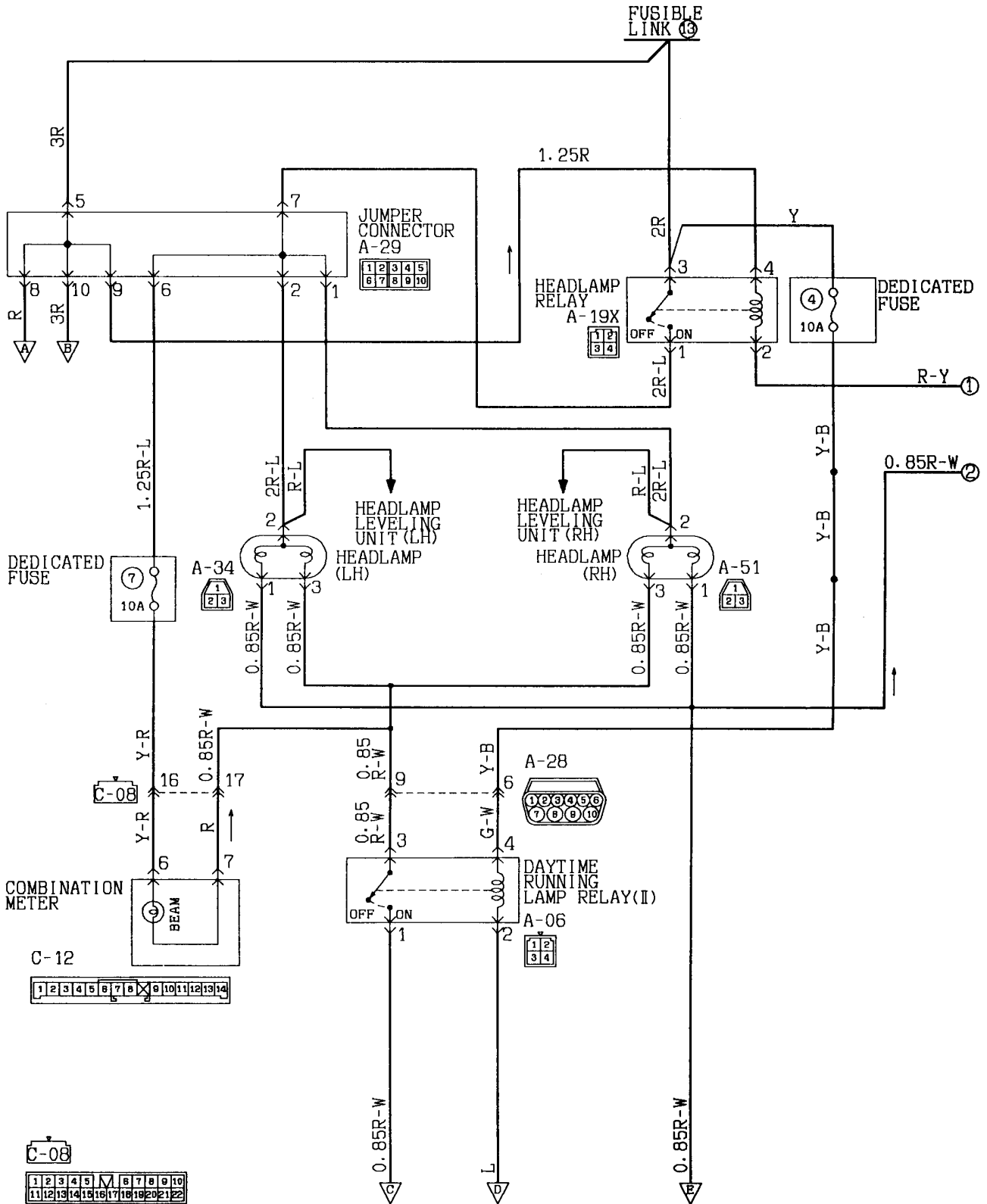

Wire colour code

B:Black LG:Light green G:Green L:Blue W:White Y:Yellow SB:Sky blue
BR:Brown O:Orange GR:Gray R:Red P:Pink V:Violet

KX35-AC-00818-EC

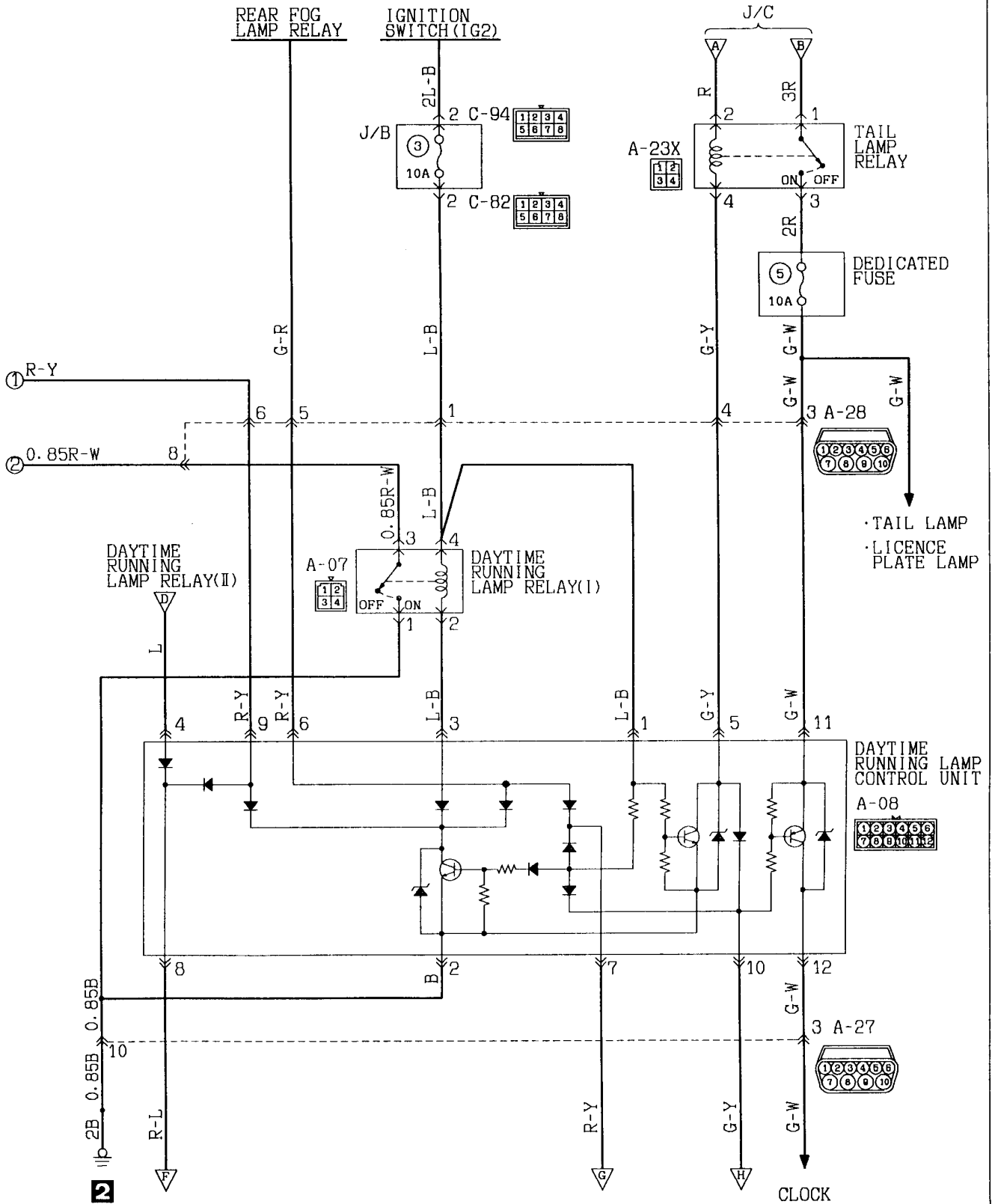

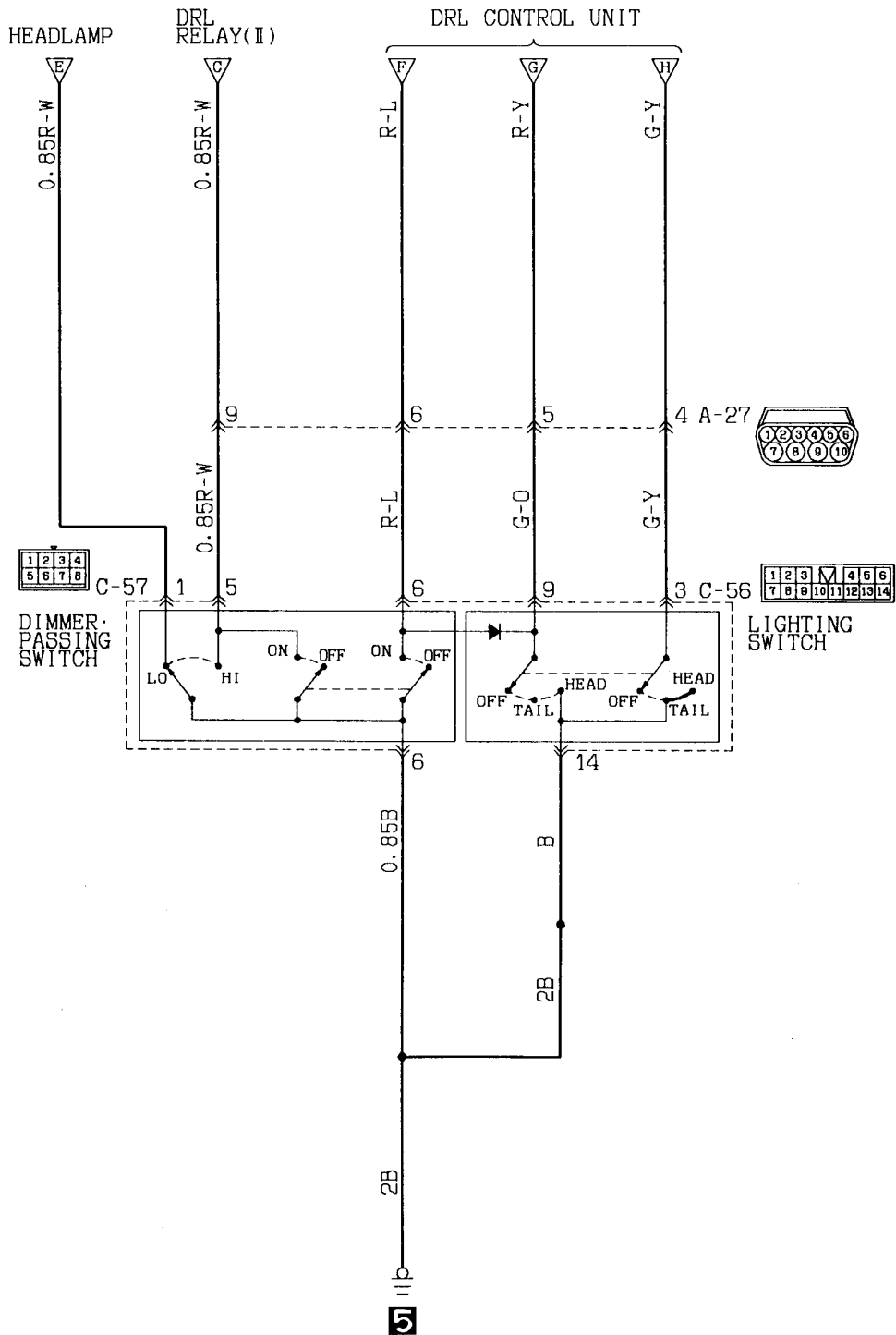

Wire colour code
 B:Black LG:Light green G:Green L:Blue W:White Y:Yellow SB:Sky blue
 BR:Brown O:Orange GR:Gray R:Red P:Pink V:Violet

HEADLAMP <L.H.drive vehicles with daytime running lamp> (See P. 4-46.)**OPERATION**

Headlamp Relay ON Conditions
<1991 Models>

Ignition switch	Lighting switch	Dimmer/passing switch	Headlamp relay
"ON"	—	—	ON
"ACC" or "ON"	"HEAD"	—	ON
"ACC" or "ON"	—	ON	ON

<1993 Models>

Ignition switch	Lighting switch	Dimmer/passing switch	Headlamp relay
"ON"	—	—	ON
—	"HEAD"	—	ON
—	—	ON	ON

<Daytime running lamp operation>

- Turning the ignition switch to the ON position causes the headlamp relay, daytime running lamp relay (I), and tail lamp relay to be energized, which causes the headlamps, tail lamps, etc. to come on.

<Low-beam operation>

- Placing the lighting switch in the HEAD position causes the headlamp relay and daytime running lamp relay (II) to be energized.
- If the dimmer/passing switch is placed in the LO position at this time, the headlamps light up in low beam.

<Upper-beam operation>

- Placing the lighting switch in the HEAD position causes the headlamp relay and daytime running lamp relay (II) to be energized.
- If the dimmer/passing switch is placed in the HI position at this time, the headlamps light up in upper beam.

<Upper-beam indicator lamp>

- This lamp lights up when the upper/passing beams are on, indicating that the headlamps are on in upper beam.

TROUBLESHOOTING HINTS

1. Headlamps don't come on.
 - 1) But the tail lamps do illuminate.
 - Check the headlamp relay.
 - Check the lighting switch.
 - 2) The tail lamps also don't illuminate.
 - Check the fusible link No. ⑬.
2. The low beam at both sides doesn't illuminate.
 - Check the dimmer switch LO contacts.
3. The upper beam at both sides doesn't illuminate.
 - 1) The passing signal functions OK.
 - Check the dimmer switch HI contacts.
 - 2) The passing signal doesn't function.
 - Check the dimmer switch.
 - Check the daytime running lamp relay (II).
 - Check the daytime running lamp control unit.
4. One headlamp doesn't illuminate.
 - Check the bulb.
5. Can't switch from low to upper beam or vice-versa.
 - Check the dimmer switch.
6. With the ignition switch at the "ON" position, the headlamps' low beam does not illuminate.
 - Check the daytime running lamp relay (I).
 - Check the daytime running lamp control unit.
7. Upper-beam indicator lamp does not come on.
 - 1) Headlamp upper beams are operational.
 - Check dedicated fuse No. ⑦.
 - Check the indicator lamp bulb.

8-3 R. H. drive vehicles <1991 MODELS>

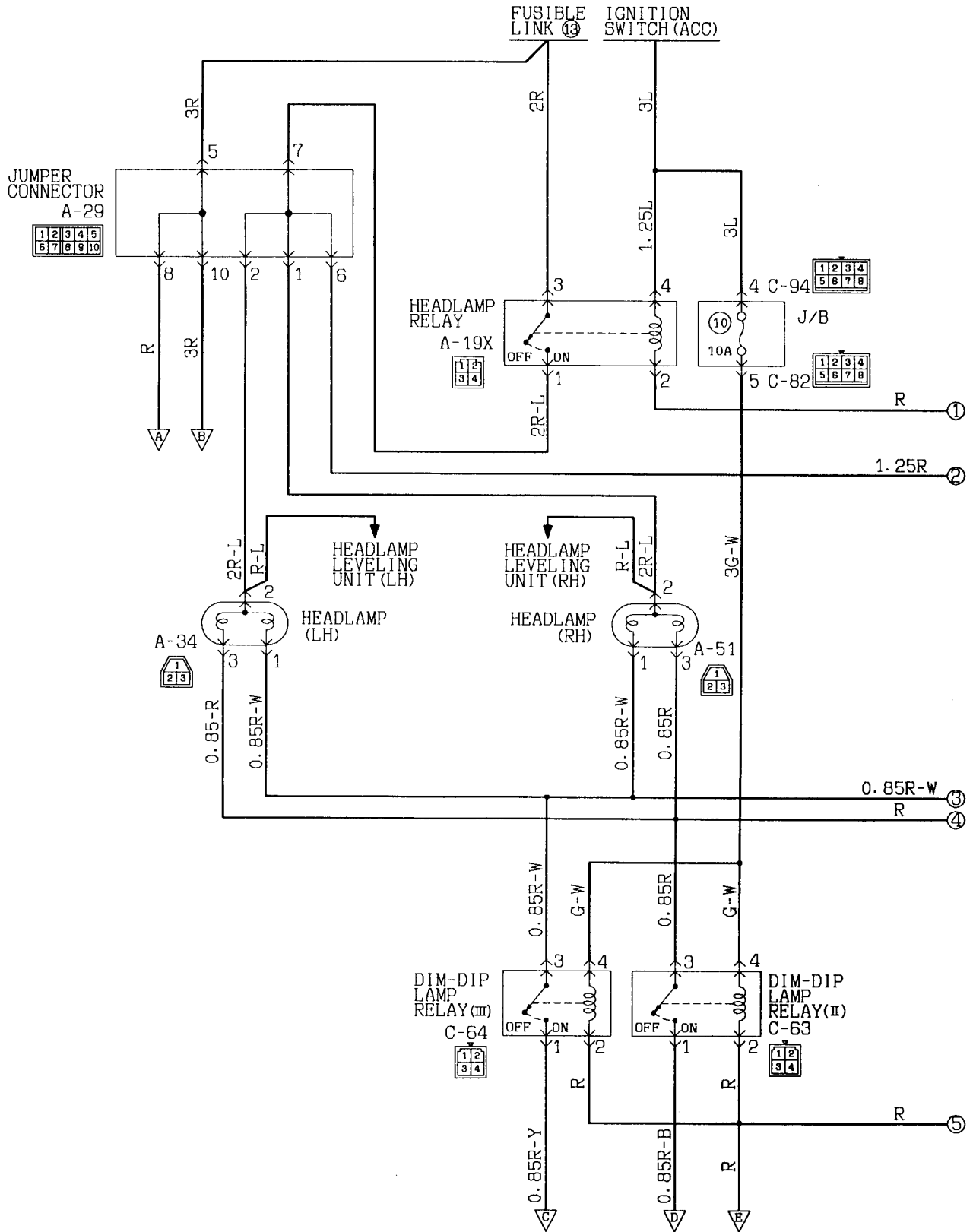

KX35-AC-00822-ZC

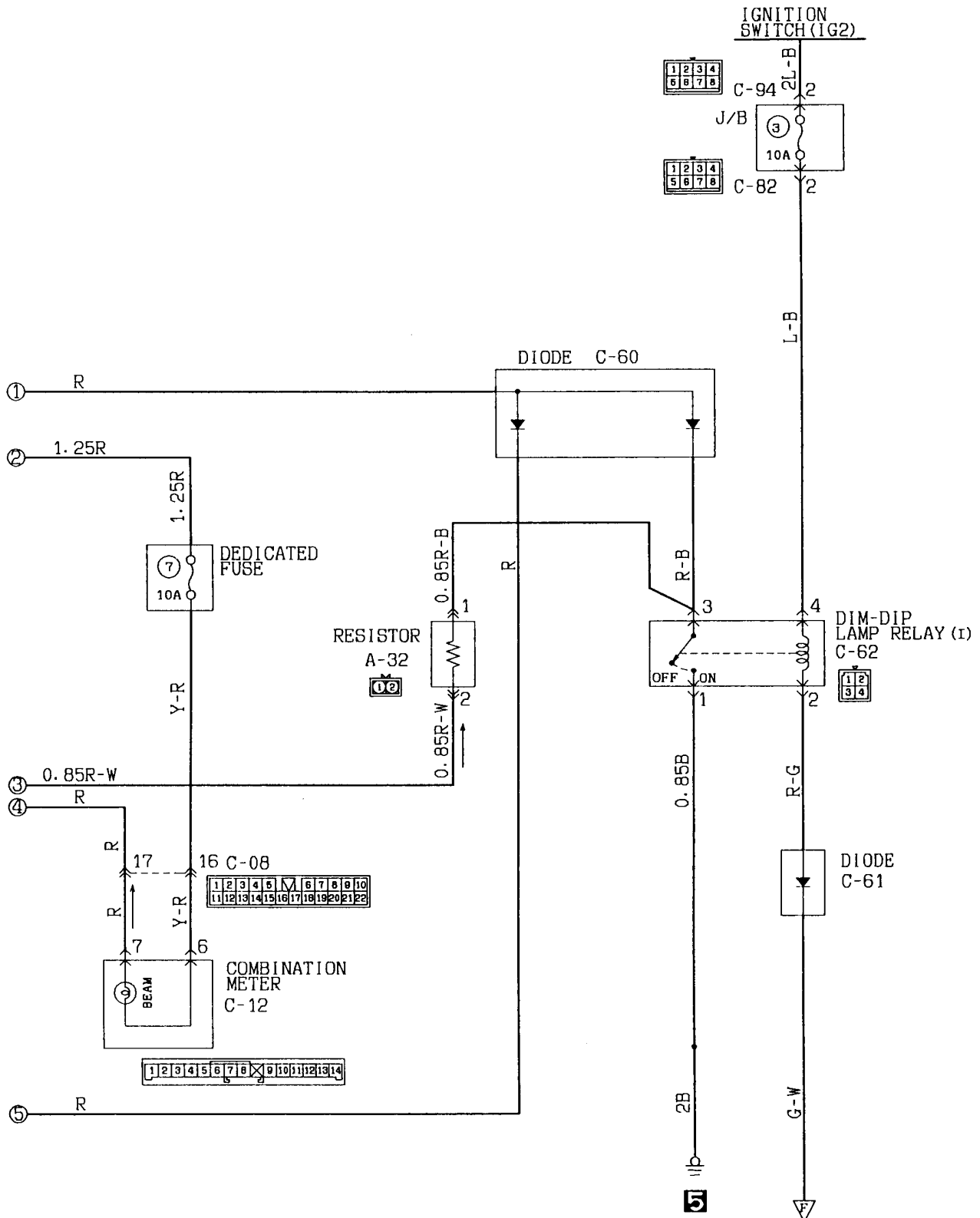

Wire colour code
 B:Black LG:Light green G:Green L:Blue W:White Y:Yellow SB:Sky blue
 BR:Brown O:Orange GR:Gray R:Red P:Pink V:Violet

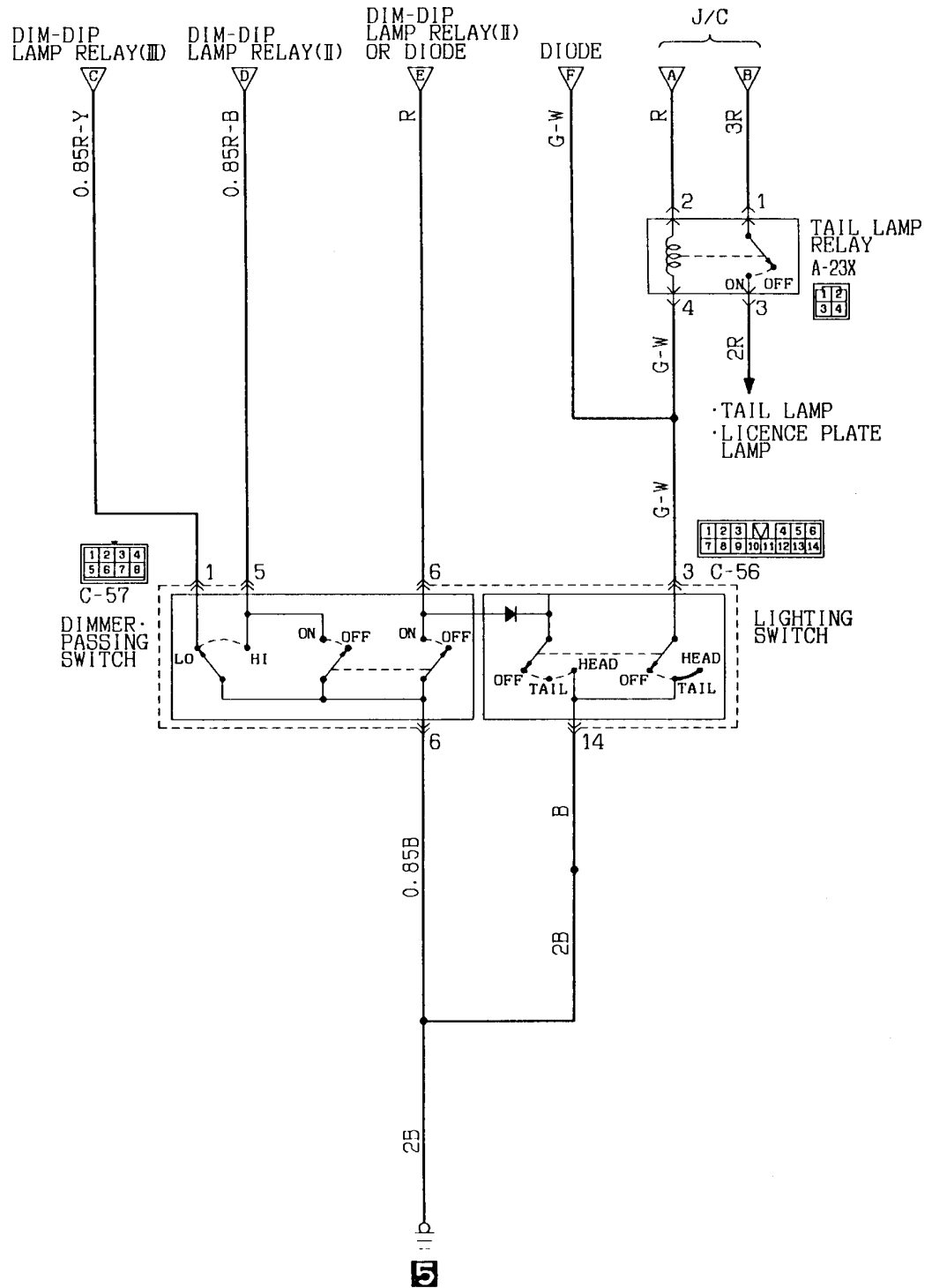

Wire colour code
 B:Black LG:Light green G:Green L:Blue W:White Y:Yellow SB:Sky blue
 BR:Brown O:Orange GR:Gray R:Red P:Pink V:Violet

KX35-AC-00803A-EC

NOTES

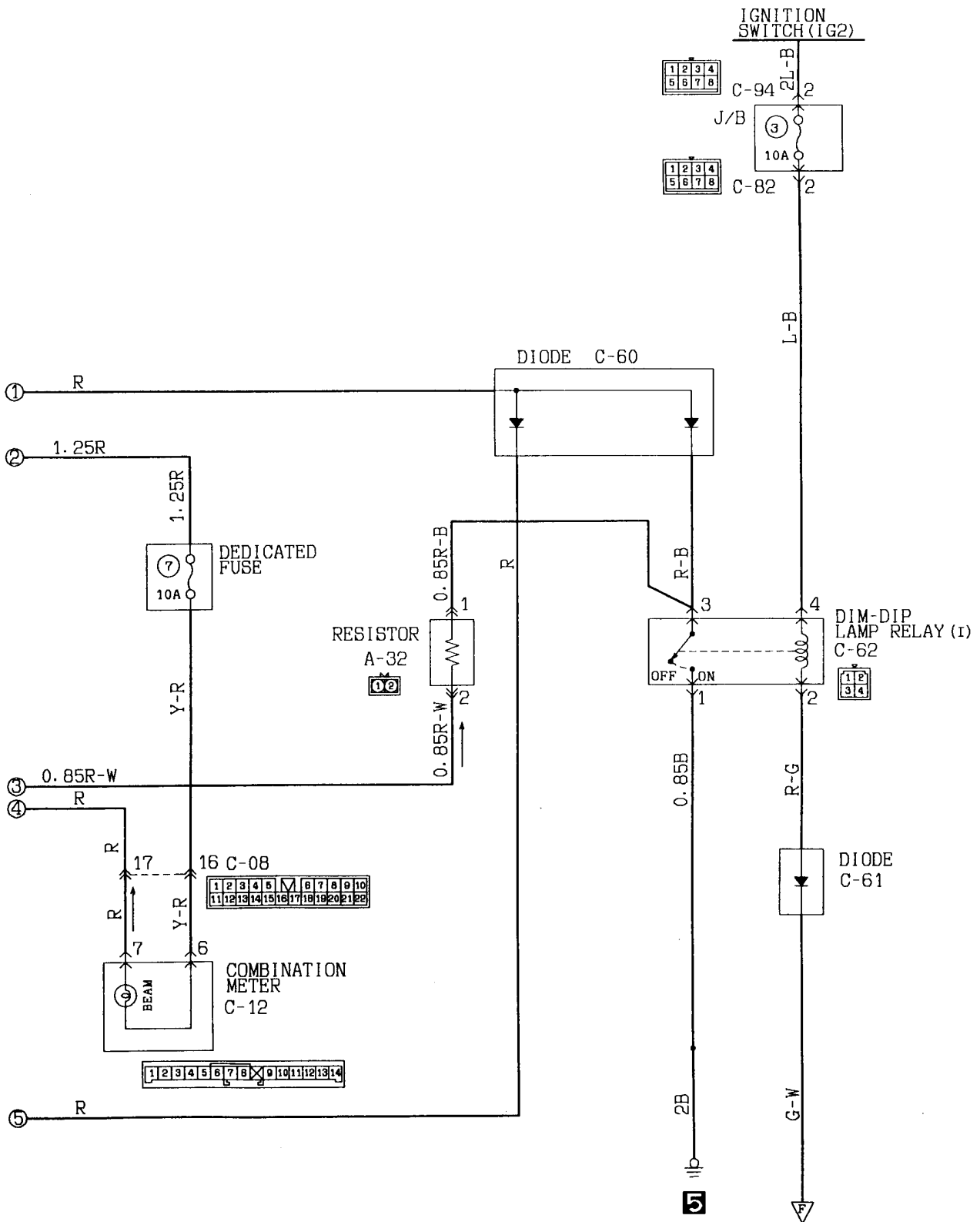

Wire colour code
 B:Black LG:Light green G:Green L:Blue W:White Y:Yellow SB:Sky blue
 BR:Brown O:Orange GR:Gray R:Red P:Pink V:Violet

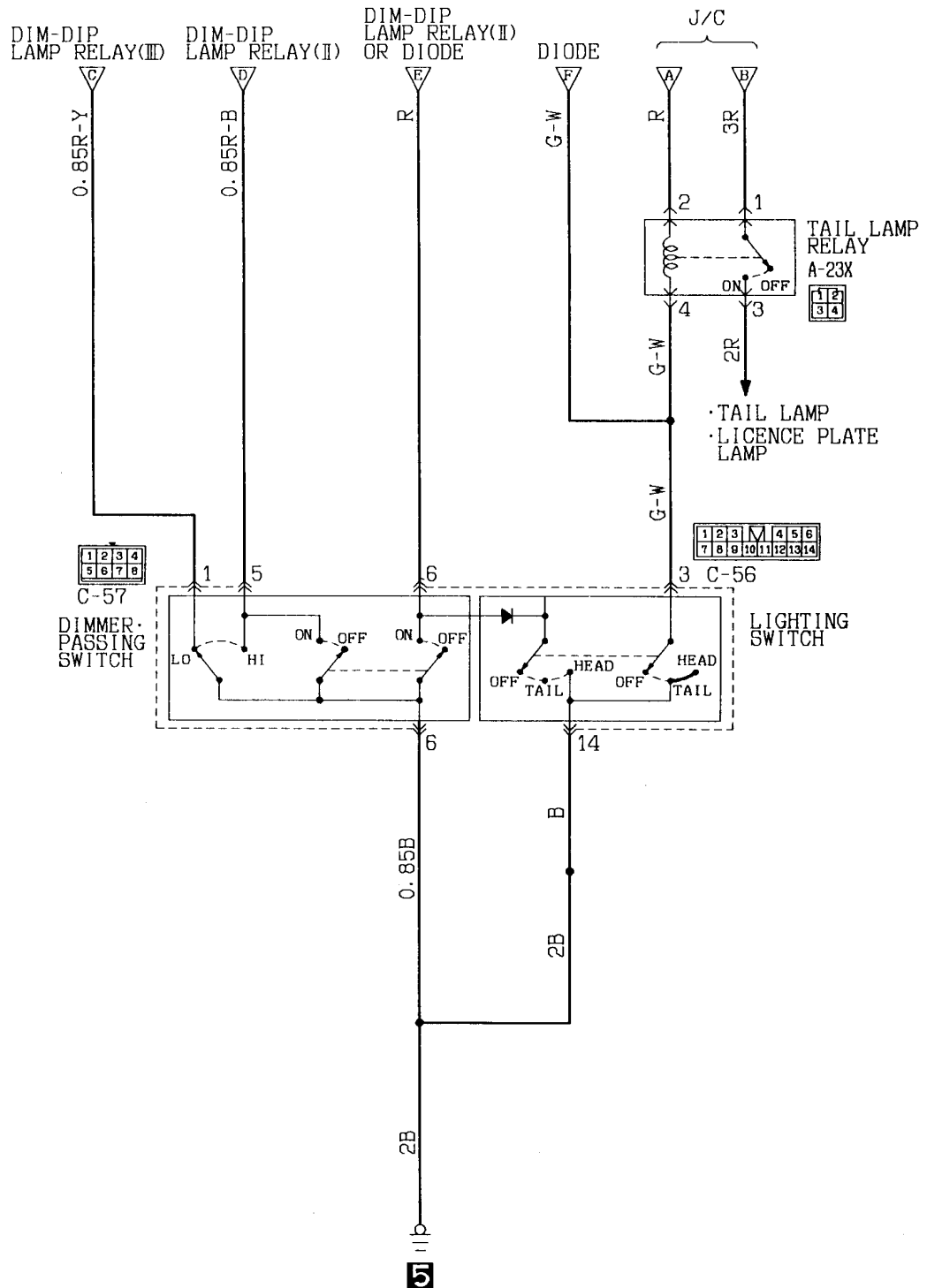

Wire colour code
 B:Black LG:Light green G:Green L:Blue W:White Y:Yellow SB:Sky blue
 BR:Brown O:Orange GR:Gray R:Red P:Pink V:Violet

HEADLAMP <R.H.drive vehicles> (See P. 4-50.)**OPERATION**

Headlamp Relay ON Conditions
<1991 Models>

Ignition switch	Lighting switch	Dimmer/passing switch	Headlamp relay
"ON"	"TAIL"	—	ON
"ACC" or "ON"	"HEAD"	—	ON
"ACC" or "ON"	—	ON	ON

<1993 Models>

Ignition switch	Lighting switch	Dimmer/passing switch	Headlamp relay
"ON"	"TAIL"	—	ON
—	"HEAD"	—	ON
—	—	ON	ON

<Dim-dip lamp operation>

- Placing the lighting switch in the TAIL position causes dim-dip lamp relay (I) to be energized.
- This causes the headlamp relay to be also energized resulting in the headlamps being lit up dimly through the circuit by way of resistor.

<Low-beam operation>

- Placing the lighting switch in the HEAD position causes the headlamp relay, dim-dip lamp relay (II), and dim-dip lamp relay (III) to be energized.
- If the dimmer/passing switch is placed in the LO position at this time, the headlamps light up in low beam.

<Upper-beam operation>

- Placing the lighting switch in the HEAD position causes the headlamp relay, dim-dip lamp relay (II) and dim-dip lamp relay (III) to be energized.
- If the dimmer/passing switch is placed in the HI position at this time, the headlamps light up in upper beam.

<Upper-beam indicator lamp>

- This lamp lights up when the upper/passing beams are on, indicating that the headlamps are on in upper beam.

TROUBLESHOOTING HINTS

1. Headlamps don't come on.
 - 1) But the tail lamps do illuminate.
 - Check the headlamp relay.
 - Check the lighting switch.
 - Check the dim-dip lamp relays (II) and (III).
 - 2) The tail lamps also don't illuminate.
 - Check the fusible link No. ⑬.
2. The low beam at both sides doesn't illuminate.
 - Check the dimmer switch LO contacts.
3. The upper beam at both sides doesn't illuminate.
 - 1) The passing signal functions OK.
 - Check the dimmer switch HI contacts.
 - 2) The passing signal doesn't function.
 - Check the dimmer switch.
4. One headlamp doesn't illuminate.
 - Check the bulb.
5. Can't switch from low to upper beam or vice-versa.
 - Check the dimmer switch.
6. The headlamps' low beam does not illuminate at the "TAIL" position of the lighting switch.
 - 1) The low beam does illuminate, however, when, with lighting switch at the "HEAD" position, the dimmer switch is set to "LO".
 - Check the dim-dip lamp relay (I).
 - Check the resistor.
 - Check the diode.
7. Upper-beam indicator lamp does not come on.
 - 1) Headlamp upper beams are operational.
 - Check dedicated fuse No. ⑦.
 - Check the indicator lamp bulb.

HEADLAMP <R.H.drive vehicles> (See P. 4-50.)**OPERATION**

Headlamp Relay ON Conditions

Ignition switch	Lighting switch	Dimmer/passing switch	Headlamp relay
"ON"	"TAIL"	—	ON
"ACC" or "ON"	"HEAD"	—	ON
"ACC" or "ON"	—	ON	ON

<Dim-dip lamp operation>

- Placing the lighting switch in the TAIL position causes dim-dip lamp relay (I) to be energized.
- This causes the headlamp relay to be also energized resulting in the headlamps being lit up dimly through the circuit by way of resistor.

<Low-beam operation>

- Placing the lighting switch in the HEAD position causes the headlamp relay, dim-dip lamp relay (II), and dim-dip lamp relay (III) to be energized.
- If the dimmer/passing switch is placed in the LO position at this time, the headlamps light up in low beam.

<Upper-beam operation>

- Placing the lighting switch in the HEAD position causes the headlamp relay, dim-dip lamp relay (II) and dim-dip lamp relay (III) to be energized.
- If the dimmer/passing switch is placed in the HI position at this time, the headlamps light up in upper beam.

<Upper-beam indicator lamp>

- This lamp lights up when the upper/passing beams are on, indicating that the headlamps are on in upper beam.

TROUBLESHOOTING HINTS

1. Headlamps don't come on.
 - 1) But the tail lamps do illuminate.
 - Check the headlamp relay.
 - Check the lighting switch.
 - Check the dim-dip lamp relays (II) and (III).
 - 2) The tail lamps also don't illuminate.
 - Check the fusible link No. ⑬.
2. The low beam at both sides doesn't illuminate.
 - Check the dimmer switch LO contacts.
3. The upper beam at both sides doesn't illuminate.
 - 1) The passing signal functions OK.
 - Check the dimmer switch HI contacts.
 - 2) The passing signal doesn't function.
 - Check the dimmer switch.
4. One headlamp doesn't illuminate.
 - Check the bulb.
5. Can't switch from low to upper beam or vice-versa.
 - Check the dimmer switch.
6. The headlamps' low beam does not illuminate at the "TAIL" position of the lighting switch.
 - 1) The low beam does illuminate, however, when, with lighting switch at the "HEAD" position, the dimmer switch is set to "LO".
 - Check the dim-dip lamp relay (I).
 - Check the resistor.
 - Check the diode.
7. Upper-beam indicator lamp does not come on.
 - 1) Headlamp upper beams are operational.
 - Check dedicated fuse No. ⑦.
 - Check the indicator lamp bulb.

9 HEADLAMP LEVELING SYSTEM
9-1 L.H. drive vehicles

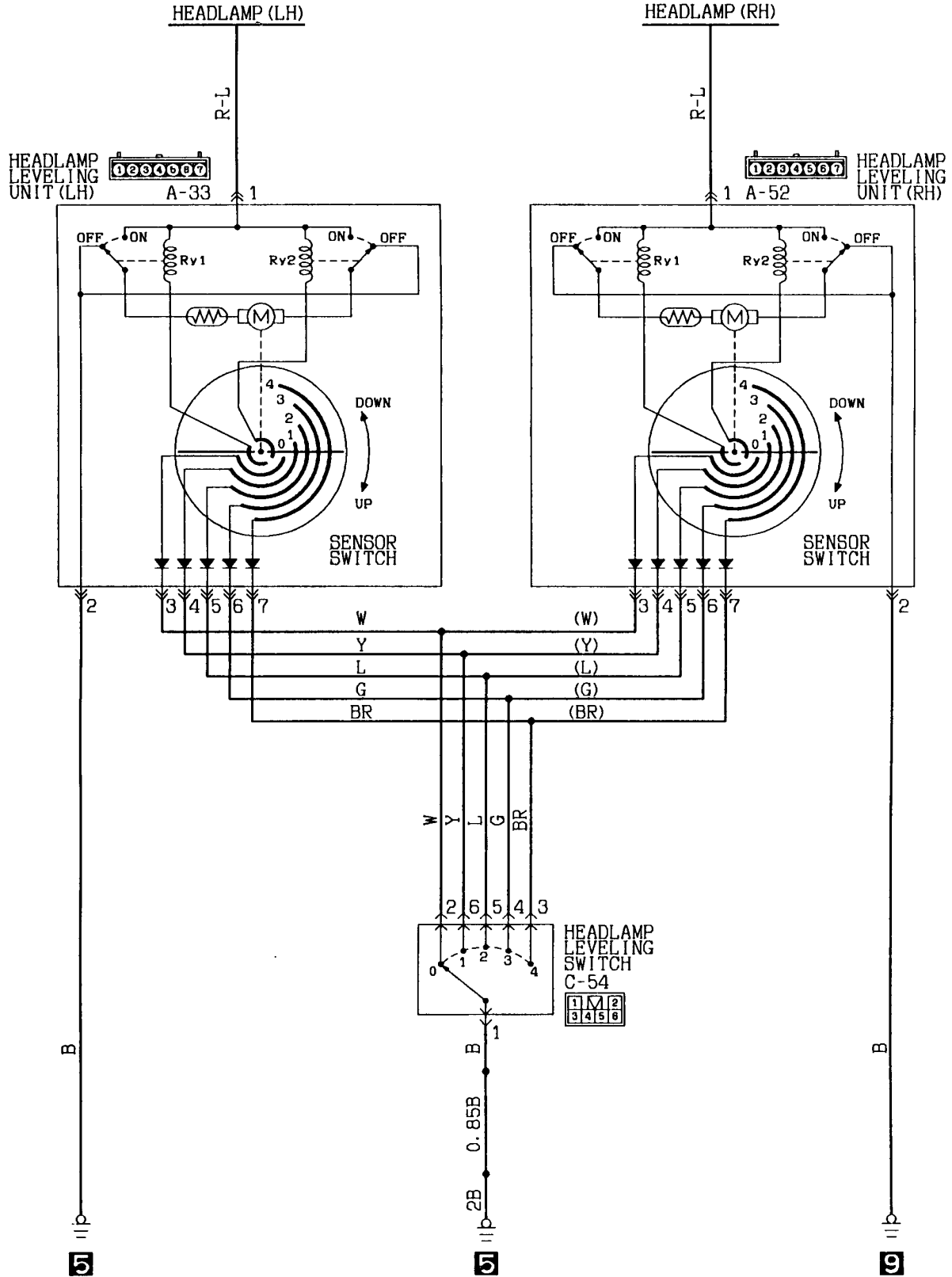

Wire colour code
 B:Black LG:Light green G:Green L:Blue W:White Y:Yellow SB:Sky blue
 BR:Brown O:Orange GR:Gray R:Red P:Pink V:Violet

9 HEADLAMP LEVELING SYSTEM

9-1 L.H. drive vehicles

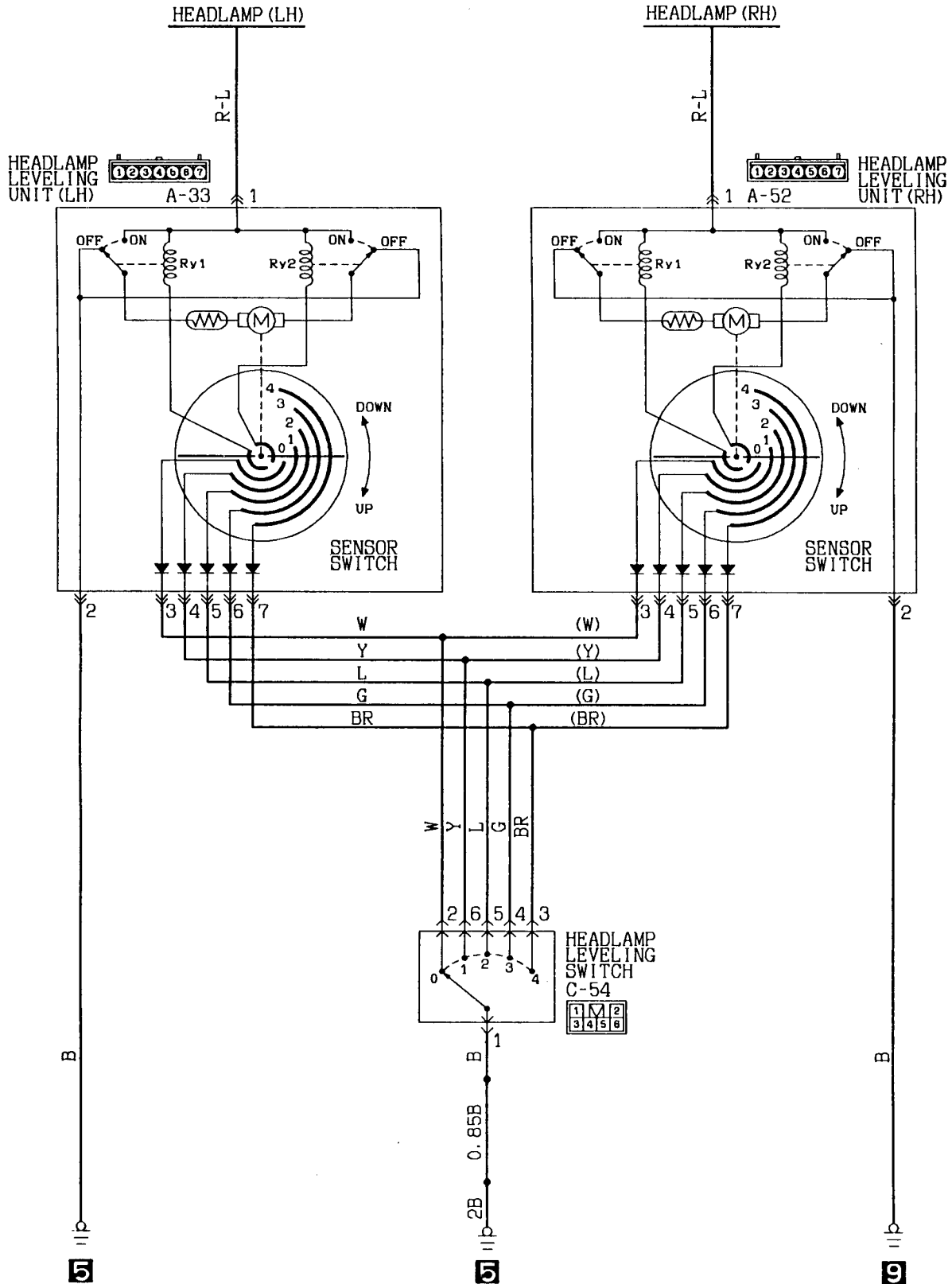

Wire colour code

B:Black LG:Light green G:Green L:Blue W:White Y:Yellow SB:Sky blue
 BR:Brown O:Orange GR:Gray R:Red P:Pink V:Violet

9-2 R.H. drive vehicles

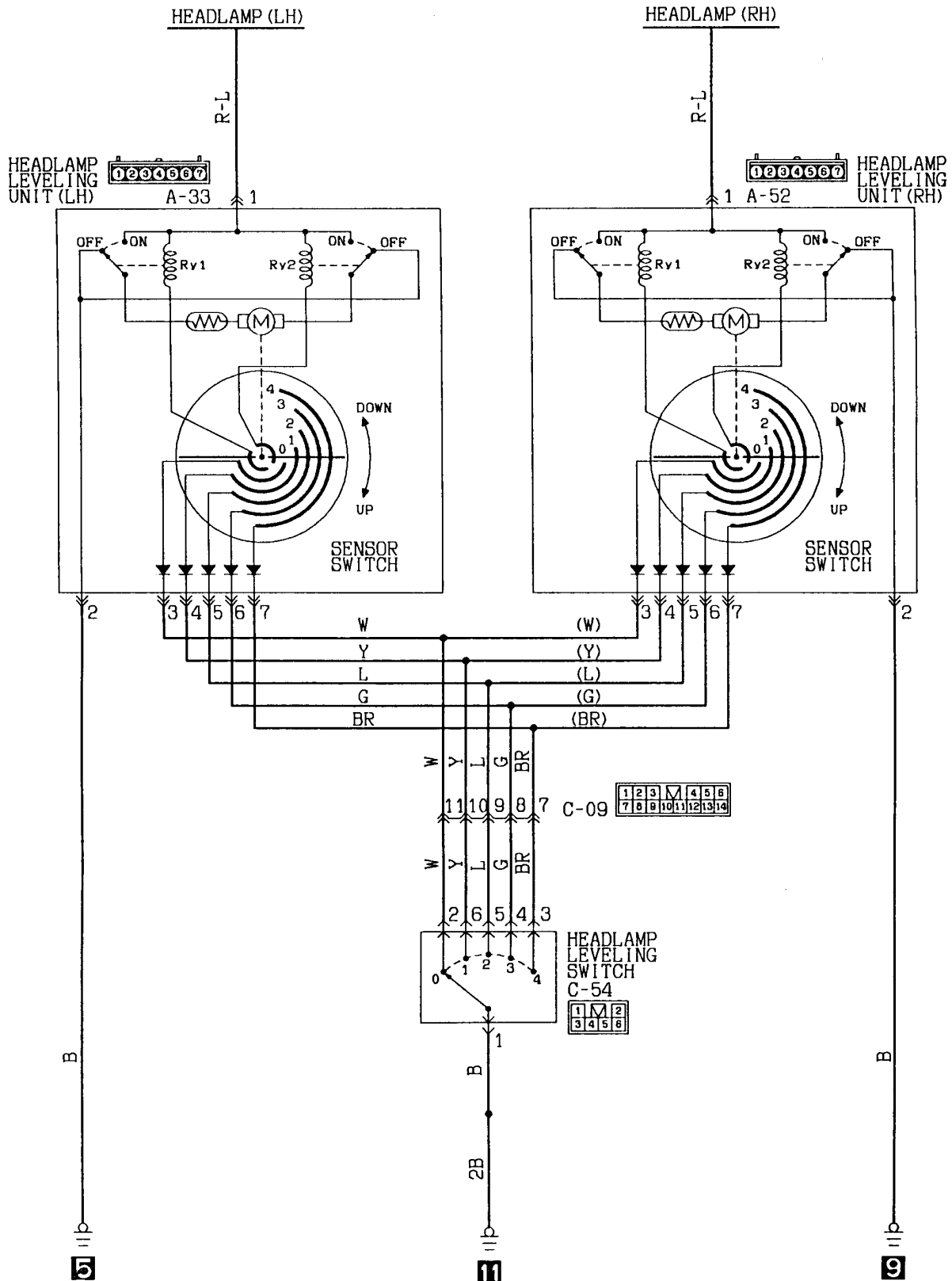

Wire colour code
 B:Black LG:Light green G:Green L:Blue W:White Y:Yellow SB:Sky blue
 BR:Brown O:Orange GR:Gray R:Red P:Pink V:Violet

HEADLAMP LEVELING SYSTEM (See P. 4-54, 55.)**OPERATION****Downtilt operation**

- When the headlamps are switched ON, battery voltage is applied, from the headlamp relay to the headlamp leveling unit.
- When the headlamp leveling switch setting is changed from the "0" position to the "1" position, electricity flows from Relay 2 to print base 1 to the headlamp leveling switch and to earth; the Relay 2 contacts are thus switched ON and the motor is activated. As a result, the headlamp leveling unit's shaft is pushed outward, the reflector tilts downward, and the optical axis of the headlamps is tilted in the downward direction.
- At the same time, the contacts of the sensor switch, which are interlocked with the movement of the motor, also turn in the "DOWN" direction, and, at the position where there is no longer contact of print base 1 and the brush contact, Relay 2 is switched OFF and the motor stops.
- In the same way as described above, when the headlamp leveling switch setting is changed from the "1" position to the "2" position and further to the "3" position and the "4" position, the motor continues to rotate so that the headlamp leveling unit's shaft is pushed outward, tilting the reflector further downward; the optical axis of the headlamps is at the maximum downward tilt at the "4" position of the headlamp leveling switch.

Return operation

- When the setting of the headlamp leveling switch is changed from the "4" position to the "3" position, electricity flows from Relay 1 to print base 3 to the headlamp leveling switch and to earth; the Relay 1 contacts are thus switched ON, and the motor rotates in the direction opposite to that for downtilt.
As a result, the headlamp leveling unit's shaft is drawn inward, the tilt of the reflector is reduced, and the optical axis of the headlamps is changed in the upward direction.
- At the same time, the contacts of the sensor switch turn in the "UP" direction, and, at the position where there is no longer contact of print base 3 and the brush contact, Relay 1 is switched OFF and the motor stops.
- When the setting of the headlamp leveling switch is further changed from the "3" position to the "2" position and to the "1" position, the motor continues to rotate, and the optical axis of the headlamps returns to the minimum tilt position at the "0" setting of the switch.
- In order to prevent overheat damage to the motor as a result of frequent operation of the headlamp leveling system, a thermistor is provided in the circuitry within the headlamp leveling unit.

TROUBLESHOOTING HINTS

1. No operation of the headlamp leveling system.
 - Check the headlamp leveling switch.
 - Check the headlamp leveling unit.
2. Either the left or right part of the headlamp leveling system does not operate.
 - Check the headlamp leveling unit for the side that does not operate.
3. Either the downtilt operation or the return operation does not function.
 - Check the headlamp leveling unit.

TAIL LAMP, CLEARANCE LAMP AND LICENSE PLATE LAMP (See P. 4-58.)**OPERATION**

- Placing the lighting switch in the TAIL or HEAD position causes the tail lamp relay to be energized.
- As a result, current flows by way of dedicated fuse No. ⑤ and No. ⑥ to each lamp, causing the lamp to come on.

TROUBLESHOOTING HINTS

1. No lamp come on.
 - 1) Headlamps do not come on, either.
 - Check fusible link No. ⑬.
 - 2) Headlamps do come on.
 - Check tail lamp relay.
 - Check dedicated fuse No. ⑤ and No. ⑥.

10 TAIL LAMP, CLEARANCE LAMP, LICENSE PLATE LAMP

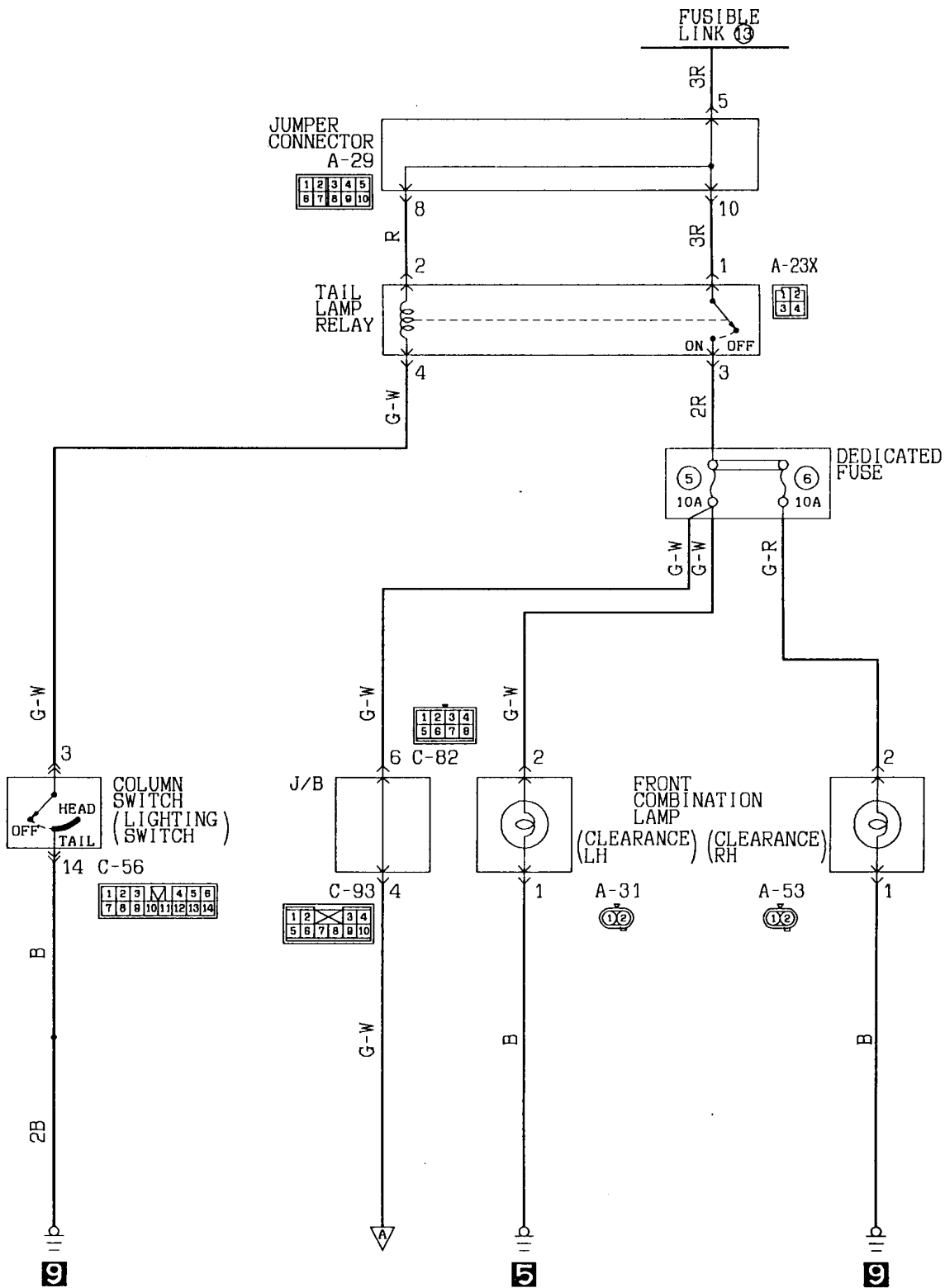

Wire colour code
 B:Black LG:Light green G:Green L:Blue W:White Y:Yellow SB:Sky blue
 BR:Brown O:Orange GR:Gray R:Red P:Pink V:Violet

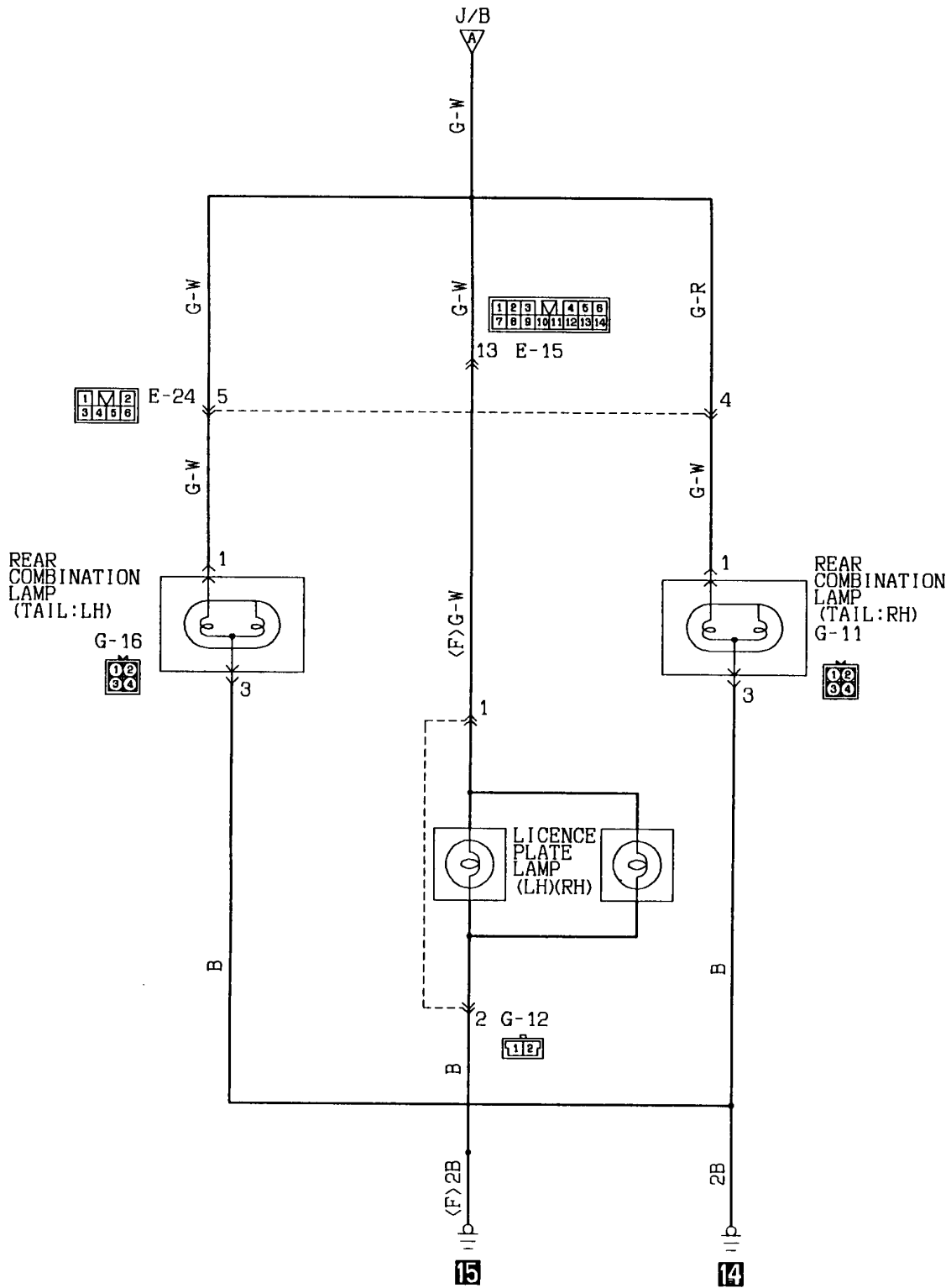

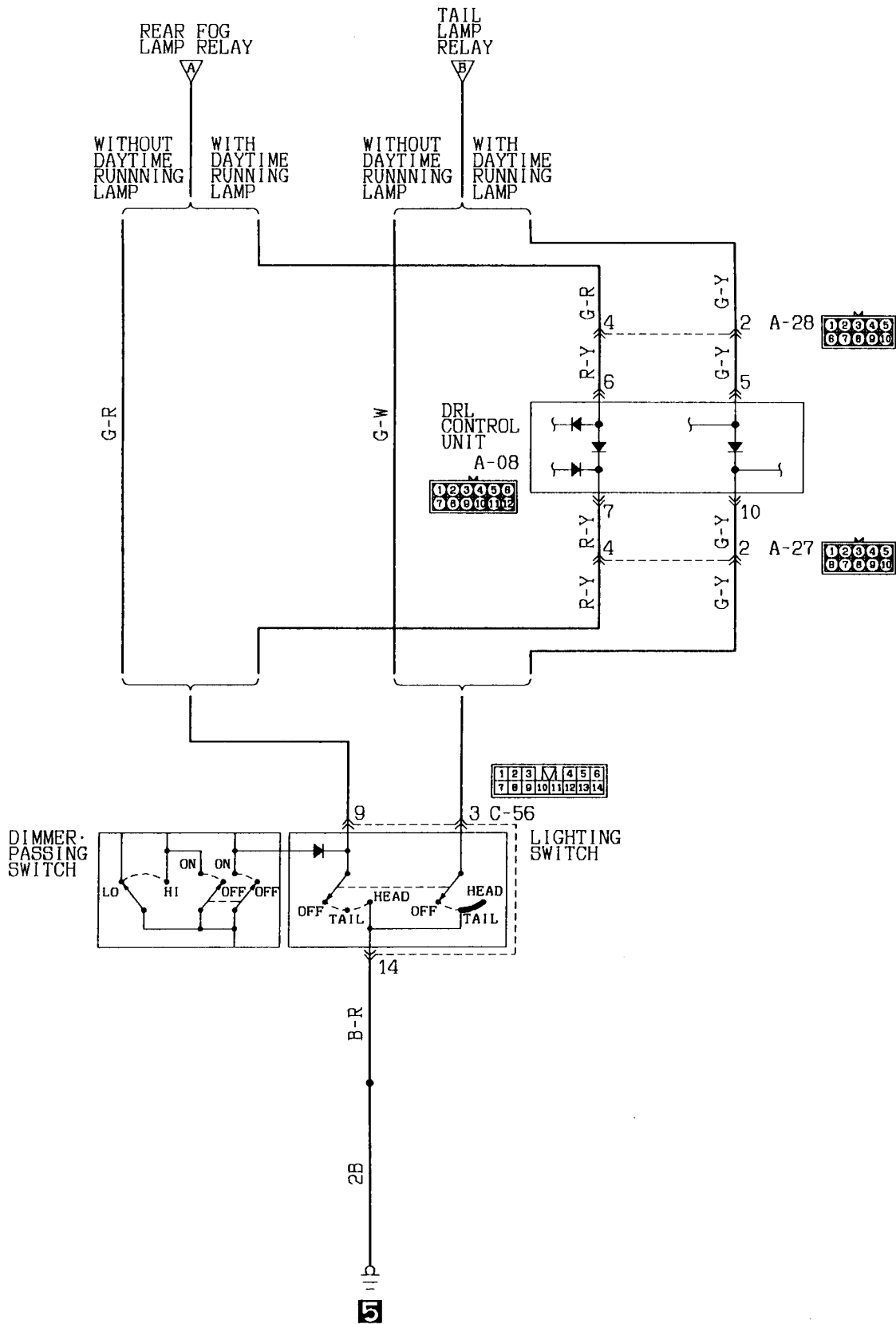

Wire colour code
 B:Black LG:Light green G:Green L:Blue W:White Y:Yellow SB:Sky blue
 BR:Brown O:Orange GR:Gray R:Red P:Pink V:Violet

11-1 L.H. drive vehicles <1993 MODELS>

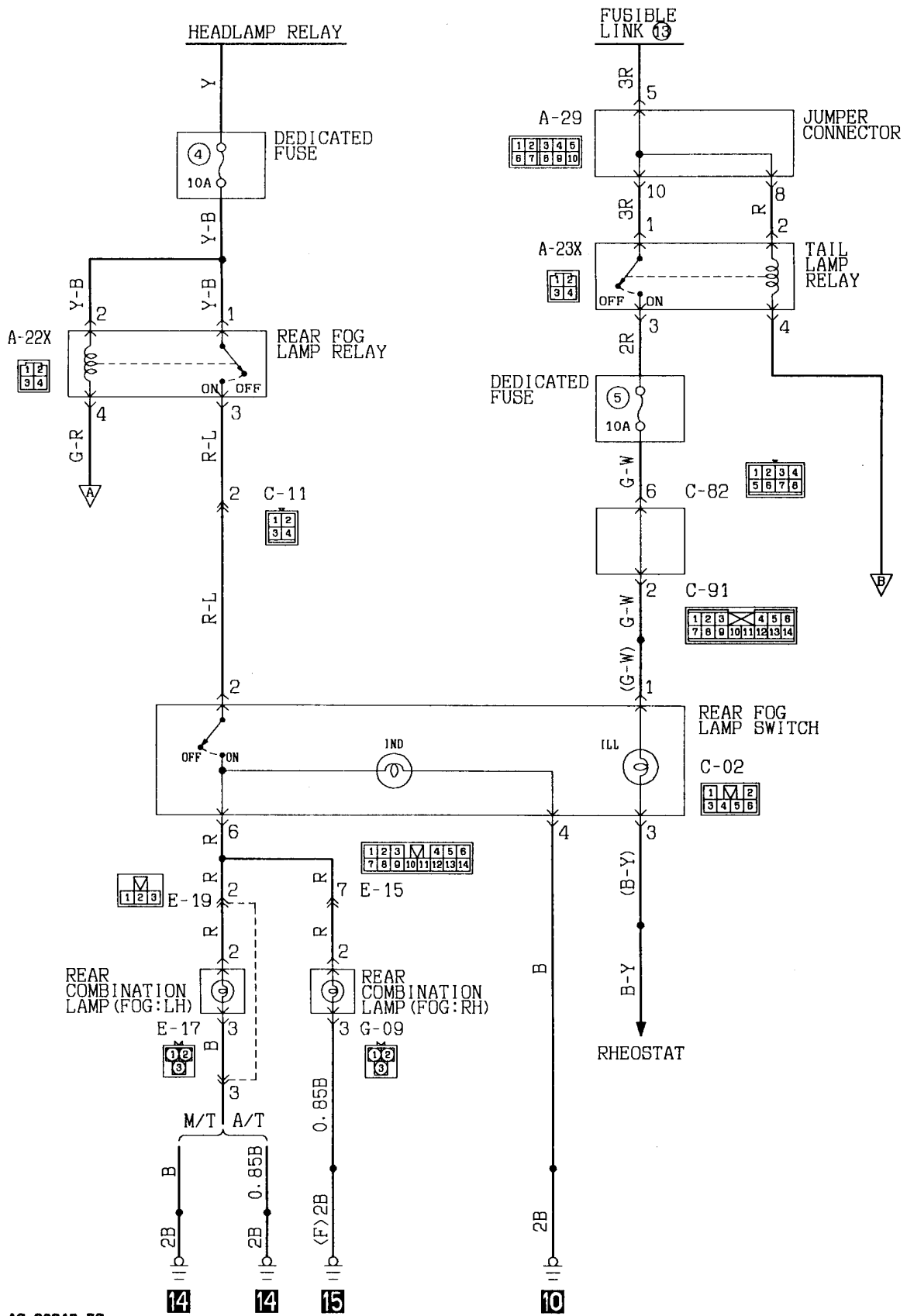

KX35-AC-00818-EC

CIRCUIT DIAGRAM — Rear Fog Lamp

4-61-2

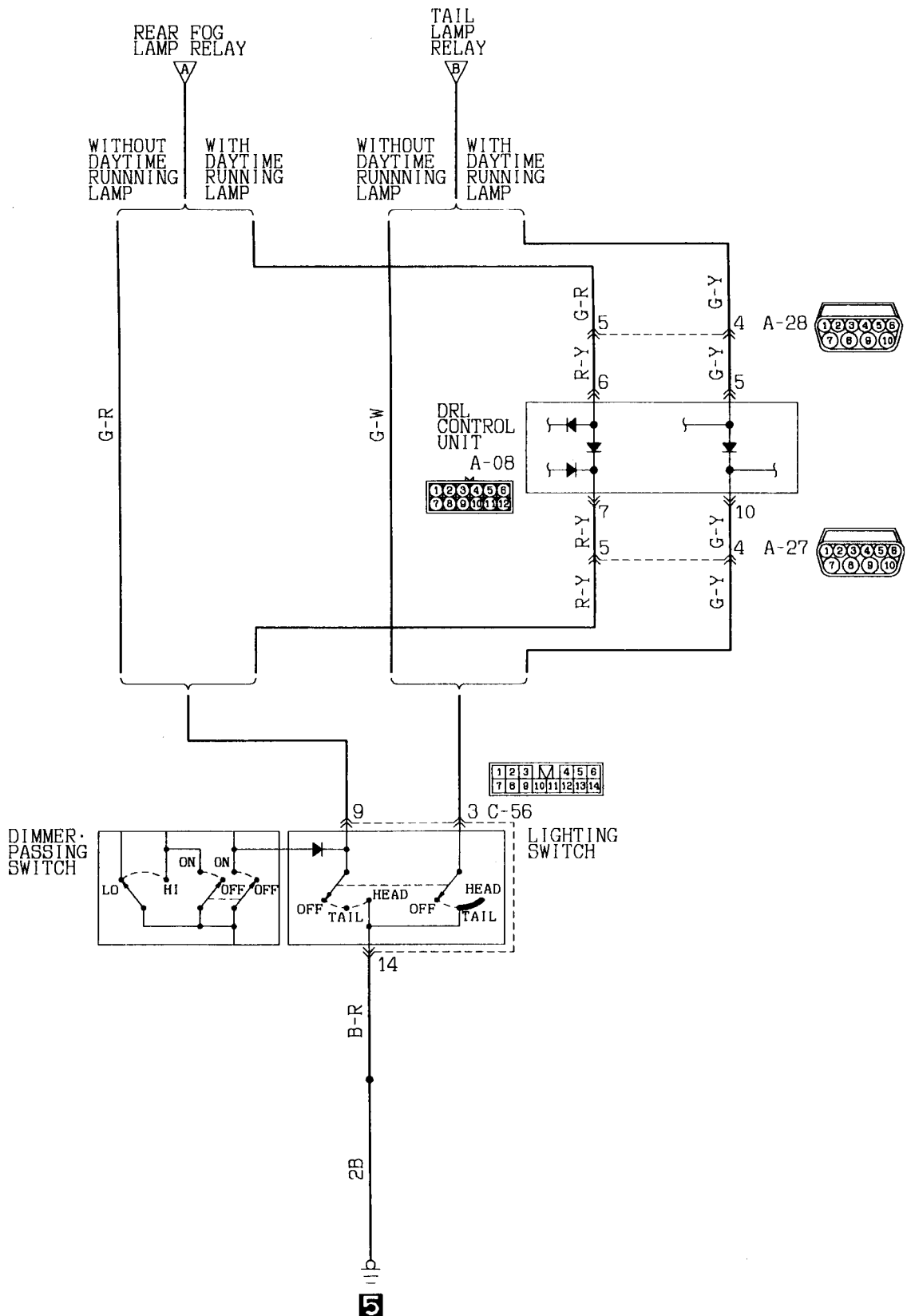

Wire colour code
 B:Black LG:Light green G:Green L:Blue W:White Y:Yellow SB:Sky blue
 BR:Brown O:Orange GR:Gray R:Red P:Pink V:Violet

11-2 R.H. drive vehicles (1991 MODELS)

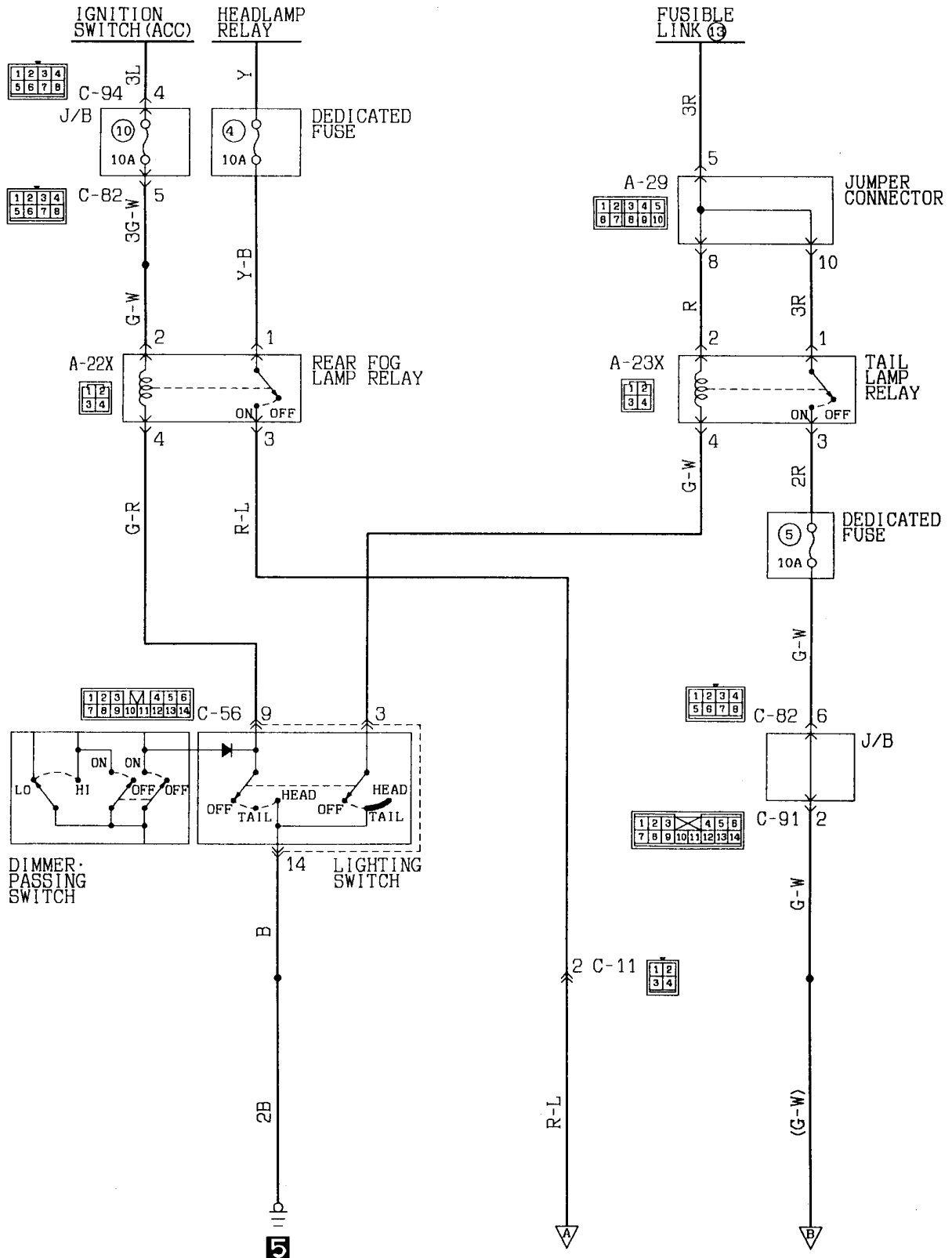

Wire colour code
 B:Black LG:Light green G:Green L:Blue W:White Y:Yellow SB:Sky blue
 BR:Brown O:Orange GR:Gray R:Red P:Pink V:Violet

KX35-AC-00824-EC

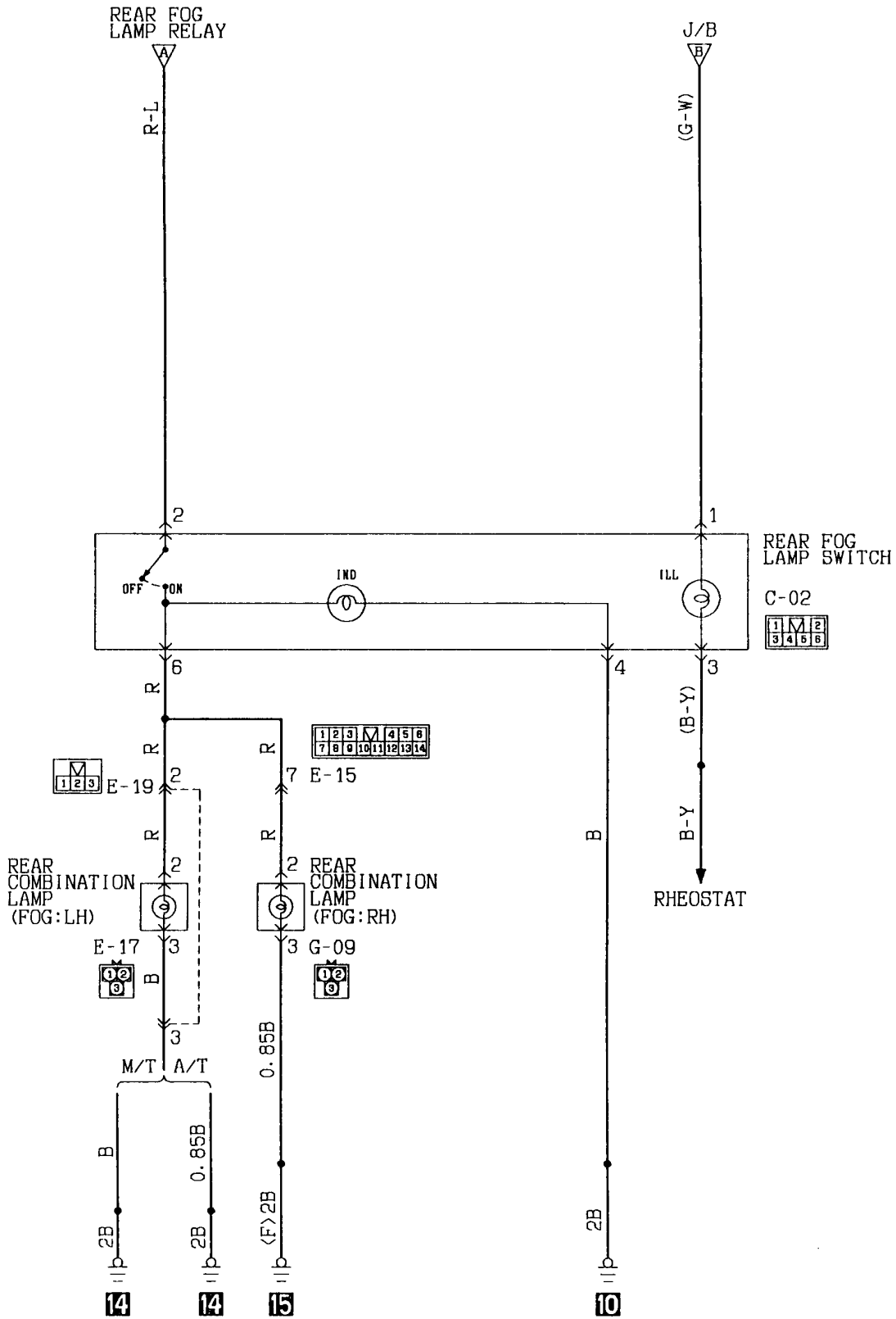

11-2 R. H. drive vehicles (1993 MODELS)

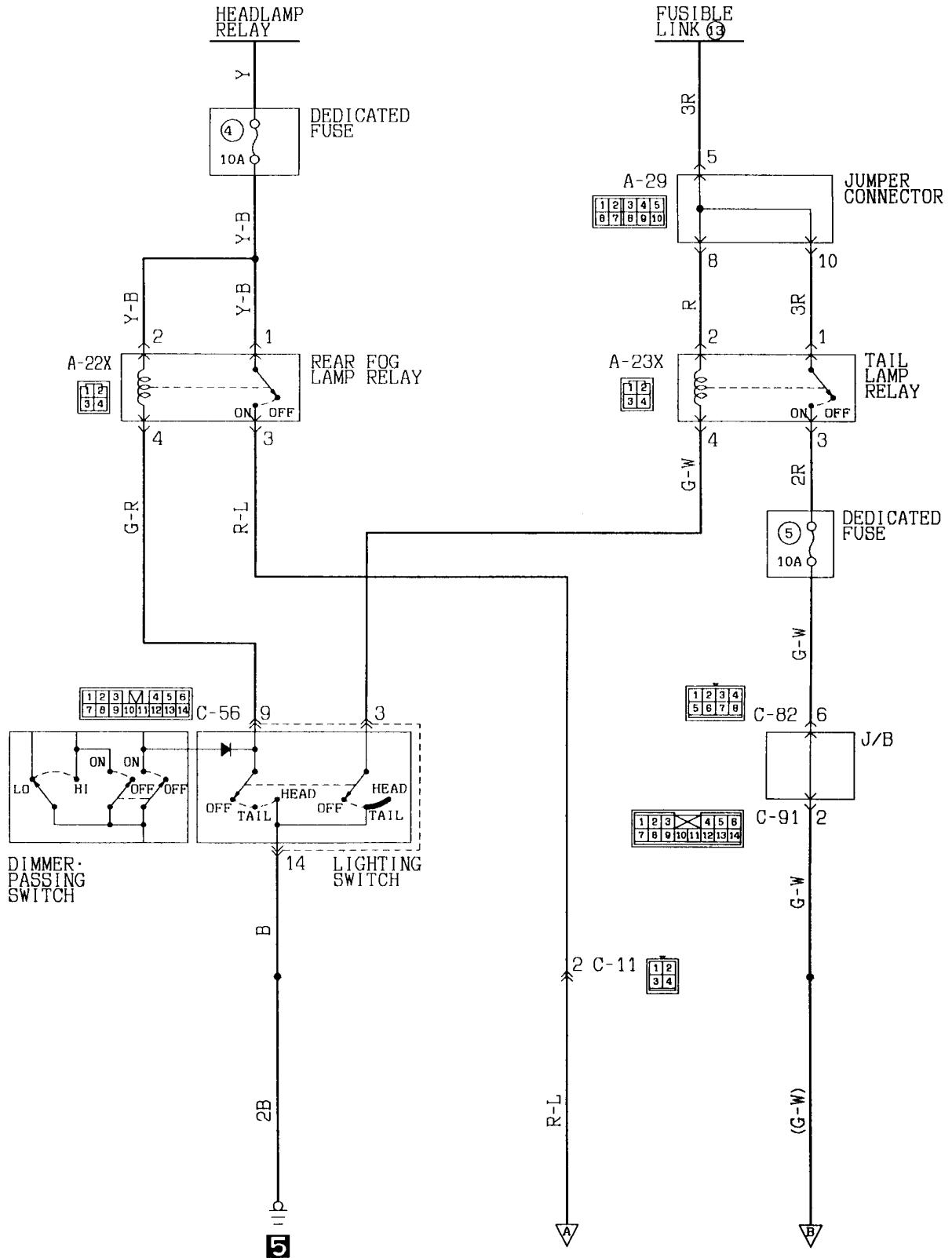

Wire colour code
 B:Black LG:Light green G:Green L:Blue W:White Y:Yellow SB:Sky blue
 BR:Brown O:Orange GR:Gray R:Red P:Pink V:Violet

REAR FOG LAMP (See P. 4-60, 62.)**OPERATION**

- Placing the lighting switch in the HEAD position causes the rear fog lamp relay to be energized.
- When the rear fog lamp switch is turned ON in this condition, the rear fog lamp comes on.

TROUBLESHOOTING HINTS

1. The rear fog lamp doesn't illuminate.
 - 1) Headlamps come on.
 - Check the rear fog lamp relay.
 - Check the rear fog lamp switch.
 - Check the dedicated fuse No. ④.
 - 2) Headlamps do not come on, either.
 - Check the headlamp relay.
 - Check the lighting switch.
 - Check the fusible link No. ⑬.
2. The rear fog lamp at the one side doesn't illuminate.
 - Check the bulb.

ROOM LAMP (See P. 4-66, 67, 68, 69.)**OPERATION**

- Placing the room lamp switch in the ON position causes the room lamp to come on at all times.
- Opening any one of the doors with the room lamp switch in the DOOR position causes the room lamp to come on.
- Closing all doors causes the room lamp to go out.

TROUBLESHOOTING HINTS

1. Room lamp does not come on.
 - 1) Clock is not operating, either.
 - Check multi-purpose fuse No. ⑱.
 - 2) Room lamp does not come on when any door is opened with the room lamp switch in the DOOR position.
 - Check bulb.
 - Check room lamp switch.
 - 3) Room lamp does not come on when a door is opened with the room lamp switch in the DOOR position.
 - Check door switch (of the suspected door).

12 ROOM LAMP
12-1 Canvas top

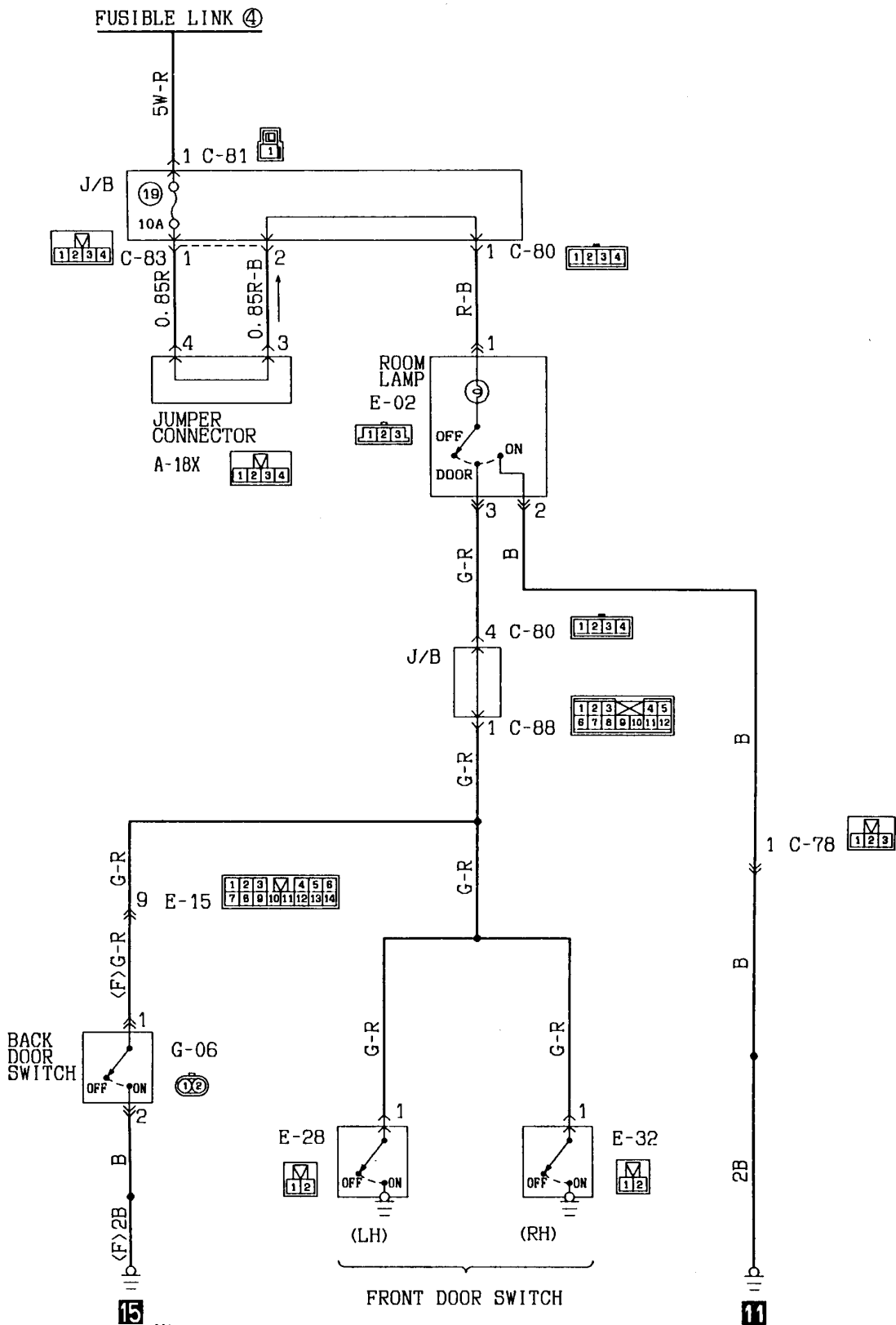

Wire colour code
 B:Black LG:Light green G:Green L:Blue W:White Y:Yellow SB:Sky blue
 BR:Brown O:Orange GR:Gray R:Red P:Pink V:Violet

12-2 2-door models without sunroof

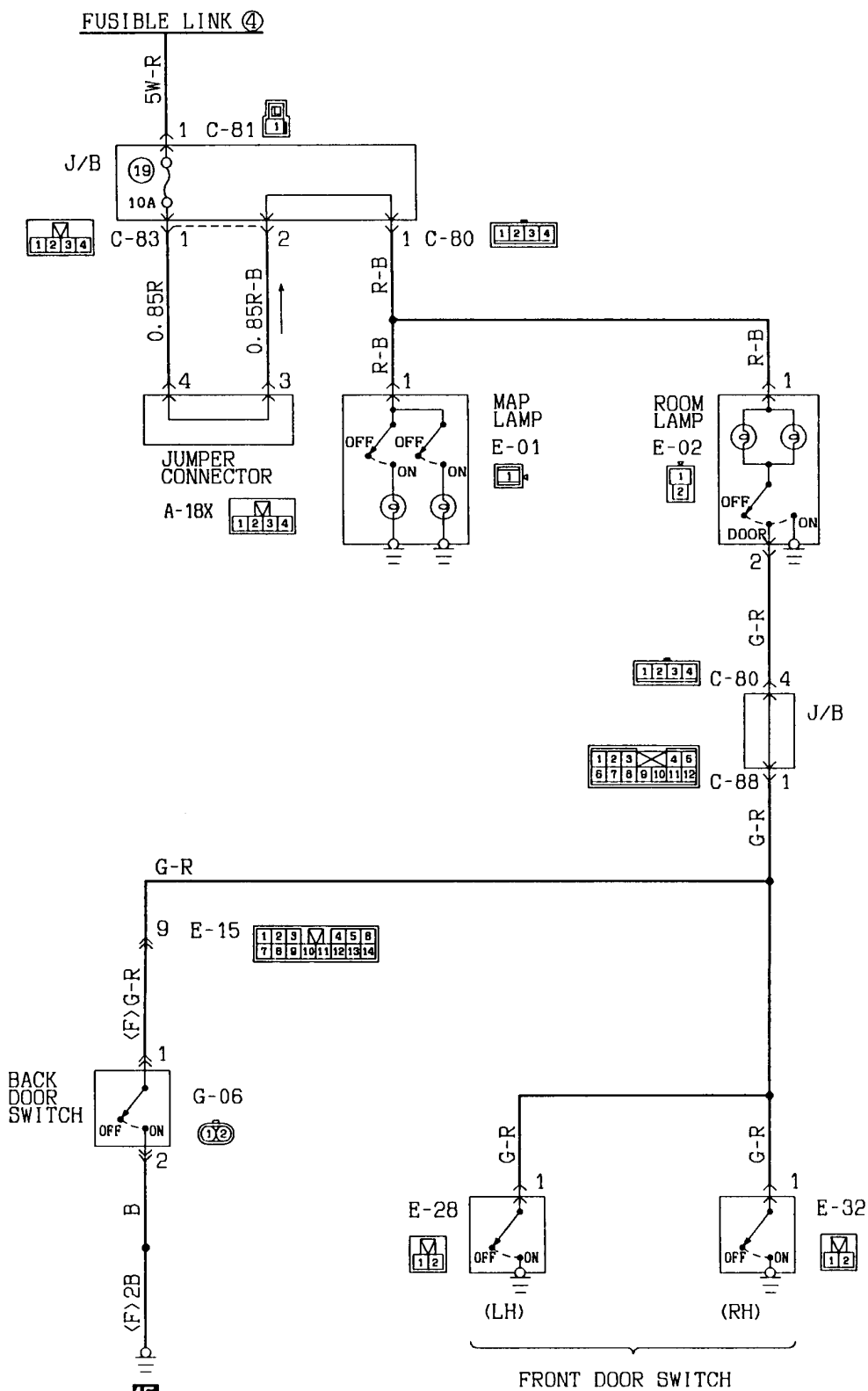

Wire colour code
 B:Black LG:Light green G:Green L:Blue W:White Y:Yellow BB:Sky blue
 BR:Brown O:Orange GR:Gray R:Red P:Pink V:Violet

12-4 4-door models

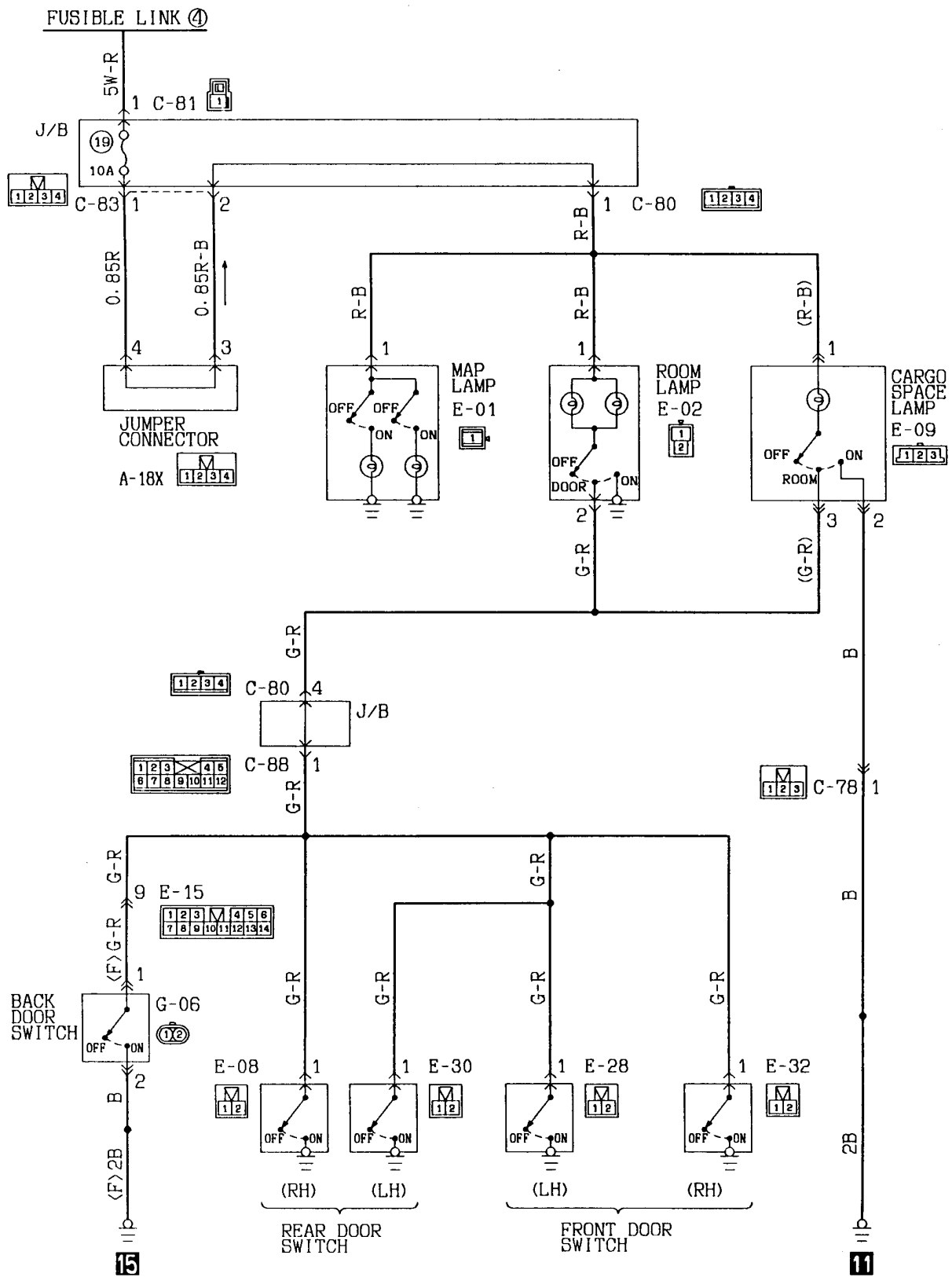

KX35-AC-00811-EC

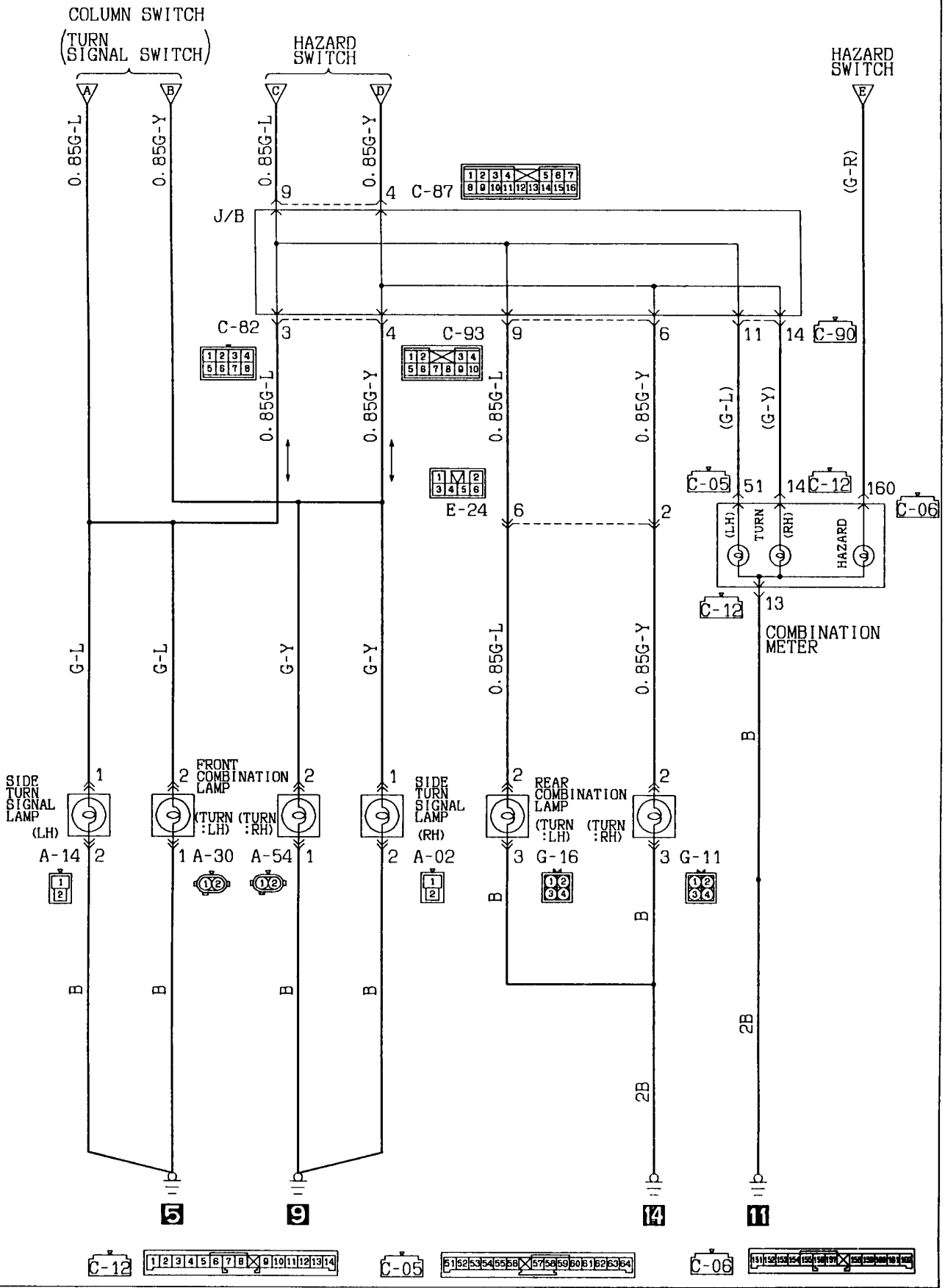

TURN-SIGNAL LAMP AND HAZARD LAMP (See P. 4-70.)**OPERATION****<Turn-signal lamp>****1. In normal operating condition**

- When the ignition switch is placed in the ON position, battery voltage is applied through the hazard switch to the turn-signal and hazard flasher unit.
- When the turn-signal switch is placed in the LH (or RH) position, Tr_1 in the flasher unit turns ON, causing the relay contacts in the flasher unit to close. This results in the LH (or RH) turn-signal lamp and turn-signal indicator lamp lighting up.
- At the same time, the capacitor is charged through R^2 up to the lower limit as set by COM3.
- As soon as the capacitor is fully charged, the output from COM3 is inverted, turning OFF Tr_1 . This opens the relay contacts and, as a result, the LH (or RH) turn-signal lamp and turn-signal indicator lamp go out.
- At the same time when Tr_1 turns OFF, the capacitor starts discharging. As soon as the capacitor completes discharging, the COM3 output is inverted again causing Tr_1 to turn ON. This results in the LH (or RH) turn-signal lamp and turn-signal indicator lamp coming on.
- These sequences of operation repeat, which results in the LH (or RH) turn-signal lamp and turn-signal indicator lamp flashing off and on.

2. When one bulb is burnt

- When either one of the turn-signal lamp bulbs goes out, it causes the resistance of the entire lamp circuit to increase; hence a smaller voltage drop at $R1$ in the flasher unit.
- This smaller voltage drop is sensed and the lower voltage limit set by COM3 is raised, thus shortening the time required by the capacitor before it is fully charged.
- As a result, the on-off cycle of Tr_1 becomes shorter with the resultant greater number of times the lamp flashes on and off.

<Hazard lamp>

- When the hazard switch is placed in the ON position, the flasher unit relay contacts repeatedly close and open, which results in the LH and RH turn-signal lamps, turn-signal indicator lamps, and hazard warning indicator lamps flashing on and off at the same time.

Remark

- The number of times the hazard lamps flash on and off does not change even when one bulb is out.

TROUBLESHOOTING HINTS

1. Neither the turn-signal lamps nor hazard lamps operate.
 - Check hazard switch contacts (on power source end).
 - Check flasher unit.
2. All LH or RH turn-signal lamps do not operate.
 - 1) Hazard lamp is fully operational.
 - Check hazard switch contacts (on turn-signal end).
 - Check turn-signal switch.
3. Flashing cycle of turn signal lamps is shorter.
 - Check bulb.
4. Hazard lamp does not operate.
 - 1) Turn-signal lamps are operational.
 - Check hazard switch contacts (on hazard lamp end).

14 STOP LAMP

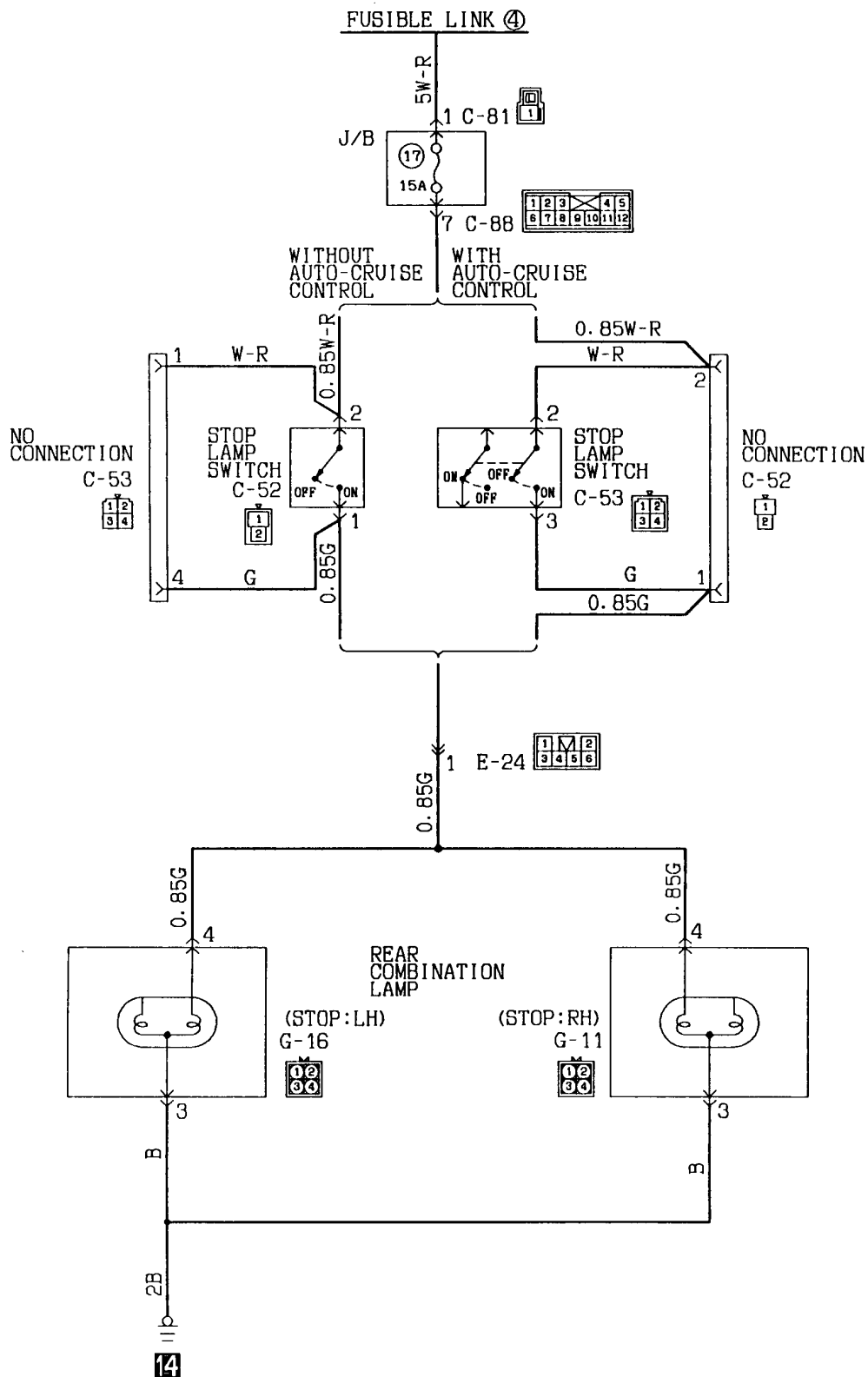

Wire colour code
 B:Black LG:Light green G:Green L:Blue W:White Y:Yellow SB:Sky blue
 BR:Brown O:Orange GR:Gray R:Red P:Pink V:Violet

15 BACK-UP LAMP
15-1 M/T

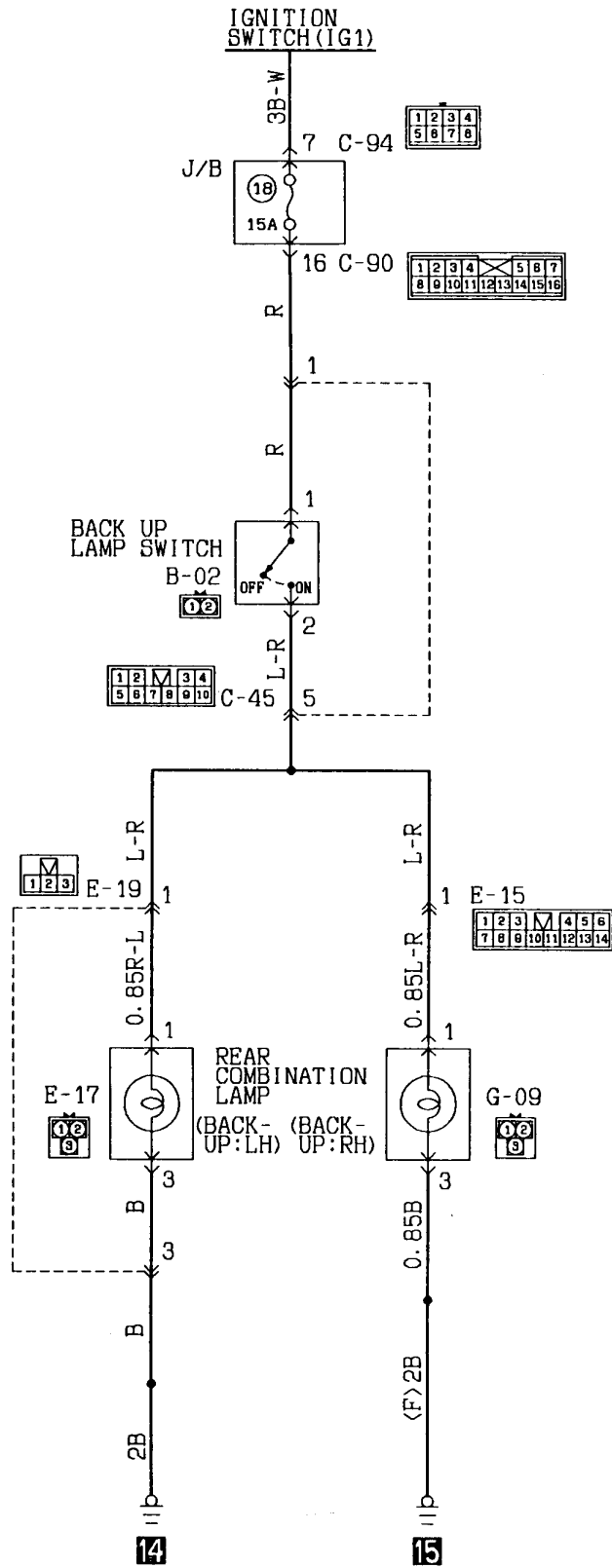

Wire colour code

KX35-AC-00903-EC

B:Black LG:Light green G:Green L:Blue W:White Y:Yellow 8B:Sky blue
BR:Brown O:Orange GR:Gray R:Red P:Pink V:Violet

15-2 A/T

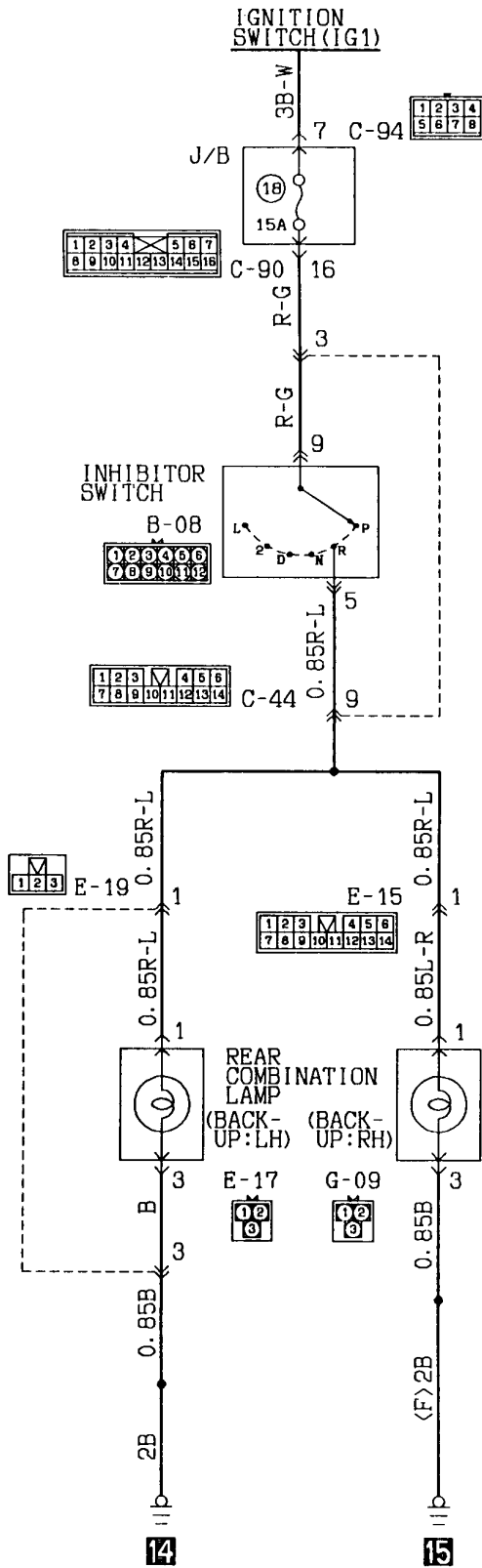

Wire colour code
 B:Black LG:Light green G:Green L:Blue W:White Y:Yellow BB:Sky blue
 BR:Brown O:Orange GR:Gray R:Red P:Pink V:Violet

KX35-AC-00804-EC

16 HORN

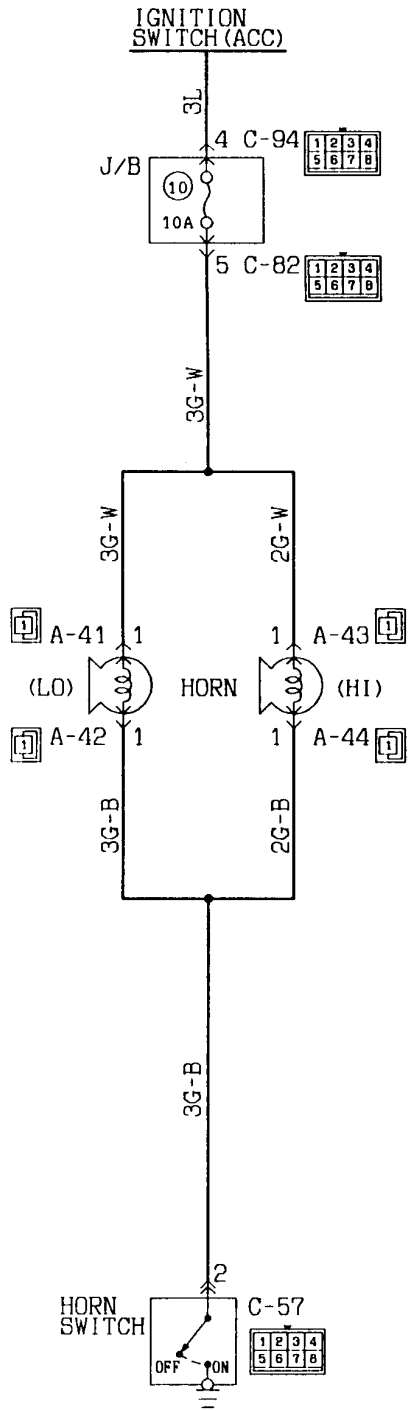

Wire colour code
 B:Black LG:Light green G:Green L:Blue W:White Y:Yellow SB:Sky blue
 BR:Brown O:Orange GR:Gray R:Red P:Pink V:Violet

KX35-AC-00905-EC

METER AND GAUGE (See P. 4-78, 80.)**OPERATION****<Fuel gauge>**

- When the ignition switch is at the "ON" position, the fuel gauge is activated.
- When there is much fuel, the unit's resistance is small and the current flowing in the circuit is great, so the gauge's indicator indicates in the "F" area.
- When there is little fuel, the unit's resistance is high and the current flowing in the circuit is small, so the gauge's indicator indicates in the "E" area.

<Engine coolant temperature gauge>

- When the ignition switch is at the "ON" position, the engine coolant temperature gauge is activated.
- When the engine coolant temperature is high, the unit's resistance is low and there is a great, flow of current in the circuit, so the gauge's indicator indicates in the "H" area.
- When the engine coolant temperature is low, the unit's resistance is high and there is a small flow of current in the circuit, so the gauge's indicator indicates in the "C" area.

<Reed switch>

- This switch generates pulses according to the current vehicle speed and provides a vehicle-speed signal for the control systems using vehicle speeds as an input source (such as engine control system).

TROUBLESHOOTING HINTS

1. Fuel gauge does not operate, or registers incorrectly.
 - 1) The fuel gauge indicates "F" when the fuel gauge unit connector is disconnected and the "1" terminal is earthed.
 - Check fuel gauge.
2. Engine coolant temperature gauge does not operate, or registers incorrectly.
 - 1) When the engine coolant temperature gauge is earthed with its connector unplugged, it registers "H".
 - Check engine coolant temperature gauge unit.
3. Vehicle-speed-dependent control systems do not operate.
 - Check reed switch of speedometer.
4. Meter illumination lamp does not come on.
 - 1) Tail lamps do come on.
 - Check rheostat.

17 METER AND GAUGE

17-1 4G64 engine

TAIL LAMP RELAY

IGNITION SWITCH (IG1)

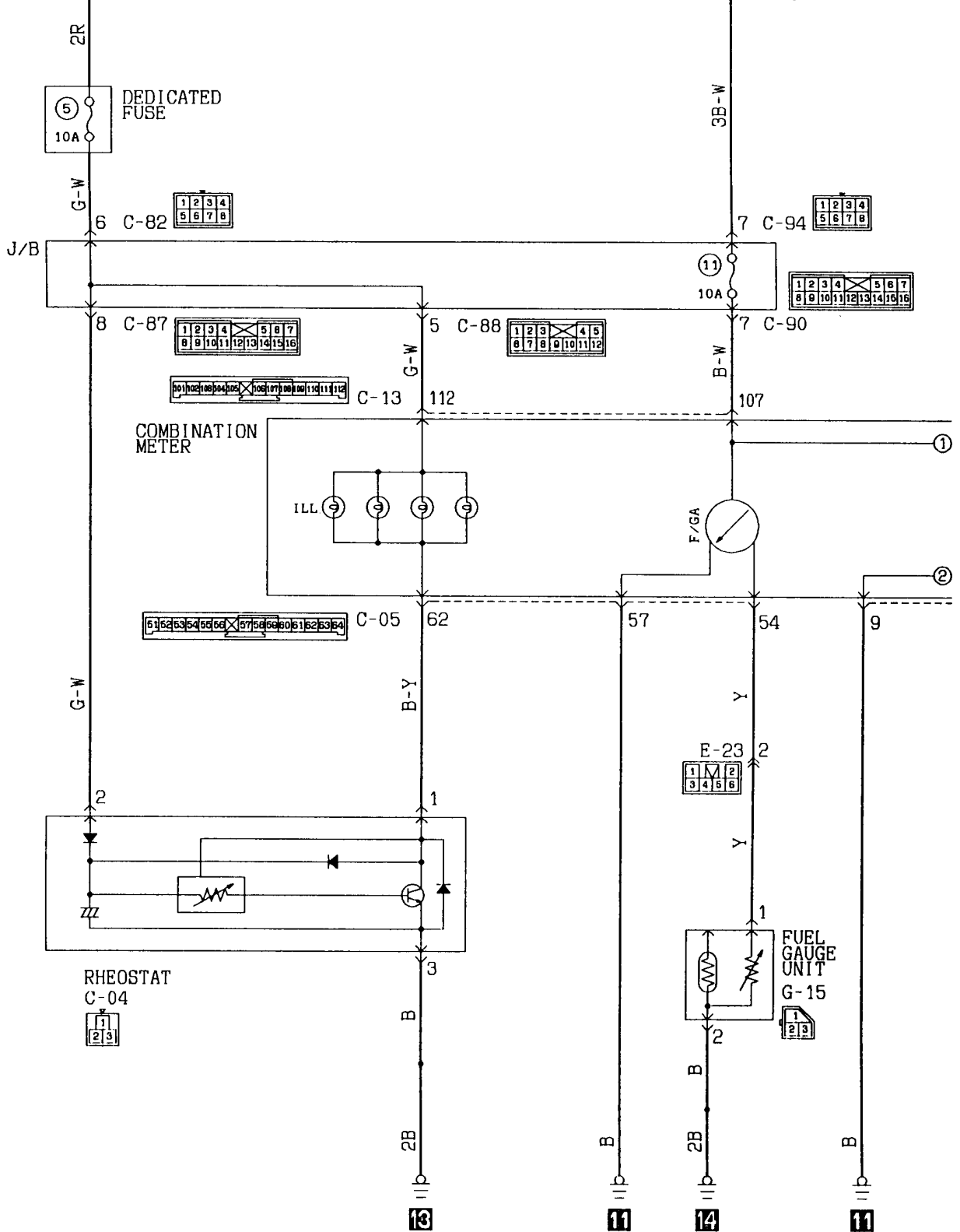

Wire colour code
 B:Black LG:Light green G:Green L:Blue W:White Y:Yellow
 BR:Brown O:Orange GR:Gray R:Red P:Pink V:Violet SB:Sky blue

KX35-AC-Q1001-EC

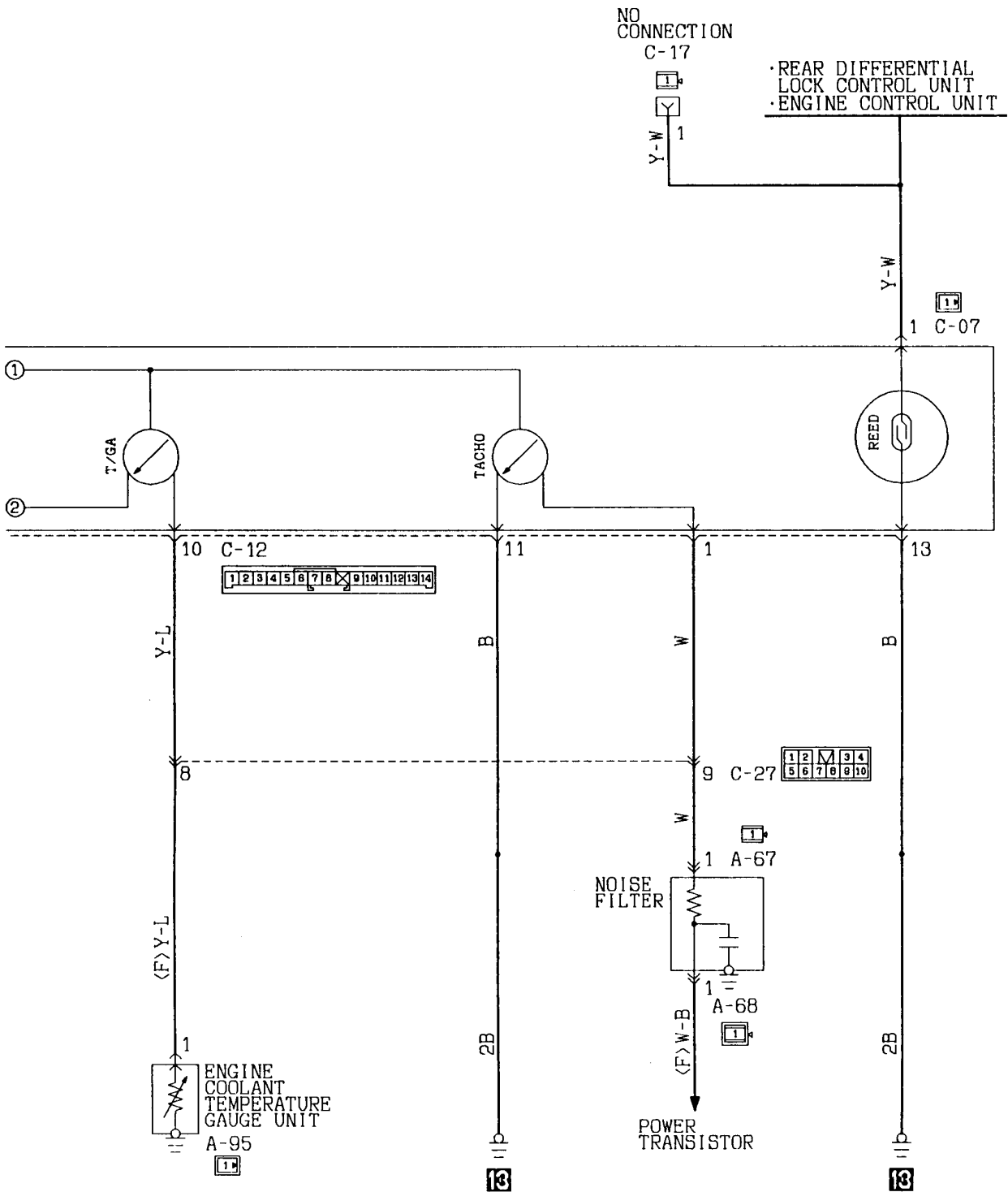

17-2 6G72.4D56 engine

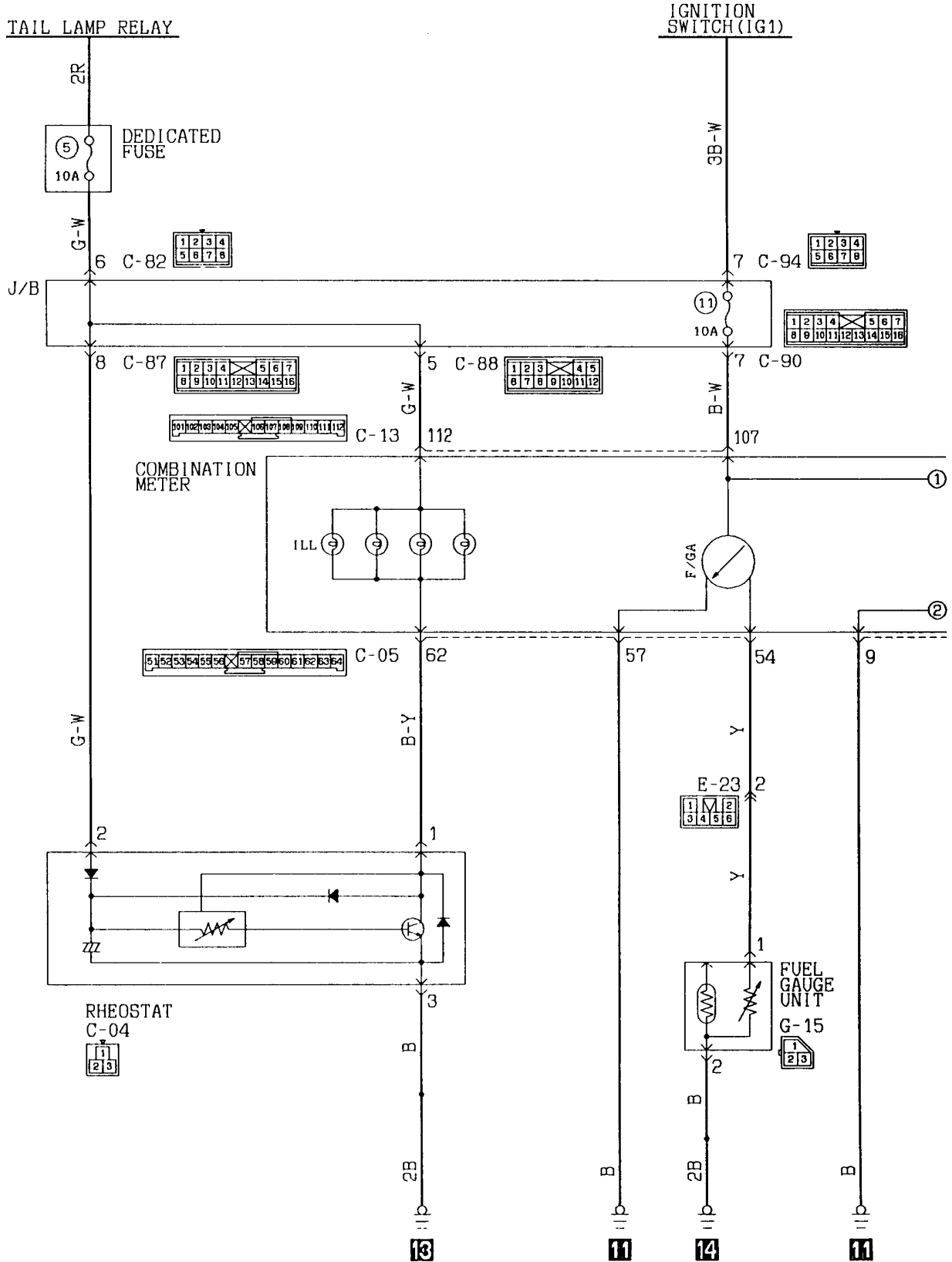

KX35-AC-Q1002-EC Wire colour code
 B:Black LG:Light green G:Green L:Blue W:White Y:Yellow SB:Sky blue
 BR:Brown O:Orange GR:Gray R:Red P:Pink V:Violet

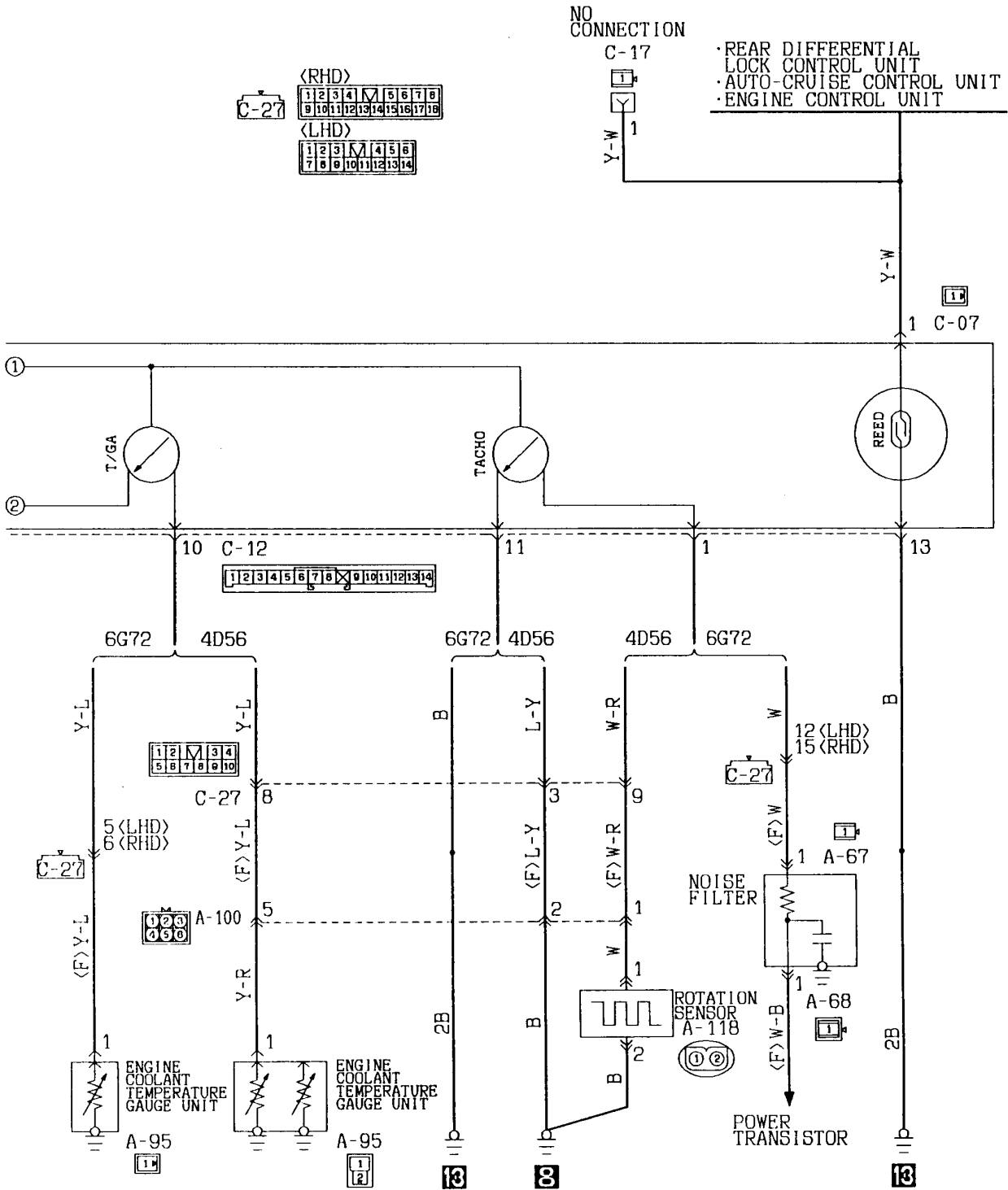

WARNING LAMP (See P. 4-83, 86.)**OPERATION****<Brake warning lamp>**

- When the brake fluid level goes down below a predetermined level or parking brake lever is pulled, with the ignition switch in the ON position, the brake fluid level sensor is activated or the parking brake switch is turned ON, causing the brake warning lamp to light up.
- On diesel-powered vehicles, when the brake booster vacuum line fails, the vacuum switch is turned ON causing the brake warning lamp to light up.

<Low fuel warning lamp>

- When the fuel level goes down causing the level sensor to be exposed, with the ignition switch in the ON position, the resistance of level sensor becomes small. When this resistance goes down below the predetermined level, the fuel warning lamp lights up to warn the driver that the amount of fuel still available for use is small.

<Oil pressure warning lamp>

- When the lubrication system fails after engine starting, resulting in the oil pressure failing to build up, the oil pressure switch turns ON causing the oil pressure warning lamp to light up.

<Low engine oil warning lamp>

- When the ignition switch is turned to the "ON" position (in the state where the engine is stopped), electric current will flow to terminal "L" of the alternator through the multi-purpose fuse No. ①, low engine oil warning lamp and engine oil level relay and the low engine oil warning lamp will also light up.
- When the engine starts, the charging voltage will be applied to the terminal "L" of the alternator. Therefore, the low engine oil warning lamp will go out.
- When the engine oil temperature rises to approx. 55°C (131°F), the engine oil level sensor (TEMP) provided in the oil pan will be turned off.
- When the engine oil amount in the oil pan drops below the set level in this state, the engine oil level sensor (LEVEL) will be turned off to apply the voltage to the delay circuit.
- If the "OFF" state continues for approx. 20 seconds or more, the power transistor will be turned on to light the low engine oil warning lamp to indicate a shortage of engine oil.

Remark

The delay circuit is provided to prevent the low engine oil warning lamp from going on even if the engine oil level sensor is temporarily turned off due to cornering or other running conditions of the vehicle.

<Charge warning lamp>

- See CHARGING SYSTEM (P. 4-24.)

<Check engine warning lamp>

- See the Service Adjustment Procedure, in Group 11 of the separate WORKSHOP MANUAL (Pub. No. PWJE9086)

<Fuel filter warning lamp>**(Diesel-powered vehicles)**

- When the ignition switch is turned to the "ON" position (with the engine stopped), the fuel filter warning lamp comes on and the lamp switches OFF when the engine is started. This feature can be used to check for a failure of the lamp's bulb.
- When condensate has accumulated in the fuel filter, the water level switch turns ON causing the fuel filter warning lamp to light up.

<ABS warning lamp>

- See the Troubleshooting of Anti-skid Brake in Group 35 of the separate WORKSHOP MANUAL (Pub. No. PWJE9086)

<Automatic transmission oil temperature warning lamp>

- When the ignition switch is turned to the "ON" position (with the engine stopped), the automatic transmission oil temperature warning lamp comes on and the lamp switches OFF when the engine is started. This feature can be used to check for a failure of the lamp's bulb.
- When the automatic transmission oil temperature becomes abnormally high, the automatic transmission oil temperature switch turns ON causing the automatic transmission oil temperature warning lamp to light up.

18 WARNING LAMP
18-1 4G64 engine

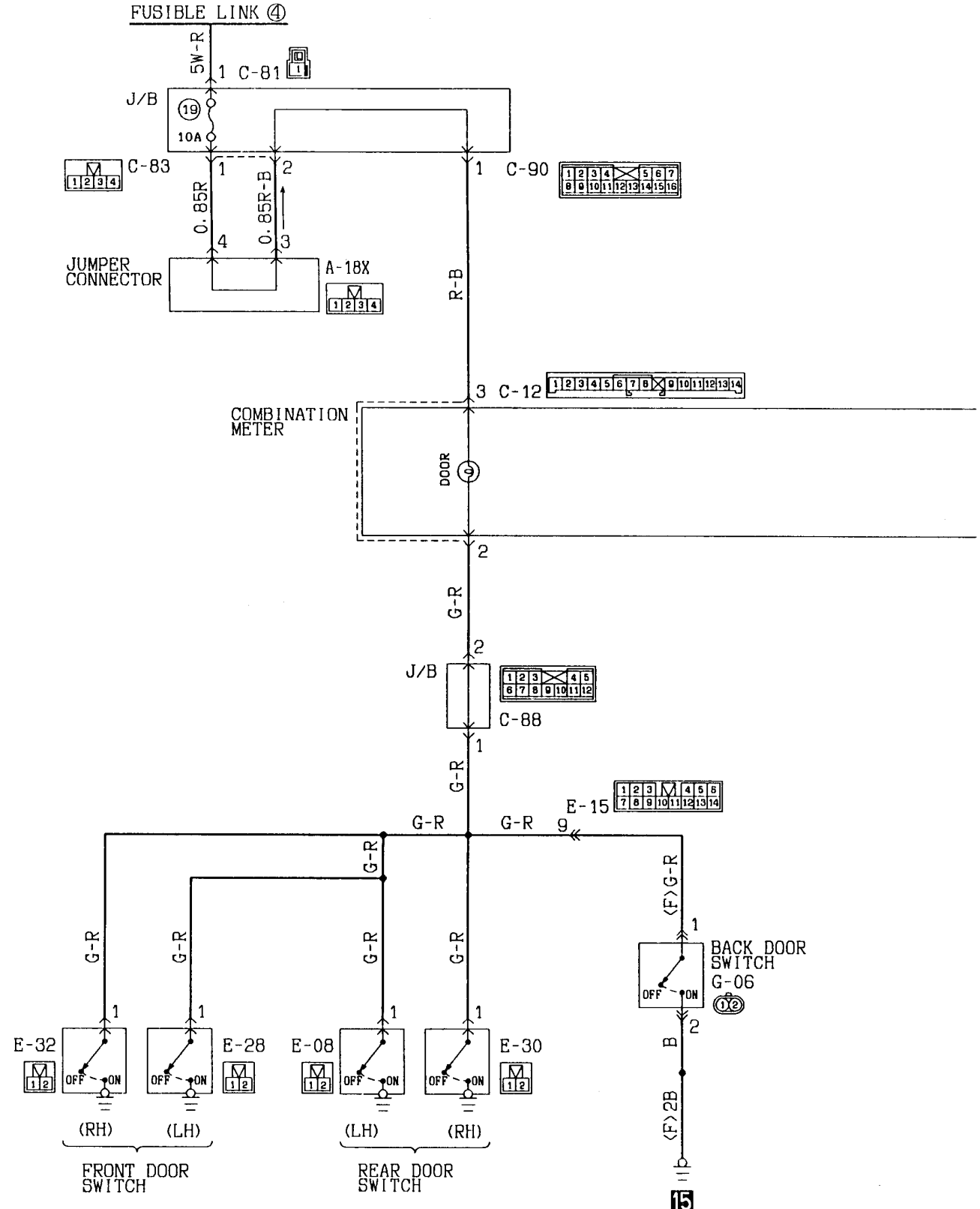

Wire colour code
 B:Black LG:Light green G:Green L:Blue W:White Y:Yellow SB:Sky blue
 BR:Brown O:Orange GR:Gray R:Red P:Pink V:Violet

KX35-AC-01003-EC

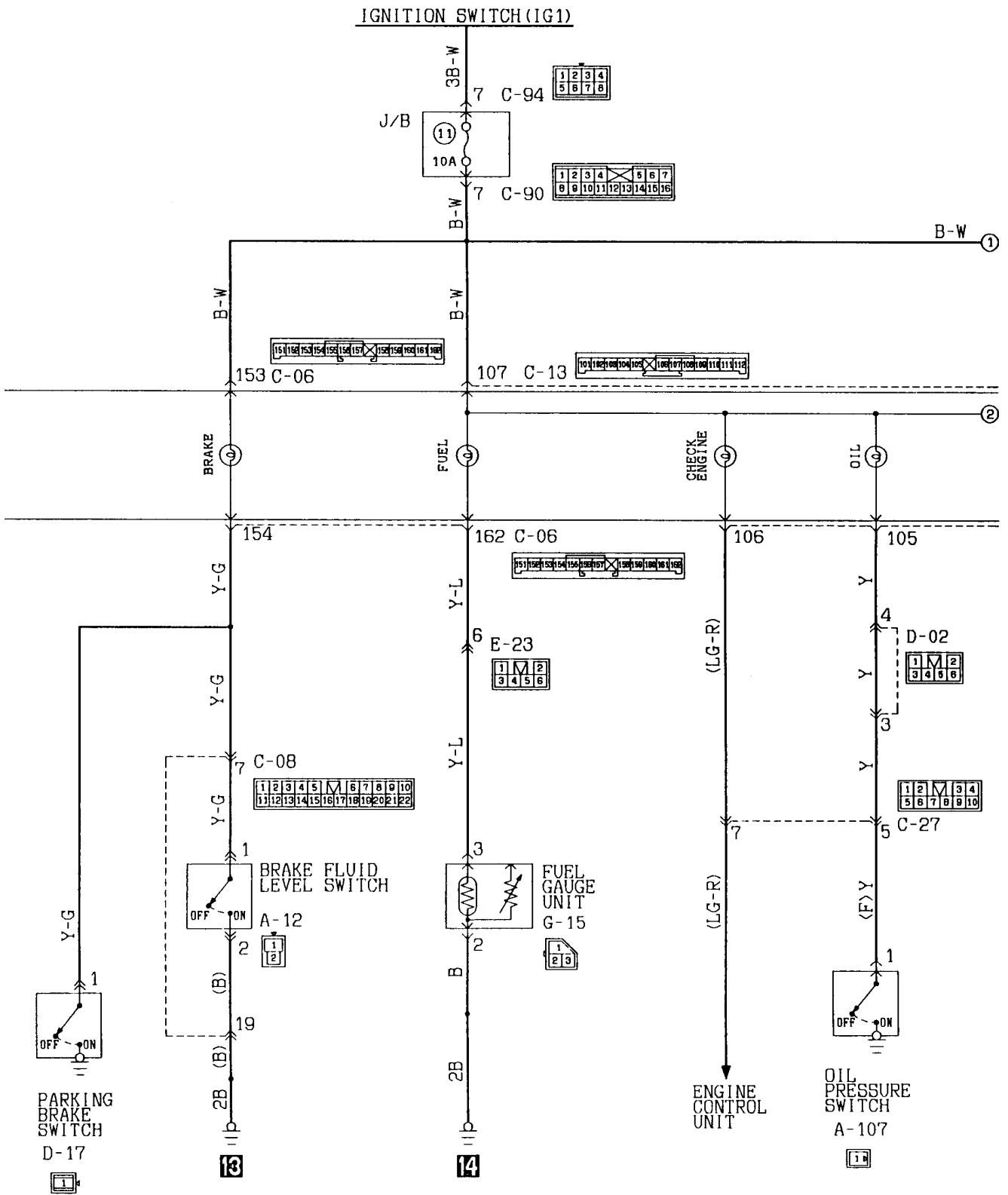

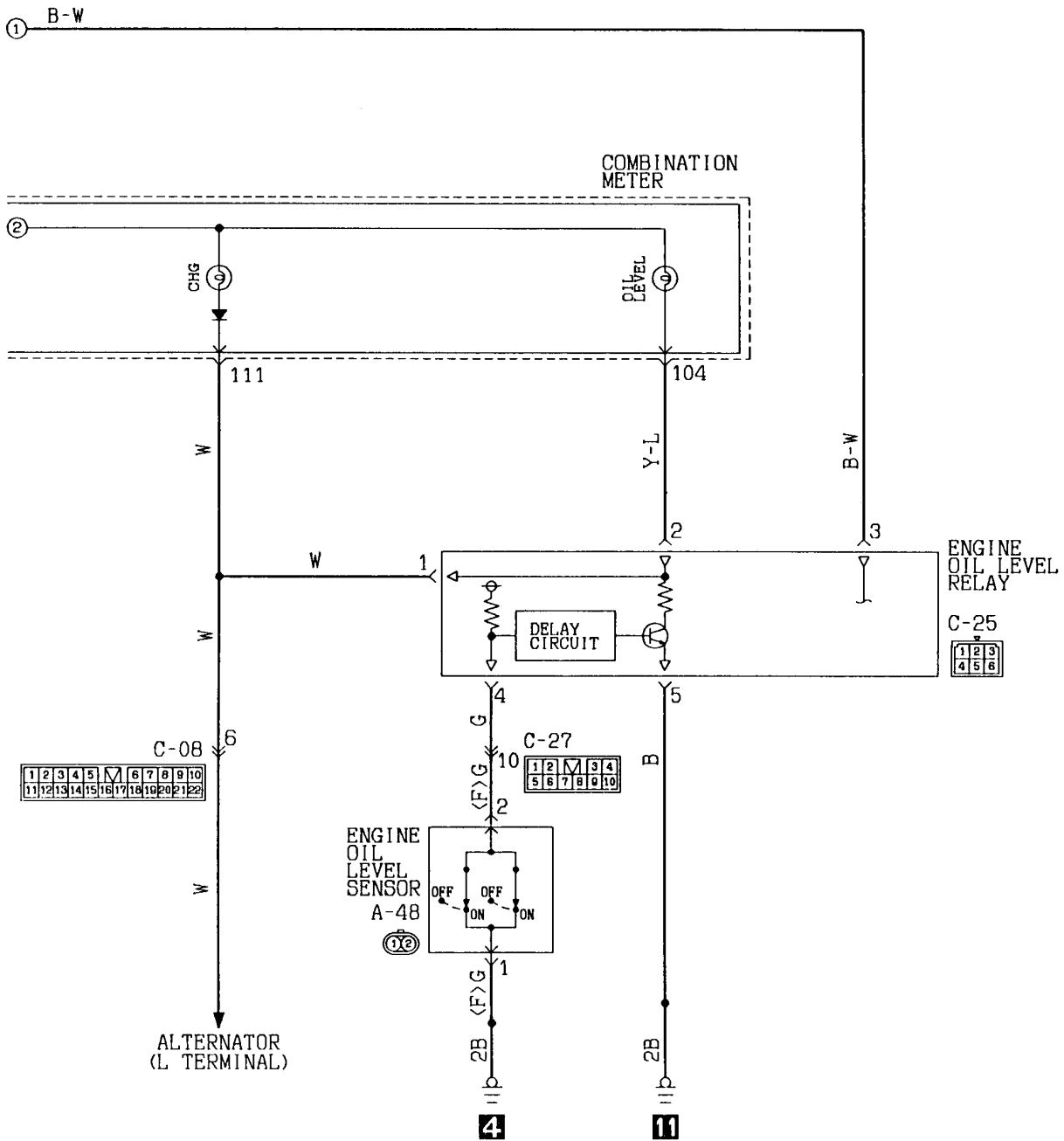

Wire colour code
 B:Black LG:Light green G:Green L:Blue W:White Y:Yellow SB:Sky blue
 BR:Brown O:Orange GR:Gray R:Red P:Pink V:Violet

18-2 6G72, 4D56 engine

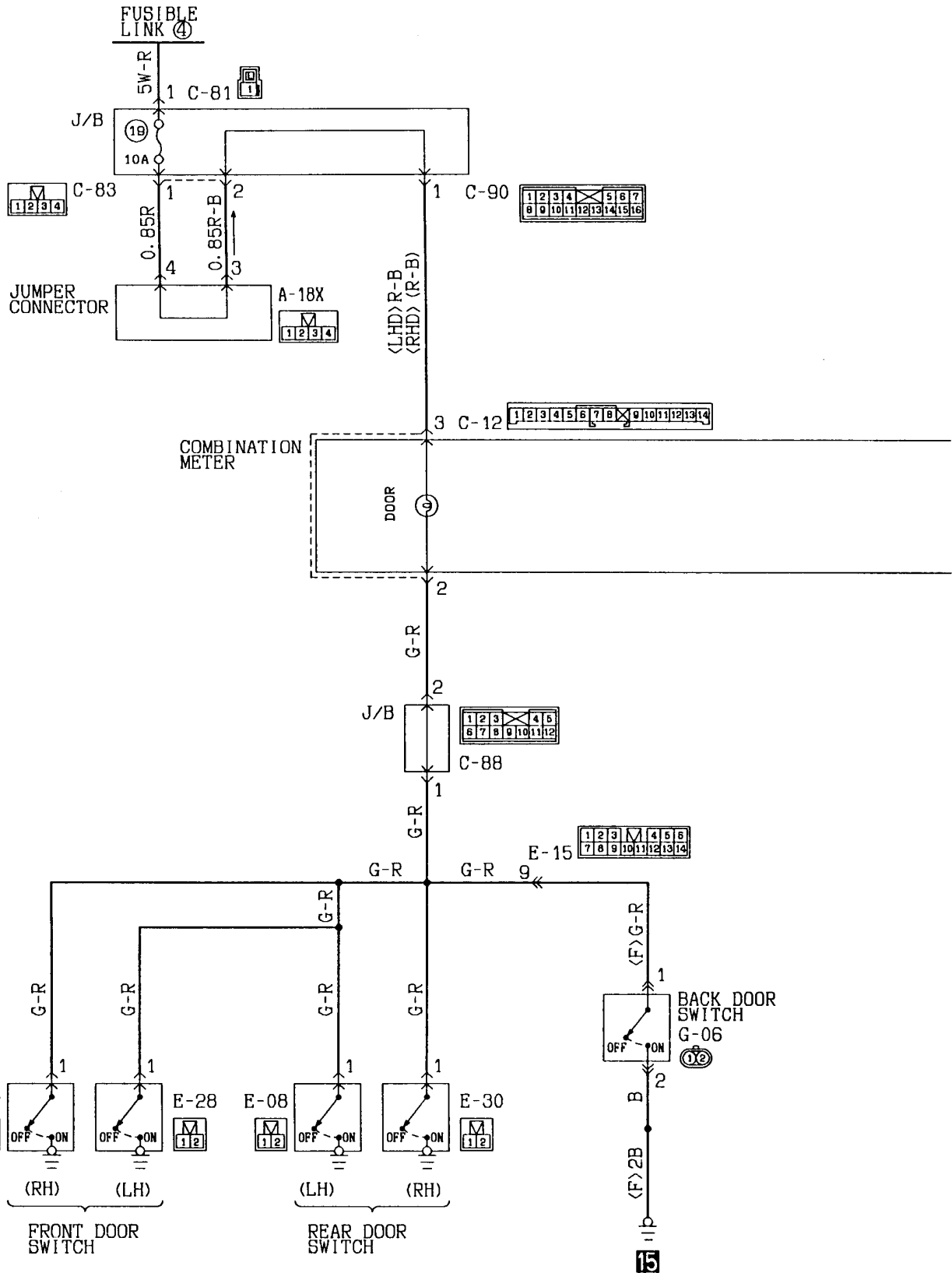

Wire colour code
 B:Black LG:Light green G:Green L:Blue W:White Y:Yellow SB:Sky blue
 BR:Brown O:Orange GR:Gray R:Red P:Pink V:Violet

KX35-AC-Q1004-EC

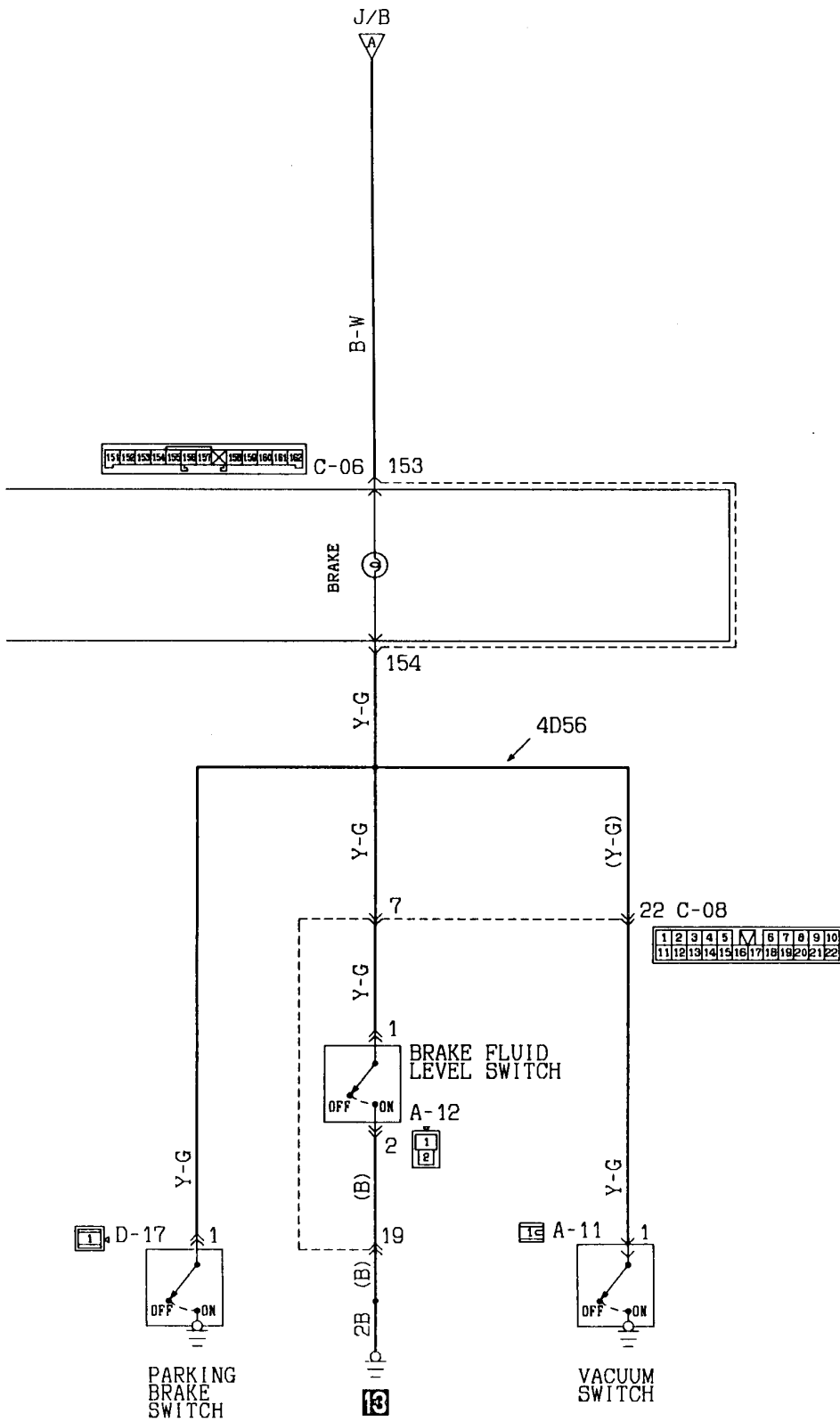

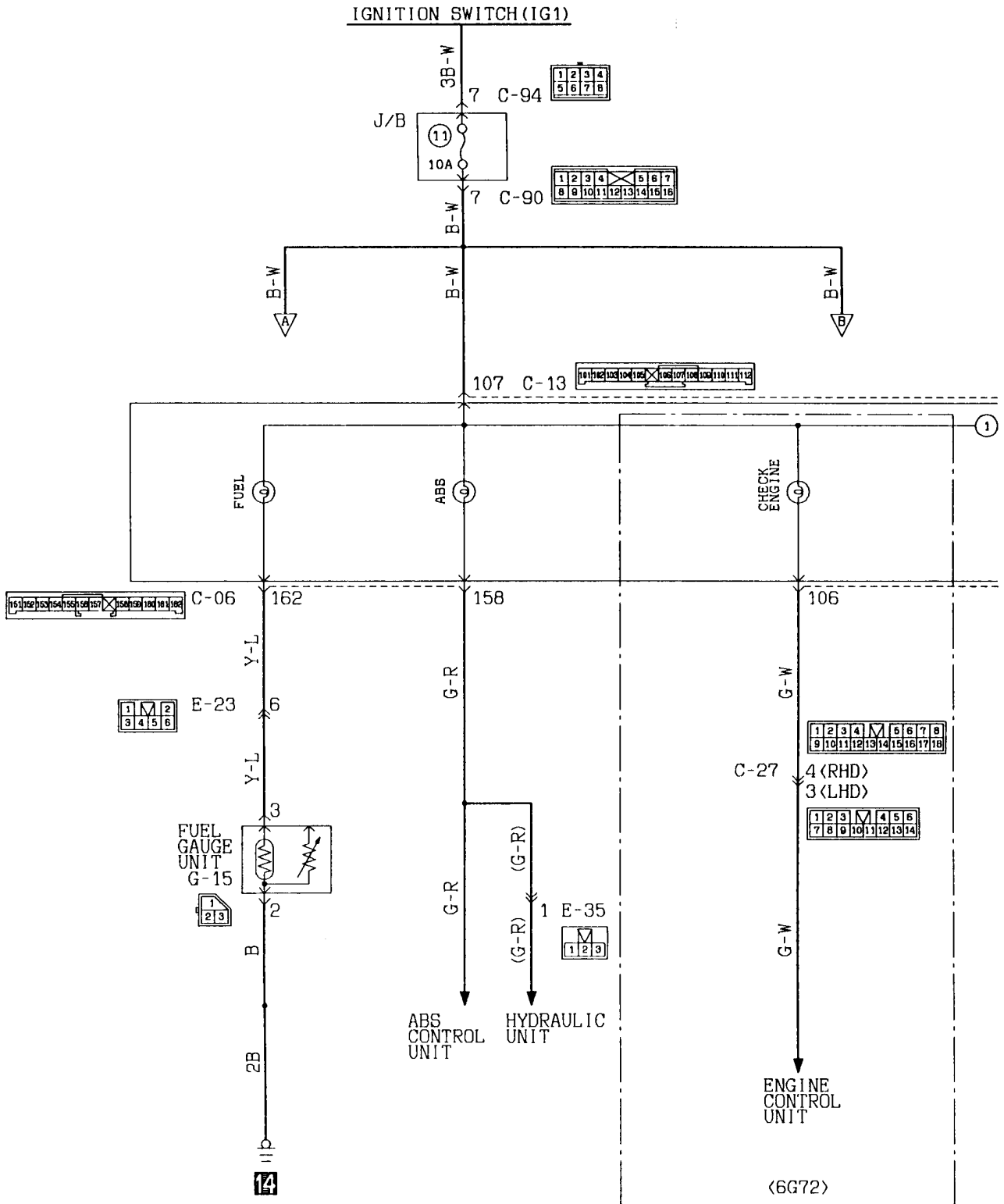

KX35-AC-Q1004A-EC

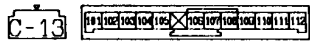

Wire colour code
 B:Black LG:Light green G:Green L:Blue
 BR:Brown O:Orange GR:Gray R:Red
 W:White SB:Sky blue P:Pink Y:Yellow
 V:Violet

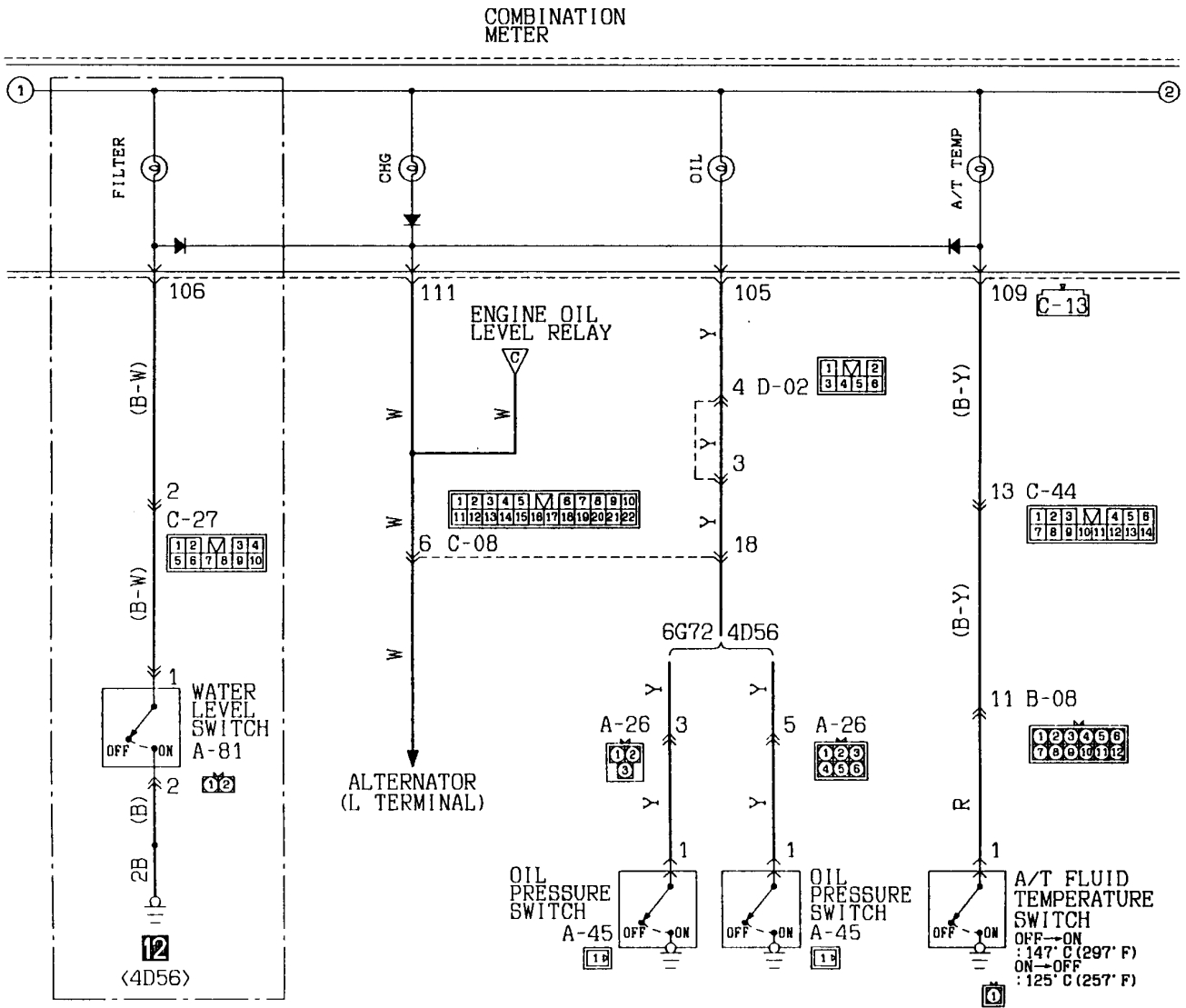

19 INDICATOR LAMP

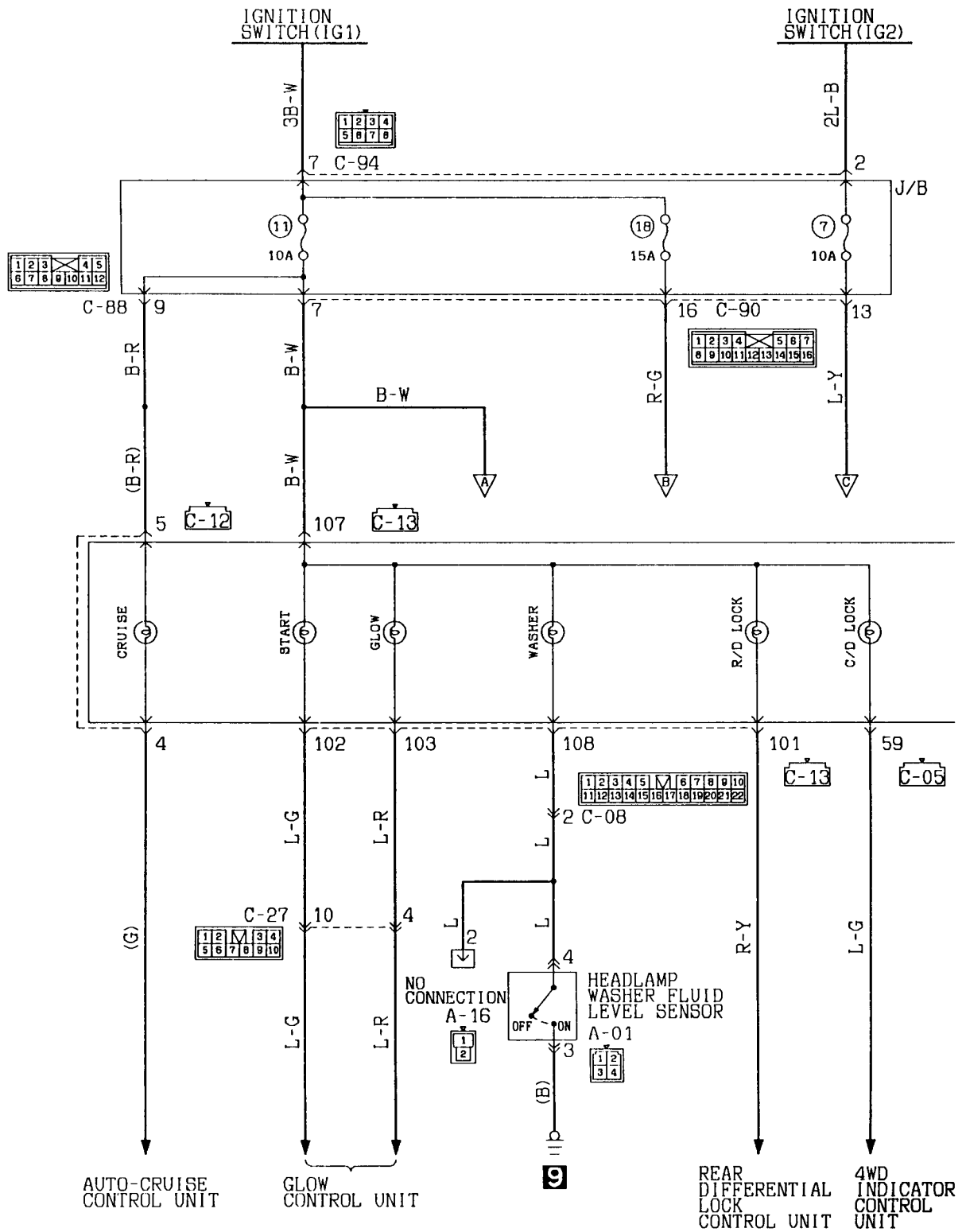

Wire colour code
 B:Black LG:Light green G:Green L:Blue W:White Y:Yellow SB:Sky blue
 BR:Brown O:Orange GR:Gray R:Red P:Pink V:Violet

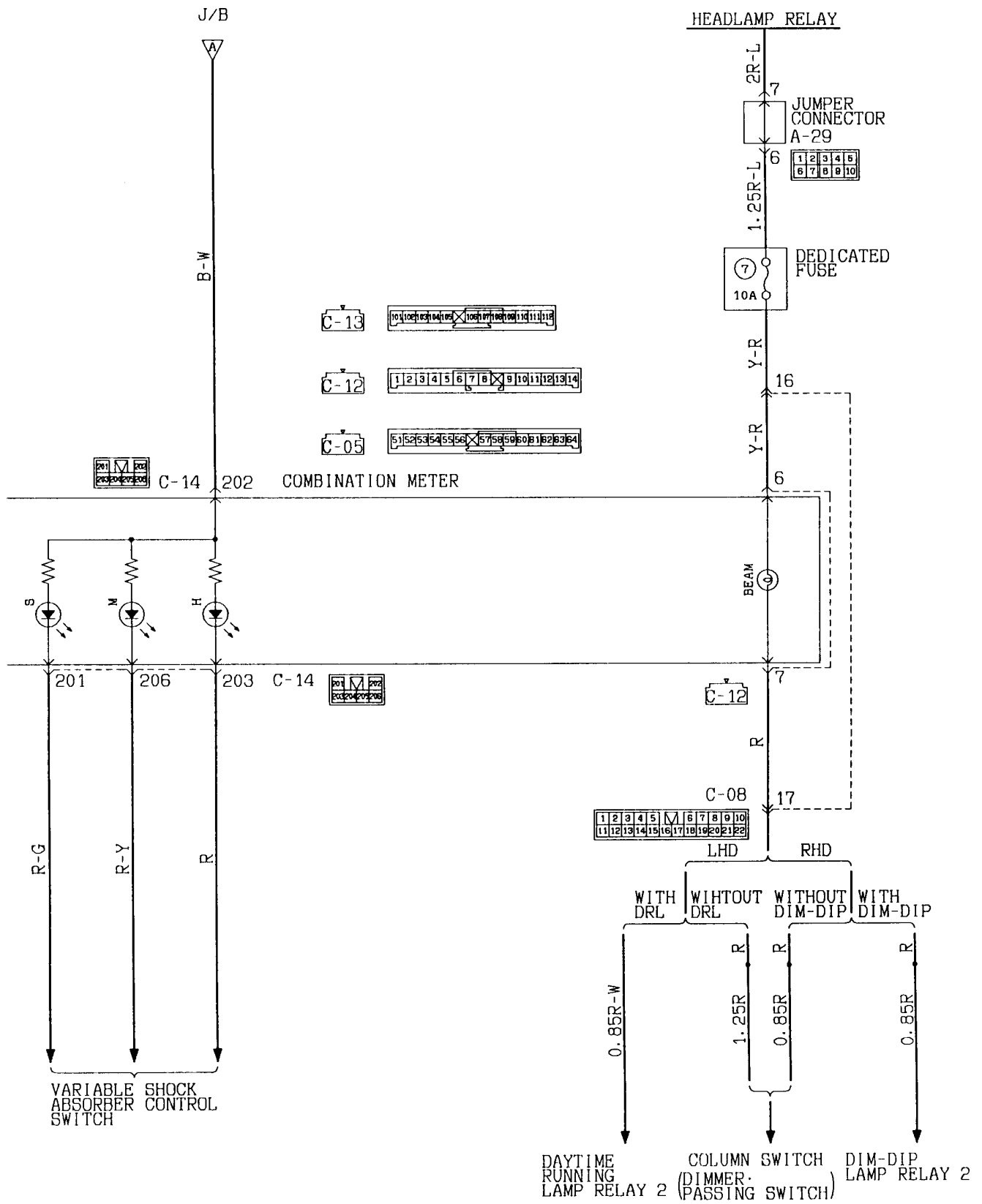

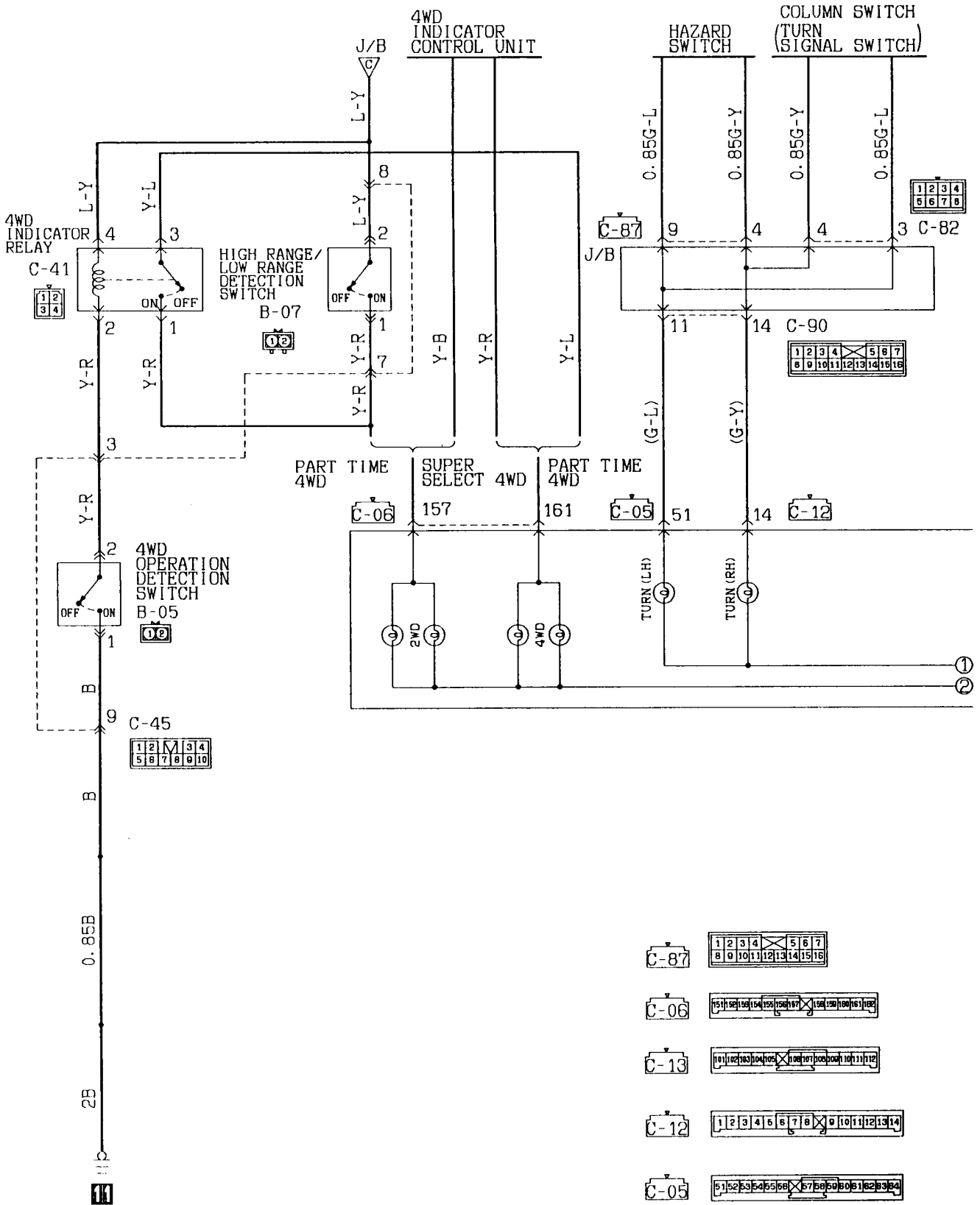

Wire colour code
 B:Black LG:Light green G:Green L:Blue W:White Y:Yellow SB:Sky blue
 BR:Brown O:Orange GR:Gray R:Red P:Pink V:Violet

KX35-AC-01005A-EC

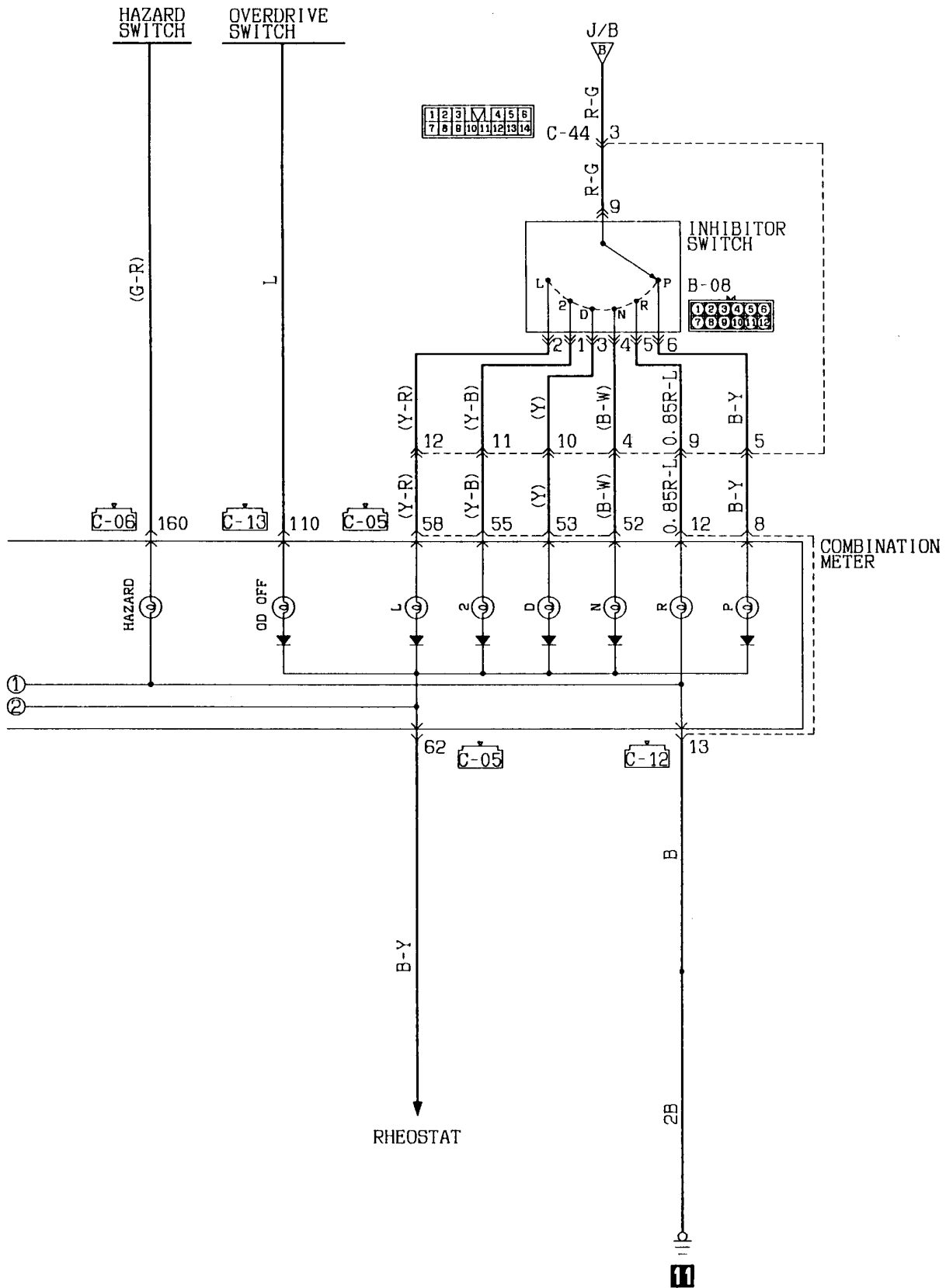

20-2 Vehicles with electronic compass

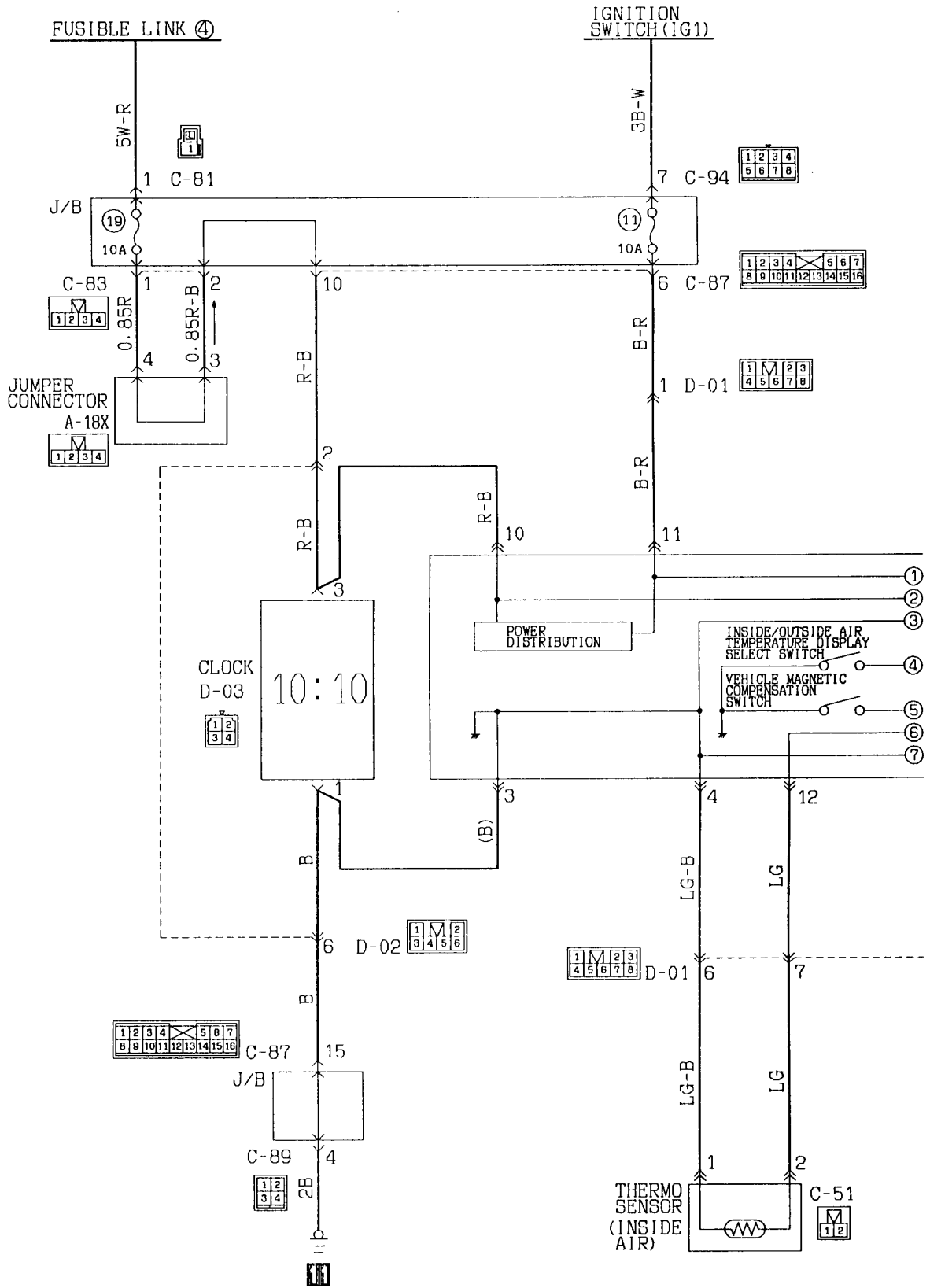

KX35-AC-Q1007-EC

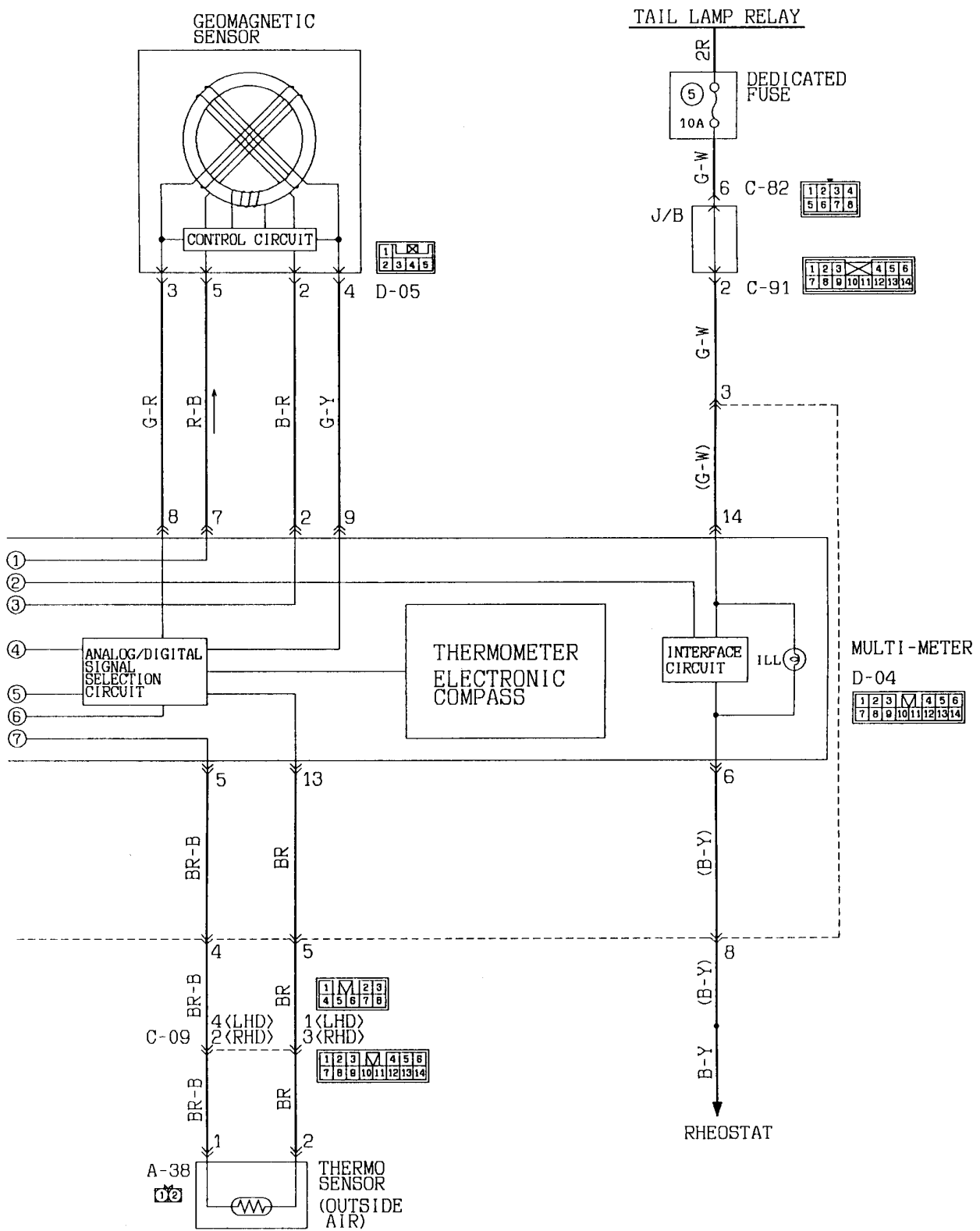

Wire colour code
 B:Black LG:Light green G:Green L:Blue W:White Y:Yellow SB:Sky blue
 BR:Brown O:Orange GR:Gray R:Red P:Pink V:Violet

21 POWER WINDOW
21-1 L.H. drive vehicles (2-door models)

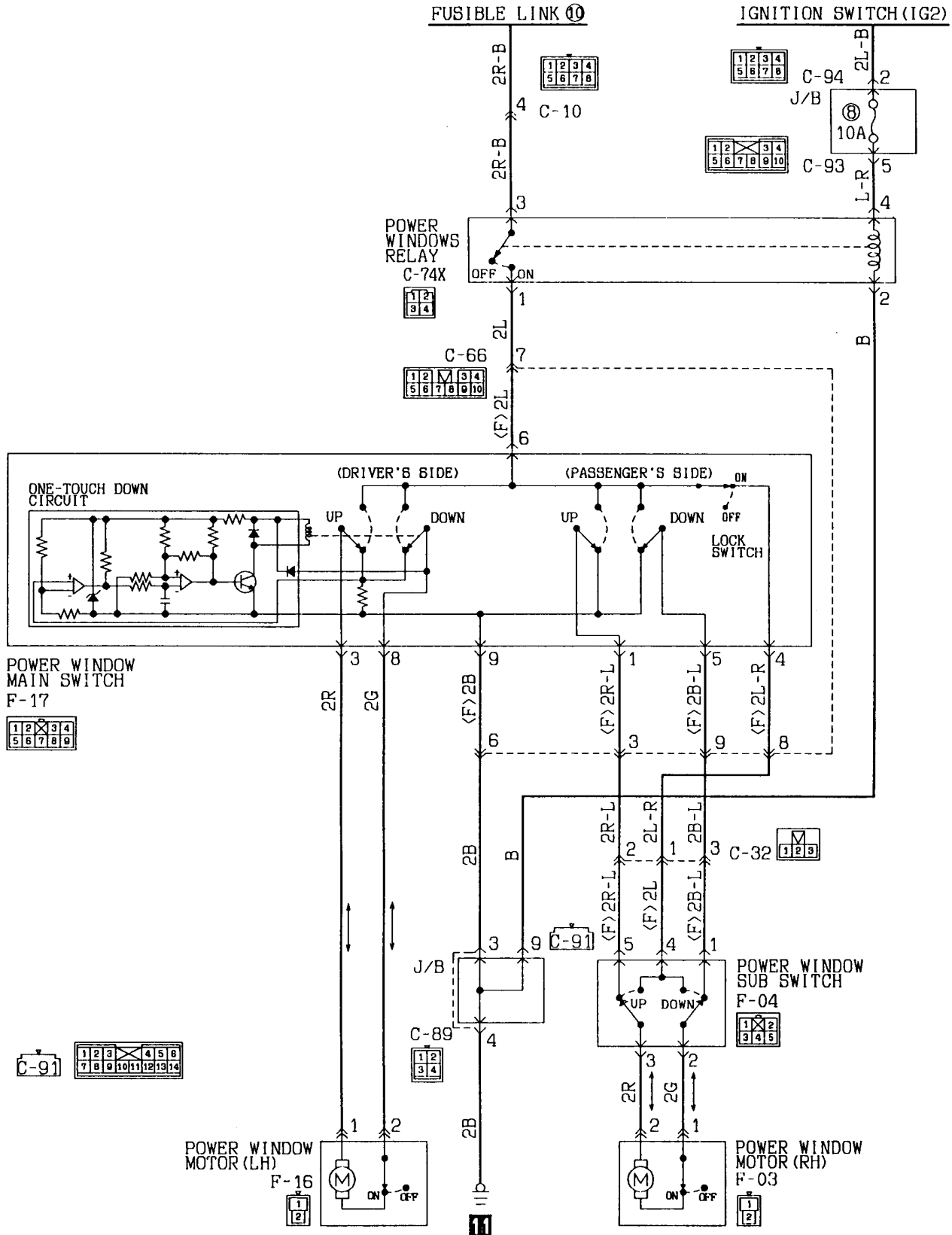

Wire colour code
 B:Black LG:Light green G:Green L:Blue W:White Y:Yellow SB:Sky blue
 BR:Brown O:Orange GR:Gray R:Red P:Pink V:Violet

21-2 R. H. drive vehicles (2-door models)

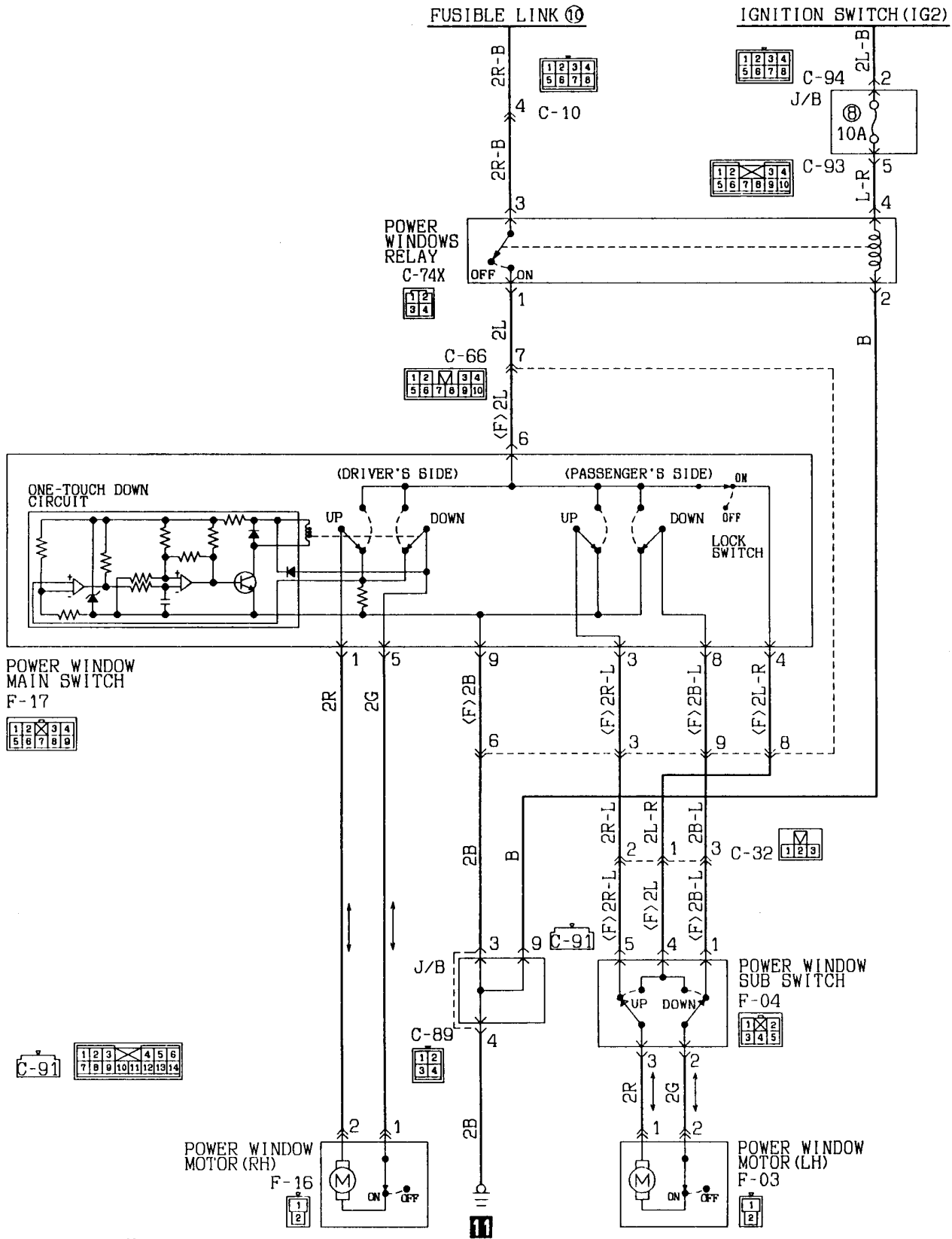

Wire colour code
 B:Black LG:Light green G:Green L:Blue W:White Y:Yellow SB:Sky blue
 BR:Brown O:Orange GR:Gray R:Red P:Pink V:Violet

21-3 L.H. drive vehicles <4-door models>

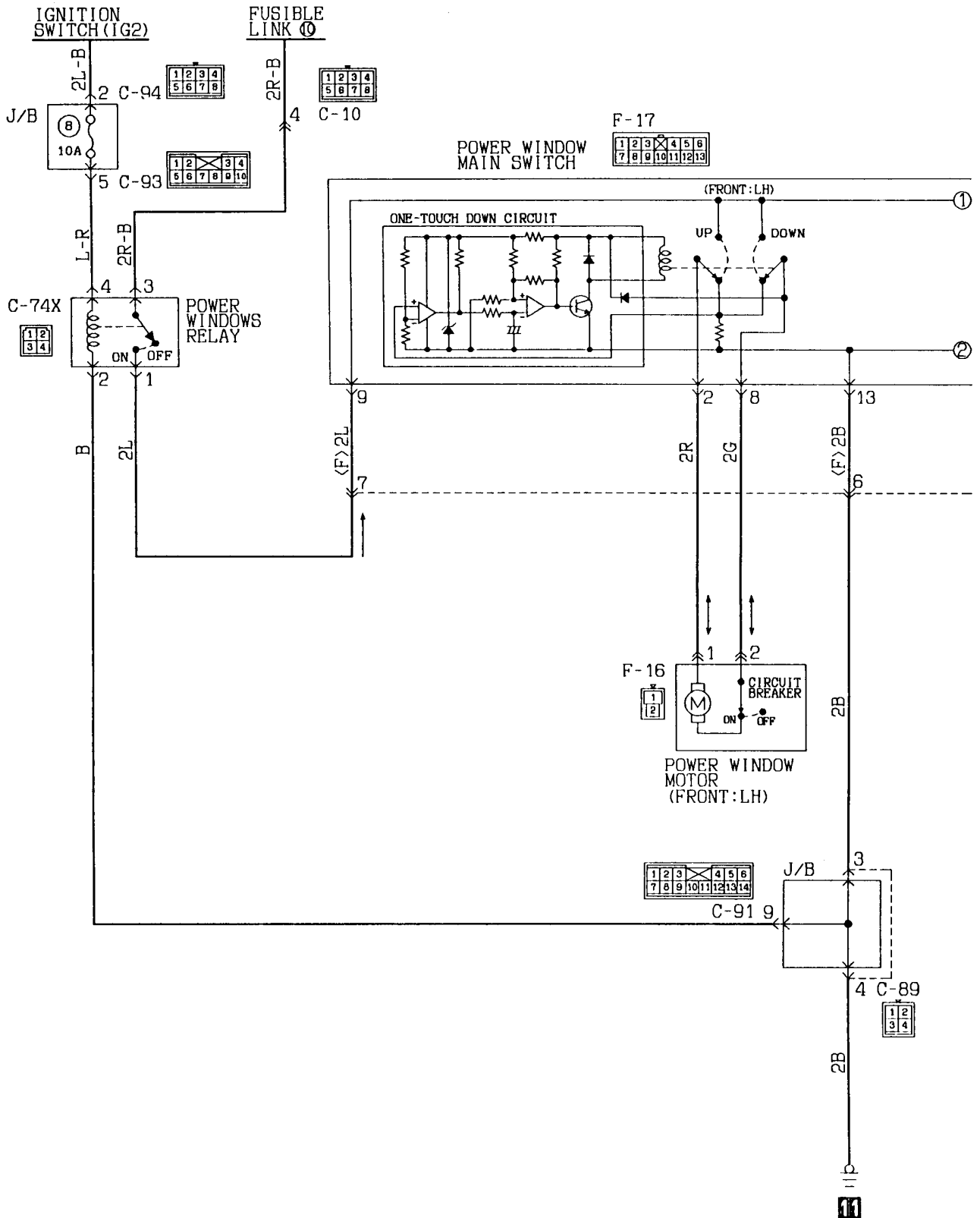

Wire colour code
 B:Black LG:Light green G:Green L:Blue W:White Y:Yellow SB:Sky blue
 BR:Brown O:Orange GR:Gray R:Red P:Pink V:Violet

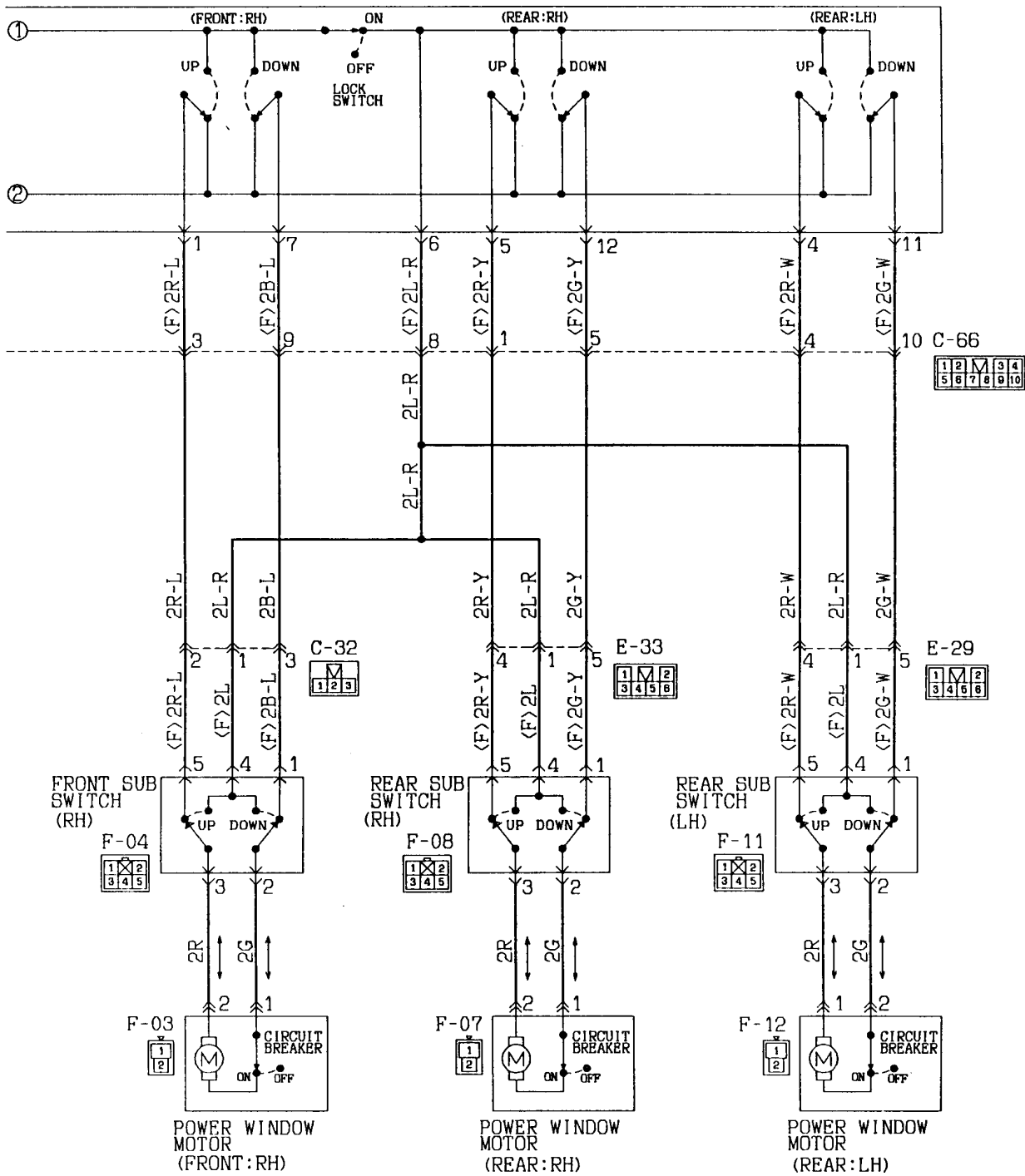

21-4 R. H. drive vehicles (4-door models)

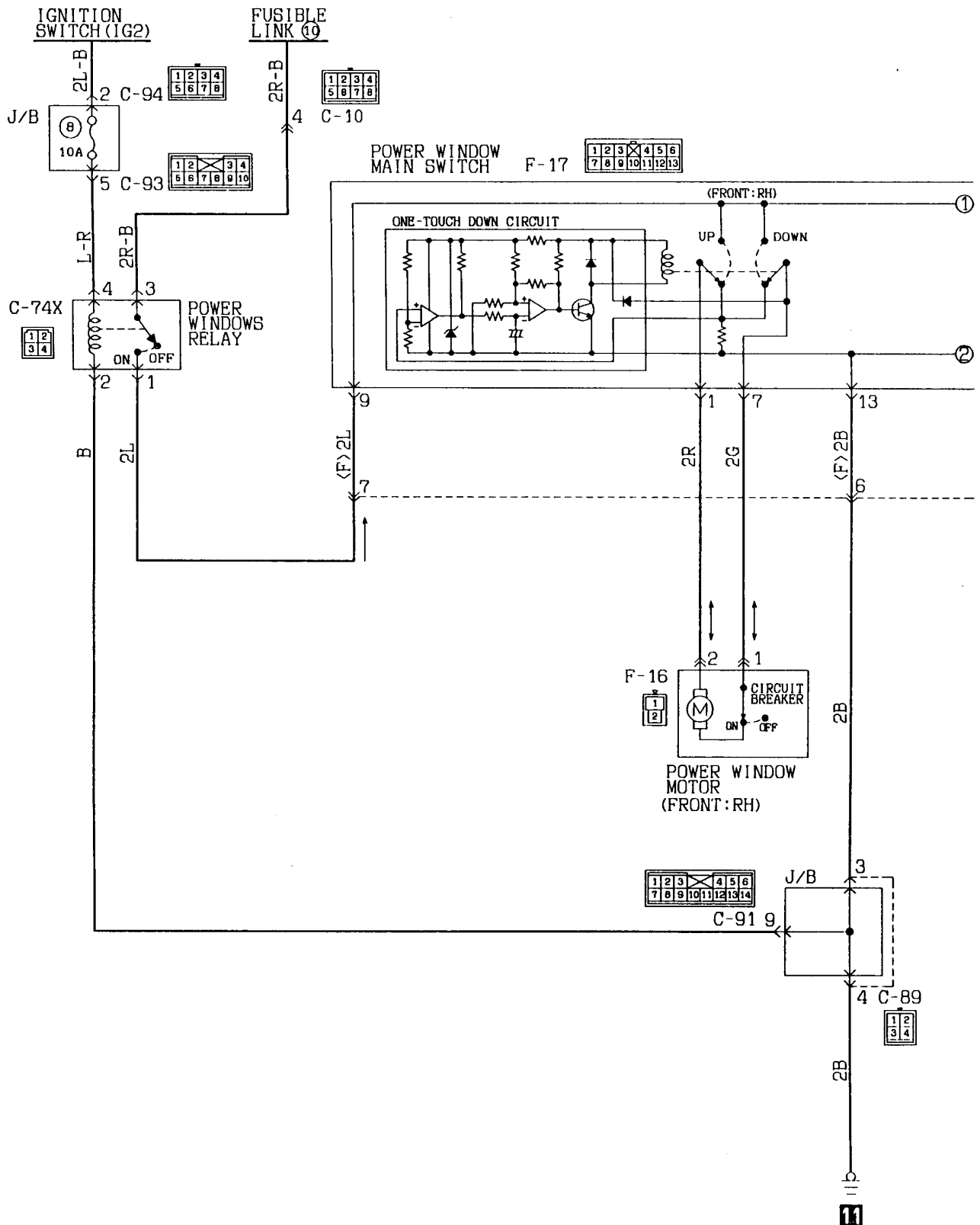

Wire colour code
 B:Black LG:Light green G:Green L:Blue W:White Y:Yellow SB:6kv blue
 BR:Brown O:Orange GR:Gray R:Red P:Pink V:Violet

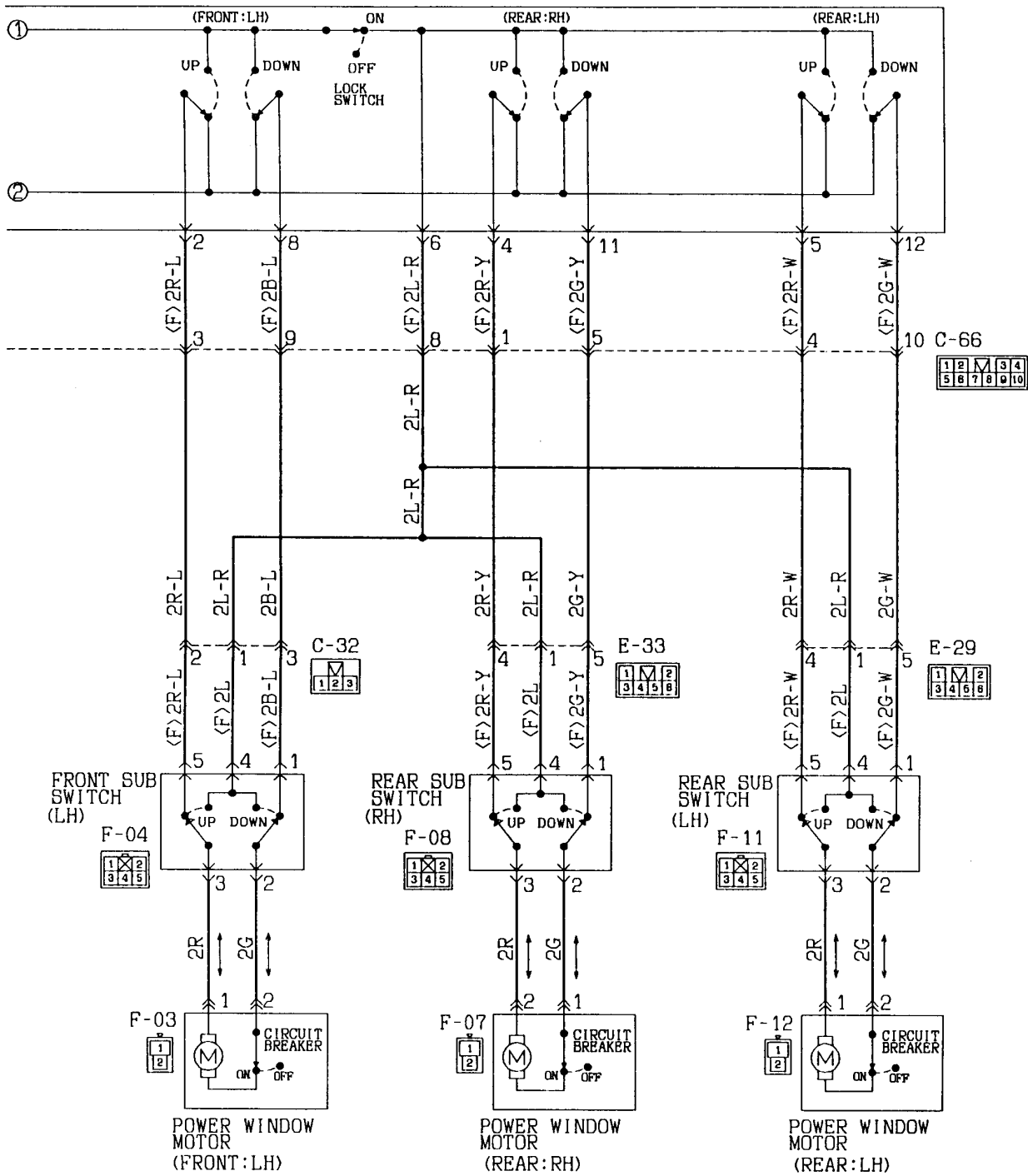

POWER WINDOW (See P. 4-98, 99, 100, 102.)**OPERATION**

- When the power window (main or sub) switch is depressed (UP or DOWN) with the ignition switch in the ON position, current flows through fusible link No. ⑩ to the power window motor. This energizes the power window motor causing the door window glass to open or close.
- When the DOWN side of the power window main switch (driver's seat side switch) is depressed all the way, it is locked in the depressed position and the power window motor is operated until the door glass is fully opened.
- When the power window lock switch is placed in the LOCK (OFF) position, operating a switch other than the ones for the driver's side and front passenger's side window (main) does not cause the power window motor to be operated.
- The power window motor is provided with a circuit breaker that protects the motor from damage caused by overcurrent.
Reference: Circuit breaker characteristics
Restricts the motor at room temperature [20 to 25°C (68 to 77°F)];
Opens following 4-to-40-sec. initial energization time;
Resets within 60 seconds if left open thereafter.

TROUBLESHOOTING HINTS

1. All door glasses cannot be opened or closed.
 - Check fusible link No. ⑩.
 - Check multi-purpose fuse No. ⑧.
 - Check power window relay.
 - Check power window main switch.
2. Some door glass cannot be opened or closed.
 - 1) Neither power window main nor sub switch is activated.
 - Check power window main switch.
 - Check defective power window motor.
 - 2) Either power window main or sub switch is inoperative.
 - Check inoperative power window switch.
3. One-touch switch function is not operational.
 - Replace power window main switch.

CENTRAL DOOR LOCKING SYSTEM (See P. 4-106.)**OPERATION****1. Operation with the inside lock knob on the driver's side (including door lock key operation).**

- If the inside lock knob on the driver's side is locked (or unlocked), the switch in the front door lock actuator (driver's side) goes off (or on) and the lock side (or unlock side) relay in the door lock control unit goes on for 0.5 second and the actuators for all doors function.

2. Operation with the door lock key.

- If the door lock key (passenger's side) is turned to the lock side (or unlock side), the lock side (or unlock side) relay in the door lock control unit goes on for 0.5 second and the actuators for all doors function.

TROUBLESHOOTING HINTS

1. Any one of the door lock actuators is inoperative.
 - Check the defective door actuator.
2. Locking (or unlocking) is possible with the door lock key (passenger's side) but locking (or unlocking) is not possible with the inside lock knob on the driver's side (including door lock key operation).
 - Inspect the front door lock actuator (driver's side)
 - Inspect the door lock control unit.
3. Locking (or unlocking) is possible with the inside lock knob (including door lock key operation) on the driver's side but locking (or unlocking) is not possible with the door lock key (passenger's side).
 - Inspect the door lock key cylinder (passenger's side).
 - Inspect the door lock control unit.

22 CENTRAL DOOR LOCKING SYSTEM

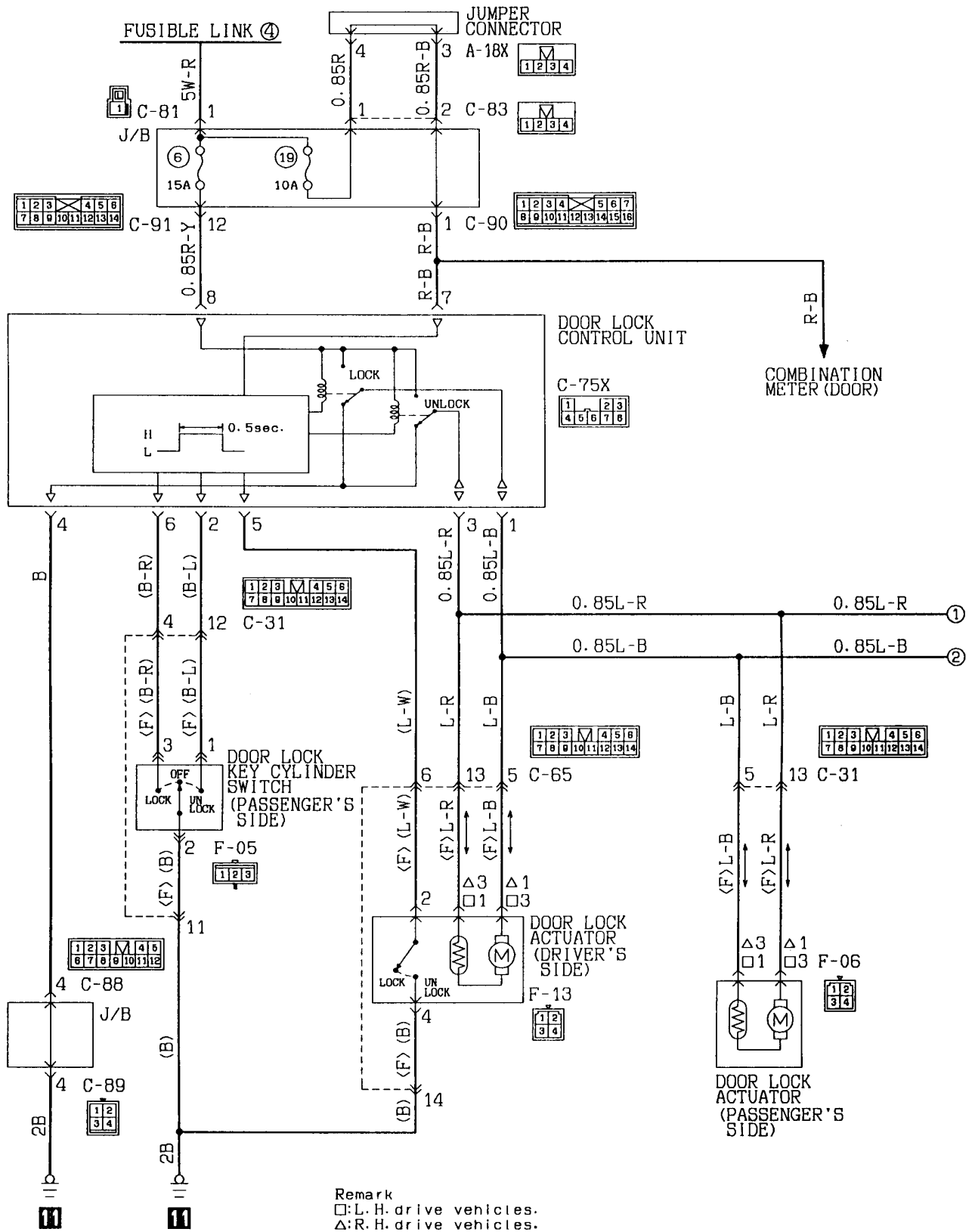

KX35-AC-01105-EC

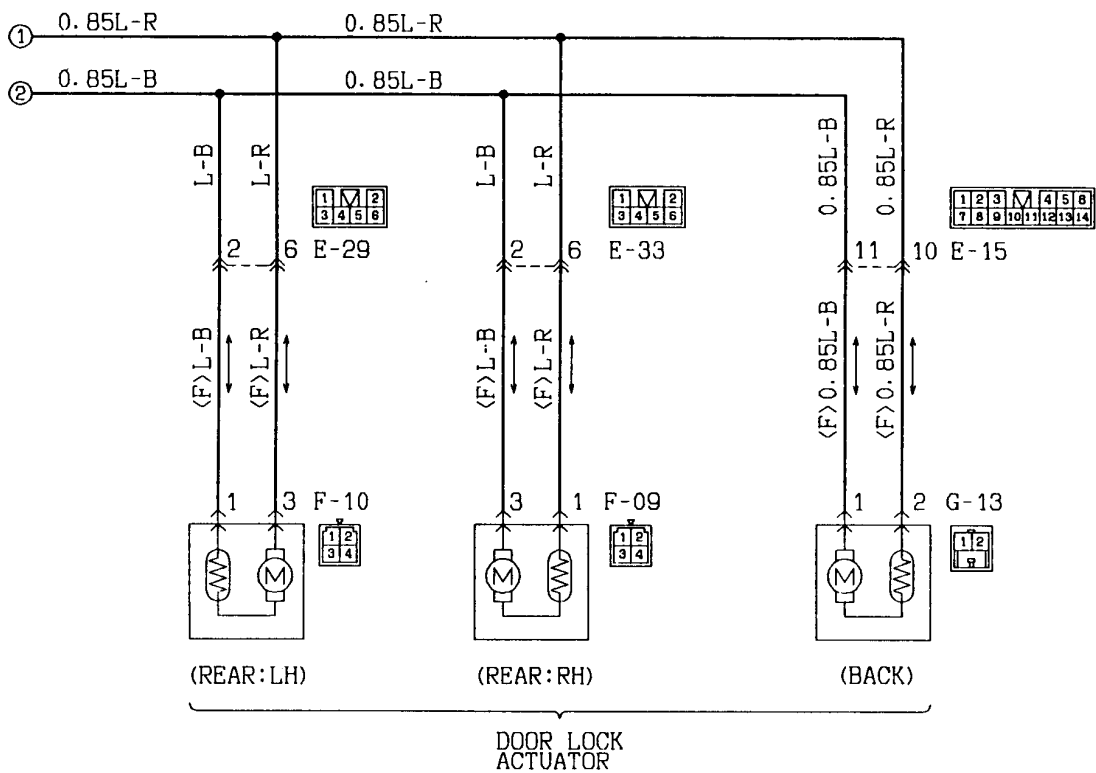

Wire colour code
 B:Black LG:Light green G:Green L:Blue W:White Y:Yellow SB:Sky blue
 BR:Brown O:Orange GR:Gray R:Red P:Pink V:Violet

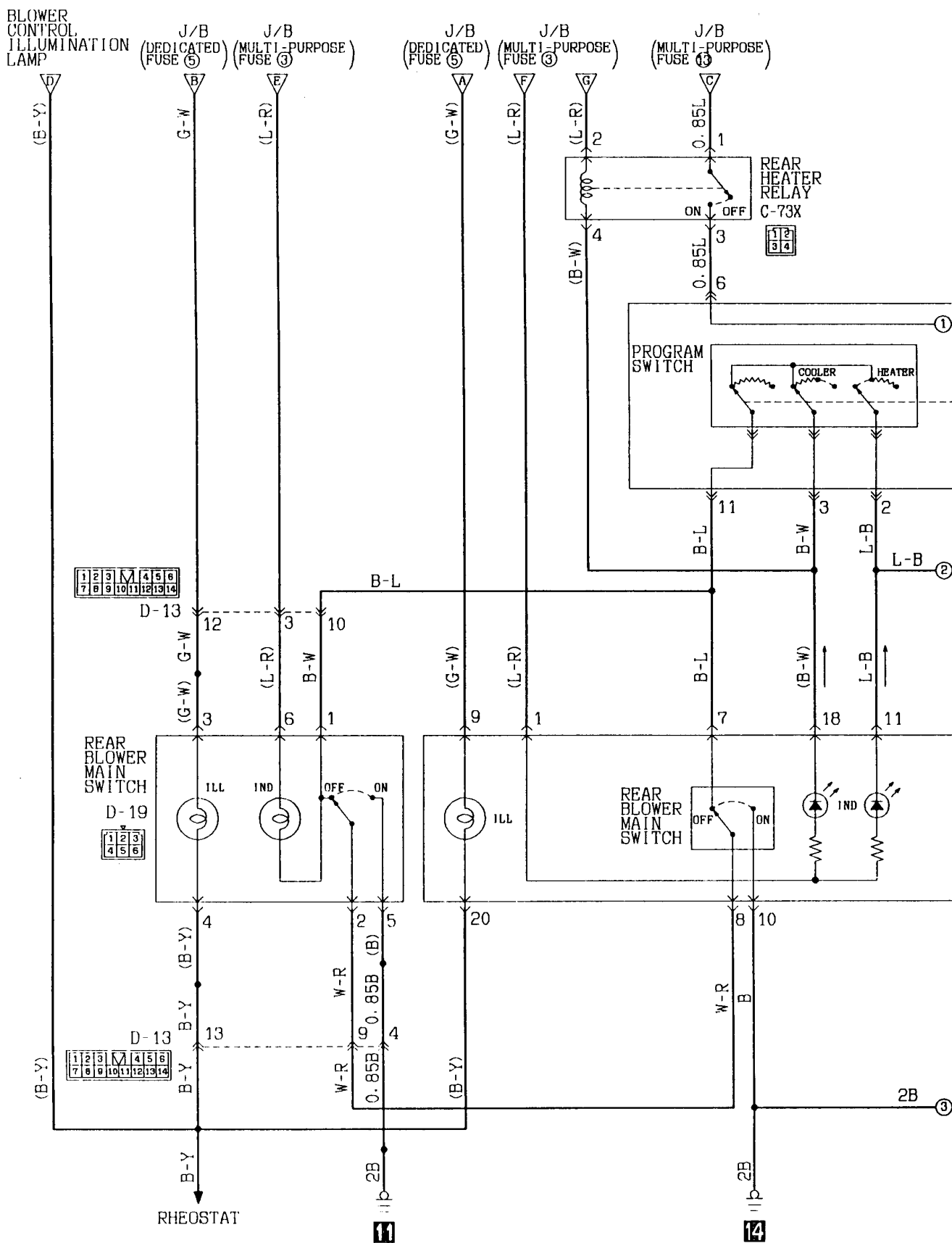

KX35-AC-Q1201A-EC

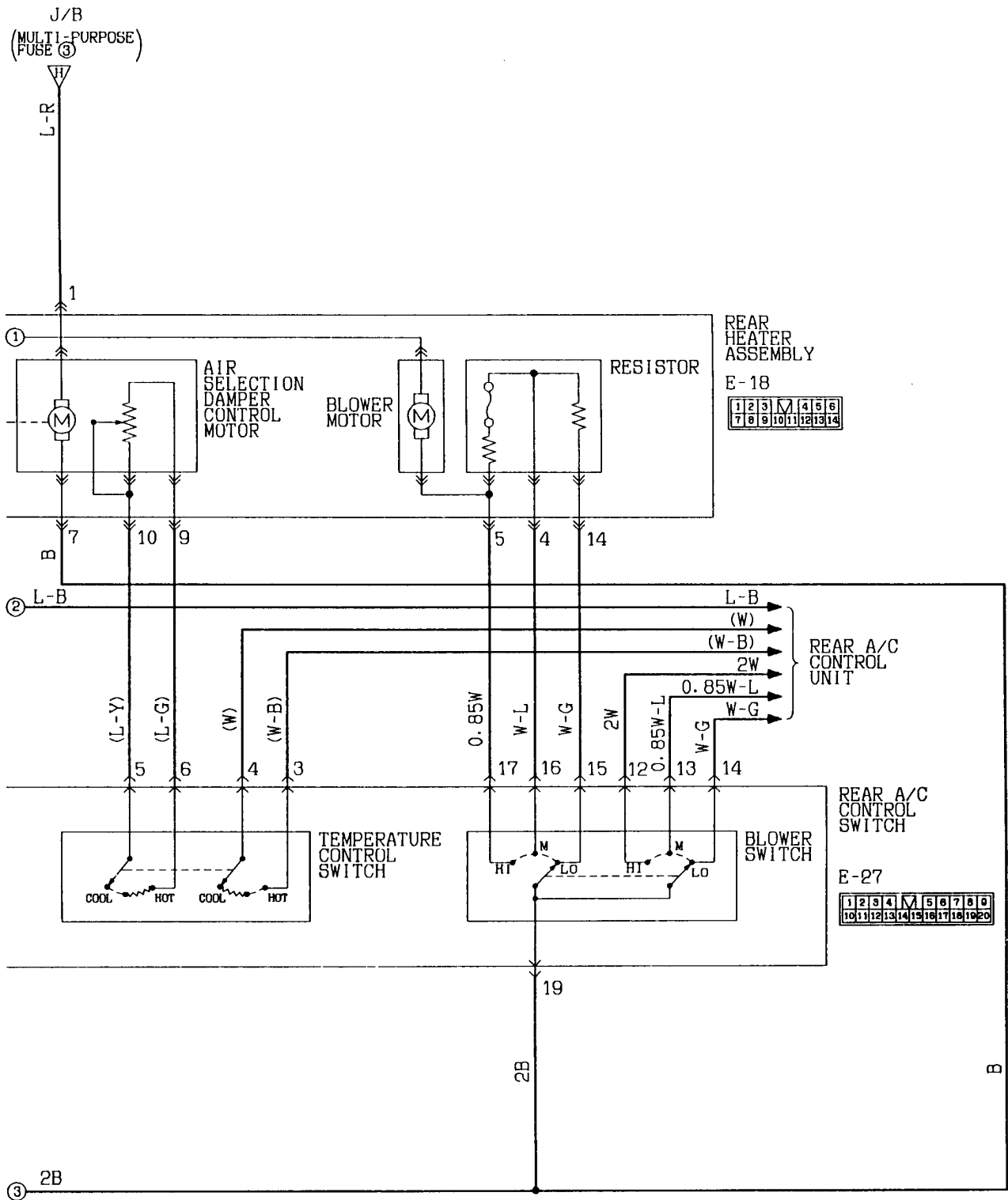

Wire colour code
 B:Black LG:Light green G:Green L:Blue W:White Y:Yellow SB:Sky blue
 BR:Brown O:Orange GR:Gray R:Red P:Pink V:Violet

23-2 Vehicles with rear heater (without dual air conditioner)

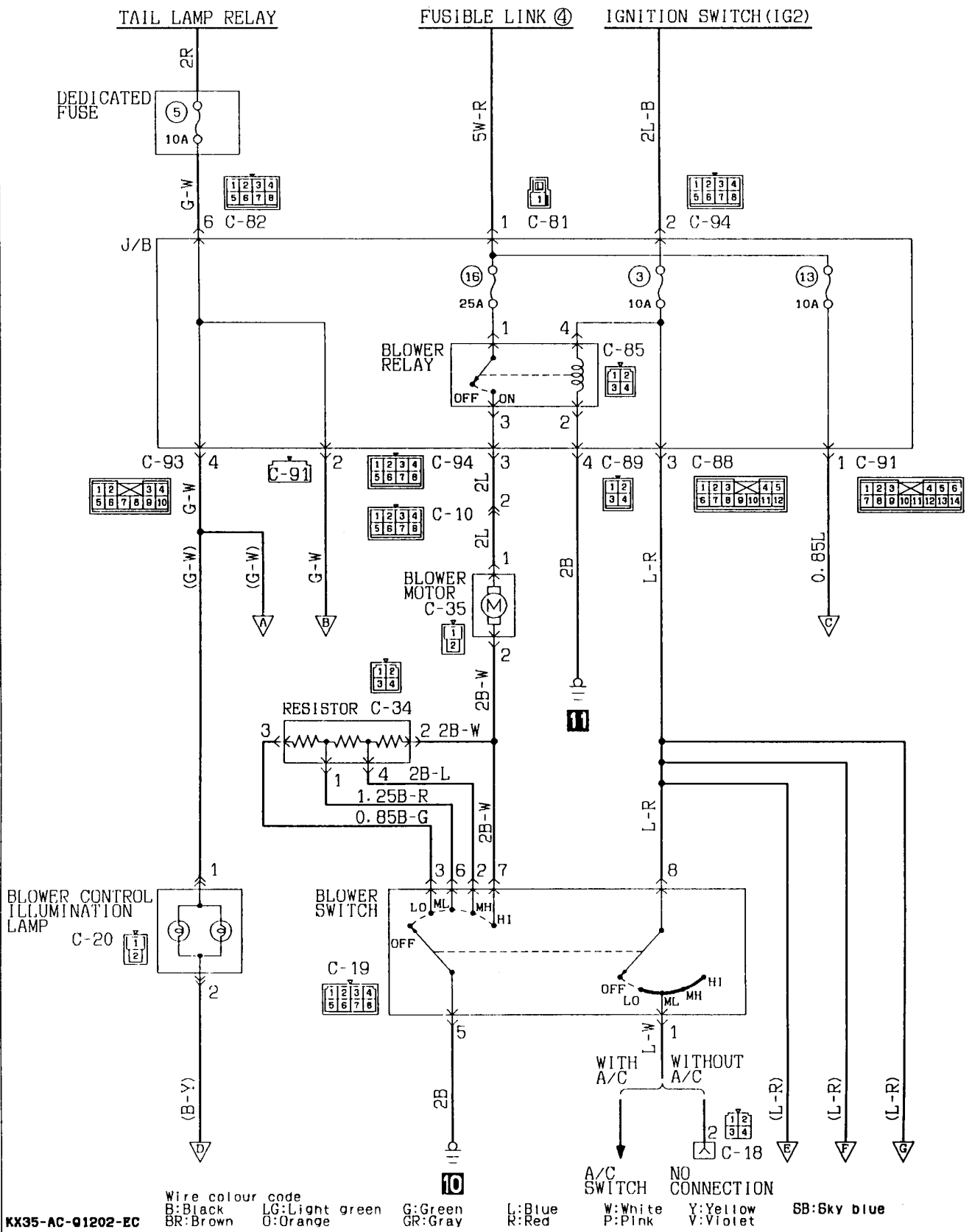

KX35-AC-Q1202-EC

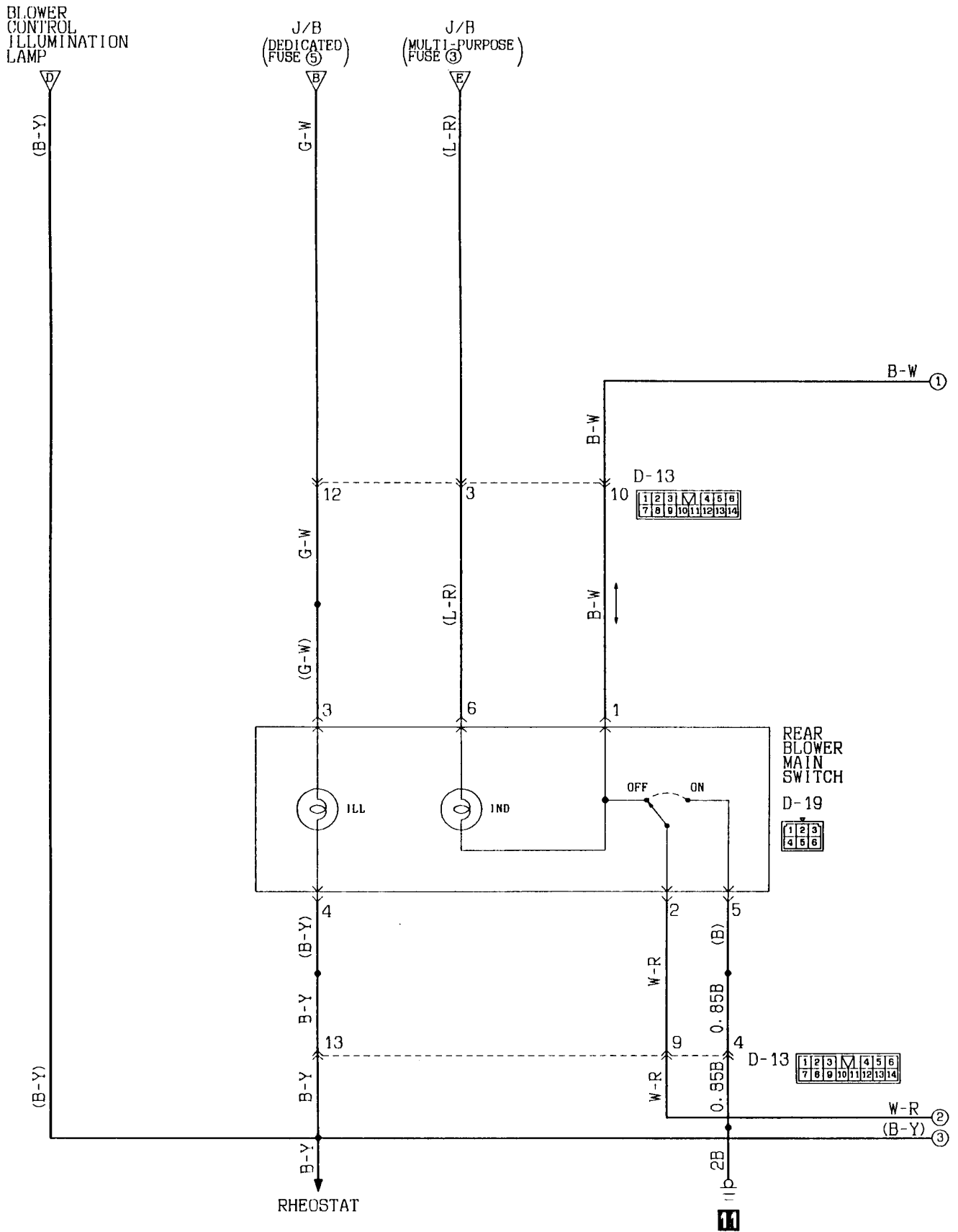

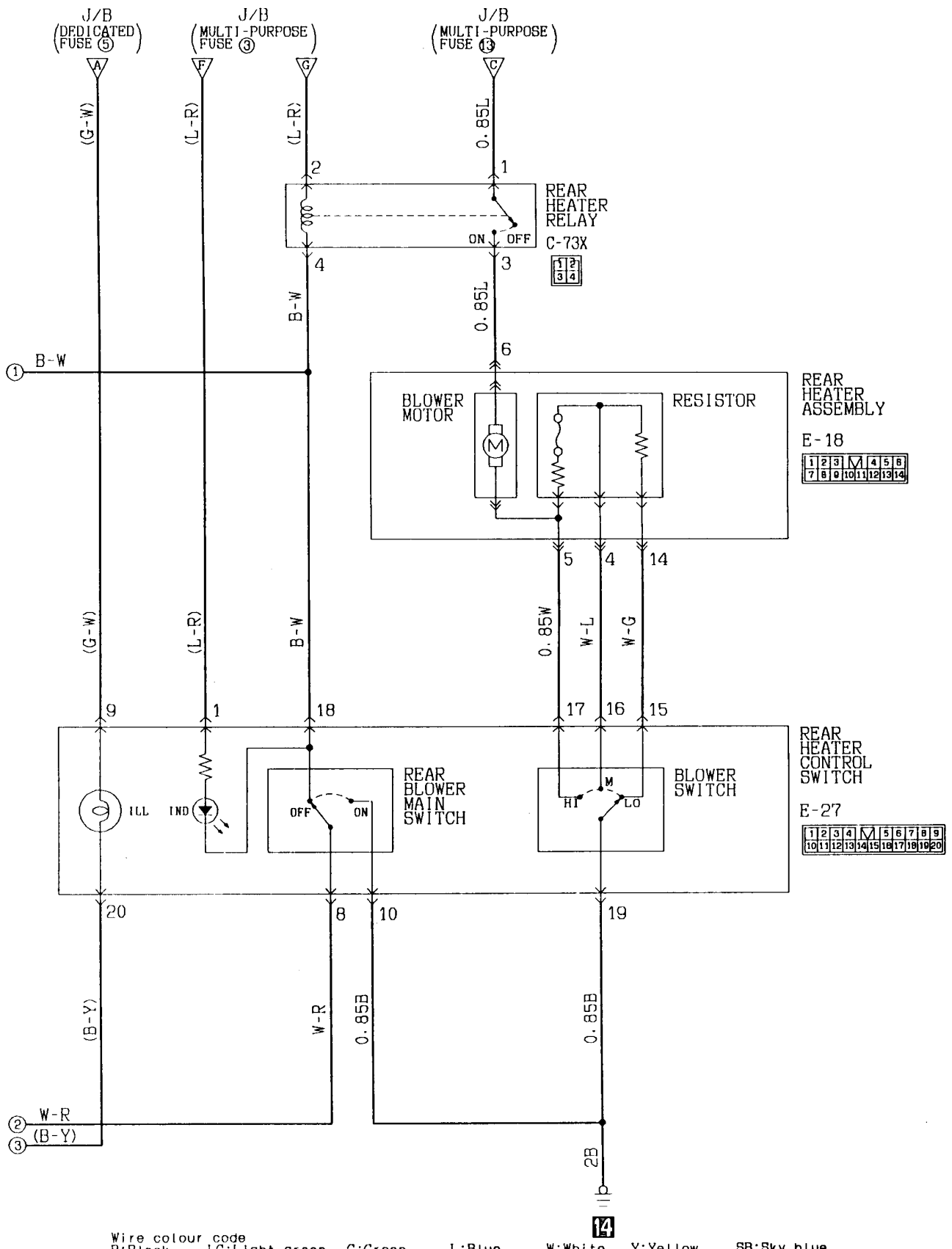

23-3 Vehicles without rear heater

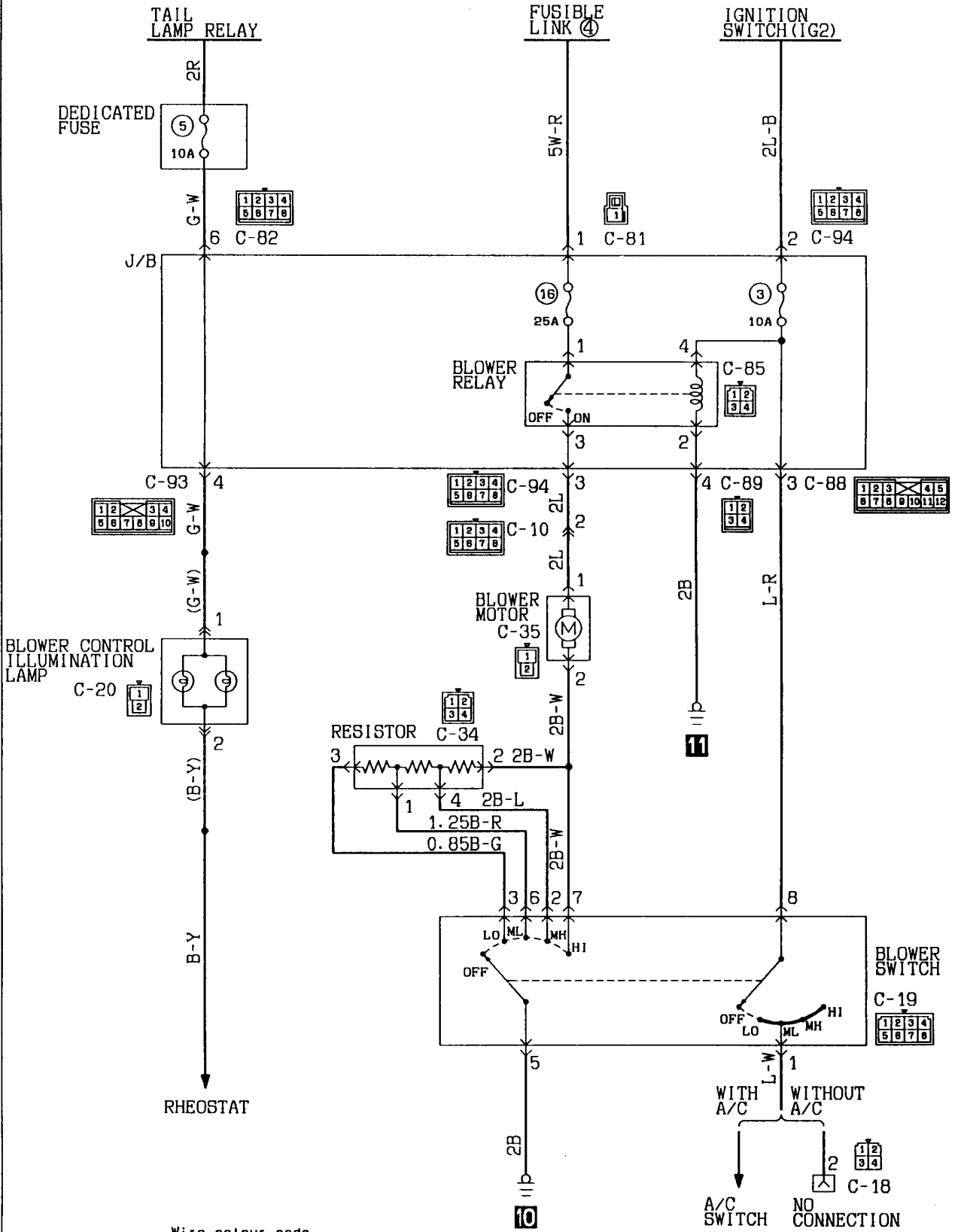

Wire colour code
 B:Black LG:Light green G:Green L:Blue W:White Y:Yellow
 BR:Brown O:Orange GR:Gray R:Red P:Pink V:Violet
 SB:Sky blue

HEATER (See P. 4-108, 111, 114.)**OPERATION****<Front heater operation>**

- When the ignition switch is turned ON, the blower relay is energized. If the blower switch is turned ON (LO, ML, MH, or HI position) in this condition, the blower is activated through the circuit via resistor at a speed corresponding to the blower switch position.

<Rear heater operation>

- When the ignition switch is in the ON position and the rear heater control switch is turned to ON, the rear heater relay turns ON and the blower motor is activated via the resistor at a speed corresponding to the blower switch position (LO, M, HI).

TROUBLESHOOTING HINTS

1. Blower motor is energized at one switch position and not energized at another.
 - Check harness and connectors between defective switch position and resistor (or blower motor in HI position).
2. Blower motor is energized only when switch is positioned in HI.
 - Check resistor.
3. Blower motor speed does not represent the switch position.
 - Check blower switch.

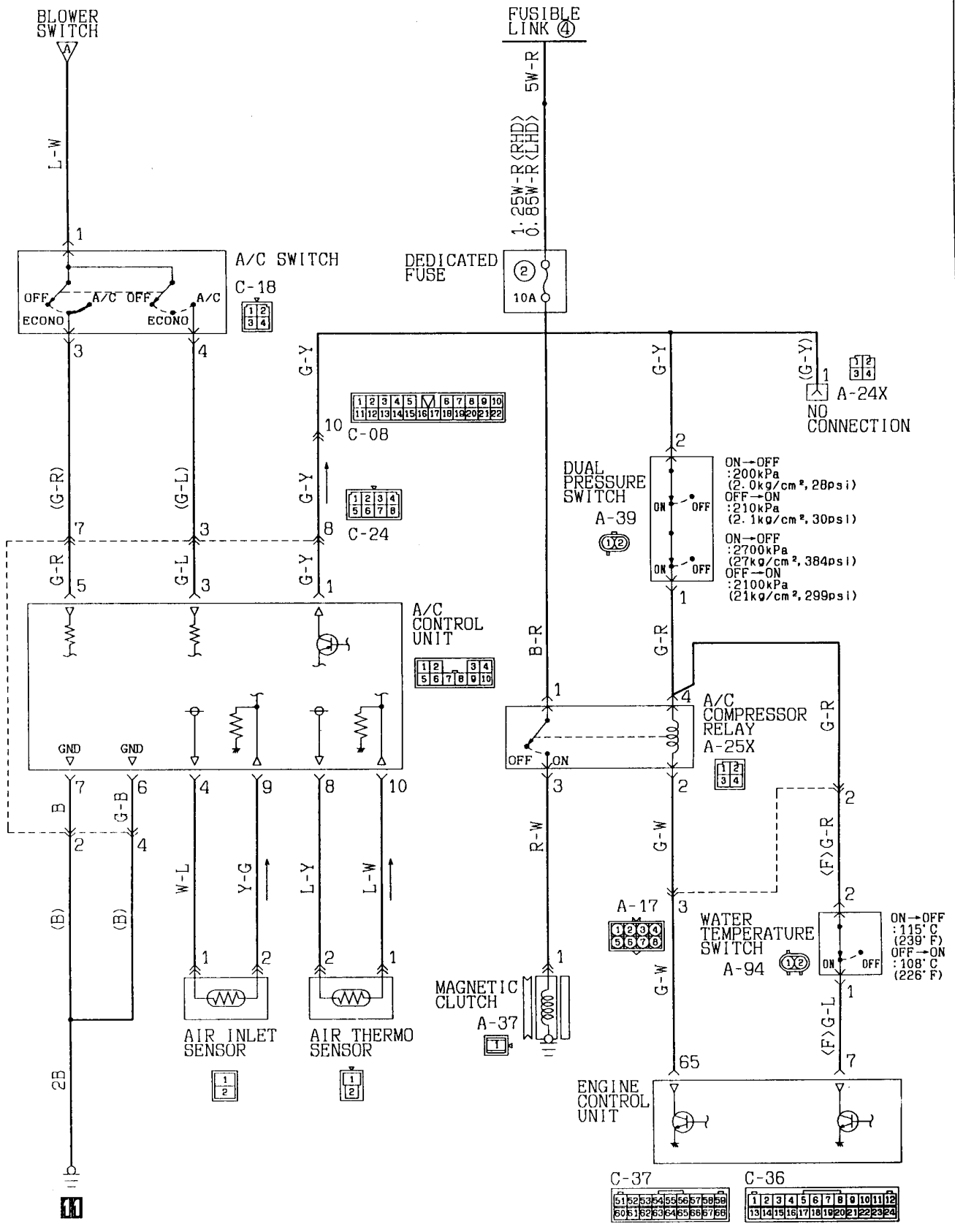

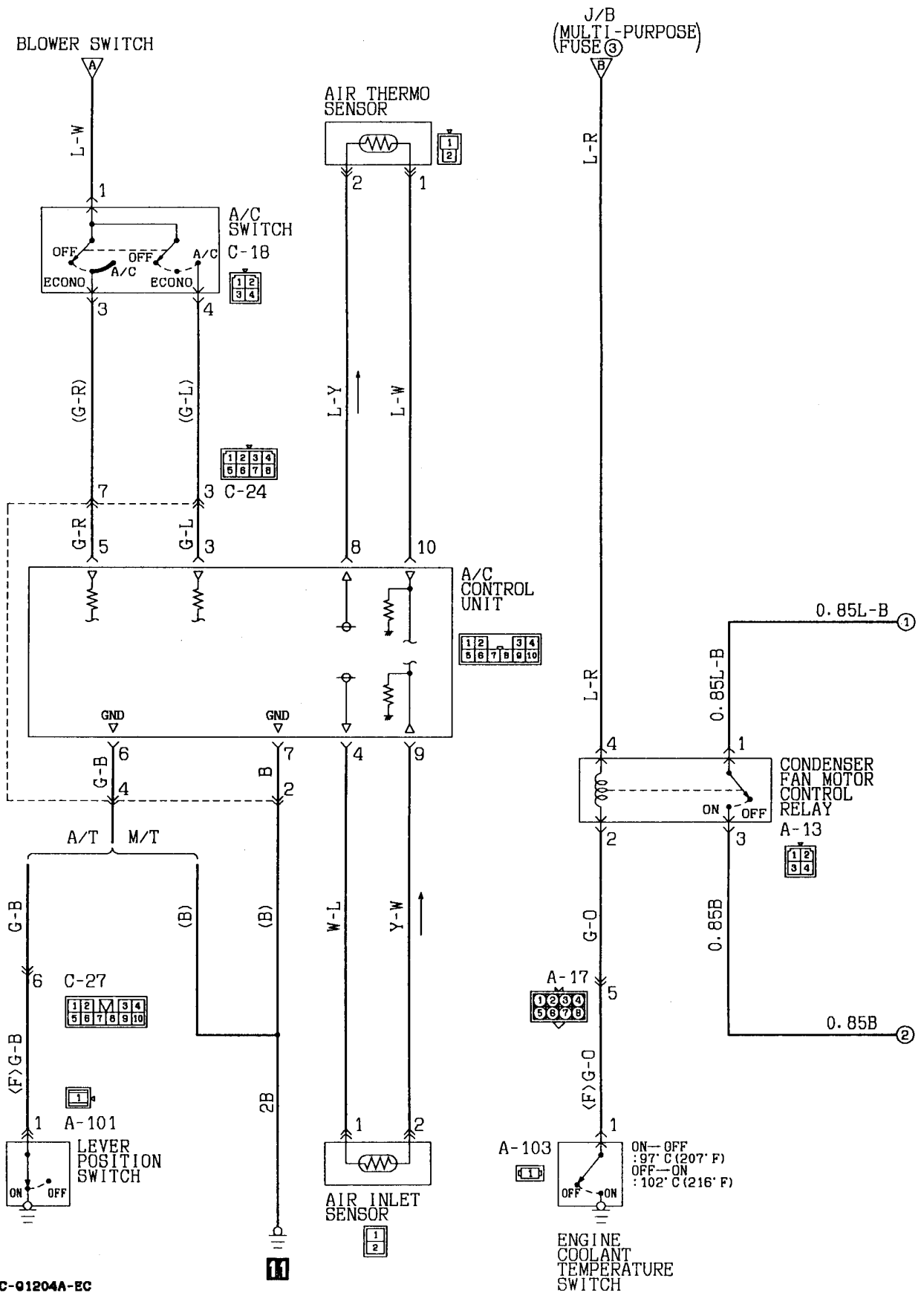

KX35-AC-01204A-EC

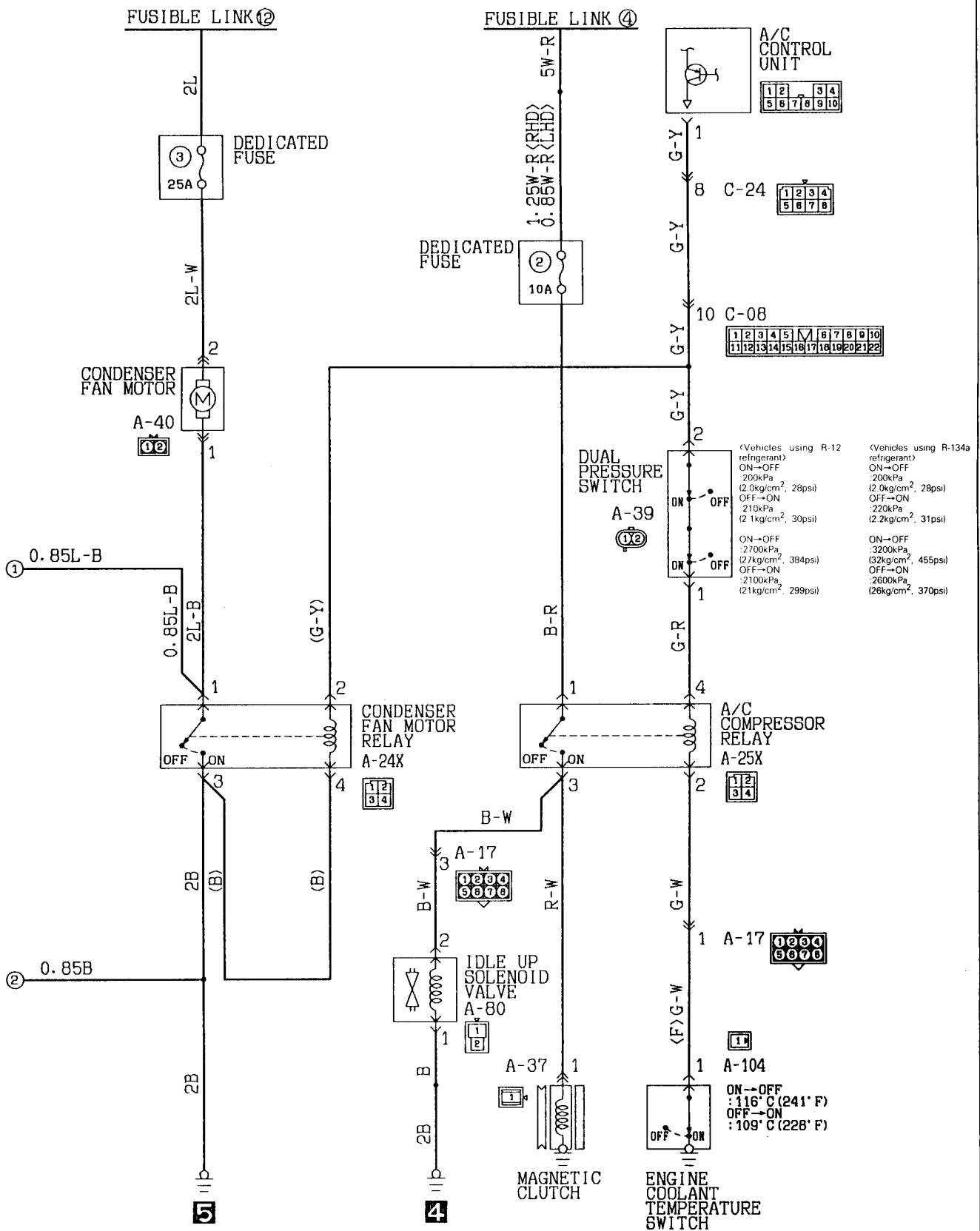

25 DUAL AIR CONDITIONER

25-1 Petrol-powered vehicles with rear heater

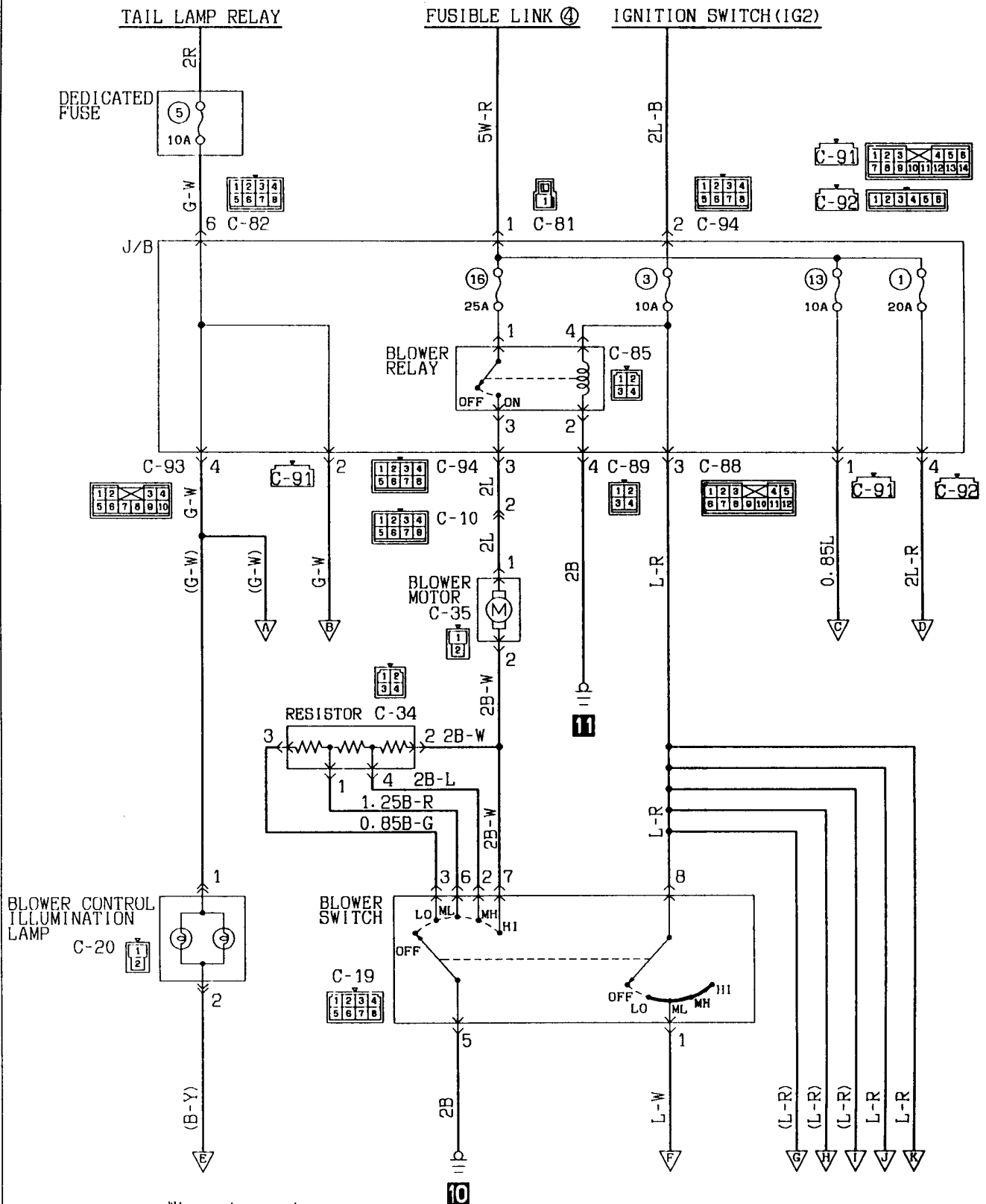

Wire colour code
 B:Black LG:Light green G:Green L:Blue W:White Y:Yellow SB:6ky blue
 BR:Brown O:Orange GR:Gray R:Red P:Pink V:Violet

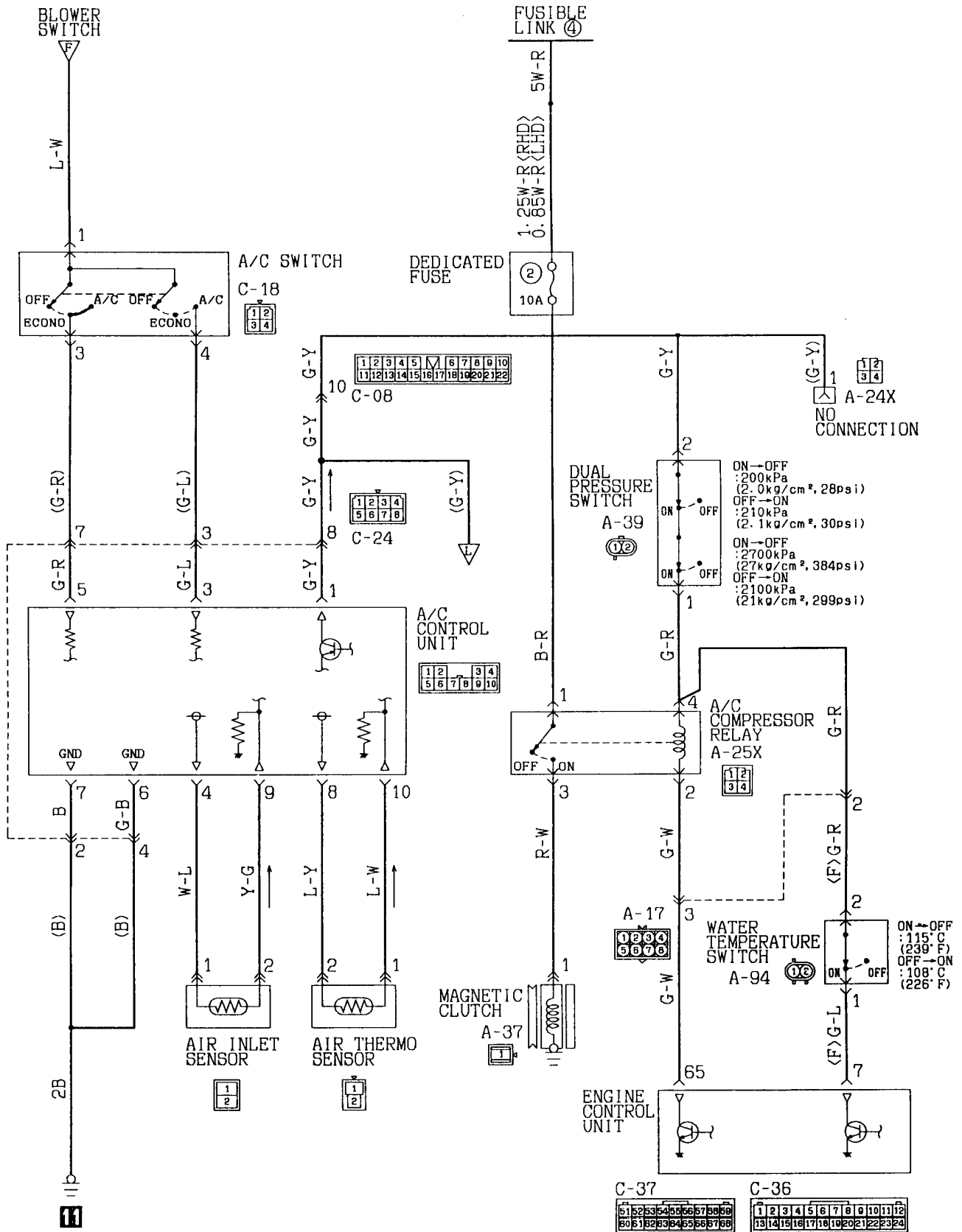

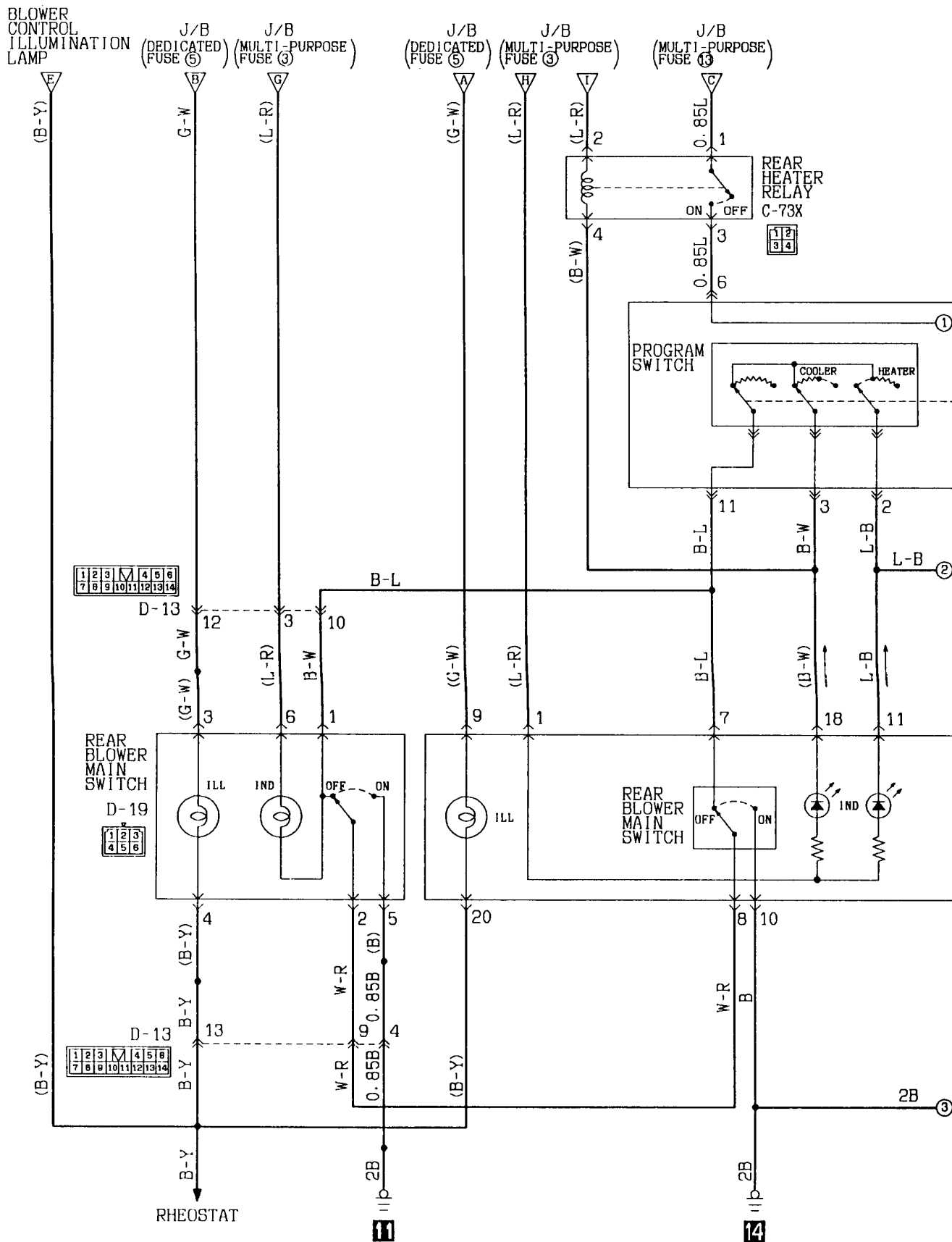

KX35-AC-Q1205A-EC

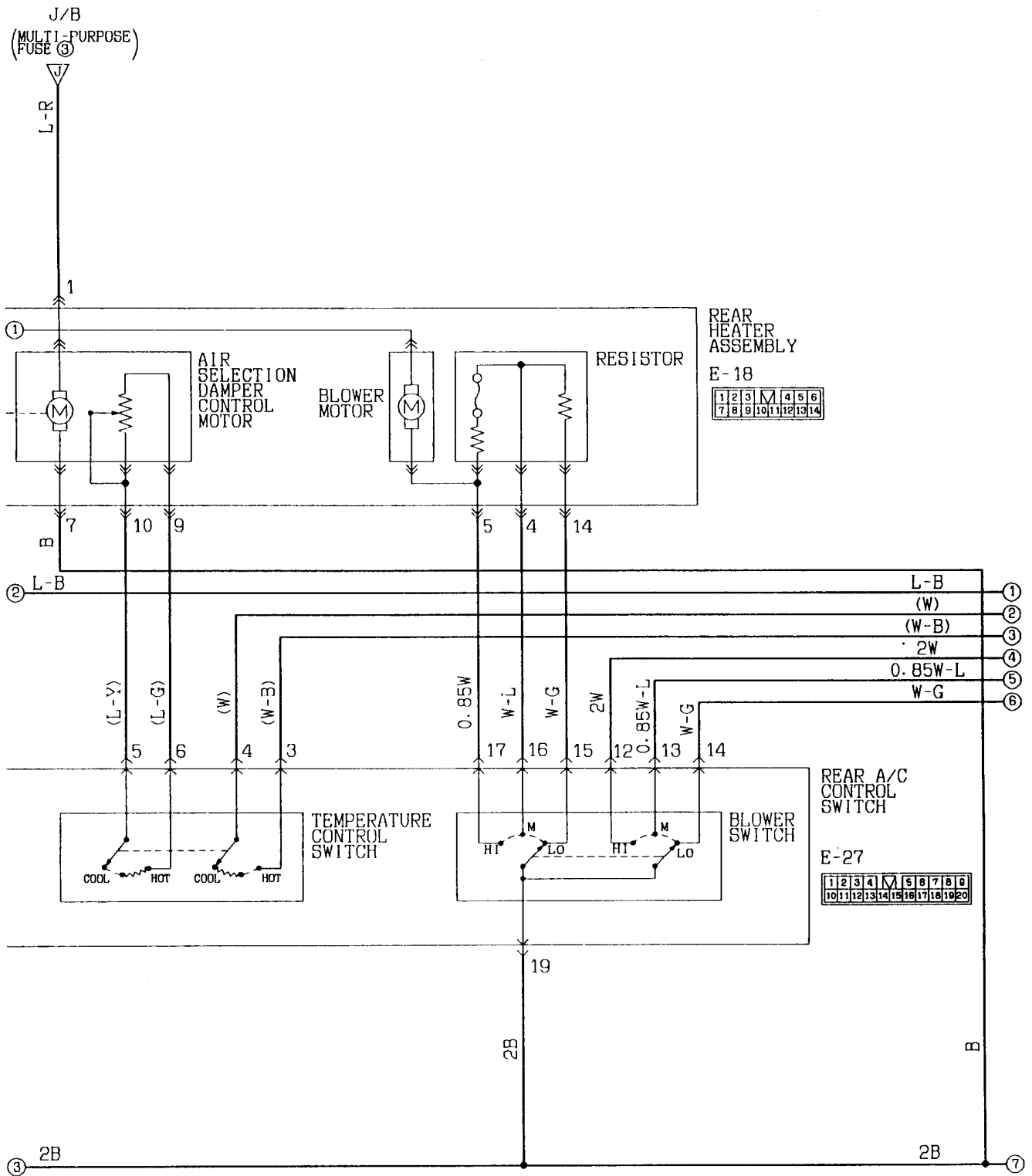

Wire colour code
 B:Black LG:Light green G:Green L:Blue W:White Y:Yellow SB:Sky blue
 BR:Brown O:Orange GR:Gray R:Red P:Pink V:Violet

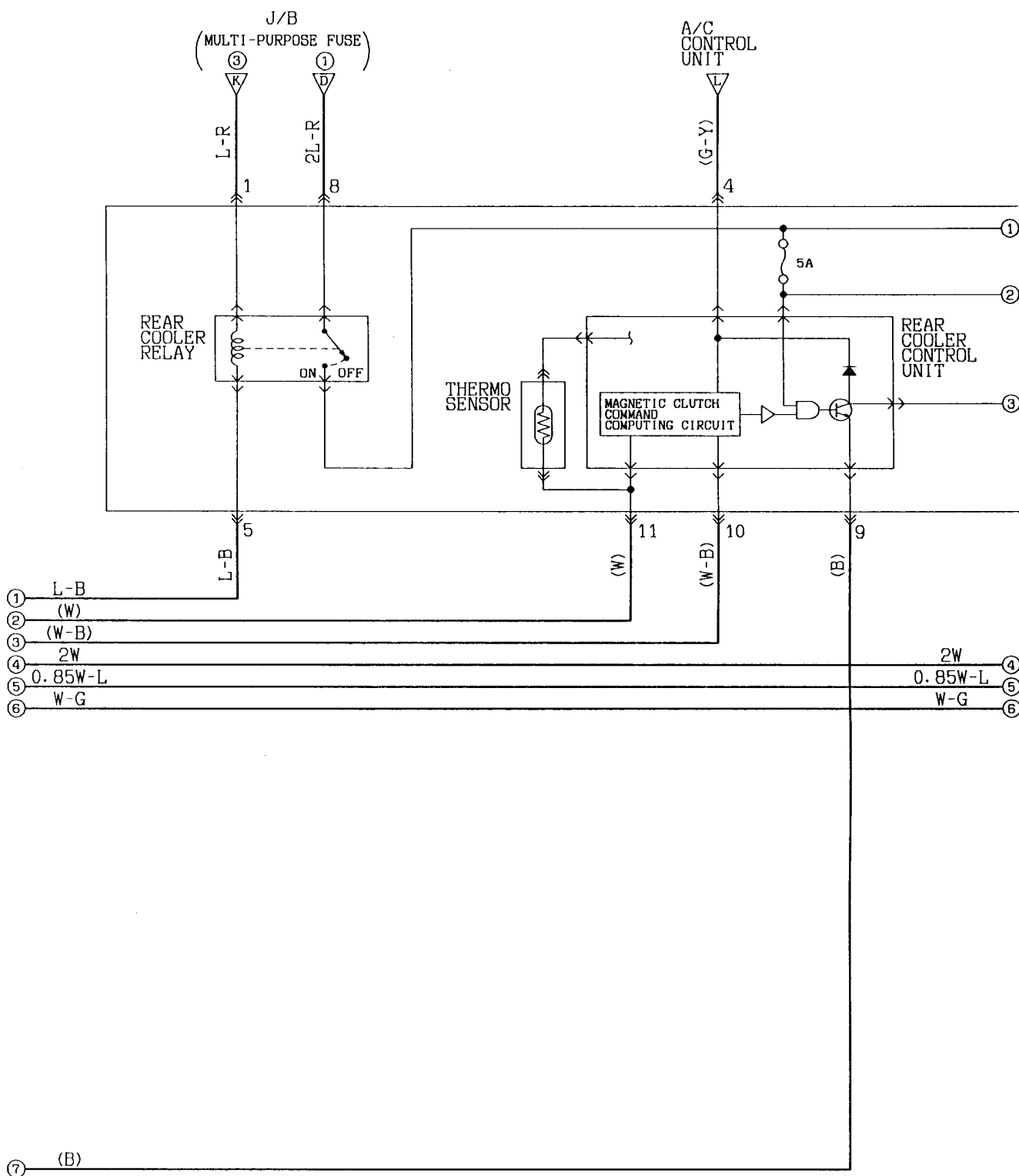

KX35-AC-01205B-EC

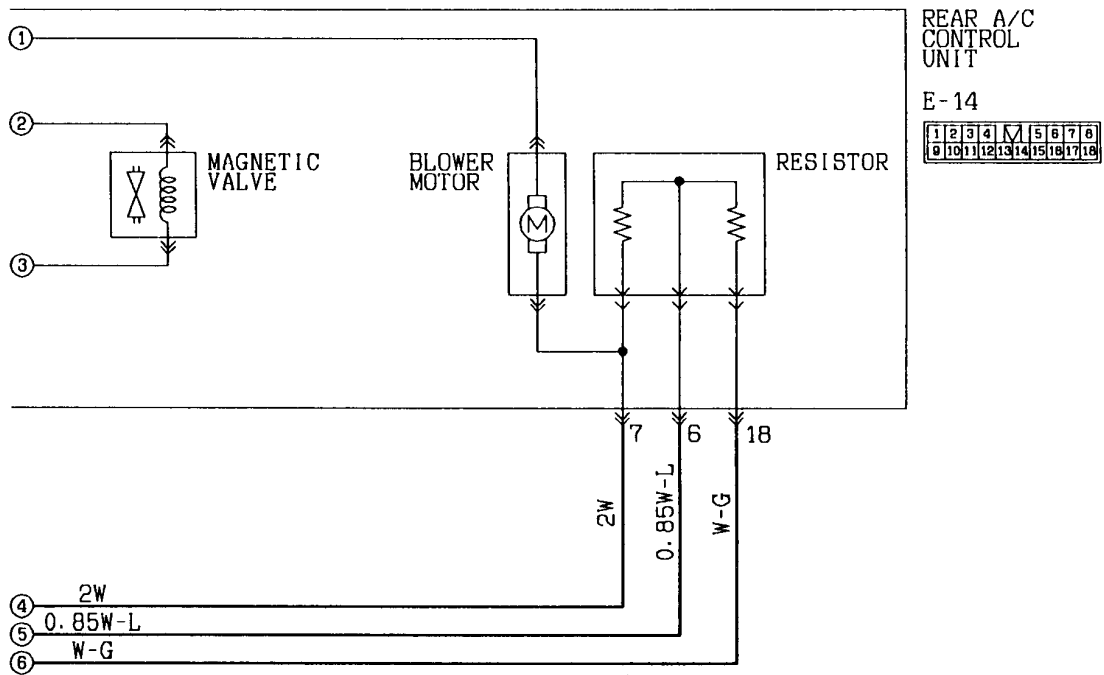

Wire colour code
 B:Black LG:Light green G:Green L:Blue W:White Y:Yellow BB:Sky blue
 BR:Brown O:Orange GR:Gray R:Red P:Pink V:Violet

25-2 Petrol-powered vehicles without rear heater

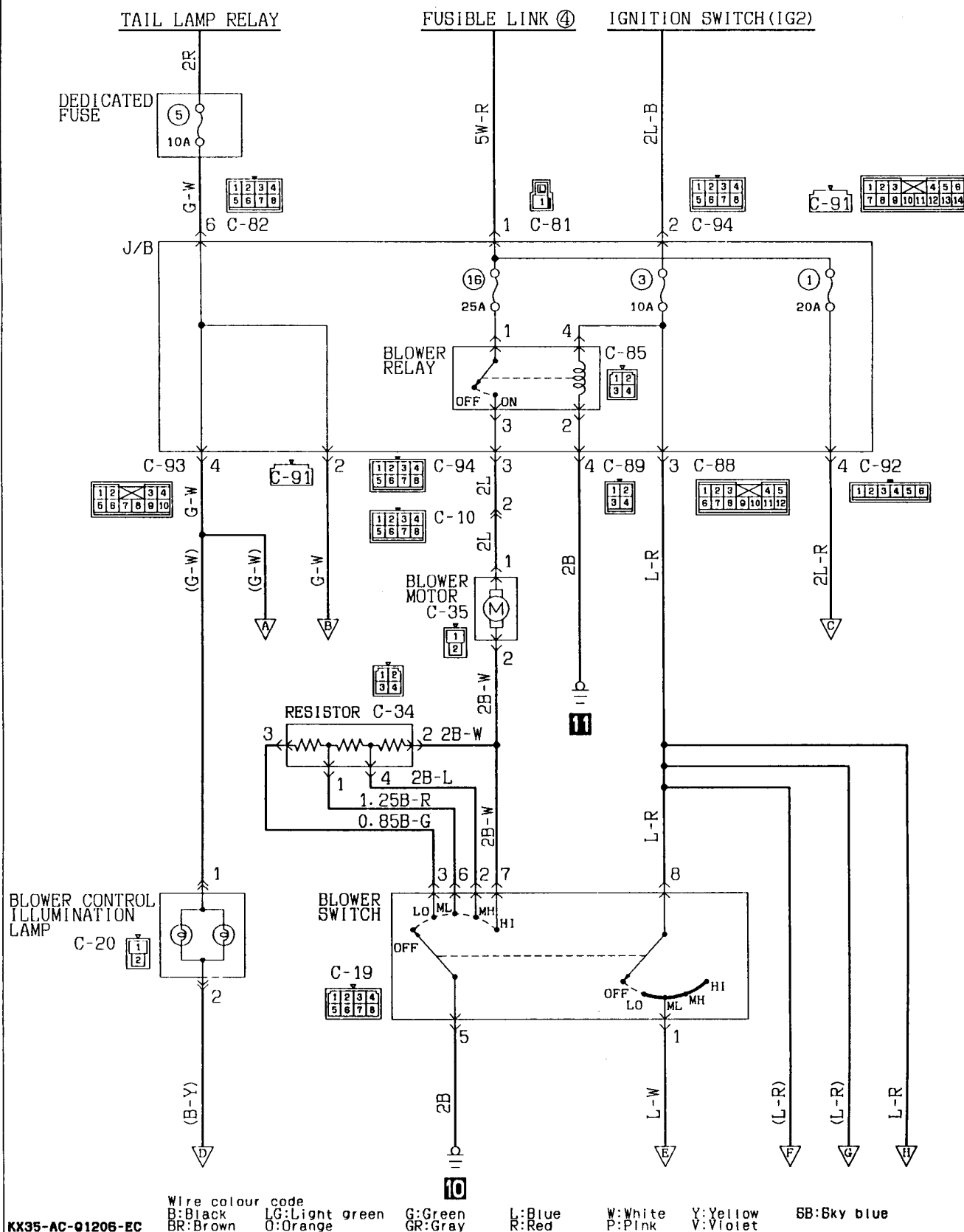

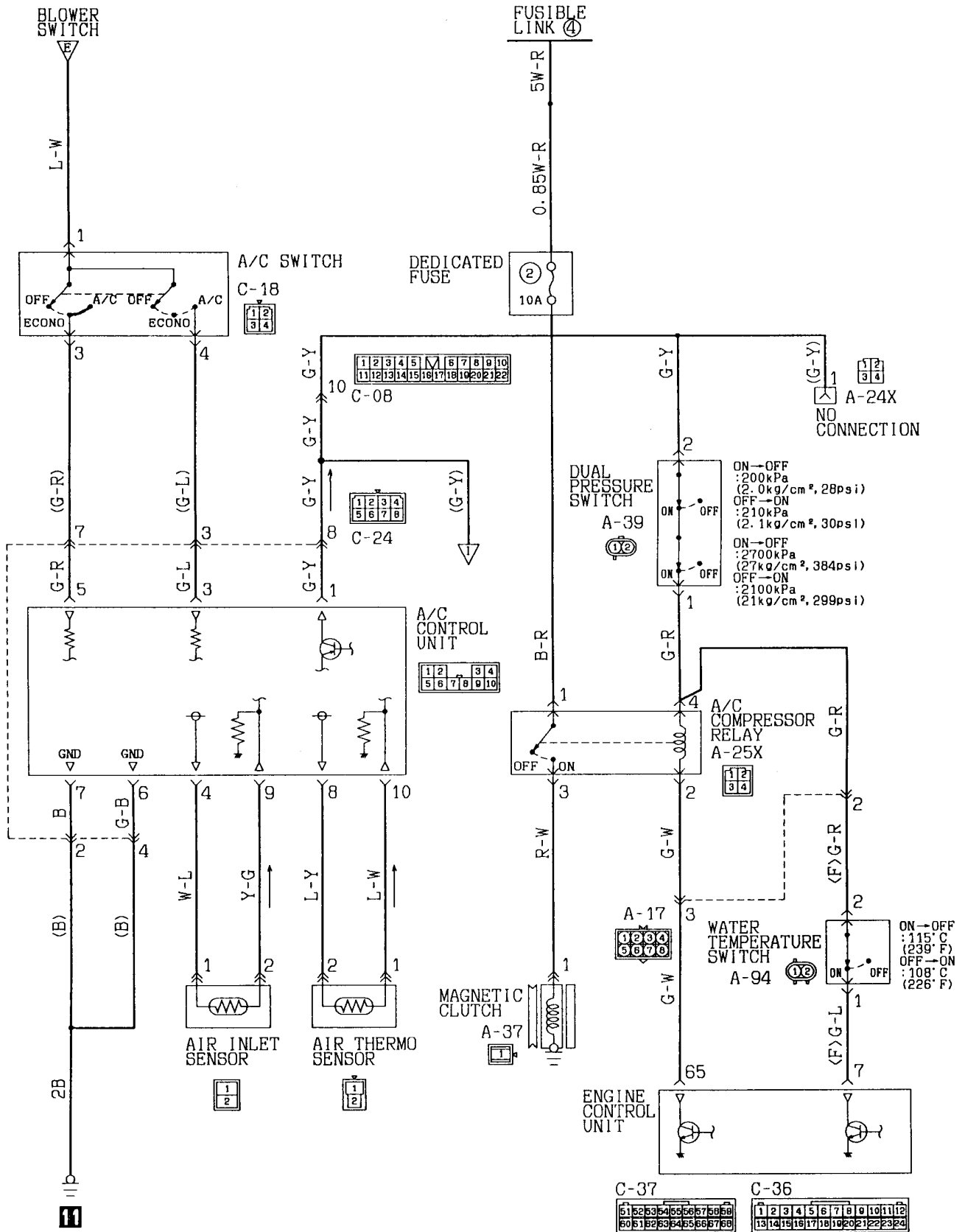

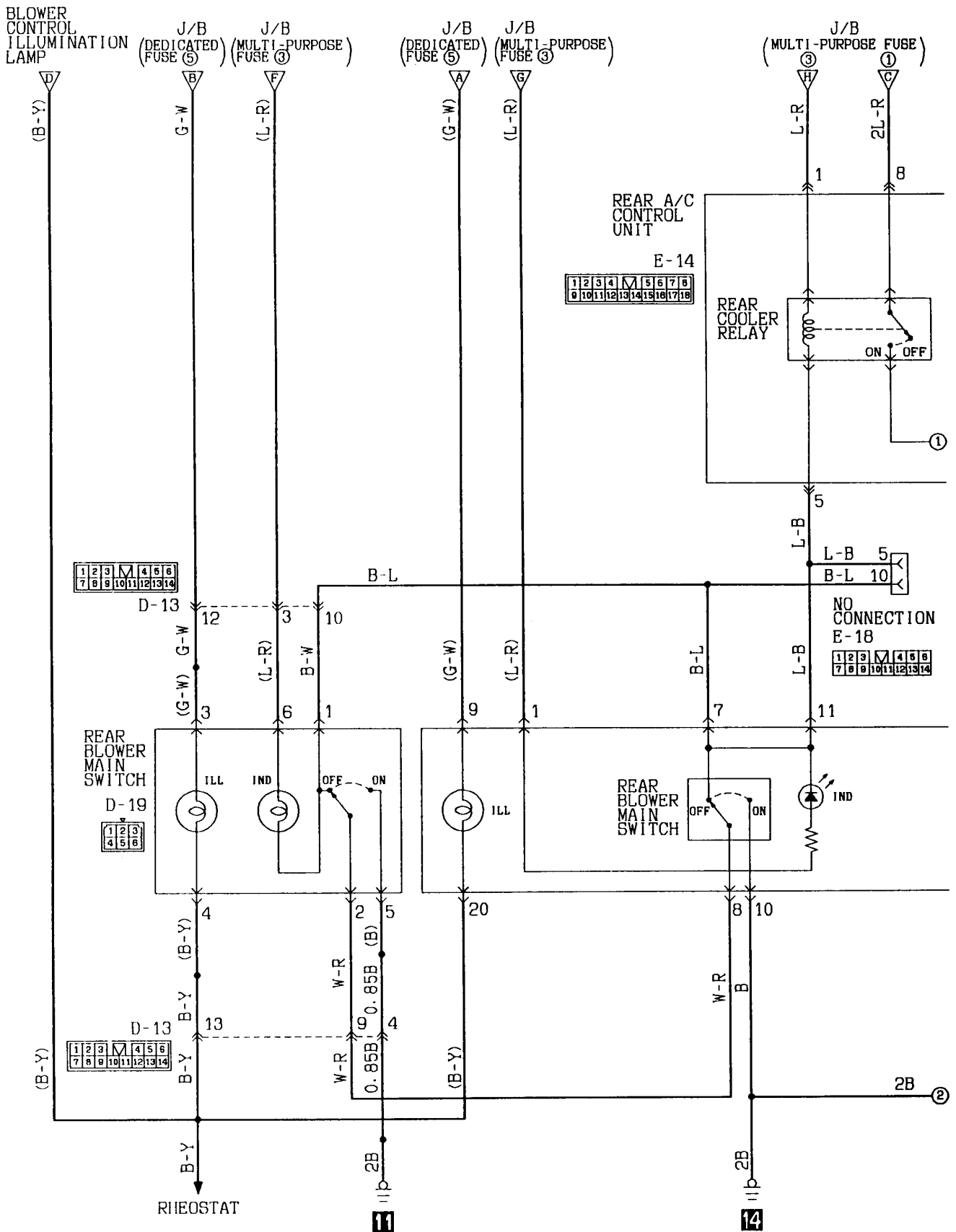

KX35-AC-Q1206A-EC

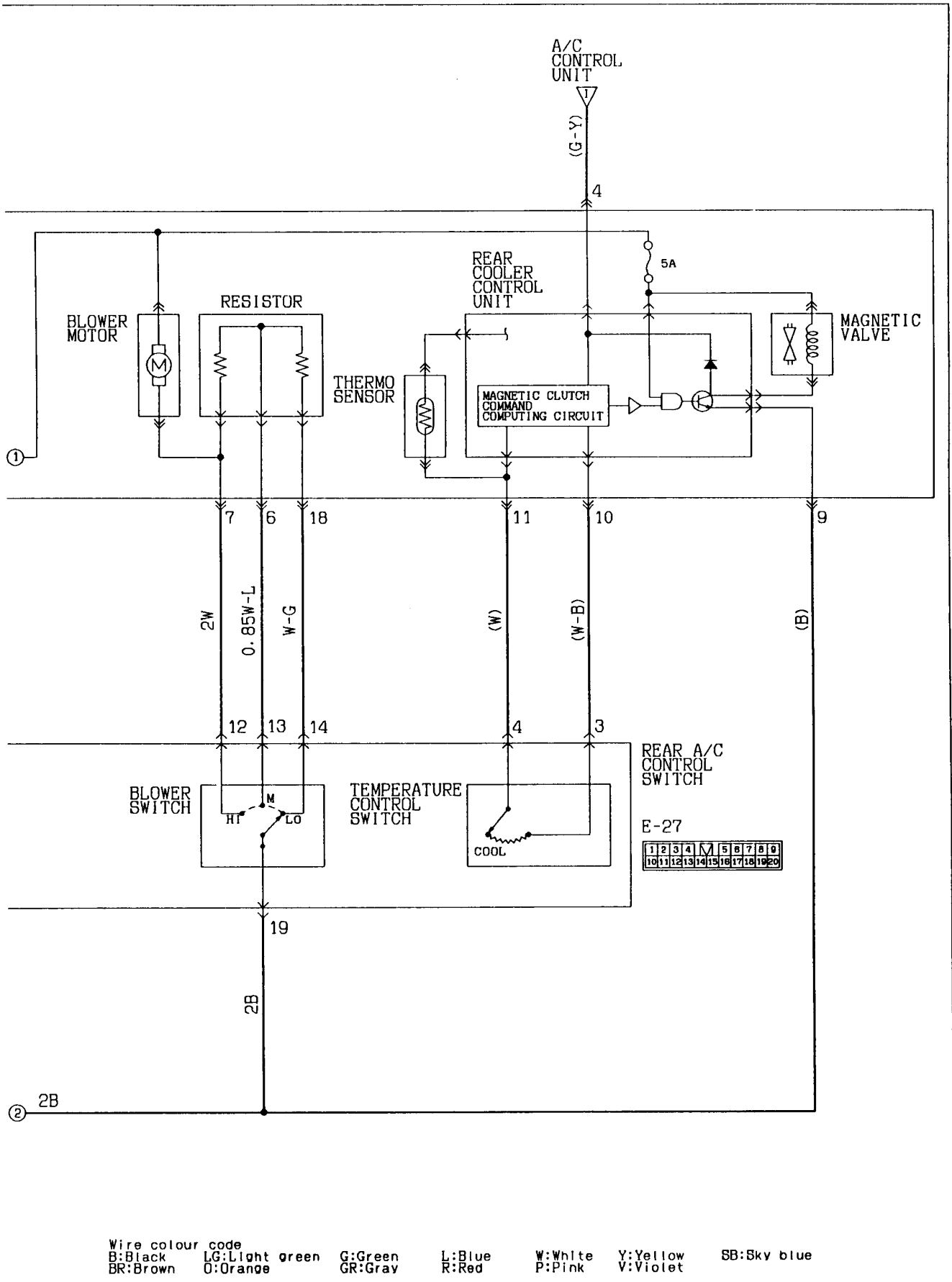

25-3 Diesel-powered vehicles with rear heater

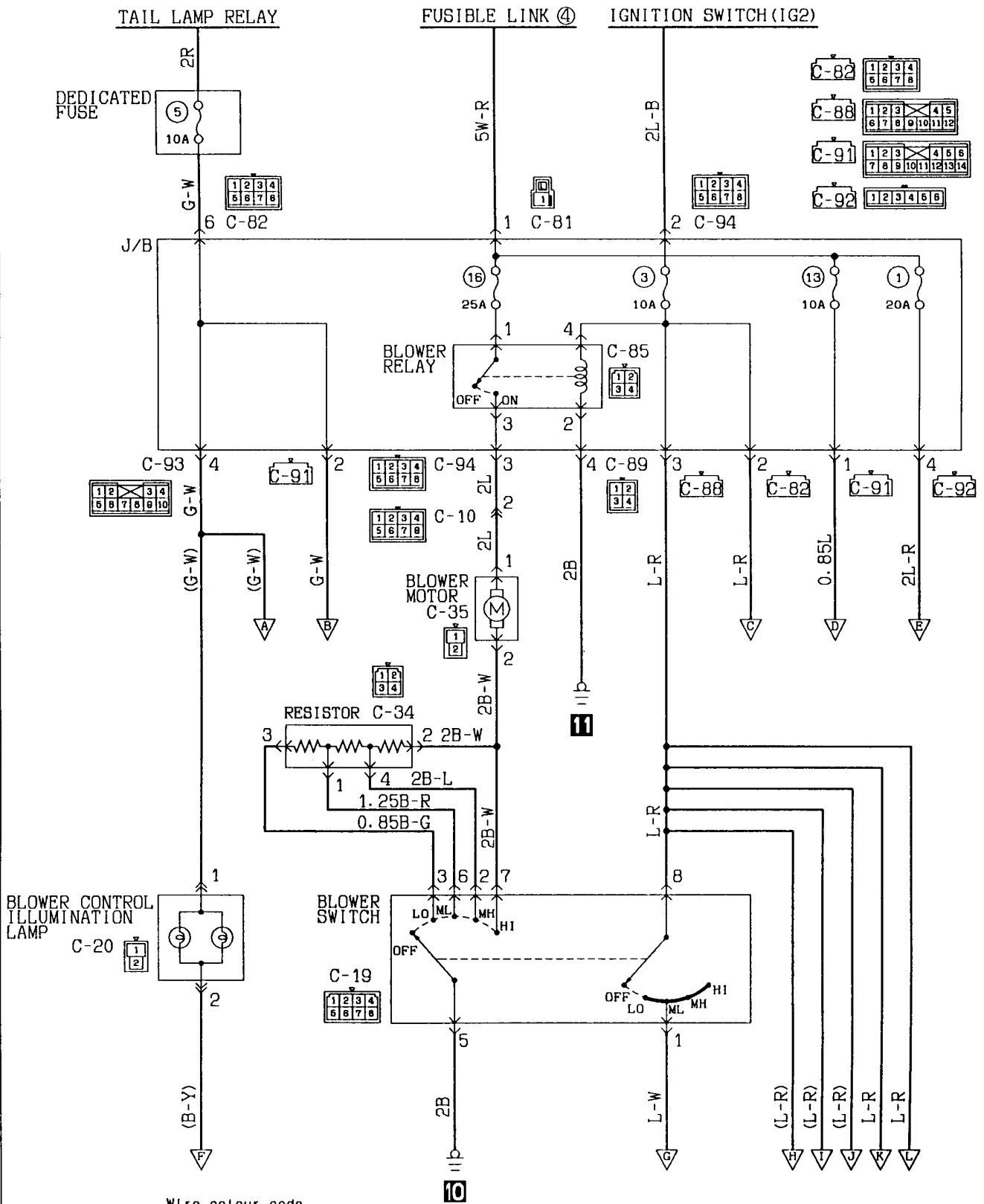

Wire colour code
 B:Black LG:Light green G:Green L:Blue W:White Y:Yellow
 BR:Brown O:Orange GR:Gray R:Red P:Pink V:Violet SB:Sky blue

KX35-AC-01207-EC

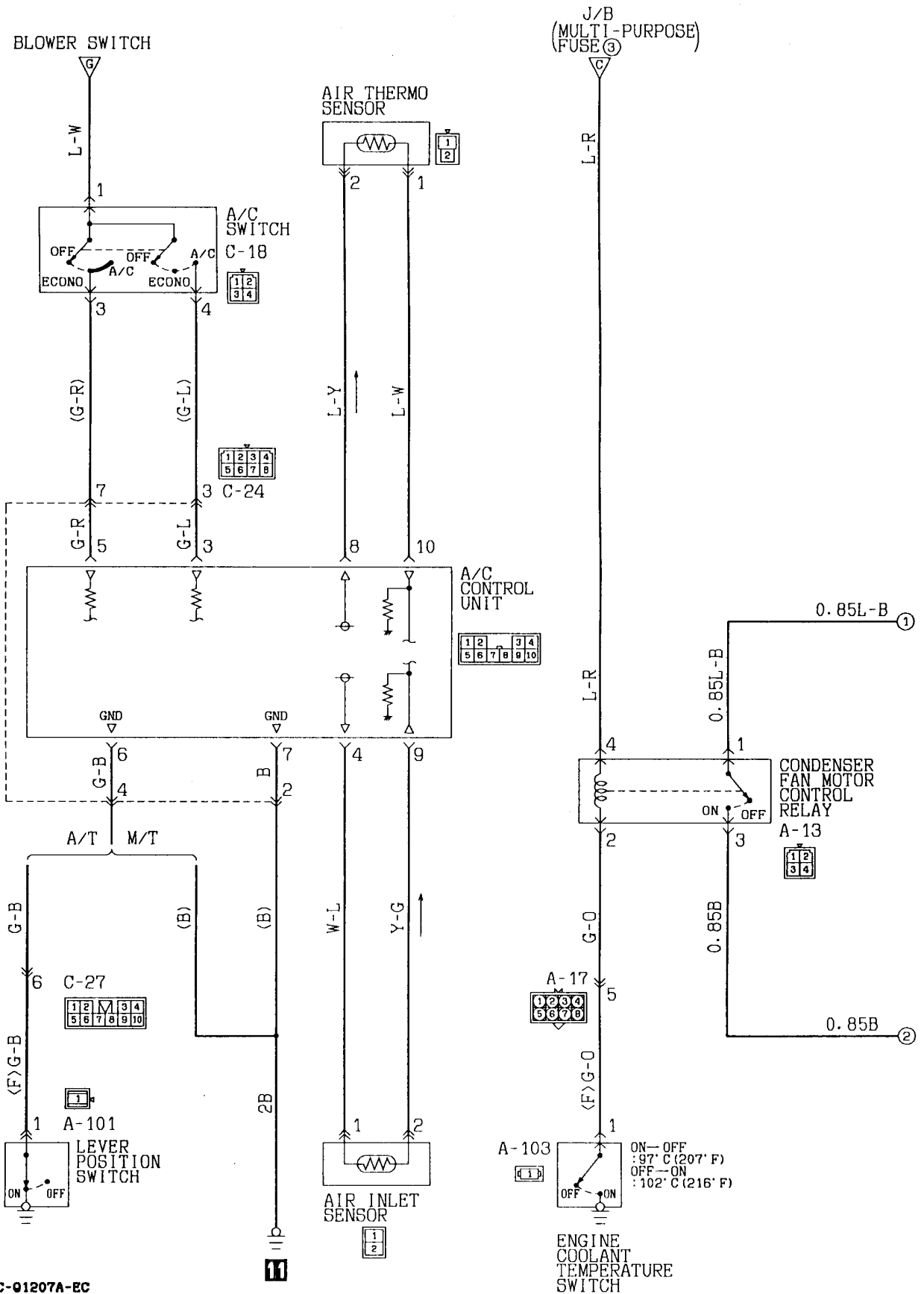

KX35-AC-01207A-EC

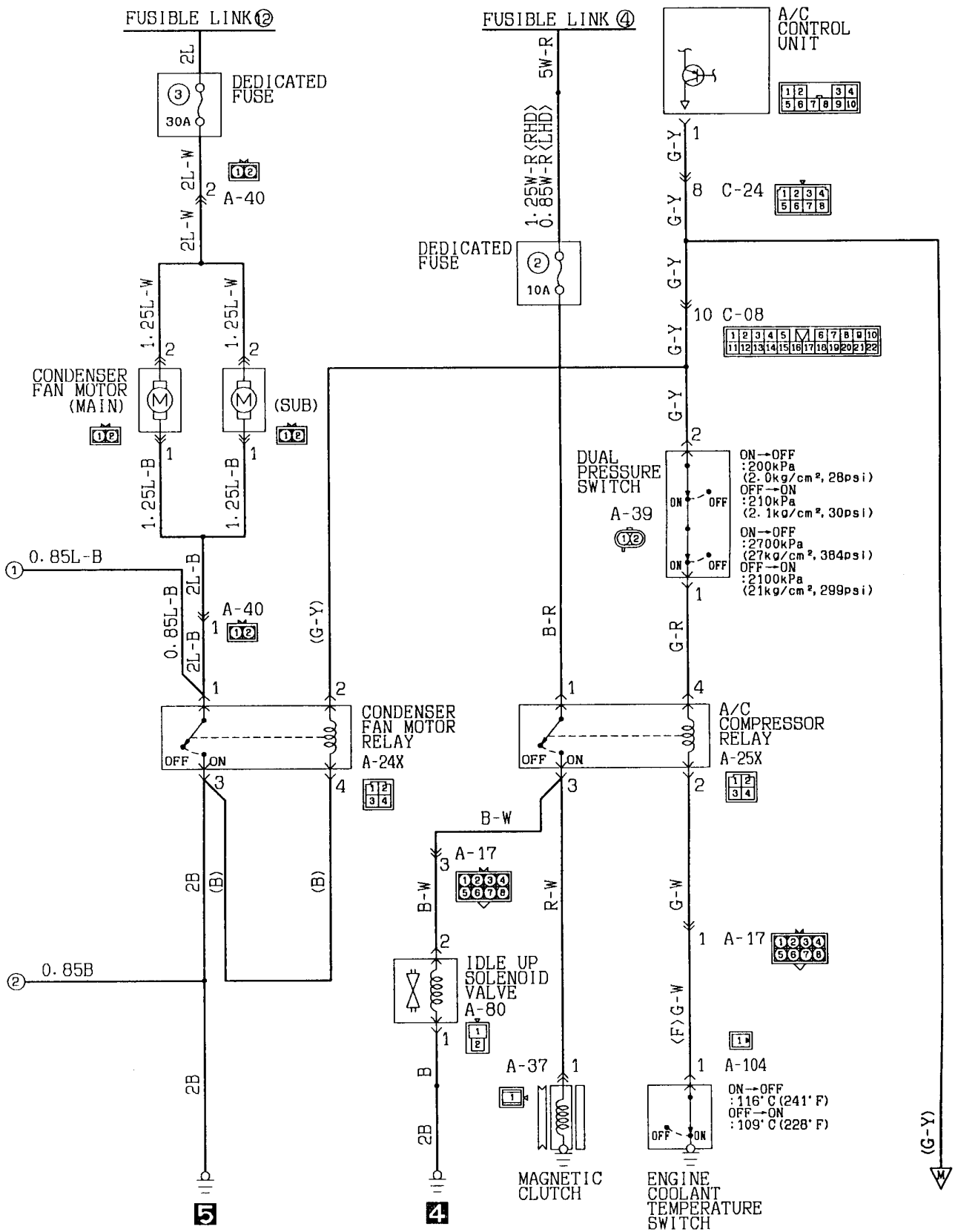

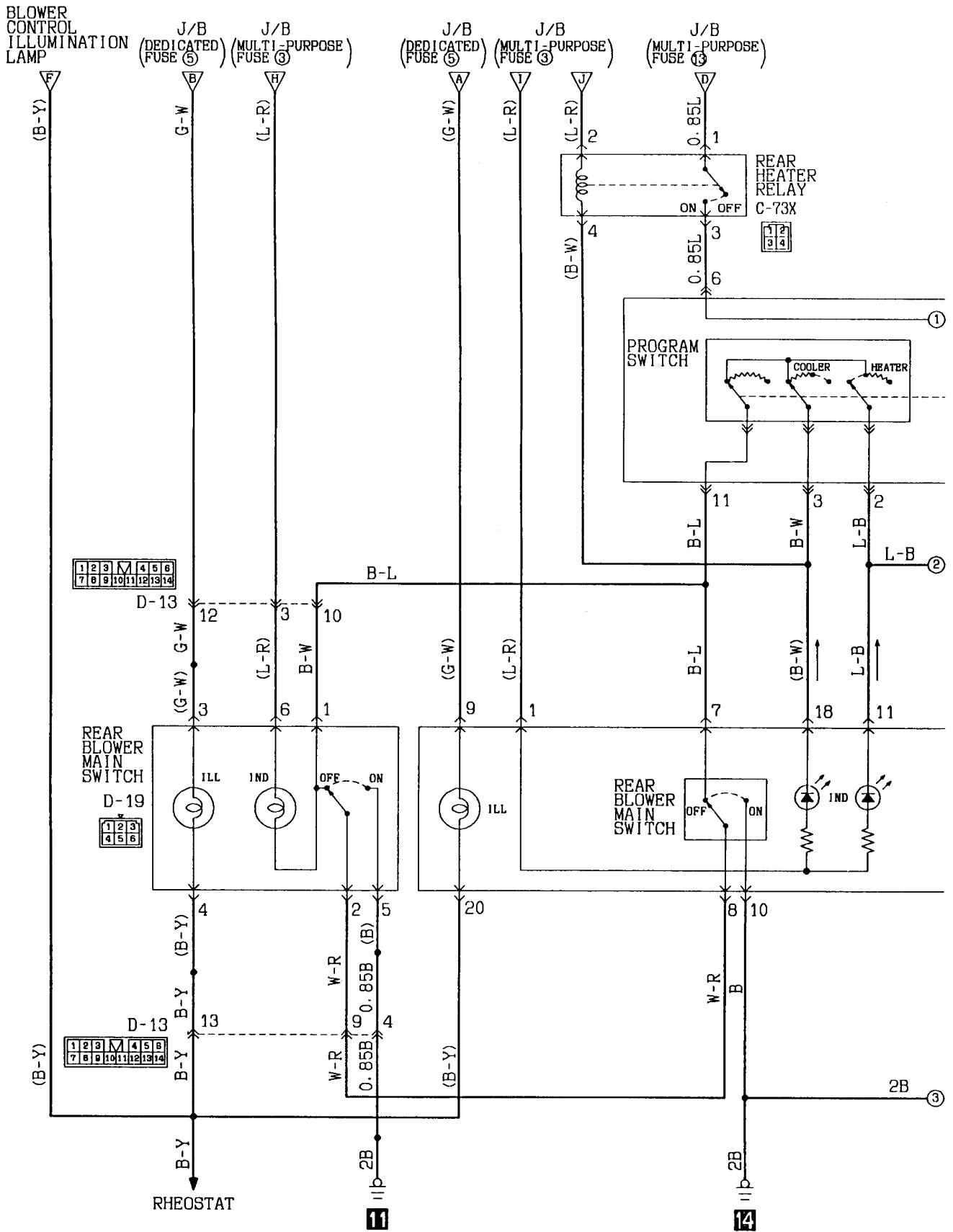

KX35-AC-01207B-EC

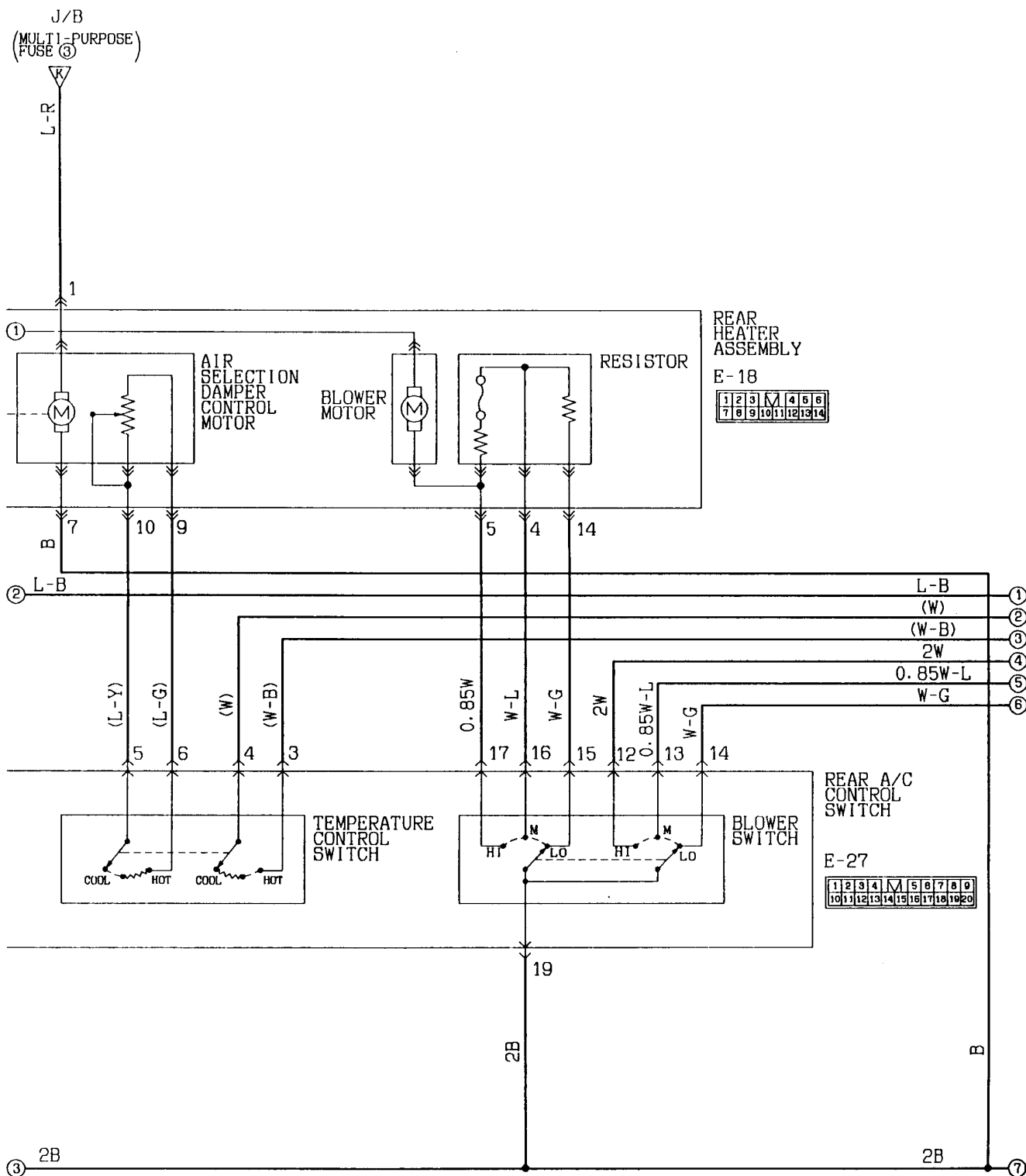

Wire colour code
 B:Black LG:Light green G:Green L:Blue W:White Y:Yellow SB:Sky blue
 BR:Brown O:Orange GR:Gray R:Red P:Pink V:Violet

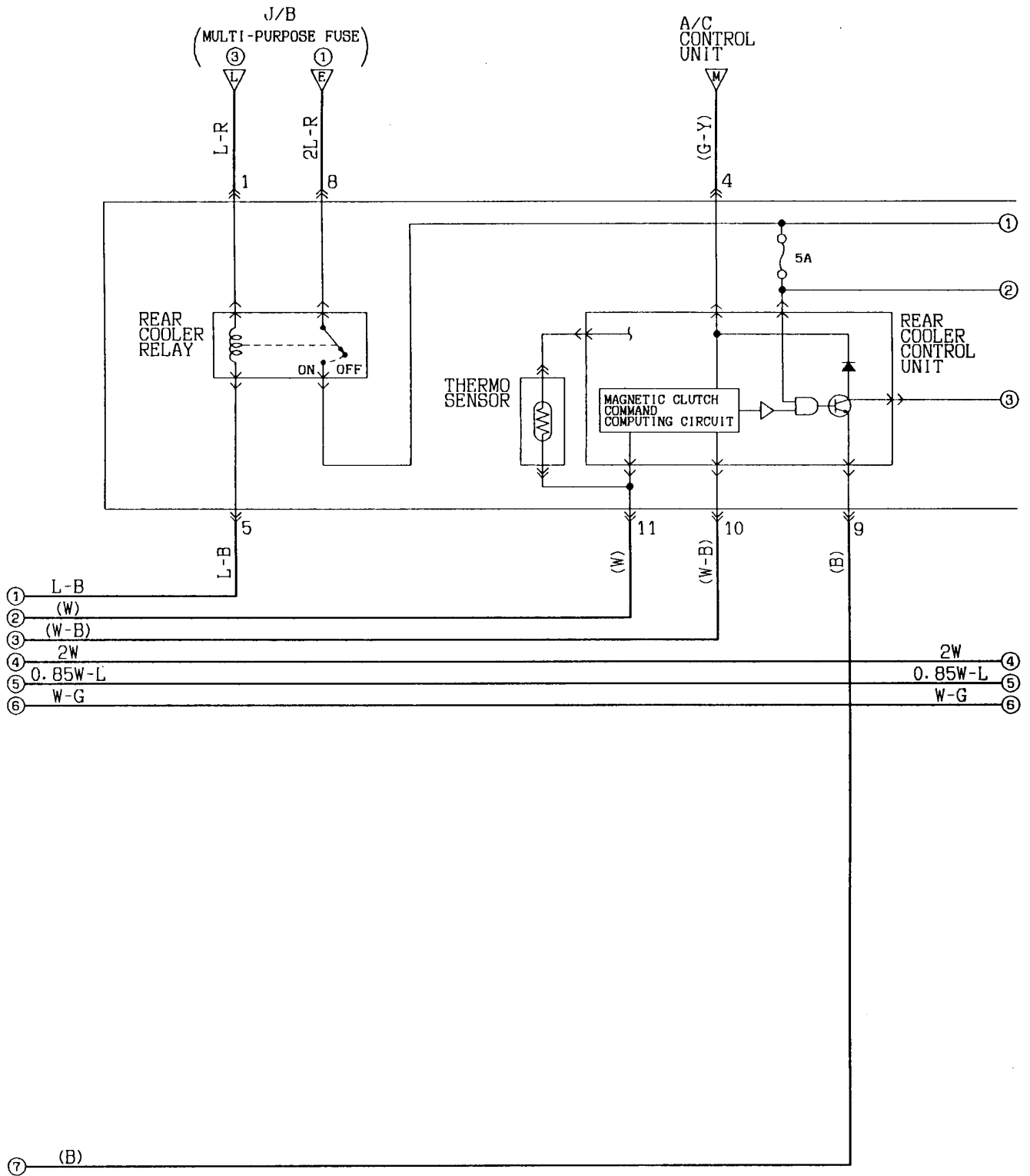

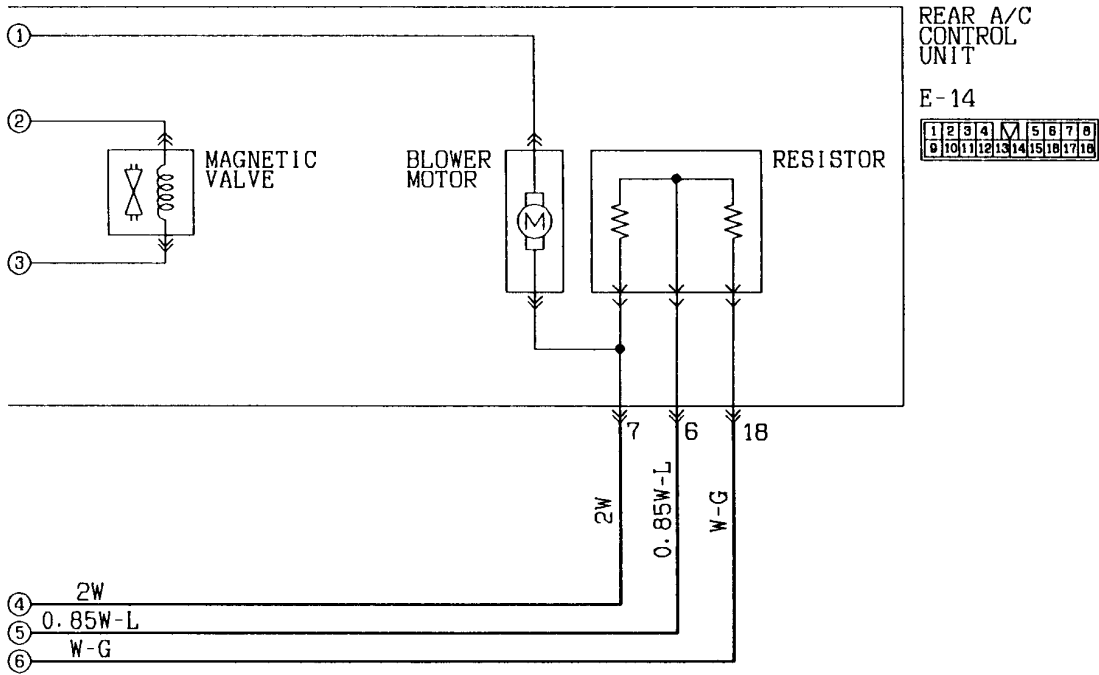

Wire colour code
 B:Black LG:Light green G:Green L:Blue W:White Y:Yellow BB:Sky blue
 BR:Brown O:Orange GR:Gray R:Red P:Pink V:Violet

25-4 Diesel-powered vehicles without rear heater

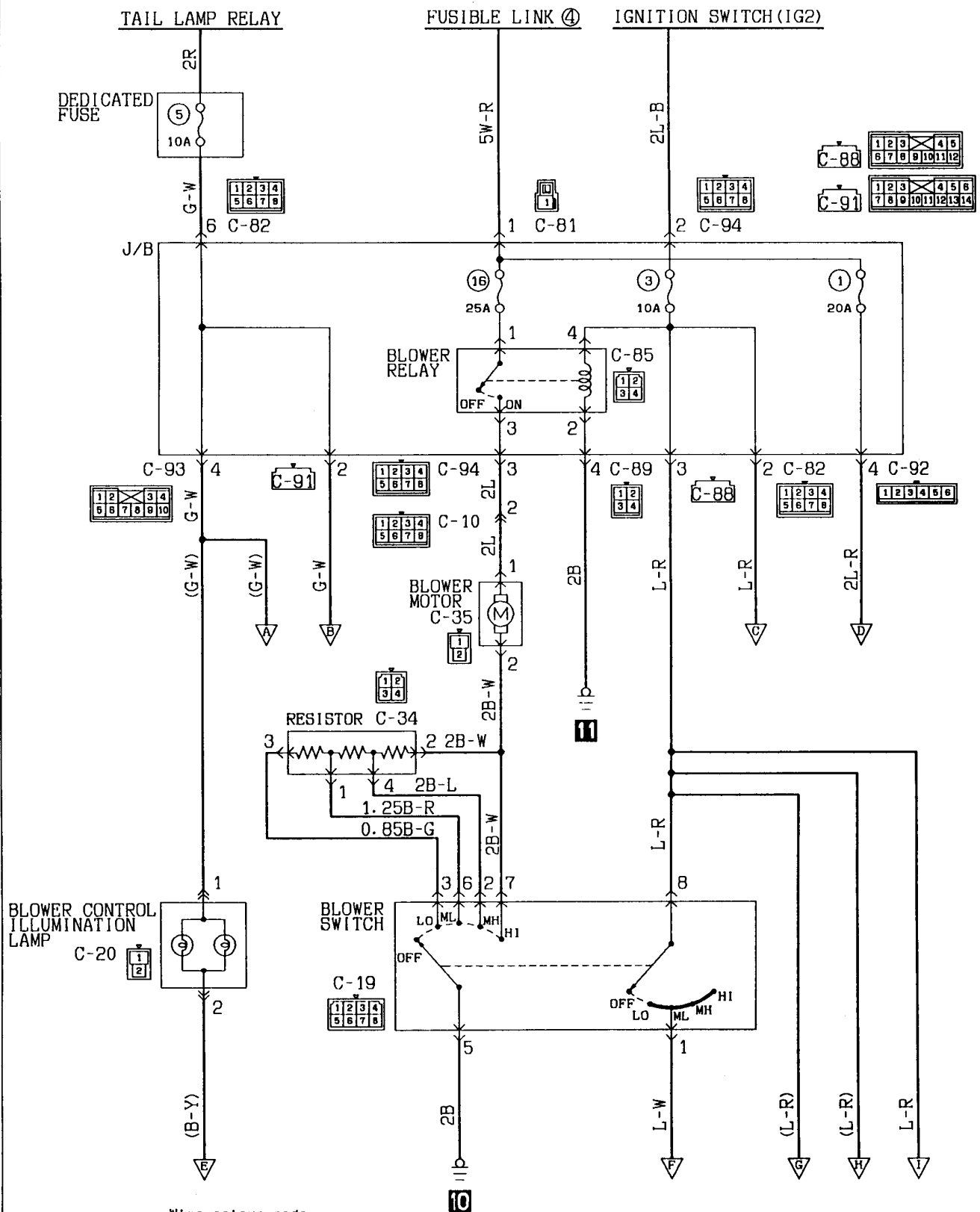

Wire colour code
 B:Black LG:Light green G:Green L:Blue W:White Y:Yellow
 BR:Brown O:Orange GR:Gray R:Red P:Pink V:Violet BB:Sky blue

KX35-AC-01208-EC

PHJE9026

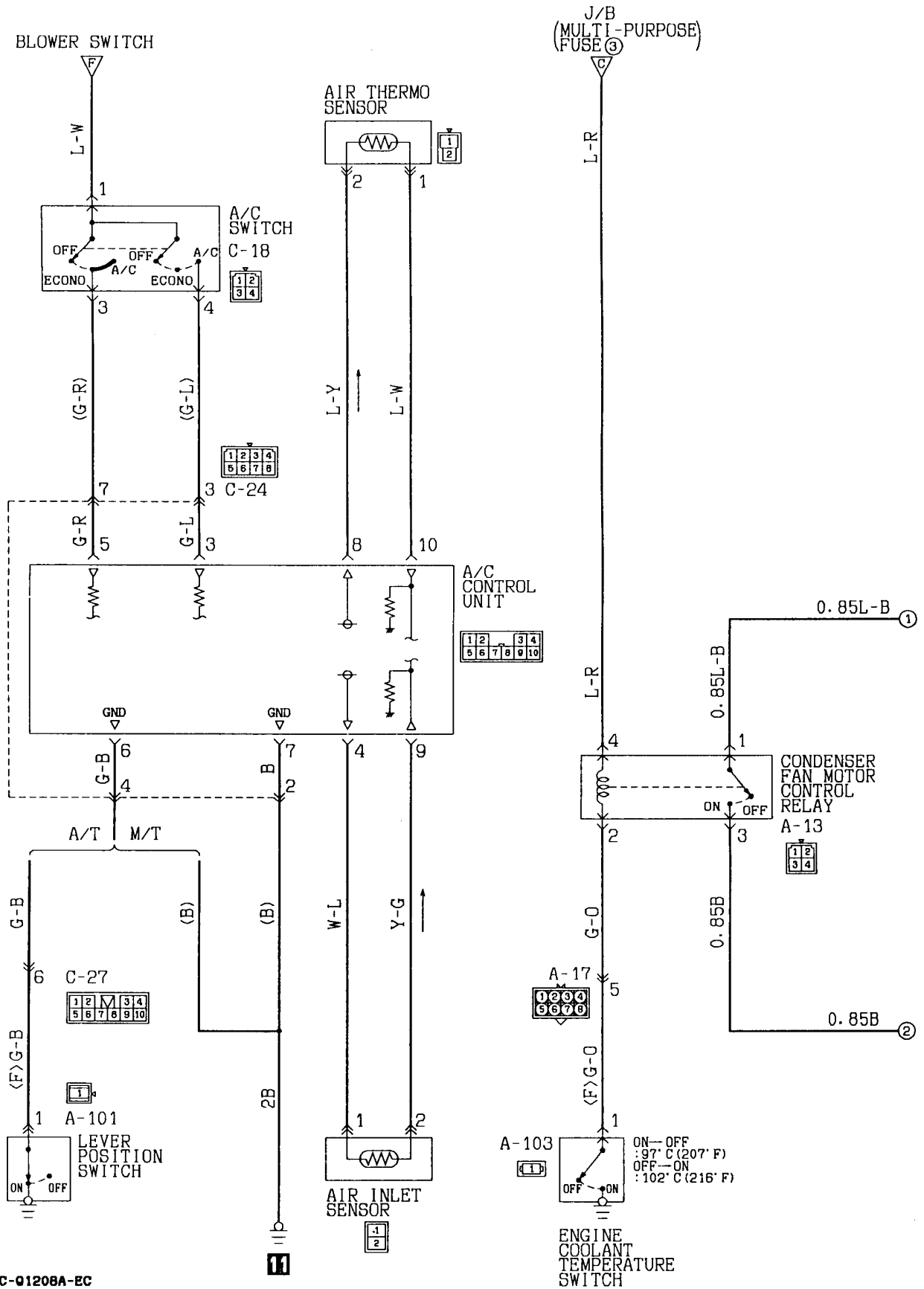

KX35-AC-01208A-EC

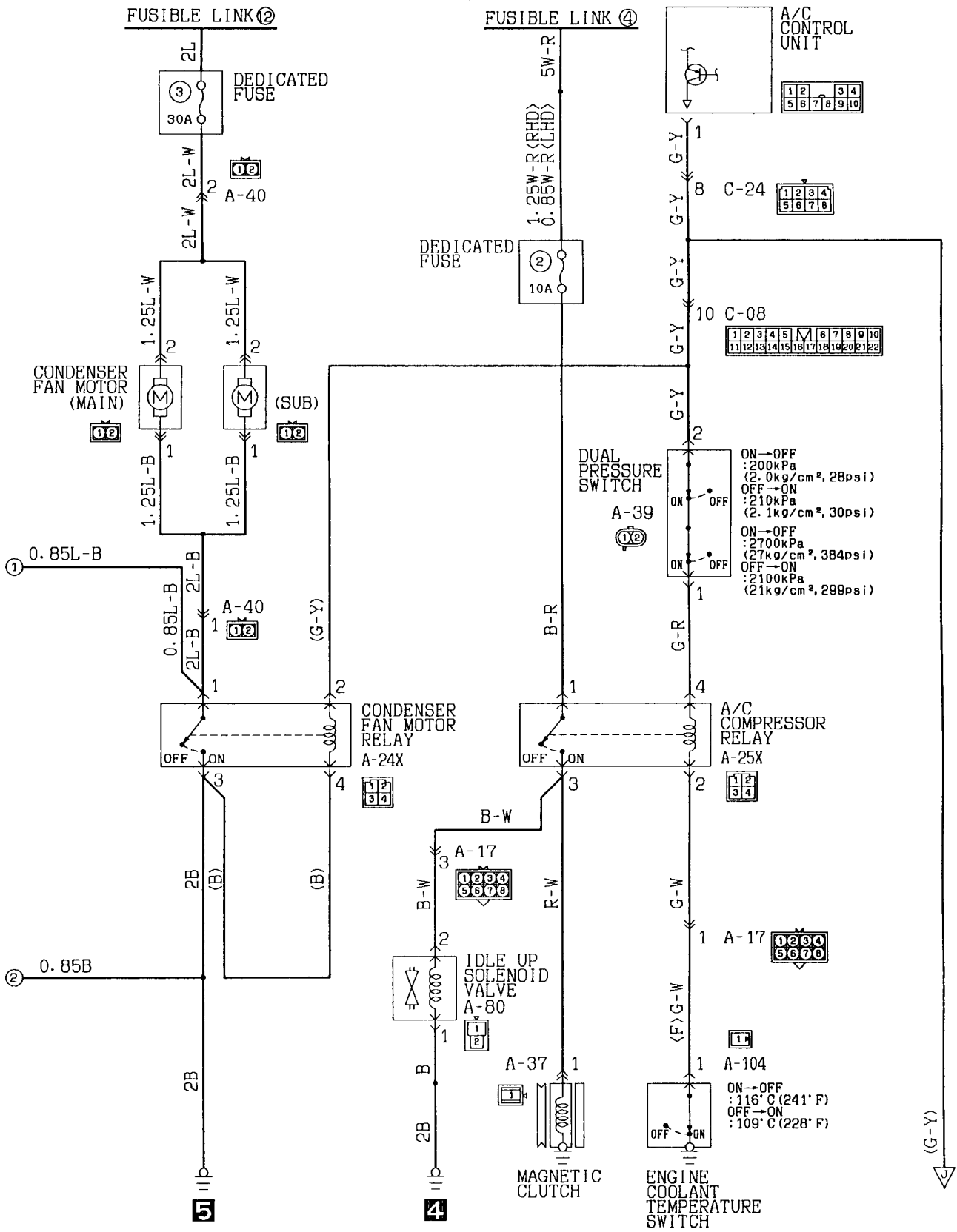

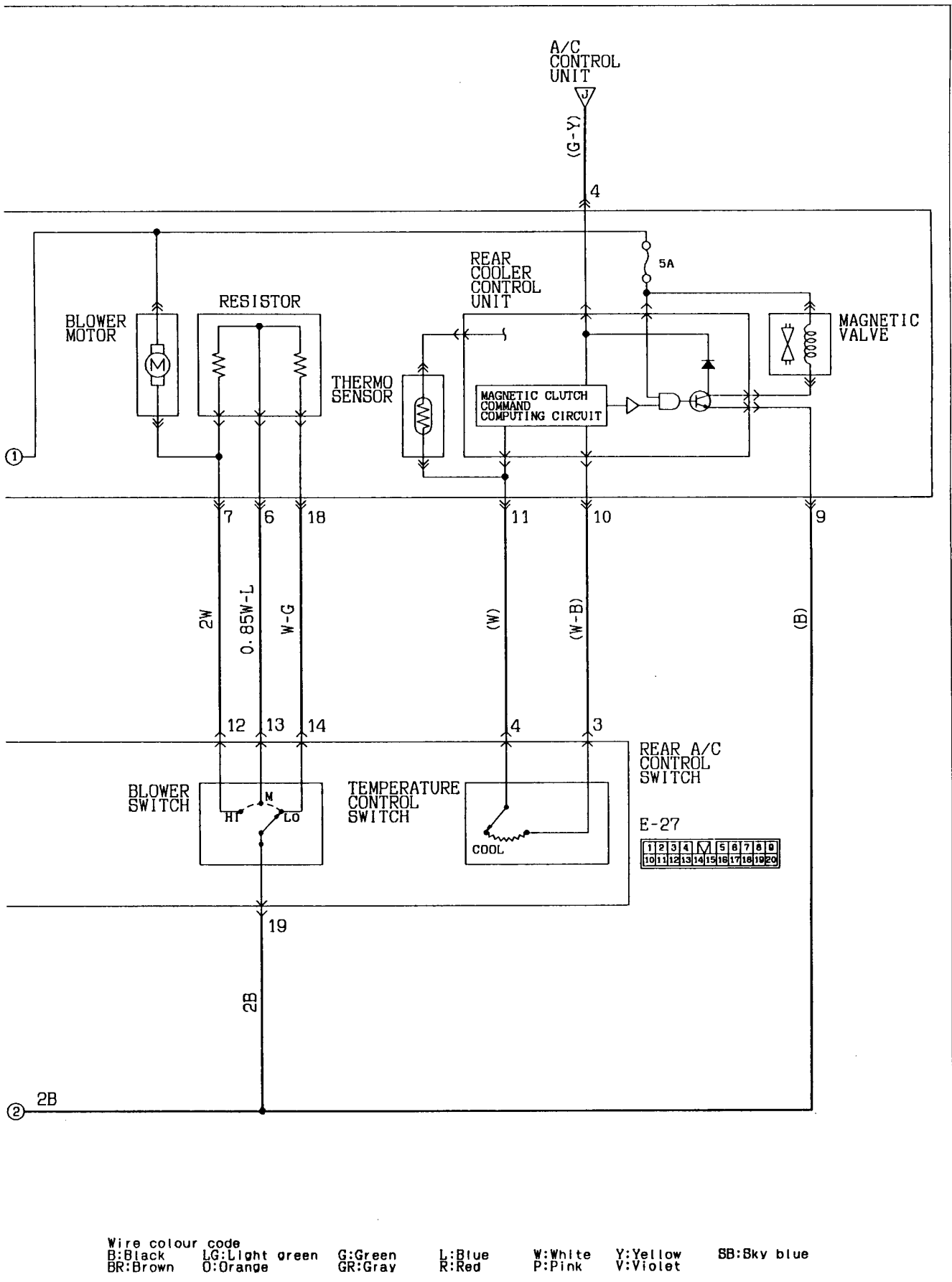

Wire colour code
 B:Black LG:Light green G:Green L:Blue W:White Y:Yellow SB:Sky blue
 BR:Brown O:Orange GR:Gray R:Red P:Pink V:Violet

NOTES

26 WINDSHIELD WIPER AND WASHER

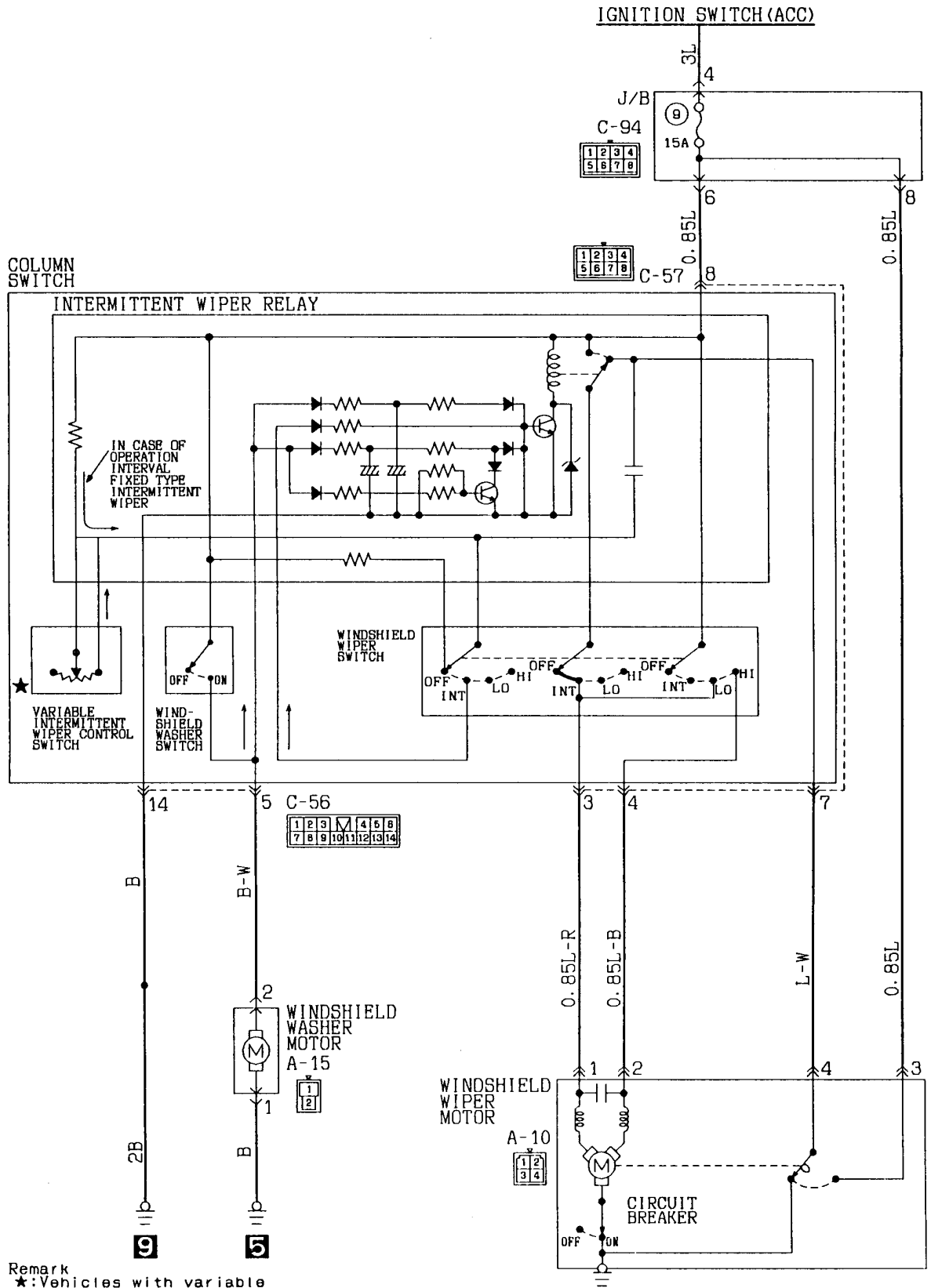

Remark
★: Vehicles with variable intermittent wiper.

Wire colour code
B:Black LG:Light green G:Green L:Blue W:White Y:Yellow SB:Sky blue
BR:Brown O:Orange GR:Gray R:Red P:Pink V:Violet

WINDSHIELD WIPER AND WASHER (See P. 4-144.)**OPERATION****⟨Low-speed (and high-speed) wiper operation⟩**

- When the wiper switch is placed in the LO position with the ignition switch in the ACC or ON position, wipers operate continuously at low speed.
- Placing the wiper switch in the HI position causes the wipers to operate at high speed.

⟨Auto wiper stop operation⟩

- When the wiper switch is placed in the OFF position, the cam contacts of wiper motor caused current to flow through the auto wiper stop circuit, allowing the wiper blades to cycle before they reach to the stop positions.

⟨Intermittent wiper operation⟩

- When the wiper switch is placed in the INT position with the ignition switch in ACC or ON position, the intermittent wiper relay is energized causing the intermittent wiper relay contacts to close and open repeatedly.
- When the contacts are closed, the wiper motor is energized.
- When the wiper motor is energized, the relay contacts open; however, the cam contacts keep the wiper motor energized until the wiper blades return to their stop position.

⟨Washer-Wiper operation⟩

- When the washer switch is turned ON, the intermittent wiper relay contacts close causing wipers to cycle two to three times.

TROUBLESHOOTING HINTS

1. Wipers do not operate.
 - 1) Washer is not operative, either.
 - Check multi-purpose fuse No. ⑨.
 - Check earth.
2. Low-speed (or high-speed) wiper operation only is inoperative.
 - Check wiper switch.
3. Wipers do not stop.
 - Check wiper motor.
 - Check intermittent wiper relay.
 - Check wiper switch.
4. Intermittent wiper operation is inoperative.
 - Check terminal voltage of steering-column switch (with a built-in intermittent wiper relay) with the intermittent wiper relay energized.

Terminal No.	Voltage	Check
3	0V	Intermittent wiper relay or wiper switch
	System voltage	Intermittent wiper relay
	0V ↔ System voltage (alternating)	— (Normal)

5. The length of pause for intermittent operation cannot be varied.
 - Check variable intermittent wiper control switch.
 - Check intermittent wiper relay.
6. Washer is inoperative.
 - 1) Wiper is operative on washer-wiper operation.
 - Check washer motor.
 - 2) Washer-wiper operation is inoperative also.
 - Check washer switch.
7. Washer-wiper operation is inoperative.
 - Check intermittent wiper relay.

27 REAR WIPER AND WASHER

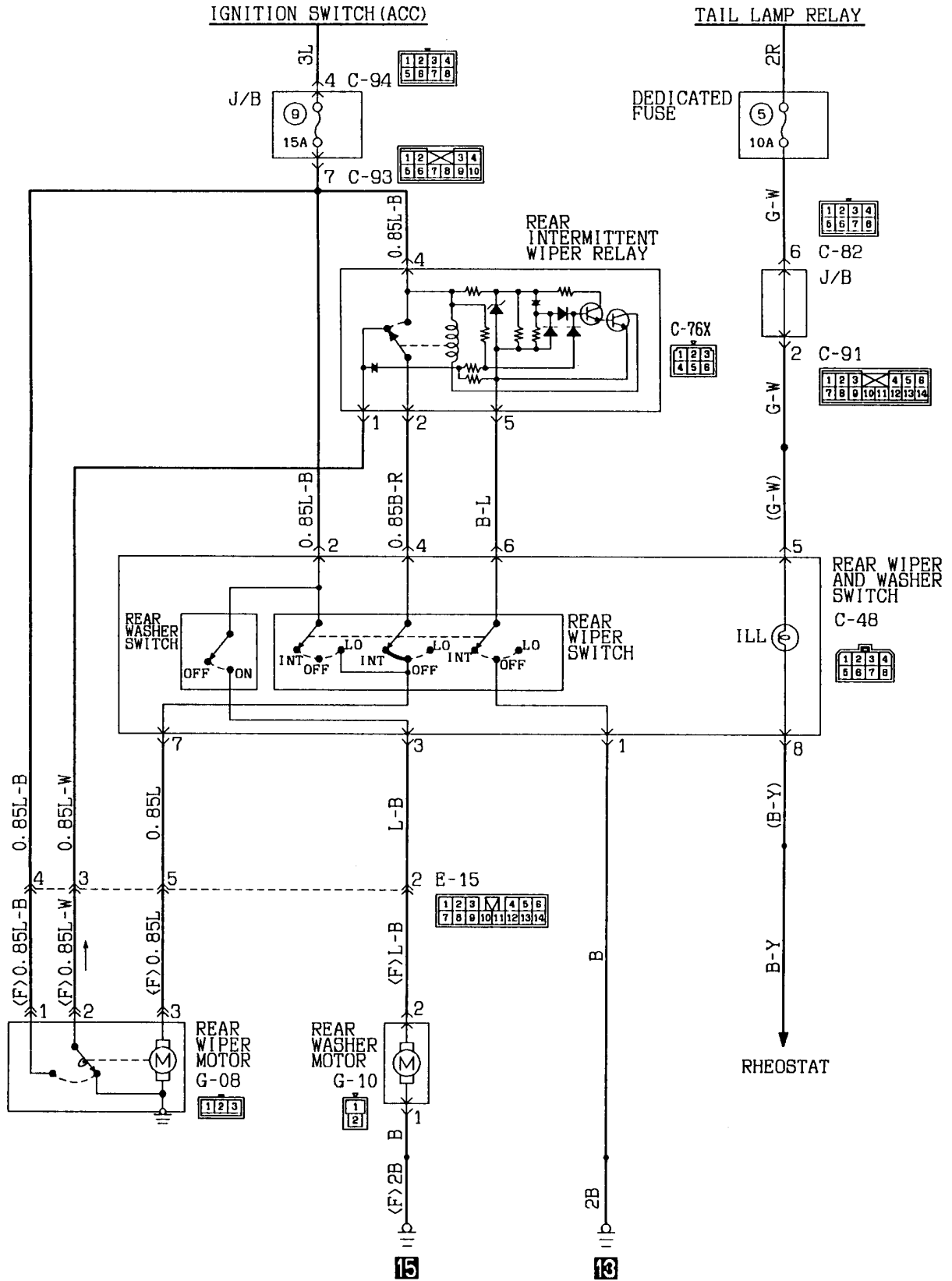

Wire colour code
 B:Black LG:Light green G:Green L:Blue W:White Y:Yellow SB:Sky blue
 BR:Brown O:Orange GR:Gray R:Red P:Pink V:Violet

REAR WIPER AND WASHER (See P. 4-146.)**OPERATION****⟨Low-speed wiper operation⟩**

- When the wiper switch is placed in the LO (or ON) position with the ignition switch in the ACC or ON position, wipers operate continuously at low speed.

⟨Auto wiper stop operation⟩

- When the wiper switch is placed in the OFF position, the cam contacts of wiper motor causes current to flow through the auto wiper stop circuit, allowing the wiper blades to cycle before they reach to the stop positions.

⟨Intermittent wiper operation⟩

- When the wiper switch is placed in the INT position with the ignition switch in ACC or ON position, the intermittent wiper relay is energized causing the intermittent wiper relay contacts to close and open repeatedly.
- When the contacts are closed, the wiper motor is energized.
- When the wiper motor is energized, the relay contacts open; however, the cam contacts keep the wiper motor energized until the wiper blades return to their stop position.

TROUBLESHOOTING HINTS

1. Wipers do not operate.
 - 1) Washer is not operative, either.
 - Check multi-purpose fuse No. ⑨.
 - Check earth.
 - Check wiper switch.
2. Wipers do not stop.
 - Check wiper motor.
 - Check intermittent wiper relay.
 - Check wiper switch.
3. Intermittent wiper operation is inoperative.
 - Check terminal voltage of the intermittent wiper relay energized.

Terminal No.	Voltage	Check
2	0 V	Intermittent wiper relay or wiper switch
	System voltage	Intermittent wiper relay
	0V ↔ System voltage (alternating)	— (Normal)

4. Washer is inoperative.
 - Check washer motor.
 - Check washer switch.

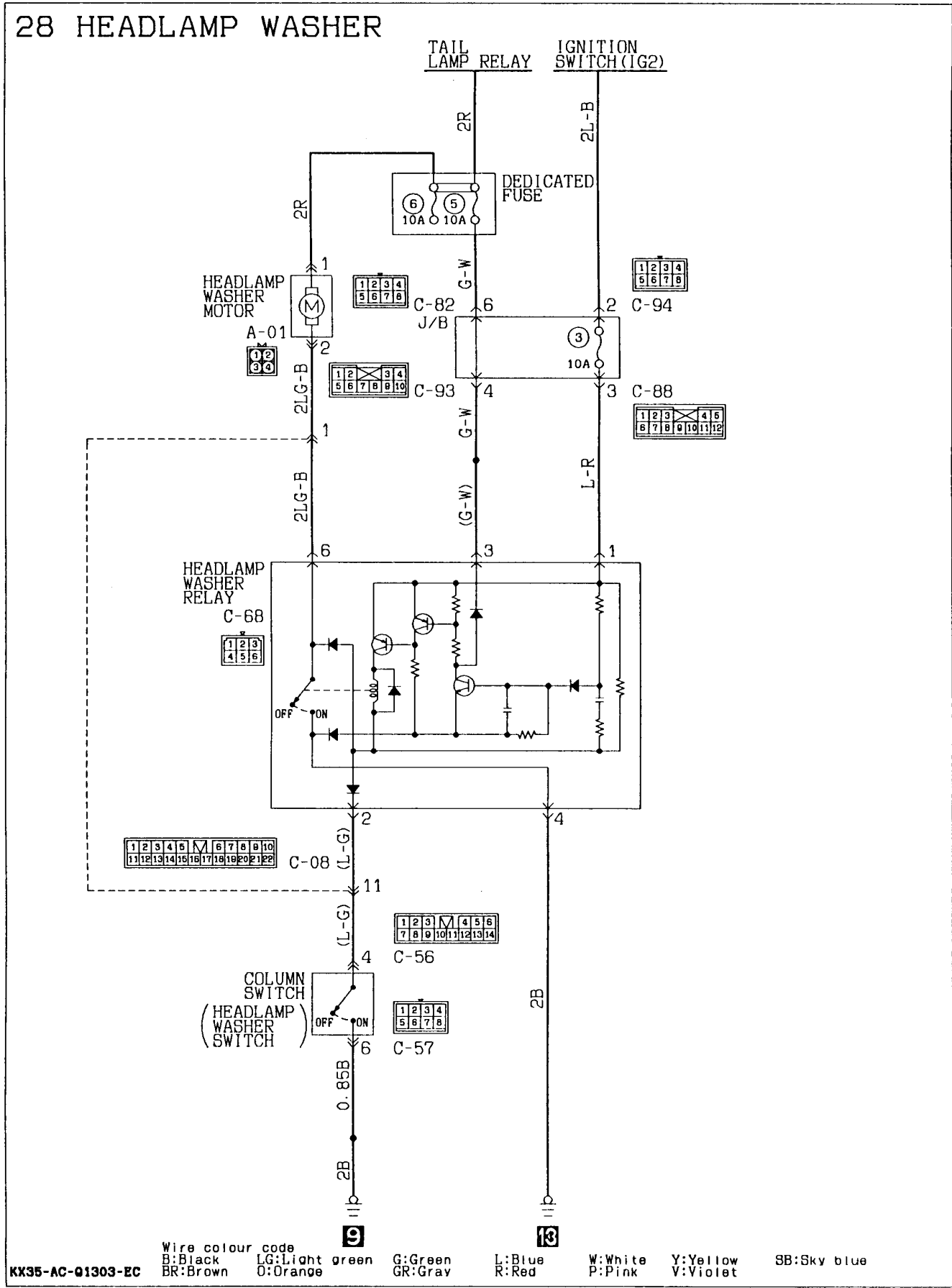

HEADLAMP WASHER (See P. 4-148.)**OPERATION**

- When the headlamp washer switch is turned ON with ignition switch in ON and lighting switch in TAIL or HEAD position, the headlamp washer relay is energized causing the headlamp washer motor to start.

TROUBLESHOOTING HINTS

1. Headlamp washer motor does not start.
 - 1) Blower motor does not start, either.
 - Check multi-purpose fuse No. ③.
 - 2) Blower motor does start.
 - Check headlamp washer motor.
 - Check headlamp washer relay.
 - Check headlamp washer switch.

30 REMOTE CONTROLLED MIRROR

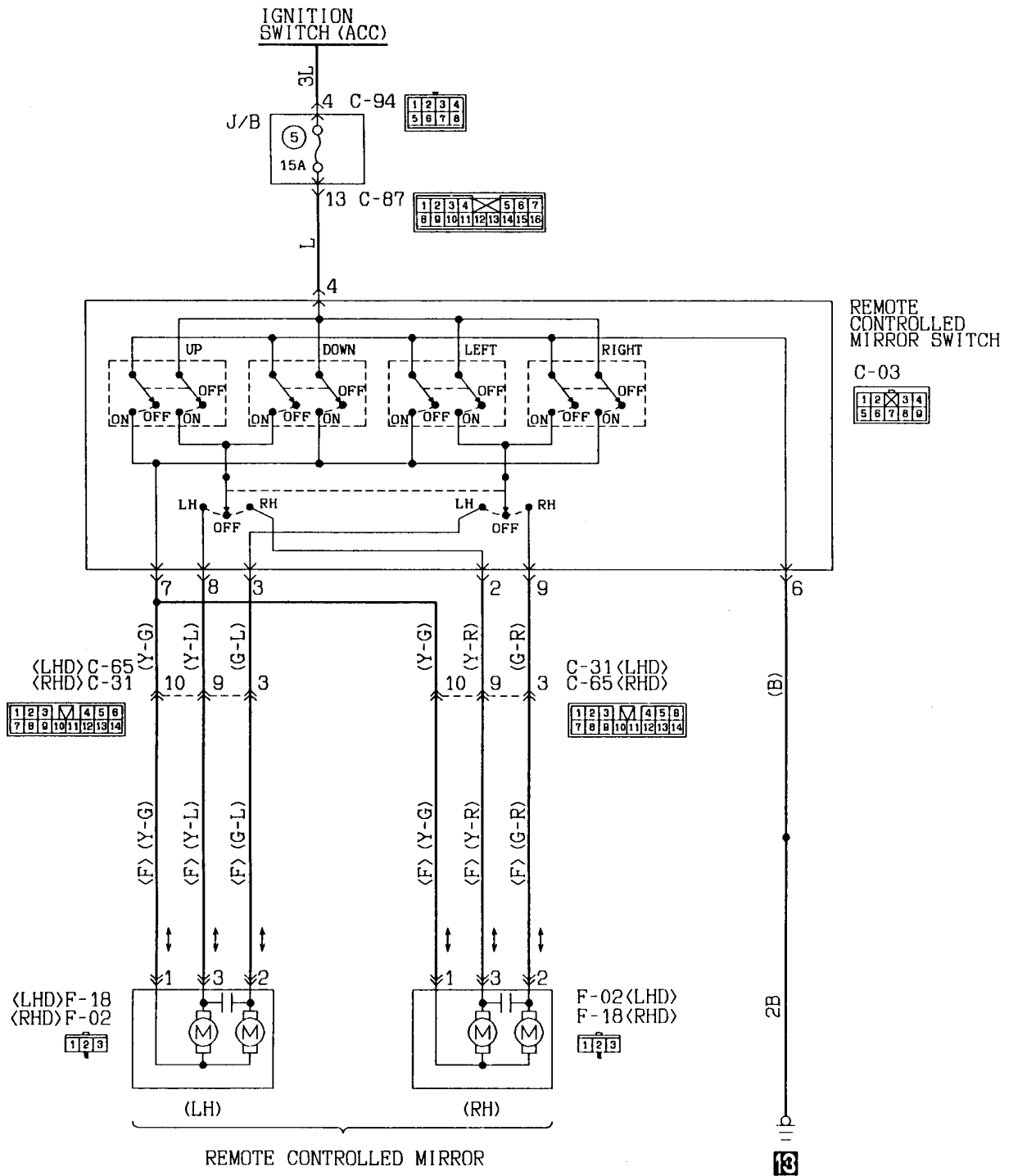

Wire colour code

B:Black LG:Light green

BR:Brown O:Orange

G:Green GR:Gray

L:Blue R:Red

W:White P:Pink

Y:Yellow V:Violet

SB:Sky blue

REMOTE CONTROLLED MIRROR (See P. 4-151.)**OPERATION**

- When the remote controlled mirror switch is operated with the ignition switch in ACC or ON position, the motor is started allowing the driver to adjust the orientation of the mirror surface.

TROUBLESHOOTING HINTS

1. LH and RH mirrors do not move.
 - 1) Cigarette lighter is also inoperative.
 - Check multi-purpose fuse No. ⑤.
 - 2) Cigarette lighter is operative.
 - Check remote controlled mirror switch.

31 AUDIO

31-1 AM/FM radio without cassette player

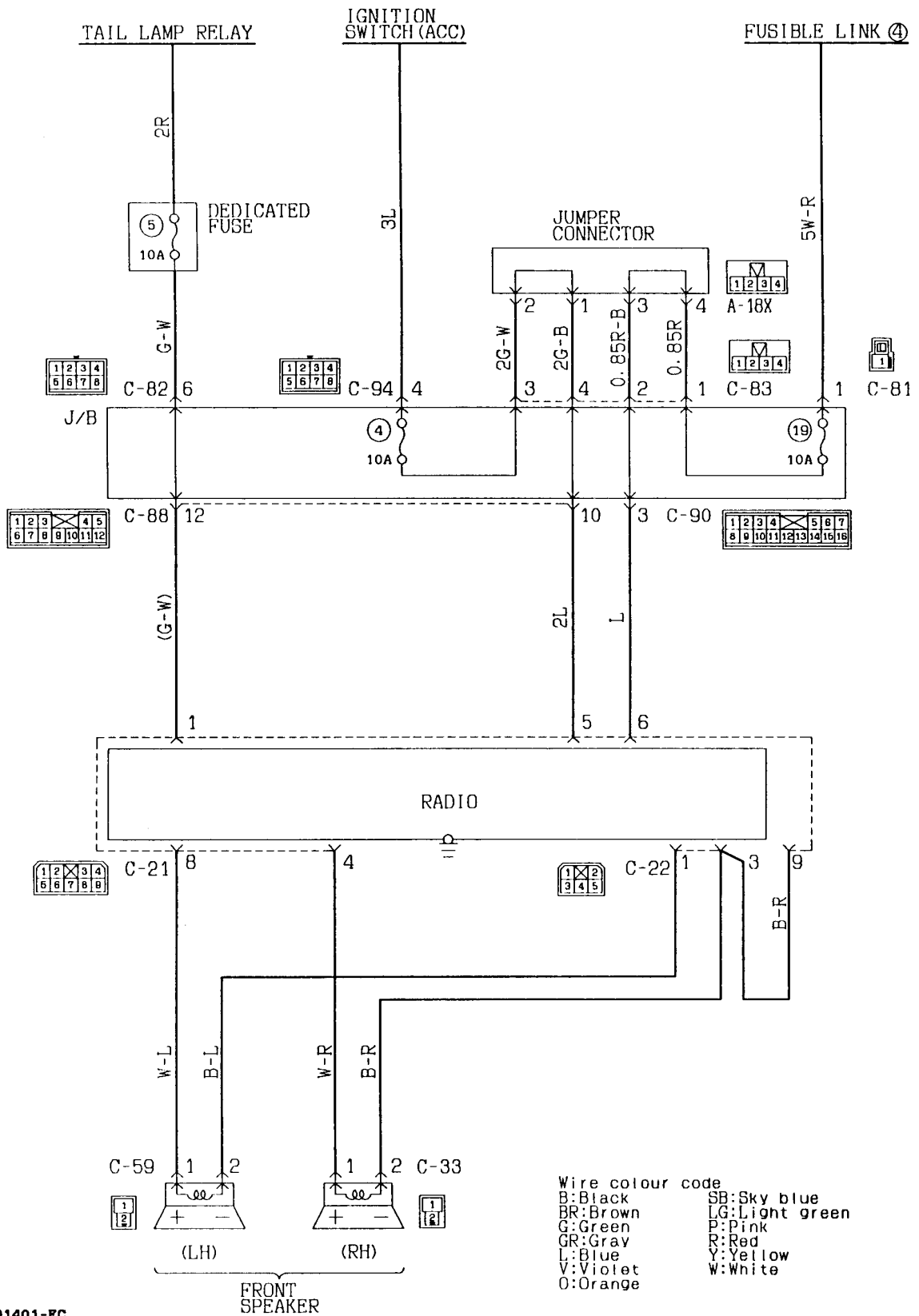

KX35-AC-01401-EC

31-2 AM/FM, LW/MW/FM radio with cassette player

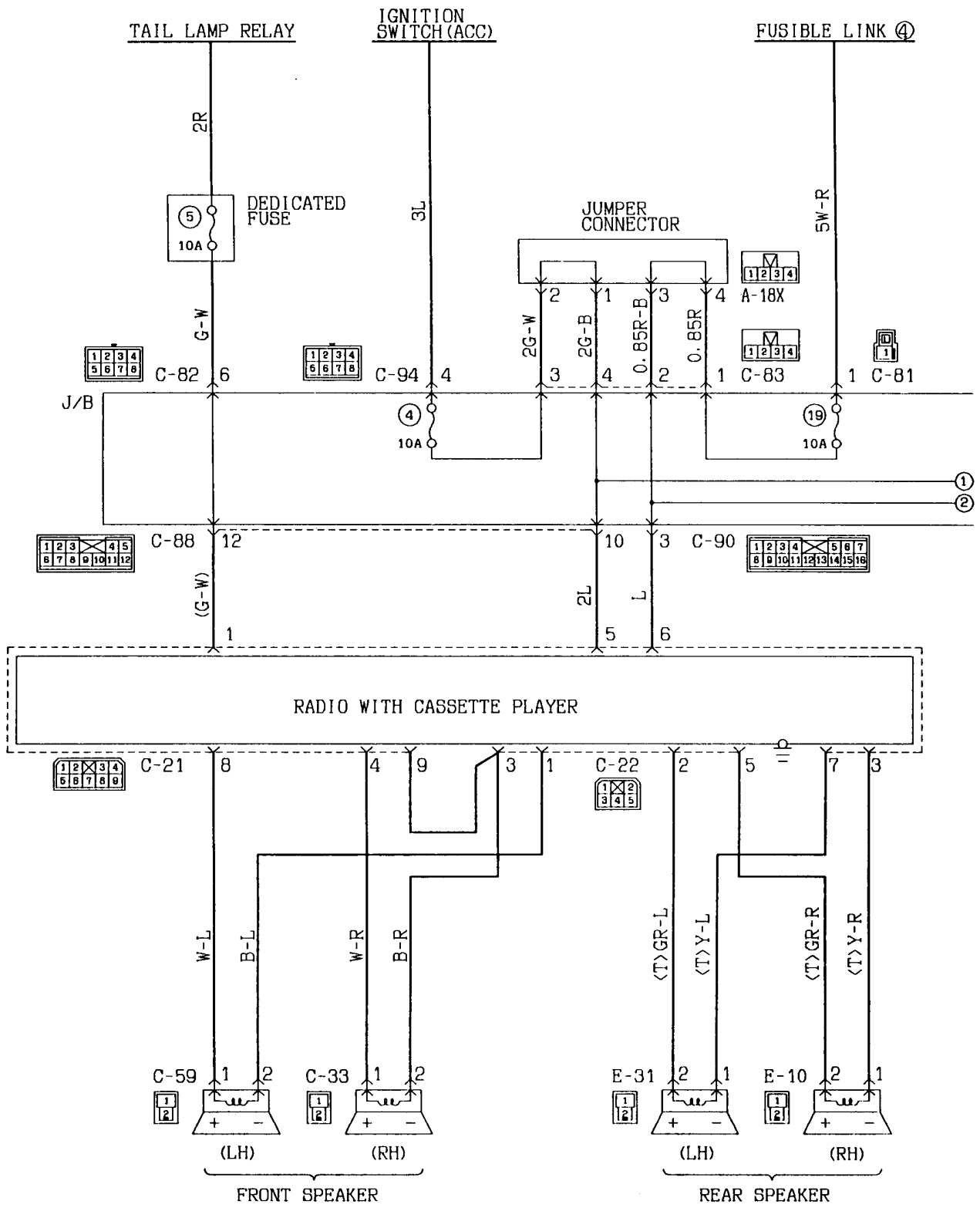

Wire colour code
 B:Black LG:Light green G:Green L:Blue W:White Y:Yellow SB:Sky blue
 BR:Brown O:Orange GR:Gray R:Red P:Pink V:Violet

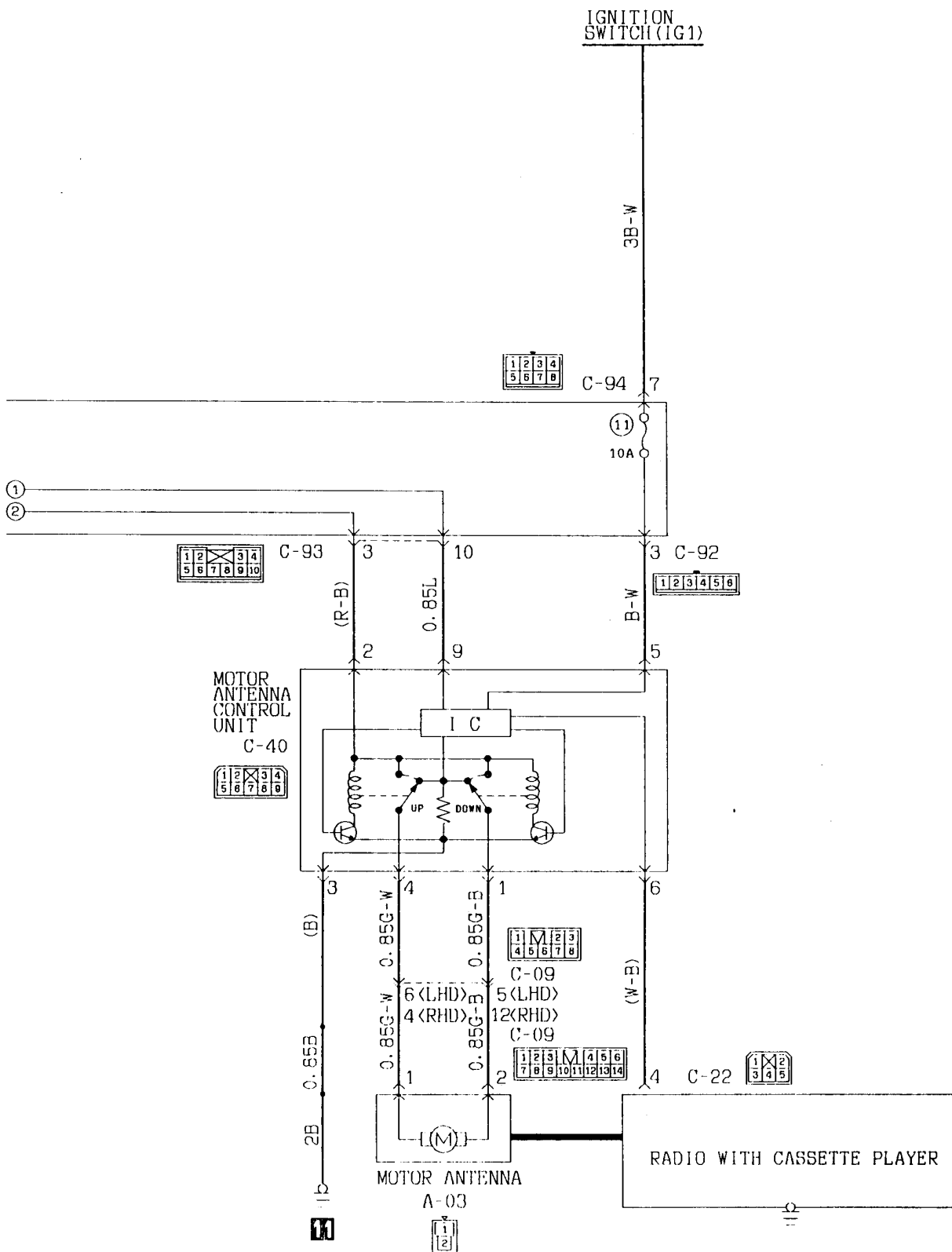

32 CLOCK

IGNITION SWITCH (ACC)

FUSIBLE LINK ④

TAIL LAMP RELAY

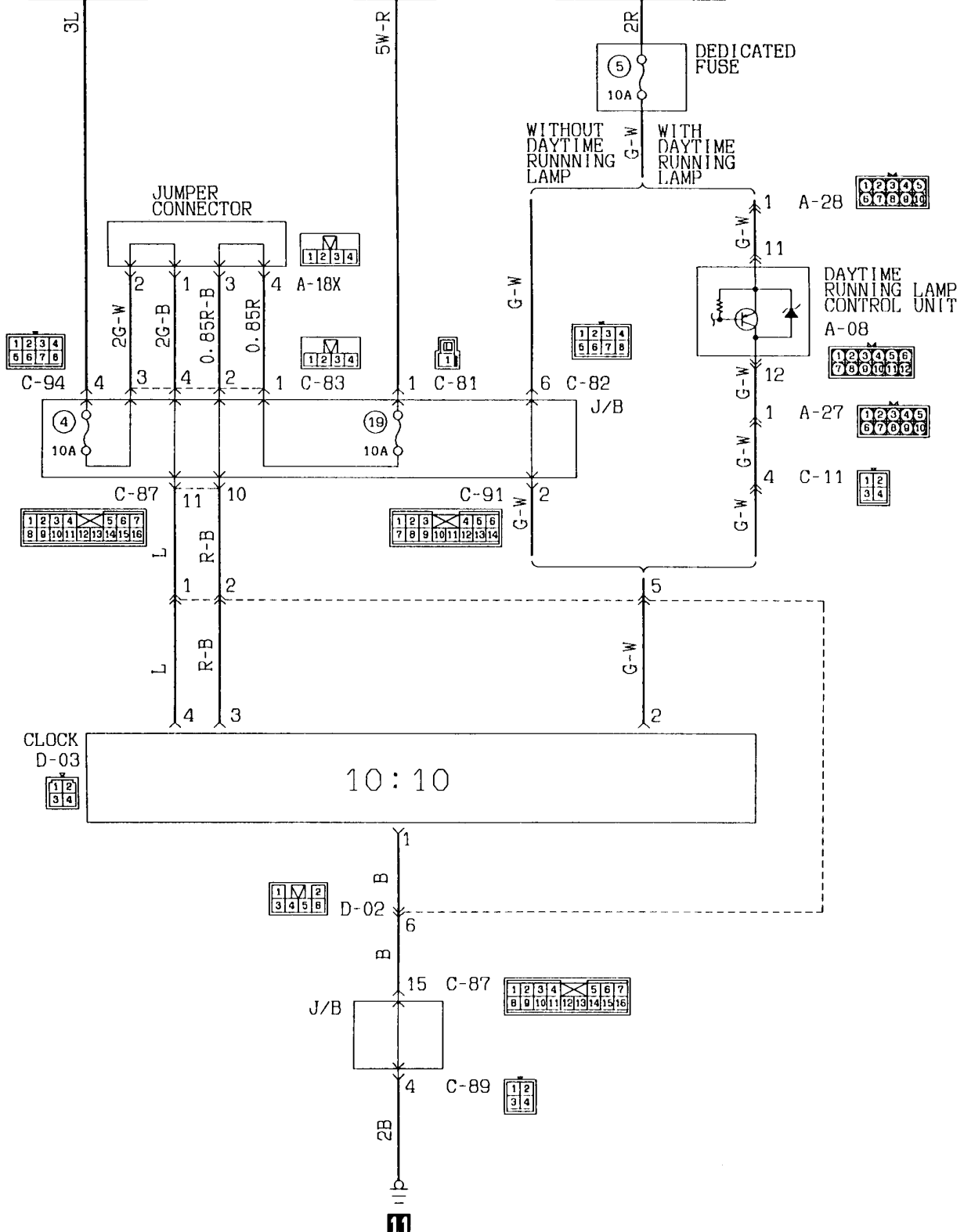

CLOCK D-03

10:10

Wire colour code
 B:Black LG:Light green G:Green L:Blue W:White Y:Yellow SB:Sky blue
 BR:Brown O:Orange GR:Gray R:Red P:Pink V:Violet

33 CIGARETTE LIGHTER

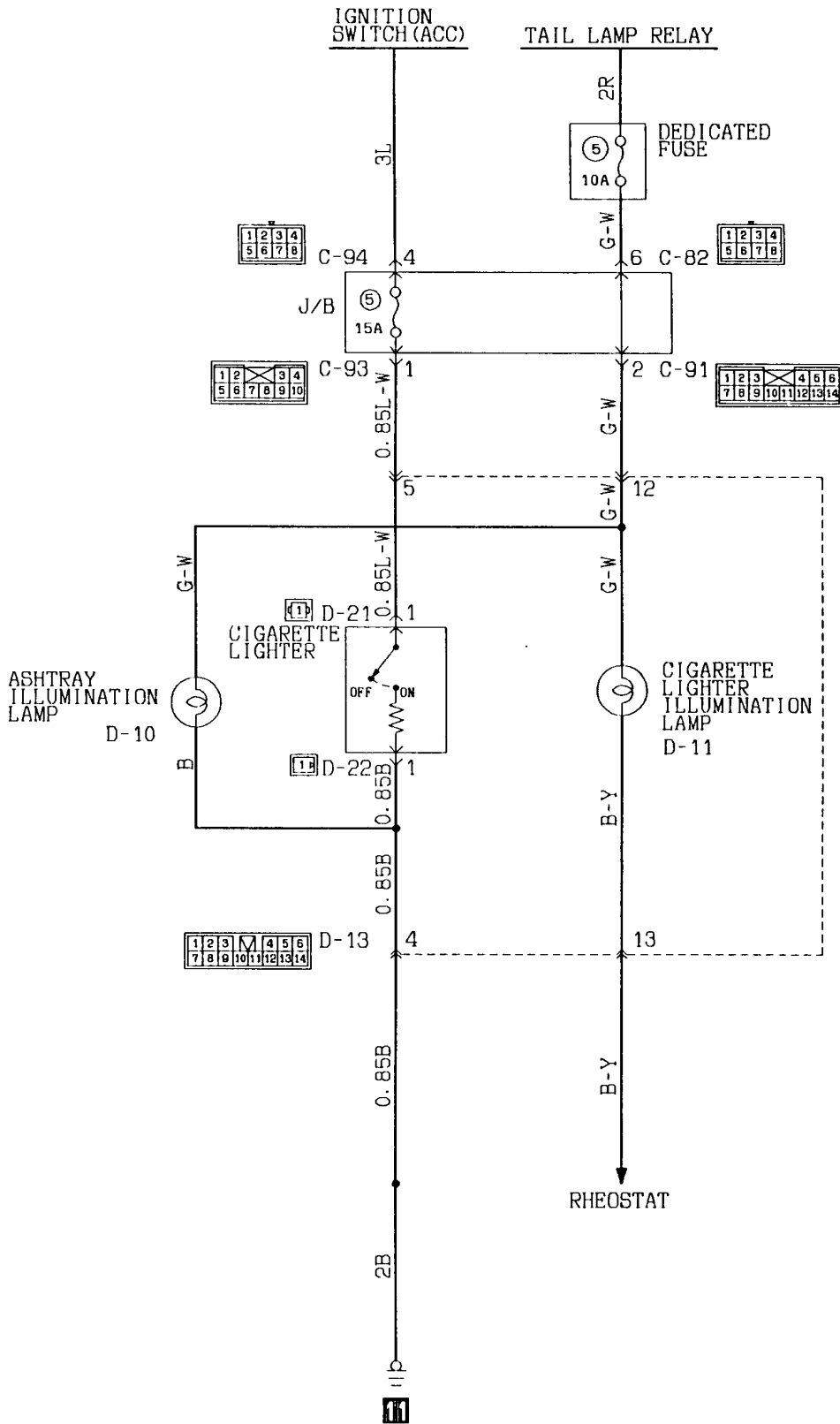

Wire colour code
 B:Black LG:Light green G:Green L:Blue W:White Y:Yellow SB:Sky blue
 BR:Brown O:Orange GR:Gray R:Red P:Pink V:Violet

KX35-AC-Q1404-EC

34 SUNROOF
34-1 Metal top

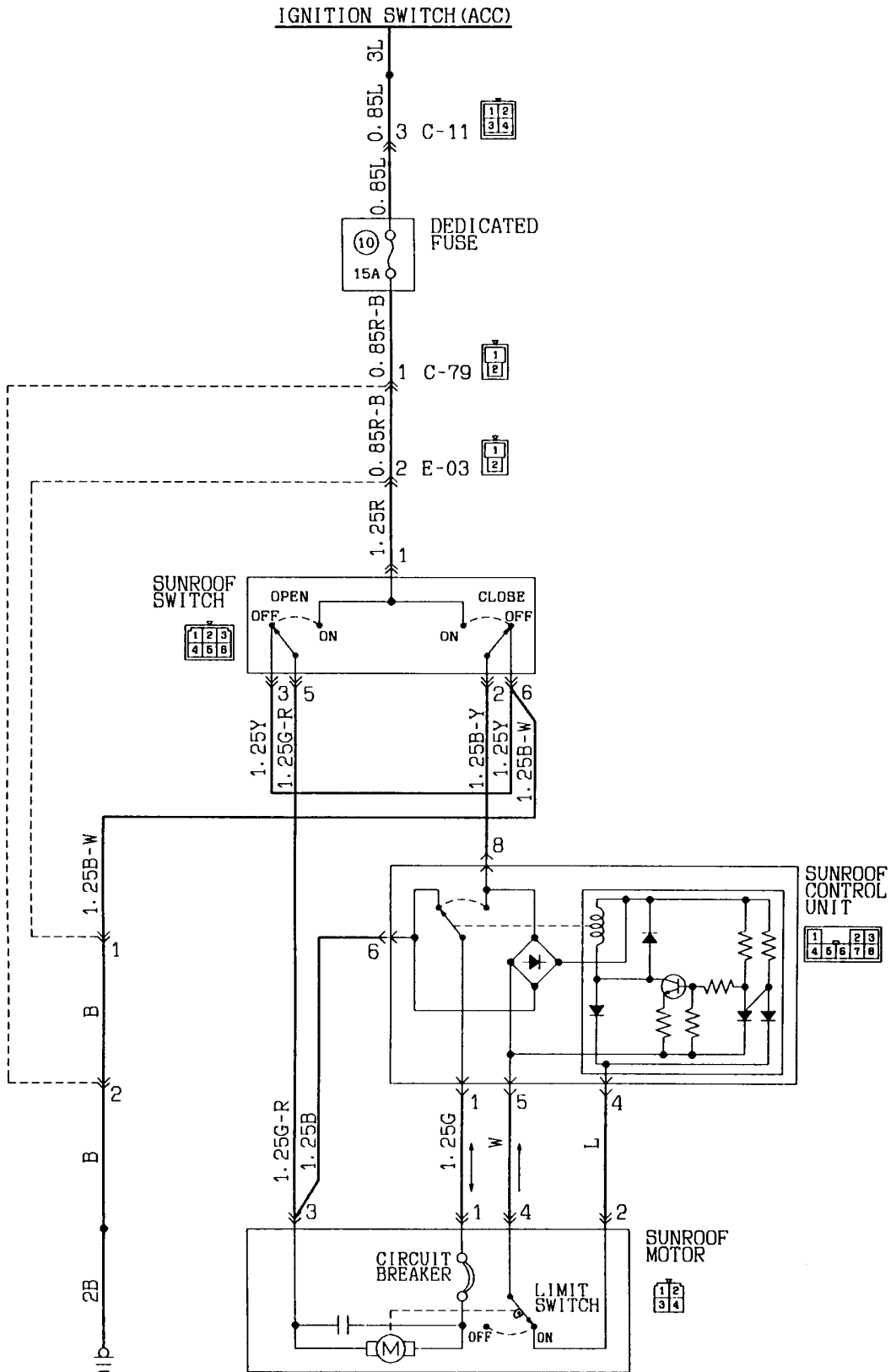

1 Wire colour code
 B:Black LG:Light green G:Green L:Blue W:White Y:Yellow SB:Sky blue
 BR:Brown O:Orange GR:Gray R:Red P:Pink V:Violet

KX35-AC-Q1405-EC

34-2 Canvas top

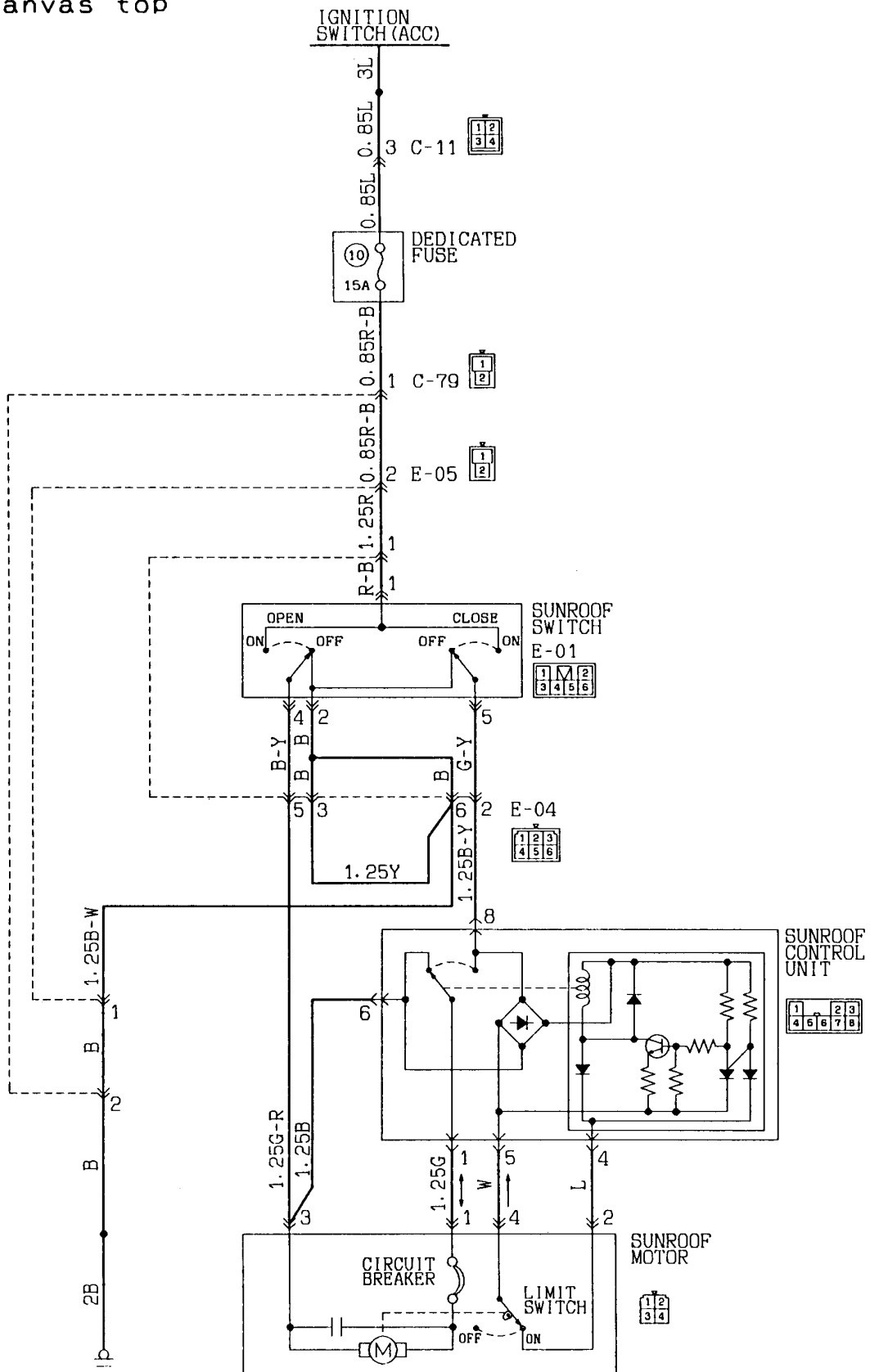

 Wire colour code
 B:Black LG:Light green G:Green L:Blue W:White Y:Yellow SB:Sky blue
 BR:Brown O:Orange GR:Gray R:Red P:Pink V:Violet

KX35-AC-Q1406-EC

35 ACCESSORY SOCKET

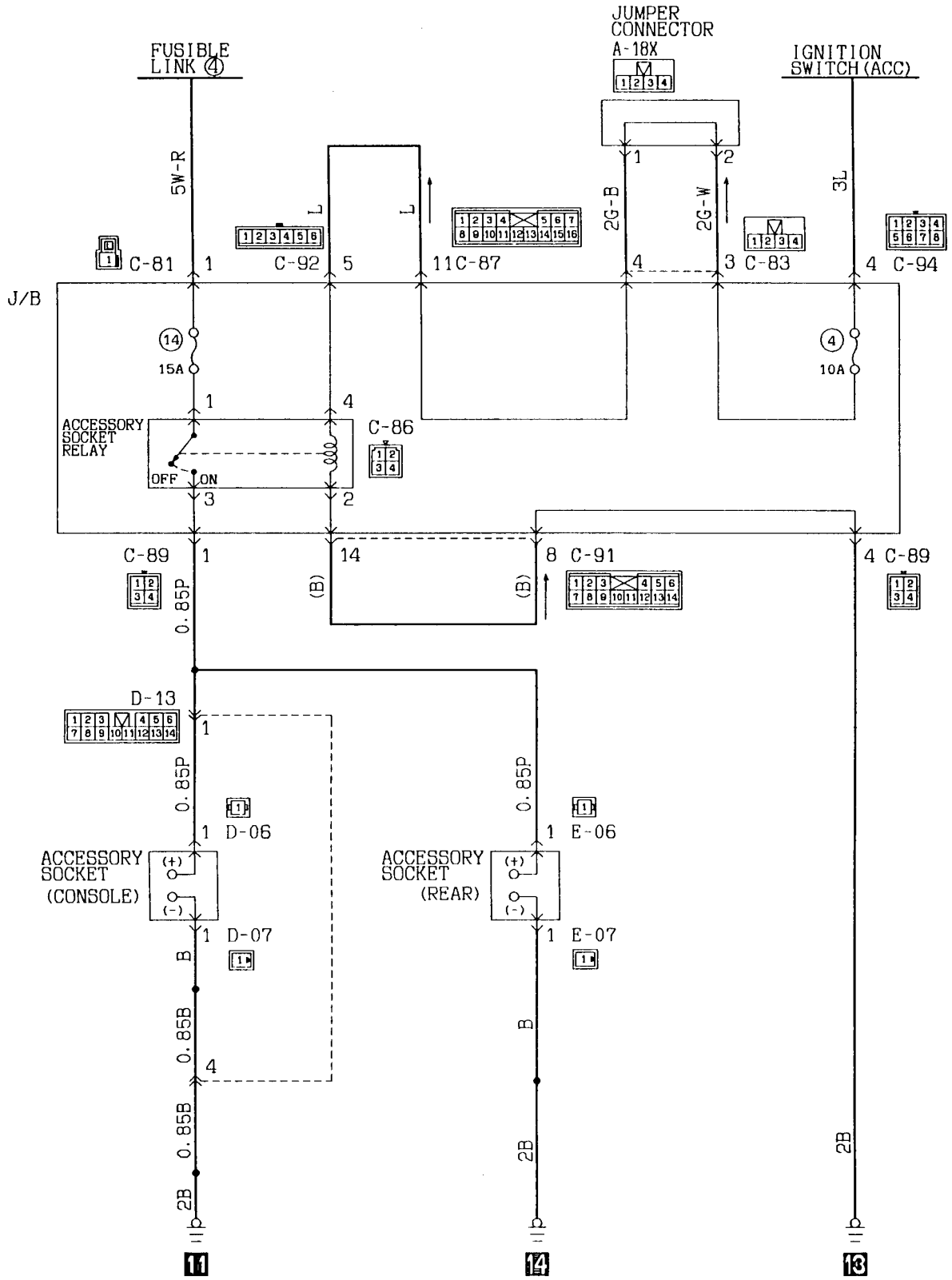

Wire colour code
 B:Black LG:Light green G:Green L:Blue W:White Y:Yellow SB:Sky blue
 BR:Brown O:Orange GR:Gray R:Red P:Pink V:Violet

KX35-AC-Q1407-EC

36 INTERCOOLER FAN

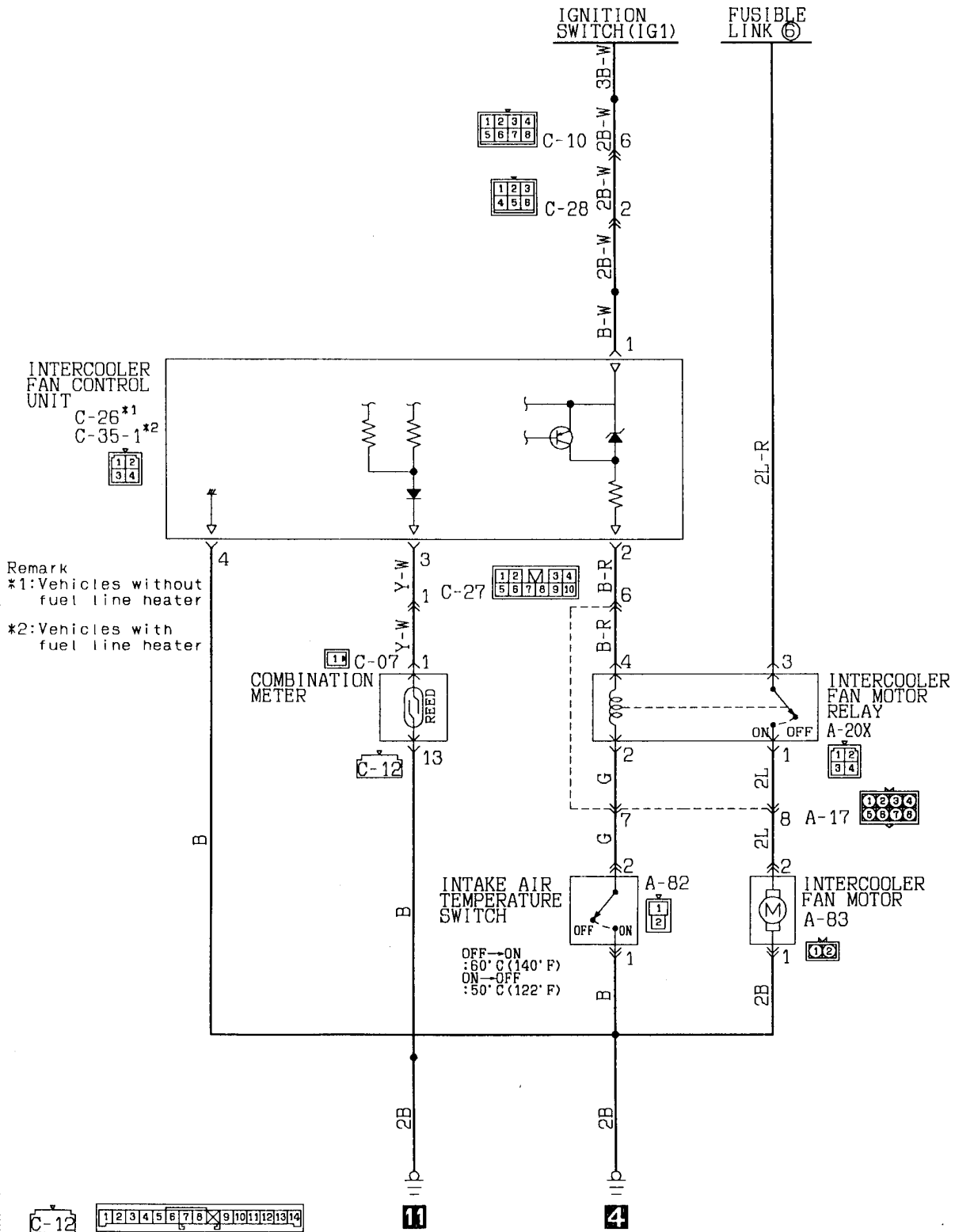

Remark
 *1: Vehicles without fuel line heater
 *2: Vehicles with fuel line heater

Wire colour code
 B:Black LG:Light green G:Green L:Blue W:White Y:Yellow SB:Sky blue
 BR:Brown O:Orange GR:Gray R:Red P:Pink V:Violet

KX35-AC-Q1522-EC

PHJE9026-A

REVISED

37 REAR DIFFERENTIAL LOCK SYSTEM

<Vehicles built from March 1991>

TAIL LAMP RELAY

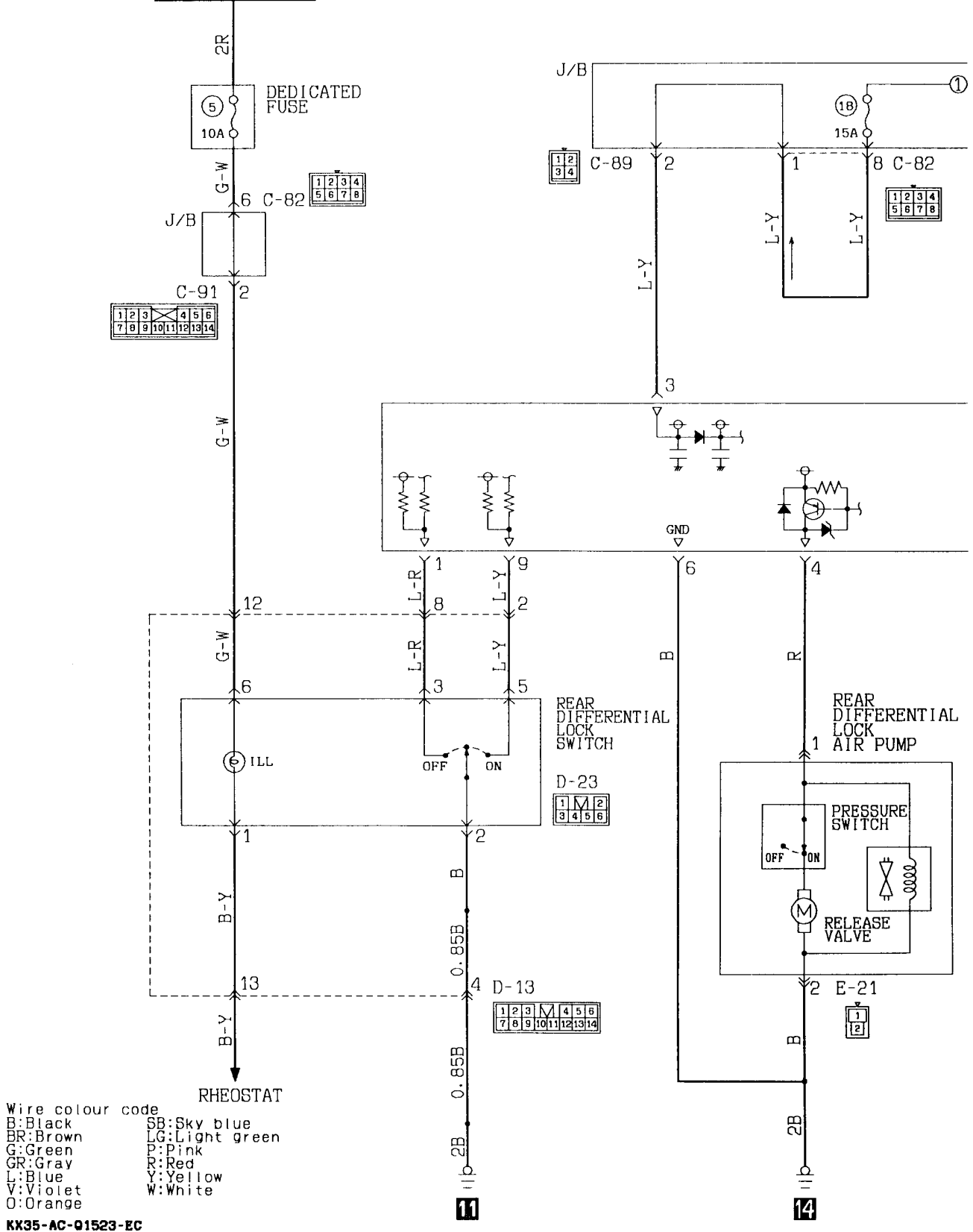

Wire colour code
 B:Black
 BR:Brown
 G:Green
 GR:Gray
 L:Blue
 V:Violet
 O:Orange
 SB:Sky blue
 LG:Light green
 P:Pink
 R:Red
 Y:Yellow
 W:White

KX35-AC-01523-EC

<Vehicles built up to February 1991>

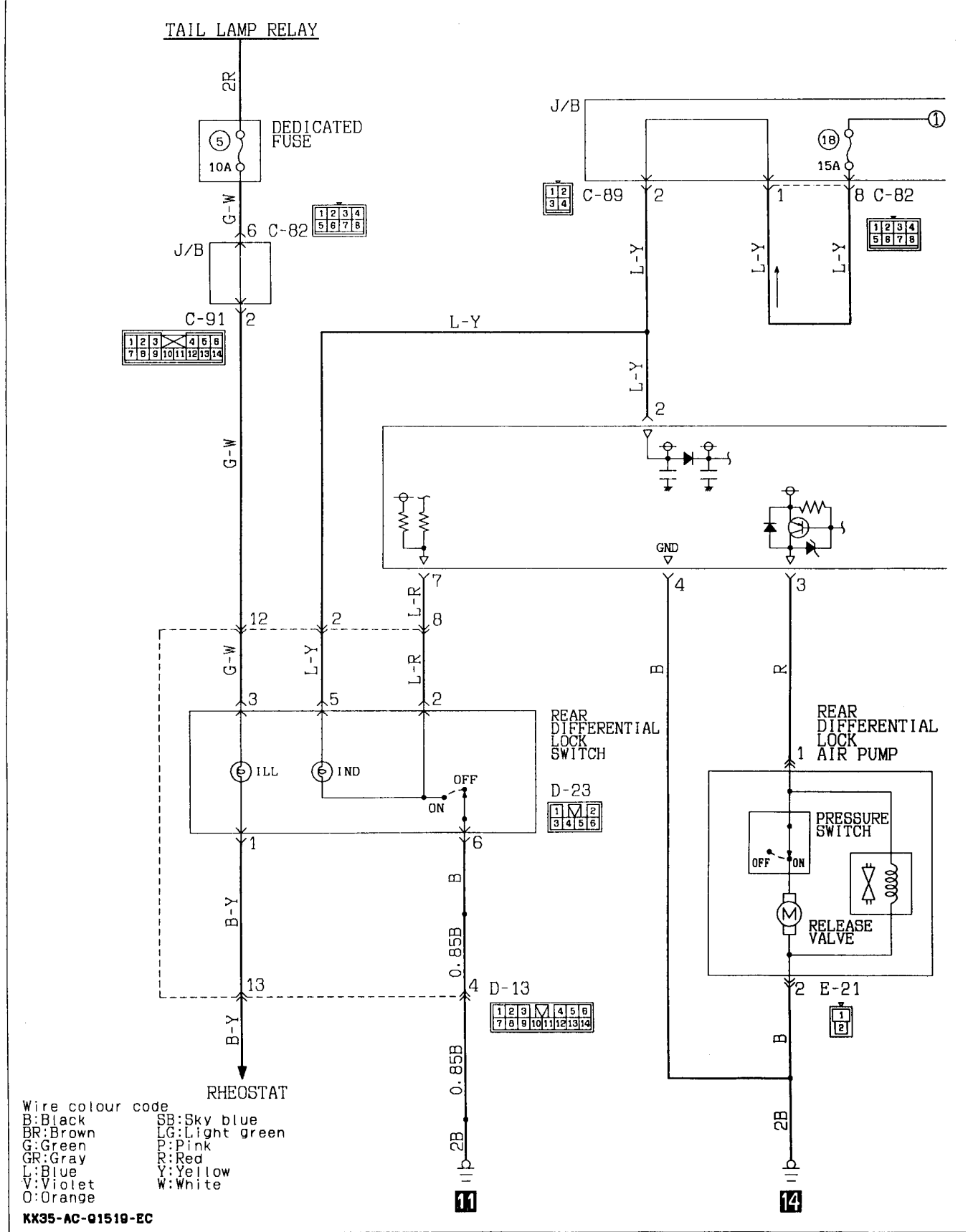

38 SUPER SELECT 4WD SYSTEM

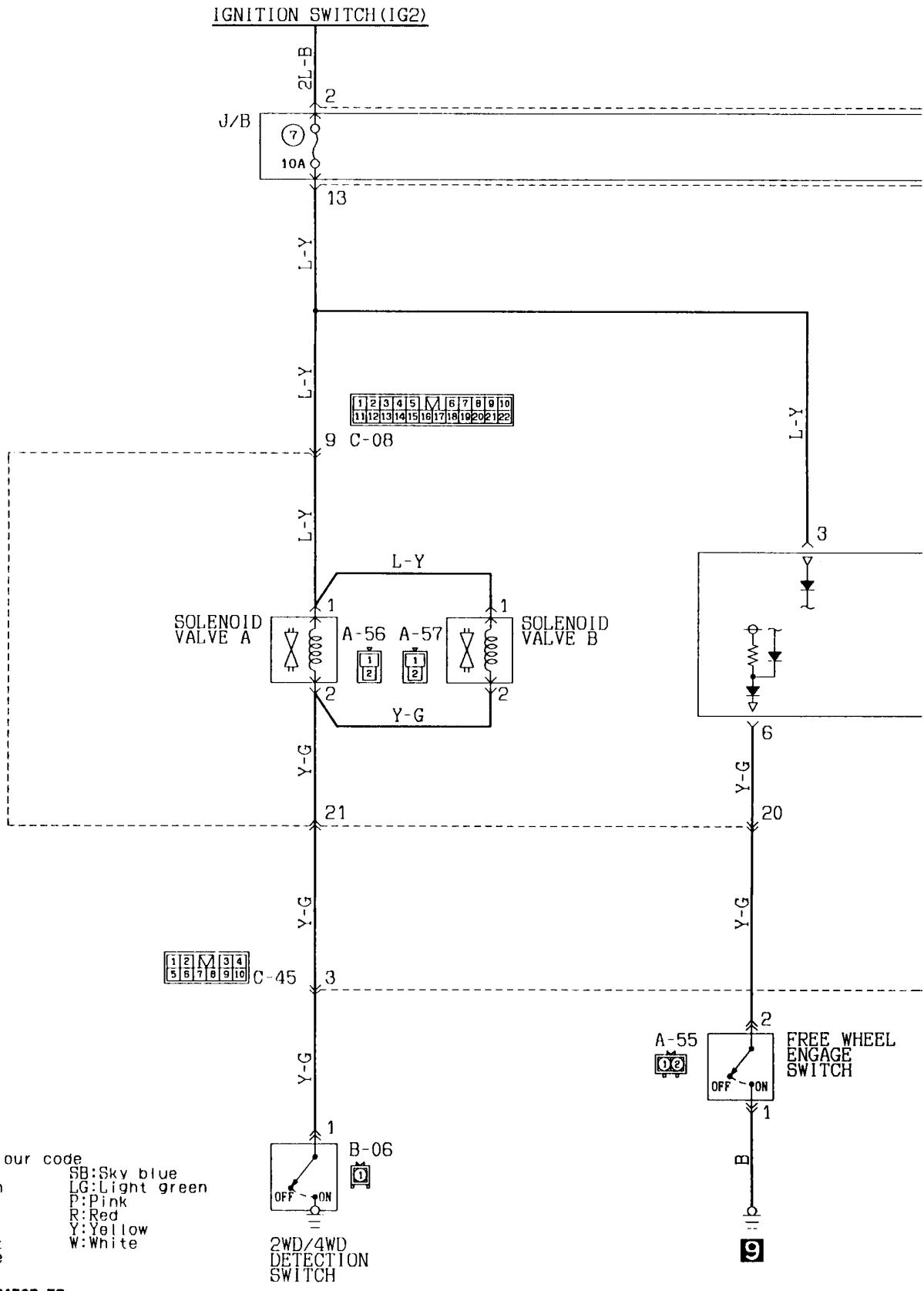

Wire colour code
 B:Black SB:Sky blue
 BR:Brown LG:Light green
 G:Green P:Pink
 GR:Gray R:Red
 L:Blue Y:Yellow
 V:Violet W:White
 O:Orange

2WD/4WD
 DETECTION
 SWITCH

FREE WHEEL
 ENGAGE
 SWITCH

KX35-AC-01503-EC

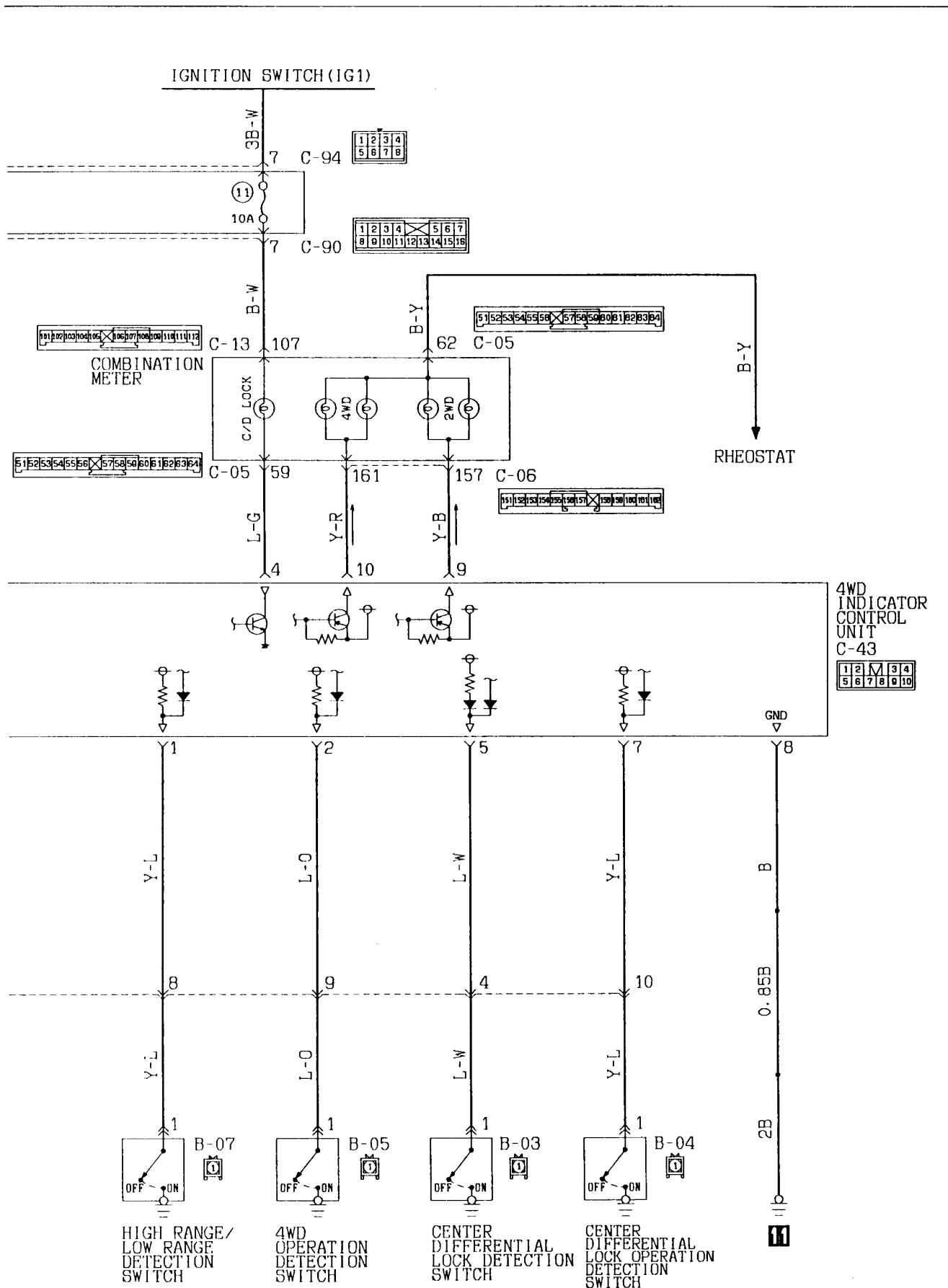

4-166 CIRCUIT DIAGRAM — Remote Controlled Variable Shock Absorber

39 REMOTE CONTROLLED VARIABLE SHOCK ABSORBER

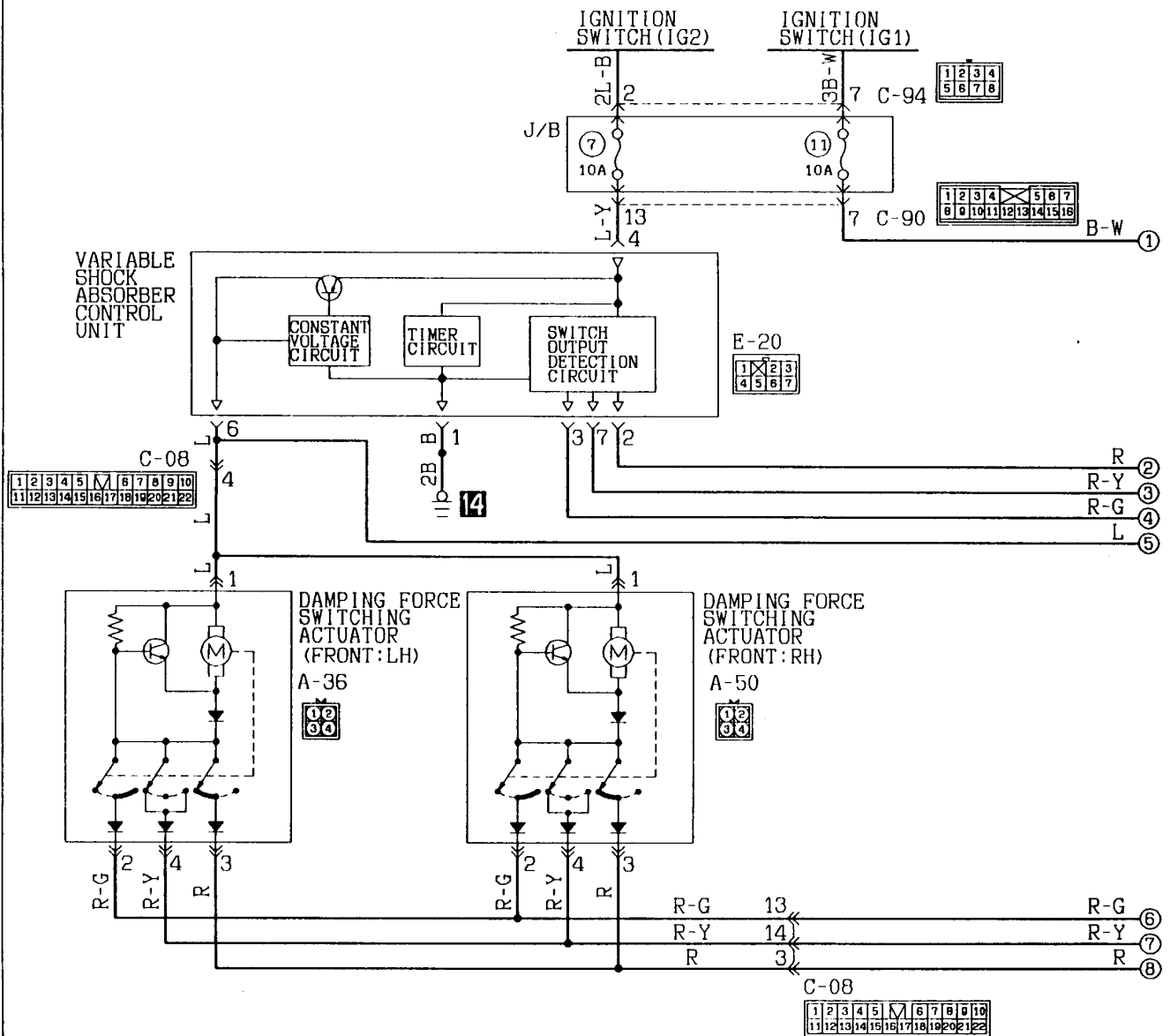

Wire colour code
 B:Black LG:Light green G:Green L:Blue W:White Y:Yellow SB:Sky blue
 BR:Brown O:Orange GR:Gray R:Red P:Pink V:Violet

KX35-AC-01504-EC

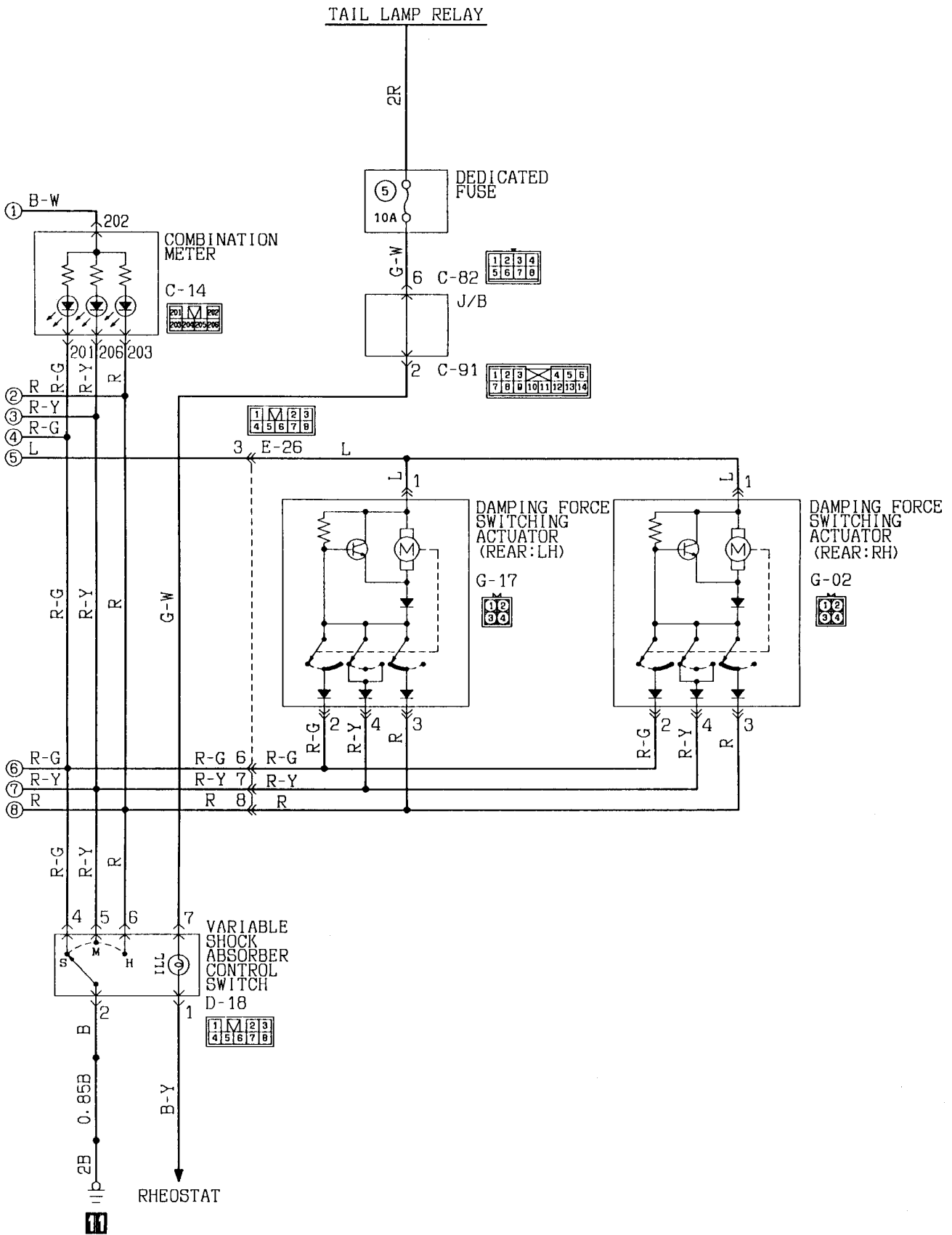

40 HEATED SEAT

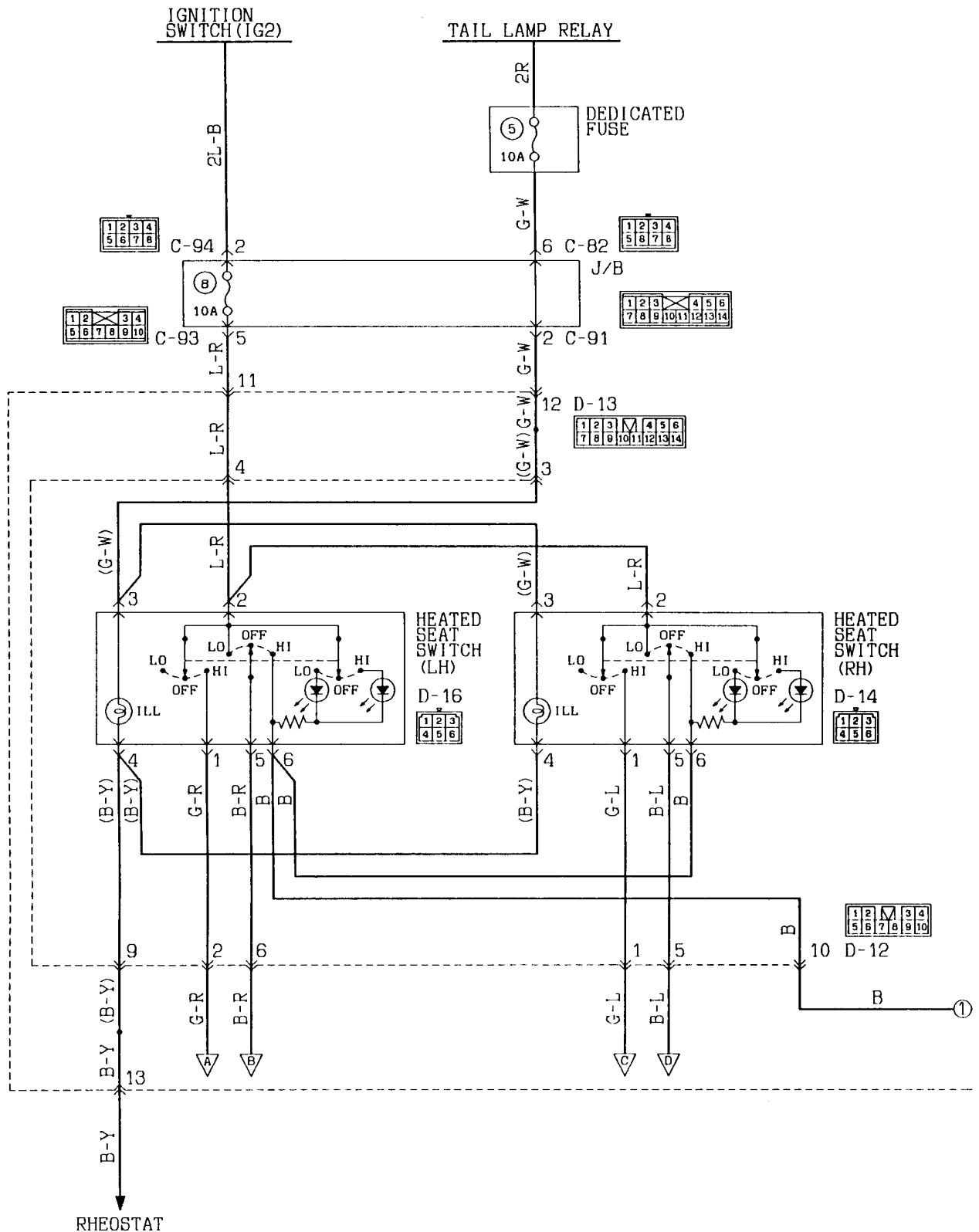

KX35-AC-01505-EC

Wire colour code						
B:Black	LG:Light green	G:Green	L:Blue	W:White	Y:Yellow	SB:Sky blue
BR:Brown	O:Orange	GR:Gray	R:Red	P:Pink	V:Violet	

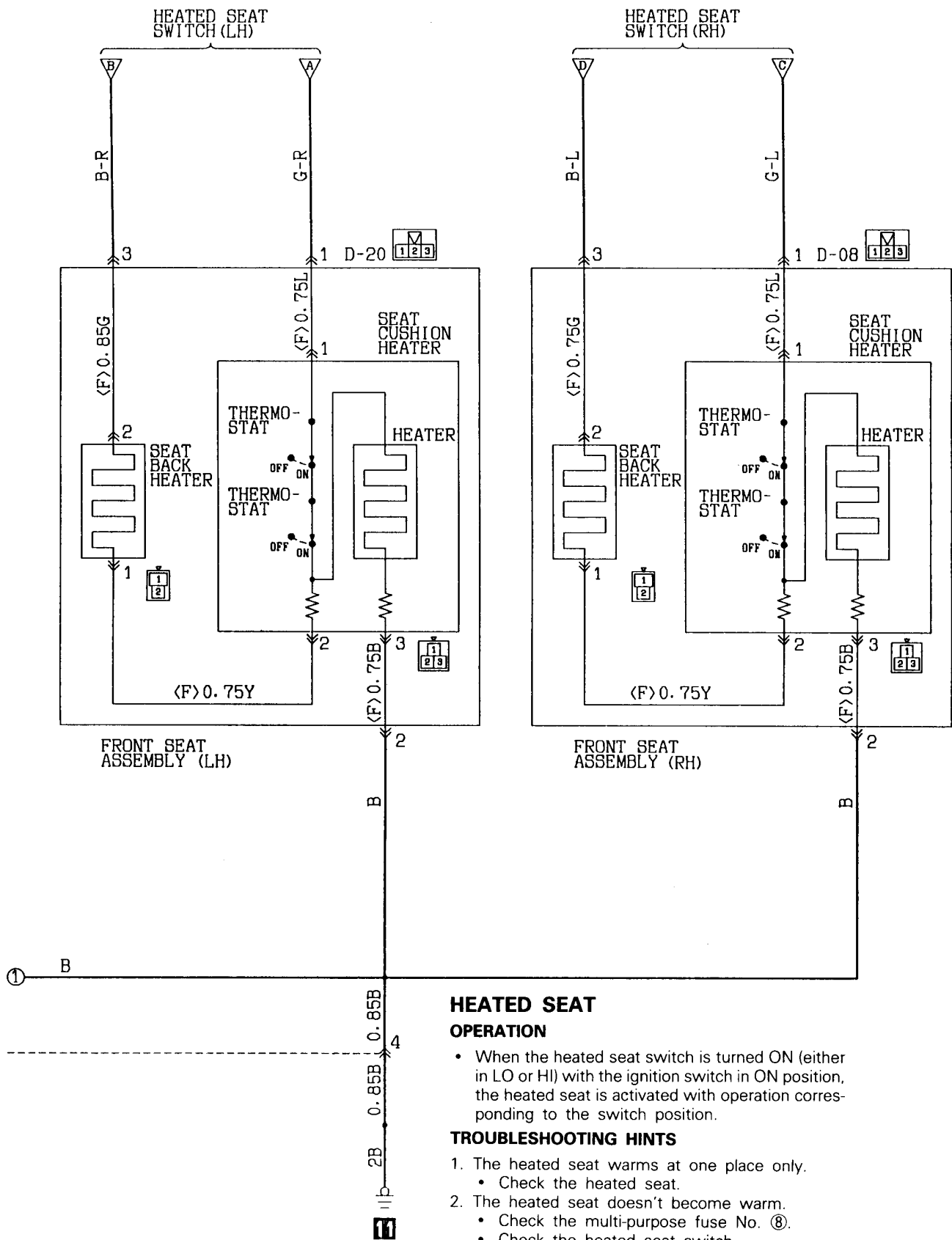

HEATED SEAT OPERATION

- When the heated seat switch is turned ON (either in LO or HI) with the ignition switch in ON position, the heated seat is activated with operation corresponding to the switch position.

TROUBLESHOOTING HINTS

1. The heated seat warms at one place only.
 - Check the heated seat.
2. The heated seat doesn't become warm.
 - Check the multi-purpose fuse No. ⑧.
 - Check the heated seat switch.

41 ANTI-SKID BRAKE SYSTEM

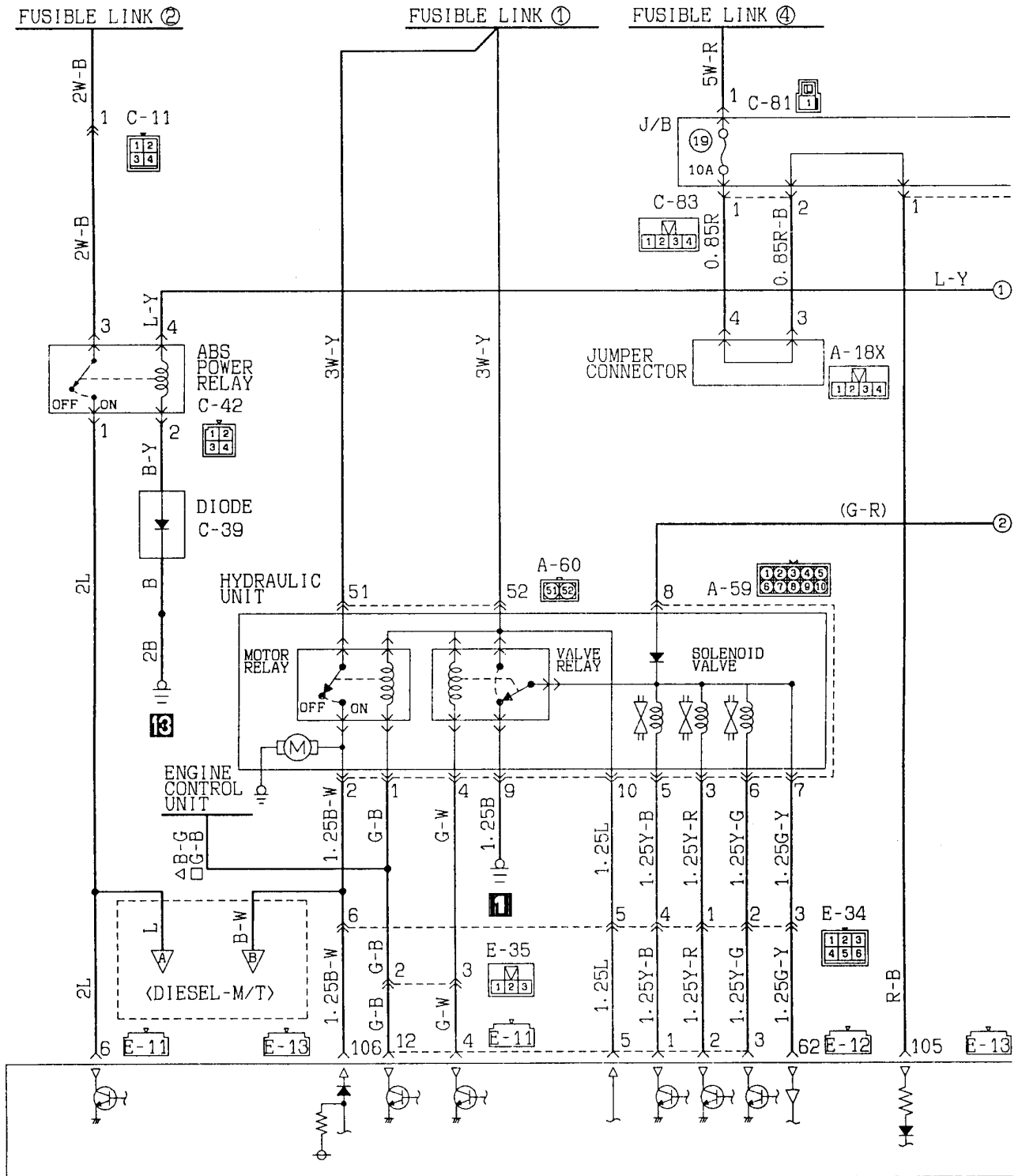

ABS CONTROL UNIT

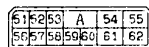
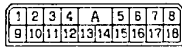

Remark
 Δ: R. H. drive vehicles
 □: L. H. drive vehicles

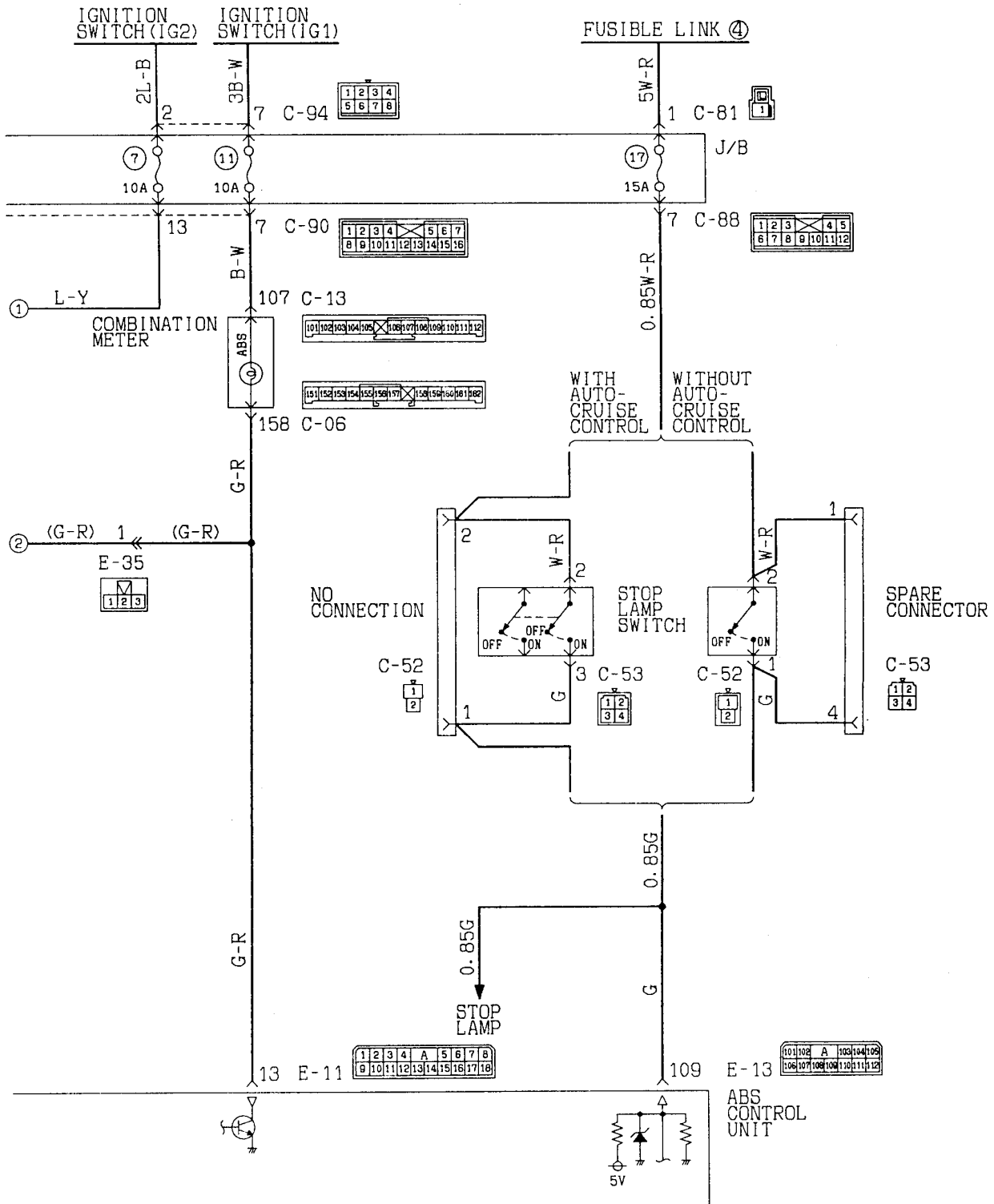

Wire colour code
 B:Black LG:Light green G:Green L:Blue W:White Y:Yellow SB:Sky blue
 BR:Brown O:Orange GR:Gray R:Red P:Pink V:Violet

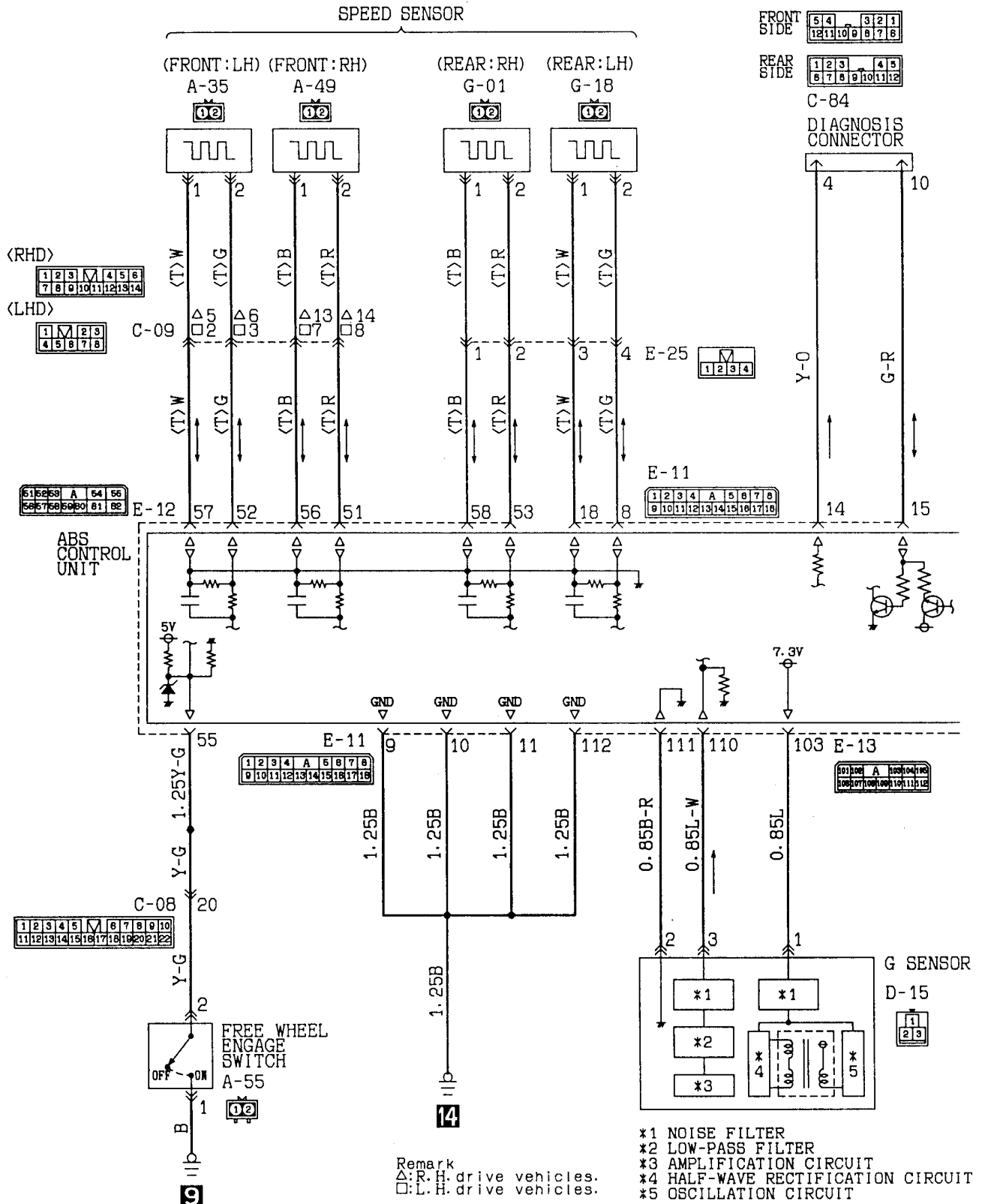

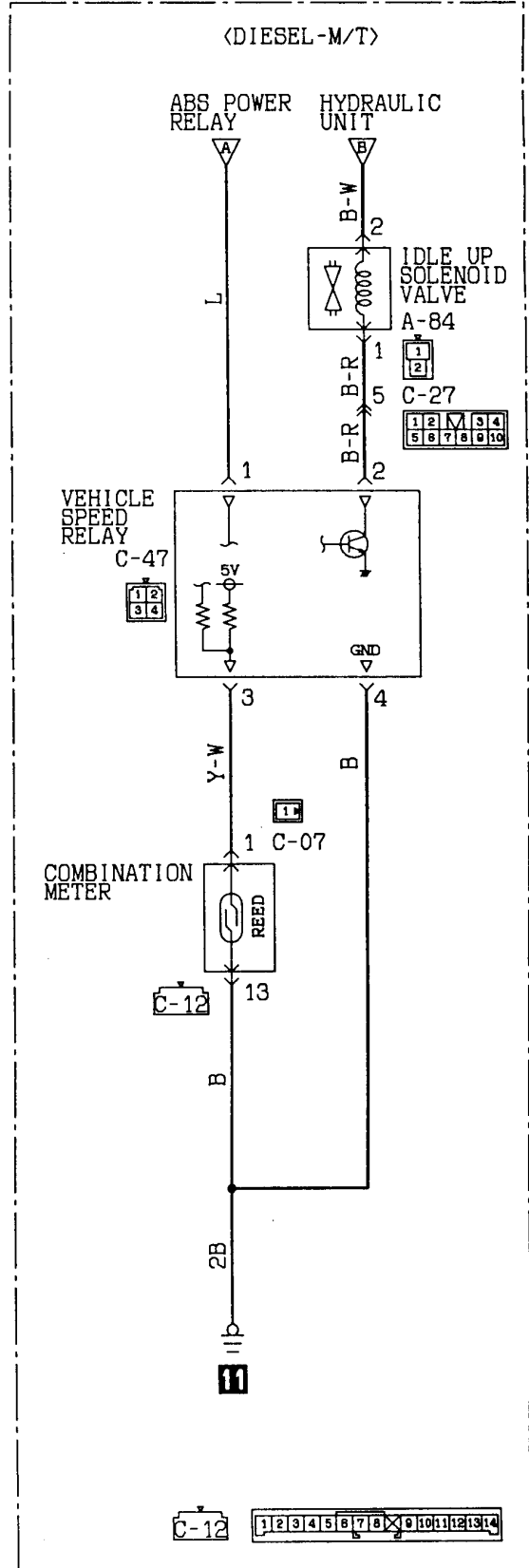
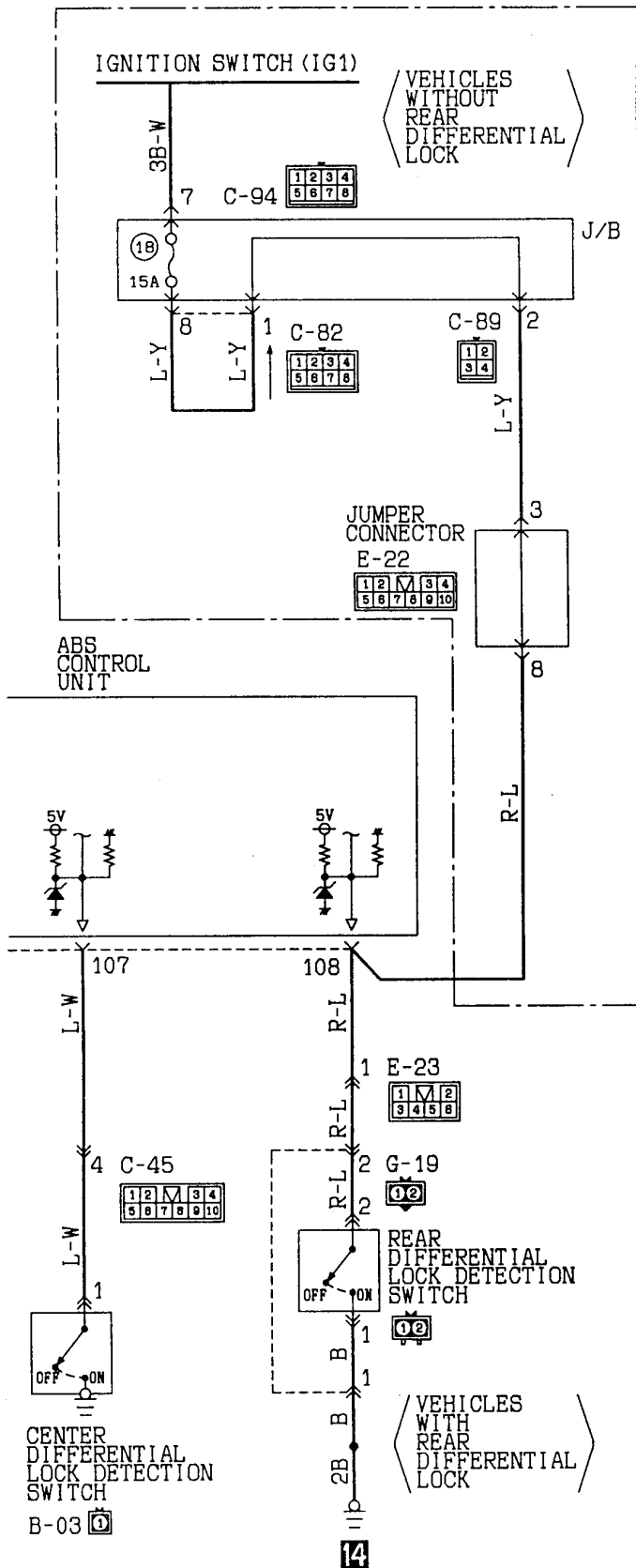

42 AUTO-CRUISE CONTROL SYSTEM

42-1 Petrol Link-powered vehicles

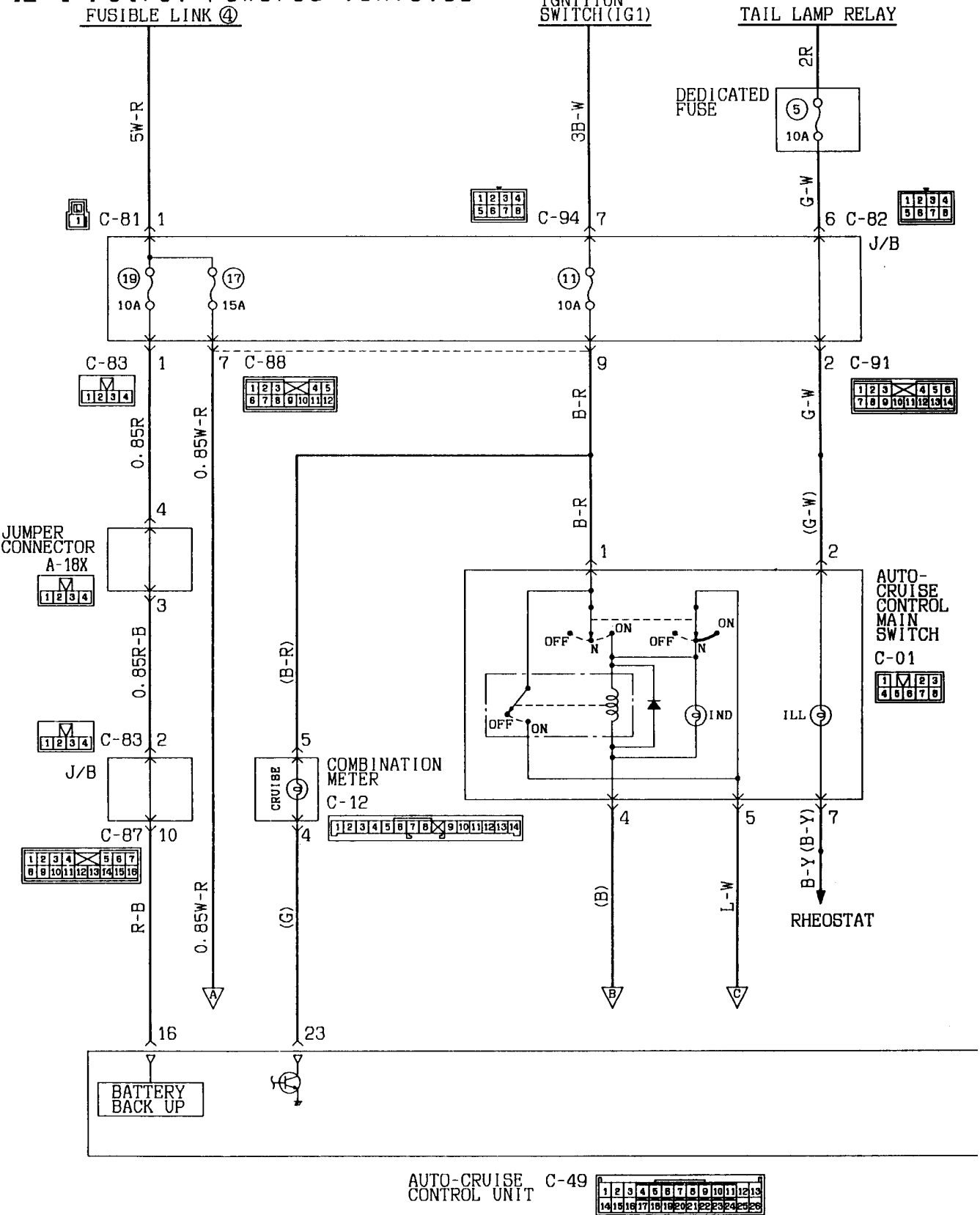

KX35-AC-Q1507-EC

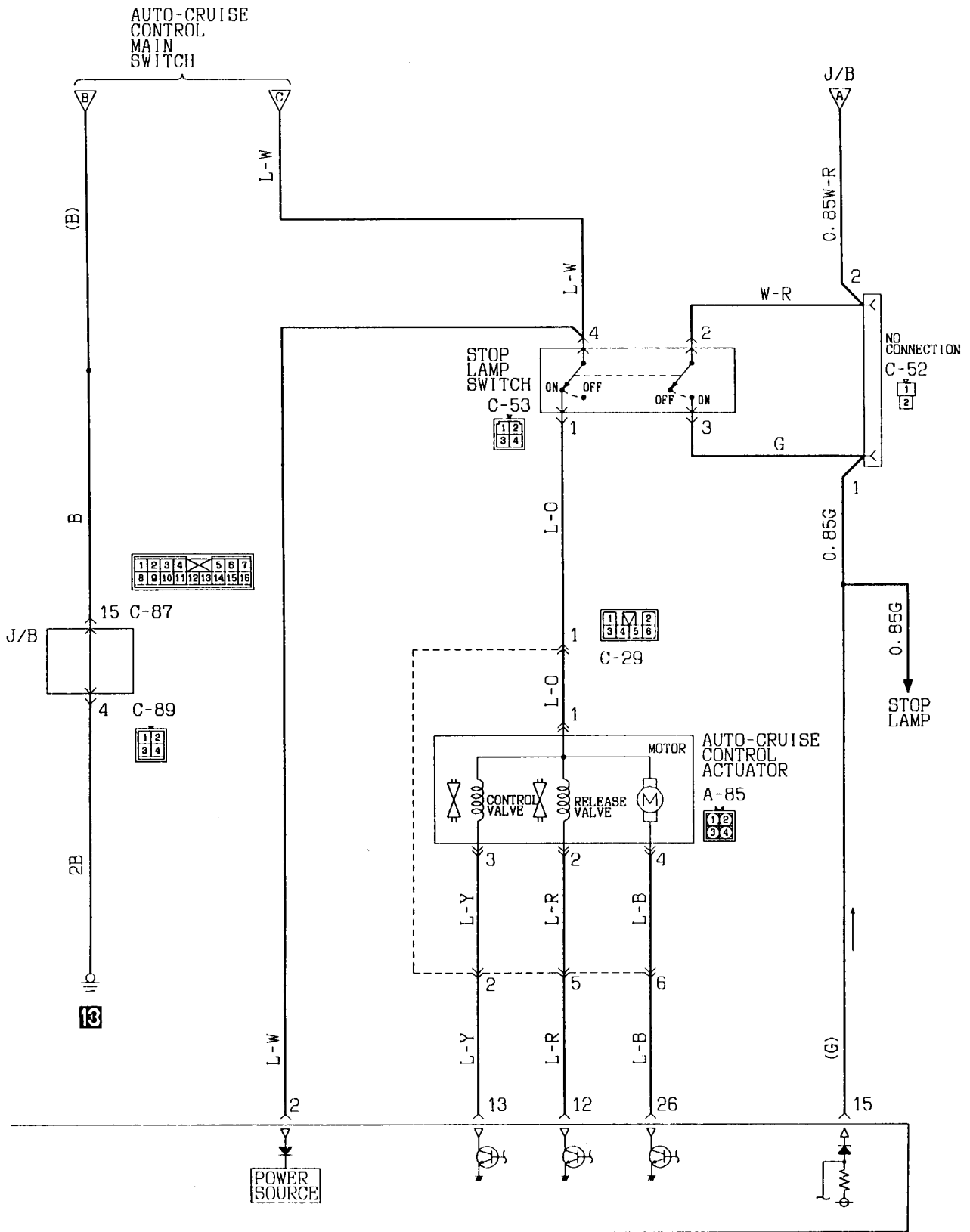

Wire colour code
 B:Black LG:Light green G:Green L:Blue W:White Y:Yellow SB:Sky blue
 BR:Brown O:Orange GR:Gray R:Red P:Pink V:Violet

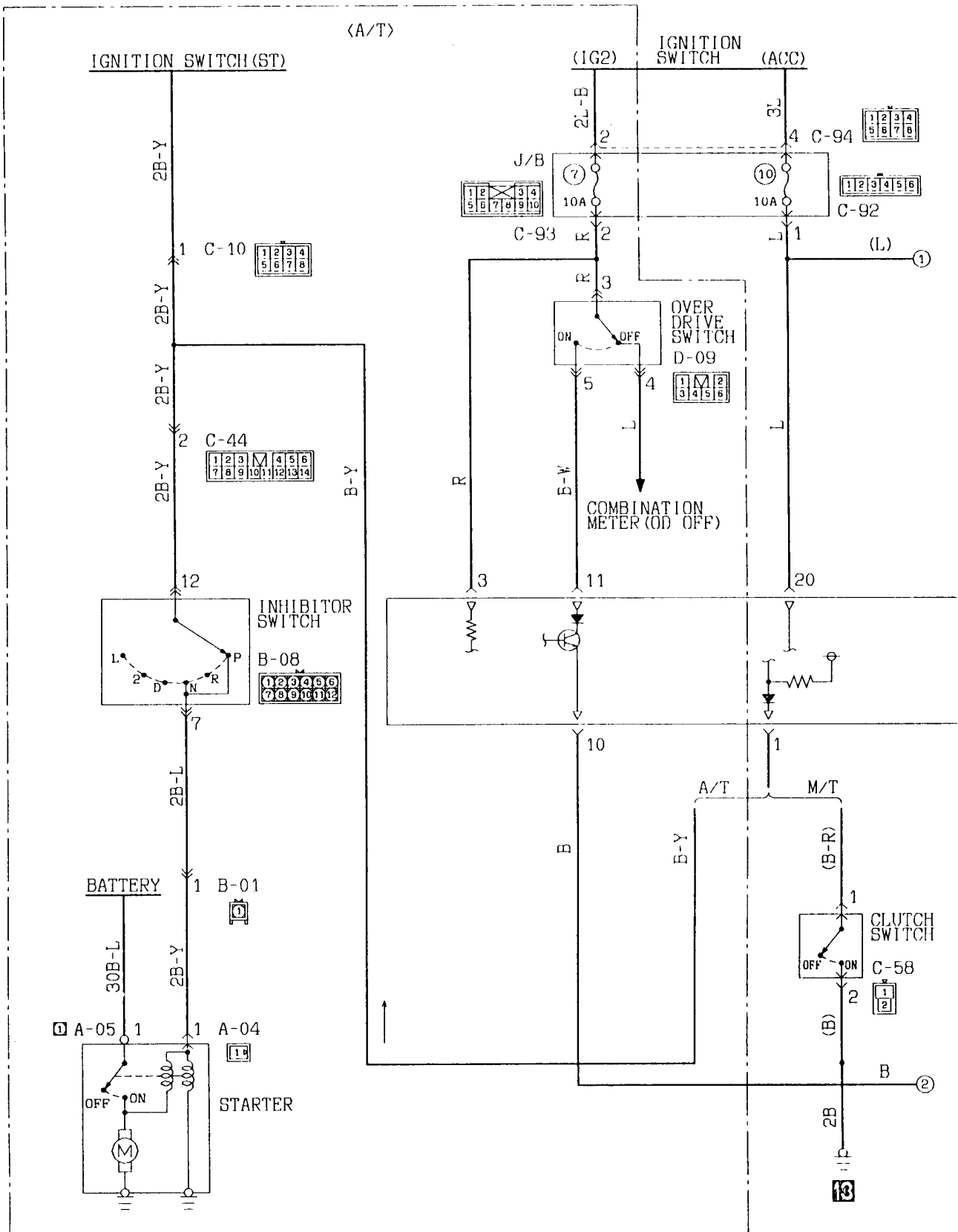

KX35-AC-Q1507A-EC

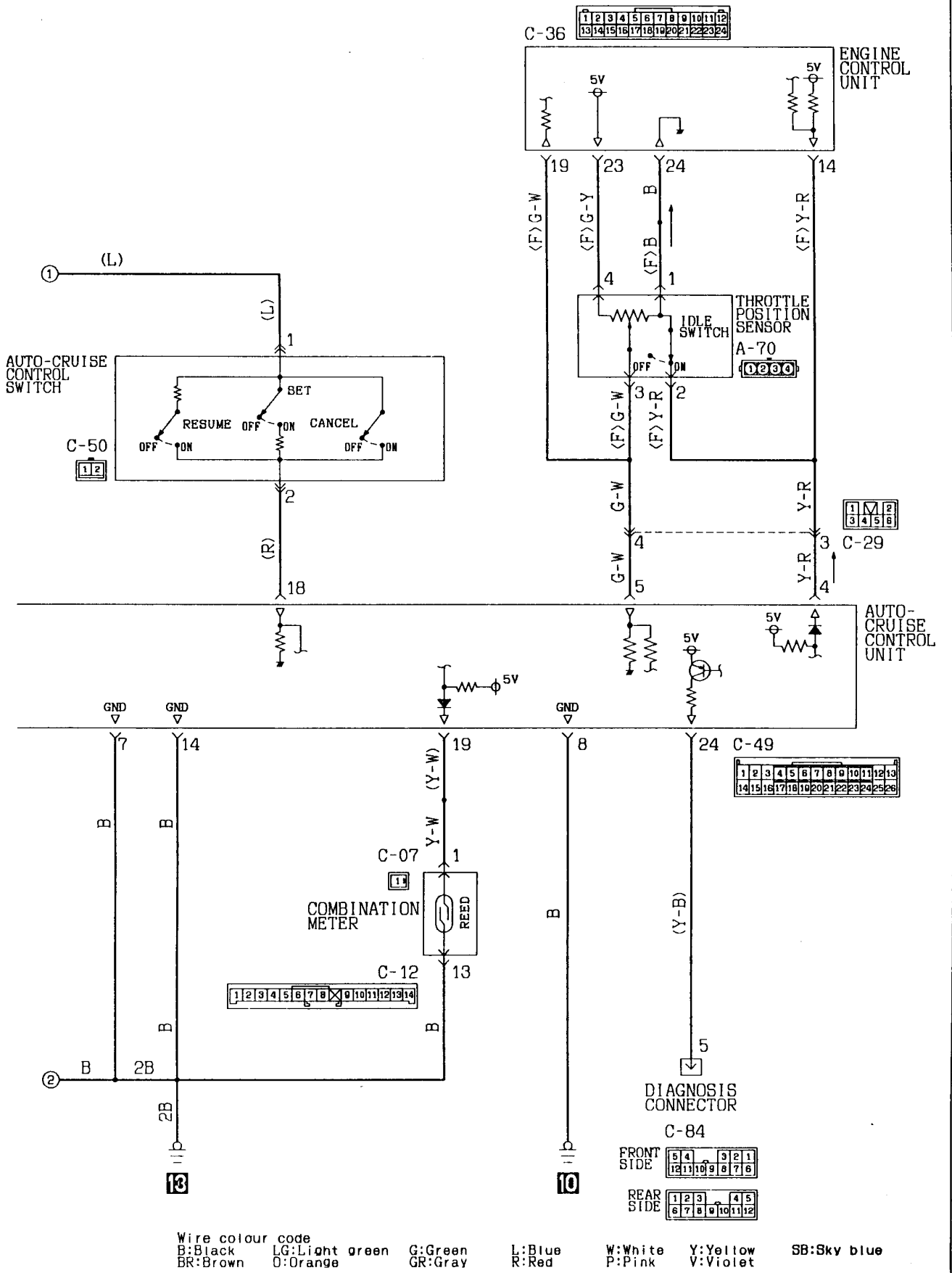

42-2 Diesel-powered vehicles

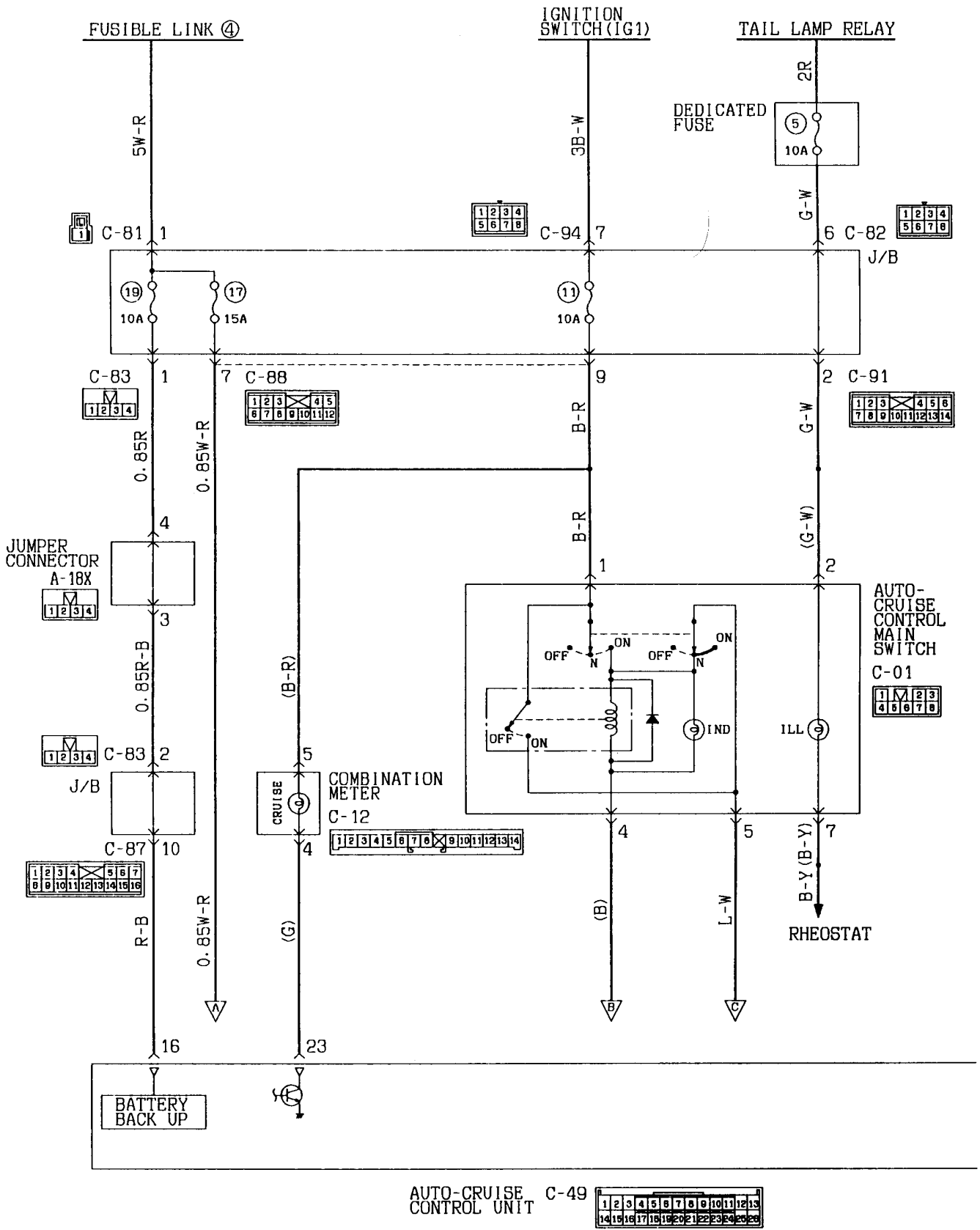

KX35-AC-Q1508-EC

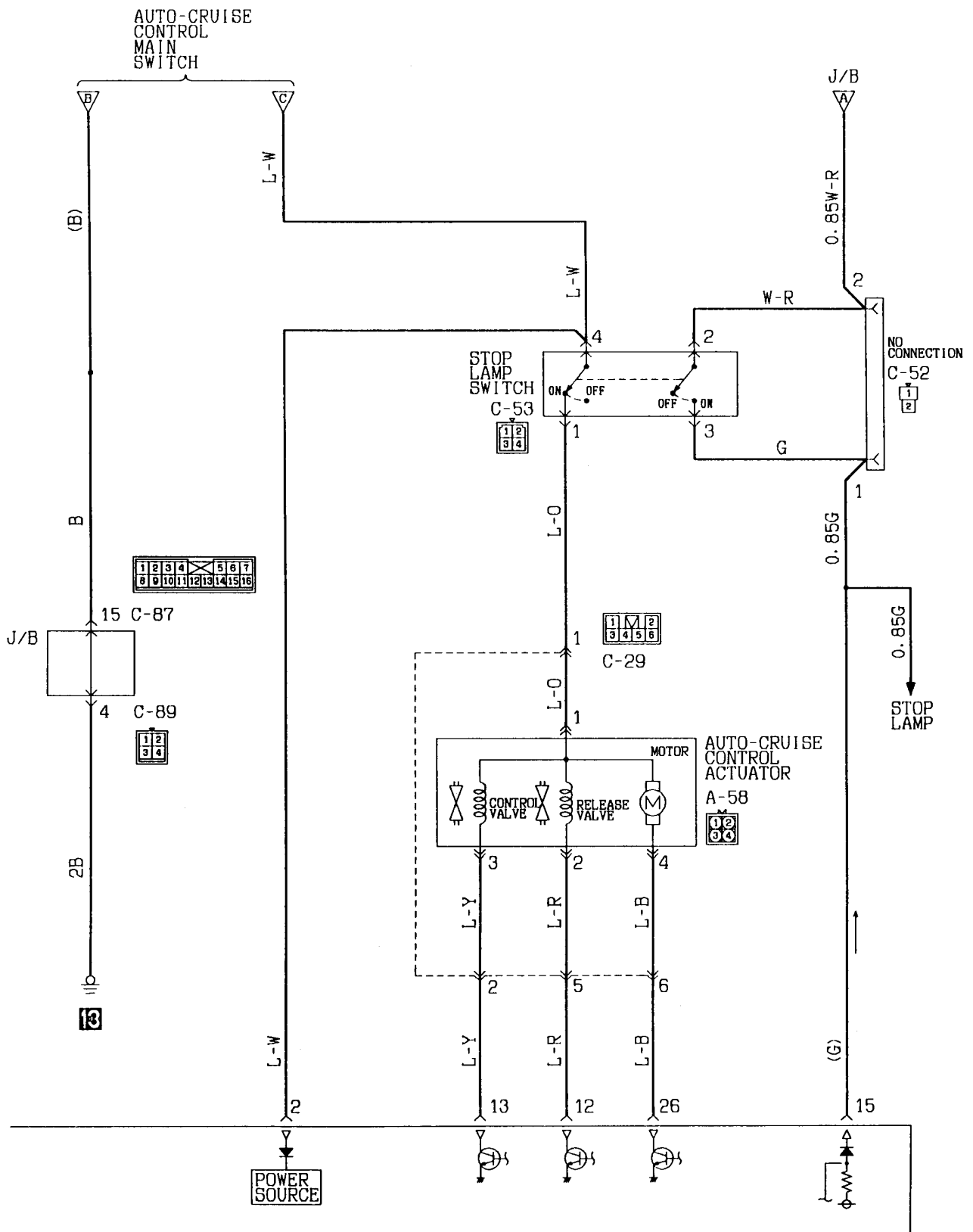

Wire colour code
 B:Black LG:Light green G:Green L:Blue W:White Y:Yellow SB:Sky blue
 BR:Brown O:Orange GR:Gray R:Red P:Pink V:Violet

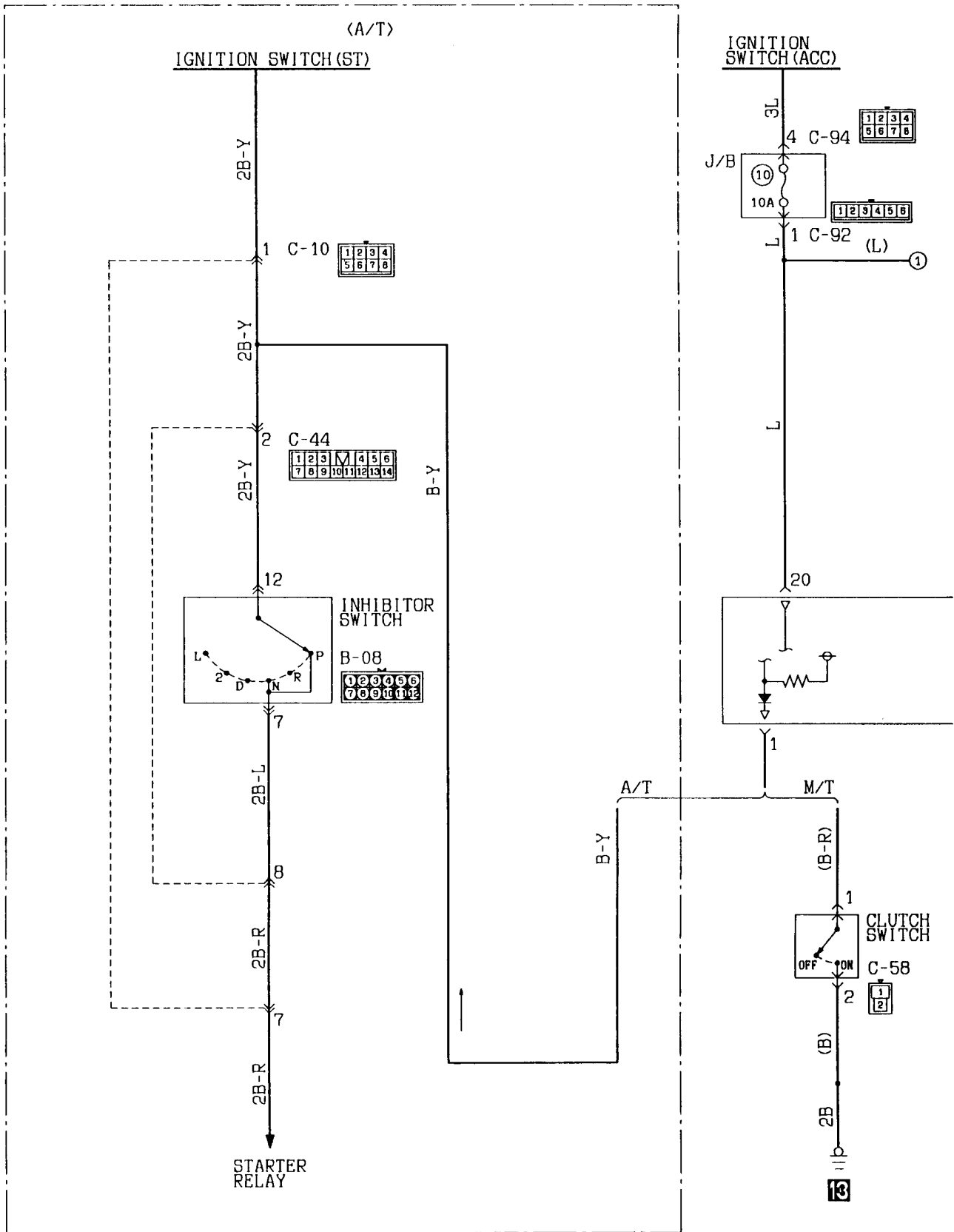

KX35-AC-Q1508A-EC

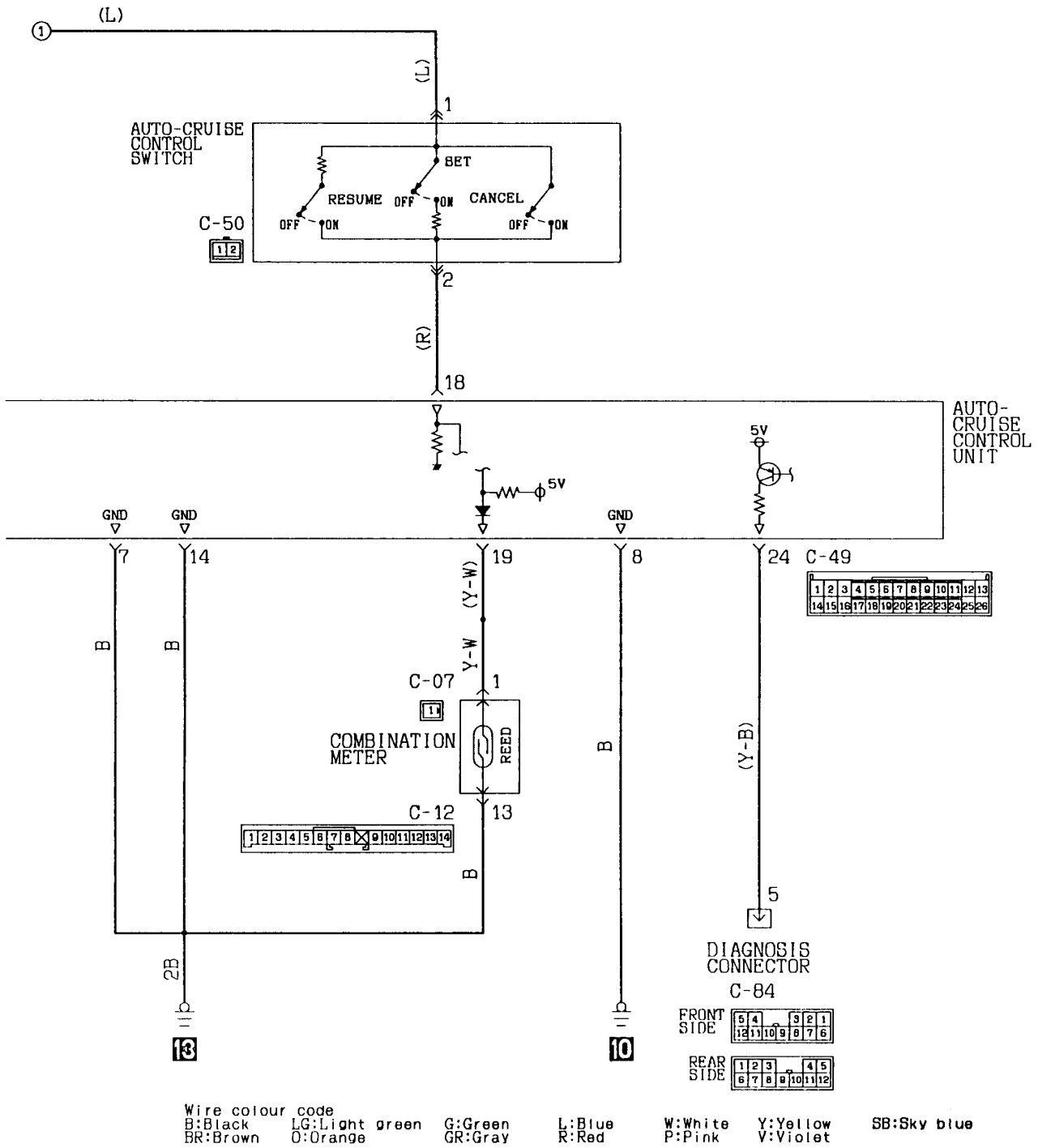

43 JUNCTION BLOCK

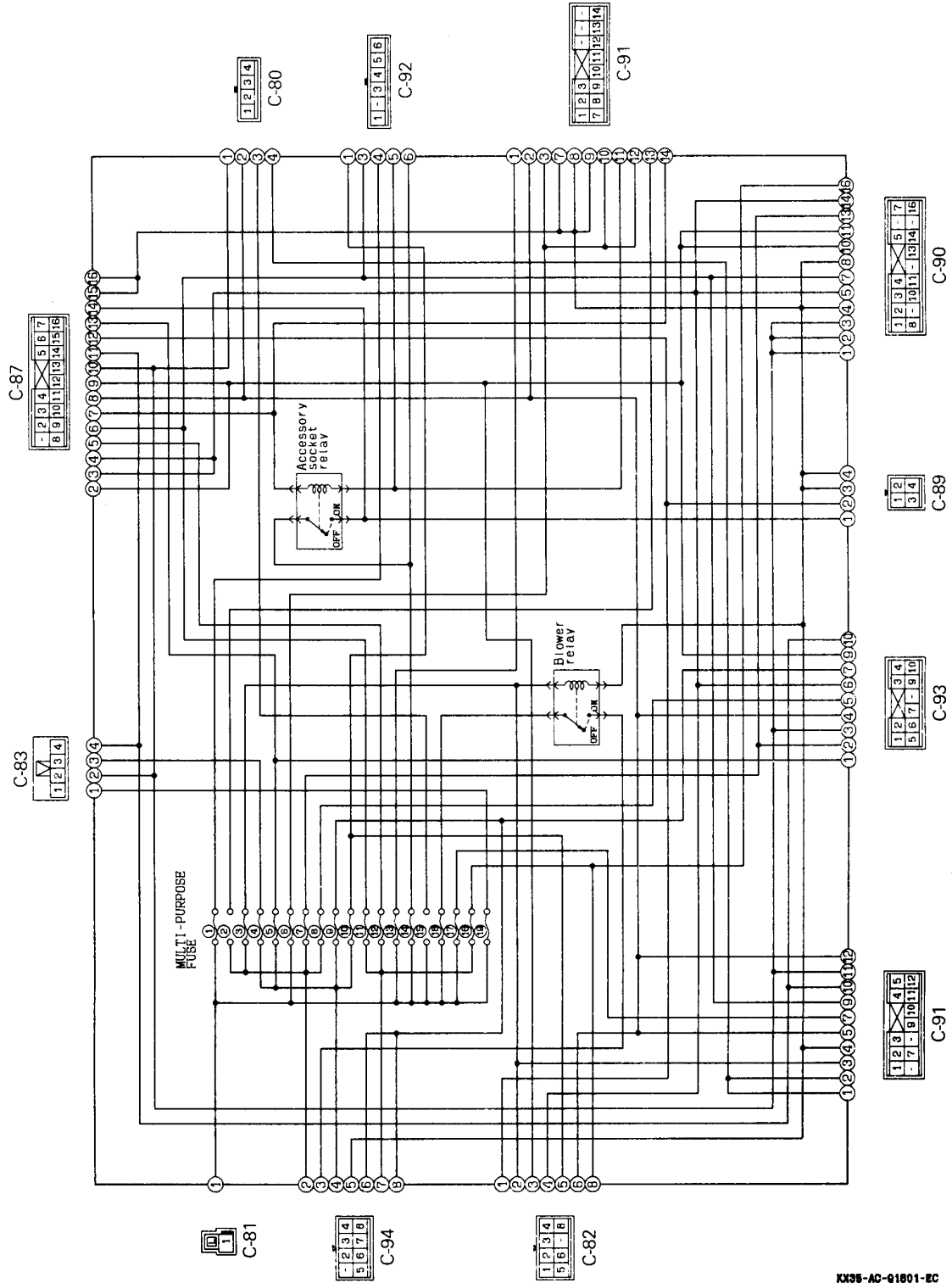

Remark

- Connector numbers are keyed to the configuration diagram (dashboard panel) and each circuit diagram.

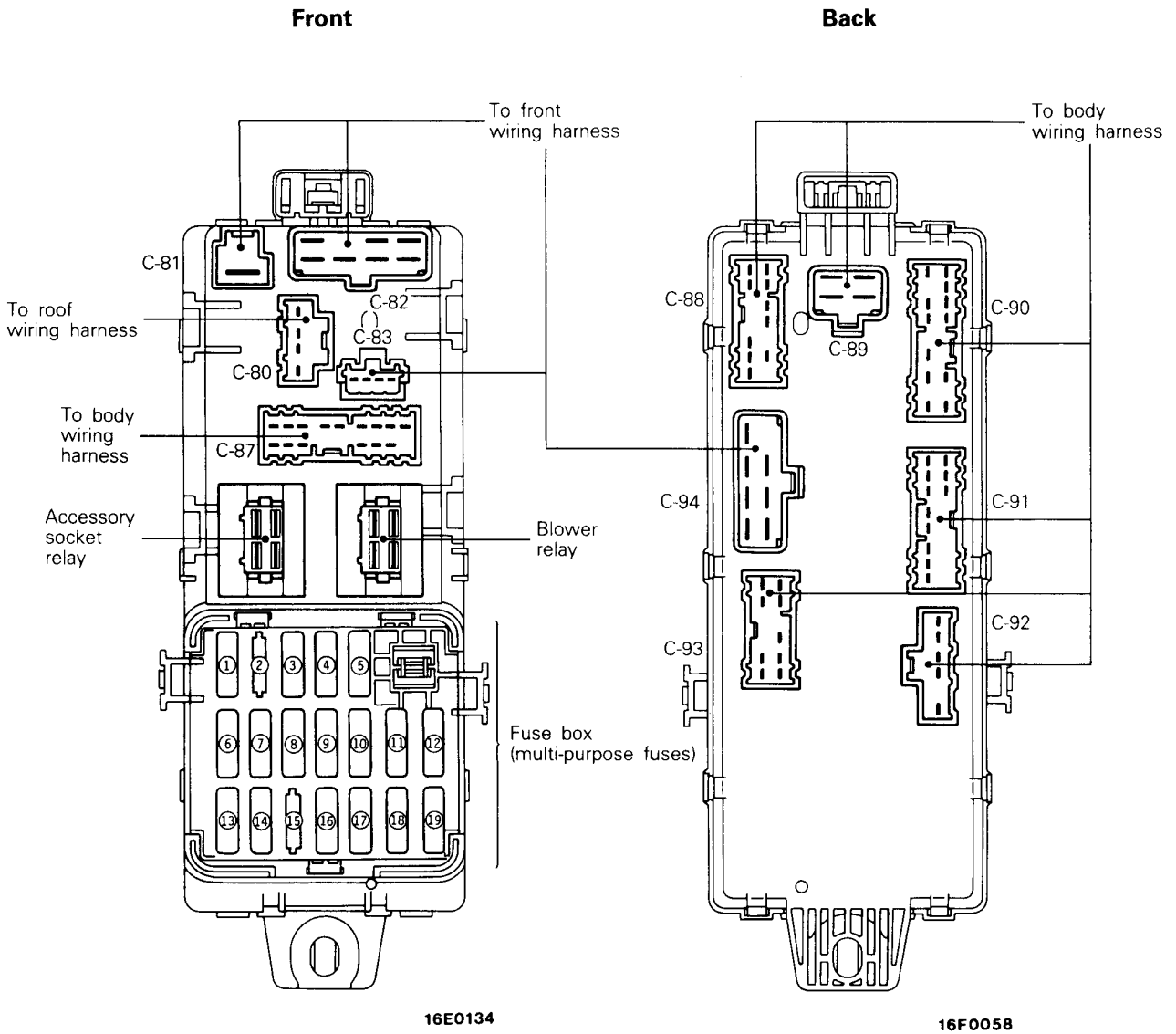

**44 CENTRALIZED JUNCTION
FUSIBLE LINK**

No.	Circuit	Housing colour	Rated capacity (A)
1	ABS circuit (hydraulic unit power source)	Yellow	60
2	ABS circuit (control unit power source)	Light blue	20
3	Glow control circuit	Black	80
4	Junction block (Multi-purpose fuse ①, ⑥, ⑬, ⑭, ⑯, ⑰, ⑱ A/C circuit)	Yellow	60
5	Alternator circuit	Blue	100
6	MPI and intercooler fan circuit	Light blue	20
7	Ignition switch and starting circuit	Green	40
8	—	—	—
9	—	—	—
10	Power window circuit	Pink	30
11	—	—	—
12	Condenser fan motor circuit	Pink	30
13	Alternator, headlamp and tail lamp circuit	Green	40

(Connected directly to battery positive terminal)

〈Vehicles with ABS〉

〈Diesel-powered vehicles without ABS〉

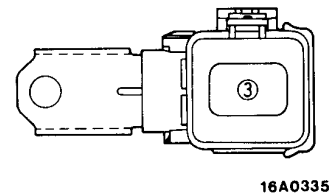
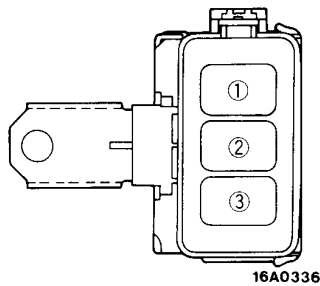

(Relay box in engine compartment)

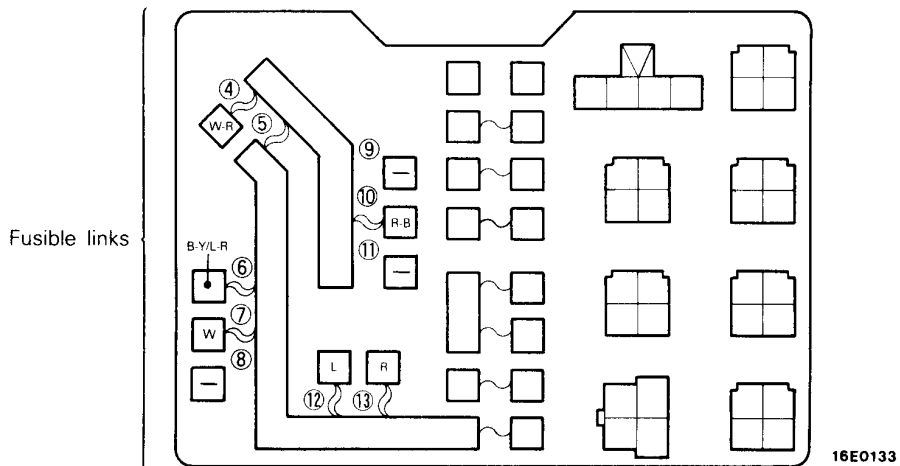

DEDICATED FUSE

Power supply circuit	No.	Rated capacity (A)	Housing Colour	Circuit
Battery	1	15	Blue	Fuel line heater
Battery	2	10	Red	A/C compressor circuit
Battery	3	25* ¹	Transparent	Condenser fan motor circuit
		30* ²	Green	
Headlamp relay (Battery)	4	10	Red	Rear fog lamp circuit
Tail lamp relay (Battery)	5	10	Red	Tail lamp circuit
Tail lamp relay (Battery)	6	10	Red	Tail lamp circuit
Headlamp relay (Battery)	7	10	Red	Upper beam indicator circuit
Battery	8	10	Red	Hazard lamp circuit
Ignition switch (IG2)	9	20	Yellow	Defogger circuit
Ignition switch (ACC)	10	15	Blue	Sunroof circuit

NOTE

(1)*1: Diesel-powered vehicles with single air conditioner.

*2: Diesel-powered vehicles with dual air conditioner.

(Relay box in engine compartment)

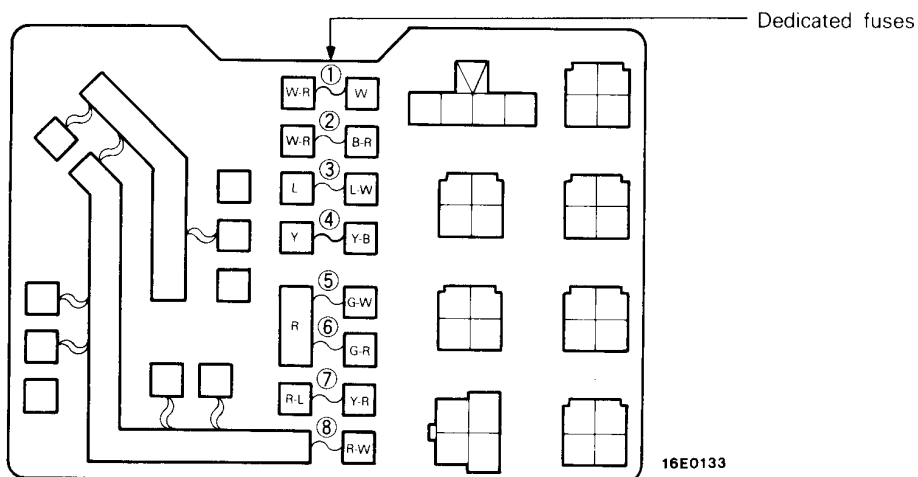

(Relay box in passenger compartment)

<L.H. drive vehicles>

<R.H. drive vehicles>

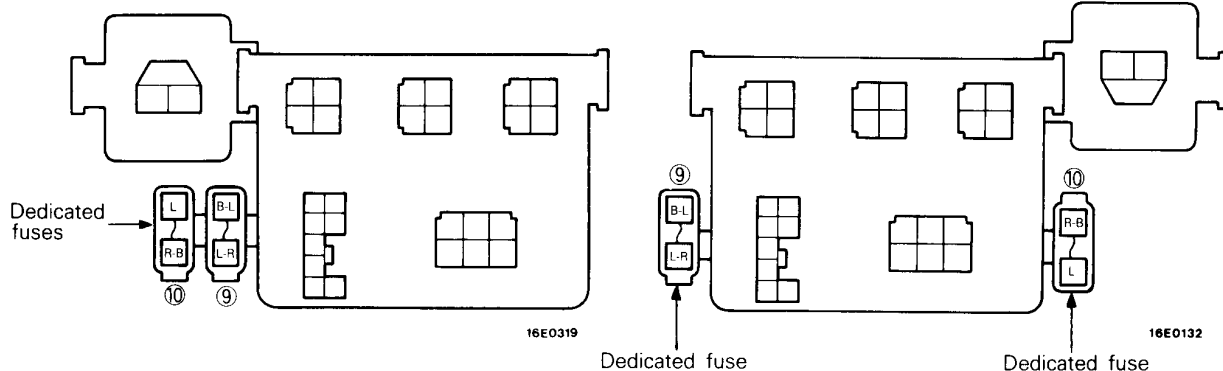

MULTI-PURPOSE FUSES

Power supply circuit	No.	Rated capacity (A)	Load circuit	
Battery	1	20	Rear A/C control unit	
Ignition switch	(IG2)	2	—	
		3	DRL control unit, blower relay, rear heater relay and headlamp washer relay	
	(ACC)	4	Radio and clock	
		5	Remote control mirror, cigarette lighter and accessory socket relay	
		6	Door lock control unit	
Ignition switch	(IG2)	7	Over drive control relay, variable shock absorber control unit and ABS power relay	
		8	Power window relay and heated seat	
	(ACC)	9	Wiper and washer	
		10	Horn and auto-cruise control unit	
	(IG1)	11	Combination meter and motor antenna control unit	
		12	Turn-signal lamp and hazard lamp	
Battery	13	10	Rear heater blower motor	
	14	15	Accessory socket	
	15	—	—	
	16	25	Blower motor	
	17	15	Stop lamp	
Ignition switch	(IG1)	18	15	Back-up lamp and rear differential lock control unit
Battery	19	10	Engine control unit, room lamp, map lamp, cargo space lamp, combination meter, clock, door lock control unit, radio, clock and auto-cruise control unit	

(In junction block)

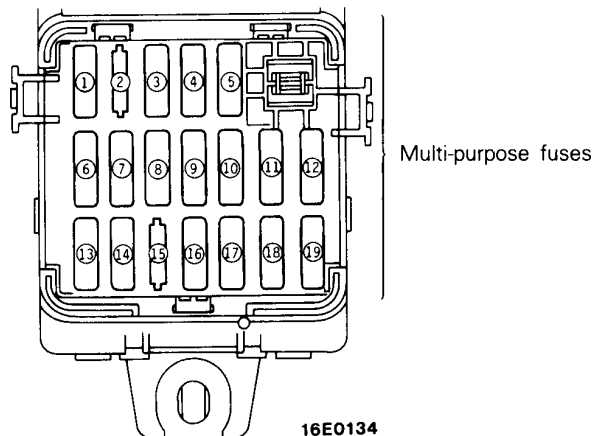

CENTRALIZED RELAY

Classification		Name	Classification		Name
Relay box in engine compartment	A-18X	Jumper connector	Relay box in passenger compartment	C-72X	—
	A-19X	Headlamp relay		C-73X	Rear heater relay
	A-20X	Intercooler fan motor relay		C-74X	Power window relay
	A-21X	Alternator relay		C-75X	Door lock control unit
	A-22X	Rear fog lamp relay		C-76X	Rear intermittent wiper relay
	A-23X	Tail lamp relay		C-77X	Turn and hazard flasher unit
	A-24X	Condenser fan motor relay			
	A-25X	A/C compressor relay			

(Relay box in engine compartment)

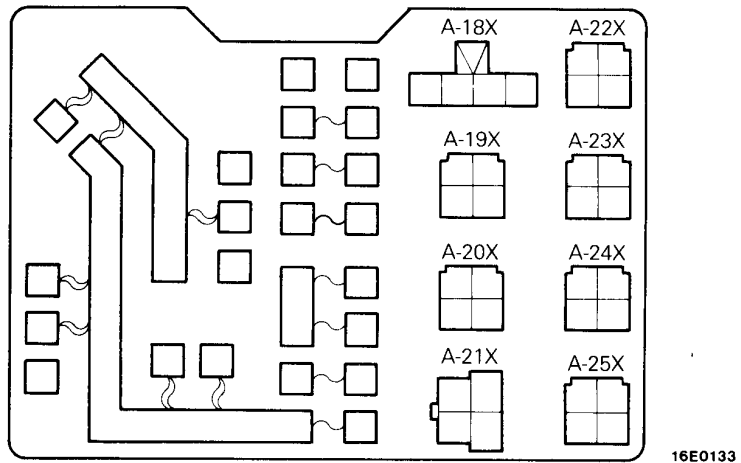

16E0133

(Relay box in passenger compartment)

〈L.H. drive vehicles〉

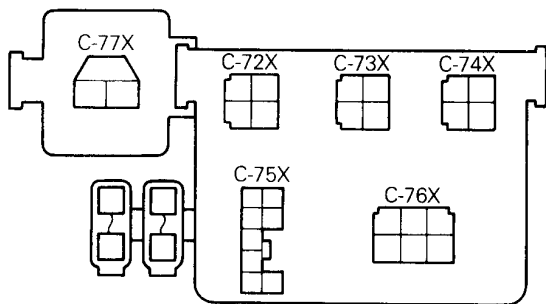

16E0319

〈R.H. drive vehicles〉

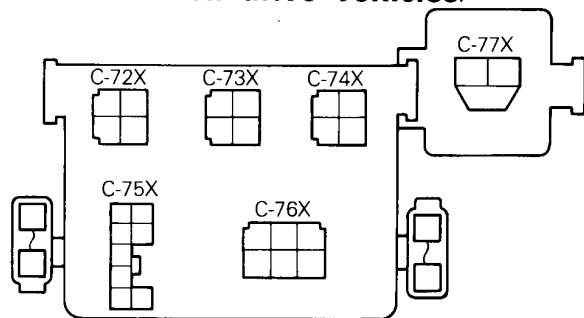

16E0132

45 LIGHTING MONITOR BUZZER

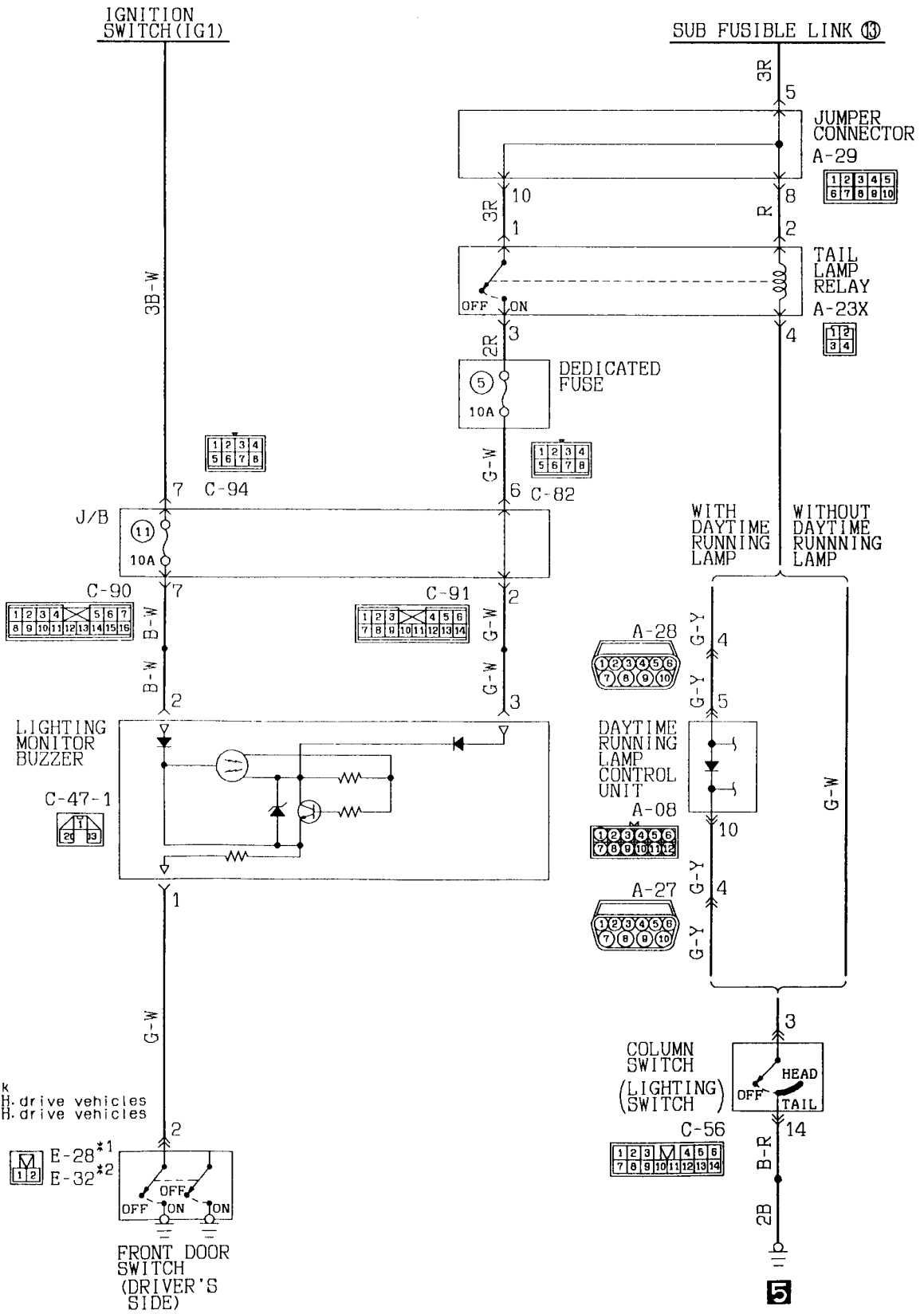

Remark
 *1: L.H. drive vehicles
 *2: R.H. drive vehicles

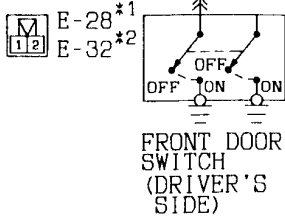

Wire colour code
 B:Black LG:Light green G:Green L:Blue W:White Y:Yellow SB:Sky blue
 BR:Brown O:Orange GR:Gray R:Red P:Pink V:Violet

LIGHTING MONITOR BUZZER (See P. 4-188.)

OPERATION

- Placing the lighting switch in the TAIL or HEAD position causes the tail lamp relay to be energized.
- When the ignition switch is in the "OFF" position in this condition, if the driver's side door is opened and the front door switch turns "ON", the buzzer sounds to indicate that the lamps are not switched off.

TROUBLESHOOTING HINTS

1. Lighting monitor buzzer doesn't sound
 - (1) But the tail lamps do illuminate.
 - Check the lightning monitor buzzer.
 - Check the front door switch (driver's side).
 - (2) The tail lamps also don't illuminate.
 - Check the sub fusible link No. ⑬.
 - Check the dedicated fuse No. ⑤.

FUEL LINE HEATER CIRCUIT (See P. 4-190.)

OPERATION

- When the engine is started, the fuel thermo sensor operates to detect the fuel temperature. If the fuel temperature drops below 0~6°C (32~43°F), the fuel line heater control unit operates to turn the heater on in order to warm the fuel. When the fuel temperature is between 1.5~7.5°C (34.5~45.5°F), the heater turns off.
- If there is a malfunction of the fuel thermo sensor and the heater becomes too warm, the thermo switch operates when the temperature becomes 36~46°C (97~115°F) to turn the heater circuit off. If there is a malfunction of the thermo switch, the thermo fuse will burn out at 114~124°C (237~255°F) to fully isolate the heater circuit.

46 FUEL LINE HEATER

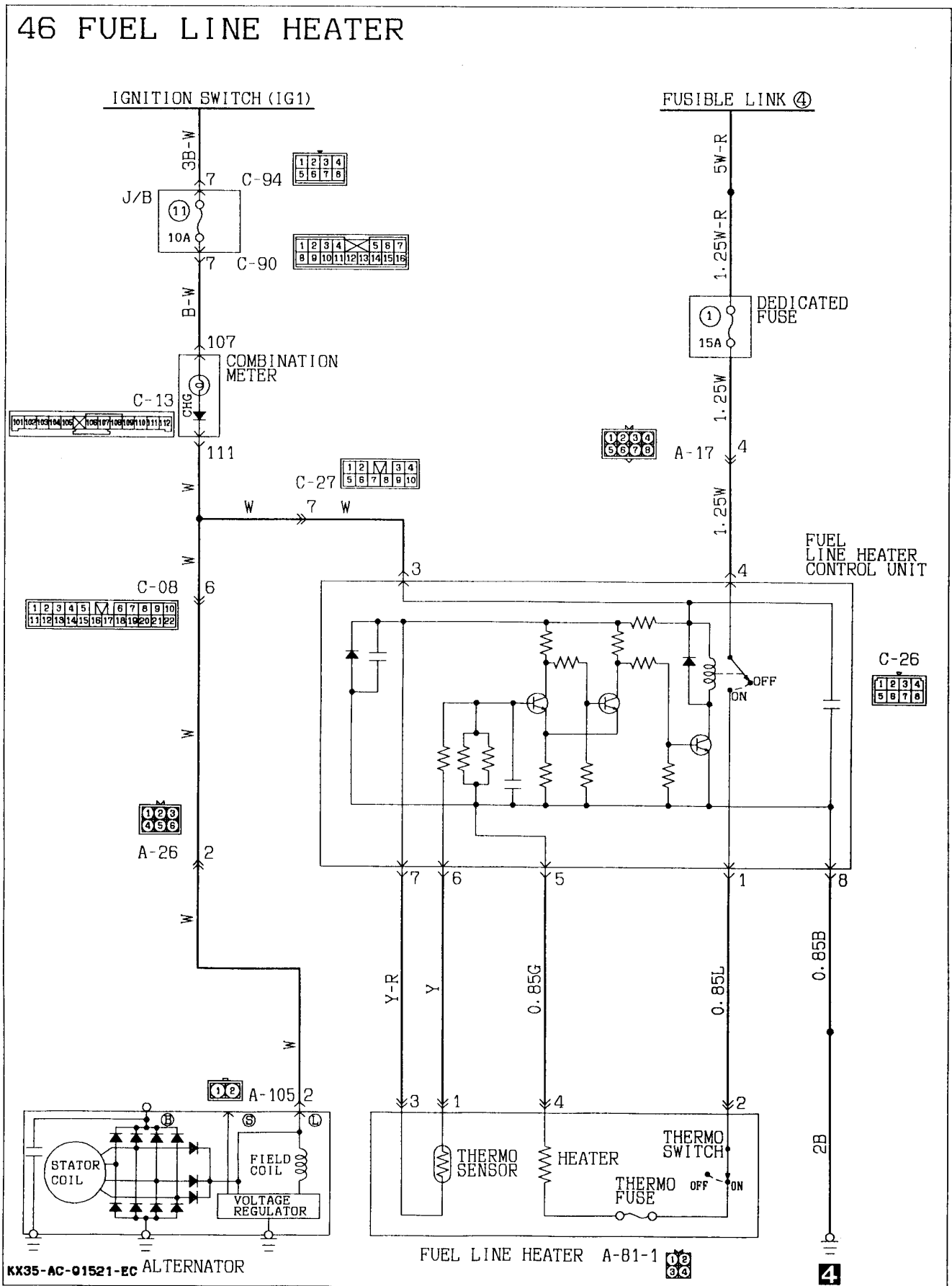

KX35-AC-01521-EC ALTERNATOR

FUEL LINE HEATER A-81-1