



# Workshop Manual

## chassis

### SUPPLEMENT

# PAJERO '96

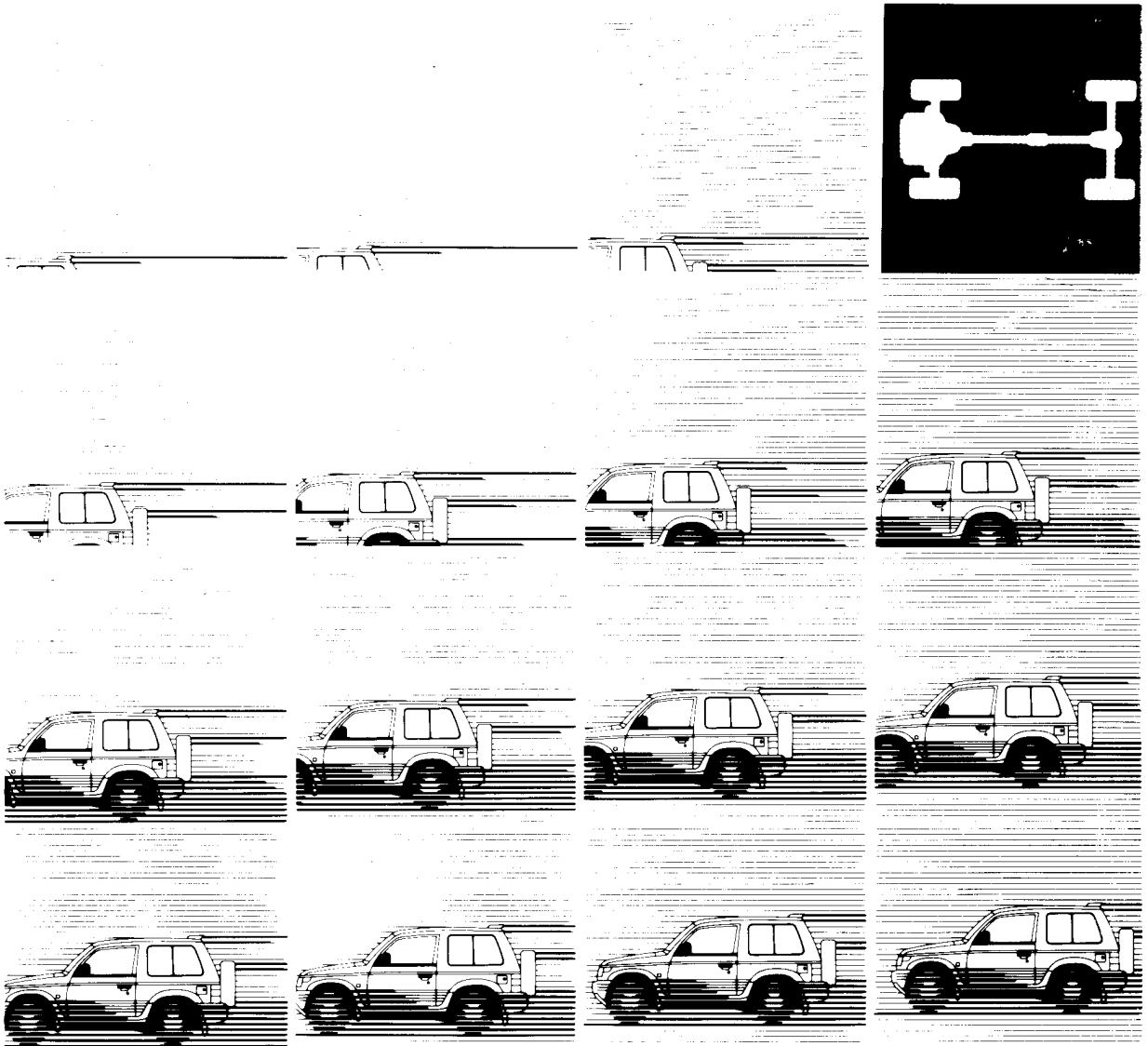

# MITSUBISHI PAJERO

## WORKSHOP MANUAL SUPPLEMENT

### FOREWORD

This Workshop Manual contains procedures for removal, disassembly, inspection, adjustment, reassembly and installation, etc. for service mechanics.

Use the following manuals in combination with this manual as required.

TECHNICAL INFORMATION MANUAL  
PYJE9002

WORKSHOP MANUAL  
ENGINE GROUP PWEE□□□□  
(Looseleaf edition)  
CHASSIS GROUP PWJE9086  
(Looseleaf edition)  
ELECTRICAL WIRING PHJE9026  
(Looseleaf edition)  
PHJE9026-D  
(Supplement)  
PHJE9026-E  
(Supplement)

PARTS CATALOGUE B6035606A□

All information, illustrations and product descriptions contained in this manual are current as at the time of publication. We, however, reserve the right to make changes at any time without prior notice or obligation.

General .....	00
Engine .....	11
Fuel .....	13
Automatic Transmission .....	23
Rear Axle .....	27
Service Brakes .....	35
Body .....	42
Interior and Supplemental Restraint System (SRS) .....	52
Chassis Electrical .....	54



---

# GENERAL

## CONTENTS

<b>VEHICLE IDENTIFICATION</b> .....	<b>2</b>	How to Use the Inspection Procedures .....	13
Models .....	2	Connector Measurement Service Points .....	14
Chassis Number .....	4	Connector Inspection .....	15
<b>MAJOR SPECIFICATIONS</b> .....	<b>5</b>	Inspection Service Points for a Blown Fuse ...	16
<b>HOW TO USE TROUBLESHOOTING/ INSPECTION SERVICE POINTS</b> .....	<b>12</b>	Points to Note for Intermittent Malfunctions ...	16
Troubleshooting Contents .....	12		

---

## VEHICLE IDENTIFICATION

### MODELS

#### <2-DOOR MODELS>



Model code		Body style	Engine model	Transmission model	Fuel supply system
V24C	NSFL6	Canvas top	4D56 [2,477 ml] with turbocharger and inter-cooler	V5MT1 (5M/T)	Injection
V23C	GNHVL6/R6	Canvas top with wide fender	6G72 [2,972 ml]	V5MT1 (5M/T)	MPI
	GRHVL6/R6			V4AW3 (4A/T)	
V24W	NDFL6	Wagon	4D56 [2,477 ml] with turbocharger and inter-cooler	V5MT1 (5M/T)	Injection
	NHFL6/R6				
	NAFL6				
	NBFL6				
V24WG	NXFL6/R6	Wagon with wide fender			
	NCFL6				
V26W	NHFL6	Wagon	4M40 [2,835 ml] with turbocharger and inter-cooler	V5M31 (5M/T)	
V26WG	NXFL6/R6	Wagon with wide fender			
V23W	NHVL6	Wagon	6G72 [2,972 ml]	V5MT1 (5M/T)	MPI
	GNXVL6/R6	Wagon with wide fender		V5MT1 (5M/T)	
	GRXVL6/R6			V4AW3 (4A/T)	
V25W	GNXML6/R6		6G74 [3,497 ml]	V5M31 (5M/T)	
	GRXML6/R6			V4AW3 (4A/T)	

<4-DOOR MODELS>

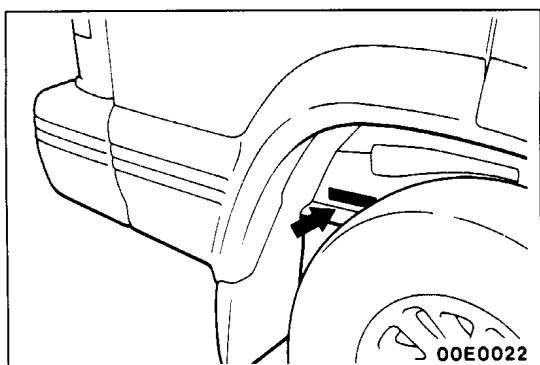
Model code		Body style	Engine model	Transmission model	Fuel supply system
V44W	NDFL6	Wagon	4D56 [2,477 mℓ] with turbocharger and inter-cooler	V5MT1 (5M/T)	Injection
	NDFCL6	Wagon without 3rd seat row			
	NHFL6	Wagon			
V44WG	NXFL6/R6	Wagon with wide fender			
V46W	NDFL6	Wagon	4M40 [2,835 mℓ] with turbocharger and inter-cooler	V5M31 (5M/T)	Injection
	NDFCL6	Wagon without 3rd seat row			
	NHFL6/R6	Wagon		V4AW3 (4A/T)	
	RHFR6				
	NAFCL6	Wagon without 3rd seat row		V5M31 (5M/T)	
	NBFL6	Wagon			
V46WG	NXFL6/R6	Wagon with wide fender		V5M31 (5M/T)	
	RXFL6/R6		V4AW3 (4A/T)		
	NCFL6		V5M31 (5M/T)		
V43W	NHVL6/R6	Wagon	6G72 [2,972 mℓ]	V5MT1 (5M/T)	MPI
	RHVL6/R6			V4AW3 (4A/T)	
	GNXVL6/R6	Wagon with wide fender		V5MT1 (5M/T)	
	GRXVL6/R6			V4AW3 (4A/T)	
V45W	GNXML6/R6		6G74 [3,497 mℓ]	V5M31 (5M/T)	
	GRXML6/R6			V4AW3 (4A/T)	

**CHASSIS NUMBER**

The chassis number is stamped on the side wall of the frame near the right rear wheel.



**J M B 0 N V24 0 T J 3 00001**

┆	┆	┆	┆	┆	┆	┆	┆	┆	┆	┆	┆
1	2	3	4	5	6	7	8	9	10	11	

- |  |  |
|--|--|
| <p>1. Asia</p> <p>2. Japan</p> <p>3. MITSUBISHI<br/>A: Right hand drive for Europe<br/>B: Left hand drive for Europe</p> <p>4. Sort<br/>0: 4 or 2-door with tailgate (backdoor)<br/>A: 2-door semi-open (canvas top)</p> <p>5. Transmission<br/>N: 5 × 2-speed manual transmission<br/>R: 4 × 2-speed automatic transmission</p> <p>6. Development order<br/>V23: 2,972 ml<br/>Petrol engine &lt;2-door models&gt;<br/>V24: 2,477 ml<br/>Diesel engine &lt;2-door models&gt;<br/>V25: 3,497 ml<br/>Petrol engine &lt;2-door models&gt;<br/>V26: 2,835 ml<br/>Diesel engine &lt;2-door models&gt;<br/>V43: 2,972 ml<br/>Petrol engine &lt;4-door models&gt;<br/>V44: 2,477 ml<br/>Diesel engine &lt;4-door models&gt;<br/>V45: 3,497 ml<br/>Petrol engine &lt;4-door models&gt;<br/>V46: 2,835 ml<br/>Diesel engine &lt;4-door models&gt;</p> | <p>7. Body style<br/>0: Frame</p> <p>8. Model year<br/>T: 1996</p> <p>9. Plant<br/>J,P,Y: Oye Plant of NAGOYA Motor Vehicle Works</p> <p>10. Engine specification<br/>0: Without turbocharger, with catalyzer.<br/>3: With turbocharger, without catalyzer.</p> <p>11. Serial number<br/>00001 ~</p> |
|--|--|

# MAJOR SPECIFICATIONS

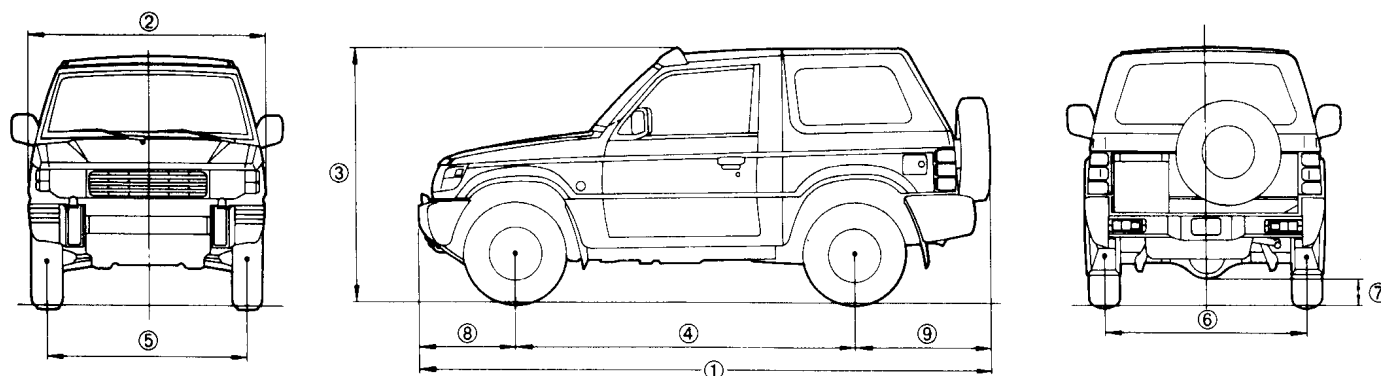
## CANVAS TOP



00E0038

Items			V24CNSFL6	V23CGNHVL6/R6	V23CGRHVL6/R6
Dimensions	mm				
Overall length		①	4,075		4,145
Overall width		②	1,695		1,785
Overall height (unladen)		③	1,805		1,845
Wheelbase		④	2,420		2,420
Track-front		⑤	1,420		1,465
Track-rear		⑥	1,435		1,480
Ground clearance (laden)		⑦	205		215
Overhang-front		⑧	675		720
Overhang-rear		⑨	980		1,005
Weight	kg				
Kerb weight			1,655 – 1,800	1,725 – 1,855	1,735 – 1,865
Max. gross vehicle weight			2,510	2,350	2,350
Max. front axle load			1,100 or 1,070 *1	1,200 or 1,030*1	1,200 or 1,030*1
Max. rear axle load			1,650 or 1,565*1	1,650 or 1,405*1	1,650 or 1,405*1
Seating capacity			4		
Engine					
Model			4D56	6G72	
Total displacement	ml		2,477	2,972	
Transmission					
Type			5-speed manual	5-speed manual	4-speed automatic
Model			V5MT1	V5MT1	V4AW3

NOTE

\*1 : Vehicles for Belgium and France

## METAL TOP

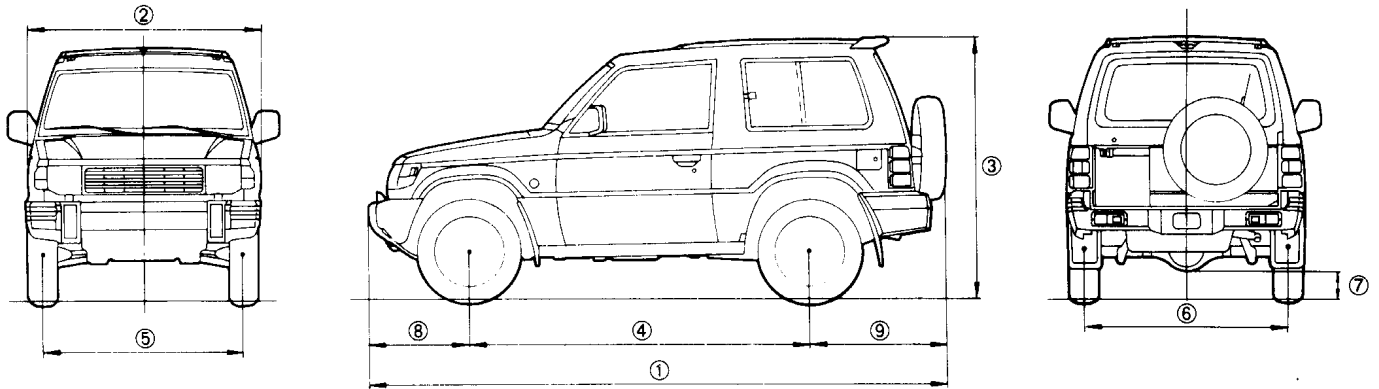

## &lt;VEHICLES WITH PETROL ENGINE&gt;

00E0039

Items		V23WNHVL6	V23WGNXVL6/R6	V23WGRXVL6/R6	V25WGNXML6/R6 V25WGRXML6/R6
Dimensions	mm				
Overall length	①	4,120		4,145	4,145
Overall width	②	1,695		1,785	1,785
Overall height (unladen)	③	1,835		1,845	1,845
Wheelbase	④	2,420		2,420	2,420
Track-front	⑤	1,420		1,465	1,465
Track-rear	⑥	1,435		1,480	1,480
Ground clearance (laden)	⑦	205		215	205
Overhang-front	⑧	720		720	720
Overhang-rear	⑨	980		1,005	1,005
Weight	kg				
Kerb weight		1,735 – 1,865	1,760 – 1,875	1,770 – 1,885	1,810 – 1,925
Max. gross vehicle weight		2,350	2,350	2,350	2,350
Max. front axle load		1,200 or 1,030* <sup>1</sup>	1,200 or 1,030* <sup>1</sup>	1,200 or 1,030* <sup>1</sup>	1,200 or 1,050* <sup>1</sup>
Max. rear axle load		1,650 or 1,405* <sup>1</sup>	1,650 or 1,405* <sup>1</sup>	1,650 or 1,405* <sup>1</sup>	1,780 or 1,345* <sup>1</sup>
Seating capacity		5			
Engine					
Model		6G72	6G72	6G72	6G74
Total displacement	ml	2,972	2,972	2,972	3,497
Transmission					
Type		5-speed manual	5-speed manual	4-speed automatic	5-speed manual or 4-speed automatic* <sup>2</sup>
Model		V5MT1	V5MT1	V4AW3	V5M31 or V4AW3* <sup>2</sup>

## NOTE

\*<sup>1</sup> : Vehicles for Belgium and France\*<sup>2</sup> : V25WGRXML6/R6



<VEHICLES WITH DIESEL ENGINE>

Items	V24WNAFL6 V24WNDFL6	V24WNBFL6 V24WNHFL6 /R6	V24WGNCF6 V24WGNXFL6/ R6	V26WNHFL6	V26WGNXFL6/R6
Dimensions mm					
Overall length ①	4,075	4,120	4,145	4,120	4,145
Overall width ②	1,695	1,695	1,785	1,695	1,785
Overall height (unladen) ③	1,805	1,805	1,815	1,835	1,845
Wheelbase ④	2,420	2,420	2,420	2,420	2,420
Track-front ⑤	1,420	1,420	1,465	1,420	1,465
Track-rear ⑥	1,435	1,435	1,480	1,435	1,480
Ground clearance (laden) ⑦	205	205	225	190	205
Overhang-front ⑧	675	720	720	720	720
Overhang-rear ⑨	980	980	1,005	980	1,005
Weight kg					
Kerb weight	1,680 – 1,820	1,730 – 1,900	1,755 – 1,905	1,830 – 2,000	1,855 – 2,005
Max. gross vehicle weight	2,510	2,510	2,510	2,510	2,510
Max. front axle load	1,100 or 1,070* <sup>1</sup>	1,100 or 1,070* <sup>1</sup>	1,100 or 1,070* <sup>1</sup>	1,200 or 1,115* <sup>1</sup>	1,200 or 1,115* <sup>1</sup>
Max. rear axle load	1,650 or 1,565* <sup>1</sup>	1,650 or 1,565* <sup>1</sup>	1,650 or 1,565* <sup>1</sup>	1,780 or 1,440* <sup>1</sup>	1,780 or 1,440* <sup>1</sup>
Seating capacity	5				
Engine Model	4D56			4M40	
Total displacement ml	2,477			2,835	
Transmission Type	5-speed manual			5-speed manual	
Model	V5MT1			V5M31	

NOTE

\*1: Vehicles for Belgium and France

## WAGON

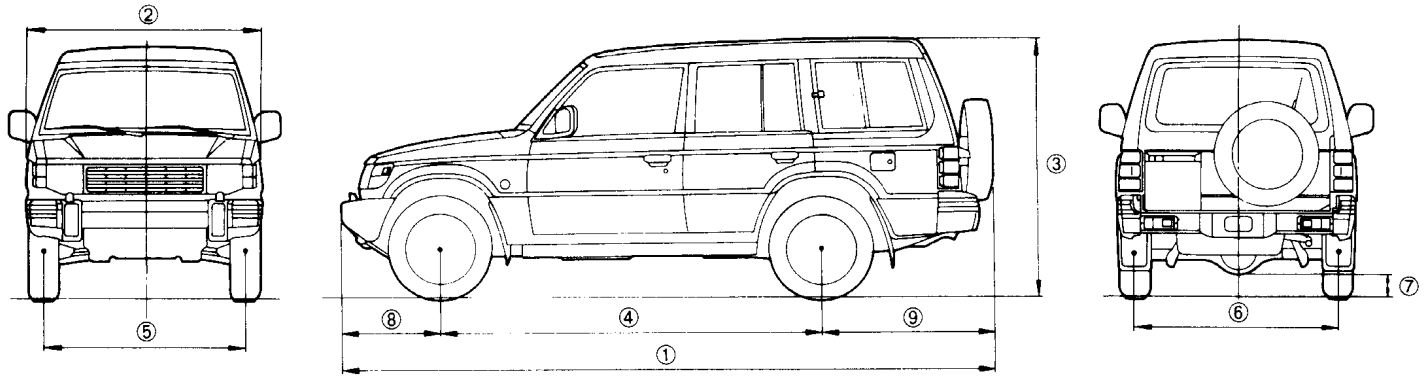

## &lt;VEHICLES WITH PETROL ENGINE&gt;

00E0040

Items	V43WNHVL6/R6 V43WRHVL6/R6	V43WGNXVL6/R6 V43WGRXVL6/R6	V45WGNXML6/R6	V45WGRXML6/R6
Dimensions	mm			
Overall length	① 4,700	4,725	4,725	4,725
Overall width	② 1,695	1,785	1,785	1,785
Overall height (unladen)	③ 1,890	1,900	1,900	1,900
Wheelbase	④ 2,725	2,725	2,725	2,725
Track-front	⑤ 1,420	1,465	1,465	1,465
Track-rear	⑥ 1,435	1,480	1,480	1,480
Ground clearance (laden)	⑦ 205	215	205	205
Overhang-front	⑧ 720	720	720	720
Overhang-rear	⑨ 1,255	1,280	1,280	1,280
Weight	kg			
Kerb weight	1,925 – 2,085 or 1,920 – 2,105* <sup>3</sup>	1,955 – 2,115	1,995 – 2,150	1,990 – 2,145
Max. gross vehicle weight	2,650	2,650	2,720	2,720
Max. front axle load	1,200 or 1,075* <sup>1</sup>	1,200 or 1,075* <sup>1</sup>	1,200 or 1,090* <sup>1</sup>	1,200 or 1,090* <sup>1</sup>
Max. rear axle load	1,650	1,650	1,780 or 1,670* <sup>1</sup>	1,780 or 1,670* <sup>1</sup>
Seating capacity	7			
Engine	6G72		6G74	
Model				
Total displacement	2,972		3,497	
Transmission				
Type	5-speed manual or 4-speed automatic* <sup>3</sup>	5-speed manual or 4-speed automatic* <sup>4</sup>	5-speed manual	4-speed automatic
Model	V5MT1 or V4AW3* <sup>3</sup>	V5MT1 or V4AW3* <sup>4</sup>	V5M31	V4AW3

## NOTE

\*<sup>1</sup> : Vehicles for Belgium and France\*<sup>3</sup> : V43WRHVL6/R6\*<sup>4</sup> : V43WGRXVL6/R6

<VEHICLES WITH DIESEL ENGINE>

Items		V46WNDFL6	V46WNDFCL6 V46WNAFCL6	V46WNBFL6 V46WNHFL6/R6
Dimensions	mm			
Overall length	①	4,655		4,700
Overall width	②	1,695		1,695
Overall height (unladen)	③	1,890		1,890
Wheelbase	④	2,725		2,725
Track-front	⑤	1,420		1,420
Track-rear	⑥	1,435		1,435
Ground clearance (laden)	⑦	190		190
Overhang-front	⑧	675		720
Overhang-rear	⑨	1,255		1,255
Weight	kg			
Kerb weight		1,960 – 2,095	1,920 – 2,055	2,010 – 2,180
Max. gross vehicle weight		2,720	2,720	2,720
Max. front axle load		1,200 or 1,145*1	1,200 or 1,145*1	1,200 or 1,145*1
Max. rear axle load		1,780 or 1,655	1,780 or 1,655*1	1,780 or 1,655*1
Seating capacity		7	5	7
Engine				
Model		4M40		
Total displacement	mℓ	2,835		
Transmission				
Type		5-speed manual		
Model		V5M31		

NOTE

\*1 : Vehicles for Belgium and France

Items			V46WRHFR6	V46WGNCF6 V46WGNXFL6/R6	V46WGRXFL6/R6
Dimensions	mm				
Overall length		①	4,700		4,725
Overall width		②	1,695		1,785
Overall height (unladen)		③	1,890		1,900
Wheelbase		④	2,725		2,725
Track–front		⑤	1,420		1,465
Track–rear		⑥	1,435		1,480
Ground clearance (laden)		⑦	190		205
Overhang–front		⑧	720		720
Overhang–rear		⑨	1,255		1,280
Weight	kg				
Kerb weight			2,005 – 2,175	2,045 – 2,180	2,050 – 2,185
Max. gross vehicle weight			2720	2,720	2,720
Max. front axle load			1,200 or 1,145* <sup>1</sup>	1,200 or 1,145* <sup>1</sup>	1,200 or 1,145* <sup>1</sup>
Max. rear axle load			1,780 or 1,655	1,780 or 1,655* <sup>1</sup>	1,780 or 1,655* <sup>1</sup>
Seating capacity			7		
Engine					
Model				4M40	
Total displacement	mℓ			2,835	
Transmission					
Type			4-speed automatic	5-speed manual	4-speed automatic
Model			V4AW3	V5M31	V4AW3

## NOTE

\*<sup>1</sup> : Vehicles for Belgium and France

## GENERAL – Major Specifications

**00-11**

Items	V44WNDFL6	V44WPDFCL6	V44WNHFL6	V44WGNXFL6/R6
<b>Dimensions</b> <b>mm</b>				
Overall length      ①	4,655	4,655	4,700	4,725
Overall width      ②	1,695	1,695	1,695	1,785
Overall height (unladen)      ③	1,860	1,860	1,860	1,870
Wheelbase      ④	2,725	2,725	2,725	2,725
Track–front      ⑤	1,420	1,420	1,420	1,465
Track–rear      ⑥	1,435	1,435	1,435	1,480
Ground clearance (laden)      ⑦	205	205	205	215
Overhang–front      ⑧	675	675	720	720
Overhang–rear      ⑨	1,255	1,255	1,255	1,280
<b>Weight</b> <b>kg</b>				
Kerb weight	1,865 – 2,000	1,840 – 1,975	1,915 – 2,110	1,950 – 2,120
Max. gross vehicle weight	2,650	2,650	2,650	2,650
Max. front axle load	1,200 or 1,075* <sup>1</sup>	1,100 or 1,090* <sup>1</sup>	1,100 or 1,090* <sup>1</sup>	1,100 or 1,090* <sup>1</sup>
Max. rear axle load	1,650	1,650	1,650	1,650
Seating capacity	7	5	7	7
<b>Engine</b>				
Model	4D56			
Total displacement <b>ml</b>	2,477			
<b>Transmission</b>				
Type	5-speed manual			
Model	V5MT1			

**NOTE**

\*<sup>1</sup> : Vehicles for Belgium and France

# **HOW TO USE TROUBLESHOOTING/INSPECTION SERVICE POINTS**

Troubleshooting of electronic control systems for which the MUT-II can be used follows the basic outline described below. Furthermore, even in systems for which the MUT-II cannot be used, part of these systems still follow this outline.

## **TROUBLESHOOTING CONTENTS**

### **1. STANDARD FLOW OF DIAGNOSTIC TROUBLESHOOTING**

The main procedures for diagnostic troubleshooting are shown.

### **2. SYSTEM OPERATION AND SYMPTOM VERIFICATION TESTS**

If verification of the trouble symptoms is difficult, procedures for checking operation and verifying trouble symptoms are shown.

### **3. DIAGNOSTIC FUNCTION**

The following diagnostic functions are shown.

- Method of reading diagnostic codes
- Method of erasing diagnostic codes
- Input inspection service points

### **4. INSPECTION CHART FOR DIAGNOSTIC TROUBLE CODES**

### **5. INSPECTION PROCEDURE FOR DIAGNOSTIC TROUBLE CODES**

Indicates the inspection procedures corresponding to each diagnosis code. (Refer to the next page for how to read the inspection procedures.)

### **6. INSPECTION CHART FOR TROUBLE SYMPTOMS**

If there are trouble symptoms even though the results of inspection using the MUT-II show that all diagnosis codes are normal, inspection procedures for each trouble symptom will be found by means of this chart.

### **7. INSPECTION PROCEDURE FOR DIAGNOSTIC SYMPTOM**

Indicates the inspection procedures corresponding to each trouble symptoms classified in the Inspection Chart for Trouble Symptoms. (Refer to the next page for how to read the inspection procedures.)

### **8. SERVICE DATA REFERENCE TABLE**

Inspection items and normal judgement values have been provided in this chart as reference information.

### **9. CHECK AT ECU TERMINALS**

Terminal numbers for the ECU connectors, inspection items and standard values have been provided in this chart as reference information.

### **10. INSPECTION PROCEDURES USING AN OSCILLOSCOPE**

When there are inspection procedures using an oscilloscope, these are listed here.

## HOW TO USE THE INSPECTION PROCEDURES

The causes of a high frequency of problems occurring in electronic circuitry are generally the connectors, components, the ECU and the harnesses between connectors, in that order. These inspection procedures follow this order, and they first try to discover a problem with a connector or a defective component.

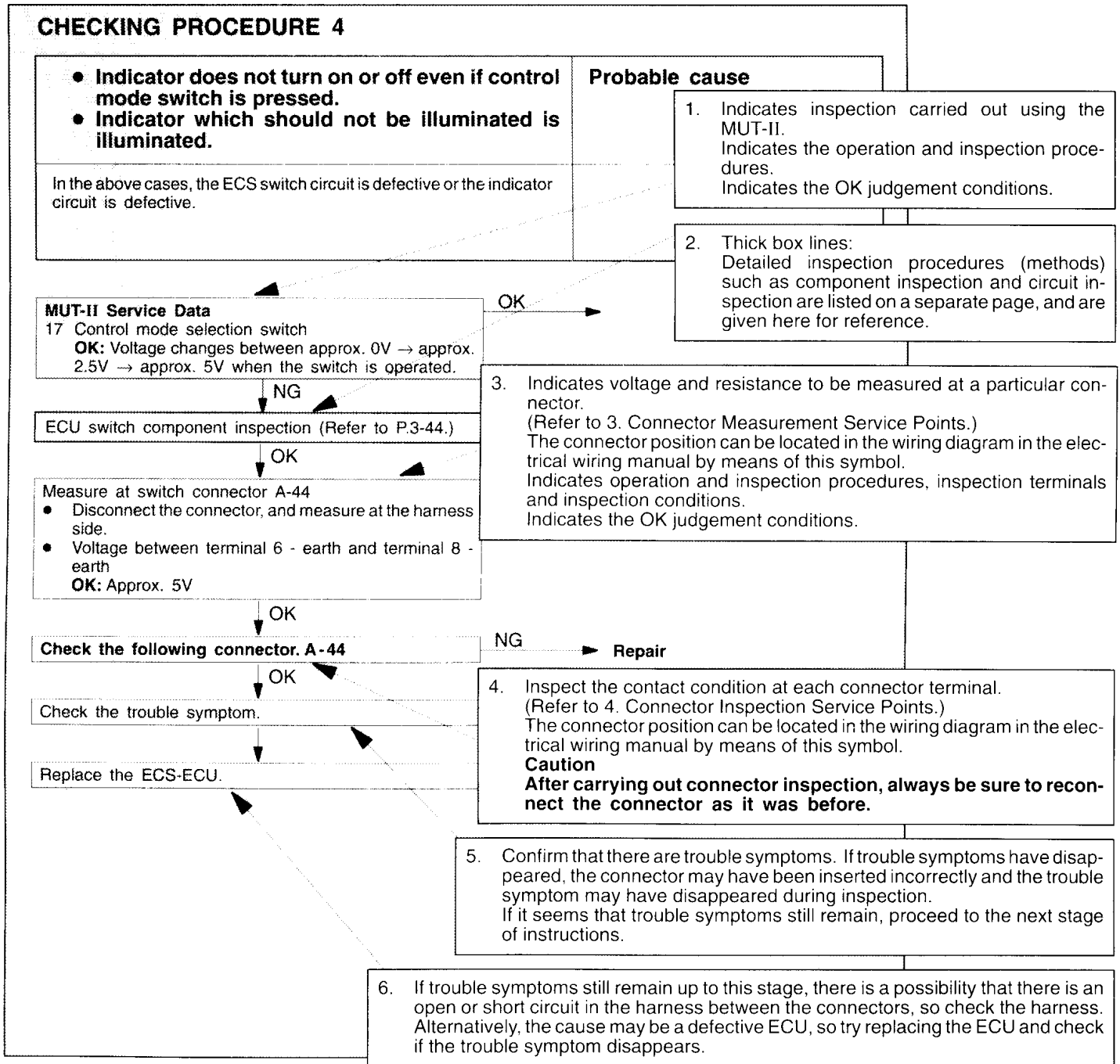

## HARNESS INSPECTION

Check for an open or short circuit in the harness between the terminals which were defective according to the connector measurements. Carry out this inspection while referring to Volume 2 Electrical manual. Here, "Check harness between power supply and terminal xx" also includes checking for blown fuses. For inspection service points when there is a blown fuse, refer to "Inspection Service Points for a Blown Fuse."

## MEASURES TO TAKE AFTER REPLACING THE ECU

If the trouble symptoms have not disappeared even after replacing the ECU, repeat the inspection procedure from the beginning.

**CONNECTOR MEASUREMENT SERVICE POINTS**

Turn the ignition switch to OFF when connecting and disconnecting the connectors, and turn the ignition switch to ON when measuring if there are no instructions to the contrary.

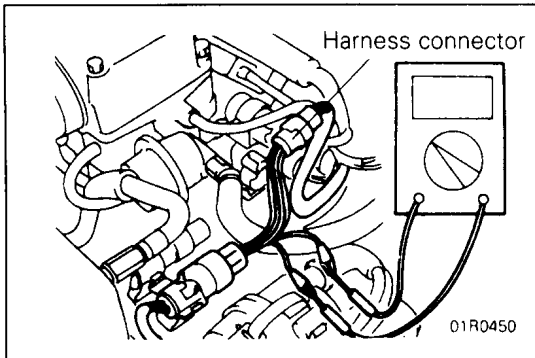

**IF INSPECTING WITH THE CONNECTOR CONNECTED (WITH CIRCUIT IN A CONDITION OF CONTINUITY)**

**Waterproof Connectors**

Be sure to use the special tool (harness connector). Never insert a test bar from the harness side, because to do so will reduce the waterproof performance and result in corrosion.

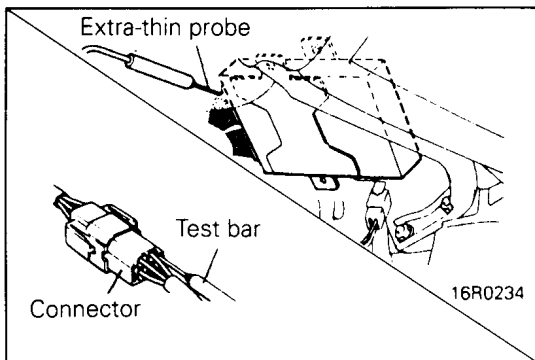

**Ordinary (non-waterproof) Connectors**

Check by inserting the test bar from the harness side. Note that if the connector (control unit, etc.) is too small to permit insertion of the test bar, it should not be forced; use a special tool (the extra-thin probe in the harness set for checking) for this purpose.

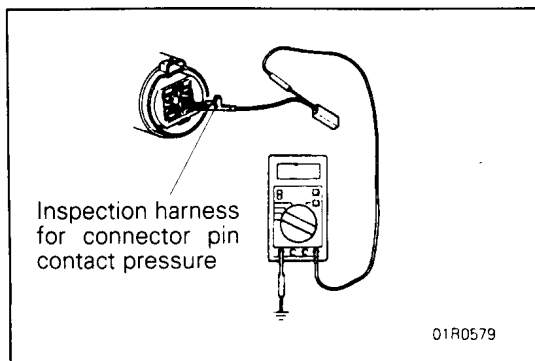

**IF INSPECTING WITH THE CONNECTOR DISCONNECTED**

**<When Inspecting a Female Pin>**

Use the special tool (inspection harness for connector pin contact pressure in the harness set for inspection). The inspection harness for connector pin contact pressure should be used. The test bar should never be forcibly inserted, as it may cause a defective contact.

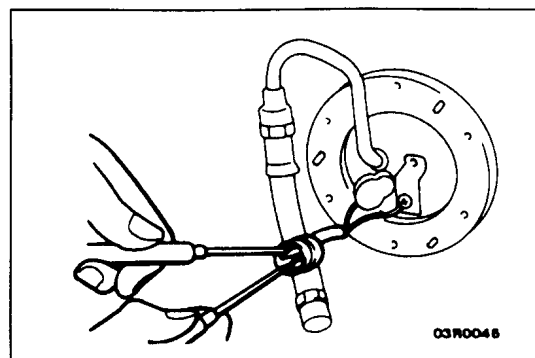

**<When Inspecting a Male Pin>**

Touch the pin directly with the test bar.

**Caution**

**At this time, be careful not to short the connector pins with the test bars. To do so may damage the circuits inside the ECU.**



**Connector disconnected or improperly connected**

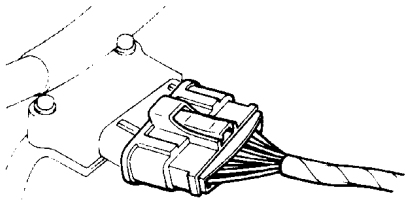

16S0256

**Defective connector contact**

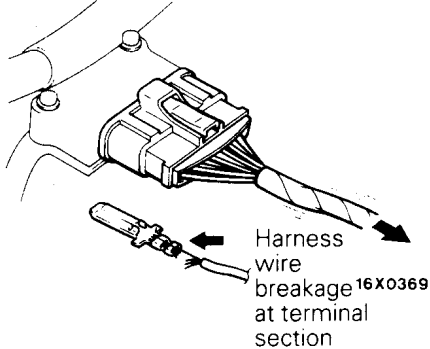

**Low contact pressure**

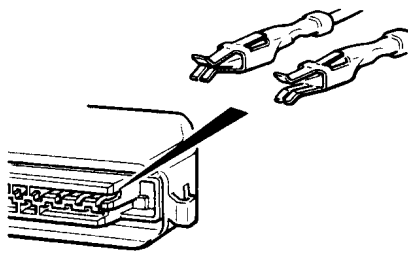

16S0254

**CONNECTOR INSPECTION**

**VISUAL INSPECTION**

- Connector is disconnected or improperly connected
- Connector pins are pulled out
- Due to harness tension at terminal section
- Low contact pressure between male and female terminals
- Low connection pressure due to rusted terminals or foreign matter lodged in terminals

**CONNECTOR PIN INSPECTION**

If the connector pin stopper is damaged, the terminal connections (male and female pins) will not be perfect even if the connector body is connected, and the pins may pull out of the reverse side of the connector. Therefore, gently pull the harnesses one by one to make sure that no pins pull out of the connector.

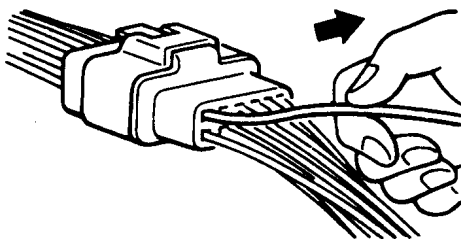

16R1317

**CONNECTOR ENGAGEMENT INSPECTION**

Use the special tool (connector pin connection pressure inspection harness of the inspection harness set) to inspect the engagement of the male pins and female pins. (Pin drawing force : 1 N or more)

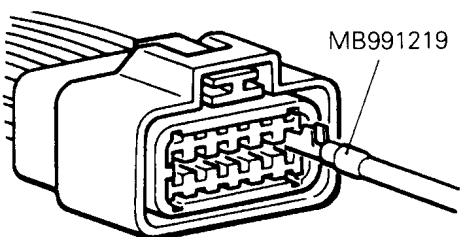

MB991219

16R1318

### INSPECTION SERVICE POINTS FOR A BLOWN FUSE

Remove the fuse and measure the resistance between the load side of the fuse and the earth. Set the switches of all circuits which are connected to this fuse to a condition of continuity. If the resistance is almost 0 W at this time, there is a short somewhere between these switches and the load. If the resistance is not 0 W, there is no short at the present time, but a momentary short has probably caused the fuse to blow.

The main causes of a short circuit are the following.

- Harness being clamped by the vehicle body
- Damage to the outer casing of the harness due to wear or heat
- Water getting into the connector or circuitry
- Human error (mistakenly shorting a circuit, etc.)

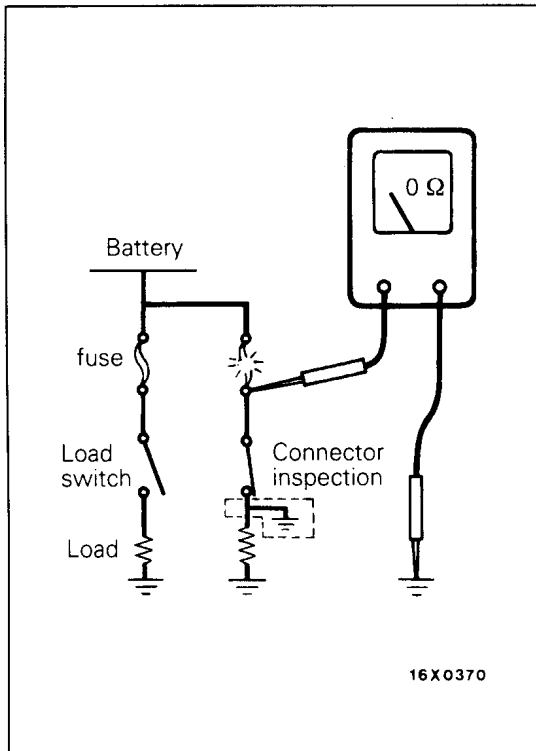

### POINTS TO NOTE FOR INTERMITTENT MALFUNCTIONS

Intermittent malfunctions often occur under certain conditions, and if these conditions can be ascertained, determining the cause becomes simple. In order to ascertain the conditions under which an intermittent malfunction occurs, first ask the customer for details about the driving conditions, weather conditions, frequency of occurrence and trouble symptoms, and then try to recreate the trouble symptoms. Next, ascertain whether the reason why the trouble symptom occurred under these conditions is due to vibration, temperature or some other factor. If vibration is thought to be the cause, carry out the following checks with the connectors and components to confirm whether the trouble symptom occurs.

The objects to be checked are connectors and components which are indicated by inspection procedures or given as probable causes (which generate diagnosis codes or trouble symptoms).

- Gently shake the connector up, down and to the left and right.
- Gently shake the wiring harness up, down and to the left and right.
- Gently rock each sensor and relay, etc. by hand.
- Gently shake the wiring harness at suspensions and other moving parts.

#### NOTE

If determining the cause is difficult, the flight recorder function of the MUT-II can also be used.

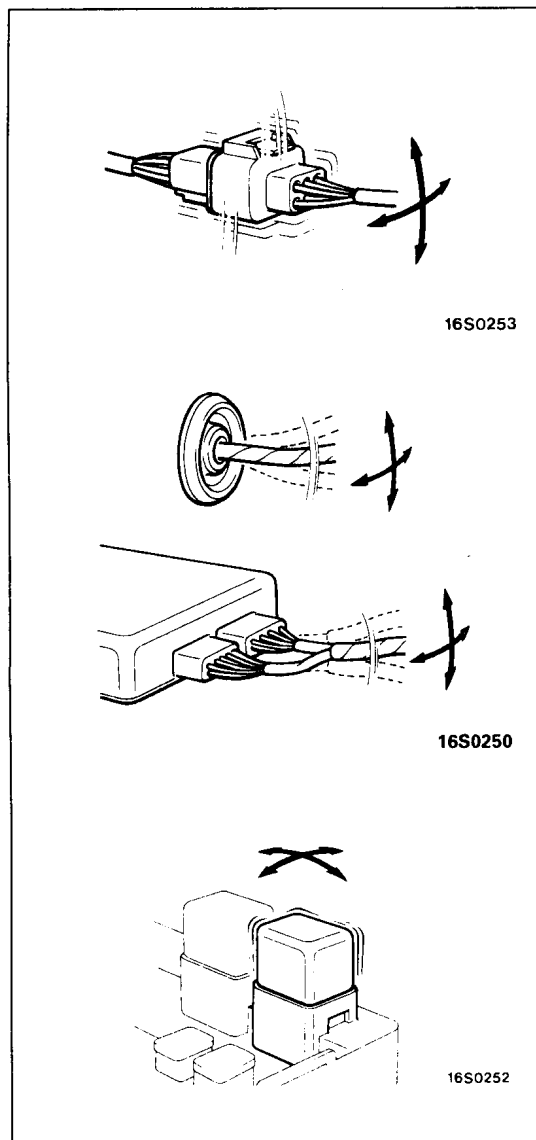

---

# ENGINE

## CONTENTS

<b>GENERAL</b> .....	<b>2</b>	<b>ENGINE &lt;4M40&gt;</b> .....	<b>2</b>
Outline of Change .....	2	<b>SERVICE ADJUSTMENT PROCEDURES</b> .....	<b>2</b>
<b>SPECIFICATION</b> .....	<b>2</b>	Idle Speed Inspection and Adjustment .....	2
Service Specifications .....	2		



**GENERAL**

**OUTLINE OF CHANGE**

The idle speed for the 4M40 engine has been changed. Other specifications are the same as before.

**SPECIFICATIONS**

**SERVICE SPECIFICATIONS**

Items	4M40
Standard value Idle speed r/min	750 ± 100

**ENGINE<4M40>**

**SERVICE ADJUSTMENT PROCEDURES**

**IDLE SPEED INSPECTION AND ADJUSTMENT**

Inspection and adjustment service points are the same as before. Only the standard value has changed.

**Standard value: 750 ± 100 r/min**

# FUEL

## CONTENTS

<b>FUEL SYSTEM</b>		<b>FUEL SYSTEM</b>	
<b>&lt;6G72 – 24 Valve Engine, 6G74</b>		<b>&lt;4D56 Engine, 4M40 Engine&gt;</b>	<b>9</b>
<b>Engine&gt;</b>	<b>2</b>	<b>GENERAL</b>	<b>9</b>
<b>GENERAL</b>	<b>2</b>	Outline of Change	9
Outline of Change	2	<b>SERVICE ADJUSTMENT PROCEDURES</b>	<b>9</b>
<b>SPECIFICATION</b>	<b>2</b>	Fuel Cut Valve Controller Inspection	9
General Specifications	2	<b>FUEL FILTER</b>	
<b>TROUBLESHOOTING</b>	<b>2</b>	<b>&lt;VEHICLES WITH LINE HEATER&gt;</b>	<b>9</b>
Engine Warning Lamp (Check Engine Lamp) ...	2		
Self-Diagnosis	2		
Problem Diagnosis Content Chart	3		
Check Chart Classified by Problem			
Symptoms	4		
<b>ON-VEHICLE INSPECTION OF MPI</b>			
<b>COMPONENTS</b>	<b>5</b>		
Fuel Pump	5		
Air Conditioner Switch and Power Relay	8		

# FUEL SYSTEM <6G72-24 Valve Engine, 6G74 Engine>

## GENERAL

### OUTLINE OF CHANGE

The following service points have been established to correspond to the addition of vehicles with immobilizer system.

- An engine-ECU has been added.
- An engine warning lamp illumination topic and a diagnosis topic have been added.
- The following check items have been added.
  - (1) Fuel pump
  - (2) Air conditioner switch and power relay

## SPECIFICATIONS

### GENERAL SPECIFICATIONS

Items			Specifications
Engine-ECU	Identification model No.	SOHC	E2T37486 <Vehicles with immobilizer system>
		DOHC	E2T39983 <Vehicles with immobilizer system>

## TROUBLESHOOTING

### ENGINE WARNING LAMP (CHECK ENGINE LAMP)

#### ITEMS INDICATED BY THE ENGINE WARNING LAMP

Immobilizer system
--------------------

## SELF-DIAGNOSIS

### Diagnosis Chart

Diagnosis item	Malfunction code		Check item (Remedy)
	No.	Memory	
Immobilizer system	54	Retained	<ul style="list-style-type: none"> <li>● Harness and connector</li> <li>● Immobilizer-ECU</li> </ul> Refer to GROUP 54 – Immobilizer Troubleshooting.

#### NOTE

- If the engine is started while several ignition keys are in the vicinity, then interference between the different keys may occur, which will cause this code to be generated.
- This code may also be generated when registering a key ID code.

**PROBLEM DIAGNOSIS CONTENT CHART**

Malfunction code No.	Diagnosis item	Diagnosis contents	Probable cause	Remark (Trouble symptom, etc.)
54	Immobilizer system	Improper communication between engine-ECU and immobilizer-ECU	<ol style="list-style-type: none"><li>(1) ID code interference</li><li>(2) Non-identical ID codes</li><li>(3) Improper communication line between engine-ECU and immobilizer-ECU</li><li>(4) Malfunction of immobilizer-ECU</li><li>(5) Malfunction of the engine – ECU</li></ol>	<ul style="list-style-type: none"><li>● Starting is impossible.</li></ul>

# 13-4 FUEL SYSTEM <6G72 – 24 Valve Engine, 6G74 Engine> – Troubleshooting

## CHECK CHART CLASSIFIED BY PROBLEM SYMPTOMS

<Vehicles with immobilizer system>

Problem symptoms Check Items	Starting		Idling stability			Driving						Stopping	Reference page
	Will not start	Starting problem	Idling instability (Rough idling)	Incorrect idling speed	Improper idling continuity	Hesitation, sag	Poor acceleration	Stumble	Shock	Surge	Knocking	Run-on (Dieseling)	
Power Supply and Ignition Switch-IG	①①												*13-79-34
Engine Control Unit Power Earth	②②												*13-79-37
Fuel Pump	③③	①①			①①	①①	①①						*13-79-38 13-5
Air Flow Sensor					⑩⑩	⑩⑩		⑤⑤	⑤⑤		④④		*13-79-41
Intake Air Temperature Sensor			⑤			⑥⑥	⑥⑤				②②		*13-79-46
Barometric Pressure Sensor			⑦			⑨⑨	⑦⑦				③③		*13-79-49
Engine Coolant Temperature Sensor		③	⑥⑤	①①	⑥⑤	⑧⑧	⑥⑥	④④		③③			*13-79-51
Throttle Position Sensor						⑦⑦		③③	④④				*13-79-54
Idle Position Switch			③③	②②	④④								*13-79-57
Cam Position Sensor	⑥⑤	⑥⑦			⑧⑦				②②				*13-79-60
Crank Angle Sensor	⑥⑥	⑦⑧			⑨⑧				③③				*13-79-64
Ignition Switch-ST <M/T>	④④	③④											*13-79-67
Ignition Switch-ST and Inhibitor Switch <A/T>	④④	③④		⑤									*13-79-68
Vehicle Speed Sensor					⑥				⑥				*13-79-70
Power Steering Fluid Pressure Switch				③									*13-79-72
Air Conditioner Switch and Power Relay				④									*13-79-74 13-8
Detonation Sensor <DOHC>											①①		*13-79-76
Oxygen Sensor			⑨										*13-79-80
Injectors	⑧⑧	②②	②②		③③	②②	②②	①①		①①		①	*13-79-83
Idle Speed Control Servo (Stepper Motor)		④⑤	①①	⑥③	②②				⑧⑧				*13-79-88
Ignition Coil and Power Transistor	⑦⑦				⑩⑨		⑧⑧		①①		⑤⑤		*13-79-93, 99
Variable Induction Control Solenoid Valve						④④	④④						*13-79-103
Purge Solenoid			⑧										*13-79-105
EGR Control Solenoid Valve						⑤⑤		⑥⑥		④④			*13-79-107
Anti-skid Brake Signal									⑦				*13-79-109
Fuel Pressure		⑤⑥	④④		⑦⑥	③③	③③	②②		②②			*13-79-110, 113

○ : Warm engine (figures inside the ○ indicate the checking sequence.)

□ : Cold engine (figures inside the □ indicate the checking sequence.)

\* : Refer to PAJERO Workshop Manual (PWJE9086).



# ON-VEHICLE INSPECTION OF MPI COMPONENTS

## FUEL PUMP

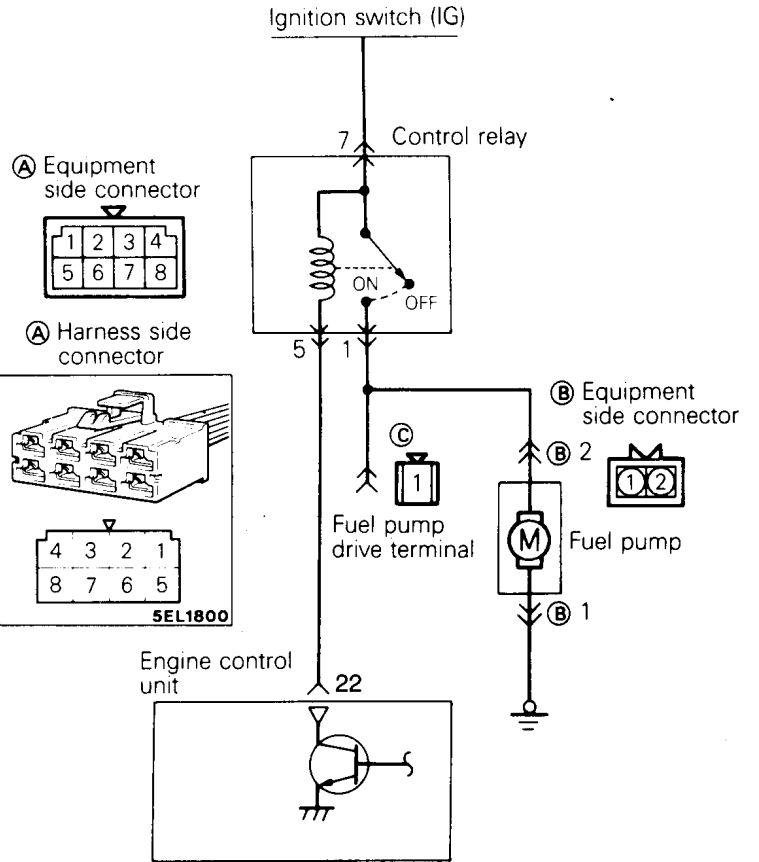
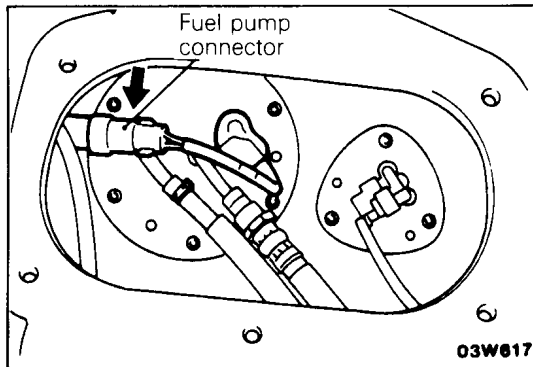
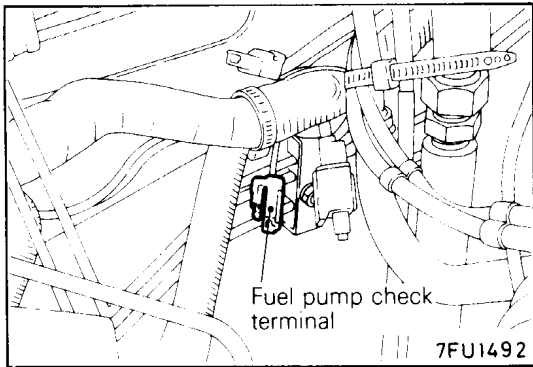

Engine control unit connector

1	2	3	4	5	6	7	8	9	10	11	12	13	14	15	16	17	18	19	20	21	22	23	24	25	26	27	28	29	30	31	32	33	34	35	36	37	38	39	40	41	42	43	44	45	46	47	48	49	50	51	52	53	54	55	56	57	58	59	60	61	62	63	64	65	66	67	68	69	70	71	72	73	74	75	76	77	78	79	80	81	82	83	84	85	86	87	88	89	90	91	92	93	94	95	96	97	98	99	100
---	---	---	---	---	---	---	---	---	----	----	----	----	----	----	----	----	----	----	----	----	----	----	----	----	----	----	----	----	----	----	----	----	----	----	----	----	----	----	----	----	----	----	----	----	----	----	----	----	----	----	----	----	----	----	----	----	----	----	----	----	----	----	----	----	----	----	----	----	----	----	----	----	----	----	----	----	----	----	----	----	----	----	----	----	----	----	----	----	----	----	----	----	----	----	----	----	----	----	-----

9FU0101

6AF0159

HARNESS INSPECTION

**1**

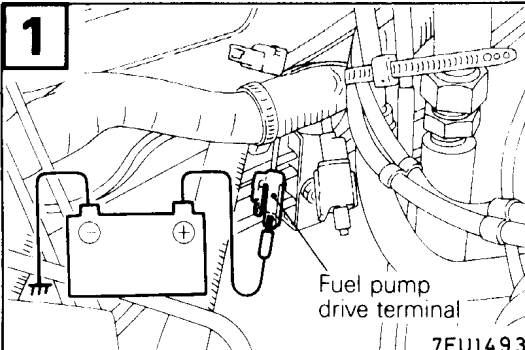

Fuel pump drive terminal  
7FU1493

Check the fuel pump.

- Apply battery voltage to the fuel pump drive terminal and operate the pump.

OK → **4**

✗ → **2**

**2**

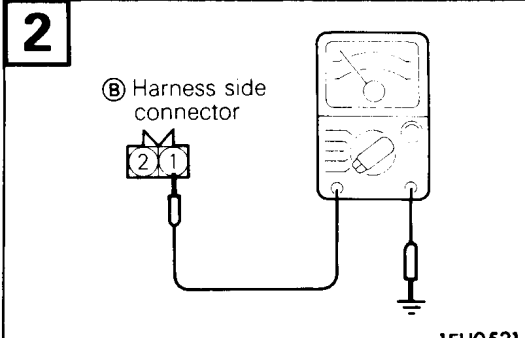

B Harness side connector  
1FU0521

Check for continuity of the fuel pump earthing line.

- Fuel pump connector: Disconnected

OK → **3**

✗ → Repair the harness. (B1 - Earth)

**3**

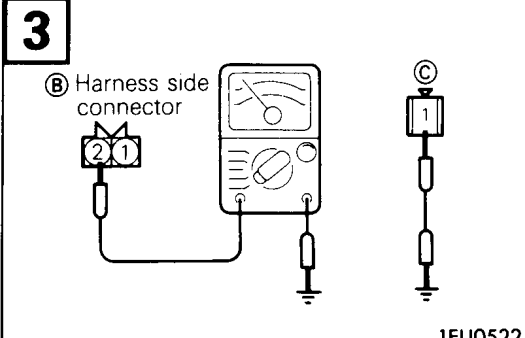

B Harness side connector  
C  
1FU0522

Check for open-circuit or short-circuit between the fuel pump and the fuel pump drive terminal.

- Fuel pump connector: Disconnected
- Control relay connector: Disconnected

OK → **4**

✗ → Repair the harness. (B2 - C1)

**4**

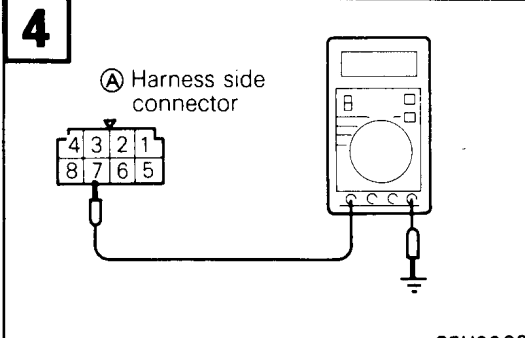

A Harness side connector  
9FU0023

Measure the power supply voltage of the control relay.

- Control relay connector: Disconnected

Ignition switch	Voltage (V)
OFF	0-1
START	SV

OK → **5**

✗ → Repair the harness. (Ignition switch - A7) or check for ignition switch.

**5**

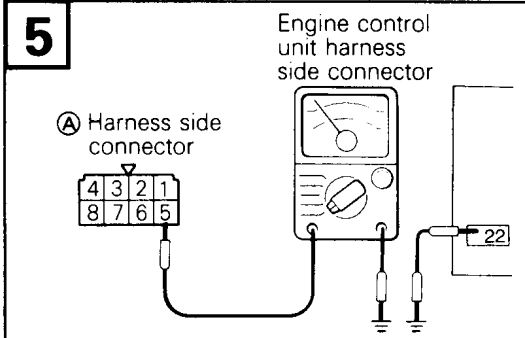

Engine control unit harness side connector  
A Harness side connector  
22  
01A0354

Check for an open-circuit, or a short-circuit to earth between the control relay and the engine control unit.

- Control relay connector: Disconnected
- Engine control unit connector: Disconnected

OK → **6**

✗ → Repair the harness. (A5 - 22)

**6**

④ Harness side connector

9FU0024

Check for continuity between the fuel pump drive terminal and the control relay.

- Control relay connector: Disconnected
- Fuel pump connector: Disconnected

**OK** → **7**

**OK** → Repair the harness. (④1 - ①1)

**7**

④ Harness side connector

6AF0162

Check for an open-circuit, or a short-circuit to earth between the control relay and the fuel pump.

- Control relay connector: Disconnected
- Fuel pump connector: Disconnected

**OK** → **8**

**OK** → Repair the harness. (④1 - ②2)

**8**

④ Harness side connector

6FU1753

Measure the power supply voltage of the fuel pump.

- Control relay connector: Connected
- Engine control unit connector: Connected

Engine	Voltage (V)
Cranking	8V or more
Racing	SV

**OK** → **STOP**

**OK** → Control relay or engine control unit is defective.

**AIR CONDITIONER SWITCH AND POWER RELAY**

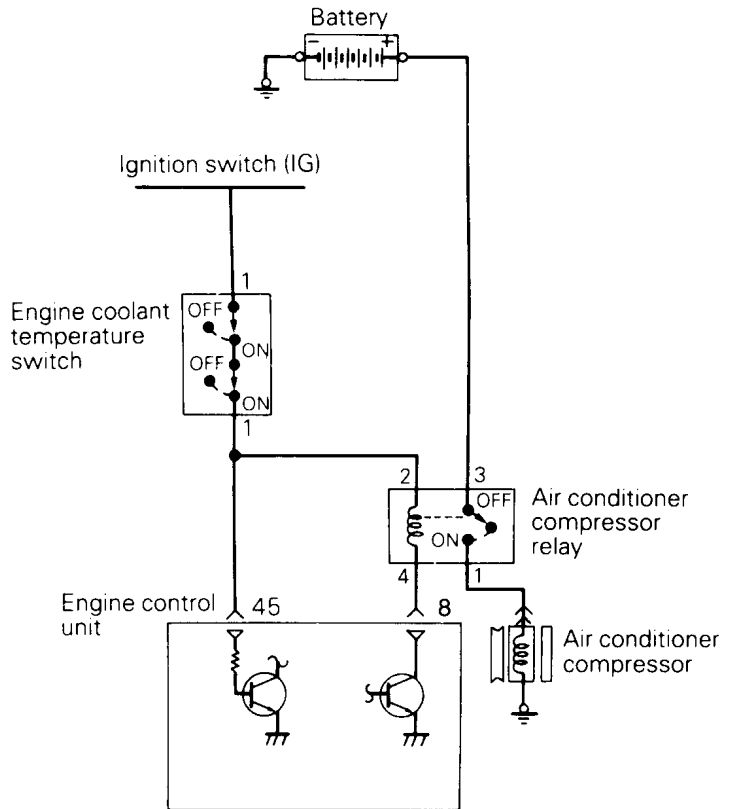
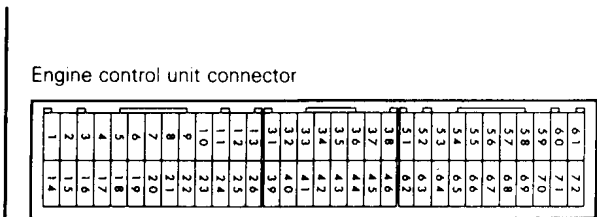
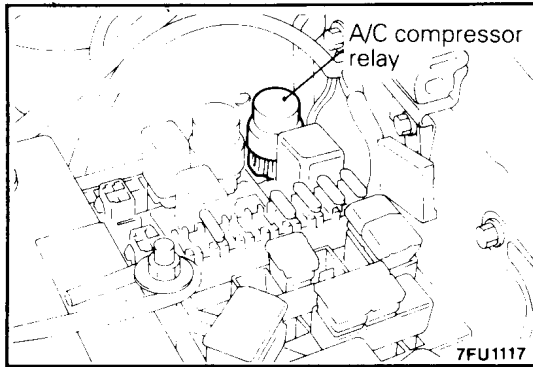
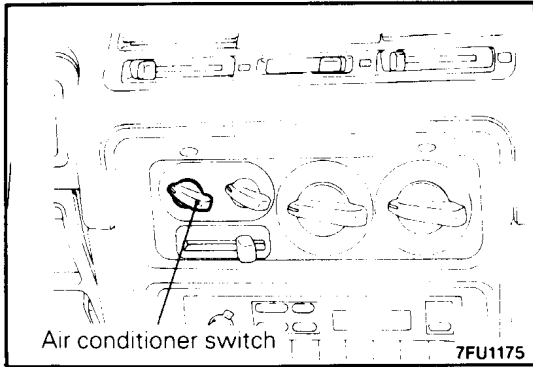

7FU0821

**HARNES INSPECTION**

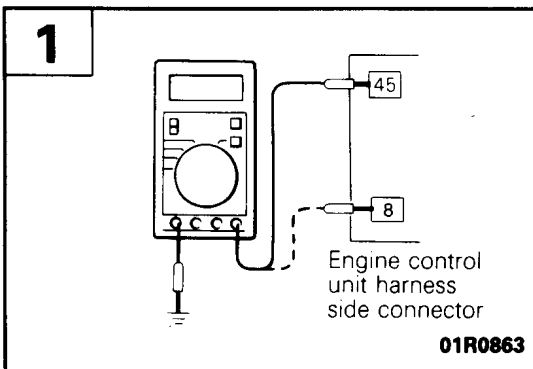

Measure the power supply voltage of the air conditioner circuit.

- Engine control unit connector: Disconnect
- Ignition switch: ON
- Air conditioner switch: ON

<b>Voltage (V)</b>
<b>SV</b>



Check the Air conditioner circuit.

# FUEL SYSTEM <4D56 Engine, 4M40 Engine>

## GENERAL

### OUTLINE OF CHANGE

- The fuel cut valve controller with integrated fuel cut solenoid valve has been installed to the fuel injection pump to correspond to the addition of vehicles with immobilizer system.
- The fuel line heater has been changed and new maintenance service points have been established. As a result, the fuel line heater control unit has been abolished.

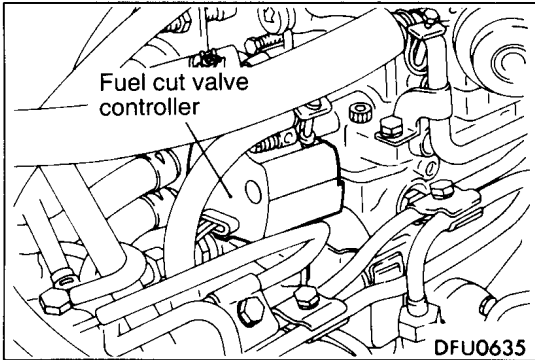

## SERVICE ADJUSTMENT PROCEDURES

### FUEL CUT VALVE CONTROLLER INSPECTION

#### Operation Inspection

When a sound scope is held against the fuel cut valve controller and the ignition switch is turned to "ON", check that the sound of the valve operating can be heard.

If no operating sound can be heard, check the immobilizer system while referring to GROUP 54 – Immobilizer System.

## FUEL FILTER <VEHICLES WITH LINE HEATER>

### REMOVAL AND INSTALLATION

#### Pre-removal Operation

- Inter-cooler Removal

#### Post-installation Operation

- (1) Inter-cooler Installation
- (2) Air Bleeding of Fuel Line

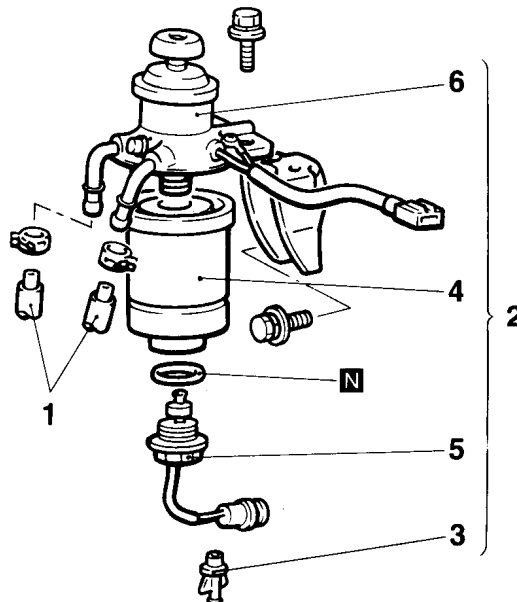

#### Removal steps



1. Main hose connection
2. Fuel filter assembly
3. Drain plug



4. Fuel filter cartridge
5. Water level sensor
6. Fuel filter pump body

### REMOVAL SERVICE POINT

#### ◀A▶ MAIN HOSE REMOVAL

#### Caution

Cover with a rag to prevent fuel from spraying out.

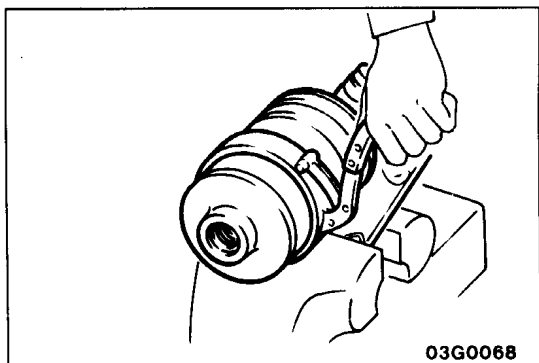
**◀B▶ FUEL FILTER CARTRIDGE REMOVAL**

Hold fuel filter pump in vice. Remove fuel filter cartridge with oil filter wrench.

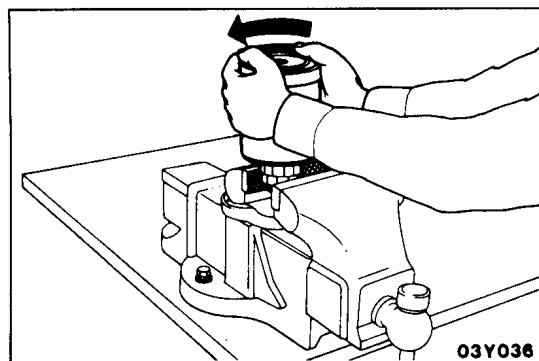
**◀C▶ WATER LEVEL SENSOR REMOVAL**

Hold water level sensor in vice. Remove fuel filter cartridge by hand.

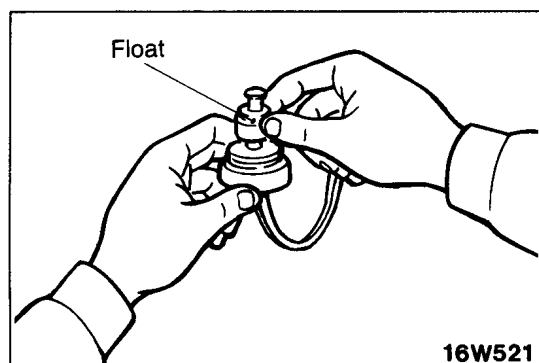
**INSPECTION**

- Check hoses and line for cracks, bends, deterioration or clogging.
- Check fuel filter for clogging or damage.

**WATER LEVEL SENSOR OPERATION**

Connect circuit tester to water level sensor connector. Water level sensor is operating correctly if there is continuity when float is raised and no continuity when lowered.

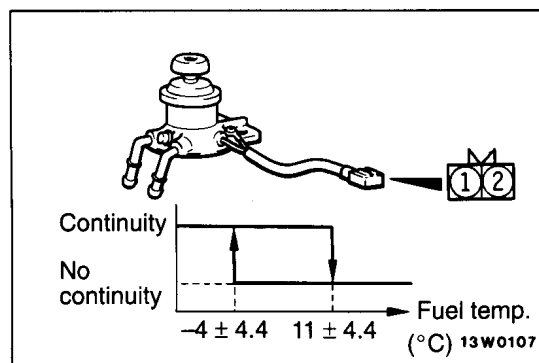
**FUEL LINE HEATER CONTINUITY INSPECTION**

There should be continuity between the terminals when the fuel filter pump is cooled to  $-4^{\circ}\text{C}$  or below and continuity should disappear when the pump is gradually heated. If this is true, then the heater is working properly.

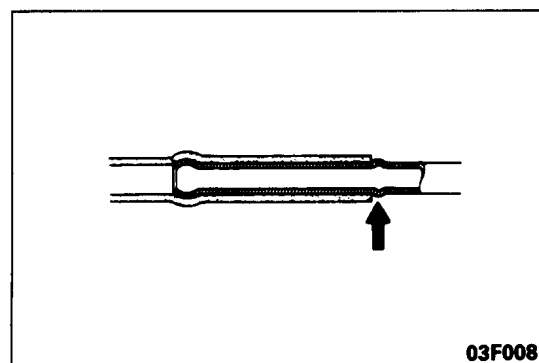
**INSTALLATION SERVICE POINT****▶A◀ MAIN HOSE INSTALLATION**

Insert each hose securely as far as the stepped section on the pipes.

---

# AUTOMATIC TRANSMISSION

## CONTENTS

<b>GENERAL</b> .....	<b>2</b>	<b>TROUBLESHOOTING &lt;V4AW3&gt;</b> .....	<b>3</b>
Outline of Change .....	2	Road Test .....	3
<b>SPECIFICATIONS</b> .....	<b>2</b>		
Transmission Model Table .....	2		
Gear Ratio Table .....	2		

---

## GENERAL

### OUTLINE OF CHANGE

- Different varieties of the V4AW3 automatic transmission have been added. Maintenance service points are the same as before.
- The shift pattern for vehicles with the 4M40 (2800-D) engine has been changed. In addition, the input from the engine coolant temperature switch to the A/T-ECU has been abolished. To correspond to this, mention of the engine coolant temperature switch has been deleted from the maintenance service points. Other contents are the same as before.

## SPECIFICATIONS

### TRANSMISSION MODEL TABLE

Transmission model	Speedometer gear ratio	Vehicle model	Engine model (Engine displacement)
V4AW3-7-LIA	29/9	V23C, V23W, V43W	6G72 – 24 valve (3000 – 24V)
V4AW3-7-LILA	29/9	V23C, V23W, V43W	6G72 – 24 valve (3000 – 24V)
V4AW3-7-MHA	28/9	V25W	6G74 (3500)
V4AW3-7-MHLA	28/9	V25W	6G74 (3500)

### GEAR RATIO TABLE

	Gear ratio
1st	2.804
2nd	1.531
3rd	1.000
4th	0.754
Reverse	2.393



**TROUBLESHOOTING <V4AW3>**

**ROAD TEST**

**SHIFT PATTERN**

<4M40 engine>

**Normal pattern**

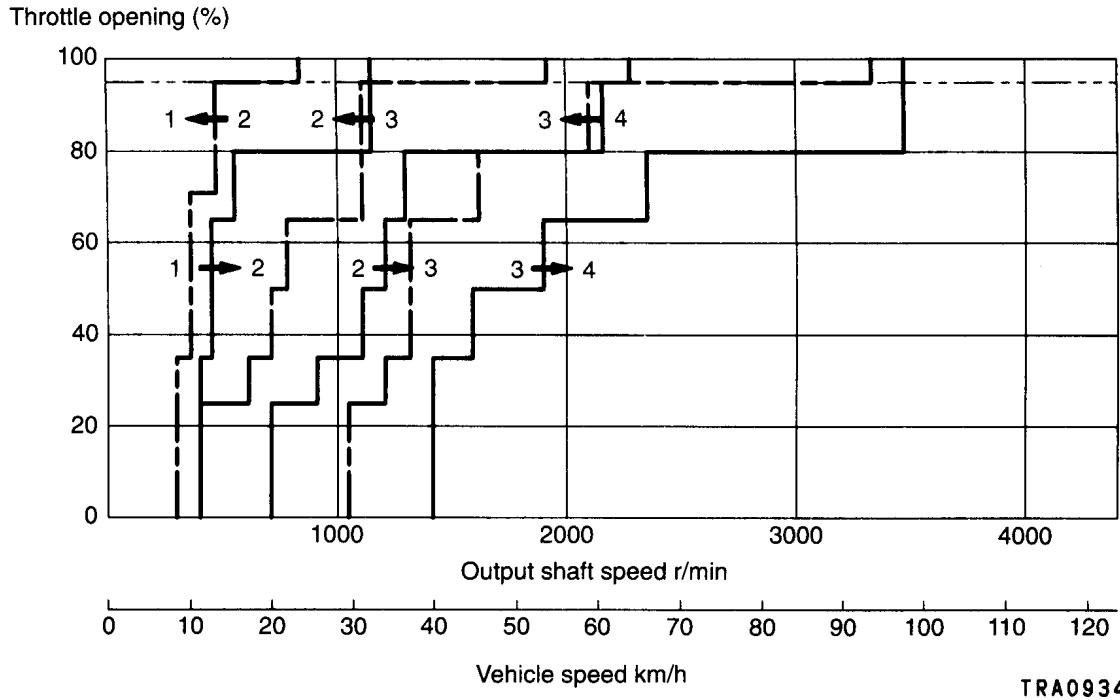

**Power pattern**

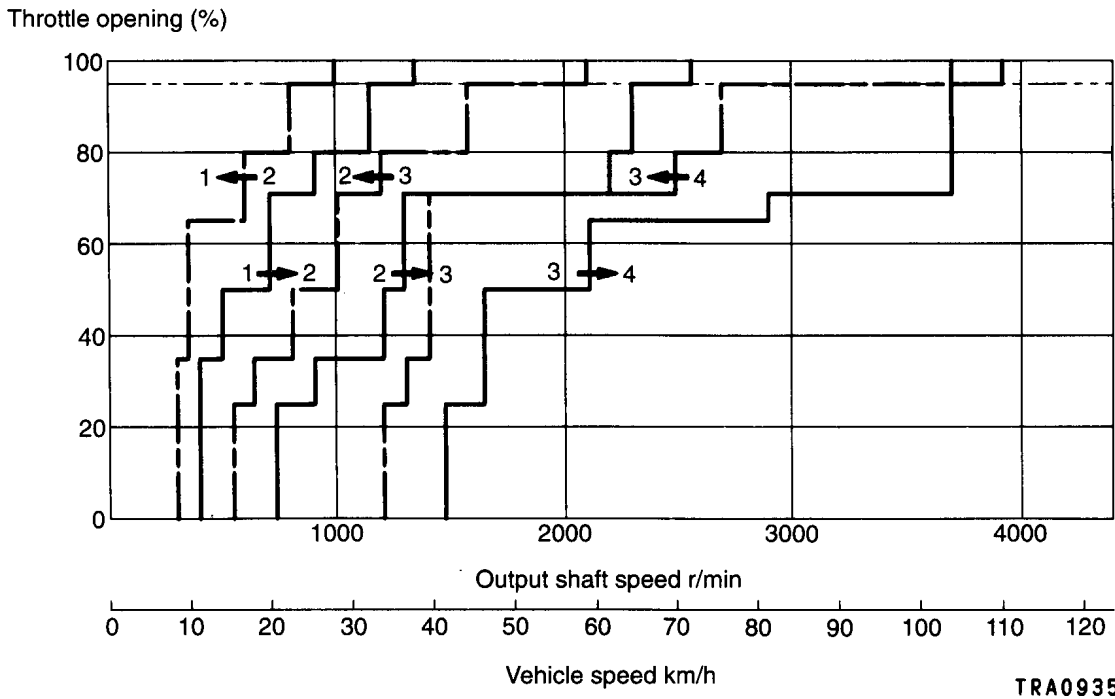

Hold pattern (Upshift)

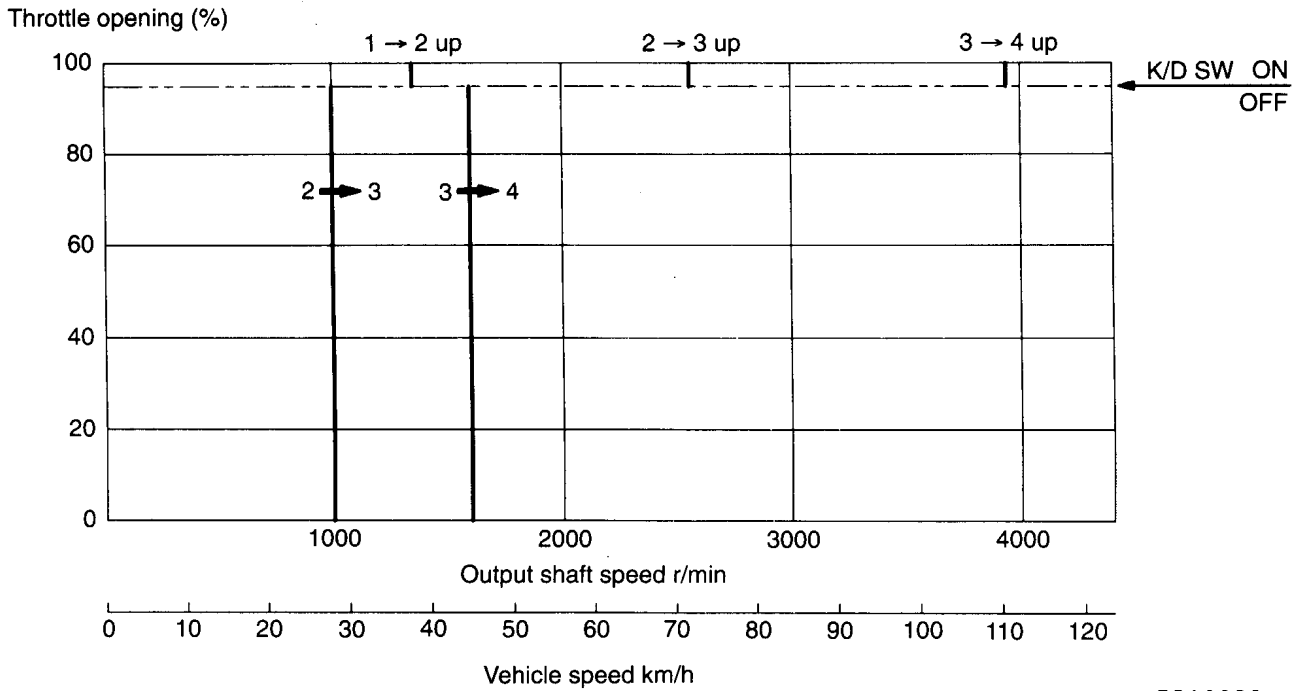

TRA0936

Hold pattern (Downshift)

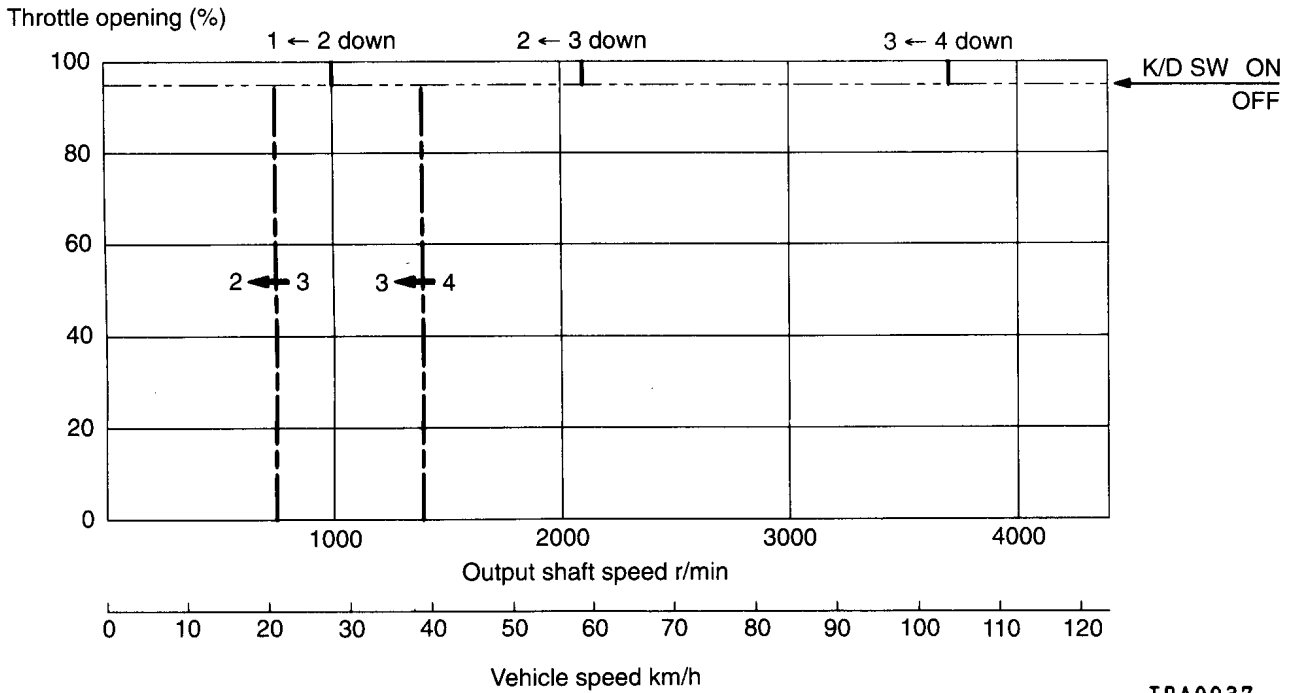

TRA0937

---

# REAR AXLE

## CONTENTS

<b>GENERAL</b> .....	2	<b>SPECIAL TOOLS</b> .....	3
Outline of Changes .....	2	<b>AXLE SHAFT</b> .....	6
<b>SPECIFICATIONS</b> .....	2	<b>DIFFERENTIAL CARRIER</b>	
General Specifications .....	2	<HYBRID TYPE LSD> .....	12
Service Specifications .....	2		
Lubricants .....	3		
Sealant and Adhesives .....	3		

---

**GENERAL****OUTLINE OF CHANGES**

- The dust cover of the rear axle shaft and the ABS wheel-speed sensor rotor have been redesigned. With this change, the service procedure for the axle shaft has been added.
- Vehicles with 3500 petrol engine and 2800D Diesel engine has used a hybrid type LSD. With this change, the service procedure has been added.

**SPECIFICATIONS****GENERAL SPECIFICATIONS**

Items	Standard wheelbase 2800D, 3500	Long wheelbase 2800D
Differential		
Differential size	No. 7.5	No. 7.5
Reduction gear type	Hypoid gear (fine pitch type)	Hypoid gear (fine pitch type)
Reduction ratio	4.636	4.900
LSD type	Hybrid type (Helical gear + VCU*)	Hybrid type (Helical gear + VCU*)

## NOTE

\* : Viscous Coupling Unit

**SERVICE SPECIFICATIONS**

Items	Specifications
Standard value	
Press-fitting force of retainer N	
Initial press-fitting force	49,000
Final press-fitting force	98,000 – 108,000
Clearance of snap ring and retainer mm	0 – 0,166
Final drive gear backlash mm	0.13 – 0.18
Drive pinion turning torque	
Without oil seal Nm	
With anti-rust agent (new)	0.6 – 0.9
With gear oil applied (new or used)	0.4 – 0.5
With oil seal Nm	
With anti-rust agent (new)	0.85 – 1.15
With gear oil applied (new or used)	0.65 – 0.75
Limit	
Drive gear runout mm	0.05



**LUBRICANTS**



Items	Specified lubricant	Quantity /
Rear axle gear oil Hybrid type LSD	Hypoid gear oil API classification GL-5 or higher SAE viscosity No. 90, 80W	3.2

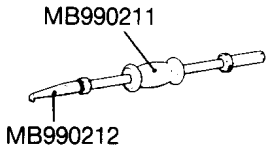
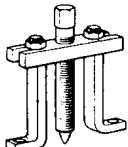

**SEALANT AND ADHESIVES**

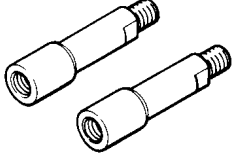
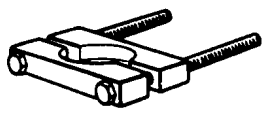
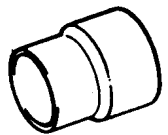
Items	Specified sealants and adhesives	Remarks
Bearing case Differential carrier mounting surface of axle housing	3M ATD Part No. 8663 or equivalent	Semi-drying sealant
Drive gear threaded hole	3M Stud Locking 4170 or equivalent	Anaerobic sealant

**SPECIAL TOOLS**

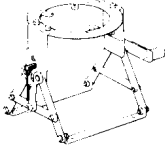
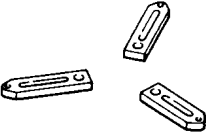
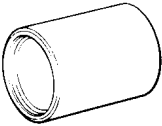
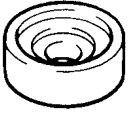
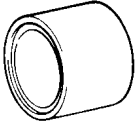
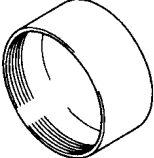
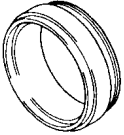
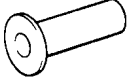
Tool	Number	Name	Use
 <p>MB990211 MB990212</p>	MB990590	Sliding hammer	Removal of axle shaft (Use together with MB990241) Removal of axle housing oil seal
	MB990241	Rear axle shaft puller	Removal of axle shaft (Use together with MB990590)
	MB991552	Axle shaft bearing and case remover	Removal of the axle shaft bearing and bearing case
	MB991601	Extension bar	
	MB990560	Axle shaft bearing remover	Removal of the axle shaft bearing inner race
	MB990799	Bearing inner race installer	Press-fitting of the axle shaft bearing inner race Press-fitting of the axle shaft retainer

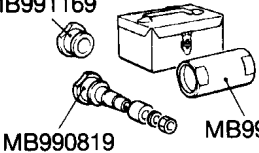
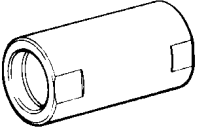
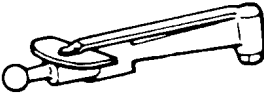
Tool	Number	Name	Use
	MB990810	Side bearing puller	Removal of the side bearing inner race
	MB990850	End yoke holder	Removal of the companion flange
	MB990909	Working base	Support of rear differential carrier assembly
	MB991116	Adapter	
	MB990890 or MB990891	Rear suspension bushing base	Installation of bearing outer race
	MB991407	Differential rear support arbor	Removal of side bearing inner race
	MB991445	Bush remover and installer base	Pressing of drive pinion rear bearing outer race
	MD998812	Installer cap	Pressing of side bearing inner race
	MD998829	Installer adaptor	
	MB991168	Drive pinion oil seal installer	Press-fitting of the drive pinion oil seal

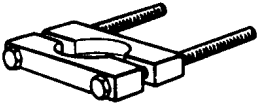
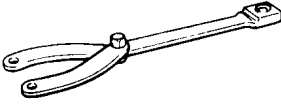
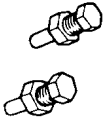
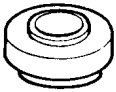
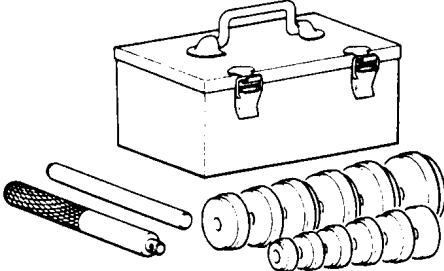
Tool	Number	Name	Use
 <p>MB991169 MB990819 MB991170</p>	MB991171	Pinion height gauge set	Measurement of the pinion height
	MB991534	Cylinder cage	
	MB991151 or MB990685	Torque wrench	Measurement of the starting torque of drive pinion
	MB990326	Preload socket	
	MD998801	Bearing remover	Removal of drive pinion rear bearing inner race
	MB991367	Special spanner	Removal and installation of side bearing nut
	MB991385	Pin	
	MB990802	Bearing installer	Press-fitting of the drive pinion rear bearing inner race Press-fitting of the side bearing inner race
	MB990925	Bearing and oil seal installer set	Press-fitting of the axle housing oil seal MB990938, MB990930 Press-fitting of the axle shaft bearing case oil seal MB990938, MB990936 Driving-out of the drive pinion front bearing, drive pinion rear bearing, outer race and oil seal MB990939 Press-fitting of the drive pinion rear bearing outer race MB990938 use together with MB991445 Press-fitting of the drive pinion front bearing outer race MB990938, MB990934

## AXLE SHAFT

## REMOVAL AND INSTALLATION

## Post-installation Operation

- Air Bleeding from Brake Lines
- Parking Brake Lever Stroke Adjustment

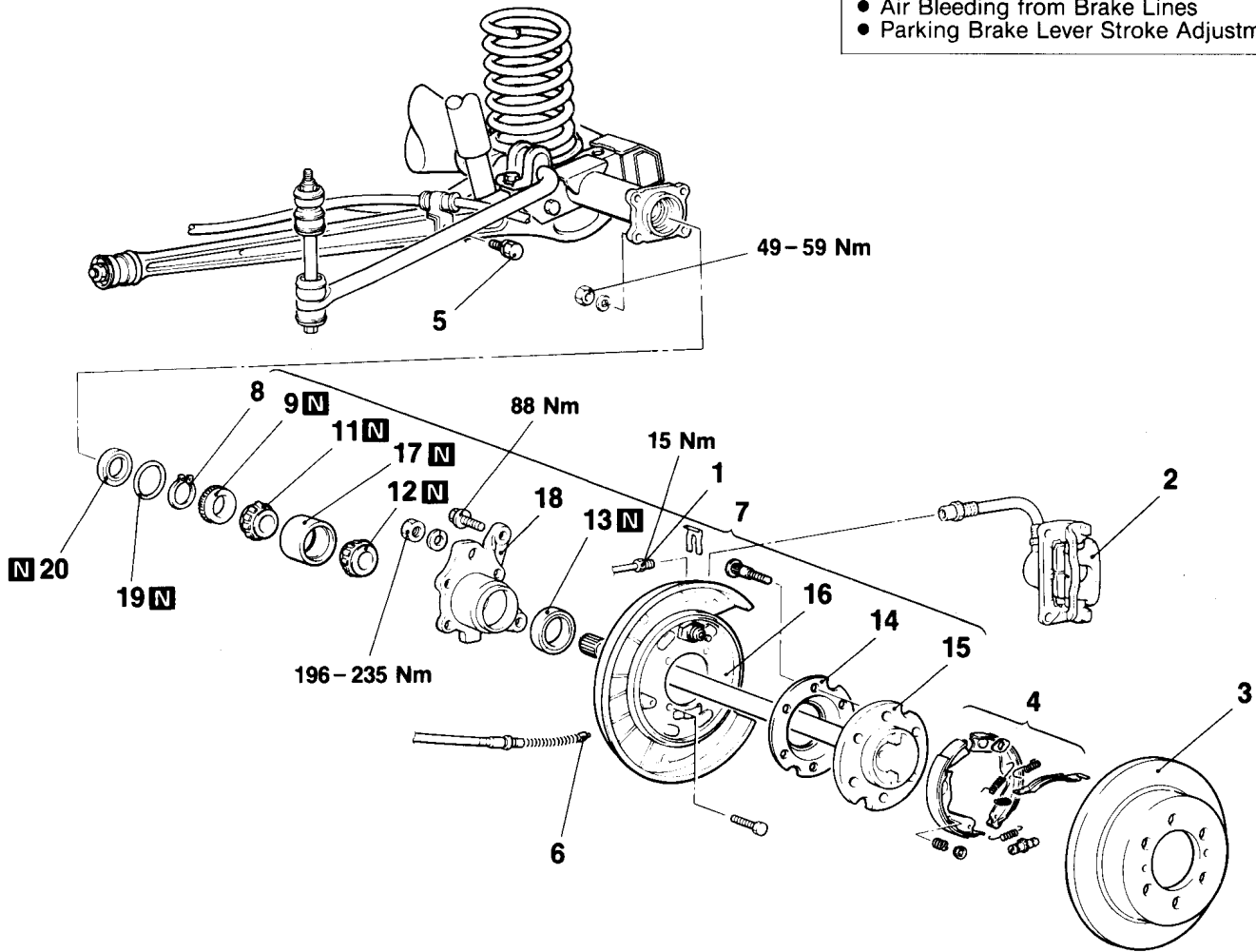

11E0218

## Removal steps

1. Brake tube connection
2. Rear brake assembly
3. Brake disc
4. Parking brake assembly
5. Parking brake cable attaching bolt
6. Parking brake cable end
7. Axle shaft assembly
8. Snap ring
9. Retainer\*
10. Axle shaft sub assembly  
(Parts from step 12 to step 15)
11. Bearing inner race (inner)
12. Bearing inner race (outer)
13. Oil seal
14. Dust cover
15. Axle shaft
16. Backing plate
17. Bearing outer race
18. Bearing case
19. O-ring
20. Oil seal

◀A▶

◀B▶

◀C▶

◀D▶

◀E▶

◀F▶

## Installation steps

- ▶A◀ 20. Oil seal
19. O-ring
18. Bearing case
- ▶B◀ 17. Bearing outer race
16. Backing plate
15. Axle shaft
14. Dust cover
12. Bearing inner race (outer)
- ▶C◀ 13. Oil seal
- ▶D◀ 11. Bearing inner race (inner)
- ▶E◀ 9. Retainer
- ▶F◀ 8. Snap ring
7. Axle shaft assembly
6. Parking brake cable end
5. Parking brake cable attaching bolt
4. Parking brake assembly
3. Brake disc
2. Rear brake assembly
1. Brake tube connection

## NOTE

\* : For vehicles with ABS, the sensor rotor has been integrated.



LUBRICATION AND SEALING POINTS

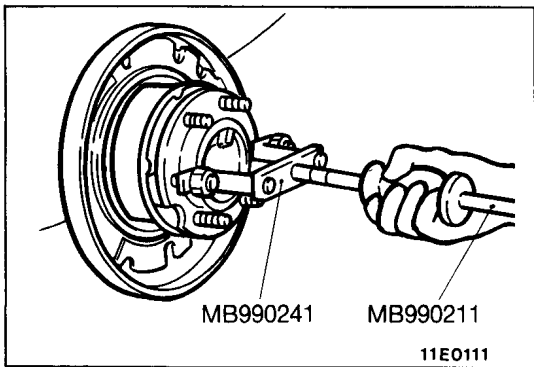
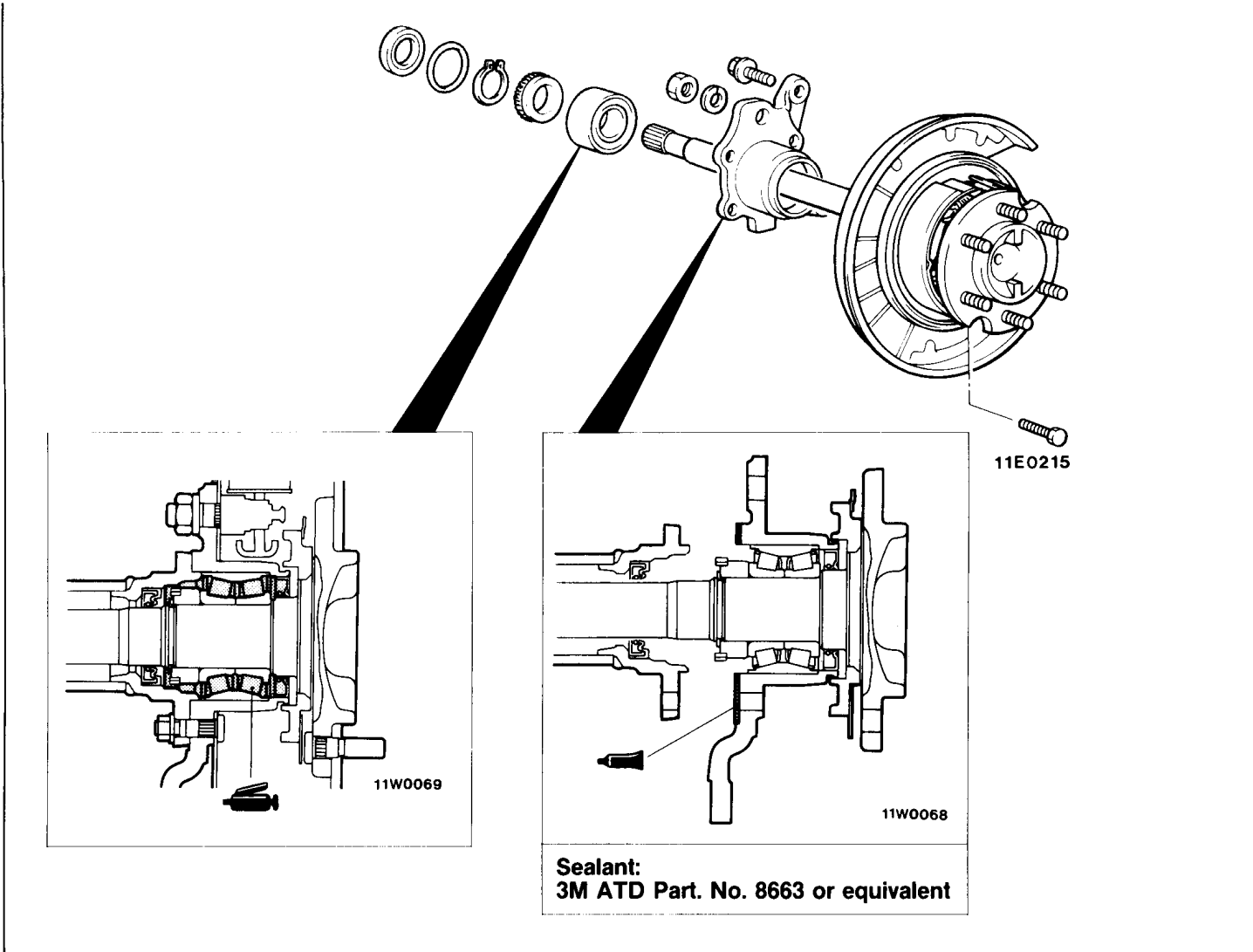

REMOVAL SERVICE POINTS

◀A▶ AXLE SHAFT ASSEMBLY REMOVAL

Pull the rear axle shaft. If the rear axle shaft is difficult to remove, use the special tools.

NOTE

Do not damage the oil seal during removal.

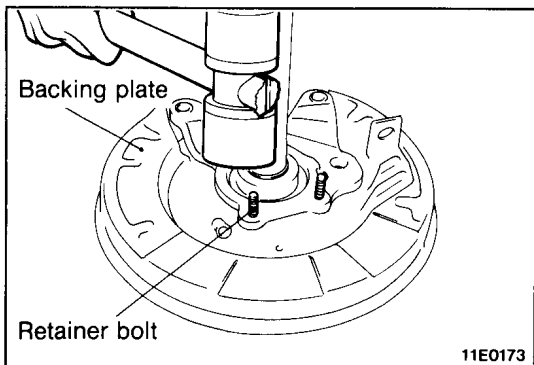

◀B▶ RETAINER REMOVAL

(1) Remove one retainer bolt from the backing plate.

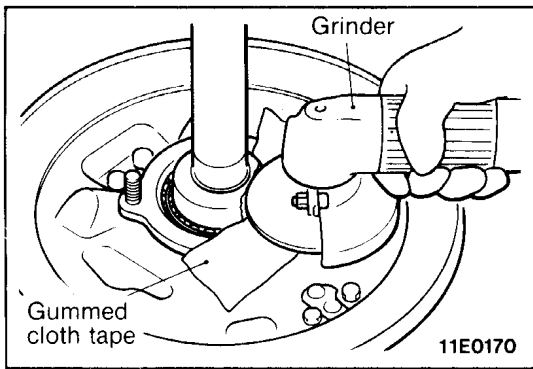

- (2) Apply gummed cloth tape around the edge of the bearing case for protection.
- (3) As shown in the figure, fix the axle shaft and shave off with grinder a point of its circumference locally until the wall thickness on the side of axle shaft of retainer ring and the side of bearing become approximately 1.0–2.0 mm and 2.0 mm respectively.

**Caution**

**Be careful not to damage the bearing case and the axle shaft.**

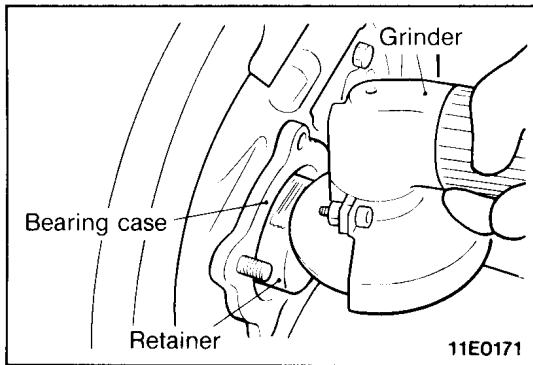

- (4) Fix the axle shaft and shave off the remaining 2.0 mm on the side of the bearing of the retainer.

**Caution**

**Be careful not to damage the bearing case and the axle shaft.**

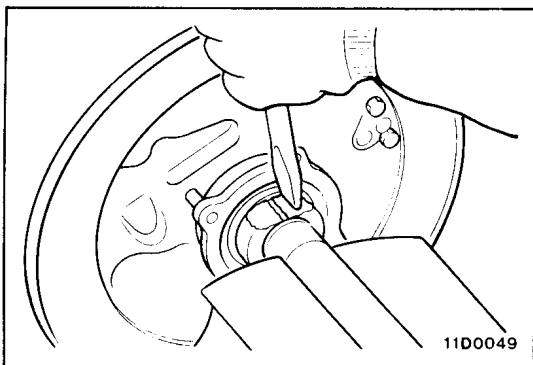

- (5) Cut in with a chisel the place where the retainer ring has been shaven and remove the retainer.

**Caution**

**Be careful not to damage the axle shaft.**

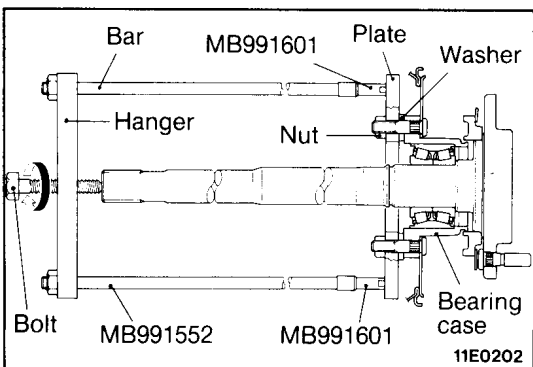
**◀C▶ AXLE SHAFT SUB ASSEMBLY REMOVAL**

- (1) Adjust the height of the hanger, and install the plate, washer, nut in the shown order.

**NOTE**

If the bar of the special tool (MB991552) is too short, install the extension bar (MB991601).

- (2) Place the end of the bolt against the centre of the axle shaft, and then tighten the nut to remove the axle shaft from the bearing case assembly.

**Caution**

**The hanger and plate should be placed so that they are parallel.**

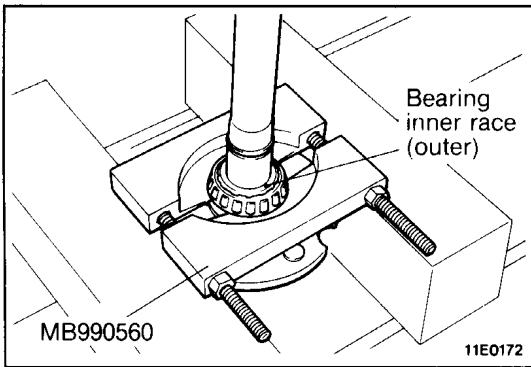

**◀D▶ BEARING INNER RACE (OUTER) REMOVAL**

Install the special tool as shown in the illustration, and then use a press to remove the bearing inner race (outer) from the axle shaft.

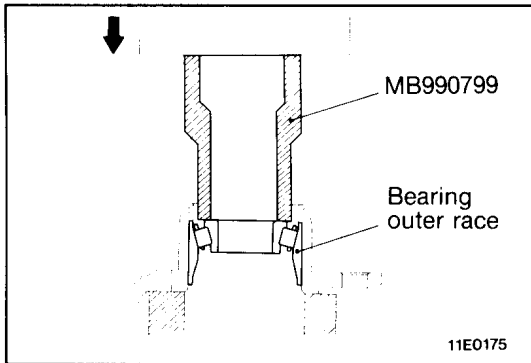

**◀E▶ BEARING OUTER RACE REMOVAL**

Reinstall the bearing inner race that was removed previously, and then use the special tool and press to remove the bearing outer race.

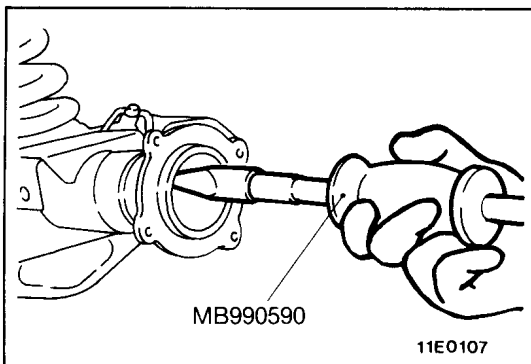

**◀F▶ OIL SEAL REMOVAL**

Remove the oil seal from the end of rear axle housing using the special tool, if necessary.

**INSPECTION**

- Check the dust cover for deformation or damage.
- Check the oil seal for damage.
- Check the inner and outer bearings for seizure, discoloration and rough raceway surface.
- Check the axle shaft for cracks, wear and damage.

**INSTALLATION SERVICE POINTS**

**▶A◀ OIL SEAL INSTALLATION**

Drive the new oil seal into the rear axle housing end by using the special tools.

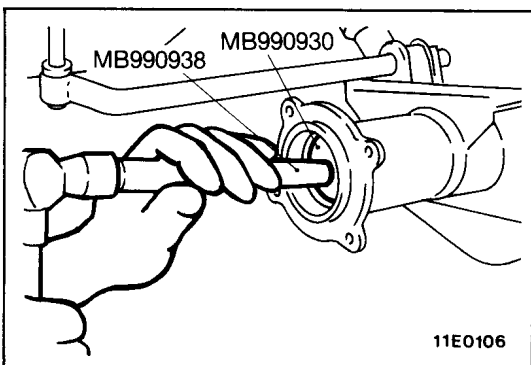

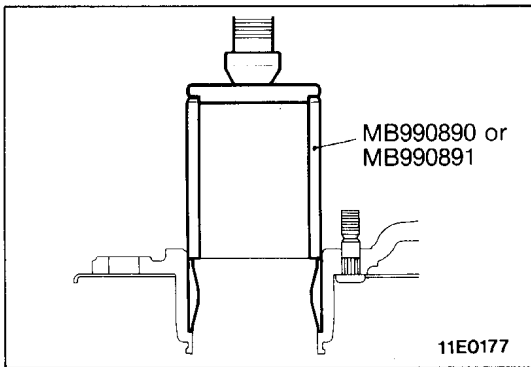

**►B◄ BEARING OUTER RACE INSTALLATION**

- (1) Apply the multi-purpose grease to the external surface of the bearing outer race.
- (2) Press-fit the bearing outer race into the bearing case by using special tools.

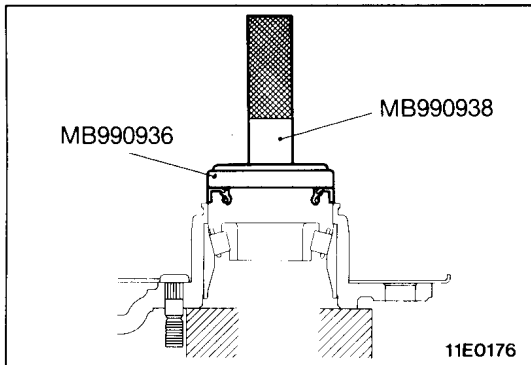

**►C◄ OIL SEAL INSTALLATION**

- (1) Apply multi-purpose grease to the outside of the oil seal.
- (2) Use the special tools to press-fit the oil seal until it is flush with the end of the bearing case.
- (3) Apply multi-purpose grease to the lip of the oil seal.

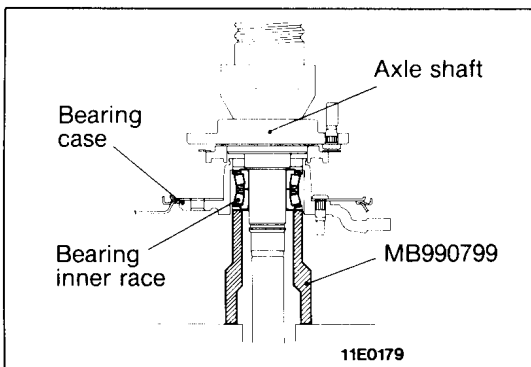

**►D◄ BEARING INNER RACE (INNER) INSTALLATION**

- (1) Pass the axle shaft through the bearing inner race, the bearing case and the second bearing inner race in that order.
- (2) Use the special tool to press-fit the bearing inner race to the axle shaft.

**Caution**

**Both bearing inner race sets should be press-fitted together.**

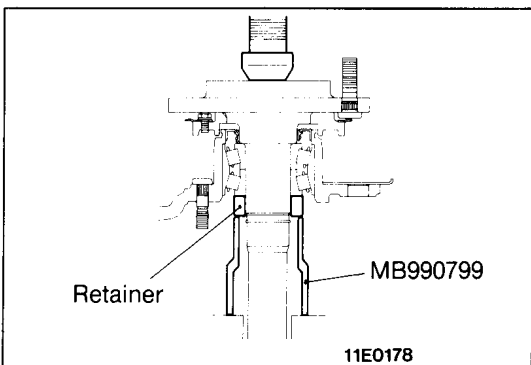

**►E◄ RETAINER PRESS-FITTING**

Use the special tool to press-fit the retainer onto the axle shaft, while checking that the press-fitting force is at the standard value.

If the initial press-fitting force is less than the standard value, replace the axle shaft.

**Standard value:**

Initial press-fitting force	N	49,000 or more
Final press-fitting force	N	98,000 – 108,000

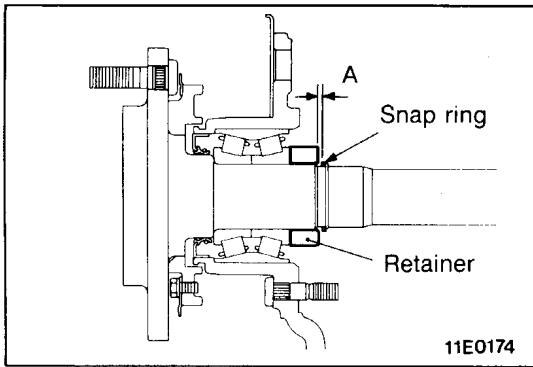

### ►F◄ SNAP RING INSTALLATION

- (1) After installing the snap ring, measure the clearance (A) between the snap ring and the retainer with a thickness gauge, and check that it is within the standard values.

**Standard value (A): 0–0.166 mm**

- (2) If the clearance exceeds the standard value, change the snap ring so that the clearance is at the standard value.

Thickness of snap ring mm	Identification colour
2.17	—
2.01	Yellow
1.85	Blue
1.69	Purple
1.53	Red

**DIFFERENTIAL CARRIER <HYBRID TYPE LSD>**

**REMOVAL AND INSTALLATION**

**Pre-removal Operation**

- Differential Gear Oil Draining

**Post-installation Operation**

- Air Bleeding from Brake Lines
- Parking Brake Lever Stroke Adjustment
- Differential Gear Oil Filling

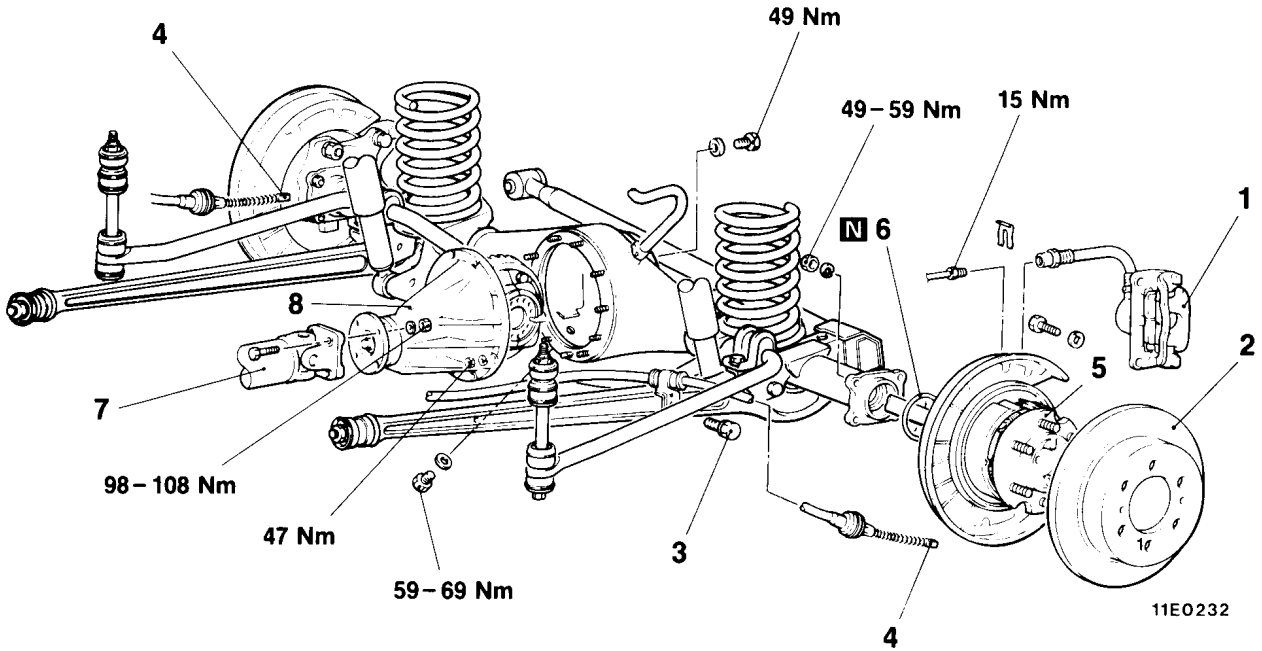

**Removal steps**

1. Rear brake assembly
2. Brake disc
3. Parking brake cable attaching bolt
4. Parking brake cable end
5. Rear axle shaft assembly
6. O-ring
7. Rear propeller shaft
8. Differential carrier

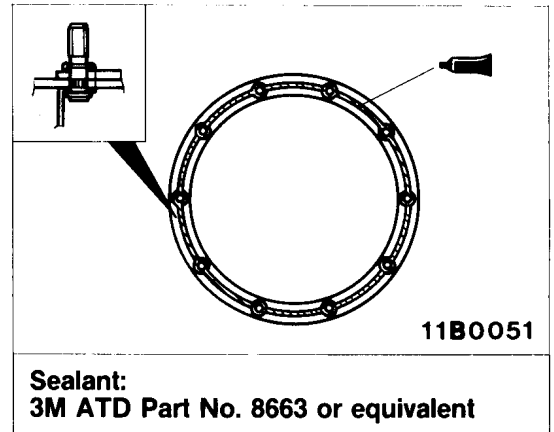

**REMOVAL SERVICE POINTS**

**<A> REAR AXLE SHAFT ASSEMBLY REMOVAL**

Pull out the right and left axle shafts by about 70 mm. If it is difficult to pull out, use the special tools.

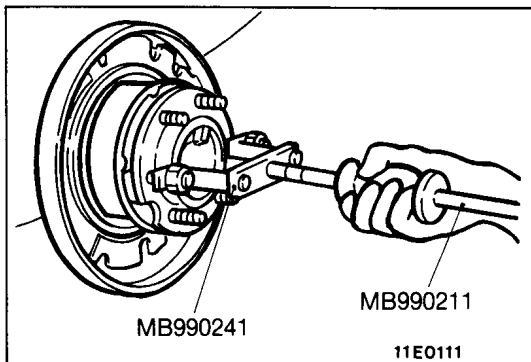

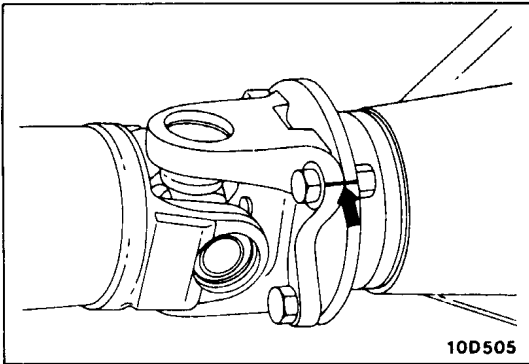

**◀B▶ REAR PROPELLER SHAFT REMOVAL**

Make the mating marks on the flange yoke of the rear propeller shaft and the companion flange of the differential case.

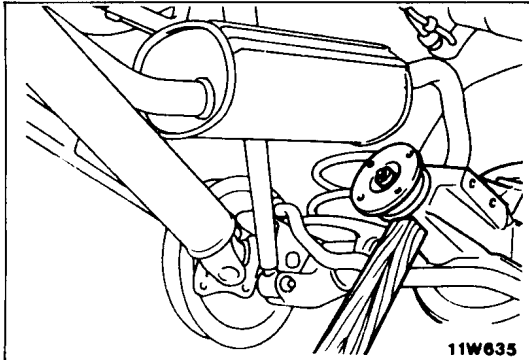

**◀C▶ DIFFERENTIAL CARRIER REMOVAL**

Remove the mounting nuts and strike the lower part of differential carrier assembly with a piece of timber several times to loosen it, and then remove the assembly.

**Caution**

1. Do not remove the uppermost nut but keep it loosened all the way to the stud bolt end.
2. Use care not to strike the companion flange.

**INSTALLATION SERVICE POINT**

**▶A◀ REAR PROPELLER SHAFT INSTALLATION**

Align the mating marks on the flange yoke and the companion flange to install the rear propeller shaft.

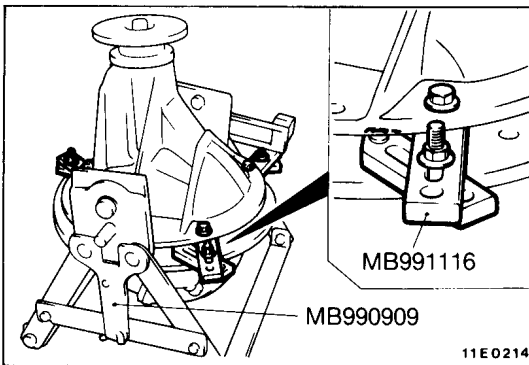

**INSPECTION BEFORE DISASSEMBLY**

Hold the special tool (MB990909) in a vise. Use the two special tools (two sets of MB991116) as shown to hold the differential carrier.

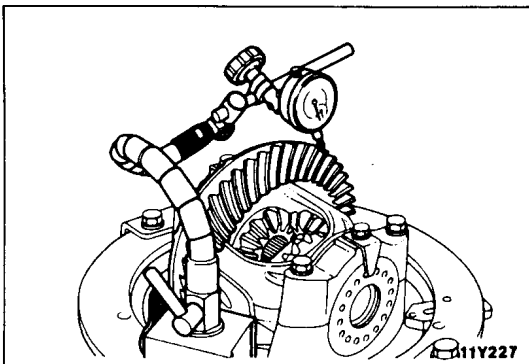

**FINAL DRIVE GEAR BACKLASH**

With the drive pinion locked in place, measure the final drive gear backlash with a dial indicator on the drive gear.

**NOTE**

Measure at four points or more on the circumference of the drive gear.

**Standard value: 0.13 – 0.18 mm**

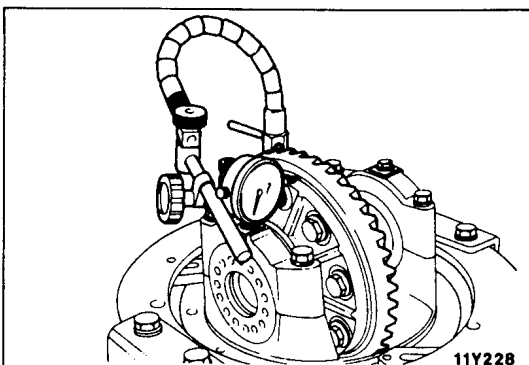

**DRIVE GEAR RUNOUT**

Measure the drive gear runout at the shoulder on the reverse side of the drive gear.

**Limit: 0.05 mm**

DISASSEMBLY

**Inspection Before Disassembly**

- (1) Final Drive Gear Inspection (Refer to P.27-13.)
- (2) Drive Gear Run-out Inspection (Refer to P.27-13.)

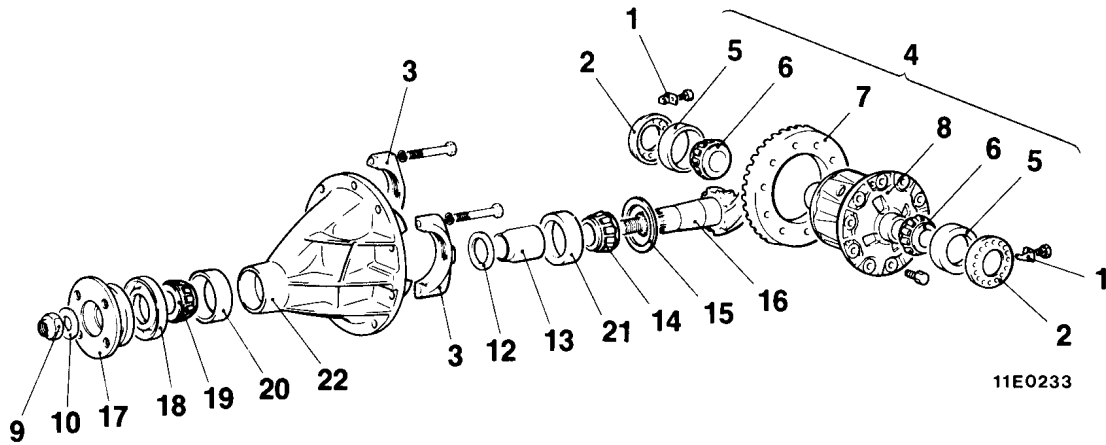

**Disassembly steps**

- |  |   |
|--|---|
| <ul style="list-style-type: none"> <li>◀A▶ 1. Lock plate</li> <li>◀B▶ 2. Side bearing nut</li> <li>◀C▶ 3. Bearing cap</li> <li>◀D▶ 4. Differential case assembly</li> <li>◀E▶ 5. Side bearing outer race</li> <li>◀F▶ 6. Side bearing inner race</li> <li>7. Drive gear</li> <li>8. Differential case*</li> <li>9. Self-locking nut</li> <li>10. Washer</li> <li>11. Drive pinion assembly</li> <li>12. Drive pinion front shim<br/>(For adjusting of drive pinion bearing preload)</li> </ul> | <ul style="list-style-type: none"> <li>◀G▶ 13. Drive pinion spacer</li> <li>14. Drive pinion rear bearing inner race</li> <li>15. Drive pinion rear shim<br/>(For adjusting drive pinion height)</li> <li>16. Drive pinion</li> <li>◀H▶ 17. Companion flange</li> <li>◀H▶ 18. Oil seal</li> <li>◀H▶ 19. Drive pinion front bearing inner race</li> <li>◀H▶ 20. Drive pinion front bearing outer race</li> <li>21. Drive pinion rear bearing outer race</li> <li>22. Differential carrier</li> </ul> |
|--|---|

**Caution**  
\* : Never disassemble the hybrid type LSD.

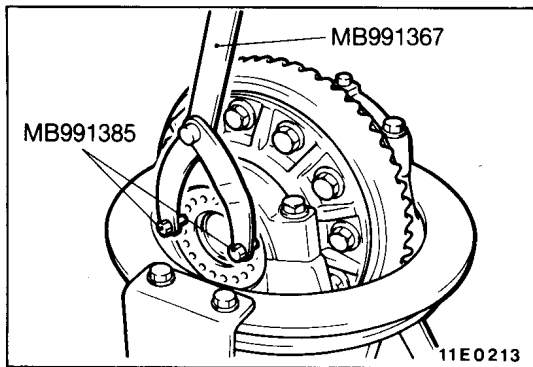

**DISASSEMBLY SERVICE POINTS**

◀A▶ **SIDE BEARING NUT REMOVAL**

Use the special tool to remove the side bearing nut.

◀B▶ **DIFFERENTIAL CASE ASSEMBLY REMOVAL**

Use hammer handles to take out the differential case assembly.

**NOTE**

Make mating marks on the bearings.  
Keep the right and left side bearings and side bearing nuts separate in order to be able to distinguish them for reassembly.



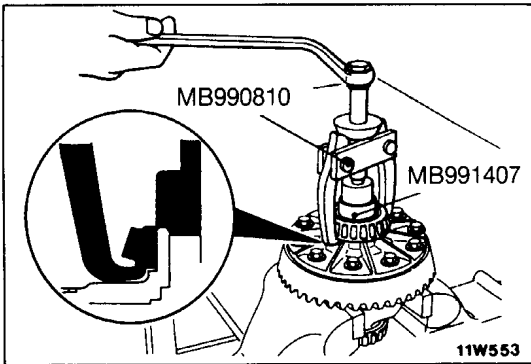

**◀C▶ SIDE BEARING INNER RACE REMOVAL**

Use the special tools to pull out the side bearing inner races.

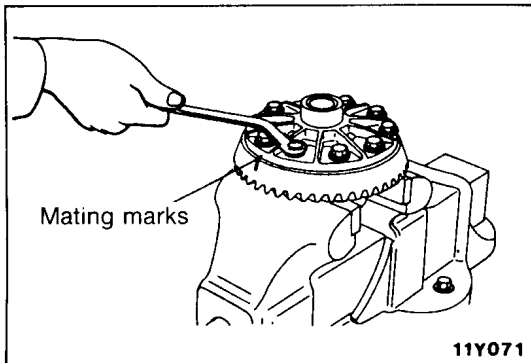

**◀D▶ DRIVE GEAR REMOVAL**

- (1) Make mating marks on the differential case and drive gear.
- (2) Loosen the drive gear mounting bolts in diagonal sequence to remove the drive gear.

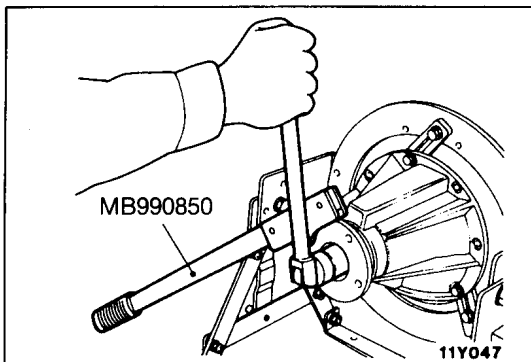

**◀E▶ SELF-LOCKING NUT REMOVAL**

Use the special tool to hold the companion flange, and then remove the companion flange self-locking nut.

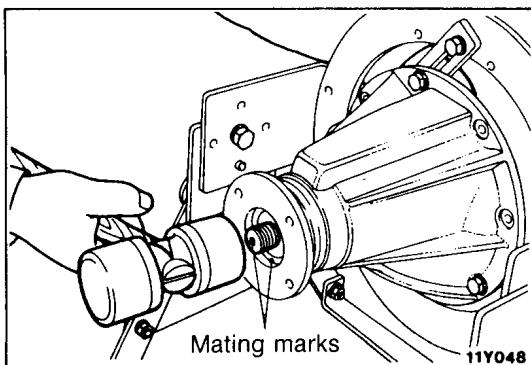

**◀F▶ DRIVE PINION ASSEMBLY REMOVAL**

- (1) Make mating marks on the drive pinion and companion flange.
- (2) Drive out the drive pinion together with the drive pinion spacer and the drive pinion front shims.

**Caution**

**Do not make mating marks on the contact surfaces of the companion flange and propeller shaft.**

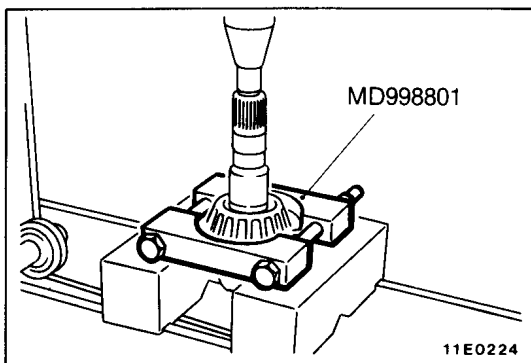

**◀G▶ DRIVE PINION REAR BEARING INNER RACE REMOVAL**

Use the special tools to pull out the drive pinion rear bearing inner race.

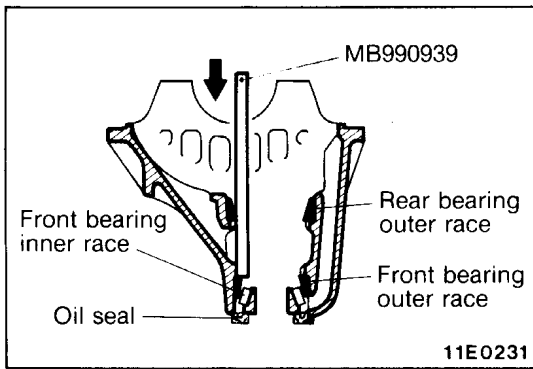

**◀H▶ OIL SEAL, DRIVE PINION FRONT BEARING INNER RACE, DRIVE PINION FRONT BEARING OUTER RACE AND DRIVE PINION REAR BEARING OUTER RACE REMOVAL**

- (1) Using the special tool, drive out the drive pinion front bearing outer race with drive pinion front bearing inner race and oil seal from the gear carrier.
- (2) Drive out the drive pinion rear bearing outer race in the same manner.

**INSPECTION**

Wash the disassembled parts in cleaning solvent, dry them using compressed air, and then check the following areas.

- Check the companion flange for wear or damage.
- Check the oil seal for wear or deterioration.
- Check the bearings for wear or discoloration.
- Check the differential case for cracks.
- Check the drive pinion and drive gear for wear or cracks.

**REASSEMBLY**

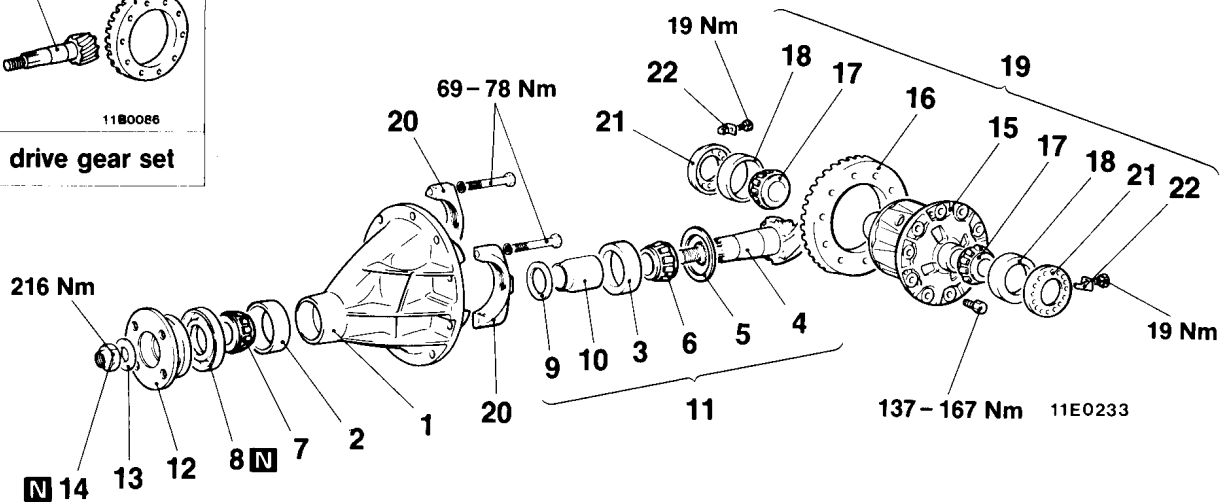
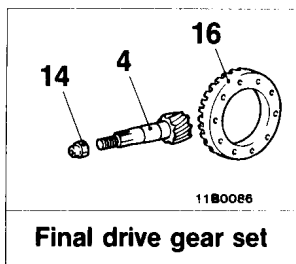

**Reassembly steps**

- |  |   |
|--|---|
| <p>▶A▶ 1. Differential carrier</p> <p>▶B▶ 2. Drive pinion front bearing outer race</p> <p>▶C▶ 3. Drive pinion rear bearing outer race</p> <p>● 4. Drive pinion height adjustment</p> <p>4. Drive pinion</p> <p>5. Drive pinion rear shim<br/>(For adjusting drive pinion height)</p> <p>6. Drive pinion rear bearing inner race</p> <p>7. Drive pinion front bearing inner race</p> <p>8. Oil seal</p> <p>9. Drive pinion front shim<br/>(For adjusting drive pinion bearing preload)</p> <p>10. Drive pinion spacer</p> | <p>▶D▶ ● Drive pinion bearing preload adjustment</p> <p>11. Drive pinion assembly</p> <p>12. Companion flange</p> <p>13. Washer</p> <p>14. Self-locking nut</p> <p>15. Differential case</p> <p>▶E▶ 16. Drive gear</p> <p>▶F▶ 17. Side bearing inner race</p> <p>18. Side bearing outer race</p> <p>19. Differential case assembly</p> <p>▶G▶ 20. Bearing cap</p> <p>▶H▶ ● Final drive gear backlash adjustment</p> <p>21. Side bearing nut</p> <p>22. Lock plate</p> |
|--|---|

LUBRICATION SEALING AND ADHESION POINTS

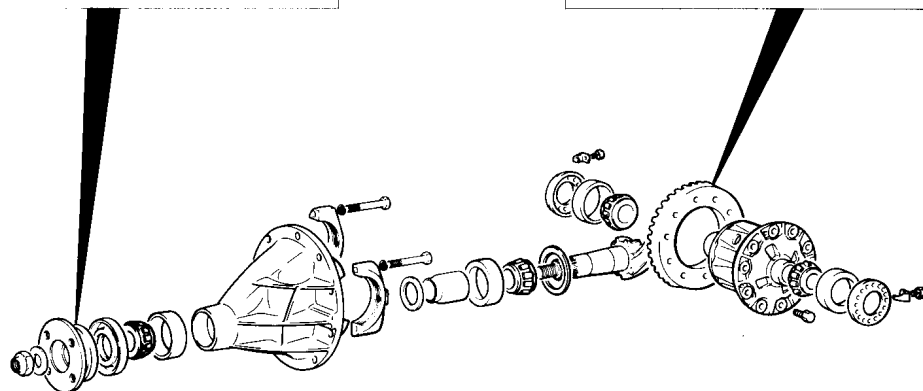
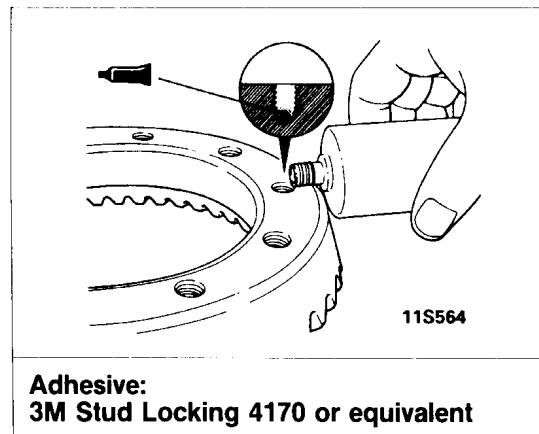
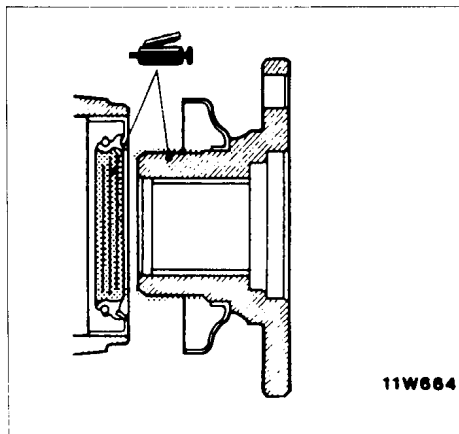

11E0233

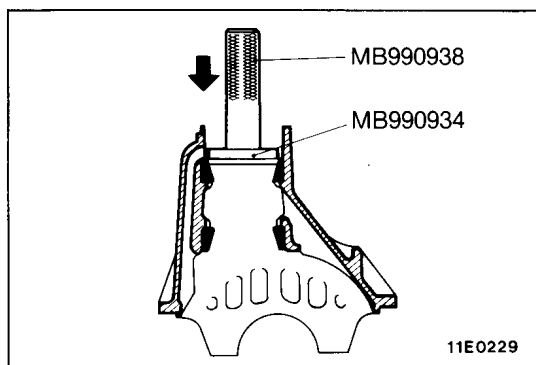

REASSEMBLY SERVICE POINTS

▶A◀ DRIVE PINION FRONT BEARING OUTER RACE INSTALLATION

Use the special tools to press-fit the drive pinion front bearing outer race into the gear carrier.

**Caution**

The bearing outer race must be fitted using a press to avoid tilt and distortion.

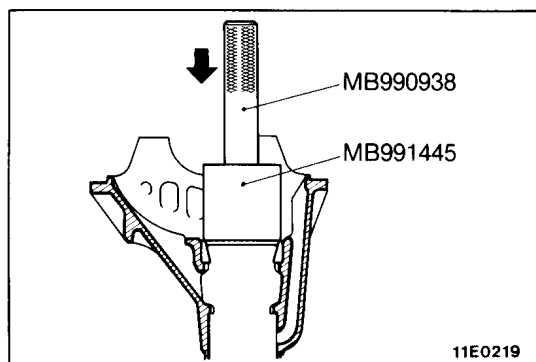

▶B◀ DRIVE PINION REAR BEARING OUTER RACE INSTALLATION

Use the special tools to press-fit the drive pinion rear bearing outer race into the gear carrier.

**Caution**

The bearing outer race must be fitted using a press to avoid tilt and distortion.

►C◄ DRIVE PINION HEIGHT ADJUSTMENT

Adjust the drive pinion height by the following procedures:

- (1) Install special pinion tools and drive pinion front and rear bearing inner races to the gear carrier in the sequence shown in the illustration.

- (2) Tighten the nut on the special tool until standard value of drive pinion turning torque is obtained.
- (3) Measure the drive pinion turning torque (without the oil seal).

**Standard value:**

Bearing division	Bearing lubrication	Rotation torque
New	None (With anti-rust agent)	0.6 – 0.9 Nm
New/reusing	Gear oil applied	0.4 – 0.5 Nm

**NOTE**

1. Gradually tighten the nut of the special tool while checking the drive pinion turning torque.
2. With small type differentials, one complete rotation cannot be given to the special tool. Rotate tool several times within the possible range to run in the bearing, and then measure the torque.

- (4) Position the special tool in the side bearing seat of the gear carrier, then select a drive pinion rear shim of a thickness which corresponds to the gap between the special tools.

**NOTE**

Thoroughly clean the side bearing seat. When positioning the special tool, be sure that the cutout sections of the special tool are in the position shown in the illustration, and also confirm that the special tool is in close contact with the side bearing seat.

When selecting the drive pinion rear shims, keep the number of shims to a minimum.

- (5) Fit the selected drive pinion rear shim(s) to the drive pinion, and press-fit the drive pinion rear bearing inner race by using the special tool.

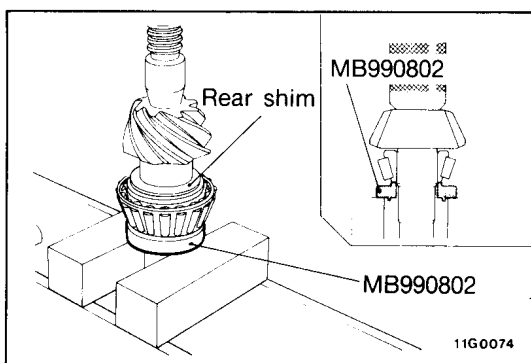
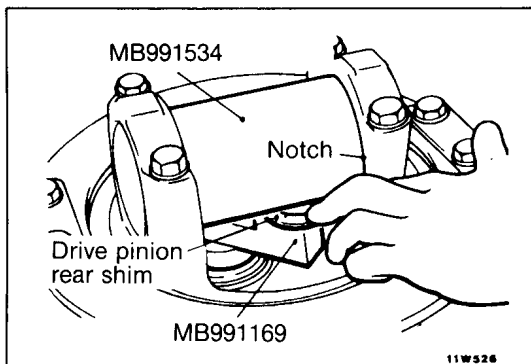
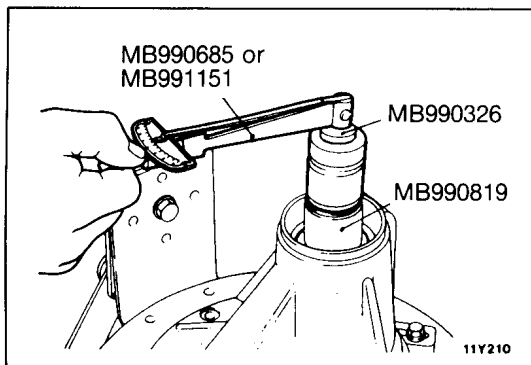
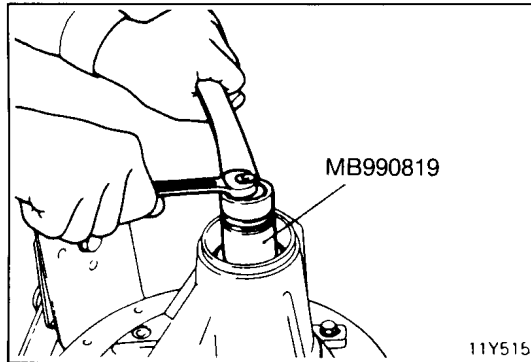
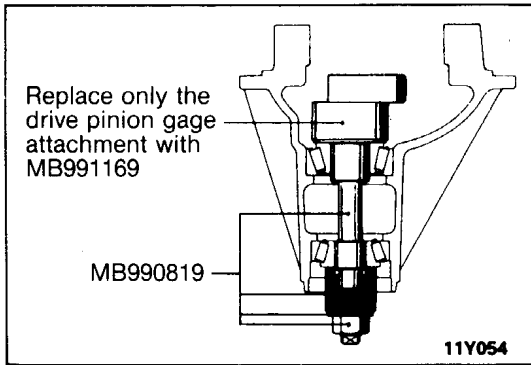

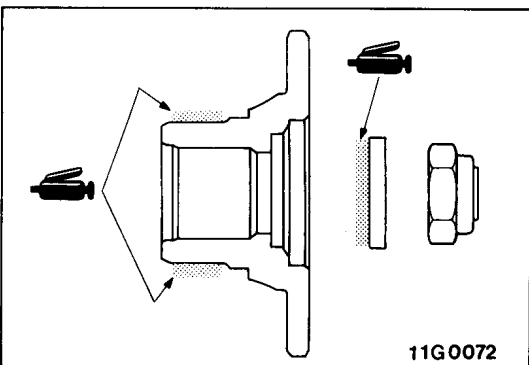
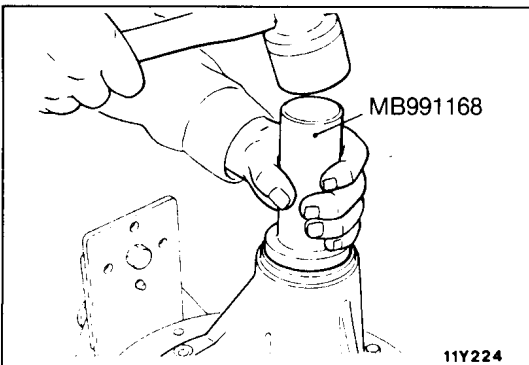
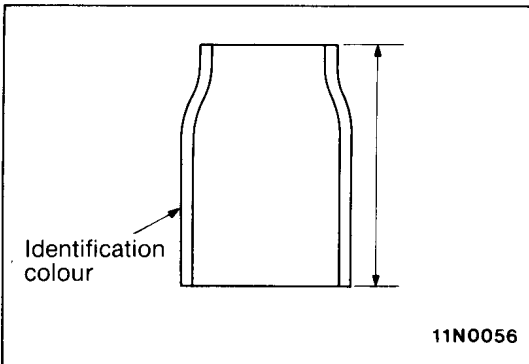
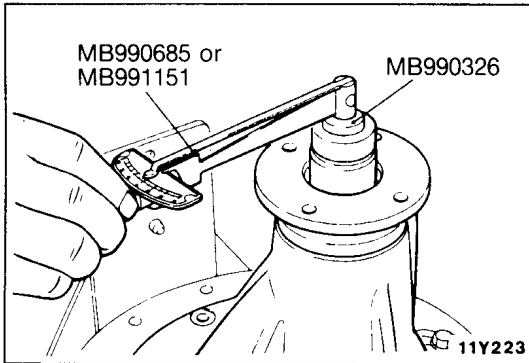
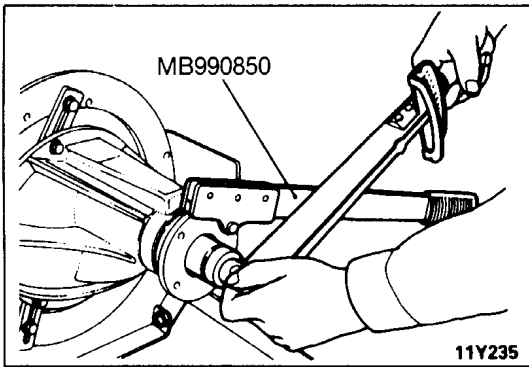

**►D◄ DRIVE PINION PRELOAD ADJUSTMENT**

Adjust the drive pinion turning torque by using the following procedure:

**Without oil seal**

- (1) Fit the drive pinion front shim(s) between the drive pinion spacer and the drive pinion front bearing inner race.
- (2) Tighten the companion flange to the specified torque by using the special tools.

**NOTE**

Do not install the oil seal.

- (3) Measure the drive pinion turning torque. (without the oil seal)

**Standard value:**

Bearing division	Bearing lubrication	Rotation torque
New	None (With anti-rust agent)	0.6–0.9 Nm
New/reusing	Gear oil applied	0.4–0.5 Nm

- (4) If the drive pinion turning torque is not within the range of the standard value, adjust the turning torque by replacing the drive pinion front shim(s) or the drive pinion spacer.

**NOTE**

When selecting the drive pinion front shims, if the number of shims is large, reduce the number of shims to a minimum by selecting the drive pinion spacers.

Also, select the drive pinion spacer from the following two types.

Height of drive pinion spacer mm	Identification colour
52.50	Yellow
52.84	Red

- (5) Remove the companion flange and drive pinion once again.

**With oil seal**

- (1) After setting the drive pinion front bearing inner race, use the special tool to drive the oil seal into the front lip of the gear carrier.
- (2) Apply a thin coat of clean multi-purpose grease to the companion flange contact surfaces of the washer and the oil seal contacting surface before installing the drive pinion assembly.

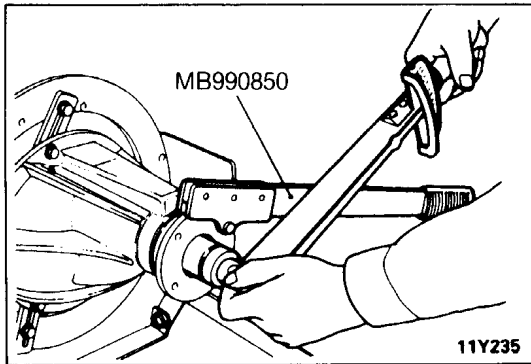

- (3) Install the drive pinion assembly and companion flange with the mating marks properly aligned, and then use the special tools to tighten the companion flange self-locking nut to the specified torque.

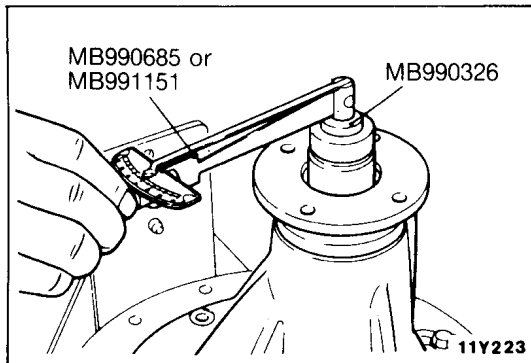

- (4) If the drive pinion rotation torque is not within the range of the standard value, adjust the rotation torque by replacing the drive pinion front shim(s) or the drive pinion spacer.

**Standard value:**

Bearing division	Bearing lubrication	Rotation torque
New	None (With anti-rust agent)	0.85 – 1.15 Nm
New/reusing	Gear oil applied	0.65 – 0.75 Nm

- (5) If the turning torque is outside the standard value, check that the tightening torque of the companion flange self-locking nuts or the installation of the oil seal are correct.

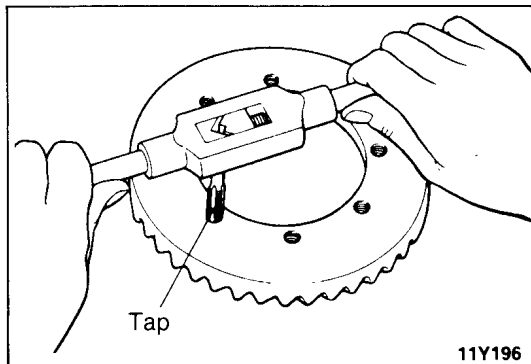

**▶◀ DRIVE GEAR INSTALLATION**

- (1) Clean the drive gear mounting bolts.
- (2) Remove the adhesive which is adhering to the threaded holes of the drive gear by turning the tap tool (M12 x 1.25), and then clean the threaded holes by applying compressed air.

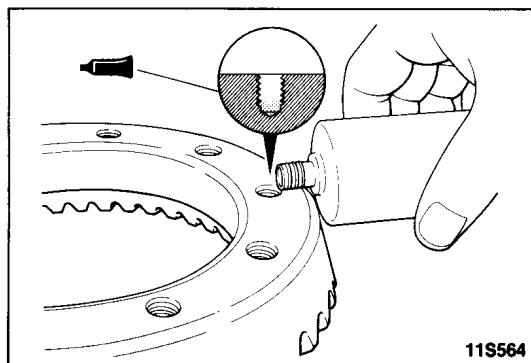

- (3) Apply specified adhesive to the threaded holes of the drive gear.

**Specified adhesive:**

**3M Stud Locking Part No.4170 or equivalent**

- (4) Install the drive gear to the differential case so that the mating marks are properly aligned. Tighten the bolts to the specified torque in a diagonal sequence.

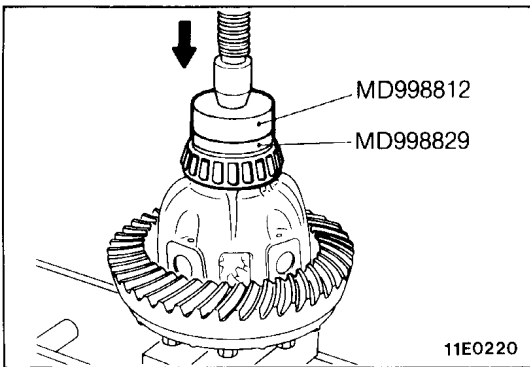

►F◄ SIDE BEARING INNER RACE INSTALLATION

Use the special tool to press-fit the side bearing inner races into the differential case.

**Caution**

**When only one side bearing inner race is installed, place a load on the differential case only.**

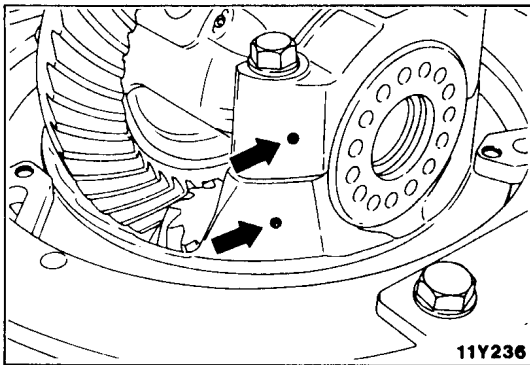

►G◄ BEARING CAP INSTALLATION

Align the mating marks on the gear carrier and the bearing cap, and then tighten the bearing cap.

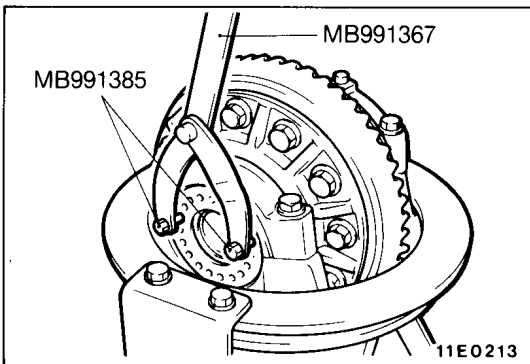

►H◄ FINAL DRIVE GEAR BACKLASH ADJUSTMENT

Adjust final drive gear backlash as follows:

(1) Using the special tool, temporarily tighten the side bearing nut until it is in the state just before preloading of the side bearing.

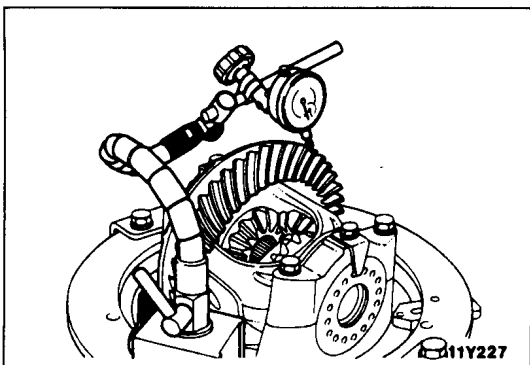

(2) Measure the final drive gear backlash.

**Standard value: 0.13 – 0.18 mm**

**NOTE**

Measure at four points or more on the circumference of the drive gear.

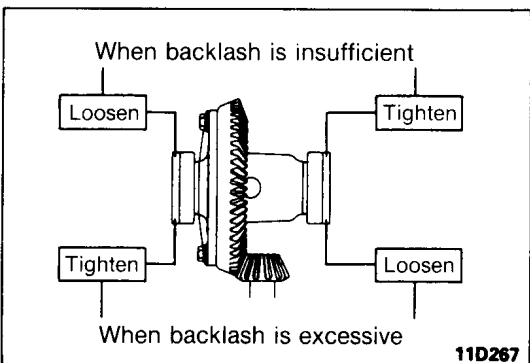

(3) Use the special tool (MB991367 and MB991385) to adjust the backlash to the standard value by moving the side bearing nut as shown.

**NOTE**

First turn the side bearing nut for loosening, and then turn the side bearing nut for tightening by the same amount.

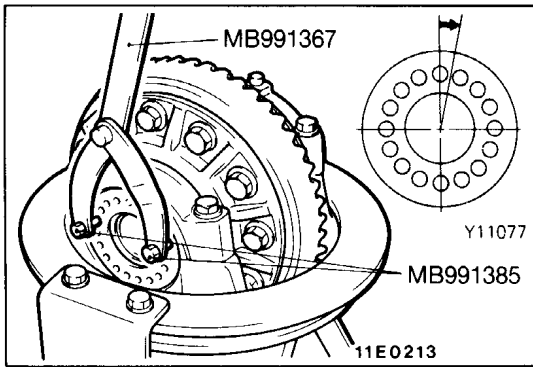

- (4) Use the special tool to turn both right and left side bearing nuts one half the distance between the centres of two neighboring holes to apply the preload.

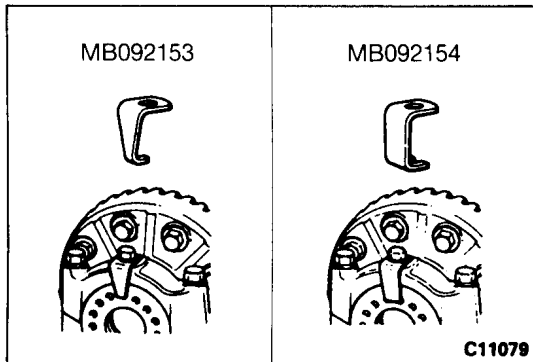

- (5) Choose and install the lock plates (two types).  
 (6) Check the final drive gear tooth contact. If poor contact is evident, carry out adjustment.

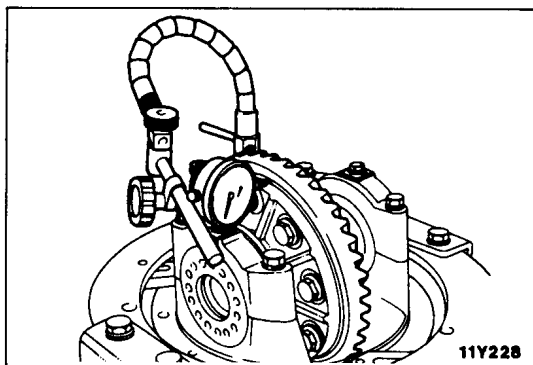

- (7) Measure the drive gear runout.

**Limit: 0.05 mm**

- (8) If the drive gear runout exceeds the limit, remove the differential case and the drive gears, move them to different positions and then reinstall them.



---

# SERVICE BRAKES

## CONTENTS

<b>GENERAL</b> .....	<b>2</b>	<b>WHEEL SPEED SENSOR &lt;ABS&gt; (REAR) ...</b>	<b>3</b>
Outline of Changes .....	2		
<b>SPECIFICATIONS</b> .....	<b>2</b>		
General Specifications .....	2		
Service Specifications .....	2		

---

## GENERAL

### OUTLINE OF CHANGES

- The mounting position of the rear ABS wheel-speed sensor has been changed.
- The ABS wheel-speed sensor has been changed. With this, the resistance value between the sensor terminals has been changed. (The inspection procedure is the same as before.)

## SPECIFICATIONS

### GENERAL SPECIFICATIONS

Items	Specifications
ABS	
Rotor teeth	
Front	47
Rear	47
Speed sensor type	Magnet coil type

### SERVICE SPECIFICATIONS

Items	Specifications
ABS	
Speed sensor's internal resistance k $\Omega$	
Front	1.4 – 1.8
Rear	1.3 – 1.5

# WHEEL SPEED SENSOR <ABS> (REAR)

## REMOVAL AND INSTALLATION

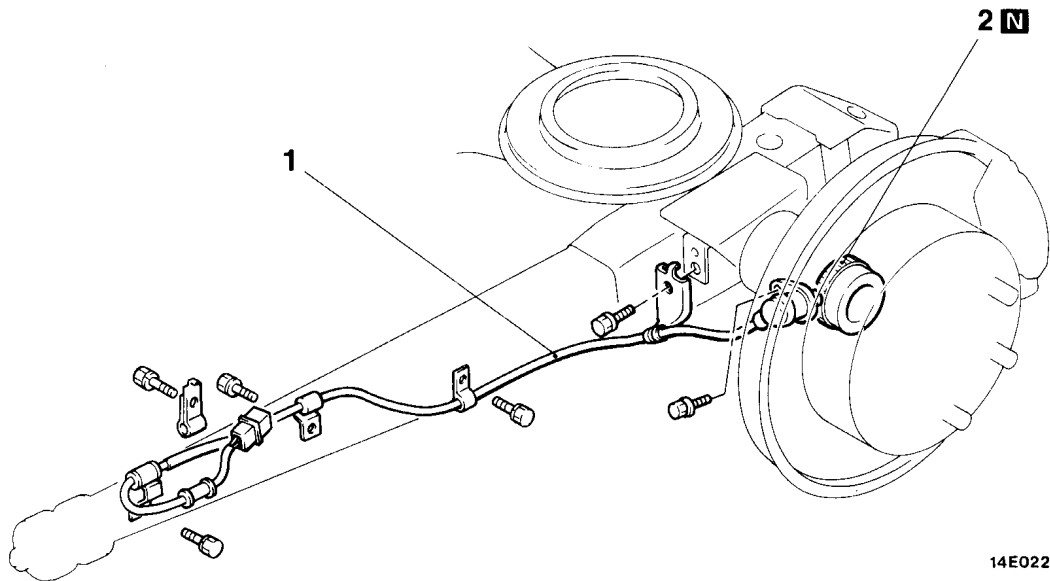

14E0226

### Rear speed sensor removal steps



1. Rear speed sensor
2. Rear rotor (Refer to GROUP 27 – Axle shaft.)

**NOTE**

The clearance between the rotor and wheel-speed sensor can not be adjusted.

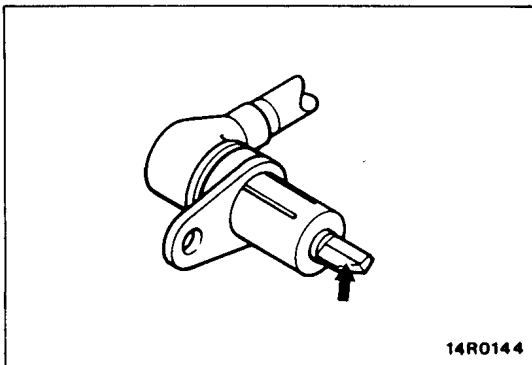

14R0144

### REMOVAL SERVICE POINT

#### ◀A▶ REAR SPEED SENSOR REMOVAL

**Caution**

Be careful when handling the pole piece at the tip of the speed sensor and the toothed edge of the rotor so as not to damage them by striking against other parts.

---

# BODY

## CONTENTS

<b>GENERAL</b> .....	<b>2</b>	<b>KEYLESS ENTRY SYSTEM</b> .....	<b>12</b>
Outline of Changes .....	2	Troubleshooting .....	12
<b>SUNROOF</b>		Keyless Entry System .....	15
<b>&lt;POWER SLIDE WITH TILT-UP TYPE&gt;</b> .....	<b>2</b>	How to Register a Secret Code .....	16
Service Specifications .....	2		
Troubleshooting .....	2		
Service Adjustment Procedures .....	4		
Sunroof <Power Slide with Tilt-up Type> .....	5		

---

**GENERAL**

**OUTLINE OF CHANGES**

- For vehicles with standard wheelbase, an electric sliding sunroof has been used as option. With this, the service procedure has been added.
- Service points of maintenance have been established to correspond to the adoption of a keyless entry system.

**SUNROOF <POWER SLIDE WITH TILT-UP TYPE>**

**SERVICE SPECIFICATIONS**

Items	Standard value
Roof lid glass sliding resistance N	108 or less
Sunroof motor clutch slippage force N	29 – 59

**TROUBLESHOOTING**

**INSPECTION CHART FOR TROUBLE SYMPTOMS**

Trouble symptom	Inspection procedure	Reference page
Sunroof does not operate within 30 seconds after driver's door is opened.	1	42-2
Sunroof does not operate at all.	2	42-2

**INSPECTION PROCEDURE FOR TROUBLE SYMPTOMS**

**Inspection Procedure 1**

Sunroof does not operate within 30 seconds after driver's door is opened.	Probable cause
After the driver's door is opened within 30 seconds after the ignition switch is turned off, the sunroof can still be operated for a further 30 seconds. If it is impossible, the driver's door switch or the front sunroof control unit may be defective.	<ul style="list-style-type: none"> <li>• Malfunction of door switch (driver's side)</li> <li>• Malfunction of front sunroof control unit</li> <li>• Malfunction of wiring harness or connector</li> </ul>

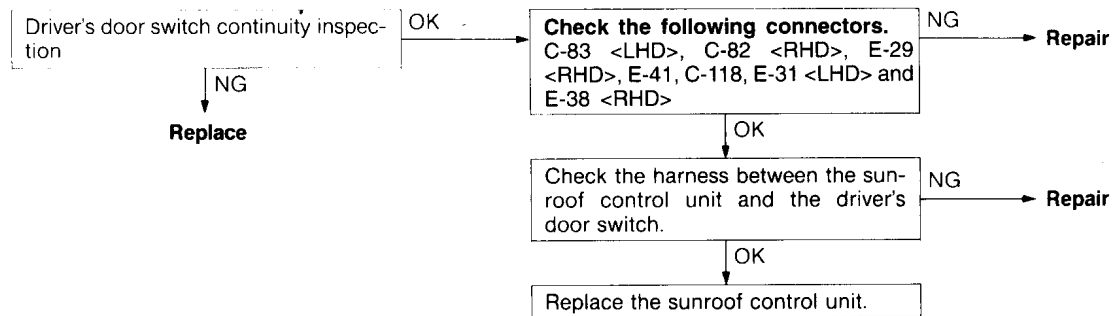

**Inspection Procedure 2**

Sunroof does not operate at all.	Probable cause
One of the following items may be defective. Sunroof switch Sunroof motor Sunroof control unit Power supply circuit (including the fuse)	<ul style="list-style-type: none"> <li>• Malfunction of sunroof switch</li> <li>• Malfunction of sunroof motor</li> <li>• Malfunction of sunroof control unit</li> <li>• Malfunction of wiring harness or connector</li> </ul>

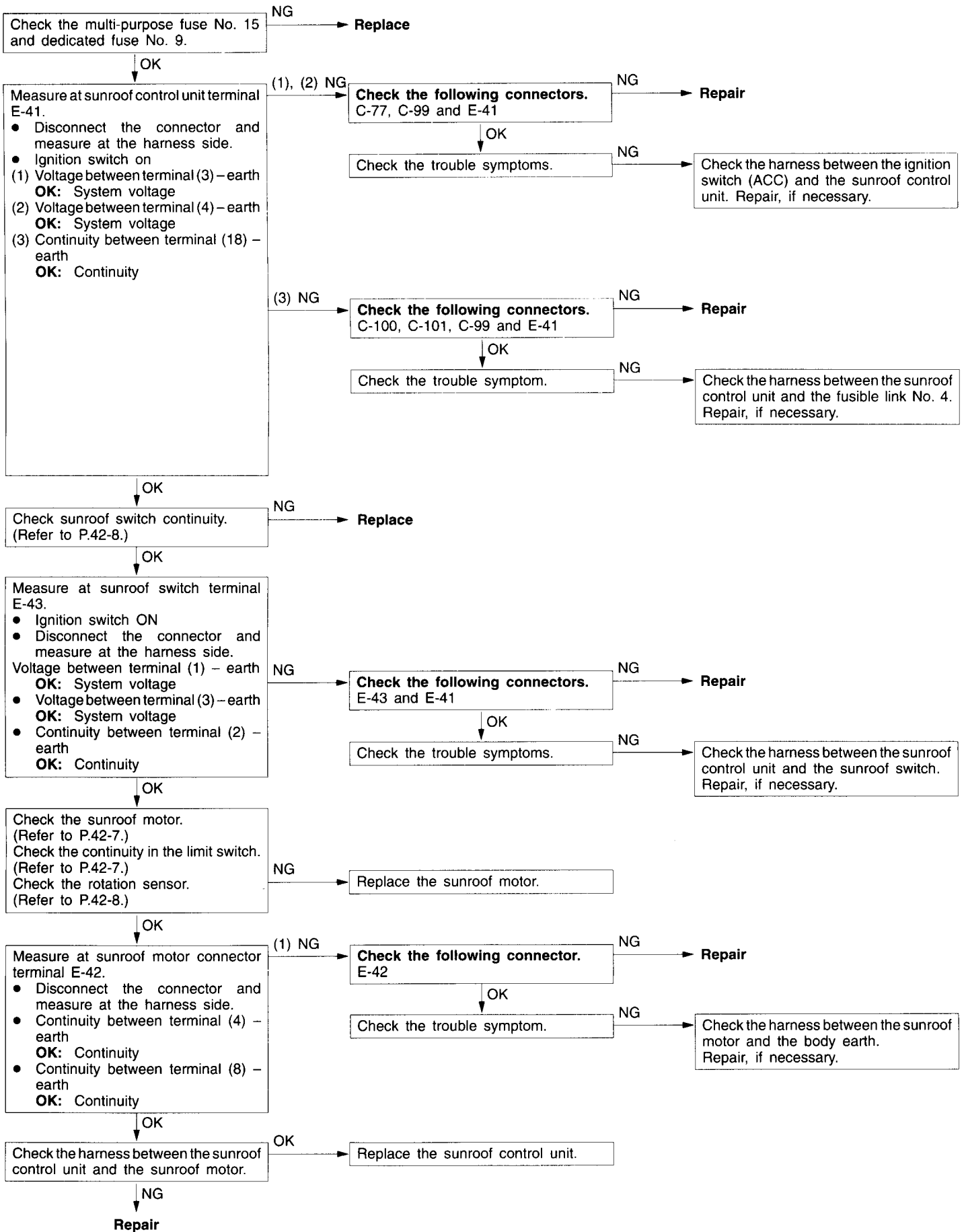

**SERVICE ADJUSTMENT PROCEDURES****SUNROOF LEAKAGE INSPECTION**

Check if there are any leaks in the sunroof by the following procedure.

- (1) Fully close the roof lid glass.
- (2) Adjust the water pressure so that water comes out of the hose to a height of approximately 50 cm when the hose is held vertically facing upwards.
- (3) Hold the end of the hose approximately 30 cm above the roof and let the water run onto the weatherstrip for 5 minutes or more.
- (4) While doing this, check if any water leaks through into the passenger compartment from around the roof lid glass.

**SUNROOF FIT ADJUSTMENT**

1. Fully close the roof lid glass.
2. Fully open the sunshade.
3. Lower the front edge of the decoration cover and then pull the rear edge into the passenger compartment to remove the decoration cover.
4. Loosen the four roof lid glass assembly mounting nuts to adjust the roof lid glass assembly forward and back or to the left and right.

**NOTE**

If impossible by the above step, adjust the sunroof motor by tilting up the sunroof fully. (Refer to P.42-8.)

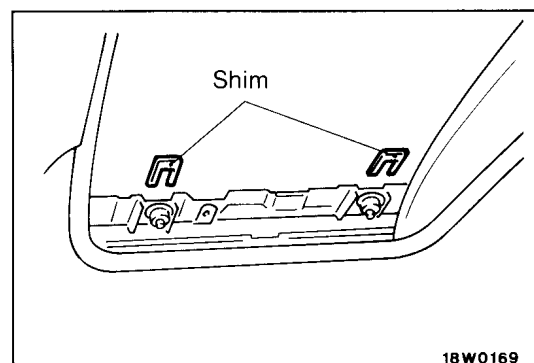
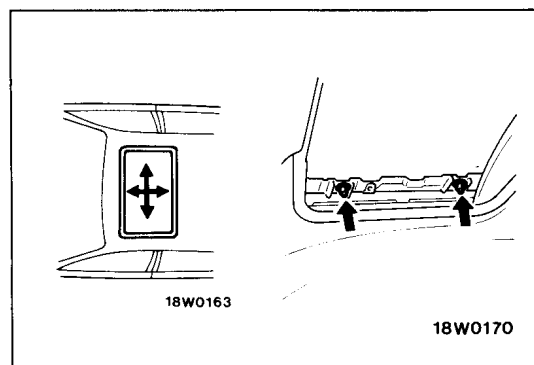
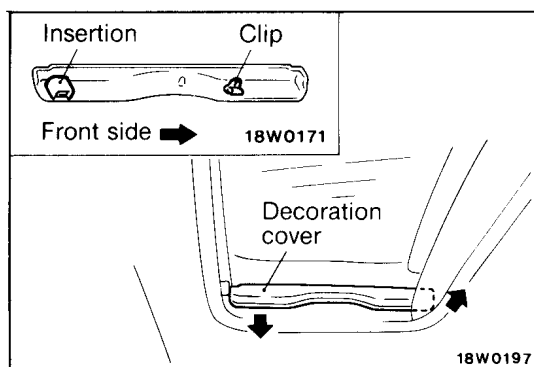
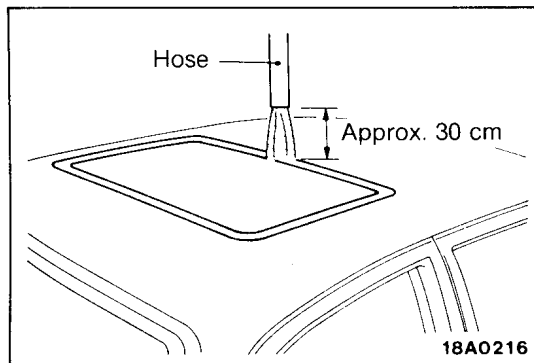
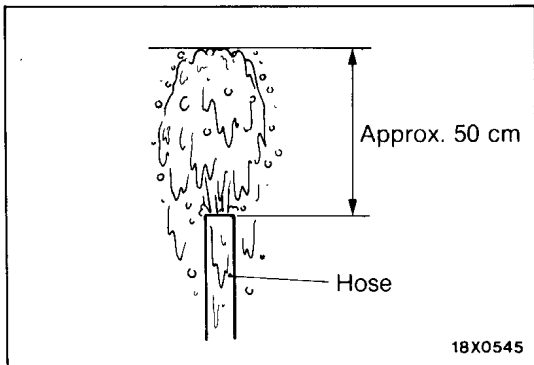

5. To adjust the height of the roof lid glass, loosen the four roof lid glass assembly mounting nuts. Then change the shims between the roof lid glass assembly and the lifter.
6. Check that the sunroof operates smoothly.

**SUNROOF <Power Slide with Tilt-up Type>**

**REMOVAL AND INSTALLATION**

**Post-installation Operation**

- Sunroof Water Test (Refer to P.42-4.)
- Sunroof Fit Adjustment (Refer to P.42-4.)

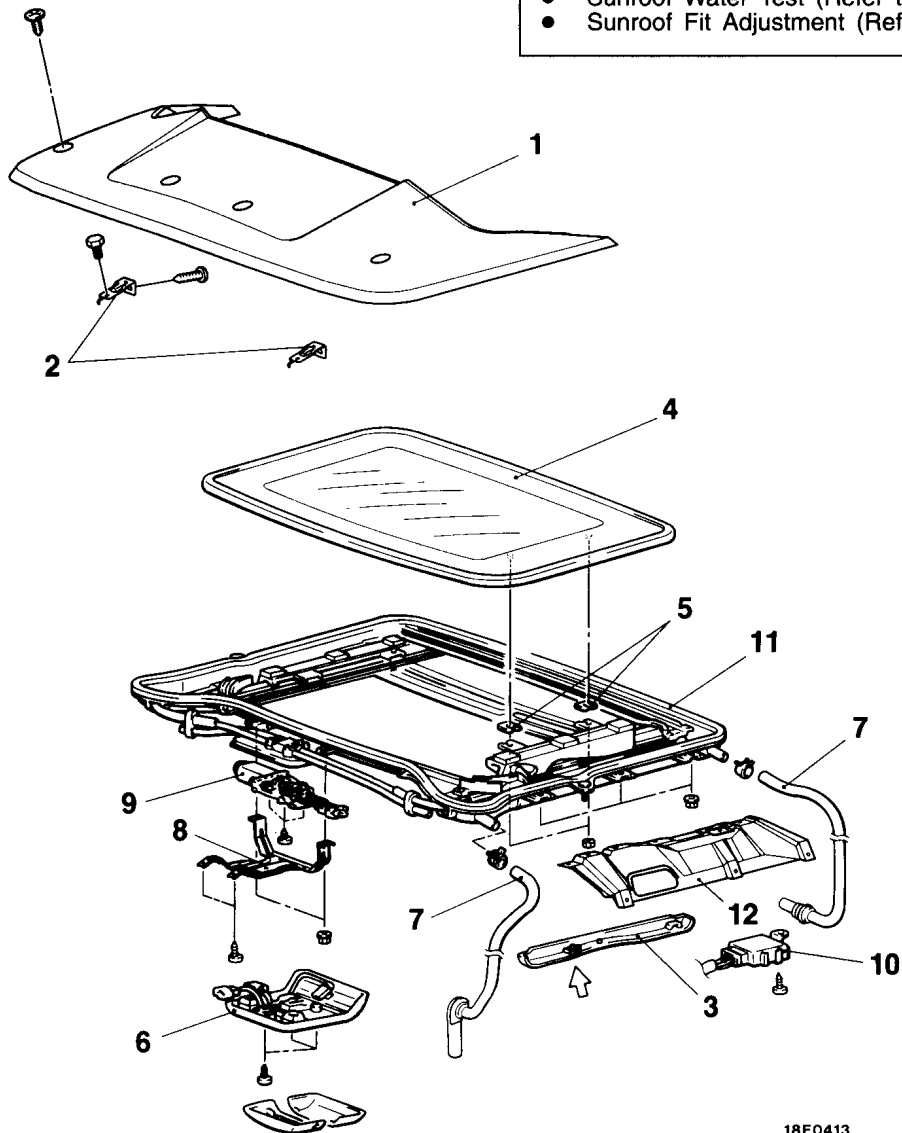

18E0413

**Deflector removal steps**

1. Deflector
2. Deflector bracket

**Roof lid glass assembly removal steps**

3. Decoration cover
4. Roof lid glass assembly
5. Shims

**Sunroof switch and room lamp assembly removal step**

6. Sunroof switch and room lamp assembly

**Drain hose removal steps**

- Headlining
- 7. Drain hose

**Sunroof motor and sunroof control unit removal steps**

- Headlining
- 8. Room lamp bracket
- 9. Sunroof motor
- 10. Sunroof control unit

**Sunroof assembly removal steps**

- Headlining
- 7. Drain hose connection
- 8. Room lamp bracket
- 11. Sunroof assembly
- 12. Set bracket

**NOTE**  
The ← mark indicates the sheet metal clip position.



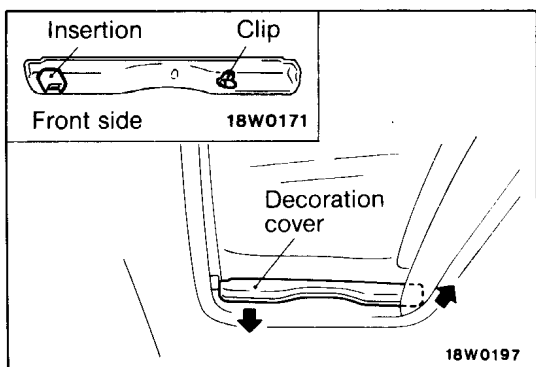

**REMOVAL SERVICE POINTS****◀A▶ DECORATION COVER REMOVAL**

Lower the front edge of the decoration cover and then pull the rear edge into the passenger compartment to remove the decoration cover.

**◀B▶ DRAIN HOSE REMOVAL**

Tie a rope to the end of the drain hose, wind a tape around it so that there is no unevenness, and pull the drain hose into the inside of the passenger compartment.

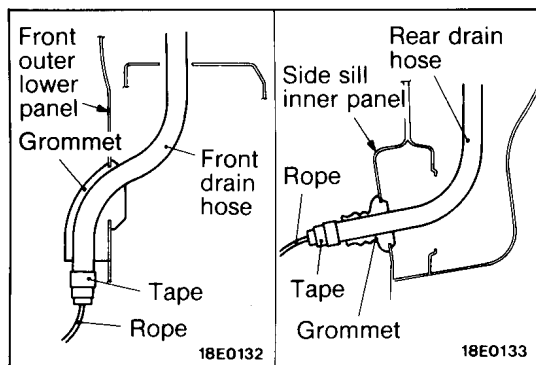
**◀C▶ SUNROOF MOTOR REMOVAL****Caution**

**Always tilt up the roof lid glass fully before removing the sunroof motor. Otherwise, the sunroof will not operate properly after reinstalling the motor.**

**INSPECTION****SLIDING RESISTANCE OF ROOF LID GLASS CHECK**

Remove the sunroof motor, and then check the sliding resistance of the roof lid glass by the following procedure.

- (1) Remove the headlining. [Refer to BASIC MANUAL (Looseleaf edition) GROUP 52A – Headlining.]
- (2) Remove the decoration cover.
- (3) Loosen the roof lid glass front mounting nuts and tie a rope to them.
- (4) Tilt up the roof lid glass fully and then remove the sunroof motor.
- (5) Use a spring balance to measure the sliding resistance of the roof lid glass.

**Standard value: 108 N or less**

- (6) If the sliding resistance of the roof lid glass is higher than the standard value, check the following.
  - Sunroof assembly installation, warping or jamming by foreign materials
  - Drive cable connection
  - Tilt of roof lid glass
- (7) Tilt up the roof lid glass fully, and set the sunroof motor to the specified position, and then install the sunroof motor.

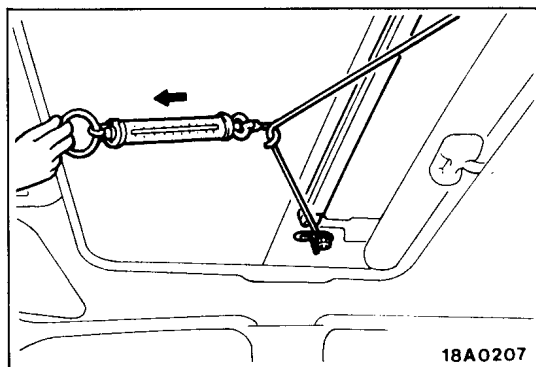

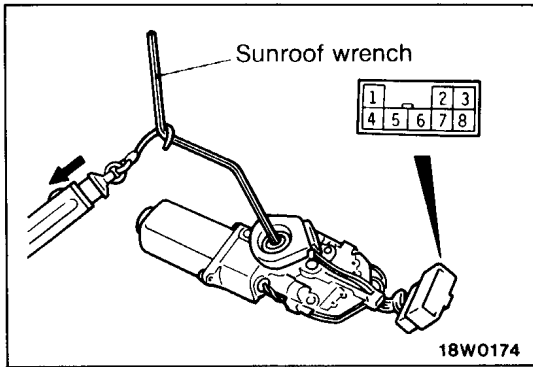

**SLIDING FORCE OF SUNROOF MOTOR'S CLUTCH CHECK**

1. Insert the sunroof wrench of the on-board tools into the hexagonal hole in the motor drive shaft, and hook a spring balance as shown in the illustration.
2. Apply battery voltage between terminals (1) and (2) of the sunroof motor connector to operate the motor.
3. Measure the load on the spring balance at the point where the rotation torque of the motor matches the spring force of the spring balance.

**Standard value: 29 – 59 N**

**Caution**

1. The spring balance should be kept a right angle to the sunroof wrench.
2. If a wrench other than that in the on-board tools is used, the value for the clutch sliding force will be different, so only the on-board tool should be used.
4. If the clutch sliding force is outside the standard value, turn the motor adjuster to adjust it.

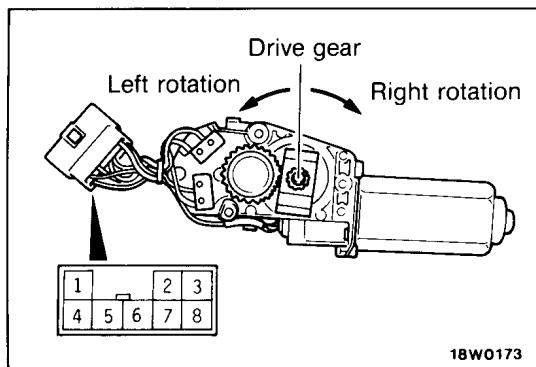

**SUNROOF MOTOR CHECK**

Check the direction of rotation of the drive gear when the battery is connected to the connector.

Battery connection terminal		Drive gear rotation direction
1	2	
⊖	⊕	Left
⊕	⊖	Right

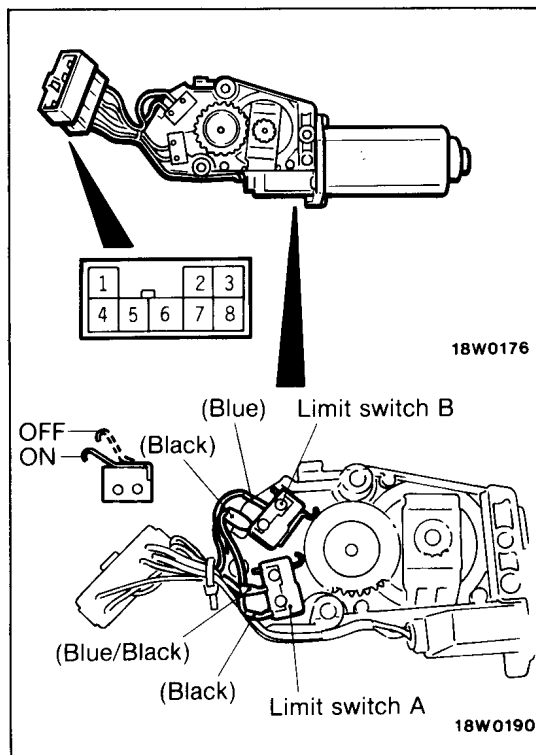

**LIMIT SWITCH CONTINUITY CHECK**

1. Remove the limit switches from the sunroof motor, and then check the operation of the limit switches.

Switch		Terminal No.		
		4	5	6
Limit switch A	ON	○	—	○
	OFF			
Limit switch B	ON	○	—	○
	OFF			

2. Check the identification colours. Then install the limit switches as shown in the illustration.

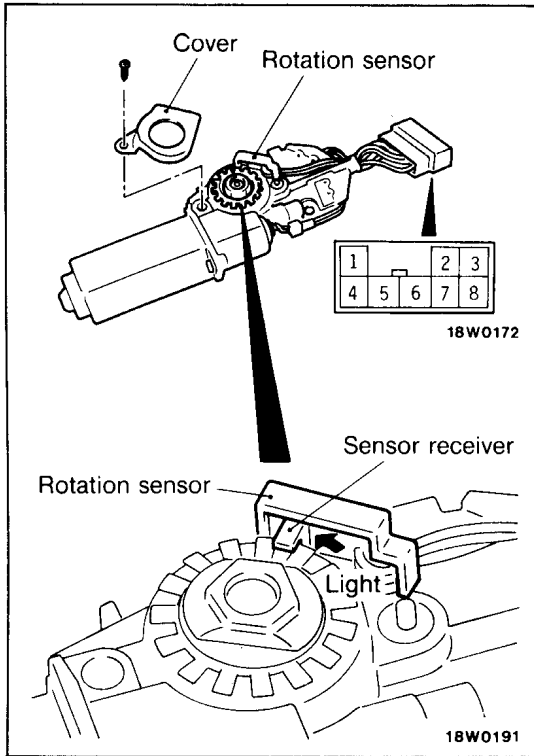

**ROTATION SENSOR INSPECTION**

1. When connecting an ohmmeter negative probe to terminal (3) and the positive probe to terminal (8), there should be continuity. When the probes are reversed, there should be no continuity.
2. Remove the cover, and then check that there is no continuity when connecting the negative probe to terminal (7) and the positive probe to terminal (8). Also check that there is continuity when the probes are connected to the same terminals and light is shined onto the sensor receiver.

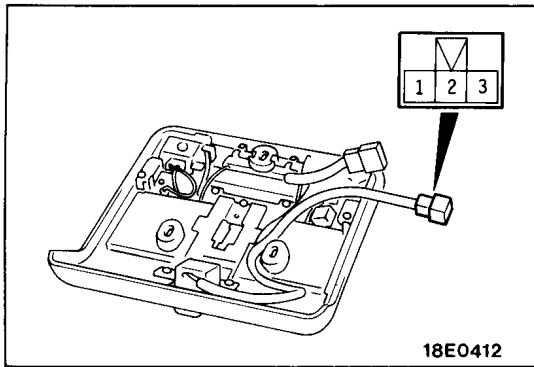

**SUNROOF SWITCH CONTINUITY INSPECTION**

Switch position	Terminal No.		
	1	2	3
Open	○	○	
Close		○	○

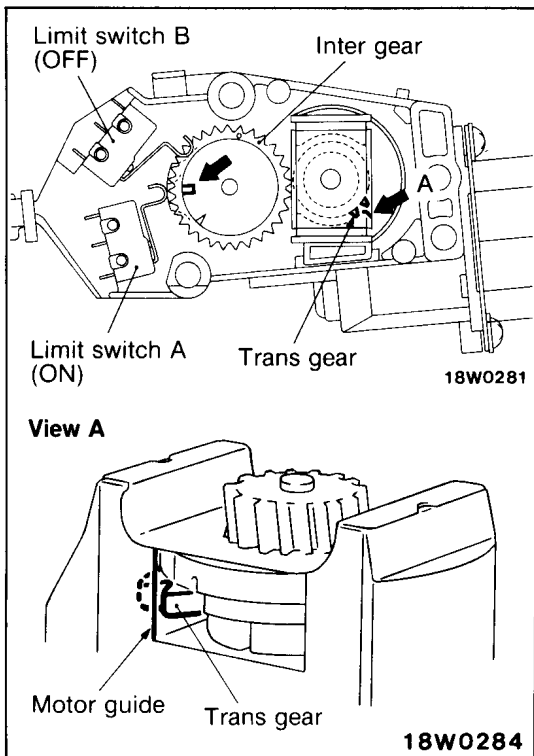

**INSTALLATION SERVICE POINTS**

**▶◀ SUNROOF MOTOR INSTALLATION**

- Use the sunroof wrench to set the sunroof motor to the full tilt-up position by the following procedure.
- (1) Align the pawl (Square mark) of the inter gear with the on position of limit switch (A).
  - (2) Align the groove of the trans gear with the corner of the motor guide.

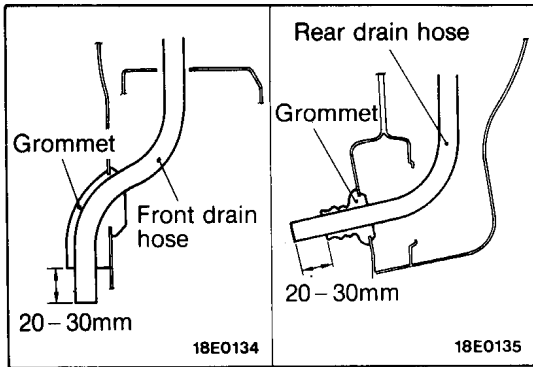

►B◄ DRAIN HOSE INSTALLATION

- (1) Tie the rope that was used during removal to the end of the drain hose, and wind tape around it so that there is no unevenness.
- (2) Pull the rope to pull the drain hose through.
- (3) Pull the drain hose until the protruding length from the grommet is as shown in the figure.

DISASSEMBLY AND REASSEMBLY

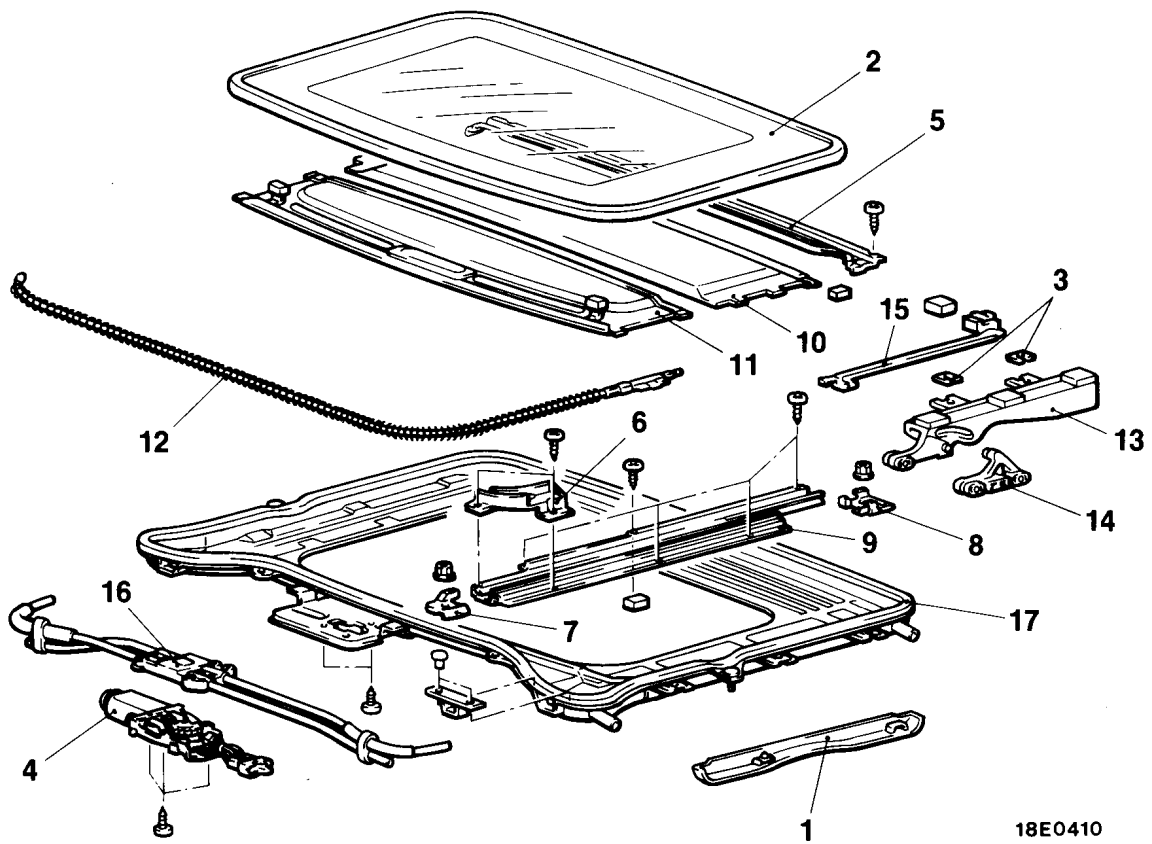
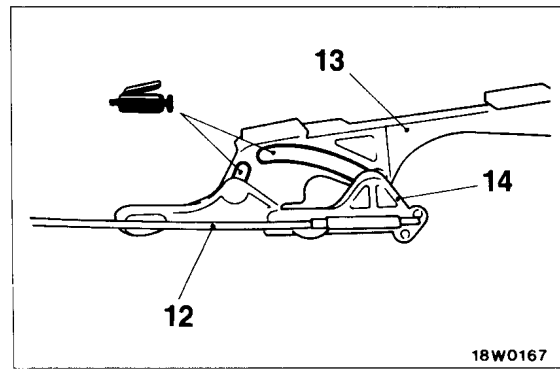
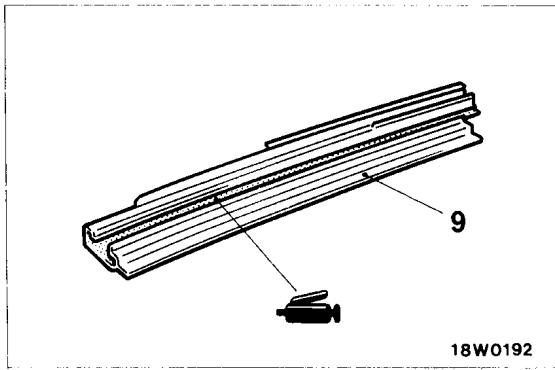

**Disassembly steps**

◀A▶

1. Decoration cover
2. Roof lid glass assembly
3. Shim
4. Sunroof motor
5. Drip rail
6. Front drip
7. Front holder
8. Rear holder
9. Rail assembly

◀B▶ ▶A▶

10. Sunshade (B)
11. Sunshade (A)
12. Drive cable
13. Lifter assembly
14. Slider assembly
15. Timing rear assembly
16. Drive unit assembly
17. Frame assembly

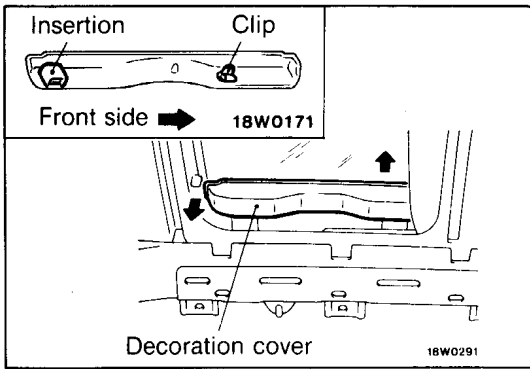

**DISASSEMBLY SERVICE POINTS**

**◀A▶ DECORATION COVER REMOVAL**

Lower the front edge of the decoration cover and then pull the rear edge into the passenger compartment to remove the decoration cover.

**◀B▶ SUNROOF MOTOR REMOVAL**

**Caution**

Always tilt up the roof lid glass fully before removing the sunroof motor. Otherwise, the sunroof will not operate properly after reinstalling the motor.

**REASSEMBLY SERVICE POINT**

**▶A◀ SUNROOF MOTOR INSTALLATION**

Use the sunroof wrench to set the sunroof motor to the full tilt-up position by the following procedure.

- (1) Align the pawl (Square mark) of the inter gear with the on position of limit switch (A).
- (2) Align the groove of the trans gear with the corner of the motor guide.

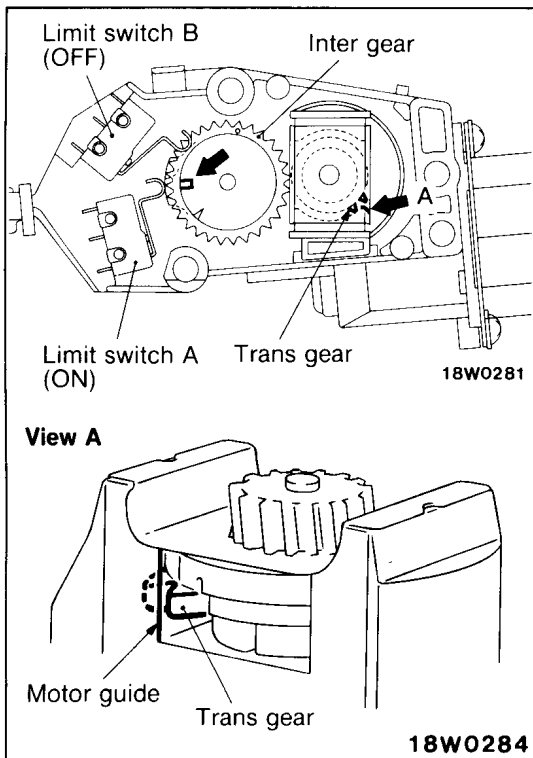

# KEYLESS ENTRY SYSTEM

## TROUBLESHOOTING

### INSPECTION CHART FOR TROUBLE SYMPTOMS

Trouble Symptom		Inspection Procedure No.	Reference Page
All doors can be locked and unlocked, but the room lamp does not flash or illuminate (but the room lamp operates as normal when the doors are opened and closed).		1	42-12
None of the doors can be locked or unlocked.	The LED does not illuminate when the transmitter send switch is pressed.	2	42-12
	Signals are being sent from the transmitter (the LED illuminates) but the system does not operate.	3	42-13
Some of the doors cannot be locked or unlocked.		4	42-13

### INSPECTION PROCEDURE FOR TROUBLE SYMPTOM

#### Inspection Procedure 1

All doors can be locked and unlocked, but the room lamp does not flash or illuminate (but the room lamp operates as normal when the doors are opened and closed).	Probable cause
If the room lamps operates normally when the doors are opened and closed, there may be a malfunction of the keyless entry receiver-ECU or a malfunction in the harness between the room lamp and the keyless entry receiver-ECU.	<ul style="list-style-type: none"> <li>Malfunction of keyless entry receiver-ECU</li> <li>Malfunction of harness or connector</li> </ul>

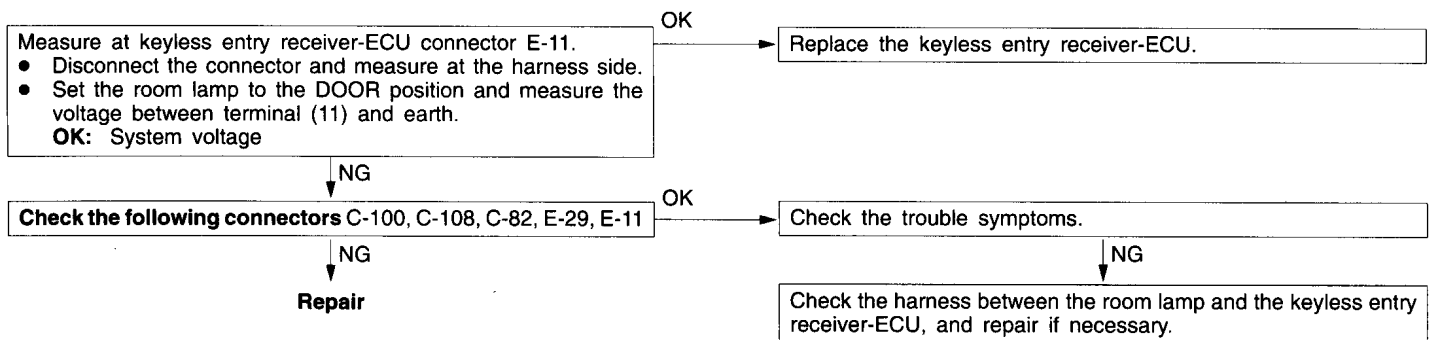

#### Inspection Procedure 2

The LED does not illuminate when the transmitter send switch is pressed.	Probable cause
If the LED on the transmitter does not illuminate, the cause may be a flat battery or a malfunction of the transmitter.	<ul style="list-style-type: none"> <li>Flat transmitter battery</li> <li>Malfunction of transmitter</li> </ul>

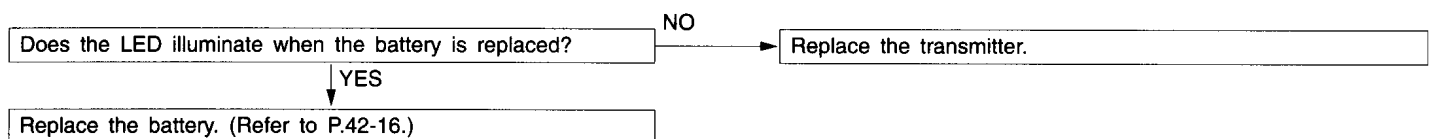

**Inspection Procedure 3**

Signals are being sent from the transmitter (the LED illuminates) but the system does not operate.	Probable cause
If the keyless entry system does not operate even though a signal is being sent from the transmitter, and if the central door locking system is normal, the cause may be a problem with the antenna reception, or the lock and unlock signals are not being input to the door lock control unit.	<ul style="list-style-type: none"> <li>• Malfunction of central door locking system</li> <li>• Malfunction of keyless entry receiver-ECU</li> </ul>

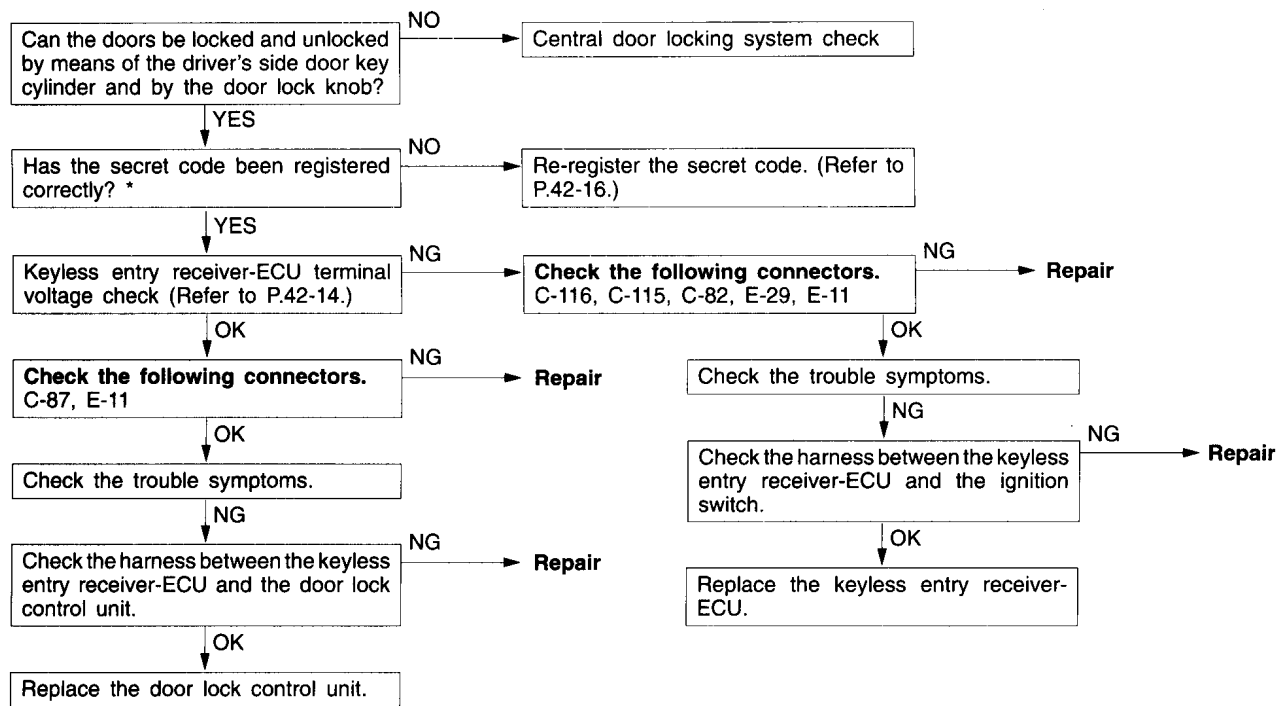

**NOTE**

\*: Carry out this check if the transmitter or the keyless entry receiver-ECU has been replaced or if the secret code is not properly registered.

**Inspection Procedure 4**

Some of the doors cannot be locked or unlocked.	Probable cause
If some of the doors cannot be locked or unlocked, the cause may be a malfunction of the harness between the door lock control unit and one of the door lock actuators.	<ul style="list-style-type: none"> <li>• Malfunction of door lock actuator</li> <li>• Malfunction of harness or connector</li> </ul>

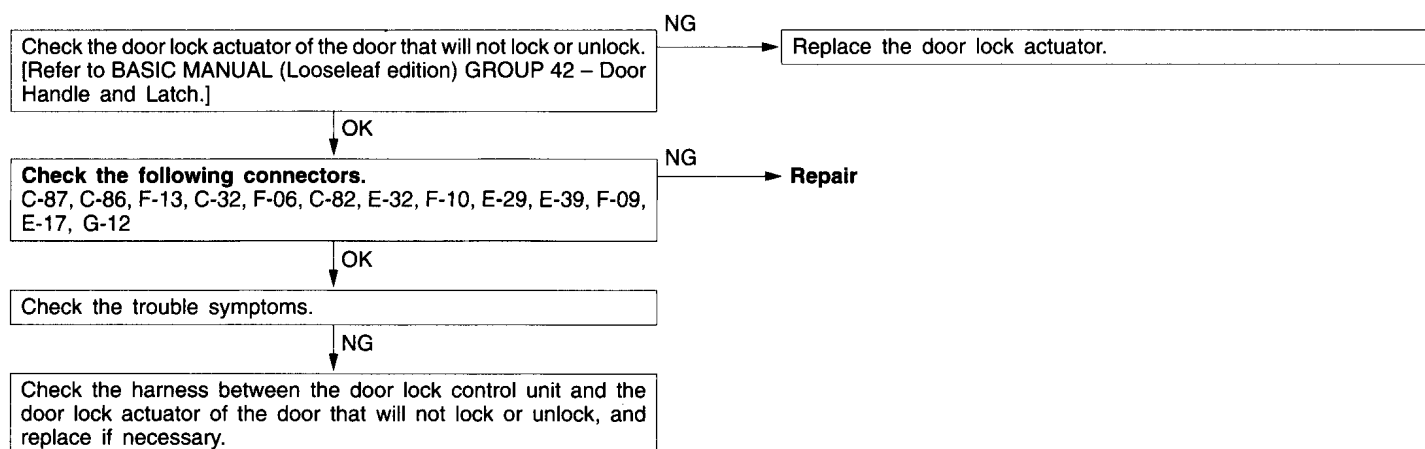



## INSPECTION AT KEYLESS ENTRY RECEIVER ECU TERMINALS

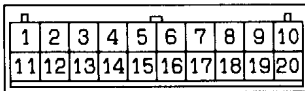

18W0311

- (1) Remove the combination meter. [Refer to BASIC MANUAL (Looseleaf edition) GROUP 54 – Combination Meter.]
- (2) Disconnect the amplifier and inspect the connector on the wire harness side as shown in the chart below.

Terminal	Signal name	Conditions		Terminal voltage
2	Door switch	Room lamp switch: OFF or ON	One or more doors are open (Door switch: ON)	0 V
			All doors are closed (Door switch: OFF)	0 V
		Room lamp switch: DOOR	One or more doors are open (Door switch: ON)	0 V
			All doors are closed (Door switch: OFF)	System voltage
6	Door lock actuator switch (driver's side)	LOCK	5 V and pulse output*	
		UNLOCK	0 V	
8	Key remainder switch	OFF (When ignition key is inserted)	5 V and pulse output*	
		ON (When ignition key is removed)	0 V	
9	Ignition switch	Ignition switch: ACC or ON	System voltage	
		Ignition switch: OFF	0 V	
10	Receiver power supply	At all times	System voltage	
11	Room lamp output	All doors are closed (Door switch: OFF)	Room lamp switch: OFF or ON	0 V
			Room lamp switch: DOOR	System voltage
12	Door lock output	During door lock control unit output, or door lock switch: LOCK	0 V	
		Other than above	System voltage	
14	Door unlock output	During door lock control unit output, or door lock switch or door lock key cylinder: UNLOCK	0 V	
		Other than above	System voltage	
20	Earth	At all times	0 V	

## NOTE

Values marked with \* should be measured using an oscilloscope. (The value will alternate between 0 V and 0.03 V if a circuit tester is used.)

**KEYLESS ENTRY SYSTEM**

**REMOVAL AND INSTALLATION**

**Pre-removal and Post-installation Operation**

- Removal and Installation of the Quarter Trim, Lower (R.H.)

**<Standard wheelbase>**

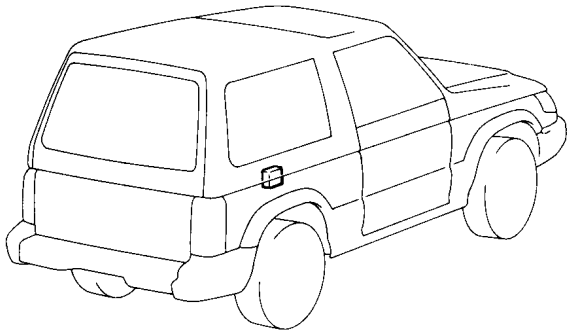

18E0422

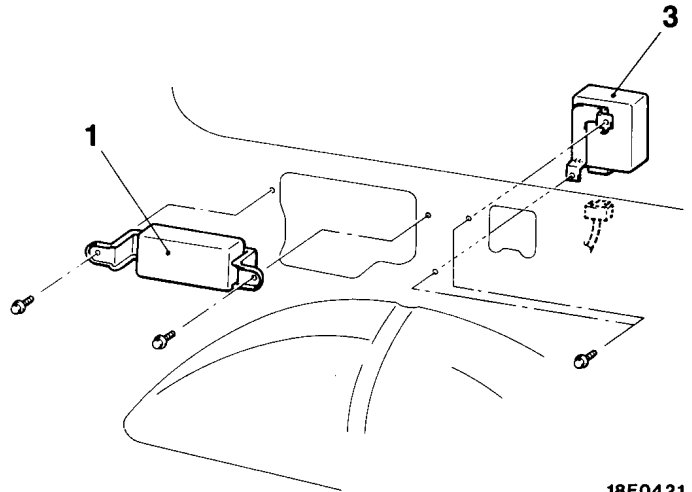

18E0421

**<Long wheelbase>**

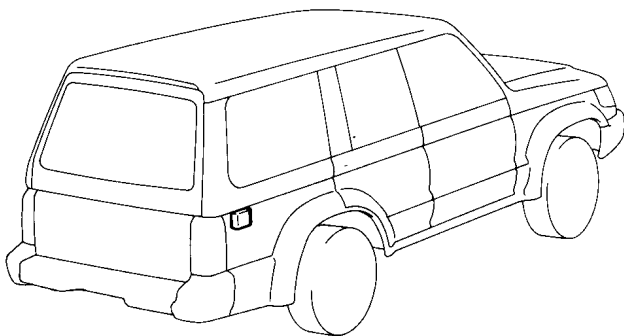

18E0423

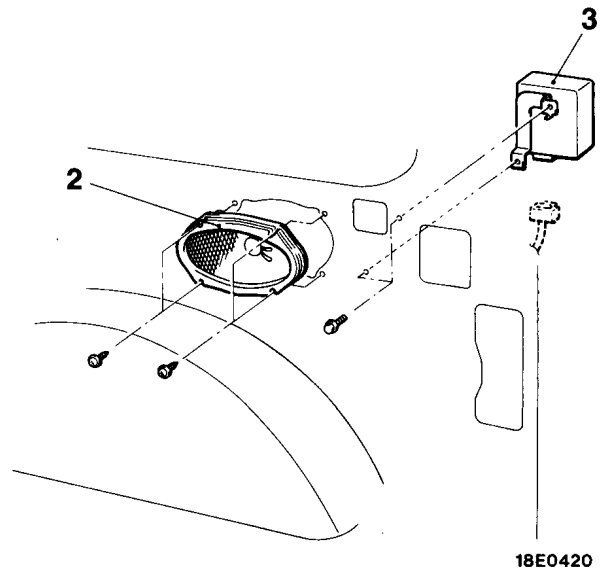

18E0420

**Removal steps**

**<Standard wheelbase>**

- Rear seat belt retractor (R.H.)
- 1. ABS control unit
- <Vehicles with ABS>
- 3. Keyless entry receiver ECU

**Removal steps**

**<Long wheelbase>**

- 3rd seat belt retractor (R.H.)
- 2. Rear speaker and speaker cover
- <Vehicles with rear speaker>
- 3. Keyless entry receiver ECU

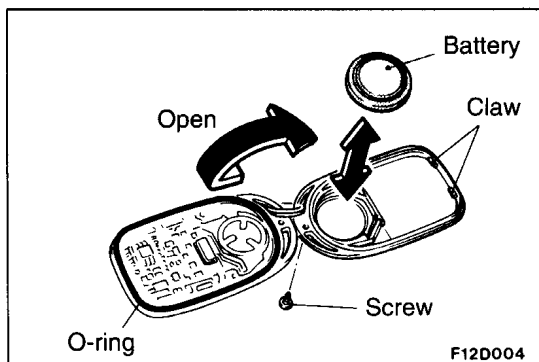

## INSPECTION

### HOW TO REPLACE A BATTERY OF THE TRANSMITTER

1. Remove the set screw to remove the battery from the transmitter.
2. Install a battery with its (+) side face-down.

**Battery required for replacement: Coin type battery CR2032**

3. Insert the claw first, and with care not to displace the O-ring, assemble the transmitter.
4. Check to see if the keyless entry system operates.

#### NOTE

- (1) Do not let water or dust stick to the inside of the transmitter when its open. Also, do not touch the precision electronic device.
- (2) If the O-ring is displaced during the assembly of the transmitter, water or dust penetrates in it, causing trouble.

## HOW TO REGISTER A SECRET CODE

Since the transmitter is memorized by each individual code, it is necessary to register a code on EEPROM in the keyless entry receiver ECU if the transmitter or keyless entry receiver ECU is replaced, or cause of the trouble is presumed to be due to faulty registration of the code. Since two different codes at the most can be memorized in the memory space of EEPROM, the old code will become unable to be used if the following registration operation is repeated twice. Meanwhile, register a code after confirming that an ordinary door lock function can be worked through key operation.

1. Connect the MUT-II to the diagnosis connector (16 pin.).

#### NOTE

Terminal (1) of the diagnosis connector will be earthed at this time and the mode will switch to the secret code registration preparation mode.

#### Caution

**Connection and disconnection of the MUT-II should always be carried out with the ignition switch in the OFF position.**

2. Close all of the doors.
3. Turn the ignition switch to ACC and then to OFF.

#### NOTE

The doors will lock and then unlock at this time, and the mode will then switch to the secret code registration mode.

4. After pressing any switch on the transmitter once, and then press it two more times within 10 seconds. The secret code will then be registered.
5. After registration is completed, the doors will lock and then unlock once.

#### NOTE

If there are two transmitters, register the secret code for the first one, and then within one minute after doing this, register the secret code for the second one by following the same procedure as given above.

6. After registration for the second transmitter has been completed, the doors will lock and then unlock once.
7. The registration mode will be cleared under any of the following conditions.
  - After the secret codes have been registered for two transmitters
  - After one minute elapses since registration mode was set
  - If the MUT-II is disconnected (if the earth connection is broken)
  - If the ignition switch is turned to ON
  - If any of the doors are opened

## GROUP 52A

### INTERIOR

#### GENERAL

#### OUTLINE OF CHANGES

- A split type rear seat has been used <Long body>. With this, the service procedure has been added.
- The inner seat belt and center seat belt have been changed <Vehicles with rear split seat – Long body>. With this, the removal and installation have been changed.

#### REAR SEAT

#### REMOVAL AND INSTALLATION

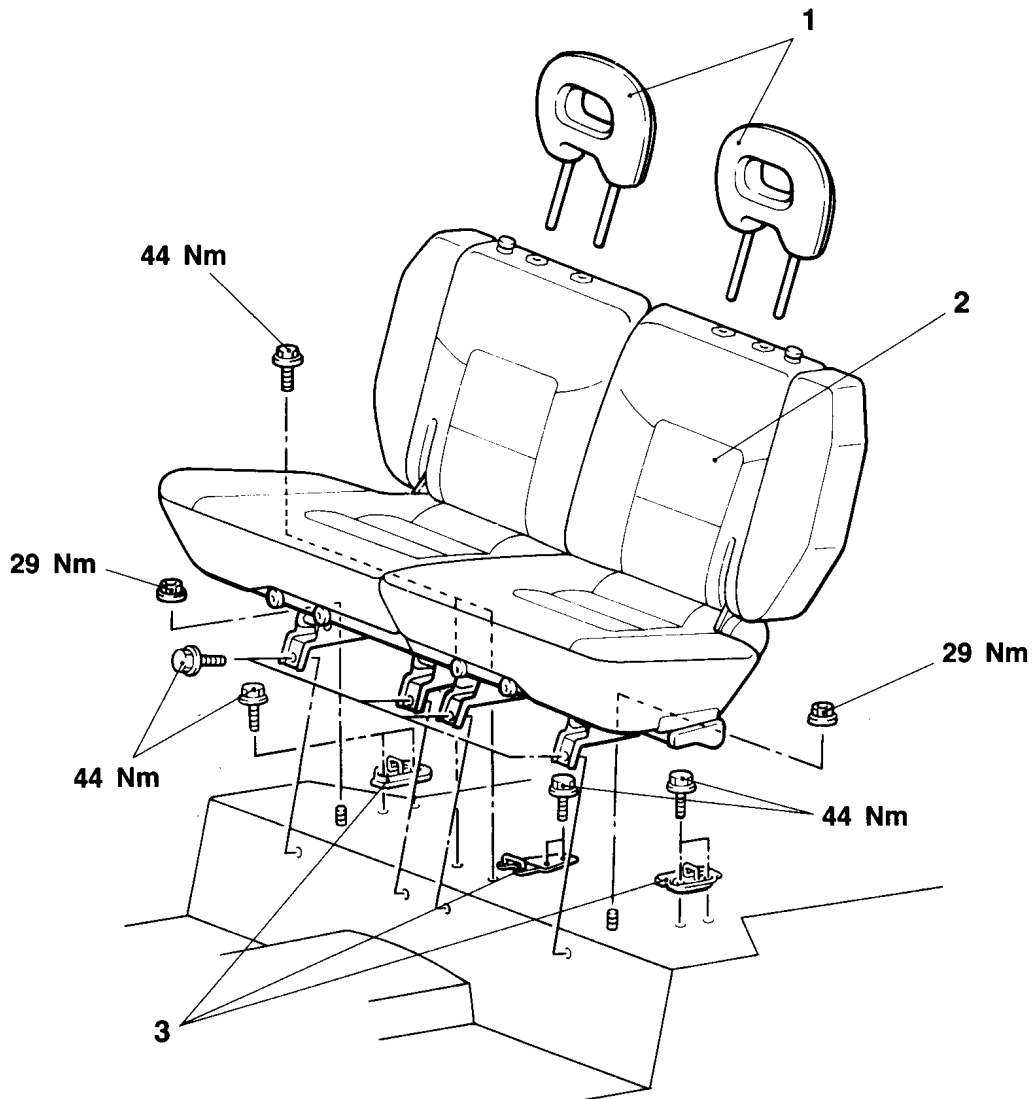

19E0220

#### Removal steps

1. Headrestraint
2. Rear seat assembly
3. Striker

## DISASSEMBLY AND REASSEMBLY

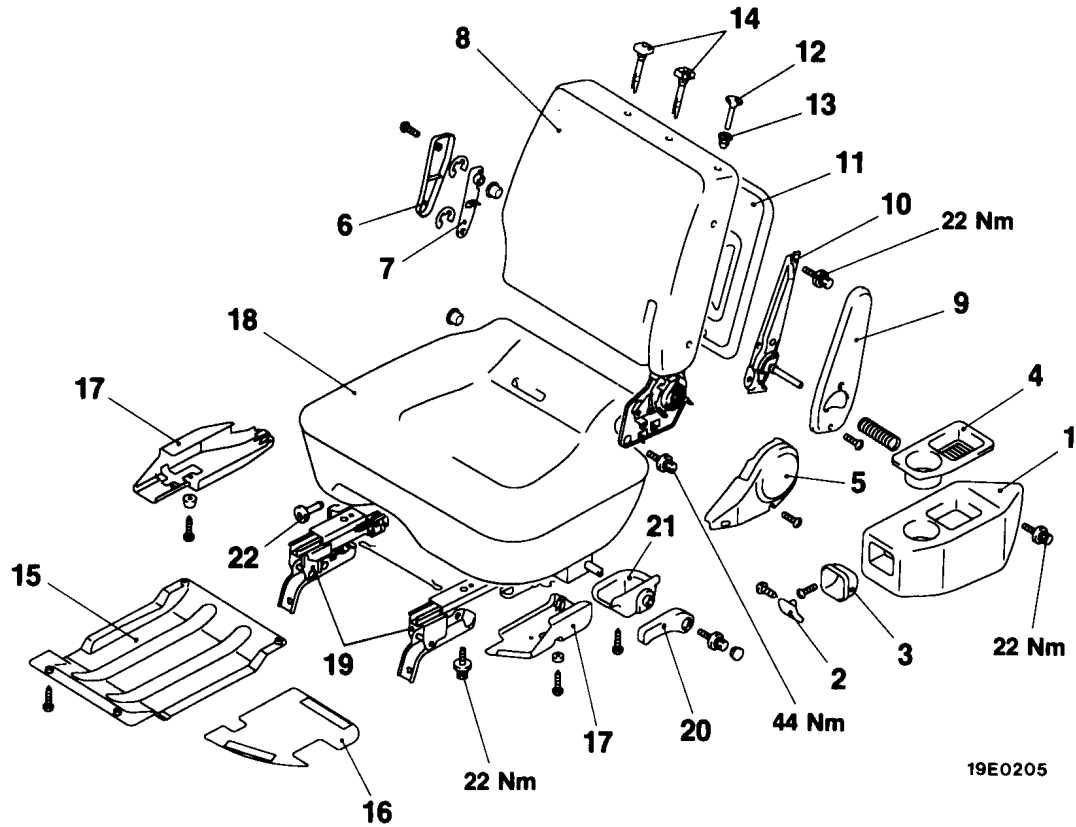
**Disassembly steps**

- |                             |                           |
|-----------------------------|---------------------------|
| 1. Side back assembly       | 12. Knob                  |
| 2. Side back knob           | 13. Knob guide            |
| 3. Side back garnish        | 14. Headrest guide        |
| 4. Side back tray           | 15. Cushion board         |
| 5. Reclining cover          | 16. Cushion mat           |
| 6. Hinge cover              | 17. Seat adjuster cover   |
| 7. Hinge plate assembly     | 18. Seat cushion assembly |
| 8. Seat back assembly       | 19. Seat adjuster         |
| 9. Rail cover               | 20. Knob                  |
| 10. Side back hinge bracket | 21. Cover                 |
| 11. Seat back trim          | 22. Headrest guide        |

**REAR SEAT BELT  
REMOVAL AND INSTALLATION**

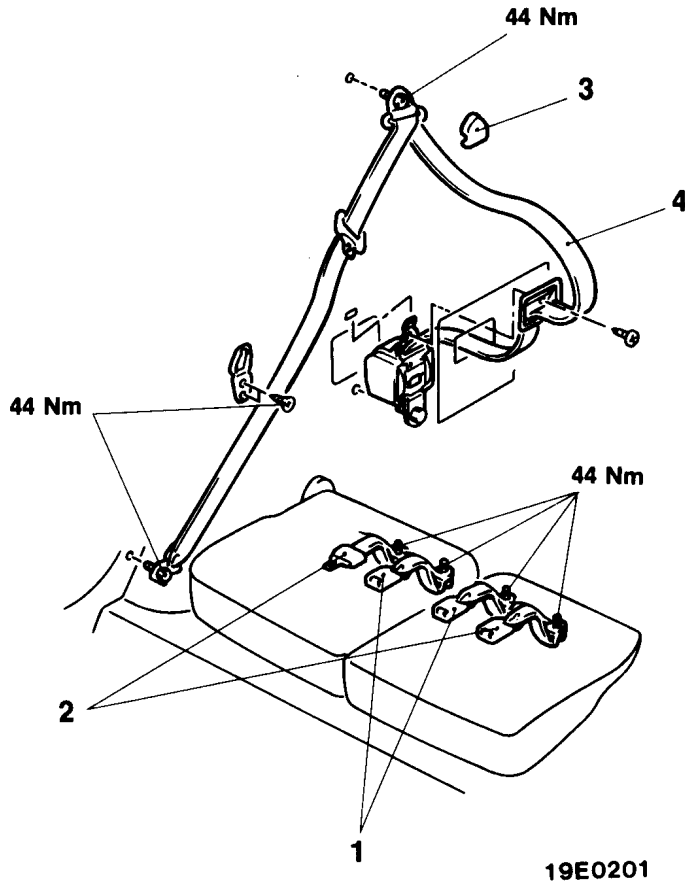

- Seat cushion board  
(Refer to P.52A-2.)
- 1. Inner seat belt assembly
- 2. Centre seat belt assembly

**Outer seat belt assembly removal steps**

- 3. Sash guide cover
- Quarter trim lower  
[Refer to BASIC MANUAL (Looseleaf edition) GROUP 52A – Trims.]
- ▶A◀ 4. Outer seat belt assembly

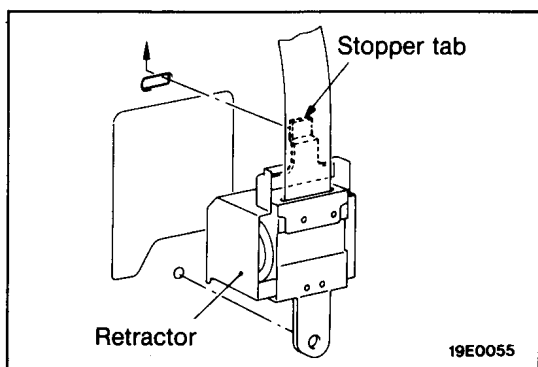

**INSTALLATION SERVICE POINT**

**▶A◀ OUTER SEAT BELT ASSEMBLY INSTALLATION**

Securely insert the retractor stopper tab into the body hole.

# SUPPLEMENTAL RESTRAINT SYSTEM (SRS)

## CONTENTS

<b>GENERAL</b> .....	<b>2</b>	<b>INDIVIDUAL COMPONENT SERVICE</b> .....	<b>20</b>
Outline of Change .....	2	<b>WARNING/CAUTION LABELS</b> .....	<b>20</b>
<b>GENERAL INFORMATION</b> .....	<b>2</b>	<b>AIR BAG MODULE</b>	
<b>SERVICE PRECAUTIONS</b> .....	<b>3</b>	(FRONT PASSENGER'S SIDE) .....	<b>21</b>
<b>SPECIAL TOOLS</b> .....	<b>6</b>	<b>AIR BAG MODULE DISPOSAL</b>	
<b>TEST EQUIPMENT</b> .....	<b>6</b>	PROCEDURES .....	<b>23</b>
<b>TROUBLESHOOTING</b> .....	<b>7</b>	Undeployed Air Bag Module Disposal .....	<b>23</b>

### CAUTION

- Carefully read and observe the information in the **SERVICE PRECAUTIONS (P.52B-3.)** prior to any service.
- For information concerning troubleshooting or maintenance, always observe the procedures in the **Troubleshooting (P.52B-7.)** section.
- If any SRS components are removed or replaced in connection with any service procedures, be sure to follow the procedures in the **INDIVIDUAL COMPONENT SERVICE** section (52B-20.) for the components involved.
- If you have any questions about the SRS, please contact your local distributor.

## GENERAL

### OUTLINE OF CHANGE

- Service points of removal and installation and inspection for the front passenger's supplemental restraint system (SRS) have been added.

## GENERAL INFORMATION

The Supplemental Restraint System (SRS) is designed to supplement the seat belt to help reduce the risk or severity of injury to the driver and front passenger\*<sup>1</sup> by activating and deploying driver's side and front passenger's side\*<sup>1</sup> air bag in certain frontal collisions.

The SRS consists of : left front and right front impact sensors (located on the radiator support panels); air bag modules for the driver's seat (located in the centre of steering wheel) and for the front passenger's seat (located above the glove box). Each module contains a folded air bag and an inflator unit. The SRS also contains: an SRS Diagnosis Unit with safing impact sensor (located under the computer cover which monitors the system): an SRS warning lamp to indicate the operational status of the SRS (located on the instrument panel): a clock spring interconnection (located within the

steering column): system wiring and wiring connectors.

The SRS is designed so that the air bag will deploy when the safing sensor, plus either or both of the left front and right front impact sensors simultaneously activate while the ignition "ON" is switched. In addition, the SRS diagnosis unit (SDU) has the following functions.

- A backup function (charging condenser for the power supply) for cases when there is a malfunction of the power supply when the SRS air bag is deployed (during an impact).
- A voltage build-up function (DC/DC converter circuit) for cases when there is a drop in system voltage.
- A self-diagnosis function to further improve the degree of safety and reliability.

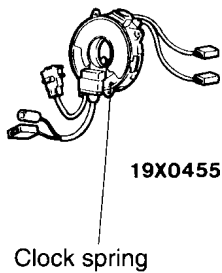
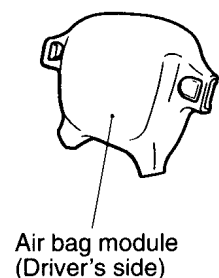
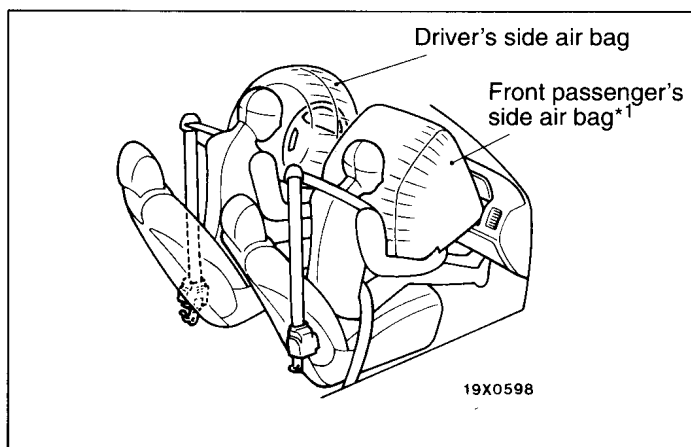

Diagnosis connector

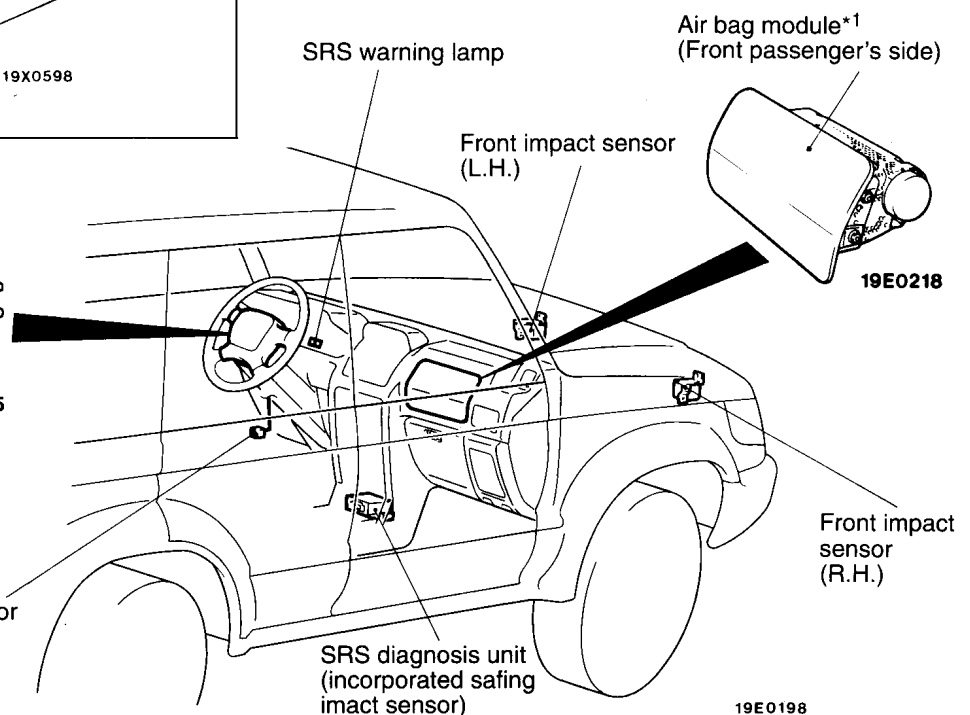



## SERVICE PRECAUTIONS

- In order to avoid injury to yourself or others from accidental deployment of the air bag during servicing, read and carefully follow all the precautions and procedures described in this manual.
- Do not use any electrical test equipment on or near SRS components, except those specified on P52B-6.  
Never use an analogue ohmmeter.
- Never Attempt to Repair the Following Components:**
  - Front Impact Sensors
  - SRS Diagnosis Unit (SDU)
  - Clock Spring
  - Air Bag Module (Driver's side or front passenger's side\*<sup>1</sup>)

If any of these components are diagnosed as faulty, they should only be replaced, in accordance with the INDIVIDUAL COMPONENTS SERVICE procedures in this manual.

- Do not attempt to repair the wiring harness connectors of the SRS. If any of the connectors are diagnosed as faulty, replace the wiring harness. If the wires are diagnosed as faulty, replace or repair the wiring harness according to the following table.

SDU Terminal No.	Harness Connector (No. of Terminals, Colour)	Destination of Harness	Corrective Action
1	2 pins, red	Dash wiring harness → Clock spring	Correct or replace each wiring harness. Replace clock spring
2			
5* <sup>1</sup>	2 pins, green	Dash wiring harness → Air bag module (Front passenger's side)	Correct or replace each wiring harness
6* <sup>1</sup>			
7 and 8	14 pins, red	–	–
9		Dash wiring harness → Diagnosis connector	Correct or replace each wiring harness
10		Dash wiring harness → Control wiring harness → Dash wiring harness → Ignition switch (ST)	
11		Dash wiring harness → Junction block (fuse No. 18)	
12		Dash wiring harness → Junction block (fuse No. 12)	
13		Dash wiring harness → Instrument panel wiring harness → SRS warning lamp	
14			
16		Dash wiring harness → Front wiring harness → Front impact sensor (LH)	Replace with sensor cable* <sup>2</sup>
17			
15		Dash wiring harness → Front wiring harness → Front impact sensor (RH)	
18			
19		Dash wiring harness → Earth	Correct or replace dash wiring harness
20			

### NOTE

- \*<sup>1</sup>: Vehicles with front passenger's air bag <L.H. drive vehicles only>
- \*<sup>2</sup>: The sensor cable marked with\*<sup>2</sup> is available as service part.
- The sensor cable used as a replacement part is routed along the dash wiring harness and front wiring harness.

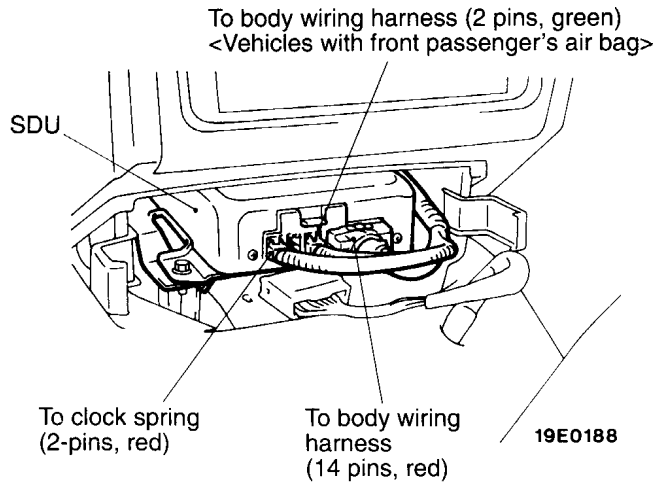
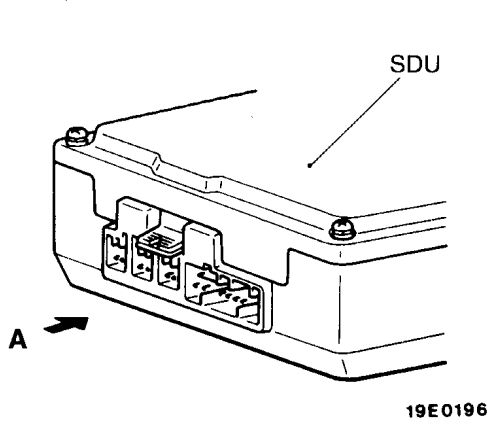

View A

<Vehicles without front passenger's air bag>

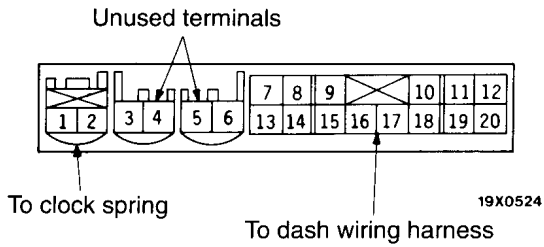

<Vehicles with front passenger's air bag>

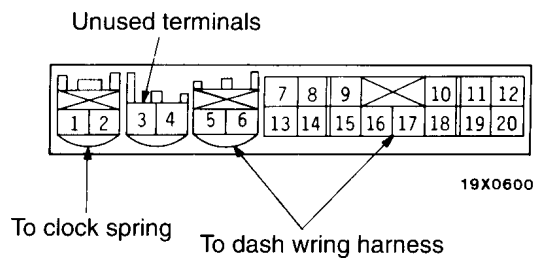

<L.H. drive vehicles>

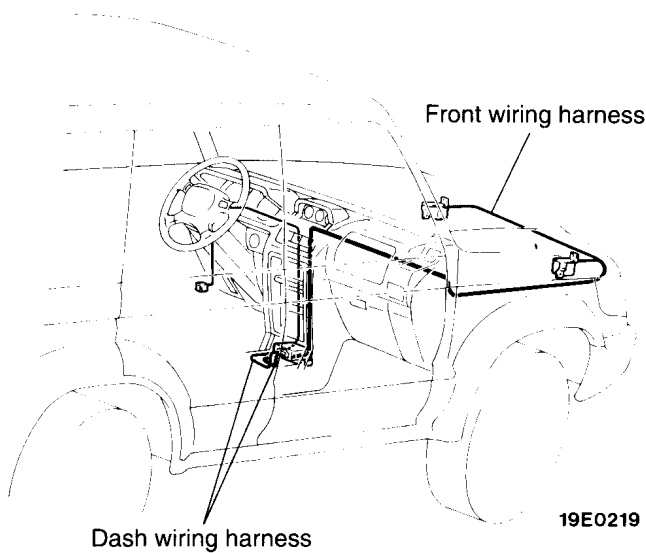

<R.H. drive vehicles>

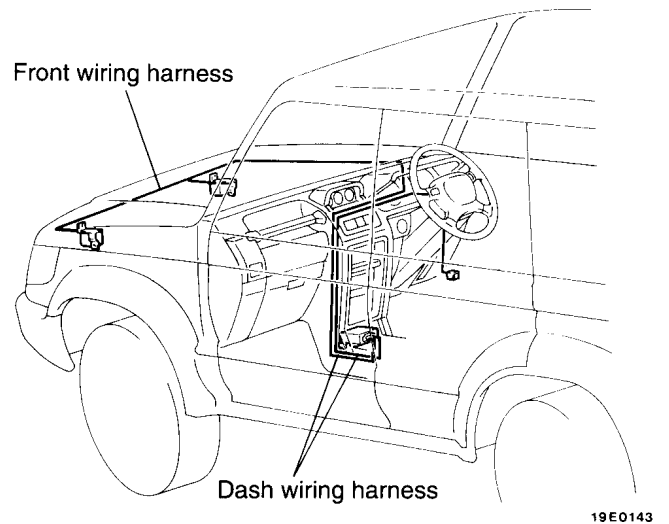

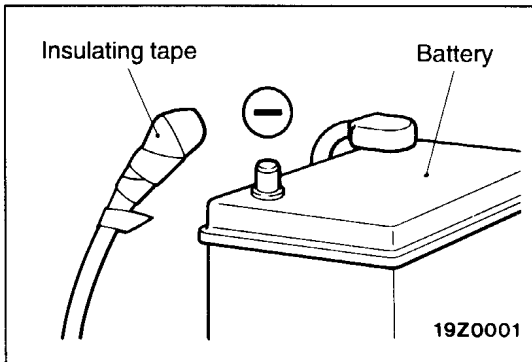

5. After disconnecting the battery cable, wait 60 seconds or more before proceeding with the following work. The SRS system is designed to retain enough voltage to deploy the air bag for short time even after the battery has been disconnected, so serious injury may result from unintended air bag deployment if work is done on the SRS system immediately after the battery cables are disconnected.

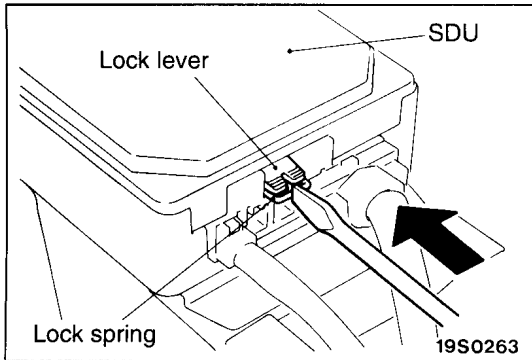



6. To unlock the SDU connector, place a flat-tipped screwdriver against the lock spring at the lock lever notch and push the spring toward the unit. In this case, do not force the lock lever up.

7. SRS components should not be subjected to heat over 93°C, so remove the front impact sensors, SRS diagnosis unit, air bag module and clock spring before drying or baking the vehicle after painting.
8. Whenever you finish servicing the SRS, erase the diagnosis codes and check the SRS warning lamp operation to make sure that the system functions properly. (Refer to P.52B-7)
9. Make certain that the ignition switch is OFF when the MUT-II is connected or disconnected.
10. If you have any questions about the SRS, please contact your local distributor.

**NOTE**

SERIOUS INJURY CAN RESULT FROM UNINTENDED AIR BAG DEPLOYMENT, SO USE ONLY THE PROCEDURES AND EQUIPMENT SPECIFIED IN THIS MANUAL.

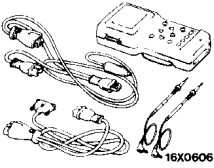
## SPECIAL TOOLS

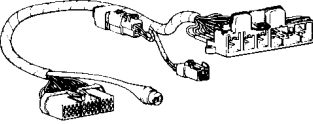
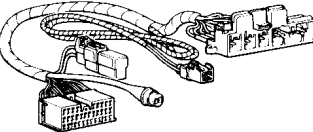
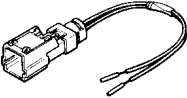
Tool	Number	Name	Use
 16X0606	MB991502	MUT-II sub assembly	<ul style="list-style-type: none"> <li>• Reading diagnosis codes</li> <li>• Erasing diagnosis code</li> <li>• Reading trouble period</li> <li>• Reading erase times</li> </ul>
 16X0607	—	ROM pack	
	MB991349	SRS Check Harness	<ul style="list-style-type: none"> <li>• Checking the SRS electrical circuitry with a digital multi-meter</li> </ul>
	MB991530	SRS Check Harness	<ul style="list-style-type: none"> <li>• Checking the SRS electrical circuitry with a digital multi-meter &lt;Vehicles with front passenger's air bag&gt;</li> </ul>
 13R0732	MB686560	SRS air bag adapter harness A	<ul style="list-style-type: none"> <li>• Deployment of air bag module inside the vehicle</li> </ul>

## TEST EQUIPMENT

Tool	Name	Use
 13R0746	Digital multi-meter	Checking the SRS electrical circuitry [ Use a multi-meter for which the maximum test current is 2 mA or less at the minimum range of resistance measurement ]

# TROUBLESHOOTING

## 1. STANDARD FLOW OF DIAGNOSTIC TROUBLESHOOTING

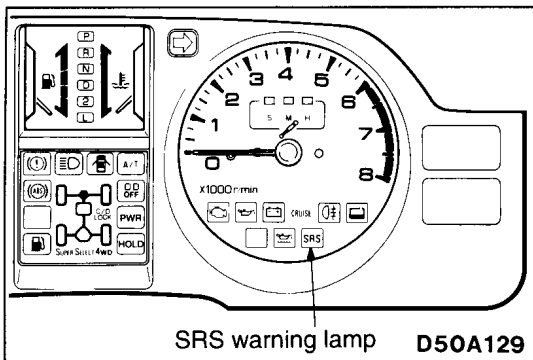
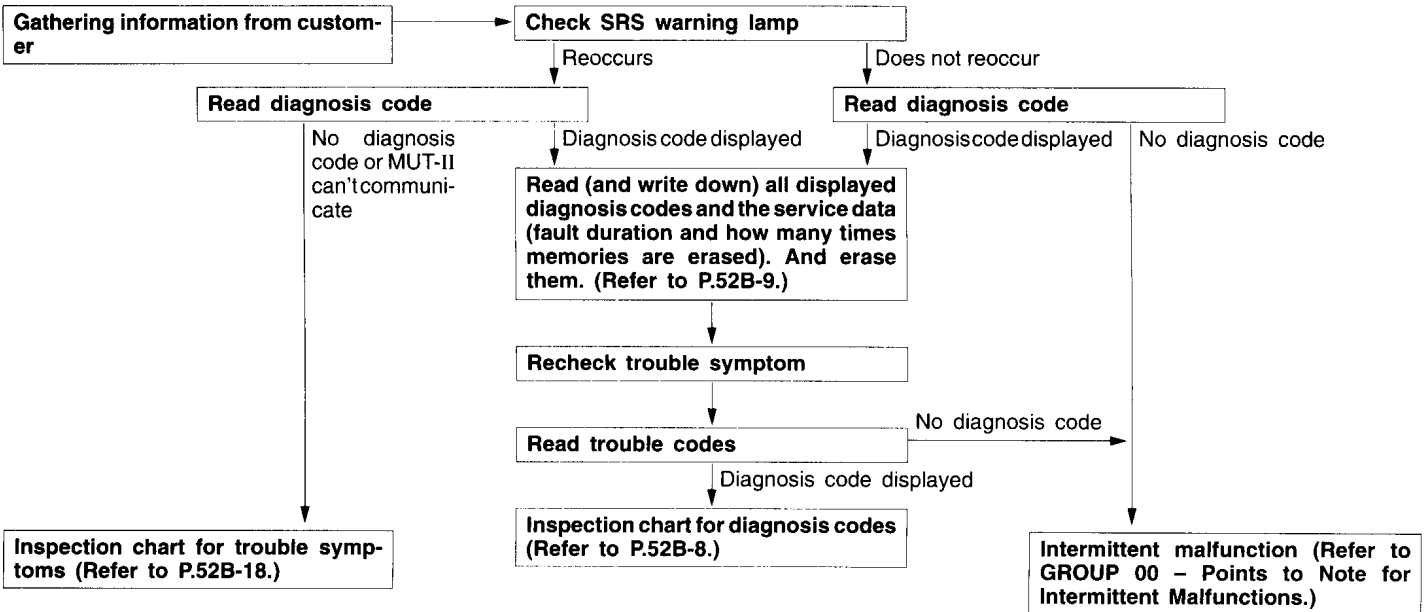

### 2. "SRS" WARNING LAMP CHECK

Turn the ignition with the key "ON" position. Does the "SRS" warning lamp illuminate for about 7 seconds, turn OFF and then remain extinguished for at least 45 seconds? If yes, SRS system is functioning properly. If no, consult page 52B-8.

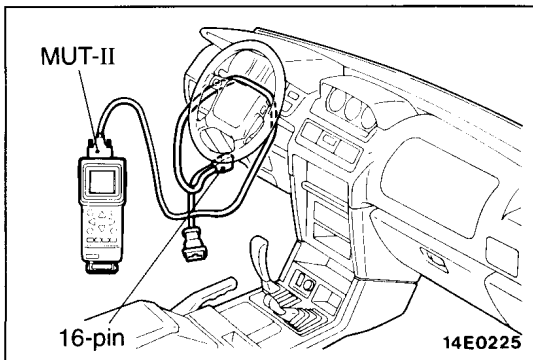

### 3. DIAGNOSIS CODE READING

- (1) Connect the MUT-II to the diagnosis connector located at the right or left side of the junction block.
- (2) Read the service date (fault duration and how many times memories are erased) using the MUT-II.

**NOTE**

1. Maximum stored period: 9999 minutes (approximately 7 days)
2. Maximum number of times to be stored: 250

#### 4. DIAGNOSIS CODES ERASING METHOD

Connect the MUT-II to the diagnosis connector and erase the diagnosis codes.

#### 5. INSPECTION CHART FOR DIAGNOSIS CODES

Inspect according to the inspection chart that is appropriate for the malfunction code.

Code No.	Diagnostic item	Reference page	
11	Front impact sensor system	52B-9	
12			
13			
21	Driver's side air bag module (squib) system	52B-10	
22			
24* <sup>3</sup>	Front passenger's side air bag module (squib)	52B-12	
25* <sup>3</sup>			
31	SDU capacitor system	52B-12	
32			
33* <sup>2</sup>	Cranking signal system	52B-13	
34* <sup>2</sup>	Connector lock system	52B-13	
41* <sup>1, 2</sup>	IG <sub>1</sub> (A) power circuit system	52B-14	
42* <sup>1, 2</sup>	IG <sub>1</sub> (B) power circuit system	52B-15	
43	SRS warning lamp drive circuit system	Lamp does not illuminate* <sup>2</sup>	52B-16
		Lamp does not switch off	52B-17
44	SDU warning lamp drive circuit system	52B-17	
45	SDU non-volatile memory (EEPROM) and A/D converter system	52B-17	

#### NOTE

\*1: If the vehicle condition returns to normal for a continuous period of  $5 \pm 0.2$  seconds, the diagnostic trouble code will be automatically erased, and the SRS warning lamp will return to normal.

\*2: If the vehicle condition returns to normal, the diagnosis code will be automatically erased, and the SRS warning lamp will return to normal.

If the vehicle has a discharged battery it will store the fault codes 41 or 42. When these diagnosis codes are displayed, check the battery.

\*3: Vehicles with front passenger's air bag.

**INSPECTION PROCEDURE CLASSIFIED BY DIAGNOSIS CODES**

Code No. 11, 12 or 13 Front impact sensor system	Probable cause
<p>(1) These diagnosis codes are output if there is abnormal resistance between the input terminals of the SDU front impact sensor. Refer to table 1 for the conditions for output of each diagnosis code.</p> <p>(2) Diagnosis codes 11, 12 and 13 are sometimes generator in combination with diagnosis codes relating to the air bag module (squib) (code Nos. 21, 22), but sometimes only one may be output instead of both being memorized. Because of this, the air bag module should also be inspected at the same time. Refer to table 2 for the failure mode combinations.</p>	<ul style="list-style-type: none"> <li>● Malfunction of front impact sensor</li> <li>● Malfunction of harnesses or connectors</li> <li>● Malfunction of SDU</li> </ul>

**TABLE 1: CONDITIONS FOR OUTPUT OF EACH DIAGNOSIS CODE**

Code No.	Trouble Symptom
11	<ul style="list-style-type: none"> <li>● Short in front impact sensor or harness short</li> <li>● Short in front impact sensor or air bag module (squib) harnesses leading to the vehicle body earth</li> <li>● Short in front impact sensor or air bag module (squib) harnesses leading to the power supply</li> </ul>
12	<ul style="list-style-type: none"> <li>● Open circuit in either left or right impact sensor or open harness</li> <li>● Short in front impact sensor or air bag module (squib) harnesses leading to the power supply</li> </ul>
13	<ul style="list-style-type: none"> <li>● Open circuit in both left and right front impact sensors or open harness</li> <li>● Short in front impact sensor or air bag module (squib) harnesses leading to the power supply</li> </ul>

**TABLE 2: FAILURE MODE COMBINATIONS**

Failure modes		Front impact sensor short	Front impact sensor open circuit (1 sensor)	Front impact sensor open circuit (2 sensors)
Driver's air bag module (squib)	Short	11 or 21	12 or 21	13 or 21
	Open circuit	11 or 22	12 or 22	13 or 22
Front passenger's air bag module (squib)	Short	11 or 24	12 or 24	13 or 24
	Open circuit	11 or 25	12 or 25	13 or 25

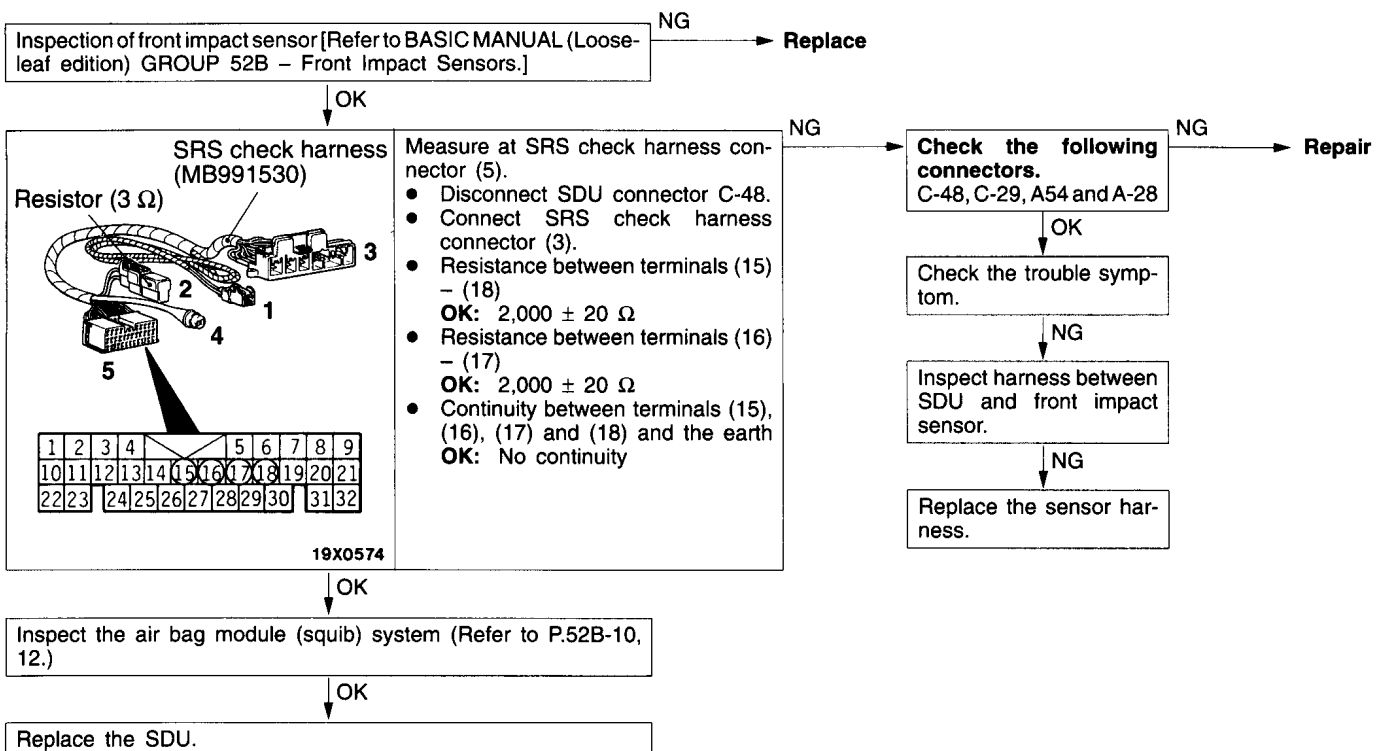

Code No. 21 or 22 Driver's air bag module (squib) system	Probable cause
<p>(1) These diagnosis codes are output if there is abnormal resistance between the input terminals of the driver's air bag module (squib). Refer to table 1 for the conditions for output of each diagnosis code.</p> <p>(2) Diagnosis codes 21 and 22 are sometimes generated in combination with diagnosis codes relating to the front impact sensor (code Nos. 11, 12 and 13), but sometimes only one may be output instead of both being memorized. Because of this, the front impact sensor should also be inspected at the same time. Refer to table 2 for the failure mode combinations.</p>	<ul style="list-style-type: none"> <li>● Malfunction of clock spring</li> <li>● Malfunction of harnesses or connectors</li> <li>● Malfunction of air bag module (driver's side squib)</li> <li>● Malfunction of SDU</li> </ul>

**TABLE 1: CONDITIONS FOR OUTPUT OF EACH DIAGNOSIS CODE**

Code No.	Trouble Symptom
21	<ul style="list-style-type: none"> <li>● Short in air bag module (driver's side squib) or harness short</li> <li>● Short in clock spring</li> <li>● Short in driver's air bag module (squib) or front impact sensor harnesses leading to the power supply</li> </ul>
22	<ul style="list-style-type: none"> <li>● Open circuit in air bag module (driver's side squib) or open harness</li> <li>● Open circuit in clock spring</li> <li>● Malfunction of connector contact</li> <li>● Short in driver's air bag module (squib) or front impact sensor harnesses leading to the power supply</li> </ul>

**TABLE 2: FAILURE MODE COMBINATIONS**

Failure modes		Front impact sensor short	Front impact sensor open circuit (1 sensor)	Front impact sensor open circuit (2 sensors)
Driver's air bag module (squib)	Short	11 or 21	12 or 21	13 or 21
	Open circuit	11 or 22	12 or 22	13 or 22

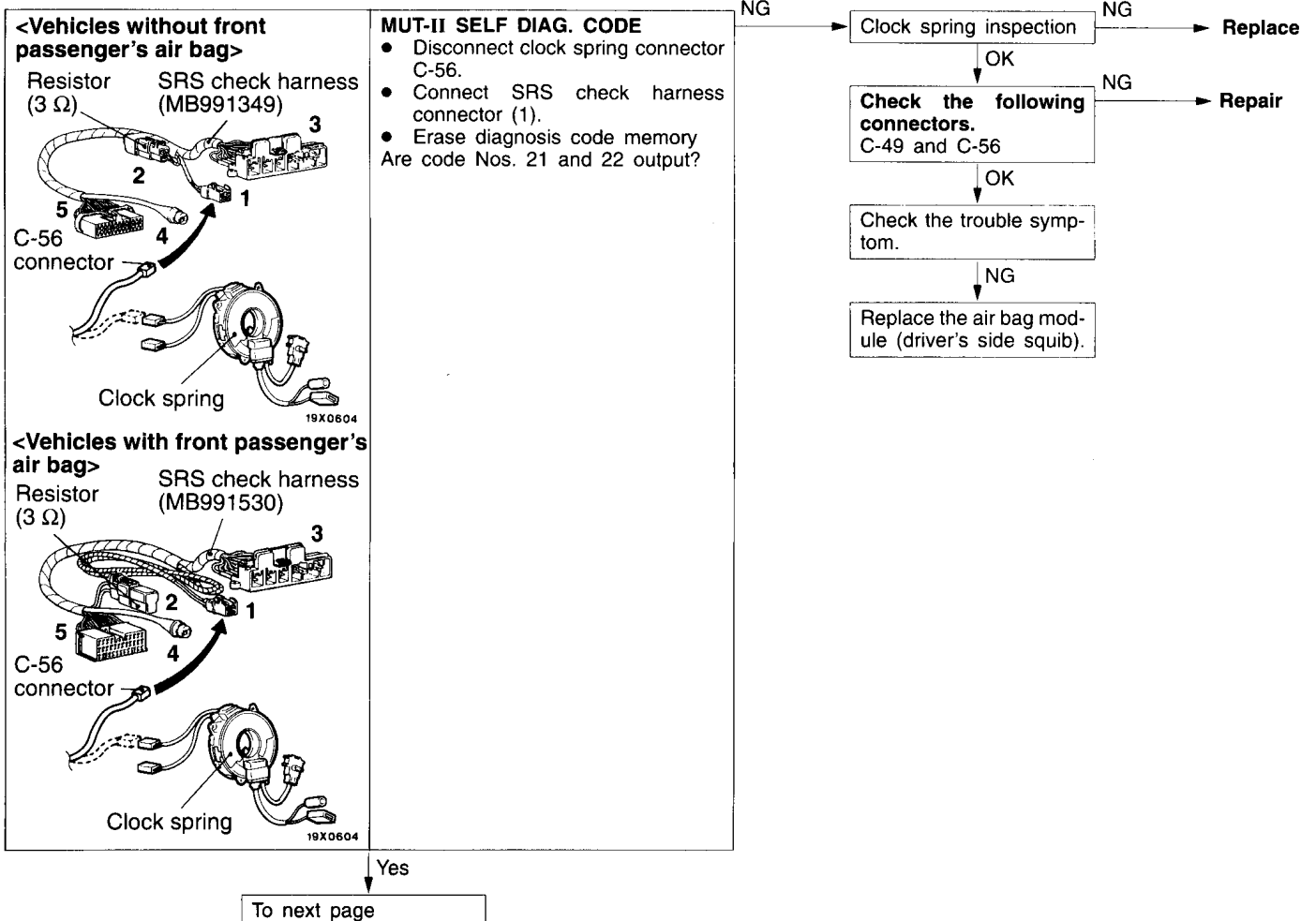



From previous page

**<Vehicles without front passenger's air bag>**

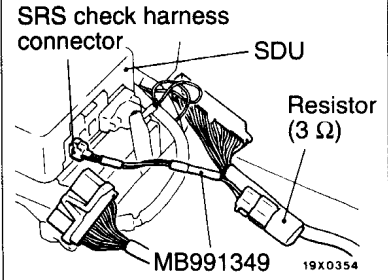

**<Vehicles with front passenger's air bag>**

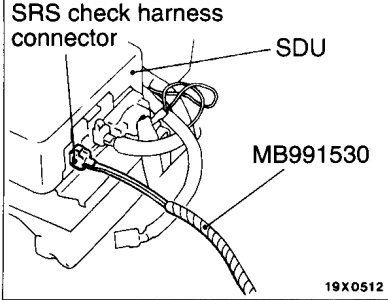

**MUT-II SELF DIAG. CODE**

- Connect clock spring connector C-56.
  - Disconnect SDU connector C-48.
  - Connect SRS check harness connector (1)
  - Erase diagnosis code memory
- Are code Nos. 21 and 22 output?

No

Clock the harness between the SDU and clock spring, and repair if necessary.

Yes

Replace the SDU.

Code No. 24 or 25 Front passenger's side air bag module (squib) system	Probable cause
<p>(1) These diagnosis codes are output if there is abnormal resistance between the input terminals of the front passenger's air bag module (squib). Refer to table 1 for the conditions for output of each diagnosis code.</p> <p>(2) Diagnosis codes 24 and 25 are sometimes generated in combination with diagnosis codes relating to the front impact sensor (code Nos. 11, 12 and 13), but sometimes only one may be output instead of both being memorized. Because of this, the front impact sensor should also be inspected at the same time. Refer to table 2 for the failure mode combinations.</p>	<ul style="list-style-type: none"> <li>• Malfunction of harnesses or connectors</li> <li>• Malfunction of air bag module (front passenger's side squib)</li> <li>• Malfunction of SDU</li> </ul>

**TABLE 1: CONDITIONS FOR OUTPUT OF EACH DIAGNOSIS CODE**

Code No.	Trouble Symptom
24	<ul style="list-style-type: none"> <li>• Short in air bag module (front passenger's side squib) or harness short</li> <li>• Short in air bag module (front passenger's side squib) or front impact sensor harnesses leading to the power supply</li> </ul>
25	<ul style="list-style-type: none"> <li>• Open circuit in air bag module (front passenger's side squib) or open harness</li> <li>• Malfunction of connector contact</li> <li>• Short in front passenger's air bag module (squib) or front impact sensor harnesses leading to the power supply</li> </ul>

**TABLE 2: FAILURE MODE COMBINATIONS**

Failure modes		Front impact sensor short	Front impact sensor open circuit (1 sensor)	Front impact sensor open circuit (2 sensors)
Driver's air bag module (squib)	Short	11 or 24	12 or 24	13 or 24
	Open circuit	11 or 25	12 or 25	13 or 25

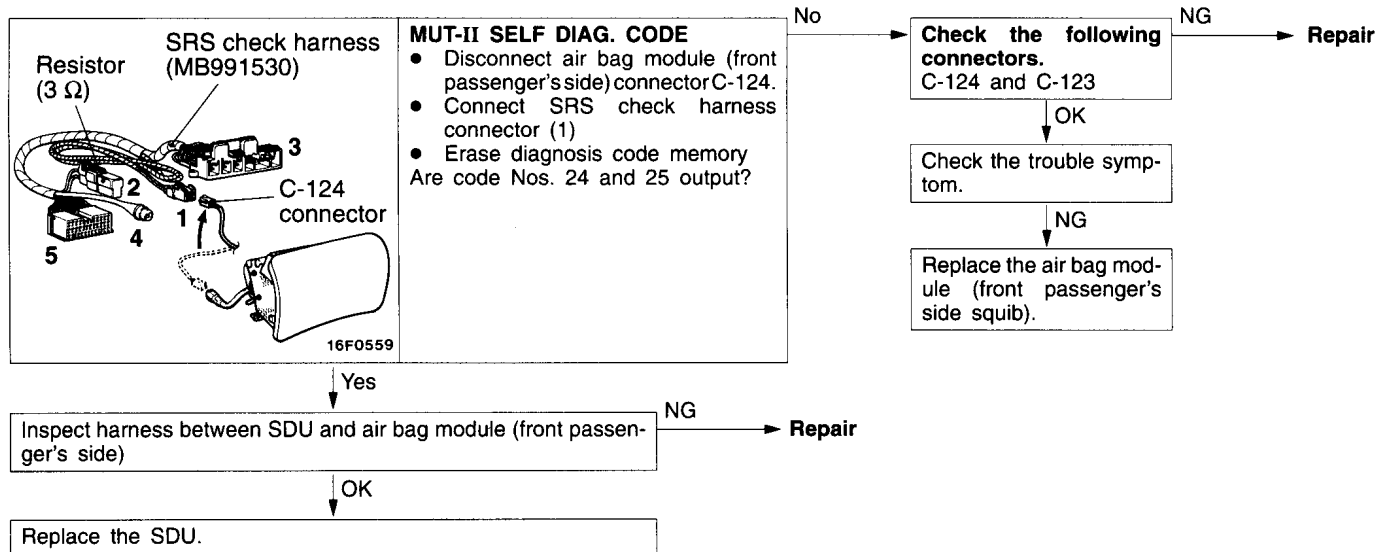

Code No. 31 or 32 SDU capacitor system	Probable cause
<p>These diagnosis codes are output if the voltage at the SDU capacitor terminals is higher (No. 31) or lower (No. 32) than the specified value for 5 seconds or more. However, if diagnosis code Nos. 41 and 42 are being output due to a drop in battery voltage, code No. 32 will not be detected.</p>	<ul style="list-style-type: none"> <li>• Malfunction of SDU</li> </ul>

The capacitor inside the SDU is probably defective, so replace the SDU.

Code No. 33 Cranking signal system	Probable cause
<p>The cranking signal is provided in order to prevent mistaken detection of power supply voltage drops at the IG1 terminal during cranking. This diagnosis code is output if the cranking signal is output for a continuous period of 45 seconds or more (cranking signal harness is shorted to the power supply). However, if the vehicle condition returns to normal for a continuous period of <math>5 \pm 0.2</math> seconds (except when cranking), diagnosis code No. 33 will be automatically erased, and the SRS warning lamp will switch off.</p>	<ul style="list-style-type: none"> <li>• Malfunction of harnesses or connectors</li> <li>• Malfunction of SDU</li> </ul>

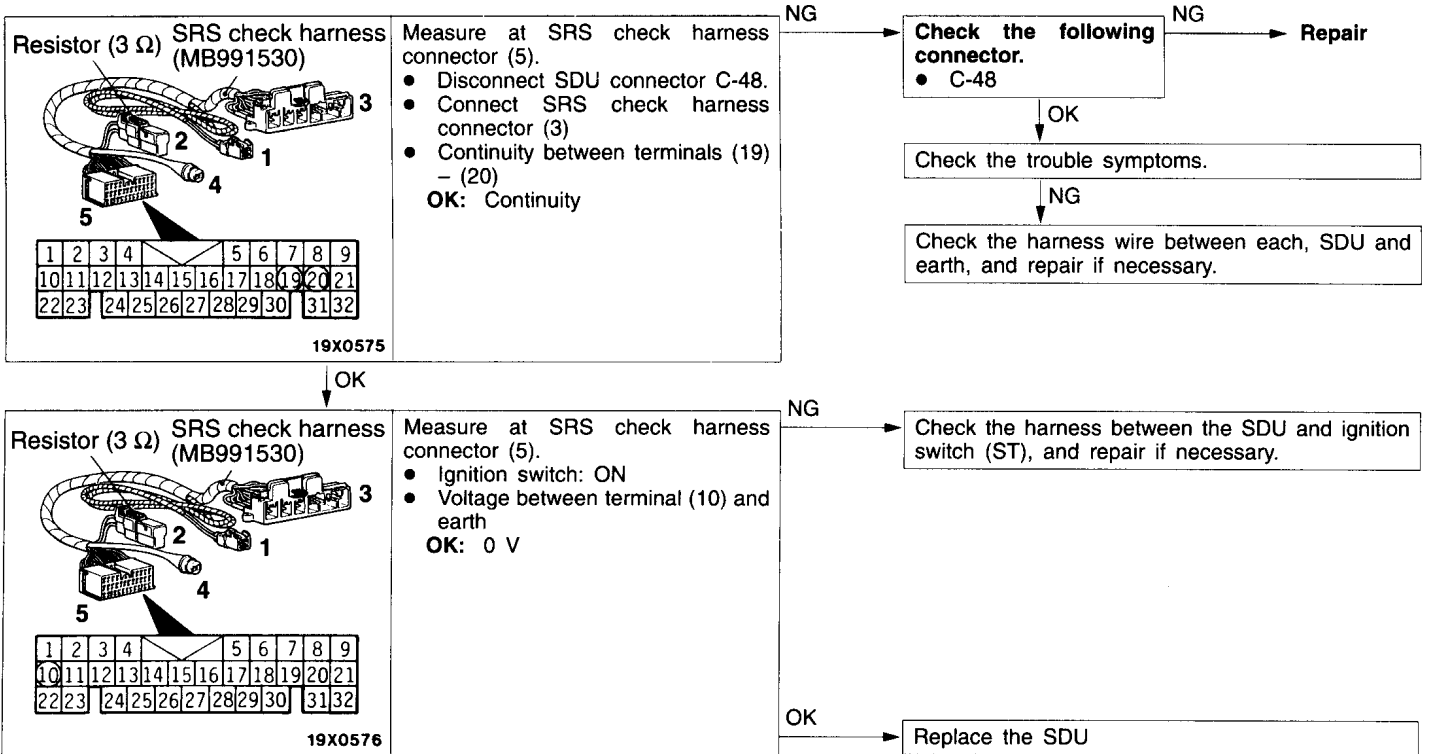

Code No. 34 Connector lock system	Probable cause
<p>This diagnosis code is output if the double lock shorting bar of the SDU connector is detected to be open. However, if the vehicle condition returns to normal, diagnosis code No. 34 will be automatically erased, and the SRS warning lamp will switch off.</p>	<ul style="list-style-type: none"> <li>• Malfunction of connectors</li> <li>• Malfunction of SDU</li> </ul>

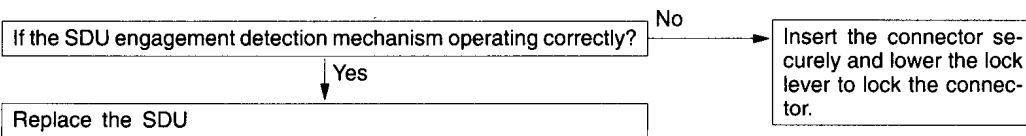

Code No. 41 IG <sub>1</sub> (A) power circuit system	Probable cause
<p>This diagnosis code is output if the voltage between the IG<sub>1</sub> (A) terminal and the earth is lower than the specified value for a continuous period of 5 seconds or more. However, if the vehicle conditions returns to normal, diagnosis code No. 41 will be automatically erased, and the SRS warning lamp will switch off.</p>	<ul style="list-style-type: none"> <li>• Malfunction of harnesses or connectors</li> <li>• Malfunction of SDU</li> </ul>

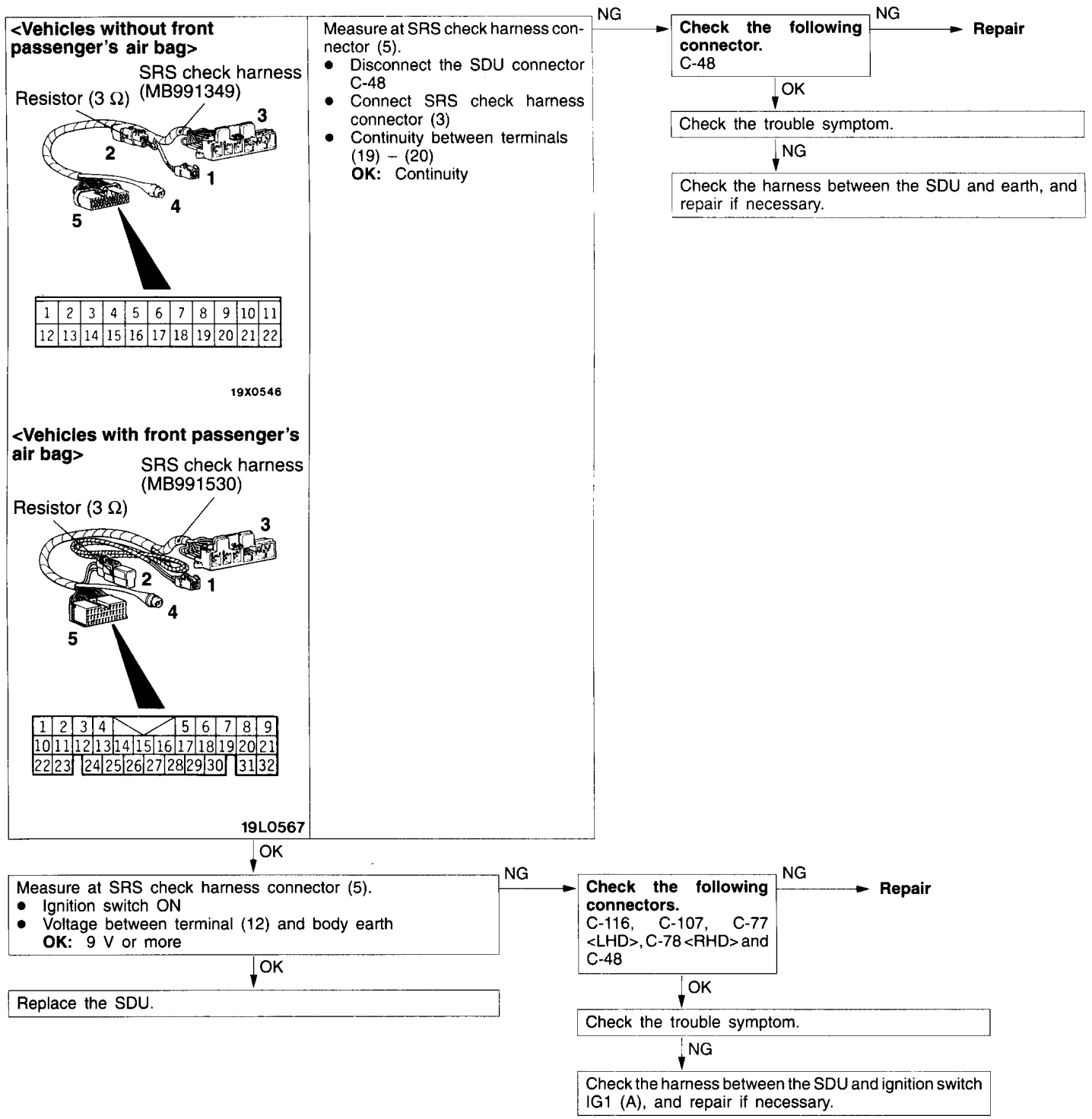

Measure at SRS check harness connector (5).

- Ignition switch ON
- Voltage between terminal (12) and body earth

**OK:** 9 V or more

Replace the SDU.

Check the following connector. C-48

OK → Check the trouble symptom.

NG → Check the harness between the SDU and earth, and repair if necessary.

Check the following connectors. C-116, C-107, C-77 <LHD>, C-78 <RHD> and C-48

OK → Check the trouble symptom.

NG → Check the harness between the SDU and ignition switch IG<sub>1</sub> (A), and repair if necessary.



Code No. 42 IG <sub>1</sub> (B) power circuit system	Probable cause
This diagnosis code is output if the voltage between the IG <sub>1</sub> (B) terminal and the earth is lower than the specified value for a continuous period of 5 seconds or more. However, if the vehicle conditions returns to normal, diagnosis code No. 42 will be automatically erased, and the SRS warning lamp will switch off.	<ul style="list-style-type: none"> <li>● Malfunction of harnesses or connectors</li> <li>● Malfunction of SDU</li> </ul>

**<Vehicles without front passenger's air bag>**

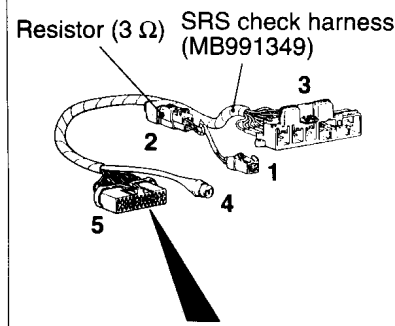

1	2	3	4	5	6	7	8	9	10	11
12	13	14	15	16	17	18	19	20	21	22

19X0546

**<Vehicles with front passenger's air bag>**

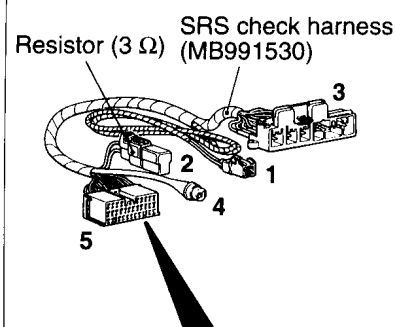

1	2	3	4	5	6	7	8	9			
10	11	12	13	14	15	16	17	18	19	20	21
22	23	24	25	26	27	28	29	30	31	32	

19L0567

Measure at SRS check harness connector (5).

- Disconnect the SDU connector C-48
- Connect SRS check harness connector (3)
- Continuity between terminals (19) – (20)

**OK:** Continuity

Measure at SRS check harness connector (5).

- Ignition switch ON
- Voltage between terminal (11) and body earth

**OK:** 9 V or more

Replace the SDU.

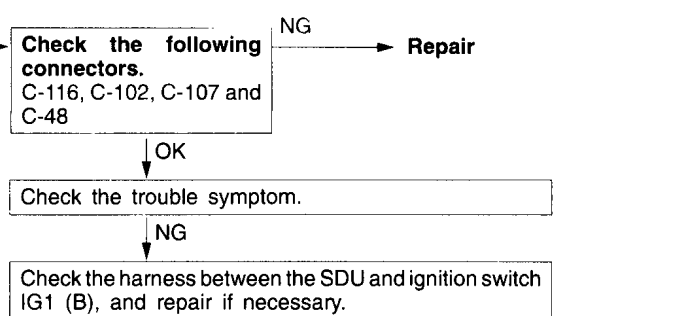
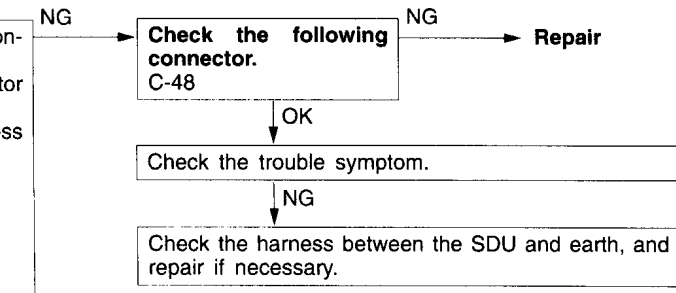

Code No. 43 SRS warning lamp drive circuit system (Lamp does not illuminate.)	Probable cause
<p>This diagnosis code is output when an open circuit occurs for a continuous period of 5 seconds while the SDU is monitoring the SRS warning lamp and the lamp is OFF (transistor OFF). However, if this code is output due to an open circuit, if the vehicle condition returns to normal, this diagnosis code No. 43 will be automatically erased, and the SRS warning lamp will return to normal.</p>	<ul style="list-style-type: none"> <li>• Malfunction of harnesses or connectors</li> <li>• Blown bulb</li> <li>• Malfunction of SDU</li> <li>• Malfunction of combination meter</li> </ul>

<Vehicles without front passenger's air bag>

Resistor (3 Ω) SRS check harness (MB991349)

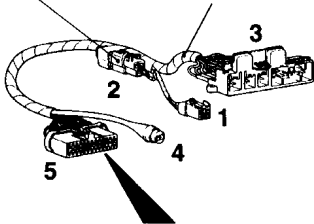

1	2	3	4	5	6	7	8	9	10	11
12	13	14	15	16	17	18	19	20	21	22

19X0546

<Vehicles with front passenger's air bag>

Resistor (3 Ω) SRS check harness (MB991530)

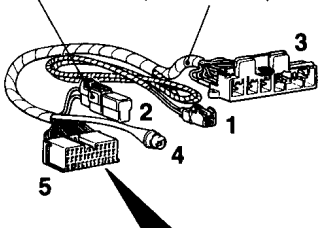

1	2	3	4	5	6	7	8	9			
10	11	12	13	14	15	16	17	18	19	20	21
22	23	24	25	26	27	28	29	30	31	32	

19L0567

Measure at SRS check harness connector (5).

- Disconnect the SDU connector C-48
- Connect SRS check harness connector (3)
- Continuity between terminals (19) – (20)

OK: Continuity

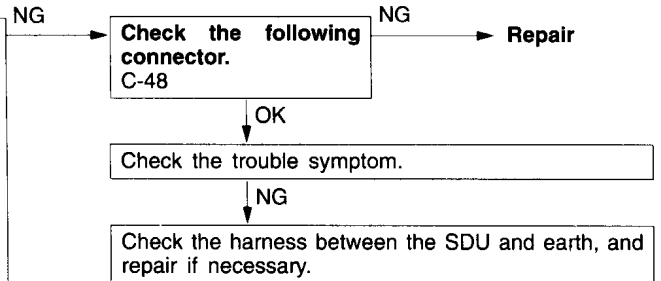

- Measure at SRS check harness connector (5).
- Ignition switch ON
  - Voltage between terminal (13) and body earth
- OK: Lamp illuminates

Replace the SDU.

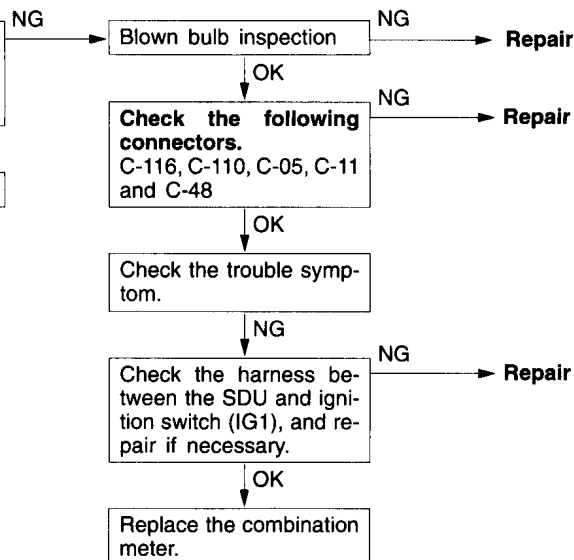

Code No. 43 SRS warning lamp drive circuit system (Lamp does not switch off.)	Probable cause
This diagnosis code is output when a short to earth occurs in the harness between the lamp and the SDU while the SDU is monitoring the SRS warning lamp and the lamp is ON.	<ul style="list-style-type: none"> <li>● Malfunction of harnesses or connectors</li> <li>● Malfunction of SDU</li> </ul>

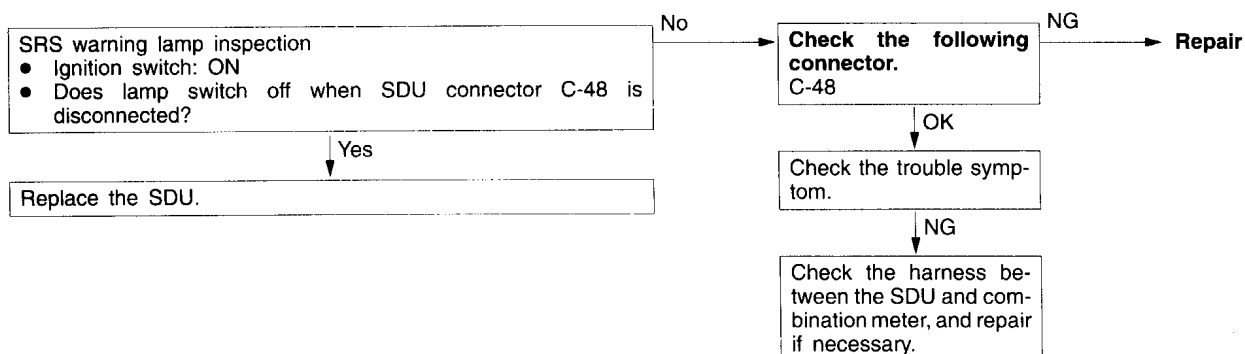

Code No. 44 SRS warning lamp drive circuit system	Probable cause
This diagnosis code is output when a short occurs in the lamp drive circuit or a malfunction of the output transistor inside the SDU is detected while the SDU is monitoring the SRS warning lamp drive circuit.	<ul style="list-style-type: none"> <li>● Malfunction of harnesses or connectors</li> <li>● Malfunction of SDU</li> </ul>

If the results of inspection of the SRS warning lamp drive circuit system are normal, the transistor inside the SDU is probably defective, so replace the SDU.

Code No. 45 SDU non-volatile memory (EEPROM) and A/D converter system	Probable cause
This diagnosis code is output if there is a malfunction in the SDU non-volatile memory (EEPROM) or A/D converter.	<ul style="list-style-type: none"> <li>● Malfunction of SDU</li> </ul>

The SDU non-volatile memory (EEPROM) or A/D converter is probably defective, so replace the SDU.

### 6. INSPECTION CHART FOR TROUBLE SYMPTOMS

Get an understanding of the trouble symptoms and check according to the inspection procedure chart.

Trouble symptom		Inspection Procedure No.	Reference page
Communication with MUT-II is not possible.	Communication with all systems is not possible.	1	52B-18
	Communication is not possible with SRS only.	2	52B-19
When the ignition key is turned to "ON" (engine stopped), the SRS warning lamp does not illuminate.		Refer to diagnosis code No. 43.	52B-16
After the ignition switch is turned to ON, the SRS warning lamp is still on after approximately 7 seconds have passed.		Refer to diagnosis code No. 43.	52B-17

### 7. INSPECTION PROCEDURE FOR TROUBLE SYMPTOMS

#### Inspection Procedure 1

Communication with MUT-II is not possible. (Communication with all system is not possible)	Probable cause
The cause is probably a power supply system (including earth circuit) of the diagnosis line.	<ul style="list-style-type: none"> <li>• Malfunction of connectors</li> <li>• Malfunction of harness</li> </ul>

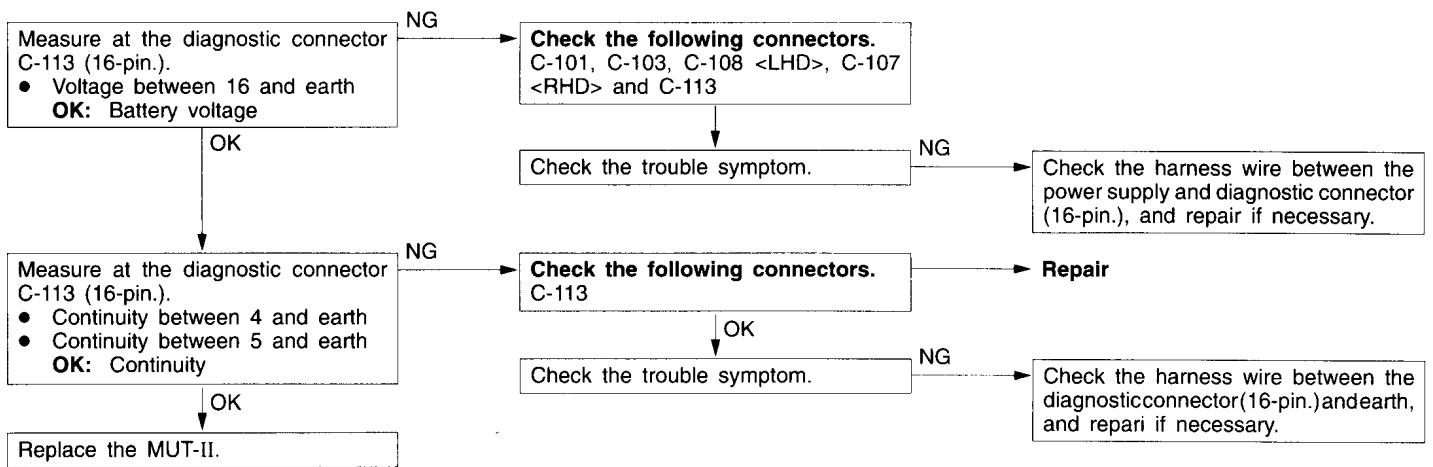



Inspection Procedure 2

Communication with MUT-II is not possible. (Communication is not possible with SRS only)	Probable cause
If communication is not possible with the SRS only, the cause is probably an open circuit in the diagnosis output circuit of the SRS or in the power circuit (including earth circuit).	<ul style="list-style-type: none"> <li>• Malfunction of harnesses or connectors</li> <li>• Malfunction of SDU</li> </ul>

<Vehicles without front passenger's air bag>

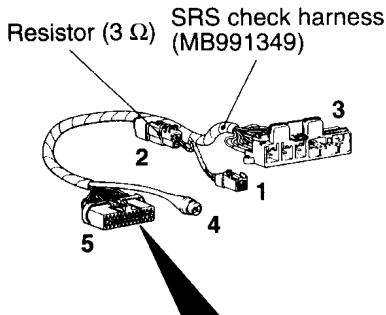

19X0546

<Vehicles with front passenger's air bag>

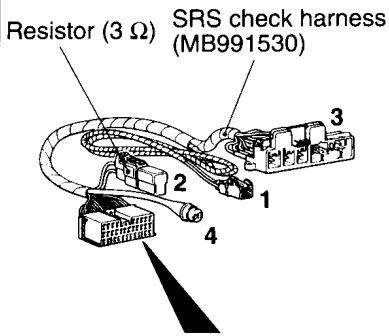

19L0567

Measure at SRS check harness connector (5).  
 • Disconnect the SDU connector C-48  
 • Connect SRS check harness connector (3)  
 • Continuity between terminals (19) – (20)  
**OK:** Continuity

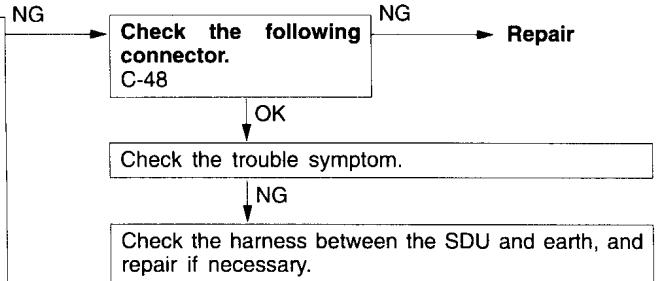

Measure at SRS check harness connector (5).  
 • Disconnect SDU connector C-48.  
 • Connect SRS check harness connector (3).  
 • Voltage between the terminal (11) and body earth.  
**OK:** 9 V or more  
 • Voltage between the terminal (12) and body earth.  
**OK:** 9 V or more

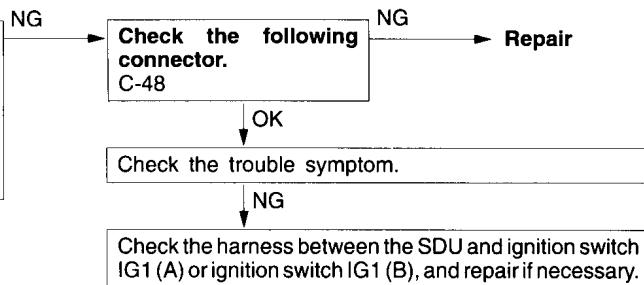

Inspect the harness between the SDU and diagnosis connector.



Replace the SDU.

## **INDIVIDUAL COMPONENT SERVICE**

If the SRS components are to be removed, follow each procedure. (P.52B-21 – P.52B-23.)

### **Caution**

1. **SRS components should not be subjected to heat over 93°C, so remove the front impact sensors, SRS diagnosis unit and air bag module and clock spring before drying or baking the vehicle after painting.**
2. **If the SRS components are removed for the purpose of check, sheet metal repair, painting, etc., they should be stored in a clean, dry place until they are reinstalled.**

## **WARNING/CAUTION LABELS**

The attachment positions for the special labels in vehicles which are equipped with a passenger's side air bag are shown below. Other labels are in the same position as in vehicles which are equipped with a driver's side air bag only.

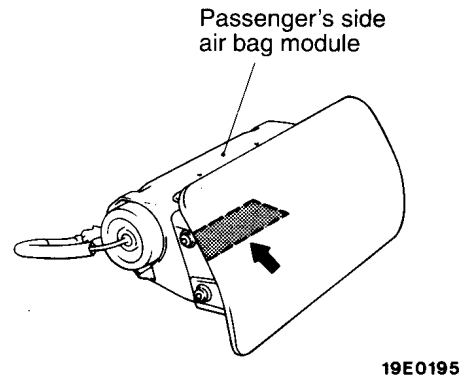
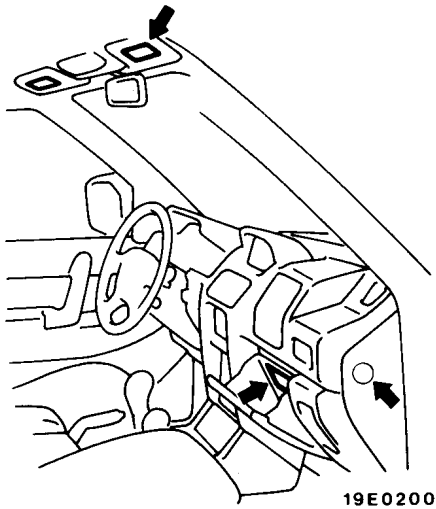

## AIR BAG MODULE (FRONT PASSENGER’S SIDE)

### Caution

1. Never attempt to disassemble or repair the air bag module or clock spring.  
If faulty, replace it.
2. Do not drop the air bag module or clock spring or allow contact with water, grease or oil.  
Replace it if a dent, crack, deformation or rust are detected.
3. The air bag module should be stored on a flat surface and placed so that the pad surface is facing upward.  
Do not place anything on top of it.
4. Do not expose the air bag module to temperature over 93°C.
5. After deployment of an air bag, replace the clock spring with a new one.
6. Wear gloves and safety glasses when handling an air bag that has already deployed.
7. An unemployed air bag module should only be disposed of in accordance with the procedures. (Refer to P.52B-23.)

### REMOVAL AND INSTALLATION

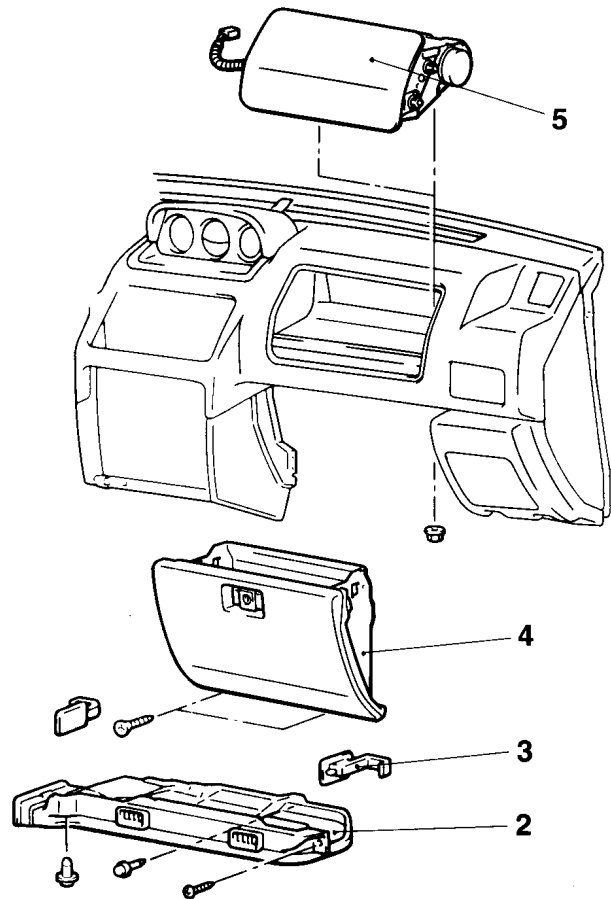
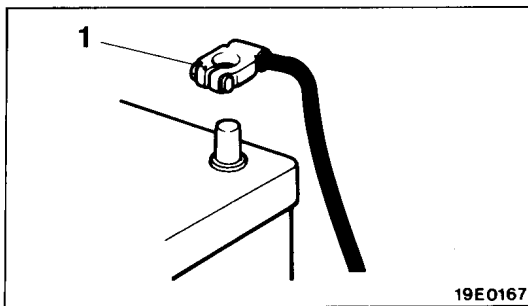

19E0197

#### Air bag module removal steps

- ◀A▶ ▶B▶ ● Post-installation inspection
1. Negative (-) battery cable connection
  2. Foot shower duct (R.H.)
  3. Stopper
  4. Glove box
  5. Air bag module
- ◀B▶ ▶A▶ ● Pre-installation inspection

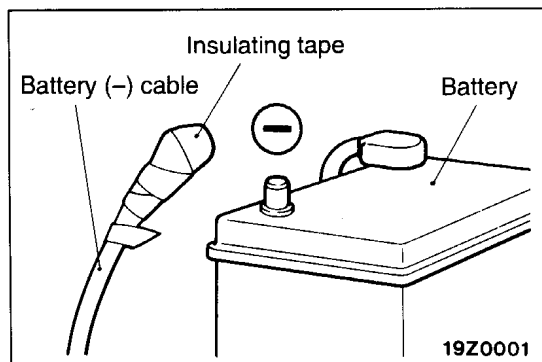

## REMOVAL SERVICE POINTS

### ◀A▶ NEGATIVE (-) BATTERY CABLE DISCONNECTION

Disconnect the negative battery cable from the battery and tape the terminal.

#### Caution

Wait at least 60 seconds after disconnecting the battery cable before doing any further work. (Refer to P.52B-5, No. 5.)

### ◀B▶ AIR BAG MODULE REMOVAL

#### Caution

The removed air bag module should be stored in a clean, dry place with the pad cover face up.

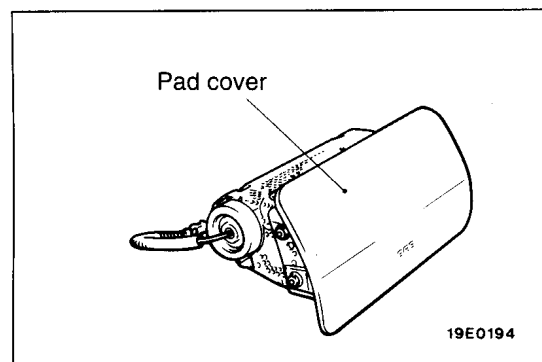

## INSPECTION

### AIR BAG MODULE

If any improper part is found during the following inspection, replace the air bag module with a new one.

Dispose of the old one according to the specified procedure. (Refer to P.52B-23.)

#### Caution

Never attempt to measure the circuit resistance of the air bag module (squib) even if you are using the specified tester. If the circuit resistance is measured with a tester, accidental air bag deployment will result in serious personal injury.

- (1) Check pad cover for dents, cracks or deformities.
- (2) Check connectors for damage, terminals for deformities, and harness for binds.
- (3) Check air bag inflator case for dents, cracks or deformities.

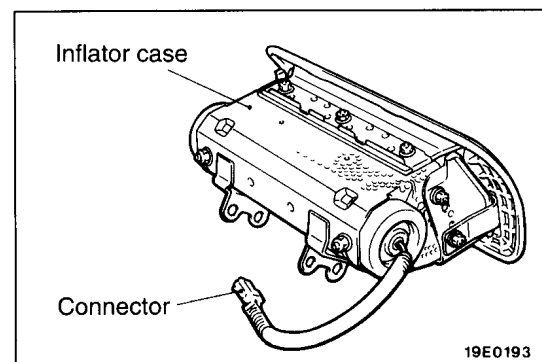

## INSTALLATION SERVICE POINTS

### ▶A◀ PRE-INSTALLATION INSPECTION

- (1) When installing the new air bag modules and clock spring, refer to "INSPECTION"

#### Caution

Dispose of air bag modules only according to the specified procedure. (Refer to P.52B-23.)

- (2) Connect the battery (-) terminal.

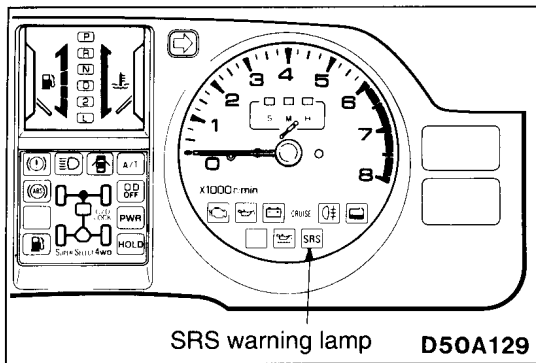
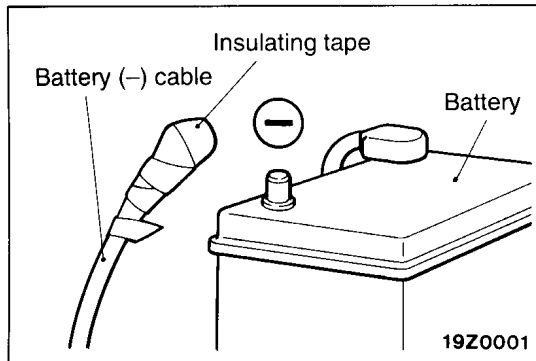
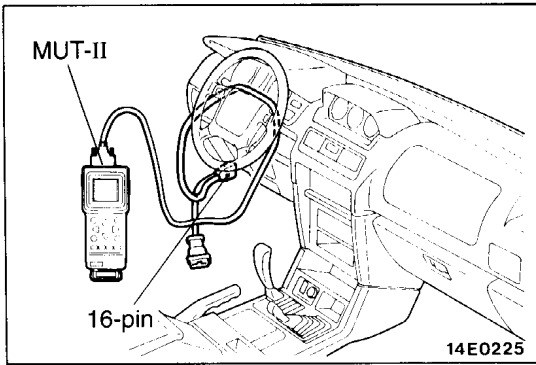

- (3) Connect the MUT-II to the diagnosis connector located at the left side of the junction block.

**Caution**

**Make certain that the ignition switch is OFF when the MUT-II is connected or disconnected.**

- (4) Reconnect negative terminal of battery, and turn the ignition key to the “ON” position.
- (5) Conduct self-diagnosis using the MUT-II to ensure entire SRS operates properly, except open circuit of air bag modules (Diagnosis code No. 22, No. 25). (Refer to P.52B-10, 12.)
- (6) Turn the ignition key to the “LOCK” position, disconnect the negative battery cable and tape the terminal.

**Caution**

**Wait at least 60 seconds after disconnecting the battery cable before doing any further work. (Refer to P.52B-5, No. 5.)**

►B◄ **POST-INSTALLATION INSPECTION**

Reconnect the negative battery terminal. Turn the ignition key to the “ON” position. Does the “SRS” warning lamp illuminate for about 7 seconds, turn OFF and then remain extinguished for at least 45 seconds? If yes, SRS system is functioning properly. If no, consult page 52B-8.

## AIR BAG MODULE DISPOSAL PROCEDURES

Before either disposing of a vehicle equipped with air bags, or prior to disposing of the air bag modules,

be sure to first follow the procedures described below to deploy the air bags.

### UNDEPLOYED AIR BAG MODULE DISPOSAL

**Caution**

1. If the vehicle is to be scrapped, or otherwise disposed of, deploy the air bags inside the vehicle. If the vehicle will continue to be operated and only the air bag modules are to be disposed of, deploy the air bags outside the vehicles.
2. Since a large amount of smoke is produced when the air bags are deployed, select a well-ventilated site. Moreover, never attempt the test near a smoke sensor.

3. Since there is a loud noise when the air bags are deployed, avoid residential areas whenever possible. If anyone is nearby, give warning of the impending noise.
4. Suitable ear protection should be worn by personnel performing these procedures or by people in the immediate area.

### DEPLOYMENT INSIDE THE VEHICLE (when disposing of a vehicle)

- (1) Open all windows and doors of the vehicle. Move the vehicle to an isolated spot.
- (2) Disconnect the negative (–) and positive (+) battery cables from the battery terminals, and then remove the battery from the vehicle.

#### Caution

**Wait at least 60 seconds after disconnecting the battery cable before doing any further work. (Refer to P.52B-5, No. 5.)**

- (3) To deploy the air bag module:
  1. Remove the glove box.
  2. Remove the connection between the air bag module connector (red; 2-pin) and the main wiring harness connector.

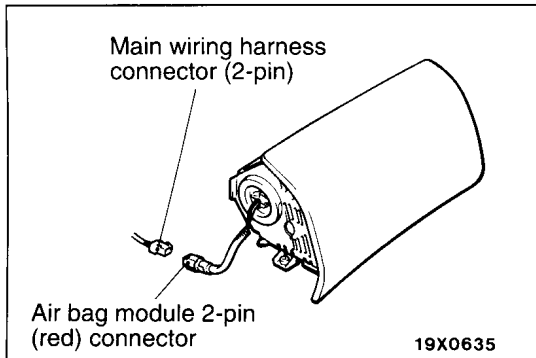

- (4) Connect two wires, each six meters long or more, to the two leads of SRS air bag adapter harness A and cover the connections with insulation tape. The other ends of the two wires should be connected to each other (short-circuited), to prevent sudden unexpected deployment of the air bag.

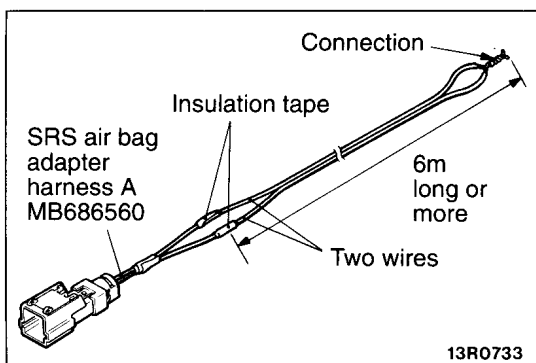

- (5) To deploy the air bag module: Connect the air bag module (front passenger's side) 2-pin connector (red) to SRS air bag adapter harness A and pass the deployment wires out of the vehicles.

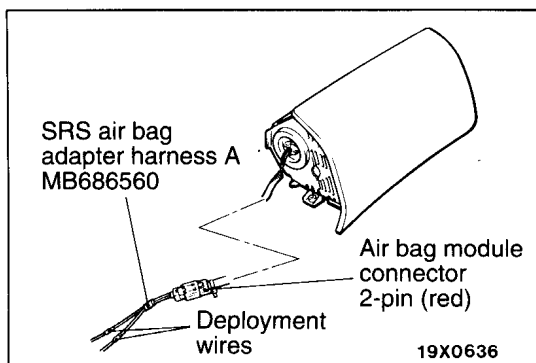

- (6) At a location as far away from the vehicles as possible, disconnect the two connected wires from each other, and connect them to the two terminals of the battery (removed from the vehicle) to deploy the air bag.

#### Caution

1. **Before deploying the air bag in this manner, first check to be sure that there is no one in or near the vehicle.**
2. **The inflator will be quite hot immediately following the deployment, so wait at least 30 minutes to allow it to cool before attempting to handle it.**

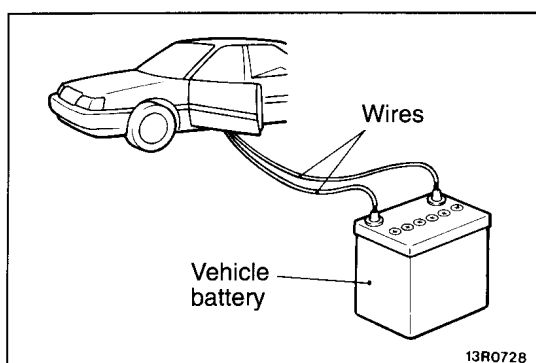

3. If the air bag module fails to deploy when the procedures above are followed, do not go near the module. Contact your local distributor.

(7) Dispose of the air bag module after deployment according to the Deployed Air Bag Module Disposal Procedures.

### DEPLOYMENT OUTSIDE THE VEHICLE

#### Caution

1. Should be carried out in a wide, flat area at least 6 m away from obstacles and other people.
2. Do not perform deployment outside, if a strong wind is blowing, and if there is even a slight breeze, the air bag module should be placed and deployed down-wind from the battery.

(1) Disconnect the negative (–) and positive (+) battery cables from the battery terminals, and then remove the battery from the vehicle.

#### Caution

Wait at least 60 seconds after disconnecting the battery cables before doing any further work. (Refer to P.52B-5, No. 5.)

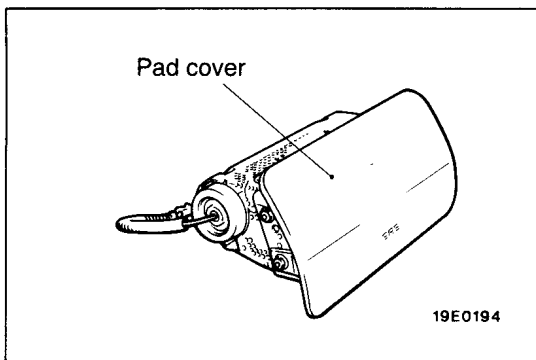

(2) Remove the air bag module from the vehicle. (Refer to P.52B-21.)

#### Caution

The air bag module should be stored on a flat surface and placed so that the pad cover face up. Do not place anything on top of it.

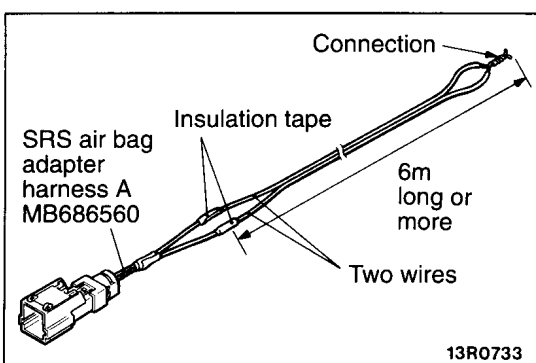

(3) Connect two wires, each six meters long or more, to the two leads of SRS air bag adapter harness A, and cover the connections with insulation tape. The other ends of the two wires should be connected to each other (short-circuited), to prevent sudden unexpected deployment of the air bag.

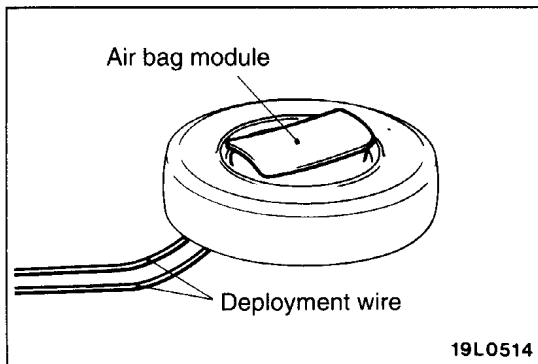

- (4) Connect the deployment wires to the SRS air bag adaptor harness A, pass it beneath the tyre, and wheel assembly, and connect it to the air bag module.
- (5) Pass the thick wires into the hole of the air bag module bracket, and secure it to the wheel of the old tyre with wheel (4 locations), with the air bag facing upwards.

#### Caution

1. Leave some space below the wheel for the deployment wires.  
If there is no space, the reaction of the air bag deployment could result in damage of the adaptor harness.
2. While deployment takes place, do not have the connector of the SRS air bag adaptor harness A inserted between the tyres.

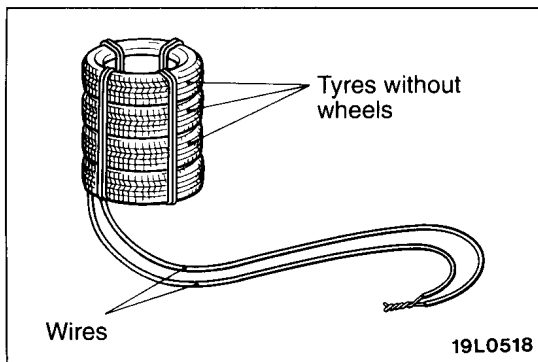

- (6) Place three old tyres with no wheels on top of the tyre secured to the air bag module, and secure all tyres with ropes (4 locations).
- (7) At a location as far away from the air bag module as possible, and from a shielded position, if possible, disconnect the two connected wires from each other and connect them to the two terminals of the battery (removed from the vehicle) to deploy the air bag.

#### Caution

1. Before deployment, check carefully to be sure that no one is nearby.
  2. The inflator will be quite hot immediately following deployment, so wait at least 30 minutes to allow it to cool before attempting to handle it. Although not poisonous, do not inhale gas from air bag deployment. See Deployed Air Bag Module Disposal Procedures (as shown below) for post-deployment handling instructions.
  3. If the air bag module fails to deploy when the procedures above are followed, do not go near the module. Contact your local distributor.
- (8) Dispose of the air bag module after deployment according to the Deployed Air Bag Module Disposal Procedures.



---

# CHASSIS ELECTRICAL

## CONTENTS

<b>GENERAL</b> .....	<b>2</b>	<b>IMMOBILIZER SYSTEM</b> .....	<b>5</b>
Outline of Changes .....	2	Special Tools .....	5
<b>METERS AND GAUGES</b> .....	<b>2</b>	Troubleshooting	
Troubleshooting .....	2	<Petrol-powered Vehicles> .....	5
		Troubleshooting	
		<Diesel-powered Vehicles> .....	14
		Immobilizer System .....	20
		ID Code Registration Method .....	21
		Resetting the Code to the Factory Setting	
		<Diesel-powered Vehicles> .....	22

---

## GENERAL

### OUTLINE OF CHANGES

- The electronic compass has been changed. With this, the troubleshooting has been changed.
- The immobiliser system has been used as option. With this, the service procedure has been added.

## METERS AND GAUGES

### TROUBLESHOOTING

#### INSPECTION CHART FOR TROUBLE SYMPTOMS

Get an understanding of the trouble symptoms and check according to the inspection procedure chart.

Trouble symptom	Inspection procedure No.	Reference page
Bearing indicator is off when moving forward	1	54-2
Vehicle magnetic compensation cannot be made	2	54-3
Discrepancy between the outside temperature and display temperature	3	54-3
Display is hard to see or no display appears	4	54-4

#### INSPECTION PROCEDURE FOR TROUBLE SYMPTOMS

##### INSPECTION PROCEDURE 1

Bearing indicator is off when moving forward	Probable cause
The vehicle magnetism tends to be disturbed particularly at such places as tunnel, railway crossing, area along railway, elevated road, urban area crowded with high-storied buildings, area above subway, etc. If disturbed, the driving direction marker will fluctuate.	<ul style="list-style-type: none"> <li>• Vehicle magnetic compensation failed</li> </ul>

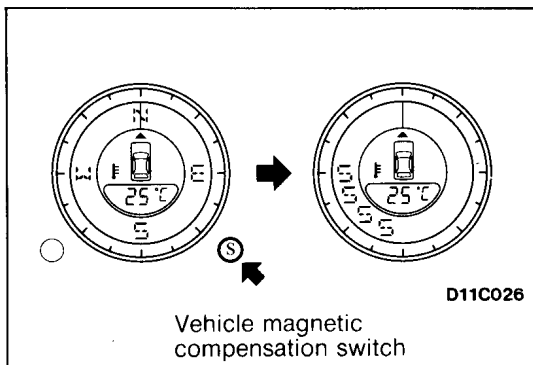

#### Vehicle magnetic compensation

- (1) If the vehicle magnetic compensation (azimuth adjustment) switch is pressed, the letters "S" are displayed around the scale. Then when the switch is pressed 0.5 seconds or more further, the letters "S" will move clockwise and anticlockwise. This turns on the magnetic compensation mode.

- (2) If the vehicle is driven slowly in a 360° circle, compensation is automatically completed.

#### NOTE

Compensation is possible if the turn is made to either the left or right.

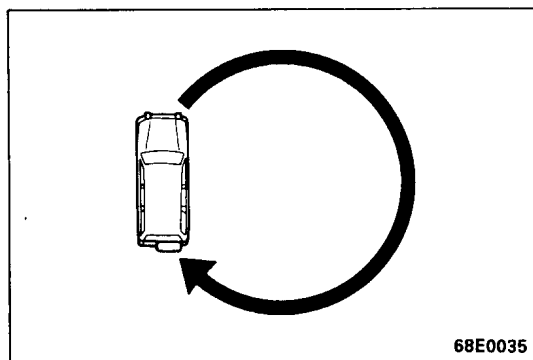

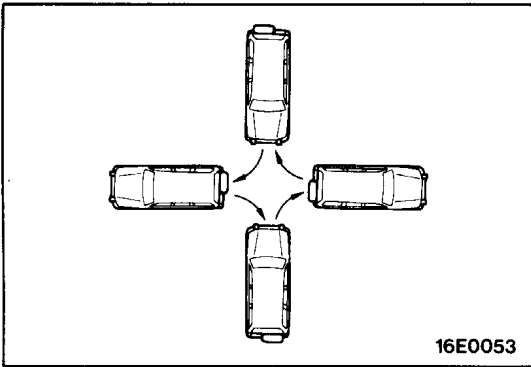

- (3) If there is no place to turn the vehicle in a circle, turn the vehicle around by moving it backwards and forwards.
- (4) After compensation is completed, a dot showing the current direction of movement will be illuminated.

**INSPECTION PROCEDURE 2**

Vehicle magnetic compensation cannot be made.	Probable cause
The multi-meter may be defective.	<ul style="list-style-type: none"> <li>• Defective multi-meter</li> </ul>

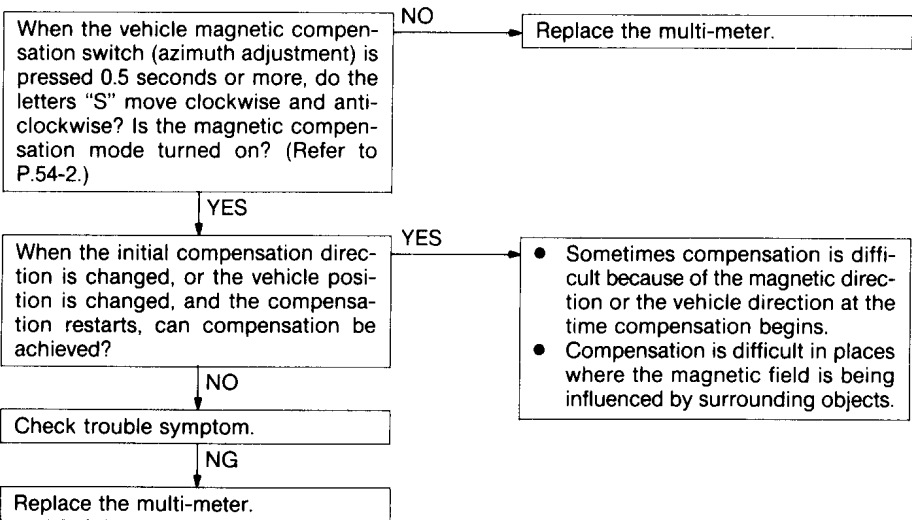

**INSPECTION PROCEDURE 3**

Discrepancy between the outside temperature and the display temperature	Probable cause
The outside thermo sensor, multi-meter, harness, or connector may be defective.	<ul style="list-style-type: none"> <li>• Defective outside thermo sensor</li> <li>• Defective multi-meter</li> <li>• Defective harness or connector</li> </ul>

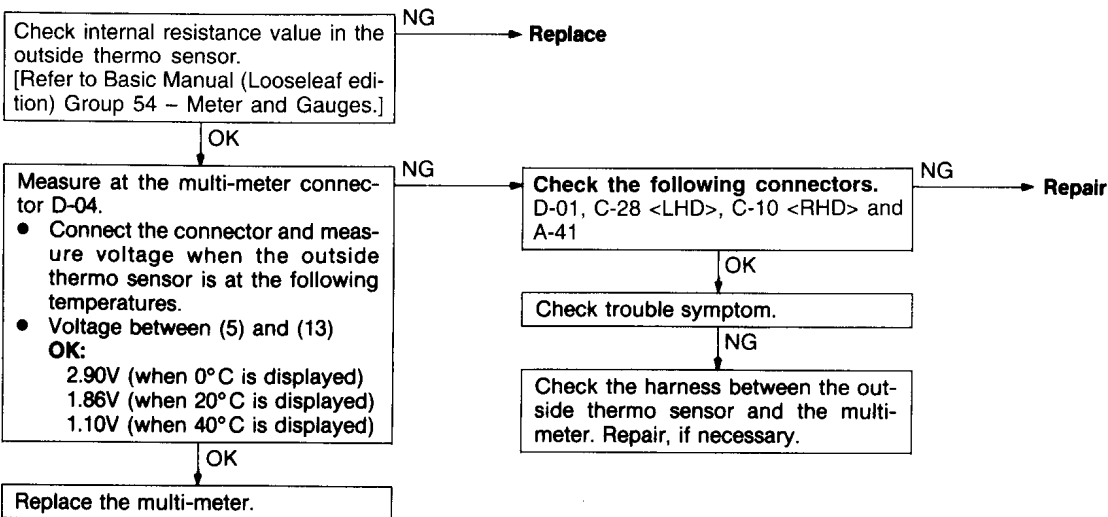

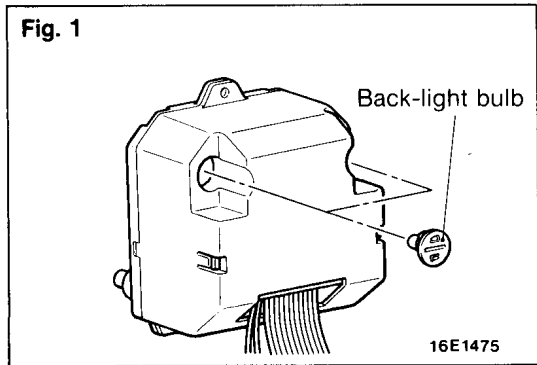
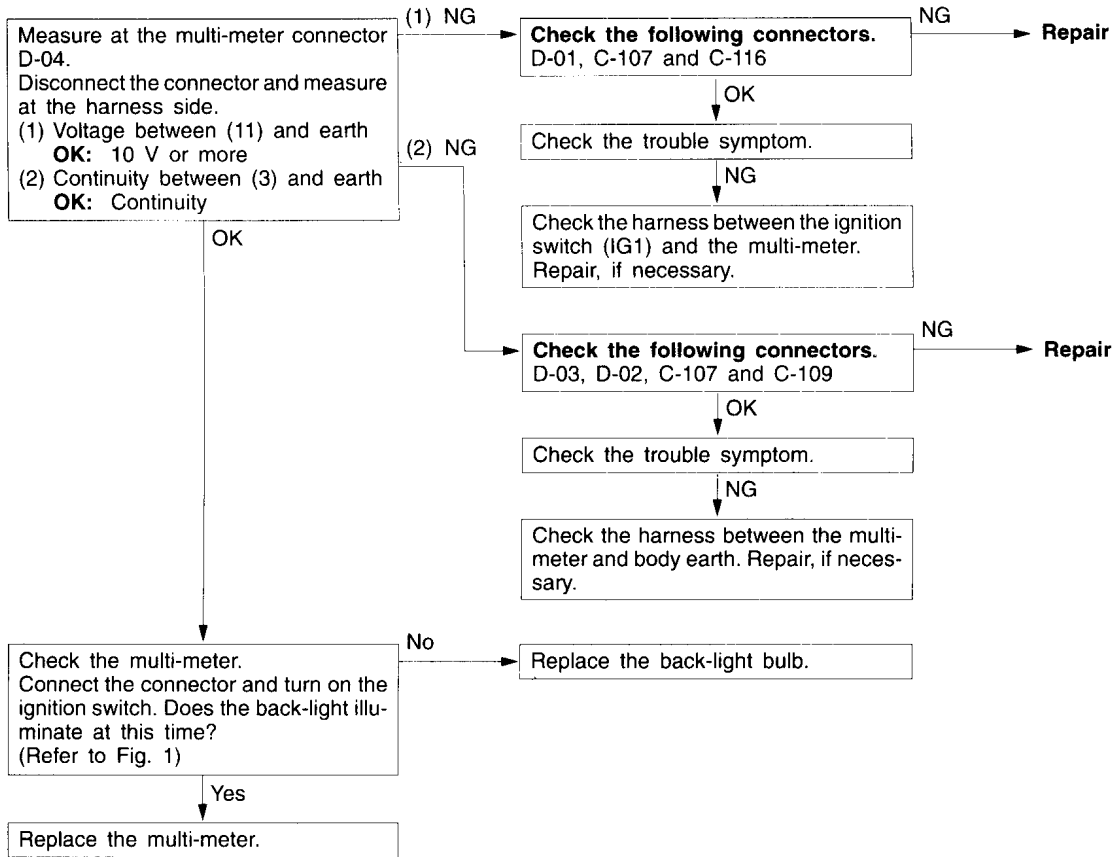

INSPECTION PROCEDURE 4

Display is hard to see or no display appears.	Probable cause
The multi-meter, harness, or connector may be defective.	<ul style="list-style-type: none"> <li>● Defective multi-meter</li> <li>● Defective harness or connector</li> </ul>

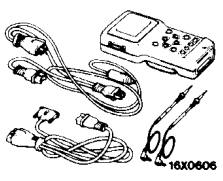

# IMMOBILIZER SYSTEM

## SPECIAL TOOLS

Tool	Number	Name	Use
	MB991502	MUT-II sub assembly	<ul style="list-style-type: none"> <li>• Immobilizer system check (Diagnosis display using the MUT-II)</li> <li>• Registration of the ID code.</li> </ul>
		ROM pack	

## TROUBLESHOOTING <PETROL-POWERED VEHICLES> STANDARD FLOW OF DIAGNOSTIC TROUBLESHOOTING

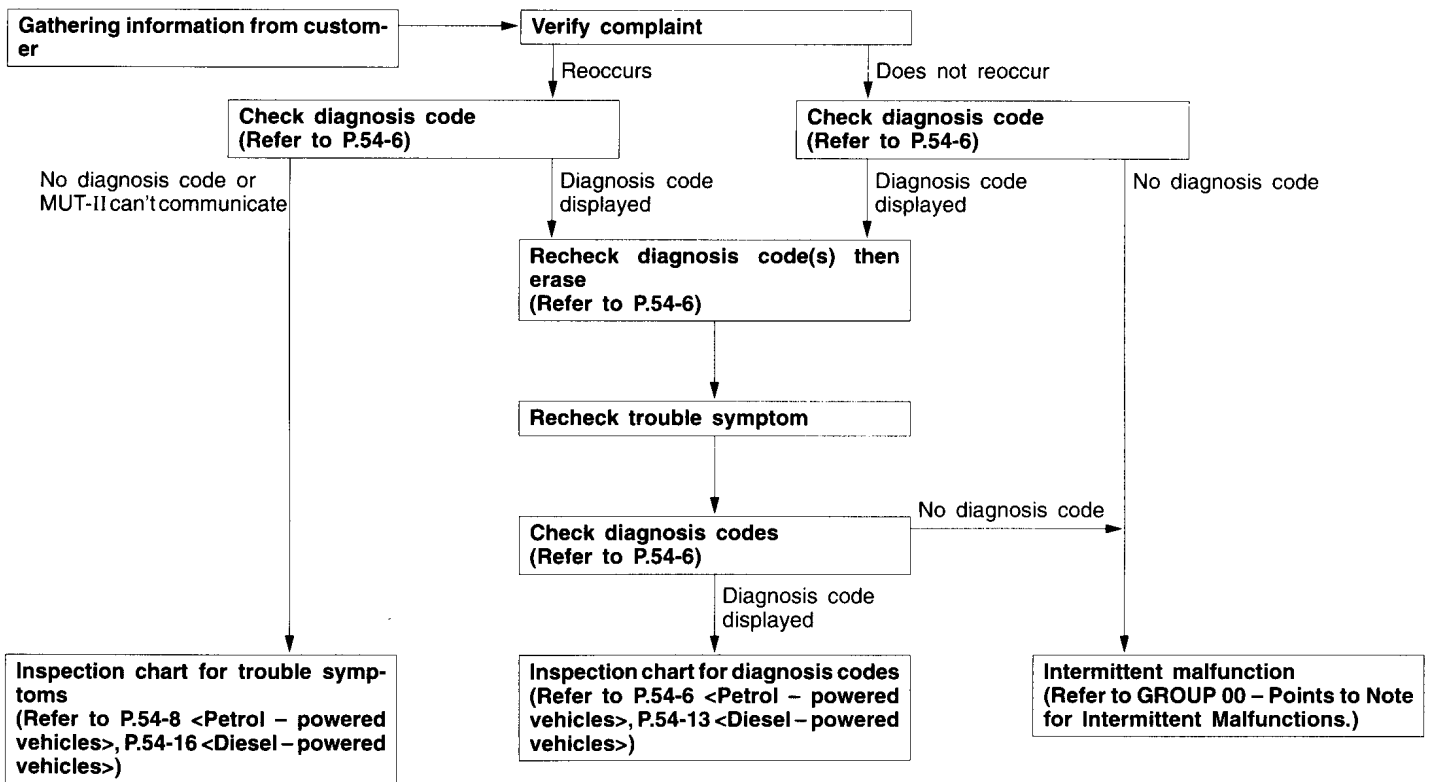

### Caution

- The ID code should always be re-registered when replacing the immobilizer-ECU.

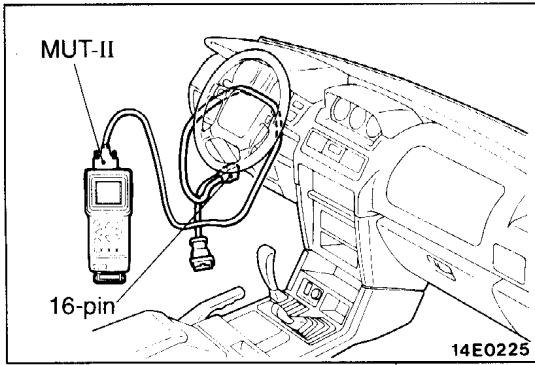

## DIAGNOSTIC FUNCTION

### DIAGNOSIS CODES CHECK

Connect the MUT-II to the diagnosis connector (16-pin), then check diagnosis codes.

#### Caution

Turn the ignition switch off before connecting or disconnecting the MUT-II.

### ERASING DIAGNOSIS CODES

Connect the MUT-II to the diagnosis connector (16-pin), and then erase the diagnosis codes.

#### Caution

- Turn the ignition switch off before connecting or disconnecting the MUT-II.
- The diagnosis codes which result from disconnecting the battery cables cannot be erased.

## INSPECTION CHART FOR DIAGNOSIS CODES

Diagnosis code No.	Inspection items	Reference page
11	Transponder communication system	54-7
12*	ID code are not the same or are not registered	54-7
21	Communication system between MUT-II and engine-ECU	54-8
31	EEPROM abnormality inside immobilizer-ECU	54-8
32	Ignition switch IG signal circuit system	54-9

#### NOTE

\*: Diagnosis code No. 12 is not recorded.

**INSPECTION PROCEDURE FOR DIAGNOSIS CODES**

Code No. 11 Transponder communication system	Probable cause
<ul style="list-style-type: none"> <li>• The ID code of the transponder is not sent to the immobilizer-ECU immediately after the ignition switch is turned to the ON position.</li> <li>• If the engine is started while several ignition keys are in the vicinity, then interference between the different keys may occur, which will cause this code to be generated.</li> </ul>	<ul style="list-style-type: none"> <li>• ID code interference</li> <li>• Malfunction of the transponder</li> <li>• Malfunction of the ignition key ring antenna</li> <li>• Malfunction of harness or connector</li> <li>• Malfunction of the immobilizer-ECU</li> </ul>

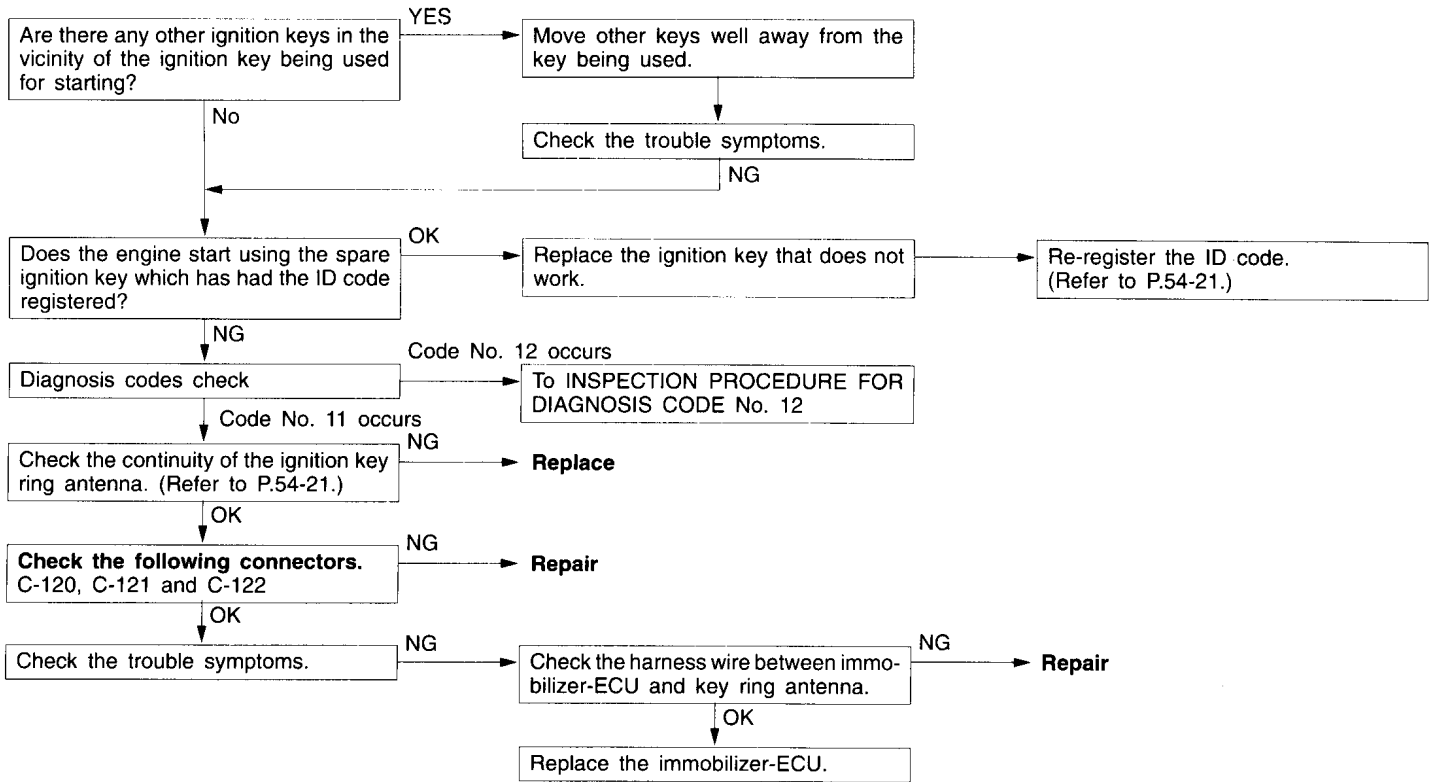

Code No. 12 ID code are not the same or are not registered	Probable cause
The ID code which is sent from the transponder is not the same as the ID code which is registered in the immobilizer-ECU.	<ul style="list-style-type: none"> <li>• The ID code in the ignition key being used has not been properly registered.</li> <li>• Malfunction of the immobilizer-ECU.</li> </ul>

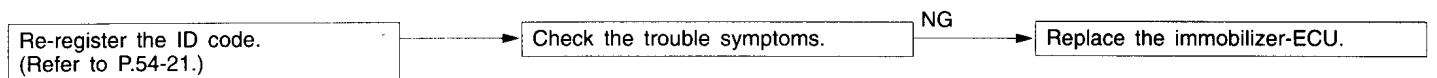

Code No. 21 Communication system between MUT-II and engine-ECU	Probable cause
After the ignition switch is turned to the ON position, the confirmation code is not received from the engine-ECU within the allowable time, or an abnormal code is received.	<ul style="list-style-type: none"> <li>● Malfunction of harness or connector</li> <li>● Malfunction of the engine-ECU</li> <li>● Malfunction of the immobilizer-ECU.</li> </ul>

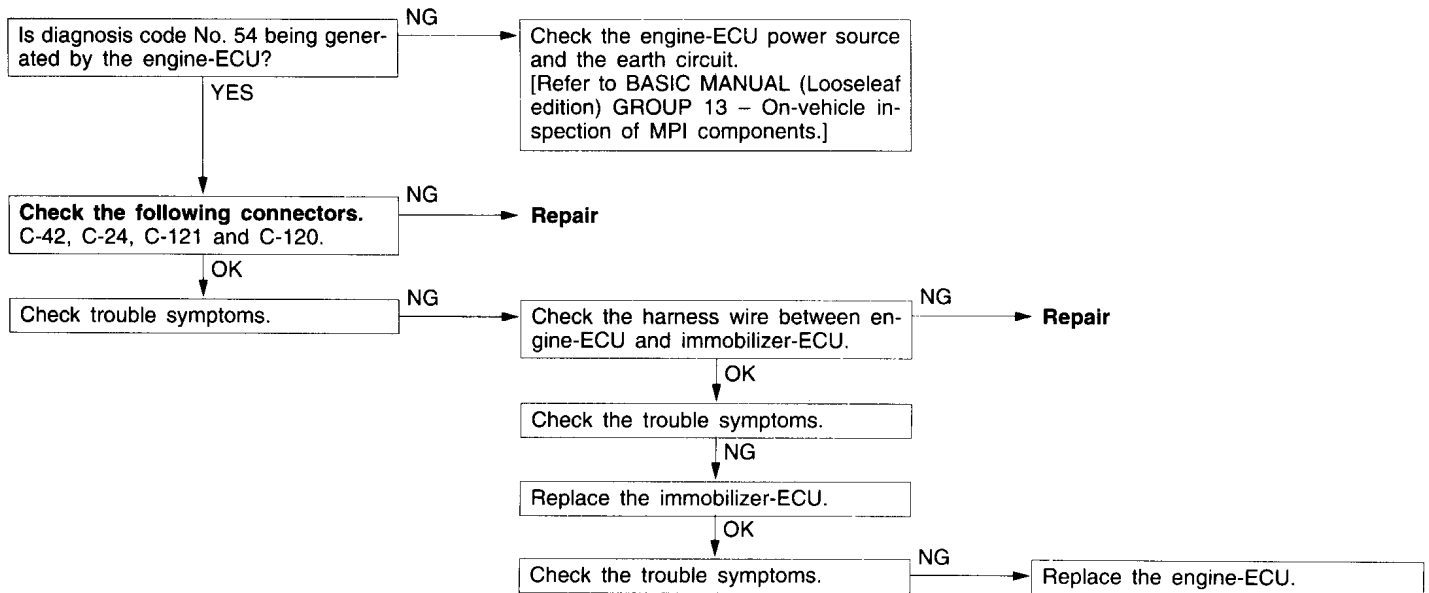

Code No. 31 EEPROM abnormality inside immobilizer-ECU	Probable cause
No data has been written to the EEPROM inside the immobilizer-ECU.	<ul style="list-style-type: none"> <li>● Malfunction of the immobilizer-ECU.</li> </ul>

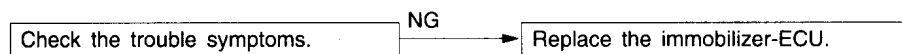



Code No. 32 Ignition switch IG signal circuit system	Probable cause
The ignition switch signal is not being input to the immobilizer-ECU.	<ul style="list-style-type: none"> <li>● Malfunction of harness or connector</li> <li>● Malfunction of the ignition switch</li> <li>● Malfunction of the immobilizer-ECU</li> </ul>

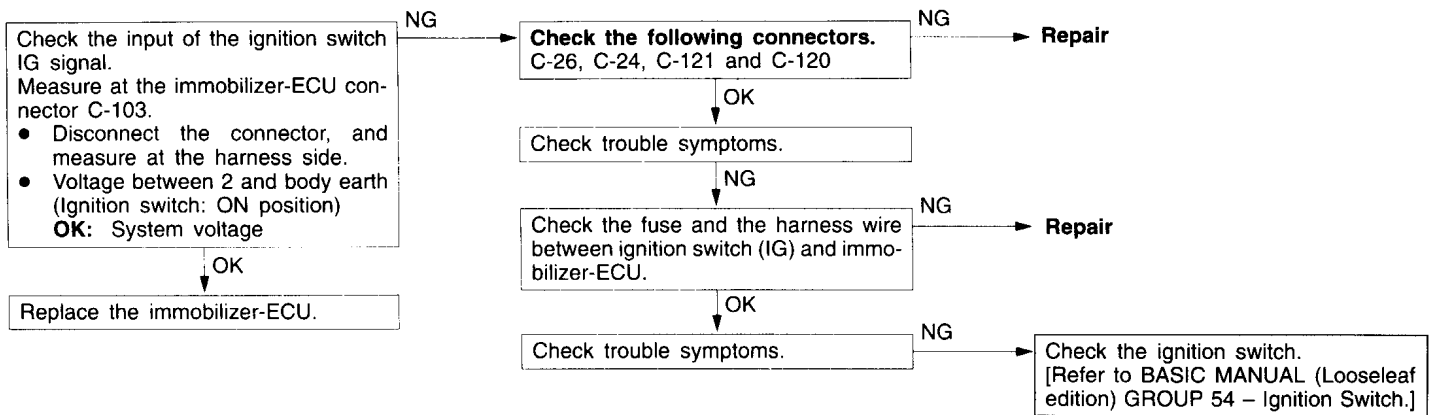

**INSPECTION CHART FOR TROUBLE SYMPTOMS**

Trouble symptom	Inspection procedure No.	Reference page
Communication with MUT-II is impossible.	1	54-10
Diagnosis code No. 54 has been generated by the engine-ECU.	2	54-11
ID code cannot be registered using the MUT-II.	3	54-11
Engine does not start (Cranking but no initial combustion).	4	54-12
Malfunction of the immobilizer-ECU power supply and earth circuit	5	54-13

INSPECTION PROCEDURE FOR TROUBLE SYMPTOMS

Inspection Procedure 1

Communication with MUT-II is impossible.	Probable cause
The cause is probably that a malfunction of the diagnosis line or the immobilizer-ECU is not functioning.	<ul style="list-style-type: none"> <li>● Malfunction of the diagnosis line</li> <li>● Malfunction of harness or connector</li> <li>● Malfunction of the immobilizer</li> </ul>

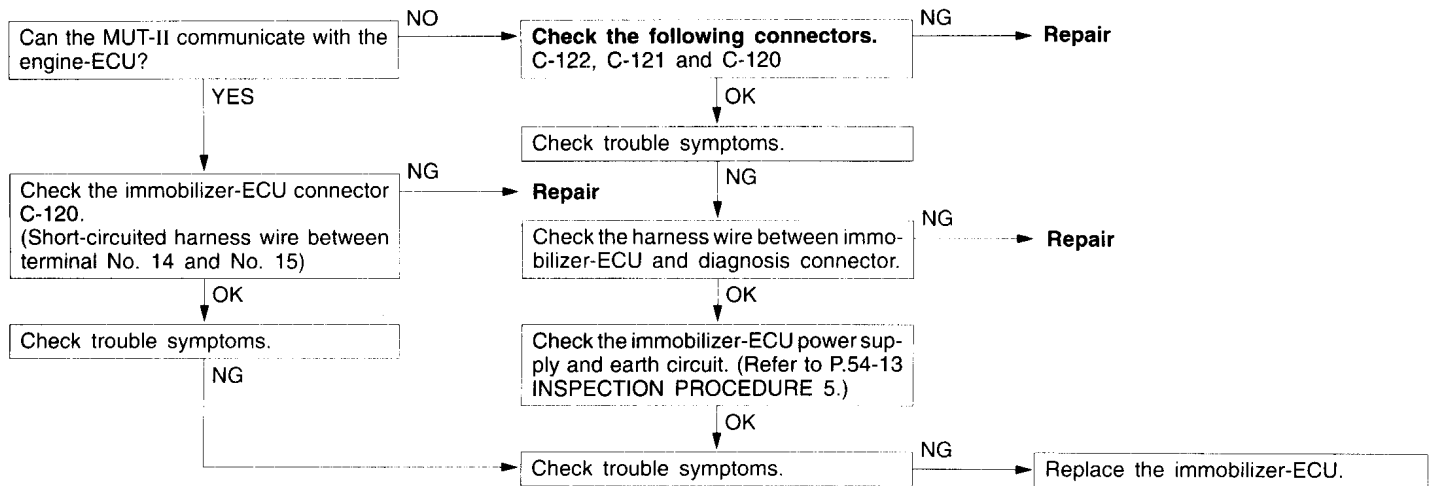

Inspection Procedure 2

Diagnosis code No. 54 has been generated by the engine-ECU.	Probable cause
<ul style="list-style-type: none"> <li>• There is a problem with communication between the engine-ECU and the immobilizer-ECU.</li> <li>• If the engine is started while several ignition keys are in the vicinity, then interference between the different keys may occur, which will cause this code to be generated.</li> <li>• This code may be generated when registering the ID code.</li> </ul>	<ul style="list-style-type: none"> <li>• ID code interference</li> <li>• Non-identical ID codes</li> <li>• Malfunction of harness or connector</li> <li>• Malfunction of the immobilizer-ECU</li> <li>• Malfunction of the engine-ECU</li> </ul>

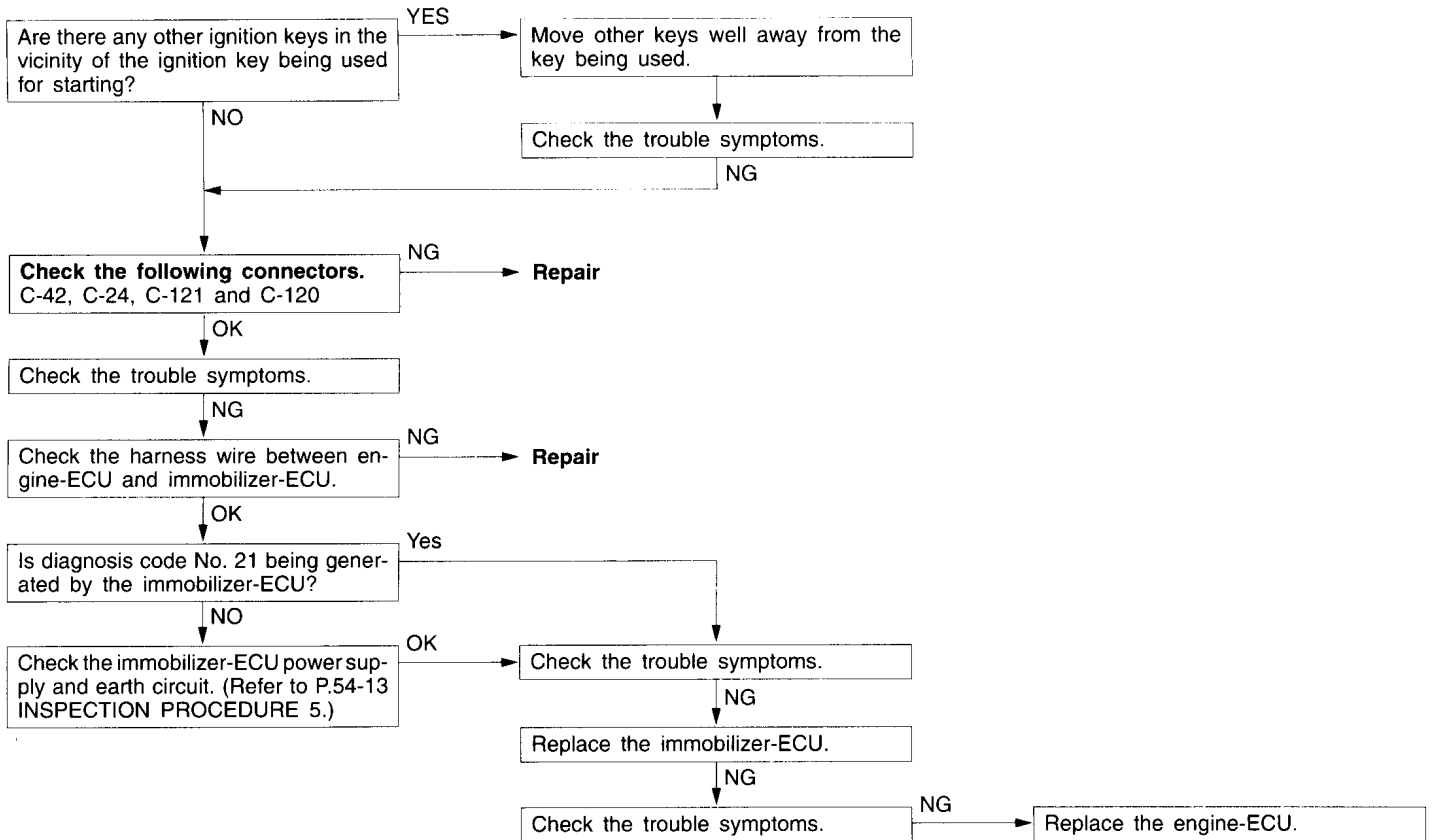

Inspection Procedure 3

ID code cannot be registered using the MUT-II.	Probable cause
<p>The cause is probably that there is no ID code registered in the immobilizer-ECU, or there is a malfunction of the immobilizer-ECU.</p>	<ul style="list-style-type: none"> <li>• Malfunction of the transponder</li> <li>• Malfunction of the ignition key ring antenna</li> <li>• Malfunction of the harness or connector</li> <li>• Malfunction of the immobilizer-ECU</li> </ul>

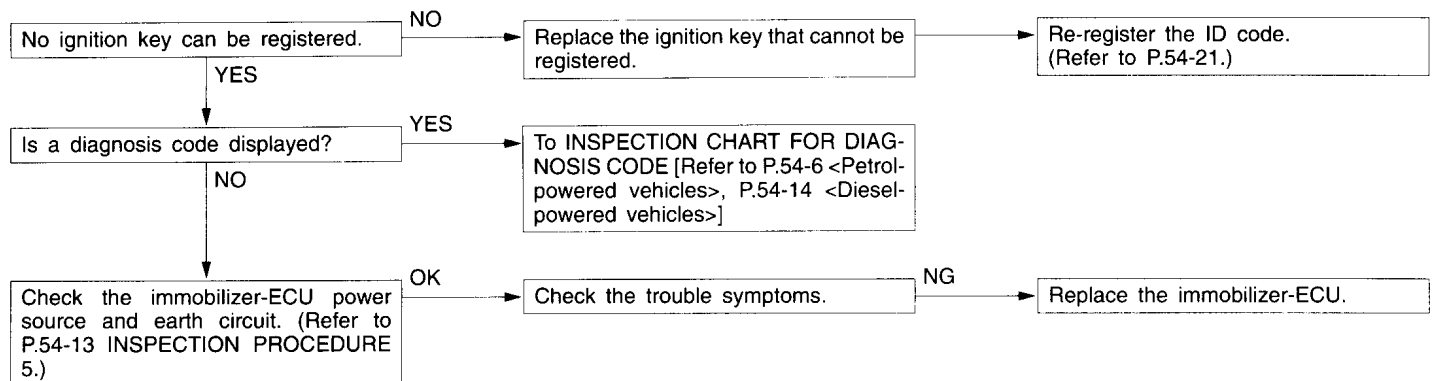

Inspection Procedure 4

Engine does not start (cranking but no initial combustion).	Probable cause
If the fuel injectors are not operating, there might be a problem with the MPI system in addition to a malfunction of the immobilizer system. It is normal for this to occur if an attempt is made to start the engine using a key that has not been properly registered.	<ul style="list-style-type: none"> <li>● Malfunction of the MPI system</li> <li>● Malfunction of the immobilizer-ECU</li> </ul>

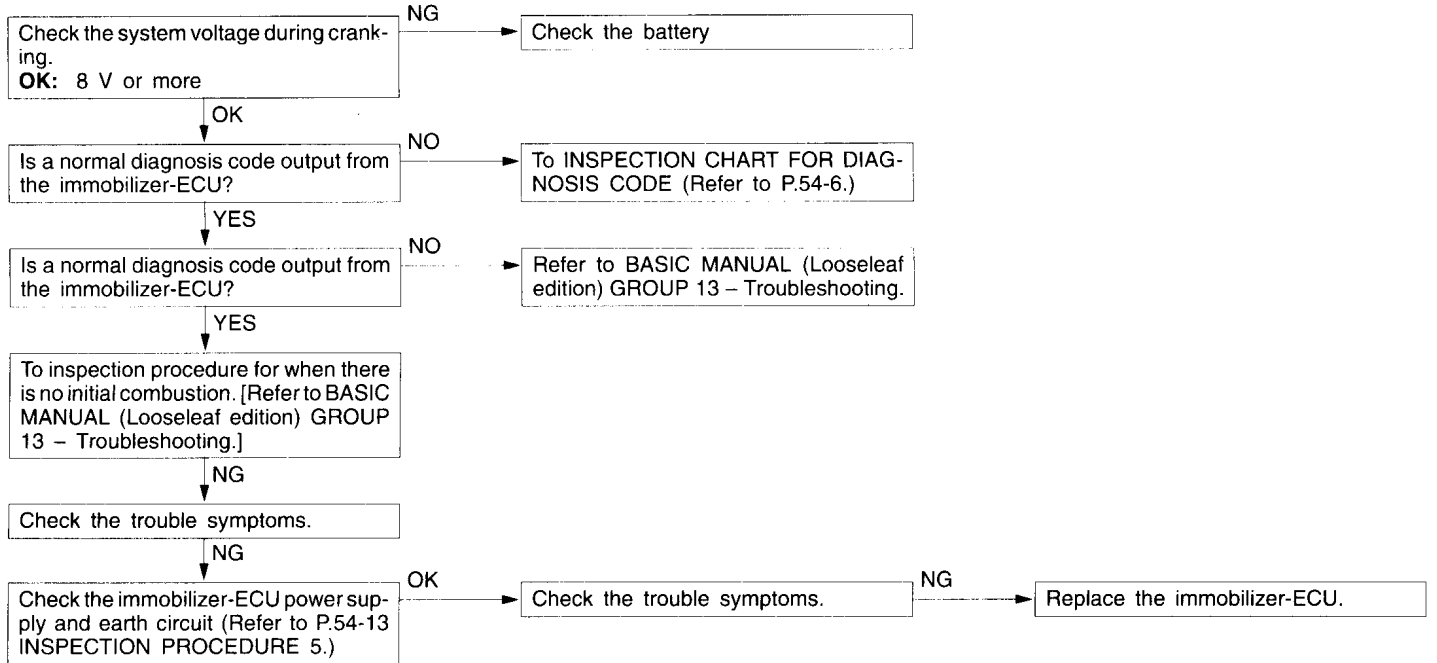

Inspection Procedure 5

**Malfunction of the immobilizer-ECU power supply and earth circuit**

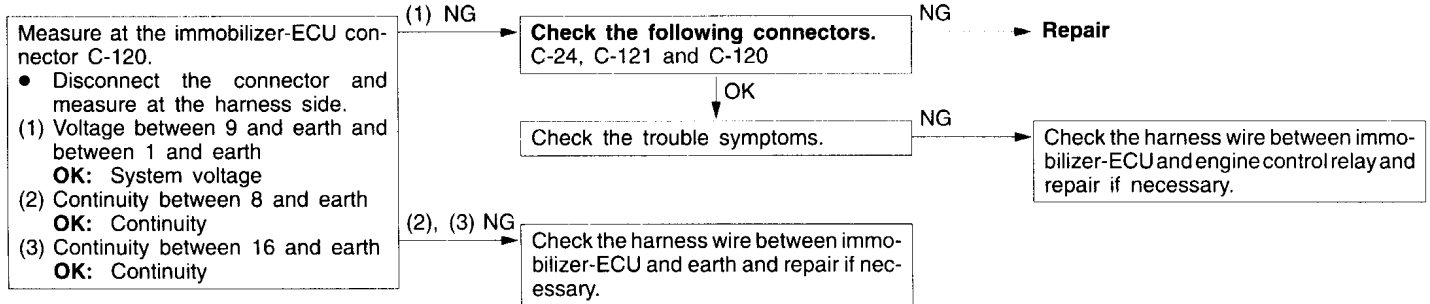

**CHECK AT IMMOBILIZER-ECU  
TERMINAL VOLTAGE CHECK CHART**

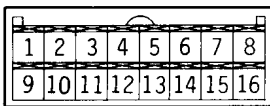

16W0390

Terminal No.	Signal	Check requirements	Terminal voltage
1	Immobilizer-ECU power supply	Ignition switch: ON	System voltage
2	Ignition switch-IG	Ignition switch: OFF	0 V
		Ignition switch: ON	System voltage
8	Immobilizer-ECU earth	–	0 V
9	Immobilizer-ECU power supply	Ignition switch: ON	System voltage
16	Immobilizer-ECU earth	–	0 V

**TROUBLESHOOTING <DIESEL-POWERED VEHICLES>****STANDARD FLOW OF DIAGNOSTIC TROUBLESHOOTING**

Refer to 54-5.

**Caution**

- If the immobilizer-ECU has been replaced, you will need to re-register the ignition key ID codes and to reset the code for the fuel cut valve-ECU to the factory setting.
- If the fuel cut valve-ECU has been replaced with another ECU that is not a new part, you will need to re-register the ignition key ID codes and to reset the code for the fuel cut valve-ECU to the factory setting.

**DIAGNOSIS FUNCTION**

Refer to 54-6.

**INSPECTION CHART FOR DIAGNOSIS CODES**

Diagnosis code	Inspection items	Reference page
11	Transponder communication system	54-7
12*	ID codes are not the same or are not registered.	54-7
21	Communication system between fuel cut valve-ECU and immobilizer-ECU	54-15
22	Fuel cut valve-ECU system	54-16
23	Starting permission codes are not identical	54-16
31	EEPROM abnormality inside the immobilizer-ECU	54-8

**NOTE**

\*: Diagnosis code No. 12 is not recorded.

**INSPECTION PROCEDURE FOR DIAGNOSIS CODES**

<b>Code No. 21 Communication system between fuel cut valve-ECU and immobilizer-ECU</b>	<b>Probable cause</b>
The confirmation code is not sent from the fuel cut valve-ECU within the specified time after the ignition key is turned to ON, or an incorrect code is sent.	<ul style="list-style-type: none"> <li>● Open or short communication line, poor contact of connector</li> <li>● Malfunction of fuel cut valve-ECU</li> <li>● Malfunction of immobilizer-ECU</li> </ul>

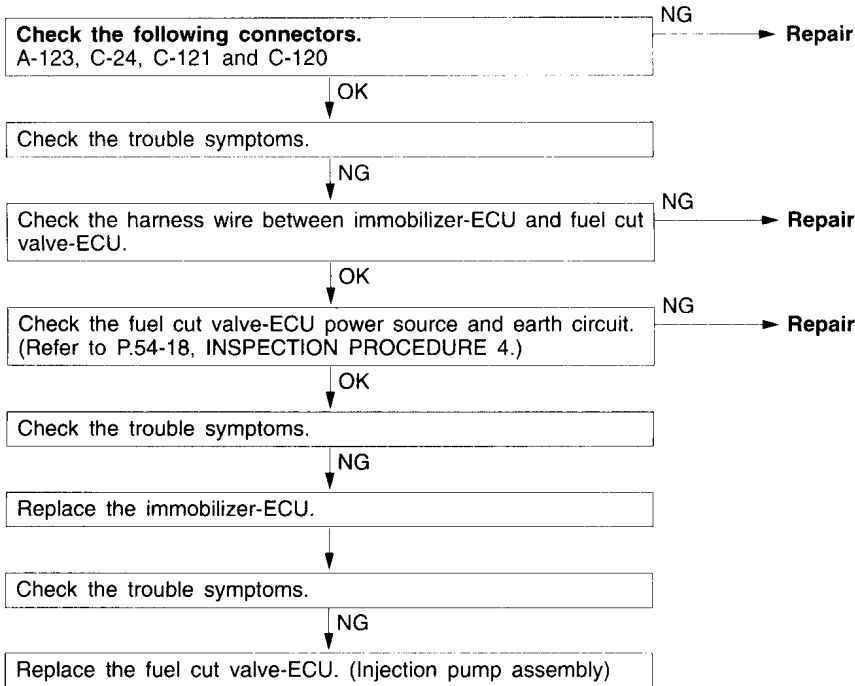

Code No. 22 Fuel cut valve-ECU system	Probable cause
The immobilizer-ECU is receiving an abnormal signal from the fuel cut valve ECU.	<ul style="list-style-type: none"> <li>• Malfunction of fuel cut valve-ECU.</li> </ul>

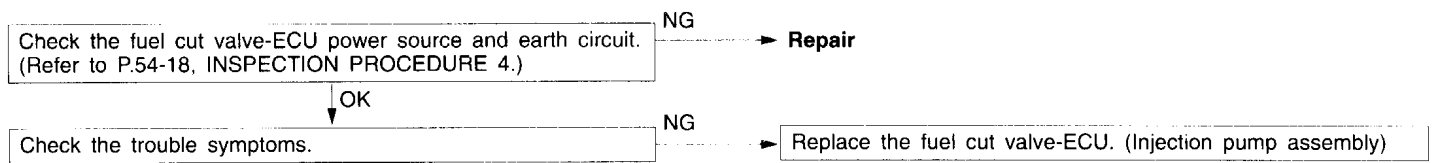

No. 23 Starting permission codes are not identical	Probable cause
The starting permission code received from the immobilizer-ECU is not identical to the starting permission code that has been recorded in the fuel cut valve ECU.	<ul style="list-style-type: none"> <li>• Resetting the code to the factory setting is not made using the MUT-II.</li> <li>• Malfunction of fuel cut valve-ECU.</li> </ul>

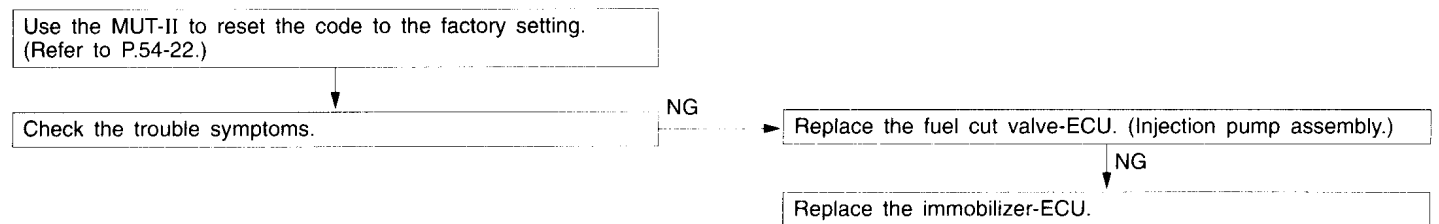



**INSPECTION CHART FOR TROUBLE SYMPTOMS**

Trouble symptom	Inspection procedure	Reference page
Communication with MUT-II is impossible.	1	54-17
Engine does not start. (Engine stops after firing momentarily. Cranking but no initial combustion.)	2	54-18
ID code cannot be registered using the MUT-II.	3	54-11
Fuel cut valve-ECU power supply and earth circuit	4	54-18

**INSPECTION PROCEDURE FOR TROUBLE SYMPTOMS**

**Inspection procedure 1**

<b>Communication with MUT-II is impossible.</b>	<b>Probable cause</b>
The cause is probably that a malfunction of the diagnosis line or the immobilizer-ECU is not functioning.	<ul style="list-style-type: none"> <li>● Malfunction of connector</li> <li>● Malfunction of diagnosis line</li> <li>● Malfunction of immobilizer-ECU power source</li> <li>● Malfunction of immobilizer-ECU</li> </ul>

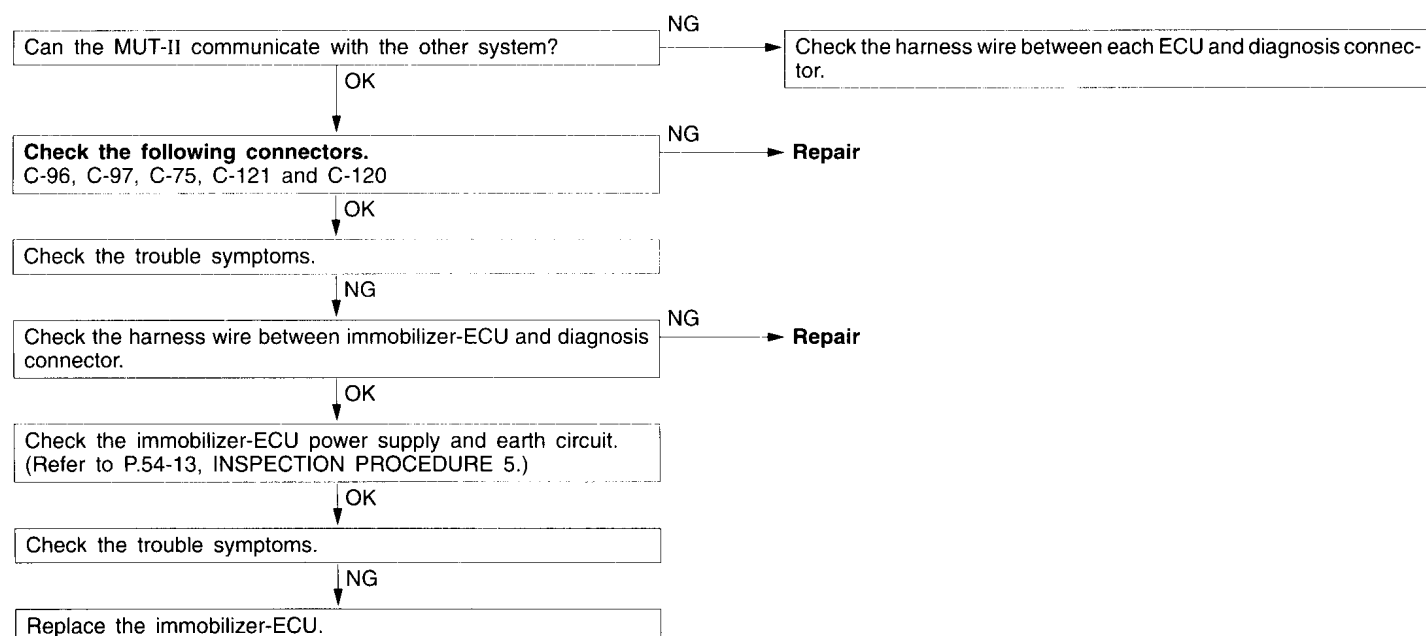

## Inspection procedure 2

Engine does not start. (Engine stops after firing momentarily Cranking but no initial combustion.)	Probable cause
If the fuel injectors are not operating, there might be a problem with the fuel system in addition to a malfunction of the immobilizer system. It is normal for this to occur if an attempt is made to start the engine using the key that has not been properly registered.	<ul style="list-style-type: none"> <li>• Malfunction of fuel system</li> <li>• Malfunction of immobilizer system</li> </ul>

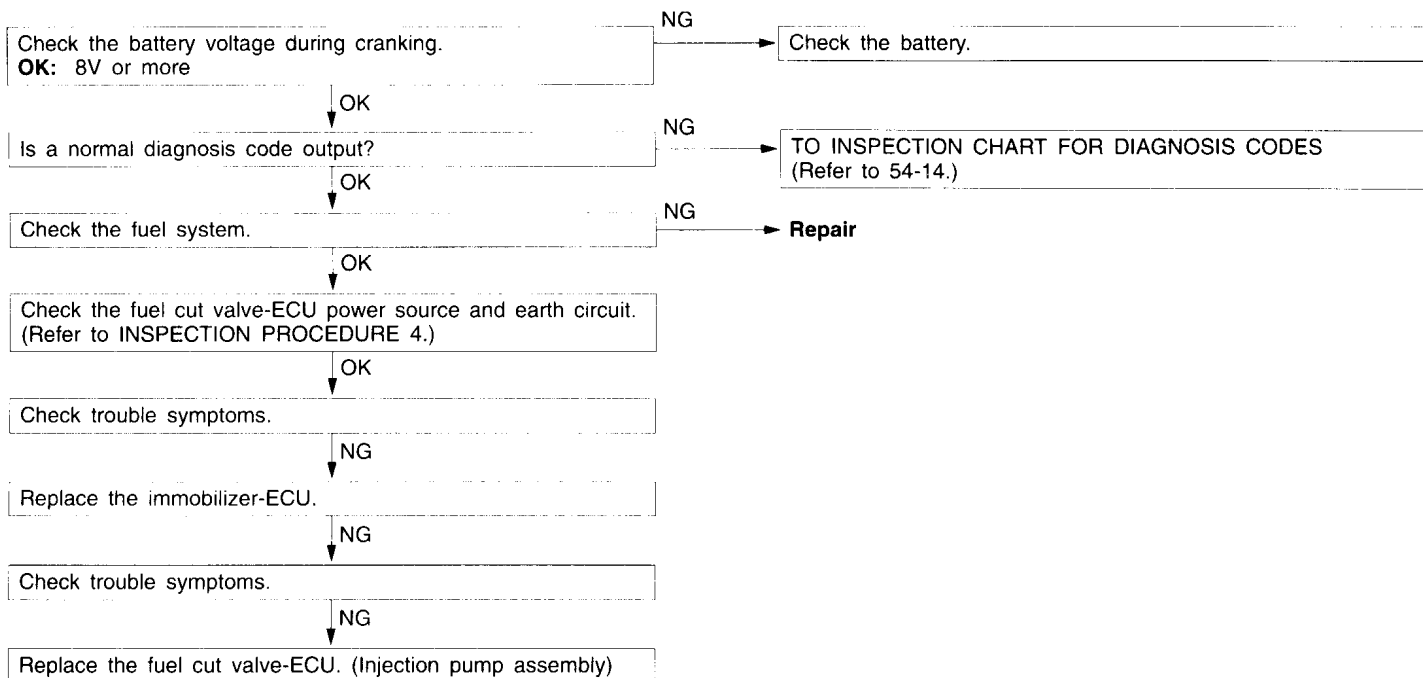

## Inspection procedure 4

## Fuel cut valve-ECU power supply and earth circuit

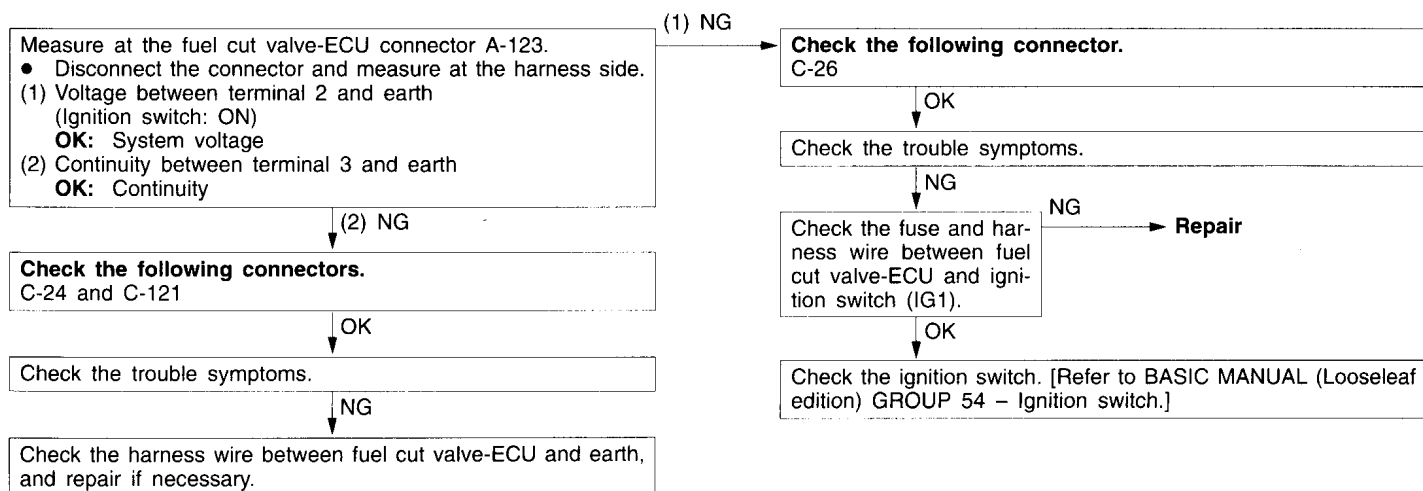

**CHECK AT IMMOBILIZER-ECU  
TERMINAL VOLTAGE CHECK CHART**

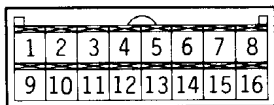

16W0390

Terminal No.	Signal	Check requirements	Terminal voltage
1	Immobilizer-ECU power supply	Ignition switch: ON	System voltage
2	Ignition switch-IG	Ignition switch: OFF	0V
		Ignition switch: ON	System voltage
8	Immobilizer-ECU earth	–	0V
9	Immobilizer-ECU power supply	Ignition switch: ON	System voltage
16	Immobilizer-ECU earth	–	0V

## IMMOBILIZER SYSTEM

## REMOVAL AND INSTALLATION

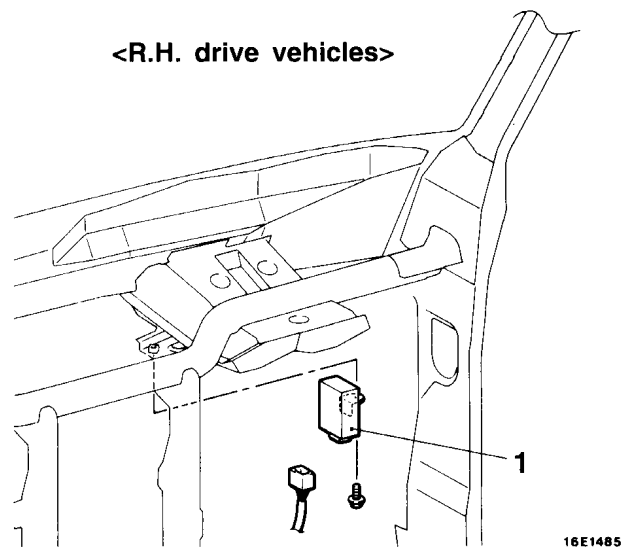
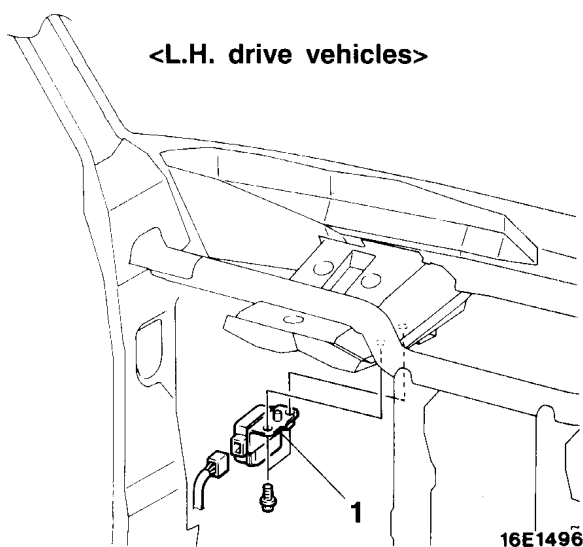
**Immobilizer-ECU removal steps**

- Instrument panel [Refer to BASIC MANUAL (Looseleaf edition) GROUP 52A – Instrument Panel.]
1. Immobilizer-ECU

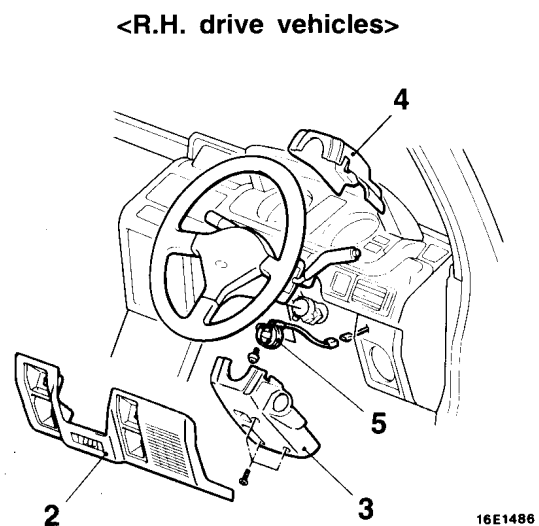
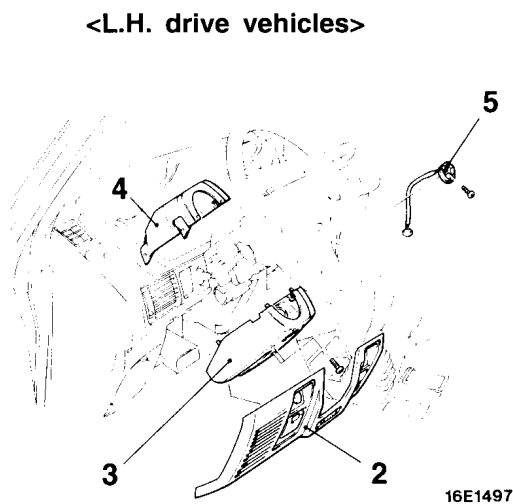
**Ignition key ring antenna removal steps**

2. Instrument under cover [Refer to BASIC MANUAL (Looseleaf edition) GROUP 52A – Instrument Panel.]
3. Column cover lower
4. Column cover upper
5. Ignition key ring antenna

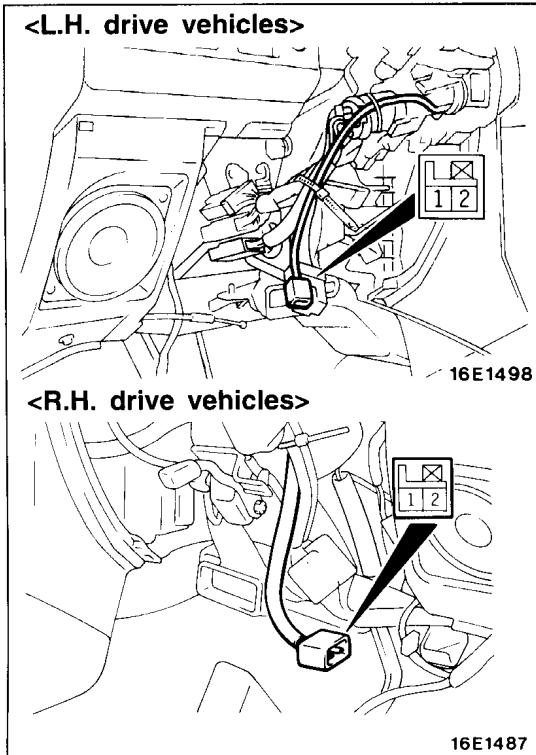

## INSPECTION

### IGNITION KEY RING ANTENNA CONTINUITY CHECK

Use a circuit tester to measure the resistance between the terminals.

## ID CODE REGISTRATION METHOD

If using an ignition key that has just been newly purchased, or if the immobilizer-ECU has been replaced, you will need to register the ID codes for each ignition key being used into the immobilizer-ECU. (A maximum of eight different ID codes can be registered.)

Moreover, when the immobilizer-ECU has been replaced, you will need to use the MUT-II to input the vehicle secret code and to register the password (secret code) that the user specifies into the immobilizer-ECU. (Refer to the MUT-II instruction manual for instructions on using the MUT-II.)

### Caution

**Because registering of the ID codes is carried out after all previously-registered codes have been erased, you should have ready all of the ignition keys that have already been registered.**

- (1) Connect the MUT-II to the diagnosis connector.

### Caution

**Turn the ignition switch off before connecting or disconnecting the MUT-II.**

- (2) Check that diagnosis code No. 54 is not being generated by the engine-ECU. If it is being generated, check according to the Troubleshooting procedures before continuing.
- (3) Use the ignition key that is to be registered to turn the ignition switch to the ON position.
- (4) Use the MUT-II to register the ID code. If you are registering two or more codes, use the next key to be registered to turn the ignition switch to the ON position without disconnecting the MUT-II.
- (5) Disconnect the MUT-II. This completes the registration operation.
- (6) Check that the engine can be started with each of the ignition keys.
- (7) Check the diagnosis output from the engine-ECU, and erase code No. 54 if it appears.

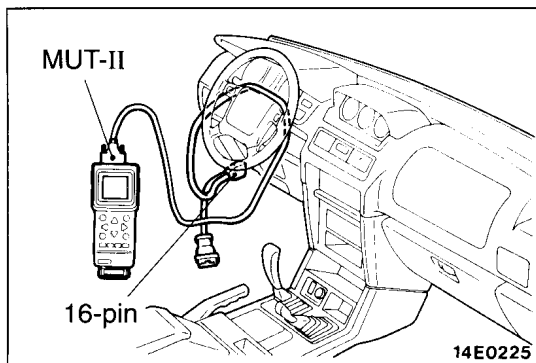

**RESETTING THE CODE TO THE FACTORY SETTING <DIESEL-POWERED VEHICLES>**

If the immobilizer-ECU in diesel-powered vehicles is replaced, it is necessary to reset the factory code that has been recorded in the fuel cut valve-ECU to make starting possible at all times, in addition to re-registering the ignition key ID code. This is also necessary if the fuel cut valve-ECU has been replaced with another ECU that is not a new part.

**NOTE**

It is necessary to re-register the ignition key ID code and to reset the factory code, but it does not matter which one is done first.

- (1) Connect the MUT-II to the diagnosis connector.

**Caution**

**Connection and disconnection of the MUT-II should always be carried out with the ignition switch in the OFF position.**

- (2) Turn the ignition switch to the ON position.
- (3) Use the MUT-II to reset the factory code.

**NOTE**

It takes a total of approximately 16 minutes for the factory code to be reset.

