

A/C COMPRESSOR OIL CHECKING

1993 Mitsubishi Montero

1993 GENERAL SERVICING
Compressor Refrigerant Oil Checking

* PLEASE READ THIS FIRST *

NOTE: For compressor applications, see COMPRESSOR APPLICATIONS TABLE below. DO NOT exceed A/C system refrigerant oil capacity, when servicing system. See REFRIGERANT OIL & REFRIGERANT SPECIFICATIONS TABLE.

COMPRESSOR APPLICATION

NOTE: Due to late changes, always refer to underhood A/C specification label in engine compartment or A/C compressor label while servicing A/C system. If A/C Specification label and specifications in this article differ, always use label specifications.

COMPRESSOR APPLICATION TABLE

Application	Compressor
Acura	Nippondenso 10-Cyl.
Audi	
90	Zexel 6-Cyl.
100	Zexel 6-Cyl.
BMW	Nippondenso Or Seiko-Seiki
Chrysler Motors/Eagle	
Colt & Summit	Sanden FX105V Scroll
Colt Vista & Summit Wagon	Nippondenso 10PA15 10-Cyl.
Stealth	Sanden FX105VS Scroll
Ram-50	Sanden FX80 Scroll
Ford Motor Co.	
Capri	Nippondenso 10-Cyl.
Festiva	Nippondenso 6-Cyl.
General Motors & Geo	
LeMans	Harrison V5 5-Cyl.
Metro & Tracker	Nippondenso 10-Cyl.
Prizm	Nippondenso 10PA15 10-Cyl.
Storm	Diesel Kiki KC-50 Rotary Vane
Honda	
Accord	Nippondenso 10-Cyl. Or Hadsys RC-17S 7-Cyl.
Civic	Sanden Scroll
Civic Del Sol	Sanden Scroll
Prelude	Sanden Scroll
Hyundai	
Elantra	Sanden TRF-090 Scroll
Excel	Sanden SD-709 7-Cyl.
Scoupe	Nippondenso 10PA15C 10-Cyl.
Sonata	Ford FX-15 10-Cyl.
Infiniti	
G20	Atsugi NVR 140S Rotary Vane
J30	Calsonic V6 6-Cyl.
Q45	Calsonic V5 5-Cyl.
Isuzu (R-12)	
Amigo	Diesel Kiki DKS-13CH 6-Cyl.
Pickup	

4-Cylinder	Diesel Kiki DKS-13CH	6-Cyl.
V6	Harrison R4	4-Cyl. Radial
Stylus	Diesel Kiki DKV-14D	Rotary Vane
Rodeo			
4-Cylinder	Diesel Kiki DKS-17CH	6-Cyl.
V6	Diesel Kiki DKV-14D	Rotary Vane
Trooper	Diesel Kiki DKV-14D	Rotary Vane
Isuzu (R-134a Option) (1)			
Amigo, Pickup, Rodeo & Trooper			
2.3L & 2.6L Engine	Zexel R-134a	6-Cyl.
3.1L Engine	Harrison R-134a R-4	4-Cyl. Radial
3.2L Engine	Zexel R-134a	Rotary Vane
Jaguar			
XJS	Sanden SD-709	7-Cyl.
XJ6	Sanden SD-7H15	7-Cyl.
Lexus	Nippondenso 10PA20	10-Cyl.
Mazda			
B2200 & B2600i	Sanden	5-Cyl.
Miata	Nippondenso TV12	Rotary Vane
MPV	Nippondenso	10-Cyl.
MX-6 & 626	Panasonic	Rotary Vane
Navajo	Ford FX-15	10-Cyl.
MX-3, Protege & 323	Panasonic	Rotary Vane
929	Panasonic	Rotary Vane
RX7	Nippondenso TV12	Rotary Vane
Mercedes-Benz			
190E	Nippondenso 10PA15	10-Cyl.
300D/E, 400E & 500E	Nippondenso 10PA17	10-Cyl.
300SE/SD, 400SE & 500SEL	Nippondenso 10PA20	10-Cyl.
Mitsubishi			
Diamante			
R-12	Sanden FX105VS	Scroll
R-134a	Sanden MSC105	
Diamante Wagon	Nippondenso 10PA17C	10-Cyl.
Galant & Mirage	Sanden FX105V	Scroll
Eclipse	Nippondenso 10PA17	10-Cyl.
Expo/Expo LRV	Nippondenso 10PA17C	10-Cyl.
Pickup	Sanden FX80	Scroll
Montero	Nippondenso 10PA15	10-Cyl.
Precis	Sanden SD-709	7-Cyl.
3000GT			
R-12	Sanden FX105VS	Scroll
R-134a	Sanden MSC105	
Nissan			
Altima	Zexel DKV-14C	Rotary Vane
Maxima & 300ZX	Zexel DKS-16H	6-Cyl.
Quest	Ford FX-15	10-Cyl.
Pathfinder & Pickup	Zexel DKV-14C	Rotary Vane
Sentra & NX	Zexel DKV-14D	Rotary Vane
240SX	Calsonic V5	5-Cyl.
Porsche			
911 America Roadster,			
RS America & Carrera 2/4	Nippondenso	10-Cyl.
Saab			
900	Sanden	5-Cyl.
9000	Seiko-Seiki SS121 DN1	Rotary Vane
Subaru			
Impreza	Zexel	Rotary Vane
Legacy	Zexel DKS-15CH	5-Cyl.
		Calsonic V5-15C	5-Cyl.
Loyale	Hitachi MJS170-5DP	6-Cyl.
SVX	Calsonic V5	5-Cyl.
Suzuki	Nippondenso	10-Cyl.

Toyota	
Camry	Nippondenso 10PA17C 10-Cyl.
Celica	
4A-FE Engine	Nippondenso 10PA15C 10-Cyl.
3S-GTE & 5S-FE Engine	Nippondenso 10PA17C/VC 10-Cyl.
Corolla	Nippondenso 10PA15 10-Cyl.
Land Cruiser	Nippondenso 10PA17 10-Cyl.
MR2	Nippondenso 10P13C 10-Cyl.
Paseo	Matsushita Rotary Vane
Pickup & 4Runner	Nippondenso 10-Cyl.
Previa	Nippondenso 10PA17E 10-Cyl.
Supra	Nippondenso 10-Cyl.
Tercel	Matsushita TV10B Rotary Vane
T100	Nippondenso 10PA15 10-Cyl.
Volkswagen	
Cabriolet	Sanden SD-508 5-Cyl. Or SD-709 7-Cyl.
Corrado SLC	Sanden SD-709 7-Cyl.
EuroVan	Sanden SD7H15 7-Cyl.
Golf, GTI & Jetta	Sanden SD7-V16/SD7-V16L 7-Cyl.
Fox	Nippondenso 6-Cyl.
Passat	Sanden SD7-V16/SD7-V16L 7-Cyl.
Volvo	
240	Seiko-Seiki SS-121DS5
850	Zexel DKS-15CH 6-Cyl.
940 & 960	Sanden SD-510 5-Cyl., Sanden SD-709 7-Cyl. Or Seiko-Seiki SS-121DS5

(1) - Standard equipment on some models built after 5/1/93.

REFRIGERANT OIL & REFRIGERANT CAPACITY

REFRIGERANT OIL & REFRIGERANT CAPACITY (ACURA THROUGH INFINITI)

Application	(1) Oil Ounces	Refrigerant Ounces
Acura		
Integra	(2) 2.0-3.4	32-34
Legend		
Sedan	(2) (3) 4.7	(4) 24.7-26.5
Coupe	(3) 4.7	24.7-26.5
Vigor	(2) 4.7-4.9	26.5-28.0
Audi		
90	7.8-9.2	(5) 23.0-24.8
100	7.8-9.2	(5) 21.0-22.8
BMW		
318 & 325 Series	3.4-4.8	(6) 35-36
525i & 535i	4.7-6.1	(6) 53.0-55.5
740i & 740iL	4.7-6.1	(6) 53.0-55.5
Chrysler Motors/Eagle		
Colt & Summit	(2) 4.4-5.1	26-30
Colt Vista & Summit		
Wagon	(2) 2.0-3.4	30
Ram-50	(2) 4.4-5.1	30
Stealth	(2) 4.6-6.0	29
Ford Motor Co.		
Capri	2.4-3.0	23-27
Festiva	10	25
General Motors & Geo		

LeMans	8.0	35
Metro	2.7	18
Prizm & Prizm LSi	6.0	25
Storm	5.1	21
Tracker	2.7	21
Honda		
Accord		
Nippondenso	3.0-4.1	28-30
Hadsys	4.1-4.3	28-30
Civic	4.0-4.7	21-23
Civic Del Sol	4.0-4.7	21-23
Prelude	(7) 4.3-5.0	21-23
Hyundai		
Excel	8.1	30-32
Scoupe	2-3	28-32
Elantra	4.0	32
Sonata	6.9-7.7	30-32
Infiniti		
G20	6.8	24-29
J30	8.5	(8) 24-26
Q45	9.7	38-42

- (1) - Total system capacity, unless otherwise noted.
(2) - Compressor refrigerant oil capacity.
(3) - Capacity revised by manufacturer in Acura Service News bulletin number ASN 0793-02.
(4) - Use R-134a refrigerant and ND-Oil 8 (Part No. 38899-PR7-003).
(5) - Use R-134a refrigerant and Polyalkylene Glycol (PAG) oil.
(6) - Use R-134a and Polyalkylene Glycol Oil (Part No. 81-22-9-407-724).
(7) - Use R-134a refrigerant and PAG Refrigerant Oil (Part No. 38899-P13-003).
(8) - Use R-134a refrigerant and Type "S" Oil (Part No. KLH00-PAGS0).

REFRIGERANT OIL & REFRIGERANT CAPACITY (ISUZU THROUGH MERCEDES)

Application	(1) Oil Ounces	Refrigerant Ounces
Isuzu (R-12)		
Amigo	5.0	26
Pickup		
2.3L & 2.6L Engine	5.0	26
3.1L Engine	6.0	26
Rodeo		
2.6L Engine	5.0	26
3.2L Engine	5.0	26
Stylus	5.0	21
Trooper	5.0	30
Isuzu (R-134a Option) (3)		
Amigo & Pickup		
2.3L & 2.6L Engine	5.0	23
3.1L Engine	7.5-8.5	23
Rodeo	5.0	23
Trooper	5.0	26
Jaguar		
XJS	(2) 4.6	40
XJ6	(2) 4.5	(4) 40
Lexus		
ES300	(2) 3.5	32-35

GS300	(2)	4.0	(5)	28-32
LS400	(2)	2.8-3.5	(5)	32
SC300 & SC400	(2)	4.0		32-35
Mazda						
B2200 & B2600i	(2)	4.5		28
Miata	(2)	2.7-3.3		28
MPV						
Dual Unit	(2)	2.7-3.3		51
Single Unit	(2)	2.7-3.3		37
MX-3	(2)	5.0		28
MX-6 & 626	(2)	4.3		26
Protege & 323	(2)	3.9-4.6		28
Navajo		7.0		28-29
929		3.6		28
RX7		3.4-4.7		21
Mercedes-Benz						
190E	(2)	4.0		36
300D/E, 400E & 500E	(2)	5.4	(6)	36
300SE/SD, 400SE & 500SEL	(2)	5.4	(7)	43

- (1) - Total system capacity, unless otherwise noted.
(2) - Compressor refrigerant oil capacity.
(3) - Standard equipment on some models built after 5/1/93.
Use R-134a Swash Plate Compressor Oil (Part No. 2-90188-300-0) on 2.3L and 2.6L engine. Use R-134a R-4 Compressor Oil (Part No. 2-90222-320-0) on 3.1L engine. Use R-134a Rotary Vane Compressor Oil (Part No. 2-90188-301-0) on 3.2L engine.
(4) - Use R-134a refrigerant and PAG SP20 refrigerant oil.
(5) - Use R-134a refrigerant and ND-Oil 8 (Part No. 38899-PR7-003).
(6) - Use R-134a refrigerant and Densooil 8 (Part No. A 001 989 08 03).
(7) - Use R-134a refrigerant and Densooil 8 (Part No. A 001 989 08 03). Use 50 ounces if equipped with rear passenger compartment A/C-heater system.

REFRIGERANT OIL & REFRIGERANT CAPACITY (MITSUBISHI THRU SUBARU)

Application	(1) Oil Ounces	Refrigerant Ounces
Mitsubishi		
Diamante		
R-12	5.4-6.0	34-38
R-134a	(3) 5.7-6.4	26-28
Diamante Wagon	5.4	28
Eclipse	(2) 2.0-3.4	33
Expo/Expo LRV		
1.8L	(2) 3.4-4.0	30
2.4L	(2) 2.0-3.4	30
Galant	(2) 5.0-5.7	33
Mirage	(2) 4.4-5.1	26-30
Pickup	(2) 4.4-5.1	30
Montero	(2) 2.0-3.4	28
Precis	8.1	30-32
3000GT		
R-12	4.7-6.0	29
R-134a	(3) 4.7-6.0	26-28
Nissan		
Altima	(4) 6.8	25-28

Maxima	(5) 6.8	30-33
Pathfinder & Pickup	(4) 6.8	26-30
Quest		
Front A/C	7.0	36
Front & Rear A/C	10	56
Sentra & NX	6.8	23-26
240SX	8.0	29-32
300ZX	6.8	26-30
Porsche		
911 America Roadster, RS		
America & Carrera 2/4	4.6	(6) 29.5
Saab		
900	5.9	34-36
9000	6.6	(3) 33-34
Subaru		
Impreza	6.1	23-26
Legacy		
Zexel	(2) 2.4	29-32
Calsonic	(2) 3.2	29-32
Loyale	(2) 2.4	26-28
SVX	(2) 2.4	(7) 22-23

(1) - Total system capacity, unless otherwise noted.

(2) - Compressor refrigerant oil capacity.

(3) - Use SUN PAG 56 refrigerant oil.

(4) - Use R-134a refrigerant and Type "R" Oil (Part No. KLH00-PAGR0).

(5) - Use R-134a refrigerant and Type "S" Oil (Part No. KLH00-PAGS0).

(6) - Use R-134a refrigerant and Nippondenso ND8 refrigerant oil.

(7) - Use R-134a refrigerant and ZXL100 PG (DH-PS) Type "S" Oil (Part No. K0010PS000).

REFRIGERANT OIL & REFRIGERANT CAPACITY (SUZUKI THROUGH VOLVO)

Application	(1) Oil Ounces	Refrigerant Ounces
Suzuki		
Samurai	2.0-3.4	18
Sidekick	2.0-3.4	21-23
Swift	2.0-3.4	18
Toyota		
Camry	(2) 3.5	32-35
Celica	3.4-4.1	24-27
Corolla	3.4-4.1	25-28
Land Cruiser	3.4-4.1	30-34
MR2	3.4-4.1	28-32
Paseo	3.4-4.1	25-28
Pickup	3.4-4.1	24-29
Previa		
Without Rear A/C	3.4-4.7	32-35
With Rear A/C	3.4-4.7	41-44
Supra	(2) 4.1	(3) 23-27
Tercel	3.4-4.1	25-28
T100	3.4-4.1	(3) 21-25
4Runner	3.4-4.1	27-30
Volkswagen		
Cabriolet	4.6	30.0-31.8
Corrado SLC	3.9-4.4	35.0-36.8
EuroVan		
Without Rear A/C	4.6	(4) 34-35

With Rear A/C	8.2	(4) 48-49
Fox	5.7	41-42
Golf, GTI & Jetta	3.9	(4) 28-30
Passat	3.9-4.4	(4) 41.0-42.8
Volvo		
240	7.4	(5) 26
850		
Cold Climates	7.0	(5) 29
Hot Climates	7.0	(5) 26
940 & 960		
Sanden SD-510	4.8	(6) 32-34
Sanden SD-709	8.5	(6) 32-34
Seiko-Seiki	7.8	(6) 32-34

- (1) - Total system capacity, unless otherwise noted.
 - (2) - Compressor refrigerant oil capacity.
 - (3) - Use R-134a refrigerant and ND-Oil 8 (Part No. 38899-PR7-003).
 - (4) - Use R-134a refrigerant and SP-10 PAG Oil (Part No. G 052 154 A2).
 - (5) - Use R-134a refrigerant and ZXL 100 PG Oil (Part No. 8708581-7).
 - (6) - Use R-134a refrigerant and PAG Oil (Part No. 8708581-9).
-

REFRIGERANT OIL

Only NEW, moisture-free refrigerant oil should be used in the air conditioning system. This oil is highly refined and dehydrated so moisture content is less than 10 parts per million. The oil container must be tightly closed at all times when not in use, or moisture from the air will be absorbed into the refrigerant oil.

SERVICING PRECAUTIONS

DISCHARGING SYSTEM

Discharge A/C system using approved refrigerant recovery/recycling equipment. Always follow recovery/recycling equipment manufacturer's instructions. After refrigerant recovery process is completed, the amount of compressor oil removed must be measured and the same amount added to A/C system.

DISCONNECTING LINES & FITTINGS

After system is discharged, carefully clean area around all fittings to be opened. Always use 2 wrenches when tightening or loosening fittings. Some refrigerant lines are connected with a coupling. Special tools may be required to disconnect lines. Cap or plug all openings as soon as lines are removed. DO NOT remove caps until connections of lines and fittings are completed.

CONNECTING LINES & FITTINGS

NOTE: All R-134a based systems use 1/2-16 ACME threaded fittings. Ensure all replacement parts match the connections of the system being worked on.

Always use a new gasket or "O" ring when connecting lines or fittings. Coat "O" ring with refrigerant oil and ensure it is not twisted during installation. Always use 2 wrenches to prevent damage

to lines and fittings.

PLACING SYSTEM IN OPERATION

After component service or replacement has been completed and all connections have been made, evacuate system thoroughly with a vacuum pump. Charge system with proper amount of refrigerant and perform leak test. See REFRIGERANT OIL & REFRIGERANT SPECIFICATIONS article in GENERAL SERVICING for system capacities. Check all fittings that have been opened. After system has been leak tested, check system performance.

NOTE: Most compressors are pre-charged with a fixed amount of refrigerant (shipping) oil. Drain compressor oil from new compressor and add refrigerant oil to new compressor according to amount removed from old compressor. Always refer to underhood A/C specification label or A/C compressor label while servicing A/C system.

ATSUGI

ROTARY VANE

1) Before checking and adjusting oil level, operate engine at 1200 RPM. Set controls at maximum cooling and high blower motor speed for 10 minutes to return oil to compressor.

2) Stop engine. Discharge refrigerant and remove compressor from vehicle. See SERVICING PRECAUTIONS. Drain compressor oil through compressor discharge port and measure oil amount.

3) If amount drained is less than 3 ounces, conduct leak tests at system connections. Repair or replace faulty parts as necessary. Check purity of oil and adjust oil level as follows.

4) If amount drained is 3 ounces or more, oil level is okay. Fill with same amount drained, using new oil. If amount drained is less than 3 ounces, pour in 3 ounces of new refrigerant oil.

COMPONENT REFRIGERANT OIL CAPACITIES (ATSUGI ROTARY VANE)

Component	Ounces
Condenser	1.0-1.7
Evaporator	1.5-2.5
Receiver-Drier	0.5-0.8
Refrigerant Lines (1)	1.0-1.7

(1) - Add only if a refrigerant oil leak is indicated.

BOSCH

6-CYLINDER

1) Before checking and adjusting oil level, operate compressor at engine idle speed, and set controls at maximum cooling and high blower motor speed for 20-30 minutes to return oil to compressor.

2) Stop engine and discharge refrigerant. See SERVICING PRECAUTIONS. Remove refrigerant oil level inspection plug on side of compressor. Oil should be at lower lip of threaded hole. If oil level is low, add new refrigerant oil as necessary. Replace inspection plug and tighten to 10-12 ft. lbs. (14-16 N.m).

CALSONIC

V5 5-CYLINDER & V6 6-CYLINDER

Infiniti & Nissan

1) Before checking and adjusting oil level, operate engine at 1200 RPM. Set controls at maximum cooling and high blower motor speed for 10 minutes to return oil to compressor.

2) Stop engine. Discharge refrigerant. See SERVICING PRECAUTIONS. Measure the amount of oil drained/discharged into refrigerant recovery/recycling equipment.

3) Remove compressor from vehicle. Drain compressor oil from compressor drain plug and measure oil amount. Add this amount to amount drained in step 2), to obtain total amount drained.

4) Fill compressor with total amount drained, using new oil. If any major components of the system were also replaced, determine the amount of additional oil needed. See appropriate COMPONENT REFRIGERANT OIL CAPACITIES table for specified amount.

COMPONENT REFRIGERANT OIL CAPACITIES (CALSONIC V5)

Component	Ounces
Condenser	1.0-1.7
Evaporator	1.5-2.5
Receiver-Drier	0.5-0.8
Refrigerant Lines (1)	1.0-1.7

(1) - Add only if a refrigerant oil leak is indicated.

COMPONENT REFRIGERANT OIL CAPACITIES (CALSONIC V6)

Component	Ounces
Condenser	2.5
Evaporator	2.5
Receiver-Drier	0.2
Refrigerant Lines (1)	1.0

(1) - Add only if a refrigerant oil leak is indicated.

Subaru

1) Before checking and adjusting oil level, operate engine at 1000-1500 RPM. Set controls at maximum cooling and high blower motor speed for 20 minutes to return oil to compressor.

2) Stop engine. Discharge refrigerant and remove compressor from vehicle. See SERVICING PRECAUTIONS. Drain compressor oil from compressor drain plug and measure oil amount.

3) Fill compressor with total amount drained, using new oil. If any major components of the system were also replaced, determine the amount of additional oil needed. See appropriate SUBARU COMPONENT REFRIGERANT OIL CAPACITIES table for specified amount.

SUBARU COMPONENT REFRIGERANT OIL CAPACITIES (LEGACY)

Component	Ounces
Compressor	2.4
Condenser	1.7

Evaporator	2.4
Refrigerant Lines (1)	1.7

(1) - Add only if a refrigerant oil leak is indicated.

SUBARU COMPONENT REFRIGERANT OIL CAPACITIES (SVX)

Component	Ounces
Compressor	2.4
Condenser	1.7
Evaporator	2.4
Refrigerant Lines (1)	1.7

(1) - Add only if a refrigerant oil leak is indicated.

DIESEL KIKI

ROTARY VANE

1) Before checking and adjusting oil level, operate engine at 800-1000 RPM. Set controls at maximum cooling and high blower motor speed for 20 minutes to return oil to compressor.

2) Stop engine. Discharge refrigerant and remove compressor from vehicle. See SERVICING PRECAUTIONS. Remove oil drain plug and measure amount of oil drained.

3) If amount drained is less than 3 ounces (1.7 ounces on Geo Storm), conduct leak tests at system connections. Repair or replace faulty parts as necessary.

4) If amount drained is more 3 ounces (1.7 ounces on Geo Storm), oil level is okay. Fill compressor with same amount drained, using new oil. If amount drained is less than 3 ounces (1.7 ounces on Geo Storm), pour in 3 (1.7) ounces of new refrigerant oil.

5) When replacing other A/C system components, add the following amount(s) of refrigerant oil. See COMPONENT REFRIGERANT OIL CAPACITIES (DIESEL KIKI ROTARY VANE) table.

COMPONENT REFRIGERANT OIL CAPACITIES (DIESEL KIKI ROTARY VANE)

Component	Ounces
Condenser	1.7
Evaporator	1.0
Receiver-Drier	1.0
Refrigerant Lines	0.3

5 & 6-CYLINDER

1) Before checking and adjusting oil level, operate engine at 800-1000 RPM. Set controls at maximum cooling and high blower motor speed for 20 minutes to return oil to compressor.

2) Stop engine. Discharge refrigerant and remove compressor from vehicle. See SERVICING PRECAUTIONS. Remove oil drain plug and measure amount of oil drained.

3) If amount drained is less than 3 ounces, conduct leak tests at system connections. Repair or replace faulty parts as necessary.

4) If amount drained is more 3 ounces, oil level is okay. Fill compressor with same amount drained, using new oil.

5) When replacing other A/C system components, add the following amount(s) of refrigerant oil. See COMPONENT REFRIGERANT OIL CAPACITIES (DIESEL KIKI 5 & 6-CYLINDER) table.

COMPONENT REFRIGERANT OIL CAPACITIES (DIESEL KIKI 5 & 6-CYLINDER)

Component	Ounces
Condenser	1.0
Evaporator	1.7
Receiver-Drier	1.0
Refrigerant Lines	0.3

FORD

FX-15 10-CYLINDER

1) Slowly discharge system. See SERVICING PRECAUTIONS. Remove A/C compressor. Drain compressor oil from suction and discharge ports. Measure amount drained and discard oil.

2) If amount drained from removed (old) compressor is between 3 and 5 ounces, add drained amount of new refrigerant oil into the NEW compressor through suction port.

3) If amount drained is less than 3 ounces, add 3 ounces to the NEW compressor. If amount drained is more than 5 ounces, add 5 ounces. Use new "O" rings on refrigerant lines. Install A/C compressor. Evacuate and recharge system. Perform leak test.

4) When replacing other A/C system components, add the following amount(s) of refrigerant oil. See COMPONENT REFRIGERANT OIL CAPACITIES (FX-15 10-CYLINDER) table.

COMPONENT REFRIGERANT OIL CAPACITIES (FX-15 10-CYLINDER)

Component	Ounces
Condenser	1.0
Evaporator	3.0
Receiver-Drier	(1) 2.0
Refrigerant Lines	(2) 1.0

(1) - On Hyundai Sonata and Mazda Navajo, drain oil from old receiver-drier. Add amount drained to amount specified.

(2) - Add only if a large oil leak is indicated.

HADSYS

7-CYLINDER

Honda (Accord)

1) Discharge system. See SERVICING PRECAUTIONS. Remove compressor from vehicle. Drain all oil from NEW compressor and fill compressor with 4 ounces of clean refrigerant oil.

2) Add one ounce of refrigerant oil when replacing evaporator. Add 1/2 ounce when replacing condenser. When replacing receiver-drier or hoses, add 1/3 ounce per component replaced.

HARRISON

R4 4-CYLINDER

1) Before checking and adjusting oil level, operate engine at 800-1000 RPM. Set controls at maximum cooling and high blower motor speed for 20 minutes to return oil to compressor.

2) Stop engine. Discharge refrigerant and remove compressor from vehicle. See SERVICING PRECAUTIONS. Remove oil drain plug and measure amount of oil drained.

3) If amount drained is less than one ounce, conduct leak tests at system connections. Repair or replace faulty parts as necessary. Fill compressor with 2 ounces, using new refrigerant oil.

4) If amount drained is more one ounce, oil level is okay. Fill compressor with same amount drained, using new oil.

5) When replacing other A/C system components, add the following amount(s) of refrigerant oil. See COMPONENT REFRIGERANT OIL CAPACITIES (HARRISON R4 4-CYLINDER) table.

COMPONENT REFRIGERANT OIL CAPACITIES (HARRISON R4 4-CYLINDER)

Component	Ounces
Condenser	1.0
Evaporator	1.7
Receiver-Drier	1.0
Refrigerant Lines	0.3

V5 5-CYLINDER

1) If system is operable, run A/C system for several minutes to stabilize system. Turn off engine. Discharge system and remove compressor. See SERVICING PRECAUTIONS. Remove drain plug and measure oil.

2) If one ounce or more is drained, add same amount. If less than one ounce is drained, add 2 ounces of new refrigerant oil to compressor.

3) If condenser is replaced, add one ounce. Add 3.5 ounces if accumulator is replaced. If evaporator is replaced or if a large refrigerant leak occurred, add 3 ounces of new refrigerant oil.

HITACHI

6-CYLINDER

1) Before checking and adjusting oil level, operate compressor at 1000-1500 engine RPM, and set controls at maximum cooling and high blower motor speed for about 10 minutes to return oil to compressor.

2) Stop engine. Discharge refrigerant and remove compressor from vehicle. See SERVICING PRECAUTIONS. Drain oil from compressor through suction port. Measure amount of oil drained.

3) If amount drained is 2.4 ounces or more, fill with same amount using new oil. If amount drained is less than 2.4 ounces, fill with 2.4 ounces. Install compressor and recharge.

4) If A/C components are replaced, add refrigerant oil to system. Add 1.7 ounces if condenser is replaced. Add 2.4 ounces if evaporator is replaced. Oil does not need to be added if receiver-drier is replaced. Add 1.7 ounces of refrigerant oil only if a refrigerant oil leak is indicated.

MATSUSHITA

ROTARY VANE

Geo (Prizm)

1) If system is operable, run A/C system for several minutes to stabilize system. Turn off engine. Discharge system and remove compressor. See SERVICING PRECAUTIONS. Remove drain plug and measure oil.

2) If one ounce or more is drained, add same amount. If less than one ounce is drained, add 2 ounces of new refrigerant oil to compressor.

3) If condenser is replaced, add one ounce. Add 3.5 ounces if receiver-drier is replaced. If evaporator is replaced or if a large refrigerant leak occurred, add 3 ounces of new refrigerant oil.

Toyota

Discharge system. See SERVICING PRECAUTIONS. Remove compressor from vehicle. Drain oil from compressor through inlet and outlet ports. Fill compressor with 3.4-4.1 ounces of oil through suction port. Add 0.7 ounces if receiver-drier was replaced. When replacing condenser or evaporator, add 1.4-1.7 ounces of refrigerant oil.

NIPPONDENSO

ROTARY VANE

1) Before checking and adjusting oil level, operate compressor at engine idle speed, and set controls at maximum cooling and high blower motor speed for 20-30 minutes to return oil to compressor.

2) Stop engine. Discharge refrigerant and remove compressor from vehicle. See SERVICING PRECAUTIONS. Drain compressor oil through compressor intake and discharge ports. Measure amount drained.

3) Fill compressor with same amount as drained, plus one ounce. When replacing condenser, add one ounce. When replacing evaporator, add 1 1/2 ounces. When replacing receiver-drier, add 1/3 ounce of new refrigerant oil.

6 & 10-CYLINDER

NOTE: Porsche and Suzuki compressor oil checking procedures are not available from manufacturer.

Acura & Honda

1) Discharge system. See SERVICING PRECAUTIONS. Remove compressor from vehicle. Drain all oil from NEW compressor and fill compressor with 3-4 ounces of clean refrigerant oil.

2) On Accord, add 5/6 ounce of refrigerant oil when replacing evaporator. Add 1/3 ounce when replacing condenser. When replacing receiver-drier or hoses, add 1/3 ounce per component replaced.

3) On Legend, add 2 ounces of refrigerant oil when replacing evaporator. Add one ounce when replacing condenser. When replacing receiver-drier or hoses, add 1/3 ounce per component replaced.

4) On Integra, add one ounce of refrigerant oil when replacing evaporator. When replacing condenser, receiver-drier or hoses, add 1/3 ounce per component replaced.

5) On Vigor, add 1/2 ounce of refrigerant oil when replacing evaporator. Add 2/3 ounce when replacing condenser. When replacing receiver-drier or hoses, add 1/3 ounce per component replaced.

Chrysler Corp. (Colt Vista/Summit Wagon)

Add 2 ounces of refrigerant oil when replacing evaporator. Add one ounce when replacing condenser. When replacing receiver-drier or hoses, add 1/3 ounce per component replaced.

Ford Motor Co.

On Capri, add 2-3 ounces when replacing compressor. Add one ounce of refrigerant oil when replacing condenser or evaporator. When replacing receiver-drier, add 1/2 ounce. On Festiva, drain and measure oil from receiver-drier. Add the amount drained plus one ounce. Add one ounce when replacing condenser. Add 3 ounces of refrigerant oil when replacing evaporator.

Geo, Hyundai & Mazda

Add one ounce of refrigerant oil when replacing condenser. Add 1-1 1/2 ounce when replacing evaporator. When replacing receiver-drier or hoses, add 1/3 ounce per component replaced.

Lexus & Toyota

The use of refrigerant recovery/recycling is recommended by manufacturer. After refrigerant recovery process is completed, the amount of compressor oil removed must be measured and the same amount added to A/C system. Add 1 1/2 ounces of refrigerant oil when replacing condenser. Add 1 1/2 ounces when replacing evaporator. When replacing receiver-drier or hoses, add 1/2 ounce per component replaced.

Mercedes-Benz

Add 2/3 ounce of refrigerant oil when replacing condenser. Add 1 1/3 ounces when replacing evaporator. When replacing receiver-drier or hoses, add 1/3 ounce per component replaced. If A/C system line has broken (sudden discharge), add 1 1/3 ounces of refrigerant oil.

NOTE: On Mercedes-Benz vehicles with rear A/C, add 2/3 ounce of refrigerant oil when replacing rear condenser. When replacing rear A/C lines, add 1/3 ounce per line replaced.

Mitsubishi

1) On Eclipse, add 2/3 ounce of refrigerant oil when replacing condenser. Add one ounce when replacing evaporator. When replacing receiver-drier or hoses, add 1/3 ounce per component replaced.

2) On Expo/Expo LRV and Montero, add one ounce of refrigerant oil when replacing condenser. Add 2 ounces when replacing evaporator. When replacing receiver-drier or hoses, add 1/3 ounce per component replaced.

Volkswagen (Fox)

1) The use of refrigerant recovery/recycling is recommended by manufacturer. After refrigerant recovery process is completed, the amount of compressor oil removed must be measured and the same amount added to A/C system.

2) Add 1 1/2 ounce of refrigerant oil when replacing evaporator. When replacing condenser, add 1 1/3 ounce of refrigerant oil. Add one ounce of refrigerant oil when replacing receiver-drier (1 1/2 ounces if relief valve on receiver-drier has burst).

PANASONIC

ROTARY VANE

Mazda

Add 1 1/3 ounce of refrigerant oil when replacing condenser (1/2 ounce on MX-6 and 626). Add 2 ounces when replacing evaporator. When replacing receiver-drier or hoses, add 1/3 ounce of refrigerant oil.

SANDEN

SCROLL

Chrysler/Mitsubishi

1) On Colt, Galant, Mirage, Pickup, Ram-50 and Summit, add 1/2 ounce of refrigerant oil when replacing condenser. Add 1 1/2 ounces when replacing evaporator. When replacing receiver-drier or hoses, add 1/3 ounce per component replaced.

2) On Stealth and 3000GT, add 1/2 ounce of refrigerant oil when replacing condenser. Add 2 ounces when replacing evaporator. When replacing receiver-drier or low-pressure hose, add 1/3 ounce per component replaced.

Honda

1) Discharge system. See SERVICING PRECAUTIONS. Remove compressor from vehicle. Drain all oil from NEW compressor and fill compressor with 4 ounces of clean refrigerant oil.

2) On Civic and Civic Del Sol, add 1 1/2 ounce of refrigerant oil when replacing evaporator. Add 2/3 ounce when replacing condenser. When replacing receiver-drier or hoses, add 1/3 ounce per component replaced.

3) On Prelude, add one ounce of refrigerant oil when replacing evaporator. When replacing other A/C components, add 1/3 ounce per component replaced (including hoses).

Hyundai

Add 1 1/2 ounces of refrigerant oil when replacing evaporator. Add one ounce when replacing condenser. When replacing receiver-drier, add 1/3 ounce of refrigerant oil.

5-CYLINDER

Mazda

Add one ounce of refrigerant oil when replacing condenser. Add 1 2/3 ounce when replacing evaporator. When replacing receiver-drier, add 1/2 ounce of refrigerant oil.

NOTE: Saab and Volvo (Sanden 5 or 7-cylinder) compressor oil checking procedures are not available from manufacturer.

7-CYLINDER

Hyundai & Mitsubishi (Excel & Precis)

1) Before checking and adjusting oil level, operate compressor at engine idle speed, and set controls at maximum cooling and high blower motor speed for 20-30 minutes to return oil to compressor.

2) Stop engine. Discharge refrigerant and remove compressor from vehicle. See SERVICING PRECAUTIONS. Remove oil drain plug and drain oil. Measure amount of oil drained. Install drain plug with new "O" ring.

3) If amount drained is 2.3 ounces or more, fill compressor with same amount using new oil. If amount drained is less than 2.3 ounces, fill with 2.3 ounces. Install filler plug. Install compressor and recharge system.

COMPONENT REFRIGERANT OIL CAPACITIES (SANDEN 7-CYLINDER)

Component	Ounces
Condenser	1.0
Evaporator	3
Receiver-Drier	1

Jaguar (XJS)

1) Operate engine at idle speed for 10 minutes, to return refrigerant oil to compressor. Stop engine. Discharge refrigerant. See SERVICING PRECAUTIONS. Clean area around compressor filler plug and remove plug slowly.

2) Determine angle at which compressor is mounted. Insert compressor dipstick diagonally until stop on dipstick contacts filler plug surface. See Fig. 1. Remove dipstick and note oil fill level. Each increment on dipstick represents one ounce of oil.

3) Determine amount of oil needed according to mounting angle. See COMPRESSOR OIL CAPACITIES (JAGUAR XJS) table for specified amount.

4) If necessary, correct compressor oil level. Install compressor oil plug, and tighten it to 72-108 INCH lbs. (8-12 N.m). Evacuate and recharge A/C system. Perform leak test.

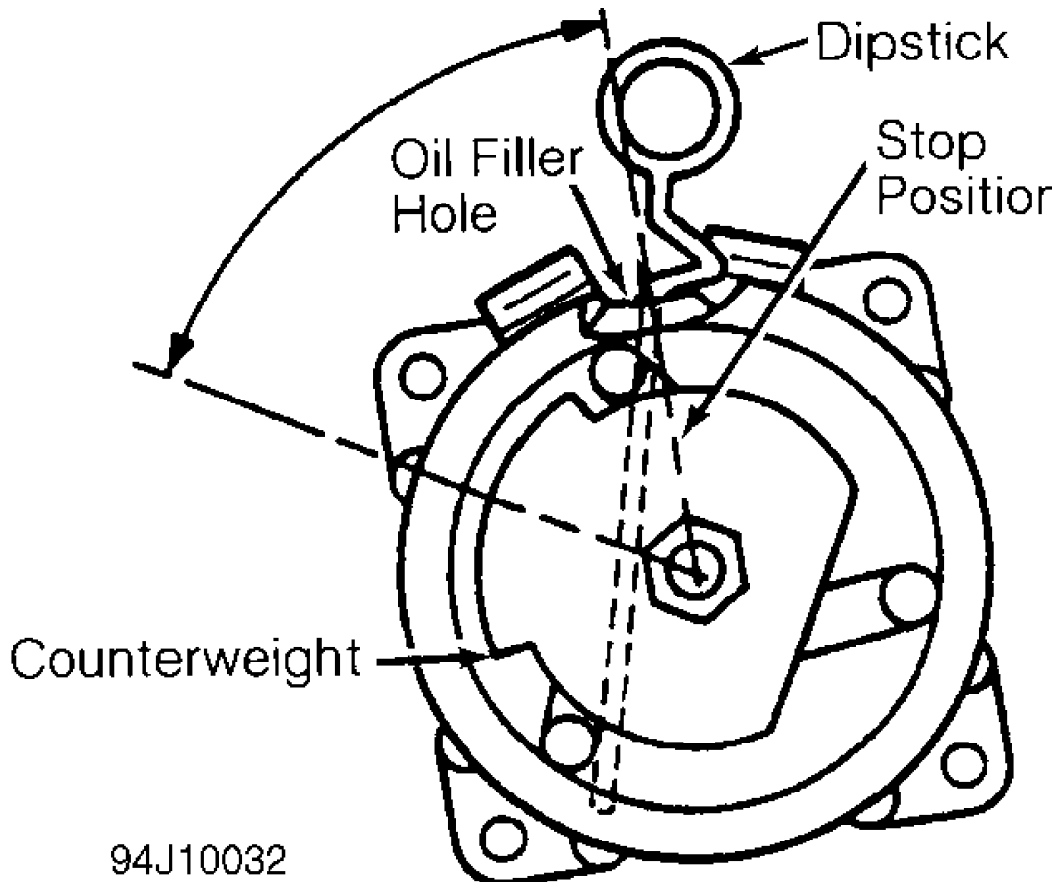

94J10032

Fig. 1: Checking Jaguar XJS Compressor Oil Level (Sanden 7-Cylinder)
 Courtesy of Jaguar Cars, Inc.

COMPRESSOR OIL CAPACITIES (JAGUAR XJS)

Mounting Angle (In Degrees)	Oil Level In Increments
0	3-5
10	4-6
20	5-7
30	6-8
40	7-9
50	8-10
60	9-11
90	10-12

Volkswagen

1) The use of refrigerant recovery/recycling is recommended by manufacturer. After refrigerant recovery process is completed, the amount of compressor oil removed must be measured and the same amount added to A/C system.

2) On Cabriolet, add 2/3 ounce of refrigerant oil when replacing evaporator. When replacing condenser or receiver-drier, add 1/3 ounce of refrigerant oil per component replaced.

3) On Corrado SLC, Golf, GTI, Jetta and Passat, add 2/3 ounce of refrigerant oil when replacing evaporator. When replacing condenser or receiver-drier, add 1/3 ounce of refrigerant oil per component replaced.

4) On EuroVan, add one ounce of refrigerant oil when replacing evaporator. Add 1/2 ounce when replacing condenser (2/3 ounce on vehicles with rear A/C). When replacing receiver-drier, add 1/3 ounce (2/3 ounce on vehicles with rear A/C).

SEIKO-SEIKI

ROTARY VANE

Saab (9000)

The A/C system is filled with 6.6 ounces of compressor oil. The compressor must be topped off with the specified amount. See COMPONENT REFRIGERANT OIL CAPACITIES (SEIKO-SEIKI ROTARY VANE) table. Topping off should be carried out on the high pressure side of the compressor.

COMPONENT REFRIGERANT OIL CAPACITIES (SEIKO-SEIKI ROTARY VANE)

Component	Ounces
Compressor	(1) 2.3
Condenser	1.3
Expansion Valve	0.6
Evaporator	1.3
Receiver-Drier	1.3
Refrigerant Lines	0.6

(1) - To avoid an excessive amount of oil in the A/C system, oil must be drained from the compressor before it is installed.

ZEXEL

NOTE: Isuzu and Subaru compressor oil checking procedures are not available from manufacturer.

ROTARY VANE

Nissan

1) Before checking and adjusting oil level, operate engine at 1200 RPM. Set controls at maximum cooling and high blower motor speed for 10 minutes to return oil to compressor.

2) Stop engine. Discharge refrigerant. See SERVICING PRECAUTIONS. Measure the amount of oil drained/discharged into refrigerant recovery/recycling equipment.

3) Remove compressor from vehicle. Drain compressor oil from compressor drain plug and measure oil amount. Add this amount to amount drained in step 2), to obtain total amount drained.

4) Fill compressor with total amount drained, using new oil. If any major components of the system were also replaced, determine the amount of additional oil needed. See COMPONENT REFRIGERANT OIL CAPACITIES (ZEXEL ROTARY VANE & 6-CYLINDER) table for specified amount.

COMPONENT REFRIGERANT OIL CAPACITIES (ZEXEL ROTARY VANE & 6-CYLINDER)

Component	Ounces
Condenser	
Altima & Maxima	2.5
NX, Pickup, Sentra & 300ZX	1.0-1.7
Evaporator	
Altima & Maxima	2.5
NX, Pickup, Sentra & 300ZX	1.5-2.5
Receiver-Drier	
Altima & Maxima	0.2
NX, Pickup, Sentra & 300ZX	0.5-0.8
Refrigerant Lines (1)	1.0

(1) - Add only if a refrigerant oil leak is indicated.

6-CYLINDER

Audi

1) The use of refrigerant recovery/recycling is recommended by manufacturer. After refrigerant recovery process is completed, the amount of compressor oil removed must be measured and the same amount added to A/C system.

2) Add one ounce of refrigerant oil when replacing accumulator. When replacing condenser, add amount drained from condenser plus 1/3 ounce of refrigerant oil. When replacing evaporator, add amount drained from evaporator plus 2/3 ounce of refrigerant oil.

Nissan

1) Before checking and adjusting oil level, operate engine at 1200 RPM. Set controls at maximum cooling and high blower motor speed for 10 minutes to return oil to compressor.

2) Stop engine. Discharge refrigerant. See SERVICING PRECAUTIONS. Measure the amount of oil drained/discharged into refrigerant recovery/recycling equipment.

3) Remove compressor from vehicle. Drain compressor oil from compressor drain plug and measure oil amount. Add this amount to amount drained in step 2), to obtain total amount drained.

4) Fill compressor with total amount drained, using new oil. If any major components of the system were also replaced, determine the amount of additional oil needed. See COMPONENT REFRIGERANT OIL CAPACITIES (ZEXEL ROTARY VANE & 6-CYLINDER) table for specified amount.

Volvo (850)

1) Discharge refrigerant. See SERVICING PRECAUTIONS. Remove compressor from vehicle. Drain compressor oil from compressor drain plug and measure oil amount. Add the same amount of oil as was drained from the old compressor.

2) Add 1 2/3 ounce of refrigerant oil when replacing evaporator. When replacing condenser or hoses, add 2/3 ounce of refrigerant oil per component replaced. Add 3 ounce of refrigerant oil when replacing receiver-drier.