

DRIVE AXLE - REAR NON-INTEGRAL

1993 Mitsubishi Montero

1993 Drive Axles - Differentials & Axle Shafts -
Rear Non-Integral

Ram-50, Montero & Pickup

DESCRIPTION

Rear axle features a rigid banjo-type housing with semi-floating axle shafts. Differential consists of hypoid reduction gears and straight bevel differential gears. Limited Slip Differential (LSD) is available on Montero RS (w/o ABS), Pickup 4WD and Ram-50 4WD. Locking rear differential is available on Montero SR model.

AXLE RATIO & IDENTIFICATION

Ratio is determined by dividing number of ring gear teeth by number of drive pinion teeth.

AXLE RATIO SPECIFICATIONS TABLE

Application	Ratio
Montero	
LT31X10.50R15 Tire	4.88:1
P235/75R15 Tire	4.63:1
Pickup & Ram-50	
2WD	3.91:1
4WD	4.22:1

LUBRICATION

CAPACITY

REAR AXLE GEAR OIL CAPACITY TABLE

Application	Pts. (L)
Montero	5.5 (2.6)
Pickup & Ram-50	
Conventional	
2WD	3.2 (1.5)
4WD	5.5 (2.6)
Limited Slip Differential	5.5 (2.6)

FLUID TYPE

Conventional differentials use SAE 80W or SAE 90W API GL-5. Limited slip differentials use Mitsubishi Gear Oil (8149630 EX), or Mopar Gear Oil (4318058) and Mopar Friction Modifier (4318060).

TROUBLE SHOOTING

See TROUBLE SHOOTING - BASIC PROCEDURES article in GENERAL INFORMATION section.

TESTING & INSPECTION

AXLE SHAFT END PLAY

Pickup & Ram-50

Using dial indicator, check axle shaft end play. End play should be .002-.008" (.05-.20 mm). If end play is not within specification, change shims to obtain correct end play. See AXLE SHAFT under REMOVAL & INSTALLATION.

Montero

Using dial indicator, check axle shaft end play. End play should be .010" (.25 mm). If end play is not within specification, replace axle bearing. See AXLE SHAFT under OVERHAUL.

AXLE TOTAL BACKLASH

1) Raise and support rear axle. Place transmission in Neutral. Apply parking brake. Rotate drive shaft clockwise. Place reference marks on pinion dust cover and differential housing.

2) Rotate drive shaft counterclockwise, and measure distance between reference marks. Differential must be removed and backlash adjusted if distance exceeds 0.2" (5 mm). See RING GEAR BACK-LASH procedure under DIFFERENTIAL ASSEMBLY (LIMITED SLIP) under OVERHAUL.

LIMITED SLIP DIFFERENTIAL PRELOAD

1) Place transmission in Neutral. Block front wheels. Raise one rear wheel off ground and remove wheel. Release parking brake.

2) Using torque wrench and axle puller adapter, measure starting torque while rotating wheel in forward direction. See Fig. 1. Differential must be repaired if torque is less than 18 ft. lbs. (25 N.m).

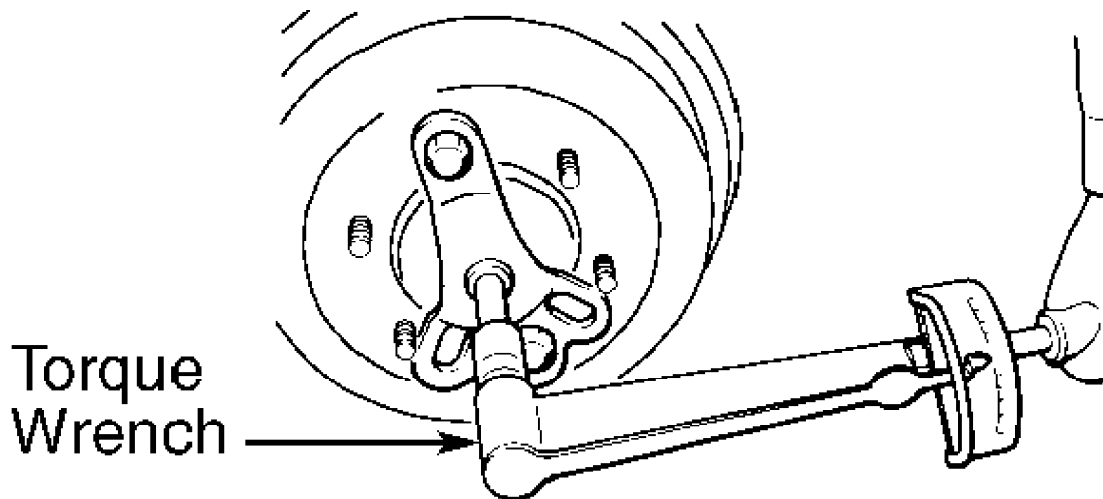

93182758

Fig. 1: Testing Limited Slip Differential Preload
Courtesy of Mitsubishi Motor Sales of America.

LOCKING DIFFERENTIAL

Air Pump

Connect air pressure gauge in-line to air hose from air pump. Air pump is located in right storage area, under rear seat. Connect battery voltage to air pump (positive lead to Red wire). The air pump is operating correctly when the following sequences occur:

- * Pump should operate for no more than 5 seconds.
- * Pressure should be 4-6 psi (28-41 kPa) within 10-20 seconds after pump has stopped.
- * After air pump has stopped operating, it should not restart operating for 5 minutes.

Center Differential Lock Operation Switch
See ANTI-LOCK - MONTERO article in BRAKES.

Differential Lock Switch
Remove switch from center console. To test switch operation, see Fig. 2. Replace as needed.

Differential Lock Control Unit
See ANTI-LOCK BRAKE SYSTEM article in BRAKES.

Lock Detection Switch

1) Raise and support vehicle. Disconnect air hose connection near rear differential. Connect air source with pressure regulator and pressure gauge. Apply 4 psi (25 kPa) pressure. Disconnect lock detection switch harness connector.

2) Using ohmmeter, check if continuity exists with air pressure applied. Continuity should exist with air pressure applied. If continuity exists, ensure axle is locked by attempting to turn rear wheels separately of each other.

3) If continuity does not exist, go to step 4). If continuity does exist but axles are not locked, see CARRIER ASSEMBLY under REMOVAL & INSTALLATION and inspect locking assembly.

4) Remove detection switch from housing. Using ohmmeter, check continuity of switch. Continuity should exist with switch plunger extended. With plunger in neutral position, continuity should not exist. Replace switch as needed.



Terminal	5	3	2	6	1
Switch position					
ON	○	—	○		
OFF		○	—	○	○

NOTE

- ○—○ indicates that there is continuity between the terminals.

50A03616

Fig. 2: Checking Differential Lock Switch Continuity
Courtesy of Mitsubishi Motor Sales of America.

REMOVAL & INSTALLATION

AXLE SHAFT

Removal (Montero)

Block front wheels. Raise and support rear axle housing. Remove brake caliper and rotor. See Fig. 3. Remove parking brake cable attaching bolts. Remove connection for parking brake cable end from rear brake assembly. Remove ABS speed sensor (if equipped). Unbolt backing plate with bearing housing from rear axle housing. Using Puller (MB990241) and Slide Hammer (MB990211), remove axle assembly. DO NOT damage oil seal. Remove "O" ring. Replace if necessary.

Installation (Montero)

Install new oil seal in axle housing as needed. To install axle assembly, reverse removal procedure.

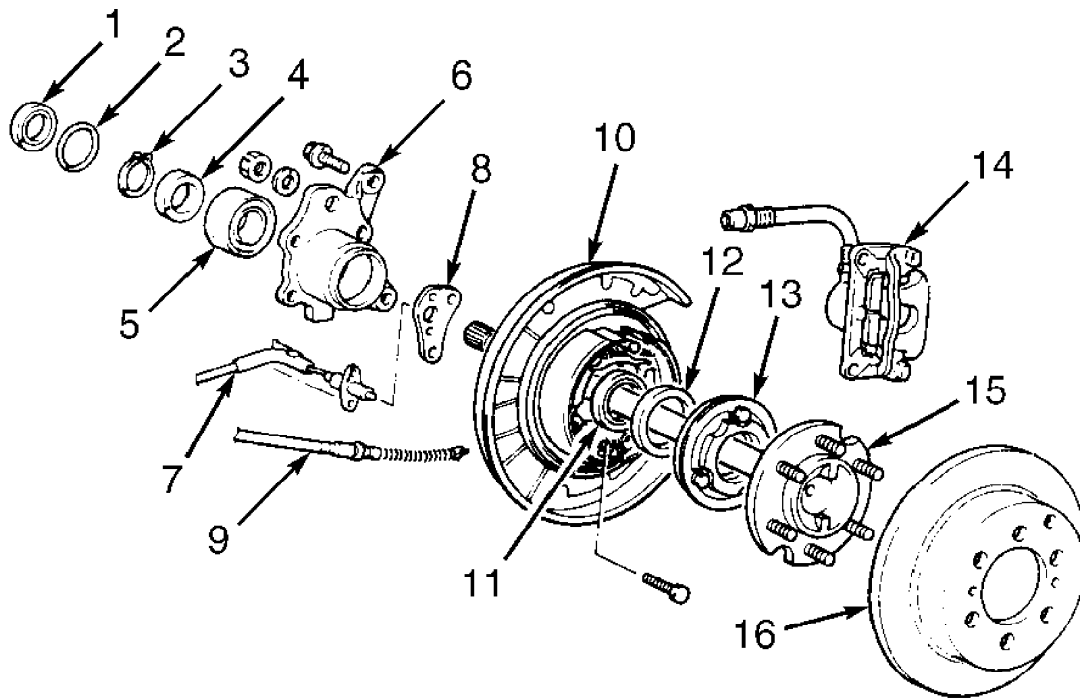

- | | |
|-------------------------|----------------------------|
| 1. Oil Seal | 9. Parking Brake Cable |
| 2. "O" Ring | 10. Dust Shield |
| 3. Snap Ring | 11. Parking Brake Assembly |
| 4. Retainer | 12. Oil Seal |
| 5. Bearing | 13. ABS Sensor Rotor |
| 6. Bearing Case | 14. Brake Caliper |
| 7. ABS Speed Sensor | 15. Axle |
| 8. Speed Sensor Bracket | 16. Brake Rotor |

93J82775

Fig. 3: Exploded View Of Axle Shaft (Montero)
Courtesy of Mitsubishi Motor Sales of America.

Removal (Pickup & Ram-50)

1) Block front wheels. Raise and support rear axle housing.

Remove brake drum. See Fig. 4. Remove parking brake cable attaching bolts. Remove connection for parking brake cable end from rear brake assembly. Drain brake fluid from bleeder screw at left side of rear brake, and disconnect brake tubes.

2) Remove flange nuts and rear axle shaft assembly. Use Puller (MB990241) and Slide Hammer (MB990211) if necessary. DO NOT damage oil seal. Remove shim(s) and "O" ring. Replace if necessary.

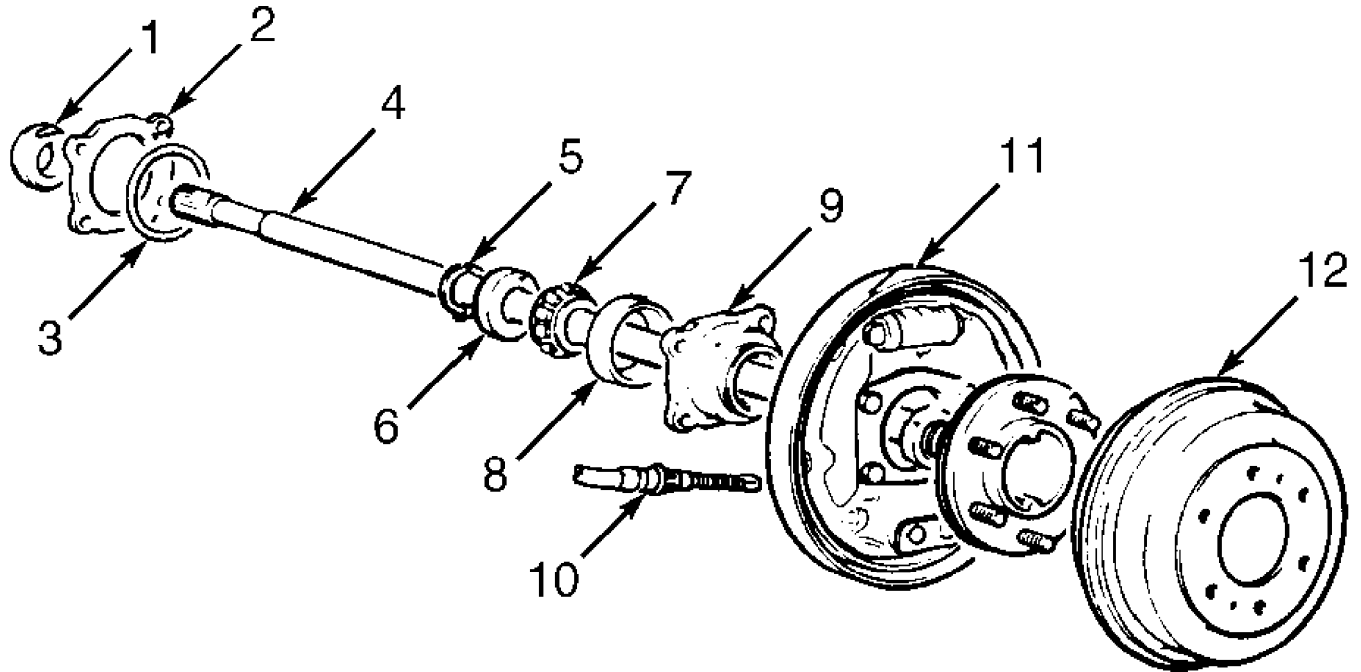

- | | |
|------------------|-------------------------|
| 1. Oil Seal | 7. Bearing |
| 2. Shim | 8. Outer Race |
| 3. "O" Ring | 9. Bearing Case |
| 4. Axle | 10. Parking Brake Cable |
| 5. Snap Ring | 11. Backing Plate |
| 6. Retainer Ring | 12. Brake Drum |

93182774

Fig. 4: Exploded View Of Axle Shaft (Pickup & Ram-50)
Courtesy of Mitsubishi Motor Sales of America.

Installation (Pickup & Ram-50)

1) Insert new "O" ring and shim of .04" (1.0 mm) thickness into left side axle housing. Install left axle shaft assembly into axle housing and tighten nuts to the proper specification. See TORQUE SPECIFICATIONS table.

2) Install right axle shaft assembly into axle housing without shim or "O" ring. Temporarily tighten nuts in diagonal sequence to 51.6 INCH lbs. (5.8 N.m) in 2 stages. Measure clearance between bearing case of right axle and rear axle housing end with feeler gauge.

3) Select shims equal to sum of measured clearance plus .002-.008" (.05-.20 mm). Remove right axle shaft, and install selected shim(s) and "O" ring into right axle housing end. Install right axle

shaft assembly into rear axle housing. Tighten nuts in diagonal sequence to specification. See TORQUE SPECIFICATIONS table.

4) Using dial indicator, check end play of axle shaft. End play should be .002-.008" (.05-.20 mm). If end play is not within specification, change shim(s) to obtain correct end play. Reverse removal procedure to install remaining components. Adjust parking brake, and bleed brake system.

CARRIER ASSEMBLY

Removal

Raise and support vehicle. Drain gear oil. Mark drive shaft flange-to-pinion flange position. Remove drive shaft. Remove axle shafts. See AXLE SHAFT under REMOVAL & INSTALLATION. Support differential carrier with jack. Remove differential carrier retaining nuts. Remove differential carrier.

Inspection

Check for leaks at vent plug, differential carrier companion flange and where carrier joins axle housing.

Installation

Apply sealant to axle housing surface. To install, reverse removal procedure. Align marks on drive shaft and pinion flange.

DRIVE SHAFT

Removal

Make match marks on drive shaft yoke flange and pinion flange. Remove bolts and drive shaft from vehicle.

Installation

To install, reverse removal procedure. Ensure match marks are aligned. Tighten bolts to specification. See TORQUE SPECIFICATIONS table.

OVERHAUL

AXLE SHAFT

Removal

1) Secure axle shaft assembly in a vise, and remove one retainer bolt from backing plate. Push bearing case completely to side of dust cover. Place adhesive tape around edge of bearing case at retainer bolt hole to prevent damage.

CAUTION: DO NOT damage bearing case or axle shaft when grinding or chiseling retainer ring.

2) Secure axle shaft, and grind retainer ring until retainer ring wall thickness is .04-.06" (1.0-1.5 mm) on axle shaft side and .08" (2.0 mm) on bearing side. See Fig. 5.

3) Change angle of grind, and remove remaining .08" (2.0 mm) of retainer ring wall on bearing side. See Fig. 5. Using a chisel, cut retainer ring. Remove ring. DO NOT damage axle shaft.

4) Install Puller (MB990787-01) to remove bearing case from axle shaft. See Fig. 6. Rotate nuts with equal force to remove wheel bearing. Remove bearing outer race using a hammer and drift. Remove oil seal from axle housing using a slide hammer and hook.

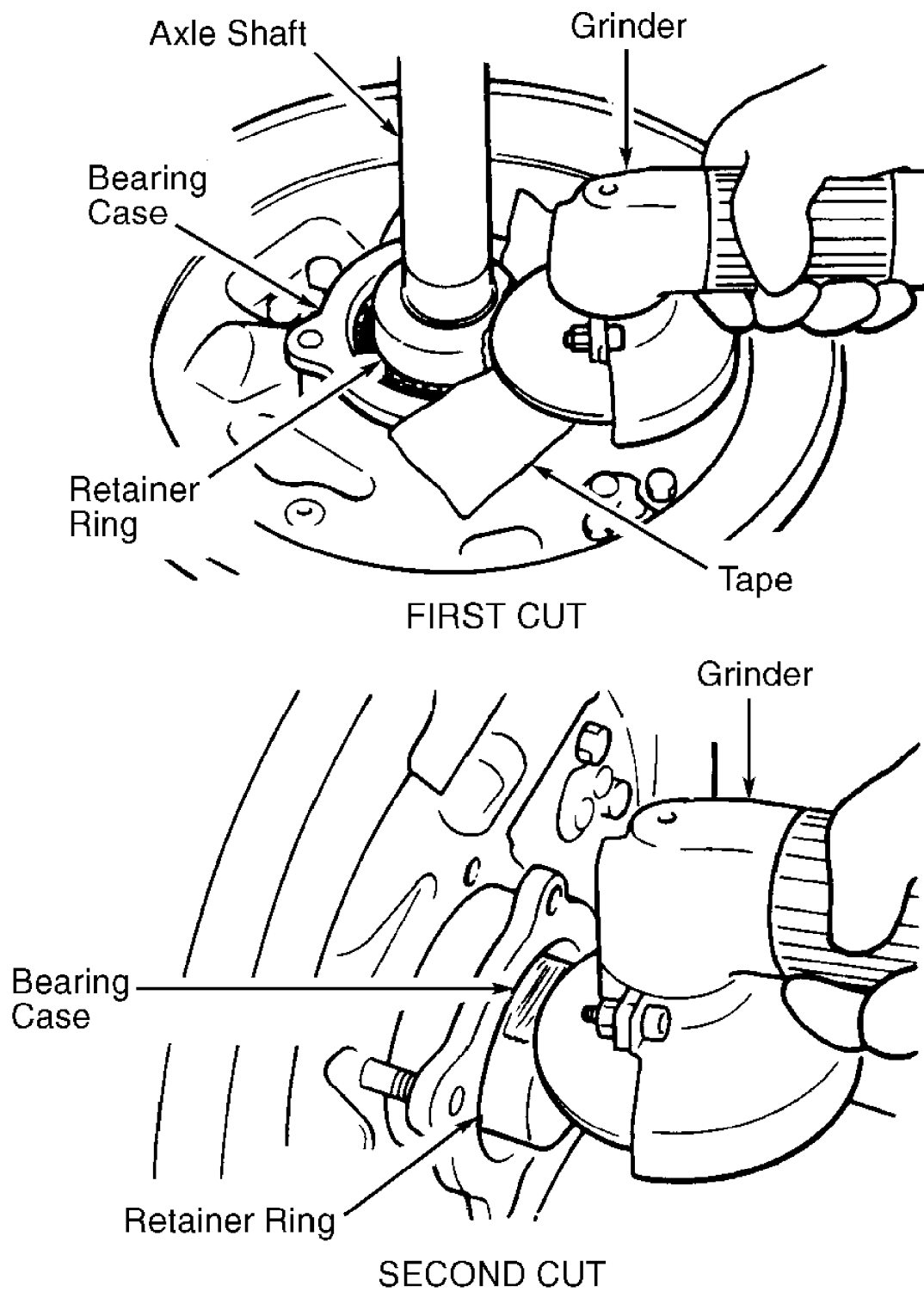

92A00216
Fig. 5: Grinding Bearing Retainer Ring
Courtesy of Mitsubishi Motor Sales of America.

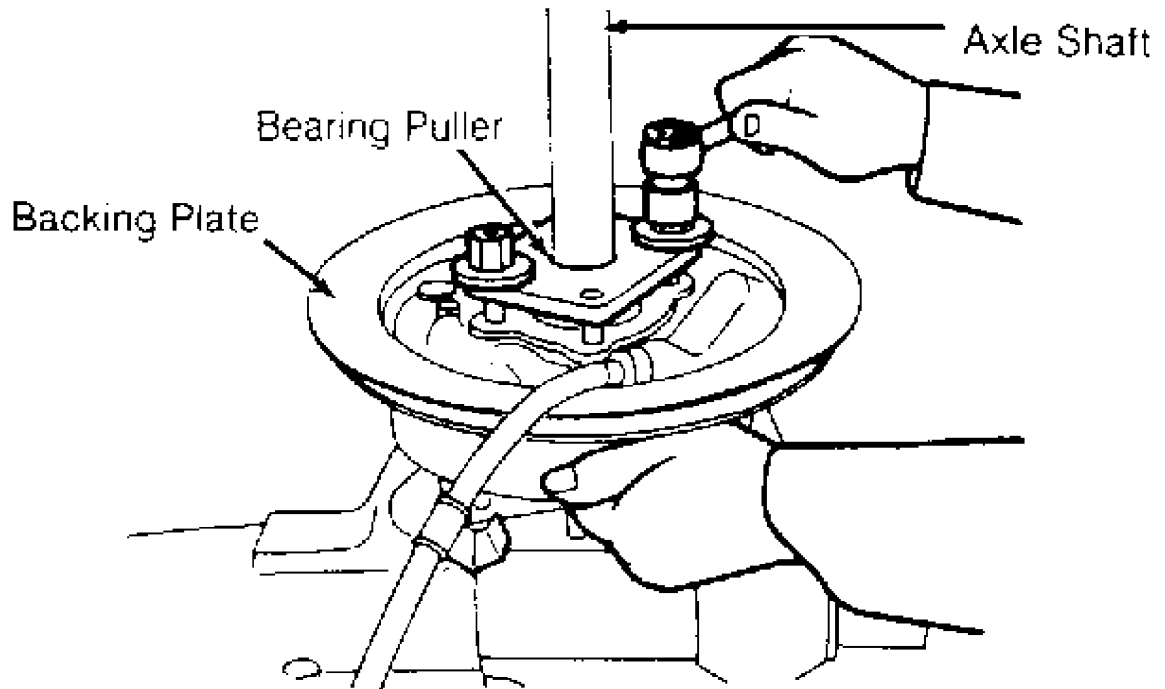

Fig. 6: Removing Bearing Case From Axle Shaft
 Courtesy of Mitsubishi Motor Sales of America.

Inspection

Inspect bearings for roughness, pitting or damage. Inspect axle shaft for damaged splines or flange. Inspect bearing case for cracks or damage.

Installation

1) Apply Multipurpose Grease (SAE J310) to oil seal, oil seal cavity and contact surfaces. Install oil seal using seal driver. Press new oil seal into bearing case until it is flush with face of bearing case. Install backing plate and bearing case.

2) Apply grease to external surfaces of bearing outer race. Press bearing outer race into bearing case. Install bearing on axle shaft. Install rear brake assembly with bearing case onto axle. On Montero, install inner bearing on axle. On all models, install new retainer ring. DO NOT exceed 22,046 lbs. (100,00 N) on Montero, 17,637 lbs. (80,000 N) on Pickup and Ram-50 when pressing on retainer ring. Install new snap ring.

3) Using a feeler gauge, measure clearance between snap ring and new retainer ring. Clearance should be less than .007" (.17 mm). If clearance exceeds specification, install correct snap ring. See SNAP RING THICKNESS SPECIFICATION table.

SNAP RING THICKNESS SPECIFICATION TABLE

Thickness In. (mm)	Color
.060 (1.52)	Red
.067 (1.70)	Purple
.073 (1.85)	Blue

.079 (2.01)	Yellow
.085 (2.16)	Neutral

DIFFERENTIAL ASSEMBLY (CONVENTIONAL)

Pre-Disassembly Inspection

1) Secure differential assembly in appropriate holder. Secure drive pinion from turning. Mount dial indicator on case and check ring gear backlash at 4 positions. See Fig. 7. Backlash should be .004-.006" (.11-.16 mm) on Pickup 2WD and Ram-50 2WD models, .005-.007" (.13-.18 mm) on Montero, Pickup 4WD & Ram-50 4WD models.

2) Remount dial indicator and measure ring gear runout. See Fig. 8. On all models, runout should not exceed .002" (.05 mm). Remount dial indicator and measure pinion gear backlash on models without limited slip differential. See Fig. 9. Secure side gear from turning with wedge. Backlash should be .0004-.0030" (.010-.080 mm) on Pickup 2WD and Ram-50 2WD models, 0-.003" (0-.08 mm) on Montero, Pickup 4WD & Ram-50 4WD models. On all models, pinion gear backlash service limit is .008" (.20 mm).

3) Check gear tooth contact pattern between ring gear and drive pinion gear. Apply Prussian Blue to both surfaces of ring gear teeth. Insert brass rod between differential housing and carrier assembly to provide resistance while turning drive pinion.

4) Turning resistance of drive pinion should be 28-33 INCH lbs. (2.5-3.0 N.m). Rotate drive pinion until ring gear completes one revolution. Reverse direction of rotation and return to original starting point. Check wear pattern. See GEAR TOOTH CONTACT PATTERN in GENERAL INFORMATION.

5) On Montero models with differential lock, connect air supply hose with pressure gauge and regulator to actuator air pipe. Apply 4 psi (25 kPa) of pressure. Using Adapter Shaft (MB990992), turn side gear on one side of carrier assembly only. Locking mechanism should engage. To disengage, release air pressure and turn side gear 1/4-1/2 turn.

6) With lock mechanism engaged, measure turning torque of drive pinion. Turning torque should not be less than 36 ft. lbs. (50 N.m). With lock mechanism disengaged, turning torque should not be more than 36 ft. lbs. (50 N.m).

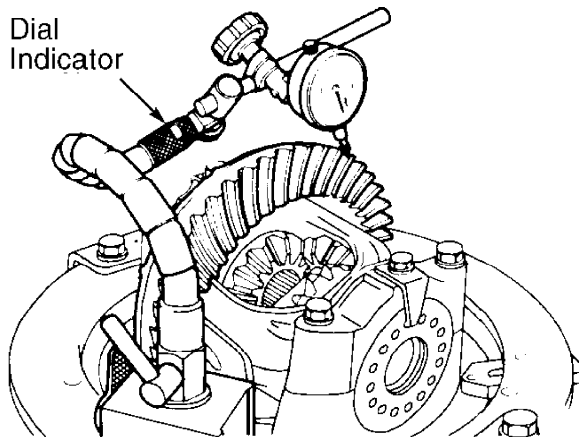

93E82788

Fig. 7: Measuring Ring Gear Backlash
 Courtesy of Mitsubishi Motor Sales of America.

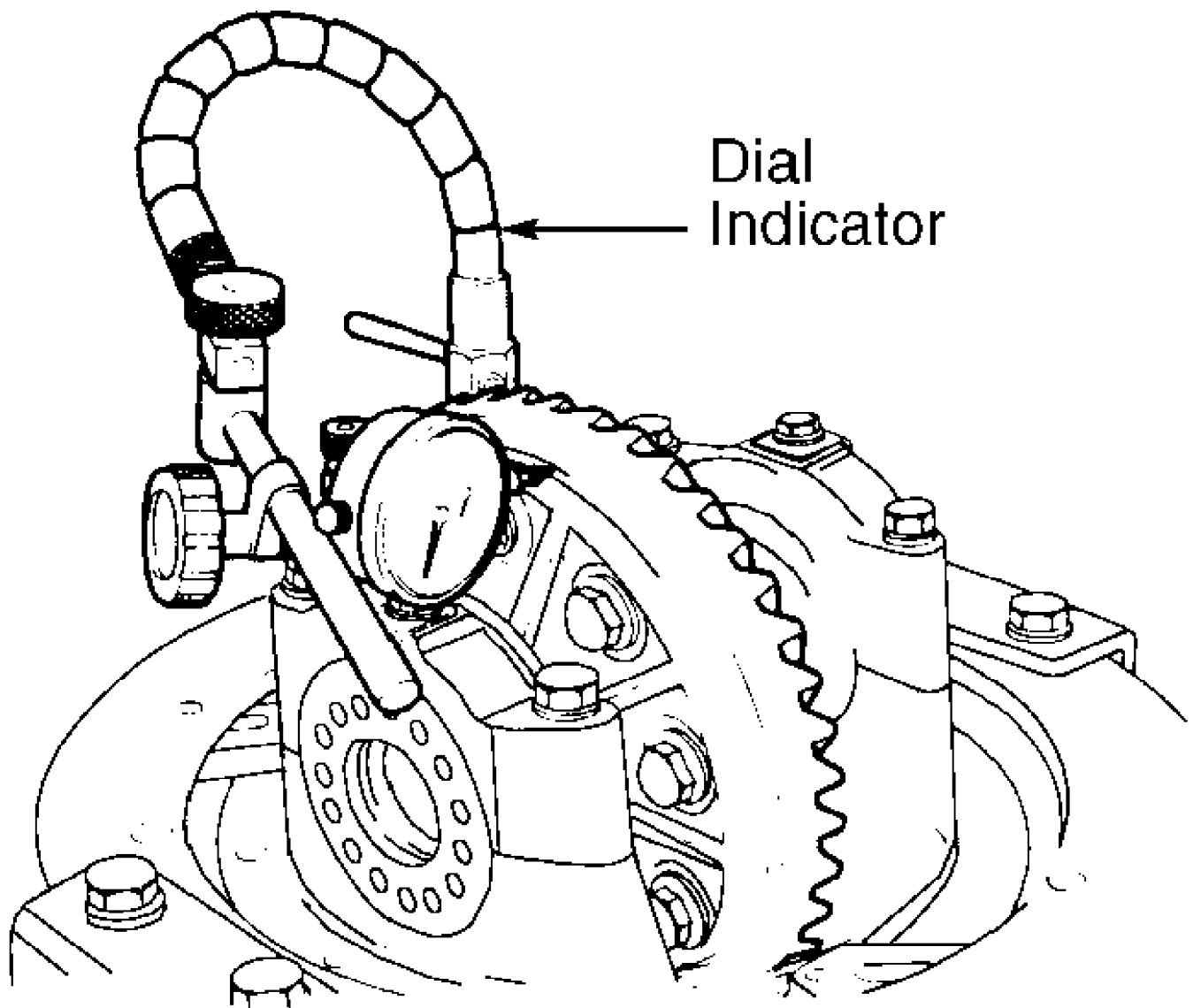

93F82789

Fig. 8: Measuring Ring Gear Runout
 Courtesy of Mitsubishi Motor Sales of America.

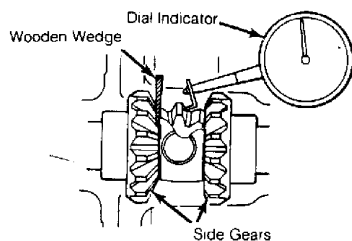
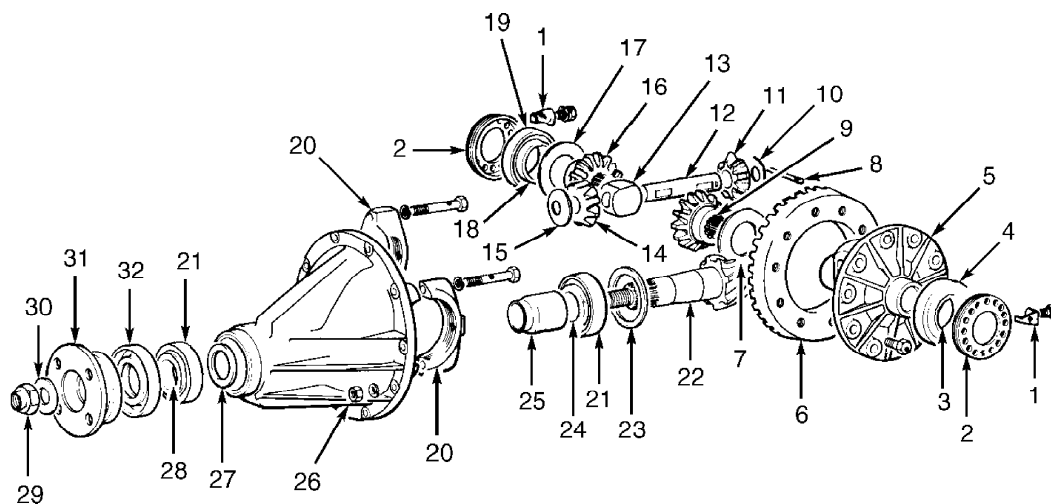

Fig. 9: Checking Pinion & Side Gear Backlash
 Courtesy of Mitsubishi Motor Sales of America.

NOTE: See DIFFERENTIAL ASSEMBLY (LIMITED SLIP) for carrier assembly and drive pinion installation.

Carrier Assembly & Drive Pinion Removal

1) Remove differential carrier from axle housing. Remove lock plates. Mark location of side bearing nuts for reassembly. Remove side bearing nuts. See Fig. 10. Mark location of bearing caps for reassembly. Remove bearing caps. Remove differential carrier assembly from differential housing.



- | | | | |
|----------------------|--------------------------------|----------------------|--------------------------|
| 1. Lock Plate | 9. Side Gear | 17. Thrust Spacer | 25. Spacer |
| 2. Side Bearing Nut | 10. Pinion Washer | 18. Bearing | 26. Differential Carrier |
| 3. Bearing | 11. Pinion Gear | 19. Bearing Race | 27. Pinion Front Shim |
| 4. Bearing Race | 12. Pinion Shaft | 20. Bearing Cap | 28. Bearing |
| 5. Differential Case | 13. Thrust Block (Some Models) | 21. Bearing Race | 29. Lock Nut |
| 6. Ring Gear | 14. Pinion Gear | 22. Pinion | 30. Washer |
| 7. Thrust Spacer | 15. Pinion Washer | 23. Pinion Rear Shim | 31. Pinion Flange |
| 8. Lock Pin | 16. Side Gear | 24. Bearing | 32. Oil Seal |

90E02464

Fig. 10: Exploded View Of Conventional Rear Differential
Courtesy of Mitsubishi Motor Sales of America.

2) Secure drive pinion companion flange from turning. Remove companion flange retaining nut. Scribe alignment marks on drive pinion and companion flange for reassembly. Using soft-faced hammer, drive pinion out of housing. Remove front adjusting shim and spacer from pinion.

3) Using bearing splitter and press, remove rear bearing from pinion. Remove rear adjusting shim from drive pinion. Remove oil seal and bearing races from differential housing.

Disassembly (Carrier Assembly)

1) Using bearing splitter and press, remove differential case side bearings. Place alignment marks on ring gear and differential case for reassembly. Loosen ring gear bolts in diagonal sequence. Remove ring gear.

2) Remove pinion shaft lock pin from differential carrier. Remove differential pinion shaft and thrust block (if equipped). Remove pinion gears and washers. Remove side gears and thrust spacers. Mark components for reassembly reference.

Inspection

Wash parts in clean solvent and dry with compressed air. Inspect bearings for discoloration and/or flaking. Check all gears for

irregular wear or damage. Ring gear and drive pinion must be replaced as matched set. Side gears and pinion gears must be replaced as matched set.

Reassembly & Adjustment

1) Install thrust spacers, side gears, pinion washers and pinion gears in differential case. DO NOT install thrust block (if equipped) at this time.

2) Install pinion shaft without lock pin. Check pinion and side gear backlash. Install wooden wedge to lock side gears. See Fig. 9. Using dial indicator, measure gear backlash. Backlash should be .0004-.0030" (.010-.080 mm). Service limit is .008" (.20 mm).

3) Adjust backlash by using different side gear spacers. Ensure both sides are equally shimmed. Install thrust block (if equipped) once correct backlash is obtained. Install pinion shaft lock pin from ring gear side of carrier housing. Securely stake pin in 2 places. Ensure adhesive is removed from ring gear mounting bolts and gear mounting surface. Clean internal threads with tap.

4) Ensure alignment marks on differential case and ring gear align. Apply Loctite 271 to bolts, and install ring gear on differential case. Tighten bolts in diagonal sequence to specification. See TORQUE SPECIFICATIONS table. Using appropriate adapter, press on carrier side bearings.

DIFFERENTIAL ASSEMBLY (LIMITED SLIP)

NOTE: Manufacturer does not provide disassembly or reassembly procedures for locking type differential. See Figs. 12 and 13 for exploded views of assembly.

NOTE: See PRE-DISASSEMBLY INSPECTION under DIFFERENTIAL ASSEMBLY (CONVENTIONAL) before disassembling carrier assembly. For carrier assembly and drive the pinion removal, see DIFFERENTIAL ASSEMBLY (CONVENTIONAL).

Disassembly

1) Once ring gear is removed, loosen carrier housing screws in diagonal pattern. Separate cases and remove components. See Fig. 11. Maintain parts in order of disassembly. Clean all parts in new solvent.

2) Inspect condition of friction and spring plates and friction discs. Replace disc and/or plates if worn or heat damaged. Distortion of discs will cause incorrect clutch pressure. Scratches, nicks or burrs on components can be repaired with an oil stone.

3) Discs must be flat and free of distortion. Check discs on surface plate with dial indicator. Maximum warpage of friction plate or disc is .003" (.08 mm). Inspect thickness of discs and plates. Thickness limit between discs and plates is .004" (.10 mm).

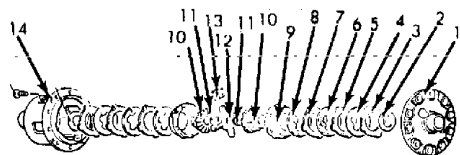

- | | |
|---------------------------|----------------------|
| 1 Differential Case Cover | 8 Friction Disc |
| 2 Thrust Washer | 9 Pressure Ring |
| 3 Spring Plate | 10 Side Gear |
| 4 Spring Disc | 11 Thrust Block |
| 5 Friction Plate | 12 Pinion Shaft |
| 6 Friction Disc | 13 Pinion Gear |
| 7 Friction Plate | 14 Differential Case |

Fig. 11: Exploded View Of Limited Slip Differential
Courtesy of Mitsubishi Motor Sales of America.

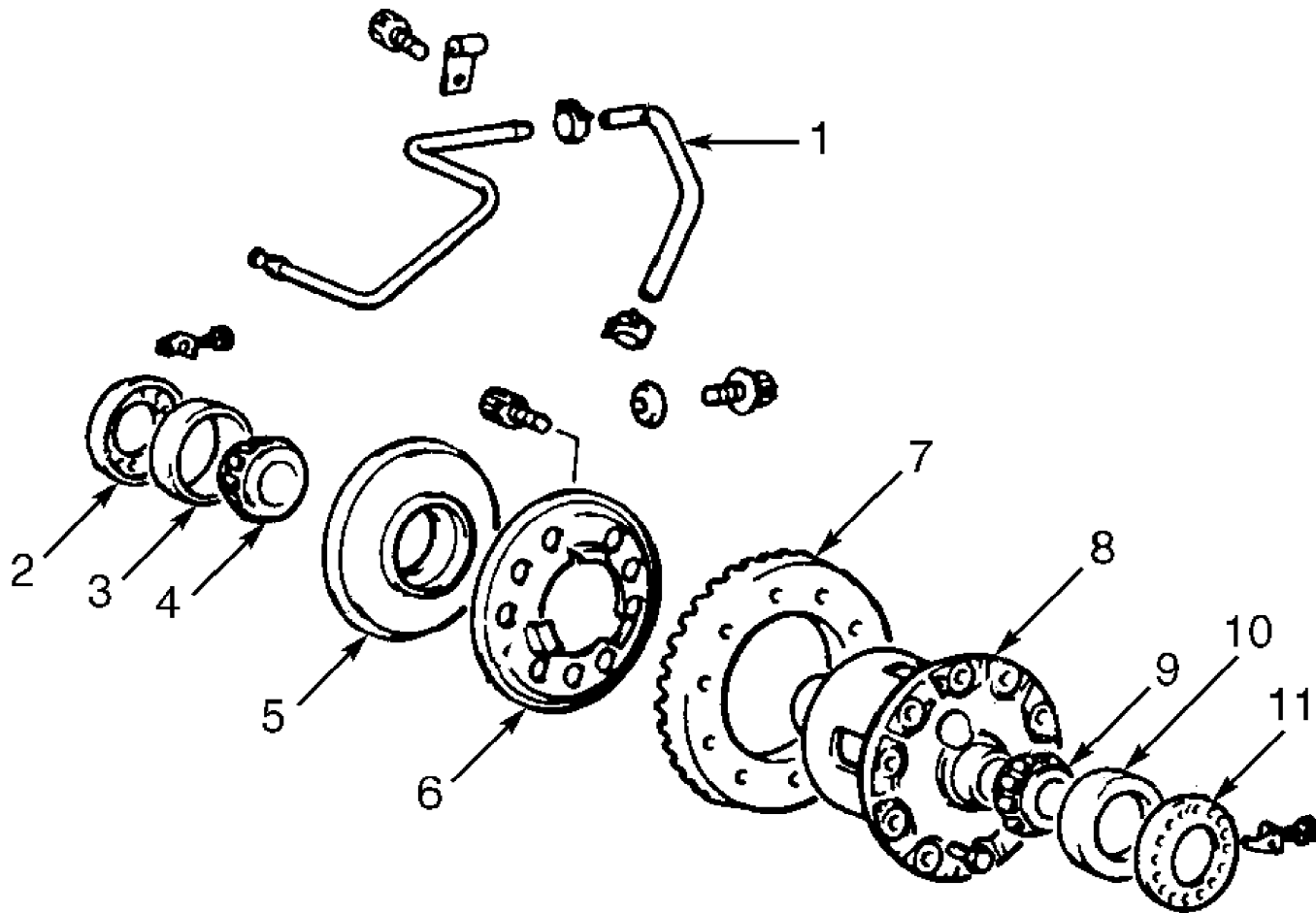

- 1. Air Pipe
- 2. Side Bearing Nut
- 3. Bearing Race
- 4. Bearing
- 5. Actuator Assembly
- 6. Pressure Plate

- 7. Ring Gear
- 8. Differential Case
- 9. Bearing
- 10. Race
- 11. Side Bearing Nut

93H82799

Fig. 12: Exploded View Of Locking Differential Actuator Assembly
 Courtesy of Mitsubishi Motor Sales of America.

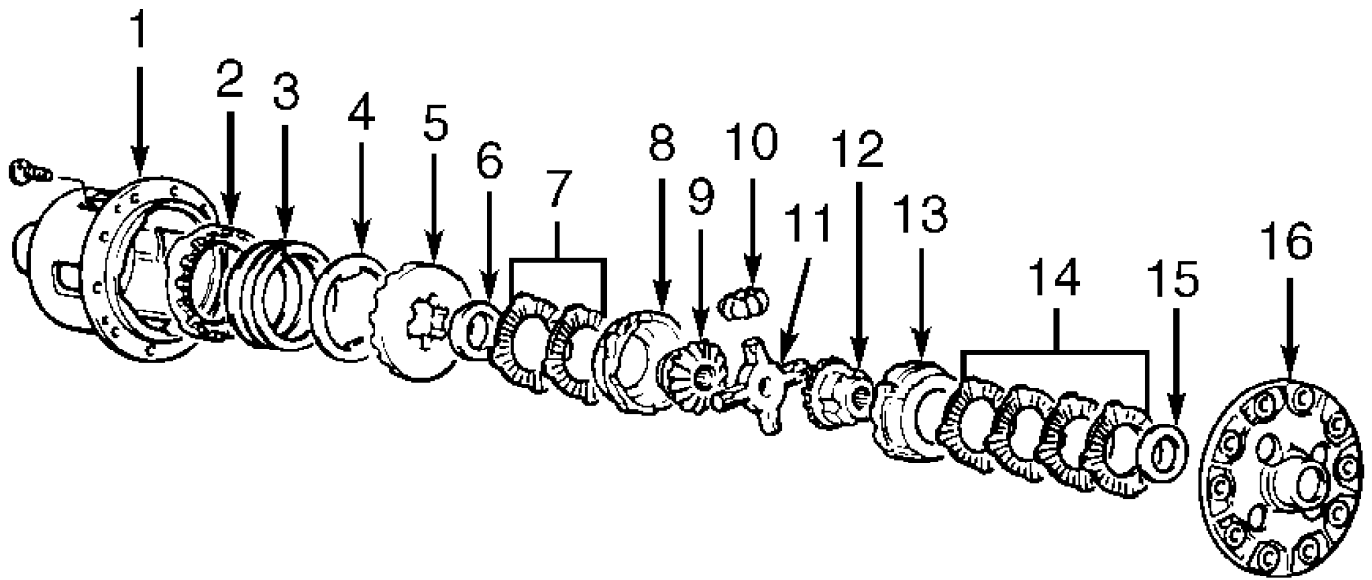

- | | |
|----------------------|-----------------------------|
| 1. Differential Case | 9. Side Gear |
| 2. Drive Cam | 10. Pinion Gear |
| 3. Spring | 11. Pinion Shaft |
| 4. Spring Washer | 12. Side Gear |
| 5. Driven Cam | 13. Pressure Ring |
| 6. Thrust Washer | 14. Friction Plate |
| 7. Friction Plate | 15. Thrust Washer |
| 8. Pressure Ring | 16. Differential Case Cover |

93A82800

Fig. 13: Exploded View Of Locking Differential
 Courtesy of Mitsubishi Motor Sales of America.

Reassembly

1) Arrange friction plates and discs of each side of differential. Measure each assembly thickness. Assembled discs and plates should not exceed a difference of .002" (.05 mm). Replace discs or plates as needed.

2) Assemble one spring plate and one spring disc on each side. Measure assembly thickness. Assemble disc and plates to obtain minimum difference in thickness between each assembly.

3) Assemble clutch assemblies, pressure rings, pinion gears, side gears and pinion shaft. Measure overall width of assembly plus spring plates and spring discs (dimension "C"). See Fig. 14.

4) Determine depth of differential case (dimension "D"). On 2,4L, dimension "D" = "E" + "F" - "G"; on 3.0L, dimension "D" = "E" + "H".

See Fig. 15 or 16. Subtract "C" from "D" to determine spring plate-to-case clearance. Adjust spring disc thickness to obtain proper spring plate-to-case clearance. Correct clearance is .0024-.0079" (.060-.200 mm).

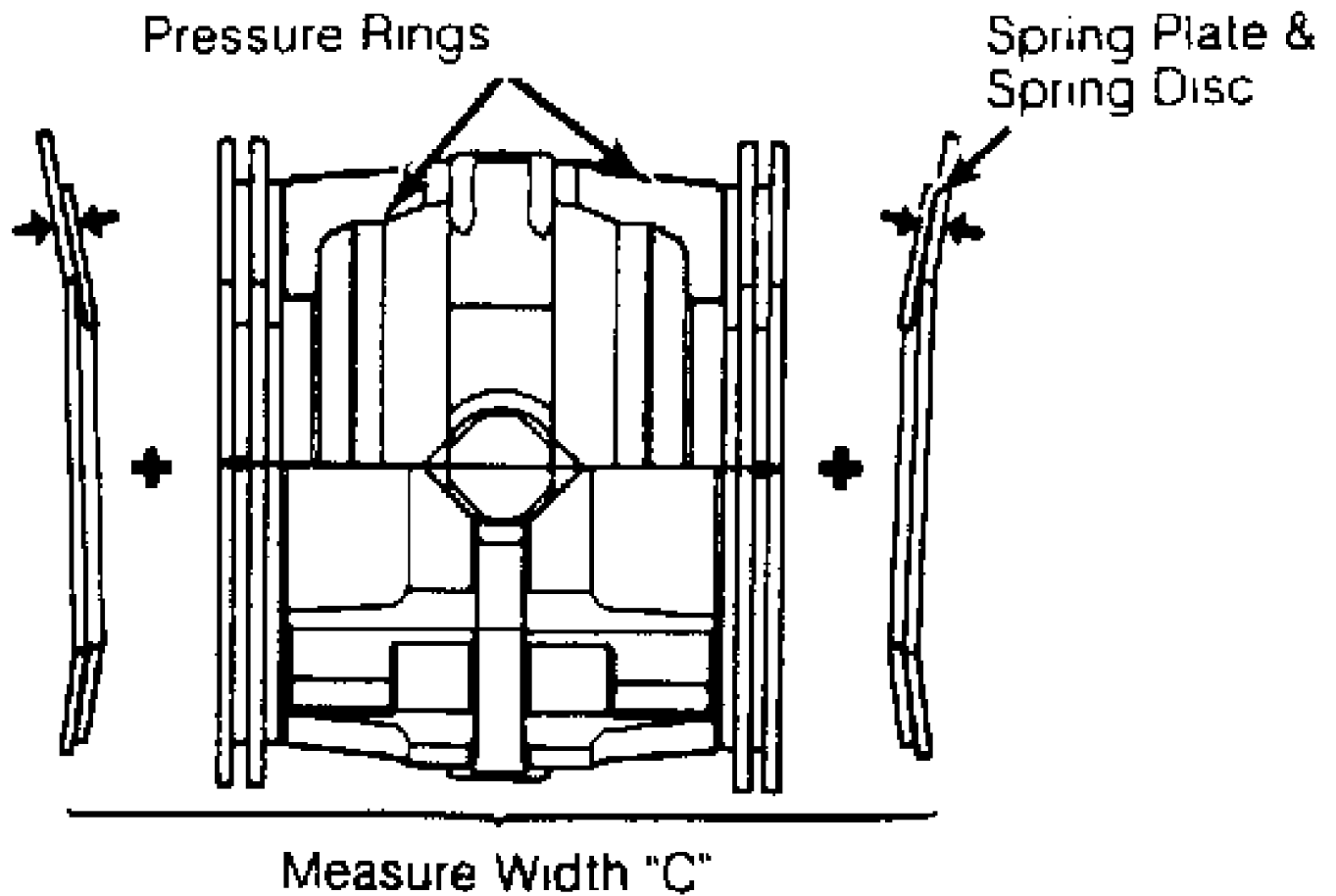

Fig. 14: Measuring Clutch Assembly Width
 Courtesy of Mitsubishi Motor Sales of America.

Differential Case Cover

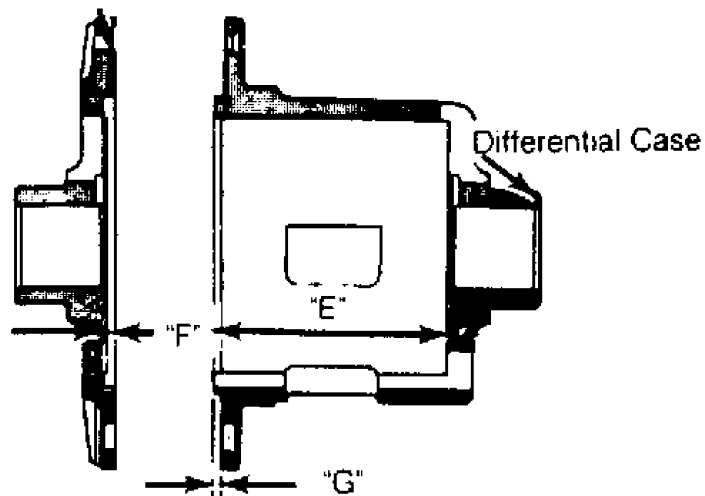
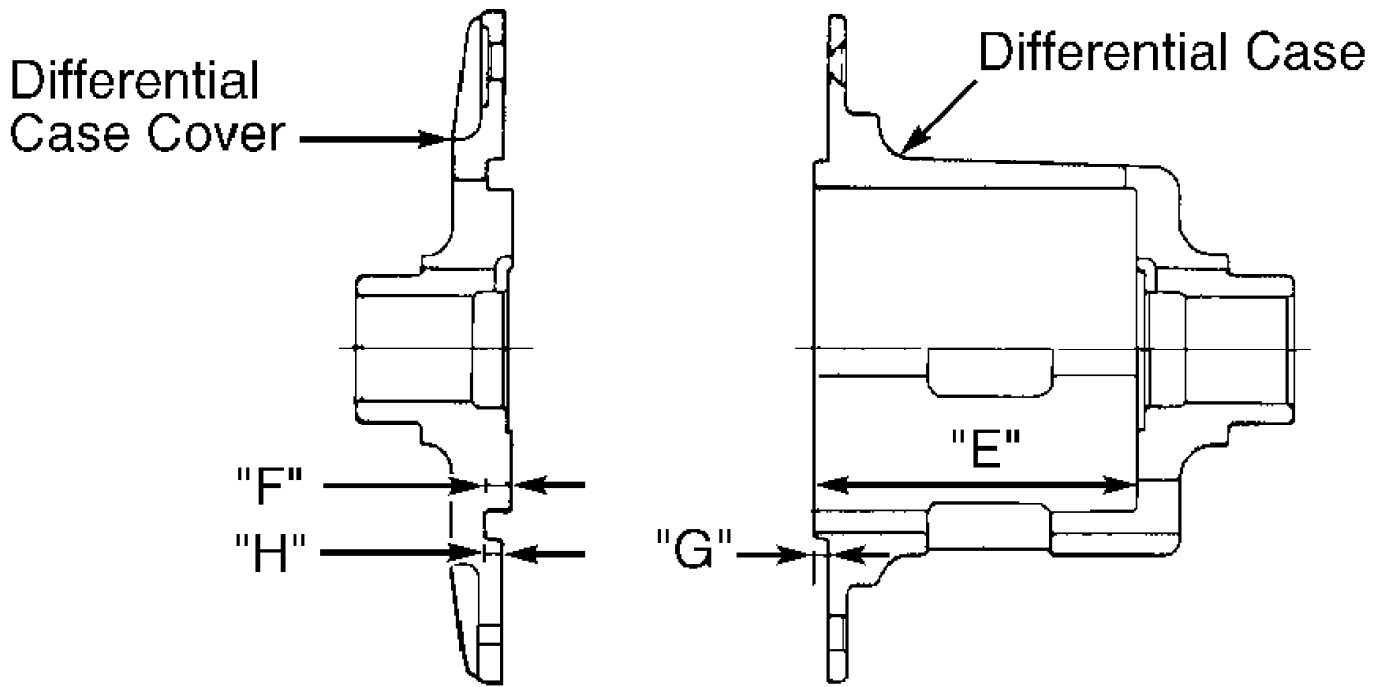

Fig. 15: Measuring Limited Slip Case Depth (Pickup & Ram-50 - 2.4L)
 Courtesy of Mitsubishi Motor Sales of America.



91C01915

Fig. 16: Measuring Limited Slip Case Depth (3.0L)
 Courtesy of Mitsubishi Motor Sales of America.

5) Remove spring plates, spring discs, friction plates and friction disc from pressure rings. Mark components for location. Install thrust washers on each end of pressure rings. See Fig. 17.

6) Measure clearance from end of thrust washer to rear face of pressure ring. Clearance should be .002" (.05 mm) or less. If clearance is not as specified, select proper thickness thrust washers to obtain correct clearance.

7) Once correct thrust washers are determined, install thrust washers on pressure rings. Squeeze pressure rings together, and measure width (dimension "H") from end of thrust washer to remaining thrust washer. See Fig. 17.

8) Determine distance between thrust washer surfaces when differential case is assembled (dimension "I"). Dimension "I" = "J" + "K" + "L". Dimension "J" is the same as dimension "D" in step 4).

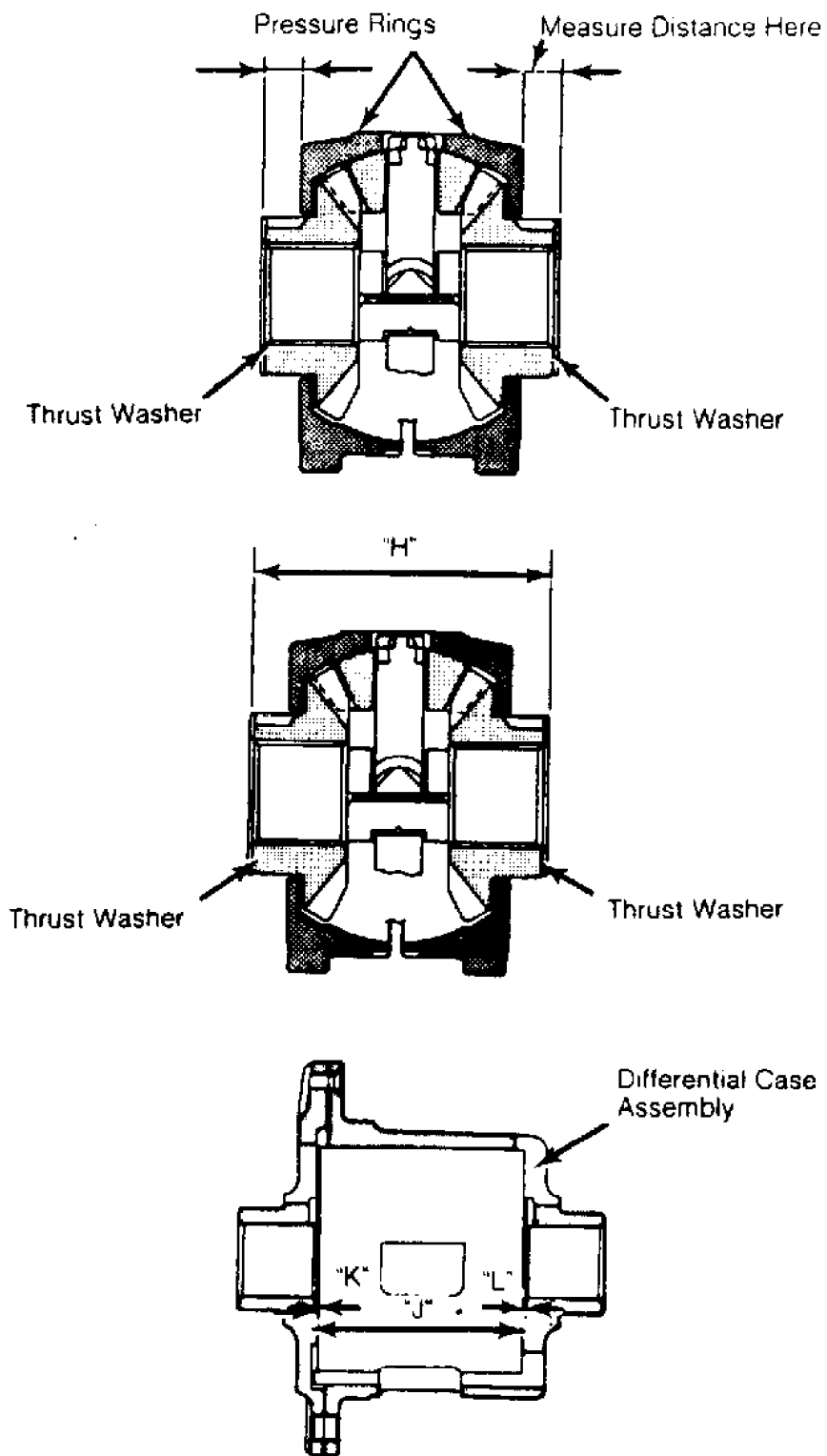

Fig. 17: Measuring Thrust Washer Clearance
 Courtesy of Mitsubishi Motor Sales of America.

9) Subtract "H" from "I". This is the clearance between thrust washer and differential case. Correct clearance is .002-.008"

(.05-.20 mm). If clearance is not within specification, change thrust washer to obtain correct clearance.

10) Apply gear oil and friction modifier to all components. Install components in differential case. Ensure assembly order and direction of clutch components are correct. See Fig. 18.

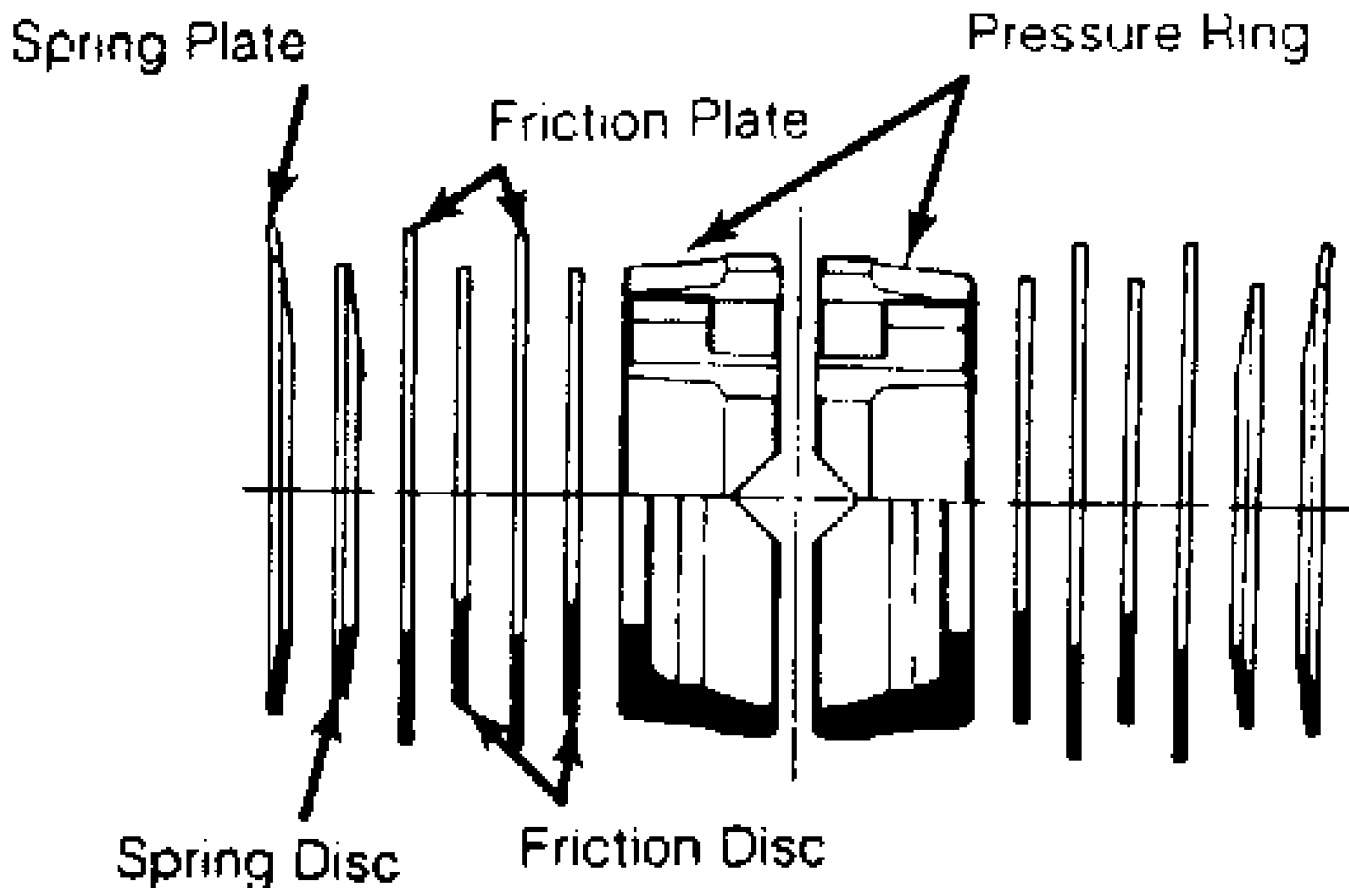

Fig. 18: Limited Slip Differential Assembly
Courtesy of Mitsubishi Motor Sales of America.

11) Install differential case cover with reference marks aligned. Tighten screws to specification in several steps. See TORQUE SPECIFICATIONS table. Ensure cases contact each other completely when fully assembled. Check for incorrect clutch assembly if gap exists.

12) Using Clutch Plate Preload Tool (MB990988), Shaft (MB990989) and torque wrench, measure starting torque. See Fig. 19. Rotate unit slightly before measuring starting torque.

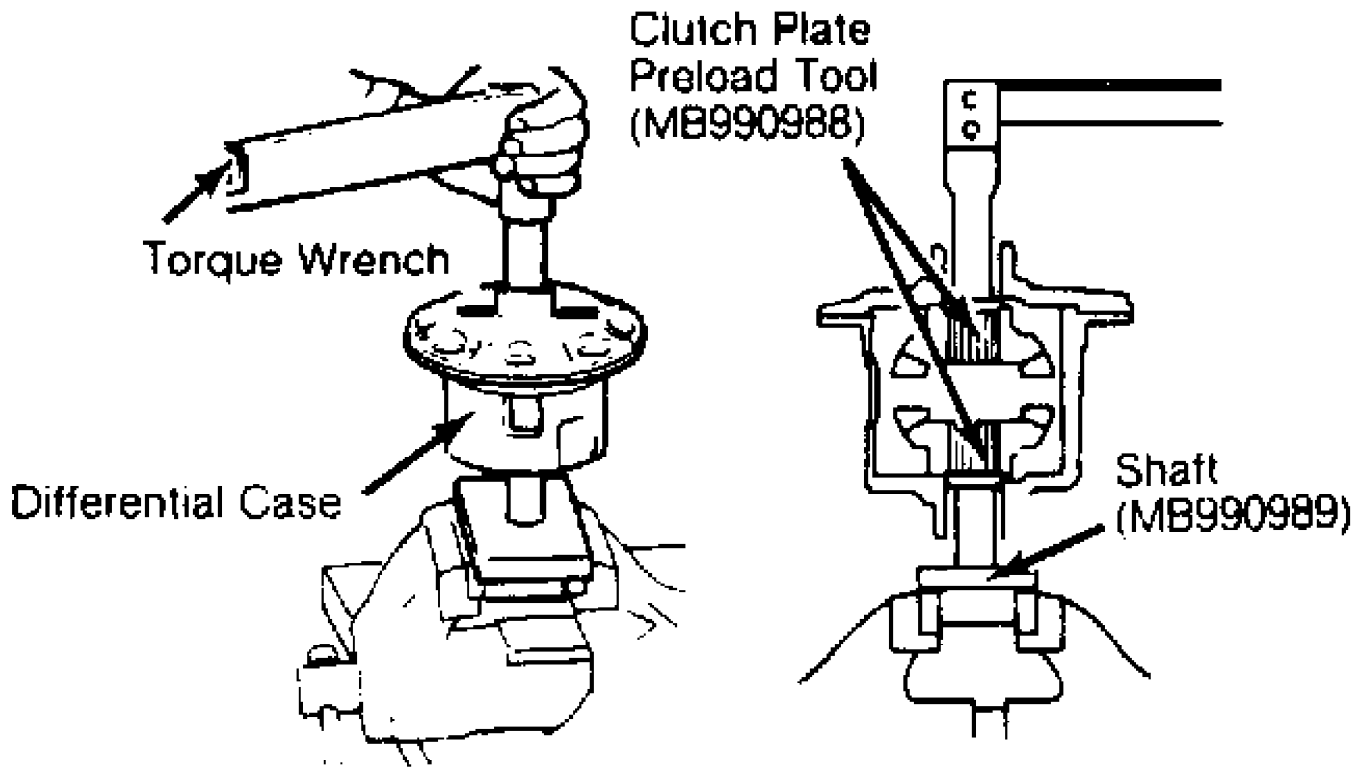

Fig. 19: Checking Differential Starting Torque
 Courtesy of Mitsubishi Motor Sales of America.

13) Ensure starting torque is within specification. See STARTING TORQUE table. Ensure adhesive is removed from ring gear mounting bolts and gear mounting surface. Clean internal threads with tap.

14) Ensure alignment marks on differential case and ring gear align. Apply Loctite 271 to bolts, and install ring gear on differential case. Tighten bolts in diagonal sequence to specification. See TORQUE SPECIFICATIONS table.

STARTING TORQUE TABLE

Application	Ft. Lbs. (N.m)
Used Clutch Plates	29-54 (40-75)
New Clutch Plates	18-54 (25-75)

Carrier Assembly & Drive Pinion Installation

1) Install pinion bearing races in differential housing. Ensure races are fully seated. Install Pinion Height Gauge (MB990901) and pinion bearings. See Fig. 20. DO NOT install oil seal.

2) Using torque wrench, measure pinion rotating torque. Gradually tighten pinion height gauge to increase rotating torque. See PINION ROTATING TORQUE SPECIFICATIONS table.

PINION ROTATING TORQUE SPECIFICATIONS TABLE

Application	INCH Lbs. (N.m)
Oil Seal Not Installed With Lubrication	3.5-4.3 (.4-.5)

Without Lubrication	5.2-7.8 (.6-.9)
Oil Seal Installed	
With Lubrication	5.6-6.5 (.65-.75)
Without Lubrication	7.4-10.0 (.85-1.15)

3) Install cylinder gauge in side bearing seats. Ensure flat areas align, and gauge contacts side bearing seat firmly. See Fig. 20. Select adjusting shim with same thickness as gap between cylinder gauge and pinion height gauge.

4) Use minimum amount of adjusting shims. Install selected adjusting shims between drive pinion gear and rear pinion bearing. See Fig. 20. Using bearing installer and press, install rear pinion bearing.

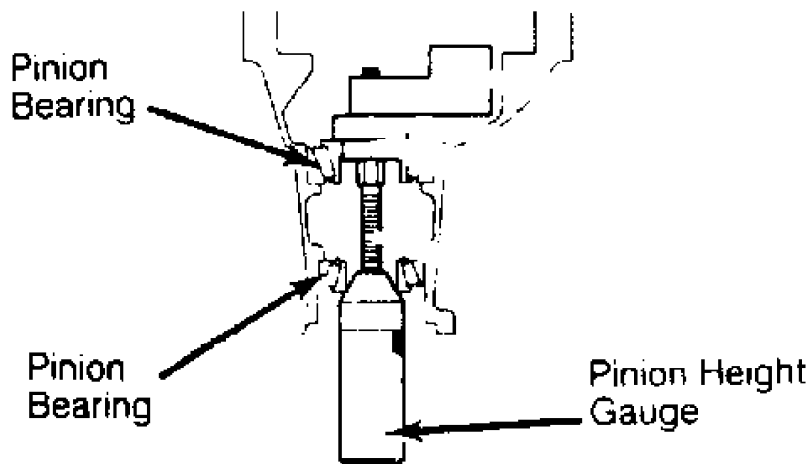
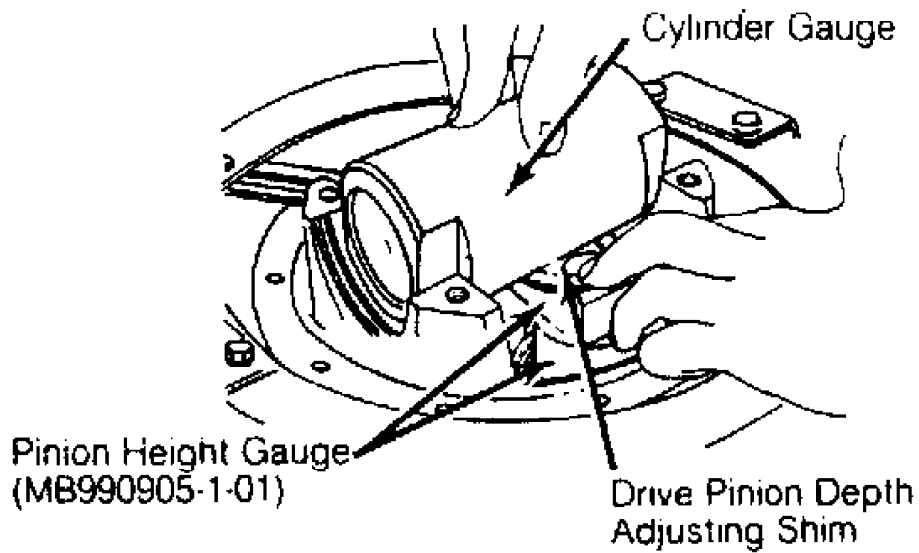

Fig. 20: Setting Pinion Height
 Courtesy of Mitsubishi Motor Sales of America.

5) Install drive pinion in differential housing. Install spacer, pinion front shim(s) and front pinion bearing. DO NOT install

oil seal. Install pinion companion flange, washer and retaining nut. Tighten nut to specification. See TORQUE SPECIFICATIONS table.

6) Check pinion rotating torque. See PINION ROTATING TORQUE SPECIFICATIONS table. Adjust rotating torque by replacing drive pinion front shims or spacer. Once correct rotating torque is obtained, install oil seal. Coat seal lip with grease. Install pinion companion flange so alignment marks are correct. Apply light coat of grease to contact area of pinion flange washer.

7) Install new retaining nut. Recheck pinion rotating torque. Ensure rotating torque is within specification. Press side bearings onto differential case. Install outer races. Install differential carrier into differential housing. Align bearing cap index marks, and snug carrier cap bolts. Ensure outer races and bearing caps are installed in original location.

8) Install side bearing nuts. Tighten bearing cap bolts to specification. See TORQUE SPECIFICATIONS table. Tighten bearing nuts until bearing outer races are seated against bearings. Adjust ring gear backlash.

Ring Gear Backlash

1) Secure drive pinion in place. Using dial indicator, check ring gear backlash at heel of ring gear tooth. See Fig. 7. Measure at 4 locations of ring gear. Gear backlash must be within specification. Backlash should be .004-.006" (.11-.16 mm) on Pickup 2WD and Ram-50 2WD models, .005-.007" (.13-.18 mm) on Montero, Pickup 4WD & Ram-50 4WD models.

2) If backlash is less than specification, loosen side bearing nut at back of ring gear, and tighten side bearing nut on tooth side of ring gear by same amount. If backlash exceeds specification, loosen side bearing nut at tooth side of ring gear, and tighten side bearing nut at back of ring gear by same amount.

3) After adjusting backlash, tighten both side bearing nuts half the distance between 2 adjacent holes on side bearing nut. Recheck backlash. Ensure bearing cap bolts are tightened to specification. See TORQUE SPECIFICATIONS table.

4) Lock plates are of 2 designs for hole location of side bearing nuts. Install proper type lock plate. Tighten lock plate bolt to specification. See TORQUE SPECIFICATIONS table. Check gear tooth contact pattern. See GEAR TOOTH CONTACT PATTERNS article in GENERAL INFORMATION.

Ring Gear Runout

Using dial indicator, measure runout at back side of ring gear. See Fig. 8. Runout must be within .002" (.05 mm). If runout is excessive, change ring gear-to-differential case mounting position. Recheck runout.

TORQUE SPECIFICATIONS

TORQUE SPECIFICATIONS TABLE

Application	Ft. Lbs. (N.m)
Bearing Cap Bolt	40-47 (54-64)
Bearing Case-To-Axle Housing Bolt	36-43 (49-58)
Brake Tube Flare Nut	10-12 (14-16)
Differential Carrier-To-Axle Housing Nut	
2.4L (2WD)	18-22 (24-30)
3.0L (4WD)	29-40 (39-54)
Drain Plug	43-50 (58-68)
Drive Shaft-To-Flange Bolt	36-43 (49-58)
Filler Plug	29-43 (39-58)

Lock Plate Bolt	11-16 (15-22)
Pinion Flange Nut	137-181 (186-245)
Ring Gear Bolt	58-65 (79-88)
Side Bearing Lock Plate Bolts	11-16 (15-22)
Wheel Lug Nut	
Montero	72-87 (98-118)
Pickup & Ram-50	87-101 (118-137)
