

GROUP 37A

POWER STEERING

CONTENTS

GENERAL DESCRIPTION	37A-3	OIL PUMP PRESSURE TEST	37A-20
POWER STEERING DIAGNOSIS	37A-3	POWER STEERING PRESSURE SWITCH CHECK	37A-21
INTRODUCTION TO POWER STEERING DIAGNOSIS	37A-3	BALL JOINT DUST COVER INSPECTION	37A-22
POWER STEERING DIAGNOSTIC TROUBLESHOOTING STRATEGY	37A-3	STEERING WHEEL AND SHAFT ASSEMBLY*	37A-23
SYMPTOM CHART	37A-4	REMOVAL AND INSTALLATION	37A-23
SYMPTOM PROCEDURES	37A-4	DISASSEMBLY AND ASSEMBLY	37A-25
SPECIAL TOOLS	37A-13	POWER STEERING GEAR BOX ASSEMBLY*	37A-27
ON-VEHICLE SERVICE	37A-15	REMOVAL AND INSTALLATION	37A-27
STEERING WHEEL FREE PLAY CHECK	37A-15	INSPECTION	37A-29
STEERING ANGLE CHECK	37A-16	DISASSEMBLY AND ASSEMBLY	37A-31
TIE ROD END BALL JOINT BREAKAWAY TORQUE CHECK	37A-16	TIE ROD END BALL JOINT DUST COVER REPLACEMENT	37A-43
STATIONARY STEERING EFFORT CHECK	37A-17	POWER STEERING OIL PUMP ASSEMBLY	37A-44
STEERING WHEEL RETURN TO CENTER CHECK	37A-17	REMOVAL AND INSTALLATION	37A-44
DRIVE BELT TENSION CHECK	37A-18	DISASSEMBLY AND ASSEMBLY	37A-45
FLUID LEVEL CHECK	37A-18	INSPECTION	37A-47
POWER STEERING FLUID REPLACEMENT	37A-19		
POWER STEERING SYSTEM AIR BLEEDING	37A-19		

Continued on next page

WARNINGS REGARDING SERVICING OF SUPPLEMENTAL RESTRAINT SYSTEM (SRS) EQUIPPED VEHICLES

⚠ WARNING

- *Improper service or maintenance of any component of the SRS, or any SRS-related component, can lead to personal injury or death to service personnel (from inadvertent firing of the air bag) or to the driver and passenger (from rendering the SRS inoperative).*
- *Service or maintenance of any SRS component or SRS-related component must be performed only at an authorized MITSUBISHI dealer.*
- *MITSUBISHI dealer personnel must thoroughly review this manual, and especially its GROUP 52B - Supplemental Restraint System (SRS) before beginning any service or maintenance of any component of the SRS or any SRS-related component.*

NOTE

The SRS includes the following components: SRS air bag control unit, SRS warning light, front impact sensors, air bag module, clock spring, and interconnecting wiring. Other SRS-related components (that may have to be removed/installed in connection with SRS service or maintenance) are indicated in the table of contents by an asterisk (*).

37A-2

POWER STEERING HOSES **37A-49**
 REMOVAL AND INSTALLATION 37A-49

SPECIFICATIONS **37A-52**
 FASTENER TIGHTENING

SPECIFICATIONS 37A-52
GENERAL SPECIFICATIONS 37A-53
SERVICE SPECIFICATIONS 37A-53
LUBRICANTS 37A-53
SEALANTS 37A-54

GENERAL DESCRIPTION

The vehicle uses engine speed-responsive hydraulic power steering.

The steering wheel has four spokes. All vehicles are equipped with SRS (Supplemental Restraint System).

CONSTRUCTION DIAGRAM

The steering column has a shock absorber mechanism and a tilt steering mechanism.

A vane-type oil pump with a fluid flow control system has been included. The steering gear and linkage is rack and pinion type.

M1372000100230

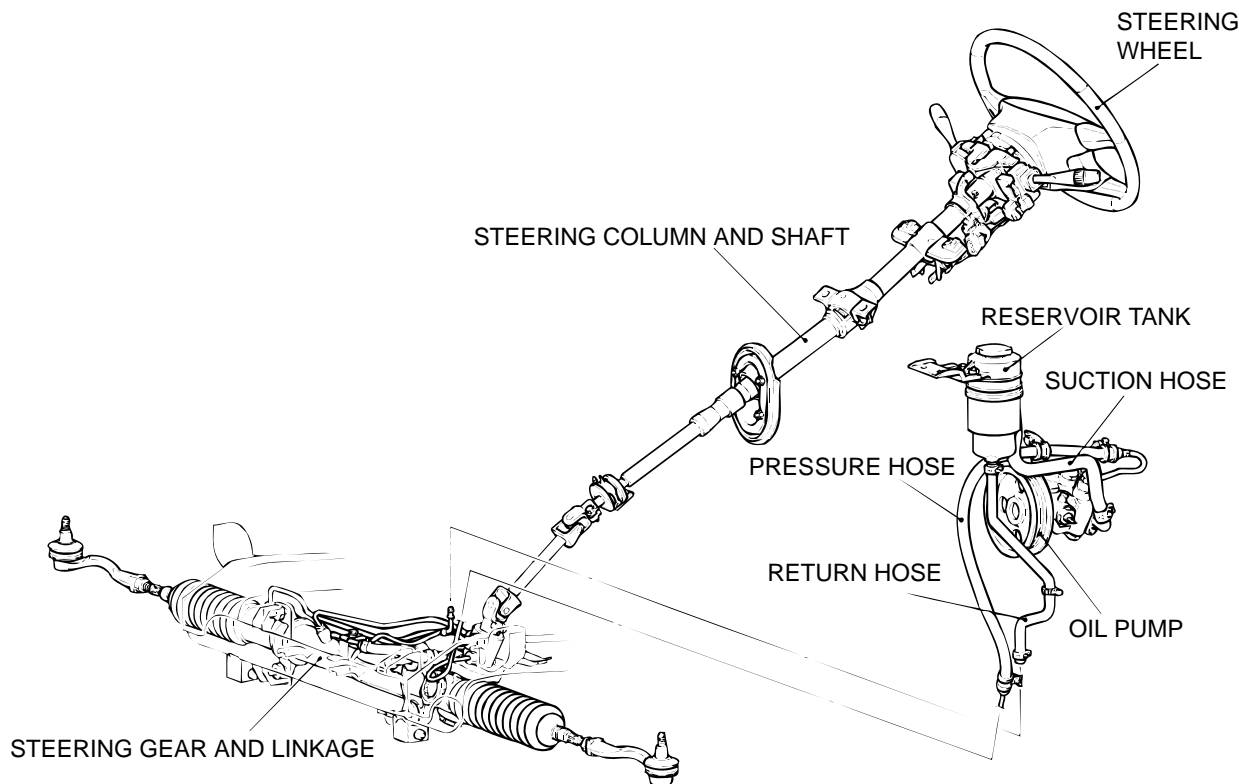

AC000757AB

POWER STEERING DIAGNOSIS

INTRODUCTION TO POWER STEERING DIAGNOSIS

Hydraulic power steering is used for all vehicles. Faults in the power steering can include excessive play of the steering wheel, difficult steering wheel operation, noise, vibration, and oil leaks, etc. Possible causes of these faults can include defects in the gear box, oil pump or steering linkage.

M1372008500179

POWER STEERING DIAGNOSTIC TROUBLESHOOTING STRATEGY

Use these steps to plan your diagnostic strategy. If you follow them carefully, you will be sure that you have exhausted most of the possible ways to find a power steering fault.

1. Gather information from the customer.

2. Verify that the condition described by the customer exists.
3. Find the malfunction by following the Symptom Chart.
4. Verify malfunction is eliminated.

M1372007300172

SYMPTOM CHART

SYMPTOM	INSPECTION PROCEDURE	REFERENCE PAGE
Excessive play of steering wheel	1	P.37A-4
Difficult steering wheel operation (insufficient power assist)	2	P.37A-5
Rattling noise	3	P.37A-7
Shrill noise	4	P.37A-7
Squealing noise	5	P.37A-8
Hissing noise	6	P.37A-9
Droning noise	7	P.37A-9
Squeaking noise	8	P.37A-10
Vibration	9	P.37A-11
Oil leakage from hose connection	10	P.37A-11
Oil leakage from hose assembly	11	P.37A-11
Oil leakage from oil reservoir	12	P.37A-12
Oil leakage from oil pump	13	P.37A-12
Oil leakage from gear box	14	P.37A-12

SYMPTOM PROCEDURES**INSPECTION PROCEDURE 1: Excessive Play of Steering Wheel****DIAGNOSIS**

STEP 1. Check for looseness at the steering shaft coupling section and at the steering wheel linkage.

Q: Is there any looseness?

YES : Repair or replace the part. Then go to Step 3.

NO : Go to Step 2.

STEP 2. Check the steering wheel free play.

- (1) With engine running (hydraulic operation), set front wheels straight ahead.
- (2) Measure the play on steering wheel circumference before wheels start to move when slightly moving the steering wheel in both directions.

Limit: 30 mm (1.2 inches)

- (3) If the free play exceeds the limit value, set steering wheel straight ahead with engine stopped. Load approximately 5 N (1.1 lb) toward steering circumference and check play.

Standard value (steering wheel play with engine stopped): 10 mm (0.3 inch) or less

Q: Does the play exceed the standard value?

YES : Remove steering gear box and check total pinion torque (Refer to [P.37A-27.](#)) Then go to Step 3.

NO : There is no action to be taken.

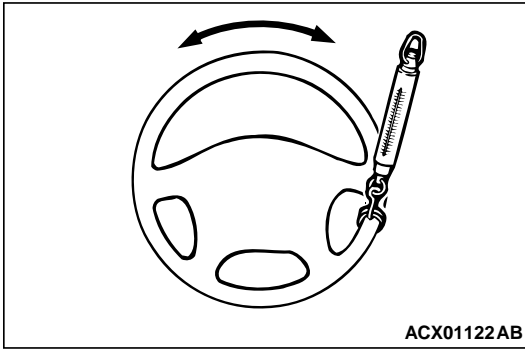

STEP 3. Check steering wheel play.

Verify that the steering wheel play is not excessive.

Q: Is the steering wheel play excessive?

YES : Repeat from Step 1.

NO : The procedure is complete.

INSPECTION PROCEDURE 2: Difficult Steering Wheel Operation (Insufficient Power Assist)

DIAGNOSIS

STEP 1. Check the power steering belt tension.

⚠ CAUTION

Perform the check after rotating the engine in the normal direction (one revolution or more).

NOTE: Since the auto-tensioner is used, it is not necessary to adjust the tension of the belt.

- (1) Check that the indicator mark of the auto-tensioner is located between the marks shown as "A" on the tensioner bracket.
- (2) If the mark is located out of the space "A," replace the drive belt.

Q: Is the indicator mark of the auto-tensioner located between the marks shown as "A" on the tensioner bracket?

YES : Go to Step 2.

NO : Replace the drive belt or auto-tensioner. Then go to Step 10.

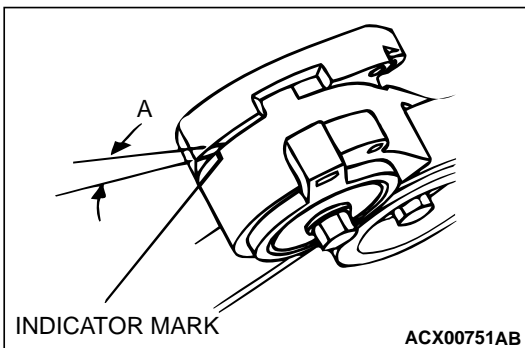

STEP 2. Check the belt for damage.**Q: Is the belt damaged?****YES** : Replace the belt. Then go to Step 10.**NO** : Go to Step 3.**STEP 3. Check the fluid level.**

- (1) Park the vehicle on a flat, level surface, start the engine, and then turn the steering wheel several times in both directions to raise the temperature of the fluid to approximately 50 – 60°C (122 – 140°F).
- (2) With the engine running, turn the wheel all the way to the left and right several times.
- (3) Check the fluid in the oil reservoir for foaming or milkiness. Check the difference of the fluid level when the engine is stopped, and while it is running. If the change of the fluid level is 5 mm (0.2 inch) or more, bleed air from the system. (Refer to [P.37A-18](#).)

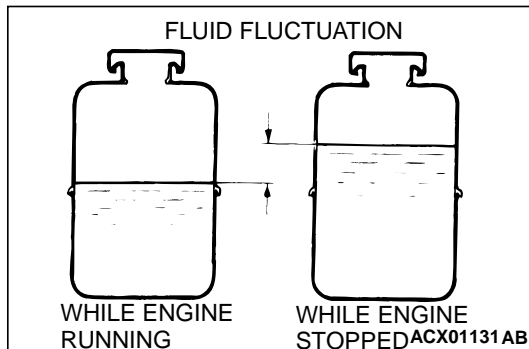
Q: Is fluid foamy?**YES** : Go to Step 4.**NO** : Go to Step 10.**STEP 4. Check for entry of air.****Q: Has air entered?****YES** : Bleed the air. Refer to [P.37A-19](#). Then go to Step 10.**NO** : Go to Step 5.**STEP 5. Check each hose for crushing or twisting.****Q: Is any hose crushed or twisted?****YES** : Repair or replace the hose. Then go to Step 10.**NO** : Go to Step 6.**STEP 6. Check for oil leaks.****Q: Are there oil leaks?****YES** : Repair it. Then go to Step 10.**NO** : Go to Step 7.**STEP 7. Check the wheel alignment (camber and caster).**Refer to GROUP 33A, On-vehicle Service – Front Wheel Alignment Check and Adjustment [P.33A-5](#).**Q: Is the camber or caster out of specification?****YES** : Adjust it. Then go to Step 10.**NO** : Go to Step 8.

STEP 8. Check for excessive tie rod end ball joint breakaway torque.

Refer to [P.37A-16](#).

Q: Is there fault?

YES : Replace the part. Then go to Step 10.

NO : Go to Step 9.

STEP 9. Check the gear box rack piston seal for damage.

Q: Is there damage?

YES : Replace it. Then go to Step 10.

NO : There is no action to be taken.

STEP 10. Check steering wheel operation.

Verify that steering wheel operation is not difficult.

Q: Is the steering wheel operation difficult?

YES : Repeat from Step 1.

NO : The procedure is complete.

INSPECTION PROCEDURE 3: Rattling Noise

DIAGNOSIS

STEP 1. Check for proper oil pump and gear box installation.

Q: Is the oil pump and gear box installation correct?

YES : Go to Step 2.

NO : Repair it. Then go to Step 4.

STEP 2. Check for interference of other parts with the steering column and power steering hoses.

Q: Is there interference?

YES : Correct the interference. Then go to Step 4.

NO : Go to Step 3.

STEP 3. Check for noise from inside the oil pump or gear box.

Q: Is there noise?

YES : Replace the part. Then go to Step 4.

NO : There is no action to be taken.

STEP 4. Check for rattling noise.

Confirm that no noise is generated.

Q: Is there noise?

YES : Repeat from Step 1.

NO : The procedure is complete.

INSPECTION PROCEDURE 4: Shrill Noise

DIAGNOSIS

STEP 1. Check for entry of air.

Q: Is the power steering fluid foamy?

YES : Bleed the air. Refer to [P.37A-19](#). Then go to Step 3.

NO : Go to Step 2.

STEP 2. Check for seizure in the oil pump.

Q: Is there seizure?

YES : Replace the part. Then go to Step 3.

NO : There is no action to be taken.

STEP 3. Retest the system.

Confirm that no noise is generated.

Q: Is there noise?

YES : Repeat from Step 1.

NO : The procedure is complete.

INSPECTION PROCEDURE 5: Squealing Noise**DIAGNOSIS****STEP 1. Check the power steering belt tension.****⚠ CAUTION**

Perform the check after rotating the engine in the normal direction (one revolution or more).

NOTE: Since the auto-tensioner is used, it is not necessary to adjust the tension of the belt.

- (1) Check that the indicator mark of the auto-tensioner is located between the marks shown as "A" on the tensioner bracket.
- (2) If the mark is located out of the space "A," replace the drive belt.

Q: Is the indicator mark of the auto-tensioner located between the marks shown as "A" on the tensioner bracket?

YES : Go to Step 2.

NO : Replace the drive belt or auto-tensioner. Then go to Step 3.

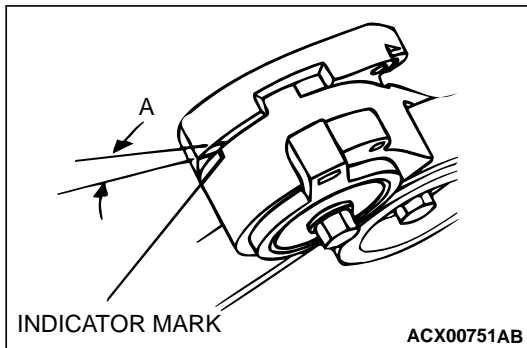
**STEP 2. Check for seizure in the oil pump.**

Q: Is there seizure?

YES : Replace the part. Then go to Step 3.

NO : There is no action to be taken.

STEP 3. Retest the system.

Confirm that no noise is generated.

Q: Is there noise?

YES : Repeat from Step 1.

NO : The procedure is complete.

INSPECTION PROCEDURE 6: Hissing Noise

DIAGNOSIS

STEP 1. Check for entry of air.

Q: Is the power steering fluid foamy?

YES : Bleed the air. Refer to [P.37A-19](#). Then go to Step 4.

NO : Go to Step 2.

STEP 2. Check each hose for crushing or twisting.

Q: Is any hose crushed or twisted?

YES : Repair or replace the hose. Then go to Step 4.

NO : Go to Step 3.

STEP 3. Check the steering box for damage.

Q: Is there damage?

YES : Repair or replace the part. Then go to Step 4.

NO : There is no action to be taken.

STEP 4. Retest the system.

Confirm that no noise is generated.

Q: Is there noise?

YES : Repeat from Step 1.

NO : The procedure is complete.

INSPECTION PROCEDURE 7: Droning Noise

DIAGNOSIS

STEP 1. Check the oil pump or oil pump bracket installation.

Q: Is the oil pump or oil pump bracket installation correct?

YES : Go to Step 2.

NO : Repair it. Then go to Step 3.

STEP 2. Check the oil pump for damage.

NOTE: If a slight "beat noise" is produced by the oil pump when the steering wheel is turned fully and held in that position, this is not a malfunction.

Q: Is there damage?

YES : Replace the oil pump. Then go to Step 3.

NO : There is no action to be taken.

STEP 3. Retest the system.

Confirm that no noise is generated.

Q: Is there noise?

YES : Repeat from Step 1.

NO : The procedure is complete.

INSPECTION PROCEDURE 8: Squeaking Noise

DIAGNOSIS

STEP 1. Check for interference of the wheel and vehicle body.

If interfering, adjust the steering angle.

- (1) Place the front wheel on a turning radius gauge and measure the steering angle.

Standard value:

ITEM	SPECIFICATION
Inside wheel	$36^{\circ}30' \pm 1^{\circ}30'$
Outside wheel (reference)	$31^{\circ}40'$

- (2) If the steering angle is not within the standard value, adjust the toe-in.

Standard value: 2.5 ± 2.5 mm(0.1± 0.1 inch)

- (3) Adjust the toe-in by undoing the clip and turning the left and right tie rod turnbuckles by the same amount (in opposite directions.)

Q: Is the steering angle normal?

YES : Go to Step 3.

NO : Go to Step 2.

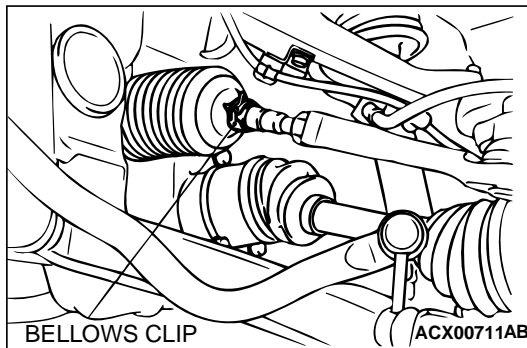
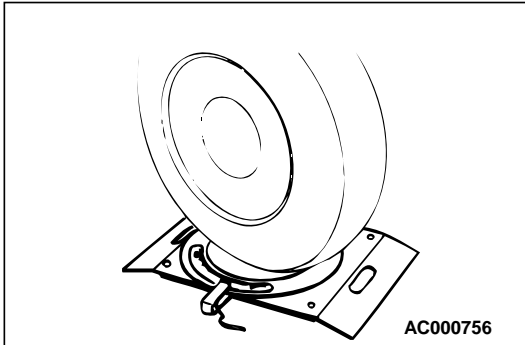
**STEP 2. Check the steering gear box for damage.****Q: Is there damage?**

YES : Repair or replace the part. Then go to Step 3.

NO : There is no action to be taken.

STEP 3. Retest the system.

Confirm that no noise is generated.

Q: Is there noise?

YES : Repeat from Step 1.

NO : The procedure is complete.

INSPECTION PROCEDURE 9: Vibration

NOTE: A slight vibration may be felt when the stationary steering effort is made due to the condition of the road surface. To check whether the vibration actually exists or not, test-drive the vehicle on a dry concrete or asphalt surface. A very slight amount of vibration is not a malfunction.

DIAGNOSIS

STEP 1. Check for entry of air.

Q: Is the power steering fluid foamy?

YES : Bleed the air. Refer to [P.37A-19](#). Then go to Step 3.

NO : Go to Step 2.

STEP 2. Check the steering gear box for damage.

Q: Is there damage?

YES : Repair or replace the part. Then go to Step 3.

NO : There is no action to be taken.

STEP 3. Retest the system.

Confirm that no vibration is generated.

Q: Is there vibration?

YES : Repeat from Step 1.

NO : The procedure is complete.

INSPECTION PROCEDURE 10: Oil Leakage from Hose Connection

DIAGNOSIS

STEP 1. Check for loosening of the flare nut.

Q: Is the flare nut loose?

YES : Tighten it to 15 ± 3 N·m (11 ± 2 ft·lb). Then go to Step 3.

NO : Go to Step 2.

STEP 2. Check the hose connection and clamp installation.

Q: Are they installed correctly?

YES : There is no action to be taken.

NO : Repair or replace the part. Then go to Step 3.

STEP 3. Retest the system.

Check that no oil is leaking.

Q: Is there oil leakage?

YES : Repeat from Step 1.

NO : The procedure is complete.

INSPECTION PROCEDURE 11: Oil Leakage from Hose Assembly

DIAGNOSIS

STEP 1. Check the hose for damage or clogging.

Q: Is the hose damaged or clogged?

YES : Repair or replace it. Then go to Step 2.

NO : There is no action to be taken.

STEP 2. Retest the system.

Check that no oil is leaking.

Q: Is there oil leakage?

YES : Repeat from Step 1.

NO : The procedure is complete.

INSPECTION PROCEDURE 12: Oil Leakage from Oil Reservoir

DIAGNOSIS

STEP 1. Check the oil reservoir for damage.**Q: Is there damage?****YES :** Repair or replace it. Then go to Step 3.**NO :** Go to Step 2.

STEP 2. Check for overflowing.**Q: Is there oil overflowing from the reservoir?****YES :** Adjust fluid level. Then go to Step 3.**NO :** Check that no oil is leaking.

STEP 3. Retest the system.**Q: Is there oil leakage?****YES :** Repeat from Step 1.**NO :** The procedure is complete.

INSPECTION PROCEDURE 13: Oil Leakage from Oil Pump

DIAGNOSIS

STEP 1. Check the oil pump body for damage.**Q: Is there damage?****YES :** Replace the part. Then go to Step 3.**NO :** Go to Step 2.

STEP 2. Check the O-ring or oil seal for damage.**Q: Is there damage?****YES :** Replace the part. Then go to Step 3.**NO :** Check that no oil is leaking.

STEP 3. Retest the system.

Check that no oil is leaking.

Q: Is there oil leakage?**YES :** Repeat t from Step 1.**NO :** The procedure is complete.

INSPECTION PROCEDURE 14: Oil Leakage from Gear Box

DIAGNOSIS

STEP 1. Check the gear box housing for damage.**Q: Is there damage?****YES :** Replace the part. Then go to Step 3.**NO :** Go to Step 2.

STEP 2. Check the oil-ring or oil seal for damage.**Q: Is there damage?****YES :** Replace the part. Then go to Step 3.**NO :** Check that no oil is leaking.

STEP 3. Retest the system.



Check that no oil is leaking.

Q: Is there oil leakage?**YES :** Repeat from Step 1.**NO :** The procedure is complete.

SPECIAL TOOLS

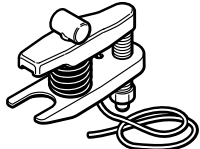
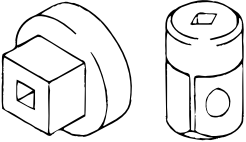
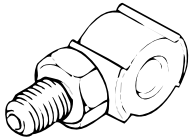
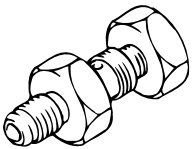
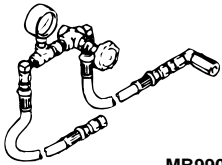
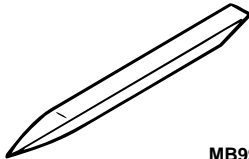
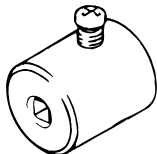
M1372000600257

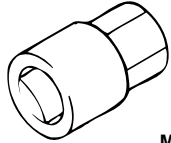
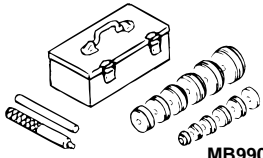
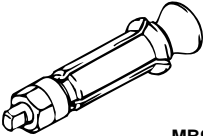
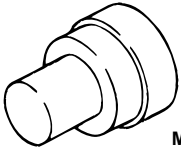
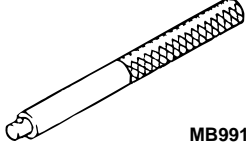
TOOL	TOOL NUMBER AND NAME	SUPERSESSION	APPLICATION
 <p>AC106827</p>	<p>MB991897 Ball joint remover</p>	<p>MB991113-01, MB990635-01 or General service tool</p>	<p>Tie rod end disconnection <i>NOTE: Steering linkage puller (MB990635 or MB991113) is also available to disconnect ball joint.</i></p>
 <p>MB990326</p>	<p>MB990326 Preload socket</p>	<p>General service tool</p>	<p>Tie rod end ball joint breakaway torque check</p>
 <p>MB991548</p>	<p>MB991548 Power steering oil pressure gauge adapter (Pump side)</p>	<p>MB991548-01</p>	<p>Oil pump pressure test</p>
 <p>MB991549</p>	<p>MB991549 Power steering oil pressure gauge adapter (Hose side)</p>	<p>MB991549-01</p>	
 <p>MB990662</p>	<p>MB990662 Oil pressure gauge assembly</p>	<p>MB990662-01</p>	
 <p>MB990784</p>	<p>MB990784 Ornament remover</p>	<p>General service tool</p>	<p>Removal of cover</p>
 <p>MB991006</p>	<p>MB991006 Preload socket</p>	<p>MB991006-01</p>	<p>Gear box total pinion torque check</p>

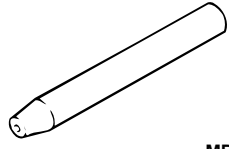
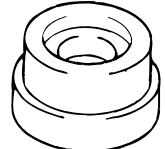
TOOL	TOOL NUMBER AND NAME	SUPERSESSION	APPLICATION
 <p>MB991204</p>	MB991204 Torque wrench socket	General service tool	<ul style="list-style-type: none"> • Rack support adjustment • Rack support cover removal
 <p>MB990925</p>	MB990925 Bearing and oil seal installer set	MB990925-01 or general service tool	<ul style="list-style-type: none"> • Oil seal and bearing installation • MB990926, MB990927, MB990938, MB990939 (For details, refer to GROUP 26, Special Tools P.26-9.)
 <p>MB991120</p>	MB991120 Needle bearing puller	Tool not available	Needle roller bearing removal
 <p>MB991199</p>	MB991199 Oil seal installer	General service tool	Oil seal installation
 <p>MB991197</p>	MB991197 Bar (long type)	General service tool	
 <p>MB991202</p>	MB991202 Oil seal and bearing installer	General service tool	Needle roller bearing installation
 <p>MB991212</p>	MB991213 Rack installer	General service tool	Rack installation
 <p>MB991203</p>	MB991203 Oil seal and bearing installer	Tool not available	Oil seal and bearing installation

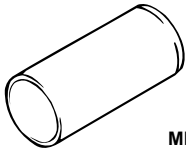
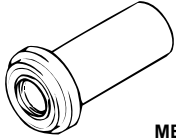
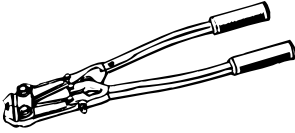
TOOL	TOOL NUMBER AND NAME	SUPERSESION	APPLICATION
 MB991317	MB991317 Seal ring installer	Tool not available	Seal ring installation
 MB990941	MB990941 Torque tube bearing installer	General service tool	Oil seal installation
 MB991561	MB991561 Boot band crimping tool	—	Bellows band installation

ON-VEHICLE SERVICE

STEERING WHEEL FREE PLAY CHECK

M1372001000236

1. With the engine running (hydraulic operation), set the front wheels straight ahead.
2. Measure the play on the steering wheel circumference before the wheels start to move when slightly moving the steering wheel in both directions.

Limit: 30 mm (1.2 inches)

3. When the play exceeds the limit, check for the play on the steering shaft and steering linkage connection. Correct or replace.
4. If the free play still exceeds the limit value, set the steering wheel straight ahead with the engine stopped. Load 5 N (1.1 pound) towards the steering wheel circumference and check the play.

Standard value (steering wheel play with the engine stopped): 10 mm (0.4 inch) or less

5. If the play exceeds the standard value, check the steering gear box and check total pinion torque (Refer to P.37A-29.).

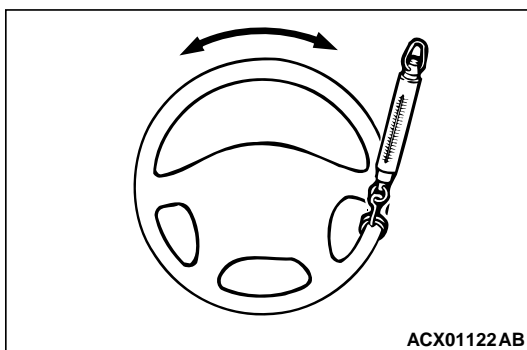

STEERING ANGLE CHECK

M1372001100266

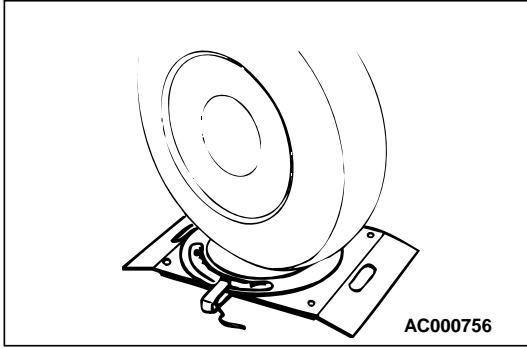

1. Place the front wheel on a turning radius gauge and measure the steering angle.

Standard value:

ITEM	SPECIFICATION
Inside wheel	36°30' ± 1°30'
Outside wheel (reference)	31°40'

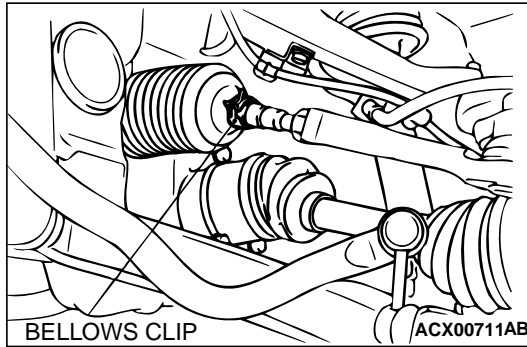

2. If the steering angle is not within the standard value, adjust the toe-in by undoing the clip and turning the left and right tie rod turnbuckles by the same amount (in opposite directions).

Standard value: 2.5 ± 2.5 mm (0.1 ± 0.1 inch)

TIE ROD END BALL JOINT BREAKAWAY TORQUE CHECK

M1372001500220

Required Special Tools:

- MB990326: Preload Socket
- MB991897: Ball Joint Remover

⚠ CAUTION

- Do not remove the nut from ball joint. Loosen it and use the special tool MB991897 to avoid possible damage to the ball joint threads.
- Hang special tool MB991897 with cord to prevent it from falling.

1. Install special tool MB991897 as shown in the figure.

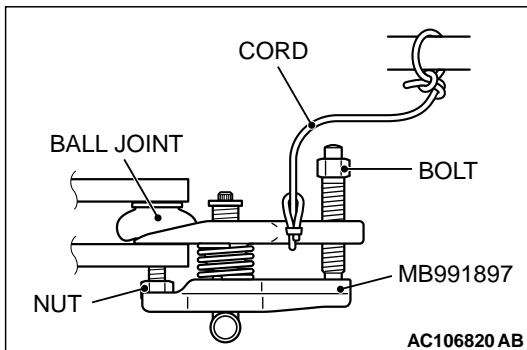

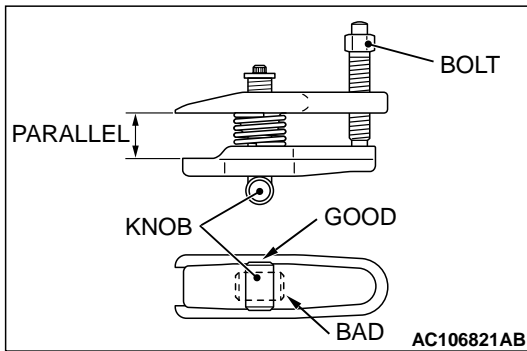

2. Turn the bolt and knob as necessary to make the jaws of special tool MB991897 parallel, tighten the bolt by hand and confirm that the jaws are still parallel.
NOTE: When adjusting the jaws in parallel, make sure the knob is in the position shown in the figure.
3. Tighten the bolt with a wrench to disconnect the tie rod end.

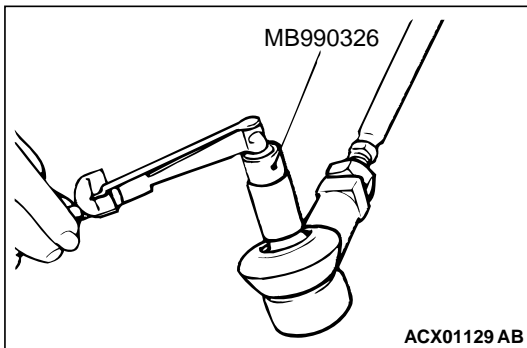

4. Move the ball joint stud several times and install the nut on the stud. Measure the ball joint breakaway torque with special tool MB990326.
Standard value: 0.49 – 2.45 N·m (4.3 – 21.7 in-lb)
5. If the breakaway torque exceeds the standard value, replace the tie rod end.

STATIONARY STEERING EFFORT CHECK

M1372001700246

1. With the vehicle stopped on a flat and paved surface, turn the steering wheel to the straight ahead position.
2. Start the engine and check the engine idle speed.
Standard value: 1,000 ± 100 r/min
3. Attach a spring scale to the outer circumference of the steering wheel and measure the steering force required to turn the steering wheel from the straight ahead position to the left and right (within a range of 1.5 turns). Also check to be sure that there is no significant change in the required steering effort.
Standard value:
 - **Steering effort: 39.2 N (8.8 pound) or less**
 - **Fluctuation allowance: 5.9 N (1.33 pound) or less**
4. If the measured value did not conform to the standard value, refer to POWER STEERING DIAGNOSIS [P.37A-3](#) to check and adjust the steering force.

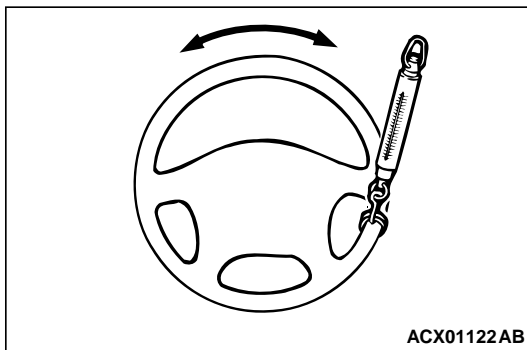

STEERING WHEEL RETURN TO CENTER CHECK

M1372001800243

Conduct a road test:

1. Make both gradual and sudden turns and check the steering wheel return.

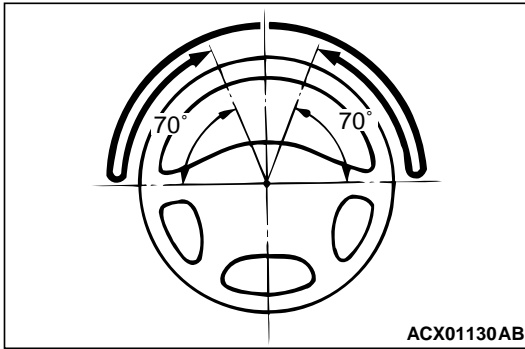

- At a vehicle speed of approximately 35 km/h (22 mph), turn the steering wheel 90 degree angle, hold a few seconds, then release. If the steering wheel then returns 70 degree angle or more, the return can be judged satisfactory.

NOTE: There will be a momentary feeling or "heaviness" when the wheel is turned quickly, but this is not abnormal. (Oil pump discharge amount is especially apt to be insufficient during idling.)

DRIVE BELT TENSION CHECK

M1372001900206

⚠ CAUTION

Perform the check after rotating the engine in the normal direction (one revolution or more).

- Check that the indicator mark of the auto-tensioner is located between the marks shown as "A" on the tensioner bracket.
- If the mark is located out of the space "A," replace the drive belt.

NOTE: Since the auto-tensioner is used, it is not necessary to adjust the tension of the belt.

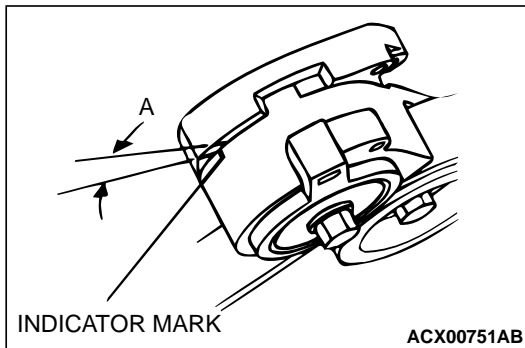

FLUID LEVEL CHECK

M1372002000228

- Park the vehicle on a flat, level surface, start the engine, and then turn the steering wheel in both directions several times to raise the temperature of the fluid to approximately 50 – 60°C (122 – 140°F).
- With the engine running, turn the wheel all the way to the left and right several times.
- Check the fluid in the oil reservoir for foaming or milkiness.
- Check the difference of the fluid level when the engine is stopped, and while it is running. If the change of the fluid level is 5 mm (0.2 inch) or more, air bleeding should be done.

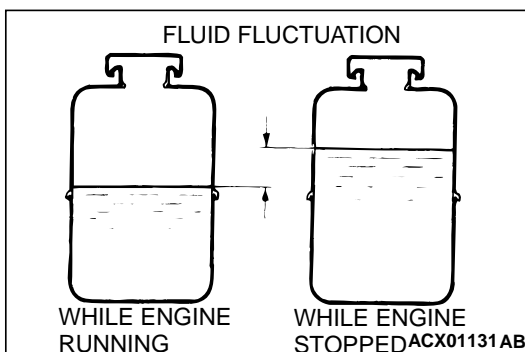

POWER STEERING FLUID REPLACEMENT

M1372002100258

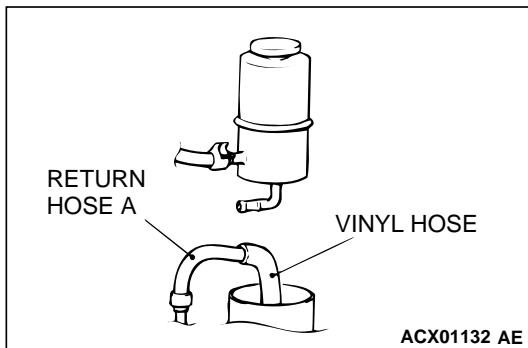

1. Jack up the front wheels and support them.
2. Disconnect the return hose A connection. (Refer to [P.37A-49.](#))
3. Connect a vinyl hose to the return hose A, and drain the fluid into a container.
4. Disconnect the ignition coil connector. (Refer to GROUP 16, IGNITION COIL [P.16-40.](#))
5. While operating the starting motor intermittently, turn the steering wheel all the way to the left and right several times to drain all of the fluid.
6. Connect the return hose A securely, and then secure with the clip.
7. Fill the oil reservoir with GENUINE MITSUBISHI POWER STEERING FLUID up to the lower position of the filler, and then bleed the air.

POWER STEERING SYSTEM AIR BLEEDING

M1372002200255

1. Jack up the front wheels and support them.
2. Disconnect the ignition coil connector.

⚠ CAUTION

- During air bleeding, fill fluid so that its level is always higher than the MIN line on the oil reservoir.
 - If the air bleeding is performed by operating the engine, air will break into small particles and melt into fluid. Be sure to perform the air bleeding while cranking the engine.
 - If the steering wheel is turned all the way to the right and left at the engine stop condition, the fluid may leak from the reservoir or the reservoir cap may pop out. Perform air bleeding while cranking the engine.
3. Turn the steering wheel all the way to the left and right five or six times while using the starter motor to crank the engine intermittently several times (for 15 to 20 seconds).
 4. Connect the ignition coil. Start the engine (idling).
 5. Turn the steering wheel to the left and right until there are no air bubbles in the oil reservoir.
 6. Confirm that the fluid is not milky, and that the level is between the high and low dipstick marks.
 7. Confirm that there is very little change in the fluid level when the steering wheel is turned left and right.

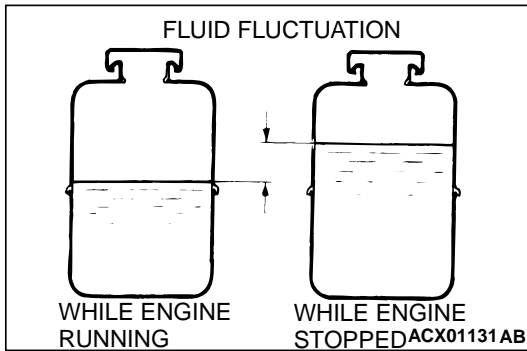

- Confirm that the change in the fluid level is no more than 5 mm (0.2 inch) when the engine is stopped and when it is running.

⚠ CAUTION

- If the fluid level rises suddenly after the engine is stopped, the air has not been completely bled.
 - If air bleeding is not complete, there will be abnormal noises from the pump and the flow-control valve, and this condition could cause reduce the life of the power steering components.
- If the change of the fluid level is 5 mm (0.2 inch) or more, the air has not been completely bled from the system. The air bleeding procedure must be repeated.

OIL PUMP PRESSURE TEST

M1372002300241

Required Special Tools:

- MB990662: Pressure Gauge
- MB991548: Power Steering Oil Pressure Gauge Adapter (Pump Side)
- MB991549: Power Steering Oil Pressure Gauge Adapter (Hose Side)

- Disconnect the pressure hose from the oil pump, and then connect special tools MB991548, MB990662 and MB991549.
- Bleed air, then turn the steering wheel several times while the vehicle is not moving so that the temperature of the fluid rises to approximately 50 – 60°C (122 – 140°F).
- Start the engine and idle it at 1,000 ± 100 r/min.

⚠ CAUTION

The pressure gauge shut-off valve must not remain closed for more than 10 seconds.

- Fully close the shut-off valve of the pressure gauge and measure the oil pump relief pressure to confirm that it is within the standard value range. Open it again immediately after checking the pressure.

Standard value: 8.3 – 9.0 MPa (1,209 – 1,305 psi)

- If it is not within the standard value, replace the oil pump.
- Check whether or not the hydraulic pressure is the standard value when no-load conditions are created by fully opening the shut-off valve of the pressure gauge.

Standard value: 0.34 MPa (49.3 psi)

- If it is not within the standard value, the probable cause is a malfunction of the oil line or steering gear box, so check these parts and repair as necessary.

- Turn the steering wheel all the way to the left or right; then check whether or not the retention hydraulic pressure is the standard value.

Standard value: 8.3 – 9.0 MPa (1,209 – 1,305 psi)

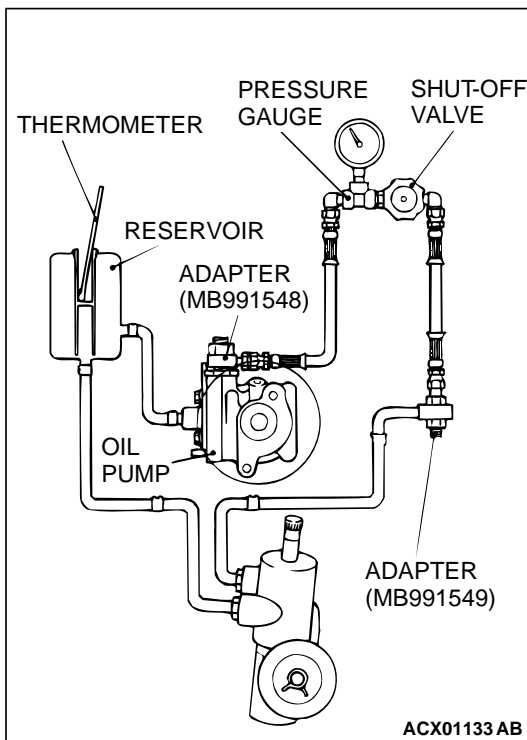

9. If the measured value is smaller than the standard value, disassemble and assemble the steering gear, and if it is larger than the standard value, disassemble and assemble the oil pump flow control valve, and then measure oil pressure again.
10. Remove special tools MB991548, MB990662 and MB991549, and then tighten the pressure hose to the specified torque.

Tightening torque: 57 ± 7 N·m (42 ± 5 ft-lb)

11. Bleed the system.

POWER STEERING PRESSURE SWITCH CHECK

M1372007200249

Required Special Tools:

- MB990662: Pressure Gauge
- MB991548: Power Steering Oil Pressure Gauge Adapter (Pump Side)
- MB991549: Power Steering Oil Pressure Gauge Adapter (Hose Side)

1. Disconnect the pressure hose from the oil pump, and then connect special tools MB991548, MB990662 and MB991549.
2. Bleed air, and then turn the steering wheel several times while the vehicle is not moving so that the temperature of the fluid rises to approximately 50 – 60°C (122 - 140°F).
3. The engine should be idling.
4. Disconnect the connector for the oil pressure switch, and place an ohmmeter at the switch.
5. Gradually close the shut-off valve of the pressure gauge and increase the hydraulic pressure, then check whether or not the hydraulic pressure that activates the switch is the standard value.

Standard value: 1.5 – 2.0 MPa (217 – 290 psi)

6. Gradually open the shut-off valve and reduce the hydraulic pressure; then check whether or not the hydraulic pressure that deactivates the switch is the standard value.

Standard value: 1.5 – 2.0 MPa (217 – 290 psi)

7. Remove special tools MB991548, MB990662 and MB991549, and then tighten the pressure hose to the specified torque.

Tightening torque: 57 ± 7 N·m (42 ± 5 ft-lb)

8. Bleed the system.

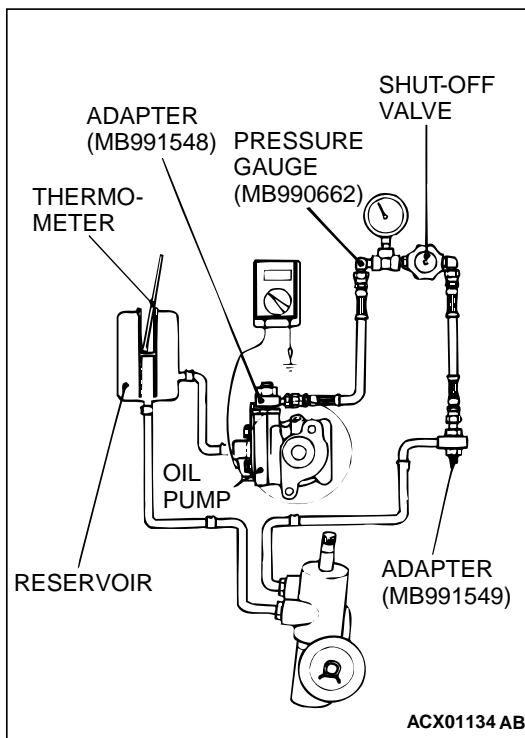

BALL JOINT DUST COVER INSPECTION

M1372008600206

1. Press the dust cover with your finger to check whether the dust cover is cracked or damaged.
2. If the dust cover is cracked or damaged, replace the tie rod end.

NOTE: If the dust cover is cracked or damaged, the ball joint could be damaged.

STEERING WHEEL AND SHAFT ASSEMBLY

REMOVAL AND INSTALLATION

M1372002600219

⚠ WARNING

- Before removing the air bag module, refer to **GROUP 52B, Service Precautions and Air Bag Module and Clock Spring P.52Ba-18.**
- When removing and installing the steering wheel, do not let it bump against the air bag module.

Pre-removal Operation	Post-installation Operation
<ul style="list-style-type: none"> • Removal of Air Cleaner, Air Intake Hose and Intake Air Duct (Refer to GROUP 15, Air Cleaner P.15-6.) • Lower Panel Removal (Refer to GROUP 52A, Instrument Panel Assembly P.52A-2.) 	<ul style="list-style-type: none"> • Lower Panel Installation (Refer to GROUP 52A, Instrument Panel Assembly P.52A-2.) • Installation of Air Cleaner, Air Intake Hose and Intake Air Duct (Refer to GROUP 15, Air Cleaner P.15-6.) • Checking Steering Wheel Position with Wheels Straight Ahead

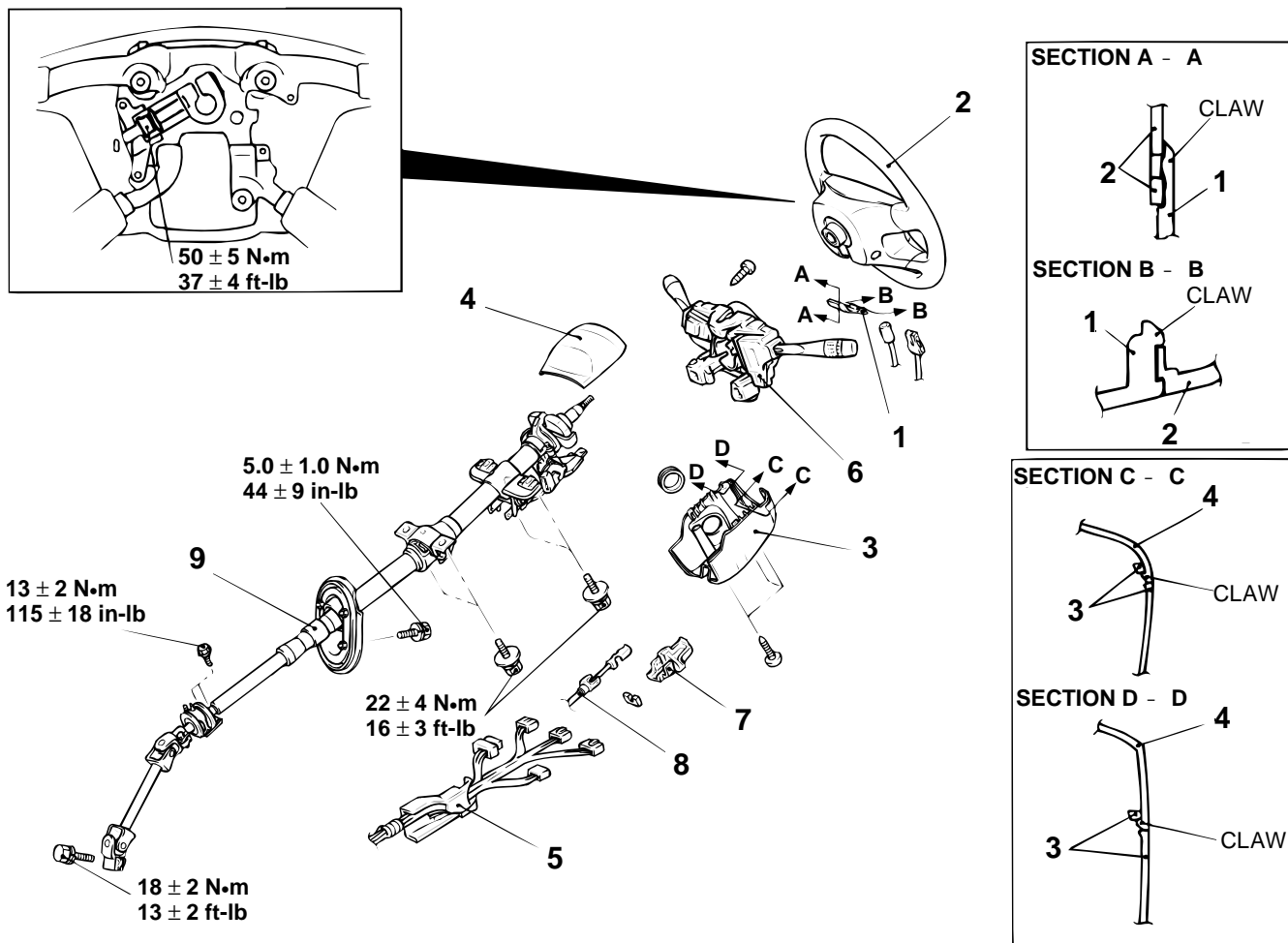

ACX01135

<<A>>
<>

REMOVAL STEPS

1. COVER
2. STEERING WHEEL AND AIR BAG MODULE ASSEMBLY
3. LOWER COLUMN COVER
4. UPPER COLUMN COVER
5. PROTECTOR

REMOVAL STEPS (Continued)

6. CLOCK SPRING AND COLUMN SWITCH ASSEMBLY (REFER TO GROUP 52B, AIR BAG MODULE AND CLOCK SPRING P.52Ba-33.)
7. COVER
8. KEY INTERLOCK CABLE

REMOVAL STEPS (Continued)

- BRAKE PEDAL RETURN SPRING (REFER TO GROUP 35A, BRAKE PEDAL P.35A-132.)
- 9. STEERING COLUMN SHAFT ASSEMBLY

Required Special Tool:

- MB990784: Ornament Remover

NOTE: When the air bag module assembly must be removed, refer to GROUP 52B, Air Bag Modules and Clock Spring P.52Ba-33.

REMOVAL SERVICE POINTS**<<A>> COVER REMOVAL**

Insert the special tool MB990784 at the indicated position to remove the cover.

NOTE: The special tool can be inserted through the notch behind the area shown.

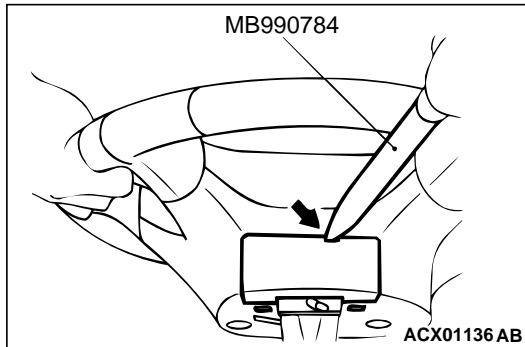
**<> STEERING WHEEL AND AIR BAG MODULE ASSEMBLY REMOVAL**

1. By sliding section A of the clock spring connector shown in the illustration in the arrow direction, disconnect the connector.

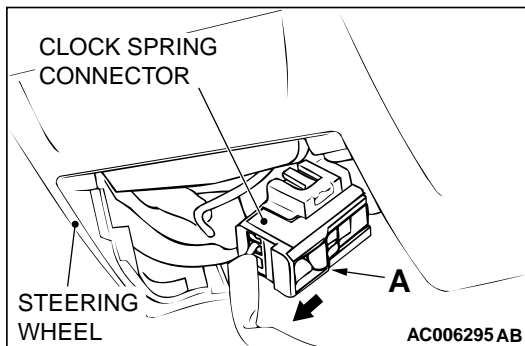

2. Loosen the bolt completely. Then remove the steering wheel and air bag module assembly.

NOTE: Use a hexagonal bit socket or a hexagonal wrench having an effective length of 75 mm (0.29 inch) or more in the hexagonal section and the diameter of 8 mm (0.031 inch) or more.

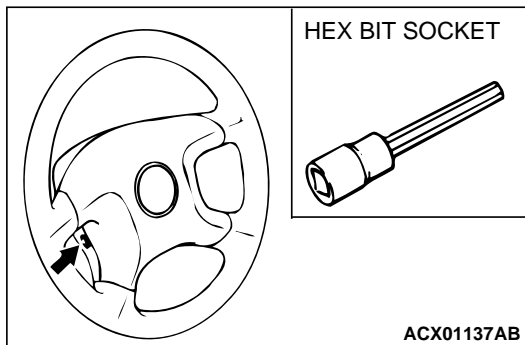

DISASSEMBLY AND ASSEMBLY

M1372002800213

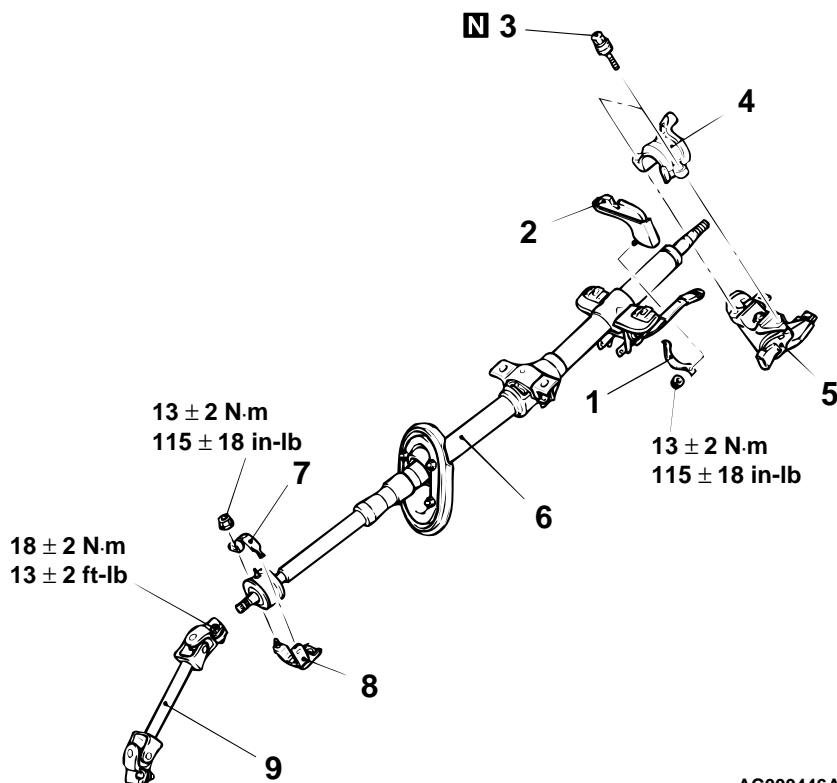

AC000446AB

DISASSEMBLY STEPS

- 1. STEERING DYNAMIC DAMPER LOWER PLATE
- 2. STEERING DYNAMIC DAMPER
- <<A>> >>A<< 3. SPECIAL BOLT
- >>A<< 4. STEERING LOCK BRACKET

DISASSEMBLY STEPS

- >>A<< 5. STEERING LOCK CYLINDER ASSEMBLY
- 6. STEERING COLUMN SHAFT
- 7. SHAFT SUPPORT BRACKET B
- 8. SHAFT SUPPORT BRACKET A
- 9. JOINT ASSEMBLY

DISASSEMBLY SERVICE POINT

<<A>> SPECIAL BOLT REMOVAL

- 1. In the special bolt, drill a hole deep enough for the tap to stand.
- 2. Using a left-hand tap, remove the special bolt.

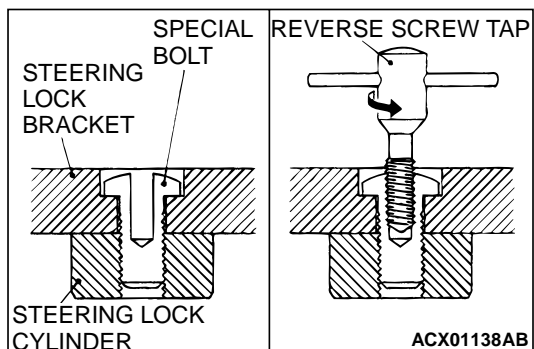

ASSEMBLY SERVICE POINT**>>A<< STEERING LOCK CYLINDER ASSEMBLY/STEERING LOCK BRACKET/SPECIAL BOLT INSTALLATION****⚠ CAUTION**

The steering lock bracket and bolts must be replaced with new ones when the steering lock is installed.

1. When installing the steering lock cylinder and steering lock bracket to the column tube, temporarily install the steering lock in alignment with the column boss.
2. After checking that the lock works properly, tighten the special bolts until the head twists off.

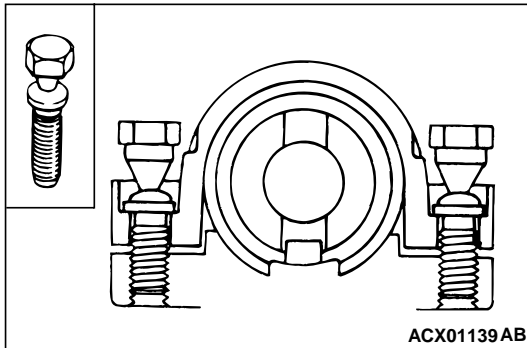

POWER STEERING GEAR BOX ASSEMBLY

REMOVAL AND INSTALLATION

M1372003900235

WARNING

Before removing the steering gear box, refer to GROUP 52B. Center the front wheels and remove the ignition key. Failure to do so may damage the SRS clock spring and render the SRS system inoperative, risking serious injury.

Pre-removal Operation

Power Steering Fluid Draining (Refer to P.37A-19.)

Post-installation Operation

- Fill power steering fluid and bleed air (Refer to P.37A-19.)
- Check the Dust Cover for Cracks or Damage by Pushing it with Your Finger.
- Check the steering angle (Refer to P.37A-16.)

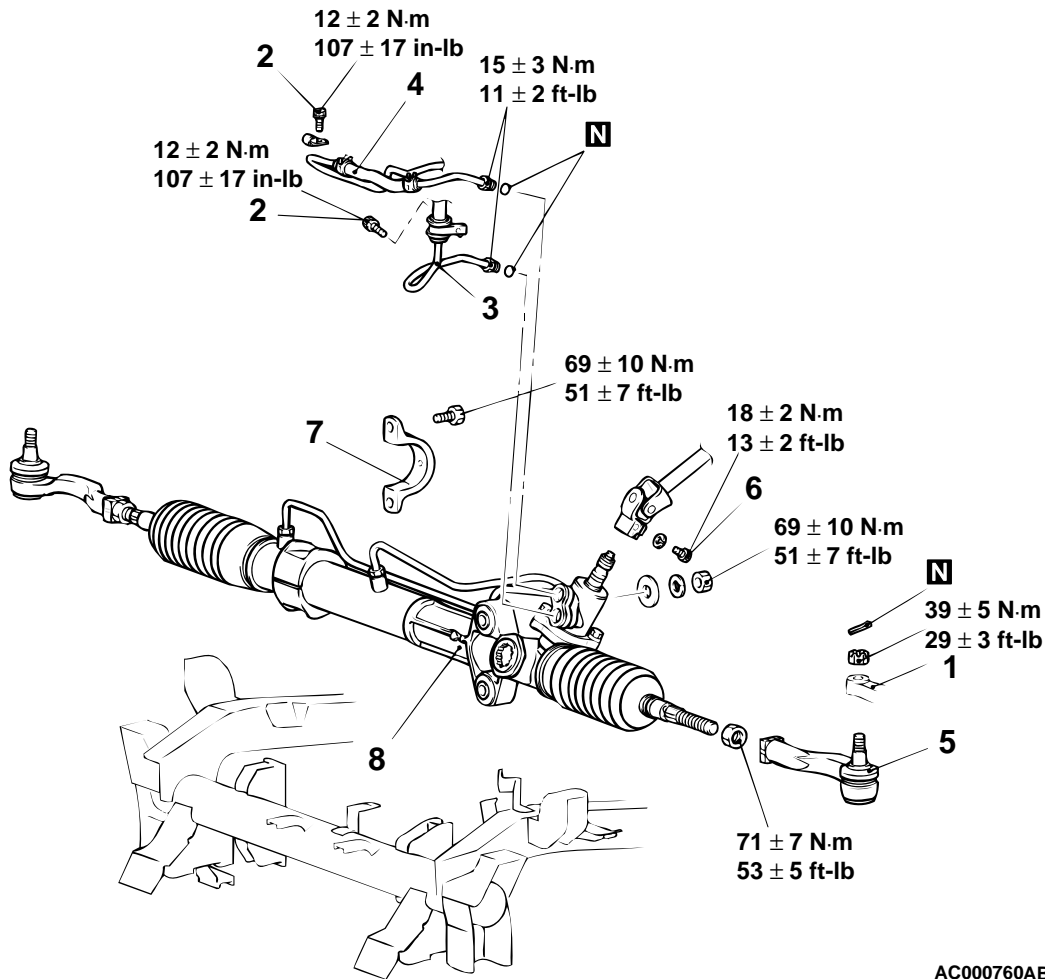

AC000760AB

REMOVAL STEPS

- REMOVAL OF UNDER COVER
- <<A>>
1. TIE ROD END AND KNUCKLE CONNECTION
 2. BOLT
- >>B<<
3. PRESSURE HOSE ASSEMBLY
 4. RETURN TUBE
- >>A<<
5. TIE ROD END (LH)
- <>
- INSTALLATION OF DIFFERENTIAL MOUNT BRACKET (LH)

REMOVAL STEPS (Continued)

6. STEERING SHAFT ASSEMBLY AND GEAR BOX CONNECTING BOLT
7. GEAR BOX CLAMP
8. GEAR BOX ASSEMBLY

<<C>>

Required Special Tool:

- MB991897: Ball Joint Remover

REMOVAL SERVICE POINTS

<<A>> TIE ROD END AND KNUCKLE DISCONNECTION

⚠ CAUTION

- Do not remove the nut from ball joint. Loosen it and use special tool MB991897 to avoid possible damage to ball joint threads.
- Hang special tool MB991897 with a cord to prevent it from falling.

1. Install special tool MB991897 as shown in the figure.

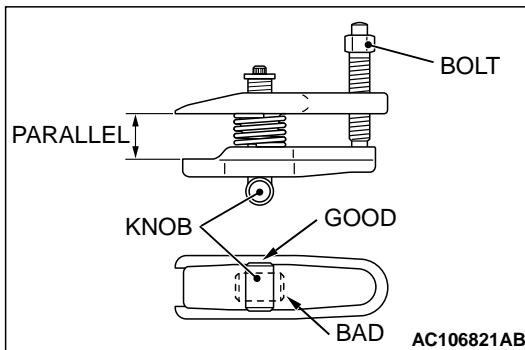
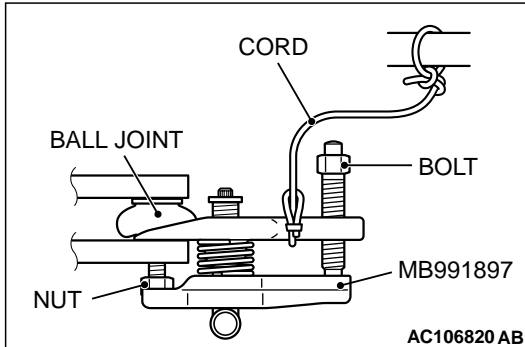

2. Turn the bolt and knob as necessary to make the jaws of special tool MB991897 parallel, tighten the bolt by hand and confirm that the jaws are still parallel.

NOTE: When adjusting the jaws in parallel, make sure the knob is in the position shown in the figure.

3. Tighten the bolt with a wrench to disconnect the tie rod end.

<>REMOVAL OF DIFFERENTIAL MOUNT BRACKET ASSEMBLY (LH)

Remove the connection bolt for the front frame assembly and the differential mount bracket assembly.

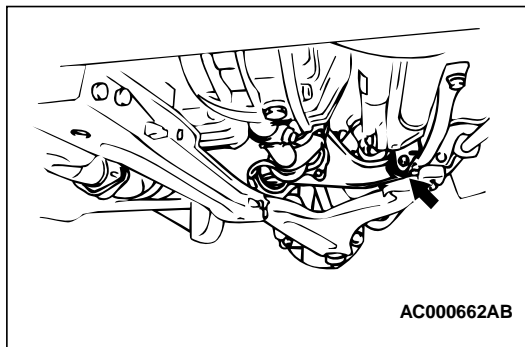

<<C>> GEAR BOX ASSEMBLY REMOVAL

⚠ CAUTION

Be sure not to damage the bellows and the tie rod end dust cover when removing the gear box assembly.

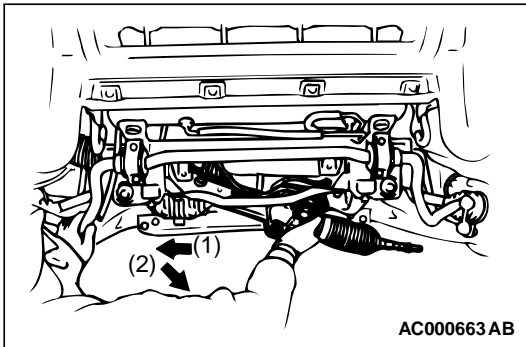

INSTALLATION SERVICE POINTS

>>A<< TIE ROD END (LH) INSTALLATION

Screw the tie rod to the dimension shown in the illustration and secure it temporarily with the jam nut.

NOTE: Tighten the locknut to the specified torque after installing the gearbox onto the body and adjusting the toe-in.

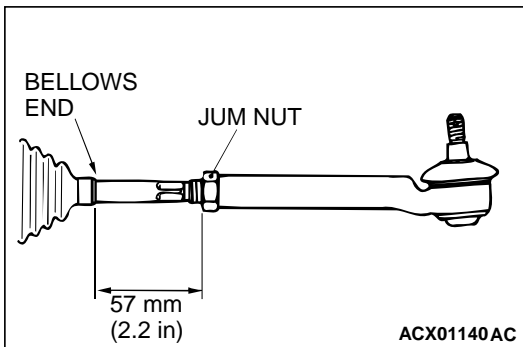

>>B<< RETURN TUBE/PRESSURE HOSE ASSEMBLY INSTALLATION

Align the markings at the gearbox side and the tube side.

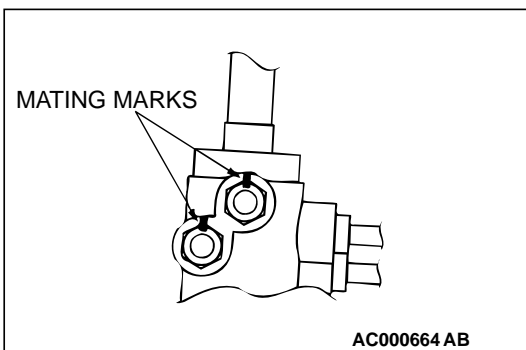

INSPECTION

M1372011000130

GEAR BOX TOTAL PINION TORQUE CHECK

Required Special Tool:

- MB991006: Preload Socket

⚠ CAUTION

When holding the steering gear box assembly in a vice, secure its mounting positions. If it is secured in any other place, the gear housing may become deformed or damaged.

Using special tool MB991006, rotate the pinion gear at the rate of one rotation in approximately 4 to 6 seconds to check the total pinion torque.

Standard value: 0.6 – 1.7 N·m (5.3 – 15.0 in-lb)
[Change in torque: 0.4 N·m (3.5 in-lb) or less]

NOTE: When measuring, remove the bellows from the rack housing.

NOTE: Measure the pinion torque through the whole stroke of the rack.

NOTE: If the measured value is not within the standard range, first adjust the rack support cover, and then check the total pinion torque again.

NOTE: If the total pinion torque cannot be adjusted to within the standard range by adjusting the rack support cover, check the rack support cover, rack support spring, rack support and replace any parts if necessary.

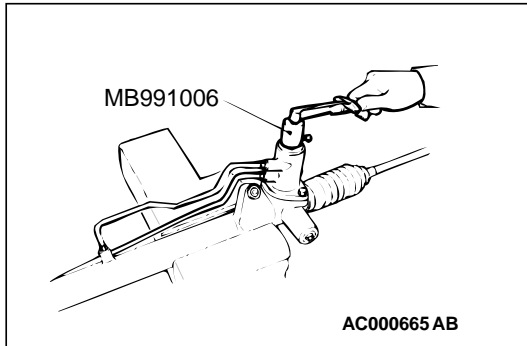
**TIE ROD SWING RESISTANCE CHECK**

1. Using a spring balance, give 10 hard swings to the tie rod.
2. Measure the tie rod swing resistance with a spring balance.

Standard value: 11 – 35 N (35.4 – 82.7 lb) [1.4 – 4.9 N·m (12.4 – 43.4 in-lb)]

3. If the measured value exceeds the standard value, replace tie rod.
4. If the measured value is below the standard value, the tie rod can be re-used if it swings smoothly without excessive play.

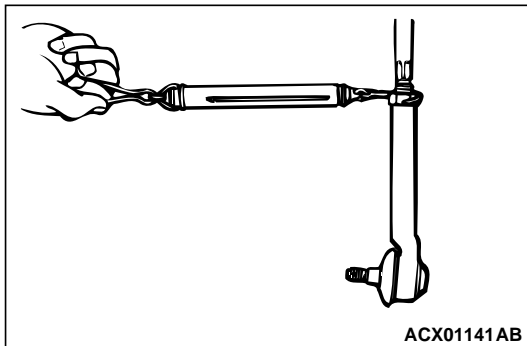
**TIE ROD END BALL JOINT DUST COVER CHECK**

1. Check the dust cover for cracks or damage by pushing it with your finger.
2. If the dust cover is cracked or damaged, replace the tie rod end. (Refer to [P.37A-27.](#))

NOTE: Cracks or damage of the dust cover may damage the ball joint. If it is damaged during service work, replace the dust cover. (Refer to [P.37A-43.](#))

DISASSEMBLY AND ASSEMBLY

M1372004100180

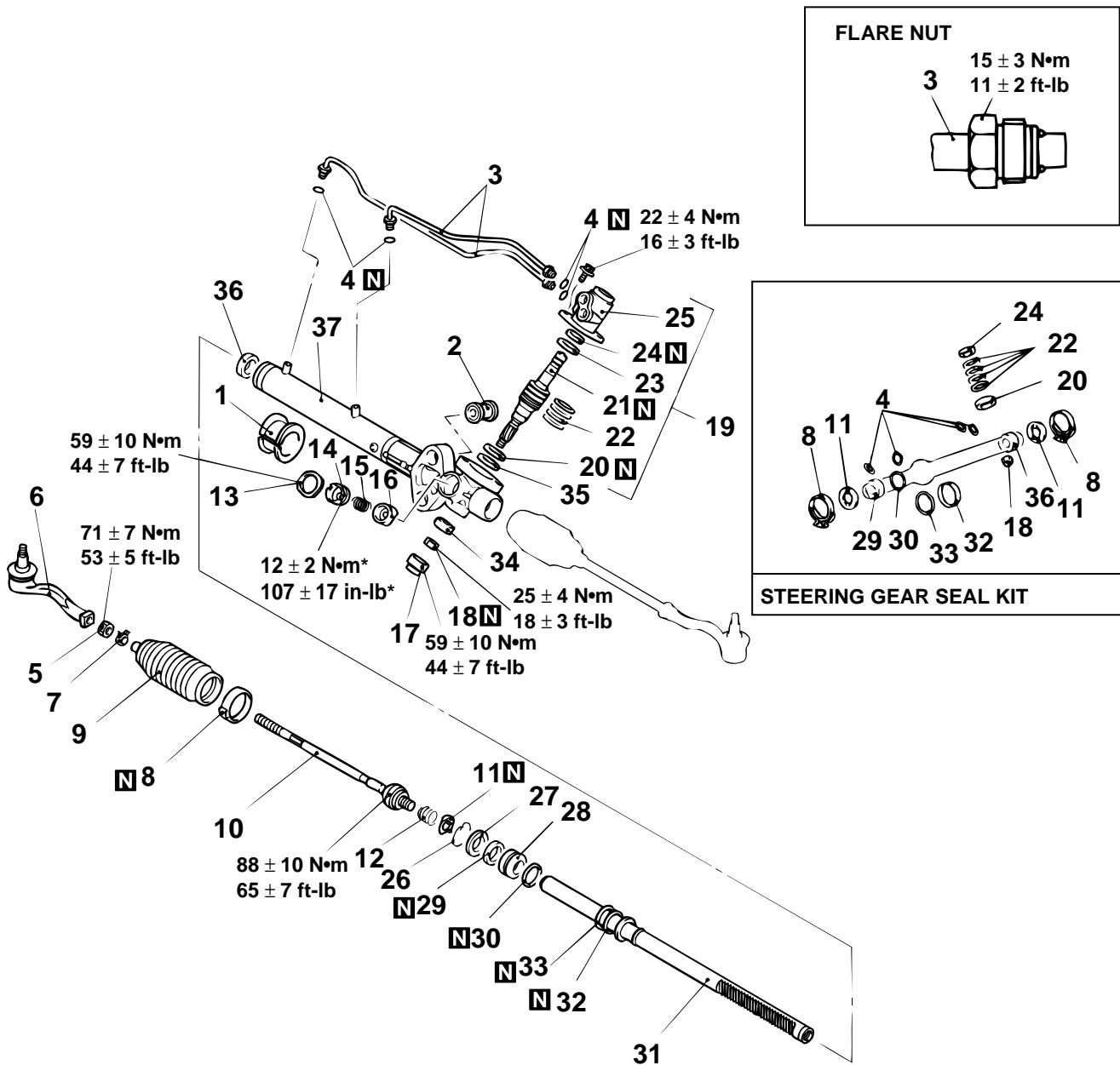

NOTE

*: Return the rack support cover - 10

AC000761AC

- DISASSEMBLY STEPS**
- >>O<< 1. GEAR MOUNTING RUBBER
 - 2. GEAR HOUSING MOUNTING BUSHING
 - 3. FEED PIPE
 - 4. O-RING
 - >>N<< 5. JAM NUT
 - >>N<< 6. TIE ROD END
 - 7. CLIP
 - >>M<< 8. BAND
 - 9. BELLOWS
 - >>L<< 10. TIE ROD
 - >>L<< 11. TAB WASHER
 - 12. COIL SPRING

- DISASSEMBLY STEPS (Continued)**
- >>K<< • TOTAL PINION TORQUE ADJUSTMENT
 - >>J<< 13. LOCK NUT
 - <<A>> >>J<< 14. RACK SUPPORT COVER
 - 15. SUPPORT SPRING
 - 16. RACK SUPPORT
 - >>I<< 17. END PLUG
 - 18. LOCK NUT
 - 19. VALVE HOUSING ASSEMBLY
 - <> >>H<< 20. LOWER OIL SEAL
 - <> 21. PINION AND VALVE ASSEMBLY
 - <<C>> >>G<< 22. SEAL RING
 - <<D>> >>F<< 23. UPPER BEARING

DISASSEMBLY STEPS (Continued)		Required Special Tools:
<<D>> >>F<< <<E>> >>E<< <<F>> <<F>> >>D<< <<F>> >>D<< <<F>> >>C<< <<C>> <<G>> >>B<< <<H>> >>B<< <<I>> >>A<<	24. UPPER OIL SEAL 25. VALVE HOUSING 26. CIRCLIP 27. RACK STOPPER 28. RACK BUSHING 29. OIL SEAL 30. O-RING 31. RACK ASSEMBLY 32. SEAL RING 33. O-RING 34. LOWER BALL BEARING 35. NEEDLE BEARING 36. OIL SEAL 37. GEAR HOUSING	<ul style="list-style-type: none"> • MB990927: Installer Adapter • MB990938: Bar (Snap-in type) • MB990939: Brass Bar • MB990941: Torque Tube Bearing Installer • MB991006: Preload Socket • MB991120: Needle Bearing Puller • MB991152: Dust Cover Installer • MB991197: Bar (Long type) • MB991199: Oil Seal Installer • MB991202: Oil Seal and Bearing Installer • MB991203: Oil Seal and Bearing Installer • MB991204: Torque Wrench Socket • MB991213: Rack Installer • MB991317: Seal Ring Installer • MB991561: Boot Band Crimping Tool

LUBRICATION AND SEALING POINTS

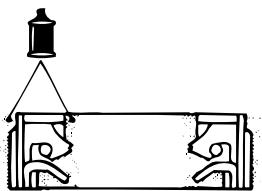

FLUID:
GENUINE MITSUBISHI POWER STEERING FLUID

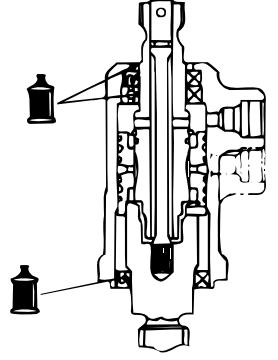

FLUID:
GENUINE MITSUBISHI POWER STEERING FLUID

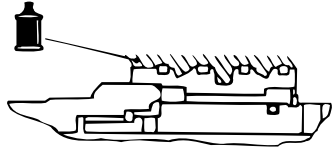

FLUID:
GENUINE MITSUBISHI POWER STEERING FLUID

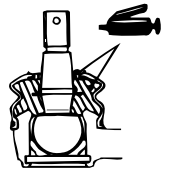
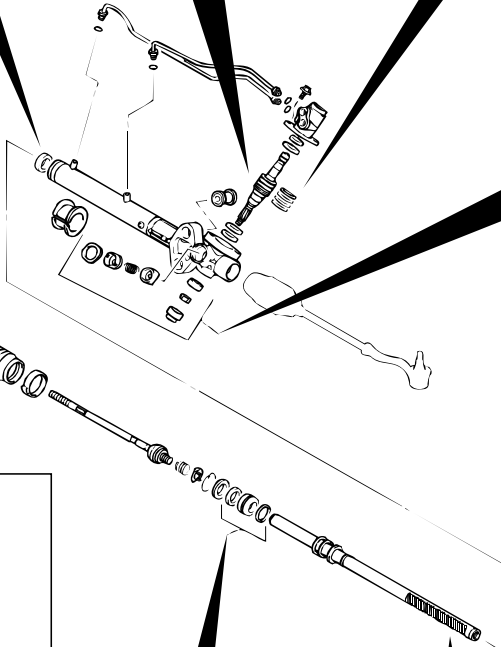
CAUTION
SEALANT MARKED BY * SHOULD BE APPLIED AROUND THE THREAD. ALSO ENSURE THAT THE SEALANT DOES NOT ENTER THE GEAR HOUSING.

SEALANT:
3M™ AAD PART NO.8672, 8679, 8678, 8661,8663 OR EQUIVALENT
FLUID:
GENUINE MITSUBISHI POWER STEERING FLUID

AC204330AB

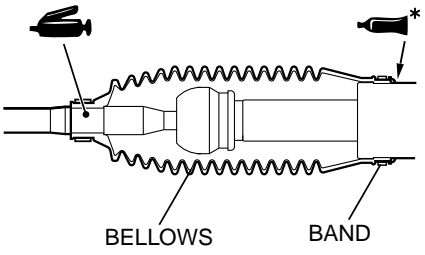

CAUTION
SEALANT MARKED BY * SHOULD BE APPLIED AROUND THE ENTIRE EDGE OF THE LARGER OUTER DIAMETER.

GREASE: SILICONE GREASE
SEALANT: MITSUBISHI GENUINE PART NO. MZ100116EX

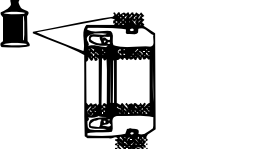

FLUID:
GENUINE MITSUBISHI POWER STEERING FLUID

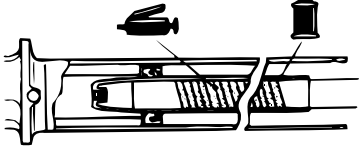

FLUID:
GENUINE MITSUBISHI POWER STEERING FLUID

DISASSEMBLY SERVICE POINTS**<<A>> RACK SUPPORT COVER REMOVAL**

Using special tool MB991204, remove the rack support cover from the gear box.

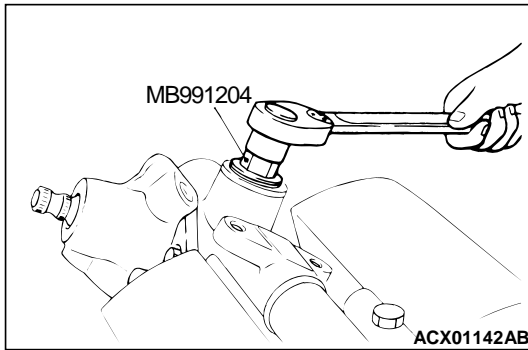
**<> LOWER OIL SEAL/PINION AND VALVE ASSEMBLY REMOVAL**

Using a plastic hammer, gently tap the pinion to remove it.

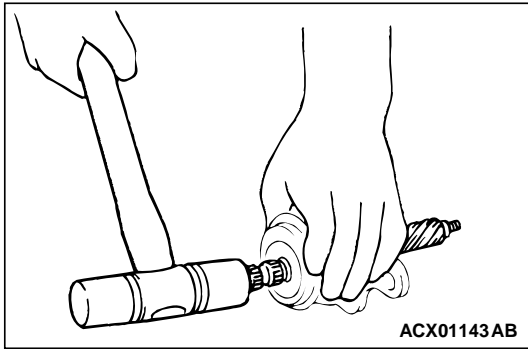
**<<C>> SEAL RING REMOVAL****⚠ CAUTION**

When cutting the seal ring, be careful not to damage the pinion and valve assembly or the rack.

Cut the seal ring and remove it from the pinion and valve assembly and the rack.

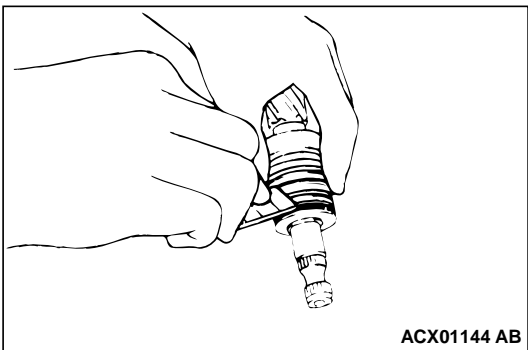

<<D>> UPPER BEARING/UPPER OIL SEAL REMOVAL

Using a socket, remove the oil seal and the ball bearing from the valve housing simultaneously.

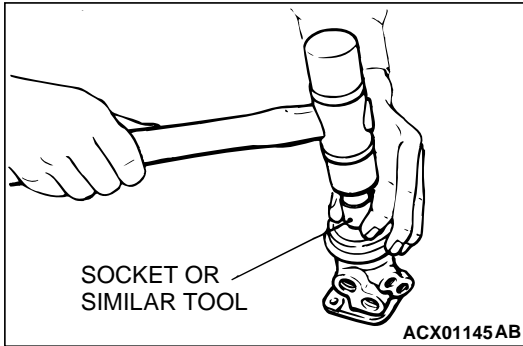

<<E>> CIRCLIP REMOVAL

CAUTION

If the rack stopper is first turned counterclockwise, the circlip will get caught in the slot in the housing and the rack stopper will not turn.

1. Turn the rack stopper clockwise until the end of the circlip comes out of the slot in the rack housing.
2. Turn the rack stopper counterclockwise to remove the circlip.

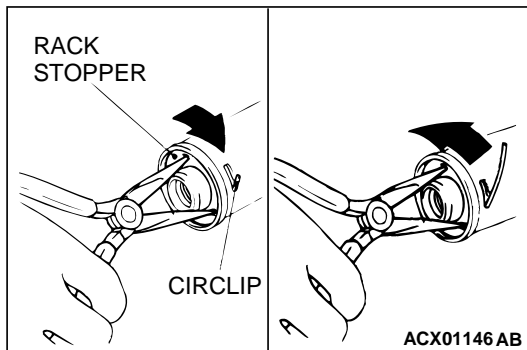

<<F>> RACK STOPPER/RACK BUSHING/OIL SEAL/O-RING/RACK ASSEMBLY REMOVAL

CAUTION

Do not damage the press-in portion of the oil seal on the rack bush.

1. Pull out the rack assembly carefully and take out the rack stopper, rack bush, oil seal and O-ring at the same time.

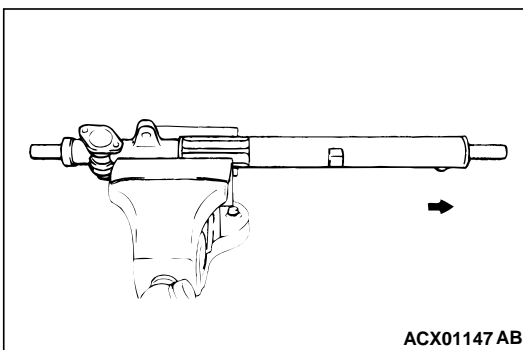

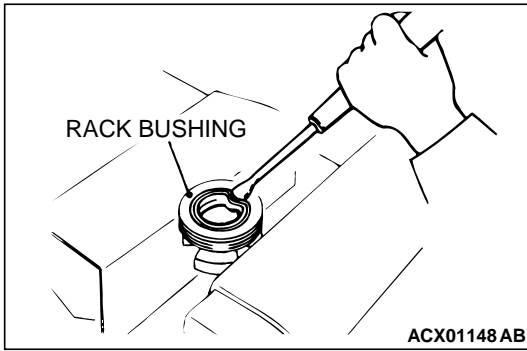

2. Bend a portion of the oil seal to remove it from the rack bushing.

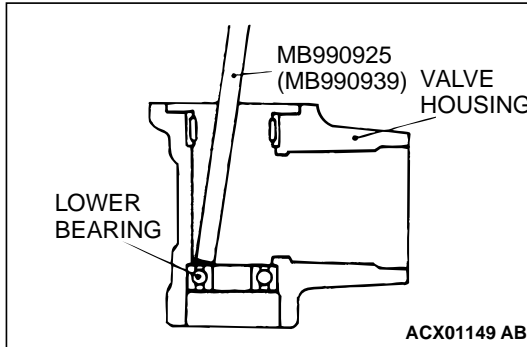

<<G>> LOWER BEARING REMOVAL

Use a brass bar or special tool MB990939 to remove the ball bearing from the gear housing.

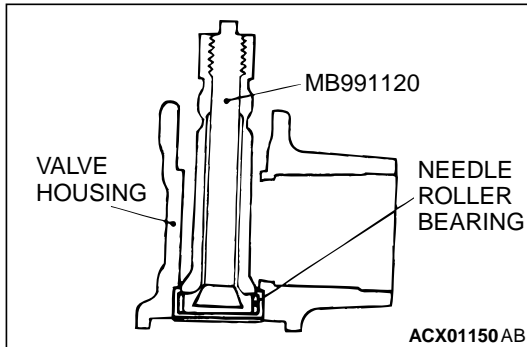

<<H>> NEEDLE BEARING REMOVAL

⚠ CAUTION

Do not open special tool MB991120 excessively to prevent damaging housing interior.

Use special tool MB991120 to remove the needle roller bearing from the rack housing.

<<I>> OIL SEAL REMOVAL

⚠ CAUTION

Be careful not to damage the inner surface of the rack cylinder of the gear housing.

Use a piece of pipe or similar tool to remove the oil seal from the gear housing.

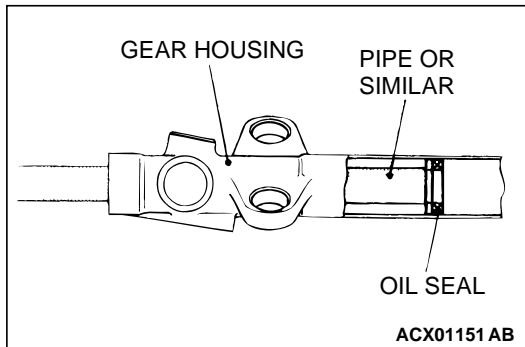

ASSEMBLY SERVICE POINTS

>>A<< OIL SEAL INSTALLATION

1. Apply a coating of GENUINE MITSUBISHI POWER STEERING FLUID to the both sides of the oil seal.
2. Using special tools MB991199 and MB991197, press the oil seal into the rack housing.

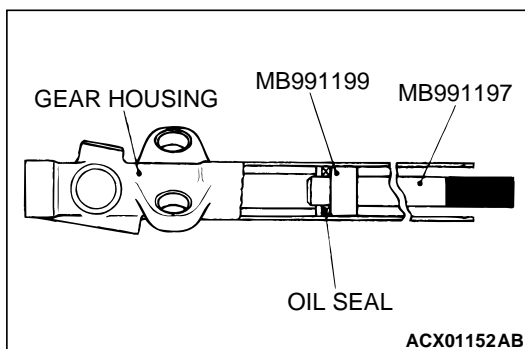

>>B<< NEEDLE BEARING/LOWER BEARING INSTALLATION

1. Apply GENUINE MITSUBISHI POWER STEERING FLUID to housing, bearing and oil seal press fitting surface.

⚠ CAUTION

Press-fit straight. The valve housing is aluminum, and may become deformed if press-fit on an angle.

2. Press fit needle roller bearing with special tools MB990938 and MB991202.

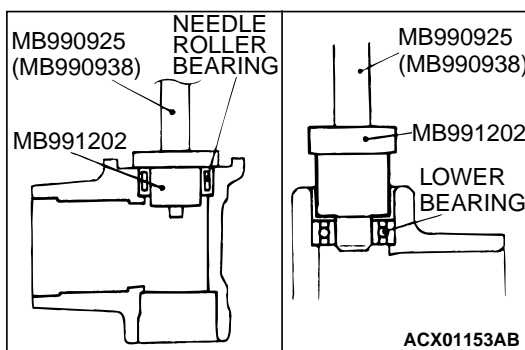

>>C<< RACK ASSEMBLY INSTALLATION

⚠ CAUTION

Do not plug the vent hole in the rack with grease.

1. Apply a coating of multipurpose grease to the rack assembly teeth face.

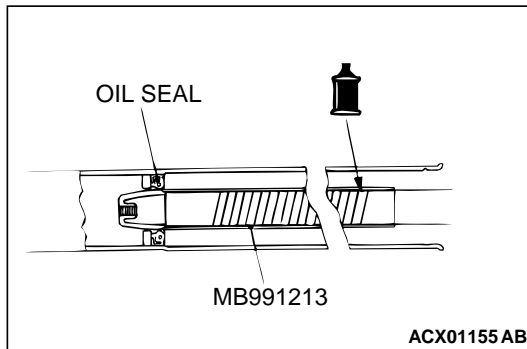
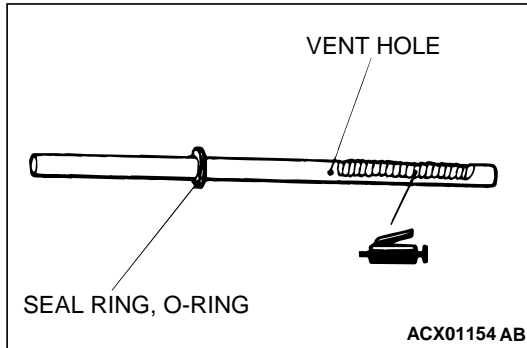

2. Cover rack serrations with special tool MB991213.
3. Apply GENUINE MITSUBISHI POWER STEERING FLUID to special tool MB991213.

⚠ CAUTION

When inserting the rack, carefully push in while aligning the center of the oil seal and the tip of special tool MB991213 so that the oil seal retainer spring does not fall out.

4. Align the center of the oil seal with the rack to prevent the retainer spring from slipping. Slowly insert the rack from power cylinder side.

>>D<< OIL SEAL/RACK BUSHING INSTALLATION

1. Use special tool MB990925 to press fit oil seal until it touches rack bush end.
2. Apply a coating of GENUINE MITSUBISHI POWER STEERING FLUID to the outside of the oil seal and O-ring.

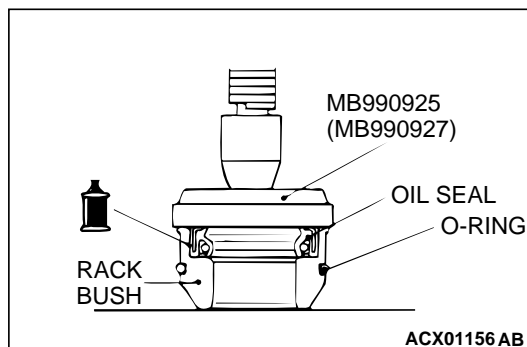

⚠ CAUTION

Do not allow oil seal retainer spring to slip out.

3. Wrap the rack end with vinyl tape, apply a coating of GENUINE MITSUBISHI POWER STEERING FLUID, and then install the rack bushing and rack stopper.

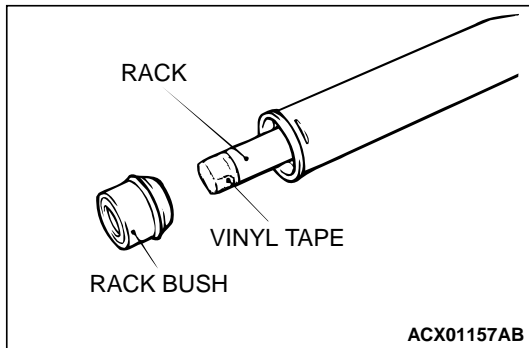

>>E<< CIRCLIP INSTALLATION

⚠ CAUTION

Insert the circlip to the rack stopper hole while turning the rack stopper clockwise.

Insert the circlip to the rack stopper hole through cylinder hole. Turn the rack stopper clockwise and insert the circlip firmly.

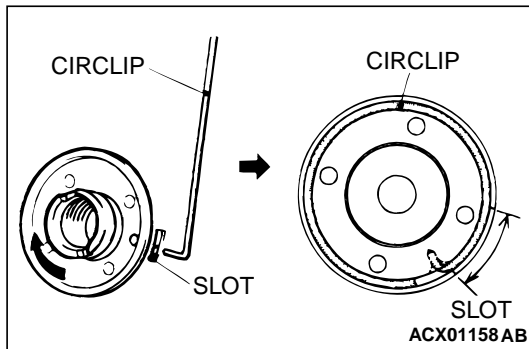

>>F<< UPPER OIL SEAL/UPPER BALL BEARING INSTALLATION

Apply a coating of GENUINE MITSUBISHI POWER STEERING FLUID to the outside of the oil seal. Using special tools MB990938 and MB991203, press the oil seal into the valve housing.

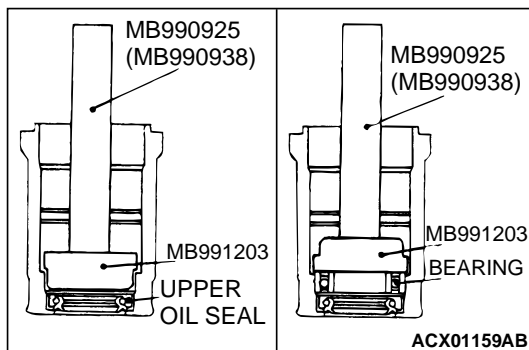

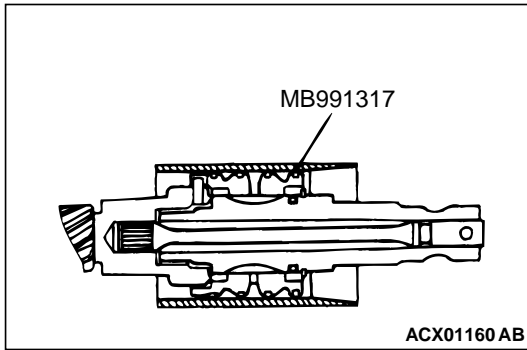
**>>G<< SEAL RING INSTALLATION**

Because the seal rings expand after installation, tighten after installing by using special tool MB991317 to compress the rings, or press down by hand.

>>H<< LOWER OIL SEAL INSTALLATION**⚠ CAUTION**

To eliminate a seal malfunction at the valve housing alignment surface, the upper surface of the oil seal should project outward approximately 1 mm (0.04 inch) from the housing edge surface.

Using special tool MB990941, press the oil seal into the valve housing.

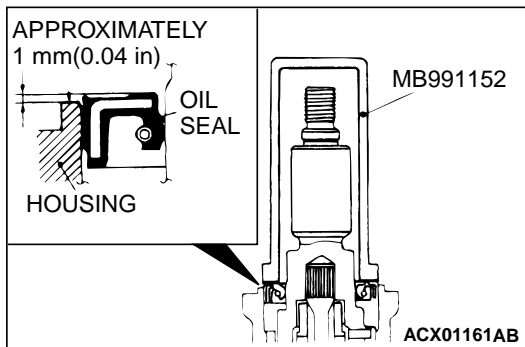
**>>I<< END PLUG INSTALLATION****⚠ CAUTION**

Apply the sealant to the entire threaded part. Ensure that no excess is squeezed out into the gear housing.

1. Apply 3M™ AAD Part number 8672, 8679, 8678, 8663, 8661 or equivalent to the threaded part of the end plug.
2. Secure the threaded portion of the end plug at two places by using a punch.

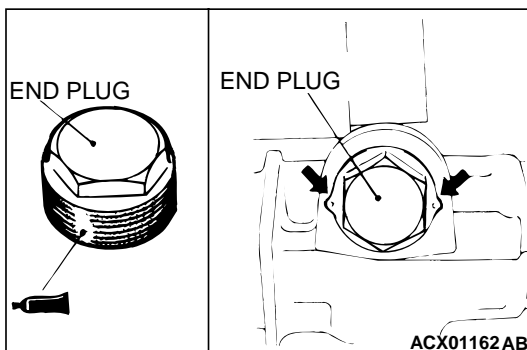
**>>J<< RACK SUPPORT COVER/LOCK NUT INSTALLATION****⚠ CAUTION**

Apply the sealant to the entire threaded part. Ensure that no excess is squeezed out into the gear housing.

1. Apply 3M™ AAD Part number 8672, 8679, 8678, 8663, 8661 or equivalent to the threaded part of the rack support cover.

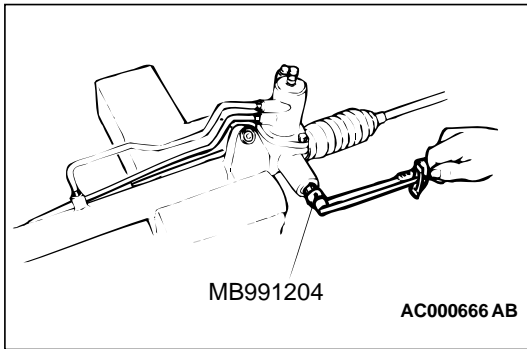

2. Use special tool MB991204 to tighten the rack support cover to 12 ± 2 N·m (106 ± 21 in-lb).
3. Turn the rack support cover 10 degree angle counterclockwise.
4. Use special tool MB991204 to hold the rack support cover, and then tighten the lock nut to 59 ± 10 N·m (44 ± 7 ft-lb).

>>K<< TOTAL PINION TORQUE ADJUSTMENT

CAUTION

- Be sure there is no ratcheting or catching when operating the rack towards the shaft.
- Measure the total pinion torque through the whole stroke of the rack.

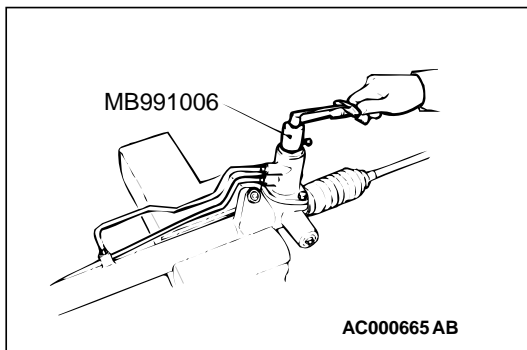

1. Using special tool MB991006, rotate the pinion shaft at the rate of one rotation in four to six seconds to check the total pinion torque and the change in torque.

Standard value:

- Total pinion torque: $0.6 - 1.7$ N·m ($5.3 - 15.0$ in-lb)
- [Change in torque: 0.4 N·m (3.5 in-lb) or less]

CAUTION

When adjusting, set at the highest value of the standard value range.

2. If the total pinion torque or the change in torque is outside the standard value, move the rack support cover 0 – 30 degree angle, and adjust the pinion torque again.

NOTE: If the total pinion torque cannot be adjusted to the standard value within the specified return angle, check the rack support cover components and replace any parts if necessary.

>>L<< TAB WASHER/TIE ROD INSTALLATION

After installing the tie rod to the rack, fold tab washer end (two locations) to tie rod notch.

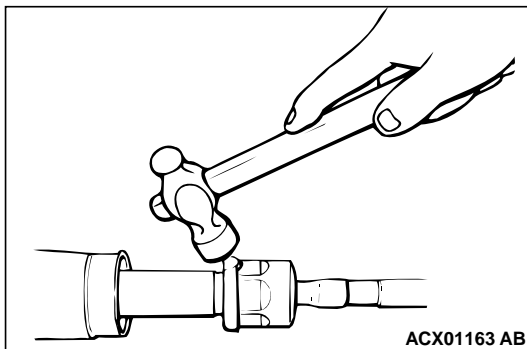

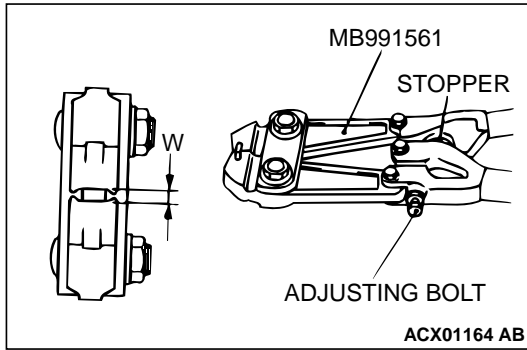
**>>M<< BELLOWS BAND INSTALLATION**

1. Turn the adjusting bolt of special tool MB991561 to adjust the opening dimension (W) to the standard value.

NOTE: The dimension (W) is adjusted by approximately 0.7 mm (0.03 inch) per one turn.

NOTE: Do not turn the adjusting bolt more than one turn.

Standard value (W): 2.9 mm (0.11 inch)

<When more than 2.9 mm (0.11 inch)>: Screw in the adjusting bolt.

<When less than 2.9 mm (0.11 inch)>: Loosen the adjusting bolt.

⚠ CAUTION

- Hold the rack housing, and use special tool MB991561 to crimp the bellows band securely.
- Crimp the bellows band until special tool MB991561 touches the stopper.

2. Use special tool MB991561 to crimp the bellows band.

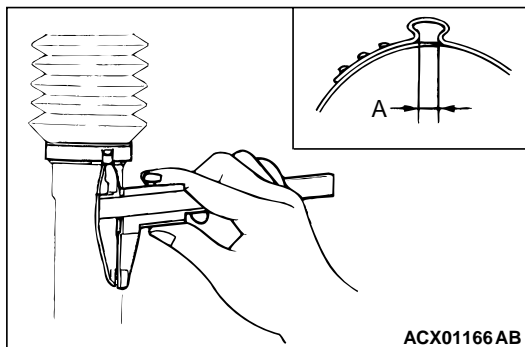
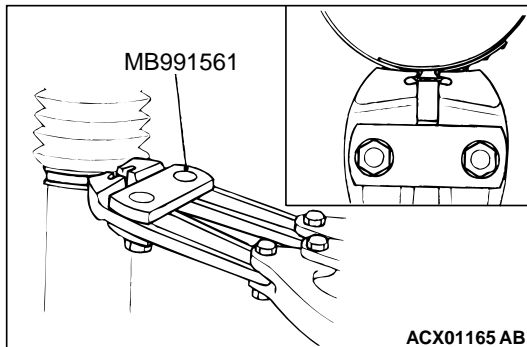

3. Check that crimped width (A) is within the standard value.

Standard value (A): 2.4 – 2.8 mm (0.09 – 0.11 inch)

<When more than 2.8 mm (0.11 inch)>: Readjust the dimension (W) of step (1) to the value calculated by the following equation, and repeat step (2).

$$W = 5.5 \text{ mm (0.22 inch)} - A$$

[Example: if (A) is 2.9 mm (0.11 inch), (W) is 2.6 mm (0.10 inch).]

<When less than 2.4 mm (0.09 inch)>: Remove the bellows band, readjust the dimension (W) of step (1) to the value calculated by the following equation, and use a new bellows band to repeat steps (2) to (3).

$$W = 5.5 \text{ mm (0.22 inch)} - A$$

[Example: if (A) is 2.3 mm (0.09 inch), (W) is 3.2 mm (0.13 inch).]

**>>N<< TIE ROD END/TIE ROD END JUM NUT
INSTALLATION**

Screw in the tie rod end to achieve the right and left length as illustrated. Lock with the lock nut.

NOTE: Tighten the locknut to the specified torque after installing the gear box assembly onto the body and adjusting the toe-in.

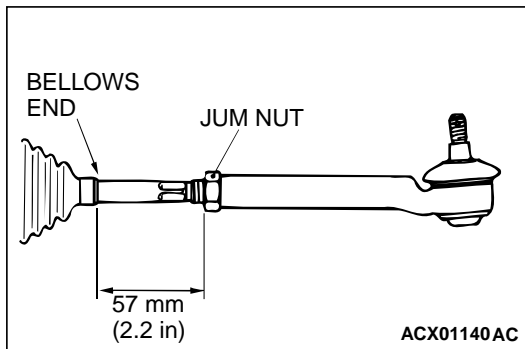

>>O<< GEAR MOUNT RUBBER INSTALLATION

Install the gear mount rubber on the race housing so that the dimension shown in the illustration can be obtained.

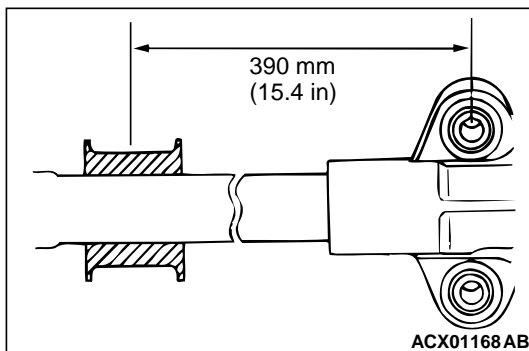

**TIE ROD END BALL JOINT DUST COVER
REPLACEMENT**

M1372008200253

If the dust cover is damaged accidentally during service work, replace the dust cover as follows:

1. Remove the clip ring and then remove the dust cover.

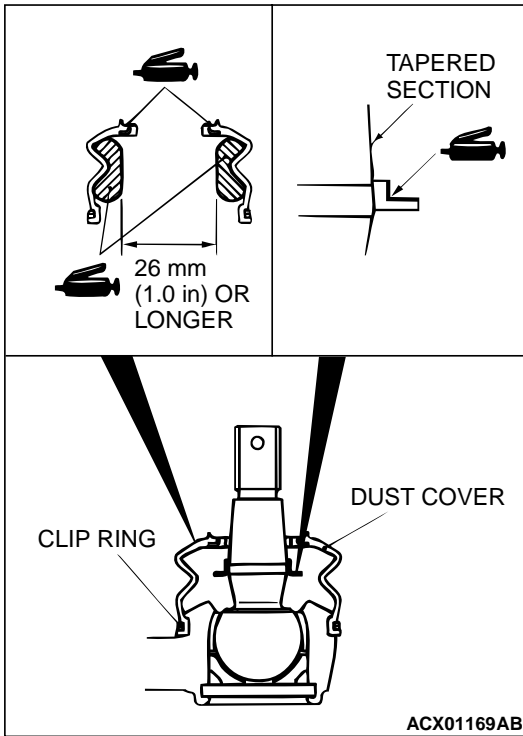

2. Apply multipurpose grease to the lip and inside of the dust cover.

CAUTION

Do not leave grease on the threaded and the knuckle connecting portion (tapered portion) of the ball joint. If grease is on those portions, wipe it off thoroughly.

3. Apply multipurpose grease on the top of the dust cover and the ball joint stud retainer.

4. Wrap the stud screw portion of the tie rod end ball joint with vinyl tape to install the dust cover on the tie rod end ball joint.

5. Secure the dust cover with the clip ring.

CAUTION

To prevent grease from contacting the knuckle connection portion (tapered portion) of the ball joint, do not compress the dust cover before installing on the vehicle.

6. Check the dust cover for cracks or damage by pushing it with your finger.

POWER STEERING OIL PUMP ASSEMBLY

REMOVAL AND INSTALLATION

M1372005200221

Pre-removal Operation

- Removal of Battery and Battery Tray
- Power Steering Fluid Draining (Refer to P.37A-19.)

Post-installation Operation

- Power Steering Fluid Line Bleeding (Refer to P.37A-19.)
- Installation of Battery and Battery Tray
- Drive Belt Tension Check (Refer to P.37A-18.)

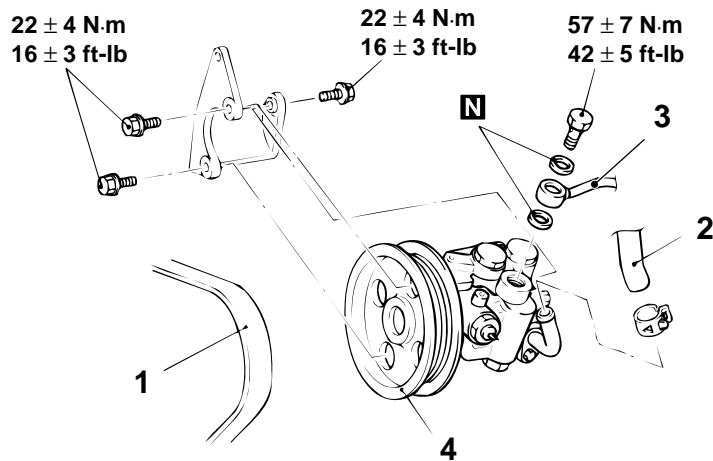

AC000667AB

REMOVAL STEPS

1. DRIVE BELT (REFER TO GROUP 11A, TIMING BELT P.11A-33.)
2. CONNECTION OF SUCTION HOSE

REMOVAL STEPS (Continued)

3. CONNECTION OF PRESSURE TUBE
4. OIL PUMP ASSEMBLY

DISASSEMBLY AND ASSEMBLY

M1372005400236

CAUTION

Never disassemble the terminal assembly. It cannot be reassembled.

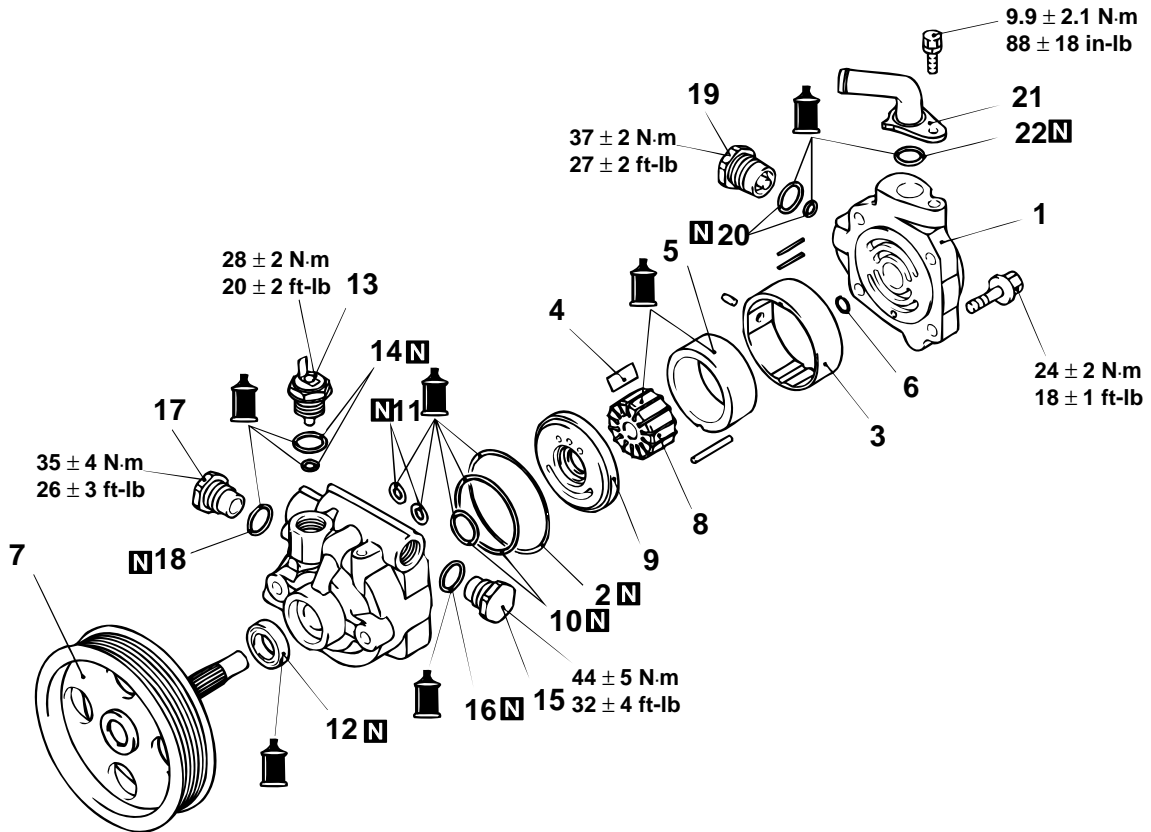

: GENUINE MITSUBISHI POWER STEERING FLUID

<p>OIL PUMP SEAL KIT</p>	<p>OIL PUMP CARTRIDGE KIT</p>	<p>OIL PUMP PULLEY AND SHAFT KIT</p>

ACX01167 AC

DISASSEMBLY STEPS

1. PUMP COVER
- >>E<< 2. O-RING
- >>D<< 3. ADAPTER RING
4. VANES
5. CAM RING
6. SNAP RING

DISASSEMBLY STEPS (Continued)

7. PULLEY AND SHAFT
- >>C<< 8. ROTOR
- >>A<< 9. SIDE PLATE
- >>A<< 10. O-RING
- >>B<< 11. O-RING
12. OIL SEAL

DISASSEMBLY STEPS (Continued)

- 13. TERMINAL ASSEMBLY
- >>A<< 14. O-RING
- 15. INNER PLUG A
- >>A<< 16. O-RING
- 17. INNER PLUG B
- >>A<< 18. O-RING
- 19. INNER PLUG C
- >>A<< 20. O-RING

DISASSEMBLY STEPS (Continued)

- 21. SUCTION CONNECTOR
- >>A<< 22. O-RING

Required Special Tools:

- MB990938: Bearing and Oil Seal Installer
- MB991203: Oil Seal and Bearing Installer

ASSEMBLY SERVICE POINTS

>>A<< O-RING INSTALLATION

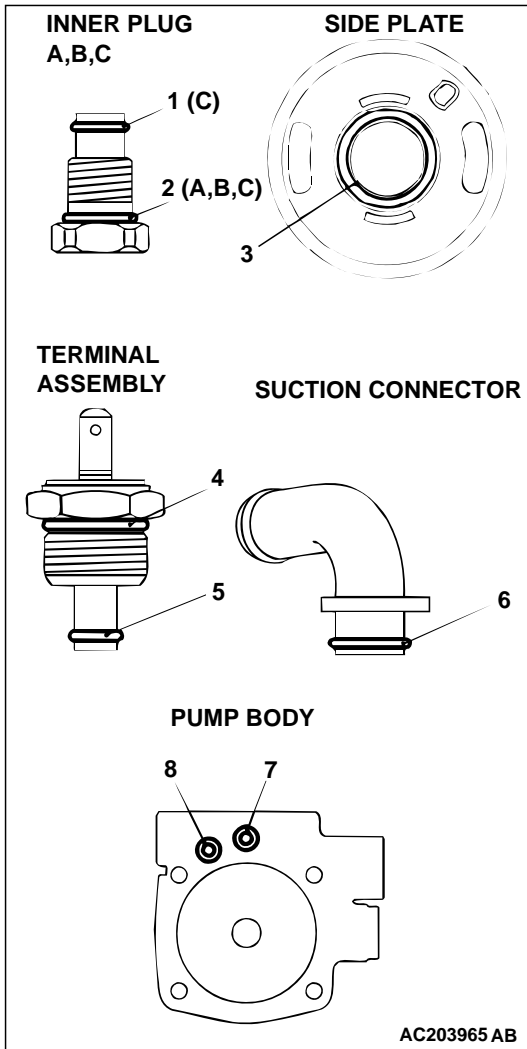

NO.		ID × WIDTH mm (in)
1		6.8 × 1.9 (0.27 × 0.07)
2	INNER PLUG A, C	12.4 × 2.6 (0.49 × 0.10)
	INNER PLUG B	14.8 × 2.4 (0.58 × 0.09)
3		21 × 1.9 (0.83 × 0.07)
4		14.8 × 1.9 (0.58 × 0.07)
5		3.8 × 1.9 (0.15 × 0.07)
6		15.8 × 2.4 (0.62 × 0.09)
7		9.8 × 1.9 (0.39 × 0.07)
8		6.8 × 1.9 (0.27 × 0.07)

>>B<< OIL SEAL INSTALLATION

Use special tool MB991203 and MB990938 to install the oil seal.

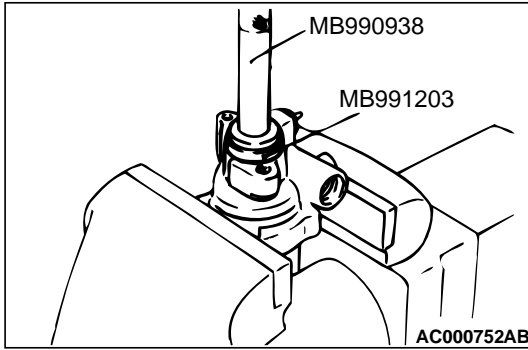

>>C<< ROTOR INSTALLATION

Install the rotor to the pulley assembly so that the rotor's punch mark is at the pump cover side.

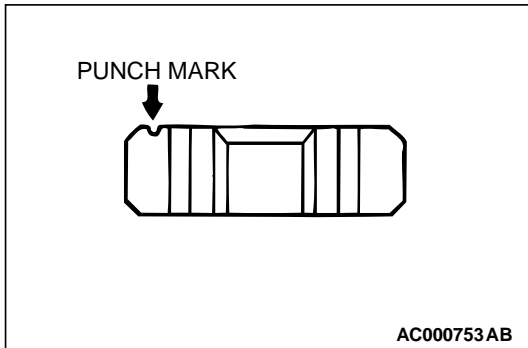

>>D<< CAM RING INSTALLATION

Install the cam ring with its identification mark towards the side plate.

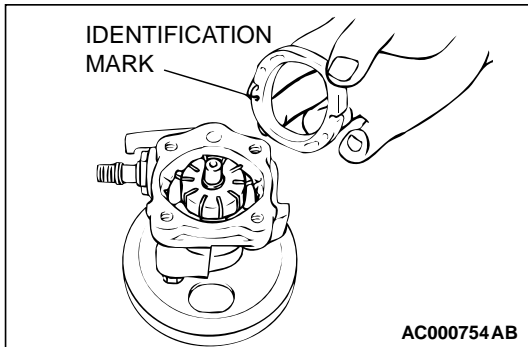

>>E<< VANE INSTALLATION

Install the vane to the rotor with its round edge outwards (facing towards cam ring).

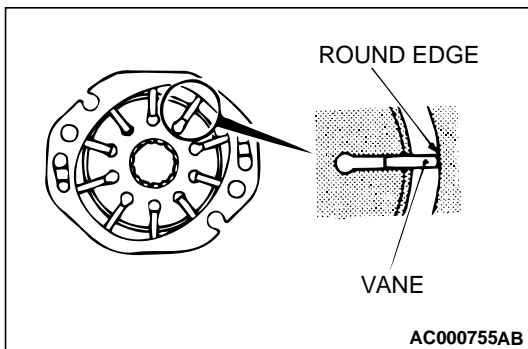

INSPECTION

- Check the valve subassembly for clogging.

M1372005500170

- Check the driveshaft assembly for wear or damage.
- Check the rotor and vane groove for "stepped" wear.
- Check the contact surface of cam ring and vanes for "stepped" wear.
- Check the vanes for damage.

POWER STEERING HOSES

REMOVAL AND INSTALLATION

M1372005700282

Pre-removal Operation

- Under Cover Removal
- Power Steering Fluid Draining (Refer to P.37A-19.)
- Removal of Battery and Battery Tray
- Removal of Condenser Tank (Refer to GROUP 14, Radiator P.14-8.)

Post-installation Operation

- Installation of Condenser Tank (Refer to GROUP 14, Radiator P.14-8.)
- Installation of Battery and Battery Tray
- Power Steering Fluid Line Bleeding (Refer to P.37A-19.)
- Under Cover Installation
- Drive Belt Tension Check (Refer to P.37A-18.)

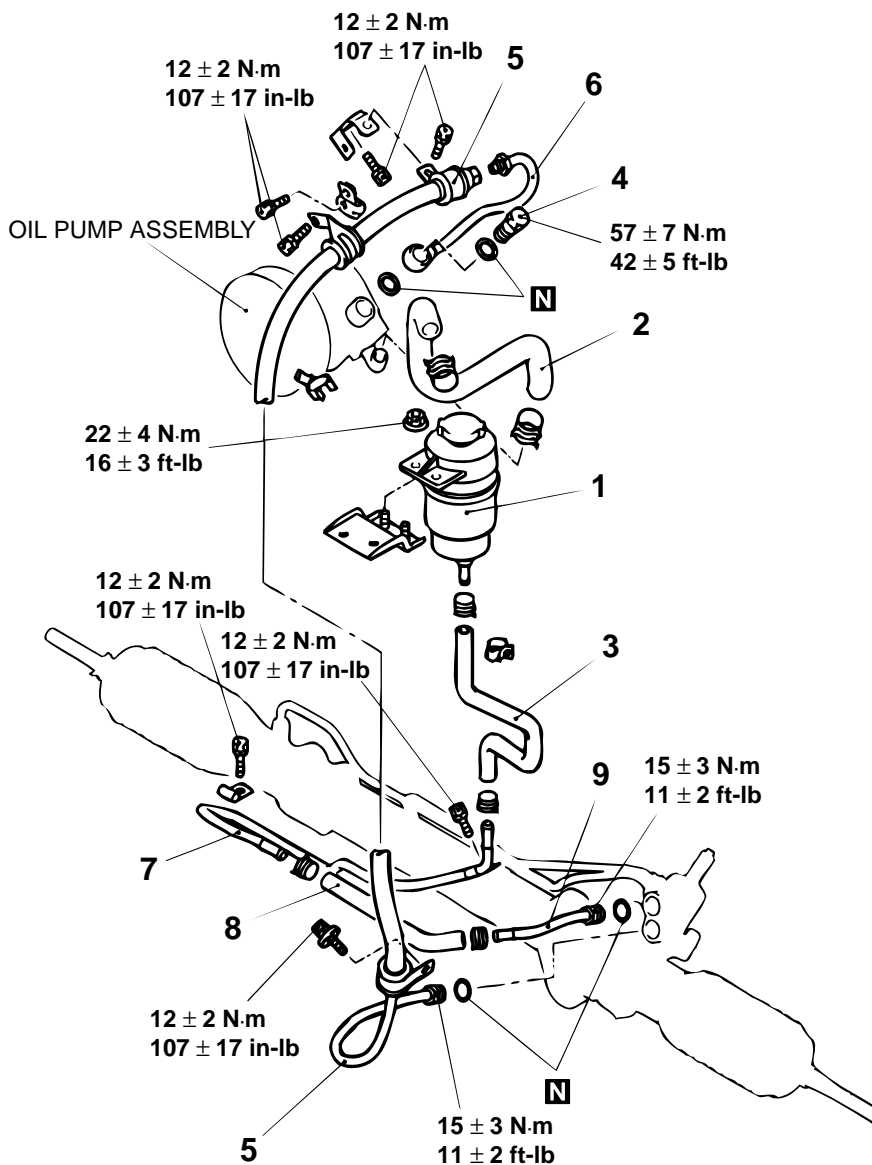

AC000668AB

REMOVAL STEPS

- >>D<< 1. OIL RESERVOIR
>>C<< 2. SUCTION HOSE
>>C<< 3. RETURN HOSE B
4. TUBE CLIP
5. EYE BOLT

REMOVAL STEPS (Continued)

- >>A<< 6. PRESSURE HOSE ASSEMBLY
>>A<< 7. PRESSURE TUBE
>>B<< 8. COOLER TUBE
>>B<< 9. RETURN HOSE A
>>A<< 10. RETURN TUBE

INSTALLATION SERVICE POINTS

>>A<< RETURN TUBE / PRESSURE TUBE / PRESSURE HOSE ASSEMBLY INSTALLATION

1. Align the markings on the gearbox side and the tube side to install.

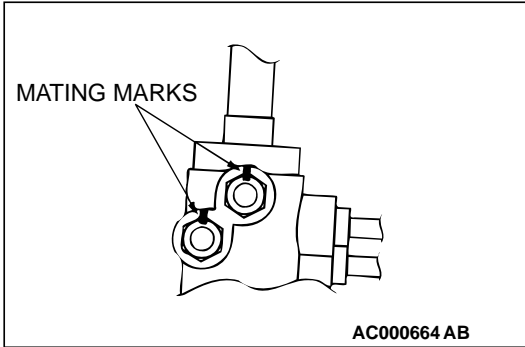

2. Install the pressure hose assembly and the pressure tube with the mating marks facing upward.

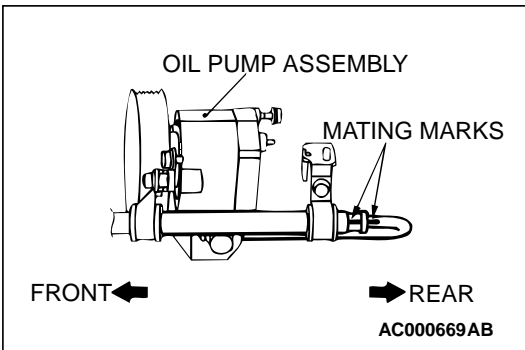

>>B<< RETURN HOSE A / COOLER TUBE INSTALLATION

Install them with the mating marks facing upward.

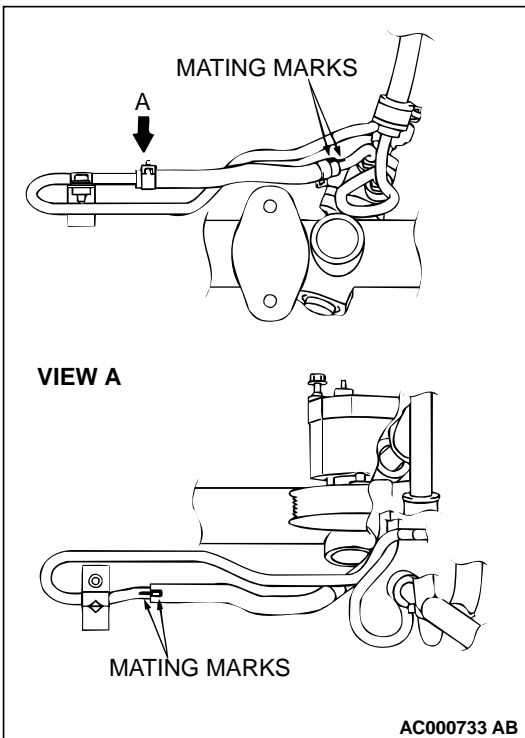

>>C<< RETURN HOSE B INSTALLATION

Install it with the mating mark facing backward.

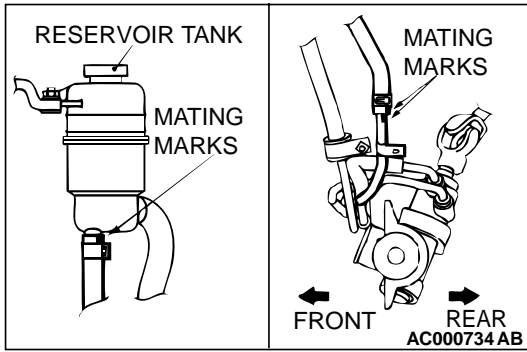

>>D<< SUCTION HOSE INSTALLATION

Install it with the mating mark facing outward.

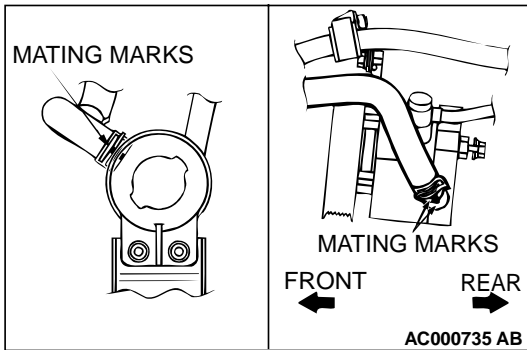

SPECIFICATIONS**FASTENER TIGHTENING SPECIFICATIONS**

M1372008400268

ITEM	SPECIFICATION
Power steering oil pump	
Eye bolt	57 ± 7 N·m (42 ± 5 ft-lb)
Inner plug assembly A	44 ± 5 N·m (32 ± 4 ft-lb)
Inner plug assembly B	35 ± 4 N·m (26 ± 3 ft-lb)
Inner plug assembly C	37 ± 2 N·m (27 ± 2 ft-lb)
Oil pump bracket and oil pump assembly connection bolt	22 ± 4 N·m (16 ± 3 ft-lb)
Oil pump case connection bolt	24 ± 2 N·m (18 ± 1 ft-lb)
Suction connector bolt	9.9 ± 2.1 N·m (88 ± 18 in-lb)
Terminal assembly	28 ± 2 N·m (20 ± 2 ft-lb)
Power steering hose	
Eye bolt	57 ± 7 N·m (42 ± 5 ft-lb)
Oil reservoir bracket bolt	22 ± 4 N·m (16 ± 3 ft-lb)
Pressure hose bracket bolt	12 ± 2 N·m (107 ± 17 in-lb)
Pressure hose	15 ± 3 N·m (11 ± 2 ft-lb)
Return tube	15 ± 3 N·m (11 ± 2 ft-lb)
Tube clip bolt	12 ± 2 N·m (107 ± 17 in-lb)
Power steering gear box	
End plug	59 ± 10 N·m (44 ± 7 ft-lb)
Flare nut	15 ± 3 N·m (11 ± 2 ft-lb)
Gear box assembly installation bolt	69 ± 10 N·m (51 ± 7 ft-lb)
Gear box clamp installation bolt	69 ± 10 N·m (51 ± 7 ft-lb)
Knuckle and tie rod connection bolt	39 ± 5 N·m (29 ± 3 ft-lb)
Lock nut A	59 ± 10 N·m (44 ± 7 ft-lb)
Lock nut B	25 ± 4 N·m (18 ± 3 ft-lb)
Pressure hose assembly	15 ± 3 N·m (11 ± 2 ft-lb)
Pressure hose assembly installation bolt	12 ± 2 N·m (107 ± 17 in-lb)
Return tube and gear box connection bolt	15 ± 3 N·m (11 ± 2 ft-lb)
Steering gear and joint assembly connection	18 ± 2 N·m (13 ± 2 ft-lb)
Tie rod	88 ± 10 N·m (65 ± 7 ft-lb)
Tie rod end lock nut	71 ± 7 N·m (53 ± 5 ft-lb)
Valve housing assembly installation bolt	22 ± 4 N·m (16 ± 3 ft-lb)
Power steering wheel and shaft	
Air bag module installation bolt	50 ± 5 N·m (37 ± 4 in-lb)
Steering column installation bolt	22 ± 4 N·m (16 ± 3 ft-lb)
Steering dynamic damper installation bolt	13 ± 2 N·m (115 ± 18 in-lb)
Steering shaft cover installation bolt	5.0 ± 1.0 N·m (44 ± 9 in-lb)
Steering shaft support bracket and front frame assembly installation bolt	13 ± 2 N·m (115 ± 18 in-lb)

ITEM	SPECIFICATION
Steering shaft support bracket installation bolt	13 ± 2 N·m (115 ± 18 in-lb)
Joint assembly and steering gear box installation bolt	18 ± 4 N·m (29 ± 3 ft-lb)
Joint assembly and steering shaft installation bolt	18 ± 2 N·m (13 ± 2 ft-lb)

GENERAL SPECIFICATIONS

M1372000200226

ITEM	SPECIFICATION	
Power steering gear box	Type	Rack and pinion
	Gear ratio	45.95
Oil pump	Type	Vane type
	Displacement cm ³ /rev (cu in/rev)	9.6 (0.59)
	Relief set pressure MPa (psi)	8.8 (1,276)

SERVICE SPECIFICATIONS

M1372000300290

ITEM	STANDARD VALUE	LIMIT
Steering wheel free play mm (in)	With engine running	–
	With engine stopped	10 (0.4) or less
Steering angle	Inside wheel	36°30' ± 1°30'
	Outside wheel (reference)	31°40'
Tie rod end ball joint breakaway torque N·m (in-lb)	0.49 – 2.45 (4.3 – 21.7)	–
Tie rod swing resistance N (lb) [N·m (in-lb)]	11 – 35 (35.4 – 82.7) [1.4 – 4.9 (12.4 – 43.4)]	–
Engine idle speed r/min	1,000 ± 100	–
Stationary steering effort N (lb) [Fluctuation allowance N (lb)]	39.2 (8.8) or less [5.9 (1.33)]	–
Oil pump pressure MPa (psi)	Oil pump relief pressure	8.3 – 9.0 (1,209 – 1,305)
	Pressure under no-load conditions	0.34(49.3)
	Steering gear retention hydraulic pressure	8.3 – 9.0 (1,209 – 1,305)
Oil pressure switch operating pressure MPa (psi)	OFF → ON	1.5 – 2.0 (217 – 290)
	ON → OFF	1.5 – 2.0 (217 – 290)
Gear box total pinion torque N·m (in-lb) [Change in torque: 0.7 N·m (6.1 in-lb) or less]	0.6 – 1.7 (5.3 – 15.0)	–
Opening dimension of special tool MB991561 mm (in)	2.9 (0.11)	–
Band crimped width mm (in)	2.4 – 2.8 (0.09 – 0.11)	–

LUBRICANTS

M1372000400264

ITEM	SPECIFIED LUBRICANT	QUANTITY dm ³ (qt)
Power steering fluid	GENUINE MITSUBISHI POWER STEERING FLUID	Approximately 0.6 (0.63)
O-ring, oil seal, rack bushing, bearing, spool assembly, cam ring, rotor	GENUINE MITSUBISHI POWER STEERING FLUID	As required

SEALANTS

M1372000500250

ITEM	SPECIFIED SEALANT	REMARK
End plug, rack support cover	3M™ AAD Part No.8672, 8679, 8678, 8661, 8663 or equivalent	Semi-drying sealant
Bellows	MITSUBISHI GENUINE PART NO. MZ100116EX	—