

# GROUP 54A

# CHASSIS

# ELECTRICAL

## CONTENTS

<b>BATTERY</b> .....	<b>54A-4</b>	DIAGNOSTIC TROUBLE CODE PROCEDURES .....	54A-9
<b>ON-VEHICLE SERVICE</b> .....	<b>54A-4</b>	SYMPTOM CHART .....	54A-12
BATTERY CHECK* .....	54A-4	SYMPTOM PROCEDURES .....	54A-13
BATTERY CHARGING .....	54A-5	<b>DATA LIST REFERENCE TABLE</b> .	54A-21
BATTERY TEST .....	54A-6	<b>CHECK AT IMMOBILIZER-ECU</b> ..	54A-21
<b>IGNITION SWITCH</b> .....	<b>54A-7</b>	<b>SPECIAL TOOLS</b> .....	54A-22
<b>GENERAL DESCRIPTION</b> .....	54A-7	<b>ON-VEHICLE SERVICE</b> .....	54A-22
<b>IGNITION KEY REMINDER TORN ALARM DIAGNOSIS</b> .....	54A-7	ENCRYPTED CODE REGISTRATION METHOD .....	54A-22
<b>IMMOBILIZER SYSTEM DIAGNOSIS</b> .....	54A-7	<b>IGNITION SWITCH</b> .....	54A-30
INTRODUCTION TO IMMOBILIZER SYSTEM DIAGNOSIS .....	54A-7	REMOVAL AND INSTALLATION .....	54A-30
IMMOBILIZER SYSTEM DIAGNOSTIC TROUBLESHOOTING STRATEGY ...	54A-7	INSPECTION .....	54A-31
IMMOBILIZER SYSTEM TROUBLE CODE DIAGNOSIS .....	54A-8	<b>COMBINATION METERS ASSEMBLY AND VEHICLE SPEED SENSOR</b> .....	<b>54A-32</b>
DIAGNOSTIC TROUBLE CODE CHART .....	54A-8		

Continued on next page

### WARNINGS REGARDING SERVICING OF SUPPLEMENTAL RESTRAINT SYSTEM (SRS) EQUIPPED VEHICLES

#### **WARNING**

- *Improper service or maintenance of any component of the SRS, or any SRS-related component, can lead to personal injury or death to service personnel (from inadvertent firing of the air bag) or to the driver and passenger (from rendering the SRS inoperative).*
- *Service or maintenance of any SRS component or SRS-related component must be performed only at an authorized MITSUBISHI dealer.*
- *MITSUBISHI dealer personnel must thoroughly review this manual, and especially its GROUP 52B - Supplemental Restraint System (SRS) before beginning any service or maintenance of any component of the SRS or any SRS-related component.*

#### NOTE

The SRS includes the following components: SRS air bag control unit, SRS warning light, front impact sensors, air bag module, clock spring, and interconnecting wiring. Other SRS-related components (that may have to be removed/installed in connection with SRS service or maintenance) are indicated in the table of contents by an asterisk (\*).

COMBINATION METERS ASSEMBLY AND VEHICLE SPEED SENSOR DIAGNOSIS .....	54A-32	<b>REAR COMBINATION LIGHT .</b>	<b>54A-77</b>
INTRODUCTION TO COMBINATION METER DIAGNOSIS.....	54A-32	<b>LIGHTING SYSTEM DIAGNOSIS .</b>	54A-77
TROUBLESHOOTING STRATEGY ...	54A-32	<b>REMOVAL AND INSTALLATION*.</b>	54A-78
SYMPTOM CHART .....	54A-32	<b>DOMELIGHT . . . . .</b>	<b>54A-79</b>
SYMPTOM PROCEDURES .....	54A-33	<b>DOMELIGHT DIAGNOSIS.....</b>	54A-79
<b>SPECIAL TOOLS.....</b>	54A-61	<b>HIGH-MOUNTED STOPLIGHT</b>	<b>54A-79</b>
<b>ON-VEHICLE SERVICE.....</b>	54A-61	<b>REMOVAL AND INSTALLATION .</b>	54A-79
SPEEDOMETER CHECK .....	54A-61	<b>SIDE STEP LIGHT . . . . .</b>	<b>54A-80</b>
TACHOMETER CHECK .....	54A-63	<b>GENERAL DESCRIPTION CONCERNING THE SIDE STEP LIGHT . . . . .</b>	54A-80
FUEL LEVEL SENSOR CHECK .....	54A-63	<b>SIDE STEP LIGHT DIAGNOSIS... .</b>	54A-80
ENGINE COOLANT TEMPERATURE GAUGE UNIT CHECK.....	54A-64	INTRODUCTION .....	54A-80
<b>COMBINATION METERS ASSEMBLY AND VEHICLE SPEED SENSOR.....</b>	54A-65	TROUBLESHOOTING STRATEGY....	54A-81
REMOVAL AND INSTALLATION .....	54A-65	SYMPTOM CHART .....	54A-81
INSPECTION.....	54A-66	SYMPTOM PROCEDURES.....	54A-82
DISASSEMBLY AND ASSEMBLY.....	54A-67	<b>SPECIAL TOOL .....</b>	54A-108
<b>HEADLIGHT, FRONT SIDE MARKER LIGHT AND POSITION LIGHT ASSEMBLY . . . . .</b>	<b>54A-68</b>	<b>SIDE STEP LIGHT-ECU INSPECTION . . . . .</b>	54A-108
<b>HEADLIGHT DIAGNOSIS . . . . .</b>	54A-68	<b>ON-VEHICLE SERVICE . . . . .</b>	54A-109
<b>ON-VEHICLE SERVICE.....</b>	54A-68	BULB REPLACEMENT .....	54A-109
HEADLIGHT AIMING.....	54A-68	<b>REMOVAL AND INSTALLATION .</b>	54A-109
LUMINOUS INTENSITY MEASUREMENT.....	54A-70	<b>RHEOSTAT . . . . .</b>	<b>54A-110</b>
BULB REPLACEMENT .....	54A-70	<b>REMOVAL AND INSTALLATION .</b>	54A-110
<b>HEADLIGHT AND FRONT COMBINATION LIGHT . . . . .</b>	54A-71	<b>INSPECTION .....</b>	54A-111
REMOVAL AND INSTALLATION*.....	54A-71	<b>HAZARD WARNING LIGHT SWITCH . . . . .</b>	<b>54A-112</b>
<b>FOG LIGHT . . . . .</b>	<b>54A-72</b>	<b>HAZARD WARNING LIGHT DIAGNOSIS . . . . .</b>	54A-112
<b>FOG LIGHT DIAGNOSIS.....</b>	54A-72	<b>REMOVAL AND INSTALLATION .</b>	54A-112
<b>ON-VEHICLE SERVICE.....</b>	54A-73	<b>INSPECTION .....</b>	54A-113
FOG LIGHT AIMING .....	54A-73		
<b>FOG LIGHT . . . . .</b>	54A-75		
REMOVAL AND INSTALLATION .....	54A-75		
INSPECTION.....	54A-76		

<b>COLUMN SWITCH</b> . . . . .	<b>54A-113</b>	REMOVAL AND INSTALLATION . . . . .	54A-184
REMOVAL AND INSTALLATION . . . . .	54A-113	<b>ANTENNA</b> . . . . .	54A-184
<b>INSPECTION</b> . . . . .	54A-114	REMOVAL AND INSTALLATION . . . . .	54A-184
<b>HORN</b> . . . . .	<b>54A-115</b>	INSPECTION . . . . .	54A-185
<b>HORN DIAGNOSIS</b> . . . . .	54A-115	ANTENNA POLE REPLACEMENT . . . . .	54A-186
<b>REMOVAL AND INSTALLATION</b> . . . . .	54A-115	<b>REAR WINDOW DEFOGGER</b> . . . . .	<b>54A-187</b>
<b>INSPECTION</b> . . . . .	54A-116	<b>ON-VEHICLE SERVICE</b> . . . . .	54A-187
<b>ACCESSORY SOCKET</b> . . . . .	<b>54A-116</b>	PRINTED-HEATER LINES CHECK . . . . .	54A-187
<b>REMOVAL AND INSTALLATION</b> . . . . .	54A-116	<b>REAR WINDOW DEFOGGER</b>	
<b>INSPECTION</b> . . . . .	54A-117	<b>SWITCH</b> . . . . .	54A-188
<b>CIGARETTE LIGHTER</b> . . . . .	<b>54A-117</b>	REMOVAL AND INSTALLATION . . . . .	54A-188
<b>REMOVAL AND INSTALLATION</b> . . . . .	54A-117	INSPECTION . . . . .	54A-188
<b>INSPECTION</b> . . . . .	54A-118	<b>RV METER</b> . . . . .	<b>54A-189</b>
<b>RADIO WITH TAPE PLAYER AND CD</b>		<b>RV METER DIAGNOSIS</b> . . . . .	54A-189
<b>PLAYER</b> . . . . .	<b>54A-118</b>	INTRODUCTION TO RV METER . . . . .	54A-189
<b>GENERAL DESCRIPTION</b> . . . . .	54A-118	SYMPTOM CHART . . . . .	54A-199
<b>RADIO WITH TAPE PLAYER AND CD</b>		SYMPTOM PROCEDURES . . . . .	54A-200
<b>PLAYER, SPEAKER AND ANTENNA</b>		<b>CHECK AT RV METER</b>	
<b>DIAGNOSIS</b> . . . . .	54A-118	<b>TERMINAL</b> . . . . .	54A-230
INTRODUCTION TO AUDIO SYSTEM		<b>SPECIAL TOOLS</b> . . . . .	54A-232
DIAGNOSIS . . . . .	54A-118	<b>ON-VEHICLE SERVICE</b> . . . . .	54A-233
AUDIO SYSTEM DIAGNOSTIC		VEHICLE MAGNETIC	
TROUBLESHOOTING STRATEGY . . . . .	54A-118	COMPENSATION . . . . .	54A-233
TROUBLE SYMPTOM CHART . . . . .	54A-119	<b>MULTI METER ASSEMBLY</b> . . . . .	54A-235
SYMPTOM PROCEDURES . . . . .	54A-120	REMOVAL AND INSTALLATION . . . . .	54A-235
<b>ON-VEHICLE SERVICE</b> . . . . .	54A-181	<b>THEFT ALARM</b> . . . . .	<b>54A-236</b>
SPEAKER TEST . . . . .	54A-181	<b>THEFT-ALARM SYSTEM</b>	
<b>SPECIAL TOOL</b> . . . . .	54A-108	<b>DIAGNOSIS</b> . . . . .	54A-236
<b>RADIO WITH TAPE PLAYER AND CD</b>		<b>REMOVAL AND INSTALLATION</b> . . . . .	54A-236
<b>PLAYER</b> . . . . .	54A-182	<b>INSPECTION</b> . . . . .	54A-237
REMOVAL AND INSTALLATION . . . . .	54A-182	<b>SPECIFICATIONS</b> . . . . .	<b>54A-238</b>
<b>SPEAKER</b> . . . . .	54A-183	<b>FASTENER TIGHTENING</b>	
REMOVAL AND INSTALLATION . . . . .	54A-183	<b>SPECIFICATIONS</b> . . . . .	54A-238
<b>AMPLIFIER</b> . . . . .	54A-184	<b>SERVICE SPECIFICATIONS</b> . . . . .	54A-238
		<b>SEALANT</b> . . . . .	54A-239

# BATTERY

## ON-VEHICLE SERVICE

### BATTERY CHECK

M1541001000193

**⚠ WARNING**

**Battery posts, terminals and related accessories contain lead and lead compounds. WASH HANDS AFTER HANDLING.**

### BATTERY VISUAL INSPECTION (1)

The battery contains a visual test indicator which gives a green signal when an adequate charge level exists, and a dark signal when charging is required.

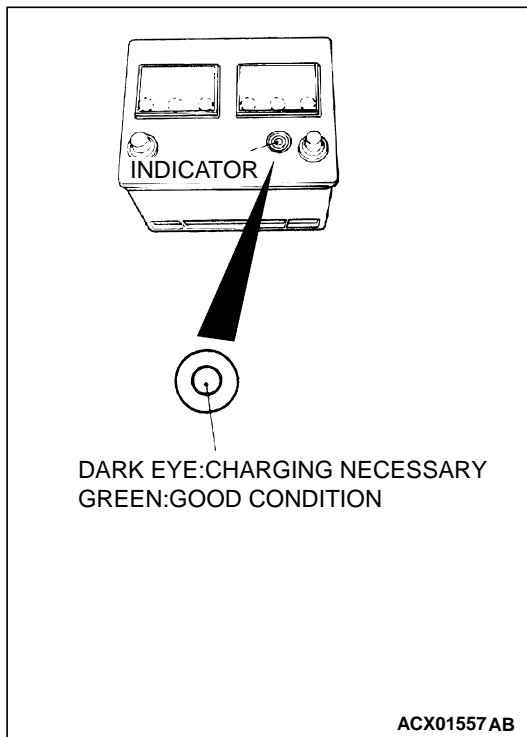

### BATTERY VISUAL INSPECTION (2)

Make sure ignition switch is in "LOCK" (OFF) position and all battery fed accessories are OFF.

1. Disconnect the negative cable from battery before disconnecting the positive cable.

**⚠ WARNING**

**Care should be taken in the event battery case is cracked or leaking to protect hands from the electrolyte. A suitable pair of rubber gloves (not the household type) should be worn when removing battery by hand.**

2. Remove the battery from the vehicle.

3. Inspect battery carrier for damage caused by loss of acid from battery. If acid damage is present, it is necessary to clean area with a solution of clean warm water and baking soda. Scrub area with a stiff bristle brush. Wipe clean with a cloth moistened with ammonia or baking soda in water.
4. Clean the battery, especially the top with same solutions as described in step 3.
5. Inspect the battery case and cover for cracks. If cracks are present, battery must be replaced.
6. Clean the battery post with a suitable battery post cleaning tool.
7. Clean the inside surfaces of the terminal clamps with a suitable battery terminal cleaning tool. Replace damaged or frayed cables and broken terminal clamps.
8. Install the battery in the vehicle.
9. Connect the positive and negative cables to the battery in the order of mention.
10. Tighten the clamp nut securely.

## BATTERY CHARGING

M1541001100350

### **WARNING**

***When batteries are being charged, an explosive gas forms beneath the cover of each cell. Do not smoke near batteries on charge or which have recently been charged. Do not break live circuits at the terminals of the batteries on charge. A spark will occur where the live circuit is broken. Keep all open flames away from the battery.***

Battery electrolyte temperature may temporarily be allowed to rise to 55°C (131°F). Increase of electrolyte temperature above 55°C (131°F) is harmful to the battery, causing deformation of battery cell, decrease in life of battery, etc.

### **CHARGE RATE**

If the test indicator is dark, the battery should be charged as outlined below. When the dot appears or when maximum charge shown below is reached, charging should be stopped.

### **Charge Rate Chart**

<b>BATTERY</b>	<b>80D26L-MF</b>
Slow charging	5 amps 12 hours
	10 amps 6 hours
Fast charging	20 amps 2.5 hours
	30 amps 0.5 hours

**BATTERY TEST****BATTERY TESTING PROCEDURE****STEP 1. Check the battery cables.**

Remove the negative cable, then the positive cable.  
Check for dirty or corroded connections.

**Q: Are the battery cables dirty or have corroded connections?**

**YES** : Clean the battery cables. Then go to Step 2.

**NO** : Go to Step 2.

**STEP 2. Check the battery post.**

Check for loose battery post.

**Q: Are the battery post faulty?**

**Yes** : Replace the battery. Then go to Step 4.

**NO** : Go to Step 3.

**STEP 3. Check the battery case and cover.**

- (1) Remove the hold-downs and shields.
- (2) Check for broken/cracked case or cover.

**Q: Is the battery case or cover faulty?**

**YES** : Replace the battery. Then go to Step 4.

**NO** : Go to Step 4.

**STEP 4. Check the open circuit voltage.**

- (1) Turn headlights on for 15 seconds.
- (2) Turn headlights off for two minutes to allow battery positive voltage to stabilize.
- (3) Disconnect the battery cables.
- (4) Read open circuit voltage.

**Q: Is open circuit voltage 12.4 volts or more?**

**NO** : Go to Step 5.

**YES** : Go to Step 6.

**STEP 5. Charge battery.**

**Q: Charging the battery?**

**YES** : Charge the battery at 5 amps for 15 hours.  
Then re-test, go to Step 4.

**NO** : Go to Step 6.

**STEP 6. Check the load test.**

- (1) Connect a load tester to the battery.
- (2) Load the battery at the recommended discharge rate (See LOAD TEST RATE CHART) for 15 seconds.
- (3) Read voltage after 15 seconds, then remove load.
- (4) Compare the measured value with the minimum voltage. (See LOAD TEST CHART.)

**Q: Is the voltage higher than minimum voltage?**

**NO** : Replace the battery. Then go to Step 4.

**YES** : The battery is normal.

**LOAD TEST CHART**

TEMPERATURE °C (°F)	21 (70) AND ABOVE	16 (60)	10 (50)	4 (40)	-1 (30)	-7 (20)	-12 (10)	-18 (0)
Minimum voltage	9.6	9.5	9.4	9.3	9.1	8.9	8.7	8.5

**LOAD TEST RATE CHART**

Load test	300 amps
Cranking ratio (0°F)	582 amps
Reserve capacity	133 minutes
Application	80D26L-MF

# IGNITION SWITCH

## GENERAL DESCRIPTION

M1543009901014

### Ignition key reminder tone alarm

The ignition key reminder tone alarm will sound under the following condition, and warn the driver to remove the ignition key.

- The driver's door is opened when the ignition switch is at "LOCK" (OFF) or "ACC" position without removing the ignition key.

However, the light reminder tone alarm will take precedence over this function.

### Immobilizer system

The immobilizer system consists of the ignition key, the key ring antenna, the immobilizer-ECU, and the PCM. The ignition key has a built-in transponder. The key ring antenna is installed on the steering lock key cylinder. Only the registered ignition key permits the engine to start, therefore, the engine can never be started by means of a forged key or by connecting the ignition wiring directly. The system is significantly safe and reliable against theft. In addition, the driver has only to turn the ignition switch to the "ON" position to activate the immobilizer system. If the requirements for starting the engine are not satisfied, the engine will be immobilized. If the ignition key is lost or another ignition key is added, the encrypted code can be registered or erased by using scan tool.

## IGNITION KEY REMINDER TORN ALARM DIAGNOSIS

M1543000700678

The Ignition key reminder tone alarms is controlled by the Simplified Wiring System (SWS). For troubleshooting, refer to GROUP 54B, SWS Diagnosis

[P.54Bb-2](#).

## IMMOBILIZER SYSTEM DIAGNOSIS

### INTRODUCTION TO IMMOBILIZER SYSTEM DIAGNOSIS

M1543009901025

#### CAUTION

**The encrypted code should always be re-registered when replacing the immobilizer-ECU.**

The immobilizer system consists of the immobilizer-ECU, PCM, ignition key and ignition key ring antenna. If the engine cannot be started by using a registered ignition key, one of these components may be defective. If the immobilizer system has immobilized the engine, MFI system DTC P1610 will be output. In this case, observe the immobilizer system troubleshooting.

### IMMOBILIZER SYSTEM DIAGNOSTIC TROUBLESHOOTING STRATEGY

M1543006900539

Use the following steps to plan your diagnostic strategy.

1. Gather information about the problem from the customer.
2. Verify that the condition as described by the customer exists.
3. Check the vehicle for any immobilizer system DTCs.
4. If you cannot verify the condition and there are no immobilizer system DTCs, the malfunction is intermittent. Refer to GROUP 00, How to Use Troubleshooting/inspection Service Points – How to Cope with Intermittent Malfunctions [P.00E-6](#).
5. If you can verify the condition but there are no immobilizer system DTCs, or the system cannot communicate with scan tool MB991502, refer to Symptom Chart and find the fault [P.54A-12](#).

6. If there is an immobilizer system DTC, record the DTC, then erase it from the memory using scan tool MB991502.
7. Recreate the immobilizer system DTC set conditions to see if the same immobilizer system DTC will resets.
  - (1) If the same immobilize system DTC resets, perform the appropriate diagnostic procedure. Refer to Diagnostic Trouble Code Chart [P.54A-8](#).
  - (2) If the same immobilizer system DTC does not reset, the malfunction is intermittent. Refer to GROUP 00, How to Use Troubleshooting/inspection Service Points – How to Cope with Intermittent Malfunctions [P.00-6](#).

**IMMOBILIZER SYSTEM TROUBLE CODE DIAGNOSIS**

M1543007000283

**Retrieving and Erasing Immobilizer System Diagnostic Trouble Codes**

**Required Special Tool:**

- MB991502: Scan Tool (MUT-II)

**⚠ CAUTION**

**Always turn the ignition switch to "LOCK" (OFF) position before connecting or disconnecting scan tool MB991502.**

1. Connect scan tool MB991502 to data link connector (16-pin).
2. Turn the ignition switch to "ON" position.
3. Use scan tool MB991502 to check or erase immobilizer system DTCs.
4. Turn the ignition switch to "LOCK" (OFF) position.
5. Disconnect scan tool MB991502.

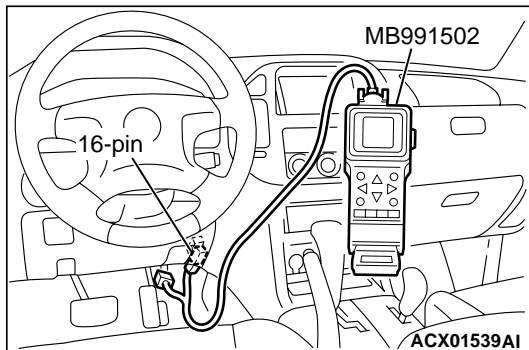

**DIAGNOSTIC TROUBLE CODE CHART**

M1543007100291

Use the following chart to develop proper diagnostic strategy.

DIAGNOSTIC TROUBLE CODE NO.	DESCRIPTION	REFERENCE PAGE
11	Transponder communication system or radio interference of encrypted code	<a href="#">P.54A-9</a> .
12	Encrypted codes are not the same or are not registered	<a href="#">P.54A-12</a> .



DIAGNOSTIC TROUBLE CODE PROCEDURES

DTC 11: Transponder Communication System or Radio Interference of Encrypted Code

Ignition Key Ring Antenna Circuit

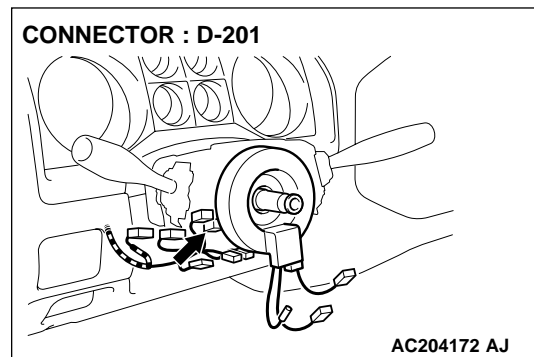
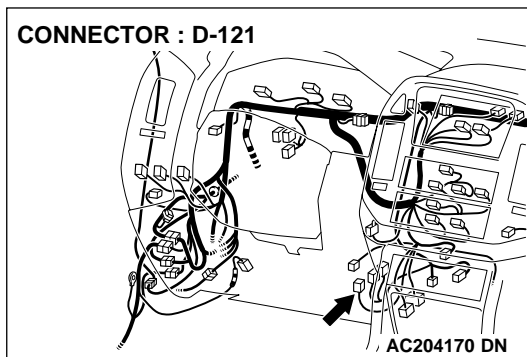
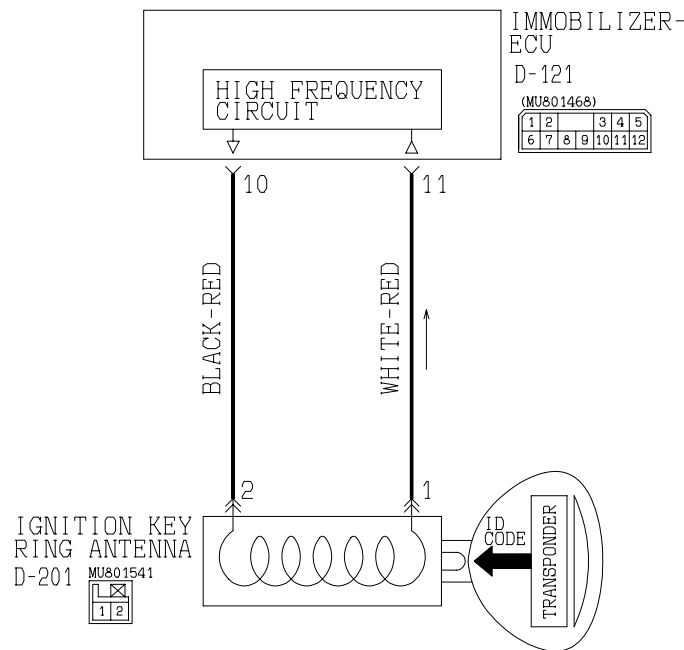

**CIRCUIT OPERATION**

The ignition key is powered by the ignition key ring antenna. The ignition key then sends an encrypted code. The ignition key ring antenna receives the encrypted code, and determines if the ignition key is registered.

**DTC SET CONDITION**

- DTC 11 may be output if other ignition keys are in the vicinity of the vehicle as it is being started.

- The transponder's encrypted code is not sent to the immobilizer-ECU immediately after the ignition switch is turned to "ON" position.

*NOTE: DTC 11 is always output together with MFI system DTC P1610.*

**TROUBLESHOOTING HINTS**

- Radio interference of the encrypted code
- Malfunction of the transponder
- Malfunction of the ignition key ring antenna
- Malfunction of the immobilizer-ECU
- Damaged wiring harness of connectors

**DIAGNOSIS****Required Special Tools:**

- MB991223: Harness Set
- MB991502: Scan Tool (MUT-II)

---

**STEP 1. Check for presence of other key near the key in the ignition.**

**Q: Is there any other key near the key in the ignition?**

**YES :** Move the other key well away from key being used.  
Retest the system.

**NO :** Go to Step 2.

---

**STEP 2. Check that the engine start using the spare ignition key which encrypted code has been registered.**

**Q: Does the engine start using the spare ignition key for which the encrypted code has been registered?**

**YES :** replace the ignition key that does not work. Then register the password (secret code) and encrypted code [P.00E-2](#). Retest the system.

**NO :** Go to Step 3.

---

**STEP 3. Check that DTC is output, DTC 11 or 12?**

**Q: Which DTC is output, DTC 11 or 12?**

**DTC12 is output :** Refer to DTC 12 [P.54A-12](#).

**DTC11 is output :** Go to Step 4.

---

**STEP 4. Check the ignition key ring antenna by backprobing.**

Do not disconnect the ignition key ring antenna connector D-201 and check the resistance on the harness side connector between terminal number 1 and terminal number 2 by backprobing.

**Q: Is the resistance less than 2 ohms?**

**YES :** Go to Step 5.

**NO :** Replace the ignition key ring antenna. Retest the system.

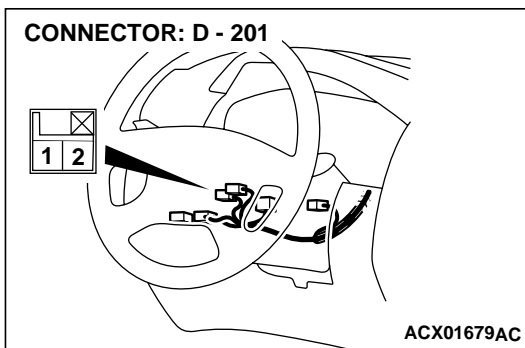

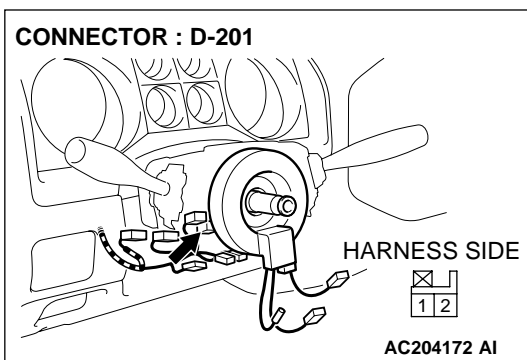
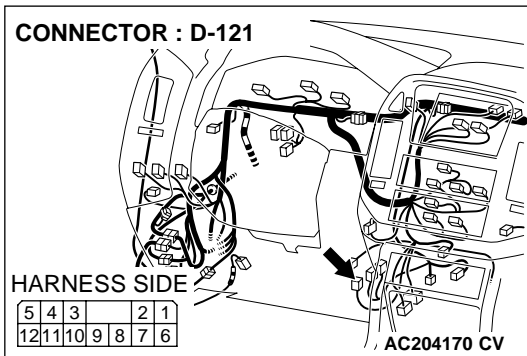

**STEP 5. Check immobilizer-ECU connector D-121 and ignition key ring antenna connector D-201 for loose, corroded or damaged terminals, or terminals pushed back in the connector.**

**Q: Are immobilizer-ECU connector D-121 and ignition key ring antenna connector D-201 in good condition?**

**YES :** Go to Step 6.

**NO :** Repair or replace them. Refer to GROUP 00E, Harness Connector Inspection [P.00E-2](#). Retest the system.

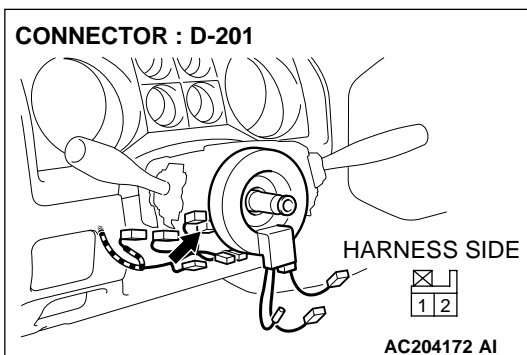
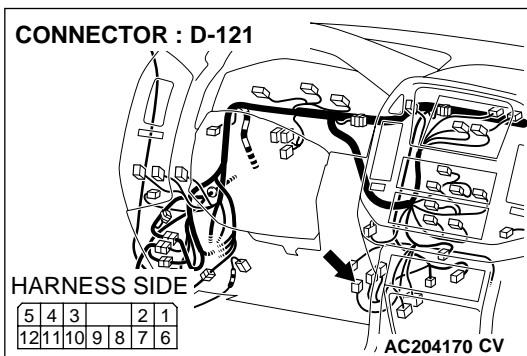

**STEP 6. Check the harness wires between immobilizer-ECU connector D-121 and ignition key ring antenna connector D-201.**

**Q: Are the harness wires between immobilizer-ECU connector D-121 and ignition key ring antenna connector D-201 in good condition?**

**YES :** replace the immobilizer-ECU. Then register the password (secret code) and encrypted code [P.54A-22](#). Retest the system.

**NO :** Repair them. Retest the system.

**DTC12: Encrypted Codes are Not the Same or Not Registered****DTC SET CONDITION**

The encrypted code sent by the transponder is not the same encrypted code which is registered in the immobilizer-ECU.

*NOTE: DTC 12 is always output together with MFI system DTC P1610.*

**TROUBLESHOOTING HINTS**

- The encrypted code in the ignition key has not been properly registered
- Malfunction of immobilizer-ECU

**DIAGNOSIS****Was the encrypted code registered?**

**YES** : Replace the immobilizer and then re-register the encrypted code (Refer to [P.54A-22.](#))

**NO** : Register the encrypted code (Refer to [P.54A-22.](#))

**SYMPTOM CHART**

M1543007200793

SYMPTOMS	INSPECTION PROCEDURE NO.	REFERENCE PAGE
Communication with scan tool MB991502 is impossible	1	<a href="#">P.54A-13</a>
The ignition key cannot be registered	2	<a href="#">P.54A-19</a>
Engine cranks but does not start	3	<a href="#">P.54A-20</a>

SYMPTOM PROCEDURES

INSPECTION PROCEDURE 1: Communication with Scan Tool MB991502 is Impossible.

Immobilizer-ECU Power Supply, Ground and Powertrain Control Module  
Communication Line Circuit

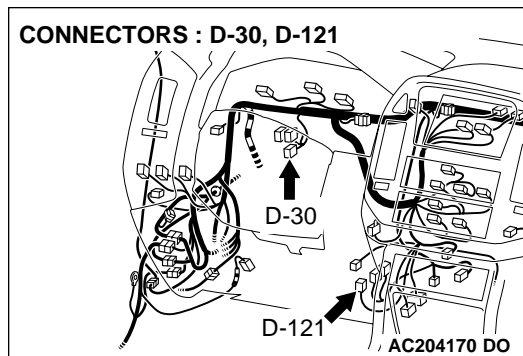
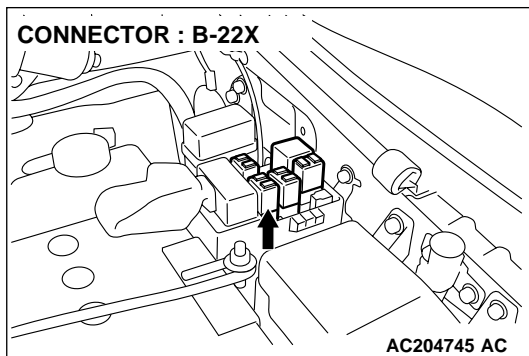
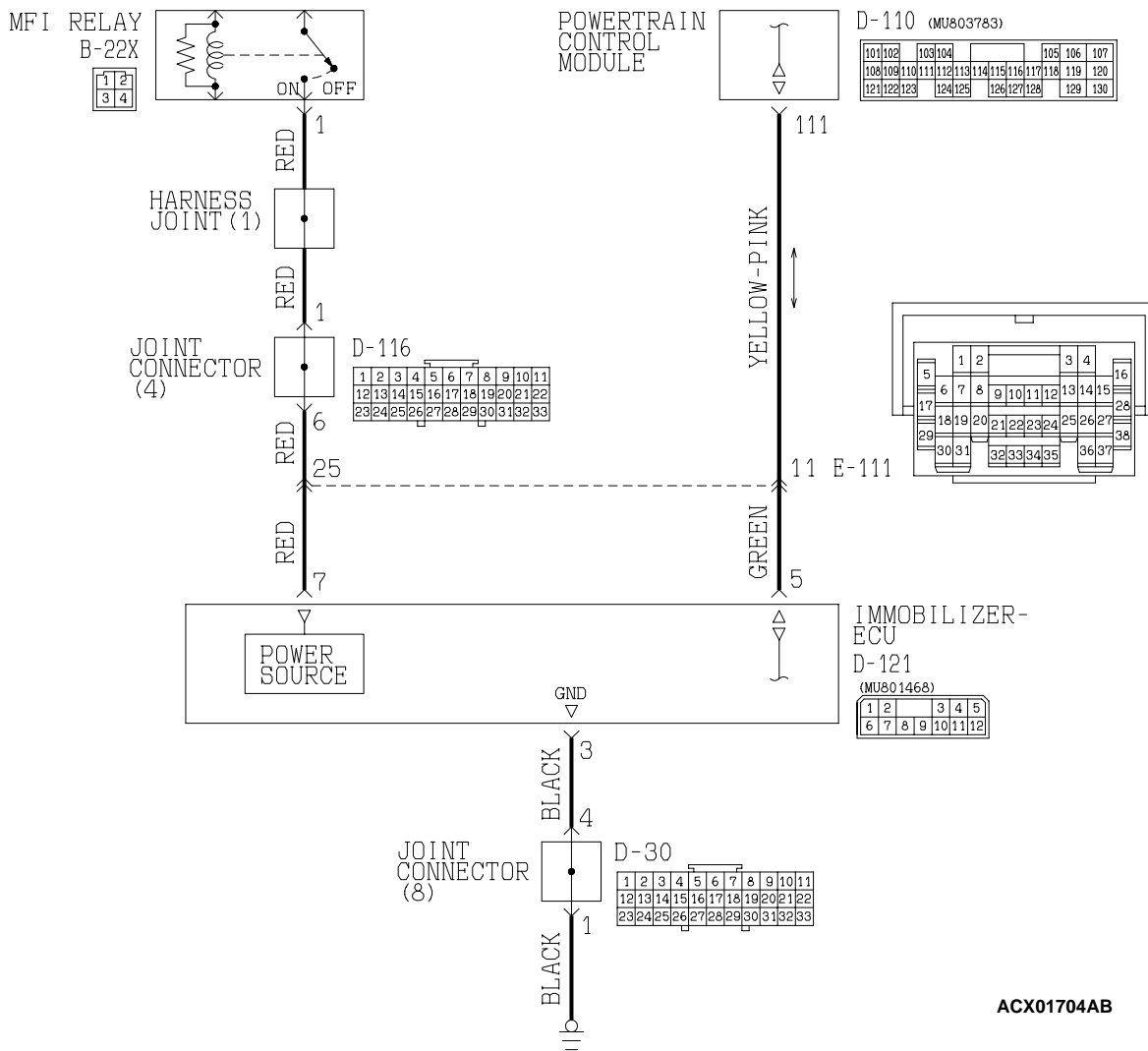

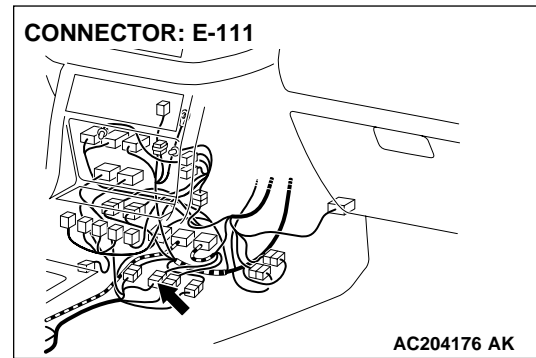
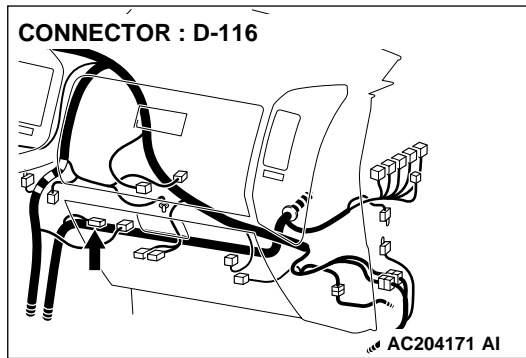

### CIRCUIT OPERATION

The Immobilizer-ECU is energized by the MFI relay when the ignition switch is turned "ON". The PCM transmits a signal from scan tool MB991502 to the immobilizer-ECU as it is. In the same way, a signal from the immobilizer-ECU is also transmitted to scan tool MB991502 as it is.

### TECHNICAL DESCRIPTION (COMMENT)

- This malfunction may be caused by a defective immobilizer-ECU, PCM, or a defect in the communication line between the immobilizer-ECU and PCM. If this malfunction appears when the MFI system and scan tool MB991502 can communicate each other, MFI system DTC P1610 will reset.

- If the MFI system is normal, the MFI relay can be determined as normal. In addition, if the MFI system and scan tool MB991502 can communicate each other, the circuits between the data link connector and the PCM can be determined as normal.

*NOTE: If this malfunction appears, MFI system DTC P1610 will be output.*

### TROUBLESHOOTING HINTS

- Malfunction of the immobilizer-ECU
- Malfunction of the PCM
- The wiring harness or connectors may have loose, corroded, or damaged terminals, or terminals pushed back in the connector

### DIAGNOSIS

#### Required Special Tools:

- MB991223: Harness Set
- MB991502: Scan Tool (MUT-II)

**STEP 1. Check if scan tool MB991502 can communicate with the MFI system and if an MFI system DTC other than P1610 is output.**

**Q: Can scan tool MB991502 communicate with the MFI system? Is an MFI system DTC other than P1610 output?**

**YES :** Go to Step 2.

**NO :** Refer to GROUP 13A, Multiport Fuel Injection Diagnosis [P.13Ab-2](#).

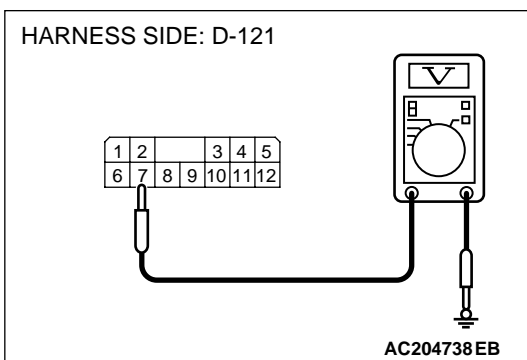
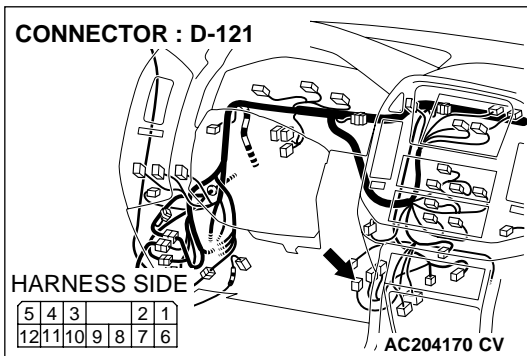

**STEP 2. Check the immobilizer-ECU power supply circuit by backprobing.**

- (1) Do not disconnect immobilizer-ECU connector D-121.
- (2) Turn the ignition switch to the "ON" position.

- (3) Measure the voltage between terminal 7 and ground by backprobing.

**Q: Is battery voltage (approximately 12 volts) present?**

- YES :** Go to Step 5.  
**NO :** Go to Step 3.

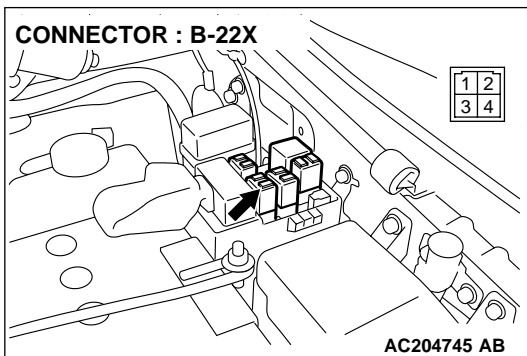

**STEP 3. Check immobilizer-ECU connector D-121 and MFI relay connector B-22X for loose, corroded or damaged terminals, or terminals pushed back in the connector.**

**Q: Are immobilizer-ECU connector D-121 and MFI relay connector B-22X damaged?**

- YES :** Repair or replace them. Refer to GROUP 00E, Harness Connector Inspection [P.00E-2](#). Confirm that scan tool MB991502 communicates normally.  
**NO :** Go to Step 4.

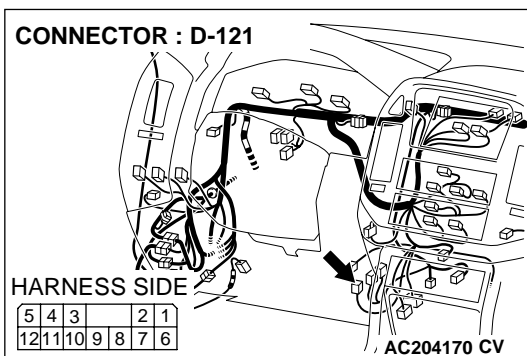

**STEP 4.** Check the harness wires between immobilizer-ECU connector D-121 and MFI relay connector B-22X.

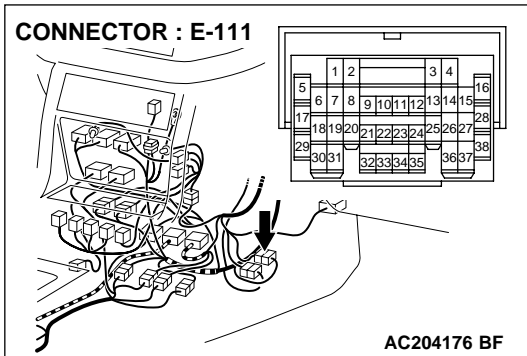
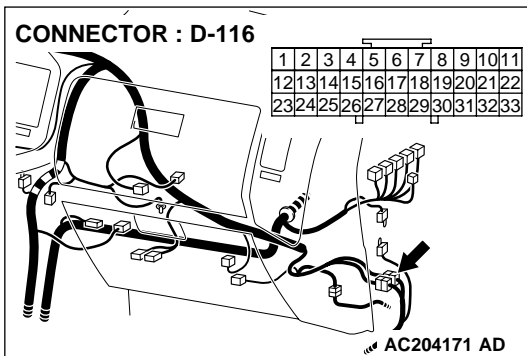
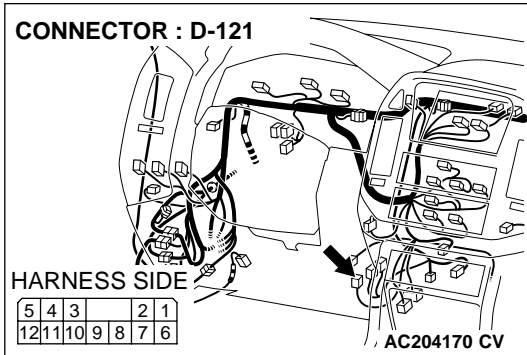
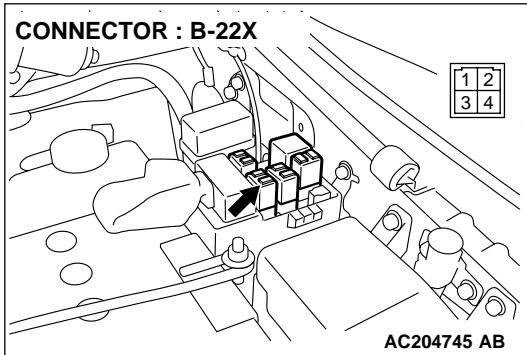

*NOTE: Also check intermediate connector E-111 and joint connector D-116, check the wires. If intermediate connector E-111 and joint connector D-116 are damaged, repair or replace them. Refer to GROUP 00E, Harness Connector Inspection P.00E-2.*

**Q: Are the harness wires between immobilizer-ECU connector D-121 and MFI relay connector B-22X damaged?**

**YES :** Replace them. Confirm that scan tool MB991502 communicates normally.

**NO :** There is no action to be taken.



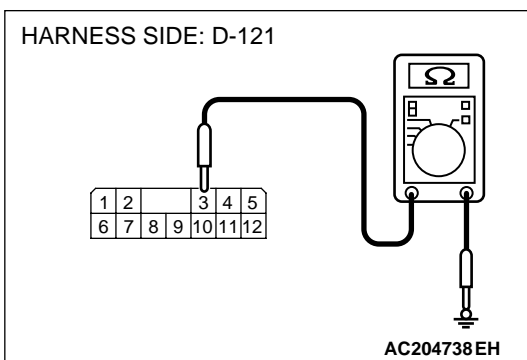
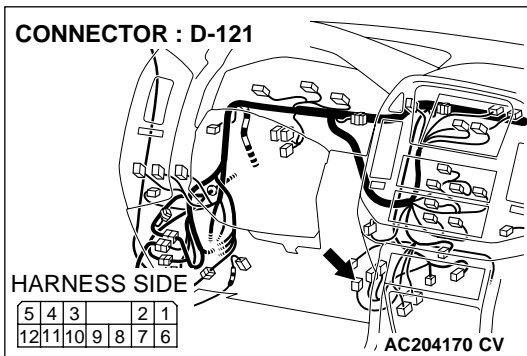

**STEP 5. Check the immobilizer-ECU ground circuit by backprobing.**

(1) Do not disconnect immobilizer-ECU connector D-121.

(2) Measure the resistance between terminal 3 and ground by backprobing.

**Q: Is the resistance less than 2 ohms?**

**YES :** Go to Step 7.

**NO :** Go to Step 8.

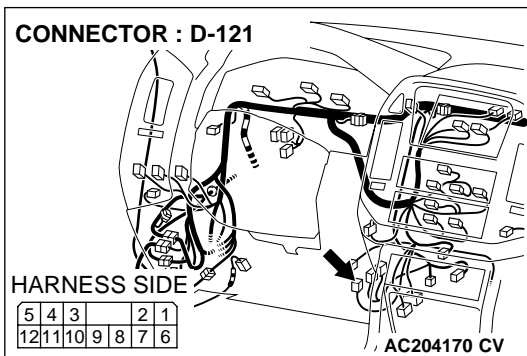

**STEP 6. Check immobilizer-ECU connector D-121 for loose, corroded or damaged terminals, or terminals pushed back in the connector.**

**Q: Is immobilizer-ECU connector D-121 in good condition?**

**YES :** Go to Step 7.

**NO :** Repair or replace it. Refer to GROUP 00E, Harness Connector Inspection [P.00E-2](#). Confirm that scan tool MB991502 communicates normally.

## CONNECTORS : D-30, D-121

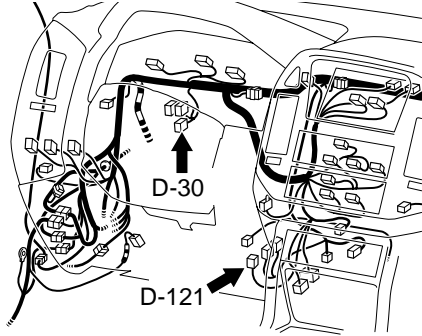

## D-30

1	2	3	4	5	6	7	8	9	10	11
12	13	14	15	16	17	18	19	20	21	22
23	24	25	26	27	28	29	30	31	32	33

## HARNESS SIDE

## D-121

5	4	3		2	1	
12	11	10	9	8	7	6

AC204188BP

**STEP 7. Check the harness wire between immobilizer-ECU connector D-121 and ground.**

*NOTE: Also check intermediate connector D-30, check the wires. If intermediate connector D-30 is damaged, repair or replace it. Refer to GROUP 00E, Harness Connector Inspection P.00E-2.*

**Q: Is the harness wire between immobilizer-ECU connector D-121 and ground damaged?**

**YES :** Repair it. Confirm that scan tool MB991502 communicates normally.

**NO :** There is no action to be taken.

## CONNECTOR : D-121

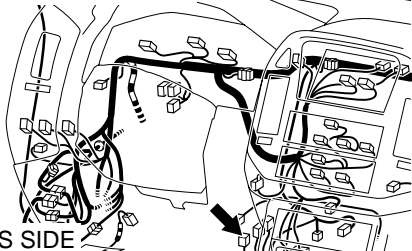

## HARNESS SIDE

5	4	3		2	1	
12	11	10	9	8	7	6

AC204170 CV

**STEP 8. Check the harness wires between immobilizer-ECU connector D-121 and PCM connector D-110.**

**Q: Are the harness wires between immobilizer-ECU connector D-121 and PCM connector D-110 damaged?**

**YES :** Repair them. Confirm that scan tool MB991502 communicates normally.

**NO :** Go to Step 9.

**STEP 9. Replace the immobilizer-ECU or PCM.**

Replace the immobilizer-ECU or PCM.

**Q: Did the communication with the scan tool become possible after replacing the immobilizer-ECU or the power train control module?**

**YES :** Register the password (secret code) and encrypted code P.54A-22. Confirm that scan tool MB991502 communicates normally

**NO :** Go to Step 10.

---

**STEP 10. Recheck for malfunction.**

**Q: Is a malfunction eliminated?**

**YES :** The procedure is complete. (If no malfunction are not found in all steps, an intermittent malfunction is suspected. Refer to GROUP 00, How to Use Troubleshooting/Inspection Service Points – How to Cope with Intermittent Malfunction [P.00E-2.](#))

**NO :** Replace the immobilizer-ECU or PCM.

---

**INSPECTION PROCEDURE 2: The Ignition Key cannot be Registered.**

---

**TECHNICAL DESCRIPTION (COMMENT)**

The ignition key transponder or the immobilizer-ECU is suspected to be defective.

**TROUBLESHOOTING HINTS**

- Malfunction of the ignition key
- Malfunction of immobilizer-ECU

**DIAGNOSIS**

**Required Special Tools:**

- MB991223: Harness Set
- MB991502: Scan Tool (MUT-II)

---

**STEP 1. Check the DTC.**

**Q: Does DTC11 reset?**

**YES :** Refer to [P.54A-8.](#)

**NO :** Replace the ignition key that cannot be registered. Then re-register the encrypted code. (Refer to [P.54A-22.](#)) Verify that the ignition key can be registered, then Go to Step 2.

---

**STEP 2. Retest the system.**

**Q: Does registered ignition key function properly?**

**YES :** The procedure is complete. (If no malfunction are not found in all steps, an intermittent malfunction is suspected. Refer to GROUP 00, How to Use Troubleshooting/Inspection Service Points – How to Cope with Intermittent Malfunction [P.00-6.](#))

**NO :** Replace the immobilizer-ECU.

---

**INSPECTION PROCEDURE 3: Engine Cranks, but does not Start.**

---

**TECHNICAL DESCRIPTION**

If the engine cranks, but does not start, an MFI system problem may exist in addition to a malfunctioning immobilizer system. The engine will not start if the ignition key has not been properly registered.

**TROUBLESHOOTING HINTS**

- Malfunction of MFI system
- Malfunction of immobilizer-ECU

**DIAGNOSIS****Required Special Tools:**

- MB991223: Harness Set
- MB991502: Scan Tool

---

**STEP 1. Check the battery voltage.**

Measure the battery voltage during cranking.

**Q: Is the voltage 8 volts or more?**

**YES :** Go to Step 2.

**NO :** Check the condition of the battery. Refer to [P.54A-4](#).

---

**STEP 2. Check for DTCs.****Q: Have any DTCs set?**

**Yes :** Go to Step 3.

**No :** Go to Step 5.

---

**STEP 3. Check for immobilizer system DTCs.****Q: Have any immobilizer system DTCs set?**

**Yes :** Refer to [P.54A-8](#).

**No :** Go to Step 4.

---

**STEP 4. Check for MFI system DTCs.****Q: Have any MFI system DTCs set?**

**Yes :** Refer to GROUP 13A, Diagnosis [P.13Ab-22](#).

**No :** Go to Step 5.

---

**STEP 5. Attempt to start the engine.****Q: Does the engine start?**

**YES :** The procedure is complete (If no malfunctions are found in all steps, an intermittent malfunction is suspected. Refer to GROUP 00, How to Use Troubleshooting/Inspection Service Points-How to Cope with Intermittent Malfunction [P.00-6](#)).

**NO :** Refer to GROUP 13A, Diagnosis – Symptom Chart [P.13Ab-26](#). If the malfunction is not resolved, replace the immobilizer-ECU. Then register the password (secret code) and encrypted code. (Refer to [P.54A-22](#).) The engine should now start.

**DATA LIST REFERENCE TABLE**

M1543007300143

MUT-II SCAN TOOL DISPLAY	ITEM NO.	INSPECTION ITEM	INSPECTION REQUIREMENT	NORMAL CONDITION
KEY REGISTERED	01	Key has been registered	-	Number of registered ignition keys

**CHECK AT IMMOBILIZER-ECU**

M1543007600230

TERMINAL VOLTAGE CHECK

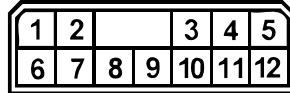

ACX01564 AB

TERMINAL NO.	SIGNAL	CHECKING REQUIREMENT	TERMINAL VOLTAGE
3	Immobilizer-ECU ground	Always	0V
5	powertrain control module	-	-
7	Immobilizer-ECU power supply	Ignition switch: "LOCK" (OFF)	0V
		Ignition switch: "ON"	Battery positive voltage
10	Ignition key ring antenna	-	-
11	Ignition key ring antenna	-	-

## SPECIAL TOOLS

M1543000600411

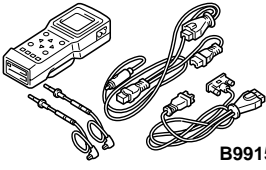
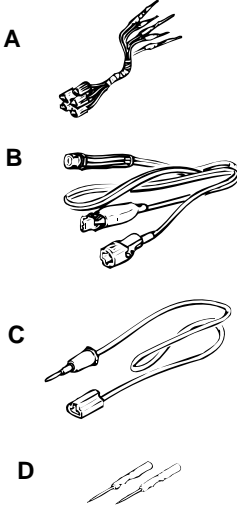
TOOL	TOOL NUMBER AND NAME	SUPERSESSION	APPLICATION
 B991502	MB991502 Scan tool (MUT-II)	MB991496-OD	<ul style="list-style-type: none"> <li>• Immobilizer system check</li> <li>• Encrypted code registration</li> </ul>
 MB991223AC	MB991223 A: MB991219 B: MB991220 C: MB991221 D: MB991222 Harness set A: Test harness B: LED harness C: LED harness adapter D: Probe	MB991223	Making voltage and resistance measurements during troubleshooting A: Connect pin contact pressure inspection B: Power circuit inspection C: Power circuit inspection D: Commercial tester connection

## ON-VEHICLE SERVICE

## ENCRYPTED CODE REGISTRATION METHOD

M1543008100205

## Required Special Tool:

- MB991502: Scan Tool (MUT-II)

 **CAUTION**

**Because registering the encrypted codes is done after all previously-registered codes have been erased, you should keep all of the ignition keys that have already been registered accessible.**

If the ignition key, Immobilizer-ECU, powertrain control module is replaced or an ignition key is added, encrypted codes of all the ignition keys must be registered. (A maximum of eight different ignition key can be registered.) Moreover, when the immobilizer-ECU has been replaced, you will need to use scan tool MB991502 to register the immobilizer-ECU and input the vehicle secret code and to register the password (secret code) that the owner specifies into the immobilizer-ECU.

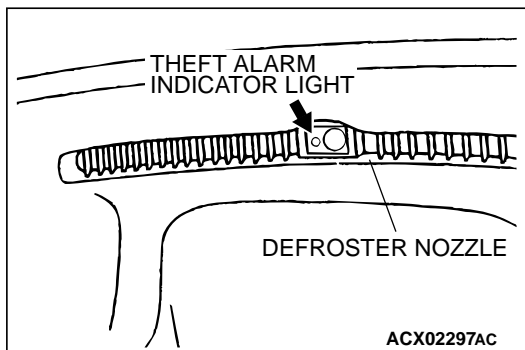

If an attempt is made to start the engine with an unregistered ignition key, cranking occurs, but fuel supply is cut off to disable the engine. In approx. 10 seconds, the theft-alarm indicator will blink for approx. 30 seconds.

*NOTE: powertrain control module has an encrypted code for immobilizer-ECU, and the encrypted code is registered in the immobilizer-ECU and ignition key.*

## POINTS TO NOTE DURING OPERATION

If none of the functions can be used, check the diagnostic trouble codes, and after carrying out any necessary repairs, repeat the operation.

If an incorrect password is input five times in a row, the immobilizer-ECU judges that an unauthorized operation is being attempted. Start-prevention mode will be set, and engine operation will stop and all special functions will be disabled. If the ignition switch is turned to "ON" position and left in that position for approximately 20 minutes, "Unauthorized operation, start-prevention mode" will be cancelled.

## KEY ID REGISTER

All ignition keys can be registered with scan tool MB991502. Additional ignition keys can be registered with or without scan tool MB991502. If an ignition key is registered using scan tool MB991502, no registered ignition keys must be lost.

### Registration with the scan tool

#### **⚠ CAUTION**

**To prevent damage to scan tool MB991502, always turn the ignition switch to "LOCK" (OFF) position before connecting or disconnecting scan tool MB991502.**

*NOTE: Using the key ID register function will cause all key IDs that have been previously registered in the immobilizer-ECU to be erased. All keys need to be registered. Those which have been registered before should be on hand before using this function.*

*NOTE: If registering more than one key, do not disconnect scan tool MB991502 halfway through the registration process.*

*NOTE: After registering key IDs, check that the engine can be started using all of the keys that have been registered. If the engine will not start, refer to Immobilizer System Diagnosis P.54A-7.*

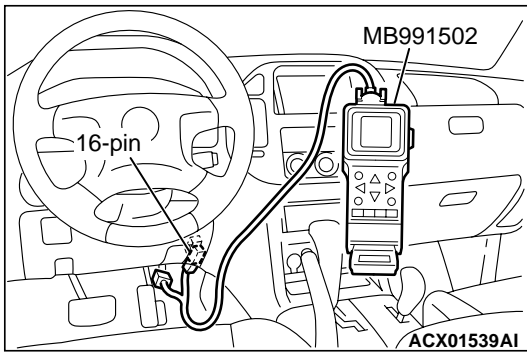

1. Connect scan tool MB991502 to data link connector (16-pin).
2. Turn the ignition switch to "ON" position.

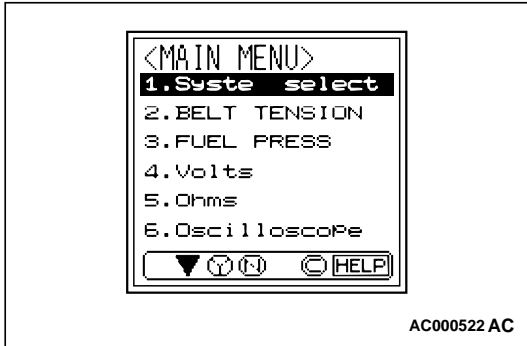

3. At "System Select," press "YES".

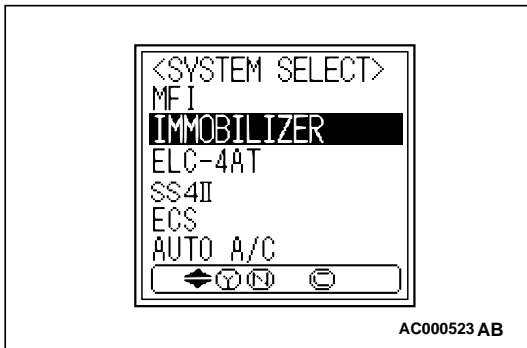

4. Select "Immobilizer," press "YES".

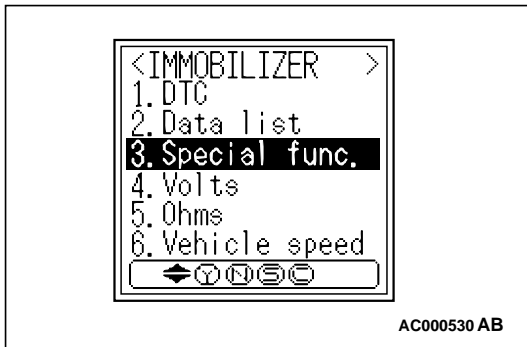

5. Select "Special Func," press "YES".  
If DTC 11 exists, "Can't execute" will be displayed. Check for DTC 11. (Refer to P.54A-8.)

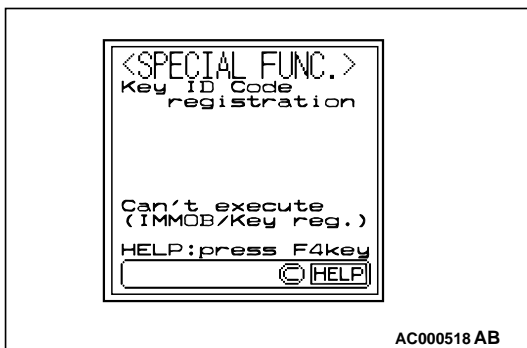



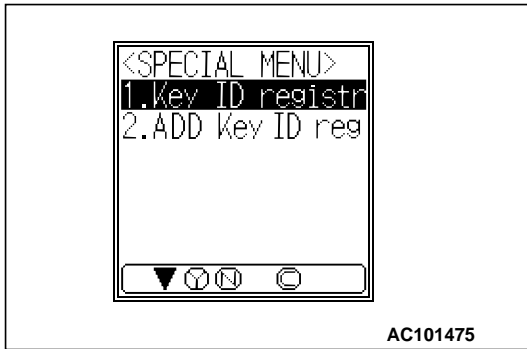

6. Select "key ID register, " press "YES".

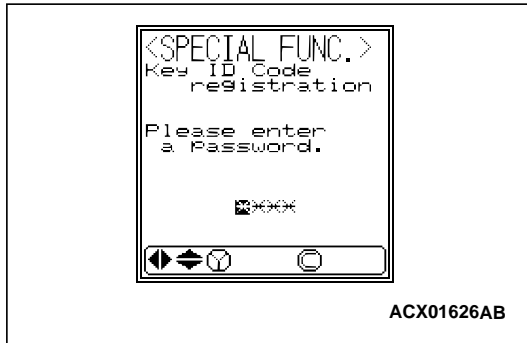

7. Input the password. Use the "UP" and "DOWN" keys to change the current password digit to a value between 0 and 9. Use the "LEFT" and "RIGHT" keys to move to a different password digit. Press the "YES" key to accept the password. If an incorrect password is input five times in a row, this screen is displayed and the Immobilizer-ECU switches to unauthorized operation, start-prevention mode.

*NOTE: Four separate digits must be input to make up the password.*

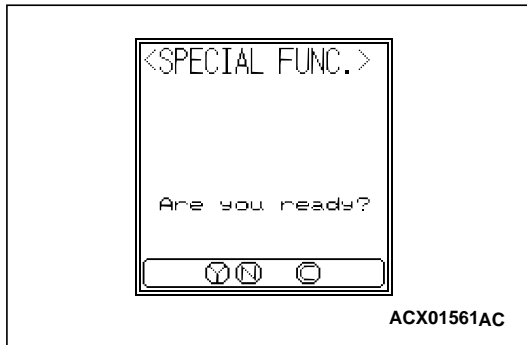

8. Press the "YES" key to start key ID registration.

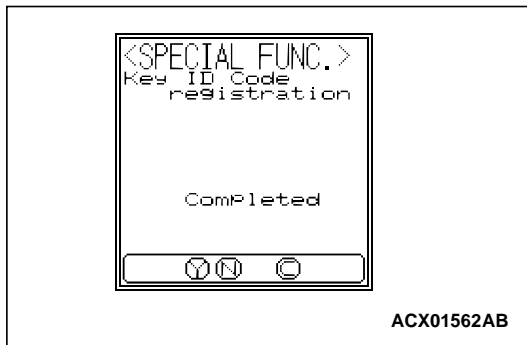

9. This will be displayed when the key ID registration is successful. If an error occurs during key ID registration, the message "Can't execute" will be displayed. If the key has already been registered, "Key ID has been registered" will be displayed.



10. The number of keys currently registered will be displayed.

To register an additional key, replace the ignition key with the next key to be registered within five seconds and then press the "YES" key. Key ID registration screen will be displayed, then register another key.

If key ID registration is complete, press the "NO" key.

*NOTE: A maximum of eight different keys can be registered.*

11. This completes the registration operation. Turn the ignition switch "LOCK" (OFF) and leave it off for approximately ten seconds.
12. Check that the engine can be started with each of the ignition keys.
13. Check that the immobilizer system DTC and MFI system DTC did not set.
14. Turn the ignition switch to "LOCK" (OFF) position.
15. Disconnect scan tool MB991502.

### Registration of additional keys with the scan tool

An additional key is registered with the scan tool while keeping all existing key data.

#### CAUTION

**To prevent damage to scan tool MB991502, always turn the ignition switch to "LOCK" (OFF) position before connecting or disconnecting scan tool MB991502.**

*NOTE: To register additional keys with the scan tool, no registered keys must be lost.*

1. Connect scan tool MB991502 to data link connector (16-pin).
2. Turn the ignition switch to "ON" position.

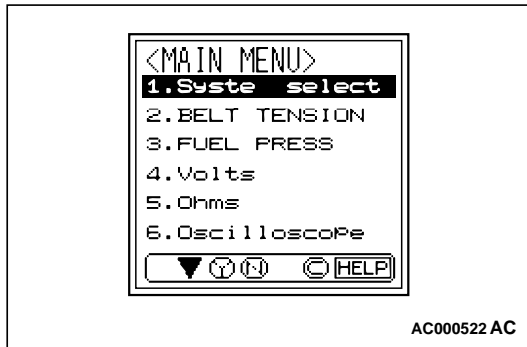
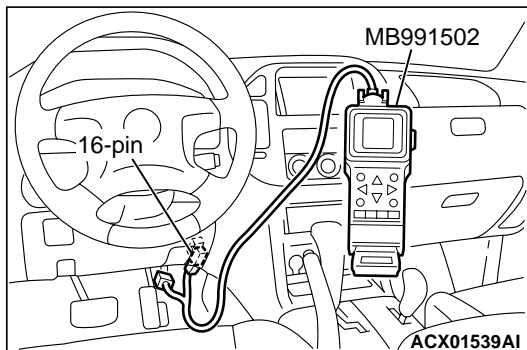

3. At "System Select," press "YES".

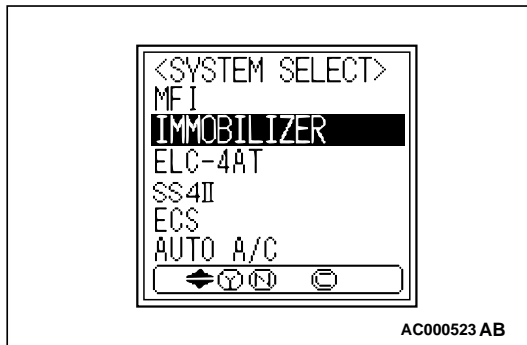

4. Select "Immobilizer," press "YES".

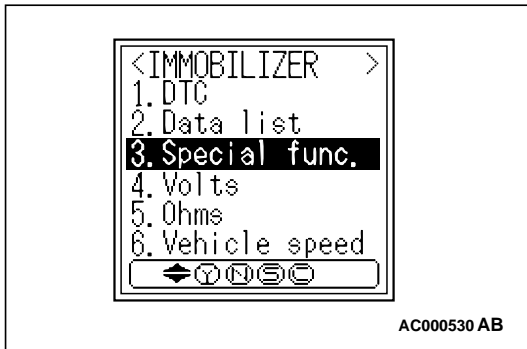

5. Select "Special Func," press "YES".  
If DTC 11 exists, "Can't execute" will be displayed. Check for DTC 11. (Refer to P.54A-8.)

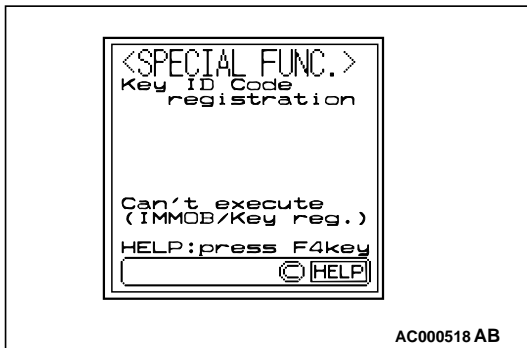

6. Select "Add key ID reg," press "YES".

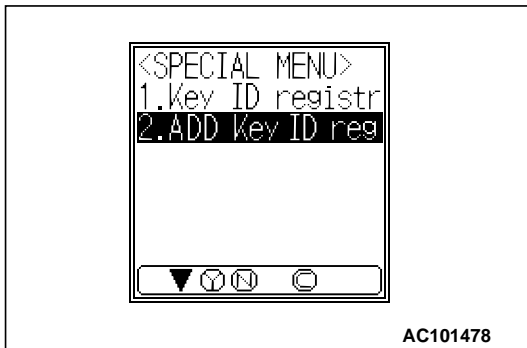

7. Press the "YES" key to start key ID registration.
8. This will be displayed when the add key ID registration is successful. If an error occurs during key ID registration, the message "Can't execute" will be displayed. If the key has already been registered, "Key ID has been registration" will be displayed.

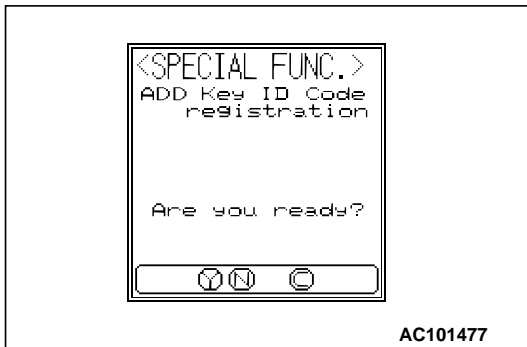

9. The number of keys currently registered will be displayed. To register an additional key, replace the ignition key with the next key to be registered within five seconds and then press the "YES" key. Key ID registration screen will be displayed, then register another key.  
If key ID registration is complete, press the "NO" key.  
*NOTE: A maximum of eight different keys can be registered.*



10. This completes the registration operation. Turn the ignition switch "LOCK" (OFF) and leave it off for approximately ten seconds.
11. Check that the engine can be started with each of the ignition keys.
12. Check that the immobilizer system DTC and MFI system DTC did not set.
13. Turn the ignition switch to "LOCK" (OFF) position.
14. Disconnect scan tool MB991502.

**Registration of additional key(s) without using the scan tool**

If the scan tool is not available, new key(s) can be registered by operating two keys which have been registered to the vehicle (A maximum of eight keys can be registered to one vehicle). Follow the procedure below to register new key(s) to the vehicle.

*NOTE: The registered key is the key that allows you to start the engine.*

1. Turn on the ignition switch by using the first registered key (key A), and wait for five seconds.
2. Within 30 seconds, remove the key.
3. Within seven seconds after the ignition switch has been turned to the "LOCK" (OFF), insert the second registered key (key B) and turn on the ignition switch again. Now the theft-alarm indicator light should blink twice for one second. If it does not blink, you have failed to register. Repeat from step 1.
4. Turn on the key B. Within 30 seconds, remove the key.
5. Within seven seconds after the ignition switch has been turned to the "LOCK" (OFF) position, turn on the ignition switch by using a new key.
6. The immobilizer-ECU identifies the new key to accept or reject it, and operates the theft-alarm indicator (See the table below).

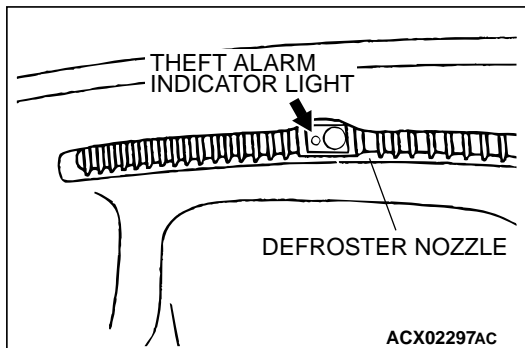

The new key is:	Registration is:	Additional registration mode:	Theft-alarm indicator:
Not registered yet	Accepted	Continues	Comes on for 3 seconds after the ECU judges that the key has not been registered yet.
Already registered	Rejected	Continues	Comes on for 3 seconds after the ECU judges that the key has already been registered
Read error	Rejected	Continues	Blinks three times after the ECU has failed to identify the key.
Eight ignition keys have been registered	Rejected	Continues	Does not come on and blink

7. A maximum of eight ignition keys can be registered to one vehicle (If you attempt to register the ninth key, the immobilizer-ECU rejects the key). Follow the procedure below to register another new key.
  - (1) Within 30 seconds after the new key has been registered on step 6, remove the key.
  - (2) Within seven seconds after the ignition switch has been turned to the "LOCK" (OFF), insert another new key and turn on the ignition switch.
  - (3) To register more other ignition key(s), repeat steps 1 and 2.
8. If any of the following conditions are satisfied, the additional key registration mode will terminate:
  - The ignition switch has been on for more than 30 seconds.
  - After the ignition key has been turned to the "LOCK" (OFF), the engine control relay is turned off.
  - The scan tool has started communicating with vehicle systems.
9. After the registration mode has terminated, the additionally registered key(s) should allow you to start the engine.

IGNITION SWITCH  
REMOVAL AND INSTALLATION

M1543002100155

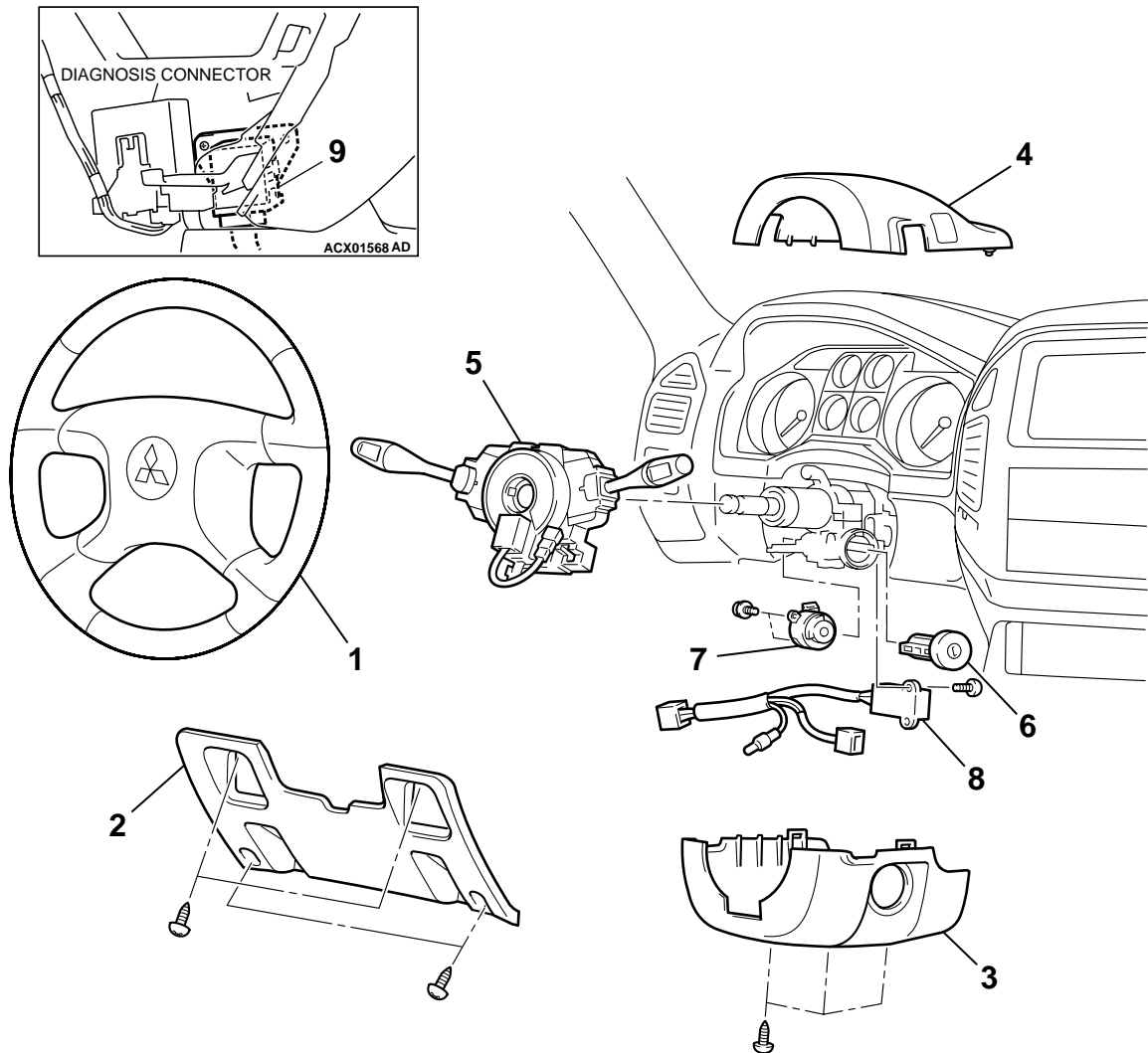

ACX01372AD

**IGNITION SWITCH REMOVAL  
STEPS**

1. STEERING WHEEL (REFER TO GROUP 37, STEERING WHEEL AND SHAFT [P.37A-23.](#))
2. INSTRUMENT UNDER COVER
3. COLUMN COVER LOWER
4. COLUMN COVER UPPER
5. COLUMN SWITCH
6. STEERING LOCK CYLINDER

**IGNITION SWITCH REMOVAL  
STEPS (Continued)**

7. IGNITION SWITCH
8. KEY REMINDER SWITCH

**IMMOBILIZER-ECU REMOVAL  
STEPS**

- LOWER CENTER PANEL <LH> (REFER TO GROUP 52A, FLOOR CONSOLE ASSEMBLY [P.52A-7.](#))
- 9. IMMOBILIZER-ECU

&lt;&lt;A&gt;&gt;

**REMOVAL SERVICE POINT**

**<<A>> STEERING LOCK CYLINDER REMOVAL**

1. Insert the key in the steering lock cylinder and turn it to the "ACC" position.
2. Using a small Phillips head screwdriver, pull the steering lock cylinder toward you.

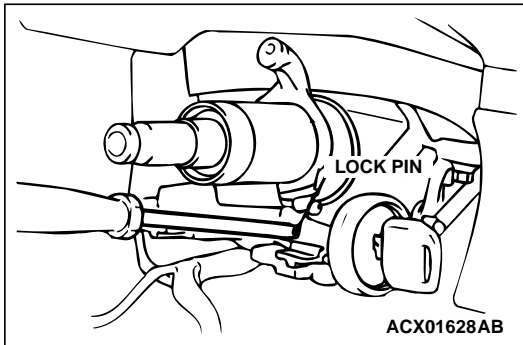

**INSPECTION**

M1543019501716

**IGNITION SWITCH LESS CONINUIITY CHECK**

Disconnect ignition switch connector without removing the ignition switch and steering lock cylinder. Then check the continuity.

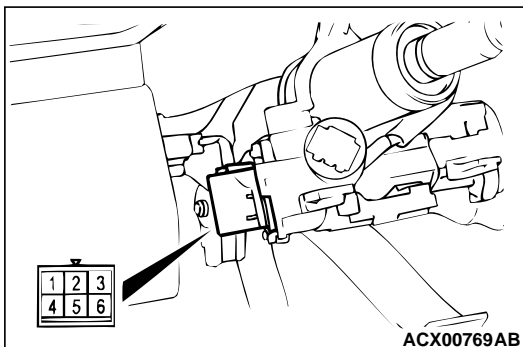

SWITCH POSITION	TESTER CONNECTION	SPECIFIED CONNECTION
"LOCK" (OFF)	1 - 2, 1 - 3, 1 - 4, 1 - 5, 1 - 6, 2 - 4, 2 - 5, 2 - 6, 4 - 5, 4 - 6	Open circuit
"ACC"	1 - 6	Less than 2 ohms
"ON"	1 - 2, 1 - 4, 1 - 6, 2 - 4, 2 - 6, 4 - 6	Less than 2 ohms
"START"	1 - 2, 1 - 4, 1 - 5, 2 - 4, 2 - 5, 4 - 5	Less than 2 ohms

**KEY REMINDER SWITCH CHECK**

Disconnect key reminder switch connector without removing the ignition switch and steering lock cylinder. Then check the continuity.

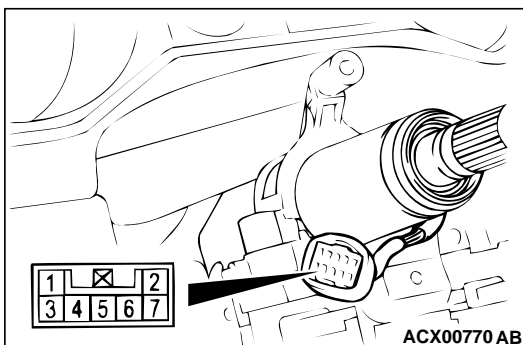

STATUS OF IGNITION KEY	TESTER CONNECTION	SPECIFIED CONNECTION
Removed	4 - 6	Less than 2 ohms
Inserted	4 - 6	Open circuit

**IGNITION KEY RING ANTENNA CHECK**

Check for continuity between terminal 3 and terminal 7.

**Standard value: 2 ohms or less**

# COMBINATION METERS ASSEMBLY AND VEHICLE SPEED SENSOR

## COMBINATION METERS ASSEMBLY AND VEHICLE SPEED SENSOR DIAGNOSIS

### INTRODUCTION TO COMBINATION METER DIAGNOSIS

M1543009900992

All vehicles are equipped with an electrical speedometer, tachometer, fuel and coolant temperature gauges. The individual gauges are not replaceable. If the gauges do not function correctly, there is most likely a fault in the electrical system. All inputs, powers and grounds must be confirmed as correct before the combination meter can be condemned.

### TROUBLESHOOTING STRATEGY

M1543006900528

Use these steps to plan your diagnostic strategy. Follow through with each step to ensure that you have exhausted all possible methods of finding a combination meter fault.

1. Gather information from the customer.

2. Verify that the condition described by the customer exists.
3. Find and repair the malfunction by following the symptom chart.
4. Verify that the malfunction has been eliminated.

### SYMPTOM CHART

M1543007200771

SYMPTOM	INSPECTION PROCEDURE	REFERENCE PAGE
Speedometer does not work.	1	<a href="#">P.54A-33</a>
Tachometer does not work.	2	<a href="#">P.54A-38</a>
Fuel gauge does not work.	3	<a href="#">P.54A-42</a>
Engine coolant temperature gauge does not work.	4	<a href="#">P.54A-50</a>
Combination meter does not work.	5	<a href="#">P.54A-55</a>



SYMPTOM PROCEDURES

INSPECTION PROCEDURE 1: Speedometer does not Work.

Speedometer Circuit

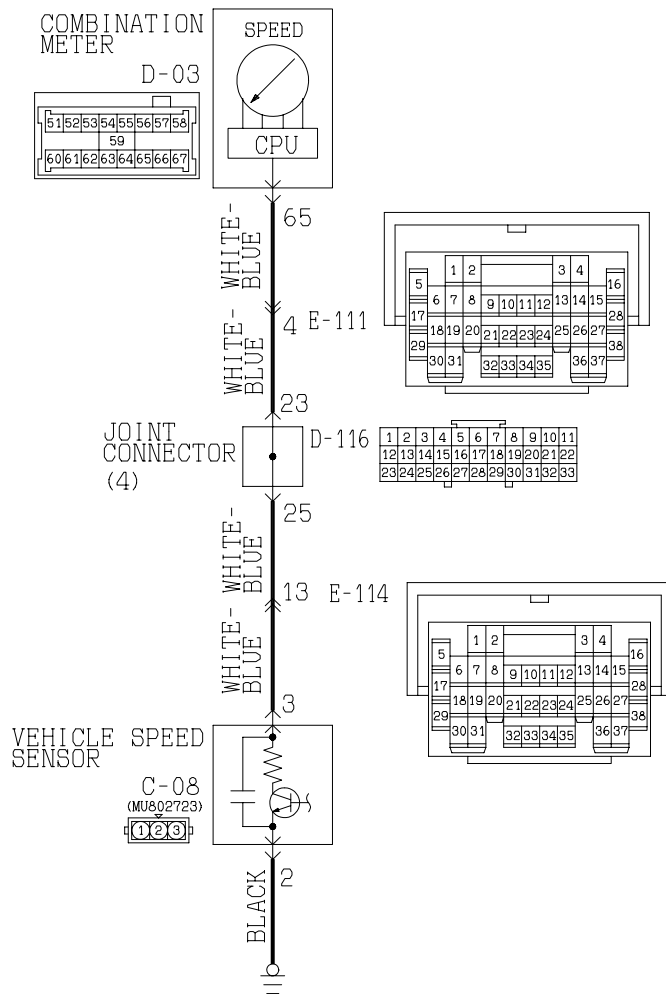

W3Q16M01AA

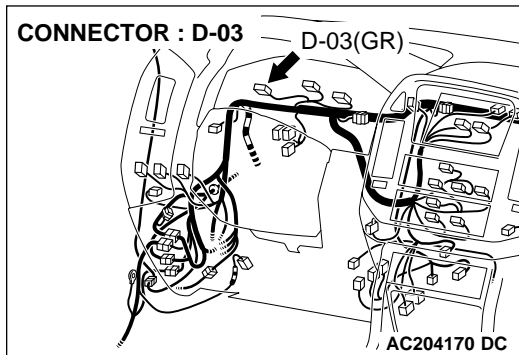
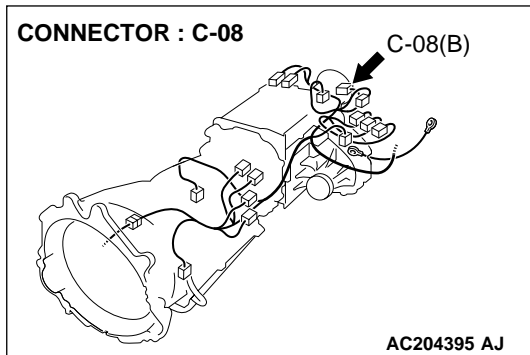

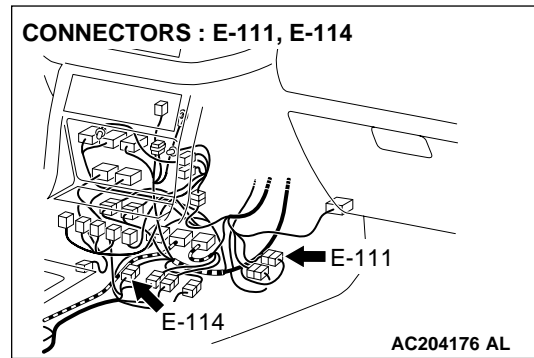
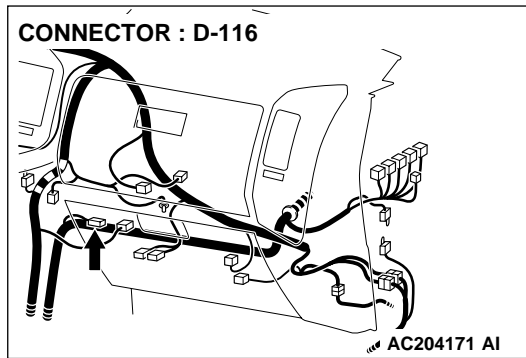

### CIRCUIT OPERATION

- The ignition switch (IG1) circuit is the power supply for the speedometer and vehicle speed sensor.
- The vehicle speed sensor is installed on the transmission. Four pulses are generated with one turn of the vehicle speed sensor shaft. These pulse signals are sent into the PCM and sent into the speedometer. The speedometer calculates the pulse signals, and operates the indicator. At the same time, the travel distance is calculated.

### TECHNICAL DESCRIPTION (COMMENT)

The cause may be a faulty vehicle speed sensor circuit system or a faulty speedometer. The vehicle speed sensor is also used by the powertrain control module (PCM), the auto-cruise control-ECU.

### TROUBLESHOOTING HINTS

- Malfunction of the vehicle speed sensor
- Malfunction of the combination meter (printed-circuit board or speedometer and tachometer)
- Malfunction of the PCM
- Malfunction of the auto-cruise control-ECU
- The wiring harness or connectors may have loose, corroded, or damaged terminals, or terminals pushed back in the connector

### DIAGNOSIS

#### Required Special Tools:

- MB991223: Harness Set
- MB991502: Scan Tool (MUT-II)

#### STEP 1. Check the speedometer by observing the other meters.

Check to see that the tachometer, fuel gauge and water thermometer are operating normally.

#### Q: Do all other meters operate?

**YES <other meters all operate>** : Go to Step 2.

**NO <one of the meters do not operate>** : Refer to INSPECTION PROCEDURE 5 [P.54A-55](#).

**STEP 2.** Using scan tool MB991502, check the MFI system diagnostic trouble code (DTC).

**⚠ CAUTION**

To prevent damage to the scan tool always turn the ignition switch to "LOCK" (OFF) position before connecting or disconnecting the scan tool.

1. Connect scan tool MB991502 to the data link connector.
2. Turn the ignition switch to the "ON" position.
3. Check the MFI system diagnostic trouble code.

**Q: Is DTC P0720 set?**

- YES :** Refer to GROUP 13A [P.13Ab-2](#), Multiport Fuel Injection (MFI) Diagnosis.
- NO :** Go to Step 3.

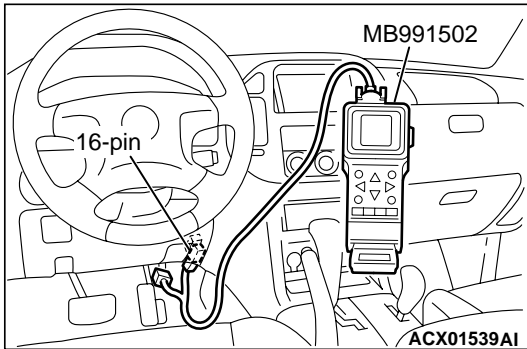

**STEP 3.** Check combination meter connector D-03 and vehicle speed sensor connector C-08 for loose, corroded or damaged terminals, or terminals pushed back in the connector.

**Q: Are combination meter connector D-03 and vehicle speed sensor connector C-08 in good condition?**

- YES :** Go to Step 4.
- NO :** Repair or replace the damaged component(s). Refer to GROUP 00E, Harness Connector Inspection [P.00E-2](#). The speedometer should work normally.

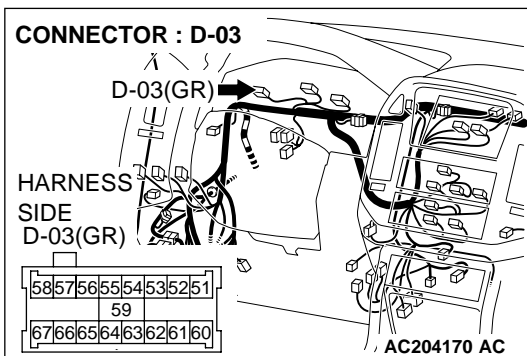
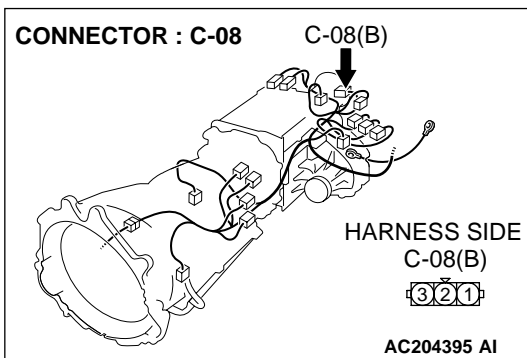

**STEP 4.** Check the wiring harness between combination meter connector D-03 (terminal 65) and vehicle speed sensor connector C-08 (terminal 3).

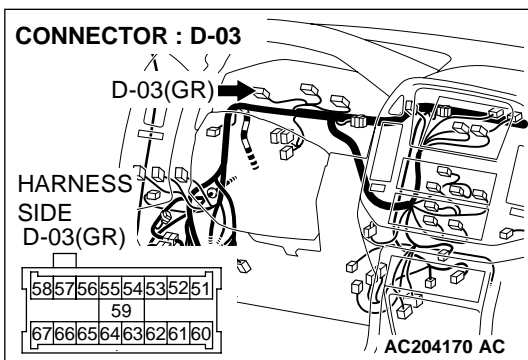
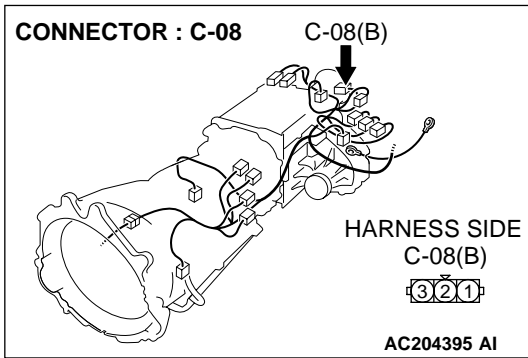

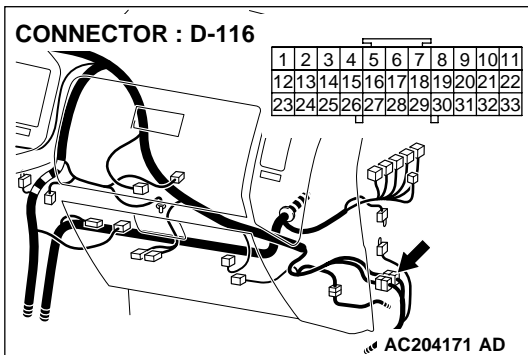

*NOTE: Also check intermediate connector E-111, E-114 and joint connector (4) D-116. If intermediate connector E-111, E-114 or joint connector (4) D-116 are damaged, repair or replace the connector as described in GROUP 00E, Harness Connector Inspection P.00E-2.*

**Q: Is the wiring harness between combination meter connector D-03 (terminal 65) and vehicle speed sensor connector C-08 (terminal 3) in good condition?**

**YES :** Go to Step 5.

**NO :** Repair the wiring harness. The speedometer should work normally.

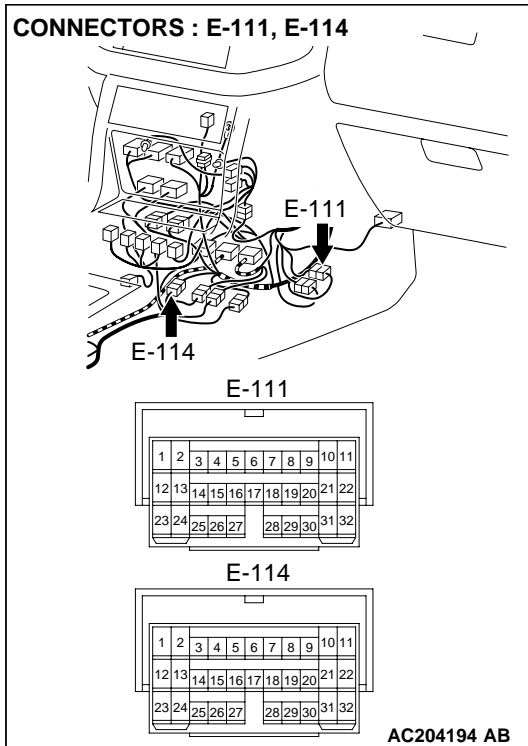

**STEP 5. Check the speedometer by operating the auto-cruise control system.**

**Q: Does auto-cruise control work normally?**

**YES :** Replace the combination meter. The speedometer should work normally.

**NO :** Replace the PCM. The speedometer should work normally.

INSPECTION PROCEDURE 2: Tachometer does not Work.

Tachometer Circuit

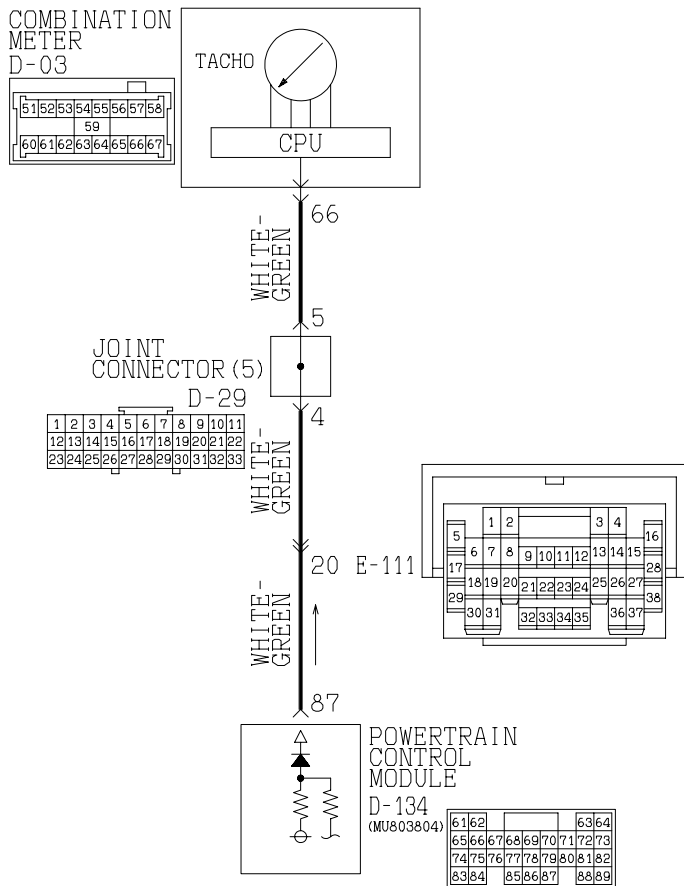

W3Q16M02AA

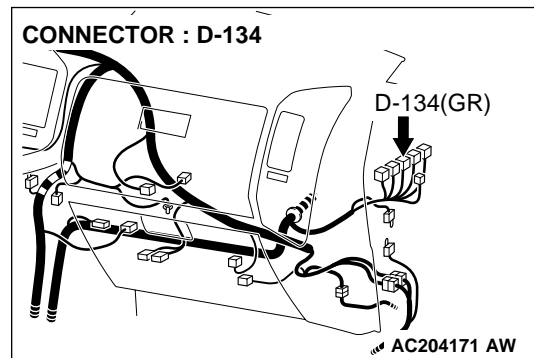
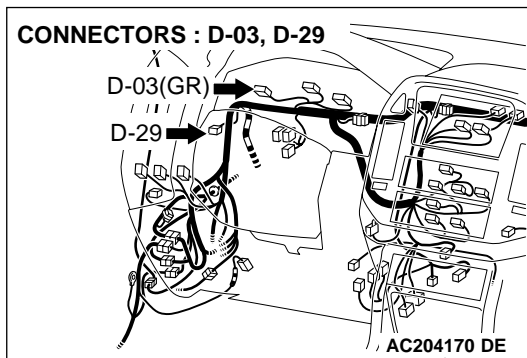

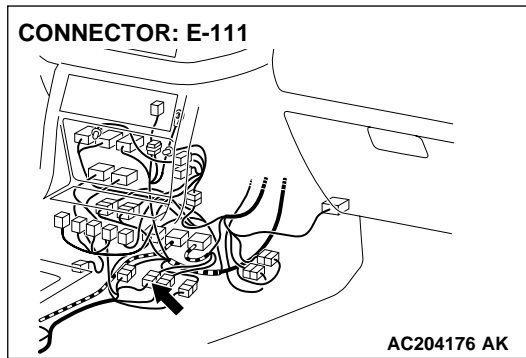

### CIRCUIT OPERATION

- The tachometer power is supplied from the ignition switch (IG) circuit.
- The tachometer detects the ignition signal control via the PCM.

### TECHNICAL DESCRIPTION (COMMENT)

The ignition signal may not be sent from the engine, or there may be a malfunction in the power supply or ground circuit.

### TROUBLESHOOTING HINTS

- Malfunction of the combination meter (printed circuit board or speedometer and tachometer)
- The wiring harness or connectors may have loose, corroded, or damaged terminals, or terminals pushed back in the connector
- Malfunction of the PCM

### DIAGNOSIS

#### Required Special Tools:

- MB991223: Harness Set
- MB991502: Scan Tool (MUT-II)

---

#### STEP 1. Check the tachometer by observing the other meters.

Check to see that the speedometer, fuel gauge and water thermometer operate normally.

#### Q: Do all other meters operate?

**YES** <other meters all operate> : Go to Step 2.

**NO** <one of the meters do not operate > : Refer to INSPECTION PROCEDURE 5 [P.54A-55](#).

**STEP 2.** Using scan tool MB991502, check the MFI system diagnostic trouble code (DTC).

**⚠ CAUTION**

To prevent damage to scan tool MB991502, always turn the ignition switch to "LOCK" (OFF) position before connecting or disconnecting scan tool.

- (1) Connect scan tool MB991502 to the data link connector.
- (2) Turn the ignition switch to "ON" position.
- (3) Check the MFI system diagnostic trouble code.

**Q: Are MFI system-related DTC(s) set? to the MFI system?**

**YES :** Refer to GROUP 13A, Multiport Fuel Injection (MFI) Diagnosis [P.13Ab-2](#).

**NO :** Go to Step 3.

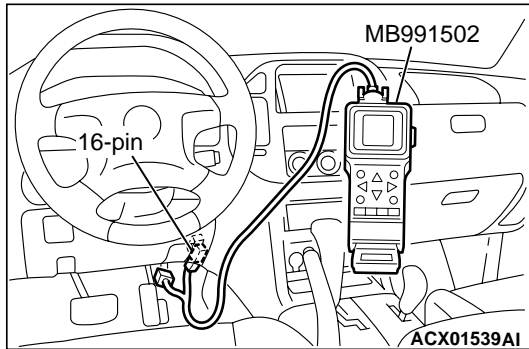

**STEP 3.** Check combination meter connector D-03 and PCM connector D-134 for loose, corroded or damaged terminals, or terminals pushed back in the connector.

**Q: Are combination meter connector D-03 and PCM connector D-134 in good condition?**

**YES :** Go to Step 4.

**NO :** Repair or replace the damaged component(s). Refer to GROUP 00E, Harness Connector Inspection [P.00E-2](#). The tachometer should work normally.

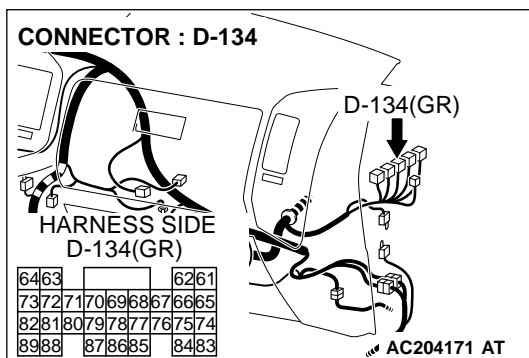
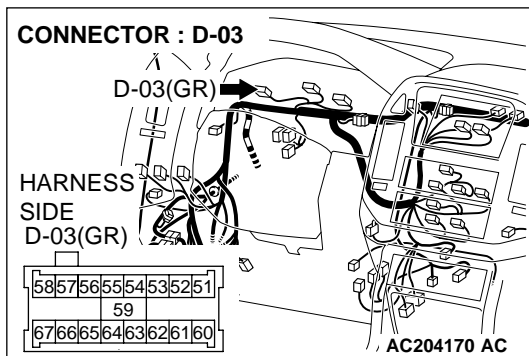



**STEP 4.** Check the wiring harness between combination meter connector D-03 (terminal 66) and PCM connector D-134 (terminal 87).

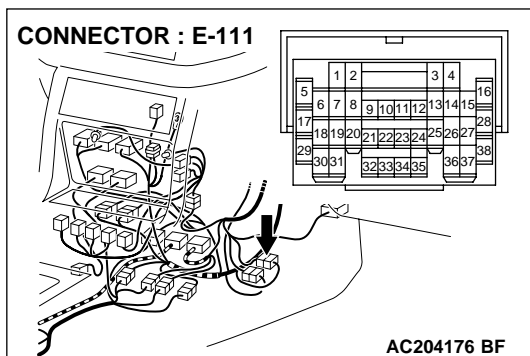
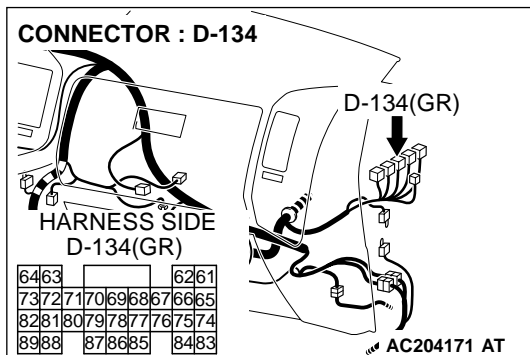
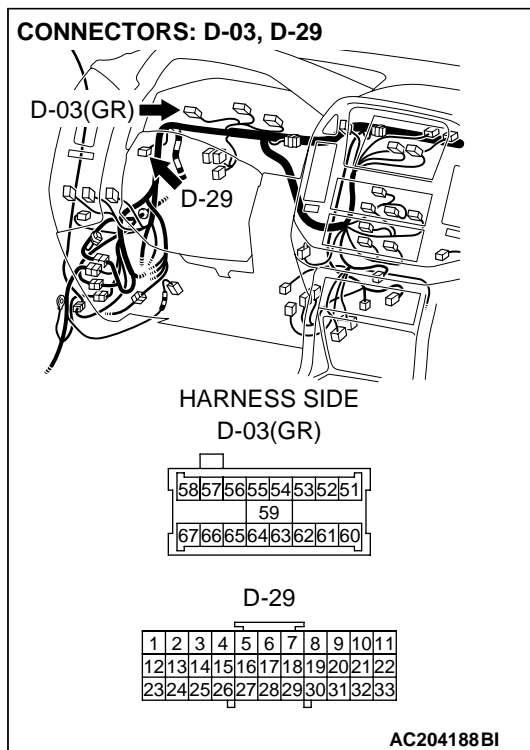

*NOTE: Also check intermediate connector E-111 and joint connector D-29. If intermediate connector E-111 or joint connector D-29 is damaged, repair or replace the connector as described in GROUP 00E, Harness Connector Inspection P.00E-2.*

**Q:** Is the wiring harness between combination meter connector D-03 (terminal 66) and PCM connector D-134 (terminal 87) in good condition?

**YES :** Go to Step 5.

**NO :** Repair the wiring harness. The tachometer should work normally.

**STEP 5. Replace and check the combination meter.**

**Q: Does the tachometer operate?**

**YES :** There is no action to be taken.

**NO :** Replace the PCM. The tachometer should work normally.

**INSPECTION PROCEDURE 3: Fuel Gauge does not Work.**

**Fuel Gauge Circuit**

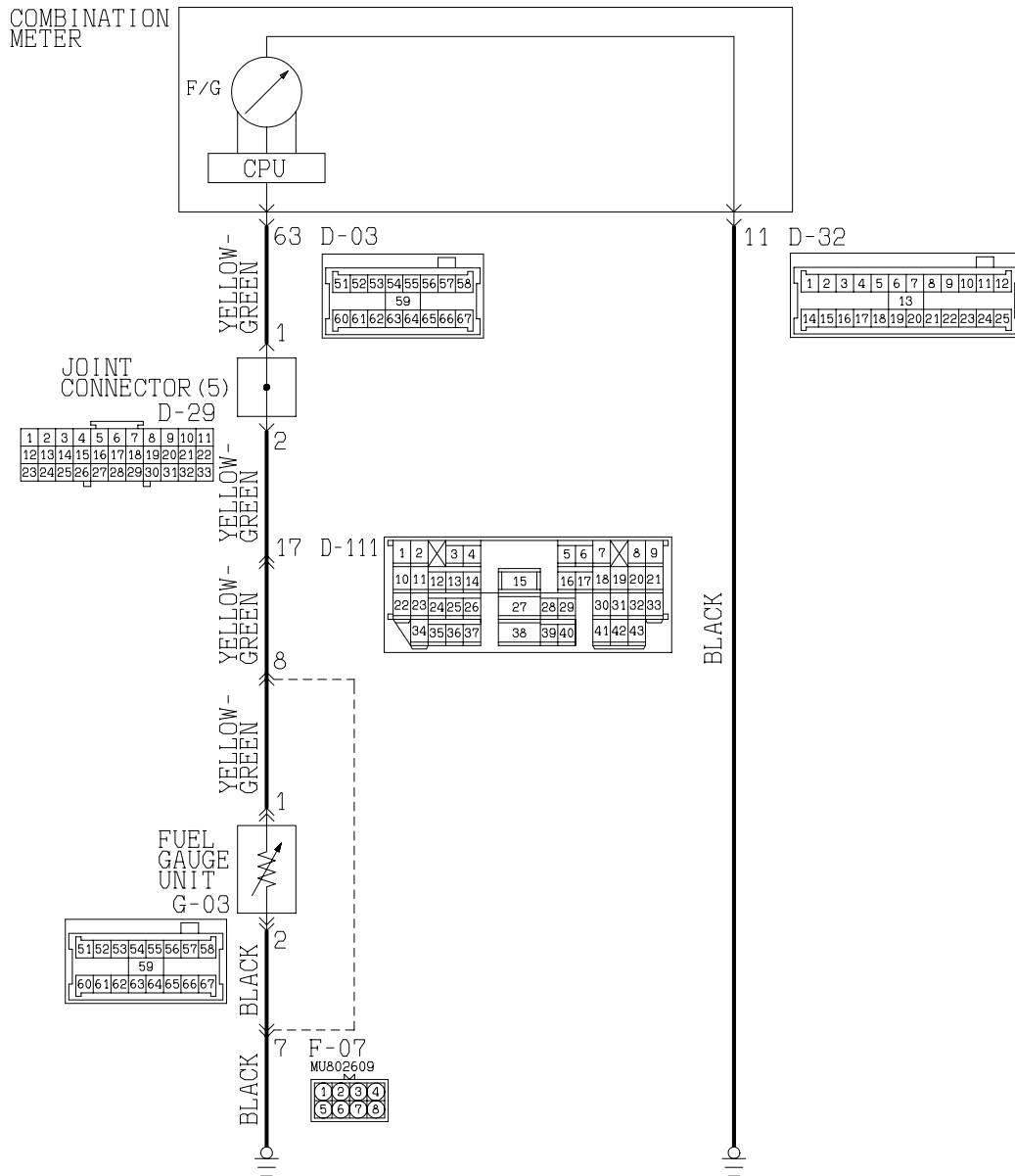

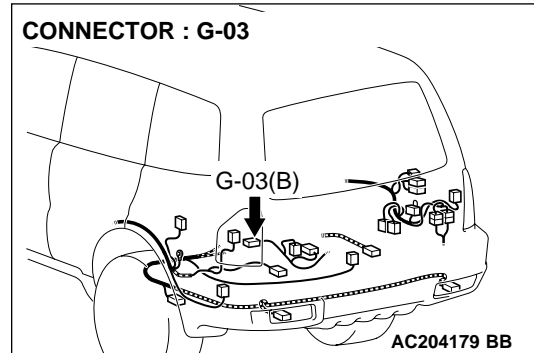
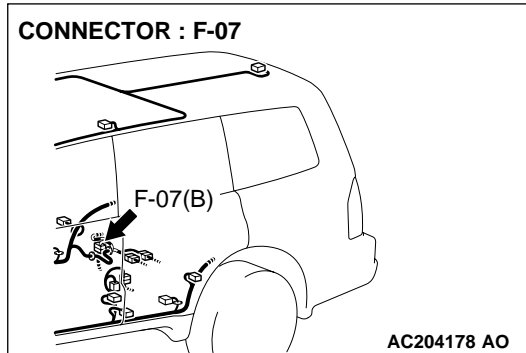
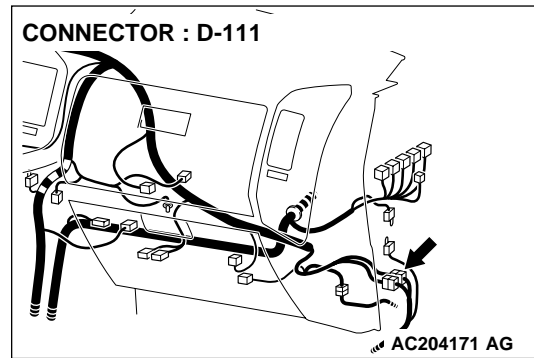
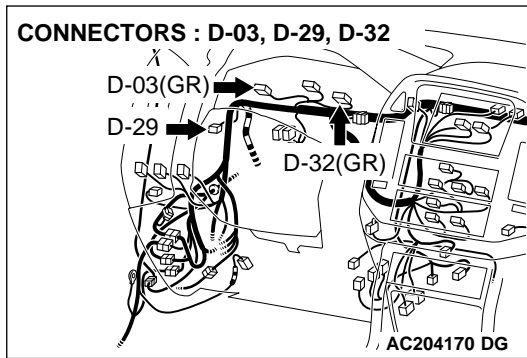

### CIRCUIT OPERATION

- The ignition switch (IG1) circuit is the power supply for the fuel gauge.
- When the float in the fuel level sensor moves, the circuit resistance will change.
- The fuel gauge needle is moved by a change in the circuit current.

### TECHNICAL DESCRIPTION (COMMENT)

If there is an open in the (IG1) circuit, the fuel gauge needle will not move at all. If there is an open in the ground circuit, the fuel gauge needle will move down to empty.

### TROUBLESHOOTING HINTS

- Malfunction of the fuel pump module (fuel level sensor)
- Malfunction of the combination meter (printed-circuit board or fuel gauge assembly)

### DIAGNOSIS

**Required Special Tool:**  
MB991223: Harness Set

#### STEP 1. Check the fuel gauge by observing the other meters.

Check to see that the speedometer, tachometer and water thermometer operate normally.

#### Q: Do all other meters operate?

**YES <other meters all operate>** : Go to Step 2.

**NO <one of the meters do not operate>** : Refer to INSPECTION PROCEDURE 5 [P.54A-55](#).

**STEP 2. Check the fuel level sensor.**

Check to see if the fuel level sensor is normal. Refer to [P.54A-63](#).

**Q: Is the fuel level sensor normal?**

**YES :** Go to Step 3.

**NO :** Replace the fuel level sensor. The fuel gauge should now operate normally.

**STEP 3. Measure at fuel level sensor connector G-03 in order to the ground circuit to the fuel level sensor.**

(1) Disconnect fuel level sensor connector G-03, and measure at the wiring harness side.

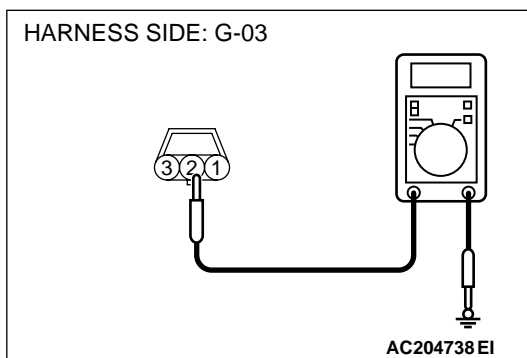
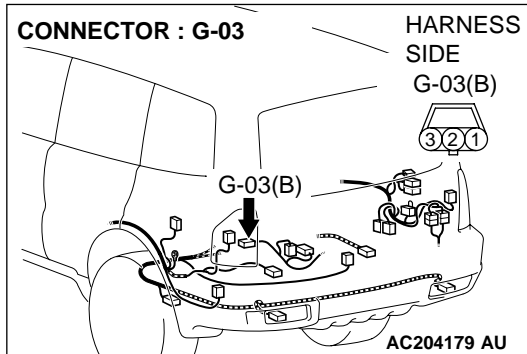

(2) Measure the resistance value between terminal 2 and ground.

- The resistance should equal 2 ohms or less.

**Q: Is the measured resistance 2 ohms or less?**

**YES :** Go to Step 6.

**NO :** Go to Step 4.

**STEP 4. Check fuel level sensor connector G-03 for loose, corroded or damaged terminals, or terminals pushed back in the connector.**

**Q: Is fuel level sensor connector G-03 in good condition?**

**YES :** Go to Step 5.

**NO :** Repair or replace the damaged component(s). Refer to GROUP 00E, Harness Connector Inspection [P.00E-2](#). The fuel gauge should now operate normally.

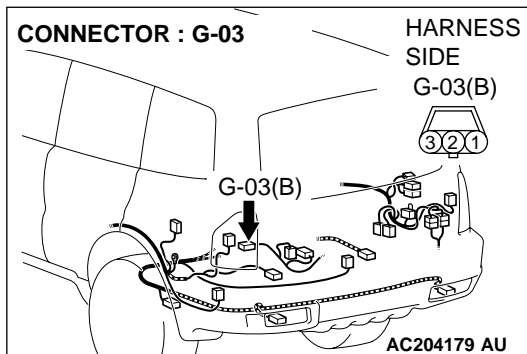

**STEP 5. Check the wiring harness between fuel level sensor connector G-03 (terminal 2) and ground.**

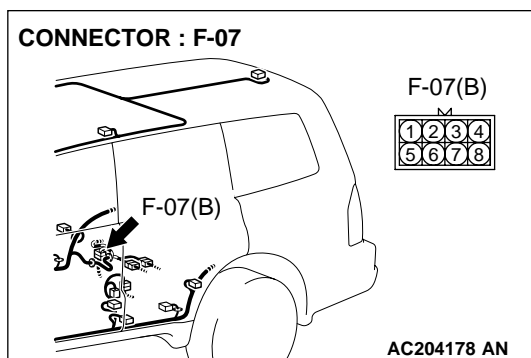
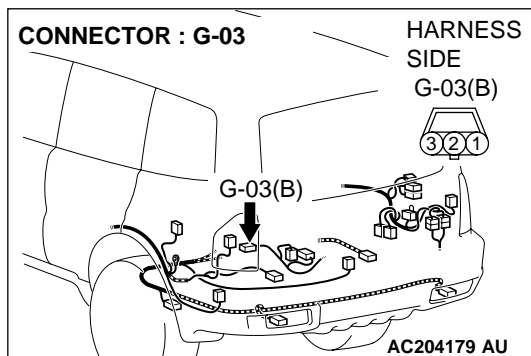

*NOTE: Also check intermediate connectors F-07. If intermediate connector F-07 is damaged, repair or replace the connector as described in GROUP 00E, Harness Connector Inspection P.00E-2.*

**Q: Is the wiring harness between fuel level sensor connector G-03 (terminal 2) and ground in good condition?**

**YES :** There is no action to be taken.

**NO :** Repair the wiring harness. The fuel gauge should now operate normally.

**STEP 6. Measure at combination meter connector D-32 in order to the ground circuit to the fuel level sensor.**

(1) Disconnect combination meter connector D-32 and measure at the wiring harness side.

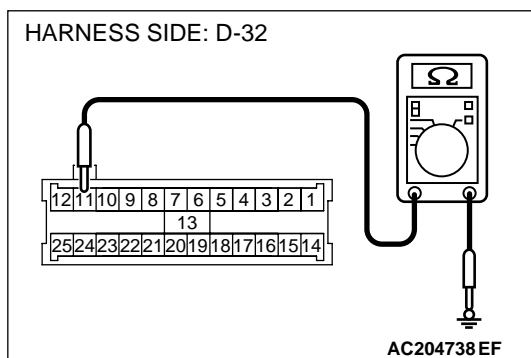
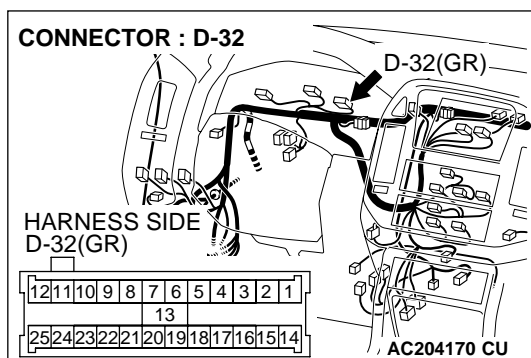

(2) Measure the resistance value between terminal 11 and ground.

- The resistance should equal 2 ohms or less.

**Q: Is the measured resistance 2 ohms or less?**

**YES :** Go to Step 9.

**NO :** Go to Step 7.

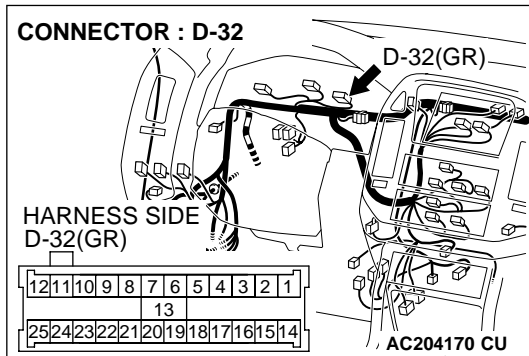

**STEP 7. Check combination meter connector D-32 for loose, corroded or damaged terminals, or terminals pushed back in the connector.**

**Q: Is combination meter connector D-32 in good condition?**

**YES :** Go to Step 8.

**NO :** Repair or replace the damaged component(s). Refer to GROUP 00E, Harness Connector Inspection [P.00E-2](#). The fuel gauge should now operate normally.

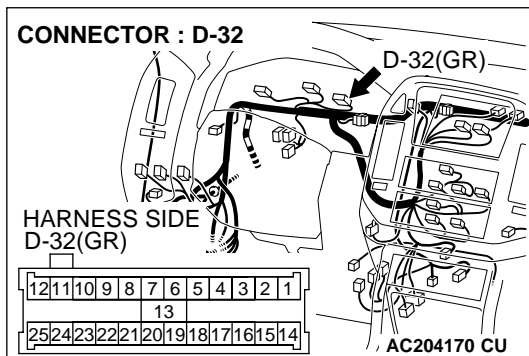

**STEP 8. Check the wiring harness between combination meter connector D-32 (terminal 11) and ground.**

**Q: Is the wiring harness between combination meter connector D-32 (terminal 11) and ground in good condition?**

**YES :** There is no action to be taken.

**NO :** Repair the wiring harness. The fuel gauge should now operate normally.

**STEP 9.** Check fuel level sensor connector G-03 and combination meter connector D-03 for loose, corroded or damaged terminals, or terminals pushed back in the connector.

**Q:** Are fuel level sensor connector G-03 and combination meter connector D-03 in good condition?

**YES :** Go to Step 10.

**NO :** Repair or replace the damaged component(s). Refer to GROUP 00E, Harness Connector Inspection

[P.00E-2](#). The fuel gauge should now operate normally.

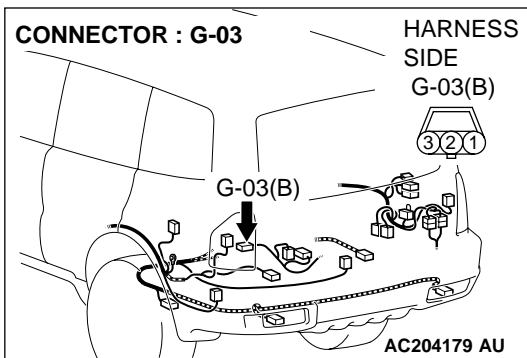
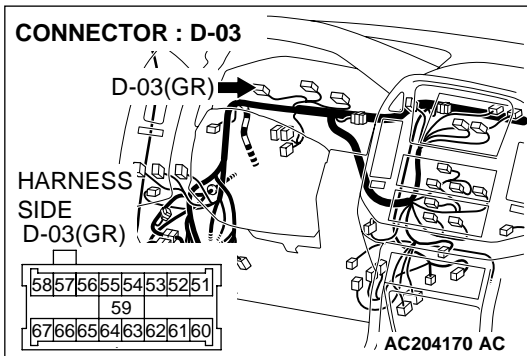

**STEP 10.** Check the wiring harness between fuel level sensor connector G-03 (terminal 1) and combination meter connector D-03 (terminal 63).

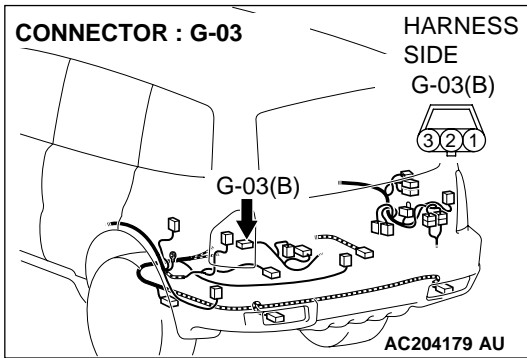
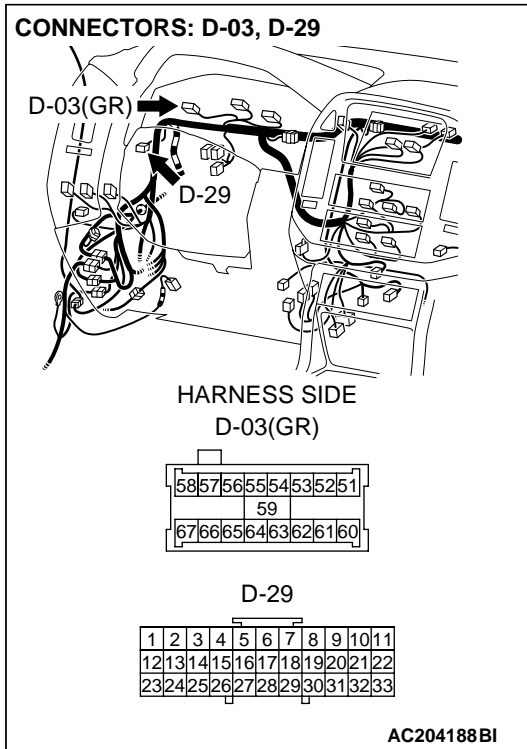



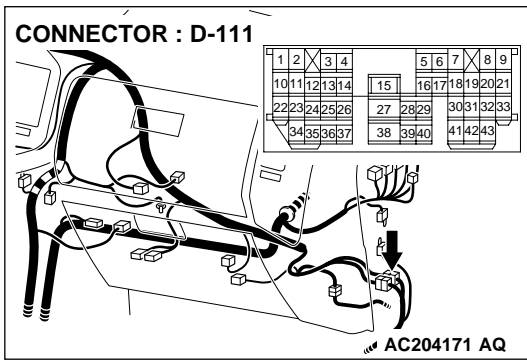

*NOTE: Also check intermediate connectors F-07, D-111 and joint connector (5) D-29. If intermediate connector F-07, D-111 or joint connector (5) D-29 is damaged, repair or replace the connector as described in GROUP 00E, Harness Connector Inspection P.00E-2.*

**Q: Is the wiring harness between fuel level sensor connector G-03 (terminal 1) and combination meter connector D-03 (terminal 63) in good condition?**

**YES :** Repair or replace the combination meter. The fuel gauge should now operate normally.

**NO :** Repair the wiring harness. The fuel gauge should now operate normally.

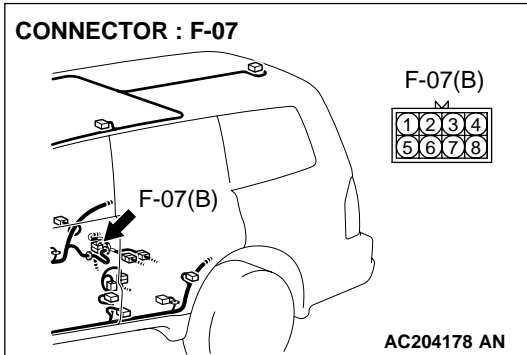

INSPECTION PROCEDURE 4: Engine Coolant Temperature Gauge does not Work.

Engine Coolant Temperature Gauge Circuit

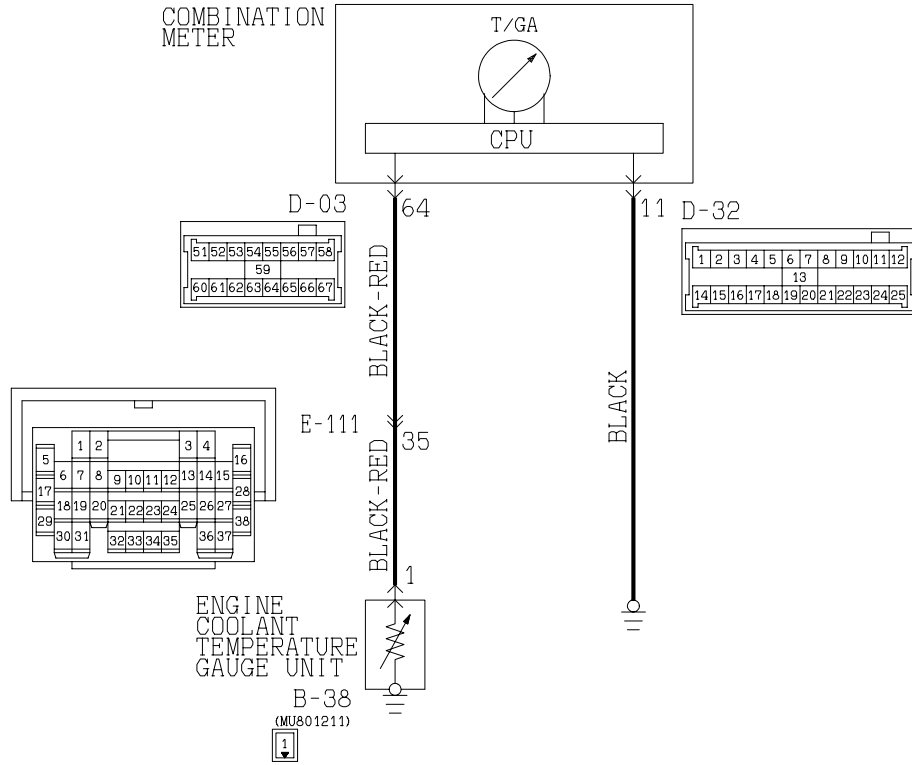

W3Q17M03AA

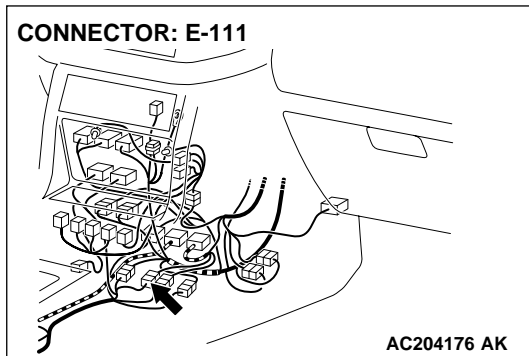
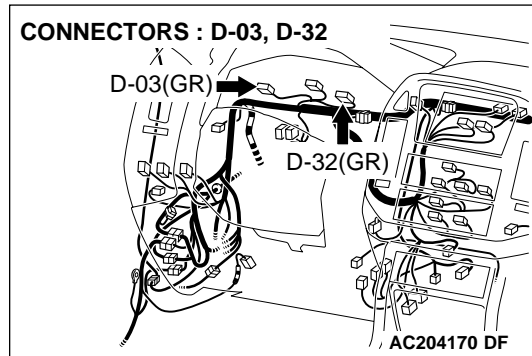
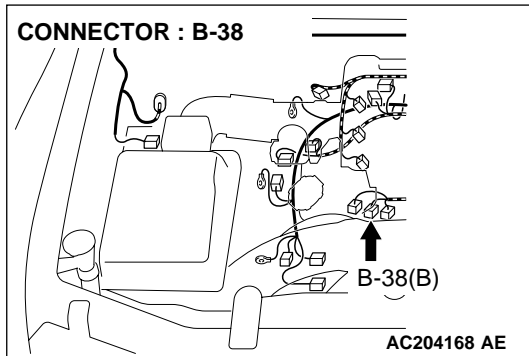

### CIRCUIT OPERATION

- The ignition switch (IG1) circuit is the power supply for the engine coolant temperature gauge.
- Resistance value, which the engine coolant temperature gauge unit sends to the combination meter, is dependent on temperature of the engine coolant. This change in resistance causes the circuit current to fluctuate, thus moving the needle on the gauge.

### TECHNICAL DESCRIPTION (COMMENT)

If there is an open in the ignition switch (IG1) circuit, the gauge needle will not move at all. If there is an open in the ground circuit, the gauge needle will move down to the extreme cold position.

### TROUBLESHOOTING HINTS

- Malfunction of the engine coolant temperature gauge unit
- Malfunction of the combination meter (printed-circuit board or engine coolant temperature gauge assembly)
- The wiring harness or connectors may have loose, corroded, or damaged terminals, or terminals pushed back in the connector

### DIAGNOSIS

**Required Special Tool:**  
MB991223: Harness Set

---

#### **STEP 1. Check the engine coolant temperature gauge by observing the other meters.**

Check to see that the speedometer, tachometer and fuel gauge operate normally.

#### **Q: Do all other meters operate?**

**YES < other meters all operate > :** Go to Step 2.

**NO < one of the meters do not operate > :** Refer to INSPECTION PROCEDURE 5 [P.54A-55](#).

---

#### **STEP 2. Check the engine coolant temperature gauge unit.**

Check to see that the engine coolant temperature gauge unit operates normally. Refer to [P.54A-64](#).

#### **Q: Is the engine coolant temperature gauge unit normal?**

**YES :** Go to Step 3.

**NO :** Replace the engine coolant gauge unit. The engine coolant gauge should work normally.

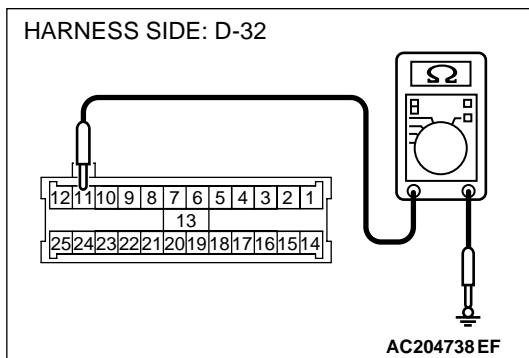
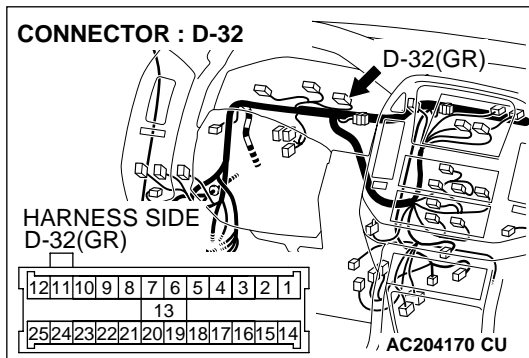

**STEP 3. Measure at combination meter connector D-32 in order to the ground circuit to the fuel level sensor.**

(1) Disconnect combination meter connector D-32 and measure at the wiring harness side.

(2) Measure the resistance value between terminal 11 and ground.

- The resistance should equal 2 ohms or less.

**Q: Is the measured resistance 2 ohms or less?**

**YES :** Go to Step 6.

**NO :** Go to Step 4.

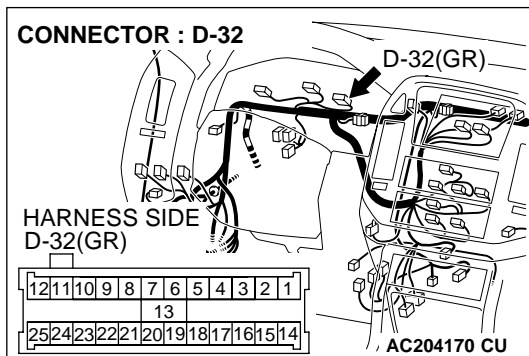

**STEP 4. Check combination meter connector D-32 for loose, corroded or damaged terminals, or terminals pushed back in the connector.**

**Q: Is combination meter connector D-32 in good condition?**

**YES :** Go to Step 5.

**NO :** Repair or replace the damaged component(s). Refer to GROUP 00E, Harness Connector Inspection [P.00E-2](#). The fuel gauge should work normally.

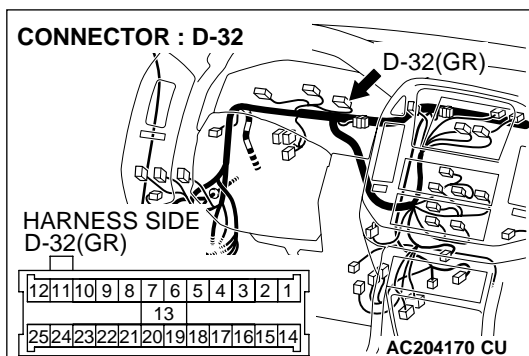

**STEP 5. Check the wiring harness between combination meter connector D-32 (terminal 11) and ground.**

**Q: Is the wiring harness between combination meter connector D-32 (terminal 11) and ground in good condition?**

**YES :** There is no action to be taken.

**NO :** Repair the wiring harness. The fuel gauge should work normally.

**STEP 6.** Check engine coolant temperature gauge unit connector B-38 and combination meter connector D-03 for loose, corroded or damaged terminals, or terminals pushed back in the connector.

**Q:** Are engine coolant temperature gauge unit connector B-38 and combination meter connector D-03 in good condition?

**YES :** Go to Step 7.

**NO :** Repair or replace the damaged component(s). Refer to GROUP 00E, Harness Connector Inspection [P.00E-2](#). The engine coolant gauge should work normally.

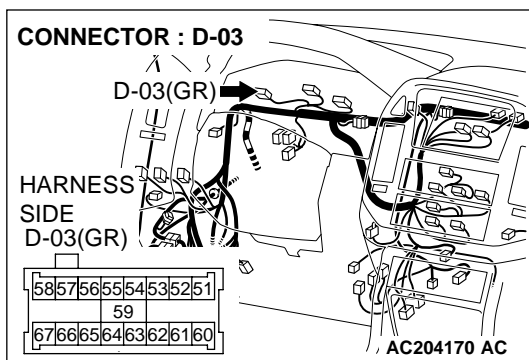
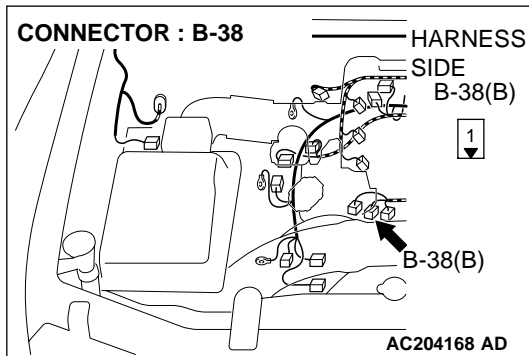

**STEP 7.** Check the wiring harness between engine coolant temperature gauge unit connector B-38 (terminal 1) and combination meter connector D-03 (terminal 64).

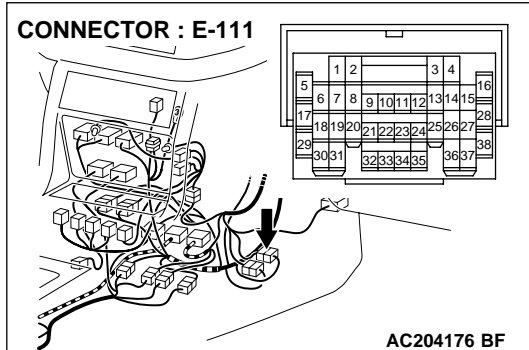
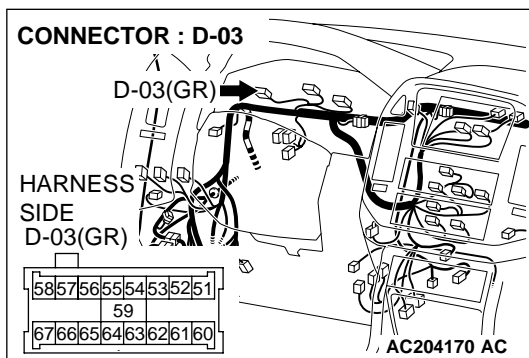
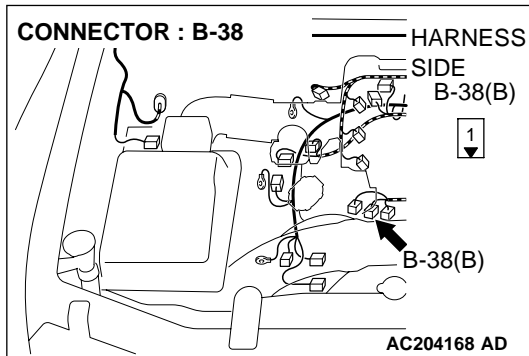

*NOTE:* Also check intermediate connector E-111. If intermediate connector E-111 is damaged, repair or replace the connector as described in GROUP 00E, Harness Connector Inspection [P.00E-2](#).

**Q:** Is the wiring harness between engine coolant temperature gauge unit connector B-38 (terminal 1) and combination meter connector D-03 (terminal 64) in good condition?

**YES :** Repair or replace the combination meter. The engine coolant gauge should work normally.

**NO :** Repair the wiring harness. The engine coolant gauge should work normally.

**INSPECTION PROCEDURE 6: Combination Meter does not Work.**

**Combination Meter Power Supply Circuit**

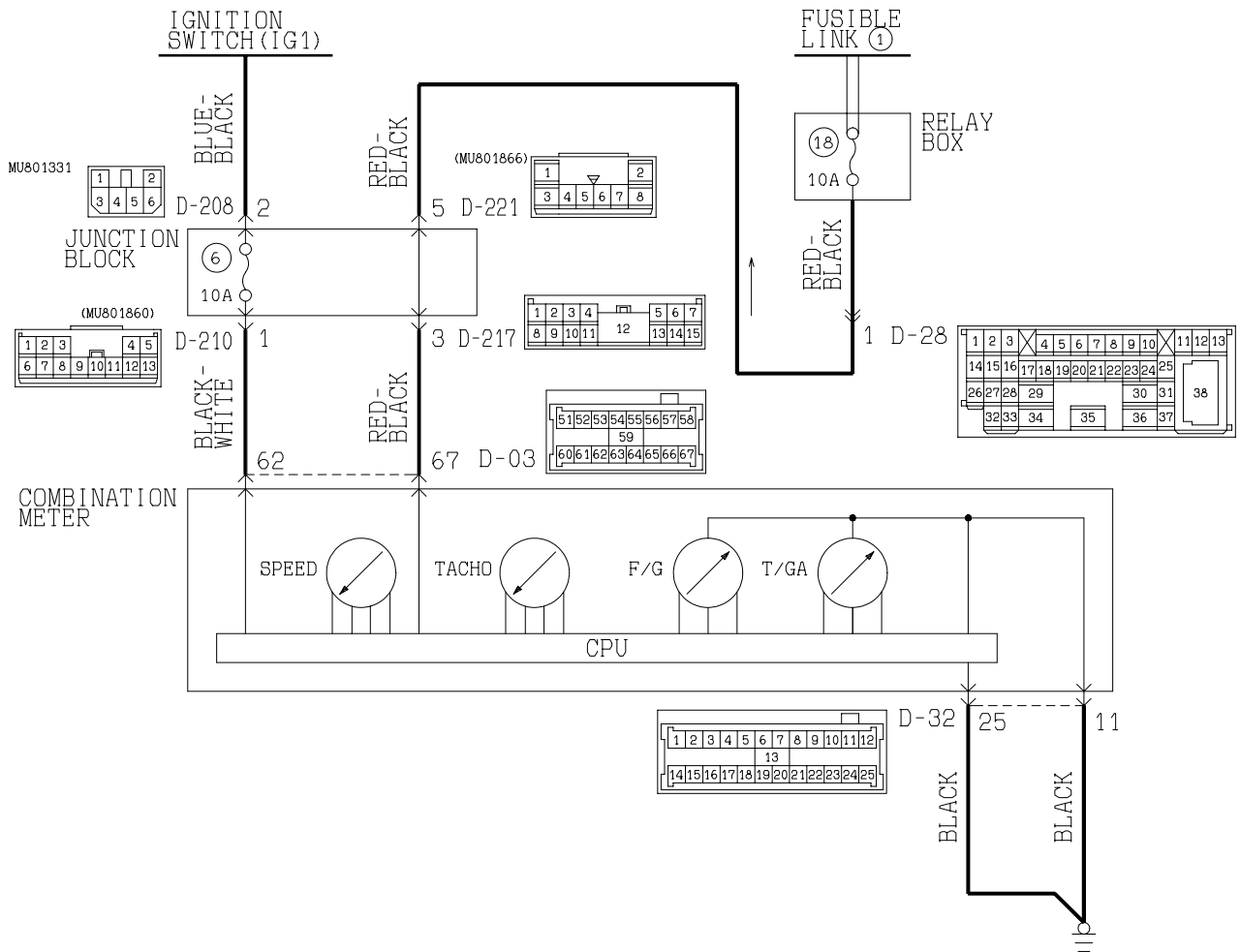

W3Q16M04AA

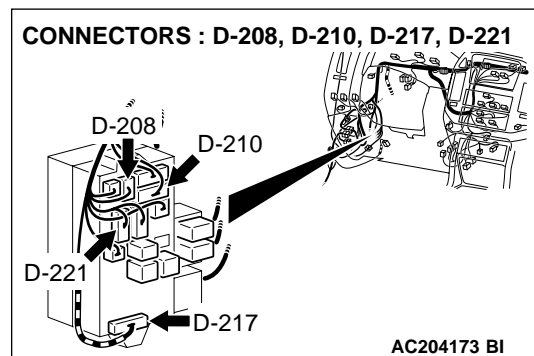
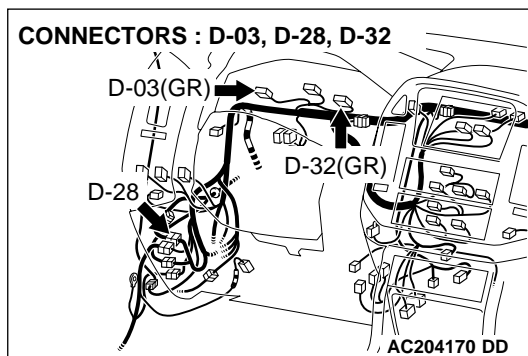

**CIRCUIT OPERATION**

The combination meter is powered by the ignition switch (IG1) and the battery.

**TROUBLESHOOTING HINTS**

- Malfunction of the combination meter (printed-circuit board or speedometer and tachometer)
- Damaged wiring harness or connectors

**TECHNICAL DESCRIPTION (COMMENT)**

The cause is thought to be malfunction of the power, ground circuitry of the combination meter.

**DIAGNOSIS****Required Special Tools:**

- MB991223: Harness Set

**STEP 1. Measure at combination meter connector D-03 in order to check the battery circuit of power supply system to the combination meter.**

(1) Disconnect combination meter connector D-03, and measure at the wiring harness side.

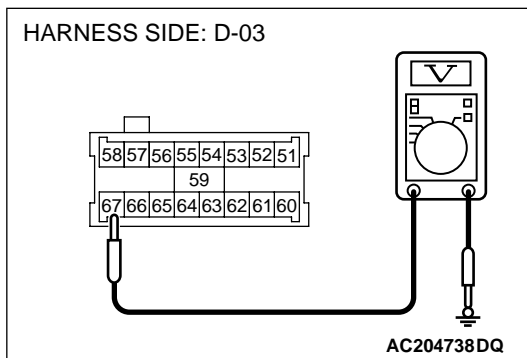
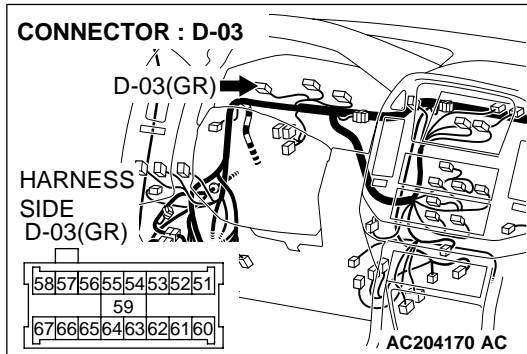

(2) Measure the voltage between terminal 67 and ground.

- The voltage should equal approximately 12 volts (battery positive voltage).

**Q: Is the measured voltage approximately 12 volts (battery positive voltage)?**

**YES :** Go to Step 4.

**NO :** Go to Step 2.

**STEP 2. Check combination meter connector D-03 for loose, corroded or damaged terminals, or terminals pushed back in the connector.**

**Q: Is combination meter connector D-03 in good condition?**

**YES :** Go to Step 3.

**NO :** Repair or replace the damaged component(s). Refer to GROUP 00E, Harness Connector Inspection

[P.00E-2](#). Check to see that all meters operate.

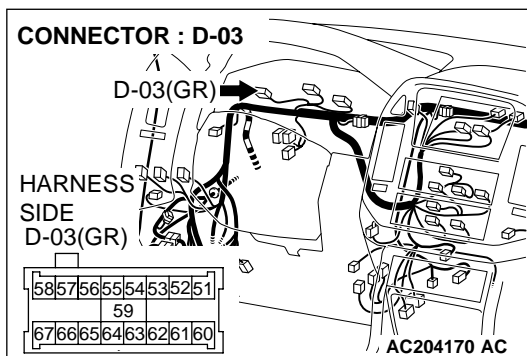



**STEP 3. Check the wiring harness between combination meter connector D-03 (terminal 67) and the battery.**

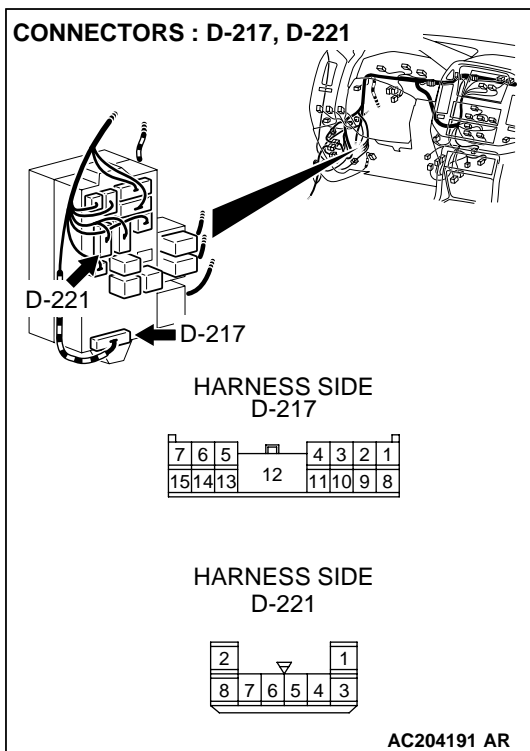
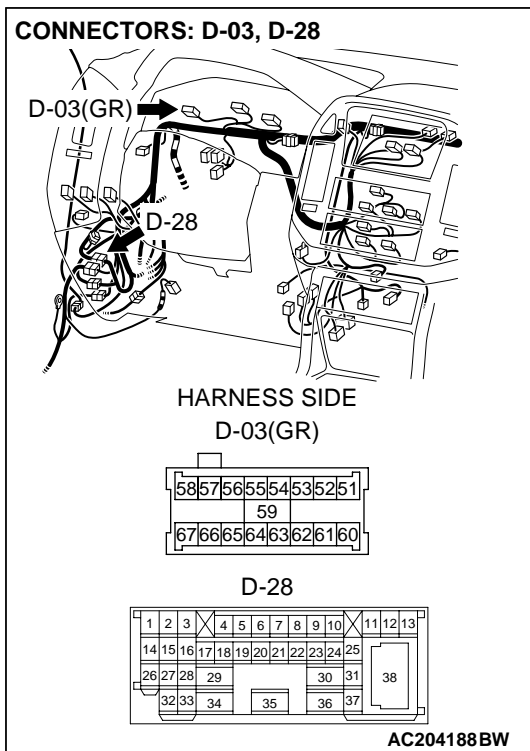

*NOTE: Also check intermediate connector D-28, junction block connector D-217 and D-221. If intermediate connector D-28, junction block connector D-217 and D-221 is damaged, repair or replace the connector as described in GROUP 00E, Harness Connector Inspection P.00E-2.*

**Q: Is the wiring harness between combination meter connector D-03 (terminal 67) and the battery in good condition?**

**YES :** There is no action to be taken.

**NO :** Repair the wiring harness. Check to see that all meters operate.

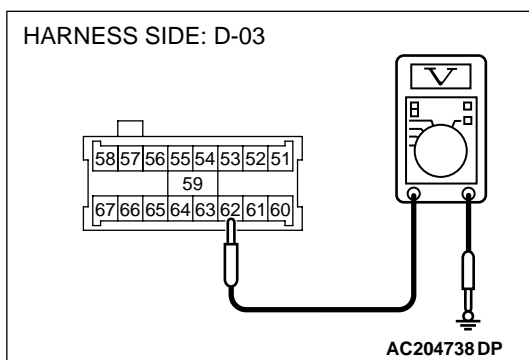
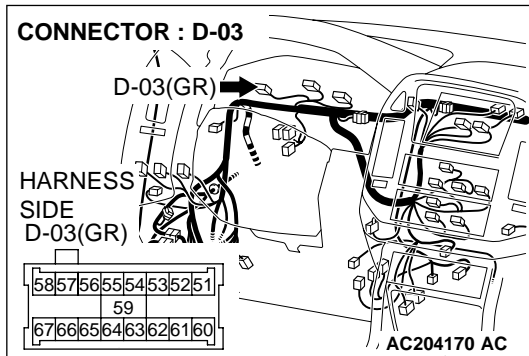

**STEP 4. Measure at combination meter connector D-03 in order to check the ignition switch (IG1) circuit of power supply system to the combination meter.**

- (1) Disconnect combination meter connector D-03, and measure at the wiring harness side.
- (2) Turn the ignition switch to "ON" position.

- (3) Measure the voltage between terminal 62 and ground.

- The voltage should equal approximately 12 volts (battery positive voltage).

**Q: Is the measured voltage approximately 12 volts (battery positive voltage)?**

**YES :** Go to Step 7.

**NO :** Go to Step 5.

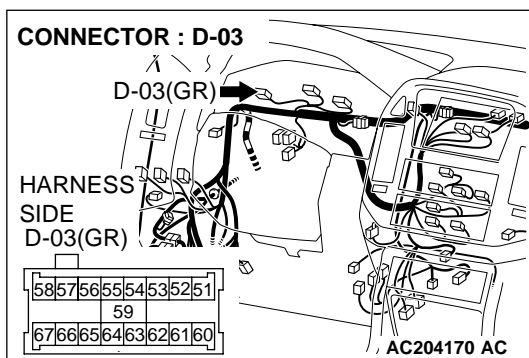

**STEP 5. Check combination meter connector D-03 for loose, corroded or damaged terminals, or terminals pushed back in the connector.**

**Q: Is combination meter connector D-03 in good condition?**

**YES :** Go to Step 6.

**NO :** Repair or replace the damaged component(s). Refer to GROUP 00E, Harness Connector Inspection

[P.00E-2](#). Check to see that all meters operate.

**STEP 6.** Check the wiring harness between combination meter connector D-03 (terminal 62) and ignition switch (IG1).

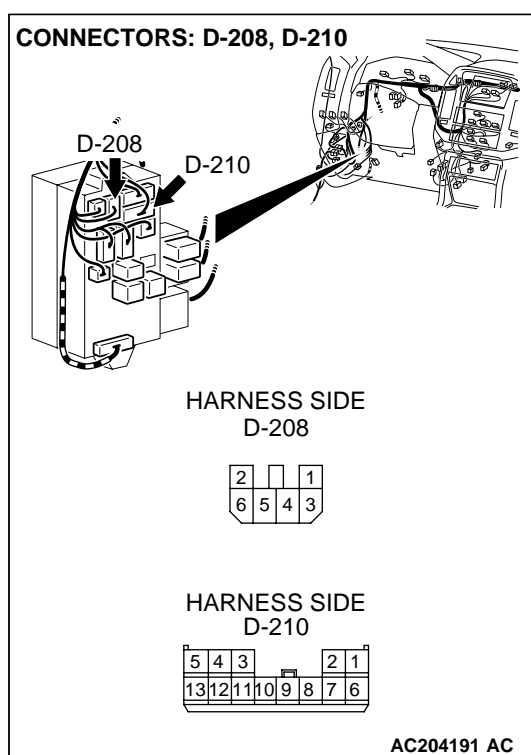
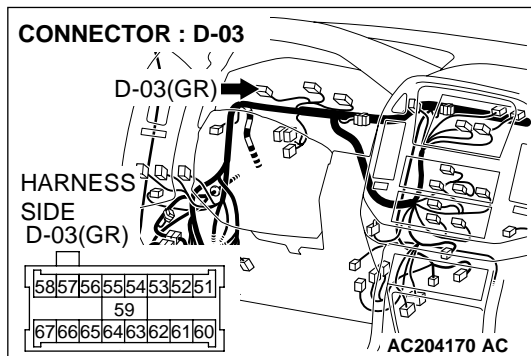

*NOTE: Also check junction block connectors D-208 and D-210. If junction block connector D-208 or D-210 is damaged, repair or replace the connector as described in GROUP 00E, Harness Connector Inspection P.00E-2.*

**Q:** Is the wiring harness between combination meter connector D-03 (terminal 62) and ignition switch (IG1) in good condition?

**YES :** There is no action to be taken.

**NO :** Repair the wiring harness. Check to see that all meters operate.

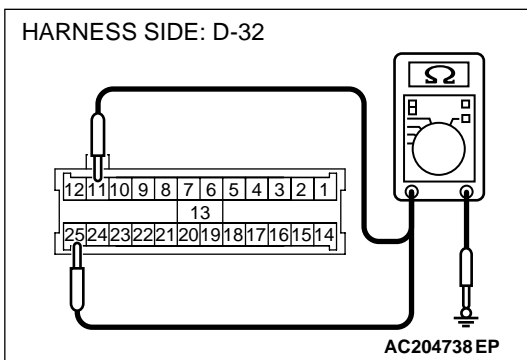
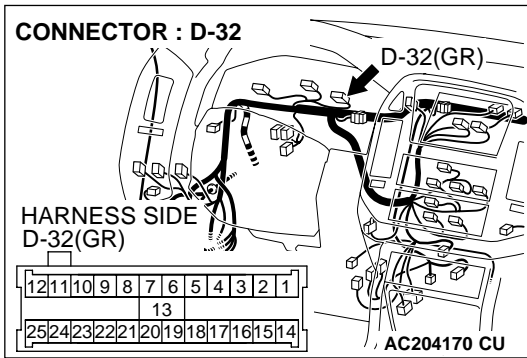

**STEP 7. Measure at combination meter connector D-32 in order to check the ground circuit to the combination meter.**

(1) Disconnect combination meter connector D-32, and measure at the wiring harness side.

- (2) Measure the resistance between terminal 25 and ground.
- The resistance should equal 2 ohms or less.
- (3) Measure the resistance between terminal 11 and ground.
- The resistance should equal 2 ohms or less.

**Q: Is the measured voltage approximately 12 volts (battery positive voltage)?**

**YES :** Repair the combination meter. Check to see that all meters operate.

**NO :** Go to Step 8.

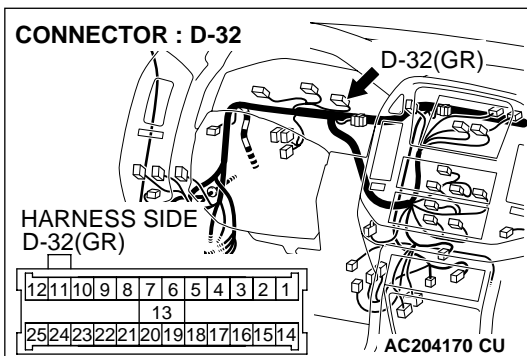

**STEP 8. Check combination meter connector D-32 for loose, corroded or damaged terminals, or terminals pushed back in the connector.**

**Q: Is combination meter connector D-32 in good condition?**

**YES :** Go to Step 9.

**NO :** Repair or replace the damaged component(s). Refer to GROUP 00E, Harness Connector Inspection

[P.00E-2](#). Check to see that all meters operate.

**STEP 9.** Check the wiring harness between combination meter connector D-32 (terminal 25 and 11) and ground.

**Q:** Is the wiring harness between combination meter connector D-32 (terminal 25 and 11) and ground in good condition?



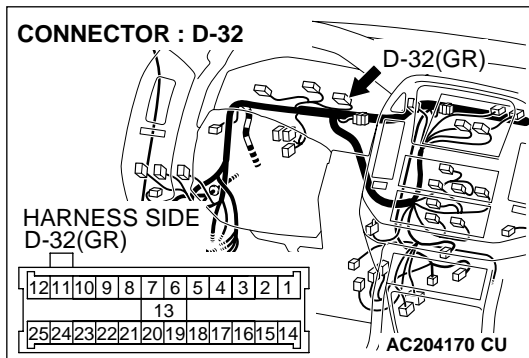

**YES :** There is no action to be taken.

**NO :** Repair the wiring harness. Check to see that all meters operate.

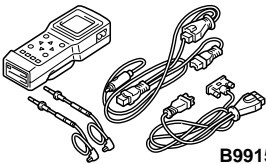

**SPECIAL TOOLS**

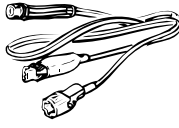
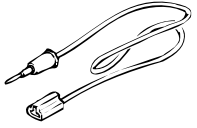
M1543000600950

TOOL	TOOL NUMBER AND NAME	REPLACED BY MILLER TOOL NUMBER	APPLICATION
 <p>B991502</p>	MB991502 Scan tool (MUT-II)	DRB-III (Scan tool)	Reading MFI system diagnostic trouble code
<p>A</p>  <p>B</p>  <p>C</p>  <p>D</p>  <p>MB991223AC</p>	<p>MB991223</p> <p>A: MB991219</p> <p>B: MB991220</p> <p>C: MB991221</p> <p>D: MB991222</p> <p>Harness set</p> <p>A: Test harness</p> <p>B: LED harness</p> <p>C: LED harness adapter</p> <p>D: Probe</p>	<p>General service tool (jumper)</p>	<p>Making voltage and resistance measurements during troubleshooting</p> <p>A: Connect pin contact pressure inspection</p> <p>B: Power circuit inspection</p> <p>C: Power circuit inspection</p> <p>D: Commercial tester connection</p>

**ON-VEHICLE SERVICE**

**SPEEDOMETER CHECK**

M1543000900296

Adjust the pressure of tires to the specified level. (Refer to GROUP 31, On-vehicle Service P.31-7.)

**⚠ CAUTION**

Place the transfer shift lever to "2H" position.

1. Set the vehicle onto a speedometer tester and use wheel chocks to hold the front wheels.

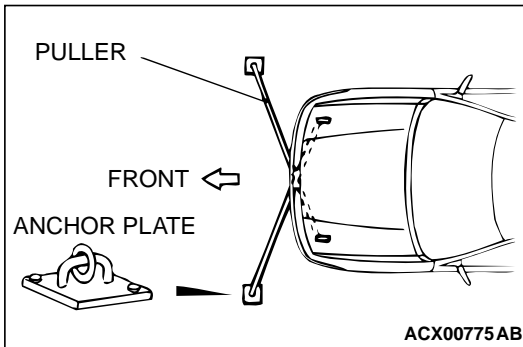
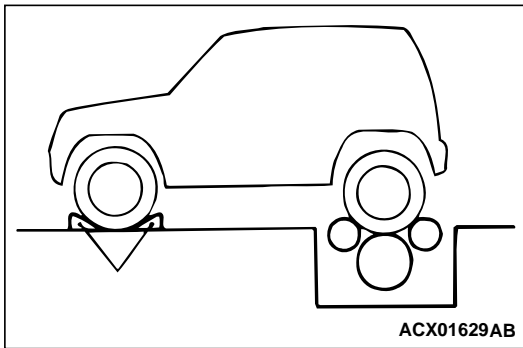

2. To prevent the sideward shaking of the front wheel, attach the puller on the towing hook and the tie down hook at front side and connect its both ends to the anchor plate.
3. To prevent the jumping out of the vehicle, attach the chain and the wire whose both ends are tightly fixed to the rear towing hook.

**⚠ CAUTION**

Do not increase/decrease speed rapidly while testing.

4. Check if the speedometer indicator range is within the standard values.

**Standard value: <Vehicles for U.S.A.>**

STANDARD INDICATION km/h (mph)	ALLOWANCE RANGE km/h (mph)
16 (10)	14 – 18 (8.5 – 11.5)
40 (25)	38 – 42 (23.5 – 26.5)
80 (50)	78 – 83 (48.5 – 51.5)
120 (75)	118 – 123 (73.5 – 76.5)
161 (100)	158 – 165 (98.5 – 102.5)

**Standard value: <Vehicles for Canada.>**

STANDARD INDICATION km/h	ALLOWANCE RANGE km/h
20	19 – 24
40	40 – 44
80	80 – 85
120	120.5 – 125.5
160	160.5 – 165.5

5. If not to the standard value, inspect for proper tire size. If not correct, replace tires with original size tires and retest. If correct, replace the speedometer. If still not to standard value, replace vehicle speed sensor.

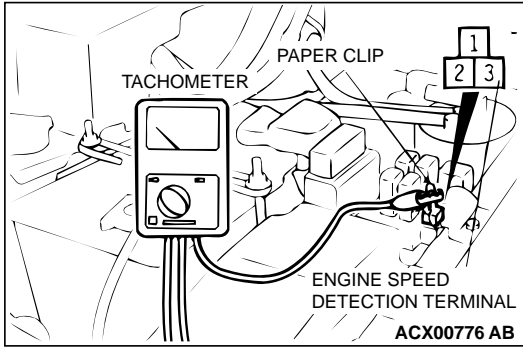

## TACHOMETER CHECK

M1543001000304

1. Attach an external high quality tachometer to the engine speed detection connector on the harness side (such as with a paper clip).  
*NOTE: For tachometer check, use an external high quality inductive tachometer.*
2. Compare the readings of the vehicle tachometer and the external tachometer at every engine speed, and check if the variations are within the standard values.

### Standard value:

Engine speed (r/min)	Indication allowance of tachometer r/min
700	600 – 800
2000	1900 – 2150
3000	2900 – 3225
4000	3875 – 4275
5000	4875 – 5325
6000	5875 – 6200

## FUEL LEVEL SENSOR CHECK

M1543001200290

Remove the fuel level sensor from fuel tank. (Refer to GROUP 13B, Fuel Tank P.13B-11.)

### FUEL LEVEL SENSOR RESISTANCE

1. Check that resistance value between the fuel gauge terminal and ground terminal is at the standard value when the fuel level sensor float is between point

#### Standard value:

- Point "F": 3 – 10.1
- Point "E": 90 – 110

2. Check that resistance value changes smoothly when the float moves slowly between point
3. If all checks are correct, go to fuel level sensor float height check. If any check is not correct, replace the fuel level sensor.

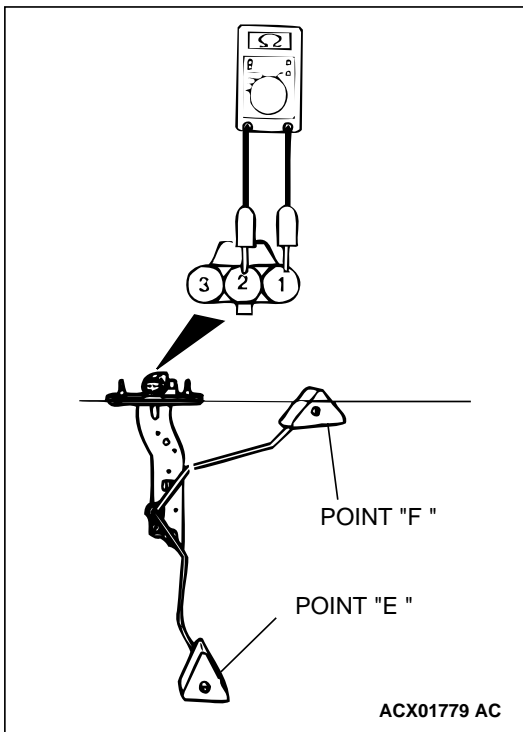

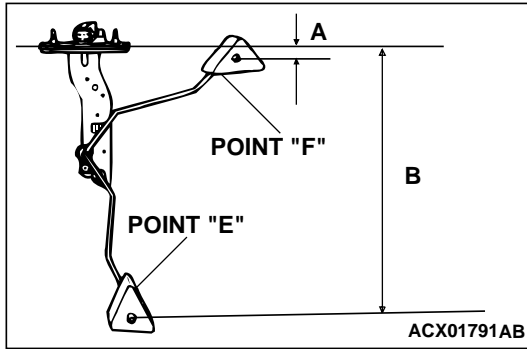

## FUEL LEVEL SENSOR FLOAT HEIGHT

1. Move the float and measure height A at point "F" (highest) and B at point "E" (lowest).

### Standard value:

- A: 11.9 mm (0.47 inch)
- B: 195.2 mm (7.69 inches)

2. Adjust the float arm to the standard value, then go to the thermistor check.

## THERMISTOR

### ⚠ CAUTION

After finishing this test, wipe the unit dry and install it in the fuel tank.

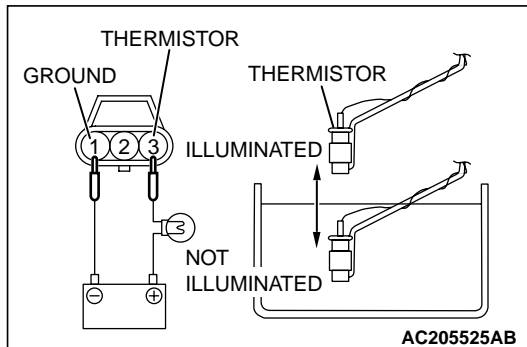

1. Connect the fuel level sensor (thermistor) to the battery via a test light (12 V – 3.4 W). Immerse the thermistor in water.
2. Condition is good if the light goes off when the thermistor is immersed in water and comes on when it is taken out of water.
3. If all check result is correct, the fuel level sensor is OK. If either check result is not correct, replace the fuel level sensor.

## ENGINE COOLANT TEMPERATURE GAUGE UNIT CHECK

M1543001500280

1. Drain the engine coolant. (Refer to GROUP 00, Maintenance Service – Engine Coolant P.00-44.)
2. Remove the engine coolant temperature gauge unit.
3. Immerse the unit in 83°C (181°F) water to measure the resistance.

**Standard value:** 65.2 ± 75.2 Ω

### Reference value

Temperature °C (°F)	Resistance Ω
50 (122)	231 – 247
105 (221)	29.9 – 39.9
122 (252)	17.5 – 25.5

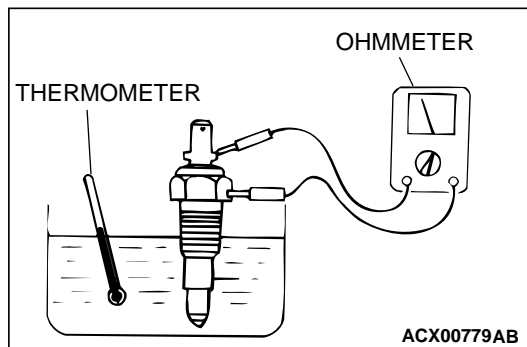

4. If within the standard value, the sensor is OK. Reinstall it, then check the engine coolant temperature gauge (Refer to P.00-44). If not within the standard value, replace it.



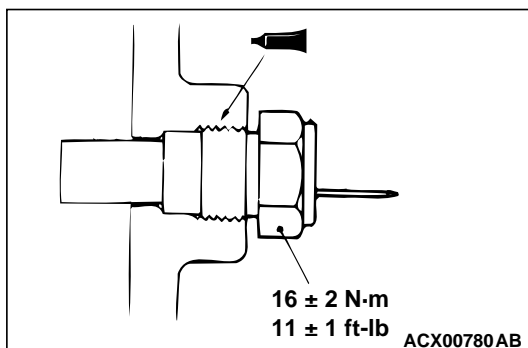

5. Also check, apply the 3M™AAD part number 8731, Loctite®242 or equivalent around the threads of the engine coolant temperature gauge unit.
6. Add engine coolant. (Refer to GROUP 00, Maintenance Service – Engine Coolant P.00-44.)

**REMOVAL AND INSTALLATION**

M1543002900195

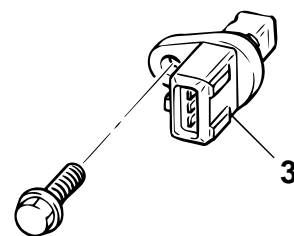
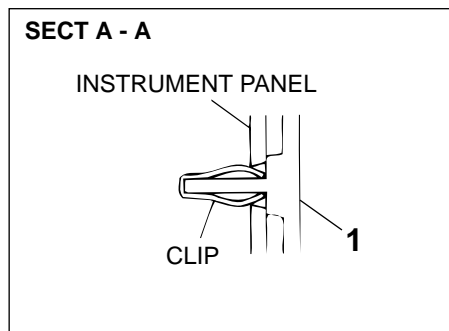
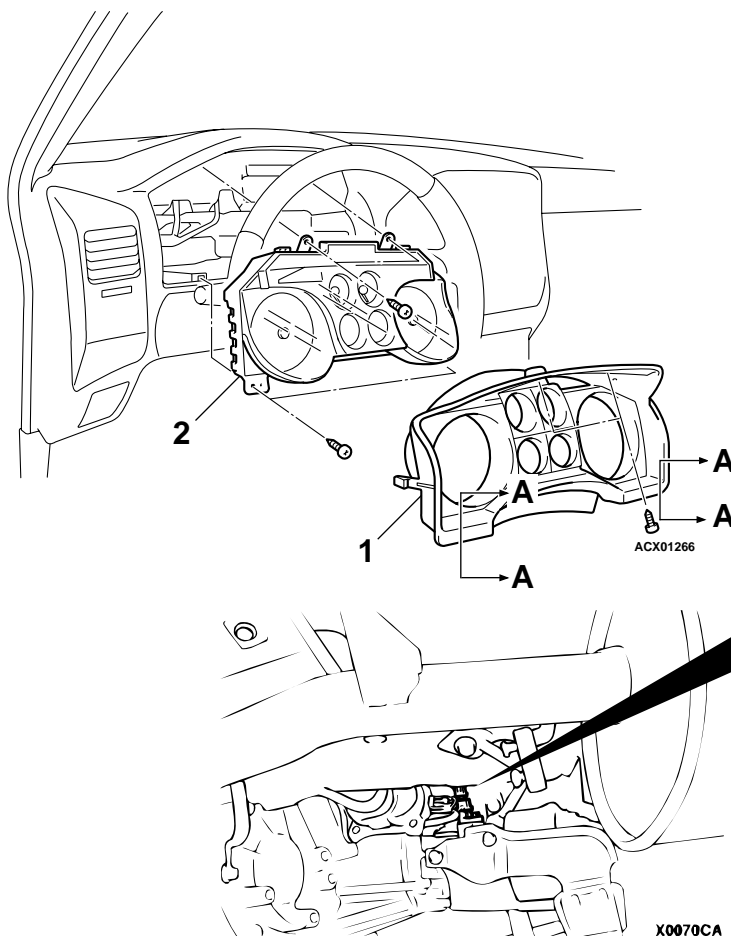

**COMBINATION METER REMOVAL STEPS**

1. METER BEZEL
2. COMBINATION METER

**VEHICLE SPEED SENSOR REMOVAL**

3. VEHICLE SPEED SENSOR

ACX01792 AC

**INSPECTION**

M1543019501783

**VEHICLES SPEED SENSOR CHECK**

1. Remove the vehicle speed sensor and connect a 3 – 10 kilo ohms resistor as shown in the illustration.
2. Turn the shaft of the vehicle speed sensor and check that there is voltage between terminals 2 and 3. (1 turn = 4 pulses)
3. If within the standard value, the vehicle speed sensor is OK. If not within the standard value, replace the vehicle speed sensor.

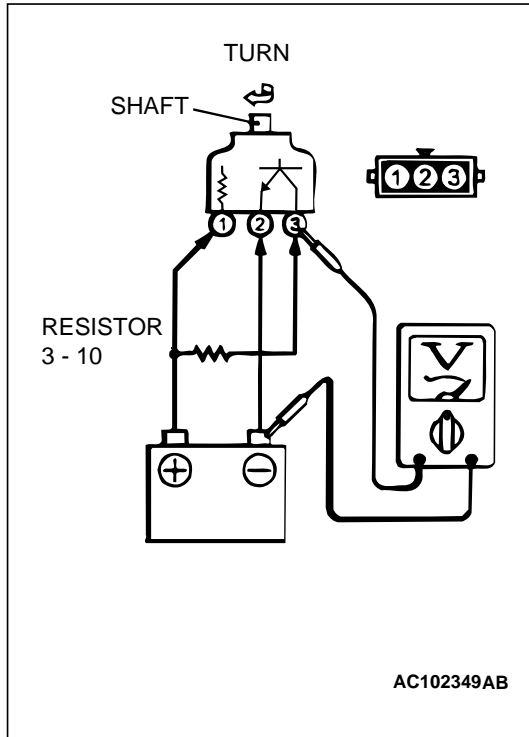

**COMBINATION METER INTERNAL RESISTANCE CHECK**

Measure the resistance between terminals using an ohmmeter.

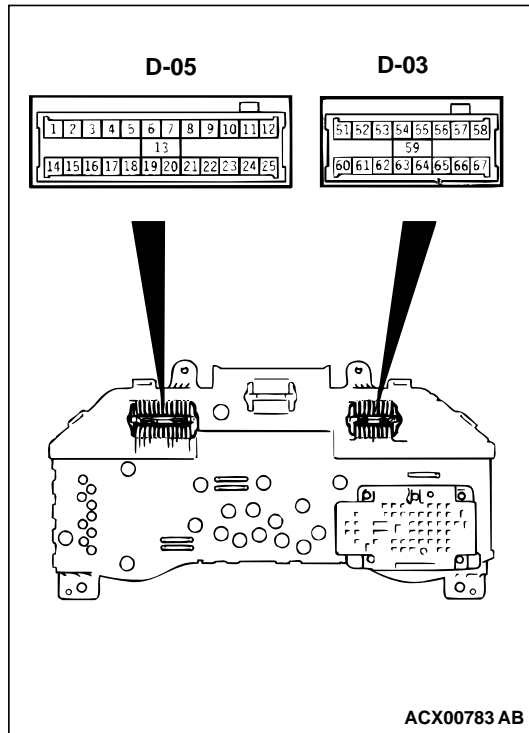

TERMINAL NO. TO MEASURE RESISTANCE	TERMINAL NAME	STANDARD VALUE
25 – 67	Battery power supply and ground	1 MΩ or more
11 – 67	Battery power supply and ground	1 MΩ or more
25 – 62	IG power supply and ground	1 MΩ or more
11 – 62	IG power supply and ground	1 MΩ or more
63 – 67	Battery power supply and fuel gauge	1 MΩ or more
62 – 63	IG power supply and fuel gauge	1 MΩ or more
25 – 63	Fuel gauge and ground	180 Ω
11 – 63	Fuel gauge and ground	180 Ω
64 – 67	Battery power supply and water temperature gauge	1 MΩ or more

TERMINAL NO. TO MEASURE RESISTANCE	TERMINAL NAME	STANDARD VALUE
62 – 64	IG power supply and water temperature gauge	1 M $\Omega$ or more
25 – 64	Water temperature gauge and ground	210 $\Omega$
11 – 64	Water temperature gauge and ground	210 $\Omega$

**DISASSEMBLY AND ASSEMBLY**

M1543003100158

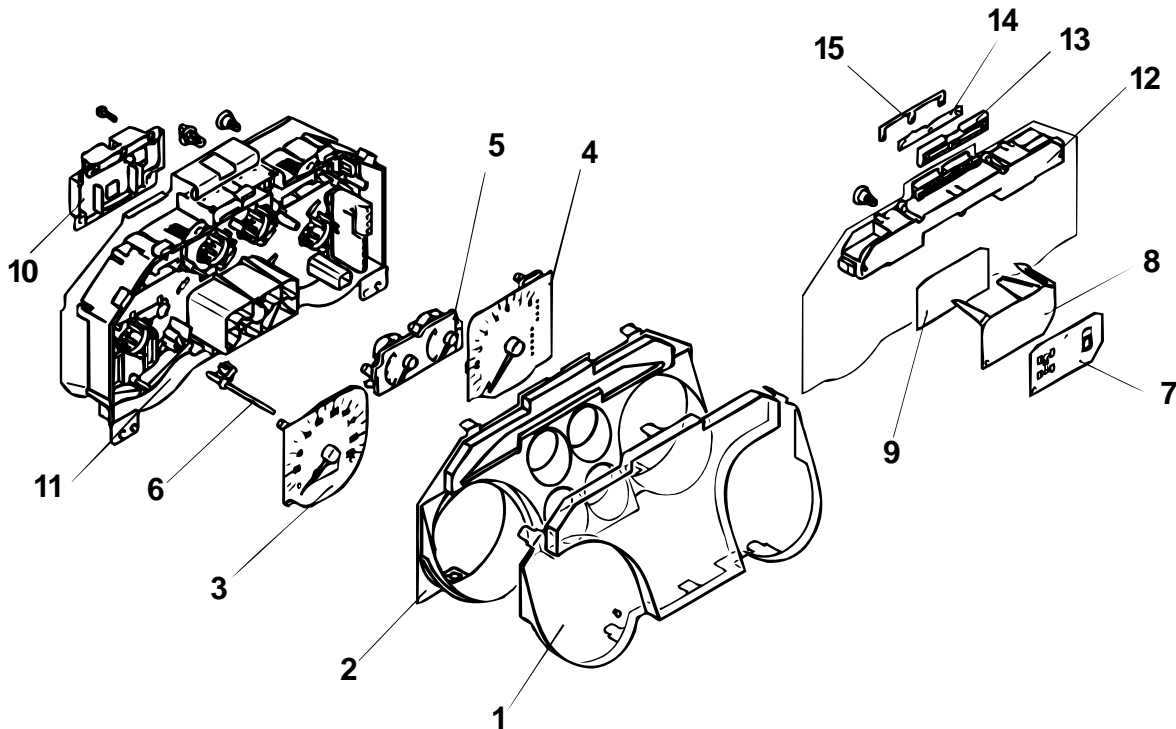

ACX00784AC

**DISASSEMBLY STEPS**

1. GLASS
2. WINDOW PLATE
3. SPEEDOMETER
4. TACHOMETER
5. FUEL GAUGE, WATER TEMPERATURE GAUGE ASSEMBLY
6. TRIP METER KNOB
7. INDICATOR PLATE

**DISASSEMBLY STEPS (Continued)**

8. INDICATOR PRISM
9. INDICATOR LENS
10. INSTRUMENT PANEL PRINTED CIRCUIT BOARD
11. COMBINATION METER CASE
12. INDICATOR CASE
13. COMBINATION PLATE "A"
14. COMBINATION PLATE "B"
15. COMBINATION PLATE "C"

# HEADLIGHT, FRONT SIDE MARKER LIGHT AND POSITION LIGHT ASSEMBLY

## HEADLIGHT DIAGNOSIS

M1542010500241

The headlights are controlled by the Simplified Wiring System (SWS). For troubleshooting, refer to GROUP 54B, SWS Diagnosis – Symptom Chart P.54Bb-2.

## ON-VEHICLE SERVICE

### HEADLIGHT AIMING

M1542000900390

#### PRE-AIMING INSTRUCTIONS

1. Inspect for badly rusted or faulty headlight assemblies.
2. These conditions must be corrected before a satisfactory adjustment can be made.
3. Inspect tire inflation, and adjust if necessary.
4. If the fuel tank is not full, place a weight in luggage room of vehicle to simulate weight of a full tank [3 kg (6.5 pounds) per gallon.]
5. There should be no other load in the vehicle other than driver or substituted weight of approximately 70 kg (150 pounds) placed in driver's position.
6. Thoroughly clean headlight lenses.
7. Place the vehicle on a level floor, perpendicular to a flat screen 7.62 m (25.0 feet) away from the bulb center-marks on the headlight lens.
8. Rock vehicle sideways to allow vehicle to assume its normal position.
9. Bounce the front suspension through three (3) oscillations by applying the body weight to hood or bumper.
10. Set the distance between the screen and the bulb center marks of the headlight as shown in the illustration.

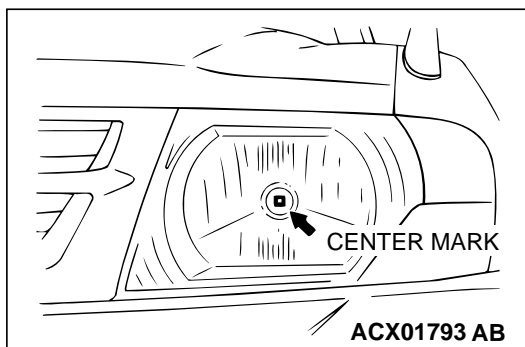

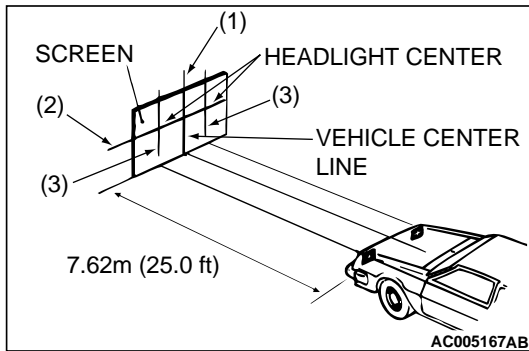

11. Four lines of adhesive tape (or equivalent markings) are required on screen or wall:
  - (1) Position a vertical tape or mark so that it is aligned with the vehicle center line.
  - (2) Measure the distance from the center-marks on the headlight lens to the floor. Transfer the measurement to the screen. Horizontal tape or mark on the screen is for reference of vertical adjustment.
  - (3) Measure the distance from the center line of the vehicle to the center of each headlight. Transfer the measurement to the screen. Vertical tape or mark on the screen with reference to the center line of each headlight bulb.

### HEADLIGHT ADJUSTMENT

1. The low beam headlight will project on the screen upper edge of the beam (cut-off).
2. Turn the adjusting screws to achieve the specified low-beam cut-off location on the aiming screen.

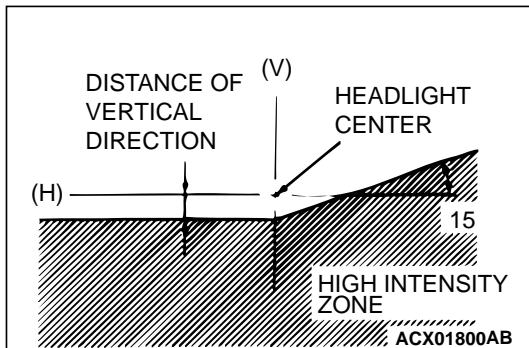
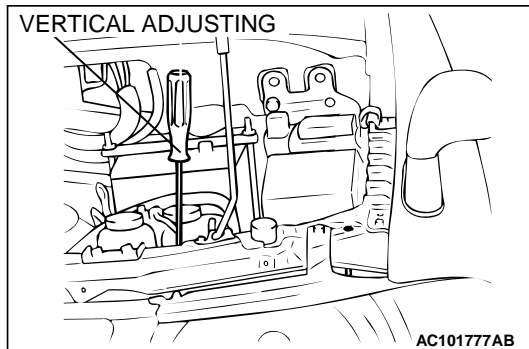

**Standard value:**

**(Vertical direction) 53 mm (2.1 inches) (0.4°) below horizontal (H)**

**Limit:**

**(Vertical direction) Standard value ± 50 mm (± 2.0 inches) (± 0.38°)**

3. When adjusting headlight, disconnect the other headlight harness.

**CAUTION**

**Do not cover a headlight for more than three minutes to prevent the plastic headlight lens deformation.**

4. There is no horizontal aim adjustment. Horizontal aim is preset and does not require adjustment. High-beam pattern should be correct when the low-beams are adjusted properly.

**LUMINOUS INTENSITY MEASUREMENT**

M1542001000118

1. Set the headlights to high-beam
2. Using a photometer, and following its manufacturer's instruction manual, measure the headlight center intensity and check to be sure that the limit value is satisfied.

**Limit: 40,000 cd or more {When a screen is set 18.3m (60 feet) ahead of the vehicle}**

*NOTE: When measuring the intensity, maintain an engine speed of 2,000 r/min, with the battery fully charged.*

*There may be special local regulations pertaining to headlight intensity. Be sure to make any adjustments necessary to satisfy such regulations.*

*If an illuminometer is used to make the measurements, convert its values to photometer values by using the following formula.*

**I = Er<sup>2</sup> Where:**

- I = intensity (cd)
- E = illumination (lux)
- r = distance (m) from headlights to illuminometer

**BULB REPLACEMENT**

M1542001300153

1. Disconnect the connector.
2. Remove the sealing cover.

**⚠ CAUTION**

**Do not touch the surface of the bulb with hands or dirty gloves as the bulb may pop after a short time. If the surface does become dirty, clean it with alcohol or thinner, and let it dry thoroughly before installing.**

3. Unhook the spring securing the bulb, and then remove the bulb.

**⚠ CAUTION**

**Do not touch the surface of the bulb with hands or dirty gloves as the bulb may pop after a short time. If the surface does become dirty, clean it with alcohol, and let it dry thoroughly before installing.**

4. Install the spring and sealing cover securely after the bulb replacement, or the lens will be out of focus, or water will get inside the light unit.

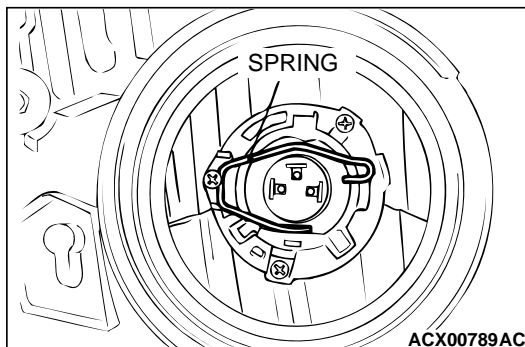

# HEADLIGHT AND FRONT COMBINATION LIGHT

## REMOVAL AND INSTALLATION

M1542002700239

**⚠ WARNING**

- Before removal of the air bag module, refer to **GROUP 52B, SRS Service Precautions and Air Bag Module and Clock Spring P.52Ba-18.**
- When removing and installing the steering wheel, do not let it bump against the air bag module.

**Post-installation operation**

- Headlight aiming adjustment (Refer to **P.54A-68.**)

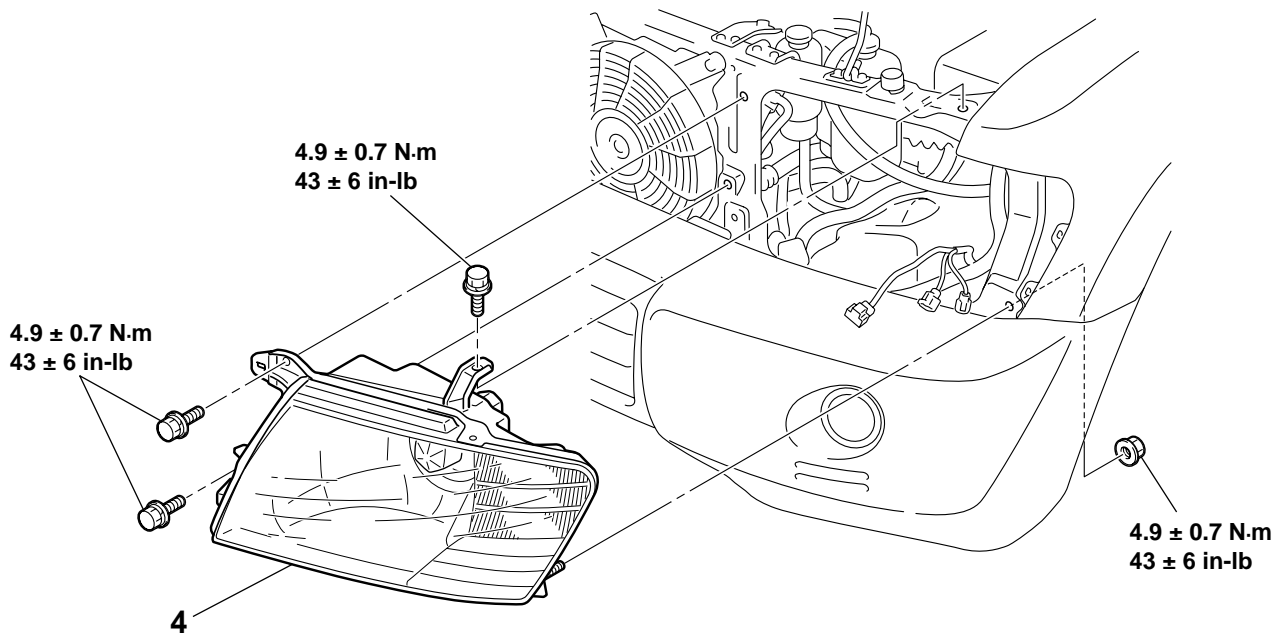
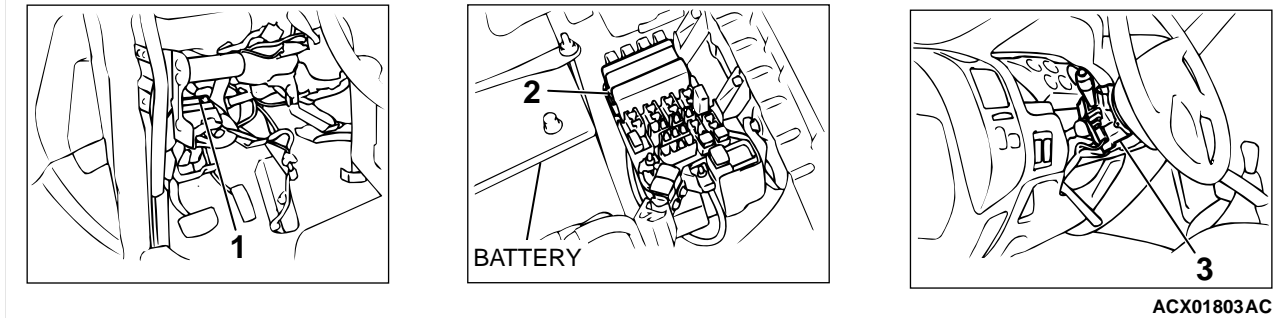

1. ETACS-ECU
2. FRONT-ECU
3. COLUMN SWITCH (REFER TO GROUP 37, STEERING WHEEL AND SHAFT P.37A-23.)

<<A>>

- HEADLIGHT REMOVAL STEPS**
- RADIATOR GRILL (REFER TO GROUP 51, FRONT BUMPER P.51-3.)
  - 4. HEADLIGHT ASSEMBLY

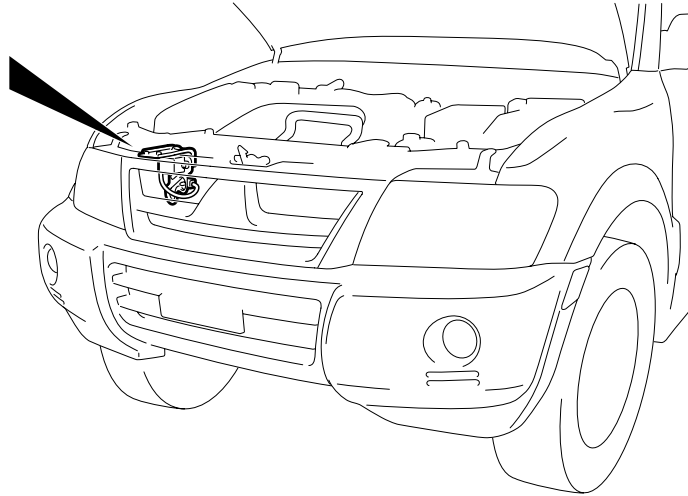
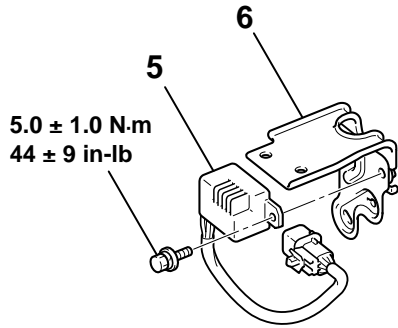

AC204789AB

**DRL-ECU REMOVAL STEPS**

5. DRL-ECU
6. DRL-ECU BRACKET

**REMOVAL SERVICE POINT****<<A>> HEADLIGHT ASSEMBLY REMOVAL**

Remove the headlight mounting nut to remove the headlight. The nut is found at the inner side of the vehicle among the nuts that appear when the splash shield is removed at the front side.

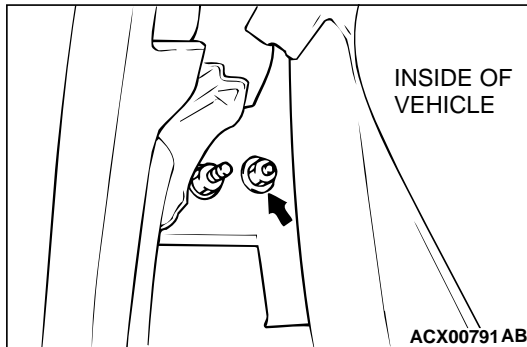
**FOG LIGHT****FOG LIGHT DIAGNOSIS**

The fog lights are controlled by the Simplified Wiring System (SWS). For troubleshooting, refer to GROUP 54B, SWS Diagnosis [P.54Ba-6](#).

M1542010500252



## ON-VEHICLE SERVICE

### FOG LIGHT AIMING

M1542001100331

#### PRE-AIMING INSTRUCTIONS

1. Inspect for badly rusted or faulty headlight assemblies.
2. These conditions must be corrected before a satisfactory adjustment can be made.
3. Inspect tire inflation, and adjust if necessary.
4. If the fuel tank is not full, place a weight in luggage room of vehicle to simulate weight of a full tank [3 kg (6.5 pounds) per gallon.]
5. There should be no other load in the vehicle other than driver or substituted weight of approximately 70 kg (150 pounds) placed in driver's position.
6. Thoroughly clean fog light lenses.
7. Place the vehicle on a level floor, perpendicular to a flat screen 7.62 m (25.0 feet) away from the bulb center-marks on the fog light lens.
8. Rock vehicle sideways to allow vehicle to assume its normal position.
9. Bounce the front suspension through three (3) oscillations by applying the body weight to hood or bumper.
10. Measure the center of the fog lights as shown in the illustration.

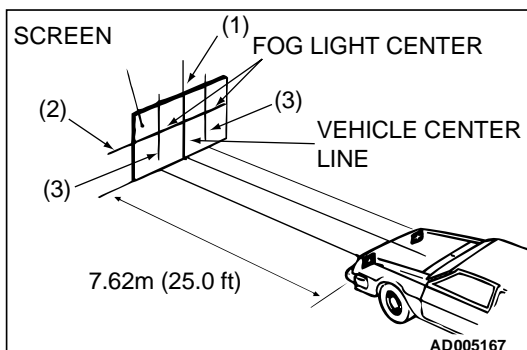
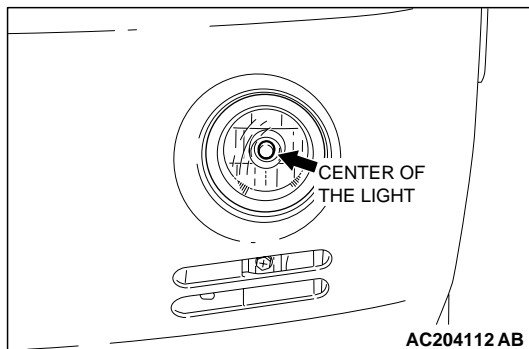

11. Four lines of adhesive tape (or equivalent markings) are required on screen or wall:
  - (1) Position a vertical tape or mark so that it is aligned with the vehicle center line.
  - (2) Measure the distance from the center-marks on the fog light lens to the floor. Transfer the measurement to the screen. Horizontal tape or mark on the screen is for reference of vertical adjustment.
  - (3) Measure the distance from the center line of the vehicle to the center of each fog light. Transfer the measurement to the screen. Vertical tape or mark on the screen with reference to the center line of each fog light bulb.

## FOG LIGHT ADJUSTMENT

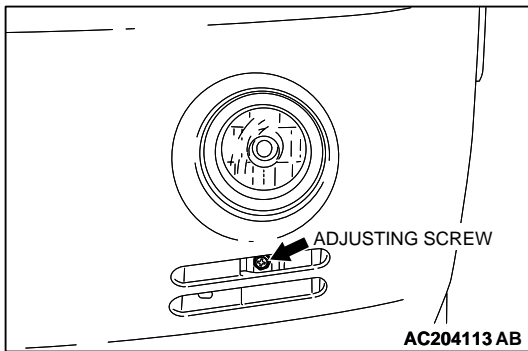
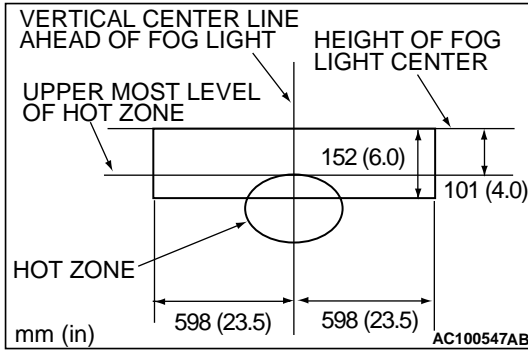

1. Check if the beam shining onto the screen is at the standard value.

**Standard value:**

**(Vertical direction): Top of the hot zone should be 101 mm (4.0 inches) below the fog light center (equivalent to the fog light beam angle of  $0.76^\circ$ ).**

**(Horizontal direction): Parallel to direction of vehicle travel**

**Limit:**

**(Vertical direction): Top of the hot zone should be 152 mm (6.0 inches) below the fog light center (equivalent to the fog light beam angle of  $1.14^\circ$ ).**

2. If the value is outside the standard value range, adjust using the adjusting screw.

*NOTE: The horizontal direction is non-adjustable. If deviation of the light beam axis exceeds the standard value, check that the mounting location or some other points are not faulty.*

**FOG LIGHT  
REMOVAL AND INSTALLATION**

M1542001500157

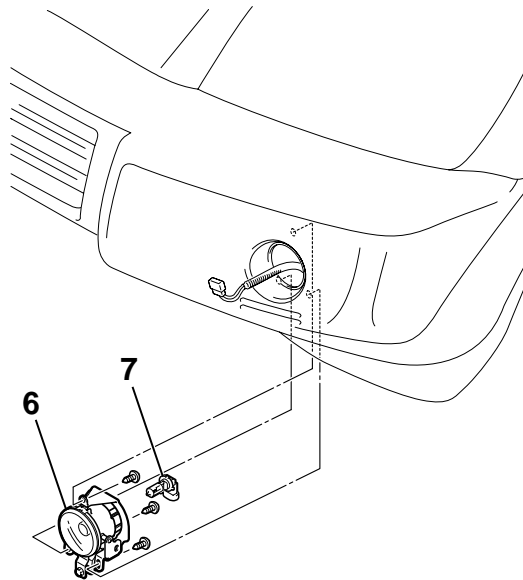
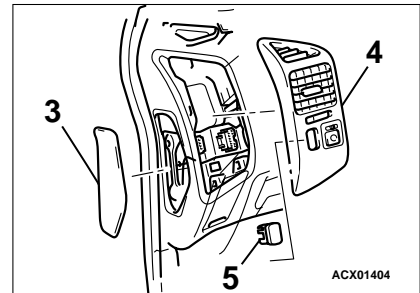
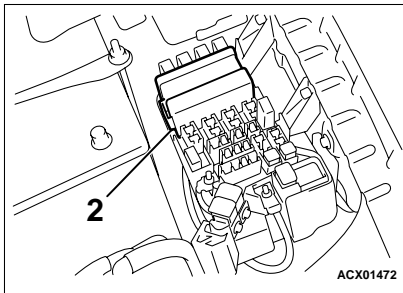
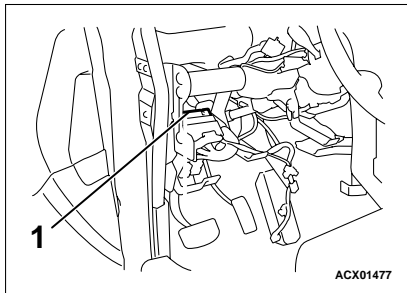

AC204148AB

- 1. ETACS-ECU
- 2. FRONT-ECU

**FOG LIGHT SWITCH REMOVAL  
STEPS**

- >>A<<
- 3. INSTRUMENT PANEL SIDE COVER
  - 4. AIR OUTLET ASSEMBLY
  - 5. FOG LIGHT SWITCH

**FOG LIGHT REMOVAL STEPS**

- 6. FOG RIGHT
- 7. BULB

<<A>>

**REMOVAL SERVICE POINT**

**<<A>> BULB REMOVAL**

**⚠ CAUTION**

- Use the specified genuine part when replacing the bulb.
- Do not touch the glass portion of bulb with bare hand or dirty gloves. Should the glass portion be spoiled, remove the soil as soon as possible using alcohol or thinner and let it dry before mounting.

Turn the bulb assembly left to remove it.

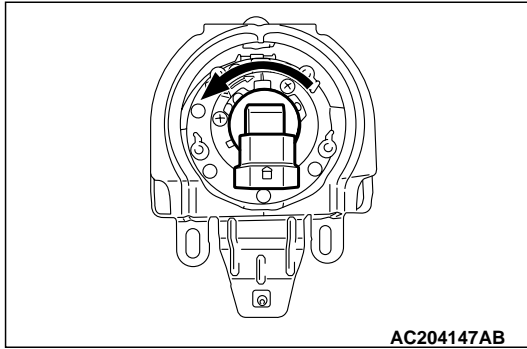

**INSTALLATION SERVICE POINT**

**>>A<< AIR OUTLET ASSEMBLY INSTALLATION**

1. Insert the hand from the mounting hole of the instrument panel side cover to hold and fix the fog light switch cover by the hand.
2. While inter fitting the air outlet assembly duct, connect the fog light switch to the connector.

*NOTE: After fitting, check that the open/close damper knob of the air outlet can be operated normally.*

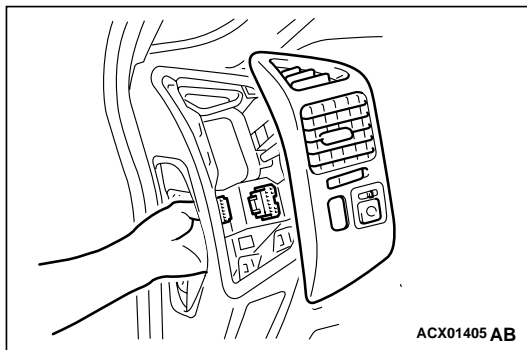

**INSPECTION**

M1542011200072

**FOG LIGHT SWITCH CONTINUITY CHECK**

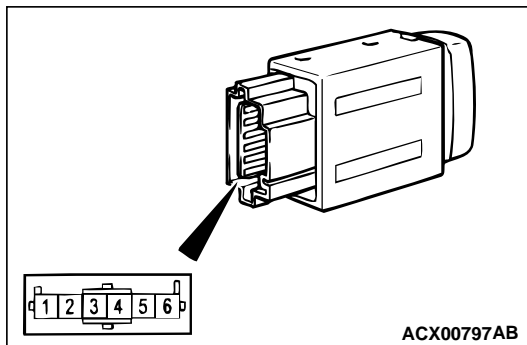

SWITCH POSITION	TESTER CONNECTION	SPECIFIED CONDITION
ON	1 – 2	Less than 2 ohms
OFF	1 – 2	Open circuit

FOG LIGHT RELAY CHECK

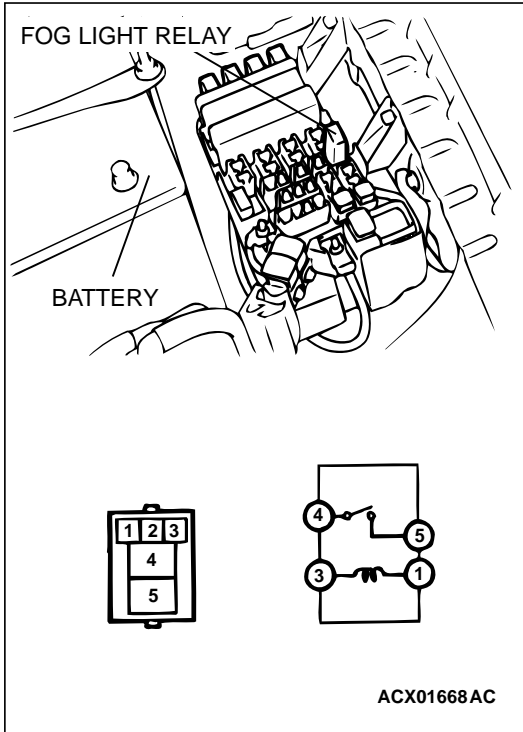

BATTERY VOLTAGE	TESTER CONNECTION	SPECIFIED CONDITION
Not applied	4 – 5	Open circuit
<ul style="list-style-type: none"> <li>• Connect terminal 3 to the positive battery terminal</li> <li>• Connect terminal 1 to the negative battery terminal</li> </ul>	4 – 5	Less than 2 ohms

REAR COMBINATION LIGHT

LIGHTING SYSTEM DIAGNOSIS

The taillights and turn-signal lights are controlled by the Simplified Wiring System (SWS). For troubleshooting, refer to GROUP 54B, SWS Diagnosis – Symptom Chart [P.54Bb-2](#).

M1542000700501

REMOVAL AND INSTALLATION

**WARNING**

- Before removal of the air bag module, refer to **GROUP 52B, SRS Service Precautions and Air Bag Module and Clock Spring P.52Ba-18.**
- When removing and installing the steering wheel, do not let it bump against the air bag module.

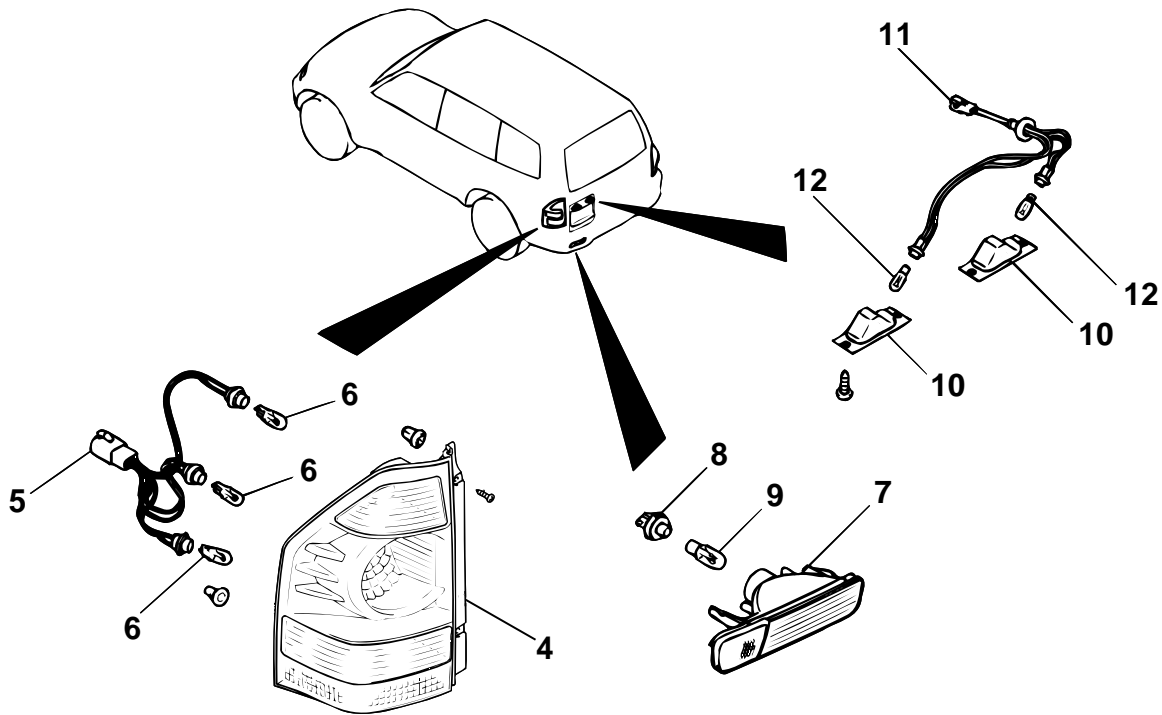
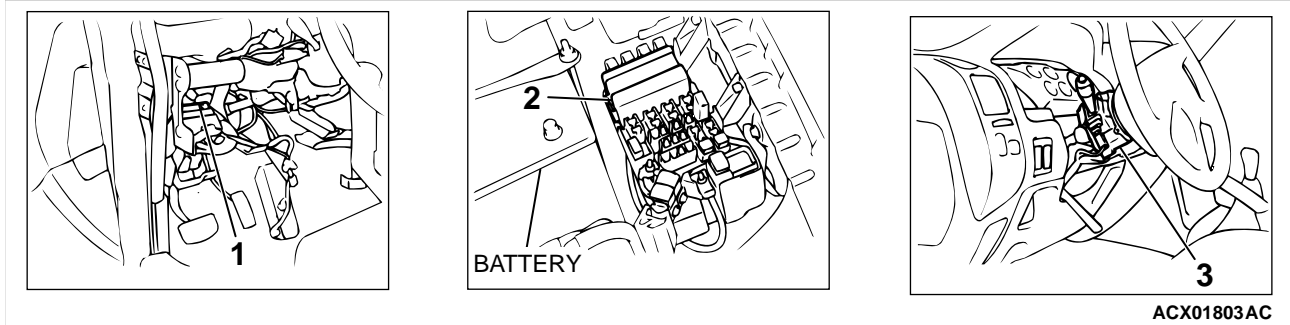

1. ETACS-ECU
  2. FRONT-ECU
  3. COLUMN SWITCH (REFER TO GROUP 37A, STEERING WHEEL AND SHAFT P.37A-23.)
- REAR COMBINATION LIGHT REMOVAL STEPS**
4. REAR COMBINATION LIGHT
  5. SOCKET ASSEMBLY
  6. BULB

- REAR LIGHT REMOVAL STEPS**
7. REAR LIGHT
  8. SOCKET ASSEMBLY
  9. BULB
- LICENSE PLATE LIGHT REMOVAL STEPS**
10. LICENSE PLATE LIGHT
  11. SOCKET ASSEMBLY
  12. BULB

## DOME LIGHT

### DOME LIGHT DIAGNOSIS

M1542010500263

The dome light is controlled by the Simplified Wiring System (SWS). For troubleshooting, refer to GROUP 54B, SWS Diagnosis – Symptom Chart [P.54Bb-2](#).

## HIGH-MOUNTED STOPLIGHT

### REMOVAL AND INSTALLATION

M1542005100151

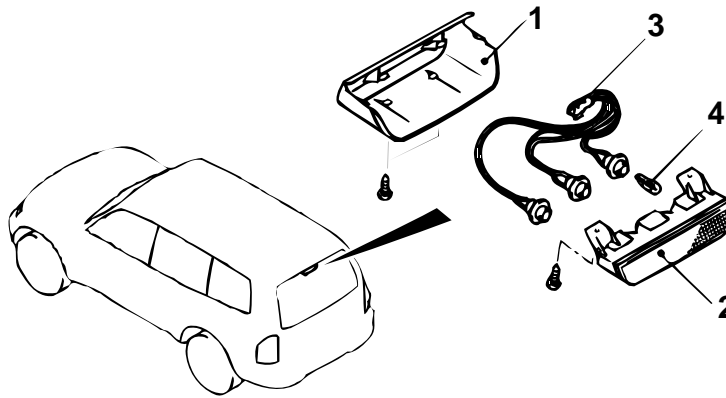

ACX00801AB

#### REMOVAL STEPS

1. HIGH-MOUNTED STOPLIGHT COVER
2. HIGH-MOUNTED STOPLIGHT BODY

#### REMOVAL STEPS (Continued)

3. SOCKET ASSEMBLY
4. BULB

## SIDE STEP LIGHT

### GENERAL DESCRIPTION CONCERNING THE SIDE STEP LIGHT

M1542013000018

#### SIDE STEP LIGHT TIMER FUNCTION

The side step light-ECU controls the side step lights as follows when the ignition switch is at "LOCK" (OFF) position and all the doors are closed:

- If the side step light-ECU receives door unlock signal from the unlock relay, the side step lights fade in over a 0.6 second period, and then illuminate for 13.2 seconds at maximum brightness. Then the lights will fade out over a 1.2 second period.
- If the side step light-ECU receives lock signal from the lock relay, the side step lights fade out over a 1.2 second period.
- If a door is opened, the side step lights fade in over a 0.6 second period, and then illuminate for 148.2 seconds at maximum brightness. Then the lights will fade out over a 1.2 second period.

The side step light-ECU controls the side step lights as follows when the ignition switch is at "LOCK" (OFF) position and any door is open:

- The side step lights do not go out until a predetermined period elapses even if the doors are locked.
- The side step lights do not illuminate even if the doors are unlocked.
- When the doors are closed while the side step lights are on, the lights illuminate for 28.8 seconds at maximum brightness immediately after that and then fade out.
- If all the doors are closed with the side step lights on and then any door is opened before the lights go out, the lights illuminate for 148.2 seconds at maximum brightness immediately after that, and then fade out.

If the ignition switch is turned from "LOCK" (OFF) to "ON" with the side step lights on, the side step light-ECU makes the side step lights fade out.

#### <SAMPLE TIMING CHART>

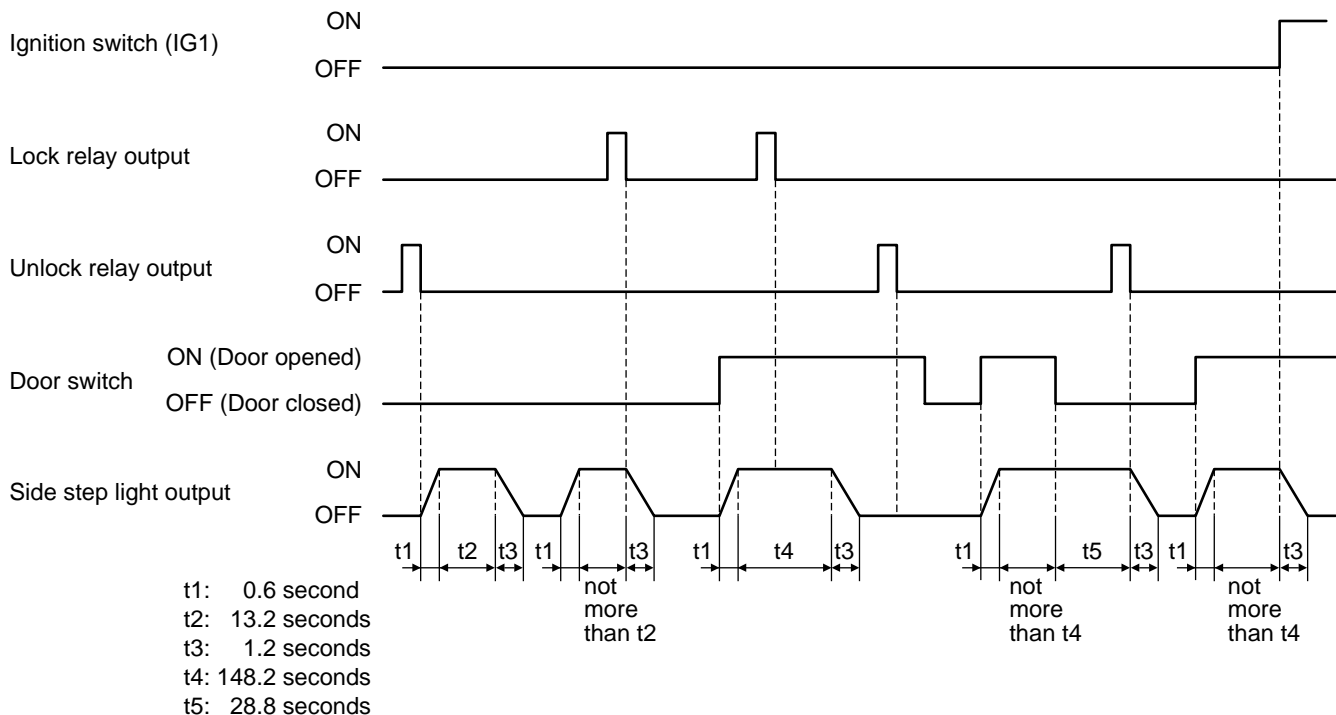

AC203828AB

### SIDE STEP LIGHT DIAGNOSIS

#### INTRODUCTION

The side step light system consists of the side step light assembly, side step light-ECU, ETACS-ECU and all door switches. If the side step light does not

illuminate, one of these components may be defective.

M1542010500564



**TROUBLESHOOTING STRATEGY**

M1542010600141

Use these steps to plan your diagnostic strategy. If you follow them carefully, you will be sure that you have exhausted most of the possible ways to find a side step light fault.

1. Gather information from the customer.

2. Verify that the condition described by the customer exists.
3. Find the malfunction by following the symptom chart.
4. Verify the malfunction is eliminated.

**SYMPTOM CHART**

M1542009100227

SYMPTOM	INSPECTION PROCEDURE	REFERENCE PAGE
The side step light do not illuminate.	1	<a href="#">P.54A-82</a>
The left or right side step light do not illuminate.	2	<a href="#">P.54A-89</a>
The side step light do not illuminate normally when the door is unlocked or locked.	3	<a href="#">P.54A-97</a>
The side step light do not illuminate normally when any door is opened or closed.	4	<a href="#">P.54A-103</a>

SYMPTOM PROCEDURES

INSPECTION PROCEDURE 1: The Side Step Lights do not Illuminate.

Side Step Light-ECU Circuit

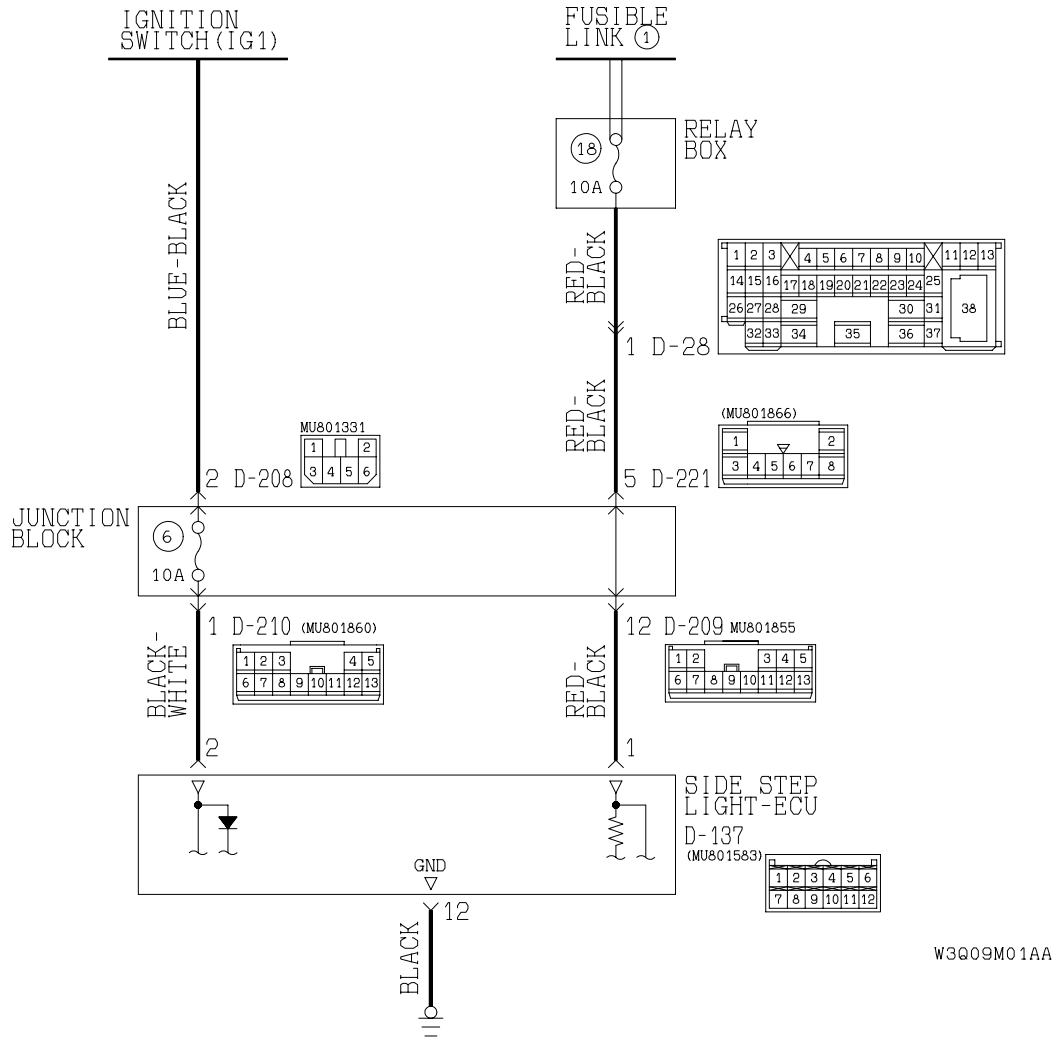

W3Q09M01AA

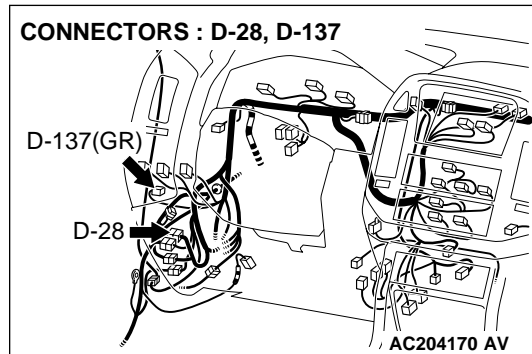
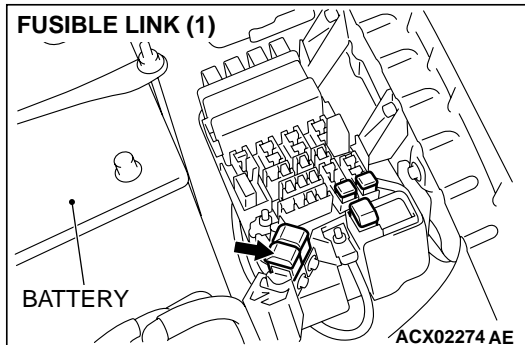

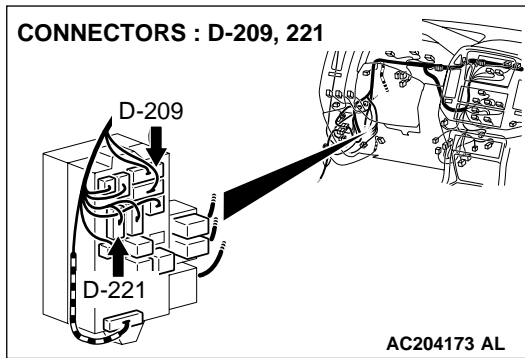

**TECHNICAL DESCRIPTION (COMMENT)**

If all of the side step light do not illuminate the side step light-ECU may be defective.

**TROUBLESHOOTING HINTS**

- The side step light-ECU may be defective
- The wiring harness or connectors may have loose, corroded, or damaged terminals, or terminals pushed back in the connector

**DIAGNOSIS**

**Required Special Tool:**

- MB991223: Harness Set

**STEP 1. Check the battery power supply circuit to the side step light-ECU. Test at side step light-ECU connector D-137.**

(1) Disconnect side step light-ECU connector D-137 and measure the voltage available at the harness side of the connector.

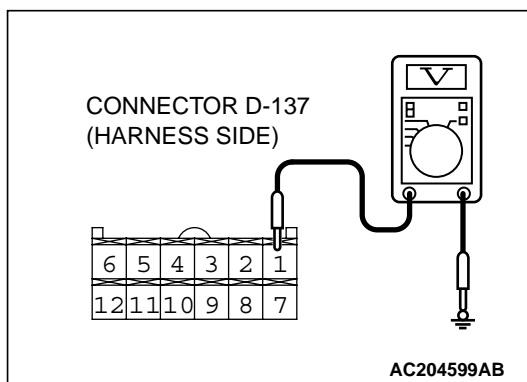
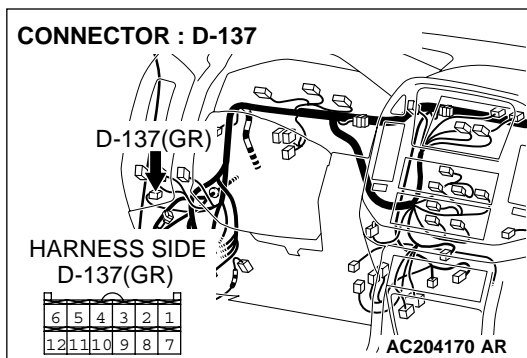

(2) Measure the voltage between terminal numbers 1 and ground.

- The voltage should measure approximately 12 volts (battery positive voltage).

**Q: Is the measured voltage approximately 12 volts (battery positive voltage)?**

**YES :** Go to Step 4.

**NO :** Go to Step 2.

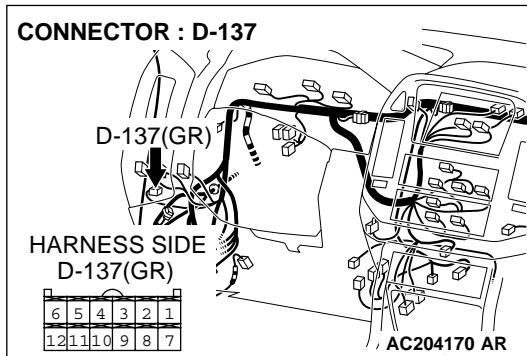

**STEP 2.** Check side step light-ECU connector D-137 for loose, corroded or damaged terminals, or terminals pushed back in the connector.

**Q:** Is side step light-ECU connector D-137 in good condition?

**YES :** Go to Step 3.

**NO :** Repair or replace the damaged component(s). Refer to GROUP 00E, Harness Connector Inspection [P.00E-2](#). Verify that the side step light illuminate normally.

**STEP 3. Check the wiring harness between side step light-ECU connector D-137 (terminal 1) and the fusible link (1).**

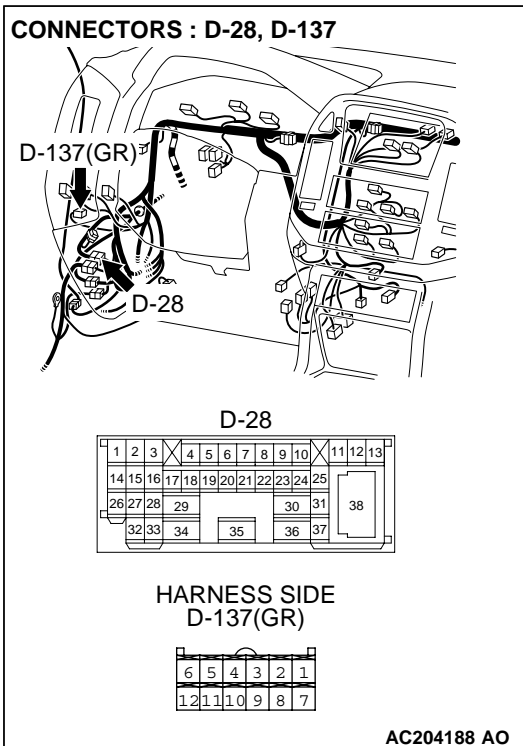
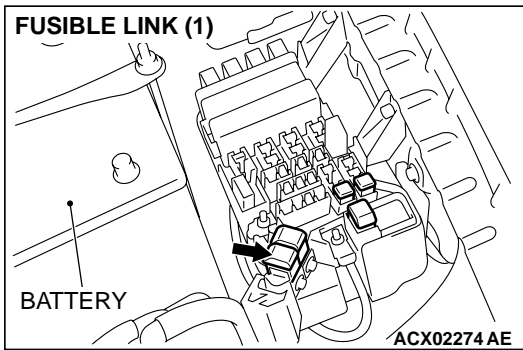

CONNECTORS : D-209, D-221

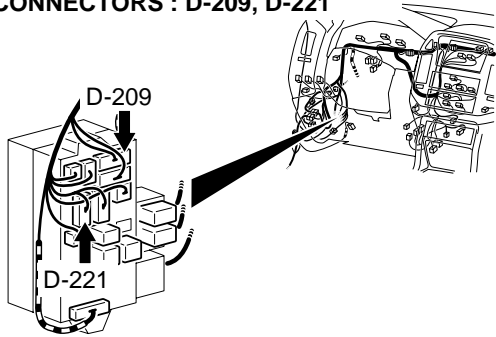

HARNESS SIDE  
D-209

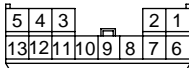

HARNESS SIDE  
D-221

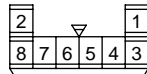

AC204191 AF

*NOTE: Also check intermediate connector D-28, junction block connectors D-209 and D-221 for loose, corroded, or damaged terminals, or terminals pushed back in the connector. If intermediate connector D-28, junction block connectors D-209 or D-221 is damaged, repair or replace the connector as described in GROUP 00E, Harness Connector Inspection P.00E-2.*

**Q: Is the wiring harness between side step light-ECU connector D-137 (terminal 1) and the fusible link (1) in good condition?**

**YES :** Replace the side step light-ECU. Verify that the side step light illuminate normally.

**NO :** The wiring harness may be damaged or the connector(s) may have loose, corroded or damaged terminals, or terminals pushed back in the connector. Repair the wiring harness as necessary. Verify that the side step light illuminate normally.

**STEP 4. Check the ignition switch (IG1) circuit to the side step light-ECU. Test at side step light-ECU connector D-137.**

- (1) Disconnect side step light-ECU connector D-137 and measure the voltage available at the harness side of the connector.
- (2) Turn the ignition switch to the "ON" position.

CONNECTOR : D-137

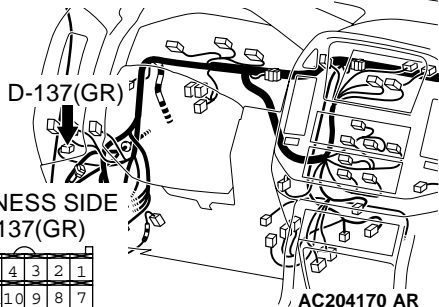

HARNESS SIDE  
D-137 (GR)

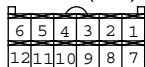

AC204170 AR

- (3) Measure the voltage between terminal numbers 2 and ground.
  - The voltage should measure approximately 12 volts (battery positive voltage).

**Q: Is the measured voltage approximately 12 volts (battery positive voltage)?**

**YES :** Go to Step 7.

**NO :** Go to Step 5.

CONNECTOR D-137  
(HARNESS SIDE)

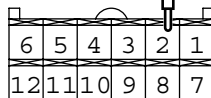

AC204600AB

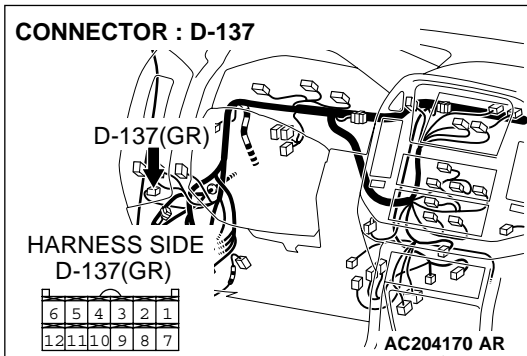

**STEP 5. Check side step light-ECU connector D-137 for loose, corroded or damaged terminals, or terminals pushed back in the connector.**

**Q: Is side step light-ECU connector D-137 in good condition?**

**YES :** Go to Step 6.

**NO :** Repair or replace the damaged component(s). Refer to GROUP 00E, Harness Connector Inspection [P.00E-2](#). Verify that the side step light illuminate normally.

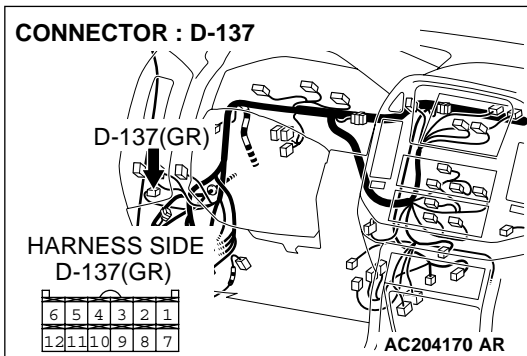

**STEP 6. Check the wiring harness between side step light-ECU connector D-137 (terminal 2) and the ignition switch (IG1).**

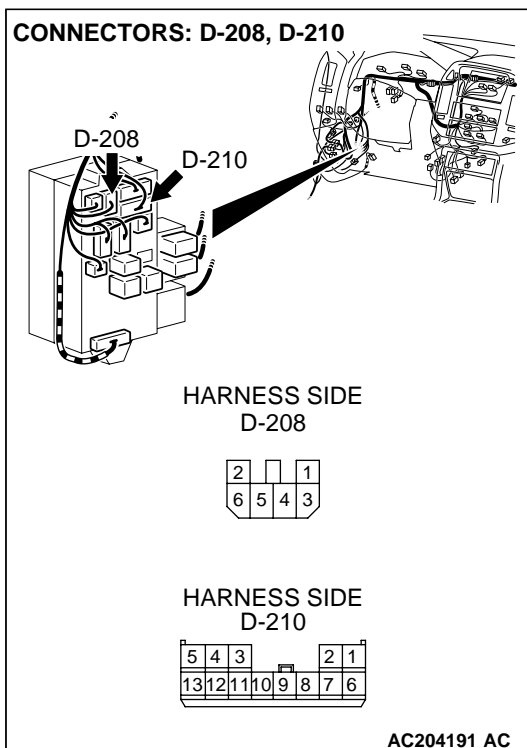

*NOTE: Also check junction block connectors D-208 and D-210 for loose, corroded, or damaged terminals, or terminals pushed back in the connector. If intermediate connector D-28, junction block connectors D-208 or D-210 is damaged, repair or replace the connector as described in GROUP 00E, Harness Connector Inspection [P.00E-2](#).*

**Q: Is the wiring harness between side step light-ECU connector D-137 (terminal 2) and the ignition switch (IG1) in good condition?**

**YES :** Replace the side step light-ECU. Verify that the side step light illuminate normally.

**NO :** The wiring harness may be damaged or the connector(s) may have loose, corroded or damaged terminals, or terminals pushed back in the connector. Repair the wiring harness as necessary. Verify that the side step light illuminate normally.

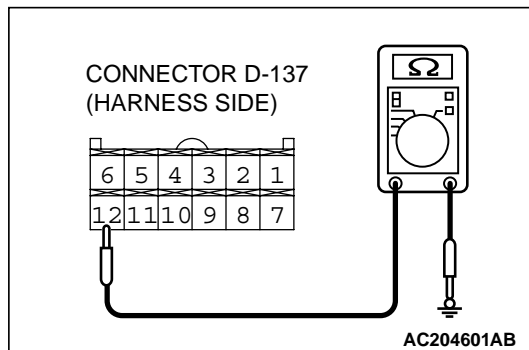
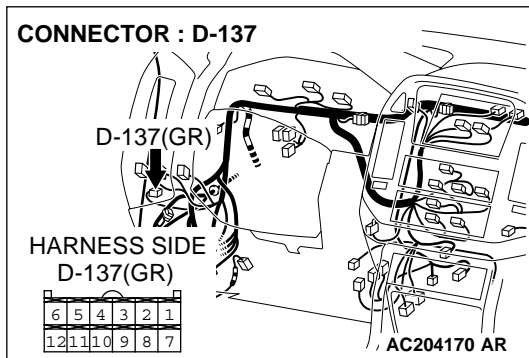

**STEP 7. Check the ground circuit to the side step light-ECU. Test at side step light-ECU connector D-137.**

(1) Disconnect side step light-ECU connector D-137 and measure the resistance available at the harness side of the connector.

(2) Measure the resistance value between terminal 12 and ground.

- The resistance should equal 2 ohms or less.

**Q: Is the measured resistance 2 ohms or less?**

**YES :** Replace the side step light-ECU. Verify that the side step light illuminate normally.

**NO :** Go to Step 8.

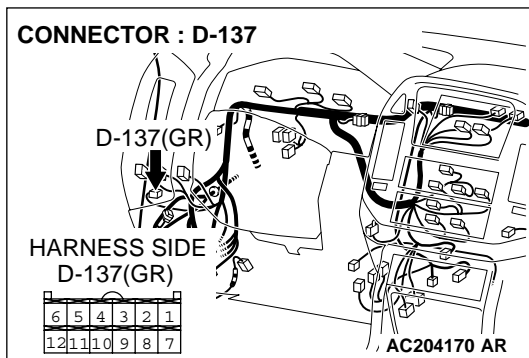

**STEP 8. Check side step light-ECU connector D-137 for loose, corroded or damaged terminals, or terminals pushed back in the connector.**

**Q: Is side step light-ECU connector D-137 in good condition?**

**YES :** Go to Step 9.

**NO :** Repair or replace the damaged component(s). Refer to GROUP 00E, Harness Connector Inspection [P.00E-2](#). Verify that the side step light illuminate normally.

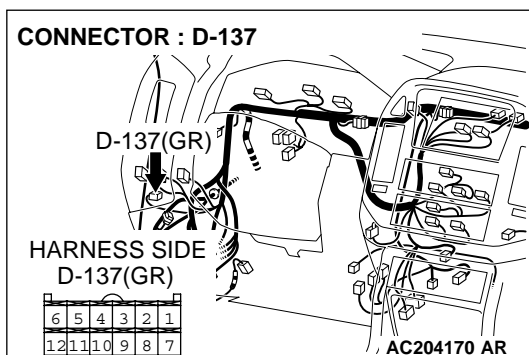

**STEP 9. Check the wiring harness between side step light-ECU connector D-137 (terminal 7) and ground.**

**Q: Is the wiring harness between side step light-ECU connector D-137 (terminal 7) and the ground in good condition?**

**YES :** Replace the side step light-ECU. Verify that the side step light illuminate normally.

**NO :** The wiring harness may be damaged or the connector(s) may have loose, corroded or damaged terminals, or terminals pushed back in the connector. Repair the wiring harness as necessary. Verify that the side step light illuminate normally.



INSPECTION PROCEDURE 2: One of the side step lights does not illuminate.

Side Step Light Circuit

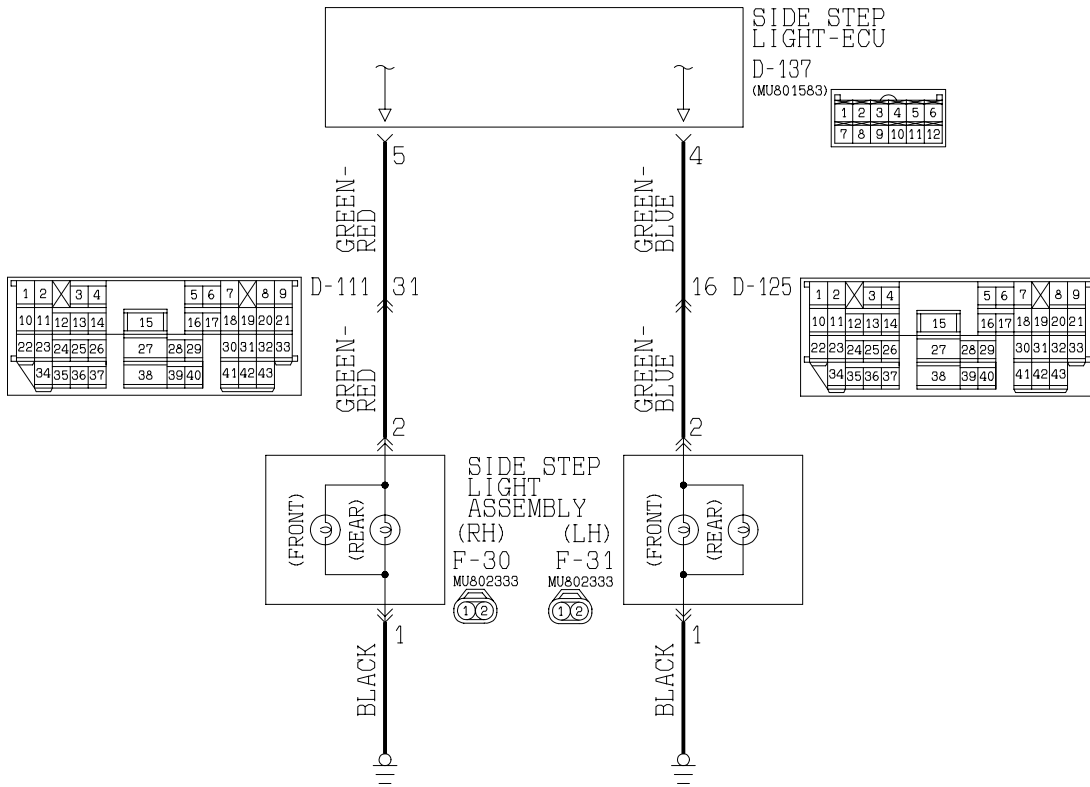

W3Q09M02AA

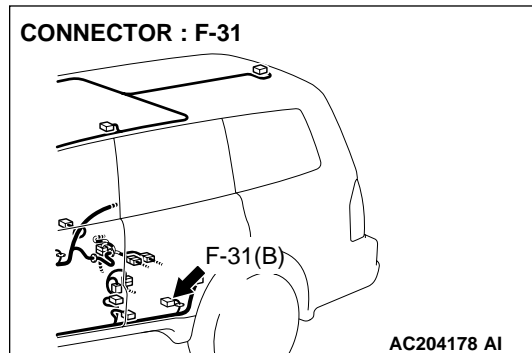
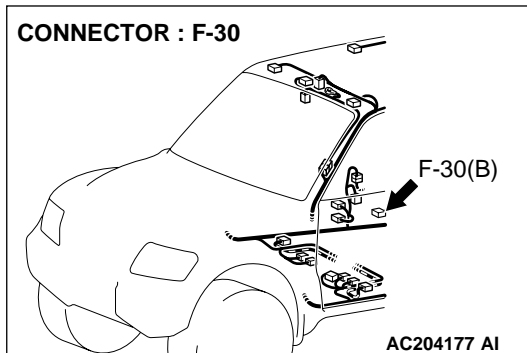
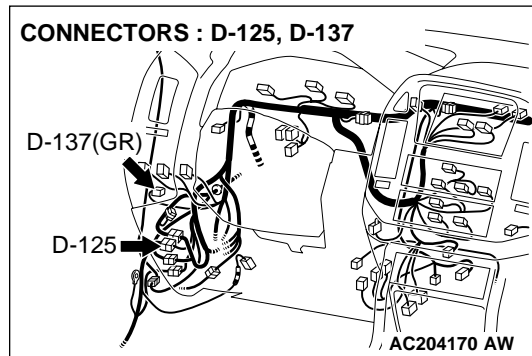
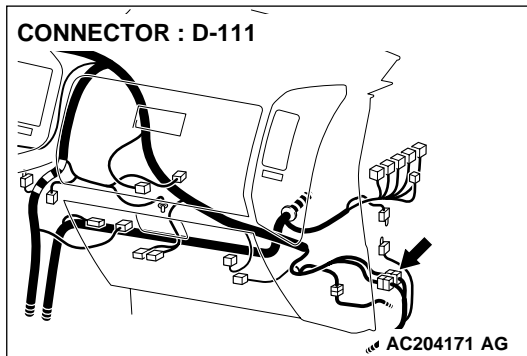

**TECHNICAL DESCRIPTION (COMMENT)**

If one of the side step lights does not illuminate, the light bulb or the side step light-ECU may be defective.

**TROUBLESHOOTING HINTS**

- The side step light bulb may be defective
- The side step light-ECU may be defective
- The side step light assembly may be defective
- The wiring harness or connectors may have loose, corroded, or damaged terminals, or terminals pushed back in the connector

**DIAGNOSIS****Required Special Tool:**

- MB991223: Harness Set

**STEP 1. Check the side step light operation.****Q: Which side step light does not illuminate?**

**LH (FRONT and REAR) :** Go to Step 2.

**RH (FRONT and REAR) :** Go to Step 8.

**LH (FRONT) :** Go to Step 14.

**LH (REAR) :** Go to Step 15.

**RH (FRONT) :** Go to Step 16.

**RH (REAR) :** Go to Step 17.

**STEP 2. Check the side step light operation.**

(1) Disconnect side step light assembly (LH) connector F-31.

(2) When battery voltage is applied between the terminals, check that the side step light (LH) illuminate.

**Q: Is side step light (LH) illuminate?**

**YES :** Go to Step 3.

**NO :** Replace the side step light harness. Verify that the side step light illuminate normally.

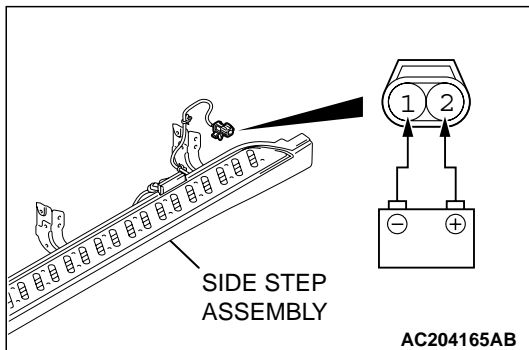

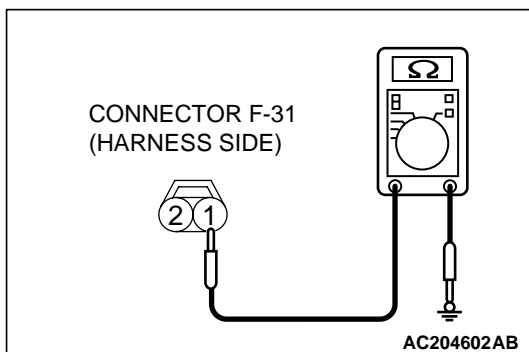
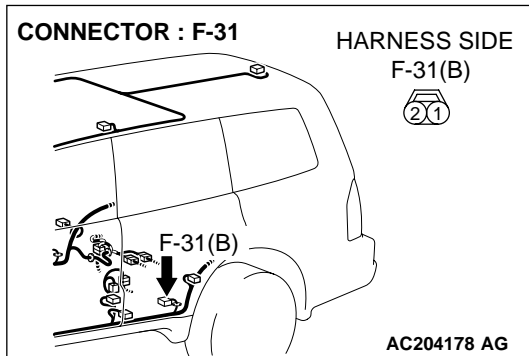

**STEP 3. Check the ground circuit to the side step light assembly (LH). Test at side step light assembly (LH) connector F-31.**

(1) Disconnect side step light assembly (LH) connector F-31 and measure the resistance available at the harness side of the connector.

(2) Measure the resistance value between terminal 1 and ground.

- The resistance should equal 2 ohms or less.

**Q: Is the measured resistance 2 ohms or less?**

**YES :** Go to Step 4.

**NO :** Go to Step 6.

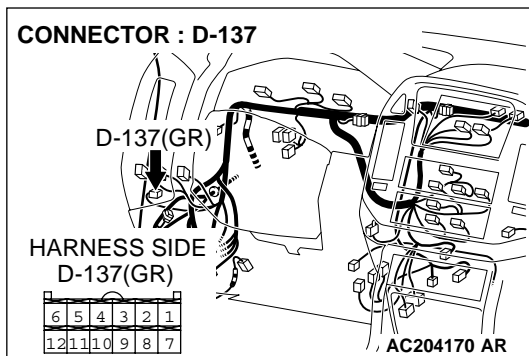

**STEP 4. Check side step light-ECU connector D-137 and side step light assembly (LH) connector F-31 for loose, corroded or damaged terminals, or terminals pushed back in the connector.**

**Q: Is side step light-ECU connector D-137 and side step light assembly (LH) connector F-31 in good condition?**

**YES :** Go to Step 5.

**NO :** Repair or replace the damaged component(s). Refer to GROUP 00E, Harness Connector Inspection [P.00E-2](#). Verify that the side step light illuminate normally.

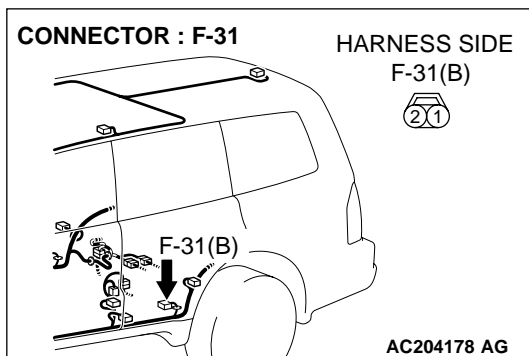

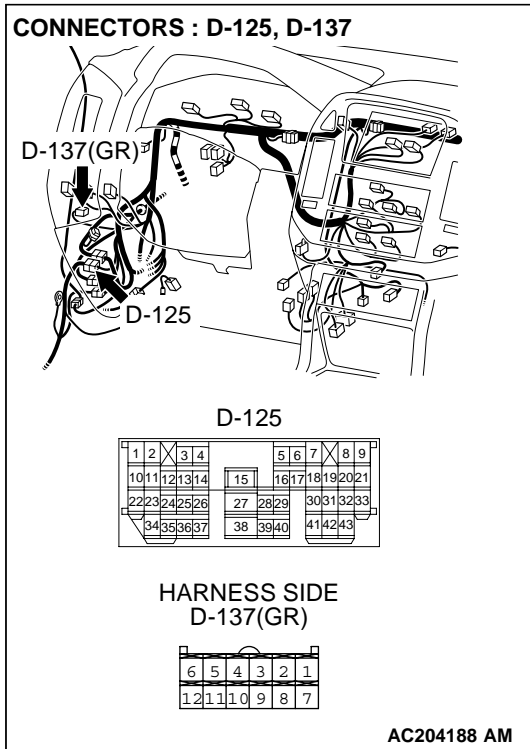

**STEP 5. Check the wiring harness between side step light-ECU connector D-137 (terminal 4) and side step light assembly (LH) connector F-31 (terminal 2).**

*NOTE: Also check intermediate connector D-125 for loose, corroded, or damaged terminals, or terminals pushed back in the connector. If intermediate connector D-125 is damaged, repair or replace the connector as described in GROUP 00E, Harness Connector Inspection P.00E-2.*

**Q: Is the wiring harness between side step light-ECU connector D-137 (terminal 4) and side step light assembly (LH) connector F-31 (terminal 2) in good condition?**

**YES :** Replace the side step light-ECU. Verify that the side step light illuminate normally.

**NO :** The wiring harness may be damaged or the connector(s) may have loose, corroded or damaged terminals, or terminals pushed back in the connector. Repair the wiring harness as necessary. Verify that the side step light illuminate normally.

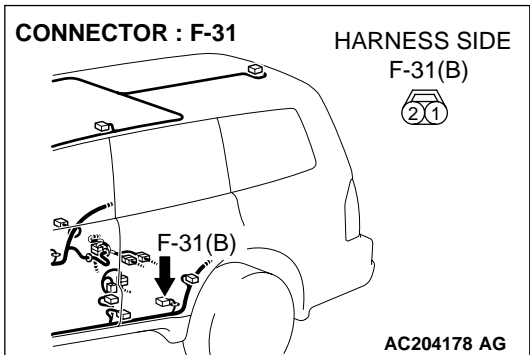

**STEP 6. Check side step light assembly (LH) connector F-31 for loose, corroded or damaged terminals, or terminals pushed back in the connector.**

**Q: Is side step light assembly (LH) connector F-31 in good condition?**

**YES :** Go to Step 7.

**NO :** Repair or replace the damaged component(s). Refer to GROUP 00E, Harness Connector Inspection P.00E-2. Verify that the side step light illuminate normally.

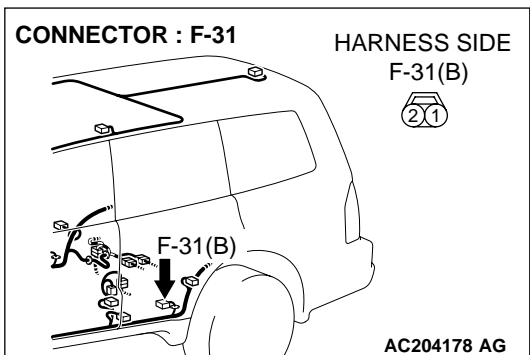

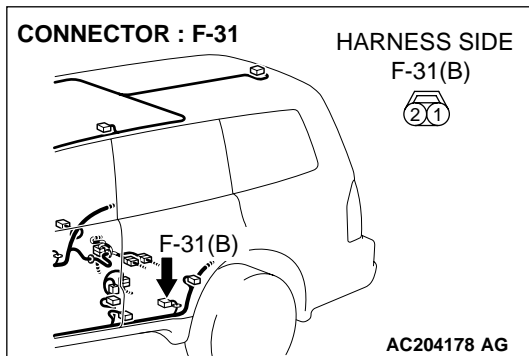

**STEP 7. Check the wiring harness between side step light assembly (LH) connector F-31 (terminal 1) and ground.**

**Q: Is the wiring harness between side step light assembly (LH) connector F-31 (terminal 1) and the ground in good condition?**

**YES :** Replace the side step light-ECU. Verify that the side step light illuminate normally.

**NO :** The wiring harness may be damaged or the connector(s) may have loose, corroded or damaged terminals, or terminals pushed back in the connector. Repair the wiring harness as necessary. Verify that the side step light illuminate normally.

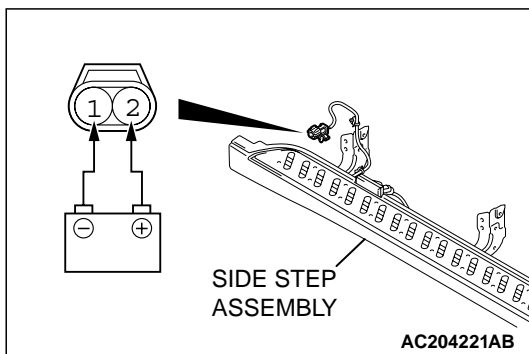

**STEP 8. Check the side step light operation.**

- (1) Disconnect side step light assembly (RH) connector F-30.
- (2) When battery voltage is applied between the terminals, check that the side step light (RH) illuminate.

**Q: Is side step light (RH) illuminate?**

**YES :** Go to Step 9.

**NO :** Replace the side step light harness. Verify that the side step light illuminate normally.

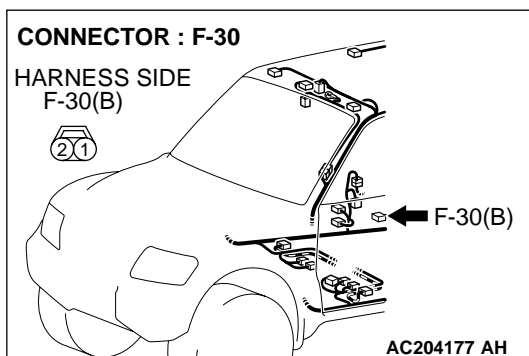

**STEP 9. Check the ground circuit to the side step light assembly (RH). Test at side step light assembly (RH) connector F-30.**

- (1) Disconnect side step light assembly (RH) connector F-31 and measure the resistance available at the harness side of the connector.

- (2) Measure the resistance value between terminal 1 and ground.

- The resistance should equal 2 ohms or less.

**Q: Is the measured resistance 2 ohms or less?**

**YES :** Go to Step 10.

**NO :** Go to Step 12.

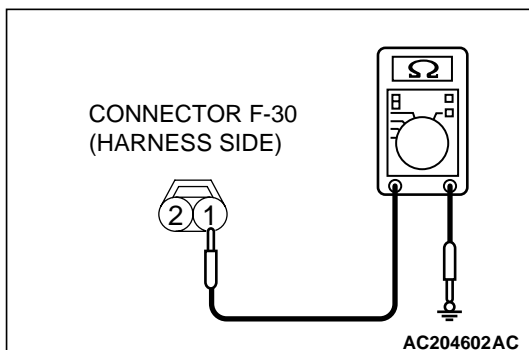

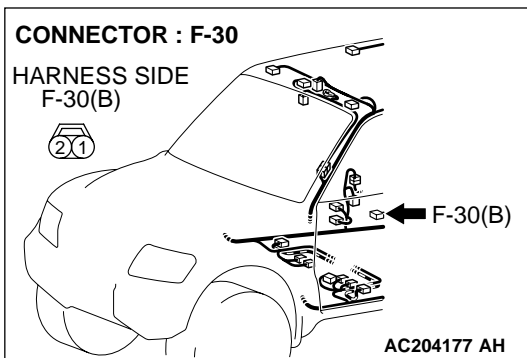
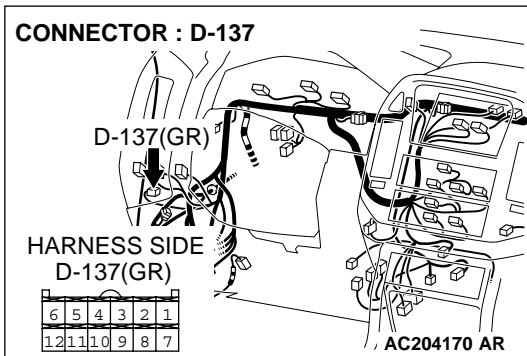

**STEP 10.** Check side step light-ECU connector D-137 and side step light assembly (RH) connector F-30 for loose, corroded or damaged terminals, or terminals pushed back in the connector.

**Q:** Is side step light-ECU connector D-137 and side step light assembly (RH) connector F-30 in good condition?

**YES :** Go to Step 11.

**NO :** Repair or replace the damaged component(s). Refer to GROUP 00E, Harness Connector Inspection

**P.00E-2.** Verify that the side step light illuminate normally.

**STEP 11.** Check the wiring harness between side step light-ECU connector D-137 (terminal 4) and side step light assembly (RH) connector F-30 (terminal 2).

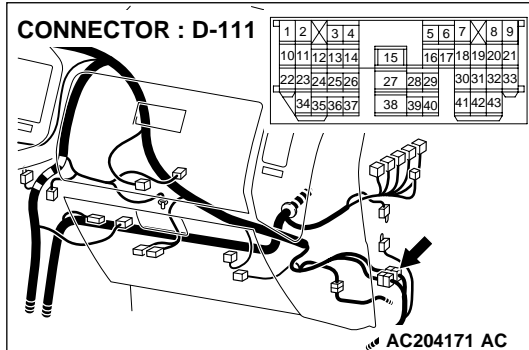
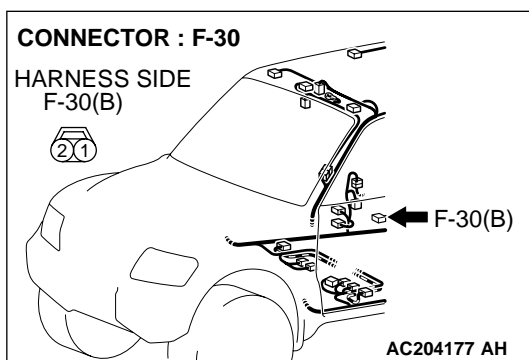
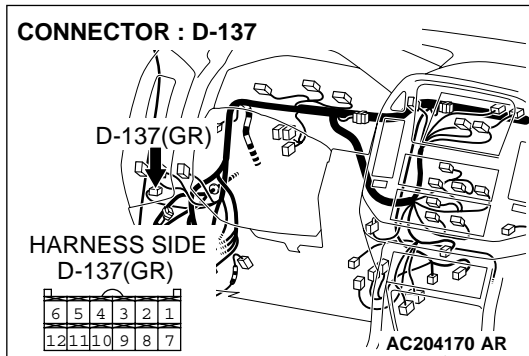

*NOTE:* Also check intermediate connector D-111 for loose, corroded, or damaged terminals, or terminals pushed back in the connector. If intermediate connector D-111 is damaged, repair or replace the connector as described in GROUP 00E, Harness Connector Inspection [P.00E-2](#).

**Q:** Is the wiring harness between side step light-ECU connector D-137 (terminal 4) and side step light assembly (RH) connector F-30 (terminal 2) in good condition?

**YES :** Replace the side step light-ECU. Verify that the side step light illuminate normally.

**NO :** The wiring harness may be damaged or the connector(s) may have loose, corroded or damaged terminals, or terminals pushed back in the connector. Repair the wiring harness as necessary. Verify that the side step light illuminate normally.

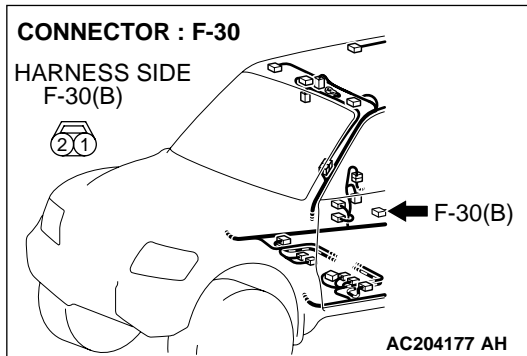

**STEP 12. Check side step light assembly (RH) connector F-30 for loose, corroded or damaged terminals, or terminals pushed back in the connector.**

**Q: Is side step light assembly (RH) connector F-30 in good condition?**

**YES :** Go to Step 13.

**NO :** Repair or replace the damaged component(s). Refer to GROUP 00E, Harness Connector Inspection [P.00E-2](#). Verify that the side step light illuminate normally.

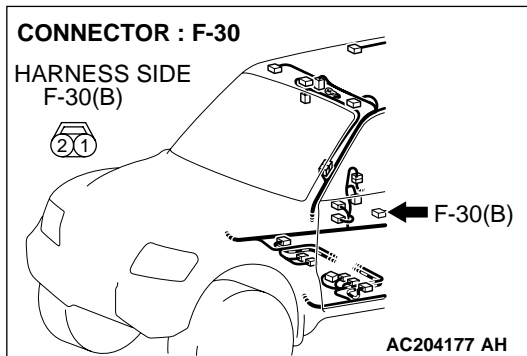

**STEP 13. Check the wiring harness between side step light assembly (RH) connector F-30 (terminal 1) and ground.**

**Q: Is the wiring harness between side step light assembly (RH) connector F-30 (terminal 1) and the ground in good condition?**

**YES :** Replace the side step light-ECU. Verify that the side step light illuminate normally.

**NO :** The wiring harness may be damaged or the connector(s) may have loose, corroded or damaged terminals, or terminals pushed back in the connector. Repair the wiring harness as necessary. Verify that the side step light illuminate normally.

**STEP 14. Check the side step light bulb (LH: FRONT).**

**Q: Is the side step light bulb in good condition?**

**YES :** Replace the side step light harness (LH). Refer to [P.54A-109](#). Verify that the side step light illuminate normally.

**NO :** Replace the bulb (LH: FRONT). Refer to [P.54A-109](#). Verify that the side step light illuminates normally.

**STEP 15. Check the side step light bulb (LH: REAR).**

**Q: Is the side step light bulb in good condition?**

**YES :** Replace the side step light harness (LH). Refer to [P.54A-109](#). Verify that the side step light illuminate normally.

**NO :** Replace the bulb (LH: REAR). Refer to [P.54A-109](#). Verify that the side step light illuminates normally.



**STEP 16. Check the side step light bulb (RH: FRONT).**

**Q: Is the side step light bulb in good condition?**

**YES :** Replace the side step light harness (RH). Refer to [P.54A-109](#). Verify that the side step light illuminate normally.

**NO :** Replace the bulb (RH: FRONT). Refer to [P.54A-109](#). Verify that the side step light illuminates normally.

**STEP 17. Check the side step light bulb (RH: REAR).**

**Q: Is the side step light bulb in good condition?**

**YES :** Replace the side step light harness (RH). Refer to [P.54A-109](#). Verify that the side step light illuminate normally.

**NO :** Replace the bulb (RH: REAR). Refer to [P.54A-109](#). Verify that the side step light illuminates normally.

**INSPECTION PROCEDURE 3: The Side Step Light do not Illuminate Normally when the Door is Unlocked or Locked.**

Side Step Light-ECU Circuit

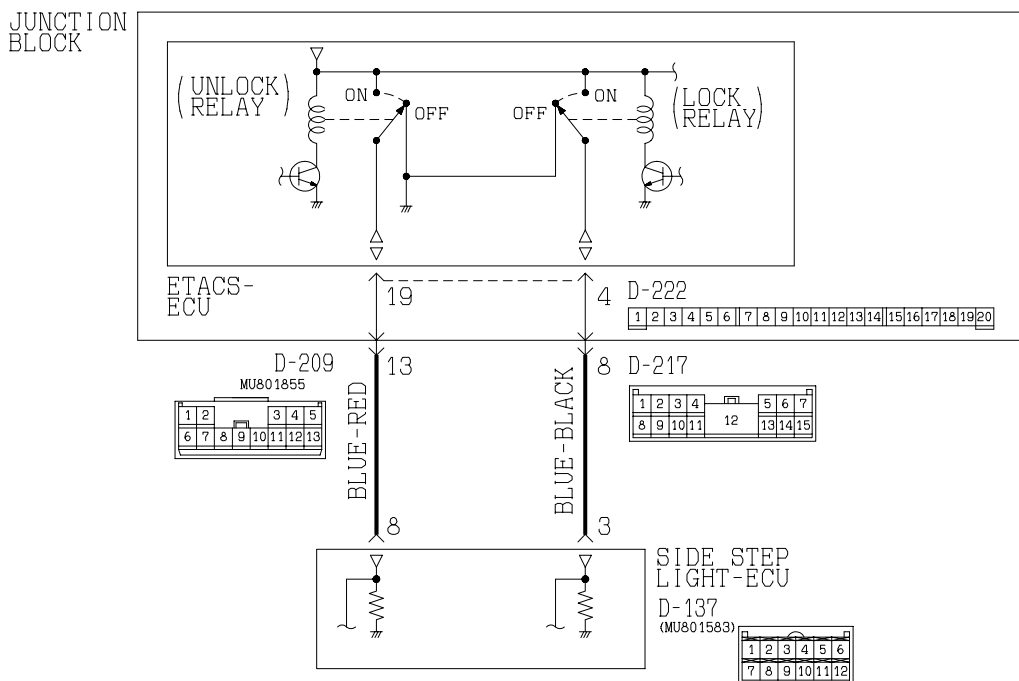

W3Q09M03AA

CONNECTOR : D-137

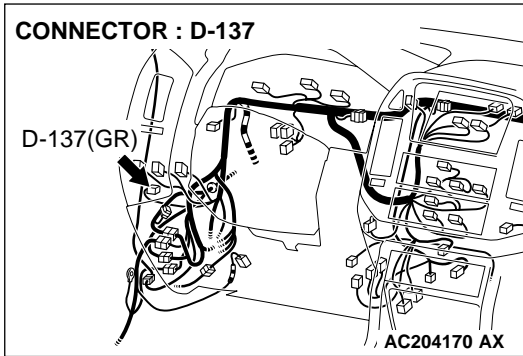

CONNECTOR : D-217

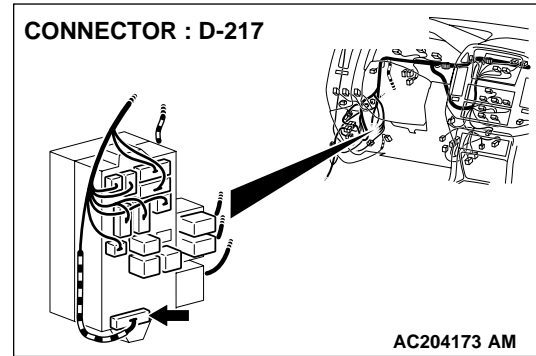

CONNECTOR : D-222

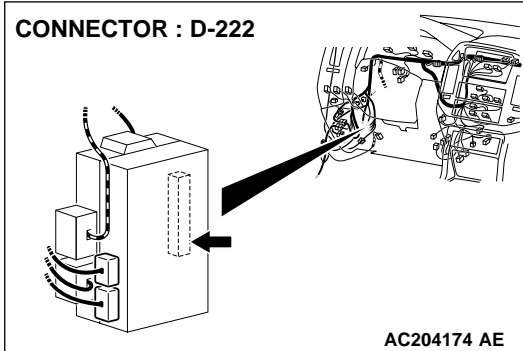
**TECHNICAL DESCRIPTION (COMMENT)**

If left or right side step light do not illuminate, the input circuit from the ETACS-ECU or the side step light-ECU may be defective.

**TROUBLESHOOTING HINTS**

- The side step light-ECU may be defective
- The ETACS-ECU may be defective
- The wiring harness or connectors may have loose, corroded, or damaged terminals, or terminals pushed back in the connector

**DIAGNOSIS****Required Special Tool:**

- MB991223: Harness Set

**STEP 1. Check the central door lock system operation.****Q: Does the central door lock system work normally?**

**YES** : Go to Step 2.

**NO** : Refer to GROUP 54B, Inspection Procedure C-1 "The central door lock system does not work at all [P.54Bb-79.](#)"

**STEP 2. Check the side step light operation.**

The side step light should operate when the doors are locked and unlocked.

**Q: Do the side step lights illuminate normally when the doors are unlocked?**

**YES** : Go to Step 3.

**NO** : Go to Step 5.

**STEP 3.** Check side step light-ECU connector D-137 and ETACS-ECU connector D-222 for loose, corroded or damaged terminals, or terminals pushed back in the connector.

**Q:** Is side step light-ECU connector D-137 and ETACS-ECU connector D-222 in good condition?

**YES :** Go to Step 4.

**NO :** Repair or replace the damaged component(s). Refer to GROUP 00E, Harness Connector Inspection

**P.00E-2.** Verify that the side step light illuminate normally.

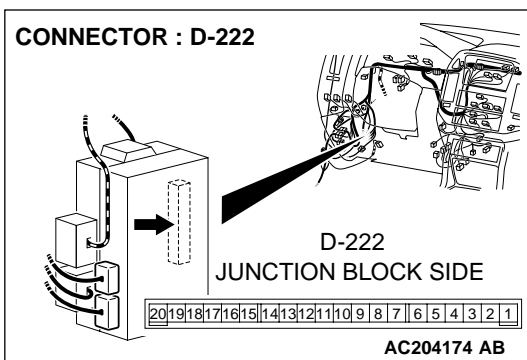
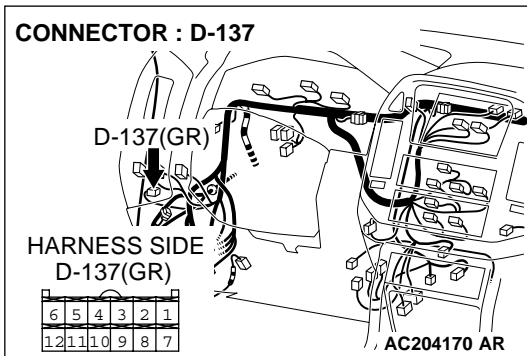

**STEP 4. Check the wiring harness between side step light-ECU connector D-137 (terminal 3) and ETACS-ECU connector D-222 (terminal 4).**

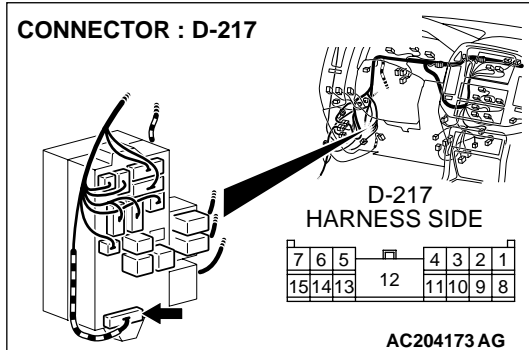
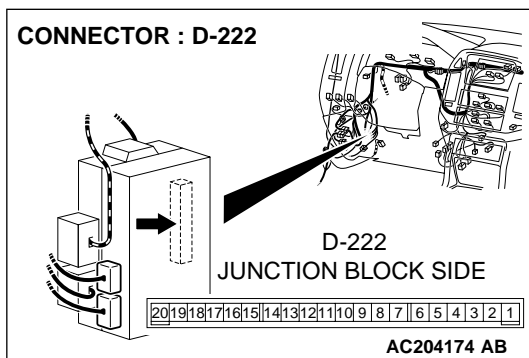
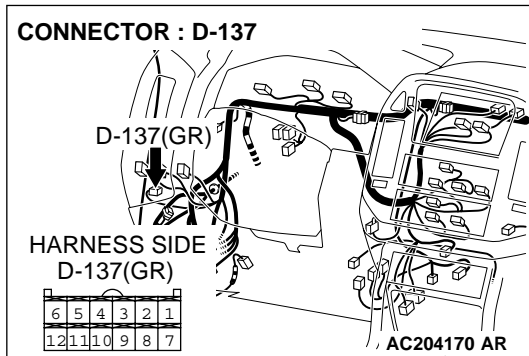

*NOTE: Also check junction block connector D-217 for loose, corroded, or damaged terminals, or terminals pushed back in the connector. If junction block connector D-217 is damaged, repair or replace the connector as described in GROUP 00E, Harness Connector Inspection [P.00E-2](#).*

**Q: Is the wiring harness between side step light-ECU connector D-137 (terminal 3) and ETACS-ECU connector D-222 (terminal 4) in good condition?**

**YES :** Replace the side step light-ECU. Verify that the side step light illuminate normally.

**NO :** The wiring harness may be damaged or the connector(s) may have loose, corroded or damaged terminals, or terminals pushed back in the connector. Repair the wiring harness as necessary. Verify that the side step light illuminate normally.

**STEP 5.** Check side step light-ECU connector D-137 and ETACS-ECU connector D-222 for loose, corroded or damaged terminals, or terminals pushed back in the connector.

**Q:** Is side step light-ECU connector D-137 and ETACS-ECU connector D-222 in good condition?

**YES :** Go to Step 6.

**NO :** Repair or replace the damaged component(s). Refer to GROUP 00E, Harness Connector Inspection

**P.00E-2.** Verify that the side step light illuminate normally.

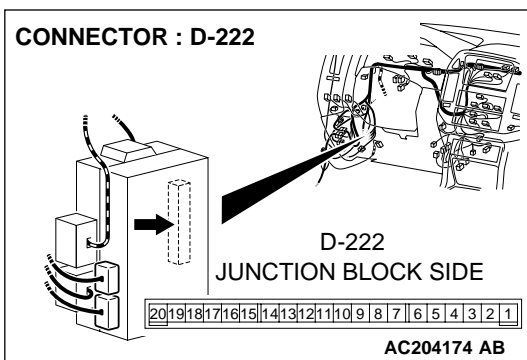
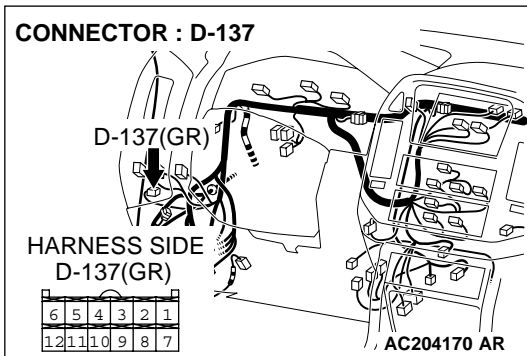

**STEP 6. Check the wiring harness between side step light-ECU connector D-137 (terminal 8) and ETACS-ECU connector D-222 (terminal 19).**

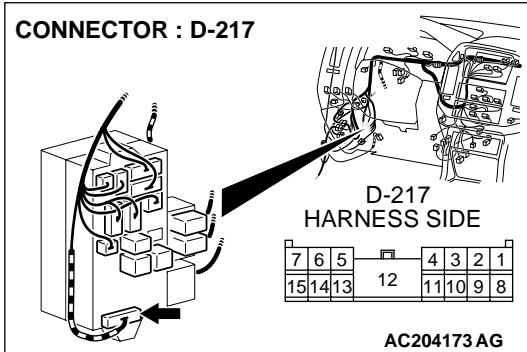
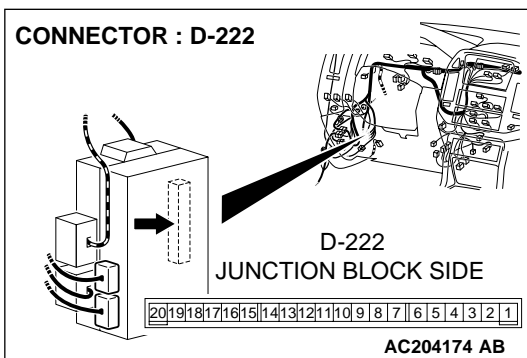
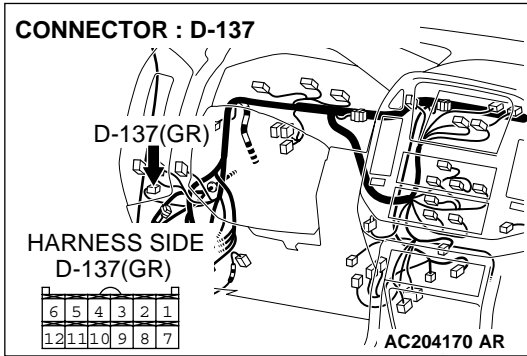

*NOTE: Also check junction block connector D-217 for loose, corroded, or damaged terminals, or terminals pushed back in the connector. If junction block connector D-217 is damaged, repair or replace the connector as described in GROUP 00E, Harness Connector Inspection P.00E-2.*

**Q: Is the wiring harness between side step light-ECU connector D-137 (terminal 8) and ETACS-ECU connector D-222 (terminal 19) in good condition?**

- YES :** Replace the side step light-ECU. Verify that the side step light illuminate normally.
- NO :** The wiring harness may be damaged or the connector(s) may have loose, corroded or damaged terminals, or terminals pushed back in the connector. Repair the wiring harness as necessary. Verify that the side step light illuminate normally.

**INSPECTION PROCEDURE 4: The Side Step Light do not Illuminate Normally when Either Door is Opened or Closed.**

Side Step Light-ECU Circuit

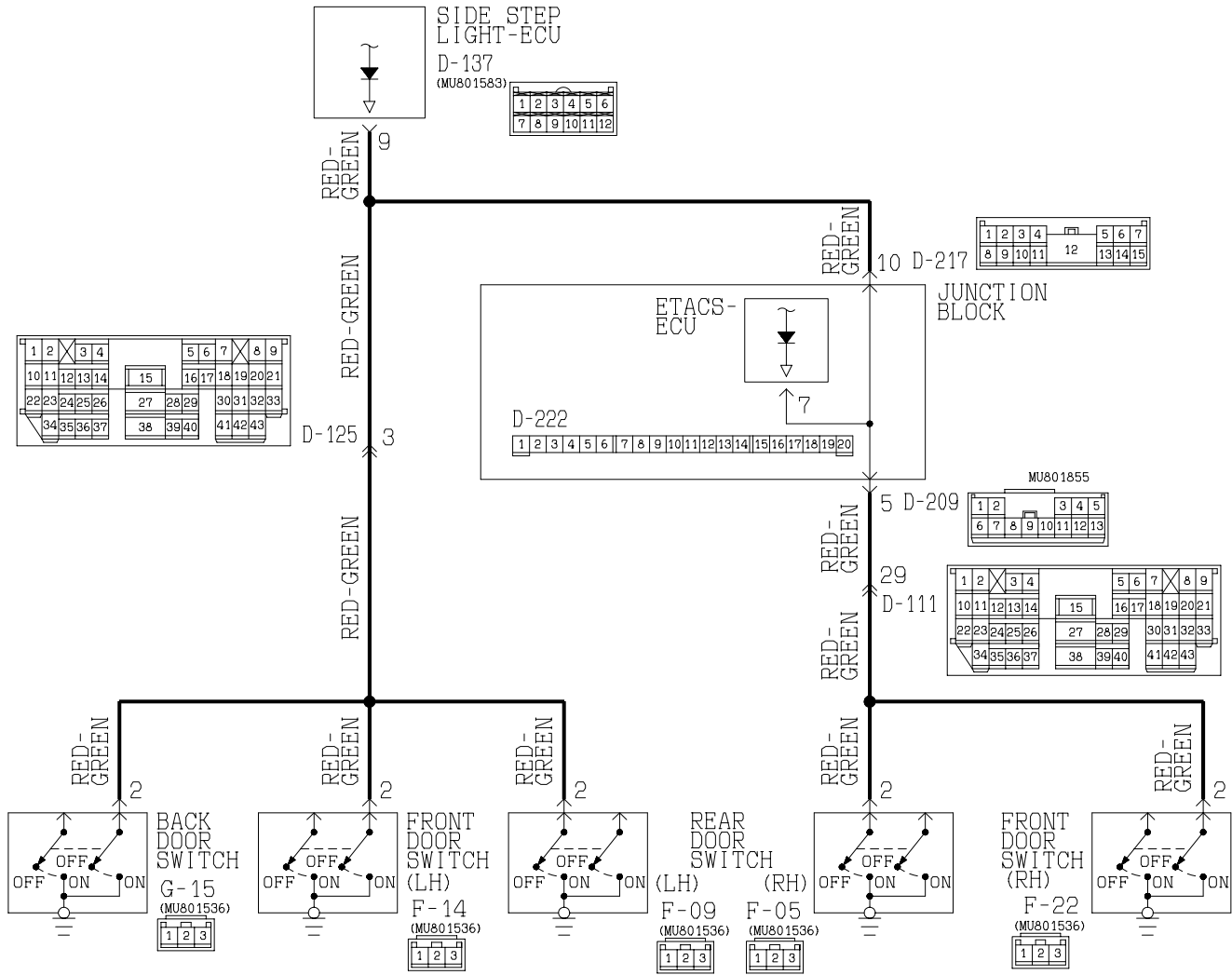

W3Q09M04AA

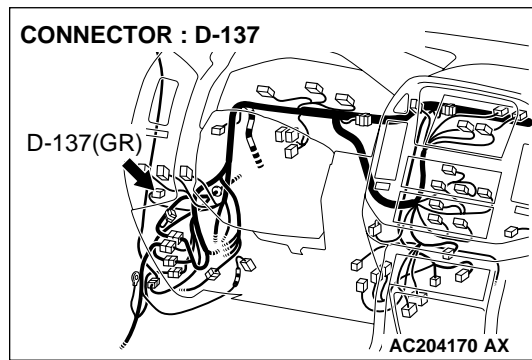
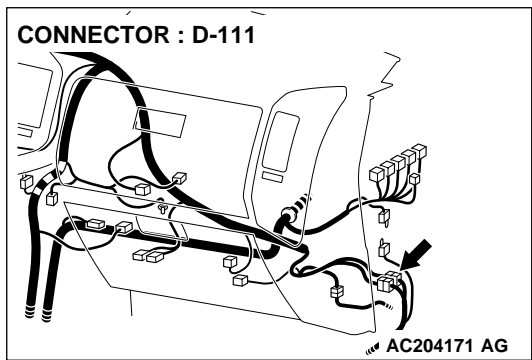

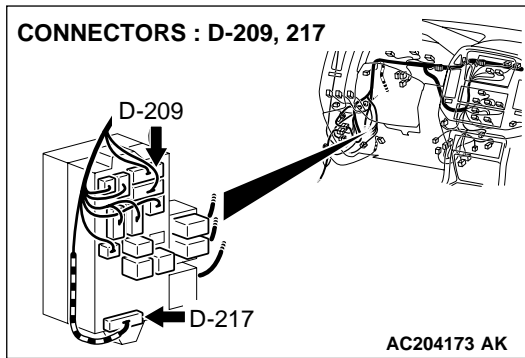
**TECHNICAL DESCRIPTION (COMMENT)**

If side step light do not illuminate normally, the input circuit from the door switch or the side step light-ECU may be defective.

**TROUBLESHOOTING HINTS**

- The front, rear or back door switch may be defective
- The side step light-ECU may be defective
- The wiring harness or connectors may have loose, corroded, or damaged terminals, or terminals pushed back in the connector

**DIAGNOSIS****Required Special Tool:**

- MB991223: Harness Set

**STEP 1. Verify the door switch.**

If the dome light switch are moved to the "door interlock position", the dome light should illuminate when either door is opened.

**Q: Do the dome light illuminate normally?**

**YES** : Go to Step 2.

**NO** : Refer to GROUP 54B, Inspection Procedure M-1 "The dome light do not illuminate or go out normally [P.54Bb-450.](#)"



**STEP 2.** Check side step light-ECU connector D-137 and rear door switch (RH) connector F-05 for loose, corroded or damaged terminals, or terminals pushed back in the connector.

**Q:** Is side step light-ECU connector D-137 and rear door switch (RH) connector F-05 in good condition?

**YES :** Go to Step 3.

**NO :** Repair or replace the damaged component(s). Refer to GROUP 00E, Harness Connector Inspection

[P.00E-2](#). Verify that the side step light illuminate normally.

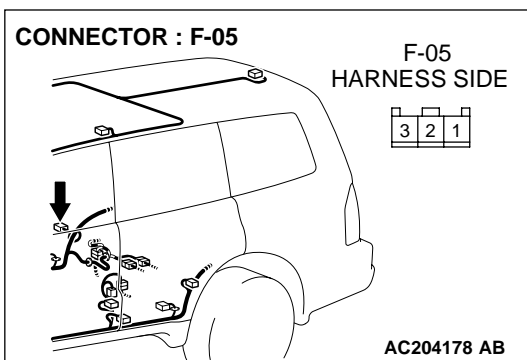
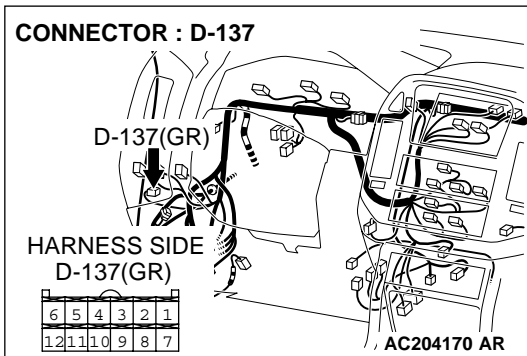

**STEP 3.** Check the wiring harness between side step light-ECU connector D-137 (terminal 9) and rear door switch (RH) connector F-05 (terminal 2).

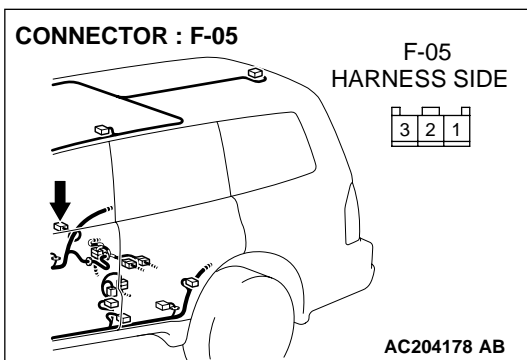
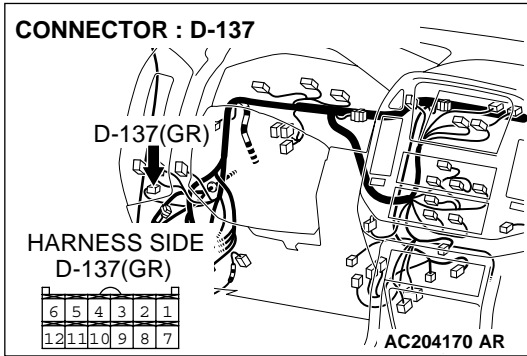

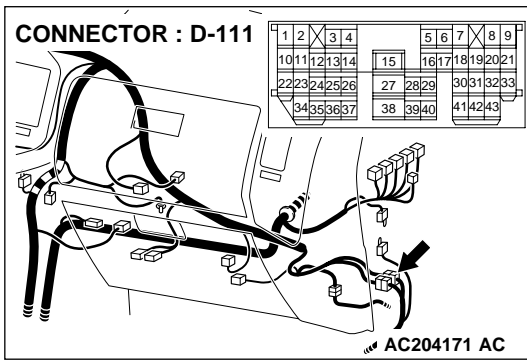

*NOTE: Also check intermediate connector D-111, junction block connectors D-209 and D-217 for loose, corroded, or damaged terminals, or terminals pushed back in the connector. If intermediate connector D-111, junction block connector D-209 or D-217 is damaged, repair or replace the connector as described in GROUP 00E, Harness Connector Inspection P.00E-2.*

**Q: Is the wiring harness between side step light-ECU connector D-137 (terminal 9) and rear door switch (RH) connector F-05 (terminal 2) in good condition?**

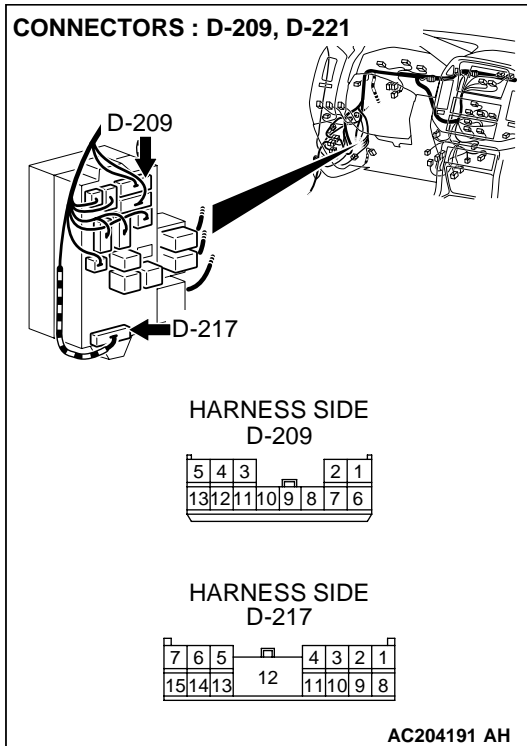

**YES :** Replace the side step light-ECU. Verify that the side step light illuminate normally.

**NO :** The wiring harness may be damaged or the connector(s) may have loose, corroded or damaged terminals, or terminals pushed back in the connector. Repair the wiring harness as necessary. Verify that the side step light illuminate normally.

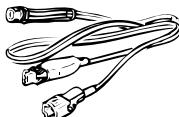
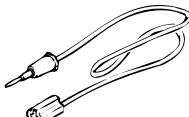

SPECIAL TOOL

M1544000600287

TOOL	TOOL NUMBER AND NAME	REPLACED BY MILLER TOOL NUMBER	APPLICATION
<p>A </p> <p>B </p> <p>C </p> <p>D </p> <p>MB991223AC</p>	<p>MB991223</p> <p>A: MB991219</p> <p>B: MB991220</p> <p>C: MB991221</p> <p>D: MB991222</p> <p>Harness set</p> <p>A: Test harness</p> <p>B: LED harness</p> <p>C: LED harness adapter</p> <p>D: Probe</p>	<p>General service tool (jumper)</p>	<p>Making voltage and resistance measurements during troubleshooting</p> <p>A: Connect pin contact pressure inspection</p> <p>B: Power circuit inspection</p> <p>C: Power circuit inspection</p> <p>D: Commercial tester connection</p>

SIDE STEP LIGHT-ECU INSPECTION

M1542012400013

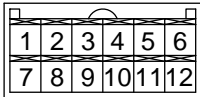

AC203981

TERMINAL NO.	SIGNAL	CHECKING REQUIREMENT	TERMINAL VOLTAGE
1	Battery power supply	Always	Battery positive voltage
2	Power supply to ignition switch (IG1)	Ignition switch "LOCK" (OFF) position	0 V
		Ignition switch "ON" position	Battery positive voltage
3	Input of lock relay signal from ETACS-ECU	When door lock actuator is operating (doors locked)	0 V
4	Output to side step light (LH)	When side step light (LH) is on	2 V or less
5	Output to side step light (RH)	When side step light (RH) is on	2 V or less
8	Input of unlock relay signal from ETACS-ECU	When door lock actuator is operating (doors unlocked)	Battery positive voltage
9	Output to all door switch	Ignition switch "LOCK"	0 V
12	Side step light-ECU ground	Always	0 V

ON-VEHICLE SERVICE

BULB REPLACEMENT

M1542001300410

<Side Step Light Bulb>

1. Turn the bulb socket counterclockwise together with the bulb, and remove the bulb.

**CAUTION**

Do not touch the surface of the bulb with hands or dirty gloves as the bulb may pop after a short time. If the surface does become dirty, clean it with alcohol or thinner, and let it dry thoroughly before installing.

2. Install the bulb to the bulb socket, and turn the bulb socket clockwise together with the bulb.

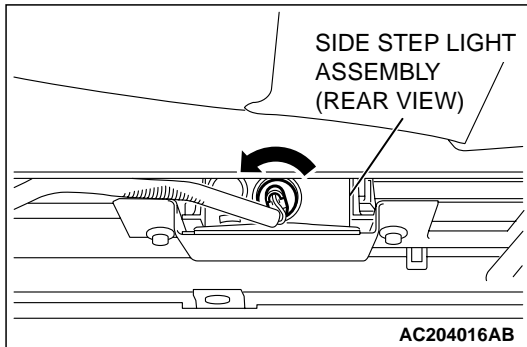

REMOVAL AND INSTALLATION

M1542012300016

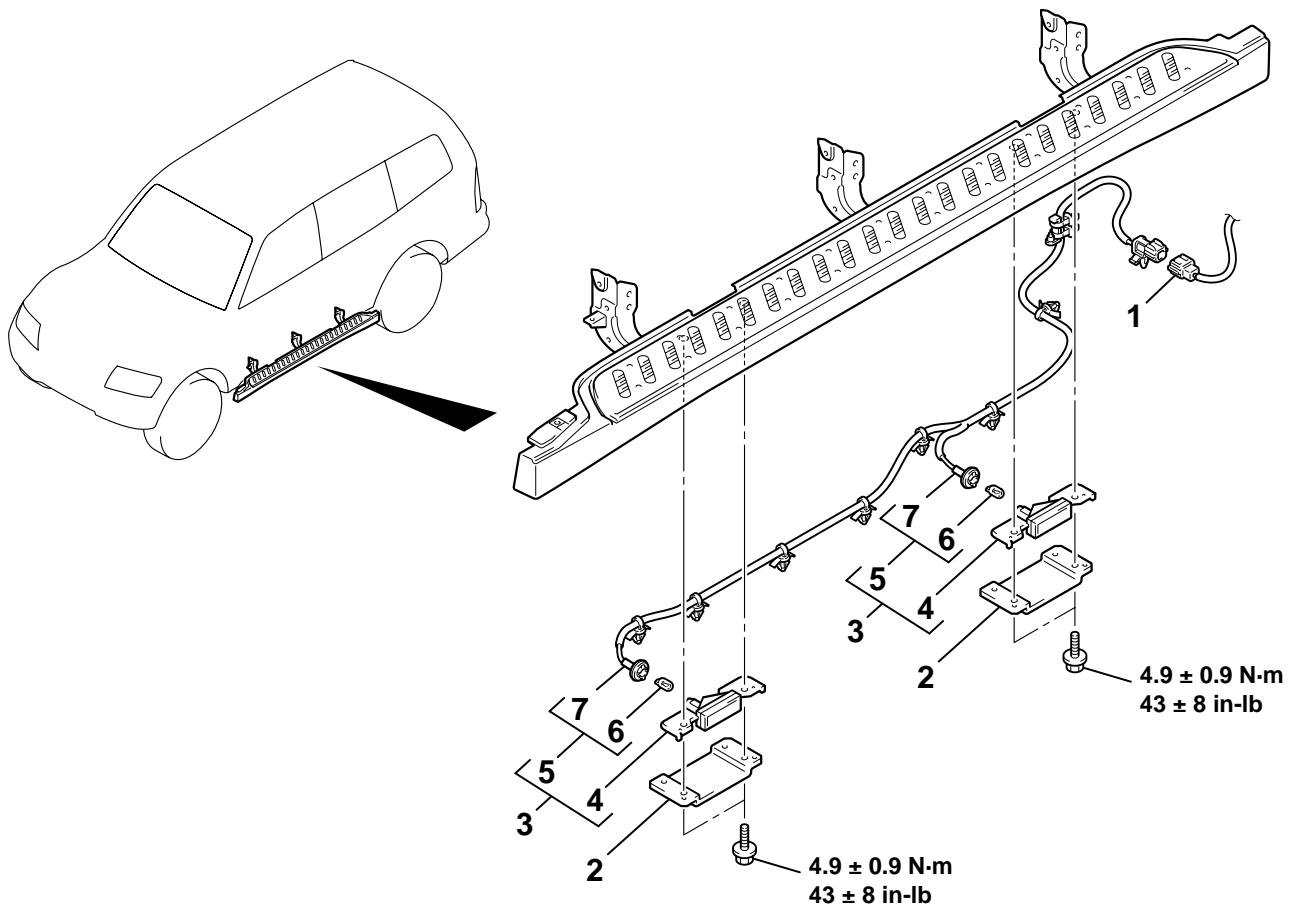

AC203940AB

**SIDE STEP LIGHT REMOVAL STEPS**

1. SIDE STEP LIGHT HARNESS CONNECTION
2. SIDE STEP LIGHT BRACKET
3. SIDE STEP LIGHT ASSEMBLY

**SIDE STEP LIGHT REMOVAL STEPS (Continued)**

4. SIDE STEP LIGHT UNIT
5. SIDE STEP LIGHT HARNESS AND BULB ASSEMBLY
6. SIDE STEP LIGHT BULB
7. SIDE STEP LIGHT HARNESS

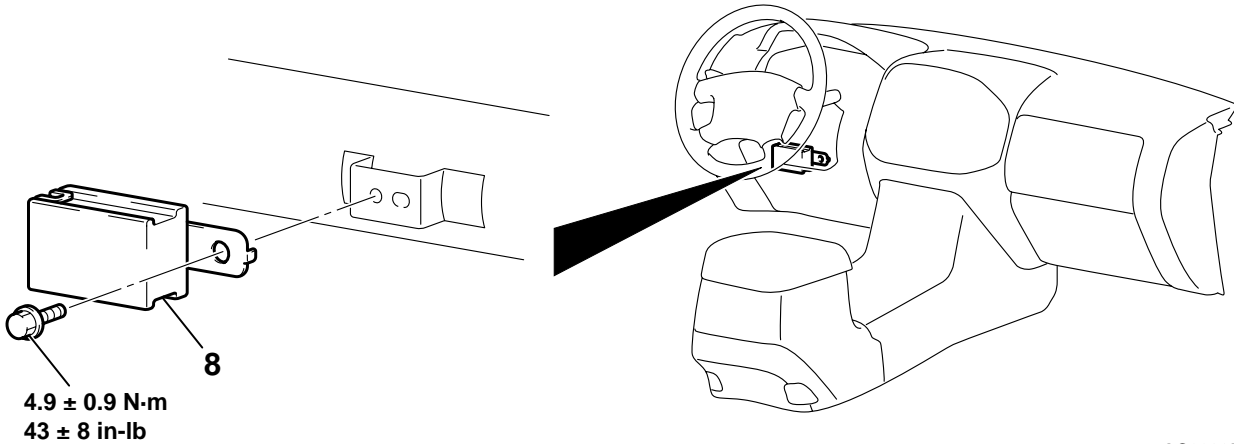

AC203956AB

### SIDE STEP LIGHT-ECU REMOVAL STEPS

- LOWER PANEL (REFER TO GROUP 52A, INTERIOR P.52A-2.)
- 8. SIDE STEP LIGHT-ECU

## RHEOSTAT

### REMOVAL AND INSTALLATION

M1542006000210

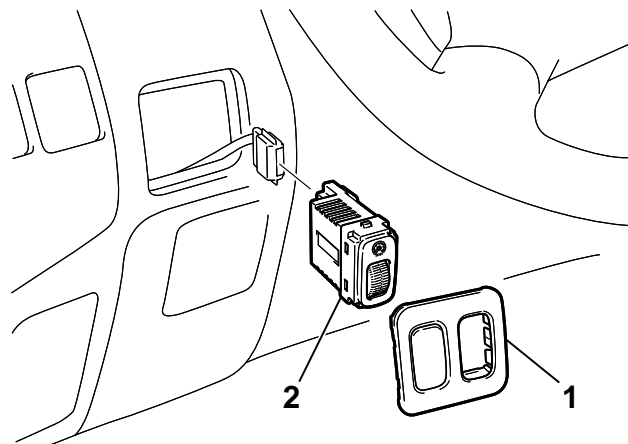

AC204146AB

### RHEOSTAT REMOVAL STEPS

1. SWITCH PANEL
2. RHEOSTAT

**INSPECTION**

M1543019500597

**REOSTAT RESISTANCE CHECK**

1. Connect the battery and the test bulb (40W) as shown in the illumination.
2. Operate the rheostat, and if brightness changes smoothly without switching off, rheostat function is normal.

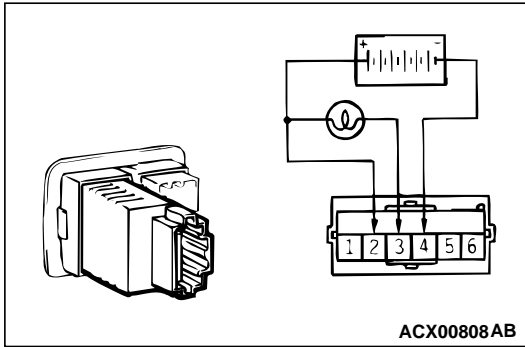

# HAZARD WARNING LIGHT SWITCH

## HAZARD WARNING LIGHT DIAGNOSIS

M1542000700512

The hazard warning lights are controlled by the Simplified Wiring System (SWS). For troubleshooting, refer to GROUP 54B, SWS Diagnosis – Symptom Chart [P.54Bb-2](#).

## REMOVAL AND INSTALLATION

M1542006600212

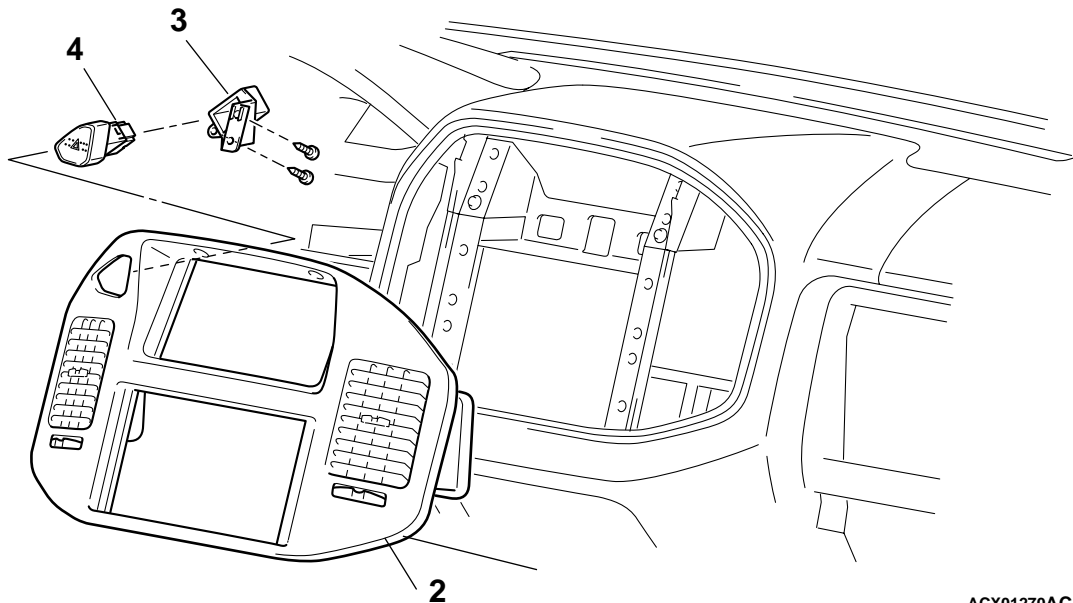
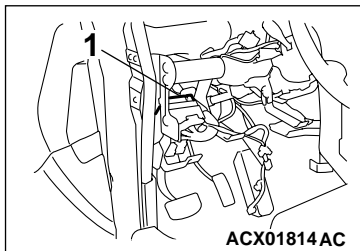

1. ETACS-ECU

### HAZARD WARNING LIGHT SWITCH REMOVAL STEPS

2. CENTER PANEL ASSEMBLY (REFER TO GROUP 52A, INSTRUMENT PANEL [P.52A-2](#).)
3. BRACKET
4. HAZARD WARNING LIGHT SWITCH



INSPECTION

M1543019501794

HAZARD WARNING LIGHT SWITCH CINTINUIITY  
CHECK

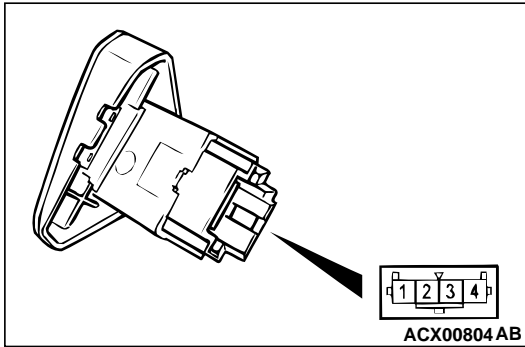

SWITCH POSITION	TESTER CONNECTION	SPECIFIED CONDITION
OFF	1 - 2	Open circuit
ON	1 - 2	Less than 2 ohms

COLUMN SWITCH

REMOVAL AND INSTALLATION

M1543009100190

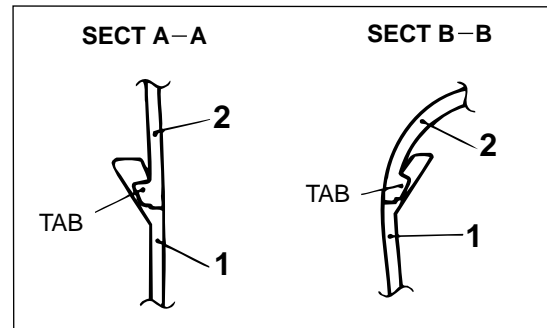
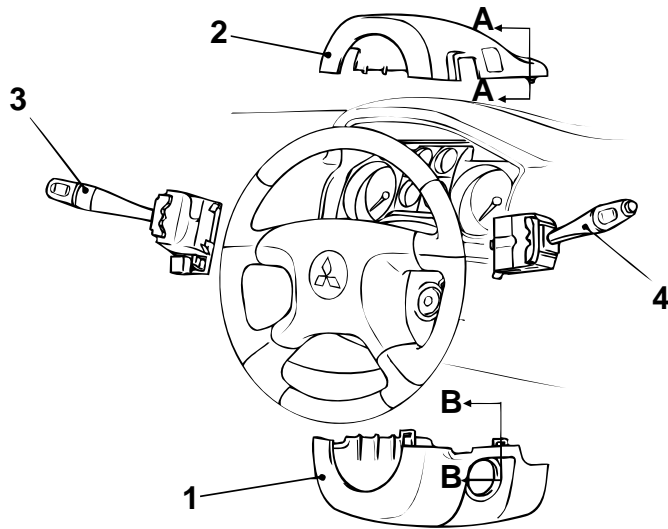

AC000744 AB

REMOVAL STEPS

1. COLUMN COVER LOWER (REFER TO GROUP 52A, INSTRUMENT PANEL ASSEMBLY P.52A-2.)
2. COLUMN COVER UPPER (REFER TO GROUP 52A, INSTRUMENT PANEL ASSEMBLY P.52A-2.)

REMOVAL STEPS (Continued)

3. TURN-SIGNAL AND LIGHTING SWITCH
4. WINDSHIELD WIPER AND WINDSHIELD WASHER WITCH

INSPECTION

M1543019501802

CLUMN SWITCH (SWITCH BODY) CHECK

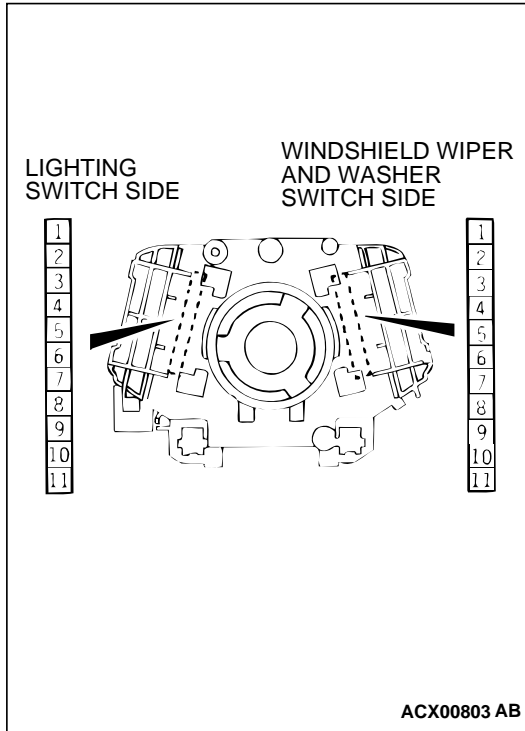

COLUMN SWITCH (BODY)	TESTER CONNECTION	SPECIFIED CONDITION
Lighting switch side – Wiper and washer switch side	3 – 3, 4 – 4, 5 – 5, 6 – 6, 7 – 7, 8 – 8, 9 – 9, 10 – 10, 11 – 11	Less than 2 ohms

## HORN

### HORN DIAGNOSIS

M1543000700407

The keyless entry system horn answerback and theft-alarm system are controlled by the Simplified Wiring System (SWS). For troubleshooting, refer to GROUP 54B, SWS Diagnosis – Symptom Chart

[P.54Bb-2.](#)

### REMOVAL AND INSTALLATION

M1543007900316

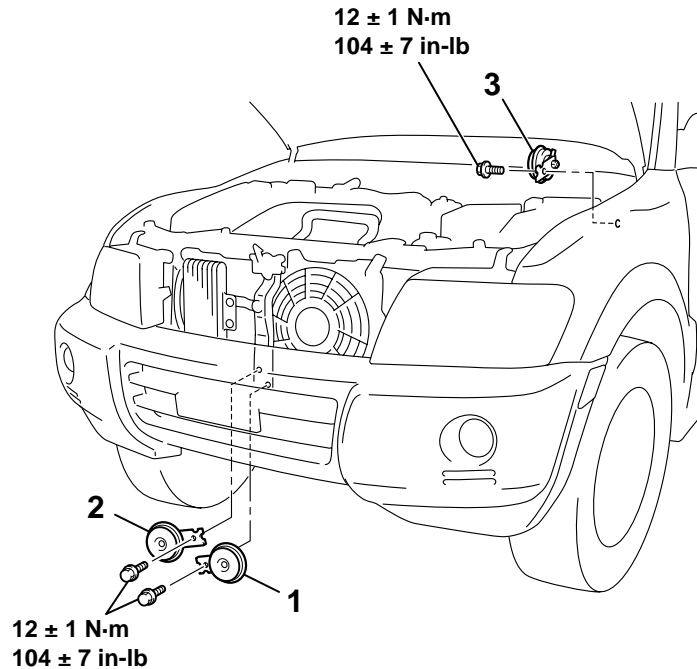

AC204110AB

#### REMOVAL STEPS

- RADIATOR GRILL (REFER TO GROUP 51, FRONT BUMPER [P.51-3.](#))
1. HORN <LO> (STANDARD TYPE)

#### REMOVAL STEPS (Continued)

2. HORN <HI> (STANDARD TYPE)
3. HORN (FOR KEYLESS ENTRY ANSWERBACK AND THEFT ALARM SYSTEM)

INSPECTION

M1543019501813

HORN RELAY, THEFT-ALARM HORN RELAY  
CONTINUITY CHECK

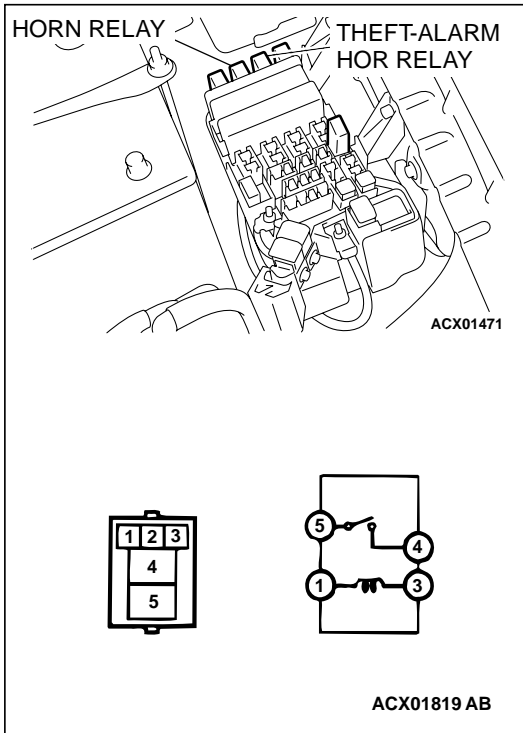

BATTERY VOLTAGE	TESTER CONNECTION	SPECIFIED CONDITION
Not applied	4 -5	Open circuit
<ul style="list-style-type: none"> <li>Connect terminal 1 to the positive battery terminal</li> <li>Connect terminal 3 to the negative battery terminal</li> </ul>	4 -5	Less than 2 ohms

ACCESSORY SOCKET

REMOVAL AND INSTALLATION

M1543008900104

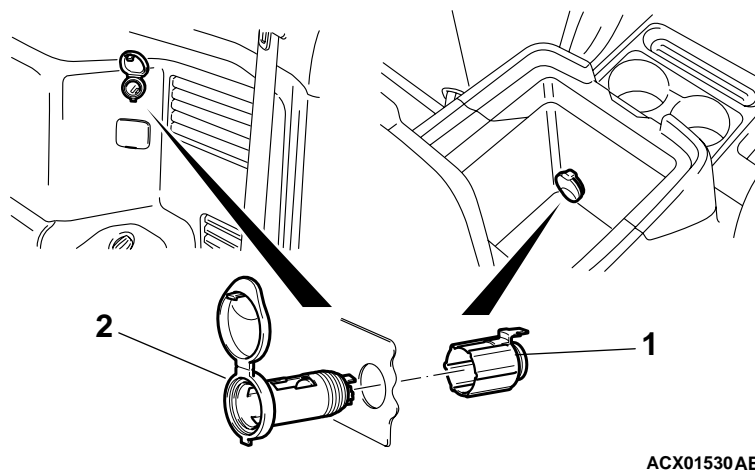

- REMOVAL STEPS**
- REAR FLOOR CONSOLE ASSEMBLY (REFER TO GROUP 52A.FLOOR CONSOLE ASSEMBLY P.52A-7.)

- REMOVAL STEPS (Continued)**
- LOWER QUARTER PANEL (LH) (REFER TO GROUP 52ATRIMS P.52A-8.)
  - 1. CASE
  - 2. SOCKET

INSPECTION

M1543019501824

ACCESSORY SOCKET RELAY CONTINUITY  
CHECK

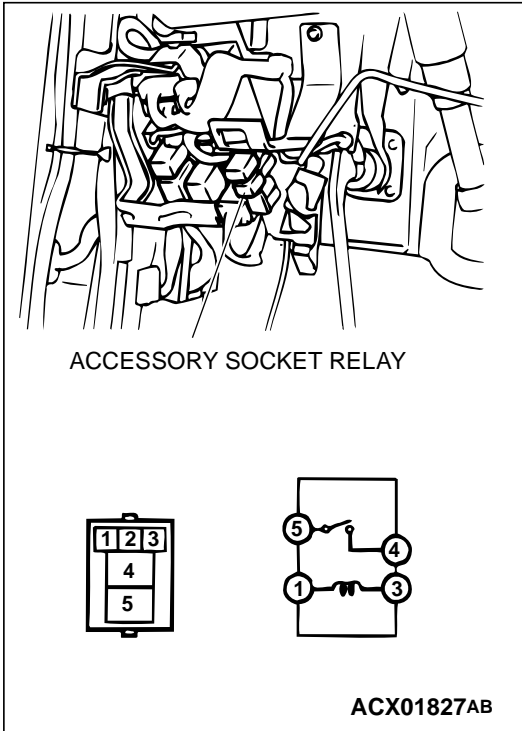

BATTERY VOLTAGE	TESTER CONDITION	SPECIFIED CONDITION
Not applied	4 – 5	Open circuit
<ul style="list-style-type: none"> <li>Connect terminal 3 to the positive battery terminal</li> <li>Connect terminal 1 to the negative battery terminal</li> </ul>	4 – 5	Less than 2 ohms

CIGARETTE LIGHTER

REMOVAL AND INSTALLATION

M1543005600115

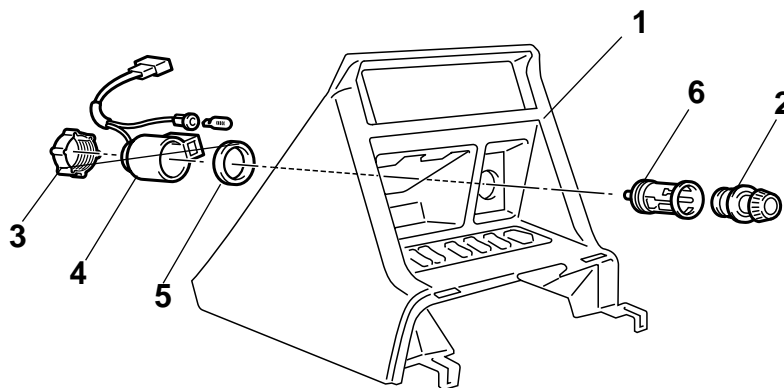

ACX01566 AB

REMOVAL STEPS

1. LOWER CENTER PANEL (REFER TO GROUP 52A, INSTRUMENT PANEL [P.52A-2.](#))
2. PLUG

REMOVAL STEPS (Continued)

3. FIXING RING
4. SOCKET CASE
5. SOCKET WASHER
6. SOCKET

## INSPECTION

M1543019500649

## CIGARETTE LIGHTER CHECK

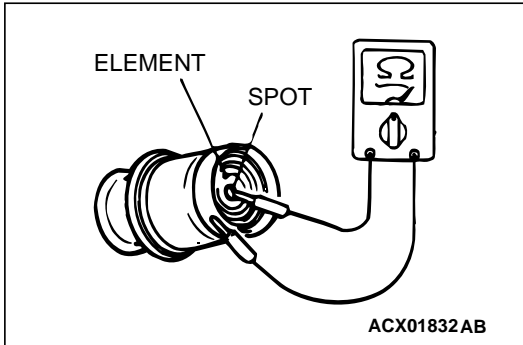

- Take out the plug, and check for a worn edge on the element spot connection, and for shreds of tobacco or other material on the element.
- Using an ohmmeter, check that the element resistance value is 1.7 ohm.

## RADIO WITH TAPE PLAYER AND CD PLAYER

## GENERAL DESCRIPTION

Anti-theft system

M1544000100077

After the power supply to the radio, tape player and CD player has been interrupted for one hour or more, the anti-theft system will prevent the radio, tape player and CD player from working, even if the power supply is restored.

RADIO WITH TAPE PLAYER AND CD PLAYER, SPEAKER AND ANTENNA  
DIAGNOSIS

## INTRODUCTION TO AUDIO SYSTEM DIAGNOSIS

M1544004700082

The diagnosis for symptoms such as noise being emitted, no sound being played, or sound coming only out of one speaker (or set of speakers) is provided.

## AUDIO SYSTEM DIAGNOSTIC TROUBLESHOOTING STRATEGY

M1544004800302

Use these steps to plan your diagnostic strategy. Follow through with each step to ensure that you have exhausted all possible methods of finding an audio system fault.

1. Gather information from the customer.

2. Verify that the condition described by the customer exists.
3. Find the malfunction by following the Symptom Chart.
4. Verify that the malfunction is eliminated.

**TROUBLE SYMPTOM CHART**

M1544004900321

SYMPTOMS		INSPECTION PROCEDURE	REFERENCE PAGE
When power switch is turned "ON," no power is available		1	P.54A-120
No sound. <vehicles with amplifier>		2	P.54A-125
No sound from one speaker. <vehicles without amplifier>		3	P.54A-130
No sound from one speaker. <vehicles with amplifier>		4	P.54A-149
Noise	Noise is present while moving (AM).	5	P.54A-165
	Noise is present while moving (FM).	6	P.54A-166
	Sound mixed with noise, only at night (AM).	7	P.54A-167
	Noise is overpowering both AM and FM.	8	P.54A-167
	Excessive noise on AM and FM.	9	P.54A-168
	Noise is detected with engine running.	10	P.54A-169
	Noise Appears during vibration or shocks.	11	P.54A-170
	Noise sometimes appears on FM during traveling.	12	P.54A-172
	Constant noise.	13	P.54A-172
Radio	There is noise but no reception for both AM and FM or no sound from AM, or no sound from FM.	14	P.54A-173
	Poor reception.	15	P.54A-173
	Distortion on AM and/or FM.	16	P.54A-174
	Distortion on FM only.	17	P.54A-175
	Using the auto select function, too few automatic stations are selected.	18	P.54A-175
	Preset stations are erased.	19	P.54A-176
CD player, CD auto changer	CD can not be inserted.	20	P.54A-178
	No sound (CD only).	21	P.54A-179
	CD sound skips.	22	P.54A-179
	Sound quality is poor.	23	P.54A-180
	CD cannot be ejected.	24	P.54A-180

SYMPTOM PROCEDURES

INSPECTION PROCEDURE 1: When Power Switch is Turned "ON," no Power is Available.

Radio and Tape Player Power Supply Circuit

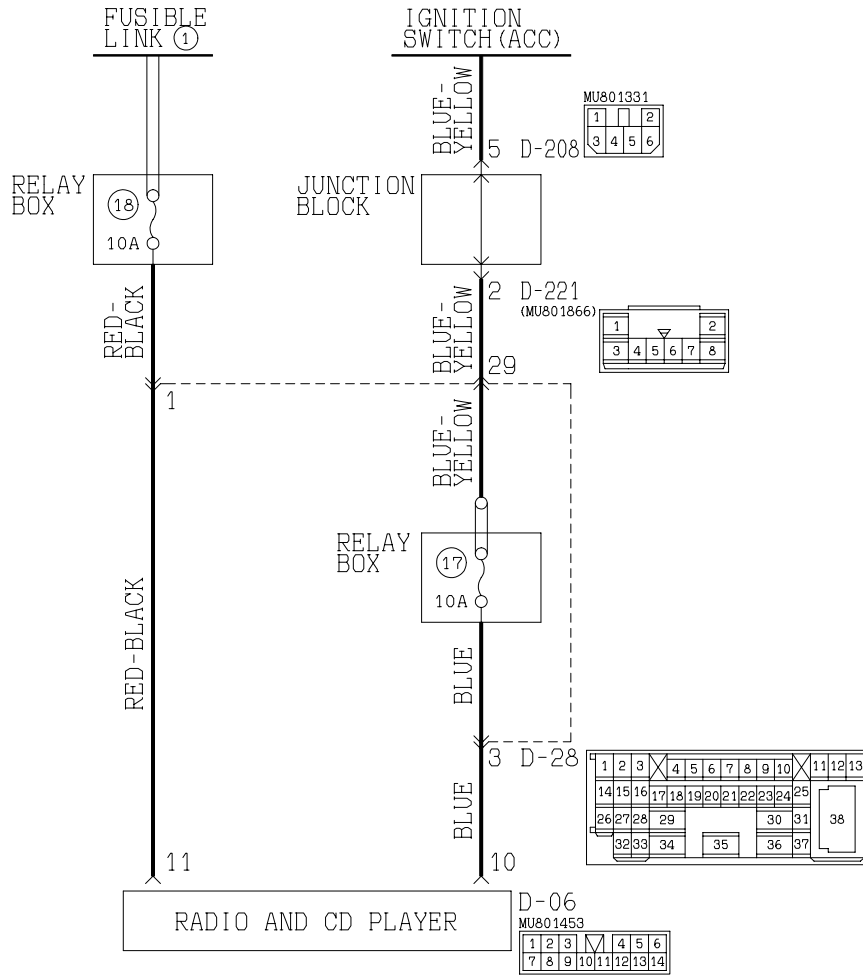

W3Q12M02AA

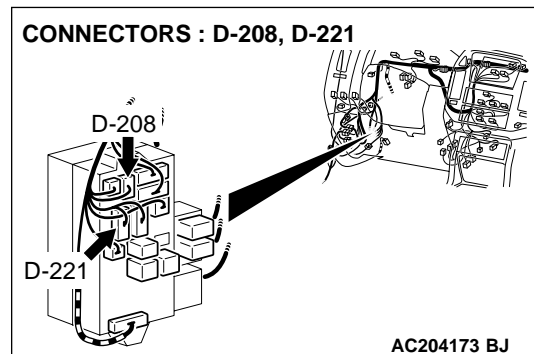
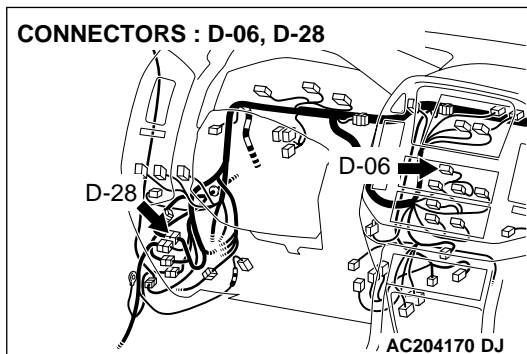



**CIRCUIT OPERATION**

Power is supplied to the radio and CD player when the ignition switch is in the "ACC" position or "ON" position. When the ignition is switched on, the radio and CD player will return to the previous state when the ignition was switch off at the last time.

**TECHNICAL DESCRIPTION (COMMENT)**

The cause is probably a faulty radio and CD player power supply circuit system circuit.

**TROUBLESHOOTING HINTS**

- Damaged wiring harness or connector.
- Malfunction of the radio and CD player.

**DIAGNOSIS**

**Required Special Tool:**

- MB991223: Harness set

**STEP 1. Check to see that the radio and CD player is energized when the power switch is turned ON.**

- (1) Turn the ignition switch to "ACC" position.
- (2) Turn ON the radio and CD player power switch.

**Q: Is the radio and CD player energized when the power switch is turned ON?**

- YES :** Go to Step 2.  
**NO :** Go to Step 5.

**STEP 2. Check radio and CD player connector D-06 for loose, corroded or damaged terminals, or terminals pushed back in the connector.**

**Q: Are radio and CD player connector D-06 in good condition?**

- YES :** Go to Step 3.  
**NO :** Repair or replace the damaged component(s). Refer to GROUP 00E, Harness Connector Inspection [P.00E-2](#). If the power switch is turned on, the radio and CD player should operate normally.

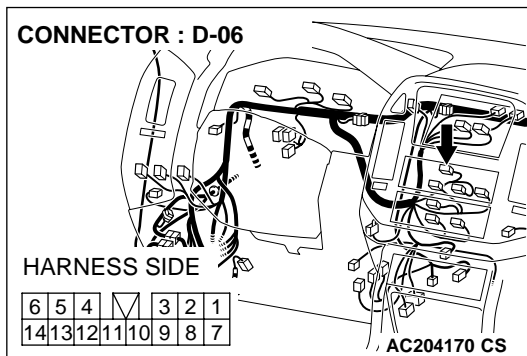

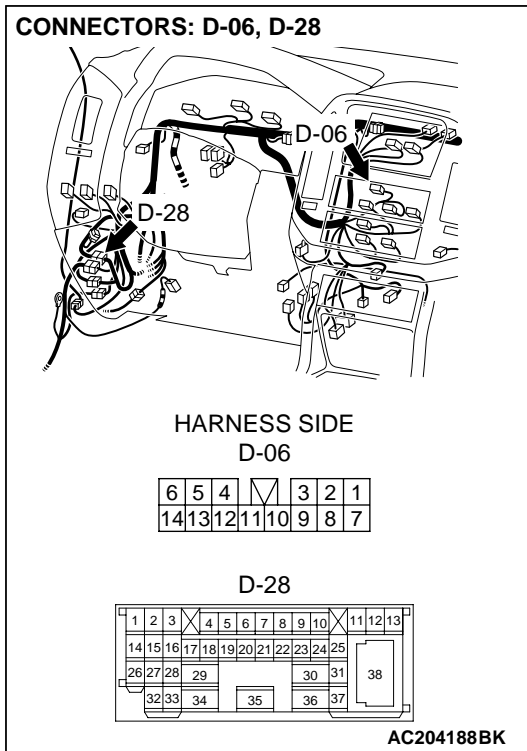

**STEP 3. Check the wiring harness between radio and CD player connector D-06 (terminal 11) and the battery.**

*NOTE: After inspecting intermediate connector D-28, inspect the wire. If intermediate connector D-28 is damaged, repair or replace it. Refer to GROUP 00E, Harness Connector Inspection P.00E-2.*

**Q: Is the wiring harness between radio and CD player connector D-06 (terminal 11) and battery in good condition?**

**YES :** Go to Step 4.

**NO :** Repair the wiring harness. If the power switch is turned on, the radio and CD player should operate normally.

**STEP 4. Check the installation condition of the radio and CD player.**

*NOTE: The radio and CD player are grounded to the instrument panel center reinforcement directly.*

**Q: Are the radio and CD player installed correctly?**

**YES :** Repair or replace the radio and CD player. If the power switch is turned on, the radio and CD player should operate normally.

**NO :** Install the radio and CD player properly. If the power switch is turned on, the radio and CD player should operate normally.

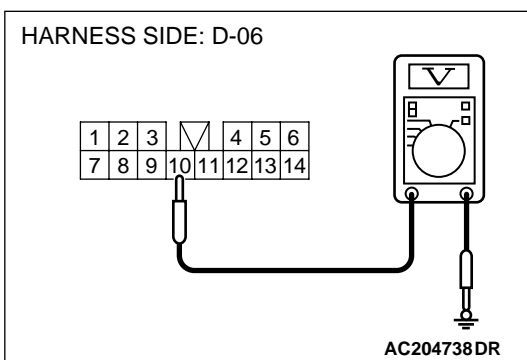
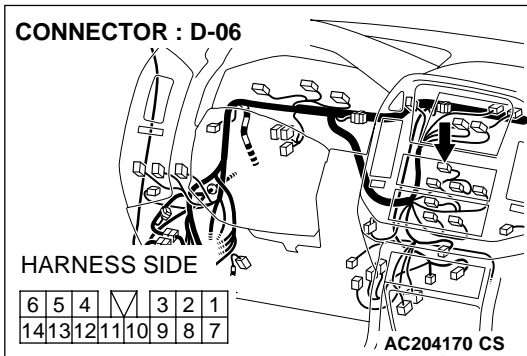

**STEP 5. Measure at radio and CD player connector D-06 in order to check the battery circuit of power supply system to the radio and CD player (ignition switch ACC).**

- (1) Disconnect radio and CD player connector D-06, and measure at the wiring harness side.
- (2) Turn the ignition switch to "ACC" position.

- (3) Measure the voltage between terminal 10 and ground by backprobing.
  - The voltage should equal approximately 12 volts (battery positive voltage).

**Q: Is the measured voltage approximately 12 volts (battery positive voltage)?**

**YES :** Go to Step 8.

**NO :** Go to Step 6.

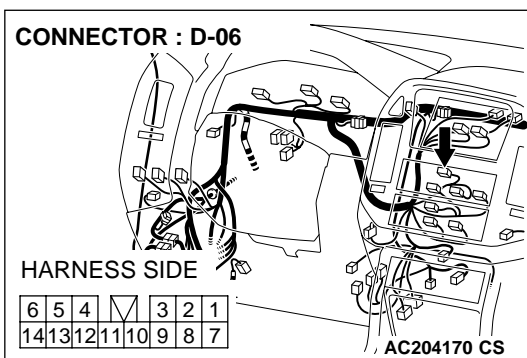

**STEP 6. Check radio and CD player connector D-06 for loose, corroded or damaged terminals, or terminals pushed back in the connector.**

**Q: Are radio and CD player connector D-06 in good condition?**

**YES :** Go to Step 7.

**NO :** Repair or replace the damaged component(s). Refer to GROUP 00E, Harness Connector Inspection

[P.00E-2](#). If the power switch is turned on, the radio and CD player should operate normally.

**STEP 7. Check the wiring harness between radio and CD player connector D-06 (terminal 10) and ignition switch (ACC).**

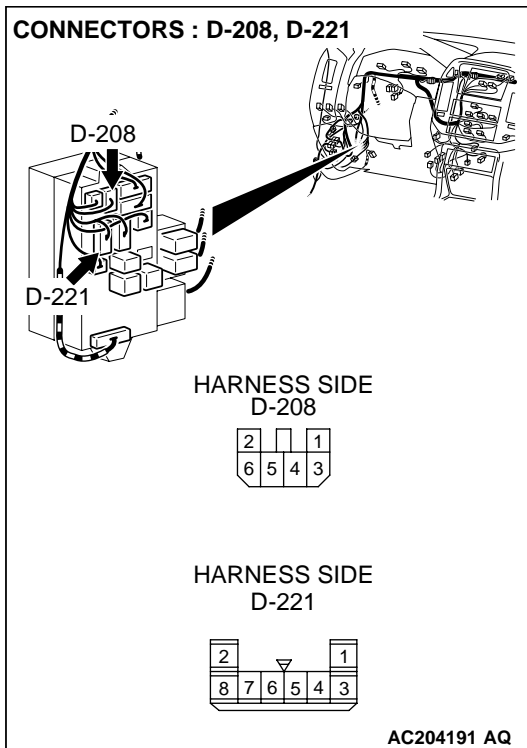
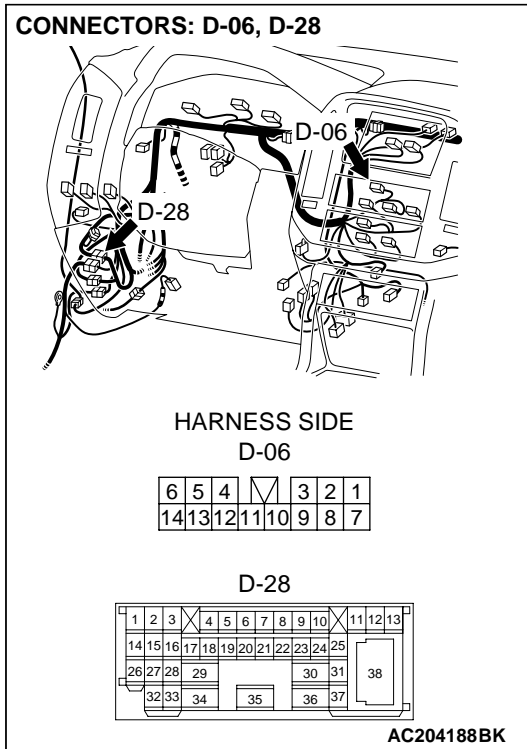

*NOTE: Also check intermediate connector D-28, junction block connector D-208 and D-221. If intermediate connector D-28, junction block connector D-208 and D-221 is damaged, repair or replace the connector as described in GROUP 00E, Harness Connector Inspection P.00E-2.*

**Q: Is the wiring harness between radio and CD player connector D-06 (terminal 10) and ignition switch (ACC) in good condition?**

**YES :** There is no action to be taken.

**NO :** Repair the wiring harness. If the power switch is turned on, the radio and CD player should operate normally.

**STEP 8. Check the installation condition of the radio and CD player.**

*NOTE: The radio and CD player are grounded to the instrument panel center reinforcement directly.*

**Q: Are the radio and CD player installed correctly?**

**YES :** Repair or replace the radio and CD player. If the power switch is turned on, the radio and CD player should operate normally.

**NO :** Install the radio and CD player properly. If the power switch is turned on, the radio and CD player should operate normally.

**INSPECTION PROCEDURE 2: No Sound. <Vehicles with Amplifier>**

**Amplifier Power Supply Circuit**

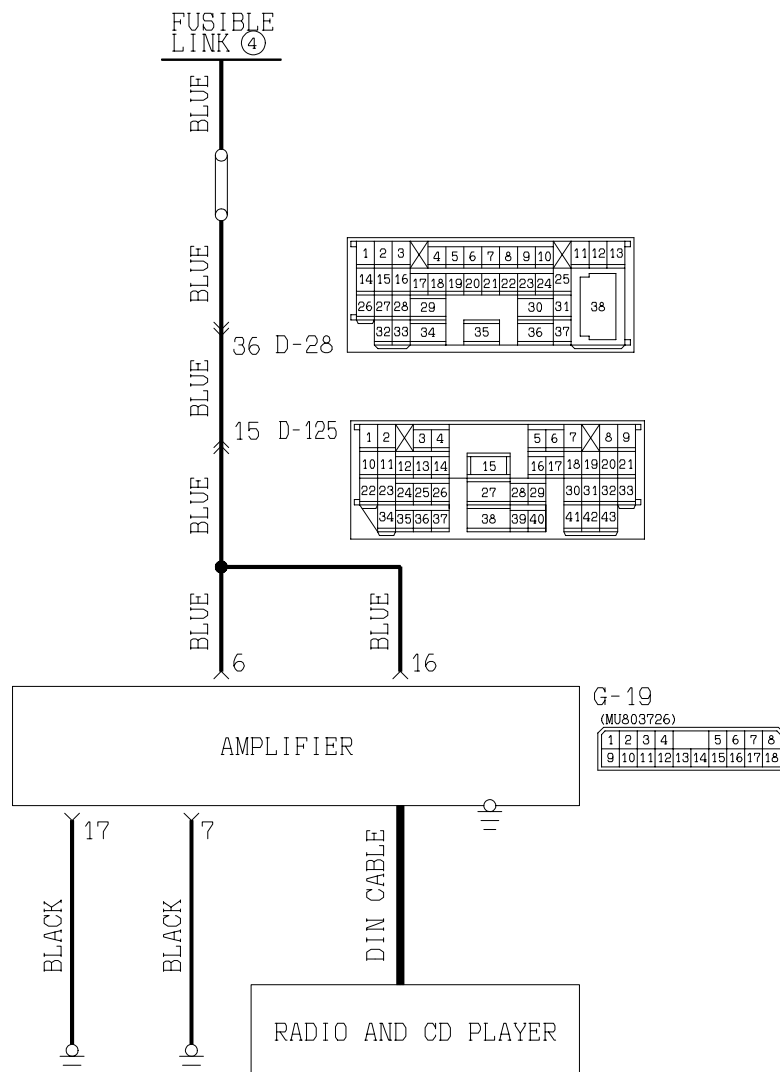

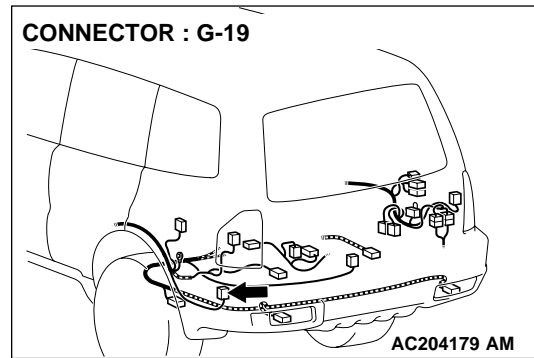
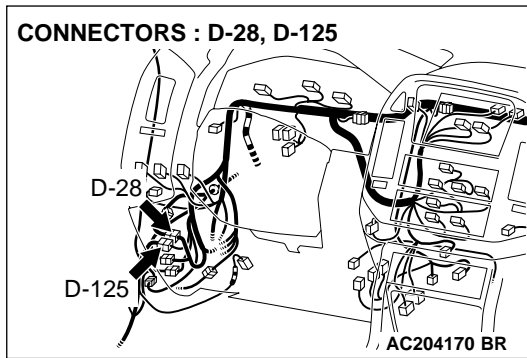

**CIRCUIT OPERATION**

Power is supplied from the battery directly to the amplifier.

**TECHNICAL DESCRIPTION (COMMENT)**

The cause is probably a faulty amplifier power supply circuit system.

**TROUBLESHOOTING HINTS**

- Damaged wiring harness or connector.
- Damaged DIN cable.
- Malfunction of the amplifier.
- Malfunction of the radio and tape player.

**DIAGNOSIS**

**Required Special Tool:**

- MB991223: Harness set

**STEP 1. Measure at amplifier connector G-19 in order to check the battery circuit of power supply system to the amplifier.**

(1) Disconnect amplifier connector G-19, and measure at the wiring harness side.

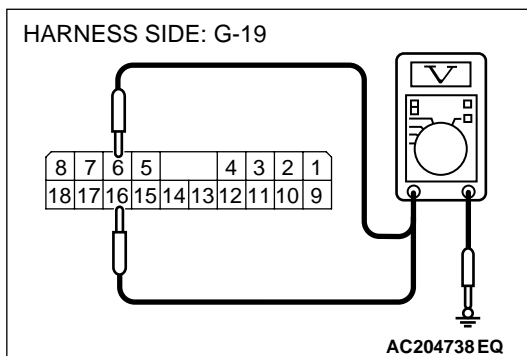
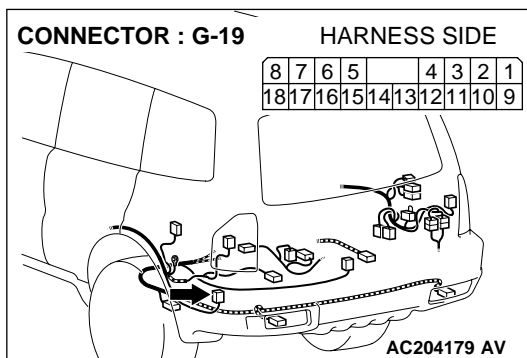

(2) Measure the voltage between terminal 6 and ground.

- The voltage should equal approximately 12 volts (battery positive voltage).

(3) Measure the voltage between terminal 16 and ground.

- The voltage should equal approximately 12 volts (battery positive voltage).

**Q: Is the measured voltage approximately 12 volts (battery positive voltage)?**

**YES :** Go to Step 4.

**NO :** Go to Step 2.

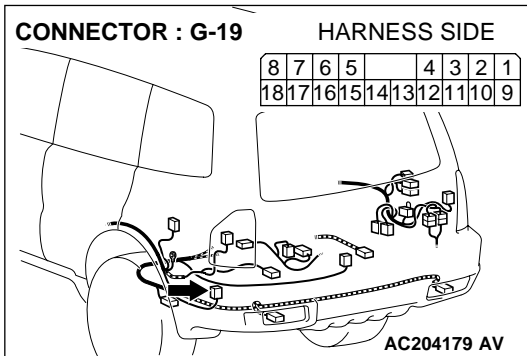

**STEP 2.** Check amplifier connector G-19 for loose, corroded or damaged terminals, or terminals pushed back in the connector.

**Q:** Is amplifier connector G-19 in good condition?

**YES :** Go to Step 3.

**NO :** Repair or replace the damaged component(s). Refer to GROUP 00E, Harness Connector Inspection P.00E-2. The speakers should sound.

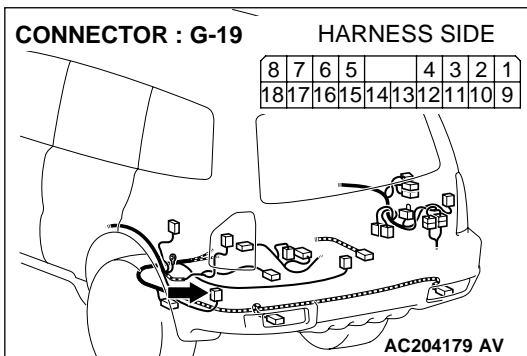

**STEP 3.** Check the wiring harness between amplifier connector G-19 (terminal 6 and 16) and the battery.

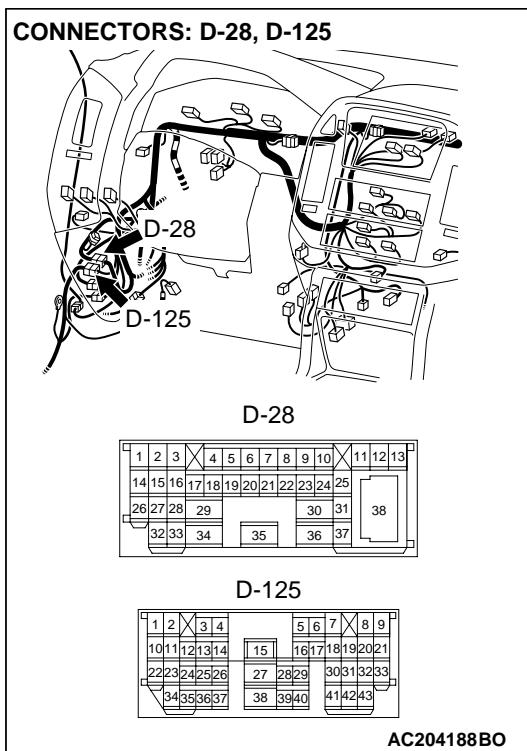

*NOTE:* Also check intermediate connector D-28 and D-125. If intermediate connectors D-28 or D-125 are damaged, repair or replace the connector as described in GROUP 00E, Harness Connector Inspection P.00E-2.

**Q:** Is the wiring harness between amplifier connector G-19 (terminal 6 and 16) and the battery in good condition?

**YES :** There is no action to be taken.

**NO :** Repair the wiring harness. The speakers should sound.

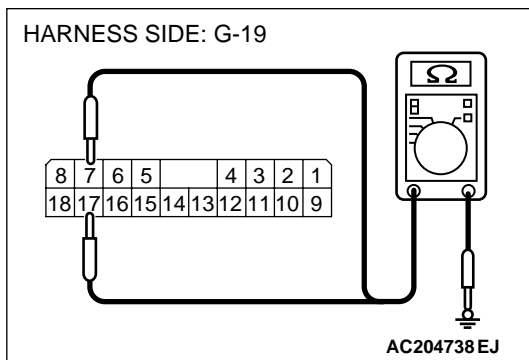
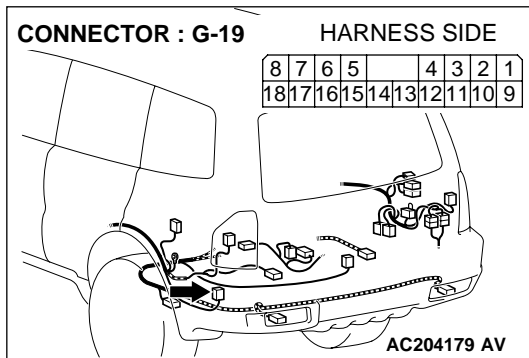

**STEP 4. Measure at amplifier connector G-19 in order to check the ground circuit to the amplifier.**

(1) Disconnect amplifier connector G-19, and measure at the wiring harness side.

- (2) Measure the resistance between terminal 7 and ground by backprobing.
- The resistance should equal 2 ohms or less.
- (3) Measure the resistance between terminal 17 and ground by backprobing.
- The resistance should equal 2 ohms or less.

**Q: Is the measured resistance 2 ohms or less?**

**YES :** Go to Step 7.

**NO :** Go to Step 5.

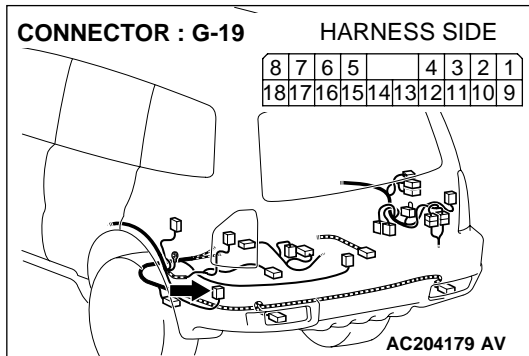

**STEP 5. Check amplifier connector G-19 for loose, corroded or damaged terminals, or terminals pushed back in the connector.**

**Q: Is amplifier connector G-19 in good condition?**

**YES :** Go to Step 6.

**NO :** Repair or replace the damaged component(s). Refer to GROUP 00E, Harness Connector Inspection [P.00E-2](#). The speakers should sound.

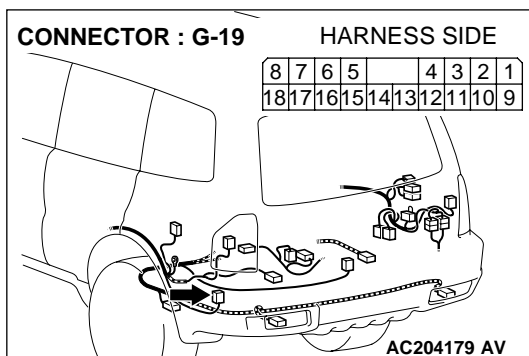

**STEP 6. Check the wiring harness between amplifier connector G-19 (terminal 7 and 17) and ground.**

**Q: Is the wiring harness between amplifier connector G-19 (terminal 7 and 17) and ground in good condition?**

**YES :** There is no action to be taken.

**NO :** Repair the wiring harness. The speakers should sound.



---

**STEP 7. Check the DIN cable between amplifier and radio and CD player.**

**Q: Is the DIN cable in good condition?**

**YES :** Go to Step 8.

**NO :** Repair or replace the DIN cable. The speakers should sound.

---

**STEP 8. Replace the radio and CD player.**

**Q: Do the speakers sound normally?**

**YES :** There is no action to be taken.

**NO :** Repair or replace the amplifier. The speakers should sound.

INSPECTION PROCEDURE 3: No Sound from One Speaker. <Vehicles without Amplifier>

Speaker System Circuit <Vehicles without Amplifier>

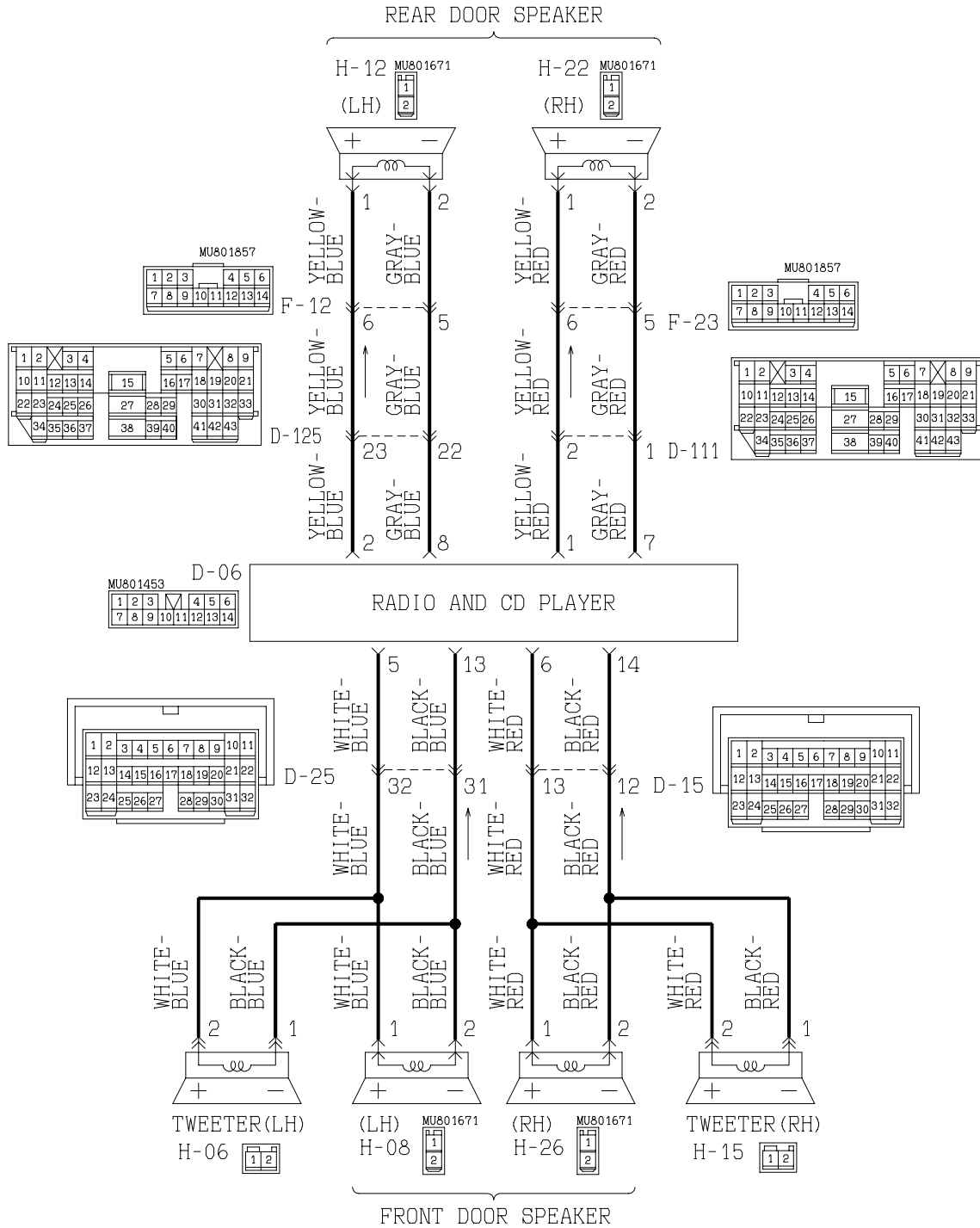

W3Q12M03AA

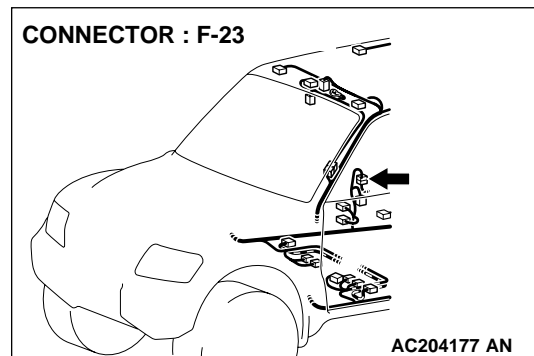
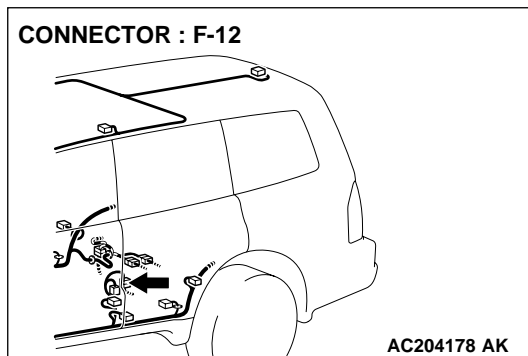
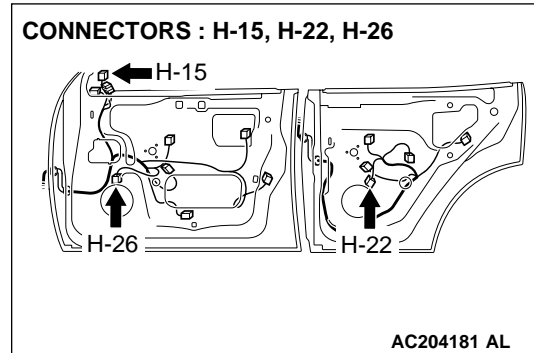
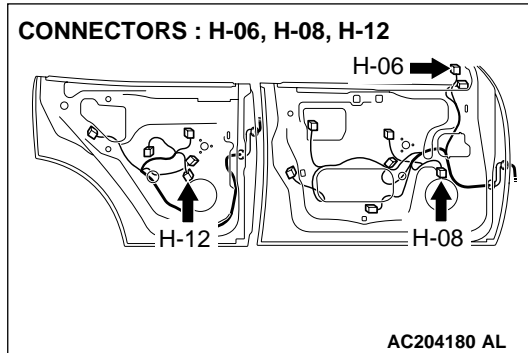
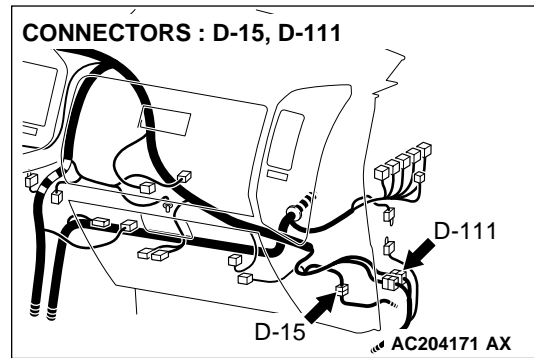
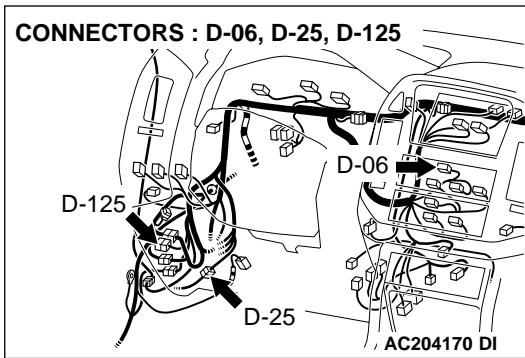

### CIRCUIT OPERATION

The speakers sound according to audio signal output from the radio and CD player.

### TECHNICAL DESCRIPTION (COMMENT)

The cause is probably a faulty speaker system.

### TROUBLESHOOTING HINTS

- Malfunction of the speaker.
- Damaged wiring harness or connector.
- Malfunction of the radio and CD player.

---

**DIAGNOSIS**

---

**STEP 1. Check to see which speaker does not sound.**

Determine which speaker does not sound.

**Q: Which speaker does not sound?**

**Tweeter (LH)** : Go to Step 2.

**Tweeter (RH)** : Go to Step 5.

**Front door speaker (LH)** : Go to Step 8.

**Front door speaker (RH)** : Go to Step 11.

**Rear door speaker (LH)** : Go to Step 14.

**Rear door speaker (RH)** : Go to Step 17.

**Front door speaker (LH) and tweeter (LH)** : Go to Step 20.

**Front door speaker (RH) and tweeter (RH)** : Go to Step 22.

---

**STEP 2. Check the tweeter (LH).**

(1) Remove the tweeter (LH). Refer to [P.54A-183](#).

(2) Check that the tweeter (LH) generates noise when a five-volt voltage is applied on the tweeter (LH) terminal.

**Q: Is the tweeter (LH) generating noise?**

**YES** : Go to Step 3.

**NO** : Replace the tweeter (LH). The tweeter (LH) should sound.

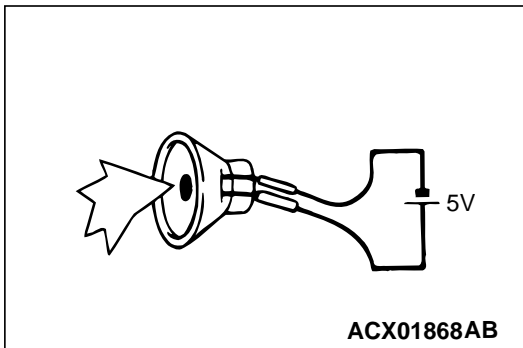

**STEP 3.** Check tweeter (LH) connector H-06 and radio and CD player connector D-06 for loose, corroded or damaged terminals, or terminals pushed back in the connector.

**Q:** Are harness connectors H-06 and D-06 in good condition?

**YES :** Go to Step 4.

**NO :** Repair or replace the damaged component(s). Refer to GROUP 00E, Harness Connector Inspection

[P.00E-2](#). The door speaker (LH) should sound.

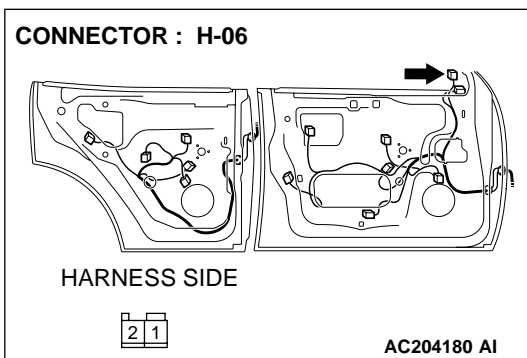
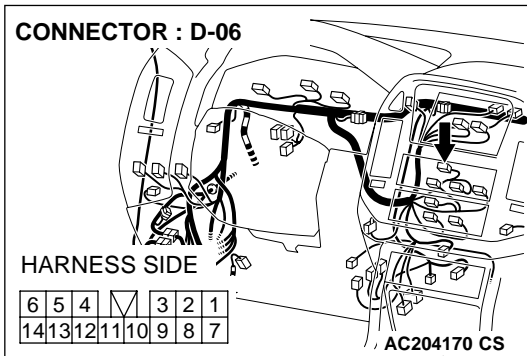

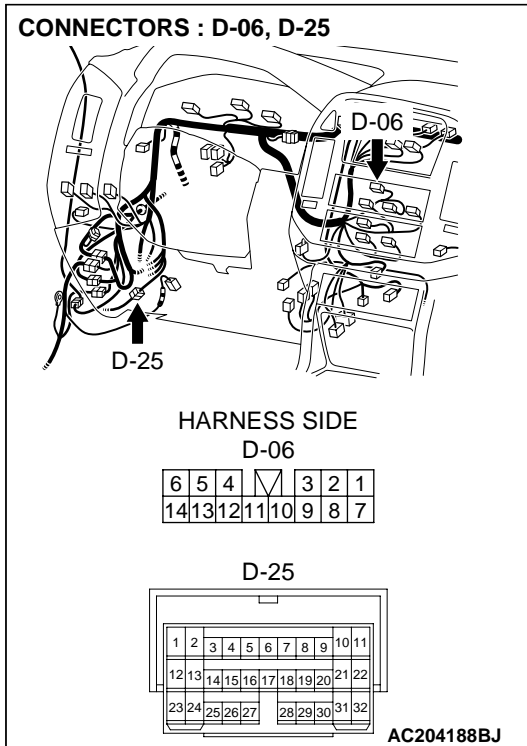

**STEP 4. Check the wiring harness between tweeter (LH) connector H-06 (terminals 1 and 2) and radio and CD player connector D-06 (terminals 5 and 13).**

*NOTE: Also check intermediate connector D-25. If intermediate connector D-25 is damaged, repair or replace the connector as described in GROUP 00E, Harness Connector Inspection*

*P.00E-2.*

**Q: Is the wiring harness between tweeter (LH) connector H-06 (terminals 1 and 2) and radio and CD player connector D-06 (terminals 5 and 13) in good condition?**

**YES :** Repair or replace the radio and CD player. The tweeter (LH) should sound.

**NO :** Repair the wiring harness. The tweeter (LH) should sound.

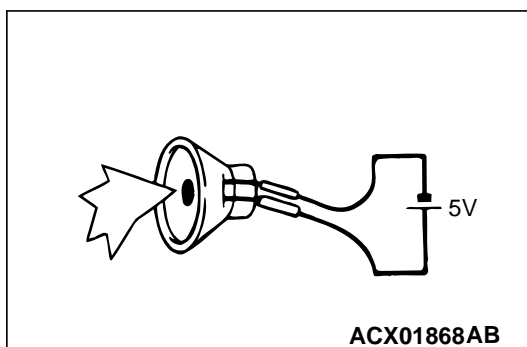
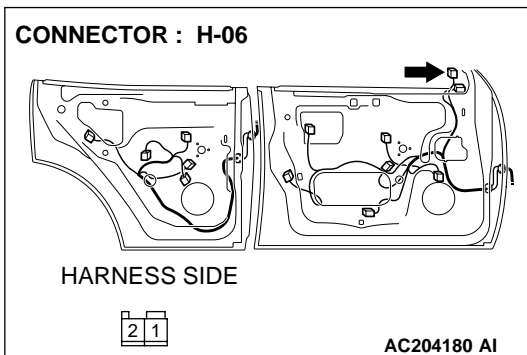

**STEP 5. Check the tweeter (RH).**

(1) Remove the tweeter (RH). Refer to [P.54A-183](#).

(2) Check that the tweeter (RH) generates noise when a five-volt voltage is applied on the tweeter (RH) terminal.

**Q: Is the tweeter (RH) generating noise?**

**YES :** Go to Step 6.

**NO :** Replace the tweeter (RH). The tweeter (RH) should sound.

**STEP 6.** Check tweeter (RH) connector H-15 and radio and CD player connector D-06 for loose, corroded or damaged terminals, or terminals pushed back in the connector.

**Q:** Are harness connectors H-15 and D-06 in good condition?

**YES :** Go to Step 7.

**NO :** Repair or replace the damaged component(s). Refer to GROUP 00E, Harness Connector Inspection

[P.00E-2](#). The door speaker (LH) should sound.

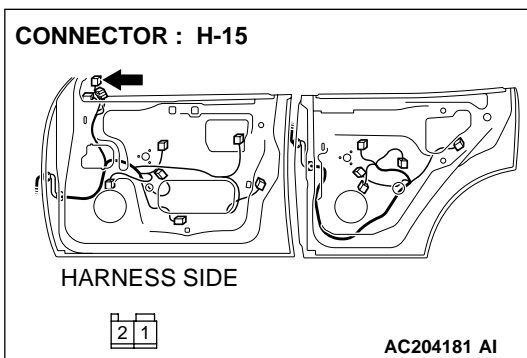
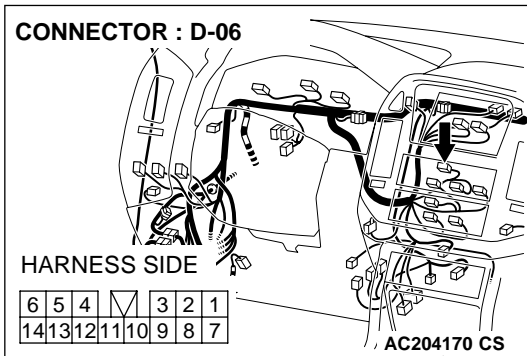

**STEP 7. Check the wiring harness between tweeter (RH) connector H-15 (terminals 1 and 2) and radio and CD player connector D-06 (terminals 6 and 14).**

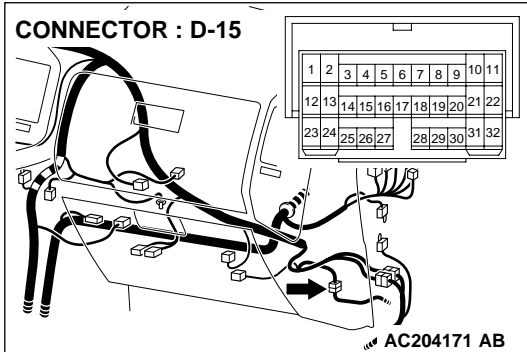
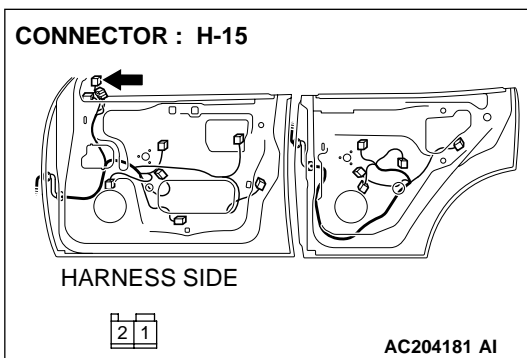
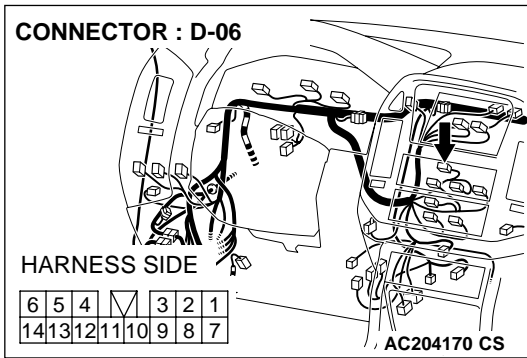

*NOTE: Also check intermediate connector D-15. If intermediate connector D-15 is damaged, repair or replace the connector as described in GROUP 00E, Harness Connector Inspection P.00E-2.*

- Q: Is the wiring harness between tweeter (RH) connector H-15 (terminals 1 and 2) and radio and CD player connector D-06 (terminals 6 and 14) in good condition?**
- YES :** Repair or replace the radio and CD player. The front door speaker (LH) should sound.
- NO :** Repair the wiring harness. The front door speaker (LH) should sound.

**STEP 8. Check the front door speaker (LH).**

(1) Remove the front door speaker (LH). Refer to P.54A-183.

(2) Check that the front door speaker (LH) generates noise when a five-volt voltage is applied on the front door speaker (LH) terminal.

- Q: Is the front door speaker (LH) generating noise?**
- YES :** Go to Step 9.
- NO :** Replace the front door speaker (LH). The front door speaker (LH) should sound.

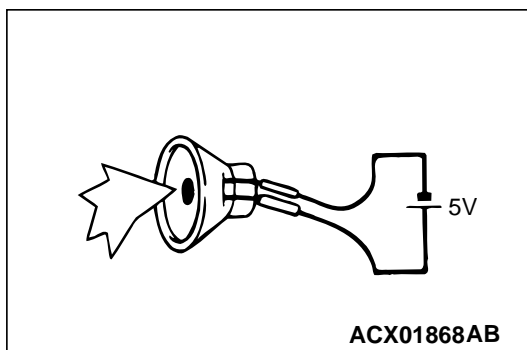



**STEP 9.** Check front door speaker (LH) connector H-08 and radio and CD player connector D-06 for loose, corroded or damaged terminals, or terminals pushed back in the connector.

**Q:** Are harness connectors H-08 and D-06 in good condition?

**YES :** Go to Step 10.

**NO :** Repair or replace the damaged component(s). Refer to GROUP 00E, Harness Connector Inspection

**P.00E-2.** The door speaker (LH) should sound.

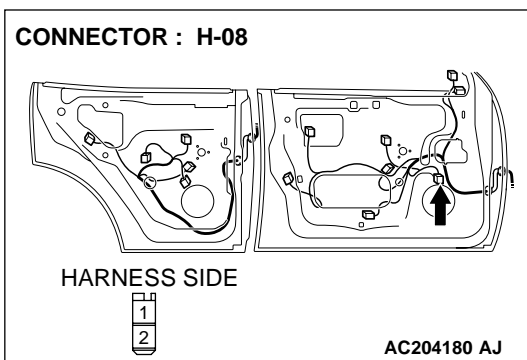
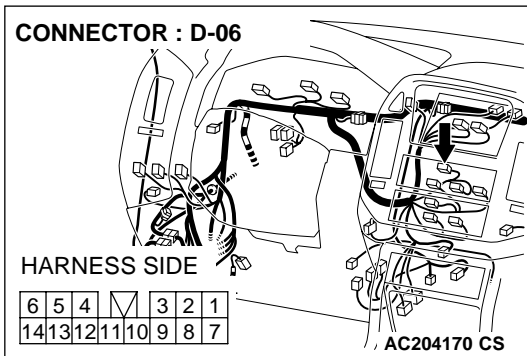

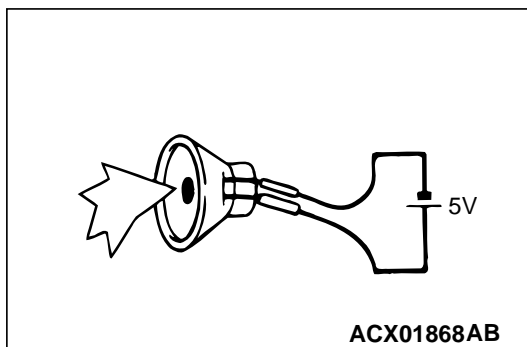
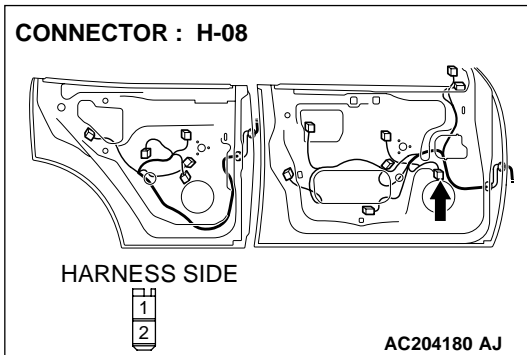
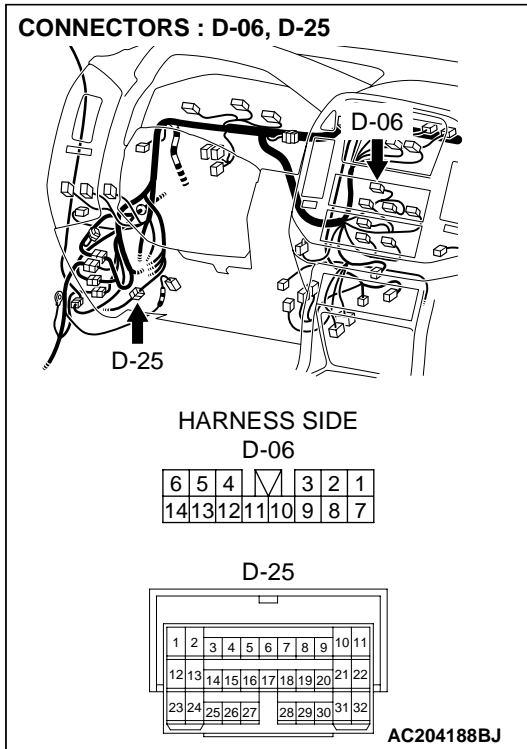

**STEP 10. Check the wiring harness between front door speaker (LH) connector H-08 (terminals 1 and 2) and radio and CD player connector D-06 (terminals 5 and 13).**

*NOTE: Also check intermediate connector D-25. If intermediate connector D-25 is damaged, repair or replace the connector as described in GROUP 00E, Harness Connector Inspection P.00E-2.*

**Q: Is the wiring harness between front door speaker (LH) connector H-08 (terminals 1 and 2) and radio and CD player connector D-06 (terminals 5 and 13) in good condition?**

**YES :** Repair or replace the radio and CD player. The front door speaker (LH) should sound.

**NO :** Repair the wiring harness. The front door speaker (LH) should sound.

**STEP 11. Check the front door speaker (RH).**

- (1) Remove the front door speaker (RH). Refer to P.54A-183.
- (2) Check that the front door speaker (RH) generates noise when a five-volt voltage is applied on the front door speaker (RH) terminal.

**Q: Is the front door speaker (RH) generating noise?**

**YES :** Go to Step 12.

**NO :** Replace the front door speaker (RH). The front door speaker (RH) should sound.

**STEP 12.** Check front door speaker (RH) connector H-26 and radio and CD player connector D-06 for loose, corroded or damaged terminals, or terminals pushed back in the connector.

**Q:** Are harness connectors H-26 and D-06 in good condition?

**YES :** Go to Step 13.

**NO :** Repair or replace the damaged component(s). Refer to GROUP 00E, Harness Connector Inspection

**P.00E-2.** The front door speaker (RH) should sound.

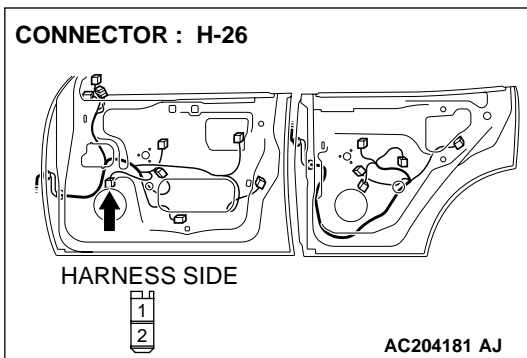
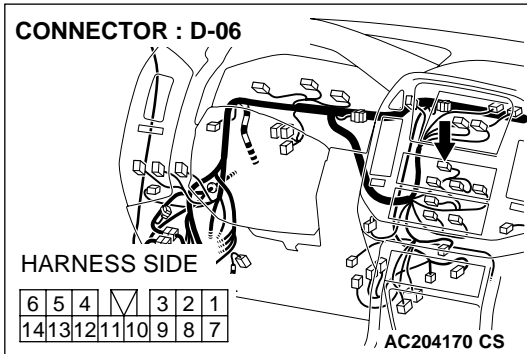

**STEP 13. Check the wiring harness between front door speaker (RH) connector H-26 (terminals 1 and 2) and radio and CD player connector D-06 (terminals 6 and 14).**

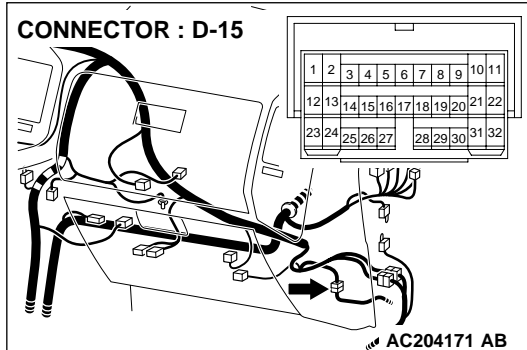
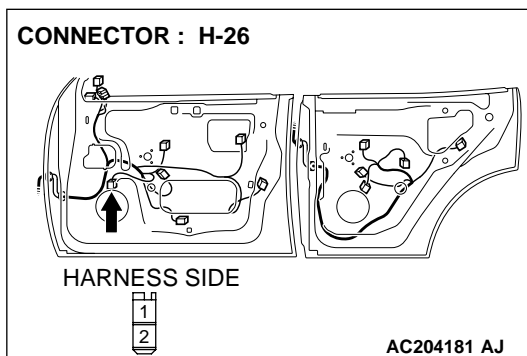
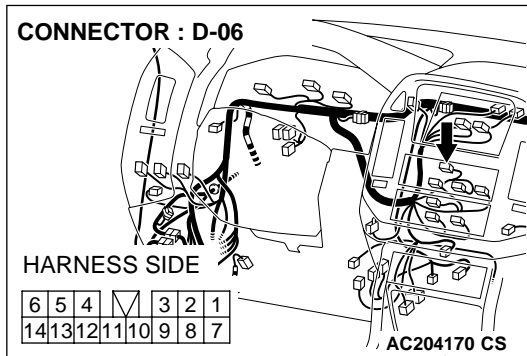

*NOTE: Also check intermediate connector D-15. If intermediate connector D-15 is damaged, repair or replace the connector as described in GROUP 00E, Harness Connector Inspection P.00E-2.*

**Q: Is the wiring harness between front door speaker (RH) connector H-26 (terminals 1 and 2) and radio and CD player connector D-06 (terminals 6 and 14) in good condition?**

**YES :** Repair or replace the radio and CD player. The front door speaker (RH) should sound.

**NO :** Repair the wiring harness. The front door speaker (RH) should sound.

**STEP 14. Check the rear door speaker (LH).**

(1) Remove the rear door speaker (LH). Refer to [P.54A-183](#).

(2) Check that the rear door speaker (LH) generates noise when a five-volt voltage is applied on the rear door speaker (LH) terminal.

**Q: Is the rear door speaker (LH) generating noise?**

**YES :** Go to Step 15.

**NO :** Replace the rear door speaker (LH). The rear door speaker (LH) should sound.

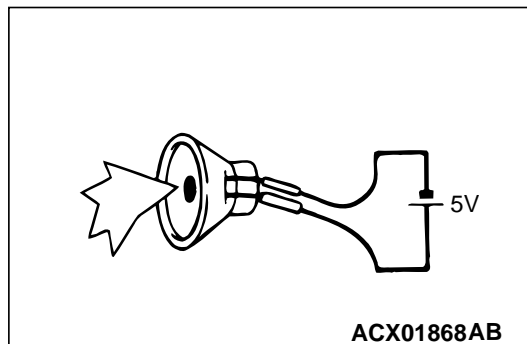

**STEP 15.** Check rear door speaker (LH) connector H-12 and radio and CD player connector D-06 for loose, corroded or damaged terminals, or terminals pushed back in the connector.

**Q:** Are harness connectors H-12 and D-06 in good condition?

**YES :** Go to Step 16.

**NO :** Repair or replace the damaged component(s). Refer to GROUP 00E, Harness Connector Inspection

**P.00E-2.** The rear door speaker (LH) should sound.

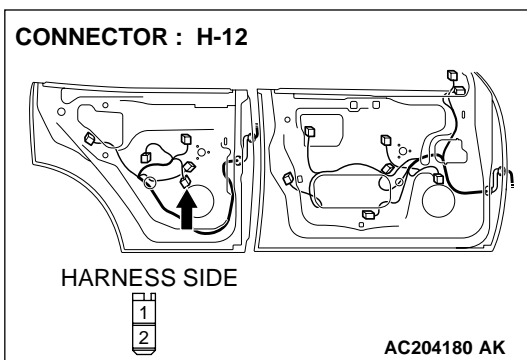
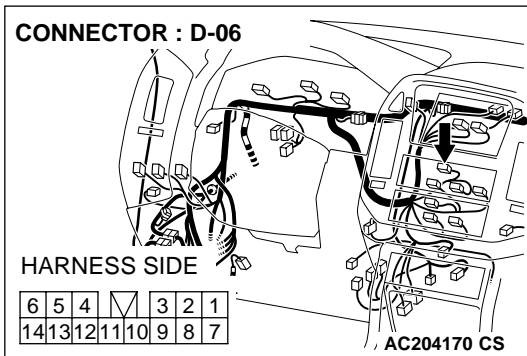

**STEP 16.** Check the wiring harness between rear door speaker (LH) connector H-12 (terminals 1 and 2) and radio and CD player connector D-06 (terminals 2 and 8).

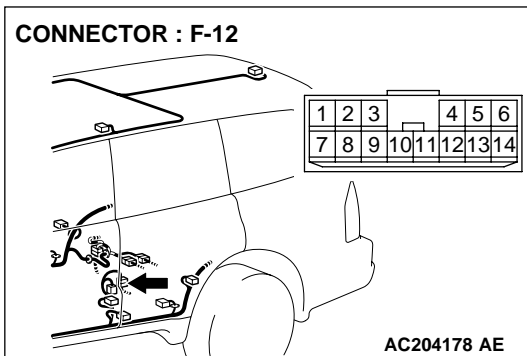
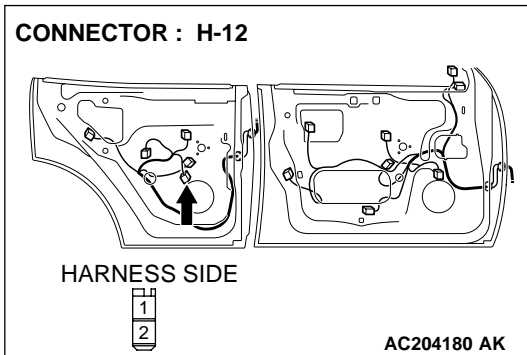
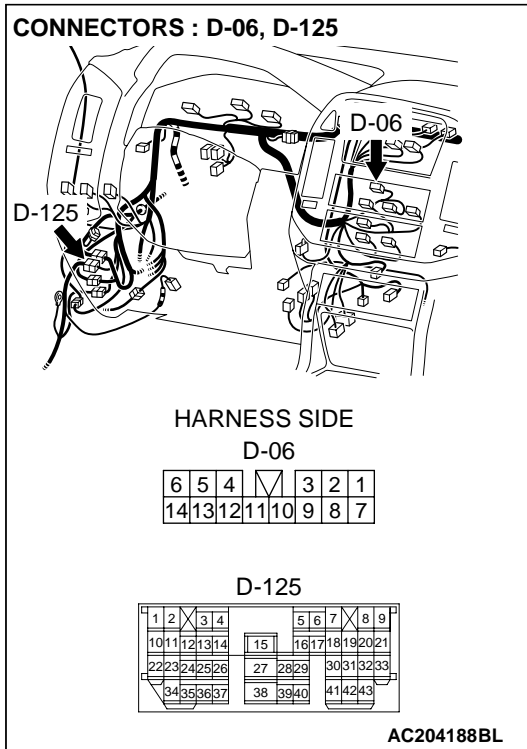

*NOTE:* Also check intermediate connector F-12 and D-125. If intermediate connector F-12 or D-125 is damaged, repair or replace the connector as described in GROUP 00E, Harness Connector Inspection [P.00E-2](#).

**Q:** Is the wiring harness between the rear door speaker (LH) connector H-12 (terminals 1 and 2) and radio and CD player connector D-06 (terminals 2 and 8) in good condition?

**YES :** Repair or replace the radio and CD player. The rear door speaker (LH) should sound.

**NO :** Repair the wiring harness. The rear door speaker (LH) should sound.

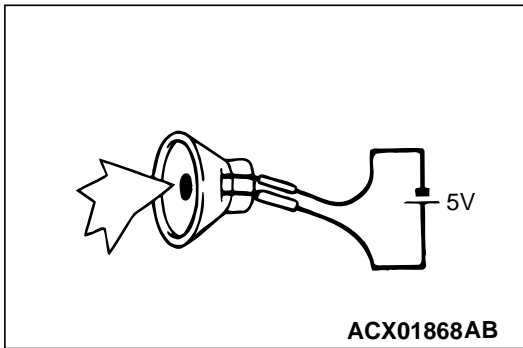

**STEP 17. Check the rear door speaker (RH).**

- (1) Remove the rear door speaker (RH). Refer to [P.54A-183](#).
- (2) Check that the rear door speaker (RH) generates noise when a five-volt voltage is applied on the rear door speaker (RH) terminal.

**Q: Is the rear door speaker (RH) generating noise?**

**YES :** Go to Step 18.

**NO :** Replace the rear door speaker (RH). The rear door speaker (RH) should sound.

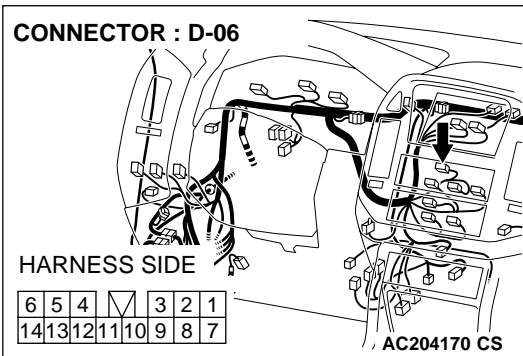

**STEP 18. Check rear door speaker (RH) connector H-22**

**and radio and CD player connector D-06 for loose, corroded or damaged terminals, or terminals pushed back in the connector.**

**Q: Are harness connectors H-22 and D-06 in good condition?**

**YES :** Go to Step 19.

**NO :** Repair or replace the damaged component(s). Refer to GROUP 00E, Harness Connector Inspection [P.00E-2](#). The rear door speaker (RH) should sound.

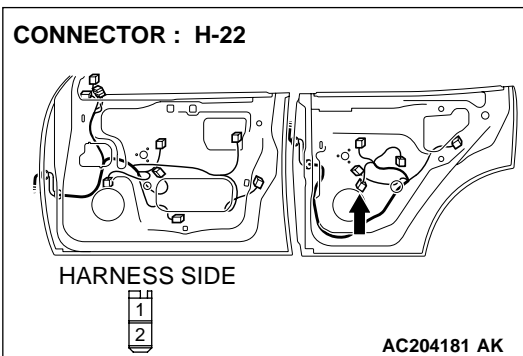

**STEP 19.** Check the wiring harness between rear door speaker (RH) connector H-22 (terminals 1 and 2) and radio and CD player connector D-06 (terminals 1 and 7).

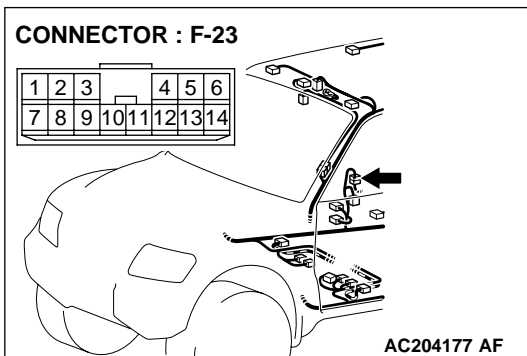
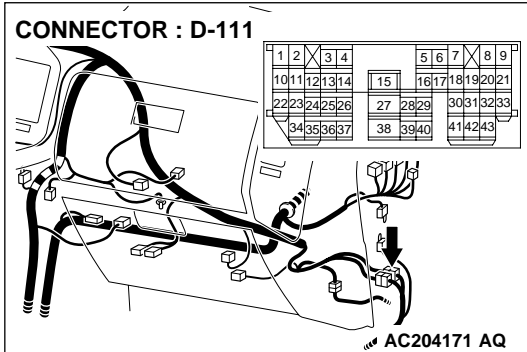
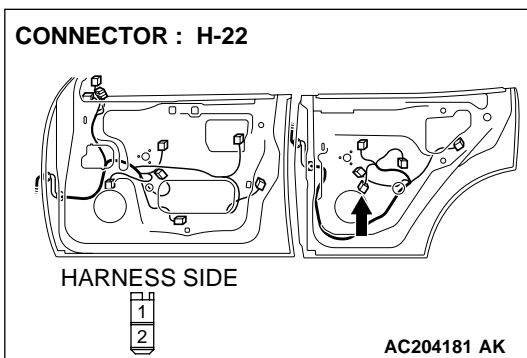
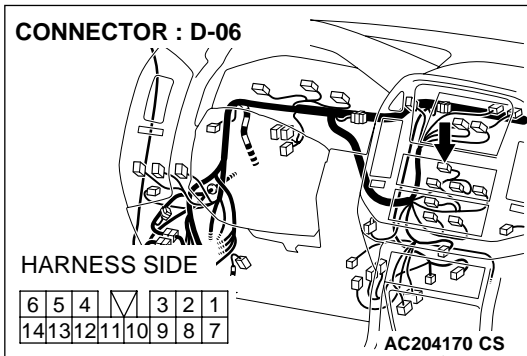

*NOTE: Also check intermediate connector F-23 and D-111. If intermediate connector F-23 and D-111 is damaged, repair or replace the connector as described in GROUP 00E, Harness Connector Inspection P.00E-2.*

**Q:** Is the wiring harness between rear door speaker (RH) connector H-22 (terminals 1 and 2) and radio and CD player connector D-06 (terminals 1 and 7) in good condition?

**YES :** Repair or replace the radio and CD player. The rear door speaker (RH) should sound.

**NO :** Repair the wiring harness. The rear door speaker (RH) should sound.



**STEP 20.** Check front door speaker (LH) connector H-08 and radio and CD player connector D-06 for loose, corroded or damaged terminals, or terminals pushed back in the connector.

**Q:** Are harness connectors H-08 and D-06 in good condition?

**YES :** Go to Step 21.

**NO :** Repair or replace the damaged component(s). Refer to GROUP 00E, Harness Connector Inspection

**P.00E-2.** The door speaker (LH) should sound.

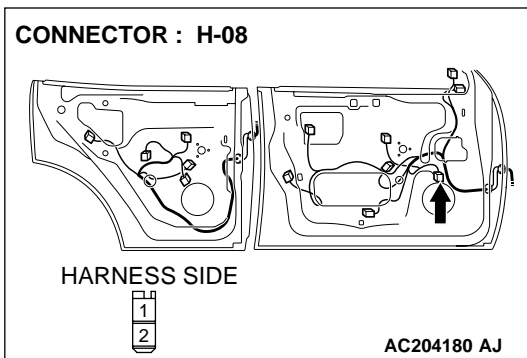
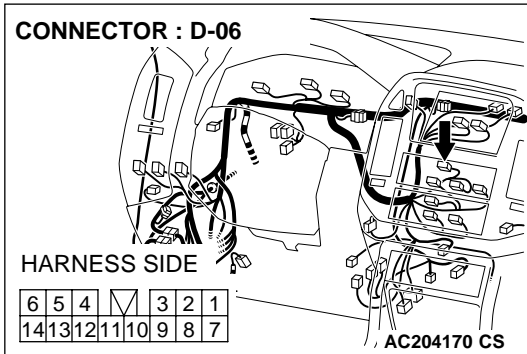

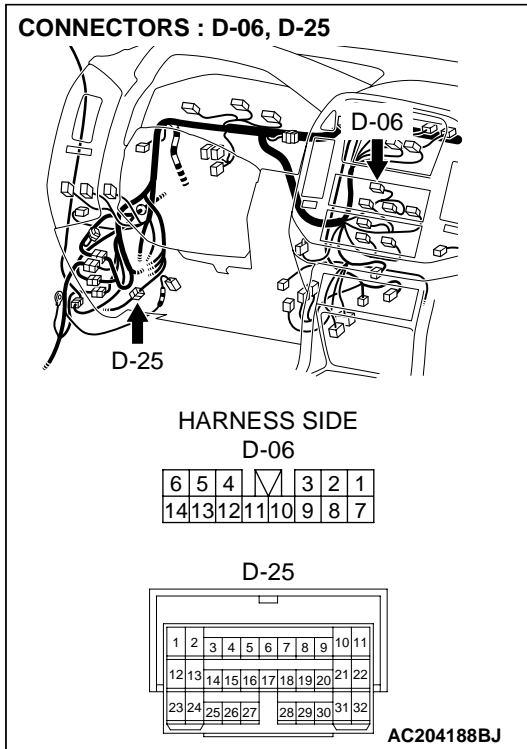

**STEP 21.** Check the wiring harness between front door speaker (LH) connector H-08 (terminals 1 and 2) and radio and CD player connector D-06 (terminals 5 and 13).

*NOTE:* Also check intermediate connector D-25. If intermediate connector D-25 is damaged, repair or replace the connector as described in GROUP 00E, Harness Connector Inspection P.00E-2.

**Q:** Is the wiring harness between front door speaker (LH) connector H-08 (terminals 1 and 2) and radio and CD player connector D-06 (terminals 5 and 13) in good condition?

**YES :** Repair or replace the radio and CD player. The front door speaker (LH) should sound.

**NO :** Repair the wiring harness. The front door speaker (LH) should sound.

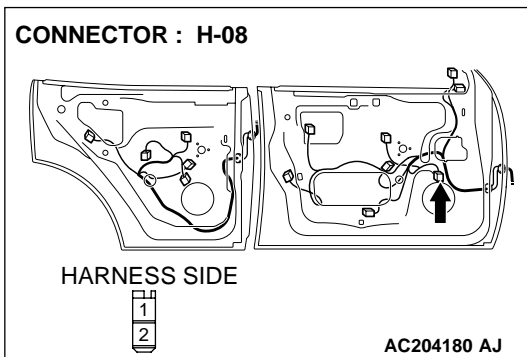

**STEP 22.** Check front door speaker (RH) connector H-26 and radio and CD player connector D-06 for loose, corroded or damaged terminals, or terminals pushed back in the connector.

**Q:** Are harness connectors H-26 and D-06 in good condition?

**YES :** Go to Step 23.

**NO :** Repair or replace the damaged component(s). Refer to GROUP 00E, Harness Connector Inspection

**P.00E-2.** The front door speaker (RH) should sound.

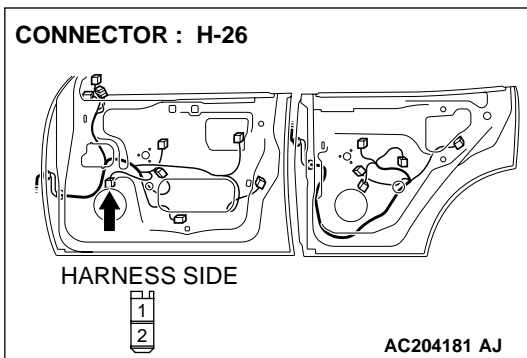
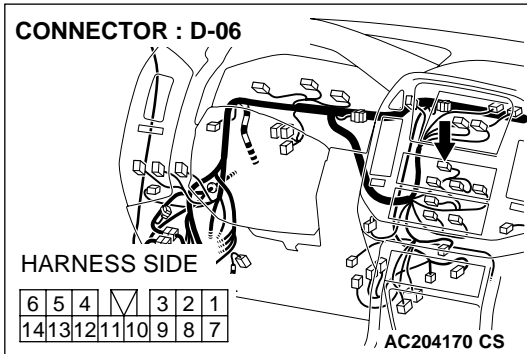

**STEP 23.** Check the wiring harness between front door speaker (RH) connector H-26 (terminals 1 and 2) and radio and CD player connector D-06 (terminals 6 and 14).

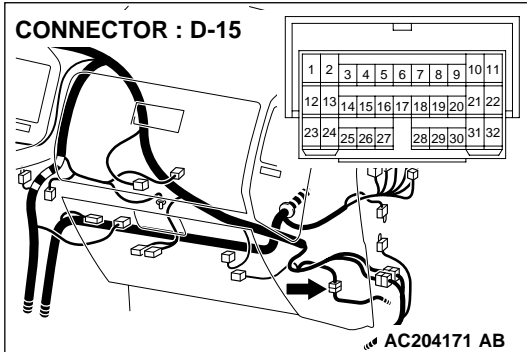
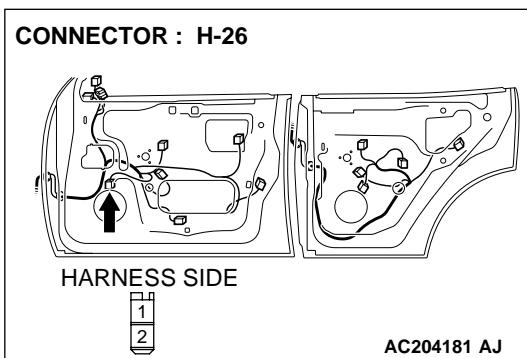
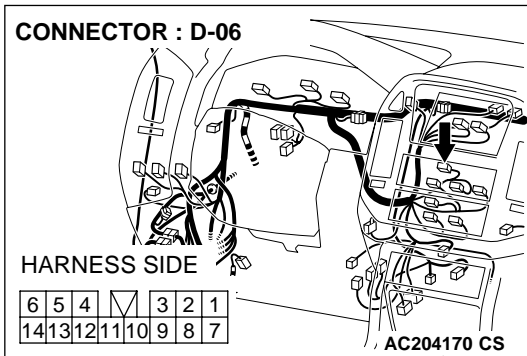

*NOTE: Also check intermediate connector D-15. If intermediate connector D-15 is damaged, repair or replace the connector as described in GROUP 00E, Harness Connector Inspection P.00E-2.*

**Q:** Is the wiring harness between front door speaker (RH) connector H-26 (terminals 1 and 2) and radio and CD player connector D-06 (terminals 6 and 14) in good condition?

**YES :** Repair or replace the radio and CD player. The front door speaker (RH) should sound.

**NO :** Repair the wiring harness. The front door speaker (RH) should sound.

INSPECTION PROCEDURE 4: No Sound from One Speaker. <vehicles with amplifier>

Speaker System Circuit <Vehicles with Seven Speakers>

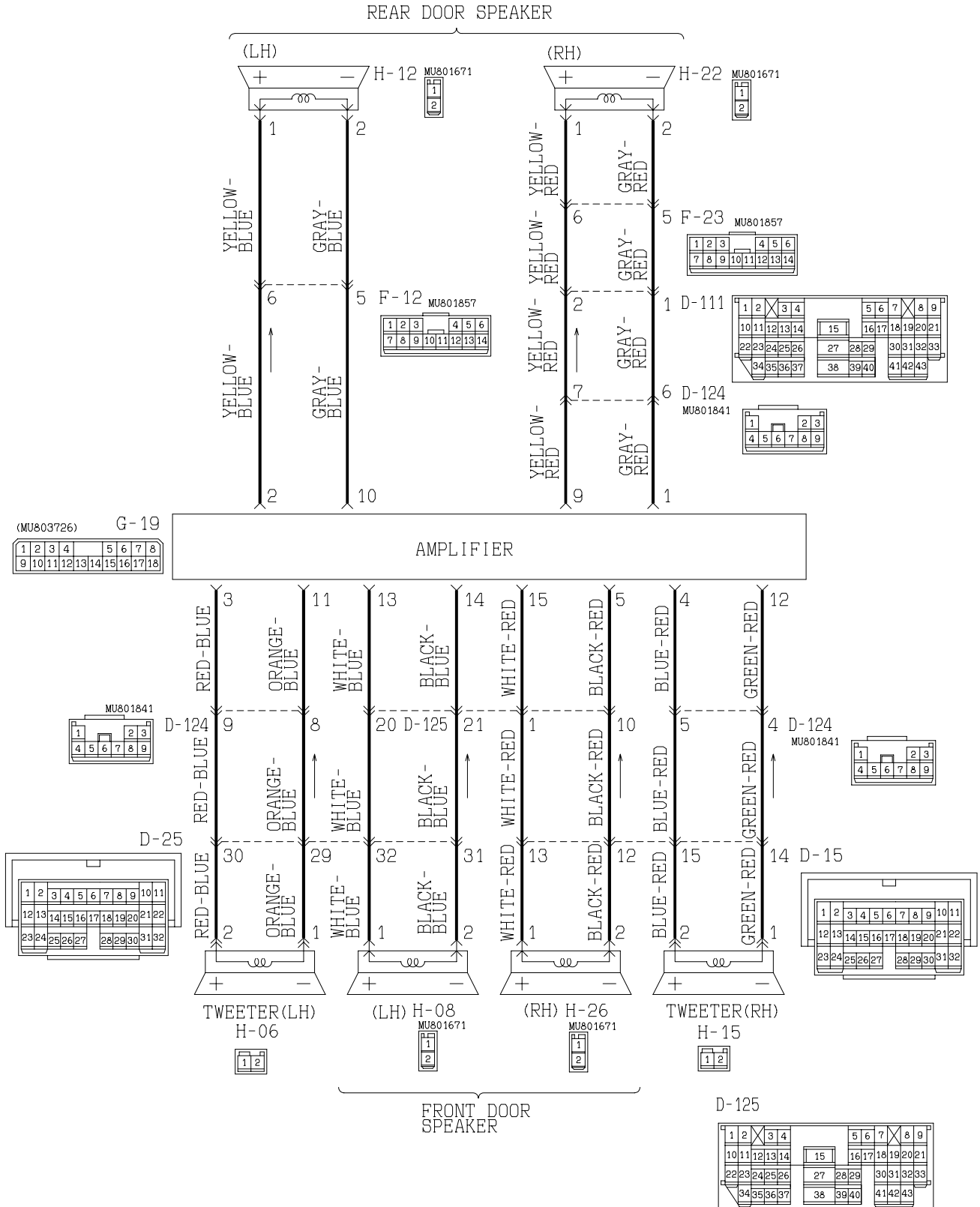

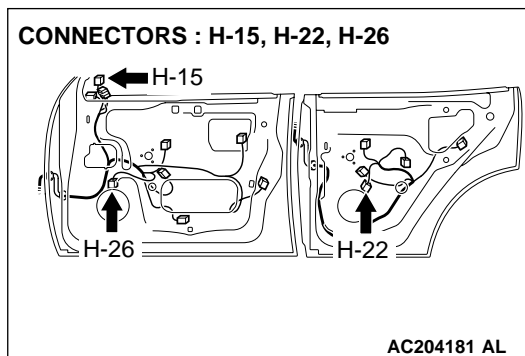
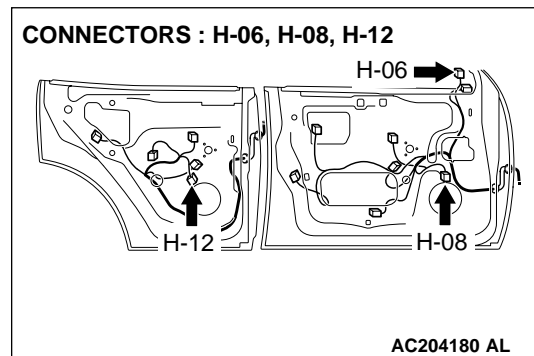
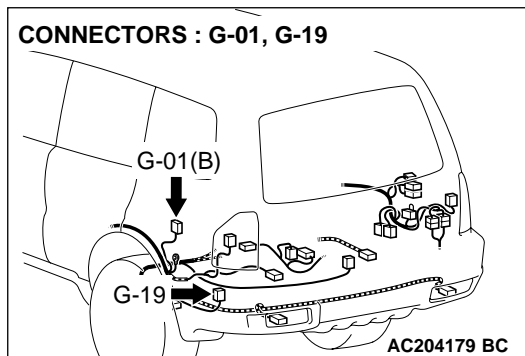
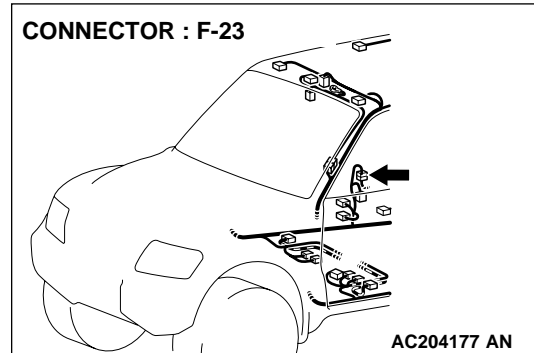
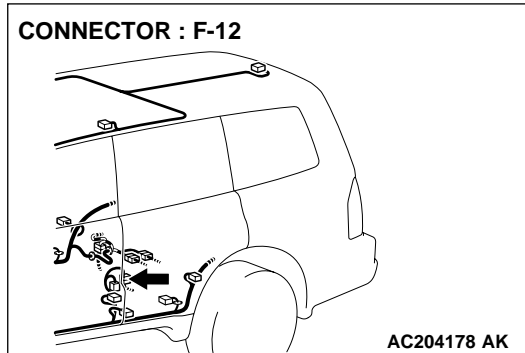
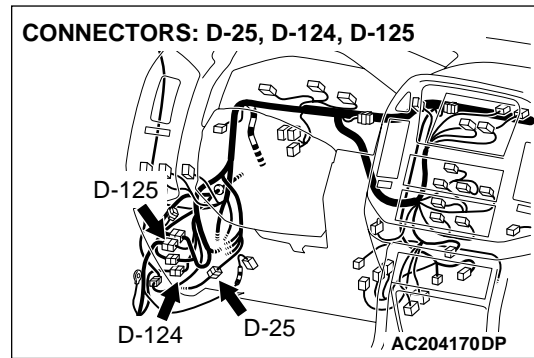
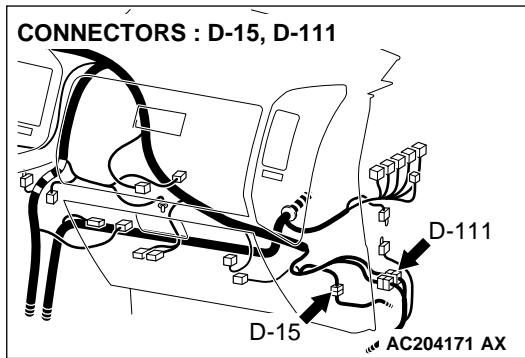

**CIRCUIT OPERATION**

The sound signals are sent from the radio and CD player into the amplifier. After the signals are amplified and filtered, the sound signals are sent to the speaker.

**TECHNICAL DESCRIPTION (COMMENT)**

The cause is probably a faulty speaker circuit system.

**TROUBLESHOOTING HINTS**

- Malfunction of the speaker.
- Damaged wiring harness or connector.
- Malfunction of the radio and CD player.
- Malfunction of the amplifier.

DIAGNOSIS

**STEP 1. Check to see which speaker does not sound.**

Determine which speaker does not sound.

**Q: Which speaker is not sounding?**

**Front door speaker (LH) :** Go to Step 2.

**Front door speaker (RH) :** Go to Step 6.

**Rear speaker (LH) :** Go to Step 10.

**Rear speaker (RH) :** Go to Step 14.

**Tweeter (LH) :** Go to Step 18.

**Tweeter (RH) :** Go to Step 22.

**woofer :** Go to Step 26.

**STEP 2. Check the front door speaker (LH).**

(1) Remove the front door speaker (LH). Refer to [P.54A-183](#).

(2) Check that the front door speaker (LH) generates noise when a five-volt voltage is applied on the front door speaker (LH) terminal.

**Q: Is the front door speaker (LH) generating noise?**

**YES :** Go to Step 3.

**NO :** Replace the front door speaker (LH). The front door speaker (LH) should sound.

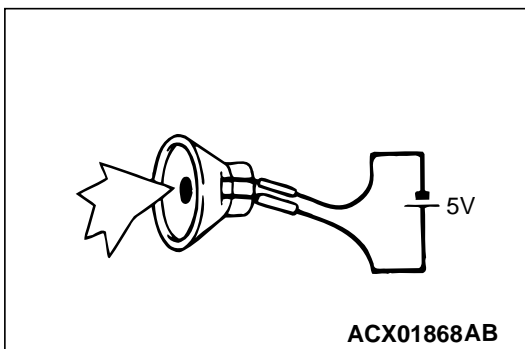

**STEP 3. Check front door speaker (LH) connector H-08 and amplifier connector G-19 for loose, corroded or damaged terminals, or terminals pushed back in the connector.**

**Q: Are front door speaker (LH) connector H-08 and amplifier connector G-19 in good condition?**

**YES :** Go to Step 4.

**NO :** Repair or replace the damaged component(s). Refer to GROUP 00E, Harness Connector Inspection [P.00E-2](#). The door speaker (LH) should sound.

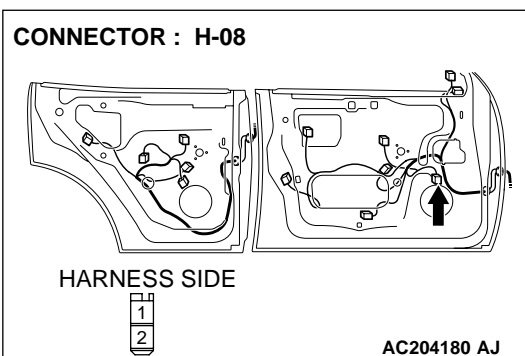
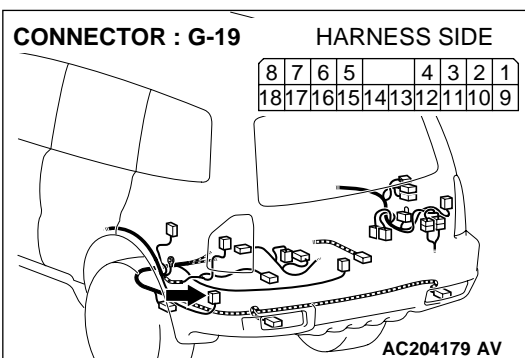

**STEP 4.** Check the wiring harness between front door speaker (LH) connector H-08 (terminals 1 and 2) and amplifier connector G-19 (terminals 13 and 14).

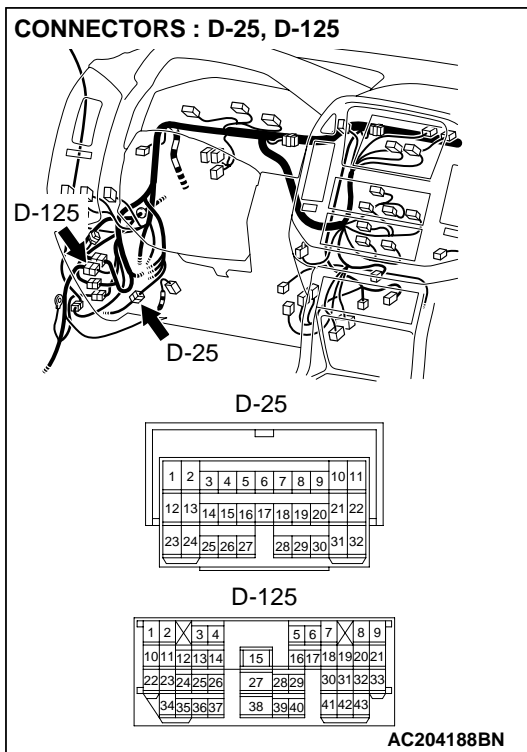
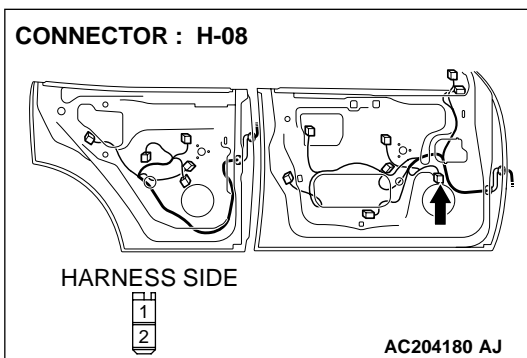
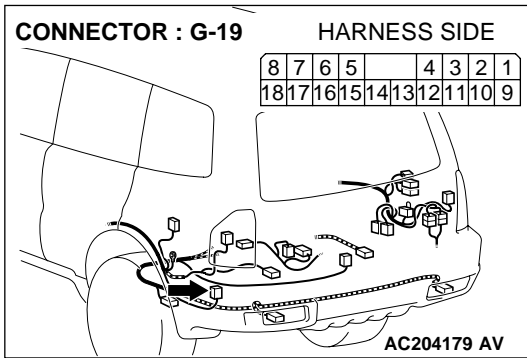

*NOTE:* Also check intermediate connectors D-25 and D-125. If intermediate connector D-25 or D-125 are damaged, repair or replace the connector as described in GROUP 00E, Harness Connector Inspection [P.00E-2](#).

**Q:** Is the wiring harness between front door speaker (LH) connector H-08 (terminals 1 and 2) and amplifier connector G-19 (terminals 13 and 14) in good condition?

**YES :** Go to Step 5.

**NO :** Repair the wiring harness. The door speaker (LH) should sound.



**STEP 5. Replace the radio and CD player.**

**Q: Do the speakers sound?**

**YES :** There is no action to be taken.

**NO :** Repair or replace the amplifier. The front door speaker (LH) should sound.

**STEP 6. Check the front door speaker (RH).**

(1) Remove the front door speaker (RH). Refer to [P.54A-183](#).

(2) Check that the front door speaker (RH) generates noise when a five-volt voltage is applied on the front door speaker (RH) terminal.

**Q: Is the front door speaker (RH) generating noise?**

**YES :** Go to Step 7.

**NO :** Replace the front door speaker (RH). The front door speaker (RH) should sound.

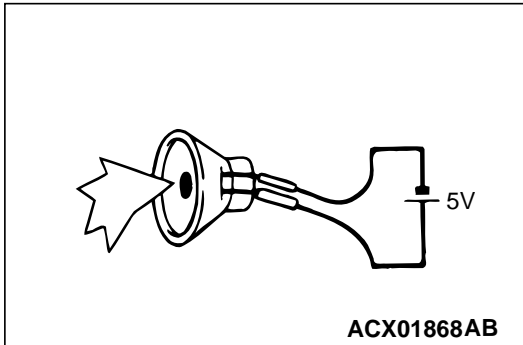

**STEP 7. Check front door speaker (RH) connector H-26 and amplifier connector G-19 for loose, corroded or damaged terminals, or terminals pushed back in the connector.**

**Q: Are front door speaker (RH) connector H-26 and amplifier connector G-19 in good condition?**

**YES :** Go to Step 8.

**NO :** Repair or replace the damaged component(s). Refer to GROUP 00E, Harness Connector Inspection [P.00E-2](#). The front door speaker (RH) should sound.

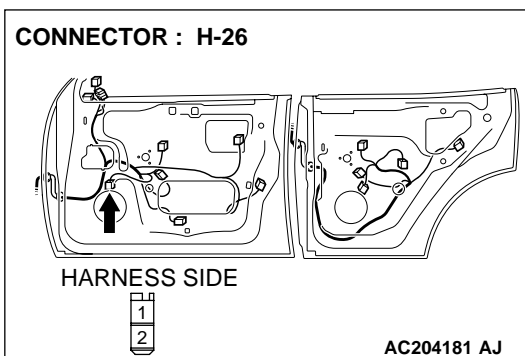
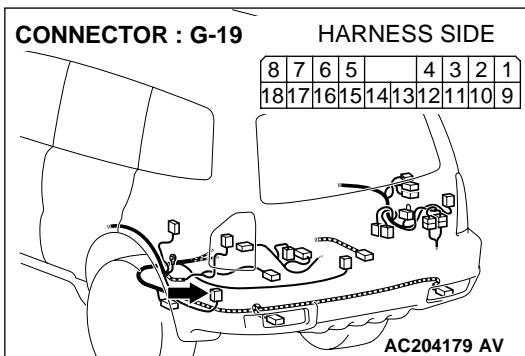

**STEP 8.** Check the wiring harness between front door speaker (RH) connector H-26 (terminals 1 and 2) and amplifier connector G-19 (terminals 15 and 5).

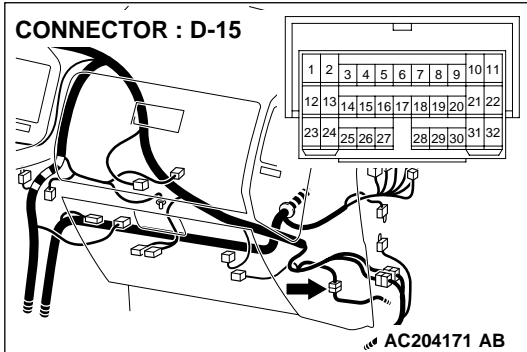
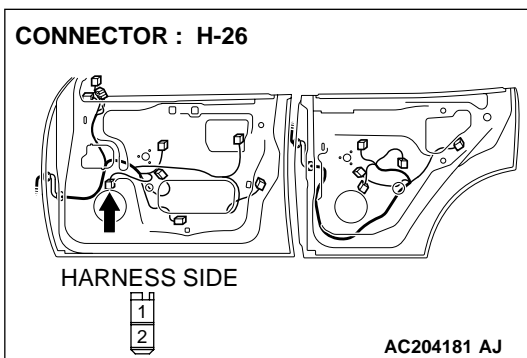
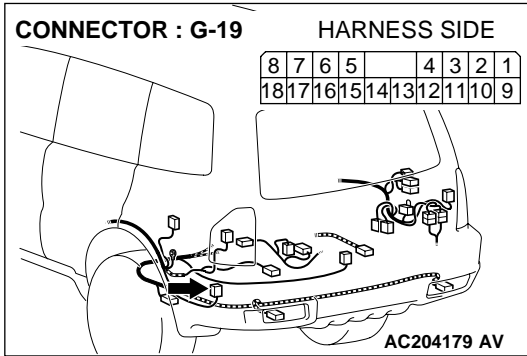

*NOTE:* Also check intermediate connectors D-15 and D-125. If intermediate connector D-15 or D-125 are damaged, repair or replace the connector as described in GROUP 00E, Harness Connector Inspection [P.00E-2](#).

**Q:** Is the wiring harness between front door speaker (RH) connector H-26 (terminals 1 and 2) and amplifier connector G-19 (terminals 15 and 5) in good condition?

**YES :** Go to Step 9.

**NO :** Repair the wiring harness. The front door speaker (RH) should sound.

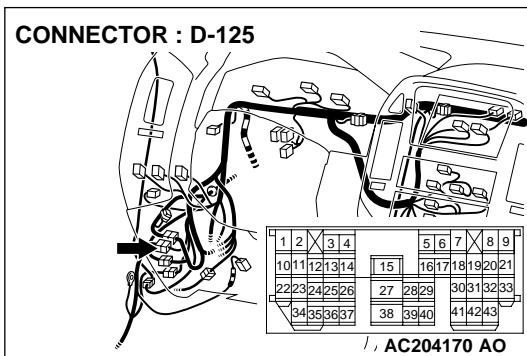

**STEP 9. Replace the radio and CD player.**

**Q: Do the speakers sound?**

**YES :** There is no action to be taken.

**NO :** Repair or replace the amplifier. The front door speaker (RH) should sound.

**STEP 10. Check the rear speaker (LH).**

(1) Remove the rear speaker (LH). Refer to [P.54A-183](#).

(2) Check that the rear speaker (LH) generates noise when a five-volt voltage is applied on the rear speaker (LH) terminal.

**Q: Is the rear speaker (LH) generating noise?**

**YES :** Go to Step 11.

**NO :** Replace the rear speaker (LH). The rear speaker (LH) should sound.

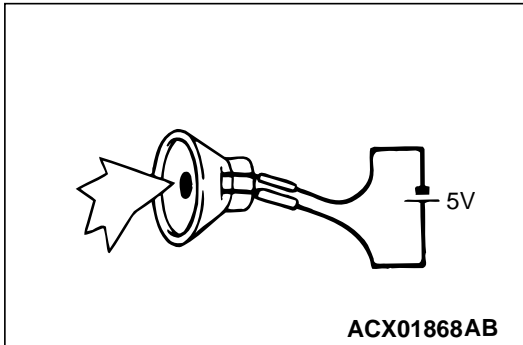

**STEP 11. Check rear speaker (LH) connector H-12 and amplifier connector G-19 for loose, corroded or damaged terminals, or terminals pushed back in the connector.**

**Q: Are rear speaker (LH) connector H-12 and amplifier connector G-19 in good condition**

**YES :** Go to Step 12.

**NO :** Repair or replace the damaged component(s). Refer to GROUP 00E, Harness Connector Inspection [P.00E-2](#). The rear speaker (LH) should sound.

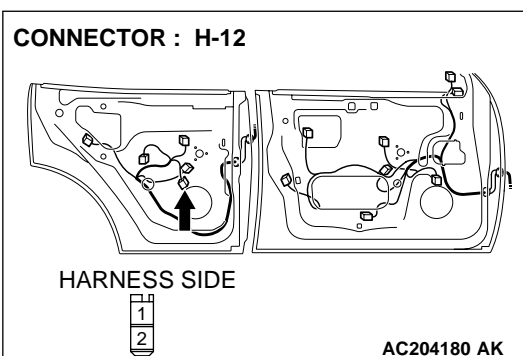
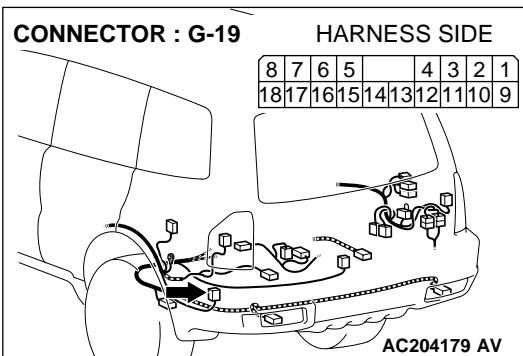

**STEP 12.** Check the wiring harness between rear speaker (LH) connector H-12 (terminals 1 and 2) and amplifier connector G-19 (terminals 2 and 10).

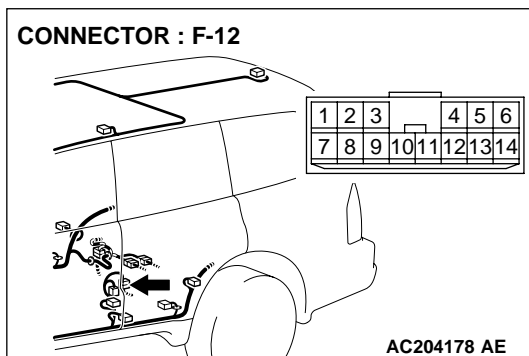
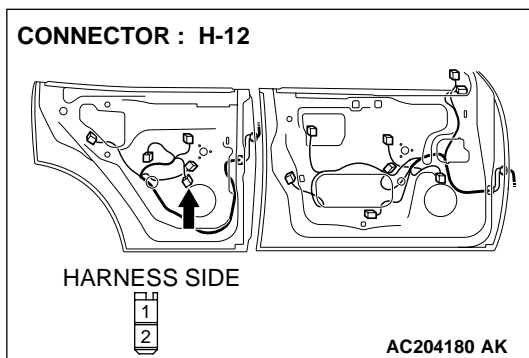
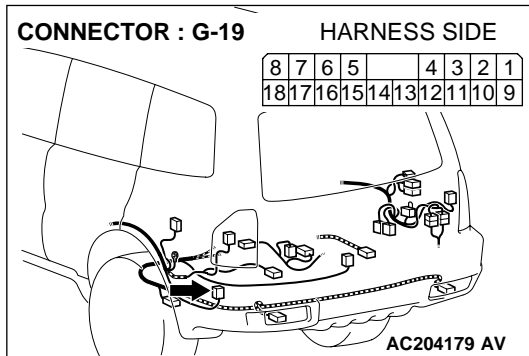

*NOTE:* Also check intermediate connectors F-12. If intermediate connector F-12 is damaged, repair or replace the connector as described in GROUP 00E, Harness Connector Inspection P.00E-2.

- Q:** Is the wiring harness between rear door speaker (LH) connector H-12 (terminals 1 and 2) and amplifier connector G-19 (terminals 2 and 10) in good condition?
- YES :** Go to Step 13.
- NO :** Repair the wiring harness. The rear speaker (LH) should sound.

**STEP 13.** Replace the radio and CD player.

- Q:** Do the speakers sound?
- YES :** There is no action to be taken.
- NO :** Repair or replace the amplifier. The rear speaker (LH) should sound.

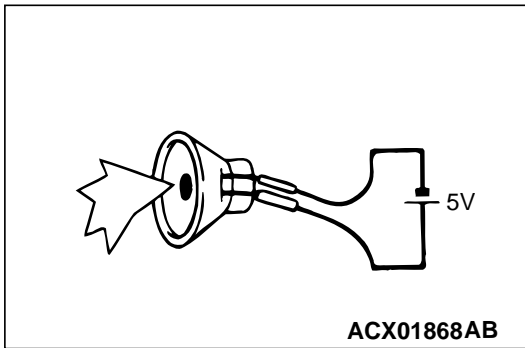

**STEP 14. Check the rear speaker (RH).**

- (1) Remove the rear speaker (RH). Refer to [P.54A-183](#).
- (2) Check that the rear speaker (RH) generates noise when a five-volt voltage is applied on the rear speaker (RH) terminal.

**Q: Is the rear speaker (RH) generating noise?**

- YES :** Go to Step 15.
- NO :** Replace the rear speaker (RH). The rear speaker (RH) should sound.

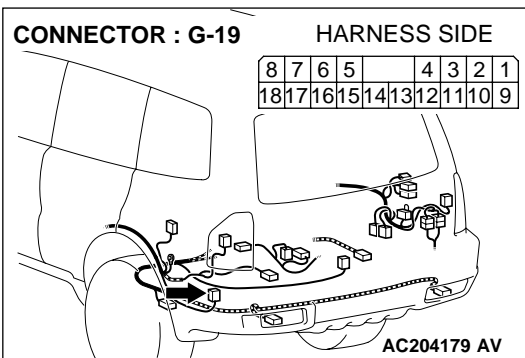

**STEP 15. Check rear speaker (RH) connector H-22 and amplifier connector G-19 for loose, corroded or damaged terminals, or terminals pushed back in the connector.**

**Q: Are rear speaker (RH) connector H-22 and amplifier connector G-19 in good condition?**

- YES :** Go to Step 16.
- NO :** Repair or replace the damaged component(s). Refer to GROUP 00E, Harness Connector Inspection [P.00E-2](#). The rear speaker (RH) should sound.

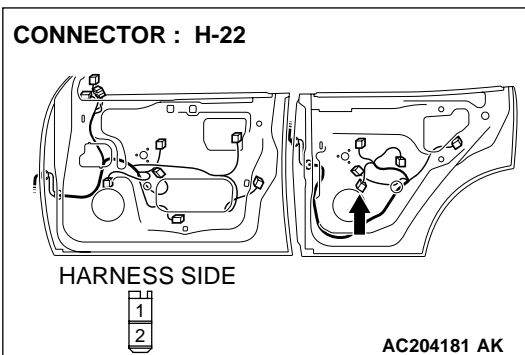

**STEP 16.** Check the wiring harness between rear speaker (RH) connector H-22 (terminal 1 and 2) and audio amplifier connector G-19 (terminal 9 and 1).

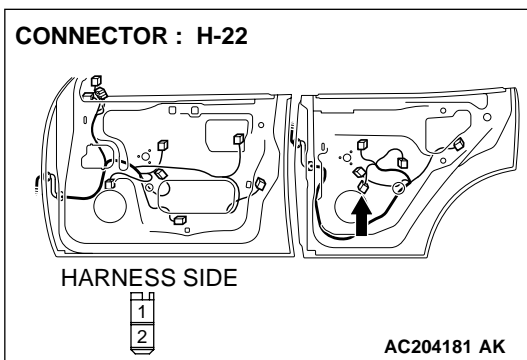
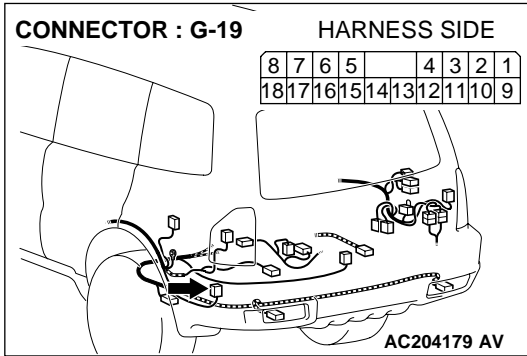

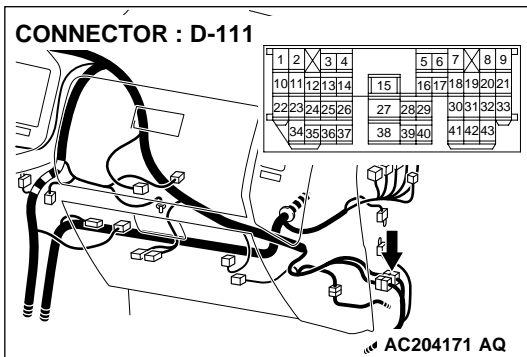

*NOTE: Also check intermediate connectors F-23, D-111 and D-124. If intermediate connector F-23, D-111 or D-124 are damaged, repair or replace the connector as described in GROUP 00E, Harness Connector Inspection P.00E-2.*

**Q: Is the wiring harness between rear speaker (RH) connector H-22 (terminal 1 and 2) and amplifier connector G-19 (terminal 9 and 1) in good condition?**

**YES :** Go to Step 17.

**NO :** Repair the wiring harness. The rear speaker (RH) should sound.

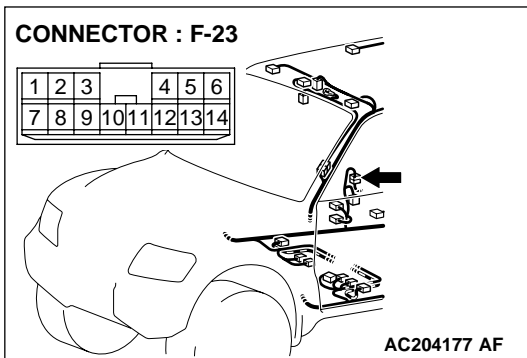
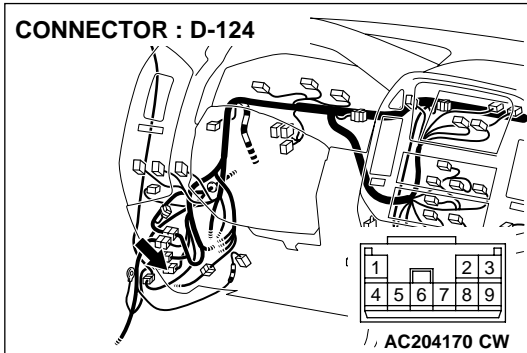

---

**STEP 17. Replace the radio and CD player.**

**Q: Do the speakers sound?**

**YES :** There is no action to be taken.

**NO :** Repair or replace the amplifier. The rear speaker (RH) should sound.

---

**STEP 18. Check the tweeter (LH).**

(1) Remove the tweeter (LH). Refer to P.54A-183.

(2) Check that the tweeter (LH) generates noise when a five-volt voltage is applied on the tweeter (LH) terminal.

**Q: Is the tweeter (LH) generating noise?**

**YES :** Go to Step 19.

**NO :** Replace the tweeter (LH). The tweeter (LH) should sound.

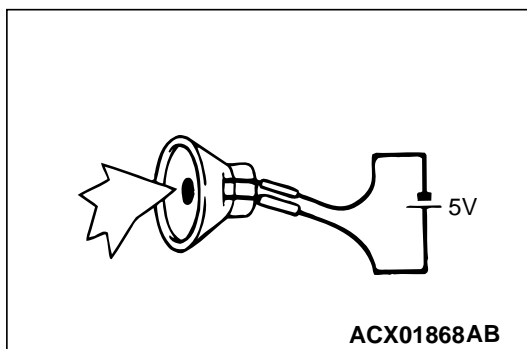

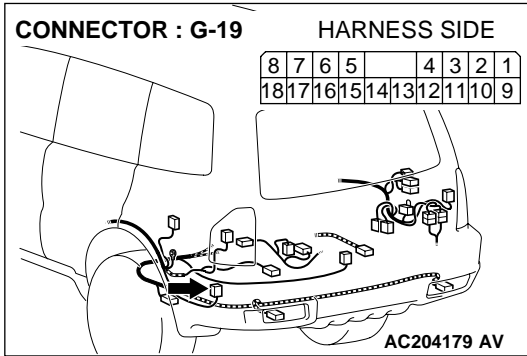

**STEP 19.** Check tweeter (LH) connector H-06 and amplifier connector G-19 for loose, corroded or damaged terminals, or terminals pushed back in the connector.

**Q:** Are tweeter (LH) connector H-06 and amplifier connector G-19 in good condition?

**YES :** Go to Step 20.

**NO :** Repair or replace the damaged component(s). Refer to GROUP 00E, Harness Connector Inspection

[P.00E-2](#). The tweeter (LH) should sound.

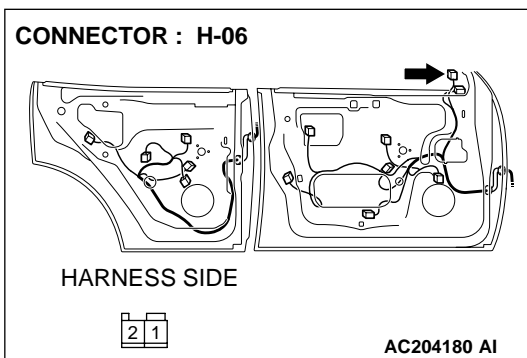



**STEP 20.** Check the wiring harness between tweeter (LH) connector H-06 (terminal 1 and 2) and amplifier connector G-19 (terminal 11 and 3).

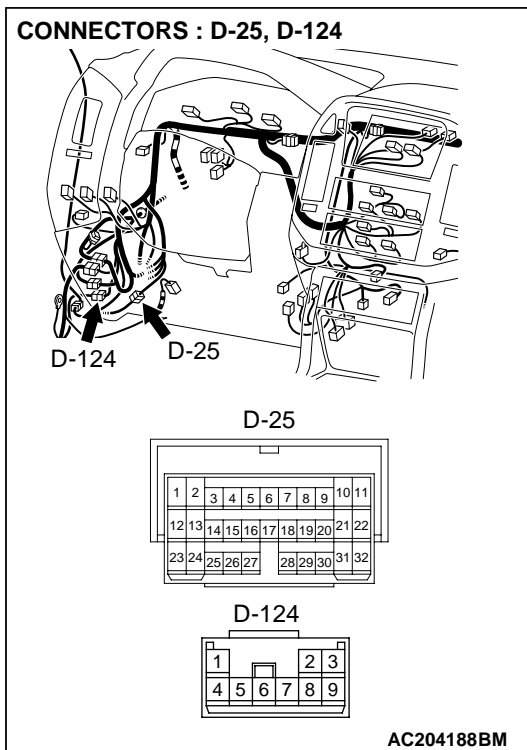
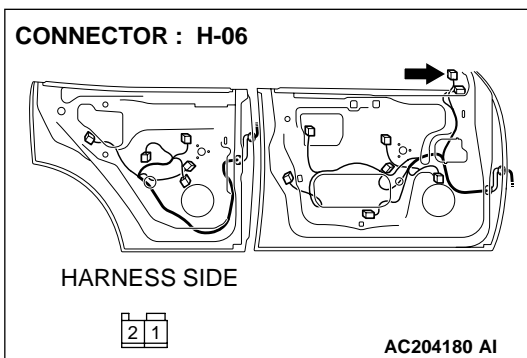
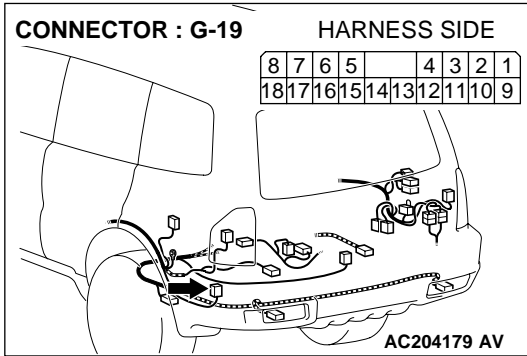

*NOTE:* Also check intermediate connectors D-25 and D-124. If intermediate connector D-25 or D-124 are damaged, repair or replace the connector as described in GROUP 00E, Harness Connector Inspection [P.00E-2](#).

**Q:** Is the wiring harness between tweeter (LH) connector H-06 (terminal 1 and 2) and amplifier connector G-19 (terminal 11 and 3) in good condition?

**YES :** Go to Step 21.

**NO :** Repair the wiring harness. The tweeter (LH) should sound.

**STEP 21. Replace the radio and CD player.**

**Q: Do the speakers sound?**

**YES :** There is no action to be taken.

**NO :** Repair or replace the amplifier. The tweeter (LH) should sound.

**STEP 22. Check the tweeter (RH).**

(1) Remove the tweeter (RH). Refer to [P.54A-183](#).

(2) Check that the tweeter (RH) generates noise when a five-volt voltage is applied on the tweeter (RH) terminal.

**Q: Is the tweeter (RH) generating noise?**

**YES :** Go to Step 23.

**NO :** Replace the tweeter (RH). The tweeter (RH) should sound.

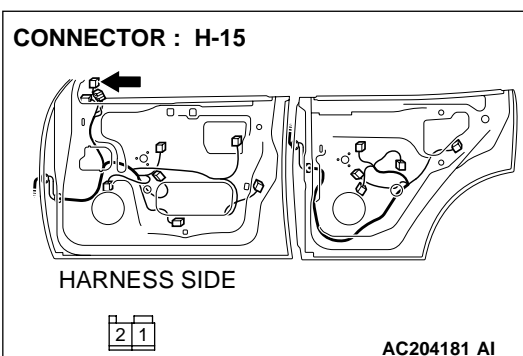
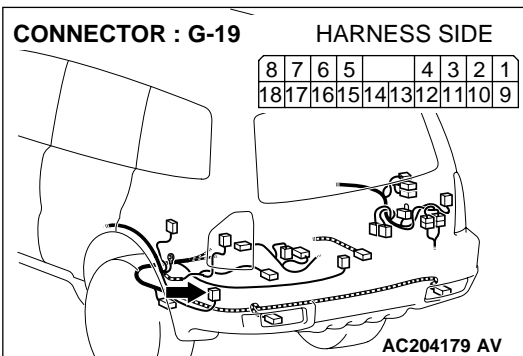
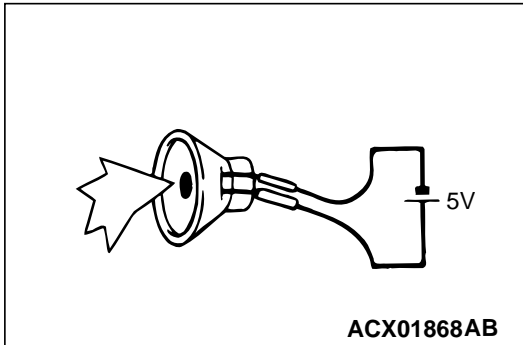

**STEP 23. Check tweeter (RH) connector H-15 and amplifier connector G-19 for loose, corroded or damaged terminals, or terminals pushed back in the connector.**

**Q: Are tweeter (RH) connector H-15 and amplifier connector G-19 in good condition?**

**YES :** Go to Step 24.

**NO :** Repair or replace the damaged component(s). Refer to GROUP 00E, Harness Connector Inspection [P.00E-2](#). The tweeter (RH) should sound.

**STEP 24.** Check the wiring harness between tweeter (RH) connector H-15 (terminals 1 and 2) and amplifier connector G-19 (terminals 12 and 4).

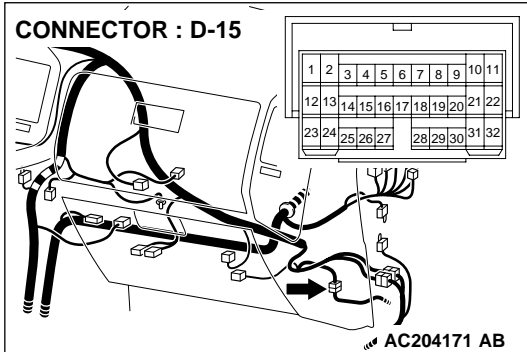
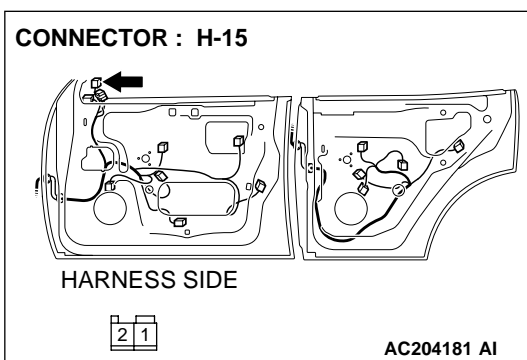
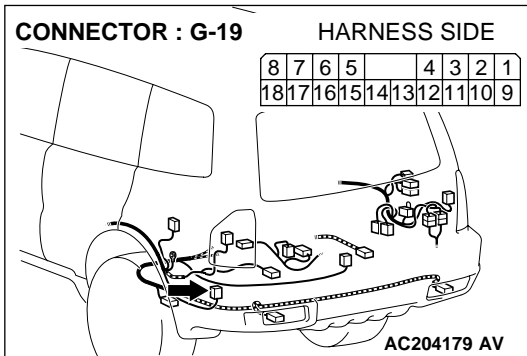

*NOTE:* Also check intermediate connectors D-15 and D-124. If intermediate connector D-15 or D-124 are damaged, repair or replace the connector as described in GROUP 00E, Harness Connector Inspection [P.00E-2](#).

**Q:** Is the wiring harness between tweeter (RH) connector H-15 (terminals 1 and 2) and amplifier connector G-19 (terminals 12 and 4) in good condition?

**YES :** Go to Step 25.

**NO :** Repair the wiring harness. The tweeter (RH) should sound.

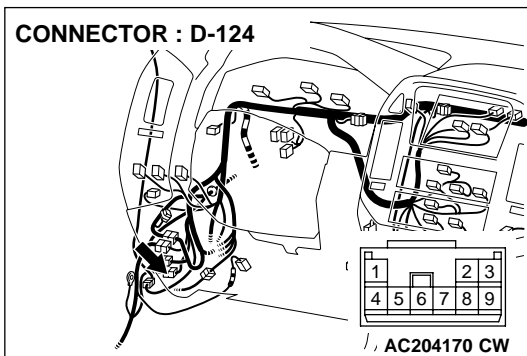

**STEP 25. Replace the radio and CD player.**

**Q: Do the speakers sound?**

**YES :** There is no action to be taken.

**NO :** Repair or replace the amplifier. The tweeter (RH) should sound.

**STEP 26. Check the woofer.**

(1) Remove the woofer. Refer to [P.54A-183](#).

(2) Check that the woofer generates noise when a five-volt voltage is applied on the woofer terminal.

**Q: Is the woofer generating noise?**

**YES :** Go to Step 27.

**NO :** Replace the woofer. The woofer should sound.

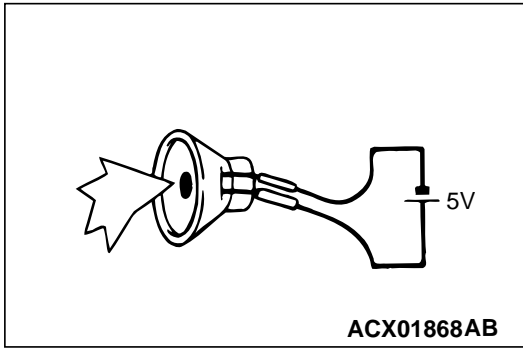

**STEP 27. Check woofer connector G-01 and amplifier connector G-19 for loose, corroded or damaged terminals, or terminals pushed back in the connector.**

**Q: Are woofer connector G-01 and amplifier connector G-19 in good condition?**

**YES :** Go to Step 28.

**NO :** Repair or replace the damaged component(s). Refer to GROUP 00E, Harness Connector Inspection [P.00E-2](#). The woofer should sound.

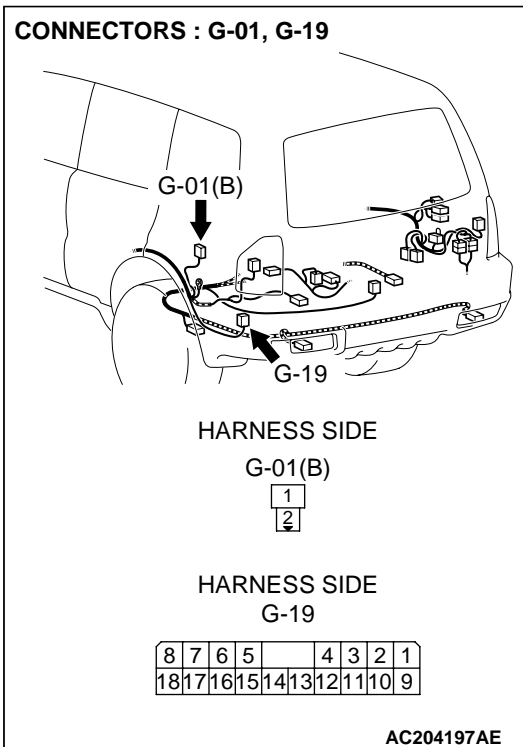

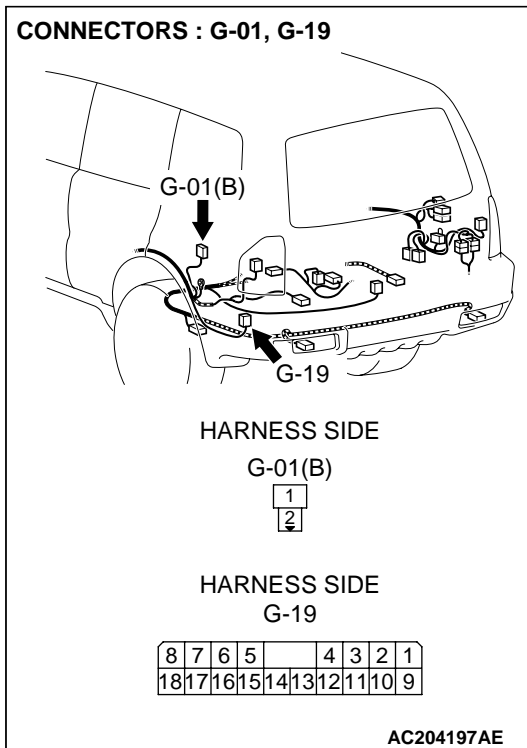

**STEP 28.** Check the wiring harness between woofer connector G-01 (terminals 1 and 2) and amplifier connector G-19 (terminals 8 and 18).

**Q:** Is the wiring harness between woofer connector G-01 (terminal 1 and 2) and amplifier connector G-19 (terminal 4 and 13) in good condition?

**YES :** Go to Step 29.

**NO :** Repair the wiring harness. The woofer should sound.

**STEP 29.** Replace the radio and CD player.

**Q:** Do the speakers sound?

**YES :** There is no action to be taken.

**NO :** Repair or replace the amplifier. The woofer should sound.

**INSPECTION PROCEDURE 5: Noise is Present while Moving (AM).**

**STEP 1. Ask the driver about the noise.**

- (1) Find out the following information from the owner.
- (2) Place where the noise occurs.
- (3) Locality conditions (valley, mountain, etc.)
- (4) Name and frequency of stations affected by noise

**Q: What type of noise is detected, vehicle noise or external noise?**

**Vehicle noise :** It may not be possible to prevent noise if the signal is weak. Go to step 2.

**External noise :** In almost all cases, prevention on the receiver side is next to impossible when the signal is weak. Go to Step 4.

**STEP 2. Ask the driver about the location where the noise occurs**

**Q: Does the noise occur when entering or near a particular structure (building, tunnel, mountain, etc.)?**

**YES :** Go to Step 3.

**NO :** Go to Step 4.

**STEP 3. Check if the noise can be eliminated by adjusting the radio.**

- (1) Adjust the radio as follows.
- (2) Change to a different station with a stronger signal. This will boost the systems resistance to outside interference.
- (3) Suppress high tones to reduce noise.

**Q: Has the noise been eliminated?**

**YES :** The noise has now been eliminated. Inform the customer that it is normal to hear noise while receiving a weak station.

**NO :** Go to Step 4.

**STEP 4. Check for the noise.****Q: Does noise still exist?**

**YES :** If there is still more noise than on other similar radio's find out the type of noise. Ask the owner for the name and frequency of the affected stations, and consult with the radio manufacturer service center.

**NO :** System is operating normally.

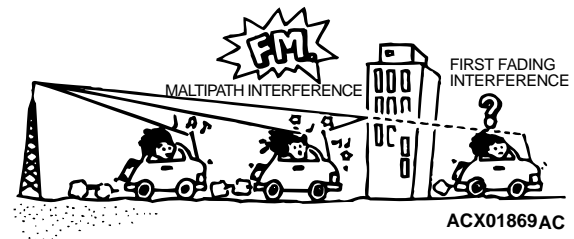
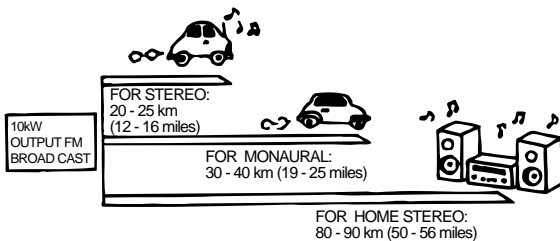
**INSPECTION PROCEDURE 6: Noise is Present while Moving (FM).****DIAGNOSIS**

**NOTE:** FM waves have the same properties as light, and can be deflected and blocked. FM signal reception is severely degraded in the shadow of obstructions such as buildings or mountains. An FM receiver will then only receive a reflected signal.

1. The signal becomes weak as the distance from the station's transmission antenna increases. The signal strength received depends on the signal strength of the transmitting station and intervening obstructions such as buildings and hills. Generally speaking, the area of good reception is approximately 20 – 25 km (12 – 16 miles) for stereo reception, and 30 – 40 km (19 – 25 miles) for monaural reception.
2. The signal will become weak when an area of shadow from the transmitting antenna (places where there are obstructions such as mountains or buildings between the station transmitter and the vehicle), and noise will appear. <This is called first fading, and gives a steady buzzing noise.>

3. If a direct signal hits the antenna at the same time as a signal reflected by obstructions such as mountains or buildings, interference of the two signals will generate noise. When moving, noise will appear each time the vehicle's antenna passes through this kind of obstructed area. The strength and interval of the noise varies according to the signal strength and the conditions of deflection. <This is called multipath noise, and is a repetitive buzzing.>
4. Since FM stereo transmission and reception has a weaker field than monaural, it is often accompanied by a hissing noise. After taking measures to prevent the noise, check that no noise occurs.
5. Change to a different station with a stronger wave to boost resistance to interference.
6. Suppress high tones to reduce noise.
7. Extend antenna completely. If there is noise, the following causes can be considered.
8. If due to vehicle noise: It may not be possible to prevent noise if the signal is weak.

9. If due to external noise: In almost all cases, prevention on the receiver side is not possible. Weak signals especially are susceptible to interference.

If there is more noise than on radios in other vehicles, find out the noise condition and the name and frequency of the receiving stations from the owner, and consult with the radio manufacturer's service center.

---

### INSPECTION PROCEDURE 7: Sound mixed with Noise, Only at Night (AM).

---

The following can be considered as possible causes of noise appearing only at night.

1. It is significantly easier to receive long-distance signals at night. This means that even stations that are received without a problem during the day may experience important to remember that the weaker station is more susceptible to interference. The appearance of a beat sound may occur in the evening. A beat sound is created when two signals close in frequency interfere with each other. A common sign of this type of interference is a repetitious high-pitched sound that may overpower the desired radio station. This sound is generated not only by sound signals but electrical waves as well.
2. The changing system may also be a source of noise. When diagnosing radio noise, do not overlook the possibility of a problem with the vehicle's generator.

### DIAGNOSIS

---

#### STEP 1. Check the vehicle's lighting system.

**Q: Does the noise disappear when the vehicle's headlights are turned "OFF"?**

- YES :** Go to Step 2.  
**NO :** Go to Step 3.

---

#### STEP 2. Check that the following actions disappear the noise.

Tune to a station with a stronger wave.

**Q: Is there more noise than on radio in other vehicles?**

- YES :** Consult the radio manufacturer's service center.  
**NO :** Check that there is no noise.

---

#### STEP 3. Check that the noise fades away when the vehicle harness is moved away from the radio (if the harness is not in the proper position).

**Q: Does the noise fade away when the vehicle harness is moved away from the radio (if the harness is not in the proper position)?**

- YES :** Consult the radio manufacturer's service center.  
**NO :** If there is more noise than other radios, consult the radio manufacturer's service center.

---

### INSPECTION PROCEDURE 8: Noise is Overpowering both AM and FM.

---

### DIAGNOSIS

---

#### STEP 1. Check the state of the antenna.

**Q: Is the mast antenna assembled?**

- YES :** Go to Step 2.  
**NO :** Assemble the mast antenna. Check to see that the noise is gone.

---

#### STEP 2. Verify that the noise occurs when the engine is stopped or the engine is running.

**Q: Does noise occur when the engine is stopped or the engine is running?**

- When the engine is stopped :** Go to Step 3.  
**When the engine is running :** Check the vehicle's noise suppressor. (Refer to Inspection Procedure 11 [P.54A-169.](#))

**STEP 3. Verify that the following actions disappear the noise.**

- (1) Tune to a station with a stronger wave.
- (2) Extend the antenna completely (Mast antenna).
- (3) Adjust the sound quality to suppress high tones.

**Q: Is the noise eliminated?**

- YES** : Consult the radio manufacturer's service center.
- NO** : Go to Step 4.

**STEP 4. Verify that the radio is correctly grounded**

The radio is connected to the ground with an assembling screw.

**Q: Is the radio correctly grounded?**

- YES** : Go to Step 5.
- NO** : Consult the radio manufacturer's service center.

**STEP 5. Check the connection of the antenna plug and radio and CD player.****Q: Is the antenna plug thoroughly connected to the radio and CD player?**

- YES** : Go to Step 7.
- NO** : Go to Step 6.

**STEP 6. Verify that the noise is eliminated when the antenna plug is properly attached.****Q: Is the noise eliminated?**

- YES** : Consult the radio manufacturer's service center.
- NO** : Go to Step 7.

**STEP 7. Verify that the antenna is in good condition and is it properly mounted.****Q: Is the antenna in good condition and is it properly mounted?**

- YES** : Consult the radio manufacturer's service center.
- NO** : Either repair or replace the antenna assembly. Check to see that the noise is gone.

**INSPECTION PROCEDURE 9: Excessive Noise on AM and FM.****DIAGNOSIS**

Radio reception can be affected by Radio Frequency (RF) emissions from a variety of sources. The disturbance is even greater if the station is weak or poorly tuned. FM reception is not as sensitive to disturbances as AM. AM reception is sensitive to electrical disturbances such as power lines, lightening and other types of similar electrical phenomena.

**STEP 1. Check if the customer heard the noise under any of the following conditions.**

- A motorcycle was passing.
- Lighting was flashing.
- Passed beneath a power line.
- Passed beneath a telephone line.
- Passed by a signal generator.
- Passed by any other sources of electrical noise.
- Passed under a bridge or through a tunnel.

**Q: Did the noise occur during any of the circumstances listed above?**

- YES** : The observed noise is normal.
- NO** : Go to Step 2.

**STEP 2. Compare the customers radio to another identical model.**

Operate the radio in a vehicle with a known good audio system of the same type as the customer's.

**Q: Is there more noise on the customers radio?**

- YES** : Check all power and ground connections. If all connections are in good condition, consult the radio manufacturers service center.
- NO** : The observed noise is normal.



**INSPECTION PROCEDURE 10: Noise is Detected with Engine Running.**

**DIAGNOSIS**

**⚠ CAUTION**

- **Never connect a noise filter to the high tension cable (spark plug wire). Spark plug wires incorporate resistors which have the effect of suppressing noise. If a spark plug wire is found to be causing noise, it must be replaced.**
- **Confirm that the noise is not from an external source.**
- **Noise prevention should be performed by suppressing strong sources of noise first.**

*NOTE: Voltage surges can be induced in the electrical system by the collapse of a field (i.e. When power is removed from the coil in an A/C compressor clutch). This induced voltage surge will radiate a Radio Frequency (RF) signal that is picked up by the*

*audio unit. In the case of the compressor clutch a "pop" will be heard through the speakers. The capacitor, installed on this vehicle, will store the excess voltage and prevent the production of RF noise. This is because the capacitor will charge and discharge as the voltage fluctuates. This has the effect of "attracting" noise and bleeding it to ground without interfering with the normal flow of current through the system.*

DESCRIPTION OF NOISE	CONDITIONS	CAUSE	SOLUTION
AM, FM: ignition noise (popping, snapping, cracking, buzzing)	<ul style="list-style-type: none"> <li>• Increasing the engine speed causes the generator whine to speed up and the volume to decrease.</li> <li>• Disappears when the ignition switch turned to "ACC", and engine is off.</li> </ul>	<ul style="list-style-type: none"> <li>• Electrical interference from the spark plugs.</li> <li>• Engine noise.</li> </ul>	<ul style="list-style-type: none"> <li>• Check or replace the ground cable.</li> <li>• Check or replace spark plug wires.</li> <li>• Check or replace the noise capacitor.</li> </ul>
Other electrical components	-	<ul style="list-style-type: none"> <li>• Noise may intensify due to aging electrical components.</li> </ul>	<ul style="list-style-type: none"> <li>• Repair or replace the electrical components.</li> </ul>
Static electricity (cracking, crinkling)	<ul style="list-style-type: none"> <li>• Noise disappears when the vehicle is completely stopped.</li> <li>• Noise is severe when the clutch is engaged.</li> </ul>	<ul style="list-style-type: none"> <li>• Noise occurs when parts or wiring move and contact vehicle body.</li> </ul>	<ul style="list-style-type: none"> <li>• Return parts or wiring to their proper position.</li> </ul>
Static electricity (cracking, crinkling)	<ul style="list-style-type: none"> <li>• Various noises are produced depending on the body part of the vehicle.</li> </ul>	<ul style="list-style-type: none"> <li>• This may be due to the recent removal of the front hood, bumpers, exhaust pipe and muffler, suspension, etc.</li> </ul>	<ul style="list-style-type: none"> <li>• Properly ground parts.</li> <li>• Properly ground all body parts.</li> </ul>

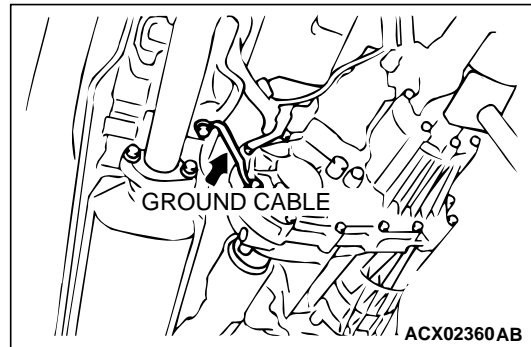
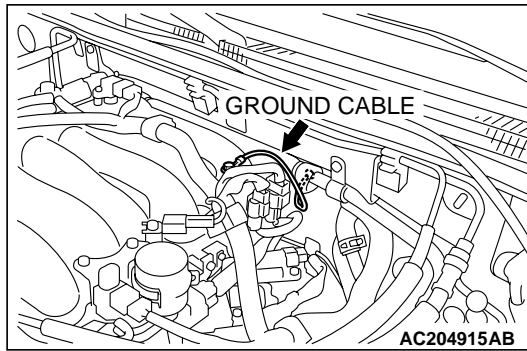

**INSPECTION PROCEDURE 11: Noise Appears During Vibration or Shocks.**

**DIAGNOSIS**

**STEP 1.** Check radio and CD player connector D-06 and amplifier connector G-19 <with amplifier> for loose, corroded or damaged terminals, or terminals pushed back in the connector.

**Q:** Are radio and CD player connector D-06 and amplifier connector G-19 <with amplifier> in good condition?

**YES :** Go to Step 2.

**NO :** Repair or replace the damaged component(s). Refer to GROUP 00E, Harness Connector Inspection [P.00E-2](#). Check that there is no noise.

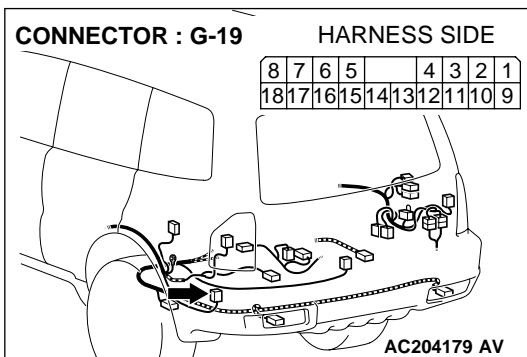
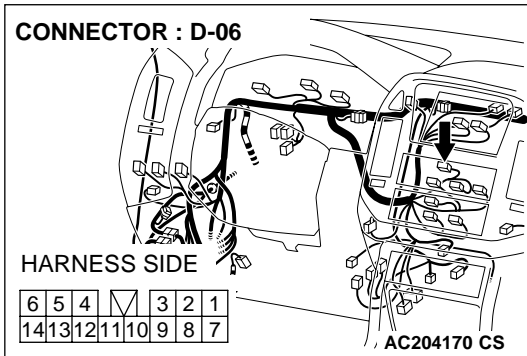

---

**STEP 2. Check that noise appears when the radio switch is turned on while the vehicle is stopped and the radio is tapped while tuned away from a station.**

*NOTE: Body static electric from the shock absorber rubber bushings used to prevent vibration, tires, etc. occurs because of separation from the ground, causing a buzzing noise. Since no measures can be taken to discharge the static electricity of the vehicle body. Check that there is no noise.*

**Q: Does noise appear when the radio switch is turned on while the vehicle is stopped and the radio is tapped while tuned away from a station?**

**YES :** Go to Step 3.

**NO :** It may be static electricity noise.

---

**STEP 3. Verify that the radio is correctly grounded.**

The radio is connected to the ground with an assembling screw.

**Q: Is the radio correctly grounded?**

**YES :** Go to Step 4.

**NO :** Tighten the screw securely. Check that there is no noise.

---

**STEP 4. Check by replacing radio and CD player.**

**Q: Do the other radio and CD player work normally?**

**YES :** Either repair or replace the original radio and CD player. Check that there is no noise.

**NO :** Either repair or replace the antenna assembly. Check that there is no noise.

**INSPECTION PROCEDURE 12: Noise is Present While Moving (FM).****DIAGNOSIS****STEP 1. Check the state of the antenna.****Q: Is the mast antenna assembled?****YES :** Go to Step 2.**NO :** Assemble the mast antenna. Check that there is no noise.**STEP 2. Check the radio after adjusting it.****Q: Readjust the radio. Is the noise eliminated?****YES :** Check that there is no noise.**NO :** Go to Step 3.**STEP 3. Check with several broadcasting stations.**

*NOTE: Multipath noise and fading noise: Because of the frequency of FM waves in extremely high, it is highly susceptible to effects from geological formations and buildings. These effects disrupt the broadcast signal and obstruct reception in several ways.*

- **Multipath noise**  
*This describes the echo that occurs when the broadcast signal is reflected by a large obstruction and enters the receiver with a slight time delay relative to the direct signal (repetitious buzzing).*
- **Fading noise**  
*This is a buzzing noise that occurs when the broadcast signal is disrupted by obstructing objects and the signal strength fluctuates intricately within a narrow range.*

**Q: Is the problem station or location specific?****YES :** The effect of an electrical field condition (multipath noise, fading noise) could be the cause. Check that there is not noise.**NO :** Go to Step 4.**STEP 4. Check that noise appears when the radio switch is turned on while the vehicle is stopped.**

*NOTE: Body static electric from the shock absorber rubber bushings used to prevent vibration, tires, etc. occurs because of separation from the ground, causing a buzzing noise. There is no measures to discharge the static electricity of the vehicle body. Check that there is no noise.*

**Q: Does noise appear when the radio switch is turned on while the vehicle is stopped and the radio is tapped while tuned away from a station?****YES :** Go to Step 5.**NO :** It may be static electricity noise.**STEP 5. Verify that the radio is correctly grounded.**

The radio is connected to the ground with an assembling screw.

**Q: Is the radio correctly grounded?****YES :** Go to Step 6.**NO :** Tighten the screw securely. Check that there is no noise.**STEP 6. Check by replacing radio and CD player.****Q: Do the other radio and CD player work normally?****YES :** Either repair or replace the original radio and CD player. Check that there is no noise.**NO :** Either repair or replace the antenna assembly. Check that there is no noise.**INSPECTION PROCEDURE 13: Constant Noise.****DIAGNOSIS**

Use the Symptom Chart to diagnose the possible cause(s) of the noise. Noise is often created by the following factors:

- Traveling conditions of the vehicle
- Terrain of area traveled through
- Surrounding buildings
- Signal conditions

- Time period

If there are still problems with noise, even after performing inspection procedures 7 to 14, obtain information on the factors listed above. Determine whether the problem occurs on AM or FM, the station names, frequencies, etc. and contact the radio manufacturer's service center.

---

**INSPECTION PROCEDURE 14: No reception (AM).**

---

**DIAGNOSIS**

---

**STEP 1. Check the state of the antenna.**

**Q: Is the mast antenna assembled?**

**YES :** Go to Step 2.

**NO :** Assemble the mast antenna. The radio should sound normally.

---

**STEP 2. Check to see if inspections are taking place in an area exposed to special electric fields.**

**Q: Are inspections taking place under special electric field conditions? (underground garage, inside a building, etc.)?**

**YES :** Go to Step 3.

**NO :** Go to Step 4.

---

**STEP 3. Relocate and check the radio.**

Automatically receive in a good reception area that is not exposed to special electric fields.

**Q: Is reception of the strongest radio frequency possible within the area?**

**YES :** There is no action to be taken.

**NO :** Go to Step 4.

---

**STEP 4. Tune the radio, and then check it.**

**Q: Did the sensitivity improve after tuning?**

**YES :** There is no action to be taken.

**NO :** Go to Step 5.

---

**STEP 5. Check the connection of the antenna plug and radio and CD player.**

**Q: Is the antenna plug thoroughly connected to the radio and CD player?**

**YES :** Go to Step 6.

**NO :** Thoroughly connect the antenna plug and the radio and CD player. The radio should sound normally.

---

**STEP 6. Check by replacing radio and CD player.**

**Q: Do the other radio and CD player work normally?**

**YES :** Either repair or replace the original radio and CD player. The radio should sound normally.

**NO :** Either repair or replace the antenna assembly. The radio should sound normally.

---

**INSPECTION PROCEDURE 15: Poor Reception.**

---

**DIAGNOSIS**

---

**STEP 1. Check the state of the antenna.**

**Q: Is the mast antenna assembled?**

**YES :** Go to Step 2.

**NO :** Assemble the mast antenna. Check that a poor reception is resolved.

---

**STEP 2. Check to see if inspections are taking place in an area exposed to special electric fields.**

**Q: Are inspections taking place under special electric field conditions? (underground garage, inside a building, etc.)?**

**YES :** Go to Step 3.

**NO :** Go to Step 4.

---

**STEP 3. Relocate and check.**

Automatically receive in a good reception area that is not exposed to special electric fields.

**Q: Is reception of the strongest radio frequency possible within the area?**

**YES :** Check that a poor reception is resolved.

**NO :** Go to Step 4.

---

**STEP 4. Tune the radio, and then check it.**

**Q: Did the sensitivity improve after tuning?**

**YES :** Check that a poor reception is resolved.

**NO :** Go to Step 5.

**STEP 5. Check with several broadcasting stations.**

*NOTE: Two types of noise are addressed in this procedure, multipath and fading noise. The frequency of FM waves is extremely high. This makes them susceptible to effects from geological formations and buildings. These effects disrupt the broadcast signal and obstruct reception in many ways.*

- *Multipath noise is the echo that occurs when the broadcast signal is reflected by a large obstruction and enters the receiver with a slight time delay relative to the direct signal (repetitious buzzing).*
- *A fading or buzzing noise may occur when the broadcast beam is disrupted by obstructing objects and the signal strength fluctuates within a narrow range.*

**Q: Is the abnormality in reception generated only within a certain range?**

**YES :** Check that a poor reception is resolved.

**NO :** Go to Step 6.

**STEP 6. Check the connection of the antenna plug and radio and CD player.**

**Q: Is the antenna plug thoroughly connected to the radio and CD player?**

**YES :** Go to Step 7.

**NO :** Thoroughly connect the antenna plug and the radio and CD player. Check that a poor reception is resolved.

**STEP 7. Check by replacing radio and CD player.**

**Q: Do the other radio and CD player work normally?**

**YES :** Either repair or replace the original radio and CD player. Check that a poor reception is resolved.

**NO :** Either repair or replace the antenna assembly. Check that a poor reception is resolved.

**INSPECTION PROCEDURE 16: Distortion on AM and/or FM.****DIAGNOSIS****STEP 1. Check the level of distortion.**

**Q: How much distortion is there?**

**Occasional distortion :** Go to Step 2.

**Constant distortion :** Go to Step 3.

**STEP 2. Check the location of the distortion.**

**Q: Is there distortion when the vehicle is near the radio station?**

**YES :** The antenna is receiving too strong a signal.

**NO :** Go to Step 3.

**STEP 3. Check the wires at each speaker.**

**Q: Are the speaker wires contacting the paper speaker cone?**

**YES :** Move the speaker wires away from the paper speaker cone. The speaker should now be free of distortion.

**NO :** Go to Step 4.

**STEP 4. Remove the speakers, and check the paper cone for foreign material or damage.**

**Q: Is there foreign material or damage on the paper cone of the speaker?**

**YES :** Repair or replace the speakers. The speaker should now be free of distortion.

**NO :** Go to Step 5.

**STEP 5. Check for distortion with the speaker installed.**

**Q: Does a distortion occur?**

**YES :** Install the speaker securely. The speaker should now be free of distortion.

**NO :** Repair or replace the radio and CD player. The speaker should now be free of distortion.

---

**INSPECTION PROCEDURE 17: Distortion on FM Only.**

---

**DIAGNOSIS**

---

**STEP 1. Check that the distortion is present when the radio is tuned to another station.**

**Q: Does the distortion persist when the radio is tuned to another station?**

**YES :** Go to Step 2.

**NO :** The signal from that station is too weak.

---

**STEP 2. Relocate the reception area and check.**

**Q: When relocating the reception area does the distortion increase or decrease?**

**YES :** The cause may be multipath or fading noise. Multipath noise is the echo that occurs when the broadcast signal is reflected by a large obstruction and enters the receiver with a slight time delay relative to the direct signal (repetitious buzzing). A fading or buzzing noise may occur when the broadcast beam is disrupted by obstructing objects and the signal strength fluctuates within a narrow range.

**NO :** Repair or replace the radio and CD player. Check that a distortion is resolved.

---

**INSPECTION PROCEDURE 18: Auto Select Function Inoperative, too Few Automatic Stations are Selected.**

---

**DIAGNOSIS**

---

**STEP 1. Check the state of the antenna.**

**Q: Is the mast antenna assembled?**

**YES :** Go to Step 2.

**NO :** Assemble the mast antenna. The auto-select function should operate normally.

---

**STEP 2. Check the number of radio stations.**

**Q: Are there sufficient numbers of radio stations within the area?**

**YES :** Go to Step 3.

**NO :** Go to Step 4.

---

**STEP 3. Check the distance from the transmission antenna.**

**Q: Is there a transmission antenna within a range of 2 miles?**

**YES :** Go to Step 5.

**NO :** Go to Step 4.

---

**STEP 4. The check if there are not that many radio stations and when there is no transmission antenna in the vicinity.**

Execute automatic selection and check to see that the strongest radio frequency is receivable within the area.

**Q: Is reception of the strongest radio frequency possible within the area?**

**YES :** There is no action to be taken.

**NO :** Go to Step 5.

---

**STEP 5. Check to see if inspections are taking place in an area exposed to special electric fields.**

**Q: Are inspections taking place under special electric field conditions? (underground garage, inside a building, etc.)?**

**YES :** Go to Step 6.

**NO :** Go to Step 7.

---

**STEP 6. Relocate and check.**

Automatically receive in a good reception area that is not exposed to special electric fields.

**Q: Is reception of the strongest radio frequency possible within the area?**

**YES :** There is no action to be taken.

**NO :** Go to Step 7.

**STEP 7. Check the connection of the antenna plug and radio and CD player.**

- Q: Is the antenna plug thoroughly connected to the radio and CD player?**  
**YES :** Repair or replace the radio and CD player. The auto-select function should operate normally.  
**NO :** Thoroughly connect the antenna plug and the radio and CD player. The auto-select function should operate normally.

**INSPECTION PROCEDURE 19: Preset Stations are Erased.**

Memory Backup Power Supply Circuit

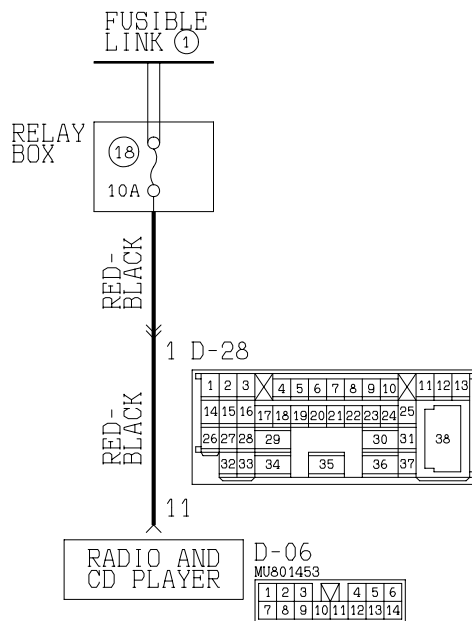

W3Q12M05AA

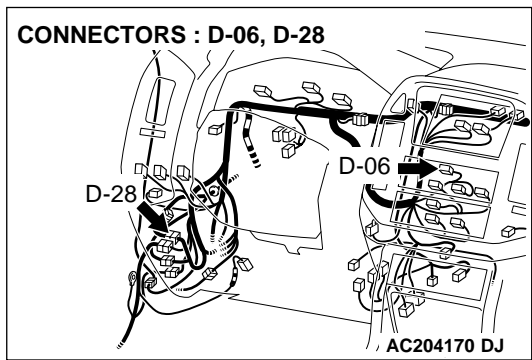

**CIRCUIT OPERATION**

Power is continuously supplied to the radio and CD player.

**TECHNICAL DESCRIPTION (COMMENT)**

The cause is probably a faulty radio and CD player memory backup power supply system circuit.

**TROUBLESHOOTING HINTS**

- Damaged wiring harness or connector.
- Malfunction of the radio and CD player.



## DIAGNOSIS

### Required Special Tool:

- MB991223: Harness set

**STEP 1. Measure at radio and CD player connector D-06 in order to check the power supply circuit to the radio and CD player (through the battery).**

(1) Disconnect radio and CD player connector D-06, and measure at the wiring harness side.

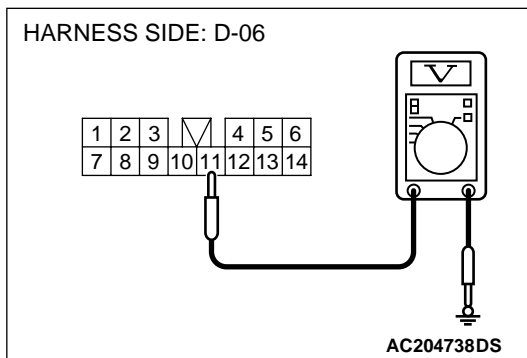
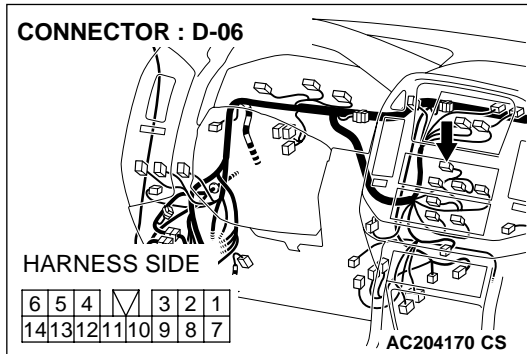

(2) Measure the voltage between terminal number 11 and ground by backprobing.

- The voltage should equal approximately 12 volts (battery positive voltage).

**Q: Is the measured voltage approximately 12 volts (battery positive voltage)?**

**YES :** Either repair or replace the radio and CD player. Check that a memory is retained.

**NO :** Go to Step 2.

**STEP 2. Check radio and CD player connector D-06 for loose, corroded or damaged terminals, or terminals pushed back in the connector.**

**Q: Is radio and CD player connector D-06 in good condition?**

**YES :** Go to Step 3.

**NO :** Repair or replace the damaged component(s). Refer to GROUP 00E, Harness Connector Inspection

[P.00E-2](#). Check that a memory is retained.

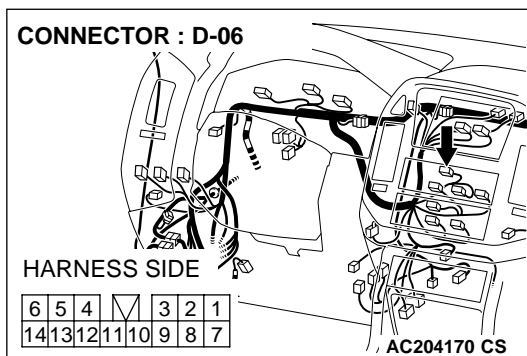

## CONNECTORS: D-06, D-28

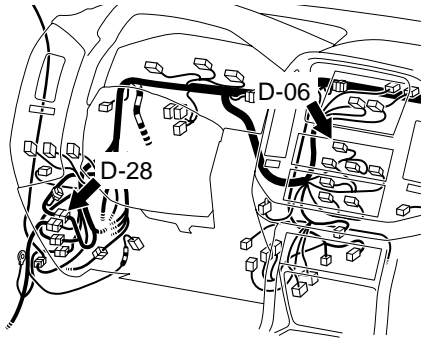
HARNESS SIDE  
D-06

6	5	4	3	2	1
14	13	12	11	10	9
8	7				

## D-28

1	2	3	4	5	6	7	8	9	10	11	12	13
14	15	16	17	18	19	20	21	22	23	24	25	
26	27	28	29				30	31			38	
32	33	34		35			36	37				

AC204188BK

**STEP 3. Check the wiring harness between radio and CD player connector D-06 (terminal 11) and the battery.**

**NOTE:** Also check intermediate connector D-28. If intermediate connector D-28 is damaged, repair or replace the connector as described in GROUP 00E, Harness Connector Inspection P.00E-2.

**Q: Is the wiring harness between radio and CD player connector D-06 (terminal 11) and the battery in good condition?**

**YES :** Repair or replace the radio and CD player. Check that a memory is retained.

**NO :** Repair the wiring harness. Check that a memory is retained.

**INSPECTION PROCEDURE 20: CD can not be Inserted.****DIAGNOSIS****STEP1. Check that a CD has been already loaded.****Q: Has a CD been already loaded?**

**YES :** Take out the CD (If the CD can not be ejected, refer to INSPECTION PROCEDURE 24 P.54A-180.) Check that a CD can be inserted.

**NO :** Go to Step 2.

**STEP 2. Check how a CD is inserted.**

Ensure that the ignition switch is at "ACC" or "ON".

**NOTE:** If you try to load a CD when the ignition switch is at the positions other than "ACC" or "ON," the CD will not be inserted completely and then rejected.

**Q: If you try to load the CD, does the CD stops halfway and then rejected?**

**YES :** Refer to INSPECTION PROCEDURE 24

P.54A-180.

**NO :** Go to Step 3.

**STEP 3. Check after the CD is loaded.**

**NOTE:** Even though the CD is loaded, "E" (error) is sometimes displayed with the CD rejected because of vibration/shock or dew on the CD face or optical lens.

**Q: Though the CD is inserted completely, is "E" (error) displayed and the CD ejected?**

**YES :** Go to Step 4.

**NO :** There is no action to be taken.

**STEP 4. Check the CD.**

Check the CD for the conditions below:

- Is the CD loaded with its label facing down?
- Is the recorded face dirty or scratched?
- Is there dew on the recorded face?

**Q: Is the CD in good condition?**

**YES :** Go to Step 5.

**NO :** The original CD is defective. Check that a CD can be inserted.

---

**STEP 5. Check again using a normal CD, which is not dirty or scratched.**

- Load another normal CD.
- Check that the CD player recognizes and play the CD.

**Q: When you substitute another normal CD, is the CD loaded correctly?**

**YES :** The original CD is defective. Check that a CD can be inserted.

**NO :** Replace or repair the CD player. Check that a CD can be inserted.

---

**INSPECTION PROCEDURE 21: No Sound. (CD Only)**

---

**DIAGNOSIS**

---

**STEP 1. Check again using a normal CD, which is not dirty or scratched.**

**Q: When you substitute another normal CD, is the CD played normally?**

**YES :** The original CD is defective. The CD player should sound normally.

**NO :** Go to Step 2.

---

**STEP 2. Check power supply to the CD player when the ignition switch is at "ACC" or "ACC".**

**Q: Is the radio and CD player energized when the ignition switch is turned to the "ACC" or "ON" position?**

**YES :** Replace or repair the CD player. The CD player should sound normally.

**NO :** Check the memory backup power supply circuit. Refer to Inspection Procedure 1

[P.54A-120.](#)

---

**INSPECTION PROCEDURE 22: CD Sound Skips.**

---

**DIAGNOSIS**

---

**STEP 1. Check the state in which the sound on the CD jumps.**

**Q: Does the sound jump when the car is parked?**

**YES :** Go to Step 2.

**NO :** Go to Step 4.

---

**STEP 2. Check the surface of the CD.**

**Q: Are there any scratches or soiling on the CD?**

**YES :** The CD is defective if there are any scratches. Clean the CD surface if it is dirty. Check that a CD sound skip is resolved.

**NO :** Go to Step 3.

---

**STEP 3. Check when replacing with a CD that can be played normally without any scratches or soiling.**

**Q: Does the CD play normally when replaced with a CD that is not scratched or dirty and can play normally?**

**YES :** Defective CD used. Check that a CD sound skip is resolved.

**NO :** Go to Step 4.

---

**STEP 4. Check by tapping the radio and CD player.**

*NOTE: Check by using a proper CD which is free from scratches, dirt or any other abnormality.*

**Q: Does the sound jump when tapping the radio and CD player?**

**YES :** Securely mount the radio and CD player. Check that a CD sound skip is resolved.

**NO :** Either repair or replace the radio and CD player. (Take the following measures if a servicing shop is closely).

1. Investigate in detail the state when the sound jumps while driving the car.
2. Describe the state to the service shop for consultation.
3. Either repair or replace the radio and CD player according to the instructions of the service shop.

Check that a CD sound skip is resolved.

---

**INSPECTION PROCEDURE 23: Sound Quality is Poor.**

---

**DIAGNOSIS**

---

**Check to see that the CD can be played normally and that it is free of any scratches or soiling.**

Replace with better sound quality CD.

**Q: Is the sound quality better replacing the CD with a clean CD without any scratches that can be played?**

**YES :** The CD is defective. The sound quality should return to normal.

**NO :** Repair or replace the CD payer. The sound quality should return to normal.

---

**INSPECTION PROCEDURE 24: CD can not be Ejected.**

---

**DIAGNOSIS**

---

**Check the power of ignition switch "ACC".**

**Q: Does the radio and CD player power turn ON when the ignition switch is in the "ACC" or "ON" position?**

**YES :** Either repair or replace the radio and CD player. Check that a CD can be ejected normally.

**NO :** Check the memory backup power supply circuit. Refer to Inspection Procedure 1

[P.54A-120.](#)

## ON-VEHICLE SERVICE

### SPEAKER TEST

M1544005400192

Enter the speaker test mode according to the following steps:

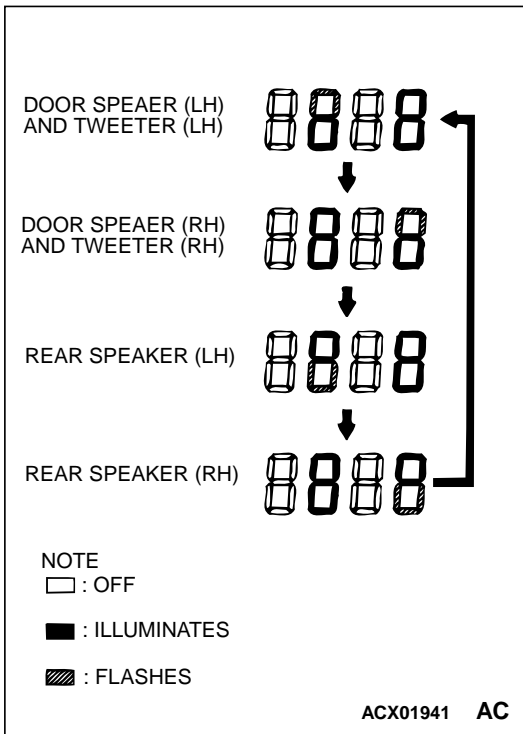
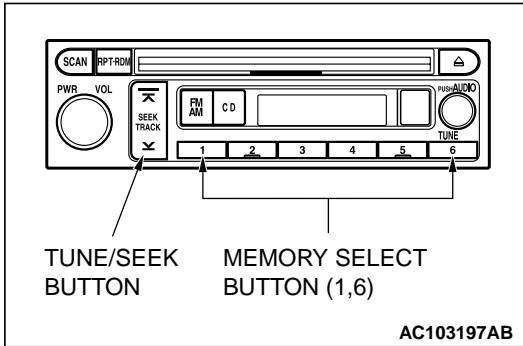

1. Turn the ignition switch to "ACC" or "ON" position and switch off the radio, tape player, CD player and CD auto changer.
2. Press the following buttons in that order within 60 seconds from step (1).
  - (1) Memory select "1" button
  - (2) "TUNE/SEEK (DOWN)" button
  - (3) "TUNE/SEEK (UP)" button
  - (4) Memory select "6" button



3. Check that the speaker, which is displayed on the display, sounds (If the memory select "6" button is pressed, the speaker will be changed).
4. If a button other than the memory select "6" button and "EJECT" button (tape or CD) is pressed, or the ignition switch is turned to "LOCK" (OFF) position, you will exit from the speaker test mode.

SPECIAL TOOL

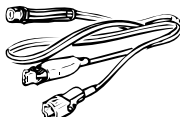
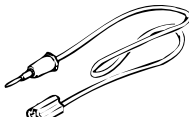
M154400600287

TOOL	TOOL NUMBER AND NAME	REPLACED BY MILLER TOOL NUMBER	APPLICATION
<p>A</p> 	<p>MB991223 A: MB991219 B: MB991220 C: MB991221 D: MB991222 Harness set A: Test harness B: LED harness C: LED harness adapter D: Probe</p>	<p>General service tool (jumper)</p>	<p>Making voltage and resistance measurements during troubleshooting A: Connect pin contact pressure inspection B: Power circuit inspection C: Power circuit inspection D: Commercial tester connection</p>
<p>B</p> 			
<p>C</p> 			
<p>D</p>  <p>MB991223AC</p>			

RADIO WITH TAPE PLAYER AND CD PLAYER

REMOVAL AND INSTALLATION

M1544001100122

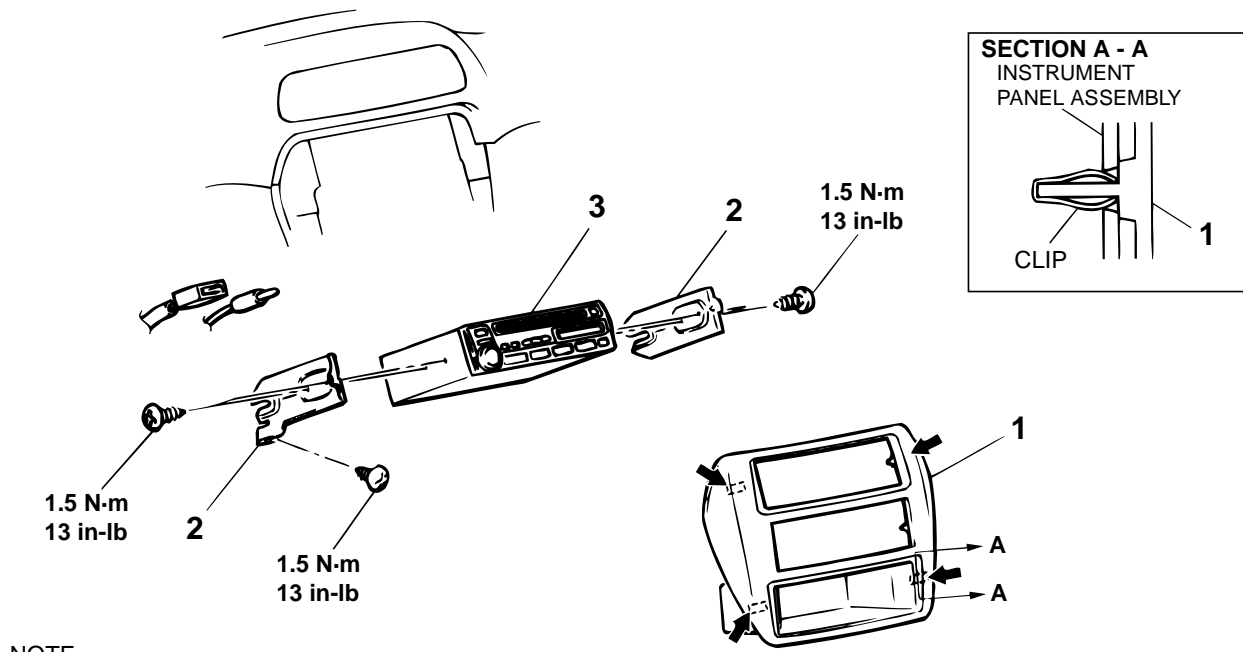

NOTE  
← :CLIP POSITION

- RADIO REMOVAL STEPS**
1. CENTER PANEL ASSEMBLY

- RADIO REMOVAL STEPS (Continued)**
2. RADIO BRACKET
  3. RADIO AND CD PLAYER

AC002923AB

## SPEAKER REMOVAL AND INSTALLATION

M1544002600175

### TWEETER

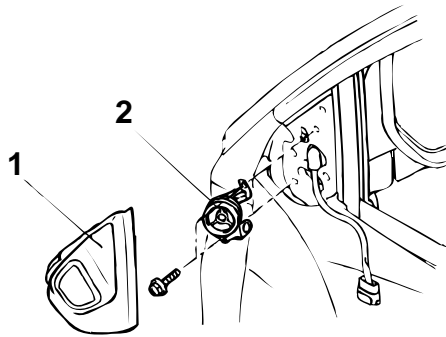

### FRONT DOOR SPEAKER

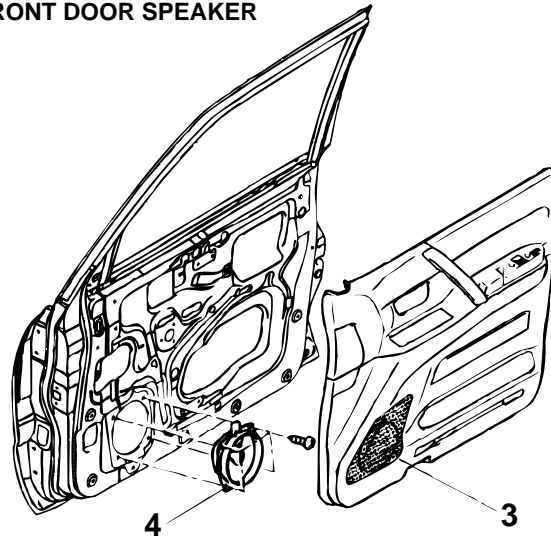

### REAR DOOR SPEAKER

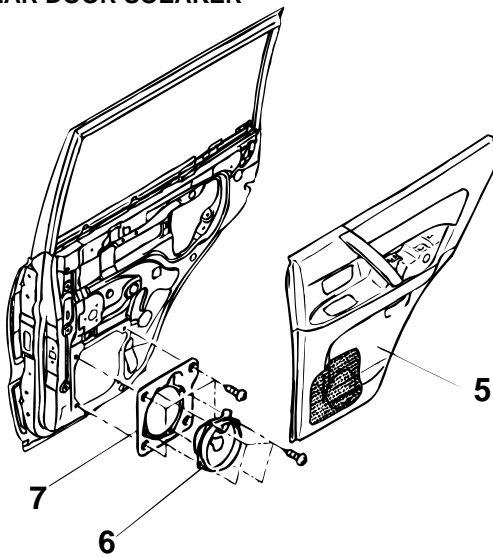

### WOOFER

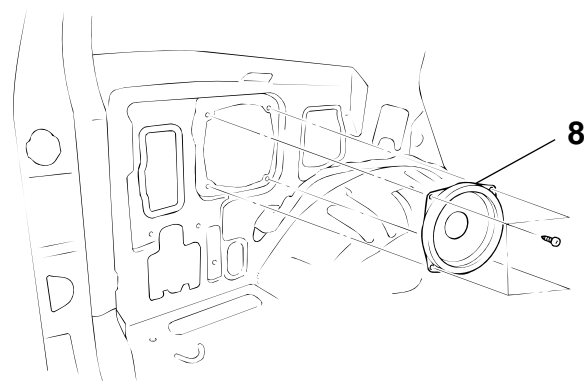

ACX01932 AB

#### TWEETER REMOVAL STEPS

1. DELTA INNER COVER
2. TWEETER

#### FRONT DOOR SPEAKER REMOVAL STEPS

3. FRONT DOOR TRIM (REFER TO GROUP 42, DOOR TRIM AND WATERPROOF FILM P.42-30.)
4. FRONT DOOR SPEAKER

#### REAR DOOR SPEAKER REMOVAL STEPS

5. REAR DOOR TRIM (REFER TO GROUP 42, DOOR TRIM AND WATERPROOF FILM P.42-30.)
6. REAR SPEAKER
7. REAR SPEAKER BRACKET

#### WOOFER REMOVAL STEPS

- LOWER QUARTER PANEL (REFER TO GROUP 52A, TRIM P.52A-8.)
- 8. WOOFER

**AMPLIFIER  
REMOVAL AND INSTALLATION**

M1544004100132

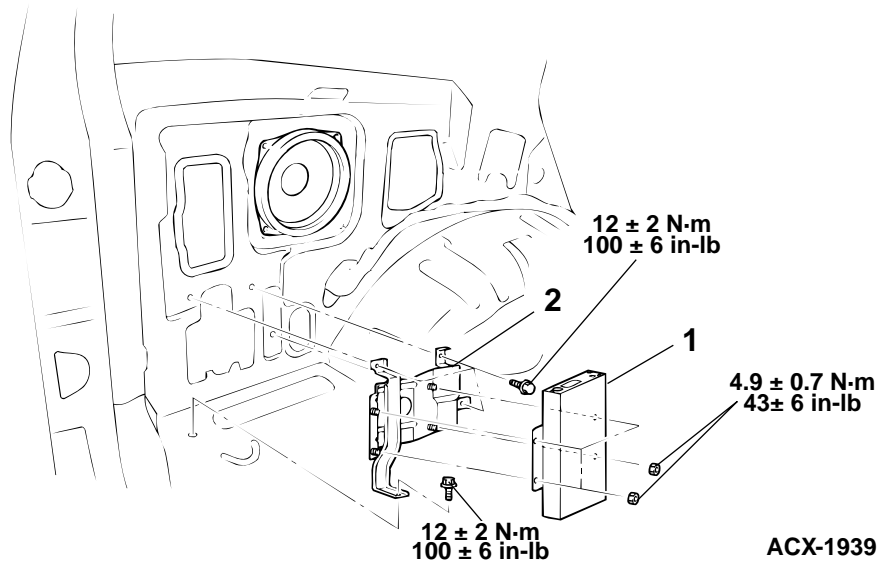

- AMPLIFIER REMOVAL STEPS**
- LOWER QUARTER PANEL (LH)  
(REFER TO GROUP 52A, TRIM P.52A-8.)

- AMPLIFIER REMOVAL STEPS**
1. AMPLIFIER
  2. BRACKET

**ANTENNA  
REMOVAL AND INSTALLATION**

M1544002900217

<VEHICLES WITH MAST ANTENNA>

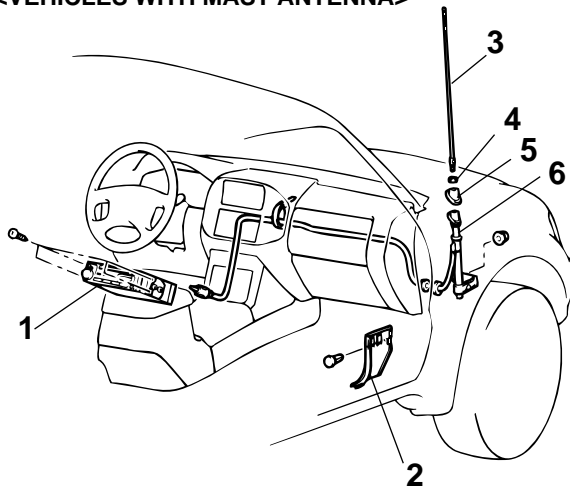

<VEHICLES WITH MOTOR ANTENNA>

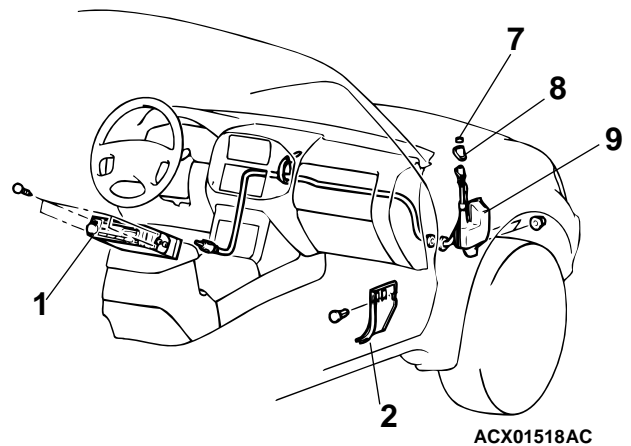

ACX01518AC



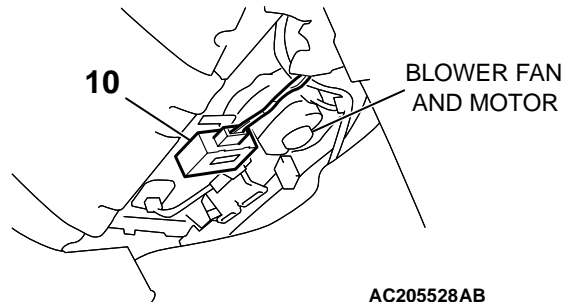

AC205528AB

**MAST ANTENNA REMOVAL STEPS**

- SPLASH SHIELD
- 1. RADIO AND CD PLAYER (REFER TO P.52A-8.)
- 2. COWL SIDE TRIM <RH> (REFER TO GROUP 52A, TRIM P.52A-8.)
- 3. MAST ANTENNA
- 4. MOUNTING NUT
- 5. BASE
- 6. MAST ANTENNA BODY

**MOTOR ANTENNA REMOVAL STEPS**

- SPLASH SHIELD
  - 1. RADIO (REFER TO P.54A-182.)
  - 2. COWL SIDE TRIM <RH> (REFER TO GROUP 52A, TRIM P.52A-8.)
  - 7. RING NUT
  - 8. BASE
  - 9. MOTOR ANTENNA BODY
- MOTOR ANTENNA-ECU REMOVAL**
- 10. MOTOR ANTENNA-ECU

**INSPECTION**

M1544003000132

**MTOTR ANTENNA CHECK**

Disconnect the motor antenna-ECU connector. Verify that the antenna extends when the positive terminal of the battery is connected to terminal number 1 and the negative terminal of the battery is connected to terminal number 2. Verify that the antenna retracts when the connection is reversed.

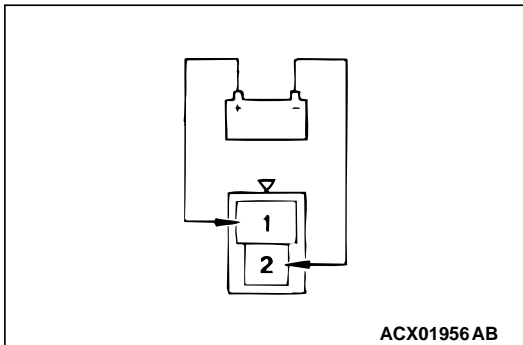

**MOTOR ANTENNA-ECU CHECK**

1. Remove the motor antenna-ECU installation bolt.
2. Operate the radio switch when the ignition switch is turned to the "ACC" or "ON" position, and check the voltage between the terminals while the antenna is extending or retracting.

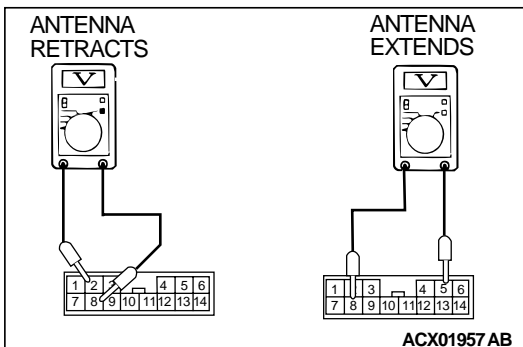

**GLASS ANTENNA CHECK**

1. Wrap an aluminum foil around the tester probe as shown.

**⚠ CAUTION**

**Be careful not to damage the print wire.**

2. Check continuity while pressing the aluminum foil along the antenna print wire.

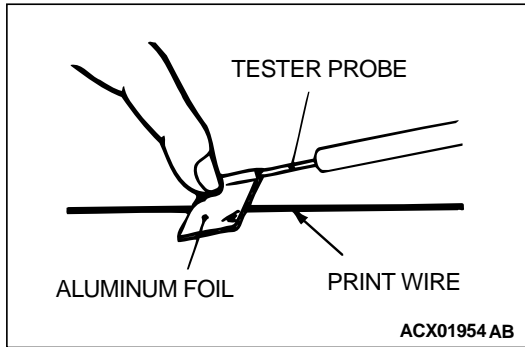
**ANTENNA POLE REPLACEMENT**

M1544000900125

1. Remove the ring nut.

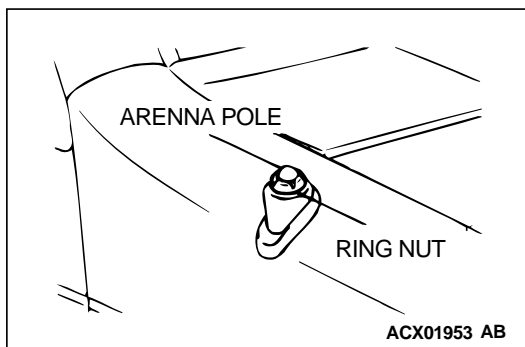

2. After setting the ignition switch to "ACC" or "ON," turn the radio switch on. Extend the antenna pole and remove it together with the rack cable.
3. Pull the antenna out the farthest end.

*NOTE: If the motor end side of the rack cable is bent, straighten it out.*

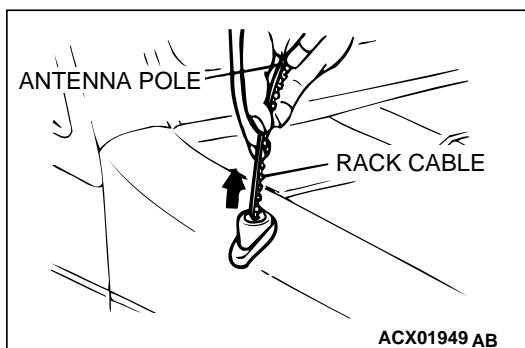

4. Face the teeth side of the rack cable toward the engine compartment, and feed the rack cable into the motor assembly.

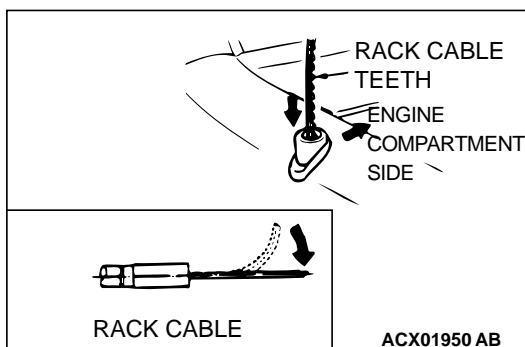

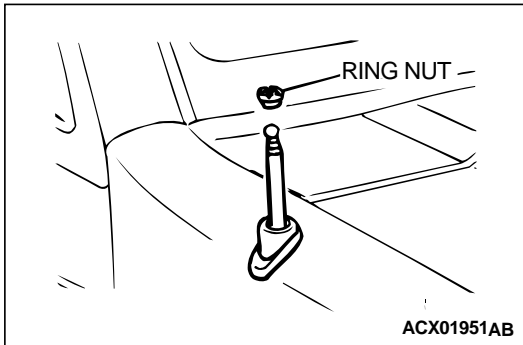
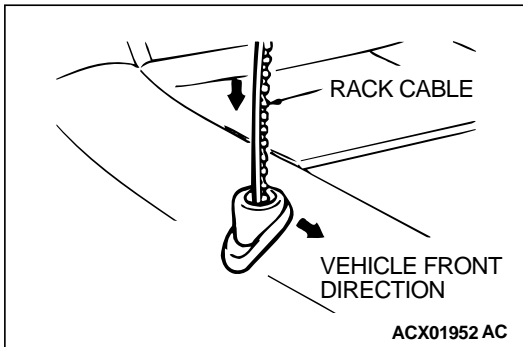

5. Turn the teeth side of the rack cable toward the front of the vehicle (90 degree angle to the right), and engage the rack cable with the motor gears.
6. Pull lightly on the rack cable. If there is no resistance and it comes out, it is not engaged with the motor gears. Check that the end of the rack gear is not bent again, and then repeat steps (3) and (4) above again.
7. Set up the antenna pole vertically, and turn the radio off to wind in the rack cable. The antenna pole will be pulled into the motor antenna as the rack cable is wound in.
8. After tightening the ring nut, turn the radio on and off and check the operation of the antenna pole.

## REAR WINDOW DEFOGGER

### ON-VEHICLE SERVICE

#### PRINTED-HEATER LINES CHECK

M1543001800139

1. Run engine at 2,000 r/min. Check heater element with battery at full.
2. Turn "ON" rear window defogger switch. Measure heater element voltage with circuit tester at rear window glass centre A. Condition is good if it indicates about 6 V.
3. If 12 V is indicated at A, there is a break in the negative terminals from A. Move test bar slowly to negative terminal to detect where voltage changes suddenly (0V).
4. If 0 V is indicated at A, there is a break in the positive terminals from A. Defect where the voltage changes suddenly (12 volts, battery positive voltage) in the same method described above.

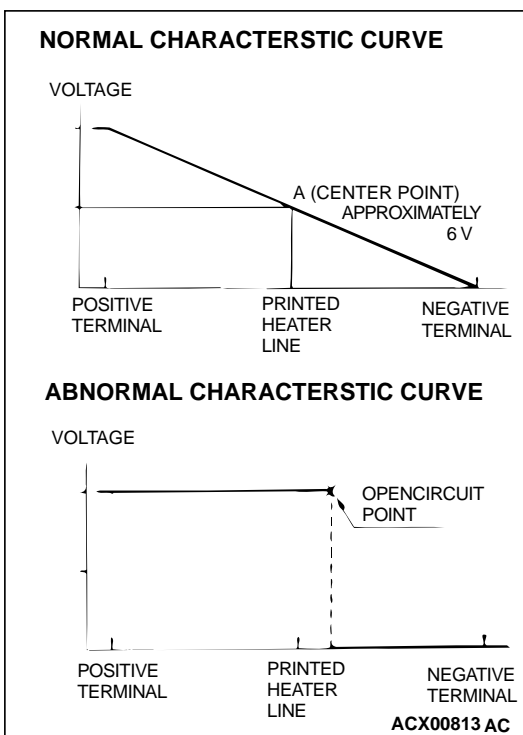

**REAR WINDOW DEFOGGER SWITCH**

**REMOVAL AND INSTALLATION**

M1543006200217

**<Vehicles with manual A/C>**

Refer to GROUP 55A, Heater Control Assembly and Blower Switch Assembly P.55A-126.

**<Vehicles with auto A/C>**

Refer to GROUP 55B, A/C Control Panel, A/C Control Unit P.55B-136.

**INSPECTION**

M1543019501835

**REAR WINDOW DEFOGGER SWITCH CHECK**

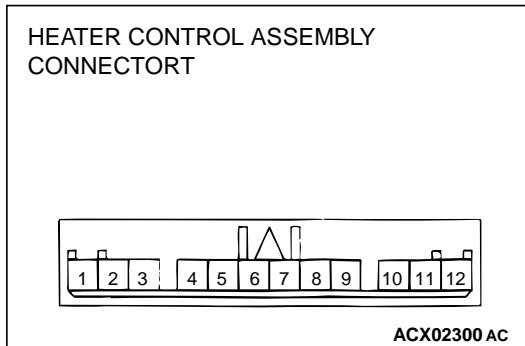

SWITCH POSITION	TESTER CONNECTION	SPECIFIED CONDITION
OFF	11 – 12	Open circuit
ON	11 – 12	Less than 2 ohms

**REAR WINDOW DEFOGGER RELAY CONTINUITY CHECK**

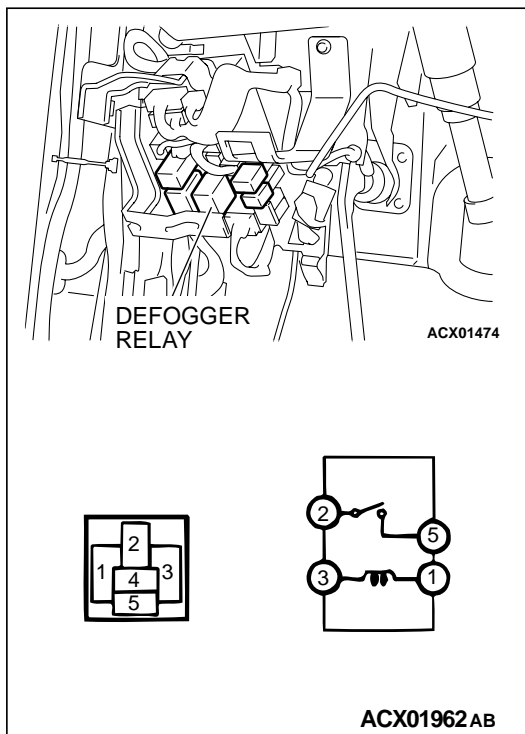

BATTERY VOLTAGE	TESTER CONNECTION	SPECIFIED CONDITION
Not applied	2 – 5	Open circuit
<ul style="list-style-type: none"> <li>Connect terminal 1 to the positive battery terminal</li> <li>Connect terminal 3 to the negative battery terminal</li> </ul>	2 – 5	Less than 2 ohms

# RV METER

## RV METER DIAGNOSIS

### INTRODUCTION TO RV METER

The RV meter has the following function for the failure diagnosis service, and is used for the system check of units such as the main body and the sensor. By virtue of this service function, the cause of failure can be conjectured.

### FAILURE DIAGNOSIS SERVICE FUNCTION

M1543009901003

The RV meter is equipped with the following functions for the failure diagnosis service.

FUNCTION		CONTENTS
Service function	Automatic check mode	Performs communication check and connection check in succession.
	Diagnosis mode	Performs version check of each unit, vehicle signal check and communication and connection check
	History mode	Displays the number of errors as the result of communication and connection checks
Monitor check mode	Display check mode	Checks whether the screen display function.
	Geomagnetic sensor check mode	Checks whether the geomagnetism sensor are working normally.

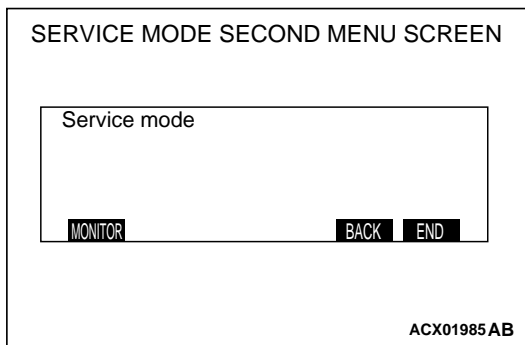
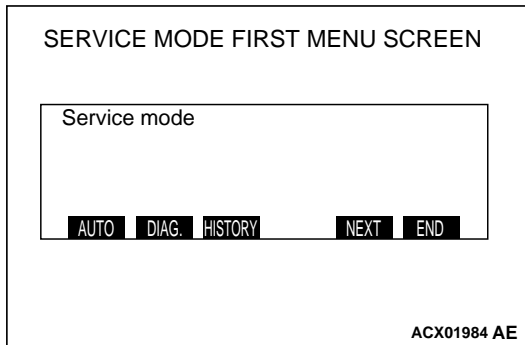

#### Start service function

1. Press the "ADJ" switch with the ignition switch at "LOCK" (OFF) position, and while keeping on pressing, turn the ignition switch to the "ACC" or "ON." position. When the ADJ switch is pressed continuously for more than five seconds, the service function is activated at the same time with the reception signal (pip sound) and the first menu screen of the service mode is displayed.
2. When respective function switches are pressed on this screen, the screen is switched as follows.
  - When the function switch 1 [AUTO] is pressed, the screen is switched to the automatic check mode.
  - When the function switch 2 [DIAG] is pressed, the screen is switched to the diagnosis mode.
  - When the function switch 3 [HISTORY] is pressed, the screen is switched to the history mode.
  - When the "ADJ" switch [NEXT] is pressed, the screen is switched to the service mode second menu screen.
  - When the "DISP" switch [NEXT] is pressed, the service mode is terminated.
3. When the function switch 1 is pressed on this screen, the screen is switched as follows.
  - When the function switch 1 [MONITOR] is pressed, the screen is switched to the monitor check mode.
  - When the "ADJ" switch [BACK] is pressed, the screen is switched to the service mode first menu screen.
  - When the "DISP" switch [END] is pressed, the service mode is terminated.

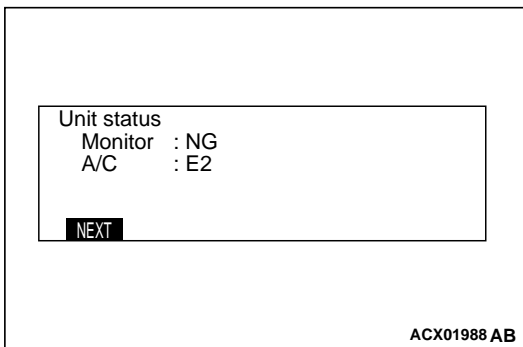
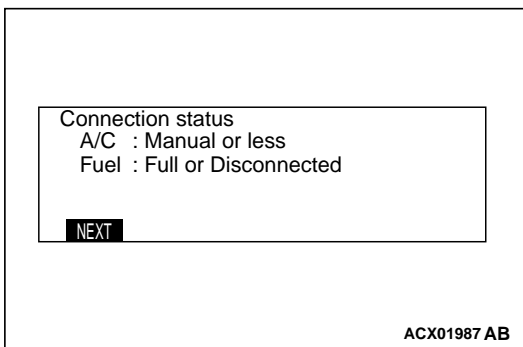
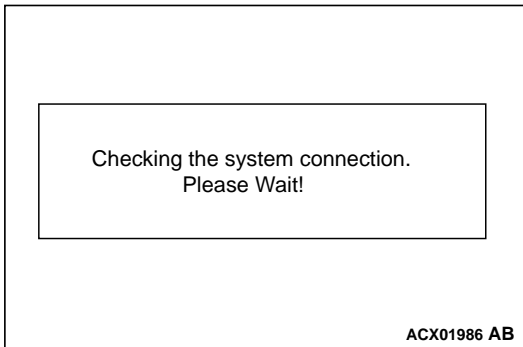
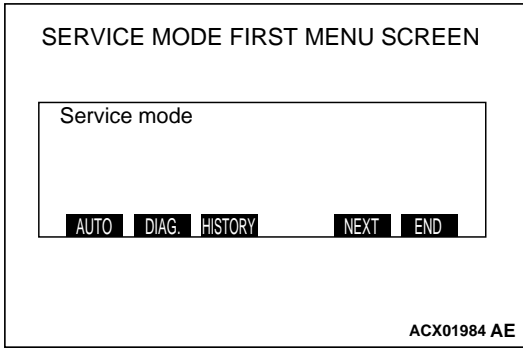

**Automatic check mode**

1. Press the "ADJ" switch with the ignition switch at "LOCK" (OFF) position, and while keeping on pressing, turn the ignition switch to the "ACC" or "ON." position. When the "ADJ" switch is pressed continuously for more than five seconds, the service function is activated at the same time with the reception signal (pip sound) and the first menu screen of the service mode is displayed.
2. Press the function switch 1 [AUTO] on the service mode first menu screen. The screen is switched to the automatic check mode. Follow the on-screen instructions to turn the ignition switch to "ON." position.
3. Press the ignition switch is turned "ON." The communication and connection checks are performed. The checks will be finished with 10 seconds.

4. After the communication check and connection check are completed, the check results are displayed. Air-conditioner input (Auto, manual or less are displayed.) Fuel gauge input (OK, full or disconnected are displayed.)

**NOTE:**

*Auto: Automatic A/C*

*Manual or less: No-automatic A/C circuit or automatic A/C circuit open*

*OK: Some fuel in tank.*

*Full or Disconnected: Full tank of fuel or fuel level circuit open.*

5. Press the function switch 1 [NEXT]. The unit status is displayed.

**NOTE:**

*Monitor: RV meter*

*A/C: Automatic A/C*

DISPLAY EXAMPLE	CONTENTS OR CONDITION
OK	System check OK
NG	Some kind of error exists, further diagnosis required
E1	Communication error
E2	Open circuit or disconnected

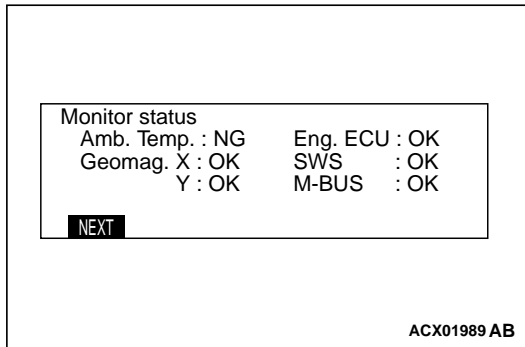

6. Press the function switch 1 [NEXT] on this screen. The inner status of the monitor is displayed.

**NOTE:**

*Amb.:* Outside air temperature sensor

*Geomag.:* Geomagnetic sensor

*Eng. ECU:* Powertrain control module.

*SWS:* Simplified Wiring System

*M-BUS:* Communications for A/C-ECU

DISPLAY EXAMPLE	CONTENTS OR CONDITION
OK	System check OK
NG	Some kind of error exists, further diagnosis required
E1	Communication error
E2	Open circuit or disconnected

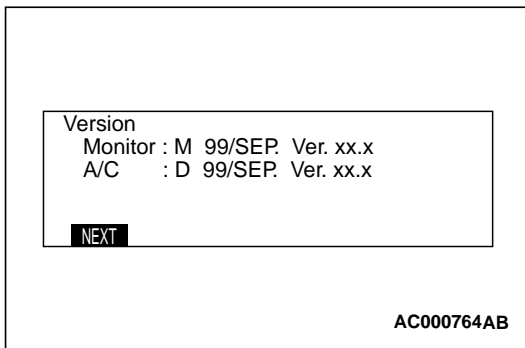

7. Press the function switch 1 [NEXT] on this screen. The versions of monitor and the automatic air-conditioner (if equipment) are displayed. In the case of air-conditioner-less or manual air-conditioner, the version is not displayed.

**NOTE:**

*M:* Mitsubishi Electric

*D:* Denso

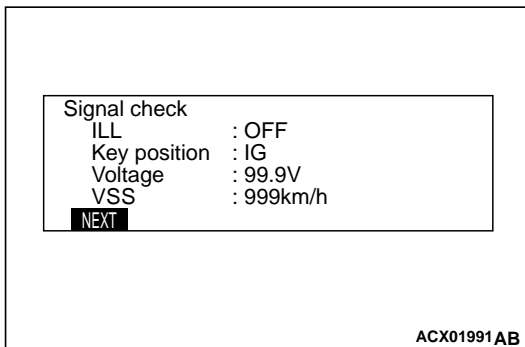

8. Press the function switch 1 [NEXT] on this screen. The vehicle signal status is displayed.

- ILL: ON or OFF
- Key position: "ACC" or "IG"
- Voltage: Battery voltage
- VSS: Vehicle speed

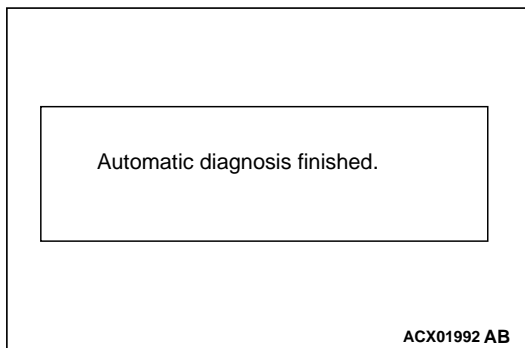

9. Press the function switch 1 [NEXT] on this screen. The message stating [Automatic diagnosis finished.] is displayed and within seven seconds later the screen moves to the screen just before the service mode screen.

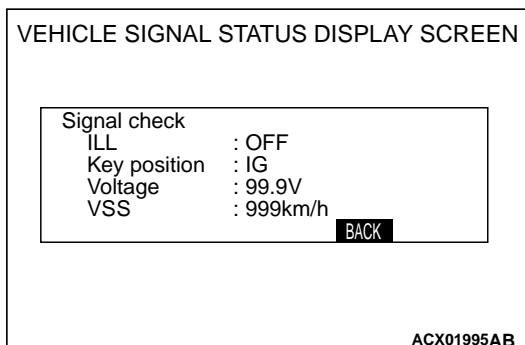
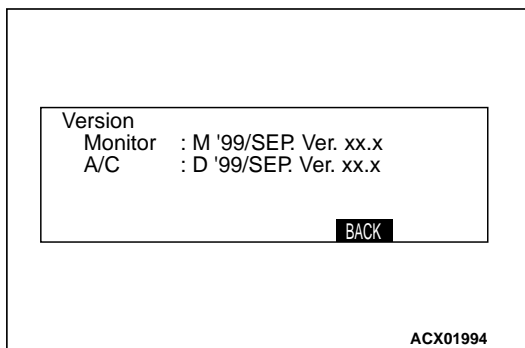
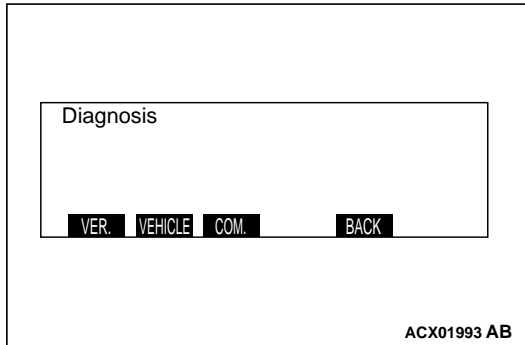
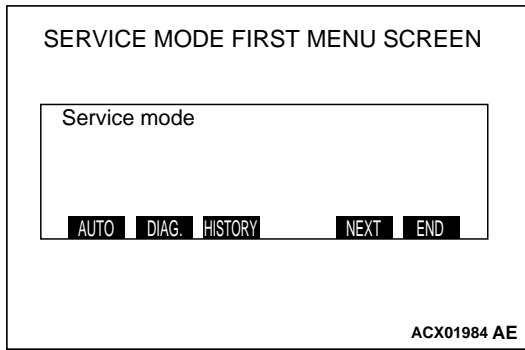

### Diagnosis mode

1. Press the "ADJ" switch with the ignition switch at "LOCK" (OFF) position, and while keeping on pressing, turn the ignition switch to the "ACC" or "ON" position. When the "ADJ" switch is pressed continuously for more than five seconds, the service function is activated at the same time with the reception signal (pip sound) and the first menu screen of the service mode is displayed.
2. Press the function switch 2 [DIAG]. The screen is switched to the diagnosis mode.
3. When respective function switches are pressed, the screen is switched as follows.
  - When the function switch 1 [VER.] is pressed, versions of the monitor and the air-conditioner are displayed.
  - When the function switch 2 [VEHICLE] is pressed, the status of the vehicle signal is displayed.
  - When the function switch 3 [COM.] is pressed, the communication and the connection are checked and the results are displayed.
  - When the "ADJ" switch is pressed, the screen returns to the service mode second menu screen.
4. Version display screen  
Press the function switch1 [VER.]. In the case of No-automatic A/C circuit or automatic A/C circuit open, version is not displayed. Press "AD" J [BACK], returns to Diagnosis display.  
*NOTE:*  
*M: Mitsubishi Electric*  
*D: Denso*
5. Vehicle signal status display screen. Press the function switch 2 [VEHICLE]. Press "ADJ" [BACK], returns to Diagnosis display.



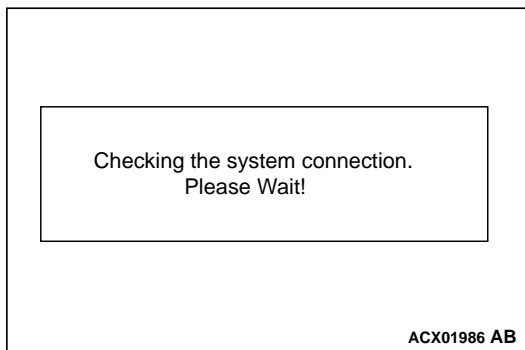

- Press the function switch 3 [COM.]. When the ignition key is at "ACC" position, turn the ignition switch to "ON". Refer to "Automatic check mode". The check will be finished within 10 seconds after ignition switch "ON" or pressing the function switch 3[COM.].

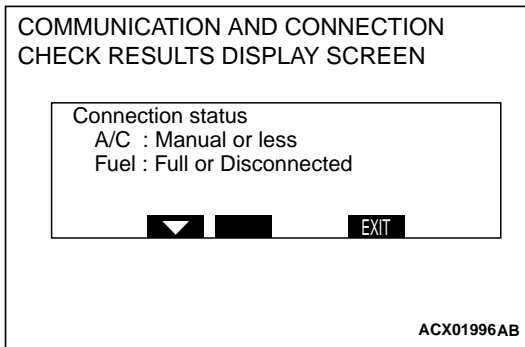

- Communication and connection check results display screen

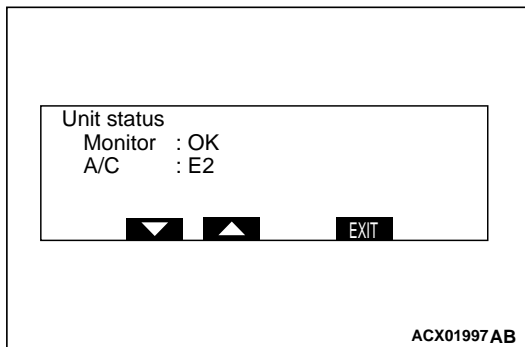

- When the function switch 2 is pressed on this screen, the unit status is displayed.

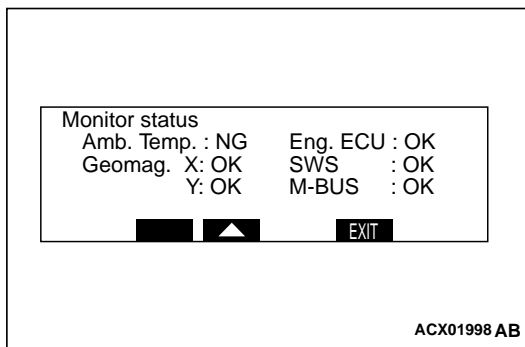

- When the function switch 2 is pressed on this screen, the inner status of the monitor is displayed.
- Press the function switch 3 on this screen, unit status displayed. The inner status of the monitor is displayed.
- Press the function switch "ADJ" [EXIT] to return to diagnosis menu.
- Press the function switch "ADJ" [BACK] to service mode first menu.

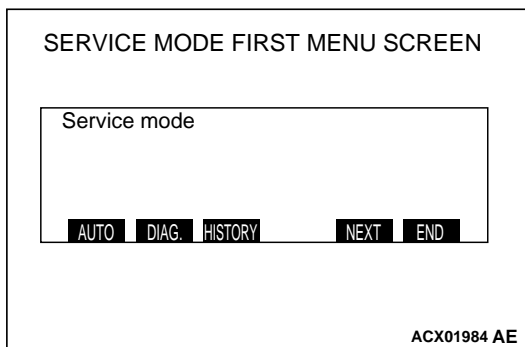
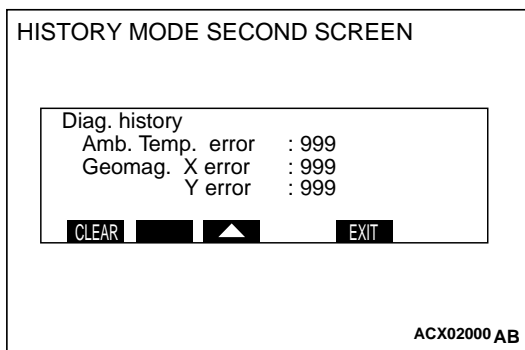
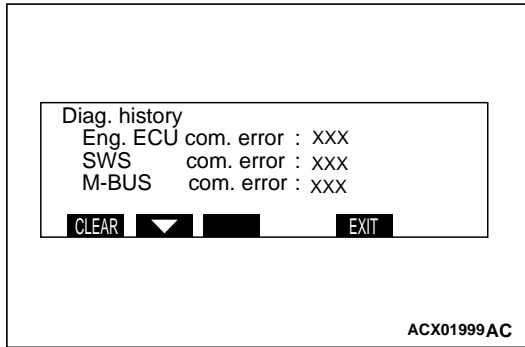
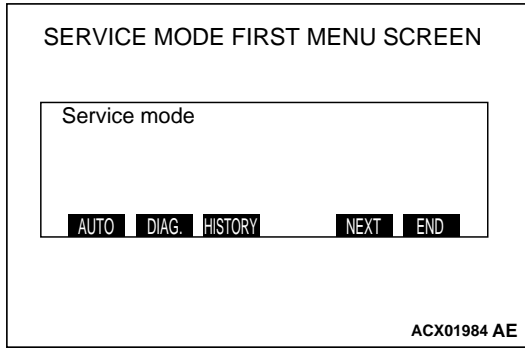

**History mode**

1. Press the "ADJ" switch with the ignition switch at "LOCK" (OFF) position, and while keeping on pressing, turn the ignition switch to the "ACC" or "ON" position. When the "ADJ" switch is pressed continuously for more than five seconds, the service function is activated at the same time with the reception signal (pip sound) and the first menu screen of the service mode is displayed.
2. Press the function switch 3 [HISTORY]. The screen is switched to the history mode.

ITEM	DISPLAY EXAMPLE	CONTENTS OR CONDITION
Engine-ECU (Powertrain control module) SWS M-BUS	000	Number of communication errors

3. Press the function switch 1 [CLEAR] on this screen, The number of errors is erased; when the function switch 2 is pressed, the screen is switched to the history mode second menu screen. When [EXIT] is pressed, the service mode display returns.

ITEM	DISPLAY EXAMPLE	CONTENTS OR CONDITION
Amb. Temp Geomag. X, Y	000	Number of connection errors

4. When the function switch 1 [CLEAR] is pressed on this screen, the number of errors is erased; when the function switch 2 is pressed, the screen switched to the history mode first menu screen. When [EXIT] is pressed, the service mode display returns.

**Monitor check mode**

1. Press the "ADJ" switch with the ignition switch at "LOCK" (OFF) position, and while keeping on pressing, turn the ignition switch to the "ACC" or "ON" position. When the "ADJ" switch is pressed continuously for more than five seconds, the service function is activated at the same time with the reception signal (pip sound) and the first menu screen of the service mode is displayed.

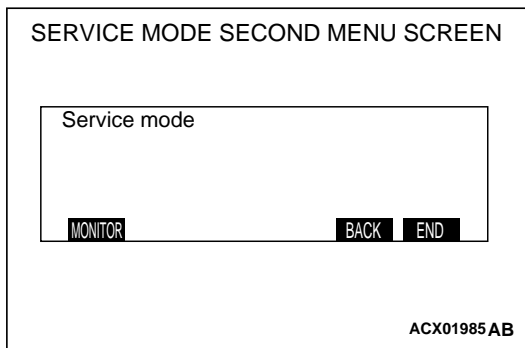

2. Press the "ADJ" [NEXT] switch.  
The screen is switched to the service mode second menu screen.

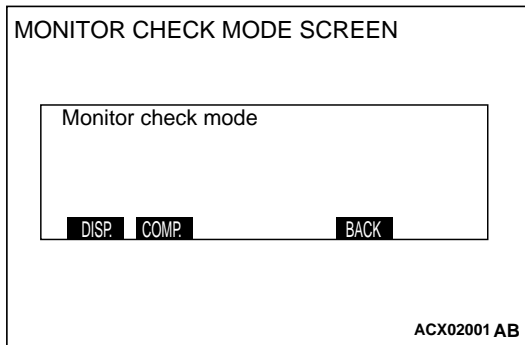

3. Press the function switch 1 [MONITOR]. The screen is switched to the monitor check mode.
4. When respective function switches are pressed on this screen, the screen is switched as follows.
  - When the function switch 1 [DISP.] is pressed, the screen is switched to the display check mode.
  - When the function switch 2 [COMP.] is pressed, the screen changes to the geomagnetic sensor check mode.
  - When the "ADJ" switch is pressed, the screen changes to the service mode second menu screen.

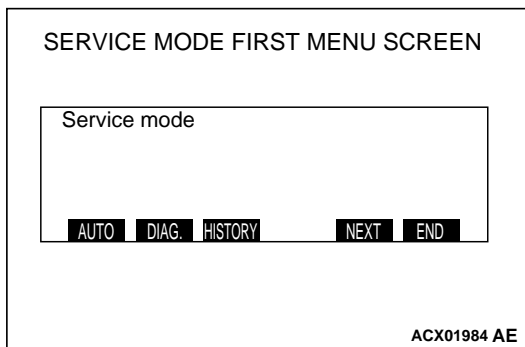

#### Display check mode

1. Press the "ADJ" switch with the ignition switch at "LOCK" (OFF) position, and while keeping on pressing, turn the ignition switch to the "ACC" or "ON" position. When the "ADJ" switch is pressed continuously for more than five seconds, the service function is activated at the same time with the reception signal (pip sound) and the first menu screen of the service mode is displayed.

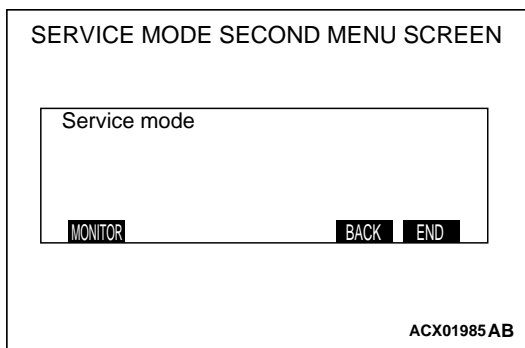

2. Press the "ADJ" [NEXT] switch is pressed. The screen changes to the service mode second menu screen.

MONITOR CHECK MODE SCREEN

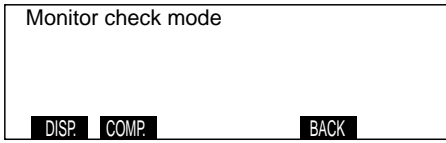

ACX02001 AB

COLOR BAR

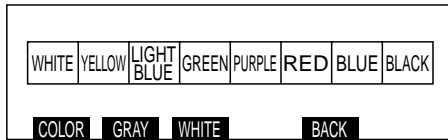

ACX02006 AB

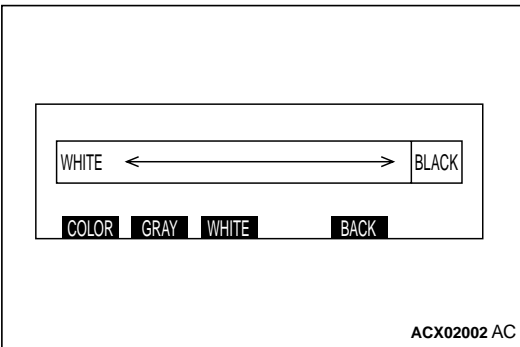

ACX02002 AC

WHITE



ACX02003 AB

3. Press the function switch 1 [MONITOR]. The screen is switched to the monitor check mode.
4. Press the function switch 1 [DISP] on the monitor check mode screen. The screen changes to the display check mode screen. When respective function switches are pressed on this screen, the screen changes as follows.

- When the function switch 1 [COLOR] is pressed, the color bar is displayed.

- When the function switch 2 [GRAY] is pressed, the gray scale is displayed.

- When the function switch 3 [WHITE] is pressed, the white screen is displayed.
- When the "ADJ" [BACK] is pressed, the service mode display returns.

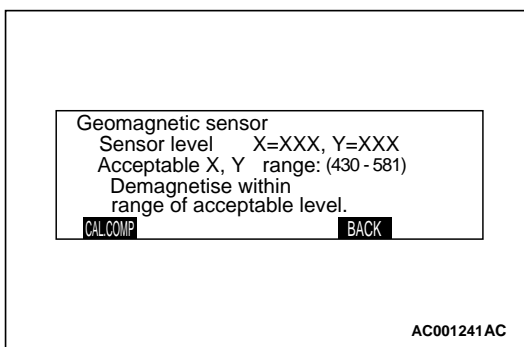
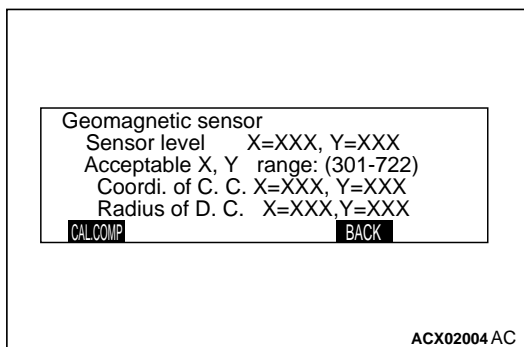
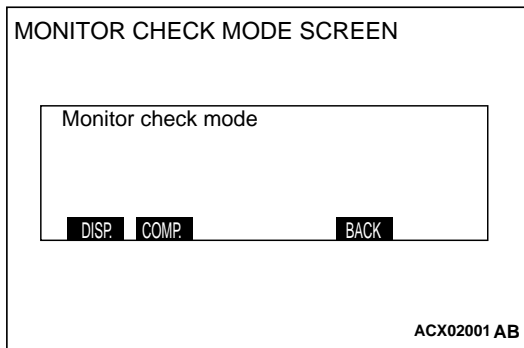
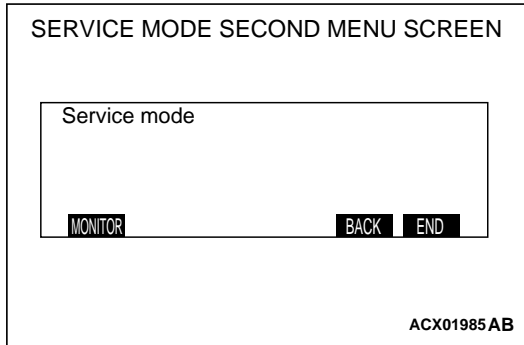
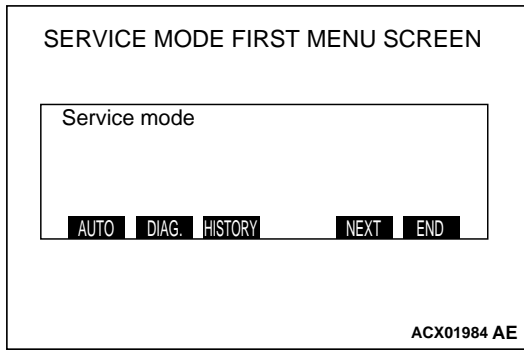

**Geomagnetic sensor check mode**

1. Press the "ADJ" switch with the ignition switch at "LOCK" (OFF) position, and while keeping on pressing, turn the ignition switch to the "ACC" or "ON" position. When the "ADJ" switch is pressed continuously for more than five seconds, the service function is activated at the same time with the reception signal (pip sound) and the first menu screen of the service mode is displayed.
2. Press the "ADJ" switch [next].  
The screen changes to the service mode second menu screen.
3. Press the function switch 1 [MONITOR] on the service mode second menu screen.  
The screen is switched to the monitor check mode.
4. Press the function switch 2 [COMP.].
  - <Normal case that the body is not magnetized>  
The geomagnetic sensor mode screen is displayed. Each of X- and Y-outputs of the geomagnetic sensor, center coordinates, and radius of the direction circle are displayed. For degeomagnetization, refer to [P.54A-233](#).
  - <Case that the body is magnetized>  
If the sensor value is outside the range between 450 and 580, it is meant that the body is magnetized. The screen that calls upon to demagnetize the body stating "Demagnetize within range of acceptable level" is displayed. In this case, it is necessary to demagnetize the body and to correct the geomagnetic sensor. Refer to on-vehicle service-vehicle magnetic compensation [P.34-6](#).

- When function switch 1 [CAL.COMP] is pressed at the previous screen, a message of urging rotation compensation is displayed. For the method of magnetization compensation by rotation, refer to [P.54A-233](#).

### Release of service mode

The service mode is released by pressing the "DISP" switch [END] is pressed on the service mode first screen or the service mode second screen, or by turning the ignition switch to the "LOCK" (OFF) position.

## BATTERY DISCONNECTION

When the battery cable is disconnected, the stored data may disappear. In that case, the system connection should be checked using the procedure described below

### Checking connection of system

When the connection data has disappeared, turning the ignition key to "ACC" position will make the following message appear.

1. Start the engine (or turn the ignition key to "ON" position).
2. When the engine is started or when the ignition key is in the "ON" position, the monitor will display the message.
3. After a short while the system will beep. When the connection is completed, the message will be displayed.

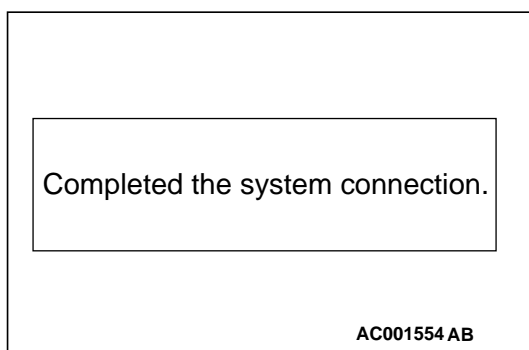
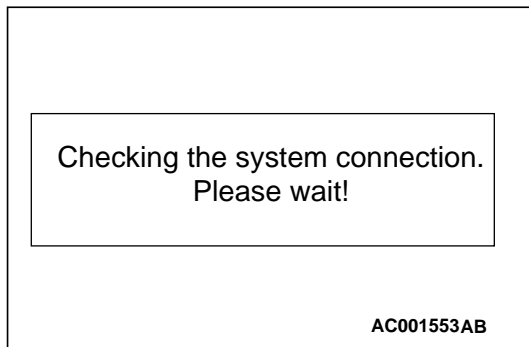
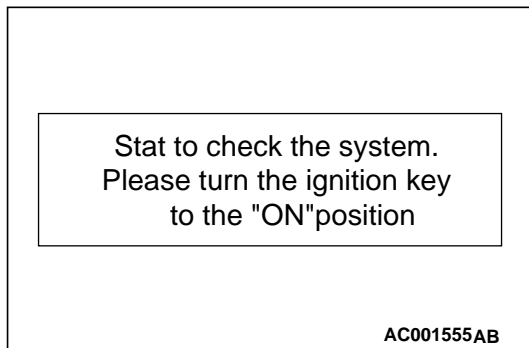

**SYMPTOM CHART**

M1543007200384

<b>SYMPTOMS</b>	<b>INSPECTION PROCEDURE</b>	<b>REFERENCE PAGE</b>
The RV meter does not shown any information	1	<a href="#">P.54A-200</a>
The low battery warning screen is displayed.	2	<a href="#">P.54A-207</a>
The abnormal drive range is displayed.	3	<a href="#">P.54A-210</a>
The ambient temperature is not displayed normally.	4	<a href="#">P.54A-217</a>
The compass does not indicate normally.	5	<a href="#">P.54A-224</a>
The air-conditioner information is not displayed.	6	<a href="#">P.54A-225</a>

SYMPTOM PROCEDURES

INSPECTION PROCEDURE 1: The RV Meter does not Show Any Information.

RV Meter Power Supply Circuit

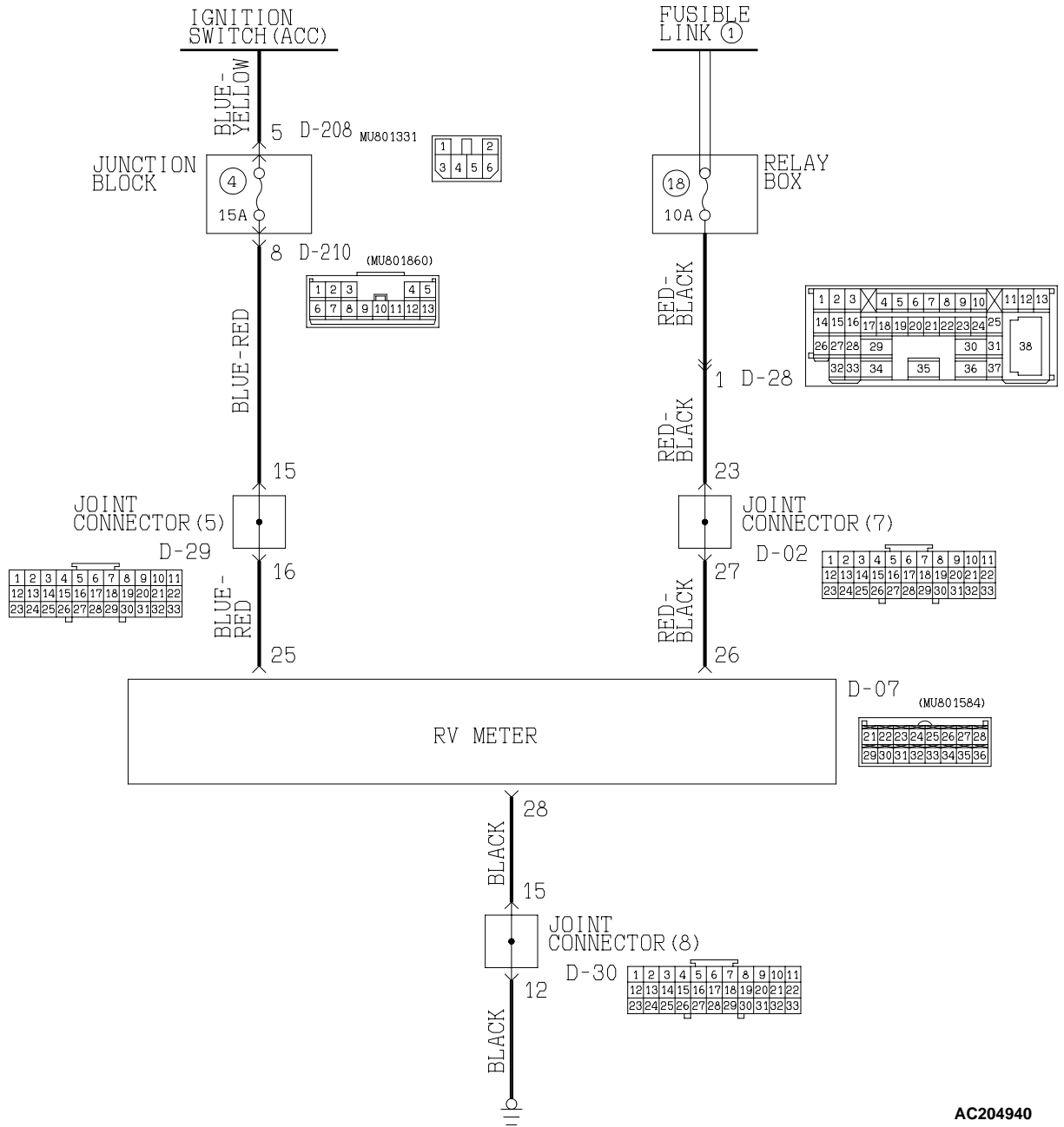

AC204940



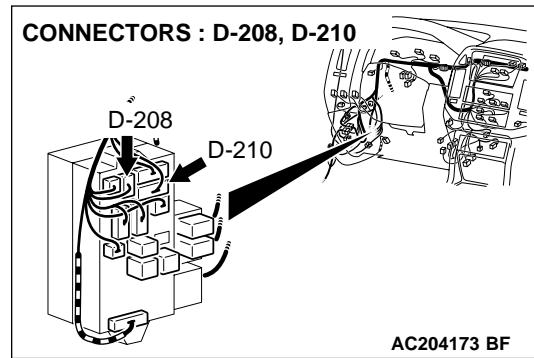
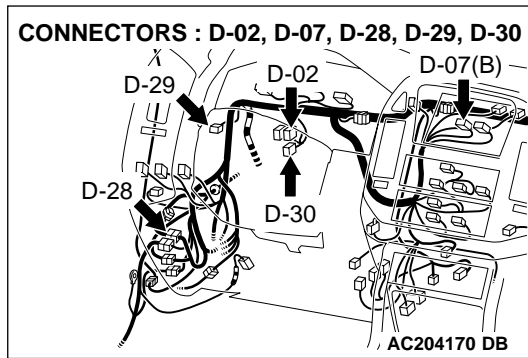

**CIRCUIT OPERATION**

The RV meter is energized by the battery through the ignition switch (ACC) and (IG1).

**TECHNICAL DESCRIPTION (COMMENT)**

The ground circuit, the battery circuit, the ignition switch (ACC) circuit or the ignition switch (IG1) circuit is suspected to be open or defective.

**TROUBLESHOOTING HINTS**

- Malfunction of the RV meter
- Damaged harness wires and connectors

**DIAGNOSIS**

**Required Special Tool:**

- MB991223: Harness Set

**STEP 1. Check the RV meter ground circuit at the RV meter connector D-07 by backprobing.**

(1) Do not disconnect the RV meter connector D-07.

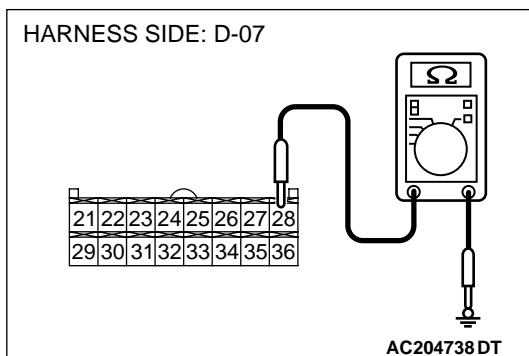
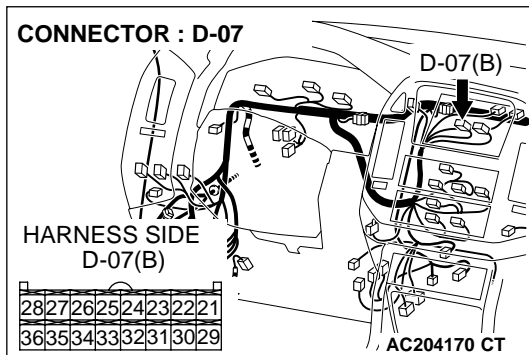

(2) Measure the resistance between terminal 28 and ground by backprobing.

**Q: Is the resistance value less than 2 ohms?**

**YES :** Go to Step 4.

**NO :** Go to Step 2.

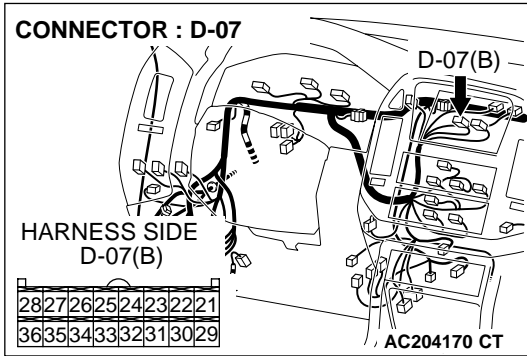

**STEP 2.** Check the RV meter connector D-07 for loose, corroded or damaged terminals, or terminals pushed back in the connector.

**Q:** Is the RV meter connector D-07 in good condition?

**YES :** Go to Step 3.

**NO :** Repair or replace it. Refer to GROUP 00E, Harness Connector Inspection [P.00E-2](#).

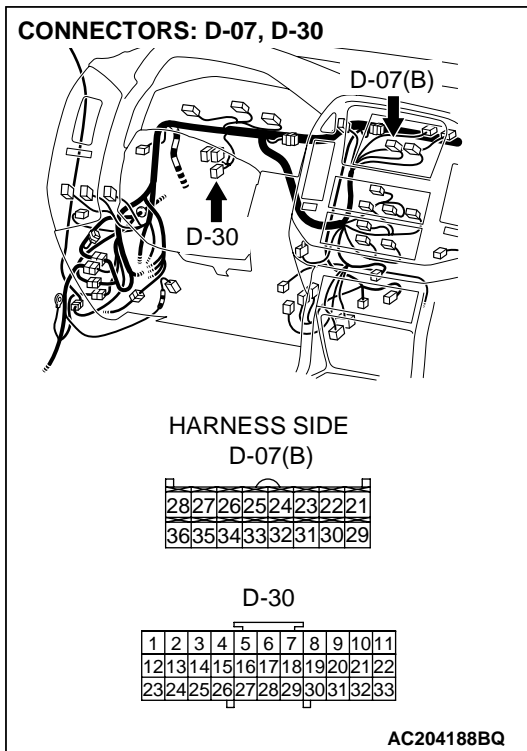

**STEP 3.** Check the harness wires between RV meter connector D-07 (terminal 28) and ground.

*NOTE:* Also check joint connectors D-30, check the wires. If joint connectors D-30 is damaged, repair or replace it. Refer to GROUP 00E, Harness Connector Inspection [P.00E-2](#).

**Q:** Is the harness wires between RV meter connector D-07 (terminal 28) and ground in good condition?

**YES :** Go to Step 4.

**NO :** Replace the RV meter. The RV meter should work normally.

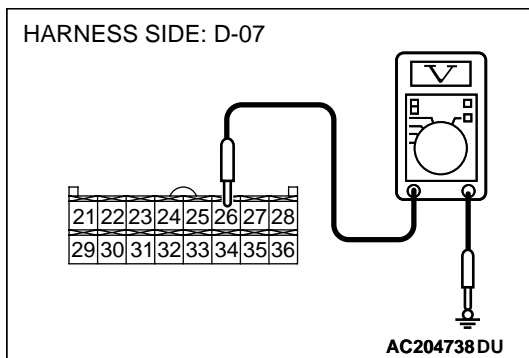
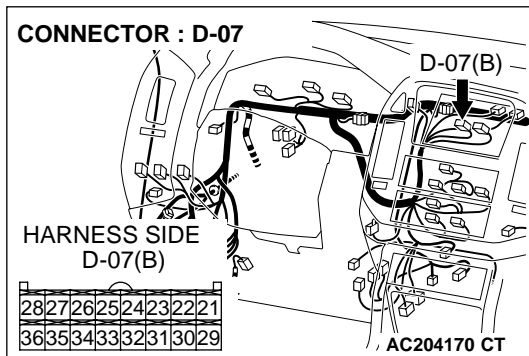

**STEP 4. Check the RV meter power supply circuit (battery) at the RV meter connector D-07 by backprobing.**

(1) Do not disconnect the RV meter connector D-07.

(2) Measure the voltage between terminal 26 and ground by backprobing.

**Q: Is the voltage approximately 12 volts (battery positive voltage)?**

**YES :** Go to Step 7.

**NO :** Go to Step 5.

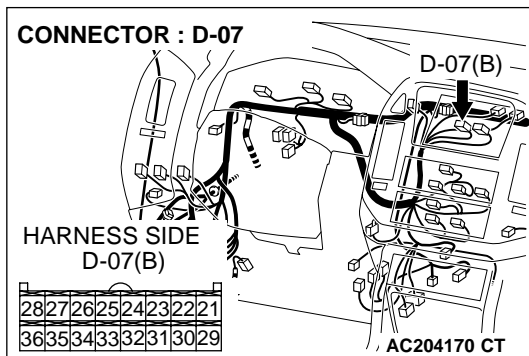

**STEP 5. Check RV meter connector D-07 for loose, corroded or damaged terminals, or terminals pushed back in the connector.**

**Q: Is RV meter connector D-07 in good condition?**

**YES :** Go to Step 6.

**NO :** Repair or replace it. Refer to GROUP 00E, Harness Connector Inspection [P.00E-2](#). The RV meter should work normally.

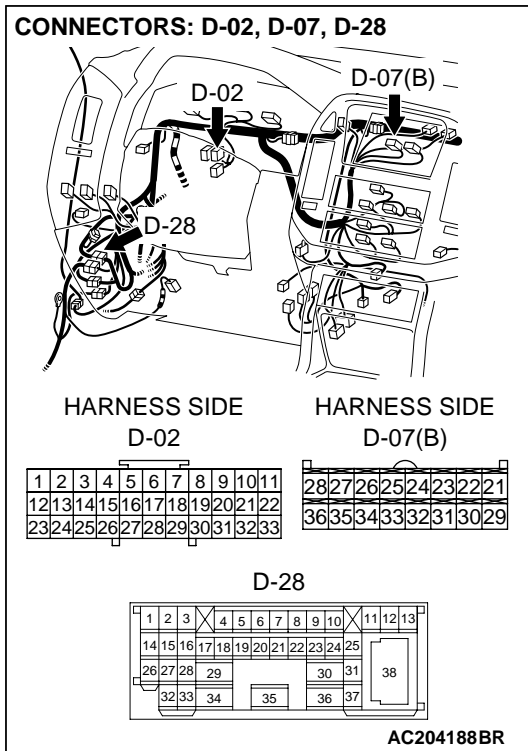

**STEP 6. Check the harness wires between D-07 (terminal 26) and battery.**

*NOTE: Also check joint connector D-02 and intermediate connector D-28, check the wires. If joint connector D-02 and intermediate connector D-28 are damaged, repair or replace them. Refer to GROUP 00E, Harness Connector Inspection P.00E-2.*

**Q: Is the harness wires between D-07 (terminal 26) and battery in good condition?**

**YES :** There is no action to be taken.

**NO :** Repair them. The RV meter should work normally.

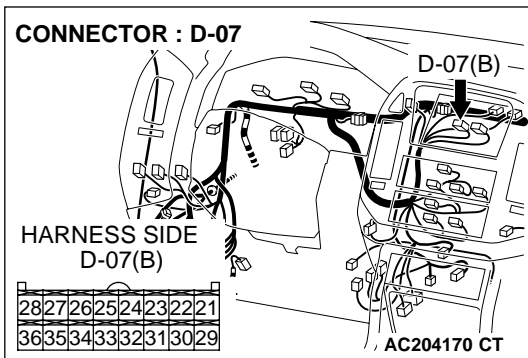

**STEP 7. Check the RV meter power supply circuit [ignition switch (ACC)] at the RV meter connector D-07 by backprobing.**

- (1) Do not disconnect the RV meter connector D-07.
- (2) Turn the ignition switch to "ACC" position.

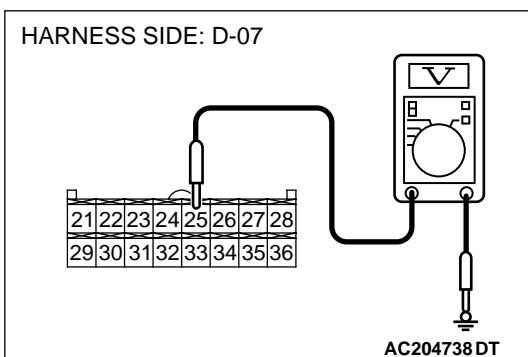

- (3) Measure the voltage between terminal 25 and ground by backprobing.

**Q: Is the voltage approximately 12 volts (battery positive voltage)?**

**YES :** The RV meter should work.

**NO :** Go to Step 8.

**STEP 8.** Check RV meter connector D-07 for loose, corroded or damaged terminals, or terminals pushed back in the connector.

**Q:** Is RV meter connector D-07 in good condition?

**YES :** Go to Step 9.

**NO :** Repair or replace it. Refer to GROUP 00E, Harness Connector Inspection [P.00E-2](#). The RV meter should work normally.

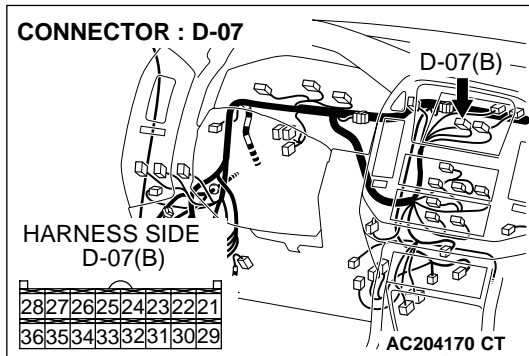

**STEP 9.** Check the harness wires between D-07 (terminal 25) and ignition switch (ACC).

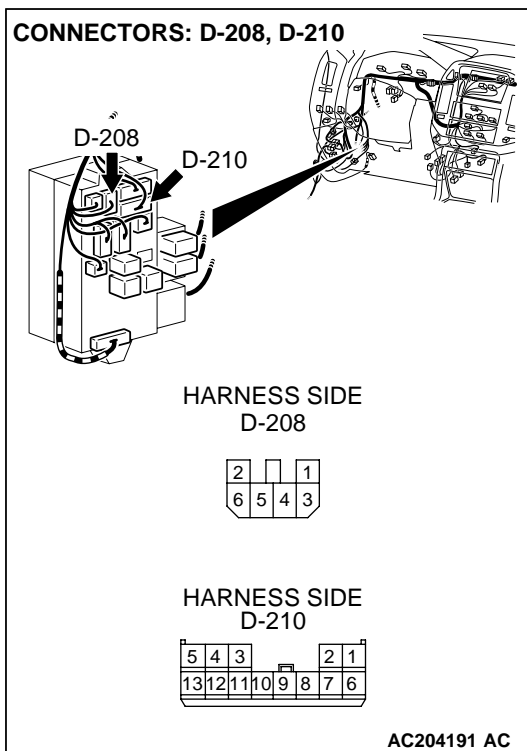
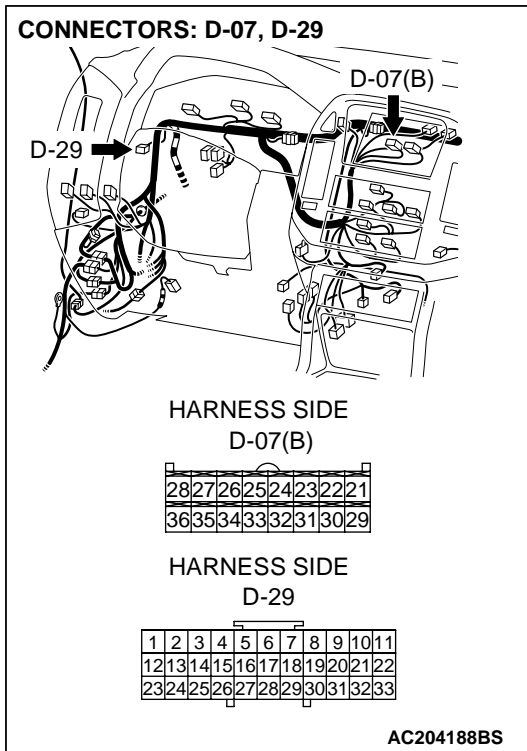

*NOTE: Also check joint connector D-29 and junction block connector D-208 and D-210, check the wires. If joint connector D-29 and junction block connector D-208 and D-210 are damaged, repair or replace them. Refer to GROUP 00E, Harness Connector Inspection P.00E-2.*

**Q:** Is the harness wires between D-07 (terminal 25) and ignition switch (ACC) in good condition?

**YES :** There is no action to be taken.

**NO :** Repair them. The RV meter should work normally.

**STEP 10. Recheck for malfunction.**

**Q: Is a malfunction eliminated?**

**YES :** If no malfunctions are not found in all steps, an intermittent malfunction is suspected. Refer to GROUP 00,How to Use Troubleshooting/Inspection Service Points – How to Cope with Intermittent Malfunction [P.00E-2](#).

**NO :** Replace the RV meter.

**INSPECTION PROCEDURE 2: The Low Battery Warning Screen is Displayed.**

RV Meter Power Supply Circuit

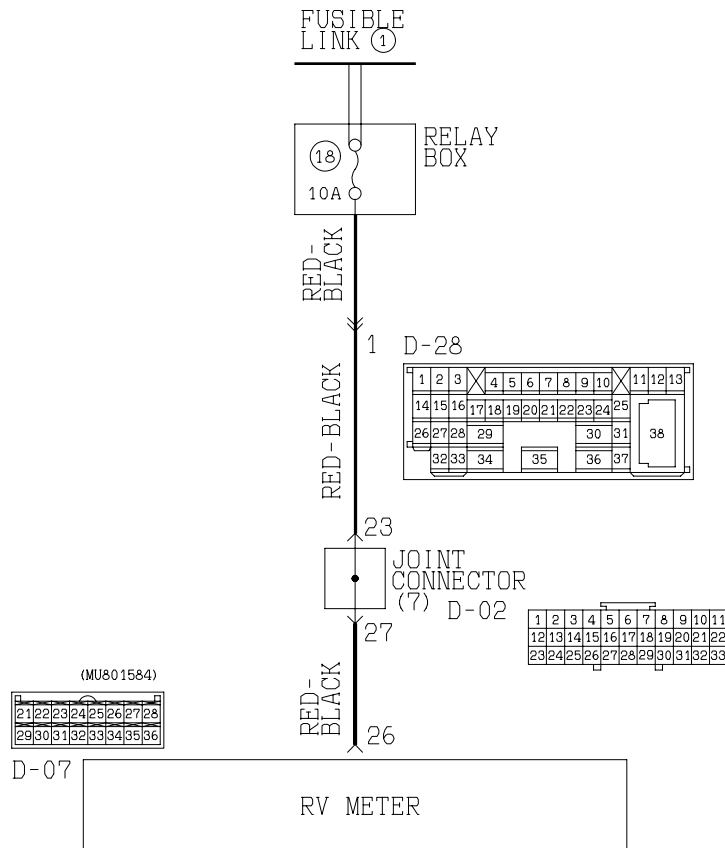

AC204943

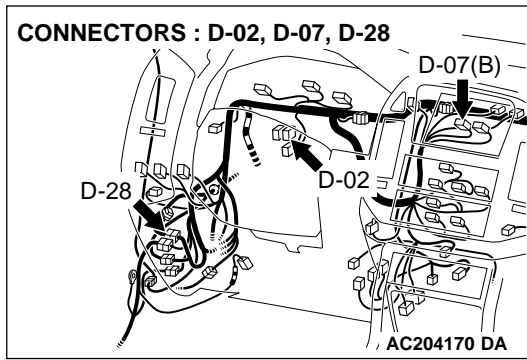

**CIRCUIT OPERATION**

The RV meter is energized by the battery.

**TECHNICAL DESCRIPTION (COMMENT)**

the battery circuit is suspected to be open or defective.

**TROUBLESHOOTING HINTS**

- Malfunction of the battery
- Damaged harness wires and connectors

**DIAGNOSIS**

**Required Special Tool:**

- MB991223: Harness Set

**STEP 1. Check the RV meter power supply.**

**Q: Is the abnormal voltage screen displayed immediately after the ignition switch is turned to the ACC position?**

**YES :** Go to Step 2.

**NO :** There is no action to be taken.

**STEP 2. Check the RV meter battery power supply circuit by backprobing.**

(1) Do not disconnect RV meter connector D-07.

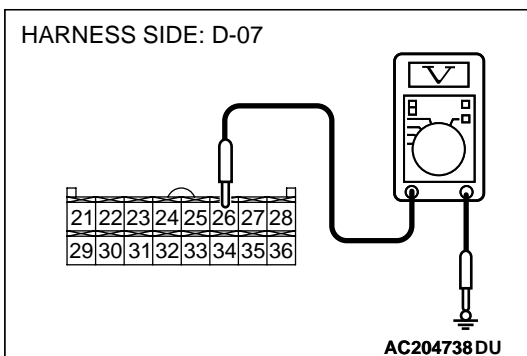
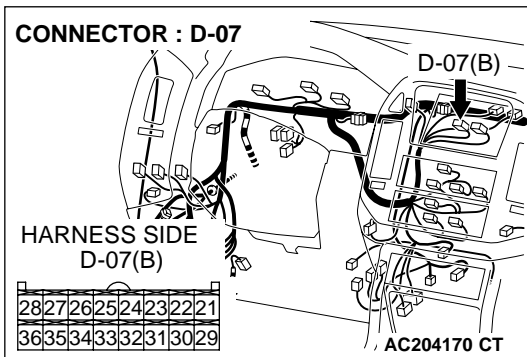

(2) Measure the voltage between terminal 26 and ground by backprobing.

**Q: Is the voltage approximately 12 volts (battery positive voltage)?**

**YES :** There is no action to be taken.

**NO :** Go to Step 3.



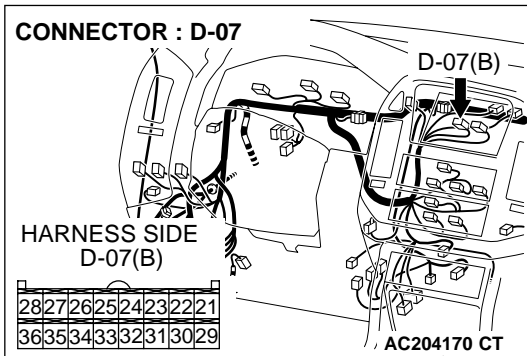

**STEP 3.** Check RV meter connector D-07 for loose, corroded or damaged terminals, or terminals pushed back in the connector.

**Q:** Are RV meter connector D-07 in good condition?

**YES :** Go to Step 4.

**NO :** Repair or replace it. Refer to GROUP 00E, Harness Connector Inspection [P.00E-2](#). The RV meter display should operate normally.

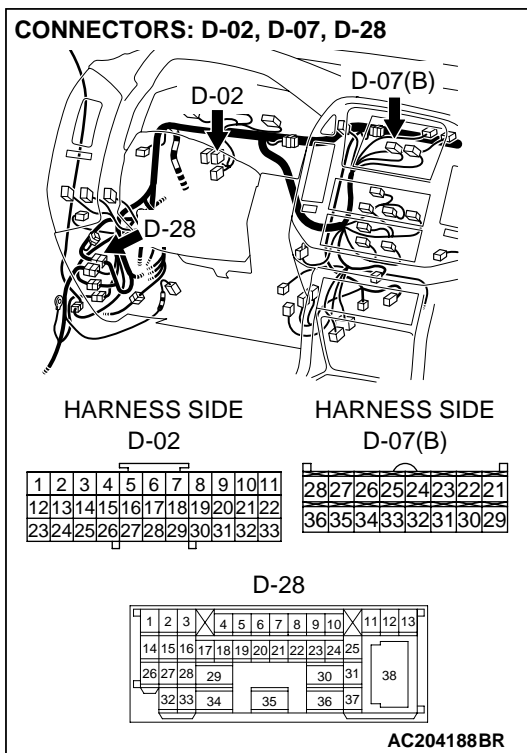

**STEP 4.** Check the harness wires between RV meter connector D-07 (terminal 26) and fusible link (1).

**NOTE:** Also check joint connector D-02 and intermediate connector D-28, check the wires. If joint connector D-02 and intermediate connector D-28 damaged, repair or replace them. Refer to GROUP 00E, Harness Connector Inspection [P.00E-2](#).

**Q:** Are the harness wires between RV meter connector D-07 (terminal 26) and fusible link (1) in good condition?

**YES :** Check the battery. (Refer to [P.54A-4](#).) If the battery condition is normal, go to Step 5.

**NO :** Repair them. The RV meter should operate normally.

**STEP 5.** Recheck for malfunction.

**Q:** Is a malfunction eliminated?

**YES :** If no malfunctions are not found in all steps, an intermittent malfunction is suspected. Refer to GROUP 00, How to Use Troubleshooting/Inspection Service Points – How to Cope with Intermittent Malfunction [P.00-6](#).

**NO :** Replace the RV meter.

INSPECTION PROCEDURE 3: The Abnormal Drive Range is Displayed.

Range Distance Display Circuit

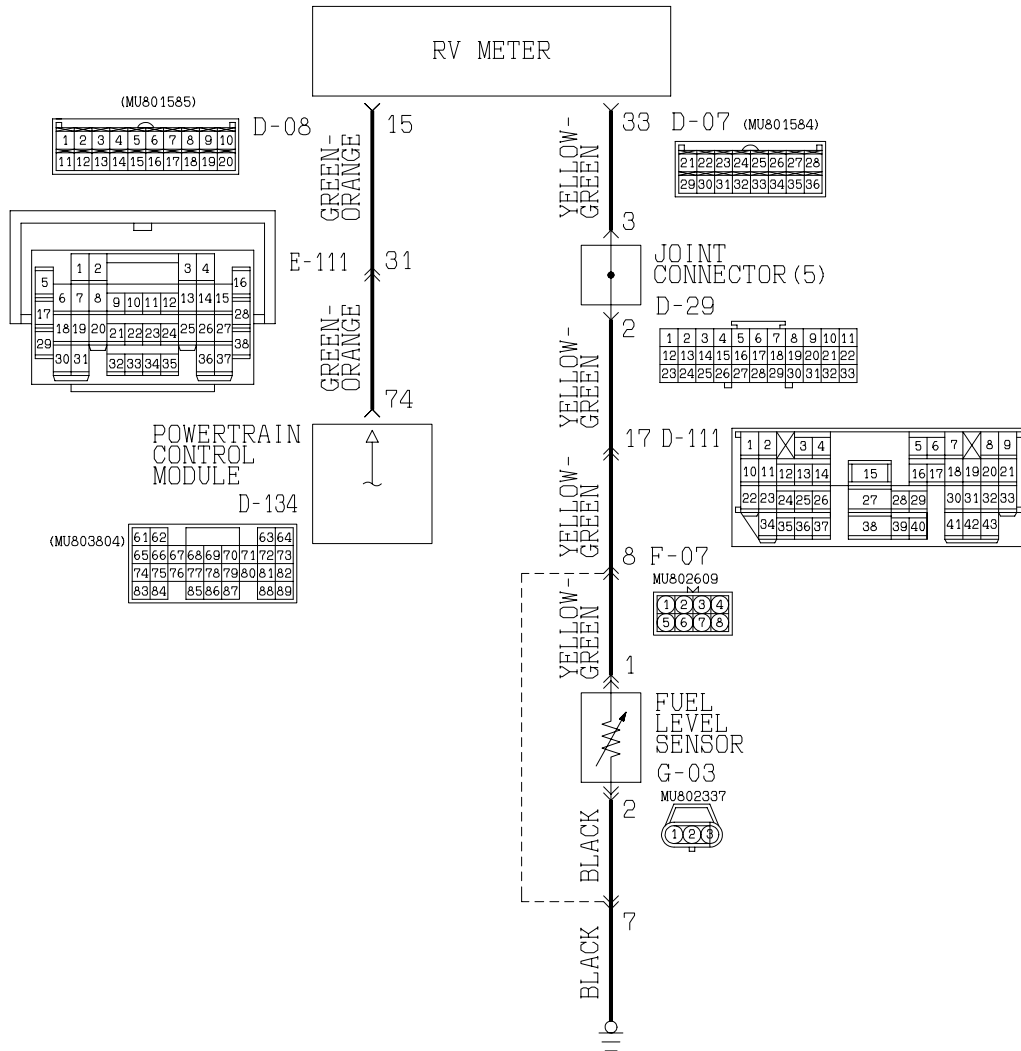

W3017M02AA

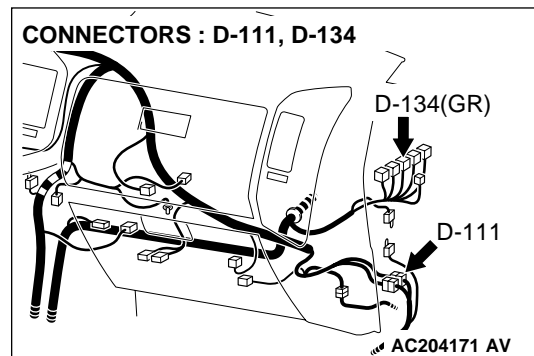
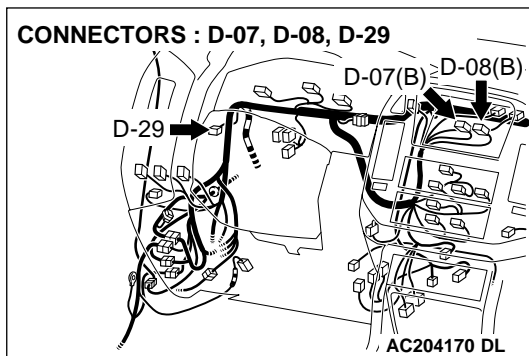

CONNECTOR: E-111

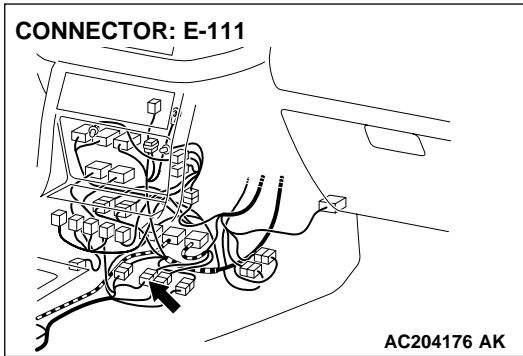

CONNECTOR : F-07

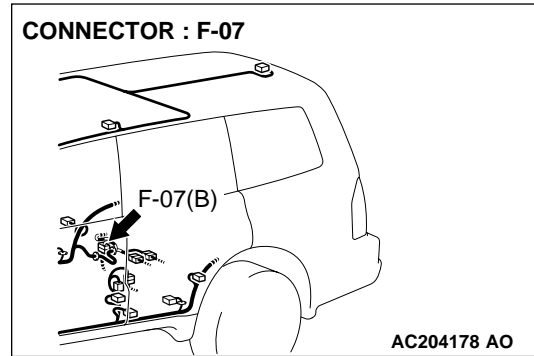

CONNECTOR : G-03

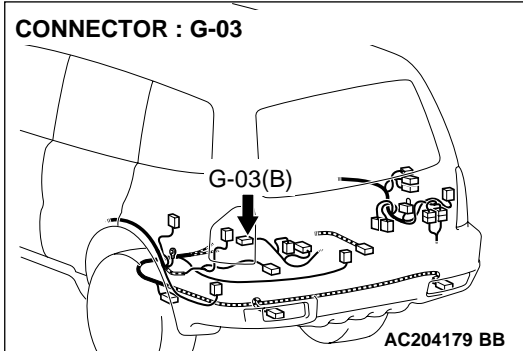

### CIRCUIT OPERATION

The RV meter calculates the drive range, based on the residual fuel quantity signal from the fuel level sensor, receiving the fuel injection quantity data from the power train control module.

### TECHNICAL DESCRIPTION (COMMENT)

When the abnormal vibration of fuel gage pointer in the combination meter is found, the fuel level sensor is considered to be failed.

### TROUBLESHOOTING HINTS

- Malfunction of the fuel level sensor
- Damaged harness wires and connectors

### DIAGNOSIS

#### Required Special Tool:

- MB991223: Harness Set

#### STEP 1. Check the powertrain control module.

**Q:** Is the diagnostic trouble code of the power train control module output?

**YES :** Carry out troubleshooting of the powertrain control module [P.13Ab-22](#).

**NO :** Go to Step 2.

**STEP 2.** Check the RV meter connector D-08 and powertrain control module connector D-134 for loose, corroded or damaged terminals, or terminals pushed back in the connector.

**Q:** Are RV meter connector D-08 and powertrain control module connector D-134 in good condition?

**YES :** Go to Step 3.

**NO :** Repair or replace it. Refer to GROUP 00E, Harness Connector Inspection [P.00E-2](#).

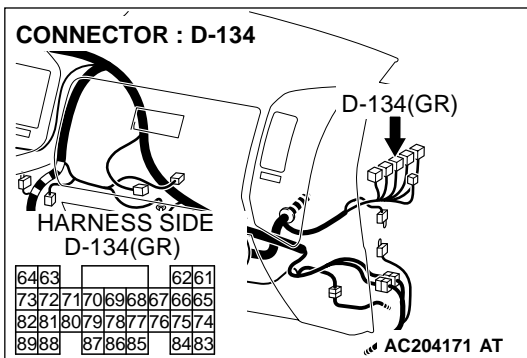
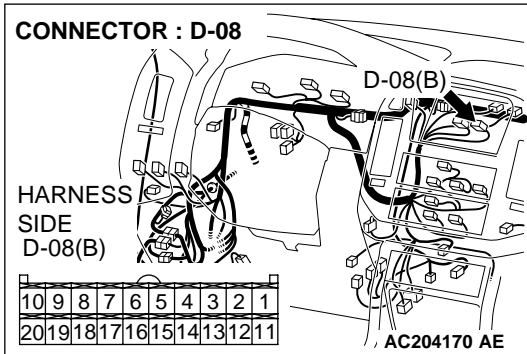

**STEP 3.** Check the harness wires between RV meter connector D-08 (terminal 15) and powertrain control module connector D-134 (terminal 74).

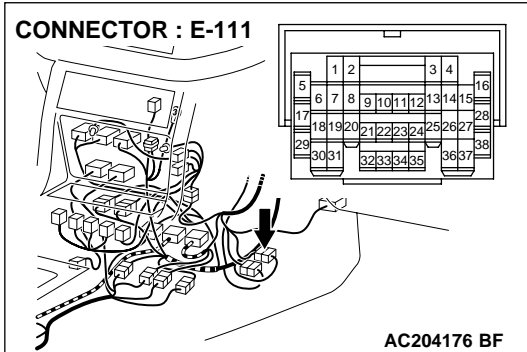
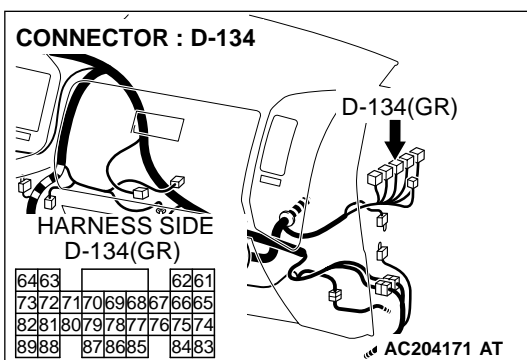
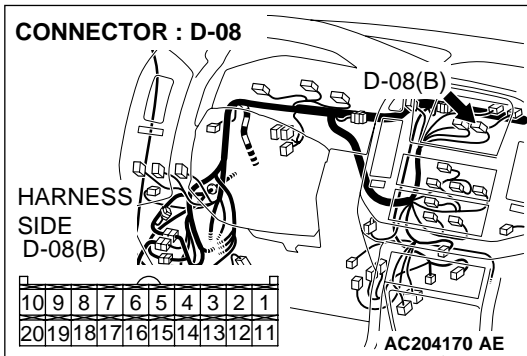

*NOTE: After inspecting intermediate connector E-111 inspect the wires. If intermediate connector E-111 is damaged, repair or replace it. Refer to GROUP 00E, Harness Connector Inspection P.00E-2.*

**Q:** Are the harness wires between RV meter connector D-08 (terminal 15) and powertrain control module connector D-134 (terminal 74) in good condition?

**YES :** Go to Step 4.

**NO :** Repair or replace it. Refer to GROUP 00E, Harness Connector Inspection P.00E-2.

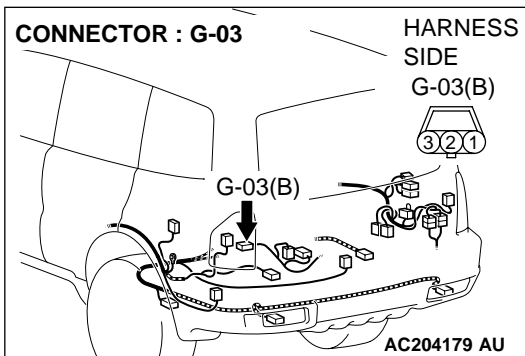
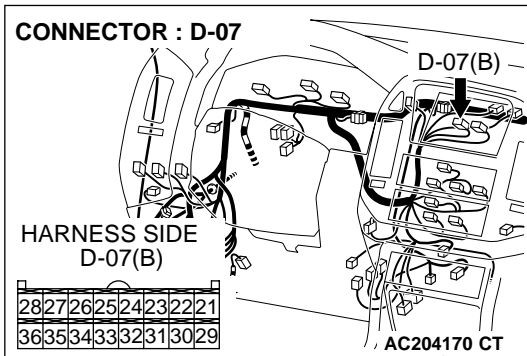

**STEP 4.** Check the RV meter connected D-07 and fuel level sensor connector G-03 for loose, corroded or damaged terminals, or terminals pushed back in the connector.

**Q:** Is the RV meter connected D-07 and fuel level sensor connector G-03 in good condition?

**YES :** Go to Step 5.

**NO :** Repair or replace it. Refer to GROUP 00E, Harness Connector Inspection [P.00E-2](#).

**STEP 5.** Check the harness wires between RV meter connected D-07 (terminal 33) and fuel level sensor connector G-03 (terminal 1).

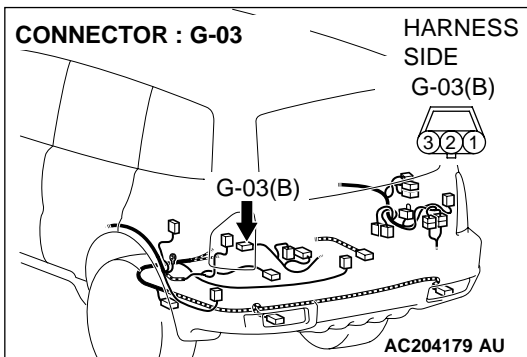
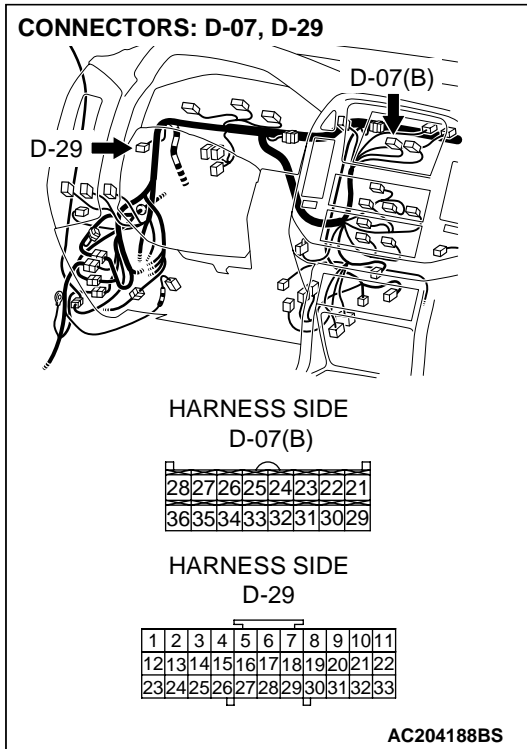

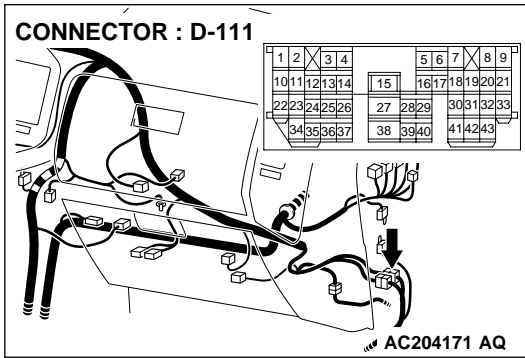

**NOTE:** After inspecting intermediate connector F-07, D-111 and joint connector D-29, inspect the wires. If intermediate connector F-07, D-111 and joint connector D-29 are damaged, repair or replace them. Refer to GROUP 00E, Harness Connector Inspection P.00E-2.

**Q:** Are the harness wires between RV interconnected D-07 (terminal 33) and fuel level sensor G-03 (terminal 1) in good condition?

**YES :** Go to Step 6.

**NO :** Repair them. The RV meter should operate normally.

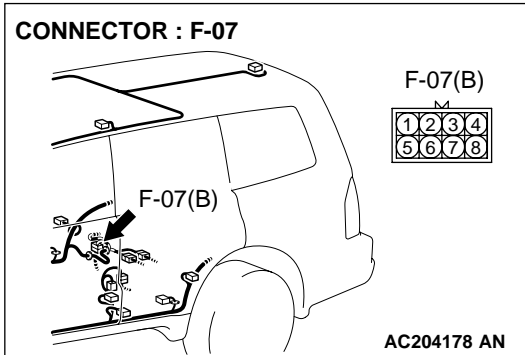

#### STEP 6. Recheck for malfunction.

**Q:** Is a malfunction eliminated?

**YES :** If no malfunctions are not found in all steps, an intermittent malfunction is suspected. Refer to GROUP 00, How to Use Troubleshooting/Inspection Service Points – How to Cope with Intermittent Malfunction P.00-6.

**NO :** Replace the RV meter.



INSPECTION PROCEDURE 4: The outside air Temperature is not Displayed Normal.

Outside Air Temperature Sensor Circuit

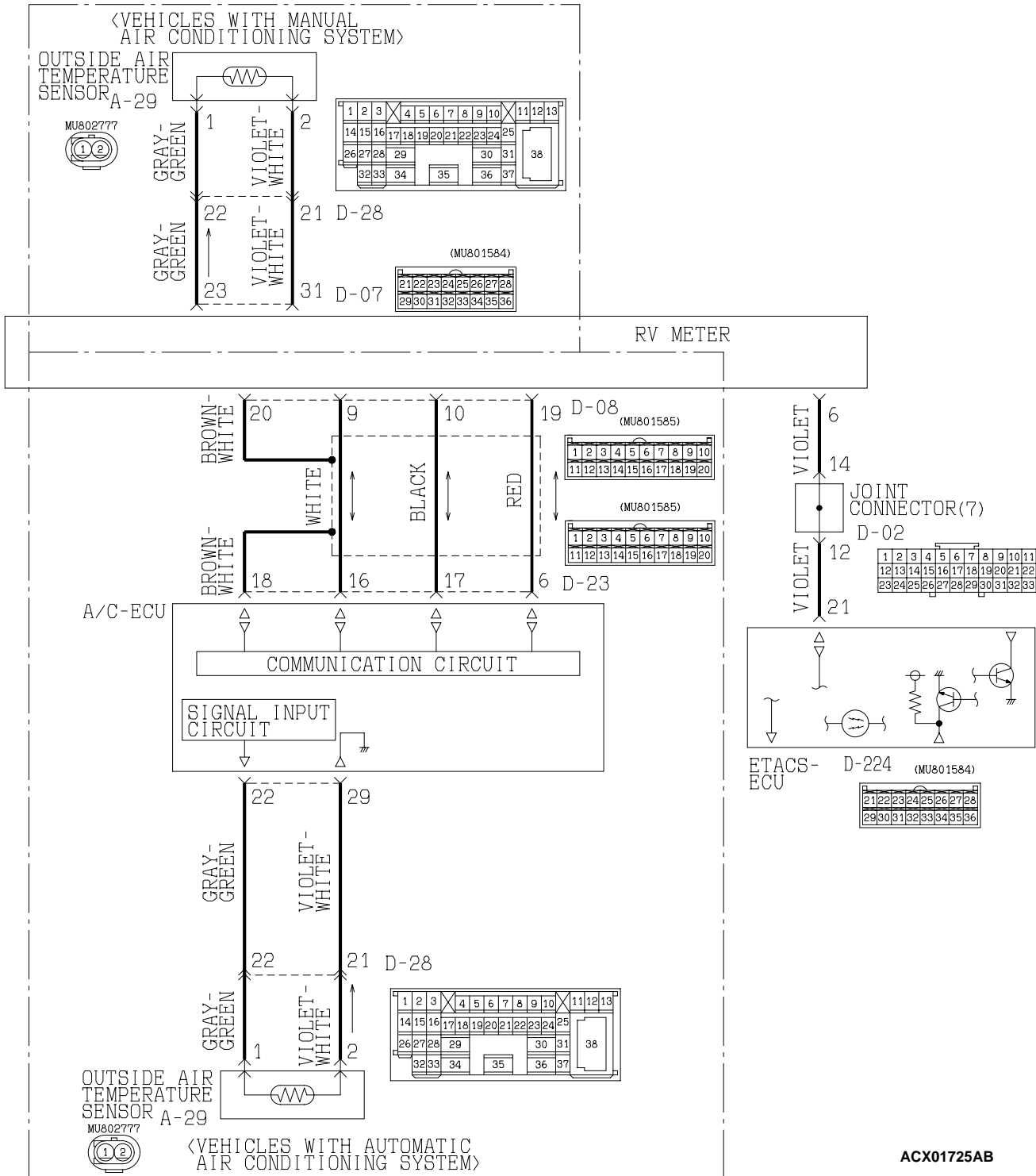

ACX01725AB

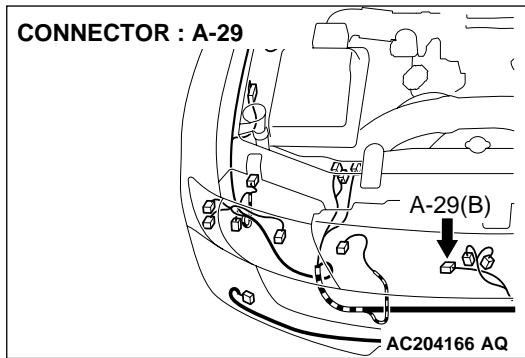
**CIRCUIT OPERATION**

The RV meter calculates the outside air temperature using the outside air temperature sensor fitted on the vehicle side.

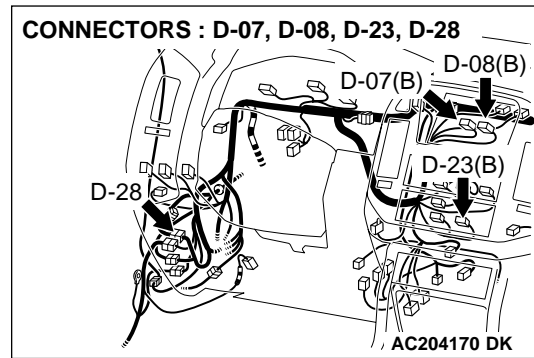
**TECHNICAL DESCRIPTION (COMMENT)**

When other indications are normal, the malfunction of outside air temperature sensor is considered.

**TROUBLESHOOTING HINTS**

- Malfunction of the outside air temperature sensor
- Damaged harness wires and connectors

**DIAGNOSIS****Required Special Tools:**

- MB991223: Harness Set
- MB991502: Scan Tool (MUT-II)

**STEP 1. Check the communication and connection (M-BUS) of the service function.**

- (1) Press the adjusting switch with the ignition switch at the "LOCK" (OFF) position. While holding the switch on the pressed condition, turn the ignition switch to "ACC" position.
- (2) When the adjusting switch is continuously pressed for more than five seconds, the service function is activated at the same time with the reception signal sound (pip sound) and the service mode screen is displayed.
- (3) Check the communication and connection [P.52A-7](#).

**Q: Isn't there any abnormality on the M-BUS?**

**YES** : Go to Step 2.

**NO** : Go to Step 3.

**STEP 2. Check the communication and connection of the service function (SWS).****Q: Isn't there any abnormality on SWS?**

**YES** : the RV meter display should operate normally.

**NO** : Refer to Group 54B, SWS Symptom Procedure

[P.54Bb-55](#).

**STEP 3. Check the A/C-ECU.**

**⚠ CAUTION**

To Prevent to damage to scan toll MB991502, always turn the ignition switch to "LOCK" (OFF) position before connecting or disconnecting scan tool MB991502.

- (1) Connect scan tool MB991502 to the data link connector.
- (2) Turn the ignition switch to "ON" position.
- (3) Read the A/C diagnostic trouble code.

**Q: Is A/C diagnostic trouble code 13 or 14 set?**

- YES :** Go to Step 4.  
**NO :** Go to Step 5.

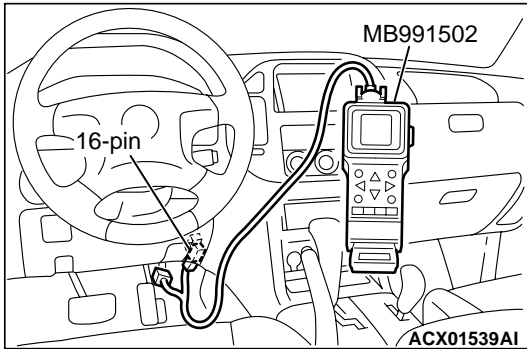

**STEP 4. Check the outside air temperature sensor.**

- (1) Remove the radiator grille. (Refer to P.36-4.)
- (2) Remove the outside air temperature sensor.
- (3) Measure the resistance between the outside air temperature sensor terminals at two or more temperature conditions.

**Q: Does the resistance value exist within the characteristic graph?**

- YES :** There is no action to be taken.  
**NO :** Replace the outside air temperature sensor.

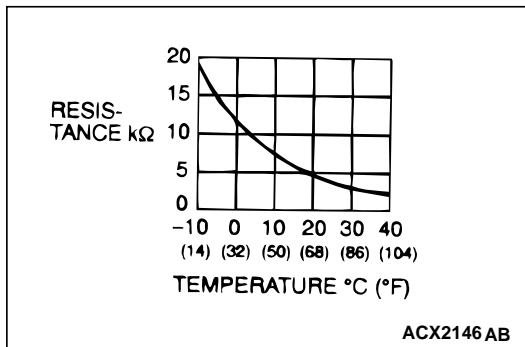

**STEP 5.** Check outside air temperature sensor connector A-29 and RV meter connector D-08 <vehicles with automatic air conditioning system> or RV meter connector D-07 <vehicles with manual air conditioning system> for loose, corroded or damaged terminals, or terminals pushed back in the connector.

**Q:** Are outside air temperature sensor connector A-29 and RV meter connector D-08 <vehicles with automatic air conditioning system> or RV meter connector D-07 <vehicles with manual air conditioning system> in good condition?

**YES :** Go to Step 6 <vehicles with automatic air conditioning system> or go to Step 8 <vehicles with manual air conditioning system>.

**NO :** Repair or replace them. Refer to GROUP 00E, Harness Connector Inspection [P.52A-7](#).

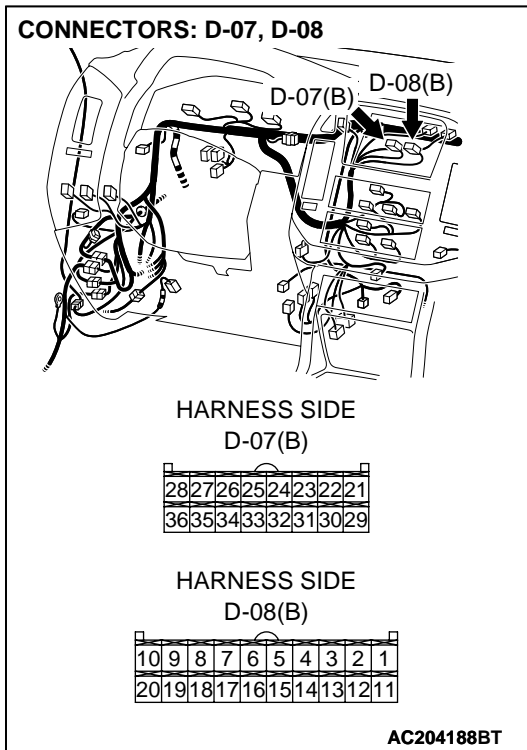
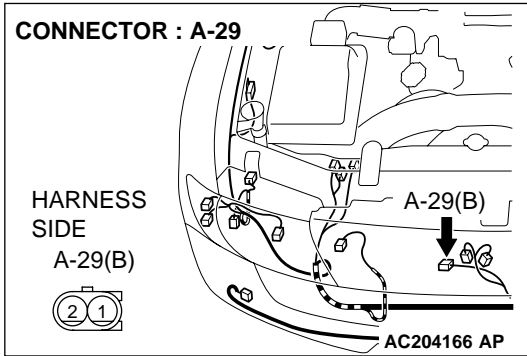

**STEP 6. Check the RV meter and A/C-ECU <vehicles with automatic air conditioning system> circuit by backprobing.**

- (1) Do not disconnect RV meter connector D-08.
- (2) Ignition switch: "ACC" position.
- (3) Measure the voltage (waveform) between the terminal 9 and the ground using an oscilloscope by backprobing.

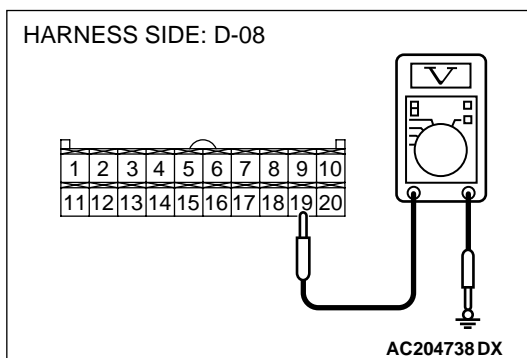
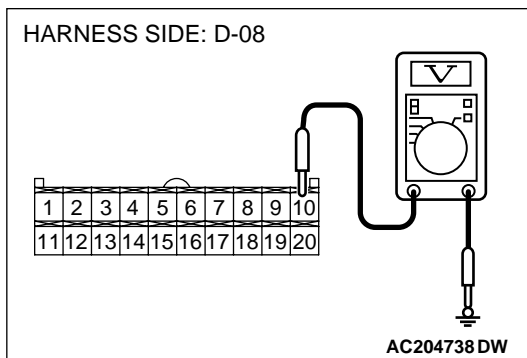
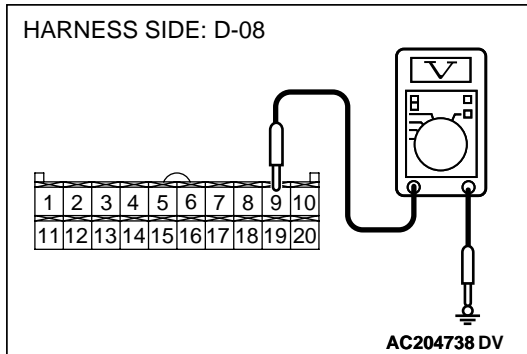

- (4) Measure the voltage (waveform) between terminal 10 and ground by backprobing.

- (5) Measure the voltage (waveform) between terminal 19 and ground by backprobing.

**Q: Is the measured voltage Hi = 4 to 5 volts and Lo = 0 to 1 volt?**

**YES :** Replace the RV meter display.

**NO :** Go to Step 7.

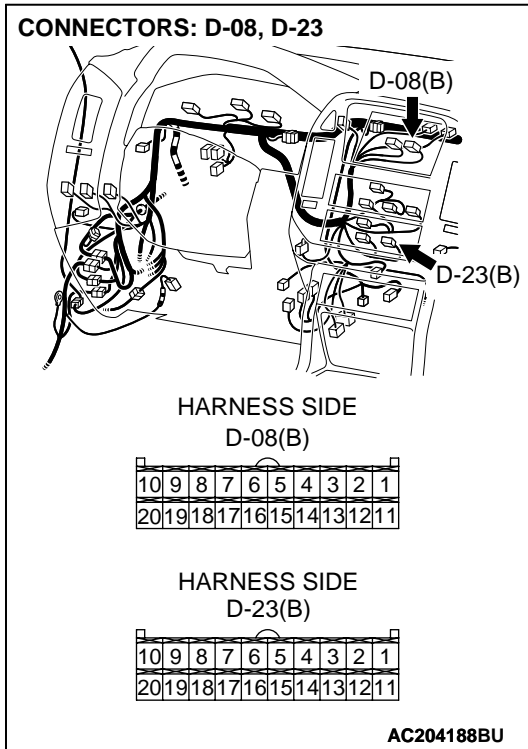

**STEP 7.** Check the harness wires between RV meter connector D-08 (terminal 9 and 10 and 19) and A/C-ECU connector D-23 (terminal 16 and 17 and 6).

**Q:** Are harness wires between RV meter connector D-08 (terminal 9 and 10 and 19) and A/C-ECU connector D-23 (terminal 16 and 17 and 6) in good condition?

**YES :** Go to Step 9.

**NO :** Repair or replace them. Refer to GROUP 00E, Harness Connector Inspection [P.52A-18](#).

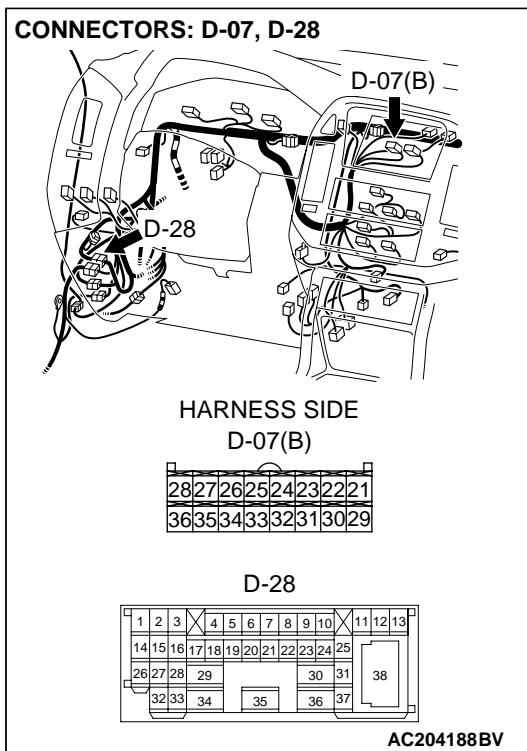
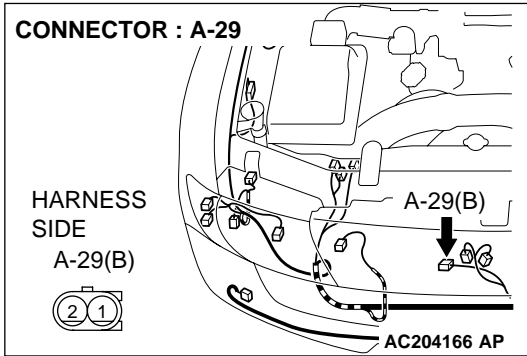

**STEP 8. Check the harness wires between RV meter connector D-07 (terminal 23 and 31) and outside air temperature sensor connector A-29 (terminal 1 and 2).**

*NOTE: After inspecting intermediate connector D-28 inspect the wires. If intermediate connector D-28 is damaged, repair or replace it. Refer to GROUP 00E, Harness Connector Inspection P.00E-2.*

**Q: Are harness wires between RV meter connector D-07 (terminal 23 and 31) and outside air temperature sensor connector A-29 (terminal 1 and 2) in good condition?**

**YES :** Go to Step 9.

**NO :** Repair or replace them. Refer to GROUP 00E, Harness Connector Inspection P.52A-18.

**STEP 9. Recheck for malfunction.**

**Q: Is a malfunction eliminated?**

**YES :** If no malfunctions are not found in all steps, an intermittent malfunction is suspected. Refer to GROUP 00, How to Use Troubleshooting/Inspection Service Points – How to Cope with Intermittent Malfunction P.00-6.

**NO :** Replace the RV meter.

---

**INSPECTION PROCEDURE 5: The Compass does not Indicate Normally.**

---

**TECHNICAL DESCRIPTION (COMMENT)**

The geomagnetism sensor integrated in the RV meter is abnormal, or it is seemed that the indication is affected by some nearby magnetized matter.

**TROUBLESHOOTING HINTS**

Malfunction of the RV meter

**DIAGNOSIS**

---

**STEP 1. Check the geomagnetism sensor mode in service mode.**

- (1) When the adjusting switch is continuously pressed for more than five seconds, the reception sound (pip sound) is heard and at the same time the service function is activated to display the service mode screen.
- (2) Press the adjusting switch with the ignition switch at the "LOCK" (OFF) position. Then while keeping the switch on the pressed condition, turn the ignition switch to "ACC" position.
- (3) Check the geomagnetism sensor at the geomagnetism sensor mode (Refer to [P.54A-233.](#))

**Q: Isn't there any abnormality on the geomagnetism sensor?**

**YES** : There is no action to be taken.

**NO** : Step 2.

---

**STEP 2. Check of own vehicle position.****Q: Is the geomagnetism stable at the place?**

**YES** : Go to Step 4.

**NO** : Go to Step 3.

---

**STEP 3. Move the vehicle to the geomagnetically stable location to re-check the geomagnetism.****Q: Isn't there any abnormality at the geomagnetism sensor mode?**

**YES** : There is no action to be taken.

**NO** : Step 4.

---

**STEP 4. Check of RV meter for magnetization.****Q: Does the indication return to normal when the carrier antenna that is mounted on the body by a magnet, a magnet or metal existing nearby the RV meter is removed?**

**YES** : There is no action to be taken.

**NO** : Replace the RV meter.



**STEP 5. Recheck for malfunction.**

**Q: Is a malfunction eliminated?**

**YES :** If no malfunctions are not found in all steps, an intermittent malfunction is suspected. Refer to GROUP 00,How to Use Troubleshooting/Inspection Service Points-How to Cope with Intermittent Malfunction P.00-6.

**NO :** Replace the RV meter.

**INSPECTION PROCEDURE 6: The Air-Conditioner Information is not Displayed.**

**A/C-ECU Circuit**

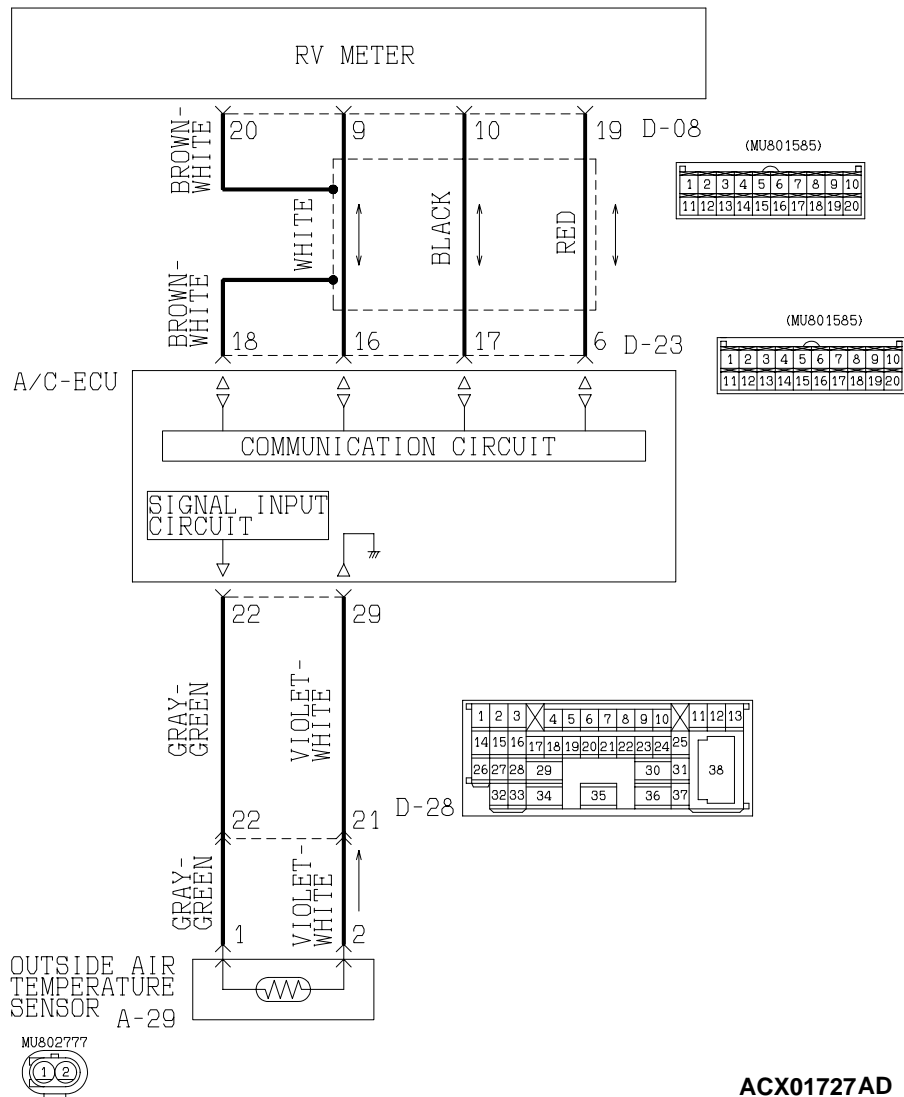

ACX01727AD

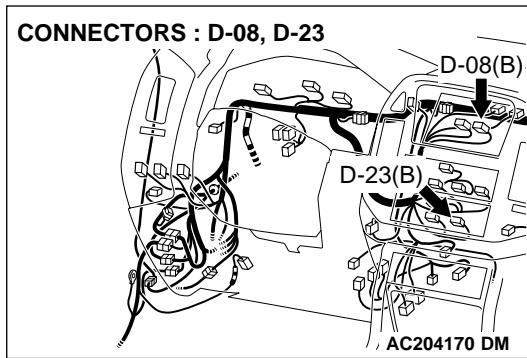

### CIRCUIT OPERATION

The RV meter receives operation picture image (M-BUS communication line) from the A/C-ECU and displays it. The RV meter receives operation picture image (M-BUS communication line) from the A/C-ECU and displays it.

### TECHNICAL DESCRIPTION (COMMENT)

If there is a problem on the picture display of RV meter even though the function of A/C operates normally, it may be an abnormality on the M-BUS communication line. When there is a problem on the function itself, the abnormality of A/C-ECU is considered to be the cause.

### TROUBLESHOOTING HINTS

- Malfunction of the RV meter
- Damaged harness wires and connectors

### DIAGNOSIS

#### Required Special Tools:

- MB991223: Harness Set
- MB991502: Scan Tool (MUT-II)

#### STEP 1. Check the communication and connection of the service function (M-BUS).

- (1) Press the adjusting switch with the ignition switch at the "LOCK" (OFF) position. Then while keeping the switch on the pressed condition, turn the ignition switch to "ACC" position.
- (2) When the adjusting switch is continuously pressed for more than five seconds, the reception sound (pip sound) is heard and at the same time the service function is activated to display the service mode screen.
- (3) Check the communication and connection [P.54A-189](#).

#### Q: Which of the following M-BUS is indicated?

- " E1 " (Communication error) : Go to Step 2.
- " E2 " (Open circuit or not connected) : Go to Step 3.
- OK : Go to Step 4.

**STEP 2. Check the RV meter and A/C-ECU circuit by backprobing.**

- (1) Do not disconnect RV meter connector D-08.
- (2) ignition switch "ACC" position.
- (3) Measure the voltage (waveform) between terminal 9 and ground using an oscilloscope by backprobing.

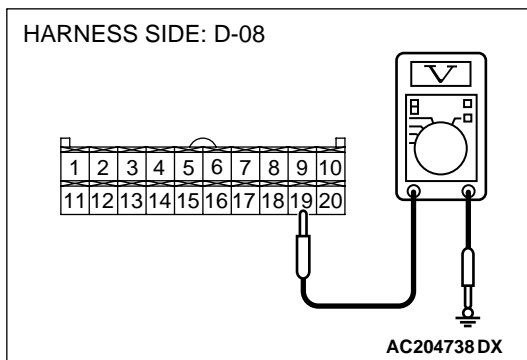
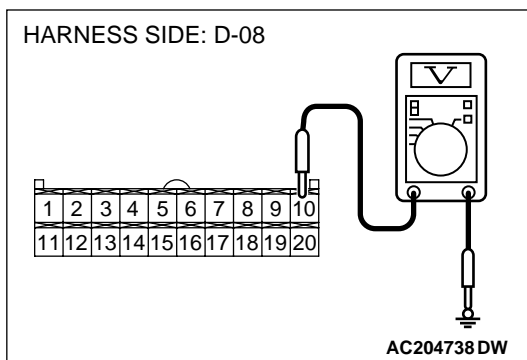
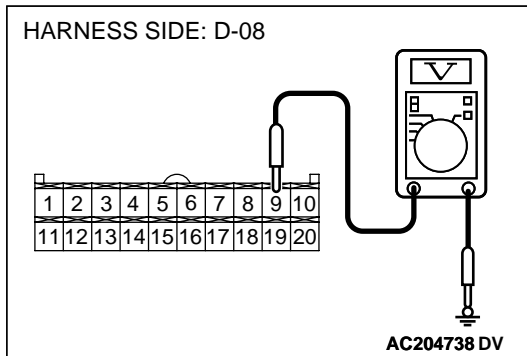

- (4) Measure the voltage (waveform) between terminal 10 and ground by backprobing.

- (5) Measure the voltage (waveform) between terminal 19 and ground by backprobing.

**Q: Is the measured voltage Hi = 4 to 5 volts and Lo = 0 to 1 volt?**

- YES :** Replace the RV meter display.  
**No :** Go to Step 5.

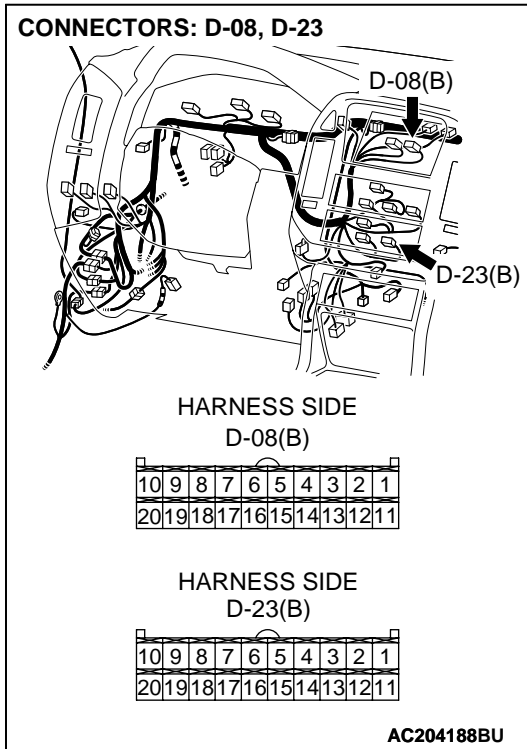

**STEP 3. Check the harness wires between RV meter connector D-08 (terminal 9 and 10 and 19) and A/C-ECU connector D-23 (terminal 16 and 17 and 6).**

**Q: Are harness wires between RV meter connector D-08 (terminal 9 and 10 and 19) and A/C-ECU connector D-23 (terminal 16 and 17 and 6) in good condition?**

**YES :** There is no action to be taken.

**NO :** Repair or replace them. Refer to GROUP 00E, Harness Connector Inspection [P.00E-2](#).

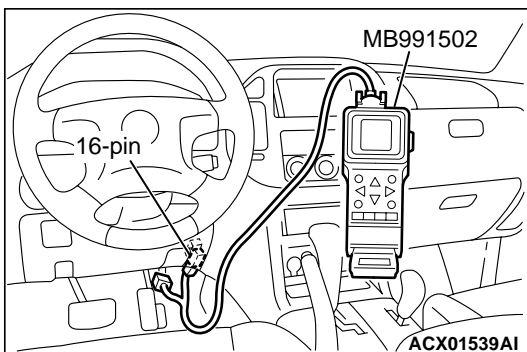

**STEP 4. Check the A/C-ECU.**

**CAUTION**

To Prevent to damage to scan toll MB991502, always turn the ignition switch to "LOCK" (OFF) position before connecting or disconnecting scan tool MB991502.

- (1) Connect scan tool MB991502 to the data link connector.
- (2) Turn the ignition switch to "ON" position.
- (3) Read the A/C diagnostic trouble code.

**Q: Is the A/C diagnostic trouble code set?**

**YES :** Carry out troubleshooting of the A/C.

**NO :** There is no action to be taken.

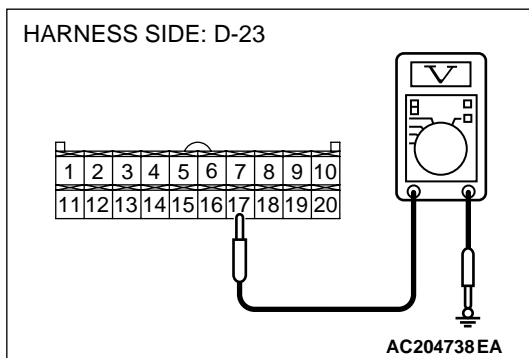
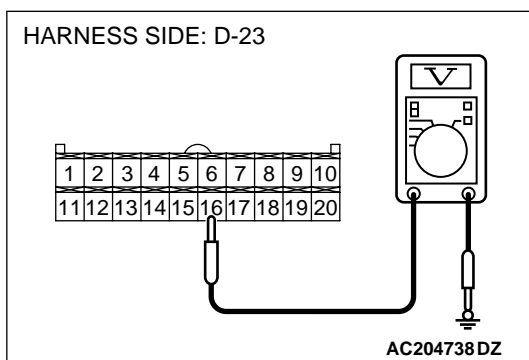
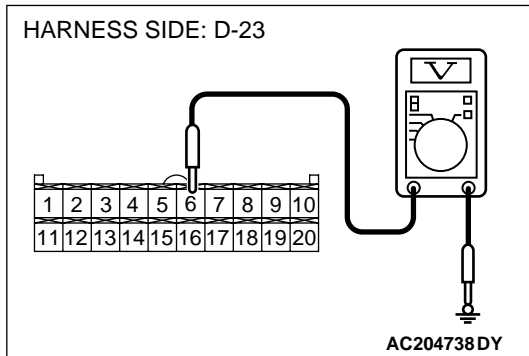

**STEP 5. Check the A/C-ECU by backprobing.**

- (1) Do not disconnect A/C-ECU connector D-23.
- (2) Ignition switch "ACC" position.
- (3) Measure the voltage (waveform) between terminal 6 and ground using an oscilloscope by backprobing.

- (4) Measure the voltage (waveform) between terminal 16 and ground by backprobing.

- (5) Measure the voltage (waveform) between terminal 17 and ground by backprobing.

**Q: Is the measured voltage Hi = 4 to 5 volts and Lo = 0 to 1 volt?**

**YES :** Go to Step 6.

**NO :** Replace the A/C-ECU.

**STEP 6. Recheck for malfunction.**

**Q: Is a malfunction eliminated?**

**YES :** If no malfunctions are not found in all steps, an intermittent malfunction is suspected. Refer to GROUP 00, How to Use Troubleshooting/Inspection Service Points – How to Cope with Intermittent Malfunction [P.00-6](#).

**NO :** Replace the RV meter.

CHECK AT RV METER TERMINAL

M1543007600241

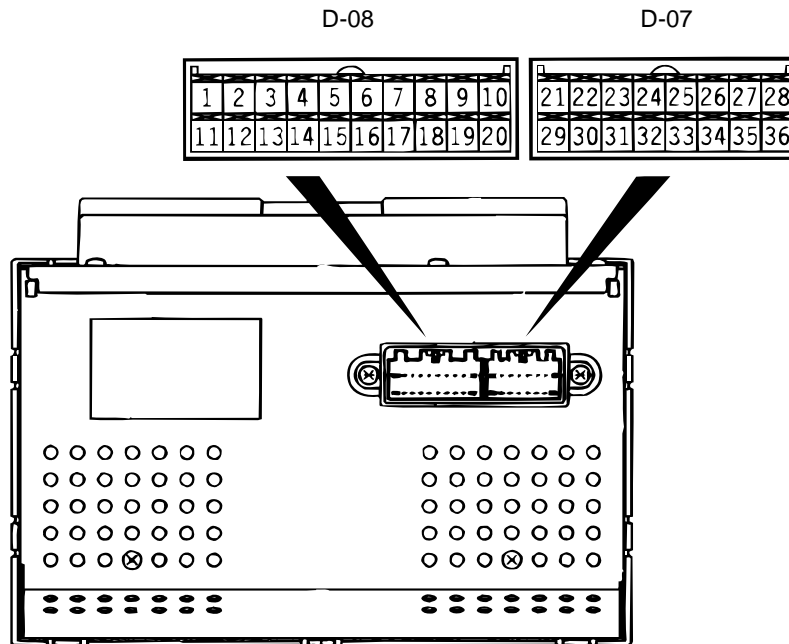

ACX02122 AB





TERMINAL NO.	INPUT/ OUTPUT	SIGNAL SYMBOL	TERMINAL VOLTAGE (V)	HARNESS DISCREPANCY		FAILURE SYMPTOM DUE TO HARNESS DISCREPANCY
1 – 4	–	–	–	–	–	–
5	Input	ISOK (MUT-II data signal)	Hi: Battery positive voltage Lo: 0 – 1	Open circuit	Short circuit	Impossible to communicate between power train control module and the scan tool by the scan tool
6	Input/output	DATA (ETACS SWS data signal)	Hi: Battery positive voltage Lo: 0 – 1	Open circuit	Short circuit	<ul style="list-style-type: none"> <li>•Switch operating sound (buzzer) cannot be heard.</li> <li>•Daytime/night display mode interlocked with tail lamp is not switched.</li> <li>•Lamp (illuminated button) is not lighted</li> </ul>
7 – 8	–	–	–	–	–	–
9	Input/output	M-DATA (A/C) (M-BUS data signal)	Hi: 4 – 5 Lo: 0 – 1	Open circuit	Short circuit	<ul style="list-style-type: none"> <li>•Air-conditioner information screen is not displayed.</li> <li>•Ambient temperature is not indicated.</li> </ul>
10	Input/output	M-CLOCK (A/C) (M-BUS clock signal)	Hi: 4 – 5 Lo: 0 – 1	Open circuit	Short circuit	<ul style="list-style-type: none"> <li>•Air-conditioner information screen is not displayed.</li> <li>•Ambient temperature is not indicated.</li> </ul>
11 – 14	–	–	–	–	–	–

TERMINAL NO.	INPUT/ OUTPUT	SIGNAL SYMBOL	TERMINAL VOLTAGE (V)	HARNESS DISCREPANCY		FAILURE SYMPTOM DUE TO HARNESS DISCREPANCY
				Open circuit	Short circuit	
15	Input/output	K (engine K-line signal)	Hi: Battery positive voltage Lo: 0 – 1	Open circuit	Short circuit	<ul style="list-style-type: none"> <li>•Drive range is not displayed.</li> <li>•Connection, communication error.</li> <li>•Impossible to communicate between power train control module and the scan tool.</li> <li>•Values of drive information display are abnormal.</li> </ul>
16 – 18	–	–	–	–	–	–
19	Input/output	M-BUSY (A/C)	Hi: 5 Lo: 0 – 1	Open circuit	Short circuit	<ul style="list-style-type: none"> <li>•Air-conditioner information screen is not displayed.</li> <li>•Ambient temperature is not indicated.</li> </ul>
20	–	SHIELD-GND	–	–	–	–
21 – 22	–	–	–	–	–	–
23	Input	EX-TEMP (ambient temperature sensor signal)	0 – 5	Open circuit	Short circuit	Ambient temperature is not displayed. (MANUAL A/C)
24	Input	ILL + (lighting switch)	Hi: Battery positive voltage Lo: 0 – 1	Open circuit	Short circuit	Not lighted.
25	Input	ACC (ACC power supply)	Battery positive voltage	Open circuit	–	Screen is not displayed. All operations are not possible.
				–	Short circuit	Multi-use fuse is blown.
26	Input	+B	Battery positive voltage	Open circuit	–	Screen is not displayed. All operations are not possible.
				–	Short circuit	Multi-use fuse is blown.
27	Input	VSS (Vehicle speed pulse signal)	Hi: Battery positive voltage Lo: 0 – 1	Open circuit	Short circuit	Abnormal maintenance screen display
28	–	GND (earth)	–	Open circuit	–	Screen is not displayed.
29 – 30	–	–	–	–	–	–
31	–	GND – TEMP	–	Open circuit	Short circuit	Ambient temperature is not displayed. (MANUAL A/C)

TERMINAL NO.	INPUT/ OUTPUT	SIGNAL SYMBOL	TERMINAL VOLTAGE (V)	HARNESS DISCREPANCY		FAILURE SYMPTOM DUE TO HARNESS DISCREPANCY
				Open circuit	Short circuit	
32	–	ILL (illumination light control signal)	0.4	Open circuit	Short circuit	Screen control is not possible.
33	Input	FUEL GAUGE	0 – 3	Open circuit	Short circuit	Abnormal drive range value indication
34 – 36	–	–	–	–	–	–

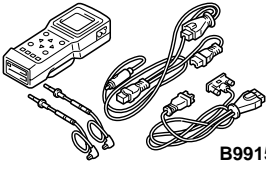
## SPECIAL TOOLS

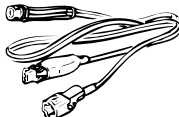
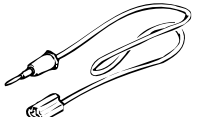
M1543000600433

TOOL	TOOL NUMBER AND NAME	SUPERSESSION	APPLICATION
 <p>B991502</p>	MB991502 Scan tool (MUT-II)	MB991496-OD	Check the A/C-ECU
<p>A</p>  <p>B</p>  <p>C</p>  <p>D</p>  <p>MB991223AC</p>	MB991223 A: MB991219 B: MB991220 C: MB991221 D: MB991222 Harness set A: Test harness B: LED harness C: LED harness adapter D: Probe	MB991223	Making voltage and resistance measurements during troubleshooting A: Connect pin contact pressure inspection B: Power circuit inspection C: Power circuit inspection D: Commercial tester connection



## ON-VEHICLE SERVICE

### VEHICLE MAGNETIC COMPENSATION

M1543009700158

#### Confirmation of magnetization and demagnetization

The RV meter automatically conducts geomagnetization calibration by sampling direction data while the vehicle is normally driving. The calibration can be done manually at any time.

1. Press function switch 3 for three seconds or more during the environment information screen to call up the screen as shown in the illustration.

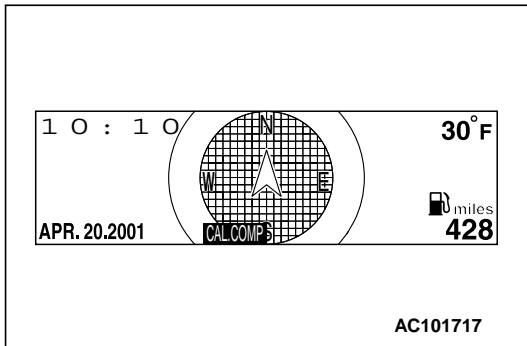

2. When function switch 3 (CAL.COMP) is pressed, a message of urging geomagnetization calibration is displayed.

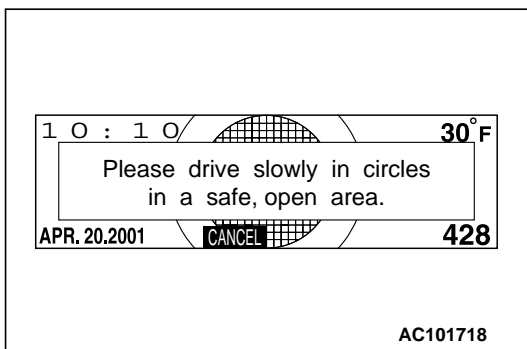

3. Drive around the vehicle.

*NOTE: When driving around the vehicle to correct the sensor, select a safe and open area where there are no structures exist such as the high-tension line and the iron bridge that affect the geomagnetic sensor in circumference.*

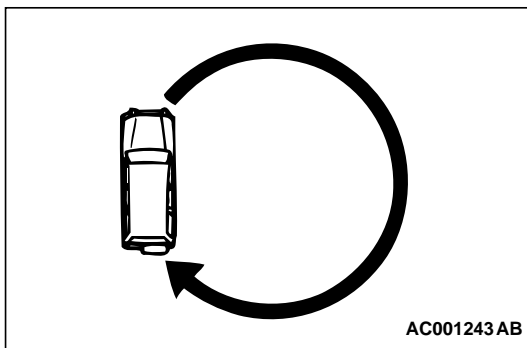

4. A message of completing geomagnetization calibration is displayed.
  - When pressing "DISP" and "ADJ" switches
  - When pressing function switch 3 (CANCEL)
  - When operating auto A/C and audio
  - When turning the ignition switch to the "OFF" (LOCK) position

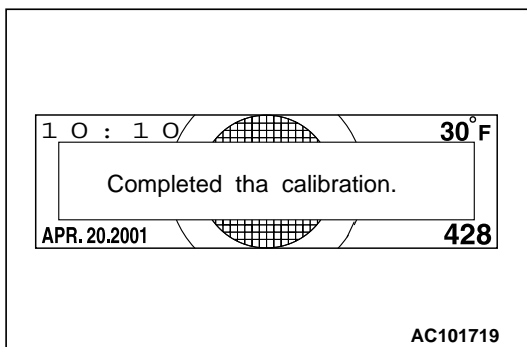

COMMERCIAL DEMAGNETIZER

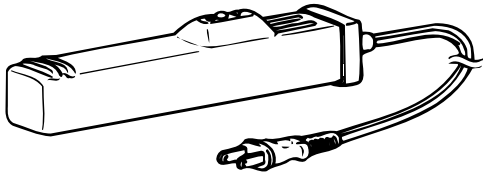

AC001246AB

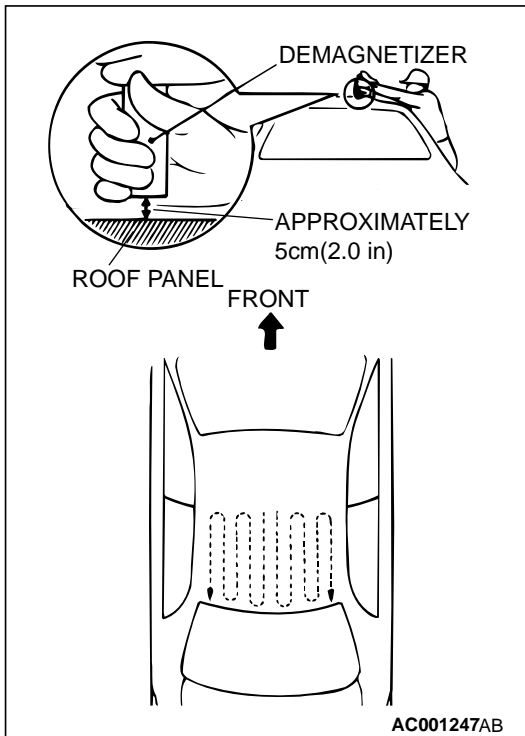

AC001247AB

## Demagnetization and correction method

1. Demagnetize the body using a commercial demagnetizer.

2. While keeping the distance between the tip of demagnetizer and the roof panel to approximately 5 cm (2.0 inches), move the demagnetizer slowly with a sweeping manner on the rear-half surface of roof panel.

### ⚠ CAUTION

**If the tip of demagnetizer touches the roof panel, the magnetizing condition of body becomes worse to the contrary. Absolutely avoid this.**

3. Slowly draw the demagnetizer apart from the body. Turn OFF the switch of demagnetizer when it is apart from the body more than 5 cm.

### ⚠ CAUTION

**If the demagnetizer is turned OFF near the body or it is suddenly separated from the body, the magnetizing condition of body becomes worse to the contrary. Absolutely avoid these.**

4. After degeomagnetization, geomagnetization calibration is carried out.

**MULTI METER ASSEMBLY  
REMOVAL AND INSTALLATION**

M1543003900068

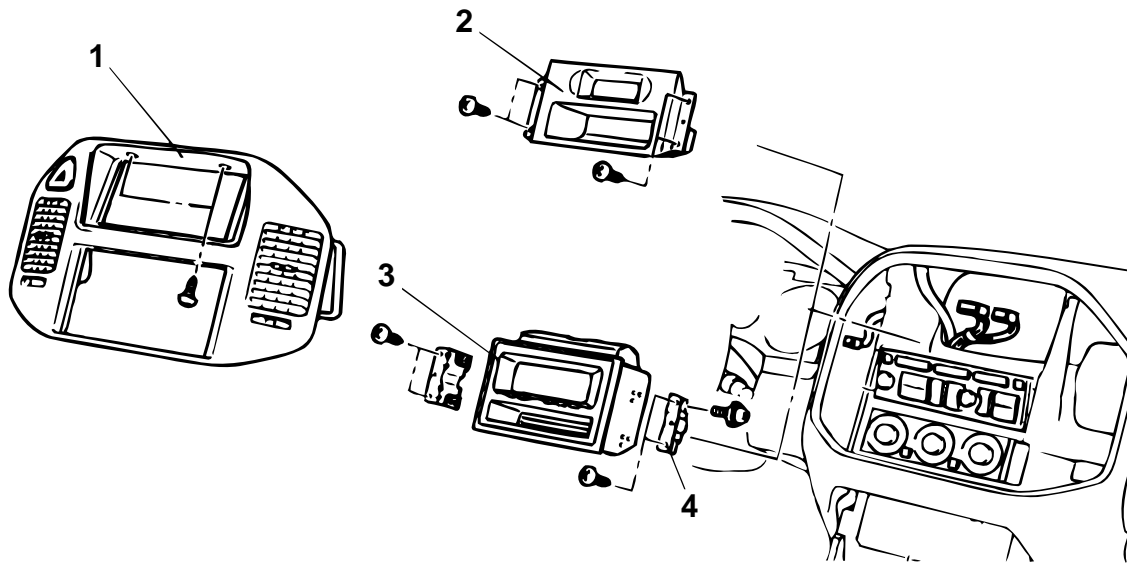

ACX01973 AB

**REMOVAL STEPS**

1. CENTER PANEL (REFER TO GROUP 52A, INSTRUMENT PANEL-TRIM P.52A-8.)

2. CLOCK
3. RV METER
4. BRACKET

# THEFT ALARM

## THEFT-ALARM SYSTEM DIAGNOSIS

M1547000900146

The theft-alarm system is controlled by the Simplified Wiring System (SWS). For troubleshooting, refer to GROUP 54B, SWS Diagnosis – Symptom Chart

[P.54Bb-2.](#)

## REMOVAL AND INSTALLATION

M1547001000191

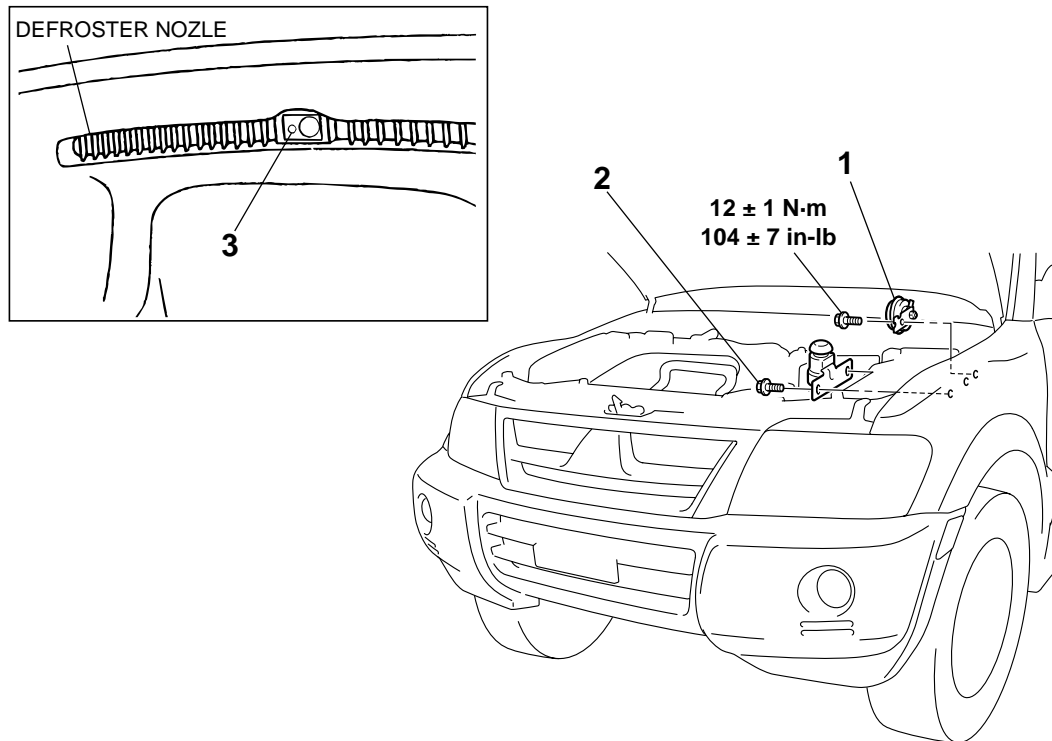

AC204114AB

### REMOVAL STEPS

1. HORN (FOR KEYLESS ENTRY ANSWERBACK AND THEFT ALARM SYSTEM)
2. HOOD SWITCH
3. SECURITY INDICATOR

INSPECTION

M1547001100110

THEFT-ALARM HORN RELAY CONTINUITY CHECK

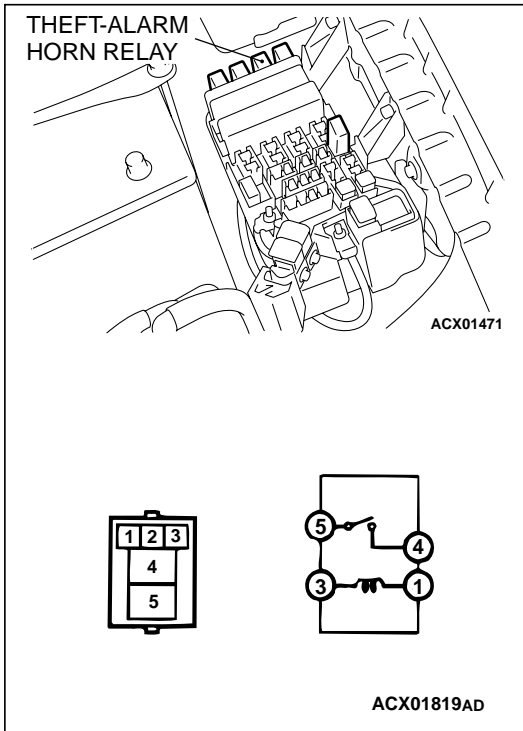

BATTERY VOLTAGE	TESTER CONNECTION	SPECIFIED CONDITION
Not applied	4 – 5	Open circuit
1 – Negative battery terminals 3 – Positive battery terminals	4 – 5	Less than 2 ohms

HOOD SWITCH CONTINUITY CHECK

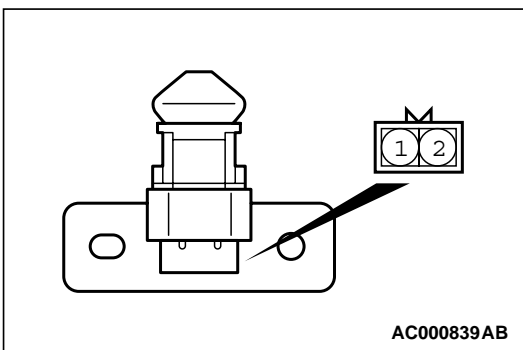

BATTERY VOLTAGE	TESTER CONNECTION	SPECIFIED CONDITION
Hood switch not depressed	1 – 2	Less than 2 ohms
Hood switch depressed	1 – 2	Open circuit

SECURITY INDICATOR LIGHT CHECK

Connect the positive battery terminal to security indicator light terminal No. 2, and connect the negative battery terminal to security indicator light No.1. Then, confirm that the security indicator light illuminates.

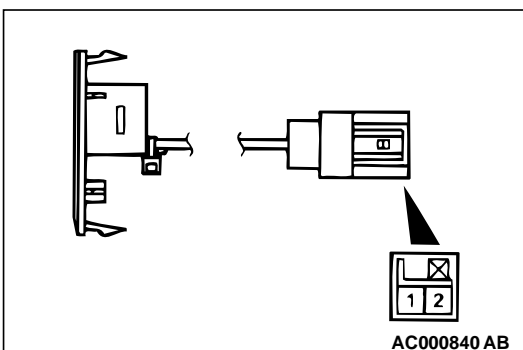

**SPECIFICATIONS****FASTENER TIGHTENING SPECIFICATIONS**

M1544004600212

ITEM	SPECIFICATION
Amplifier mounting nut	4.9 ± 0.7 N·m (43 ± 6 in-lb)
Amplifier bracket mounting bolt	12 ± 2 N·m (100 ± 22 in-lb)
Engine coolant temperature gauge unit	16 ± 2 N·m (11 ± 2 ft-lb)
Fog light assembly mounting bolt	4.9 ± 0.7 N·m (43 ± 6 in-lb)
Headlight mounting bolt	4.9 ± 0.7 N·m (43 ± 6 in-lb)
Horn mounting bolt	12 ± 1 N·m (104 ± 7 in-lb)
Radio mounting screw	1.4 ± 0.1 N·m (12 ± 1 in-lb)
Radio bracket mounting bolt	1.4 ± 0.1 N·m (12 ± 1 in-lb)

**SERVICE SPECIFICATIONS**

M1543000300090

**<IMMOBILIZER SYSTEM>**

ITEM	STANDARD VALUE
Ignition key ring antenna resistance	2 or less

**<COMBINATION METER>**

ITEM		STANDARD VALUE
Speedometer indication error km/h (mph)	32 (20)	31 – 35 (19 – 22)
	64 (40)	61 – 71 (38 – 44)
	97 (60)	92 – 106 (57 – 66)
	129 (80)	122 – 142 (76 – 88)
	161 (100)	151 – 177 (94 – 110)
Tachometer indication error r/min	700	+100
	3,000	+150
	5,000	+250
	6,000	+300
Fuel level sensor resistance	Float point "F"	3 – 5
	Float point "E"	110 – 112
Fuel level sensor float height mm (in)	A (Float point "F")	11.9 (0.47)
	B (Float point "E")	195.2 (7.69)
Engine coolant temperature gauge unit resistance		104 + 13.5

ITEM	STANDARD VALUE	
Combination meter resistance (terminal number)	Power supply and ground (67-25)	Approximately 1 M or more
	Power supply and ground (67-11)	Approximately 1 M or more
	IG power supply and ground (62-25)	Approximately 1 M or more
	IG power supply and ground (62-11)	Approximately 1 M or more
	Battery power supply and fuel gage (67-63)	Approximately 1 M or more
	IG power supply and fuel gage (62-63)	Approximately 1 M or more
	Fuel gauge and ground (63-25)	Approximately 180
	Fuel gauge and ground (63-11)	Approximately 180
	Battery power supply and engine coolant temperature (67-64)	Approximately 1 M or more
	IG power supply and engine coolant temperature (62-64)	Approximately 1 M or more
	Engine coolant temperature and ground (64-25)	Approximately 210
	Engine coolant temperature and ground (64-11)	Approximately 210

**<HEADLIGHT>**

ITEM	STANDARD VALUE	LIMIT
Headlight aiming (Vertical direction)	53 mm (2.1 inches) (0.4°) below horizontal (H)	Standard value ± 50 mm (2.0 inches) (± 0.38°)
Headlight intensity cd (at high-beam)	-	40,000 or more {when a screen is set 18.3 m (60 feet) ahead of the vehicles}

**<FOG LIGHT>**

ITEM	STANDARD VALUE	LIMIT
Fog light aiming (Vertical direction)	Top of the hot zone should be 101 mm (4.0 inches) below the fog light center (equivalent to the fog light beam angle of 0.76°).	Top of the hot zone should be at most 152 mm (6.0 inches) below the fog light center (equivalent to the fog light beam angle of 1.14°).

**SEALANT**

M1543000500191

**<COMBINATION METER>**

ITEM	SPECIFIED SEALANT	REMARK
Engine coolant temperature gauge unit threaded portion	3M™ AAD part No. 8731, Loctite ®242 or equivalent	Drying sealant

---

## NOTES