

GROUP 90

CIRCUIT DIAGRAMS

CONTENTS

HOW TO READ CIRCUIT DIAGRAMS	90-4	DOOR LIGHT	90-78
JUNCTION BLOCK	90-10	GLOVE BOX LIGHT	90-80
JOINT CONNECTOR	90-12	VANITY MIRROR LIGHT	90-81
CENTRALIZED JUNCTION	90-16	IGNITION KEY HOLE ILLUMINATION LIGHT AND KEY REMINDER TONE ALARM	90-82
POWER DISTRIBUTION SYSTEM	90-24	SIDE STEP LIGHT	90-84
STARTING SYSTEM	90-33	TURN-SIGNAL LIGHT AND HAZARD WARNING LIGHT	90-88
IGNITION SYSTEM	90-34	STOPLIGHT	90-92
CHARGING SYSTEM	90-36	BACKUP LIGHT	90-94
MFI SYSTEM	90-38	HORN	90-95
INVECS-II 5A/T	90-52	METER AND GAUGE	90-96
HEADLIGHT	90-62	FUEL WARNING LIGHT, OIL PRESSURE WARNING LIGHT, BRAKE WARNING LIGHT	90-100
TAILLIGHT, POSITION LIGHT, SIDE MARKER LIGHT, LICENSE PLATE LIGHT AND LIGHTING MONITOR TONE ALARM	90-66	POWER WINDOWS	90-102
FOG LIGHT	90-70		
DOME LIGHT, REAR PERSONAL LIGHT AND CARGO SPACE LIGHT	90-74		

Continued on next page

CENTRAL DOOR LOCKING SYSTEM AND FORGOTTEN KEY PREVENTION FUNCTION	90-106	RADIO AND CD PLAYER <VEHICLES WITH AMPLIFIER>	90-190
SINGLE MANUAL AIR CONDITIONING SYSTEM	90-116	VIDEO ENTERTAINMENT SYSTEM (VES)	90-194
DUAL MANUAL AIR CONDITIONING SYSTEM <VEHICLES WITH REAR HEATER>	90-122	CIGARETTE LIGHTER AND ASHTRAY ILLUMINATION LIGHT	90-200
DUAL MANUAL AIR CONDITIONING SYSTEM <VEHICLES WITH REAR COOLER>	90-132	ACCESSORY SOCKET	90-201
DUAL MANUAL AIR CONDITIONING SYSTEM <VEHICLES WITH REAR AIR CONDITIONING SYSTEM>	90-140	RV METER	90-202
AUTOMATIC AIR CONDITIONING SYSTEM <VEHICLES WITH REAR COOLER>	90-150	SUNROOF	90-206
AUTOMATIC AIR CONDITIONING SYSTEM <VEHICLES WITH REAR AIR CONDITIONING SYSTEM>	90-160	SEAT BELT TONE ALARM	90-210
REMOTE CONTROLLED MIRROR	90-171	AUTO-CRUISE CONTROL SYSTEM	90-212
WINDSHIELD WIPER AND WASHER	90-172	ACTIVE TRAC 4WD II SYSTEM	90-218
REAR WIPER AND WASHER	90-176	HYDRAURIC BRAKE BOOSTER (HBB), ELECTRONIC BRAKE-FORCE DISTRIBUTION (EBD), ANTI-LOCK BRAKING SYSTEM (ABS), MITSUBISHI ACTIVE SKID AND TRACTION CONTROL SYSTEM (M-ASTC)	90-226
DEFOGGER AND DOOR MIRROR HEATER <VEHICLES WITH AUTOMATIC AIR CONDITIONING SYSTEM>	90-180	SUPPLEMENTAL RESTRAINT SYSTEM (SRS)	90-236
DEFOGGER AND DOOR MIRROR HEATER <VEHICLES WITH MANUAL AIR CONDITIONING SYSTEM>	90-182	POWER SEAT	90-240
CLOCK	90-185	HEATED SEAT	90-244
RADIO AND CD PLAYER <VEHICLES WITHOUT AMPLIFIER>	90-186	THEFT-ALARM SYSTEM	90-248
		IMMOBILIZER SYSTEM	90-256
		TIRE PRESSURE MONITORING SYSTEM (TPMS)	90-260
		RHEOSTAT	90-264

NOTES

HOW TO READ CIRCUIT DIAGRAMS

M1901000100793

The circuit of each system from the fuse (or fusible link) to ground is shown. The power supply is shown at the top and the ground at the bottom to facilitate understanding of how the current flows. Some variations are included in one circuit diagram. Accordingly, some diagrams may not be applicable for individual vehicles.

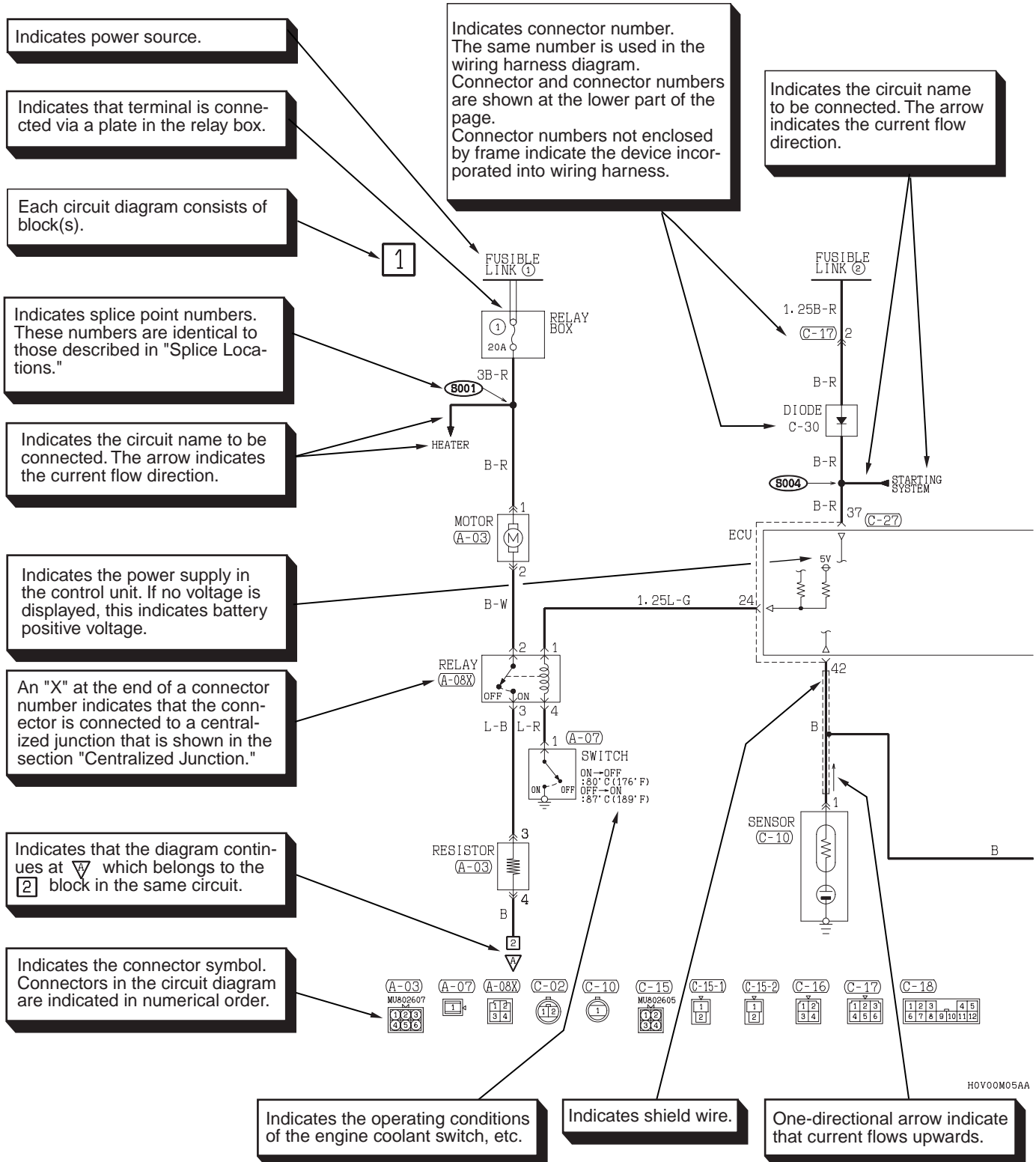

HOV00M05AA

AC106603AG

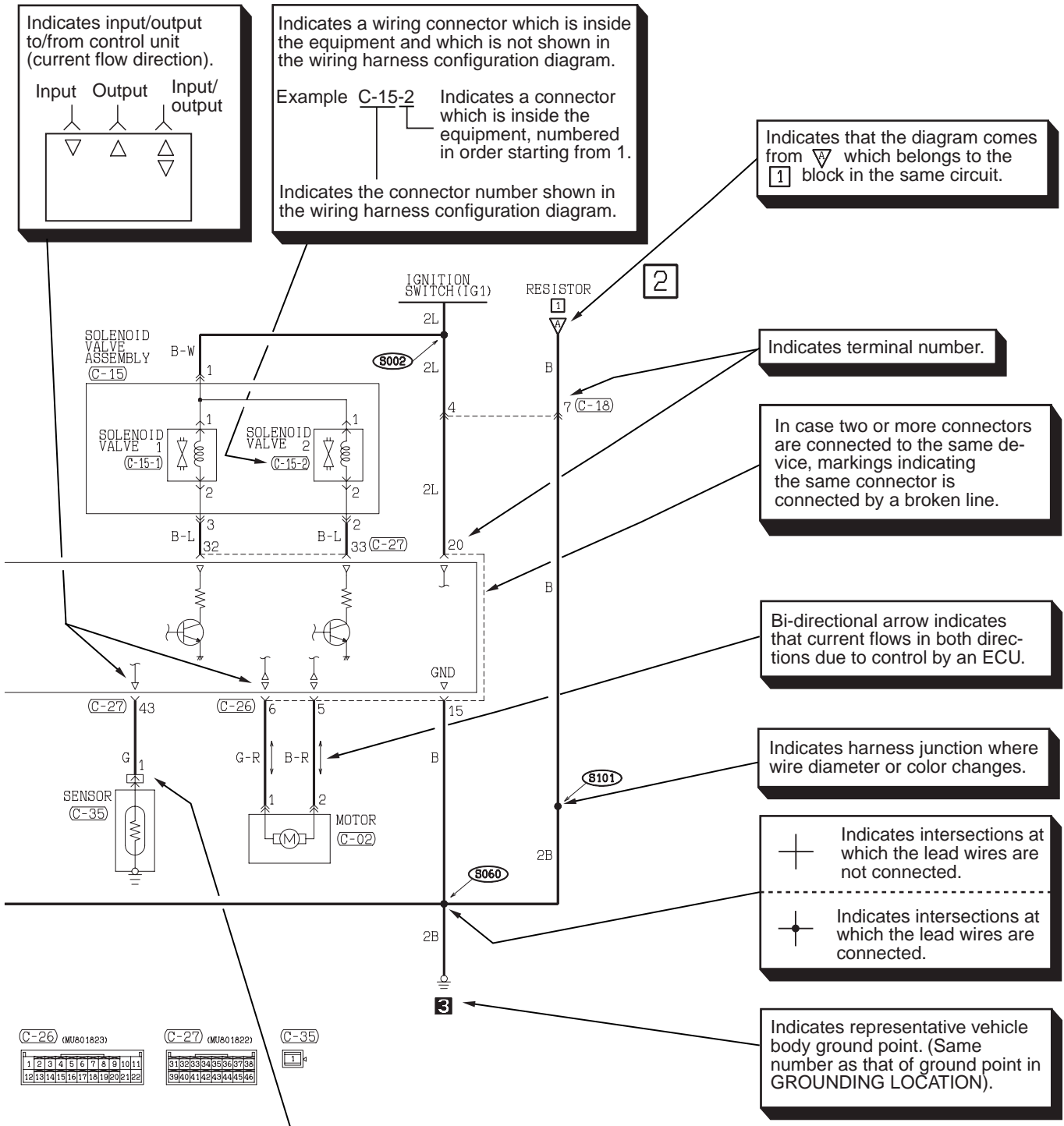





H0V00M05AB

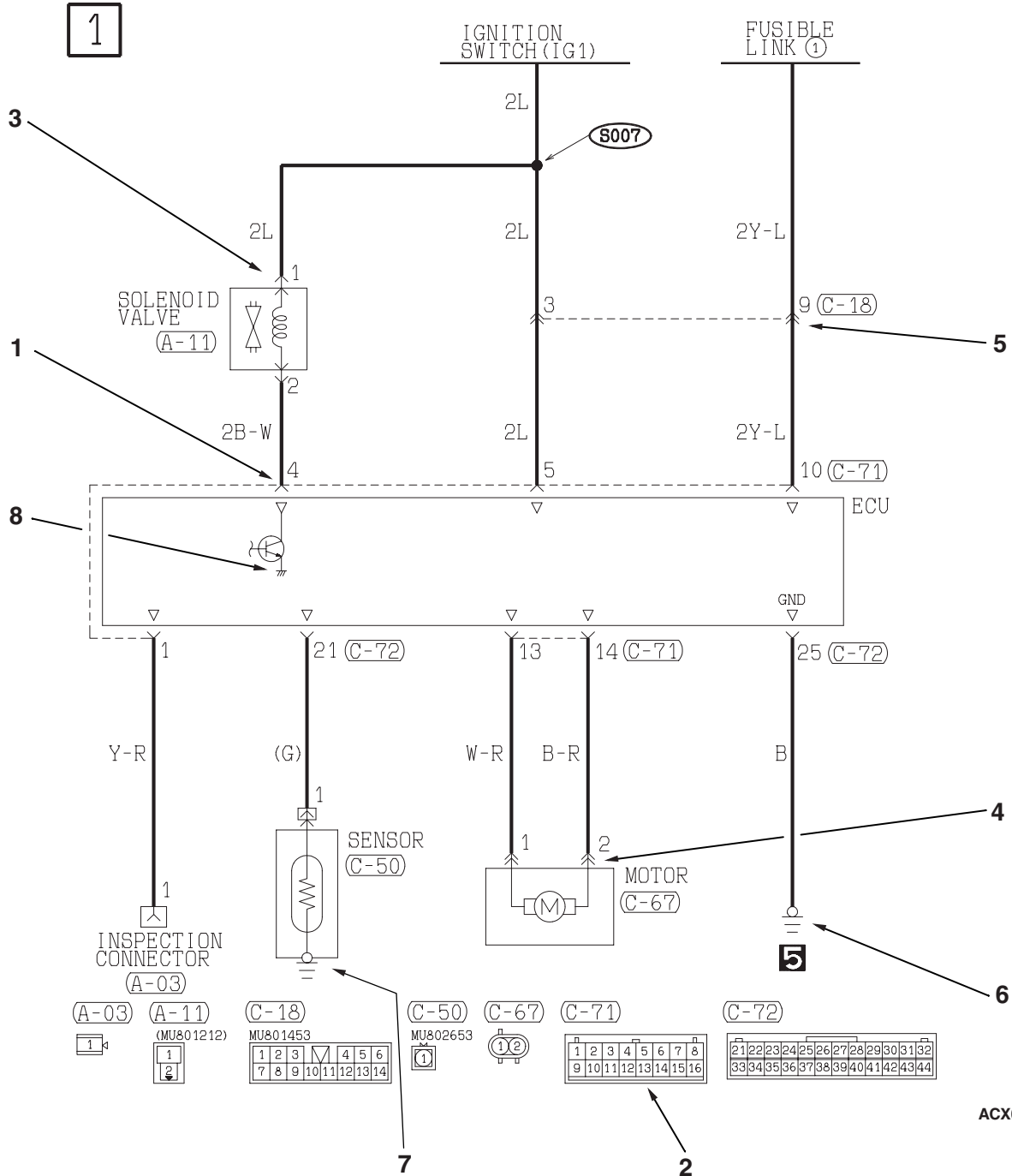



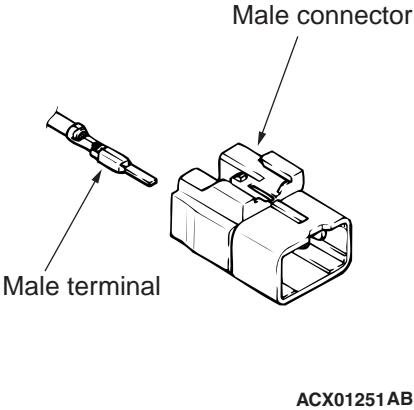

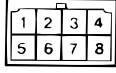
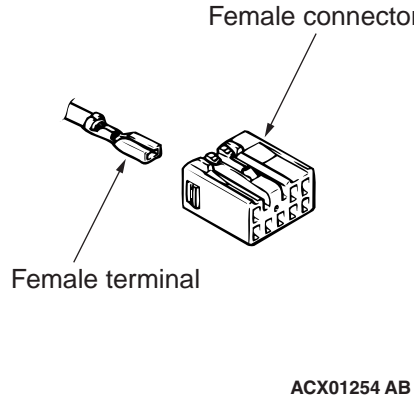

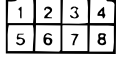
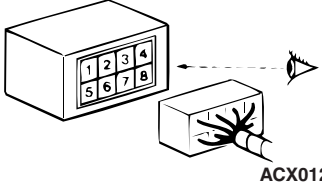
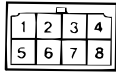
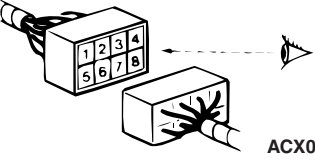
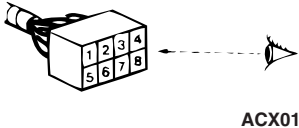
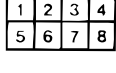
AC106604AE

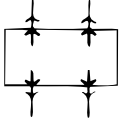
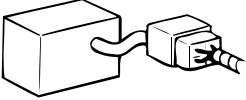
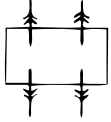
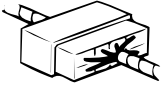
CONNECTOR/GROUNDING INDICATIONS



























ACX02364 AC

ITEM	NO.	CONNECTOR/ GROUNDING	SYMBOL	CONTENTS
Connector and terminal marking	1		<p>Male terminal</p>  <p>ACX01252 AB</p>	The male and female terminals are indicated as shown. The connector with male terminal(s) is called as male connector and indicated by two connector contour lines, while the connector with female terminal(s) is called as female connector and indicated by single connector contour line.
			<p>Male connector</p>  <p>ACX01253 AB</p>	
			<p>Female terminal</p>  <p>ACX01255 AB</p>	
			<p>Female connector</p>  <p>ACX01256 AB</p>	
Connector symbol marking	2	<p>Device</p> 	 <p>ACX01253</p>	The symbol indicates the connector is viewed as shown. At a device connection, the connector symbol on the device side is shown. For an intermediate connector, the male connector symbol is shown. For spare connectors and check connectors, no device is connected, and so the harness-side connector symbol is shown for these connectors. However, a data link connector is exceptional.
		<p>Intermediate connector</p> 		
		<p>Spare connector, check connector</p> 	 <p>ACX01256</p>	

ITEM	NO.	CONNECTOR/ GROUNDING	SYMBOL	CONTENTS
Connector connection marking	3	Direct connection type  ACX01260 AB	 ACX01261	Connection between a device and the harness is either by direct insertion in the device (direct connection type) or by connection with a harness connector furnished on the device side (harness connection type). The two types are indicated as illustrated.
	4	Harness connection type  ACX01262 AB	 ACX01263	
	5	Intermediate connector  ACX01264 AB	 ACX01265	
Ground marking	6	Body ground  ACX01273 AB	 ACX01274	Grounding is either by body ground, device ground or control unit interior ground. These are indicated as illustrated.
	7	Device ground  ACX01275 AB	 ACX01276	
	8	Ground in control unit  ACX01277 AB	 ACX01278	

SYMBOLS (EXCEPT CONNECTOR AND GROUNDING)

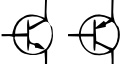
Devices appearing in circuit diagrams are indicated by the following symbols.

<p>Battery</p>  <p>ACX02377 AB</p>	<p>Buzzer</p>  <p>ACX02378 AB</p>	<p>Capacitor</p>  <p>ACX02379 AB</p>	<p>Electrolytic capacitor</p>  <p>ACX02380 AB</p>	<p>Variable capacitor</p>  <p>ACX02381 AB</p>	<p>Coil</p>  <p>ACX02382 AB</p>
<p>Diode</p>  <p>ACX02383 AB</p>	<p>Light emitting diode</p>  <p>ACX02384 AB</p>	<p>Photo diode</p>  <p>ACX02385 AB</p>	<p>Zener diode</p>  <p>ACX02386 AB</p>	<p>Dual filament bulb</p>  <p>ACX02387 AC</p>	<p>Single filament bulb</p>  <p>ACX02388 AC</p>
<p>Fuse</p>  <p>ACX02389 AB</p>	<p>Fusible link</p>  <p>ACX02390 AB</p>	<p>Horn</p>  <p>ACX02391 AB</p>	<p>Motor</p>  <p>ACX02392 AB</p>	<p>Pulse generator</p>  <p>ACX02393 AB</p>	<p>Piezoelectric device</p>  <p>ACX02394 AB</p>
<p>Resistor</p>  <p>ACX02395 AB</p>	<p>Variable resistor</p>  <p>ACX02396 AB</p>	<p>Speaker</p>  <p>ACX02397 AB</p>	<p>Thermistor</p>  <p>ACX02398 AB</p>	<p>Transistor</p>  <p>ACX02399 AB</p>	<p>Photo transistor</p>  <p>ACX02400 AB</p>

WIRE COLOR CODES

Wire colors are identified by the following color codes.

CODE	WIRE COLOR	CODE	WIRE COLOR	CODE	WIRE COLOR	CODE	WIRE COLOR
B	Black	L	Blue	PU	Purple	V	Violet
BR	Brown	LG	Light green	R	Red	W	White
G	Green	O	Orange	SB	Sky blue	Y	Yellow
GR	Gray	P	Pink	SI	Silver	-	-

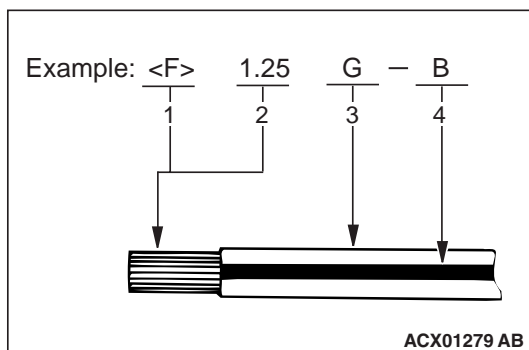

If a cable has two colors, the first of the two color code characters indicates the basic color (color of the cable coating) and the second indicates the marking (tracer) color.

NO.	MEANING
1	<F>: Flexible wire <T>: Twisted wire
2	Wire size (mm ²)*
3	Basic color (color of the cable coating)
4	Marking color

NOTE:

*: No code indicates 0.5 mm² (0.0008 in²). Cable color code in parentheses indicates 0.3 mm² (0.0005 in²).

JUNCTION BLOCK

M1901000201469

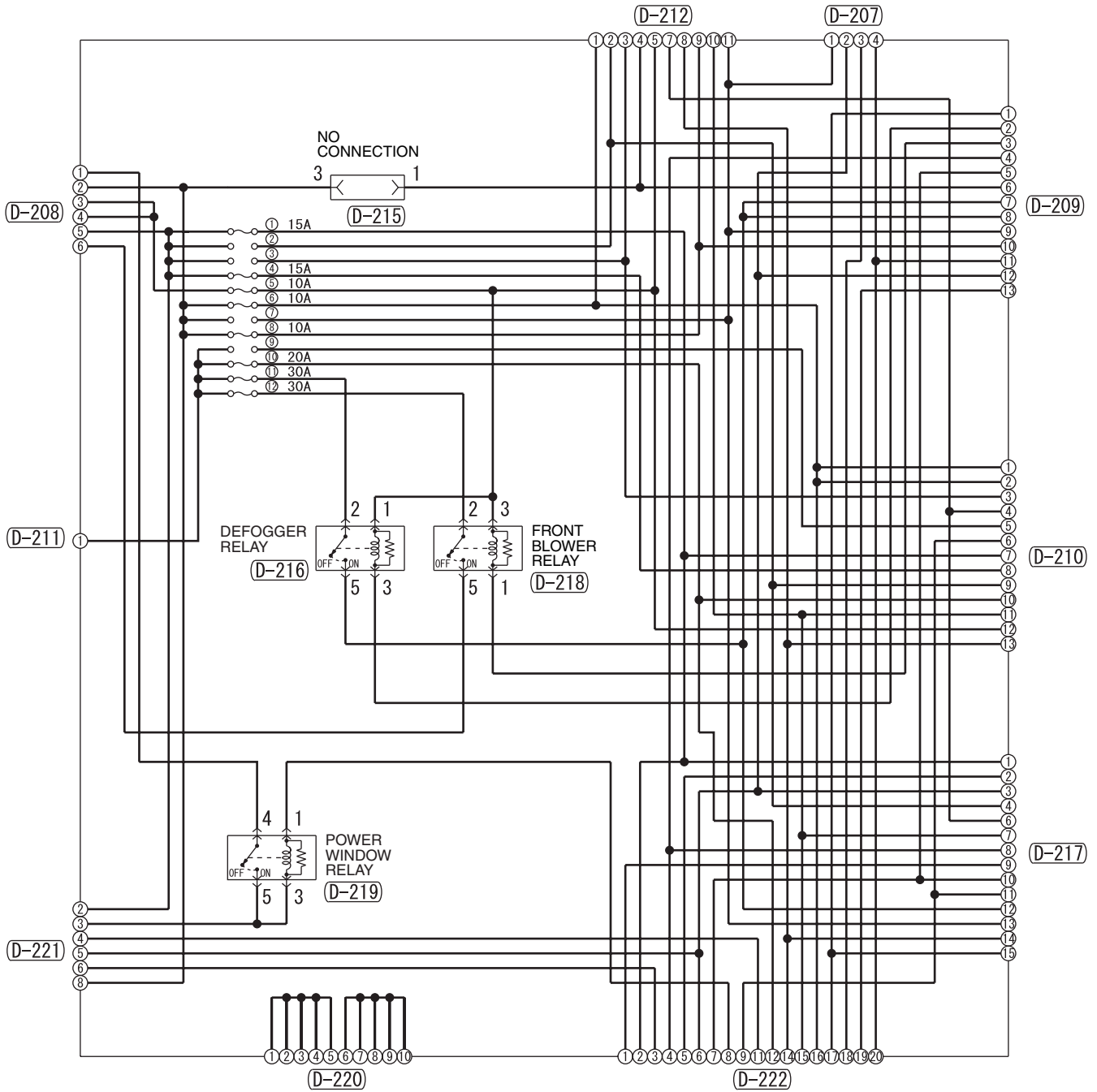

NOTE
CONNECTOR NUMBERS ARE KEYED TO THE CONFIGURATION
DIAGRAM (DASH PANEL) AND EACH CIRCUIT DIAGRAM.

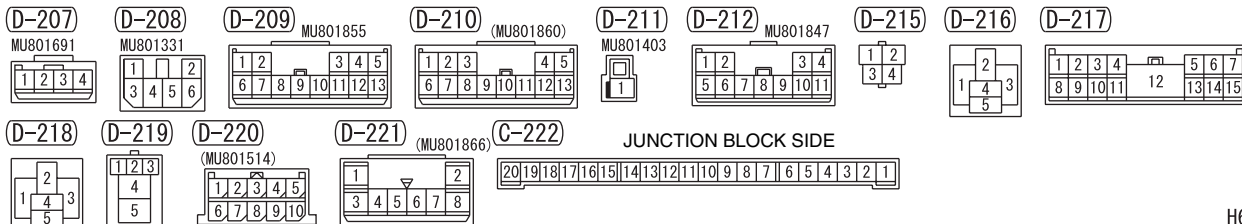

H6Q00M00AA

FRONT SIDE

REAR SIDE

TO INSTRUMENT
PANEL WIRING HARNESS

TO INSTRUMENT
PANEL WIRING HARNESS

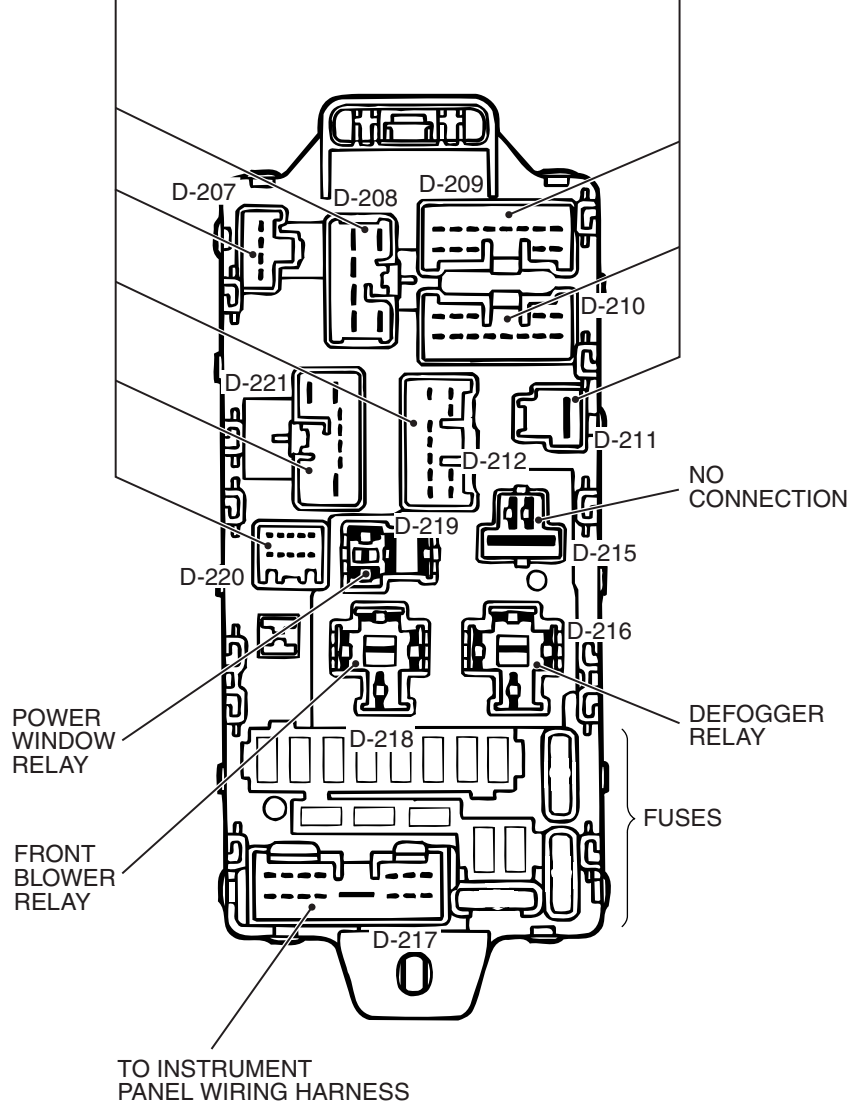

ETACS-ECU

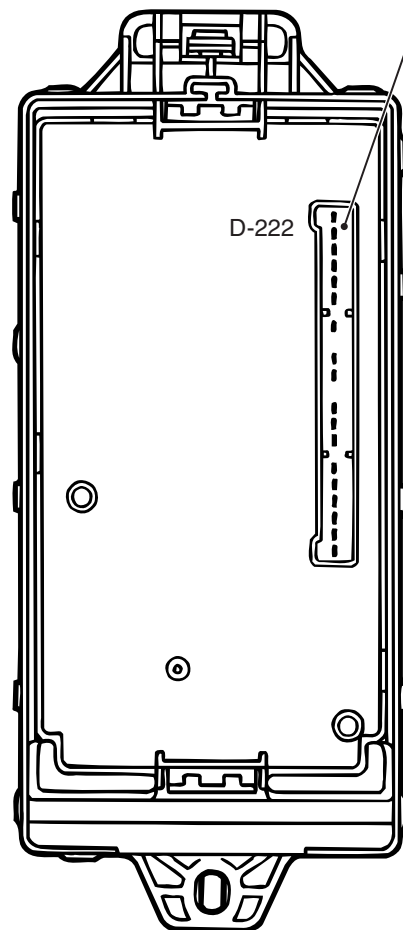

AC203967AB

JOINT CONNECTOR

M1901014201741

NOTE
IN THE ACTUAL VEHICLES, SOME OF THE JOINT CONNECTOR TERMINALS IN THE SAME BUS ARE USED, SO IN SOME CASES, THE TERMINAL ARRANGEMENT INDICATED ON THE CIRCUIT DIAGRAMS DOES NOT COINCIDE WITH THE ONES IN THE ACTUAL VEHICLES.

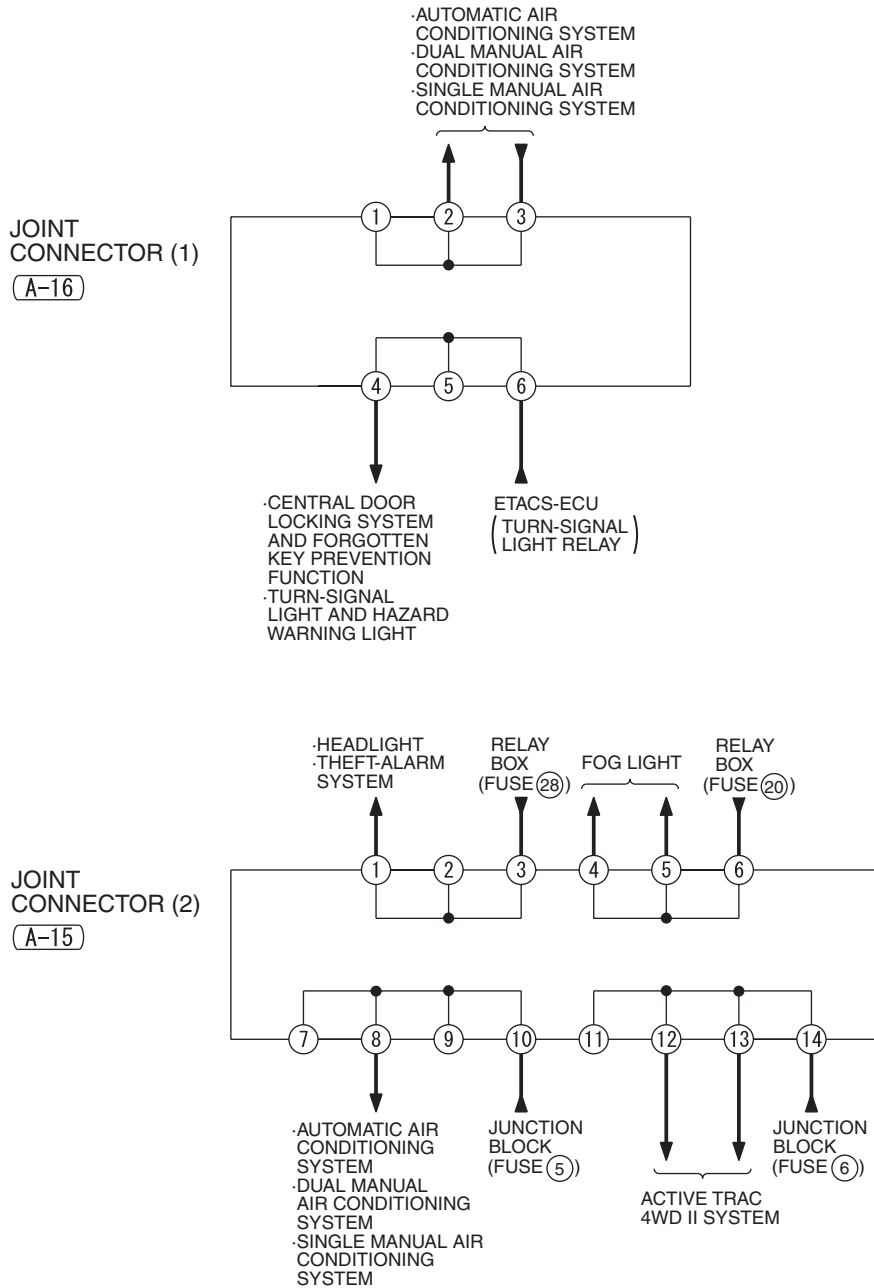

A-15

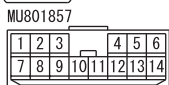

A-16

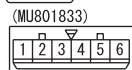

A-17

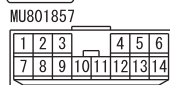

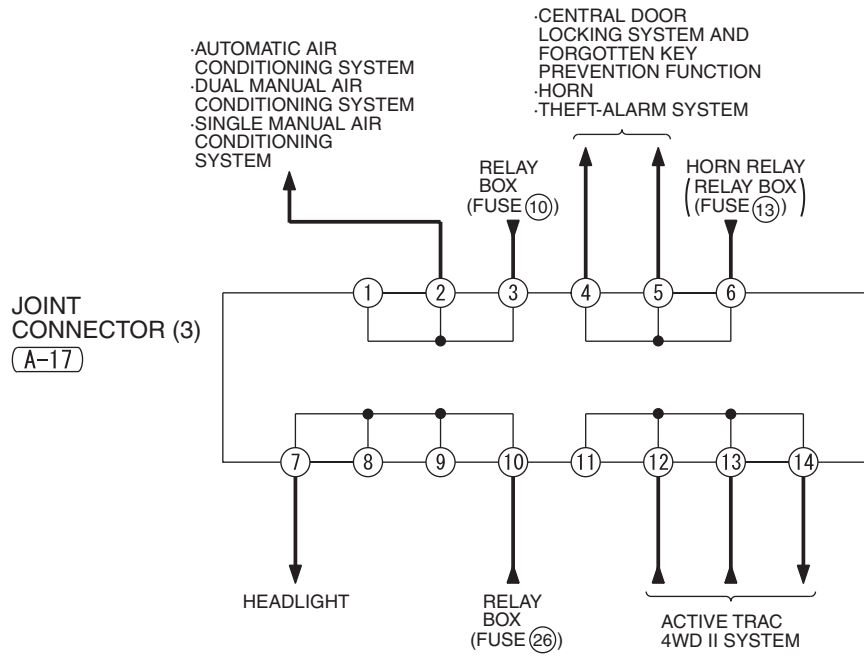

JOINT CONNECTOR (CONTINUED)

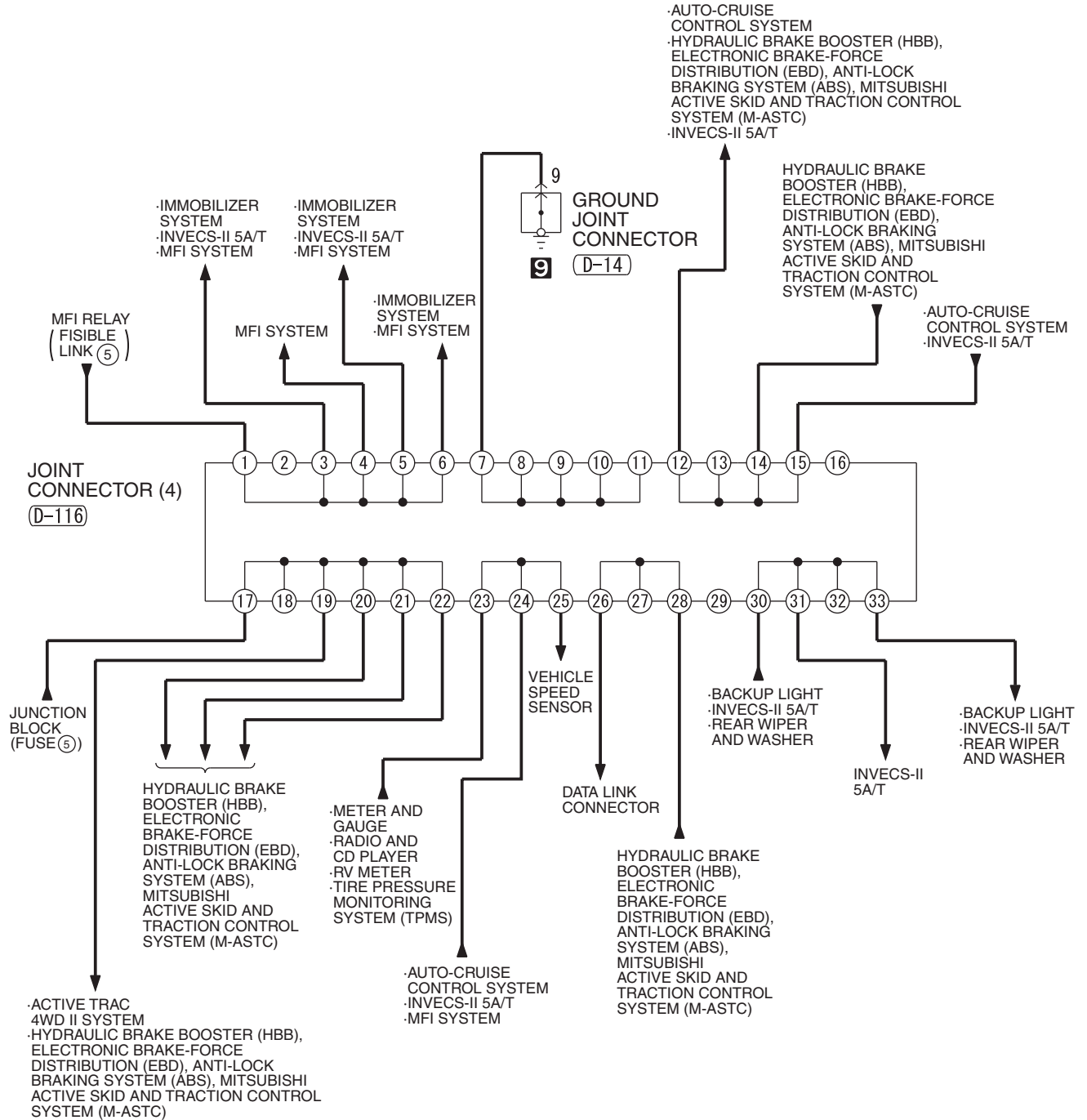

D-14

MU801335

1	2	3	4
5	6	7	8
9	10		

D-116

1	2	3	4	5	6	7	8	9	10	11
12	13	14	15	16	17	18	19	20	21	22
23	24	25	26	27	28	29	30	31	32	33

D-131

(MU801852)

1	2	3	4	5
6	7	8	9	10
11	12			

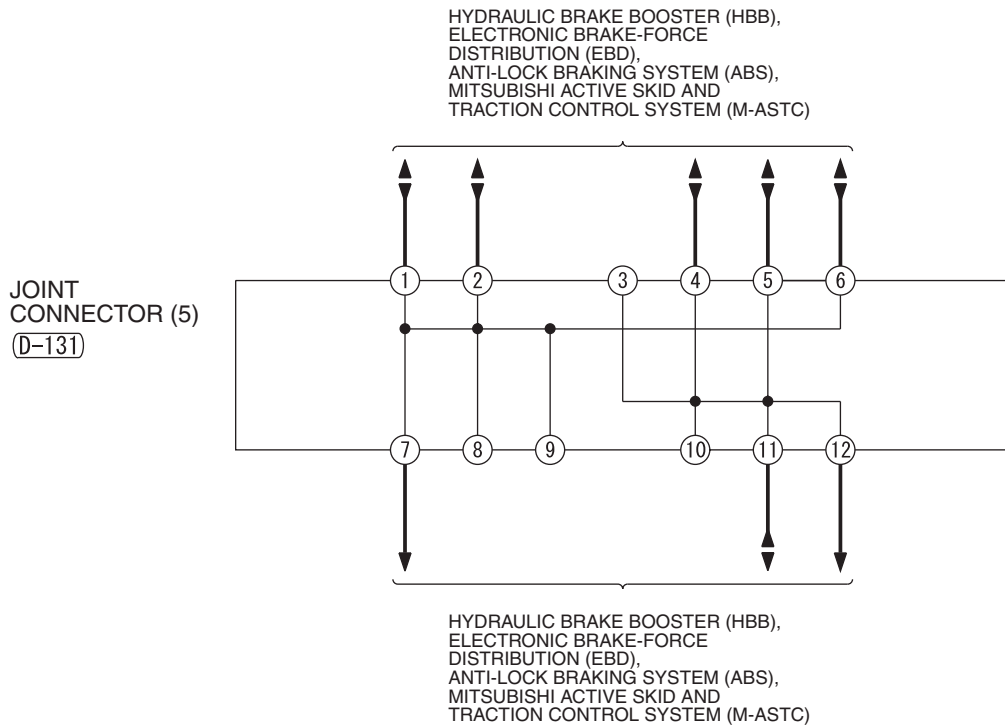

CENTRALIZED JUNCTION

M1901000301002

FUSIBLE LINK AND FUSE

ENGINE COMPARTMENT (RELAY BOX IN ENGINE COMPARTMENT)

NO.	POWER SUPPLY CIRCUIT	NAME	RATED CAPACITY (A)	HOUSING COLOR	LOAD CIRCUIT
1	Battery/Generator	Fusible link	120	White	Fusible link Nos.2 and fuse Nos.6, 8, 10, 11, 12, 18 and 19 (relay box in engine compartment) circuit <when the engine is stopped> Fusible link Nos.3, 4 and 5, fuse Nos.13, 14, 15 and 16, fog light relay and front-ECU circuit <after starting the engine>
2	Fusible link No. 1/ Generator		60	Yellow	Fuse Nos.10, 11 and 12 (in junction block) circuit
3	Battery/Generator (Fusible link No.1)		40	Green	Fuse No.20 (in junction block) and Ignition switch circuit
4			30	Pink	Fuse No.19 (in junction block) circuit, power seat assembly, power window main switch, power window motor, power window relay and power window sub switch
5			20	Blue	Camshaft position sensor, crankshaft position sensor, EGR valve, evaporative emission purge solenoid, evaporative emission ventilation solenoid, immobilizer-ECU, injector, intake manifold tuning solenoid, left bank heated oxygen sensor, MFI relay, powertrain control module, right bank heated oxygen sensor, throttle actuator control motor relay and volume airflow sensor
6	Fusible link No. 1/ Generator	Fuse	20	Yellow	Fuel pump module
7			—	—	—
8			15	Blue	Accessory socket
9			—	—	—
10			25	Transparent	Condenser fan control relay and condenser fan motor
11			20	Yellow	Rear A/C unit, rear blower relay and rear blower unit
12			10	Red	Theft-alarm horn and theft-alarm horn relay
13	Battery/Generator (Fusible link No.1)	10	Red	Horn and horn relay	

NO.	POWER SUPPLY CIRCUIT	NAME	RATED CAPACITY (A)	HOUSING COLOR	LOAD CIRCUIT
14	Battery/Generator (Fusible link No.1)	Fuse	20	Yellow	A/T control solenoid valve assembly and powertrain control module
15			10	Red	ETACS-ECU and generator
16			15	Blue	High-mounted stop light, rear combination light and rear light
17	Ignition switch (ACC)		10	Red	Accessory socket relay, A/C-ECU, clock, DVD player, motor antenna-ECU, radio/CD player, rear display and video controller unit
18	Fusible link No. 1/ Generator		15	Blue	A/C-ECU, cargo space light, clock, column switch, combination meter, dome light, ETACS-ECU, DVD player, front door light, front-ECU, key reminder switch, motor antenna-ECU, radio/CD player, rear door light, rear personal light, RV meter, side step light-ECU, steering wheel sensor, sunroof motor assembly, theft-alarm indicator light, TPMS receiver, transfer-ECU, vanity mirror light and video controller unit
19			10	Red	A/C compressor, A/C compressor clutch relay, A/C-ECU and automatic compressor controller
20			Fog light relay	20	Yellow
21	Ignition switch (ACC)		–	–	–
22			20	Yellow	Front-ECU and windshield wiper motor
23	Front-ECU (Taillight relay)		10	Red	A/C-ECU, A/C switch, active skid control switch, A/T shift illumination light, ashtray illumination light, automatic compressor controller, cigarette lighter illumination light, clock, combination meter, fog light switch, glove box light, hazard warning light switch, heated seat switch, heater control panel illumination light, position light (RH), radio/CD player, rear A/C switch, rear combination light (RH), rear cooler switch, rear display, rear fan control switch (front), rear heater switch, rear light (RH), rheostat, RV meter and sunroof switch
24			10	Red	License plate light assembly, position light (LH), rear combination light (LH) and rear light (LH)

NO.	POWER SUPPLY CIRCUIT	NAME	RATED CAPACITY (A)	HOUSING COLOR	LOAD CIRCUIT
25	Front-ECU (Headlight relay: Low or field effect transistor for headlight, low)	Fuse	10	Red	Headlight (RH)
26			10	Red	Headlight (LH)
27			10	Red	Headlight (RH)
28			10	Red	Headlight (LH)
29	Fusible link No. 1/ Generator	Fusible link	20	Blue	Amplifier
30	-		-	-	-

(RELAY BOX IN ENGINE COMPARTMENT)

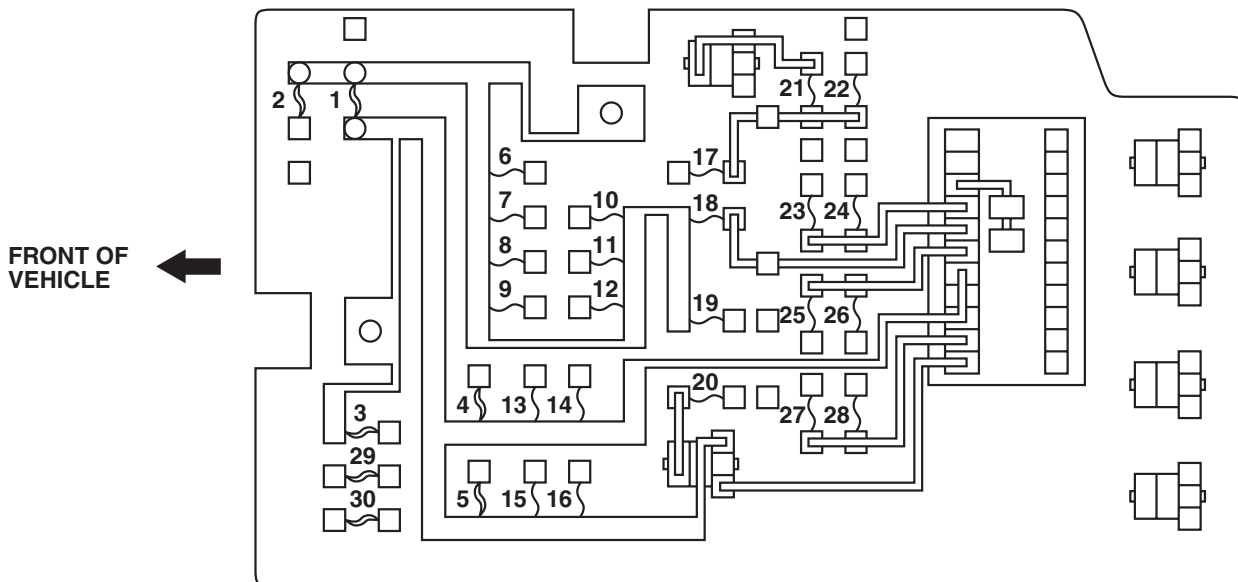

AC303851AB

ENGINE COMPARTMENT (CONNECTED DIRECTLY TO BATTERY POSITIVE TERMINAL)

NO.	POWER SUPPLY CIRCUIT	NAME	RATED CAPACITY (A)	HOUSING COLOR	LOAD CIRCUIT
31	Battery/Generator (Fusible link No.1)	Fusible link	60	Yellow	Hydraulic brake booster (HBB)
32			40	Green	Hydraulic brake booster (HBB) and motor relay A, B
33			—	—	—

(CONNECTED DIRECTLY TO BATTERY POSITIVE TERMINAL)

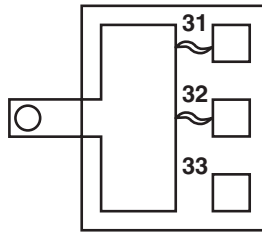

ACX01517AC

PASSENGER COMPARTMENT

NO.	POWER SUPPLY CIRCUIT	NAME	RATED CAPACITY (A)	HOUSING COLOR	LOAD CIRCUIT
1	Ignition switch (ACC)	Fuse	15	Blue	ETACS-ECU, rear wiper motor, remote controlled mirror and remote controlled mirror switch
2			–	–	–
3			–	–	–
4			15	Blue	Cigarette lighter and RV meter
5	Ignition switch (IG2)		10	Red	A/C compressor clutch relay, A/C-ECU, A/C switch, automatic compressor controller, condenser fan control relay, defogger relay, front blower relay, front-ECU, heated seat relay, M-ASTC-ECU, motor relay A, outside/inside air selection damper control motor, rear A/C control unit, rear A/C switch, rear A/C unit, rear blower relay, rear cooler control unit, rear cooler switch, rear cooler unit, rear fan control switch (front), rear heater control unit, rear heater switch, steering wheel sensor, sunroof motor assembly, tone alarm, transfer-ECU and valve relay
6	Ignition switch (IG1)		10	Red	Column switch, combination meter, ETACS-ECU, motor antenna-ECU, side step light-ECU, solenoid valve A, B, SRS-ECU, TPMS receiver and vehicle speed sensor
7			–	–	–
8			10	Red	A/T control relay, ETACS-ECU, front propeller shaft speed sensor, G/yaw rate sensor, input shaft speed sensor, output shaft speed sensor, powertrain control module, rear combination light, rear propeller shaft speed sensor, shift switch assembly, SRS-ECU, transfer-ECU, transfer shift lever switch and transmission range switch

NO.	POWER SUPPLY CIRCUIT	NAME	RATED CAPACITY (A)	HOUSING COLOR	LOAD CIRCUIT
9	Fusible link No.2	Fuse	–	–	–
10			20	Yellow	Combination meter, data link connector and ETACS-ECU
11			30	Pink	Defogger and fuse No.18 (in junction block) circuit
12			30	Pink	Blower switch, front blower relay and heater blower controller unit
13			–	–	–
14			–	–	–
15			–	–	–
16			–	–	–
17	Ignition switch (IG2)		10	Red	M-ASTC-ECU and motor relay B
18	Defogger relay		10	Red	Remote controlled mirror
19	Fusible link No.4		20	Yellow	Sunroof motor assembly
20	Fusible link No.3		20	Yellow	Heated seat switch

(IN JUNCTION BLOCK)

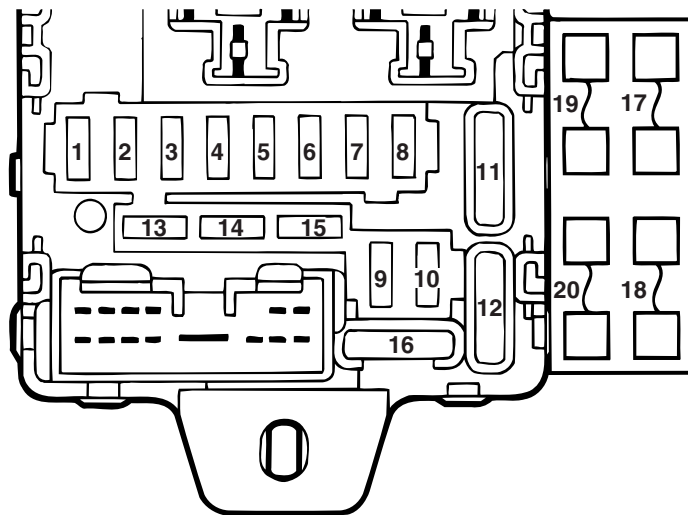

AC203972AB

CENTRALIZED RELAY

CONNECTOR NO.	NAME	CONNECTOR NO.	NAME
A-06X	-	B-20X	-
A-07X	Front-ECU	B-21X	Valve relay
A-08X	Front-ECU	B-22X	MF1 relay
A-09X	Condenser fan control relay	B-23X	Throttle actuator control motor relay
A-10X	Horn relay		
A-11X	Theft-alarm horn relay	B-24X	Fuel pump relay (2)
A-12X	A/C compressor clutch relay	B-25X	Inspection connector (engine speed detection connector)
A-13X	Fog light relay	B-53X	Motor relay A
B-19X	Fuel pump relay (1)	B-54X	Motor relay B

(RELAY BOX IN ENGINE COMPARTMENT)

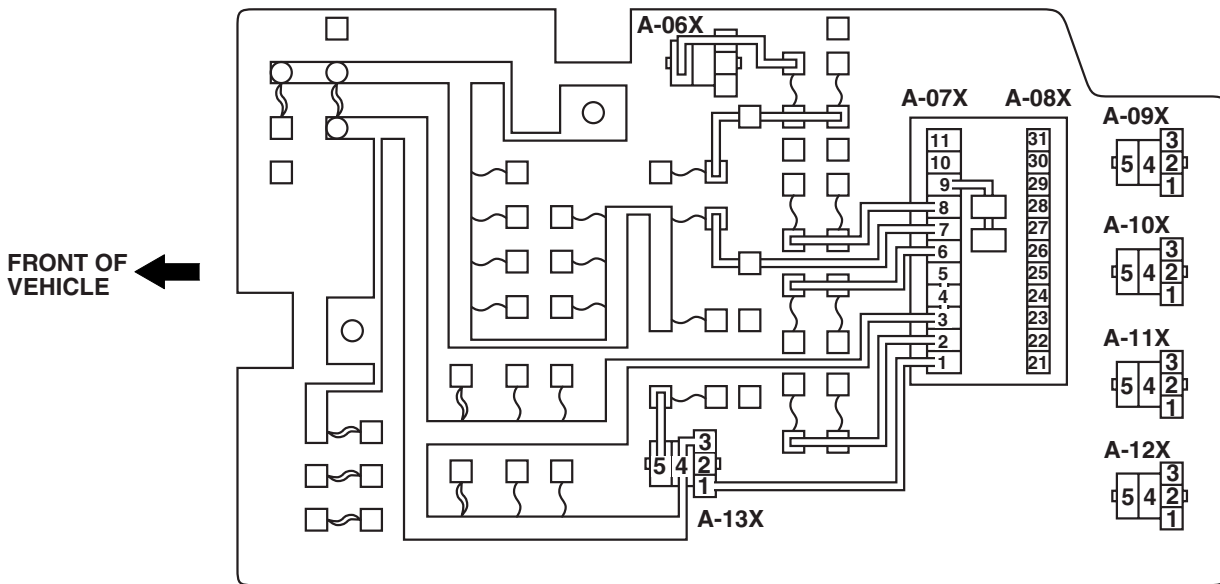

AC303851AC

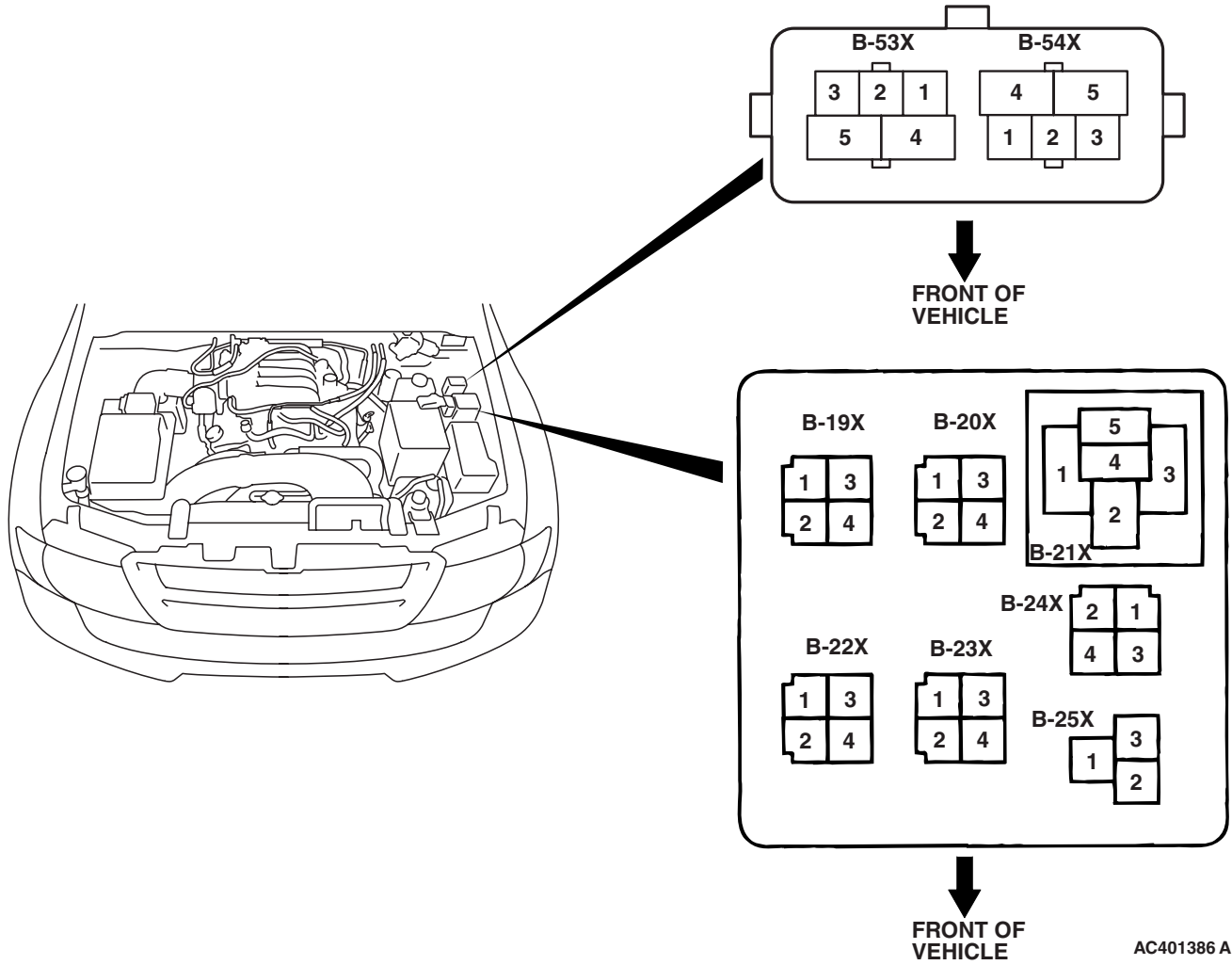

AC401386 AB

POWER DISTRIBUTION SYSTEM

M1901000401786

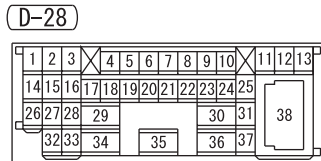
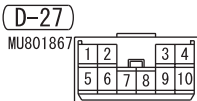
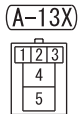
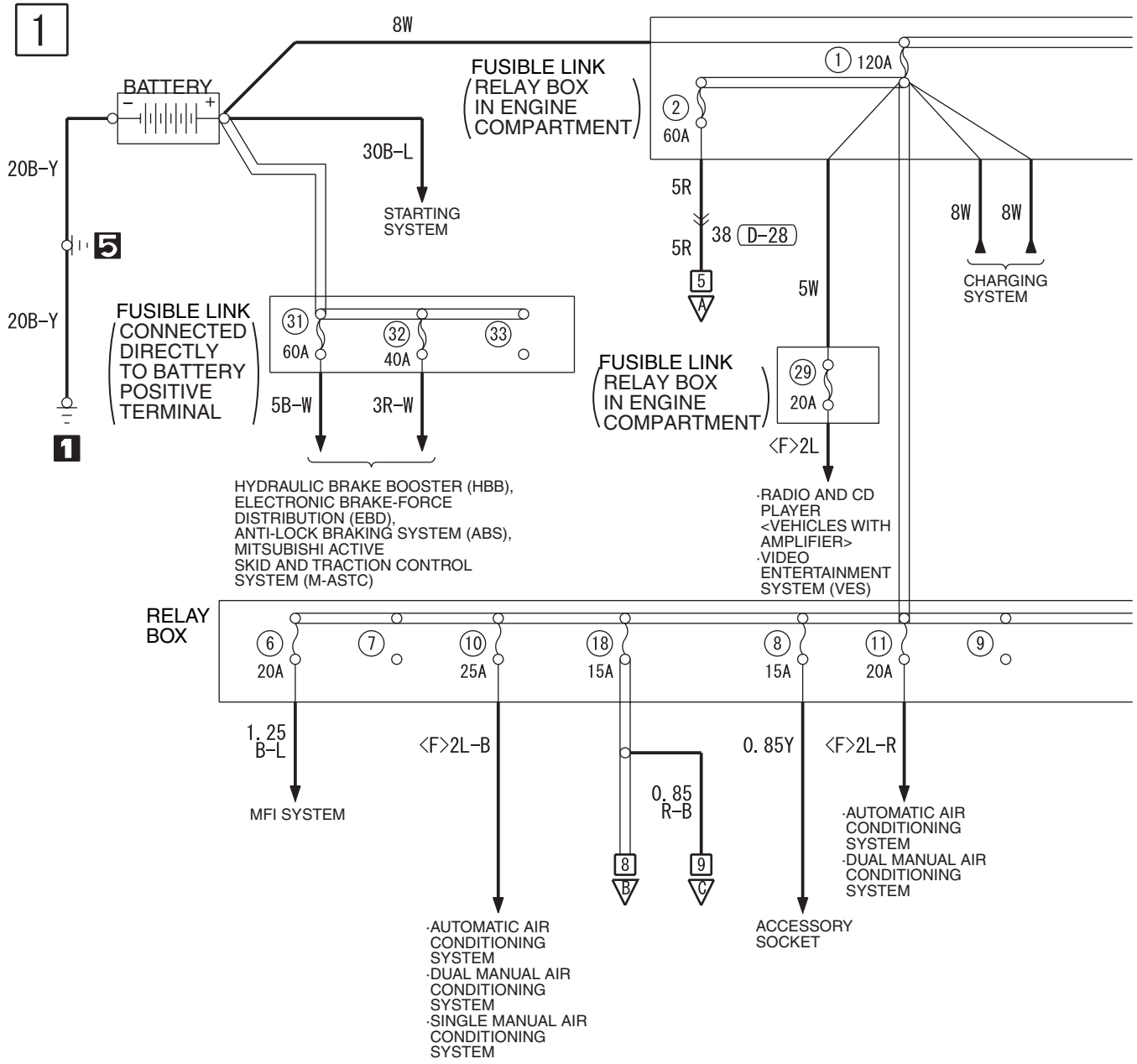

2

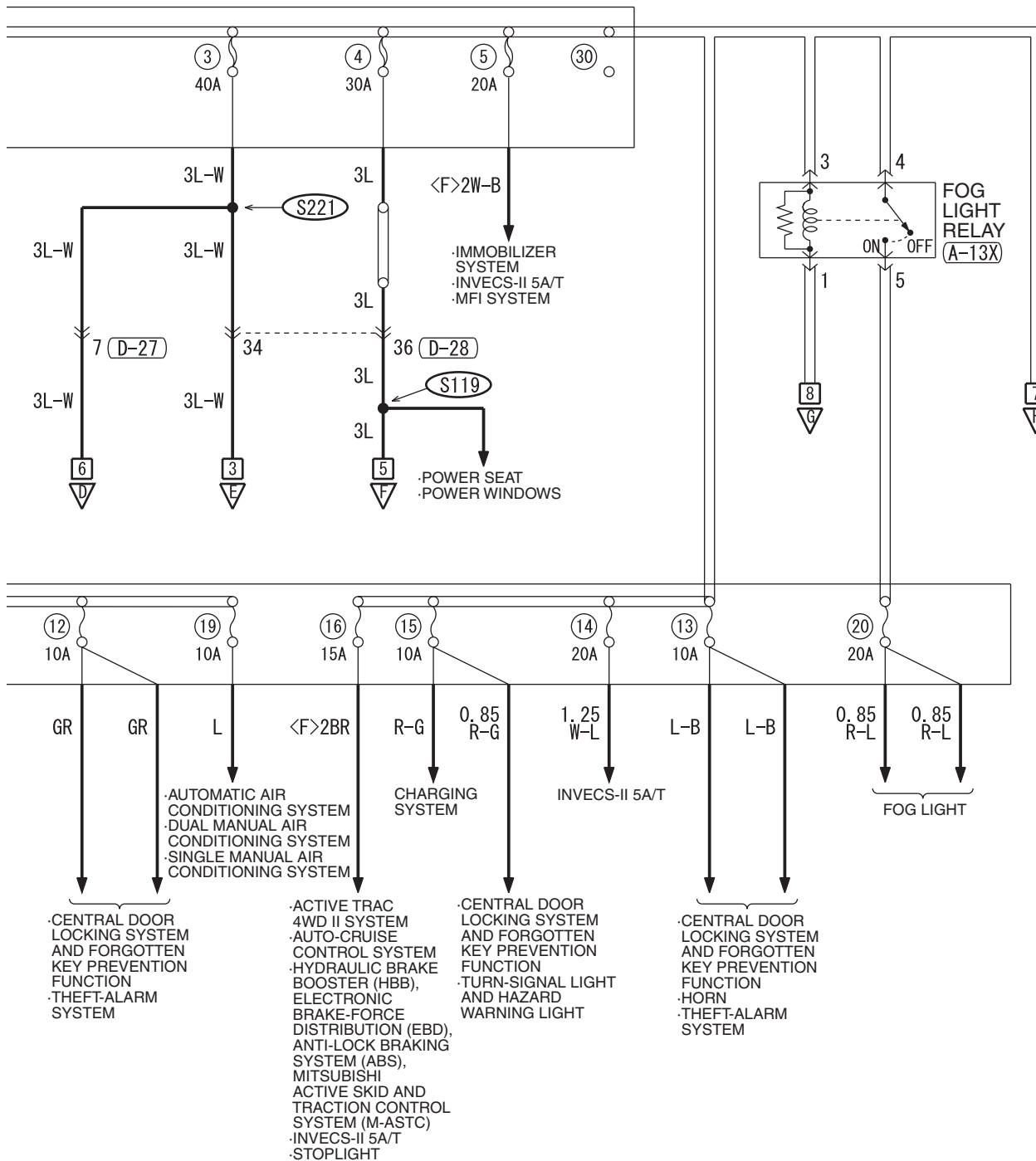

WIRE COLOR CODE

B : BLACK LG : LIGHT GREEN G : GREEN L : BLUE W : WHITE Y : YELLOW
 SB : SKY BLUE BR : BROWN O : ORANGE GR : GRAY R : RED P : PINK V : VIOLET

POWER DISTRIBUTION SYSTEM (CONTINUED)

3

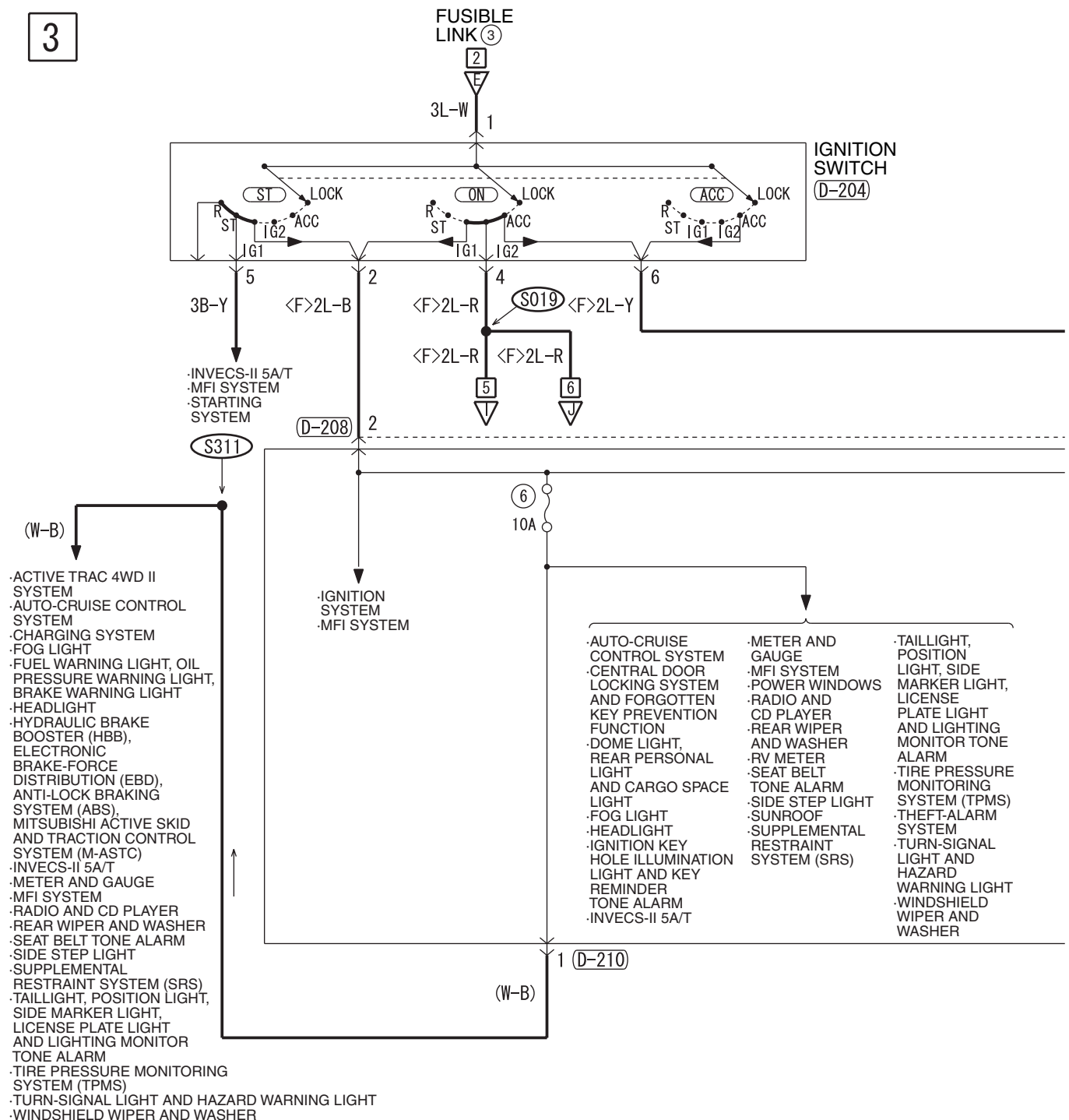

D-28

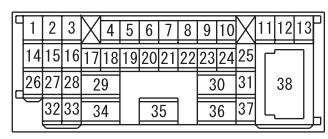

D-204



D-208



D-210

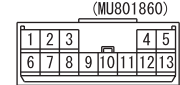

D-221

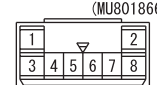

4

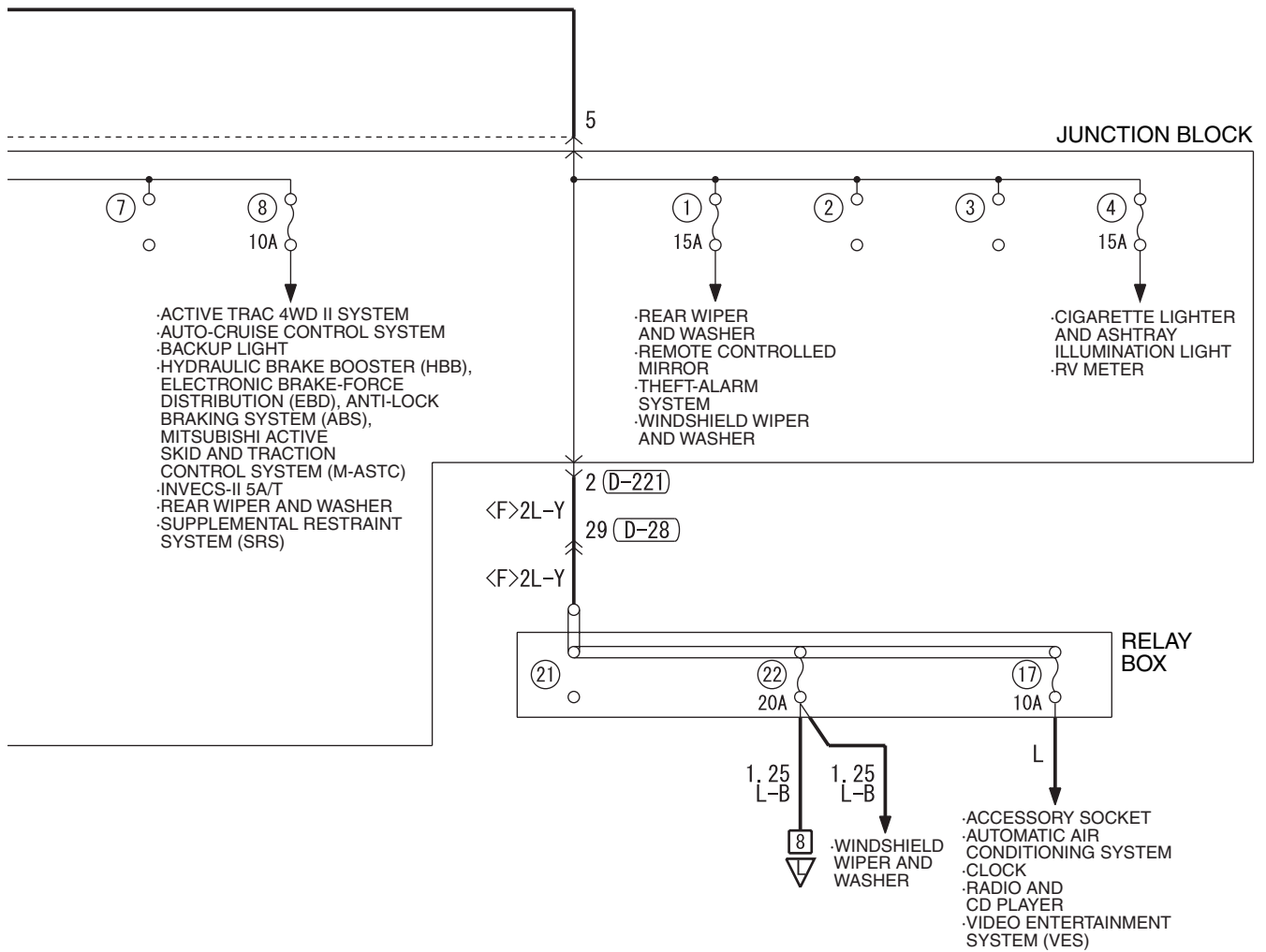

WIRE COLOR CODE

B: BLACK LG: LIGHT GREEN G: GREEN L: BLUE W: WHITE Y: YELLOW
SB: SKY BLUE BR: BROWN O: ORANGE GR: GRAY R: RED P: PINK V: VIOLET

TSB Revision

POWER DISTRIBUTION SYSTEM (CONTINUED)

5

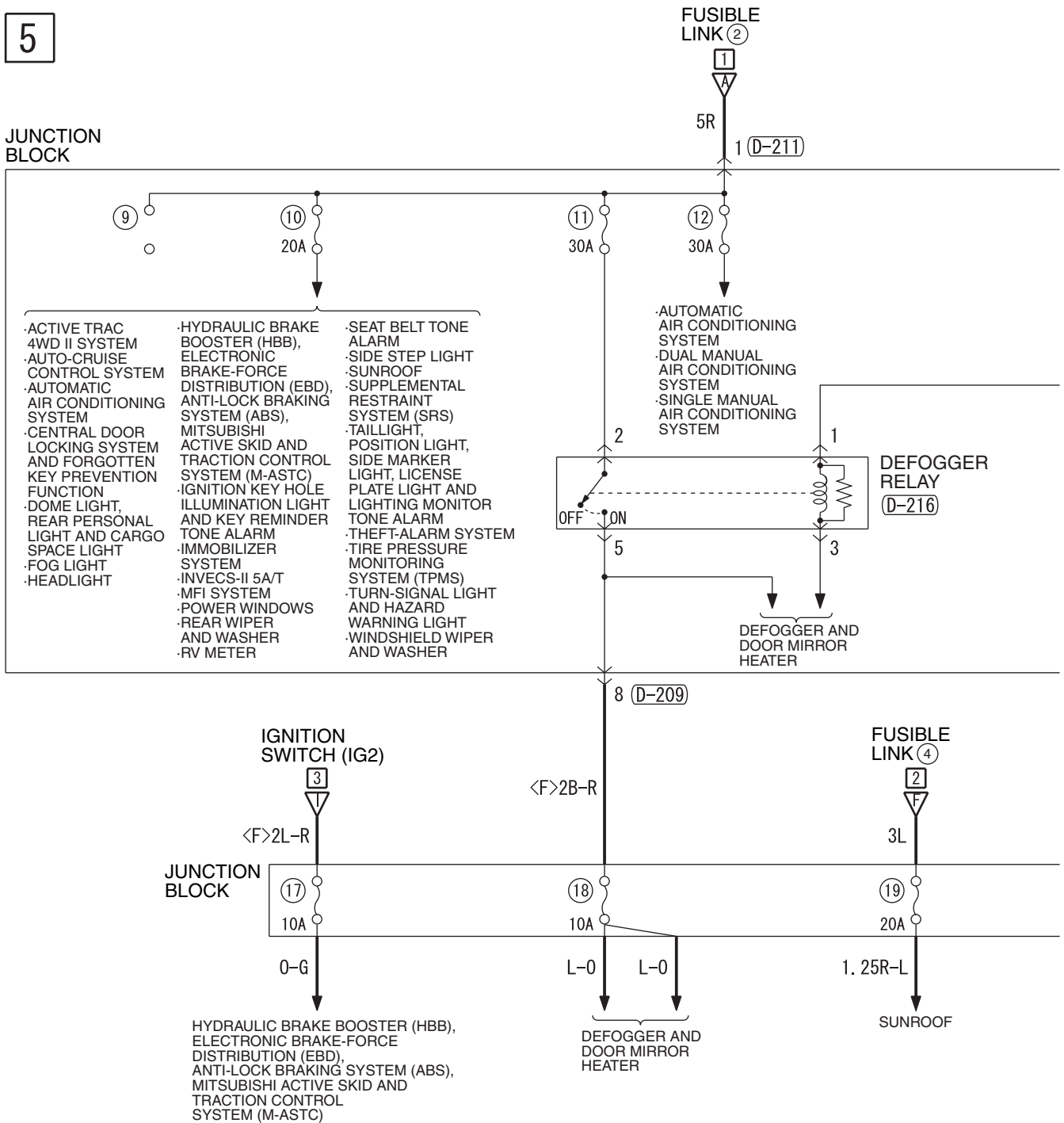

D-28

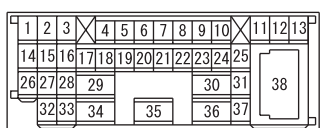

D-208



D-209

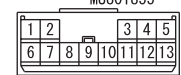

D-210

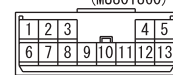

D-211



D-216



6

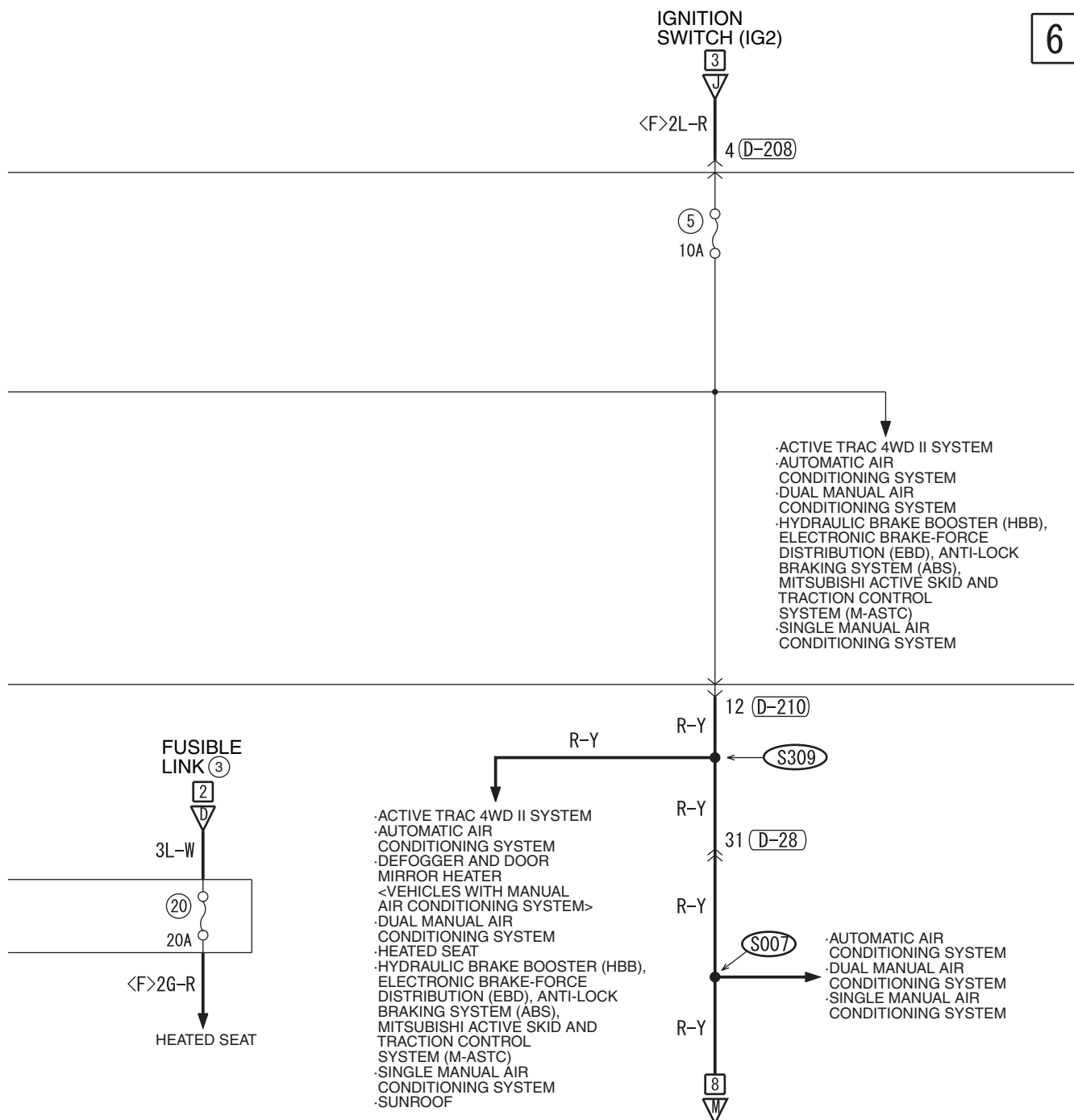

WIRE COLOR CODE

B: BLACK LG: LIGHT GREEN G: GREEN L: BLUE W: WHITE Y: YELLOW
SB: SKY BLUE BR: BROWN O: ORANGE GR: GRAY R: RED P: PINK V: VIOLET

H6Q01M00CB

TSB Revision

POWER DISTRIBUTION SYSTEM (CONTINUED)

7

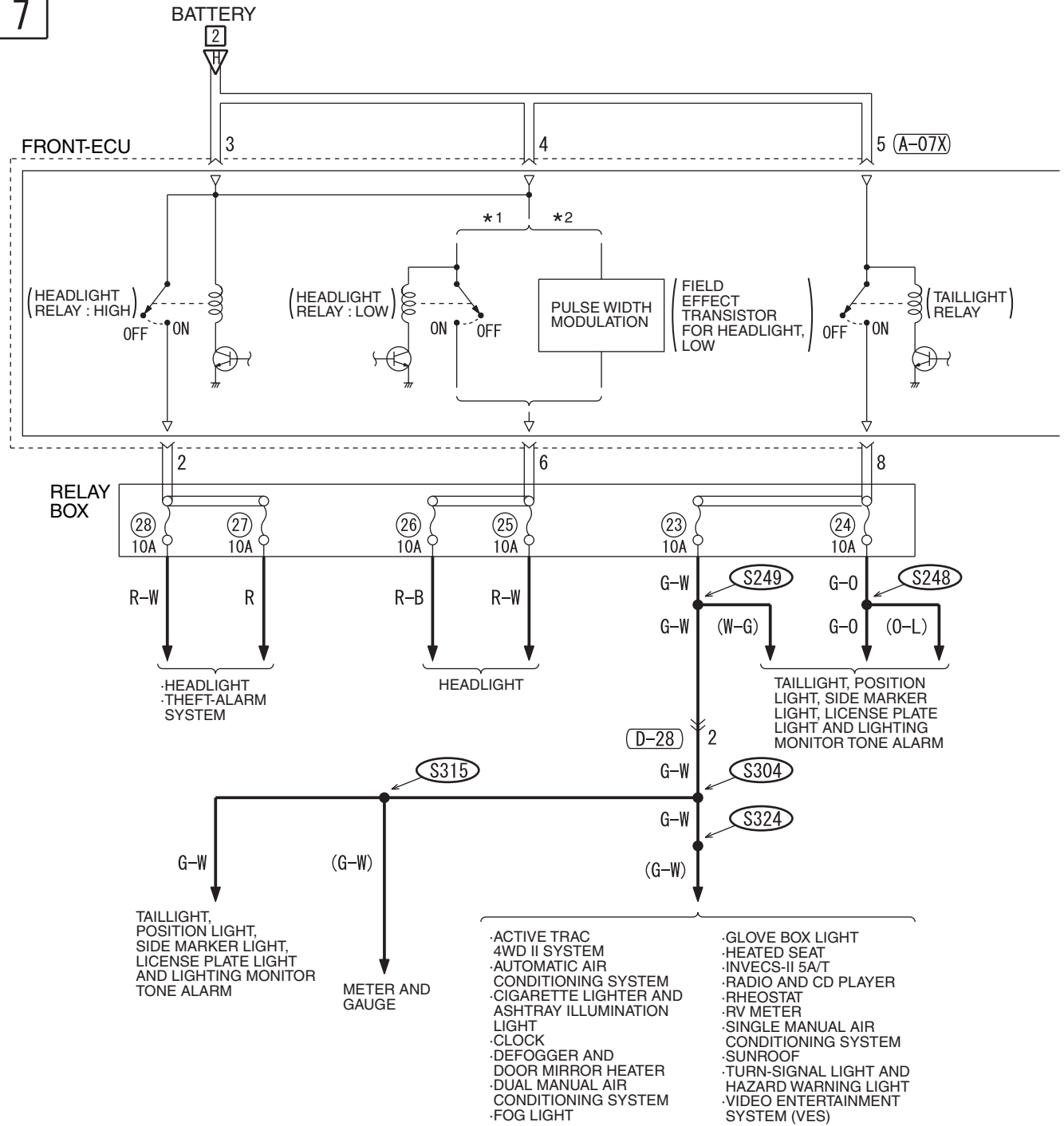

(A-07X)

1	2	3	4	5	6	7	8	9	10	11
---	---	---	---	---	---	---	---	---	----	----

(A-08X)

21	22	23	24	25	26	27	28	29	30	31
----	----	----	----	----	----	----	----	----	----	----

(D-28)

1	2	3	4	5	6	7	8	9	10	11	12	13
14	15	16	17	18	19	20	21	22	23	24	25	
26	27	28	29			30	31					38
32	33	34		35		36	37					

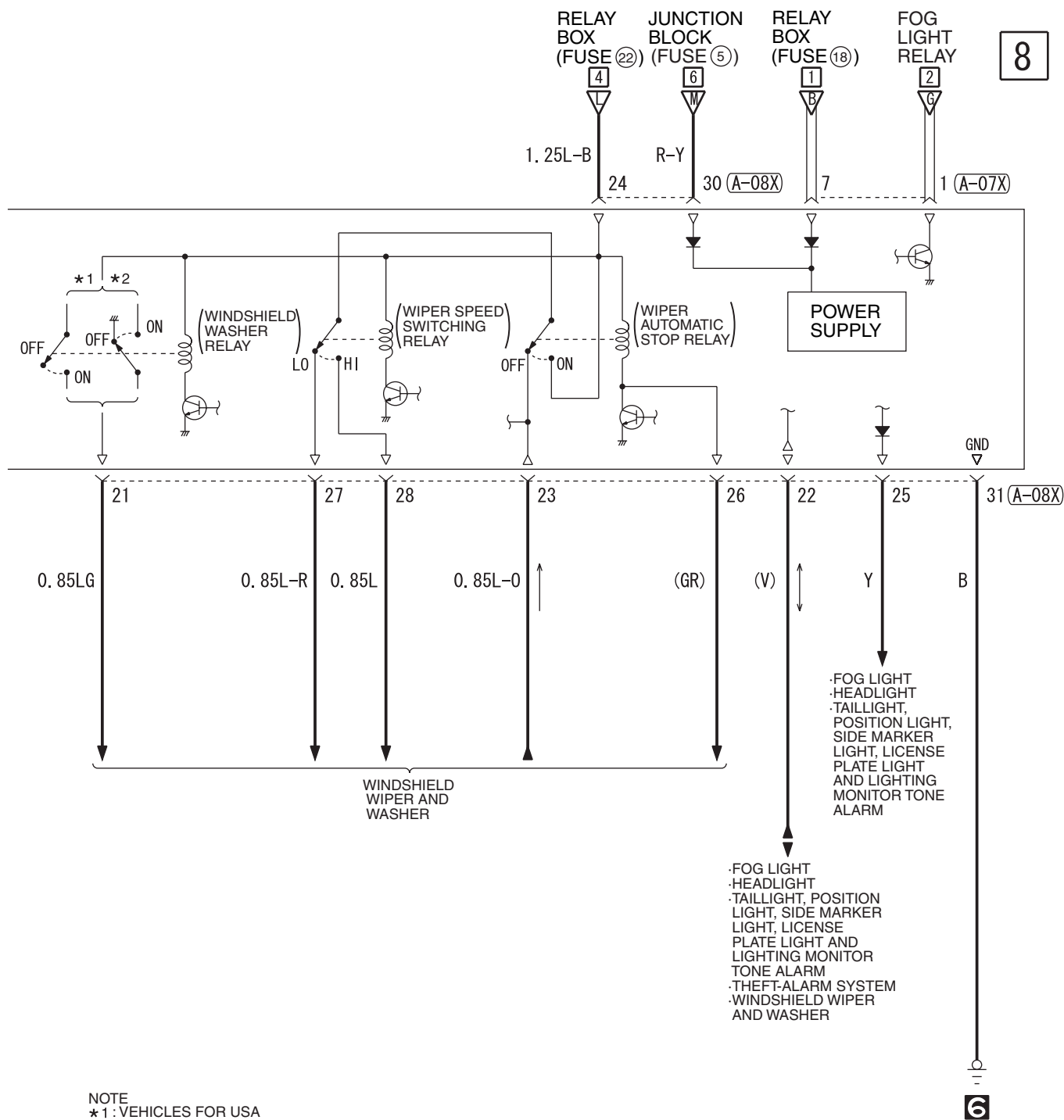

WIRE COLOR CODE
 B : BLACK LG : LIGHT GREEN G : GREEN L : BLUE W : WHITE Y : YELLOW
 SB : SKY BLUE BR : BROWN O : ORANGE GR : GRAY R : RED P : PINK V : VIOLET

POWER DISTRIBUTION SYSTEM (CONTINUED)

9

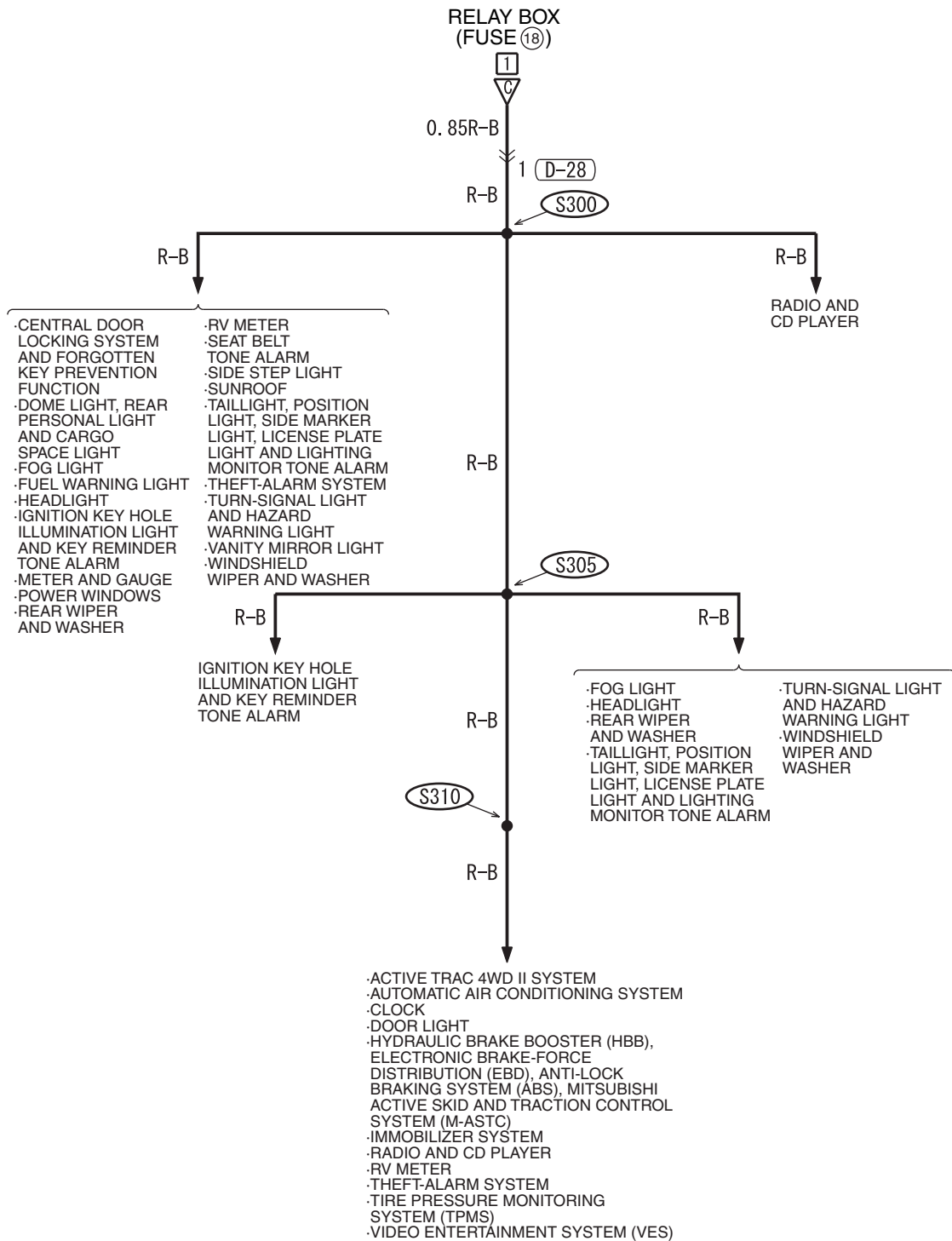

D-28

1	2	3	4	5	6	7	8	9	10	11	12	13
14	15	16	17	18	19	20	21	22	23	24	25	
26	27	28	29					30	31	38		
32	33	34	35					36	37			

WIRE COLOR CODE

B : BLACK LG : LIGHT GREEN G : GREEN L : BLUE
BR : BROWN O : ORANGE GR : GRAY R : RED W : WHITE
SB : SKY BLUE P : PINK Y : YELLOW V : VIOLET

STARTING SYSTEM

M1901000502009

1

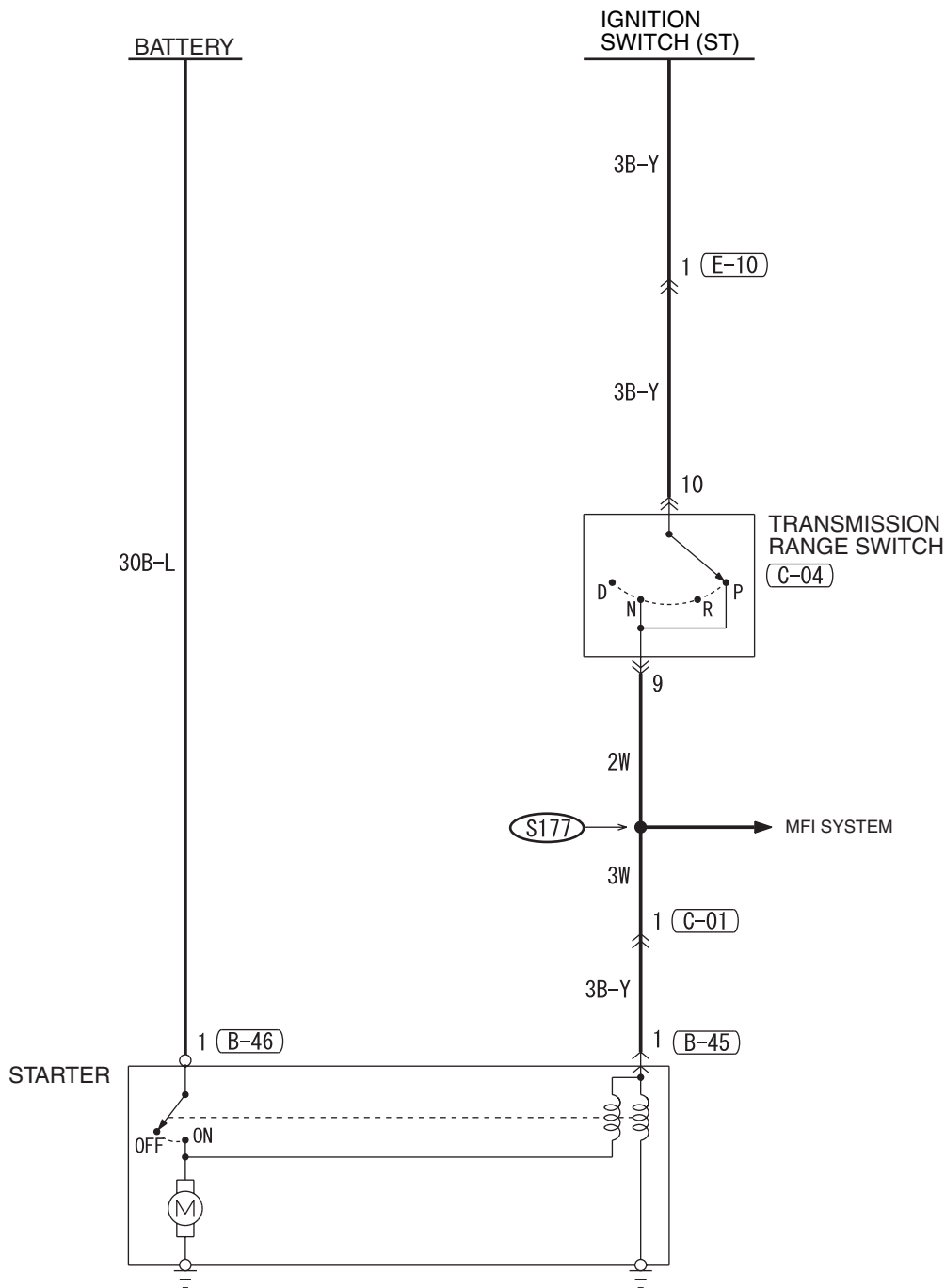

WIRE COLOR CODE
 B: BLACK LG: LIGHT GREEN G: GREEN L: BLUE W: WHITE Y: YELLOW
 SB: SKY BLUE BR: BROWN O: ORANGE GR: GRAY R: RED P: PINK V: VIOLET

H6Q02M00AA

TSB Revision

IGNITION SYSTEM

M1901000602772

1

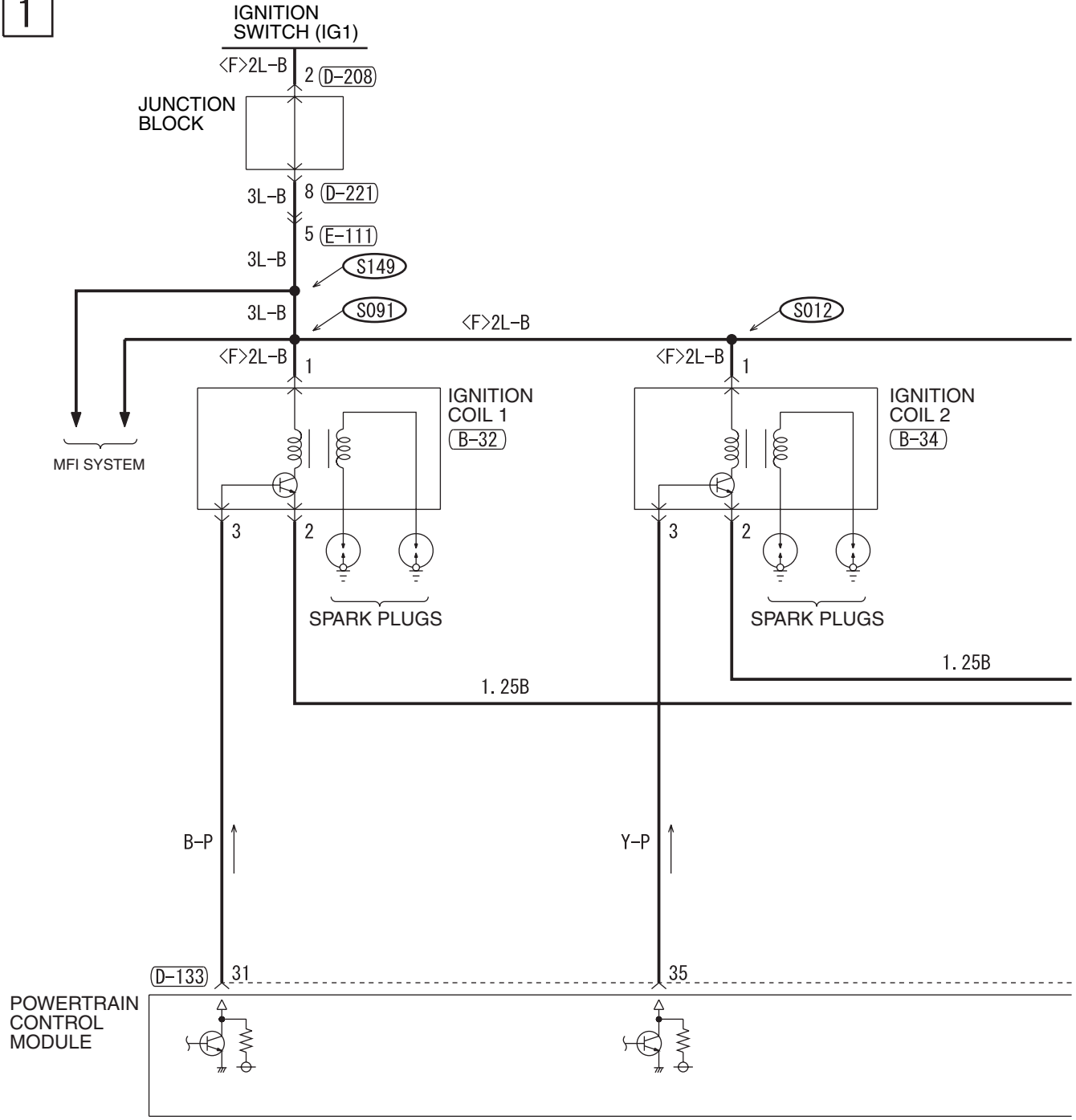

(B-25X)

1
2 3

(B-31)
(MU802064)

1	2	3
---	---	---

(B-32)
(MU802064)

1	2	3
---	---	---

(B-34)
(MU802064)

1	2	3
---	---	---

(D-14)
MU801335

1	2	3	4
5	6	7	8 9 10

(D-133)
(MU803803)

31	32	JAE	33	34
35	36	37	38	39 40 41
42	43	44	45	46 47 48 49
50	51	52	53	54 55 56
57	58			

(D-134)
(MU803804)

61	62	JAE	63	64
65	66	67	68	69 70 71
72	73	74	75	76 77 78 79 80
81	82	83	84	85 86 87
88	89			

2

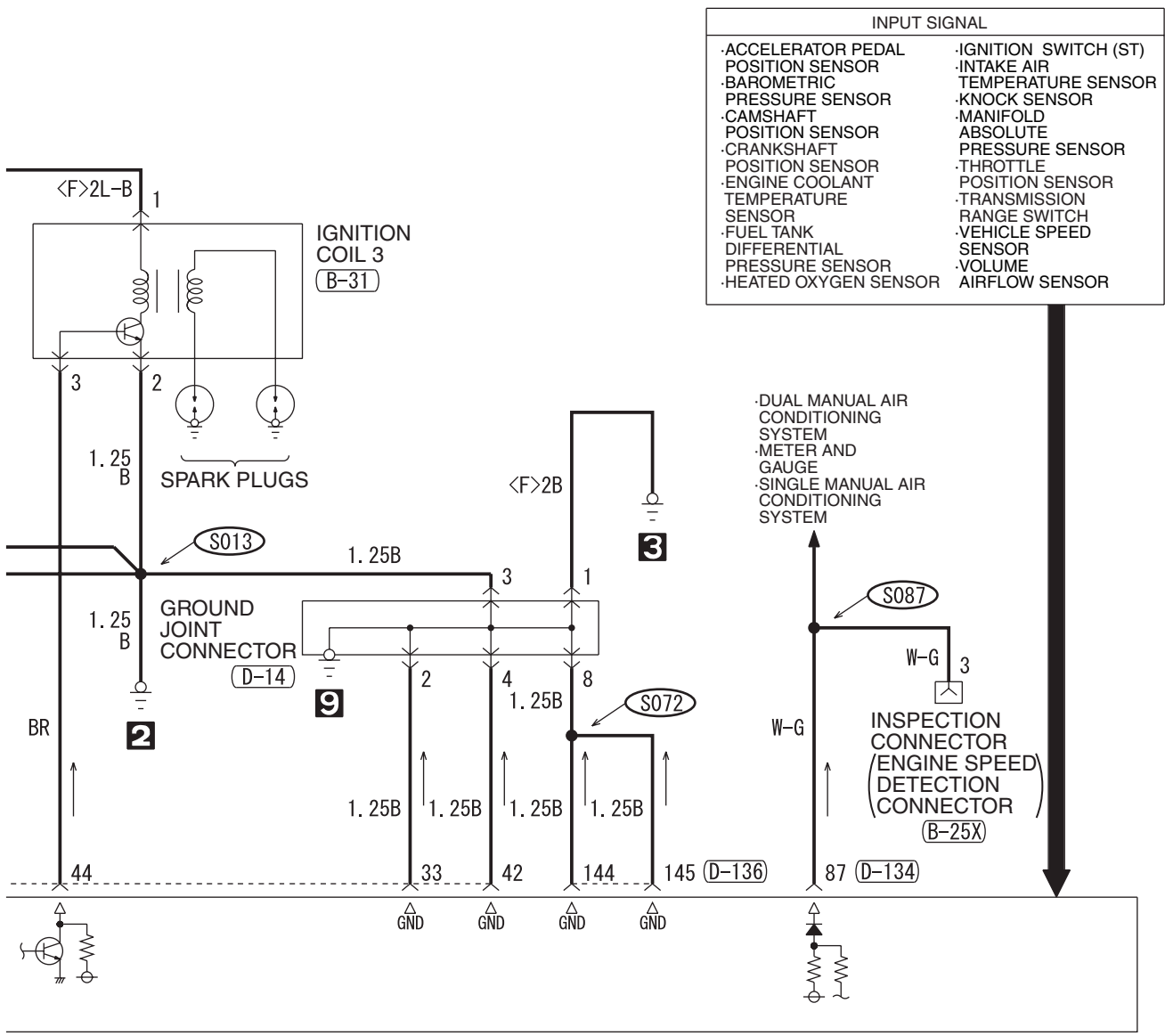

(D-136)
(MU803801)

121	122	JAE		123	124
125	126	127	128	129	130
131	132	133	134	135	136
137	138	139	140	141	142
143	144	145	146		

(D-208)
MU801331

1	2
3	4
5	6

(D-221) (MU801866)

1	2
3	4
5	6
7	8

(E-111)

1	2	3	4	5	6	7	8	9	10	11	12	13	14	15	16
17	18	19	20	21	22	23	24	25	26	27	28	29	30	31	32
33	34	35	36	37	38										

CHARGING SYSTEM

M1901000701958

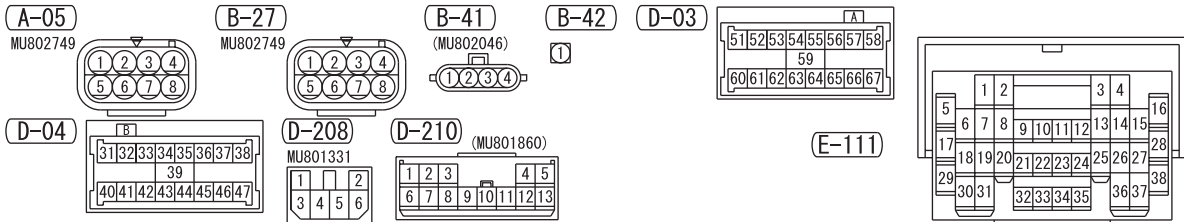
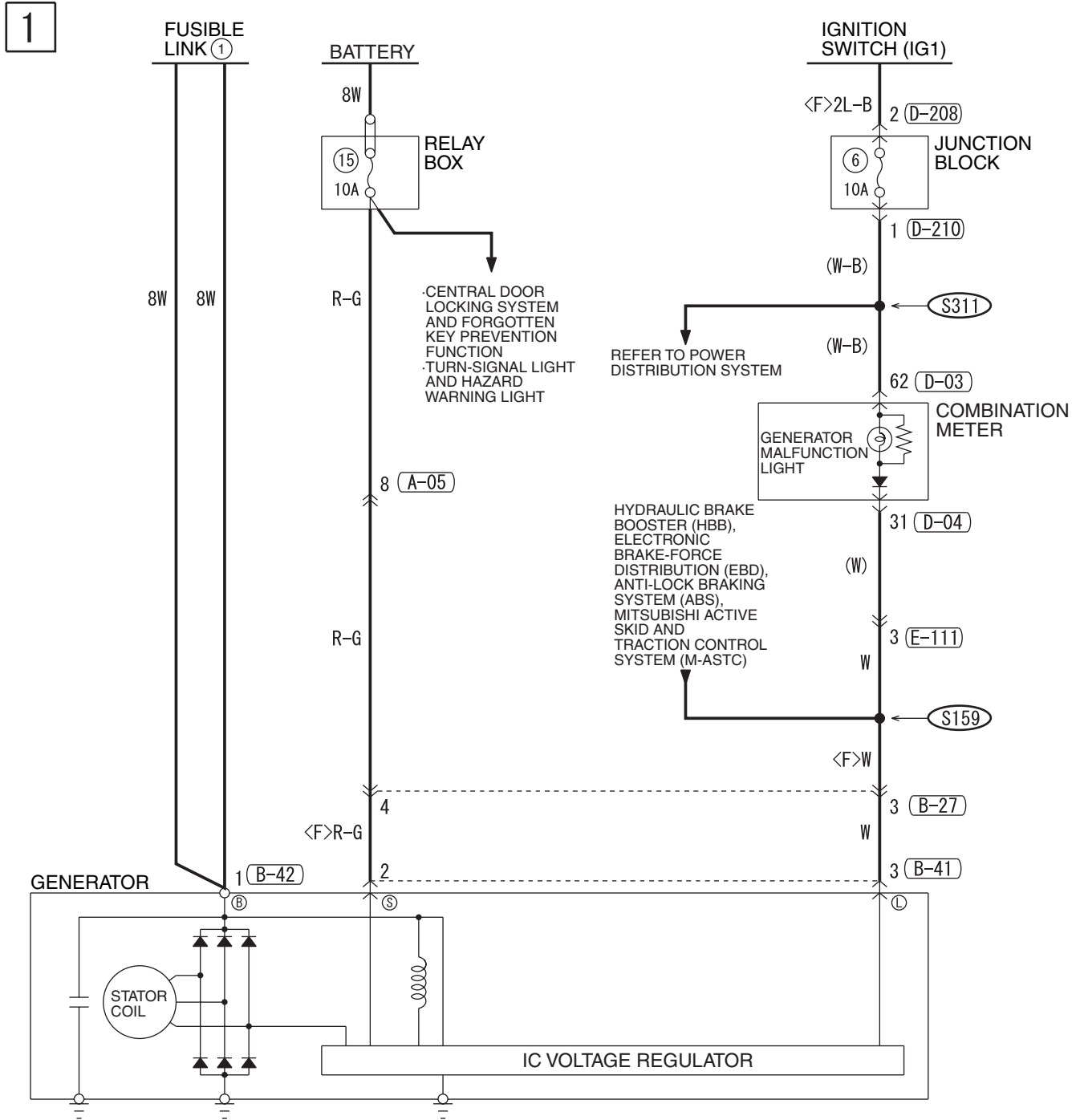

NOTES

MFI SYSTEM

M1901000803791

1

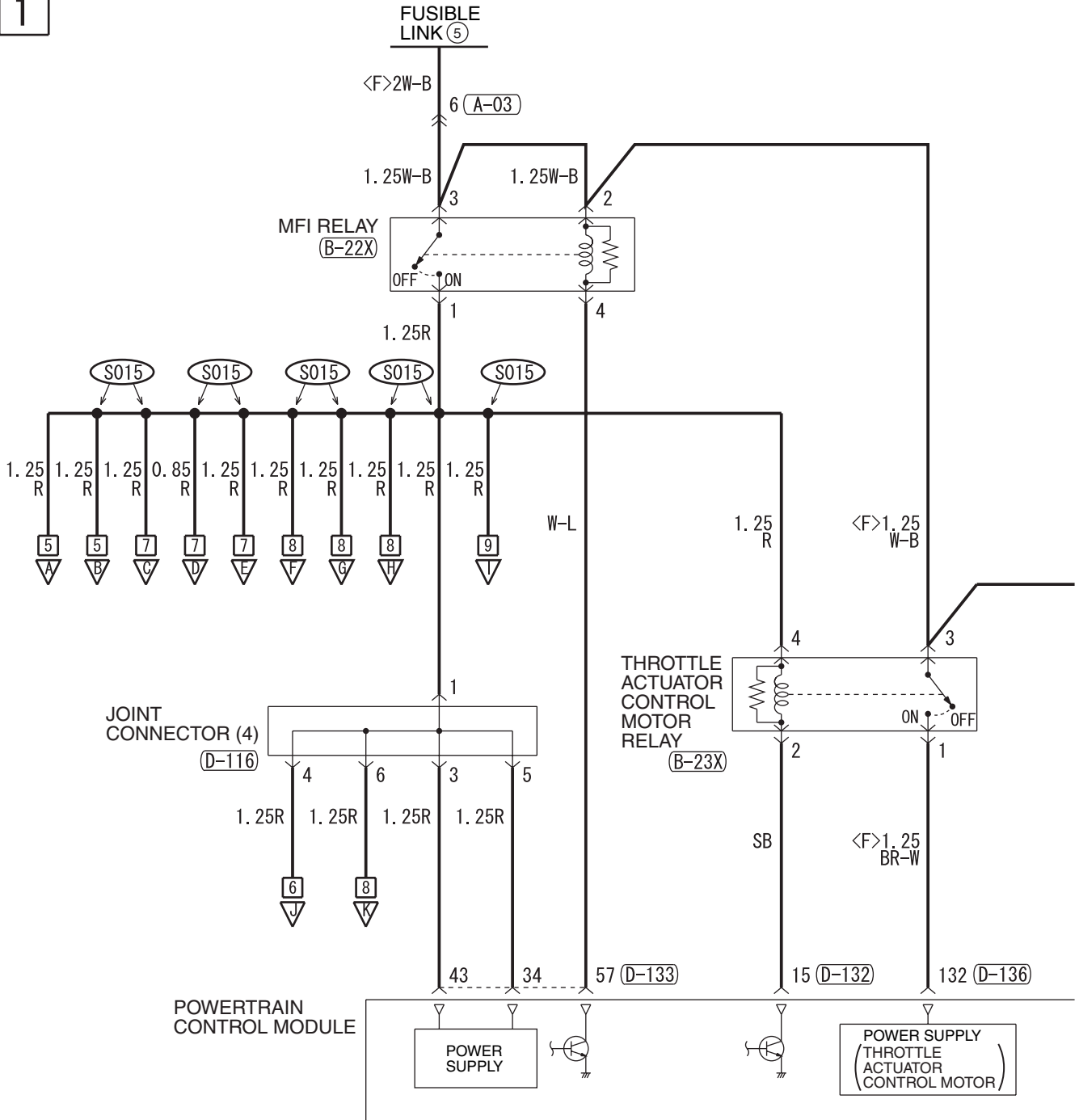

A-03



B-22X



B-23X



D-03

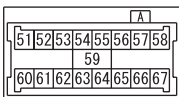

D-04

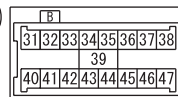

D-136

(MU803801)

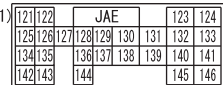

D-208



D-210



D-212



E-111

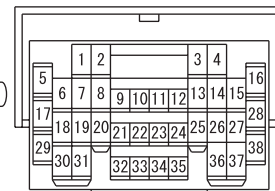

H6Q05M00AA

2

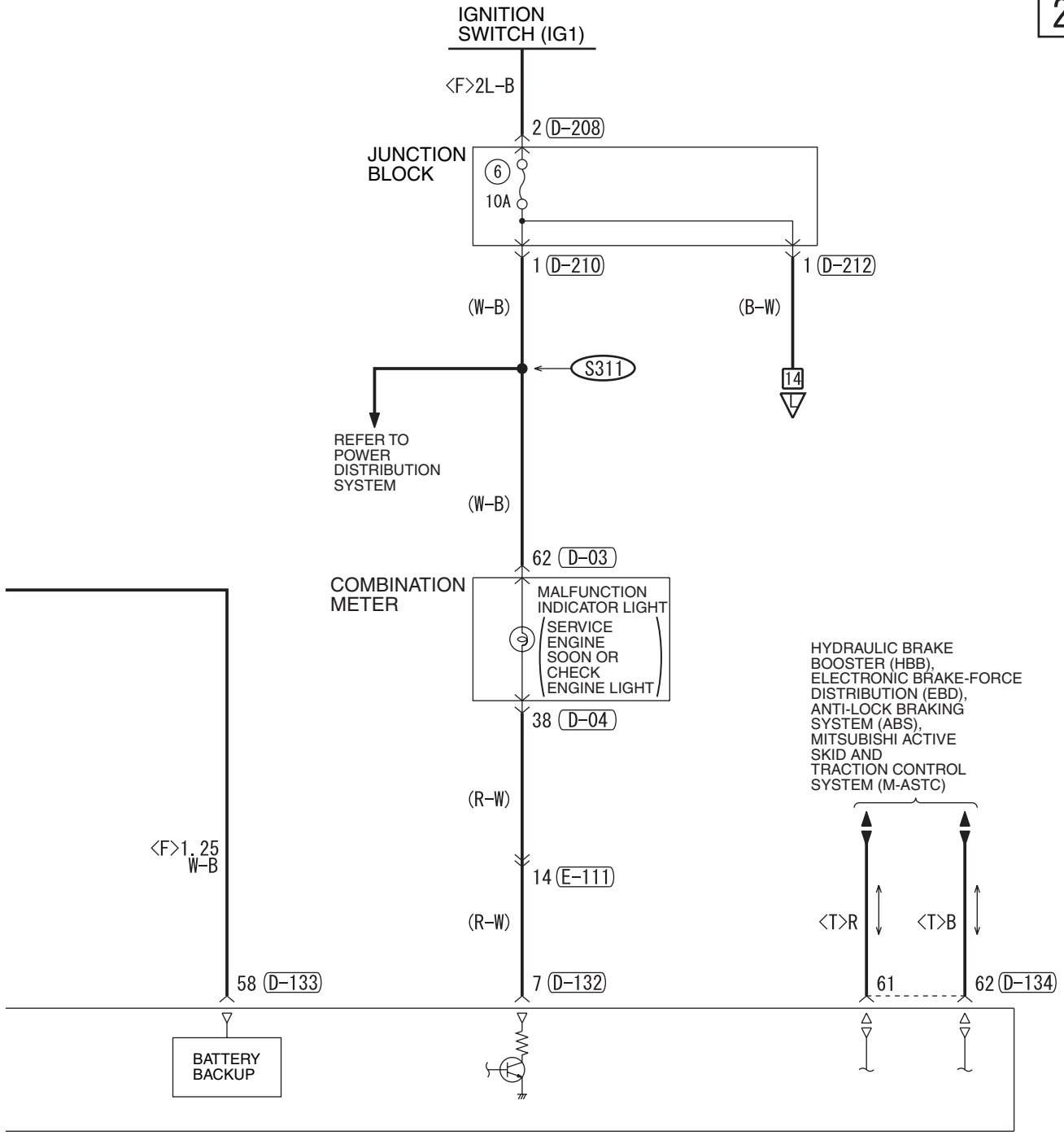

D-116

1	2	3	4	5	6	7	8	9	10	11
12	13	14	15	16	17	18	19	20	21	22
23	24	25	26	27	28	29	30	31	32	33

D-132 (MU803802)

1	2	JAE		3	4
5	6	7	8	9	10
11	12	13	14	15	16
17	18	19	20	21	22
23	24	25	26	27	

D-133 (MU803803)

31	32	JAE		33	34
35	36	37	38	39	40
41	42	43	44	45	46
47	48	49	50	51	52
53	54	55	56	57	58

D-134 (MU803804)

61	62	JAE		63	64
65	66	67	68	69	70
71	72	73	74	75	76
77	78	79	80	81	82
83	84	85	86	87	88
89					

WIRE COLOR CODE
 B : BLACK LG : LIGHT GREEN G : GREEN L : BLUE
 BR : BROWN O : ORANGE GR : GRAY R : RED W : WHITE
 SB : SKY BLUE P : PINK Y : YELLOW V : VIOLET

TSB Revision

MFI SYSTEM (CONTINUED)

3

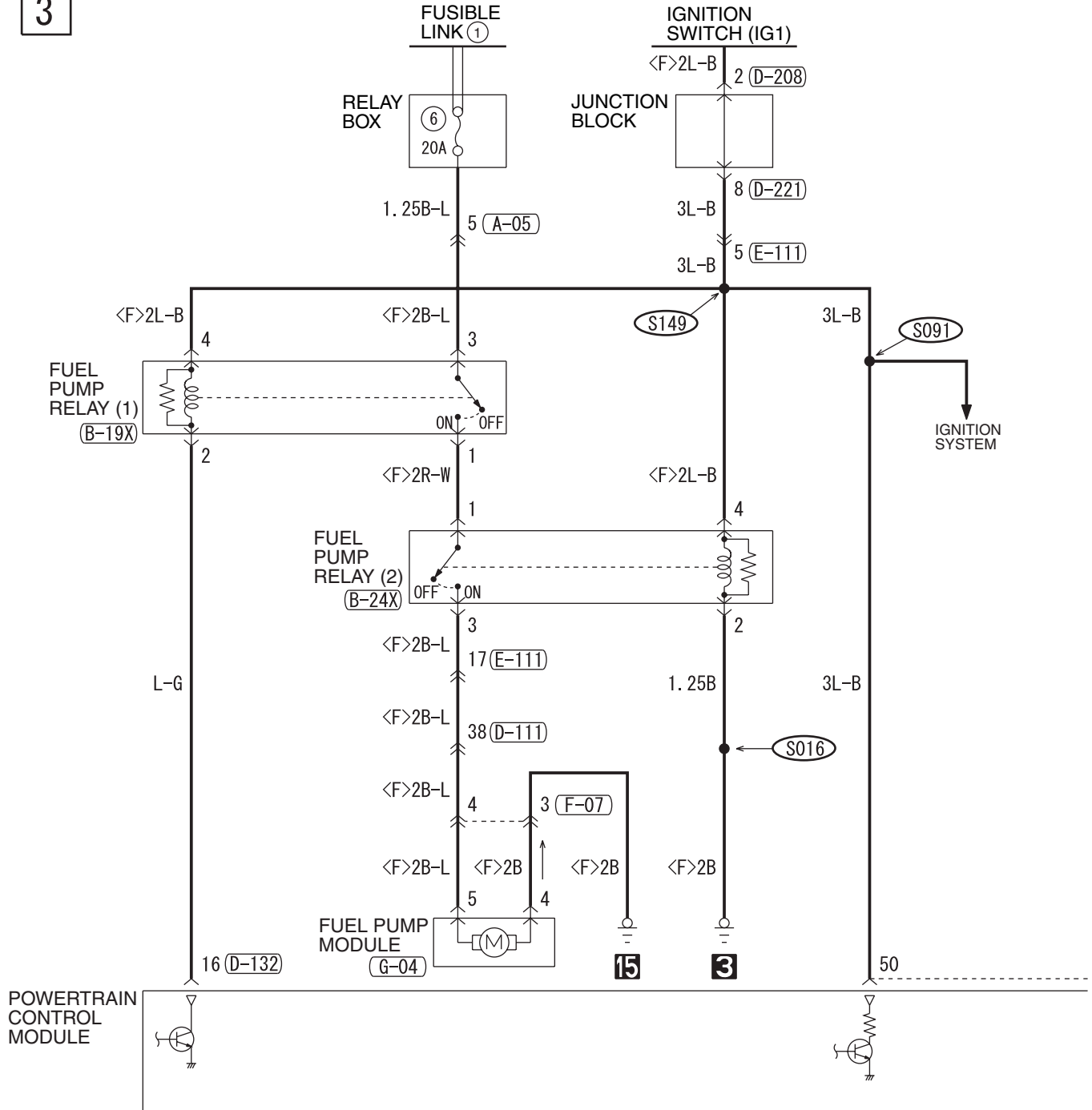

A-05
MU802749

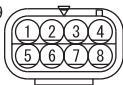

B-19X



B-24X



C-04
MU802645

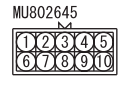

D-111

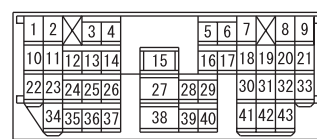

D-132



D-133

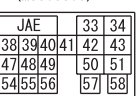

4

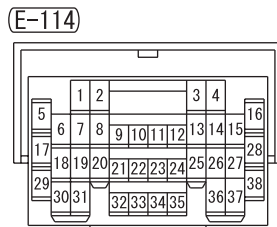
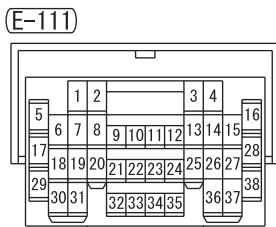
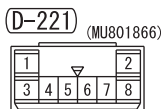
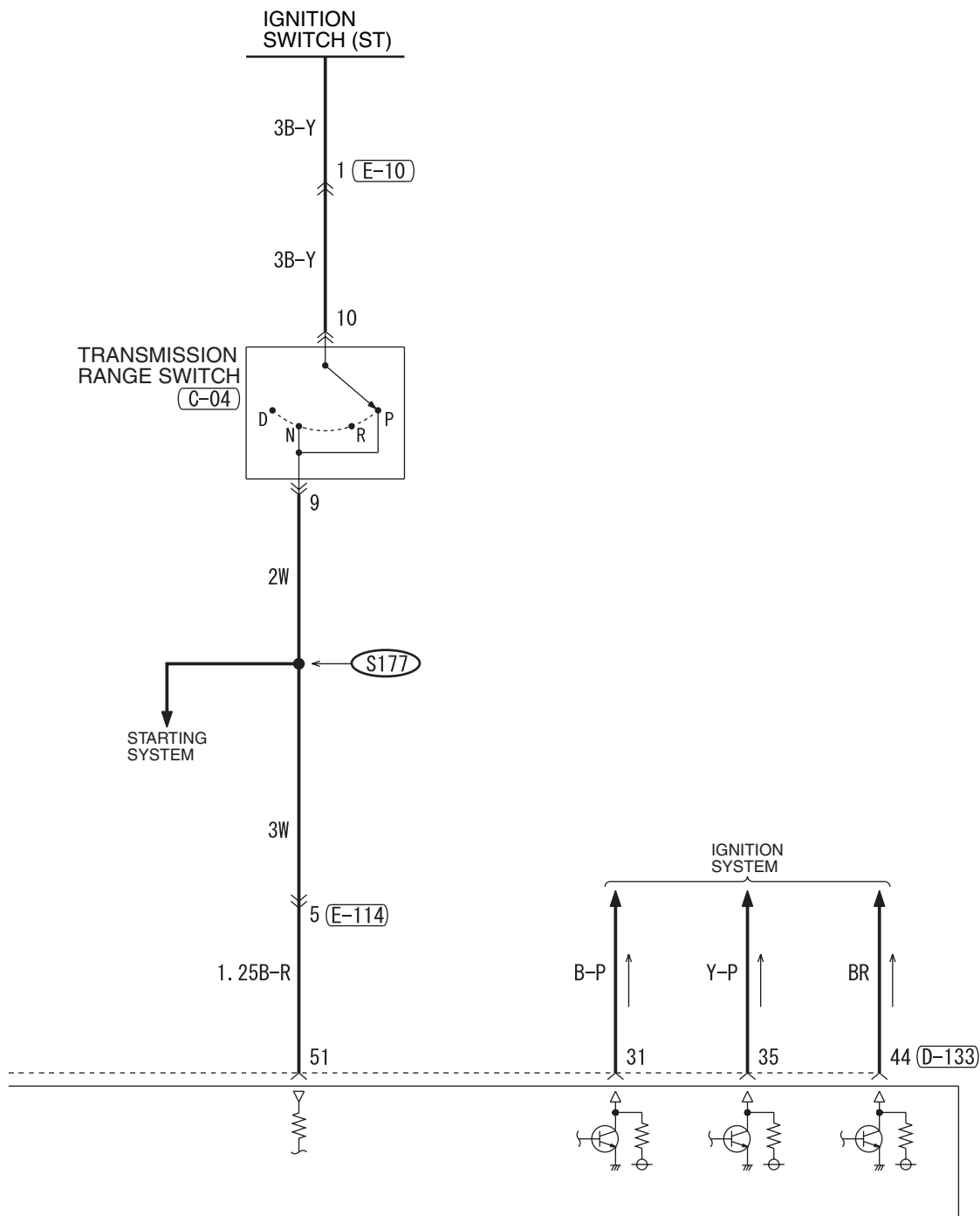

TSB Revision

MFI SYSTEM (CONTINUED)

5

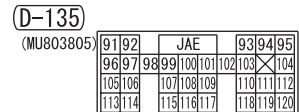
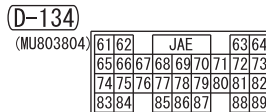
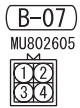
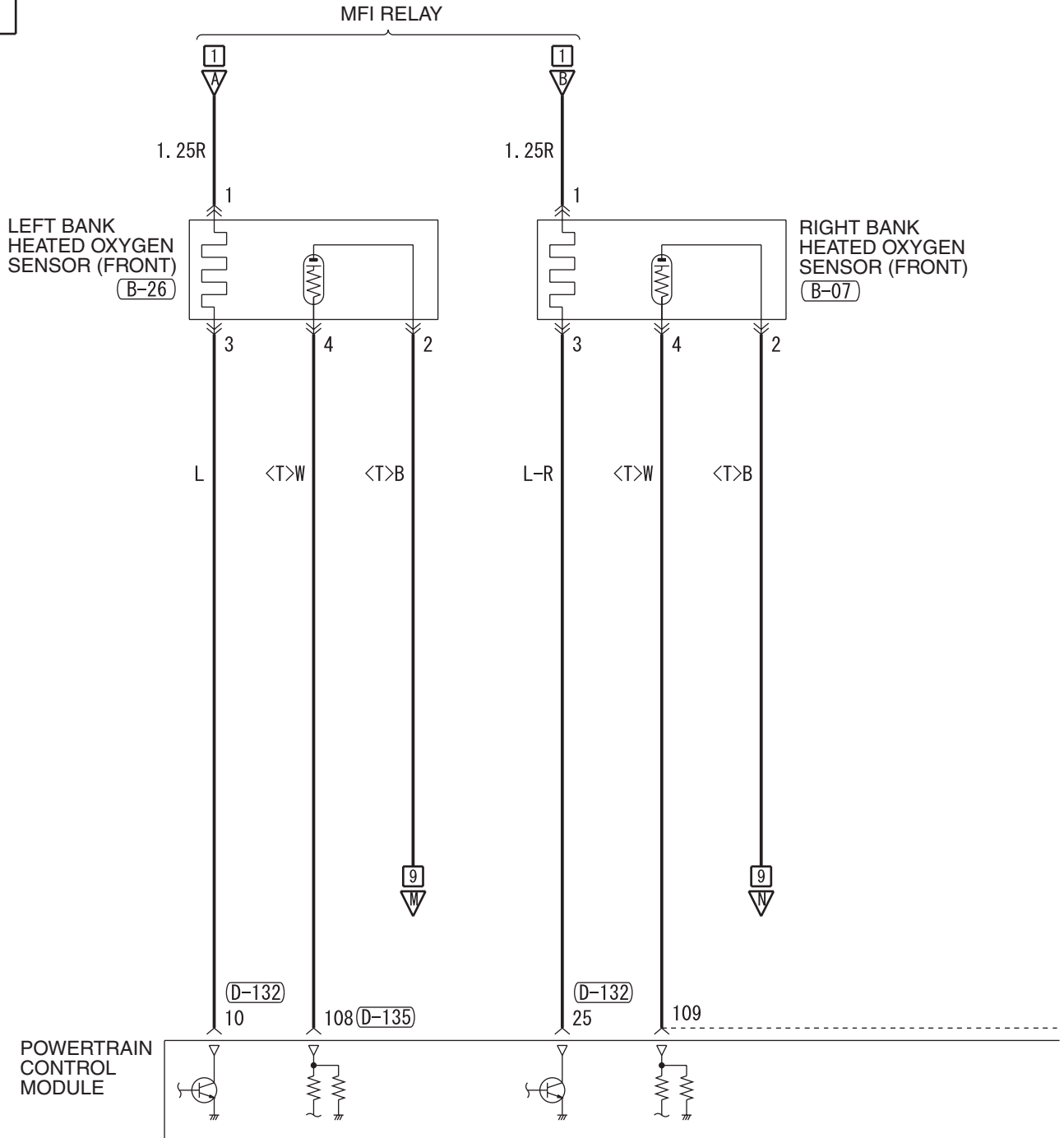

6

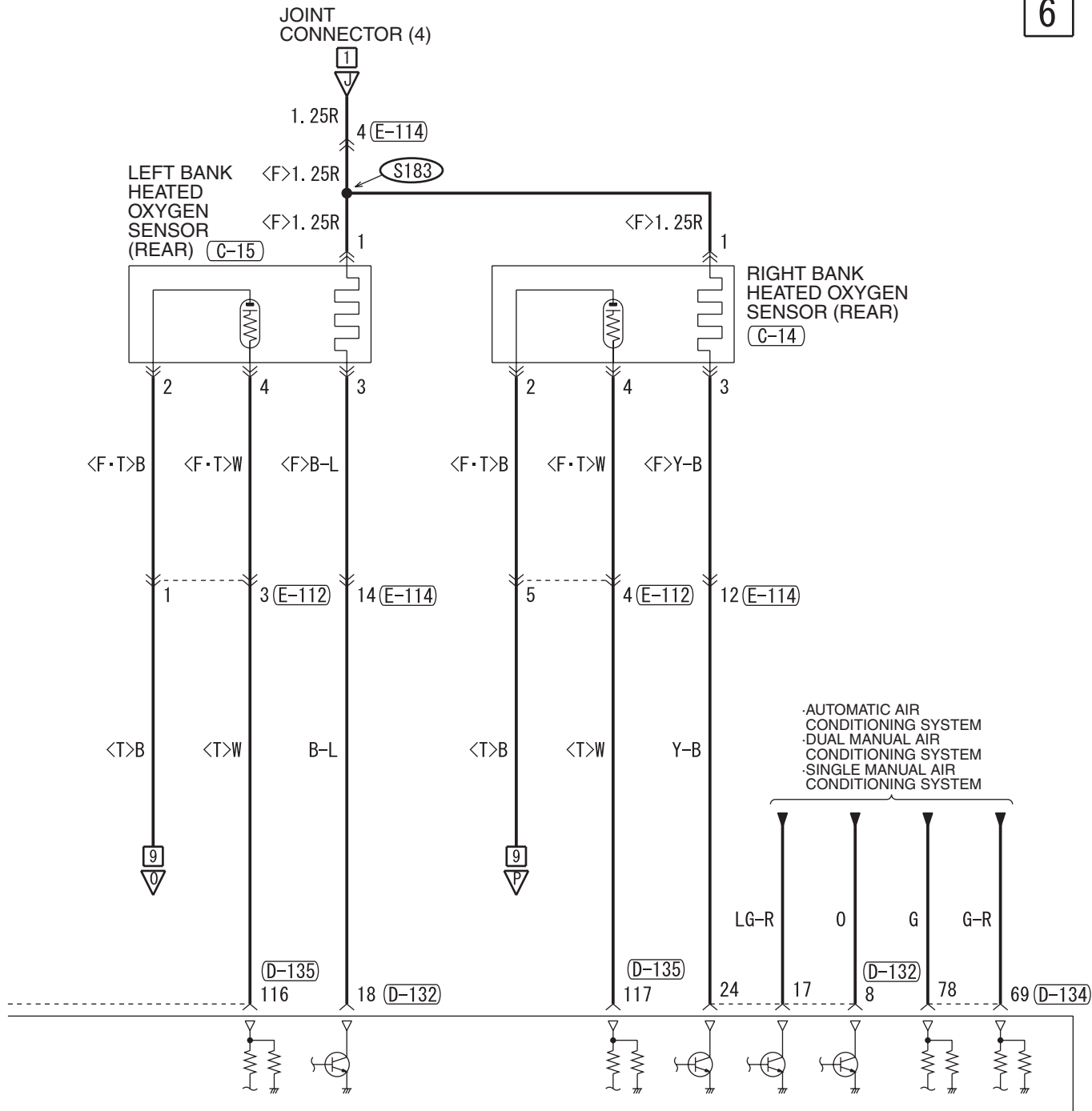

(E-112)

(E-114)

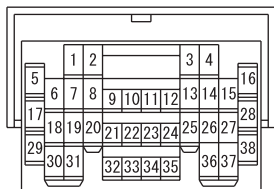

WIRE COLOR CODE
 B : BLACK SB : SKY BLUE
 BR : BROWN LG : LIGHT GREEN
 G : GREEN P : PINK GR : GRAY
 R : RED L : BLUE Y : YELLOW
 V : VIOLET W : WHITE O : ORANGE

H6Q05M00CB

TSB Revision

MFI SYSTEM (CONTINUED)

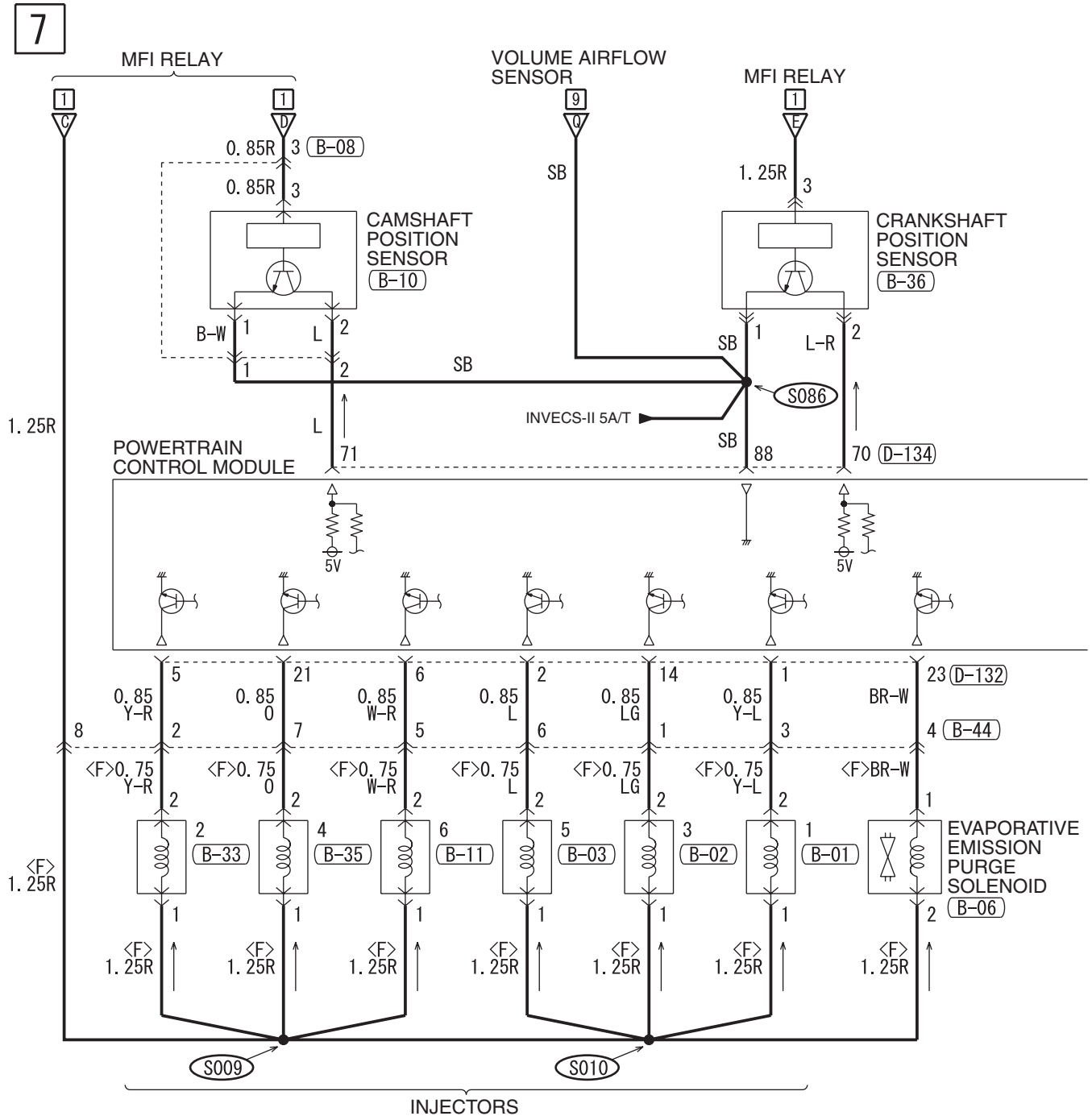

- B-01**
(MU802044)
- B-02**
(MU802044)
- B-03**
(MU802044)
- B-04**
(MU802722)
- B-06**
(MU802779)
- B-08**
(MU802663)
- B-09**
(MU802661)
- B-10**
(MU802337)
- B-11**
(MU802044)
- B-29**
(MU801211)

D-132
(MU803802)

1	2	JAE	3	4
5	6	7	8	9
10	11	12	13	14
15	16	17	18	19
20	21	22	23	24
25	26	27	28	29

D-133
(MU803803)

31	32	JAE	33	34
35	36	37	38	39
40	41	42	43	44
45	46	47	48	49
50	51	52	53	54
55	56	57	58	59

D-134
(MU803804)

61	62	JAE	63	64
65	66	67	68	69
70	71	72	73	74
75	76	77	78	79
80	81	82	83	84
85	86	87	88	89

E-111

1	2	3	4
5	6	7	8
9	10	11	12
13	14	15	16
17	18	19	20
21	22	23	24
25	26	27	28
29	30	31	32
33	34	35	36
37	38	39	40

8

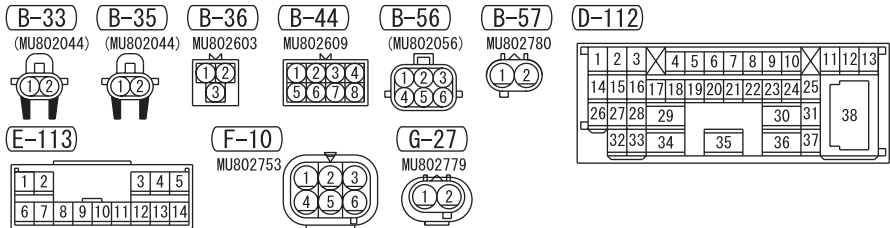
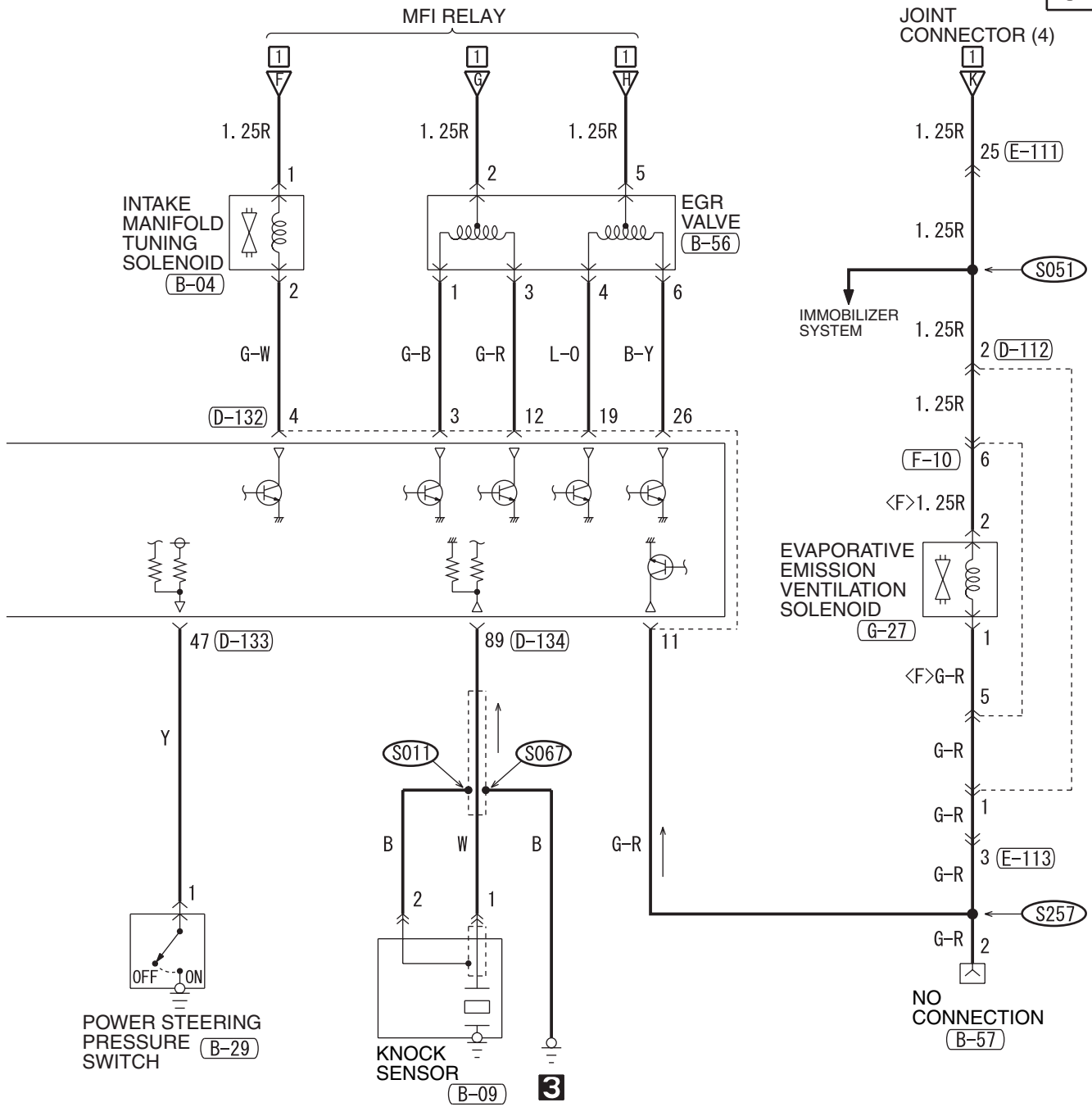

MFI SYSTEM (CONTINUED)

9

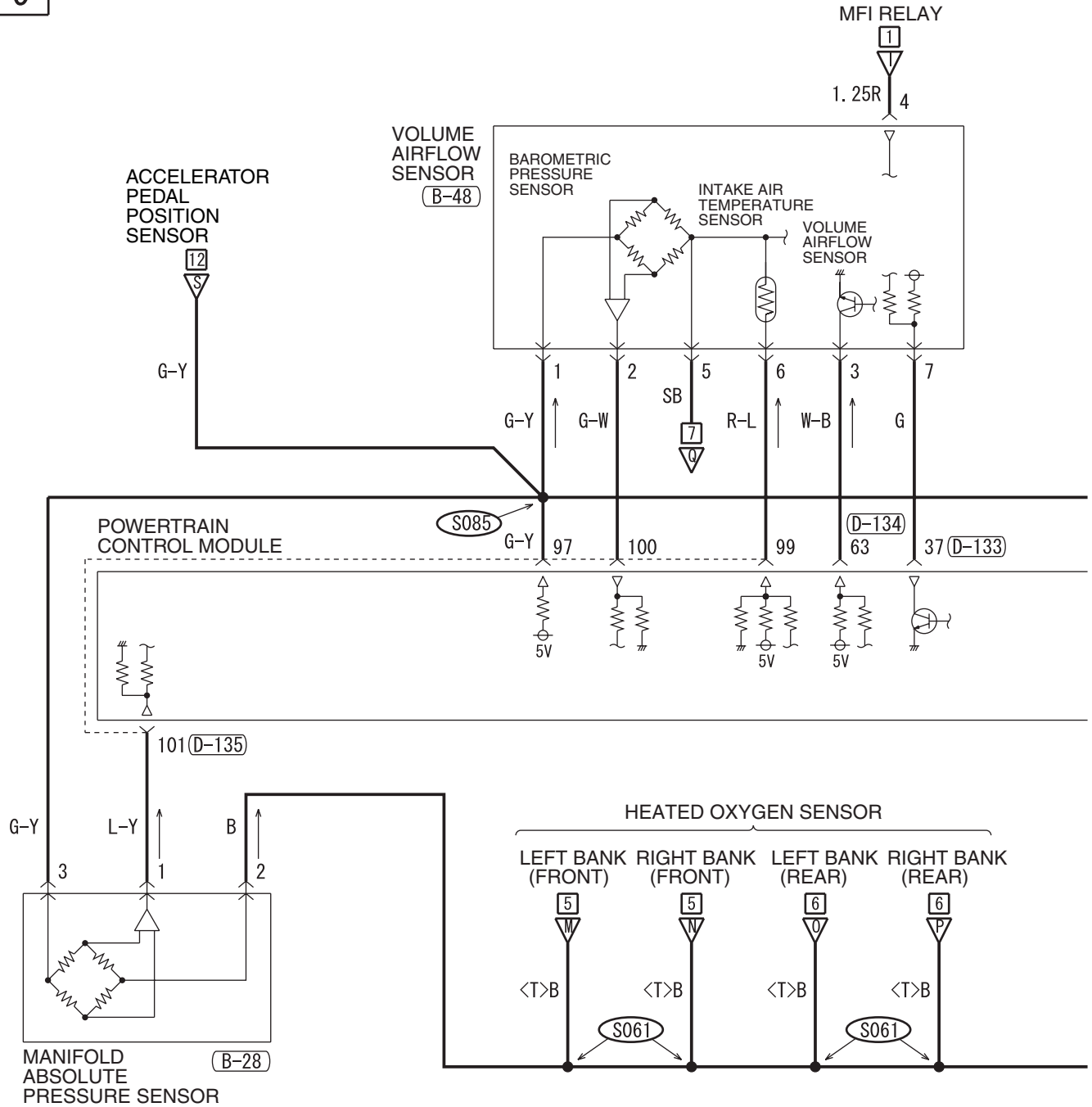

B-28 (MU802723) **B-37** (MU802406) **B-48** (MU802552)



D-136 (MU803801)

121	122	JAE	123	124
125	126	127	128	129
130	131	132	133	134
135	136	137	138	139
140	141	142	143	144
145	146			

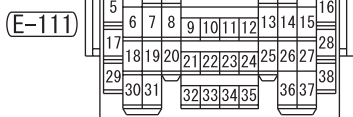

D-14 (MU801335) **D-111**

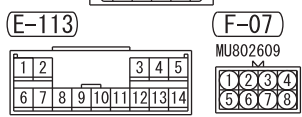

10

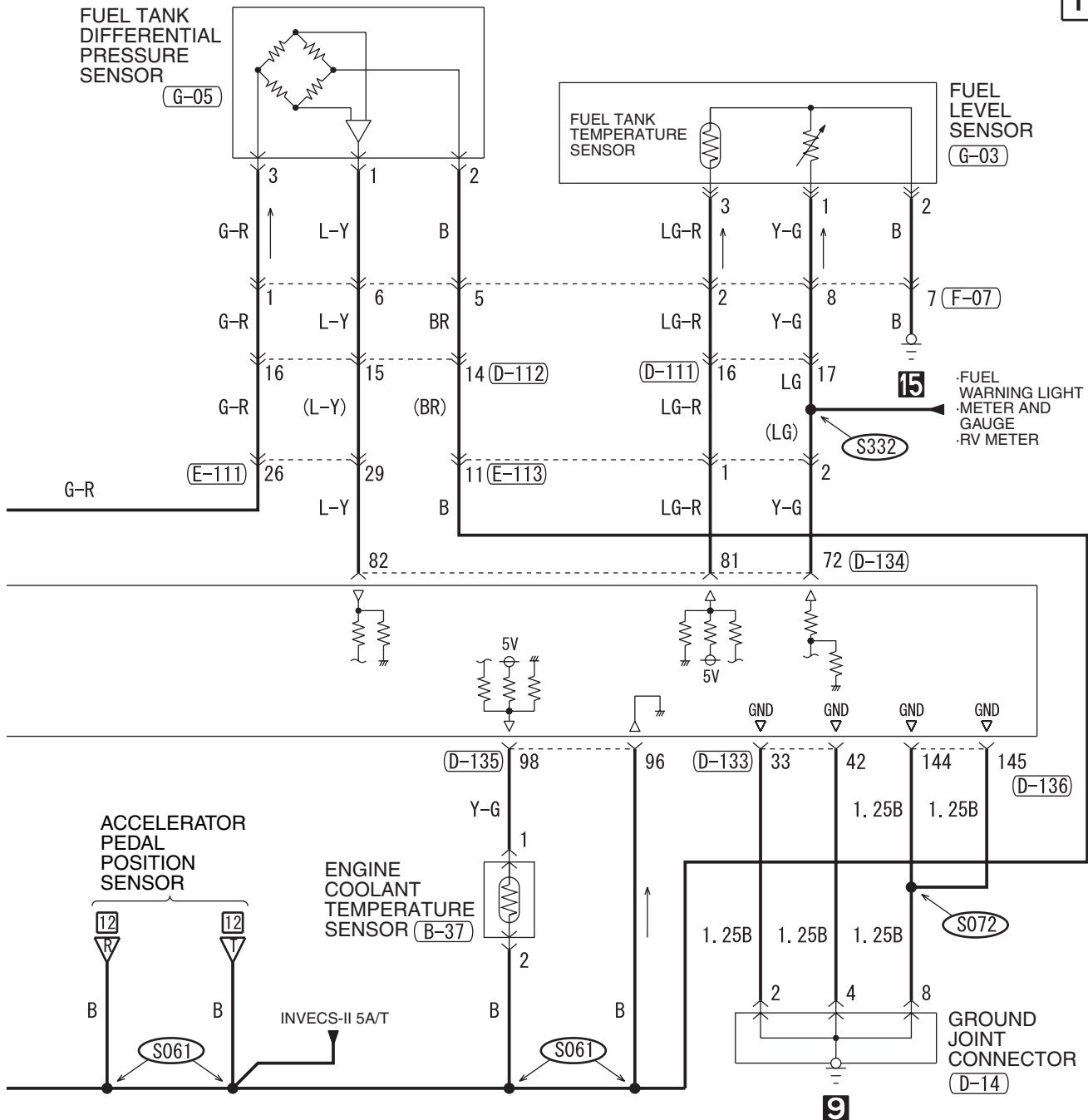

D-112

1	2	3	4	5	6	7	8	9	10	11	12	13
14	15	16	17	18	19	20	21	22	23	24	25	
26	27	28	29			30	31				38	
32	33	34		35		36	37					

D-133

(MU803803)

31	32	JAE	33	34
35	36	37	38	39
40	41	42	43	
44	45	46	47	48
49	50	51		
52	53	54	55	56
57	58			

D-134

(MU803804)

61	62	JAE	63	64
65	66	67	68	69
70	71	72	73	
74	75	76	77	78
79	80	81	82	
83	84	85	86	87
88	89			

D-135

(MU803805)

91	92	JAE	93	94	95
96	97	98	99	100	101
102	103	104			
105	106	107	108	109	
110	111	112			
113	114	115	116	117	118
119	120				



WIRE COLOR CODE

B : BLACK LG : LIGHT GREEN G : GREEN L : BLUE

BR : BROWN O : ORANGE GR : GRAY R : RED W : WHITE

SB : SKY BLUE P : PINK Y : YELLOW V : VIOLET

H6Q05M00EB

MFI SYSTEM (CONTINUED)

11

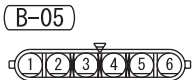
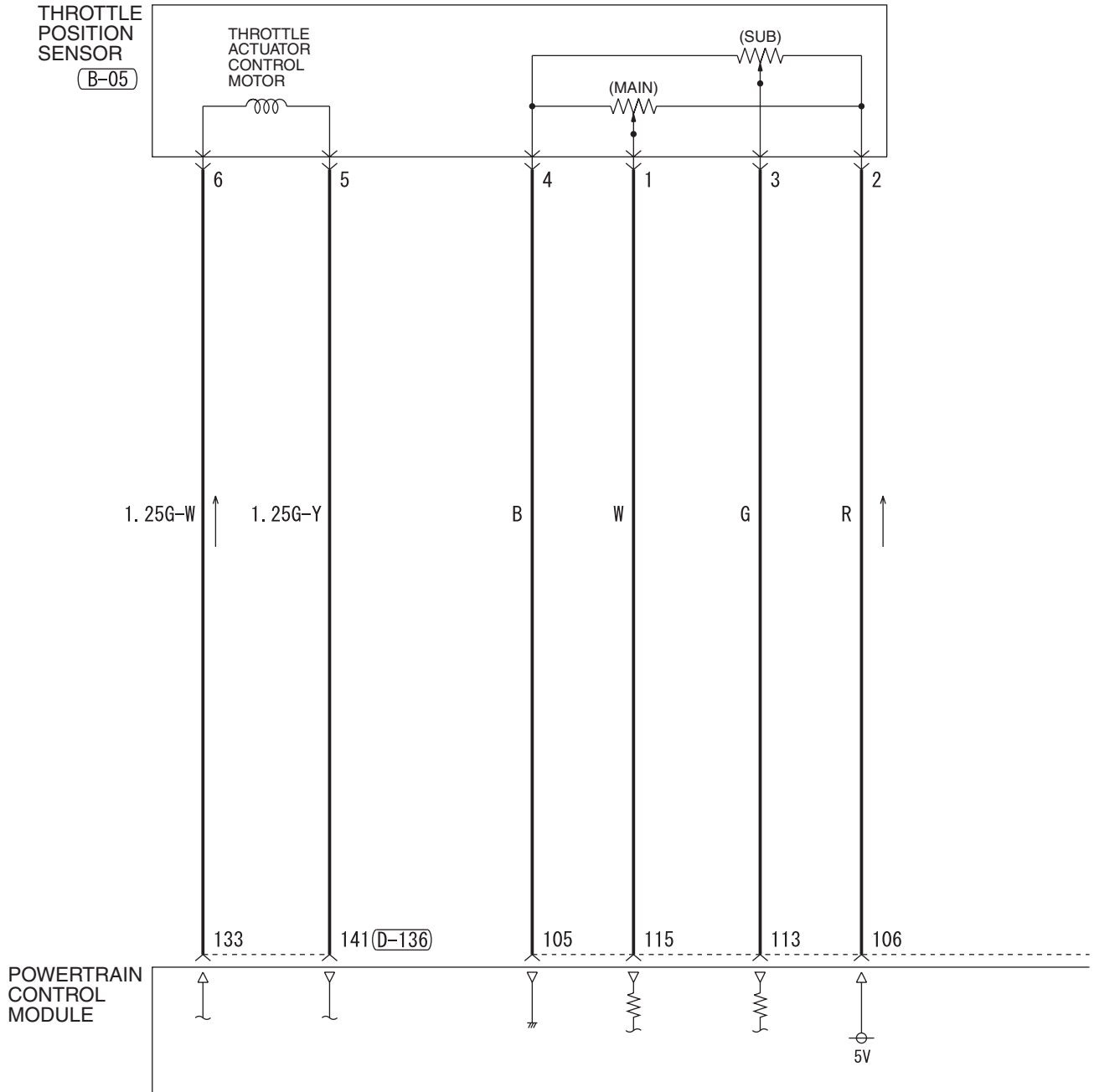

(D-132) (MU803802)

1	2	JAE		3	4
5	6	7	8	9	10
11	12	13	14	15	16
17	18	19	20	21	22
23	24	25	26	27	

(D-133) (MU803803)

31	32	JAE		33	34
35	36	37	38	39	40
41	42	43	44	45	46
47	48	49	50	51	52
53	54	55	56	57	58

(D-135) (MU803805)

91	92	JAE		93	94	95
96	97	98	99	100	101	102
103	104	105	106	107	108	109
110	111	112	113	114	115	116
117	118	119	120			

12

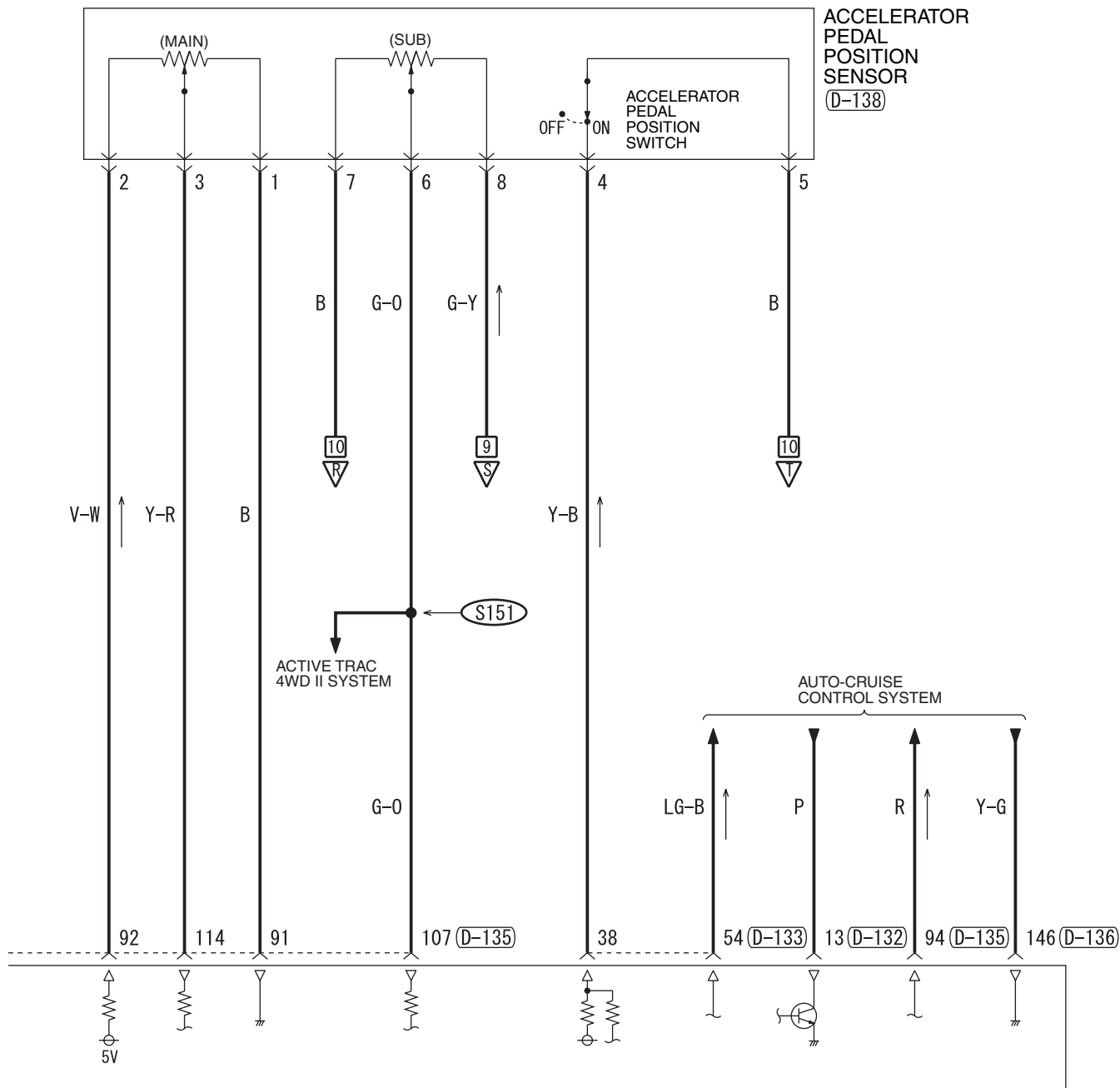

(D-136)

(MU803801)

121	122	JAE		123	124
125	126	127	128	129	130
131	132	133	134	135	136
137	138	139	140	141	142
143	144	145	146		

(D-138)

(MU802073)



WIRE COLOR CODE

B: BLACK LG: LIGHT GREEN G: GREEN L: BLUE W: WHITE Y: YELLOW
SB: SKY BLUE BR: BROWN O: ORANGE GR: GRAY R: RED P: PINK V: VIOLET

H6Q05M00FB

TSB Revision

MFI SYSTEM (CONTINUED)

13

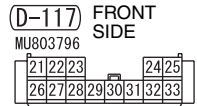
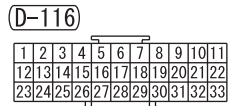
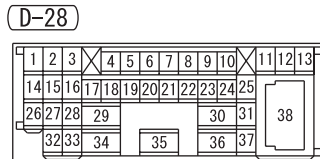
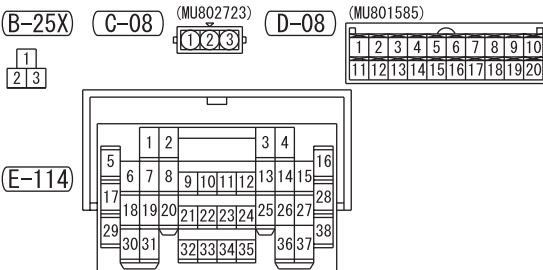
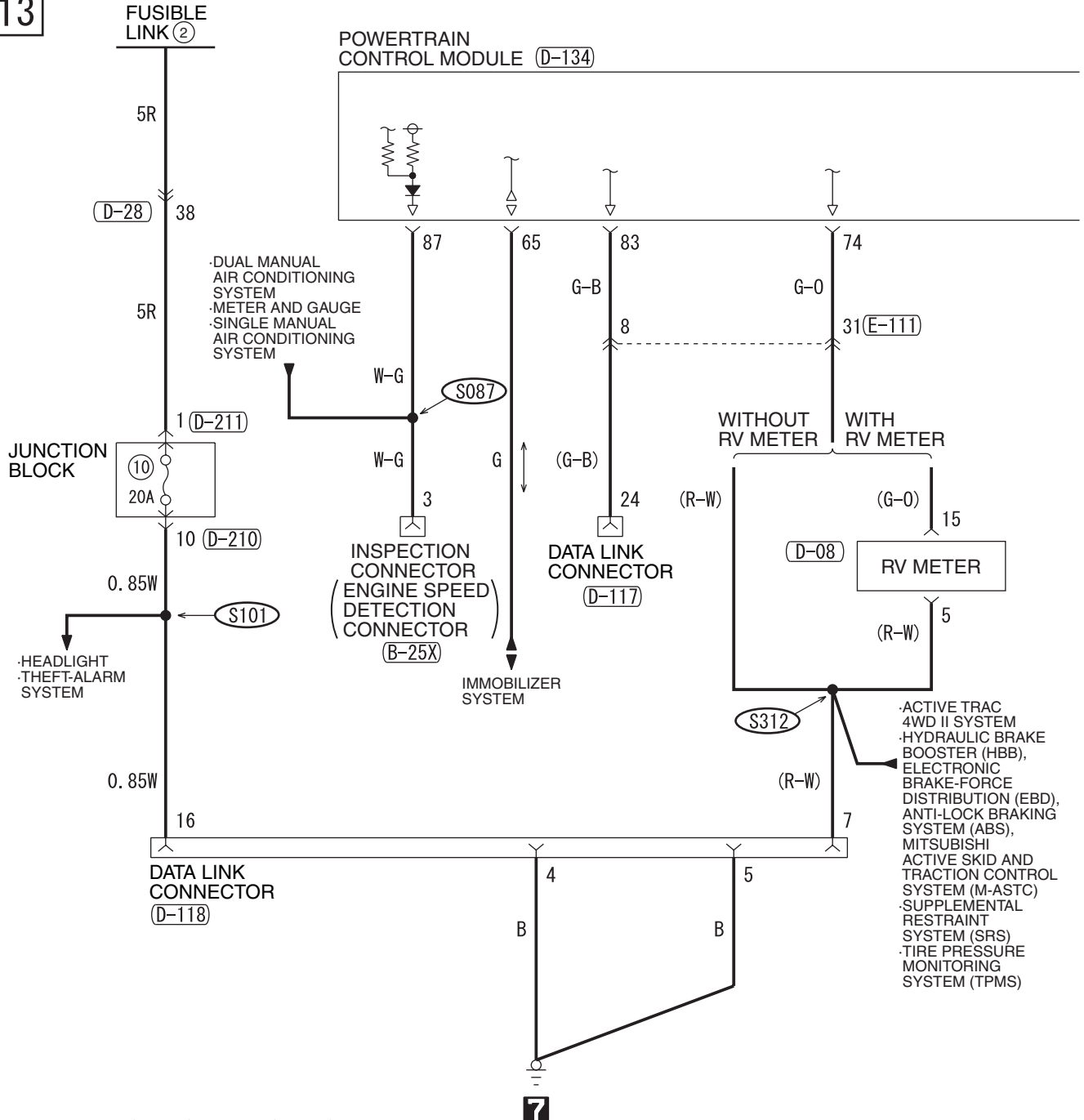

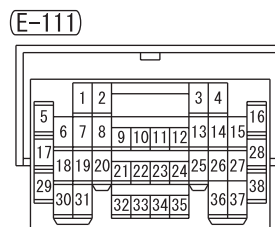
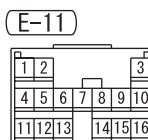
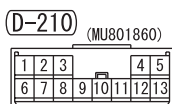
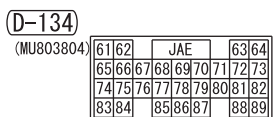
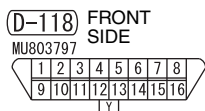
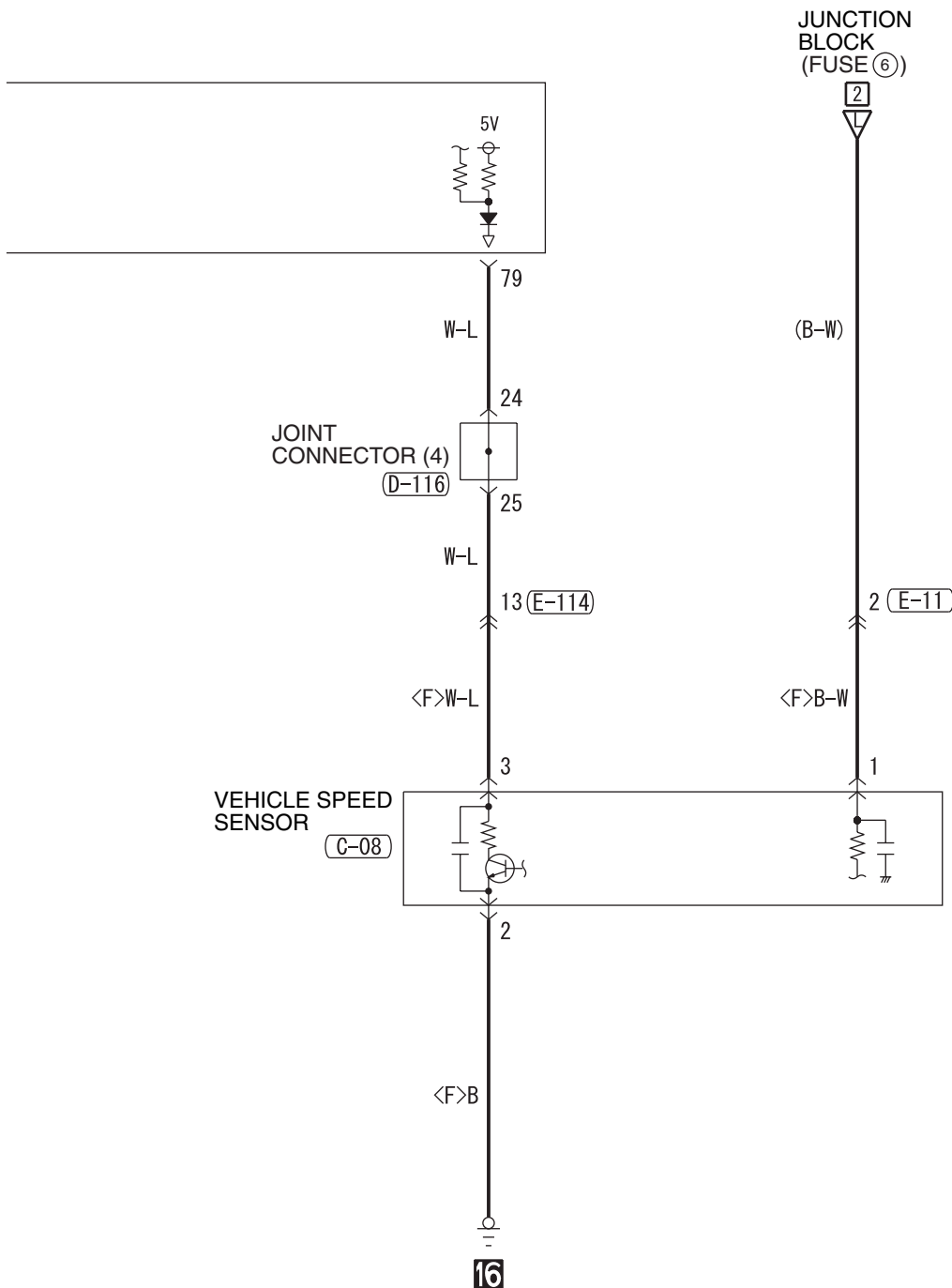

WIRE COLOR CODE
 B : BLACK LG : LIGHT GREEN G : GREEN L : BLUE
 BR : BROWN O : ORANGE GR : GRAY R : RED W : WHITE
 SB : SKY BLUE P : PINK Y : YELLOW V : VIOLET

H6Q05M00GB

INVECS-II 5A/T

1

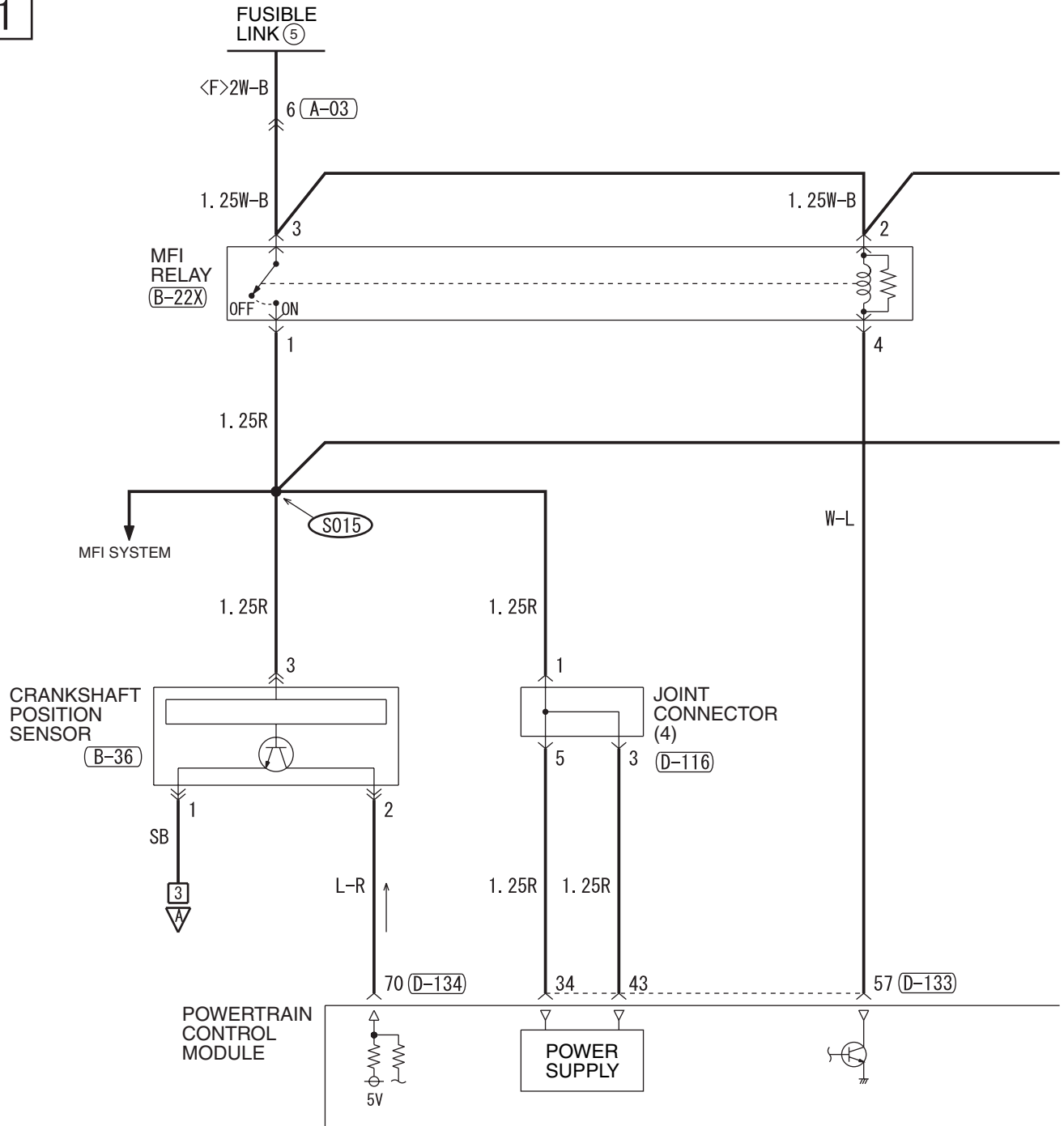

A-03
MU802611



B-22X



B-23X



B-36



D-28

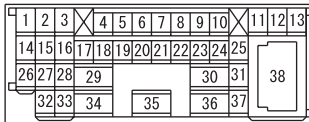

D-116

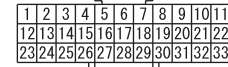

D-123



E-111

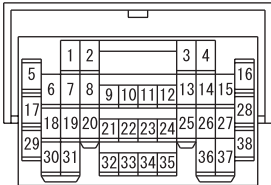

TSB Revision

2

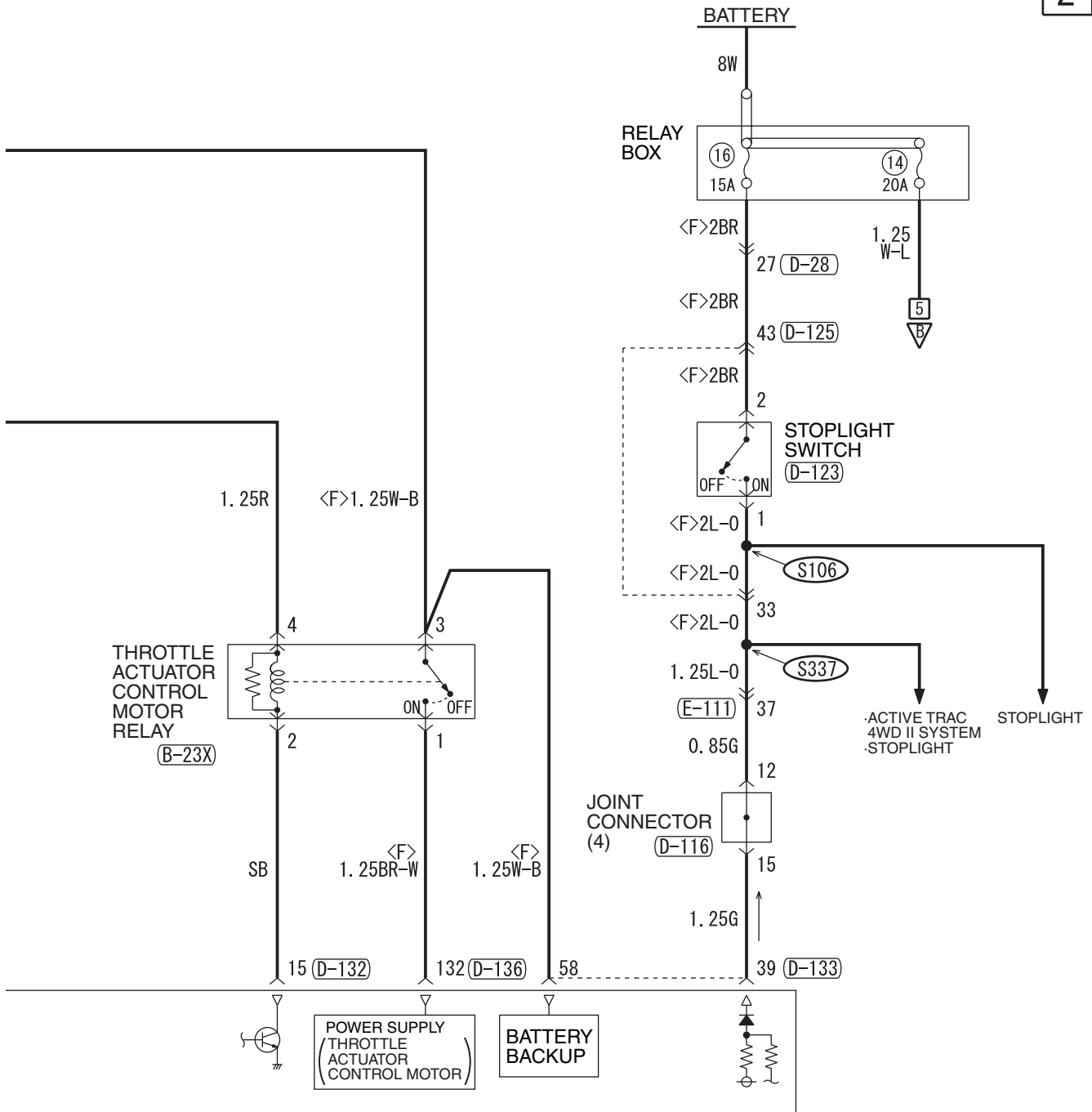

D-125

1	2	3	4	5	6	7	8	9
10	11	12	13	14	15	16	17	18
19	20	21	22	23	24	25	26	27
28	29	30	31	32	33	34	35	36
37	38	39	40	41	42	43		

D-132

1	2	JAE	3	4
5	6	7	8	9
10	11	12	13	14
15	16	17	18	19
20	21	22	23	24
25	26	27		

D-133

31	32	JAE	33	34
35	36	37	38	39
40	41	42	43	44
45	46	47	48	49
50	51	52	53	54
55	56	57	58	

D-134

61	62	JAE	63	64
65	66	67	68	69
70	71	72	73	74
75	76	77	78	79
80	81	82	83	84
85	86	87	88	89

D-136

121	122	JAE	123	124
125	126	127	128	129
130	131	132	133	134
135	136	137	138	139
140	141	142	143	144
145	146			

INVECS-II 5A/T (CONTINUED)

3

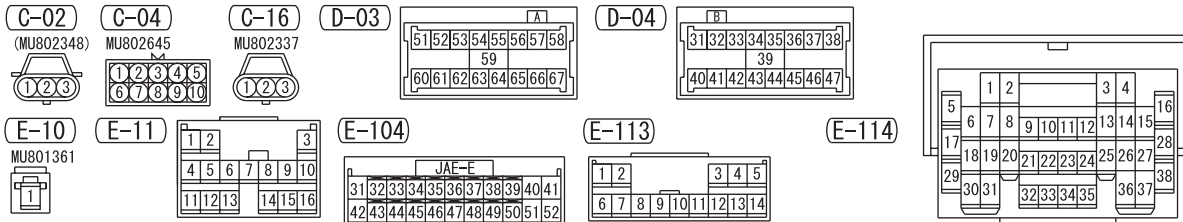
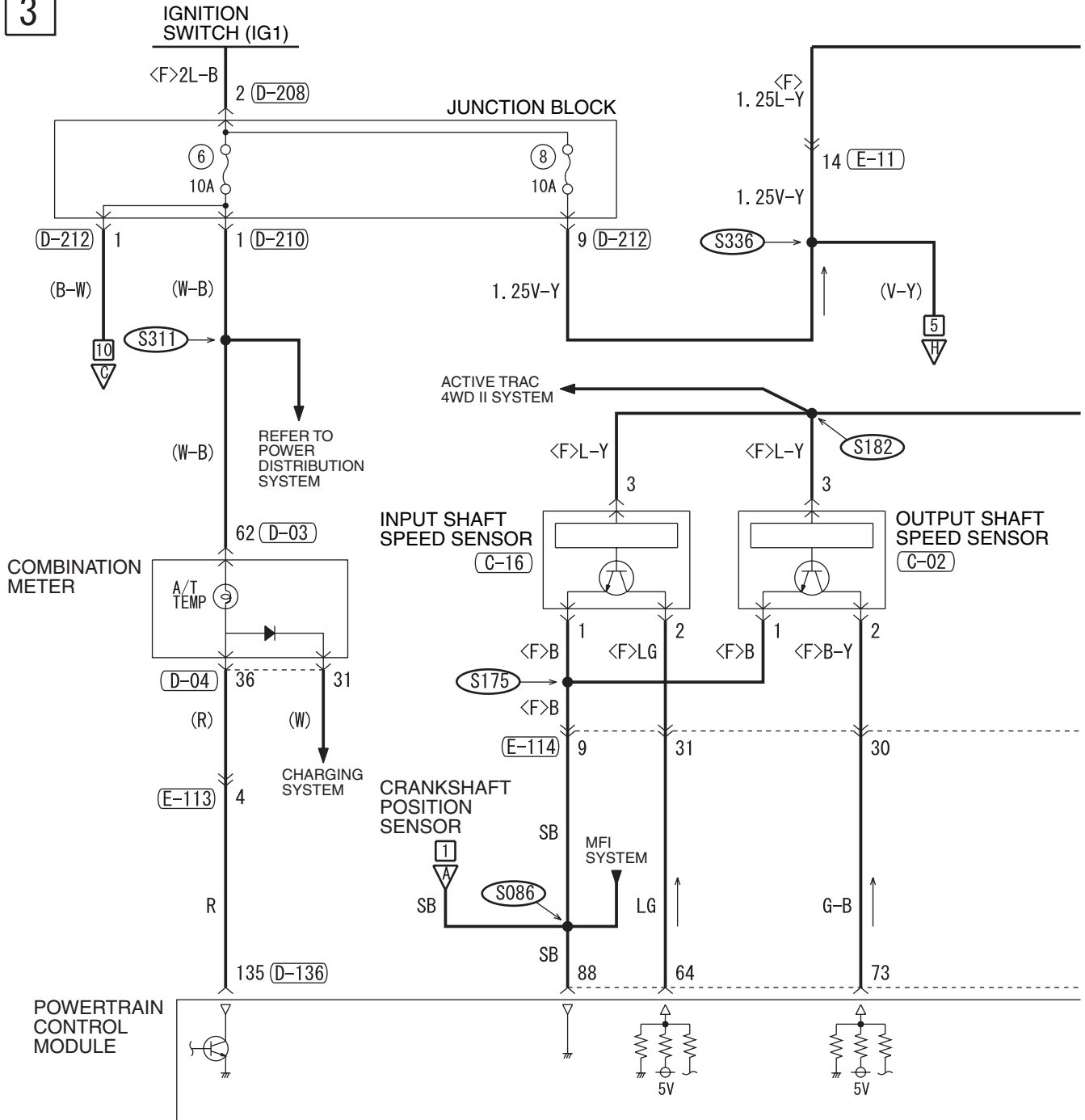

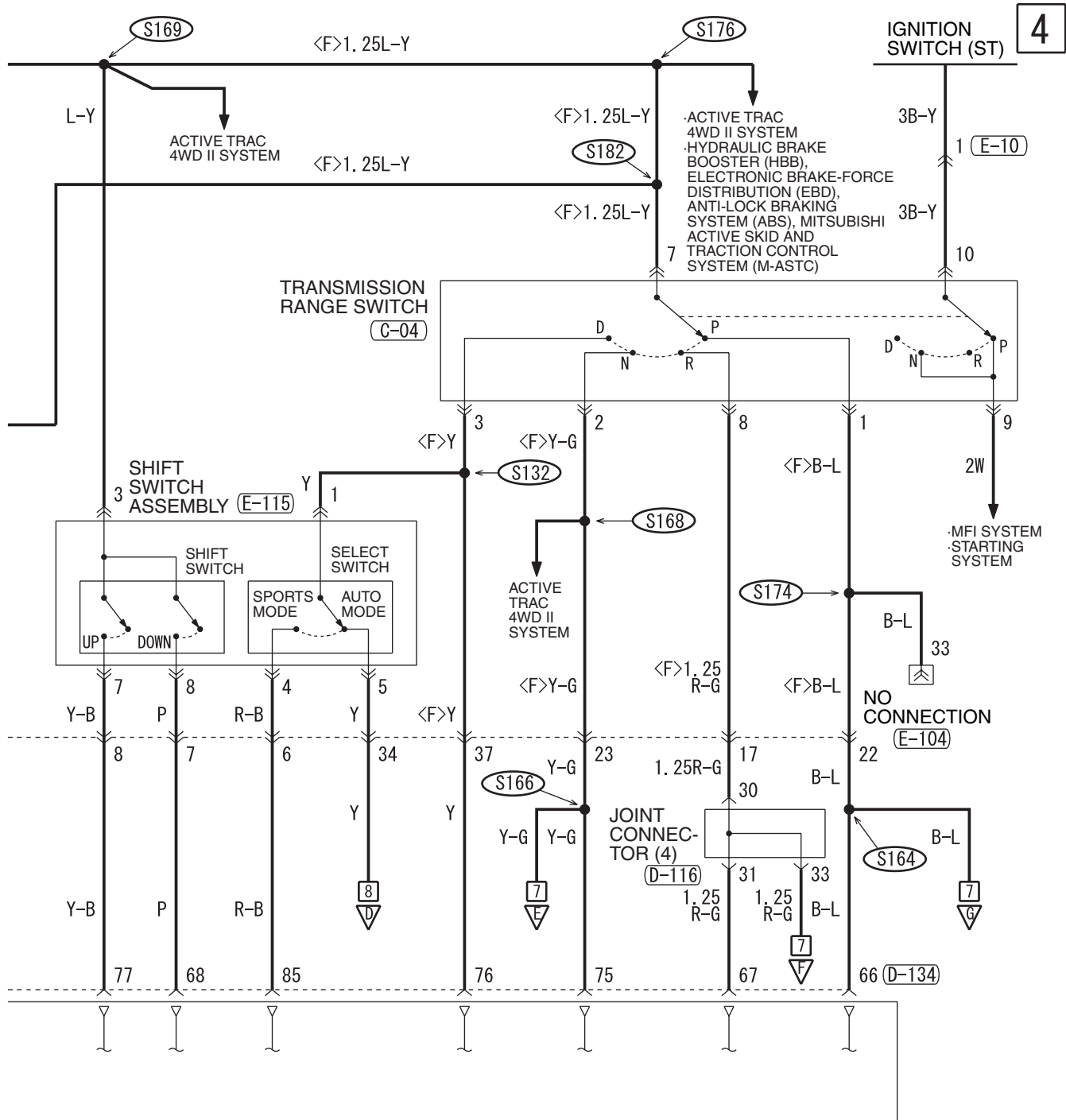

(D-116)

1	2	3	4	5	6	7	8	9	10	11
12	13	14	15	16	17	18	19	20	21	22
23	24	25	26	27	28	29	30	31	32	33

(D-134)

61	62	JAE	63	64
65	66	67	68	69
70	71	72	73	74
75	76	77	78	79
80	81	82	83	84
85	86	87	88	89

(D-136)

121	122	JAE	123	124
125	126	127	128	129
130	131	132	133	134
135	136	137	138	139
140	141	142	143	144
145	146			

(D-208)

1	2
3	4
5	6

(D-210)

1	2	3	4	5
6	7	8	9	10
11	12	13		

(D-212)

1	2	3	4
5	6	7	8
9	10	11	

(E-115)

1	2	3
4	5	6
7	8	

WIRE COLOR CODE

B: BLACK LG: LIGHT GREEN G: GREEN L: BLUE W: WHITE Y: YELLOW
SB: SKY BLUE BR: BROWN O: ORANGE GR: GRAY R: RED P: PINK V: VIOLET

H6Q07M00BB

INVECS-II 5A/T (CONTINUED)

5

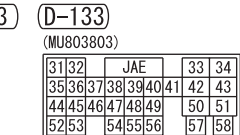
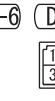
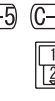
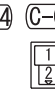
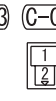
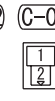
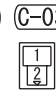
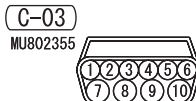
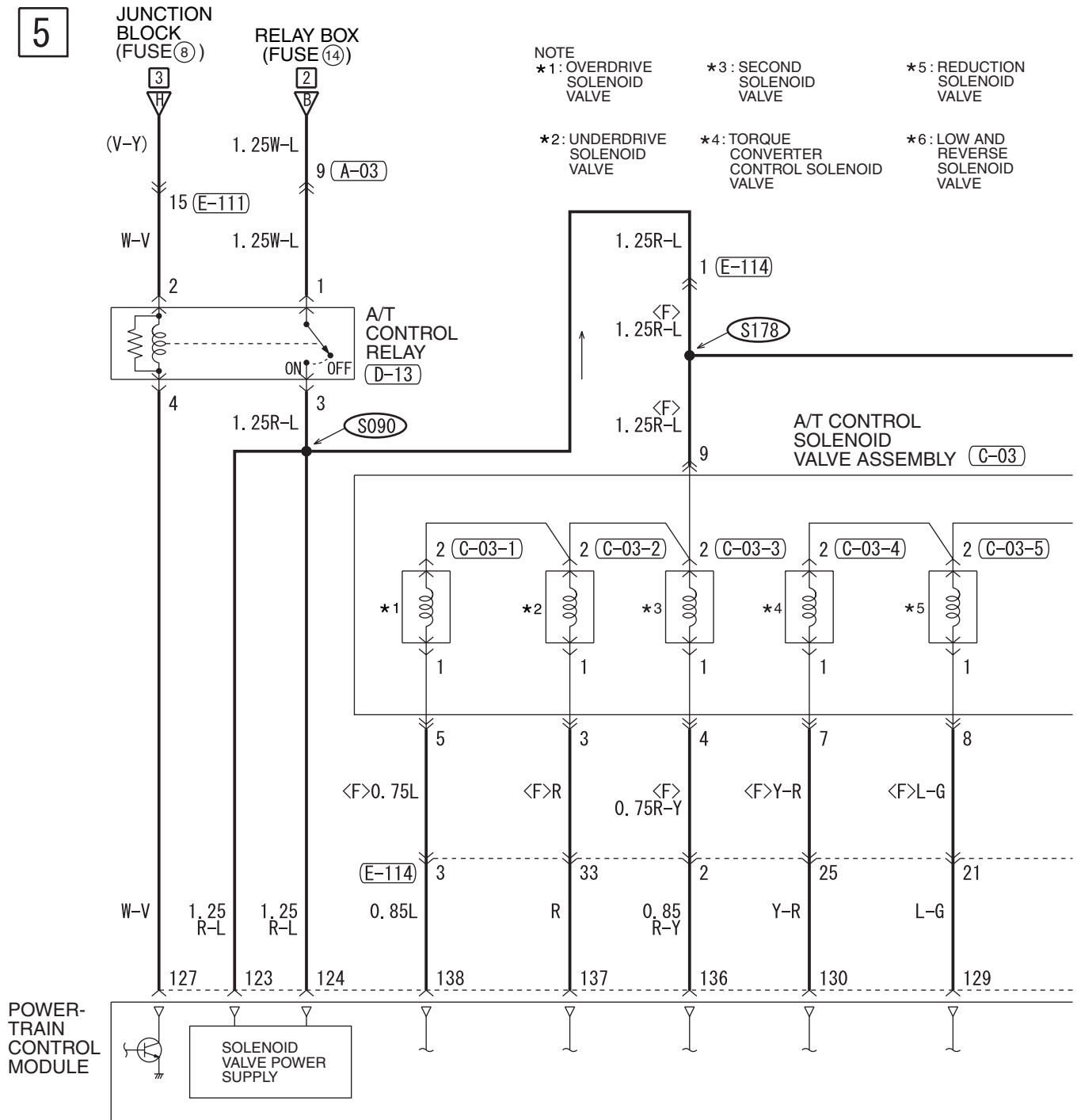

6

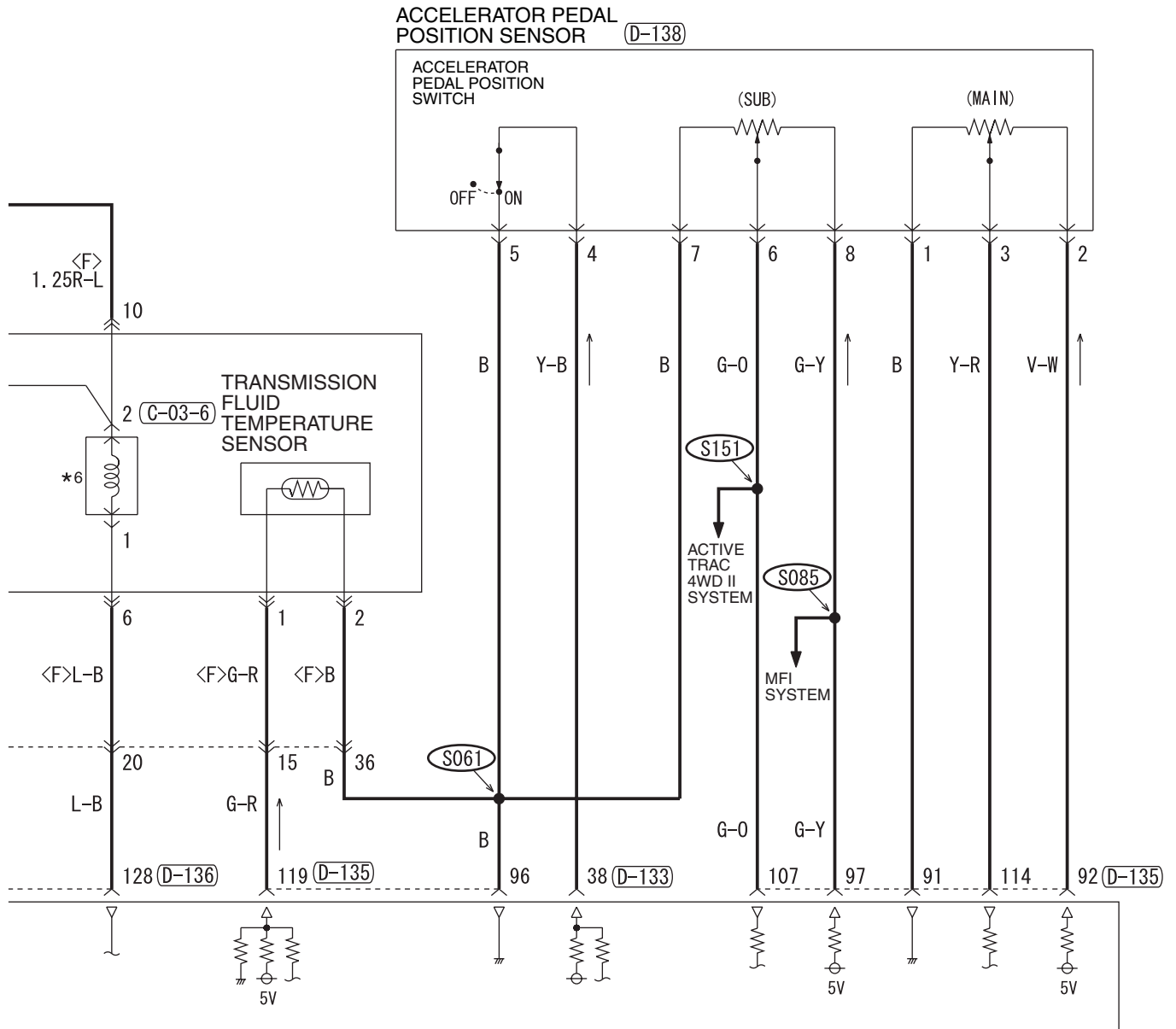

(D-135)
(MU803805)

91	92	JAE	93	94	95
96	97	98	99	100	101
102	103	104	105	106	107
108	109	110	111	112	113
114	115	116	117	118	119
120					

(D-136)
(MU803801)

121	122	JAE	123	124
125	126	127	128	129
130	131	132	133	134
135	136	137	138	139
140	141	142	143	144
145	146			

(D-138)
(MU802073)



(E-111)

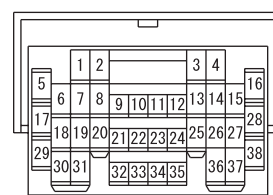

(E-114)

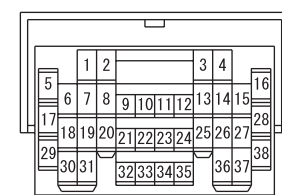

H6Q07M00CB

INVECS-II 5A/T (CONTINUED)

7

POWERTRAIN
CONTROL
MODULE

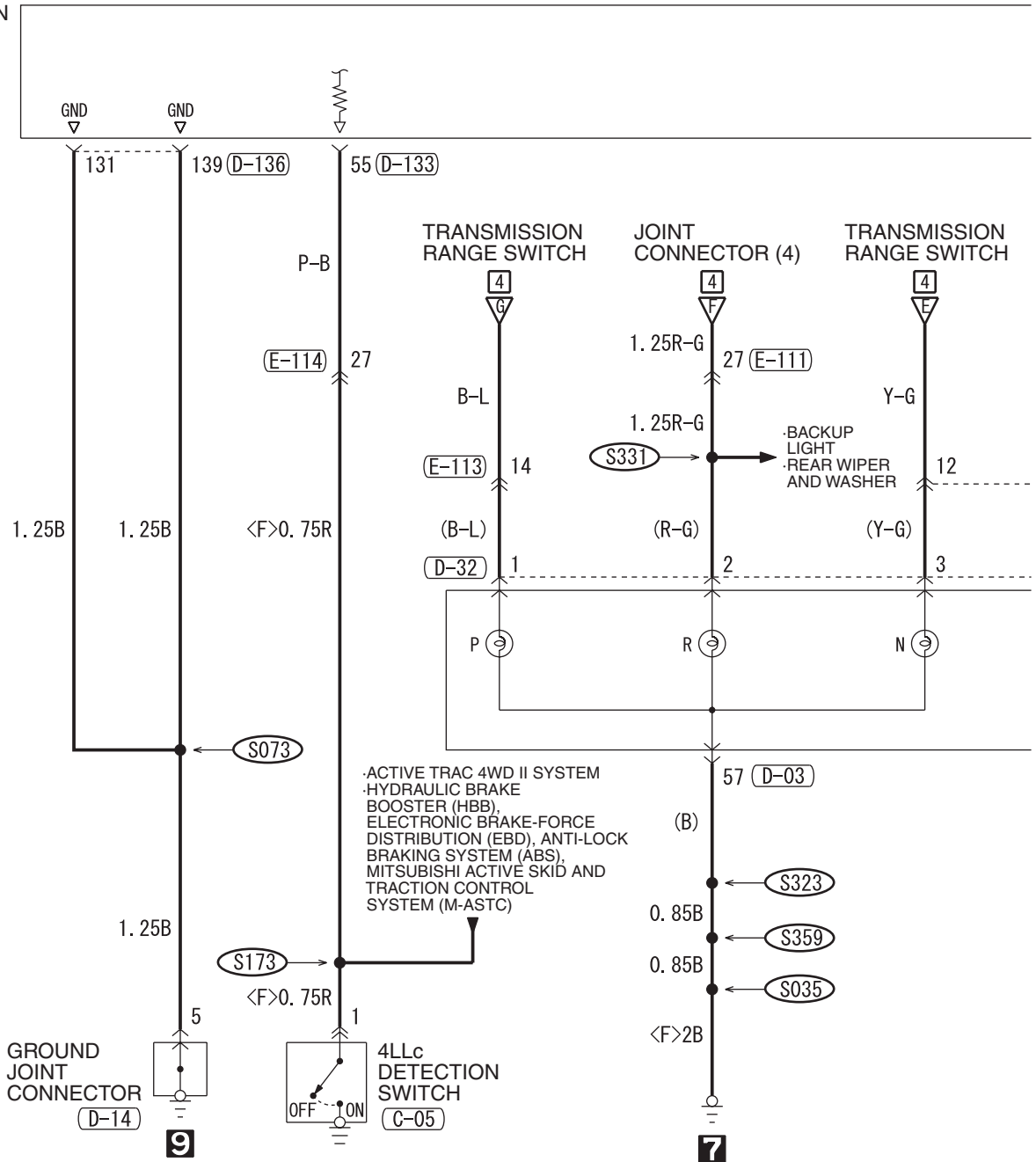

C-05
MU802653

1

D-03

5	15	25	35	45	55	65	75	85
6	16	26	36	46	56	66	76	86
59								
60	61	62	63	64	65	66	67	

D-14
MU801335

1	2	3	4
5	6	7	8
9	10		

D-28

1	2	3	4	5	6	7	8	9	10	11	12	13	
14	15	16	17	18	19	20	21	22	23	24	25		
26	27	28	29					30	31				
32	33	34			35			36	37				
38													

D-32

1	2	3	4	5	6	7	8	9	10	11	12
13											
14	15	16	17	18	19	20	21	22	23	24	25

D-133
(MU803803)

31	32	JAE	33	34
35	36	37	38	39
40	41	42	43	
44	45	46	47	48
49	50	51		
52	53	54	55	56
57	58			

8

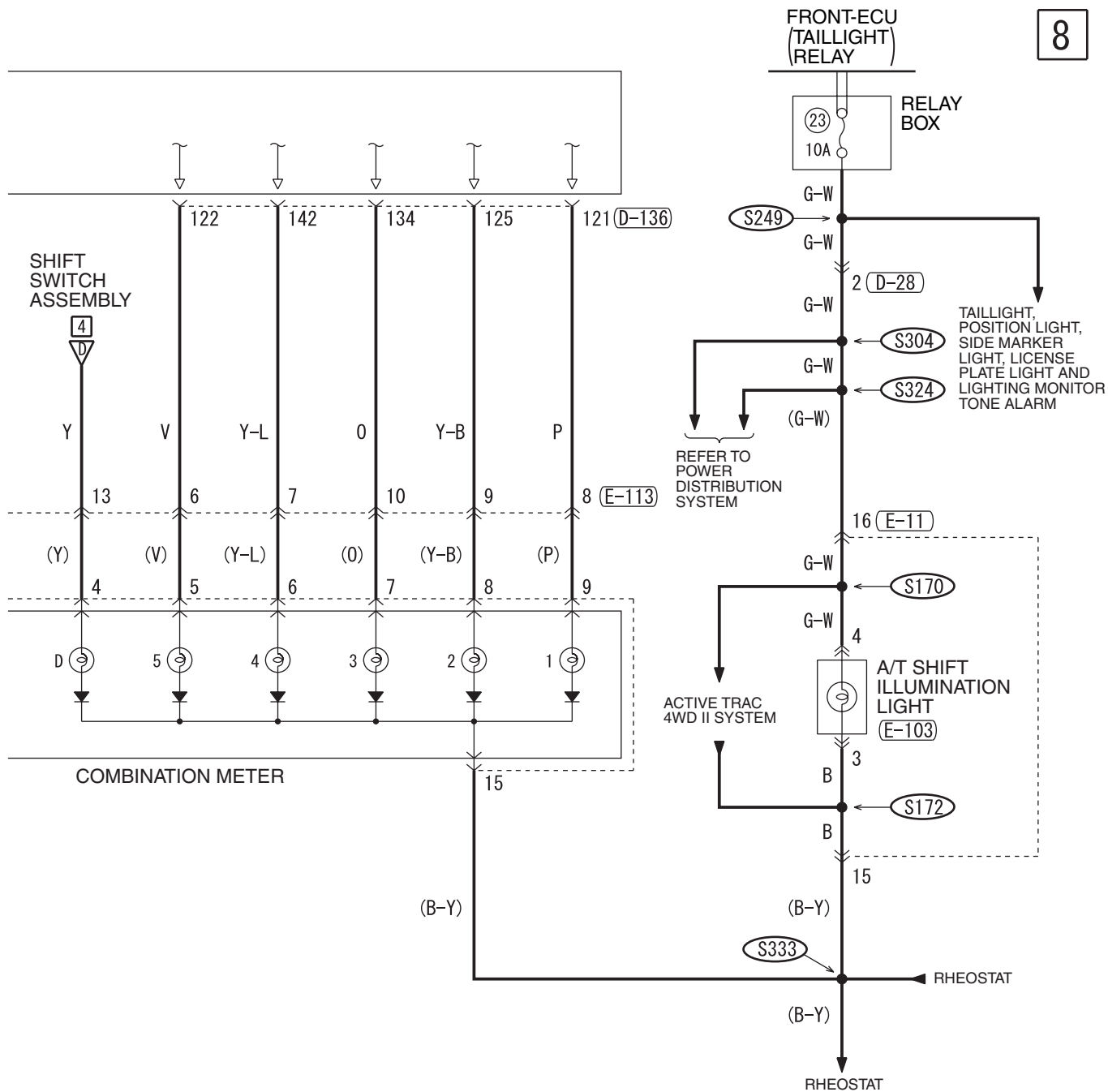

D-136

(MU803801)

121	122	JAE	123	124
125	126	127	128	129
130	131	132	133	
134	135	136	137	138
139	140	141		
142	143	144	145	146

E-11

1	2	3
4	5	6
7	8	9
10		
11	12	13
14	15	16

E-103

MU801445

1	2	3	4
---	---	---	---

E-111

See ★1

E-113

1	2	3	4	5
6	7	8	9	10
11	12	13	14	

E-114

See ★1

★1

1	2	3	4	5	6	7	8	9	10	11	12	13	14	15	16
17	18	19	20	21	22	23	24	25	26	27	28	29	30	31	32
33	34	35	36	37	38										

WIRE COLOR CODE

B: BLACK LG: LIGHT GREEN G: GREEN L: BLUE W: WHITE Y: YELLOW
SB: SKY BLUE BR: BROWN O: ORANGE GR: GRAY R: RED P: PINK V: VIOLET

H6Q07M00DB

INVECS-II 5A/T (CONTINUED)

9

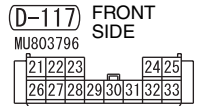
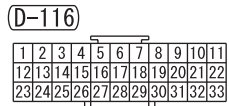
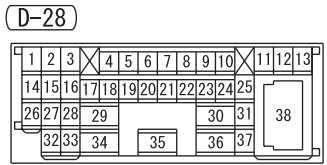
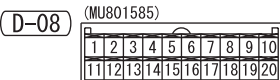
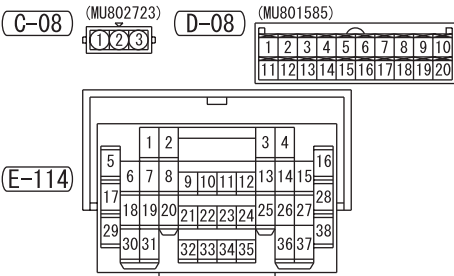
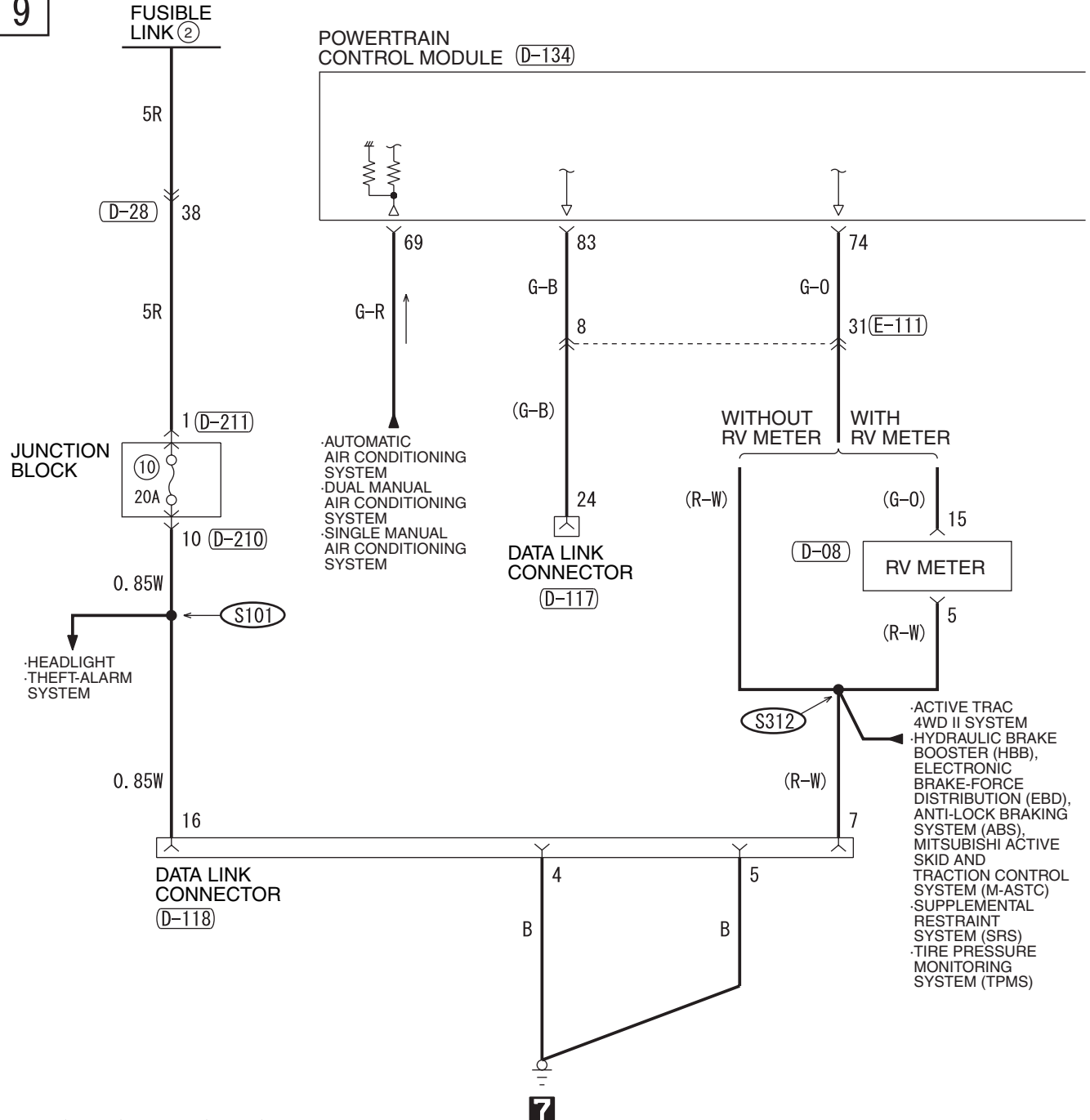

10

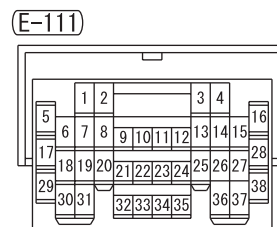
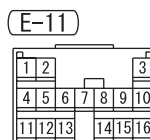
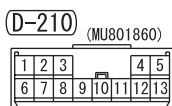
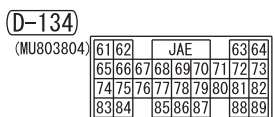
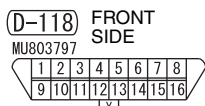
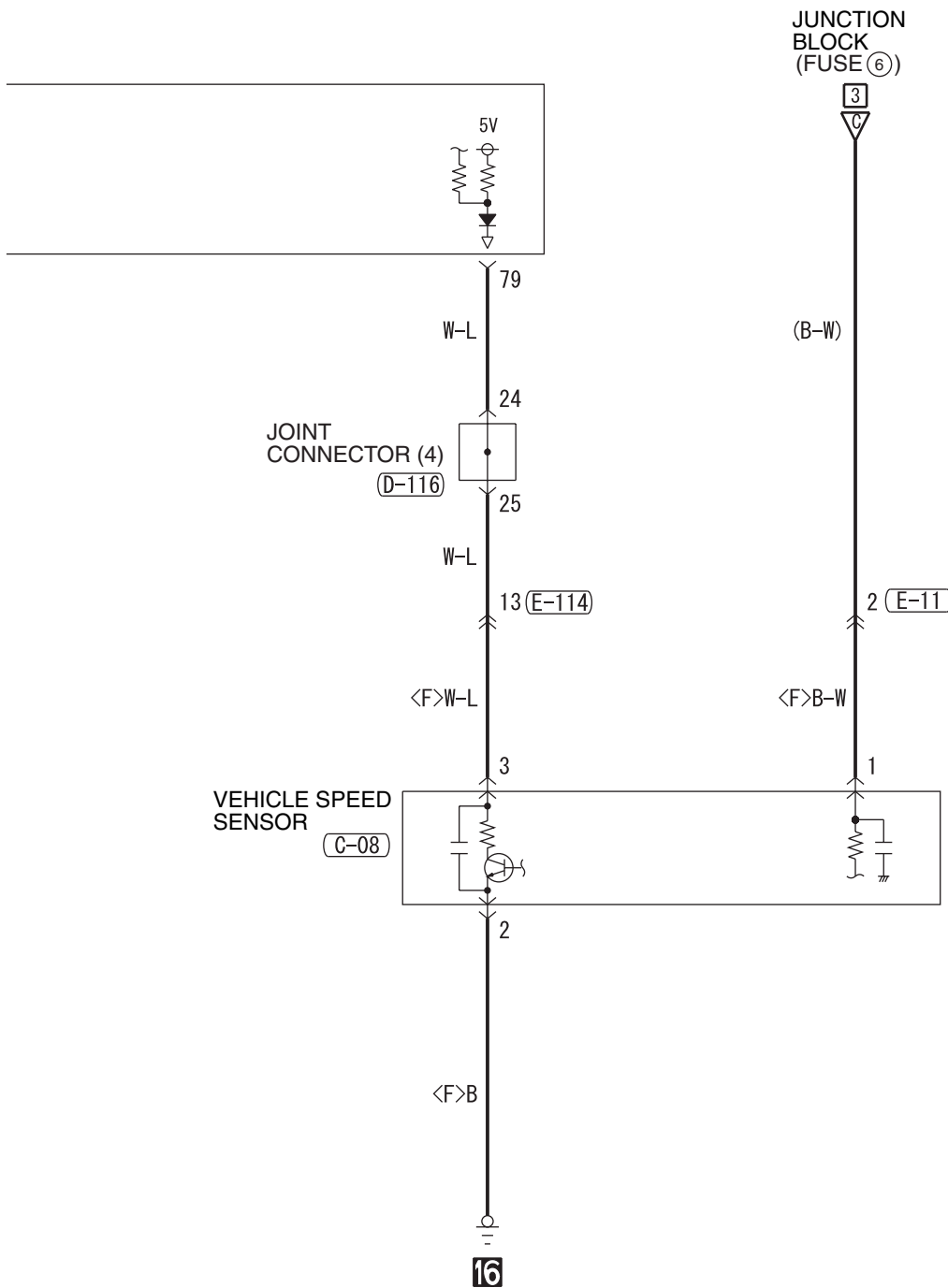

WIRE COLOR CODE
 B: BLACK LG: LIGHT GREEN G: GREEN L: BLUE
 BR: BROWN O: ORANGE GR: GRAY R: RED W: WHITE
 SB: SKY BLUE P: PINK Y: YELLOW V: VIOLET

H6Q07M00EB

HEADLIGHT

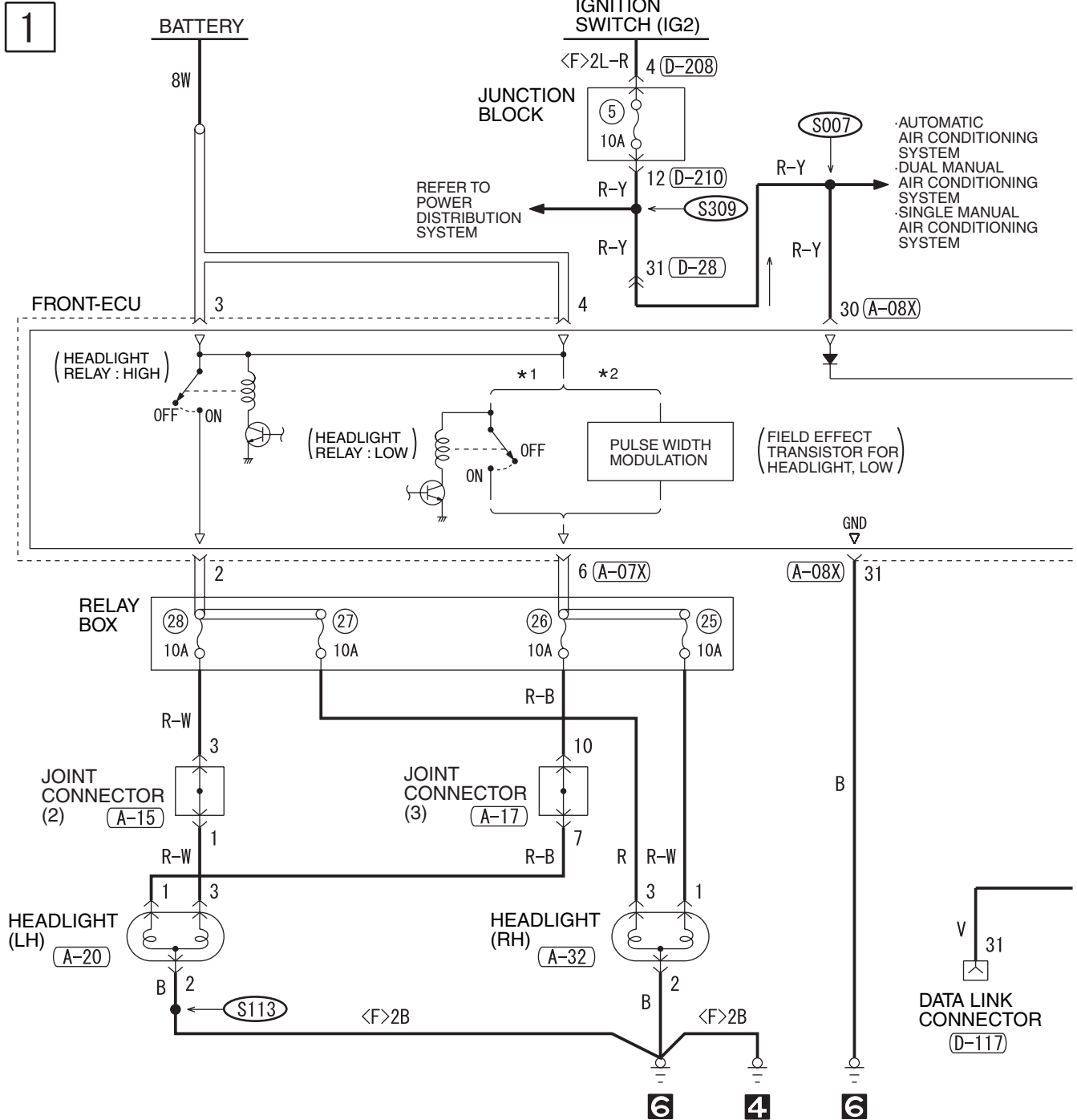

(A-07X)

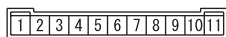

(A-08X)

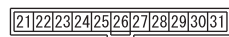

(A-15)

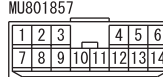

(A-17)

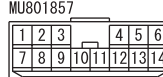

(A-20)



(A-32)



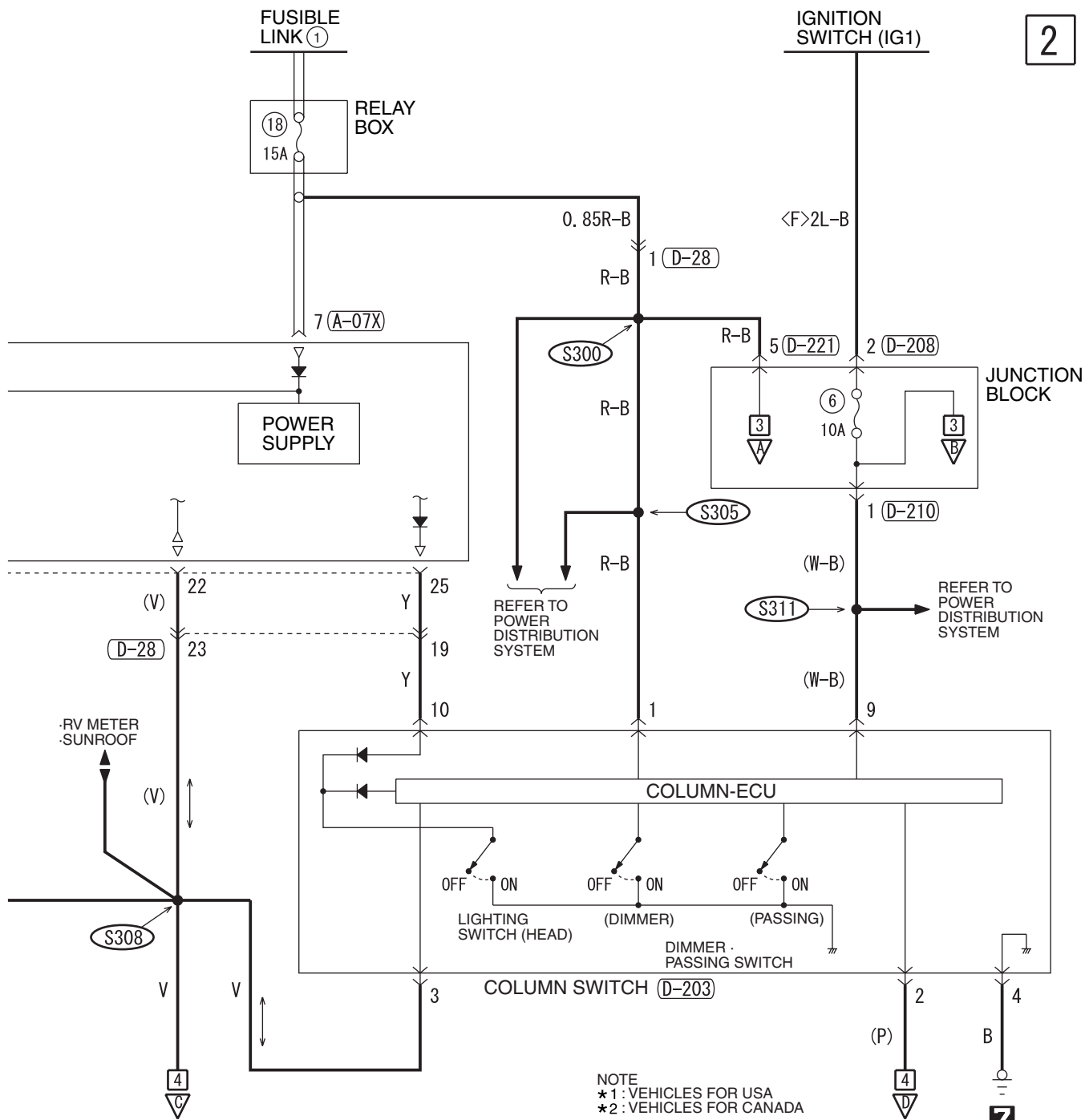

D-28

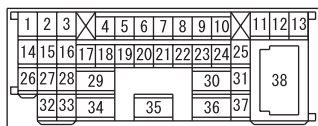

D-117 FRONT SIDE



D-203

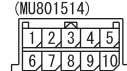

D-208



D-210

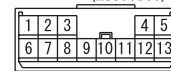

D-221

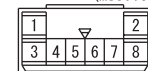

WIRE COLOR CODE

B : BLACK LG : LIGHT GREEN G : GREEN L : BLUE
 BR : BROWN O : ORANGE GR : GRAY R : RED W : WHITE
 SB : SKY BLUE P : PINK Y : YELLOW V : VIOLET

HEADLIGHT (CONTINUED)

3

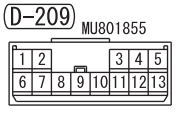
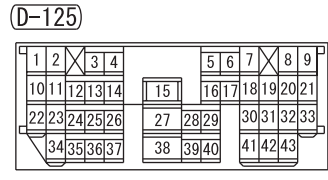
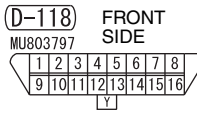
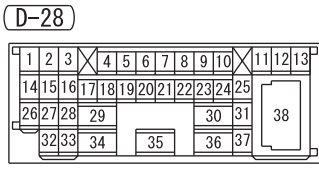
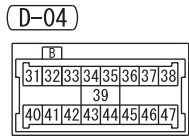
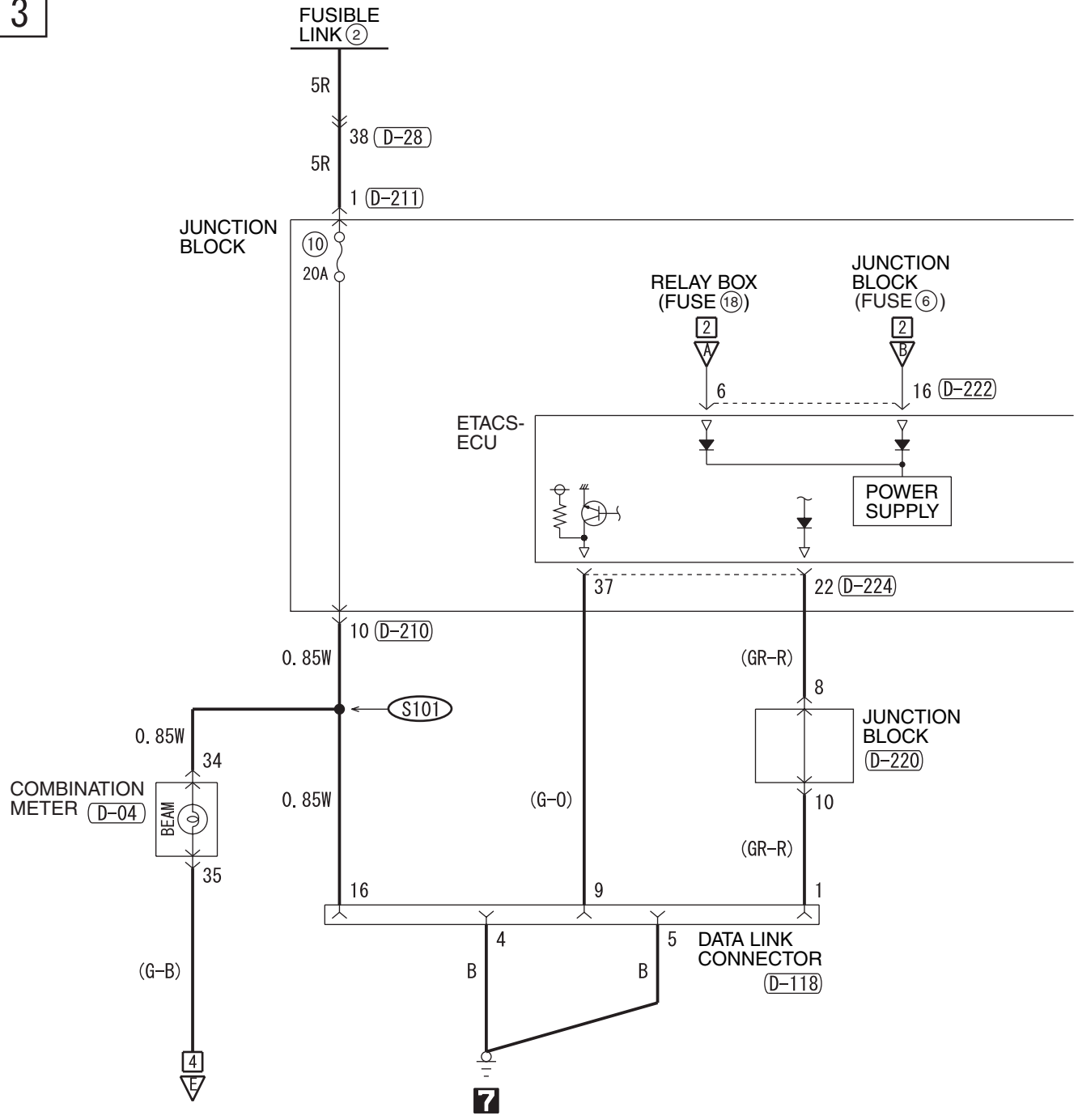

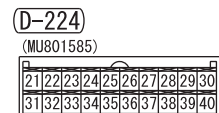
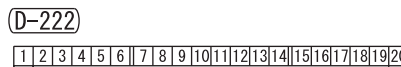
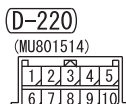
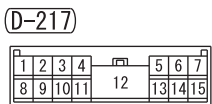
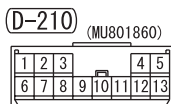
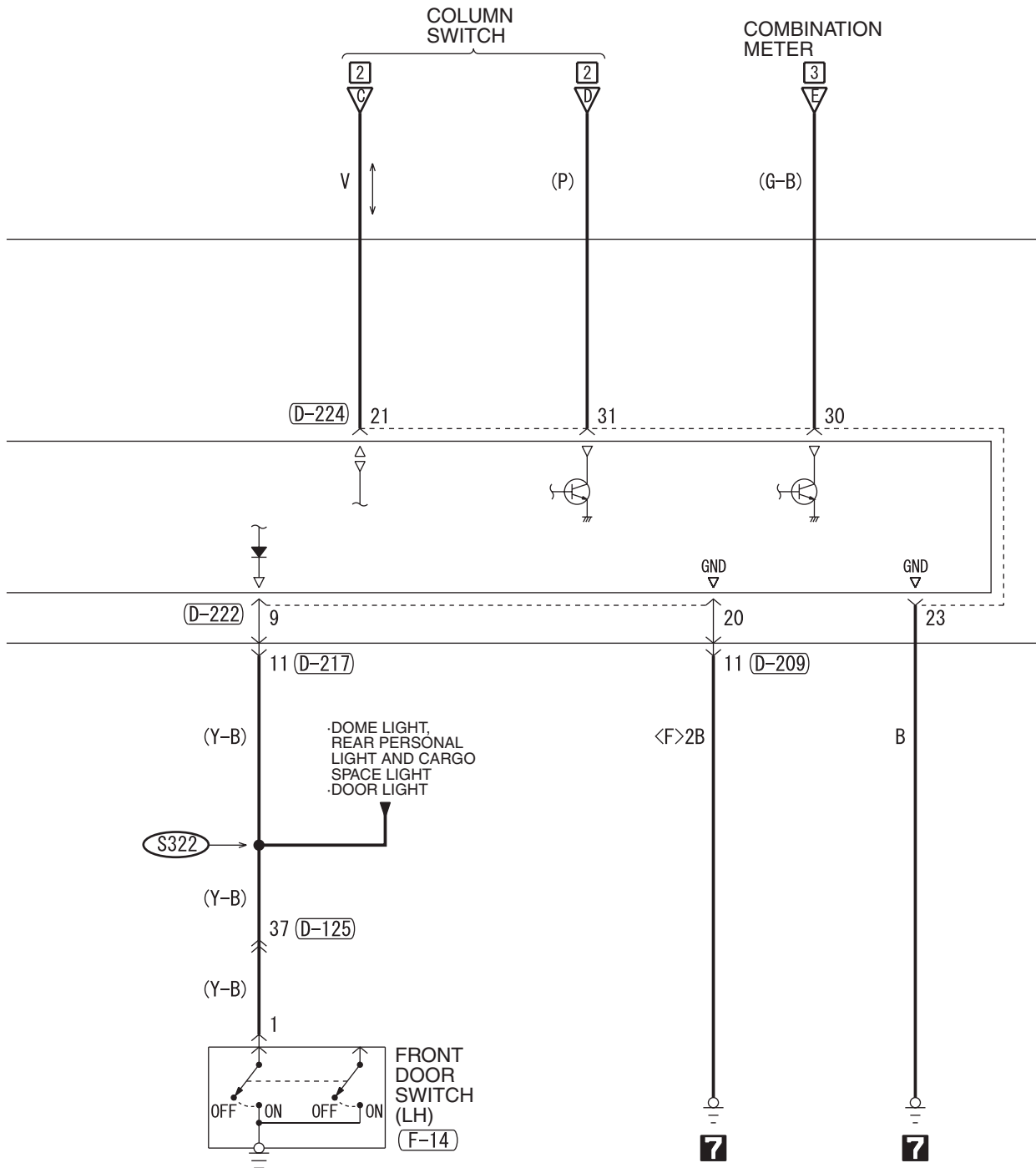

WIRE COLOR CODE
 B: BLACK LG: LIGHT GREEN G: GREEN L: BLUE W: WHITE Y: YELLOW
 SB: SKY BLUE BR: BROWN O: ORANGE GR: GRAY R: RED P: PINK V: VIOLET

TAILLIGHT, POSITION LIGHT, SIDE MARKER LIGHT, LICENSE PLATE LIGHT AND LIGHTING MONITOR TONE ALARM

M1901016400339

1

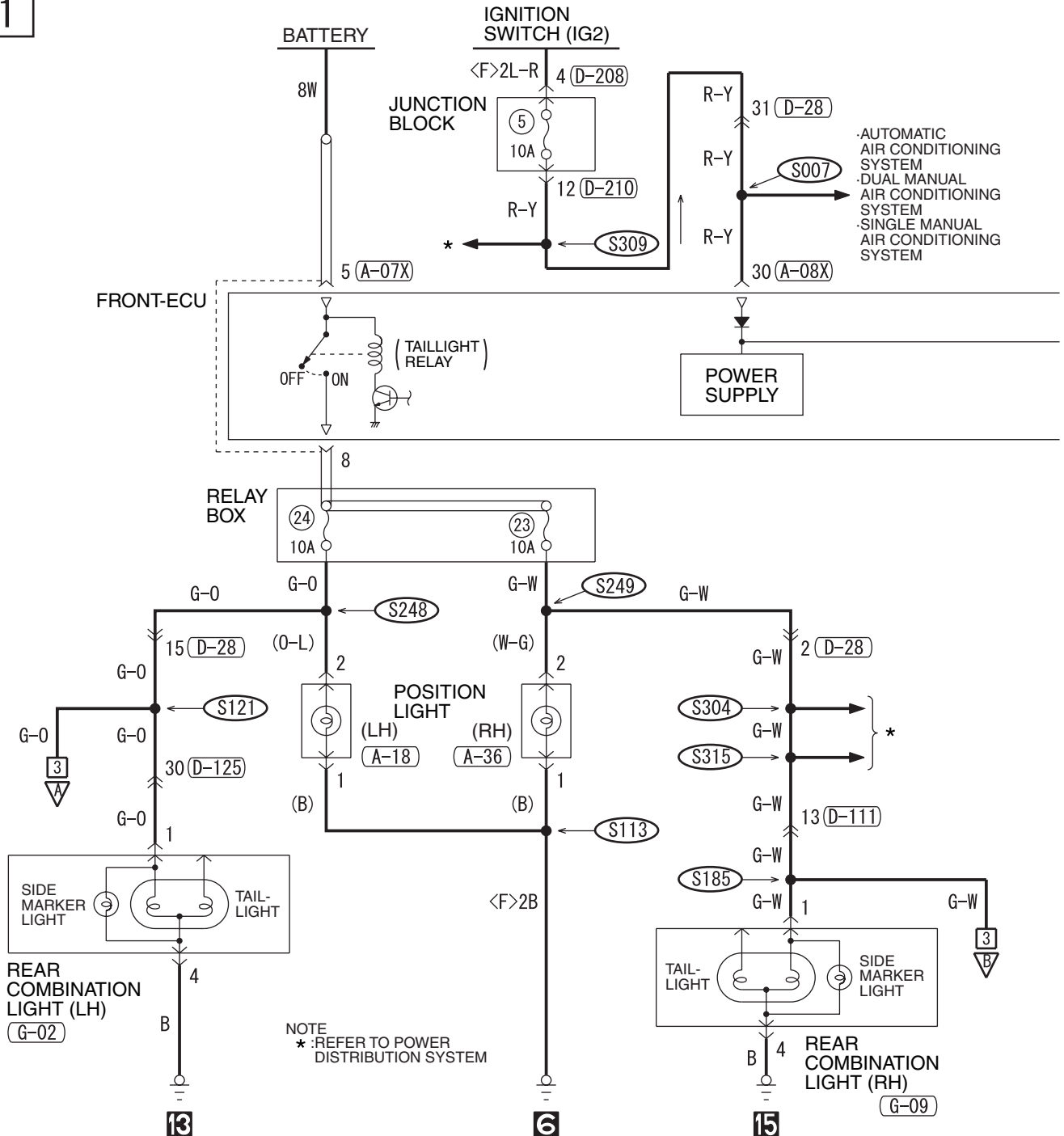

- AUTOMATIC AIR CONDITIONING SYSTEM
- DUAL MANUAL AIR CONDITIONING SYSTEM
- SINGLE MANUAL AIR CONDITIONING SYSTEM

NOTE
* :REFER TO POWER DISTRIBUTION SYSTEM

(A-07X)

1	2	3	4	5	6	7	8	9	10	11
---	---	---	---	---	---	---	---	---	----	----

(A-08X)

21	22	23	24	25	26	27	28	29	30	31
----	----	----	----	----	----	----	----	----	----	----

(A-18)

1	2
---	---

(A-36)

1	2
---	---

(D-28)

1	2	3	4	5	6	7	8	9	10	11	12	13
14	15	16	17	18	19	20	21	22	23	24	25	38
26	27	28	29	30	31	32	33	34	35	36	37	

(D-111)

1	2	3	4	5	6	7	8	9			
10	11	12	13	14	15	16	17	18	19	20	21
22	23	24	25	26	27	28	29	30	31	32	33
34	35	36	37	38	39	40	41	42	43		

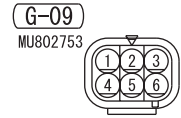
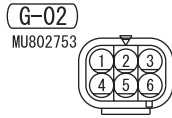

2

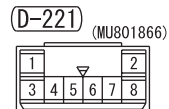
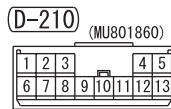
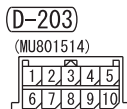
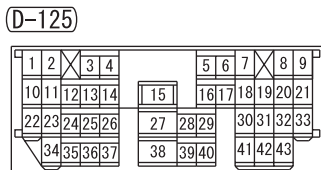
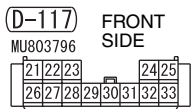
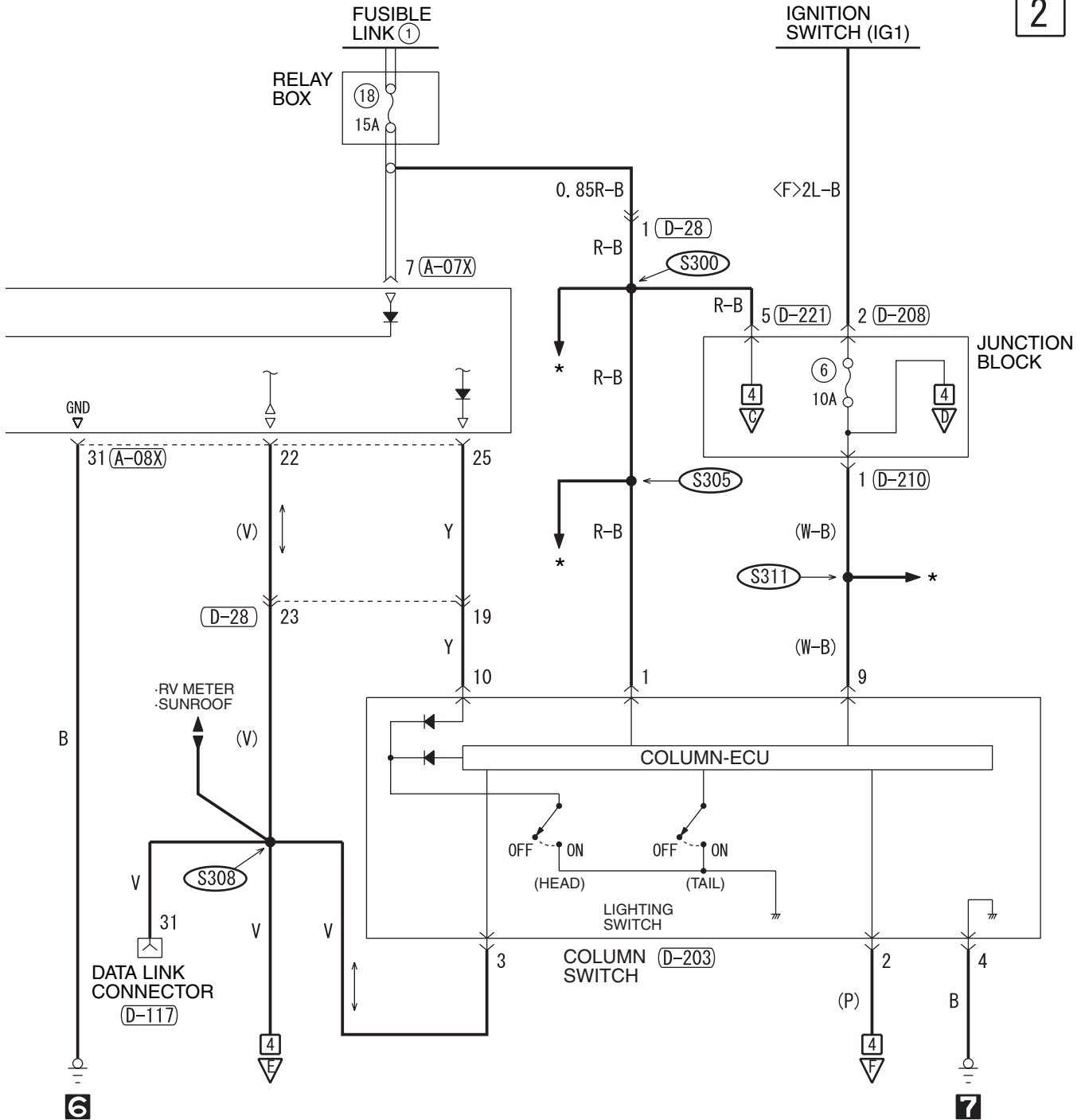

WIRE COLOR CODE
 B : BLACK LG : LIGHT GREEN G : GREEN L : BLUE
 BR : BROWN O : ORANGE GR : GRAY R : RED W : WHITE
 SB : SKY BLUE P : PINK Y : YELLOW V : VIOLET H6Q08M01AB

TAILLIGHT, POSITION LIGHT, SIDE MARKER LIGHT, LICENSE PLATE LIGHT AND LIGHTING MONITOR TONE ALARM (CONTINUED)

3

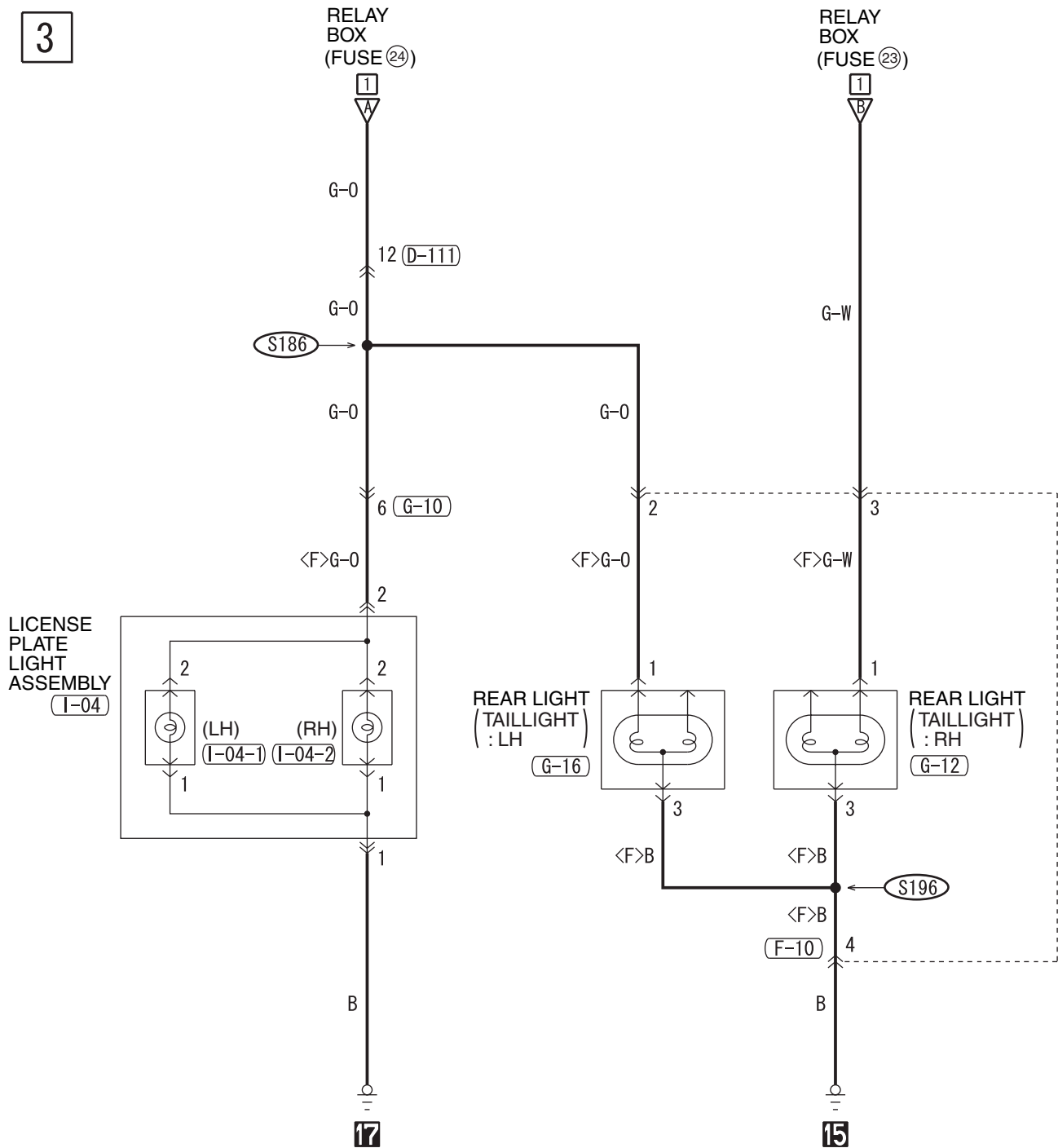

D-28

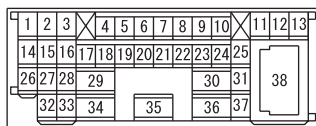

D-111

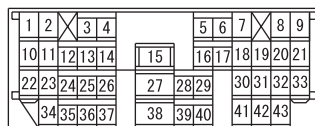

D-118 FRONT SIDE

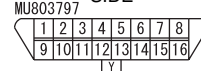

D-224

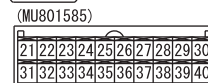

D-125

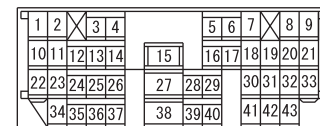

4

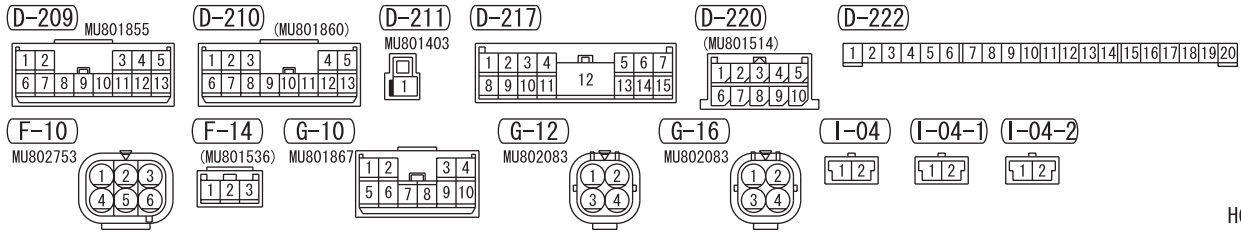
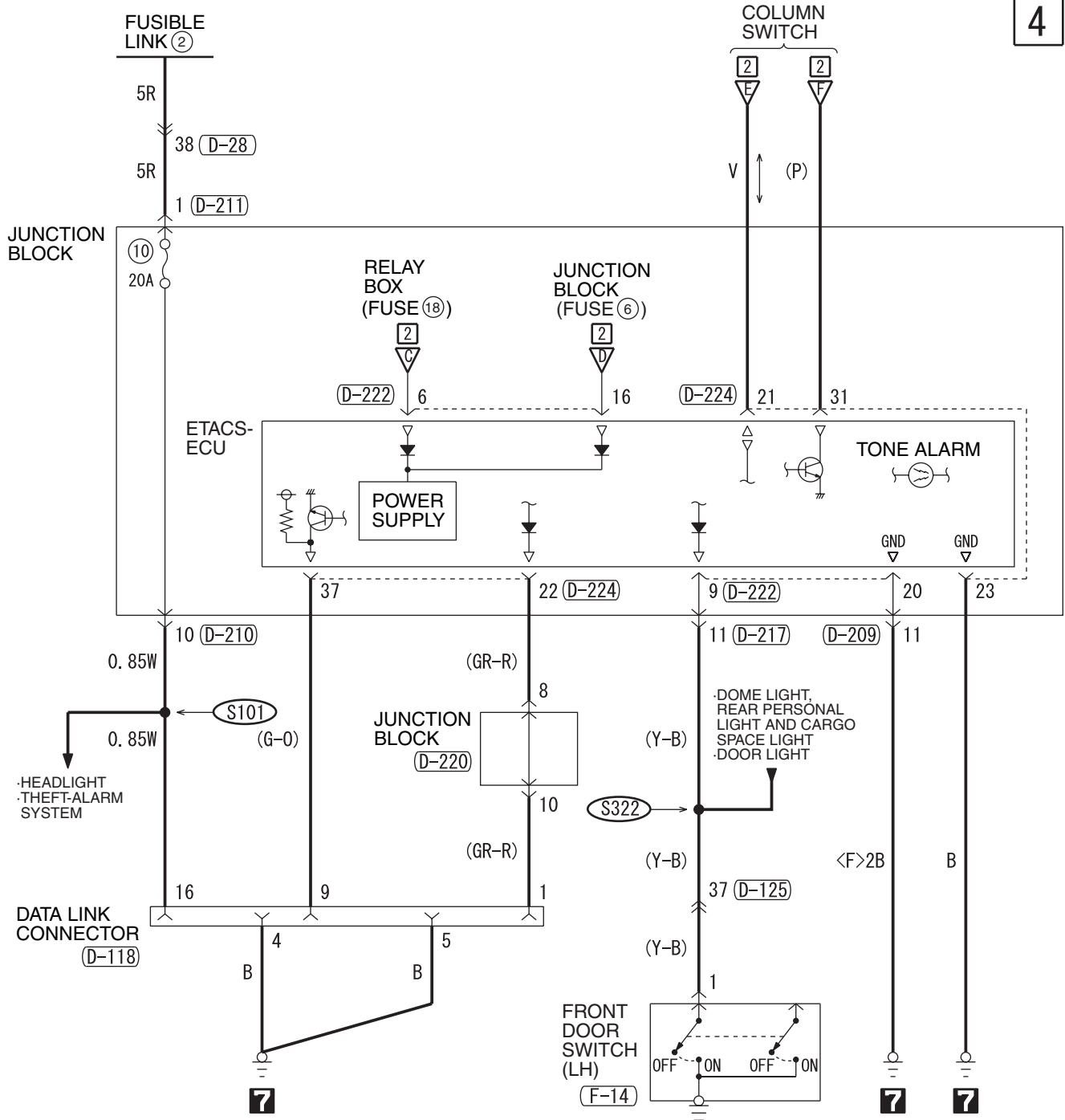

TSB Revision

FOG LIGHT

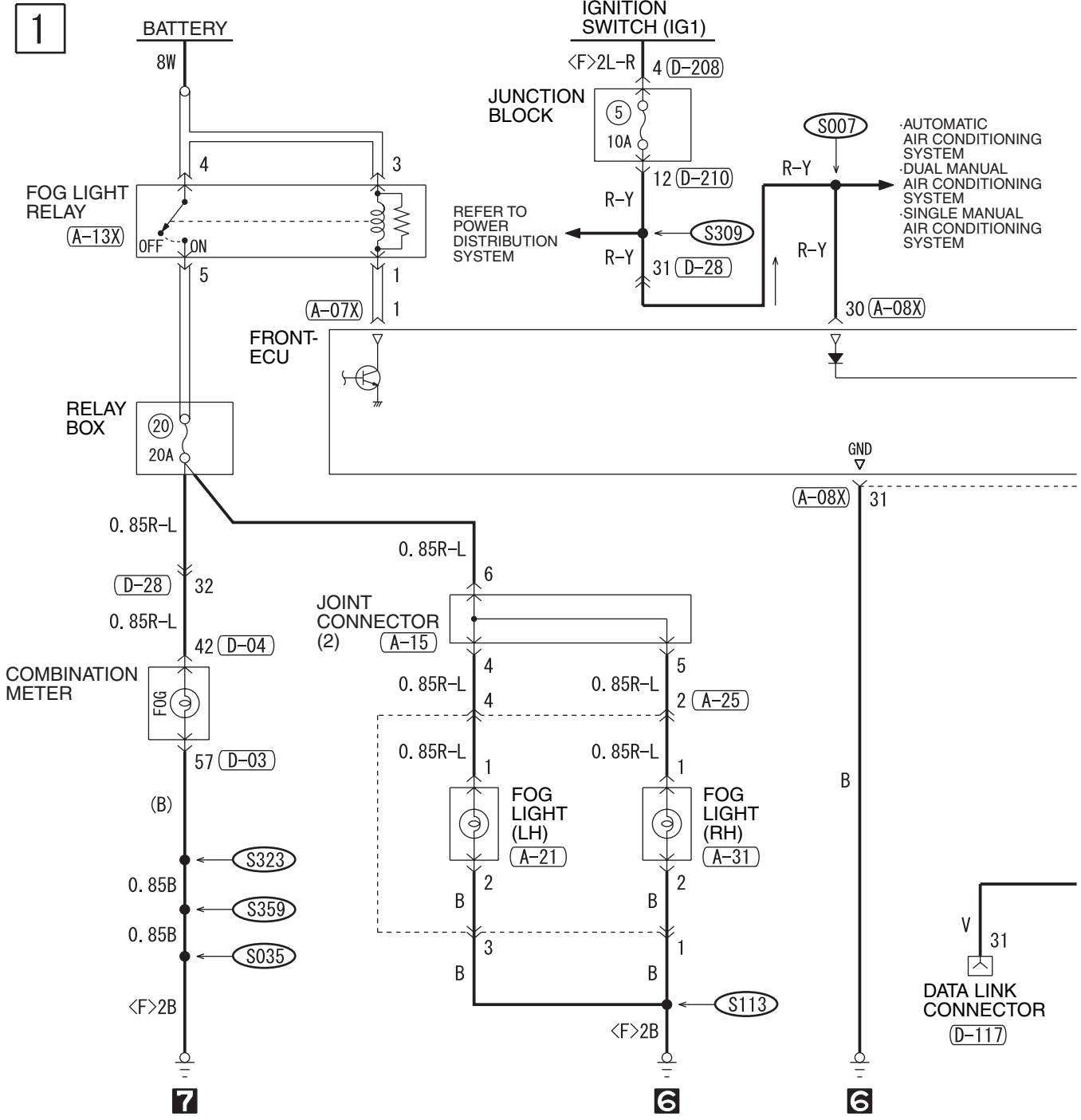

- AUTOMATIC AIR CONDITIONING SYSTEM
- DUAL MANUAL AIR CONDITIONING SYSTEM
- SINGLE MANUAL AIR CONDITIONING SYSTEM

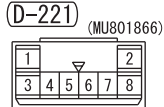
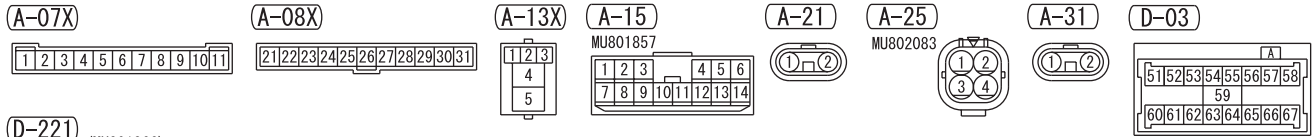

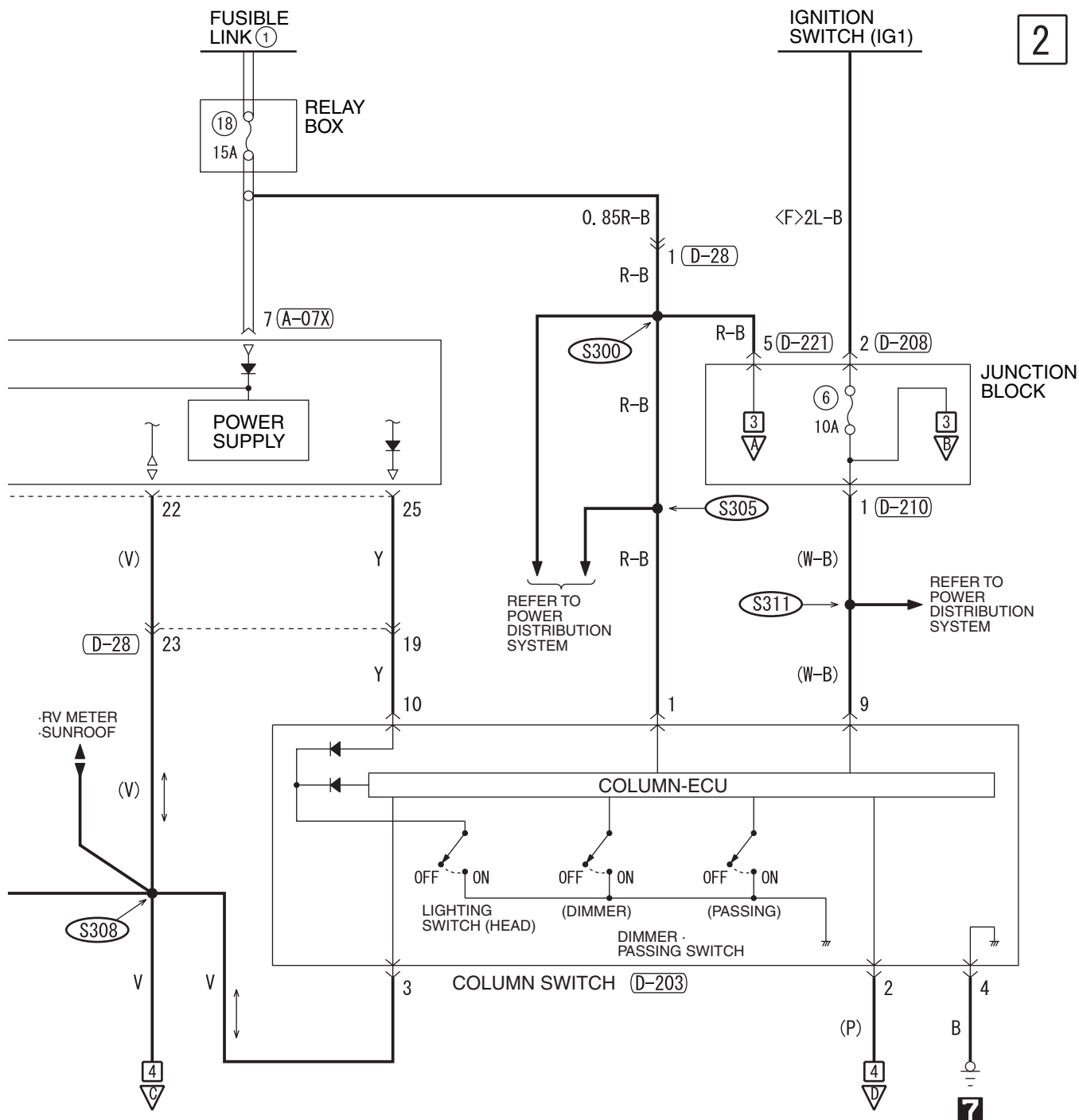

D-04

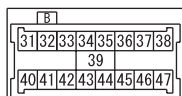

D-28

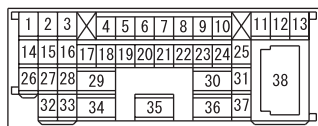

D-117 FRONT SIDE



D-203

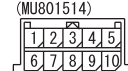

D-208



D-210 (MU801860)

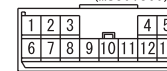

FOG LIGHT (CONTINUED)

3

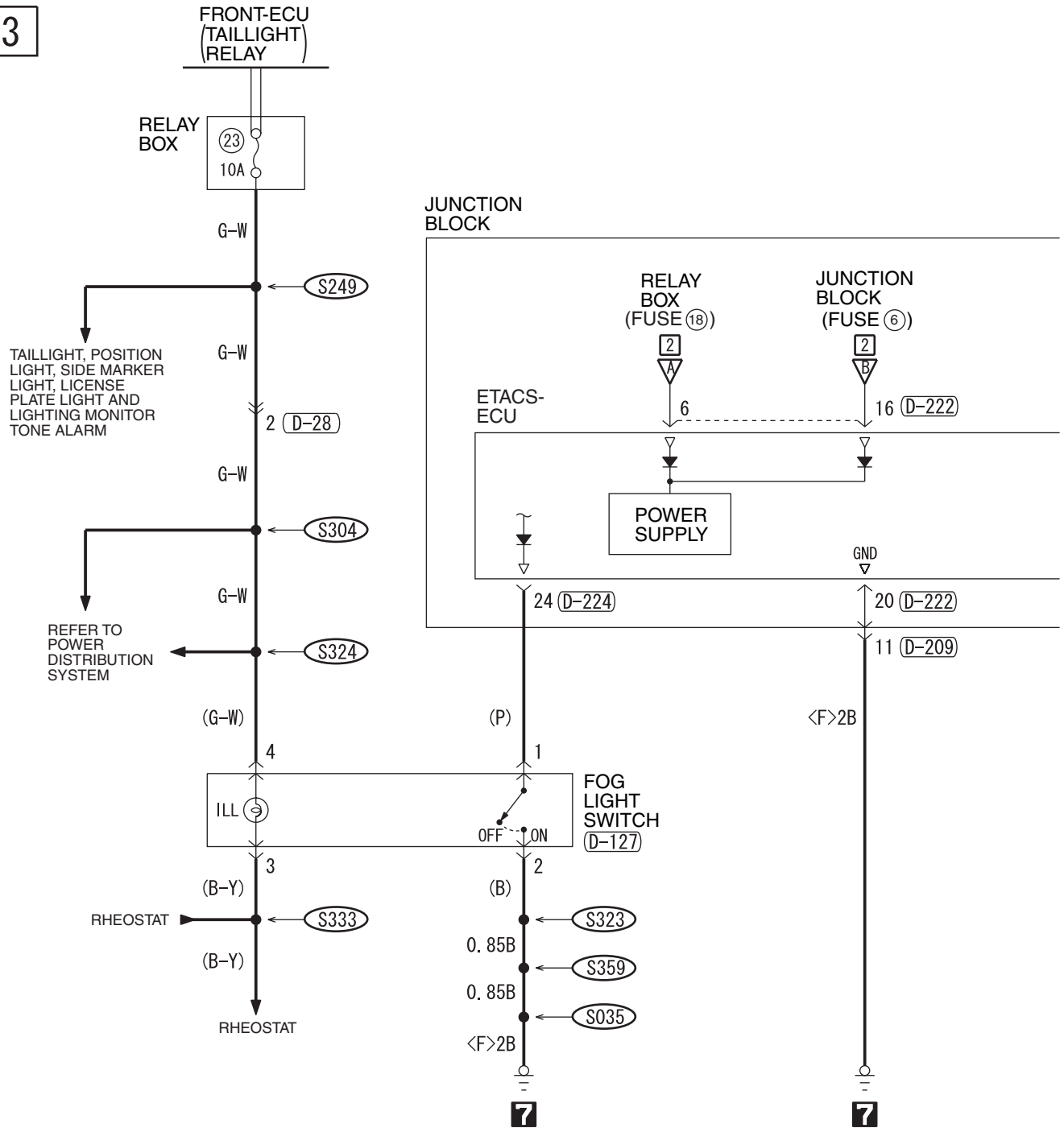

D-28

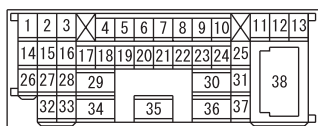

D-118 FRONT SIDE

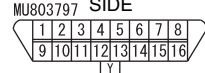

D-127

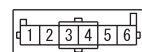

D-209 MU801855

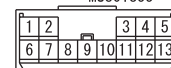

D-210 (MU801860)

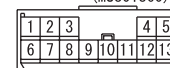

D-211 MU801403



4

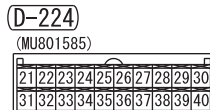
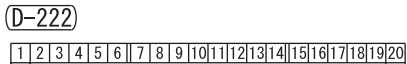
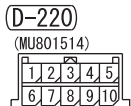
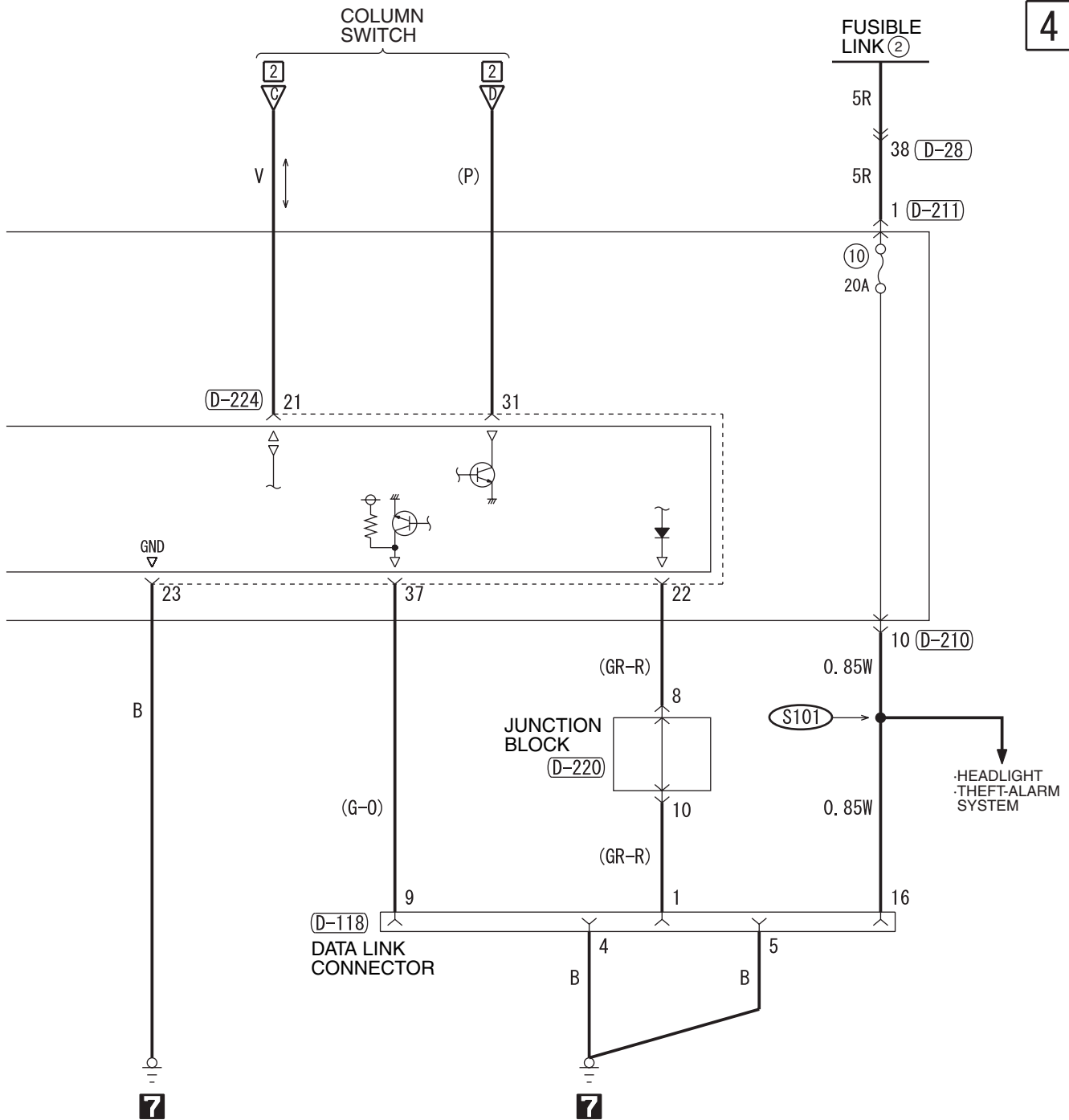

WIRE COLOR CODE
 B: BLACK LG: LIGHT GREEN G: GREEN L: BLUE W: WHITE Y: YELLOW
 SB: SKY BLUE BR: BROWN O: ORANGE GR: GRAY R: RED P: PINK V: VIOLET

DOME LIGHT, REAR PERSONAL LIGHT AND CARGO SPACE LIGHT

M1901016500198

1

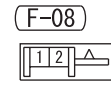
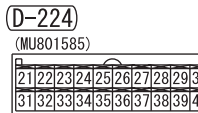
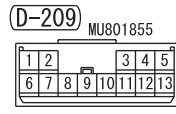
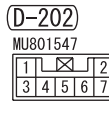
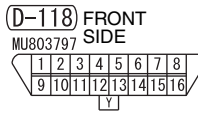
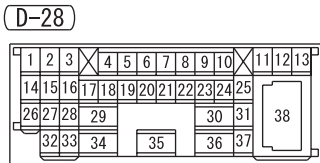
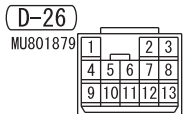
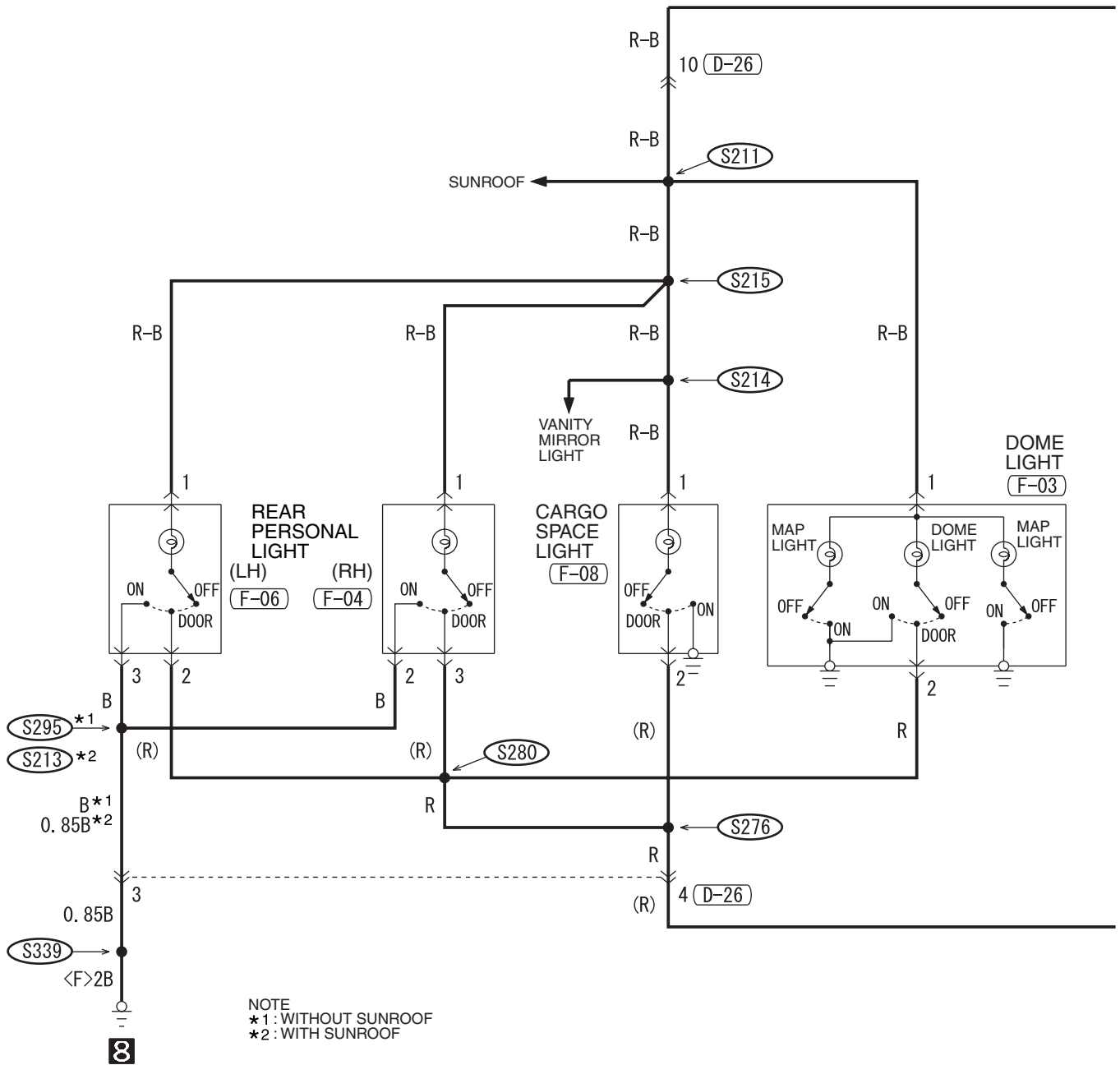

H6Q08M03AA

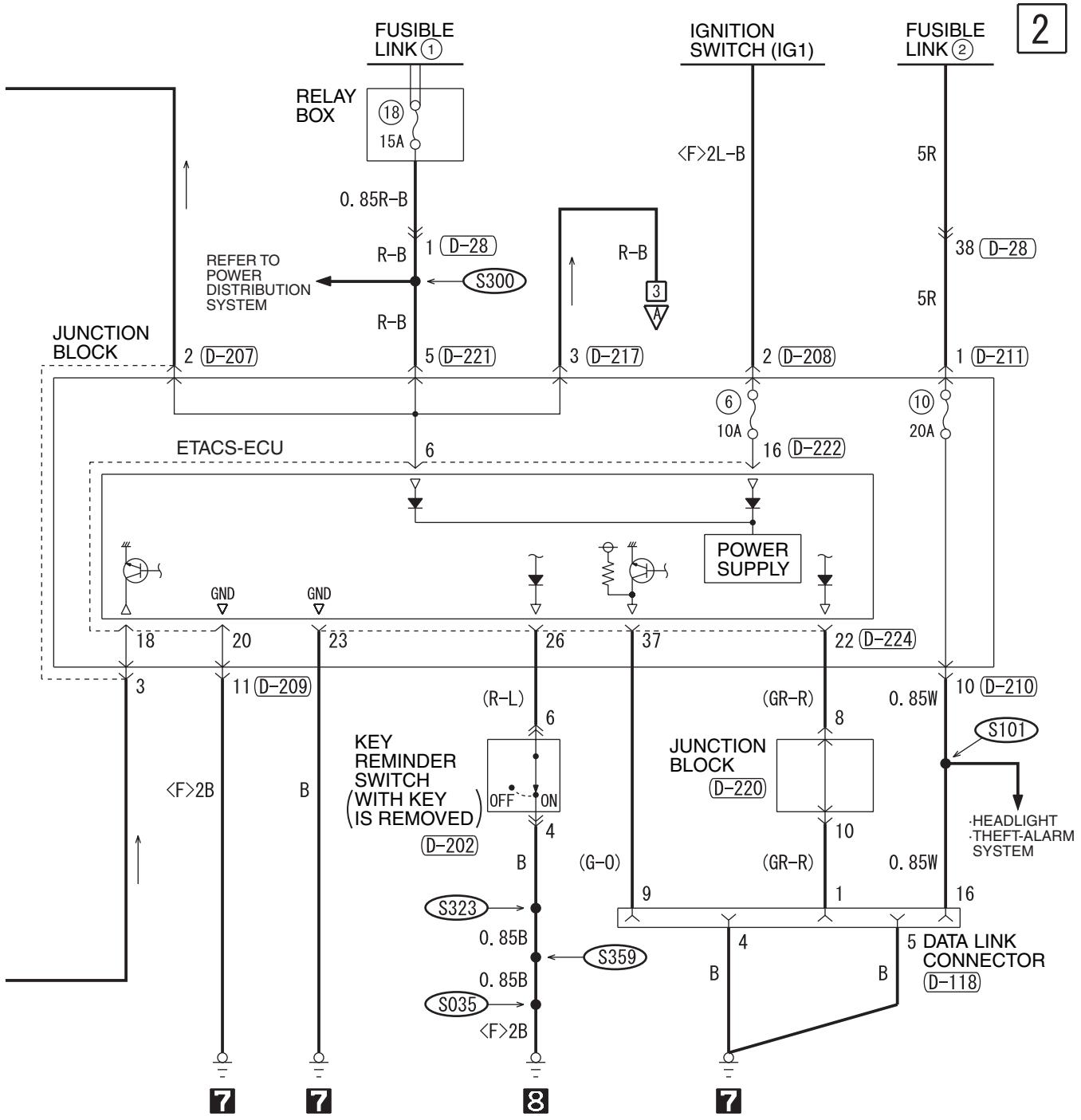

2

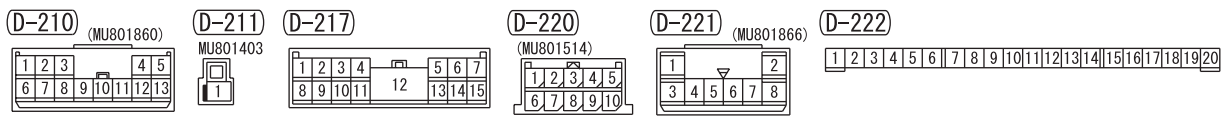

WIRE COLOR CODE
 B : BLACK LG : LIGHT GREEN G : GREEN L : BLUE W : WHITE Y : YELLOW
 SB : SKY BLUE BR : BROWN O : ORANGE GR : GRAY R : RED P : PINK V : VIOLET

TSB Revision

DOME LIGHT, REAR PERSONAL LIGHT AND CARGO SPACE LIGHT (CONTINUED)

3

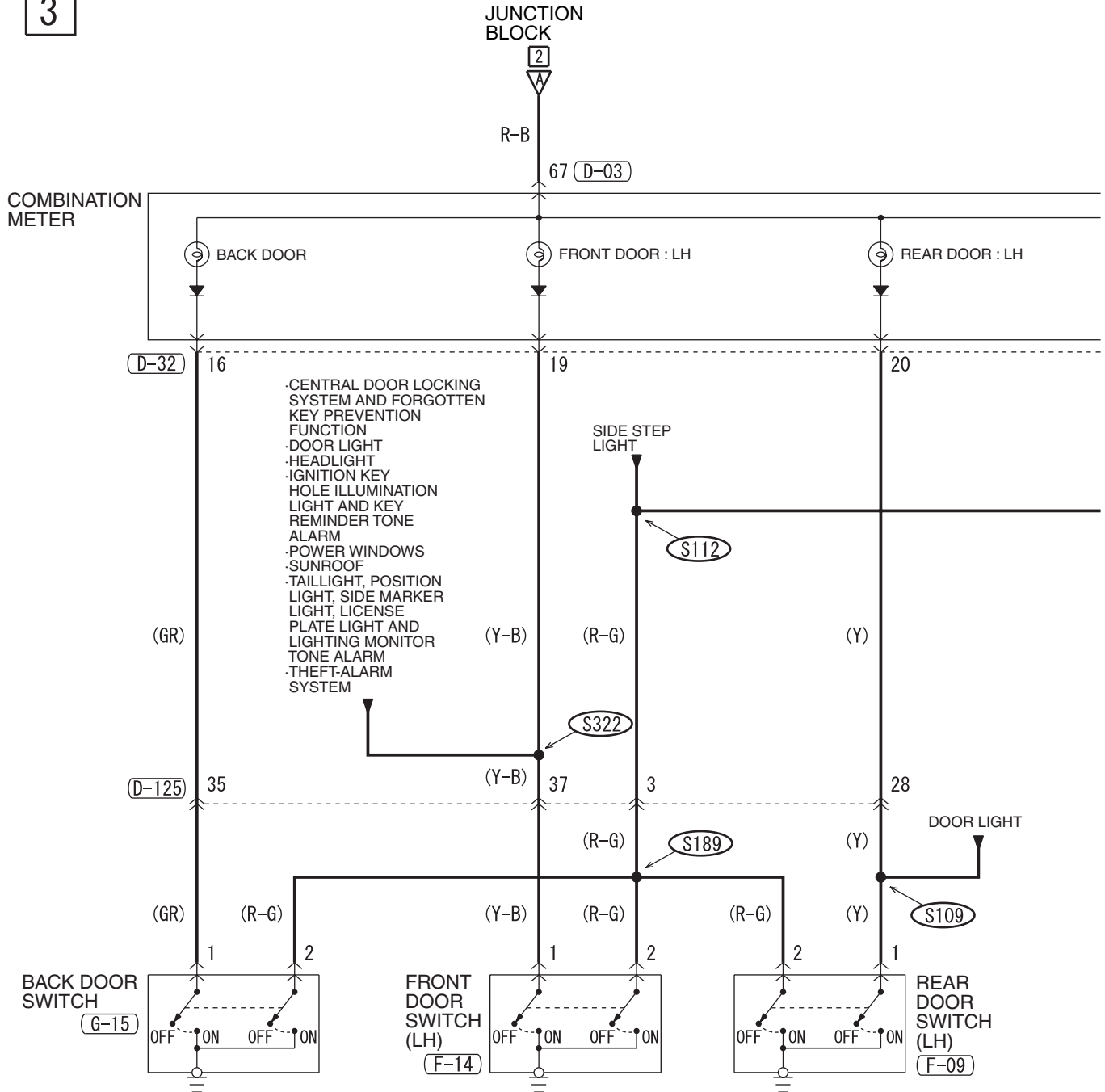

D-03

5	15	25	35	45	55	65	75	85
60	61	62	63	64	65	66	67	

D-32

1	2	3	4	5	6	7	8	9	10	11	12
14	15	16	17	18	19	20	21	22	23	24	25

D-111

1	2	3	4	5	6	7	8	9			
10	11	12	13	14	15	16	17	18	19	20	21
22	23	24	25	26	27	28	29	30	31	32	33
34	35	36	37	38	39	40	41	42	43		

D-125

1	2	3	4	5	6	7	8	9			
10	11	12	13	14	15	16	17	18	19	20	21
22	23	24	25	26	27	28	29	30	31	32	33
34	35	36	37	38	39	40	41	42	43		

D-209 MU801855

1	2	3	4	5			
6	7	8	9	10	11	12	13

4

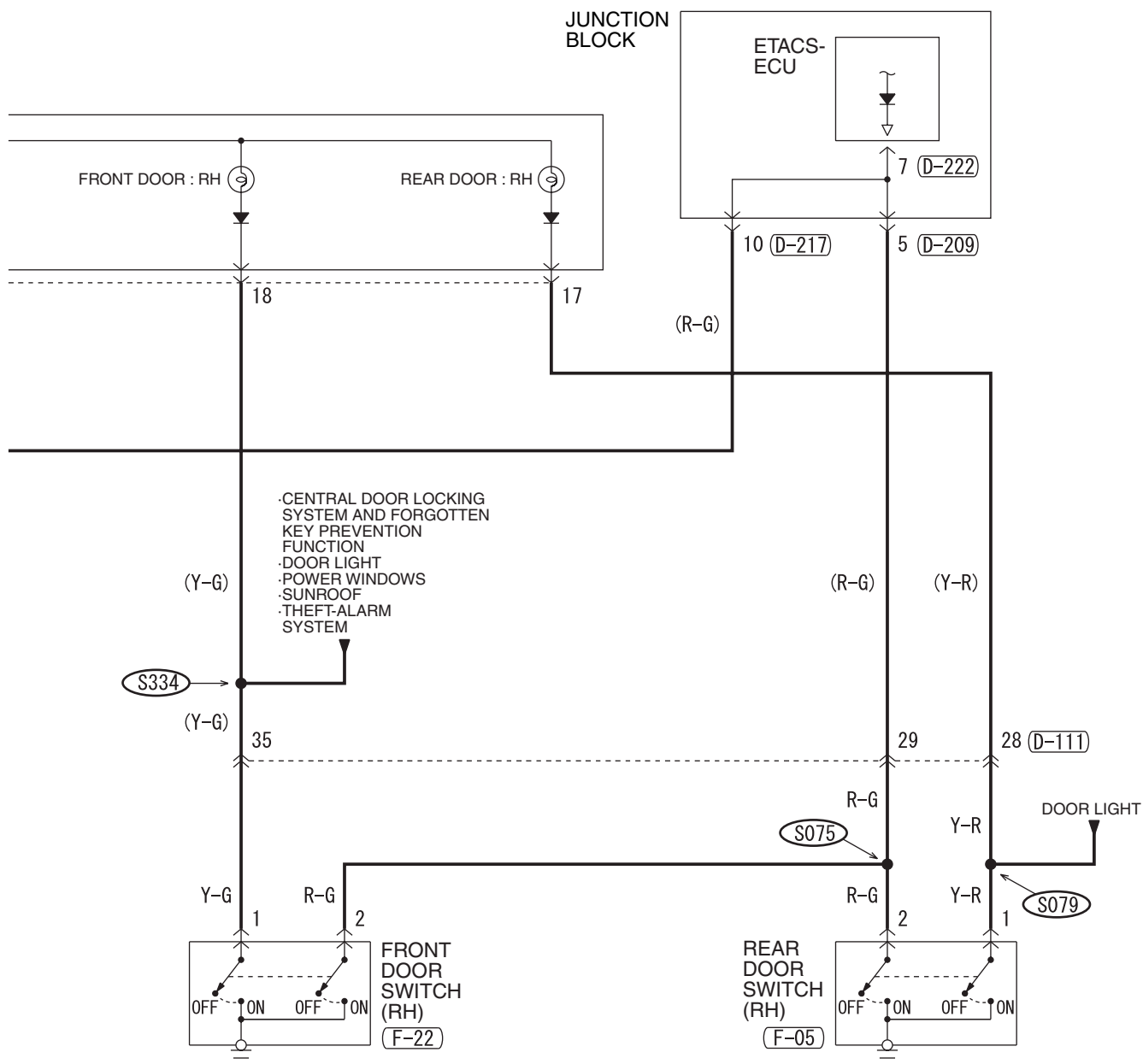

(D-217)

1	2	3	4	5	6	7
8	9	10	11	12	13	14
15	16	17	18	19	20	

(D-222)

1	2	3	4	5	6	7	8	9	10	11	12	13	14	15	16	17	18	19	20
---	---	---	---	---	---	---	---	---	----	----	----	----	----	----	----	----	----	----	----

(F-05)

1	2	3
---	---	---

(F-09)

1	2	3
---	---	---

(F-14)

1	2	3
---	---	---

(F-22)

1	2	3
---	---	---

(G-15)

1	2	3
---	---	---

WIRE COLOR CODE

B : BLACK LG : LIGHT GREEN G : GREEN L : BLUE W : WHITE Y : YELLOW
 SB : SKY BLUE BR : BROWN O : ORANGE GR : GRAY R : RED P : PINK V : VIOLET

DOOR LIGHT

M1901002500281

1

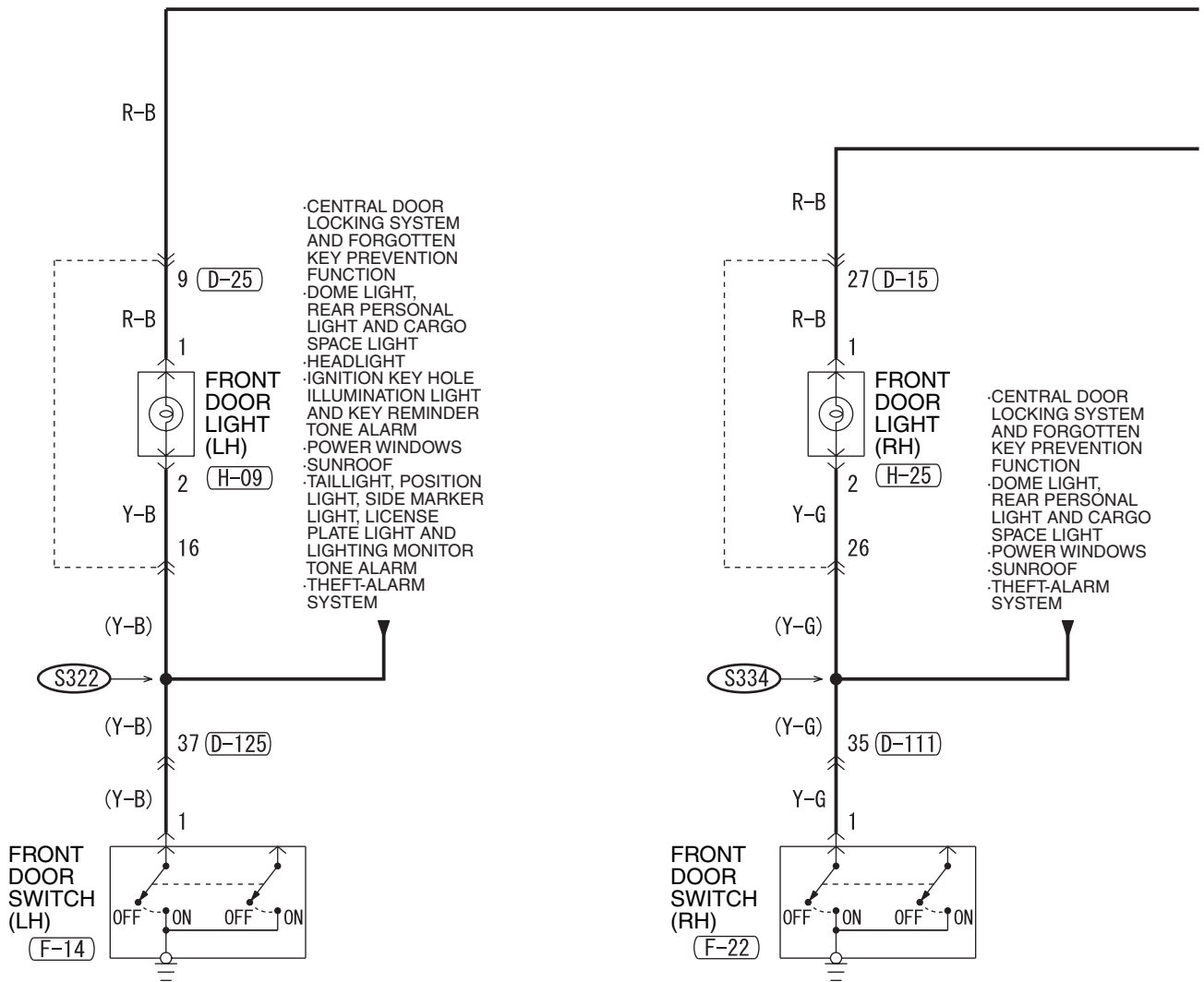

D-15

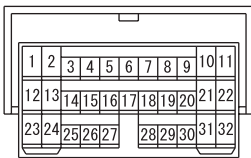

D-25

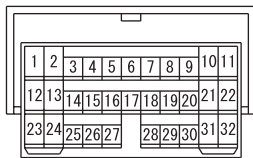

D-28

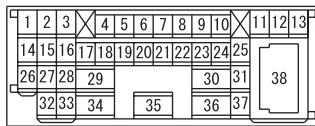

D-111

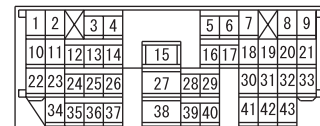

H6Q08M04AA

2

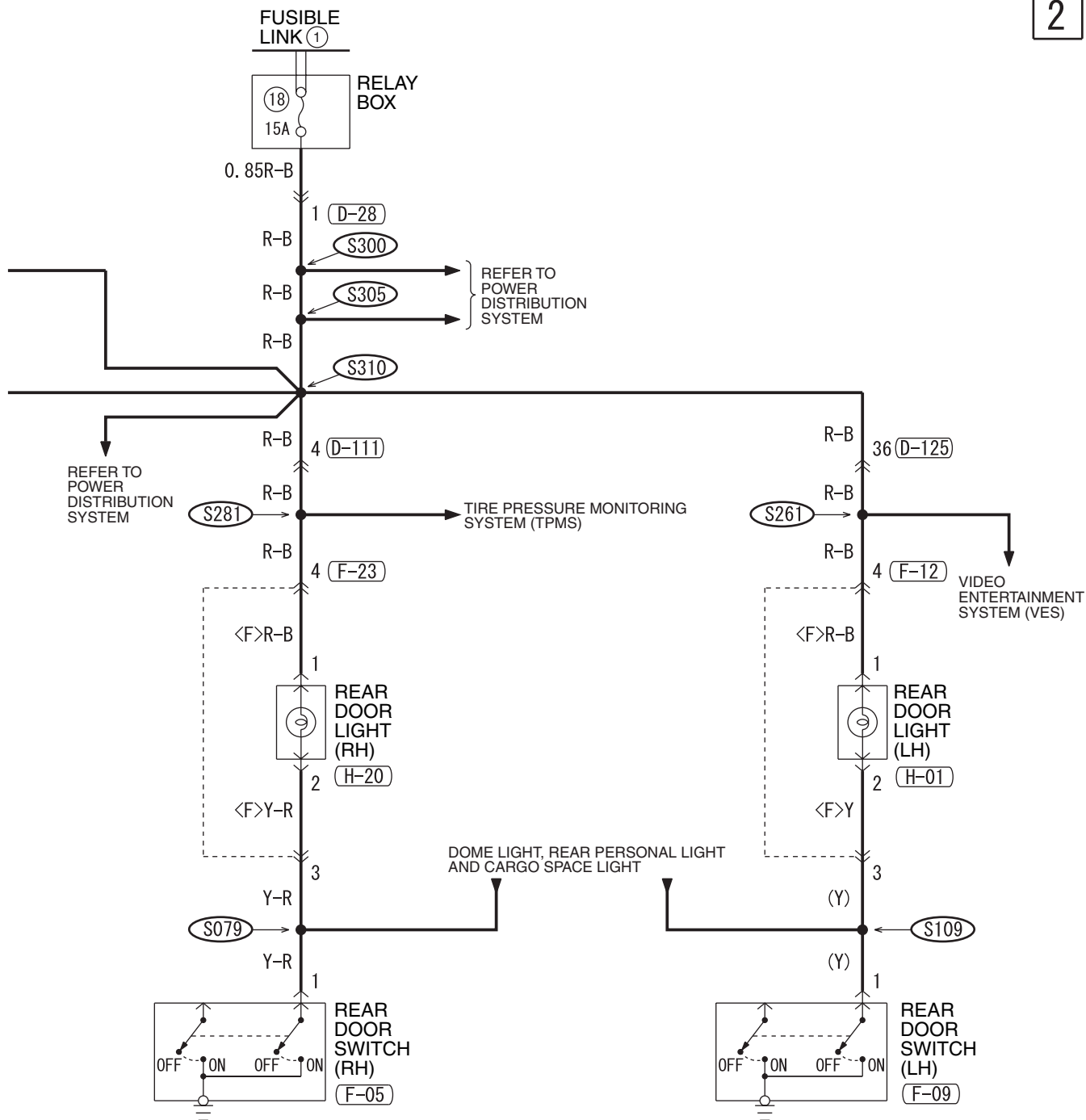

D-125

1	2	3	4	5	6	7	8	9			
10	11	12	13	14	15	16	17	18	19	20	21
22	23	24	25	26	27	28	29	30	31	32	33
34	35	36	37	38	39	40	41	42	43		

F-05

1	2	3
---	---	---

F-09

1	2	3
---	---	---

F-12

1	2	3	4	5	6		
7	8	9	10	11	12	13	14

F-14

1	2	3
---	---	---

F-22

1	2	3
---	---	---

F-23

1	2	3	4	5	6		
7	8	9	10	11	12	13	14

H-01

1
2

H-09

1
2

H-20

1
2

H-25

1
2

WIRE COLOR CODE

B: BLACK LG: LIGHT GREEN G: GREEN L: BLUE

BR: BROWN O: ORANGE GR: GRAY R: RED W: WHITE

SB: SKY BLUE P: PINK Y: YELLOW V: VIOLET

H6Q08M04AB

TSB Revision

GLOVE BOX LIGHT

M1901002200848

1

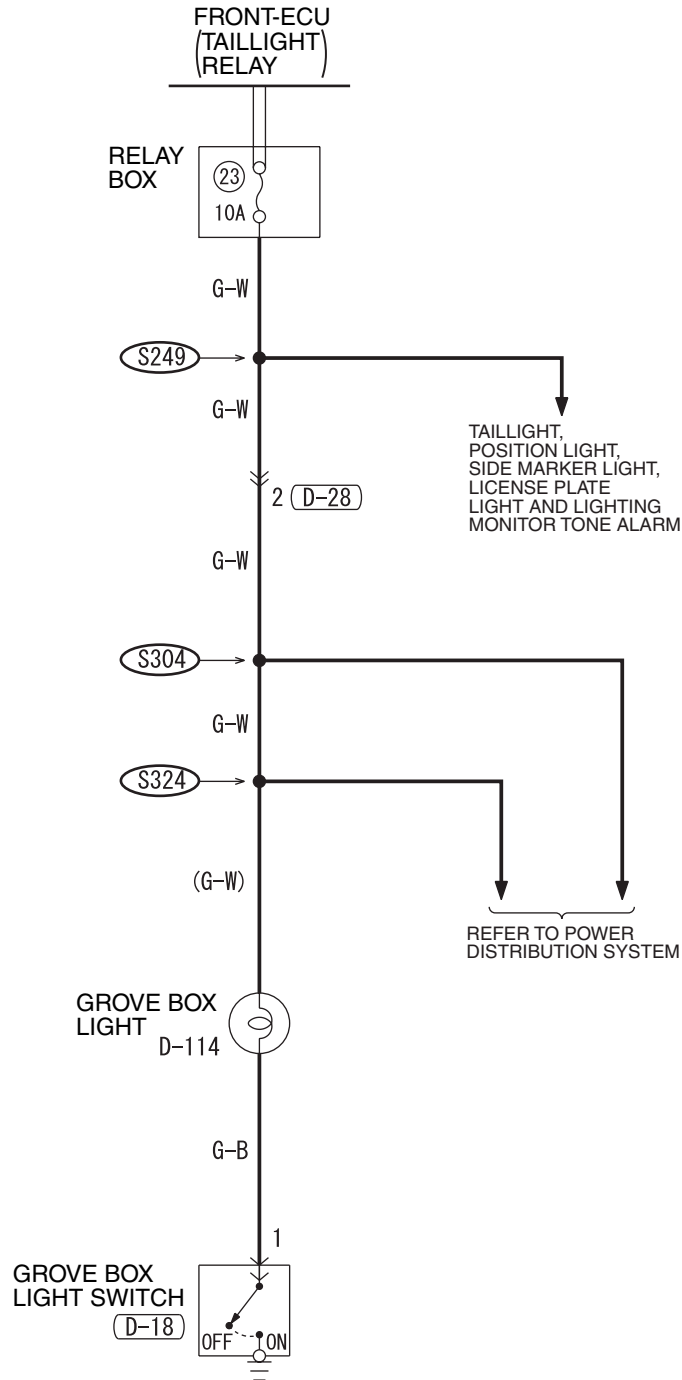

(D-18)

(D-28)



1	2	3	4	5	6	7	8	9	10	11	12	13
14	15	16	17	18	19	20	21	22	23	24	25	
26	27	28	29					30	31		38	
32	33	34		35				36	37			

WIRE COLOR CODE

B : BLACK LG : LIGHT GREEN G : GREEN L : BLUE
 BR : BROWN O : ORANGE GR : GRAY R : RED W : WHITE
 SB : SKY BLUE P : PINK Y : YELLOW V : VIOLET

H6Q08M05AA

TSB Revision

M1901002400574

VANITY MIRROR LIGHT

1

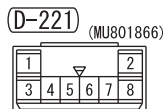
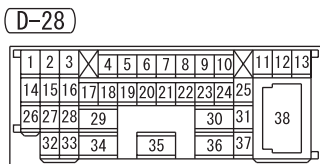
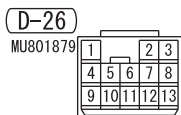
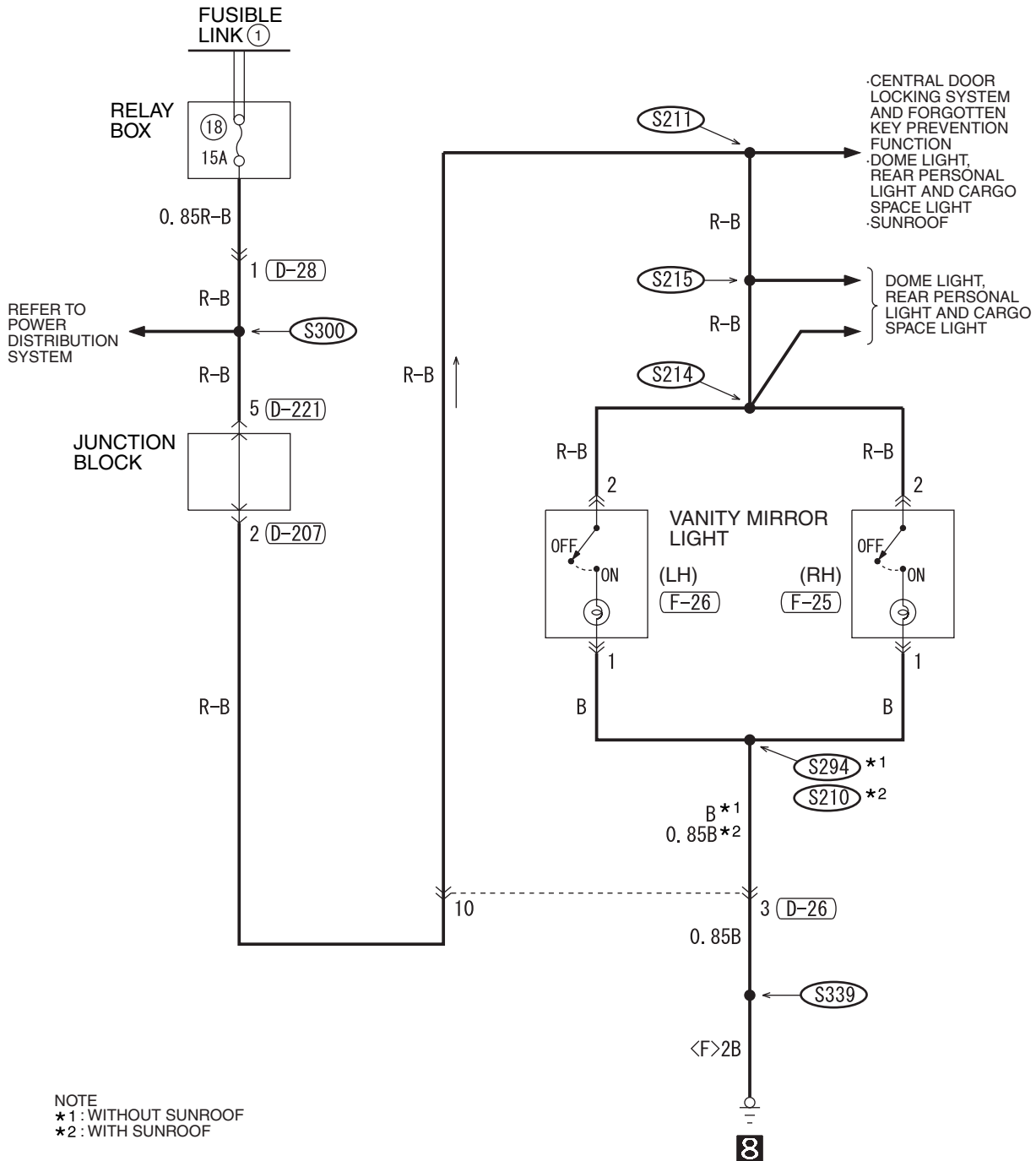

WIRE COLOR CODE

B : BLACK LG : LIGHT GREEN G : GREEN L : BLUE
BR : BROWN O : ORANGE GR : GRAY R : RED W : WHITE
SB : SKY BLUE P : PINK Y : YELLOW V : VIOLET

H6Q08M06AA

IGNITION KEY HOLE ILLUMINATION LIGHT AND KEY REMINDER TONE ALARM

M1901002600288

1

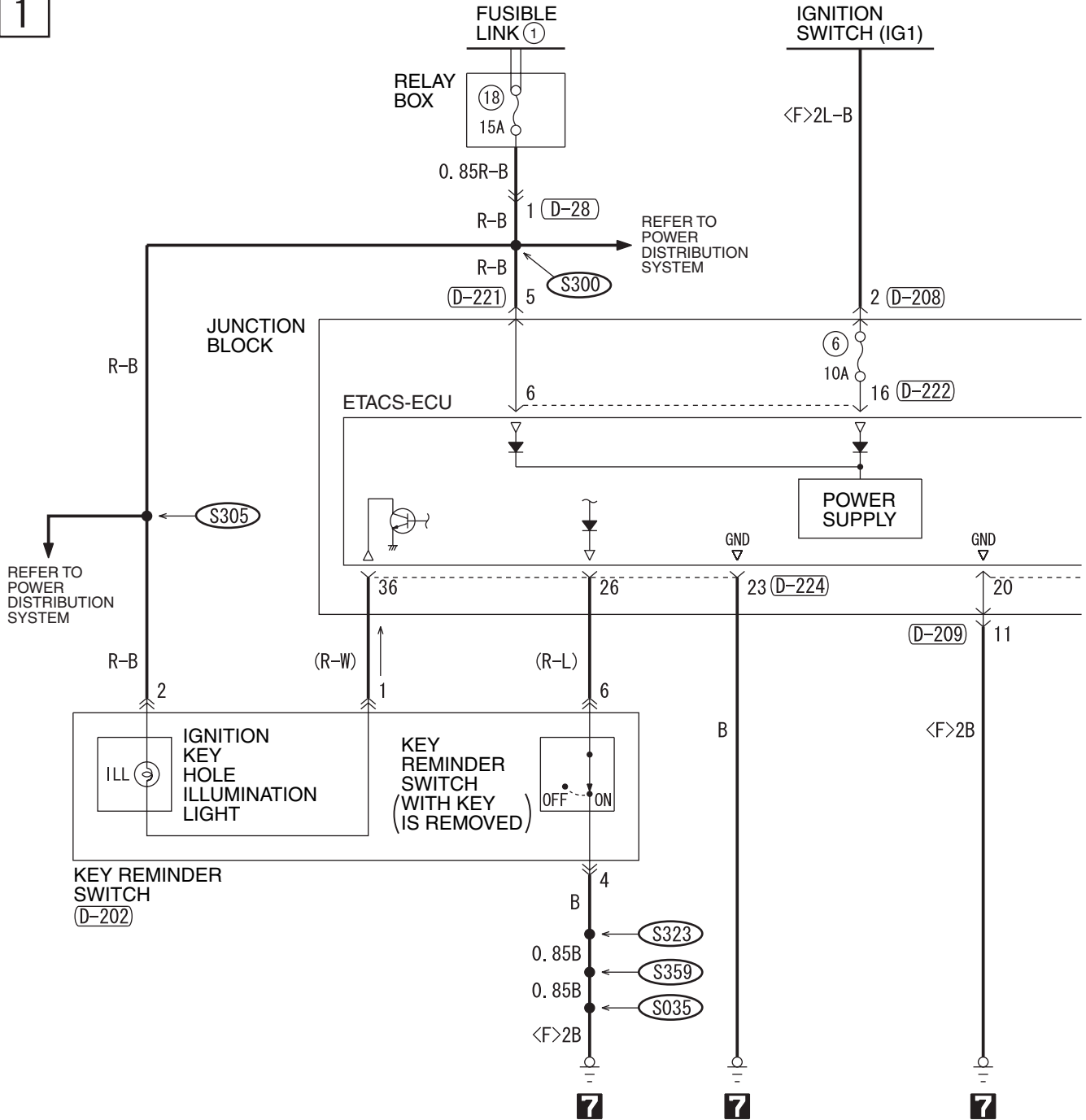

D-28

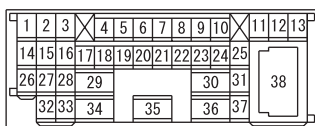

D-118 FRONT SIDE

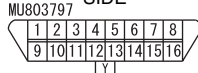

D-125

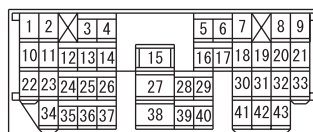

D-202

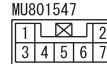

D-208



D-209 MU801855

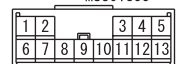

D-224 (MU801585)

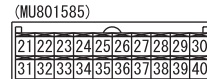

F-14 (MU801536)



H6Q08M07AA

2

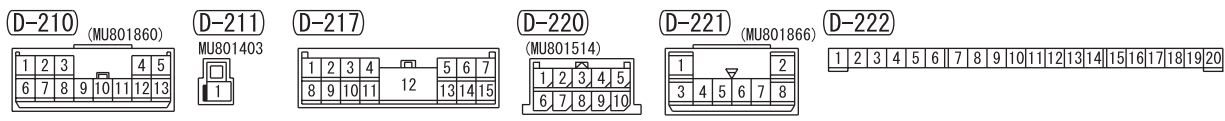
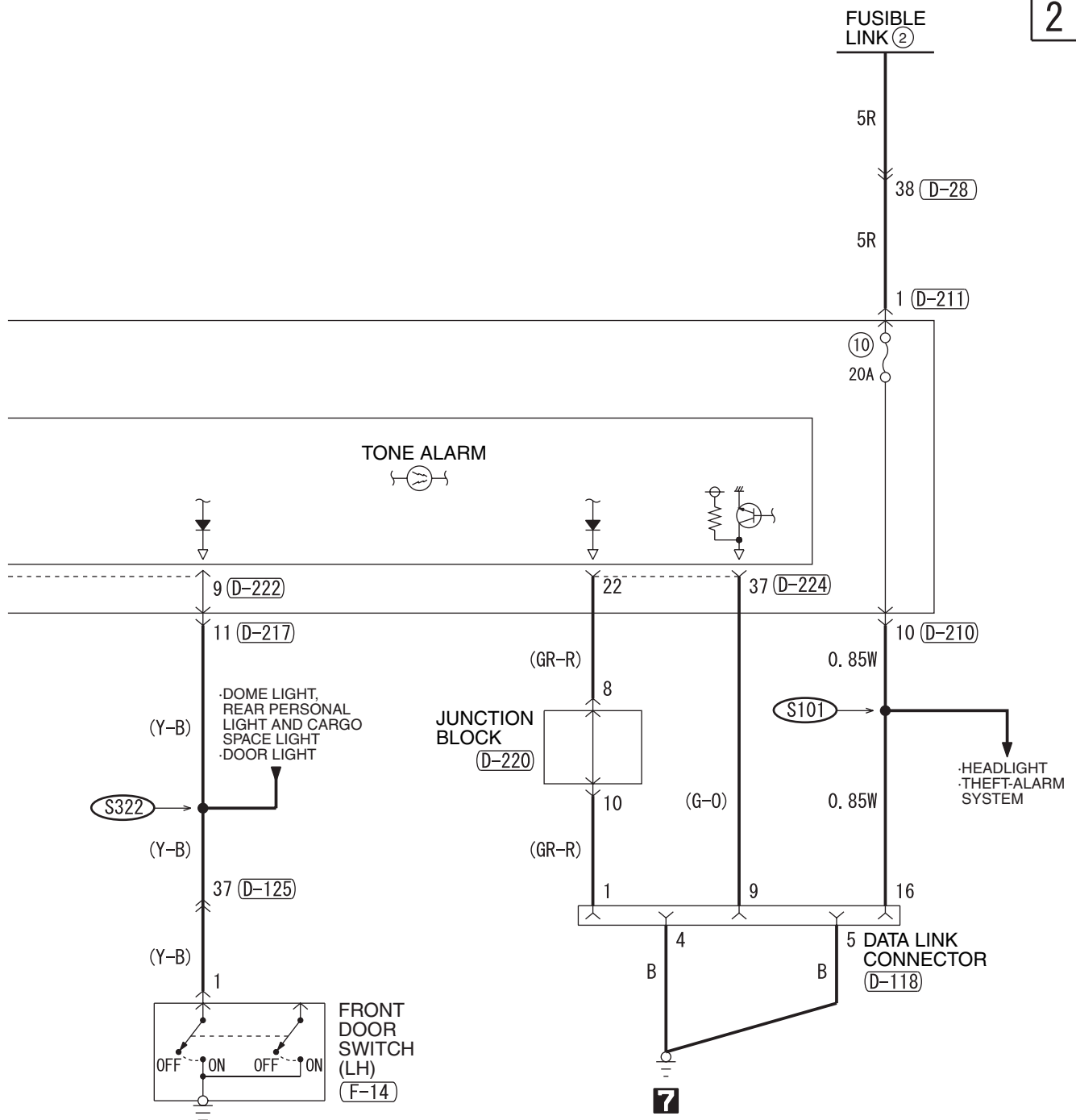

WIRE COLOR CODE
 B : BLACK LG : LIGHT GREEN G : GREEN L : BLUE W : WHITE Y : YELLOW
 SB : SKY BLUE BR : BROWN O : ORANGE GR : GRAY R : RED P : PINK V : VIOLET

H6Q08M07AB

TSB Revision

SIDE STEP LIGHT

1

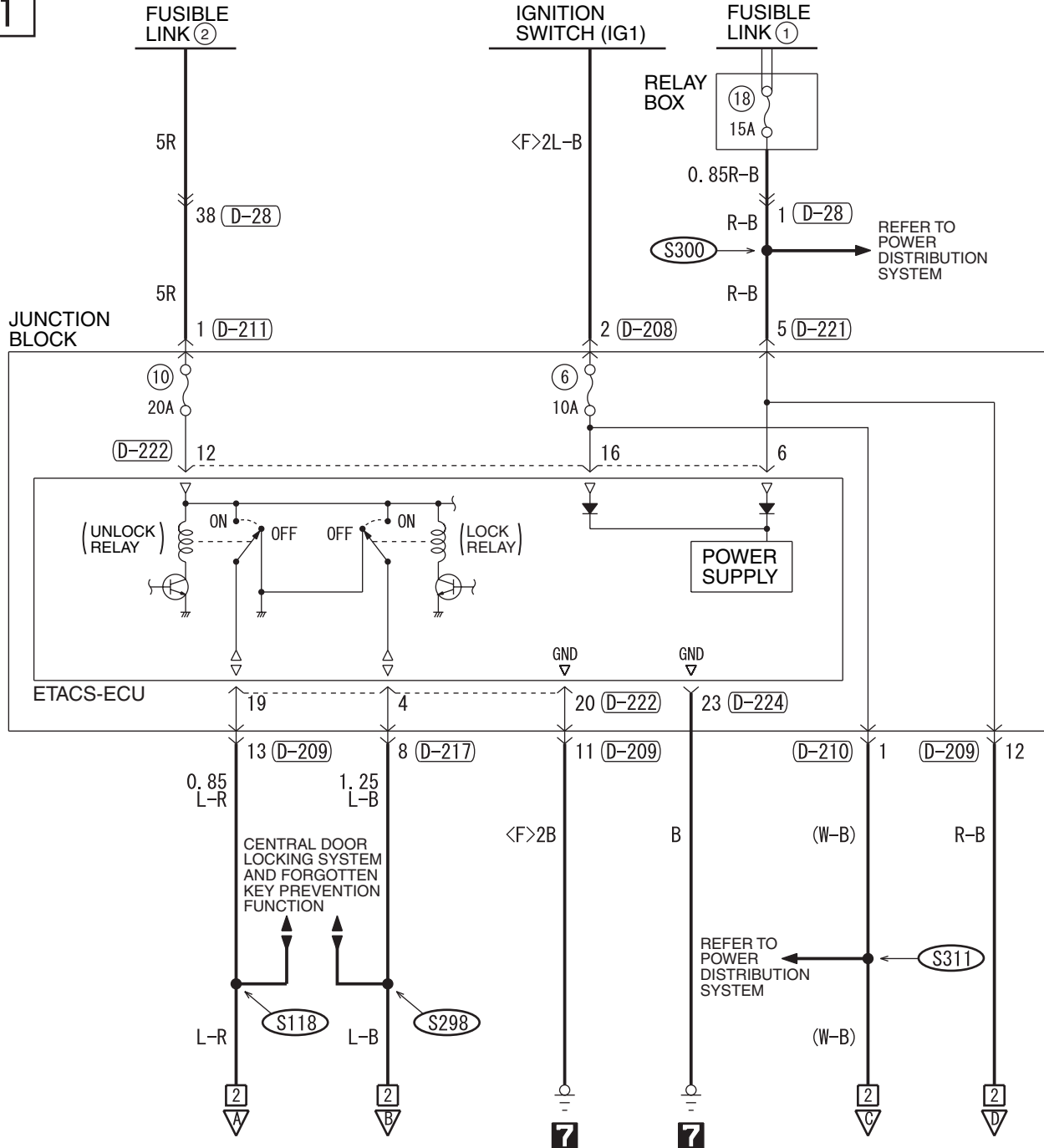

D-28

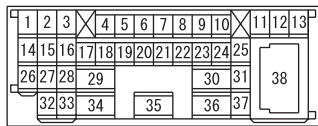

D-111

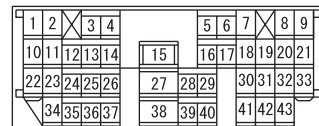

D-125

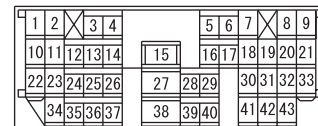

D-137



D-208



2

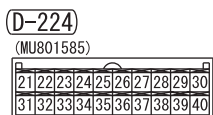
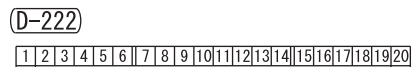
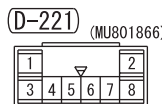
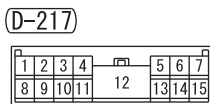
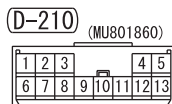
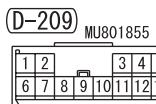
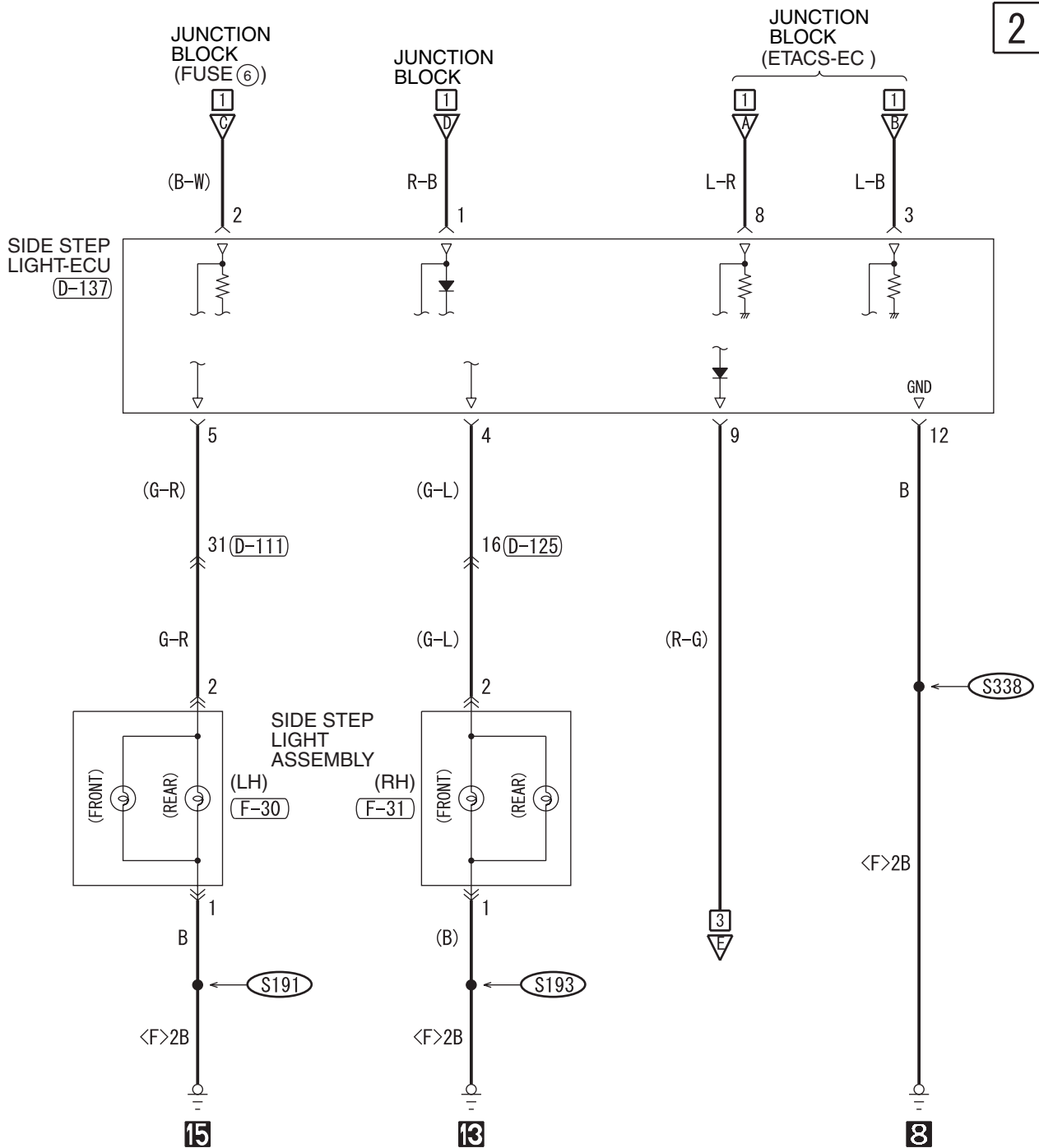

WIRE COLOR CODE
 B : BLACK LG : LIGHT GREEN G : GREEN L : BLUE
 BR : BROWN O : ORANGE GR : GRAY R : RED W : WHITE
 SB : SKY BLUE P : PINK Y : YELLOW V : VIOLET

H6Q08M08AB

SIDE STEP LIGHT (CONTINUED)

3

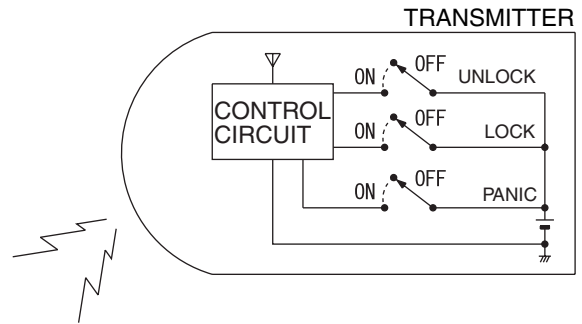

JUNCTION BLOCK

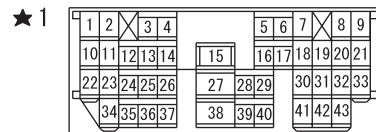
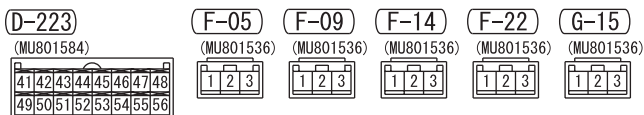
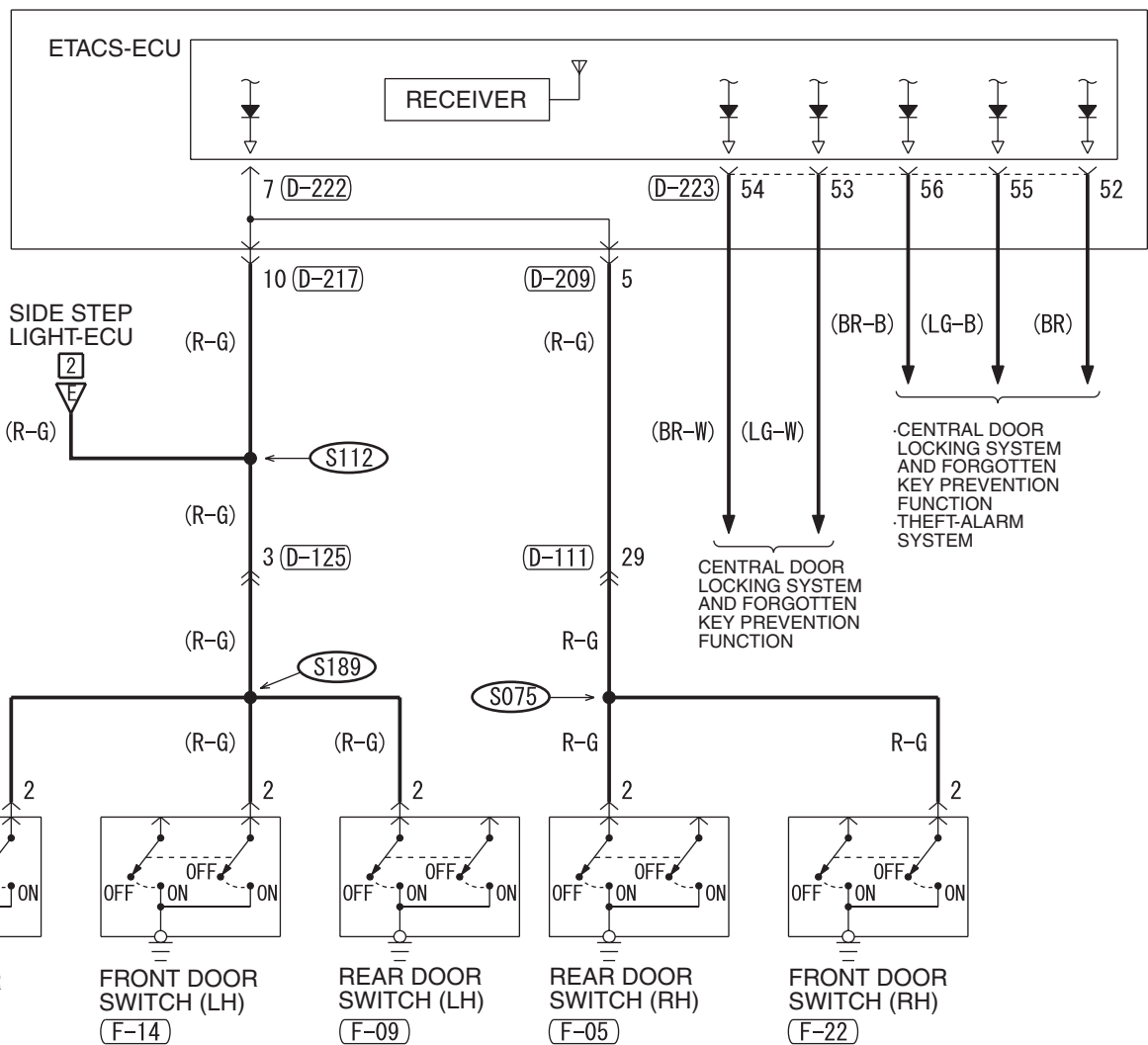

H6Q08M08BA

NOTES

TURN-SIGNAL LIGHT AND HAZARD WARNING LIGHT

M1901002901679

1

NOTE
 *1: .RV METER
 .SUNROOF
 .HEADLIGHT
 .TAILLIGHT, POSITION LIGHT, SIDE
 MARKER LIGHT, LICENSE PLATE LIGHT
 AND LIGHTING MONITOR TONE ALARM
 .FOG LIGHT
 .WINDSHIELD WIPER AND WASHER
 .THEFT-ALARM SYSTEM
 *2: REFER TO
 POWER
 DISTRIBUTION
 SYSTEM

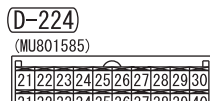
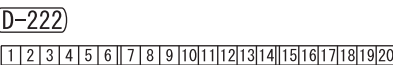
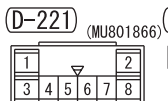
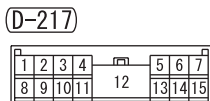
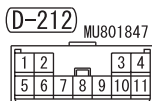
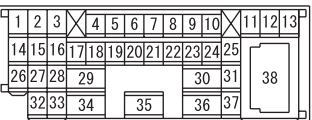
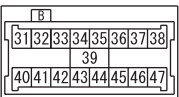
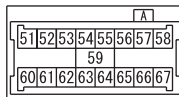
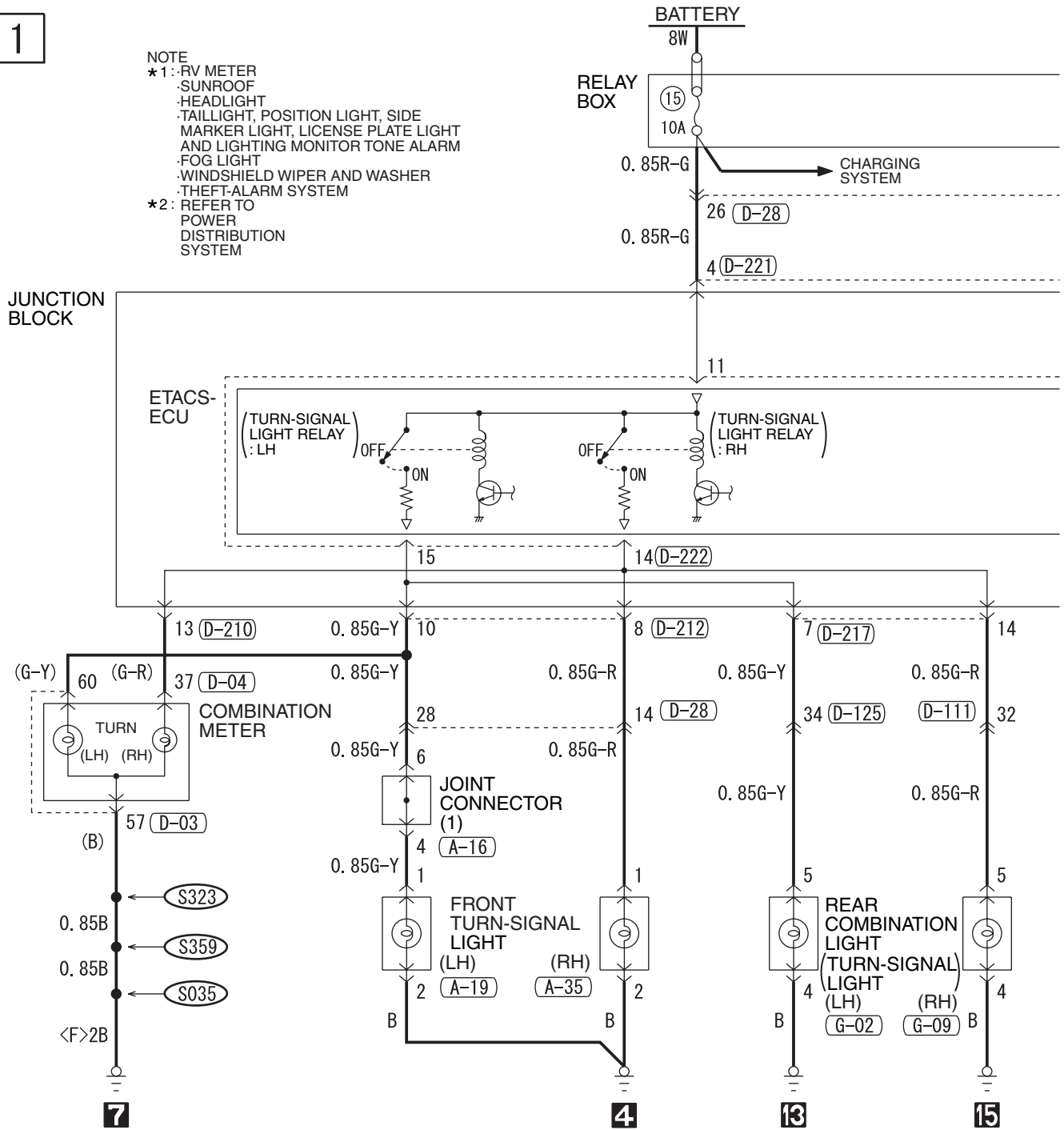

H6Q09M00AA

2

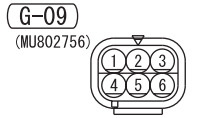
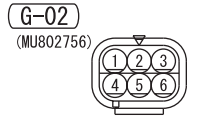
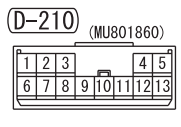
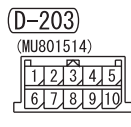
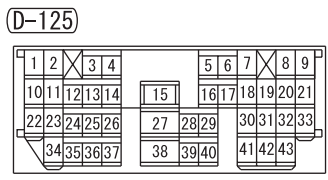
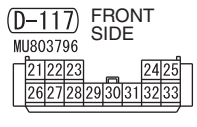
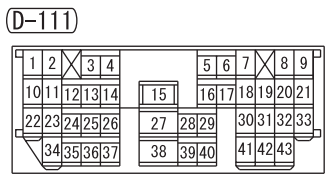
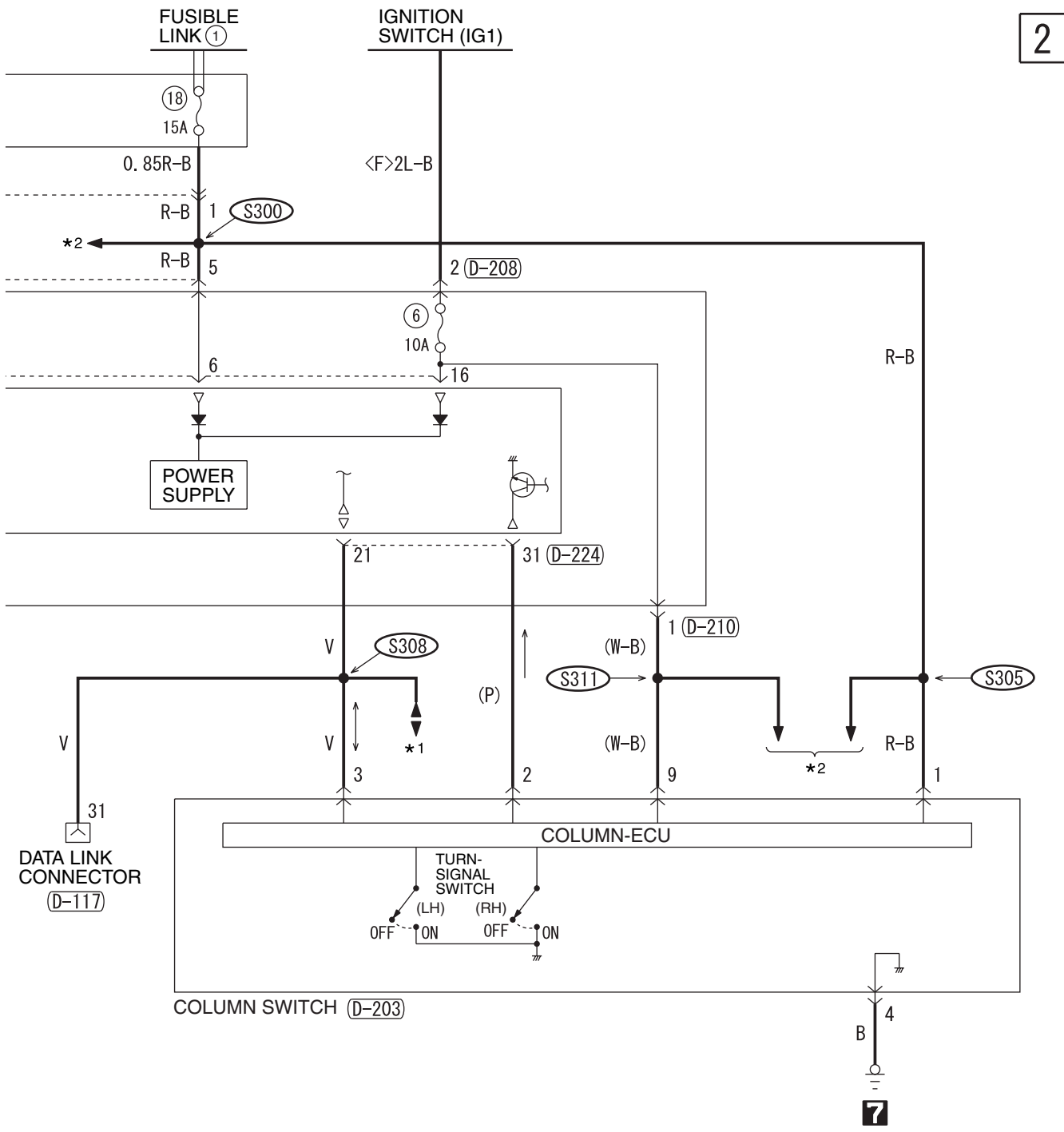

TURN-SIGNAL LIGHT AND HAZARD WARNING LIGHT (CONTINUED)

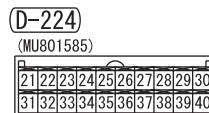
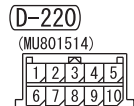
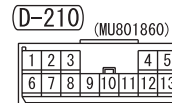
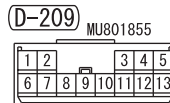
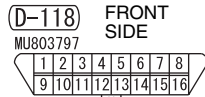
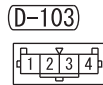
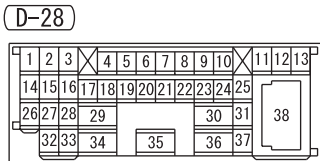
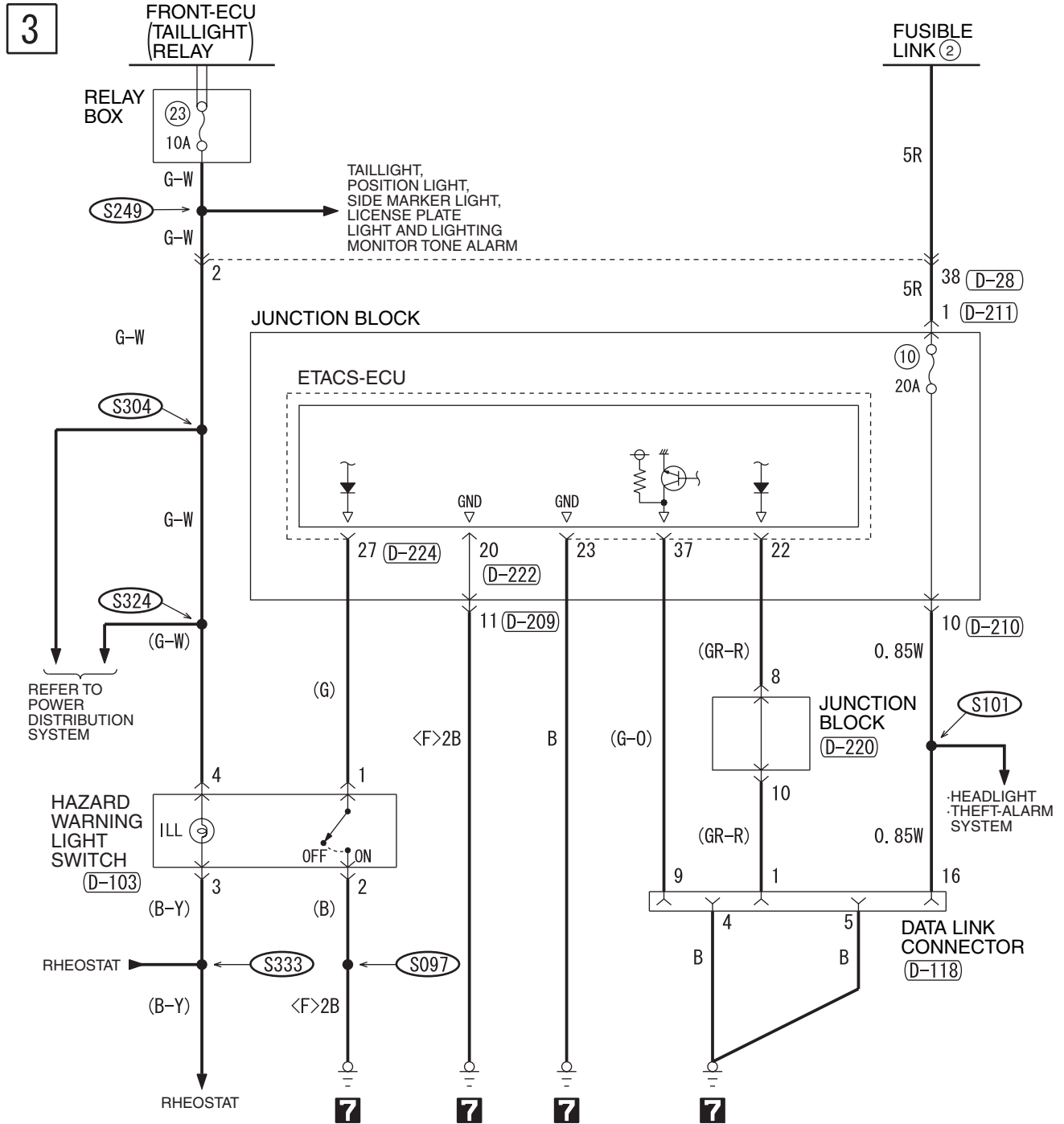

NOTES

STOPLIGHT

M1901003001743

1

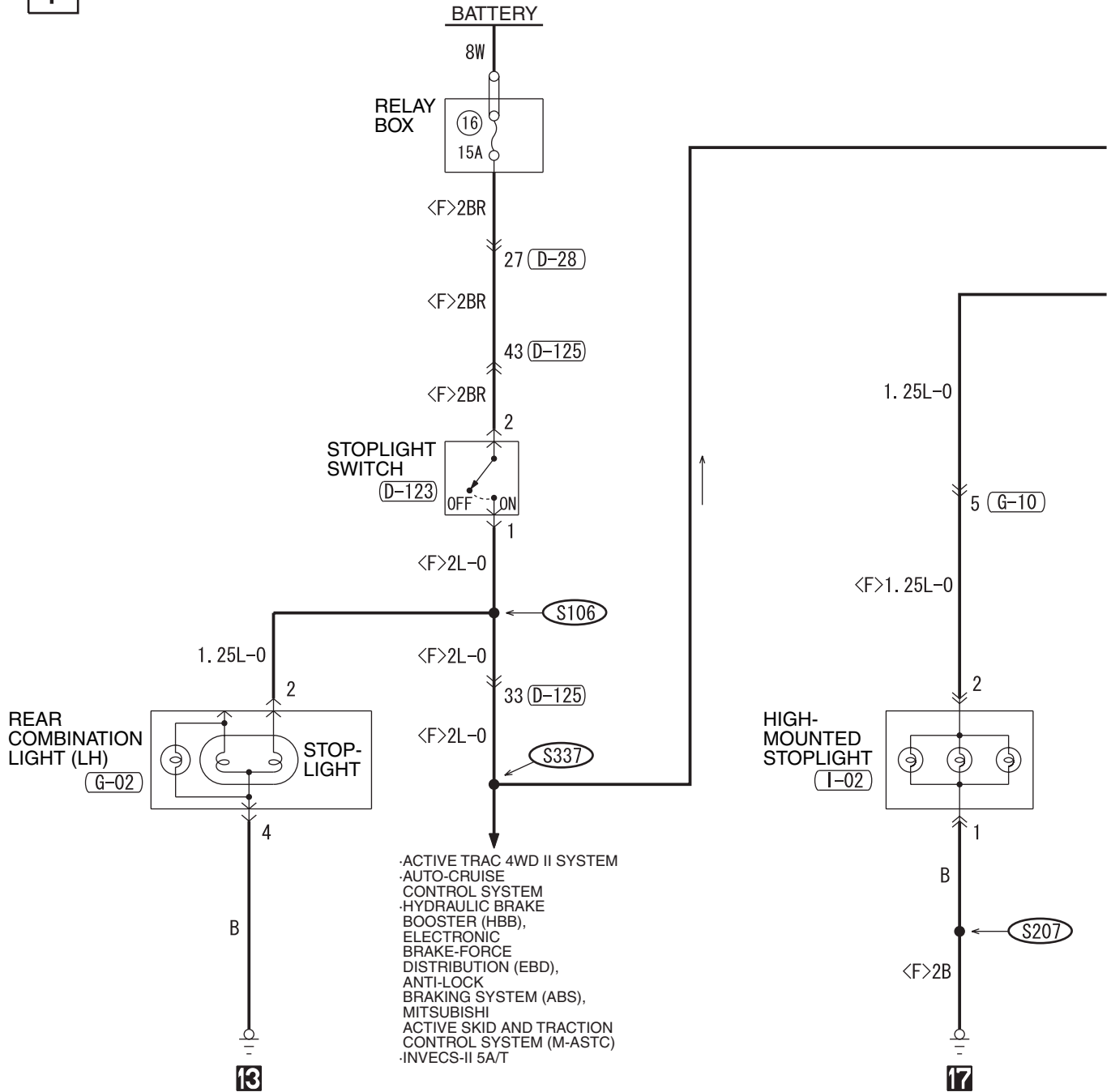

D-28

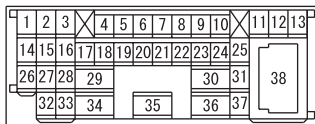

D-111

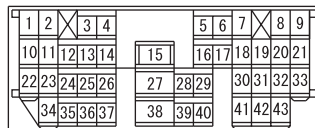

D-123



D-125

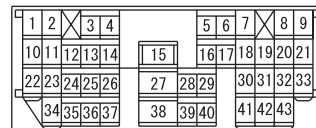

2

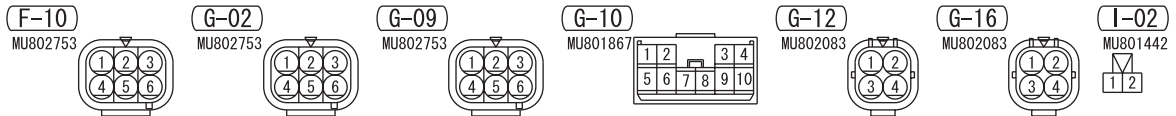
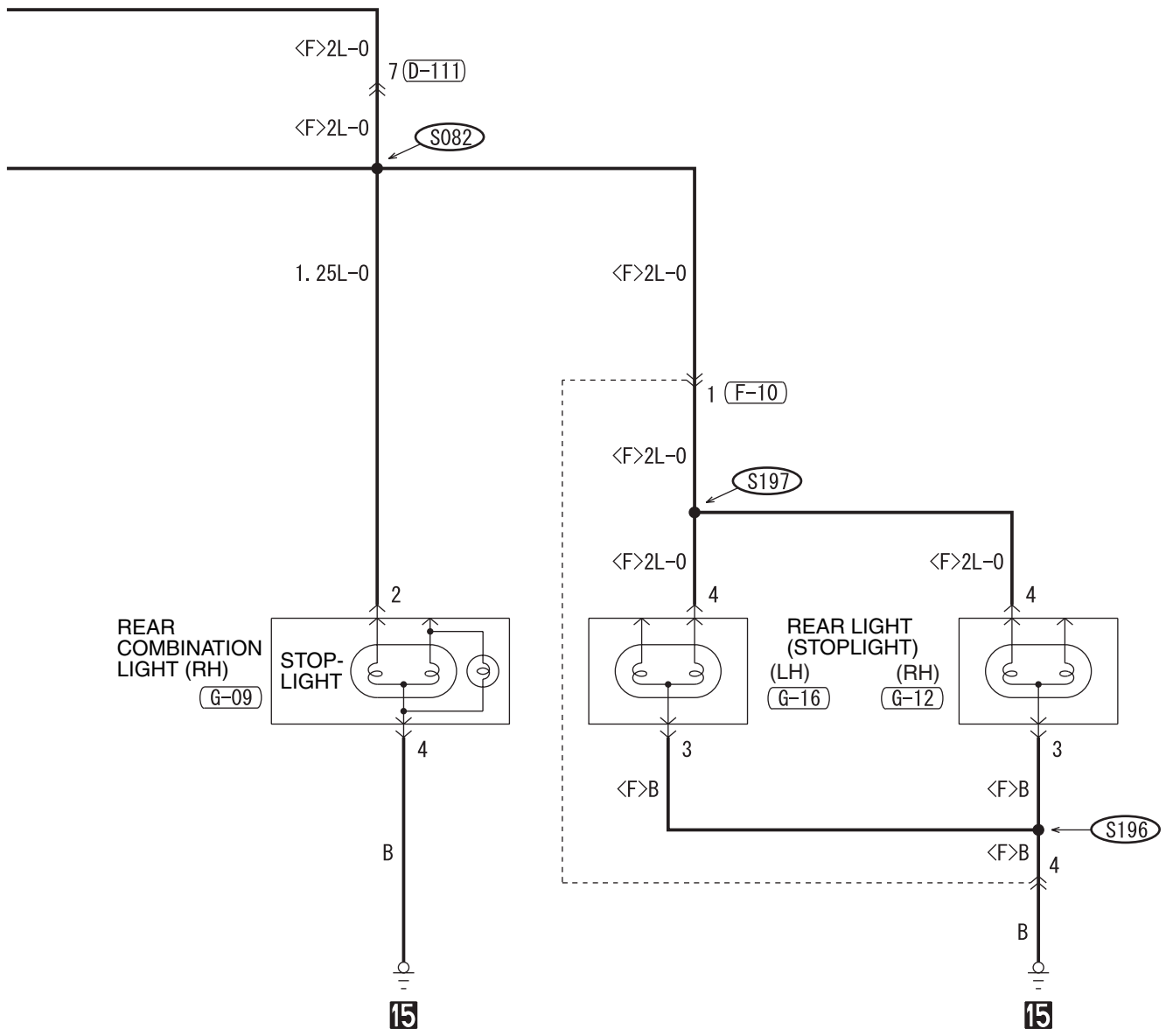

WIRE COLOR CODE
 B : BLACK LG : LIGHT GREEN G : GREEN L : BLUE W : WHITE Y : YELLOW
 SB : SKY BLUE BR : BROWN O : ORANGE GR : GRAY R : RED P : PINK V : VIOLET

H6Q09M01AB

TSB Revision

BACKUP LIGHT

M1901003101870

1

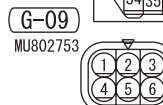
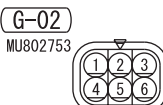
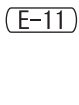
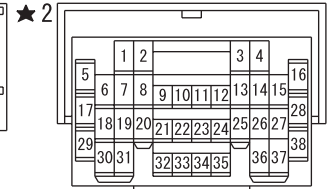
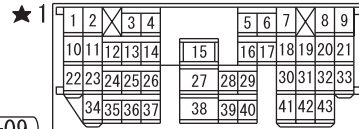
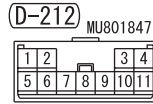
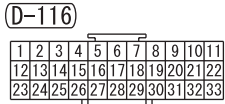
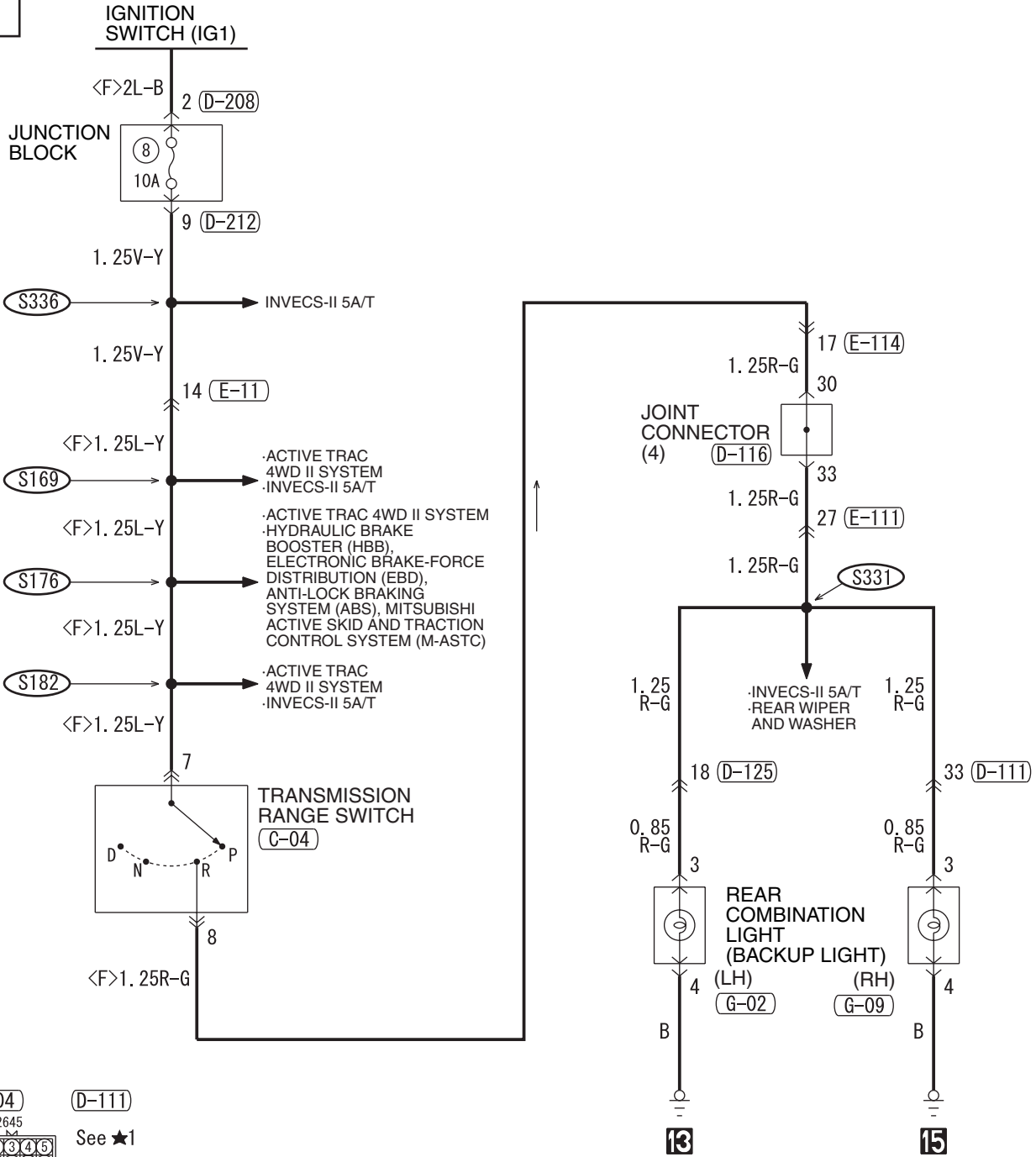

H6Q09M02AA

HORN

M1901003301335

1

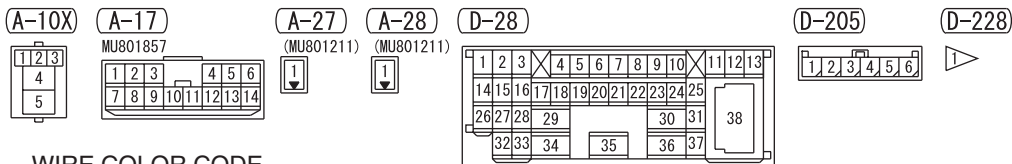
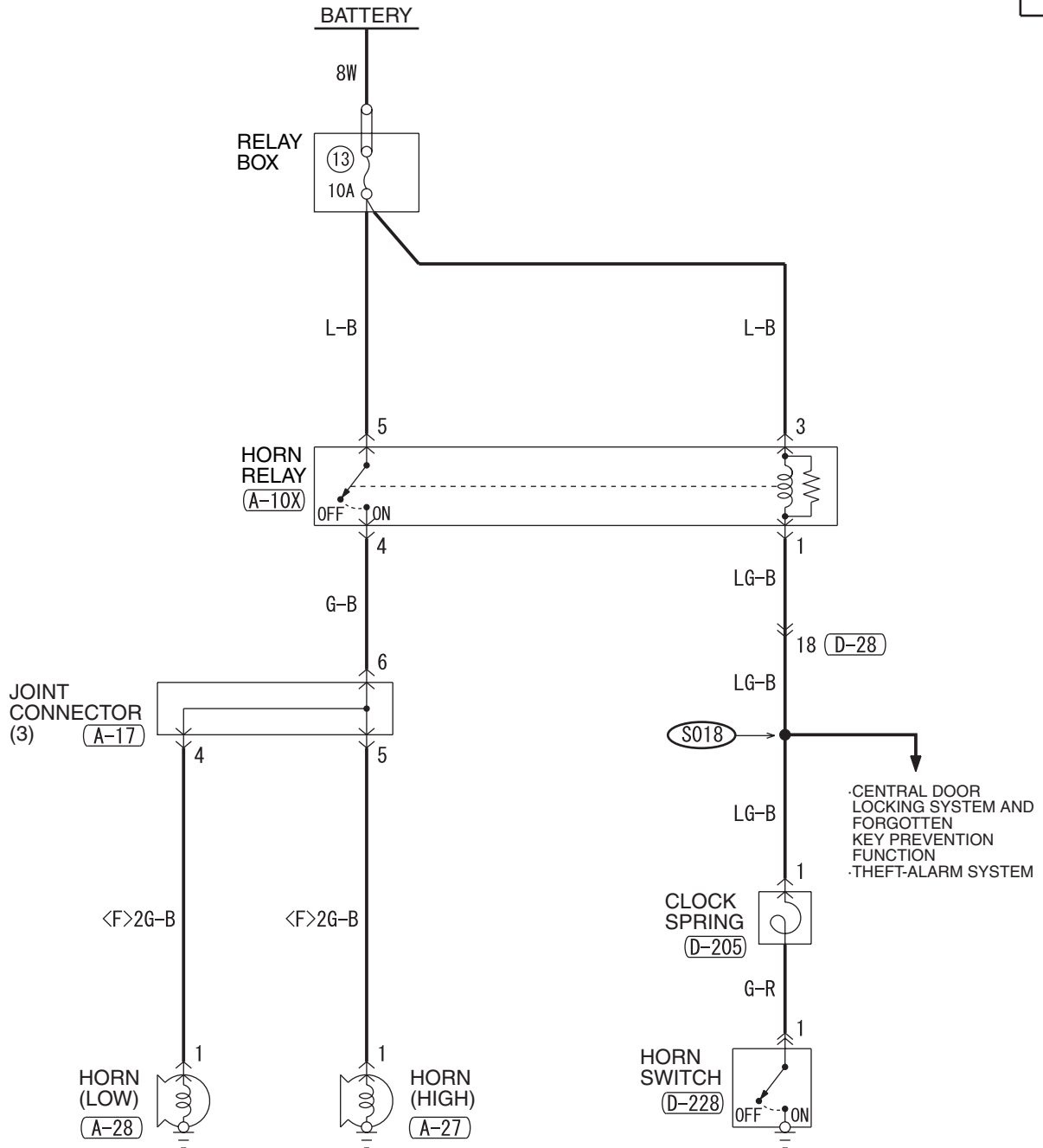

WIRE COLOR CODE
 B: BLACK LG: LIGHT GREEN G: GREEN L: BLUE W: WHITE Y: YELLOW
 SB: SKY BLUE BR: BROWN O: ORANGE GR: GRAY R: RED P: PINK V: VIOLET

H6Q09M03AA

TSB Revision

METER AND GAUGE

M1901003501942

1

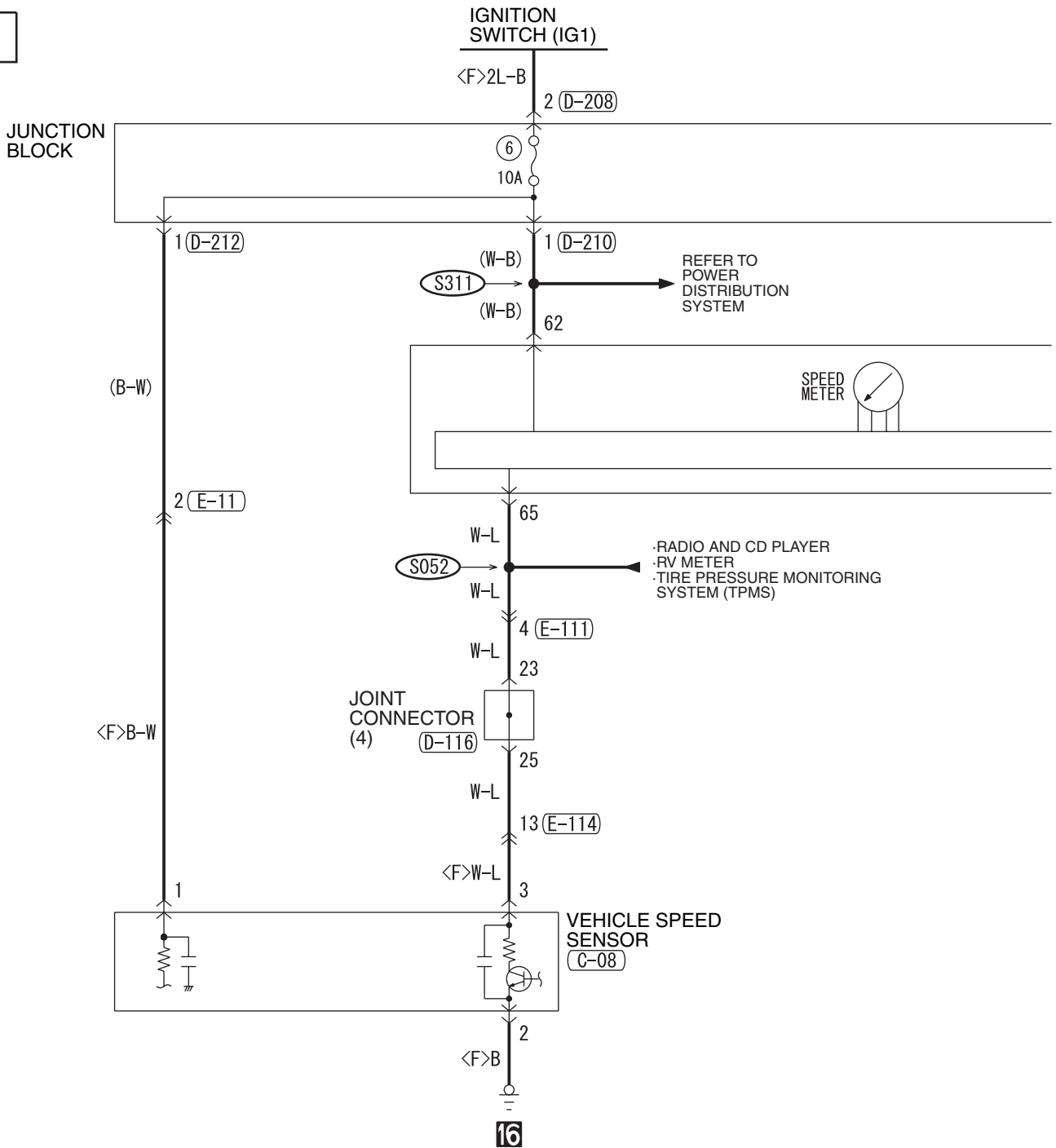

(B-25X) (C-08)



(D-03)

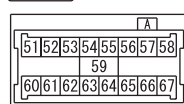

(D-28)

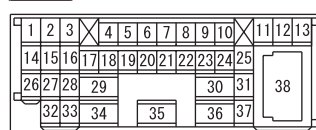

(D-116)



(D-134)

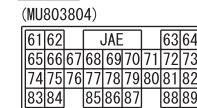

(D-208)



(E-111) (E-114)

See ★1 See ★1

TSB Revision

2

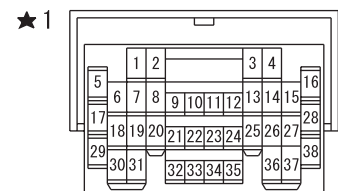
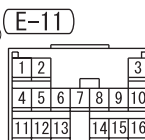
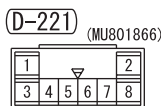
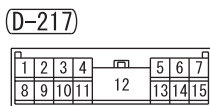
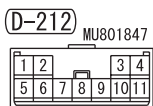
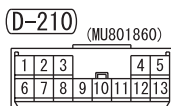
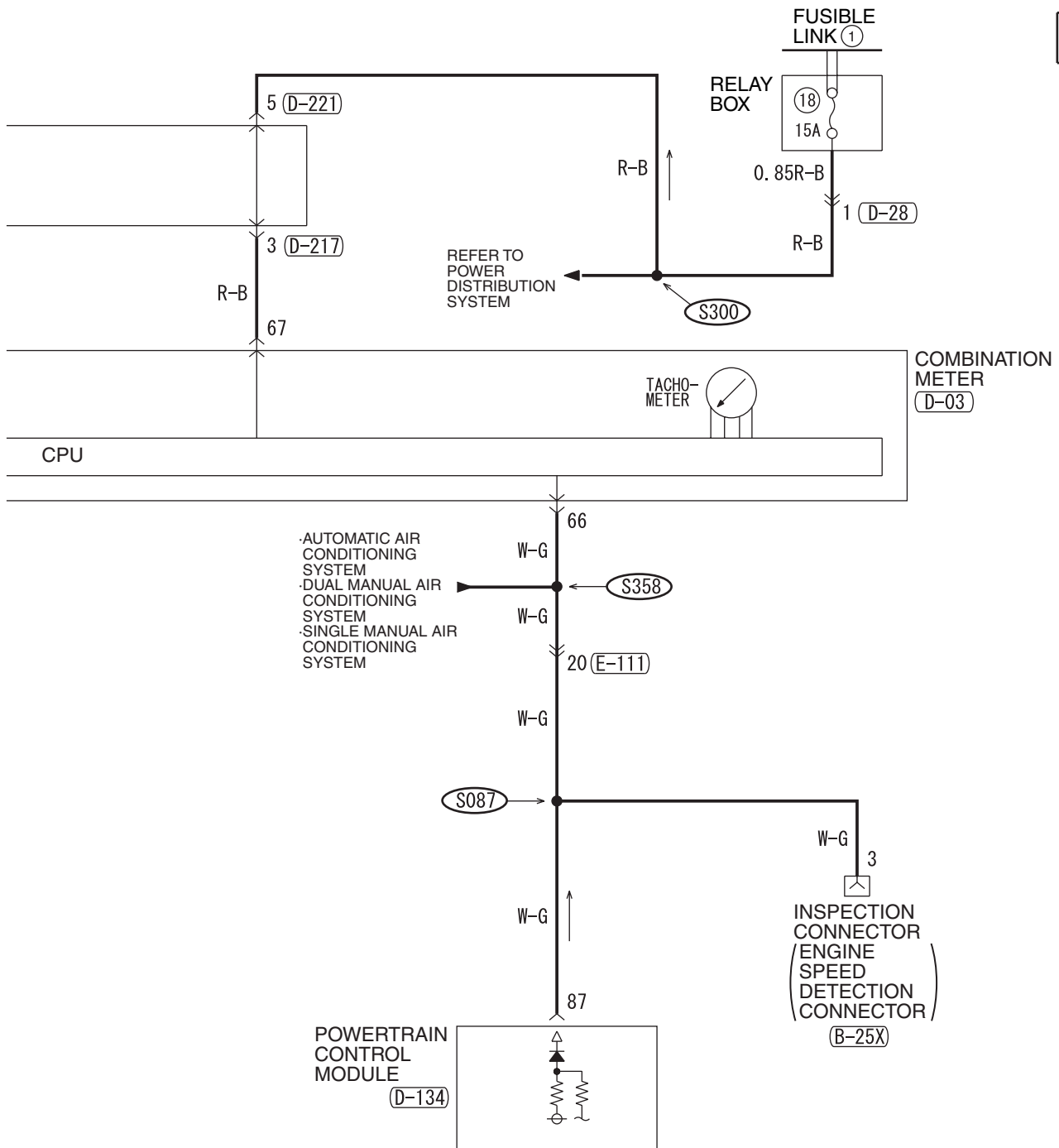

WIRE COLOR CODE
 B : BLACK LG : LIGHT GREEN G : GREEN L : BLUE W : WHITE Y : YELLOW
 SB : SKY BLUE BR : BROWN O : ORANGE GR : GRAY R : RED P : PINK V : VIOLET

H6Q10M00AB

TSB Revision

METER AND GAUGE (CONTINUED)

3

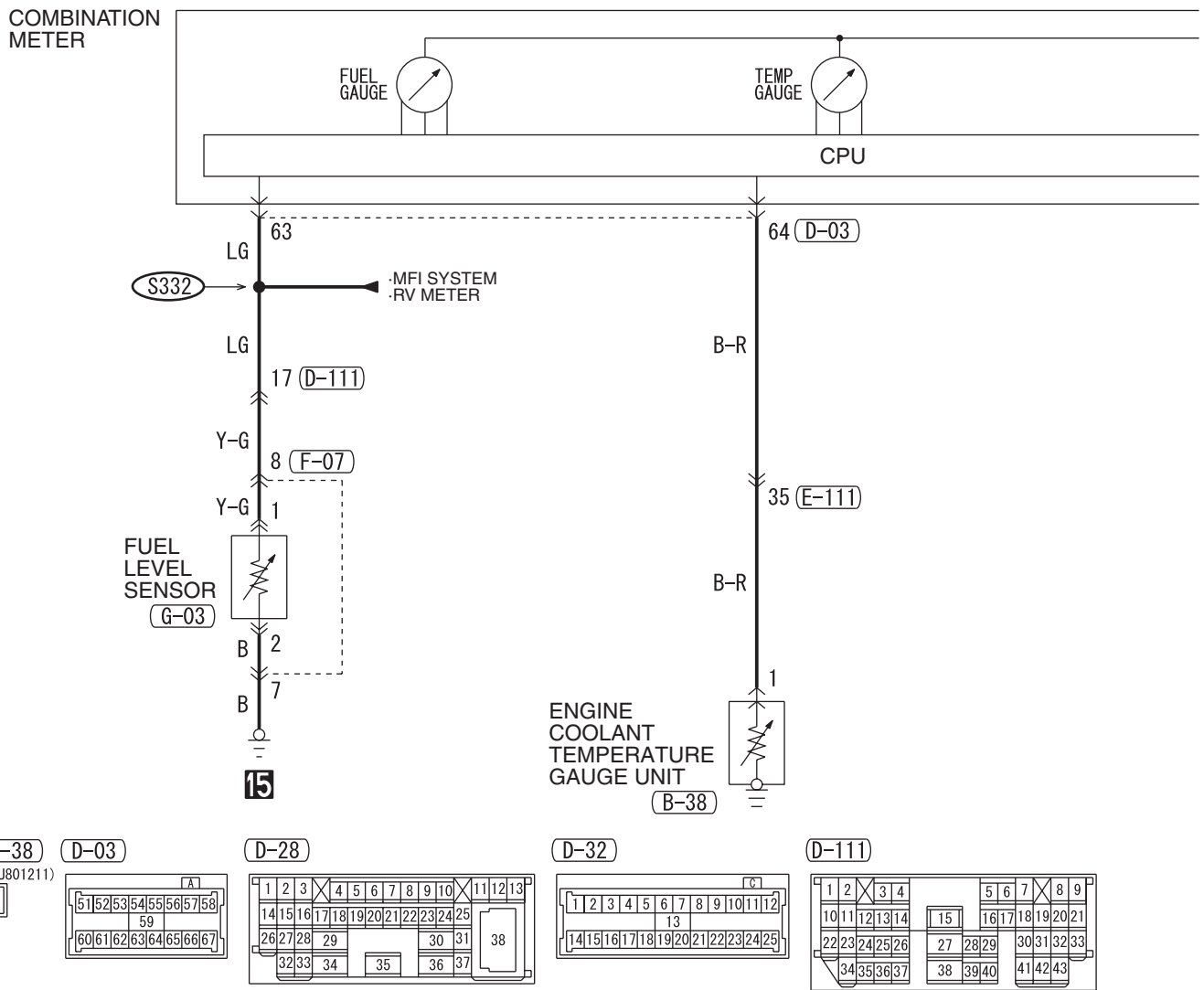

4

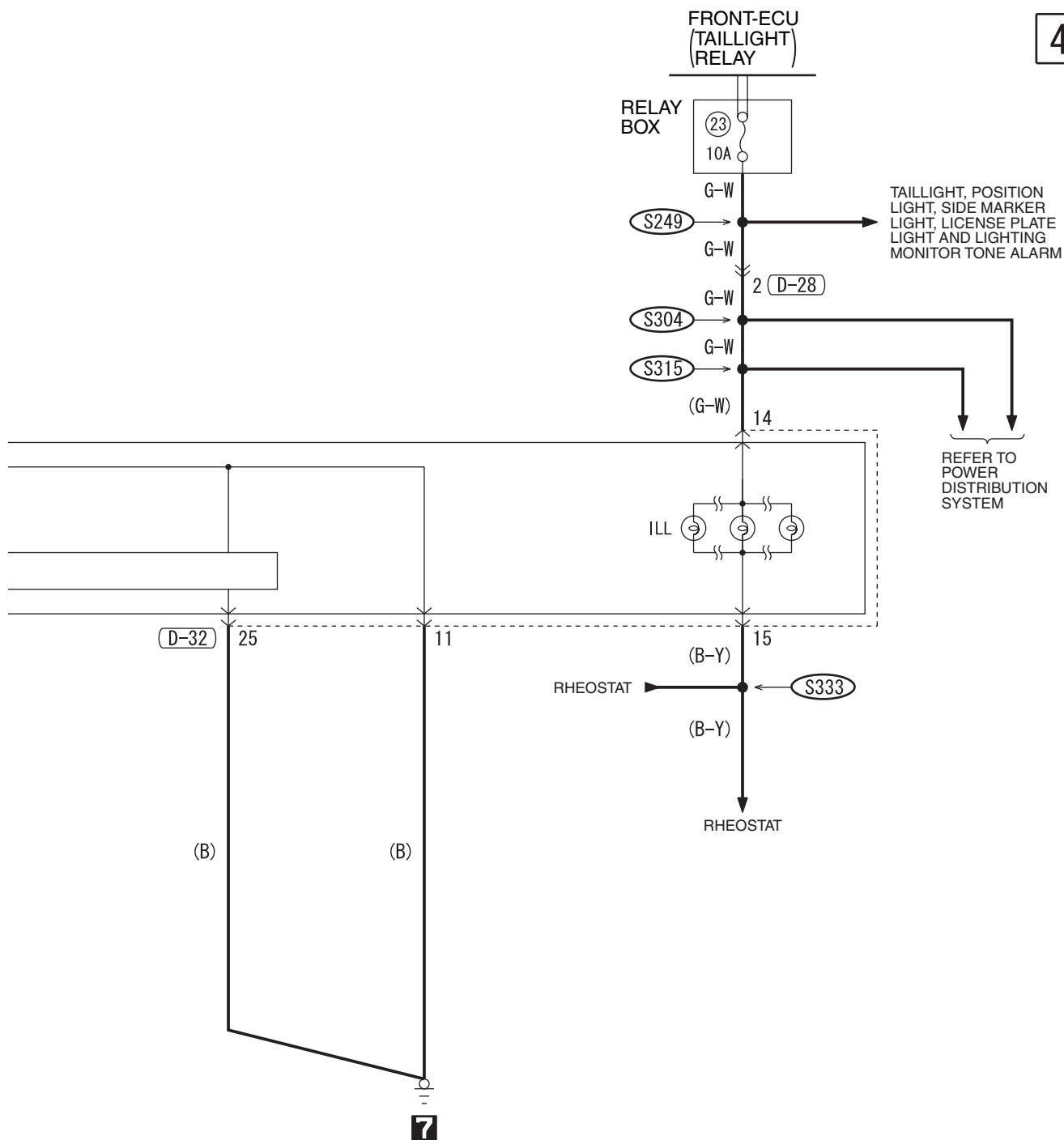

E-111

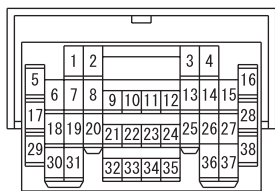

F-07



G-03



WIRE COLOR CODE
 B: BLACK LG: LIGHT GREEN G: GREEN L: BLUE
 BR: BROWN O: ORANGE GR: GRAY R: RED W: WHITE
 SB: SKY BLUE P: PINK Y: YELLOW V: VIOLET

H6Q10M00BB

TSB Revision

FUEL WARNING LIGHT, OIL PRESSURE WARNING LIGHT, BRAKE WARNING LIGHT

M1901011801205

1

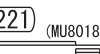
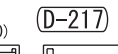
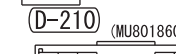
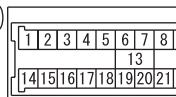
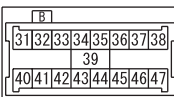
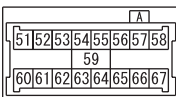
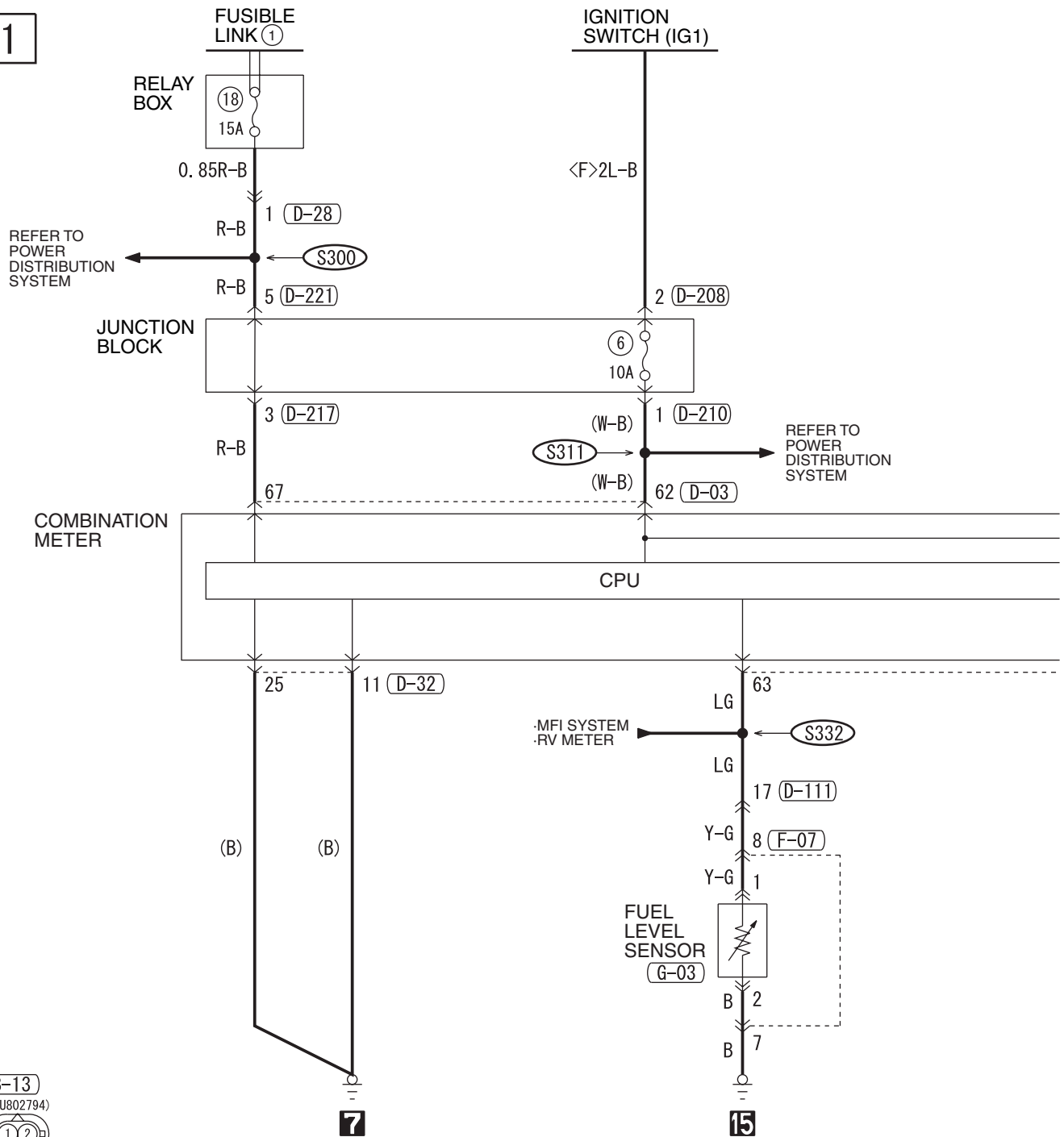

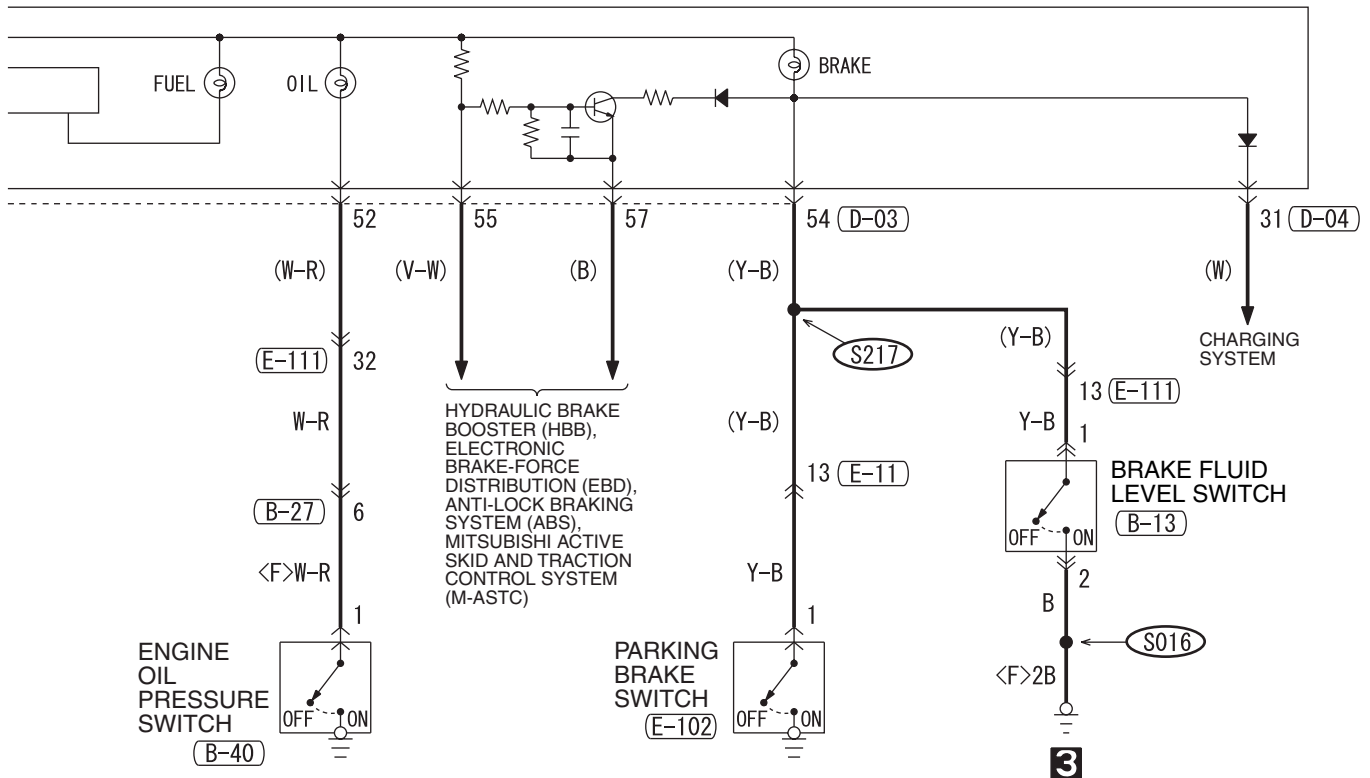

(D-111)

See ★2



★ 1

1	2	3	X	4	5	6	7	8	9	10	X	11	12	13	
14	15	16	17	18	19	20	21	22	23	24	25	38			
26	27	28	29	30			31	32			33	34	35	36	37

★ 2

1	2	X	3	4	5			6	7	X	8	9		
10	11	12	13	14	15	16	17	18	19	20	21			
22	23	24	25	26	27	28	29	30	31	32	33			
34	35	36	37	38	39	40	41	42	43					

★ 3

5			6	7	8	9			10	11	12	13	14	15	16
17	18	19	20	21	22	23	24	25	26	27	38			28	
29	30	31	32	33	34	35	36	37							

WIRE COLOR CODE
 B : BLACK LG : LIGHT GREEN G : GREEN L : BLUE
 BR : BROWN O : ORANGE GR : GRAY R : RED W : WHITE
 SB : SKY BLUE P : PINK Y : YELLOW V : VIOLET

H6Q10M01AB

POWER WINDOWS

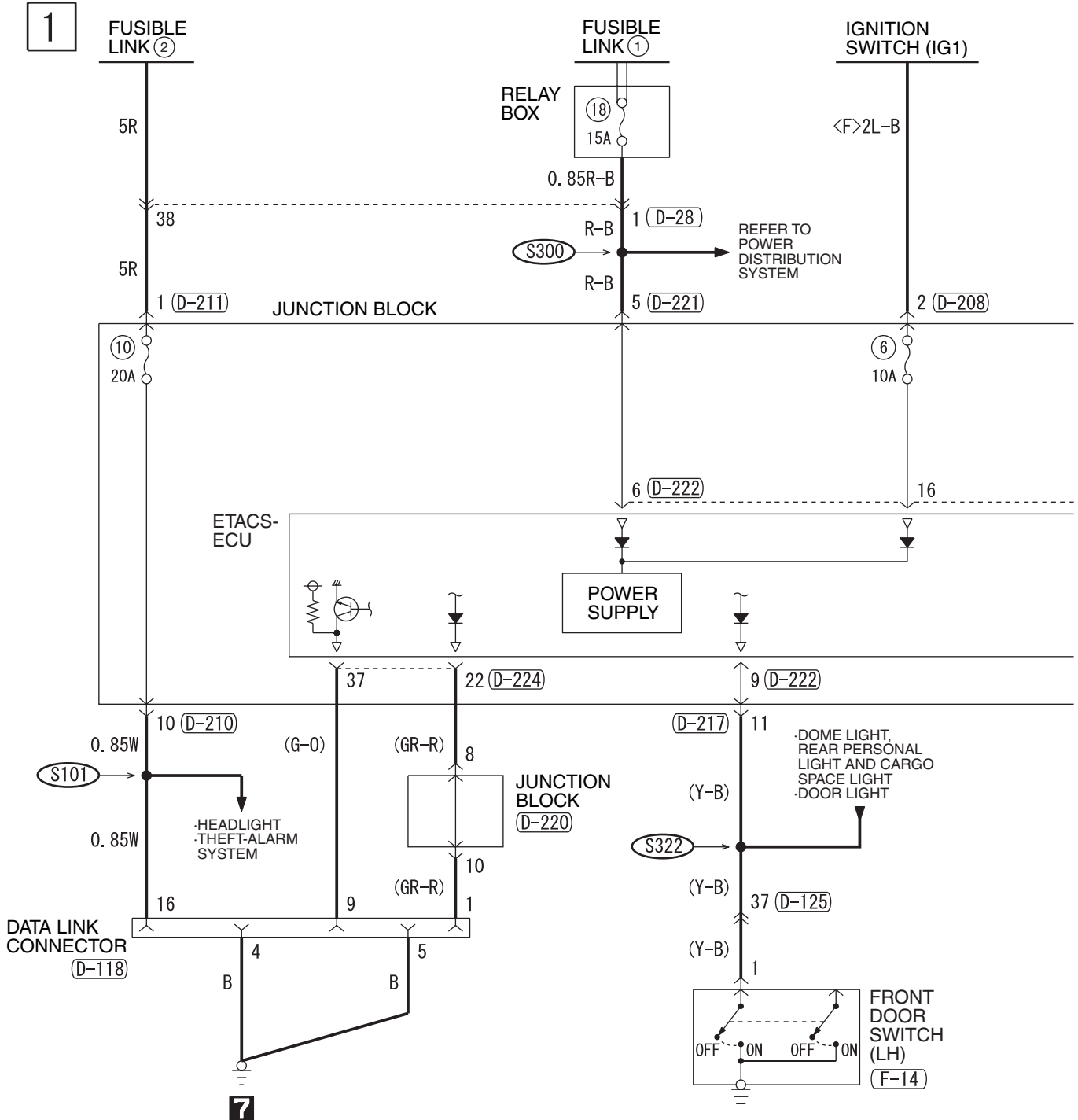

D-28

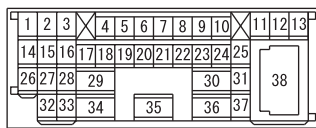

D-111

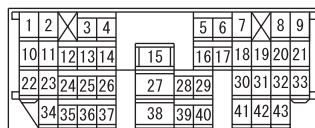

D-118 FRONT SIDE

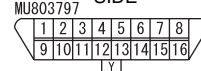

D-125

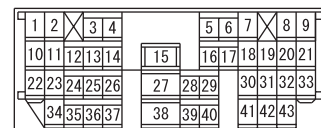

2

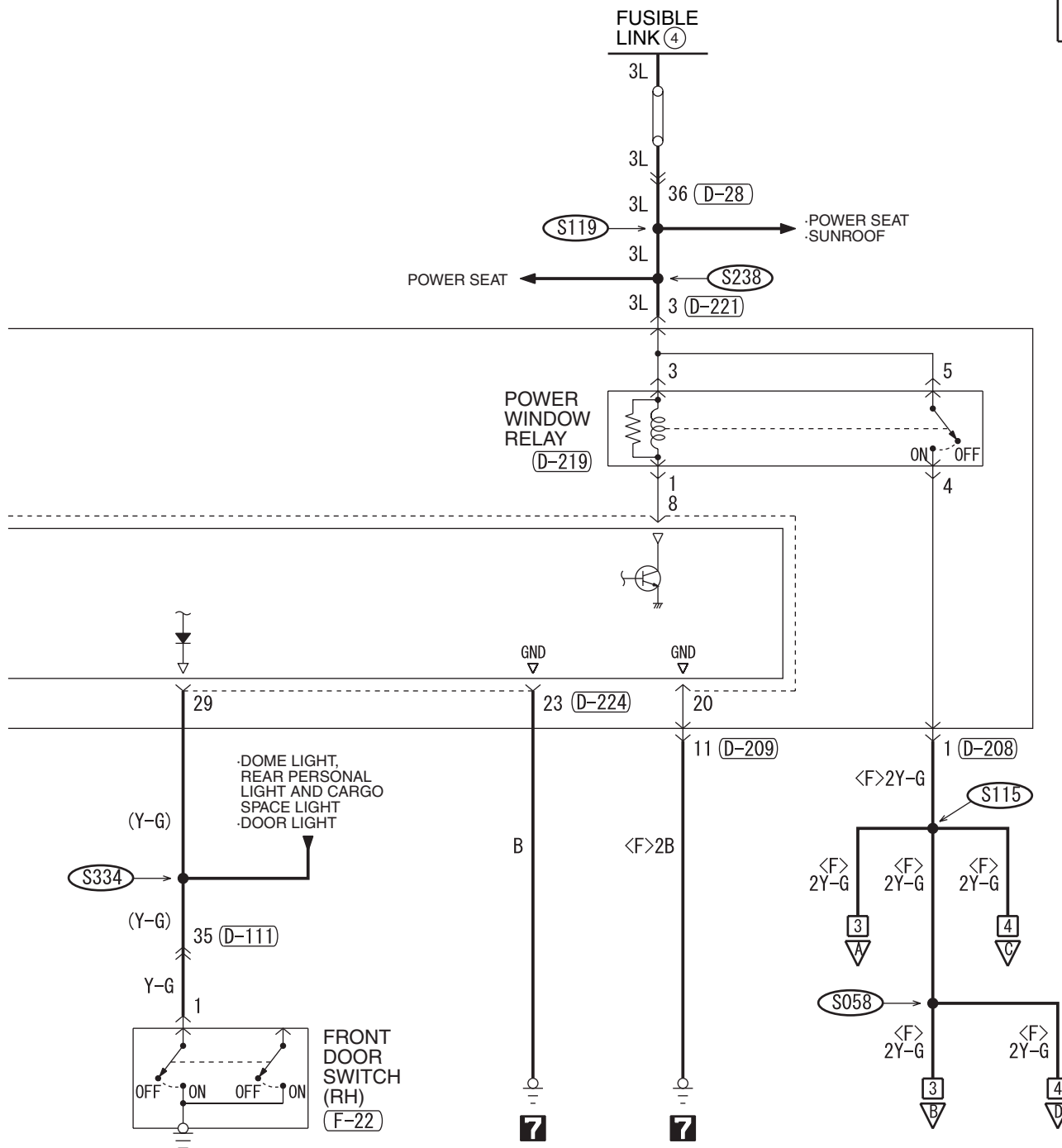

- D-208**
 MU801331

1	2
3	4
- D-209**
 MU801855

1	2	3	4	5
6	7	8	9	10
11	12	13	14	15
- D-210**
 (MU801860)

1	2	3	4	5
6	7	8	9	10
11	12	13	14	15
- D-211**
 MU801403

1

- D-217**

1	2	3	4	5	6	7
8	9	10	11	12	13	14
15	16	17	18	19	20	21
- D-219**

1	2	3
4	5	6
- D-220**
 (MU801514)

1	2	3	4	5
6	7	8	9	10
- D-221**
 (MU801866)

1	2	3	4	5	6	7	8
---	---	---	---	---	---	---	---
- D-222**

1	2	3	4	5	6	7	8	9	10	11	12	13	14	15	16	17	18	19	20
---	---	---	---	---	---	---	---	---	----	----	----	----	----	----	----	----	----	----	----
- D-224**
 (MU801585)

21	22	23	24	25	26	27	28	29	30
31	32	33	34	35	36	37	38	39	40
- F-14**
 (MU801536)

1	2	3
---	---	---
- F-22**
 (MU801536)

1	2	3
---	---	---

POWER WINDOWS (CONTINUED)

3

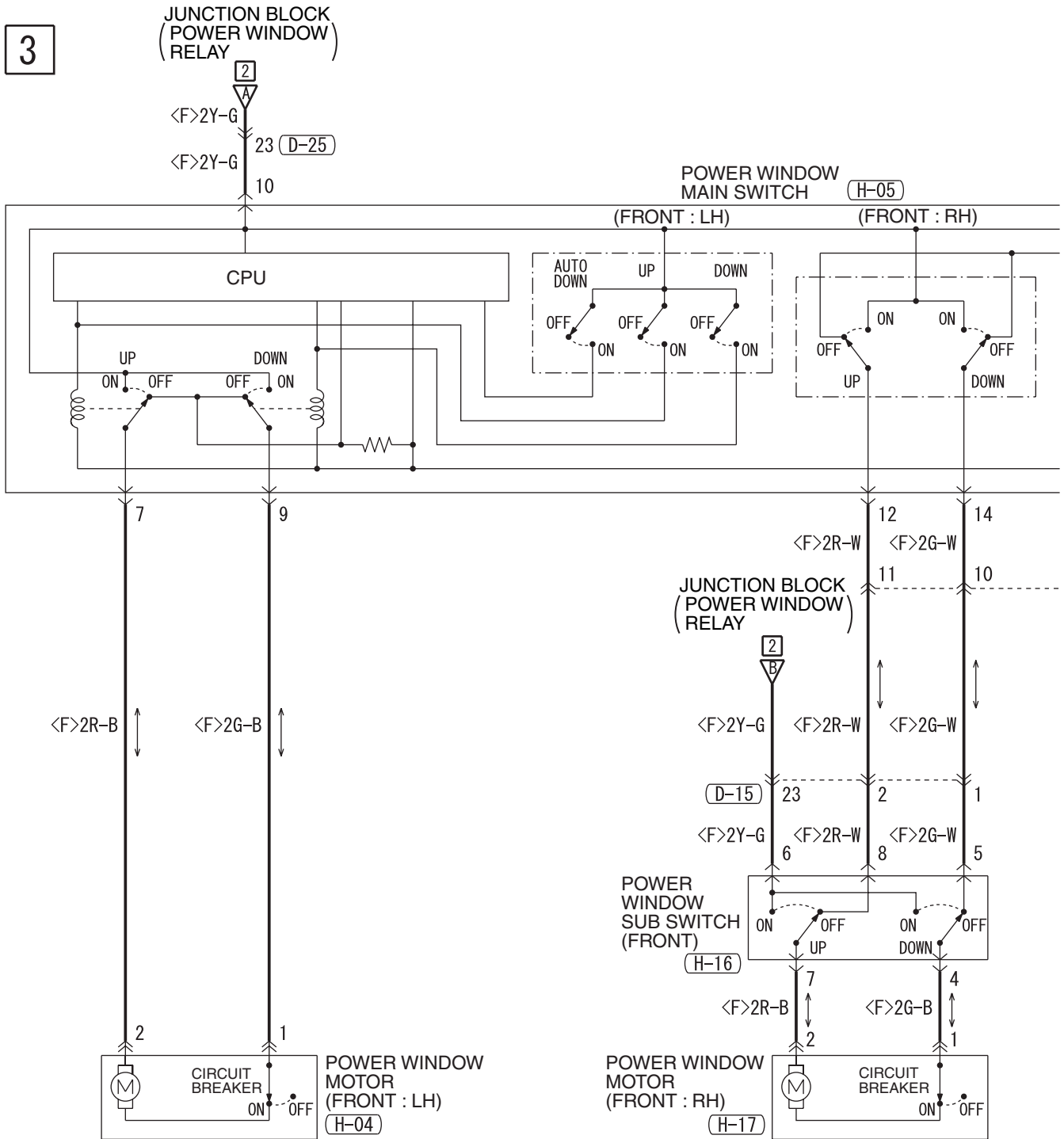

D-15

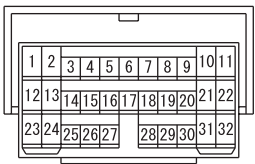

D-25

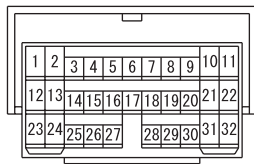

D-111

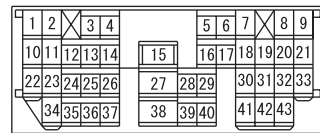

D-125

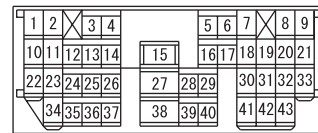

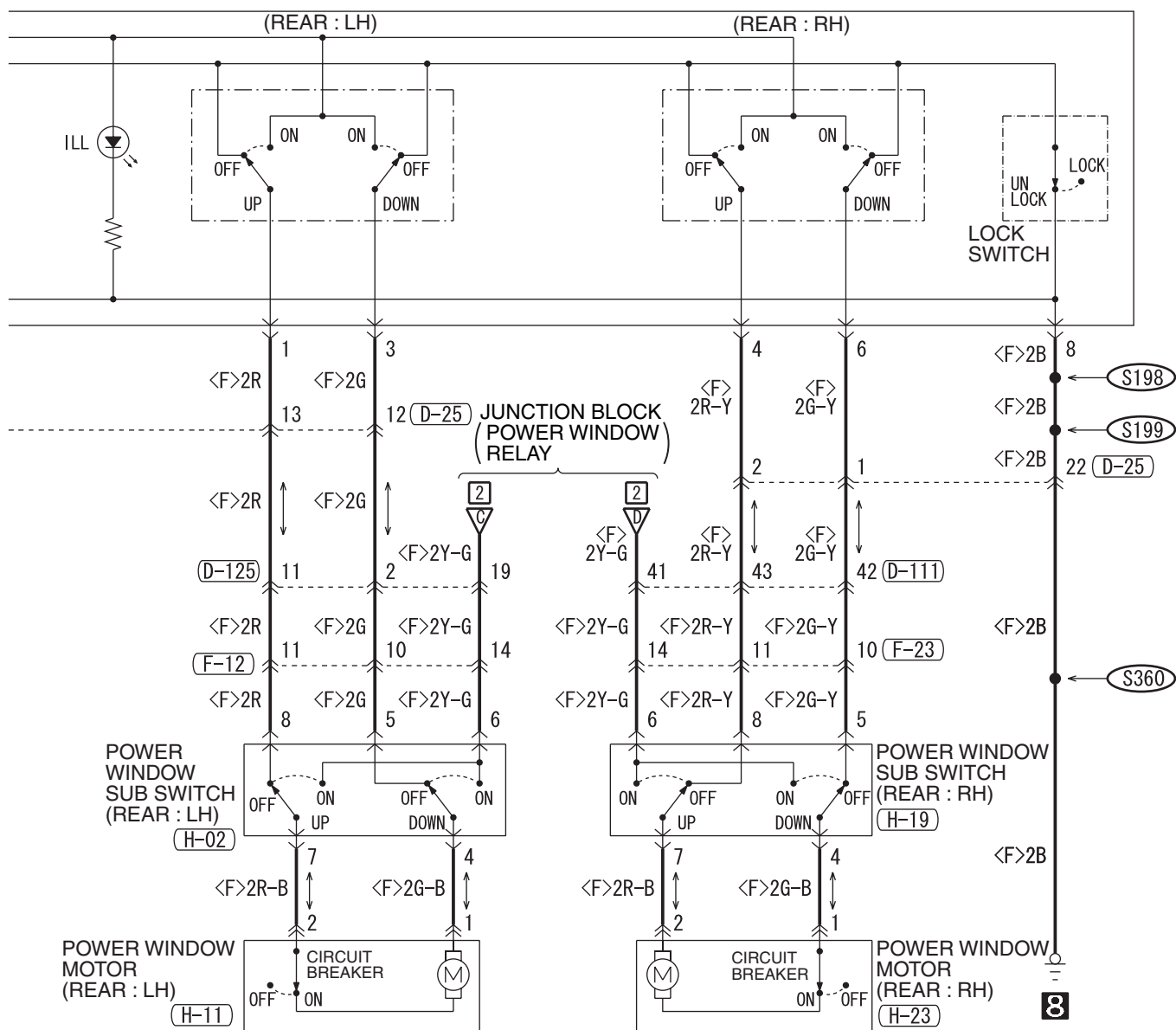

F-12

MU801857

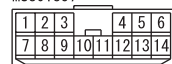

F-23

MU801857

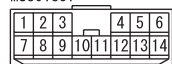

H-02

MU801839



H-04

(1)(2)



H-05

MU801857

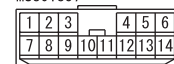

H-11

(1)(2)



H-16

MU801839



H-17

(1)(2)



H-19

MU801839



H-23

(1)(2)



WIRE COLOR CODE

B : BLACK LG : LIGHT GREEN G : GREEN L : BLUE
BR : BROWN O : ORANGE GR : GRAY R : RED W : WHITE
SB : SKY BLUE P : PINK Y : YELLOW V : VIOLET

CENTRAL DOOR LOCKING SYSTEM AND FORGOTTEN KEY PREVENTION FUNCTION

M1901004702890

1

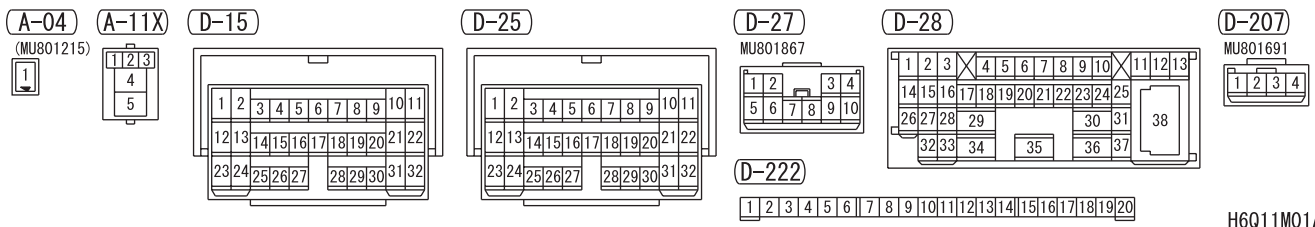
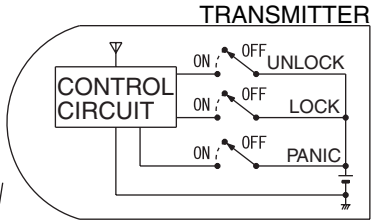
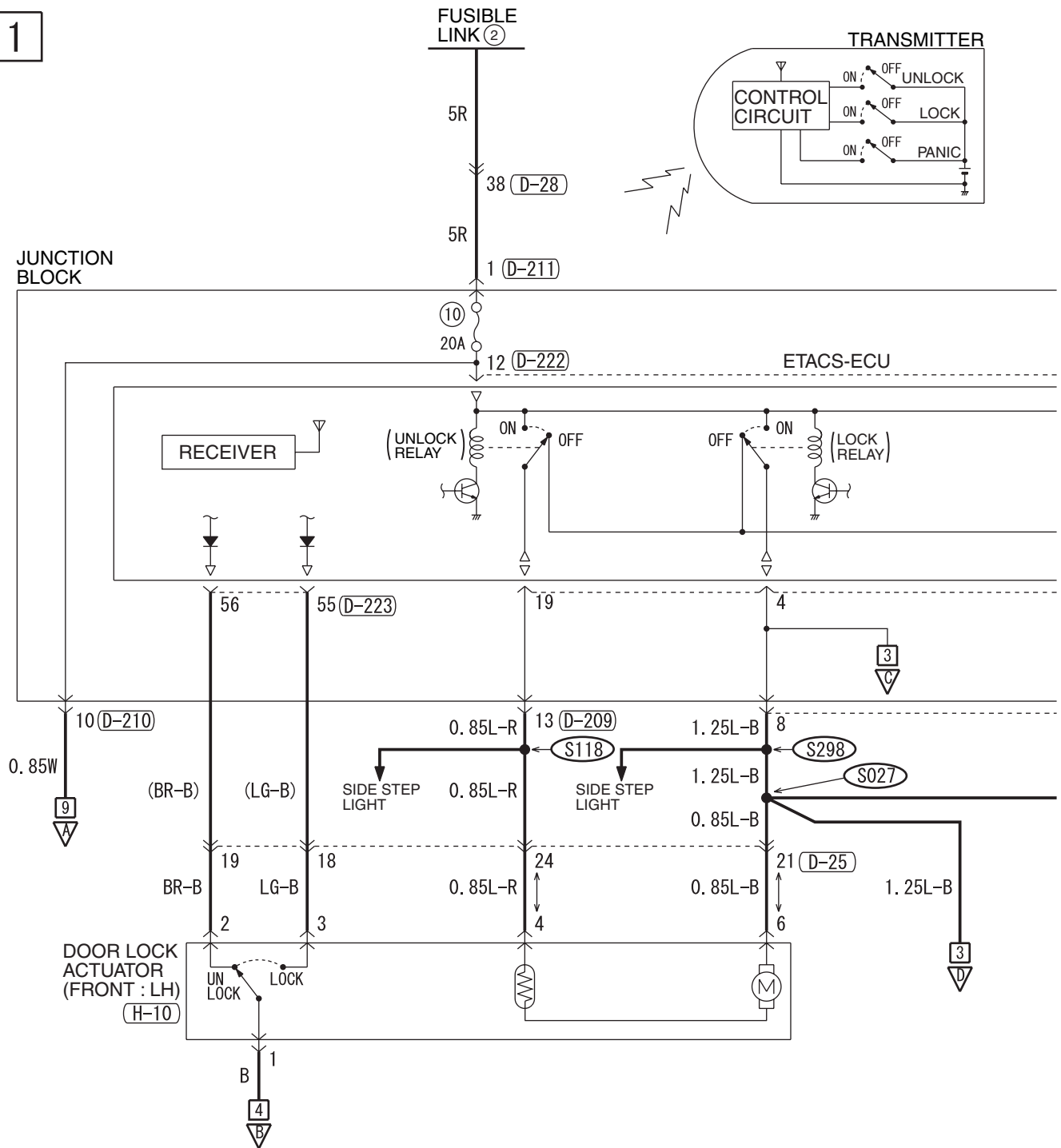

H6Q11M01AA

2

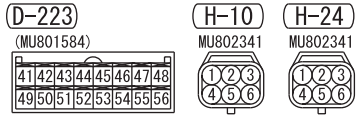
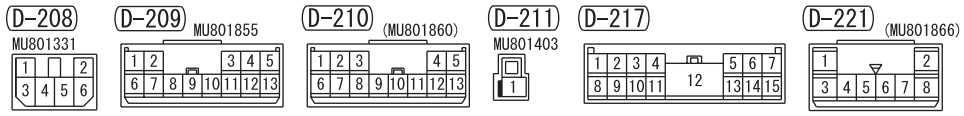
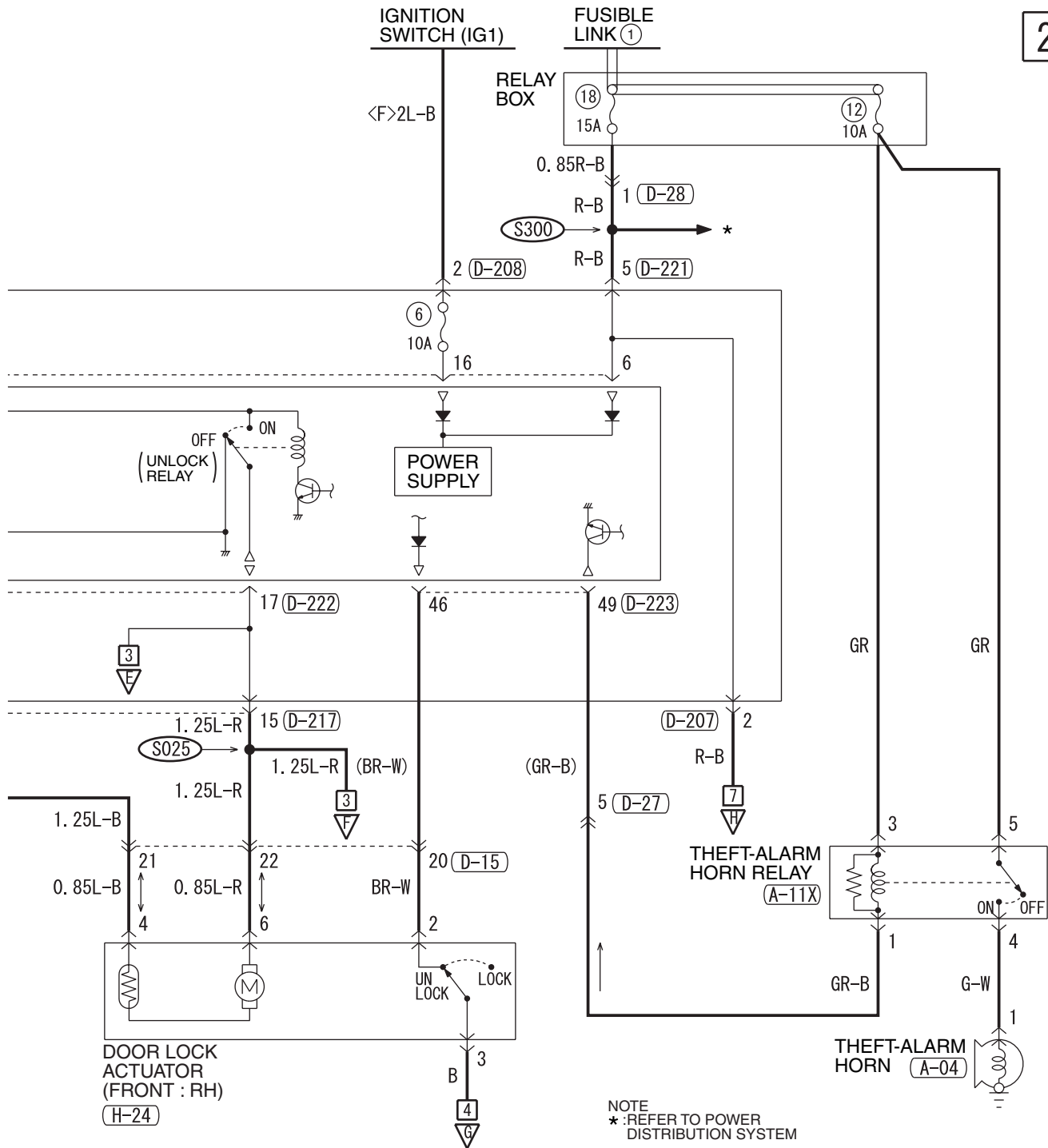

WIRE COLOR CODE
 B : BLACK LG : LIGHT GREEN G : GREEN L : BLUE
 BR : BROWN O : ORANGE GR : GRAY R : RED W : WHITE
 SB : SKY BLUE P : PINK Y : YELLOW V : VIOLET

H6Q11M01AB

TSB Revision

CENTRAL DOOR LOCKING SYSTEM AND FORGOTTEN KEY PREVENTION FUNCTION (CONTINUED)

3

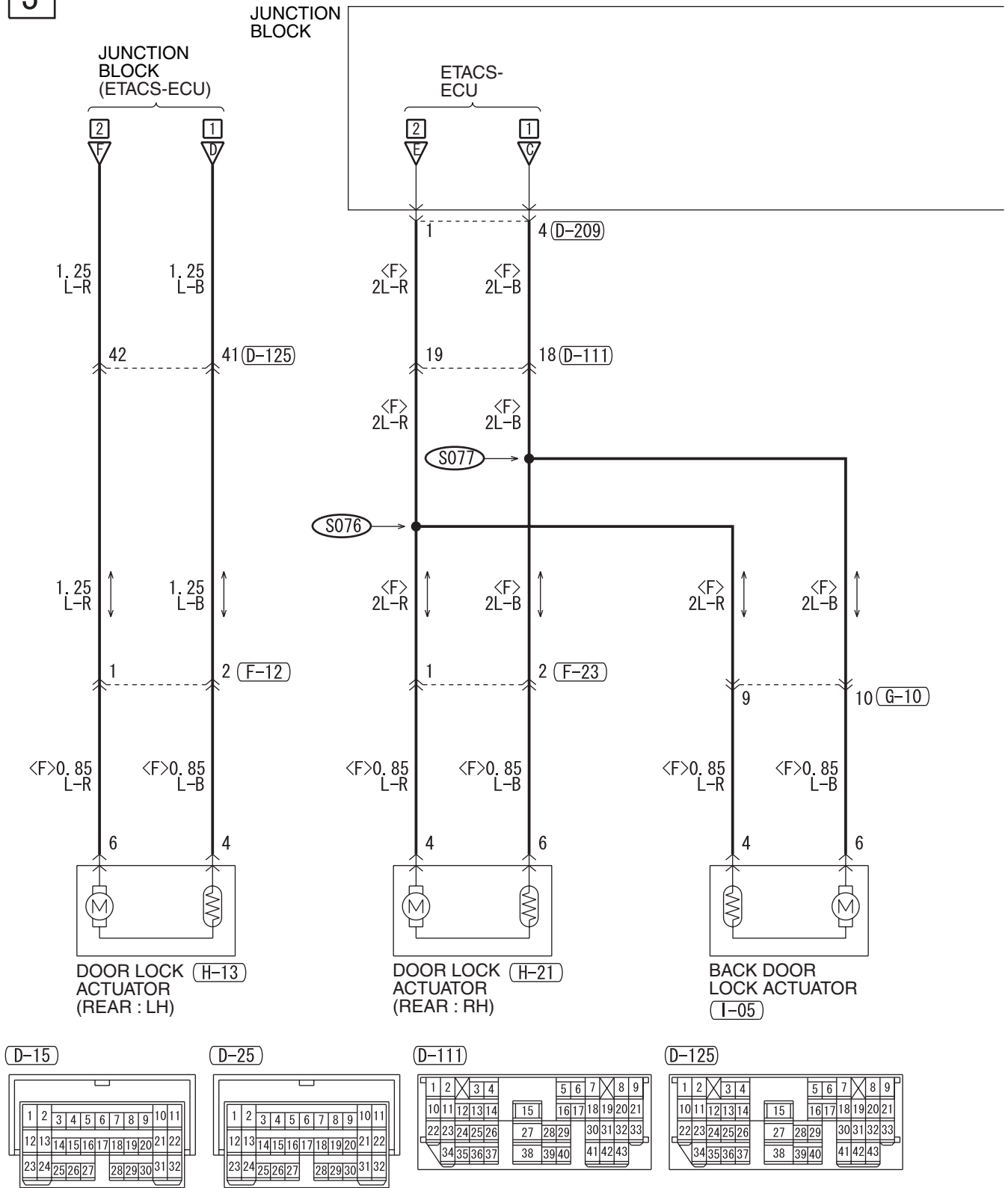

4

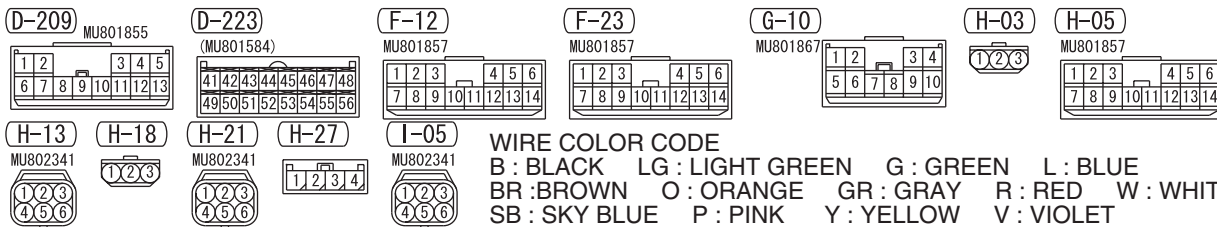
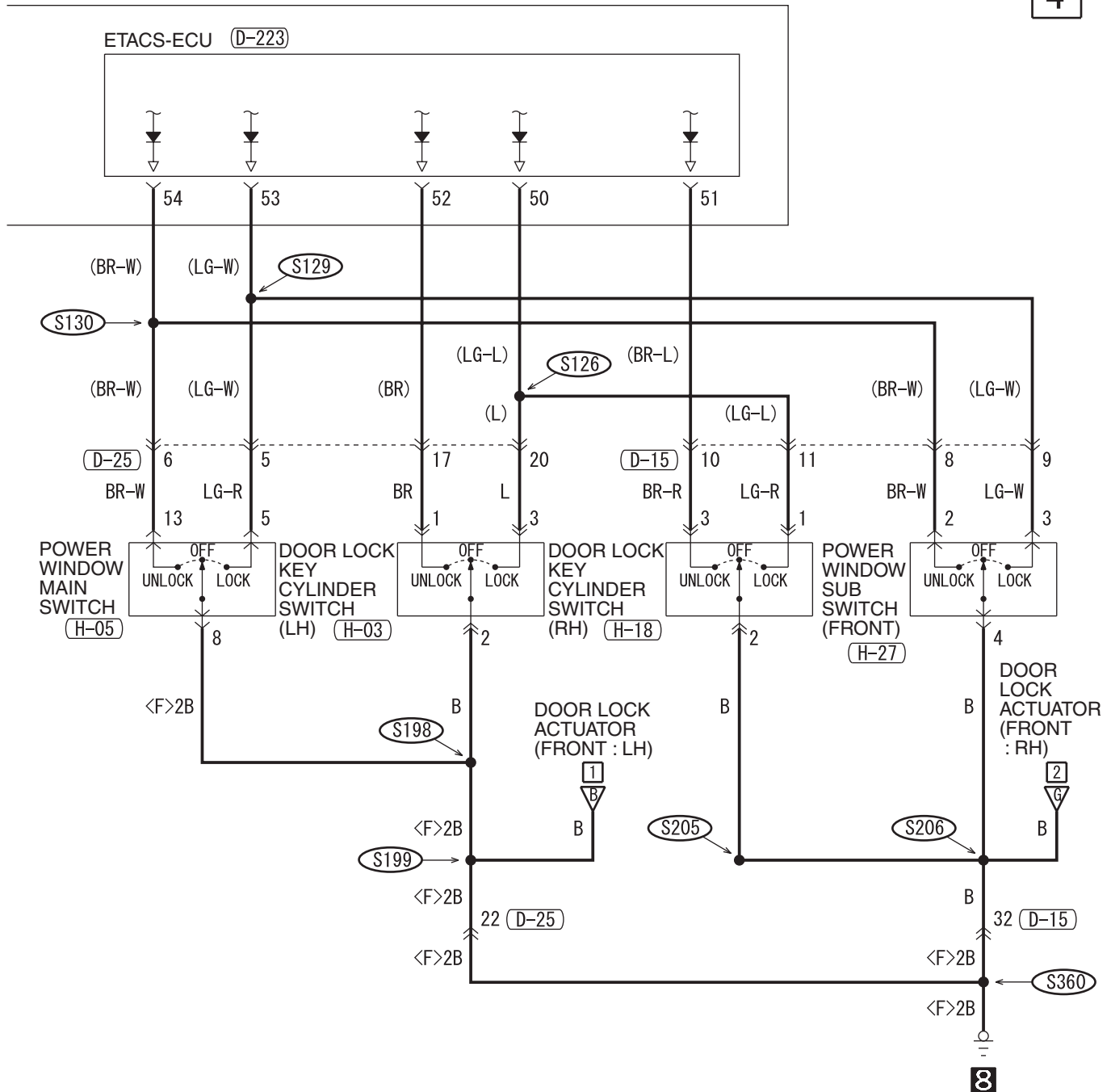

H6Q11M01BB

TSB Revision

CENTRAL DOOR LOCKING SYSTEM AND FORGOTTEN KEY PREVENTION FUNCTION (CONTINUED)

5

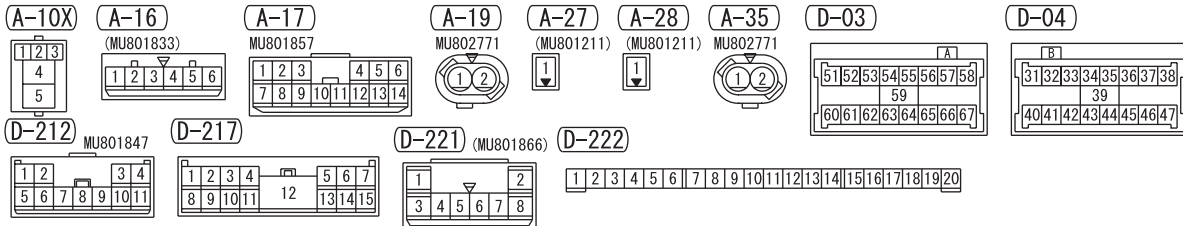
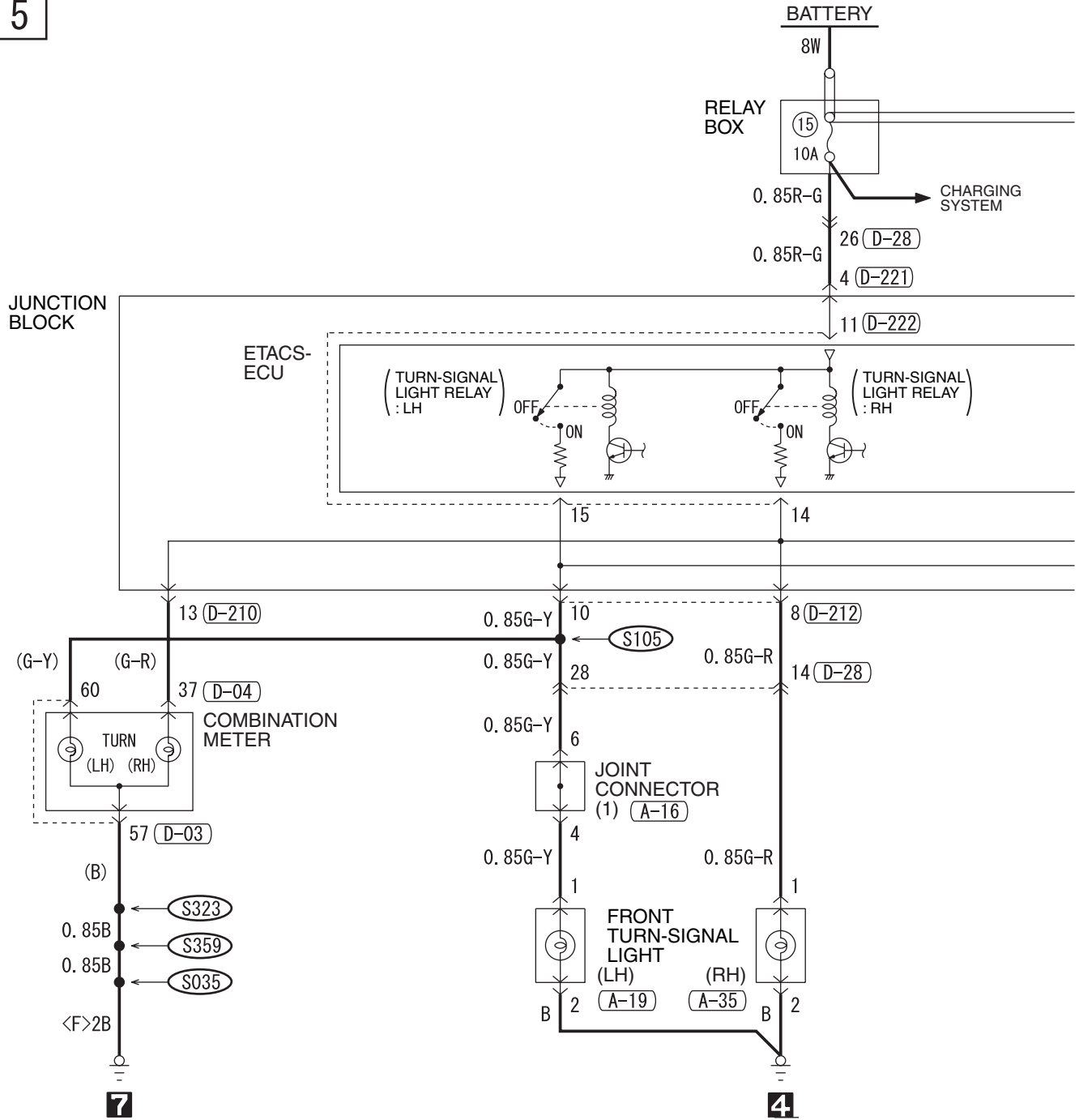

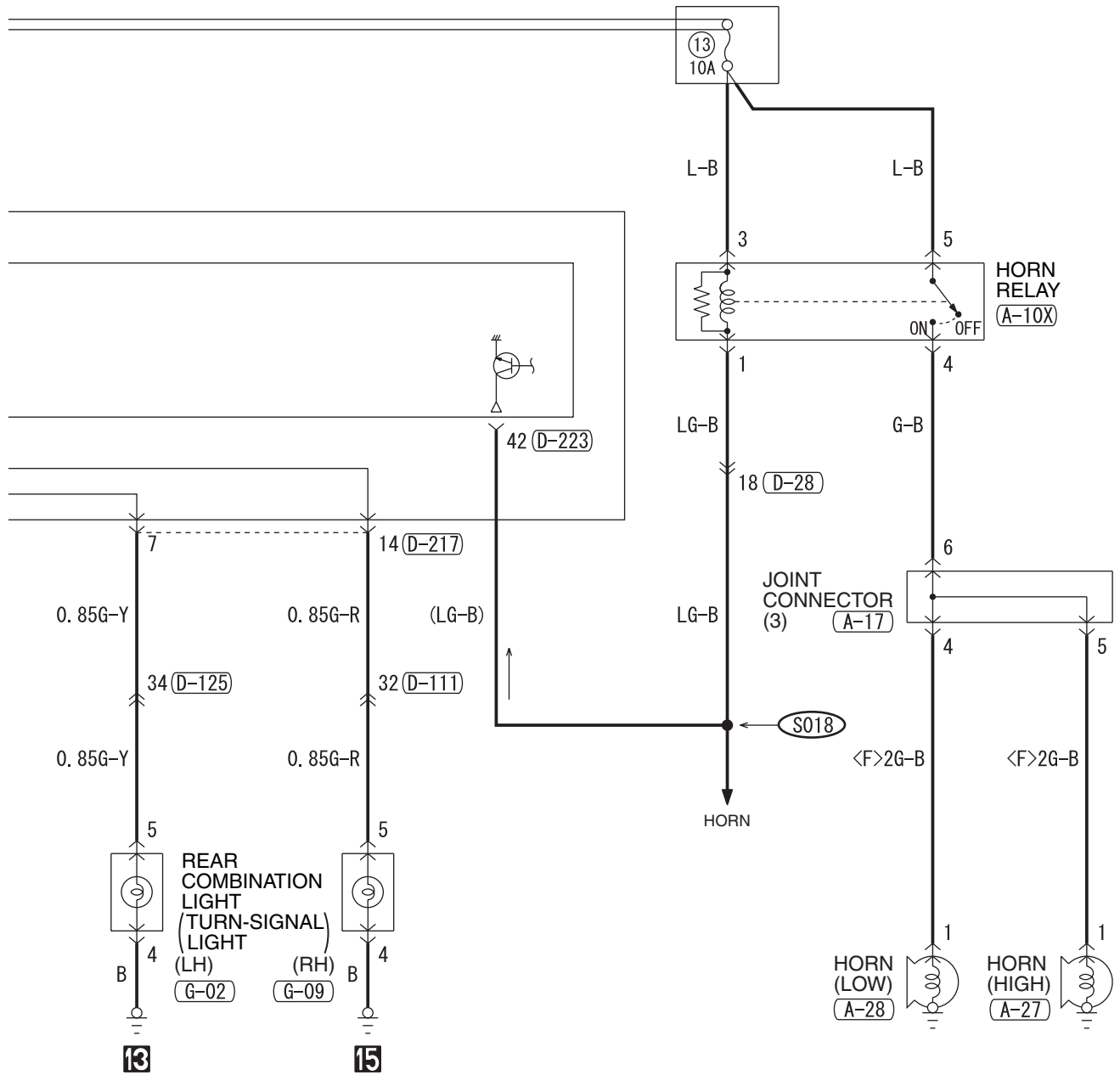

(D-28) (D-111) (D-125) (D-210) (MU801860)

See ★1 See ★2 See ★2

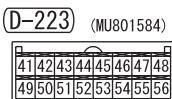
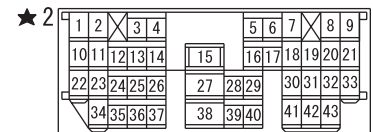
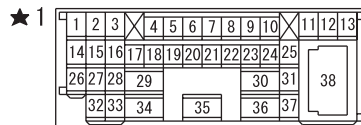
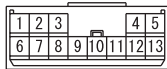

WIRE COLOR CODE

B : BLACK LG : LIGHT GREEN G : GREEN L : BLUE
 BR : BROWN O : ORANGE GR : GRAY R : RED W : WHITE
 SB : SKY BLUE P : PINK Y : YELLOW V : VIOLET H6Q11M01CB

CENTRAL DOOR LOCKING SYSTEM AND FORGOTTEN KEY PREVENTION FUNCTION (CONTINUED)

7

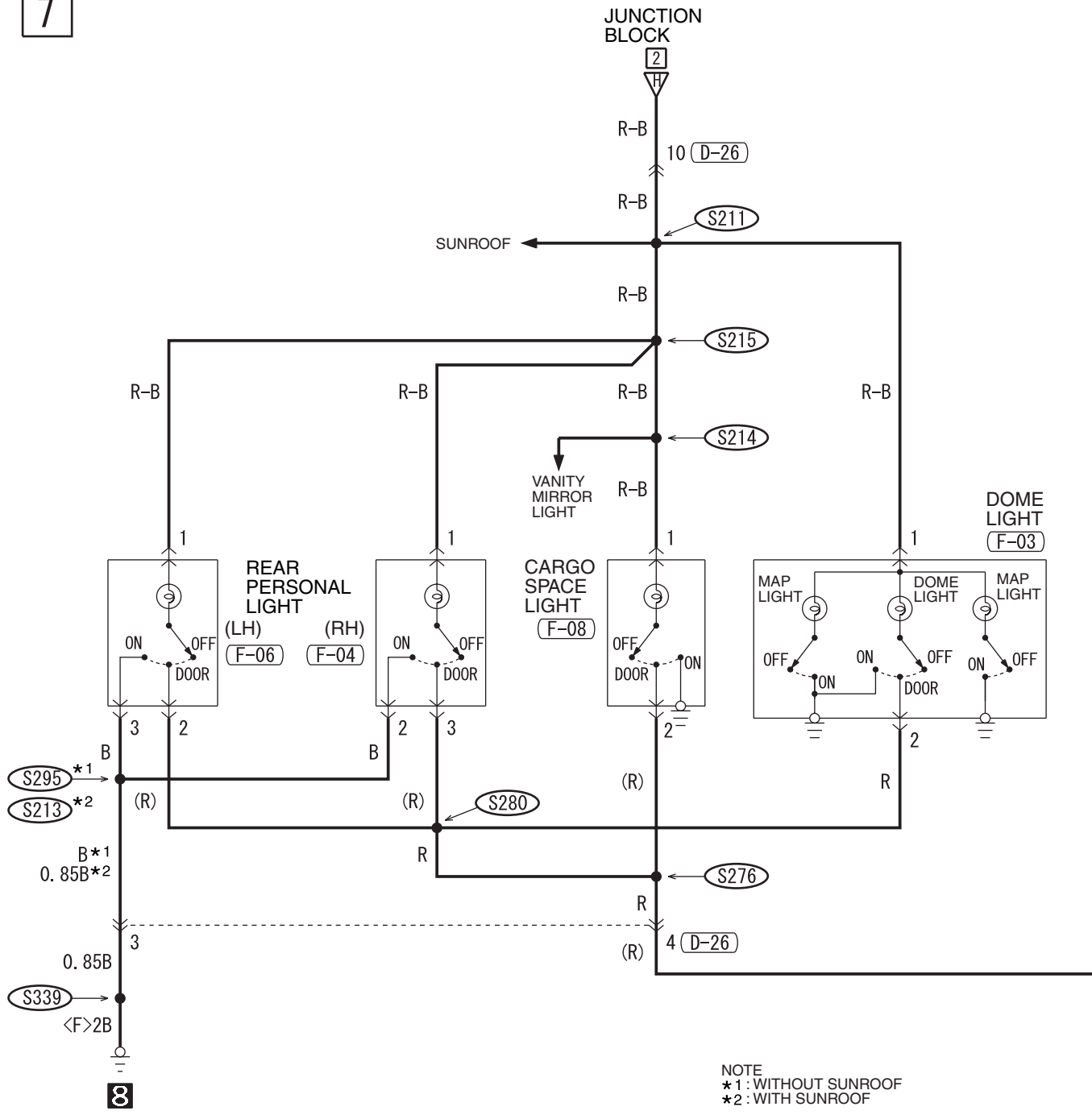

NOTE
* 1 : WITHOUT SUNROOF
* 2 : WITH SUNROOF

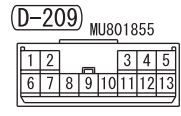
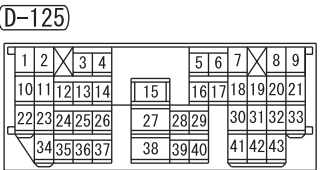
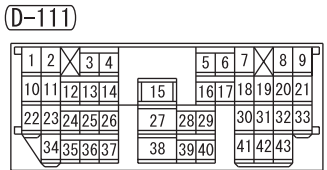
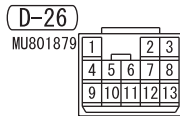

JUNCTION BLOCK

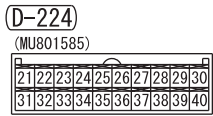
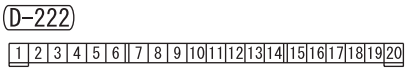
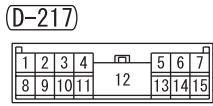
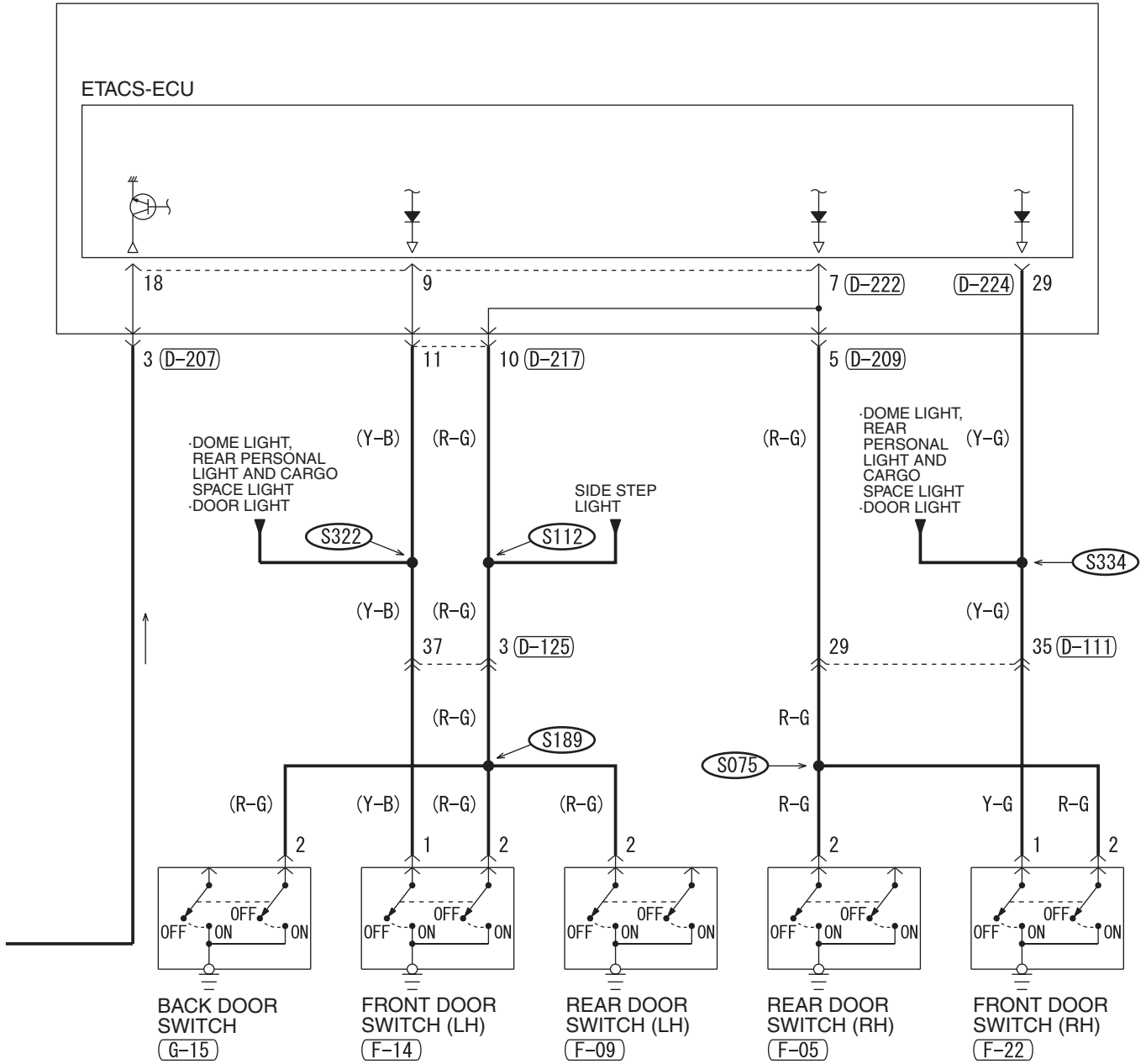

WIRE COLOR CODE
 B : BLACK LG : LIGHT GREEN G : GREEN L : BLUE W : WHITE Y : YELLOW
 SB : SKY BLUE BR : BROWN O : ORANGE GR : GRAY R : RED P : PINK V : VIOLET

CENTRAL DOOR LOCKING SYSTEM AND FORGOTTEN KEY PREVENTION FUNCTION (CONTINUED)

9

JUNCTION BLOCK

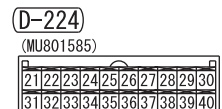
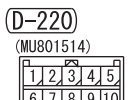
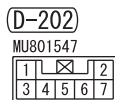
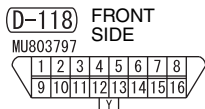
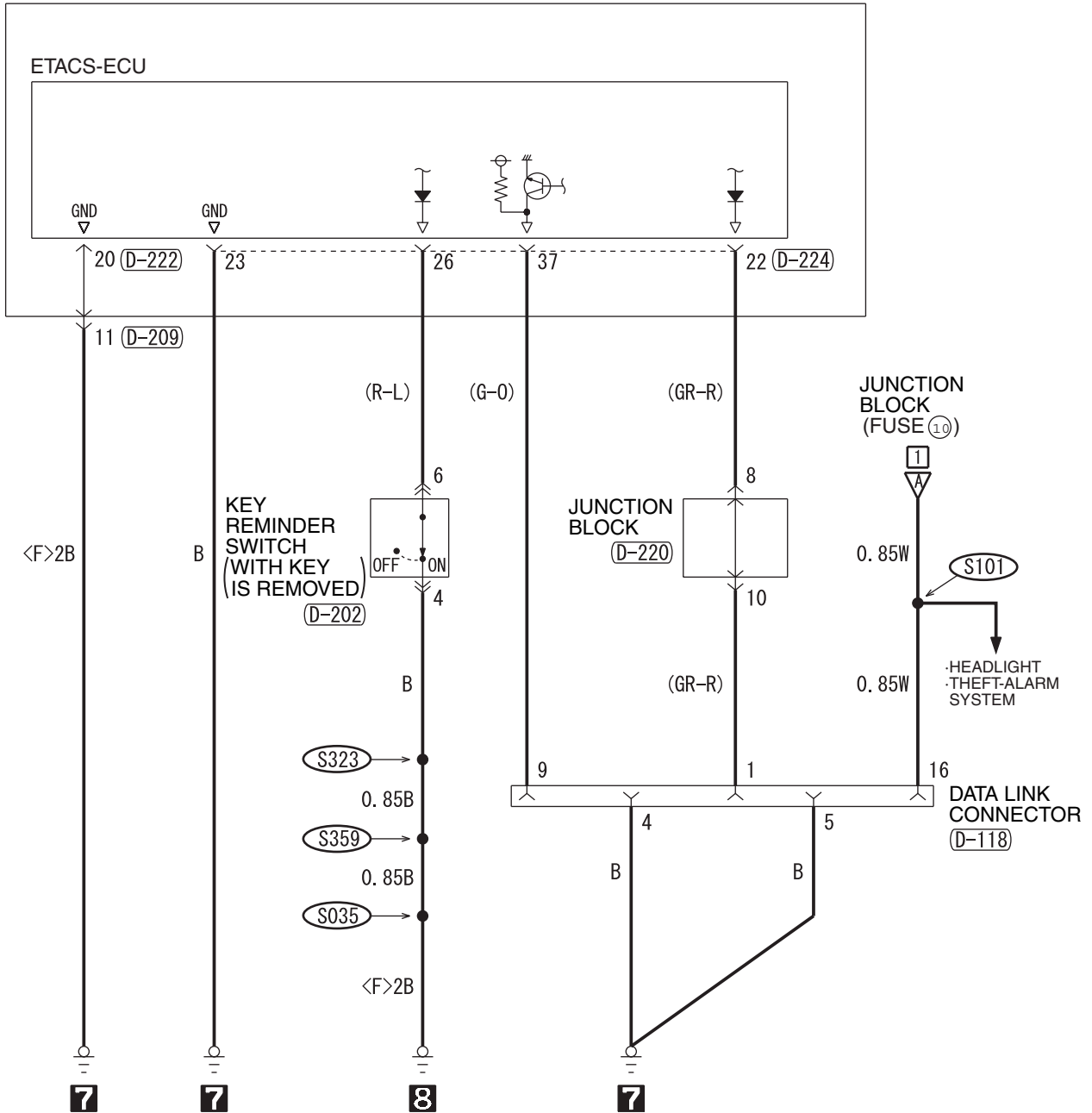

WIRE COLOR CODE

B: BLACK LG: LIGHT GREEN G: GREEN L: BLUE W: WHITE Y: YELLOW
SB: SKY BLUE BR: BROWN O: ORANGE GR: GRAY R: RED P: PINK V: VIOLET

NOTES

SINGLE MANUAL AIR CONDITIONING SYSTEM

M1901005300082

1

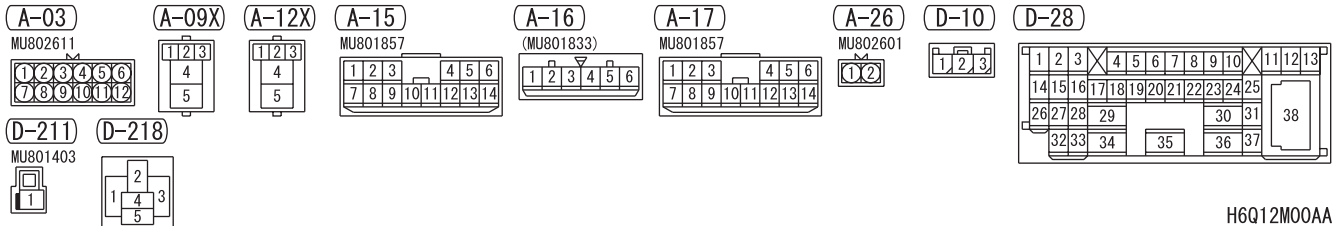
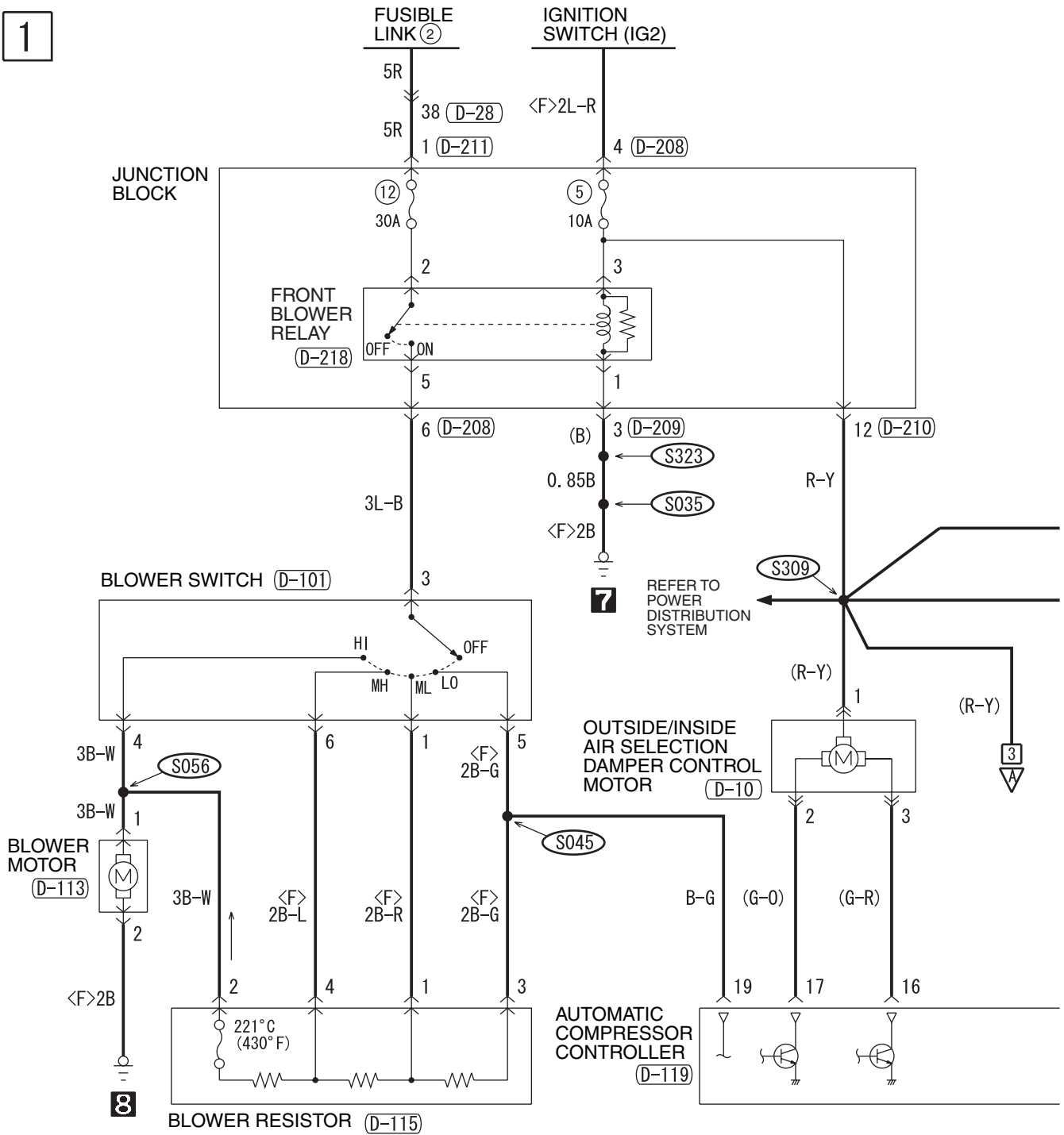

H6Q12M00AA

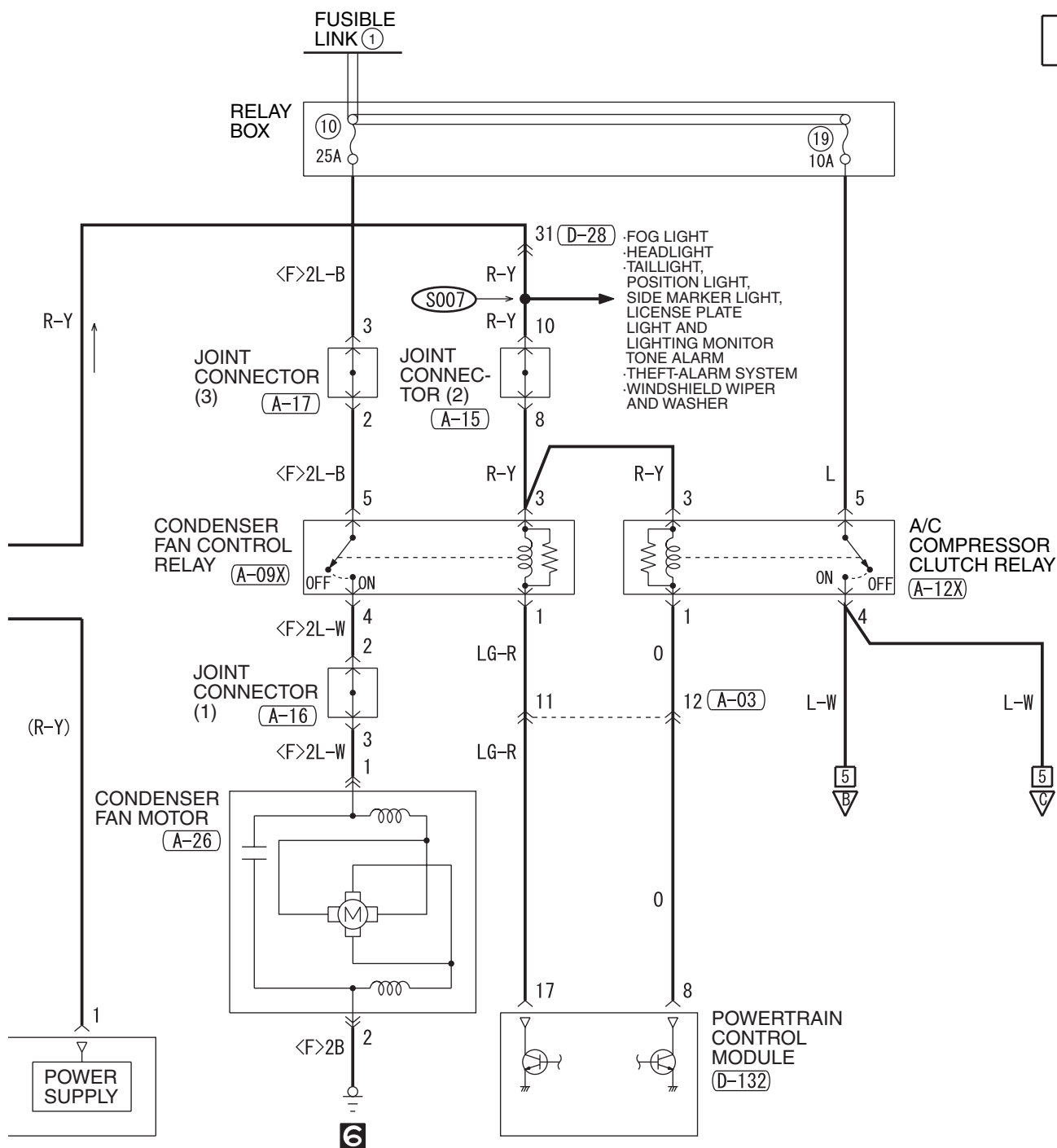

(D-101)

1	2	3
4	5	6

(D-113)

1	2
---	---

(D-115) MU801365

1	2
3	4

(D-119) (MU801585)

1	2	3	4	5	6	7	8	9	10
11	12	13	14	15	16	17	18	19	20

(D-132) (MU803802)

1	2	JAE	3	4				
5	6	7	8	9	10	11	12	13
14	15	16	17	18	19	20	21	22
23	24	25	26	27				

(D-208) MU801331

1	2		
3	4	5	6

(D-209) MU801855

1	2	3	4	5			
6	7	8	9	10	11	12	13

(D-210) (MU801860)

1	2	3	4	5			
6	7	8	9	10	11	12	13

WIRE COLOR CODE
 B : BLACK LG : LIGHT GREEN G : GREEN L : BLUE W : WHITE Y : YELLOW
 SB : SKY BLUE BR : BROWN O : ORANGE GR : GRAY R : RED P : PINK V : VIOLET

SINGLE MANUAL AIR CONDITIONING SYSTEM (CONTINUED)

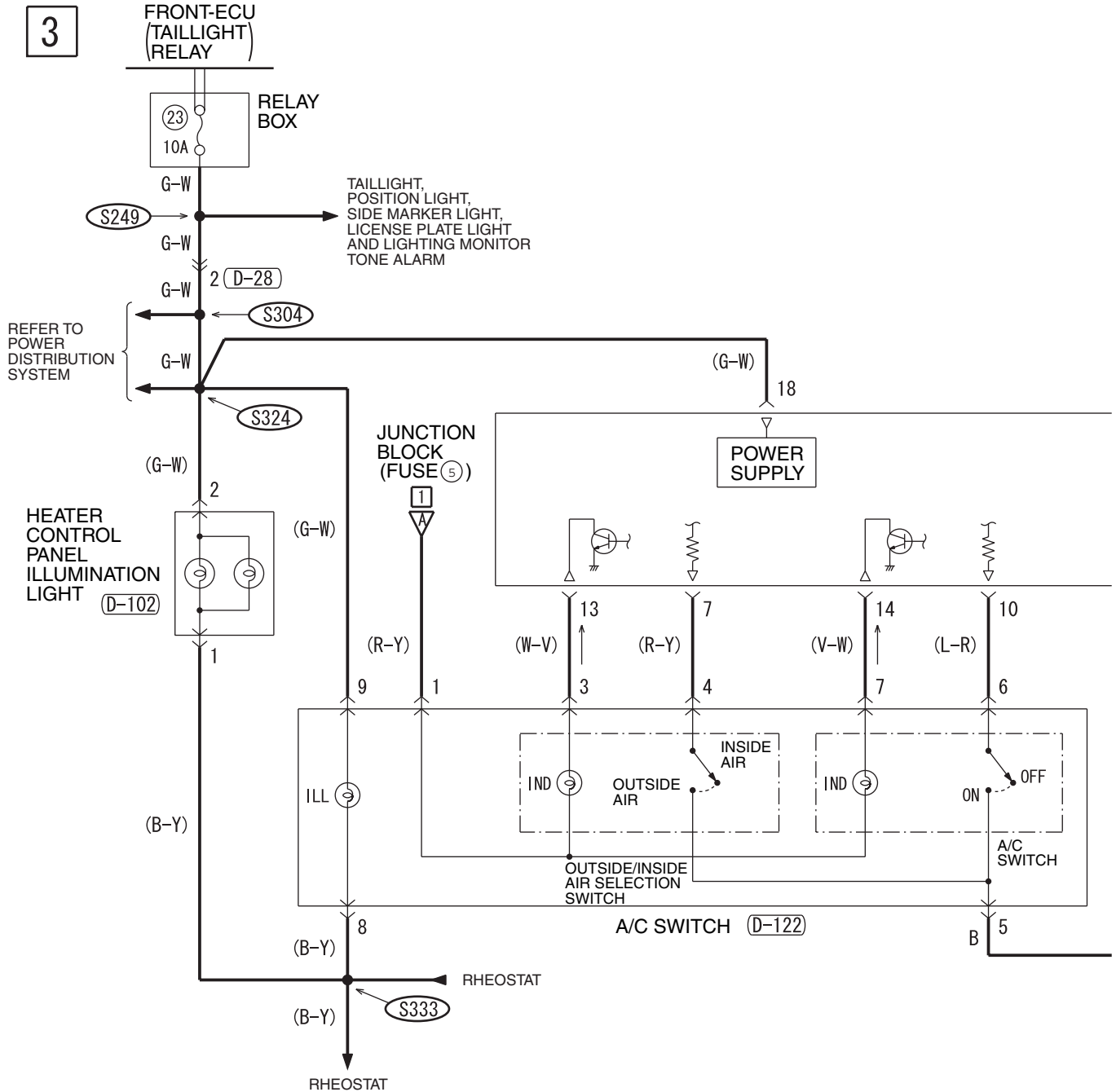

A-03



A-22



D-28

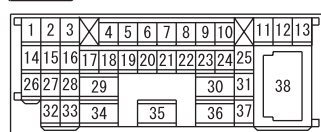

D-102



D-104



D-106



D-119

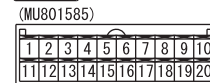

4

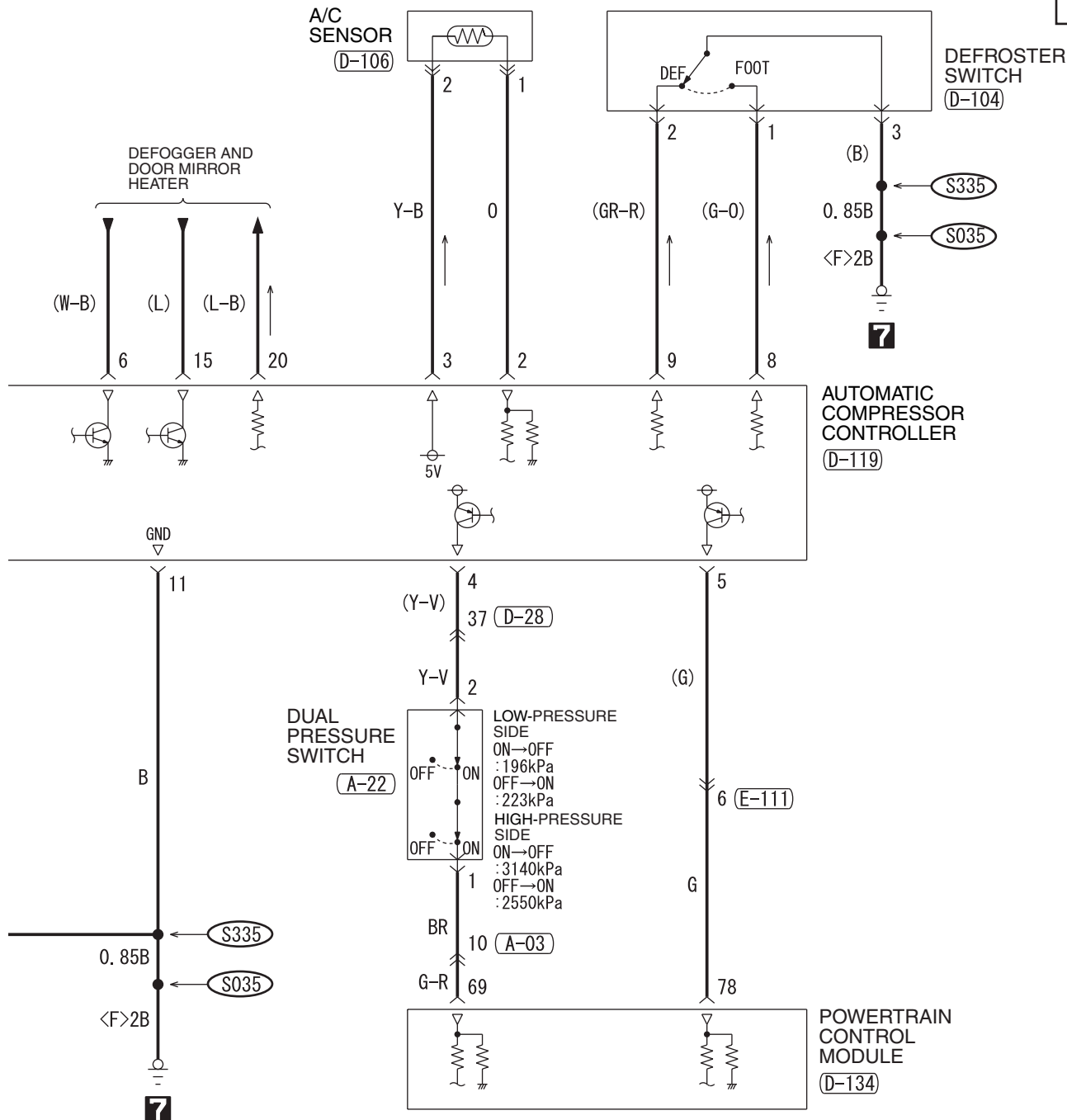

D-122

(MU802098)



D-134

(MU803804)

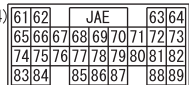

E-111

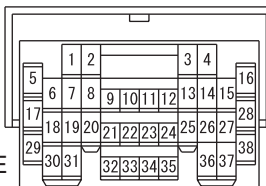

WIRE COLOR CODE
 B : BLACK LG : LIGHT GREEN G : GREEN L : BLUE
 BR : BROWN O : ORANGE GR : GRAY R : RED
 W : WHITE SB : SKY BLUE P : PINK Y : YELLOW V : VIOLET

SINGLE MANUAL AIR CONDITIONING SYSTEM (CONTINUED)

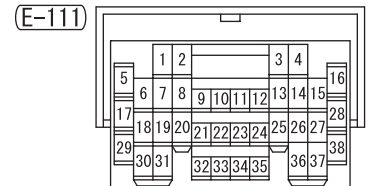
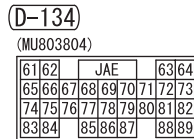
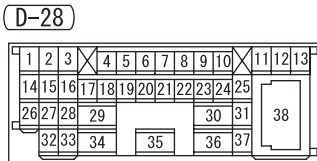
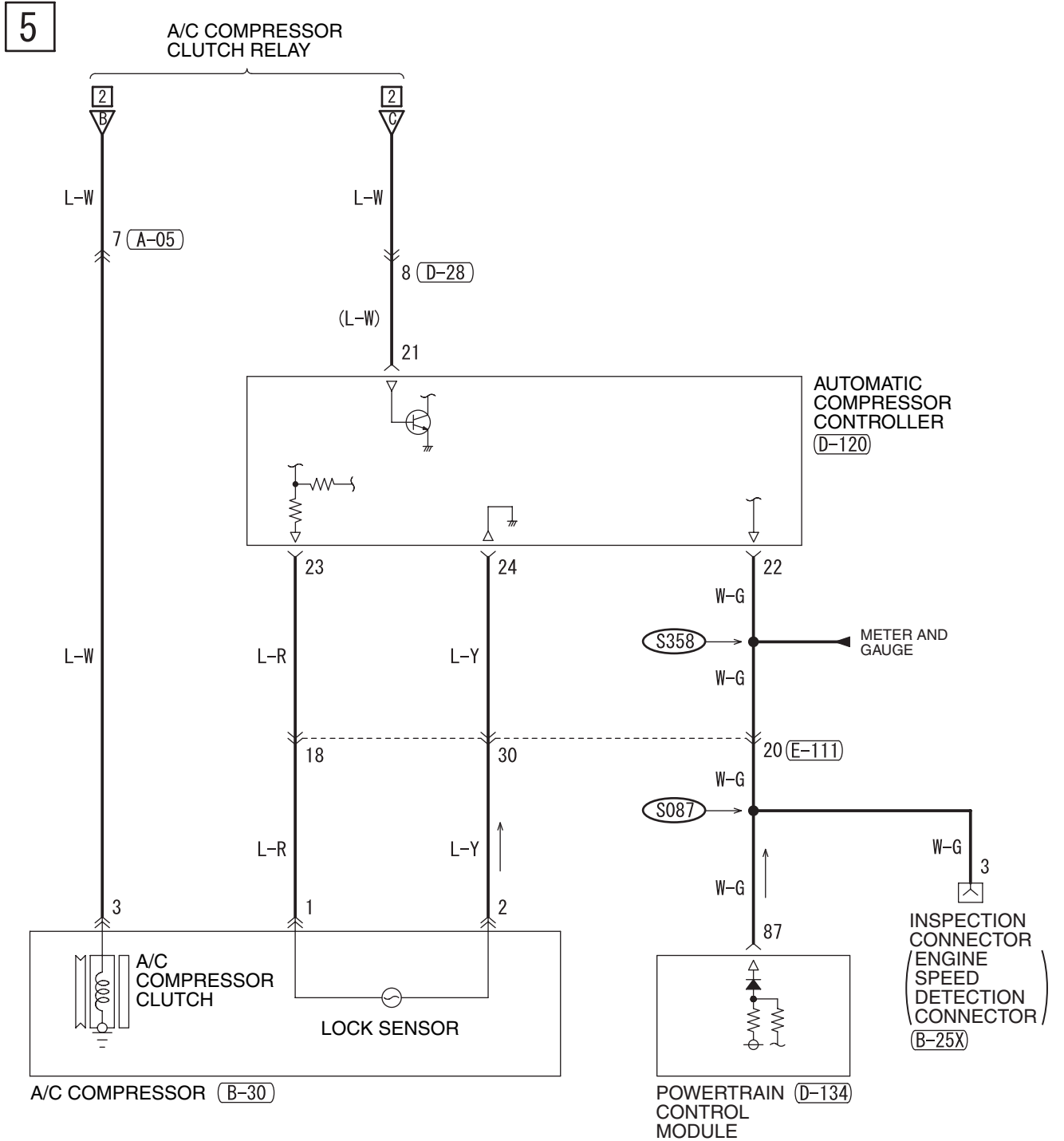

NOTES

DUAL MANUAL AIR CONDITIONING SYSTEM <VEHICLES WITH REAR HEATER>

M1901005400205

1

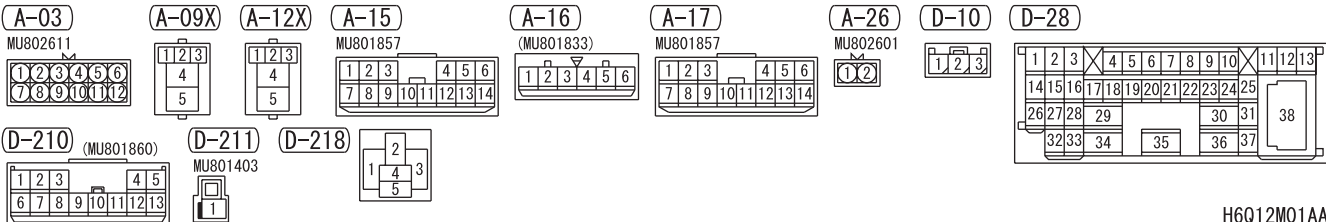
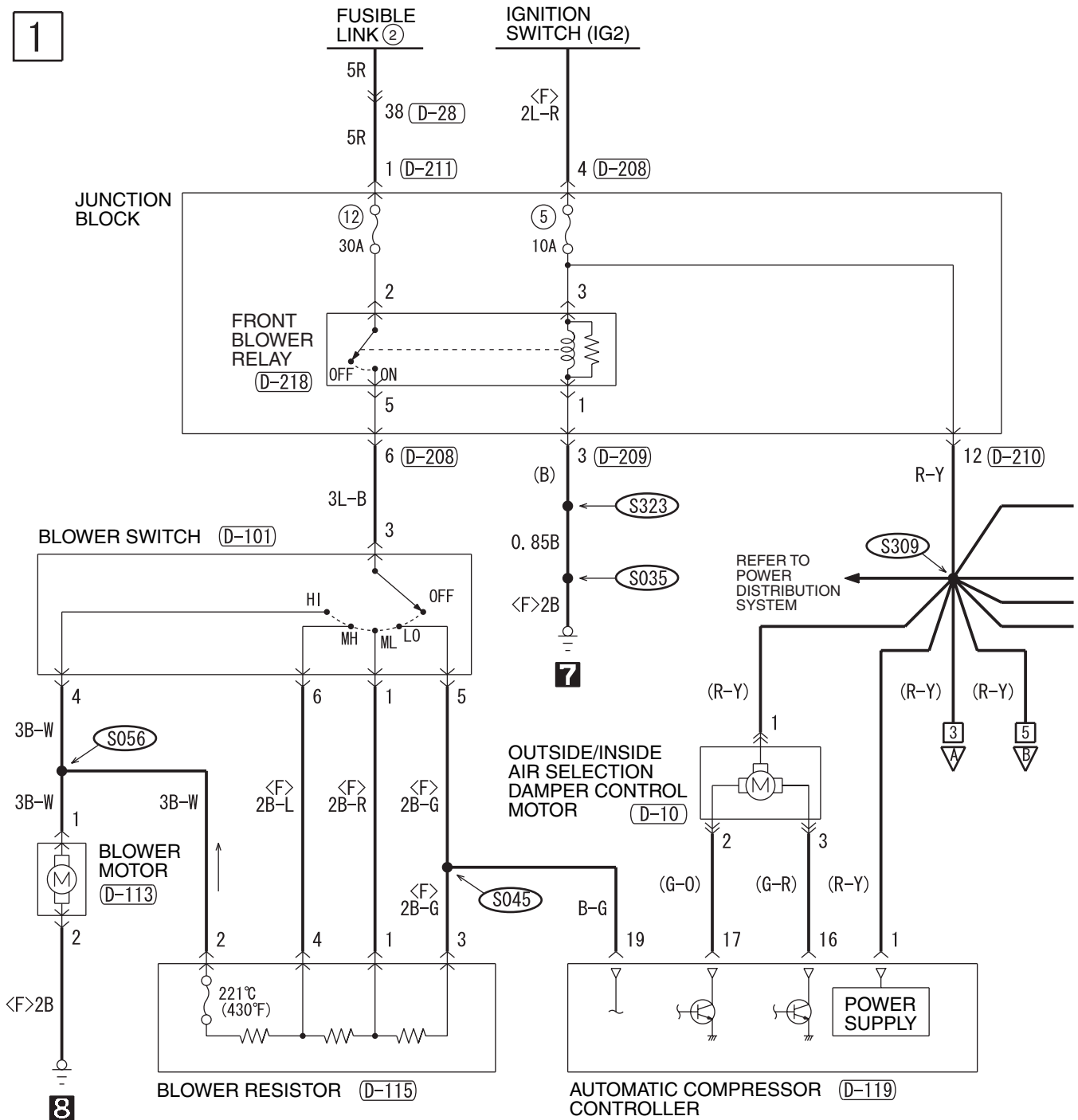

H6Q12M01AA

2

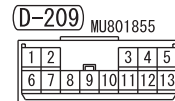
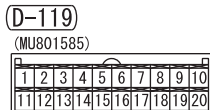
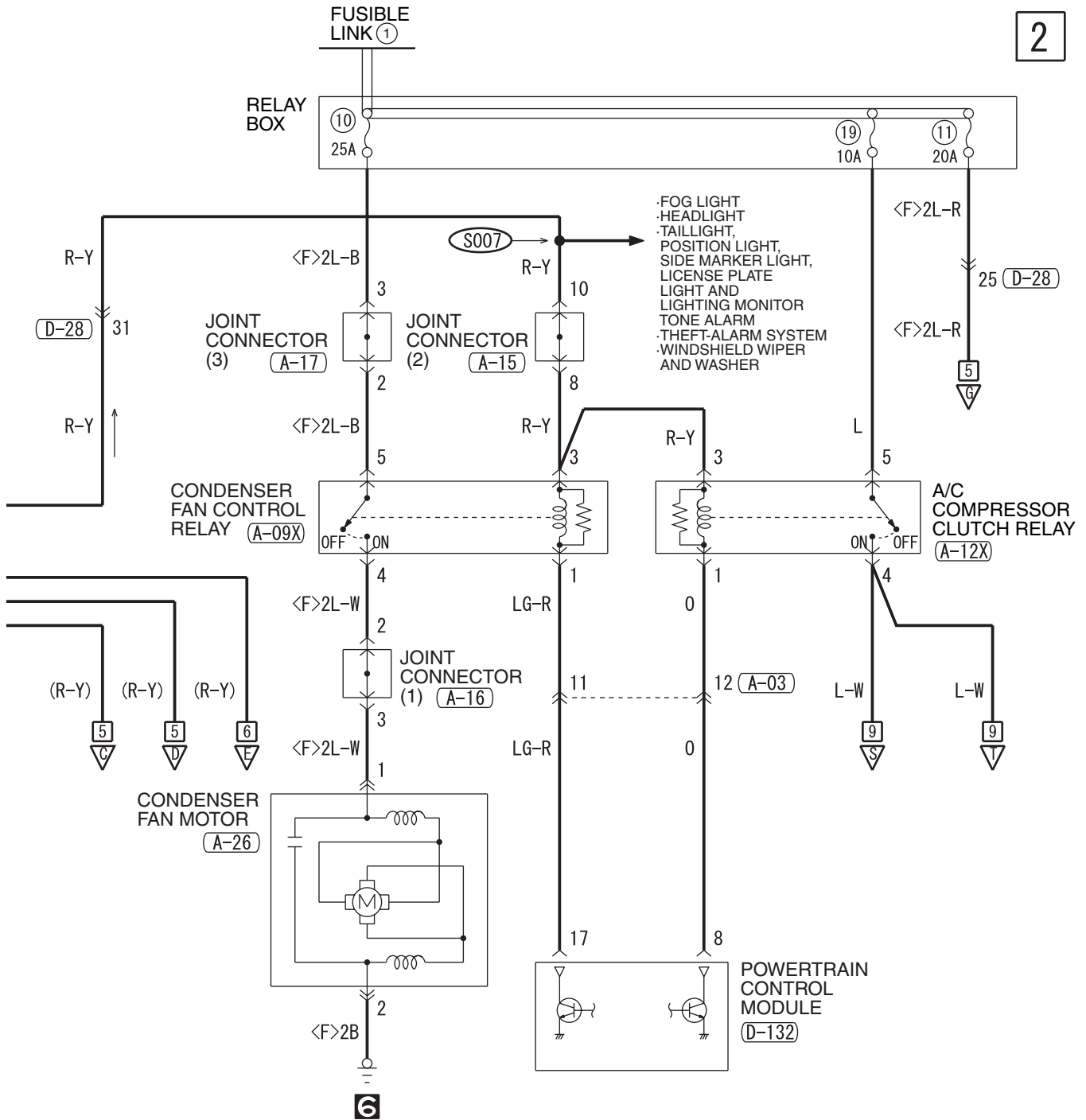

WIRE COLOR CODE

B : BLACK LG : LIGHT GREEN G : GREEN L : BLUE W : WHITE Y : YELLOW
 SB : SKY BLUE BR : BROWN O : ORANGE GR : GRAY R : RED P : PINK V : VIOLET

DUAL MANUAL AIR CONDITIONING SYSTEM <VEHICLES WITH REAR HEATER> (CONTINUED)

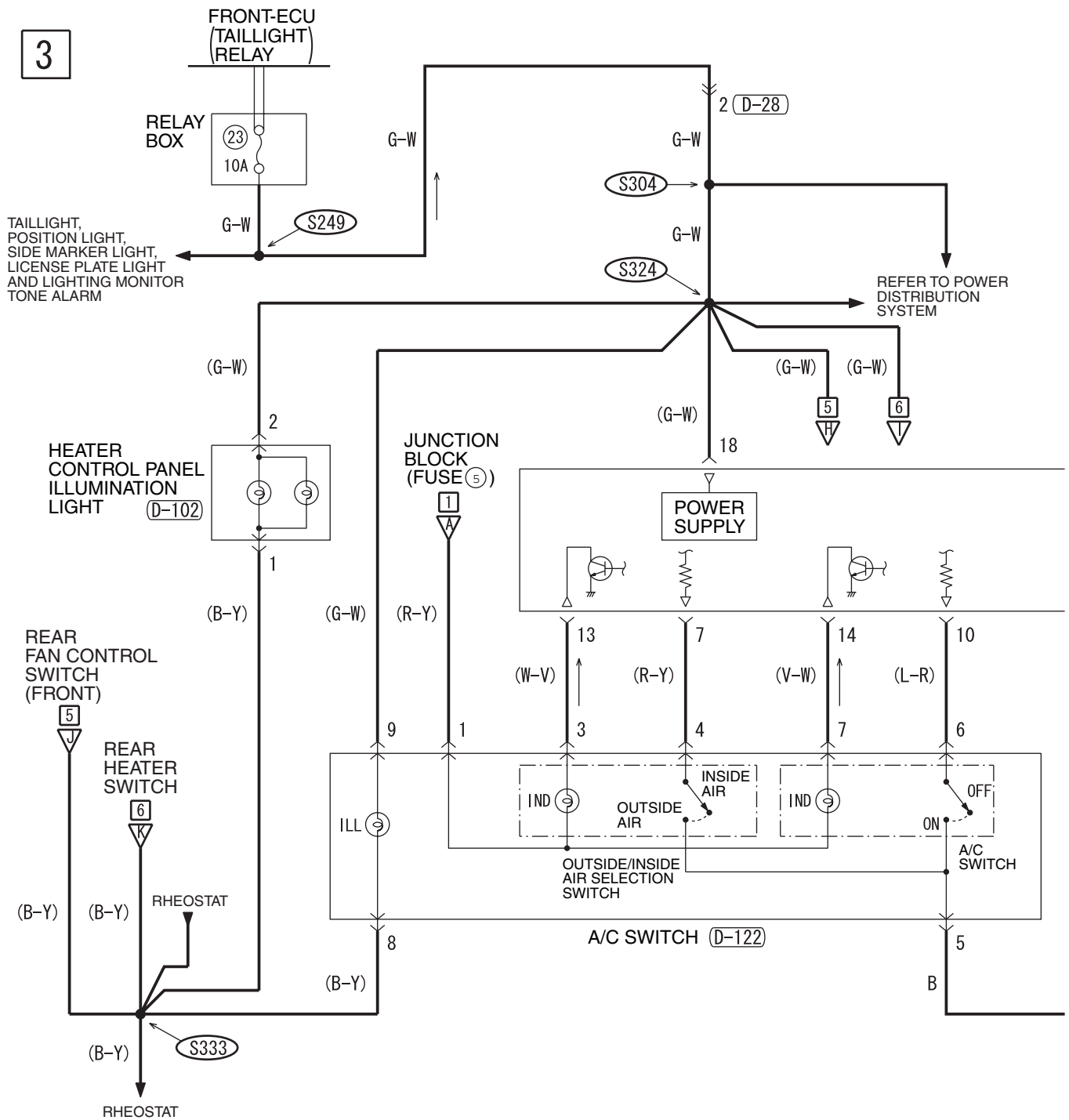

A-03

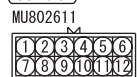

A-22



D-28

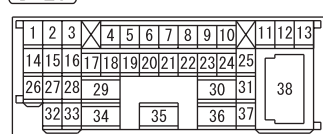

D-102



D-104



D-106



D-119

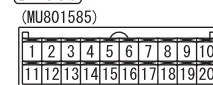

4

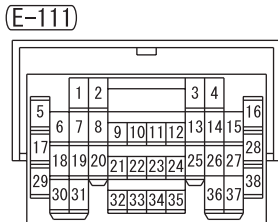
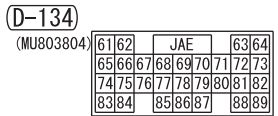
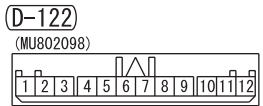
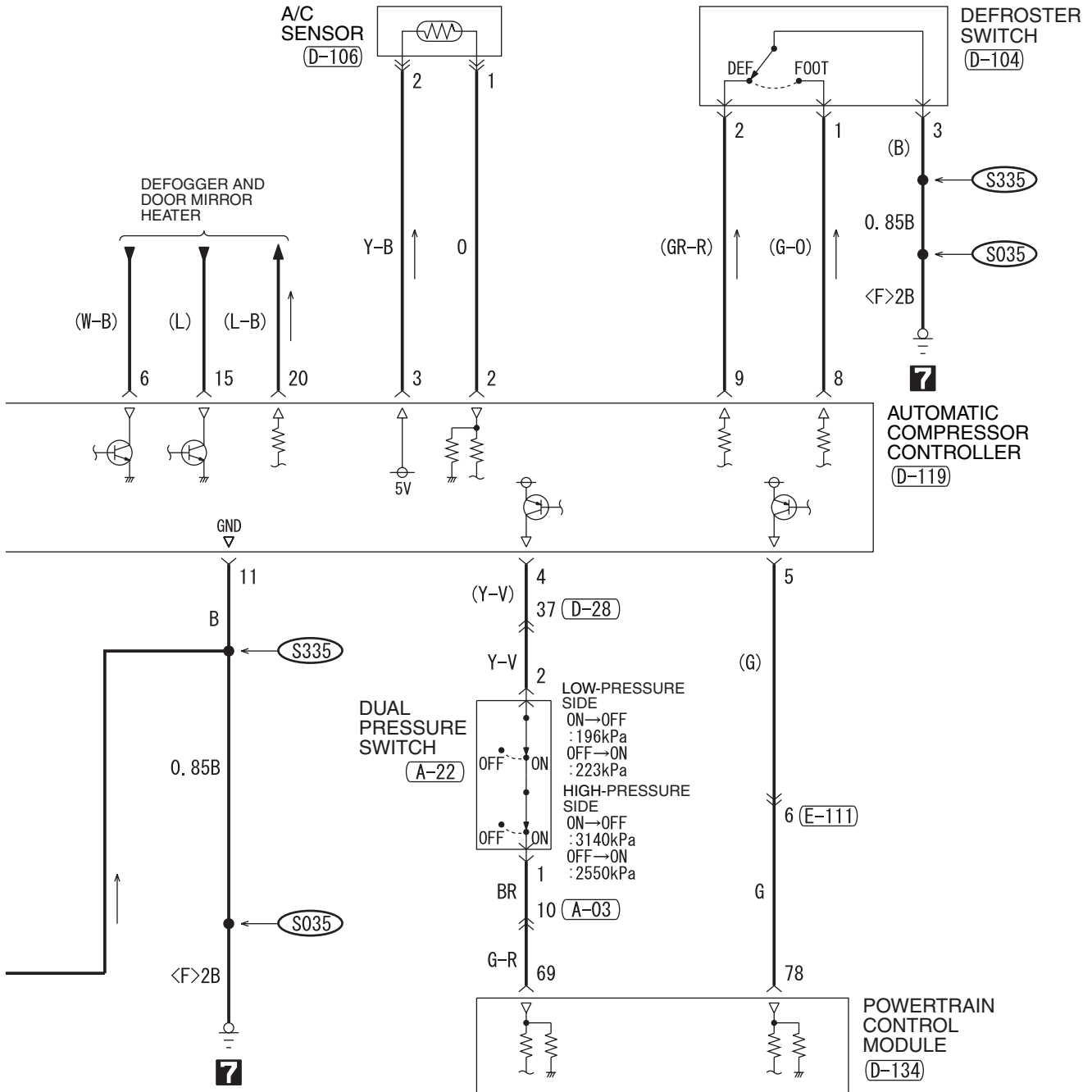

WIRE COLOR CODE
 B : BLACK LG : LIGHT GREEN
 G : GREEN L : BLUE BR : BROWN
 O : ORANGE GR : GRAY R : RED
 W : WHITESB : SKY BLUE P : PINK
 Y : YELLOW V : VIOLET

DUAL MANUAL AIR CONDITIONING SYSTEM <VEHICLES WITH REAR HEATER> (CONTINUED)

5

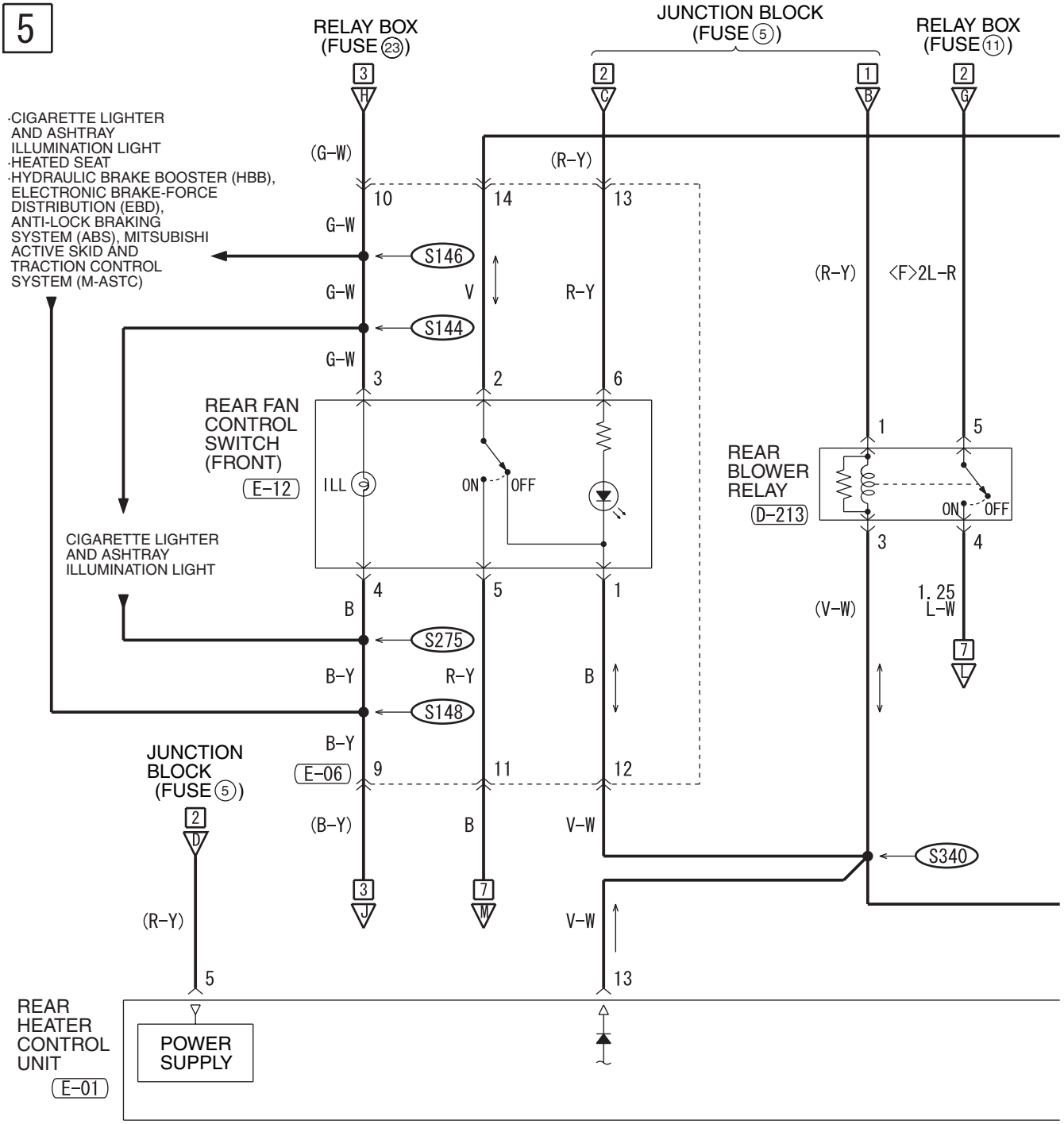

D-112

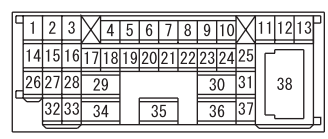

D-213



E-01

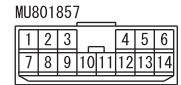

E-06

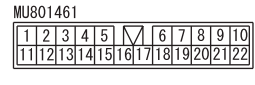

E-12



E-21

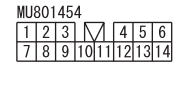

DUAL MANUAL AIR CONDITIONING SYSTEM <VEHICLES WITH REAR HEATER> (CONTINUED)

7

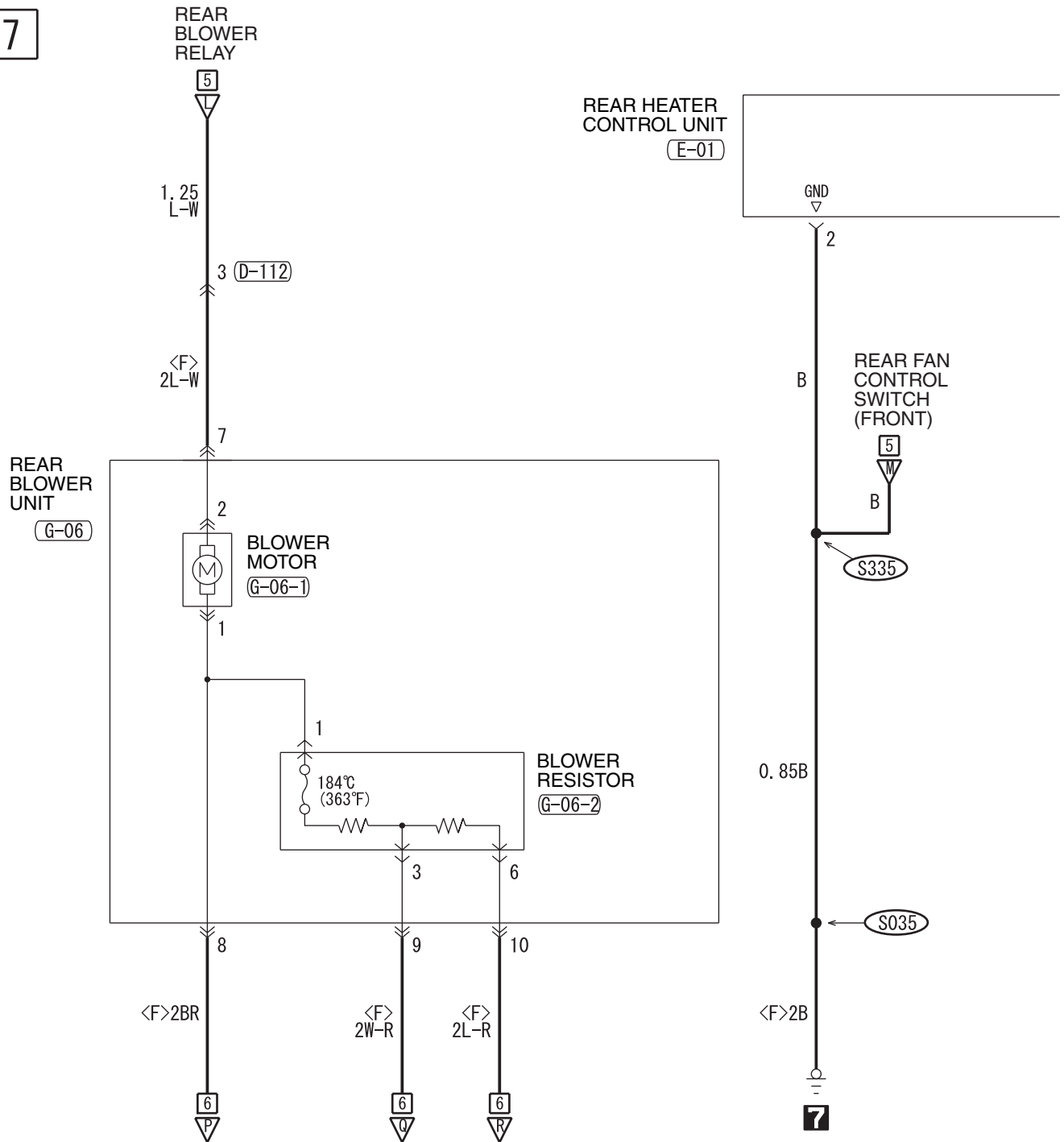

D-112

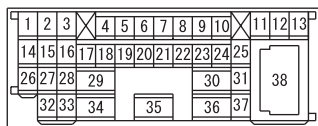

E-01

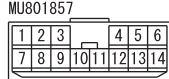

G-06

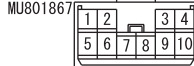

G-06-1



G-06-2



G-23



G-25



8

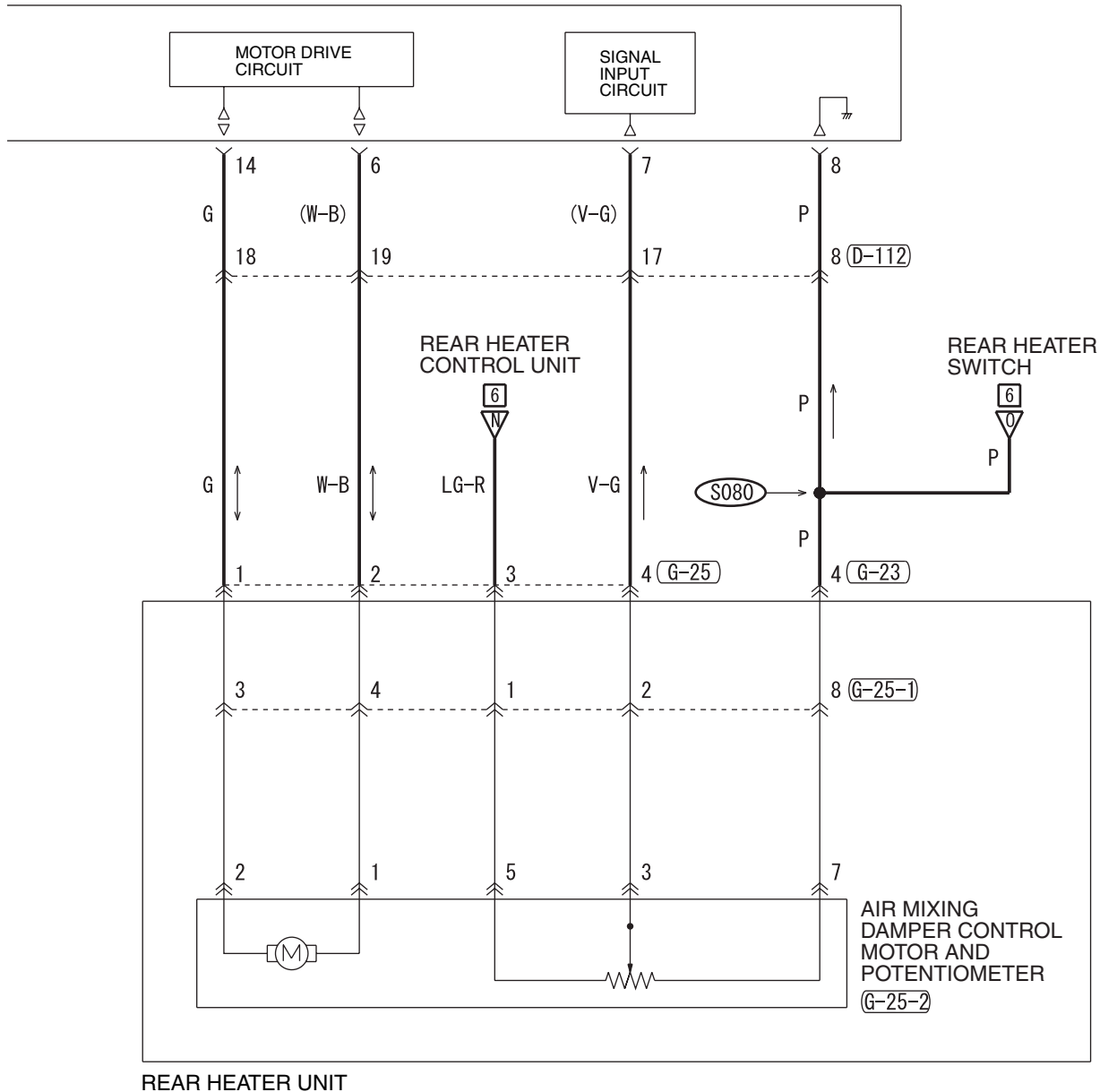

(G-25-1)
MU802749

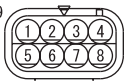

(G-25-2)

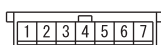

WIRE COLOR CODE

B: BLACK LG: LIGHT GREEN G: GREEN L: BLUE W: WHITE Y: YELLOW
 SB: SKY BLUE BR: BROWN O: ORANGE GR: GRAY R: RED P: PINK V: VIOLET

TSB Revision

DUAL MANUAL AIR CONDITIONING SYSTEM <VEHICLES WITH REAR HEATER> (CONTINUED)

9

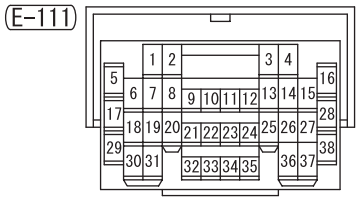
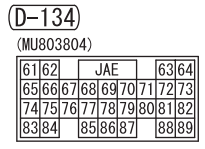
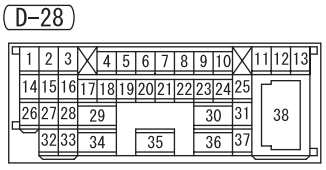
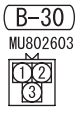
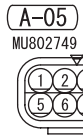
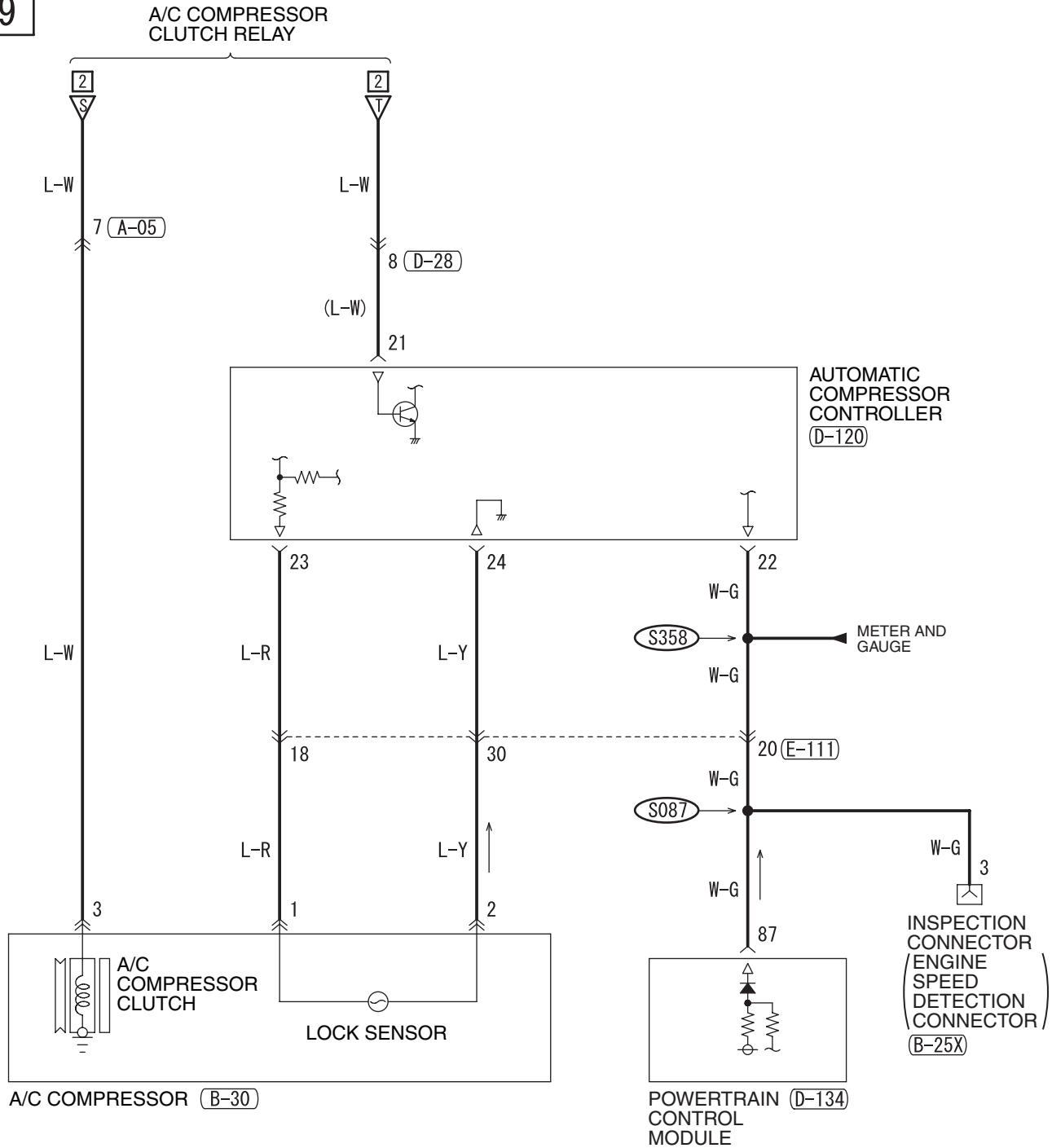

NOTES

DUAL MANUAL AIR CONDITIONING SYSTEM <VEHICLES WITH REAR COOLER>

M1901005400216

1

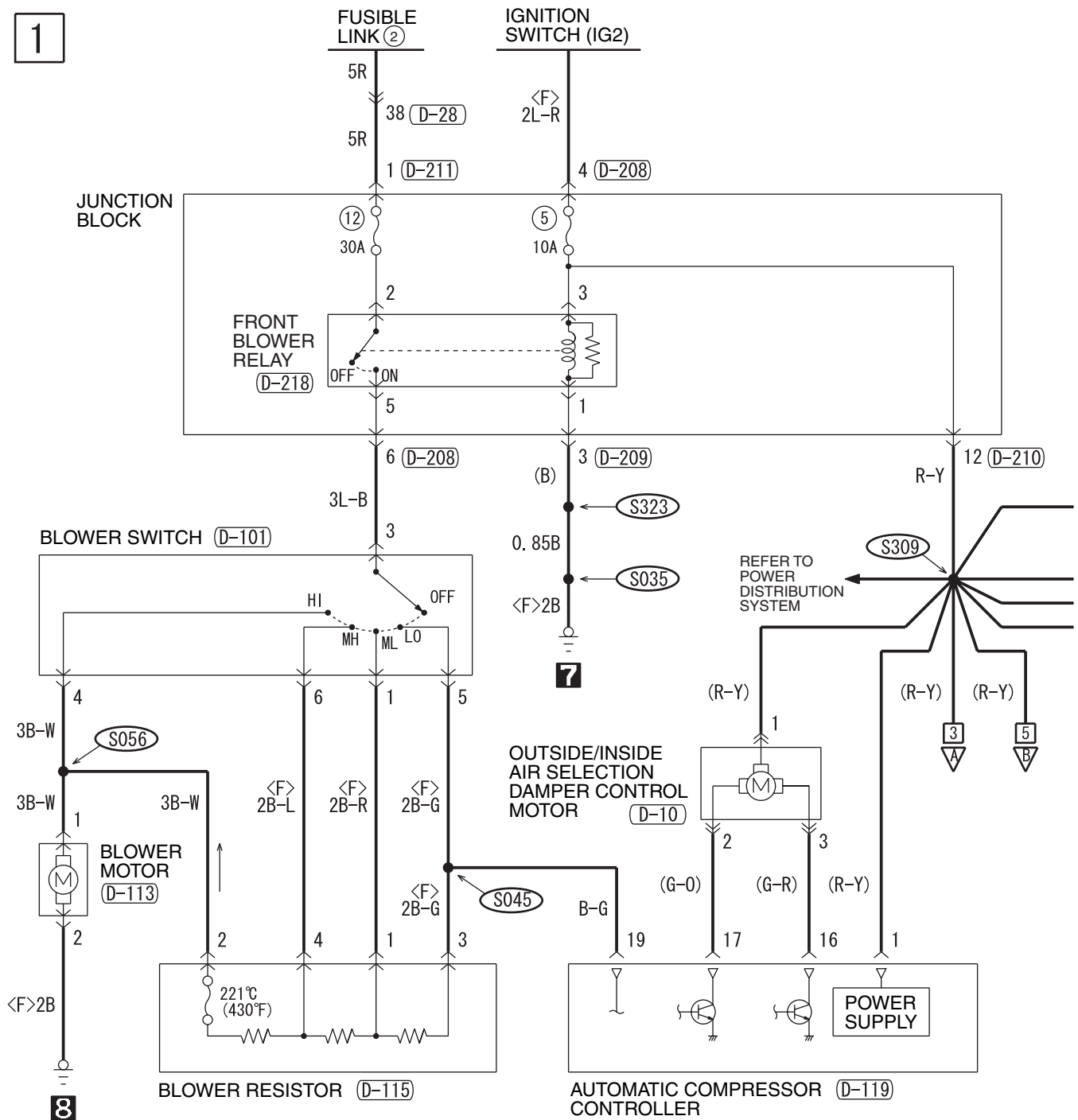

A-03



A-09X



A-12X



A-15



A-16



A-17



A-26



D-10



D-28

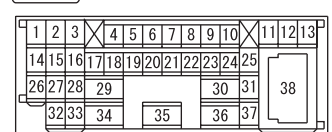

D-210



D-211



D-218



H6Q12M02AA

2

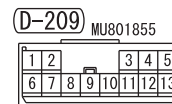
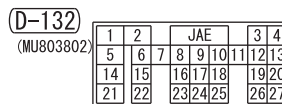
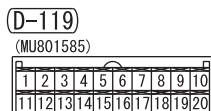
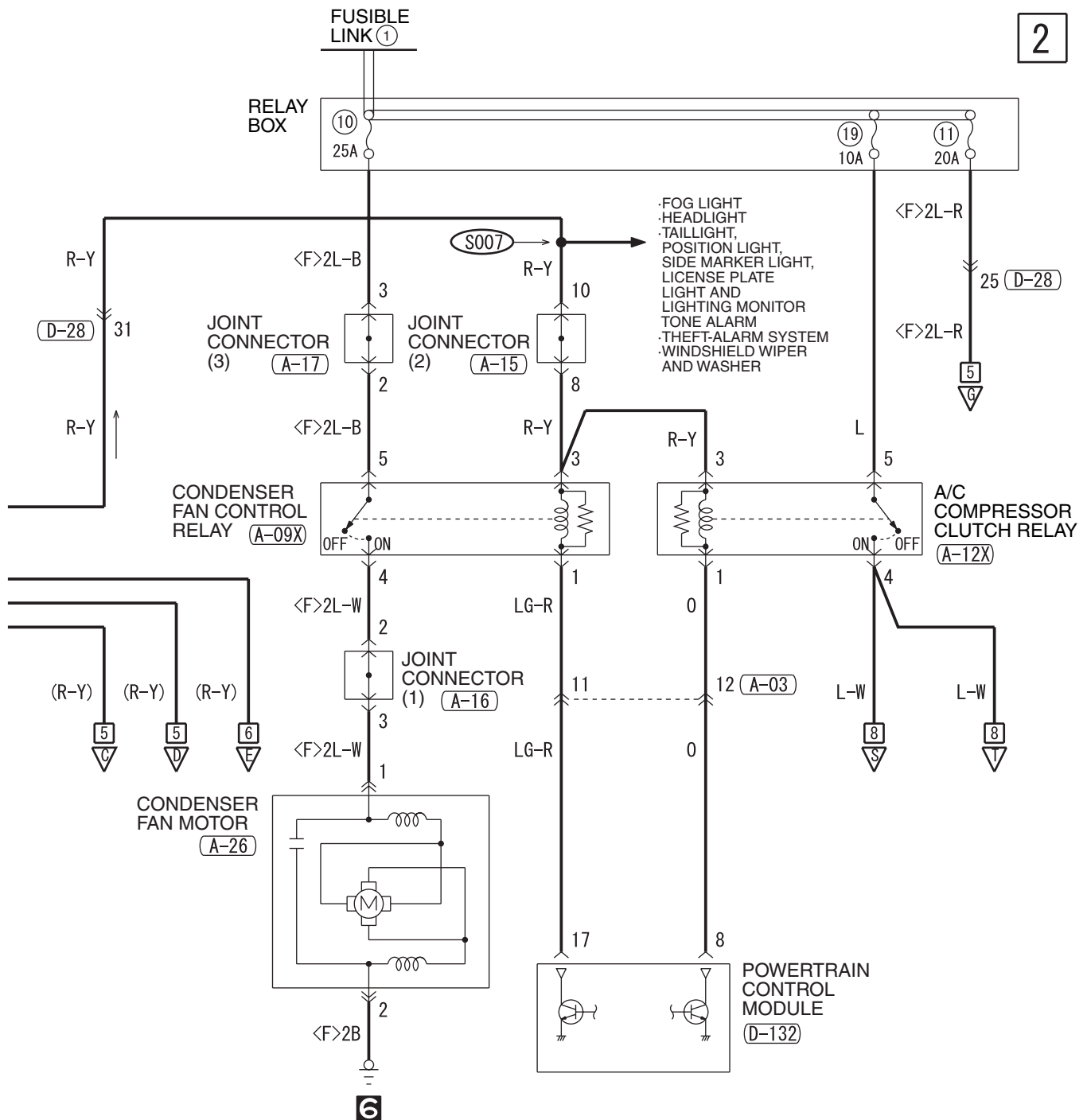

WIRE COLOR CODE
 B : BLACK LG : LIGHT GREEN G : GREEN L : BLUE W : WHITE Y : YELLOW
 SB : SKY BLUE BR : BROWN O : ORANGE GR : GRAY R : RED P : PINK V : VIOLET

DUAL MANUAL AIR CONDITIONING SYSTEM <VEHICLES WITH REAR COOLER> (CONTINUED)

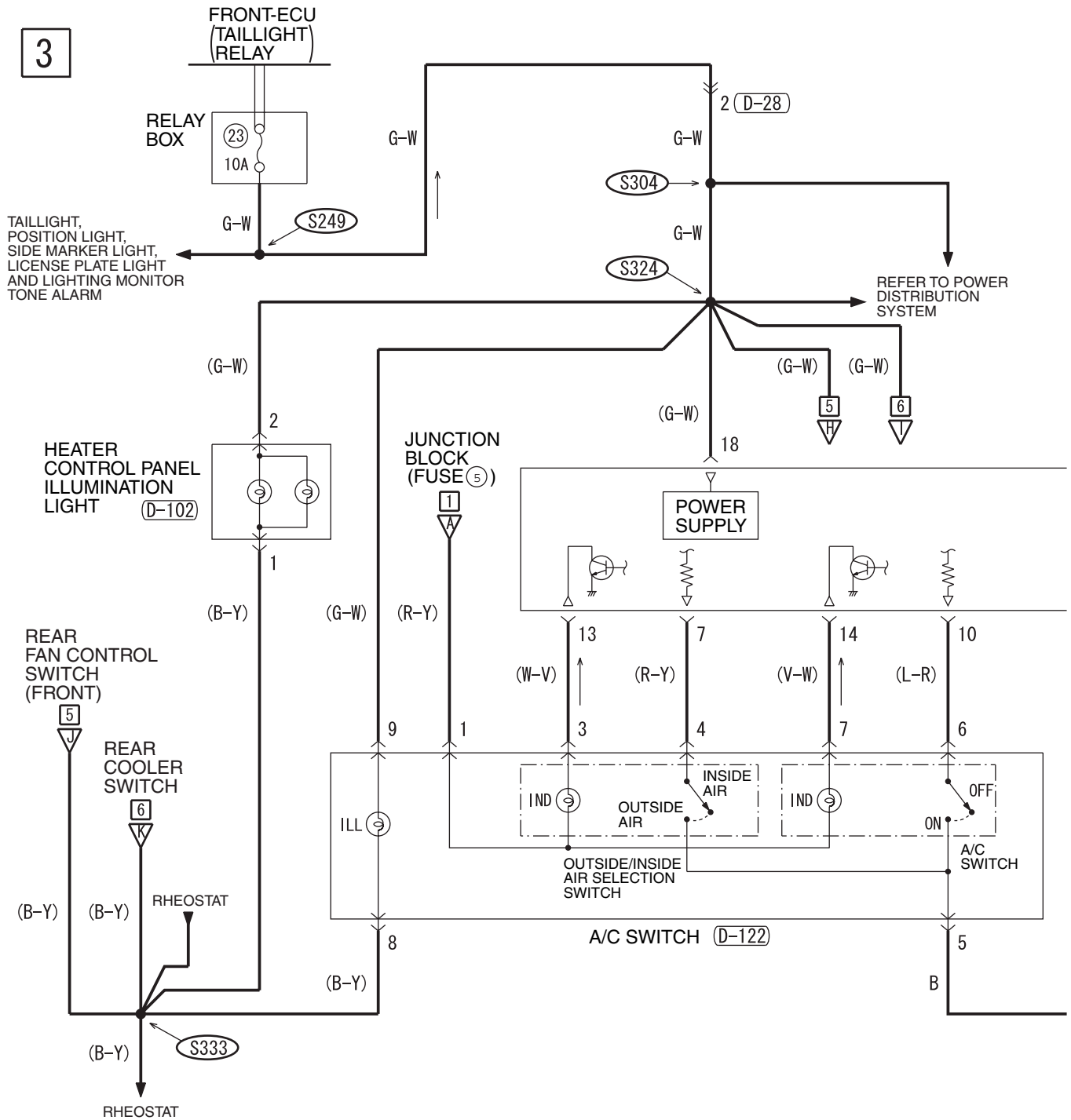

A-03

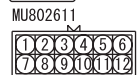

A-22



D-28

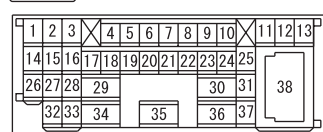

D-102



D-104



D-106



D-119

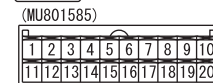

4

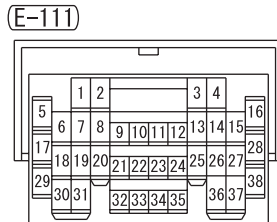
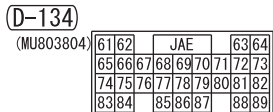
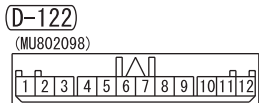
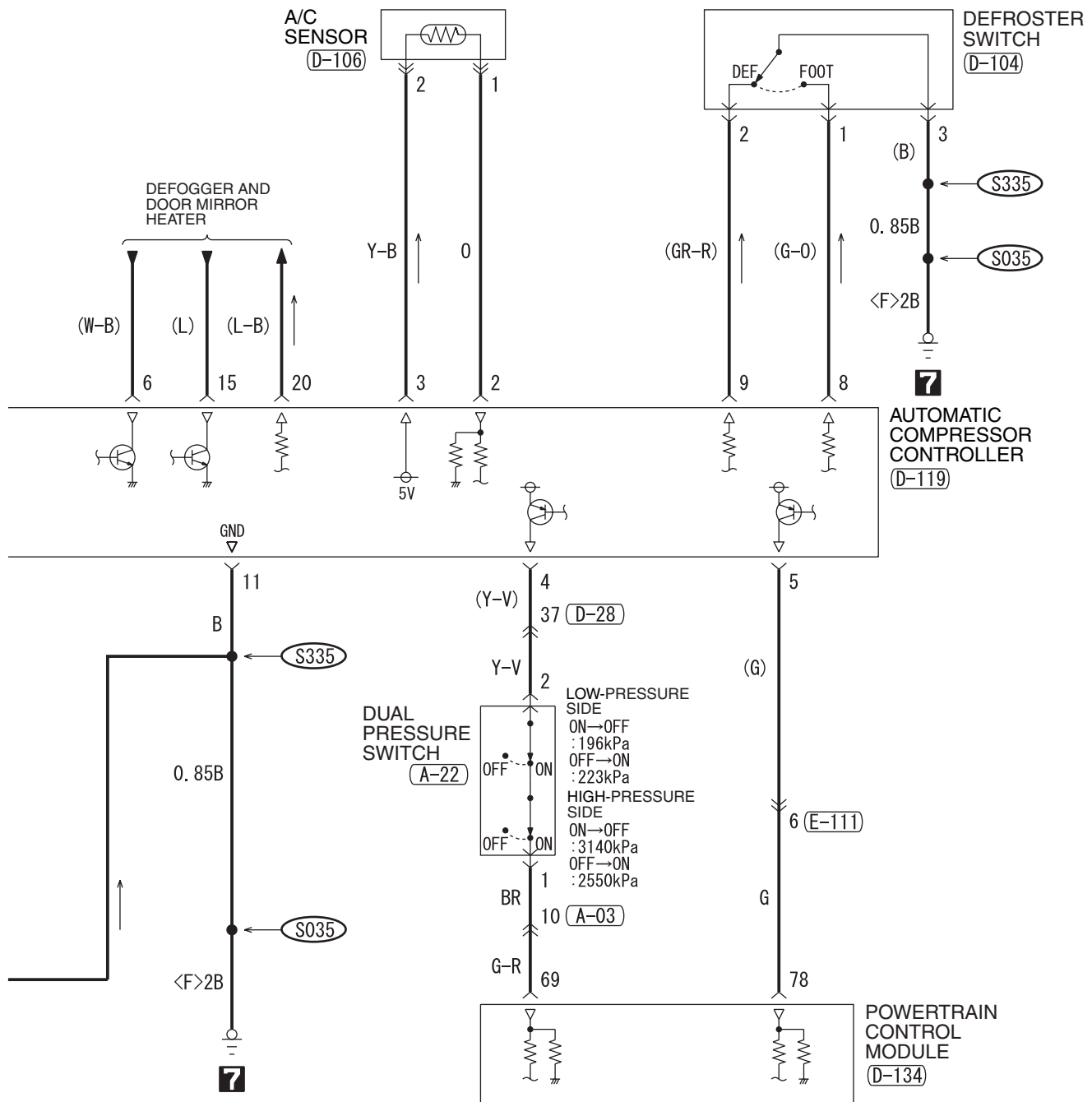

DUAL MANUAL AIR CONDITIONING SYSTEM <VEHICLES WITH REAR COOLER> (CONTINUED)

5

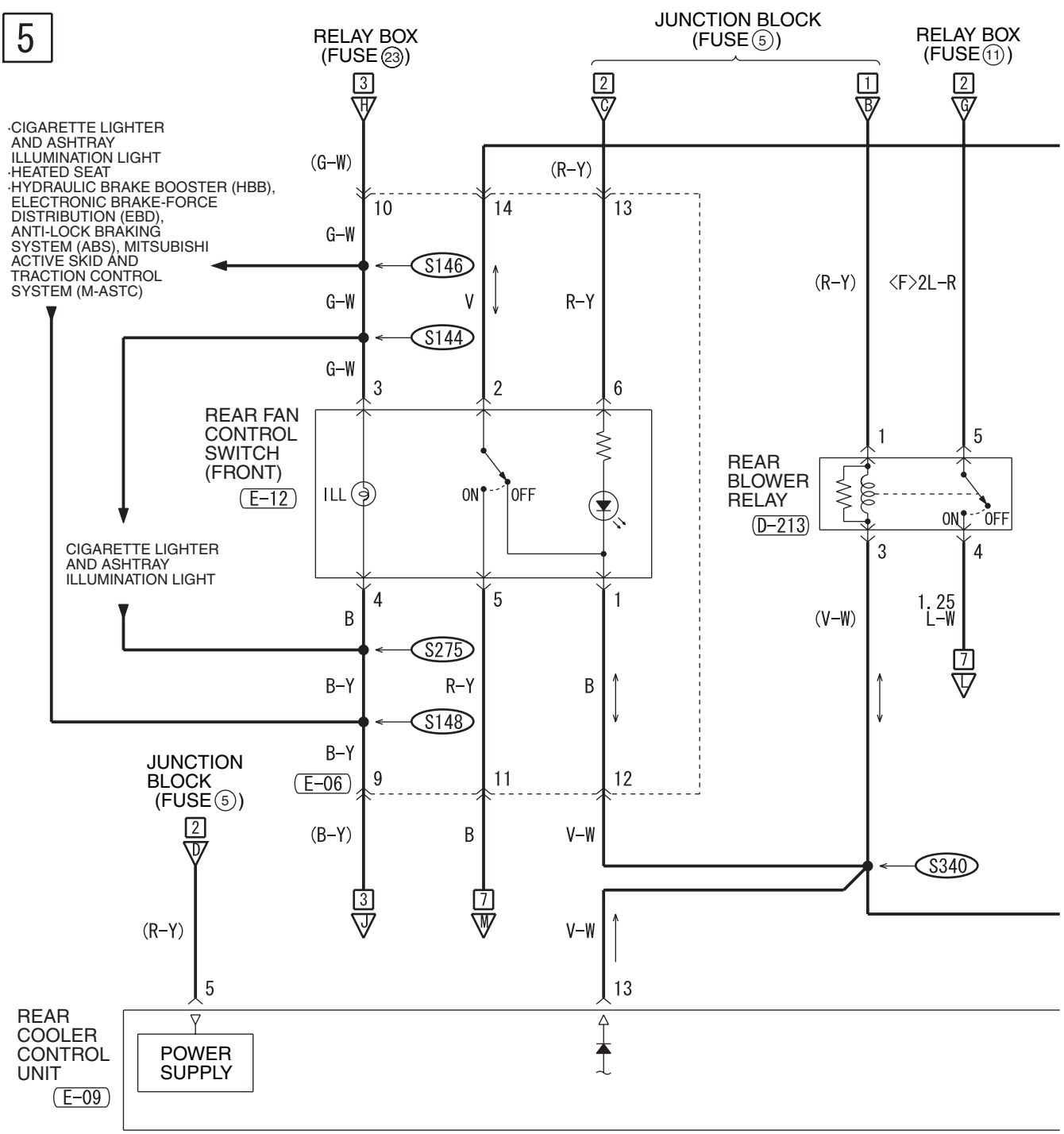

D-112

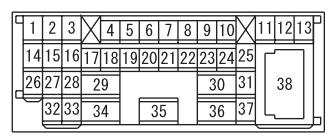

D-213



E-06

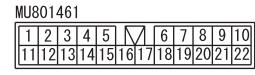

E-09

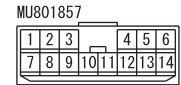

E-12



E-17

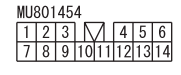

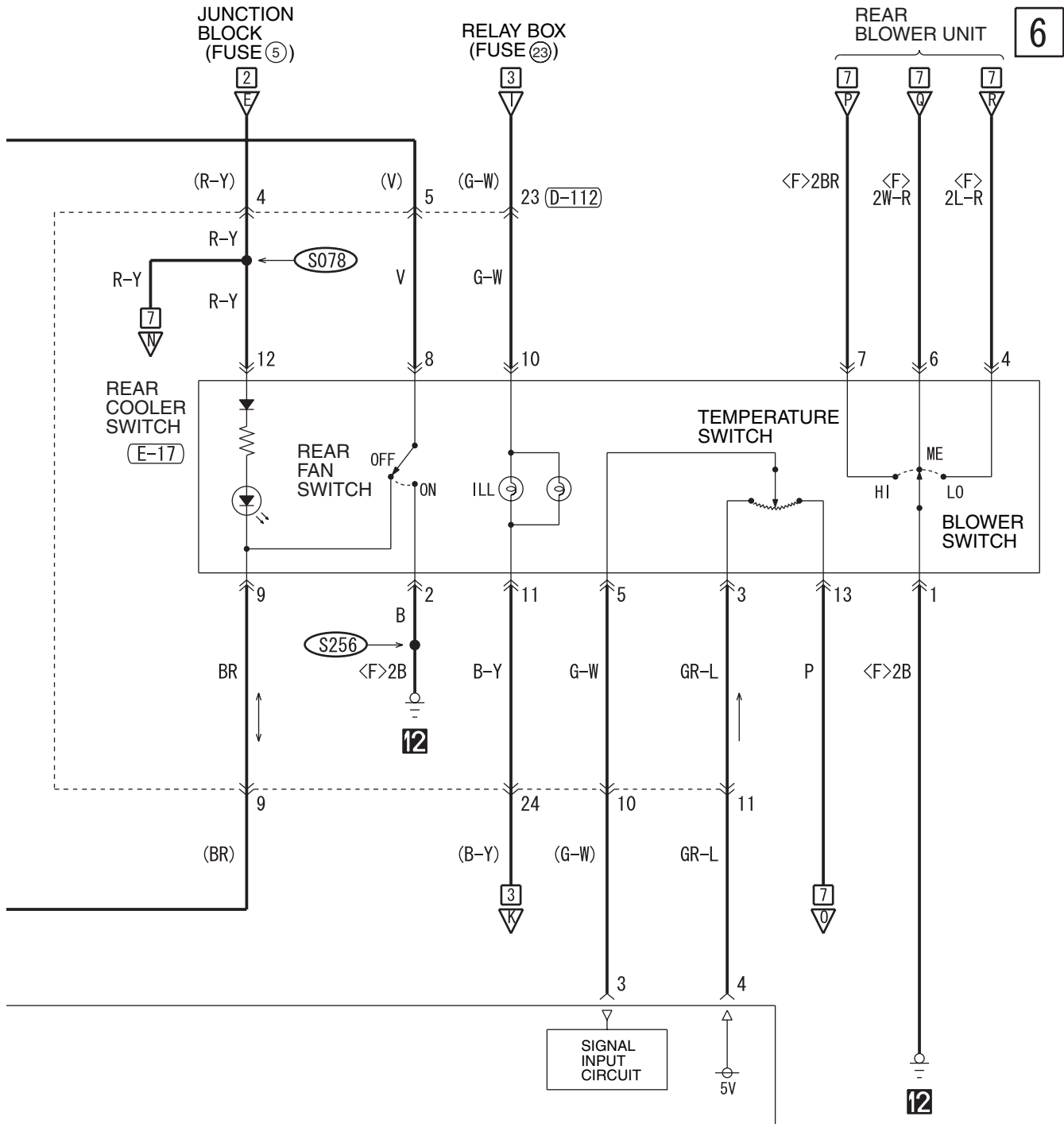

WIRE COLOR CODE

B : BLACK LG : LIGHT GREEN G : GREEN L : BLUE W : WHITE Y : YELLOW
 SB : SKY BLUE BR : BROWN O : ORANGE GR : GRAY R : RED P : PINK V : VIOLET

DUAL MANUAL AIR CONDITIONING SYSTEM <VEHICLES WITH REAR COOLER> (CONTINUED)

7

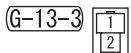
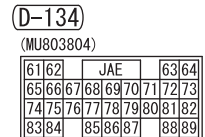
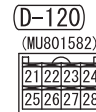
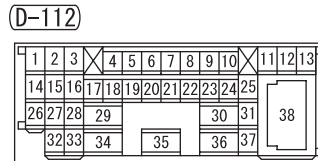
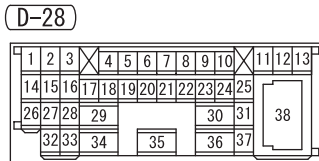
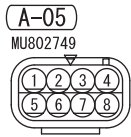
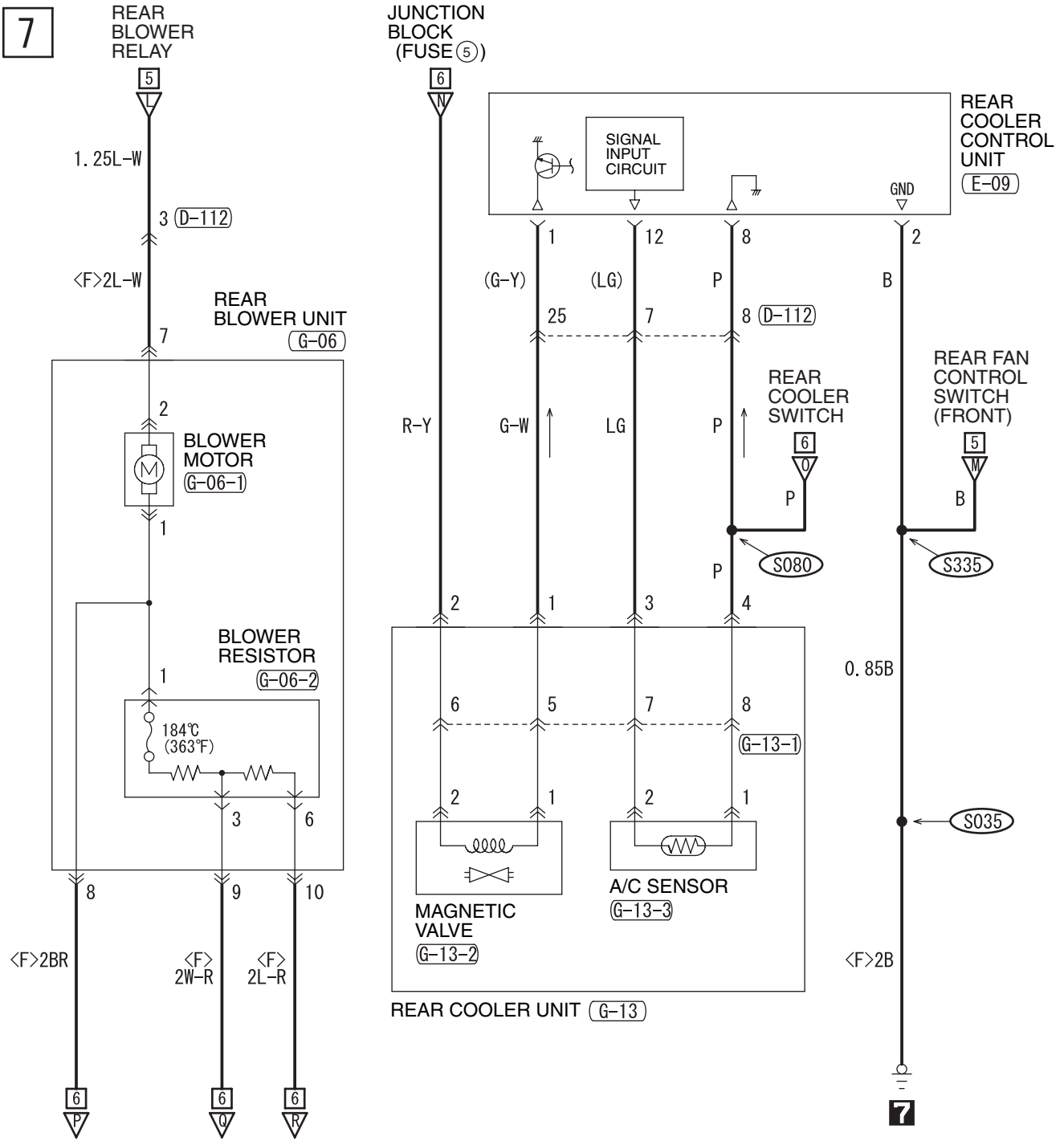

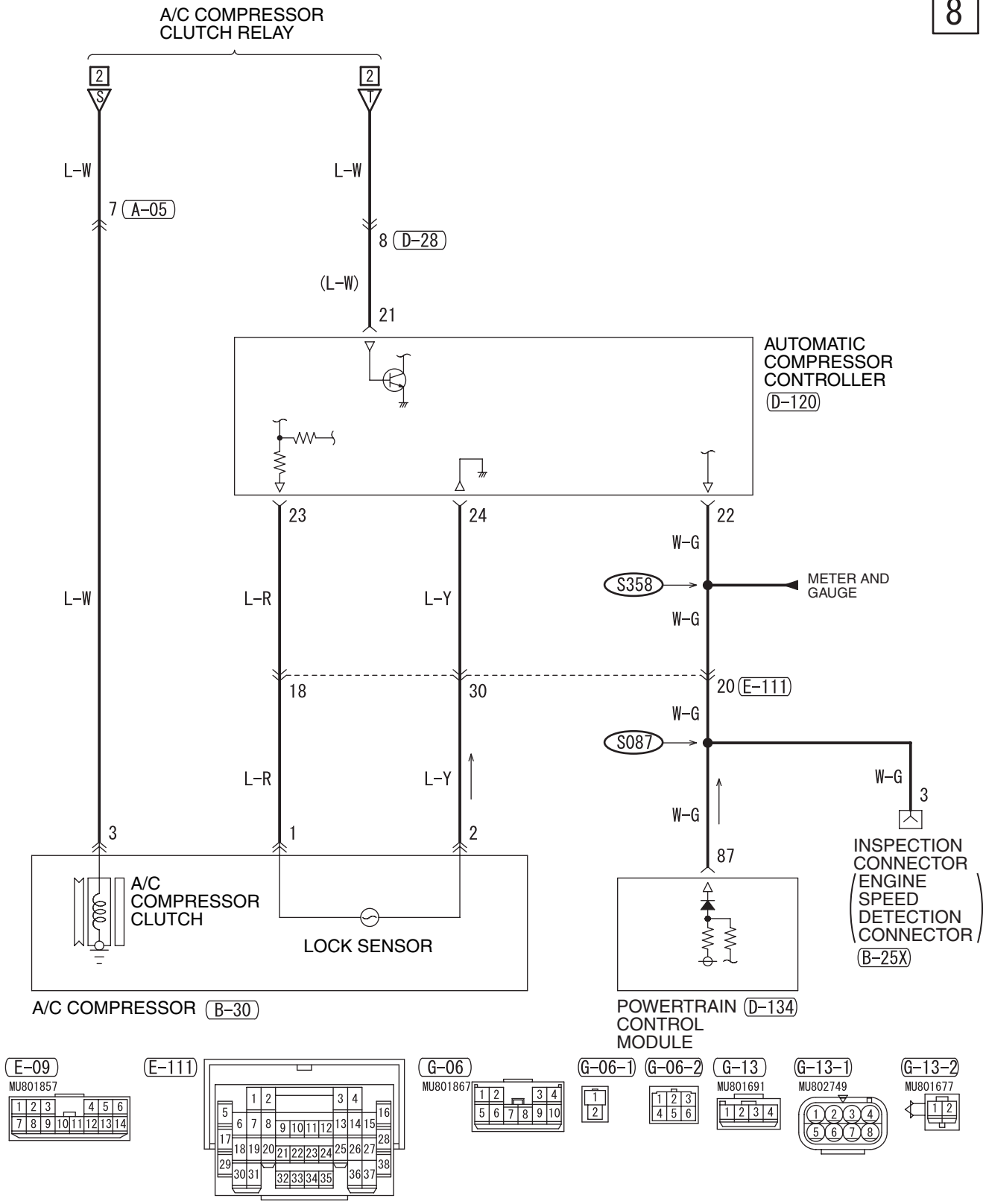

DUAL MANUAL AIR CONDITIONING SYSTEM <VEHICLES WITH REAR AIR CONDITIONING SYSTEM>

M1901005400227

1

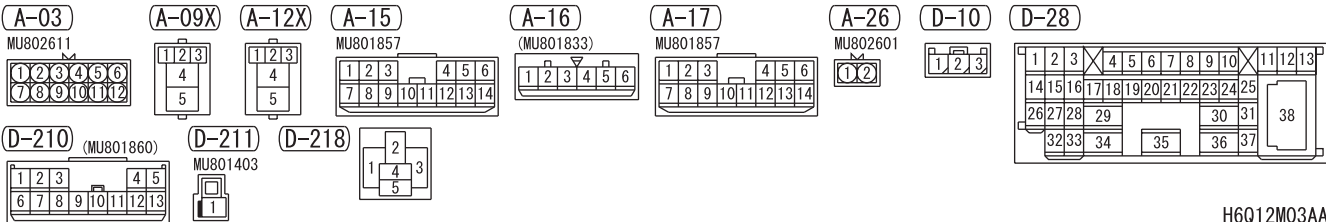
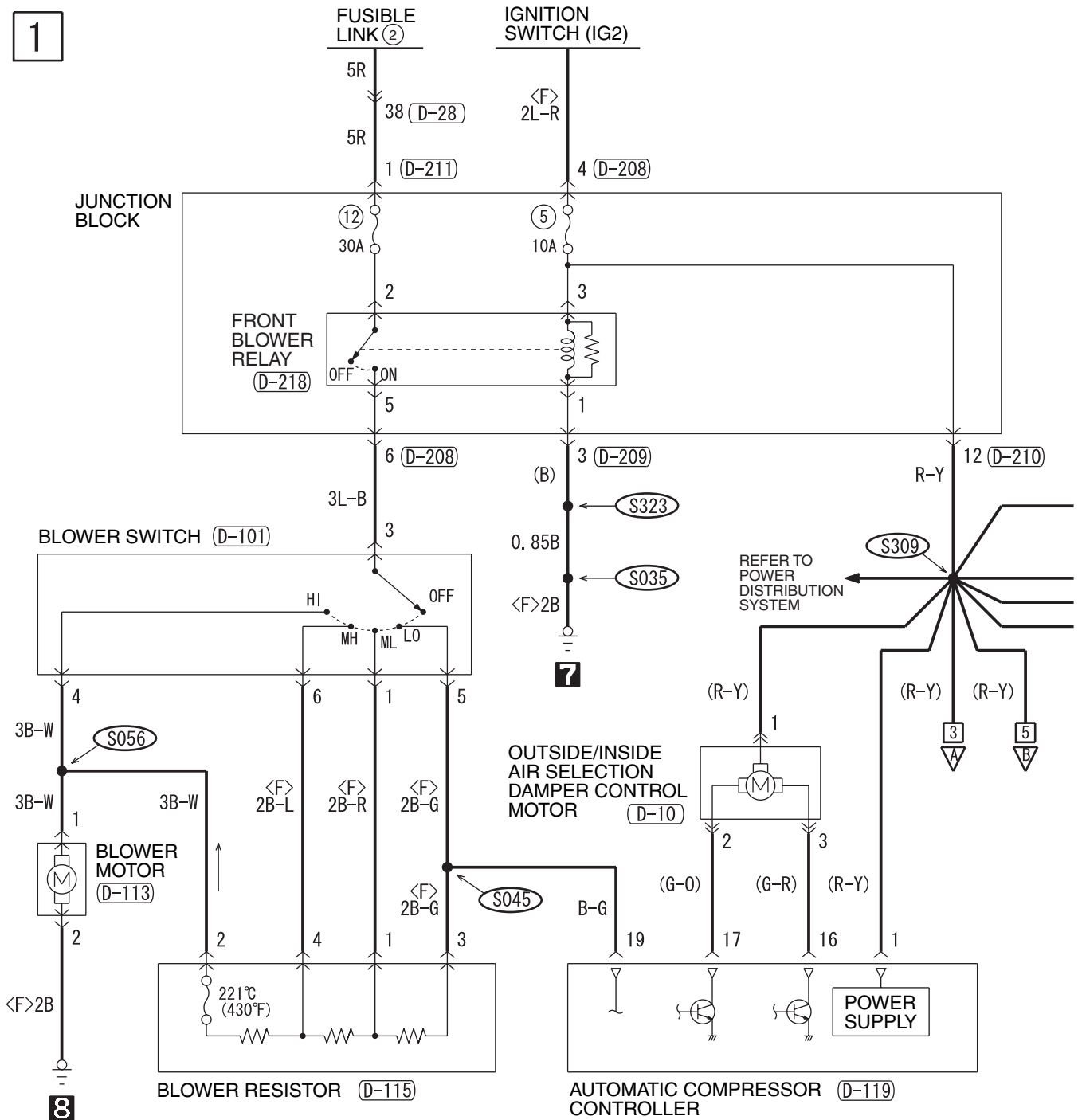

H6Q12M03AA

2

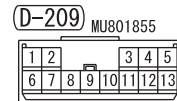
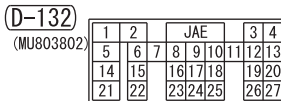
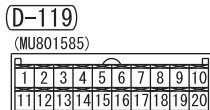
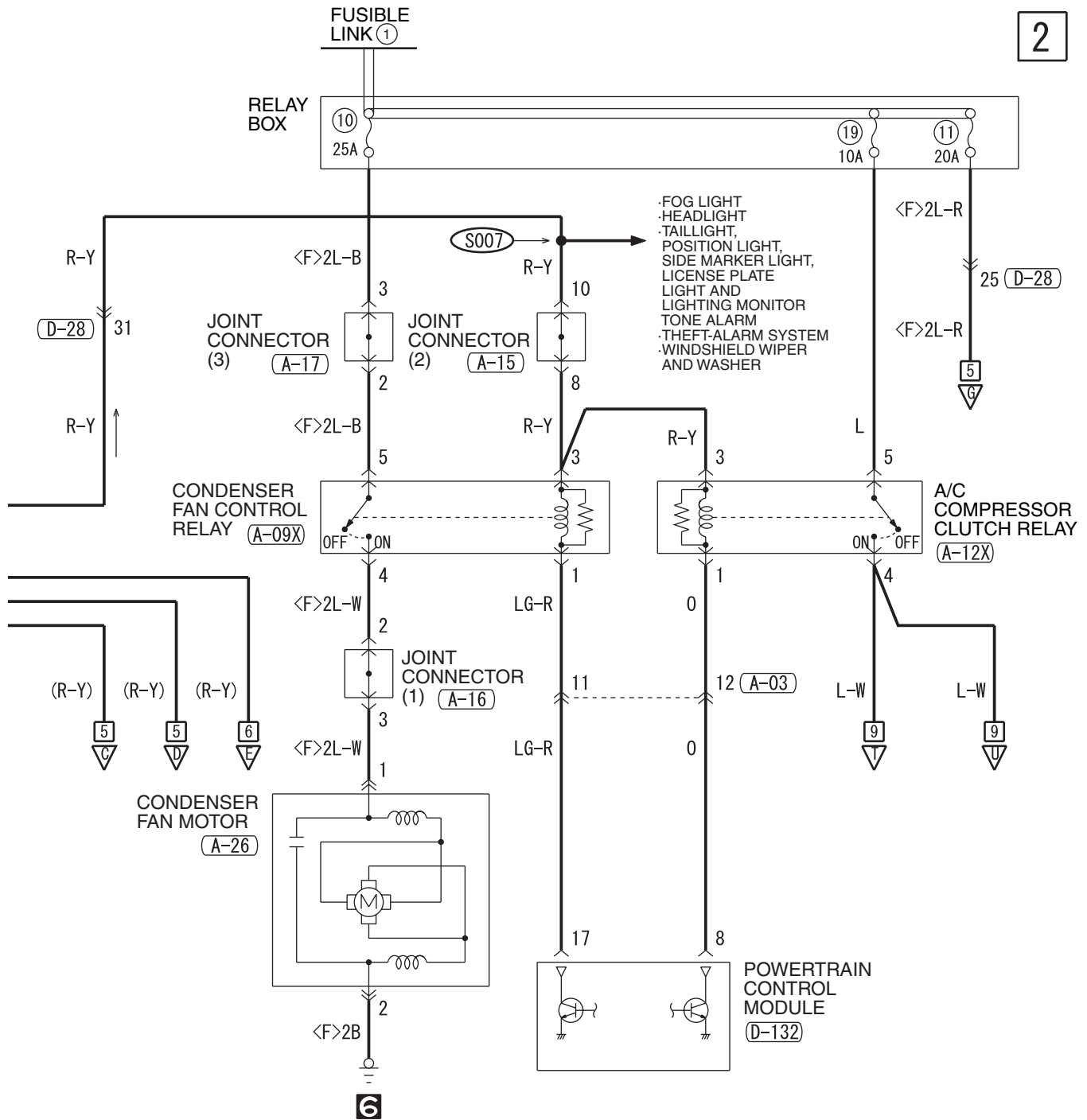

WIRE COLOR CODE

B : BLACK LG : LIGHT GREEN G : GREEN L : BLUE W : WHITE Y : YELLOW
 SB : SKY BLUE BR : BROWN O : ORANGE GR : GRAY R : RED P : PINK V : VIOLET

DUAL MANUAL AIR CONDITIONING SYSTEM <VEHICLES WITH REAR AIR CONDITIONING SYSTEM>
(CONTINUED)

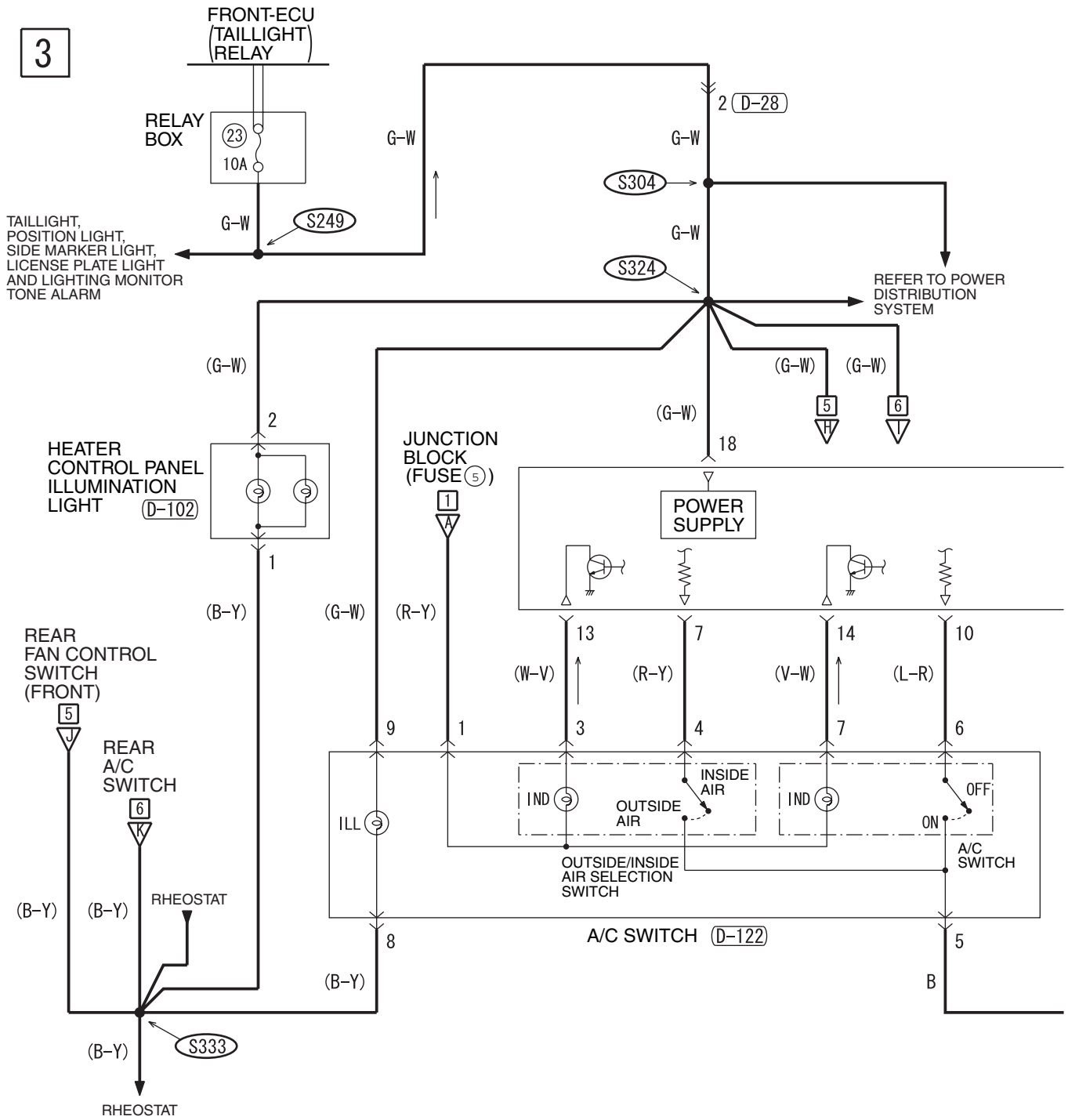

A-03

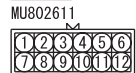

A-22



D-28

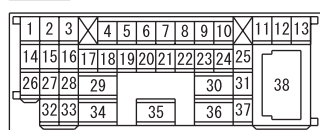

D-102



D-104



D-106



D-119

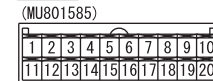

4

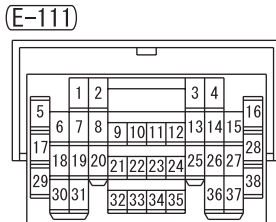
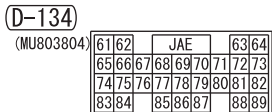
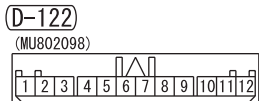
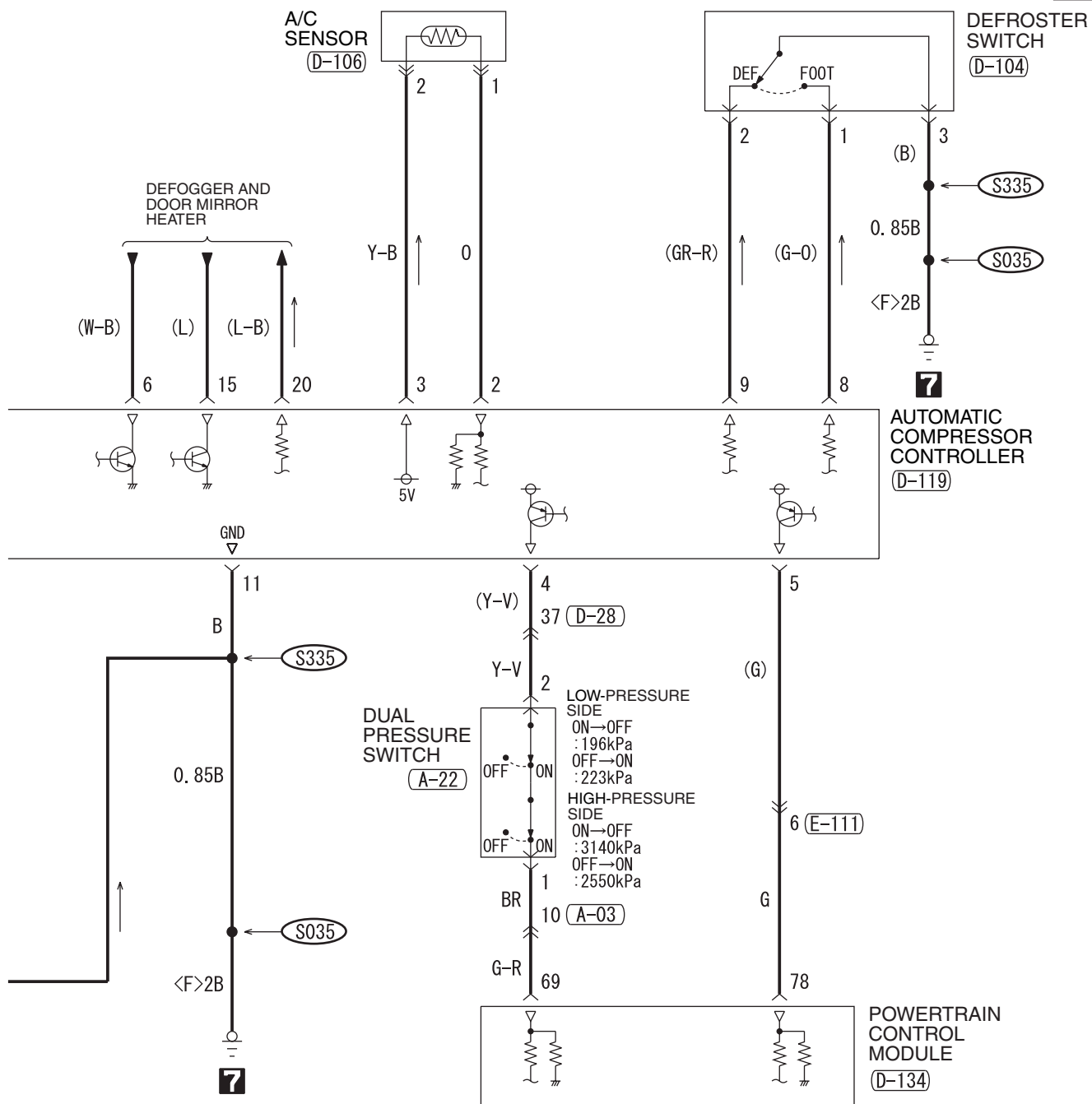

WIRE COLOR CODE
 B : BLACK LG : LIGHT GREEN
 G : GREEN L : BLUE BR : BROWN
 O : ORANGE GR : GRAY R : RED
 W : WHITESB : SKY BLUE P : PINK
 Y : YELLOW V : VIOLET

H6Q12M03BB

DUAL MANUAL AIR CONDITIONING SYSTEM <VEHICLES WITH REAR AIR CONDITIONING SYSTEM>
(CONTINUED)

5

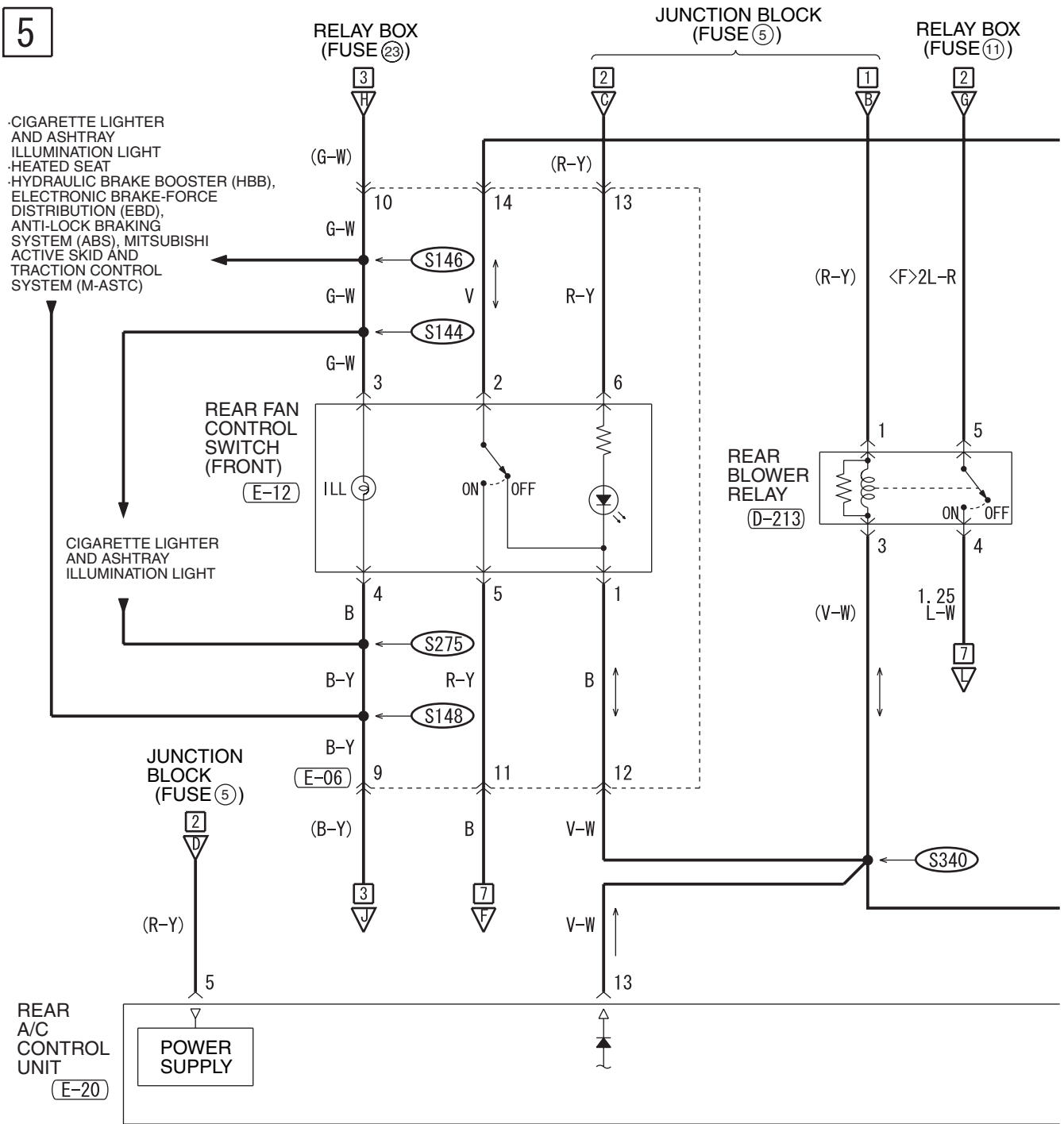

D-112

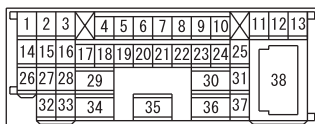

D-213



E-06

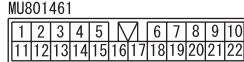

E-12



E-20

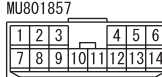

E-22

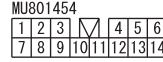

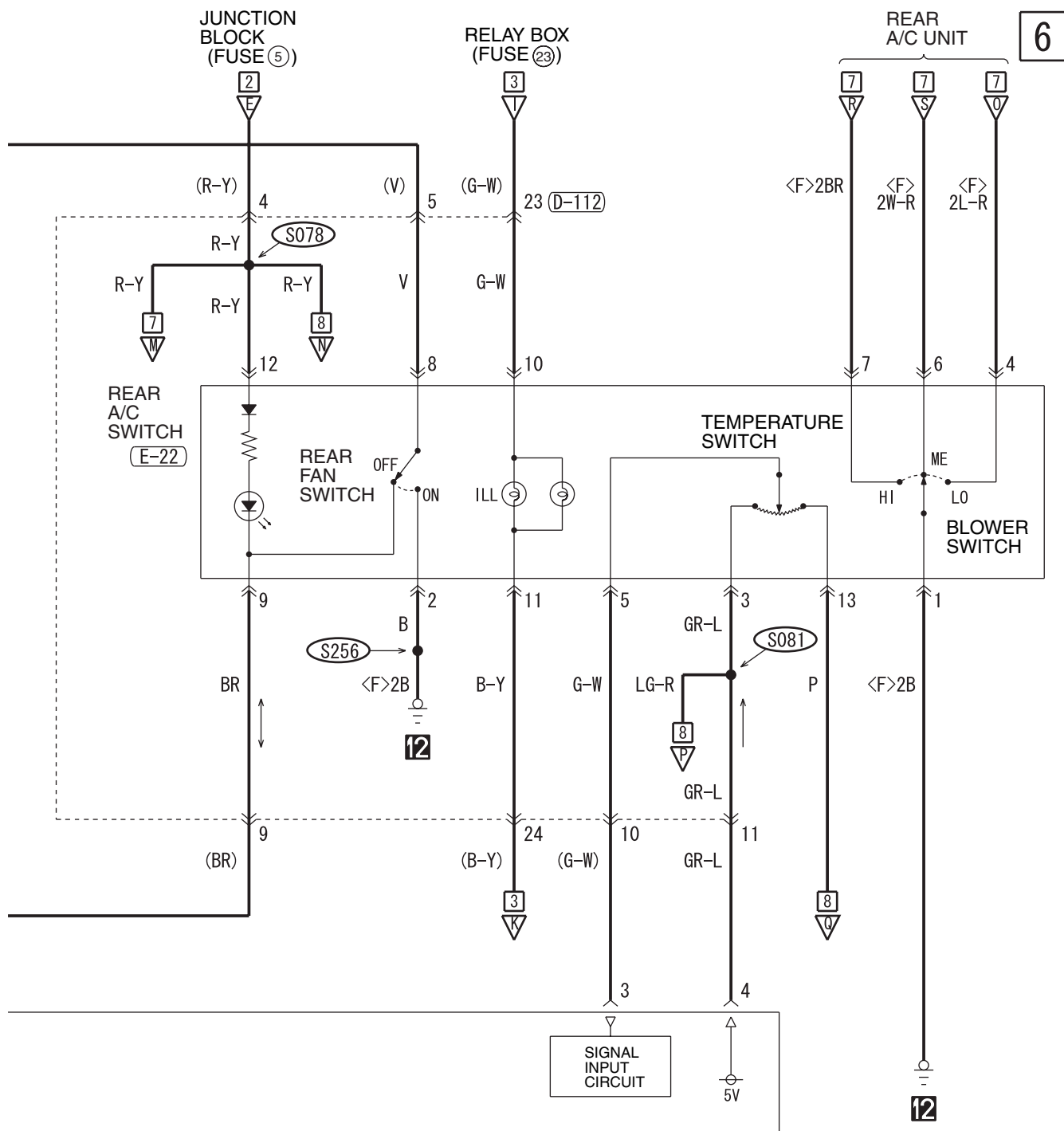

WIRE COLOR CODE

B: BLACK LG: LIGHT GREEN G: GREEN L: BLUE W: WHITE Y: YELLOW
 SB: SKY BLUE BR: BROWN O: ORANGE GR: GRAY R: RED P: PINK V: VIOLET

DUAL MANUAL AIR CONDITIONING SYSTEM <VEHICLES WITH REAR AIR CONDITIONING SYSTEM>
(CONTINUED)

7

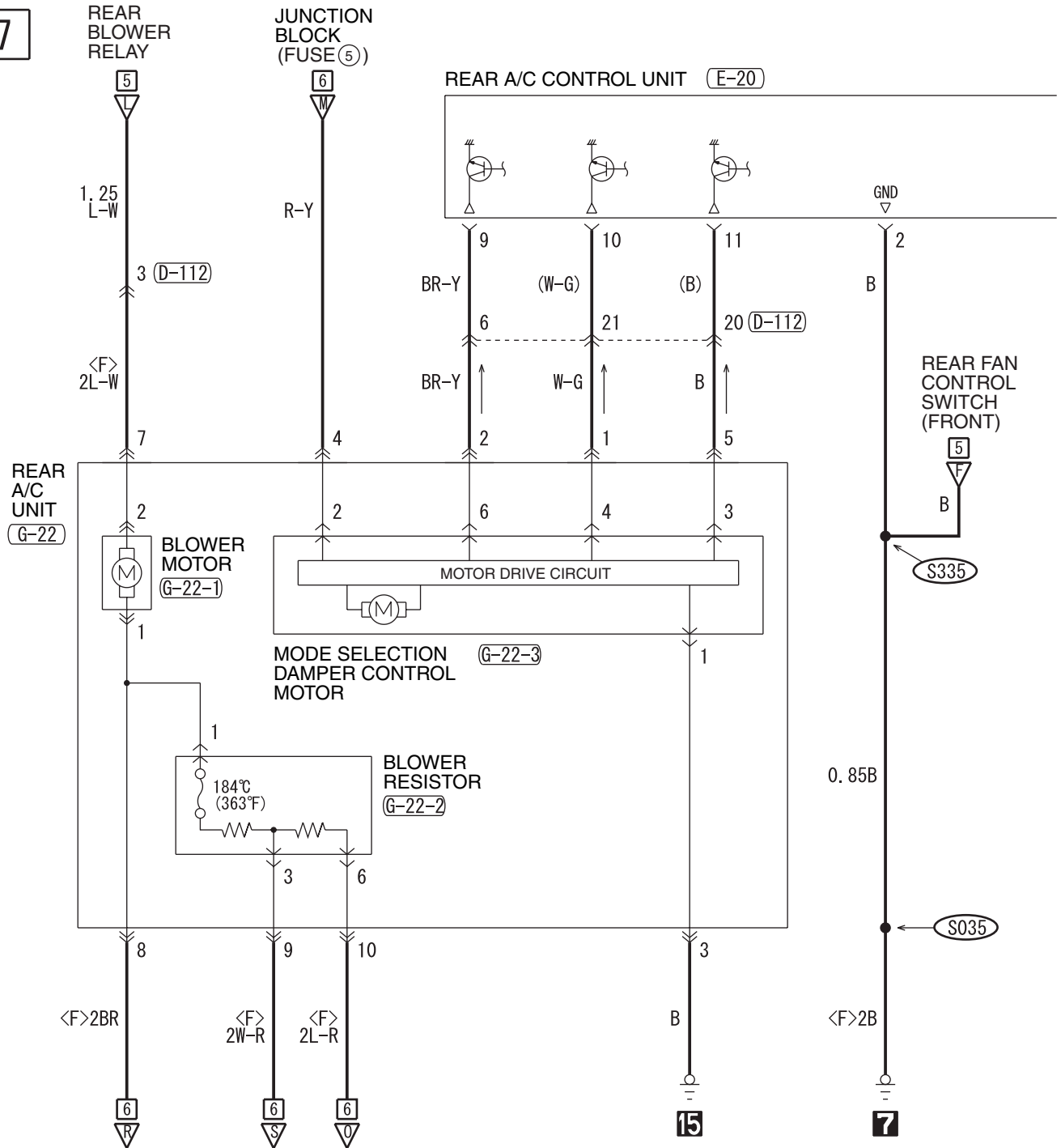

D-112

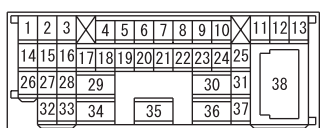

E-20

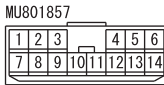

G-22

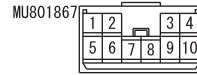

G-22-1



G-22-2



G-22-3

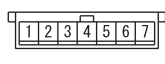

G-24



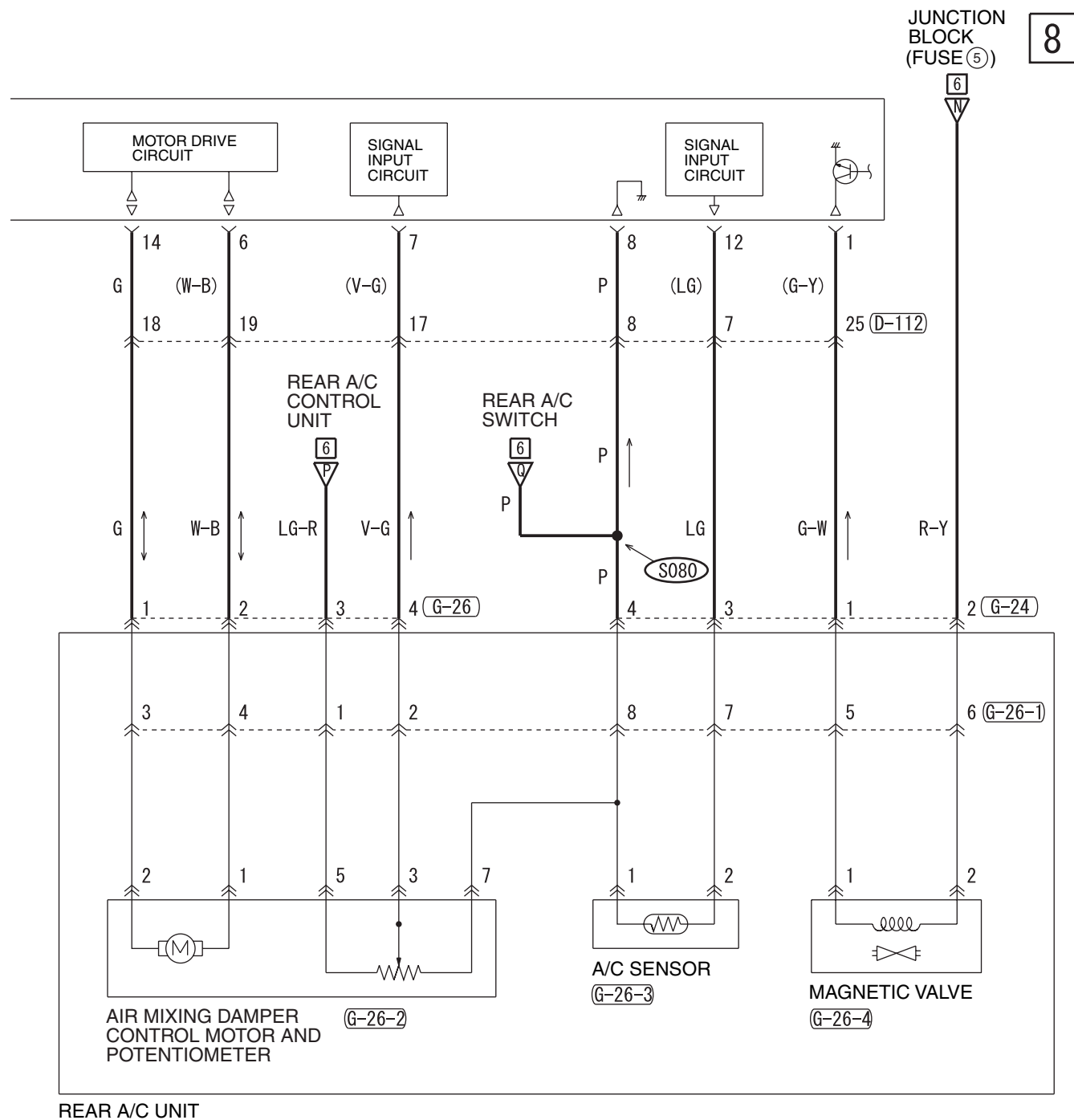

8

JUNCTION BLOCK (FUSE 5)

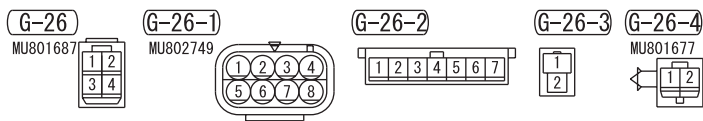

WIRE COLOR CODE
 B : BLACK LG : LIGHT GREEN G : GREEN L : BLUE W : WHITE Y : YELLOW
 SB : SKY BLUE BR : BROWN O : ORANGE GR : GRAY R : RED P : PINK V : VIOLET

TSB Revision

NOTES

AUTOMATIC AIR CONDITIONING SYSTEM <VEHICLES WITH REAR COOLER>

M1901005600771

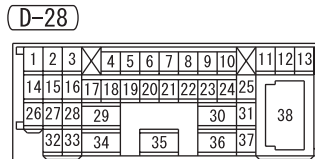
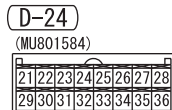
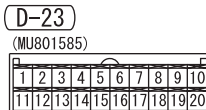
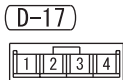
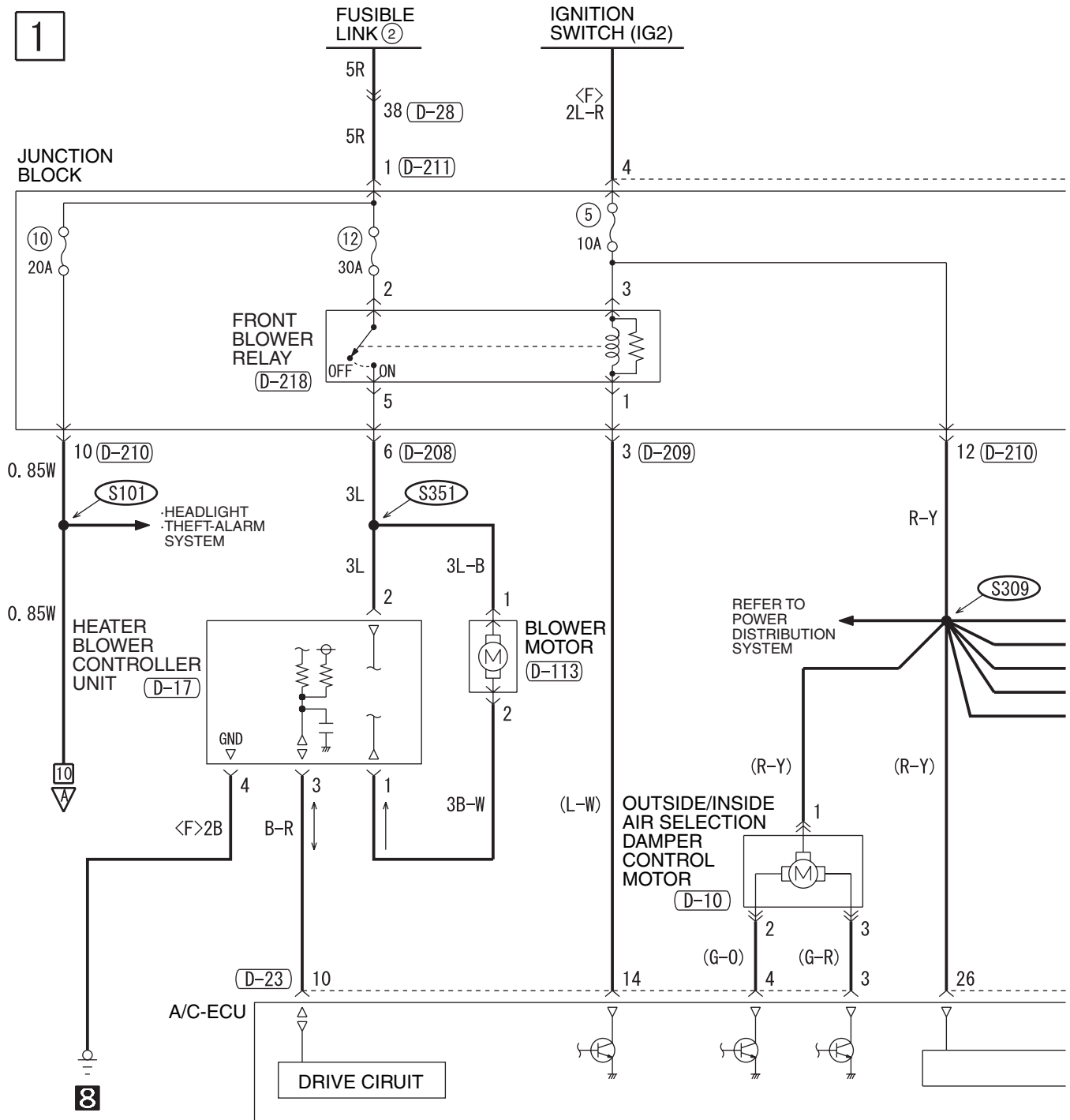

2

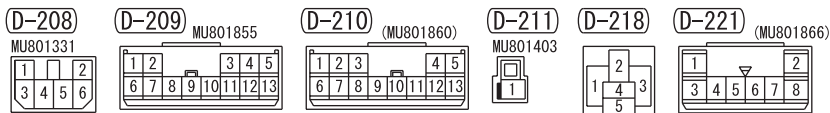
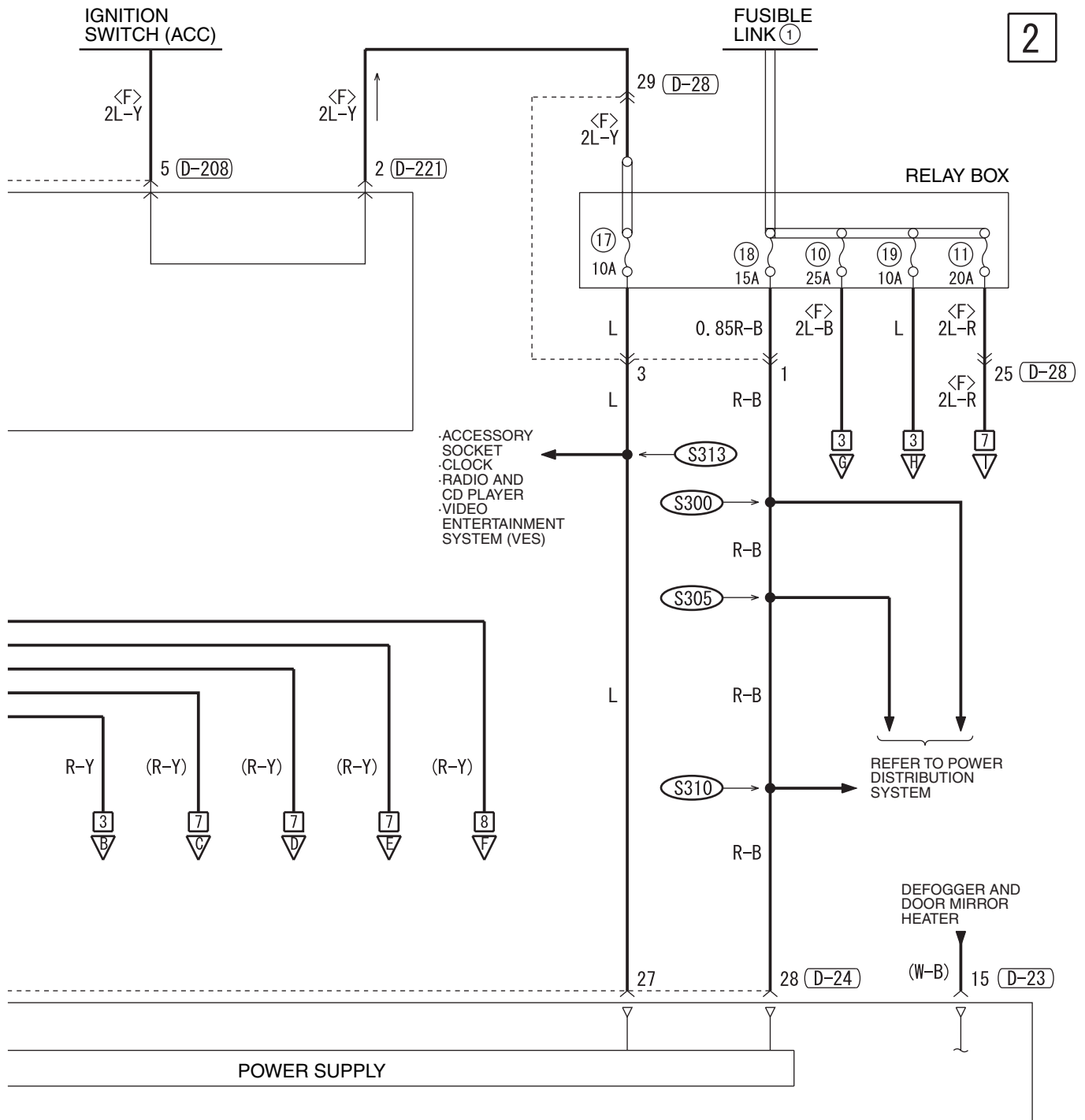

WIRE COLOR CODE
 B : BLACK LG : LIGHT GREEN G : GREEN L : BLUE W : WHITE Y : YELLOW
 SB : SKY BLUE BR : BROWN O : ORANGE GR : GRAY R : RED P : PINK V : VIOLET

AUTOMATIC AIR CONDITIONING SYSTEM <VEHICLES WITH REAR COOLER> (CONTINUED)

3

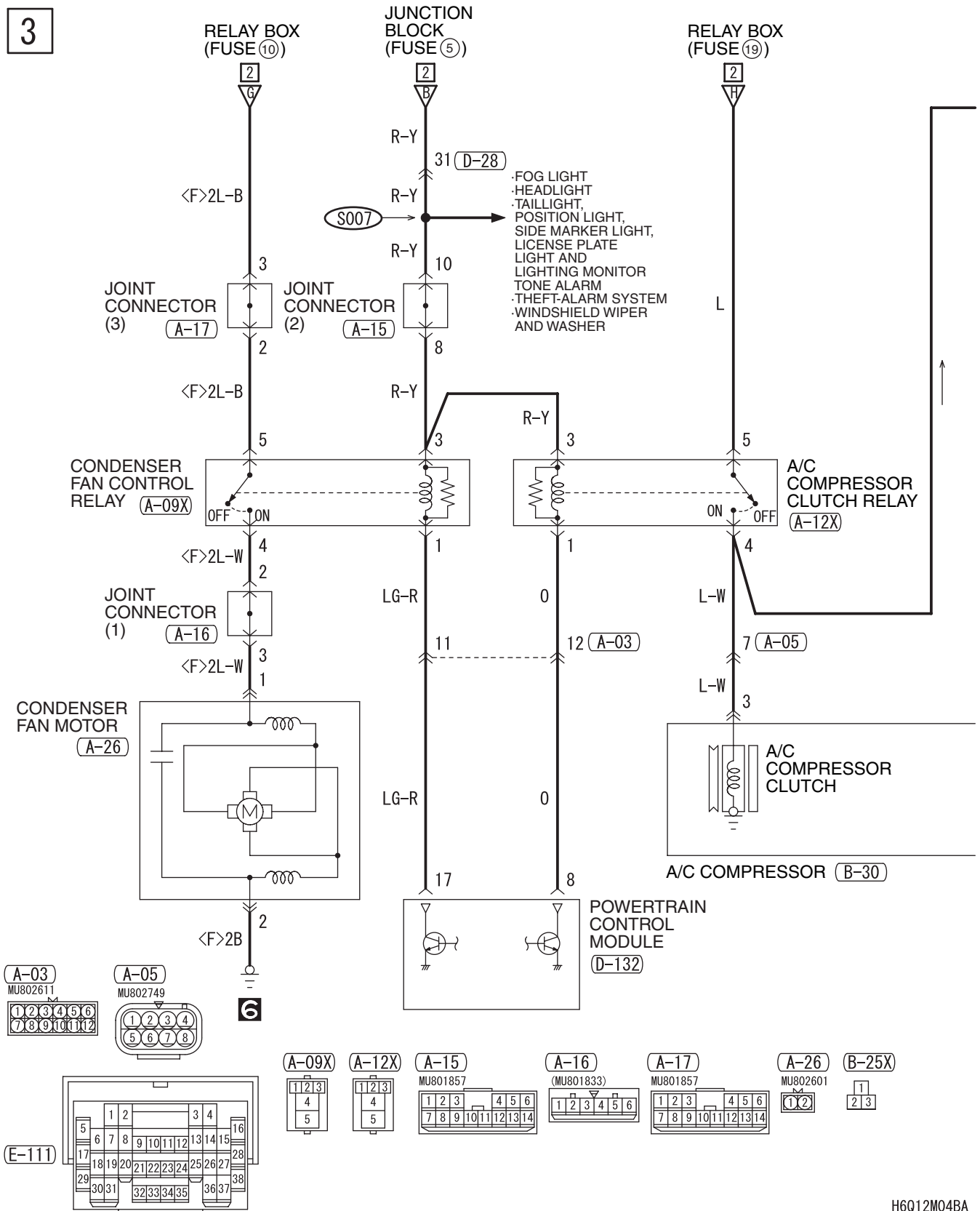

4

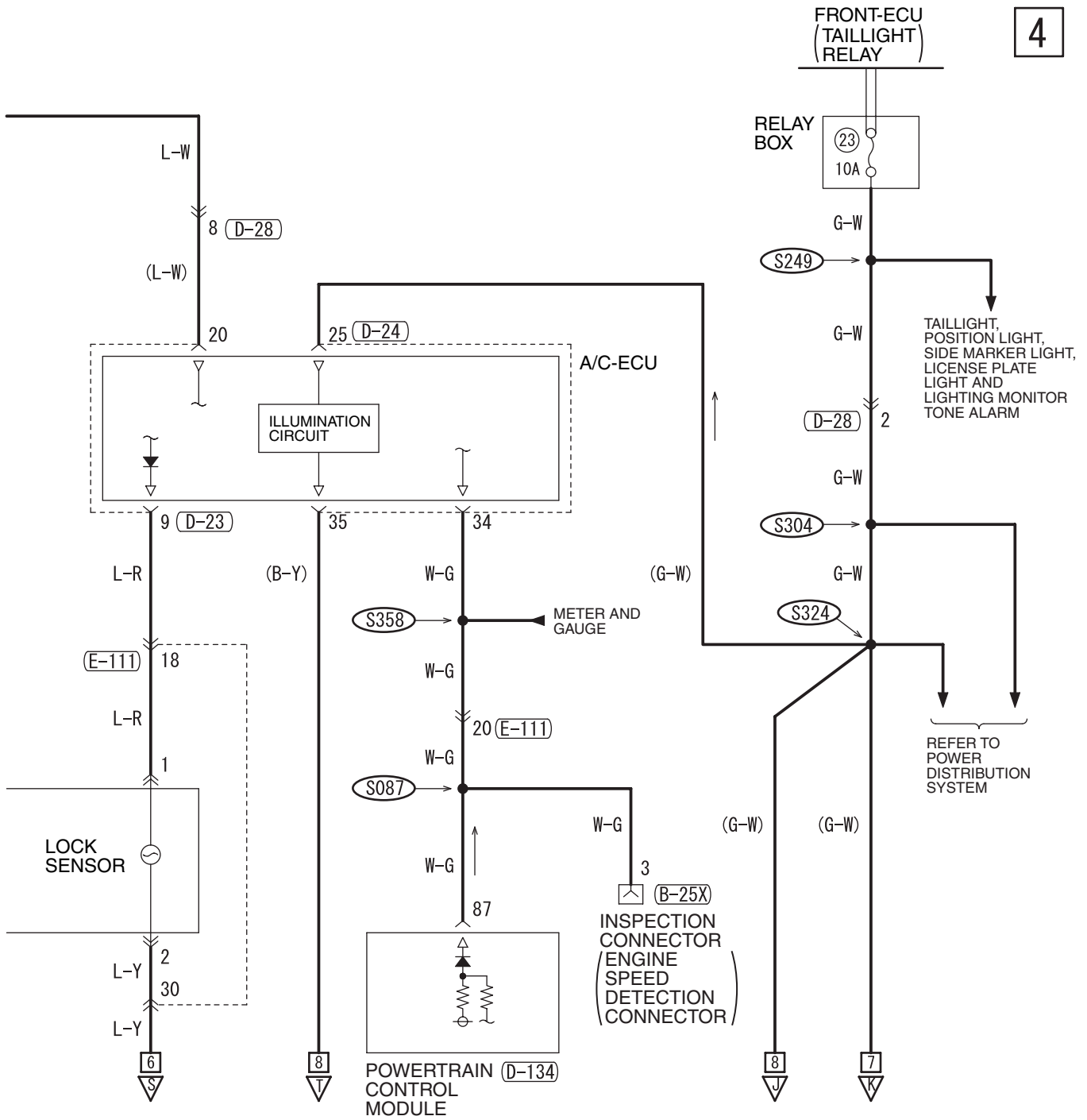

B-30
(MU802603)

1	2
3	

D-23
(MU801585)

1	2	3	4	5	6	7	8	9	10
11	12	13	14	15	16	17	18	19	20

D-24
(MU801584)

21	22	23	24	25	26	27	28
29	30	31	32	33	34	35	36

D-28

1	2	3	4	5	6	7	8	9	10	11	12	13
14	15	16	17	18	19	20	21	22	23	24	25	
26	27	28	29					30	31			38
32	33	34		35		36	37					

D-132
(MU803802)

1	2	JAE	3	4				
5	6	7	8	9	10	11	12	13
14	15	16	17	18	19	20		
21	22	23	24	25	26	27		

D-134
(MU803804)

61	62	JAE	63	64				
65	66	67	68	69	70	71	72	73
74	75	76	77	78	79	80	81	82
83	84	85	86	87	88	89		

AUTOMATIC AIR CONDITIONING SYSTEM <VEHICLES WITH REAR COOLER> (CONTINUED)

5

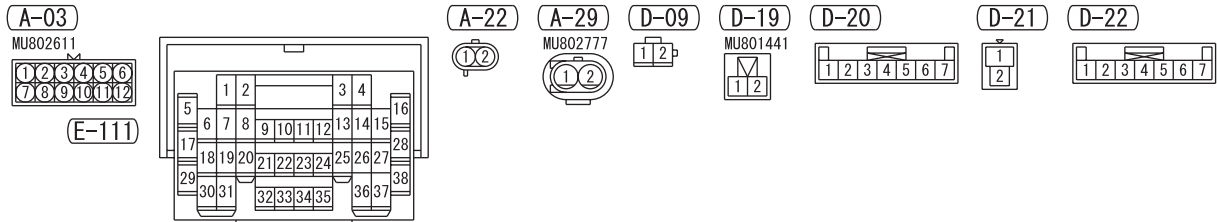
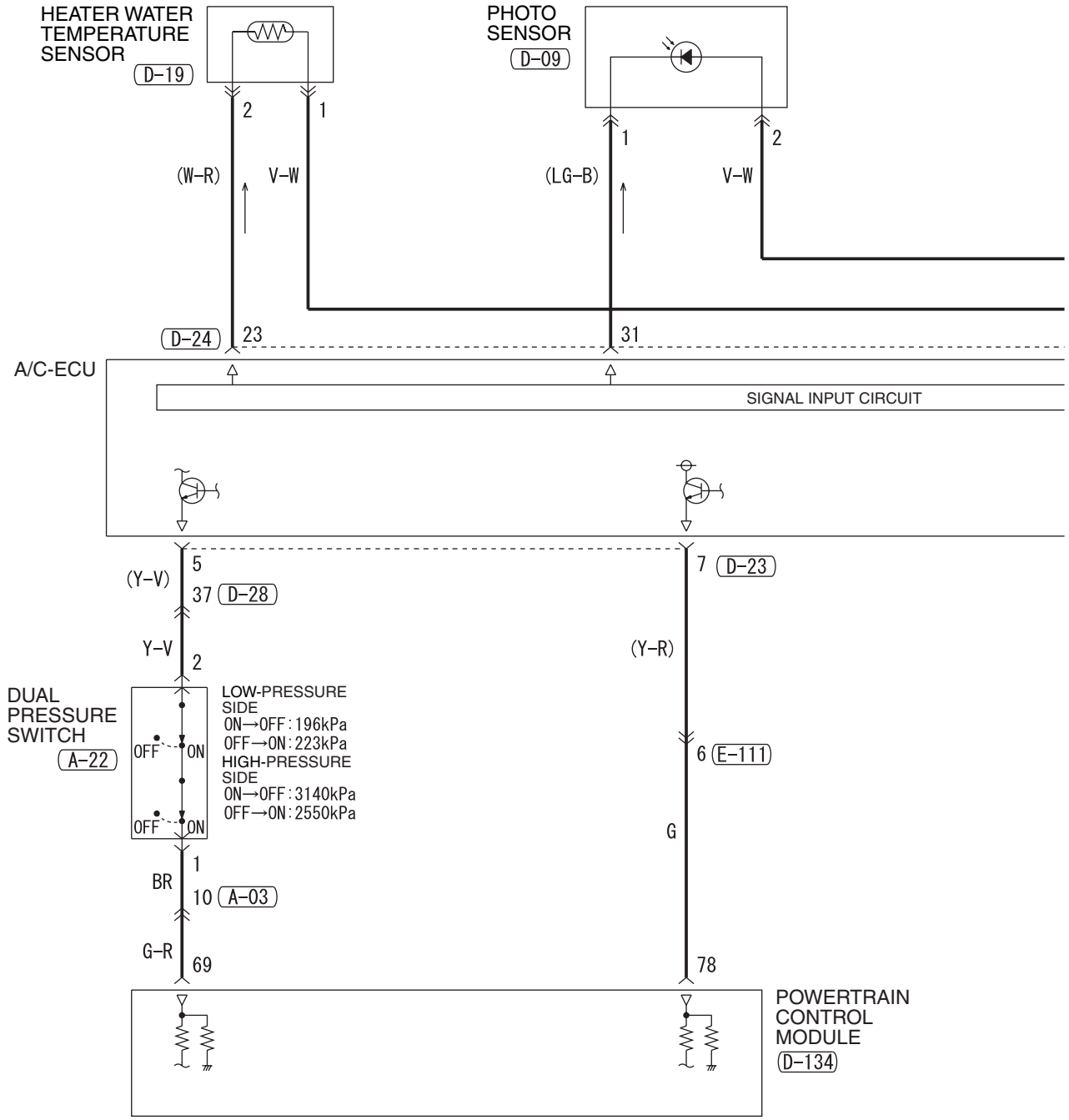

6

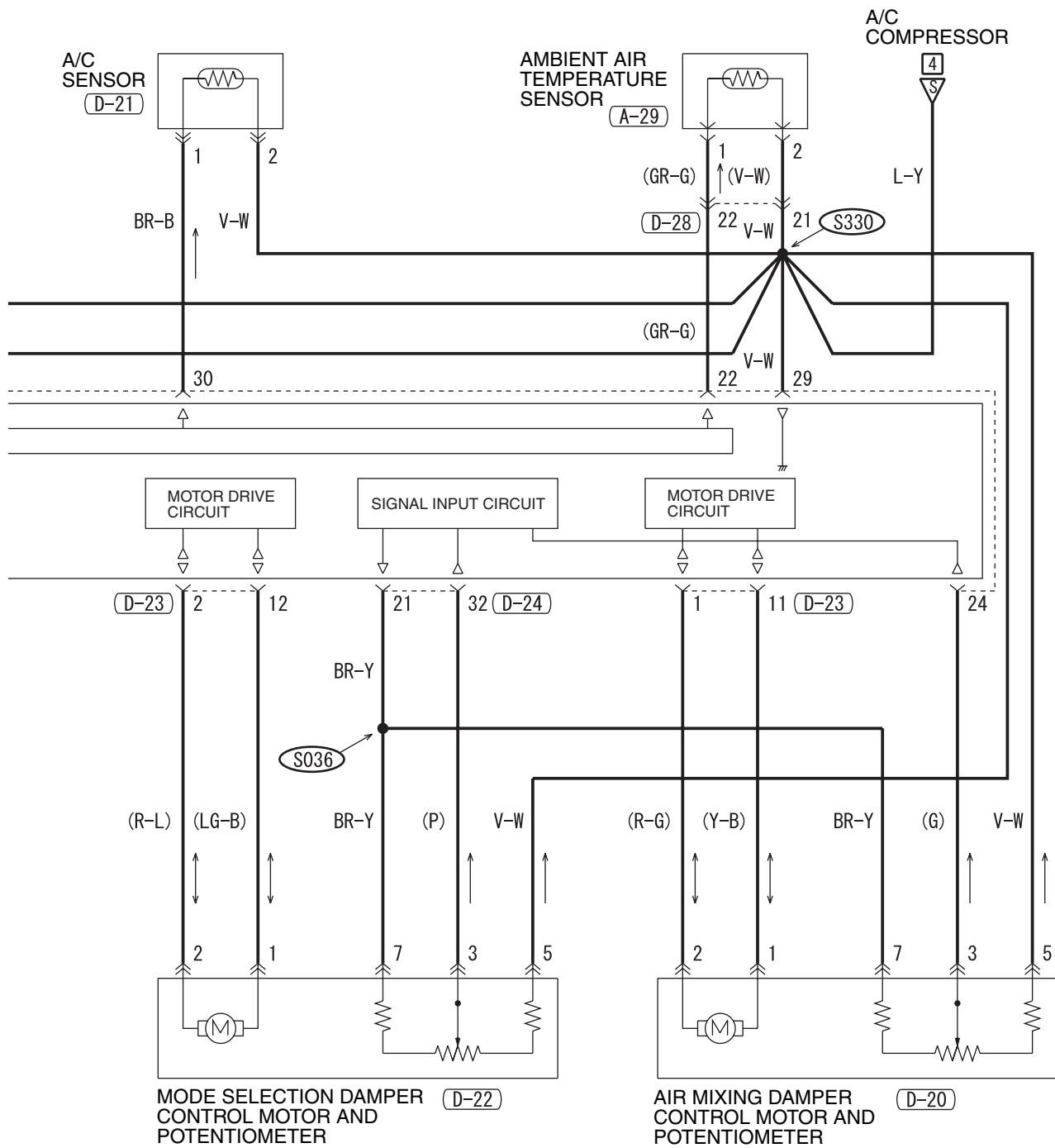

D-23
(MU801585)

1	2	3	4	5	6	7	8	9	10
11	12	13	14	15	16	17	18	19	20

D-24
(MU801584)

21	22	23	24	25	26	27	28
29	30	31	32	33	34	35	36

D-28

1	2	3	4	5	6	7	8	9	10	11	12	13
14	15	16	17	18	19	20	21	22	23	24	25	
26	27	28	29			30	31			38		
	32	33	34		35		36	37				

D-134
(MU803804)

61	62	JAE	63	64				
65	66	67	68	69	70	71	72	73
74	75	76	77	78	79	80	81	82
83	84	85	86	87	88	89		

WIRE COLOR CODE
 B : BLACK LG : LIGHT GREEN G : GREEN L : BLUE W : WHITE Y : YELLOW
 SB : SKY BLUE BR : BROWN O : ORANGE GR : GRAY R : RED P : PINK V : VIOLET

H6Q12M04CB

TSB Revision

AUTOMATIC AIR CONDITIONING SYSTEM <VEHICLES WITH REAR COOLER> (CONTINUED)

7

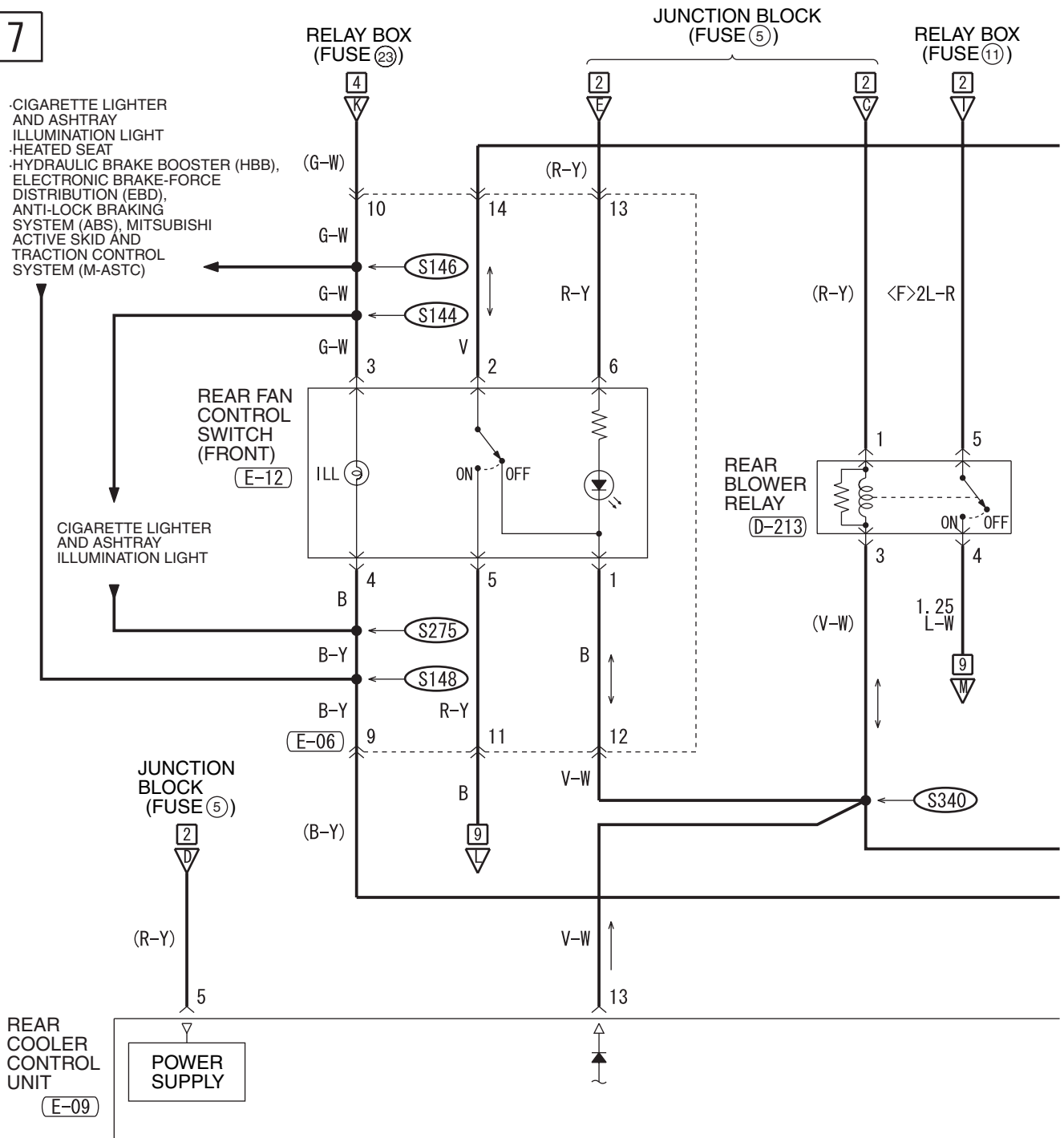

D-112

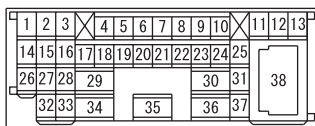

D-213



E-06

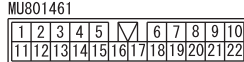

E-09

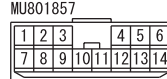

E-12



E-17

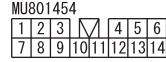

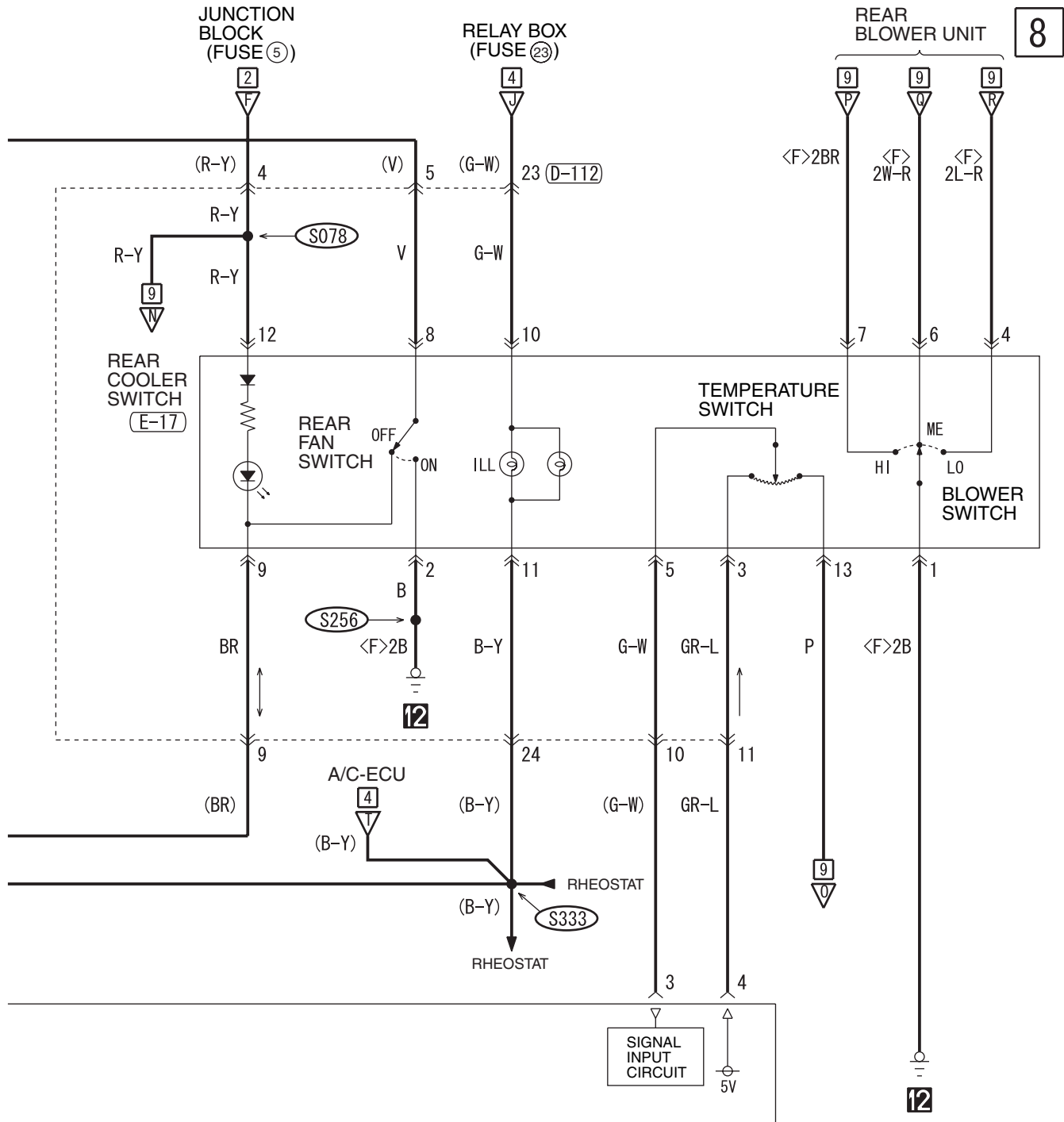

WIRE COLOR CODE

B : BLACK LG : LIGHT GREEN G : GREEN L : BLUE W : WHITE Y : YELLOW
 SB : SKY BLUE BR : BROWN O : ORANGE GR : GRAY R : RED P : PINK V : VIOLET

AUTOMATIC AIR CONDITIONING SYSTEM <VEHICLES WITH REAR COOLER> (CONTINUED)

9

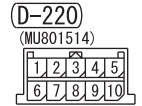
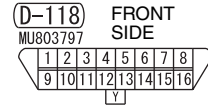
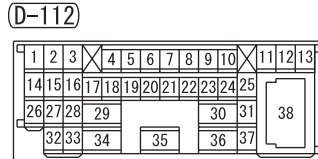
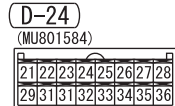
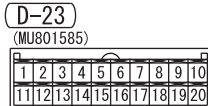
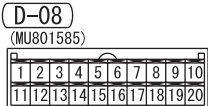
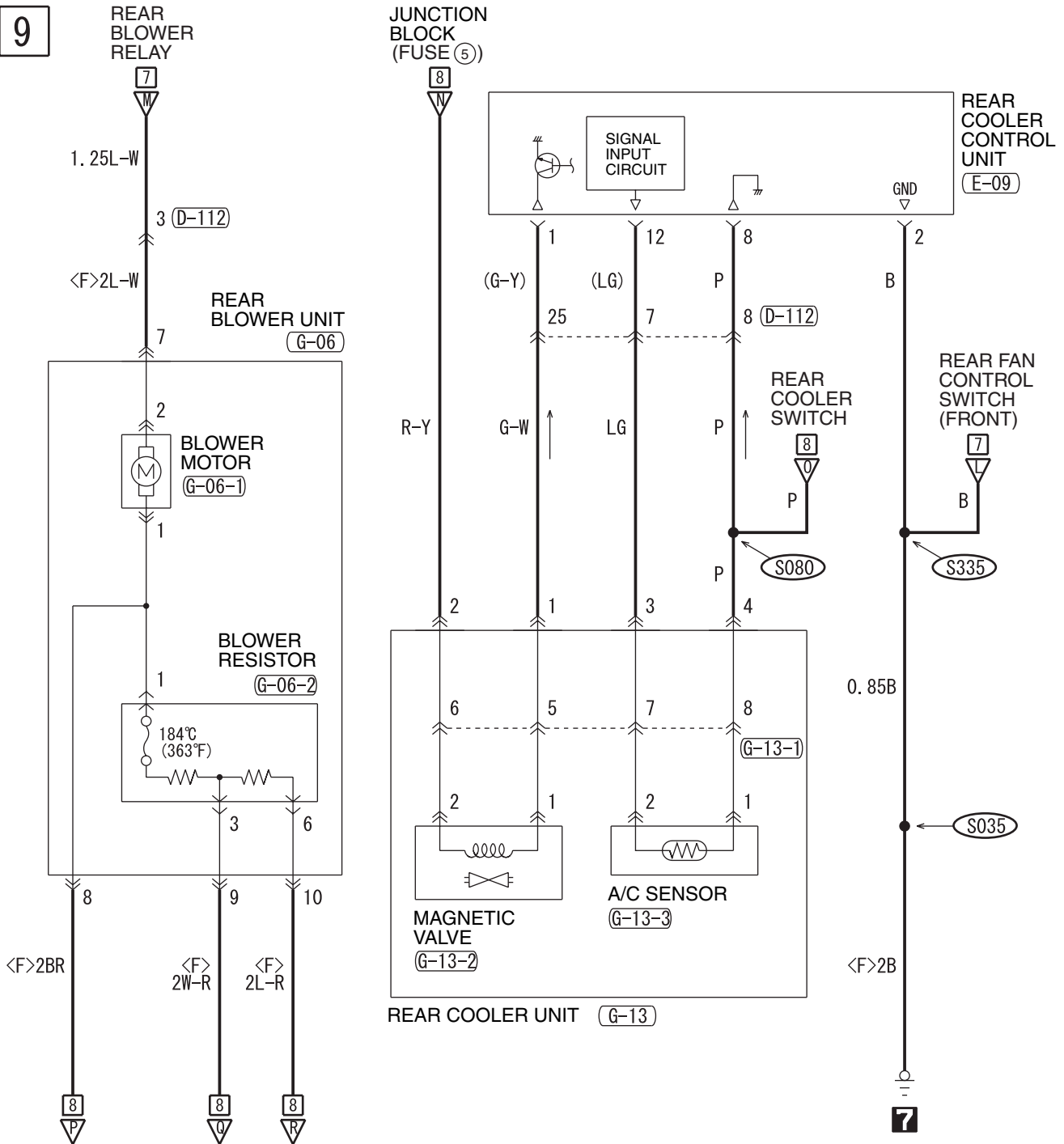

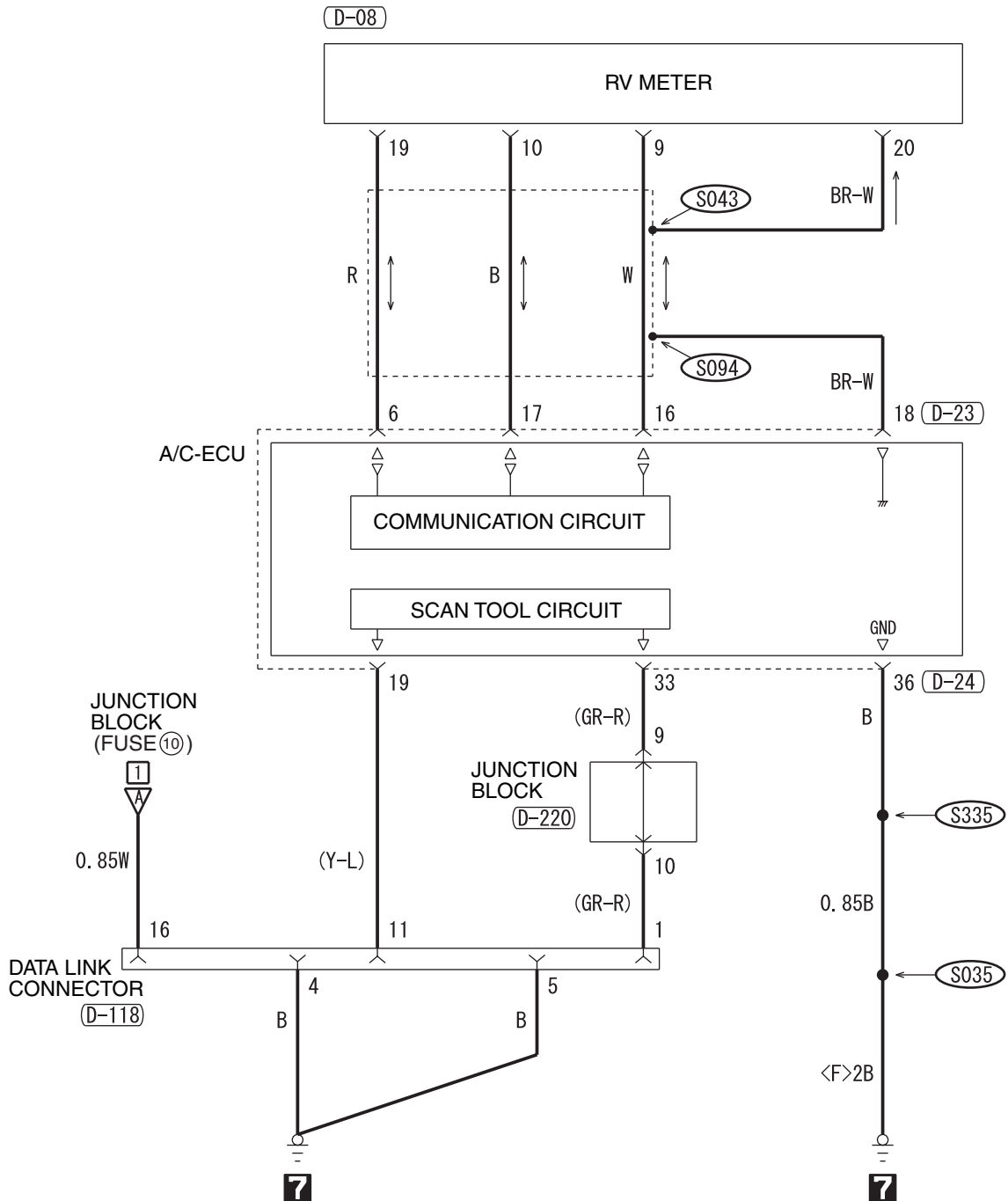

E-09

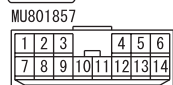

G-06

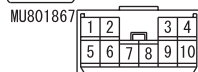

G-06-1



G-06-2



G-13



G-13-1

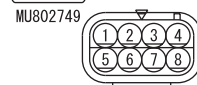

G-13-2



G-13-3



WIRE COLOR CODE

B : BLACK LG : LIGHT GREEN G : GREEN L : BLUE W : WHITE Y : YELLOW
 SB : SKY BLUE BR : BROWN O : ORANGE GR : GRAY R : RED P : PINK V : VIOLET

AUTOMATIC AIR CONDITIONING SYSTEM <VEHICLES WITH REAR AIR CONDITIONING SYSTEM>

M1901005600782

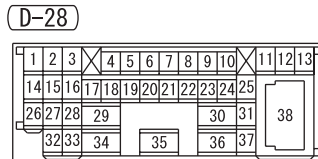
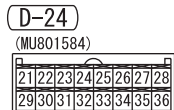
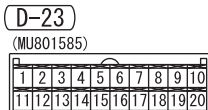
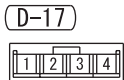
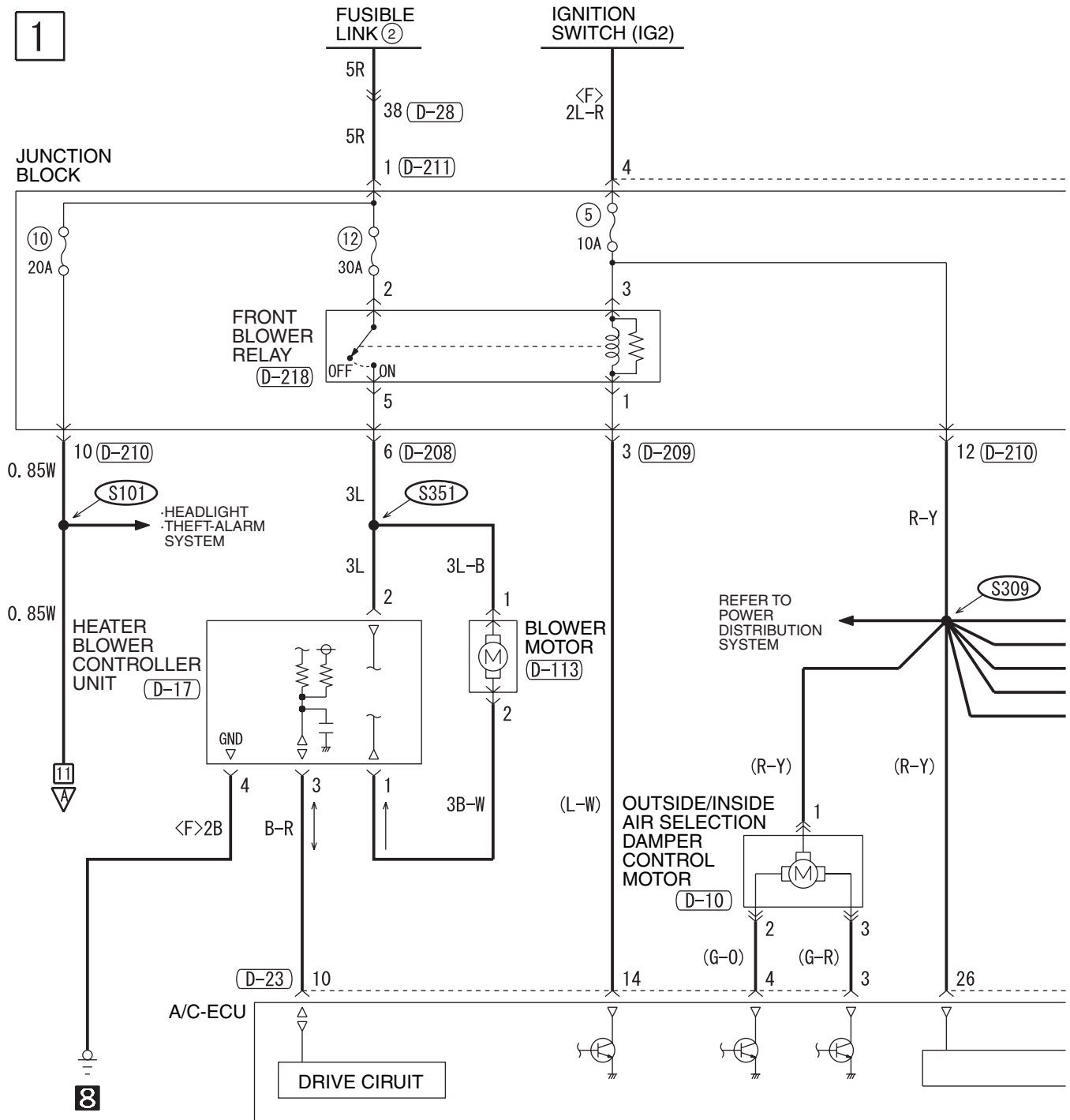

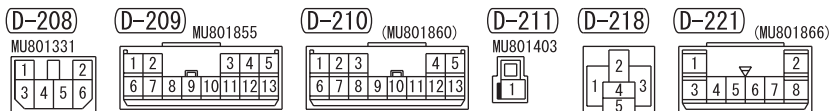
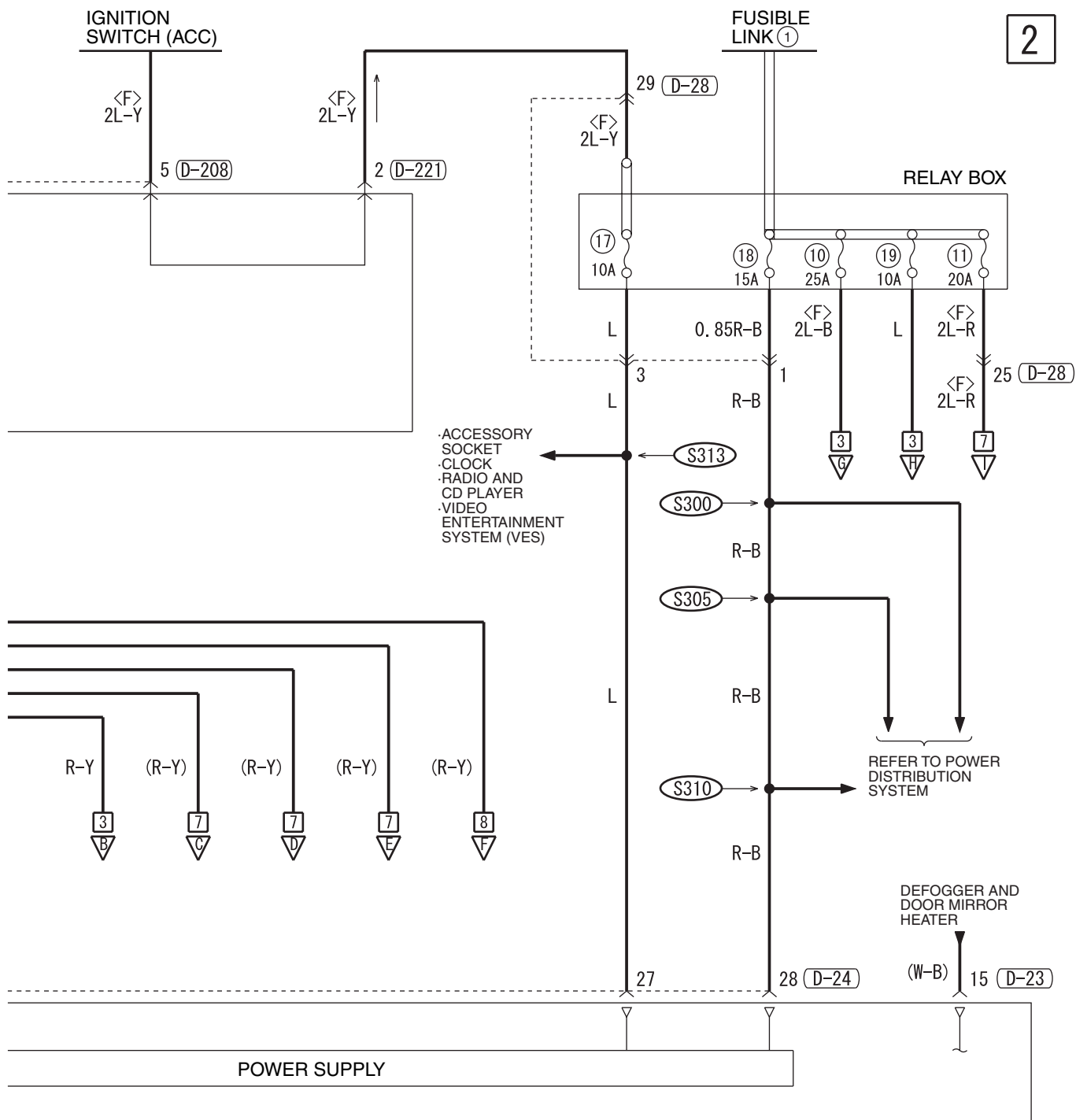

WIRE COLOR CODE

B : BLACK LG : LIGHT GREEN G : GREEN L : BLUE W : WHITE Y : YELLOW
 SB : SKY BLUE BR : BROWN O : ORANGE GR : GRAY R : RED P : PINK V : VIOLET

AUTOMATIC AIR CONDITIONING SYSTEM <VEHICLES WITH REAR AIR CONDITIONING SYSTEM>
(CONTINUED)

3

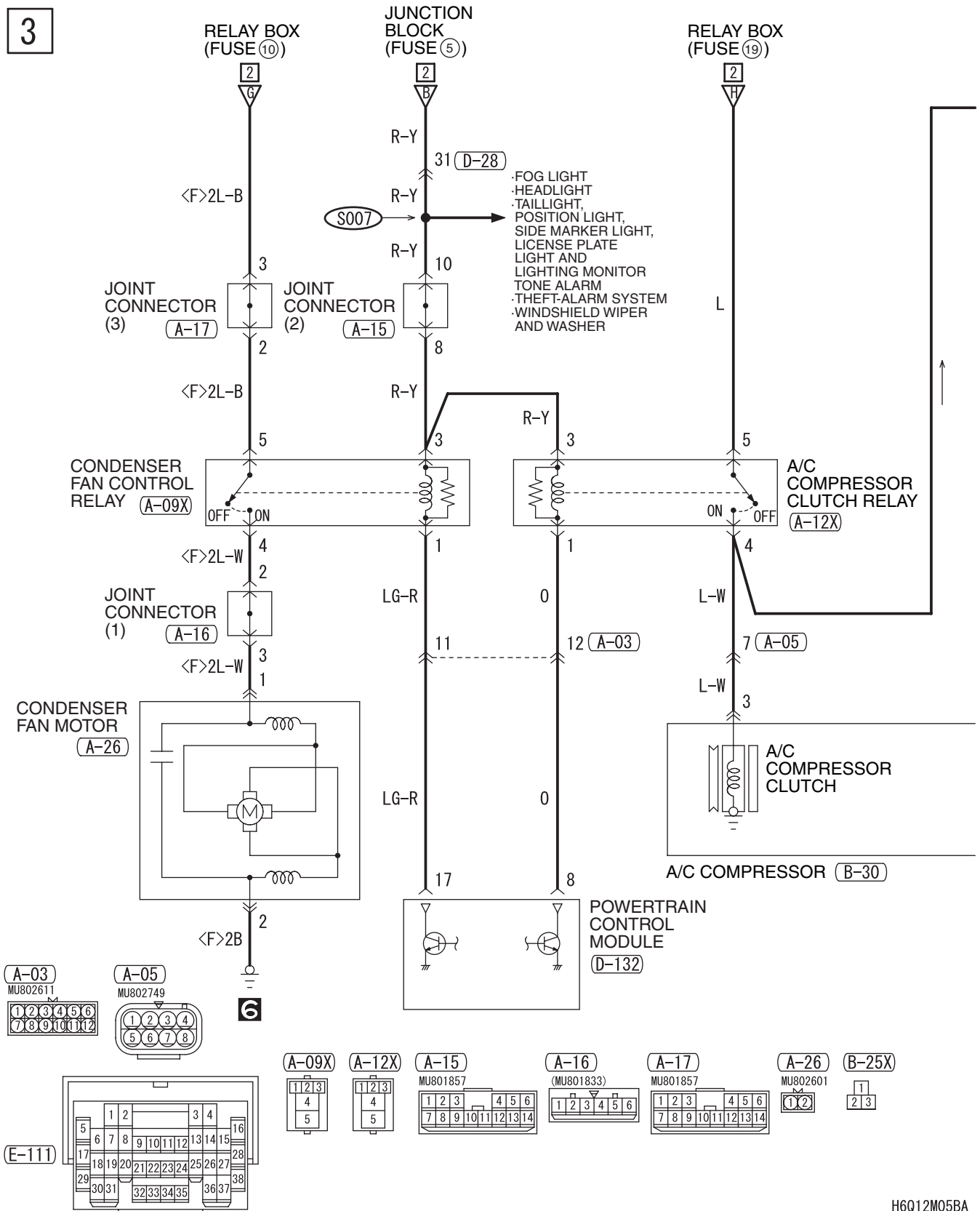

4

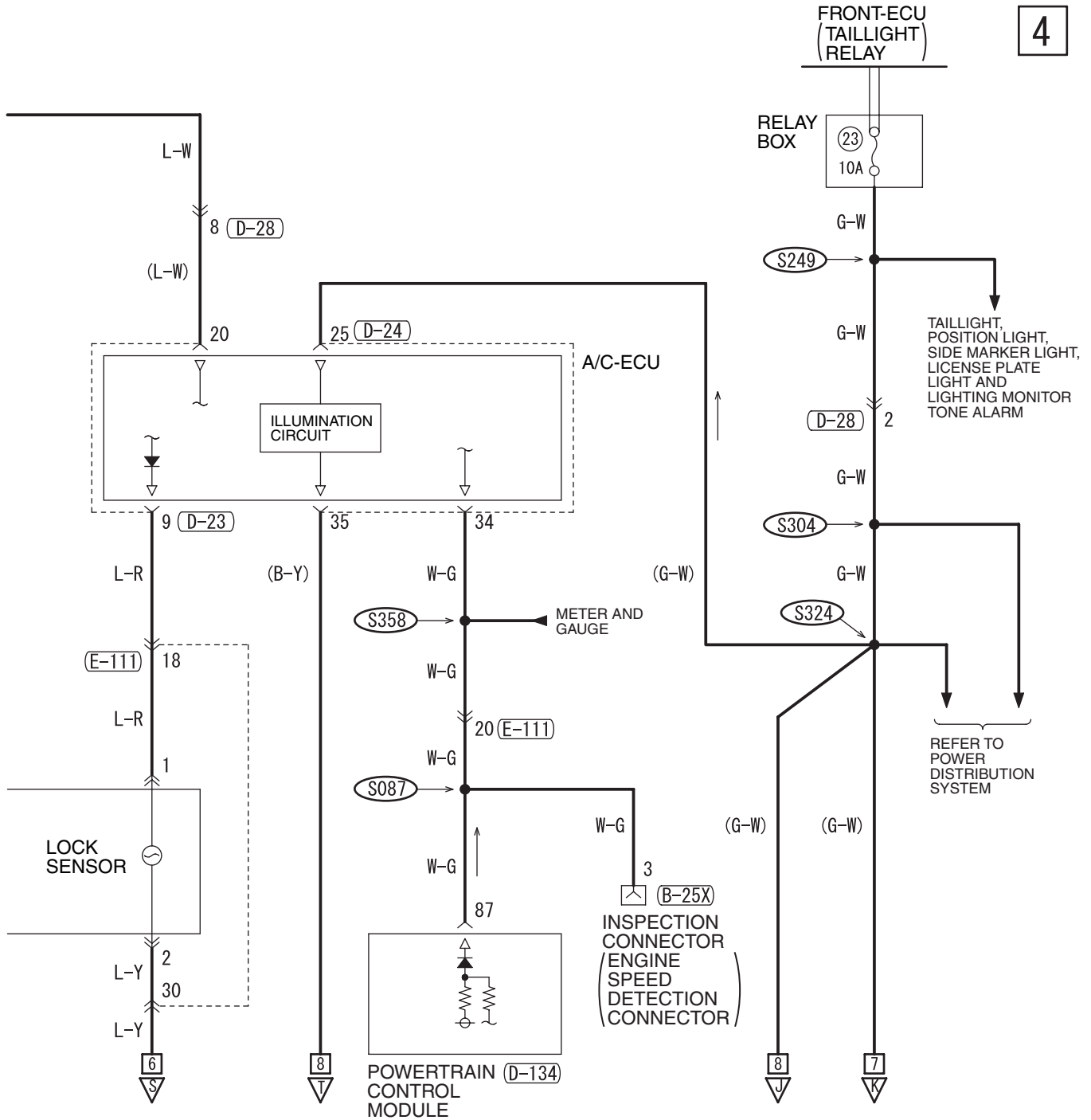

B-30
(MU802603)

1	2
3	

D-23
(MU801585)

1	2	3	4	5	6	7	8	9	10
11	12	13	14	15	16	17	18	19	20

D-24
(MU801584)

21	22	23	24	25	26	27	28
29	30	31	32	33	34	35	36

D-28

1	2	3	4	5	6	7	8	9	10	11	12	13
14	15	16	17	18	19	20	21	22	23	24	25	
26	27	28	29			30	31			38		
32	33	34		35		36	37					

D-132
(MU803802)

1	2	JAE	3	4				
5	6	7	8	9	10	11	12	13
14	15	16	17	18	19	20		
21	22	23	24	25	26	27		

D-134
(MU803804)

61	62	JAE	63	64				
65	66	67	68	69	70	71	72	73
74	75	76	77	78	79	80	81	82
83	84	85	86	87	88	89		

AUTOMATIC AIR CONDITIONING SYSTEM <VEHICLES WITH REAR AIR CONDITIONING SYSTEM>
(CONTINUED)

5

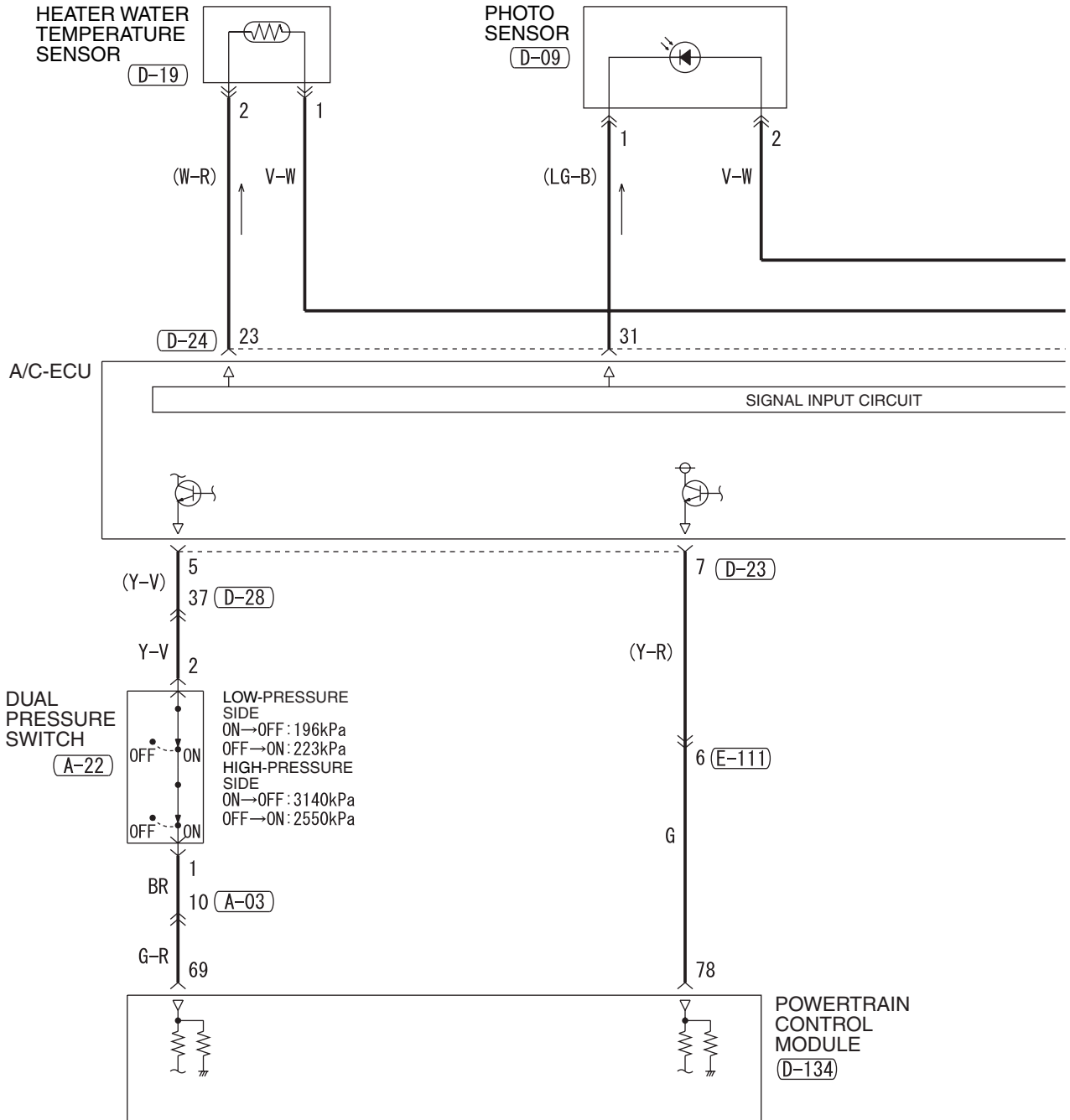

A-03

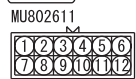

E-111

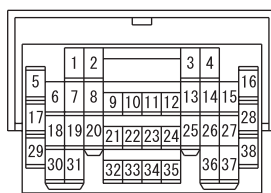

A-22



A-29



D-09



D-19



D-20



D-21



D-22

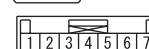

6

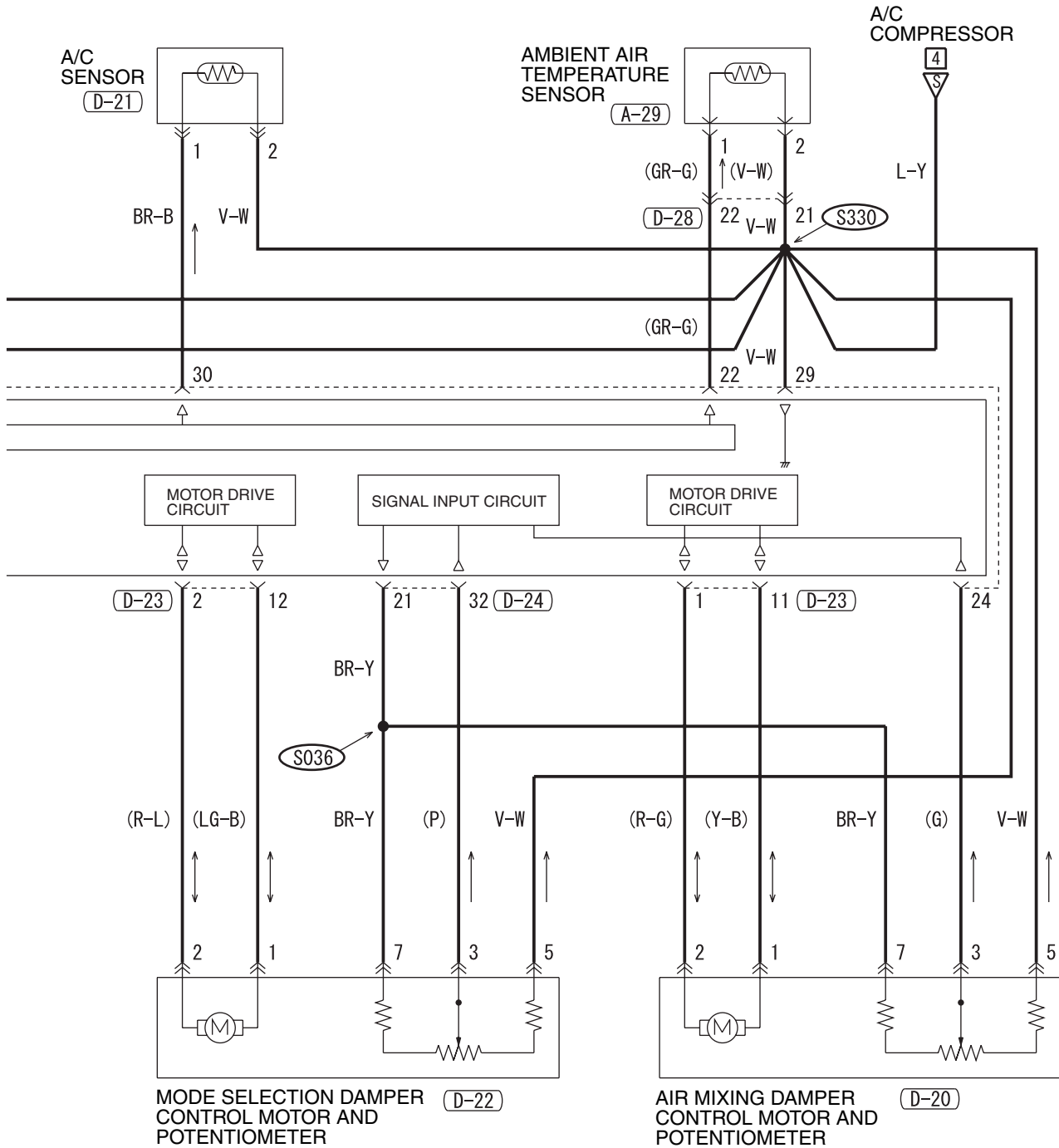

D-23 (MU801585)

1	2	3	4	5	6	7	8	9	10
11	12	13	14	15	16	17	18	19	20

D-24 (MU801584)

21	22	23	24	25	26	27	28
29	30	31	32	33	34	35	36

D-28

1	2	3	4	5	6	7	8	9	10	11	12	13
14	15	16	17	18	19	20	21	22	23	24	25	
26	27	28	29			30	31			38		
32	33	34		35		36	37					

D-134 (MU803804)

61	62	JAE	63	64				
65	66	67	68	69	70	71	72	73
74	75	76	77	78	79	80	81	82
83	84	85	86	87	88	89		

WIRE COLOR CODE

B : BLACK LG : LIGHT GREEN G : GREEN L : BLUE W : WHITE Y : YELLOW
 SB : SKY BLUE BR : BROWN O : ORANGE GR : GRAY R : RED P : PINK V : VIOLET

AUTOMATIC AIR CONDITIONING SYSTEM <VEHICLES WITH REAR AIR CONDITIONING SYSTEM> (CONTINUED)

7

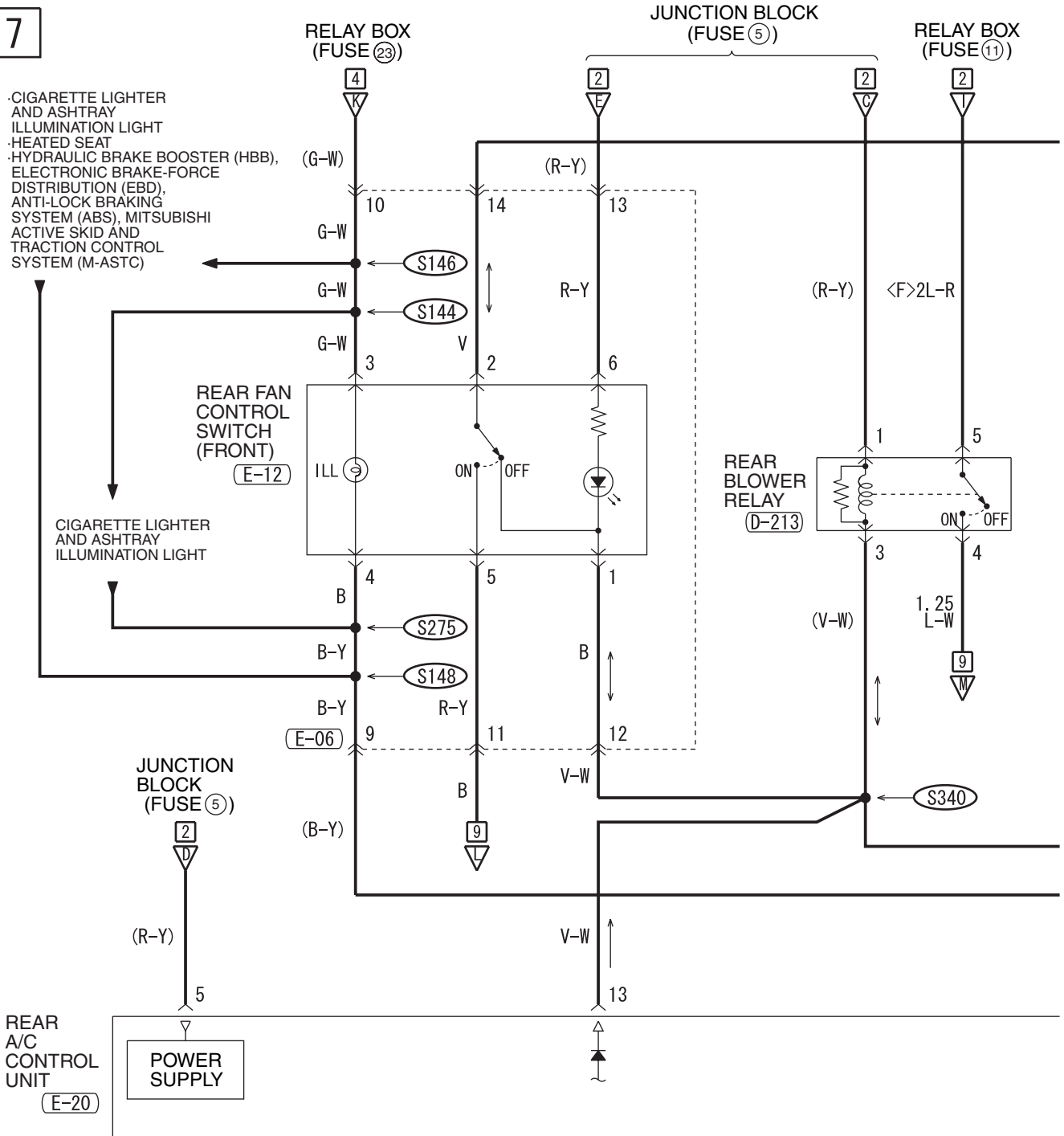

D-112

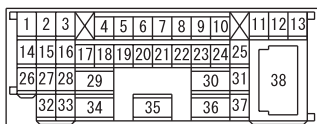

D-213



E-06

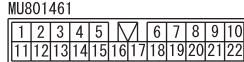

E-12



E-20

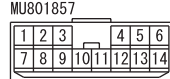

E-22

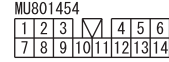

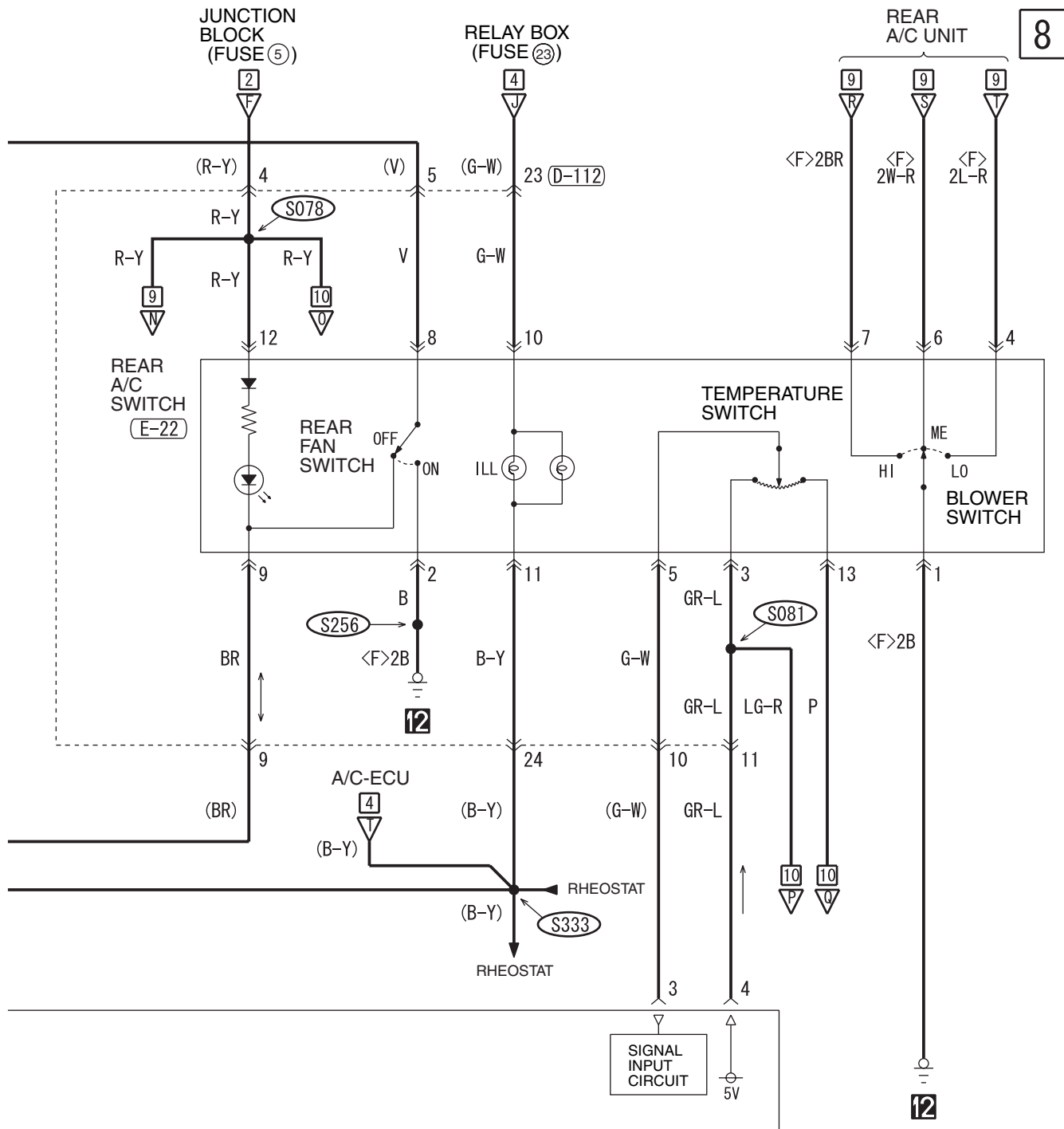

WIRE COLOR CODE

B : BLACK LG : LIGHT GREEN G : GREEN L : BLUE W : WHITE Y : YELLOW
 SB : SKY BLUE BR : BROWN O : ORANGE GR : GRAY R : RED P : PINK V : VIOLET

AUTOMATIC AIR CONDITIONING SYSTEM <VEHICLES WITH REAR AIR CONDITIONING SYSTEM>
(CONTINUED)

9

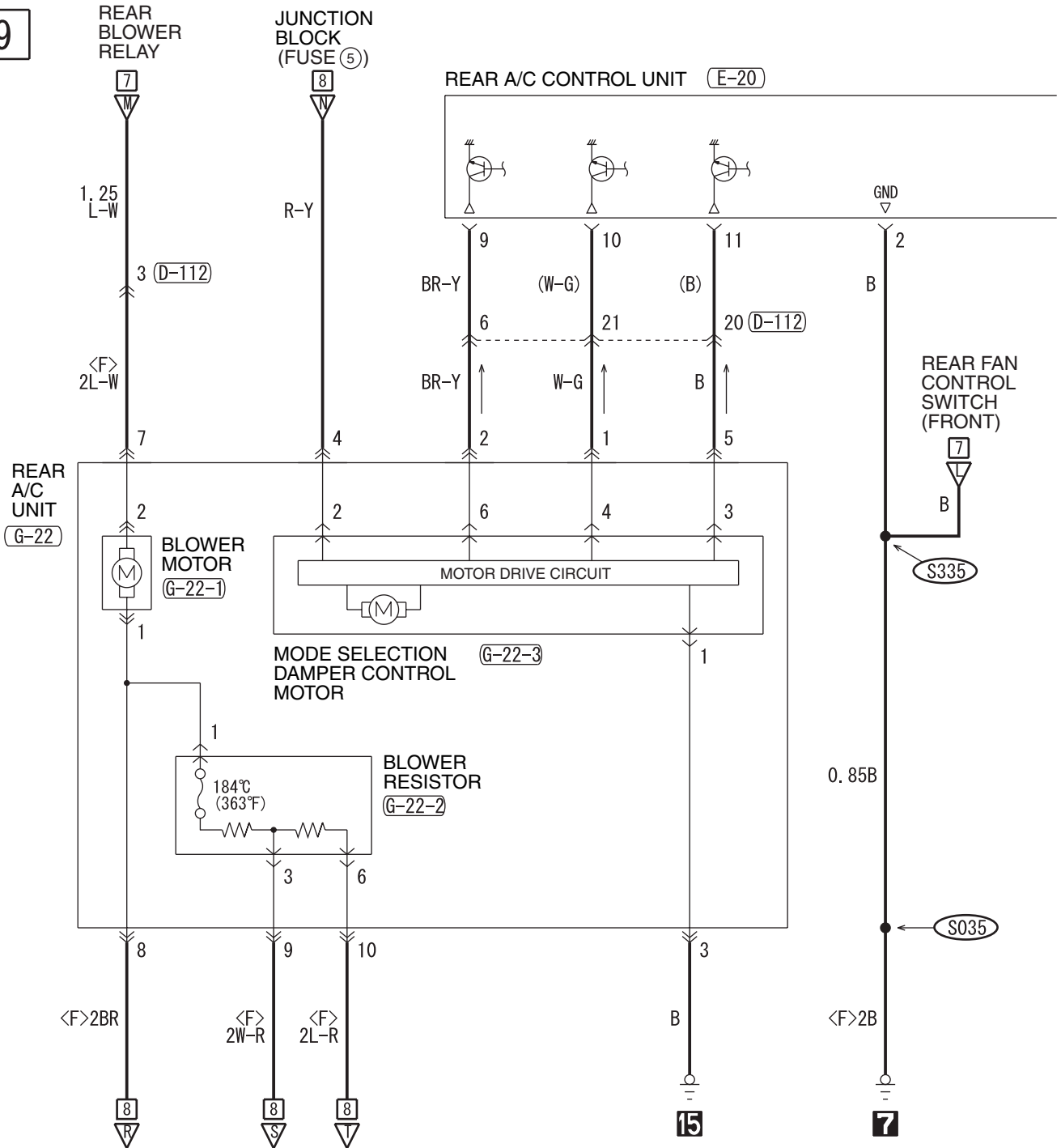

D-112

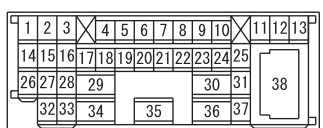

E-20

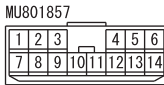

G-22

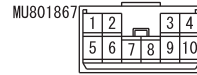

G-22-1



G-22-2



G-22-3

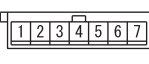

G-24



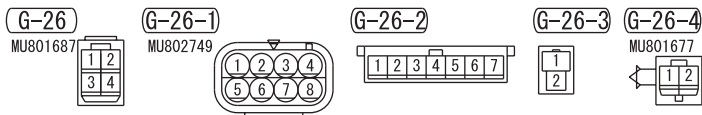
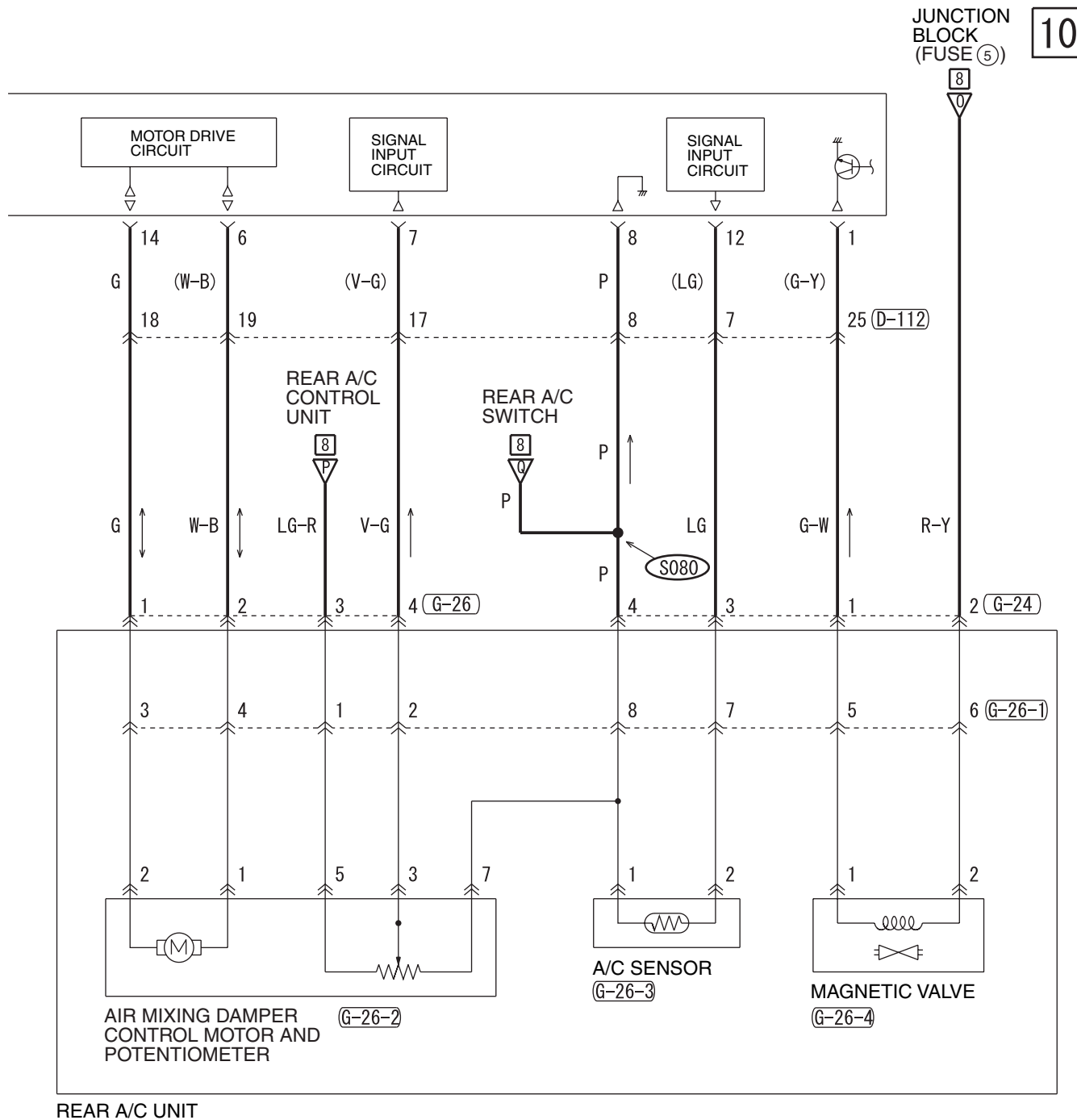

WIRE COLOR CODE

B : BLACK LG : LIGHT GREEN G : GREEN L : BLUE W : WHITE Y : YELLOW
 SB : SKY BLUE BR : BROWN O : ORANGE GR : GRAY R : RED P : PINK V : VIOLET

AUTOMATIC AIR CONDITIONING SYSTEM <VEHICLES WITH REAR AIR CONDITIONING SYSTEM>
(CONTINUED)

11

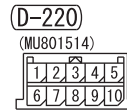
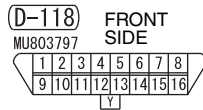
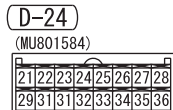
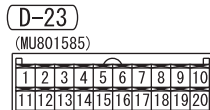
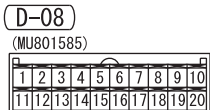
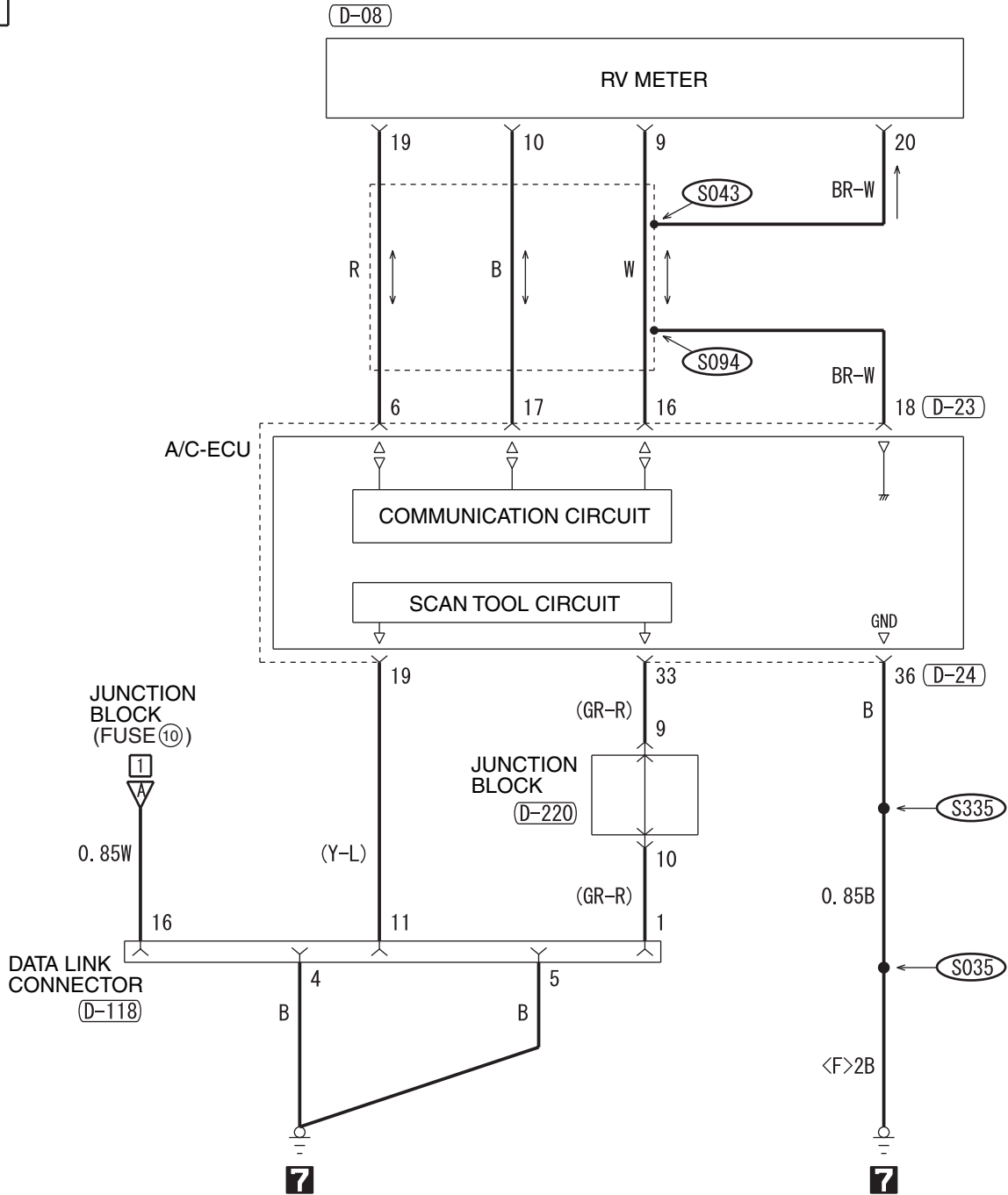

WIRE COLOR CODE
 B : BLACK LG : LIGHT GREEN G : GREEN L : BLUE W : WHITE Y : YELLOW
 SB : SKY BLUE BR : BROWN O : ORANGE GR : GRAY R : RED P : PINK V : VIOLET

TSB Revision

REMOTE CONTROLLED MIRROR

1

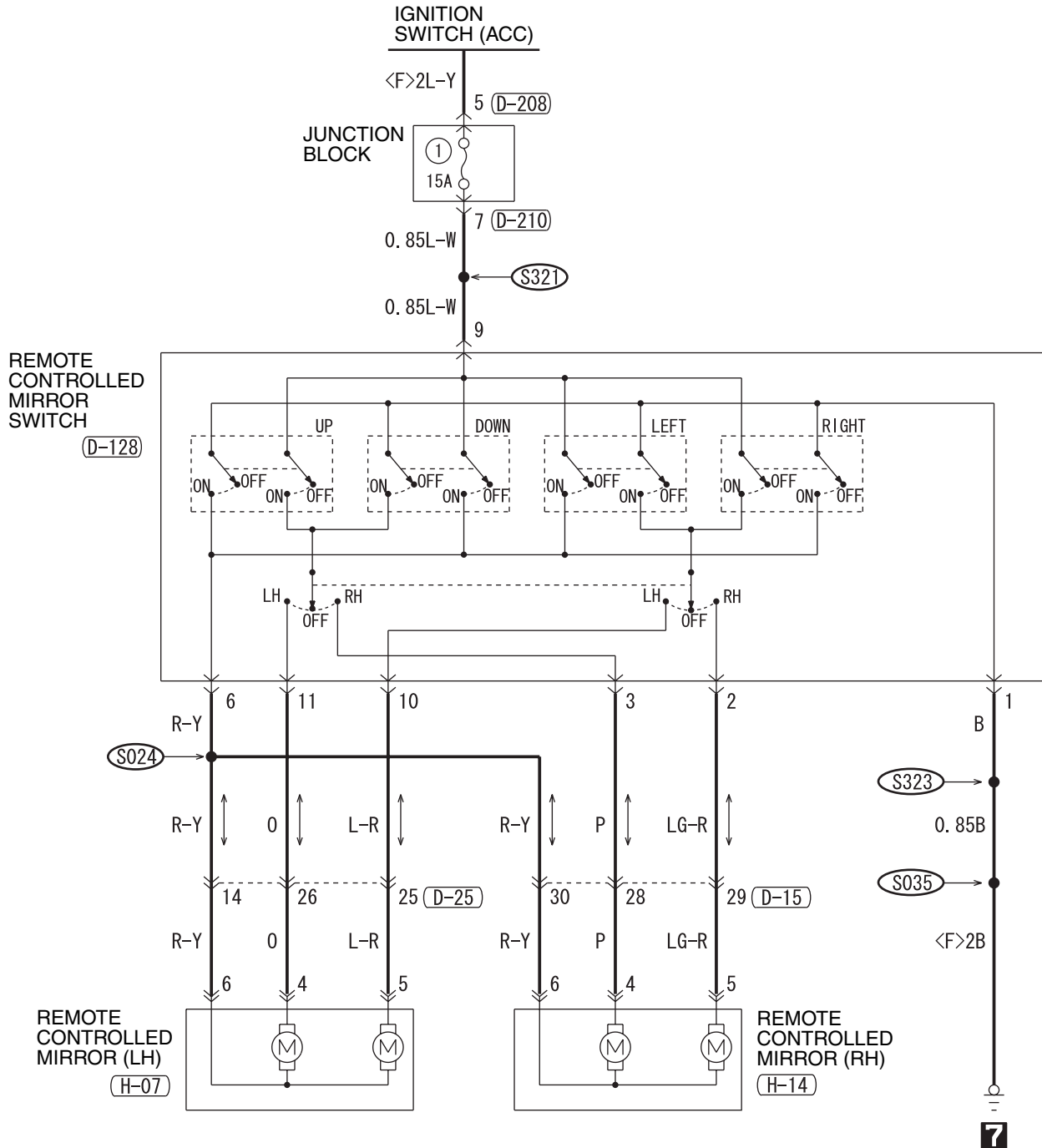

D-15

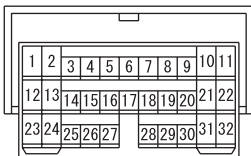

D-25

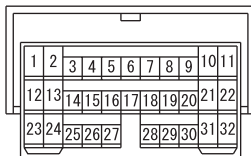

D-128

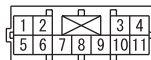

D-208



D-210



H-07



H-14



WIRE COLOR CODE

B : BLACK LG : LIGHT GREEN G : GREEN L : BLUE
BR : BROWN O : ORANGE GR : GRAY R : RED W : WHITE
SB : SKY BLUE P : PINK Y : YELLOW V : VIOLET

WINDSHIELD WIPER AND WASHER

M1901006101802

1

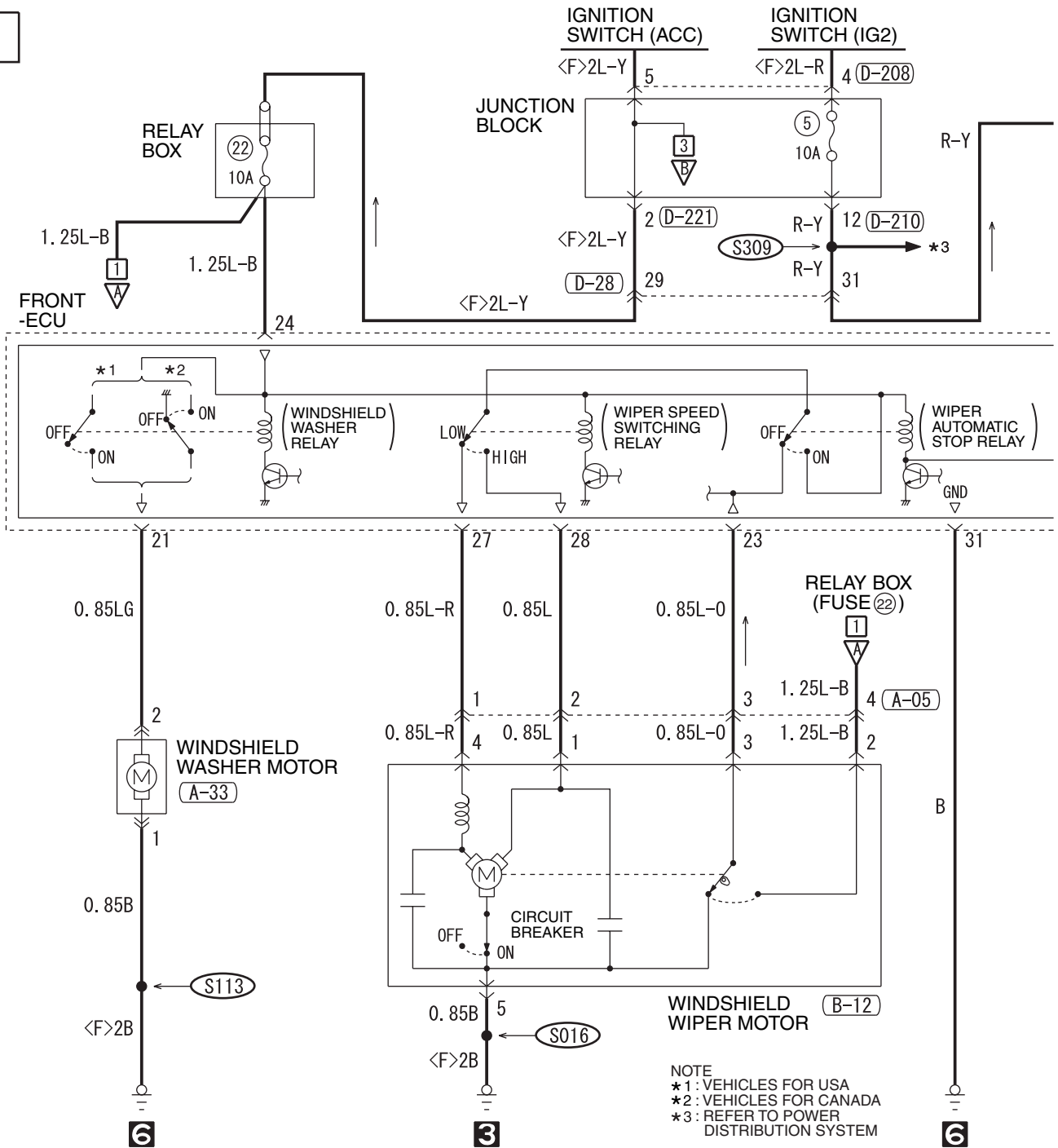

NOTE
 *1: VEHICLES FOR USA
 *2: VEHICLES FOR CANADA
 *3: REFER TO POWER DISTRIBUTION SYSTEM

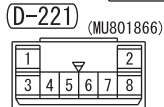
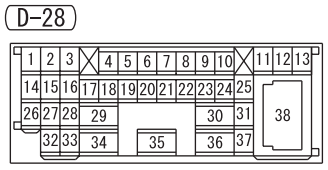
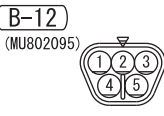
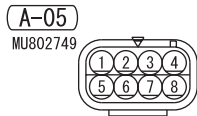

H6Q13M01AA

2

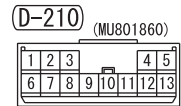
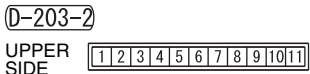
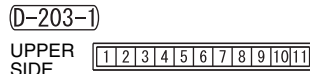
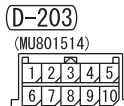
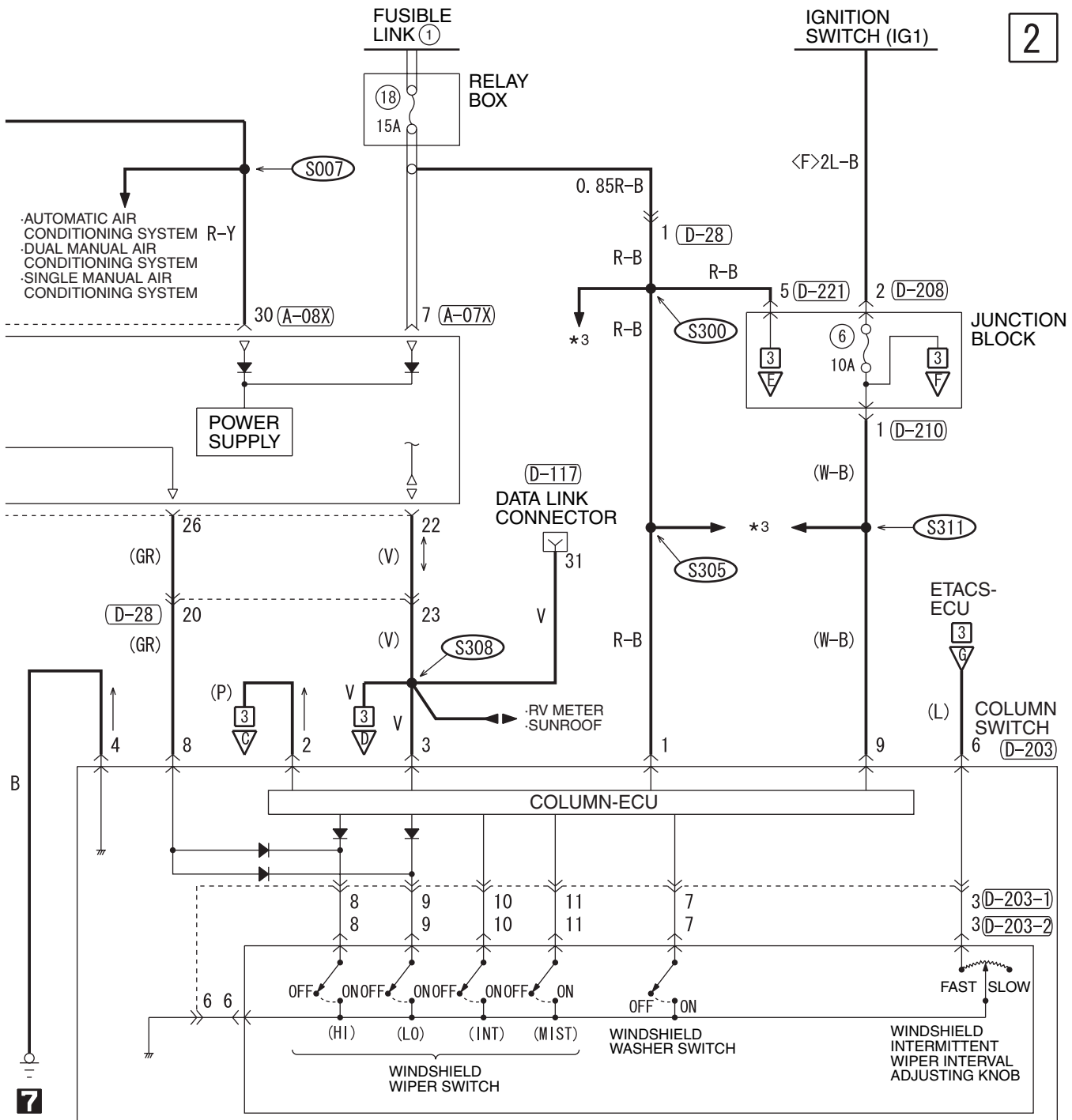

WIRE COLOR CODE
 B : BLACK LG : LIGHT GREEN G : GREEN L : BLUE W : WHITE Y : YELLOW
 SB : SKY BLUE BR : BROWN O : ORANGE GR : GRAY R : RED P : PINK V : VIOLET

WINDSHIELD WIPER AND WASHER (CONTINUED)

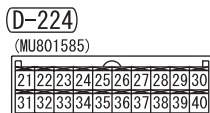
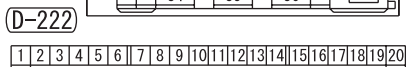
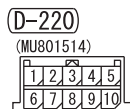
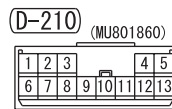
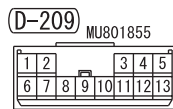
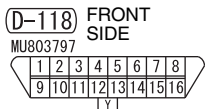
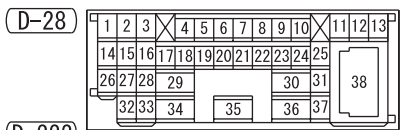
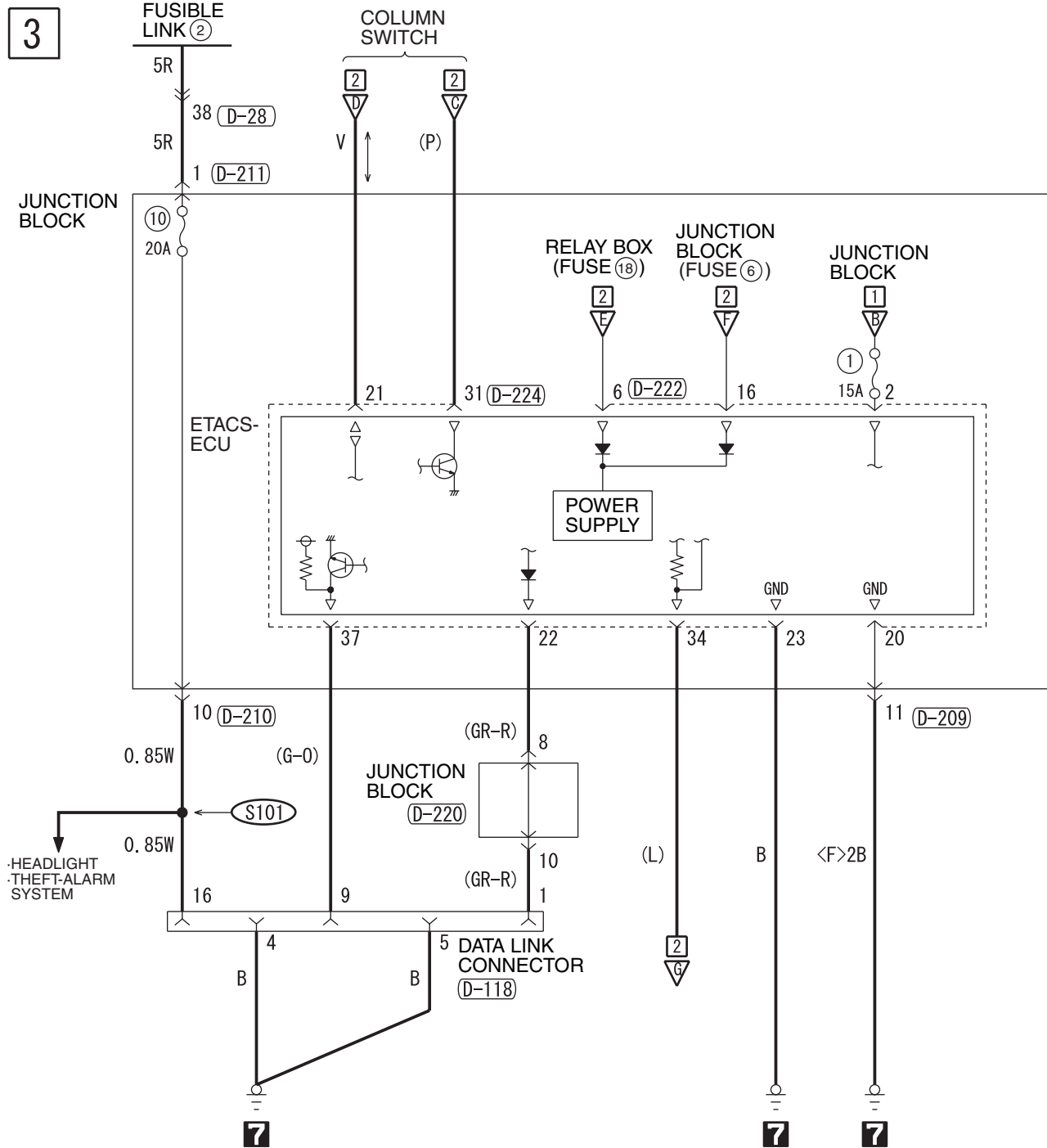

NOTES

REAR WIPER AND WASHER

M1901006201467

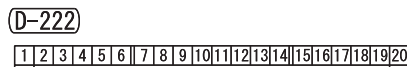
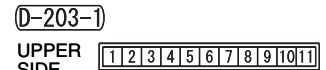
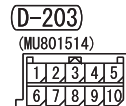
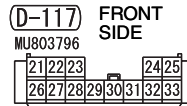
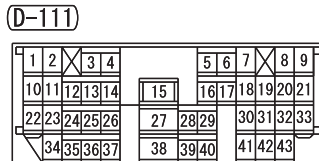
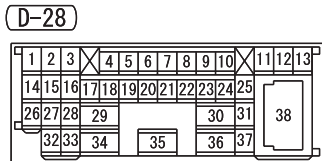
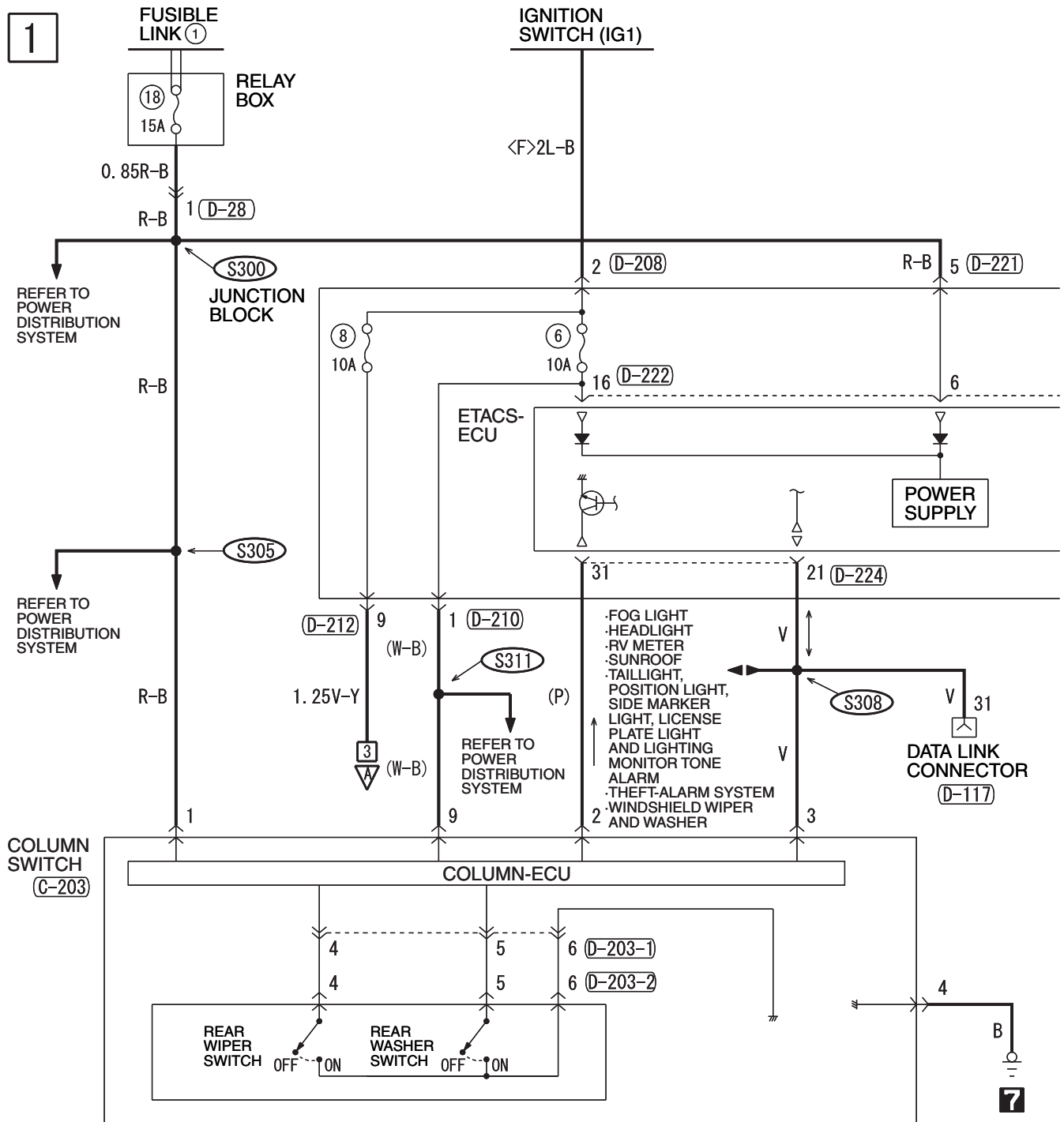

H6Q13M02AA

2

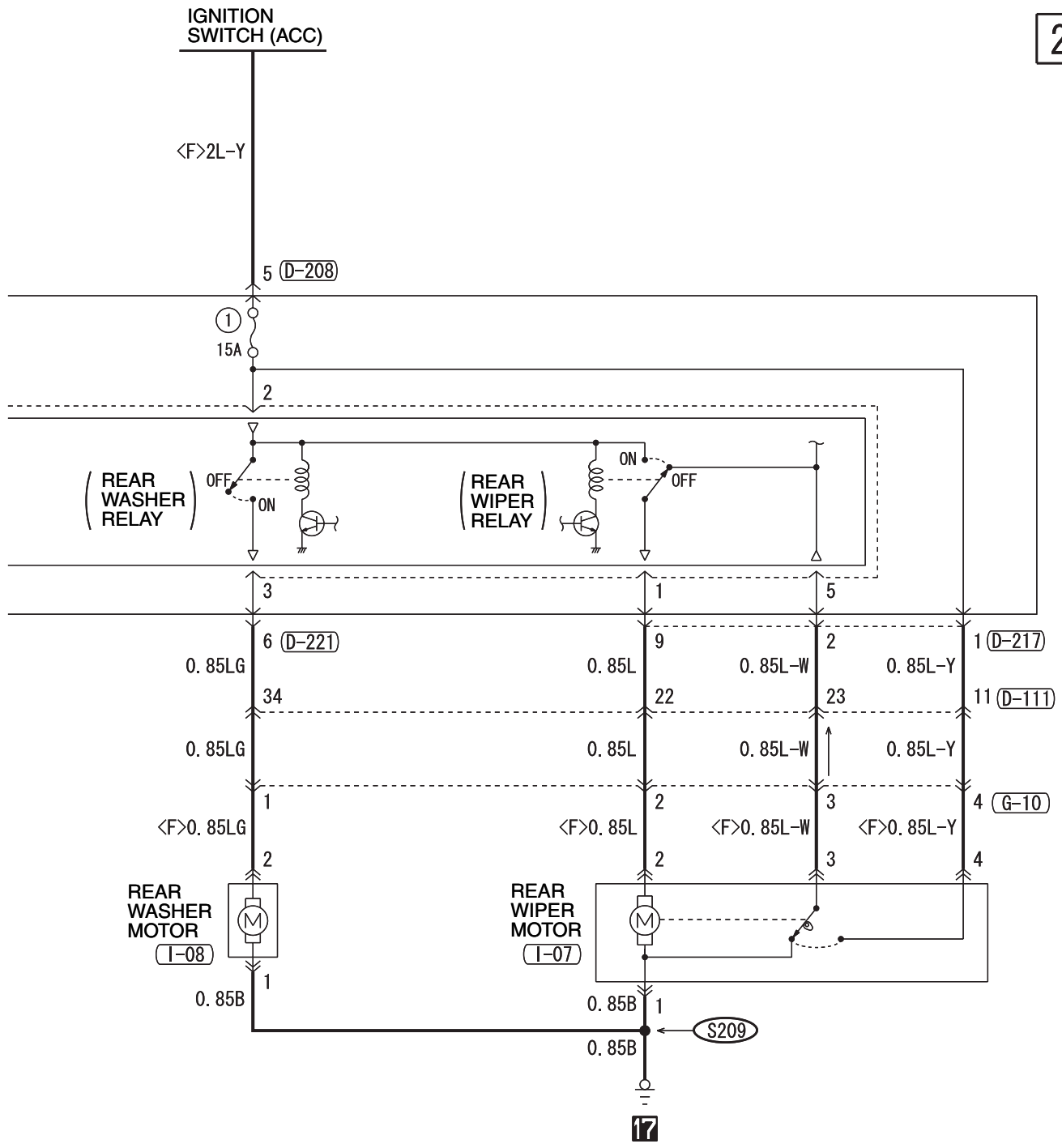

- D-203-2
UPPER SIDE
- D-208
MU801331
- D-210 (MU801860)
- D-212 MU801847
- D-217
- D-221 (MU801866)
- D-224 (MU801585)
- G-10 MU801867
- I-07 MU801445
- I-08

REAR WIPER AND WASHER (CONTINUED)

3

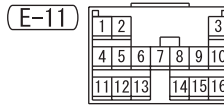
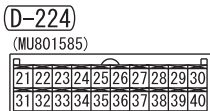
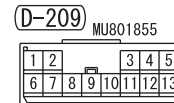
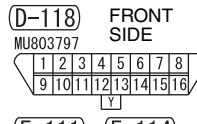
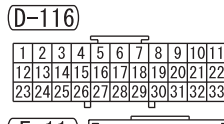
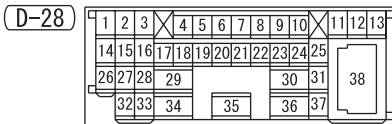
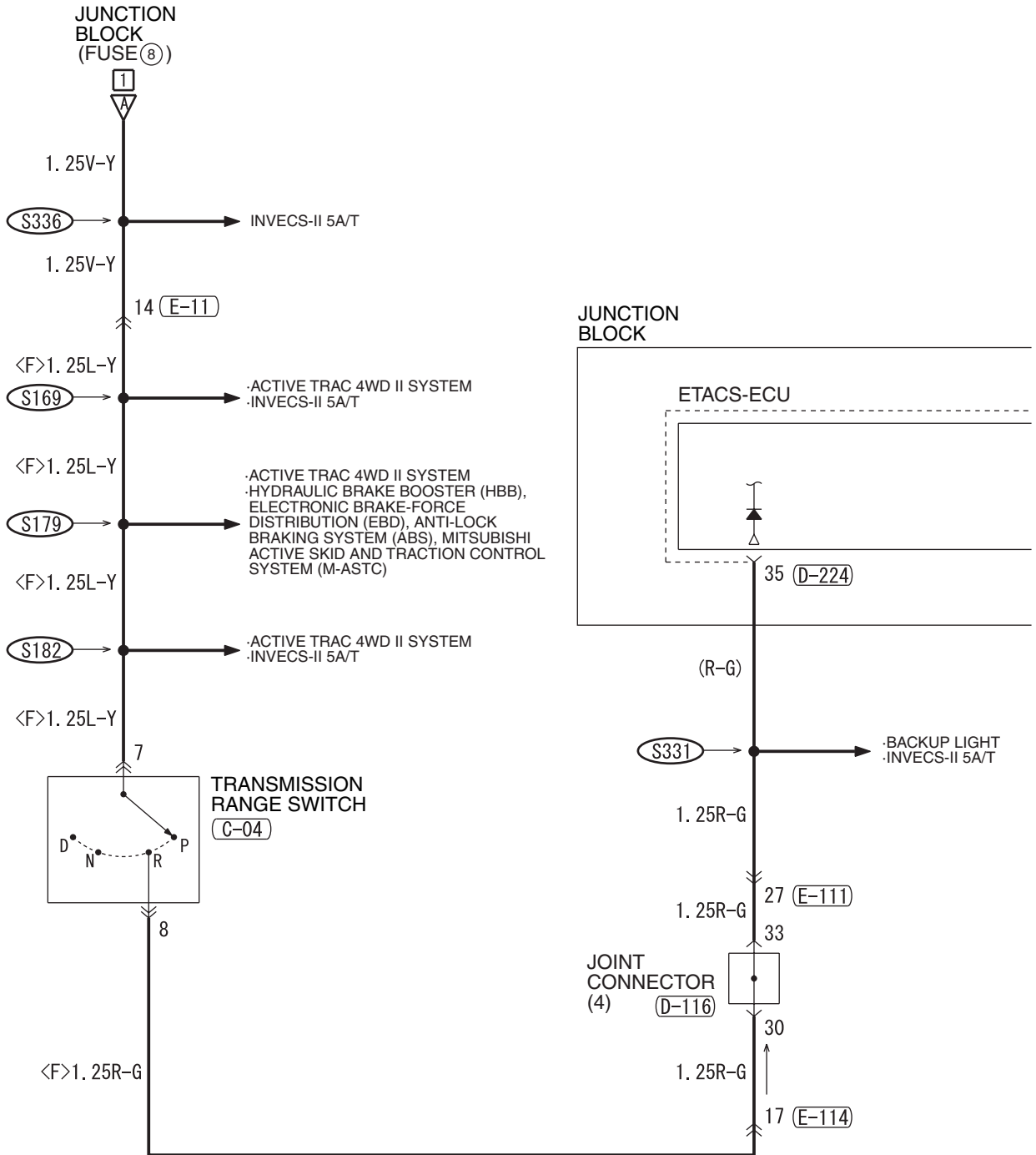

E-111 E-114
See ★1 See ★1

4

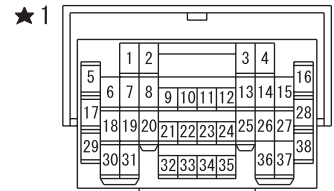
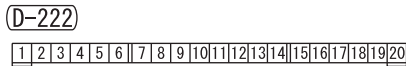
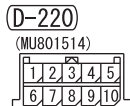
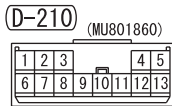
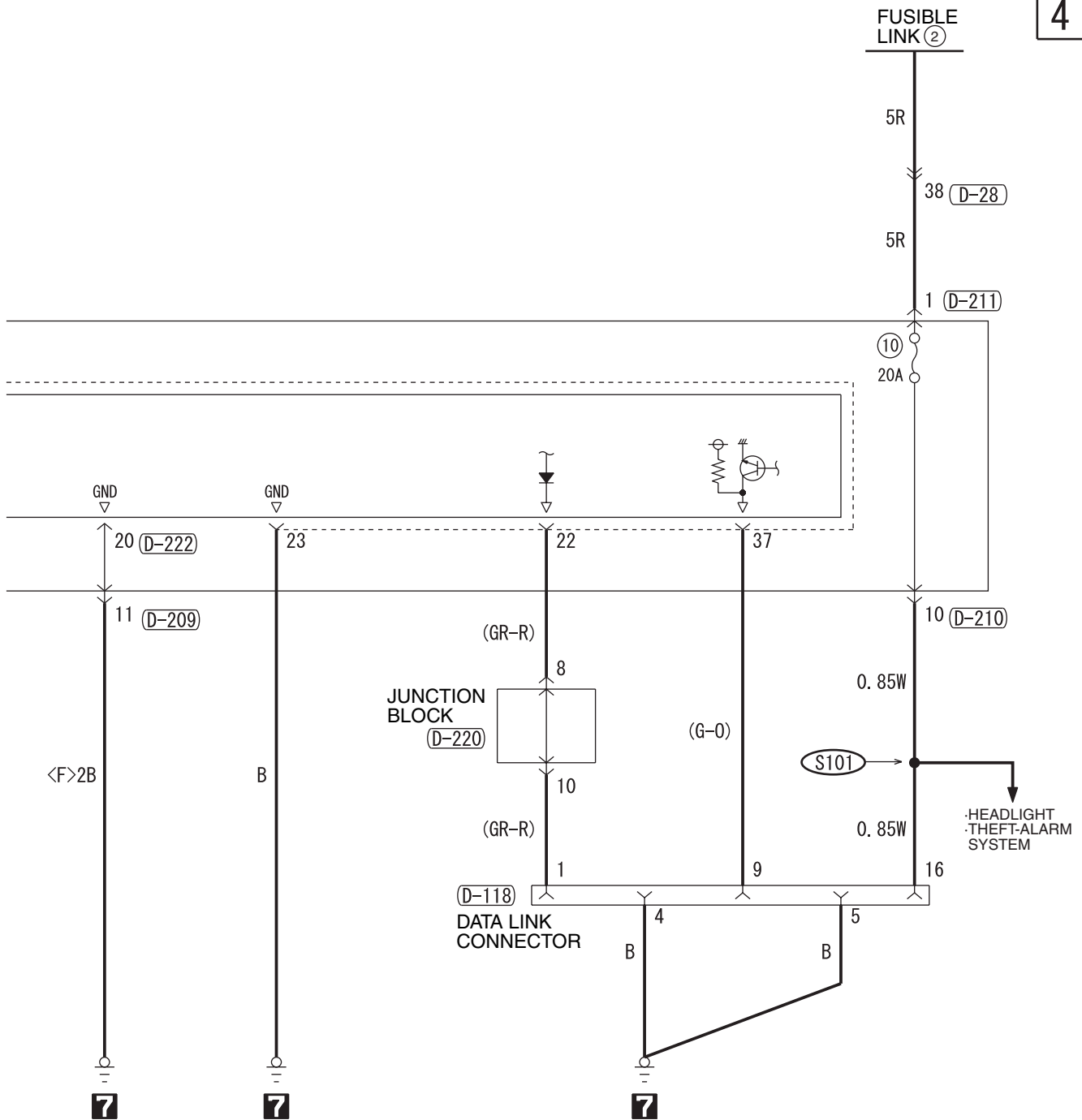

WIRE COLOR CODE
 B : BLACK LG : LIGHT GREEN G : GREEN L : BLUE W : WHITE Y : YELLOW
 SB : SKY BLUE BR : BROWN O : ORANGE GR : GRAY R : RED P : PINK V : VIOLET

H6Q13M02BB

TSB Revision

DEFOGGER AND DOOR MIRROR HEATER <VEHICLES WITH AUTOMATIC AIR CONDITIONING SYSTEM>

M1901013501017

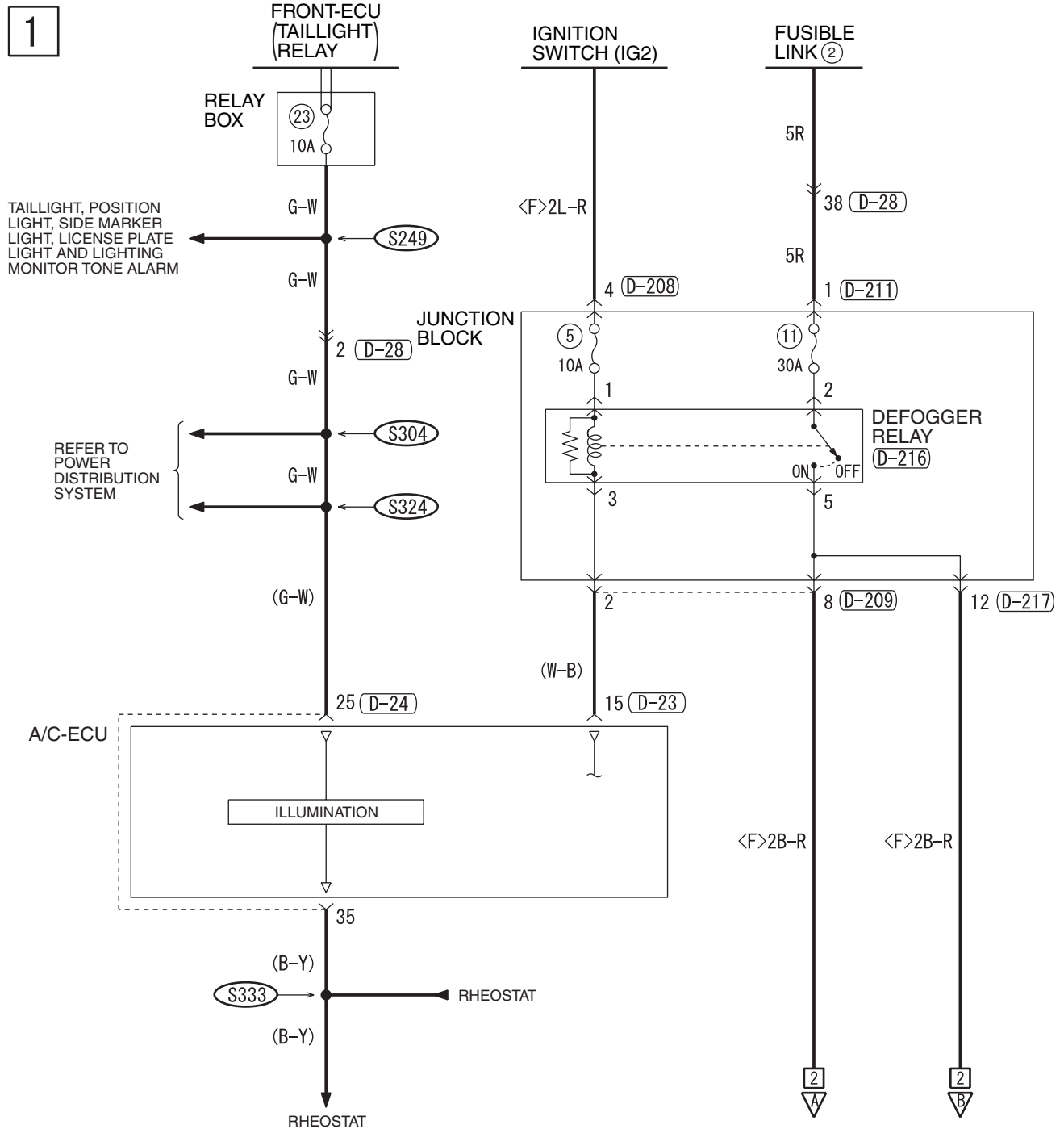

D-15

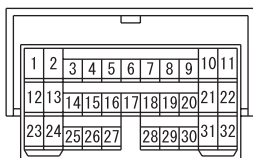

D-23 (MU801585)



D-24 (MU801584)



D-25

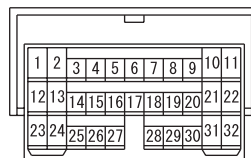

D-28

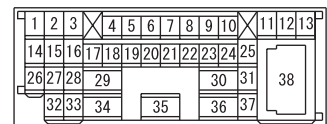

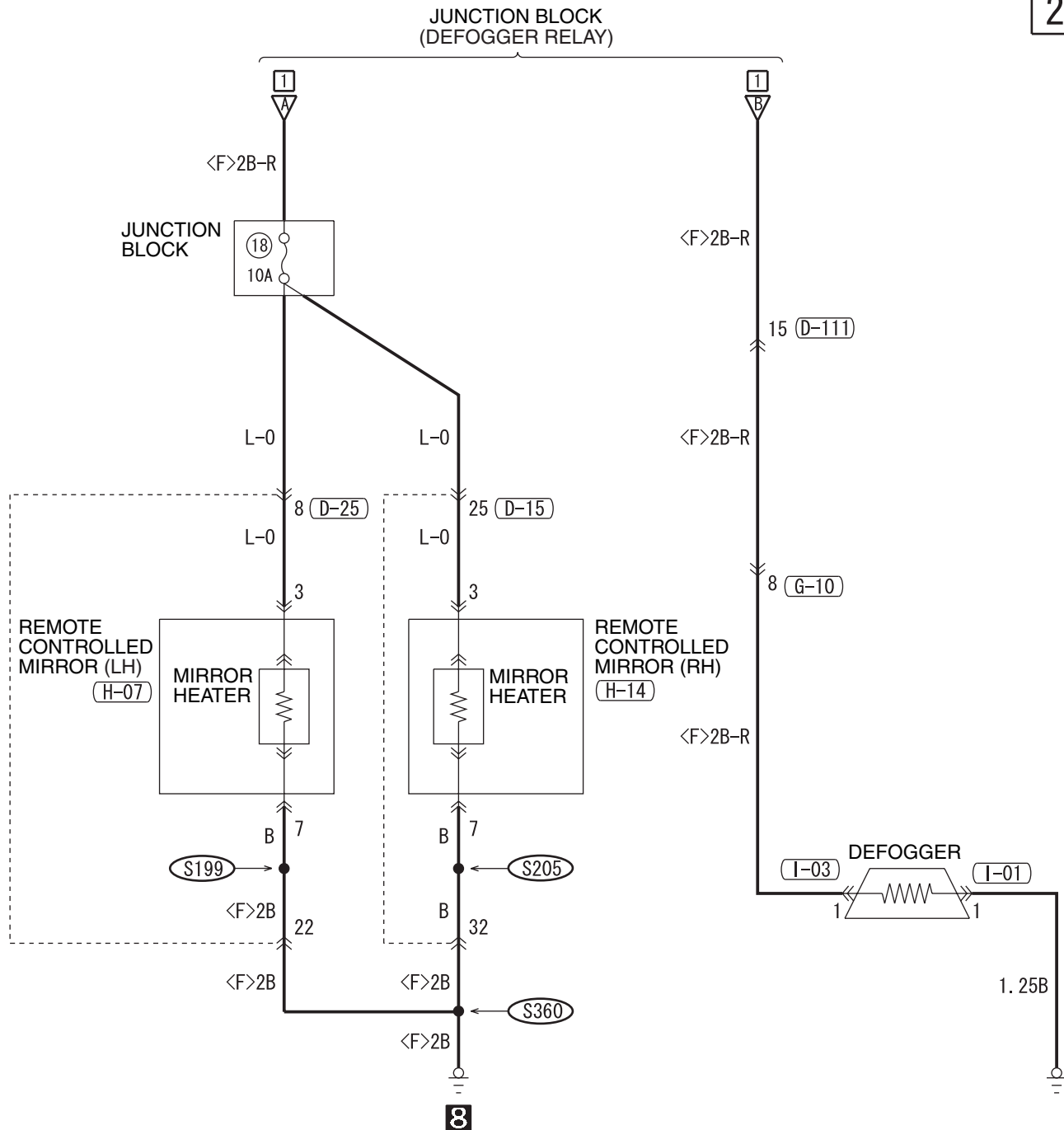

D-111

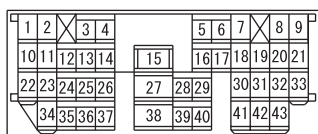

D-208



D-209

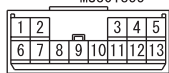

D-211



D-216



D-217

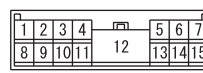

G-10

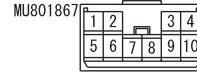

H-07



H-14



I-01



I-03



DEFOGGER AND DOOR MIRROR HEATER <VEHICLES WITH MANUAL AIR CONDITIONING SYSTEM>

M1901013501028

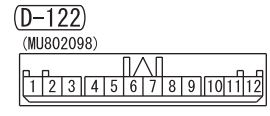
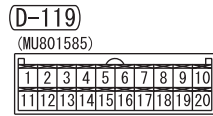
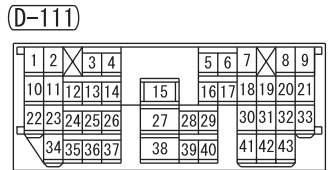
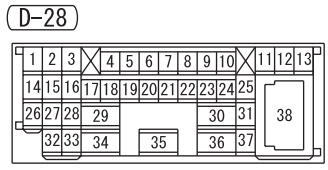
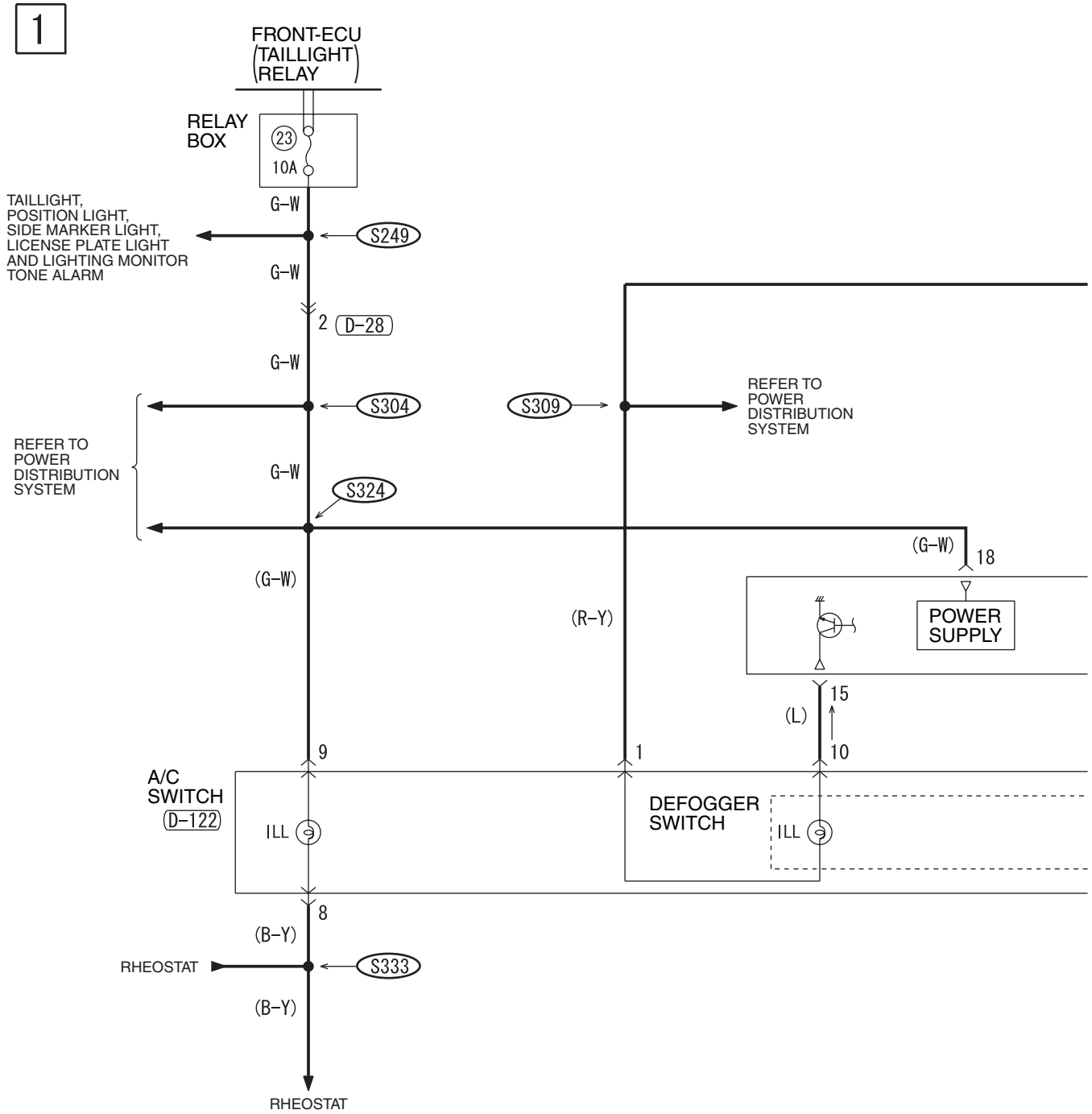

2

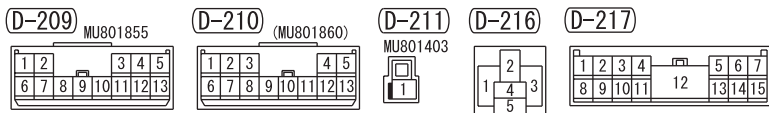
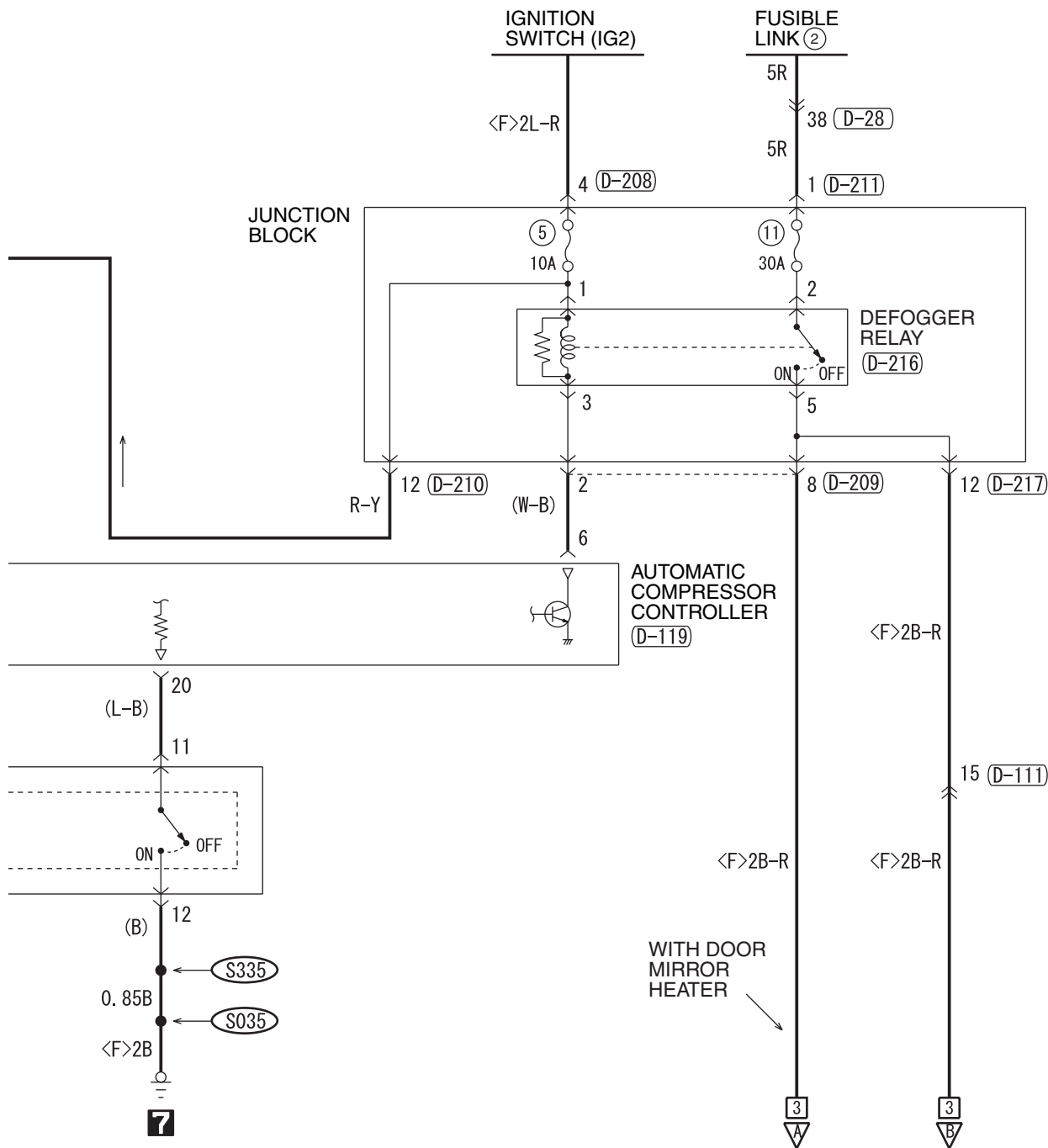

WIRE COLOR CODE
 B : BLACK LG : LIGHT GREEN G : GREEN L : BLUE W : WHITE Y : YELLOW
 SB : SKY BLUE BR : BROWN O : ORANGE GR : GRAY R : RED P : PINK V : VIOLET

DEFOGGER AND DOOR MIRROR HEATER <VEHICLES WITH MANUAL AIR CONDITIONING SYSTEM>
(CONTINUED)

3

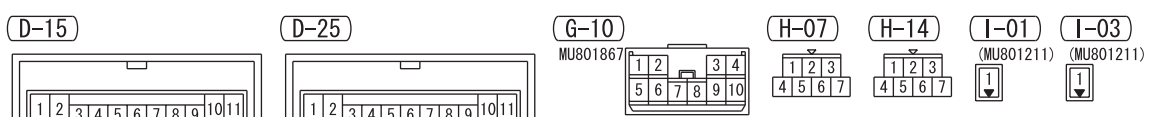
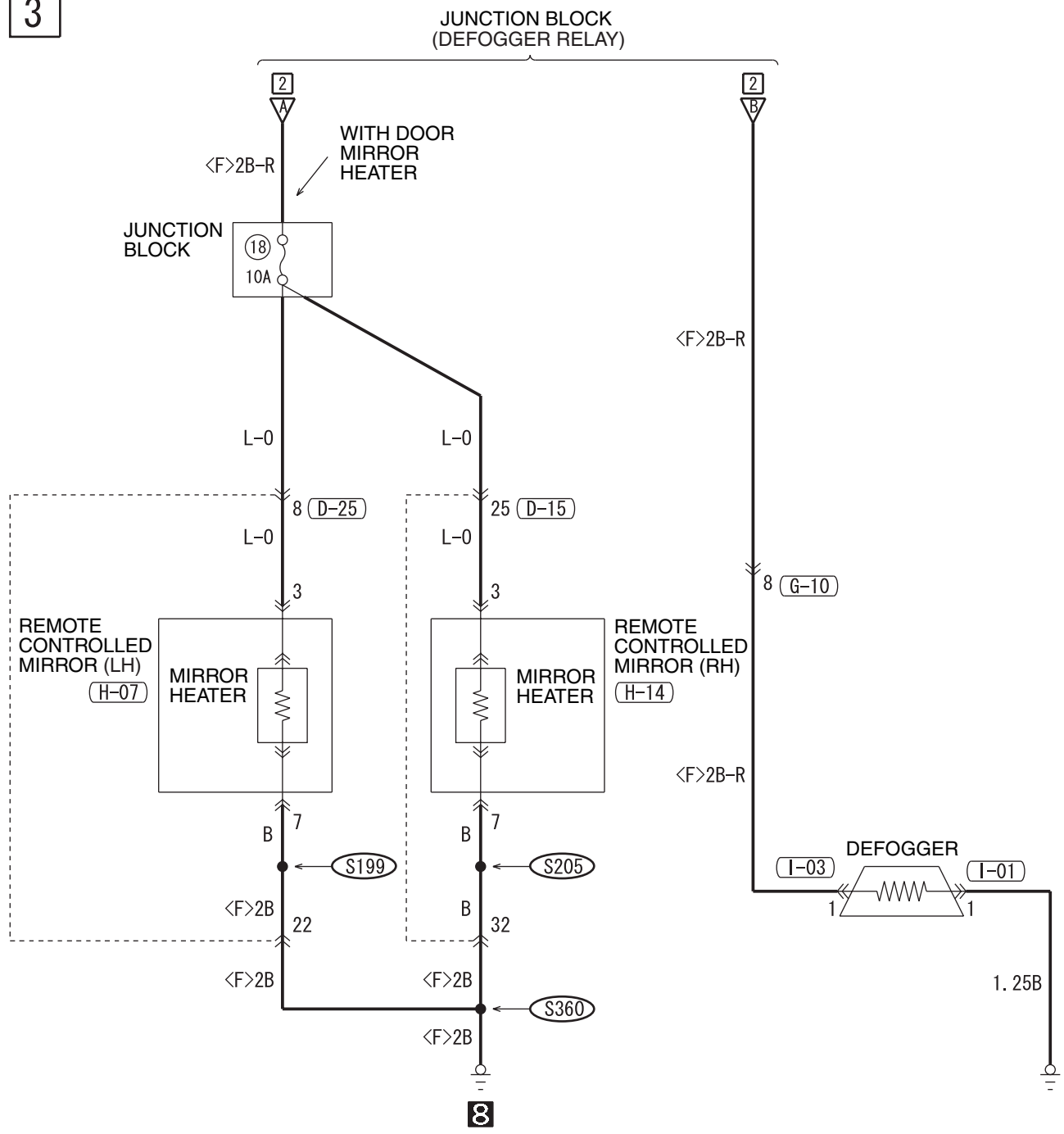

WIRE COLOR CODE
 B : BLACK LG : LIGHT GREEN G : GREEN L : BLUE
 BR : BROWN O : ORANGE GR : GRAY R : RED W : WHITE
 SB : SKY BLUE P : PINK Y : YELLOW V : VIOLET

H6Q13M04BA

TSB Revision

CLOCK

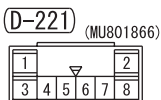
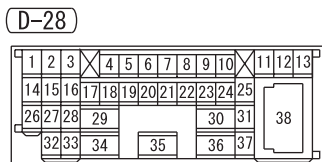
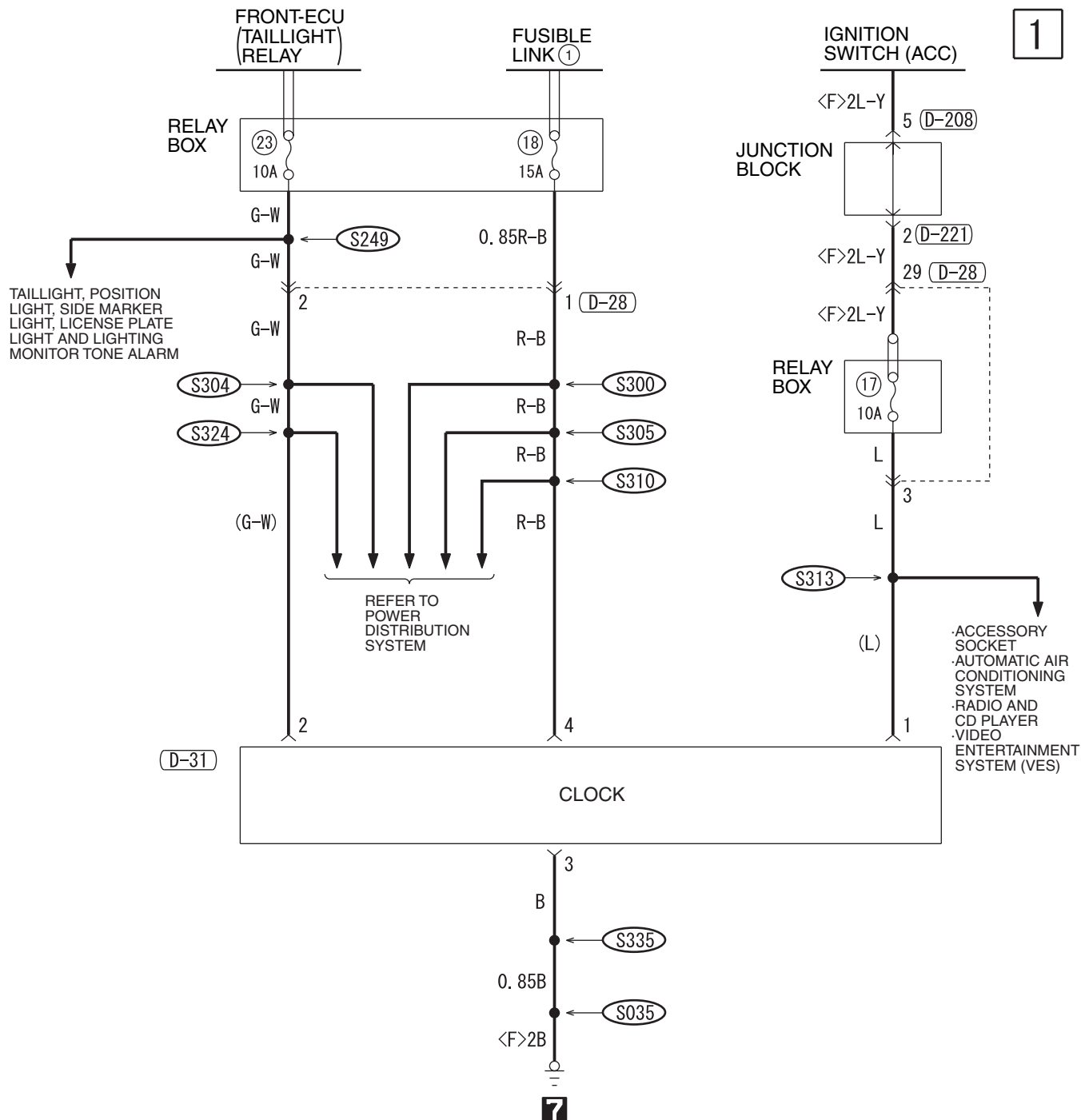

WIRE COLOR CODE
 B : BLACK LG : LIGHT GREEN G : GREEN L : BLUE
 BR : BROWN O : ORANGE GR : GRAY R : RED W : WHITE
 SB : SKY BLUE P : PINK Y : YELLOW V : VIOLET

RADIO AND CD PLAYER <VEHICLES WITHOUT AMPLIFIER>

M1901015601924

1

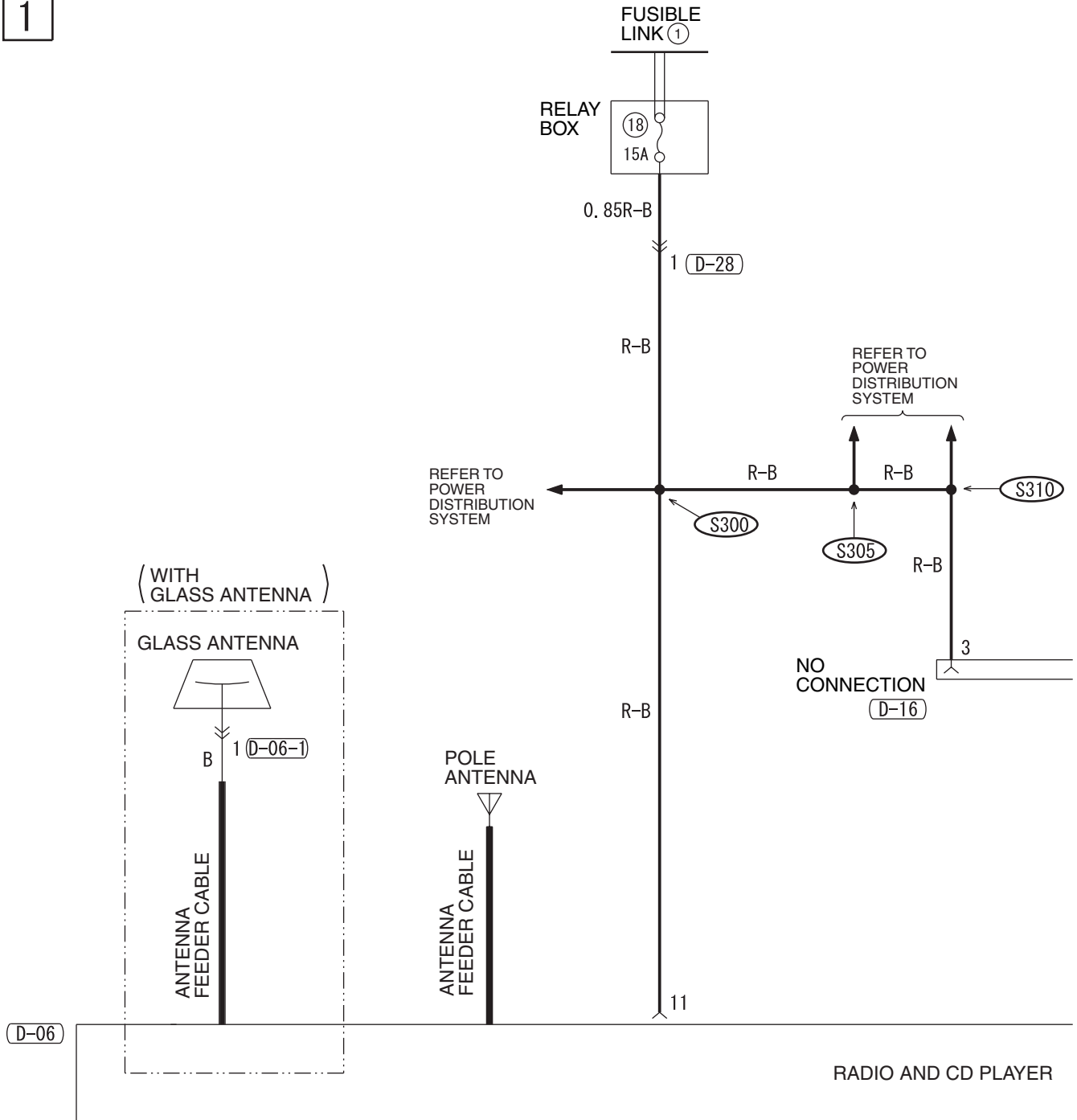

D-06

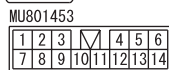

D-06-1



D-16

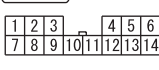

D-28

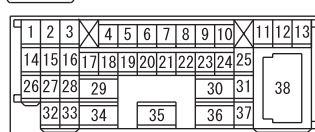

D-208



D-210

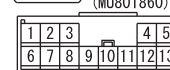

D-212



2

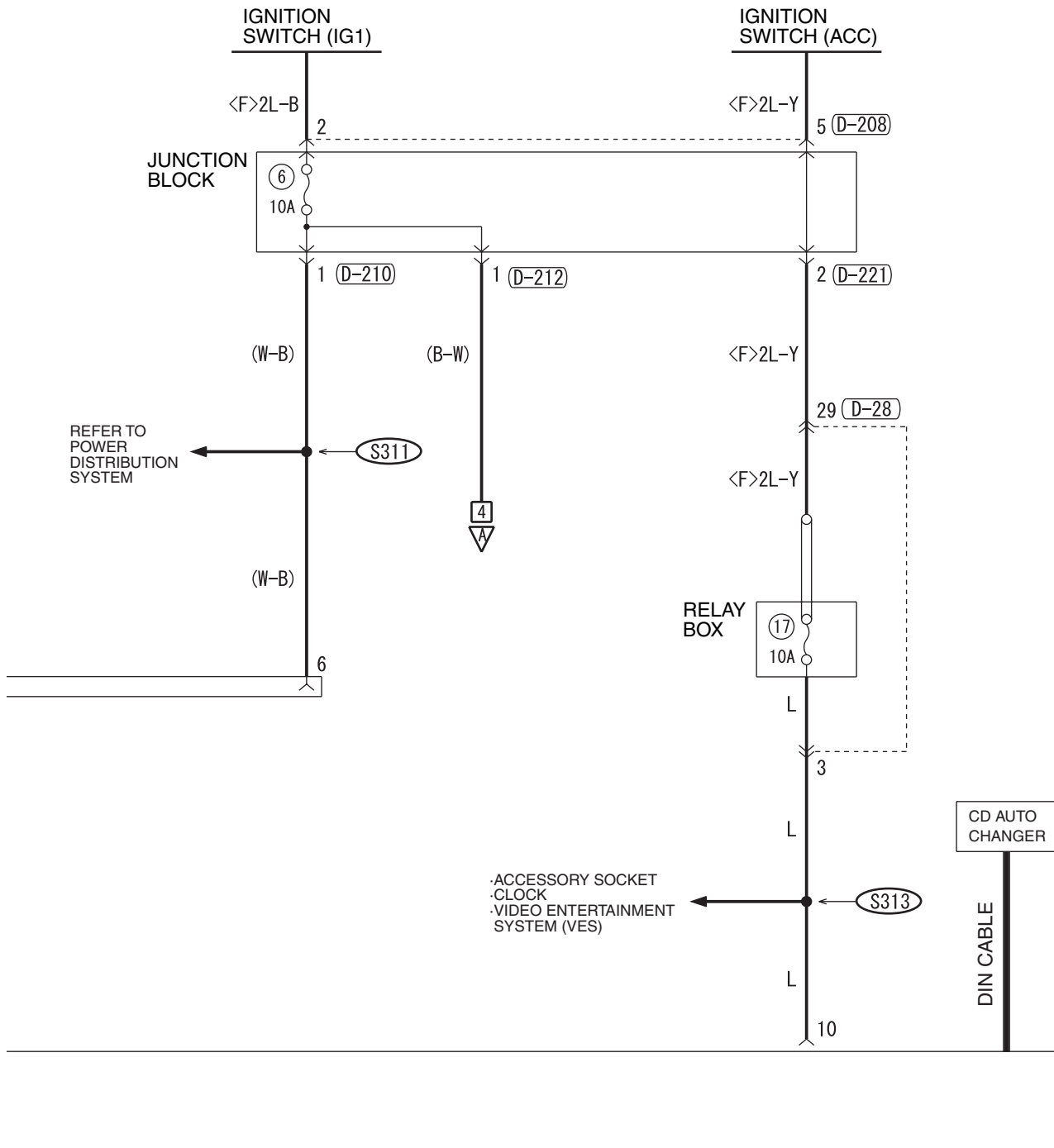

(D-221) (MU801866)

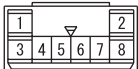

WIRE COLOR CODE

B : BLACK LG : LIGHT GREEN G : GREEN L : BLUE W : WHITE Y : YELLOW
 SB : SKY BLUE BR : BROWN O : ORANGE GR : GRAY R : RED P : PINK V : VIOLET

H6Q14M01AB

TSB Revision

RADIO AND CD PLAYER <VEHICLES WITHOUT AMPLIFIER> (CONTINUED)

3

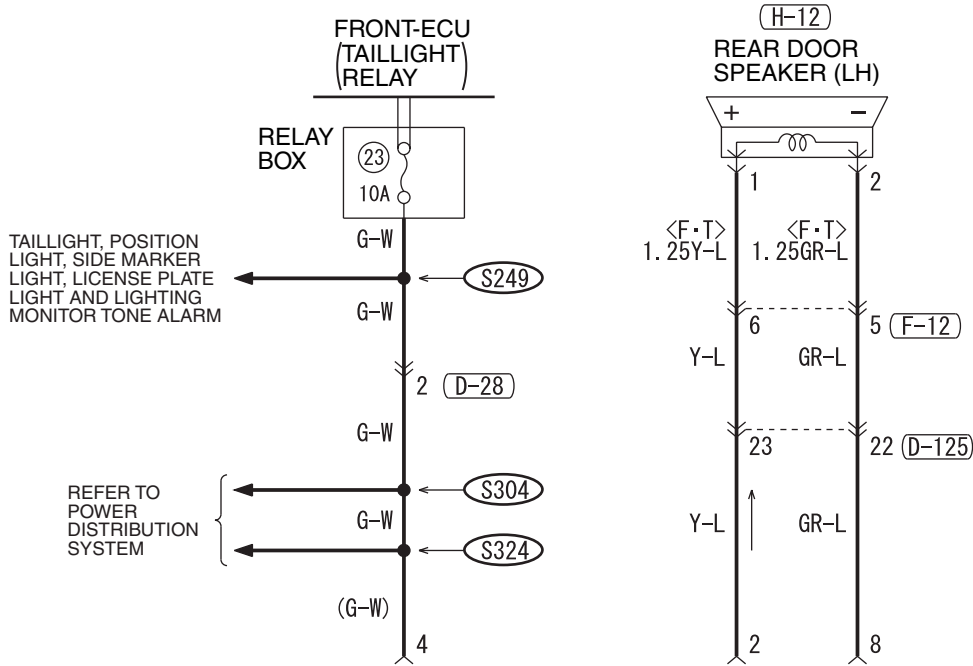

D-06

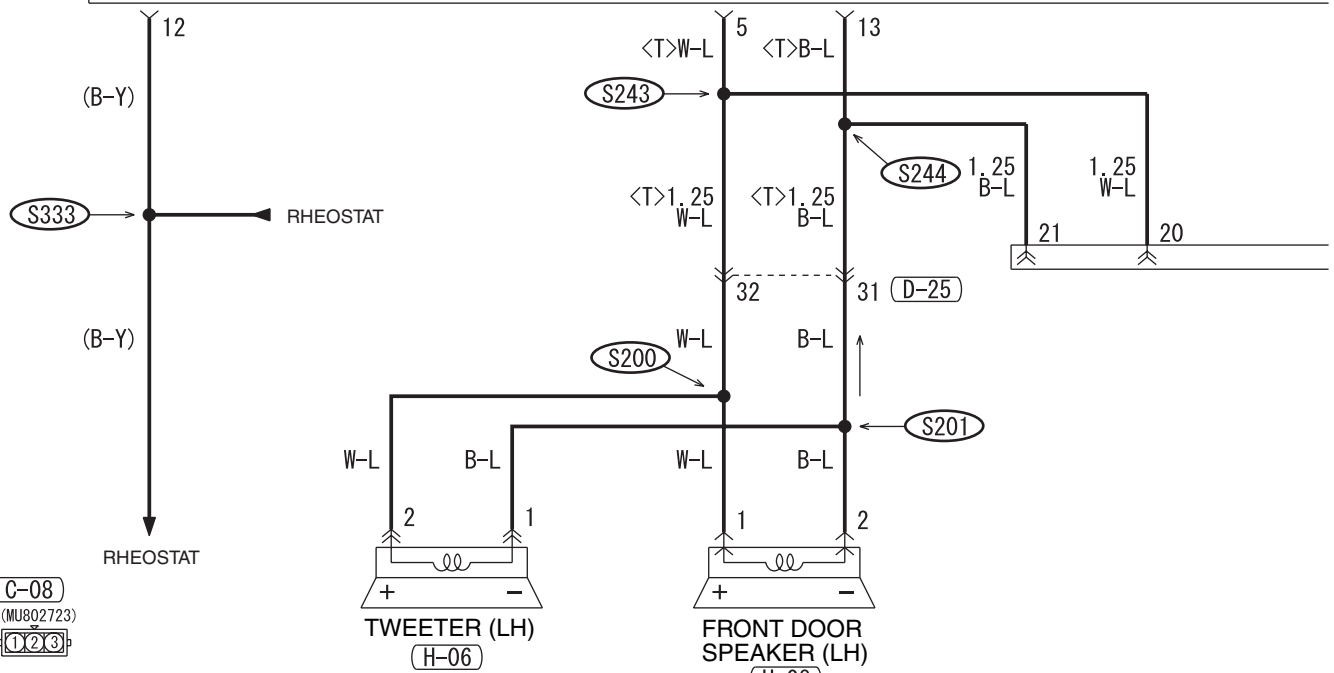

C-08
MU802723
1 2 3

D-06
MU801453

D-15

D-25

D-28

D-111

D-116

D-124

D-125

E-111

E-114

F-12

F-23

H-06

H-08

H-12

H-15

See ★3 See ★3

See ★1 See ★1

See ★2

See ★2

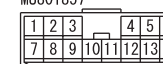
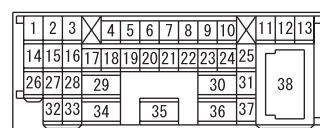
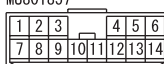

H6Q14M01BA

TSB Revision

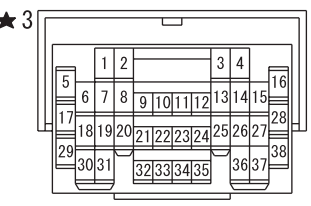
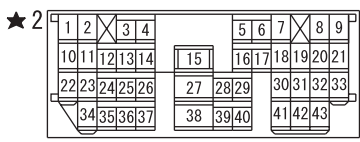
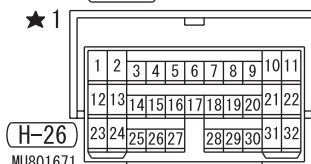
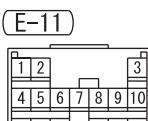
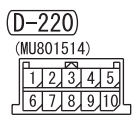
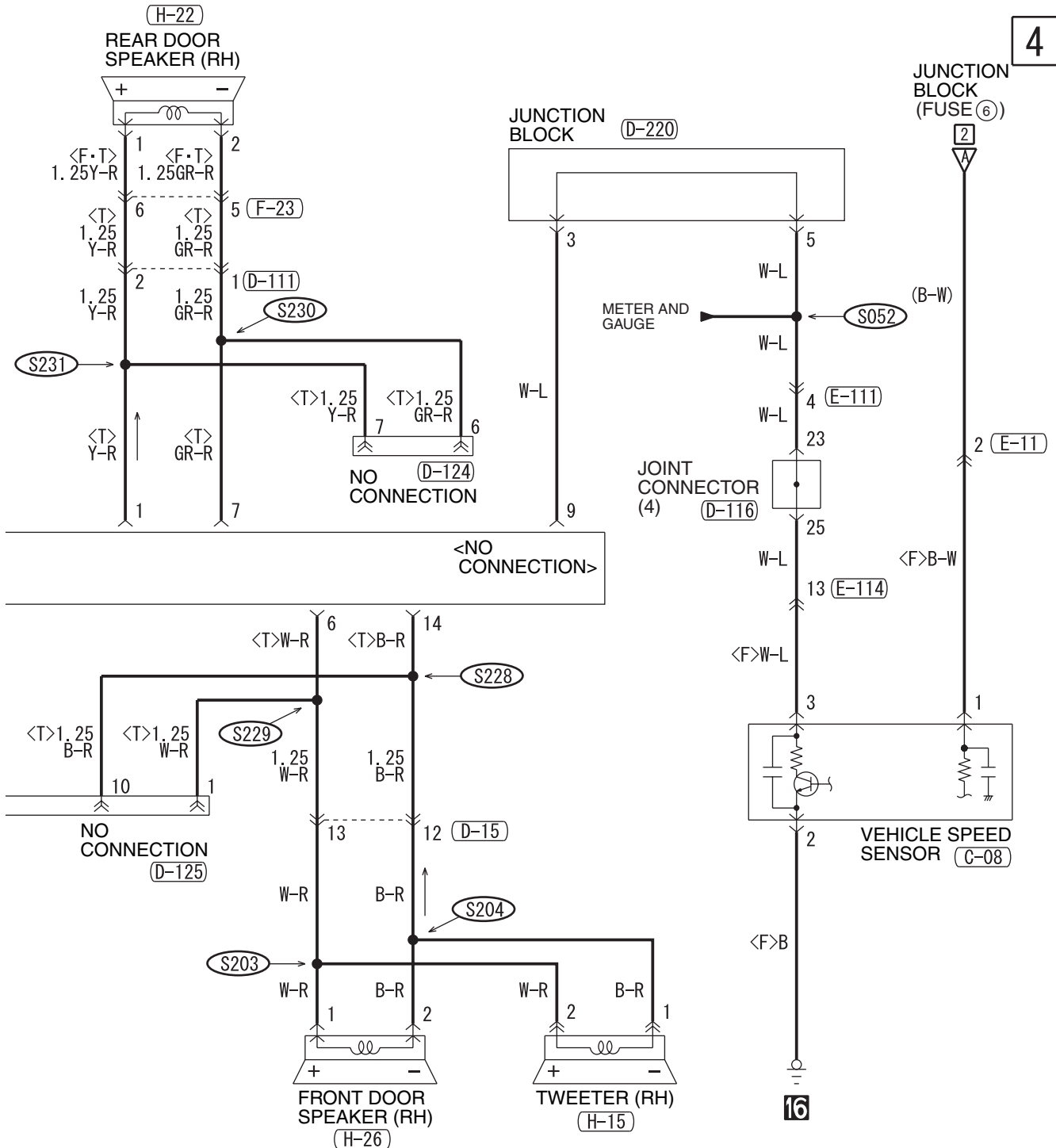

H6Q14M01BB

RADIO AND CD PLAYER <VEHICLES WITH AMPLIFIER>

M1901015601935

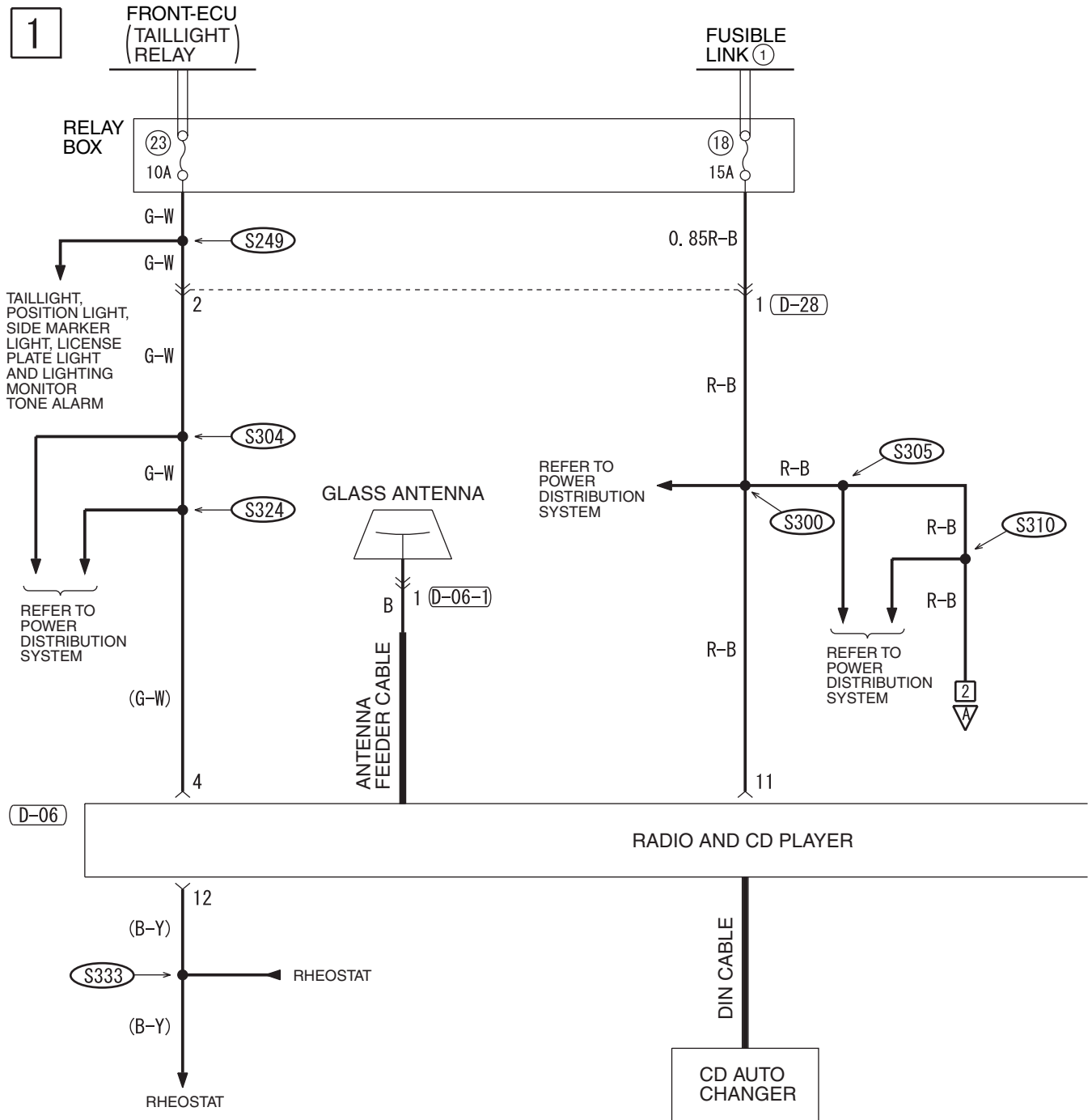

A-01

D-06

D-06-1

D-16

D-27

D-28

D-208

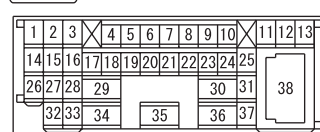
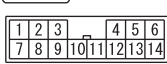
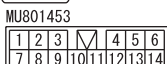

2

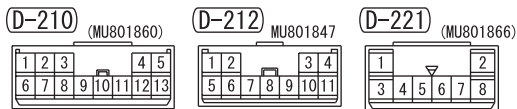
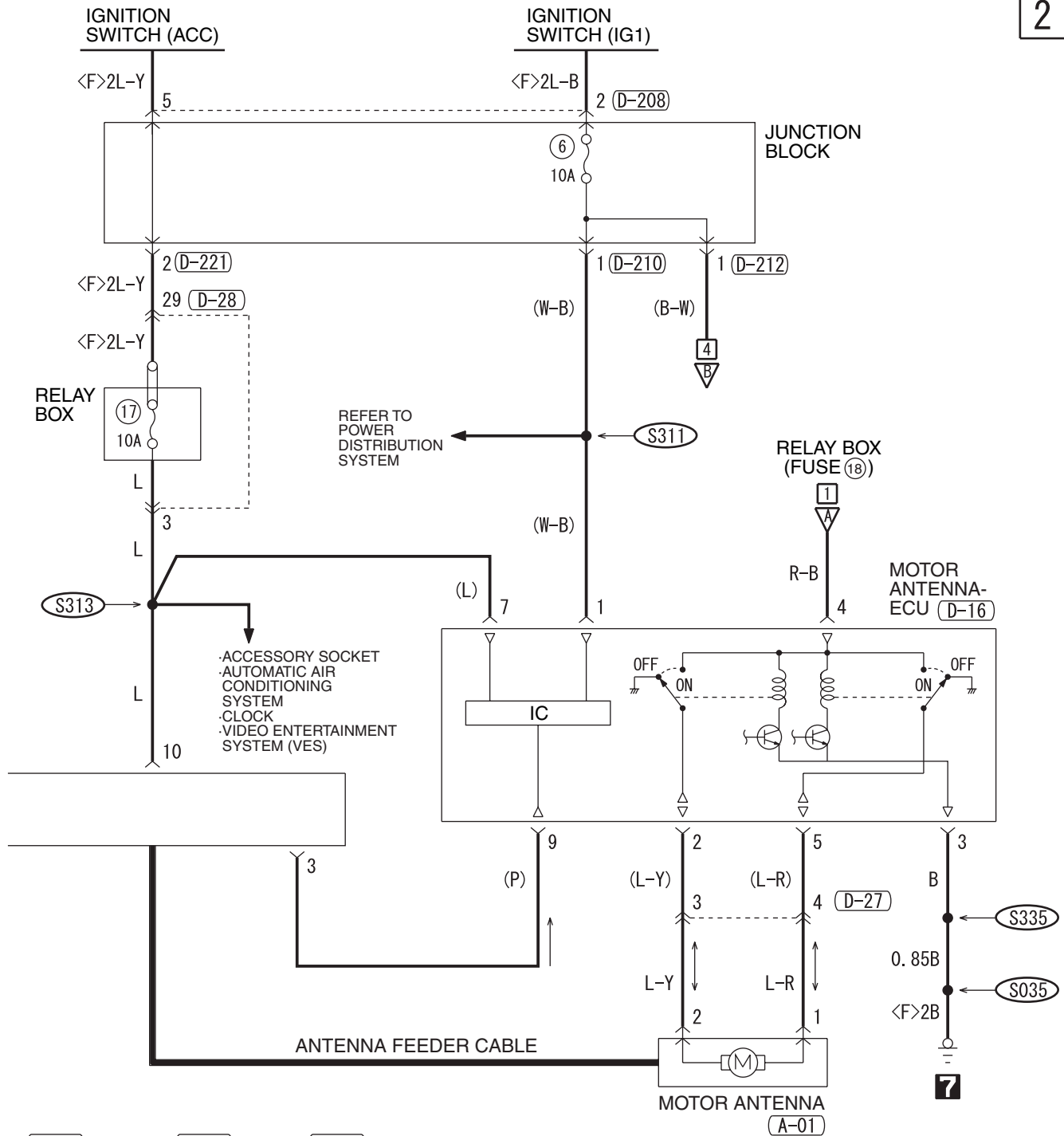

WIRE COLOR CODE
 B: BLACK LG: LIGHT GREEN G: GREEN L: BLUE W: WHITE Y: YELLOW
 SB: SKY BLUE BR: BROWN O: ORANGE GR: GRAY R: RED P: PINK V: VIOLET

TSB Revision

RADIO AND CD PLAYER <VEHICLES WITH AMPLIFIER> (CONTINUED)

3

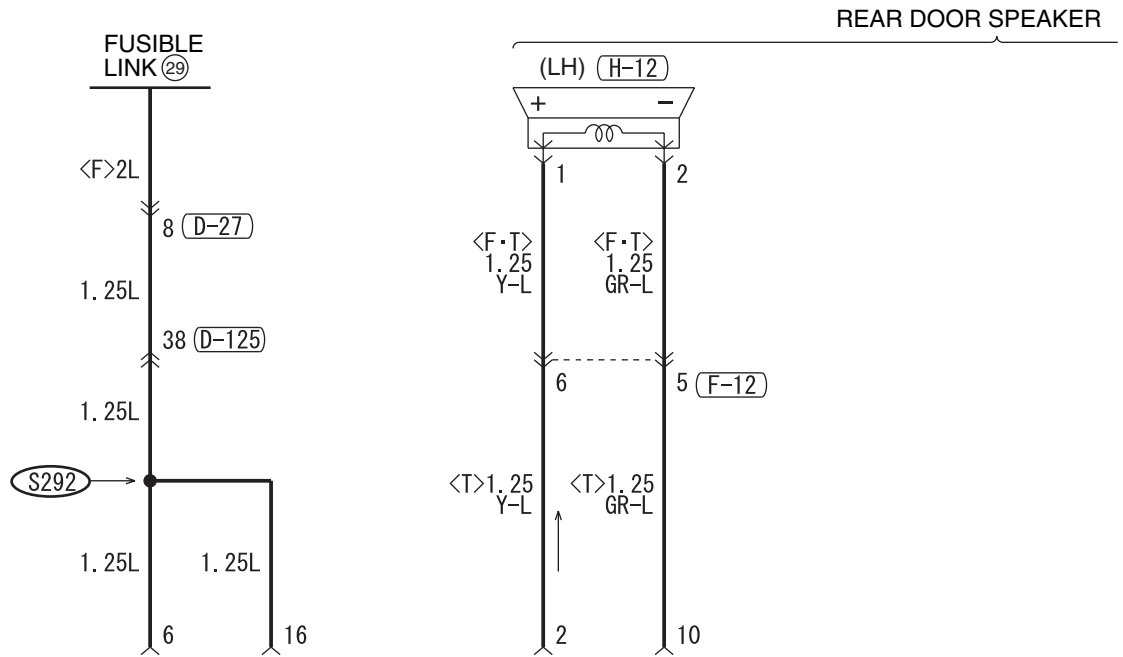

(G-19)

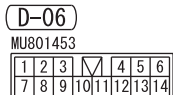
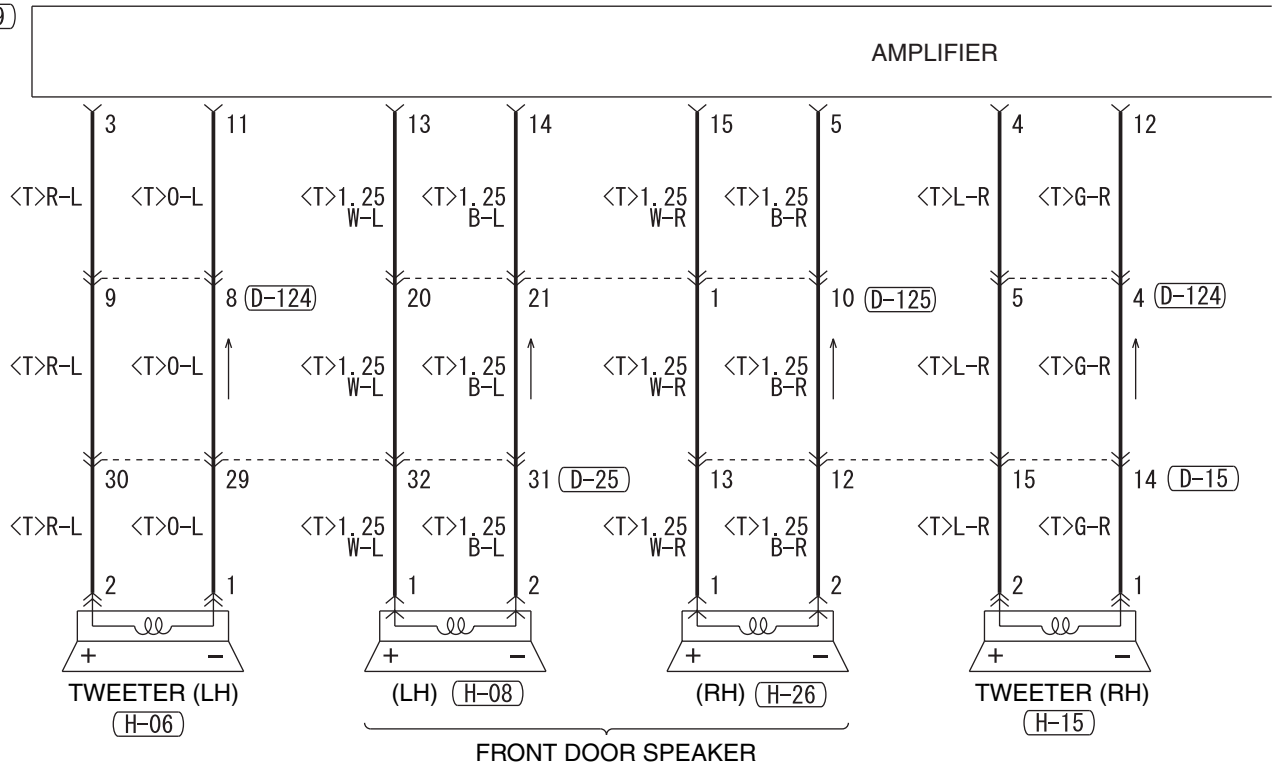

(D-15) See ★1
 (D-25) See ★1

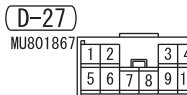

(D-111) See ★2
 (D-116) See ★2

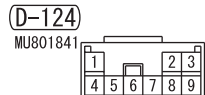
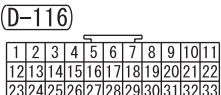

(D-125) See ★2

(E-111) See ★3
 (E-114) See ★3

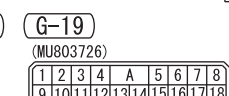
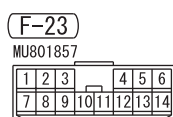
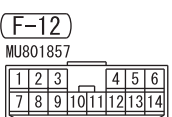

H6Q14M02BA

TSB Revision

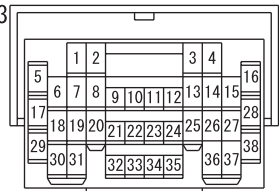
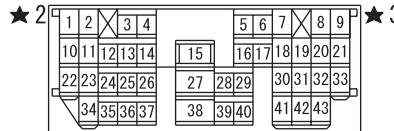
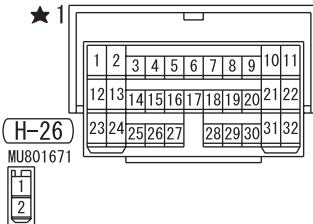
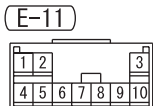
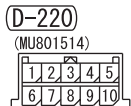
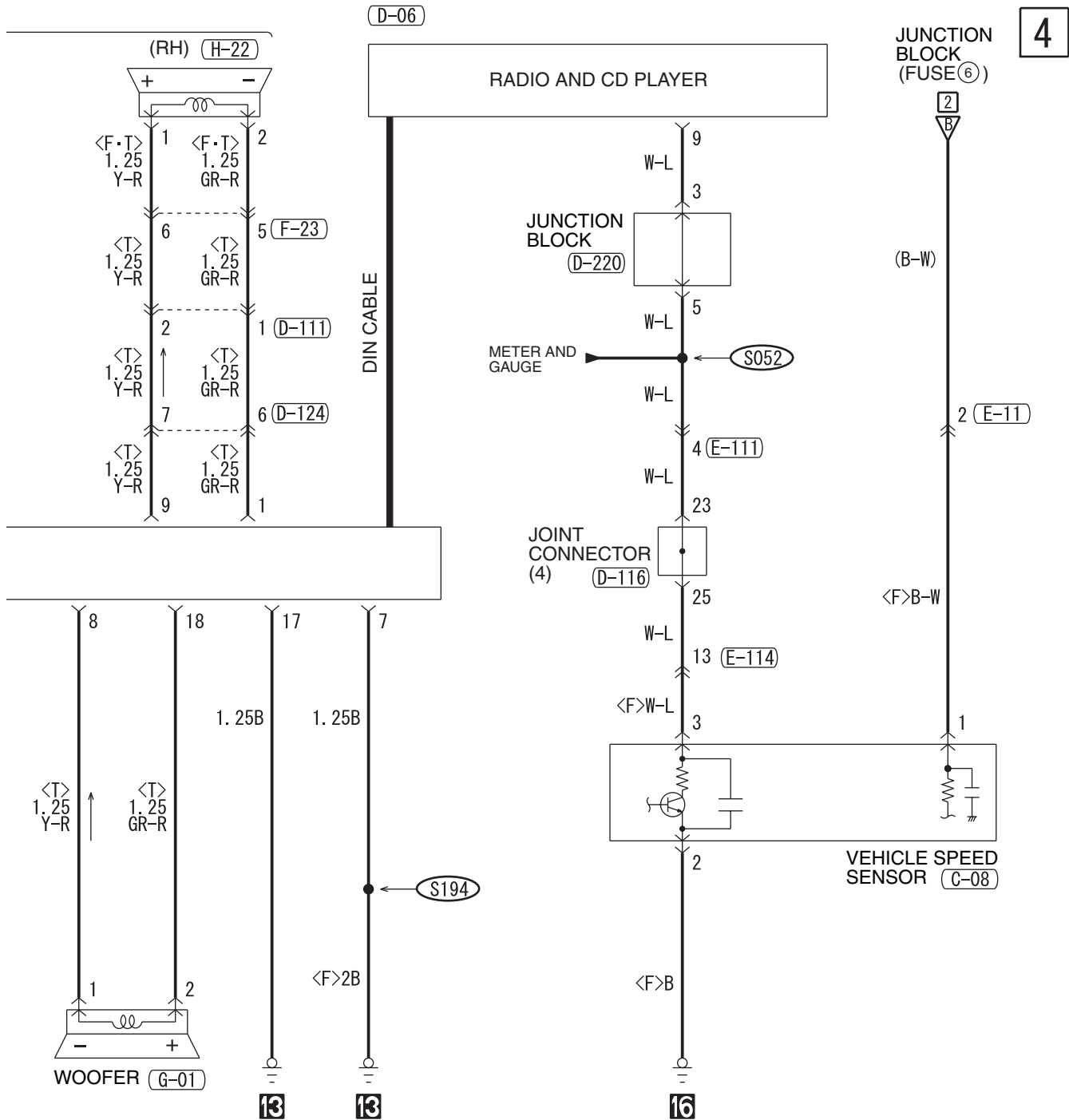

H6Q14M02BB

VIDEO ENTERTAINMENT SYSTEM (VES)

M1901019500108

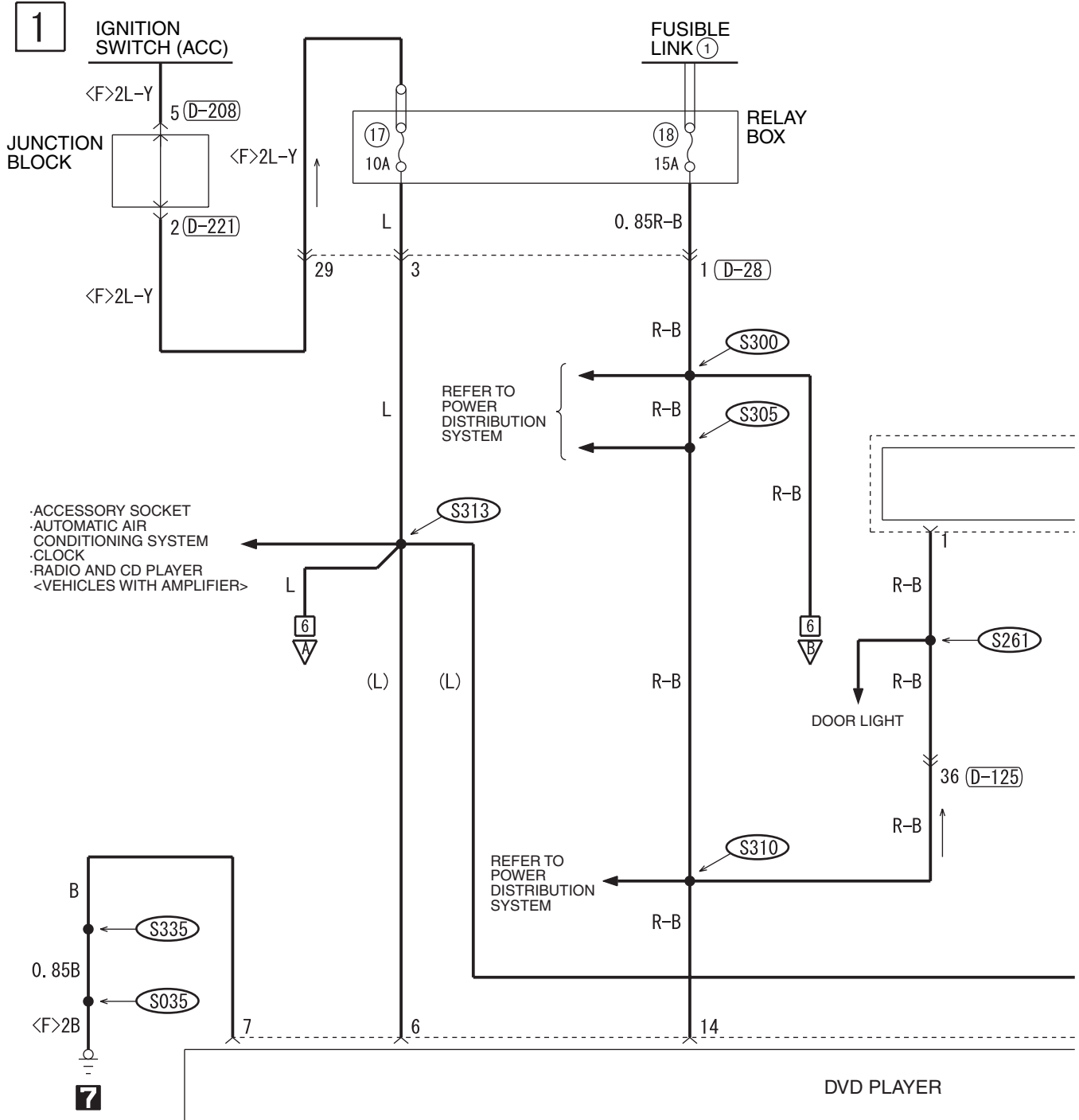

D-28

1	2	3	4	5	6	7	8	9	10	11	12	13
14	15	16	17	18	19	20	21	22	23	24	25	
26	27	28	29			30	31					38
32	33	34		35		36	37					

D-33

1	2	3	4	5	6	7
8	9	10	11	12	13	14

D-35

21	22	23
24	25	26

D-125

1	2	3	4	5	6	7	8	9
10	11	12	13	14	15	16	17	18
19	20	21						
22	23	24	25	26	27	28	29	30
31	32	33	34	35	36	37	38	39
40	41	42	43					

D-139

1	2	3	4	5
6	7	8	9	10

D-208

MU801331

1		2
3	4	5
6		

2

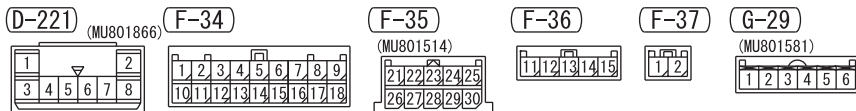
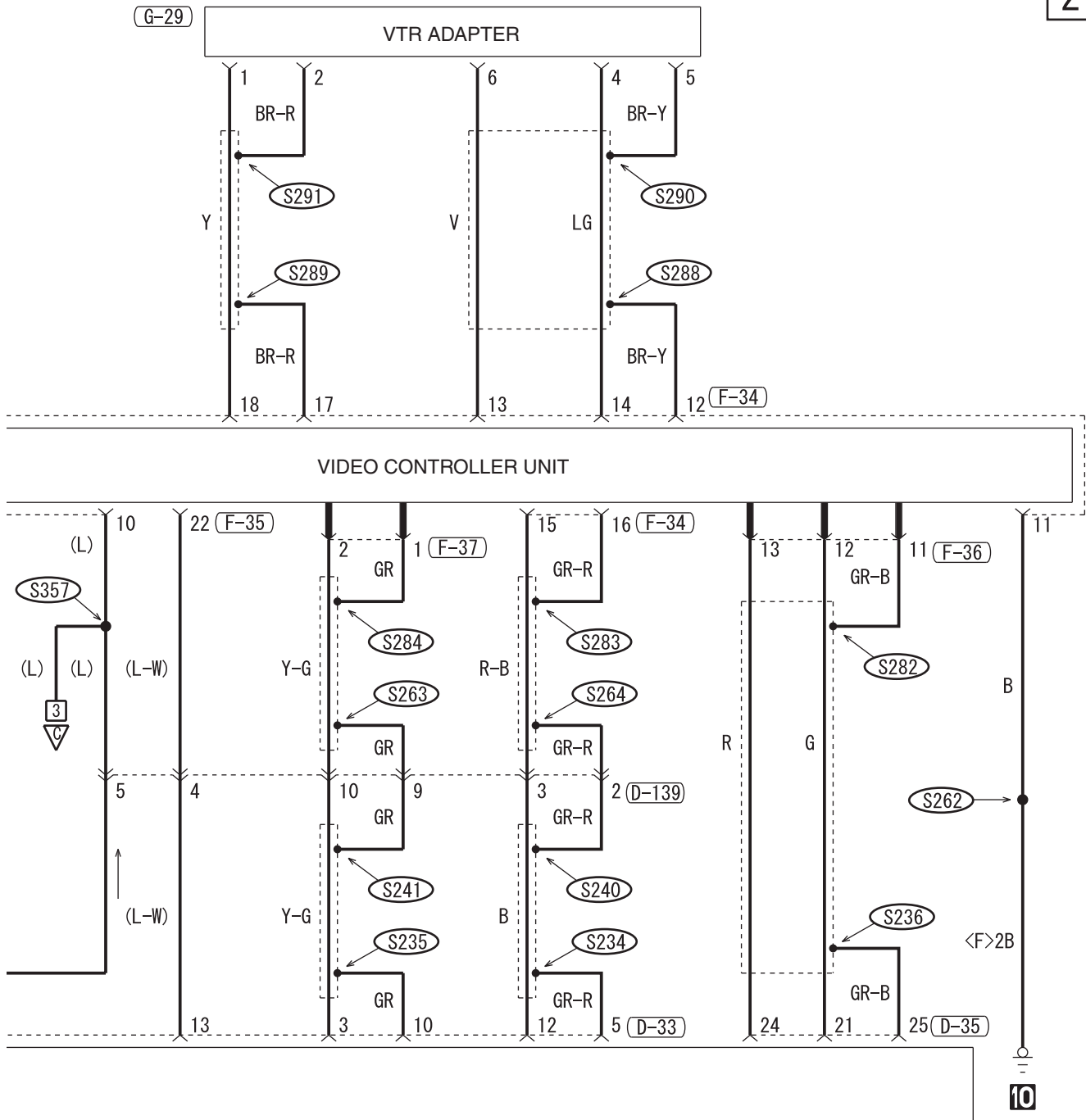

WIRE COLOR CODE
 B : BLACK LG : LIGHT GREEN G : GREEN L : BLUE W : WHITE Y : YELLOW
 SB : SKY BLUE BR : BROWN O : ORANGE GR : GRAY R : RED P : PINK V : VIOLET

VIDEO ENTERTAINMENT SYSTEM (VES) (CONTINUED)

3

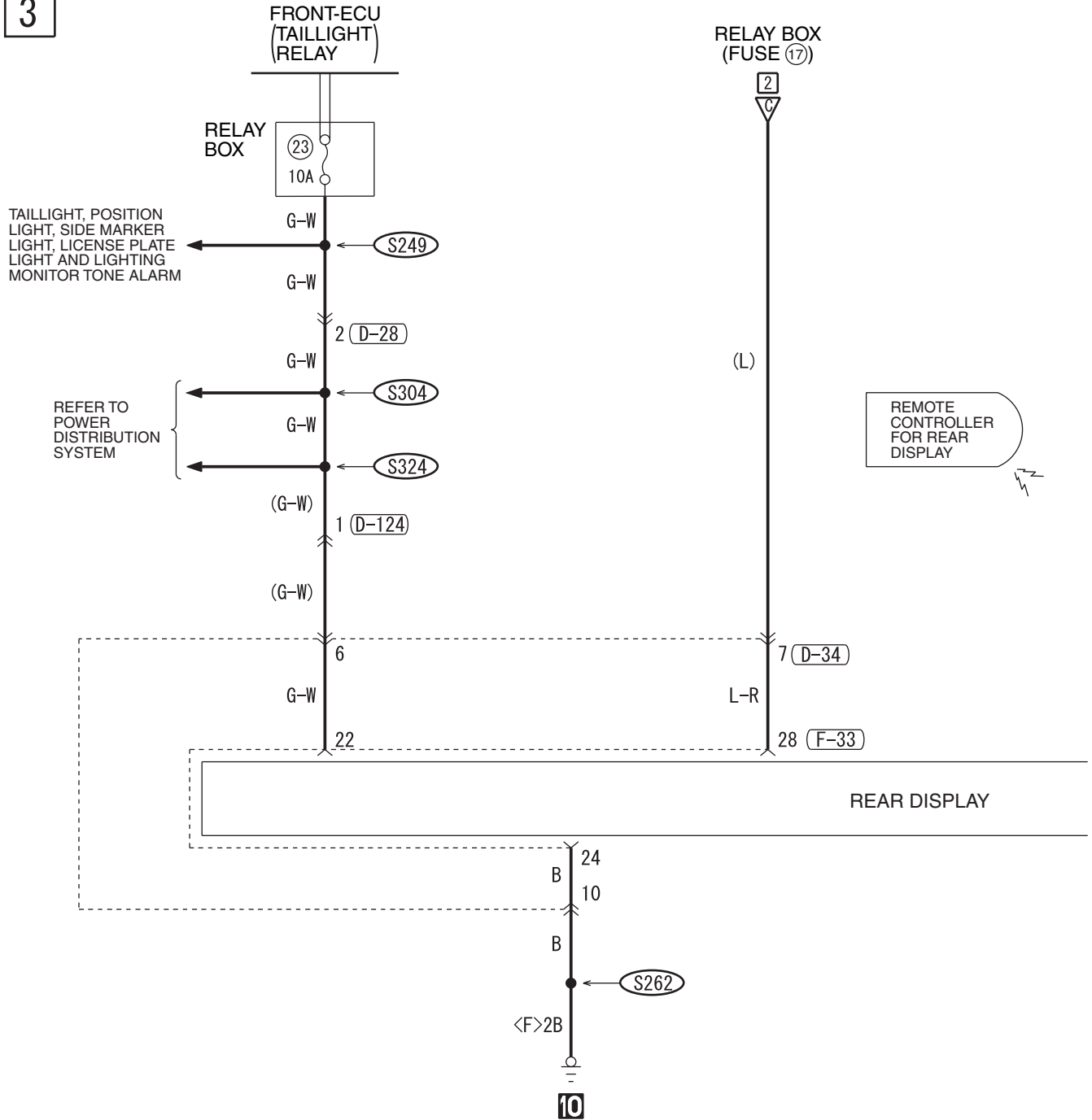

D-28

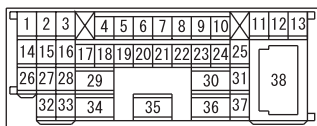

D-34



D-124

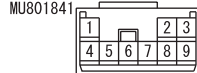

F-32

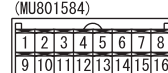

F-33



F-35

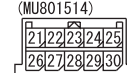

(F-35)

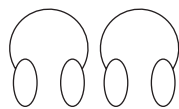
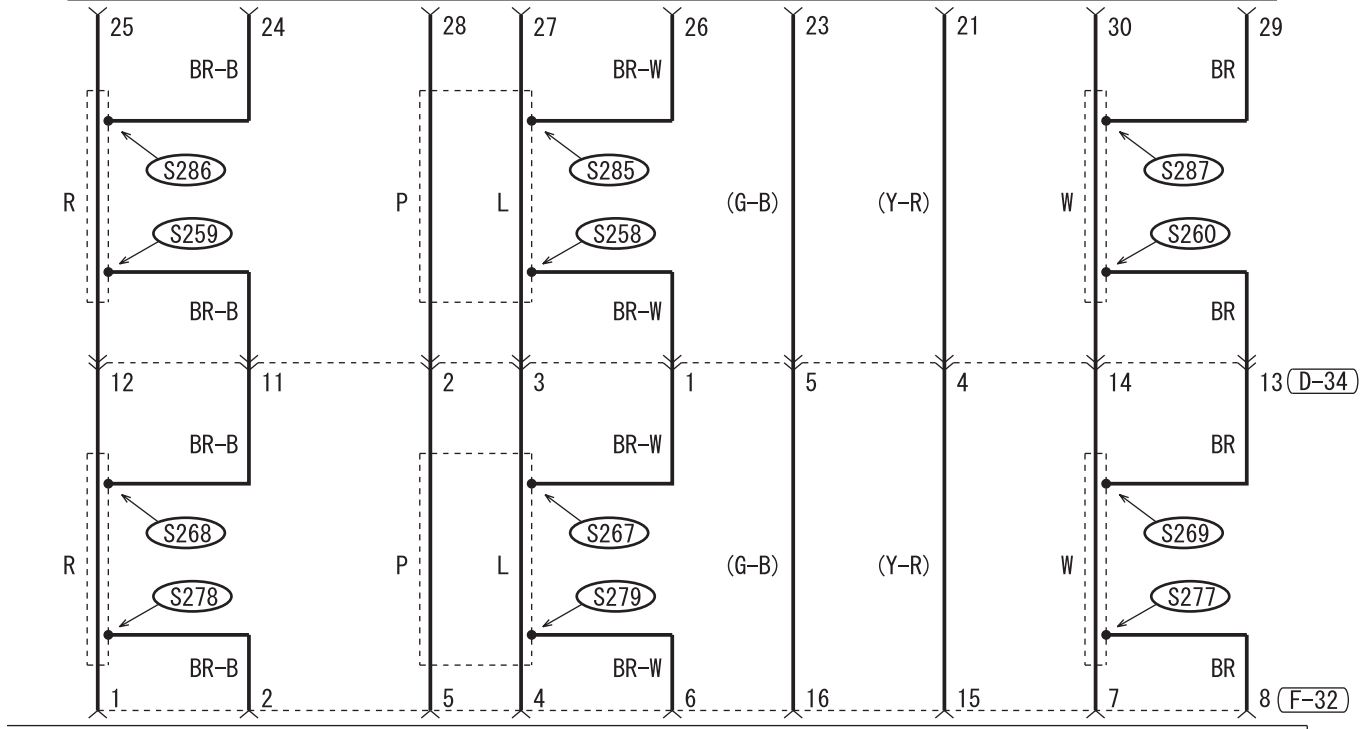

HEADPHONE

WIRE COLOR CODE

B : BLACK LG : LIGHT GREEN G : GREEN L : BLUE W : WHITE Y : YELLOW
SB : SKY BLUE BR : BROWN O : ORANGE GR : GRAY R : RED P : PINK V : VIOLET

H6Q14M03BB

TSB Revision

VIDEO ENTERTAINMENT SYSTEM (VES) (CONTINUED)

5

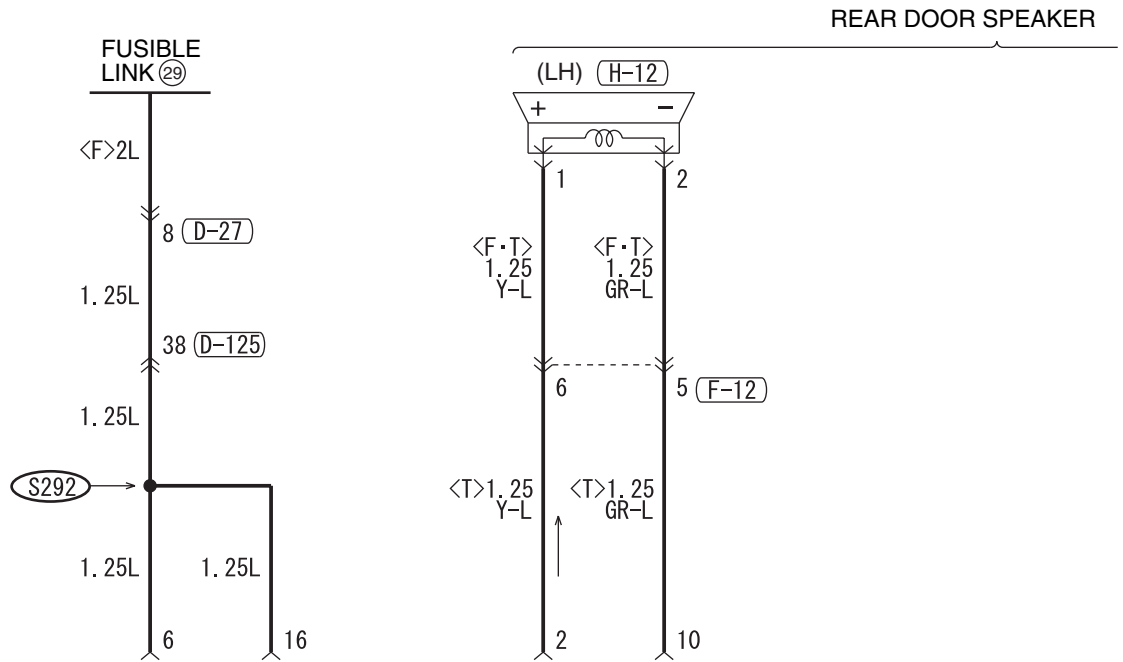

(G-19)

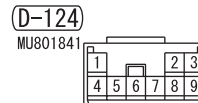
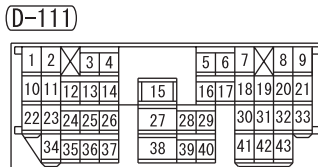
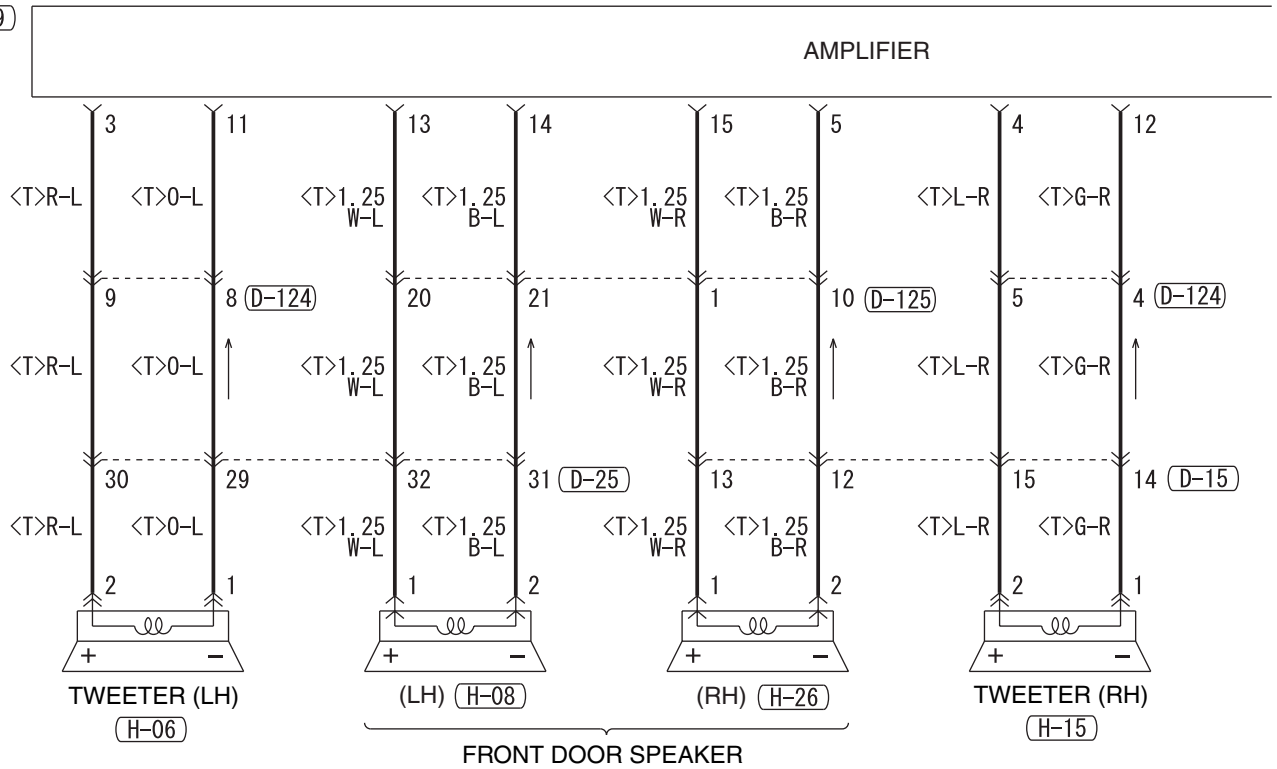

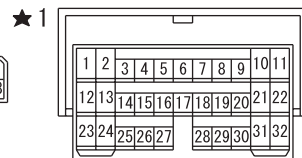
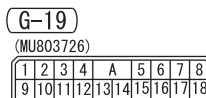
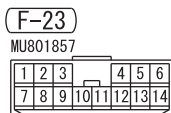
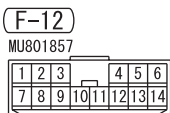
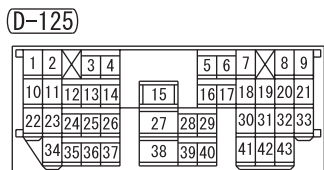
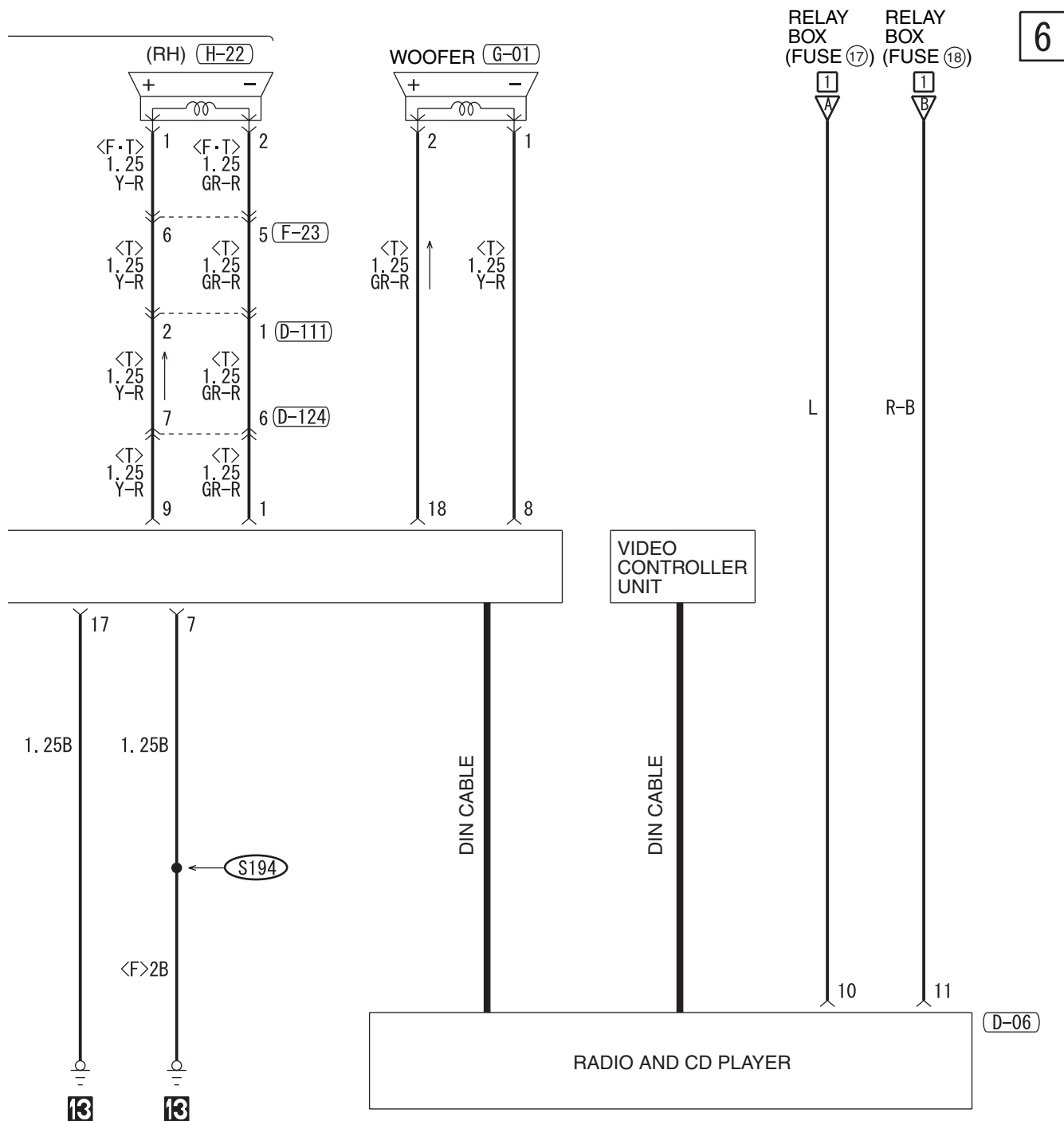

WIRE COLOR CODE
 B: BLACK LG: LIGHT GREEN G: GREEN L: BLUE
 BR: BROWN O: ORANGE GR: GRAY R: RED W: WHITE
 SB: SKY BLUE P: PINK Y: YELLOW V: VIOLET

H6Q14M03CB

CIGARETTE LIGHTER AND ASHTRAY ILLUMINATION LIGHT

M1901007801097

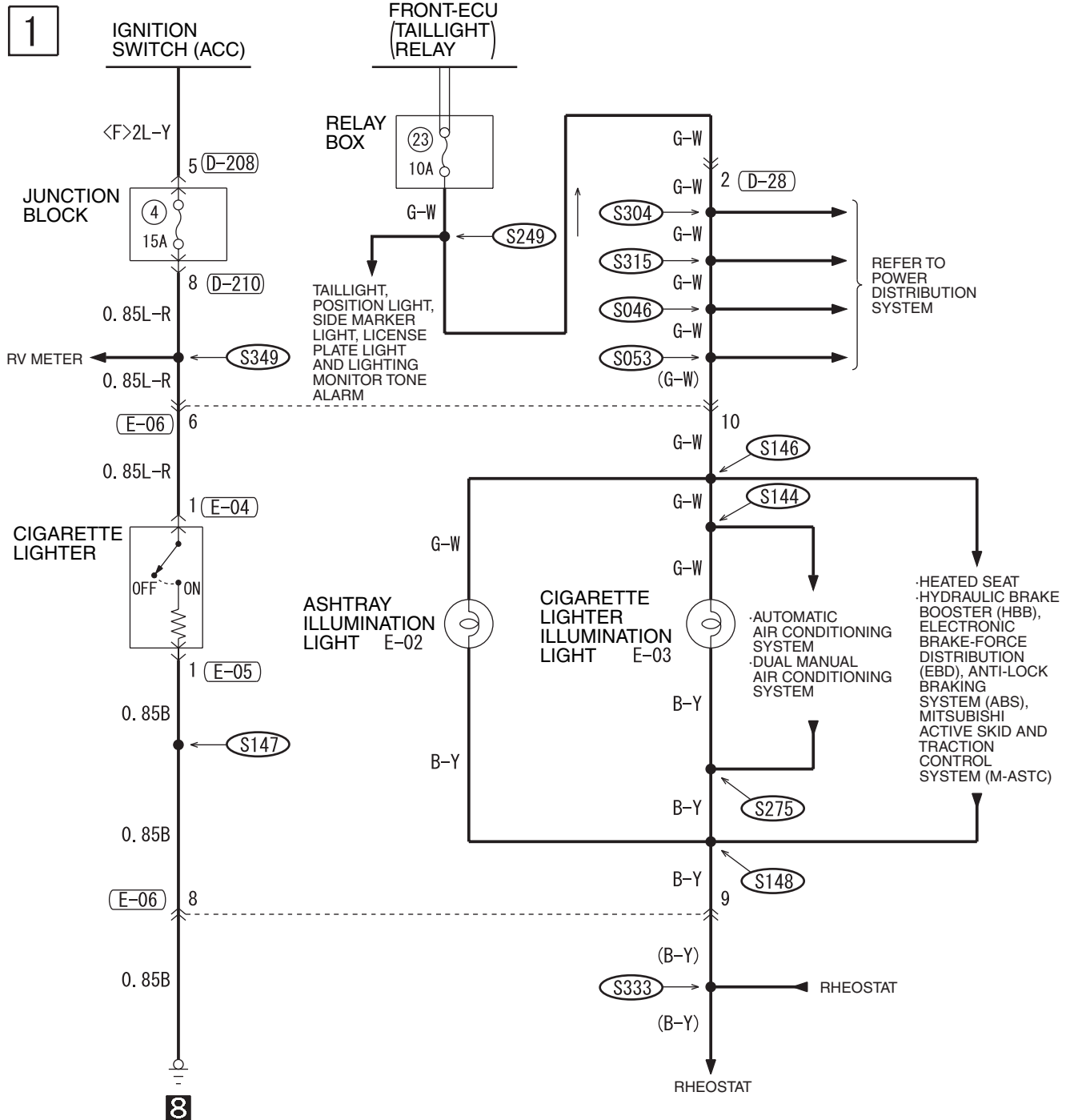

D-28

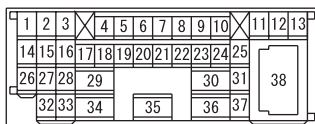

D-208



D-210

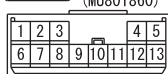

E-04



E-05



E-06

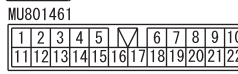

WIRE COLOR CODE
B : BLACK LG : LIGHT GREEN G : GREEN L : BLUE
BR : BROWN O : ORANGE GR : GRAY R : RED W : WHITE
SB : SKY BLUE P : PINK Y : YELLOW V : VIOLET

H6Q14M04AA

ACCESSORY SOCKET

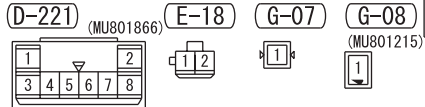
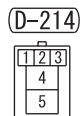
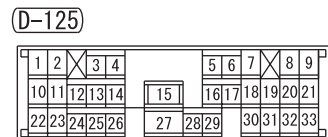
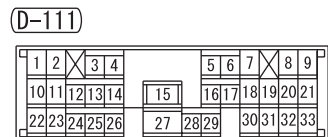
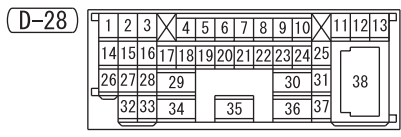
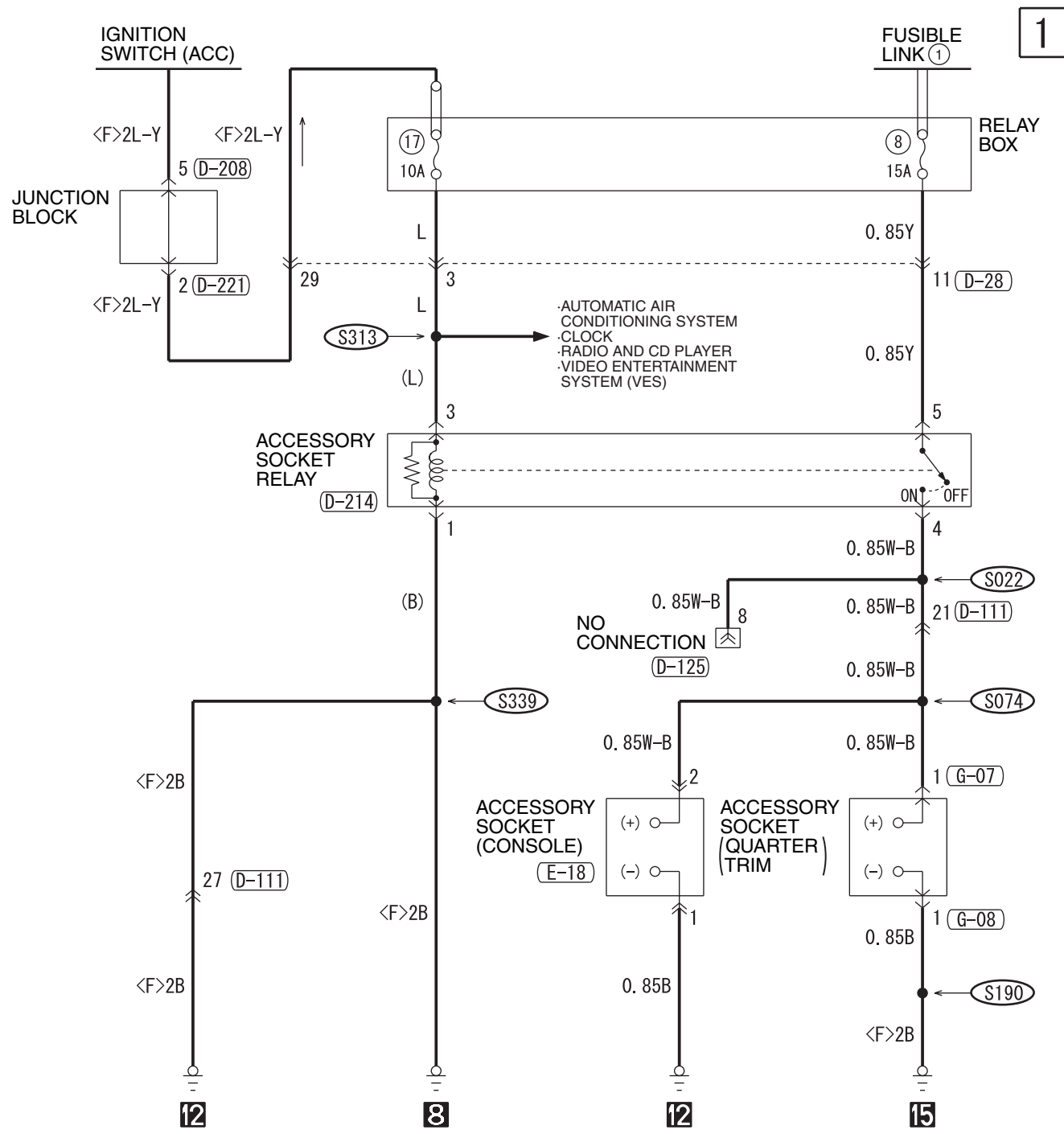

RV METER

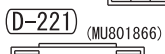
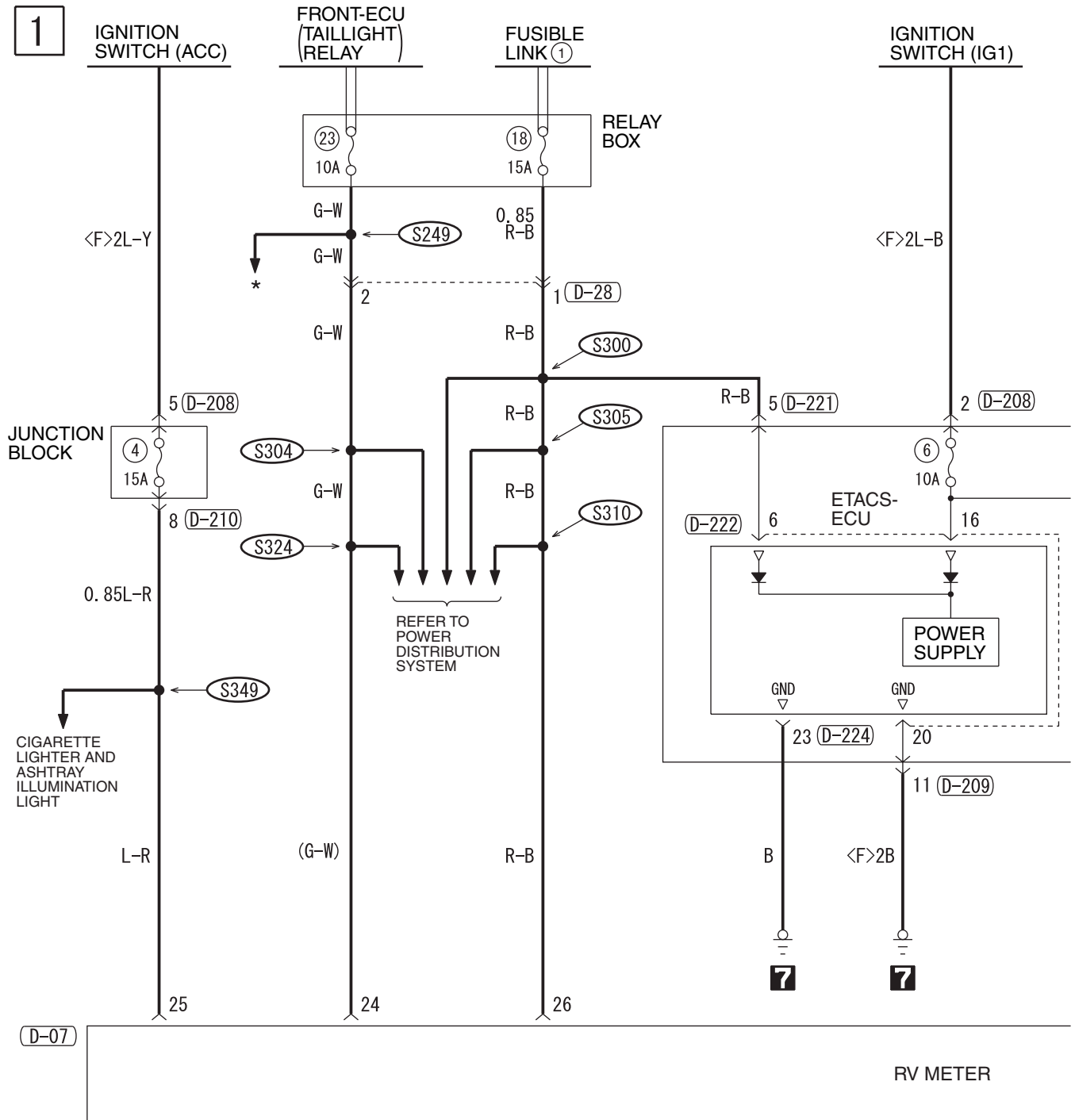

2

NOTE
* : TAILLIGHT, POSITION LIGHT, SIDE MARKER LIGHT, LICENSE PLATE LIGHT AND LIGHTING MONITOR TONE ALARM

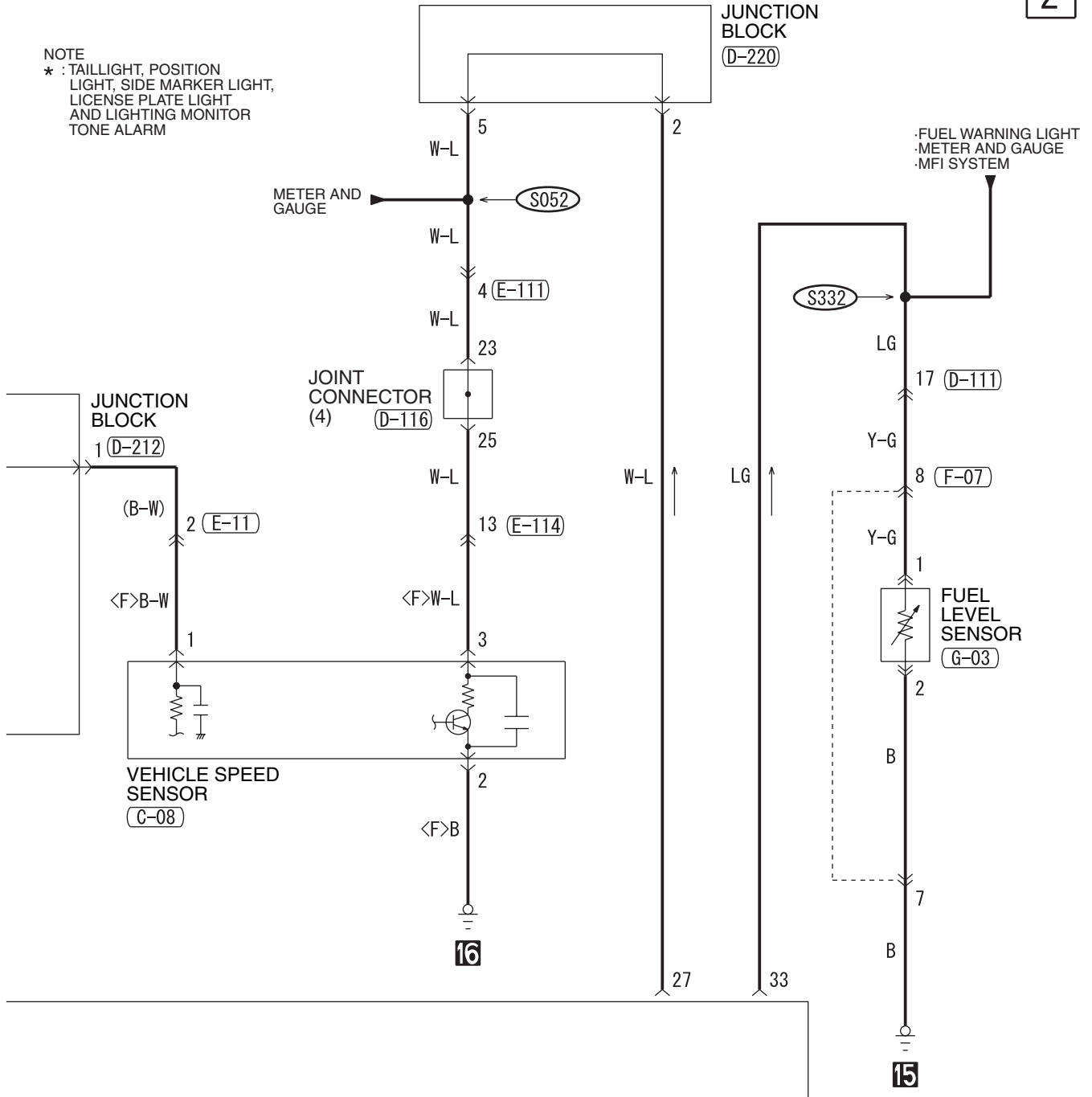

D-208



D-209

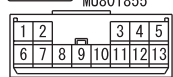

D-210

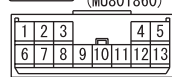

D-212



D-220

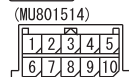

D-224

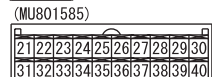

E-11

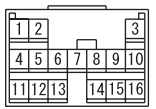

E-111



E-114



F-07



G-03



See ★1 See ★1

★1

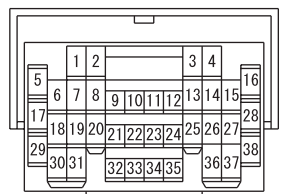

H6Q14M06AB

RV METER (CONTINUED)

3

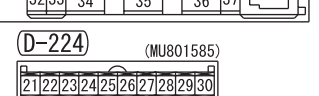
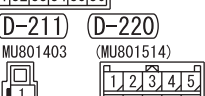
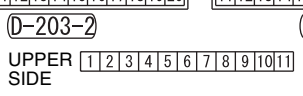
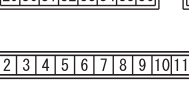
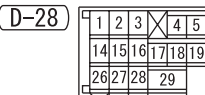
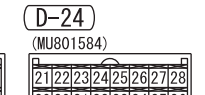
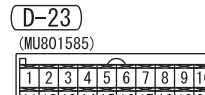
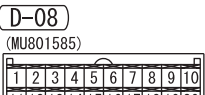
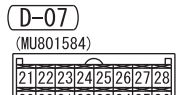
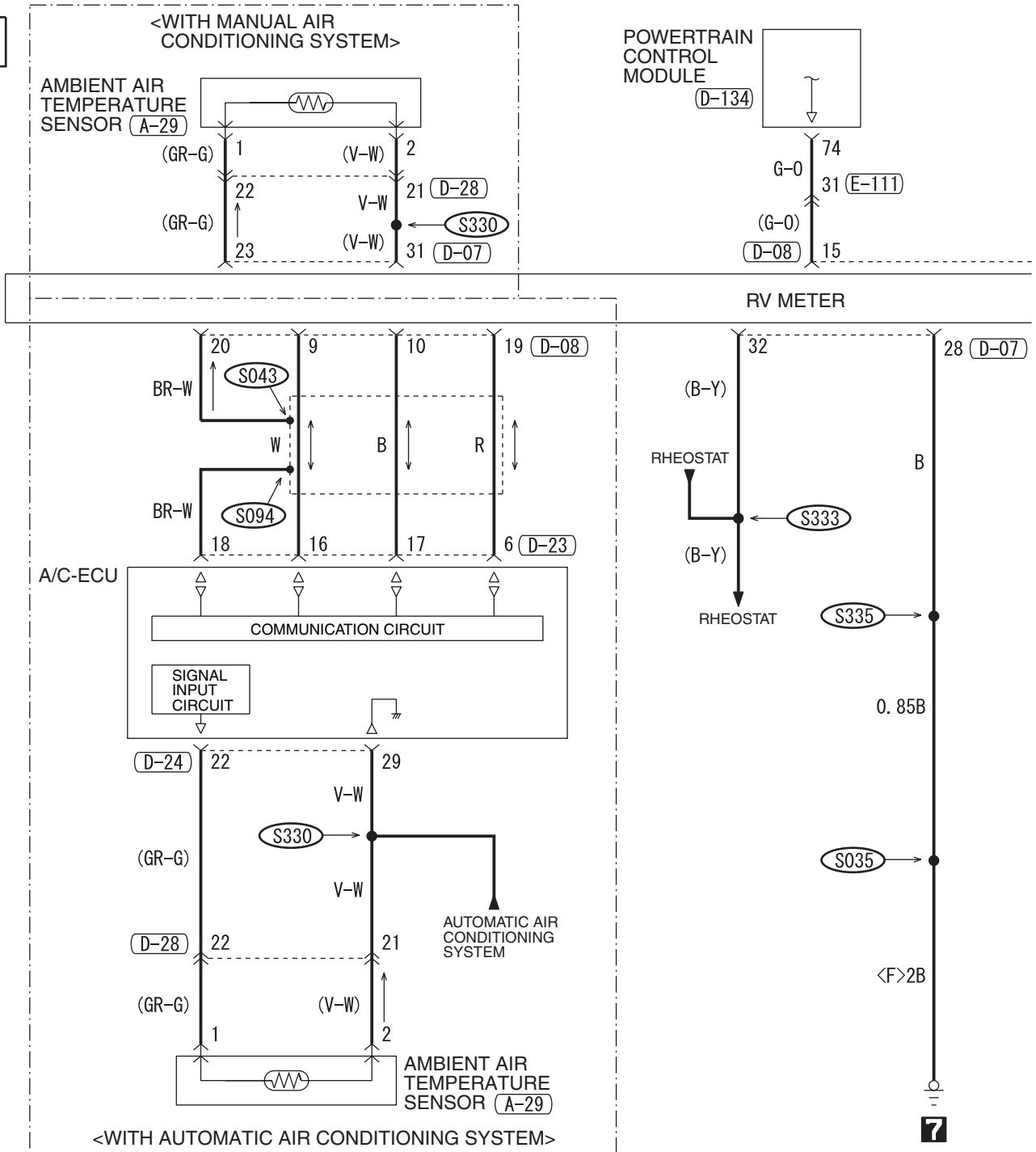

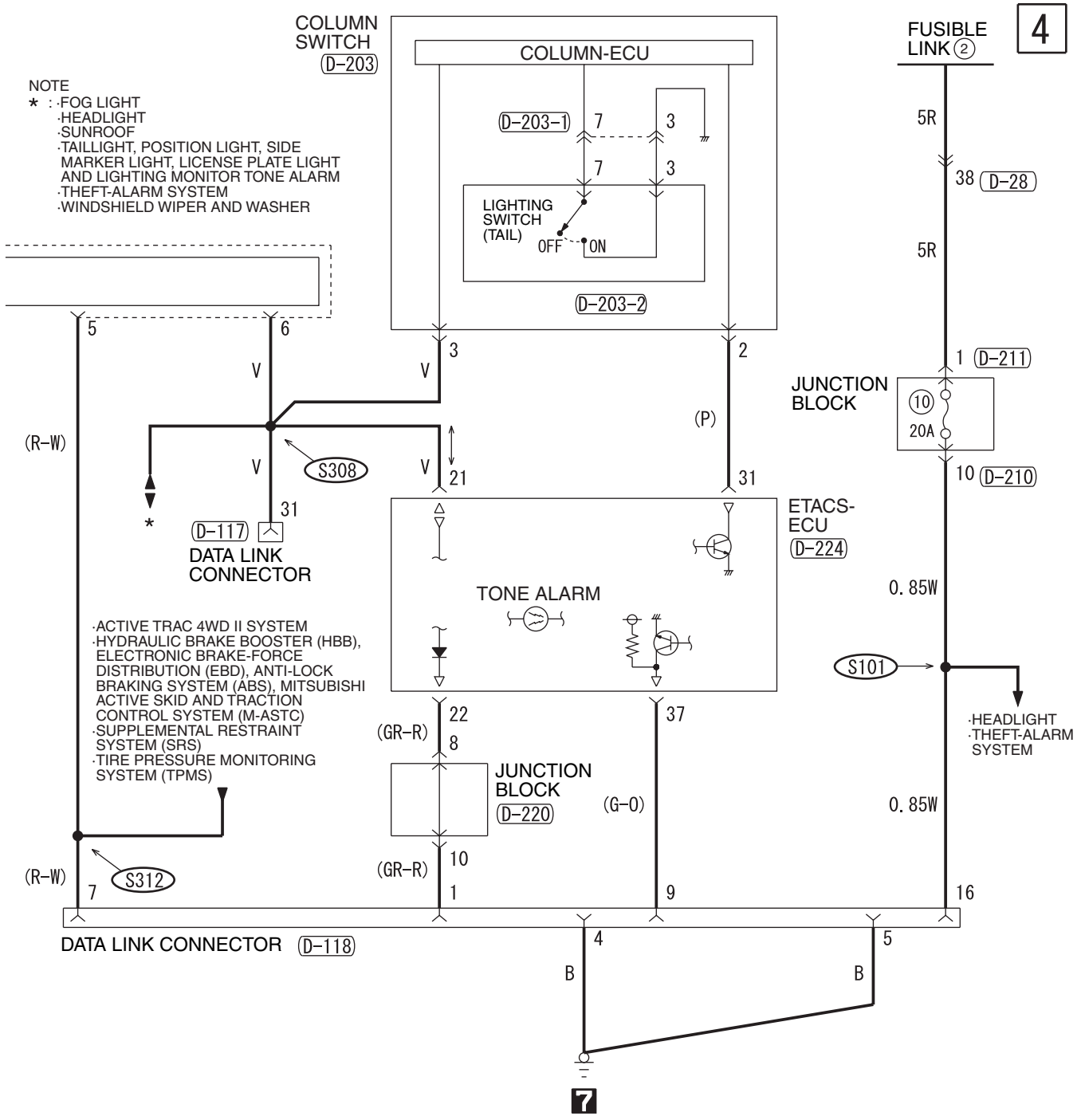

NOTE

- * : FOG LIGHT
- . HEADLIGHT
- . SUNROOF
- . TAILLIGHT, POSITION LIGHT, SIDE MARKER LIGHT, LICENSE PLATE LIGHT AND LIGHTING MONITOR TONE ALARM
- . THEFT-ALARM SYSTEM
- . WINDSHIELD WIPER AND WASHER

- . ACTIVE TRAC 4WD II SYSTEM
- . HYDRAULIC BRAKE BOOSTER (HBB), ELECTRONIC BRAKE-FORCE DISTRIBUTION (EBD), ANTI-LOCK BRAKING SYSTEM (ABS), MITSUBISHI ACTIVE SKID AND TRACTION CONTROL SYSTEM (M-ASTC)
- . SUPPLEMENTAL RESTRAINT SYSTEM (SRS)
- . TIRE PRESSURE MONITORING SYSTEM (TPMS)

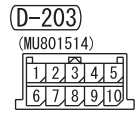
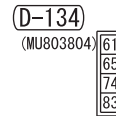
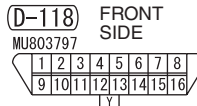
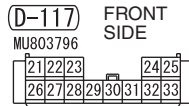
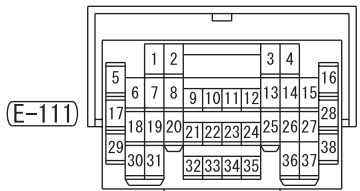

WIRE COLOR CODE
 B : BLACK LG : LIGHT GREEN G : GREEN L : BLUE
 BR : BROWN O : ORANGE GR : GRAY R : RED W : WHITE
 SB : SKY BLUE P : PINK Y : YELLOW V : VIOLET

SUNROOF

M1901009901302

1

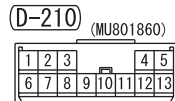
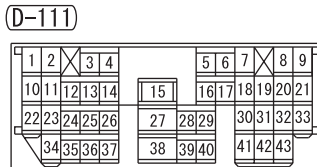
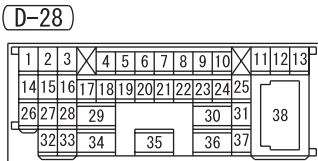
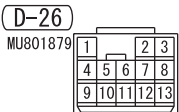
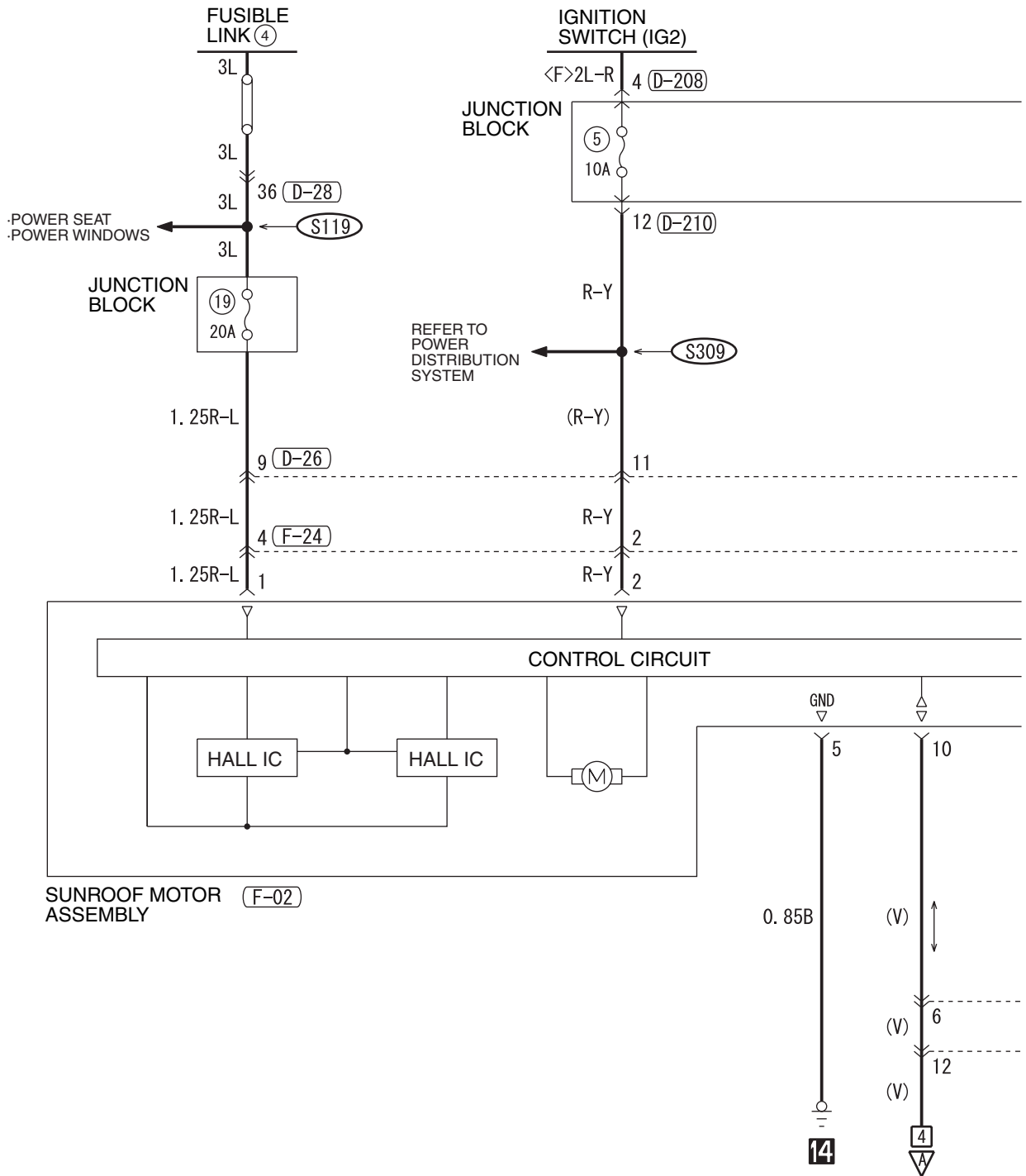

H6Q15M00AA

2

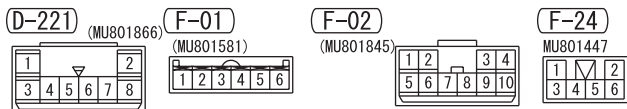
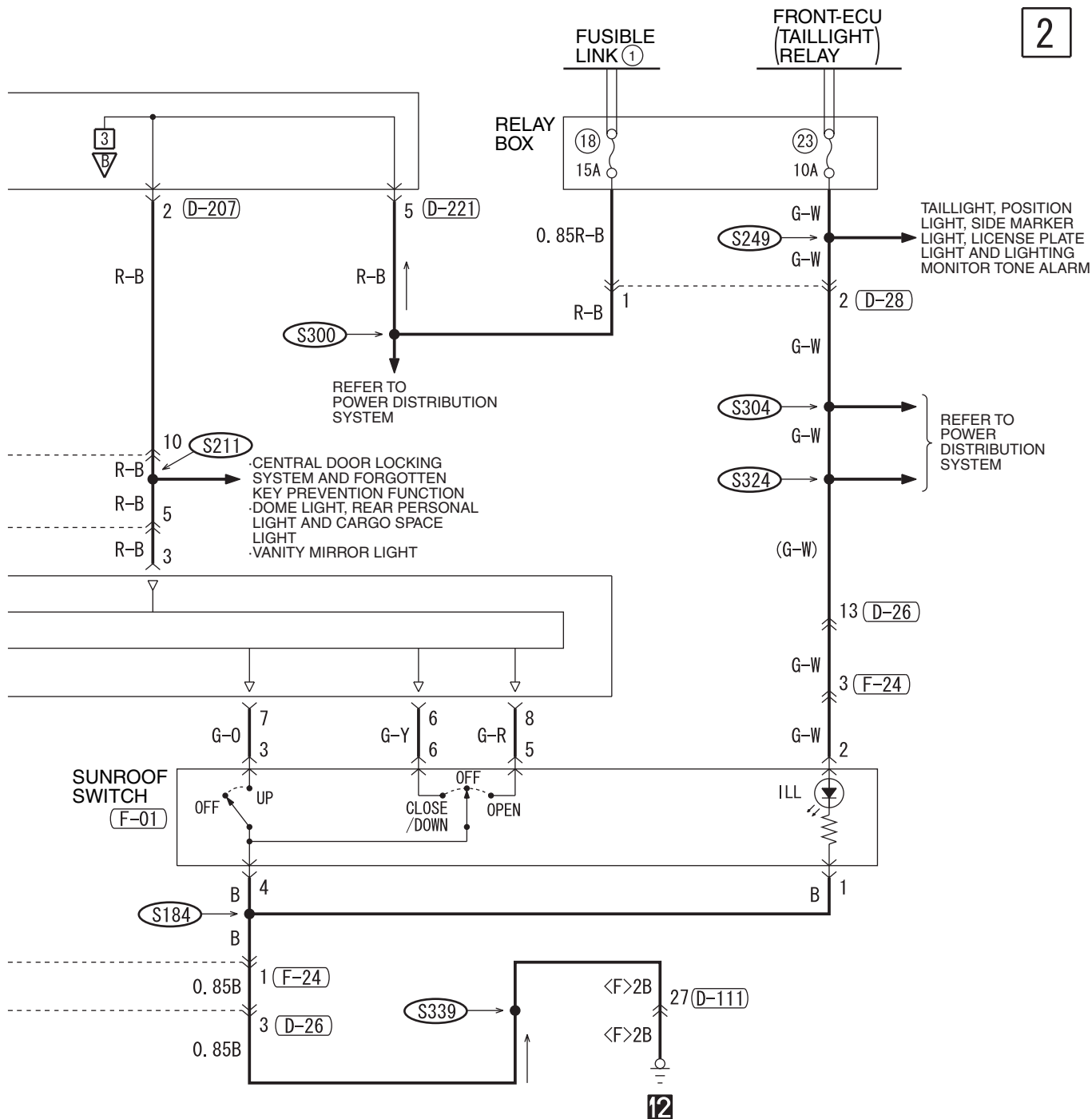

WIRE COLOR CODE
 B : BLACK LG : LIGHT GREEN G : GREEN L : BLUE W : WHITE Y : YELLOW
 SB : SKY BLUE BR : BROWN O : ORANGE GR : GRAY R : RED P : PINK V : VIOLET

SUNROOF (CONTINUED)

3

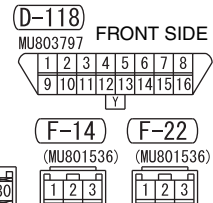
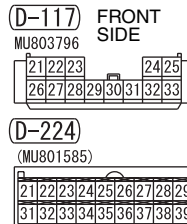
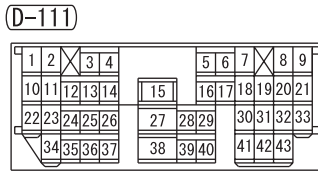
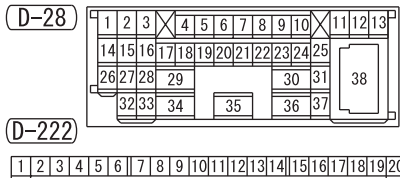
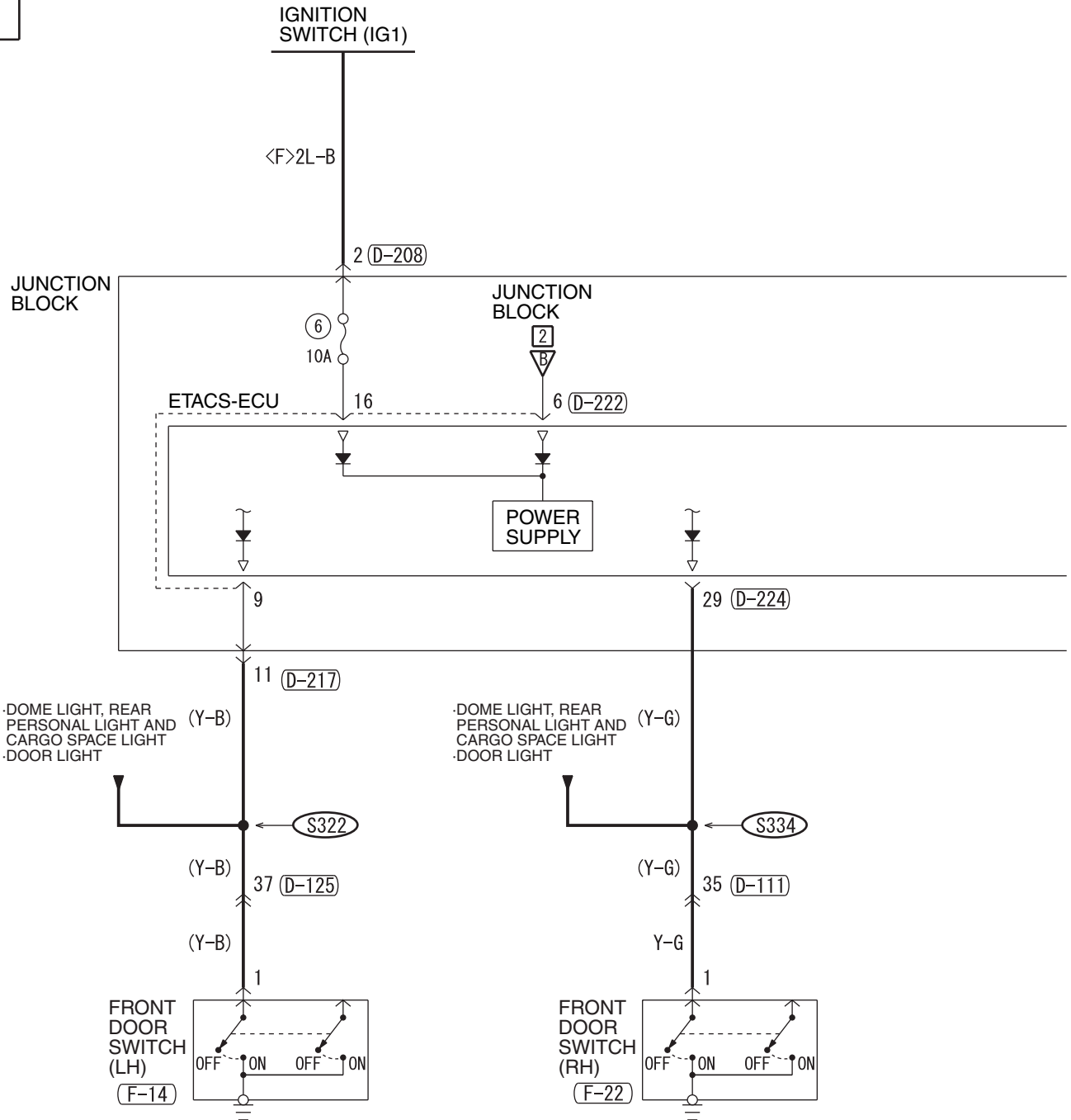

4

- FOG LIGHT
- HEADLIGHT
- REAR WIPER AND WASHER
- RV METER
- TAILLIGHT, POSITION LIGHT, SIDE MARKER LIGHT, LICENSE PLATE LIGHT AND LIGHTING MONITOR TONE ALARM
- TURN-SIGNAL LIGHT AND HAZARD WARNING LIGHT
- WINDSHIELD WIPER AND WASHER

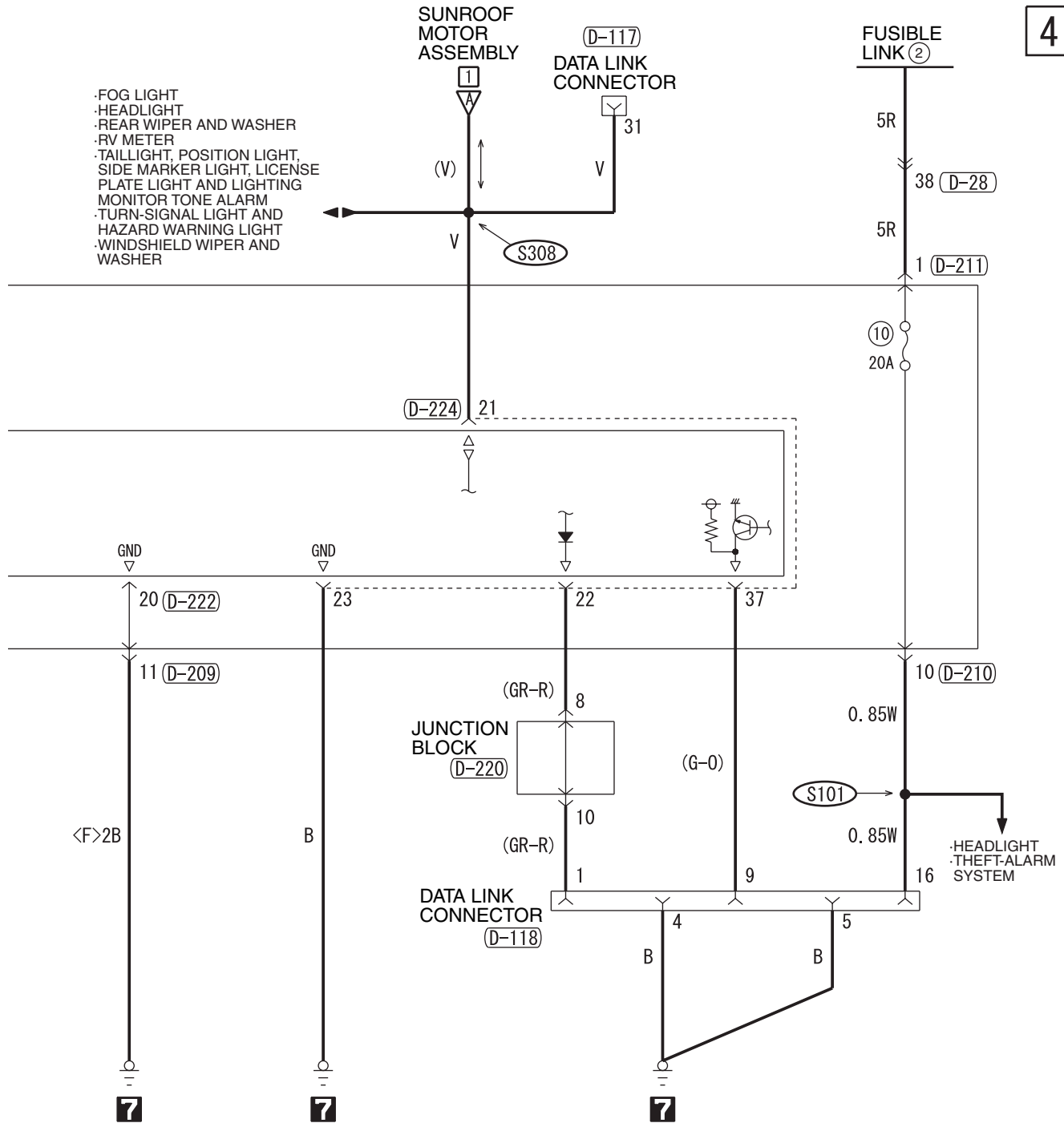

D-125

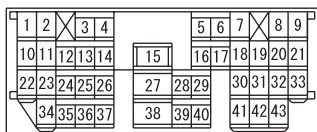

D-208



D-209

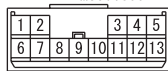

D-210

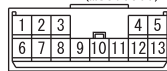

D-211



D-217

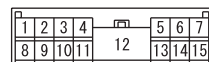

D-220



WIRE COLOR CODE

- B : BLACK
- LG : LIGHT GREEN
- G : GREEN
- L : BLUE
- BR : BROWN
- O : ORANGE
- GR : GRAY
- R : RED
- W : WHITE
- SB : SKY BLUE
- P : PINK
- Y : YELLOW
- V : VIOLET

SEAT BELT TONE ALARM

M1901011200965

1

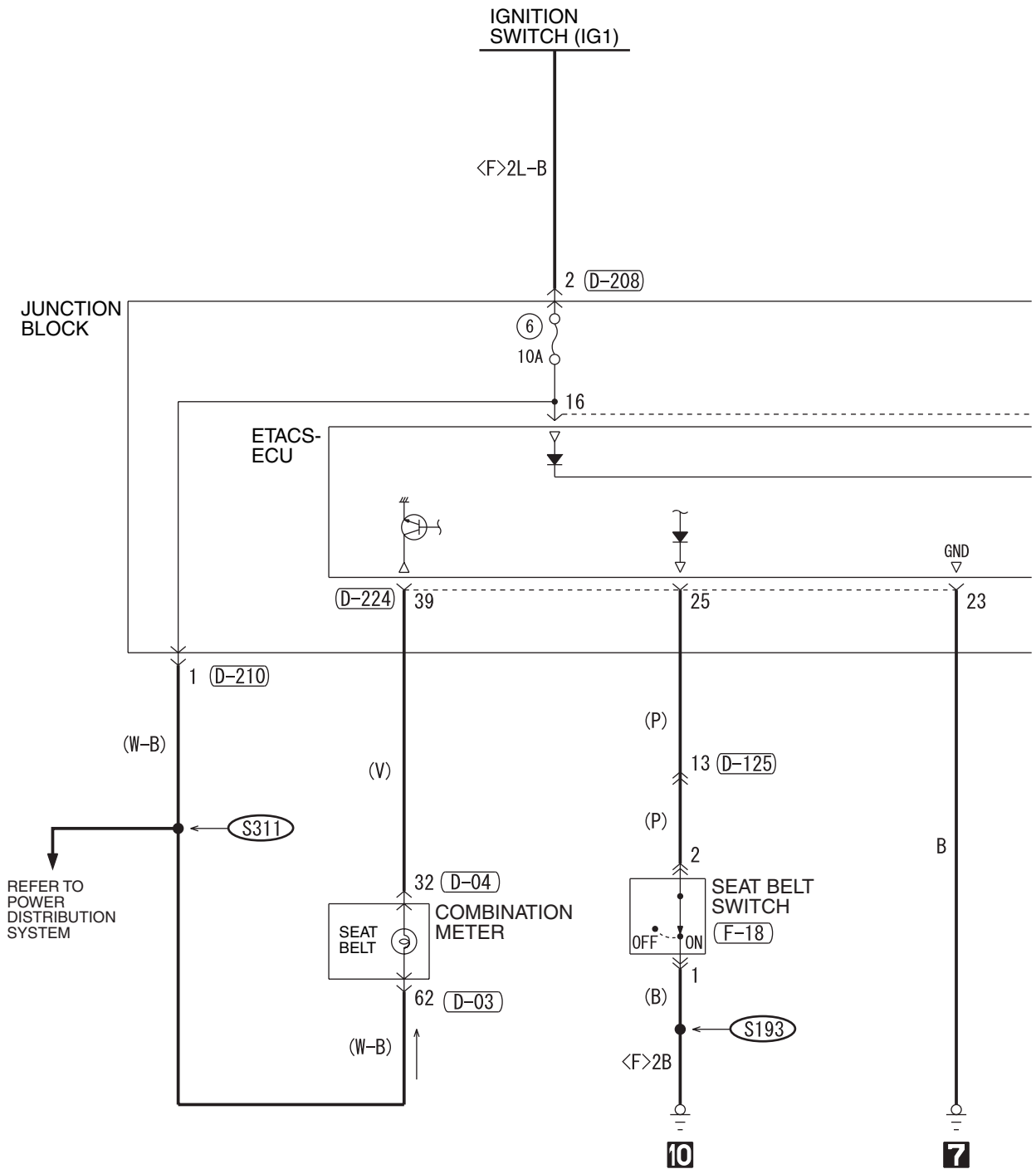

D-03

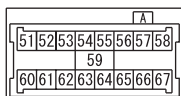

D-04

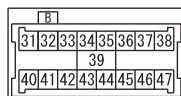

D-28

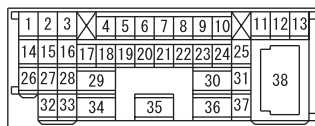

D-118

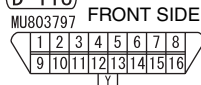

D-125

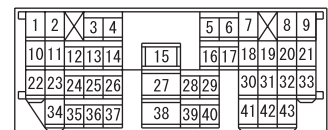

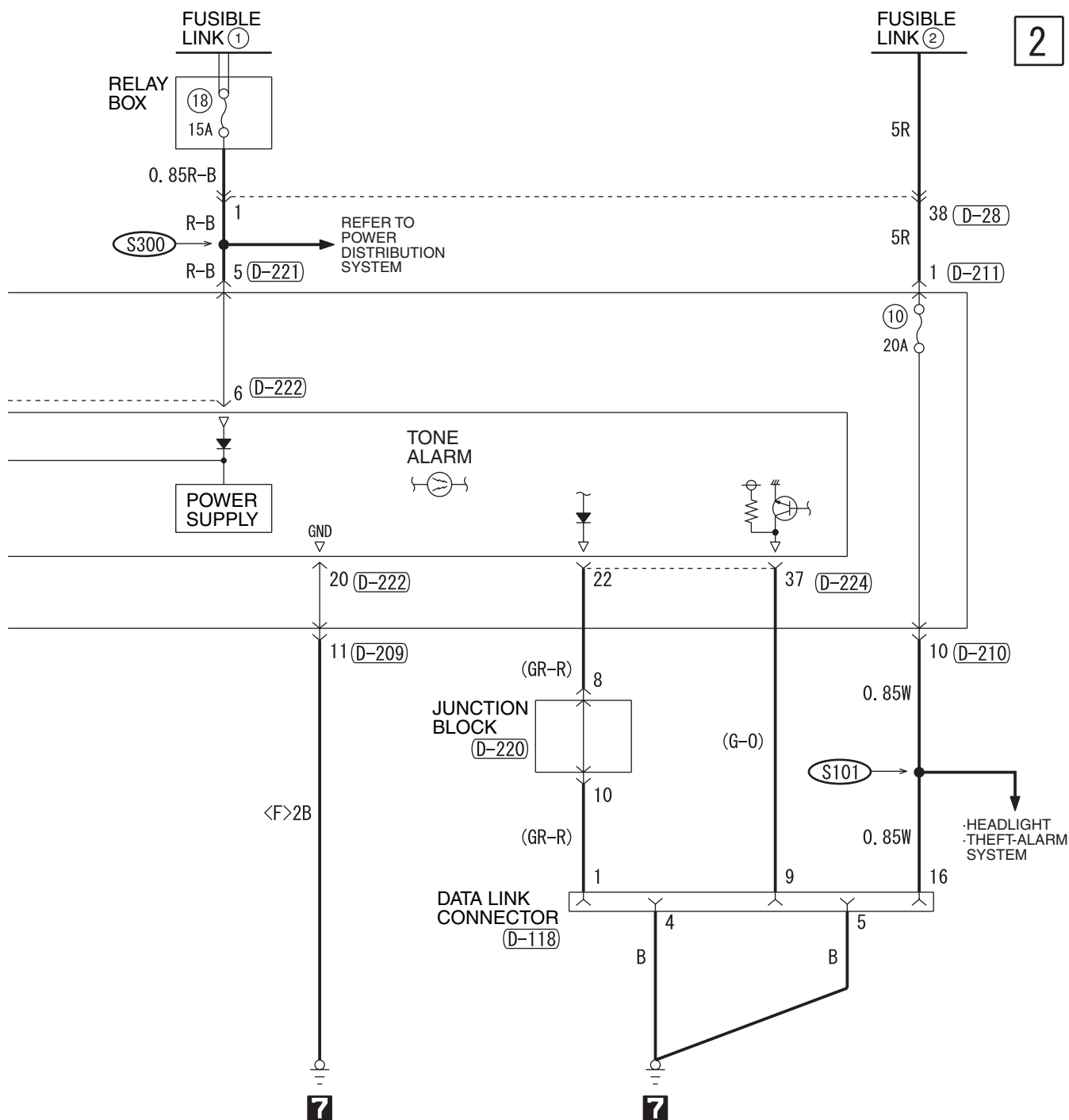

D-208



D-209

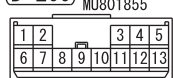

D-210

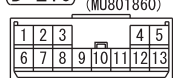

D-211



D-220

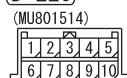

D-221

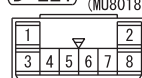

D-222

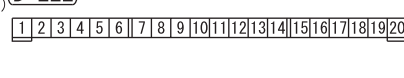

D-224

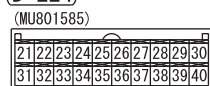

F-18



WIRE COLOR CODE

B: BLACK LG: LIGHT GREEN G: GREEN L: BLUE
BR: BROWN O: ORANGE GR: GRAY R: RED W: WHITE
SB: SKY BLUE P: PINK Y: YELLOW V: VIOLET

AUTO-CRUISE CONTROL SYSTEM

M1901009301935

1

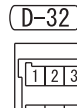
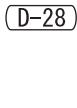
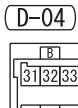
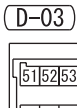
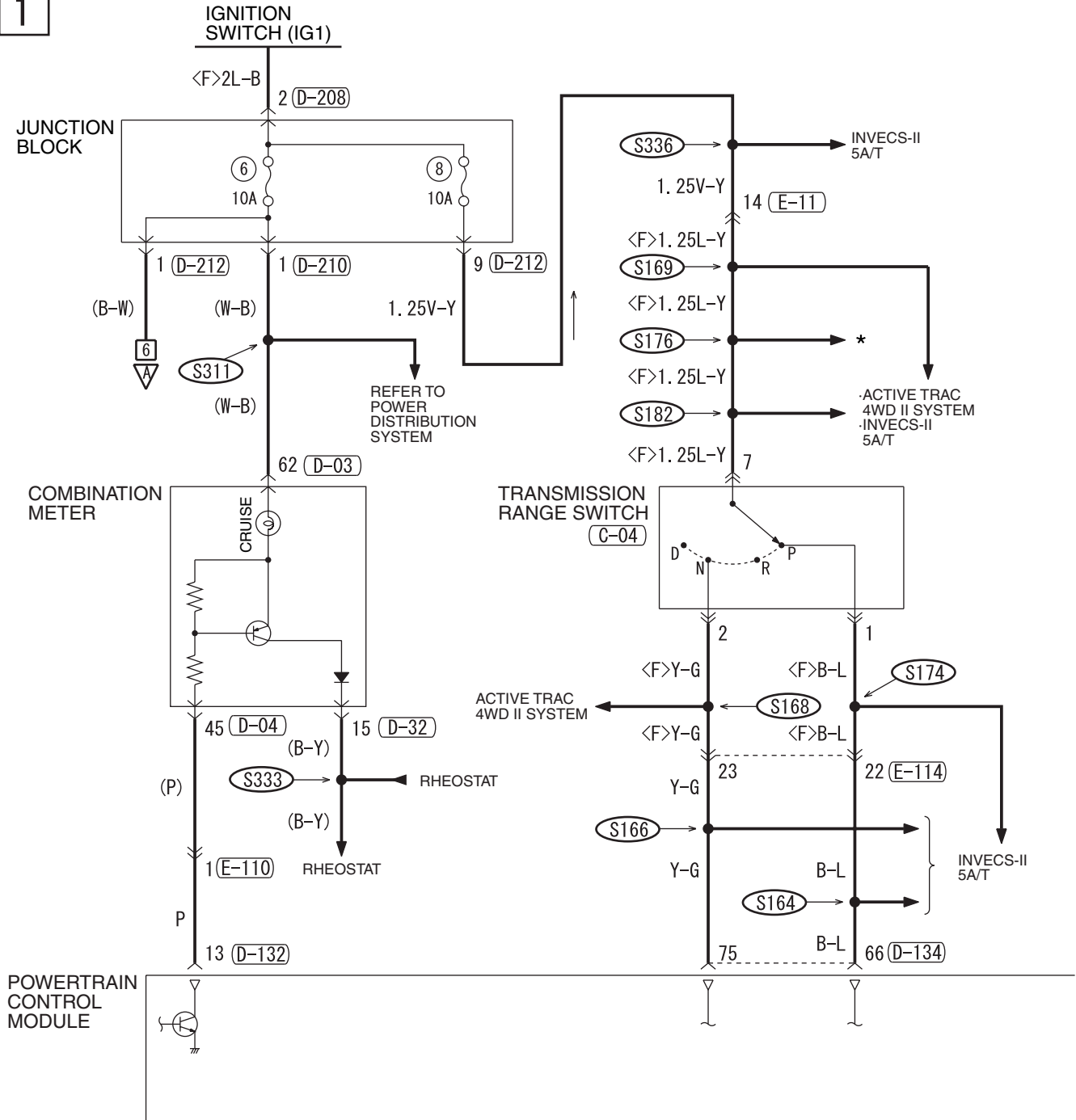

H6Q15M02AA

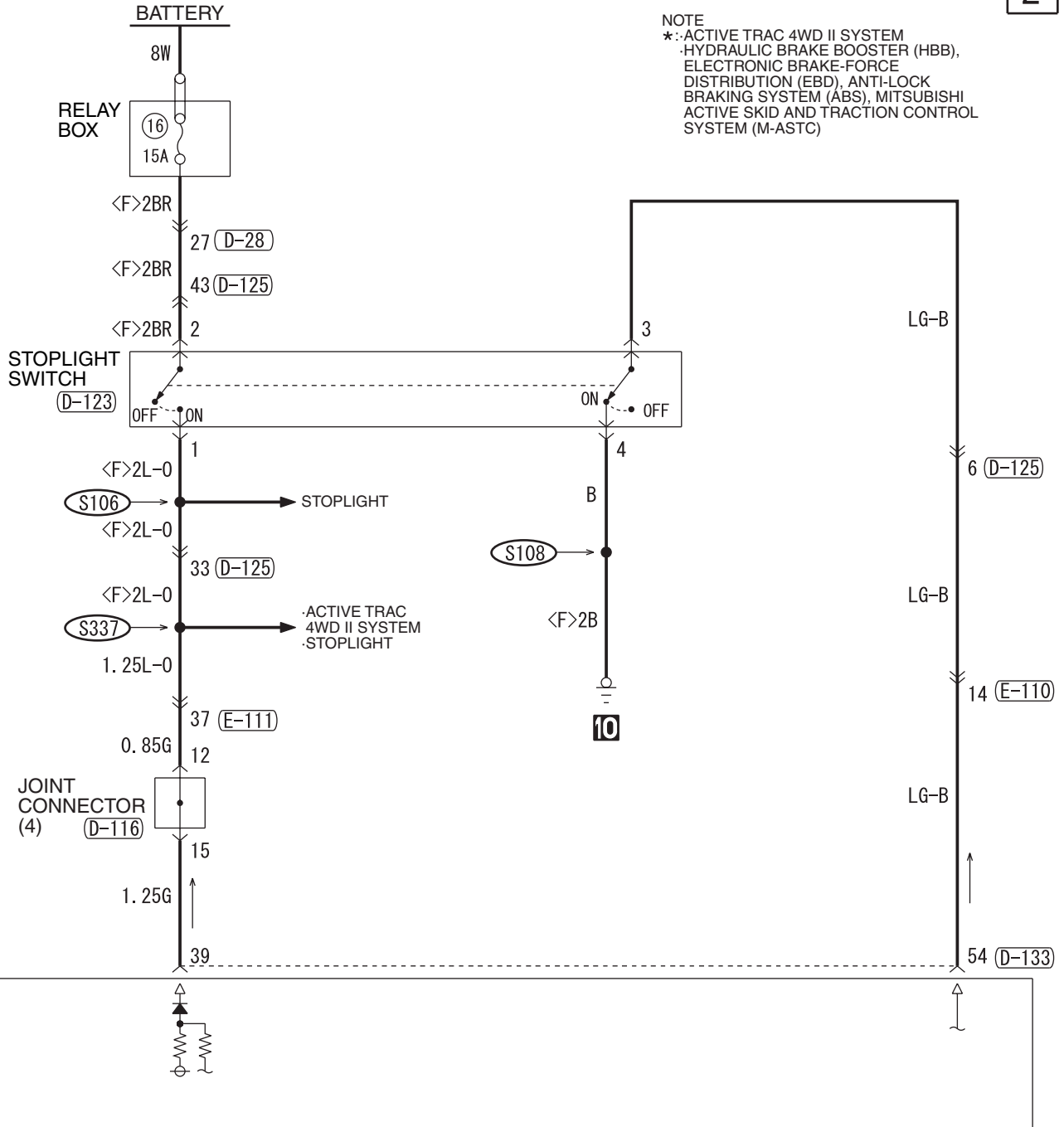

NOTE
★: ACTIVE TRAC 4WD II SYSTEM
HYDRAULIC BRAKE BOOSTER (HBB),
ELECTRONIC BRAKE-FORCE
DISTRIBUTION (EBD), ANTI-LOCK
BRAKING SYSTEM (ABS), MITSUBISHI
ACTIVE SKID AND TRACTION CONTROL
SYSTEM (M-ASTC)

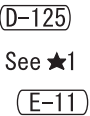
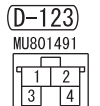
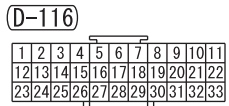

★ 1

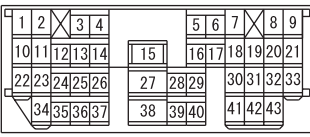

★ 2

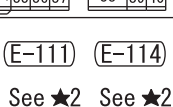
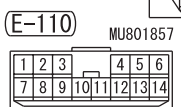
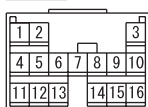
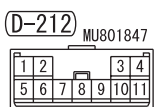
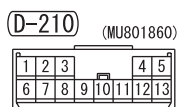
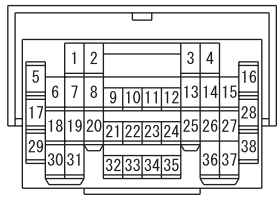

H6Q15M02AB

AUTO-CRUISE CONTROL SYSTEM (CONTINUED)

3

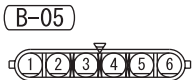
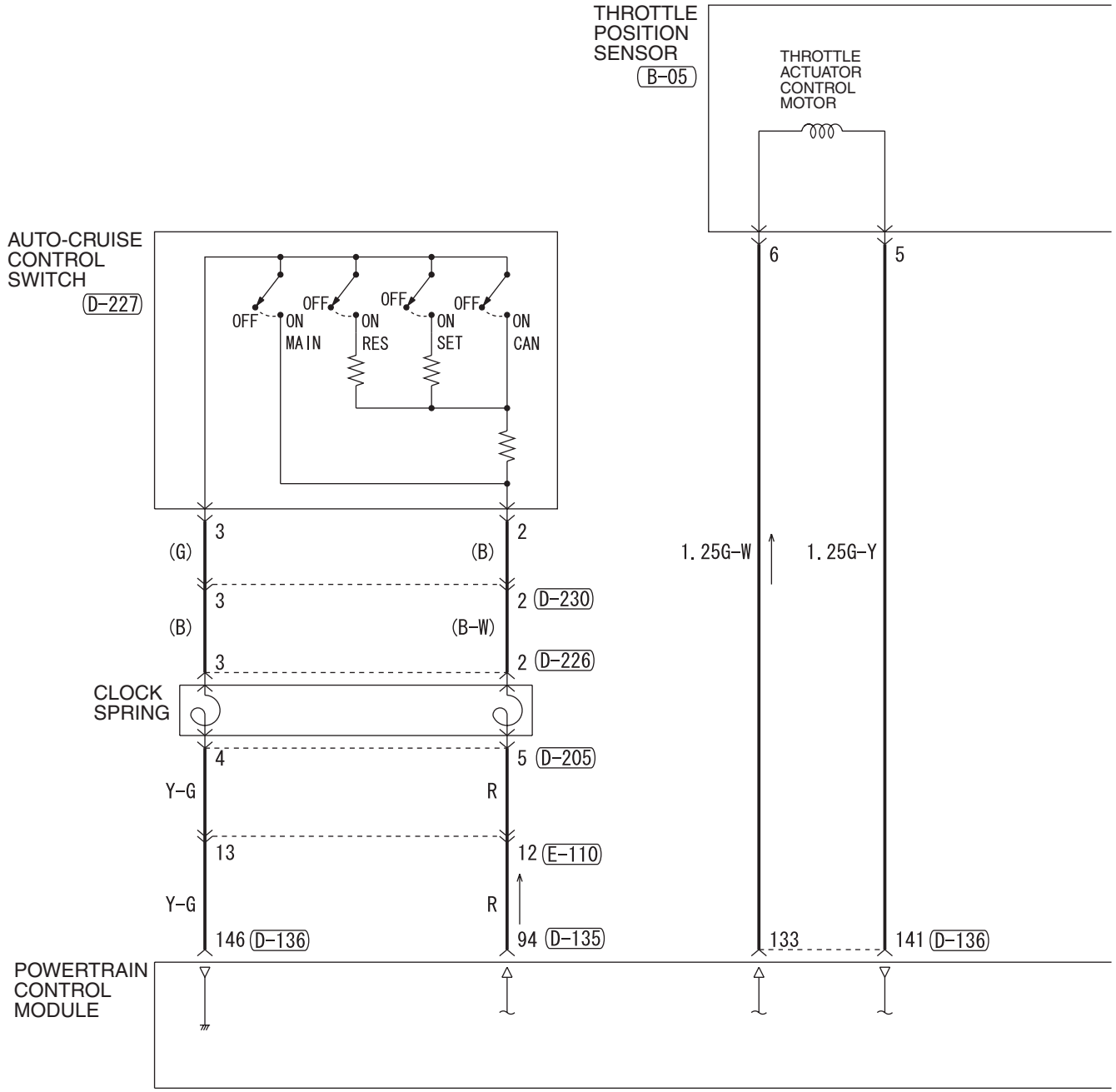

(D-133)
(MU803803)

31	32	JAE	33	34
35	36	37	38	39
40	41	42	43	
44	45	46	47	48
49	50	51		
52	53	54	55	56
57	58			

(D-135)
(MU803805)

91	92	JAE	93	94	95
96	97	98	99	100	101
102	103	104			
105	106	107	108	109	
110	111	112			
113	114	115	116	117	
118	119	120			

(D-136)
(MU803801)

121	122	JAE	123	124
125	126	127	128	129
130	131	132	133	
134	135	136	137	138
139	140	141		
142	143	144	145	146

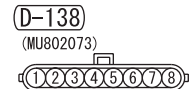

4

ACCELERATOR PEDAL POSITION SENSOR (D-138)

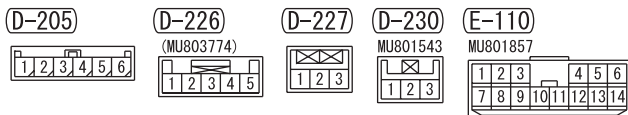
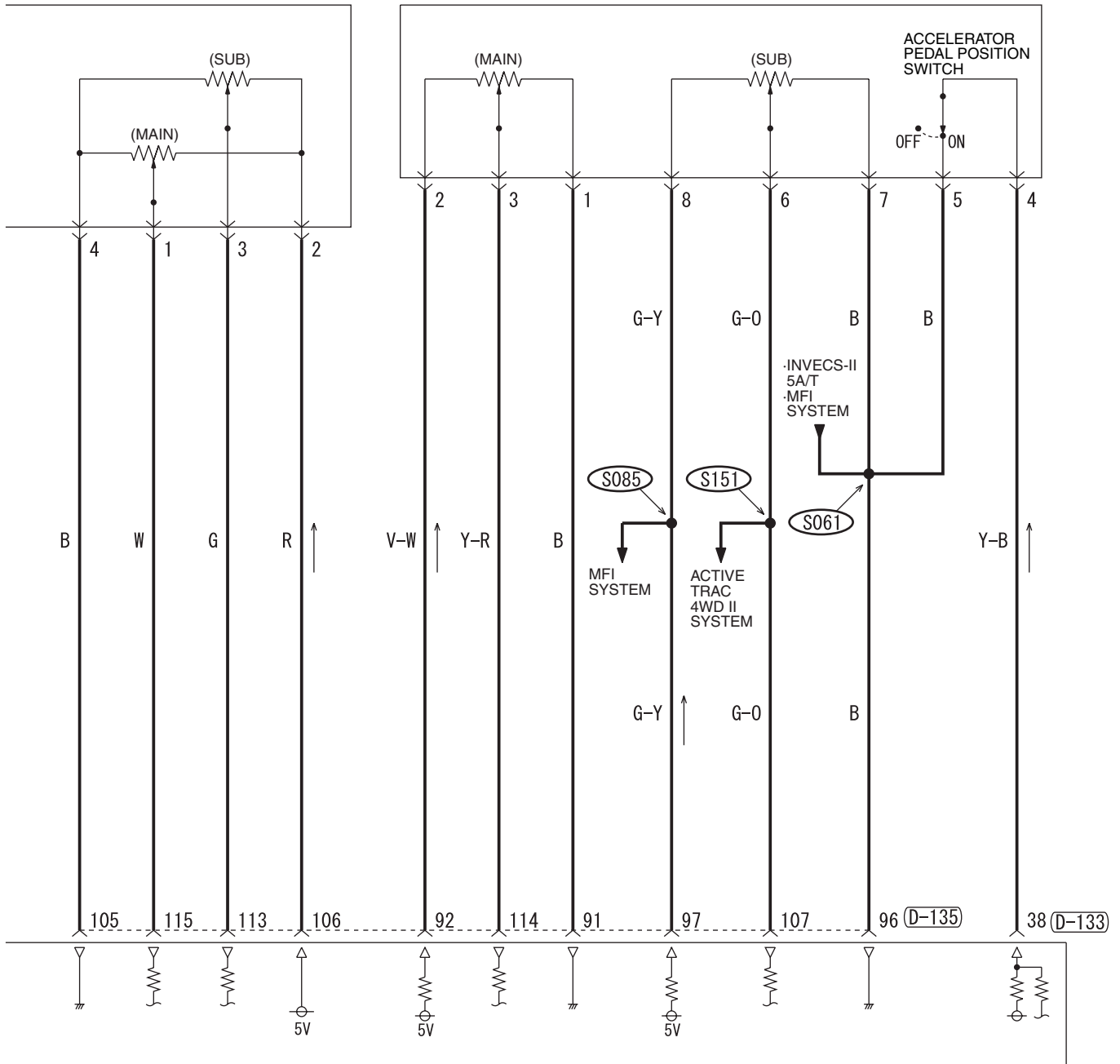

WIRE COLOR CODE
 B : BLACK LG : LIGHT GREEN G : GREEN L : BLUE W : WHITE Y : YELLOW
 SB : SKY BLUE BR : BROWN O : ORANGE GR : GRAY R : RED P : PINK V : VIOLET

TSB Revision

AUTO-CRUISE CONTROL SYSTEM (CONTINUED)

5

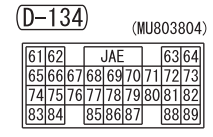
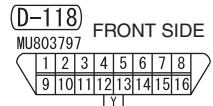
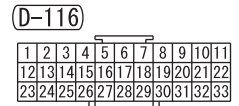
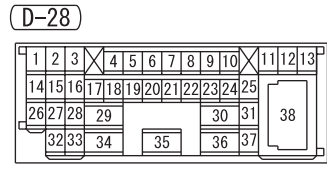
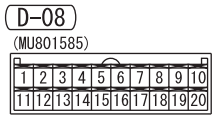
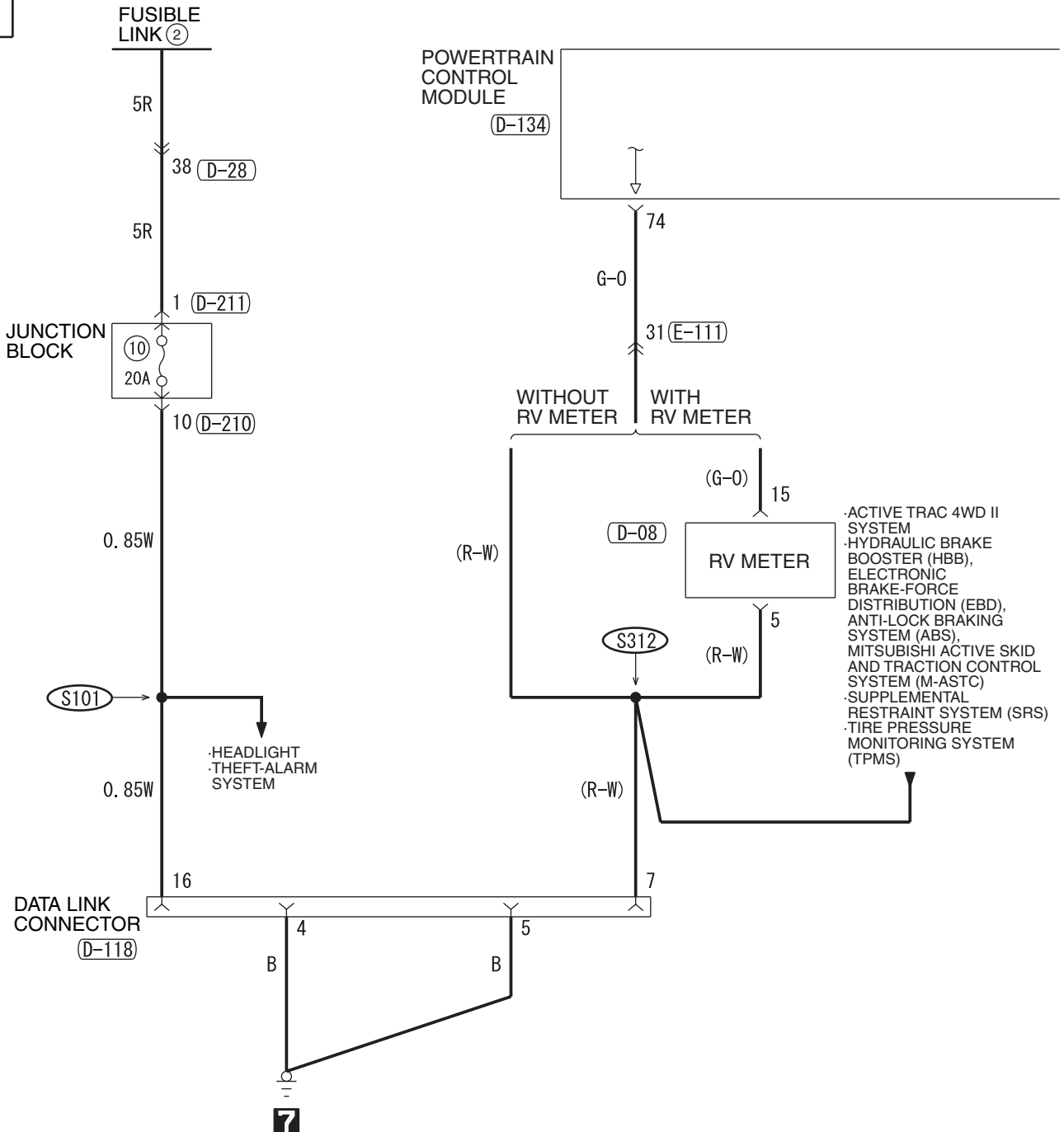

6

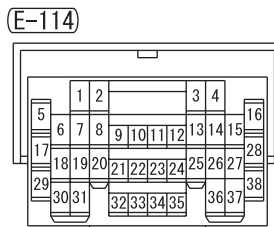
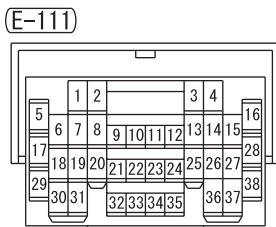
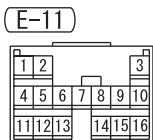
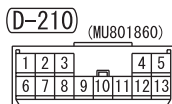
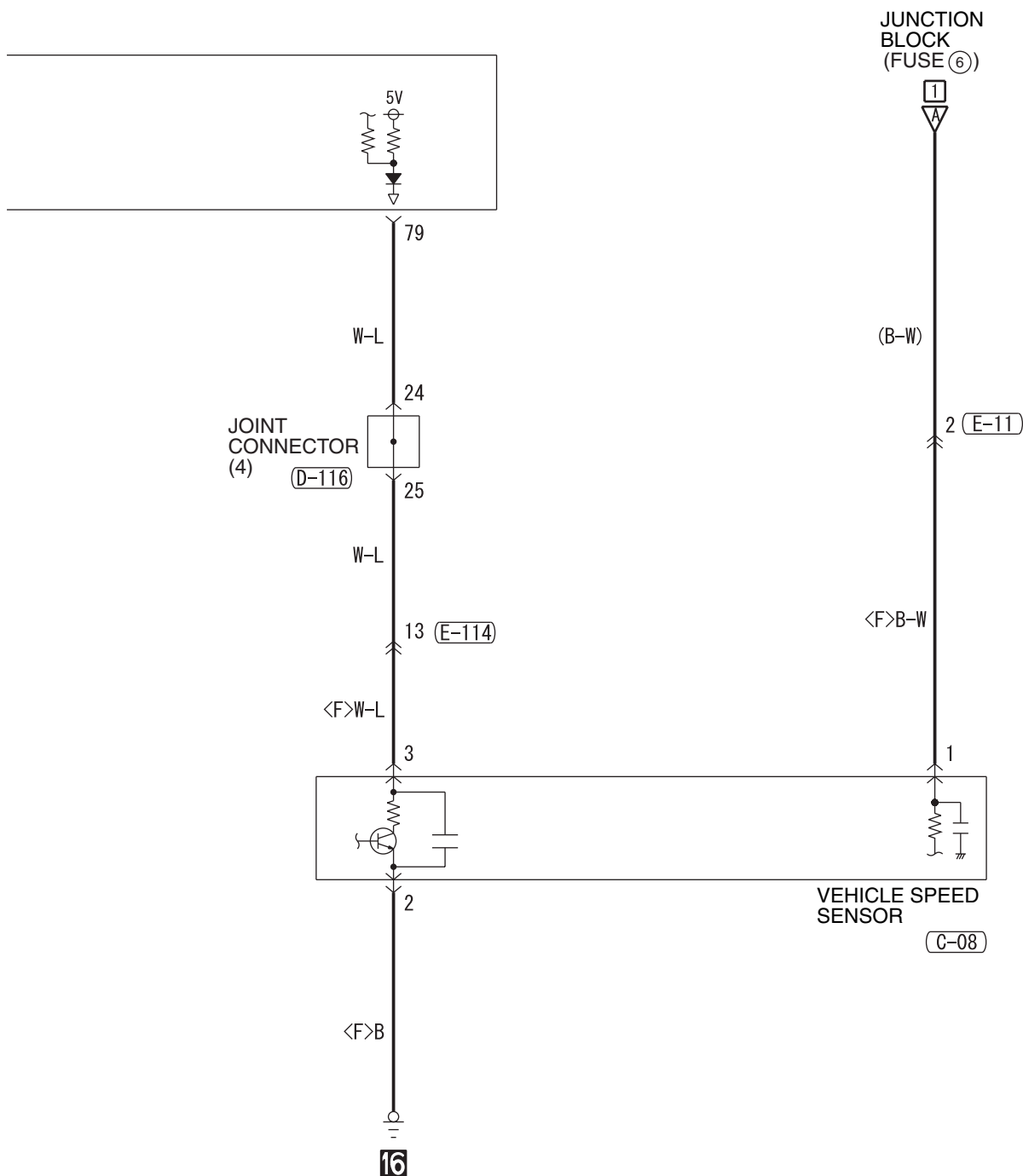

ACTIVE TRAC 4WD II SYSTEM

M1901009200195

1

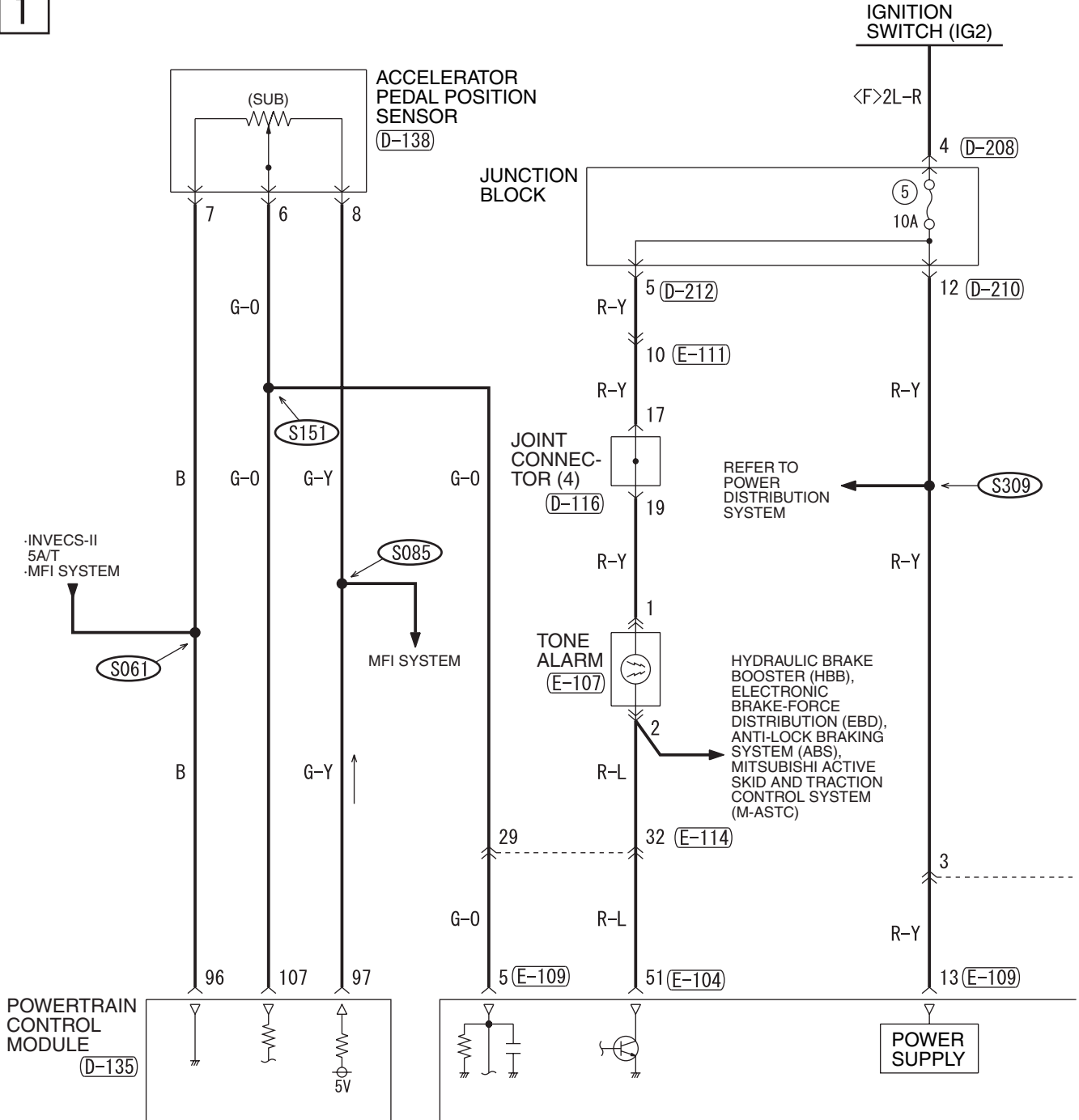

D-28

1	2	3	4	5	6	7	8	9	10	11	12	13
14	15	16	17	18	19	20	21	22	23	24	25	38
26	27	28	29					30	31			
32	33	34	35	36	37							

D-116

1	2	3	4	5	6	7	8	9	10	11
12	13	14	15	16	17	18	19	20	21	22
23	24	25	26	27	28	29	30	31	32	33

D-123

1	2
3	4

D-125

1	2	3	4		5	6	7	8	9		
10	11	12	13	14	15	16	17	18	19	20	21
22	23	24	25	26	27	28	29	30	31	32	33
34	35	36	37	38	39	40	41	42	43		

D-135

91	92	JAE	93	94	95			
96	97	98	99	100	101	102	103	104
105	106	107	108	109	110	111	112	
113	114	115	116	117	118	119	120	

E-104

JAE-E											
31	32	33	34	35	36	37	38	39	40	41	
42	43	44	45	46	47	48	49	50	51	52	

E-107

1
2

2

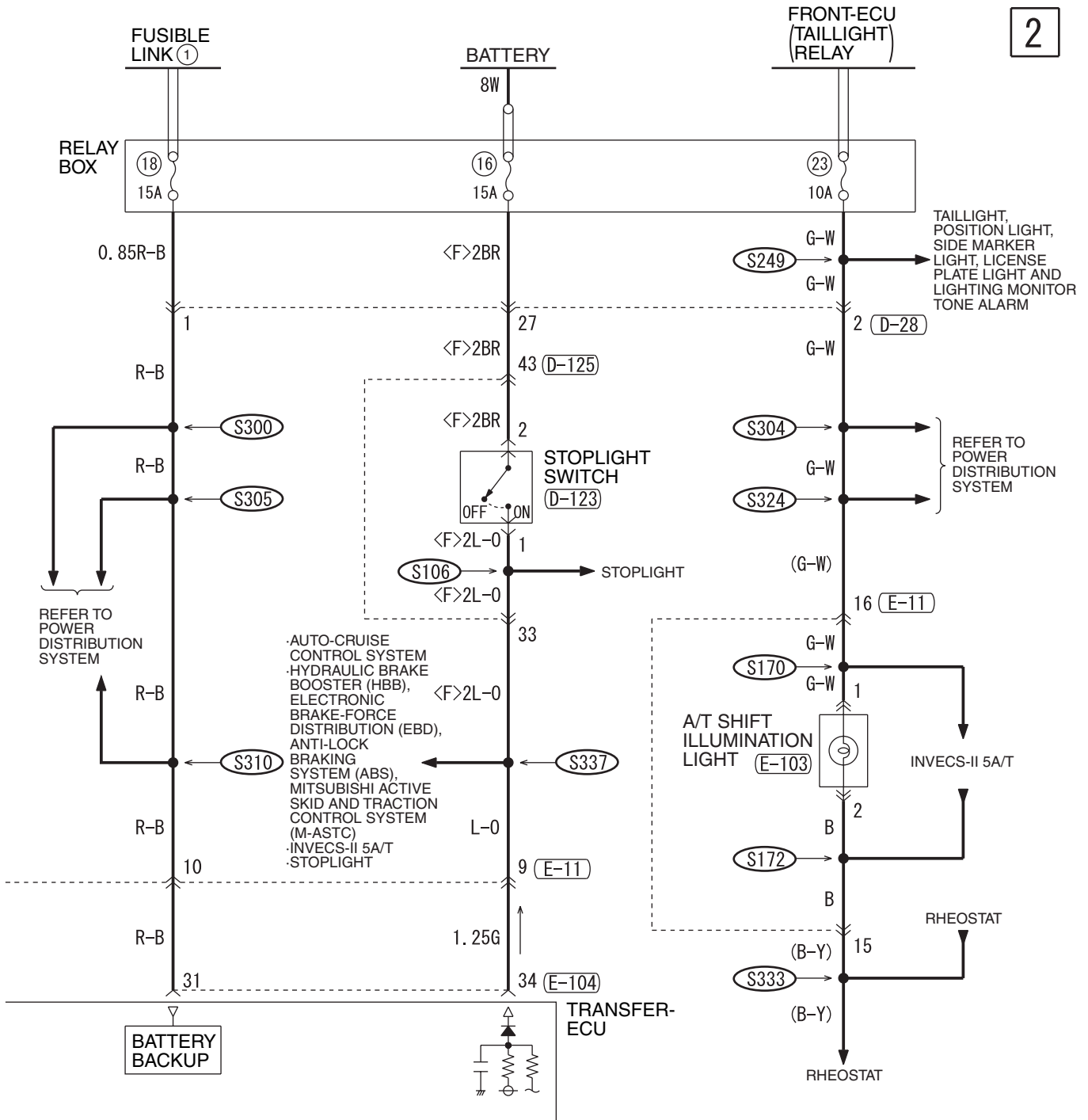

D-138

(MU802073)



D-208

MU801331



D-210

(MU801860)

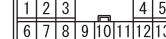

D-212

MU801847



E-11

MU801445



E-103

MU801445



E-109



E-111 E-114

See ★1 See ★1

★1

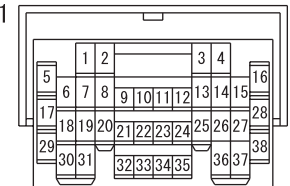

H6Q15M03AB

ACTIVE TRAC 4WD II SYSTEM (CONTINUED)

3

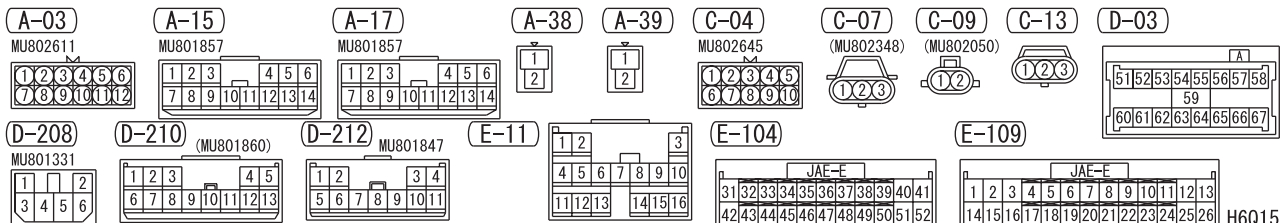
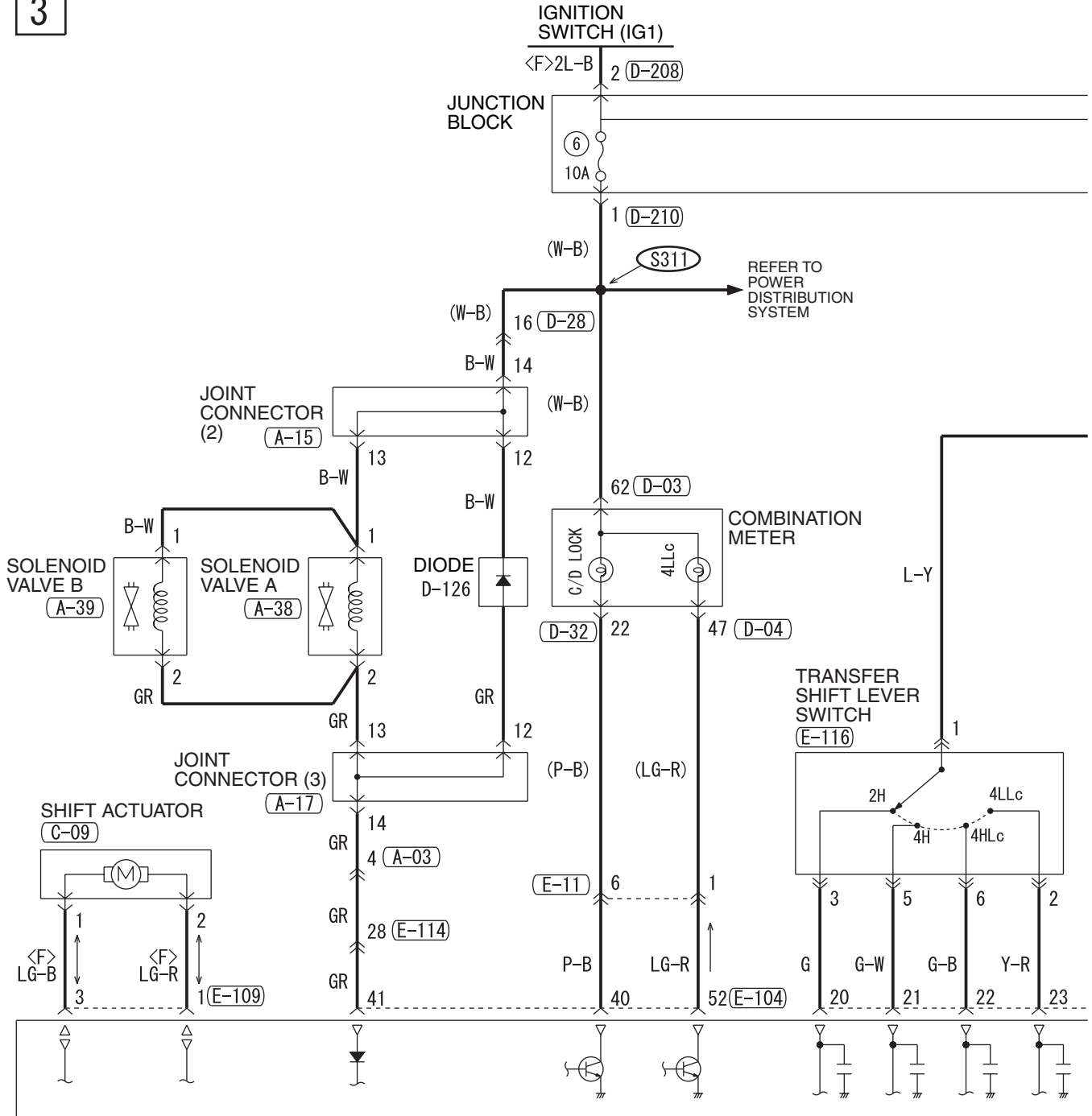

H6Q15M03BA

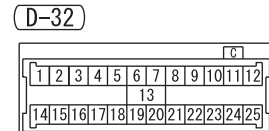
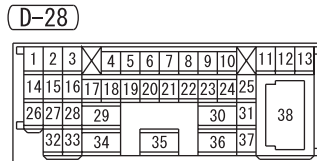
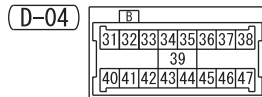
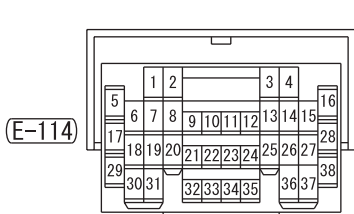
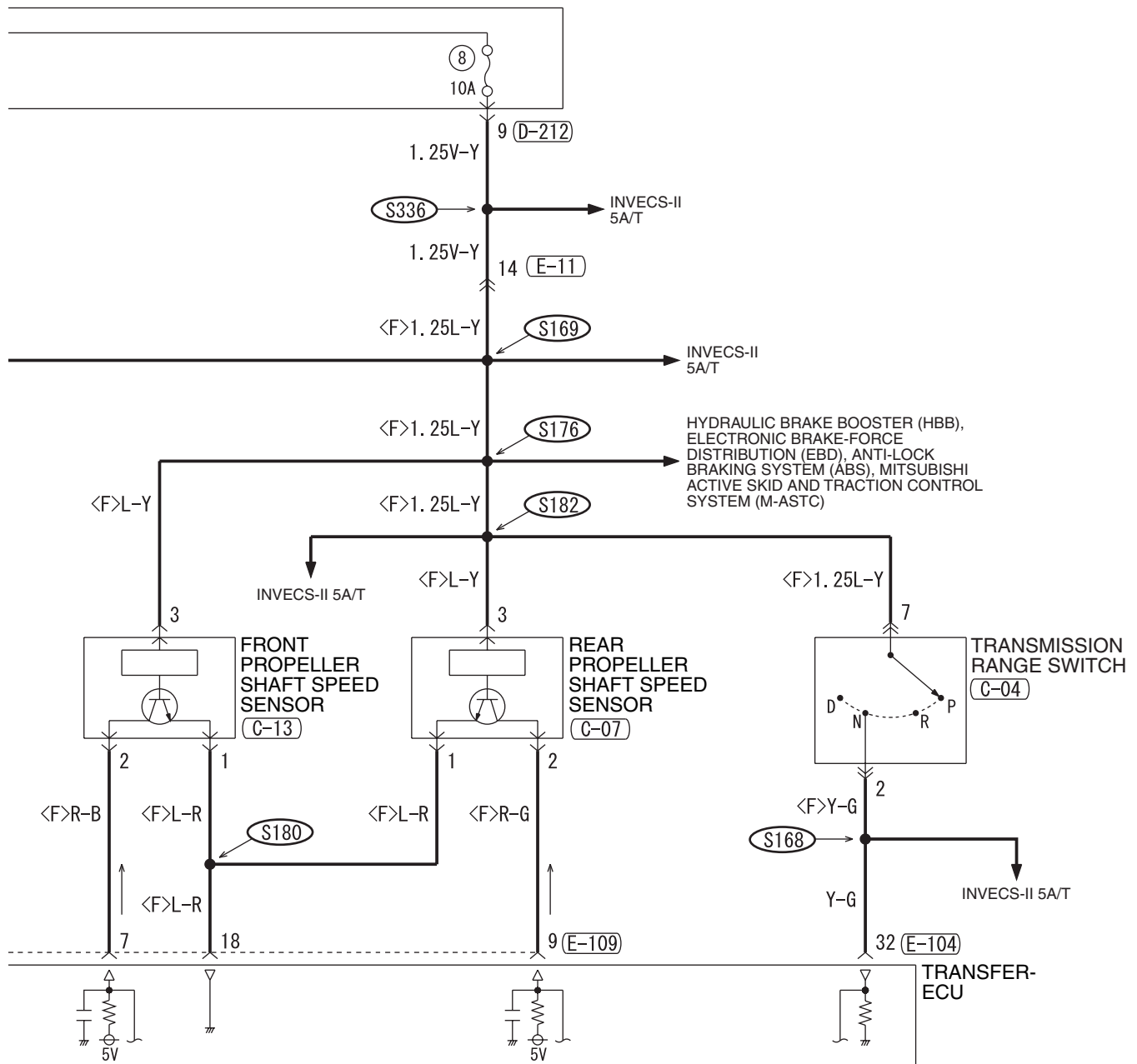

TSB Revision

ACTIVE TRAC 4WD II SYSTEM (CONTINUED)

5

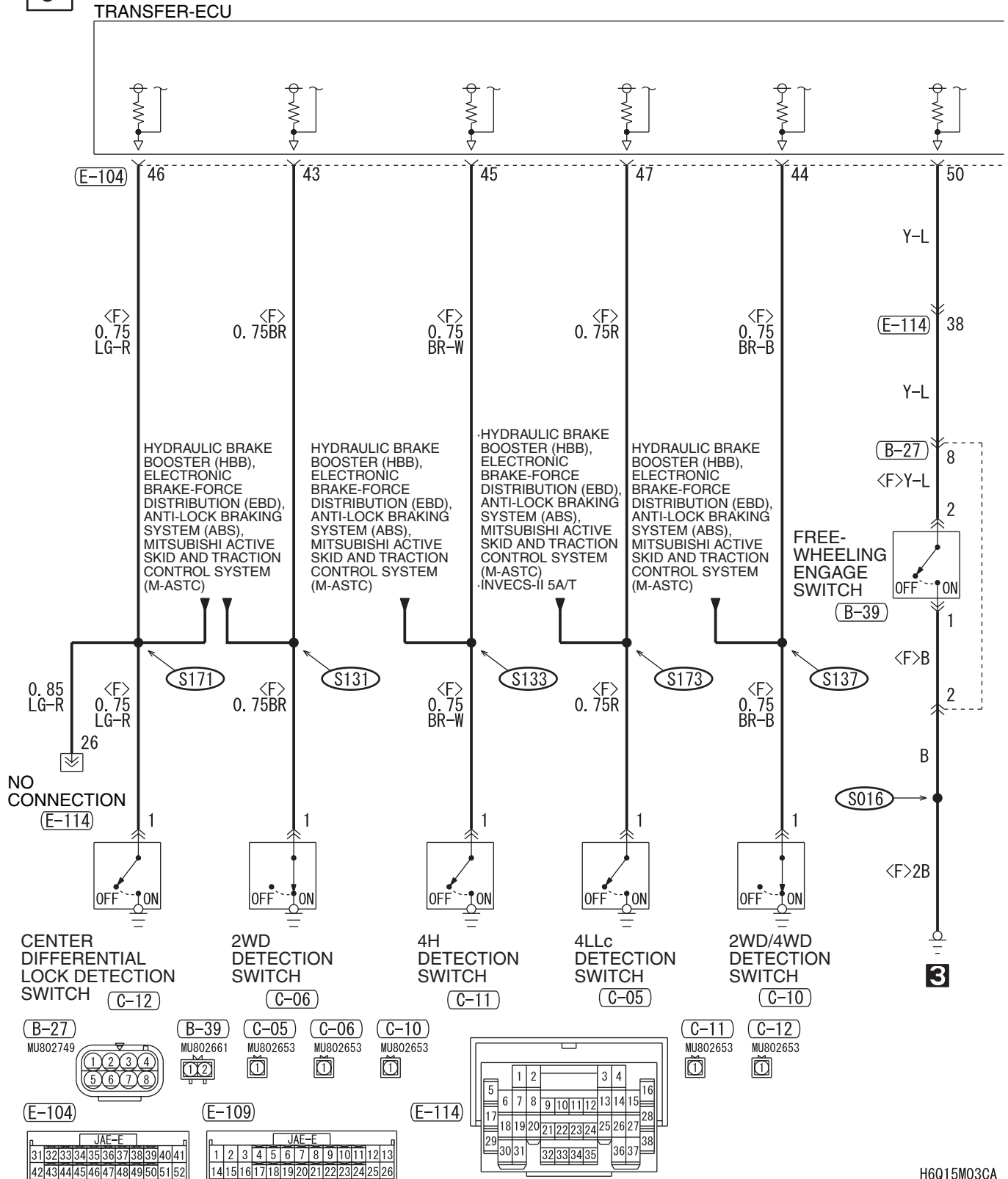

6

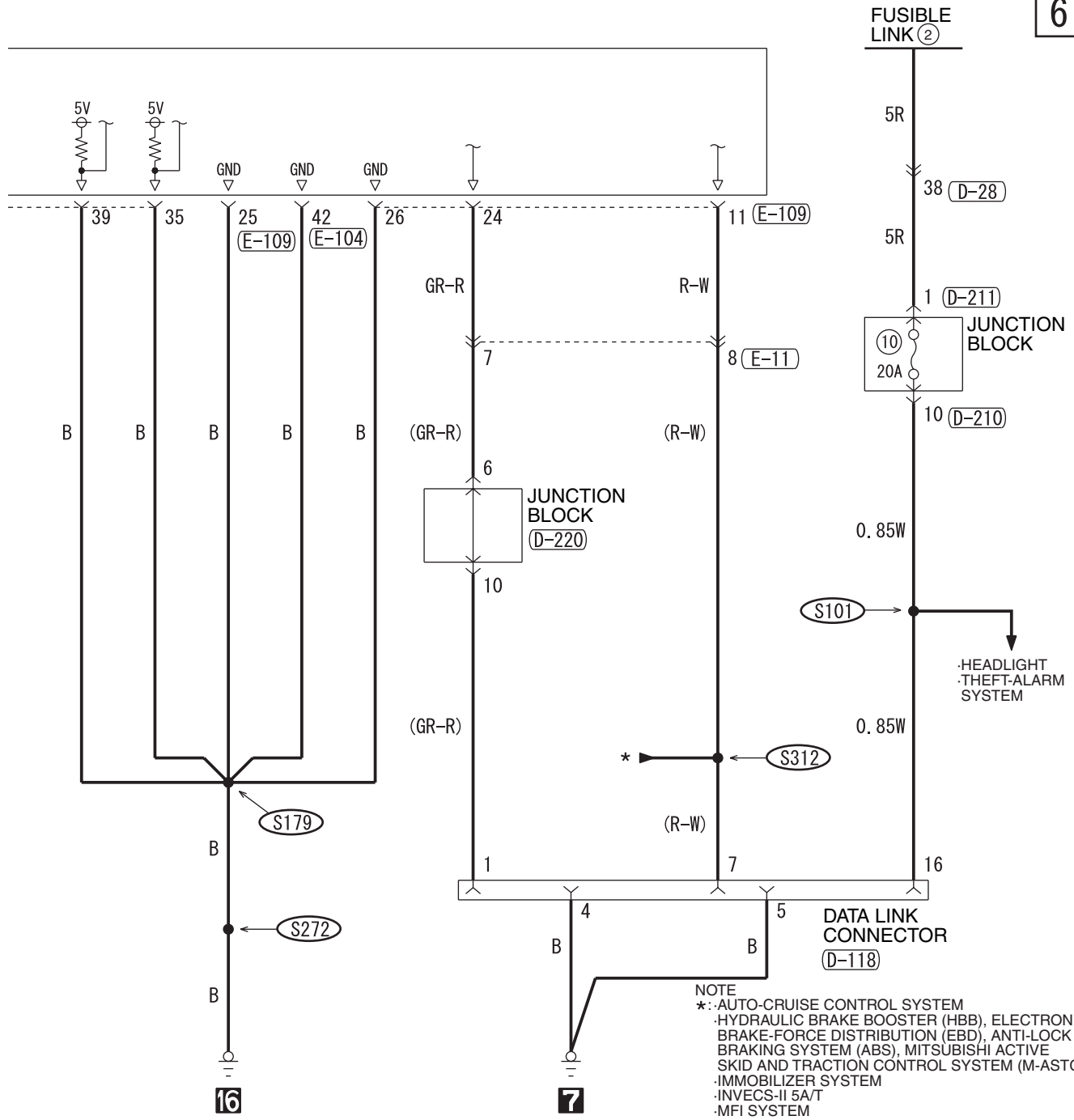

NOTE
* : AUTO-CRUISE CONTROL SYSTEM
· HYDRAULIC BRAKE BOOSTER (HBB), ELECTRONIC BRAKE-FORCE DISTRIBUTION (EBD), ANTI-LOCK BRAKING SYSTEM (ABS), MITSUBISHI ACTIVE SKID AND TRACTION CONTROL SYSTEM (M-ASTC)
· IMMOBILIZER SYSTEM
· INVECS-II 5A/T
· MFI SYSTEM
· SUPPLEMENTAL RESTRAINT SYSTEM (SRS)
· TIRE PRESSURE MONITORING SYSTEM (TPMS)

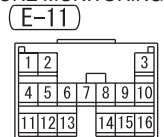
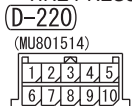
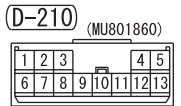
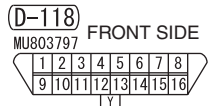
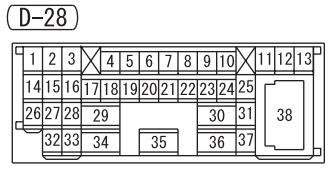

WIRE COLOR CODE
B : BLACK LG : LIGHT GREEN G : GREEN L : BLUE
BR : BROWN O : ORANGE GR : GRAY R : RED W : WHITE
SB : SKY BLUE P : PINK Y : YELLOW V : VIOLET

TSB Revision

ACTIVE TRAC 4WD II SYSTEM (CONTINUED)

7

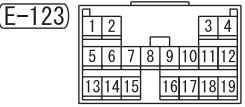
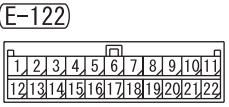
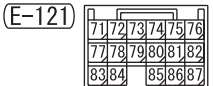
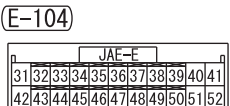
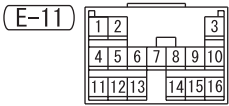
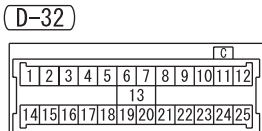
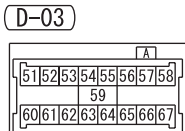
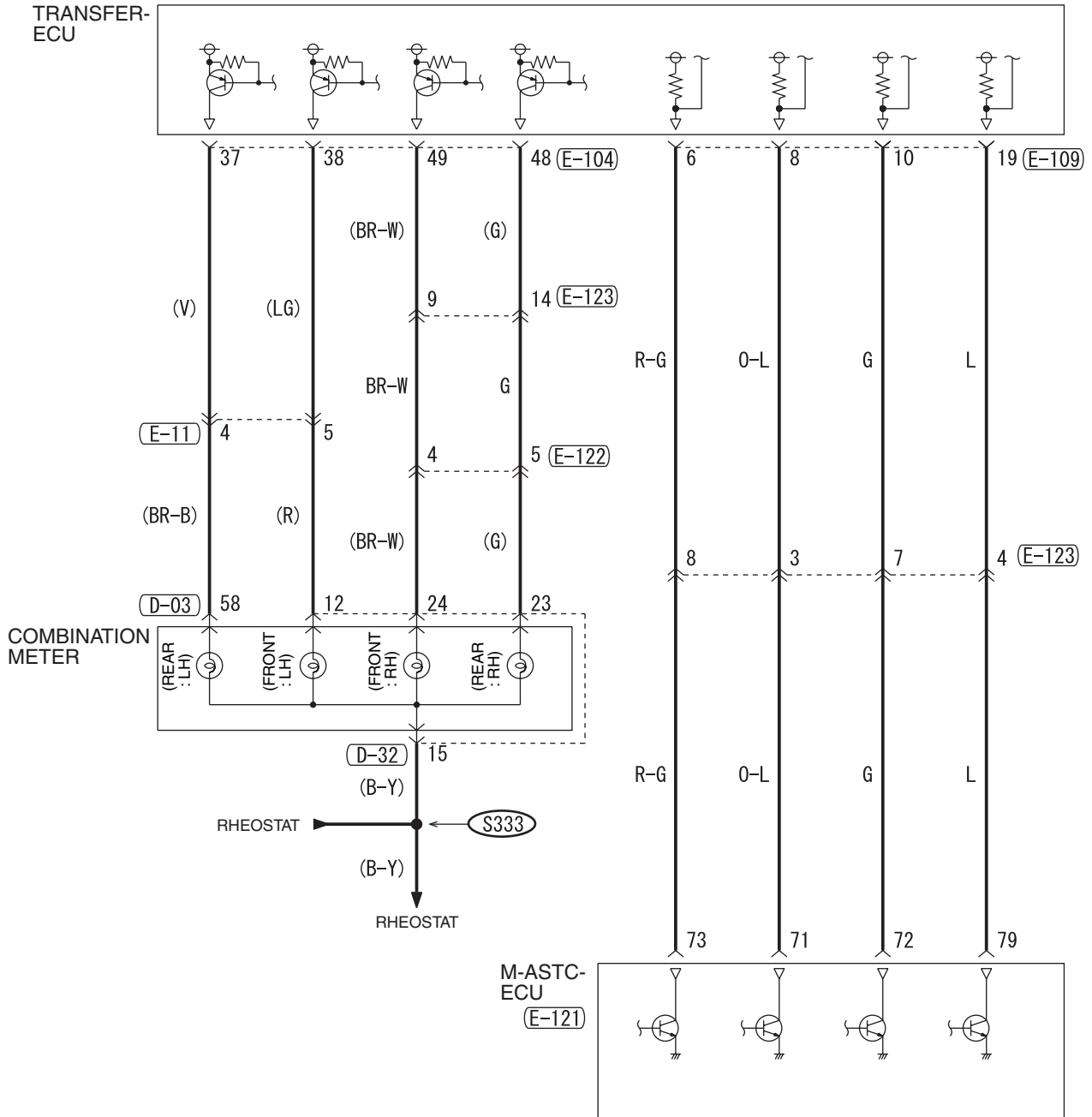

NOTES

HYDRAULIC BRAKE BOOSTER (HBB), ELECTRONIC BRAKE-FORCE DISTRIBUTION (EBD), ANTI-LOCK BRAKING SYSTEM (ABS), MITSUBISHI ACTIVE SKID AND TRACTION CONTROL SYSTEM (M-ASTC)

1

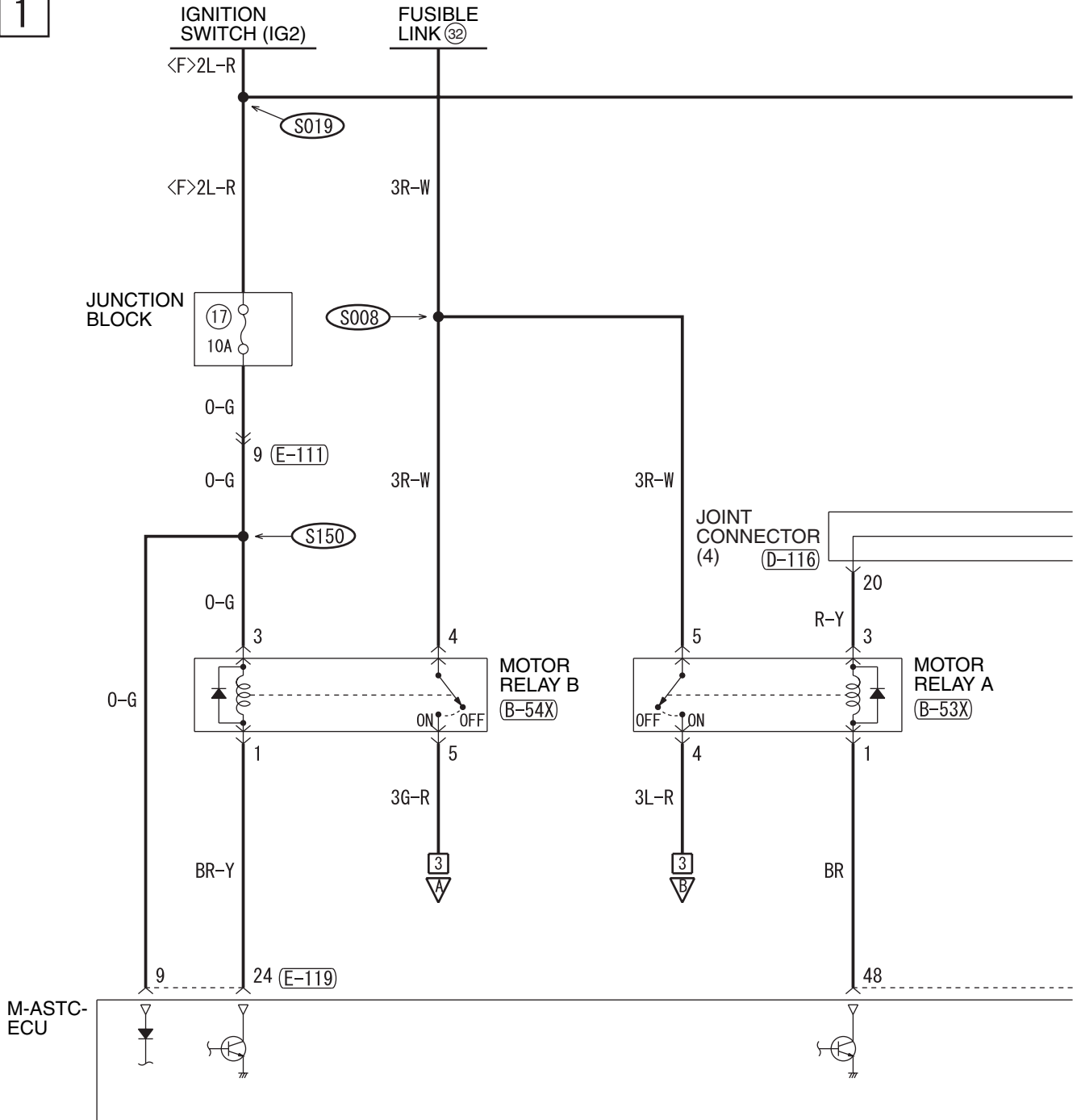

(B-53X)

(B-54X)

(D-28)

(D-116)

(D-123)

(D-125)

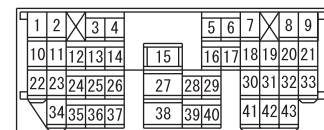
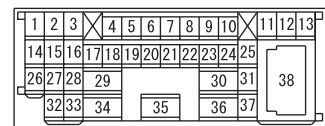

2

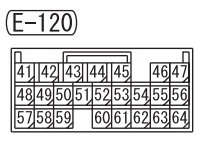
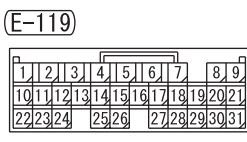
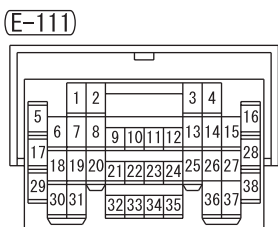
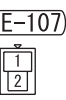
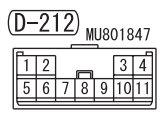
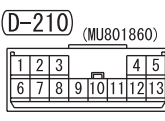
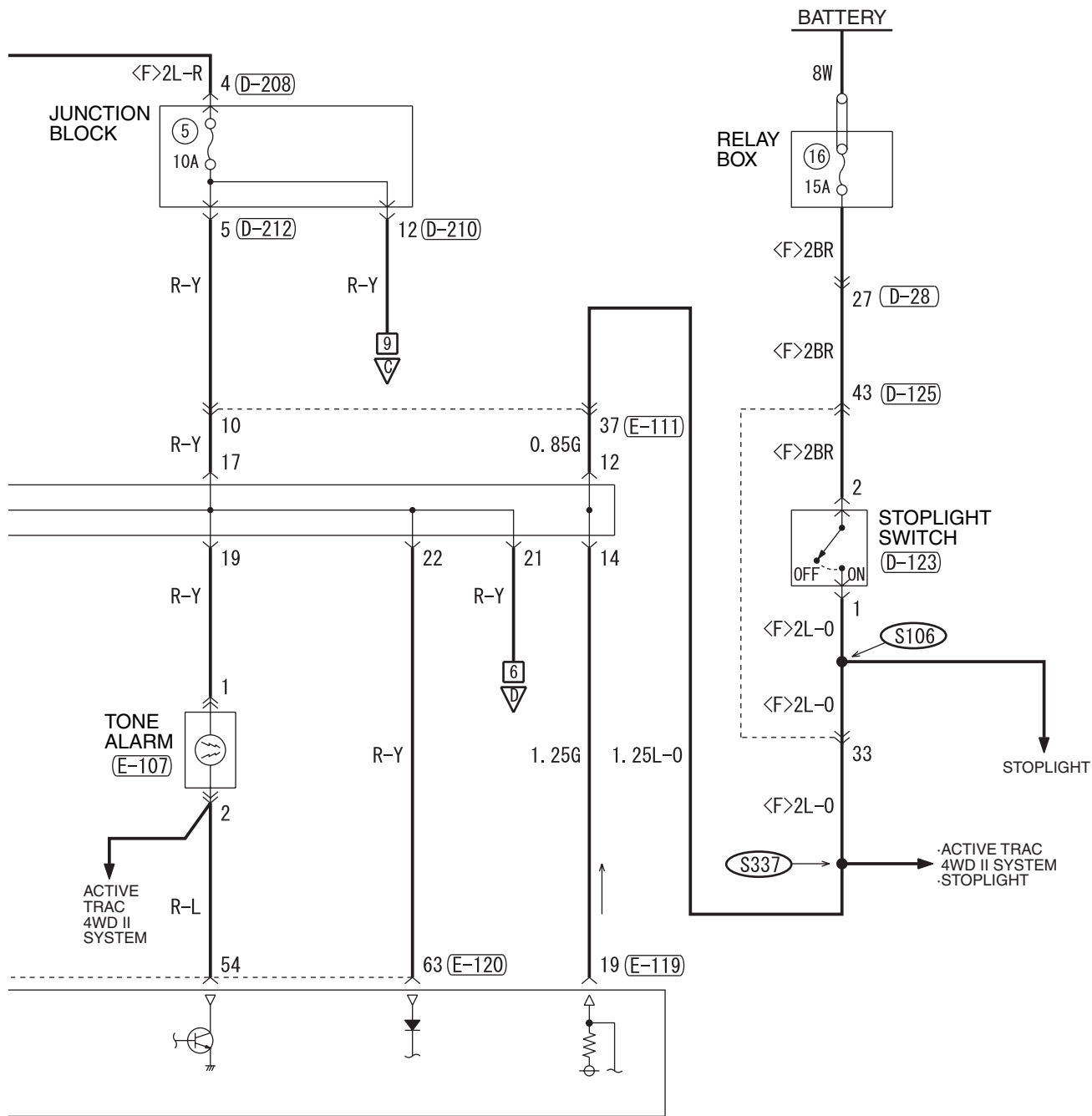

HYDRAULIC BRAKE BOOSTER (HBB), ELECTRONIC BRAKE-FORCE DISTRIBUTION (EBD), ANTI-LOCK BRAKING SYSTEM (ABS), MITSUBISHI ACTIVE SKID AND TRACTION CONTROL SYSTEM (M-ASTC) (CONTINUED)

3

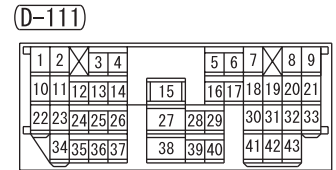
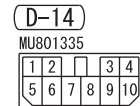
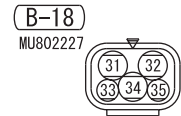
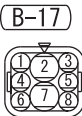
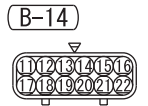
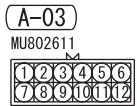
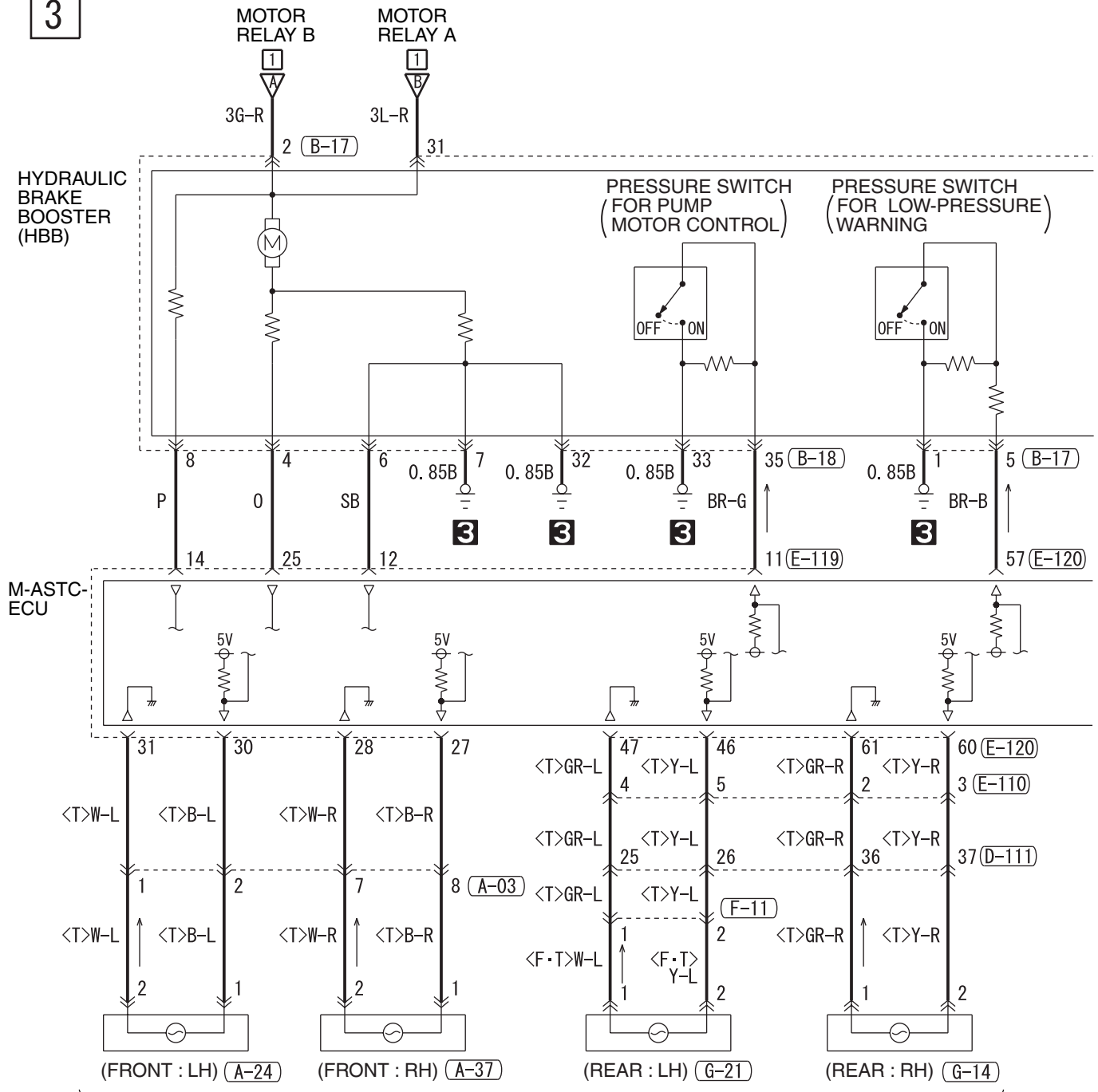

4

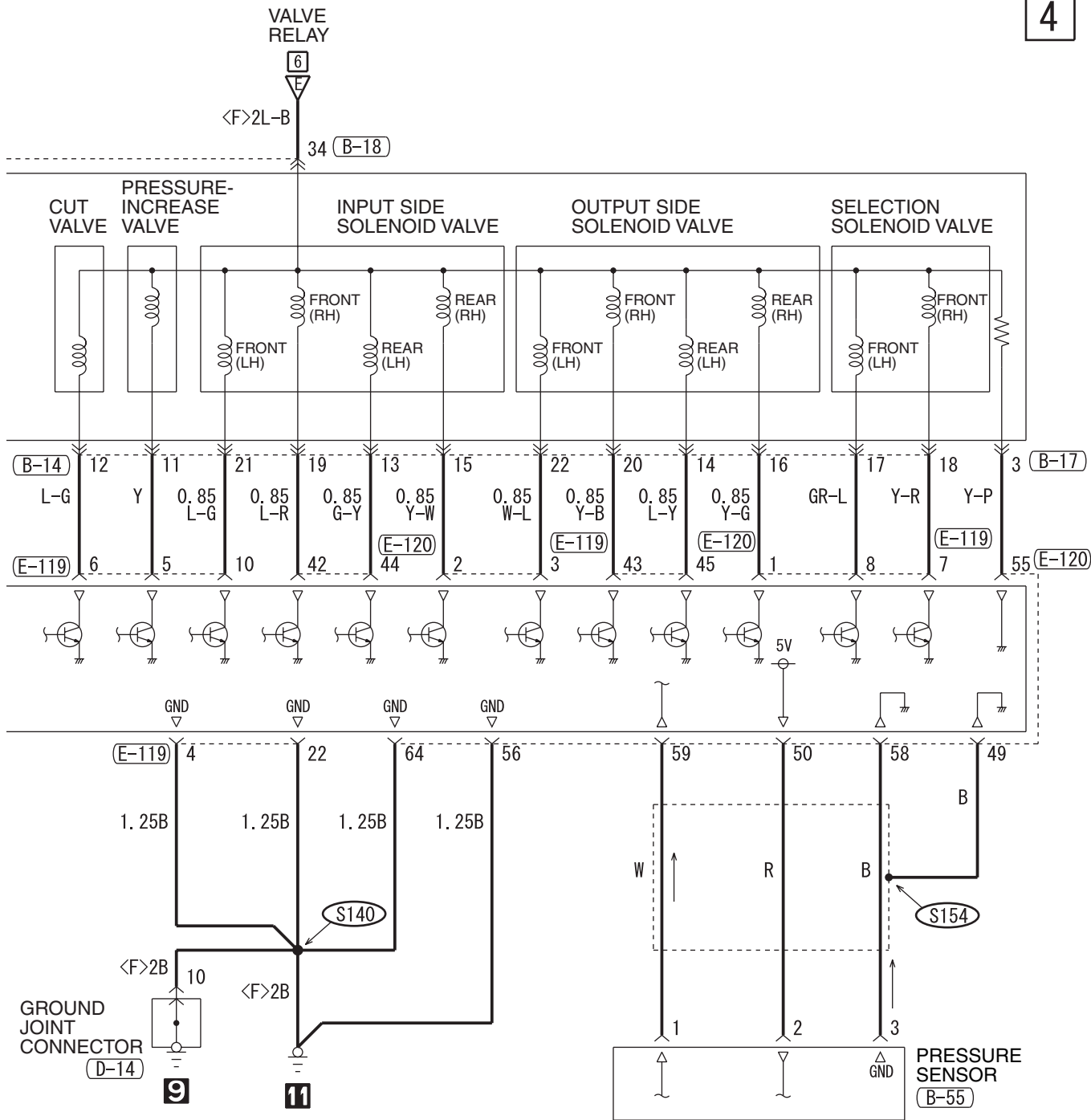

WIRE COLOR CODE
 B : BLACK LG : LIGHT GREEN G : GREEN L : BLUE
 BR : BROWN O : ORANGE GR : GRAY R : RED W : WHITE
 SB : SKY BLUE P : PINK Y : YELLOW V : VIOLET

HYDRAULIC BRAKE BOOSTER (HBB), ELECTRONIC BRAKE-FORCE DISTRIBUTION (EBD), ANTI-LOCK BRAKING SYSTEM (ABS), MITSUBISHI ACTIVE SKID AND TRACTION CONTROL SYSTEM (M-ASTC) (CONTINUED)

5

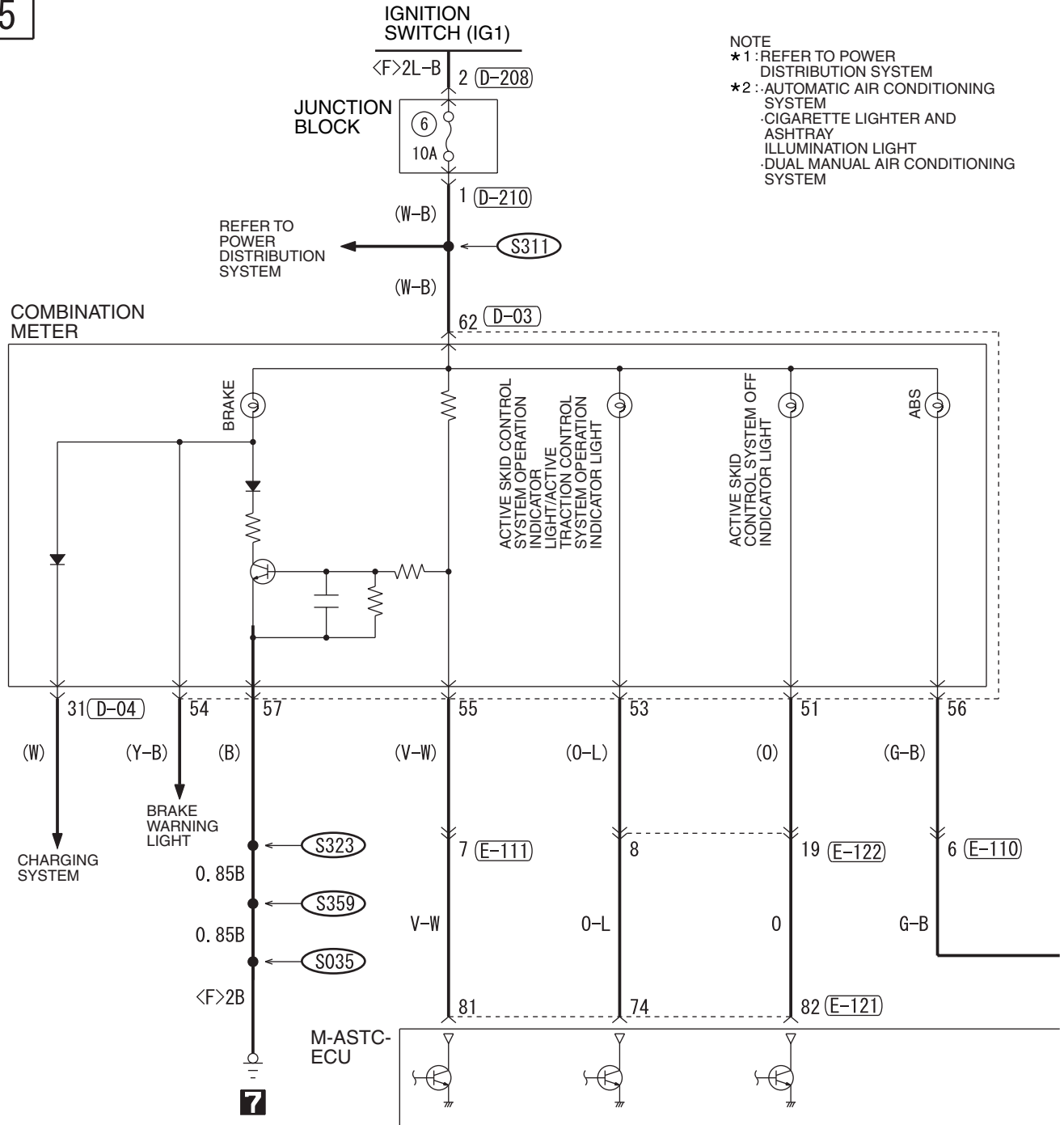

NOTE
 *1: REFER TO POWER DISTRIBUTION SYSTEM
 *2: AUTOMATIC AIR CONDITIONING SYSTEM
 CIGARETTE LIGHTER AND ASHTRAY ILLUMINATION LIGHT
 DUAL MANUAL AIR CONDITIONING SYSTEM

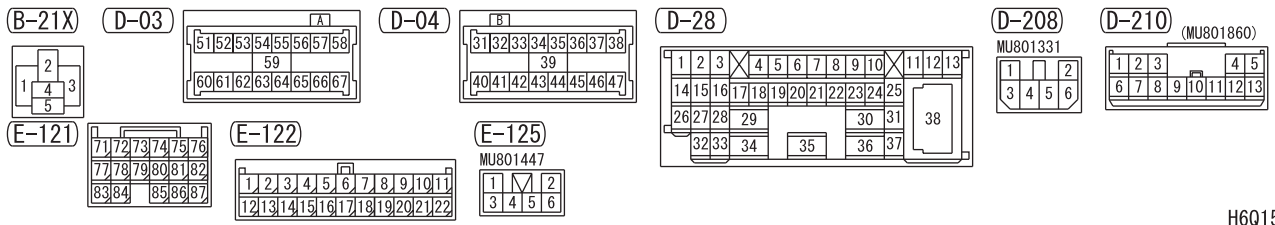

6

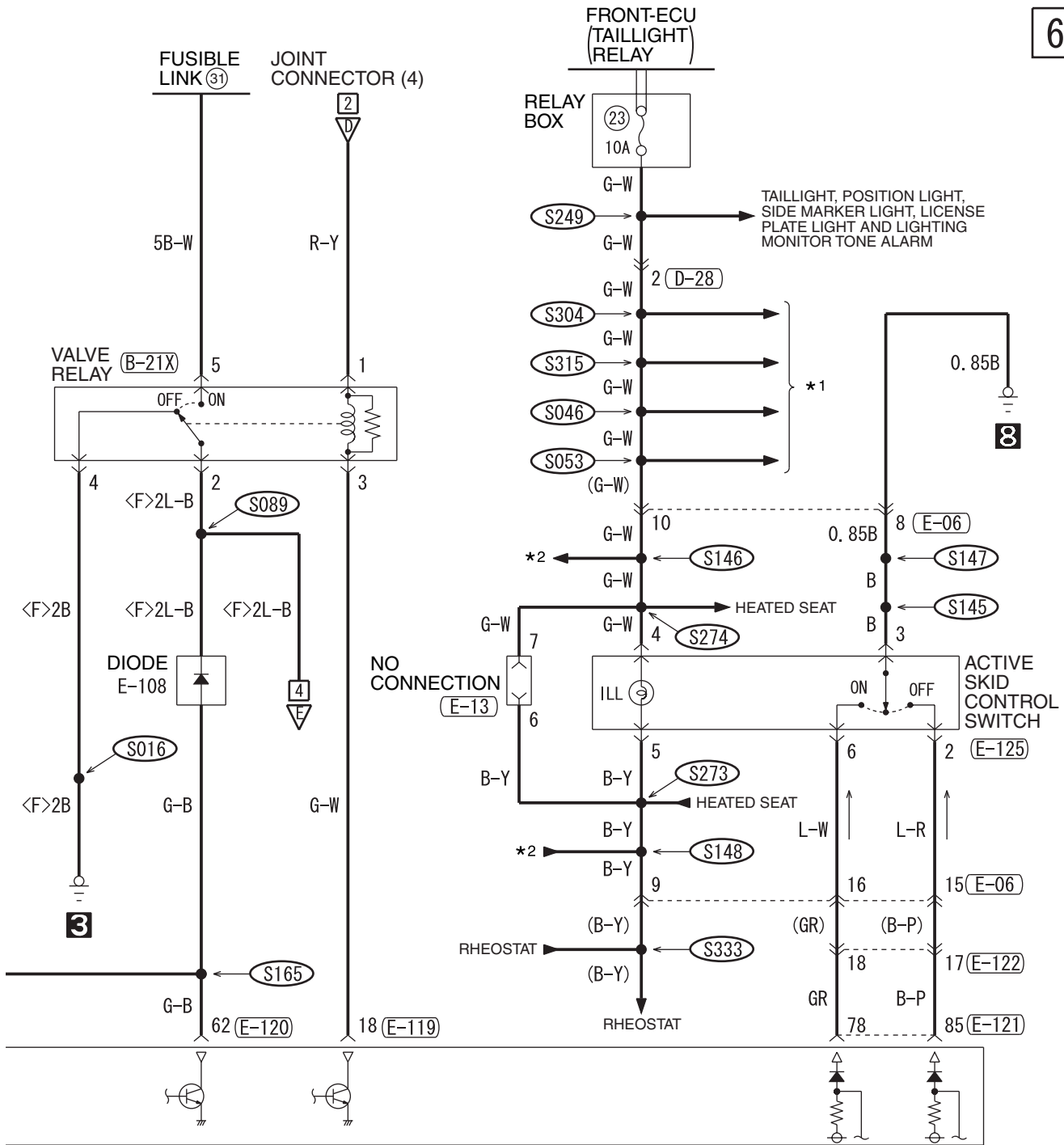

(E-06)

1	2	3	4	5	6	7	8	9	10
11	12	13	14	15	16	17	18	19	20
21	22								

(E-13)

1	2	3	4
5	6	7	8

(E-110)

1	2	3	4	5	6
7	8	9	10	11	12
13	14				

(E-111)

1	2	3	4	5	6	7	8	9	10
11	12	13	14	15	16	17	18	19	20
21	22	23	24	25	26	27	28	29	30
31	32	33	34	35	36	37	38		
39	40								

(E-119)

1	2	3	4	5	6	7	8	9
10	11	12	13	14	15	16	17	18
19	20	21	22	23	24	25	26	27
28	29	30	31					

(E-120)

41	42	43	44	45	46	47
48	49	50	51	52	53	54
55	56	57	58	59	60	61
62	63	64				

HYDRAULIC BRAKE BOOSTER (HBB), ELECTRONIC BRAKE-FORCE DISTRIBUTION (EBD), ANTI-LOCK BRAKING SYSTEM (ABS), MITSUBISHI ACTIVE SKID AND TRACTION CONTROL SYSTEM (M-ASTC) (CONTINUED)

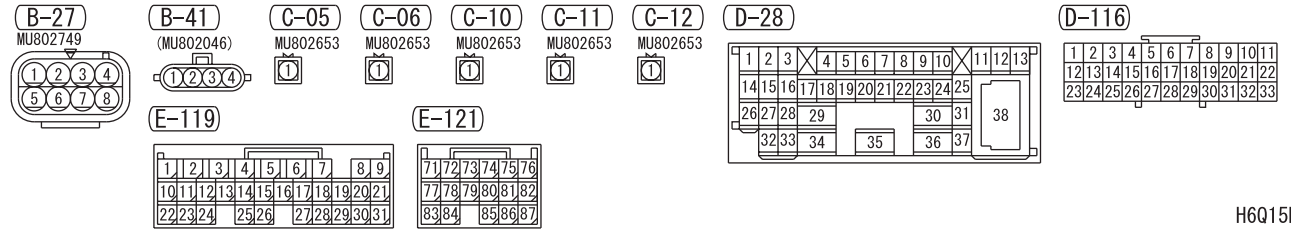
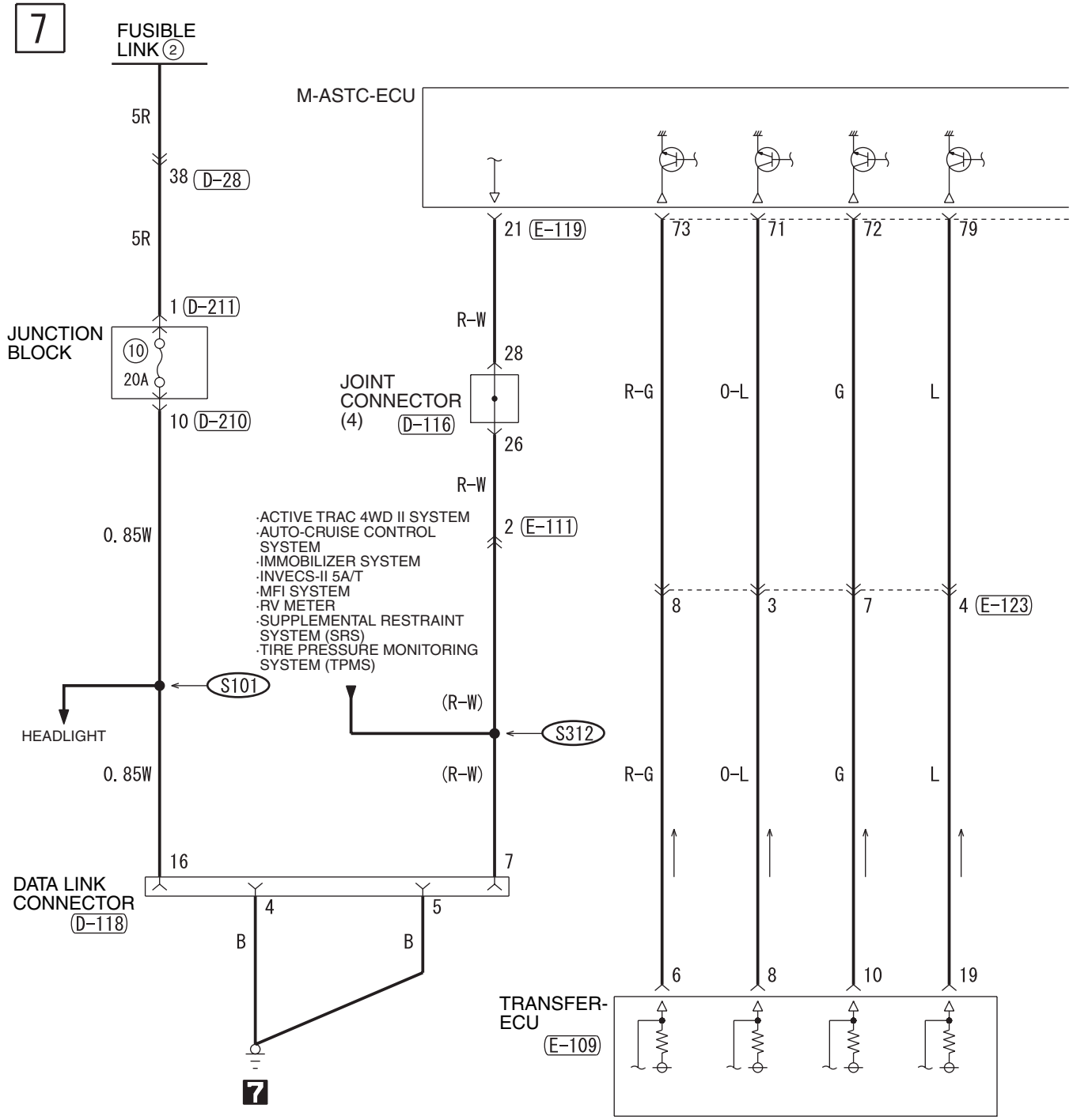

8

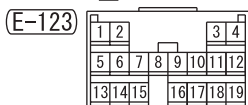
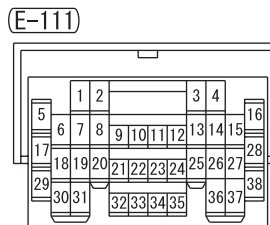
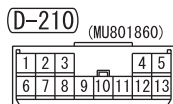
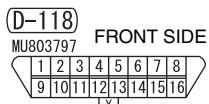
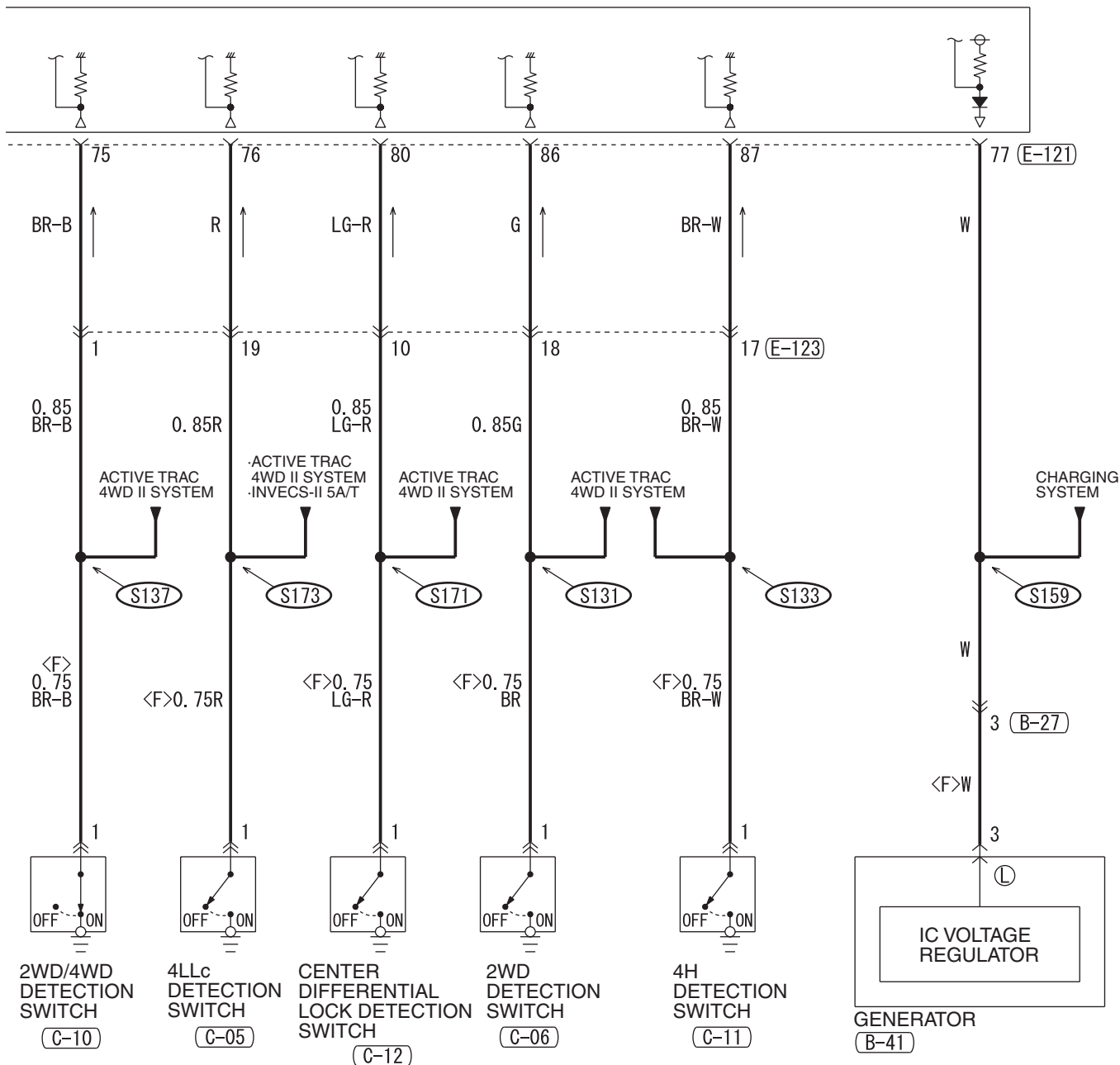

HYDRAULIC BRAKE BOOSTER (HBB), ELECTRONIC BRAKE-FORCE DISTRIBUTION (EBD), ANTI-LOCK BRAKING SYSTEM (ABS), MITSUBISHI ACTIVE SKID AND TRACTION CONTROL SYSTEM (M-ASTC) (CONTINUED)

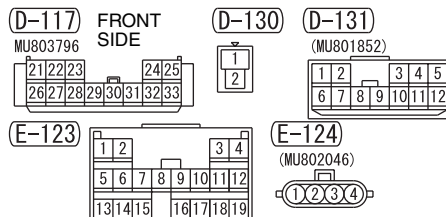
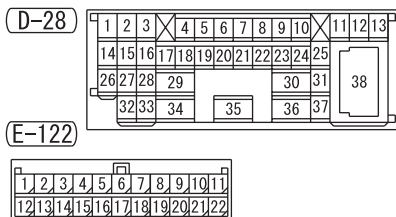
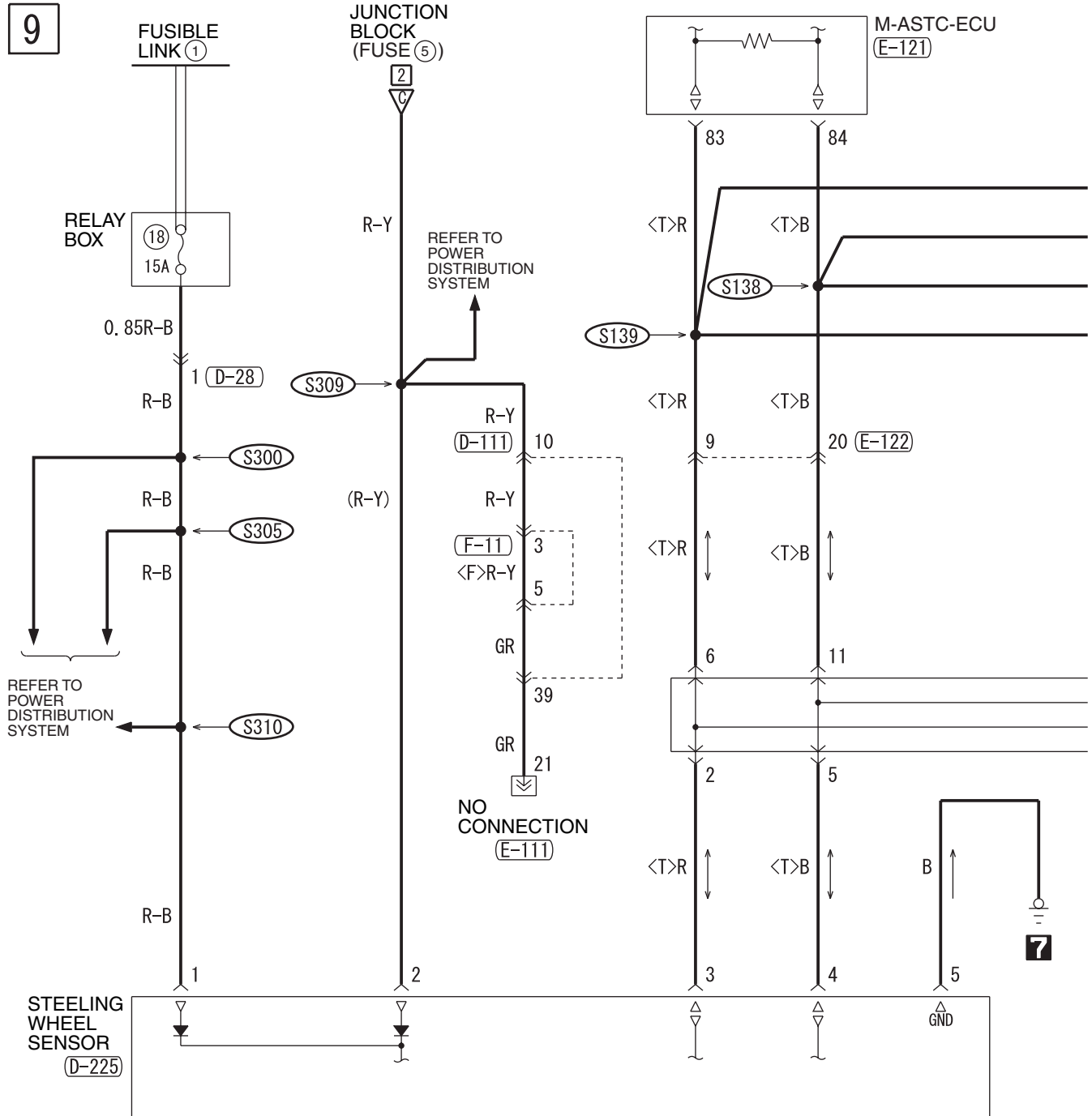

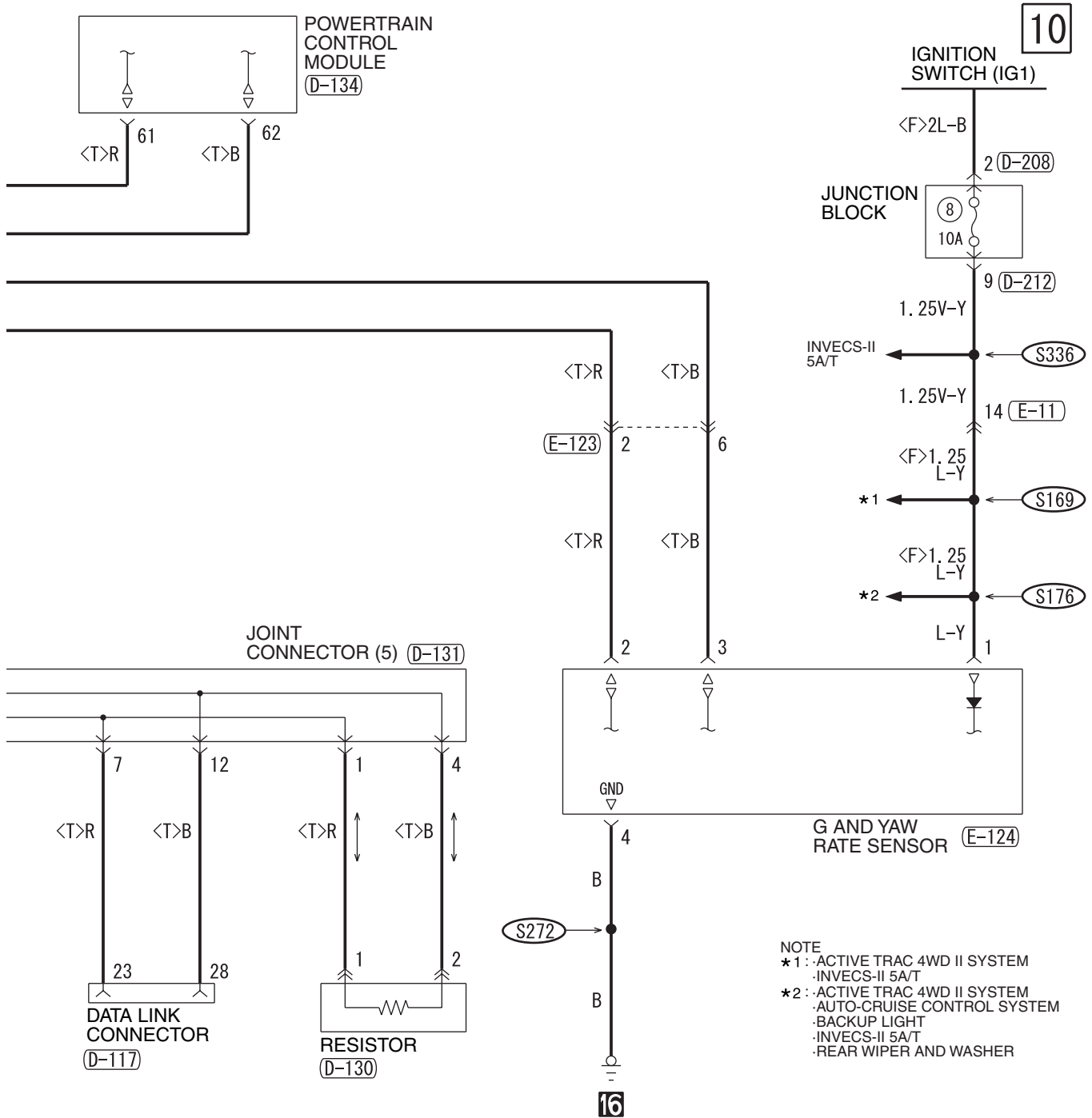

D-134 (MU803804)

61	62	JAE	63	64
65	66	67	68	69
70	71	72	73	74
75	76	77	78	79
80	81	82	83	84
85	86	87	88	89

D-208

1	2
3	4
5	6

D-212

1	2	3	4
5	6	7	8
9	10	11	

D-225

1	2	3	4	5

E-11

1	2	3
4	5	6
7	8	9
10	11	12
13	14	15
16		

E-111

1	2	3	4	5	6	7	8	9	10	11	12	13	14	15	16	17	18	19	20	21	22	23	24	25	26	27	28	29	30	31	32	33	34	35	36	37	38
---	---	---	---	---	---	---	---	---	----	----	----	----	----	----	----	----	----	----	----	----	----	----	----	----	----	----	----	----	----	----	----	----	----	----	----	----	----

E-121

71	72	73	74	75	76
77	78	79	80	81	82
83	84	85	86	87	

F-11 (MU802749)

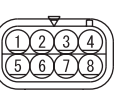

2

NOTE
* : CONNECTOR
COUPLED : ON
CONNECTOR
UNCOUPLD : OFF

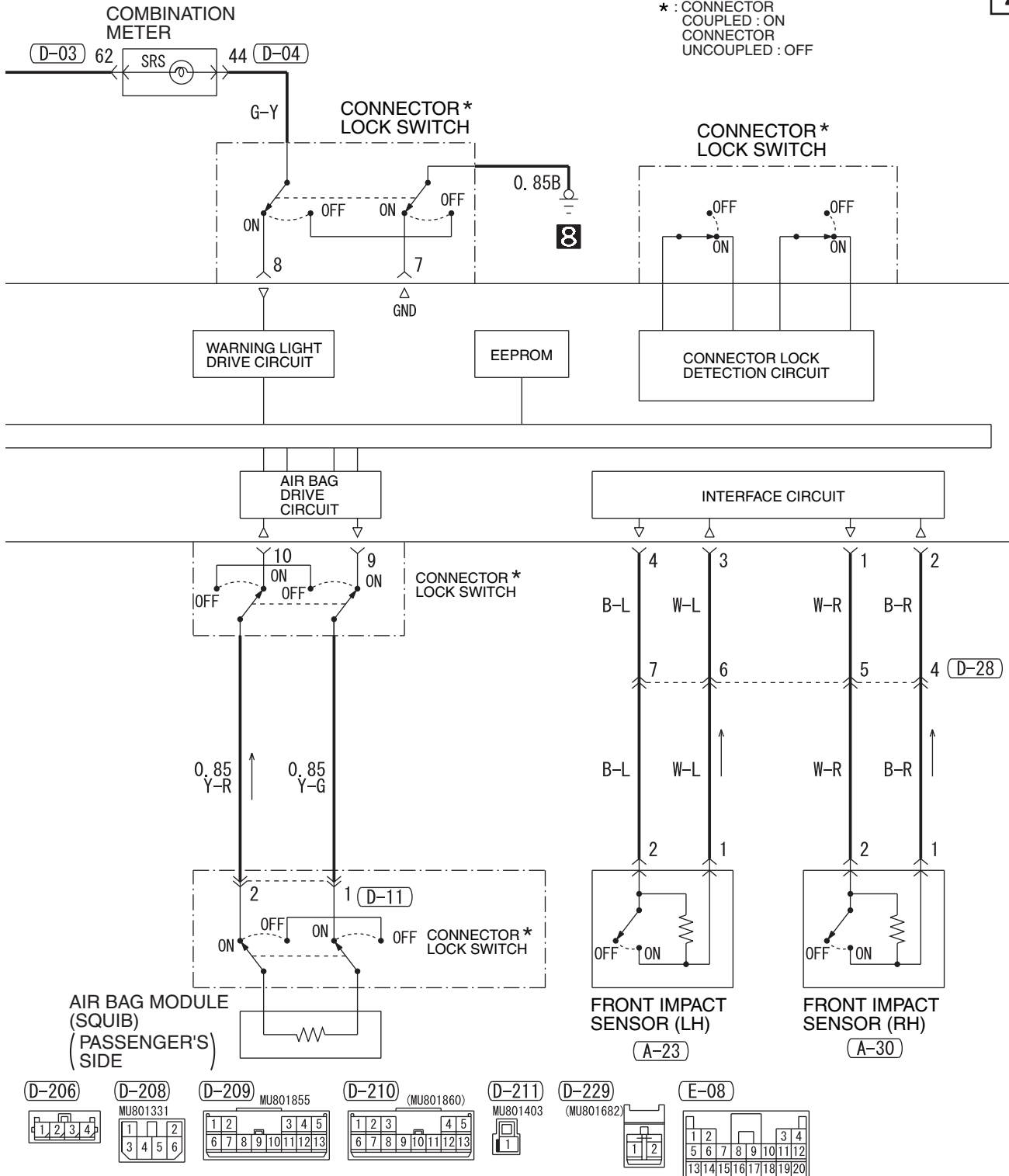

WIRE COLOR CODE
 B : BLACK LG : LIGHT GREEN G : GREEN L : BLUE W : WHITE Y : YELLOW
 SB : SKY BLUE BR : BROWN O : ORANGE GR : GRAY R : RED P : PINK V : VIOLET

SUPPLEMENTAL RESTRAINT SYSTEM (SRS) (CONTINUED)

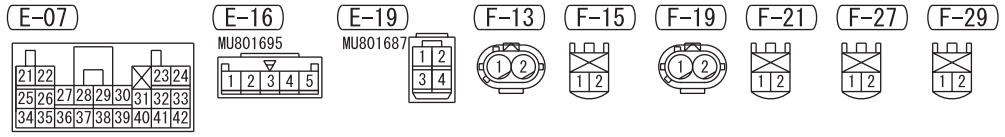
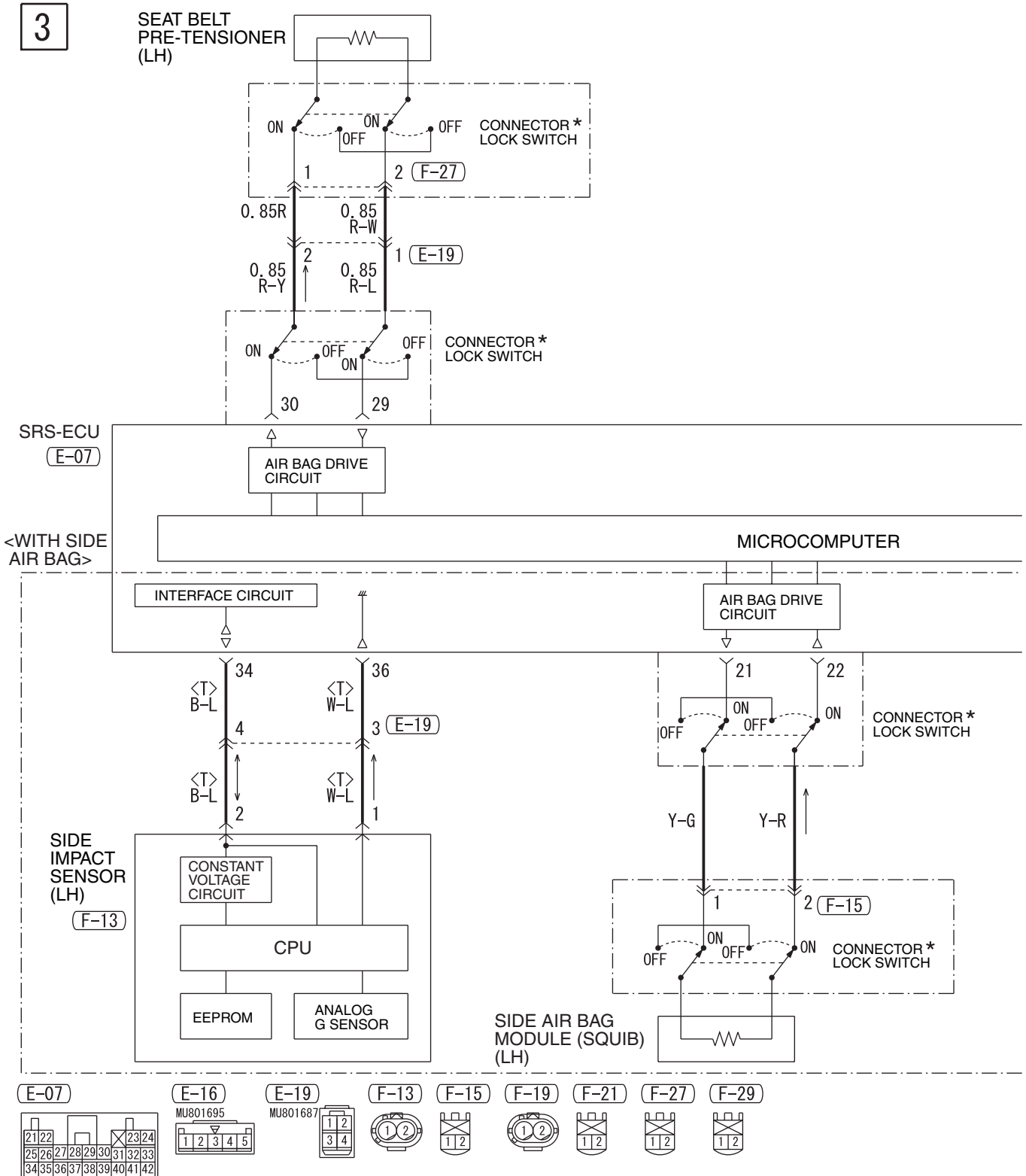

4

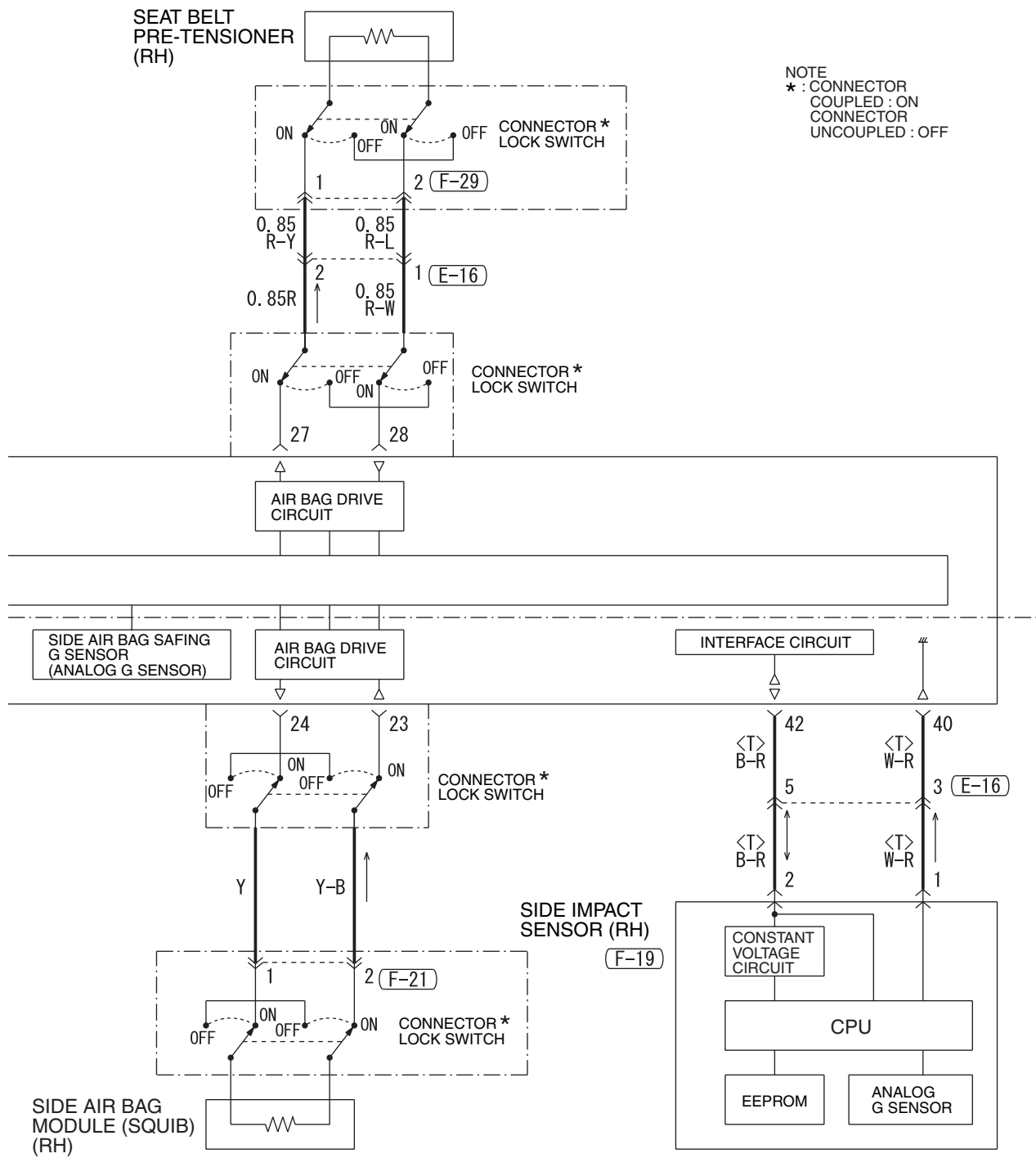

WIRE COLOR CODE
B : BLACK LG : LIGHT GREEN G : GREEN L : BLUE W : WHITE Y : YELLOW
SB : SKY BLUE BR : BROWN O : ORANGE GR : GRAY R : RED P : PINK V : VIOLET

POWER SEAT

M1901010400513

1

POWER SEAT ASSEMBLY (DRIVER'S SIDE) (F-17)

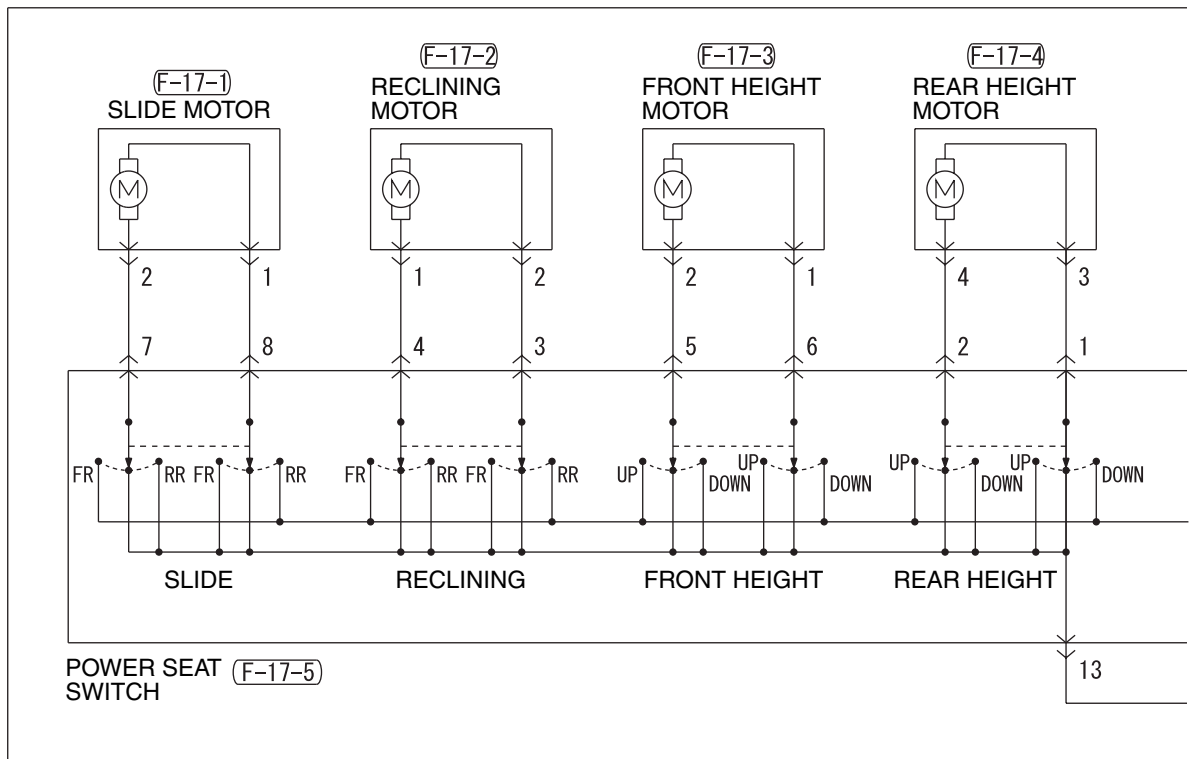

(D-28)

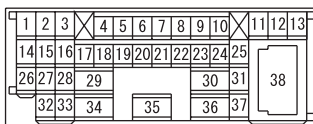

(D-125)

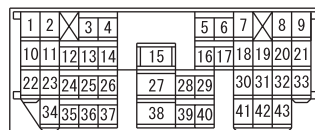

(F-17)



(F-17-1)



(F-17-2)



(F-17-3)



(F-17-4)



(F-17-5)

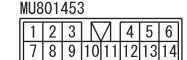

2

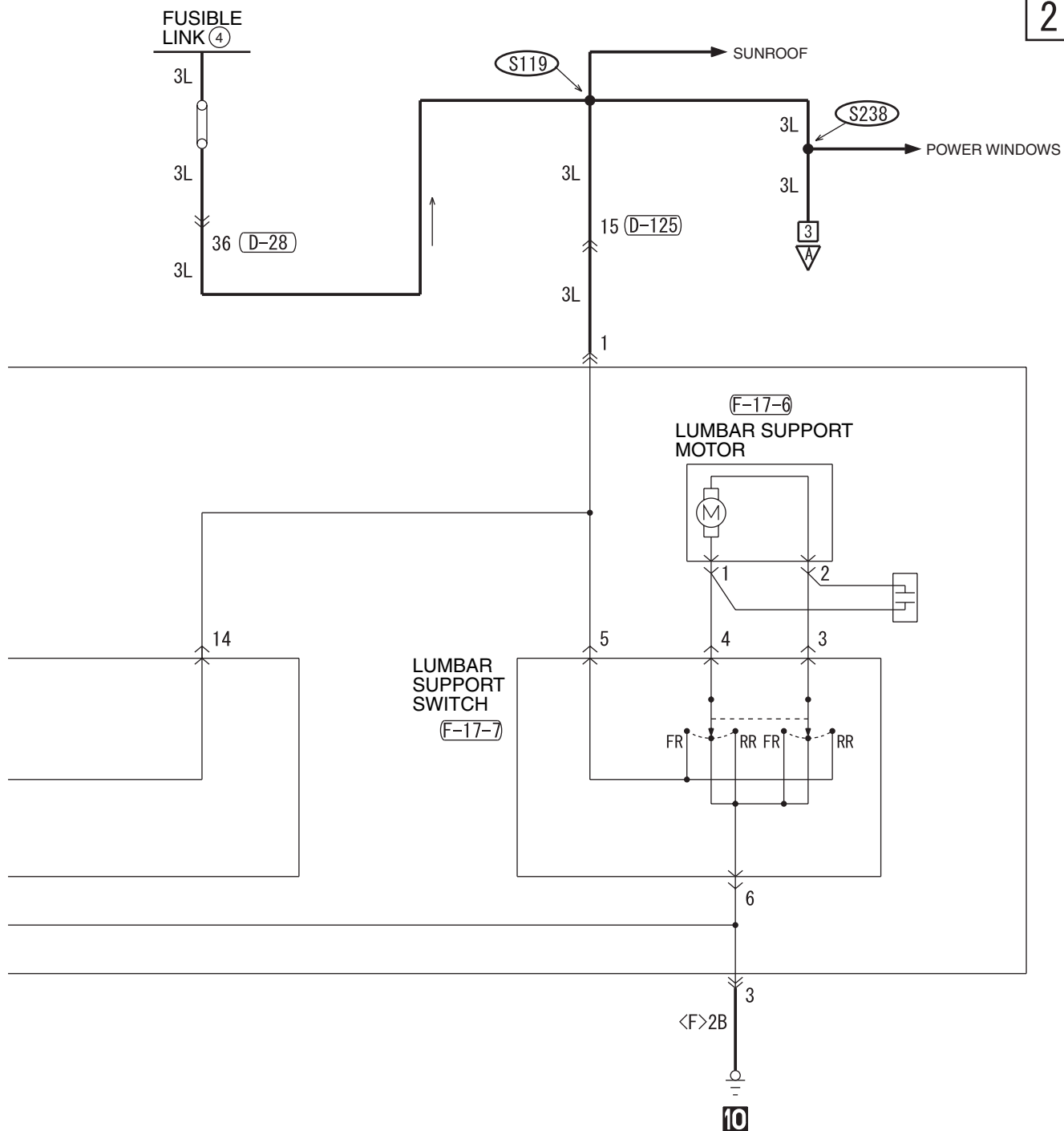

(F-17-6) (F-17-7)

MU801447



WIRE COLOR CODE

B: BLACK LG: LIGHT GREEN G: GREEN L: BLUE W: WHITE Y: YELLOW
SB: SKY BLUE BR: BROWN O: ORANGE GR: GRAY R: RED P: PINK V: VIOLET

H6Q15M06AB

TSB Revision

POWER SEAT (CONTINUED)

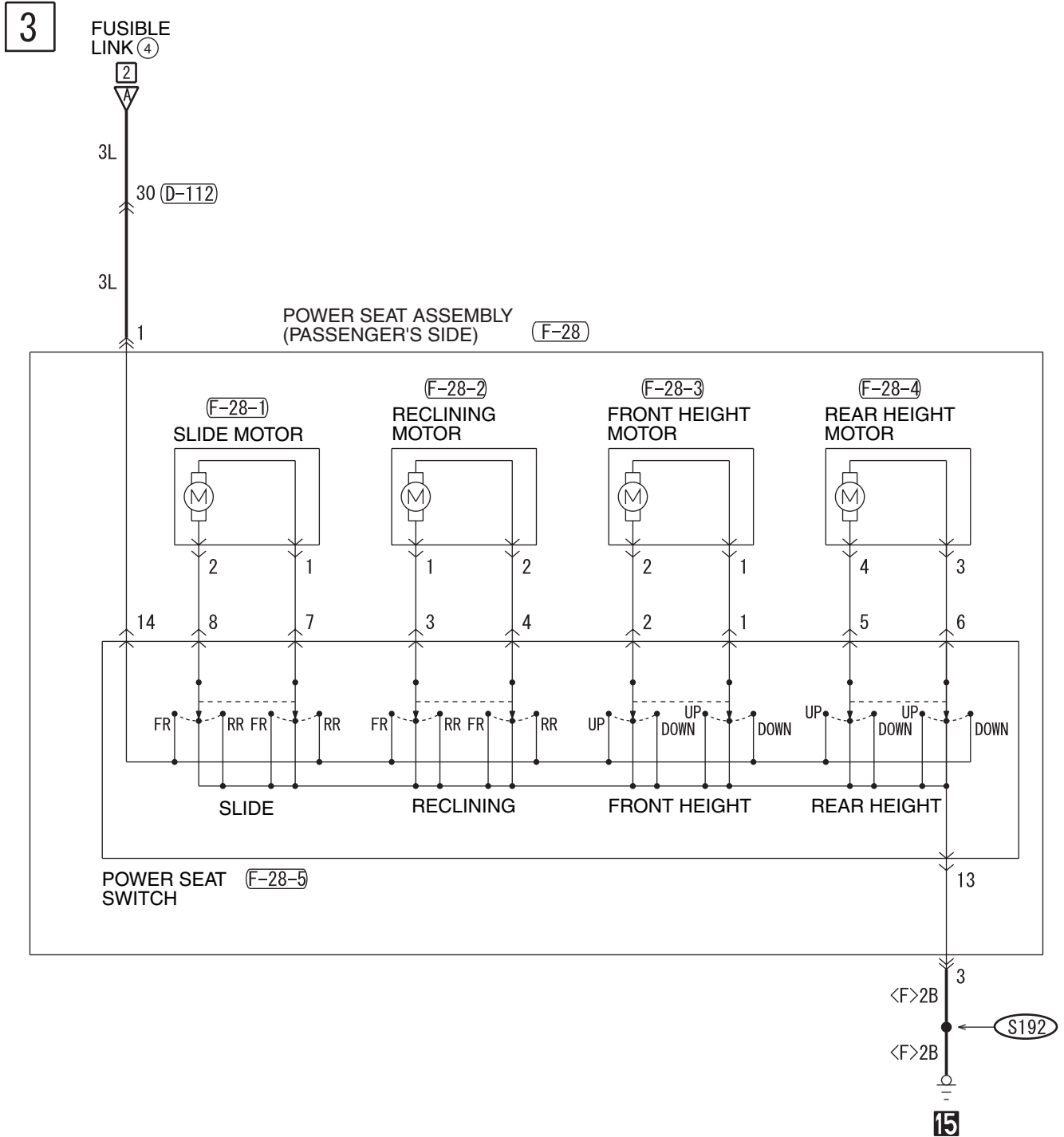

(D-112)

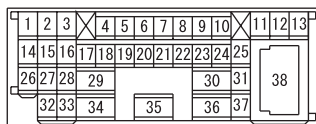

(F-28)



(F-28-1)



(F-28-2)



(F-28-3)



(F-28-4)



(F-28-5)



WIRE COLOR CODE

B : BLACK LG : LIGHT GREEN G : GREEN L : BLUE
 BR : BROWN O : ORANGE GR : GRAY R : RED W : WHITE
 SB : SKY BLUE P : PINK Y : YELLOW V : VIOLET

NOTES

HEATED SEAT

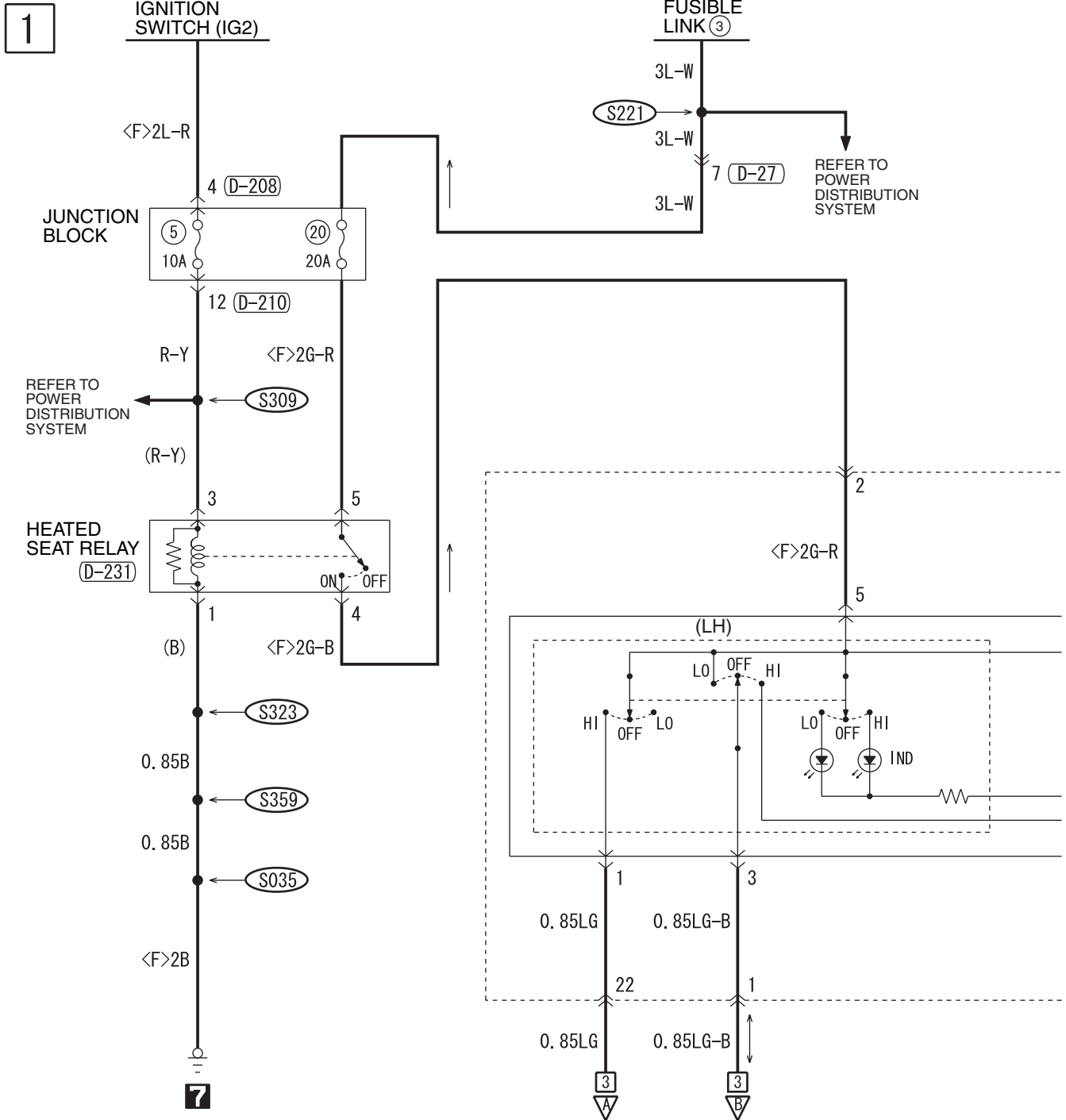

D-27

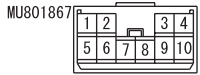

D-28

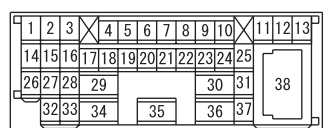

D-208



D-210

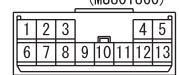

D-231



E-06

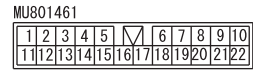

2

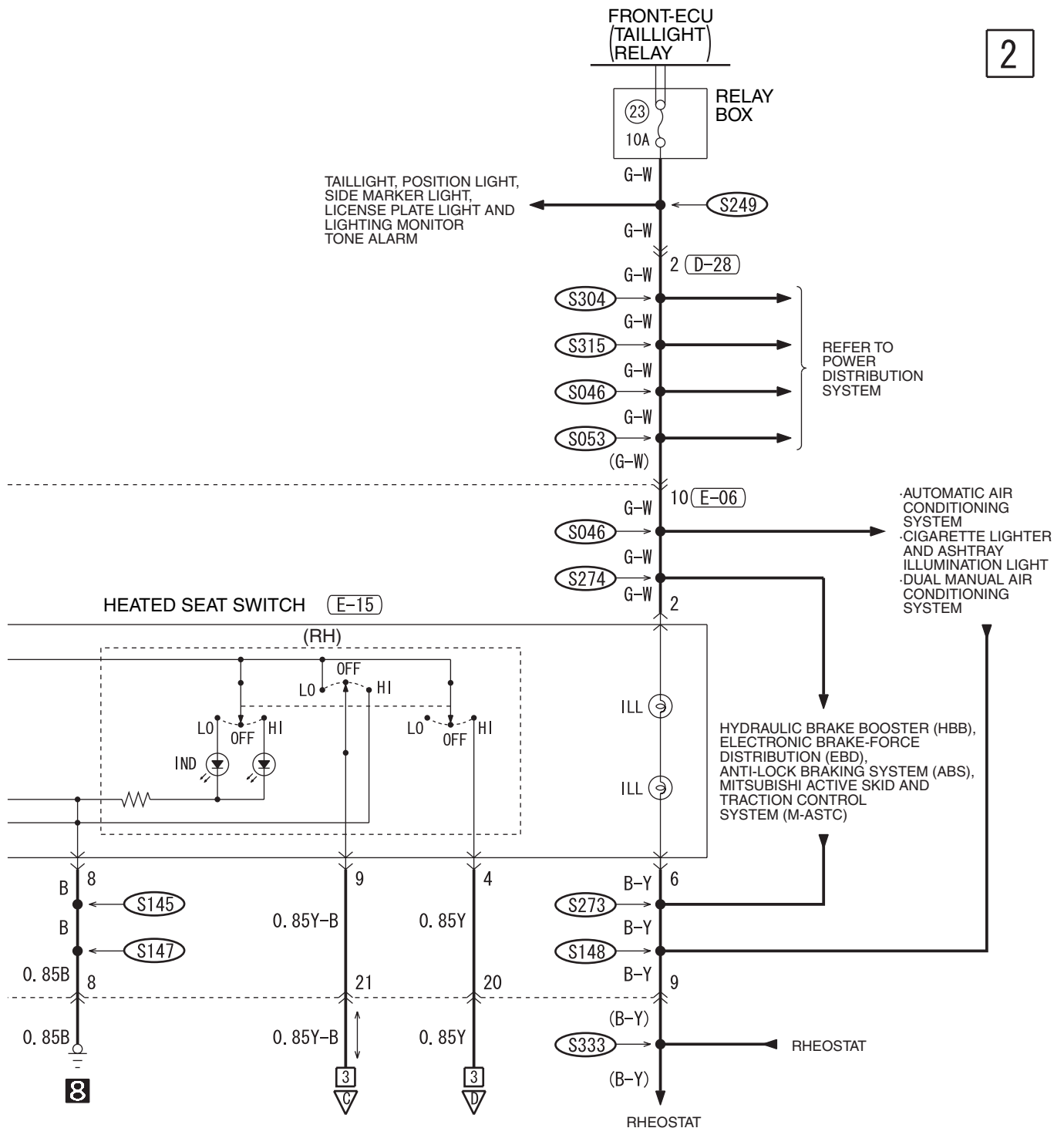

HEATED SEAT SWITCH (E-15)

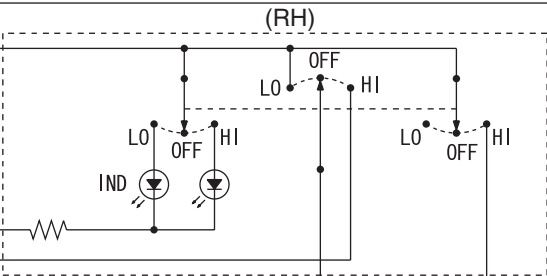

(E-15)

1	2	3
4	5	6
7	8	9

WIRE COLOR CODE

B : BLACK LG : LIGHT GREEN G : GREEN L : BLUE W : WHITE Y : YELLOW
SB : SKY BLUE BR : BROWN O : ORANGE GR : GRAY R : RED P : PINK V : VIOLET

HEATED SEAT (CONTINUED)

3

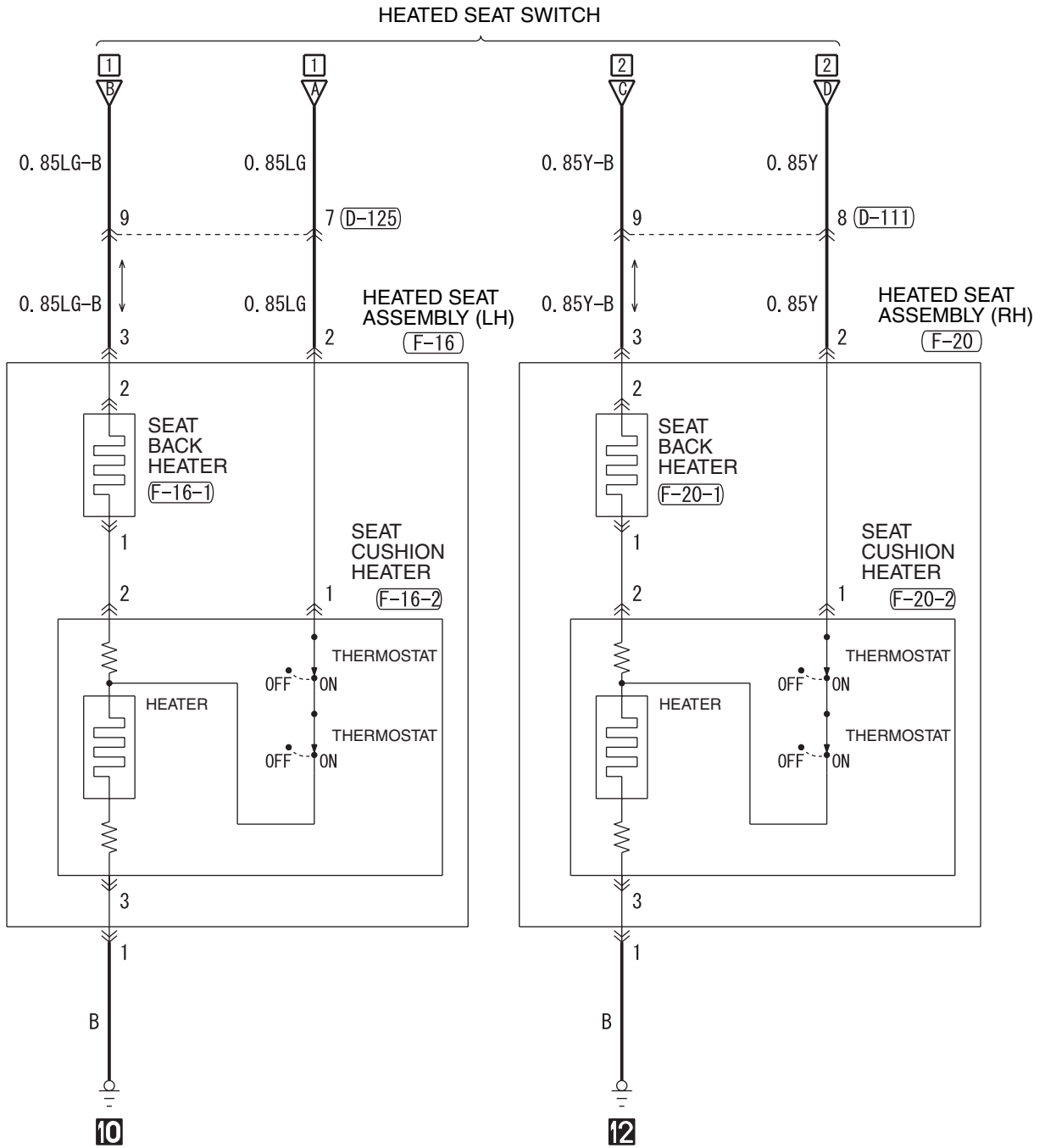

D-111

1	2	3	4	5	6	7	8	9
10	11	12	13	14	15	16	17	18
19	20	21	22	23	24	25	26	27
28	29	30	31	32	33	34	35	36
37	38	39	40	41	42	43		

D-125

1	2	3	4	5	6	7	8	9
10	11	12	13	14	15	16	17	18
19	20	21	22	23	24	25	26	27
28	29	30	31	32	33	34	35	36
37	38	39	40	41	42	43		

F-16

1	2	3
1	2	3

F-16-1

1	2
1	2

F-16-2

1	2	3
1	2	3

F-20

1	2	3
1	2	3

F-20-1

1	2
1	2

F-20-2

1	2	3
1	2	3

NOTES

THEFT-ALARM SYSTEM

M1901012400683

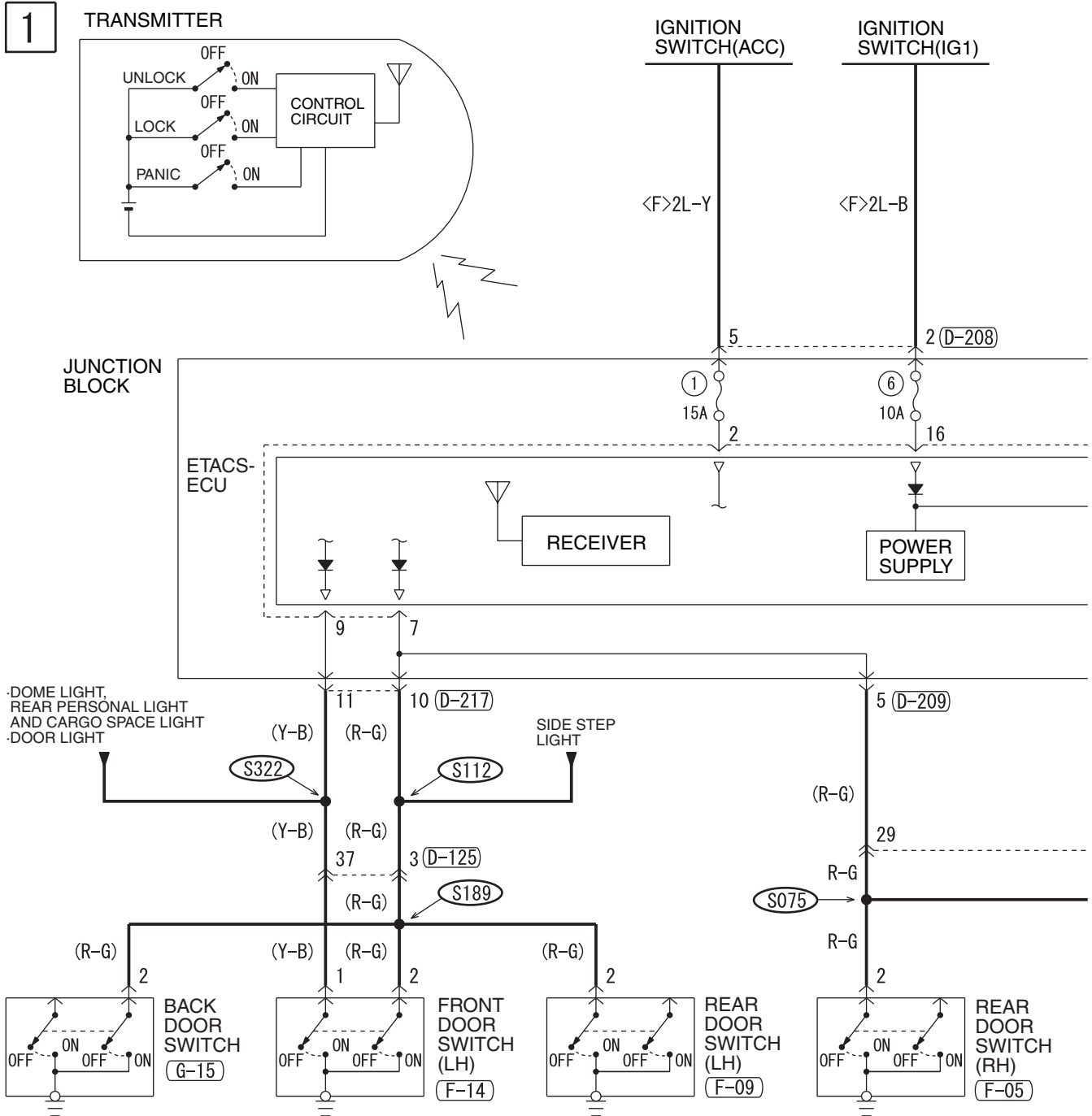

2

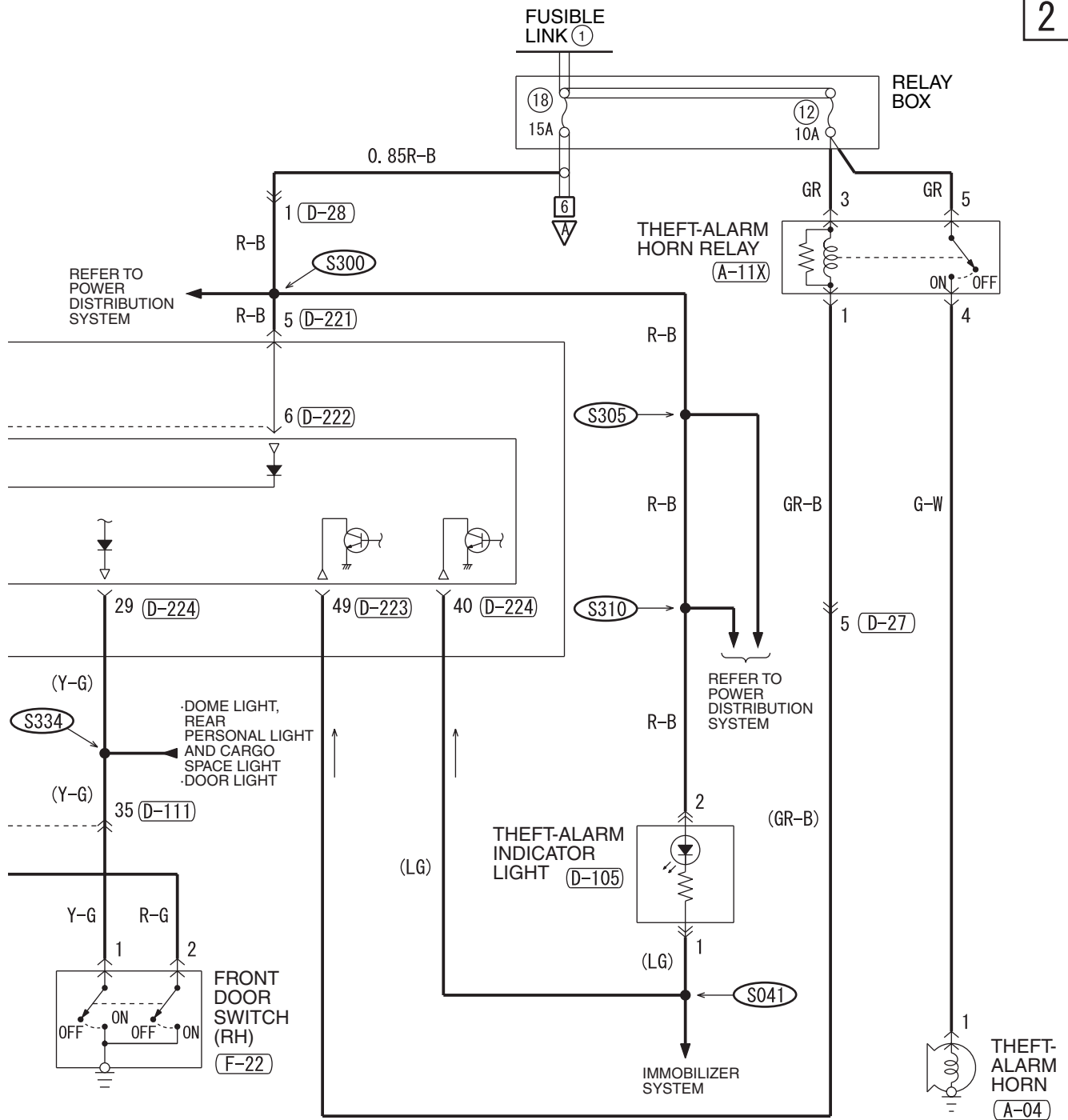

D-125

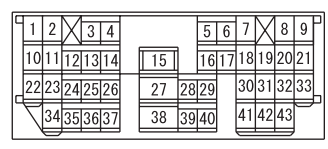

D-208



D-209

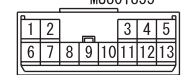

D-217

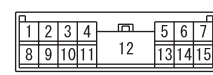

D-221

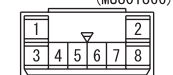

F-05



F-09



F-14



F-22



G-15



THEFT-ALARM SYSTEM (CONTINUED)

3

ETACS-ECU

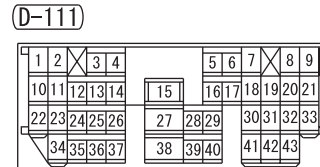
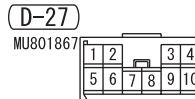
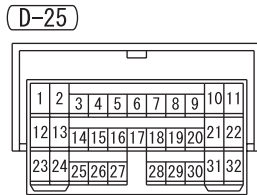
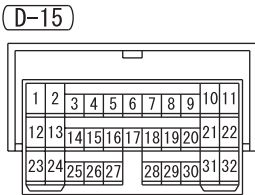
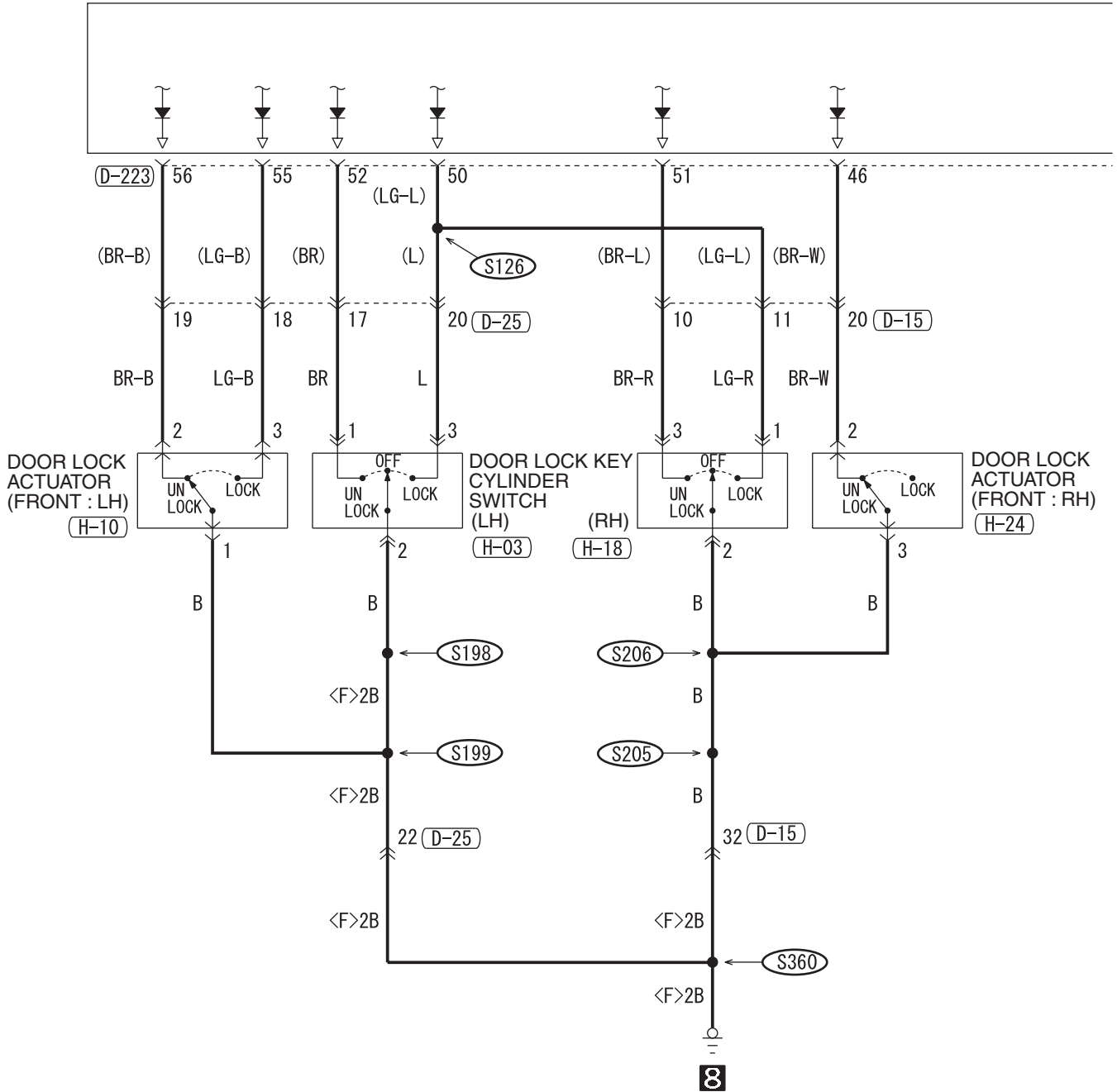

4

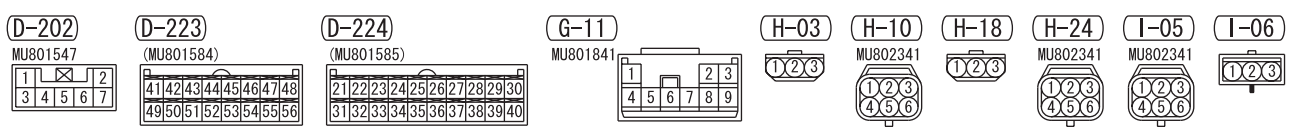
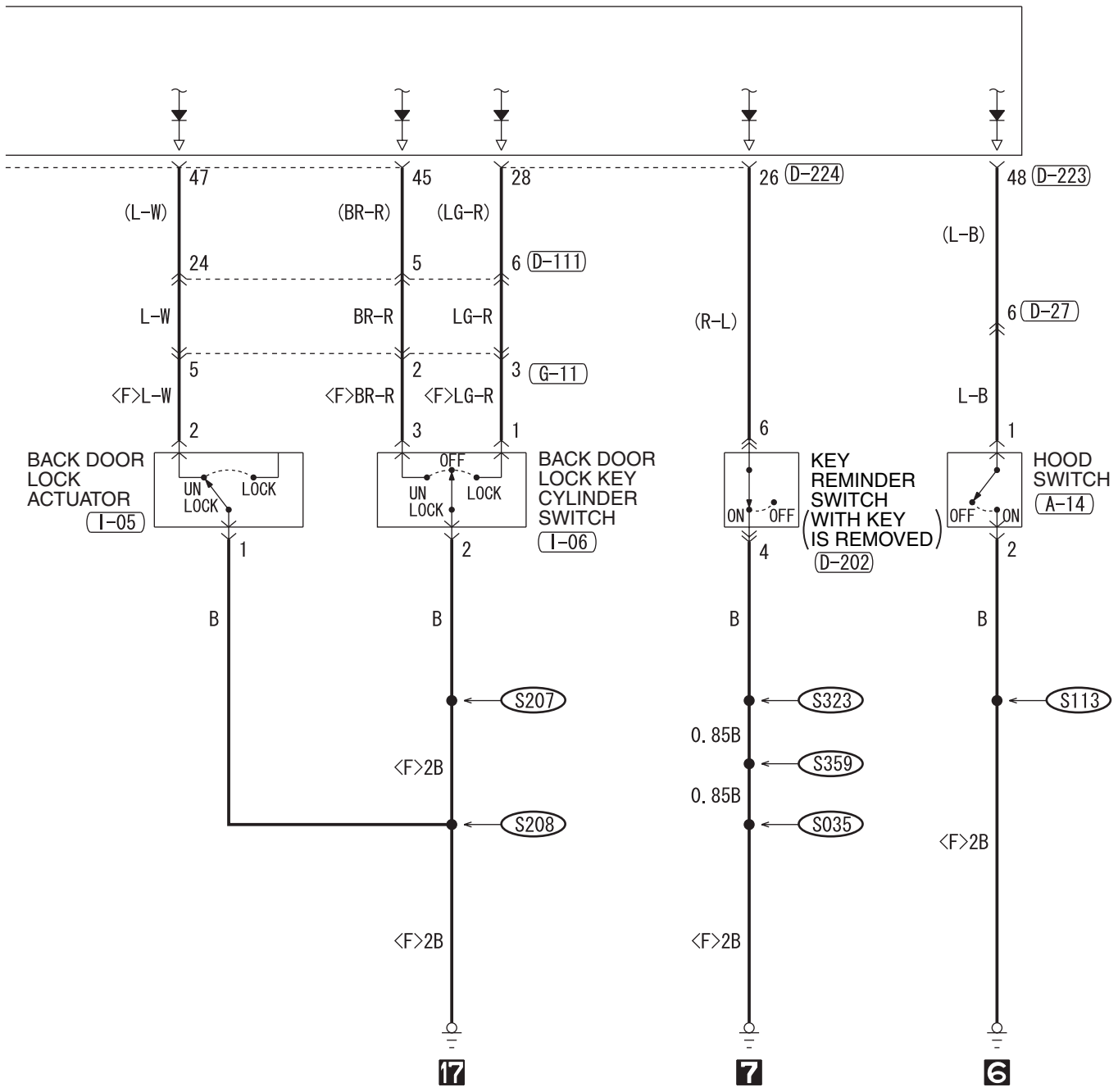

WIRE COLOR CODE
 B : BLACK LG : LIGHT GREEN G : GREEN L : BLUE W : WHITE Y : YELLOW
 SB : SKY BLUE BR : BROWN O : ORANGE GR : GRAY R : RED P : PINK V : VIOLET

H6Q15M08BB

TSB Revision

THEFT-ALARM SYSTEM (CONTINUED)

5

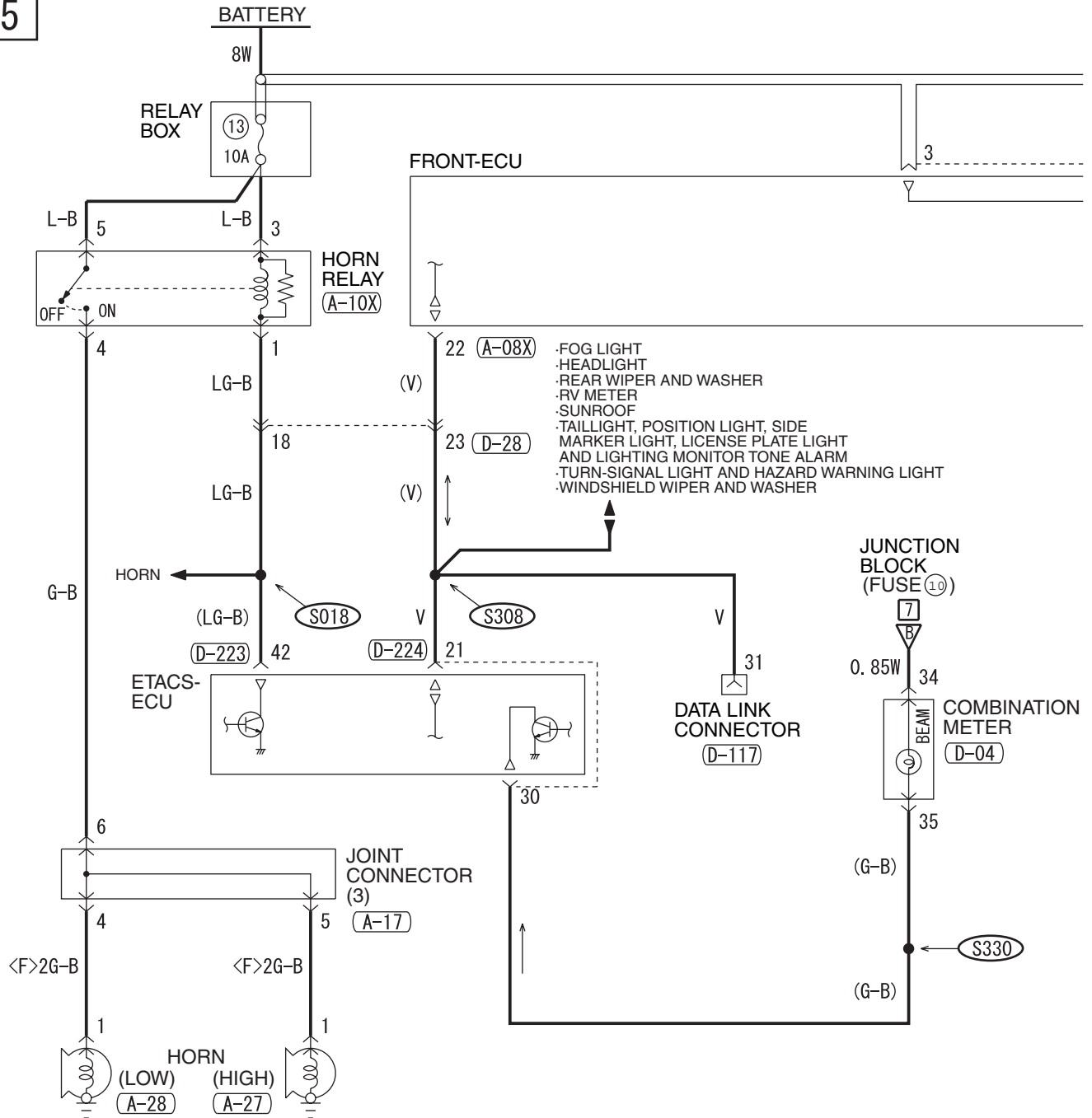

(A-07X)

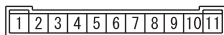

(A-08X)

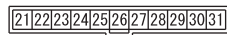

(A-10X)



(A-15)

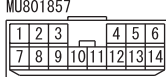

(A-17)

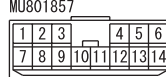

(A-20)



(A-27)



(A-28)



(A-32)



(D-224)

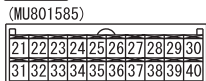

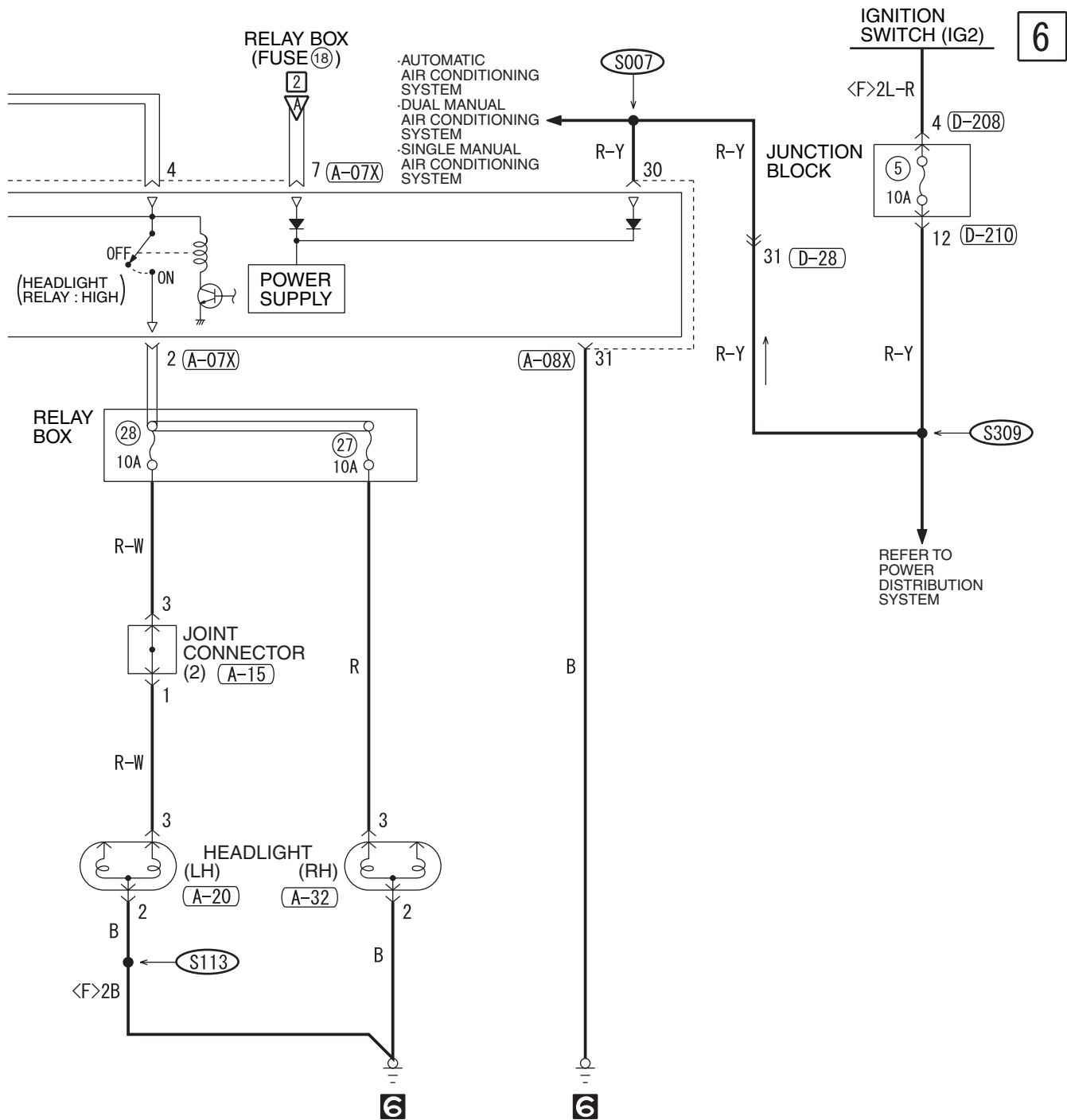

D-04

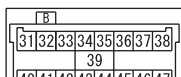

D-28

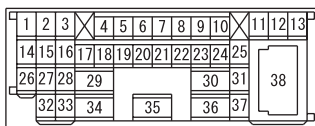

D-117



D-208



D-210

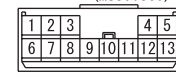

D-223

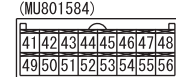

WIRE COLOR CODE

B : BLACK LG : LIGHT GREEN G : GREEN L : BLUE
 BR : BROWN O : ORANGE GR : GRAY R : RED W : WHITE
 SB : SKY BLUE P : PINK Y : YELLOW V : VIOLET

H6Q15M08CB

THEFT-ALARM SYSTEM (CONTINUED)

7

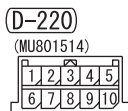
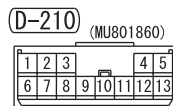
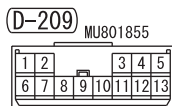
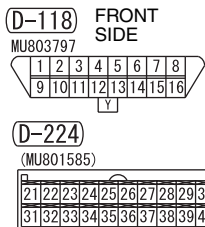
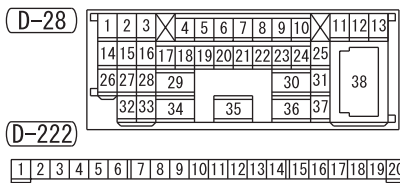
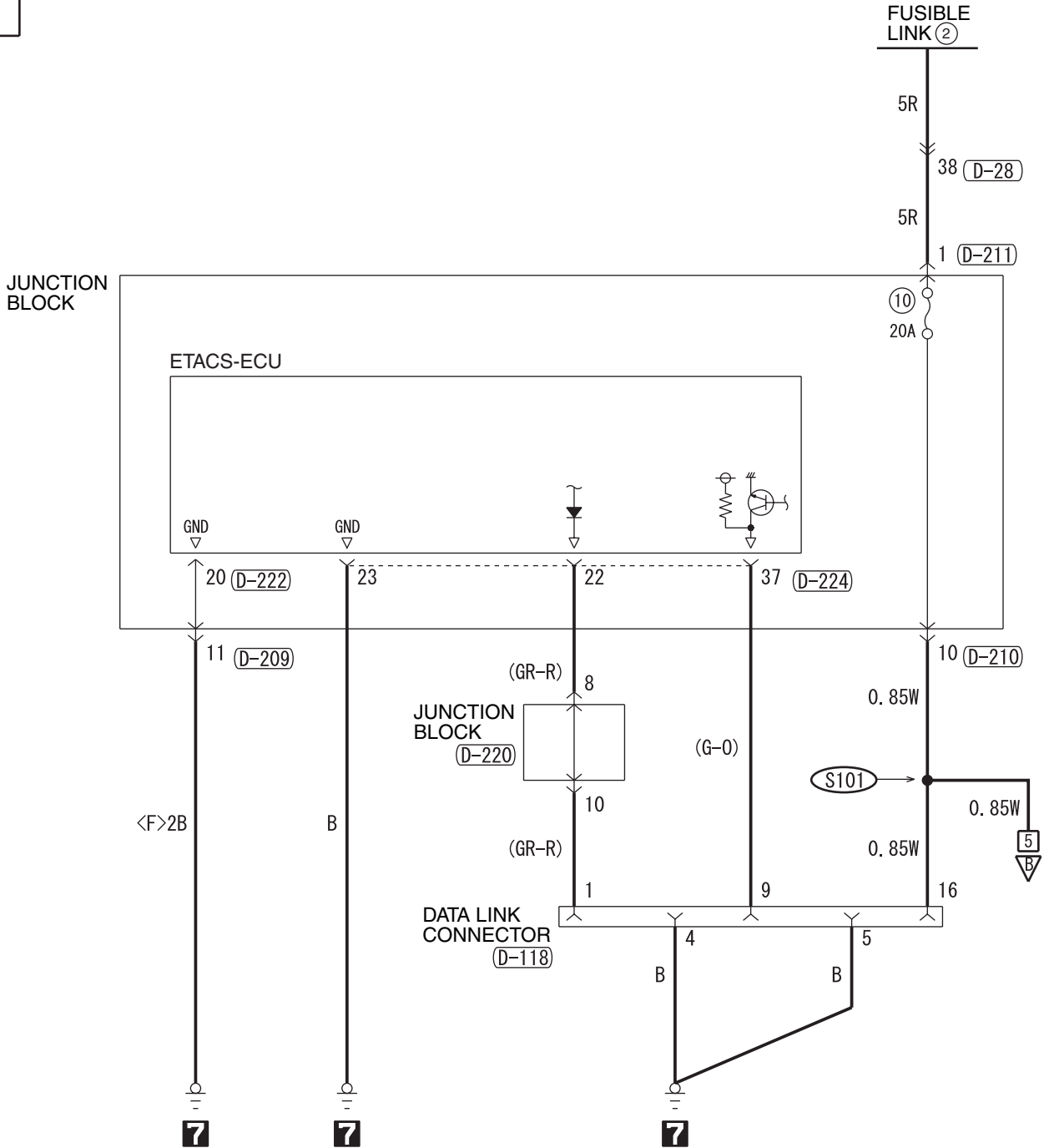

NOTES

IMMOBILIZER SYSTEM

M1901013602051

1

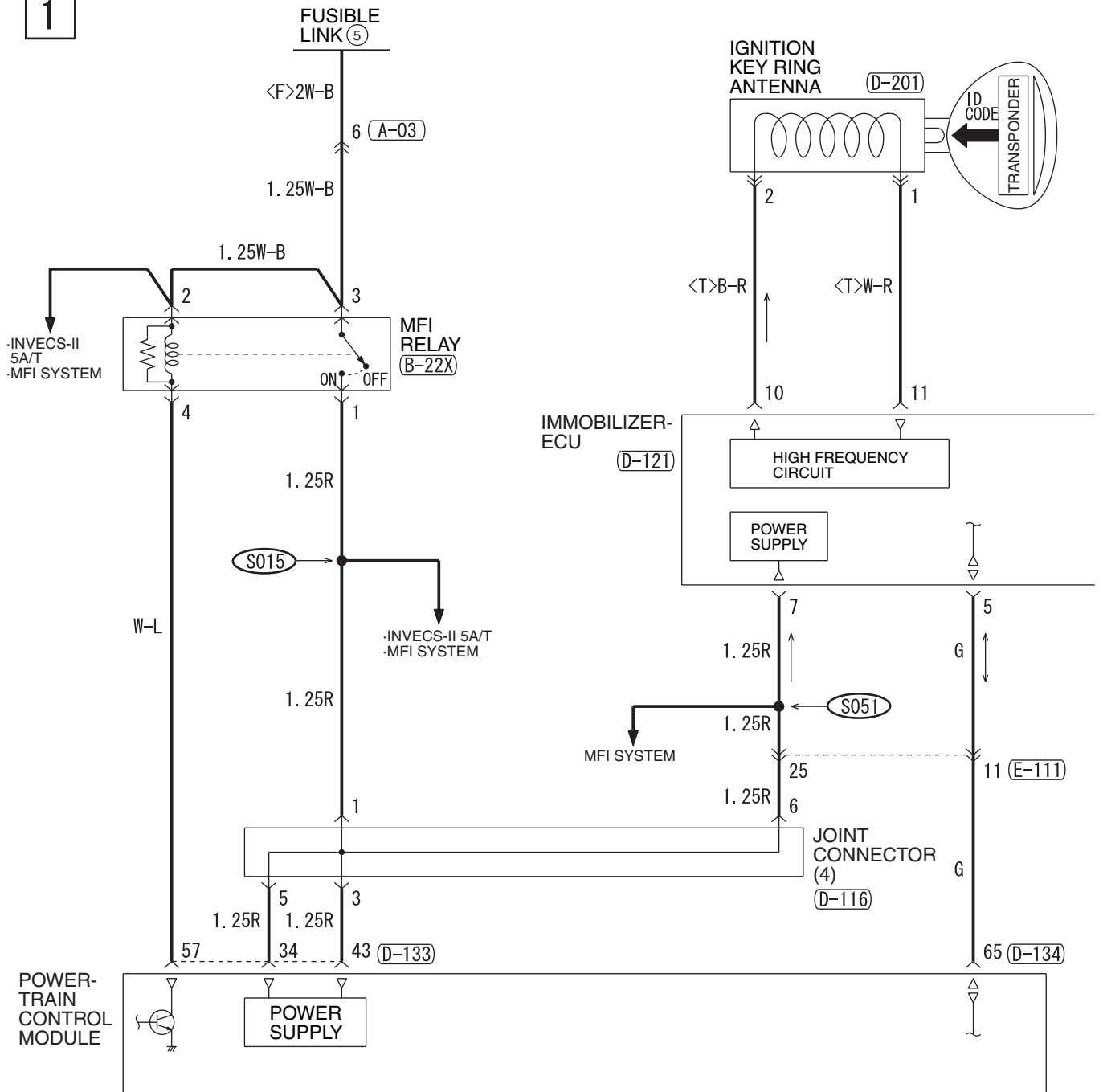

A-03



B-22X



D-28

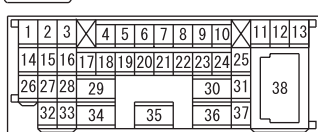

D-105



D-116

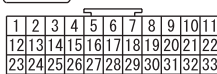

D-121

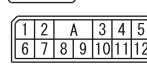

2

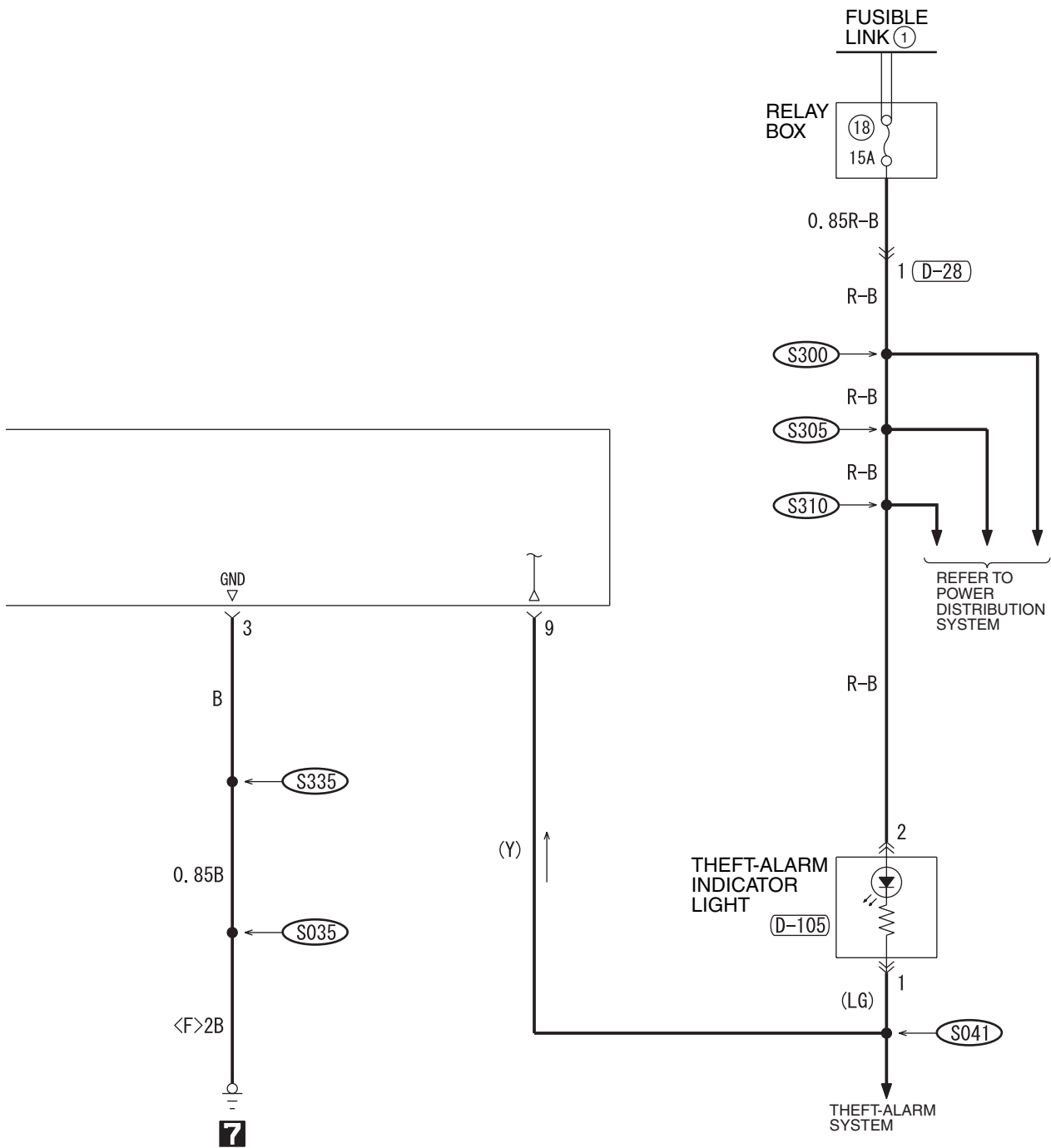

D-133
(MU803803)

31	32	JAE	33	34
35	36	37	38	39
40	41	42	43	44
45	46	47	48	49
50	51	52	53	54
55	56	57	58	

D-134
(MU803804)

61	62	JAE	63	64
65	66	67	68	69
70	71	72	73	74
75	76	77	78	79
80	81	82	83	84
85	86	87	88	89

D-201
MU801541

1	2
---	---

E-111

1	2	3	4
5	6	7	8
9	10	11	12
13	14	15	16
17	18	19	20
21	22	23	24
25	26	27	28
29	30	31	32
33	34	35	36
37	38		

NOTES

TIRE PRESSURE MONITORING SYSTEM (TPMS)

M1901003900141

1

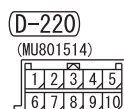
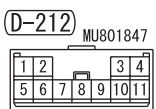
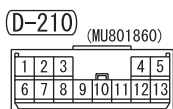
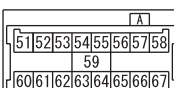
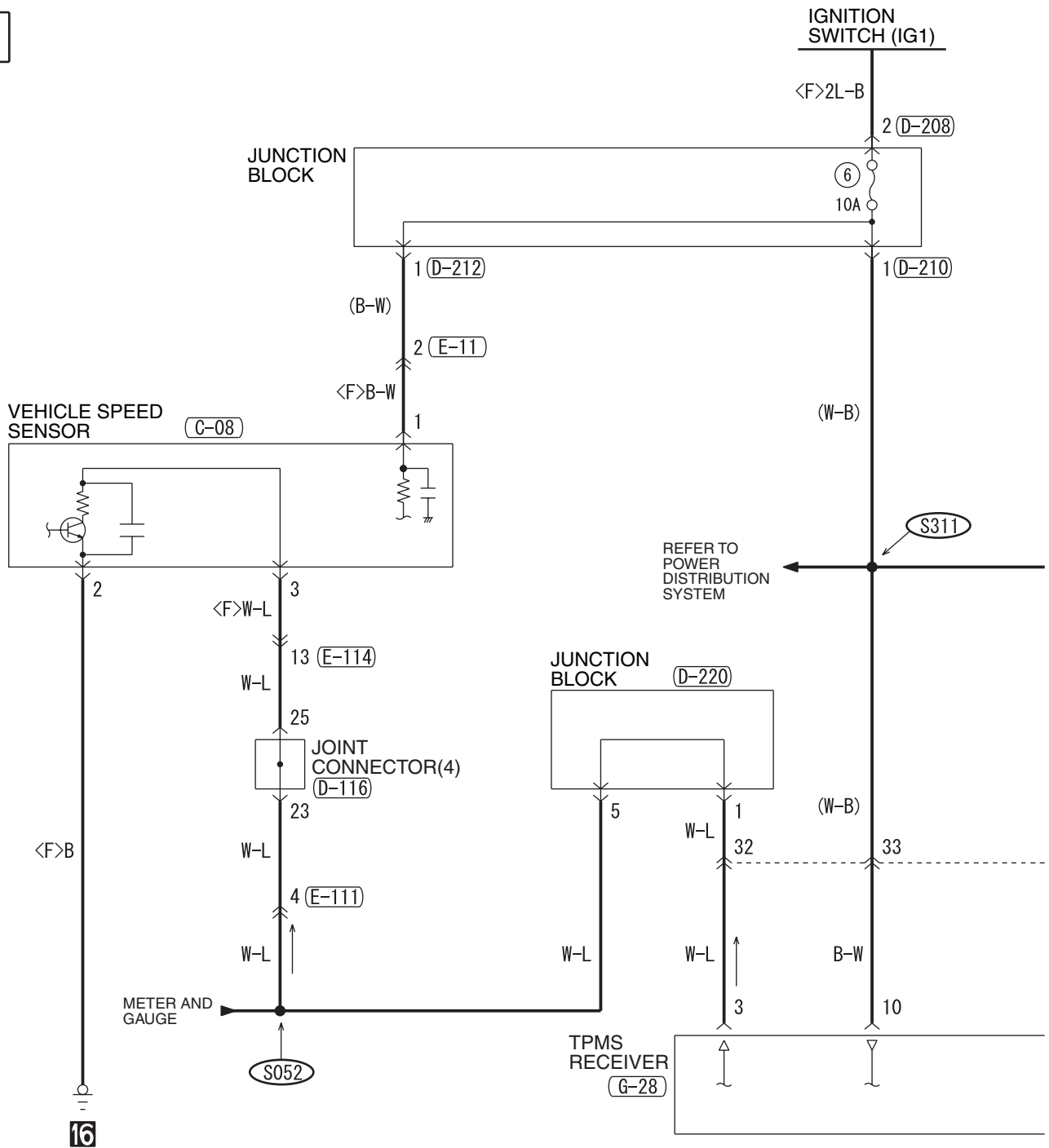

2

NOTE

- *: ACTIVE TRAC 4WD II SYSTEM
- AUTO-CRUISE CONTROL SYSTEM
- HYDRAULIC BRAKE BOOSTER (HBB)
- ELECTRONIC BRAKE-FORCE DISTRIBUTION (EBD)
- ANTI-LOCK BRAKING SYSTEM (ABS)
- MITSUBISHI ACTIVE SKID AND TRACTION CONTROL SYSTEM (M-ASTC)
- IMMOBILIZER SYSTEM
- INVECS-II 5A/T
- MFI SYSTEM
- RV METER
- SUPPLEMENTAL RESTRAINT SYSTEM (SRS)

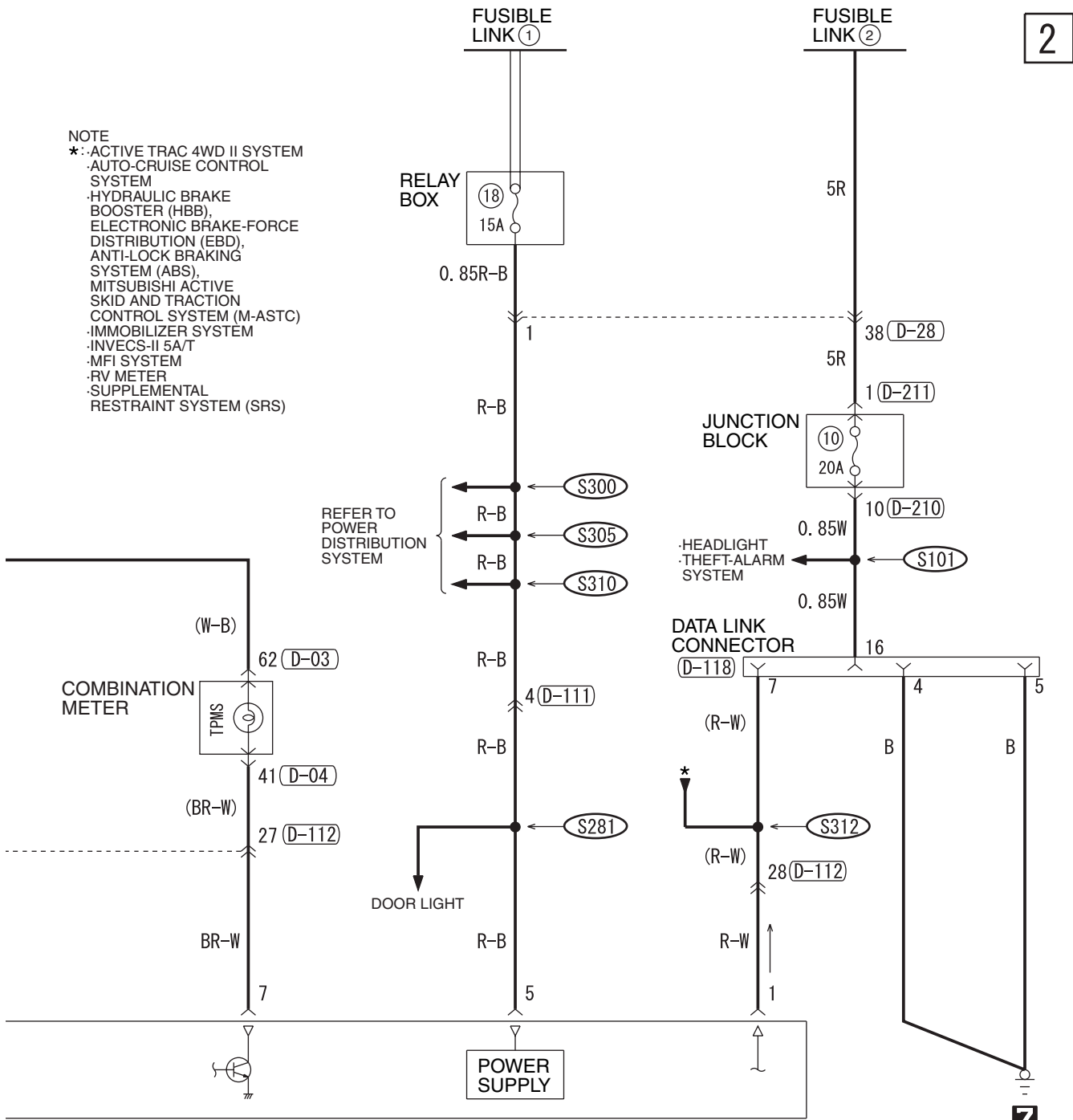

D-112

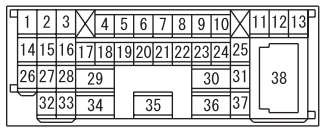

D-116

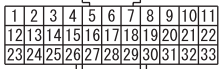

E-11

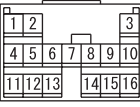

D-118 FRONT SIDE



E-11

E-114

See ★1 See ★1

D-208



G-28

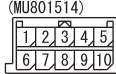

★1

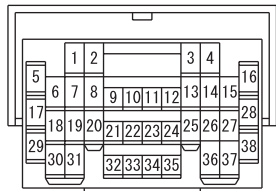

H6Q15M10AB

TIRE PRESSURE MONITORING SYSTEM (TPMS) (CONTINUED)

3

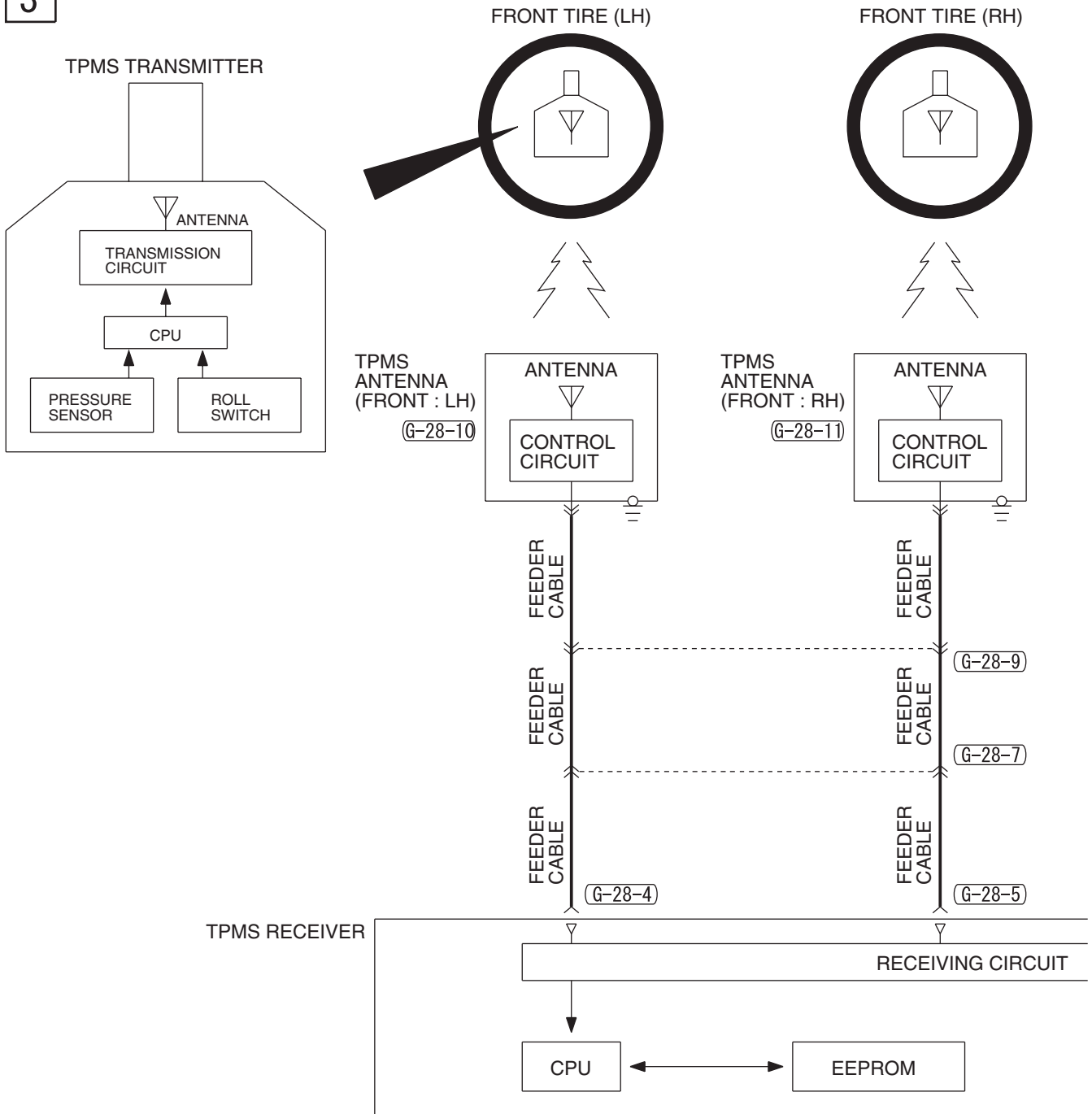

- (G-28) (MU801514)
 - (G-28-1) 1
 - (G-28-2) 1
 - (G-28-3) 1
 - (G-28-4) 1
 - (G-28-5) 1
 - (G-28-6) 1
 - (G-28-7) 1 2
 - (G-28-8) 1
 - (G-28-9) 1 2
 - (G-28-10) 1
 - (G-28-11) 1
- | | | | | |
|---|---|---|---|----|
| 1 | 2 | 3 | 4 | 5 |
| 6 | 7 | 8 | 9 | 10 |

4

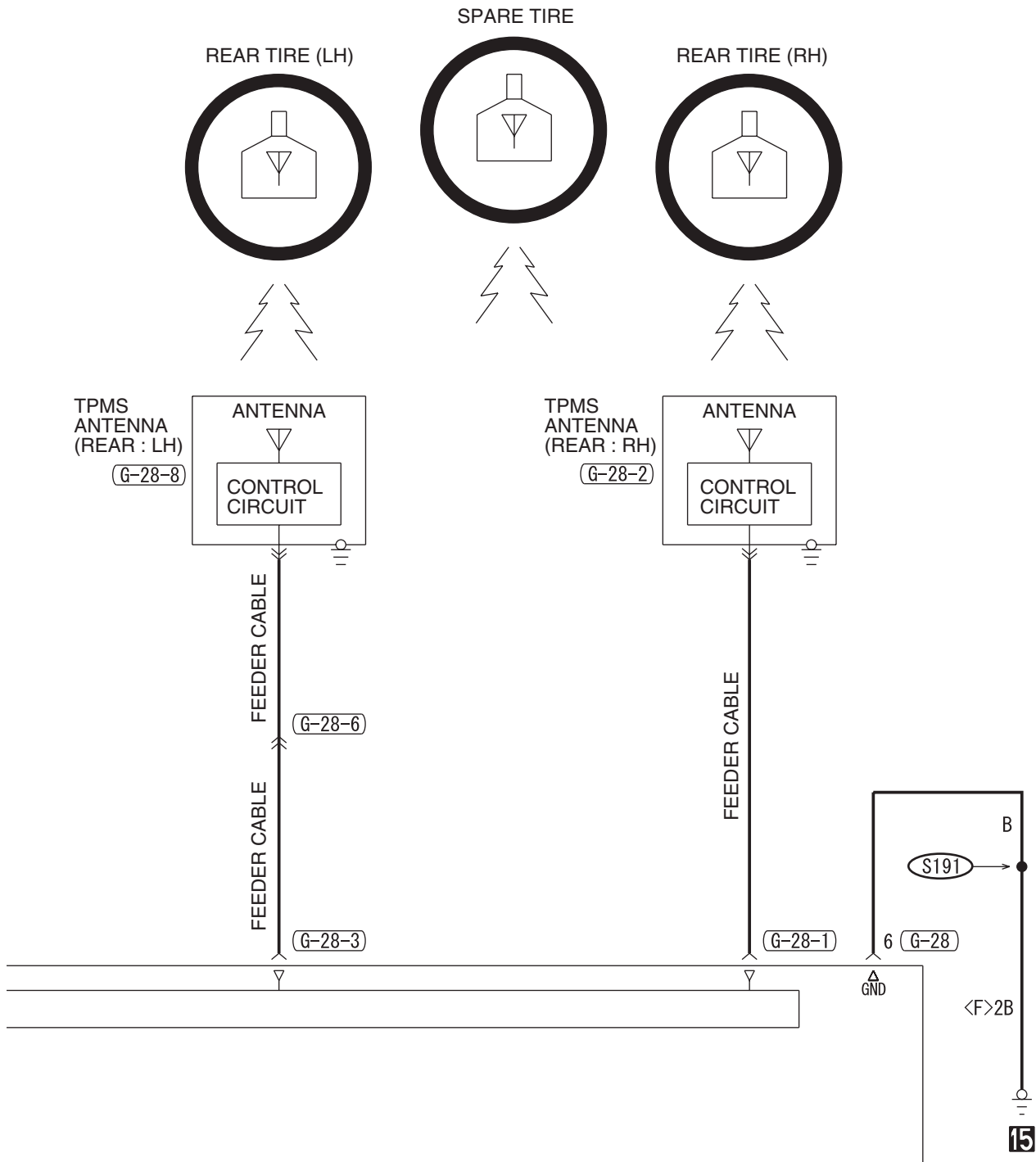

WIRE COLOR CODE
 B : BLACK LG : LIGHT GREEN G : GREEN L : BLUE W : WHITE Y : YELLOW
 SB : SKY BLUE BR : BROWN O : ORANGE GR : GRAY R : RED P : PINK V : VIOLET

TSB Revision

RHEOSTAT

M1901011101198

1

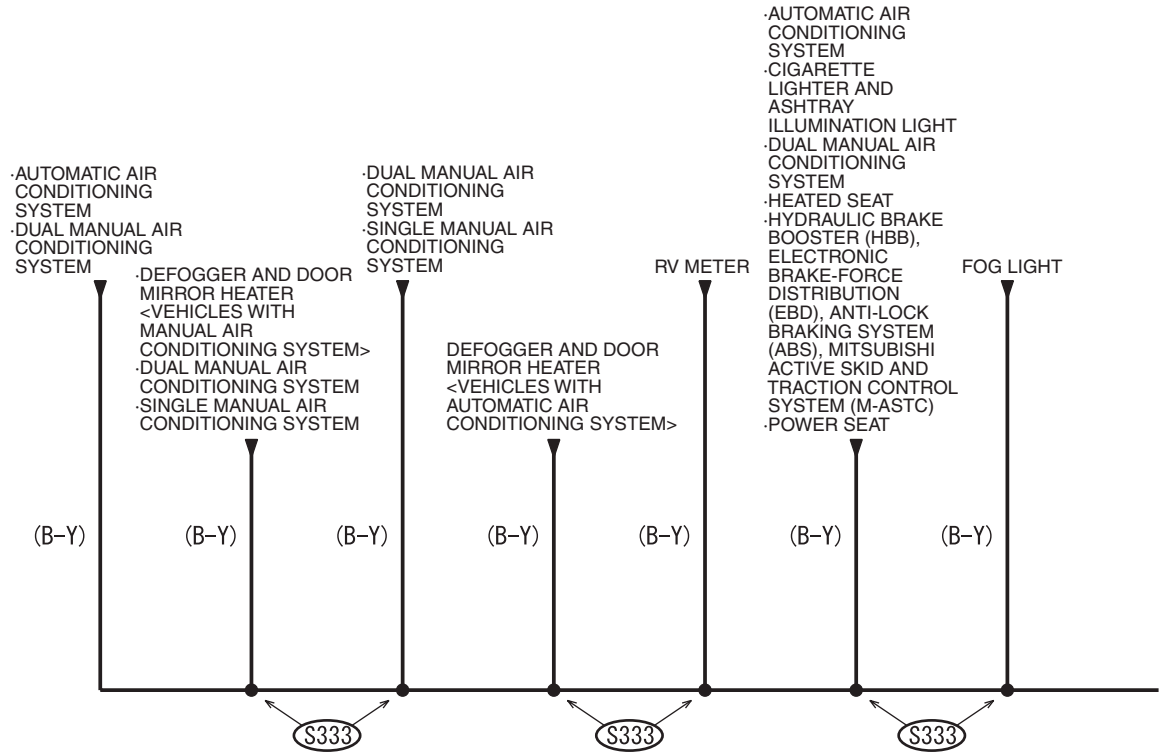

D-28

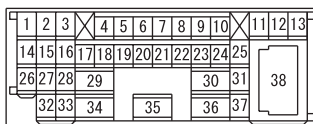

D-129



2

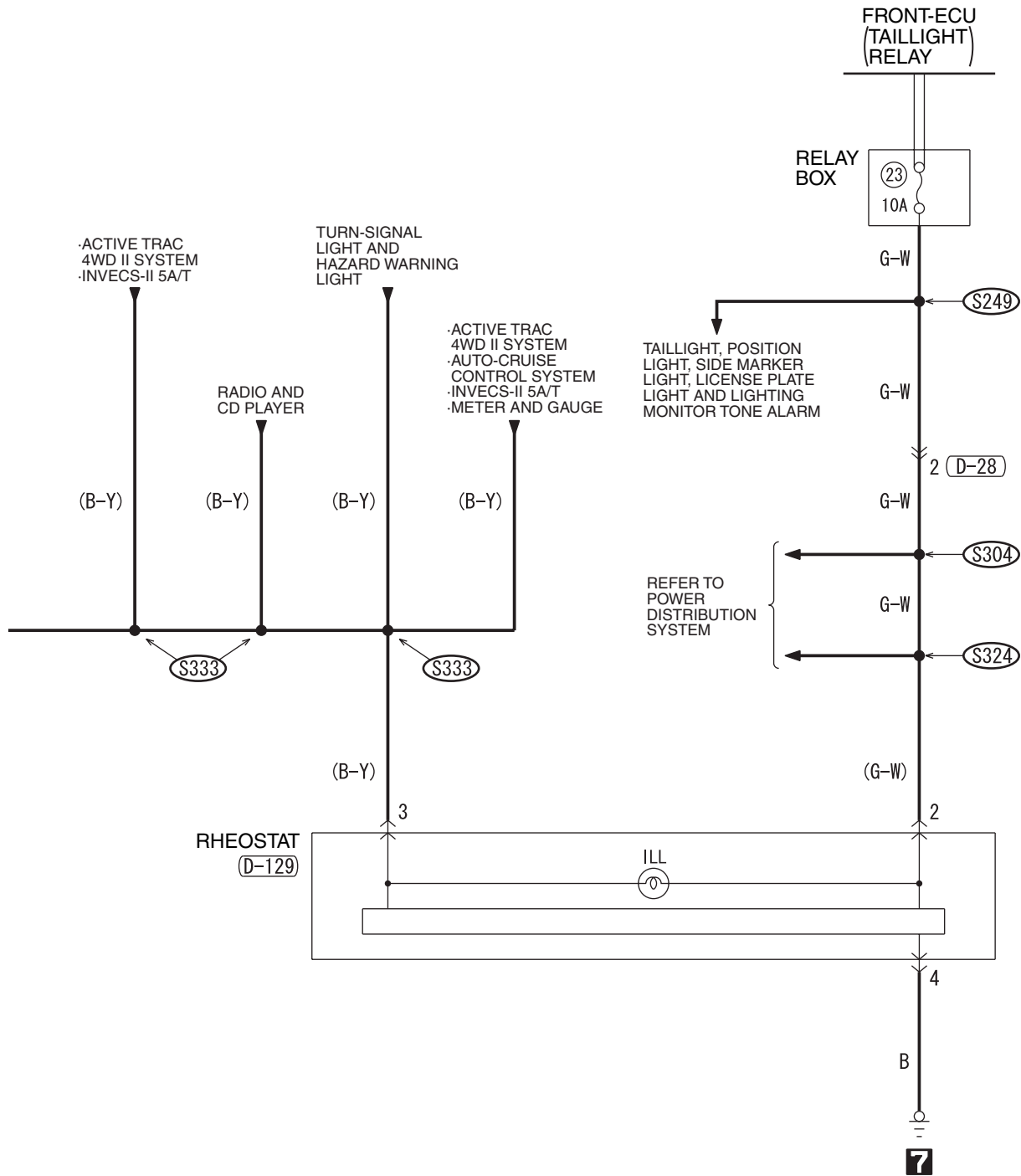

WIRE COLOR CODE
 B : BLACK LG : LIGHT GREEN G : GREEN L : BLUE W : WHITE Y : YELLOW
 SB : SKY BLUE BR : BROWN O : ORANGE GR : GRAY R : RED P : PINK V : VIOLET

NOTES