

GROUP 14

ENGINE COOLING

CONTENTS

GENERAL DESCRIPTION	14-2	COOLING FAN	14-10
SPECIAL TOOL	14-2	REMOVAL AND INSTALLATION	14-10
ENGINE COOLING DIAGNOSIS	14-2	INSPECTION.....	14-12
INTRODUCTION.....	14-2	THERMOSTAT	14-13
TROUBLESHOOTING STRATEGY	14-2	REMOVAL AND INSTALLATION	14-13
SYMPTOM CHART.....	14-2	INSPECTION.....	14-15
SYMPTOM PROCEDURES	14-3	WATER PUMP	14-16
ON-VEHICLE SERVICE	14-5	REMOVAL AND INSTALLATION	14-16
ENGINE COOLANT LEAK CHECK	14-5	WATER HOSE AND WATER PIPE ..	14-18
RADIATOR CAP PRESSURE CHECK....	14-5	REMOVAL AND INSTALLATION	14-18
ENGINE COOLANT REPLACEMENT	14-6	INSPECTION.....	14-20
ENGINE COOLANT CONCENTRATION TEST	14-7	SPECIFICATIONS	14-20
DRIVE BELT TENSION CHECK AND		FASTENER TIGHTENING SPECIFICATION	14-20
ADJUSTMENT	14-7	SERVICE SPECIFICATION	14-21
RADIATOR	14-8	CAPACITIES	14-21
RADIATOR REMOVAL AND INSTALLATION	14-8	SEALANT	14-21

GENERAL DESCRIPTION

The cooling system is designed to keep every part of the engine at appropriate temperature in whatever condition the engine may be operated. The cooling method is of the water-cooled, pressure forced circulation type in which the water pump pressurizes cool-

ant and circulates it throughout the engine. If the coolant temperature exceeds the prescribed temperature, the thermostat opens to circulate the coolant through the radiator as well so that the heat absorbed by the coolant may be radiated into the air. The water pump is of the centrifugal type and is driven by the drive belt from the crankshaft. The radiator is the corrugated fin, down flow type and is cooled by the cooling fan.

M1141000100304

SPECIAL TOOL

M1141000600149

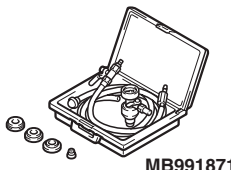
TOOL	TOOL NUMBER AND NAME	SUPERSESSION	APPLICATION
 MB991871	MB991871 LLC changer	General service tool	Coolant refilling

ENGINE COOLING DIAGNOSIS**INTRODUCTION**

The system cools the engine so that it does not overheat and maintains the engine at an optimum temperature. The system components are the radiator, water pump, thermostat, cooling fan and fan clutch assembly. Possible faults include low coolant, contamination, belt loosening and component damage.

M1141005300295

TROUBLESHOOTING STRATEGY

Use these steps to plan your diagnostic strategy. If you follow them carefully, you will be sure to find most of the engine cooling faults.

1. Gather information from the customer.

2. Verify that the condition described by the customer exists.
3. Find the malfunction by following the Symptom Chart.
4. Verify that the malfunction is eliminated.

M1141005200298

SYMPTOM CHART

M1141005600296

SYMPTOM	INSPECTION PROCEDURE	REFERENCE PAGE
Coolant Leak	1	P.14-3
Engine Overheating	2	P.14-4

SYMPTOM PROCEDURES

INSPECTION PROCEDURE 1: Coolant Leak

DIAGNOSIS

STEP 1. Check for coolant leaks.

⚠ WARNING

When pressure testing the cooling system, slowly release cooling system pressure to avoid getting burned by hot coolant.

⚠ CAUTION

- Be sure to completely clean away any moisture from the places checked.
- When the tester is removed, be careful not to spill any coolant.
- When installing and removing the tester and when testing, be careful not to deform the filler neck of the radiator.

Check that the coolant level is up to the filler neck. Install a radiator tester and apply 160 kPa (23 psi) pressure, and then check for leakage from the radiator hose or connections.

Q: Is leakage present from the radiator hose or connections?

YES : Repair or replace the appropriate part, then go to Step 2.

NO : There is no action to be taken.

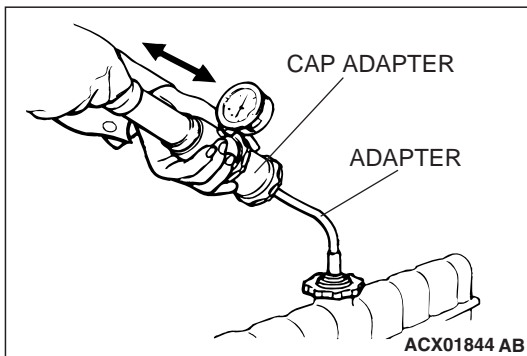

STEP 2. Retest the system.

Q: It there still coolant leakage?

YES : Return to Step 1.

NO : The procedure is complete.

INSPECTION PROCEDURE 2: Engine Overheating

DIAGNOSIS

STEP 1. Remove the radiator cap and check for coolant contamination.

Q: Is the coolant contaminated with rust and oil?

YES : Replace it. Refer to [P.14-6](#).

NO : There is no action to be taken. Go to Step 2.

STEP 2. Check the radiator cap valve opening pressure.

NOTE: Be sure that the cap is clean before testing. Rust or other foreign material on the cap seal will cause an improper reading.

- (1) Use a cap adapter to attach the cap to the tester.
- (2) Increase the pressure until the gauge indicator stops moving.

Minimum limit: 83 kPa (12 psi)

Standard value: 93 – 123 kPa (14 – 18 psi)

Q: Does the reading remain at or above the minimum limit?

YES : Go to Step 3.

NO : Replace the radiator cap. Then go to Step 5.

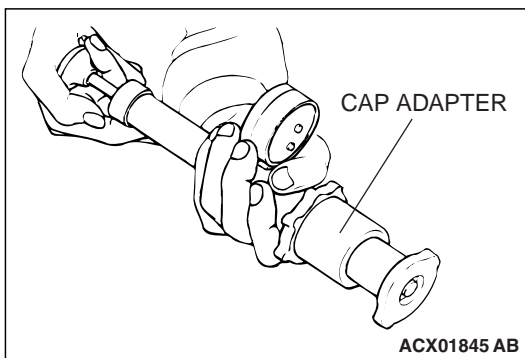

STEP 3. Check thermostat operation.

Refer to [P.14-15](#).

Q: Does the thermostat operate correctly?

YES : Go to Step 4.

NO : Replace the thermostat, then go to Step 5.

STEP 4. Check the drive belt for slippage or damage.

Refer to GROUP 00, Maintenance Service – Drive Belts (Check Condition) [P.00-43](#).

Q: Is the drive belt loose or damaged?

YES : Adjust or replace the drive belt, then go to Step 5.

NO : There is no action to be taken.

STEP 5. Retest the system.

Check the coolant temperature gauge.

Q: Is the coolant temperature abnormally high?

YES : Return to Step 2.

NO : The procedure is complete.

ON-VEHICLE SERVICE

ENGINE COOLANT LEAK CHECK

M1141001000247

⚠ WARNING

When pressure testing the cooling system, slowly release cooling system pressure to avoid getting burned by hot coolant.

⚠ CAUTION

- Be sure to completely clean away any moisture from the places checked.
- When the tester is taken out, be careful not to spill any coolant.
- Be careful when installing and removing the tester and when testing not to deform the filler neck of the radiator.

1. Check that the coolant level is up to the filler neck. Install a radiator tester and apply 160 kPa (23 psi) pressure, and then check for leakage from the radiator hose or connections.
2. If there is leakage, repair or replace the appropriate part.

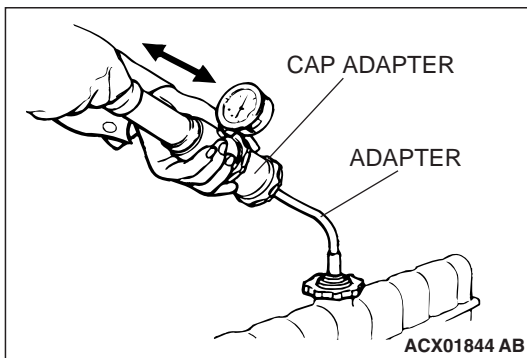

RADIATOR CAP PRESSURE CHECK

M1141001300293

NOTE: Be sure that the cap is clean before testing. Rust or other foreign material on the cap seal will cause an improper reading.

1. Use a cap adapter to attach the cap to the tester.
2. Increase the pressure until the indicator of the gauge stops moving.

Minimum limit: 83 kPa (12 psi)

Standard value: 93 – 123 kPa (14 – 18 psi)

3. Replace the radiator cap if the reading does not remain at or above the limit.

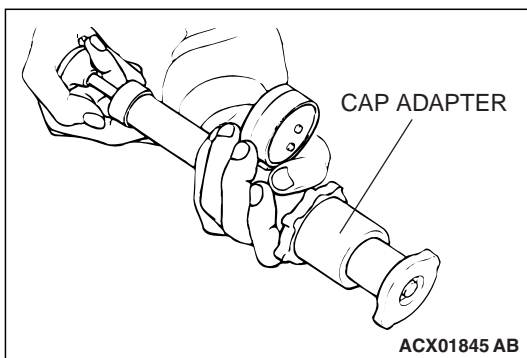

ENGINE COOLANT REPLACEMENT

M1141001200791

CHANGING COOLANT

1. Set the temperature control knob to the "HOT" position.

⚠ WARNING

When removing the radiator cap, use care to avoid contact with hot coolant or steam. Place a shop towel over the cap and turn the cap counterclockwise a little to let the pressure escape through the vinyl tube. After relieving the steam pressure, remove the cap by slowly turning it counterclockwise.

2. Remove the radiator cap, radiator drain plug and engine drain plug to drain the coolant.
3. Remove the condenser tank and drain the coolant.
4. Drain the cooling water then clean the path of the cooling water by injecting water into the radiator from the radiator cap area.
5. Apply the designated sealant to the screw area of the cylinder block drain plug, and then tighten to the standard torque.

Specified sealant: 3M™ AAD Part No.8731 or equivalent

Tightening torque: 39 ± 5 N·m (29 ± 3 ft·lb)

6. Securely tighten the drain plug of the radiator.
7. Assemble the reservoir tank.

⚠ CAUTION

Do not use alcohol or methanol anti-freeze or any engine coolants mixed with alcohol or methanol anti-freeze. The use of an improper anti-freeze can cause the corrosion of the aluminum components.

8. <Refilling engine coolant without the special tool>

- (1) Loosen the air bleed bolt.
- (2) By referring to the section on coolant, select an appropriate concentration for safe operating temperature within the range of 30 to 60%. Refill the system with a high quality ethylene glycol antifreeze at the selected concentration. A convenient mixture is a 50% water and 50% antifreeze solution [freezing point: -31°C (-32.8°F)]. Pour in coolant until it overflows from the air bleed bolt hole, and then tighten the air bleed bolt.

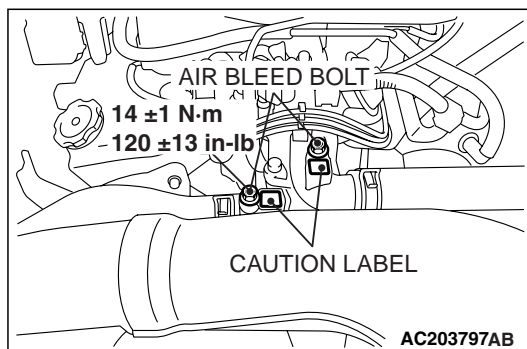
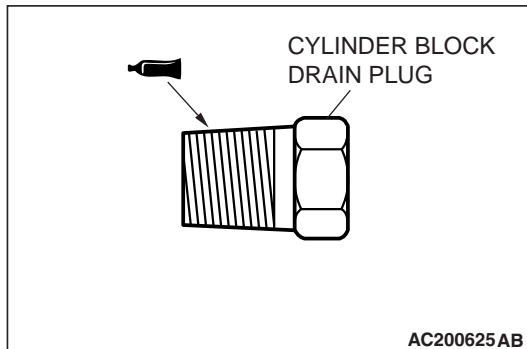

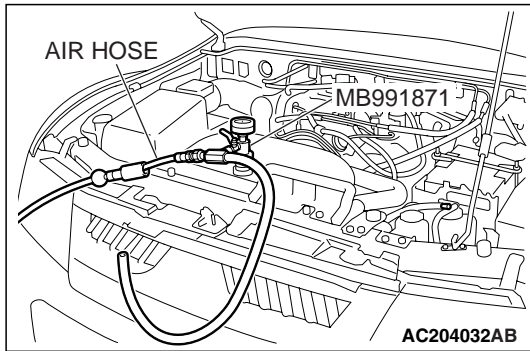

9. <When special tool MB991871 is used>

By referring to the section on coolant, select an appropriate concentration for safe operating temperature within the range of 30 to 60 %. Use special tool MB991871 to refill the coolant. A convenient mixture is a 50 % water and 50 % antifreeze solution [freezing point: -31°C (-32.8°F)].

NOTE: For how to use special tool MB991871, refer to its manufacturer's instructions.

Recommended antifreeze:

Long life antifreeze coolant or an equivalent

Quantity: 9.0 dm³ (9.5 quarts)

10. Reinstall the radiator cap.

11. Start the engine and let it warm up until the thermostat opens.

12. After repeatedly revving the engine up to 3,000 r/min several times, then stop the engine.

13. Remove the radiator cap after the engine has become cold, and pour in coolant up to the brim. Reinstall the cap.

⚠ CAUTION

Do not overfill the condenser tank.

14. Add coolant to the condenser tank between the "FULL" and "LOW" mark if necessary.

ENGINE COOLANT CONCENTRATION TEST

M1141001100277

Refer to GROUP 00, RECOMMENDED LUBRICANTS AND LUBRICANT CAPACITIES TABLE [P.00-36](#).

**DRIVE BELT TENSION CHECK AND
ADJUSTMENT**

M1141004500100

Refer to GROUP 00, Maintenance Service [P.00-43](#).

RADIATOR

RADIATOR REMOVAL AND INSTALLATION

M1141001501018

Pre-removal Operation

- Engine Coolant Draining (Refer to P.14-6.)
- Air Intake Duct Removal (Refer to GROUP 15 P.15-6.)

Post-installation Operation

- Engine Coolant Refilling and Level Check (Refer to P.14-6.)
- Transmission Fluid Refilling and Level Check (Refer to GROUP 00, Maintenance Service P.00-46.)
- Air Intake Duct Installation (Refer to GROUP 15 P.15-6.)

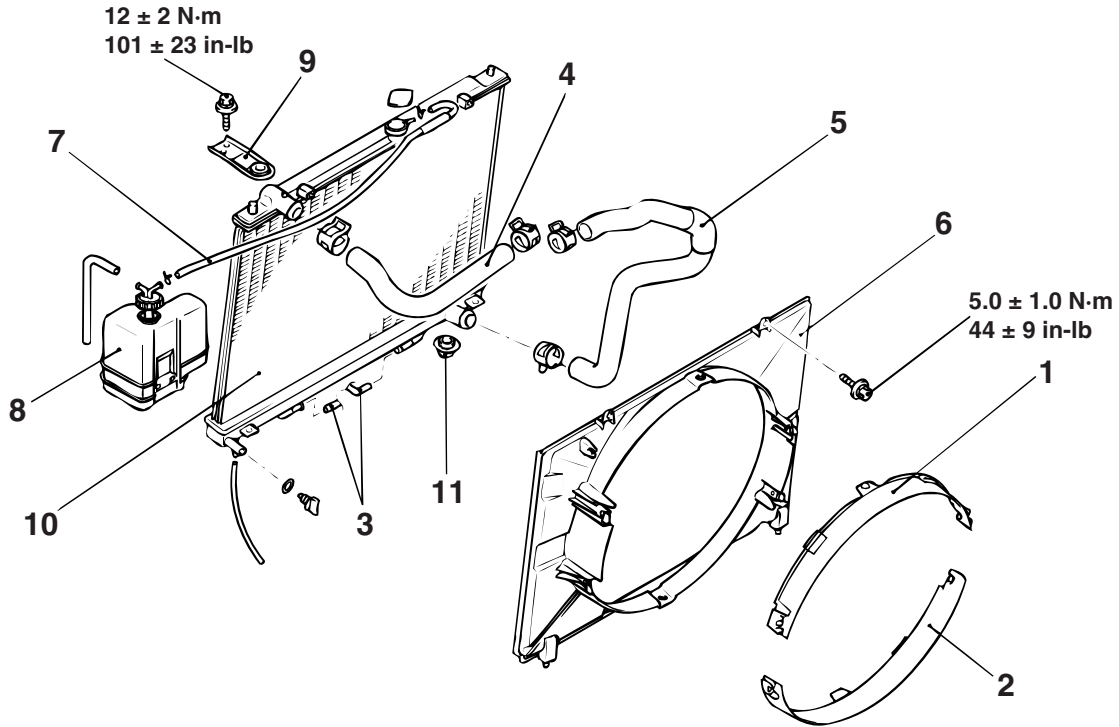

ACX00403AB

- REMOVAL STEPS**
- <<A>> >>B<< 1. RADIATOR SHROUD UPPER COVER
 - <<A>> >>B<< 2. RADIATOR SHROUD LOWER COVER
 - <> 3. TRANSMISSION FLUID COOLER HOSE CONNECTION
 - <<C>> >>A<< 4. RADIATOR UPPER HOSE

- REMOVAL STEPS (Continued)**
- <<C>> >>A<< 5. RADIATOR LOWER HOSE
 - 6. SHROUD
 - 7. OVERFLOW HOSE
 - 8. CONDENSER TANK
 - 9. UPPER INSULATOR
 - 10. RADIATOR
 - 11. LOWER INSULATOR

REMOVAL SERVICE POINTS

<<A>> RADIATOR SHROUD UPPER COVER/RADIATOR SHROUD LOWER COVER REMOVAL

⚠ CAUTION

Be careful not to break or bend the fixing lever by tilting it outward too excessively.

Tilt the fixing lever at the shroud housing cover outward slightly, and remove the cover toward the fan axis from its four fixing points.

<> TRANSMISSION FLUID COOLER HOSE REMOVAL

After removing the hose from the radiator, plug the hose and the radiator nipple to prevent dust or foreign particles from getting in.

<<C>> RADIATOR UPPER HOSE/RADIATOR LOWER HOSE DISCONNECTION

Make mating marks on the radiator hose and the hose clamp. Disconnect the radiator hose.

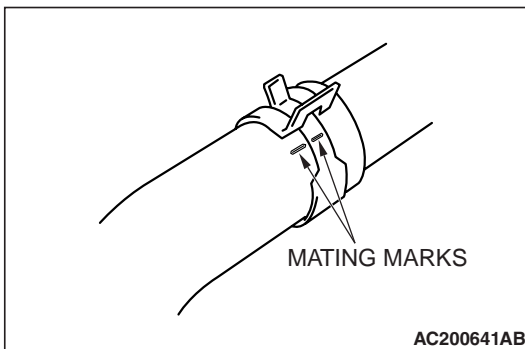

INSTALLATION SERVICE POINTS

>>A<< RADIATOR LOWER HOSE/RADIATOR UPPER HOSE CONNECTION

1. Insert each hose as far as the projection of the water inlet fitting, water outlet fitting or radiator.
2. Align the mating marks on the radiator hose and hose clamp, and then connect the radiator hose.

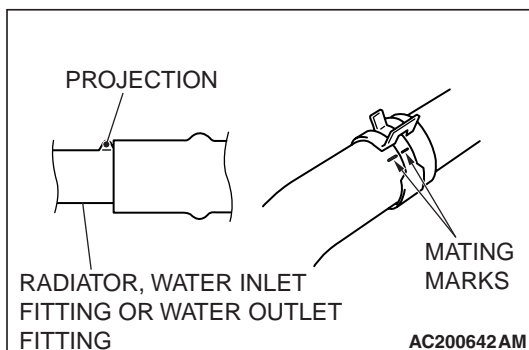

>>B<< RADIATOR SHROUD LOWER COVER/RADIATOR SHROUD UPPER COVER INSTALLATION

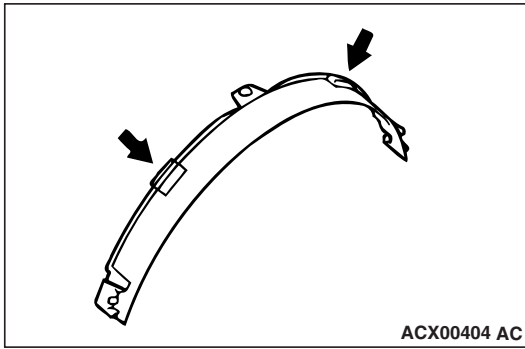

1. Install the covers securely until the click can be heard from the four fixing points.
2. Two lugs around the circumference of the covers should be seen on the outside of the shroud.
3. After installation, check that the covers are fixed securely.

COOLING FAN

REMOVAL AND INSTALLATION

M1141002100106

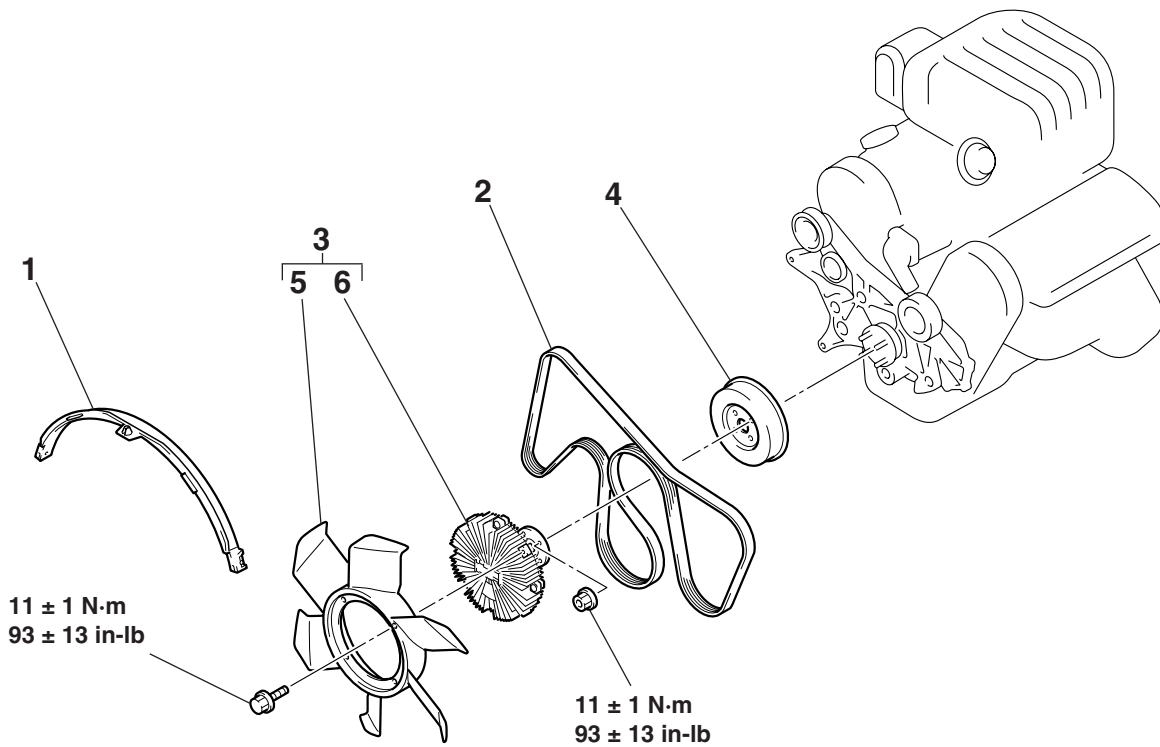

AC204071 AB

REMOVAL STEPS

- >>B<< 1. RADIATOR SHROUD UPPER COVER
- <<A>> >>A<< 2. DRIVE BELT
3. COOLING FAN AND FAN CLUTCH ASSEMBLY

REMOVAL STEPS (Continued)

4. FAN PULLEY
5. COOLING FAN
6. FAN CLUTCH

REMOVAL SERVICE POINT

<<A>> DRIVE BELT REMOVAL

The following operations will be needed due to the introduction of the serpentine drive system with the drive belt auto tensioner.

1. Insert a 12.7 mm (1/2 inch) breaker bar into the square hole on the drive belt auto tensioner, and rotate it clockwise until the tensioner touches the stopper.
2. Align hole B with hole A, and insert a 5.0 mm (0.20 inch) Allen wrench to hold the tensioner. Then loosen the drive belt, and then remove the drive belt auto tensioner.

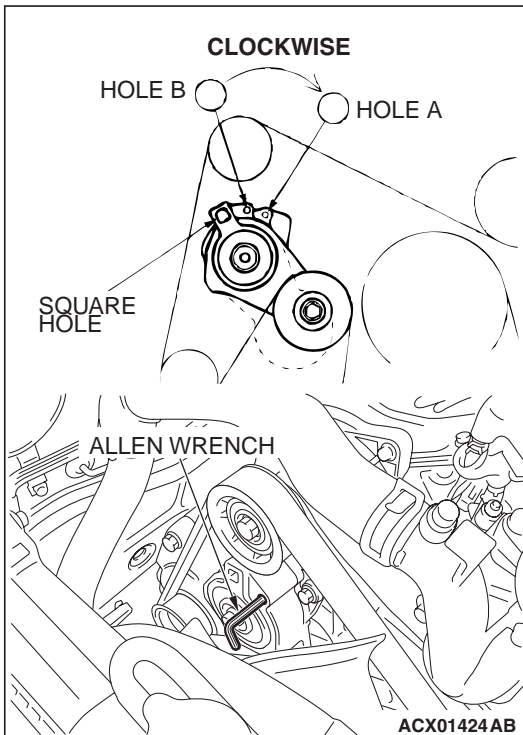

INSTALLATION SERVICE POINTS

>>A<< DRIVE BELT INSTALLATION

1. Install the drive belt auto tensioner with the Allen wrench inserted.
2. After the drive belt has been installed, remove the Allen wrench while holding the drive belt auto tensioner with a socket wrench drive. Then release the drive belt auto tensioner slowly.
3. Check for proper tension. (Refer to GROUP 00-Maintenance Service [P.00-43.](#))

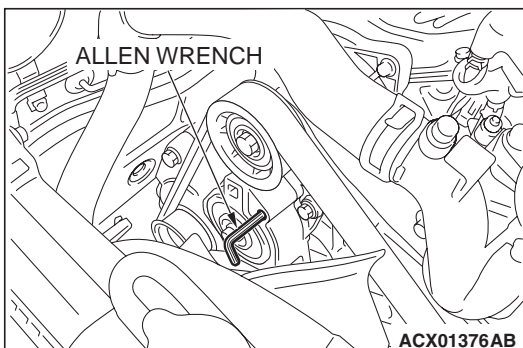

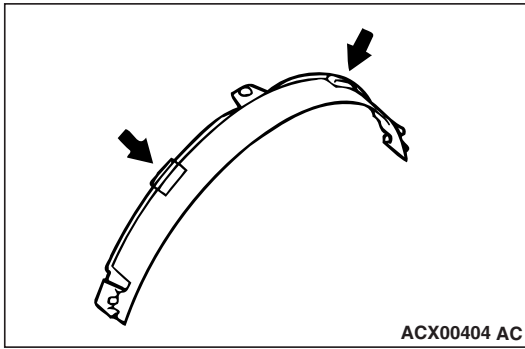
**>>B<< RADIATOR SHROUD UPPER COVER
INSTALLATION**

1. Install the covers securely until the click can be heard from the four fixing points.
2. Two lugs around the circumference of the covers should be seen on the outside of the shroud.
3. After installation, check that the covers are fixed securely.

INSPECTION

M1141002200103

Cooling Fan Check

- Check the blades for damage and cracks.
- Check for cracks and damage around bolt holes in the fan hub.
- If any portion of the fan is damaged or cracked, replace the cooling fan.

Fan Clutch Check

- Check to ensure that fluid in the fan clutch is not leaking at the case joint and seals. If fluid quantity decreases due to leakage, the fan speed will decrease and engine overheating might result.
- When the fan attached to the engine is turned by hand, it should have some resistance. If the fan turns lightly or freely with no resistance, it is faulty.
- Check the bimetal strip for damage.

THERMOSTAT

REMOVAL AND INSTALLATION

M1141002400787

Pre-removal and Post-installation Operation

- Engine Coolant Draining and Refilling (Refer to P.14-6.)
- Intake Air Duct Removal and Installation (Refer to GROUP 15, Air Cleaner P.15-6.)

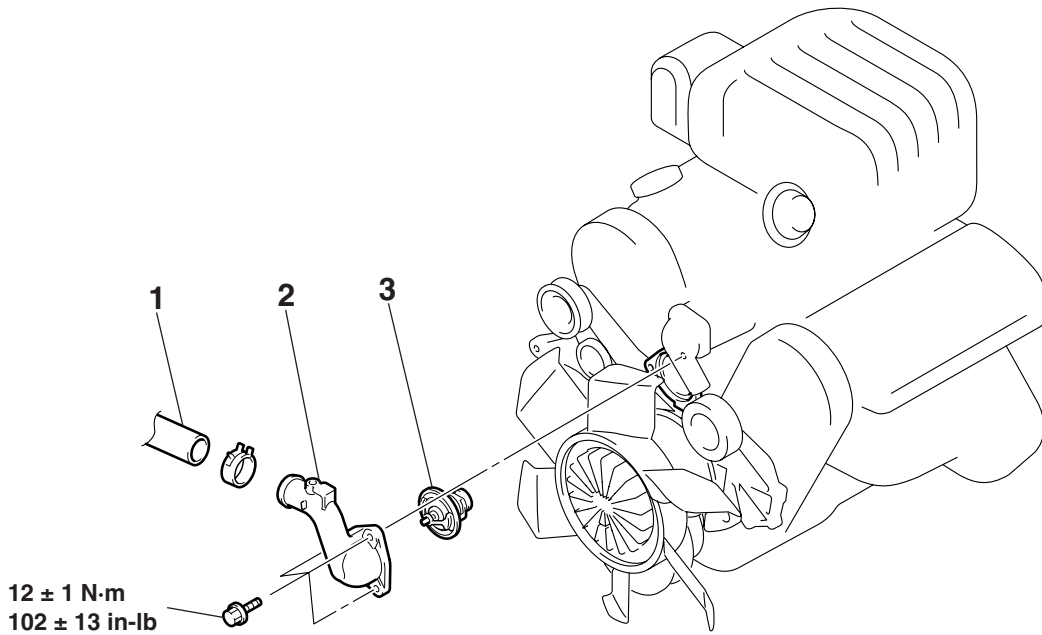

AC204072AB

<<A>> >>B<< 1. **REMOVAL STEPS**
RADIATOR LOWER HOSE
CONNECTION

REMOVAL STEPS (Continued)
2. WATER INLET FITTING
>>A<< 3. THERMOSTAT

REMOVAL SERVICE POINT

<<A>> RADIATOR LOWER HOSE DISCONNECTION

Make mating marks on the radiator hose and the hose clamp. Disconnect the radiator hose.

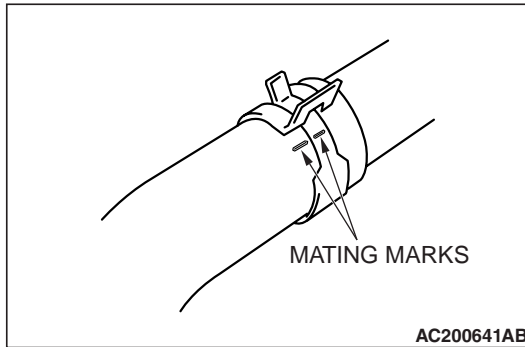

INSTALLATION SERVICE POINTS

>>A<< THERMOSTAT INSTALLATION

⚠ CAUTION

Make absolutely sure that no oil adheres to the rubber ring of the thermostat. Also do not fold or scratch the rubber ring during installation.

Install the thermostat so that the jiggle valve is facing straight up. Be careful not to fold or scratch the rubber ring.

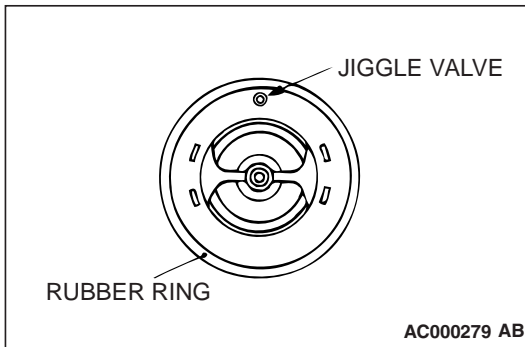

>>B<< RADIATOR LOWER HOSE CONNECTION

1. Insert each hose as far as the projection of the water inlet fitting.
2. Align the mating marks on the radiator hose and hose clamp, and then connect the radiator hose.

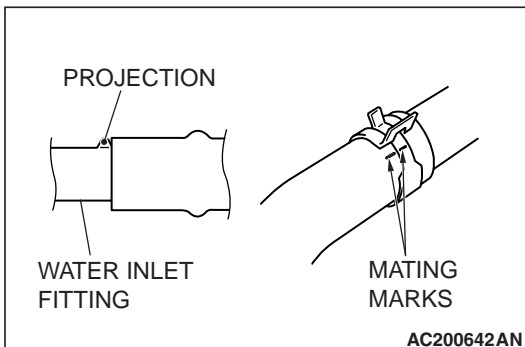

INSPECTION

M1141002500308

Thermostat Check

1. Immerse the thermostat in water, and heat the water while stirring. Check the thermostat valve opening temperature.

Standard value:

Valve opening temperature: $82 \pm 2^{\circ}\text{C}$ ($180 \pm 36^{\circ}\text{F}$)

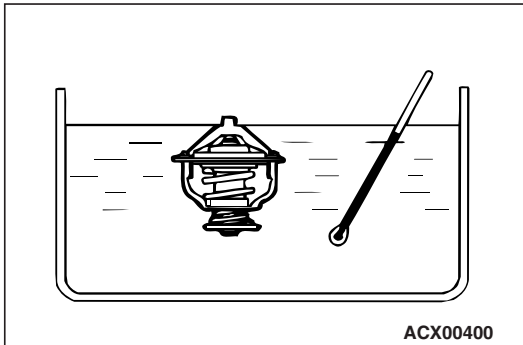

2. Check that the amount of valve lift is at the standard value when the water is at the full-opening temperature.

NOTE: Measure the valve height when the thermostat is fully closed, and use this measurement to compare the valve height when the thermostat is fully open.

Standard value:

Full-opening temperature: 95°C (203°F)

Amount of valve lift: 10 mm (0.39 inch) or more

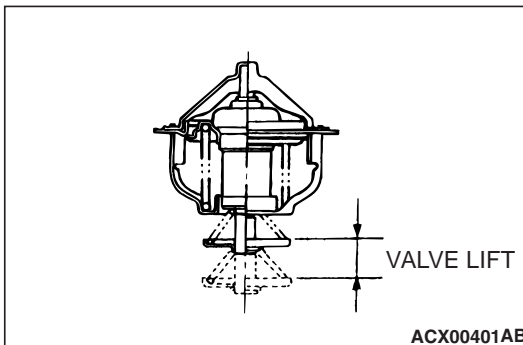

WATER PUMP

REMOVAL AND INSTALLATION

M1141002700658

Pre-removal and Post-installation Operation

- Engine Coolant Draining and Refilling (Refer to P.14-6.)
- Timing Belt Removal and Installation (Refer to GROUP 11A, Timing Belt P.11A-35.)
- Thermostat Removal and Installation (Refer to P.14-13.)

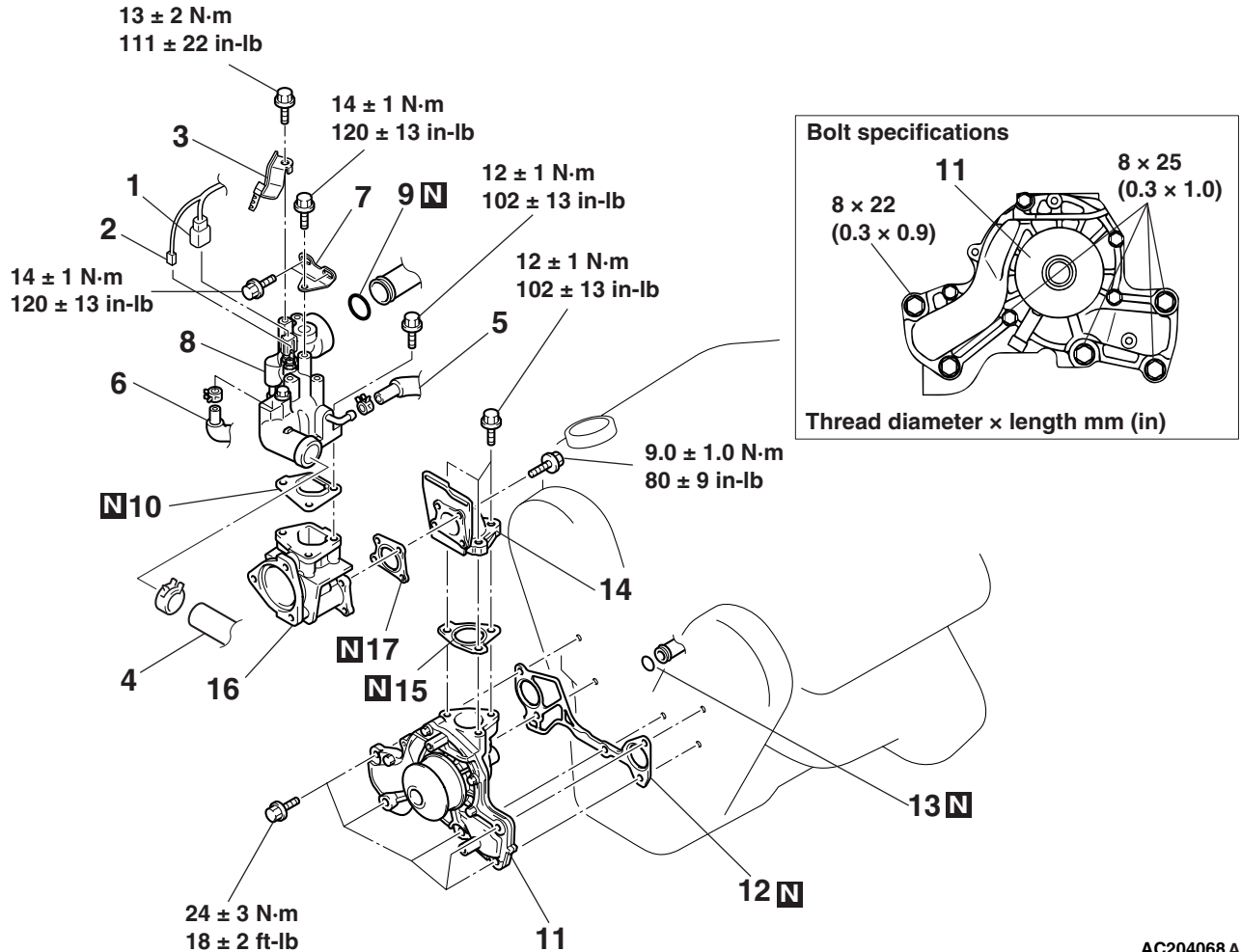

REMOVAL STEPS

1. ENGINE COOLANT TEMPERATURE SENSOR CONNECTOR
2. ENGINE COOLANT TEMPERATURE GAUGE UNIT CONNECTOR
3. SPARK PLUG CABLE SUPPORT
4. RADIATOR UPPER HOSE CONNECTION
5. WATER HOSE
6. WATER HOSE

REMOVAL STEPS (Continued)

7. WATER OUTLET FITTING BRACKET
8. WATER OUTLET FITTING
9. O-RING
10. GASKET
11. WATER PUMP ASSEMBLY
12. GASKET
13. O-RING
14. FITTING
15. GASKET
16. THERMOSTAT CASE
17. GASKET

<<A>> >>B<<

>>A<<

>>A<<

REMOVAL SERVICE POINT

<<A>> RADIATOR UPPER HOSE DISCONNECTION

After making mating marks on the radiator hose and hose clamp, disconnect the radiator hose.

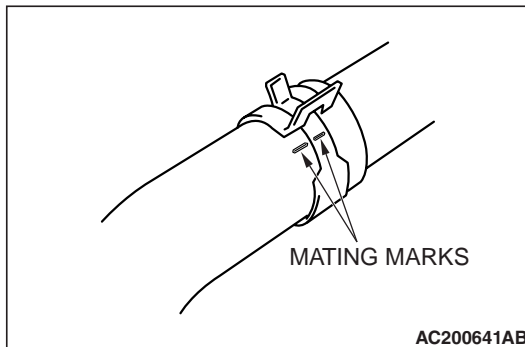

INSTALLATION SERVICE POINTS

>>A<< O-RING INSTALLATION

Fit the O rings into the groove of the water pipe ends, and apply water to the circumference of the O ring and the pipe bores to insert the pipe assembly.

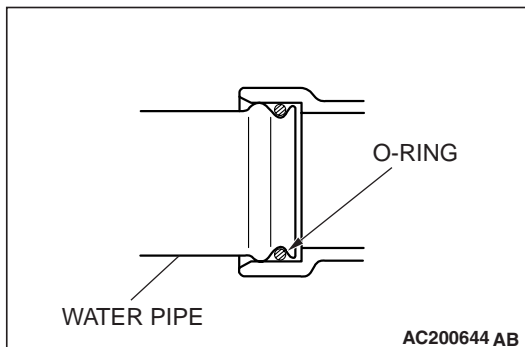

>>B<< RADIATOR UPPER HOSE CONNECTION

1. Insert each hose as far as the projection of the water outlet fitting.
2. Align the mating marks on the radiator hose and hose clamp, and then connect the radiator hose.

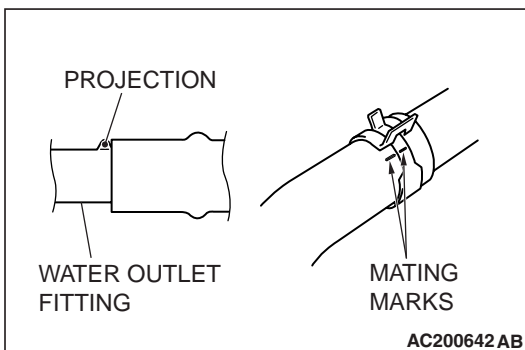

WATER HOSE AND WATER PIPE

REMOVAL AND INSTALLATION

M1141003300288

Pre-removal and Post-installation Operation

- Engine Coolant Draining and Supplying (Refer to P.14-6.)
- Intake Manifold Removal and Installation (Refer to GROUP 15, Intake Manifold P.15-7.)
- Thermostat Removal and Installation (Refer to P.14-13.)

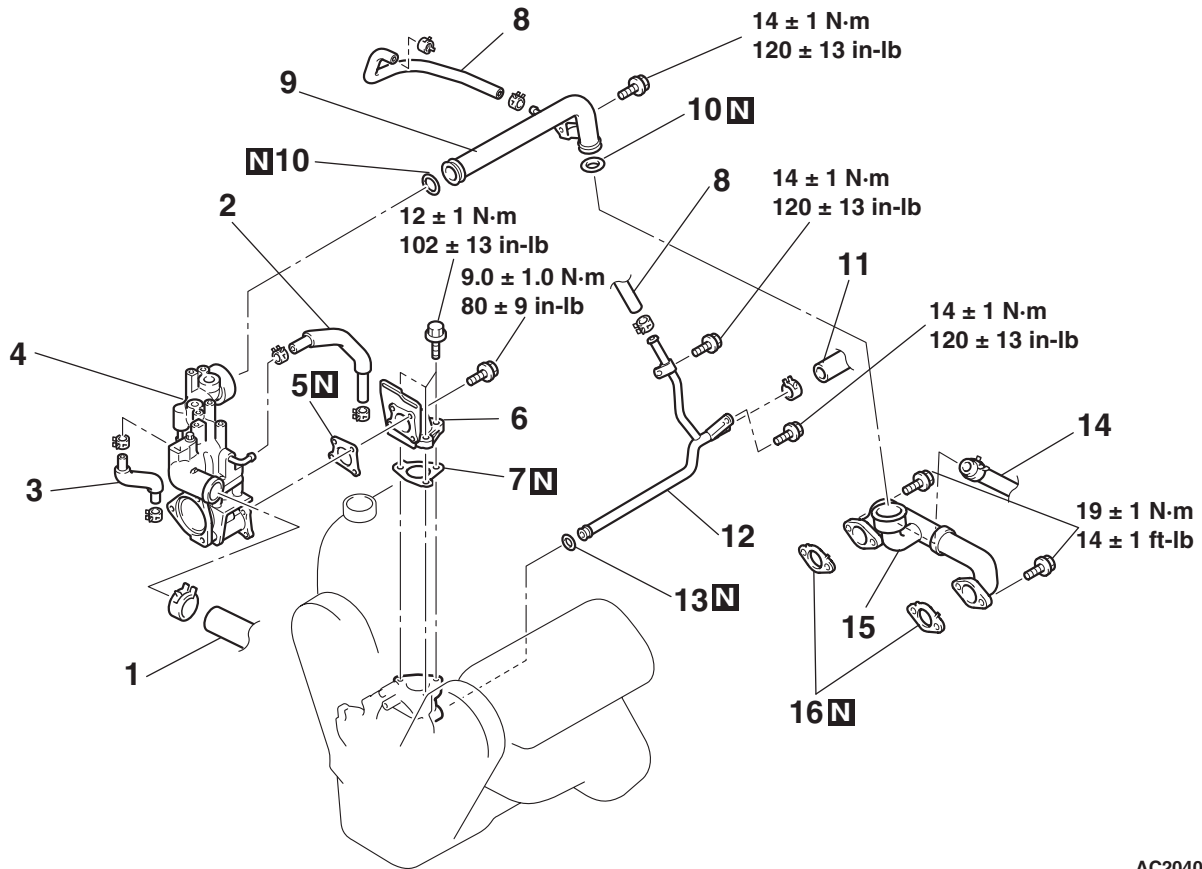

AC204094 AB

- <<A>> >>D<<
- REMOVAL STEPS**
1. RADIATOR UPPER HOSE CONNECTION
 2. WATER HOSE
 3. WATER HOSE
 4. WATER OUTLET FITTING AND THERMOSTAT CASE
 5. GASKET
 6. FITTING
 7. GASKET
 8. WATER HOSE

- REMOVAL STEPS (Continued)**
9. WATER OUTLET PIPE ASSEMBLY
 - >>C<< 10. O-RING
 11. HEATER HOSE CONNECTION
 12. WATER PIPE ASSEMBLY
 - >>C<< 13. O-RING
 - >>B<< 14. HEATER HOSE CONNECTION
 15. WATER PASSAGE ASSEMBLY
 - >>A<< 16. GASKET

REMOVAL SERVICE POINT

<<A>> RADIATOR UPPER HOSE DISCONNECTION

After making mating marks on the radiator hose and hose clamp, disconnect the radiator hose.

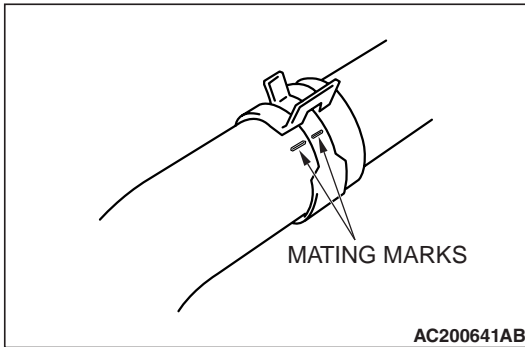

INSTALLATION SERVICE POINTS

>>A<< GASKET INSTALLATION

Bend over the tabs to secure the gasket to the water passage assembly.

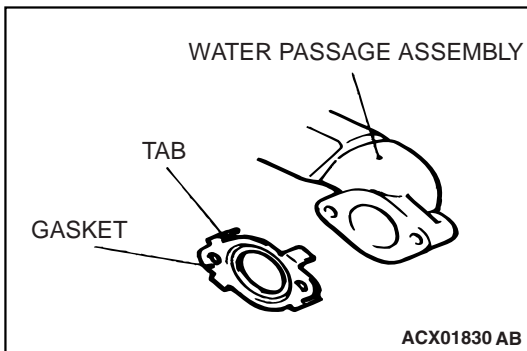

>>B<< HEATER HOSE CONNECTION

To reuse the heater hose, align the mating marks that were made during removal, and then install the hose clamp.

>>C<< O-RING INSTALLATION

⚠ CAUTION

Do not allow engine oil or other grease to adhere to the O-ring

Insert the O-ring to the water pipe, and coat the outer portion of the O-ring with water or engine coolant.

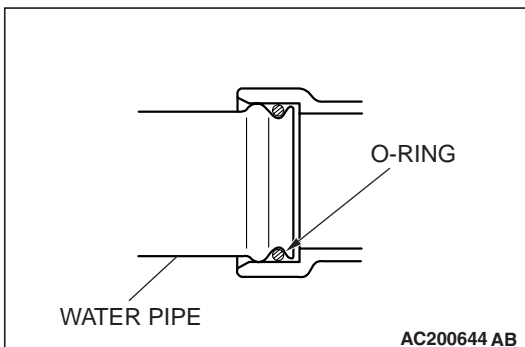

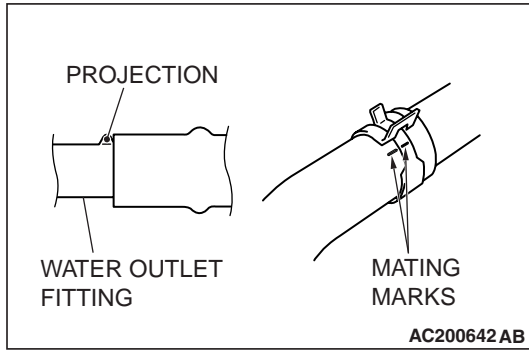

>>D<< RADIATOR UPPER HOSE CONNECTION

1. Insert each hose as far as the projection of the water outlet fitting.
2. Align the mating marks on the radiator hose and hose clamp, and then connect the radiator hose.

INSPECTION

M1141003400230

Water Pipe and Hose Check

Check the water pipe and hose for cracks, damage and clogs. Replace them if necessary.

SPECIFICATIONS

FASTENER TIGHTENING SPECIFICATION

M1141005000379

ITEM	SPECIFICATION
Air bleed bolt	14 ± 1 N·m (120 ± 13 in-lb)
Cylinder block drain plug	39 ± 5 N·m (29 ± 3 ft-lb)
Cooling fan	
Cooling fan bolt	11 ± 1 N·m (93 ± 13 in-lb)
Fan clutch nut	11 ± 1 N·m (93 ± 13 in-lb)
Radiator	
Radiator support bolt	12 ± 2 N·m (101 ± 23 in-lb)
Shroud bolt	5.0 ± 1.0 N·m (44 ± 9 in-lb)
Thermostat	
Water inlet fitting bolt	12 ± 1 N·m (102 ± 13 in-lb)
Water pump	
Fitting and Water pump bolt	12 ± 1 N·m (102 ± 13 in-lb)
Intake manifold plenum and Bracket bolt	14 ± 1 N·m (120 ± 13 in-lb)
Spark plug cable support bolt	13 ± 2 N·m (111 ± 22 in-lb)
Thermostat case and Fitting bolt	9.0 ± 1.0 N·m (80 ± 9 in-lb)
Water pump bolt	24 ± 3 N·m (18 ± 2 ft-lb)
Water outlet fitting and Thermostat case bolt	12 ± 1 N·m (102 ± 13 in-lb)
Water outlet fitting and Bracket bolt	14 ± 1 N·m (120 ± 13 in-lb)

ITEM	SPECIFICATION
Water hose and water pipe	
Fitting bolt	12 ± 1 N·m (102 ± 13 in-lb)
Water pipe assembly bolt	14 ± 1 N·m (120 ± 13 in-lb)
Water outlet pipe assembly bolt	14 ± 1 N·m (120 ± 13 in-lb)
Water passage assembly bolt	19 ± 1 N·m (14 ± 1 ft-lb)
Water outlet fitting and Thermostat case and Fitting bolt	9.0 ± 1.0 N·m (80 ± 9 in-lb)

SERVICE SPECIFICATION

M1141000300308

ITEM	STANDARD VALUE	LIMIT
High-pressure valve opening pressure of radiator cap kPa (psi)	93 – 123 (14 – 18)	Minimum 83 (12)
Thermostat	Valve opening temperature of thermostat °C (°F)	82 ± 2 (180 ± 36)
	Full-opening temperature of thermostat °C (°F)	95 (203)
	Valve lift mm (in)	10 (0.39) or more

CAPACITIES

M1141005100116

ITEM	QUANTITY dm3 (qt)
Long life antifreeze coolant or an equivalent	9.0 (9.5)

SEALANT

M1141000500410

ITEM	SPECIFIED SEALANT
Cylinder block drain plug	3M™ AAD Part No.8731 or equivalent

NOTES