

## GROUP 25

# PROPELLER SHAFT

## CONTENTS

<b>GENERAL DESCRIPTION</b> .....	<b>25-2</b>	<b>PROPELLER SHAFT</b> .....	<b>25-5</b>
<b>PROPELLER SHAFT DIAGNOSIS</b> ..	<b>25-2</b>	REMOVAL AND INSTALLATION .....	25-5
INTRODUCTION TO PROPELLER SHAFT DIAGNOSIS .....	25-2	INSPECTION .....	25-9
PROPELLER SHAFT DIAGNOSTIC TROUBLESHOOTING STRATEGY .....	25-2	DISASSEMBLY AND ASSEMBLY .....	25-10
SYMPTOM CHART .....	25-3	<b>SPECIFICATIONS</b> .....	<b>25-14</b>
SYMPTOM PROCEDURES .....	25-3	FASTENER TIGHTENING SPECIFICATION	25-14
<b>SPECIAL TOOL</b> .....	<b>25-4</b>	GENERAL SPECIFICATIONS .....	25-14
		SERVICE SPECIFICATIONS .....	25-14
		LUBRICANT .....	25-14
		COMPONENT IDENTIFICATION .....	25-14

## GENERAL DESCRIPTION

M1251000100119

The MONTERO has two propeller shafts. The front propeller shaft connects the transfer case to the front axle, and the rear propeller shaft connects the transfer case to the rear axle. Each propeller shaft is a two-joint type propeller shaft, and they have the following features.

- A snap-ring method of securing the journal bearing of the universal joint has been adopted.
- The CFRP (Carbon Fiber Reinforced Plastic) tube equipped with a shock absorbing mechanism (contraction) improves safety in collision. (Rear only)

### CONSTRUCTION DIAGRAM

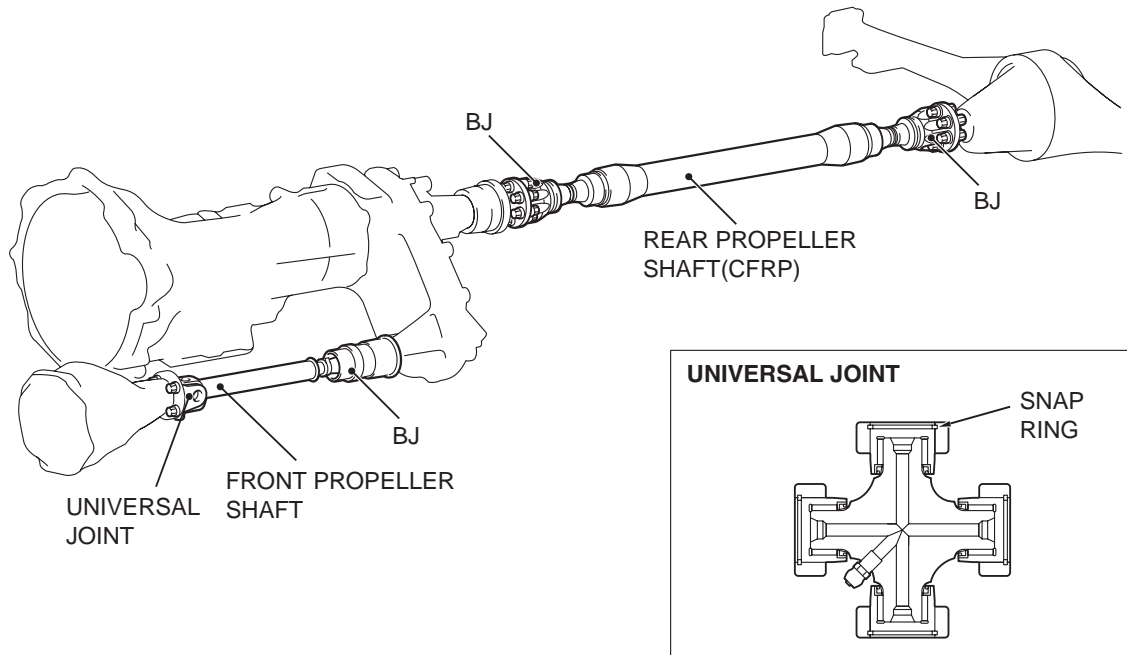

AC203528AB

## PROPELLER SHAFT DIAGNOSIS

### INTRODUCTION TO PROPELLER SHAFT DIAGNOSIS

M1251001800058

If an abnormal noise is heard from the propeller shaft while driving, some parts of the propeller shaft may be worn or damaged, or some mounting bolts may be loose.

### PROPELLER SHAFT DIAGNOSTIC TROUBLESHOOTING STRATEGY

M1251001900066

Use these steps to plan your diagnostic strategy. If you follow them carefully, you will be sure that you have exhausted all of the possible ways to find a propeller shaft fault.

1. Gather information from the customer.

2. Verify that the condition described by the customer exists.
3. Find the malfunction by following the Symptom Chart.
4. Verify malfunction is eliminated.

**SYMPTOM CHART**

M1251002000044

SYMPTOMS	INSPECTION PROCEDURE	REFERENCE PAGE
Noise at start	1	P.25-3
Noise and vibration at high speed	2	P.25-3

**SYMPTOM PROCEDURES**

**INSPECTION PROCEDURE 1: Noise at Start**

**DIAGNOSIS**

**STEP 1. Check if the propeller shaft mounting bolts and nuts are loose. (Refer to P.25-5.)**

**Q: Are the bolts and nuts tightened to  $60 \pm 10$  N·m ( $45 \pm 7$  ft-lb)?**

**YES :** Go to Step 2.

**NO :** Tighten the bolts and nuts to  $60 \pm 10$  N·m ( $45 \pm 7$  ft-lb). Then go to Step 5.

**STEP 2. Check the universal joint's journal bearing of front propeller shaft for wear or damage. (Refer to P.25-10.)**

**Q: Is wear or damage apparent?**

**YES :** Replace the journal bearing. Then go to Step 5.

**NO :** Go to Step 3.

**STEP 3. Check the BJ assembly's spline of front propeller shaft for wear.**

**Q: Is wear apparent?**

**YES :** Replace the propeller shaft. Then go to Step 5.

**NO :** Go to Step 4.

**STEP 4. Check the flange sleeve spline of rear propeller shaft for wear.**

**Q: Is wear apparent?**

**YES :** Replace the rear propeller shaft. Then go to Step 5.

**NO :** Go to Step 5.

**STEP 5. Retest the system.**

**Q: Is the abnormal noise eliminated?**

**YES :** The procedure is complete.

**NO :** Recheck from Step 1.

**INSPECTION PROCEDURE 2: Noise and Vibration at High Speed**

**DIAGNOSIS**

**STEP 1. Check the front propeller shaft run-out.**

**Q: Is the measured value within the limit: 0.5 mm (0.02 inch)?**

**YES :** Go to Step 2.

**NO :** Replace the front propeller shaft. Then go to Step 6.

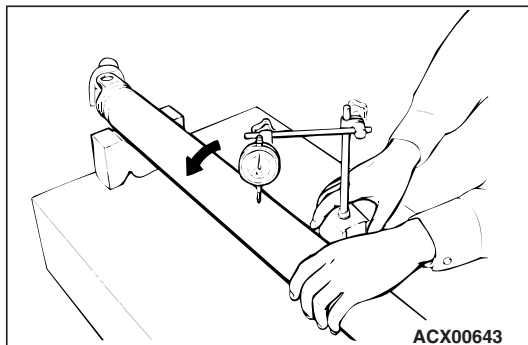

ACX00643

**STEP 2. Check the front propeller shaft snap rings thickness. (Refer to P.25-10.)**

**Q: Are they correct?**

**YES :** Go to Step 3.

**NO :** Replace the snap ring. Then go to Step 6.

**STEP 3. Check the front propeller shaft journal bearings for wear or damage. (Refer to P.25-10.)**

**Q: Is wear or damage apparent?**

**YES :** Replace the journal bearing. Then go to Step 6.

**NO :** Go to Step 4.

**STEP 4. Check the rear propeller shaft for wear or damage. (Refer to P.25-9.)**

**Q: Is wear or damage apparent?**

**YES :** Replace the rear propeller shaft. Then go to Step 6.

**NO :** Go to Step 5.

**STEP 5. Measure the clearance between the tube and the shaft at the end portion of the rear propeller shaft tube.**

**Q: Is the measured value is within the standard value: 0.2 – 0.5 mm (0.008 – 0.020 inch)?**

**YES :** Go to Step 6.

**NO :** Replace the rear propeller shaft. Then go to Step 6.

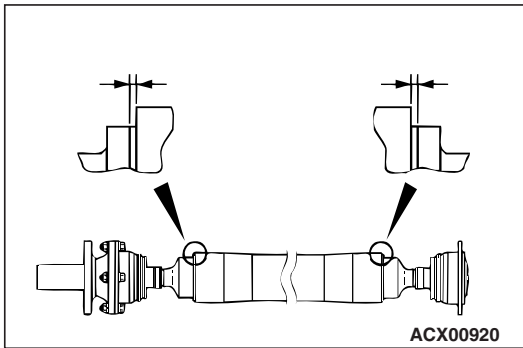

**STEP 6. Retest the system.**

**Q: Is the abnormal noise eliminated?**

**YES :** The procedure is complete.

**NO :** Recheck from Step 1.

## SPECIAL TOOL

M1251000600062

TOOL	TOOL NUMBER AND NAME	SUPERSESSION	APPLICATION
<p>MB990840</p>	<p>MB990840 Universal joint remover/ installer</p>	<p>MB990840-01</p>	<p>Disassembly and reassembly of universal joint</p>

## PROPELLER SHAFT

### REMOVAL AND INSTALLATION

M1251001000148

**⚠ WARNING**

Since the rear propeller shaft is made of CFRP, it is important to observe the following warning items strictly.

- If a tear, chip or distortion is found on the tube, replace it with new one.
- Do not drop, shock, or scratch the tube.
- If the propeller shaft is scratched on the surface, inspect whether it is damaged or not using a dye penetrant. (Refer to [P.25-9.](#))
- If the propeller shaft is dropped on the ground, replace it with new one. If the dropped rear propeller shaft is reinstalled, the rear propeller shaft may be broken.
- When working with the propeller shaft, wrap the propeller shaft tube with the rubber sheet of 10 mm (0.39 inch) thick and over or with the propeller shaft protector (part number MR534564) so that it is not scratched.

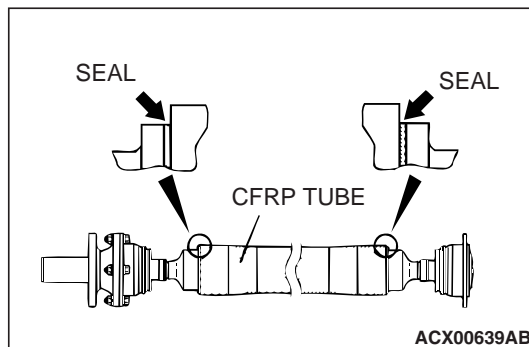
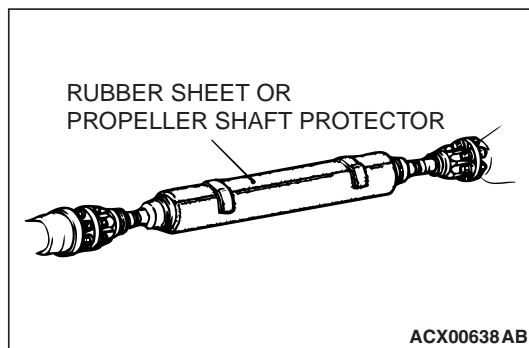

- If a crack or a tear is found on the seal portion at the end of CFRP tube shown in the illustration, replace the tube with new one.
- Dispose of the damaged CFRP propeller shaft in compliance with Federal, state, and local laws. For disposing of CFRP products, we do not recommend incineration.

**Pre-removal Operation**

Wrap a rubber sheet around the rear CFRP propeller shaft.  
<Before removing the rear CFRP propeller shaft>

**Post-installation Operation**

- Remove the rubber sheet wrapped around the rear CFRP propeller shaft and visually check whether the shaft is scratched. <After mounting the rear CFRP propeller shaft>
- Transfer Gear Oil Supplying <After mounting the front propeller shaft> (Refer to GROUP 23A, On-vehicle Service [P.23A-552.](#))

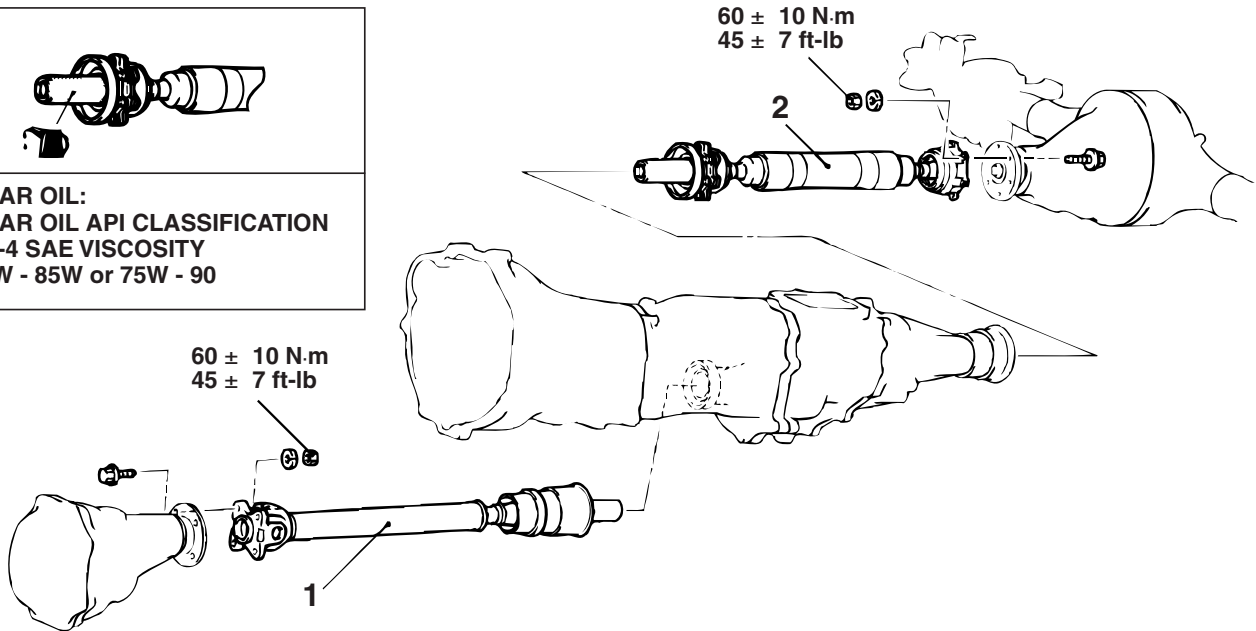
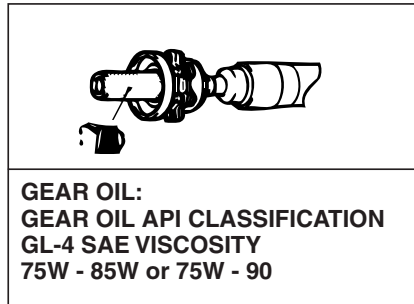

ACX00640 AB

**REMOVAL STEPS**

- <<A>> >>B<< 1. FRONT PROPELLER SHAFT ASSEMBLY
- <<B>> >>A<< 2. REAR PROPELLER SHAFT ASSEMBLY

**REMOVAL SERVICE POINTS****<<A>> FRONT PROPELLER SHAFT ASSEMBLY REMOVAL**

1. Move the transfer shift lever to "2H."
2. Drain transfer gear oil. (Refer to GROUP 23A, On-vehicle Service [P.23A-552.](#))
3. Make mating marks on the differential companion flange and the flange yoke.

**⚠ CAUTION**

Be careful not to bend the joint portion when removing the propeller shaft, because this will damage the joint boot.

4. Remove the front propeller shaft assembly after placing a rag around the joint boot portion.
5. Cover the transfer case opening to prevent foreign material from entering.

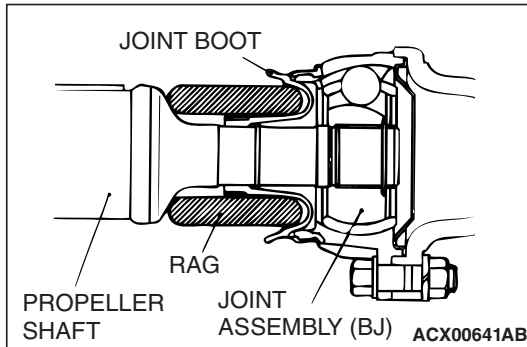

**<<B>> REAR PROPELLER SHAFT ASSEMBLY REMOVAL**

**⚠ CAUTION**

When working with the CFRP propeller shaft assembly, wrap the shaft with rubber sheet to prevent damage.

1. Check that the rear propeller shaft assembly is wrapped with the rubber sheet.
2. Make mating marks on the differential companion flange and the outer race of ball joint assembly.

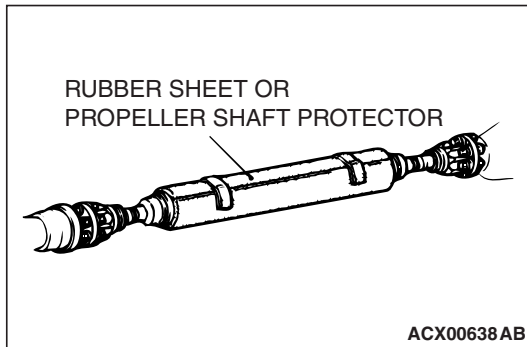

**⚠ CAUTION**

- Do not bend the joint portion when removing the propeller shaft because this will damage the joint boot.
- Do not drop the air breather at the end portion of propeller shaft differential side into the propeller shaft ball joint.
- Do not drop, shock, or scratch the propeller shaft.
- If the propeller shaft is dropped on the ground, replace it with new one. If the dropped rear propeller shaft is reinstalled, the rear propeller shaft may be broken.

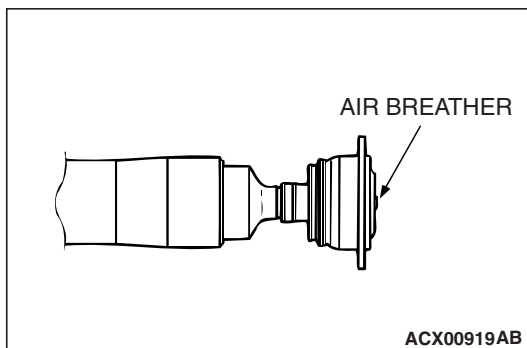

3. Remove the rear propeller shaft assembly after placing a rag around the joint boot portion.
4. Cover the transfer case opening to prevent foreign material from entering.

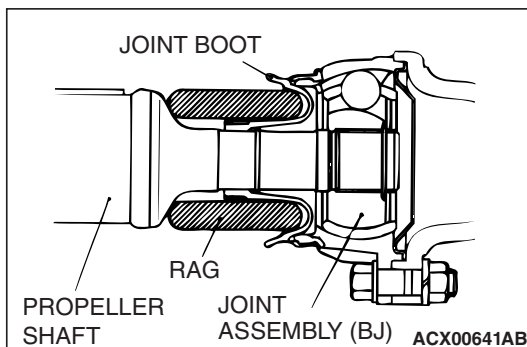

## INSTALLATION SERVICE POINTS

## &gt;&gt;A&lt;&lt; REAR PROPELLER SHAFT ASSEMBLY INSTALLATION

1. Check that the rear propeller shaft assembly is wrapped with the rubber sheet.

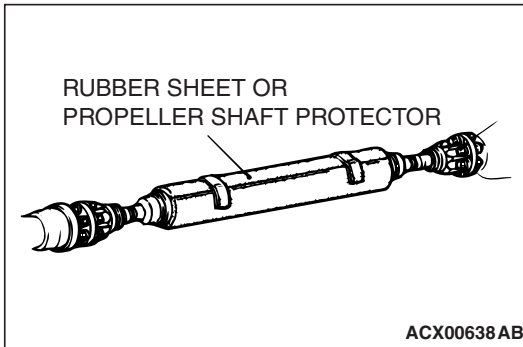

**⚠ CAUTION**

- Work with the CFRP tube of the propeller shaft assembly under the condition that the tube is wrapped with rubber sheet to prevent scratch on the outer surface. Do not drop, shock or scratch the rear propeller shaft.
- Remove oil and grease from the threads of the mounting bolts and nuts before tightening, or they will loosen.
- If the propeller shaft is dropped on the ground, replace it with new one. If the dropped rear propeller shaft is reinstalled, the rear propeller shaft may be broken.
- Do not drop the air breather at the end portion of propeller shaft differential side into the propeller shaft ball joint.

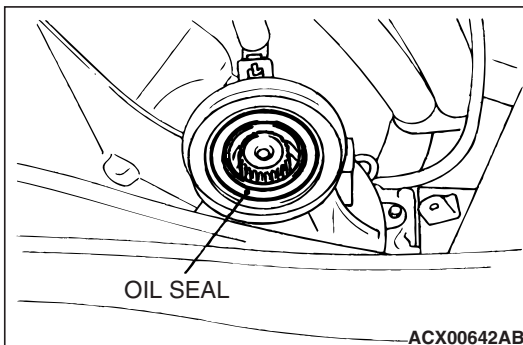
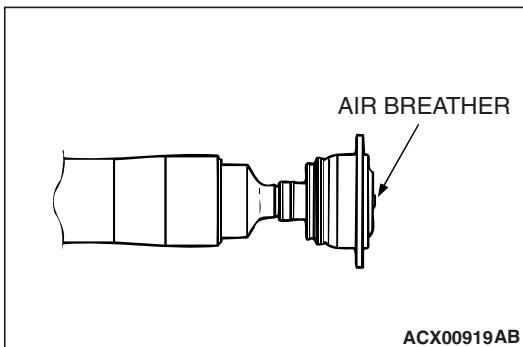

- Do not damage the oil seal lips on the transfer case.
2. If reusing the propeller shaft, align the mating marks of differential companion flange and outer race of ball joint assembly to install.



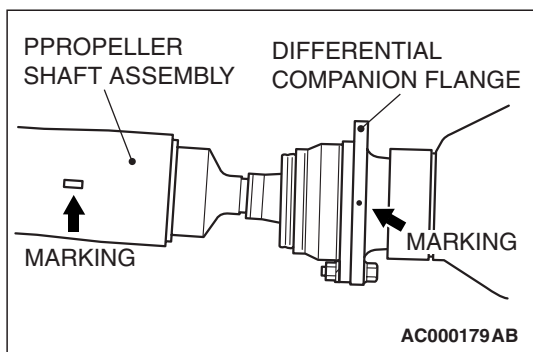

- When installing a new rear propeller shaft assembly, align the mark on the propeller shaft tube with the mark at the side of the differential companion flange.

### >>B<< FRONT PROPELLER SHAFT ASSEMBLY INSTALLATION

#### ⚠ CAUTION

- Do not damage the oil seal lips on the transfer case.
- Remove oil and grease from the threads of the mounting bolts and nuts before tightening, or they will loosen.

If reusing the propeller shaft, align the mating mark to install.

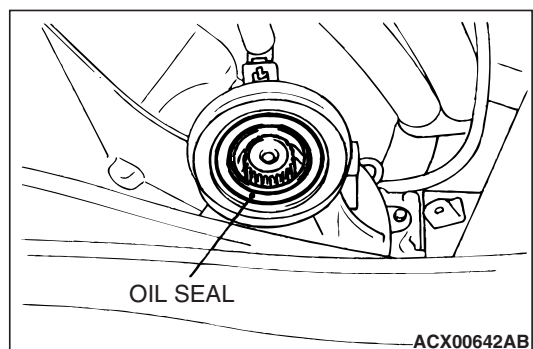

### INSPECTION

M1251001100048

### FRONT PROPELLER SHAFT RUNOUT

Limit: 0.5 mm (0.02 inch)

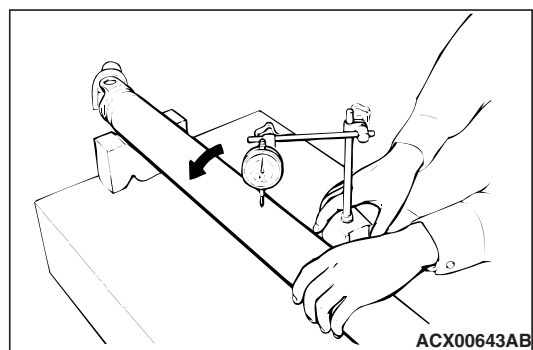

### REAR PROPELLER SHAFT

- Check whether there is any damage such as crack or peel at the seal portion shown in the illustration. If it is found, replace the propeller shaft with new one.

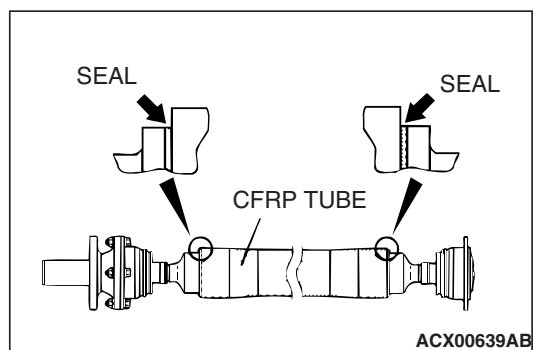

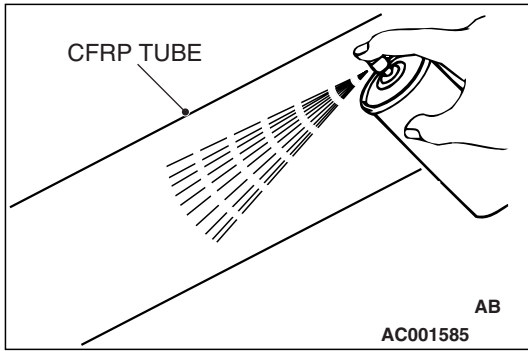

2. Check the condition of the tube. If crack, chip or deformation is found, replace the propeller shaft with new one. When flaw is found, confirm whether there is any failure by using a dye penetrant. If a failure is found, replace the propeller shaft.

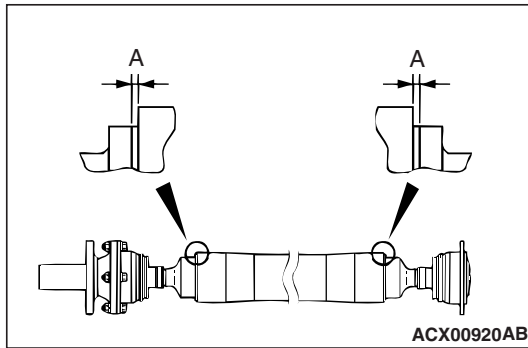

3. Measure the clearance (A) between the tube and the shaft at the end portion of the tube.

**Standard value (A): 0.2 – 0.5 mm (0.008 – 0.020 inch)**

4. If the standard value is not met, replace the rear propeller shaft.

**DISASSEMBLY AND ASSEMBLY  
REAR PROPELLER SHAFT**

M1251001200131

**⚠ CAUTION**

The CFRP rear propeller shaft cannot be separated.

**FRONT PROPELLER SHAFT**

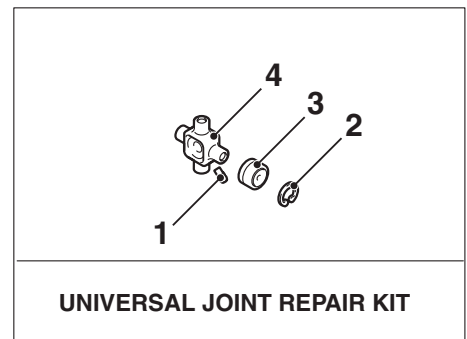
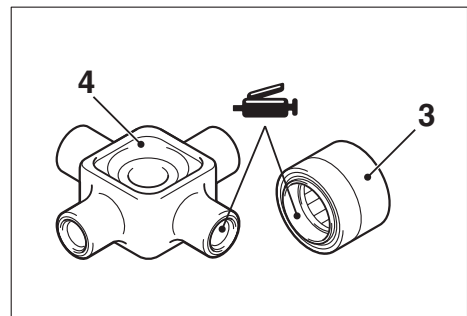
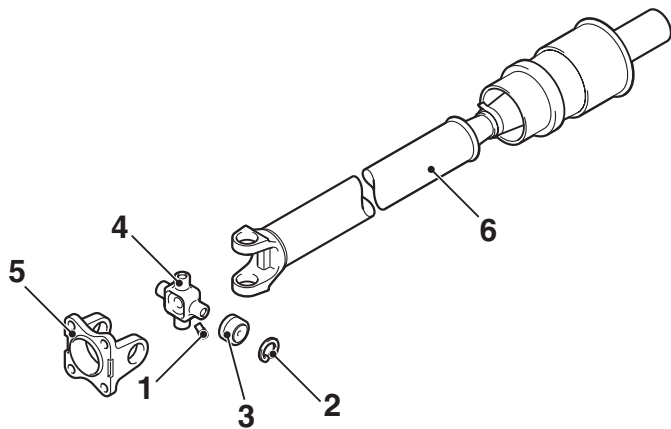

AC203529AB

**DISASSEMBLY STEPS**

- <<A>> >>B<<  
<<B>> >>A<<
1. GREASE NIPPLE
  2. SNAP RING
  3. JOURNAL BEARING

**DISASSEMBLY STEPS**

4. JOURNAL
5. FLANGE YOKE
6. PROPELLER SHAFT

**Required Special Tool:**

- MB990840: Universal Joint Remover/Installer

**DISASSEMBLY SERVICE POINTS**

**<<A>> SNAP RING REMOVAL**

Make mating marks on the flange yoke and propeller shaft. Then, remove the snap rings.

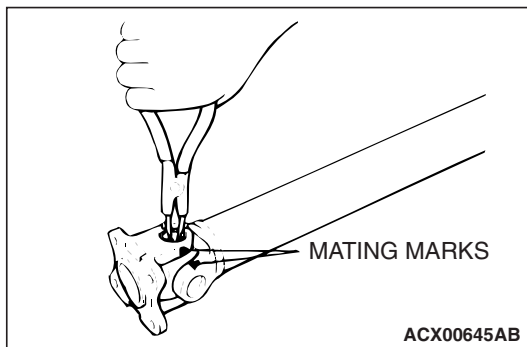

**<<B>> JOURNAL BEARING REMOVAL**

**⚠ CAUTION**

**Do not tap the journal bearings to remove them, as this will upset the balance of the propeller shaft.**

1. Use special tool MB990840 to press in the journal bearing on one side, and take out the journal bearing on the opposite side.
2. Insert special tool MB990840 into the other side and press the journal to remove the first journal bearing that was pushed.

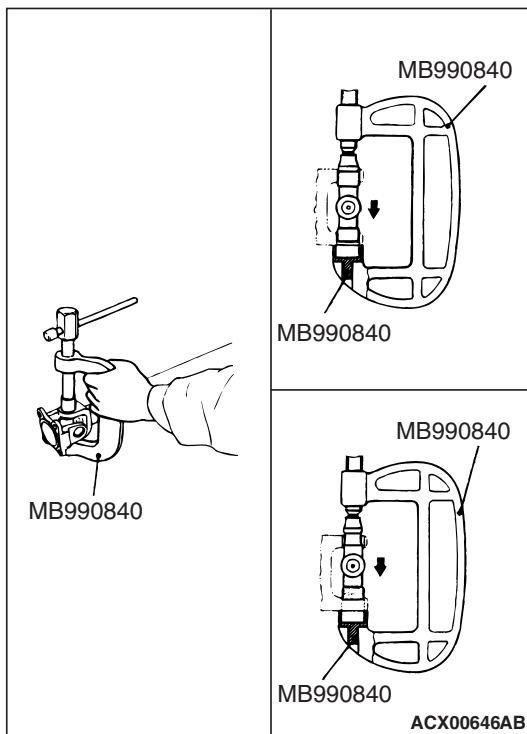

**ASSEMBLY SERVICE POINTS****>>A<< JOURNAL BEARING INSTALLATION****⚠ CAUTION**

Be careful when pressing the journal bearings. If they are pressed at an angle, the inside of the journal bearings will be damaged.

1. Use special tool MB990840 to press the journal bearing into the yoke until the snap ring groove is fully visible.

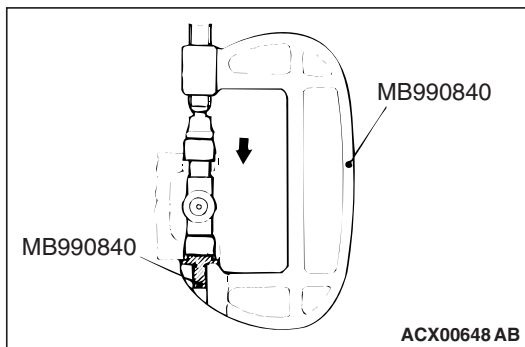
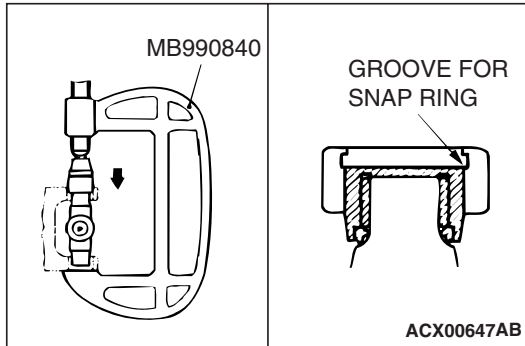

2. Use special tool MB990840 to press the opposite side journal bearing into the yoke.
3. Align the mating marks on the yoke and propeller shaft, and install the propeller shaft journal bearings.

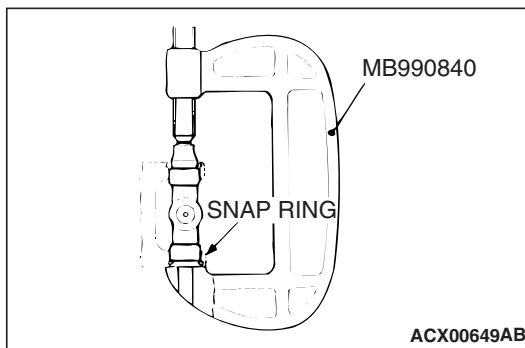
**>>B<< SNAP RING INSTALLATION**

1. Install a snap ring to one side of the journal.
2. Use special tool MB990840 at the opposite side of the installed snap ring to press in the journal bearing toward the snap ring.

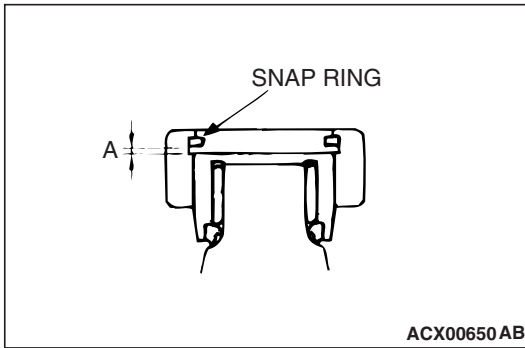

**⚠ CAUTION**

**Always use snap rings of equal thickness on both sides.**  
 3. Install the snap ring on the opposite side, and measure the clearance of the snap ring groove with a feeler gauge.

**Standard value (A): 0.06 mm (0.002 inch) or less**

4. If the clearance exceeds the standard value, adjust by changing the thickness of the snap ring.

THICKNESS mm (in)	IDENTIFICATION COLOR
1.28 (0.050)	–
1.31 (0.052)	Yellow
1.34 (0.053)	Blue
1.37 (0.054)	Purple

**SPECIFICATIONS****FASTENER TIGHTENING SPECIFICATION**

M1251001600043

ITEM	SPECIFICATION
Propeller shaft assembly nut	60 ± 10 N-m (45 ± 7 ft-lb)

**GENERAL SPECIFICATIONS**

M1251000200150

ITEM	SPECIFICATION		
Propeller shaft	Type	Front	2-joint type propeller shaft
		Rear	2-joint type propeller shaft, CFRP tube
	Length × Outside diameter mm (in)	Front	685 × 50.8 (27.0 × 2.0)
		Rear	775 × 79.1 (30.5 × 3.1)
Joint type	Front	Universal joint and BJ	
	Rear	BJ × 2	
Universal joint	Type	Cross type (snap ring method)	
	Bearing	Non-lubrication type needle roller bearing	
	Journal diameter mm (in)	14.689 (0.578)	

*NOTE: The propeller shaft length indicates the length between the center points of each joint.*

**SERVICE SPECIFICATIONS**

M1251000300113

ITEM	STANDARD VALUE	LIMIT
Front propeller shaft run-out mm (in)	–	0.5 (0.02)
Clearance between tube and shaft at end portion of rear propeller shaft tube mm (in)	0.2 – 0.5 (0.008 – 0.020)	–
Clearance of snap ring groove mm (in)	0.06 (0.002) or less	–

**LUBRICANT**

M1251000400068

ITEM	SPECIFIED LUBRICANT	QUANTITY
Propeller shaft sleeve yoke	Gear oil API classification GL-4 SAE 75W-85W or 75W-90	As required

**COMPONENT IDENTIFICATION**

M1251001700040

**SNAP RING**

THICKNESS OF SNAP RING mm (in)	IDENTIFICATION COLOR
1.28 (0.050)	–
1.31 (0.052)	Yellow
1.34 (0.053)	Blue
1.37 (0.054)	Purple