

GROUP 27

REAR AXLE

CONTENTS

GENERAL DESCRIPTION	27-2	KNUCKLE	27-17
SPECIAL TOOLS	27-2	REMOVAL AND INSTALLATION	27-17
REAR AXLE DIAGNOSIS	27-6	DRIVE SHAFT ASSEMBLY	27-19
INTRODUCTION.....	27-6	REMOVAL AND INSTALLATION	27-19
TROUBLESHOOTING STRATEGY	27-6	DISASSEMBLY AND ASSEMBLY	27-21
SYMPTOM CHART.....	27-6	DIFFERENTIAL CARRIER	
SYMPTOM PROCEDURES	27-6	ASSEMBLY	27-25
ON-VEHICLE SERVICE	27-12	REMOVAL AND INSTALLATION	27-25
REAR AXLE TOTAL BACKLASH CHECK .	27-12	DISASSEMBLY	27-28
GEAR OIL LEVEL CHECK	27-12	ASSEMBLY	27-32
GEAR OIL REPLACEMENT.....	27-13	SPECIFICATIONS	27-41
WHEEL BEARING END PLAY CHECK ...	27-13	FASTENER TIGHTENING	
REAR AXLE HUB ASSEMBLY	27-14	SPECIFICATIONS.....	27-41
REMOVAL AND INSTALLATION	27-14	GENERAL SPECIFICATIONS	27-41
INSPECTION	27-16	SERVICE SPECIFICATIONS	27-42
		LUBRICANTS	27-42
		SEALANT AND ADHESIVE	27-42
		COMPONENT IDENTIFICATION	27-42

GENERAL DESCRIPTION

M1271000100207

The rear axle has the following features.

- DOJ-type on the differential side and BJ-type on the hub side constant velocity joints are featured in the drive shaft.
- Large capacity and high rigidity taper-roller type unit bearing in the wheel bearing is featured.

- ABS rotor to detect wheel speed is press-fitted into the drive shaft.

NOTE: The structure of differential is basically the same as featured in existing models.

CONSTRUCTION DIAGRAM

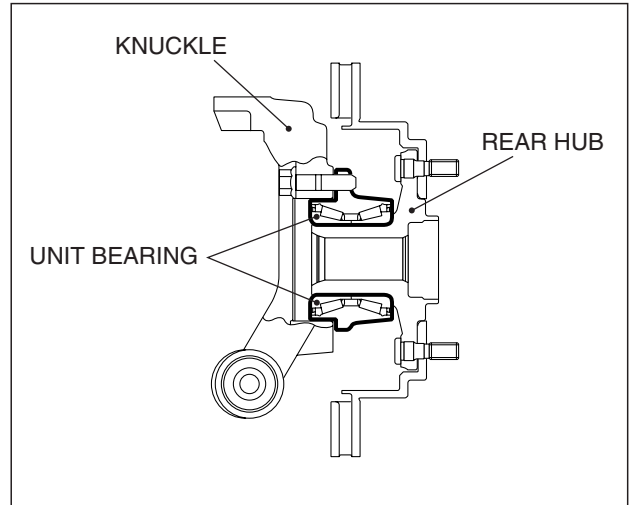
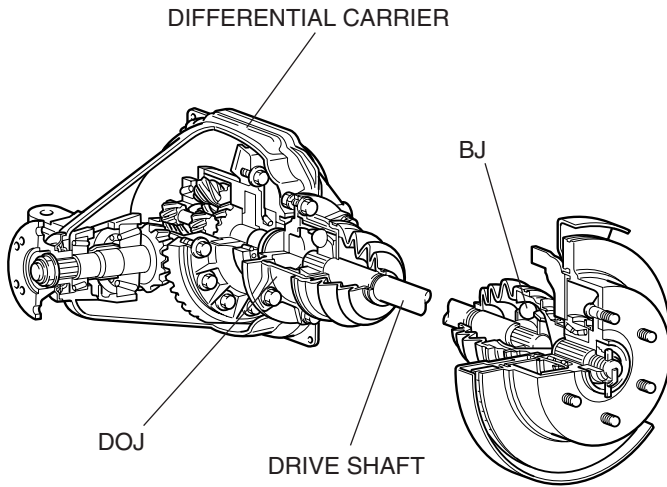



ACX02216AB

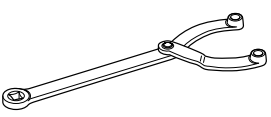
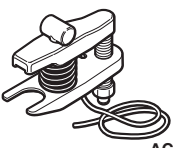
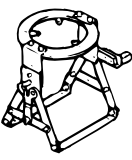

SPECIAL TOOLS

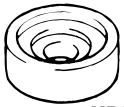
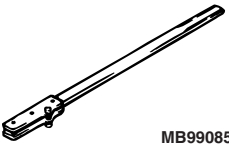
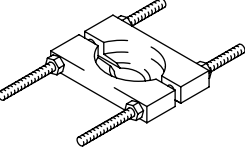
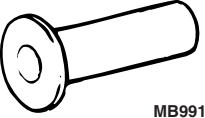
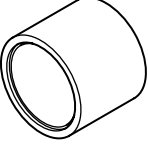
M1271000600291

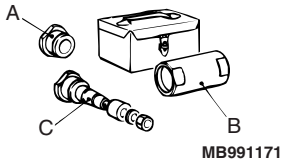
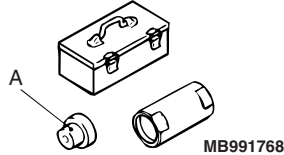
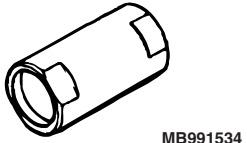
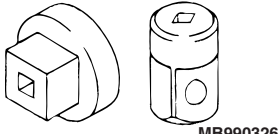
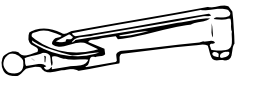
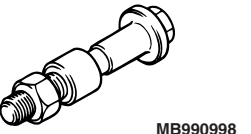
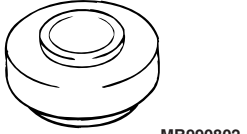
TOOL	TOOL NUMBER AND NAME	SUPERSESSON	APPLICATION
 B990767	MB990767 Front hub and flange yoke holder	MB990767-01	Removal and installation of the drive shaft nut
 AC106827	MB991897 Ball joint remover	MB991113-01, MB990635-01 or General service tool	Disconnection of ball joint <i>NOTE: Steering linkage puller (MB990635 or MB991113) is also used to disconnect knuckle and tie rod end ball joint.</i>
 MB990909	MB990909 Working base	-	Supporting of the differential carrier

TOOL	TOOL NUMBER AND NAME	SUPERSESION	APPLICATION
 <p>MB990810</p>	<p>MB990810 Side bearing puller</p>	<p>MB990810-01</p>	<ul style="list-style-type: none"> • Removal of the side bearing inner race • Removal of the companion flange
 <p>MB991407</p>	<p>MB991407 Differential rear support arbor</p>	<p>–</p>	<p>Removal of the side bearing inner race</p>
 <p>MB990850</p>	<p>MB990850 End yoke holder</p>	<p>–</p>	<ul style="list-style-type: none"> • Removal of the self-locking nut • Adjustment of the drive pinion turning torque
	<p>MD998801 Bearing remover</p>	<p>–</p>	<p>Removal of the drive pinion rear bearing inner race</p>
 <p>MB991168</p>	<p>MB991168 Drive pinion oil seal installer</p>	<p>–</p>	<p>Press-fitting of the drive pinion oil seal</p>
	<p>MB991445 Bushing remover and installer base</p>	<p>–</p>	<p>Press-fitting of the drive pinion rear bearing outer race (Use together with MB990938)</p>

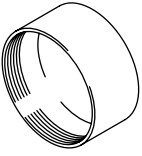
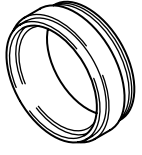
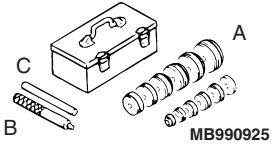
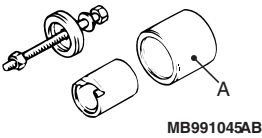
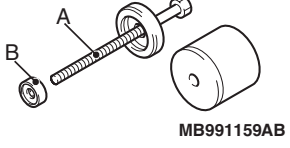
TOOL	TOOL NUMBER AND NAME	SUPERSESSION	APPLICATION
 <p>MB991171</p>	MB991171 Pinion height gauge set A: MB991169 Drive pinion gauge attachment B: MB991170 Cylinder gauge C: MB990819 Drive pinion gauge	-	Measurement of the pinion height
 <p>MB991768</p>	MB991768 Drive pinion gauge set A: MB991770 Head	-	
 <p>MB991534</p>	MB991534 Cylinder gauge	-	
 <p>MB990326</p>	MB990326 Preload socket	General service tool	<ul style="list-style-type: none"> • Measurement of the starting torque of ball bearing • Measurement of the starting torque of ball bearing
 <p>MB990685AC</p>	MB990685 Torque wrench		
 <p>MB990998</p>	MB990998 Front hub remover and installer	MB990998-01 or General service tool	<ul style="list-style-type: none"> • Measure at the wheel bearing rotation starting torque • Wheel bearing backlash check
 <p>MB990802</p>	MB990802 Bearing installer	MB990802-01	Press-fitting of the drive pinion rear bearing inner race
 <p>MB990727</p>	MB990727 Drive pinion oil seal installer	-	Press-fitting of the drive pinion oil seal

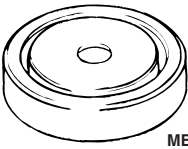
TOOL	TOOL NUMBER AND NAME	SUPERSESION	APPLICATION
	MD998812 Installer cap	–	Press-fitting of the side bearing inner race
	MD998829 Installer adapter	–	
	MB990925 Bearing and oil seal installer set A: MB990926 – MB990937 Installer adapter B: MB990938 Bar C: MB990939 Brass bar	MB990925-01 or General service tool	<ul style="list-style-type: none"> • Press-fitting of oil seal • Inspection of drive gear tooth contact • Removal of bearing outer race For details of each installer, refer to GROUP 26 – Special Tools P.26-9 .
	MB991045 Bushing remover and installer A: MB991050 Base(B)	–	Removal of the rear suspension crossmember bushing
	MB991159 Bushing remover and installer A: MB991162 Bolt B: MB991218 Bearing	–	Removal and press-fitting of the rear suspension crossmember bushing
	MB991816 Bushing remover and installer base	–	
	MB990955 Oil seal installer	–	Press-fitting of the rear suspension crossmember bushing

REAR AXLE DIAGNOSIS**INTRODUCTION**

M1271004100102

Noise from the drive shaft or differential may be caused by defects in the components.

TROUBLESHOOTING STRATEGY

M1271004200109

Use these steps to plan your diagnostic strategy. If you follow them carefully, you will be sure that you have exhausted most of the possible ways to find a rear axle fault.

1. Gather information from the customer.

2. Verify that the condition described by the customer exists.
3. Find the malfunction by following the Symptom Chart.
4. Verify malfunction is eliminated.

SYMPTOM CHART

M1271004300214

SYMPTOM		INSPECTION PROCEDURE	REFERENCE PAGE
Drive shaft	Noise while wheels are rotating	1	P.27-6
	Grease leakage	2	P.27-7
Differential	Constant noise	3	P.27-7
	Gear noise while driving	4	P.27-8
	Gear noise while coasting	5	P.27-9
	Bearing noise while driving or coasting	6	P.27-10
	Noise while turning	7	P.27-10
	Heat	8	P.27-10
	Oil leakage	9	P.27-11

SYMPTOM PROCEDURES**INSPECTION PROCEDURE 1: Noise while Wheels are Rotating <DRIVE SHAFT>****DIAGNOSIS**

STEP 1. Check whether the drive shaft is bent.

Q: Is the drive shaft bent?

YES : Replace the part. Then go to Step 3.

NO : Go to Step 2.

STEP 2. Check the wheel bearing of rear hub assembly for wear or damage.

Q: Is the wheel bearing damaged or worn?

YES : Replace the part. Then go to Step 3.

NO : Go to Step 3.

STEP 3. Retest the system.

Q: Is the abnormal noise eliminated?

YES : The procedure is complete.

NO : Start over at Step 1.

INSPECTION PROCEDURE 2: Grease Leakage <DRIVE SHAFT>

DIAGNOSIS

STEP 1. Check the DOJ boot and the BJ boot for wear or damage.

- Q: Is the DOJ boot or the BJ boot worn or damaged?**
YES : Replace the part and apply grease (Refer to [P.27-21](#)).. Then go to Step 2.
NO : Go to Step 2.

STEP 2. Retest the system.

- Q: Is there grease leakage?**
YES : Start over at Step 1.
NO : The procedure is complete.

INSPECTION PROCEDURE 3: Constant Noise <DIFFERENTIAL>

DIAGNOSIS

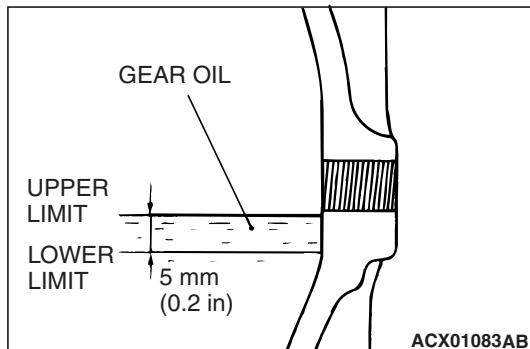

STEP 1. Check the oil level.

Remove the filler plug and check the gear oil level.

Q: Is the gear oil level more than 5 mm (0.2 inch) below the bottom of the filler plug hole?

- YES :** Check the oil leakage from differential carrier, and repair if necessary. Then, refill Hypoid gear oil API classification GL-5 or higher; Above $-23^{\circ}\text{C}(-10^{\circ}\text{F})$: SAE 90, 85W-90, 80W-90, From -34 to $-23^{\circ}\text{C}(-30$ to $-10^{\circ}\text{F})$: SAE 80W, 80W-90, Below $-34^{\circ}\text{C}(-30^{\circ}\text{F})$: SAE 75W. Then go to Step 9.
NO : Go to Step 2.

STEP 2. Check the tooth contact (engagement) of the drive gear and drive pinion. Refer to GROUP 26, Differential Carrier – Inspection Before Disassembly [P.26-43](#).

Q: Is the tooth contact (engagement) of the drive gear and drive pinion correct?

- YES :** Go to Step 3.
NO : Adjust or replace the part. Then go to Step 9.

STEP 3. Check the side bearing for looseness, wear or damage.

Q: Is the side bearing loosened, worn or damaged?

- YES :** Adjust or replace the part. Then go to Step 9.
NO : Go to Step 4.

STEP 4. Check the drive pinion bearing for wear or damage.

Q: Is the drive pinion bearing worn or damaged?

- YES :** Adjust or replace the part. Then go to Step 9.
NO : Go to Step 5.

STEP 5. Check the drive gear and drive pinion for wear.

Q: Is the drive gear or drive pinion worn?

YES : Replace the part. Then go to Step 9.

NO : Go to Step 6.

STEP 6. Check the side gear thrust washer or pinion shaft for wear.

Q: Is the side gear thrust washer or pinion shaft worn?

YES : Replace the part. Then go to Step 9.

NO : Go to Step 7.

STEP 7. Check the drive gear and differential case for wear or damage.

Q: Is the drive gear or differential case worn or damaged?

YES : Replace the part. Then go to Step 9.

NO : Go to Step 8.

STEP 8. Check for foreign material.

Q: Is any foreign material found?

YES : Remove the foreign material and then inspect for damage. If necessary, replace the part. Then go to Step 9.

NO : Go to Step 9.

STEP 9. Retest the system.

Q: Is the abnormal noise eliminated?

YES : The procedure is complete.

NO : Start over at Step 1.

INSPECTION PROCEDURE 4: Gear Noise while Driving <DIFFERENTIAL>

DIAGNOSIS

STEP 1. Check the oil level.

Remove the filler plug and check the gear oil level.

Q: Is the gear oil level more than 5 mm (0.2 inch) below the bottom of the filler plug hole?

YES : Check the oil leakage from differential carrier, and repair if necessary. Then, refill Hypoid gear oil API classification GL-5 or higher; Above -23°C (-10°F): SAE 90, 85W-90, 80W-90, From -34 to -23°C (-30 to -10°F): SAE 80W, 80W-90, Below -34°C (-30°F): SAE 75W. Then go to Step 6.

NO : Go to Step 2.

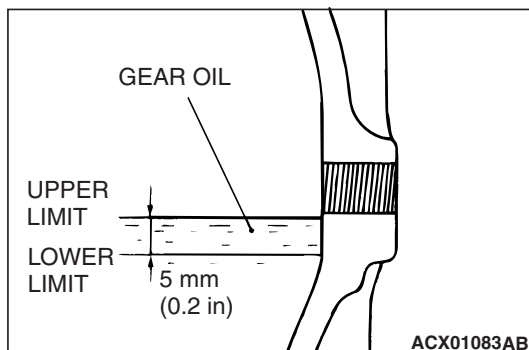

STEP 2. Check the gear engagement.

Q: Is the gear engagement in good condition?

YES : Go to Step 3.

NO : Adjust or replace the part. Then go to Step 6.

STEP 3. Check the drive pinion turning torque.

Q: Is the drive pinion turning torque correct?

YES : Go to Step 4.

NO : Adjust the turning torque. Then go to Step 6.

STEP 4. Check the gear for damage.

Q: Is the gear damaged?

YES : Replace the gear. Then go to Step 6.

NO : Go to Step 5.

STEP 5. Check for foreign material.

Q: Is foreign material found?

YES : Remove the foreign material and then inspect for damage. If necessary, replace the part. Then go to Step 6.

NO : Go to Step 6.

STEP 6. Retest the system.

Q: Is the abnormal noise eliminated?

YES : The procedure is complete.

NO : Start over at Step 1.

INSPECTION PROCEDURE 5: Gear Noise while Coasting <DIFFERENTIAL>

DIAGNOSIS

STEP 1. Check the drive pinion turning torque.

Q: Is the drive pinion turning torque correct?

YES : Go to Step 2.

NO : Adjust the turning torque. Then go to Step 3.

STEP 2. Check the gear for damage.

Q: Is the gear damaged?

YES : Replace the gear. Then go to Step 3.

NO : Go to Step 3.

STEP 3. Retest the system.

Q: Is the abnormal noise eliminated?

YES : The procedure is complete.

NO : Start over at Step 1.

INSPECTION PROCEDURE 6: Bearing Noise while Driving or Coasting <DIFFERENTIAL>**DIAGNOSIS**

STEP 1. Check the drive pinion rear bearing for cracks or damage.

Q: Is the drive pinion rear bearing cracked or damaged?

YES : Replace the part. Then go to Step 2.

NO : Go to Step 2.

STEP 2. Retest the system.

Q: Is the abnormal noise eliminated?

YES : The procedure is complete.

NO : Start over at Step 1.

INSPECTION PROCEDURE 7: Noise while Turning < DIFFERENTIAL >**DIAGNOSIS**

STEP 1. Check the side bearing for wear or damage.

Q: Is the side bearing worn or damaged?

YES : Replace the part. Then go to Step 3.

NO : Go to step 2.

STEP 2. Check the side gear, pinion gear or pinion shaft for damage.

Q: Is the side gear, pinion gear or pinion shaft damaged?

YES : Replace the part. Then go to Step 3.

NO : Go to Step 3.

STEP 3. Retest the system.

Q: Is the abnormal noise eliminated?

YES : The procedure is complete.

NO : Start over at Step 1.

INSPECTION PROCEDURE 8: Heat <DIFFERENTIAL>**DIAGNOSIS**

STEP 1. Check the oil level.

Remove the filler plug and check the gear oil level.

Q: Is the gear oil level more than 5 mm (0.2 inch) below the bottom of the filler plug hole?

YES : Check the oil leakage from differential carrier, and repair if necessary. Then, refill Hypoid gear oil API classification GL-5 or higher; Above -23°C (-10°F): SAE 90, 85W-90, 80W-90, From -34 to -23°C (-30 to -10°F): SAE 80W, 80W-90, Below -34°C (-30°F): SAE 75W. Then go to Step 3.

NO : Go to Step 2.

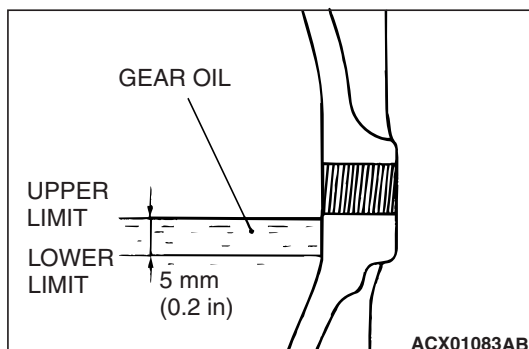

STEP 2. Check for excessive gear backlash. Refer to GROUP 26, Differential Carrier – Inspection before Disassembly P.26-43.

Q: Is the gear backlash correct?

YES : Go to Step 3.

NO : Adjust the backlash. Then go to step 3.

STEP 3. Retest the system.

Q: Is the heat eliminated?

YES : The procedure is complete.

NO : Start over at Step 1.

INSPECTION PROCEDURE 9: Oil Leakage <DIFFERENTIAL>

DIAGNOSIS

STEP 1. Check the breather hose for clogging.

Q: Is the breather hose clogged?

YES : Clean or replace the part. Then go to Step 5.

NO : Go to step 2.

STEP 2. Check the cover installation.

Q: Is the cover installed correctly?

YES : Go to Step 3.

NO : Repair. Then go to Step 5.

STEP 3. Check the oil seal for wear or damage.

Q: Is the oil seal worn or damaged?

YES : Replace the seal. Then go to Step 5.

NO : Go to Step 4.

STEP 4. Check the oil level.

Remove the filler plug and check the gear oil level.

Q: Is the gear oil level more than 5 mm (0.2 inch) below the bottom of the filler plug hole?

YES : Refill Hypoid gear oil API classification GL-5 or higher; Above -23°C (-10°F): SAE 90, 85W-90, 80W-90, From -34 to -23°C (-30 to -10°F): SAE 80W, 80W-90, Below -34°C (-30°F): SAE 75W. Then go to Step 5.

NO : Go to Step 5.

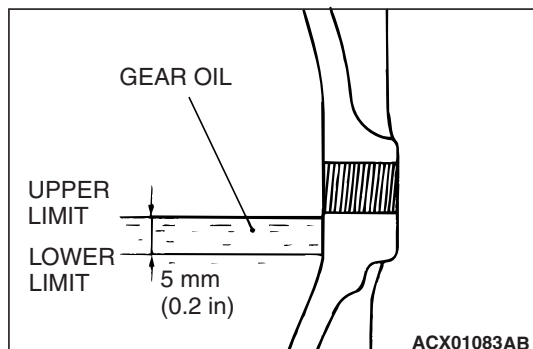

STEP 5. Retest the system.

Q: Is there oil leakage?

YES : Start over at Step 1.

NO : The procedure is complete.

ON-VEHICLE SERVICE**REAR AXLE TOTAL BACKLASH CHECK**

M1271001200069

1. Park the vehicle on a flat, level surface.
2. Move the transmission control lever to the neutral position.
Move the transfer control lever to the neutral position. Apply the parking brake. Raise the vehicle on a jack.
3. Turn the companion flange clockwise as far as it will go.
Make the mating mark on the dust cover of the companion flange and on the differential carrier.

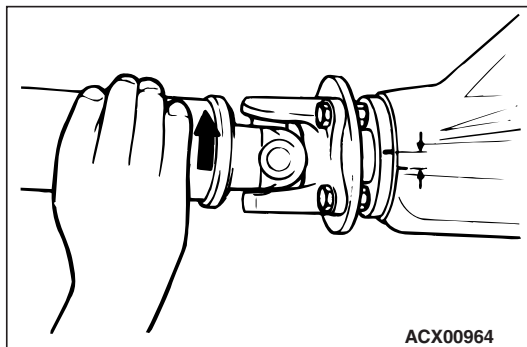
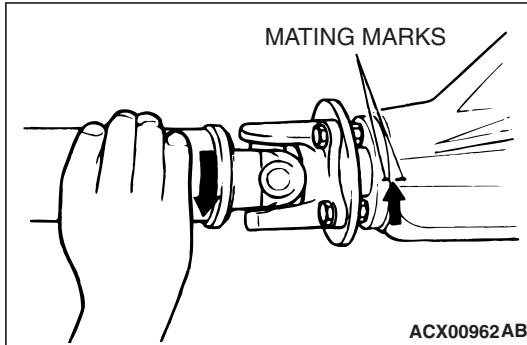

4. Turn the companion flange counterclockwise as far as it will go, and measure the amount of distance the mating marks moved.

Limit: 5 mm (0.2 inch)

5. If the backlash exceeds the limit value, remove the differential carrier assembly and check the following.
 - Final drive gear backlash
 - Differential gear backlash

GEAR OIL LEVEL CHECK

M1272001200277

1. Remove the filler plug and check the gear oil level.
2. Check that gear oil level is not 5 mm (0.2 inch) below the bottom of filler plug hole.

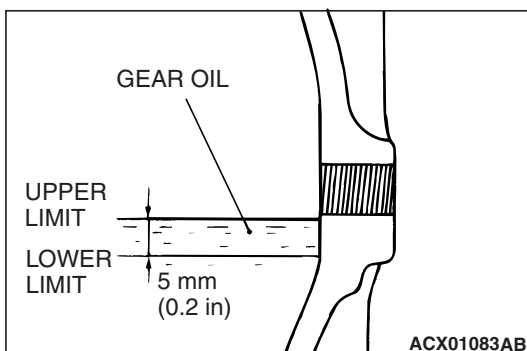

GEAR OIL REPLACEMENT

M1272004600058

1. Remove the filler plug.
2. Remove the drain plug and drain oil.
3. Tighten the drain plug to the specified torque.
Tightening torque: 63 ± 4 N·m (47 ± 2 ft-lb)
4. Add the oil until the level comes to the lower portion of the filler plug hole.

Specified gear oil: Hypoid gear oil API classification GL-5 or higher

Above -23°C (-10°F): SAE90, 85W-90, 80W-90

From -34 to -23°C (-30 to -10°F): SAE80W, 80W-90

Below -34°C (-30°F): SAE75W

5. Tighten the filler plug to the specified torque.

Tightening torque: 49 ± 9 N·m (37 ± 6 ft-lb)

WHEEL BEARING END PLAY CHECK

M1271000900258

1. Remove the rear brake assembly and remove the brake disc while holding it with wires to prevent it from falling.
2. Fit the dial gauge as shown in the diagram and move the hub in the axial direction to measure the play.

Limit: 0 mm (0 inch)

3. If the play exceeds the limit, replace the rear hub assembly.

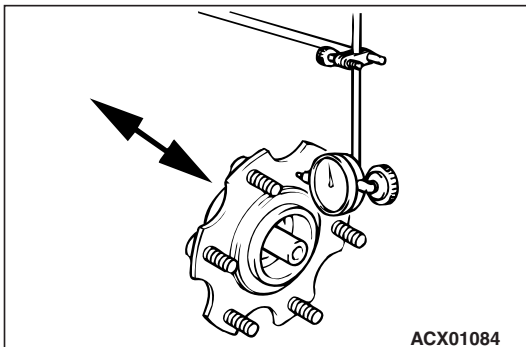

REAR AXLE HUB ASSEMBLY

REMOVAL AND INSTALLATION

M1271002000217

Post-installation Operation

Parking Brake Lever Stroke Adjustment (Refer to GROUP 36, On-vehicle Service P.36-4).

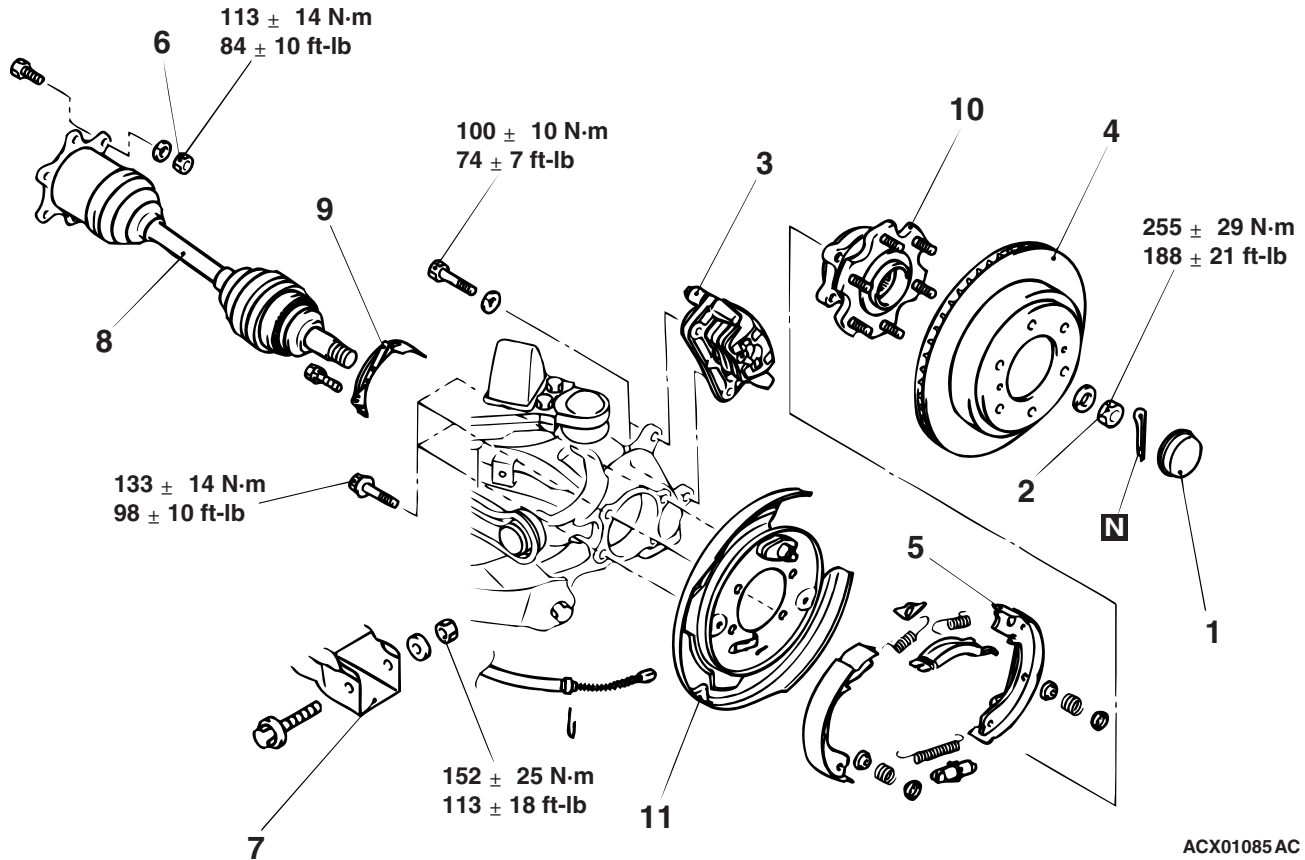

ACX01085 AC

REMOVAL STEPS

- <<A>> >>B<<
<>
1. HUB CAP
 2. DRIVE SHAFT NUT
 3. DISC BRAKE ASSEMBLY
 4. BRAKE DISC
 5. SHOE AND LINING ASSEMBLY (REFER TO GROUP 36, PARKING BRAKE DRUM P.36-8).
 6. COMPANION SHAFT AND DRIVE SHAFT CONNECTION

REMOVAL STEPS (Continued)

- <<C>> >>A<<
7. LOWER ARM AND KNUCKLE CONNECTION
 8. REAR DRIVE SHAFT ASSEMBLY
 9. ABS ROTOR PROTECTOR
 10. REAR HUB ASSEMBLY
 11. BACKING PLATE

Required Special Tools:

- MB990767: Front Hub and Flange Yoke Holder
- MB990998: Front Hub Remover and Installer
- MB990326: Preload Socket

REMOVAL SERVICE POINTS

<<A>> DRIVE SHAFT NUT REMOVAL

⚠ CAUTION

Do not apply pressure to wheel bearing by the vehicle weight to avoid possible damage to wheel bearing before tightening drive shaft nut fully.

Use special tool MB990767 to fix the hub and remove the drive shaft nut.

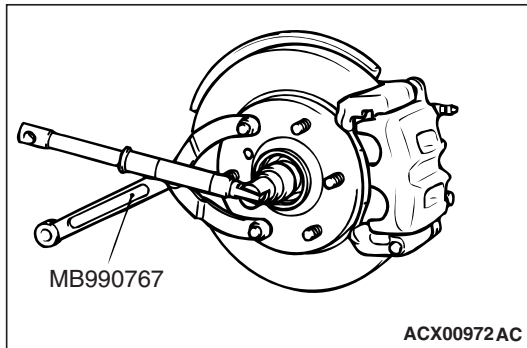

<> DISC BRAKE ASSEMBLY REMOVAL

Suspend the disc brake assembly from the body with wire, etc. to prevent it from falling.

<<C>> LOWER ARM AND KNUCKLE DISCONNECTION

Position a wooden block to the lower arm as shown in the illustration and use the floor jack to remove the lower arm mounting bolt by compressing the coil spring.

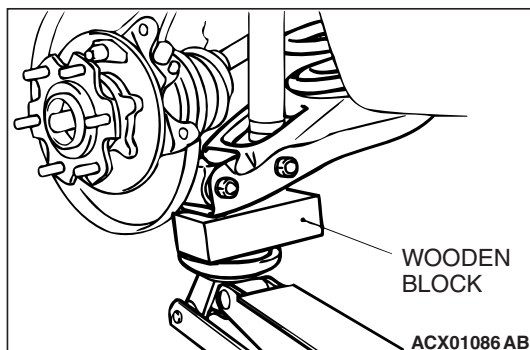

INSTALLATION SERVICE POINTS

>>A<< LOWER ARM AND KNUCKLE CONNECTION

Position a wooden block to the lower arm as shown in the illustration and use the floor jack to install the lower arm mounting bolt by compressing the coil spring.

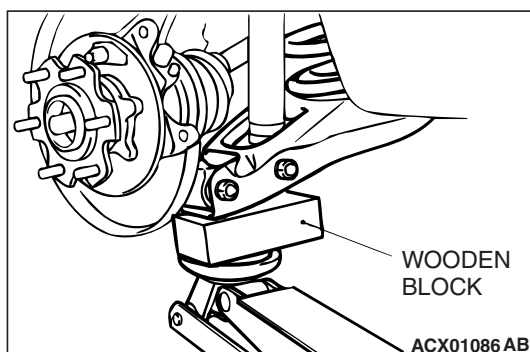

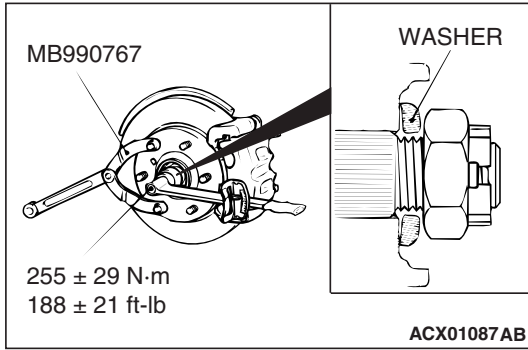

>>B<< DRIVE SHAFT NUT INSTALLATION

1. Assemble the drive shaft washer in the illustrated direction.

⚠ CAUTION

Do not apply pressure to wheel bearing by the vehicle weight to avoid possible damage to wheel bearing before tightening drive shaft nut fully.

2. Tighten the drive shaft nut fully with special tool MB990767.
3. If the pin hole does not align with another, tighten the drive shaft nut [less than 284 N·m (209 ft-lb)] and find the nearest hole then bend the split pin to fit in.

INSPECTION

M1271002100098

WHEEL BEARING ROTATION STARTING TORQUE CHECK

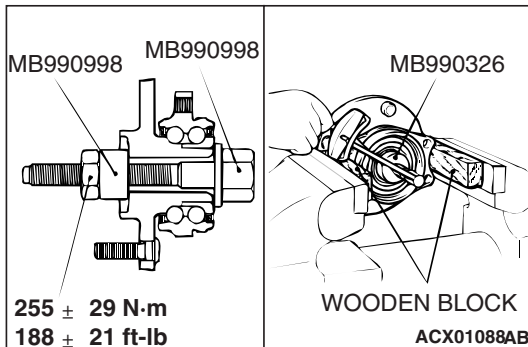

1. Tighten special tool MB990998 in rear hub assembly to the specified torque.
2. Hold the rear hub assembly in a vice using of wood blocks.
3. Measure the wheel bearing rotation torque with special tool MB990326.

Limit: 1.76 N·m (15.6 in-lb)

4. Hub rotation starting torque must be under the limit value and the hub should rotate smoothly.

WHEEL BEARING END PLAY CHECK

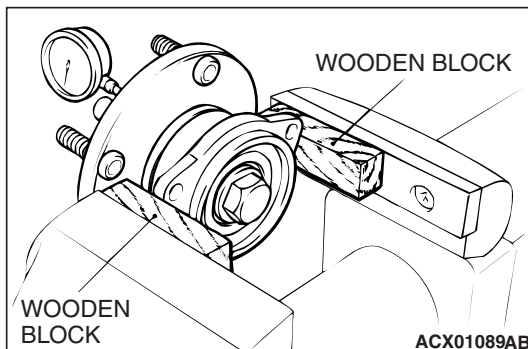

1. Check the wheel bearing end play.
Limit: 0 mm (0 inch)
2. If the wheel bearing end play exceeds the limit value at the specified torque of [255 ± 29 N·m (188 ± 21ft-lb)], replace the rear hub assembly.

KNUCKLE

REMOVAL AND INSTALLATION

M1271003000221

Pre-removal Operation

Rear Hub Assembly Removal (Refer to P.27-14).

Post-installation Operation

- Check the Dust Cover for Cracks or Damage by Pushing it with Finger.
- Rear Hub Assembly Installation (Refer to P.27-14).

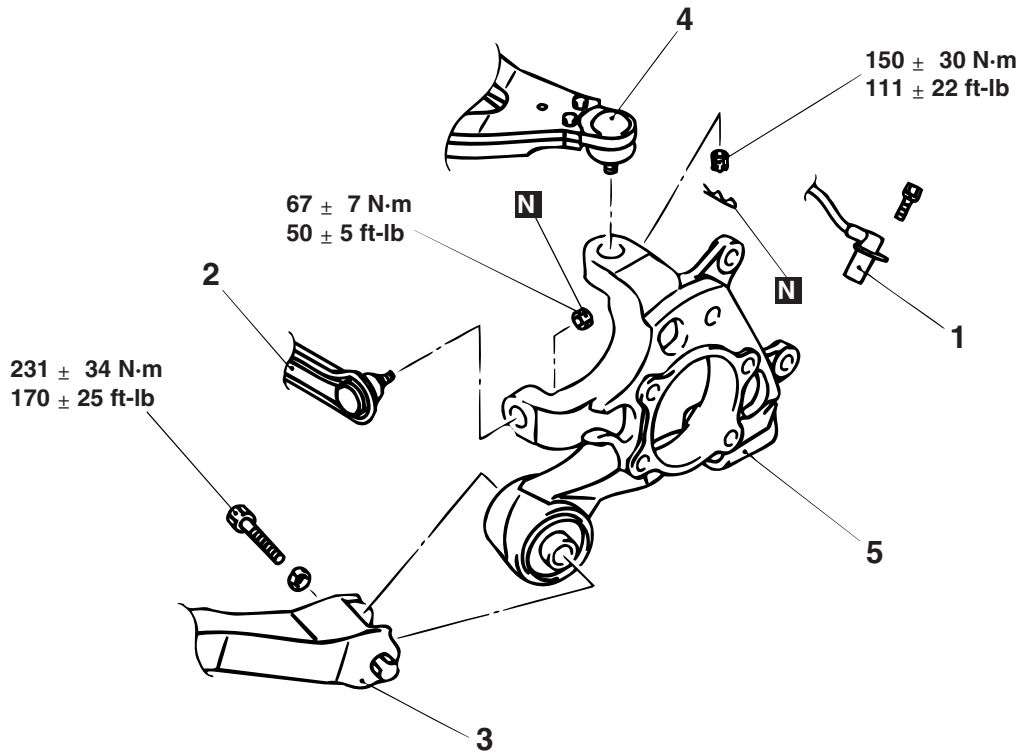

ACX01090 AB

REMOVAL STEPS

<<A>>

1. VEHICLE SPEED SENSOR
2. KNUCKLE AND TOE-CONTROL ARM CONNECTION
3. KNUCKLE AND TRAILING ARM CONNECTION

REMOVAL STEPS (Continued)

<<A>> >>A<<

4. KNUCKLE AND UPPER ARM CONNECTION
5. KNUCKLE ASSEMBLY

Required Special Tool:

MB991897:Ball Joint Remover

REMOVAL SERVICE POINT

<<A>> KNUCKLE AND TOE-CONTROL ARM/UPPER ARM
DISCONNECTION**⚠ CAUTION**

- Do not remove the nut from ball joint. Loosen it and use special tool MB991897 to avoid possible damage to ball joint threads.
- Hang special tool MB991897 with cord to prevent it from falling.

1. Install special tool MB991897 as shown in the figure.

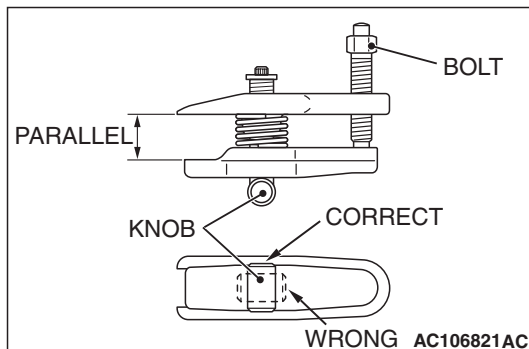
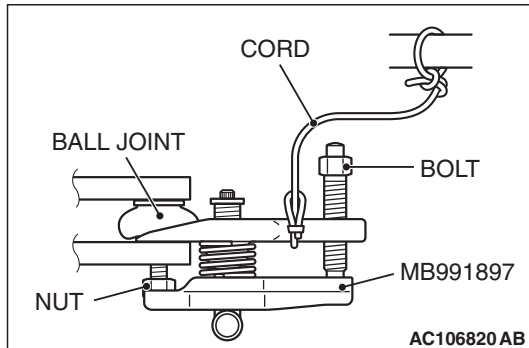

2. Turn the bolt and knob as necessary to make the jaws of special tool MB991897 parallel, tighten the bolt by hand and confirm that the jaws are still parallel.

NOTE: When adjusting the jaws in parallel, make sure the knob is in the position shown in the figure.

3. Tighten the bolt with a wrench to disconnect the knuckle and toe-control arm, upper arm.

INSTALLATION SERVICE POINT

>>A<< UPPER ARM CONNECTION

If the upper arm ball joint is disengaged from the knuckle, always renew the upper arm ball joint dust cover and retainer. (Refer to GROUP 34-Upper Arm P.34-11.)

DRIVE SHAFT ASSEMBLY

REMOVAL AND INSTALLATION

M1271003300073

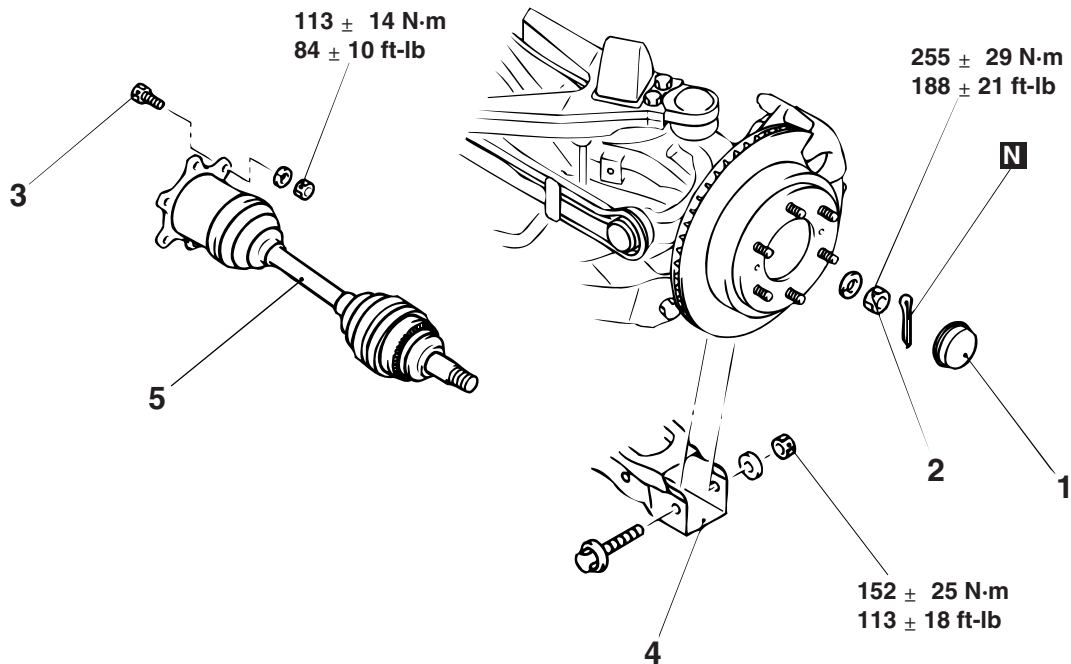

REMOVAL STEPS

- <<A>> >>B<<
1. HUB CAP
 2. DRIVE SHAFT NUT
 3. COMPANION SHAFT AND DRIVE SHAFT CONNECTION

REMOVAL STEPS (Continued)

- <> >>A<<
4. KNUCKLE AND LOWER ARM CONNECTION
 5. REAR DRIVE SHAFT ASSEMBLY

Required Special Tool:

MB990767: Front Hub and Flange Yoke Holder

REMOVAL SERVICE POINTS

<<A>> DRIVE SHAFT NUT REMOVAL

⚠ CAUTION

Do not apply pressure to wheel bearing by the vehicle weight to avoid possible damage to wheel bearing before tightening drive shaft nut fully.

Use special tool MB990767 to fix the hub and remove the drive shaft nut.

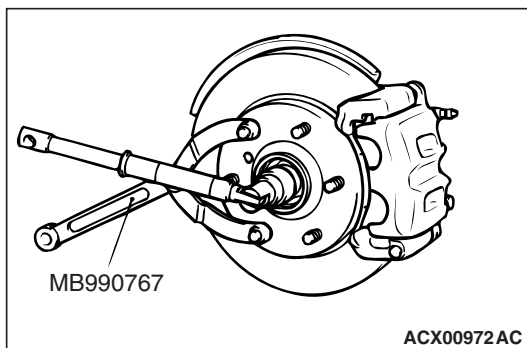

<> KNUCKLE AND LOWER ARM DISCONNECTION

Position a wooden block to the lower arm as shown in the illustration and use the floor jack to remove the lower arm mounting bolt by compressing the coil spring.

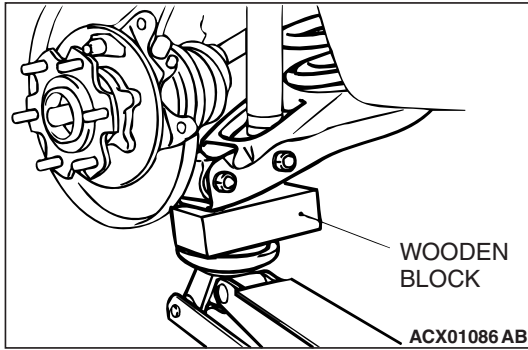

INSTALLATION SERVICE POINTS

>>A<< KNUCKLE AND LOWER ARM CONNECTION

Position a wooden block to the lower arm as shown in the illustration and use the floor jack to install the lower arm mounting bolt by compressing the coil spring.

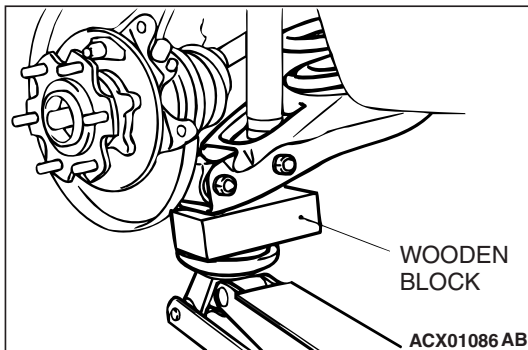

>>B<< DRIVE SHAFT NUT INSTALLATION

1. Assemble the drive shaft washer in the illustrated direction.

⚠ CAUTION

Do not apply pressure to wheel bearing by the vehicle weight to avoid possible damage to wheel bearing before tightening drive shaft nut fully.

2. Tighten the drive shaft nut to the torque specification with special tool MB990767.
3. If the pin hole does not align with another, tighten the drive shaft nut [less than 284 N·m (209 ft-lb)] and find the nearest hole then bend the split pin to fit in.

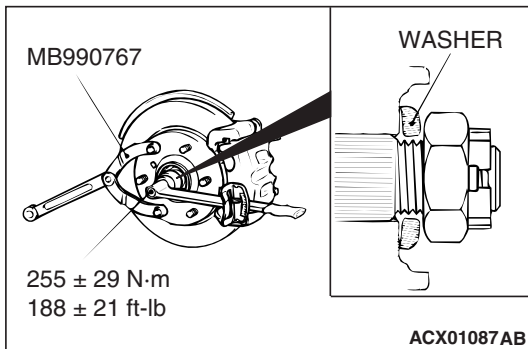

DISASSEMBLY AND ASSEMBLY

M1271003500099

CAUTION

Never disassemble the BJ assembly except when replacing the BJ boot.

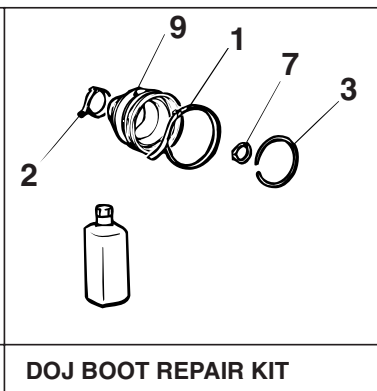
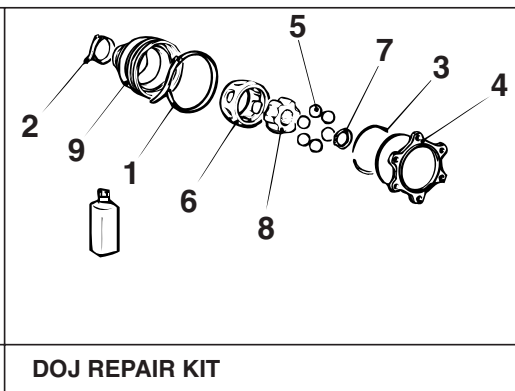
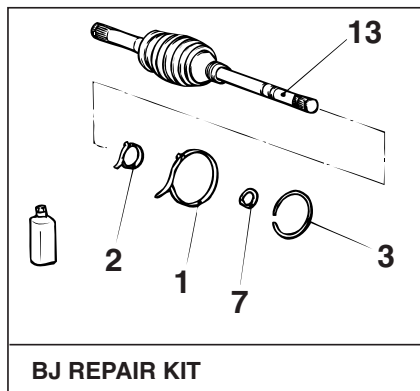
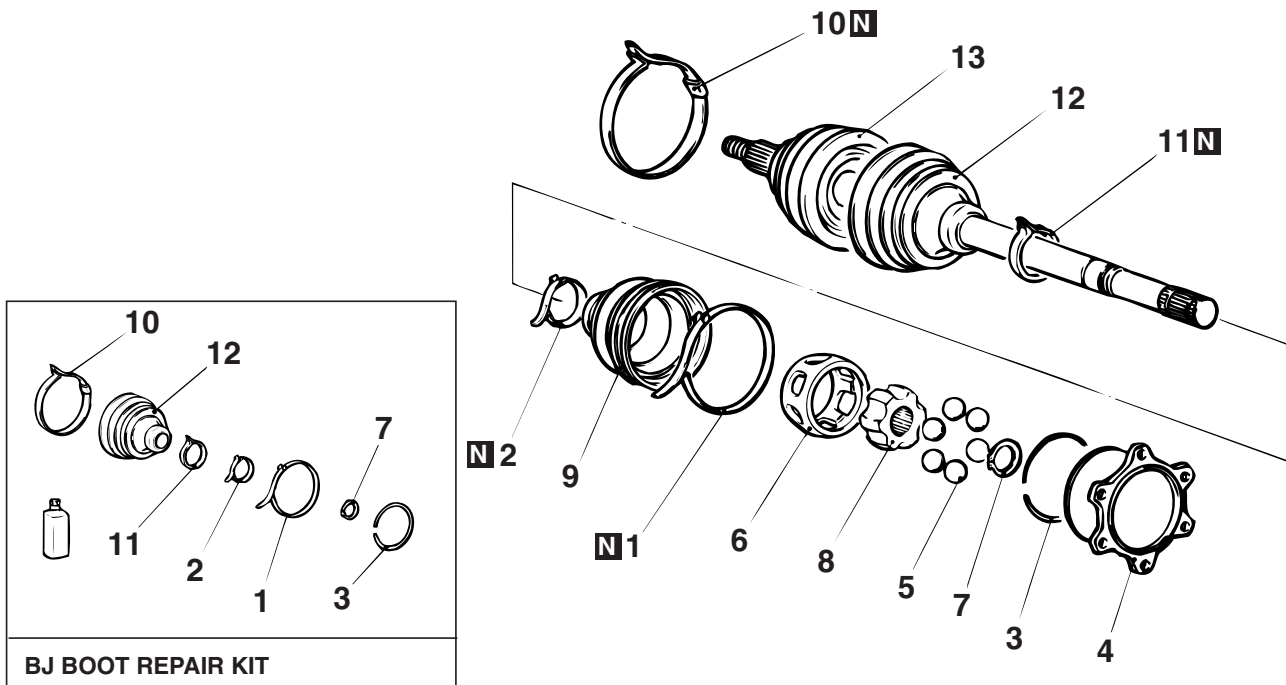

ACX01092 AC

DISASSEMBLY STEPS

- 1. DOJ BOOT BAND (LARGE)
- 2. DOJ BOOT BAND (SMALL)
- 3. CIRCLIP
- 4. DOJ OUTER RACE
- <<A>> 5. BALLS
- <> 6. DOJ CAGE
- 7. SNAP RING
- <<C>> 8. DOJ INNER RACE
- 9. DOJ BOOT
- 10. BJ BOOT BAND (LARGE)
- 11. BJ BOOT BAND (SMALL)
- <<C>> 12. BJ BOOT
- 13. BJ ASSEMBLY

ASSEMBLY STEPS

- 13. BJ ASSEMBLY
- >>A<< 12. BJ BOOT
- 11. BJ BOOT BAND (SMALL)
- 10. BJ BOOT BAND (LARGE)
- >>A<< 9. DOJ BOOT
- >>B<< 6. DOJ CAGE
- >>B<< 8. DOJ INNER RACE
- 7. SNAP RING
- 5. BALLS
- >>C<< 4. DOJ OUTER RACE
- 3. CIRCLIP
- >>D<< 2. DOJ BOOT BAND (SMALL)
- >>D<< 1. DOJ BOOT BAND (LARGE)

Required Special Tool:
MB990939: Brass Bar

LUIBRICATION POINTS

⚠ CAUTION

Do not mix old and new or different types of grease, as a special grease is used in the joint.

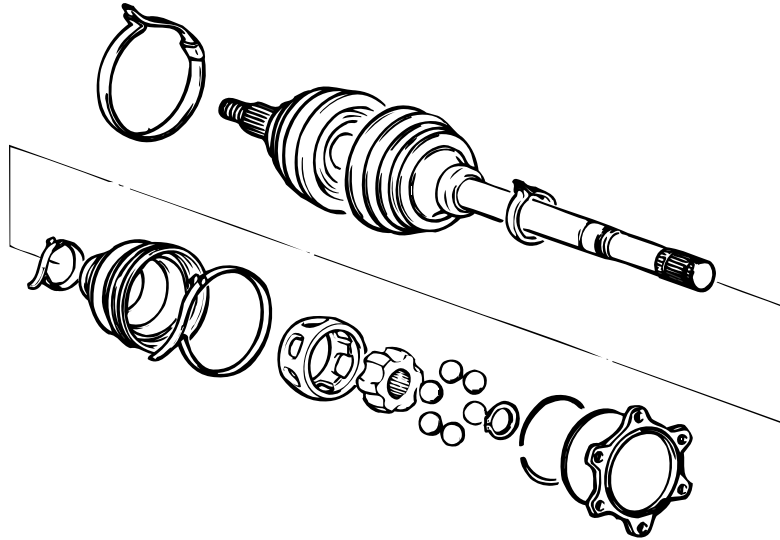

	<p>DOJ</p>	<p>BJ</p>
<p>GREASE: REPAIR KIT GREASE</p>	<p>GREASE: REPAIR KIT GREASE USED AMOUNT: <BJ> 245 ± 10 g (8.7 ± 0.3 oz) [INSIDE JOINT: 135 ± 5 g (4.8 ± 0.1 oz), INSIDE BOOT: 110 ± 5 g (3.9 ± 0.2 oz)] <DOJ> 295 ± 10 g (10.5 ± 0.3 oz) [INSIDE JOINT: 185 ± 5 g (6.5 ± 0.2 oz), INSIDE BOOT: 110 ± 5 g (3.9 ± 0.2 oz)]</p> <p>NOTE THE GREASE IN THE REPAIR KIT SHOULD BE DIVIDED IN HALF FOR USE, RESPECTIVELY, AT THE JOINT AND INSIDE THE BOOT.</p>	

ACX01093 AD

DISASSEMBLY SERVICE POINTS

<<A>> BALLS REMOVAL

Remove the balls from the DOJ cage.

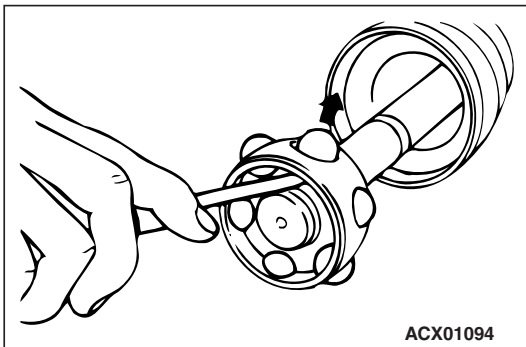

ACX01094

<> DOJ CAGE REMOVAL

Remove the DOJ cage from the DOJ inner race in the direction of the BJ.

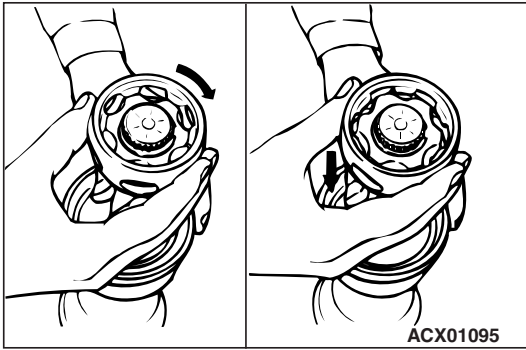

<<C>> DOJ BOOT/BJ BOOT REMOVAL

Wrap plastic tape around the spline part on the DOJ side of the drive shaft so that DOJ boot/BJ boot are not damaged when they are removed.

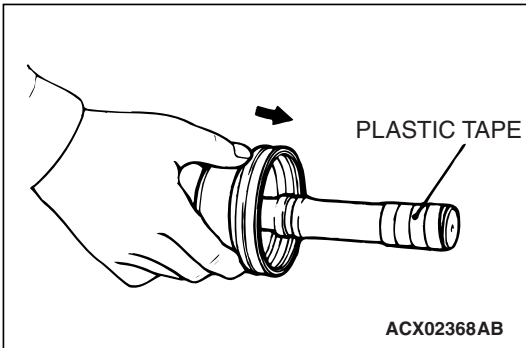

ASSEMBLY SERVICE POINTS

>>A<< BJ BOOT/DOJ BOOT INSTALLATION

1. Wrap the tape around the spline of the shaft, then install BJ boot and DOJ boot in order.

⚠ CAUTION

Do not mix old and new or different types of grease, as a special grease is used in the joint.

2. Fill the inside of BJ and BJ boot with specified grease.

NOTE: The grease in the repair kit should be divided in half for use, respectively, at the joint and inside the boot.

Specified grease: Repair kit grease

Used amount: 245 ± 10 g (8.7 ± 0.3 oz) [inside joint: 135 ± 5 g (4.8 ± 0.1 oz), inside boot: 110 ± 5 g (3.9 ± 0.2 oz)]

⚠ CAUTION

In order to fill the specified amount of air inside the BJ boot, keep the bent angle of the drive shaft to 0 degree angle during the operation.

3. Tighten the boot band.

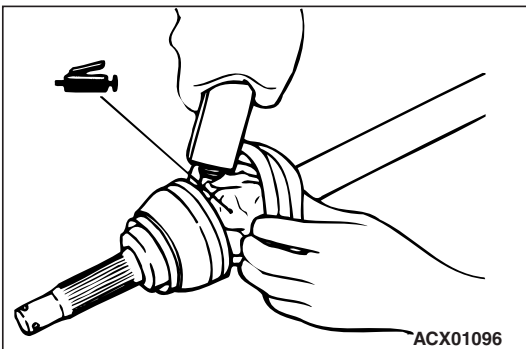

>>B<< DOJ CAGE/DOJ INNER RACE INSTALLATION

1. Install DOJ cage to the drive shaft and put it aside to BJ assembly side.
2. Align the mating mark of DOJ inner race with that of the shaft.
3. Tap the inner race with even force to press-fit into the bump of the shaft with special tool MB990939.

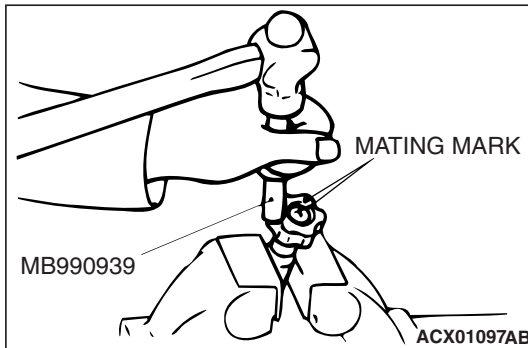
**>>C<< DOJ OUTER RACE INSTALLATION****⚠ CAUTION**

The drive shaft joint use special grease. Do not mix old and new or different types of grease.

Fill the inside of the DOJ outer race and DOJ boot with the specified grease.

Specified grease: Repair kit grease

Used amount: 295 ± 10 g (10.5 ± 0.3 oz) [inside joint: 185 ± 5 g (6.5 ± 0.2 oz), inside boot: 110 ± 5 g (3.9 ± 0.2 oz)]

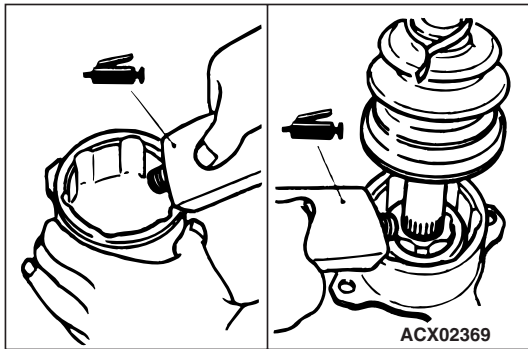
**>>D<< DOJ BOOT BAND (SMALL)/DOJ BOOT BAND (LARGE) INSTALLATION**

1. Position the DOJ outer race so that the distance between the boot bands is at the standard value.

Standard value (A): 110 ± 3 mm (4.3 ± 0.1 inches)

2. Remove part of the DOJ boot from the DOJ outer race to release the air pressure inside the boot.

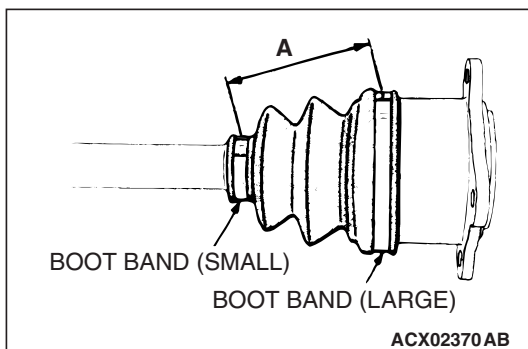

DIFFERENTIAL CARRIER ASSEMBLY

REMOVAL AND INSTALLATION

M1272002000470

CAUTION

Since a carbon fiber fortified plastic tube is used in the rear propeller shaft, make sure to refer to GROUP 25 (P.25-5) for removal procedure.

Pre-removal and Post-installation Operation
Differential Gear Oil Draining and Refilling (Refer to P.27-13).

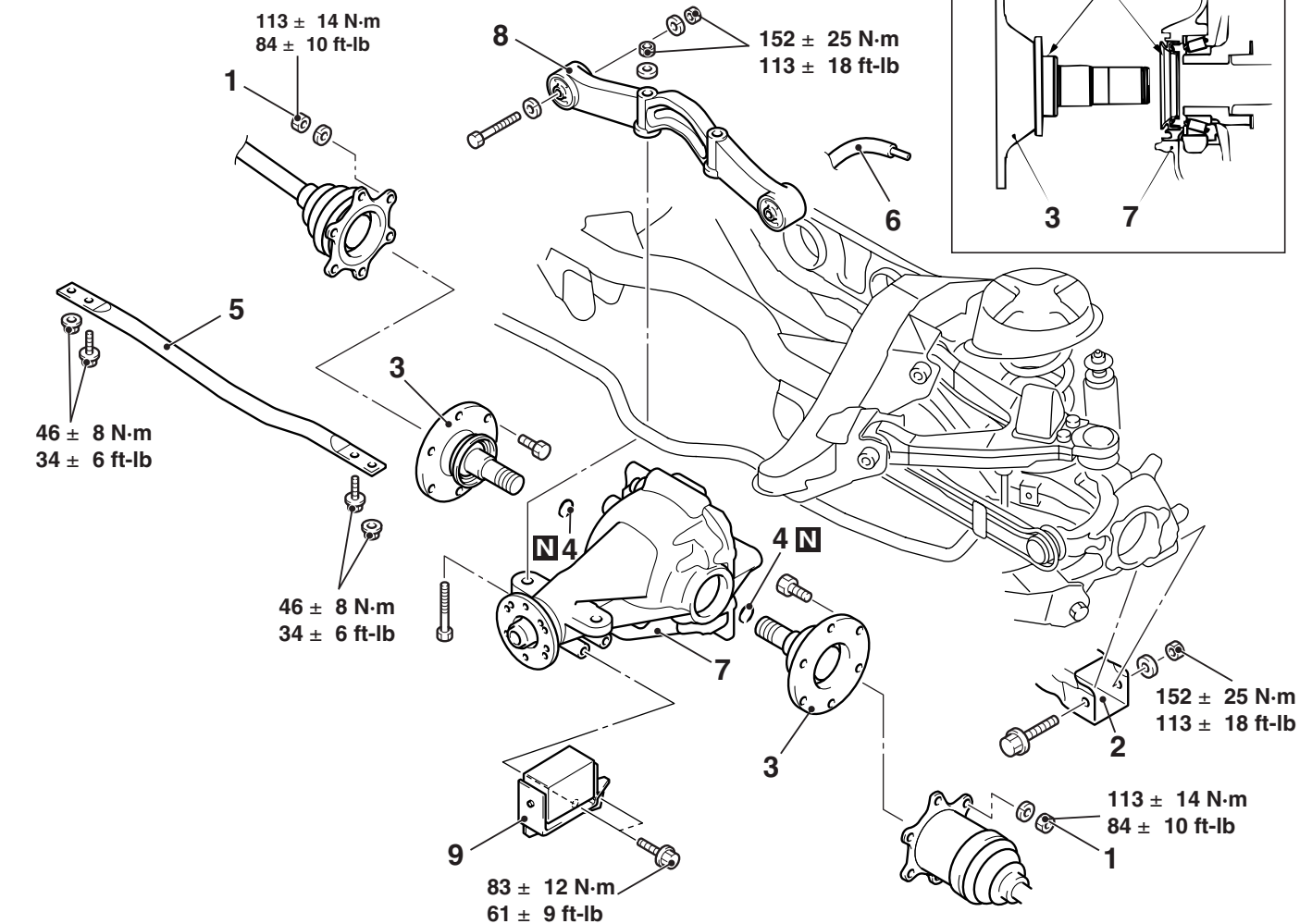
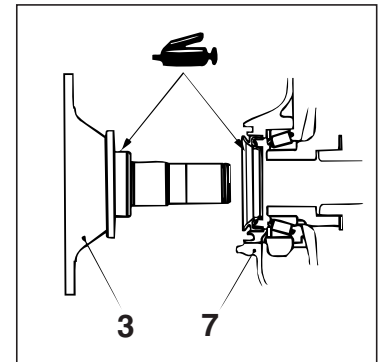

AC400775AB

REMOVAL STEPS

- PROPELLER SHAFT (REFER TO GROUP 25 P.25-5).
- 1. DRIVE SHAFT AND COMPANION SHAFT CONNECTION
- 2. KNUCKLE AND LOWER ARM CONNECTION
- 3. COMPANION SHAFT
- 4. CLIP
- 5. TOE CONTROL TOWER BAR
- 6. BREATHER HOSE CONNECTION
- 7. DIFFERENTIAL CARRIER ASSEMBLY

<<A>> >>A<<

<>

REMOVAL STEPS (Continued)

- FUEL TANK (REFER TO GROUP 13B P.13B-8).
- 8. REAR DIFFERENTIAL MOUNT MEMBER
- 9. DYNAMIC DAMPER

Required Special Tools:

- MB991050: Base (B)
- MB991218: Bearing
- MB991162: Bolt
- MB991816: Bearing Remover and Installer Base
- MB990955: Oil Seal Installer

REMOVAL SERVICE POINTS

<<A>> KNUCKLE AND LOWER ARM DISCONNECTION

Position a wooden block to the lower arm as shown in the illustration and use the floor jack to remove the lower arm mounting bolt by compressing the coil spring.

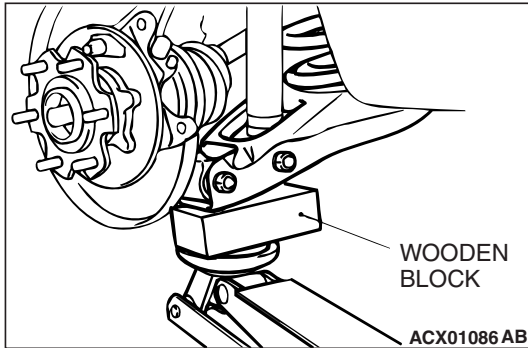

<> DIFFERENTIAL CARRIER ASSEMBLY REMOVAL

Support the differential carrier assembly lower part by jacking to remove the joint bolt and the differential carrier assembly.

INSTALLATION SERVICE POINT

>>A<< KNUCKLE AND LOWER ARM CONNECTION

Position a wooden block to the lower arm as shown in the illustration and use the floor jack to install the lower arm mounting bolt by compressing the coil spring.

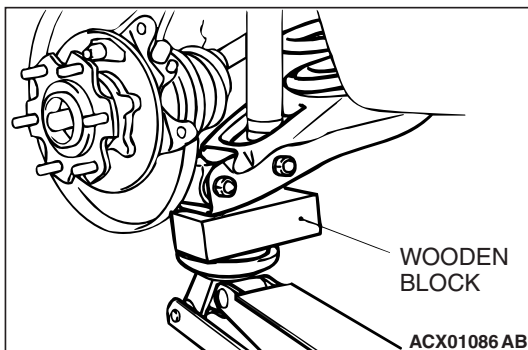

REAR SUSPENSION CROSSMEMBER BUSHING (FOR REAR DIFFERENTIAL MOUNT) REPLACEMENT

1. Remove the rear differential.

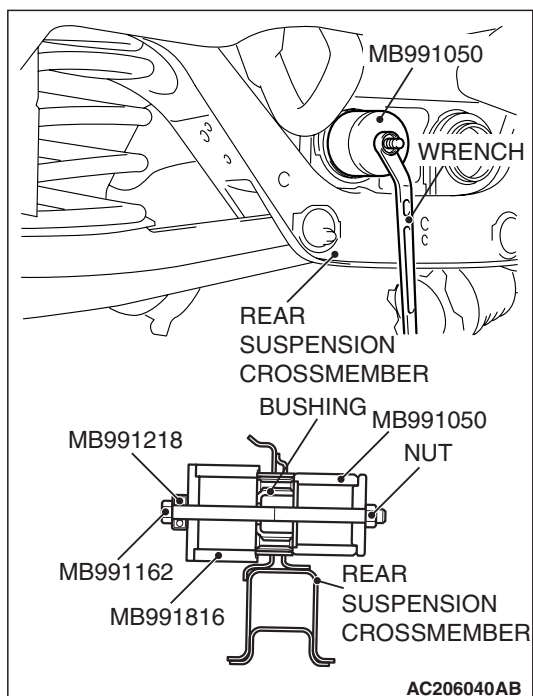

- Use special tools MB991050, MB991218, MB991162 and MB991816 to remove the bushing.

NOTE: When removing the bushing, insert special tool MB991162 from the forward of vehicle and fix the nut with a wrench.

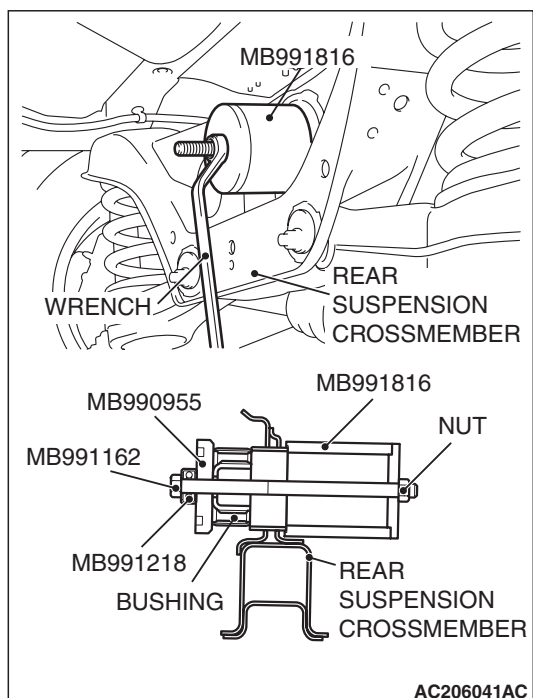

- Use special tools MB991816, MB991218, MB991162 and MB990955 to press-fit the bushing.

NOTE: When installing the bushing, insert special tool MB991162 from the forward of vehicle and fix the nut with a wrench. Press-fit the bushing until the bushing end face is flush with the rear suspension crossmember.

- Install the rear differential.

DISASSEMBLY

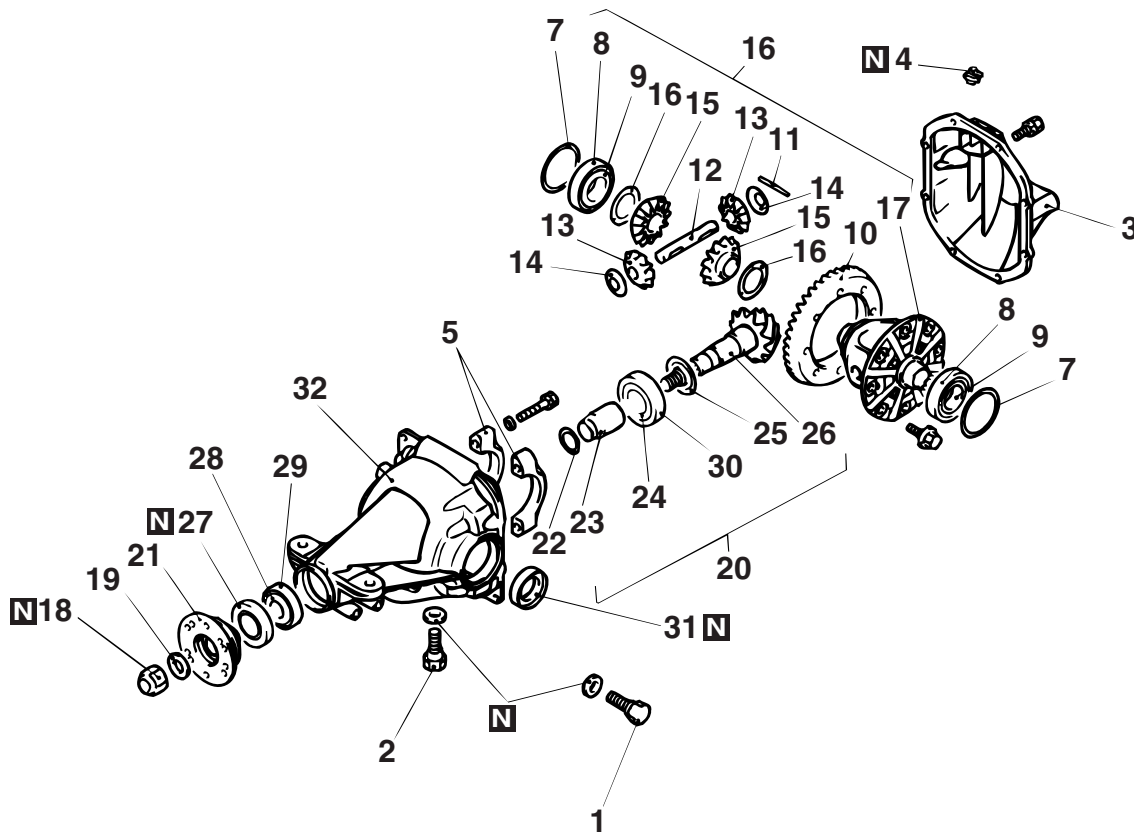

AC203533 AC

DISASSEMBLY STEPS

- <<A>>
 - INSPECTION BEFORE DISASSEMBLY
 - 1. FILLER PLUG
 - 2. DRAIN PLUG
 - 3. DIFFERENTIAL COVER
 - 4. VENT PLUG
 - 5. BEARING CAP
- <> 6. DIFFERENTIAL CASE ASSEMBLY
- <> 7. DIFFERENTIAL SIDE SHIM
- <> 8. SIDE BEARING OUTER RACE
- <<C>> 9. SIDE BEARING INNER RACE
- <<D>> 10. DRIVE GEAR
- <<E>> 11. LOCK PIN
- 12. PINION SHAFT
- 13. PINION GEAR
- 14. PINION WASHER
- 15. SIDE GEAR
- 16. SIDE GEAR SPACER
- 17. DIFFERENTIAL CASE
- <<F>> 18. SELF-LOCKING NUT
- 19. WASHER

DISASSEMBLY STEPS (Continued)

- <<G>> 20. DRIVE PINION ASSEMBLY
- <<G>> 21. COMPANION FLANGE
- 22. DRIVE PINION FRONT SHIM (FOR ADJUSTING PRELOAD OF DRIVE PINION)
- 23. DRIVE PINION SPACER
- <<H>> 24. DRIVE PINION REAR BEARING INNER RACE
- 25. DRIVE PINION REAR SHIM (FOR ADJUSTING DRIVE PINION HEIGHT)
- 26. DRIVE PINION
- <<I>> 27. OIL SEAL
- <<I>> 28. DRIVE PINION FRONT BEARING INNER RACE
- <<I>> 29. DRIVE PINION FRONT BEARING OUTER RACE
- <<J>> 30. DRIVE PINION REAR BEARING OUTER RACE
- 31. OIL SEAL
- 32. DIFFERENTIAL CARRIER

Required Special Tools:

- MB990810: Side Bearing Puller
- MB991407: Differential Rear Support Arbor
- MB990850: End Yoke Holder
- MD998801: Bearing Remover
- MB990939: Brass Bar

DISASSEMBLY SERVICE POINTS

<<A>> INSPECTION BEFORE DISASSEMBLY

Except for the following standard values, inspection procedure is the same as GROUP 26, inspection before disassembly P.26-43.

DRIVE GEAR BACKLASH

Standard value: 0.13 – 0.18 mm (0.005 – 0.007 inch)

DIFFERENTIAL GEAR BACKLASH

Standard value: 0 – 0.076 mm (0 – 0.0030 inch)

Limit: 0.2 mm (0.01 inch)

<> DIFFERENTIAL CASE ASSEMBLY/DIFFERENTIAL SIDE SHIM/SIDE BEARING OUTER RACE REMOVAL

CAUTION

When taking out the differential case assembly, be careful not to drop and damage the differential side shims or the side bearing outer races.

Use the wooden handle of a hammer to remove the differential case assembly, differential side shims and side bearings.

NOTE: Keep the right and left side bearings and side bearing outer race separated, so that they do not become mixed during assembly.

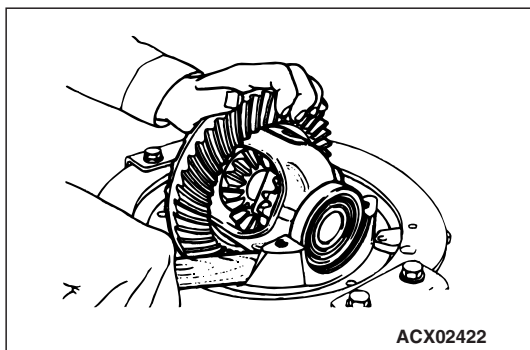

<<C>> SIDE BEARING INNER RACE REMOVAL

Use special tools MB990810 and MB991407 to pull out the side bearing inner race.

NOTE: Attach the prongs of special tools to the inner race of the side bearing through the openings in the differential case.

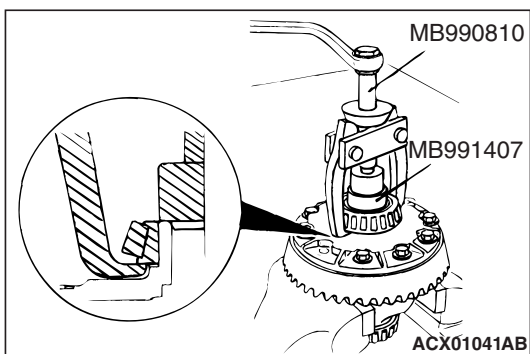

<<D>> DRIVE GEAR REMOVAL

1. Make mating marks to the differential case and the drive gear.
2. Loosen the drive gear attaching bolts in a diagonal sequence to remove the drive gear.

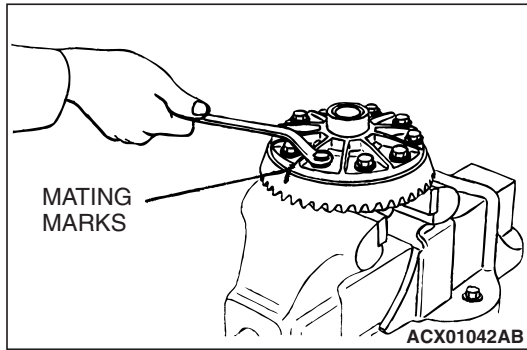
**<<E>> LOCK PIN REMOVAL**

Drive out the lock pin with a punch.

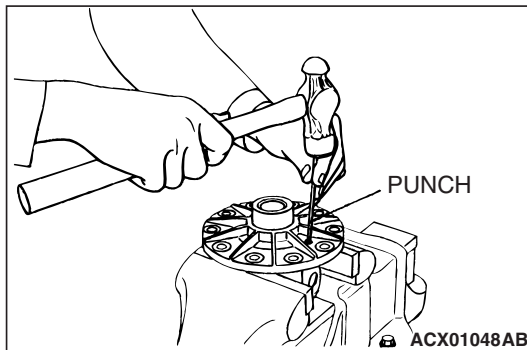
**<<F>> SELF-LOCKING NUT REMOVAL**

Use special tool MB990850 to hold the companion flange, and then remove the companion flange self-locking nut.

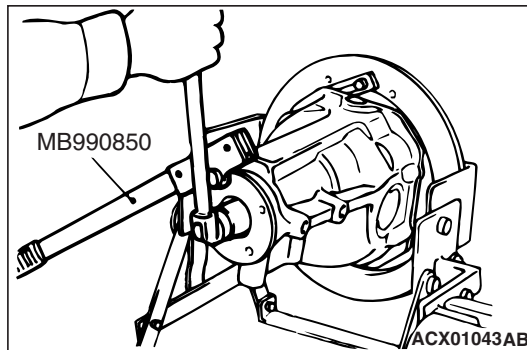
**<<G>> DRIVE PINION ASSEMBLY/COMPANION FLANGE REMOVAL****⚠ CAUTION**

Do not make mating marks on the contact surfaces of the companion flange and propeller shaft.

1. Make mating marks to the drive pinion and companion flange.

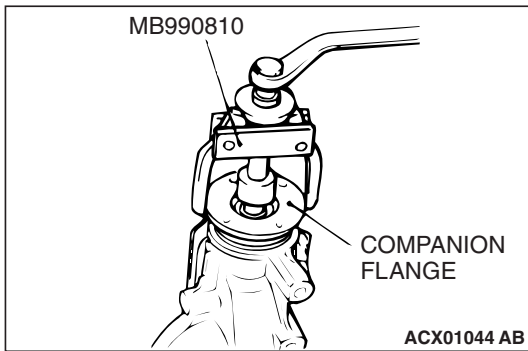

2. Use special tool MB990810 to pull out the companion flange.

<<H>> DRIVE PINION REAR BEARING INNER RACE REMOVAL

Use special tool MD998801 to pull out the front bearing inner race.

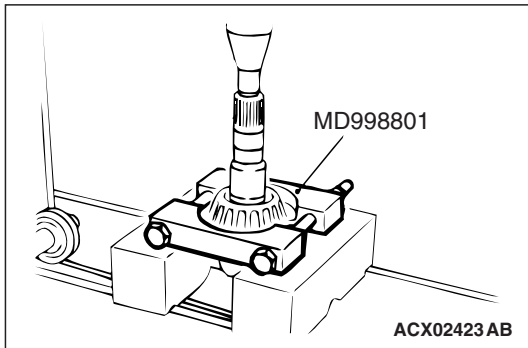

<<I>> OIL SEAL/DRIVE PINION FRONT BEARING INNER RACE/DRIVE PINION FRONT BEARING OUTER RACE REMOVAL

Use special tool MB990939 to remove the drive pinion front bearing outer race.

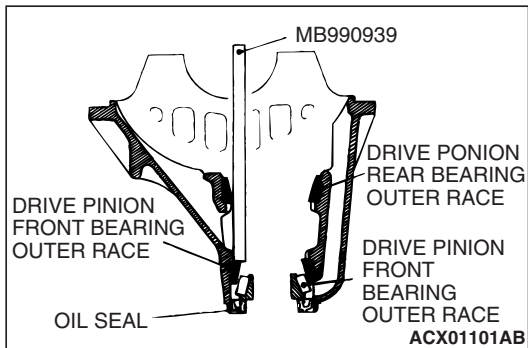

<<J>> DRIVE PINION REAR BEARING OUTER RACE REMOVAL

Use special tool MB990939 to remove the drive pinion rear bearing outer race.

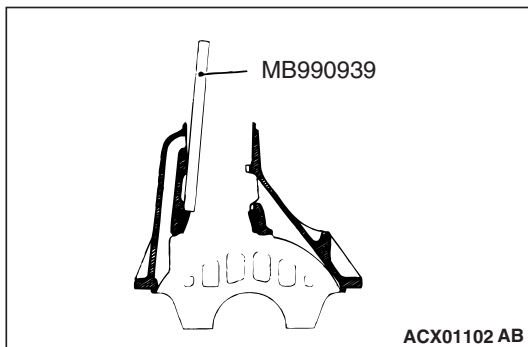

ASSEMBLY

M1272002300266

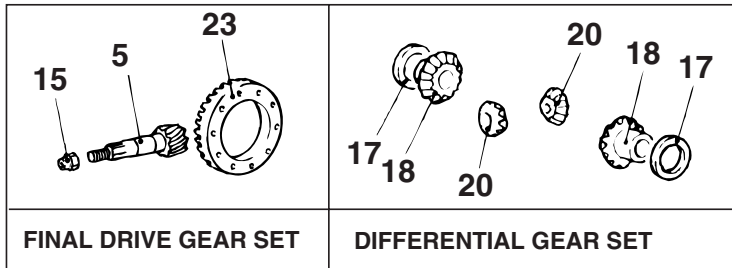
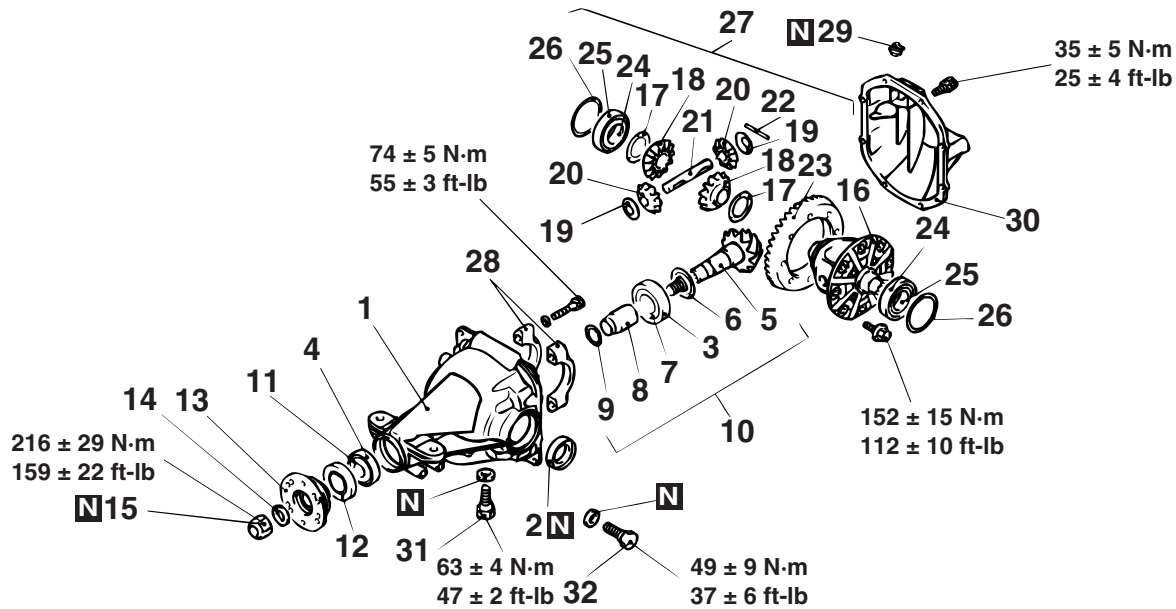

AC203534 AC

ASSEMBLY STEPS

- 1. DIFFERENTIAL CARRIER
- >>A<< 2. OIL SEAL
- >>B<< 3. DRIVE PINION REAR BEARING
OUTER RACE
- >>C<< 4. DRIVE PINION FRONT BEARING
OUTER RACE
- >>D<< • DRIVE PINION HEIGHT
ADJUSTMENT
- 5. DRIVE PINION
- 6. DRIVE PINION REAR SHIM (FOR
ADJUSTING DRIVE PINION
HEIGHT)
- 7. DRIVE PINION REAR BEARING
INNER RACE
- 8. DRIVE PINION SPACER
- >>E<< • DRIVE PINION TURNING TORQUE
ADJUSTMENT
- 9. DRIVE PINION FRONT SHIM (FOR
ADJUSTING DRIVE PINION
PRELOAD)
- 10. DRIVE PINION ASSEMBLY
- 11. DRIVE PINION FRONT BEARING
INNER RACE
- >>E<< 12. OIL SEAL

ASSEMBLY STEPS (Continued)

- 13. COMPANION FLANGE
- 14. WASHER
- 15. SELF-LOCKING NUT
- 16. DIFFERENTIAL CASE
- >>F<< • DIFFERENTIAL GEAR BACKLASH
ADJUSTMENT
- 17. SIDE GEAR SPACER
- 18. SIDE GEAR
- 19. PINION WASHER
- 20. PINION GEAR
- 21. PINION SHAFT
- >>G<< 22. LOCK PIN
- >>H<< 23. DRIVE GEAR
- >>I<< 24. SIDE BEARING INNER RACE
- 25. SIDE BEARING OUTER RACE
- 26. SIDE BEARING SHIM
- 27. DIFFERENTIAL CASE ASSEMBLY
- >>J<< 28. BEARING CAP
- 29. VENT PLUG
- 30. DIFFERENTIAL COVER
- 31. DRAIN PLUG
- 32. FILLER PLUG
- >>J<< • FINAL DRIVE GEAR BACKLASH
ADJUSTMENT

Required Special Tools:

- MB991168: Drive Pinion Oil Seal Installer
- MB990938: Bar
- MB991445: Bushing Remover and Installer Base
- MB990934: Installer Adapter
- MB991770: Head
- MB990819: Drive Pinion Gauge
- MB990326: Preload Socket
- MB990685: Torque Wrench
- MB991169: Drive Pinion Gauge Attachment
- MB991534: Cyliner Gauge
- MB990802: Bearing Installer
- MB990850: End Yoke Holder
- MB990727: Drive Pinion Oil Seal Installer
- MD998812: Installer Cap
- MD998829: Installer Adapter
- MB990810: Side Bearing Puller
- MB991407: Differential Rear Support Arbor

LUBRICATION AND ADHESIVE POINTS

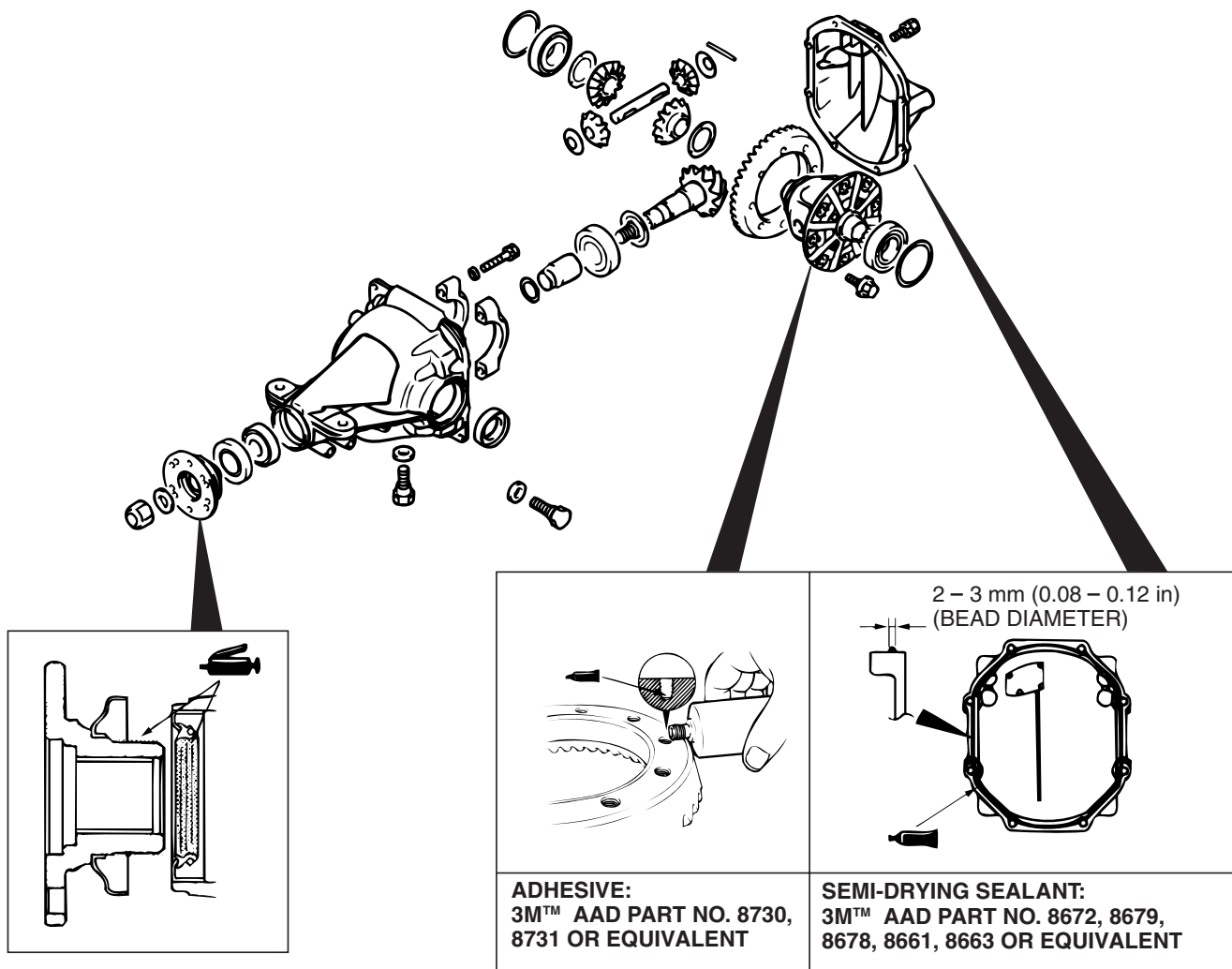

ACX01104 AC

ASSEMBLY SERVICE POINTS

>>A<< OIL SEAL PRESS-FITTING

Use special tool MB991168 to press-fit the oil seal.

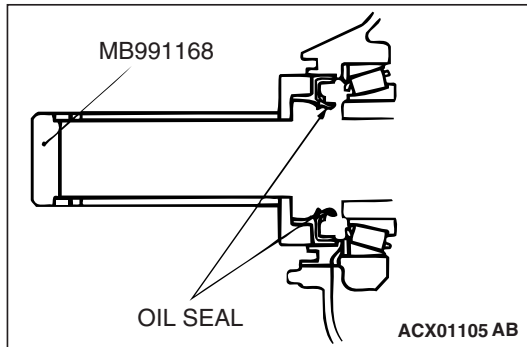

>>B<< DRIVE PINION REAR BEARING OUTER RACE PRESS-FITTING

Use special tools MB990938 and MB991445 to press-fit the drive pinion rear bearing outer race.

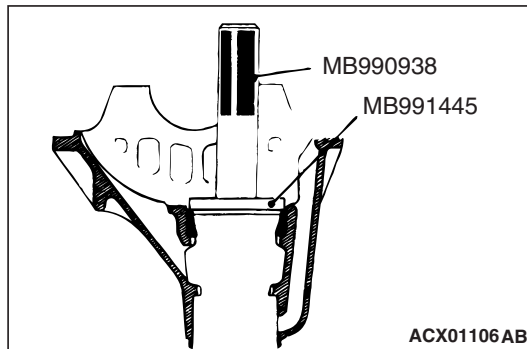

>>C<< DRIVE PINION FRONT BEARING OUTER RACE PRESS-FITTING

Use special tools MB990938 and MB990934 to press-fit the drive pinion front bearing outer race.

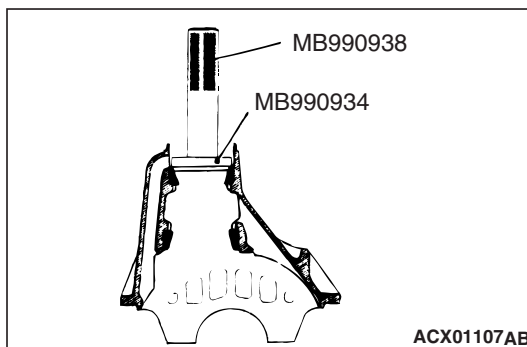

>>D<< DRIVE PINION HEIGHT ADJUSTMENT

Adjust the drive pinion height by the following procedures:

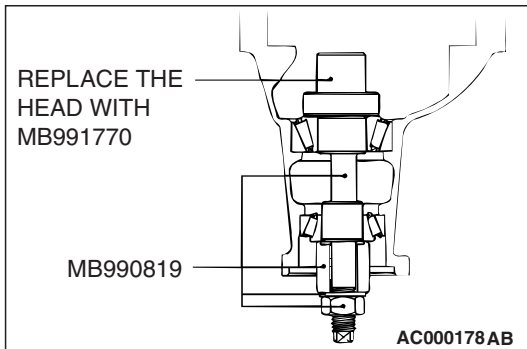

1. Apply multipurpose grease to the washer of special tool MB990819.
2. Install special tool MB990819, MB991770 and drive pinion front and rear bearing inner races to the gear carrier as shown in the illustration.

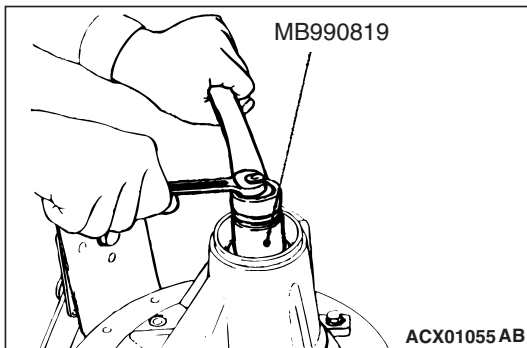

3. Tighten the nut of special tool MB990819 a little at a time, while measuring the turning torque of the drive pinion with special tools MB990685 and MB990326. Then confirm that the turning torque (without the oil seal) is at the standard value.

Standard value:

BEARING DIVISION	TURNING TORQUE
New	1.94 – 2.25 N·m (17.2 – 19.9 in-lb)

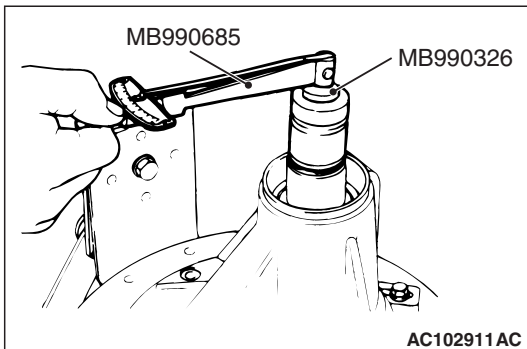

4. Clean the side bearing hub.

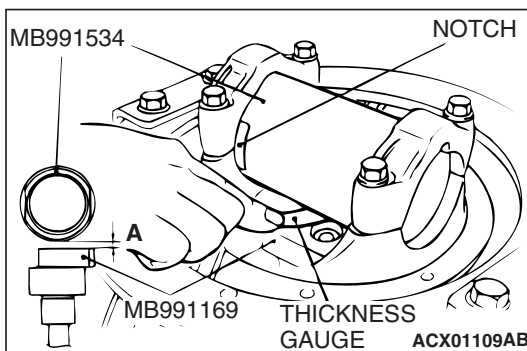

5. Place special tool MB991534 between the side bearing hub of the gear carrier, and position the notch as shown in the illustration. Then tighten side bearing mounting bolt.
6. Use a thickness gauge to measure the clearance (A) between special tools MB991169 and MB991534.
7. Remove special tools MB991169 and Mb991534.

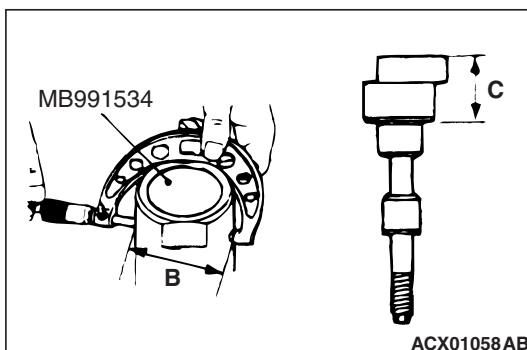

8. Use a micrometer to measure the shown dimensions (B, C) of special tools MB991169 and MB991534.

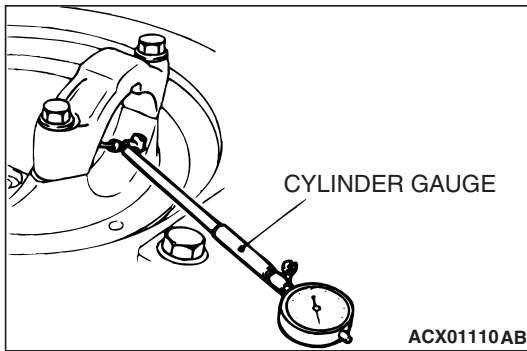

9. Install the bearing cap, and then use a cylinder gauge to measure the inside diameter (D) of the bearing cap.
10. Calculate thickness (F) of the required drive pinion rear shim twice by the following formula. Select a shim which most closely matches this thickness.

$$F = A + B + C - 1/2D - 120.00 \text{ mm (4.724 inches)}$$

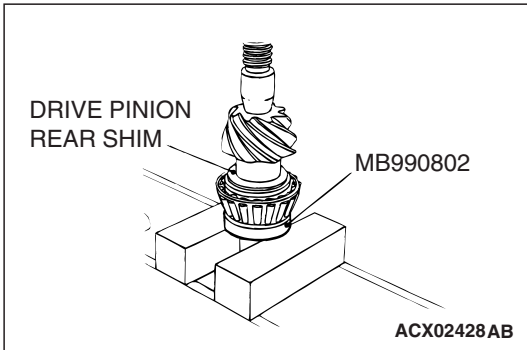

11. Fit the selected drive pinion rear shim(s) to the drive pinion, and press-fit the drive pinion rear bearing inner race by using special tool MB990802.

**>>E<< DRIVE PINION TURNING TORQUE ADJUSTMENT/
OIL SEAL INSTALLATION**

1. Insert the drive pinion into the gear carrier, and then install the following parts in sequence from the carrier rear side: Drive pinion spacer, drive pinion front shim and drive pinion front bearing inner race, companion flange.

NOTE: Do not install the oil seal.

2. Tighten the companion flange to the specified torque by using special tool MB990850.

Tightening torque: 216 ± 29 N·m (159 ± 22 ft-lb)

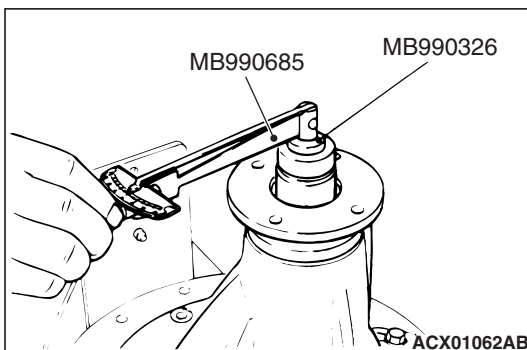
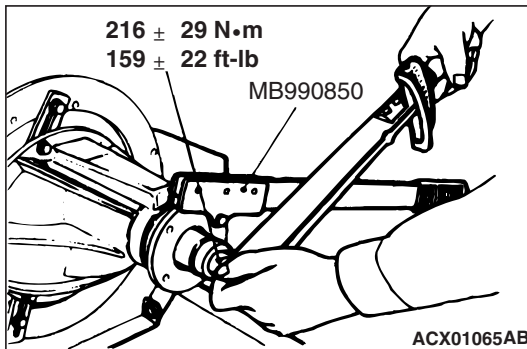

3. Measure the drive pinion turning torque (without the oil seal) with special tools MB990685 and MB990326.

Standard value:

BEARING DIVISION	TURNING TORQUE
New	1.94 – 2.25 N·m (17.2 – 19.9 in-lb)

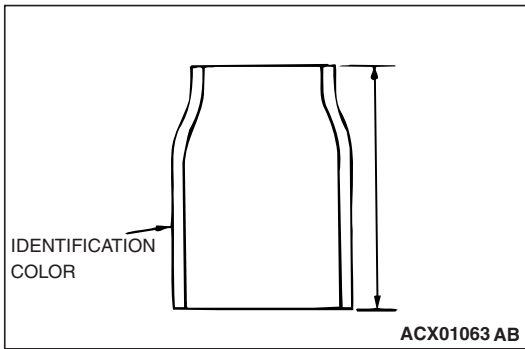

4. If the drive pinion turning torque is not within the standard value, adjust the turning torque by replacing the drive pinion front shim(s) or the drive pinion spacer.

NOTE: When selecting the drive pinion front shims, if the number of shims is large, reduce the number of shims to a minimum by selecting the drive pinion spacers.

Also, select the drive pinion spacer from the following two types.

HEIGHT OF DRIVE PINION SPACER mm (in)	IDENTIFICATION COLOR
52.50 (2.067)	Yellow
52.84 (2.080)	Red

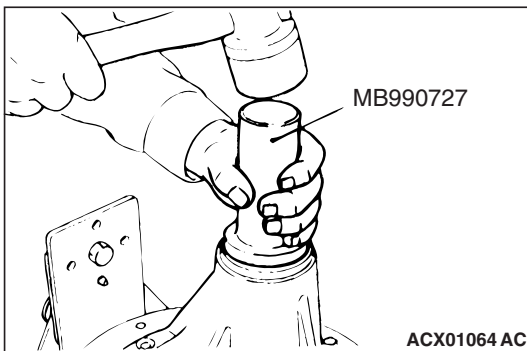

5. Remove the companion flange and drive pinion again. Then insert the drive pinion front bearing inner race into the gear carrier. Use special tool MB990727 to press-fit the oil seal.

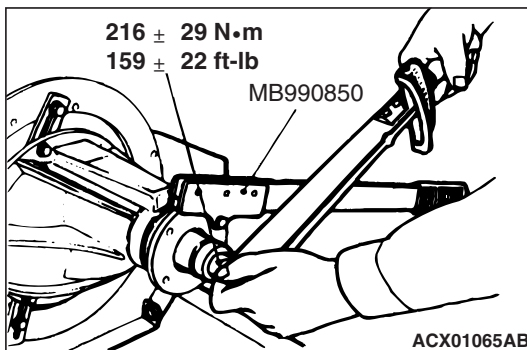

6. Install the drive pinion assembly and companion flange with the mating marks properly aligned. Tighten the companion flange self-locking nut to the specified torque using special tool MB990850.

Tightening torque: 216 ± 29 N·m (159 ± 22 ft-lb)

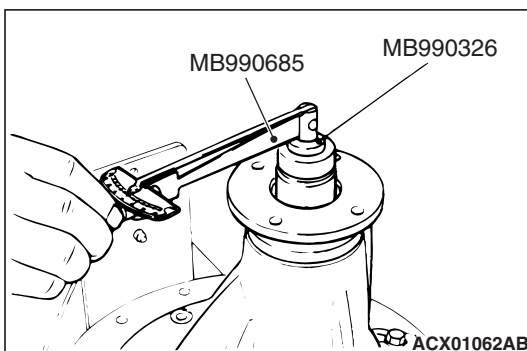

7. Measure the drive pinion turning torque (with oil seal) with special tools MB990685 and MB990326 to verify that the drive pinion turning torque complies with the standard value.

Standard value:

BEARING DIVISION	COMPANION FLANGE LUBRICATION	TURNING TORQUE
New	None (with anti-rust agent)	2.03 – 2.34 N·m (18.0 – 20.7 in-lb)
	Gear oil applied	2.10 – 2.40 N·m (18.6 – 21.2 in-lb)

8. If the turning torque is not within the standard value, check the tightening torque of the companion flange self-locking nut, and the installation of the oil seal.

>>F<< DIFFERENTIAL GEAR BACKLASH ADJUSTMENT

Adjust the differential gear backlash by the following procedure:

1. Assemble the side gears, side gear thrust spacers, pinion gears, and pinion washers into the differential case.
2. Temporarily install the pinion shaft.

NOTE: Do not assemble the thrust block and lock pin yet.

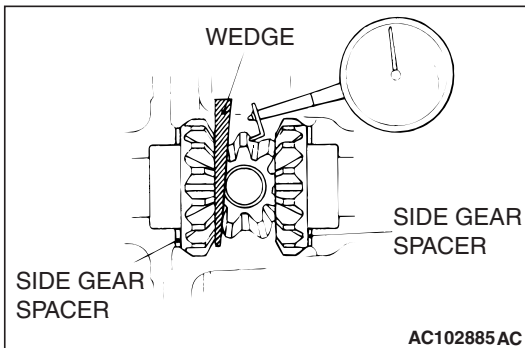
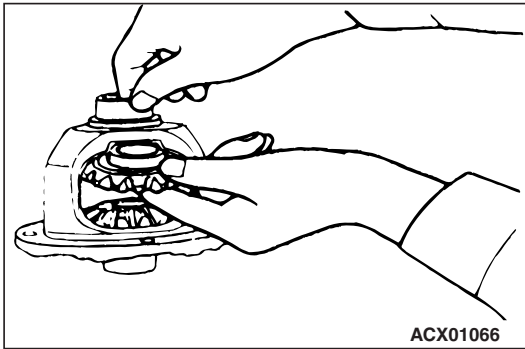

3. Insert a wedge between the side gear and the pinion shaft to lock the side gear.
4. While locking the side gear with the wedge, measure the differential gear backlash with a dial indicator on the pinion gear.

Standard value: 0 – 0.076 mm (0 – 0.0030 inch)

Limit: 0.2 mm (0.01 inch)

5. Measure by the same procedure for the other pinion gear.
6. If the backlash exceeds the limit value, replace side bearing adjustment spacers.
7. If adjustment is not possible, replace the side gears and pinion gears as a set.
8. Check that the backlash is within the limit value and that the differential gear turns smoothly.

>>G<< LOCK PIN INSTALLATION

1. Align the pinion shaft lock pin hole with the differential case lock pin hole, and drive in the lock pin.
2. Stake the lock pin with a punch on both sides.

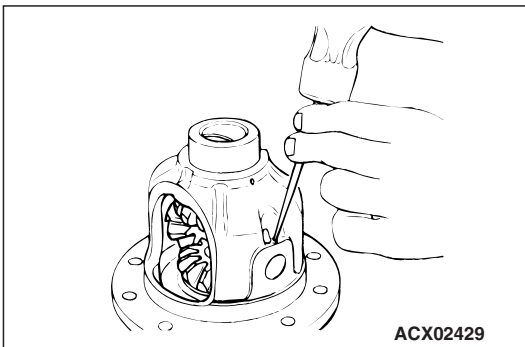

>>H<< DRIVE GEAR INSTALLATION

1. Clean the drive gear attaching bolts.
2. Remove the adhesive adhered to the threaded holes of the drive gear by turning the tap (M10 x 1.25). Clean the threaded holes by applying compressed air.

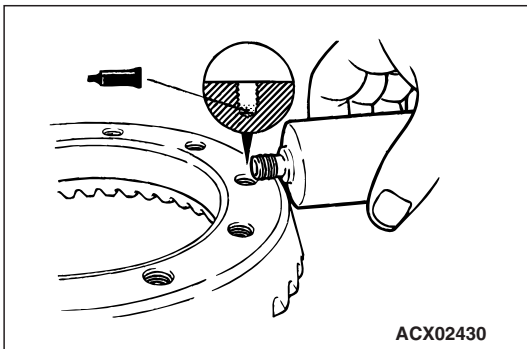
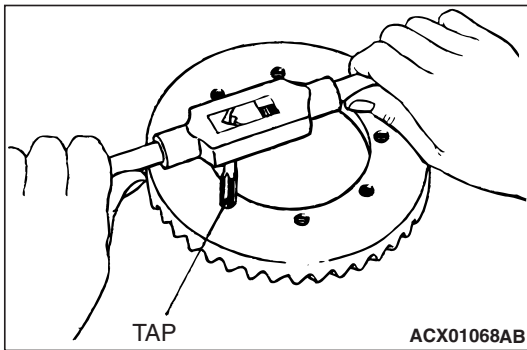

3. Apply 3M™ AAD Part No. 8730, 8731 or equivalent to the threaded holes of the drive gear.
4. Install the drive gear onto the differential case with the mating marks properly aligned. Tighten the bolts to the specified torque in a diagonal sequence.

Tightening torque: 152 ± 15 N·m (112 ± 10 ft-lb)

>>I<< SIDE BEARING INNER RACE INSTALLATION

Use special tools MD998812 and MD998829 to press-fit the side bearing inner races into the differential case.

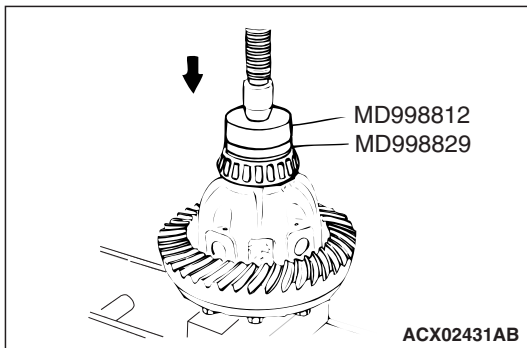

>>J<< BEARING CAP INSTALLATION/FINAL DRIVE GEAR BACKLASH ADJUSTMENT

Adjust drive gear backlash as follows:

1. Assemble the differential case with the side bearing outer race to the gear carrier.
2. Press the differential case to one side to measure the clearance of the side bearing outer race and the gear carrier.
3. Select two pairs of side bearing spacer. Determine the thickness by adding 1/2 of the clearance to the pre-load 0.05mm (0.002 inch).

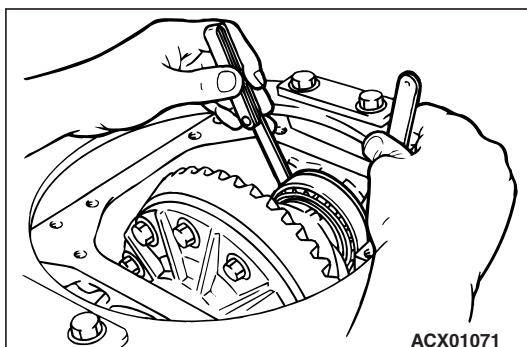

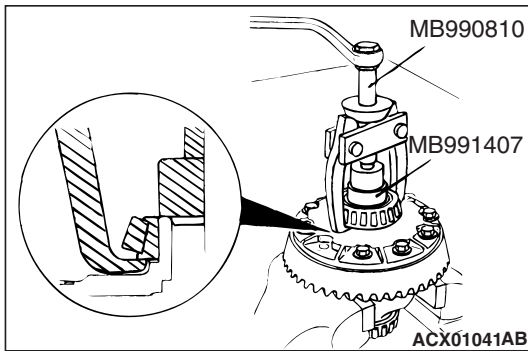

4. Remove the side bearing, using special tools MB990810 and MB991407.
NOTE: Hook the claws of the special tool MB990810 with the side bearing inner race by using the notches (two areas) of the differential case side.
5. Assemble the selected side bearing spacers to each side.

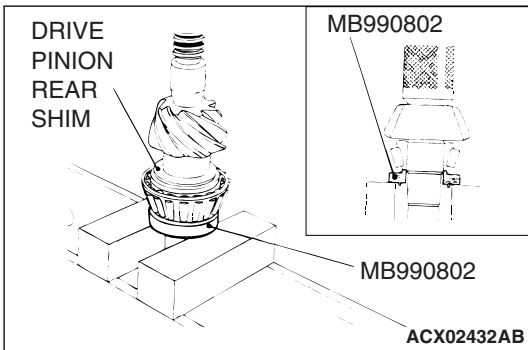

6. Use special tool MB990802 to press-fit the side bearing inner case into the differential case. After installing the outer race, assemble the differential case to the gear carrier.
7. Align the mating marks of differential carrier and the bearing cap with each other and tighten to the specified torque.

Tightening torque: 74 ± 5 N·m (55 ± 3 ft-lb)

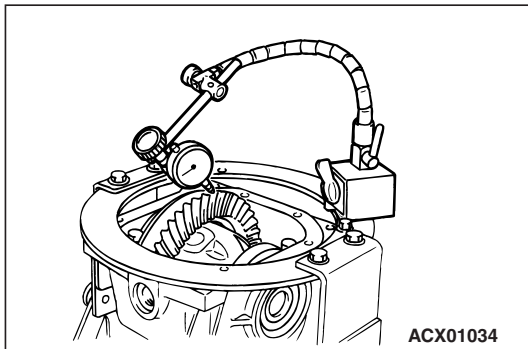

8. Measure the drive gear backlash.
NOTE: Measure at four points or more on the circumference of the drive gear.
Standard value: 0.13 – 0.18 mm (0.005 – 0.007 inch)

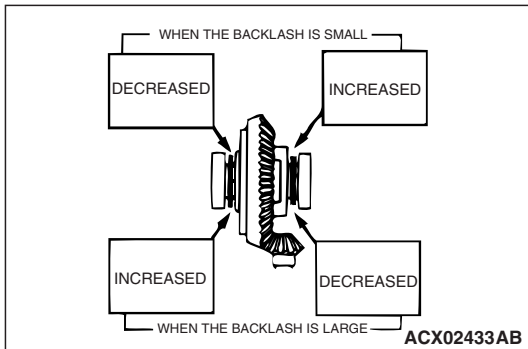

9. If the backlash is not within the standard value, move the side bearing spacer as shown in the illustration to adjust the backlash.
NOTE: The increment of side bearing spacer must be the same as the decreased amount.
10. Inspect the tooth condition at the final drive gear and adjust if required. (Refer to GROUP 26, Inspection Before Disassembly P.26-43).

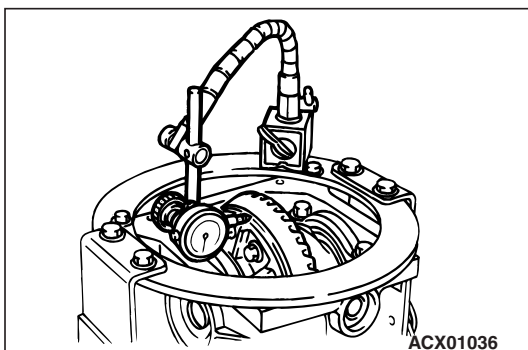

11. Measure the drive gear runout.
Limit: 0.05 mm (0.002 inch)
12. If drive gear runout exceeds the limit, remove the differential case and then the drive gears, moving them to different positions and reinstall them.
13. If adjustment is not possible, replace the differential case or drive gear and drive pinion as a set.

SPECIFICATIONS

FASTENER TIGHTENING SPECIFICATIONS

M1271004000257

ITEM	SPECIFICATION
Rear axle hub assembly, drive shaft assembly	
Backing plate bolt	133 ± 14 N·m (98 ± 10 ft-lb)
Disc brake assembly bolt	100 ± 10 N·m (74 ± 7 ft-lb)
Lower arm and knuckle connection nut	152 ± 25 N·m (113 ± 18 ft-lb)
Rear drive shaft and companion shaft connection nut	113 ± 14 N·m (84 ± 10 ft-lb)
Rear drive shaft nut	255 ± 29 N·m (188 ± 21 ft-lb)
Knuckle	
Toe-control arm and knuckle connection nut	67 ± 7 N·m (50 ± 5 ft-lb)
Trailing arm and knuckle connection bolt	231 ± 34 N·m (170 ± 25 ft-lb)
Upper arm and knuckle connection nut	150 ± 30 N·m (111 ± 22 ft-lb)
Differential carrier assembly	
Bearing cap bolt	74 ± 5 N·m (55 ± 3 ft-lb)
Differential cover bolt	35 ± 5 N·m (25 ± 4 ft-lb)
Dynamic damper bolt	83 ± 12 N·m (61 ± 9 ft-lb)
Drain plug	63 ± 4 N·m (47 ± 2 ft-lb)
Drive gear bolt	152 ± 15 N·m (112 ± 10 ft-lb)
Drive pinion self-locking nut	216 ± 29 N·m (159 ± 22 ft-lb)
Filler plug	49 ± 9 N·m (37 ± 6 ft-lb)
Lower arm and knuckle connection nut	152 ± 25 N·m (113 ± 18 ft-lb)
Rear drive shaft and companion shaft connection nut	113 ± 14 N·m (84 ± 10 ft-lb)
Rear differential mount member nut	152 ± 25 N·m (113 ± 18 ft-lb)
Toe-control tower bar bolt and nut	46 ± 8 N·m (34 ± 6 ft-lb)

GENERAL SPECIFICATIONS

M1271000200130

ITEM	SPECIFICATION	
Reduction gear type	Hypoid gear	
Reduction ratio	4.300	
Differential gear type (Type × number of gears)	Side gear	Straight bevel gear × 2
	Pinion gear	Straight bevel gear × 2
Number of teeth	Drive gear	43
	Drive pinion	10
	Side gear	18
	Pinion gear	10
Bearings (Outside diameter × Inside diameter) mm (in)	Side	90.0 × 55.0 (3.54 × 2.17)
	Front	68.3 × 30.2 (2.69 × 1.19)
	Rear	79.4 × 36.5 (3.13 × 1.44)

SERVICE SPECIFICATIONS

M1271000300308

ITEM		STANDARD VALUE	LIMIT
Rear axle total backlash mm (in)		–	5 (0.2)
Wheel bearing end play mm (in)		–	0 (0)
Wheel bearing rotation starting torque N·m (in-lb)		–	1.76 (15.6)
DOJ boot assembly dimension mm (in)		110 ± 3 (4.3 ± 0.1)	–
Drive gear backlash mm (in)		0.13 – 0.18 (0.005 – 0.007)	–
Drive gear runout mm (in)		–	0.05 (0.002)
Differential gear backlash mm (in)		0 – 0.076 (0 – 0.0030)	0.2 (0.01)
Drive pinion turning torque N·m (in-lb)	Without oil seal	1.94 – 2.25 (17.2 – 19.9)	–
	With oil seal	Companion flange (oil seal contacting area) with anti-rust agent	2.03 – 2.34 (18.0 – 20.7)
		Companion flange (oil seal contacting area) with gear oil applied	2.10 – 2.40 (18.6 – 21.2)

LUBRICANTS

M1271000400242

ITEM	SPECIFIED LUBRICANT	QUANTITY
Rear differential gear oil	Hypoid gear oil API classification GL-5 or higher <ul style="list-style-type: none"> • Above –23°C(–10°F): SAE 90, 85W-90, 80W-90 • From –34 to –23°C(–30 to –10°F): SAE 80W, 80W-90 • Below –34°C(–30°F): SAE 75W 	Approximately 1.6 dm ³ (1.7 qt)
BJ joint	Repair kit grease	245 ± 10 g (8.7 ± 0.3 oz)
DOJ joint	Repair kit grease	295 ± 10 g (10.5 ± 0.3 oz)

SEALANT AND ADHESIVE

M1271000500142

ITEM	SPECIFIED SEALANT AND ADHESIVE
Differential cover	3M™ AAD Part No. 8672, 8679, 8678, 8661, 8663 or equivalent
Drive gear and differential case mounting part	3M™ AAD Part No. 8730, 8731 or equivalent

COMPONENT IDENTIFICATION

M1271003800045

DRIVE PINION SPACER

HEIGHT OF DRIVE PINION SPACER mm (in)	IDENTIFICATION COLOR
52.50 (2.067)	Yellow
52.84 (2.080)	Red