

GROUP 33

FRONT SUSPENSION

CONTENTS

GENERAL DESCRIPTION	33-2	SHOCK ABSORBER ASSEMBLY ...	33-11
FRONT SUSPENSION DIAGNOSIS .	33-2	REMOVAL AND INSTALLATION	33-11
INTRODUCTION TO FRONT SUSPENSION		DISASSEMBLY AND ASSEMBLY	33-12
DIAGNOSIS	33-2	LOWER ARM	33-15
TROUBLESHOOTING STRATEGY	33-2	REMOVAL AND INSTALLATION	33-15
SYMPTOM CHART.....	33-3	INSPECTION.....	33-18
SYMPTOM PROCEDURES	33-3	LOWER ARM BALL JOINT DUST COVER	
SPECIAL TOOLS	33-5	REPLACEMENT	33-19
ON-VEHICLE SERVICE	33-5	STABILIZER BAR	33-20
FRONT WHEEL ALIGNMENT CHECK AND		REMOVAL AND INSTALLATION	33-20
ADJUSTMENT	33-5	INSPECTION.....	33-21
UPPER ARM BALL JOINT END PLAY CHECK	33-7	STABILIZER LINK BALL JOINT DUST COVER	
BALL JOINT DUST COVER CHECK	33-7	REPLACEMENT	33-22
UPPER ARM ASSEMBLY	33-8	SPECIFICATIONS	33-22
REMOVAL AND INSTALLATION.....	33-8	FASTENER TIGHTENING SPECIFICATIONS	33-22
INSPECTION	33-10	GENERAL SPECIFICATIONS	33-23
		SERVICE SPECIFICATIONS	33-23

GENERAL DESCRIPTION

M1331000100084

This is a coil spring-type double wishbone independent-type front suspension. This type of suspension is rigid, has very little variation in roll center height and provides excellent riding comfort.

CONSTRUCTION DIAGRAM

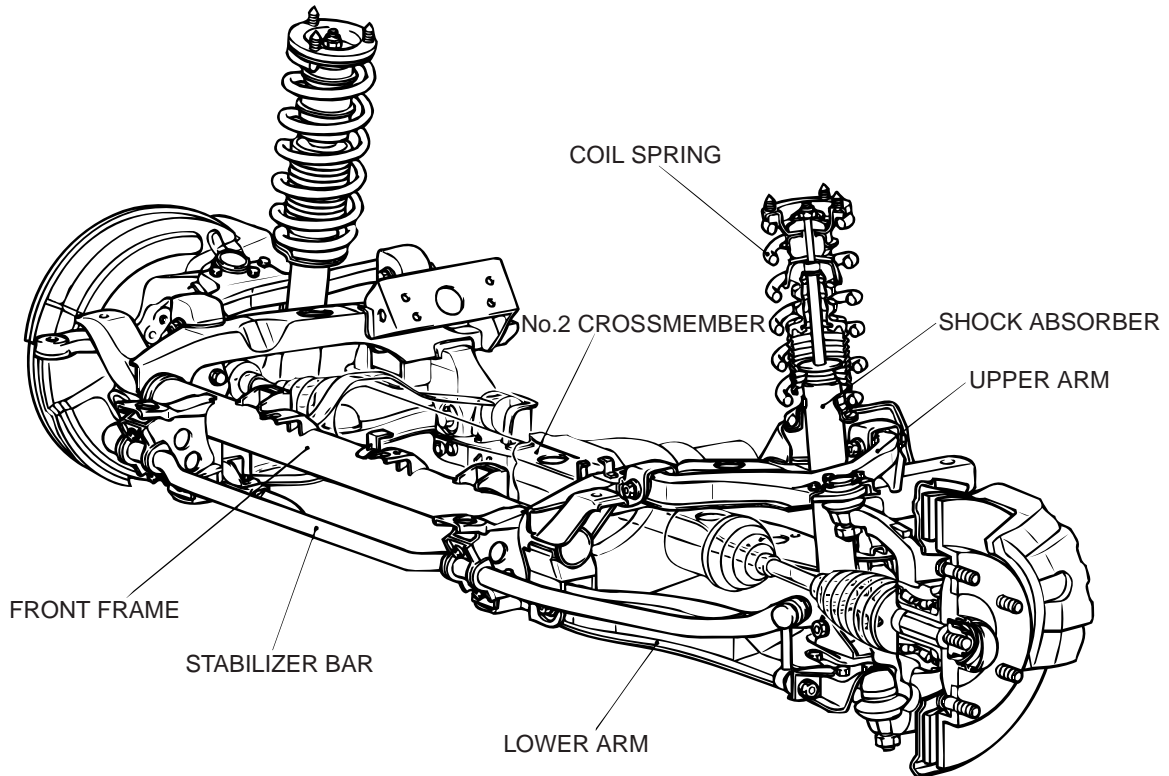

ACX02227AB

FRONT SUSPENSION DIAGNOSIS

INTRODUCTION TO FRONT SUSPENSION DIAGNOSIS

M1332009000184

If the rear suspension is faulty, the vehicle will not track straight or unusual noise will occur. Incorrect wheel alignment, malfunction of shock absorber, stabilizer bar, coil spring, control arms or out-of-balance tires may cause these problems.

TROUBLESHOOTING STRATEGY

M1332009100170

Use these steps to plan your diagnostic strategy. If you follow them carefully, you will be sure that you have exhausted most of the possible ways to find a rear suspension fault.

1. Gather information from the customer.

2. Verify that the condition described by the customer exists.
3. Find the malfunction by following the Symptom Chart.
4. Verify malfunction is eliminated.

SYMPTOM CHART

M1332009400212

SYMPTOM	INSPECTION PROCEDURE	REFERENCE PAGE
Steering wheel is heavy, vibrates or pulls to one side	1	P.33-3
Excessive body rolling	2	P.33-3
Poor ride	3	P.33-4
Unequal ride height	4	P.33-4
Noise	5	P.33-4

SYMPTOM PROCEDURES

INSPECTION PROCEDURE 1: Steering Wheel is Heavy, Vibrates or Pulls to One Side

DIAGNOSIS

STEP 1. Check the tires.

Refer to GROUP 31, Wheel and Tire Diagnosis P.31-10.

Q: Are the tires at normal condition?

YES : Replace the tires as necessary, then go to Step 2.

NO : If out of balance, balance the tires as necessary. If excessively worn, replace the tires as necessary and go to Step 5.

STEP 2. Check the wheel alignment.

Q: Is the wheel alignment correct?

YES : Go to Step 3.

NO : Adjust it, then go to Step 5.

STEP 3. Check the ball joint.

Q: Is the ball joint in good condition?

YES : Go to Step 4.

NO : Replace it, then go to Step 5.

STEP 4. Check the coil spring.

Q: Is the coil spring in good condition?

YES : Go to Step 5.

NO : Replace it, then go to Step 5.

STEP 5. Retest the system.

Q: Is the malfunction eliminated?

YES : The procedure is complete.

NO : Return to Step 1.

INSPECTION PROCEDURE 2: Excessive Body Rolling

DIAGNOSIS

STEP 1. Check for broken or deteriorated stabilizer bar.

Q: Is the stabilizer bar in good condition?

YES : Go to Step 2.

NO : Replace it, then go to Step 3.

STEP 2. Check for shock absorber damage.

Q: Is the shock absorber in good condition?

YES : Go to Step 3.

NO : Replace it, then go to Step 3.

STEP 3. Retest the system.

Q: Is the malfunction eliminated?

YES : The procedure is complete.

NO : Return to Step 1.

INSPECTION PROCEDURE 3: Poor Ride**DIAGNOSIS****STEP 1. Check for improper tire inflation pressure.**

Refer to GROUP 31, On-vehicle Service – Tire Inflation Pressure Check [P.31-85](#).

Q: Is the tire inflation correct?

YES : Go to Step 2.

NO : Adjust it, then go to Step 4.

STEP 2. Check for broken or deteriorated coil spring(s).

Q: Are the coil spring(s) broken or deteriorated?

YES : Replace it, then go to Step 4.

NO : Go to Step 3.

STEP 3. Check for shock absorber damage.

Q: Is the shock absorber damaged?

YES : Replace it, then go to Step 4.

NO : Go to Step 4.

STEP 4. Retest the system.

Q: Is the malfunction eliminated?

YES : The procedure is complete.

NO : Return to Step 1.

INSPECTION PROCEDURE 4: Unequal Ride Height**DIAGNOSIS****STEP 1. Check for broken or deteriorated coil spring(s).**

Q: Are the coil spring(s) broken or deteriorated?

YES : Replace it, then go to Step 2.

NO : Go to Step 2.

STEP 2. Retest the system.

Q: Is the malfunction eliminated?

YES : The procedure is complete.

NO : Return to Step 1.

INSPECTION PROCEDURE 5: Noise**DIAGNOSIS****STEP 1. Check for lack of lubrication.**

Q: Is lubrication inadequate?

YES : Lubricate it, then go to Step 5.

NO : Go to Step 2.

STEP 2. Check the tightened parts for looseness as well as the bushings for wear.

Q: Are the tightened parts and bushings in good condition?

YES : Go to Step 3.

NO : Replace it, then go to Step 5.

STEP 3. Check for broken coil spring(s).

Q: Are the coil spring(s) broken?

YES : Replace it, then go to Step 5.

NO : Go to Step 4.

STEP 4. Check for shock absorber damage.

Q: Is the shock absorber damaged?

YES : Replace it, then go to Step 5.

NO : Go to Step 5.

STEP 5. Retest the system.

Q: Is the malfunction eliminated?

YES : The procedure is complete.

NO : Return to Step 1.

SPECIAL TOOLS

M1331000600089

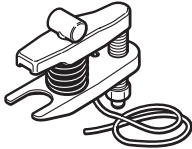
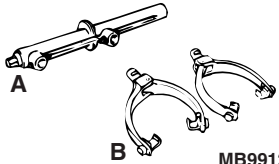
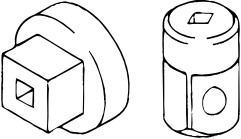
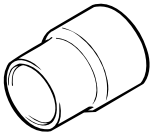
TOOL	TOOL NUMBER AND NAME	SUPERSESION	APPLICATION
 AC106827	MB991897 Ball joint remover	MB991113-01, MB990635-01 or General service tool	Ball joint disconnection <i>NOTE: Steering linkage puller (MB990635 or MB991113) is also available to disconnect ball joint.</i>
 A B MB991237	A:MB991237 spring compressor body B:MB991238 arm set	MIT221369	Coil spring removal and installation
 MB990326	MB990326 Preload socket	General service tool	Ball joint rotating torque check
 MB990799	MB990799 Ball joint remover and installer	MB990799-01	Dust cover installation

ON-VEHICLE SERVICE

FRONT WHEEL ALIGNMENT CHECK AND ADJUSTMENT

M1331000900820

Required Special Tool:

- MB991004: Wheel Alignment Gauge Attachment.

Measure wheel alignment with alignment equipment on a level surface. The front suspension, steering system, and wheels should be serviced to normal condition before measuring wheel alignment.

TOE-IN

Standard value: 2.5 ± 2.5 mm (0.10 ± 0.10 inch)

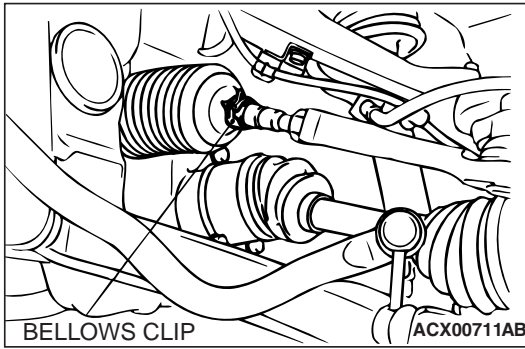

1. Adjust the toe-in by undoing the bellows clip and turning the left and right tie rod turnbuckles by the same amount (in opposite directions).

NOTE: The toe will move out as the left turnbuckle is turned toward the front of the vehicle and the right turnbuckle is turned toward the rear of the vehicle.

2. Use a turning radius gauge to check that the steering angle is at the standard value (Refer to GROUP 37, On-vehicle Service P.37-15).

STEERING ANGLE

Standard value:

Inner wheel	36°30' ± 1°30'
Outer wheel (reference)	31°40'

CAMBER AND CASTER

Standard value:

Camber: 0°00' ± 30' (difference between right and left wheels: within 30')

Caster: 3°50' ± 1° (difference between right and left wheels: within 30')

If the standard value is not obtained, make adjustment by the following procedure.

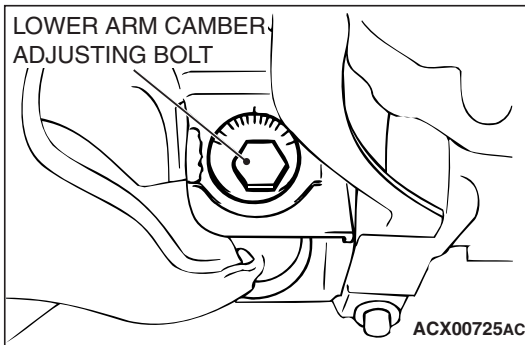
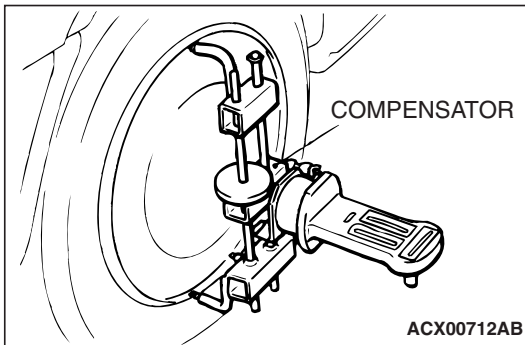

1. Adjust the camber and caster until they meet the standard value by turning the lower arm camber adjusting bolt according to the camber and caster reference table (Refer to P.33-6).

2. After adjusting the camber, the toe should be adjusted.

CAMBER AND CASTER REFERENCE TABLE

HOW TO READ THIS TABLE (EXAMPLE)

If the camber difference -0°35' and the caster difference is 0°18' by comparing the measurement value with the standard value, rotate the front adjusting cam by 1.5 graduations and the rear adjusting cam by 2.5 graduations to the opposite direction against the "A" direction.

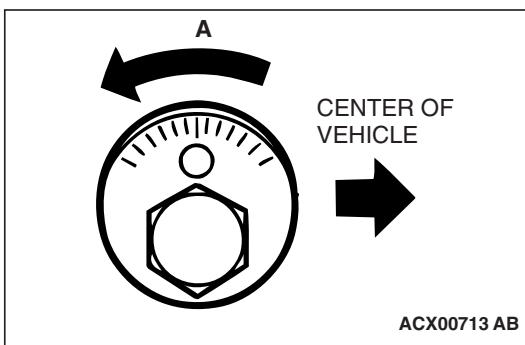

UPPER ARM ASSEMBLY

REMOVAL AND INSTALLATION

M1332004300094

CAUTION

*: Indicates parts which should be temporarily tightened, and then fully tightened with the vehicle on the ground in an unladen condition.

Post-installation Operation

- Check the dust cover for cracks or damage by pushing it with your finger.
- Wheel Alignment Check and Adjustment (Refer to P.33-5).

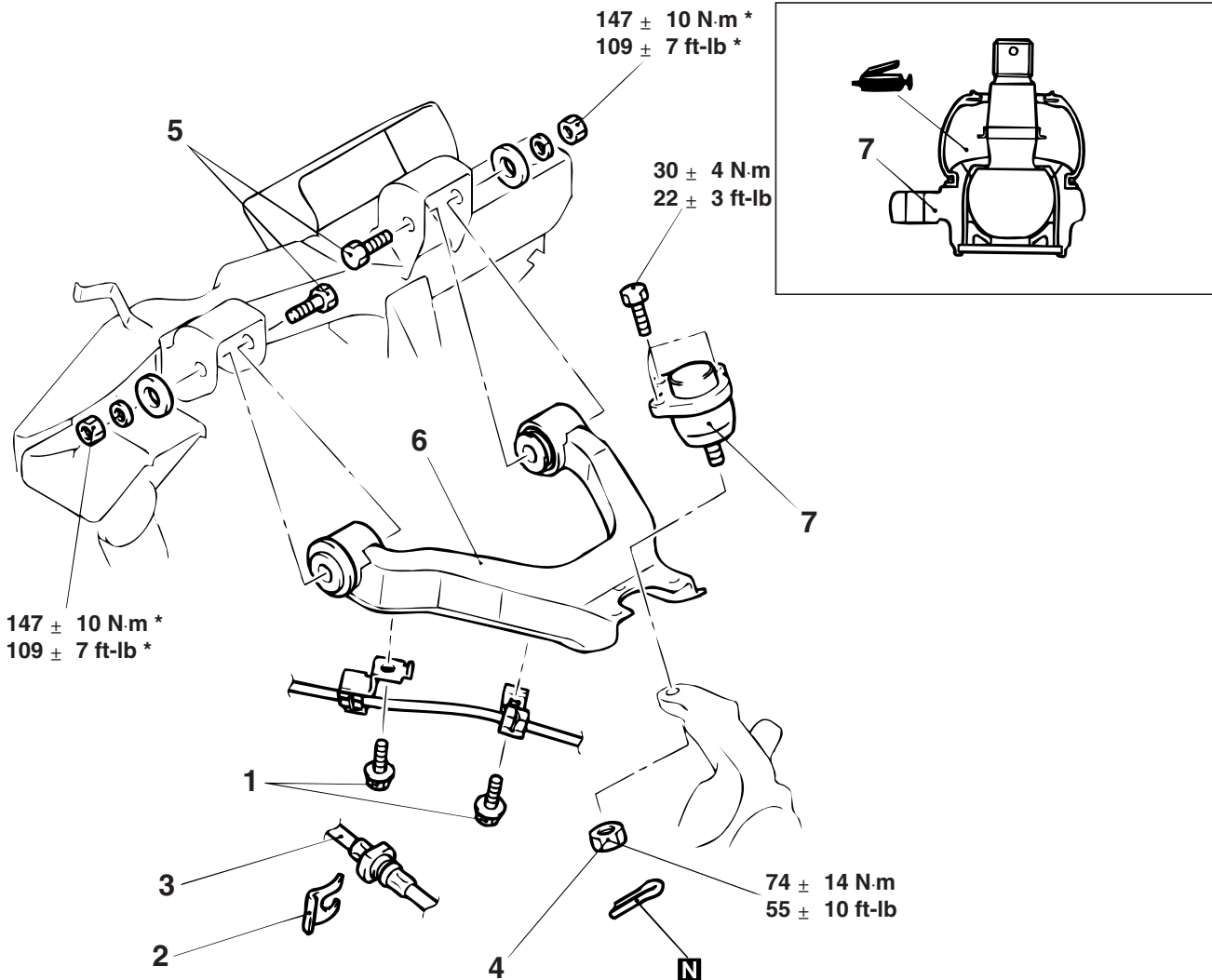

ACX00714 AB

REMOVAL STEPS

1. FRONT WHEEL SPEED SENSOR BRACKET MOUNTING BOLT
2. CLIP
3. BRAKE HOSE
4. UPPER ARM BALL JOINT AND KNUCKLE CONNECTION
5. UPPER ARM ASSEMBLY AND FRONT FRAME CONNECTION

REMOVAL STEPS (Continued)

6. UPPER ARM ASSEMBLY
7. UPPER ARM BALL JOINT ASSEMBLY

Required Special Tool:

- MB991897: Ball Joint Remover

<<A>> >>A<<

REMOVAL SERVICE POINT

<<A>> UPPER ARM BALL JOINT AND KNUCKLE DISCONNECTION

⚠ CAUTION

- Do not remove the nut from ball joint. Loosen it and use special tool MB991897 to avoid possible damage to ball joint threads.
- Hang special tool MB991897 with a cord to prevent it from falling.

1. Install special tool MB991897 as shown in the figure.

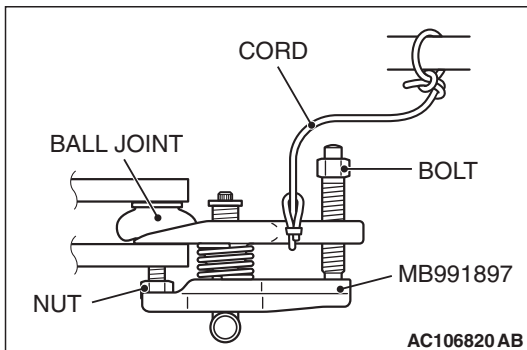

2. Turn the bolt and knob as necessary to make the jaws of special tool MB991897 parallel, tighten the bolt by hand and confirm that the jaws are still parallel.

NOTE: When adjusting the jaws in parallel, make sure the knob is in the position shown in the figure.

3. Tighten the bolt with a wrench to disconnect the ball joint.

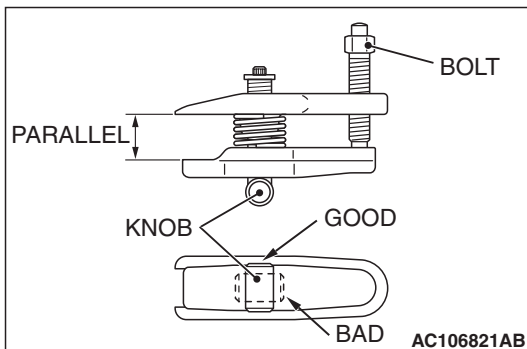

INSTALLATION SERVICE POINT

>>A<< UPPER ARM BALL JOINT AND KNUCKLE CONNECTION

If the upper arm ball joint is disengaged from the knuckle, always renew the upper arm ball joint dust cover and retainer by following the procedure below.

1. Unclip the spring ring to remove the dust cover.

⚠ CAUTION

Be careful not to damage the ball joint stud.

2. Use a flat-tipped screwdriver to remove the retainer.

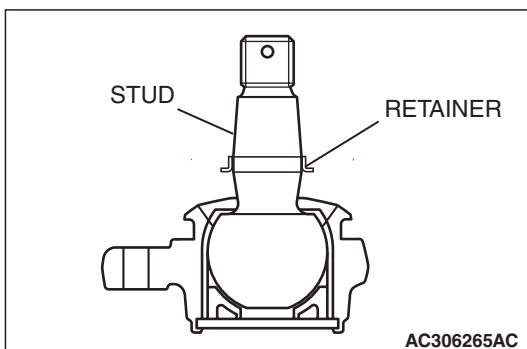

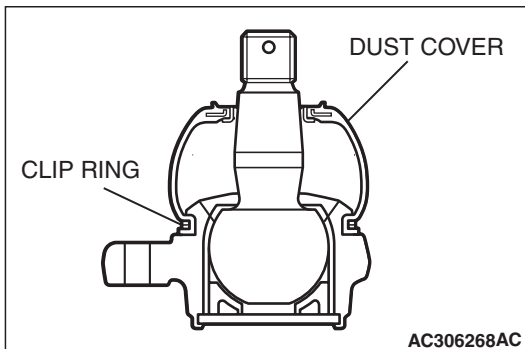
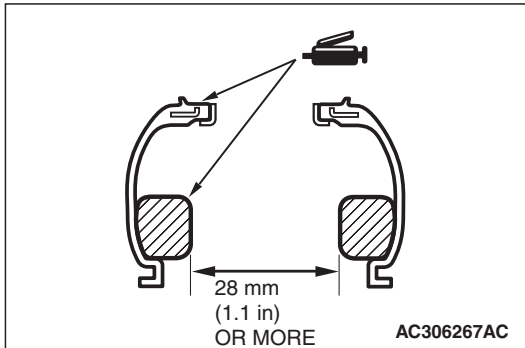
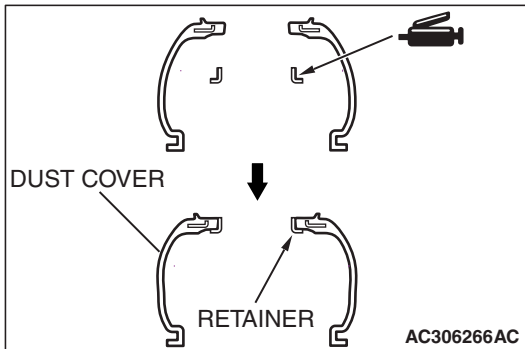

3. Apply multi-purpose grease to the new retainer, and assemble it to the new dust cover.

4. Fill multi-purpose grease inside the dust cover as shown.

Amount to use: 12 ± 1 g (0.4 ± 0.04 oz)

5. Apply multi-purpose grease to the dust cover lip.
6. Tape the stud threads to avoid damage.

⚠ CAUTION

Ensure grease does not come into contact with the ball joint threads and tapers. Wipe off the grease if contaminated.

7. Install the ball joint to the dust cover.
8. Secure the dust cover with the clip ring.
9. Engage the upper arm ball joint with the knuckle.

NOTE: The retainer is secured in a predetermined position by tightening the ball joint nut to the specified torque.

INSPECTION

M1332004400068

- Check the bushing for wear and deterioration.
- Check the upper arm for bend or breakage.
- Check all bolts for condition and straightness.

UPPER ARM BALL JOINT TURNING TORQUE CHECK

Required Special Tool:

- MB990326: Preload Socket

1. After shaking the ball joint stud several times, install the nut to the stud and use special tool MB990326 to measure the turning torque of the ball joint.

Standard value: 0.4 – 2.5 N·m (4 – 22 in-lb)

2. If the measured value exceeds the standard value, replace the upper arm ball joint assembly.
3. If the measured value is lower than the standard value, check that the upper arm ball joint turns smoothly without excessive play. If so, it is possible to use that ball joint.

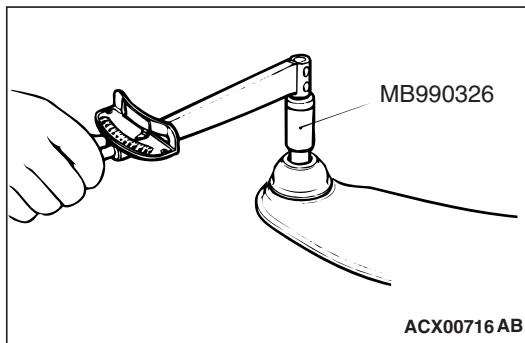

UPPER ARM BALL JOINT DUST COVER CHECK

1. Press the dust cover with your finger to check that there are no cracks or damage in the dust cover.
2. If the dust cover is cracked or damaged, replace the upper arm ball joint assembly.

NOTE: If the dust cover is cracked or damaged, it is possible that there may also be damage to the ball joint.

SHOCK ABSORBER ASSEMBLY

REMOVAL AND INSTALLATION

M1332004600051

CAUTION

To prevent bushings from breakage, the parts indicated by * should be temporarily tightened, and then fully tightened with the vehicle on the ground in the unladen condition.

Pre-removal Operations

- Upper Arm Assembly Removal (Refer to P.33-8.)
- Battery, Battery Tray Removal
- Condenser Tank Removal (Refer to GROUP 14, Radiator P.14-8.)
- Air Cleaner Assembly Removal (Refer to GROUP 15, Air Cleaner P.15-6.)

Post-installation Operations

- Air Cleaner Assembly Installation (Refer to GROUP 15, Air Cleaner P.15-6.)
- Condenser Tank Installation (Refer to GROUP 14, Radiator P.14-8.)
- Battery, Battery Tray Installation
- Upper Arm Assembly Installation (Refer to P.33-8.)
- Wheel Alignment Check and Adjustment (Refer to P.33-5.)

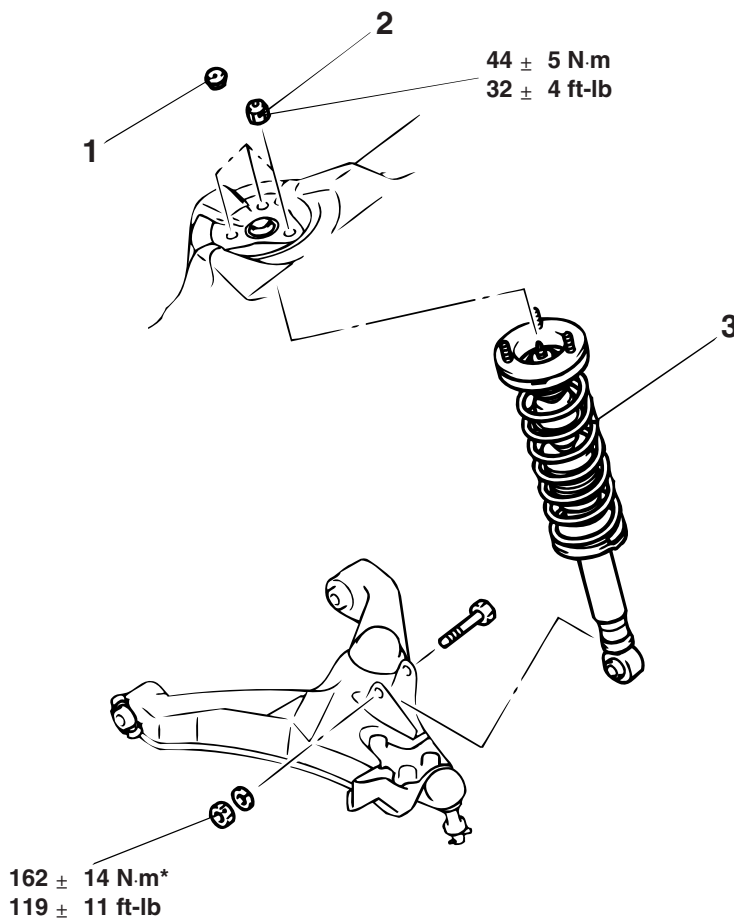

ACX00718 AB

REMOVAL STEPS

1. CAP

REMOVAL STEPS (Continued)

2. SHOCK ABSORBER MOUNTING NUT
3. SHOCK ABSORBER ASSEMBLY

DISASSEMBLY AND ASSEMBLY

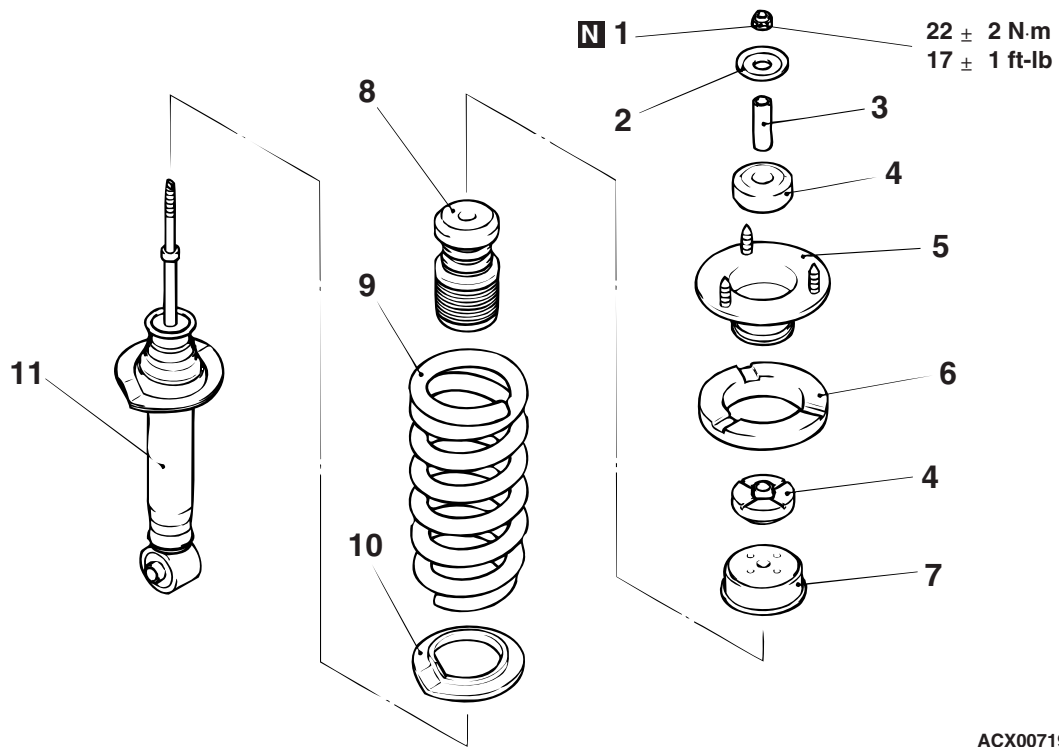

ACX00719 AB

DISASSEMBLY STEPS

- <<A>> >>C<< 1. SELF-LOCKING NUT
- 2. SEAT
- 3. COLLAR
- 4. UPPER BUSH
- >>B<< 5. SPRING BRACKET ASSEMBLY
- 6. SPRING UPPER PAD
- 7. CUP ASSEMBLY
- 8. HELPER RUBBER

DISASSEMBLY STEPS (Continued)

- >>A<< 9. COIL SPRING
- >>A<< 10. SPRING LOWER PAD
- 11. SHOCK ABSORBER ASSEMBLY

Required Special Tools:

- MB991237: Spring Compressor
- MB991238: Arm Set

DISASSEMBLY SERVICE POINT

<<A>> SELF-LOCKING NUT REMOVAL

⚠ CAUTION

Do not tighten the special tool bolt too tight. The tool will be broken if the bolt is tightened over the allowable torque 74 N·m (55 ft·lb). Install the special tools evenly, and so that the maximum length will be attained within the installation range. Do not use an impact wrench, as it will cause the bolt of the special tool to be seized.

1. Use special tools MB991237 and MB991238 to press the coil spring.

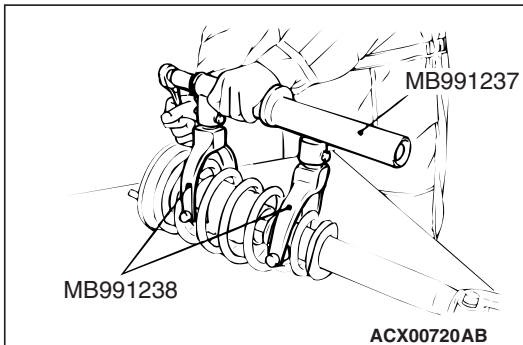

⚠ CAUTION

To prevent the piston rod lock nut inside the strut from loosening, do not use an impact wrench when the locking nuts are loosened.

2. To prevent the piston rod from turning and unscrew the self-locking nut.

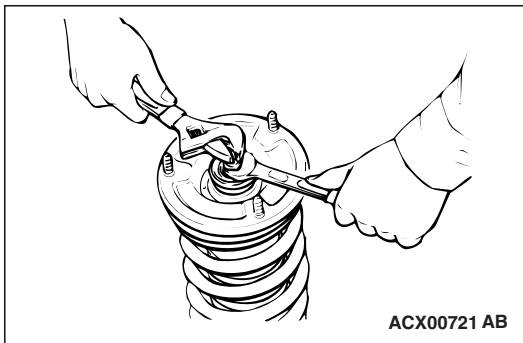

ASSEMBLY SERVICE POINTS

>>A<< SELF-LOCKING NUT INSTALLATION

⚠ CAUTION

- Do not tighten the special tool bolt too tight. The tool will be broken if the bolt is tightened over the allowable torque 74 N·m(55 ft-lb).
- Install the special tools evenly, and so that the maximum length will be attained within the installation range.
- Do not use an impact wrench, as it will cause the bolt of the special tool to be seized.

1. Install special tools MB991237 and MB991238 same as its removal and compress the coil spring to install to the shock absorber.
2. Align the coil spring lower end and the stepped spring lower pad with the shock absorber spring seat stepped part.

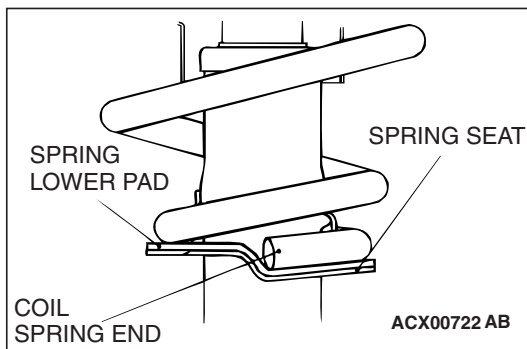

>>B<< SPRING BRACKET ASSEMBLY INSTALLATION

Install the spring bracket assembly which faces the shock absorber as shown in the illustration.

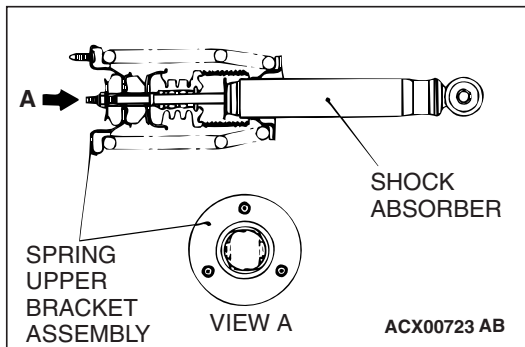

>>C<< SELF-LOCKING NUT INSTALLATION

1. Tighten the self-locking nut loosely.

⚠ CAUTION

Do not use an impact wrench, as it will cause the bolt of the special tool to be seized.

2. Remove special tools MB991237 and MB991238, and then tighten the self-locking nut to the specified torque 22 ± 2 N·m (17 ± 1 ft-lb).

LOWER ARM

REMOVAL AND INSTALLATION

M1332001500174

CAUTION

To prevent bushings from breakage, the parts indicated by * should be temporarily tightened, and then fully tightened with the vehicle on the ground in the unladen condition.

Pre-removal Operations

- Drive Shaft Removal (Refer to GROUP 26, Drive Shaft P.26-24.)

Post-installation Operations

- Check the dust cover for cracks or damage by pushing it with your finger.
- Drive Shaft Installation (Refer to GROUP 26, Drive Shaft P.26-24.)
- Wheel Alignment Check and Adjustment (Refer to P.33-5.)

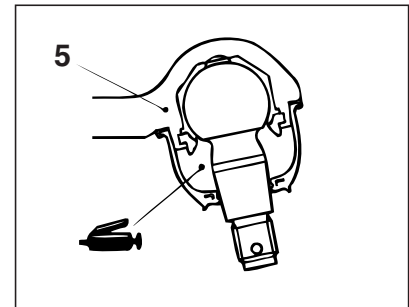
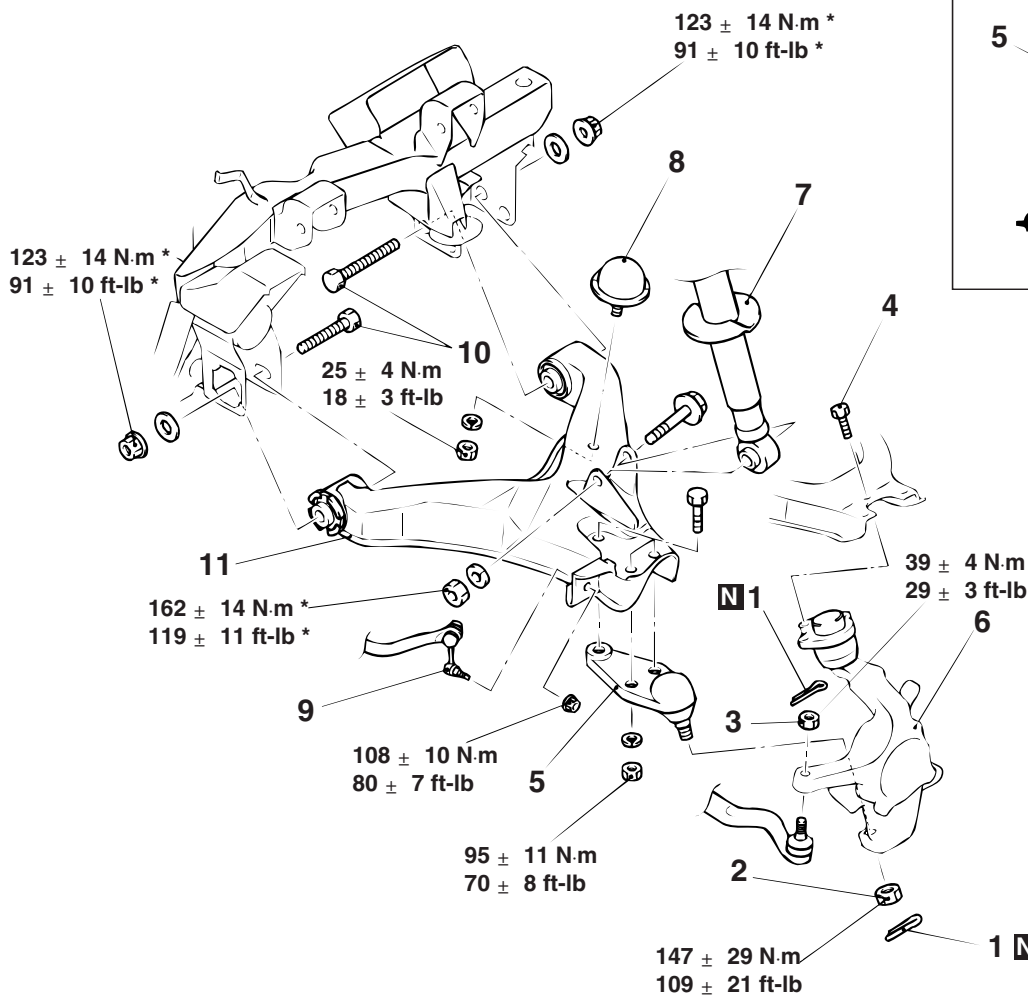

ACX00724AB

REMOVAL STEPS

1. COTTER PIN
2. LOWER ARM BALL JOINT AND KNUCKLE ASSEMBLY CONNECTION
3. TIE ROD END AND KNUCKLE ASSEMBLY CONNECTION
4. UPPER ARM AND UPPER ARM BALL JOINT CONNECTION
5. LOWER ARM BALL JOINT
6. HUB AND KNUCKLE ASSEMBLY

REMOVAL STEPS (Continued)

7. SHOCK ABSORBER AND LOWER ARM ASSEMBLY CONNECTION
8. BUMP STOPPER
9. LOWER ARM ASSEMBLY AND STABILIZER LINK CONNECTION
10. LOWER ARM MOUNTING BOLT
11. LOWER ARM ASSEMBLY

Required Special Tool:

- MB991897: Ball Joint Remover

REMOVAL SERVICE POINTS

<<A>> TIE ROD END AND KNUCKLE ASSEMBLY/LOWER ARM BALL JOINT AND KNUCKLE ASSEMBLY DISCONNECTION

⚠ CAUTION

- Do not remove the nut from ball joint. Loosen it and use special tool MB991897 to avoid possible damage to ball joint threads.
- Hang special tool MB991897 with a cord to prevent it from falling.

1. Install special tool MB991897 as shown in the figure.

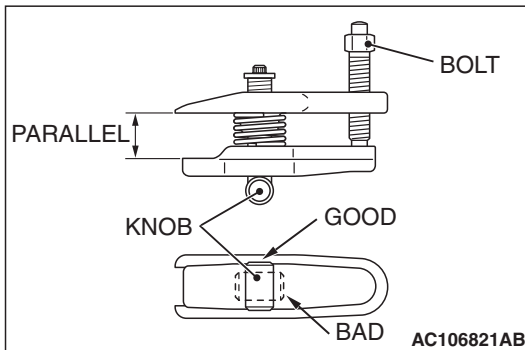
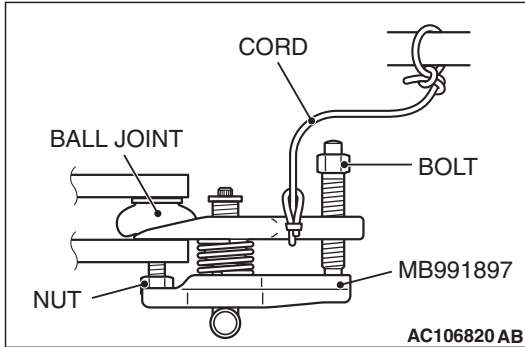

2. Turn the bolt and knob as necessary to make the jaws of special tool MB991897 parallel, tighten the bolt by hand and confirm that the jaws are still parallel.

NOTE: When adjusting the jaws in parallel, make sure the knob is in the position shown in the figure.

3. Tighten the bolt with a wrench to disconnect the ball joint.

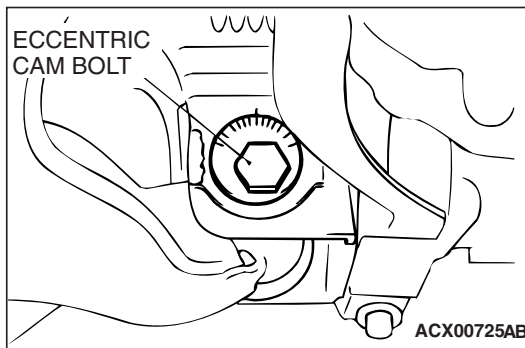

<> LOWER ARM MOUNTING BOLT REMOVAL

After making the alignment mark on the bracket and eccentric cam bolt, remove them.

INSTALLATION SERVICE POINT

>>A<< UPPER ARM BALL JOINT AND KNUCKLE CONNECTION

If the upper arm ball joint is disengaged from the knuckle, always renew the upper arm ball joint dust cover and retainer by following the procedure below.

1. Unclip the spring ring to removed the dust cover.

CAUTION

Be careful not to damage the ball joint stud.

2. Use a flat-tipped screwdriver to remove the retainer.

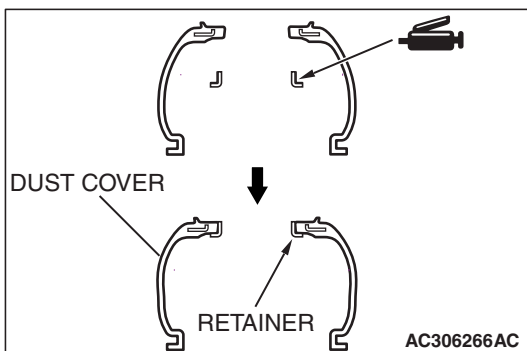
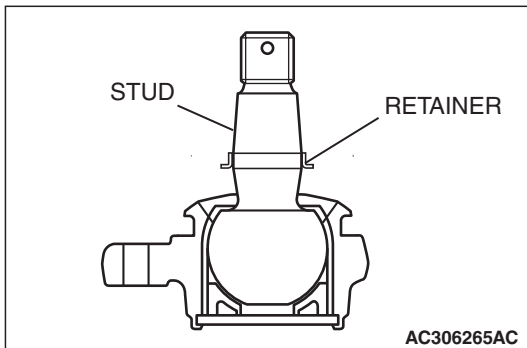

3. Apply multi-purpose grease to the new retainer, and assemble it to the new dust cover.

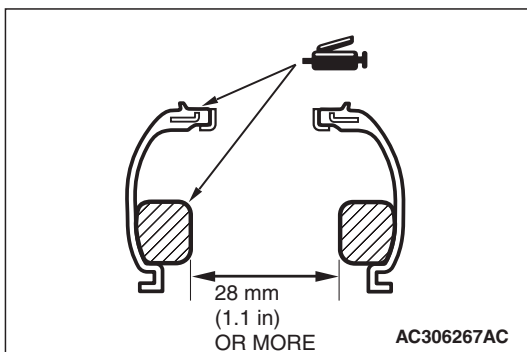

4. Fill multi-purpose grease inside the dust cover as shown.

Amount to use: 12 ± 1 g (0.4 ± 0.04 oz)

5. Apply multi-purpose grease to the dust cover lip.
6. Tape the stud threads to avoid damage.

CAUTION

Ensure grease does not come into contact with the ball joint threads and tapers. Wipe off the grease if contaminated.

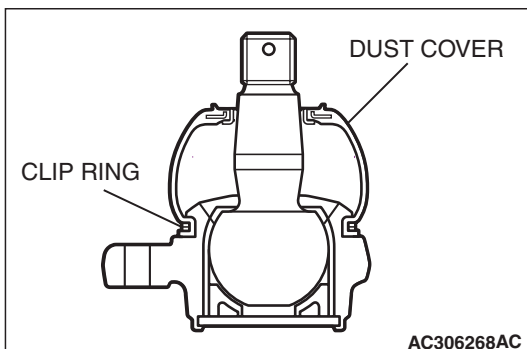

7. Install the ball joint to the dust cover.
8. Secure the dust cover with the clip ring.
9. Engage the upper arm ball joint with the knuckle.

NOTE: The retainer is secured in a predetermined position by tightening the ball joint nut to the specified torque.

INSPECTION

M1332002900056

- Check the bushing for wear and deterioration.
- Check the lower arm for bend or breakage.
- Check the lower arm for deterioration or damage.
- Check all bolts for condition and straightness.

LOWER ARM BALL JOINT TURNING TORQUE CHECK

Required Special Tool:

- MB990326: Preload Socket

1. After shaking the ball joint stud several times, use special tool MB990326 to measure the turning torque of the lower ball joint.

Standard value: 1.0 – 6.9 N·m (9 – 61 in-lb)

2. If the measured value exceeds the standard value, replace the lower arm ball joint.

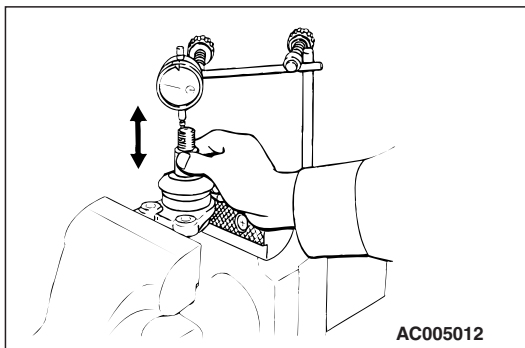
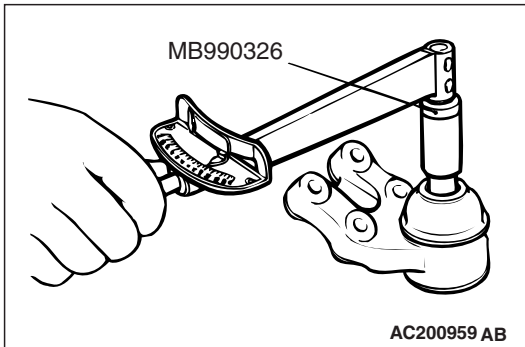

3. If the measured value is lower than the standard value, measure the lower arm ball joint end play with a dial indicator.
4. If the end play exceeds a minimum scale of the dial indicator [0.01 mm (0.0004 inch)], replace the lower arm ball joint.

LOWER ARM BALL JOINT DUST COVER CHECK

1. Press the dust cover with your finger to check that there are no cracks or damage in the dust cover.
2. If the dust cover is cracked or damaged, replace the lower arm ball joint assembly.

NOTE: If the dust cover is cracked or damaged, it is possible that there may also be damage to the ball joint. If it is damaged during service work, replace the dust cover.

LOWER ARM BALL JOINT DUST COVER REPLACEMENT

M1332007800043

Required Special Tool:

- MB990799: Ball Joint Remover and Installer

CAUTION

Do not apply grease to the place (tapered section) where the threaded section of the ball joint connects with the knuckle. Wipe the grease off if it is applied in this area. To prevent the grease from being applied to the ball joint connection (taper) with knuckle, do not compress the dust cover before installation.

If the dust cover is damaged accidentally during service work, replace the dust cover as follows:

1. Remove the clip ring, and then remove the dust cover.
2. Apply multipurpose grease to the inside of the dust cover as shown.

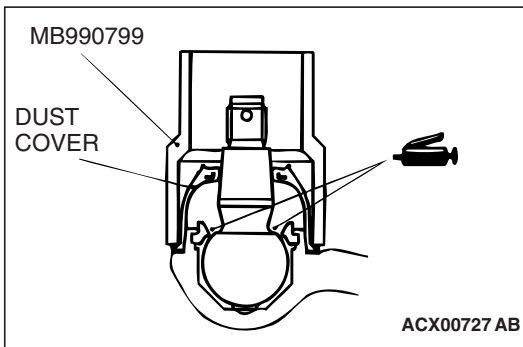
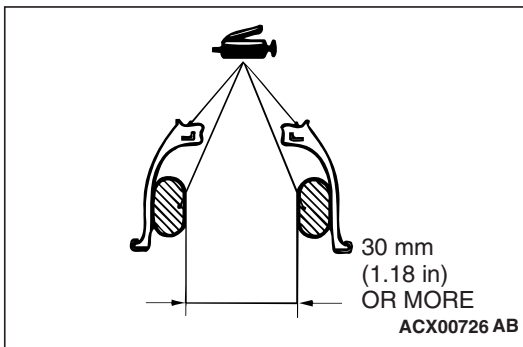

3. Apply multipurpose grease to the shown parts inside the dust cover and the ball joint stud.
4. Wrap plastic tape around the lower arm ball joint stud, and then install the dust cover to the lower arm ball joint.
5. Using special tool MB990799, drive the dust cover into the position shown in the illustration.
6. Press the dust cover with your finger to check that there are no cracks or damage in the dust cover.

STABILIZER BAR

REMOVAL AND INSTALLATION

M1332004000178

Pre-removal Operations

- Under Cover Removal

Pre-installation Operation

- Press the dust cover with your finger to check that there are no cracks or damage in the dust cover.
- Under Cover Installation

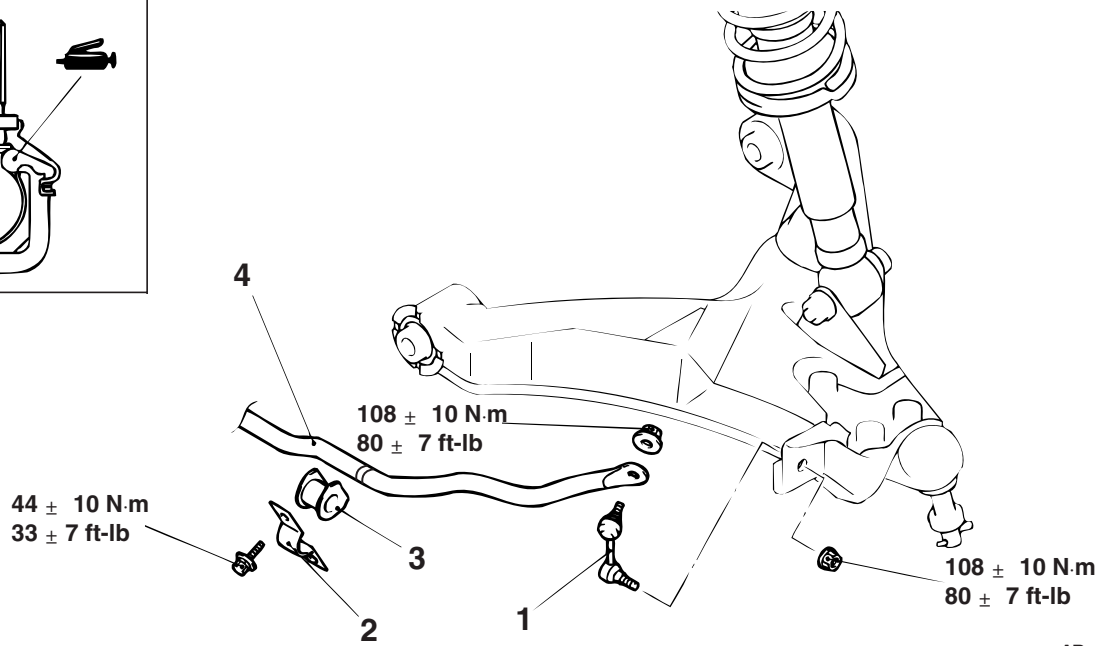
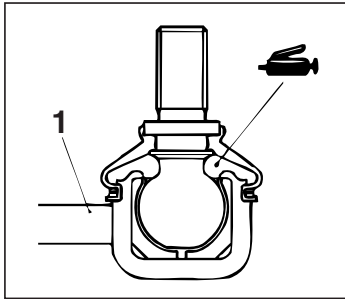

ACX00728 AB

REMOVAL STEPS

1. STABILIZER LINK
- >>B<< 2. STABILIZER CLAMP

REMOVAL STEPS (Continued)

- >>A<< 3. STABILIZER BUSHING
4. STABILIZER BAR

INSTALLATION SERVICE POINTS

>>A<< STABILIZER BAR BUSHING INSTALLATION

Position the bush slit as shown in the illustration.

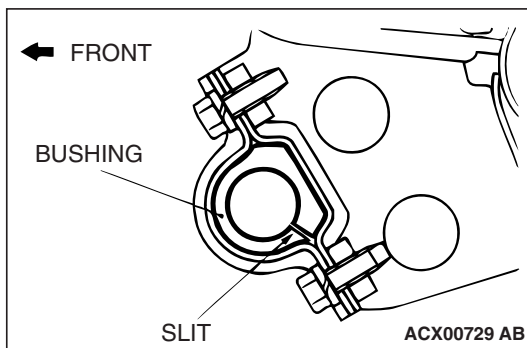

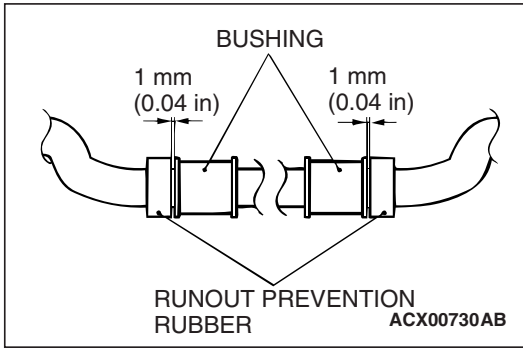

>>B<< STABILIZER CLAMP INSTALLATION

Position the stabilizer clamp as shown in the illustration and then tighten the stabilizer clamp mounting bolt.

INSPECTION

M1332002000194

- Check the bushing for wear and deterioration.
- Check the stabilizer bar for deterioration or damage.
- Check all bolts for condition and straightness.

STABILIZER LINK BALL JOINT TURNING TORQUE CHECK

Required Special Tool:

- MB990326: Preload Socket

1. After shaking the ball joint stud several times, install the nut to the stud and use special tool MB990326 to measure the turning torque of the ball joint.

Standard value: 0.5 – 2.0 N·m (4 – 17 in-lb)

2. If the measured value exceeds the standard value, replace the stabilizer link.
3. If the measured value is lower than the standard value, check that the ball joint turns smoothly without excessive play. If so, it is possible to use that ball joint.

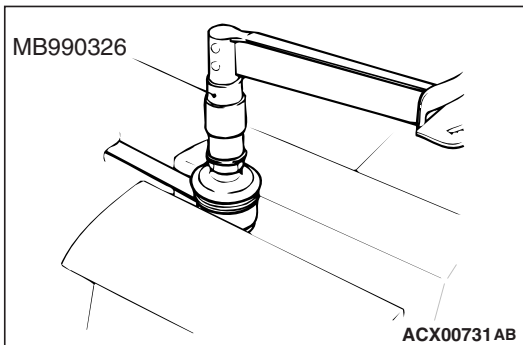

STABILIZER LINK BALL JOINT DUST COVER CHECK

1. Press the dust cover with your finger to check that there are no cracks or damage in the dust cover.
2. If the dust cover is cracked or damaged, replace the stabilizer link.

NOTE: If the dust cover is cracked or damaged, it is possible that there may also be damage to the ball joint. When it is damaged during service work, replace the dust cover.

**STABILIZER LINK BALL JOINT DUST COVER
REPLACEMENT**

M1332008300074

Only when the dust cover is damaged accidentally during service work, replace the dust cover as follows:

1. Remove the clip ring, and then remove the dust cover.
2. Apply the multipurpose grease to the inside of the dust cover.
3. Wrap plastic tape around the stabilizer link stud, and then install the dust cover to the stabilizer link.
4. Secure the dust cover in place with the clip ring.
5. Press the dust cover with your finger to check that there are no cracks or damage in the dust cover.

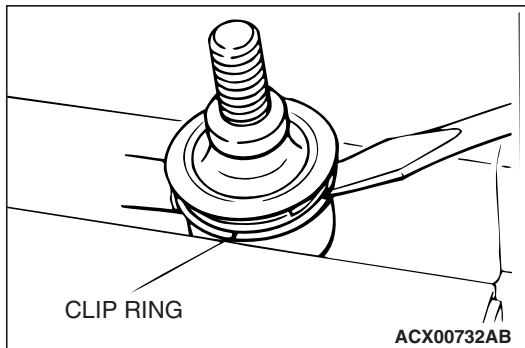
**SPECIFICATIONS****FASTENER TIGHTENING SPECIFICATIONS**

M1331001200114

ITEM	SPECIFICATION
Upper arm assembly	
Upper arm assembly to front frame securing nut	147 ± 10 N·m (109 ± 7 ft-lb)
Upper arm assembly to knuckle securing nut	74 ± 14 N·m (55 ± 10 ft-lb)
Upper arm to upper arm joint assembly securing bolt	30 ± 4 N·m (22 ± 3 ft-lb)
Shock absorber assembly	
Shock absorber to body securing nut	44 ± 5 N·m (32 ± 4 ft-lb)
Shock absorber to lower arm assembly securing nut	162 ± 14 N·m (119 ± 11 ft-lb)
Shock absorber self-lock nut	22 ± 2 N·m (17 ± 1 ft-lb)
Lower arm assembly	
Bumper stopper nut	25 ± 4 N·m (18 ± 3 ft-lb)
Shock absorber to lower arm assembly securing nut	162 ± 14 N·m (119 ± 11 ft-lb)
Lower arm assembly to stabilizer link securing nut	108 ± 10 N·m (80 ± 7 ft-lb)
Lower arm ball joint to knuckle assembly securing nut	147 ± 29 N·m (109 ± 21 ft-lb)
Lower arm ball joint to lower arm assembly securing nut	95 ± 11 N·m (70 ± 8 ft-lb)
Lower arm to body securing nut	123 ± 14 N·m (91 ± 10 ft-lb)
Tie rod end to knuckle assembly securing nut	39 ± 4 N·m (29 ± 3 ft-lb)
Stabilizer bar	
Stabilizer clamp securing bolt	44 ± 10 N·m (33 ± 7 ft-lb)
Stabilizer link securing nut	108 ± 10 N·m (80 ± 7 ft-lb)

GENERAL SPECIFICATIONS

M1331000200111

COIL SPRING

ITEM	XLS	LTD
Wire diameter mm (in)	16.3 (0.64)	16.4 (0.65)
Average diameter mm (in)	89.3 – 109.3 (3.52 – 4.30)	89.4 – 109.4 (3.52 – 4.31)
Free length mm (in)	322.5 (12.70)	327.0 (12.87)

SERVICE SPECIFICATIONS

M1331000300118

ITEM	SPECIFICATION
Toe-in mm (in)	2.5 ± 2.5 (0.10 ± 0.10)
Steering angle	Inner wheel
	Outer wheel (reference)
Camber	0°00' ± 30' (Left/right deviation within 30')
Caster	3°50' ± 1° (Left/right deviation within 30')
Upper arm ball joint turning torque N·m (in-lb)	0.4 – 2.5 (4 – 22)
Lower arm ball joint turning torque N·m (in-lb)	1.0 – 6.9 (9 – 61)
Stabilizer link ball joint turning torque N·m (in-lb)	0.5 – 2.0 (4 – 17)

NOTES