

## GROUP 55A

# HEATER, AIR CONDITIONING AND VENTILATION

## CONTENTS

<b>GENERAL DESCRIPTION</b> .....	<b>55A-3</b>	COMPRESSOR DRIVE BELT ADJUSTMENT .....	55A-115
<b>MANUAL A/C DIAGNOSIS</b> .....	<b>55A-5</b>	CHARGING .....	55A-115
INTRODUCTION TO HEATER, AIR CONDITIONING AND VENTILATION DIAGNOSIS .....	55A-5	PERFORMANCE TEST .....	55A-116
HEATER, AIR CONDITIONING AND VENTILATION DIAGNOSTIC TROUBLESHOOTING STRATEGY .....	55A-5	REFRIGERANT LEAK REPAIR .....	55A-118
SYMPTOM CHART .....	55A-6	COMPRESSOR NOISE CHECK .....	55A-118
SYMPTOM PROCEDURES .....	55A-6	POWER RELAY CHECK .....	55A-119
INSPECTION AT THE AUTOMATIC COMPRESSOR CONTROLLER TERMINAL	55A-18	IDLE-UP OPERATION CHECK .....	55A-121
<b>REAR AIR CONDITIONING DIAGNOSIS</b> .....	<b>55A-20</b>	<b>HEATER CONTROL ASSEMBLY, A/C SWITCH AND INSIDE/OUTSIDE CHANGEOVER SWITCH</b> .....	<b>55A-122</b>
INTRODUCTION .....	55A-20	REMOVAL AND INSTALLATION .....	55A-122
TROUBLESHOOTING STRATEGY .....	55A-20	INSPECTION .....	55A-123
SYMPTOM CHART .....	55A-20	HEATER CONTROL ASSEMBLY .....	55A-125
SYMPTOM PROCEDURES .....	55A-21	<b>HEATER UNIT</b> .....	<b>55A-126</b>
CHECK AT ECU TERMINAL .....	55A-113	REMOVAL AND INSTALLATION .....	55A-126
<b>SPECIAL TOOLS</b> .....	<b>55A-114</b>	HEATER UNIT DISASSEMBLY AND ASSEMBLY .....	55A-127
<b>ON-VEHICLE SERVICE</b> .....	<b>55A-114</b>	BLOWER ASSEMBLY DISASSEMBLY AND ASSEMBLY .....	55A-128
REFRIGERANT LEVEL TEST .....	55A-114	<b>BLOWER ASSEMBLY AND RESISTOR</b> .....	<b>55A-129</b>
A/C COMPRESSOR CLUTCH TEST .....	55A-114	REMOVAL AND INSTALLATION .....	55A-129
RECEIVER DRIER TEST .....	55A-115	INSPECTION .....	55A-129
DUAL PRESSURE SWITCH CHECK .....	55A-115		

Continued on next page

## **INSIDE/OUTSIDE AIR CHANGEOVER DAMPER MOTOR ASSEMBLY . . . . . 55A-130**

- REMOVAL AND INSTALLATION . . . . . 55A-130
- INSPECTION . . . . . 55A-131

## **SENSORS . . . . . 55A-132**

- REMOVAL AND INSTALLATION . . . . . 55A-132
- INSPECTION . . . . . 55A-132

## **REAR HEATER SWITCH AND FRONT REAR FAN SWITCH . . . . . 55A-133**

- REMOVAL AND INSTALLATION . . . . . 55A-133
- INSPECTION . . . . . 55A-134

## **REAR HEATER CONTROL UNIT, REAR COOLER CONTROL UNIT AND REAR A/C CONTROL UNIT . . . . . 55A-135**

- REMOVAL AND INSTALLATION . . . . . 55A-135

## **REAR HEATER UNIT . . . . . 55A-136**

- REMOVAL AND INSTALLATION . . . . . 55A-136
- REAR HEATER UNIT, REAR COOLER UNIT  
OR REAR A/C UNIT DISASSEMBLY AND  
ASSEMBLY . . . . . 55A-138
- INSPECTION . . . . . 55A-139

- REAR BLOWER DISASSEMBLY AND  
ASSEMBLY . . . . . 55A-140
- INSPECTION . . . . . 55A-141

## **COMPRESSOR ASSEMBLY . . . . . 55A-142**

- REMOVAL AND INSTALLATION . . . . . 55A-142
- INSPECTION . . . . . 55A-144
- COMPRESSOR . . . . . 55A-144

## **CONDENSER AND CONDENSER FAN MOTOR . . . . . 55A-146**

- REMOVAL AND INSTALLATION . . . . . 55A-146
- INSPECTION . . . . . 55A-147

## **REFRIGERANT LINE . . . . . 55A-148**

- REMOVAL AND INSTALLATION . . . . . 55A-148

## **VENTILATORS . . . . . 55A-150**

- REMOVAL AND INSTALLATION . . . . . 55A-150

## **SPECIFICATIONS . . . . . 55A-152**

- FASTENER TIGHTENING  
SPECIFICATIONS . . . . . 55A-152
- SERVICE SPECIFICATIONS . . . . . 55A-153
- LUBRICANTS . . . . . 55A-153

## GENERAL DESCRIPTION

M1551000100109

The heater system uses a two-way-flow full-air-mix system that features high performance and low operating noise. The air conditioning (A/C) system is basically the same as the conventional system, but a new refrigerant system has been adopted as a response to restrictions on the use of chlorofluorocarbons.

ITEM		SPECIFICATION
Heater unit	Type	Two-way-flow full-air-mix system
Heater control assembly		Dial type
Compressor	Model	10S17C
Dual pressure switch kPa (psi)	High-pressure switch	ON to OFF: 3,140 (455.5), OFF to ON: 2,550(369.9)
	Low-pressure switch	ON to OFF: 196 (28.4), OFF to ON: 223 (32.4)
Refrigerant and quantity g (oz)	Except vehicles with rear A/C or rear cooler	R134a (HFC-134a), Approximately 530 – 570 (18.7 – 20.1)
	Vehicles with rear A/ C or rear cooler	R134a (HFC-134a), Approximately 730 – 770 (26.1 – 27.1)

### SAFETY PRECAUTIONS

#### **WARNING**

***Wear safety goggles when servicing the refrigeration system to prevent severe damage to hands.***

Because R134a refrigerant is a hydro fluorocarbon (HFC) which contains hydrogen atoms in place of chlorine atoms, it will not cause damage to the ozone layer. Ozone filters out harmful radiation from the sun. To assist in protecting the ozone layer, Mitsubishi Motors Corporation recommends an R134a refrigerant recycling device. Refrigerant R134a is transparent and colorless in both the liquid and vapor state. Since it has a boiling point of  $-29.8^{\circ}\text{C}$  ( $-21.6^{\circ}\text{F}$ ) at atmospheric pressure, it will be a vapor at all normal temperatures and pressures. The vapor is heavier than air, non-flammable, and non-explosive. The following precautions must be observed when handling R134a.

#### **WARNING**

***Do not heat R134a above  $40^{\circ}\text{C}$  ( $104^{\circ}\text{F}$ ) or it may catch fire and explode.***

R134a evaporates so rapidly at normal atmospheric pressures and temperatures that it tends to freeze anything it contacts. For this reason, extreme care must be taken to prevent any liquid refrigerant from contacting the skin and especially the eyes. Always wear safety goggles when servicing the refrigeration part of the A/C system. Keep a bottle of sterile mineral oil handy when working on the refrigeration system.

1. Should any liquid refrigerant get into the eyes, use a few drops of mineral oil to wash them out. R134a is rapidly absorbed by the oil.
2. Next splash the eyes with plenty of cold water.
3. Call your doctor immediately even though irritation has ceased after treatment.

**⚠ CAUTION**

**Keep R134a containers upright when charging the system.**

In most instances, moderate heat is required to bring the pressure of the refrigerant in its container above the pressure of the system when charging or adding refrigerant. A bucket or large pan of hot water not over 40 °C (104 °F) is all the heat required for this purpose. Do not heat the refrigerant container with a blow torch or any other means that would raise temperature and pressure above this temperature. Do not weld or steam clean on or near the system components or refrigerant lines.

**⚠ WARNING**

***The leak detector for R134a should be used to check for refrigerant gas leaks.***

**⚠ CAUTION**

**Do not allow liquid refrigerant to touch bright metal or it will be stained.**

When metering R134a into the refrigeration system keep the supply tank or cans in an upright position. If the refrigerant container is on its side or upside down, liquid refrigerant will enter the system and damage the compressor. Refrigerant will tarnish bright metal and chrome surfaces, and in combination with moisture can severely corrode all metal surfaces.

**OPERATION**

When the air conditioning is working under low loads (e.g, in winter), the PCM controls the A/C compressor, condenser fan and idle-up speed more effectively, resulting in good fuel economy and quiet engine operation. In addition, the condenser fan will always run for five minutes as initial check after the battery is reconnected.

**CONDENSER FAN CONTROL**

When operating the air conditioning switch

- When the signal which turns on the compressor is sent from the automatic compressor controller, PCM activates the condenser fan relay and rotates the condenser fan.

**COMPRESSOR CONTROL**

When operating the air conditioning switch

- The automatic compressor controller stops the compressor when the air thermo sensor detects a temperature of 3.2°C (38°F) or less. However, if the ambient air temperature sensor detects a temperature of 10 – 20°C (50 – 68°F), the controller stops the compressor when the air thermo sensor detects 6.2°C (43°F) or less. Because of this control, the compressor can work efficiently when the air conditioning is under low load.
- The PCM stops the compressor when the engine coolant temperature sensor detects 115°C (239°F). In addition, the compressor stops for five seconds when the accelerator position sensor input exceeds 80%. Moreover, the compressor stops during engine start and low engine speed. Because of this control, the engine load can be reduced.
- The dual pressure switch turns OFF when the refrigerant pressure becomes excessively high or low, thus protecting the compressor circuit (See Table below).
- When these two sensors are all activated, the dual pressure switch is ON, and the ignition switch, blower switch, and air conditioning switch are ON, the A/C compressor clutch relay is energized.
- When operating the air outlet changeover control knob
- When the air outlet changeover control knob is moved to "DEFROSTER" or "DEFROSTER/FOOT" position, the micro switch, which is connected in series to the air conditioning switch, is turned on. The other compressor control than the above is the same as that when operating the air conditioning switch.

**A/C Compressor Clutch Relay ON Conditions**

Ignition switch (IG2)	ON	Remarks (1) A/C compressor clutch relay is de-energized when any one switch, sensor or control unit shown on the left turns off (HI). (2) *: Automatic compressor controller and PCM judges from input signals from the sensors.	
Blower switch	ON		
Air conditioning switch or micro switch	ON		
Air thermo sensor	*		
Outside air temperature sensor	*		
Engine coolant temperature sensor	*		
Dual pressure switch	Low-pressure side 223 kPa (32.4 psi) or higher		ON
	High-pressure side 2,550 kPa (369.9 psi) or below		ON
A/C compressor clutch relay driving transistor (within powertrain control module)	ON		

## MANUAL A/C DIAGNOSIS

### INTRODUCTION TO HEATER, AIR CONDITIONING AND VENTILATION DIAGNOSIS

M1552012200269

Air is drawn into the heater assembly from either the outside, or from the inside of the passenger cabin if DEFROST, maximum cooling or RECIRCULATION are selected. The air is then forced through the evaporator where heat is removed, cooling and de-humidifying the air. Depending on the temperature selected, a portion of this air is then forced through the heater core to achieve the selected discharge temperature.

If the system does not cool properly, look for a problem with the refrigerant, blower or air distribution systems. If the system does not heat properly, look for a problem with the coolant, blower or air distribution systems fuses, circuit breaker and relays should be checked

### HEATER, AIR CONDITIONING AND VENTILATION DIAGNOSTIC TROUBLESHOOTING STRATEGY

M1552009600289

Use these steps to troubleshoot heater and air conditioning concerns. These diagnostic step are designed to systematically check the systems and components. Follow these steps carefully, and you will be sure that you have exhausted most of the possible ways to find a heater, air conditioning and ventilation fault.

1. Gather information from the customer.
2. Verify that the condition described by the customer exists.
3. Find the malfunction by following the Symptom Chart.
4. Verify that the malfunction is eliminated and the system works properly.

## SYMPTOM CHART

SYMPTOM	INSPECTION PROCEDURE	REFERENCE PAGE
When the ignition switch is "ON," the A/C does not operate.	1	P.55A-6
When the air outlet changeover control knob is moved to DEFROSTER or DEFROSTER/FOOT position, the A/C or the inside/outside air changeover damper motor does not operate.	2	P.55A-10
When the A/C is operating, temperature inside the passenger compartment does not decrease (cool air is not emitted).	3	P.55A-10
Blower fan and motor does not turn.	4	P.55A-12
Blower fan and motor does not stop turning.	5	P.55A-14
When the A/C is operating condenser fan does not turn.*	6	P.55A-16
Outside/Inside Air changeover is not possible.	7	P.55A-17

*NOTE: For symptoms marked with an asterisk the condenser fan might not operate when there is an air conditioning low load from the air conditioning condenser control, so remove the battery terminal (-) and then check the symptoms 5 minutes after initial start control reconnection.*

## SYMPTOM PROCEDURES

## INSPECTION PROCEDURE 1: When the Ignition Switch is "ON," the A/C does not Operate.

## DIAGNOSIS

## STEP 1. Check for refrigerant leaks.

## Q: Is the refrigerant leaking?

**YES** : Repair the leak. Then go to Step 10.

**NO** : Go to Step 2.

## STEP 2. Check for excessive refrigerant.

## Q: Is the refrigerant in good condition?

**YES** : Go to Step 3.

**NO** : Use the refrigerant recovery station to remove all of the refrigerant, and then calculate the amount of the refrigerant and charge it. Then go to Step 10.

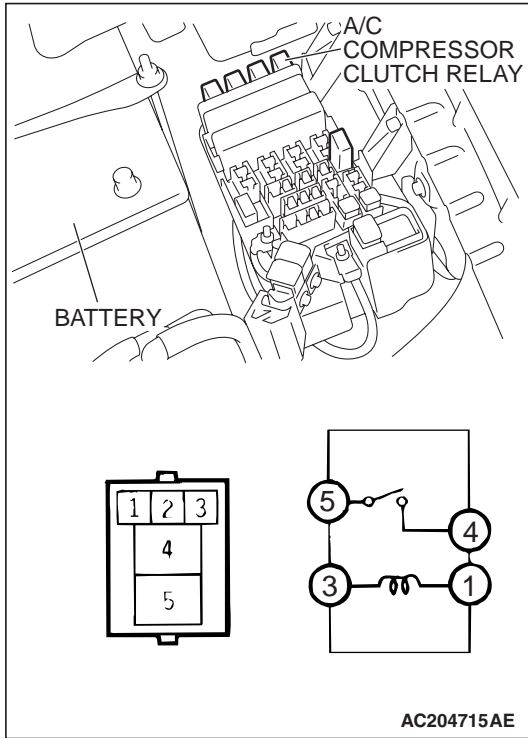

**STEP 3. Check the A/C compressor clutch relay continuity.**  
Follow the table below to check the A/C compressor clutch relay for continuity.

BATTERY VOLTAGE	TESTER CONNECTION	SPECIFIED CONDITION
Not applied	4 – 5	Open circuit
<ul style="list-style-type: none"> <li>Connect terminal 3 to the positive battery terminal</li> <li>Connect terminal 1 to the negative battery terminal</li> </ul>	4 – 5	Less than 2 ohms

**Q: Is the A/C compressor clutch relay in good condition?**

**YES :** Go to Step 4.

**NO :** Replace the A/C compressor clutch relay. Then go to Step 10.

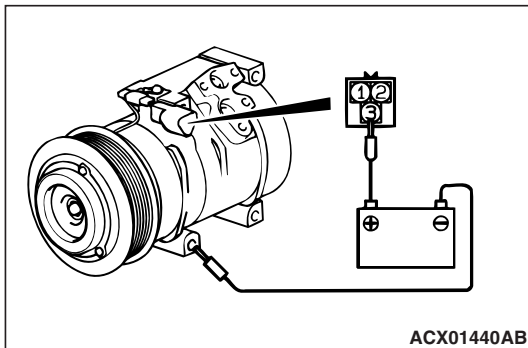

**STEP 4. Check the A/C compressor clutch operation.**

Connect the positive battery terminal to the air conditioning compressor clutch connector terminal 3 and ground the negative battery terminal to the body of the compressor.

**Q: Can the sound of the A/C compressor clutch (click) be heard?**

**YES :** Go to Step 5.

**NO :** Replace the A/C compressor clutch. Then go to Step 10.

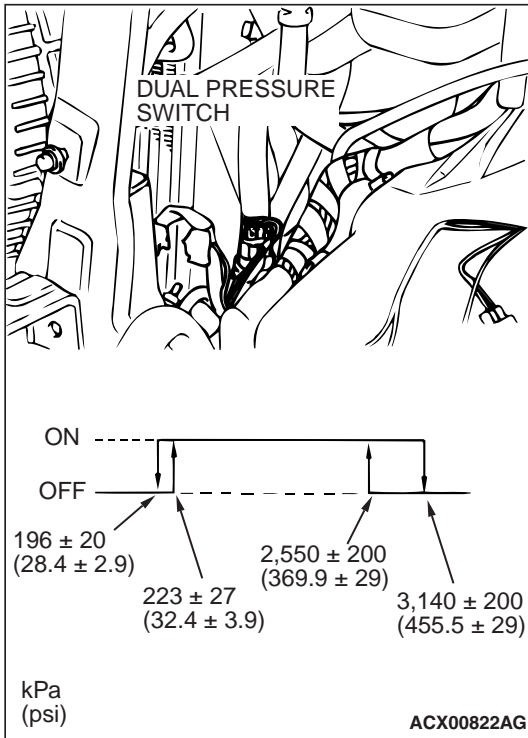

**STEP 5. Check the dual pressure switch operation.**

- (1) Remove the dual pressure switch connector and connect the high/low pressure side terminals located on the harness side as shown in the illustration.
- (2) Install a gauge manifold to the high-pressure side service valve of the refrigerant line (Refer to P.55A-148).
- (3) When the high/low pressure sides of the dual pressure switch are at operation pressure (ON) and the resistance is less than two ohm between the respective terminals, then the condition is normal. If open loop, replace the switch.

ITEM	OFF to ON	ON to OFF
Low-pressure side kPa (psi)	223 ± 27 (32.4 ± 3.9)	196 ± 20 (28.4 ± 2.9)
High-pressure side kPa (psi)	2,550 ± 200 (369.9 ± 29)	3,140 ± 200 (455.5 ± 29)

**Q: Is the dual pressure switch operating properly?**

**YES :** Go to Step 6.

**NO :** Replace the dual pressure switch. Then go to Step 10.

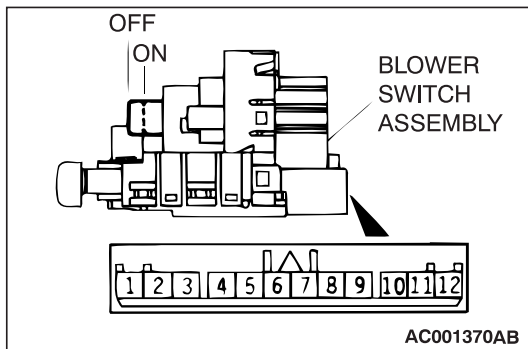

**STEP 6. Check the A/C switch continuity.**

Follow the table below to check the A/C switch for continuity.

SWITCH POSITION	TESTER CONNECTION	SPECIFIED CONDITION
Off	5 – 6	Open circuit
On	5 – 6	Less than 2 ohms

**Q: Is there continuity at the A/C switch?**

**YES :** Go to Step 7.

**NO :** Replace the A/C switch. Then go to Step 10.



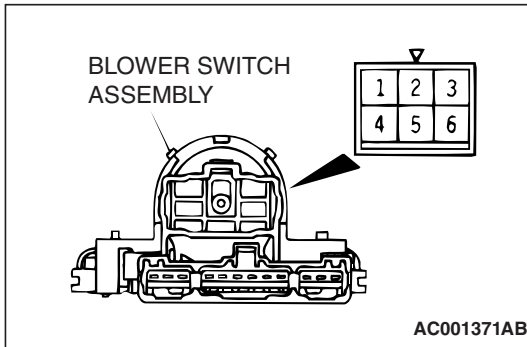

**STEP 7. Check the blower switch continuity.**

Follow the table below to check the blower switch for continuity.

SWITCH POSITION	TESTER CONNECTION	SPECIFIED CONDITION
0 (OFF)	1 – 3, 3 – 4, 3 – 5, 3 – 6	Open circuit
1 (LO)	3 – 5	Less than 2 ohms
2 (ML)	1 – 3	Less than 2 ohms
3 (MH)	3 – 6	Less than 2 ohms
4 (HI)	3 – 4	Less than 2 ohms

**Q: Is there continuity the blower switch?**

**YES :** Go to Step 8.

**NO :** Replace the blower switch. Then go to Step 10.

**STEP 8. Measure the automatic compressor controller terminal voltage.**

Refer to [P.55A-18](#).

**Q: Is the automatic compressor controller terminal voltage correct?**

**YES :** Go to Step 9.

**NO :** Replace the automatic compressor controller. Then go to Step 10.

**STEP 9. Measure the powertrain control module terminal voltage.**

Refer to GROUP 13A, Diagnosis – Check at the Powertrain Control Module (PCM) [P.13A-1021](#).

**Q: Is the terminal voltage correct?**

**YES :** Go to Step 10.

**NO :** Replace the PCM. Then go to Step 10.

**STEP 10. Retest the system.**

**Q: Is the A/C operating properly?**

**YES :** The procedure is complete (If no malfunctions are not found in all steps, an intermittent malfunction is suspected. Refer to GROUP 00, How to Use Troubleshooting/Inspection Service Points – How to Cope with Intermittent Malfunction [P.00-13](#)).

**NO :** Go to Step 1.

**INSPECTION PROCEDURE 2: When the Air Outlet Changeover Control Knob is Moved to DEFROSTER or DEFROSTER/FOOT Position, the A/C or the Inside/outside Air Changeover Damper Motor does not Operate.**

**DIAGNOSIS**

**STEP 1. Check the defroster switch continuity.**

Follow the table below to check the defroster switch for continuity.

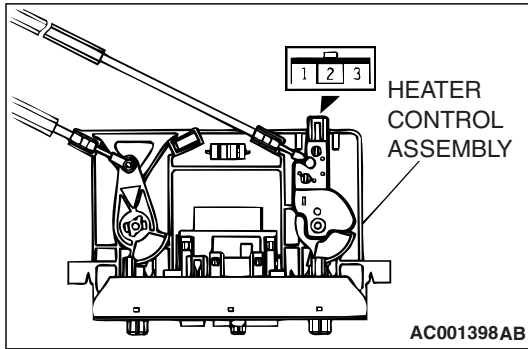

AIR OUTLET CHANGEOVER CONTROL KNOB POSITION	TESTER CONNECTION	SPECIFIED CONDITION
At the "DEFROSTER" or "DEFROSTER/FOOT" position	2 – 3	Less than 2 ohms
	1 – 3	Open circuit
At the other positions	1 – 3	Less than 2 ohms
	2 – 3	Open circuit

**Q: Is the defroster switch in good condition?**

**YES :** Go to Step 2.

**NO :** Replace defroster switch. Then go to Step 2.

**STEP 2. Check each A/C part.**

**Q: Does A/C operate normally?**

**YES :** The procedure complete. (If no malfunctions are not found in all steps, an intermittent malfunction is suspected. Refer to GROUP 00, How to Use Troubleshooting/Inspection Service Points – How to Cope with Intermittent Malfunction [P.00-13](#).)

**NO :** Go to Inspection Procedure 1.

**INSPECTION PROCEDURE 3: When the A/C is Operating, Temperature Inside the Passenger Compartment does not Decrease (Cool Air is not Emitted).**

**DIAGNOSIS**

**STEP 1. Check for refrigerant leaks.**

**Q: Is the refrigerant leaking?**

**YES :** Repair. Then go to Step 5.

**NO :** Go to Step 2.

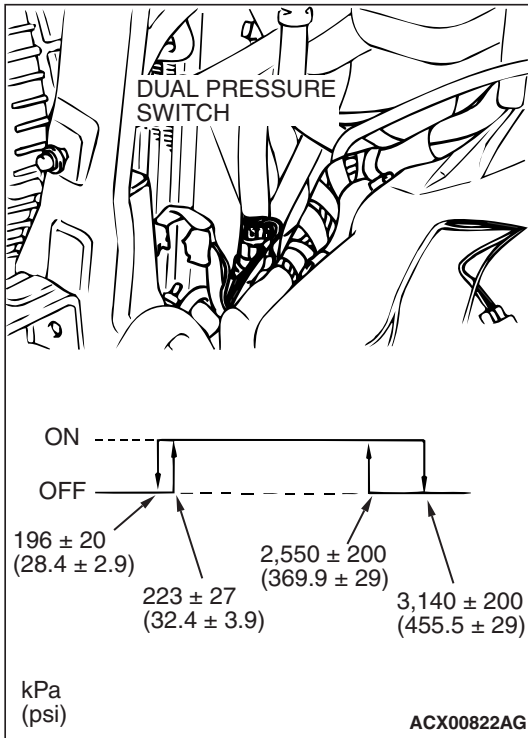

**STEP 2. Check the dual pressure switch operation.**

- (1) Remove the dual pressure switch connector and connect the high/low pressure side terminals located on the harness side as shown in the illustration.
- (2) Install a gauge manifold to the high-pressure side service valve of the refrigerant line. (Refer to P.55A-148.)
- (3) When the high/low pressure sides of the dual pressure switch are at operation pressure (ON) and there is continuity between the respective terminals.

ITEM	OFF to ON	ON to OFF
Low-pressure side kPa (psi)	223 ± 27 (32.4 ± 3.9)	196 ± 20 (28.4 ± 2.9)
High-pressure side kPa (psi)	2,550 ± 200 (369.9 ± 29)	3,140 ± 200 (455.5 ± 29)

**Q: When the high/low pressure sides of the dual pressure switch are at operation pressure (ON), is there continuity between the respective terminals?**

**YES :** Go to Step 3.

**NO :** Replace the dual pressure switch. Then go to Step 5.

**STEP 3. Measure the automatic compressor controller terminal voltage.**

Refer to P.55A-18.

**Q: Is the automatic compressor controller terminal voltage correct?**

**YES :** Go to Step 4.

**NO :** Replace the automatic compressor controller. Then go to Step 5.

**STEP 4. Measure the powertrain control module terminal voltage.**

Refer to GROUP 13A, Diagnosis – Check at the Powertrain Control Module (PCM) P.13A-1021.

**Q: Is the voltage correct?**

**YES :** Go to Step 5.

**NO :** Replace the PCM. Then go to Step 5.

**STEP 5. Retest the system.**

**Q: Does the system produce cool air?**

**YES :** The procedure complete. (If no malfunctions are not found in all steps, an intermittent malfunction is suspected. Refer to GROUP 00, How to Use Troubleshooting/Inspection Service Points – How to Cope with Intermittent Malfunction P.00-13.)

**NO :** Go to Step 1.

**INSPECTION PROCEDURE 4: Blower Fan and Motor does not turn.**

**DIAGNOSIS**

**STEP 1. Check the front blower relay continuity.**

Follow the table below to check the front blower relay for continuity.

BATTERY VOLTAGE	TESTER CONNECTION	SPECIFIED CONDITION
Not applied	2 – 5	Open circuit
<ul style="list-style-type: none"> <li>• Connect terminal 3 to the positive battery terminal</li> <li>• Connect terminal 1 to the negative battery terminal</li> </ul>	2 – 5	Less than 2 ohms

**Q: Is the front blower relay continuity in good condition?**

**YES :** Go to Step 2.

**NO :** Replace the front blower relay. Then go to Step 5.

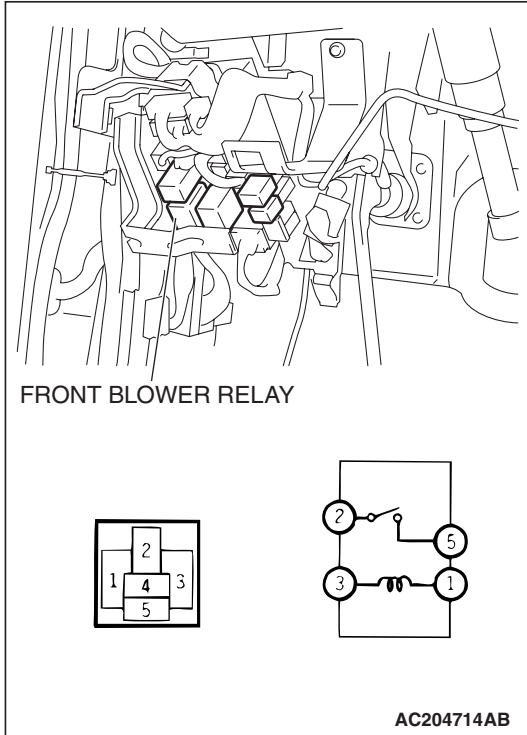

**STEP 2. Check the blower motor operation.**

When battery voltage is applied between the terminals, check that the motor operates.

**Q: Is there any abnormal noise?**

**YES :** Go to Step 3.

**NO :** Replace the blower motor. Then go to Step 5.

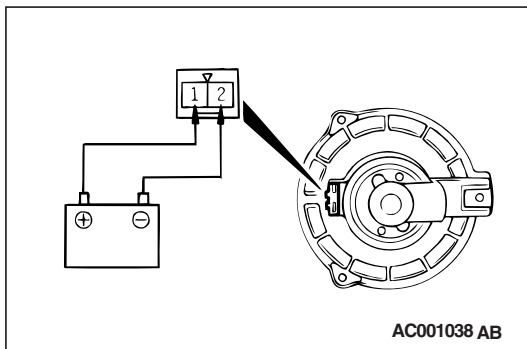

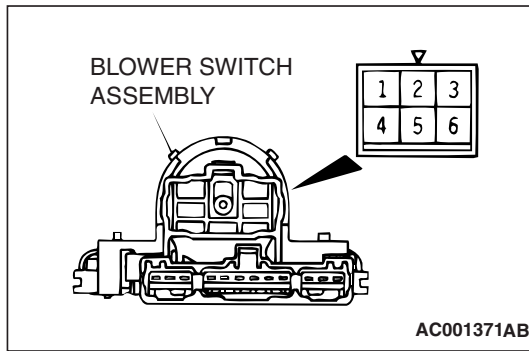

**STEP 3. Check the blower switch continuity.**

Follow the table below to check the blower switch for continuity.

SWITCH POSITION	TESTER CONNECTION	SPECIFIED CONDITION
0 (OFF)	1 – 3, 3 – 4, 3 – 5, 3 – 6	Open circuit
1 (LO)	3 – 5	Less than 2 ohms
2 (ML)	1 – 3	Less than 2 ohms
3 (MH)	3 – 6	Less than 2 ohms
4 (HI)	3 – 4	Less than 2 ohms

**Q: Is there continuity at the blower switch?**

**YES :** Go to Step 4.

**NO :** Replace the blower switch. Then go to Step 5.

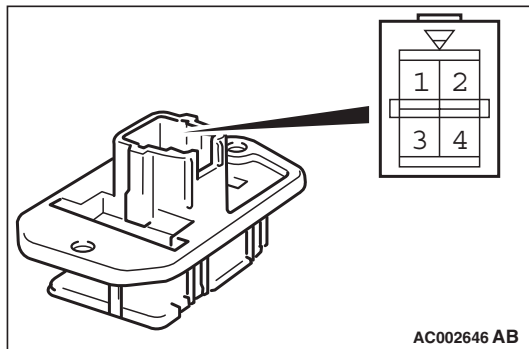

**STEP 4. Check the blower resistor resistance value.**

Use an ohmmeter to measure the resistance between the terminals as indicated below. Check that the measured value is at the standard value.

MEASUREMENT TERMINAL	STANDARD VALUE $\Omega$
Between terminals 2 and 3 (LO)	2.79
Between terminals 1 and 2 (ML)	1.49
Between terminals 2 and 4 (MH)	0.36

**Q: Is the measured value at the standard value?**

**YES :** Go to Step 5.

**NO :** Replace the blower resistor. Then go to Step 5.

**STEP 5. Retest the system.**

**Q: Do the blower fan and motor operate?**

**YES :** The procedure complete (If no malfunctions are not found in all steps, an intermittent malfunction is suspected. Refer to GROUP 00, How to Use Troubleshooting/Inspection Service Points – How to Cope with Intermittent Malfunction [P.00-13](#)).

**NO :** Go to Step 1.

**INSPECTION PROCEDURE 5: Blower Fan and Motor does not Stop turning.**

**DIAGNOSIS**

**STEP 1. Check the harness wires between the blower motor connector D-113, the blower resistor connector D-115, and the blower switch connector D-101.**

**Q: Are the harness wires between the blower motor connector D-113, the blower resistor connector D-115, and the blower switch connector D-101 in good condition?**

**YES :** Go to Step 2.

**NO :** Repair the wiring harness. Then go to Step 4.

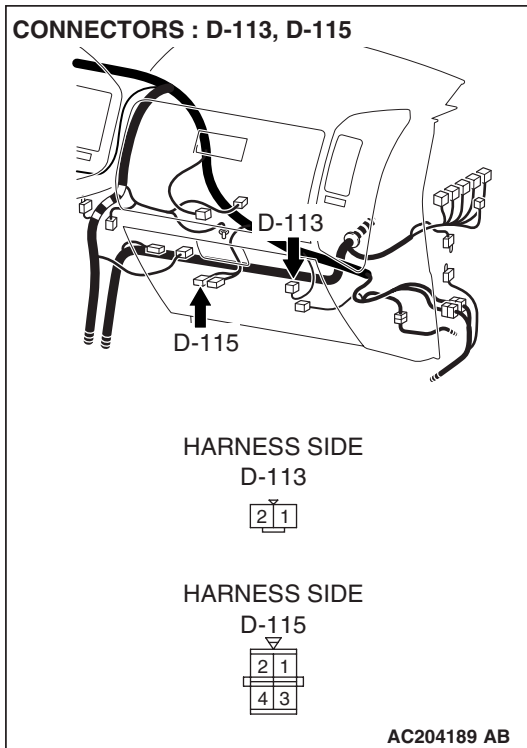
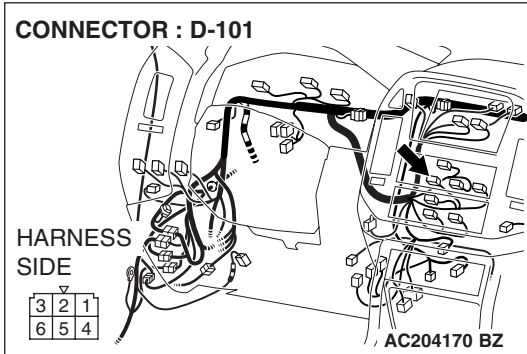

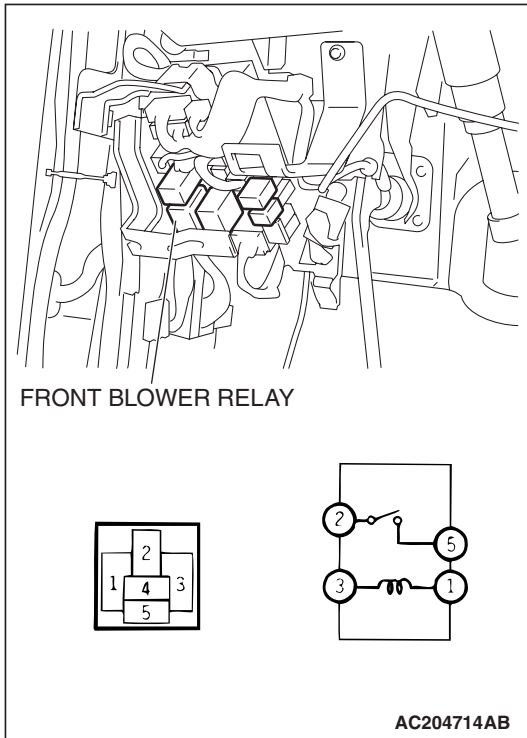

**STEP 2. Check the front blower relay continuity.**

Follow the table below to check the front blower relay for continuity.

BATTERY VOLTAGE	TESTER CONNECTION	SPECIFIED CONDITION
Not applied	2 – 5	Open circuit
<ul style="list-style-type: none"> <li>Connect terminal 3 to the positive battery terminal</li> <li>Connect terminal 1 to the negative battery terminal</li> </ul>	2 – 5	Less than 2 ohms

**Q: Is there continuity at the front blower relay?**

**YES :** Go to Step 3.

**NO :** Replace the front blower relay. Then go to Step 4.

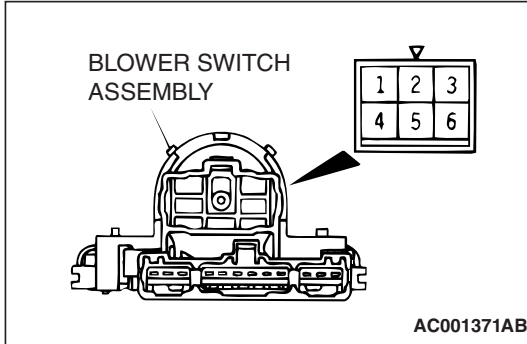

**STEP 3. Check the blower switch continuity.**

Follow the table below to check the blower switch for continuity.

SWITCH POSITION	TESTER CONNECTION	SPECIFIED CONDITION
0 (OFF)	1 – 3, 3 – 4, 3 – 5, 3 – 6	Open circuit
1 (LO)	3 – 5	Less than 2 ohms
2 (ML)	1 – 3	Less than 2 ohms
3 (MH)	3 – 6	Less than 2 ohms
4 (HI)	3 – 4	Less than 2 ohms

**Q: Is there continuity at the blower switch?**

**YES :** Go to Step 4.

**NO :** Replace the blower switch. Then go to Step 4.

**STEP 4. Retest the system.**

**Q: Does the blower motor stop operating?**

**YES :** The procedure complete (If no malfunctions are not found in all steps, an intermittent malfunction is suspected. Refer to GROUP 00, How to Use Troubleshooting/Inspection Service Points – How to Cope with Intermittent Malfunction [P.00-13](#)).

**NO :** Go to Step 1.

**INSPECTION PROCEDURE 6: When the A/C is Operating Condenser Fan does not turn.**

**DIAGNOSIS**

**STEP 1. Check the condenser fan control relay continuity.**  
Follow the table below to check the condenser fan control relay for continuity.

BATTERY VOLTAGE	TESTER CONNECTION	SPECIFIED CONDITION
Not applied	4 – 5	Open circuit
<ul style="list-style-type: none"> <li>• Connect terminal 3 to the positive battery terminal</li> <li>• Connect terminal 1 to the negative battery terminal</li> </ul>	4 – 5	Less than 2 ohms

**Q: Is there continuity at the fan control relay?**

**YES :** Go to Step 2.

**NO :** Replace the condenser fan control relay. Then go to Step 4.

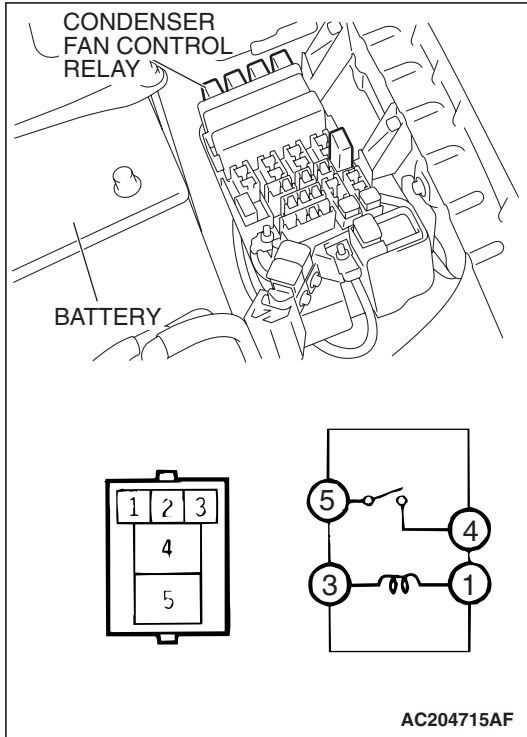

**STEP 2. Check the condenser fan motor operation.**

Follow the table below to check the condenser fan motor for continuity.

CONNECT POSITIVE BATTERY TERMINAL TO	CONNECT NEGATIVE BATTERY TERMINAL TO	MOTOR OPERATION
1	2	Rotates

**Q: Is the condenser fan motor operating correctly?**

**YES :** Go to Step 3.

**NO :** Replace the condenser fan motor. Then go to Step 3.

**STEP 3. Measure the PCM terminal voltage.**

Refer to GROUP 13A, Check at PCM terminals [P.13A-1021](#).

**Q: Is the PCM voltage correct?**

**YES :** Go to Step 4.

**NO :** Replace the PCM. Then go to Step 4.

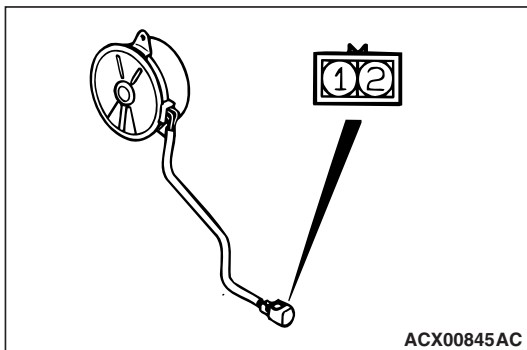



**STEP 4. Retest the system.**

*NOTE: The condenser fan might not operate when there is an air conditioning low load from the air conditioning condenser control, so remove the negative battery terminal and then check the symptoms after 5 minutes since initial start control after reconnection.*

**Q: Is the condenser fan operating correctly?**

**YES :** The procedure complete (If no malfunctions are not found in all steps, an intermittent malfunction is suspected. Refer to GROUP 00, How to Use Troubleshooting/Inspection Service Points – How to Cope with Intermittent Malfunction P.00-13).

**NO :** Go to Step 1.

**INSPECTION PROCEDURE 7: Outside/Inside Air changeover is not possible.**

**DIAGNOSIS**

**STEP 1. Check the outside/inside air selection damper control motor operation.**

**⚠ CAUTION**

**Disconnect the battery negative terminal when the damper is in the outside/inside air position.**

Check the outside/inside air selection damper control motor by the following procedures.

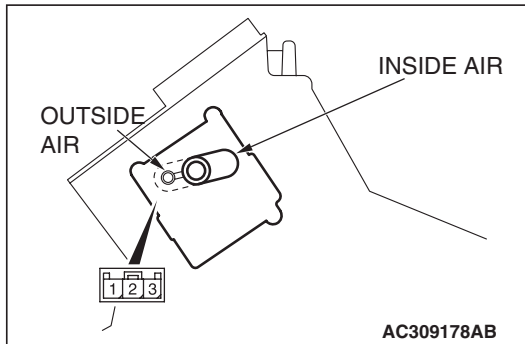

LEVER POSITION	BATTERY CONNECTION	LEVER OPERATION
At the inside air position	<ul style="list-style-type: none"> <li>• Connect terminal 1 to the positive battery terminal</li> <li>• Connect terminal 2 to the negative battery terminal</li> </ul>	The lever moves from the inside air position to the outside air position
At the outside air position	<ul style="list-style-type: none"> <li>• Connect terminal 1 to the positive battery terminal</li> <li>• Connect terminal 3 to the negative battery terminal</li> </ul>	The lever moves from the outside air position to the inside air position

**Q: Is the outside/inside air selection damper control motor operating correctly?**

**YES :** Go to Step 2.

**NO :** Replace the outside/inside air selection damper control motor. Then go to Step 4.

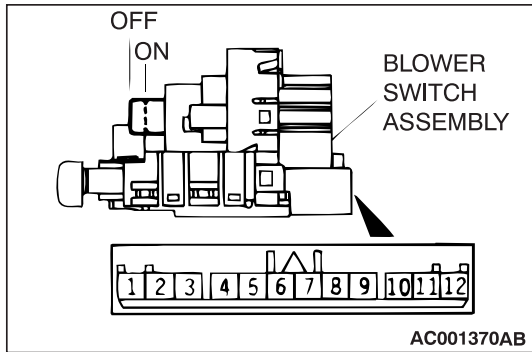

**STEP 2. Check the outside/inside air selection switch continuity.**

Follow the table below to check the inside/outside air changeover switch for continuity.

SWITCH POSITION	TESTER CONNECTION	SPECIFIED CONDITION
Inside air	4 – 5	Open circuit
Outside air	4 – 5	Less than 2 ohms

**Q: Is there continuity at the outside/inside air selection switch?**

**YES :** Go to Step 3.

**NO :** Replace the outside/inside air selection switch. Then go to Step 4.

**STEP 3. Measure the automatic compressor controller terminal voltage.**

Refer to [P.55A-18](#).

**Q: Is the automatic compressor controller terminal voltage correct?**

**YES :** Go to Step 4.

**NO :** Replace the automatic compressor controller. Then go to Step 4.

**STEP 4. Retest the system.**

**Q: Do the outside/inside air selection damper control motor operate?**

**YES :** The procedure complete (If no malfunctions are not found in all steps, an intermittent malfunction is suspected. Refer to GROUP 00, How to Use Troubleshooting/Inspection Service Points – How to Cope with Intermittent Malfunction [P.00-13](#)).

**NO :** Go to Step 1.

**INSPECTION AT THE AUTOMATIC COMPRESSOR CONTROLLER TERMINAL**

M1552010300613

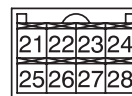
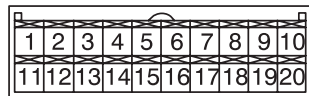

AC101882

<b>TERMINAL NO.</b>	<b>INSPECTION ITEM</b>	<b>INSPECTION REQUIREMENT</b>	<b>NORMAL CONDITION</b>
1	IG2 power supply	Ignition switch ON	Battery positive voltage
2	Input from air thermo sensor to controller	Ignition switch and A/C switch: OFF	0 V
		Ignition switch and A/C switch: ON	2 – 5 V
3	Air thermo sensor power supply	Ignition switch and A/C switch: OFF	0 V
		Ignition switch and A/C switch: ON	5 V
4	Request signal for tuning the A/C compressor	Dual pressure switch: ON	0 V
		Dual pressure switch: OFF	Battery positive voltage
5	PCM communication line	When the A/C is OFF	0 V
		When the A/C (compressor) is operating	Battery positive voltage
6	Defogger relay	Defogger switch: ON	0 V
		Defogger switch: OFF	Battery positive voltage
7	A/C switch (inside/outside)	Inside: ON	Battery positive voltage
		Outside: ON	0 V
8	Defroster switch (FOOT)	Defroster switch FOOT position	10 V
9	Defroster switch (DEF)	Defroster switch DEF position	10 V
10	A/C switch (A/C switch)	A/C switch: ON	0 V
		A/C switch: OFF	10 V
11	Ground	At all times	0 V
13	Indicator (inside/outside switch)	When inside /outside switch is ON	0 V
14	Indicator (A/C switch)	When A/C switch is ON	0 V
15	Indicator (defogger switch)	When defogger switch is ON	0 V
16	Inside/outside air changeover damper motor (inside)	When the damper flap is moving to the inside air recirculation position	0.5 V
		When the damper flap is moving to the outside air recirculation position	10 V (when the motor is stopped)
17	Inside/outside air changeover damper motor (outside)	When the damper flap is moving to the outside air recirculation position	0.5 V
		When the damper flap is moving to the inside air recirculation position	10 V (when the motor is stopped)
18	Backup power supply	At all times	Battery positive voltage
19	Blower switch (LO)	Blower switch LO position	Battery positive voltage
20	Defogger switch	Defogger switch: ON	0 V
		Defogger switch: OFF	10 V
21	A/C compressor clutch relay	A/C compressor clutch relay: ON	Battery positive voltage
		A/C compressor clutch relay: OFF	0 V
22	A/C compressor lock signal (ignition signal)	Engine speed: 3,000 r/min	0.3 – 3.0 V
23	Lock sensor power supply	Ignition switch ON	5 V
24	Ground to the lock sensor	At all times	0 V

# REAR AIR CONDITIONING DIAGNOSIS

## INTRODUCTION

M1554006200040

### REAR AIR CONDITIONING SYSTEM

The rear air conditioning system is located behind the quarter trim (RH), and supplies inside air to the evaporator through the blower motor. Then the evaporator cools the inside air. The cooled inside air is partially warmed by the heater core according to the driver's control, and then will be emitted through the air vents. The A/C control unit selects the air vents by operating the mode selection damper motor according to the temperature control knob.

### TROUBLESHOOTING STRATEGY

M1554004700038

Use these steps to plan your diagnostic strategy. If you follow them carefully, you will be sure that you have exhausted most of the possible ways to find a heater, air conditioning and ventilation fault.

1. Gather information from the customer.

2. Verify that the condition described by the customer exists.
3. Find the malfunction by following the Symptom Chart.
4. Verify malfunction is eliminated.

### SYMPTOM CHART

M1554005000236

SYMPTOM	INSPECTION PROCEDURE NO.	REFERENCE PAGE
Rear air conditioning does not operate. <vehicles with rear heater, rear cooler or rear A/C>.	1	<a href="#">P.55A-21</a>
Rear air conditioning outlet air temperature does not increase. <vehicles with rear heater>	2	<a href="#">P.55A-29</a>
Rear air conditioning outlet air temperature does not increase. <vehicles with rear cooler>	3	<a href="#">P.55A-39</a>
Rear air conditioning outlet air temperature does not increase. <vehicles with rear A/C>	4	<a href="#">P.55A-53</a>
Rear blower motor does not operate.	5	<a href="#">P.55A-70</a>
Rear blower air amount cannot be changed.	6	<a href="#">P.55A-95</a>
Air outlet vent output cannot be changed with temperature control switch. <vehicles with rear A/C>	7	<a href="#">P.55A-104</a>

SYMPTOM PROCEDURES

INSPECTION PROCEDURE 1: Rear Air Conditioning does not Operate. <Vehicles with Rear Heater, Rear Cooler or Rear A/C>

Rear Heater Power Supply Circuit  
 Rear Cooler Power Supply Circuit  
 Rear A/C Power Supply Circuit

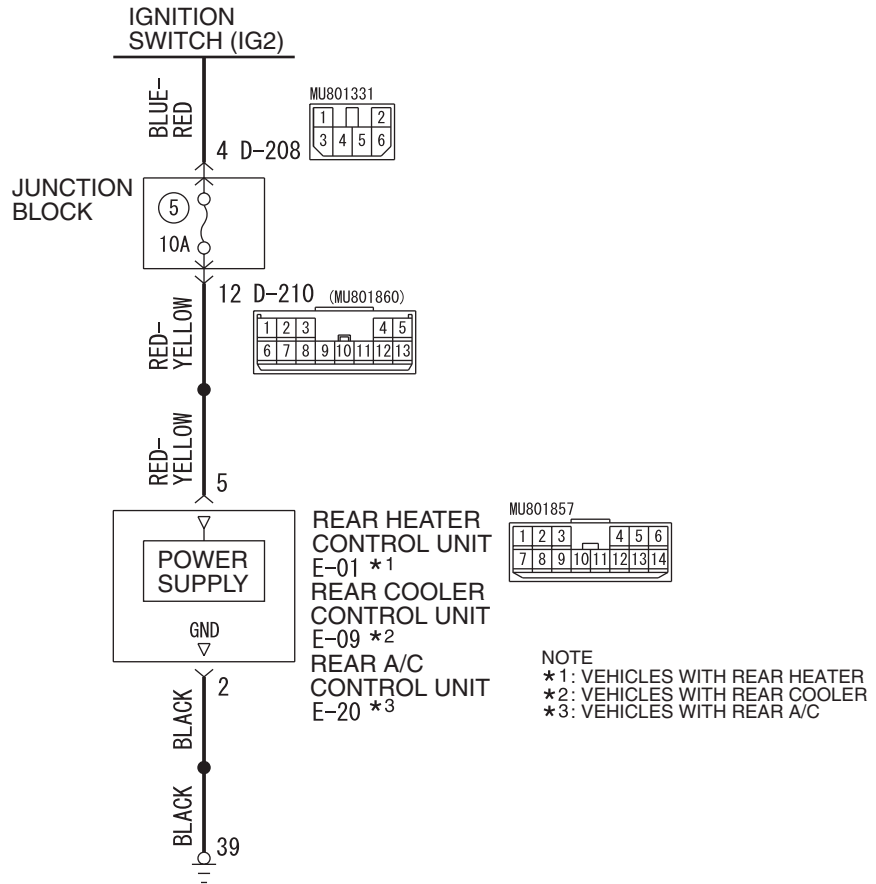

W5Q55M012A

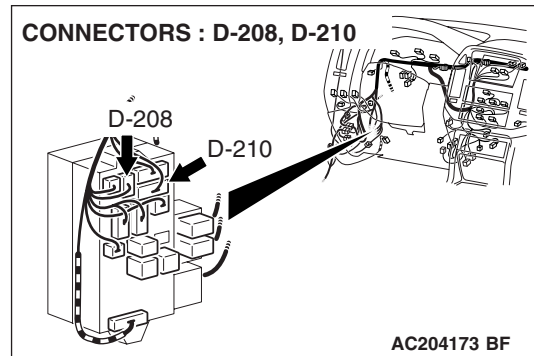
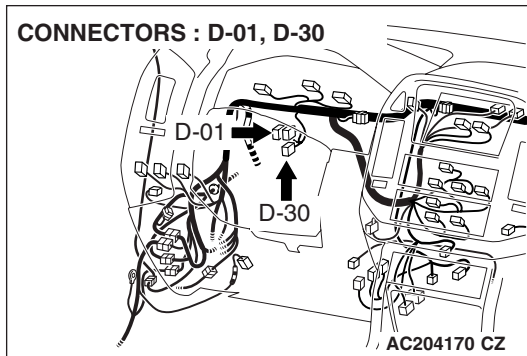

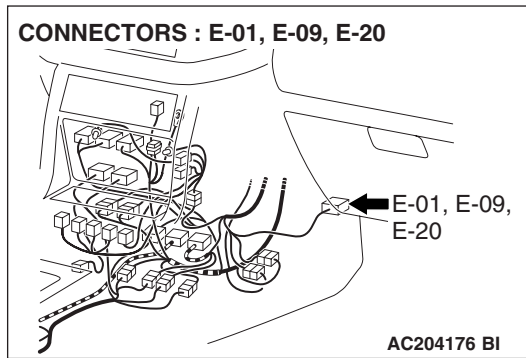

## DIAGNOSIS

---

### STEP 1. Check the front A/C operations.

#### Q: Do the front A/C work normally?

**YES** : Go to Step 2.

**NO** : Refer to Manual A/C diagnosis Inspection procedure 1 "When the ignition switch is "ON," the A/C does not operate [P.55A-6](#)."

---

### STEP 2. Check the rear blower motor operations.

#### Q: Do the rear blower motor work normally?

**YES** : Go to Step 3.

**NO** : Refer to Manual diagnosis Inspection procedure 4 "Blower fan and motor does not turn [P.55A-12](#)."

**STEP 3.** Check rear heater control unit connector E-01 <vehicles with rear heater>, rear cooler control unit connector E-09 <vehicles with rear cooler> or rear A/C control unit connector E-20 <vehicles with rear A/C> for damage.

**Q:** Is rear heater control unit connector E-01 <vehicles with rear heater>, rear cooler control unit connector E-09 <vehicles with rear cooler> or rear A/C control unit connector E-20 <vehicles with rear A/C> in good condition?

**YES :** Go to Step 4.

**NO :** Repair or replace the connector. Refer to GROUP 00E, Harness Connector Inspection [P.00E-2](#). Check that the rear air conditioning works normally.

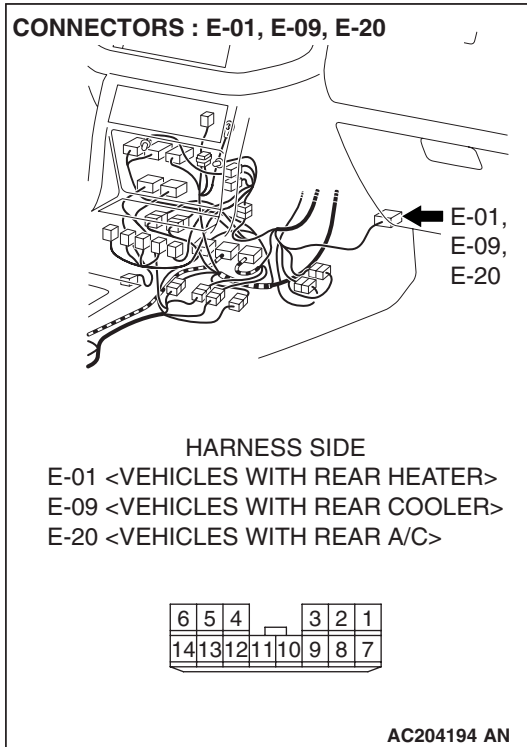

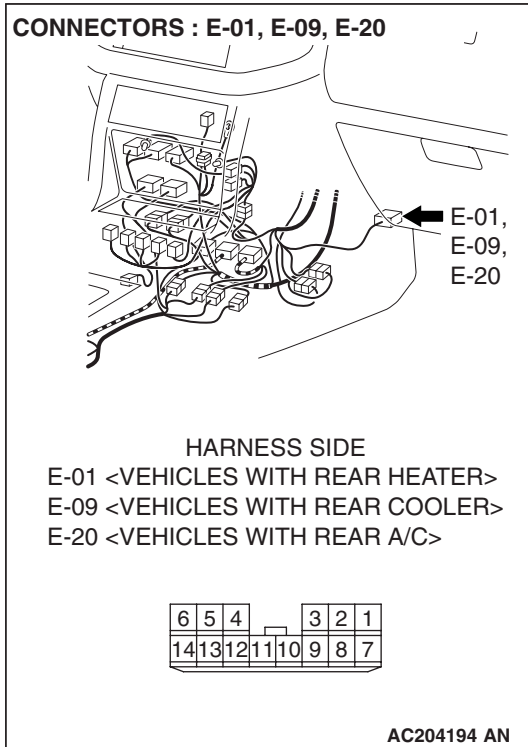

**STEP 4. Measure the voltage at rear heater control unit connector E-01 <vehicles with rear heater>, rear cooler control unit connector E-09 <vehicles with rear cooler> or rear A/C control unit connector E-20 <vehicles with rear A/C>.**

- (1) Disconnect rear heater control unit connector E-01 <vehicles with rear heater>, rear cooler control unit connector E-09 <vehicles with rear cooler> or rear A/C control unit connector E-20 <vehicles with rear A/C>, and measure the voltage at the harness side.
- (2) Turn the ignition switch to the "ON" position.

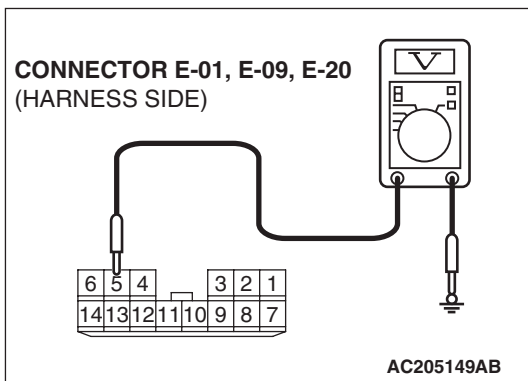

- (3) Measure the voltage between terminal 5 and ground.
  - The measured value should be approximately 12 volts (battery positive voltage).

**Q: Does the measured voltage correspond with this range?**

- YES :** Go to Step 6.  
**NO :** Go to Step 5.



**STEP 5.** Check the wiring harness between rear heater control unit connector E-01 (terminal 5) <vehicles with rear heater>, or rear cooler control unit connector E-09 (terminal 5) <vehicles with rear cooler> or rear A/C control unit connector E-20 (terminal 5) <vehicles with rear A/C> and the ignition switch (IG2).

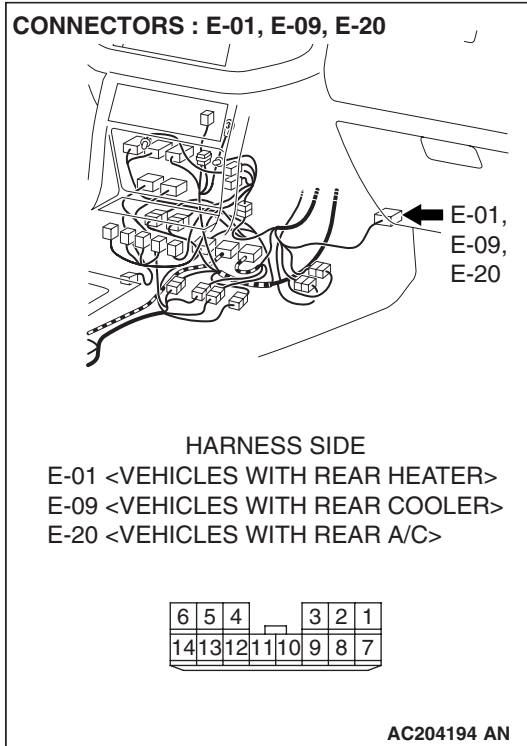

CONNECTOR: D-01

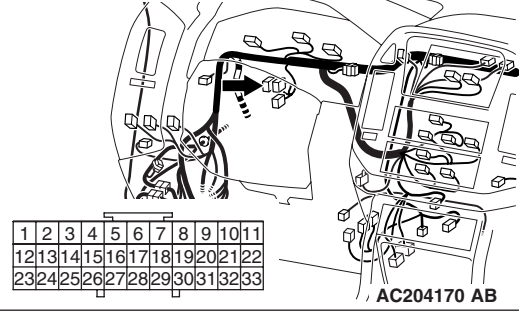

*NOTE: Also check joint connector (6) D-01, junction block connectors D-208 and D-210. If joint connector (6) D-01, junction block connectors D-208 and D-210 is damaged, repair or replace the connector as described in GROUP 00E, Harness Connector Inspection P.00E-2.*

**Q: Is the wiring harness between rear heater control unit connector E-01 (terminal 5) <vehicles with rear heater>, rear cooler control unit connector E-09 (terminal 5) <vehicles with rear cooler> or rear A/C control unit connector E-20 (terminal 5) <vehicles with rear A/C> and the ignition switch (IG2) in good condition?**

**YES :** Check that the rear air conditioning works normally.

**NO :** Repair the wiring harness. Check that the rear air conditioning works normally.

CONNECTORS: D-208, D-210

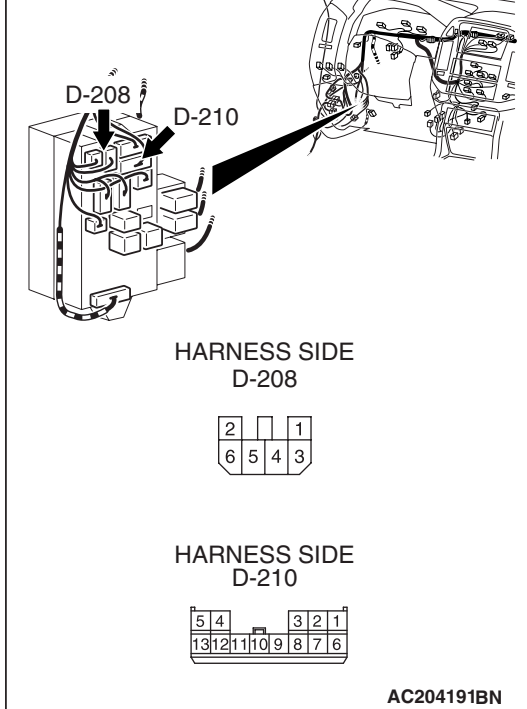

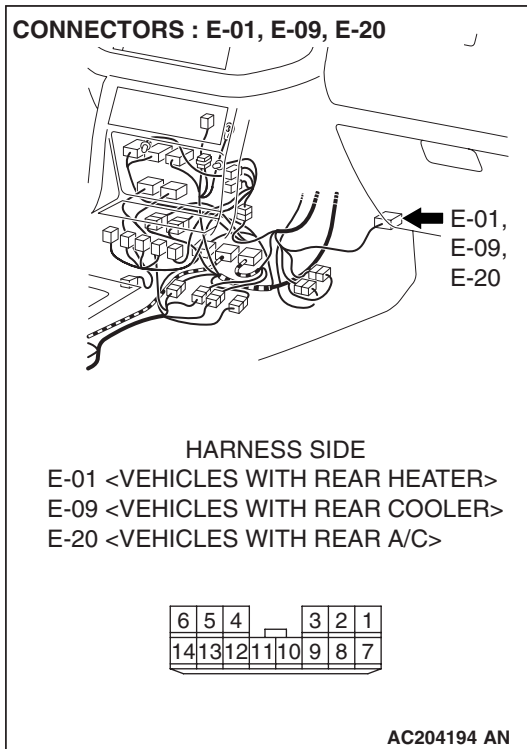

**STEP 6.** Measure the resistance at rear heater control unit connector E-01 <vehicles with rear heater>, rear cooler control unit connector E-09 <vehicles with rear cooler> or rear A/C control unit connector E-20 <vehicles with rear A/C>.

- (1) Disconnect rear heater control unit connector E-01 <vehicles with rear heater>, rear cooler control unit connector E-09 <vehicles with rear cooler> or rear A/C control unit connector E-20 <vehicles with rear A/C>, and measure at the wiring harness side.

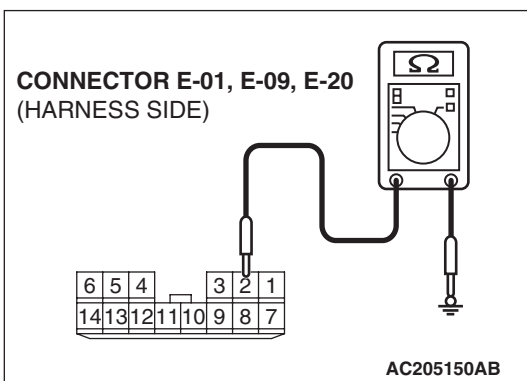

- (2) Measure the resistance between terminal 2 and ground.
  - The measured value should be 2 ohms or less.

**Q: Does the measured resistance value correspond with this range?**

**YES :** Replace the rear heater control unit <vehicles with rear heater>, rear cooler control unit <vehicles with rear cooler> or rear A/C control unit <vehicles with rear A/C>, and check that the rear air conditioning works normally.

**NO :** Go to Step 7.

CONNECTORS : E-01, E-09, E-20

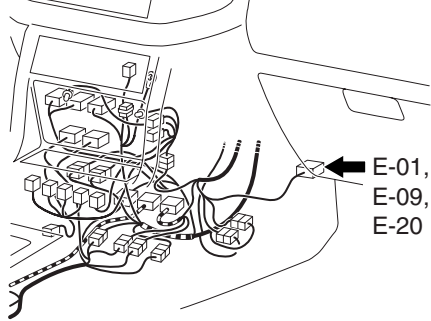

## HARNESS SIDE

E-01 <VEHICLES WITH REAR HEATER>  
 E-09 <VEHICLES WITH REAR COOLER>  
 E-20 <VEHICLES WITH REAR A/C>

6	5	4			3	2	1
14	13	12	11	10	9	8	7

AC204194 AN

**STEP 7.** Check the wiring harness between rear heater control unit connector E-01 (terminal 2) <vehicles with rear heater>, rear cooler control unit connector E-09 (terminal 2) <vehicles with rear cooler> or rear A/C control unit connector E-20 (terminal 2) <vehicles with rear A/C> and the ground.

**Q:** Is the wiring harness between rear heater control unit connector E-01 (terminal 2) <vehicles with rear heater>, rear cooler control unit connector E-09 (terminal 2) <vehicles with rear cooler> or rear A/C control unit connector E-20 (terminal 2) <vehicles with rear A/C> and the ground in good condition?

**YES :** Replace the rear heater control unit connector E-01 <vehicles with rear heater>, rear cooler control unit connector E-09 <vehicles with rear cooler> or rear A/C control unit connector E-20 <vehicles with rear A/C>, and check that the rear air conditioning works normally.

**NO :** Repair the wiring harness. Check that the rear air conditioning works normally.

**INSPECTION PROCEDURE 2: Rear Air Conditioning Outlet Air Temperature does not Increase**  
**<Vehicles with Rear Heater>**

**Air Mixing Damper Control Motor and Potentiometer Circuit**

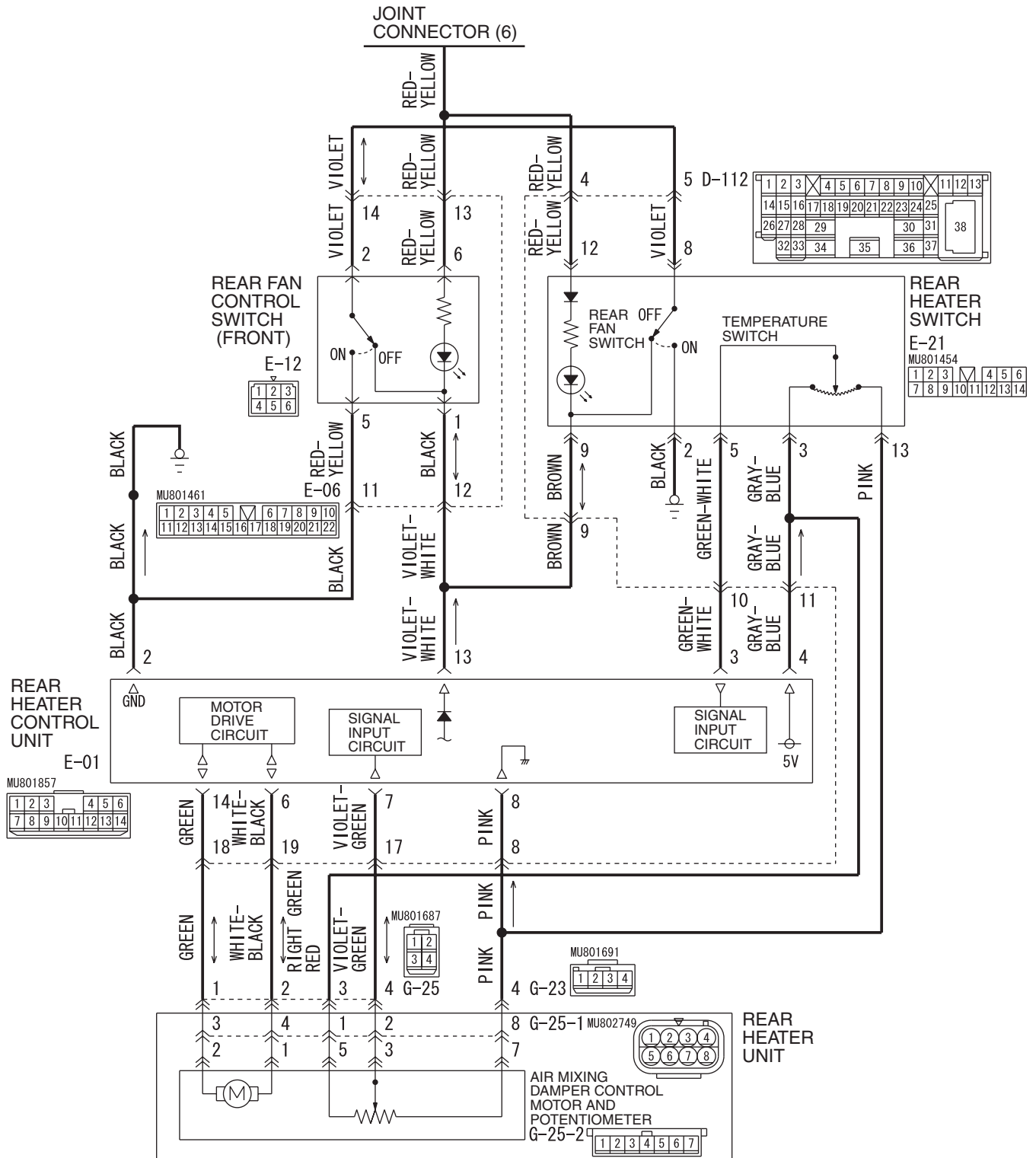

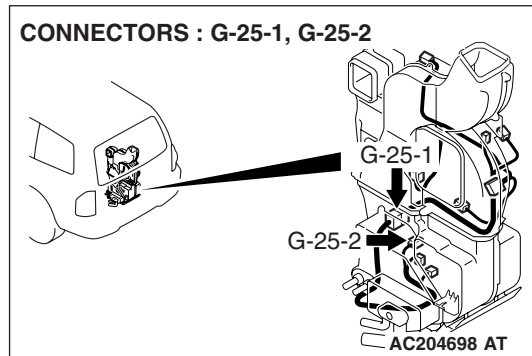
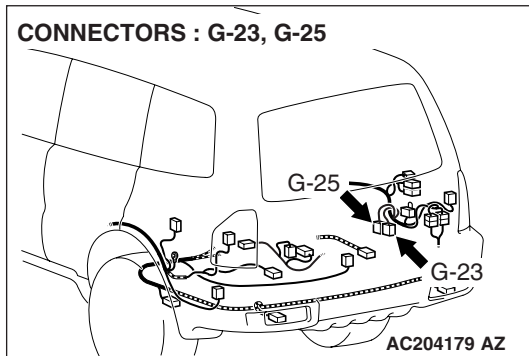
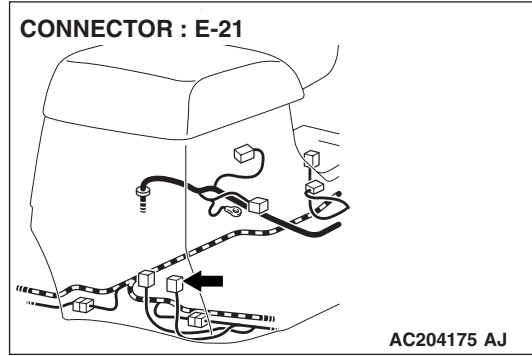
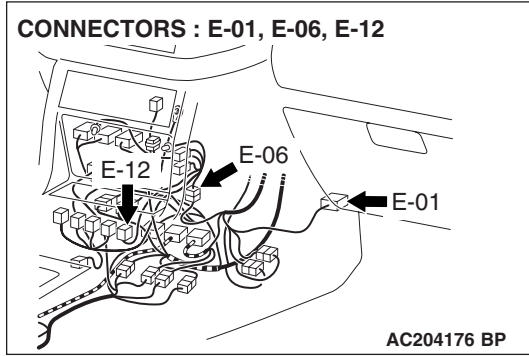
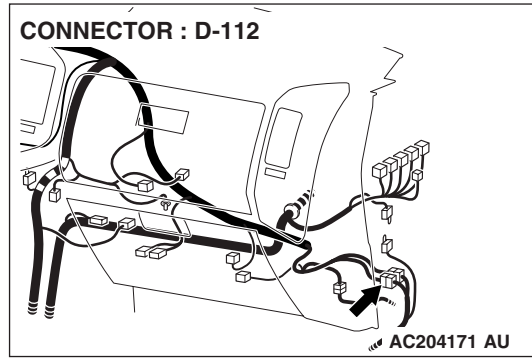
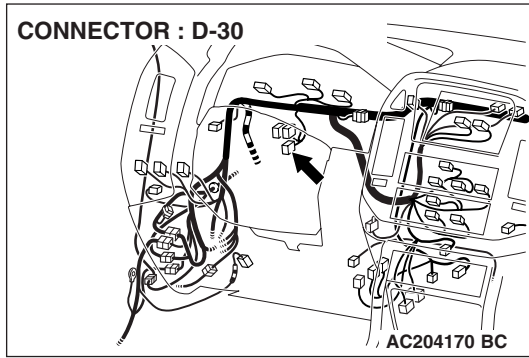

**DIAGNOSIS**

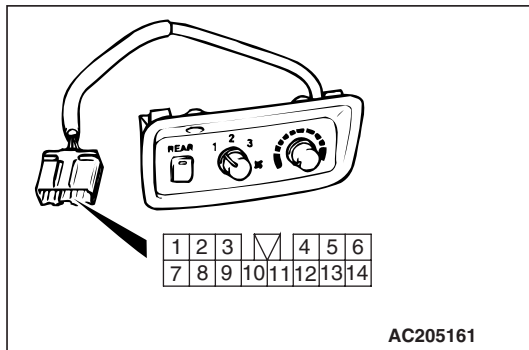

**STEP 1. Check the rear heater switch (temperature switch).**

Connect the tester between the connector terminal number 3 and number 5, between the terminal number 5 and number 13 and make sure that the resistance value changes slowly within the standard value.

**Standard value: 0 – 3 kΩ**

**Q: Is the check result normal?**

**YES :** Go to Step 2.

**NO :** Replace the rear air-conditioner switch.

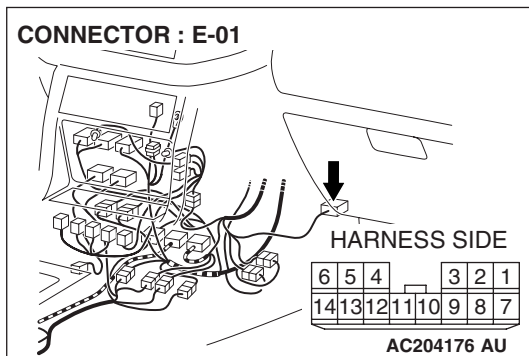

**STEP 2. Measure the resistance at rear heater control unit connector E-01.**

- (1) Disconnect rear heater control unit connector E-01, and measure at the wiring harness side.
- (2) Turn the rear fan switch to the "ON" position.
- (3) Turn the rear fan control switch to the "OFF" position.

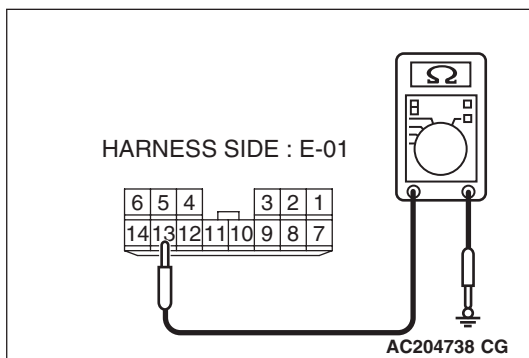

- (4) Measure the resistance between terminal 13 and ground.
  - The measured value should be 2 ohms or less.

**Q: Does the measured resistance value correspond with this range?**

**YES :** Go to Step 5.

**NO :** Go to Step 3.

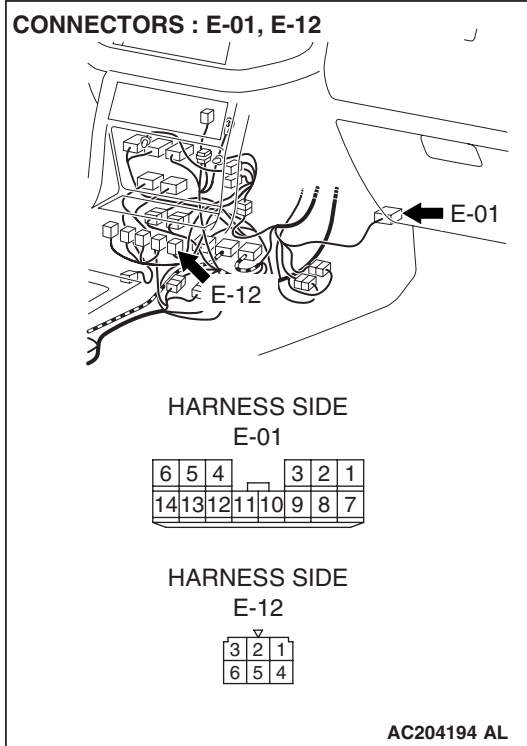

**STEP 3.** Check rear heater control unit connector E-01 and rear fan control switch connector E-12 for damage.

**Q:** Is rear heater control unit connector E-01 and rear fan control switch connector E-12 in good condition?

**YES :** Go to Step 4.

**NO :** Repair or replace the connector. Refer to GROUP 00E, Harness Connector Inspection P.00E-2. Check that the air conditioning works normally.

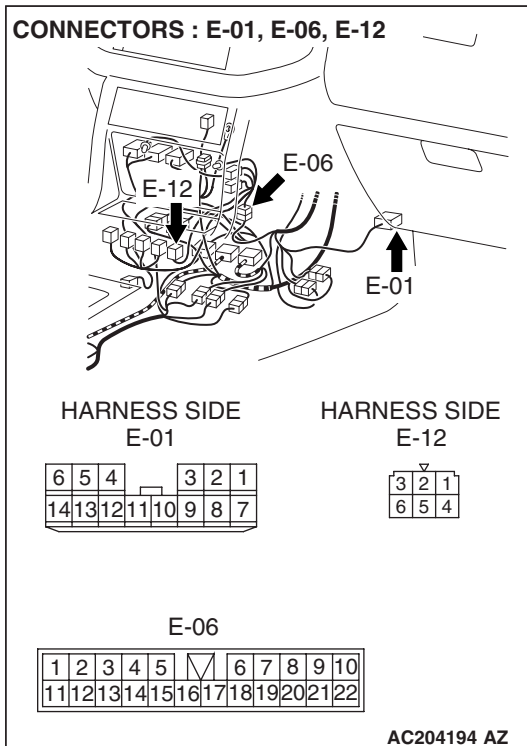

**STEP 4.** Check the wiring harness between rear heater control unit connector E-01 (terminal 13) and rear fan control switch connector E-12 (terminal 1).



*NOTE: Also check intermediate connector E-06. If intermediate connector E-06 is damaged, repair or replace the connector as described in GROUP 00E, Harness Connector Inspection P.00E-2.*

**Q: Is the wiring harness between rear heater control unit connector E-01 (terminal 13) and rear fan control switch connector E-12 (terminal 1) in good condition?**

**YES :** Check that the rear air conditioning works normally.

**NO :** Repair the wiring harness. Check that the rear air conditioning works normally.

**STEP 5. Check rear heater control unit connector E-01 and rear heater switch E-21 for damage.**

**Q: Is rear heater control unit connector E-01 and rear heater switch E-21 in good condition?**

**YES :** Go to Step 6.

**NO :** Repair or replace the connector. Refer to GROUP 00E, Harness Connector Inspection P.00E-2. Check that the rear air conditioning works normally.

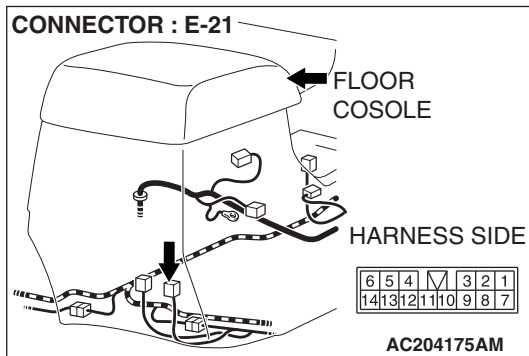
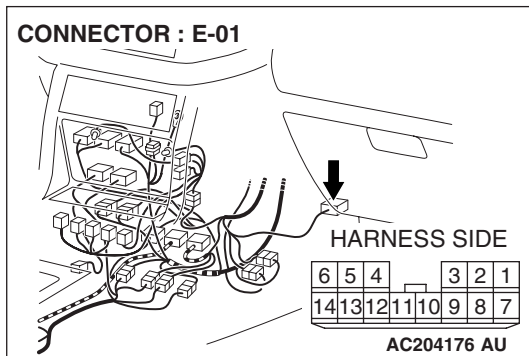

**STEP 6.** Check the wiring harness between rear heater control unit connector E-01 (terminal 3, 4 and 8) and rear heater switch connector E-21 (terminal 5, 3 and 13).

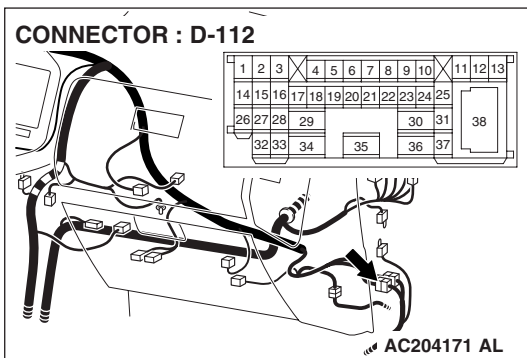
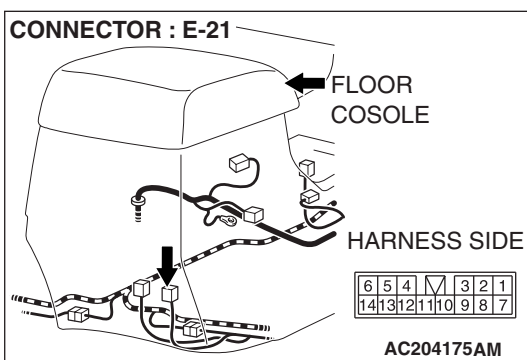
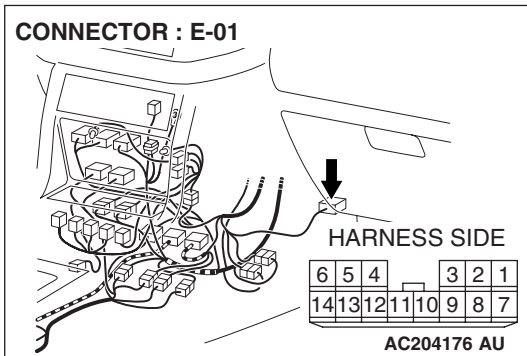

*NOTE:* Also check intermediate connector D-112. If intermediate connector D-112 is damaged, repair or replace the connector as described in *GROUP 00E, Harness Connector Inspection P.00E-2*.

**Q:** Is the wiring harness between rear heater control unit connector E-01 (terminal 3, 4 and 8) and rear heater switch connector E-21 (terminal 5, 3 and 13) in good condition?

**YES :** Go to Step 7.

**NO :** Repair the wiring harness. Check that the rear air conditioning works normally.

**STEP 7. Check the air mixing damper control motor and potentiometer**

**AIR MIX DAMPER MOTOR CHECK**

**⚠ CAUTION**

**Do not apply battery voltage when the damper is in the MAX HOT/MAX COOL position.**

Check the air mixing damper control motor by the following procedures.

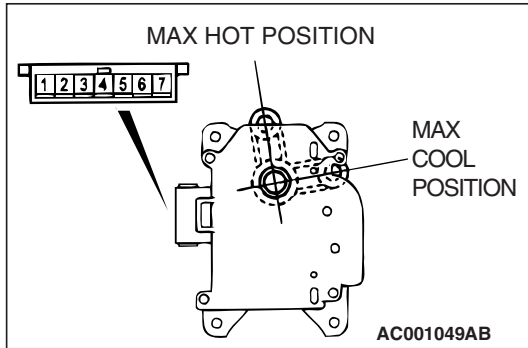

LEVER POSITION	BATTERY CONNECTION	LEVER OPERATION
At the MAX COOL position	<ul style="list-style-type: none"> <li>Connect terminal 1 to the positive battery terminal</li> <li>Connect terminal 2 to the negative battery terminal</li> </ul>	The lever moves from the MAX COOL position to the MAX HOT position
At the MAX HOT position	<ul style="list-style-type: none"> <li>Connect terminal 2 to the positive battery terminal</li> <li>Connect terminal 1 to the negative battery terminal</li> </ul>	The lever moves from the MAX HOT position to the MAX COOL position

**AIR MIX DAMPER POTENTIOMETER CHECK**

When checking the air mixing damper control motor, measure the resistance value between the terminals 3 and 5, between the terminals 3 and 7. At this time, make sure that the measured resistance value changes slowly within the standard value.

**Standard value: 1.2 – 4.8 kΩ**

**Q: Does air mixing damper control motor work normally?**

**YES :** Go to Step 8.

**NO :** Replace the air mixing damper control motor. Check that the rear air conditioning works normally.

CONNECTOR : E-01

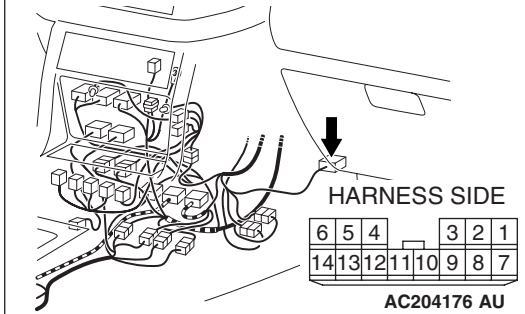

**STEP 8.** Check rear heater control unit connector E-01 and air mixing damper control motor and potentiometer connector G-25-2 for damage.

**Q:** Is rear heater control unit connector E-01 and air mixing damper control motor and potentiometer connector G-25-2 in good condition?

**YES :** Go to Step 9.

**NO :** Repair or replace the connector. Refer to GROUP 00E, Harness Connector Inspection [P.00E-2](#). Check that the rear air conditioning works normally.

CONNECTOR : G-25-2

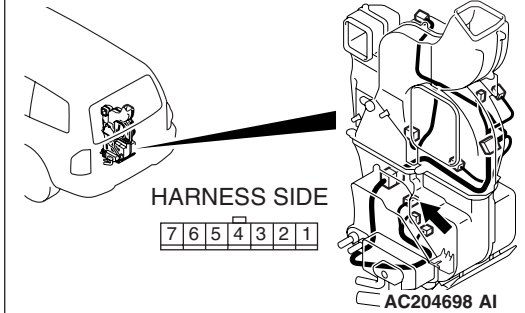

**STEP 9.** Check the wiring harness between rear heater control unit connector E-01 (terminal 14, 6, 4, 7 and 8) and air mixing damper control motor and potentiometer connector G-25-2 (terminal 2, 1, 5, 3 and 7).

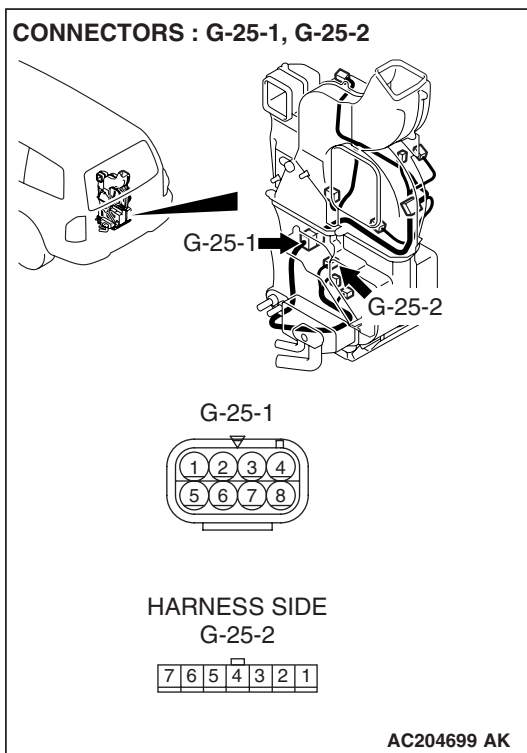
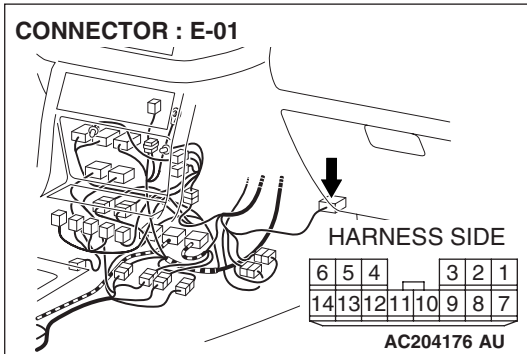

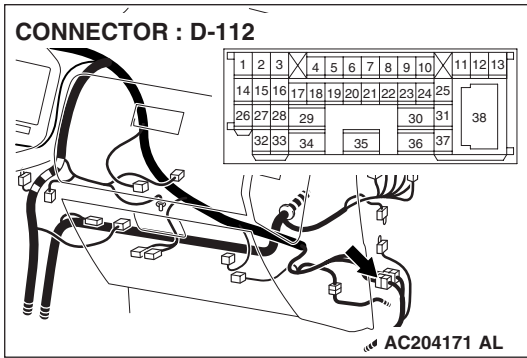

*NOTE: Also check intermediate connectors G-25-1, D-112, rear heater unit connectors G-25 and G-23. If intermediate connector G-25-1, D-112, rear heater unit connector G-25 or G-23 is damaged, repair or replace the connector as described in GROUP 00E, Harness Connector Inspection P.00E-2.*

**Q: Is the wiring harness between rear heater control unit connector E-01 (terminal 14, 6, 4, 7 and 8) and air mixing damper control motor and potentiometer connector G-25-2 (terminal 2, 1, 5, 3 and 7) in good condition?**

**YES :** Check that the rear air conditioning works normally.

**NO :** Repair the wiring harness. Check that the rear air conditioning works normally.

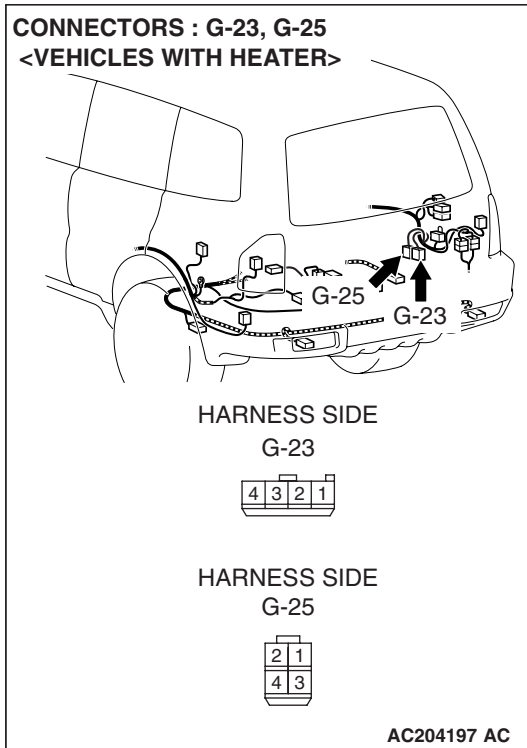

**INSPECTION PROCEDURE 3: Rear Air Conditioning Outlet Air Temperature does not Increase**  
 <Vehicles with Rear Cooler>

**Air Thermo Sensor and Magnetic Valve Circuit**

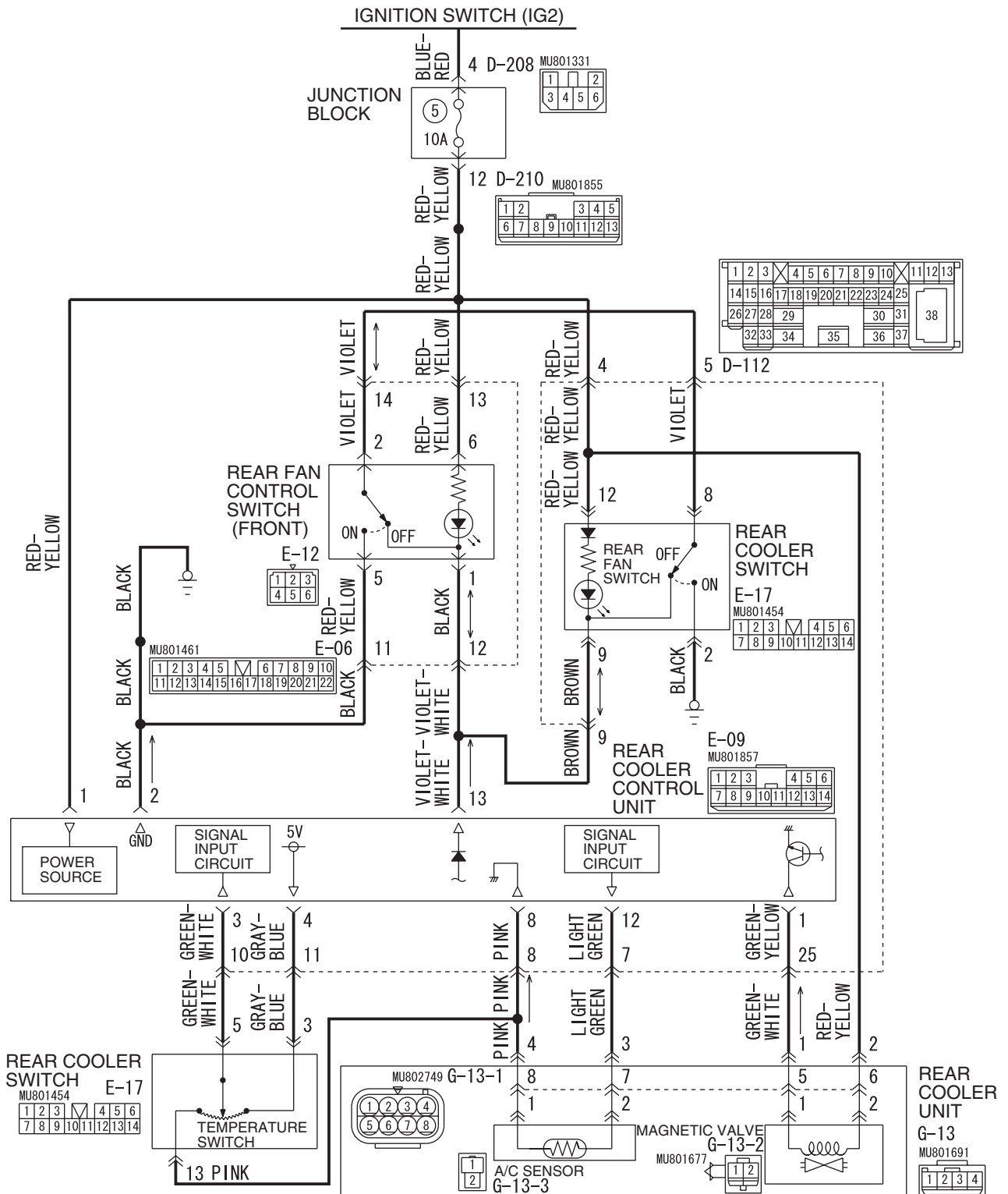

W5Q55M014A

CONNECTORS : D-01, D-30

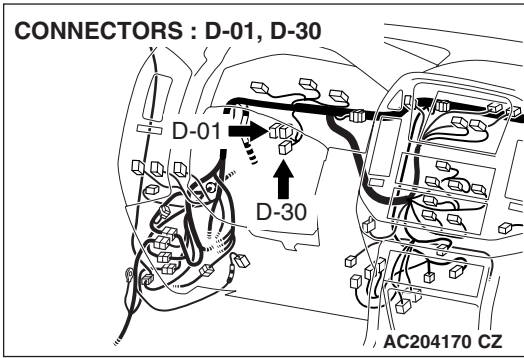

CONNECTOR : D-112

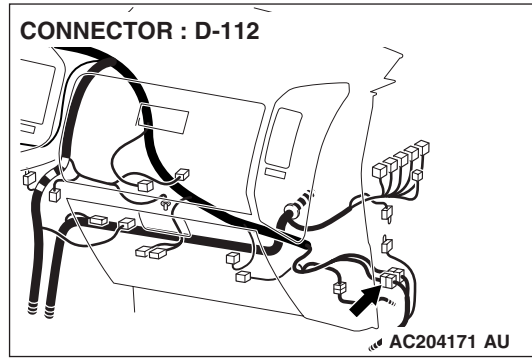

CONNECTORS : D-208, D-210

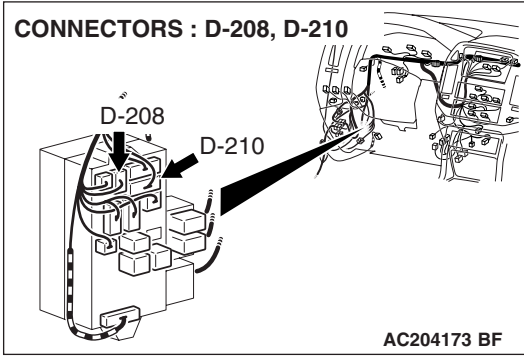

CONNECTORS : E-06, E-09, E-12

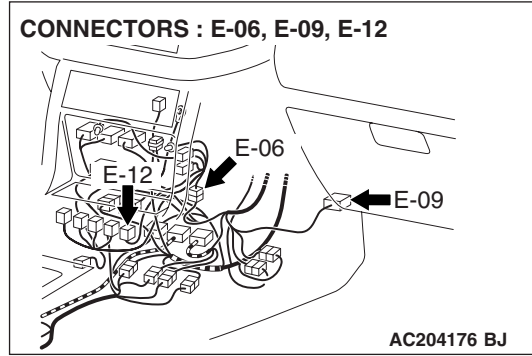

CONNECTOR : E-17

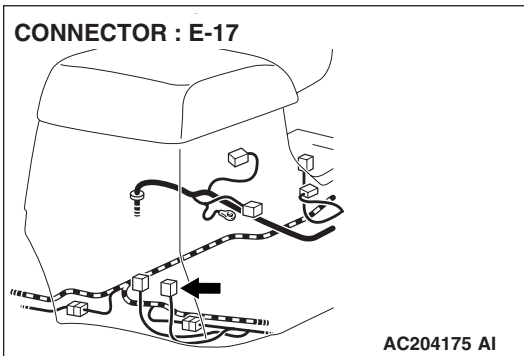

CONNECTOR : G-13

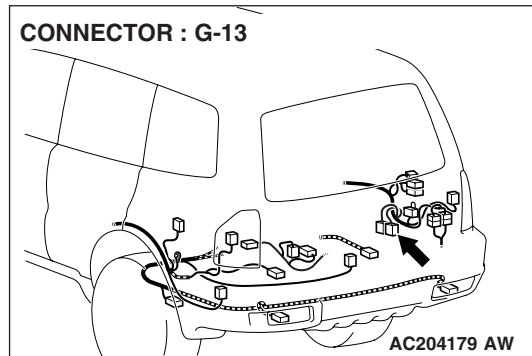

CONNECTORS : G-13-1, G-13-2, G-13-3

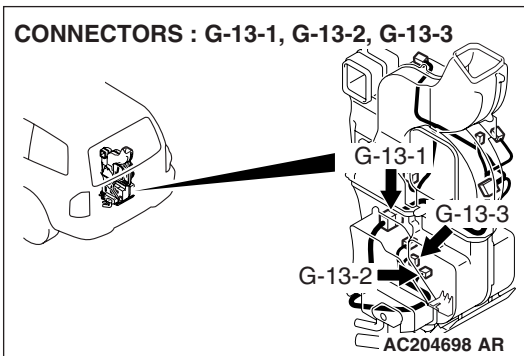



**DIAGNOSIS**

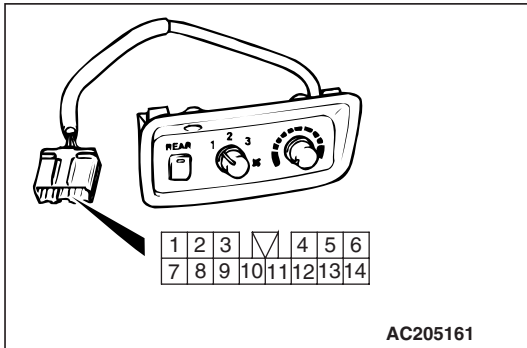

**STEP 1. Check the rear cooler switch (temperature switch).**

Connect the tester between the connector terminal number 3 and number 5, between the terminal number 5 and number 13 and make sure that the resistance value changes slowly within the standard value.

**Standard value: 0 – 3 kΩ**

**Q: Is the check result normal?**

**YES :** Go to Step 2.

**NO :** Replace the rear air-conditioner switch.

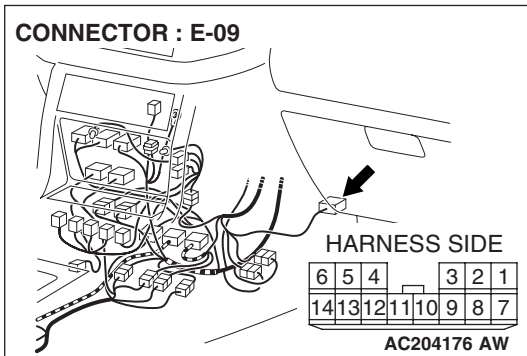

**STEP 2. Measure the resistance at rear cooler control unit connector E-09.**

- (1) Disconnect rear cooler control unit connector E-09, and measure at the wiring harness side.
- (2) Turn the rear fan switch to the "ON" position.
- (3) Turn the rear fan control switch to the "OFF" position.

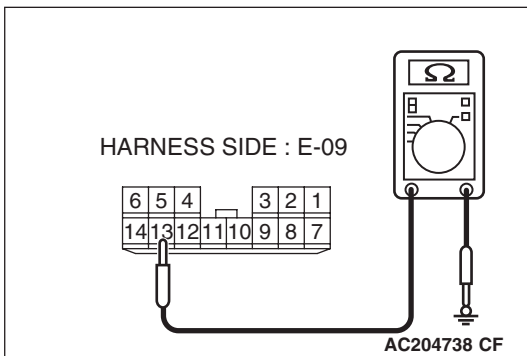

- (4) Measure the resistance between terminal 13 and ground.
  - The measured value should be 2 ohms or less.

**Q: Does the measured resistance value correspond with this range?**

**YES :** Go to Step 5.

**NO :** Go to Step 3.

CONNECTORS : E-09, E-12

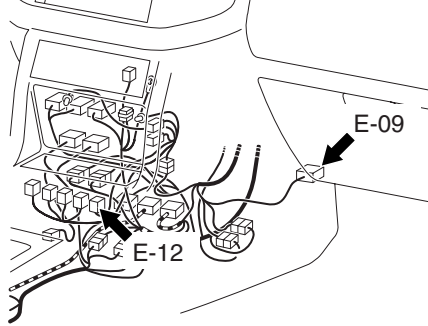

HARNESS SIDE  
E-12

3	2	1
6	5	4

HARNESS SIDE  
E-09 <VEHICLES WITH REAR COOLER>

6	5	4		3	2	1	
14	13	12	11	10	9	8	7

AC204194 AR

**STEP 3.** Check rear cooler control unit connector E-09 and rear fan control switch connector E-12 for damage.

**Q:** Is rear cooler control unit connector E-09 and rear fan control switch connector E-12 in good condition?

**YES :** Go to Step 4.

**NO :** Repair or replace the connector. Refer to GROUP 00E, Harness Connector Inspection P.00E-2. Check that the air conditioning works normally.

**STEP 4.** Check the wiring harness between rear cooler control unit connector E-09 (terminal 13) and rear fan control switch connector E-12 (terminal 1).

CONNECTORS : E-06, E-09, E-12

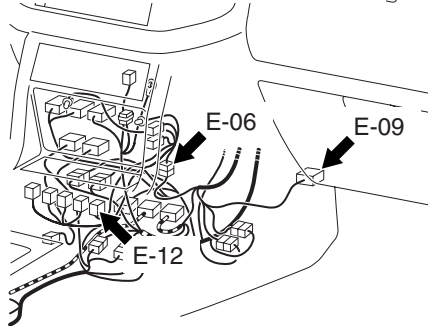

HARNESS SIDE

E-06

1	2	3	4	5	6	7	8	9	10		
11	12	13	14	15	16	17	18	19	20	21	22

E-12

3	2	1
6	5	4

HARNESS SIDE  
E-09 <VEHICLES WITH REAR COOLER>

6	5	4		3	2	1	
14	13	12	11	10	9	8	7

AC204194 AQ

*NOTE: Also check intermediate connector E-06. If intermediate connector E-06 is damaged, repair or replace the connector as described in GROUP 00E, Harness Connector Inspection P.00E-2.*

**Q: Is the wiring harness between rear cooler control unit connector E-09 (terminal 13) and rear fan control switch connector E-12 (terminal 1) in good condition?**

**YES :** Check that the rear air conditioning works normally.

**NO :** Repair the wiring harness. Check that the rear air conditioning works normally.

**STEP 5. Check rear cooler control unit connector E-09 and rear cooler switch E-17 for damage.**

**Q: Is rear cooler control unit connector E-09 and rear cooler switch E-17 in good condition?**

**YES :** Go to Step 6.

**NO :** Repair or replace the connector. Refer to GROUP 00E, Harness Connector Inspection P.00E-2. Check that the rear air conditioning works normally.

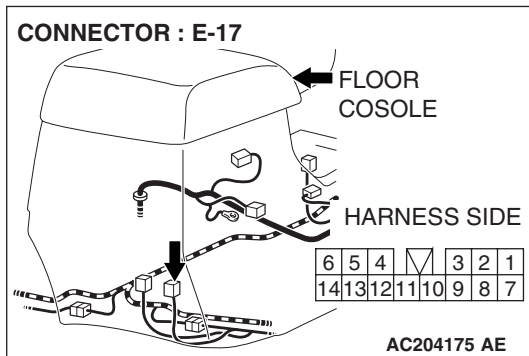
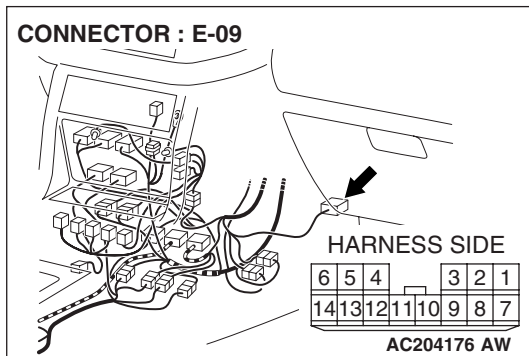

**STEP 6.** Check the wiring harness between rear cooler control unit connector E-09 (terminal 3, 4 and 8) and rear cooler switch connector E-17 (terminal 5, 3 and 13).

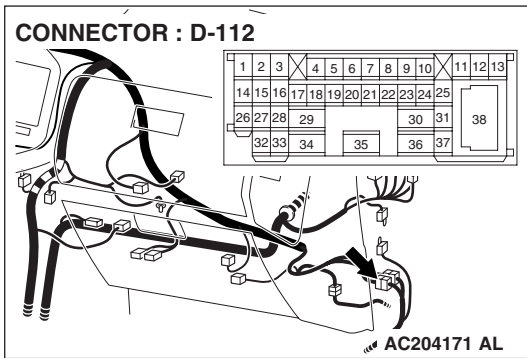
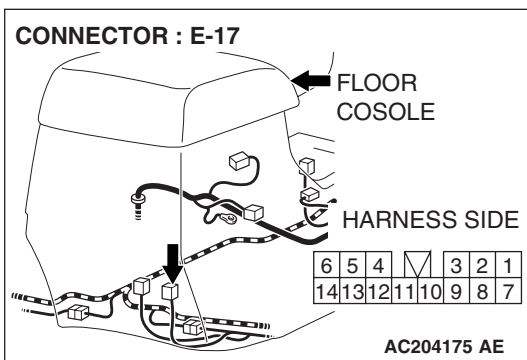
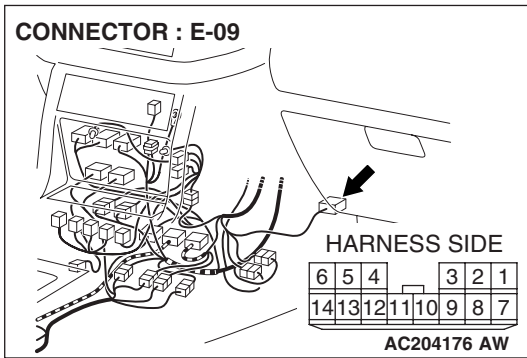

**NOTE:** Also check intermediate connector D-112. If intermediate connector D-112 is damaged, repair or replace the connector as described in *GROUP 00E, Harness Connector Inspection P.00E-2*.

**Q:** Is the wiring harness between rear cooler control unit connector E-09 (terminal 3, 4 and 8) and rear cooler switch connector E-17 (terminal 5, 3 and 13) in good condition?

**YES :** Go to Step 7.

**NO :** Repair the wiring harness. Check that the rear air conditioning works normally.

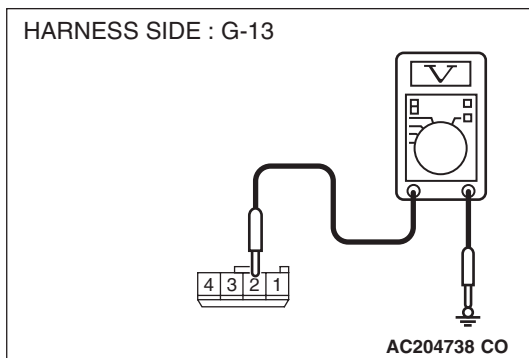
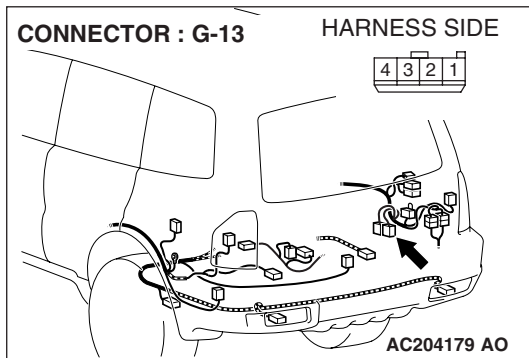

**STEP 7. Measure the voltage at rear cooler unit connector G-13.**

- (1) Disconnect rear cooler unit connector G-13, and measure the voltage at the harness side.
- (2) Turn the ignition switch to the "ON" position.

- (3) Measure the voltage between terminal 2 and ground.
  - The measured value should be approximately 12 volts (battery positive voltage).

**Q: Does the measured voltage correspond with this range?**

**YES :** Go to Step 10.

**NO :** Go to Step 8.

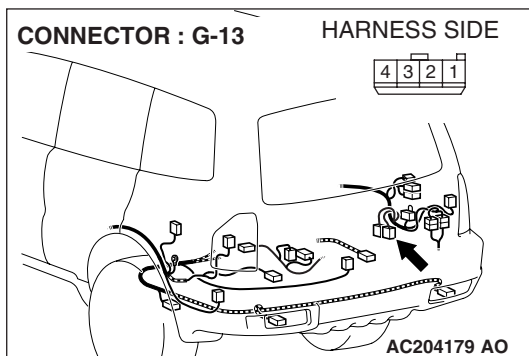

**STEP 8. Check rear cooler unit connector G-13 for damage.**

**Q: Is rear cooler unit connector G-13 in good condition?**

**YES :** Go to Step 9.

**NO :** Repair or replace the connector. Refer to GROUP 00E, Harness Connector Inspection [P.00E-2](#). Check that the rear air conditioning works normally.

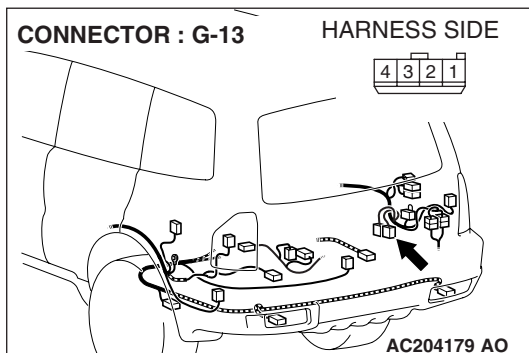

**STEP 9. Check the wiring harness between rear cooler unit connector G-13 (terminal 2) and the ignition switch (IG2).**

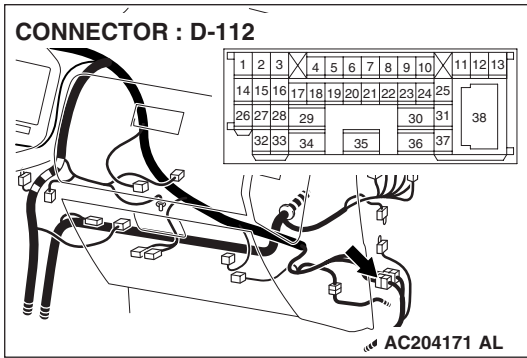

*NOTE: Also check intermediate connector D-112, junction block connectors D-210 and D-208. If intermediate connector D-112, junction block connectors D-210 or D-208 is damaged, repair or replace the connector as described in GROUP 00E, Harness Connector Inspection P.00E-2.*

**Q: Is the wiring harness between rear cooler unit connector G-13 (terminal 2) and the ignition switch (IG2) in good condition?**

**YES :** Check that the rear air conditioning works normally.

**NO :** Repair the wiring harness. Check that the rear air conditioning works normally.

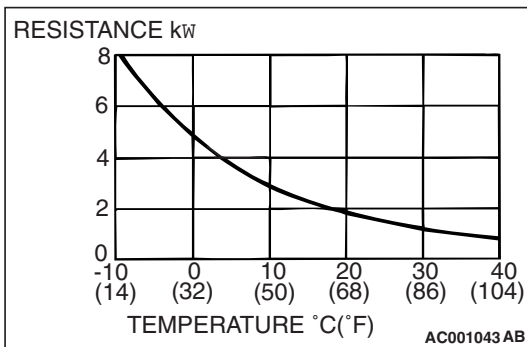
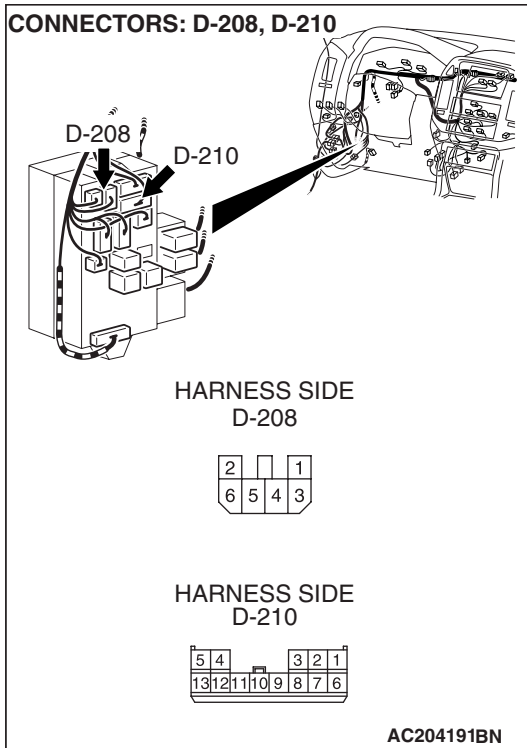

**STEP 10. Check the air thermo sensor.**

When the resistance between the sensor terminals is measured at two or more temperature conditions, the resistance should satisfy the value shown in the illustration.

*NOTE: The temperature condition at the check shall be within the range shown in the characteristic diagram.*

**Q: Does air thermo sensor work normally?**

**YES :** Go to Step 11.

**NO :** Replace the air thermo sensor.

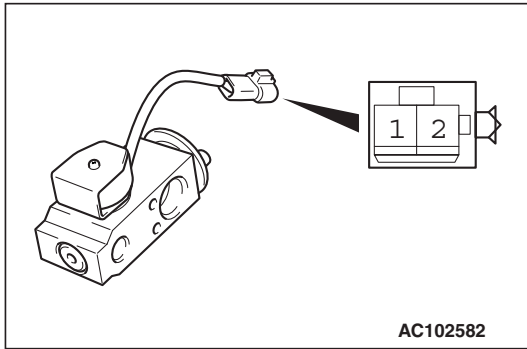

**STEP 11. Check the expansion valve (magnet valve).**

The valve is in normal condition if the actuation sound is heard from the magnet valve when battery voltage is applied to magnet valve terminal 1 and terminal 2 is grounded.

**Q: Does expansion valve work normally?**

**YES :** Go to Step 12.

**NO :** Replace the expansion valve (magnet valve).

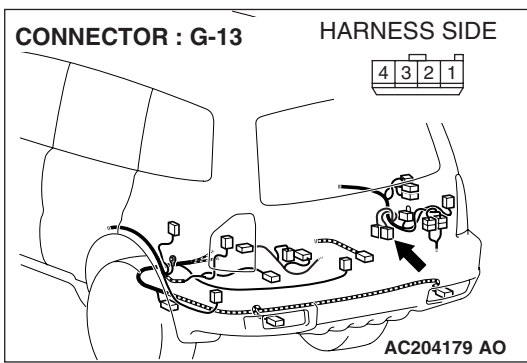

**STEP 12. Check rear cooler unit connector G-13 and magnetic valve connector G-13-2 for damage.**

**Q: Is rear cooler unit connector G-13 and magnetic valve connector G-13-2 in good condition?**

**YES :** Go to Step 13.

**NO :** Repair or replace the connector. Refer to GROUP 00E, Harness Connector Inspection [P.00E-2](#). Check that the rear air conditioning works normally.

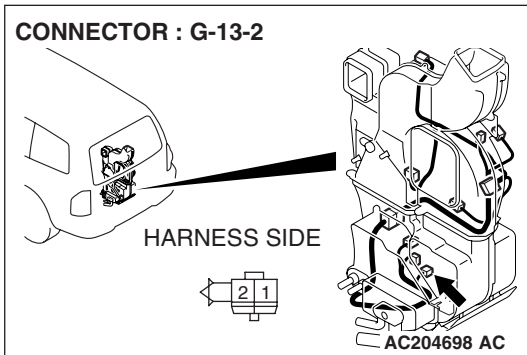

**STEP 13.** Check the wiring harness between rear cooler unit connector G-13 (terminal 1 and 2) and magnetic valve connector G-13-2 (terminal 1 and 2).

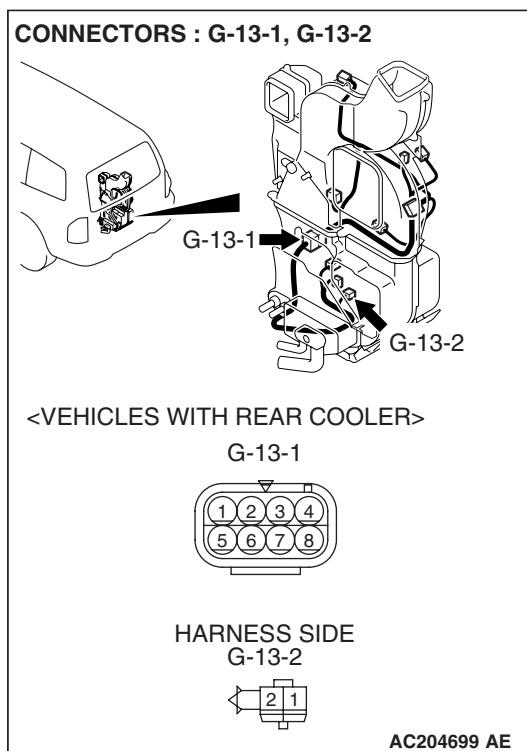
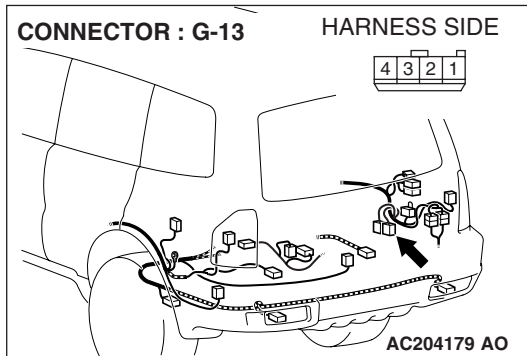

*NOTE:* Also check intermediate connector G-13-1. If intermediate connector G-13-1 is damaged, repair or replace the connector as described in GROUP 00E, Harness Connector Inspection [P.00E-2](#).

**Q:** Is the wiring harness between rear cooler unit connector G-13 (terminal 1 and 2) and magnetic valve connector G-13-2 (terminal 1 and 2) in good condition?

**YES :** Go to Step 14.

**NO :** Repair the wiring harness. Check that the rear air conditioning works normally.



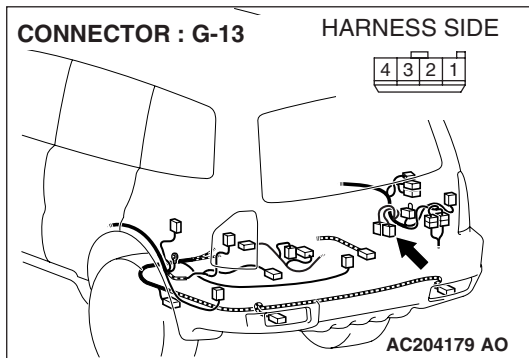

**STEP 14.** Check rear cooler unit connector G-13 and air thermo sensor connector G-13-3 for damage.

**Q:** Is rear cooler unit connector G-13 and air thermo sensor connector G-13-3 in good condition?

**YES :** Go to Step 15.

**NO :** Repair or replace the connector. Refer to GROUP 00E, Harness Connector Inspection [P.00E-2](#). Check that the rear air conditioning works normally.

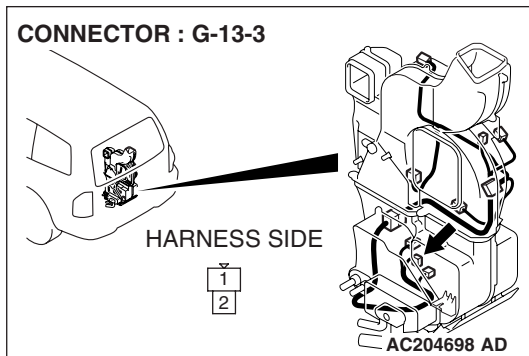

**STEP 15.** Check the wiring harness between rear cooler unit connector G-13 (terminal 4 and 3) and air thermo sensor connector G-13-3 (terminal 1 and 2).

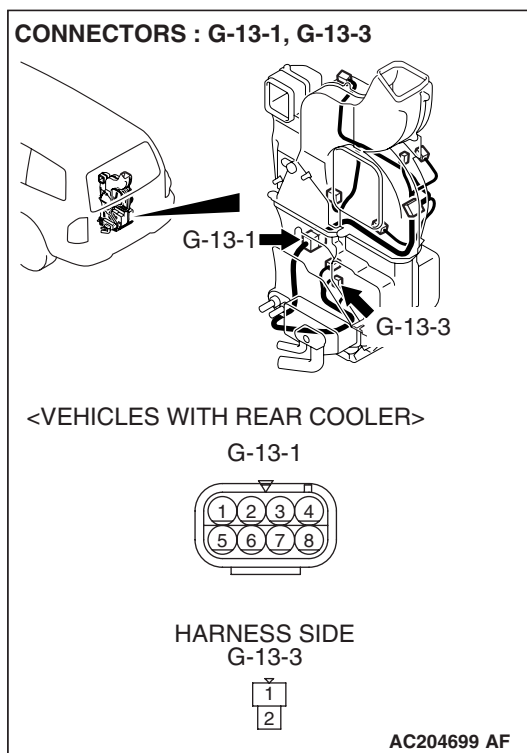
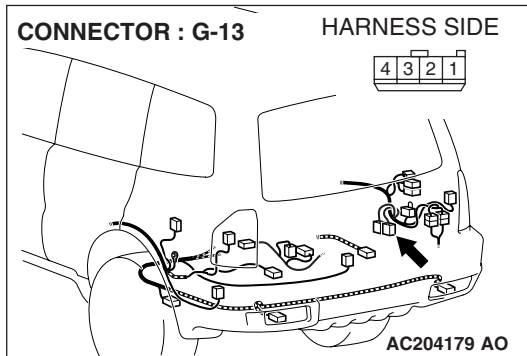

*NOTE:* Also check intermediate connector G-13-1. If intermediate connector G-13-1 is damaged, repair or replace the connector as described in GROUP 00E, Harness Connector Inspection [P.00E-2](#).

**Q:** Is the wiring harness between rear cooler unit connector G-13 (terminal 4 and 3) and air thermo sensor connector G-13-3 (terminal 1 and 2) in good condition?

**YES :** Go to Step 16.

**NO :** Repair the wiring harness. Check that the rear air conditioning works normally.

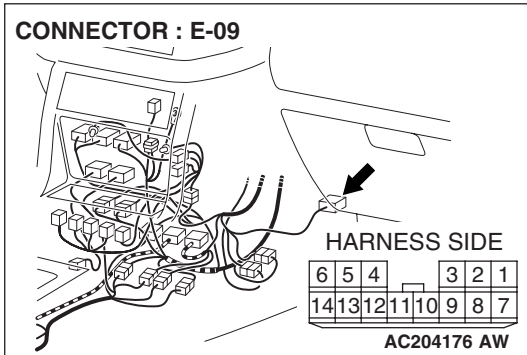

**STEP 16.** Check rear cooler unit connector G-13 and rear cooler control unit connector E-09 for damage.

**Q:** Is rear cooler unit connector G-13 and rear cooler control unit connector E-09 in good condition?

**YES :** Go to Step 17.

**NO :** Repair or replace the connector. Refer to GROUP 00E, Harness Connector Inspection [P.00E-2](#). Check that the rear air conditioning works normally.

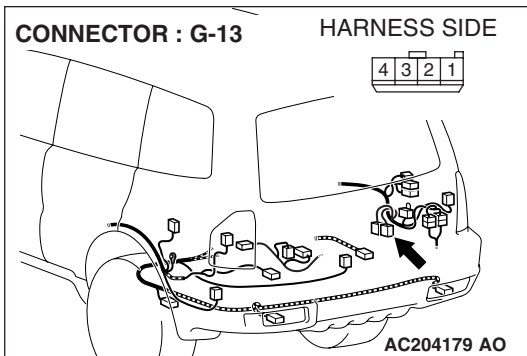

**STEP 17.** Check the wiring harness between rear cooler unit connector G-13 (terminal 1, 4 and 3) and rear cooler control unit connector E-09 (terminal 1, 8 and 12).

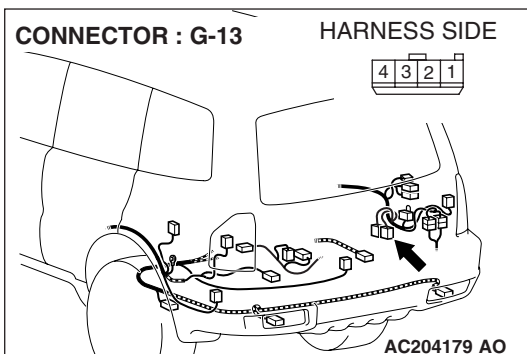
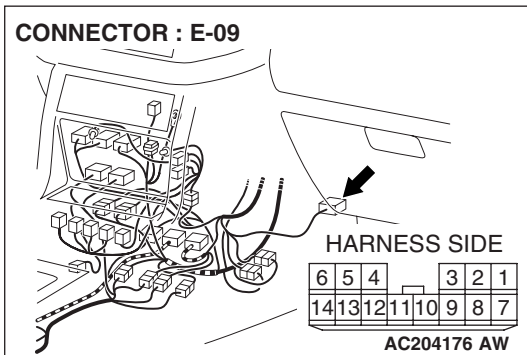

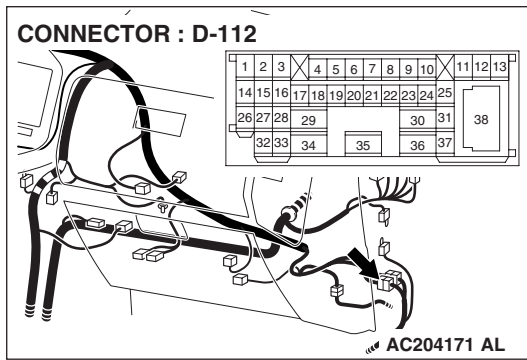

*NOTE: Also check intermediate connector D-112. If intermediate connector D-112 is damaged, repair or replace the connector as described in GROUP 00E, Harness Connector Inspection P.00E-2.*

**Q: Is the wiring harness between rear cooler unit connector G-13 (terminal 1, 4 and 3) and rear cooler control unit connector E-09 (terminal 1, 8 and 12) in good condition?**

**YES :** Check that the rear air conditioning works normally.

**NO :** Repair the wiring harness. Check that the rear air conditioning works normally.

**INSPECTION PROCEDURE 4: Rear Air Conditioning Outlet Air Temperature does not Increase**  
 <Vehicles with Rear A/C>

Air Mixing Damper Control Motor, Air Thermo Sensor and Magnetic Valve Circuit

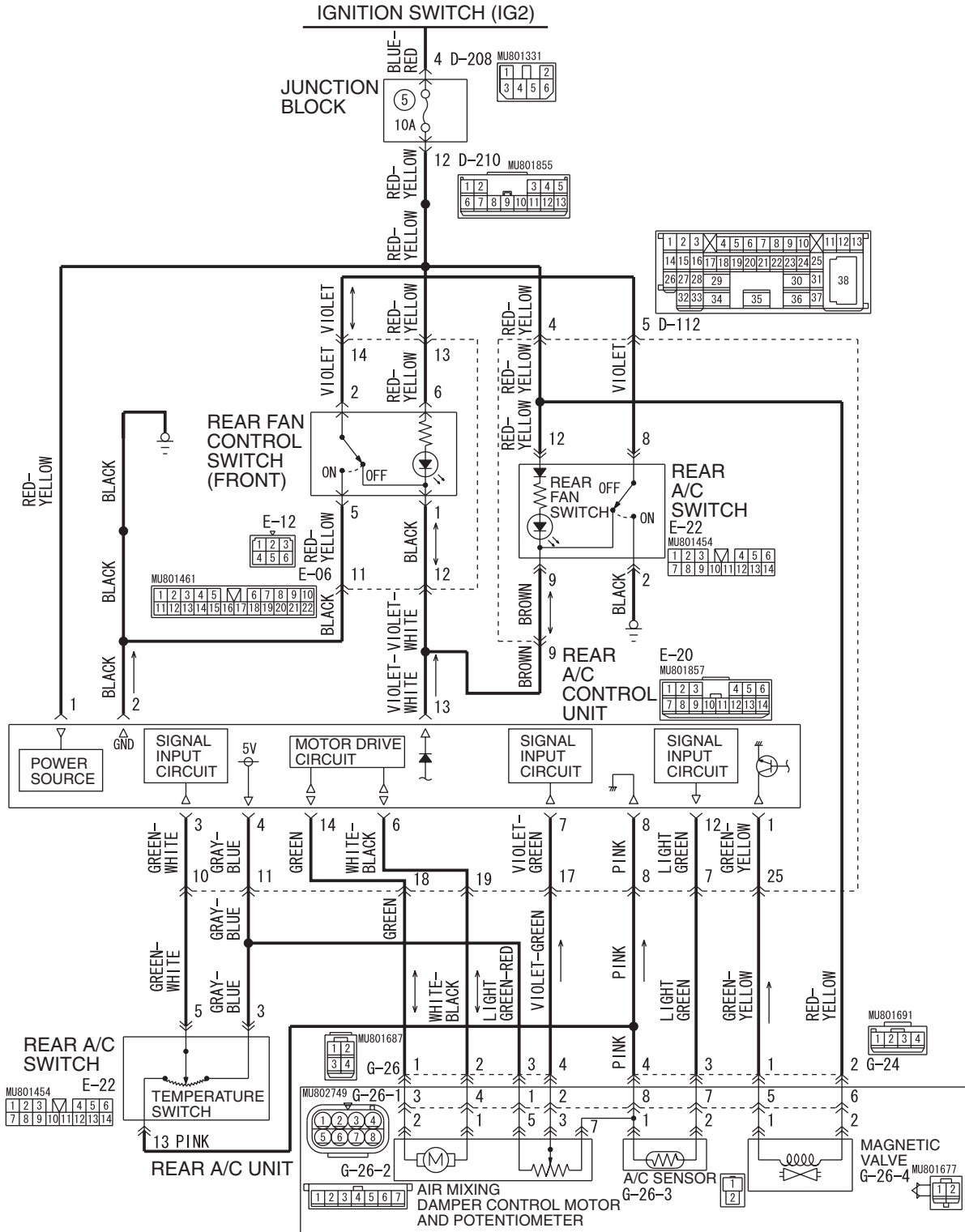

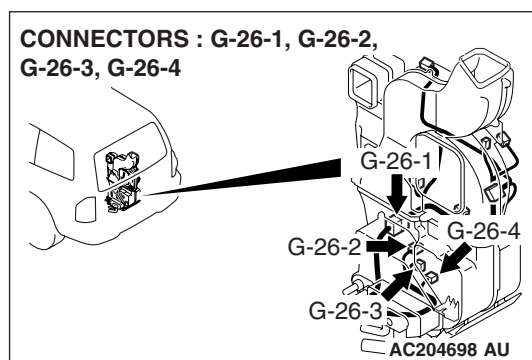
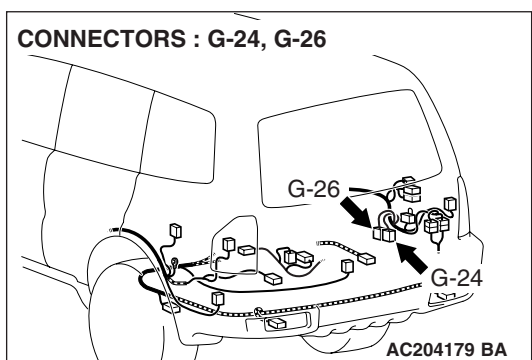
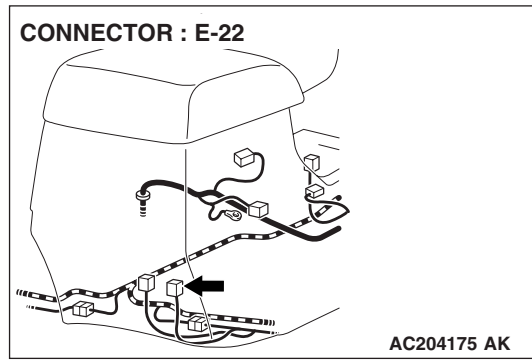
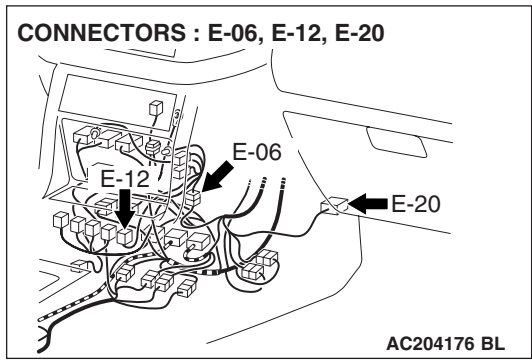
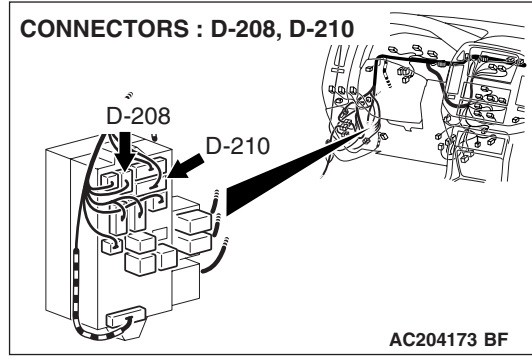
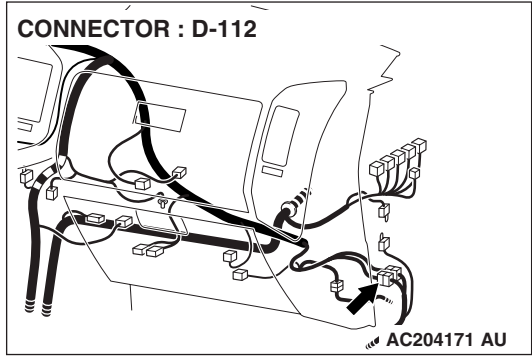

**DIAGNOSIS**

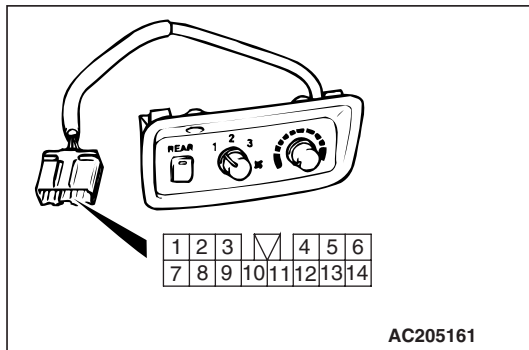

**STEP 1. Check the rear A/C switch (temperature switch).**  
 Connect the tester between the connector terminal number 3 and number 5, between the terminal number 5 and number 13 and make sure that the resistance value changes slowly within the standard value.

**Standard value: 0 – 3 kΩ**

**Q: Is the check result normal?**

**YES :** Go to Step 2.

**NO :** Replace the rear A/C switch.

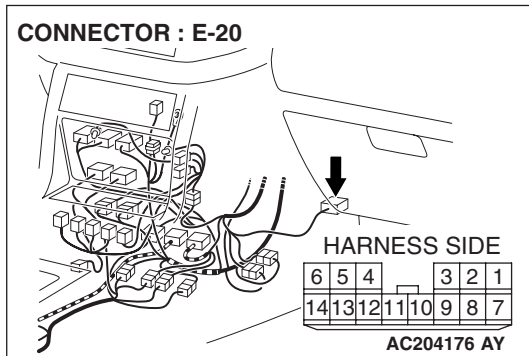

**STEP 2. Measure the resistance at rear A/C control unit connector E-20.**

- (1) Disconnect rear A/C control unit connector E-20, and measure at the wiring harness side.
- (2) Turn the rear fan switch to the "ON" position.
- (3) Turn the rear fan control switch to the "OFF" position.

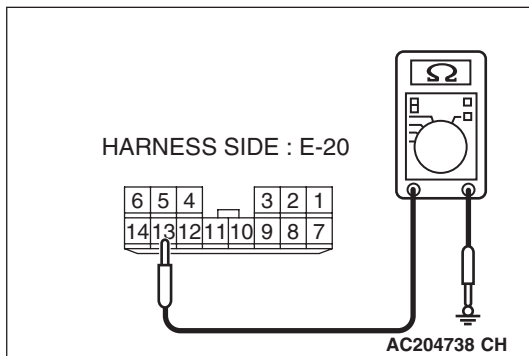

- (4) Measure the resistance between terminal 13 and ground.
  - The measured value should be 2 ohms or less.

**Q: Does the measured resistance value correspond with this range?**

**YES :** Go to Step 5.

**NO :** Go to Step 3.

CONNECTORS : E-12, E-20

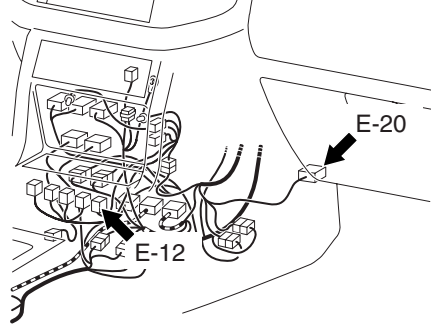

HARNESS SIDE

E-12



HARNESS SIDE

E-20 <VEHICLES WITH REAR A/C>

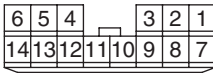

AC204194 AS

**STEP 3. Check rear A/C control unit connector E-20 and rear fan control switch connector E-12 for damage.**

**Q: Is rear A/C control unit connector E-20 and rear fan control switch connector E-12 in good condition?**

**YES :** Go to Step 4.

**NO :** Repair or replace the connector. Refer to GROUP 00E, Harness Connector Inspection [P.00E-2](#). Check that the air conditioning works normally.

**STEP 4. Check the wiring harness between rear A/C control unit connector E-20 (terminal 13) and rear fan control switch connector E-12 (terminal 1).**

CONNECTORS : E-06, E-12, E-20

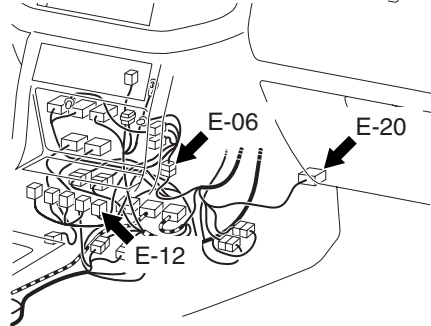

HARNESS SIDE

E-06

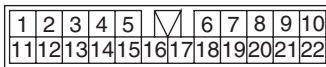

E-12



HARNESS SIDE

E-20 <VEHICLES WITH REAR A/C>

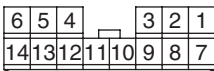

AC204194 AP



*NOTE: Also check intermediate connector E-06. If intermediate connector E-06 is damaged, repair or replace the connector as described in GROUP 00E, Harness Connector Inspection P.00E-2.*

**Q: Is the wiring harness between rear A/C control unit connector E-20 (terminal 13) and rear fan control switch connector E-12 (terminal 1) in good condition?**

**YES :** Check that the rear air conditioning works normally.

**NO :** Repair the wiring harness. Check that the rear air conditioning works normally.

**STEP 5. Check rear A/C control unit connector E-20 and rear A/C switch E-22 for damage.**

**Q: Is rear A/C control unit connector E-20 and rear A/C switch E-22 in good condition?**

**YES :** Go to Step 6.

**NO :** Repair or replace the connector. Refer to GROUP 00E, Harness Connector Inspection P.00E-2. Check that the rear air conditioning works normally.

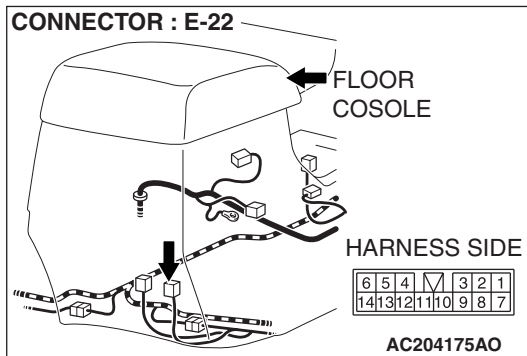
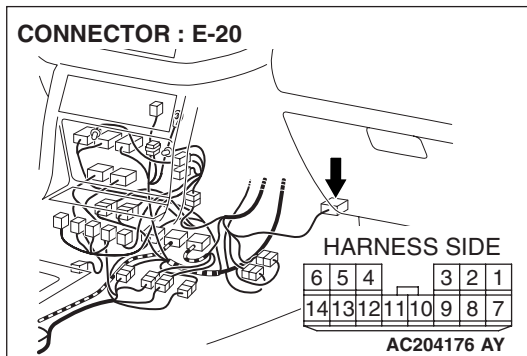

**STEP 6.** Check the wiring harness between rear A/C control unit connector E-20 (terminal 3, 4 and 8) and rear A/C switch connector E-22 (terminal 5, 3 and 13).

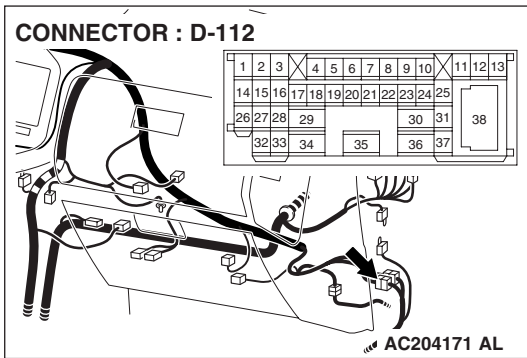
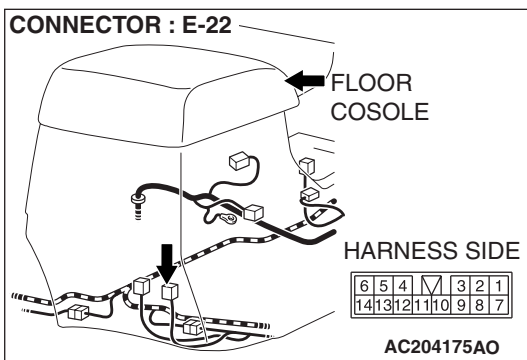
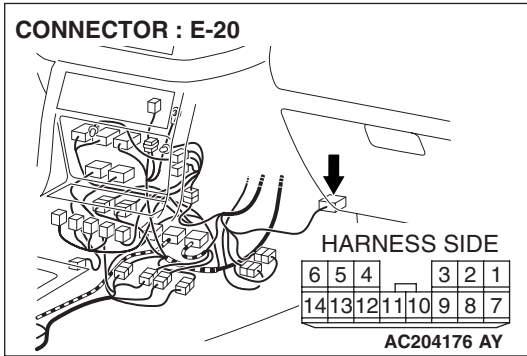

*NOTE:* Also check intermediate connector D-112. If intermediate connector D-112 is damaged, repair or replace the connector as described in GROUP 00E, Harness Connector Inspection [P.00E-2](#).

**Q:** Is the wiring harness between rear A/C control unit connector E-20 (terminal 3, 4 and 8) and rear A/C switch connector E-22 (terminal 5, 3 and 13) in good condition?

**YES :** Go to Step 7.

**NO :** Repair the wiring harness. Check that the rear air conditioning works normally.

**STEP 7. Check the air mixing damper control motor and potentiometer**

**AIR MIX DAMPER MOTOR CHECK**

**⚠ CAUTION**

**Do not apply battery voltage when the damper is in the MAX HOT/MAX COOL position.**

Check the air mixing damper control motor by the following procedures.

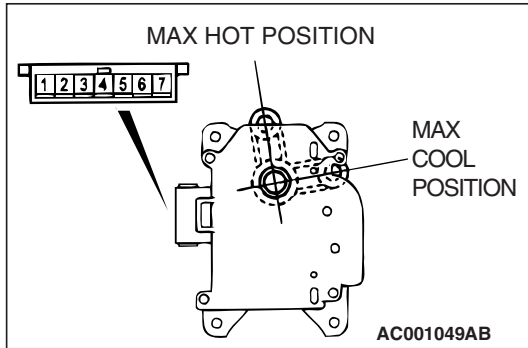

LEVER POSITION	BATTERY CONNECTION	LEVER OPERATION
At the MAX COOL position	<ul style="list-style-type: none"> <li>• Connect terminal 1 to the positive battery terminal</li> <li>• Connect terminal 2 to the negative battery terminal</li> </ul>	The lever moves from the MAX COOL position to the MAX HOT position
At the MAX HOT position	<ul style="list-style-type: none"> <li>• Connect terminal 2 to the positive battery terminal</li> <li>• Connect terminal 1 to the negative battery terminal</li> </ul>	The lever moves from the MAX HOT position to the MAX COOL position

**AIR MIX DAMPER POTENTIOMETER CHECK**

When checking the air mixing damper control motor, measure the resistance value between the terminals 3 and 5, between the terminals 3 and 7. At this time, make sure that the measured resistance value changes slowly within the standard value.

**Standard value: 1.2 – 4.8 kΩ**

**Q: Does air mixing damper control motor work normally?**

**YES :** Go to Step 8.

**NO :** Replace the air mixing damper control motor. Check that the rear air conditioning works normally.

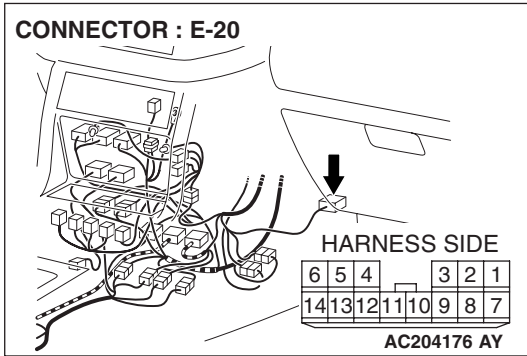

**STEP 8.** Check rear A/C control unit connector E-20 and air mixing damper control motor and potentiometer connector G-26-2 for damage.

**Q:** Is rear heater control unit connector E-20 and air mixing damper control motor and potentiometer connector G-26-2 in good condition?

**YES :** Go to Step 9.

**NO :** Repair or replace the connector. Refer to GROUP 00E, Harness Connector Inspection [P.00E-2](#). Check that the rear air conditioning works normally.

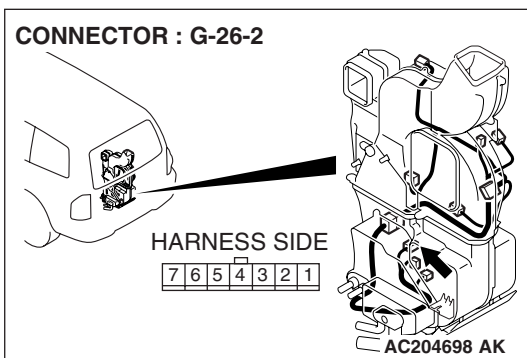

**STEP 9.** Check the wiring harness between rear A/C control unit connector E-20 (terminal 14, 6, 4, 7 and 8) and air mixing damper control motor and potentiometer G-26-2 (terminal 2, 1, 5, 3 and 7).

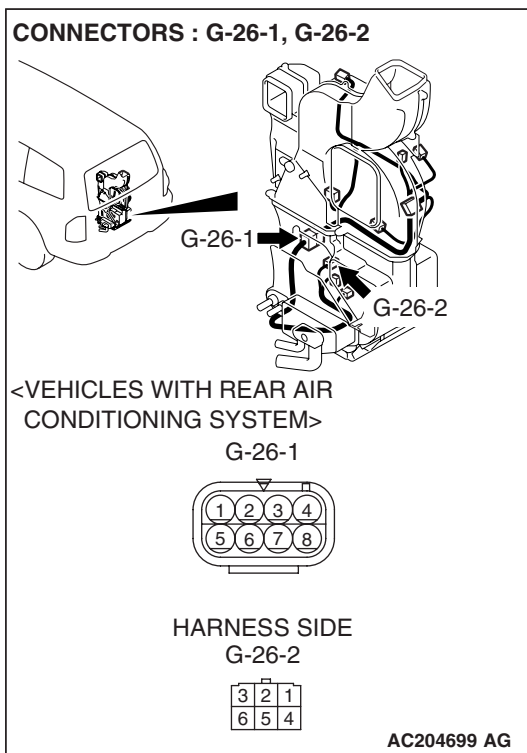
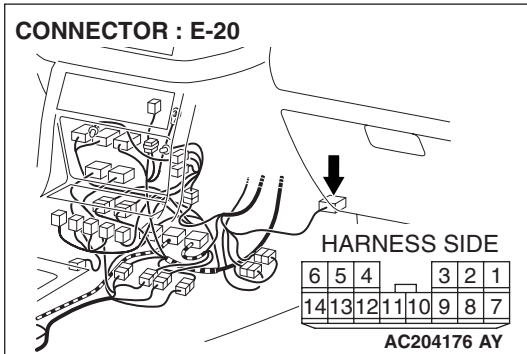

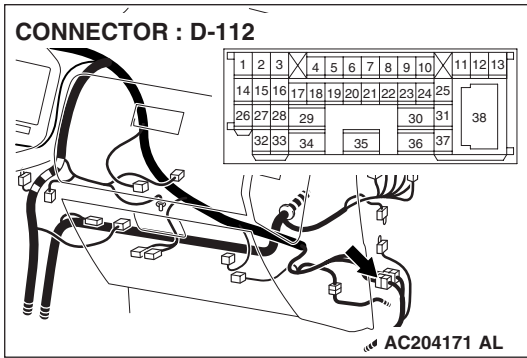

*NOTE: Also check intermediate connectors G-26-1, D-112, rear heater unit connectors G-26 and G-24. If intermediate connector G-26-1, D-112, rear heater unit connector G-26 or G-24 is damaged, repair or replace the connector as described in GROUP 00E, Harness Connector Inspection P.00E-2.*

**Q: Is the wiring harness between rear A/C control unit connector E-20 (terminal 14, 6, 4, 7 and 8) and air mixing damper control motor and potentiometer G-26-2 (terminal 2, 1, 5, 3 and 7) in good condition?**

**YES :** Go to Step 10.

**NO :** Repair the wiring harness. Check that the rear air conditioning works normally.

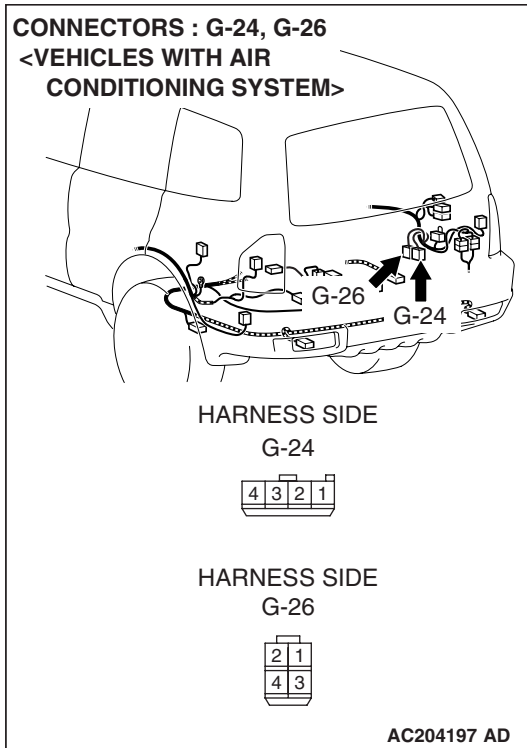

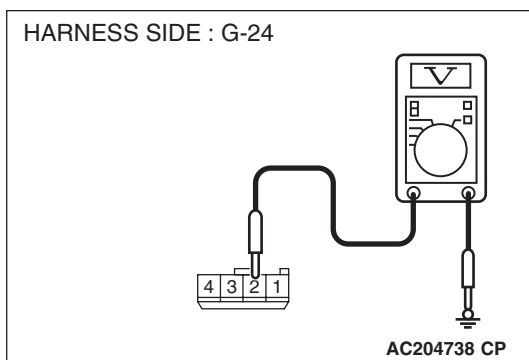
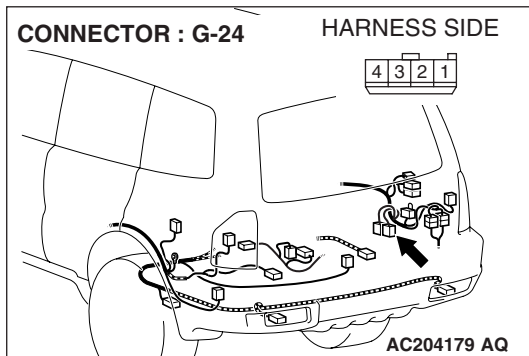

**STEP 10. Measure the voltage at rear A/C unit connector G-24.**

- (1) Disconnect rear A/C unit connector G-24, and measure the voltage at the harness side.
- (2) Turn the ignition switch to the "ON" position.

- (3) Measure the voltage between terminal 2 and ground.
  - The measured value should be approximately 12 volts (battery positive voltage).

**Q: Does the measured voltage correspond with this range?**

**YES :** Go to Step 13.

**NO :** Go to Step 11.

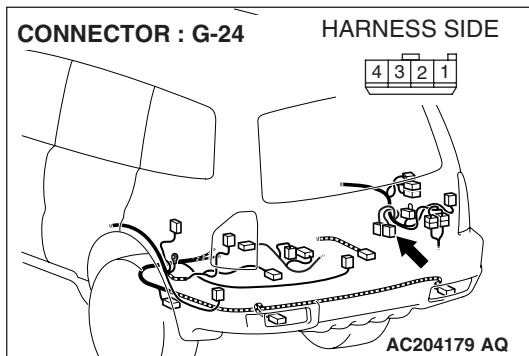

**STEP 11. Check rear A/C unit connector G-24 for damage.**

**Q: Is rear A/C unit connector G-24 in good condition?**

**YES :** Go to Step 12.

**NO :** Repair or replace the connector. Refer to GROUP 00E, Harness Connector Inspection [P.00E-2](#). Check that the rear air conditioning works normally.

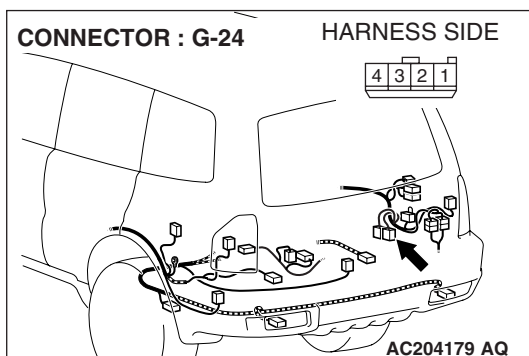

**STEP 12. Check the wiring harness between rear A/C unit connector G-24 (terminal 2) and the ignition switch (IG2).**

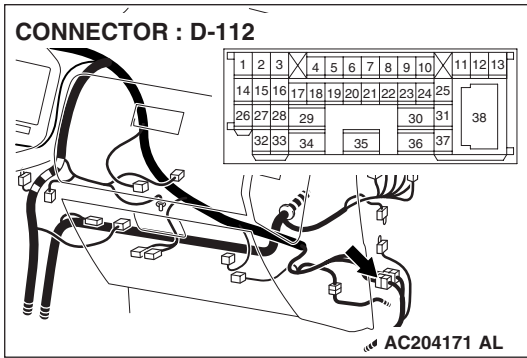

*NOTE: Also check intermediate connector D-112, junction block connectors D-210 and D-208. If intermediate connector D-112, junction block connectors D-210 and D-208 is damaged, repair or replace the connector as described in GROUP 00E, Harness Connector Inspection P.00E-2.*

**Q: Is the wiring harness between rear A/C unit connector G-24 (terminal 2) and the ignition switch (IG2) in good condition?**

**YES :** Check that the rear air conditioning works normally.

**NO :** Repair the wiring harness. Check that the rear air conditioning works normally.

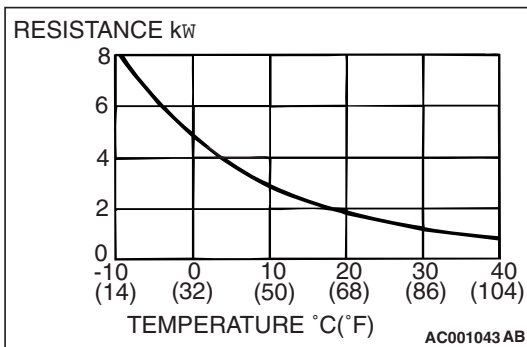
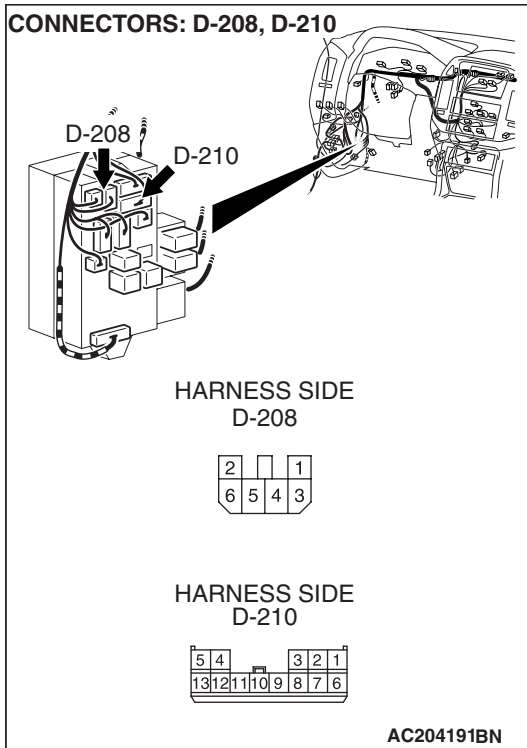

**STEP 13. Check the air thermo sensor.**

When the resistance between the sensor terminals is measured at two or more temperature conditions, the resistance should satisfy the value shown in the illustration.

*NOTE: The temperature condition at the check shall be within the range shown in the characteristic diagram.*

**Q: Does air thermo sensor work normally?**

**YES :** Go to Step 14.

**NO :** Replace the air thermo sensor.



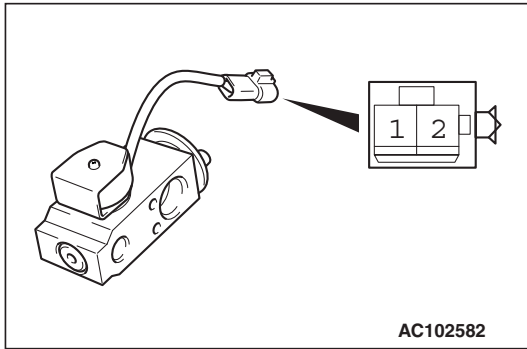

**STEP 14. Check the expansion valve (magnet valve).**

The valve is in normal condition if the actuation sound is heard from the magnet valve when battery voltage is applied to magnet valve terminal 2 and terminal 1 is grounded.

**Q: Does expansion valve work normally?**

**YES :** Go to Step 15.

**NO :** Replace the expansion valve (magnet valve).

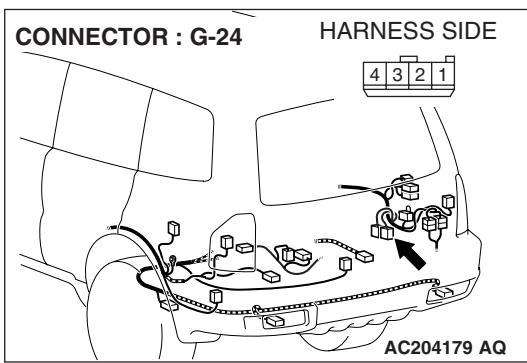

**STEP 15. Check rear A/C unit connector G-24 and magnetic valve connector G-26-4 for damage.**

**Q: Is rear A/C unit connector G-24 and magnetic valve connector G-26-4 in good condition?**

**YES :** Go to Step 16.

**NO :** Repair or replace the connector. Refer to GROUP 00E, Harness Connector Inspection [P.00E-2](#). Check that the rear air conditioning works normally.

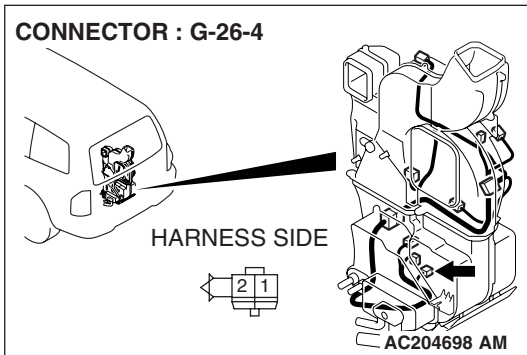

**STEP 16.** Check the wiring harness between rear A/C unit connector G-24 (terminal 1 and 2) and magnetic valve connector G-26-4 (terminal 1 and 2).

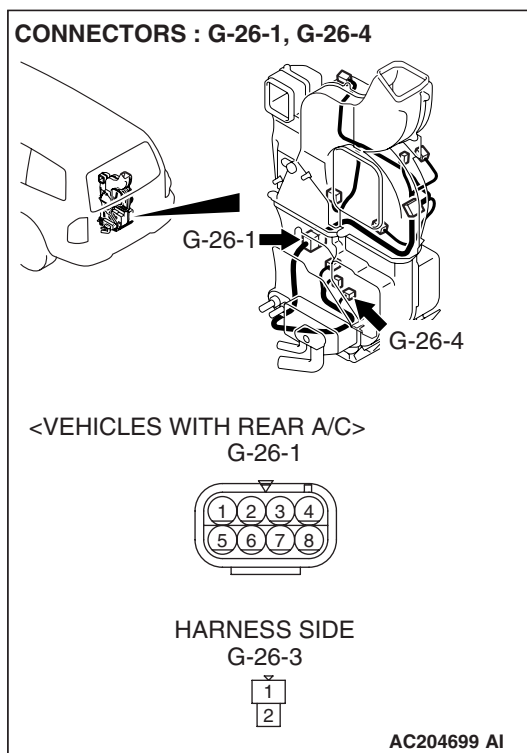
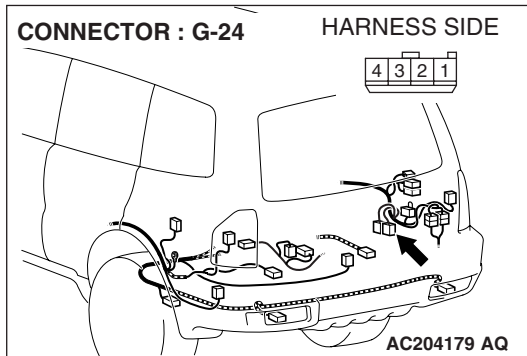

*NOTE:* Also check intermediate connector G-26-1. If intermediate connector G-26-1 is damaged, repair or replace the connector as described in GROUP 00E, Harness Connector Inspection [P.00E-2](#).

**Q:** Is the wiring harness between rear A/C unit connector G-24 (terminal 1 and 2) and magnetic valve connector G-26-4 (terminal 1 and 2) in good condition?

**YES :** Go to Step 17.

**NO :** Repair the wiring harness. Check that the rear air conditioning works normally.

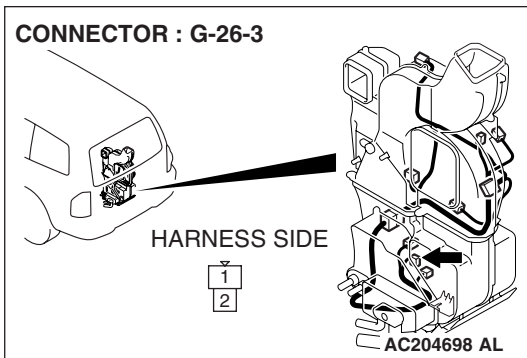
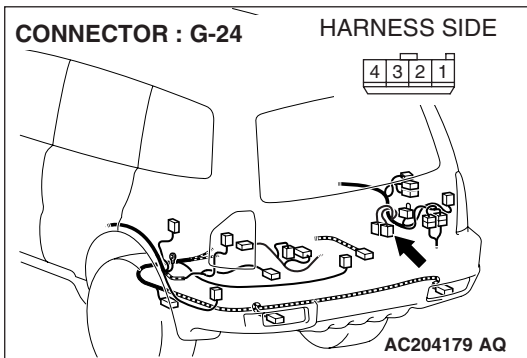

**STEP 17.** Check rear A/C unit connector G-24 and air thermo sensor connector G-26-3 for damage.

**Q:** Is rear A/C unit connector G-24 and air thermo sensor connector G-26-3 in good condition?

**YES :** Go to Step 18.

**NO :** Repair or replace the connector. Refer to GROUP 00E, Harness Connector Inspection [P.00E-2](#). Check that the rear air conditioning works normally.

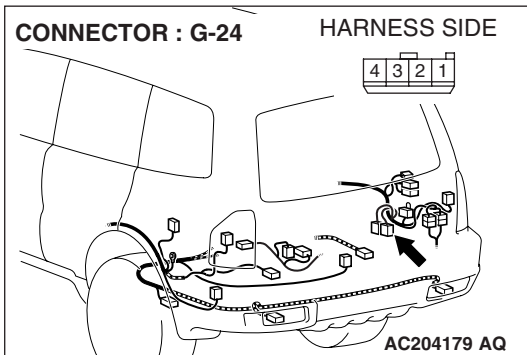

**STEP 18.** Check the wiring harness between rear A/C unit connector G-24 (terminal 4 and 8) and air thermo sensor connector G-26-3 (terminal 1 and 2).

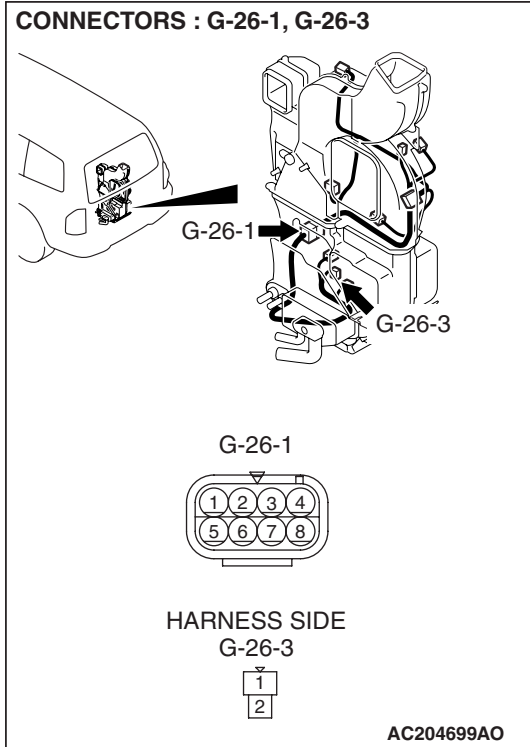

*NOTE: Also check intermediate connector G-26-1. If intermediate connector G-26-1 is damaged, repair or replace the connector as described in GROUP 00E, Harness Connector Inspection P.00E-2.*

**Q: Is the wiring harness between rear A/C unit connector G-24 (terminal 4 and 8) and air thermo sensor connector G-26-3 (terminal 1 and 2) in good condition?**

**YES :** Go to Step 19.

**NO :** Repair the wiring harness. Check that the rear air conditioning works normally.

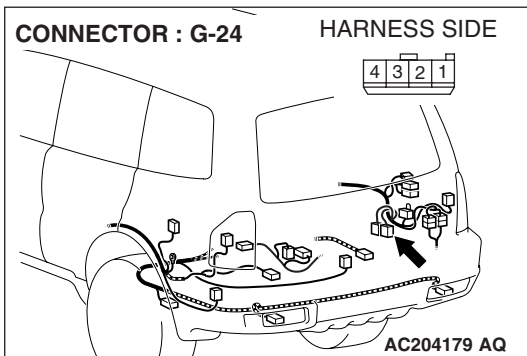

**STEP 19. Check rear A/C unit connector G-24 and rear A/C control unit connector E-20 for damage.**

**Q: Is rear A/C unit connector G-24 and rear A/C control unit connector E-20 in good condition?**

**YES :** Go to Step 20.

**NO :** Repair or replace the connector. Refer to GROUP 00E, Harness Connector Inspection P.00E-2. Check that the rear air conditioning works normally.

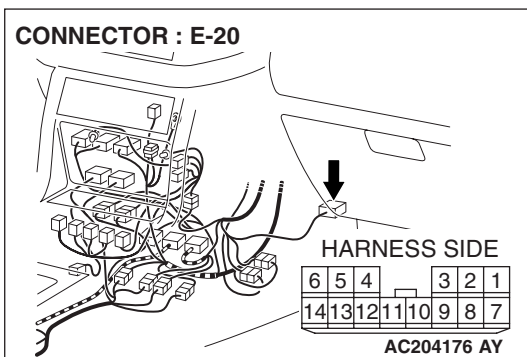

**STEP 20.** Check the wiring harness between rear A/C unit connector G-24 (terminal 1, 3 and 4) and rear A/C control unit connector E-20 (terminal 1, 12 and 8).

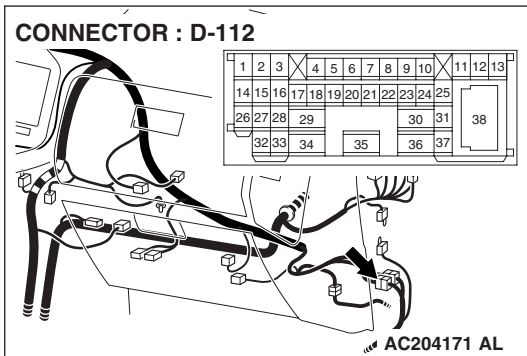
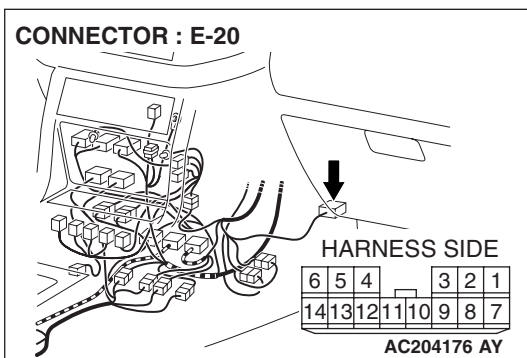
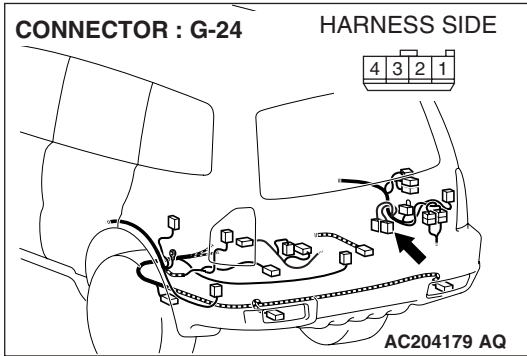

**NOTE:** Also check intermediate connector D-112. If intermediate connector D-112 is damaged, repair or replace the connector as described in GROUP 00E, *Harness Connector Inspection* P.00E-2.

**Q:** Is the wiring harness between rear A/C unit connector G-24 (terminal 1, 3 and 4) and rear A/C control unit connector E-20 (terminal 1, 12 and 8) in good condition?

**YES :** Check that the rear air conditioning works normally.

**NO :** Repair the wiring harness. Check that the rear air conditioning works normally.

INSPECTION PROCEDURE 5: Rear Blower Motor does not Operate

Rear A/C Blower Motor Circuit

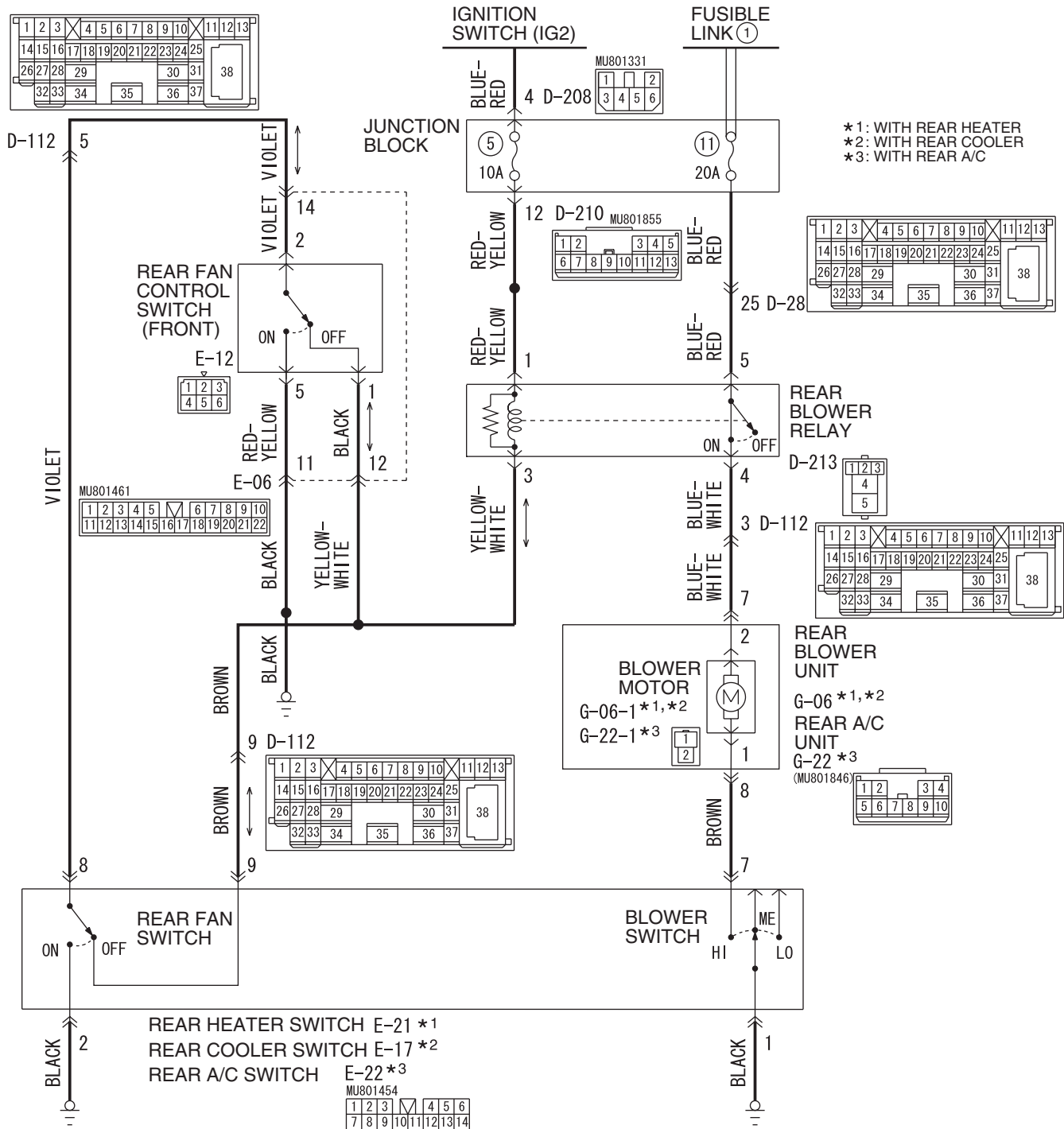

CONNECTORS : D-01, D-28, D-30

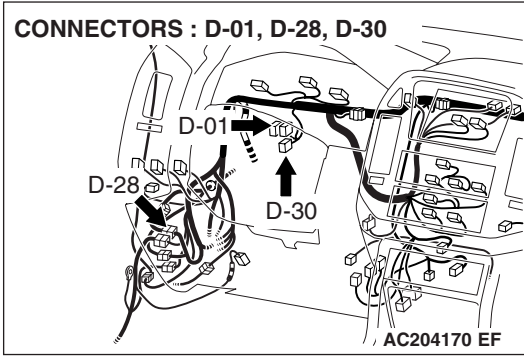

CONNECTOR : D-112

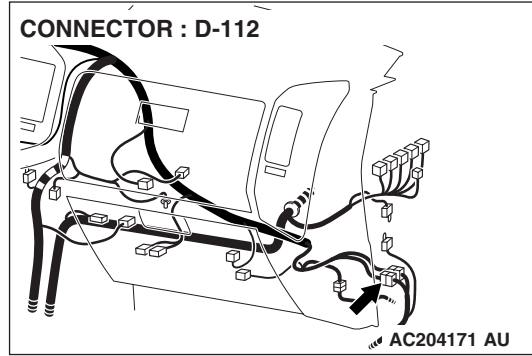

CONNECTORS : D-208, D-210, D-213

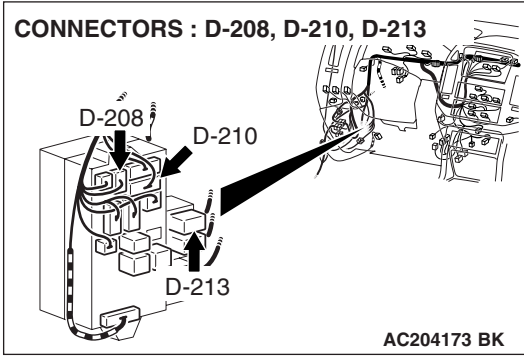

CONNECTORS : E-06, E-12

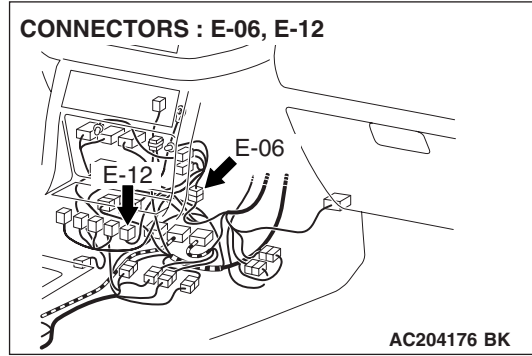

CONNECTORS : E-17, E-21, E-22

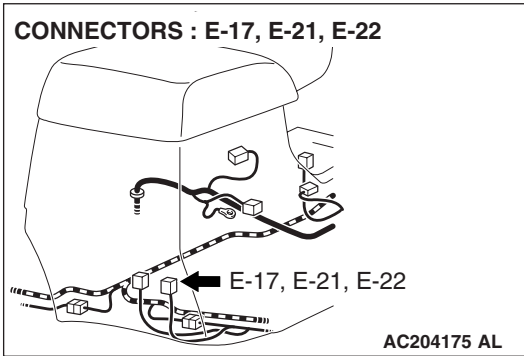

CONNECTORS : G-06, G-22

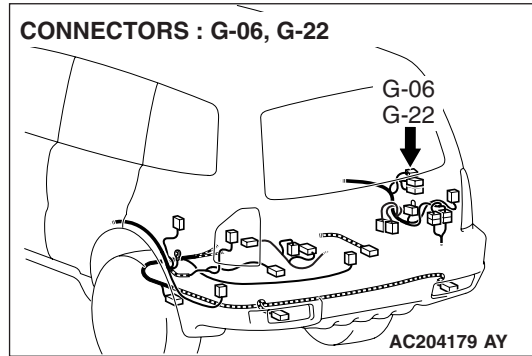

**DIAGNOSIS**

**STEP 1. Check the rear blower relay continuity.**

Follow the table below to check the rear blower relay for continuity.

BATTERY VOLTAGE	TESTER CONNECTION	SPECIFIED CONDITION
Not applied	4 – 5	Open circuit
<ul style="list-style-type: none"> <li>Connect terminal 1 to the positive battery terminal</li> <li>Connect terminal 3 to the negative battery terminal</li> </ul>	4 – 5	Less than 2 ohms

**Q: Is the rear blower relay continuity in good condition?**

**YES :** Go to Step 2.

**NO :** Replace the rear blower relay. The rear blower motor should operate normally.

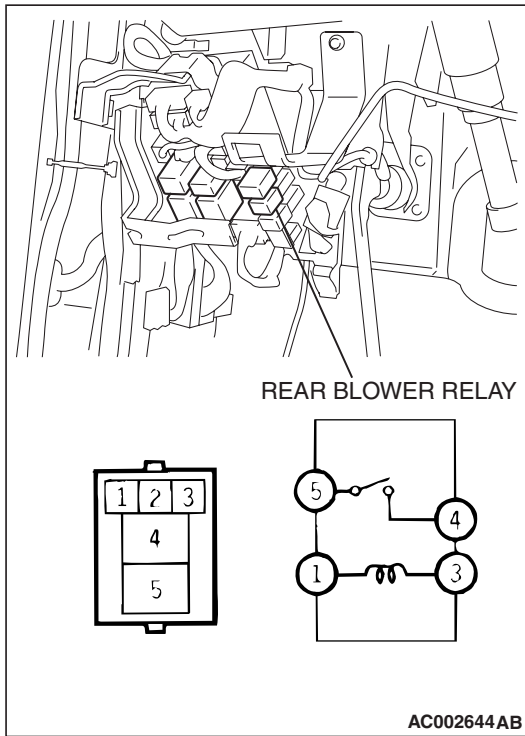

**STEP 2. Check the rear fan switch.**

Follow the table below to check the rear fan switch for continuity.

REAR FAN SWITCH POSITION	TESTER CONNECTION	SPECIFIED CONDITION
OFF	8 – 9	Less than 2 ohms
ON (while pushing)	2 – 8	Less than 2 ohms

**Q: Is the check result normal?**

**YES :** Go to Step 3.

**NO :** Replace the rear fan switch.

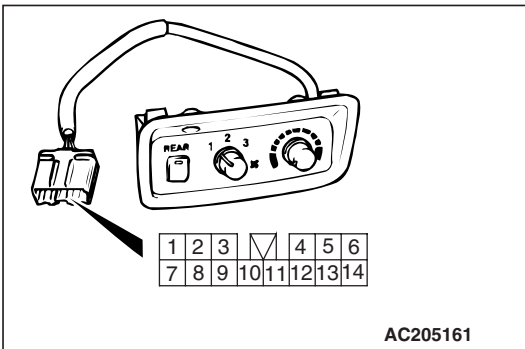

**STEP 3. Check the rear fan control switch.**

Follow the table below to check the rear fan control switch for continuity.

REAR FAN CONTROL SWITCH POSITION	TESTER CONNECTION	SPECIFIED CONDITION
OFF	1 – 2	Less than 2 ohms
ON	2 – 5	Less than 2 ohms

**Q: Is the check result normal?**

**YES :** Go to Step 4.

**NO :** Replace the rear fan control switch.

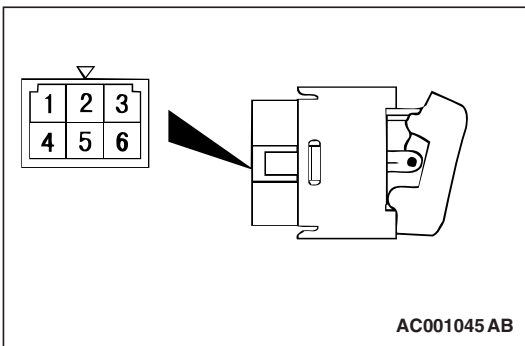



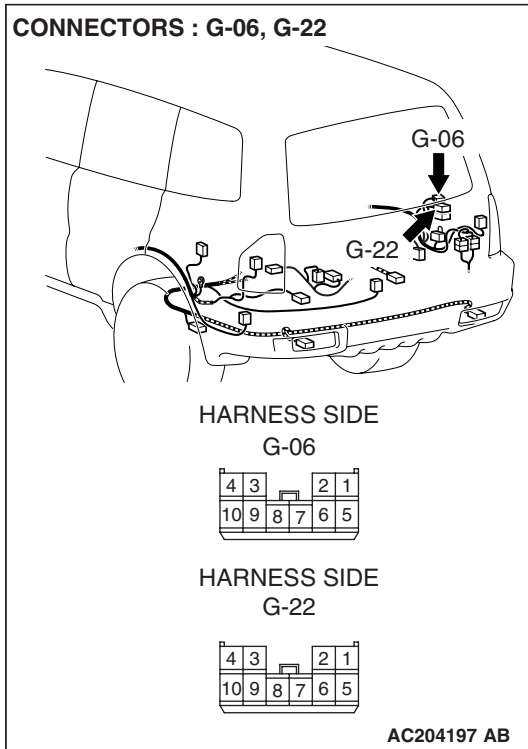

**STEP 4. Measure the voltage at rear blower unit connector G-06 <vehicles with rear heater or rear cooler> or G-22 <vehicles with rear A/C>.**

- (1) Disconnect rear blower unit connector G-06 <vehicles with rear heater or rear cooler> or G-22 <vehicles with rear A/C>, and measure the voltage at the wiring harness side.
- (2) Turn the rear fan switch to the "ON" position.

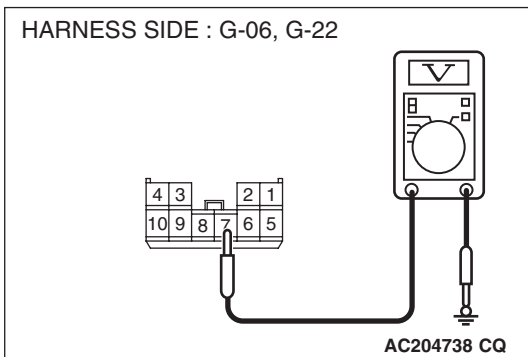

- (3) Measure the voltage between terminal 7 and ground.
  - The measured value should be approximately 12 volts (battery positive voltage).

**Q: Does the measured voltage correspond with this range?**

**YES :** Go to Step 22.

**NO :** Go to Step 5.

CONNECTOR : D-213

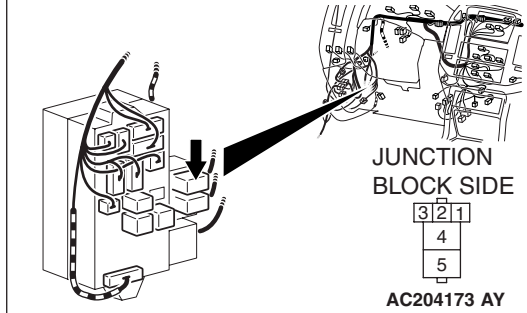

JUNCTION BLOCK SIDE : D-213

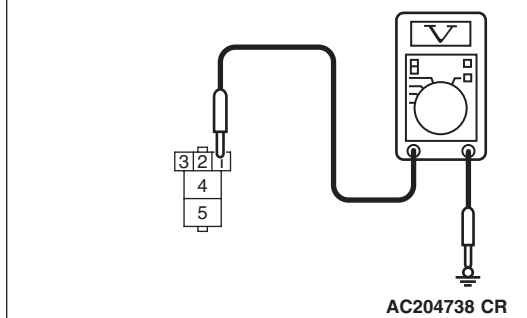
**STEP 5. Measure the voltage at rear blower relay connector D-213.**

- (1) Disconnect rear blower relay connector D-213, and measure the voltage at the junction block side.
- (2) Turn the ignition switch to the "ON" position.

- (3) Measure the voltage between terminal 1 and ground.
  - The measured value should be approximately 12 volts (battery positive voltage).

**Q: Does the measured voltage correspond with this range?**

**YES :** Go to Step 8.

**NO :** Go to Step 6.

**STEP 6. Check rear blower relay connector D-213 for damage.**

**Q: Is rear blower relay connector D-213 in good condition?**

**YES :** Go to Step 7.

**NO :** Repair or replace the connector. Refer to GROUP 00E, Harness Connector Inspection [P.00E-2](#). The blower motor should operate normally.

CONNECTOR : D-213

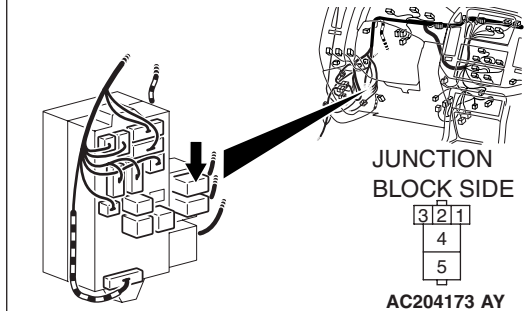
**STEP 7. Check the wiring harness between rear blower relay connector D-213 (terminal 1) and the ignition switch (IG2).**

CONNECTOR : D-213

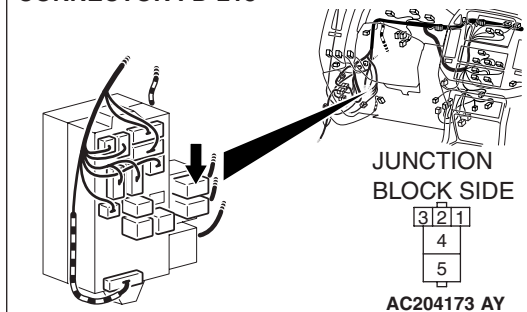

CONNECTOR: D-01

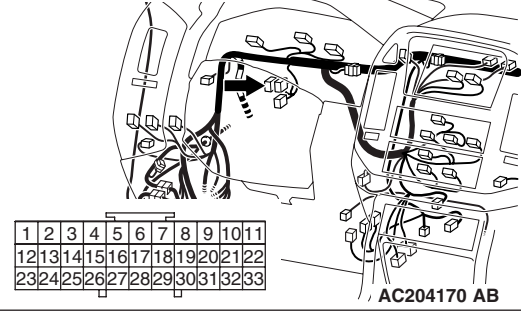

*NOTE: Also check joint connector (6) D-01, junction block connectors D-208 and D-210. If joint connector (6) D-01, junction block connectors D-208 or D-210 is damaged, repair or replace the connector as described in GROUP 00E, Harness Connector Inspection P.00E-2.*

**Q: Is the wiring harness between rear blower relay connector D-213 (terminal 1) and the ignition switch (IG2) in good condition?**

**YES :** The rear blower motor should operate normally.

**NO :** Repair the wiring harness. The rear blower motor should operate normally.

CONNECTORS: D-208, D-210

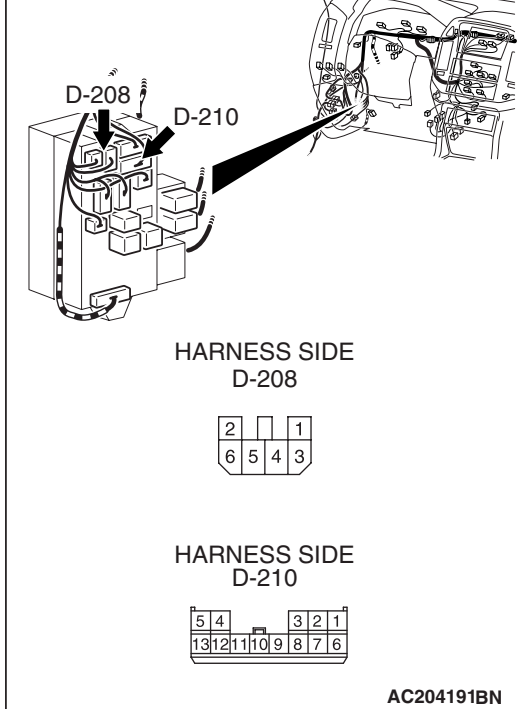

CONNECTOR : D-213

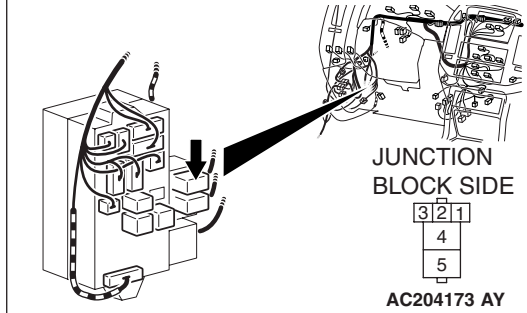

HARNESS SIDE : D-213

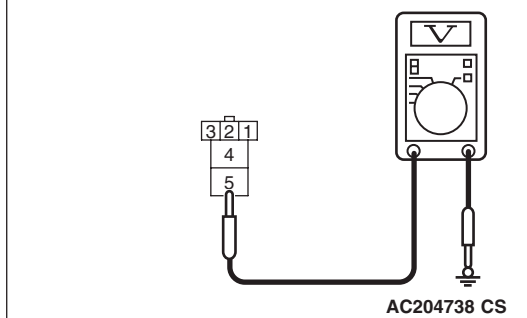
**STEP 8. Measure the voltage at rear blower relay connector D-213.**

- (1) Disconnect rear blower relay connector D-213, and measure the voltage at the junction block side.

- (2) Measure the voltage between terminal 5 and ground.
- The measured value should be approximately 12 volts (battery positive voltage).

**Q: Does the measured voltage correspond with this range?**

**YES :** Go to Step 11.

**NO :** Go to Step 9.

**STEP 9. Check rear blower relay connector D-213 for damage.**

**Q: Is rear blower relay connector D-213 in good condition?**

**YES :** Go to Step 10.

**NO :** Repair or replace the connector. Refer to GROUP 00E, Harness Connector Inspection [P.00E-2](#). The blower motor should operate normally.

CONNECTOR : D-213

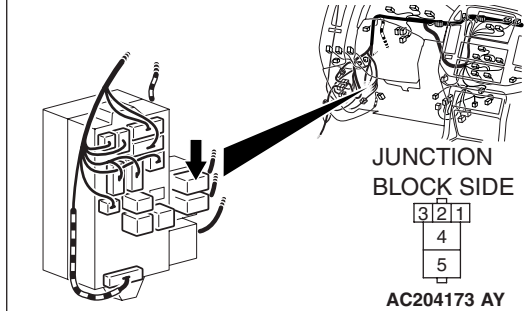
**STEP 10. Check the wiring harness between rear blower relay connector D-213 (terminal 5) and the fusible link (2).**

CONNECTOR : D-213

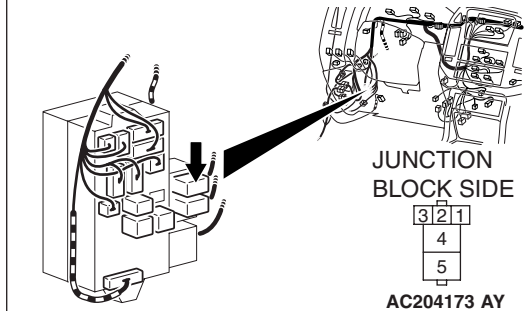

CONNECTOR : D-28

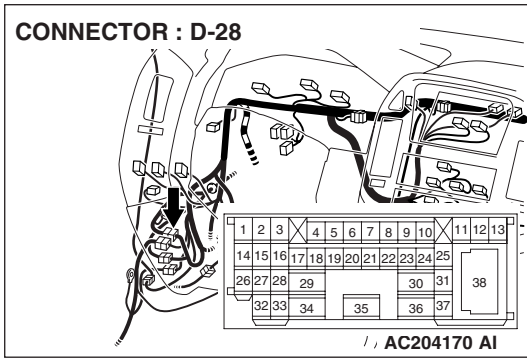

*NOTE: Also check intermediate connector D-28. If intermediate connector D-28 is damaged, repair or replace the connector as described in GROUP 00E, Harness Connector Inspection P.00E-2.*

**Q: Is the wiring harness between rear blower relay connector D-213 (terminal 5) and the fusible link (2) in good condition?**

**YES :** The rear blower motor should operate normally.

**NO :** Repair the wiring harness. The rear blower motor should operate normally.

CONNECTOR : D-213

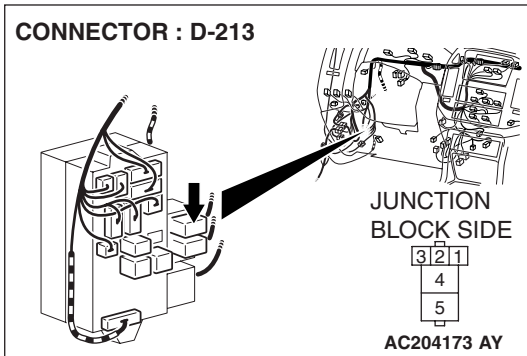

**STEP 11. Measure the resistance at rear blower relay connector D-213.**

- (1) Disconnect connector D-213, and measure the resistance at the junction block side.
- (2) Turn the rear fan switch to the "ON" position.
- (3) Turn the rear fan control switch to the "OFF" position.

JUNCTION BLOCK SIDE : D-213

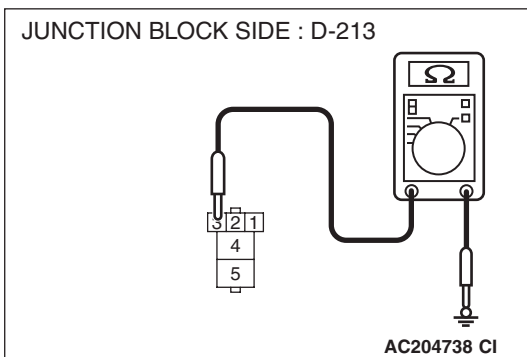

- (4) Measure the resistance value between terminal 3 and ground.

- Less than 2 ohms

**Q: Does the measured resistance value correspond with this range?**

**YES :** Go to Step 20.

**NO :** Go to Step 12.

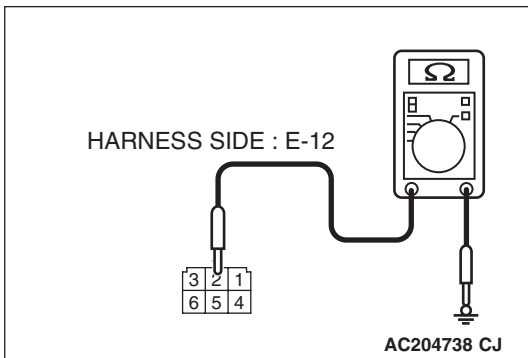
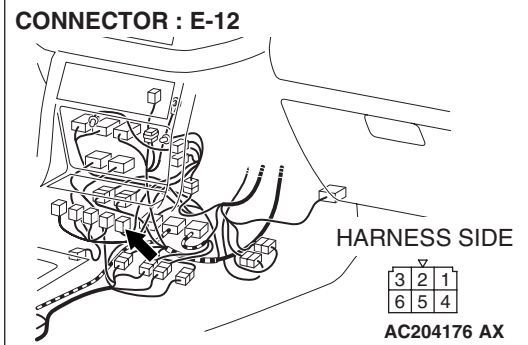

**STEP 12. Measure the resistance at rear fan control switch connector E-12.**

- (1) Disconnect connector E-12, and measure the resistance at the wiring harness side.
- (2) Turn the ignition switch to the "ON" position.

- (3) Measure the resistance value between terminal 2 and ground.
  - Less than 2 ohms

**Q: Does the measured resistance value correspond with this range?**

**YES :** Go to Step 13.

**NO :** Go to Step 15.

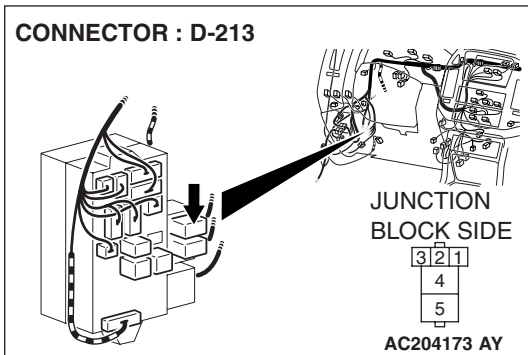

**STEP 13. Check rear fan switch connector E-12 and rear blower relay connector D-213 for damage.**

**Q: Is rear fan switch connector E-12 and rear blower relay connector D-213 in good condition?**

**YES :** Go to Step 14.

**NO :** Repair or replace the connector. Refer to GROUP 00E, Harness Connector Inspection [P.00E-2](#). The blower motor should operate normally.

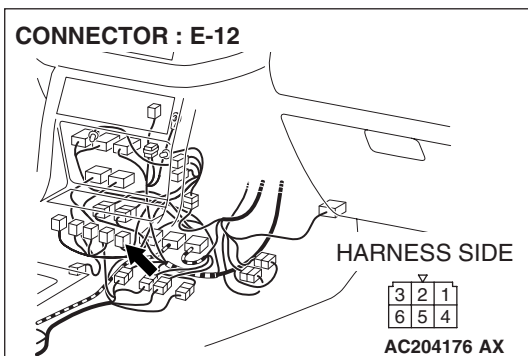

**STEP 14.** Check the wiring harness between rear blower relay connector D-213 (terminal 3) and rear fan control switch connector E-12 (terminal 1).

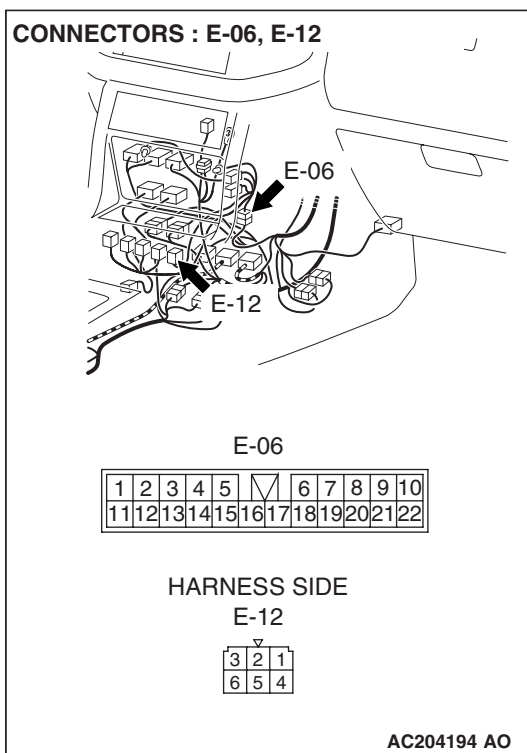
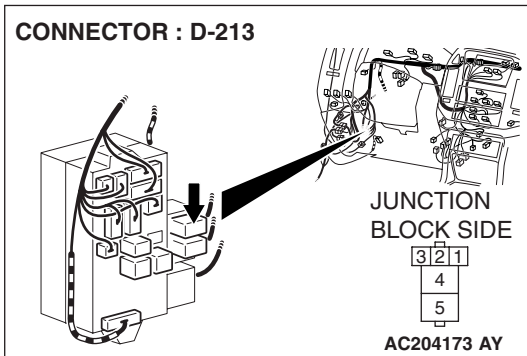

*NOTE: Also check intermediate connector E-06. If intermediate connector E-06 is damaged, repair or replace the connector as described in GROUP 00E, Harness Connector Inspection P.00E-2.*

**Q:** Is the wiring harness between rear blower relay connector D-213 (terminal 3) and rear fan control switch connector E-12 (terminal 1) in good condition?

**YES :** The rear blower motor should operate normally.

**NO :** Repair the wiring harness. The rear blower motor should operate normally.

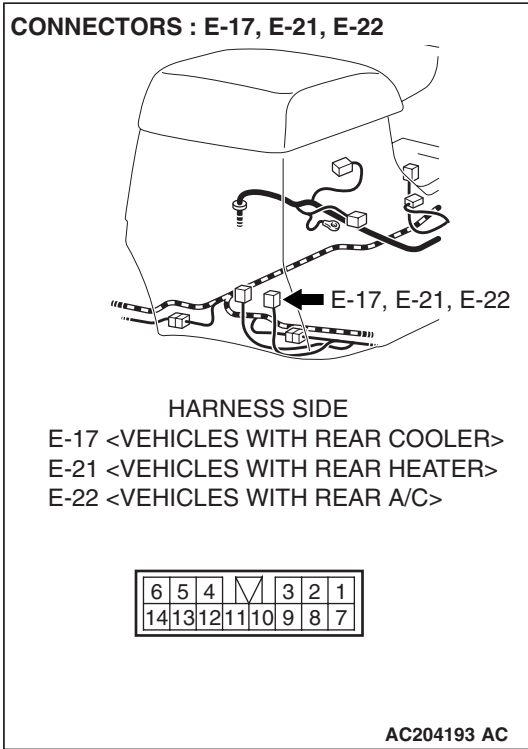

**STEP 15. Measure the resistance at rear heater switch connector E-21 <vehicles with rear heater>, rear cooler switch connector E-17 <vehicles with rear cooler> or rear A/C switch connector E-22 <vehicles with rear A/C>.**  
 (1) Disconnect connector E-21 or E-17 or E-22 and measure the resistance at the wiring harness side.

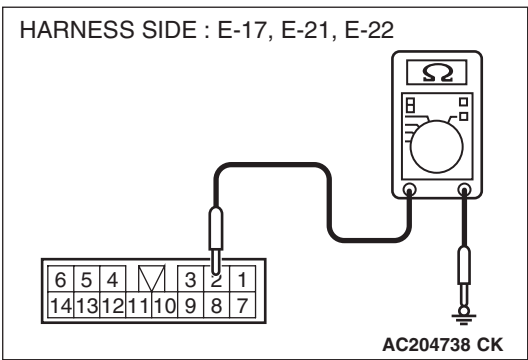

(2) Measure the resistance value between terminal 2 and ground.  
 • Less than 2 ohms

**Q: Does the measured resistance value correspond with this range?**

- YES :** Go to Step 16.
- NO :** Go to Step 18.



**STEP 16.** Check rear fan control switch connector E-12 and rear heater switch connector E-21 <vehicles with rear heater>, rear cooler switch connector E-17 <vehicles with rear cooler> or rear A/C switch connector E-22 <vehicles with rear A/C> for damage.

**Q:** Is rear fan control switch connector E-12 and rear heater switch connector E-21 <vehicles with rear heater>, rear cooler switch connector E-17 <vehicles with rear cooler> or rear A/C switch connector E-22 <vehicles with rear A/C> in good condition?

**YES :** Go to Step 17.

**NO :** Repair or replace the connector. Refer to GROUP 00E, Harness Connector Inspection [P.00E-2](#). The blower motor should operate normally.

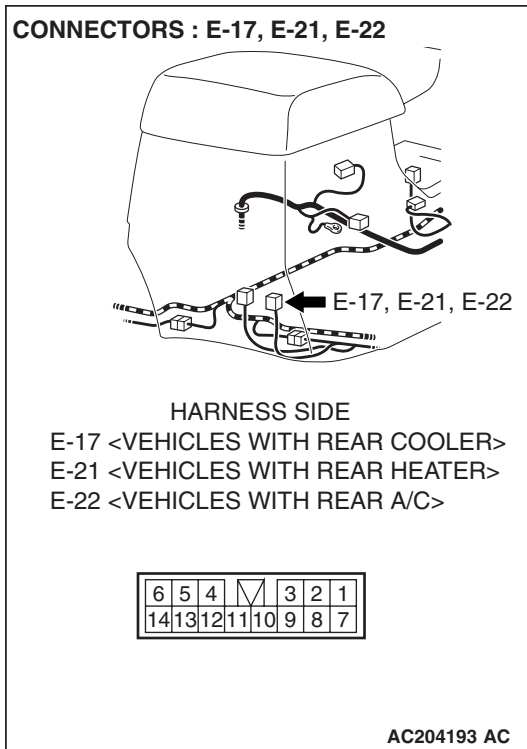
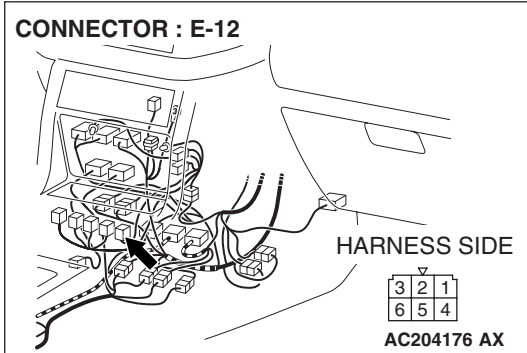

**STEP 17.** Check the wiring harness between rear fan control switch connector E-12 (terminal 2) and rear heater switch connector E-21 (terminal 8) <vehicles with rear heater>, rear cooler switch connector E-17 (terminal 8) <vehicles with rear cooler> or rear A/C switch connector E-22 (terminal 8) <vehicles with rear A/C>.

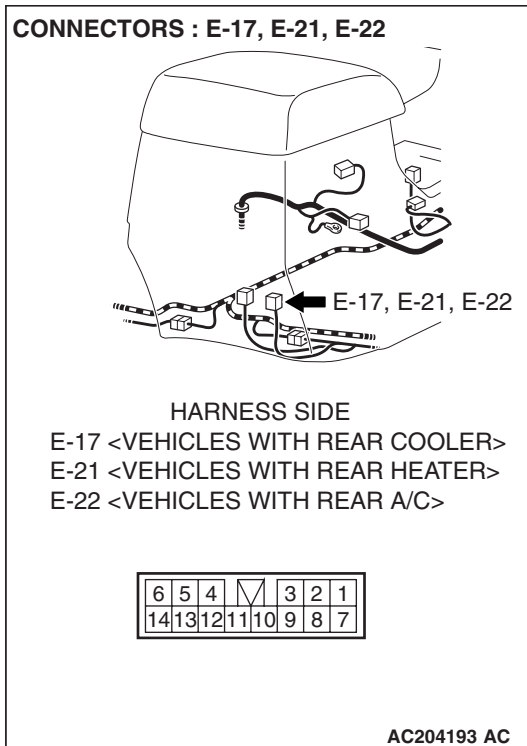
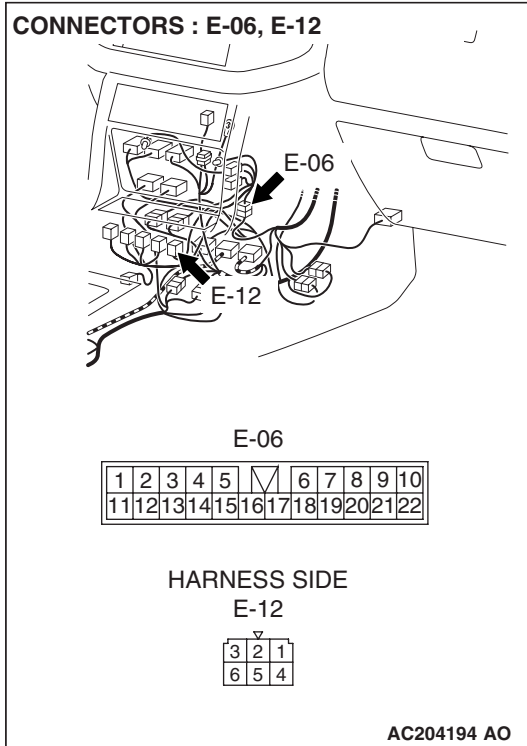

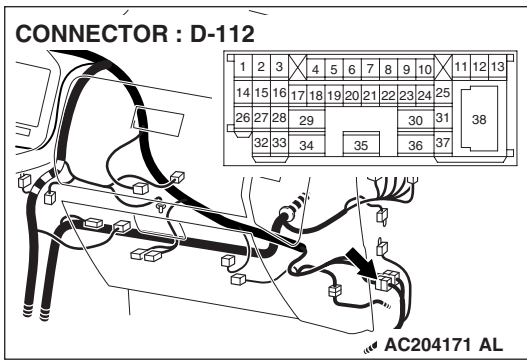

*NOTE: Also check intermediate connector E-06 and D-112. If intermediate connector E-06 or D-112 is damaged, repair or replace the connector as described in GROUP 00E, Harness Connector Inspection P.00E-2.*

**Q: Is the wiring harness between rear fan control switch connector E-12 (terminal 2) and rear heater switch connector E-21 (terminal 8) <vehicles with rear heater>, rear cooler switch connector E-17 (terminal 8) <vehicles with rear cooler> or rear A/C switch connector E-22 (terminal 8) <vehicles with rear A/C> in good condition?**

- YES :** The rear blower motor should operate normally.
- NO :** Repair the wiring harness. The rear blower motor should operate normally.

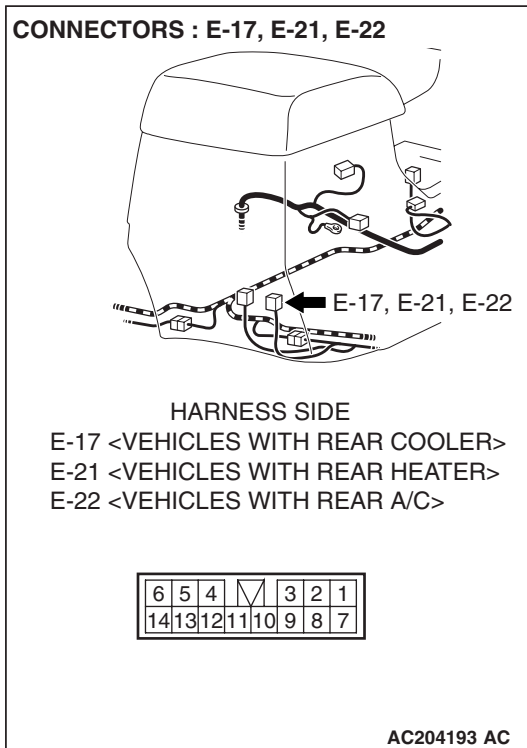

**STEP 18. Check rear heater switch connector E-21 <vehicles with rear heater>, rear cooler switch connector E-17 <vehicles with rear cooler> or rear A/C switch connector E-22 <vehicles with rear A/C> for damage.**

**Q: Is rear heater switch connector E-21 <vehicles with rear heater>, rear cooler switch connector E-17 <vehicles with rear cooler> or rear A/C switch connector E-22 <vehicles with rear A/C> in good condition?**

- YES :** Go to Step 19.
- NO :** Repair or replace the connector. Refer to GROUP 00E, Harness Connector Inspection P.00E-2. The blower motor should operate normally.

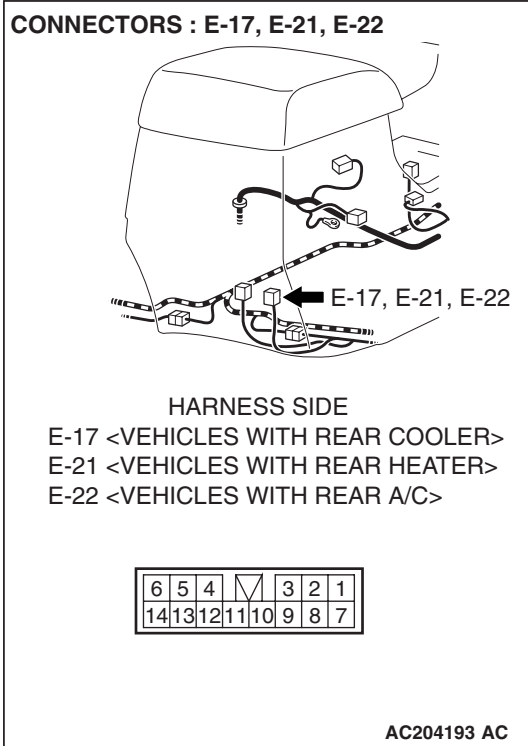

**STEP 19.** Check the wiring harness between rear heater switch connector E-21 (terminal 2) <vehicles with rear heater>, rear cooler switch connector E-17 (terminal 2) <vehicles with rear cooler> or rear A/C switch connector E-22 (terminal 2) <vehicles with rear A/C> and ground.

**Q:** Is the wiring harness between rear heater switch connector E-21 (terminal 2) <vehicles with rear heater>, rear cooler switch connector E-17 (terminal 2) <vehicles with rear cooler> or rear A/C switch connector E-22 (terminal 2) <vehicles with rear A/C> and ground in good condition?

**YES :** The rear blower motor should operate normally.

**NO :** Repair the wiring harness. The rear blower motor should operate normally.

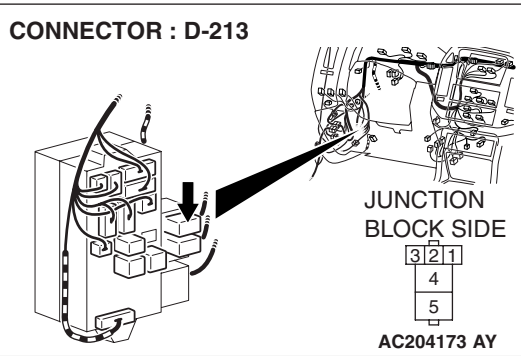

**STEP 20.** Check rear blower relay connector D-213 and rear A/C unit connector G-06 <vehicles with rear heater or rear cooler> or rear A/C unit connector G-22 <vehicles with rear A/C> for damage.

**Q:** Is rear blower relay connector D-213 and rear A/C unit connector G-06 <vehicles with rear heater or rear cooler> or rear A/C unit connector G-22 <vehicles with rear A/C> in good condition?

**YES :** Go to Step 21.

**NO :** Repair or replace the connector. Refer to GROUP 00E, Harness Connector Inspection [P.00E-2](#). The blower motor should operate normally.

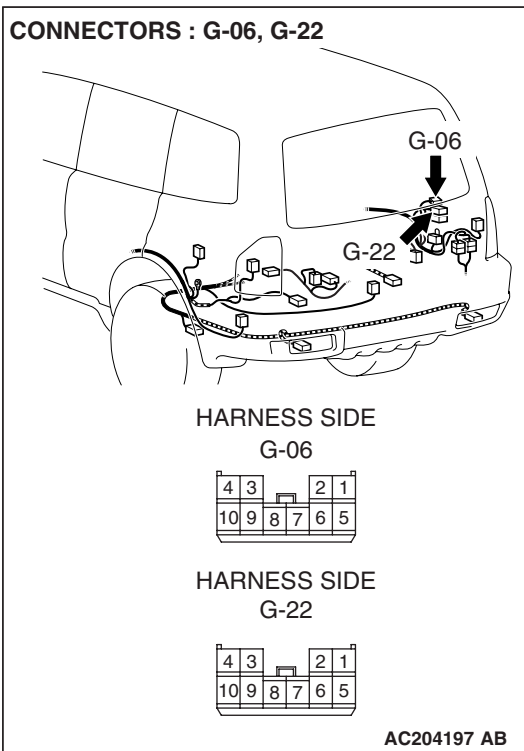

**STEP 21.** Check the wiring harness between rear blower relay connector D-213 (terminal 4) and rear A/C unit connector G-06 (terminal 7) <vehicles with rear heater or rear cooler> or rear A/C unit connector G-22 (terminal 7) <vehicles with rear A/C>.

**Q:** Is the wiring harness between rear blower relay connector D-213 (terminal 4) and rear A/C unit connector G-06 (terminal 7) <vehicles with rear heater or rear cooler> or rear A/C unit connector G-22 (terminal 7) <vehicles with rear A/C> in good condition?

**YES :** The rear blower motor should operate normally.

**NO :** Repair the wiring harness. The rear blower motor should operate normally.

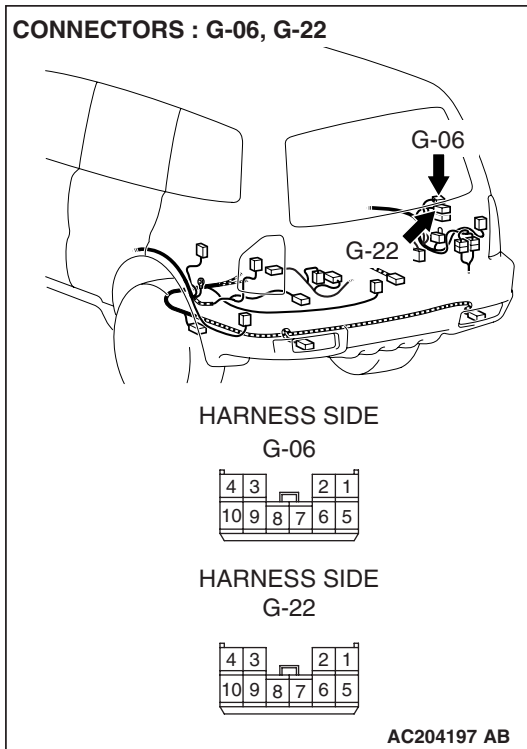
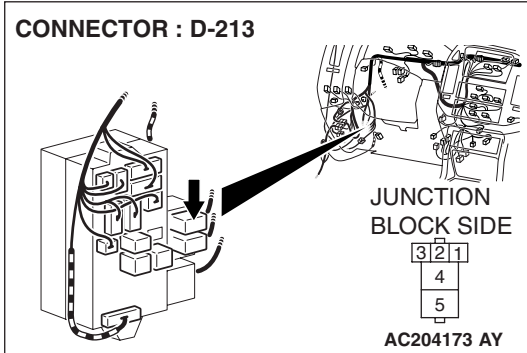

**STEP 22.** Check the rear blower motor.

When battery voltage is applied between the terminals, check that the motor operates. Also, check that there is no abnormal noise.

**Q:** Is the check result normal?

**YES :** Go to Step 23.

**NO :** Replace the rear blower motor.

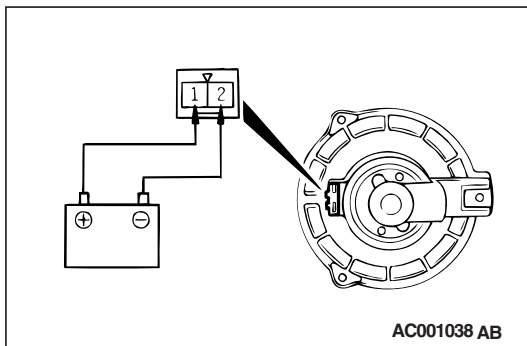

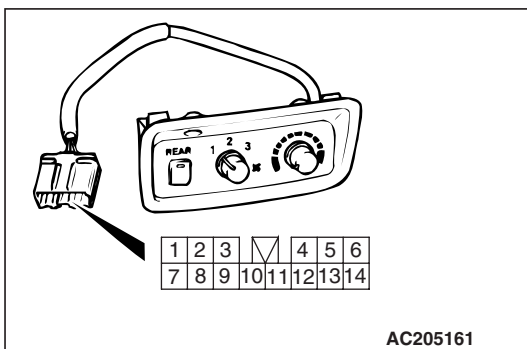
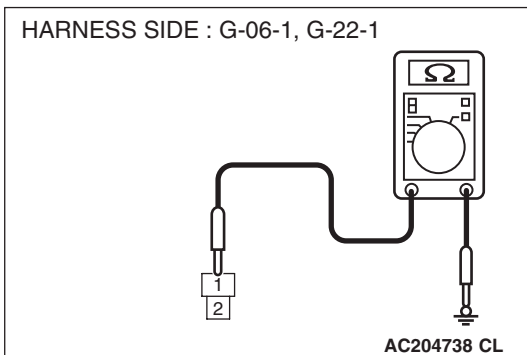
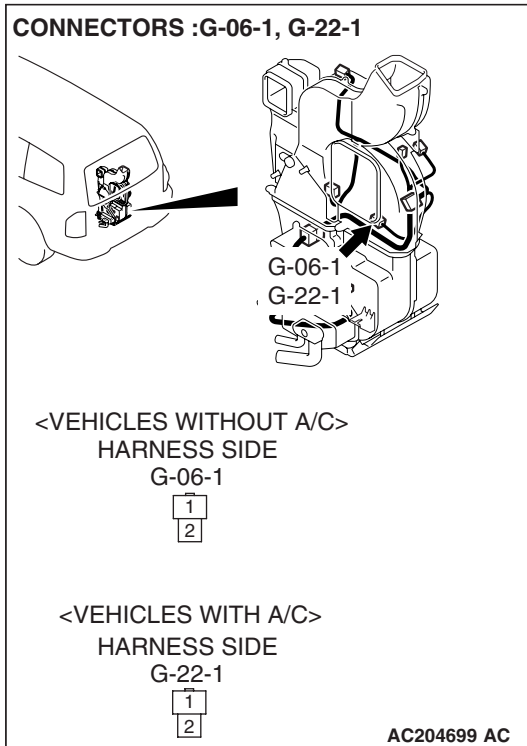

**STEP 23. Measure the resistance at rear blower motor connector G-06-1 <vehicles with rear heater or rear cooler> or G-22-1 <vehicles with rear A/C>.**

- (1) Disconnect connector G-06-1 or G-22-1 and measure the resistance at the wiring harness side.
- (2) Rear heater switch: "3" position <vehicles with rear heater>
- (3) Rear cooler switch: "3" position <vehicles with rear cooler>
- (4) Rear A/C switch: "3" position <vehicles with rear A/C>

- (5) Measure the resistance value between terminal 1 and ground.
  - 2 ohm or less

**Q: Does the measured resistance value correspond with this range?**

- YES :** Go to Step 30.  
**NO :** Go to Step 24.

**STEP 24. Check the rear blower switch.**

Follow the table below to check the rear blower switch for continuity.

BLOWER SWITCH POSITION	TESTER CONNECTION	SPECIFIED CONDITION
1	1 – 4	Less than 2 ohms
2	1 – 6	Less than 2 ohms
3	1 – 7	Less than 2 ohms

**Q: Is the check result normal?**

- YES :** Go to Step 25.  
**NO :** Replace the rear heater switch <vehicles with rear heater>, rear cooler switch <vehicles with rear cooler> or rear A/C switch <vehicles with rear A/C>.

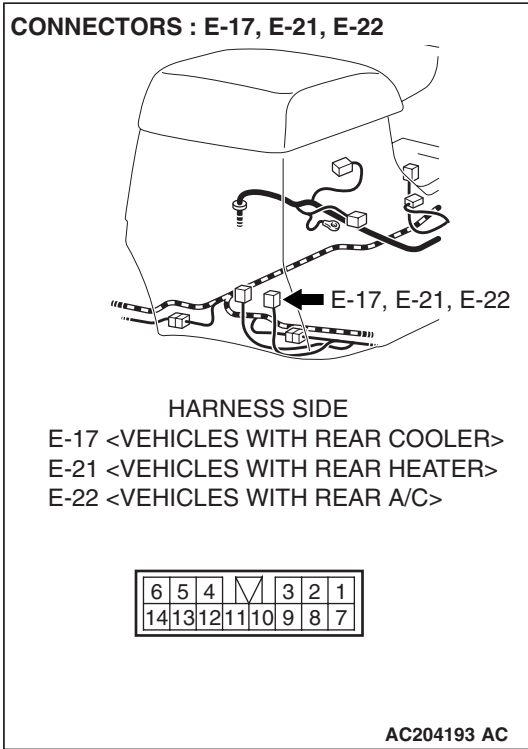

**STEP 25. Measure the resistance at rear heater switch connector E-21 <vehicles with rear heater>, rear cooler switch connector E-17 <vehicles with rear cooler> or rear A/C switch connector E-22 <vehicles with rear A/C>.**  
 (1) Disconnect connector E-21, E-17 or E-22 and measure the resistance at the wiring harness side.

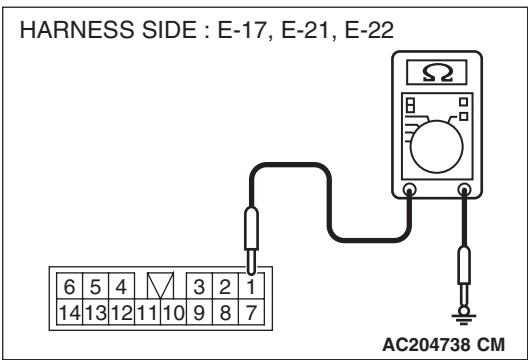

(2) Measure the resistance value between terminal 1 and ground.  
 • 2 ohm or less

**Q: Does the measured resistance value correspond with this range?**  
**YES :** Go to Step 26.  
**NO :** Go to Step 28.



**STEP 26.** Check rear blower motor connector G-06-1 <vehicles with rear heater or rear cooler> or G-22-1 <vehicles with rear A/C> and rear heater switch connector E-21 <vehicles with rear heater>, rear cooler switch connector E-17 <vehicles with rear cooler> or rear A/C switch connector E-22 <vehicles with rear A/C> for damage.

**Q:** Is rear blower motor connector G-06-1 <vehicles with rear heater or rear cooler> or G-22-1 <vehicles with rear A/C> and rear heater switch connector E-21 <vehicles with rear heater>, rear cooler switch connector E-17 <vehicles with rear cooler> or rear A/C switch connector E-22 <vehicles with rear A/C> in good condition?

**YES :** Go to Step 27.

**NO :** Repair or replace the connector. Refer to GROUP 00E, Harness Connector Inspection P.00E-2. The blower motor should operate normally.

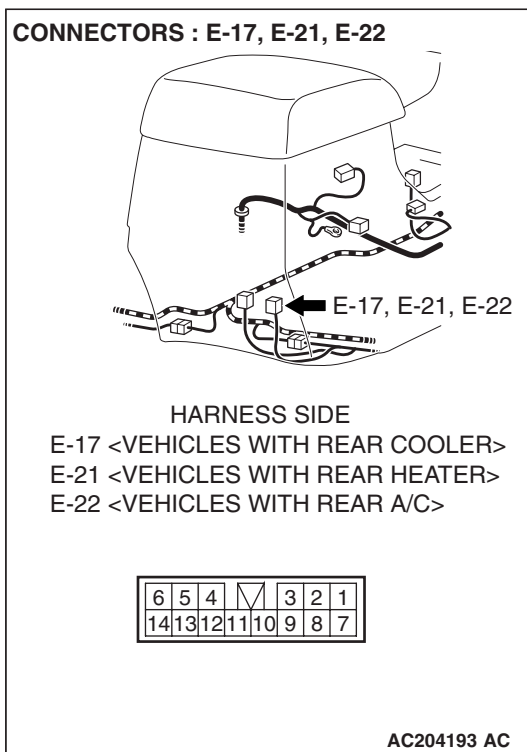
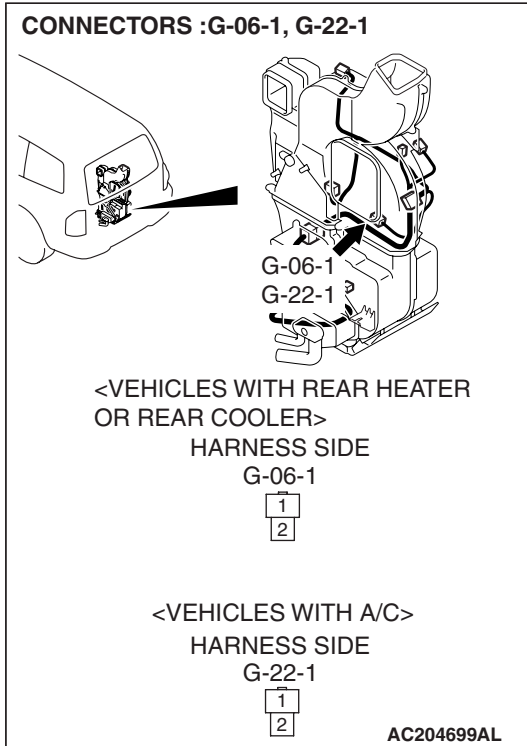

**STEP 27.** Check the wiring harness between rear blower motor connector G-06-1 (terminal 1) <vehicles with rear heater or rear cooler> or G-22-1 (terminal 1) <vehicles with rear A/C> and rear heater switch connector E-21 (terminal 7) <vehicles with rear heater>, rear cooler switch connector E-17 (terminal 7) <vehicles with rear cooler> or rear A/C switch connector E-22 (terminal 7) <vehicles with rear A/C>.

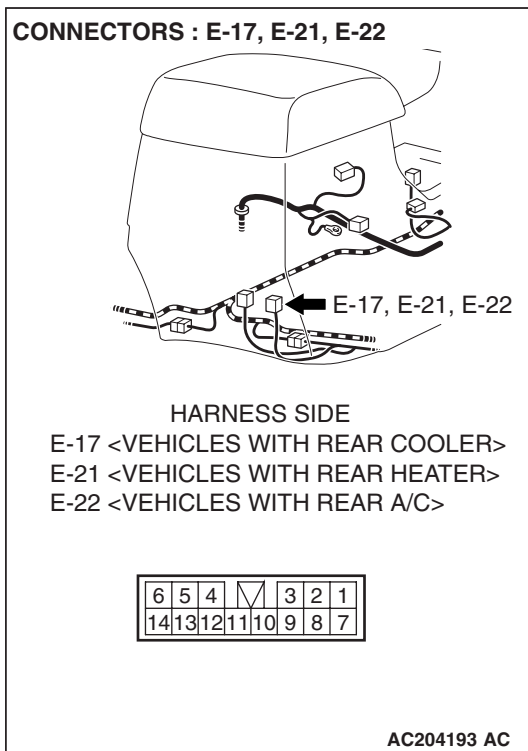
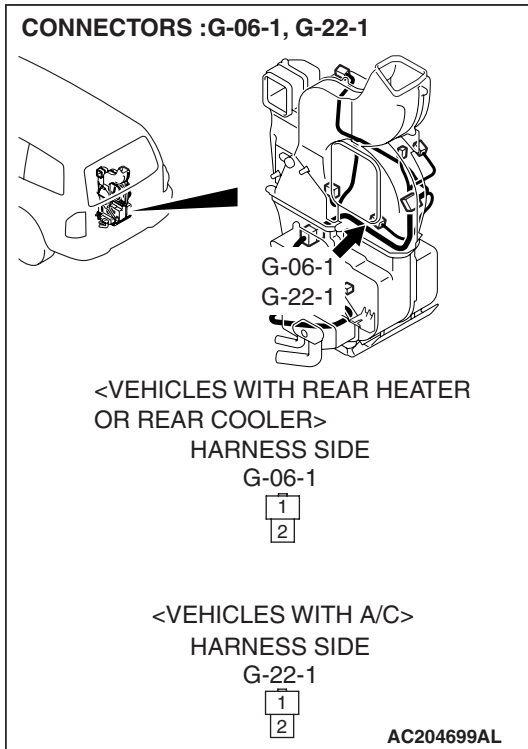

CONNECTORS : G-06, G-22

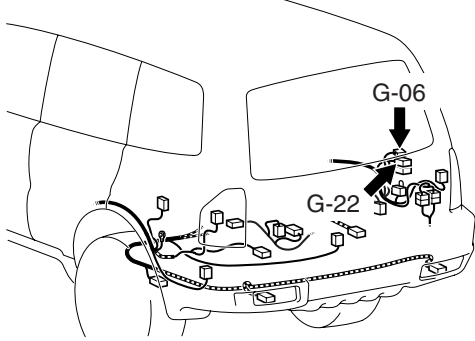

HARNESS SIDE  
 G-06

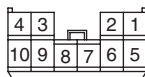

HARNESS SIDE  
 G-22

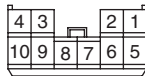

AC204197 AB

*NOTE: Also check rear blower unit connector G-06 <vehicles with rear heater or rear cooler> or G-22 <vehicles with rear A/C>. If rear blower unit connector G-06 <vehicles with rear heater or rear cooler> or G-22 <vehicles with rear A/C> is damaged, repair or replace the connector as described in GROUP 00E, Harness Connector Inspection P.00E-2.*

**Q:** Is the wiring harness between rear blower motor connector G-06-1 (terminal 1) <vehicles with rear heater or rear cooler> or G-22-1 (terminal 1) <vehicles with rear A/C> and rear heater switch connector E-21 (terminal 7) <vehicles with rear heater>, rear cooler switch connector E-17 (terminal 7) <vehicles with rear cooler> or rear A/C switch connector E-22 (terminal 7) <vehicles with rear A/C> in good condition?

**YES :** The rear blower motor should operate normally.

**NO :** Repair the wiring harness. The rear blower motor should operate normally.

CONNECTORS : E-17, E-21, E-22

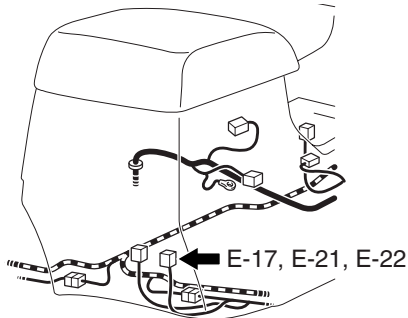

HARNESS SIDE  
 E-17 <VEHICLES WITH REAR COOLER>  
 E-21 <VEHICLES WITH REAR HEATER>  
 E-22 <VEHICLES WITH REAR A/C>

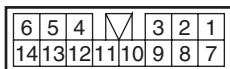

AC204193 AC

**STEP 28.** Check rear heater switch connector E-21 <vehicles with rear heater>, rear cooler switch connector E-17 <vehicles with rear cooler> or rear A/C switch connector E-22 <vehicles with rear A/C> for damage.

**Q:** Is rear heater switch connector E-21 <vehicles with rear heater>, rear cooler switch connector E-17 <vehicles with rear cooler> or rear A/C switch connector E-22 <vehicles with rear A/C> in good condition?

**YES :** Go to Step 29.

**NO :** Repair or replace the connector. Refer to GROUP 00E, Harness Connector Inspection P.00E-2. The blower motor should operate normally.

**STEP 29.** Check the wiring harness between rear heater switch connector E-21 (terminal 1) <vehicles with rear heater>, rear cooler switch connector E-17 (terminal 1) <vehicles with rear cooler> or rear A/C switch connector E-22 (terminal 1) <vehicles with rear A/C> and ground.

**Q:** Is the wiring harness between rear heater switch connector E-21 (terminal 1) <vehicles with rear heater>, rear cooler switch connector E-17 (terminal 1) <vehicles with rear cooler> or rear A/C switch connector E-22 (terminal 1) <vehicles with rear A/C> and ground in good condition?

**YES :** The rear blower motor should operate normally.

**NO :** Repair the wiring harness. The rear blower motor should operate normally.

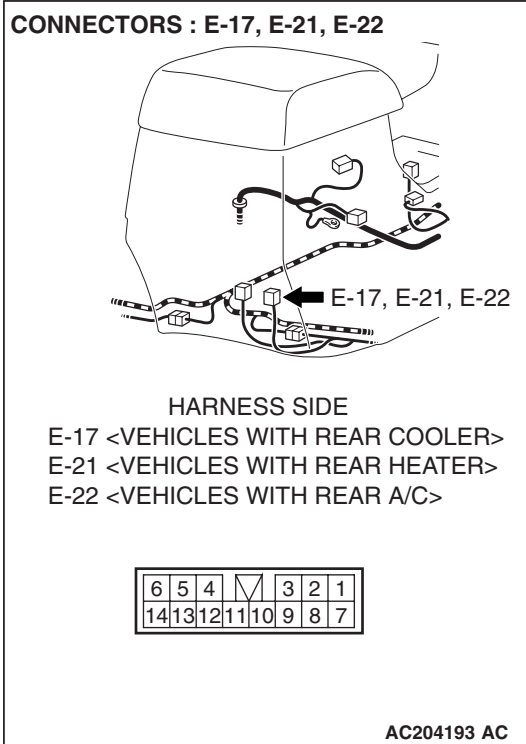

**STEP 30.** Check rear blower unit connector G-06 <vehicles with rear heater or rear cooler> or G-22 <vehicles with rear A/C> and rear blower motor connector G-06-1 <vehicles with rear heater or rear cooler> or G-22-1 <vehicles with rear A/C> for damage.

**Q:** Is rear blower unit connector G-06 <vehicles with rear heater or rear cooler> or G-22 <vehicles with rear A/C> and rear blower motor connector G-06-1 <vehicles with rear heater or rear cooler> or G-22-1 <vehicles with rear A/C> in good condition?

**YES :** Go to Step 31.

**NO :** Repair or replace the connector. Refer to GROUP 00E, Harness Connector Inspection P.00E-2. The blower motor should operate normally.

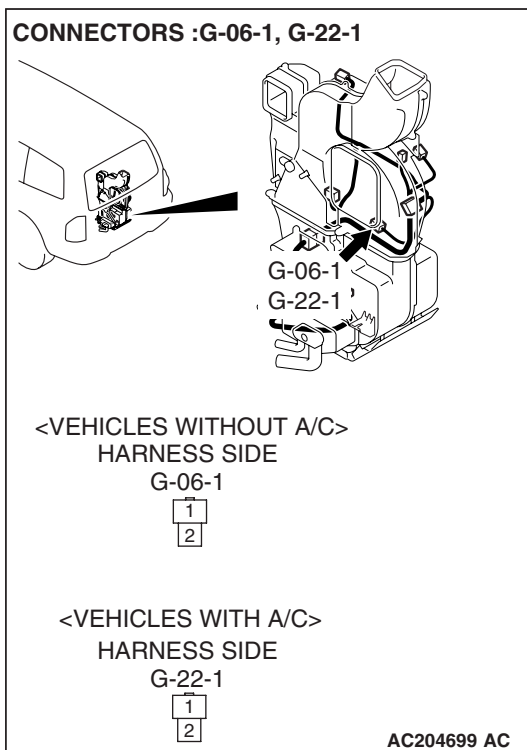
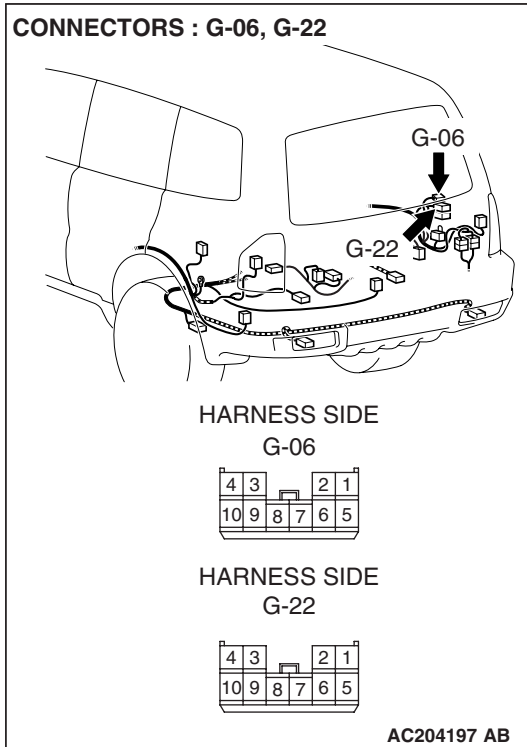

**STEP 31.** Check the wiring harness between rear blower unit connector G-06 (terminal 7 and 8) <vehicles with rear heater or rear cooler> or G-22 (terminal 7 and 8) <vehicles with rear A/C> and rear blower motor connector G-06-1 (terminal 1 and 2) <vehicles with rear heater or rear cooler> or G-22-1 (terminal 1 and 2) <vehicles with rear A/C>.

**Q:** Is the wiring harness between rear blower unit connector G-06 (terminal 7 and 8) <vehicles with rear heater or rear cooler> or G-22 (terminal 7 and 8) <vehicles with rear A/C> and rear blower motor connector G-06-1 (terminal 1 and 2) <vehicles with rear heater or rear cooler> or G-22-1 (terminal 1 and 2) <vehicles with rear A/C> in good condition?

**YES :** The rear blower motor should operate normally.

**NO :** Repair the wiring harness. The rear blower motor should operate normally.

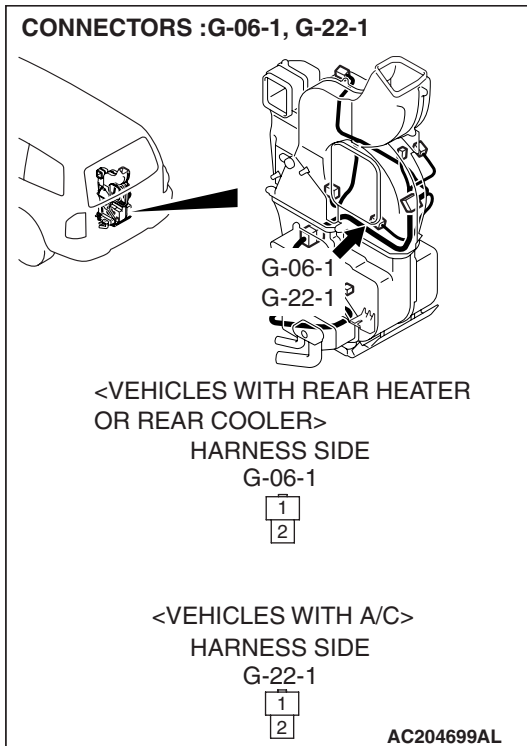
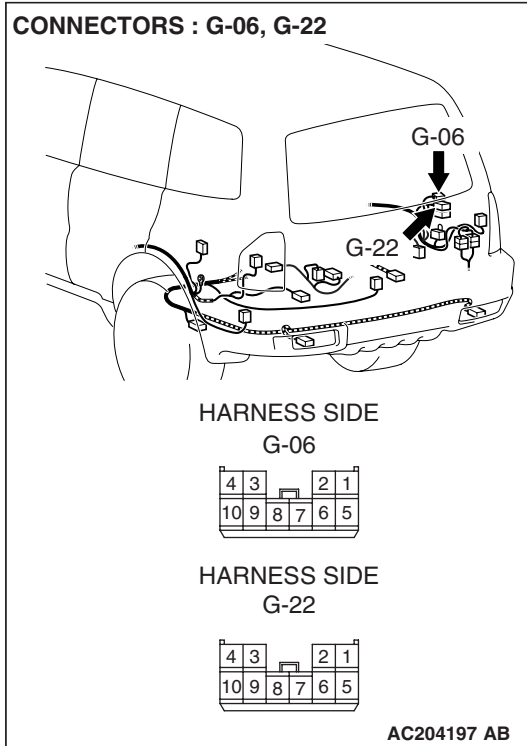

INSPECTION PROCEDURE 6: Rear Blower Air amount cannot be Changed.

Rear A/C Switch Circuit

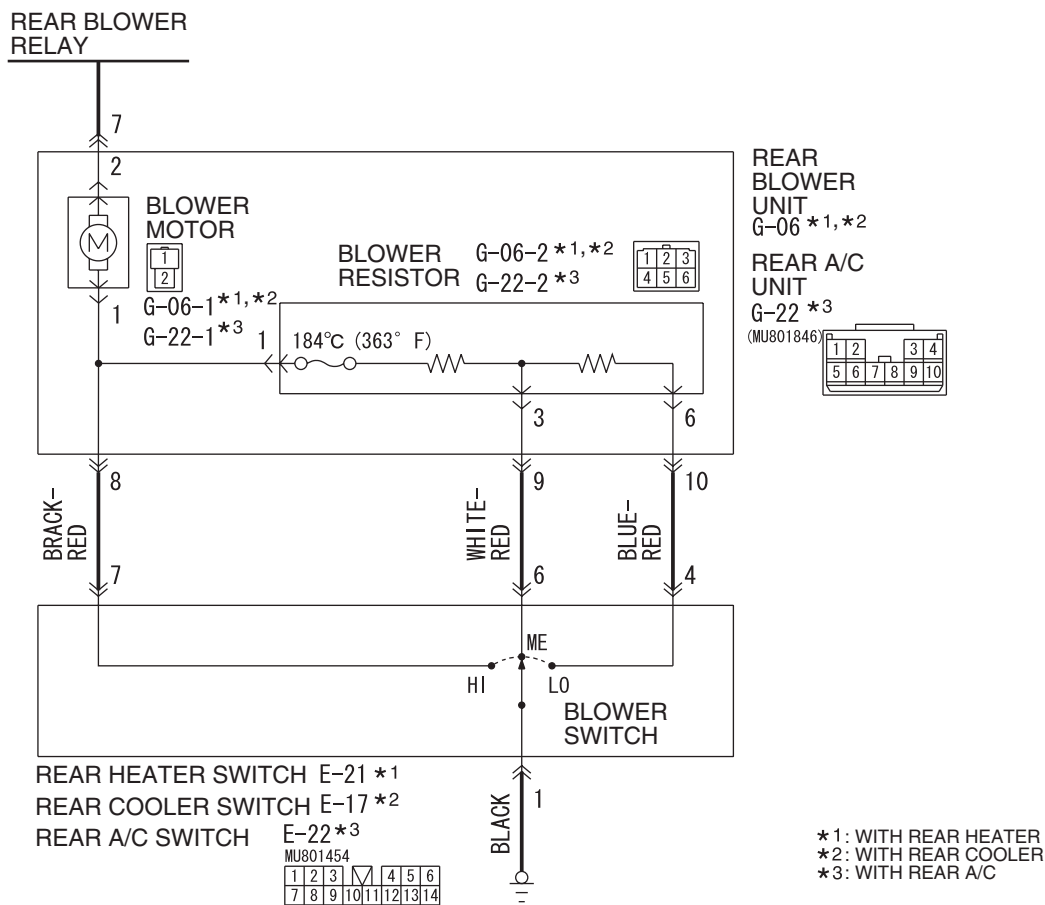

W5Q55M018A

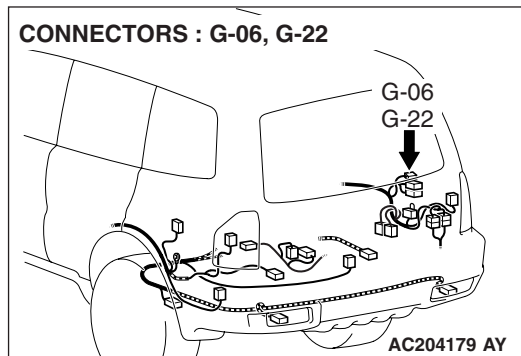
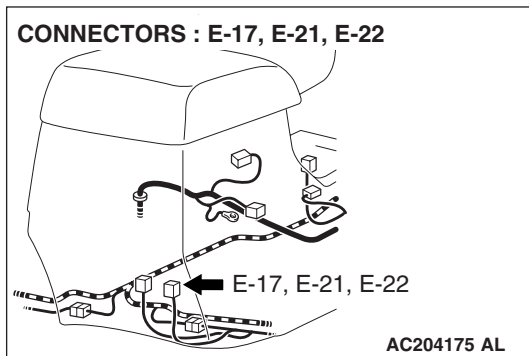

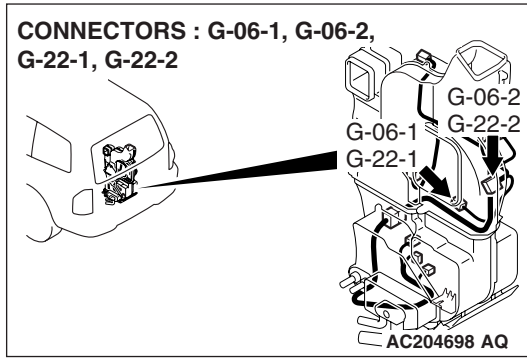

**DIAGNOSIS**

**STEP 1. Check the rear blower switch.**

Follow the table below to check the rear blower switch for continuity.

BLOWER SWITCH POSITION	TESTER CONNECTION	SPECIFIED CONDITION
1(LO)	1 – 4	Less than 2 ohms
2(ME)	1 – 6	Less than 2 ohms
3(HI)	1 – 7	Less than 2 ohms

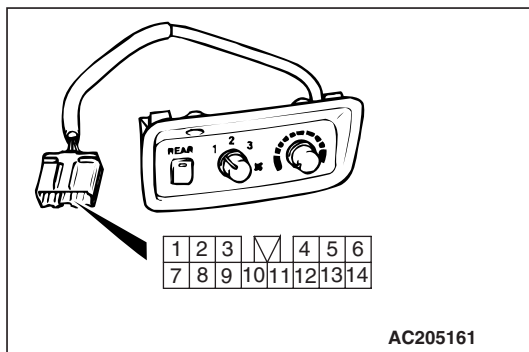

**Q: Is the check result normal?**

**YES :** Go to Step 2.

**NO :** Replace the rear heater switch <vehicles with rear heater>, rear cooler switch <vehicles with rear cooler> or rear A/C switch <vehicles with rear A/C>.

**STEP 2. Check the resistor.**

Measure the resistance between the resistor terminals.

Resistance value $\Omega$	TESTER CONNECTION
$4.9 \pm 0.34$	1 – 6
$2.15 \pm 0.15$	1 – 3

**Q: Is the check result normal?**

**YES :** Go to Step 3.

**NO :** Replace the resistor.

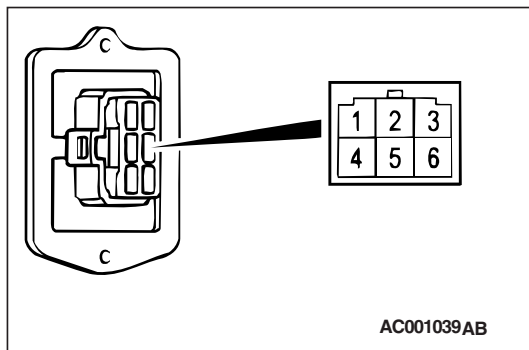



**STEP 3.** Check rear blower motor connector G-06-1 <vehicles with rear heater or rear cooler> or G-22-1 <vehicles with rear A/C> and rear heater switch connector E-21 <vehicles with rear heater> or rear cooler switch connector E-17 <vehicles with rear cooler> or rear A/C switch connector E-22 <vehicles with rear A/C> for damage.

**Q:** Is rear blower motor connector G-06-1 <vehicles with rear heater or rear cooler> or G-22-1 <vehicles with rear A/C> and rear heater switch connector E-21 <vehicles with rear heater> or rear cooler switch connector E-17 <vehicles with rear cooler> or rear A/C switch connector E-22 <vehicles with rear A/C> in good condition?

**YES :** Go to Step 4.

**NO :** Repair or replace the connector. Refer to GROUP 00E, Harness Connector Inspection P.00E-2. The blower motor should operate normally.

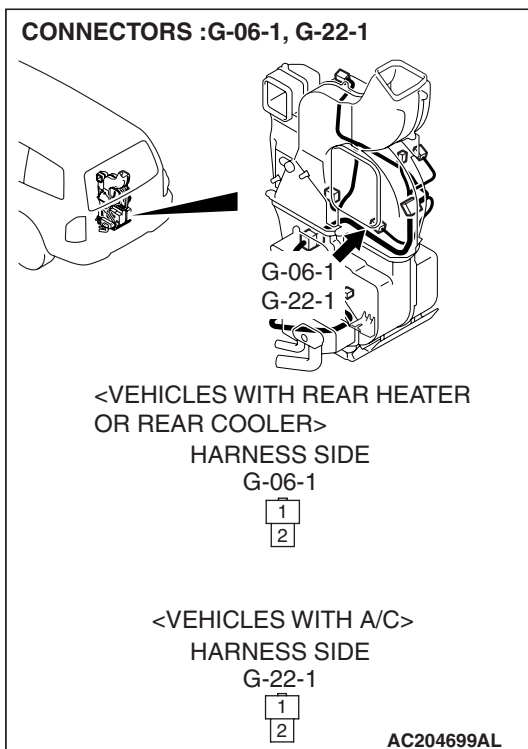
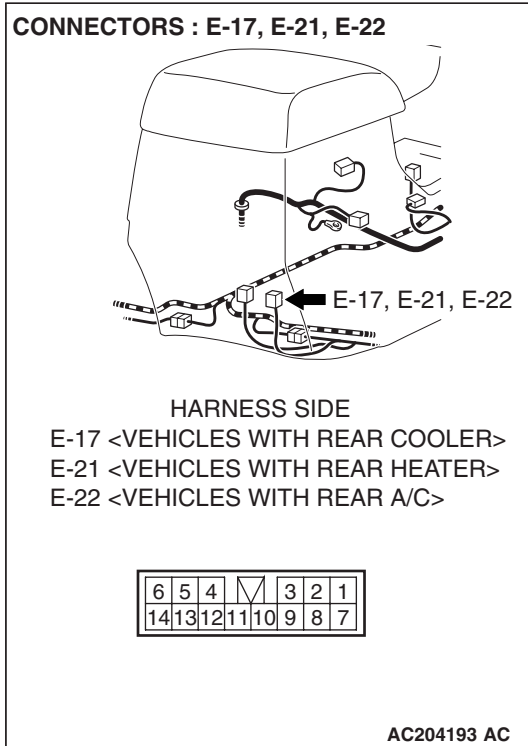

**STEP 4.** Check the wiring harness between rear blower motor connector G-06-1 (terminal 1) <vehicles with rear heater or rear cooler> or G-22-1 (terminal 1) <vehicles with rear A/C> and rear heater switch connector E-21 (terminal 7) <vehicles with rear heater> or rear cooler switch connector E-17 (terminal 7) <vehicles with rear cooler> or rear A/C switch connector E-22 (terminal 7) <vehicles with rear A/C>.

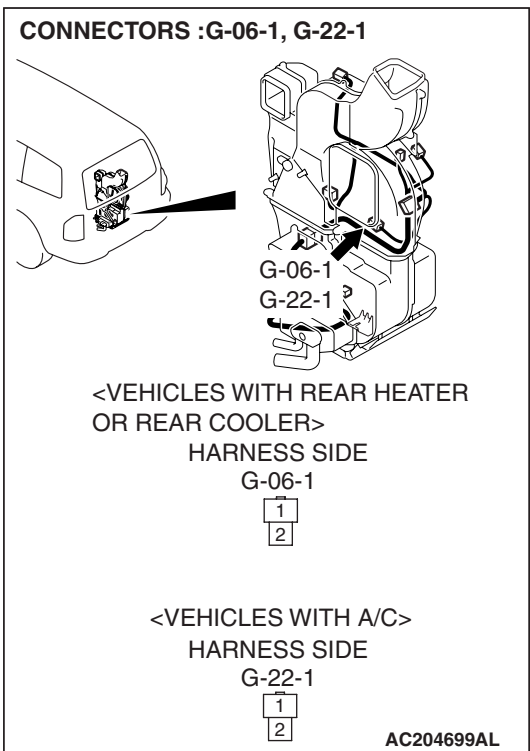
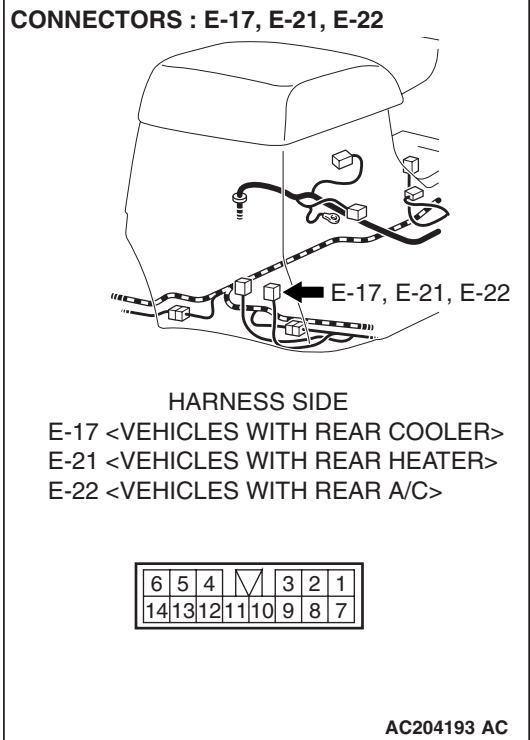

CONNECTORS : G-06, G-22

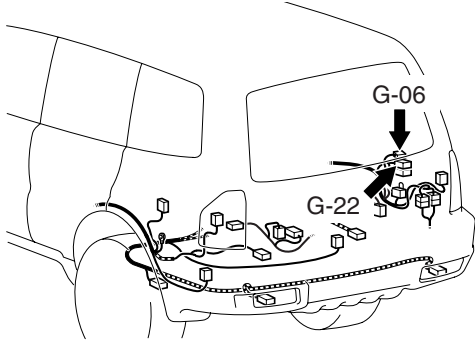

HARNESS SIDE

G-06

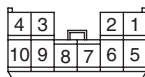

HARNESS SIDE

G-22

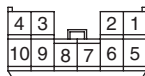

AC204197 AB

*NOTE: Also check rear blower unit connector G-06 <vehicles with rear heater or rear cooler> or G-22 <vehicles with rear A/C>. If rear blower unit connector G-06 <vehicles with rear heater or rear cooler> or G-22 <vehicles with rear A/C> is damaged, repair or replace the connector as described in GROUP 00E, Harness Connector Inspection P.00E-2.*

**Q:** Is the wiring harness between rear blower motor connector G-06-1 (terminal 1) <vehicles with rear heater or rear cooler> or G-22-1 (terminal 1) <vehicles with rear A/C> and rear heater switch connector E-21 (terminal 7) <vehicles with rear heater> or rear cooler switch connector E-17 (terminal 7) <vehicles with rear cooler> or rear A/C switch connector E-22 (terminal 7) <vehicles with rear A/C> in good condition?

**YES :** Go to Step 5.

**NO :** Repair the wiring harness. The rear blower motor should operate normally.

**STEP 5.** Check rear blower motor connector G-06-1 <vehicles with rear heater or rear cooler> or G-22-1 <vehicles with rear A/C> and blower resistor G-06-2 <vehicles with rear heater or rear cooler> or G-22-2 <vehicles with rear A/C> for damage.

**Q:** Is rear blower motor connector G-06-1 <vehicles with rear heater or rear cooler> or G-22-1 <vehicles with rear A/C> and blower resistor G-06-2 <vehicles with rear heater or rear cooler> or G-22-2 <vehicles with rear A/C> in good condition?

**YES :** Go to Step 6.

**NO :** Repair or replace the connector. Refer to GROUP 00E, Harness Connector Inspection P.00E-2. The blower motor should operate normally.

CONNECTORS : G-06-1, G-06-2, G-22-1, G-22-2

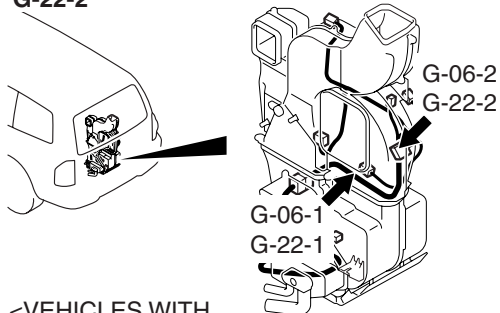

<VEHICLES WITH REAR HEATER OR REAR COOLER>  
 HARNESS SIDE

G-06-1



HARNESS SIDE

G-06-2



<VEHICLES WITH A/C>

HARNESS SIDE

G-22-1



HARNESS SIDE

G-22-2



AC204699AM

**STEP 6.** Check the wiring harness between rear blower motor connector G-06-1 (terminal 1) <vehicles with rear heater or rear cooler> or G-22-1 (terminal 1) <vehicles with rear A/C> and blower resistor G-06-2 (terminal 1) <vehicles with rear heater or rear cooler> or G-22-2 (terminal 1) <vehicles with rear A/C>.

**Q:** Is the wiring harness between rear blower motor connector G-06-1 (terminal 1) <vehicles with rear heater or rear cooler> or G-22-1 (terminal 1) <vehicles with rear A/C> and blower resistor G-06-2 (terminal 1) <vehicles with rear heater or rear cooler> or G-22-2 (terminal 1) <vehicles with rear A/C> in good condition?

**YES :** Go to Step 7.

**NO :** Repair the wiring harness. The rear blower motor should operate normally.

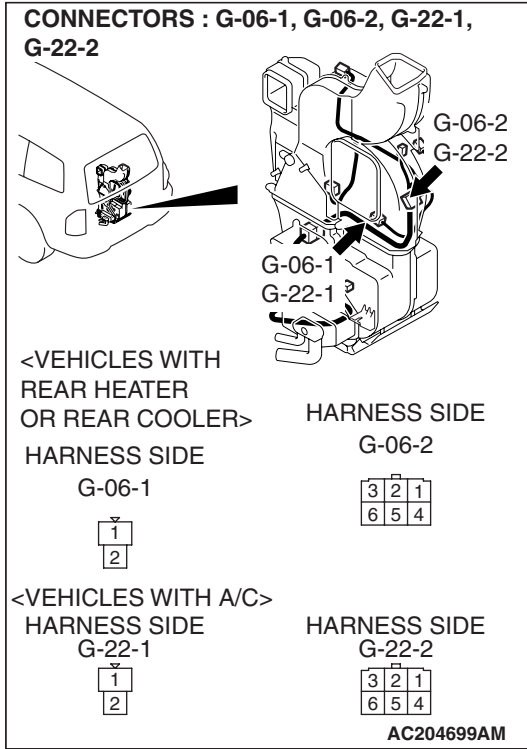

**STEP 7.** Check blower resistor connector G-06-2 <vehicles with rear heater or rear cooler> or G-22-2 <vehicles with rear A/C> and rear heater switch connector E-21 <vehicles with rear heater> or rear cooler switch connector E-17 <vehicles with rear cooler> or rear A/C switch connector E-22 <vehicles with rear A/C> for damage.

**Q:** Is blower resistor connector G-06-2 <vehicles with rear heater or rear cooler> or G-22-2 <vehicles with rear A/C> and rear heater switch connector E-21 <vehicles with rear heater> or rear cooler switch connector E-17 <vehicles with rear cooler> or rear A/C switch connector E-22 <vehicles with rear A/C> in good condition?

**YES :** Go to Step 8.

**NO :** Repair or replace the connector. Refer to GROUP 00E, Harness Connector Inspection P.00E-2. The blower motor should operate normally.

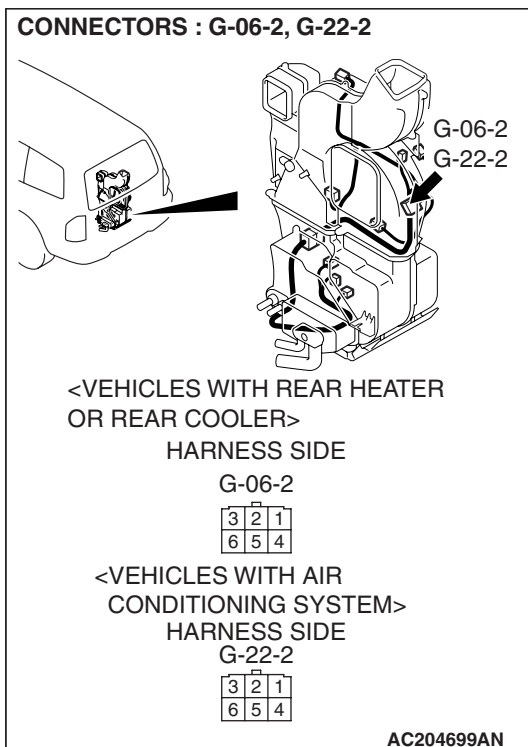
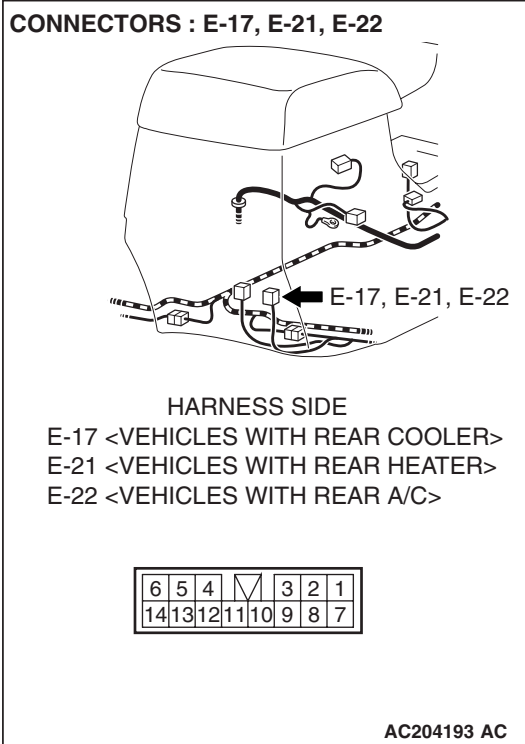

**STEP 8.** Check the wiring harness between blower resistor connector G-06-2 (terminal 3 and 6) <vehicles with rear heater or rear cooler> or G-22-2 (terminal 3 and 6) <vehicles with rear A/C> and rear heater switch connector E-21 (terminal 6 and 4) <vehicles with rear heater> or rear cooler switch connector E-17 (terminal 6 and 4) <vehicles with rear cooler> or rear A/C switch connector E-22 (terminal 6 and 4) <vehicles with rear A/C>.

**CONNECTORS : E-17, E-21, E-22**

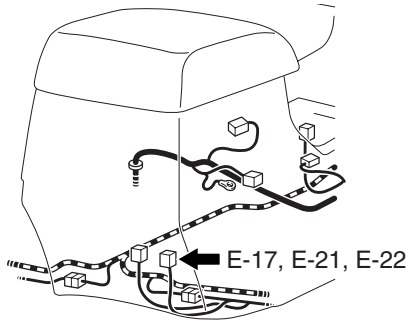

**HARNES SIDE**

- E-17 <VEHICLES WITH REAR COOLER>
- E-21 <VEHICLES WITH REAR HEATER>
- E-22 <VEHICLES WITH REAR A/C>

6	5	4	3	2	1
14	13	12	11	10	9
8	7				

AC204193 AC

**CONNECTORS : G-06-2, G-22-2**

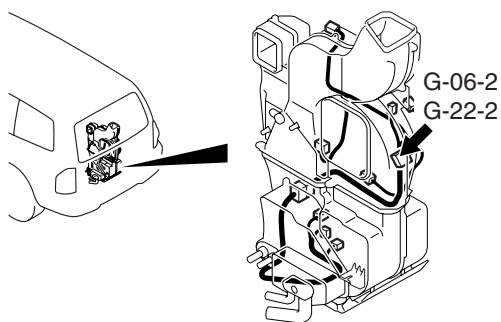

<VEHICLES WITH REAR HEATER OR REAR COOLER>

**HARNES SIDE**

G-06-2

3	2	1
6	5	4

<VEHICLES WITH AIR CONDITIONING SYSTEM>

**HARNES SIDE**

G-22-2

3	2	1
6	5	4

AC204699AN

CONNECTORS : G-06, G-22

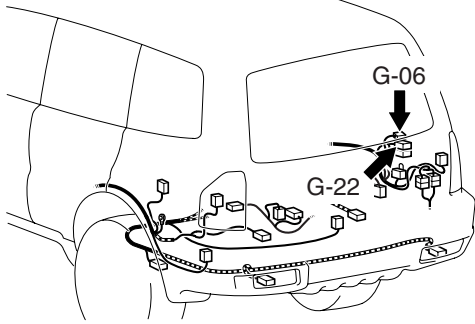

HARNESS SIDE  
 G-06

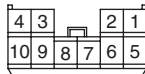

HARNESS SIDE  
 G-22

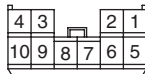

AC204197 AB

*NOTE: Also check rear blower unit connector G-06 <vehicles with rear heater or rear cooler> or G-22 <vehicles with rear A/C>. If rear blower unit connector G-06 <vehicles with rear heater or rear cooler> or G-22 <vehicles with rear A/C> is damaged, repair or replace the connector as described in GROUP 00E, Harness Connector Inspection P.00E-2.*

**Q: Is the wiring harness between blower resistor connector G-06-2 (terminal 3 and 6) <vehicles with rear heater or rear cooler> or G-22-2 (terminal 3 and 6) <vehicles with rear A/C> and rear heater switch connector E-21 (terminal 6 and 4) <vehicles with rear heater> or rear cooler switch connector E-17 (terminal 6 and 4) <vehicles with rear cooler> or rear A/C switch connector E-22 (terminal 6 and 4) <vehicles with rear A/C> in good condition?**

**YES :** The rear blower motor should operate normally.

**NO :** Repair the wiring harness. The rear blower motor should operate normally.

INSPECTION PROCEDURE 7: Air Outlet Vent Output cannot be Changed with Temperature Control Switch. <Vehicles with Rear A/C>

Mode Selection Damper Control Motor Circuit

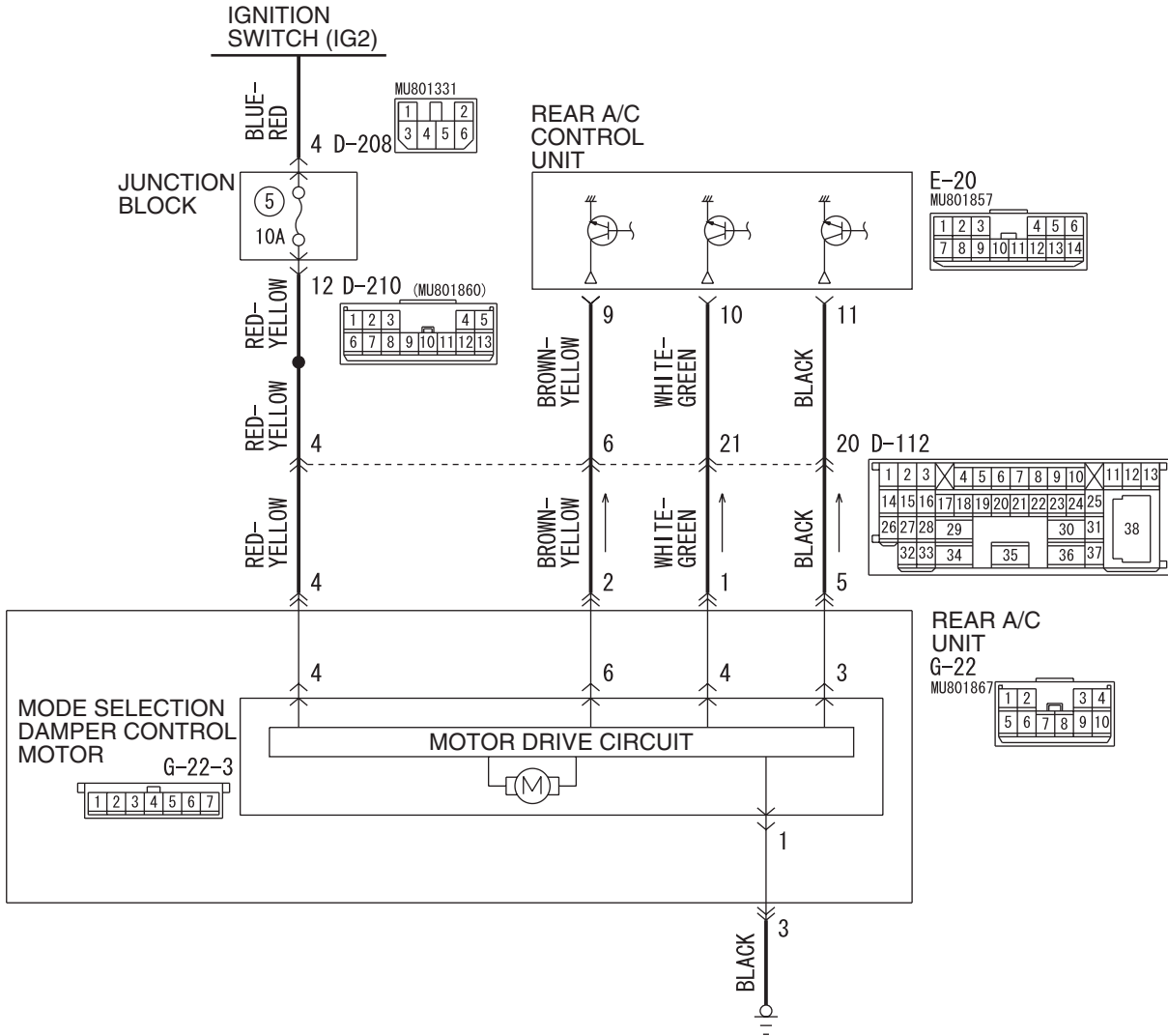

W5Q55M017A

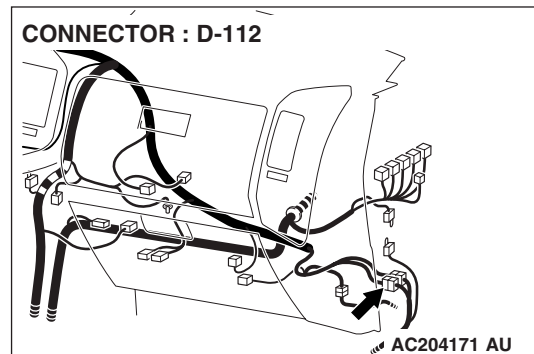
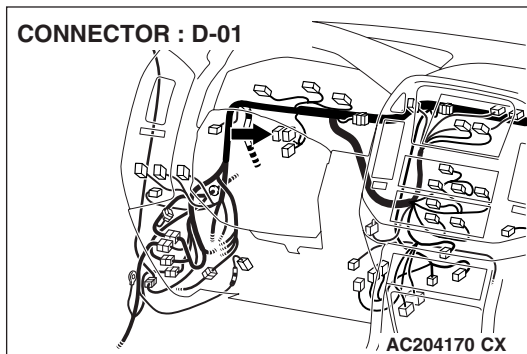



CONNECTORS : D-208, D-210

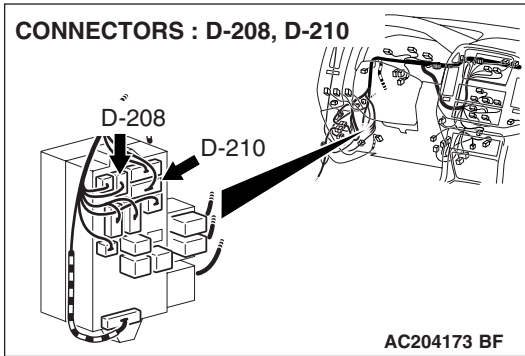

CONNECTOR : E-20

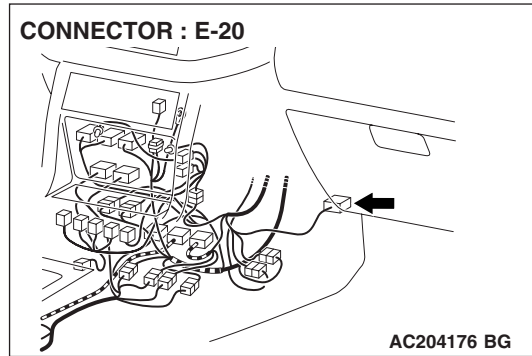

CONNECTOR : G-22

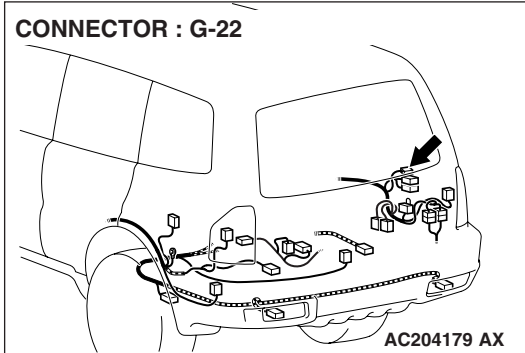

CONNECTOR : G-22-3

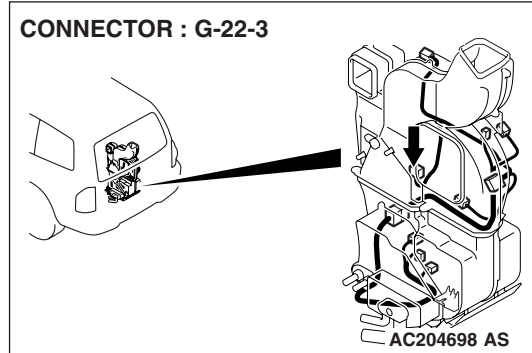

**DIAGNOSIS**

**STEP 1. Check that the rear air conditioning temperature control functions normally.**

**Q: Does the rear air conditioning temperature control function normally?**

**YES :** Go to Step 2.

**NO :** Refer to rear air conditioning diagnosis Inspection Procedure 4 "A/C Outlet Air Temperature does not Increase <Vehicles with rear A/C>P.55A-53 ."

**STEP 2. Measure the resistance at rear A/C unit connector G-22.**

(1) Disconnect rear A/C unit connector G-22, and measure at the wiring harness side.

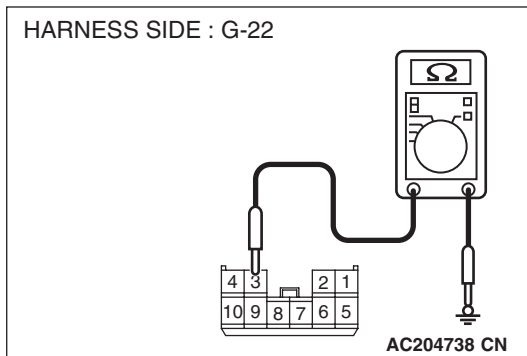
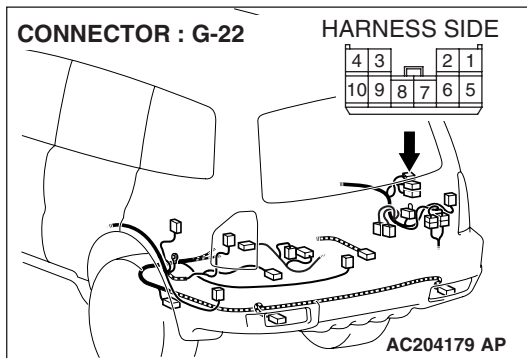

(2) Measure the resistance between terminal 3 and ground.

- Less than 2 ohms

**Q: Does the measured resistance value correspond with this range?**

**YES :** Go to Step 5.

**NO :** Go to Step 3.

**STEP 3. Check rear A/C unit connector G-22 for damage.**

**Q: Is rear A/C unit connector G-22 in good condition?**

**YES :** Go to Step 4.

**NO :** Repair or replace the connector. Refer to GROUP 00E, Harness Connector Inspection P.00E-2. Check that the air conditioning works normally.

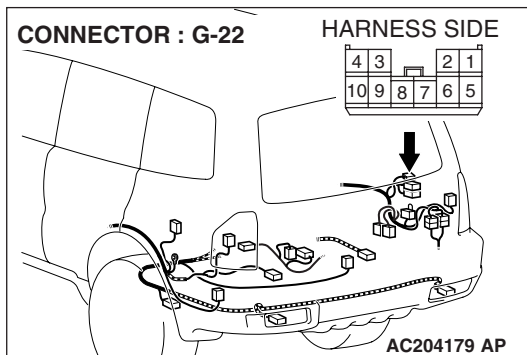

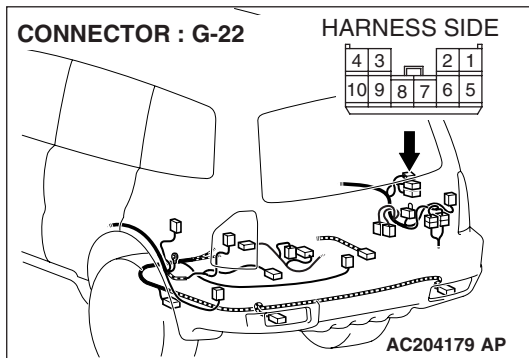

**STEP 4. Check the wiring harness between rear A/C unit connector G-22 (terminal 3) and ground.**

**Q: Is the wiring harness between rear A/C unit connector G-22 (terminal 3) and ground in good condition?**

**YES :** Check that the rear air conditioning works normally.

**NO :** Repair the wiring harness. Check that the rear air conditioning works normally.

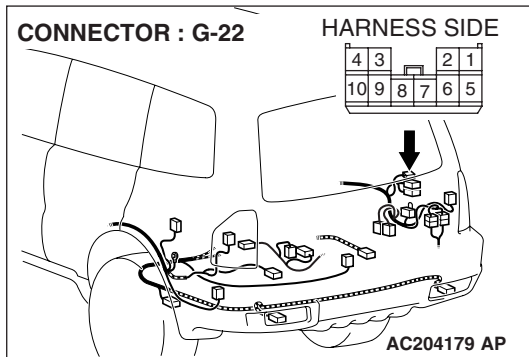

**STEP 5. Measure the voltage at rear A/C unit connector G-22.**

(1) Disconnect rear A/C unit connector G-22, and measure the voltage at the harness side.

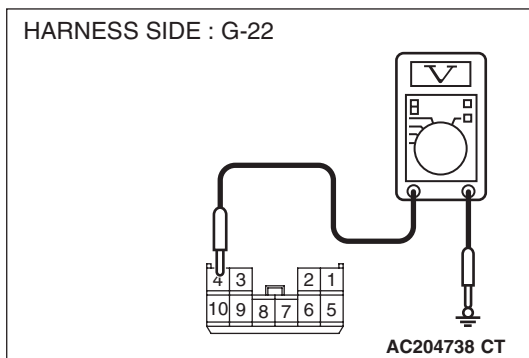

(2) Measure the voltage between terminal 4 and ground.

- The measured value should be approximately 12 volts (battery positive voltage).

**Q: Does the measured voltage correspond with this range?**

**YES :** Go to Step 8.

**NO :** Go to Step 6.

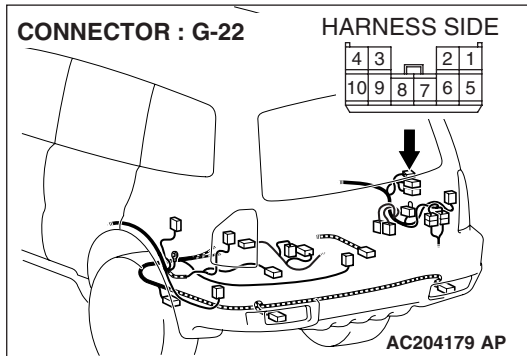

**STEP 6. Check rear A/C unit connector G-22 for damage.**

**Q: Is rear A/C unit connector G-22 in good condition?**

**YES :** Go to Step 7.

**NO :** Repair or replace the connector. Refer to GROUP 00E, Harness Connector Inspection [P.00E-2](#). Check that the rear air conditioning works normally.

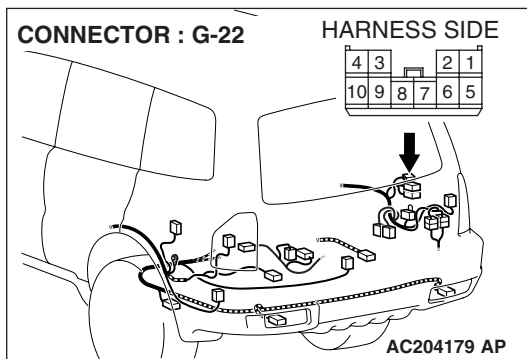

**STEP 7. Check the wiring harness between rear A/C unit connector G-22 (terminal 4) and the ignition switch (IG2).**

CONNECTOR: D-01

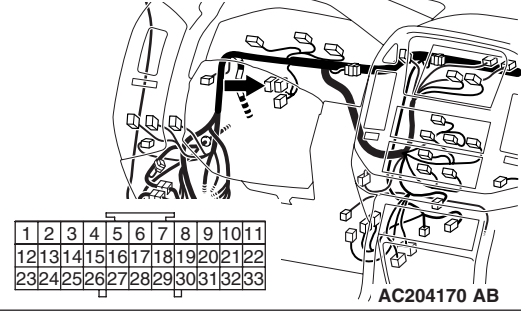

NOTE: Also check intermediate connector D-112, joint connector (6) D-01, junction block connector C-210 and D-208. If intermediate connector D-112, joint connector (6) D-01, junction block connector D-210 and D-208 is damaged, repair or replace the connector as described in GROUP 00E, Harness Connector Inspection P.00E-2.

**Q: Is the wiring harness between rear A/C unit connector G-22 (terminal 4) and the ignition switch (IG2) in good condition?**

**YES :** Check that the rear air conditioning works normally.  
**NO :** Repair the wiring harness. Check that the rear air conditioning works normally.

CONNECTOR : D-112

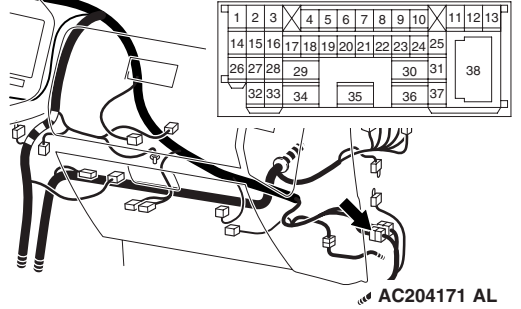

CONNECTORS: D-208, D-210

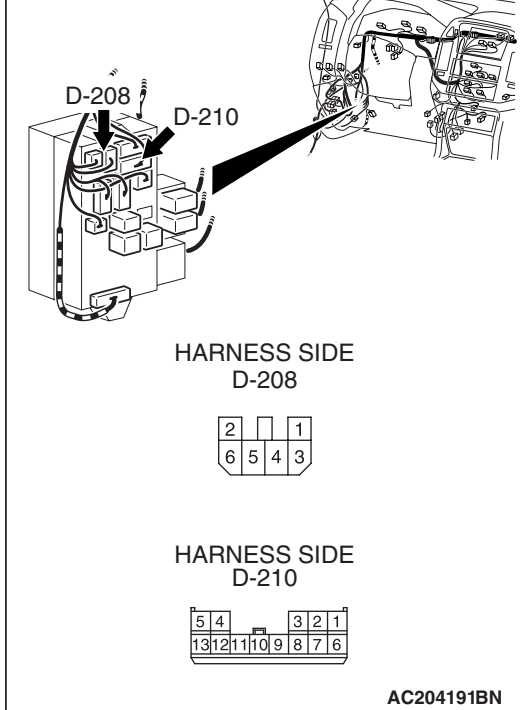

**STEP 8. Check rear A/C unit connector G-22 and mode selection damper control motor connector G-22-3 for damage.**

**Q: Is rear A/C unit connector G-22 and mode selection damper control motor connector G-22-3 for damage in good condition?**

**YES :** Go to Step 9.

**NO :** Repair or replace the connector. Refer to GROUP 00E, Harness Connector Inspection [P.00E-2](#). Check that the rear air conditioning works normally.

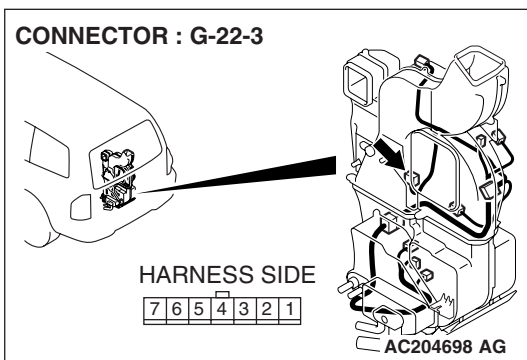
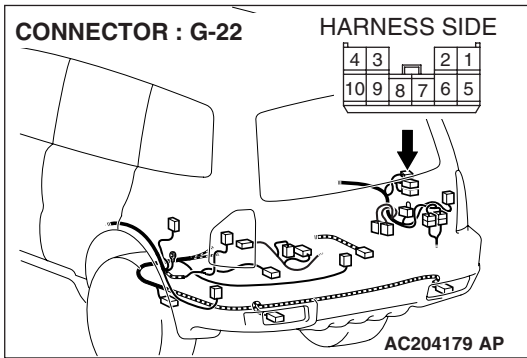

**STEP 9. Check the wiring harness between rear A/C unit connector G-22 (terminal 3 and 4) and mode selection damper control motor connector G-22-3 (terminal 1 and 2).**

**Q: Is the wiring harness between rear A/C unit connector G-22 (terminal 3 and 4) and mode selection damper control motor connector G-22-3 (terminal 1 and 2) in good condition?**

**YES :** Go to Step 10.

**NO :** Repair the wiring harness. Check that the rear air conditioning works normally.

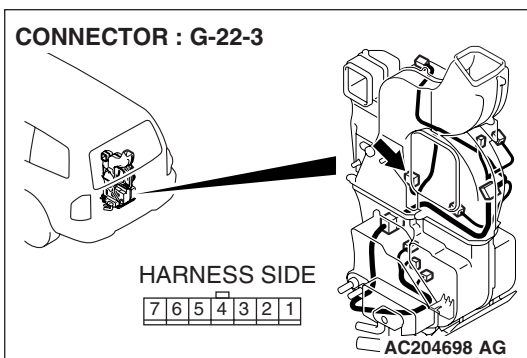
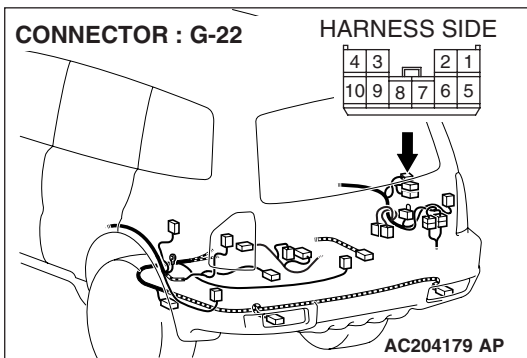

**STEP 10.** Check rear A/C control unit connector E-20 and mode selection damper control motor connector G-22-3 for damage.

**Q:** Is rear A/C control unit connector E-20 and mode selection damper control motor connector G-22-3 for damage in good condition?

**YES :** Go to Step 11.

**NO :** Repair or replace the connector. Refer to GROUP 00E, Harness Connector Inspection P.00E-2. Check that the rear air conditioning works normally.

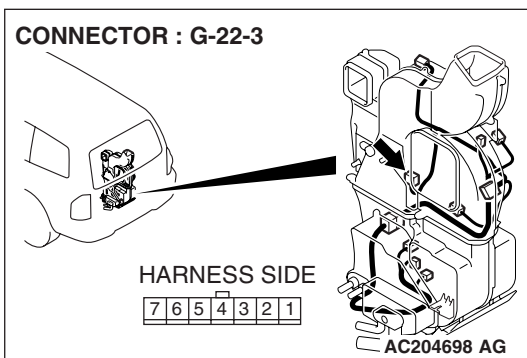
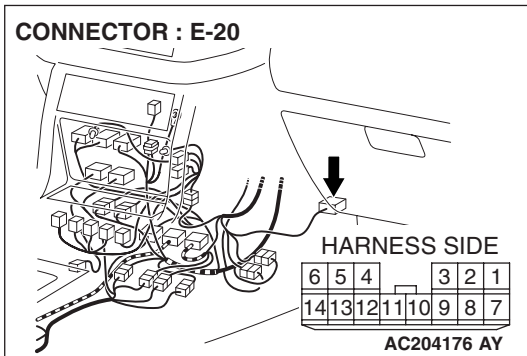

**STEP 11.** Check the wiring harness between rear A/C control unit connector E-20 (terminal 9, 10 and 11) and mode selection damper control motor connector G-22-3 (terminal 6, 4 and 3).

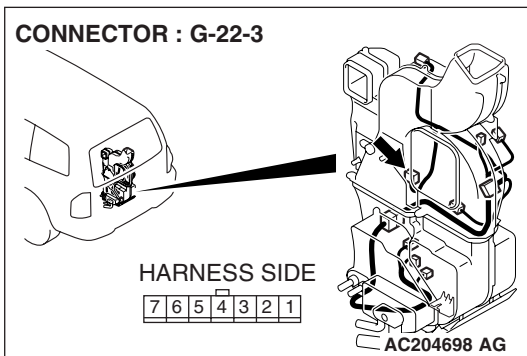
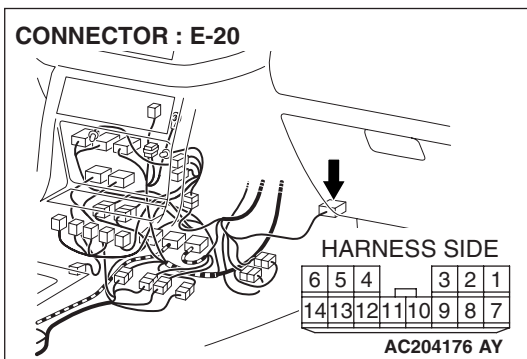

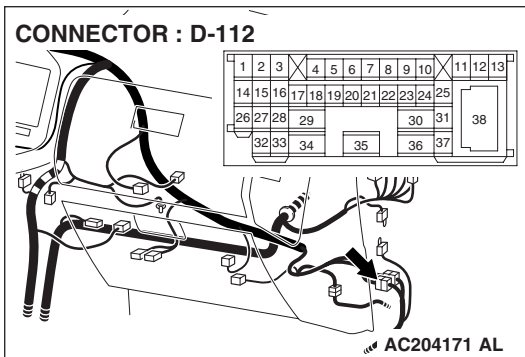

*NOTE: Also check intermediate connector D-112 and rear A/C unit connector G-22. If intermediate connector D-112 and rear A/C unit connector G-22 is damaged, repair or replace the connector as described in GROUP 00E, Harness Connector Inspection P.00E-2.*

**Q: Is the wiring harness between rear A/C control unit connector E-20 (terminal 9, 10 and 11) and mode selection damper control motor connector G-22-3 (terminal 6, 4 and 3) in good condition?**

**YES :** Go to Step 12.

**NO :** Repair the wiring harness. Check that the rear air conditioning works normally.

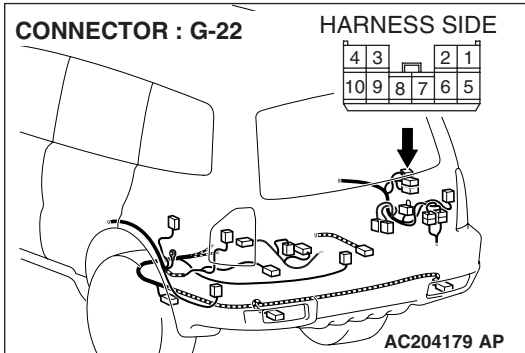

**STEP 12. Replace the mode selection damper control motor connector.**

**Q: Do the air conditioning work normally?**

**YES :** No action is necessary and testing is complete.

**NO :** Replace the rear A/C control unit. Check that the air conditioning works normally.



**CHECK AT ECU TERMINAL**

M1554005400160

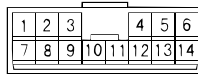

ACX00820

TERMINAL NO.	INSPECTION ITEM	INSPECTION CONDITION	NORMAL CONDITION
1	Magnetic valve	Magnetic valve: OFF	Battery positive voltage
		Magnetic valve: ON	0.5 V
2	Ground	At all times	0 V
3	Input from temperature adjusting switch	Temperature switch: MAX HOT	1 V
		Temperature switch: MAX COOL	4 V
4	Air mixing damper control motor potentiometer power supply	At all times	5 V
5	Power supply (IG2)	Ignition switch: ON	Battery positive voltage
		Ignition switch: OFF	0 V
6	Air mixing damper control motor <Vehicles with rear heater or Rear A/C>	When the damper is moving toward the MAX COOL position.	10 V
		When the damper is moving toward the MAX HOT position.	0 V
7	Air mixing damper control motor potentiometer input signal <Vehicles with rear heater or Rear A/C>	Air mix damper: MAX HOT position	1 V
		Air mix damper: MAX COOL position	4 V
8	Sensor and potentiometer ground	At all times	0 V
9	Air outlet changeover damper motor signal <Vehicles with Rear A/C>	Ignition switch: ON	0 – 12 V
10	Air outlet changeover damper motor signal <Vehicles with Rear A/C>	Ignition switch: ON	0 – 12 V
11	Air outlet changeover damper motor signal <Vehicles with Rear A/C>	Ignition switch: ON	0 – 12 V
12	Air thermo sensor input signal	Sensing part temperature: 25 °C (77 °F) (1.5 kΩ)	2.2 V
13	Rear fan switch or front rear fan switch input	Rear fan switch or front rear fan switch: ON	0 V
14	Air mixing damper control motor (MAX HOT) <Vehicles with rear heater or Rear A/C>	When the damper is moving toward the MAX COOL position.	0.5 V
		When the damper is moving toward the MAX HOT position.	Battery positive voltage

## SPECIAL TOOLS

M155200600453

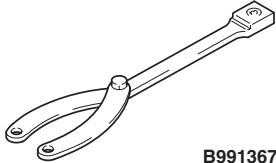
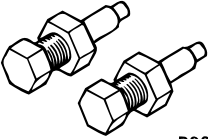
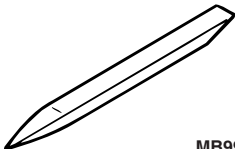
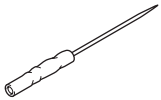
TOOL	TOOL NUMBER AND NAME	SUPERSESSION	APPLICATION
 B991367	MB991367 Special spanner	MB991367-01	Armature mounting nut of compressor removal and installation
 B991386	MB991386 Pin	MIT217213I	
 MB990784	MB990784 Ornament remover	General service tool	Center panel removal
 MB992006	MB992006 Extra fine probe	General service tool	Continuity check and voltage measurement at harness wire or connector for loose, corroded or damaged terminals, or terminals pushed back in the connector.

## ON-VEHICLE SERVICE

## REFRIGERANT LEVEL TEST

M1552008400152

Use the refrigerant recovery station to remove all of the refrigerant, and then calculate the amount of the refrigerant and charge it.

## A/C COMPRESSOR CLUTCH TEST

M1552019900087

1. Disconnect the A/C compressor clutch connector to the A/C compressor clutch.
2. Connect the positive battery terminal to the air conditioning compressor clutch connector terminal 3, and ground the negative battery terminal to the body of the compressor.
3. If the A/C compressor clutch is normal, there will be a "click." If the pulley and armature do not make contact ("click"), there is a malfunction.

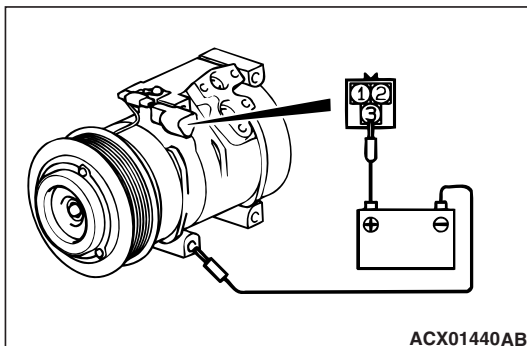

### RECEIVER DRIER TEST

M1552008600123

Turn the A/C on. Check the temperature by touching the receiver drier outlet and inlet pipes. If there is a difference in the temperatures of the two pipes, the receiver assembly is restricted. Replace the receiver assembly.

### DUAL PRESSURE SWITCH CHECK

M1552010400267

1. Remove the dual pressure switch connector and connect the high/low pressure side terminals located on the harness side as shown in the illustration.
2. Install a gauge manifold to the high-pressure side service valve of the refrigerant line. (Refer to P.55A-148.)
3. When the high/low pressure sides of the dual pressure switch are at operation pressure (ON) and there is continuity between the respective terminals, then the condition is normal. If there is no continuity, replace the switch.

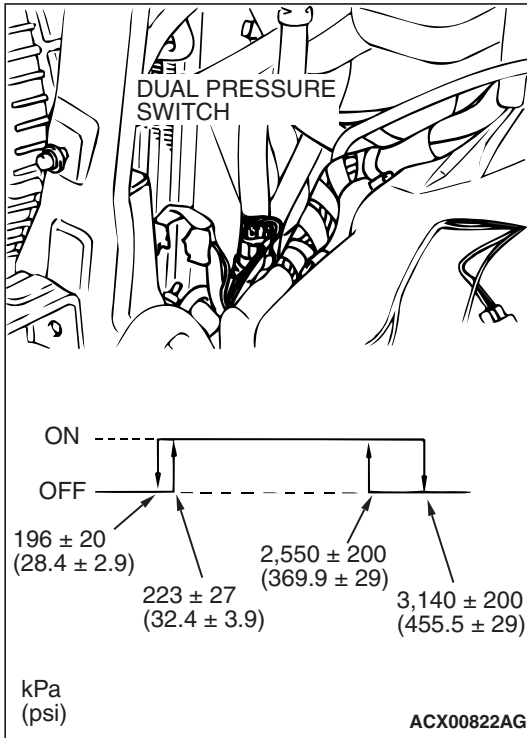

ITEM	OFF to ON	ON to OFF
Low-pressure side kPa (psi)	223 ± 27 (32.4 ± 3.9)	196 ± 20 (28.4 ± 2.9)
High-pressure side kPa (psi)	2,550 ± 200 (369.9 ± 29)	3,140 ± 200 (455.5 ± 29)

### COMPRESSOR DRIVE BELT ADJUSTMENT

M1552001000131

Refer to GROUP 00, Maintenance Service – Drive Belts P.00-43.

### CHARGING

M1552001200276

Use the refrigerant recovery station to charge the refrigerant.

### METHOD BY USING REFRIGERANT RECOVERY AND RECYCLING UNIT

Using the refrigerant recovery and recycling unit, refill the refrigerant.

*NOTE: Refer to the Refrigerant Recovery and Recycling Unit Instruction Manual for operation of the unit.*

### DISCHARGING SYSTEM

Use the refrigerant recovery unit to discharge refrigerant gas from the system.

*NOTE: Refer to the Refrigerant Recovery and Recycling Unit Instruction Manual for operation of the unit.*

**REFILLING OF OIL IN THE A/C SYSTEM**

Too little oil will provide inadequate compressor lubrication and cause a compressor failure. Too much oil will increase discharge air temperature.

When a compressor is installed at the factory, it contains 120 cm<sup>3</sup> (4.1 floz) of refrigerant oil. While the A/C system is in operation, the oil is carried through the entire system by the refrigerant. Some of this oil will be trapped and retained in various parts of the system.

When the following system components are replaced, it is necessary to add oil to the system to replace the oil being removed with the component.

**Compressor oil: ND-OIL8****Quantity:**

- **Evaporator: 60 cm<sup>3</sup> (2.0 floz)**
- **Condenser: 15 cm<sup>3</sup> (0.5 floz)**
- **Suction hose: 10 cm<sup>3</sup> (0.3 floz)**
- **Receiver: 10 cm<sup>3</sup> (0.3 floz)**

**PERFORMANCE TEST**

M1554008800026

1. The vehicles to be tested should be in a place that is not in direct sunlight.
2. Close the high and low-pressure valve of the gauge manifold.
3. Connect the charging hose (blue) to the low-pressure valve and connect the charging hose (red) to the high-pressure valve of the gauge manifold.
4. Install the quick joint (for low-pressure) to the charging hose (blue), and connect the quick joint (for high-pressure) to the charging hose (red).

**CAUTION**

- **To connect the quick joint, press section A firmly against the service valve until a click is heard.**
  - **When connecting, run your hand along the hose while pressing to ensure that there are no bends in the hose.**
5. Connect the quick joint (for low-pressure) to the low-pressure service valve and connect the quick joint (for high-pressure) to the high-pressure service valve.

*NOTE: The high-pressure service valve is on A/C pipe and the low-pressure service valve is on the suction hose.*

6. Start the engine.
7. Set the A/C controls as follows:

<Testing the front-A/C>

- A/C switch: A/C – ON position
- Mode selection: FACE position
- Temperature control: MAXIMUM COOLING position
- Air selection: RECIRCULATION position
- Blower switch: FAST position

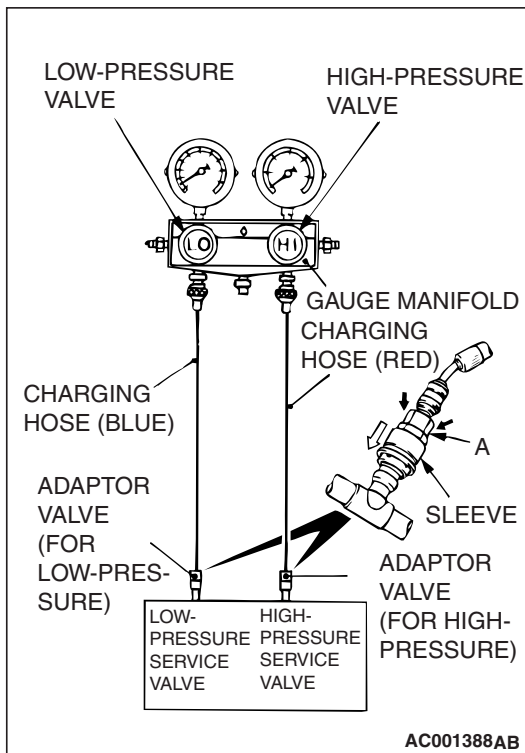

8. Set the A/C controls as follows:
  - <Testing the rear-A/C>
  - The front A/C should be set as described in step 7.
  - A/C switch: A/C-ON position
  - Temperature control: MAXIMUM COOLING position
  - Blower switch: FAST position
9. Adjust engine speed to 1,500 r/min with A/C clutch engaged.
10. Engine should be warmed up with doors and windows closed.
11. Insert a thermistor-type thermometer into the air vent shown in the figure, and measure the air temperature.
12. Note the discharge air temperature.

*NOTE: If the clutch cycles, take the reading before the clutch disengages.*

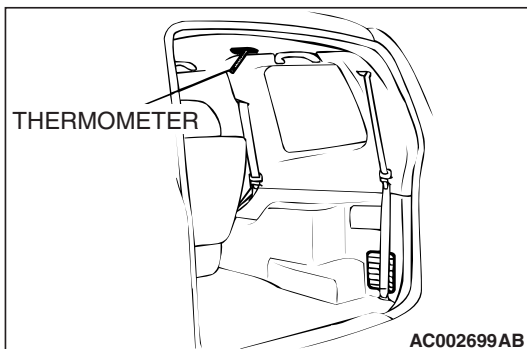
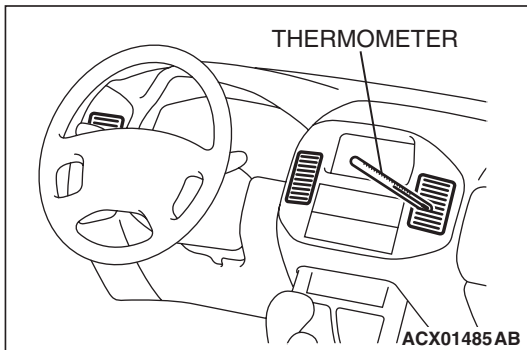

**Performance Temperature Chart <Front-A/C test>**

<b>GARAGE AMBIENT TEMPERATURE °C (°F)</b>	<b>20 (68)</b>	<b>25 (77)</b>	<b>35 (95)</b>	<b>40 (104)</b>
Discharge air temperature °C (°F)	3.5 – 5.5 (38 – 42)	3.5 – 5.5 (38 – 42)	4.5 – 6.5 (40 – 44)	5.5 – 7.5 (42 – 46)
Compressor high pressure kPa (psi)	1,050 – 1,250 (152 – 181)	1,050 – 1,250 (152 – 181)	1,400 – 1,600 (203 – 232)	1,650 – 1,850 (239 – 268)
Compressor low pressure kPa (psi)	120 – 140 (17 – 20)	120 – 140 (17 – 20)	130 – 150 (19 – 22)	160 – 180 (23 – 26)

**Performance Temperature Chart <Rear-A/C test>**

<b>GARAGE AMBIENT TEMPERATURE °C (°F)</b>	<b>20 (68)</b>	<b>25 (77)</b>	<b>35 (95)</b>	<b>40 (104)</b>
Discharge air temperature °C (°F)	5.5 – 7.5 (42 – 46)	5.5 – 7.5 (42 – 46)	6.5 – 8.5 (44 – 47)	7.5 – 9.5 (46 – 49)
Compressor high pressure kPa (psi)	1,150 – 1,350 (167 – 196)	1,150 – 1,350 (167 – 196)	1,500 – 1,700 (218 – 247)	1,750 – 1,950 (254 – 283)
Compressor low pressure kPa (psi)	130 – 150 (19 – 22)	130 – 150 (19 – 22)	140 – 160 (20 – 23)	180 – 200 (26 – 29)

## REFRIGERANT LEAK REPAIR

M1552001500330

### LOST CHARGE

If the system has lost all charge due to a leak:

1. Evacuate the system (See procedure).
2. Charge the system with approximately 0.453 kg (1 pound) of refrigerant.
3. Check for leaks.
4. Discharge the system.
5. Repair leaks.

#### **CAUTION**

**Replacement filter-drier units must be sealed while in storage. The drier used in these units will saturate water quickly upon exposure to the atmosphere. When installing a drier, have all tools and supplies ready for quick assembly to avoid keeping the system open any longer than necessary.**

6. Replace receiver drier.
7. Evacuate and charge system.

### LOW CHARGE

If the system has not lost all of its refrigerant charge, locate and repair all leaks. If it is necessary to increase the system pressure to find the leak (because of an especially low charge) add refrigerant. If it is possible to repair the leak without discharging the refrigerant system, use the procedure for correcting low refrigerant level.

### HANDLING TUBING AND FITTINGS

Kinks in the refrigerant tubing or sharp bends in the refrigerant hose lines will greatly reduce the capacity of the entire system. High pressures are produced in the system when it is operating. Extreme care must be exercised to make sure that all connections are pressure tight. Dirt and moisture can enter the system when it is opened for repair or replacement of lines or components. The following precautions must be observed. The system must be completely discharged before opening any fitting of connection in the refrigeration system. Open fittings with caution even after the system has been discharged. If any pressure is noticed as a fitting is loosened, allow trapped pressure to bleed off very slowly.

Never attempt to rebend formed lines to fit. Use the correct line for the installation you are servicing. A good rule for the flexible hose lines is keep the radius of all bends at least 10 times the diameter of the hose.

Sharper bends will reduce the flow of refrigerant. The flexible hose lines should be routed so that they are at least 80 mm (3.1 inches) from the exhaust manifold. It is good practice to inspect all flexible hose lines at least once a year to make sure they are in good condition and properly routed.

On standard plumbing fittings with O-rings, these O-rings are not reusable.

## COMPRESSOR NOISE CHECK

M1552008700120

You must first know the conditions when the noise occurs. These conditions are: weather, vehicle speed, in gear or neutral, engine temperature or any other special conditions. Noises that develop during A/C operation can often be misleading. For example: what sounds like a failed front bearing or connecting rod, may be caused by loose bolts, nuts, mounting brackets, or a loose clutch assembly. Verify accessory drive belt tension (power steering or generator). Improper accessory drive belt tension can cause a misleading noise when the compressor is engaged and little or no noise when the compressor is disengaged. Drive belts are speed-sensitive. That is, at different engine speeds, and depending upon belt tension, belts can develop unusual noises that are often mistaken for mechanical problems within the compressor.

**ADJUSTMENT**

1. Select a quiet area for testing. Duplicate conditions as much as possible. Switch compressor on and off several times to clearly identify compressor noise. To duplicate high ambient conditions (high head pressure), restrict air flow through condenser. Install manifold gauge set to make sure discharge pressure doesn't exceed 2,070 kPa (300 psi).
2. Tighten all compressor mounting bolts, clutch mounting bolt, and compressor drive belt. Check to assure clutch coil is tight (no rotation or wobble).
3. Check refrigerant hoses for rubbing or interference that can cause unusual noises.
4. Check refrigerant charge. (Refer to P.55A-115.)
5. Recheck compressor noise as in Step 1.
6. If noise still exists, loosen compressor mounting bolts and re torque. Repeat Step 1.
7. If noise continues, replace compressor and repeat Step 1.

**POWER RELAY CHECK**

M1552008800387

**FRONT BLOWER RELAY**

Follow the table below to check the front blower relay for continuity.

BATTERY VOLTAGE	TESTER CONNECTION	SPECIFIED CONDITION
Not applied	2 – 5	Open circuit
<ul style="list-style-type: none"> <li>• Connect terminal 3 to the positive battery terminal</li> <li>• Connect terminal 1 to the negative battery terminal</li> </ul>	2 – 5	Less than 2 ohms

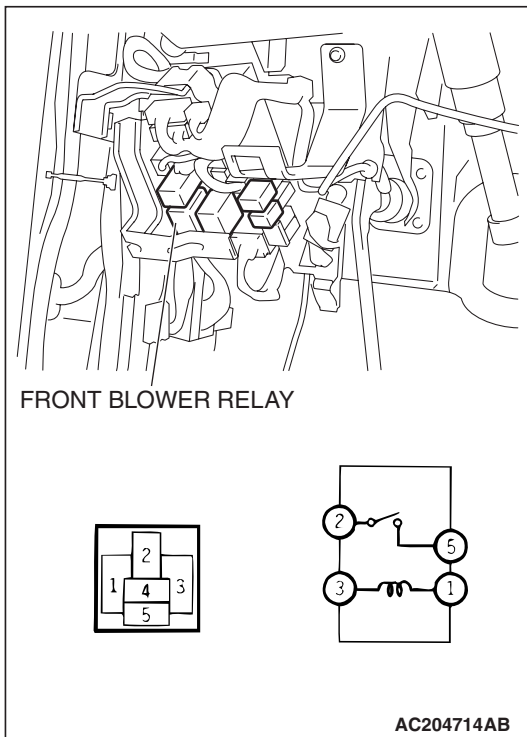

**A/C COMPRESSOR CLUTCH RELAY, CONDENSER FAN RELAY**

Follow the table below to check the A/C compressor clutch relay and condenser fan for continuity.

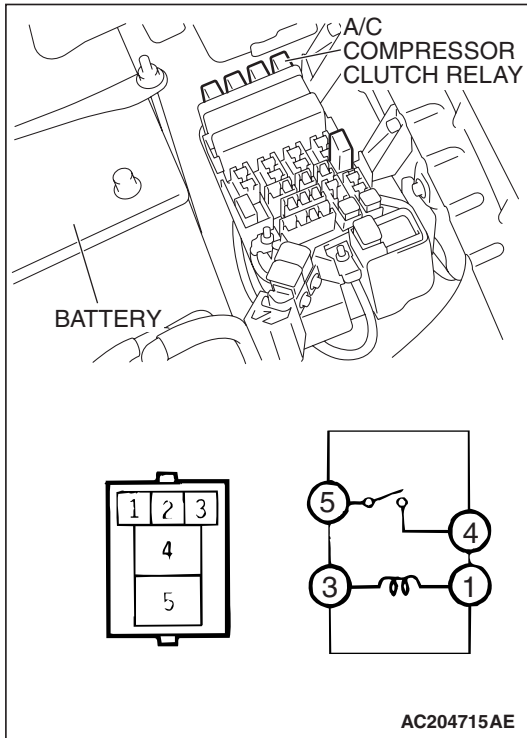

BATTERY VOLTAGE	TESTER CONNECTION	SPECIFIED CONDITION
Not applied	4 – 5	Open circuit
<ul style="list-style-type: none"> <li>Connect terminal 3 to the positive battery terminal</li> <li>Connect terminal 1 to the negative battery terminal</li> </ul>	4 – 5	Less than 2 ohms

**REAR BLOWER RELAY**

Follow the table below to check the rear blower relay for continuity.

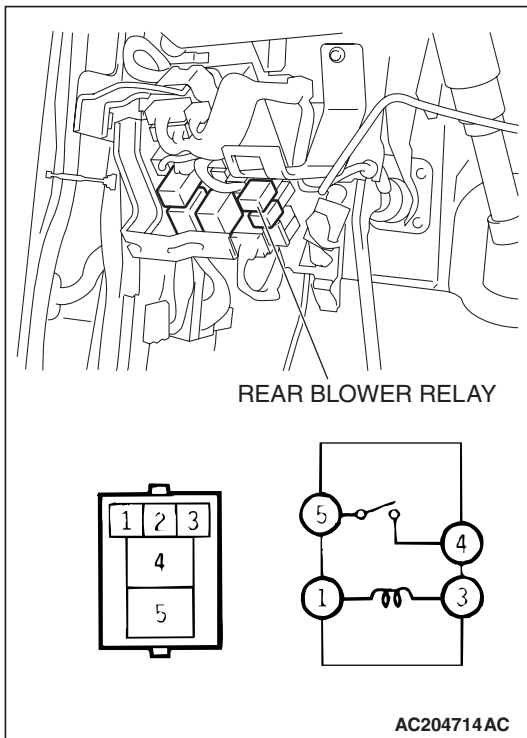

BATTERY VOLTAGE	TESTER CONNECTION	SPECIFIED CONDITION
Not applied	4 – 5	Open circuit
<ul style="list-style-type: none"> <li>Connect terminal 1 to the positive battery terminal</li> <li>Connect terminal 3 to the negative battery terminal</li> </ul>	4 – 5	Less than 2 ohms



**IDLE-UP OPERATION CHECK**

M1552001600263

1. Before inspection and adjustment, set vehicle in the following condition:
  - Engine coolant temperature: 80 – 90 °C (176 – 194 °F)
  - Lights, electric cooling fan and accessories: Set to OFF
  - Transmission: "N" or "P" position
  - Steering wheel: Straightforward
2. Check whether or not the idling speed is the standard value.

**Standard value: 700 ± 50 r/min**

*NOTE: There is no necessity to make an adjustment, because the idling speed is automatically adjusted by the idle speed control system. If, however, there occurs a deviation from the standard value for some reason, check the idle speed control system. Refer to GROUP 11A, On-vehicle Service P.11A-8.*

3. When the A/C is running after turning the A/C switch to ON, and the blower switch to the MH or HI position, check to be sure that the idle speed is at the standard value.

**Standard value:**

VEHICLE CONDITION	IDLE-UP SPEED r/min
When the air conditioning is working under low load (Outside air temperature sensor: ON)	700 ± 50
When the air conditioning is working under middle load (Outside air temperature sensor: OFF)	800 ± 50
When the air conditioning is working under high load (Outside air temperature sensor: OFF)	1,000 ± 50

*NOTE: It depends on the outside air temperature signal whether a low load, a middle load or a high load is applied to the air conditioning. The PCM receives the signal via the automatic compressor controller and determines whether the air conditioning is working under high, middle or low load.*

# HEATER CONTROL ASSEMBLY, A/C SWITCH AND INSIDE/ OUTSIDE CHANGE OVER SWITCH

## REMOVAL AND INSTALLATION

M1552012400047

**Pre-removal and Post-installation Operation**

- Front Driver's Side Under Cover Removal and Installation (Refer to GROUP 52A, Instrument Panel P.52A-3.)
- Floor Console Removal and Installation (Refer to GROUP 52A, Floor Console P.52A-7.)
- Foot Duct C and Foot Duct D Removal and Installation (Refer to P.55A-150.)

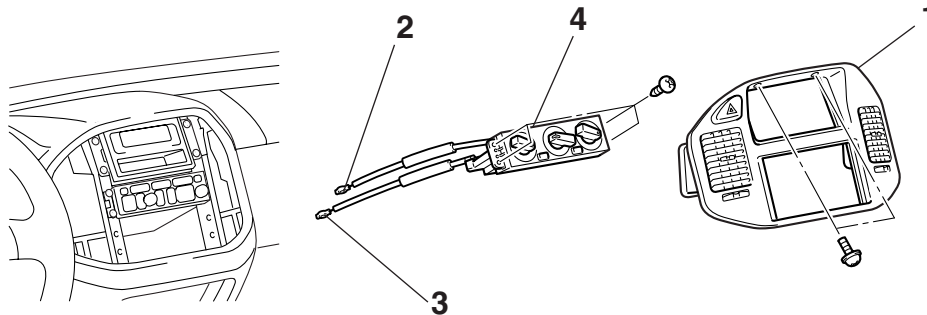

AC000934 AB

**REMOVAL STEPS**

1. CENTER PANEL (REFER TO GROUP 52A, INSTRUMENT PANEL P.52A-3.)
- >>B<< 2. AIR MIX DAMPER LEVER CABLE

**REMOVAL STEPS (Continued)**

- >>A<< 3. AIR OUTLET CHANGE OVER DAMPER LEVER CABLE
4. HEATER CONTROL ASSEMBLY

## INSTALLATION SERVICE POINTS

**>>A<< AIR OUTLET CHANGE OVER DAMPER LEVER CABLE INSTALLATION**

1. Set the air outlet changeover control knob on the heater control assembly to the defroster position.
2. Set the air outlet changeover damper lever of the heater/cooler unit to the defroster position as shown in the illustration, and then connect the cable to the link pin.
3. Push the outer cable in the direction of the arrow so that there is no looseness, and then secure it with the clip.
4. After installation, ensure that each damper operates smoothly by operating the heater control assembly knob.

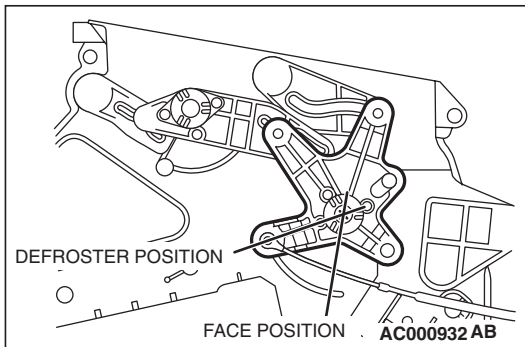

**>>B<< AIR MIX DAMPER LEVER CABLE INSTALLATION**

1. Set the temperature control knob on the heater control assembly to the maximum hot position.
2. Set the air mix damper lever of the heater/cooler unit to the maximum hot position as shown in the illustration, and then connect the cable to the lever pin.
3. Push the outer cable in the direction of the arrow so that there is no looseness, and then secure it with the clip.

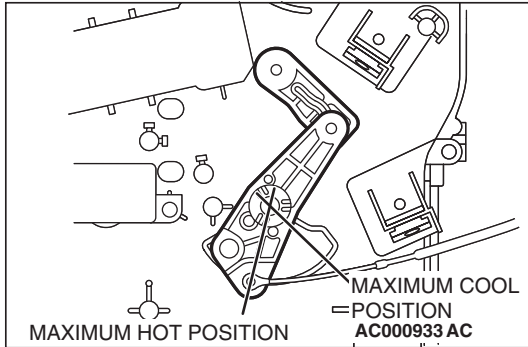

**INSPECTION**

M1552012500055

**DEFROSTER SWITCH CONTINUITY CHECK**

Follow the table below to check the defroster switch for continuity.

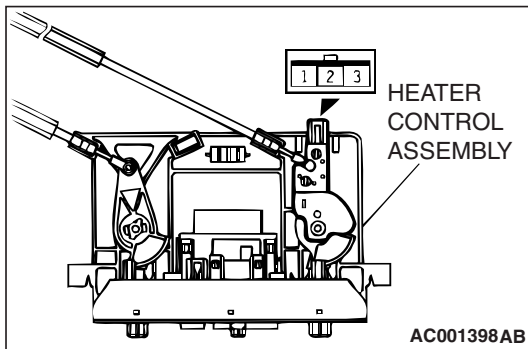

AIR OUTLET CHANGEOVER CONTROL KNOB POSITION	TESTER CONNECTION	SPECIFIED CONDITION
At the "DEFROSTER" or "DEFROSTER/FOOT" position	2 – 3	Less than 2 ohms
At the other positions	1 – 3	Less than 2 ohms

**BLOWER SWITCH ASSEMBLY CONTINUITY CHECK**

**BLOWER SWITCH**

Follow the table below to check the blower switch for continuity.

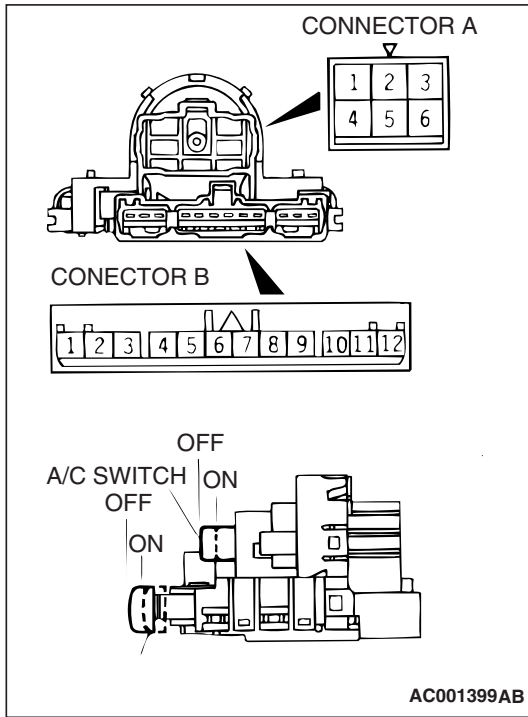

SWITCH POSITION	TESTER CONNECTION	SPECIFIED CONDITION
0 (OFF)	1 – 3, 3 – 4, 3 – 5, 3 – 6	Open circuit
1 (LO)	3 – 5	Less than 2 ohms
2 (ML)	3 – 1	Less than 2 ohms
3 (MH)	3 – 6	Less than 2 ohms
4 (HI)	3 – 4	Less than 2 ohms

**A/C SWITCH**

Follow the table below to check the A/C switch for continuity.

SWITCH POSITION	TESTER CONNECTION	SPECIFIED CONDITION
OFF	5 – 6	Open circuit
ON	5 – 6	Less than 2 ohms

**INSIDE/OUTSIDE AIR CHANGEVER SWITCH**

Follow the table below to check the inside/outside air changeover switch for continuity.

SWITCH POSITION	TESTER CONNECTION	SPECIFIED CONDITION
Inside air	4 – 5	Open circuit
Outside air	4 – 5	Less than 2 ohms

**HEATER CONTROL ASSEMBLY  
 DISASSEMBLY AND ASSEMBLY**

M1551001300065

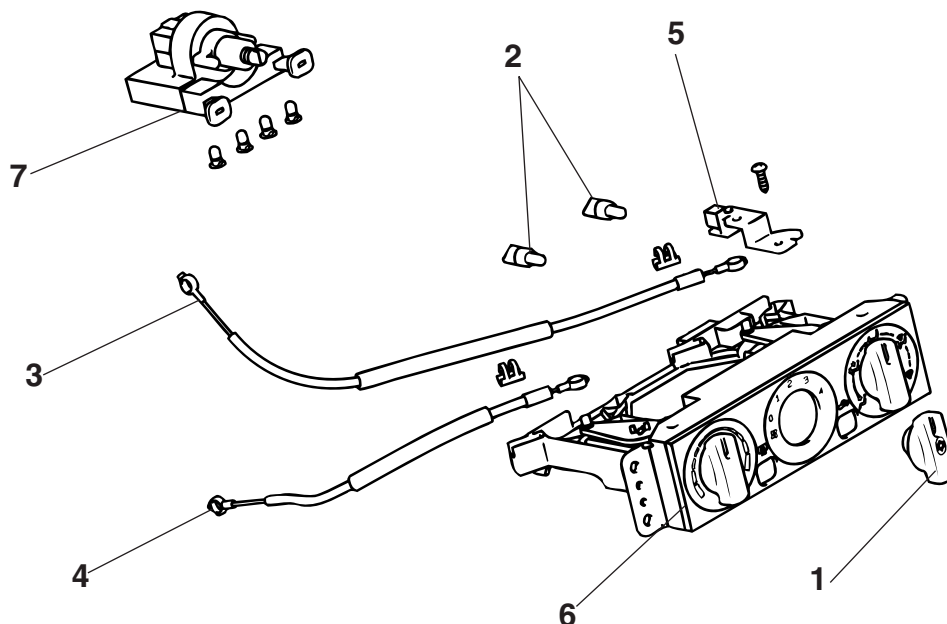

AC001035AB

**DISASSEMBLY STEPS**

**DISASSEMBLY STEPS**

<<A>>

1. KNOB
2. BULB
3. AIR OUTLET CHANGEOVER DAMPER LEVER CABLE

<<A>>

4. AIR MIX DAMPER CHANGEOVER LEVER CABLE
5. DEFROSTER SWITCH
6. HEATER CONTROL PANEL
7. BLOWER SWITCH ASSEMBLY

**DISASSEMBLY SERVICE POINT**

**<<A>> AIR OUTLET CHANGEOVER DAMPER LEVER CABLE/AIR MIX DAMPER CHANGEOVER LEVER CABLE REMOVAL**

Insert a flat-tipped screwdriver into the control base clip from inner side, and then remove the cable by lifting the claw part of the clip.

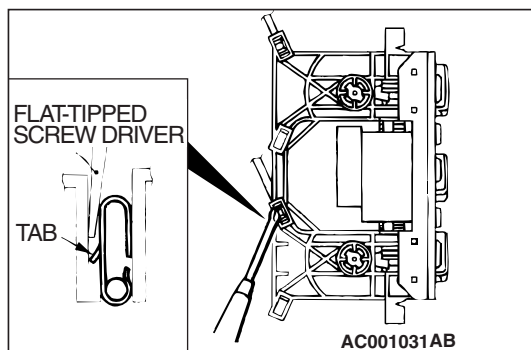

# HEATER UNIT

## REMOVAL AND INSTALLATION

M1551001600077

**⚠ WARNING**

**When removing and installing the heater unit, do not let it bump against the SRS-ECU or the components.**

**Pre-removal and Post-installation Operation**

- Refrigerant discharging and charging (Refer to P.55A-115).
- Engine coolant draining and refilling (Refer to GROUP 00, Maintenance Service – Engine Coolant (Charge) P.00-49).
- Instrument Panel Removal and Installation (Refer to GROUP 52A, Instrument Panel P.52A-3).
- Steering column shaft and front crossmember union bolt (Refer to GROUP 37, Steering Wheel and Shaft P.37-22).

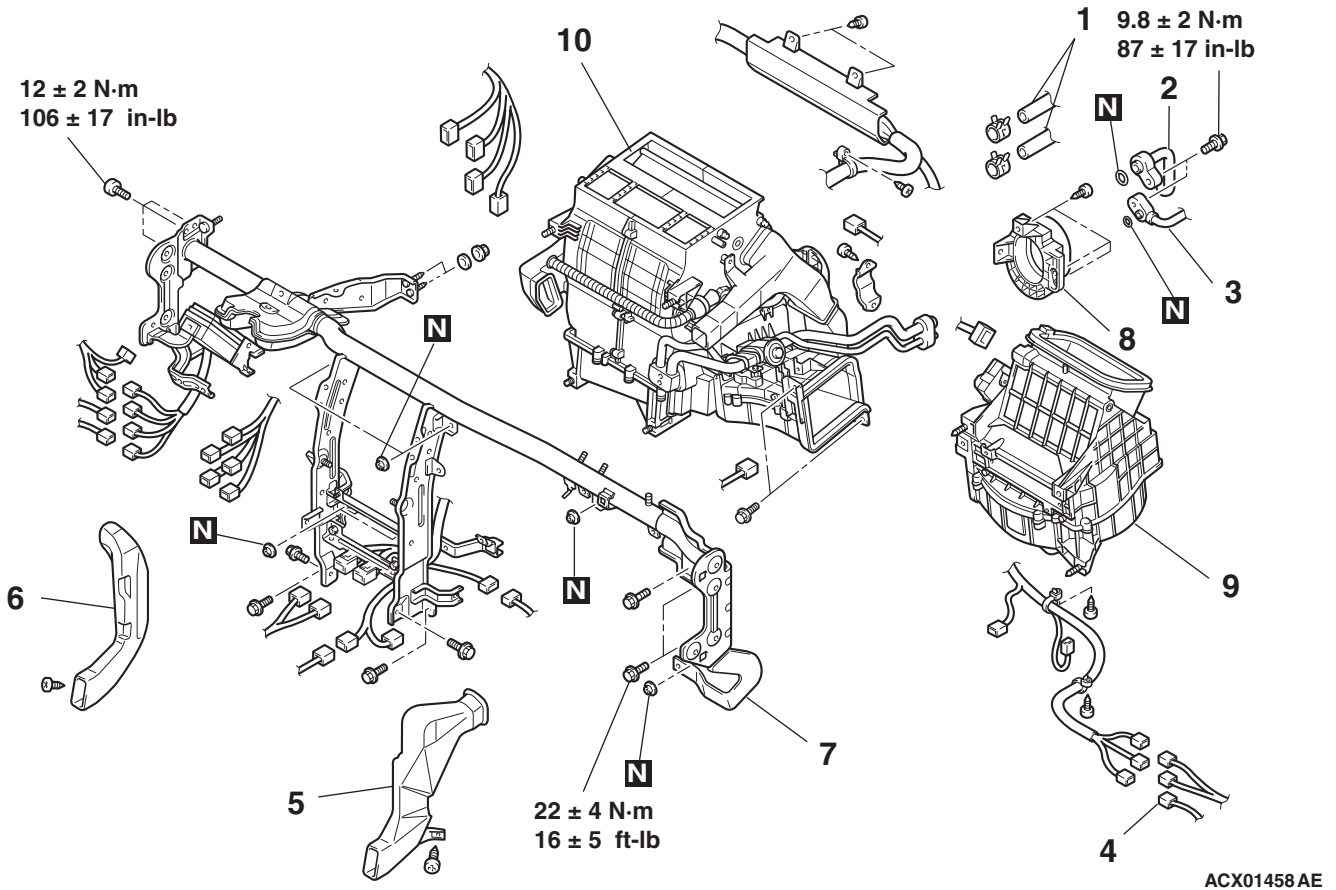

ACX01458 AE

**REMOVAL STEPS**

- <<A>> 1. HEATER HOSE  
<<A>> 2. SUCTION HOSE  
<<A>> 3. LIQUID PIPE  
4. HARNESS CONNECTORS  
5. FOOT DUCT B

**REMOVAL STEPS (Continued)**

6. FOOT DUCT D  
7. FRONT DECK CROSSMEMBER  
8. FLANGE BRACKET  
9. BLOWER ASSEMBLY  
10. HEATER UNIT

REMOVAL SERVICE POINTS

<<A>> SUCTION HOSE/LIQUID PIPE REMOVAL

**CAUTION**

Seal the pipes completely, otherwise the compressor oil and receiver will absorb water vapor easily, possibly damaging the compressor and deteriorating performance.

Plug the disconnected pipe and the evaporator nipple to prevent foreign material from getting into them.

HEATER UNIT DISASSEMBLY AND ASSEMBLY

M1551005400053

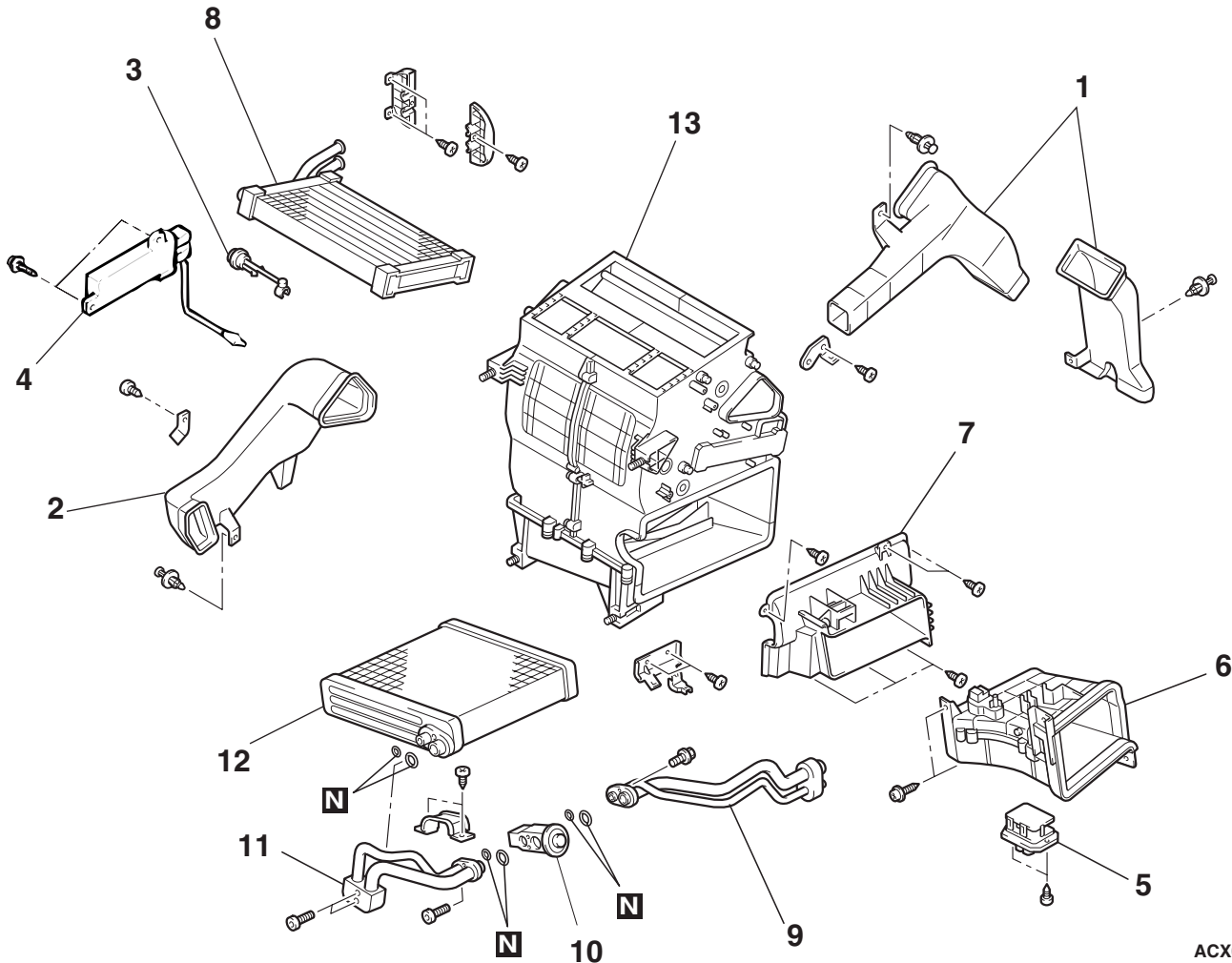

ACX01450AB

**DISASSEMBLY STEPS**

1. FOOT DUCT A
2. FOOT DUCT C
3. AIR THERMO SENSOR CLIP
4. AUTO COMPRESSOR-ECU AND AIR THERMO SENSOR ASSEMBLY
5. RESISTOR
6. JOINT DUCT

**DISASSEMBLY STEPS (Continued)**

7. AIR DUCT SUB ASSEMBLY
8. HEATER CORE
9. FRONT PIPE ASSEMBLY
10. EXPANSION VALVE
11. PIPE
12. EVAPORATOR
13. CASE

**BLOWER ASSEMBLY DISASSEMBLY AND ASSEMBLY**

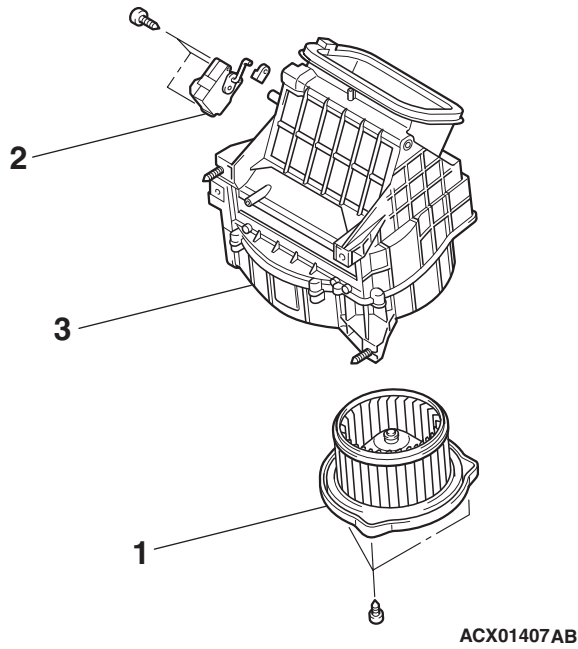

- DISASSEMBLY STEPS**
1. BLOWER MOTOR

- DISASSEMBLY STEPS**
2. INSIDE/OUTSIDE AIR  
CHANGEOVER DAMPER MOTOR
  3. CASE



# BLOWER ASSEMBLY AND RESISTOR

## REMOVAL AND INSTALLATION

M1551002800126

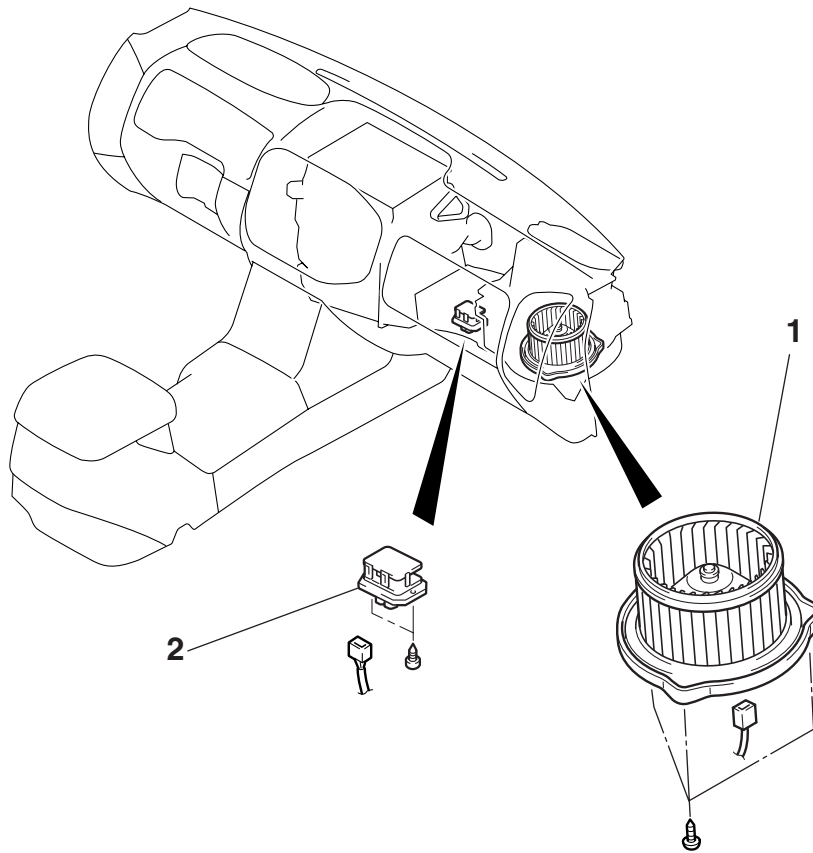

ACX01452AB

1. BLOWER MOTOR
2. RESISTOR

## INSPECTION

M1551002900123

### BLOWER FAN AND MOTOR CHECK

When battery voltage is applied between the terminals, check that the motor operates. Also, check that there is no abnormal noise.

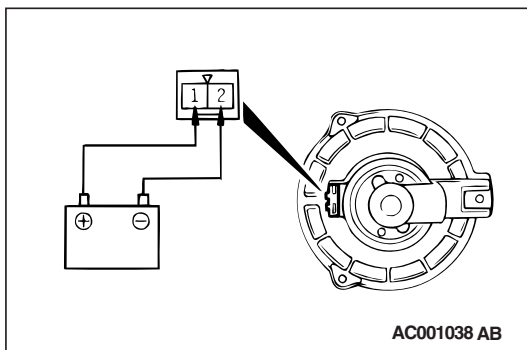

AC001038 AB

**RESISTOR CHECK**

Use an ohmmeter to measure the resistance between the terminals. Check that the measured value is at the standard value.

MEASUREMENT TERMINAL	STANDARD VALUE $\Omega$
Between terminals 2 and 3 (LO)	2.79
Between terminals 1 and 2 (ML)	1.49
Between terminals 2 and 4 (MH)	0.36

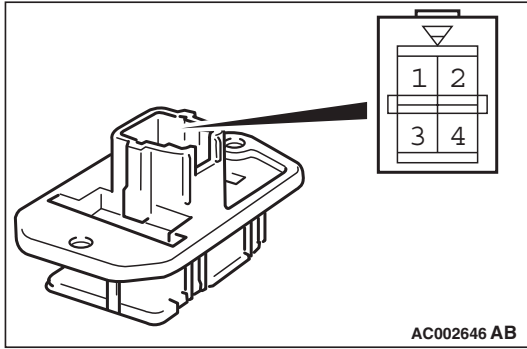

AC002646 AB

## INSIDE/OUTSIDE AIR CHANGEOVER DAMPER MOTOR ASSEMBLY

**REMOVAL AND INSTALLATION**

M1551003400046

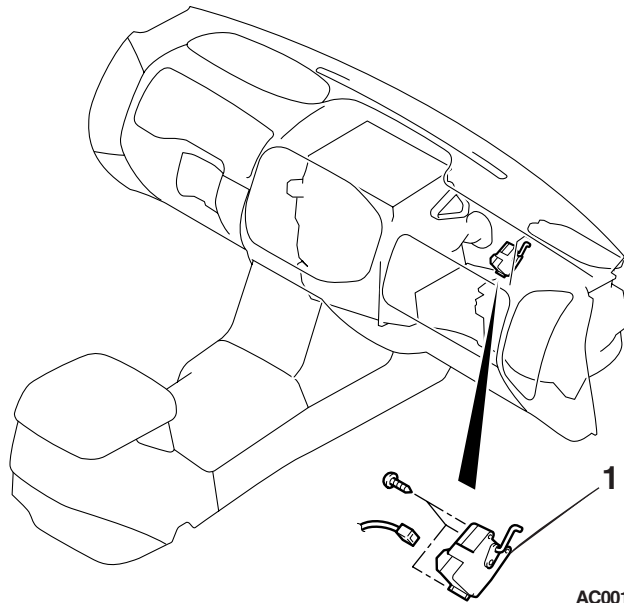

AC001040AB

**REMOVAL STEPS**

- GROVE BOX (REFER TO GROUP 52A, INSTRUMENT PANEL [P.52A-3.](#))
1. INSIDE/OUTSIDE AIR CHANGEOVER DAMPER MOTOR

M1551003500054

**INSPECTION**

**INSIDE/OUTSIDE AIR CHANGEOVER DAMPER MOTOR CHECK**

**⚠ CAUTION**

Disconnect the battery negative terminal when the damper is in the inside/outside air position.

Check the outside/inside air selection damper control motor by the following procedures.

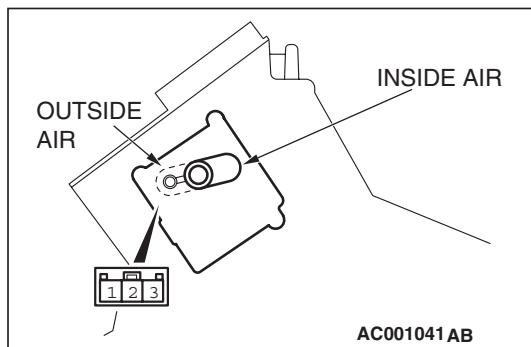

LEVER POSITION	BATTERY CONNECTION	LEVER OPERATION
At the inside air position	<ul style="list-style-type: none"> <li>• Connect terminal 1 to the positive battery terminal</li> <li>• Connect terminal 2 to the negative battery terminal</li> </ul>	The lever moves from the inside air position to the outside air position
At the outside air position	<ul style="list-style-type: none"> <li>• Connect terminal 1 to the positive battery terminal</li> <li>• Connect terminal 3 to the negative battery terminal</li> </ul>	The lever moves from the outside air position to the inside air position

# SENSORS

## REMOVAL AND INSTALLATION

M1552007600056

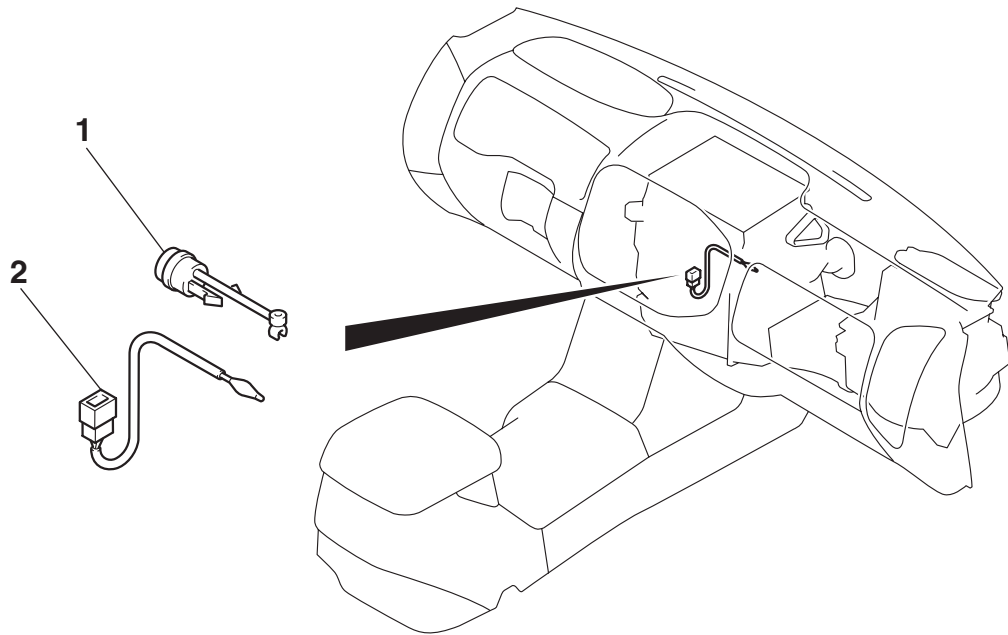

AC205083AB

### REMOVAL STEPS

- LOWER PANEL (REFER TO GROUP 52A, INSTRUMENT PANEL P.52A-3.)

### REMOVAL STEPS (Continued)

1. AIR THERMO SENSOR CLIP
2. AUTOMATIC COMPRESSOR CONTROLLER AND AIR THERMO SENSOR

## INSPECTION

M1552007700042

### AIR THERMO SENSOR CHECK

*NOTE: The temperature conditions when checking should not exceed the range shown in the diagram.*

When the resistance between the sensor terminals is measured under two or more temperature conditions, the resistance should approximately satisfy the illustrated values.

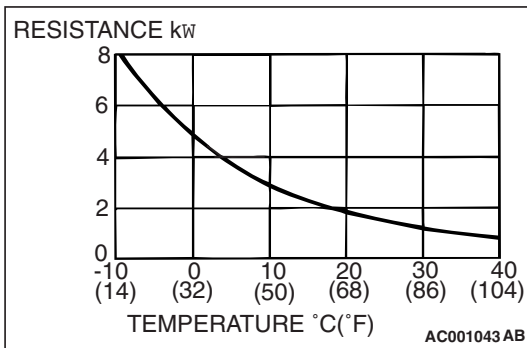

# REAR HEATER SWITCH AND FRONT REAR FAN SWITCH REMOVAL AND INSTALLATION

M1551005700032

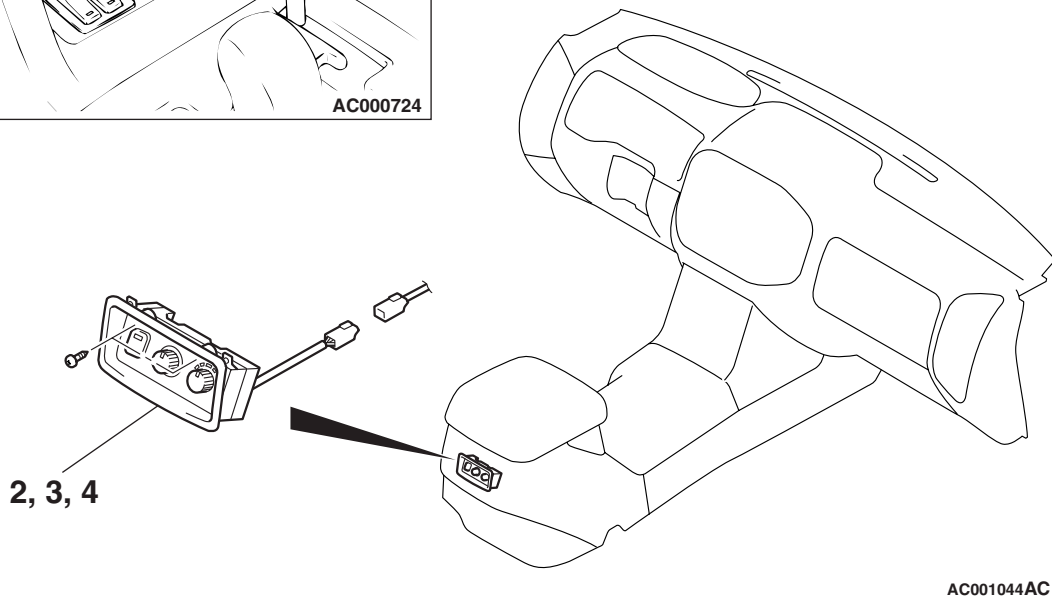
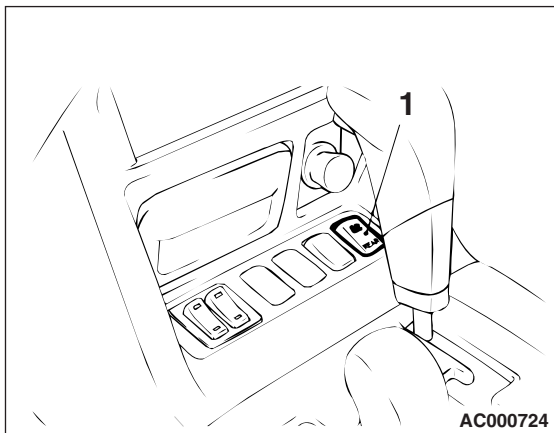

## REMOVAL STEPS

1. REAR FAN CONTROL SWITCH
2. REAR HEATER SWITCH  
<VEHICLES WITH REAR HEATER>

## REMOVAL STEPS (Continued)

3. REAR COOLER SWITCH  
<VEHICLES WITH REAR COOLER>
4. REAR A/C SWITCH <VEHICLES  
WITH REAR A/C>

## INSPECTION

M1551005800039

**REAR HEATER SWITCH <VEHICLES WITH REAR HEATER>, REAR COOLER SWITCH <VEHICLES WITH REAR COOLER> OR REAR A/C SWITCH <VEHICLES WITH REAR A/C> CHECK****BLOWER SWITCH CHECK**

Follow the table below to check the rear blower switch for continuity.

BLOWER SWITCH POSITION	TESTER CONNECTION	SPECIFIED CONDITION
1 (LO)	1 – 4	Less than 2 ohms
2 (ME)	1 – 6	Less than 2 ohms
3 (HI)	1 – 7	Less than 2 ohms

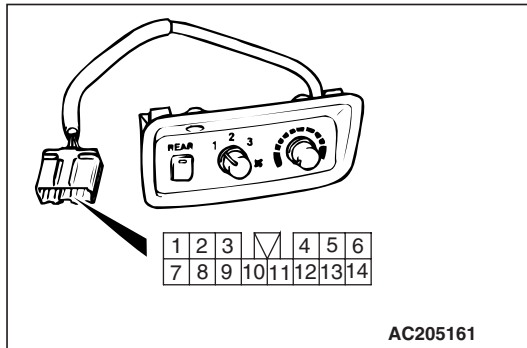
**REAR FAN SWITCH CHECK**

Follow the table below to check the rear fan switch for continuity.

REAR FAN SWITCH POSITION	TESTER CONNECTION	SPECIFIED CONDITION
OFF	8 – 9	Less than 2 ohms
ON (while pushing)	2 – 8	Less than 2 ohms

**TEMPERATURE SWITCH CHECK**

Connect the tester between the connector terminal number 3 and number 5, between the terminal number 5 and number 13 and make sure that the resistance value changes slowly within the standard value.

**Standard value: 0 – 3 kΩ**

**REAR FAN CONTROL SWITCH**

Follow the table below to check the front rear fan switch for continuity.

FRONT REAR FAN SWITCH POSITION	TESTER CONNECTION	SPECIFIED CONDITION
OFF	1 – 2	Less than 2 ohms
ON	2 – 5	Less than 2 ohms

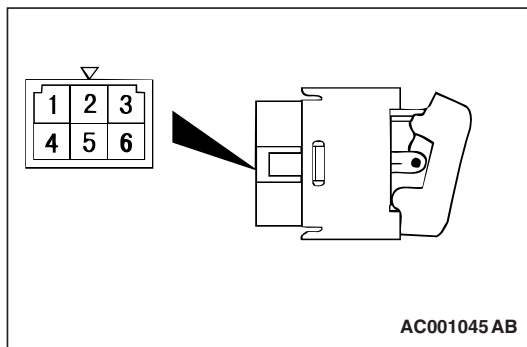

# REAR HEATER CONTROL UNIT, REAR COOLER CONTROL UNIT AND REAR A/C CONTROL UNIT REMOVAL AND INSTALLATION

M1554010000038

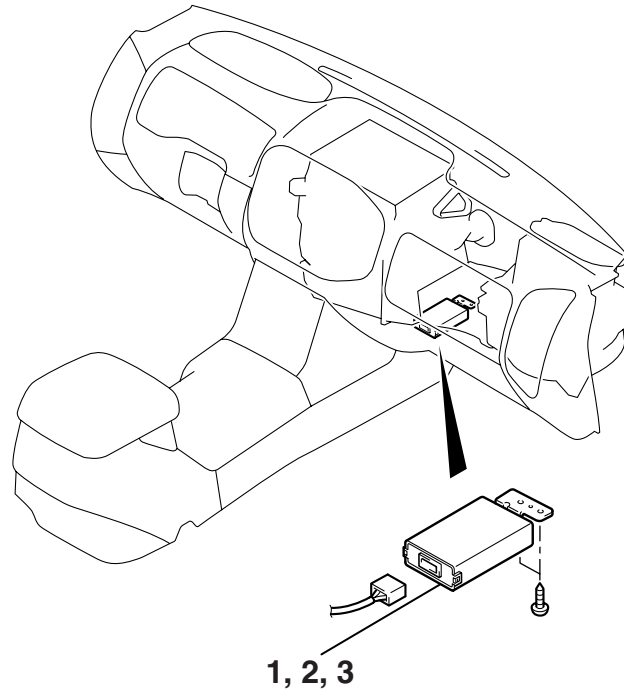

ACX01453AE

- REMOVAL STEPS**
1. REAR HEATER CONTROL UNIT  
<VEHICLES WITH REAR HEATER >

- REMOVAL STEPS (Continued)**
2. REAR COOLER CONTROL UNIT  
<VEHICLES WITH REAR COOLER >
  3. REAR A/C CONTROL UNIT  
<VEHICLES WITH REAR A/C >

# REAR HEATER UNIT

## REMOVAL AND INSTALLATION

M1554010200087

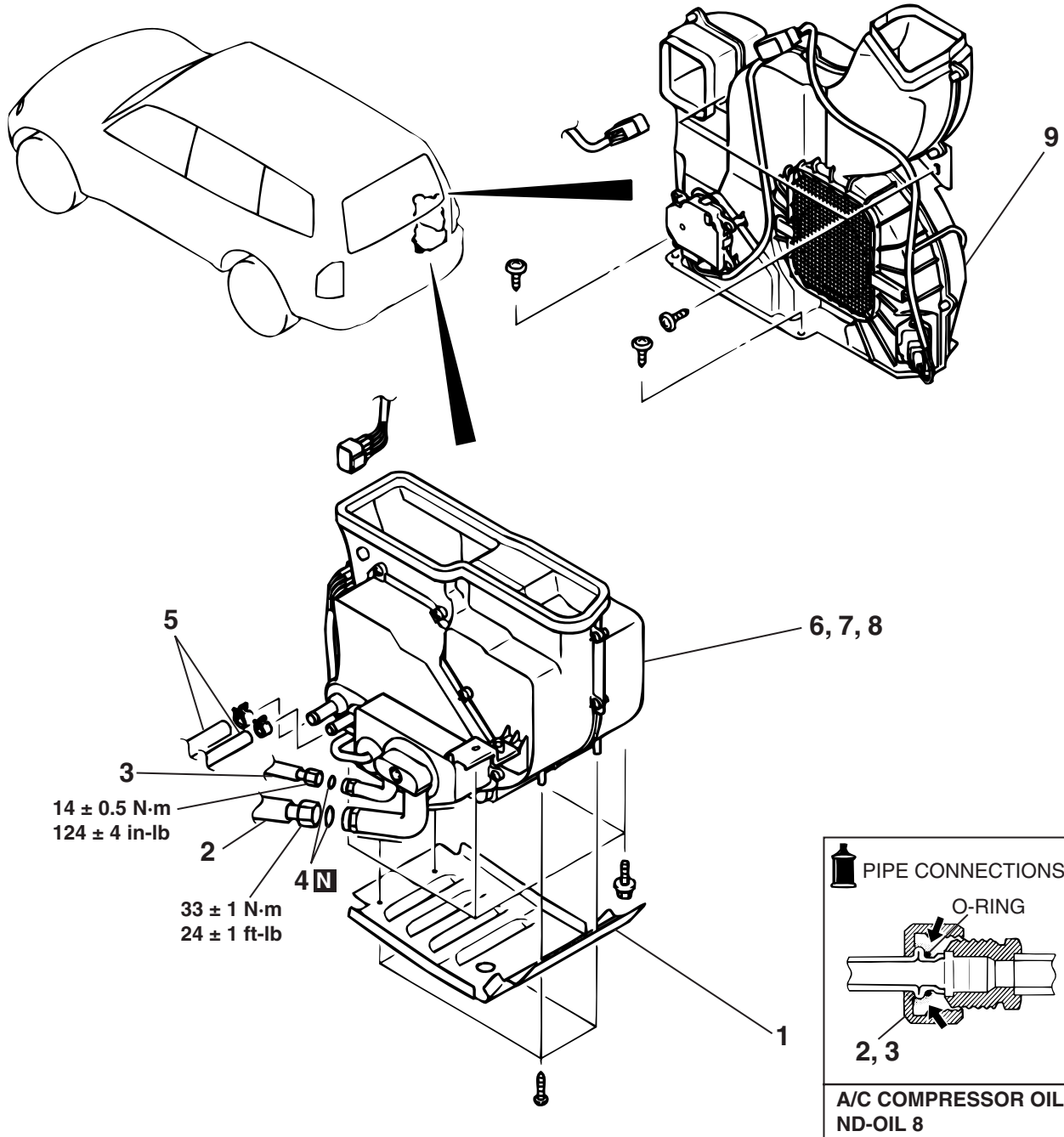

AC001676AC



**REAR HEATER UNIT REMOVAL  
STEPS**

- REFRIGERANT DISCHARGE AND REFILLING <VEHICLES WITH REAR COOLER OR REAR A/C> (REFER TO [P.55A-115.](#))
  - ENGINE COOLANT DRAINING AND REFILLING <VEHICLES WITH REAR HEATER OR REAR A/C> (REFER TO GROUP 00, MAINTENANCE SERVICE - ENGINE COOLANT [P.00-49.](#))
  - REAR MUD GUARD (REFER TO GROUP 51, MUD GUARD [P.51-17.](#))
1. HEATER UNDER COVER
  2. SUCTION PIPE C <VEHICLES WITH REAR COOLER OR REAR A/C>
  3. LIQUID PIPE D <VEHICLES WITH REAR COOLER OR REAR A/C>
  4. O-RING <VEHICLES WITH REAR COOLER OR REAR A/C>

<<A>>

<<A>>

**REAR HEATER UNIT REMOVAL  
STEPS (Continued)**

5. HEATER HOSES <VEHICLES WITH REAR HEATER OR REAR A/C>
  6. REAR HEATER UNIT<VEHICLES WITH REAR HEATER>
  7. REAR COOLER UNIT<VEHICLES WITH REAR COOLER>
  8. REAR A/C UNIT<VEHICLES WITH REAR A/C>
- REAR BLOWER ASSEMBLY  
REMOVAL STEPS**
- UPPER QUARTER TRIM (RH) AND LOWER QUARTER TRIM (RH) (REFER TO GROUP 52A, TRIMS [P.52A-8.](#))
  - REAR QUARTER DUCT, REAR FLOOR DUCT A MOUNTING BOLT AND PILLAR DUCT MOUNTING BOLT (REFER TO [P.55A-150.](#))
9. REAR BLOWER ASSEMBLY

**REMOVAL SERVICE POINT**

**<<A>> SUCTION PIPE C/LIQUID PIPE D REMOVAL**

** CAUTION**

**Seal the hoses completely, otherwise the compressor oil and receiver will absorb water vapor easily, possibly damaging the compressor and deteriorating performance.**  
Plug the disconnected hose and REAR cooler unit<vehicles with rear cooler> or rear a/c unit<vehicles with rear a/c> nipple to prevent foreign matter from getting into them.

REAR HEATER UNIT, REAR COOLER UNIT OR REAR A/C UNIT DISASSEMBLY AND  
ASSEMBLY

M1554010300028

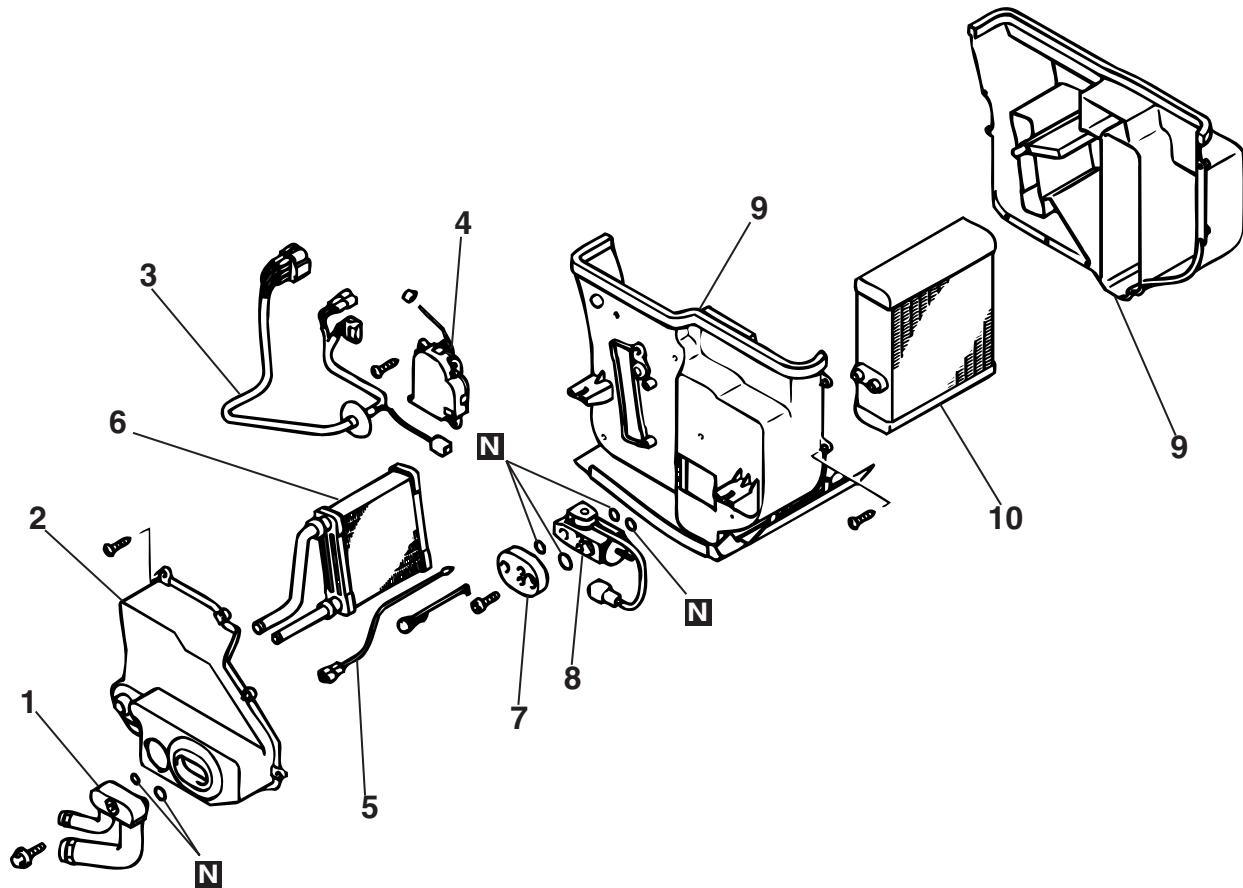

AC001677AB

**DISASSEMBLY STEPS**

1. TUBE ACCESSORY ASSEMBLY  
<VEHICLES WITH REAR  
COOLER OR REAR A/C>
2. COVER
3. HARNESS ASSEMBLY
4. AIR MIX DAMPER MOTOR  
<VEHICLES WITH REAR HEATER  
OR REAR A/C>
5. AIR THERMO SENSOR  
<VEHICLES WITH REAR  
COOLER OR REAR A/C>

**DISASSEMBLY STEPS**

6. HEATER CORE <VEHICLES WITH  
REAR HEATER OR REAR A/C>
7. JOINT <VEHICLES WITH REAR  
COOLER OR REAR A/C>
8. EXPANSION VALVE <VEHICLES  
WITH REAR COOLER OR REAR  
A/C>
9. CASE
10. EVAPORATOR <VEHICLES WITH  
REAR COOLER OR REAR A/C>

M1554010400025

**INSPECTION**

**AIR MIX DAMPER MOTOR AND POTENTIOMETER CHECK <VEHICLES WITH REAR HEATER OR REAR A/C>**

**AIR MIX DAMPER MOTOR CHECK**

**⚠ CAUTION**

Do not apply battery voltage when the damper is in the MAX HOT/MAX COOL position.

Check the air mix damper motor by the following procedures.

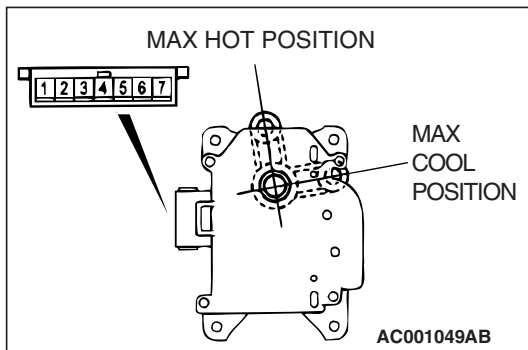

LEVER POSITION	BATTERY CONNECTION	LEVER OPERATION
At the MAX COOL position	<ul style="list-style-type: none"> <li>Connect terminal 1 to the positive battery terminal</li> <li>Connect terminal 2 to the negative battery terminal</li> </ul>	The lever moves from the MAX COOL position to the outside air position
At the MAX HOT position	<ul style="list-style-type: none"> <li>Connect terminal 2 to the positive battery terminal</li> <li>Connect terminal 1 to the negative battery terminal</li> </ul>	The lever moves from the MAX HOT position to the inside air position

**AIR MIX DAMPER POTENTIOMETER CHECK**

When checking the air mix damper motor, measure the resistance value between the terminals 3 and 5, between the terminals 3 and 7. At this time, make sure that the measured resistance value changes slowly within the standard value.

**Standard value: 1.2 – 4.8 kΩ**

**AIR THERMO SENSOR CHECK <VEHICLES WITH REAR COOLER OR REAR A/C>**

*NOTE: The temperature conditions when checking should not exceed the range shown in the diagram.*

When the resistance between the sensor terminals is measured under two or more temperature conditions, the resistance should approximately satisfy the illustrated values.

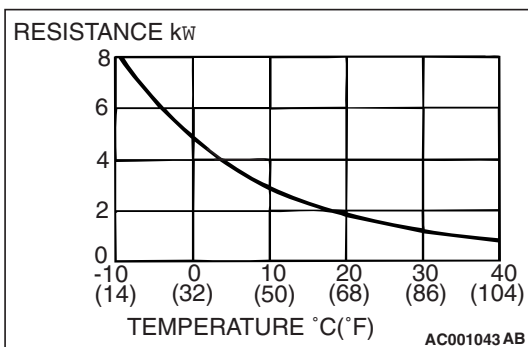

**EXPANSION VALVE (MAGNET VALVE) CHECK  
 <VEHICLES WITH REAR A/C SYSTEM>**

When battery voltage is applied to the magnetic valve terminal No.1 and No.2 terminal is ground, operating sound should be heard from the magnetic valve.

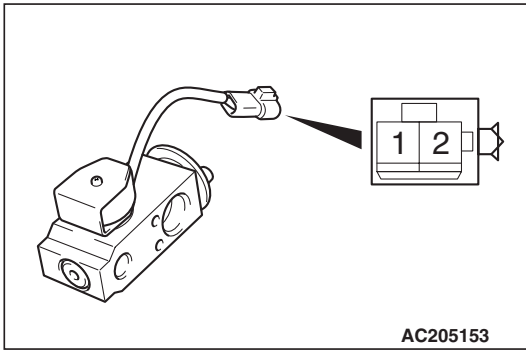

**REAR BLOWER DISASSEMBLY AND ASSEMBLY**

M1554010600029

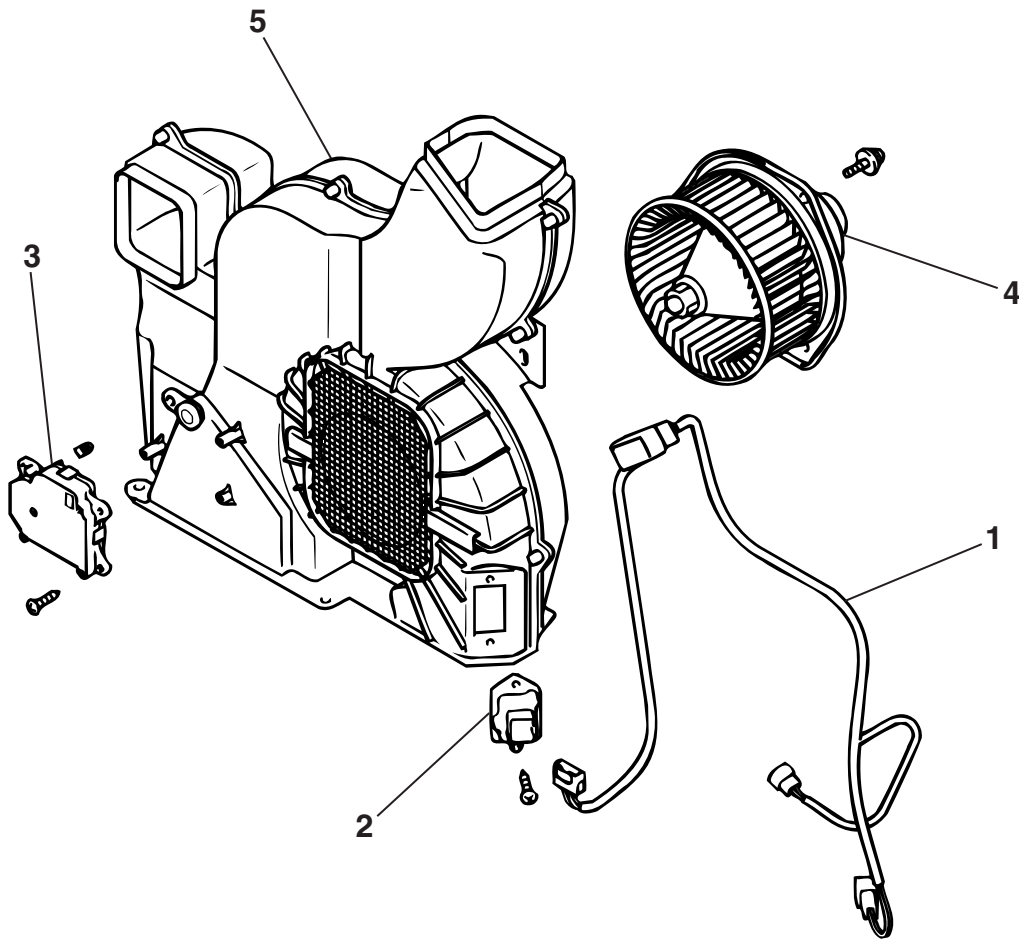

AC001679AB

**DISASSEMBLY STEPS**

1. HARNESS ASSEMBLY
2. RESISTOR
3. AIR OUTLET CHANGEOVER DAMPER MOTOR

**DISASSEMBLY STEPS**

4. BLOWER MOTOR ASSEMBLY
5. CASE

**INSPECTION**

M1554010700060

**BLOWER MOTOR CHECK**

When battery voltage is applied between the terminals, check that the motor operates. Also, check that there is no abnormal noise.

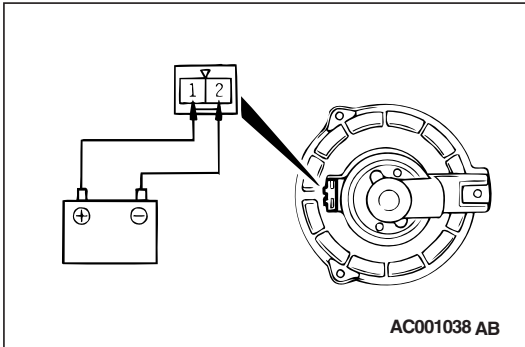

**RESISTOR CHECK**

Use an ohmmeter to measure the resistance between the terminals. Check that the measured value is at the standard value.

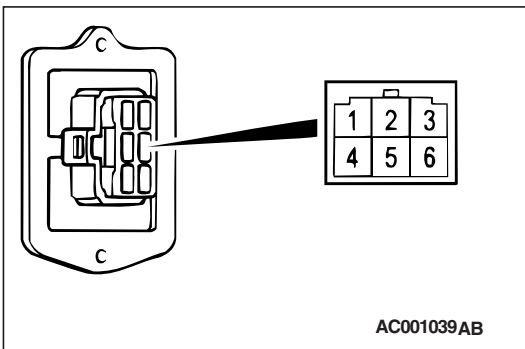

TESTER CONNECTION	STANDARD VALUE $\Omega$
1 - 6	$4.9 \pm 0.34$
1 - 3	$2.15 \pm 0.15$

**COMPRESSOR ASSEMBLY**

**REMOVAL AND INSTALLATION**

M1552004400150

<p><b>Pre-removal Operation</b> Refrigerant discharging (Refer to P.55A-115).</p>	<p><b>Post-installation Operation</b></p> <ul style="list-style-type: none"> <li>• Refrigerant charging (Refer to P.55A-115).</li> <li>• Drive Belt Tension Adjustment (Refer to GROUP 00, Maintenance Service – Drive Belts P.00-43).</li> </ul>
---	---

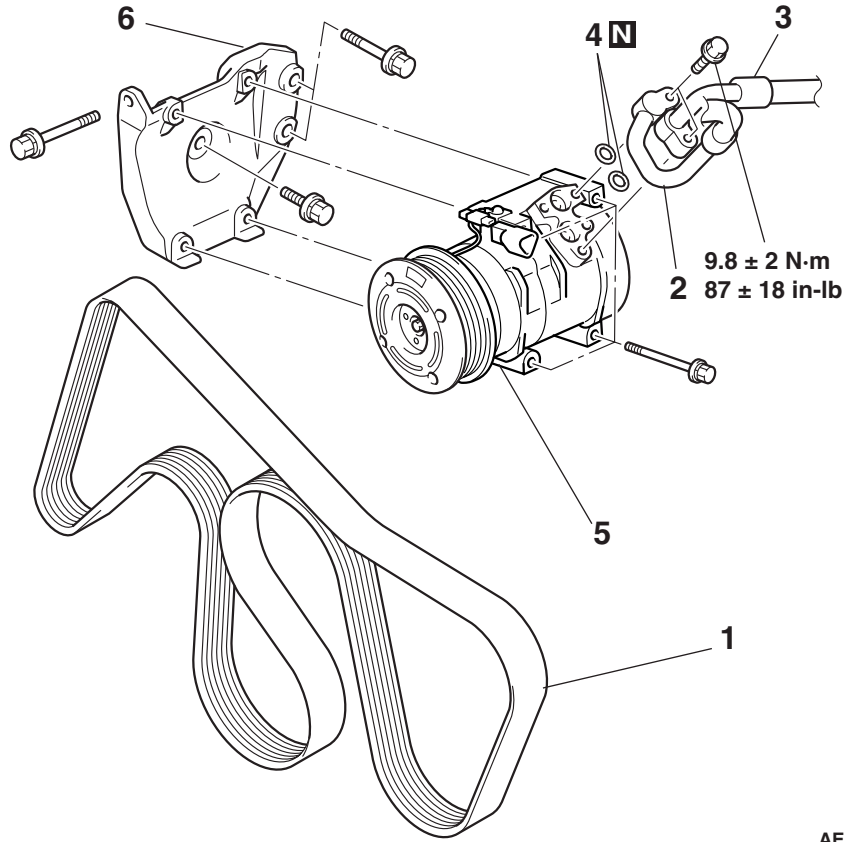

AE  
AC001052

- REMOVAL STEPS**
- <<A>> 1. DRIVE BELT
  - <<B>> 2. DISCHARGE HOSE
  - <<B>> 3. SUCTION HOSE

- REMOVAL STEPS (Continued)**
- <<C>> >>A<< 4. O-RING
  - 5. COMPRESSOR
  - 6. COMPRESSOR BRACKET

## REMOVAL SERVICE POINTS

### <<A>> DRIVE BELT REMOVAL

#### CAUTION

When reusing the drive belt, mark an arrow which indicates the turning direction (right turn) on the back of the drive belt with a chalk, etc.

Insert the socket-wrench handle into the tool hole for auto-tensioner and turn it to the arrow direction. Reduce the drive belt tension and remove the drive belt.

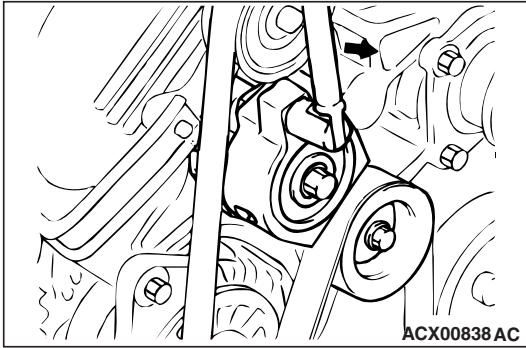

### <<B>> DISCHARGE HOSE/SUCTION HOSE REMOVAL

#### CAUTION

Seal the hoses completely, otherwise the compressor oil and receiver will absorb water vapor easily, possibly damaging the compressor and deteriorating performance.

Plug the disconnected hose and compressor nipple to prevent foreign matter from getting into them.

### <<C>> COMPRESSOR REMOVAL

When removing the compressor, be careful not to spill the compressor oil.

## INSTALLATION SERVICE POINT

### >>A<< COMPRESSOR INSTALLATION

If a new compressor is installed, first adjust the amount of oil according to the procedures described below, and then install the compressor.

1. Measure the amount [ $X \text{ cm}^3$  ( $X \text{ floz}$ )] of oil within the removed compressor.
2. Drain (from the new compressor) the amount [ $Y \text{ cm}^3$  ( $Y \text{ floz}$ )] of oil calculated according to the following formula, and then install the new compressor.

<Vehicles without rear cooler or rear A/C>

New compressor oil amount =  $120 \text{ cm}^3$  (4.2 floz)

<Vehicles with rear cooler or rear A/C>

New compressor oil amount =  $140 \text{ cm}^3$  (4.9 floz)

**<Vehicles without rear cooler or rear A/C>**

**$120 \text{ cm}^3 - X \text{ cm}^3 = Y \text{ cm}^3$  (4.2 floz -  $X \text{ floz} = Y \text{ floz}$ )**

**<Vehicles with rear cooler or rear A/C>**

**$140 \text{ cm}^3 - X \text{ cm}^3 = Y \text{ cm}^3$  (4.9 floz -  $X \text{ floz} = Y \text{ floz}$ )**

*NOTE:  $Y \text{ cm}^3$  ( $Y \text{ floz}$ ) indicates the amount of oil in the refrigerant line, the condenser, the evaporator, etc.*

*NOTE: When replacing the following parts at the same times as the compressor, subtract the rated oil amount of the each part from  $Y \text{ cm}^3$  ( $Y \text{ floz}$ ) and discharge from the new compressor.*

#### Quantity:

- Evaporator:  $60 \text{ cm}^3$  (2.0 floz)
- Condenser:  $15 \text{ cm}^3$  (0.5 floz)
- Suction hose:  $10 \text{ cm}^3$  (0.3 floz)
- Receiver:  $10 \text{ cm}^3$  (0.3 floz)

**INSPECTION**

M1552004500191

**AIR CONDITIONING COMPRESSOR CLUTCH  
OPERATION INSPECTION**

Connect the positive battery terminal to the air conditioning compressor clutch connector terminal 3, and ground the negative battery terminal to the body of the compressor. The condition is normal if the sound of the a/c compressor clutch (click) can be heard.

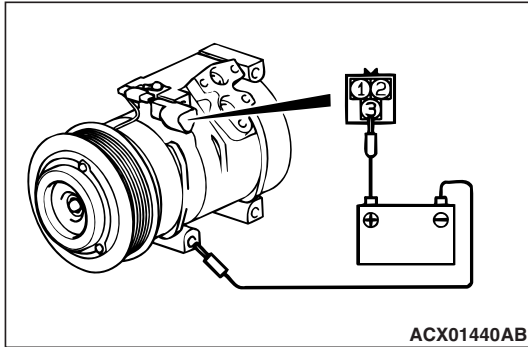

ACX01440AB

**COMPRESSOR  
DISASSEMBLY AND ASSEMBLY**

M1552004600284

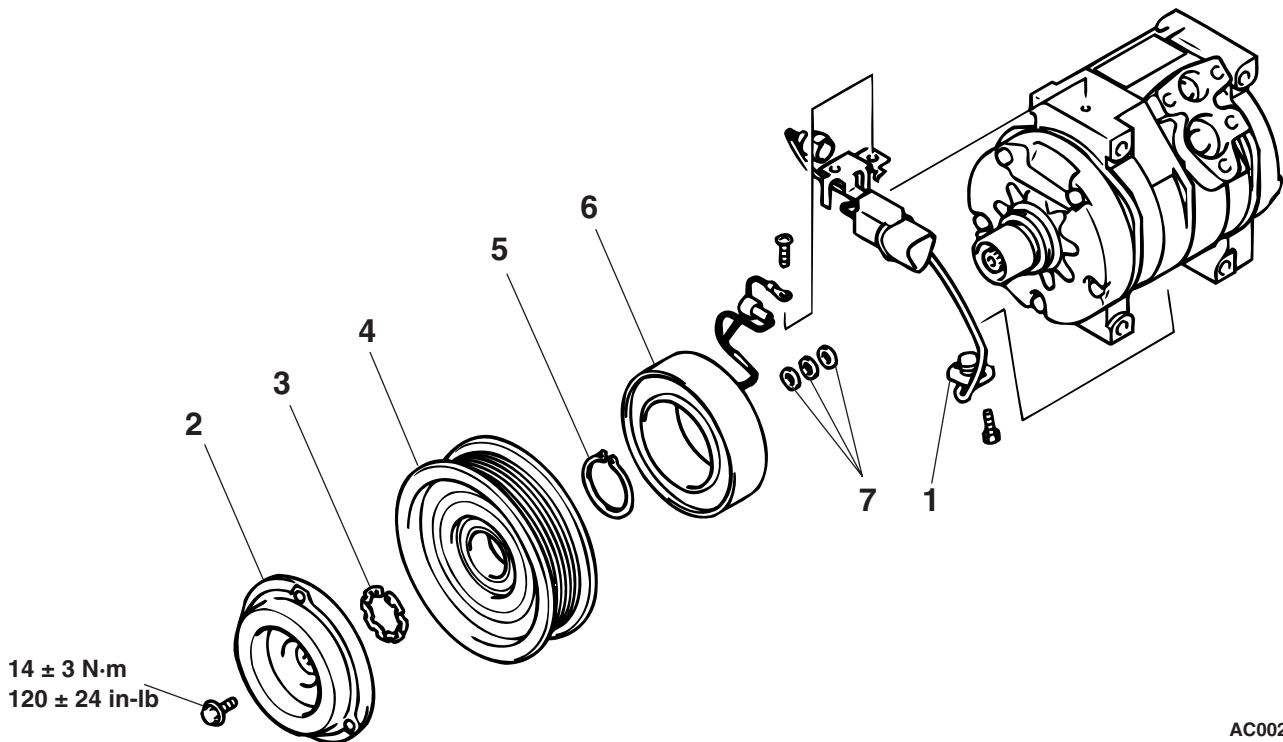

AC002662AB

**DISASSEMBLY STEPS**

- >>C<<
- AIR GAP ADJUSTMENT
- 1. LOCK SENSOR
- <<A>> 2. ARMATURE PLATE
- >>B<< 3. SNAP RING

**DISASSEMBLY STEPS**

- 4. ROTOR
- 5. SNAP RING
- >>A<< 6. CLUTCH COIL
- 7. SHIMS



## DISASSEMBLY SERVICE POINT

### <<A>> ARMATURE PLATE REMOVAL

1. Remove the armature plate mounting nut.
2. Tighten the M10 bolt into the armature plate bolt hole and disconnect the serration of the shaft and the armature plate.

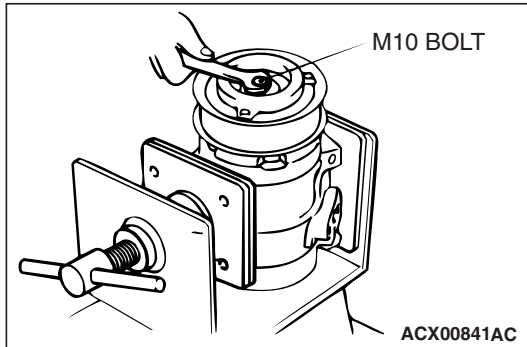

## ASSEMBLY SERVICE POINTS

### >>A<< CLUTCH COIL INSTALLATION

Install the clutch coil to the compressor, mating the compressor body slot to the clutch coil projection.

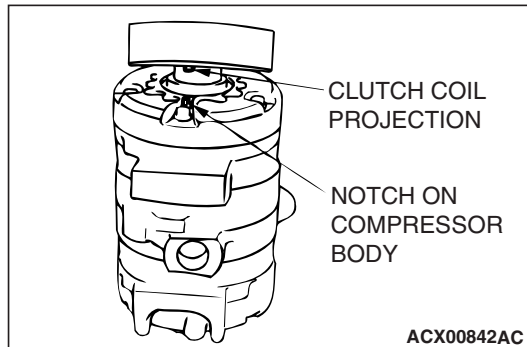

### >>B<< SNAP RING INSTALLATION

Install the snap ring taking care not to enlarge the inner diameter too much. When the inner diameter is over 30.5 mm (1.2 inch) resulting from being enlarged too much, replace the snap ring with a new one.

### >>C<< AIR GAP ADJUSTMENT

Check whether or not the air gap of the clutch is within the standard value.

**Standard value: 0.35 – 0.65 mm (0.014 – 0.026 inch)**

*NOTE: If there is a deviation of the air gap from the standard value, make the necessary adjustment by adjusting the number of shims.*

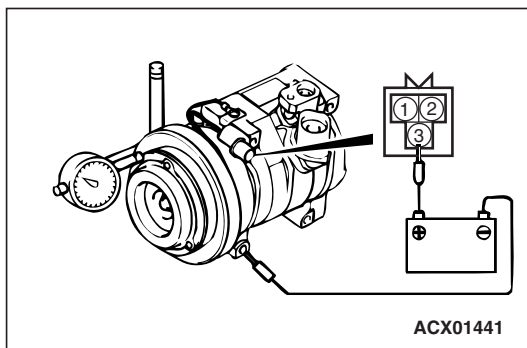

# CONDENSER AND CONDENSER FAN MOTOR

## REMOVAL AND INSTALLATION

M1552006700276

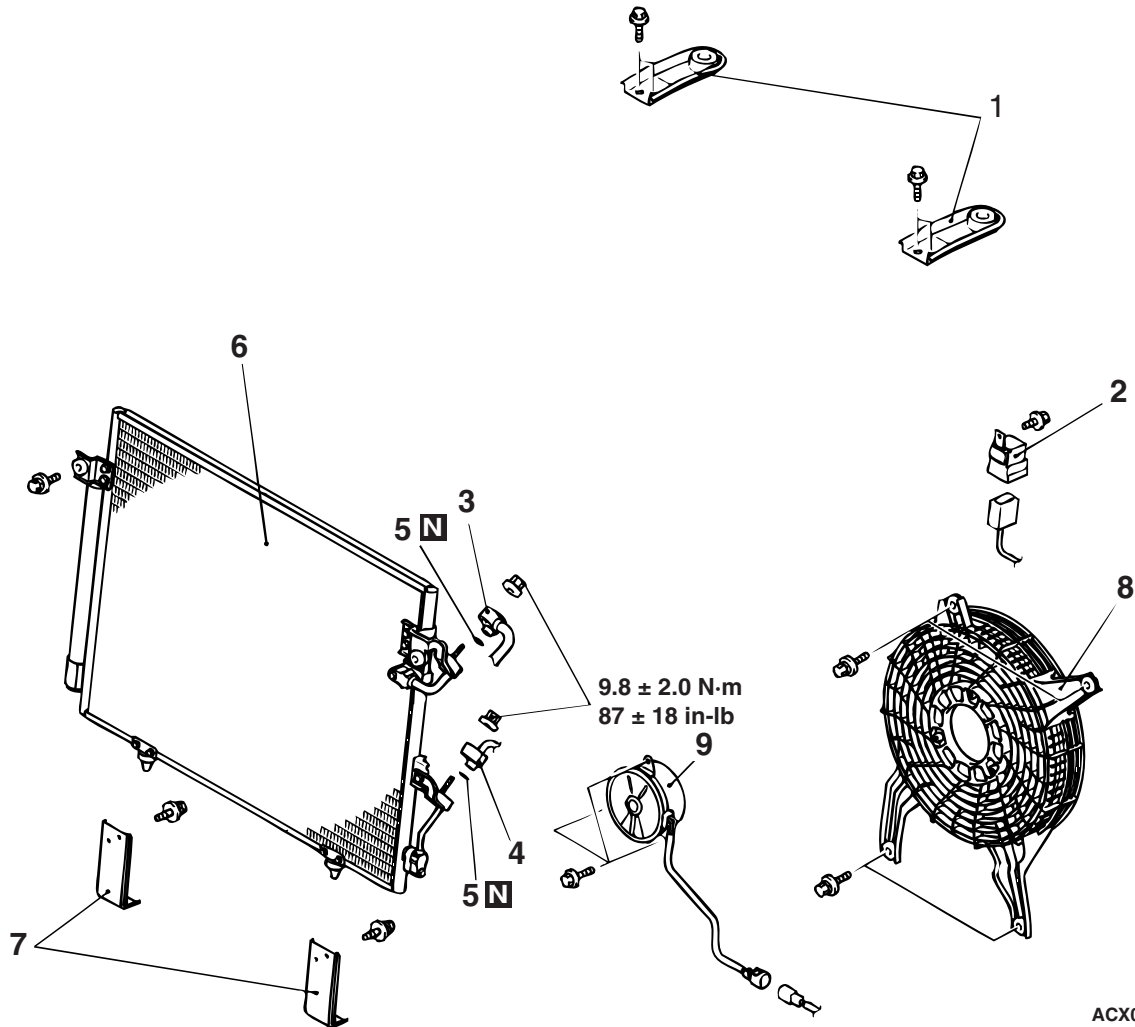

ACX00844AE

### CONDENSER REMOVAL STEPS

1. RADIATOR BRACKET
2. RELAY
3. DISCHARGE HOSE
4. LIQUID PIPE A
5. O-RING

### CONDENSER REMOVAL STEPS

6. CONDENSER
  7. CONDENSER BRACKET
- ### CONDENSER FAN REMOVAL STEPS
8. CONDENSER FAN ASSEMBLY
  9. MOTOR ASSEMBLY

<<A>>  
<<A>>

**REMOVAL SERVICE POINT**

**<<A>> DISCHARGE HOSE/LIQUID PIPE A REMOVAL**

**⚠ CAUTION**

Seal the hoses completely, otherwise the compressor oil and receiver will absorb water vapor easily, possibly damaging the compressor and deteriorating performance.

Plug the disconnected hose, pipe and condenser nipple to prevent foreign matter from getting into them.

**INSPECTION**

M1552006800121

**MOTOR ASSEMBLY CHECK**

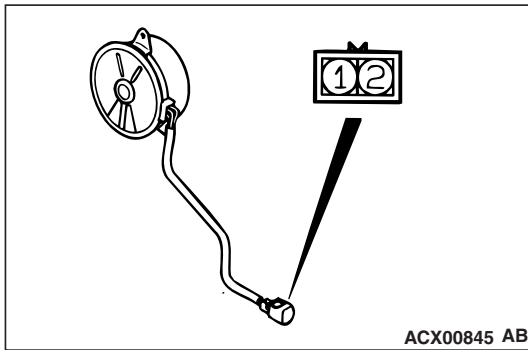

BATTERY (+) CONNECTION TERMINAL	BATTERY (-) CONNECTION TERMINAL	MOTOR OPERATION
1	2	Rotates

# REFRIGERANT LINE

## REMOVAL AND INSTALLATION

M1552006400479

### <VEHICLES WITHOUT REAR COOLER OR REAR A/C>

**Pre-removal and Post-installation Operation**

- Refrigerant Discharging and Charging (Refer to P.55A-115).
- Condense Tank Removal and Installation (Refer to GROUP 14, Radiator P.14-8).
- Engine Cover Removal and Installation.
- Battery and Battery Tray Removal and Installation.

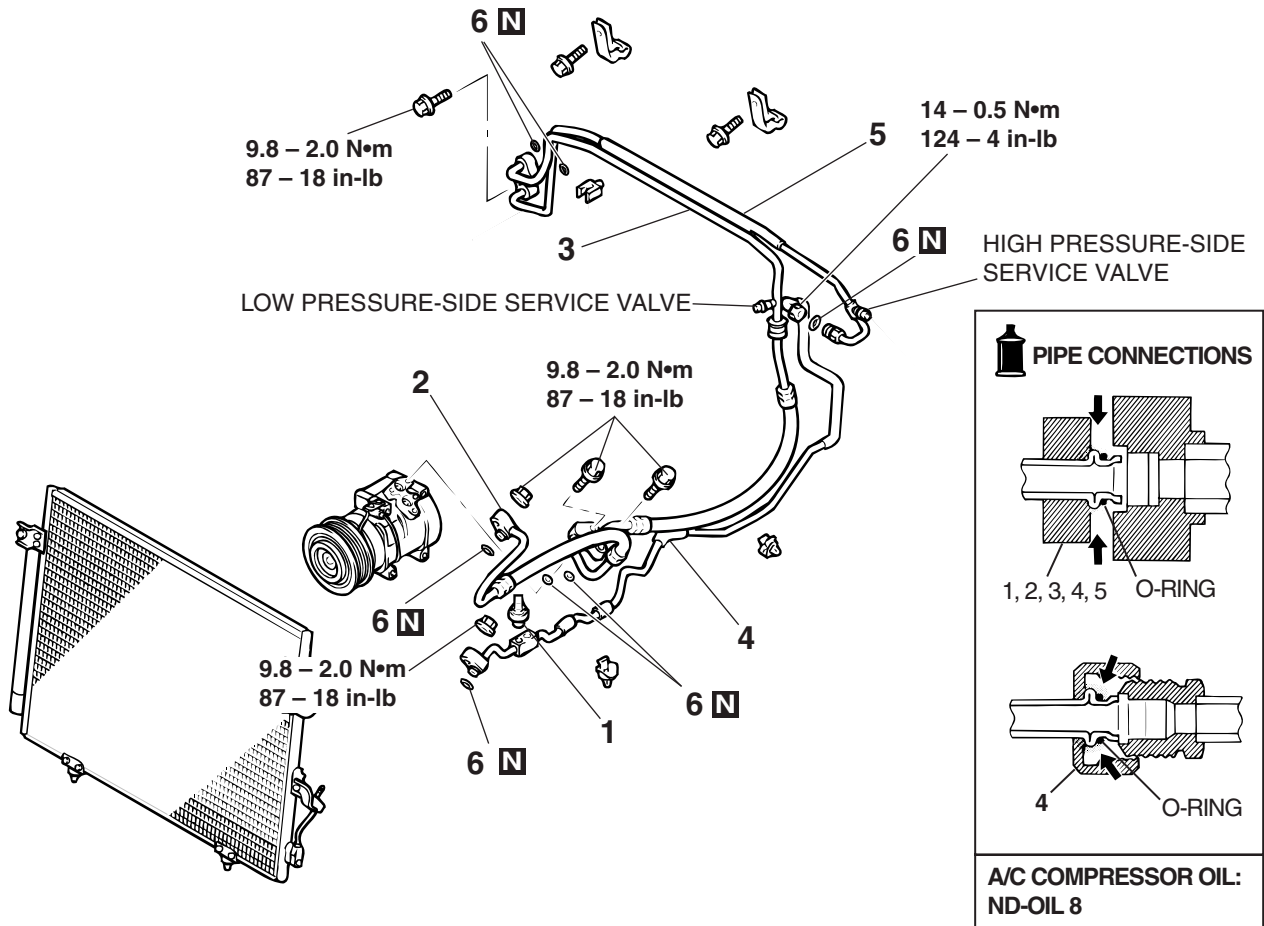

AC205154AE

**REMOVAL STEPS**

- <<A>> 1. DUAL PRESSURE SWITCH
- <<A>> 2. DISCHARGE HOSE
- <<A>> 3. SUCTION HOSE

**REMOVAL STEPS (Continued)**

- 4. LIQUID PIPE A
- 5. LIQUID PIPE B
- 6. O-RING

<VEHICLES WITH REAR COOLER OR REAR A/C>

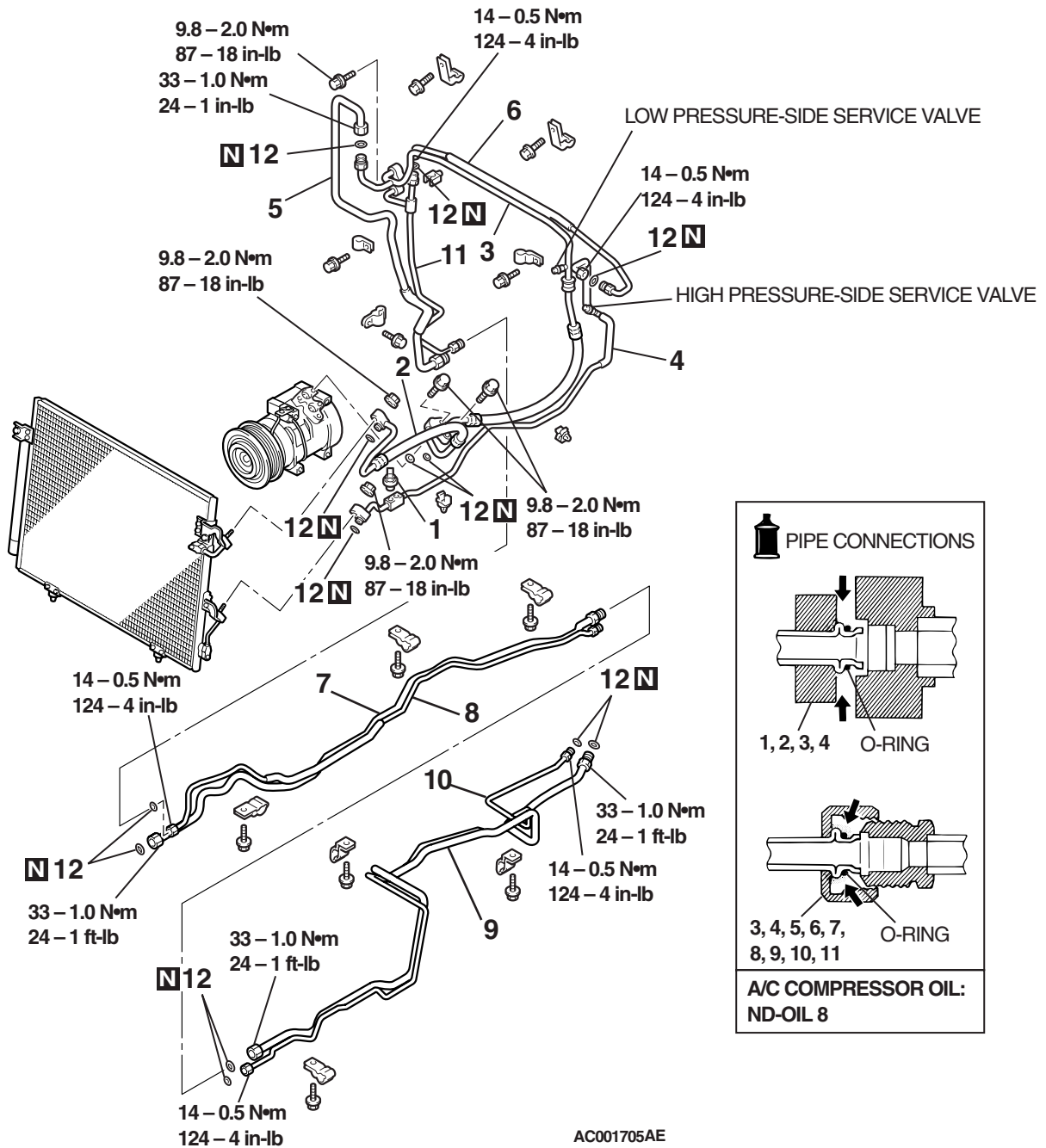

**REMOVAL STEPS**

<<A>>  
<<A>>  
<<A>>  
<<A>>  
<<A>>

1. DUAL PRESSURE SWITCH <<A>>
2. DISCHARGE FLEXIBLE HOSE <<A>>
3. SUCTION FLEXIBLE HOSE <<A>>
4. LIQUID PIPE A <<A>>
5. SUCTION PIPE A <<A>>
6. LIQUID PIPE B <<A>>

**REMOVAL STEPS (Continued)**

7. SUCTION PIPE B
8. LIQUID PIPE C
9. SUCTION PIPE C
10. LIQUID PIPE D
11. LIQUID PIPE E
12. O-RING

## REMOVAL SERVICE POINT

## &lt;&lt;A&gt;&gt; HOSE AND PIPE REMOVAL

**CAUTION**

Seal the hoses completely, otherwise the compressor oil and receiver will absorb water vapor easily, possibly damaging the compressor and deteriorating performance.

Plug the disconnected hose, pipe, condenser, compressor and heater unit nipple to prevent foreign matter from getting into them.

## VENTILATORS

## REMOVAL AND INSTALLATION

M1553001600385

## &lt;INSTRUMENT PANEL AND FLOOR&gt;

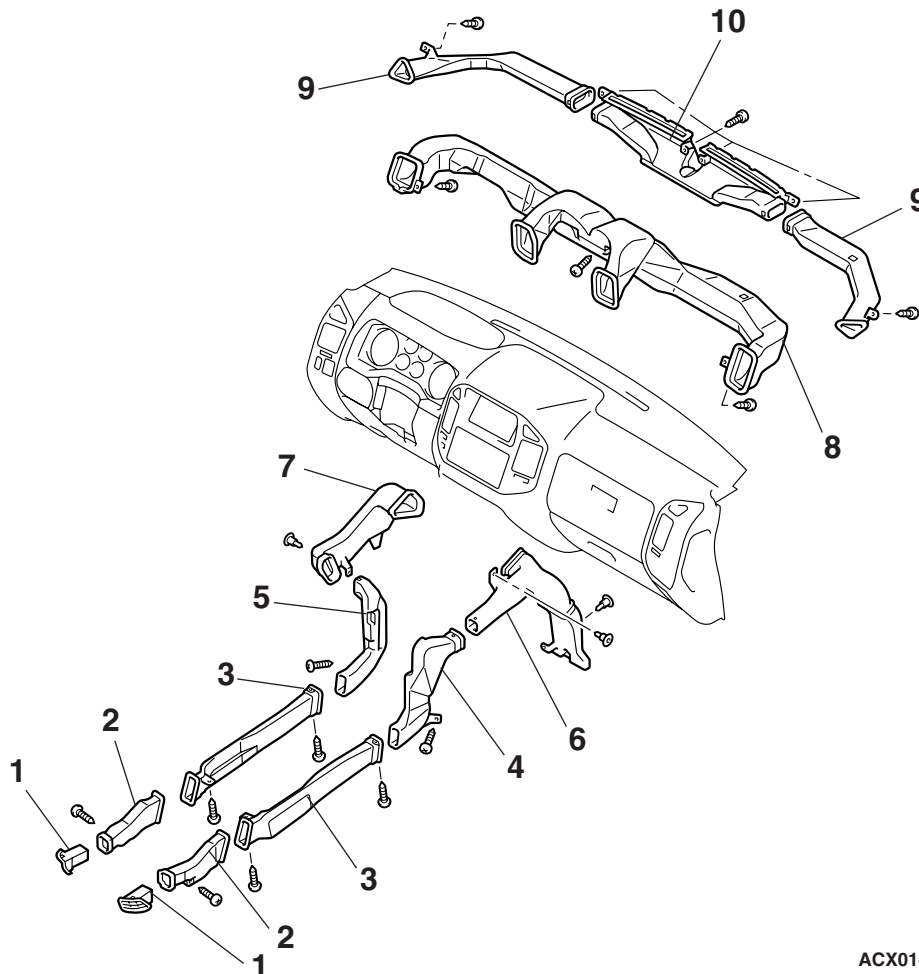

ACX01410AB

**REAR HEATER DUCT REMOVAL STEPS**

- FRONT FLOOR CONSOLE AND REAR FLOOR CONSOLE (REFER TO GROUP 52A, FLOOR CONSOLE [P.52A-7](#)).
- 1. FOOT GRILLE
- 2. REAR HEATER DUCT B
- 3. REAR HEATER DUCT A

**DEFROSTER NOZZLE, DISTRIBUTION DUCT AND FOOT DUCT REMOVAL STEPS**

- INSTRUMENT PANEL (REFER TO GROUP 52A, INSTRUMENT PANEL [P.52A-3](#)).
- 4. FOOT DUCT B
- 5. FOOT DUCT D
- 6. FOOT DUCT A
- 7. FOOT DUCT C

**DEFROSTER NOZZLE, DISTRIBUTION  
DUCT AND FOOT DUCT REMOVAL  
STEPS (Continued)**

8. DISTRIBUTION DUCT
9. SIDE DEFROSTER DUCT
10. DEFROSTER NOZZLE

**<REAR AIR CONDIONER>**

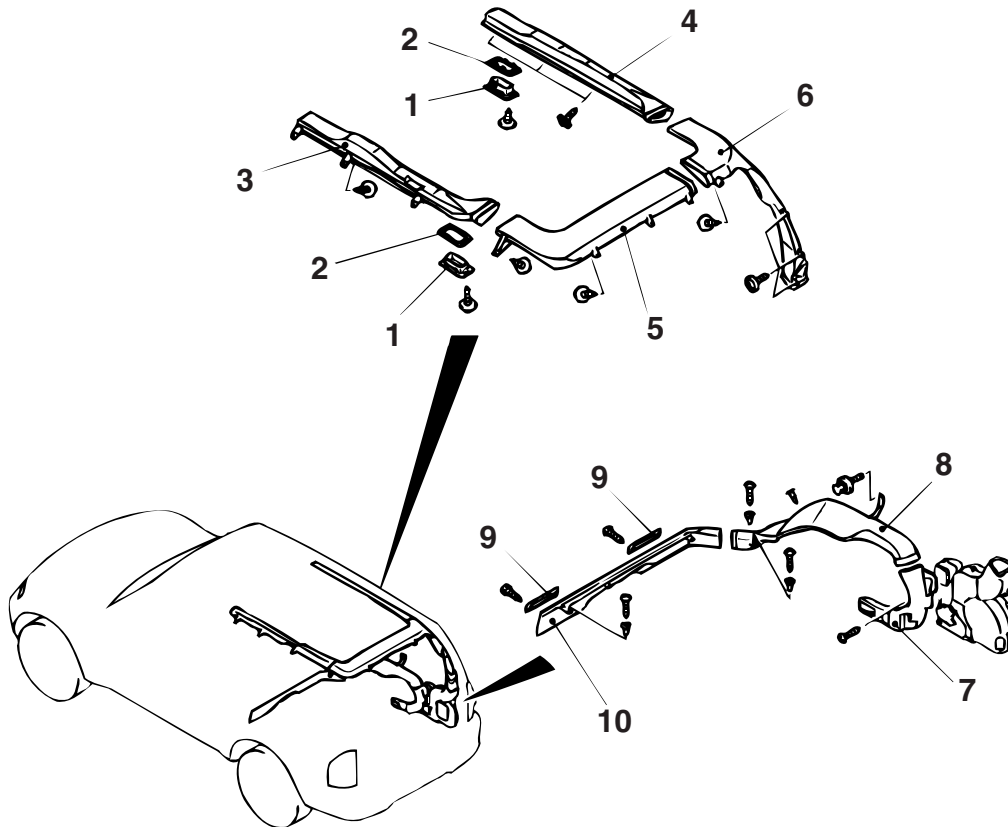

ACX00848 AB

**REAR ROOF DUCT REMOVAL  
STEPS**

- UPPER QUARTER TRIM (RH) (REFER TO GROUP 52A, TRIMS P.52A-8).
1. AIR OUTLET ASSEMBLY
  2. RETAINER
  - HEADLINING
  3. ROOF DUCT (LH)
  4. ROOF DUCT (RH)
  5. REAR ROOF DUCT
  6. PILLAR DUCT

**REAR FLOOR DUCT REMOVAL  
STEPS**

- UPPER QUARTER TRIM (RH) AND LOWER QUARTER TRIM (REFER TO GROUP 52A, TRIMS P.52A-8).
7. REAR QUARTER DUCT
  8. REAR FLOOR DUCT A
  9. REAR HEATER GRILLE
  - FLOOR CARPET
  10. REAR FLOOR DUCT B

<REAR VENTILATION>

**Pre-removal and Post-installation Operation**

Rear Bumper Removal and Installation (Refer to GROUP 51, Rear Bumper P.51-6).

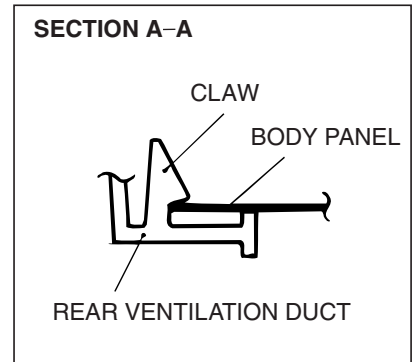
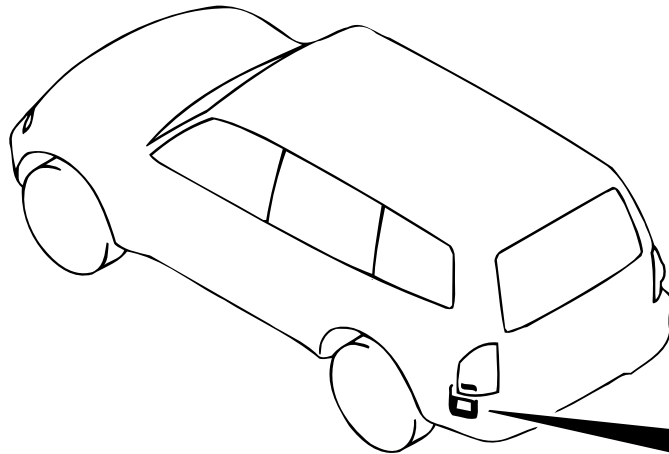

NOTE  
↔ : CLAW POSITION

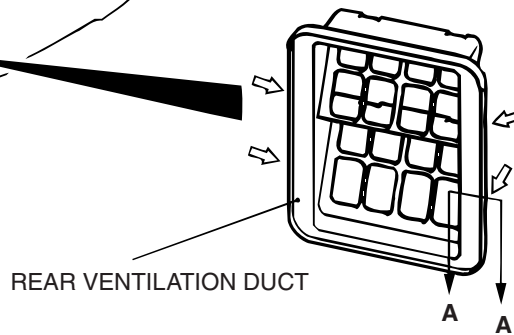

ACX00849 AB

**SPECIFICATIONS**

**FASTENER TIGHTENING SPECIFICATIONS**

M1552012100217

ITEM	SPECIFICATION
Armature plate mounting bolt	14 ± 3 N·m (120 ± 24 in-lb)
Discharge hose mounting bolt (compressor side)	9.8 ± 2.0 N·m (87 ± 18 in-lb)
Discharge hose mounting nut (condenser side)	9.8 ± 2.0 N·m (87 ± 18 in-lb)
Front deck crossmember mounting bolt (LH)	12 ± 2 N·m (106 ± 17 in-lb)
Front deck crossmember mounting bolt (RH)	22 ± 4 N·m (16 ± 5 ft-lb)
Liquid pipe A mounting nut (condenser side)	9.8 ± 2.0 N·m (87 ± 18 in-lb)
Liquid pipe B and liquid pipe A joint nut	14 ± 0.5 N·m (124 ± 4 in-lb)
Liquid pipe B mounting bolt (heater unit side)	9.8 ± 2.0 N·m (87 ± 18 in-lb)
Liquid pipe C and Liquid pipe B joint nut	14 ± 0.5 N·m (124 ± 4 in-lb)
Liquid pipe D and Liquid pipe C joint nut	14 ± 0.5 N·m (124 ± 4 in-lb)
Liquid pipe D mounting nut (rear heater unit side)	14 ± 0.5 N·m (124 ± 4 in-lb)
Suction hose mounting bolt (compressor side)	9.8 ± 2.0 N·m (87 ± 18 in-lb)
Suction hose mounting bolt (heater unit side)	9.8 ± 2.0 N·m (87 ± 18 in-lb)
Suction pipe A and suction hose joint nut	33 ± 1.0 N·m (24 ± 1 ft-lb)



ITEM	SPECIFICATION
Suction pipe B and suction pipe A joint nut	33 ± 1.0 N·m (24 ± 1 ft-lb)
Suction pipe C and suction pipe B joint nut	33 ± 1.0 N·m (24 ± 1 ft-lb)
Suction pipe C mounting nut (rear heater unit side)	33 ± 1.0 N·m (24 ± 1 ft-lb)

**SERVICE SPECIFICATIONS**

M1552000300377

ITEM	STANDARD VALUE	
Air gap (A/C compressor clutch) mm (in)	0.35 – 0.65 (0.014 – 0.026)	
Idle speed r/min	700 ± 50	
Idle-up speed r/min	Low load	700 ± 50
	Middle load	800 ± 50
	High load	1,000 ± 50
Rear heater switch <vehicles with rear heater>	temperature switch resistance kΩ	0 – 3
Rear cooler switch <vehicles with rear cooler>		
Rear A/C switch <vehicles with rear A/C>		
Rear heater unit <vehicles with rear heater>	Air mix damper potentiometer resistance kΩ	1.2 – 4.8
Rear cooler unit <vehicles with rear cooler>		
Rear A/C unit <vehicles with rear A/C>		
Resistor (for front blower motor) Ω	LO	2.79
	ML	1.49
	MH	0.36
Resistor (for rear blower motor) Ω	LO	4.9 ± 0.34
	MI	2.15 ± 0.15

**LUBRICANTS**

M1552000400385

ITEM	SPECIFIED LUBRICANT	QUANTITY	
Compressor refrigerant unit lubricant cm <sup>3</sup> (floz)	Vehicles without rear A/C	ND-OIL8	120 (4.1)
	Vehicles with rear A/C	ND-OIL8	140 (4.7)
Each connection of refrigerant line	ND-OIL8	As required	

---

## NOTES