

## GROUP 23B

# AUTOMATIC TRANSMISSION OVERHAUL

## CONTENTS

<b>GENERAL INFORMATION</b> .....	<b>23B-3</b>	<b>DISASSEMBLY AND ASSEMBLY</b> .....	<b>23B-59</b>
<b>SPECIAL TOOLS</b> .....	<b>23B-6</b>	<b>VALVE BODY</b> .....	<b>23B-63</b>
<b>TRANSMISSION AND TRANSFER</b> ..	<b>23B-10</b>	DISASSEMBLY AND ASSEMBLY .....	23B-63
DISASSEMBLY AND ASSEMBLY .....	23B-10	<b>DIRECT ANNULUS GEAR</b> .....	<b>23B-69</b>
<b>TRANSFER CASE ADAPTER</b> .....	<b>23B-12</b>	DISASSEMBLY AND ASSEMBLY .....	23B-69
DISASSEMBLY AND ASSEMBLY .....	23B-12	<b>DIRECT CLUTCH</b> .....	<b>23B-71</b>
<b>TRANSMISSION</b> .....	<b>23B-14</b>	DISASSEMBLY AND ASSEMBLY .....	23B-71
DISASSEMBLY AND ASSEMBLY .....	23B-14	<b>OUTPUTSHAFT SUPPORT</b> .....	<b>23B-74</b>
<b>REVERSE AND OVERDRIVE CLUTCHES</b> .....	<b>23B-50</b>	DISASSEMBLY AND ASSEMBLY .....	23B-74
DISASSEMBLY AND ASSEMBLY .....	23B-50	<b>TRANSFER</b> .....	<b>23B-75</b>
<b>SECOND BRAKE</b> .....	<b>23B-54</b>	DISASSEMBLY AND ASSEMBLY .....	23B-75
DISASSEMBLY AND ASSEMBLY .....	23B-54	INSPECTION .....	23B-87
<b>LOW REVERSE ANNULUS GEAR</b> ..	<b>23B-55</b>	<b>TRANSFER CASE PLATE</b> .....	<b>23B-87</b>
DISASSEMBLY AND ASSEMBLY .....	23B-55	DISASSEMBLY AND ASSEMBLY .....	23B-87
<b>CENTER SUPPORT</b> .....	<b>23B-57</b>	<b>INPUT GEAR</b> .....	<b>23B-89</b>
DISASSEMBLY AND ASSEMBLY .....	23B-57	DISASSEMBLY AND ASSEMBLY .....	23B-89
<b>UNDERDRIVE CLUTCH</b> .....	<b>23B-59</b>	<b>COUNTERSHAFT GEAR</b> .....	<b>23B-90</b>
		DISASSEMBLY AND ASSEMBLY .....	23B-90

Continued on next page

# 23B-2

<b>REAR OUTPUT SHAFT</b> .....	<b>23B-92</b>	<b>2-4 SHIFT RAIL/H-L SHIFT RAIL</b> ....	<b>23B-98</b>
DISASSEMBLY AND ASSEMBLY .....	23B-92	DISASSEMBLY AND ASSEMBLY .....	23B-98
<b>FRONT OUTPUT SHAFT</b> .....	<b>23B-94</b>	<b>SPECIFICATIONS</b> .....	<b>23B-100</b>
DISASSEMBLY AND ASSEMBLY .....	23B-94	TORQUE SPECIFICATION.....	23B-100
<b>TRANSFER DRIVE SHAFT</b> .....	<b>23B-96</b>	GENERAL SPECIFICATIONS .....	23B-101
DISASSEMBLY AND ASSEMBLY .....	23B-96	SERVICE SPECIFICATIONS .....	23B-101
<b>SHIFTRAIL DRIVE GEAR</b> .....	<b>23B-97</b>	VALVE BODY SPRING IDENTIFICATION .	23B-102
DISASSEMBLY AND ASSEMBLY .....	23B-97	ADJUSTING PLATE, SNAP RING AND SPACERS .....	23B-102
		SEALANTS AND ADHESIVES .....	23B-107

## GENERAL INFORMATION

M1233000100652

This transmission is the newly developed 5-speed automatic transmission that merges advanced electronic technology and mechanical technology. A hydraulic balance mechanism is incorporated for the transmission clutch, allowing for ultra-high speed gear changes.

The weight has been reduced by using precision sheet metal pressing of the clutch retainer, etc., and using aluminum die cast for the oil pump housing.

### SECTIONAL VIEW

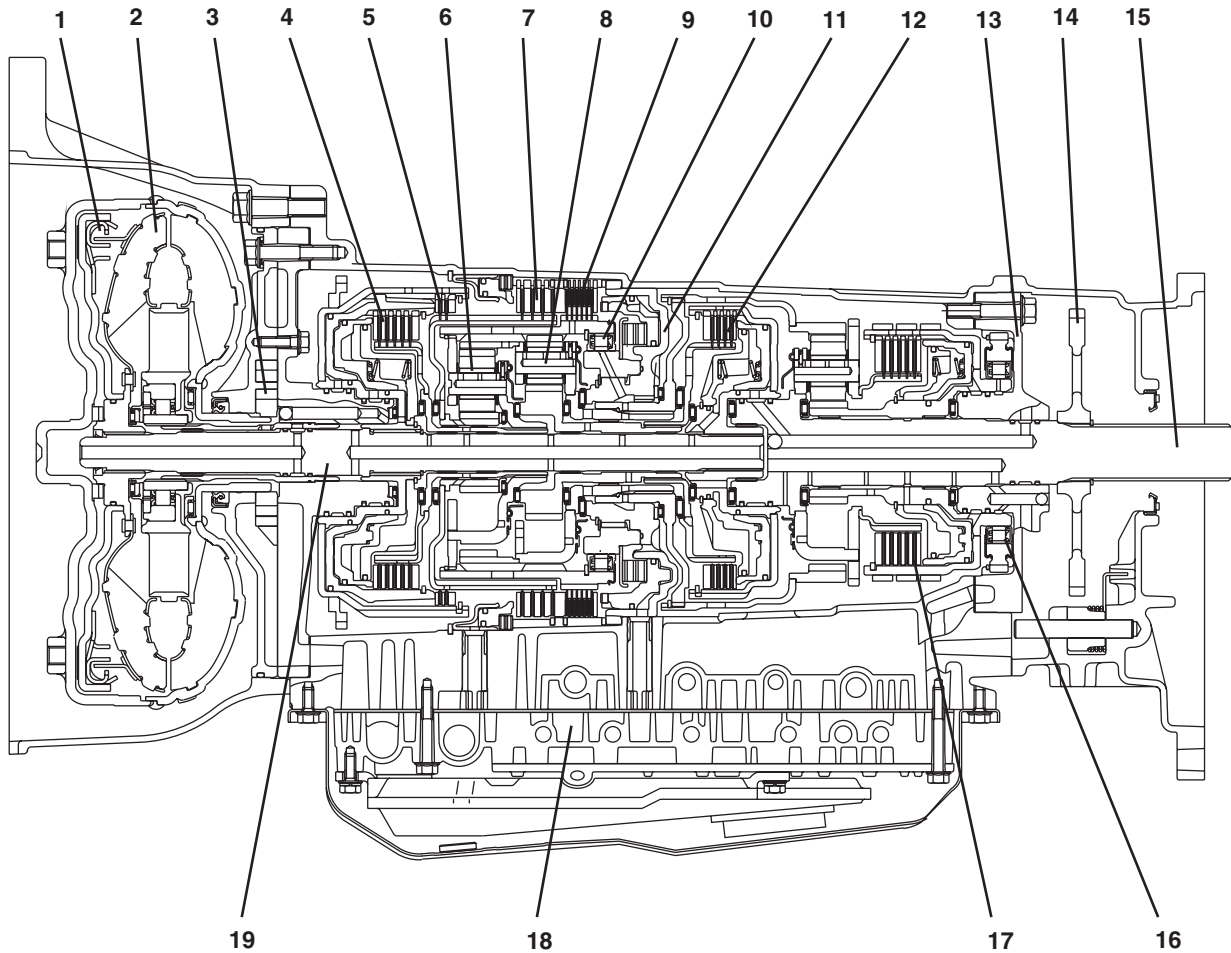

- |                                |                          |
|--------------------------------|--------------------------|
| 1. TORQUE CONVERTER CLUTCH     | 11. CENTER SUPPORT       |
| 2. TORQUE CONVERTER            | 12. UNDERDRIVE CLUTCH    |
| 3. OIL PUMP                    | 13. OUTPUT SHAFT SUPPORT |
| 4. OVERDRIVE CLUTCH            | 14. PARKING GEAR         |
| 5. REVERSE CLUTCH              | 15. OUTPUT SHAFT         |
| 6. OVERDRIVE PLANETARY CARRIER | 16. ONE-WAY CLUTCH       |
| 7. SECOND BRAKE                | 17. DIRECT CLUTCH        |
| 8. OUTPUT PLANETARY CARRIER    | 18. VALVE BODY           |
| 9. LOW/REVERSE BRAKE           | 19. INPUT SHAFT          |
| 10. ONE-WAY CLUTCH             |                          |

AK501024AB

SECTIONAL VIEW

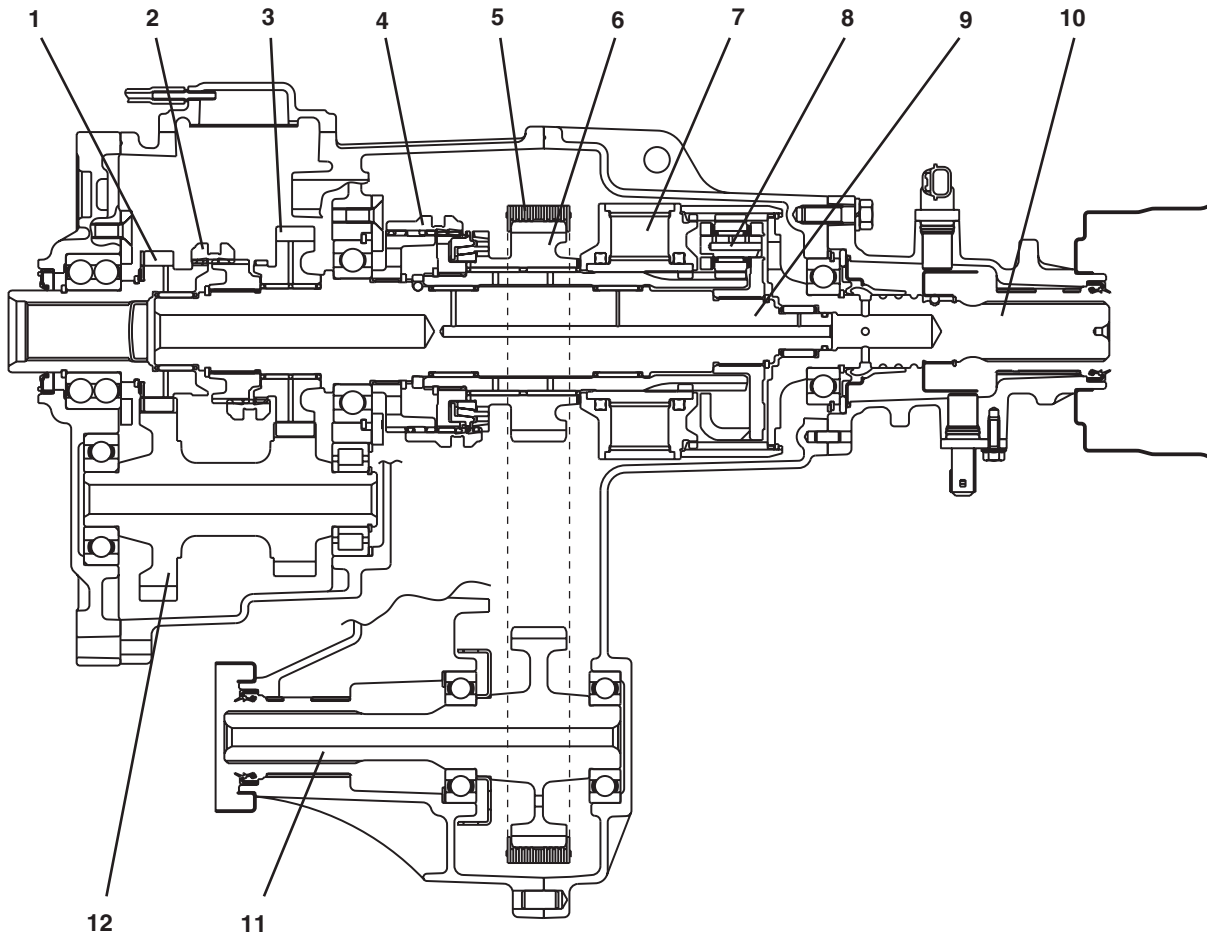

- 1. TRANSFER INPUT GEAR
- 2. H-L CLUTCH
- 3. LOW SPEED GEAR
- 4. 2-4WD SYNCHRONIZER SLEEVE
- 5. DRIVE SPROCKET
- 6. CHAIN

- 7. VISCOUS COUPLING
- 8. CENTER DIFFERENTIAL PLANETARY CARRIER
- 9. TRANSFER DRIVE SHAFT
- 10. REAR OUTPUT SHAFT
- 11. FRONT OUTPUT SHAFT
- 12. TRANSFER COUNTER GEAR

AKX00270AB

**HYDRAULIC CONTROL SYSTEM**

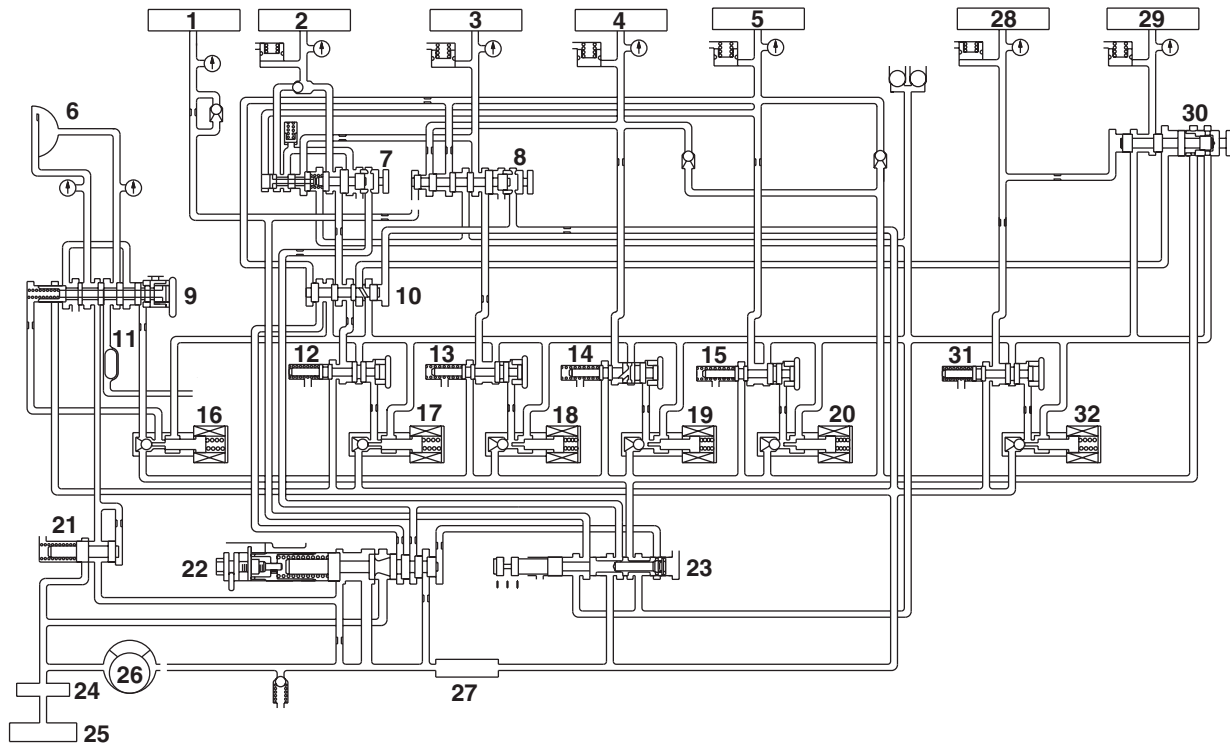

AK501010AD

- |  |  |
|--|--|
| <ul style="list-style-type: none"> <li>1. REVERSE CLUTCH</li> <li>2. LOW/REVERSE BRAKE</li> <li>3. SECOND BRAKE</li> <li>4. UNDERDRIVE CLUTCH</li> <li>5. OVERDRIVE CLUTCH</li> <li>6. TORQUE CONVERTER CLUTCH</li> <li>7. FAIL-SAFE VALVE A</li> <li>8. FAIL-SAFE VALVE B</li> <li>9. TORQUE CONVERTER CLUTCH CONTROL VALVE</li> <li>10. SWITCHING VALVE</li> <li>11. COOLER</li> <li>12. LOW-REVERSE BRAKE PRESSURE</li> <li>13. SECOND BRAKE PRESSURE CONTROL VALVE</li> <li>14. UNDERDRIVE CLUTCH PRESSURE CONTROL VALVE</li> <li>15. OVERDRIVE CLUTCH PRESSURE CONTROL VALVE</li> <li>16. TORQUE CONVERTER CLUTCH CONTROL SOLENOID VALVE</li> </ul> | <ul style="list-style-type: none"> <li>17. LOW-REVERSE BRAKE SOLENOID VALVE</li> <li>18. SECOND BRAKE SOLENOID VALVE</li> <li>19. UNDERDRIVE CLUTCH SOLENOID VALVE</li> <li>20. OVERDRIVE CLUTCH SOLENOID VALVE</li> <li>21. TORQUE CONVERTER PRESSURE CONTROL VALVE</li> <li>22. REGULATOR VALVE</li> <li>23. MANUAL VALVE</li> <li>24. OIL FILTER</li> <li>25. OIL PAN</li> <li>26. OIL PUMP</li> <li>27. OIL STRAINER</li> <li>28. REDUCTION BRAKE</li> <li>29. DIRECT CLUTCH</li> <li>30. FAIL-SAFE VALVE C</li> <li>31. REDUCTION BRAKE PRESSURE CONTROL VALVE</li> <li>32. REDUCTION BRAKE SOLENOID VALVE</li> </ul> |
|--|--|

## SPECIAL TOOLS

M1233000600323

## TRANSMISSION

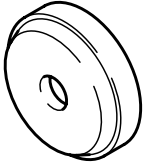
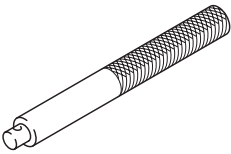
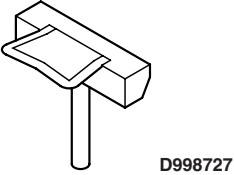
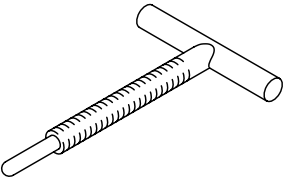
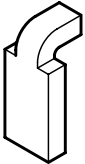
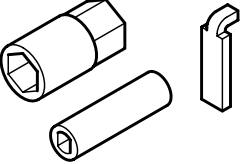
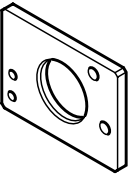
TOOL	TOOL NUMBER AND NAME	SUPERSESSION	APPLICATION
	MB990929 Installer adapter	MB990929	Installation of oil seal
	MB990938 Handle	MB990938-01	Use with installer adapter
	MD998727 Oil pan remover	–	Removal of oil pan
	MD998333 Oil pump remover	MD998333-01	Removal of oil pump
	MB991693 Reduction brake stopper	–	Adjustment reduction brake piston
	MB991633 Reduction brake wrench set	–	Adjustment reduction brake piston
	MB991603 Bearing installer stopper	–	Measurement of output shaft and center support end plays

**AUTOMATIC TRANSMISSION OVERHAUL  
SPECIAL TOOLS**

**23B-7**

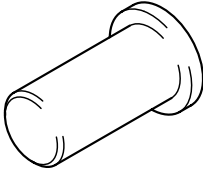
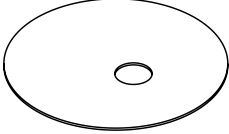
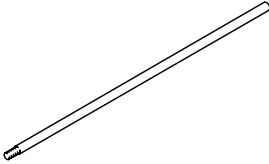
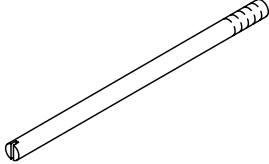
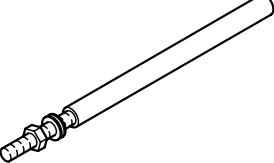
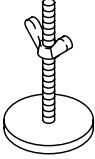
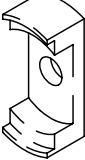
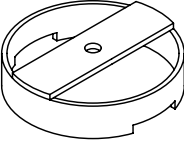
TOOL	TOOL NUMBER AND NAME	SUPERSESSION	APPLICATION
	MD998304 Oil seal installer	MD998304-01	Measurement of output shaft end play
	MB991632 Clearance dummy plate	-	Measurement of brake reaction plate, second brake and low/reverse brake end plays
	MD998913 Dial gauge extension	MD998913-01	Measurement of brake reaction plate, second brake and low/reverse brake end plays
	MD998412 Guide	MD998412	Installation of oil pump
	MD998316 Dial gauge support	MIT209038	Measurement of input shaft end play
	MD998924 Spring compressor retainer	-	Use with spring compressor
	MD999590 Spring compressor	-	Removal and installation of reverse and overdrive clutch spring retainer snap ring
	MB991629 Spring compressor	-	Measurement of overdrive clutch and underdrive clutch end plays

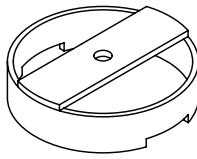
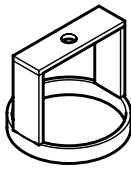
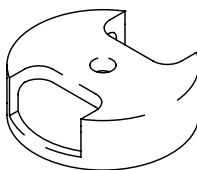
TOOL	TOOL NUMBER AND NAME	SUPERSESSION	APPLICATION
	MB991789 Spring compressor	–	Adjustment reverse clutch end plays
	MB991630 Spring compressor	–	Removal and installation of center support snap ring
	MD998907 Spring compressor	MD998907-01	Removal and installation of underdrive clutch spring retainer snap ring

**TRANSFER**

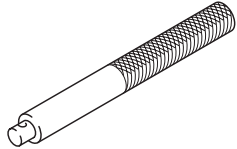
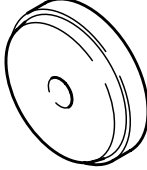
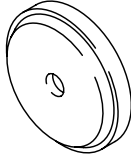
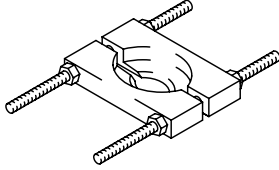
TOOL	TOOL NUMBER AND NAME	SUPERSESSION	APPLICATION
	MB990938 Handle	MB990938-01	Use with installer adapter
	MB990932 Installer adapter	–	Installation of oil seal
	MB990936 Installer adapter	–	Installation of oil seal
	MD998801 Bearing remover	MD998348-01	Removal and installation of bearing

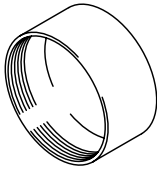
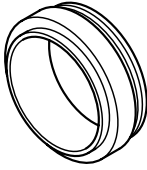
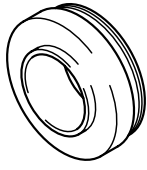
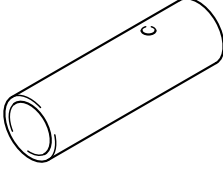
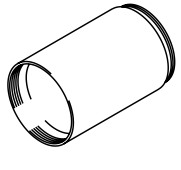
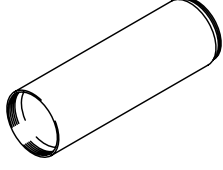
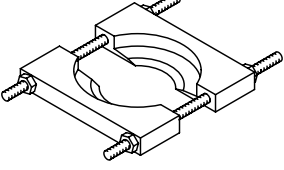

TOOL	TOOL NUMBER AND NAME	SUPERSESSION	APPLICATION
	MD998812 Installer cap	General service tool	Use with installer and installer adapter
	MD998826 Installer adapter (52)	General service tool	Installation of transfer input gear bearing
	MD998818 Installer adapter (38)	MD998818	Installation of countershaft gear bearing, front output shaft bearing
	MD998368 Bearing Installer	General service tool	Installation of countershaft gear bearing
	MD998813 Installer-100	General service tool	Use with installer cap and installer adapter
	MD998814 Installer-200	MIT304180	Use with installer cap and installer adapter
	MD998917 Bearing remover	General service tool	Removal and installation of bearing

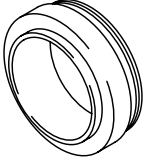
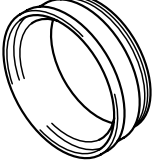
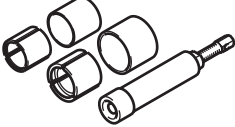
TOOL	TOOL NUMBER AND NAME	SUPERSESSION	APPLICATION
	MD998824 Installer adapter (50)	General service tool	Installation of rear output shaft bearing
	MD998830 Installer adapter (66)	-	Installation of transfer drive shaft bearing
	MD998192 Bearing Puller	General service tool	Installation of transfer drive shaft bearing

## TRANSMISSION AND TRANSFER DISASSEMBLY AND ASSEMBLY

M1233023300099

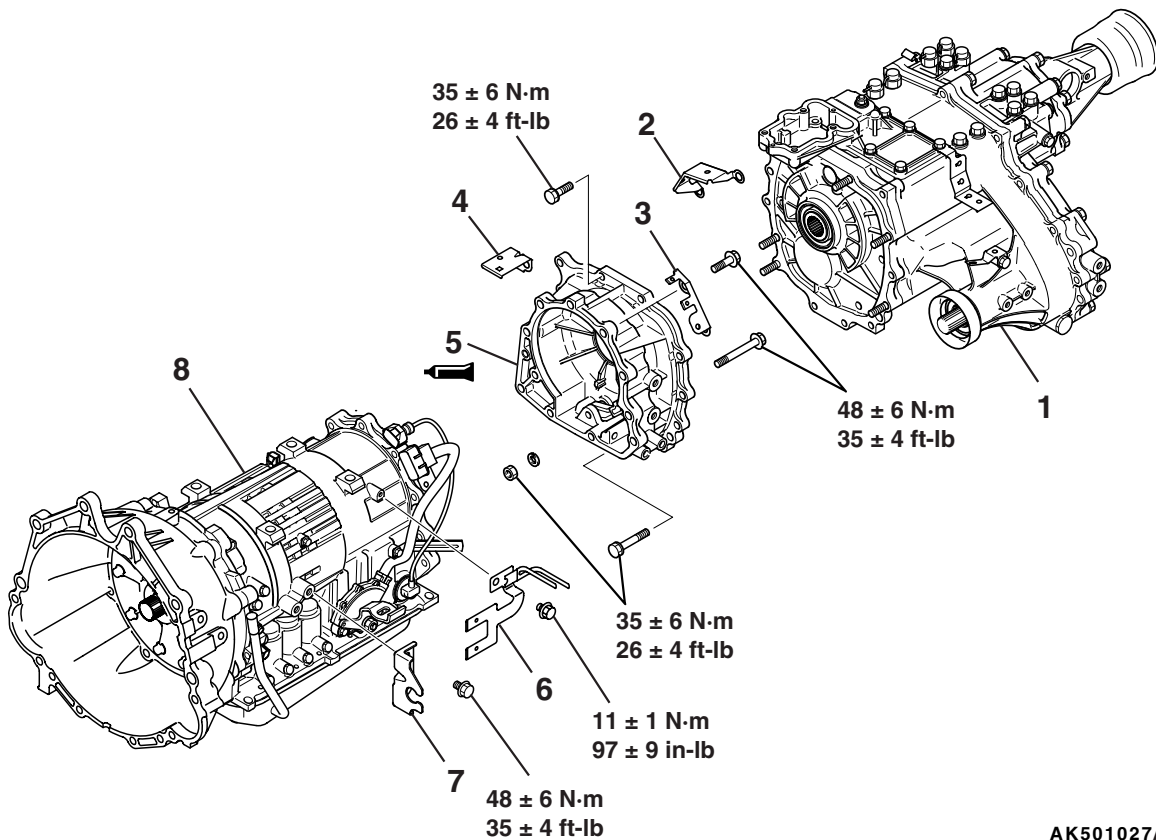

AK501027AB

**DISASSEMBLY STEPS**

1. TRANSFER
2. HARNESS BRACKET
3. HARNESS BRACKET
4. HARNESS BRACKET

**DISASSEMBLY STEPS**

- >>A<<
5. TRANSFER CASE ADAPTER
  6. HARNESS BRACKET
  7. CABLE END BRACKET
  8. TRANSMISSION

**ASSEMBLY SERVICE POINT**

**>>A<< TRANSFER CASE ADAPTER INSTALLATION**

**⚠ CAUTION**

**Evenly squeeze out and apply the sealant so that it is not excessive and does not ooze out.**

After squeezing out and applying the sealant (MITSUBISHI genuine sealant part number MR166584 or equivalent) on the transfer case adapter at the section indicated in the illustration, install onto the transmission case.

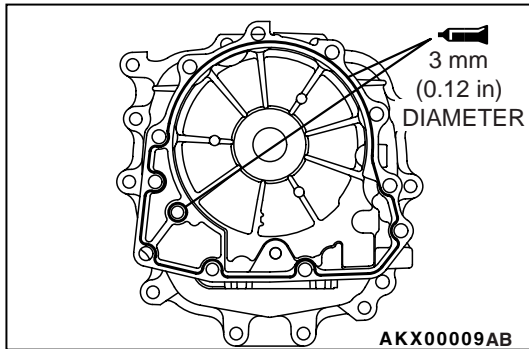

**TRANSFER CASE ADAPTER****DISASSEMBLY AND ASSEMBLY**

M1233007000054

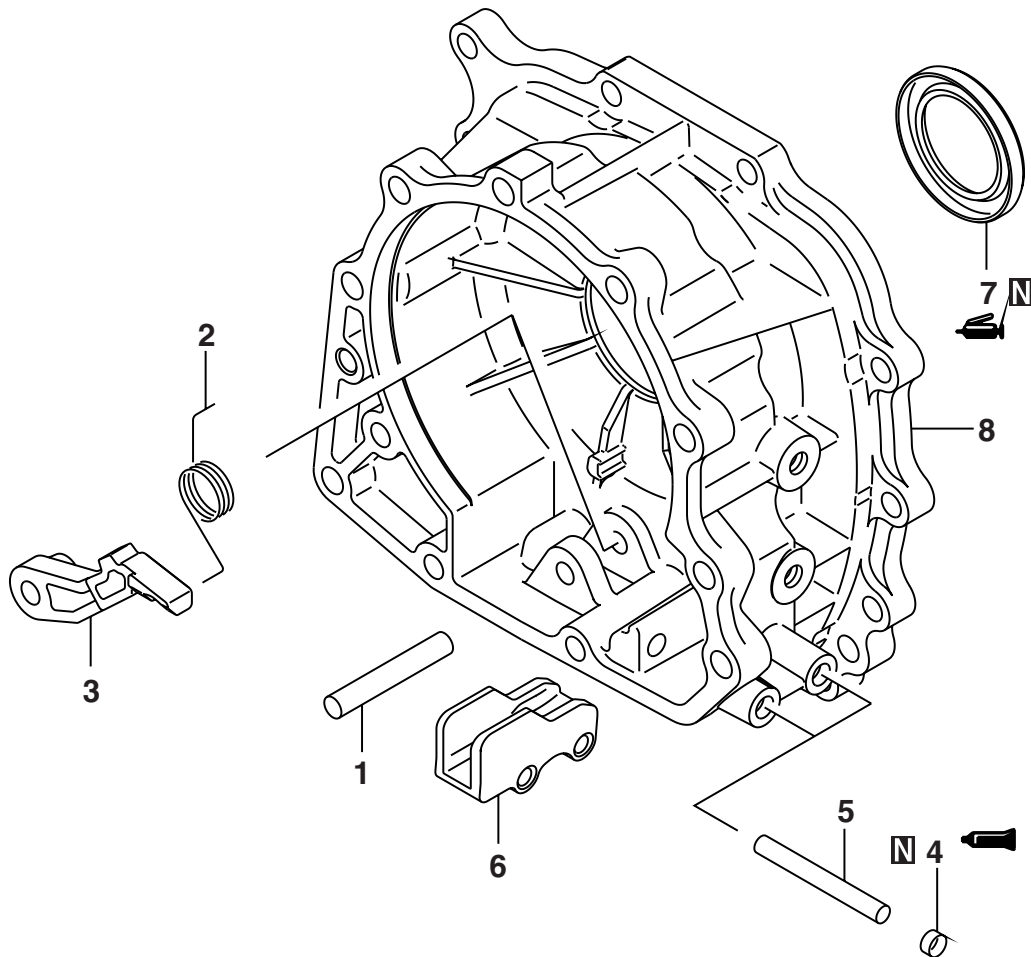

AKX00014AB

**DISASSEMBLY STEPS**

- >>C<<
1. PARKING SPRAG SHAFT
  2. PARKING SPRAG SPRING
  3. PARKING SPRAG
- >>B<<
4. SEALING CAP

**DISASSEMBLY STEPS**

- >>A<<
5. PARKING ROLLER SUPPORT SHAFT
  6. PARKING ROLLER SUPPORT
  7. OIL SEAL
  8. EXTENSION HOUSING

**Required Special Tools:**

- MB990929: Installer Adapter
- MB990938: Handle

## ASSEMBLY SERVICE POINTS

### >>A<< OIL SEAL INSTALLATION

Use special tools MB990929 and MB990938 to install the oil seal.

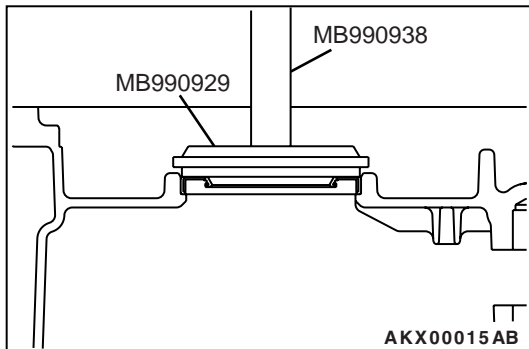

### >>B<< SEALING CAP INSTALLATION

1. Press into the dimensions shown in the illustration so that it is not slanted.
2. Apply the sealant (3M™ AAD part number 8672 or equivalent) as shown in the illustration.

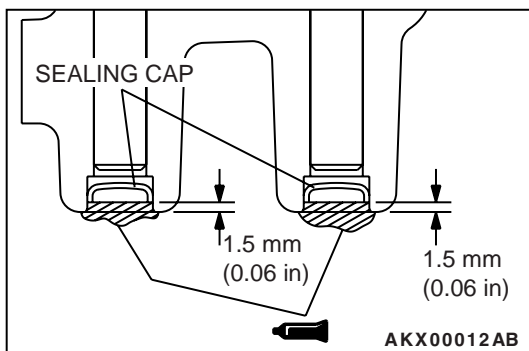

### >>C<< PARKING SPRAG SPRING INSTALLATION

Attach the end of the spring to the position shown in the illustration.

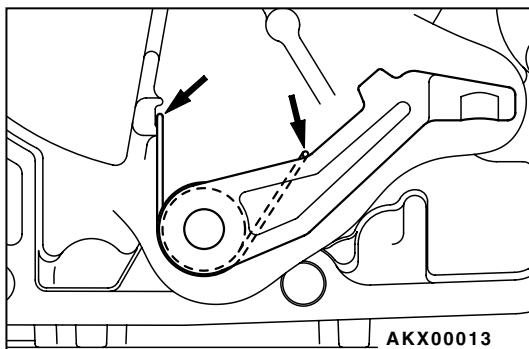

# TRANSMISSION

## DISASSEMBLY AND ASSEMBLY

M1233008200192

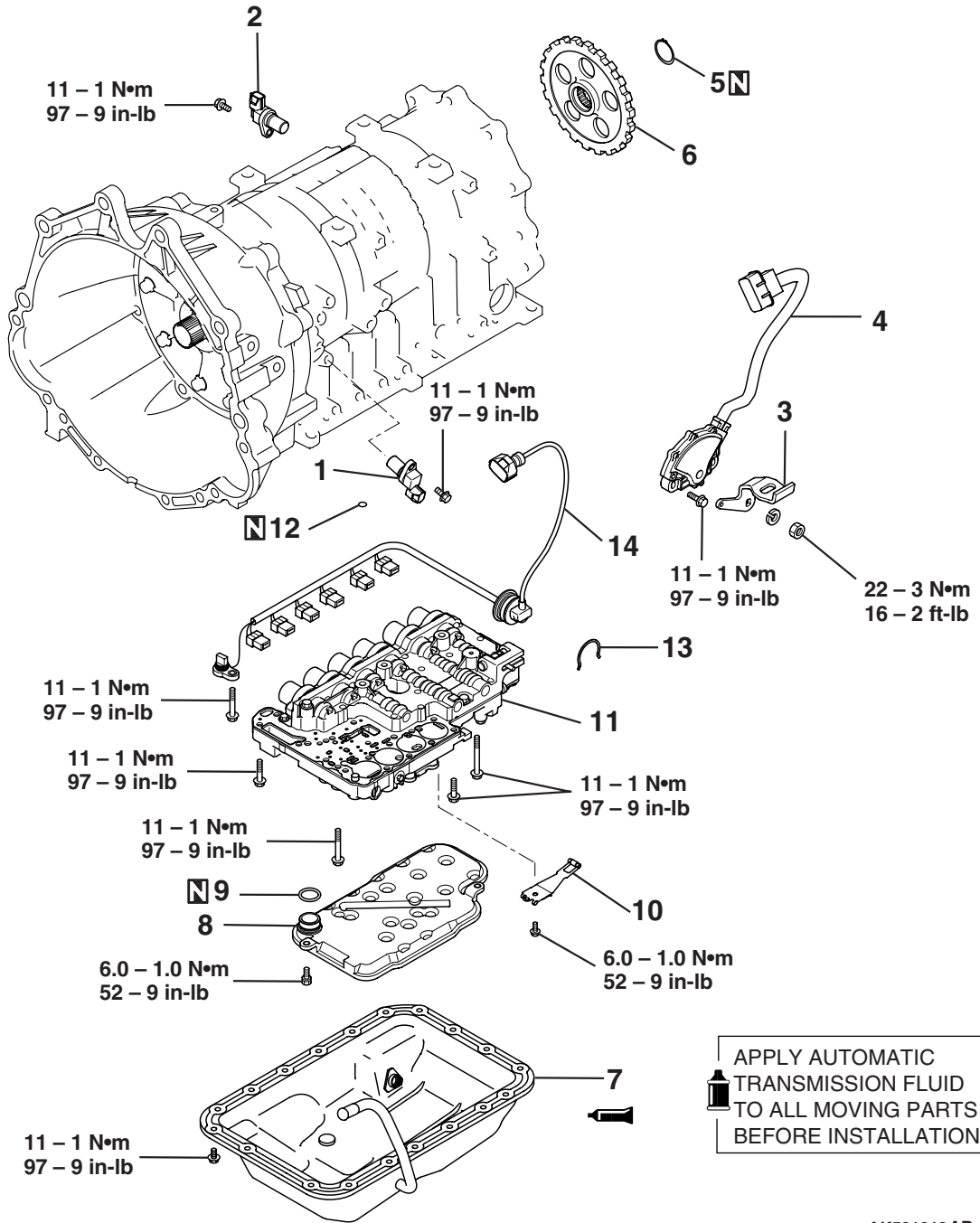

APPLY AUTOMATIC TRANSMISSION FLUID TO ALL MOVING PARTS BEFORE INSTALLATION.

AK501012AB

### DISASSEMBLY STEPS

1. INPUT SHAFT SPEED SENSOR
2. OUTPUT SHAFT SPEED SENSOR
3. MANUAL CONTROL LEVER
4. PARK/NEUTRAL POSITION SWITCH
5. SNAP RING
6. PARKING GEAR

### DISASSEMBLY STEPS

7. OIL PAN
8. OIL FILTER
9. O-RING
10. DETENT SPRING
11. VALVE BODY
12. O-RING
13. SNAP RING
14. SOLENOID VALVE HARNESS

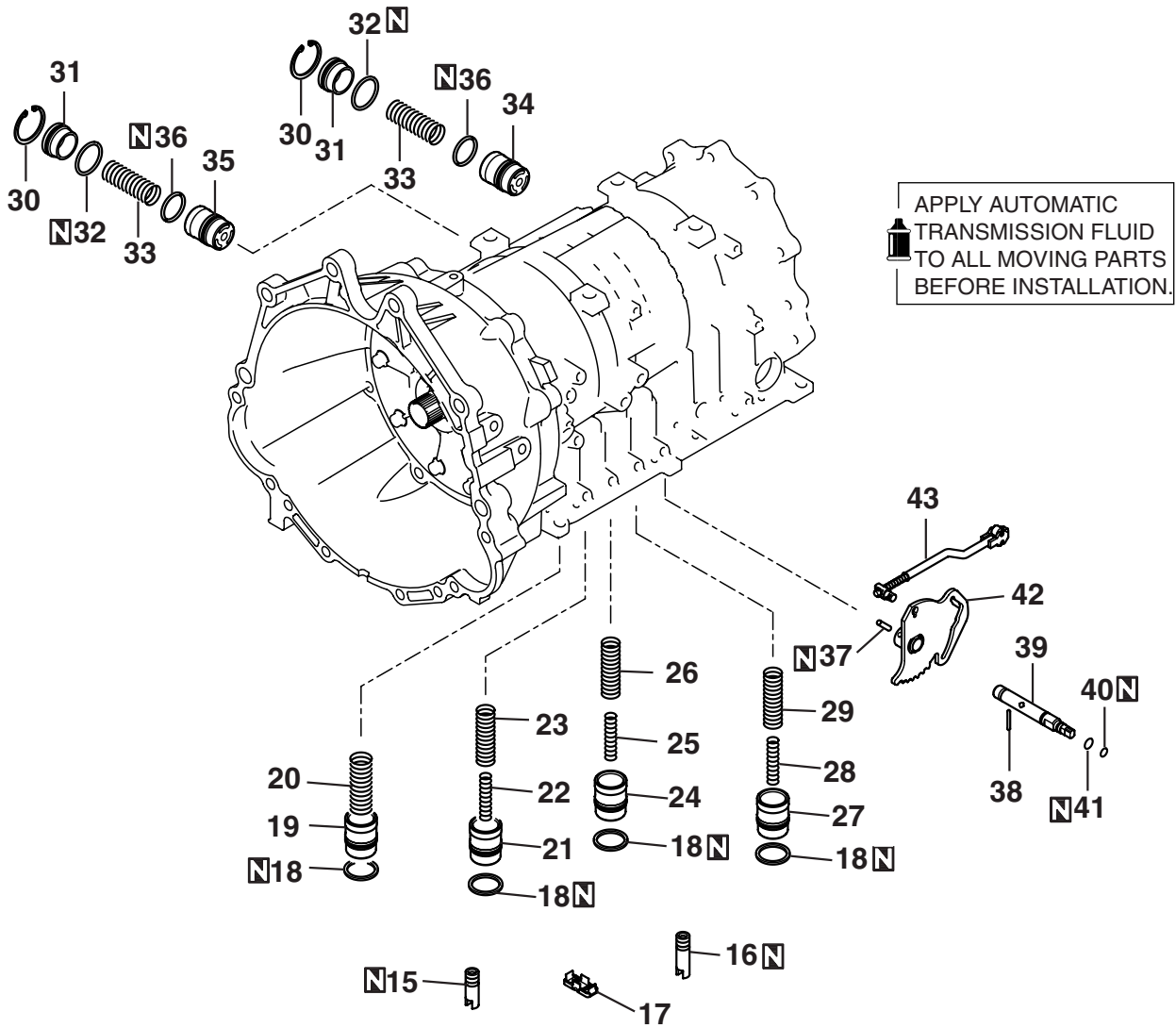

APPLY AUTOMATIC TRANSMISSION FLUID TO ALL MOVING PARTS BEFORE INSTALLATION.

**DISASSEMBLY STEPS**

- 15. OIL SEAL
- 16. OIL SEAL
- 17. OIL STRAINER
- 18. SEAL RING
- 19. ACCUMULATOR PISTON (FOR OVERDRIVE CLUTCH)
- 20. ACCUMULATOR SPRING
- 21. ACCUMULATOR PISTON (FOR SECOND BRAKE)
- 22. INNER SPRING
- 23. OUTER SPRING
- 24. ACCUMULATOR PISTON (FOR LOW/REVERSE BRAKE)
- 25. INNER SPRING
- 26. OUTER SPRING
- 27. ACCUMULATOR PISTON (FOR UNDERDRIVE CLUTCH)
- 28. INNER SPRING

**DISASSEMBLY STEPS**

- 29. OUTER SPRING
- 30. SNAP RING
- 31. ACCUMULATOR COVER
- 32. O-RING
- 33. ACCUMULATOR SPRING
- 34. ACCUMULATOR PISTON (FOR REDUCTION BRAKE)
- 35. ACCUMULATOR PISTON (FOR DIRECT CLUTCH)
- 36. SEAL RING
- 37. SPRING PIN
- 38. PIN
- 39. MANUAL CONTROL SHAFT
- 40. O-RING
- 41. O-RING
- 42. DETENT LEVER
- 43. PARKING ROLLER ROD

AK500978AB

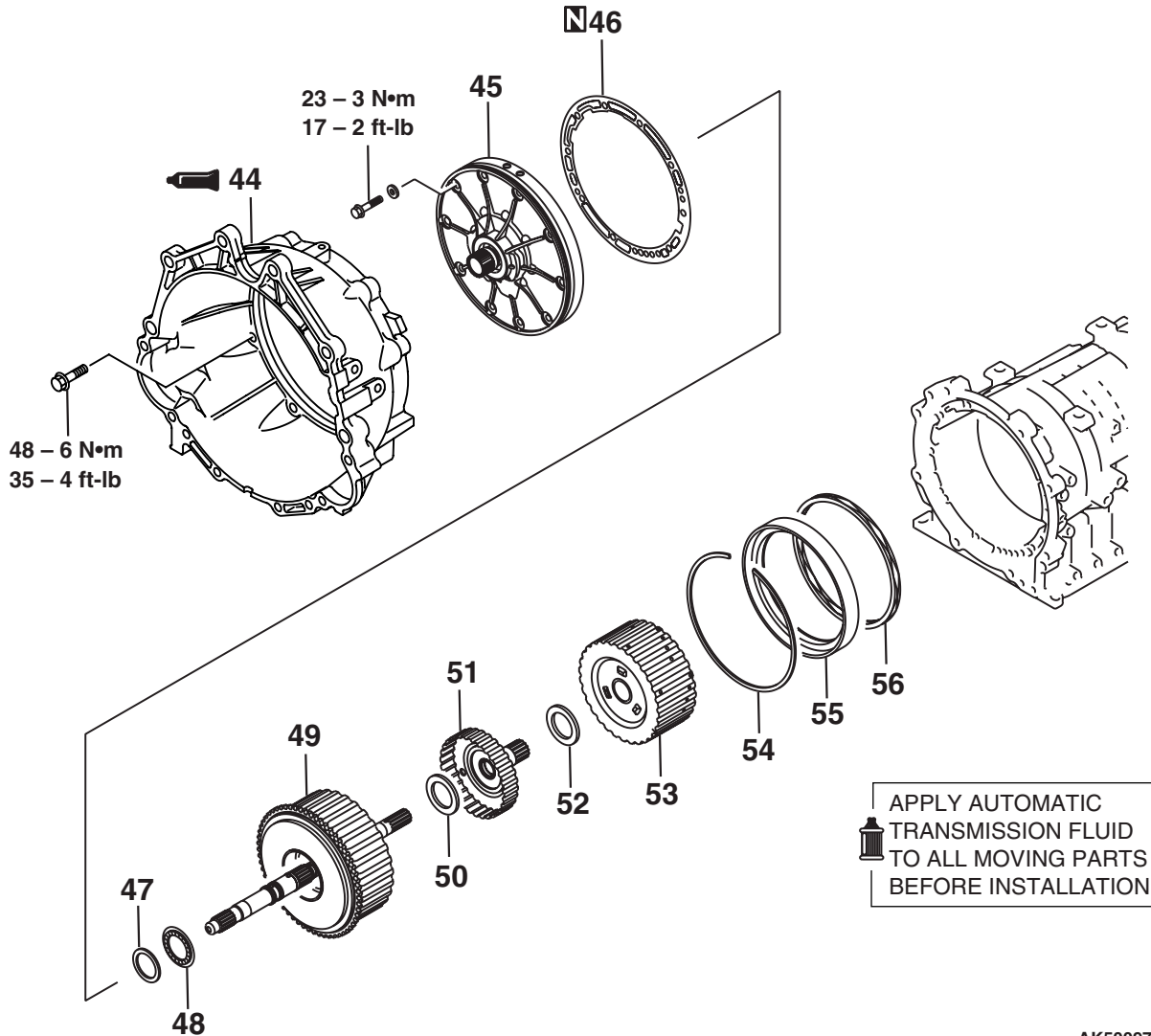

AK500977 AB

**DISASSEMBLY STEPS**

- 44. CONVERTER HOUSING
- 45. OIL PUMP
- 46. OIL PUMP GASKET
- 47. THRUST RACE NO.1
- 48. THRUST BEARING NO.2
- 49. REVERSE AND OVERDRIVE CLUTCH
- 50. THRUST BEARING NO.3

**DISASSEMBLY STEPS**

- 51. OVERDRIVE CLUTCH HUB
- 52. THRUST BEARING NO.4
- 53. REVERSE SUN GEAR
- 54. SNAP RING
- 55. SECOND BRAKE
- 56. RETURN SPRING



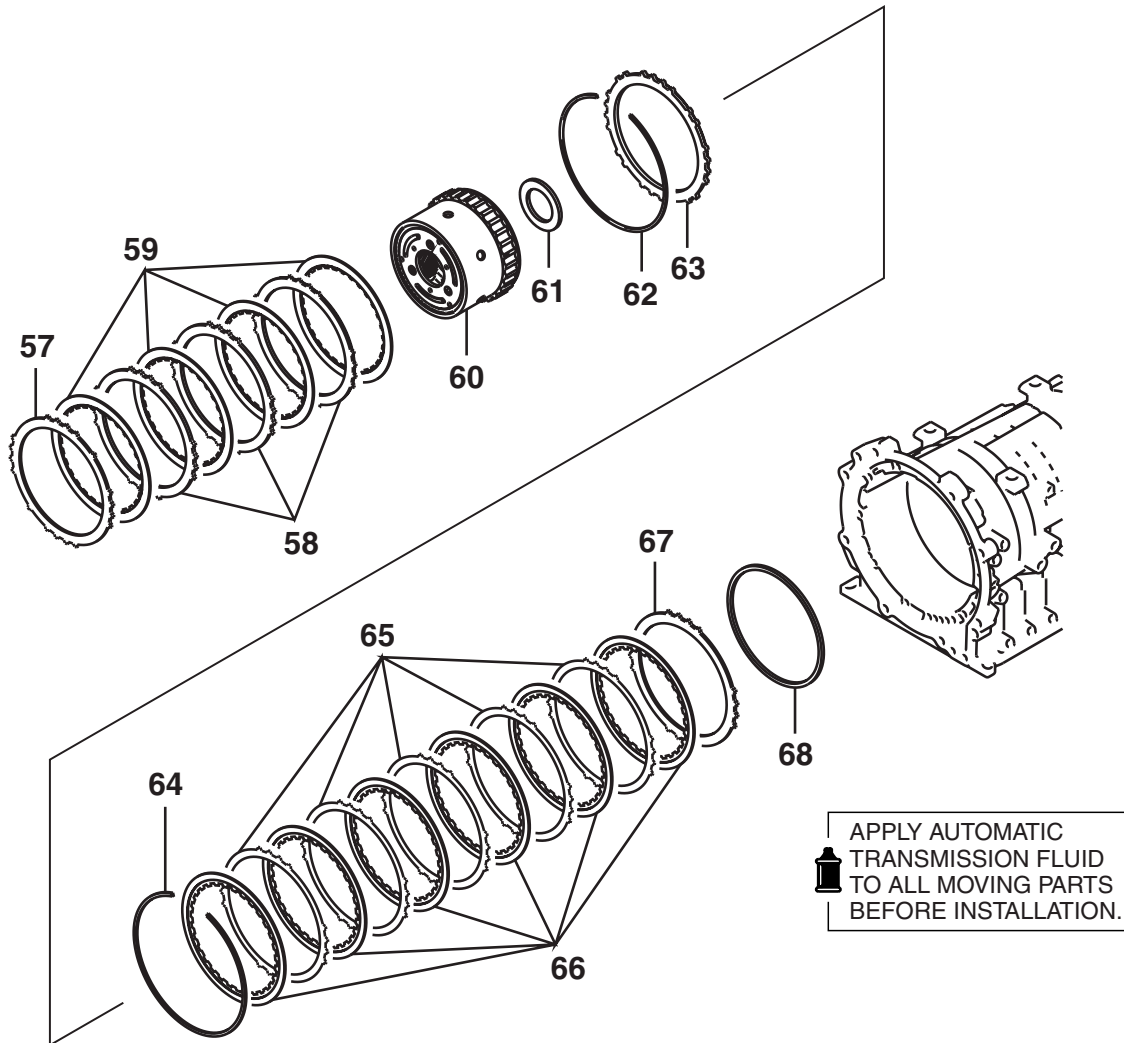

**DISASSEMBLY STEPS**

- 57. PRESSURE PLATE
- 58. BRAKE PLATE
- 59. BRAKE DISC
- 60. LOW/REVERSE ANNULUS GEAR
- 61. THRUST BEARING NO.7
- 62. SNAP RING

**DISASSEMBLY STEPS**

- 63. REACTION PLATE
- 64. SNAP RING
- 65. BRAKE PLATE
- 66. BRAKE DISC
- 67. PRESSURE PLATE
- 68. WAVE SPRING

AKX00019AE

APPLY AUTOMATIC  
TRANSMISSION FLUID  
TO ALL MOVING PARTS  
BEFORE INSTALLATION.

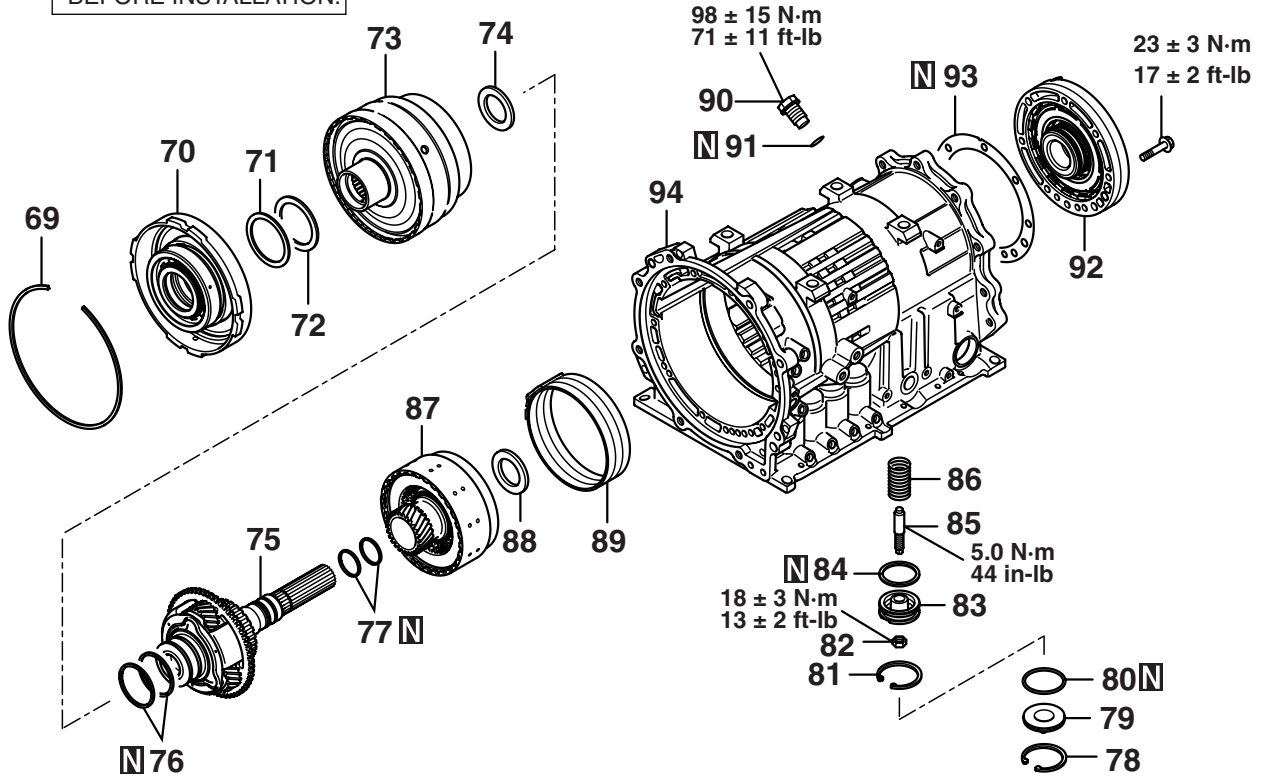

AKX00298 AC

**DISASSEMBLY STEPS**

- 69. SNAP RING
- 70. CENTER SUPPORT
- 71. THRUST RACE NO.8
- 72. THRUST BEARING NO.9
- 73. DIRECT ANNULUS GEAR
- 74. THRUST BEARING NO.12
- 75. DIRECT PLANETARY CARRIER
- 76. SEAL RING
- 77. SEAL RING
- 78. SNAP RING
- 79. REDUCTION BRAKE COVER
- 80. O-RING
- 81. SNAP RING
- 82. REDUCTION BRAKE PISTON NUT

**DISASSEMBLY STEPS**

- 83. REDUCTION BRAKE PISTON
- 84. SEAL RING
- 85. REDUCTION BRAKE PISTON ADJUST ROD
- 86. REDUCTION BRAKE SPRING
- 87. DIRECT CLUTCH
- 88. THRUST BEARING NO.13
- 89. REDUCTION BRAKE BAND
- 90. ANCHOR PLUG
- 91. O-RING
- 92. OUTPUT SHAFT SUPPORT
- 93. OUTPUT SHAFT SUPPORT GASKET
- 94. TRANSMISSION CASE

**Required Special Tools:**

- MB991603: Bearing Installer Stopper
- MB991632: Clearance Dummy Plate
- MB991633: Reduction Brake Wrench Set
- MB991693: Reduction Brake Stopper
- MD998304: Oil Seal Installer
- MD998316: Dial Gauge Support
- MD998333: Oil Pump Remover
- MD998412: Guide
- MD998727: Oil Pan Remover
- MD998913: Dial Gauge Extension

## DISASSEMBLY

### CAUTION

- Because the automatic transmission is manufactured from high-precision parts, sufficient care must be taken not to scratch or damage these parts during disassembly and reassembly.
- During the work, always use bare hands or vinyl gloves. Do not use cotton gloves. Use nylon cloth or paper towels when necessary. Do not use shop towels.
- Parts which have been disassembled should be cleaned. Metal parts can be cleaned with normal detergent, but they should be dried completely using compressed air.
- Clutch discs, plastic thrust race and rubber parts should be cleaned with ATF automatic transmission fluid so that they do not become dirty.
- If the transmission body has been damaged, disassemble and clean the cooler system also.

1. Remove the input shaft speed sensor.

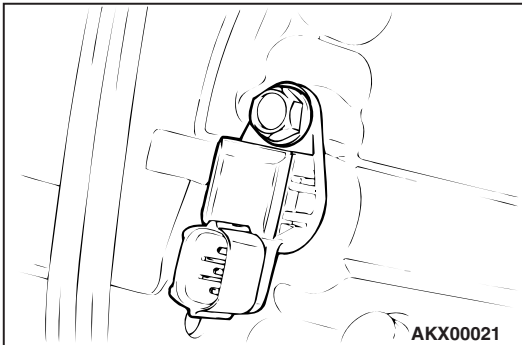

2. Remove the output shaft speed sensor.

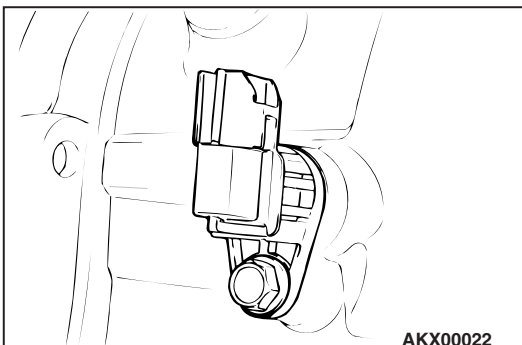

3. Remove the manual control lever, and then remove the park/neutral position switch.

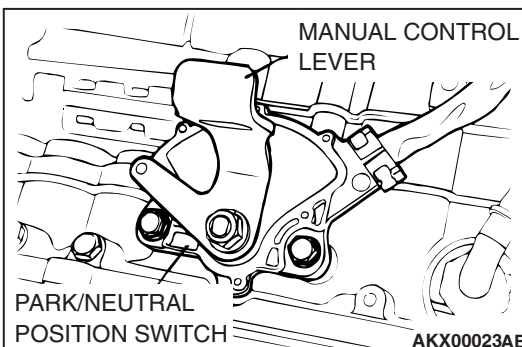

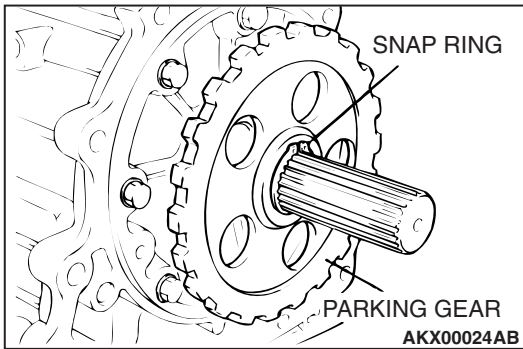

4. Remove the snap ring, and remove the parking gear using a puller [corresponding load approximately 9,800 N (2,200 pounds)].

*NOTE: Some parking gear may be removed without using a puller.*

**CAUTION**

Carefully hammer the special tool so that the oil pan mounting surface is not damaged.

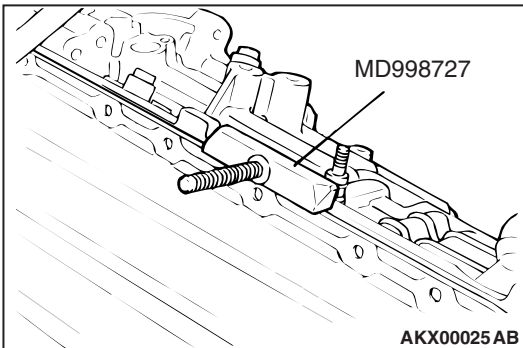

5. Remove the twenty oil pan mounting bolts and then using the special tool MD998727 to remove the oil pan.

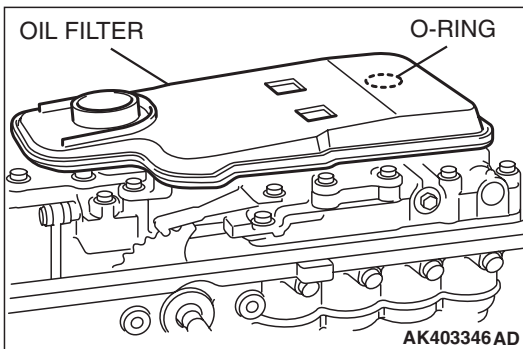

6. Remove the oil filter and O-ring.

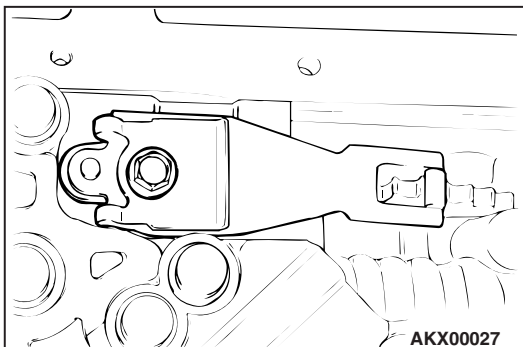

7. Remove the detent spring.

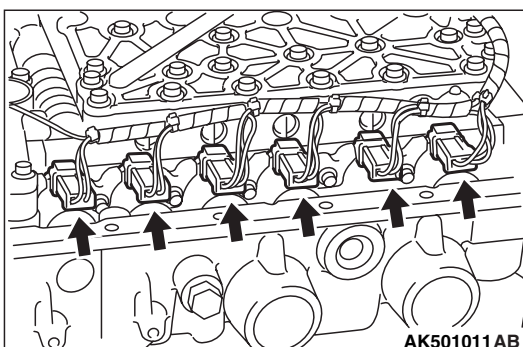

8. Disconnect the valve body harness connectors.

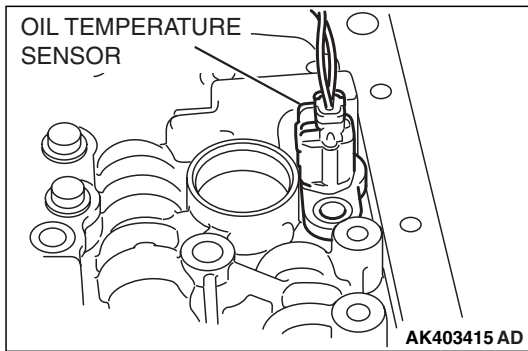

9. Remove the twenty valve body mounting bolts and then remove the valve body, O-ring and oil temperature sensor.

*NOTE: The twenty valve body mounting bolts are plated bolts.*

*NOTE: The O-ring is mounted on the transmission case side as shown in the illustration. However there may be cases when it will come off with the valve body.*

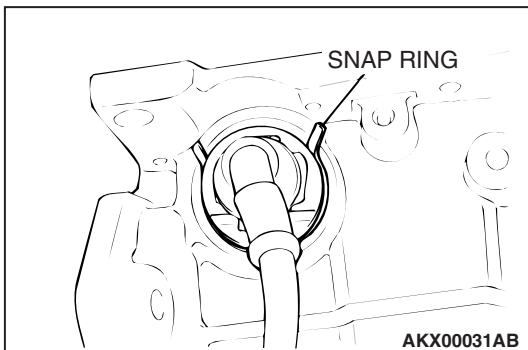
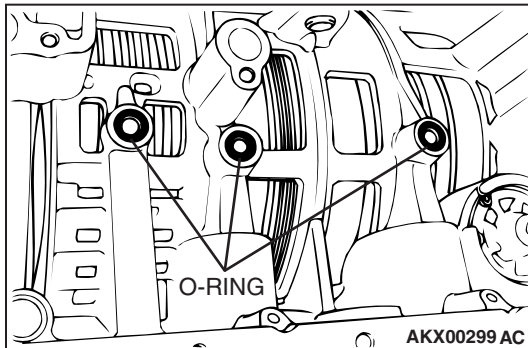

10. Remove the snap ring and disconnect the solenoid valve harness.

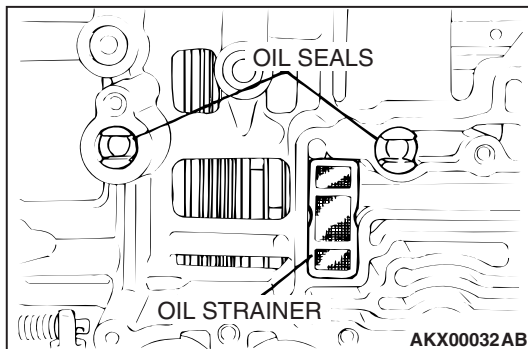

11. Remove the oil strainer and two oil seals.

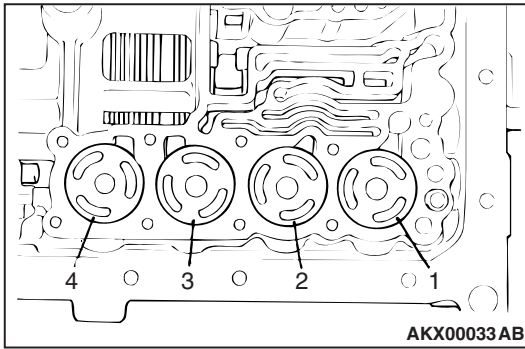

12. Remove each accumulator piston, seal ring, spring, snap ring, accumulator cover, O-ring.

NO.	NAME
1	FOR OVERDRIVE CLUTCH
2	FOR SECOND BRAKE
3	FOR LOW/REVERSE BRAKE
4	FOR UNDERDRIVE CLUTCH
5	FOR REDUCTION BRAKE
6	FOR DIRECT CLUTCH

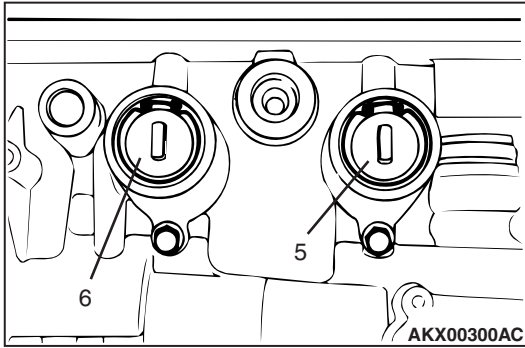

*NOTE: To make assembly easier, attach an identification tag on the removed accumulator piston.*

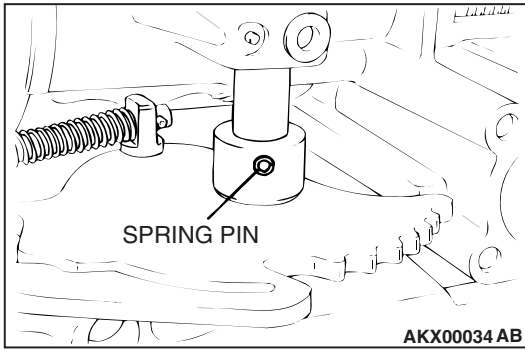

13. Remove the detent lever spring pin.

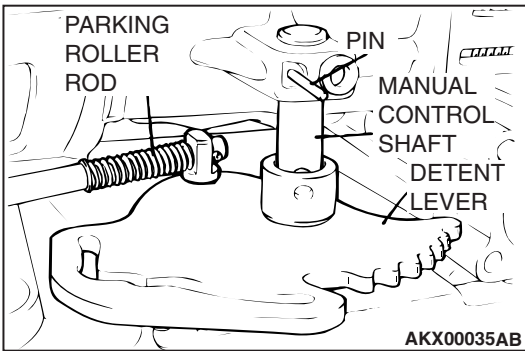

14. Remove the pin, and then remove the manual control shaft, two O-rings, detent lever and parking roller rod.

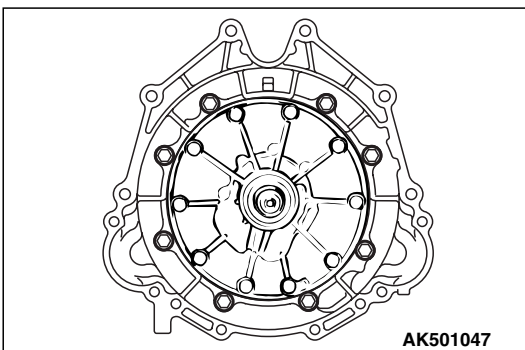

15. Remove the eight converter housing mounting bolts, and then the converter housing.

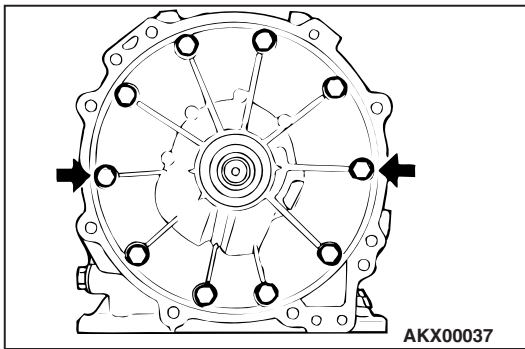

16. Remove the ten oil pump mounting bolts.
17. Install special tool MD998333 into the bolt hole shown in the illustration.

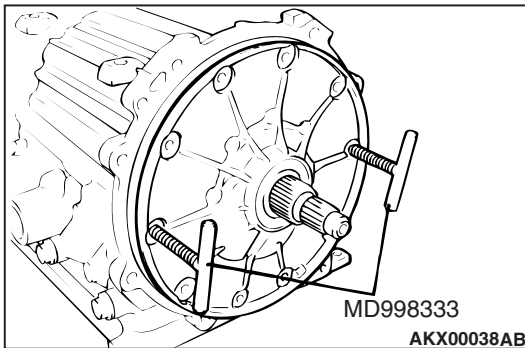

18. While screwing in special tool MD998333 evenly, remove the oil pump.
19. Remove the oil pump gasket.

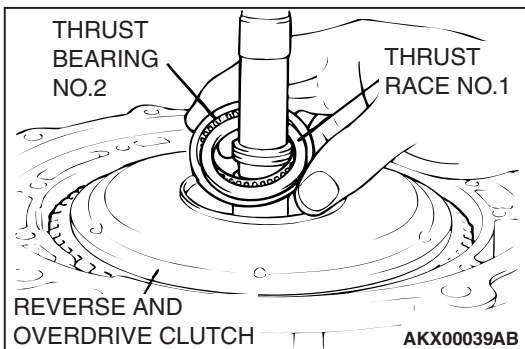

20. Remove the reverse and overdrive clutch, thrust race number 1 and thrust bearing number 2.  
*NOTE: The thrust race number 1 may be attached to the oil pump.*

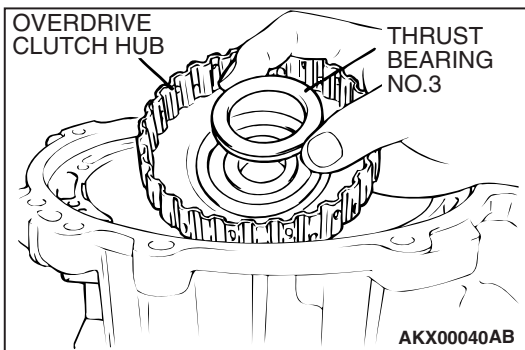

21. Remove the overdrive clutch hub and thrust bearing number 3.

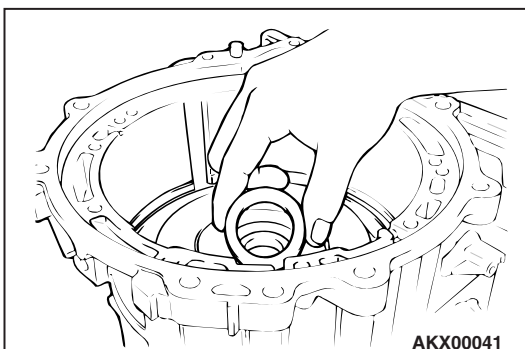

22. Remove the thrust bearing number 4.  
*NOTE: The thrust bearing number 4 may be attached to the overdrive clutch hub.*

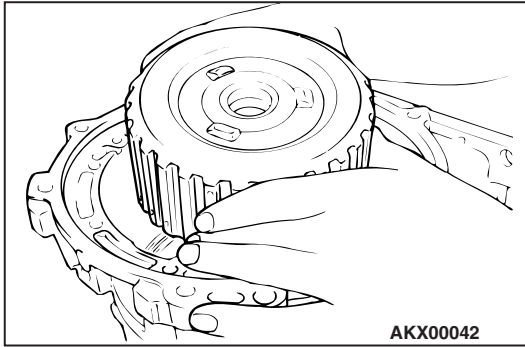

23. Remove the reverse sun gear.

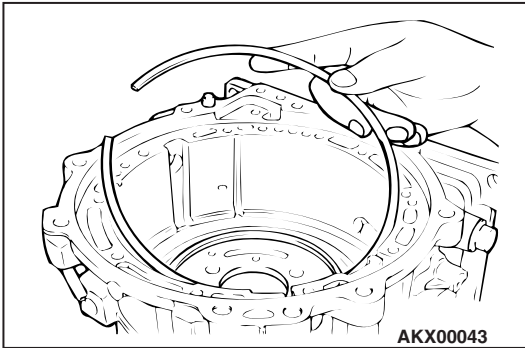

24. Remove the snap ring.

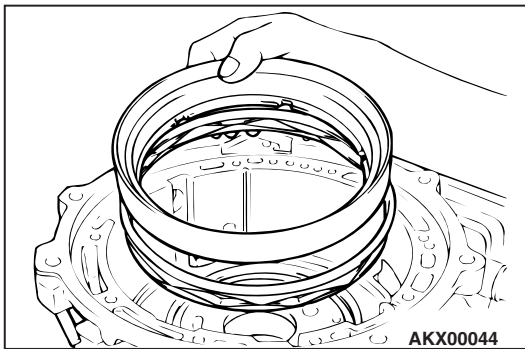

25. Remove the second brake and return spring.

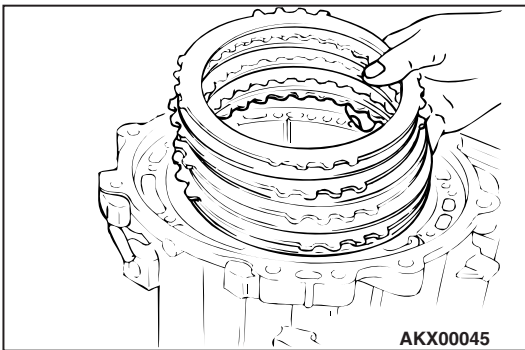

26. Remove the pressure plate, brake plate and brake disc.

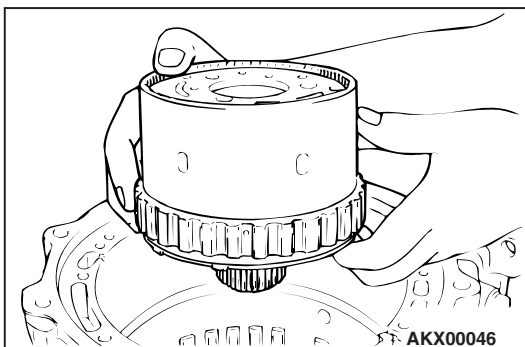

27. Remove the low/reverse annulus gear.



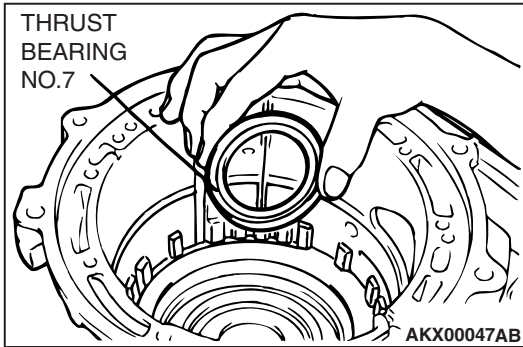

28.Remove the thrust bearing number 7.

*NOTE: The thrust bearing number 7 may be attached to the low/reverse annulus gear.*

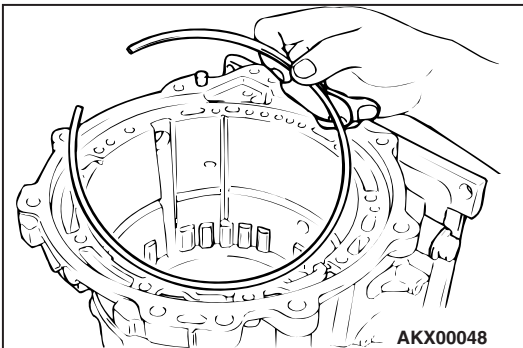

29.Remove the snap ring.

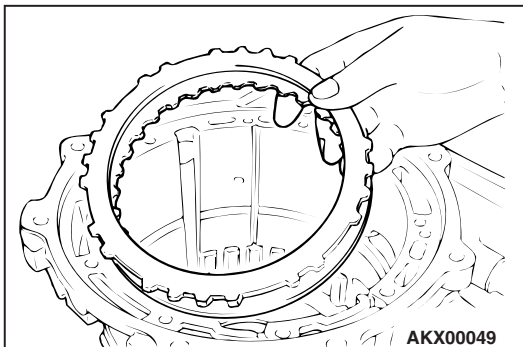

30.Remove the reaction plate and one brake disc.

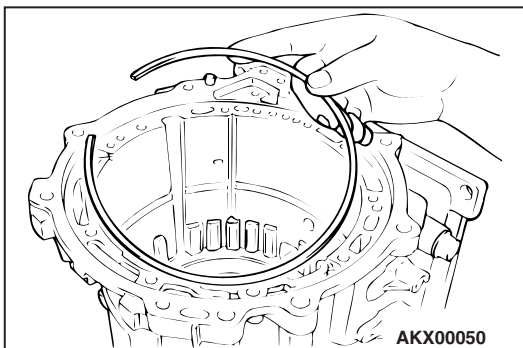

31.Remove the snap ring.

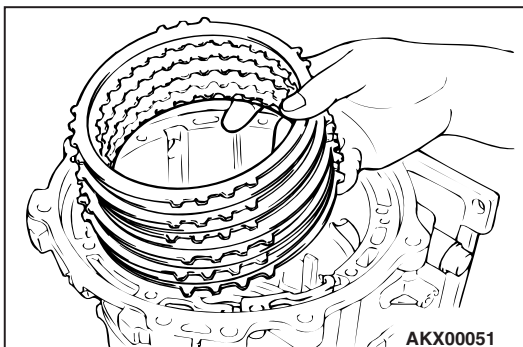

32.Remove the brake plate, brake disc, and pressure plate.

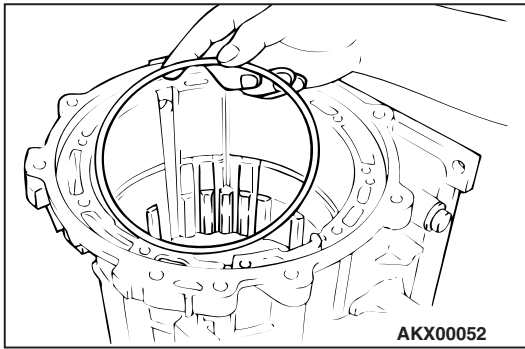

33.Remove the wave spring.

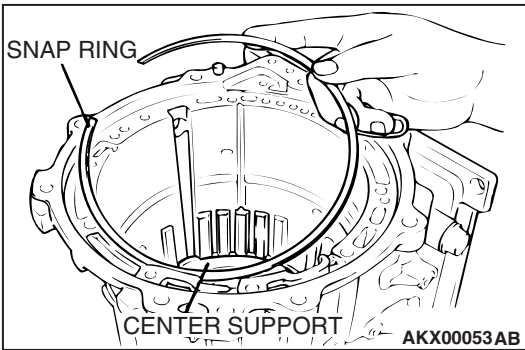

34.Remove the snap ring and center support.

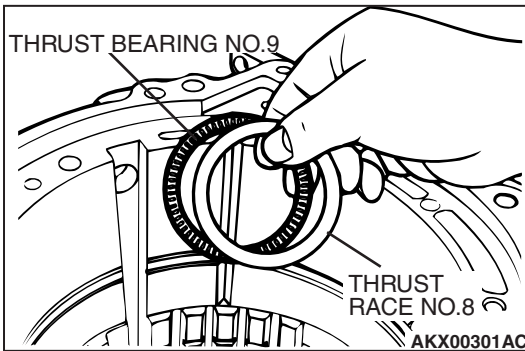

35.Remove the thrust race number 8 and thrust bearing number 9.

*NOTE: The thrust race number 8 may be attached to the center support.*

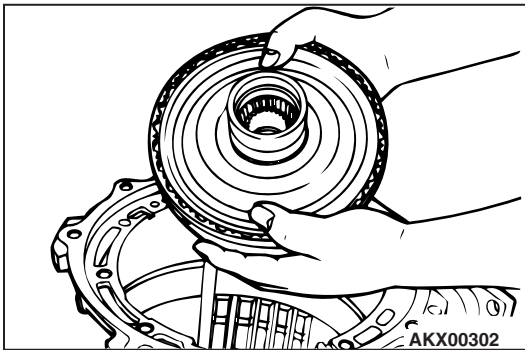

36.Remove the direct annulus gear.

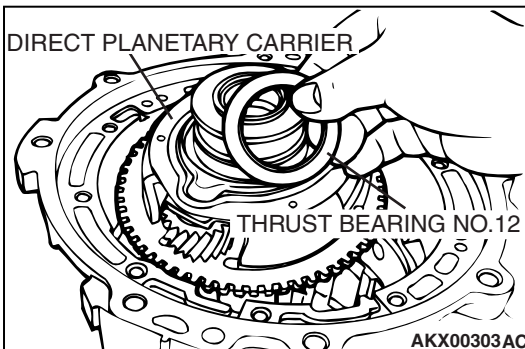

37.Remove the thrust bearing number 12 and direct planetary carrier.

*NOTE: The thrust bearing number 12 may be attached to the direct annulus gear.*

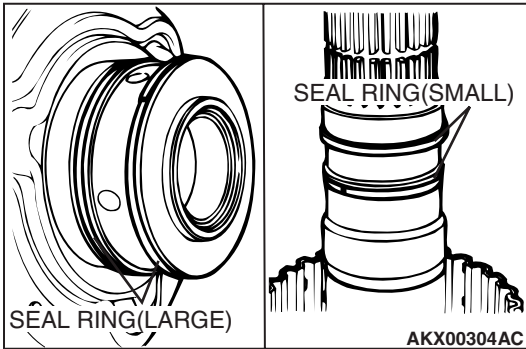

38.Remove the two large and two small seal rings from the direct planetary carrier.

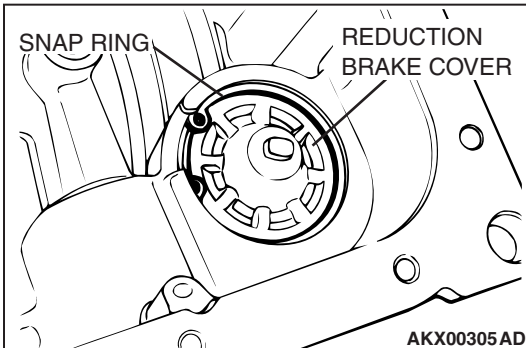

39.Remove the snap ring and then the reduction brake piston cover and O-ring.

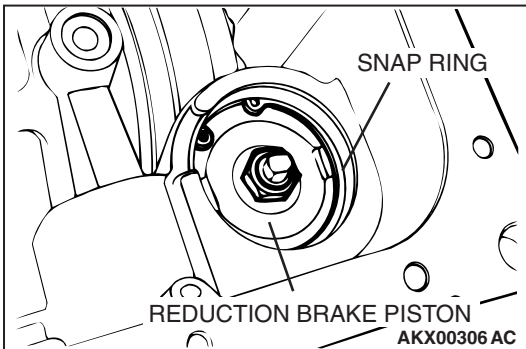

40.Remove the snap ring and then the nut, reduction brake piston, seal ring. Adjust rod and spring.

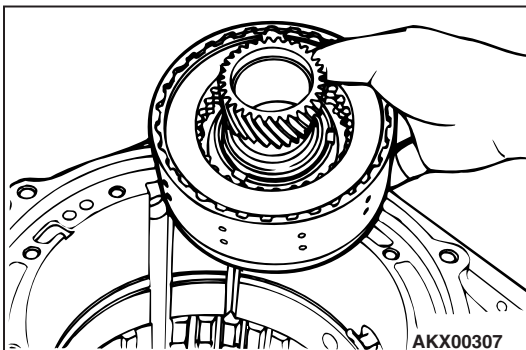

41.Remove the direct clutch.

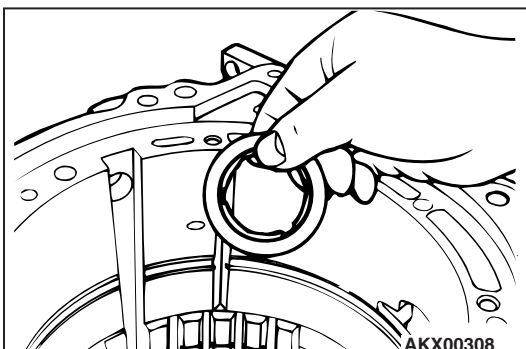

42.Remove the thrust bearing number 13.

*NOTE: The thrust bearing number 13 may be attached to the direct clutch.*

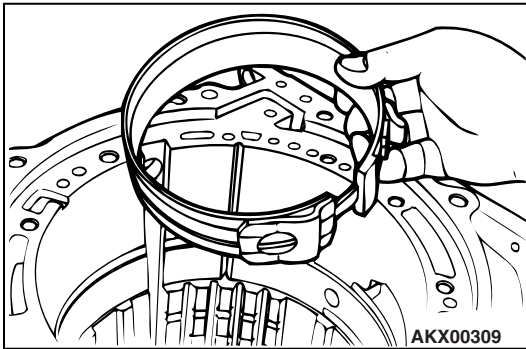

43. Remove the reduction brake band.

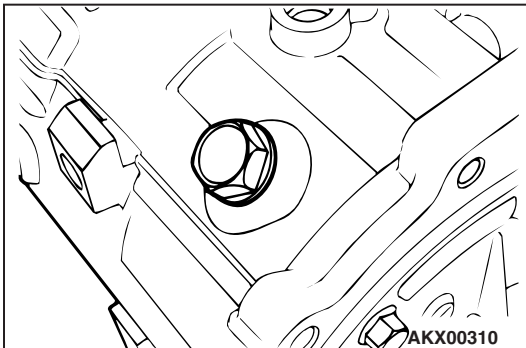

44. Remove the anchor plug and the O-ring.

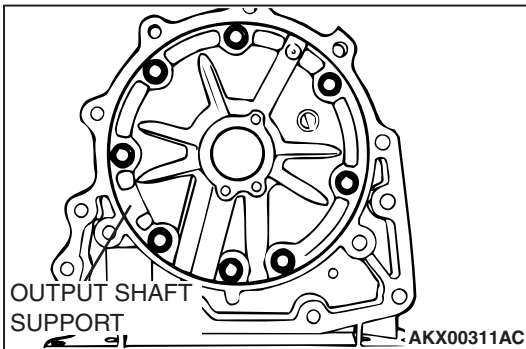

45. Remove the eight output shaft support mounting bolts, and then remove the output shaft support and gasket.

## ASSEMBLY

### **⚠ CAUTION**

- Never reuse the gasket, O-rings, oil seals, etc. Always replace with new ones when assembling.
- Never use grease other than blue petroleum jelly and white Vaseline.
- Apply ATF to friction components, rotating parts, and sliding parts before installation. Immerse a new clutch disc or brake disc in ATF for at least two hours before assembling them.
- Never apply sealant or adhesive to gaskets.
- When replacing a bushing, replace the assembly which it belongs to.
- During the work, always use bare hands or vinyl gloves. Do not use cotton gloves. Use nylon cloth or paper towels when necessary. Do not use shop towels.
- Change the oil in the cooler system.

**⚠ CAUTION**

**Never reuse a gasket.**

1. Install a new gasket and output shaft support.
2. Tighten the eight output shaft support mounting bolts to the specified torque.

**Specified torque: 23 ± 3 N·m (17 ± 2 ft-lb)**

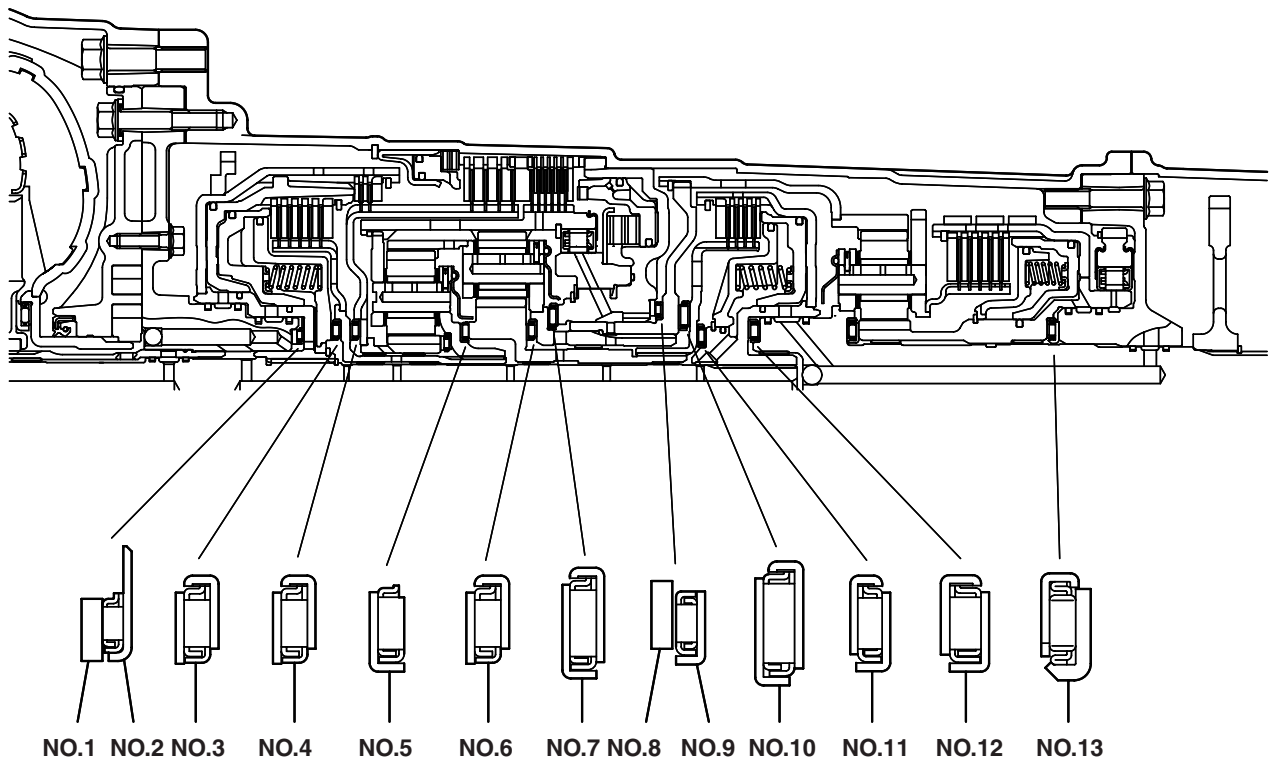
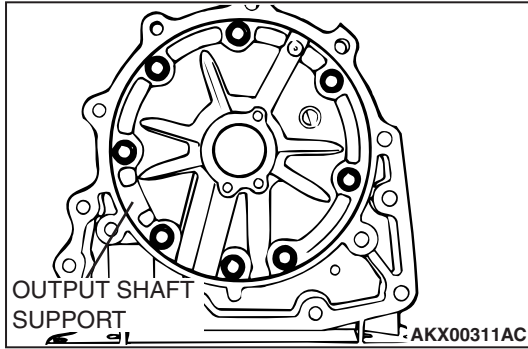

AKX00312AC

SYMBOL	OD mm (in)	ID mm (in)	THICKNESS mm (in)	PART NUMBER
NO.1	48.9 (1.93)	37 (1.46)	1.4 (0.055)	MD723063
			1.6 (0.063)	MD707267
			1.8 (0.071)	MD723064
			2.0 (0.079)	MD707268
			2.2 (0.087)	MD723065
			2.4 (0.094)	MD724358
			2.6 (0.102)	MD754798
NO.2	59 (2.32)	37 (1.46)	2.8 (0.110)	MR305718
NO.3	57 (2.24)	38.5 (1.52)	4.12 (0.162)	MD758556
NO.4	57 (2.24)	38.5 (1.52)	4.12 (0.162)	MD758556

SYMBOL	OD mm (in)	ID mm (in)	THICKNESS mm (in)	PART NUMBER
NO.5	55.4 (2.18)	38.5 (1.52)	3.3 (0.130)	MD761683
NO.6	57 (2.24)	38.5 (1.52)	4.12 (0.162)	MD758556
NO.7	70 (2.76)	48.8 (1.92)	4.0 (0.157)	MR222902
NO.8	73 (2.87)	60 (2.36)	1.6 (0.063)	MR276705
			1.8 (0.071)	MR276706
			2.0 (0.079)	MR276707
			2.2 (0.087)	MR276708
			2.4 (0.094)	MR276709
NO.9	71.45 (2.81)	57 (2.24)	2.8 (0.110)	MR276587
NO.10	71.9 (2.83)	48.25 (1.90)	4.6 (0.181)	MR263281
NO.11	53 (2.08)	34.7 (1.47)	4.0 (0.157)	MR967353
NO.12	57 (2.24)	38.5 (1.52)	4.12 (0.162)	MR967354
NO.13	58 (2.28)	37.5 (1.48)	4.8 (0.189)	MD762511

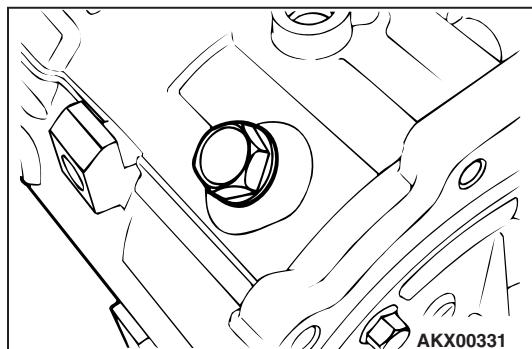

3. Install new O-ring on the anchor plug and tighten the anchor plug by specified torque.

**Specified torque: 98 ± 15 N·m (71 ± 11 ft·lb)**

**⚠ CAUTION**

Insert the anchor bracket hole of the brake band to the anchor plug tip, and then mount the apply bracket part to the hole of reduction brake piston adjust rod.

4. Install the reduction brake band.

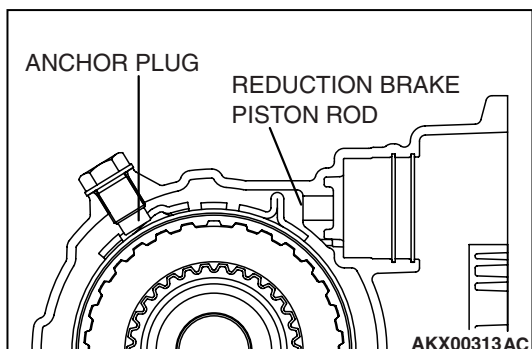
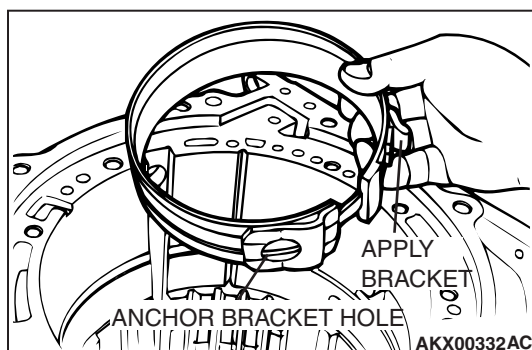

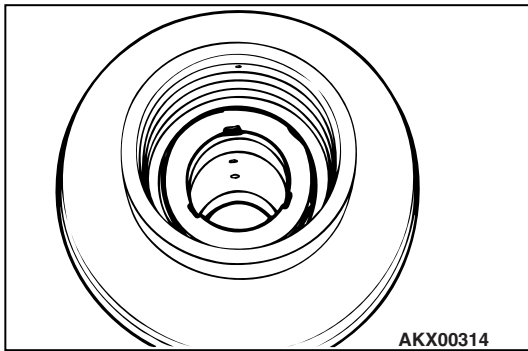

5. Install the thrust bearing number 13.

**CAUTION**

Make sure the thrust bearing number 13 is mounted in the correct direction.

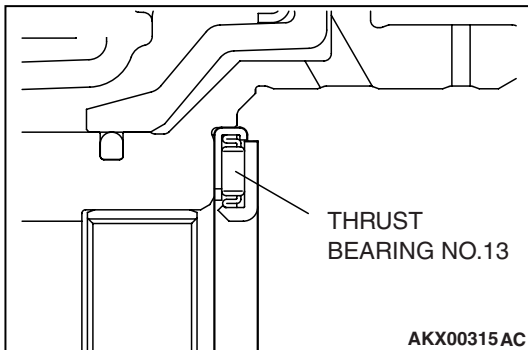

**CAUTION**

Take care that the reduction brake band does not come off the anchor rod and the hole of the reduction brake piston adjust rod.

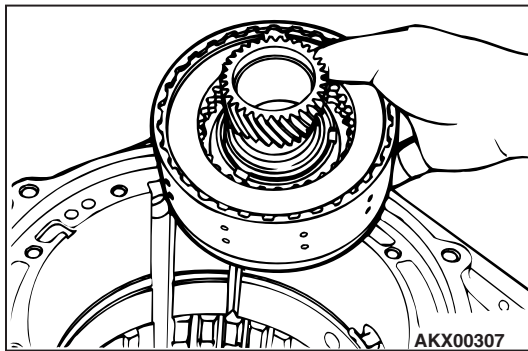

6. Install the direct clutch.

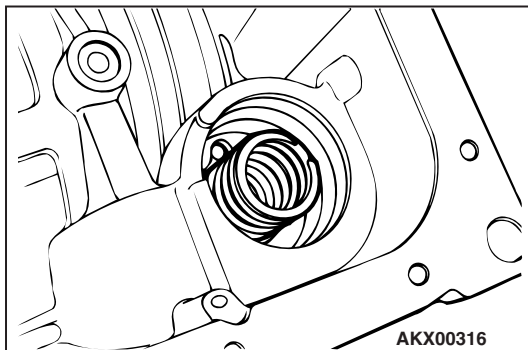

7. Install the reduction brake spring.

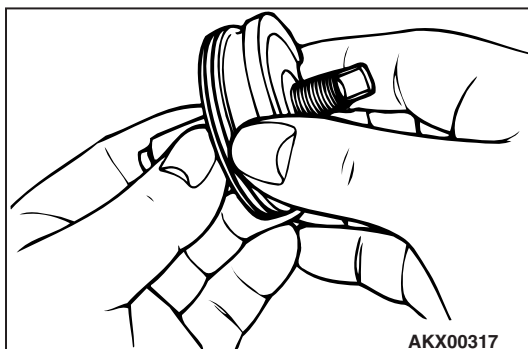

8. Tighten the reduction brake piston adjust rod into the reduction brake piston manually to the full.

9. Install new seal ring on the piston.

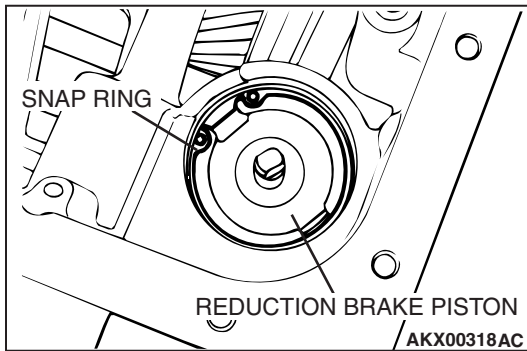

10. Press the reduction brake piston into the transmission case, and then install the snap ring.

*NOTE: Set the open end of the snap ring at indicated location.*

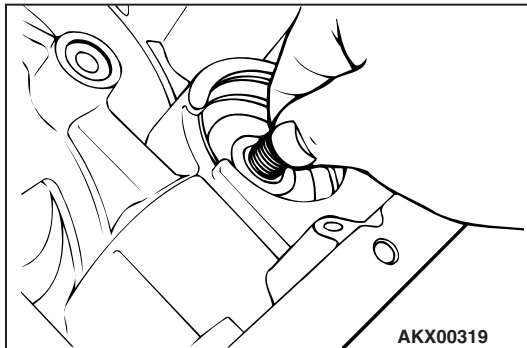

11. Fully tighten the reduction brake piston adjust rod manually.

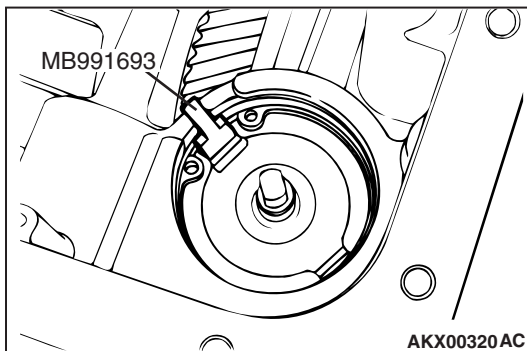

12. Adjust the reduction brake piston by following procedure.

(1) Mount the special tool so that the reduction brake piston does not rotate.

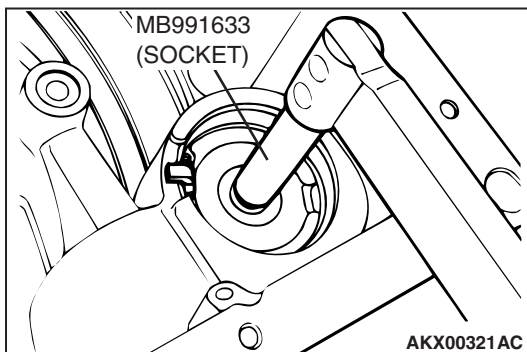

(2) Mount the torque wrench to the special tool (Socket), and after repeatedly tightening and turning back with the torque of 10 N·m (87 in - lb) twice, tighten the reduction brake piston adjust rod by the specified torque. Then turn the reduction brake piston adjust rod 5 1/2 to 5 3/4 turns backwards.

**Specified torque: 5.0 N·m (44 in-lb)**

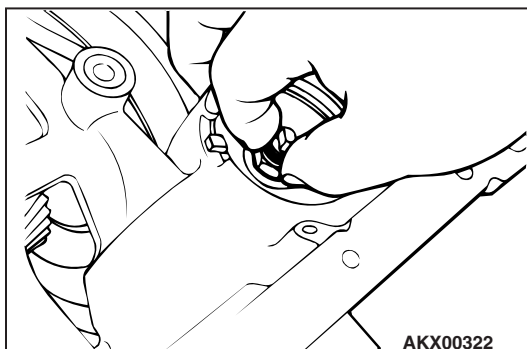

(3) Remove the special tool and tighten the reduction brake piston nut manually.



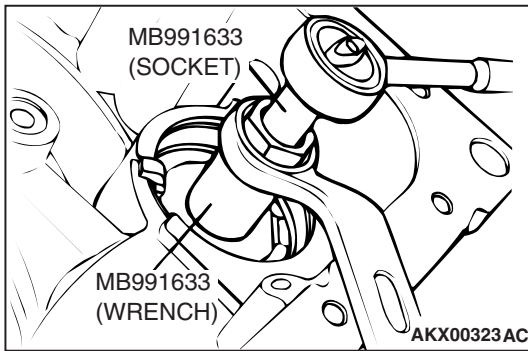

- (4) Tighten the reduction brake piston nut to the specified torque using the special tool (wrench) with the special tool (Socket) so it does not rotate.

**Specified torque:  $18 \pm 3$  N·m ( $13 \pm 2$  ft-lb)**

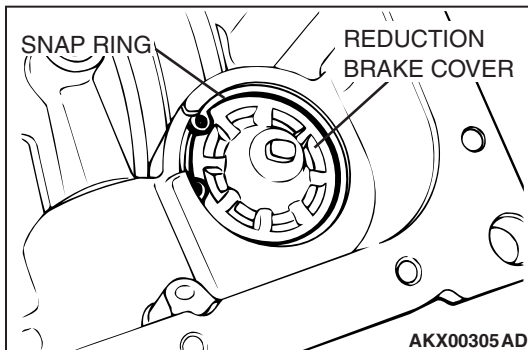

13. Install a new O-ring on the reduction brake piston cover, and then install the cover and the snap ring on the transmission case.

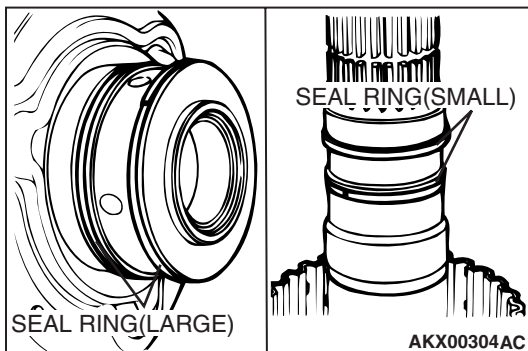

14. Install new seal rings (two large pieces and two small pieces) onto the direct planetary carrier.

15. Install the direct planetary carrier into the output shaft support.

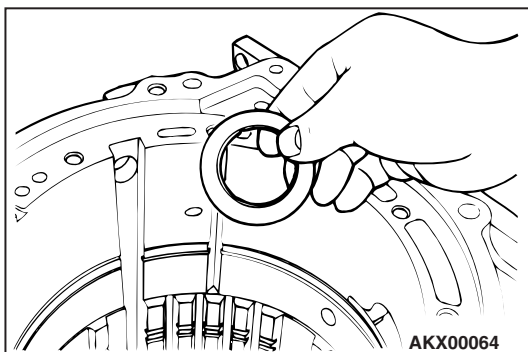

16. Apply vase line or petroleum jelly on the thrust bearing number 12, and then install on the front end of the direct planetary carrier.

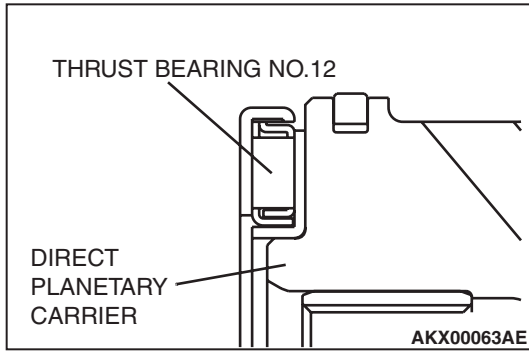
**⚠ CAUTION**

Make sure thrust bearing number 12 is mounted in the correct direction.

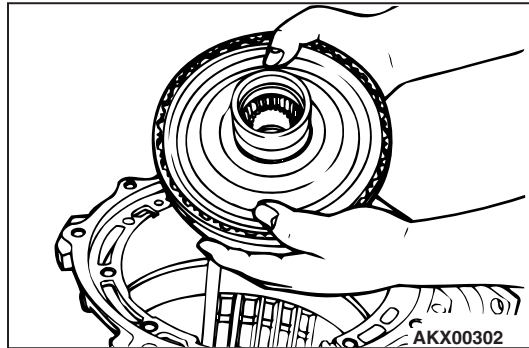
**⚠ CAUTION**

Confirm that the thrust bearing number 10 in the direct annulus gear is still at specified location.

17. Insert the direct annulus gear.

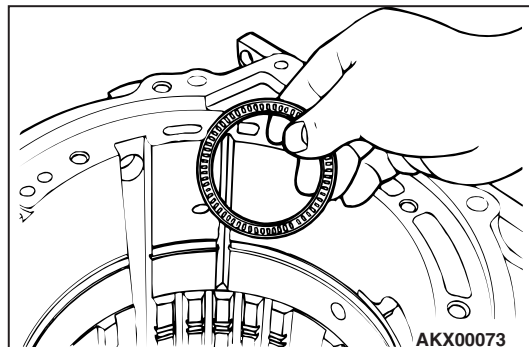

18. Apply Vaseline or petroleum jelly on the thrust bearing number 9, and then install on the direct annulus gear.

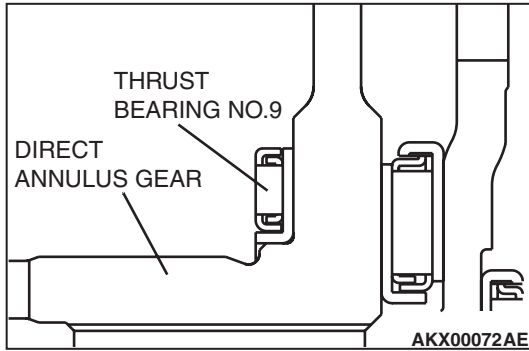

**CAUTION**

Make sure thrust bearing number 9 is mounted in the correct direction.

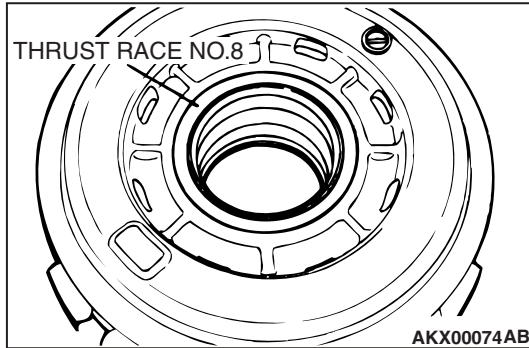

**CAUTION**

Measure and record the thickness of the thrust race number 8 to be assembled.

19. Apply Vaseline or blue petroleum jelly on the thrust race number 8 being used, and then install it on the rear side of the center support.

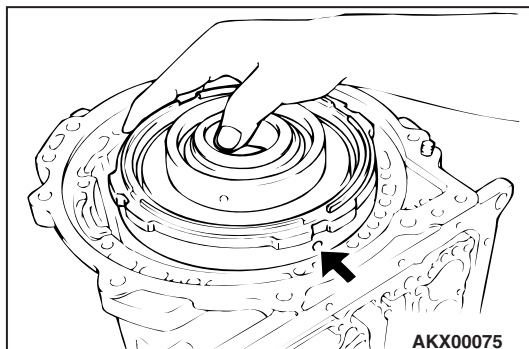

**CAUTION**

- Install the center support so that the oil holes shown in the illustration face the lower side of the transmission case.
- Make sure that the thrust race number 8 attached to the rear side of the center support does not fall off.

20. Install the center support.

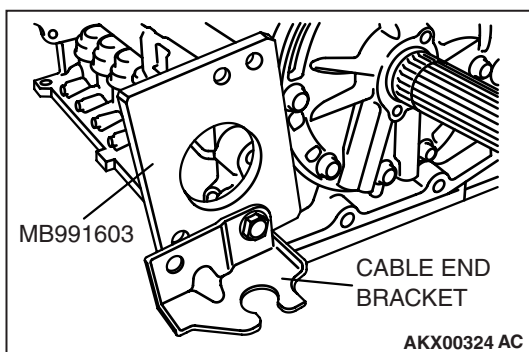

**CAUTION**

Install the cable bracket together with special tool.

21. Using the Transfer case adapter bolt, install special tool MB991603.

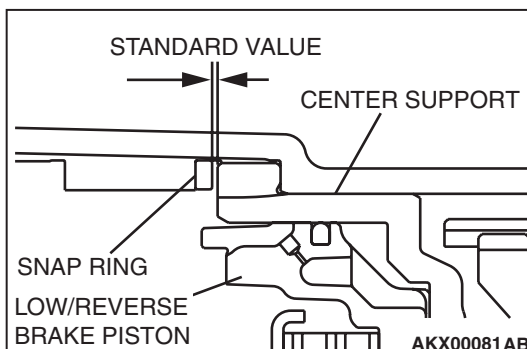
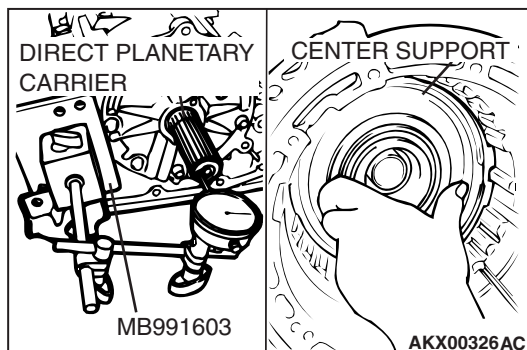
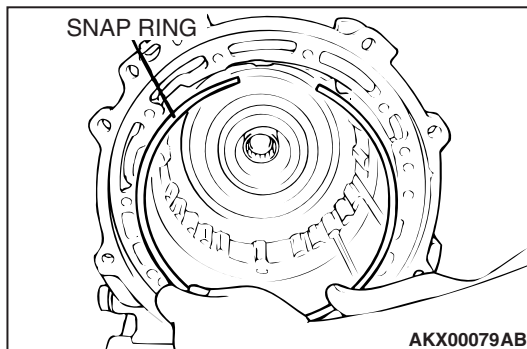
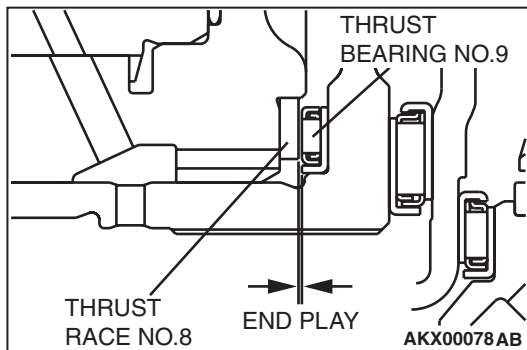
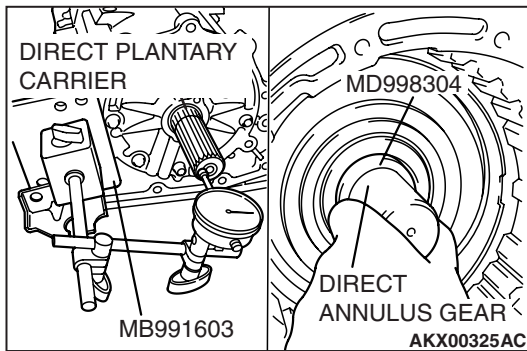

22. Select the thrust race number 8 with the following procedure:

- (1) Fix a dial gauge to special tool MB991603.
- (2) Push the direct planetary carrier, and the direct annulus gear in alternately, and then measure the end play of direct planetary carrier.

*NOTE: When pushing the direct planetary carrier in, take care that the center support does not move.*

*NOTE: When pushing the direct annulus gear in, use the special tool MB998304.*

- (3) Reinstall by selecting the thrust race number 8 installed by the procedure (19) so that the end play of direct planetary carrier becomes the standard value.

*NOTE: Refer to the thickness recorded in step 12.*

**Standard value: 0.25 – 0.71 mm (0.0098 – 0.0278 inch)**

- (4) Measure the end play again, and confirm that it is within the standard value.

*NOTE: Carry this step out with special tool MB991603 and dial gauge installed.*

23. Using the following steps, select the snap ring for fixing the center support.

- (1) Install the snap ring used for fixing the center support used.

- (2) After pushing the direct planetary carrier, and the center support in alternately, and then measure the end play of center support.

*NOTE: When pushing the direct planetary carrier in, be sure to push them in to the point where the center support touches the snap ring.*

- (3) Select the snap ring for fixing the center support installed in step 23 (1) so that the end play of the center support is at the standard value. Then, reassemble.

**Standard value: 0 – 0.16 mm (0 – 0.0063 inch)**

- (4) Measure the end play again, and confirm that it is within the standard value.

24. Using the following steps, select the snap ring for adjusting the brake reaction plate end play and second brake end play, and the pressure plate for adjusting the low/reverse brake end play.

(1) Install the wave spring onto the low/reverse brake piston.

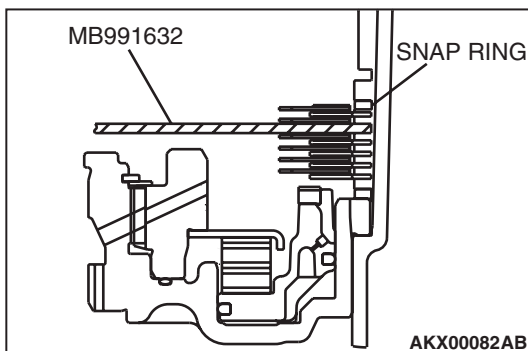
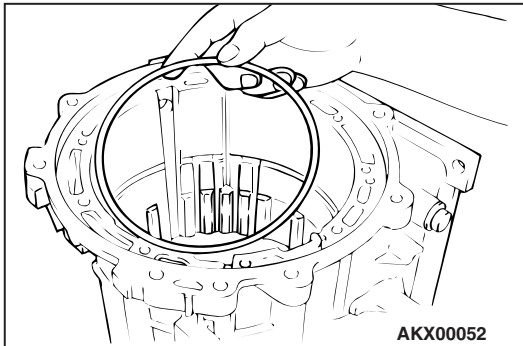

(2) Install special tool MB991632 onto the position shown in the illustration instead of the pressure plate for the low/reverse brake. Install the brake disc, brake plate and snap ring.

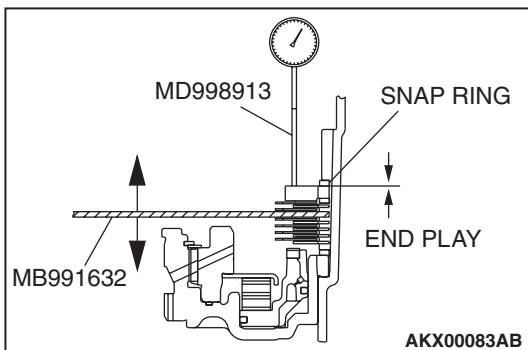

**CAUTION**

Pay close attention to the assembly direction of the reaction plate.

- (3) Install the reaction plate and snap ring that was used.
- (4) Install a dial gauge onto special tool MD998913 so that the end contacts the brake reaction plate. Measure the end play by moving special tool MB991632.
- (5) Select the snap ring installed in step 24 (3) so that the end play is within the standard value. Then, reassemble.

**Standard value: 0 – 0.16 mm (0 – 0.0063 inch)**

(6) Measure the end play again, and confirm that it is within the standard value.

**CAUTION**

Pay close attention to the shape and assembly direction of the brake plate A installation.

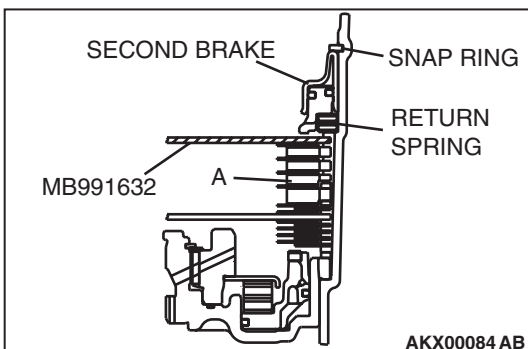

(7) Next, install special tool MB991632 instead of the pressure plate for the second brake. Install the four brake discs and three brake plates.

(8) Install the return spring, second brake and snap ring.

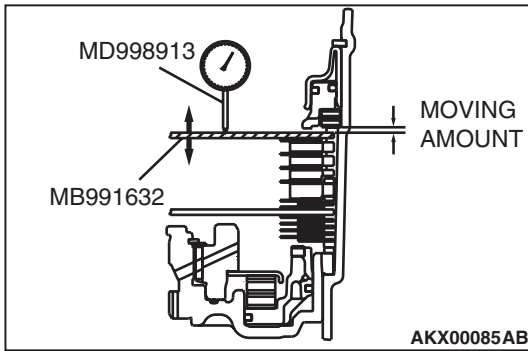

- (9) Install a dial gauge onto special tool MD998913 so the end contacts the special tool. Move special tool MB991632 and measure the moving amount. Select a pressure plate with a thickness that corresponds to the measured moving amount from the following table.

**Standard value: 1.49 – 1.95 mm (0.0587 – 0.0768 inch)**

MOVING AMOUNT mm (in)	PRESSURE PLATE		
	THICKNESS mm (in)	ID SYMBOL	ID SYMBOL
1.2 or more – less than 1.4 (0.047 or more – less than 0.055)	1.6 (0.063)	F	MR336390
1.4 or more – less than 1.6 (0.055 or more – less than 0.063)	1.8 (0.071)	E	MR336391
1.6 or more – less than 1.8 (0.063 or more – less than 0.071)	2.0 (0.079)	D	MR336392
1.8 or more – less than 2.0 (0.071 or more – less than 0.079)	2.2 (0.087)	C	MR336393
2.0 or more – less than 2.2 (0.079 or more – less than 0.087)	2.4 (0.094)	B	MR336394
2.2 or more – less than 2.4 (0.087 or more – less than 0.094)	2.6 (0.102)	A	MR336395
2.4 or more – less than 2.6 (0.094 or more – less than 0.102)	2.8 (0.110)	0	MR336396
2.6 or more – less than 2.8 (0.102 or more – less than 0.110)	3.0 (0.118)	1	MR336397

- (10) Remove the snap ring, second brake, return spring and special tool MB991632 installed in step (8).
- (11) Install the pressure plate selected in step (9), and install the return spring, second brake and snap ring again.
- (12) Install a dial gauge onto special tool MD998913 so the end contacts the special tool. Move special tool MB991632 and measure the moving amount. Select a pressure plate with a thickness that corresponds to the measured moving amount from the following table.

**End play standard value (reference)  
: 1.65 – 2.11 mm (0.0650 – 0.0831 inch)**

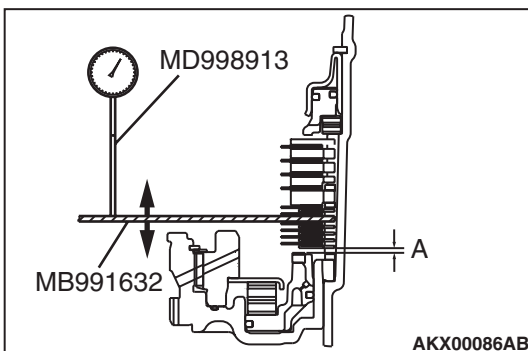

MOVING AMOUNT mm (in)	PRESSURE PLATE		
	THICKNESS mm (in)	ID SYMBOL	ID SYMBOL
1.5 or more – less than 1.7 (0.059 or more – less than 0.067)	1.8 (0.071)	E	MD759425
1.7 or more – less than 1.9 (0.067 or more – less than 0.075)	2.0(0.079)	D	MD759426
1.9 or more – less than 2.1 (0.075 or more – less than 0.083)	2.2 (0.087)	C	MD759427
2.1 or more – less than 2.3 (0.083 or more – less than 0.091)	2.4 (0.094)	B	MD759428
2.3 or more – less than 2.5 (0.091 or more – less than 0.098)	2.6 (0.102)	A	MD759429
2.5 or more – less than 2.7 (0.098 or more – less than 0.106)	2.8 (0.110)	0	MD759430
2.7 or more – less than 2.9 (0.106 or more – less than 0.114)	3.0 (0.118)	1	MD759431

(13)Remove the parts installed in steps 24 (1) to (12).

**⚠ CAUTION**

**Make sure thrust bearing number 7 is mounted in the correct direction.**

25. Apply Vaseline or petroleum jelly on the thrust bearing number 7, and then install on the rear side of the low/reverse annulus gear.

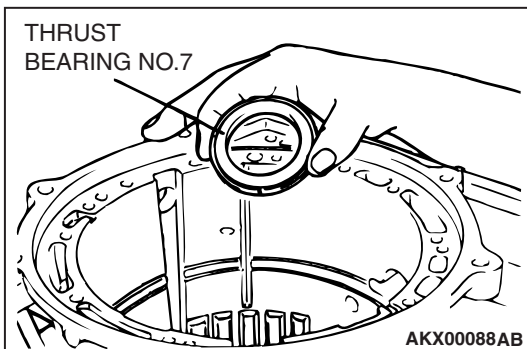
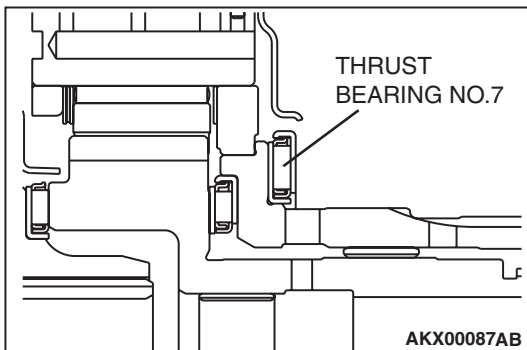

**⚠ CAUTION**

**Make sure that thrust bearing number 7 attached to the rear side of the low/reverse annulus gear does not fall off.**

26. Install the low/reverse annulus gear.

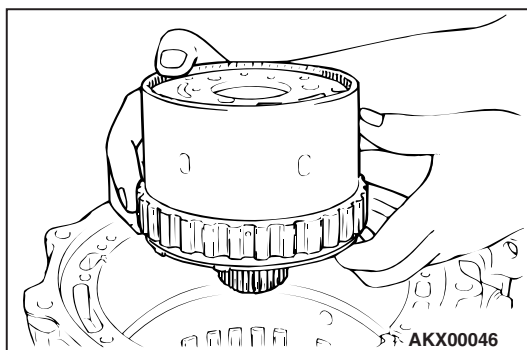

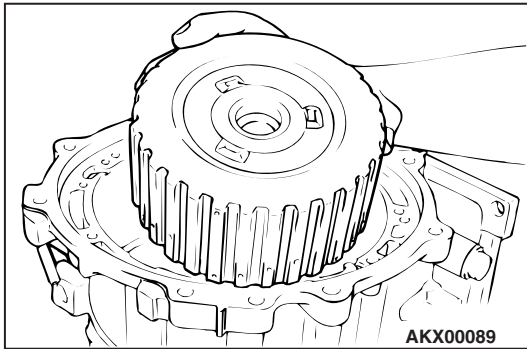

27. Install the reverse sun gear.

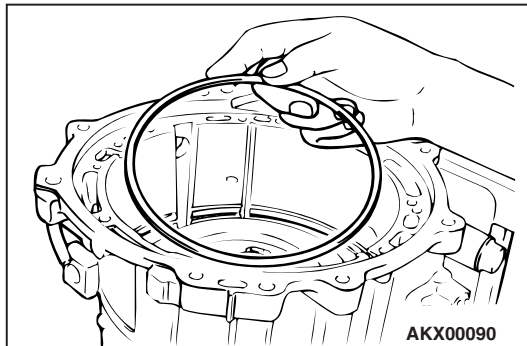

28. Install the wave spring to the low/reverse brake piston.

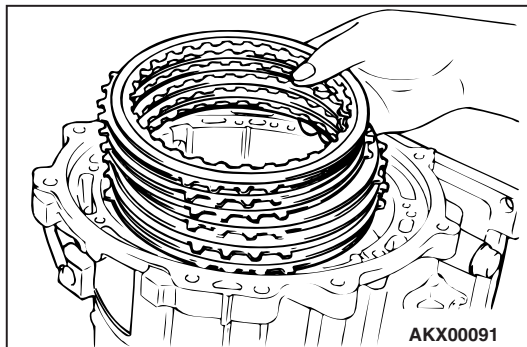

29. Install the pressure plate, brake disc and brake plate selected in step 24 (12).

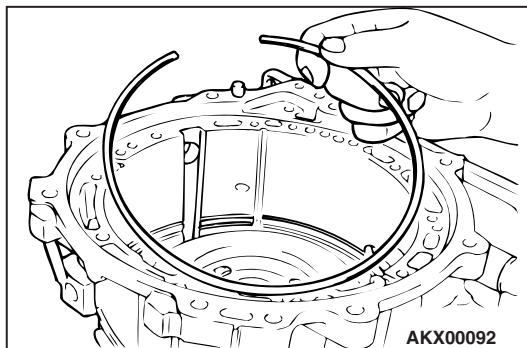

30. Install the snap ring.

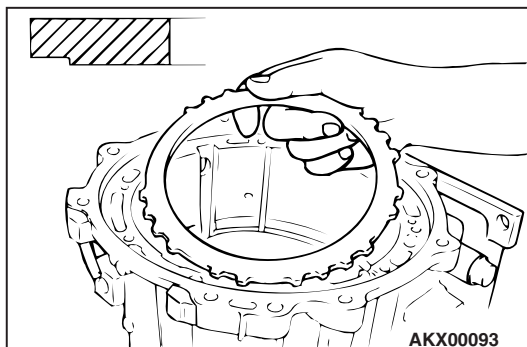

**⚠ CAUTION**

**Make sure the reaction plate is in the proper direction.**

31. Install the reaction plate.



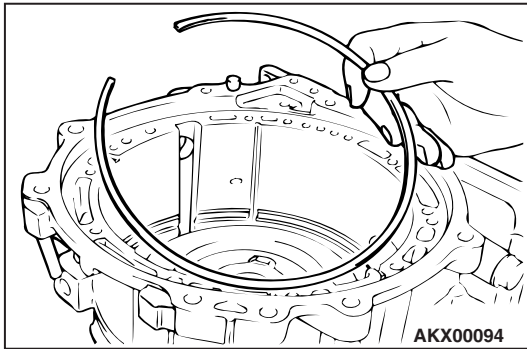

32. Install the snap ring selected in step 24 (5).

**CAUTION**

**Make sure the brake plate (reaction plate side) is installed in the proper direction.**

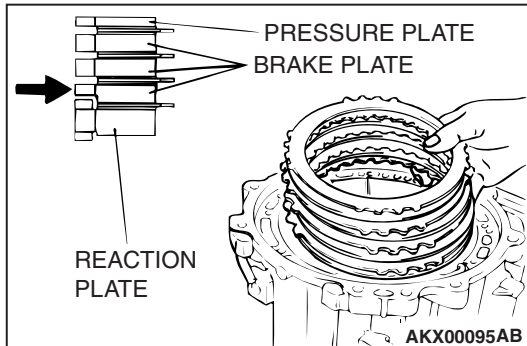

33. Install the brake disc, brake plate and pressure plate selected in step 24 (9).

**CAUTION**

**Install the return spring end coil side so that it faces the back of the transmission. (Only for one side end coil type)**

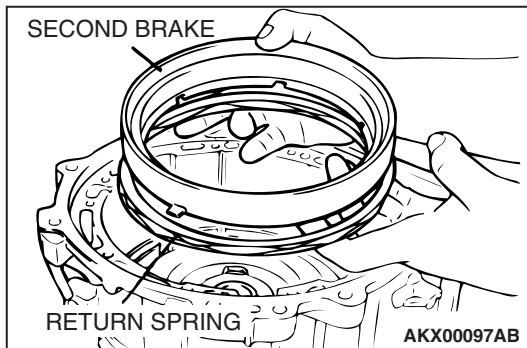
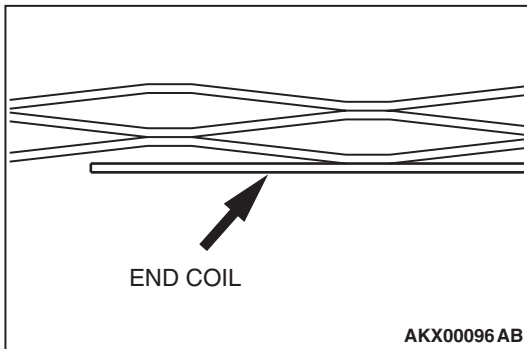

34. Install the return spring and second brake.

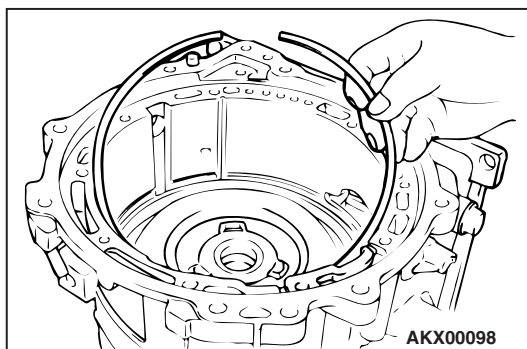

35. Install the snap ring.

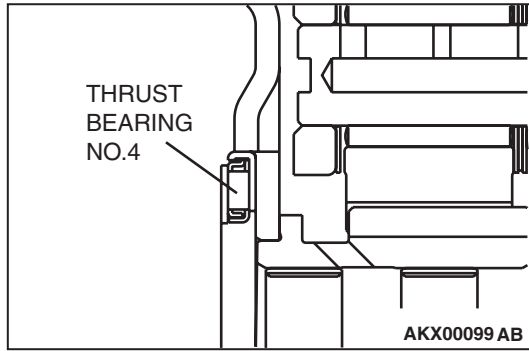
**CAUTION**

Make sure thrust bearing number 4 is installed in the proper direction.

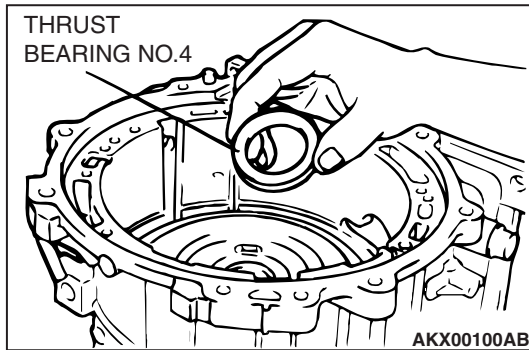

36. Apply Vaseline or petroleum jelly on the thrust bearing number 4, and then install on the reverse sun gear.

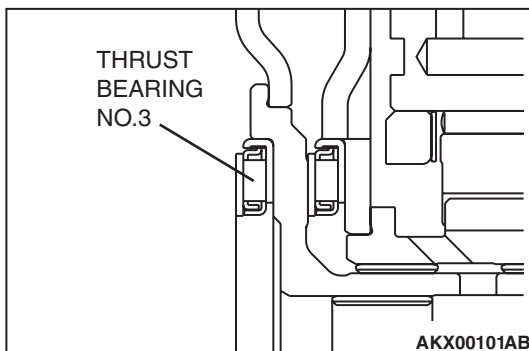
**CAUTION**

Make sure thrust bearing number 3 is mounted in the correct direction.

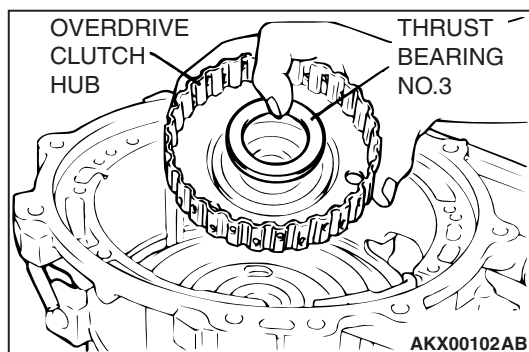

37. Apply Vaseline or petroleum jelly on the thrust bearing number 3, and then install on the overdrive clutch hub.  
38. Install the overdrive clutch hub.

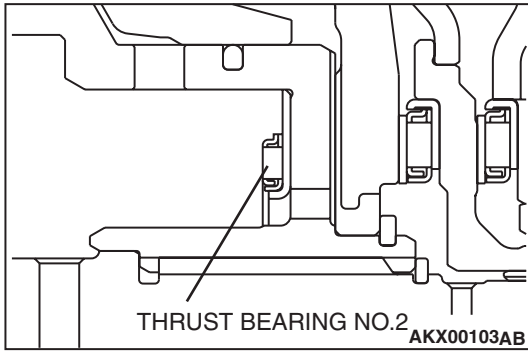

**CAUTION**

Make sure thrust bearing number 2 is mounted in the correct direction.

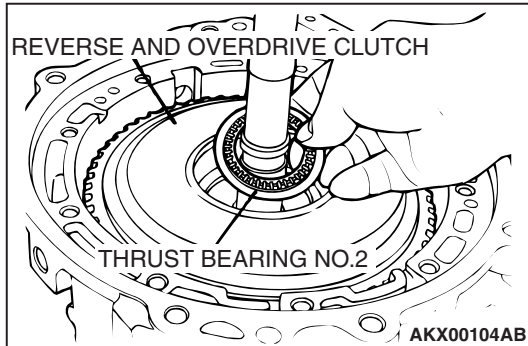

39. Install the reverse and overdrive clutch.

40. Apply Vaseline or petroleum jelly on the thrust bearing number 2, and then install on the reverse and overdrive clutch.

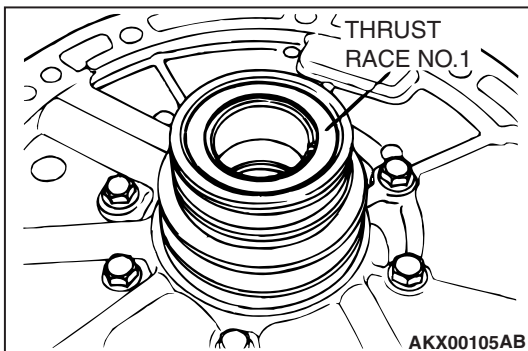

41. Apply Vaseline or petroleum jelly on the thrust race number 1 being used, and then install on the oil pump.

**CAUTION**

Never reuse a gasket.

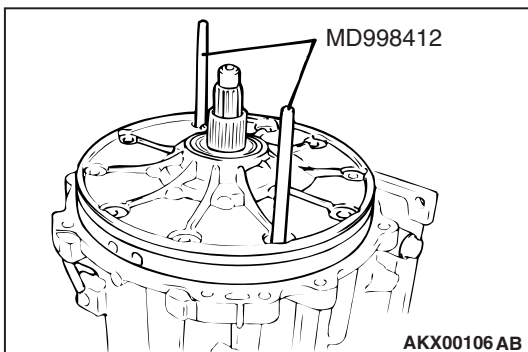

42. Install special tool MD998412 at the position shown in the illustration, and using this as a guide, install the oil pump and gasket.

43. Tighten the ten oil pump mounting bolts to the specified torque.

**Specified torque: 23 ± 3 N·m (17 ± 2 ft-lb)**

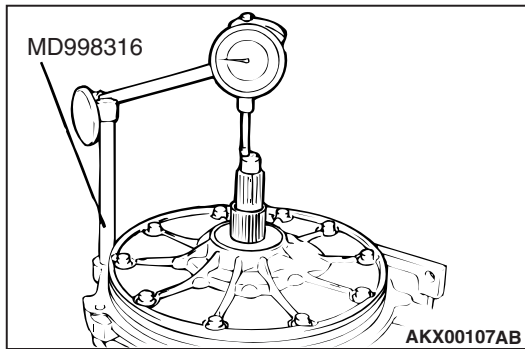

44. Using special tool MD998316, set a dial gauge as shown in the illustration. Measure the end play of the input shaft, and select the thrust race installed in step 28 so that the end play is at the standard value. Then, reassemble.

**Standard value: 0.25 – 0.81 mm (0.0098 – 0.0319 inch)**

45. Measure the end play again, and confirm that it is within the standard value.

**CAUTION**

**Evenly squeeze out the sealant so that it is not insufficient or excessive.**

46. Apply the sealant MITSUBISHI genuine sealant part number MR166584 or equivalent on the converter housing.

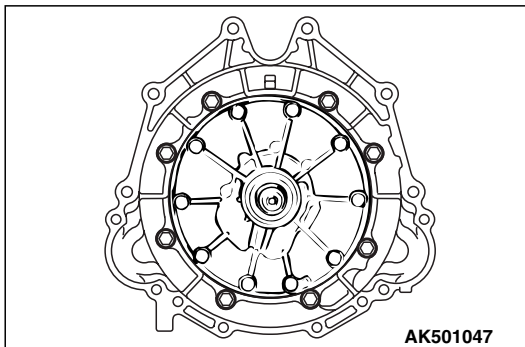
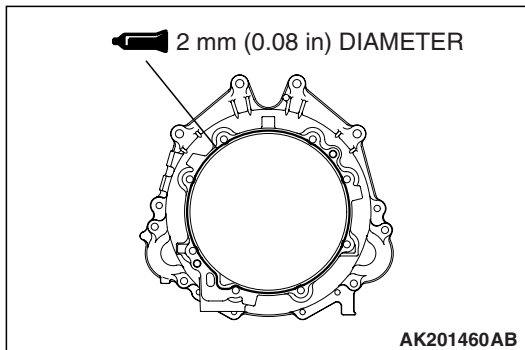

47. Install the converter housing.

48. Tighten the eight converter housing mounting bolts to the specified torque.

**Specified torque: 48 ± 6 N·m (35 ± 4 ft-lb)**

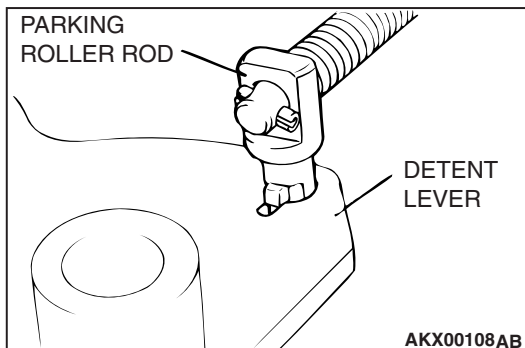

49. Install the parking roller rod to the detent lever.

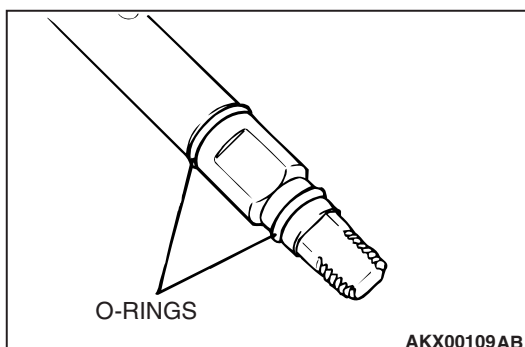

50. Install two new O-rings to the manual control shaft, and assemble onto the transmission case together with the detent lever and parking roller rod.

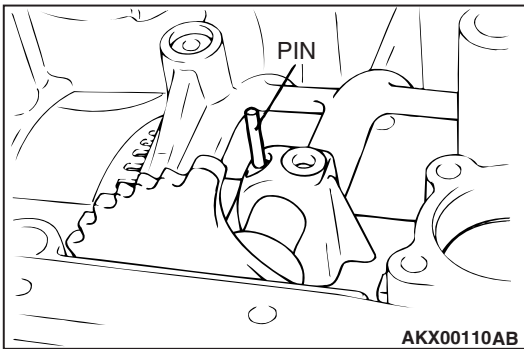

51. Install the pin.

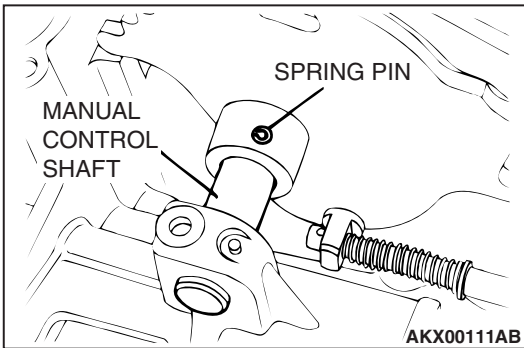

52. Hammer in so that the slit section of the spring valve is perpendicular to the axial direction of the manual control shaft.

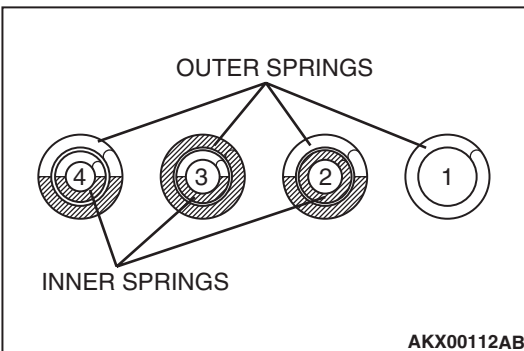

53. Install a new seal ring onto each accumulator piston.

54. Install each accumulator piston, spring and snap ring , accumulator cover, and O-ring .

*NOTE: Identification colors are applied on the spring as shown below. Assemble following this table.*

*NOTE: Install the accumulator pistons to the original positions following the identification tags attached when removed.*

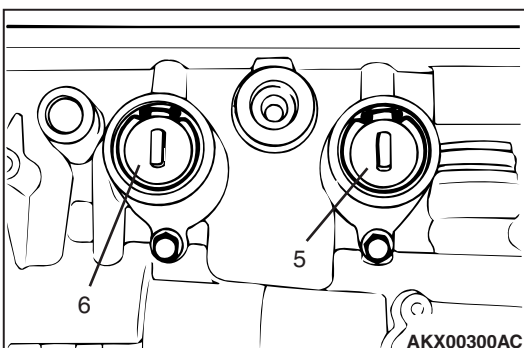
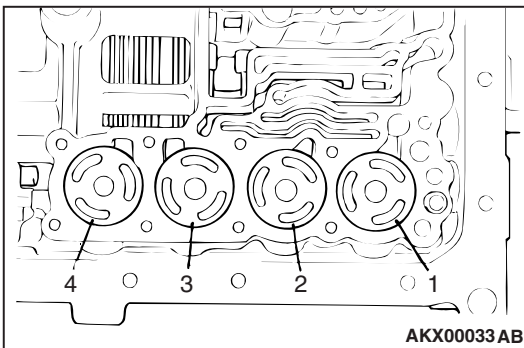

NO.	NAME	IDENTIFICATION PAINT APPLICATION POSITION	
1	For overdrive clutch	None	
2	For second brake	Inner	Applied on all surfaces including both ends
		Outer	Applied on half of surface including both ends
3	For low/reverse brake	Inner	Applied on half of surface including both ends
		Outer	Applied on entire surface of one side

NO.	NAME	IDENTIFICATION PAINT APPLICATION POSITION	
4	For underdrive clutch	Inner	Applied on half of surface including both ends
		Outer	Applied on half of surface including both ends
5	For reduction brake	None	
6	For direct clutch	None	

**⚠ CAUTION**

Pay close attention to the installation direction of the oil seal.

55. Install the oil strainer and two new oil seals. Install the oil seals so that the notched section is oriented as shown in the illustration.

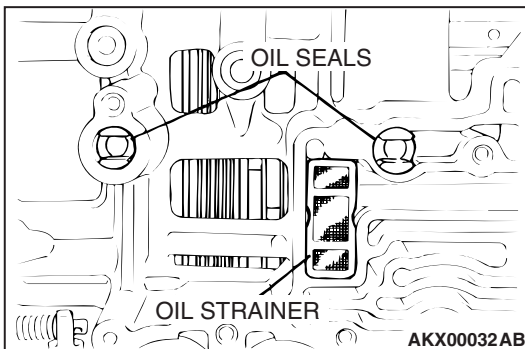

56. Install the solenoid valve harness, and then secure the snap ring into connector groove.

*NOTE: Install the harness so that it is oriented as shown in the illustration.*

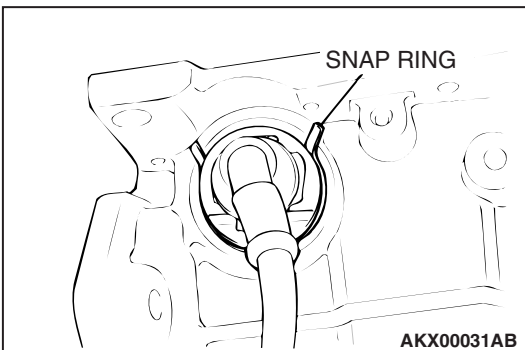

57. Install the new O-ring into the transmission case at the position shown in the illustration.

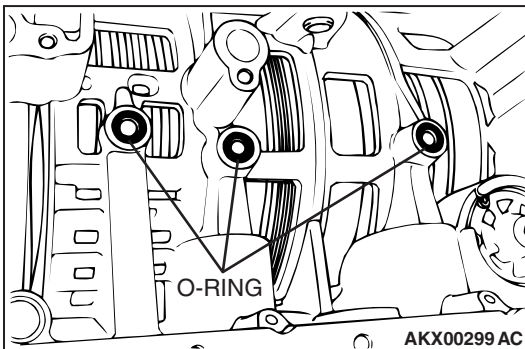

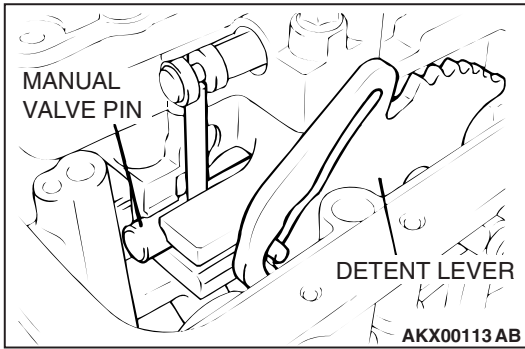

58. Install the valve body while inserting the manual valve pin into the detent lever groove.

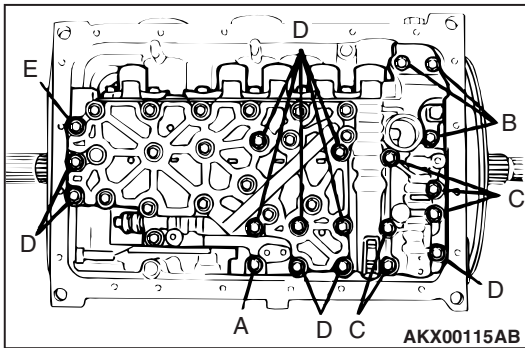

59. Tighten the twenty valve body mounting bolts to the specified torque.

BOLT	LENGTH mm (in)
A	25 (1.0)
B	30 (1.2)
C	40 (1.6)
D	45 (1.8)
E	55 (2.2)

**Specified torque: 11 ± 1 N·m (97 ± 9 in-lb)**

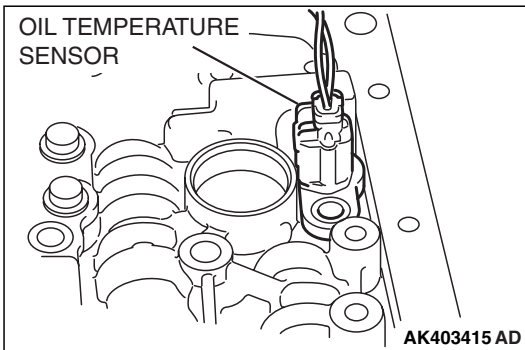

60. Install the oil temperature sensor.

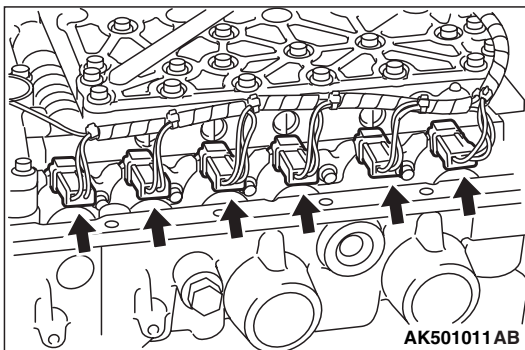

61. Connect the connector to the valve body.

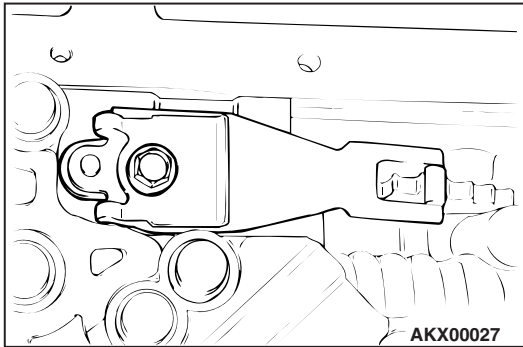

62. Install the detent spring.

63. Tighten the detent spring mounting bolt to the specified torque.

**Specified torque: 6.0 ± 1 N·m (52 ± 9 in-lb)**

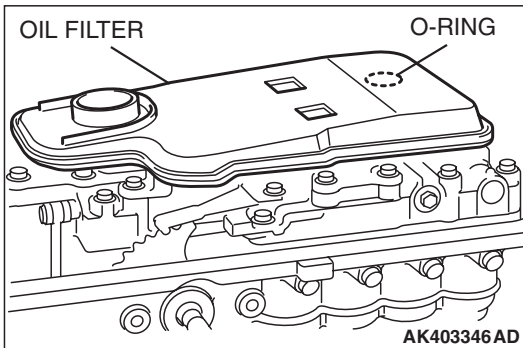

64. Install the oil filter and a new O-ring.

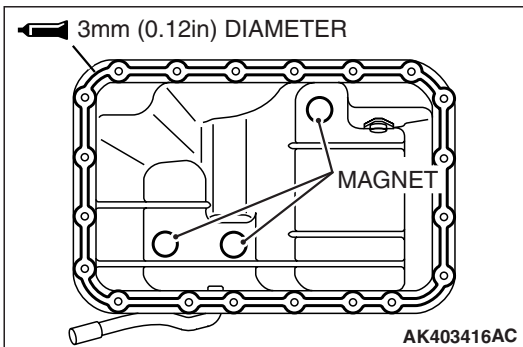

65. Install the magnet.

**CAUTION**

**Evenly squeeze out the sealant so that it is not insufficient or excessive.**

66. Apply the sealant MITSUBISHI genuine sealant part number MR166584 or equivalent on the oil pan.

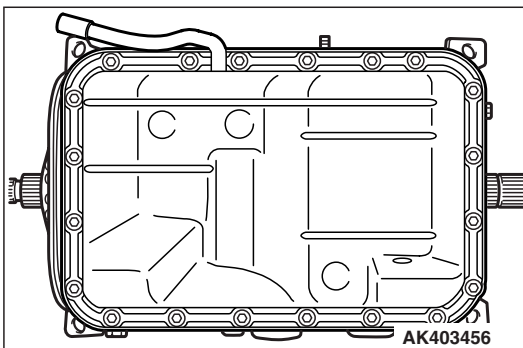

67. Install the oil pan.

68. Tighten the oil pan mounting bolts to the specified torque.

**Specified torque: 11 ± 1 N·m (97 ± 9 in-lb)**



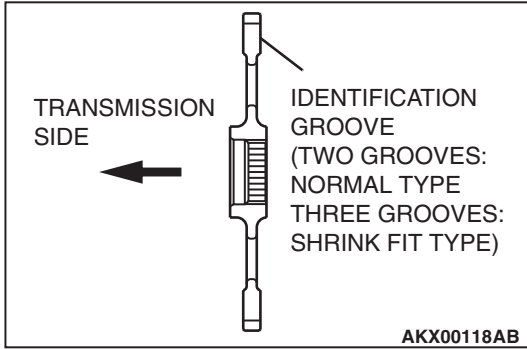

**CAUTION**

- Install the parking gear so that the side without the spline cut faces the transmission side.
- Heat the parking gear to 160 – 180°C (320 – 356°F) and shrink fit up to the stepped section of the output shaft. (Only the type with three identification grooves.) Do not heat for longer than necessary at this time.

69. Install the parking gear and snap ring.

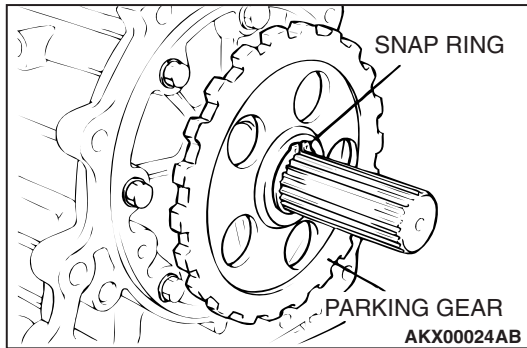

70. Install the park/neutral position switch and manual control lever.

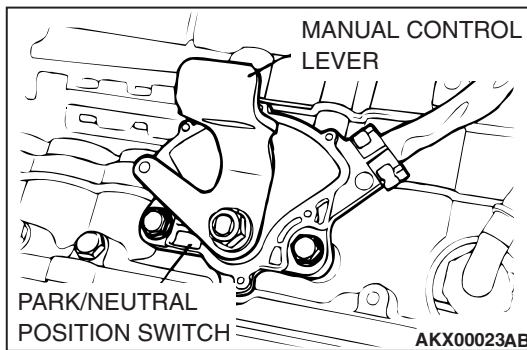

71. Install the output shaft speed sensor.

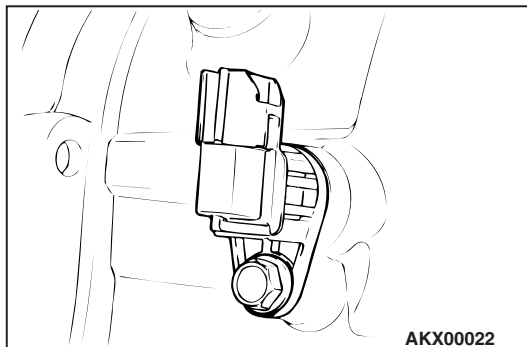

72. Install the input shaft speed sensor.

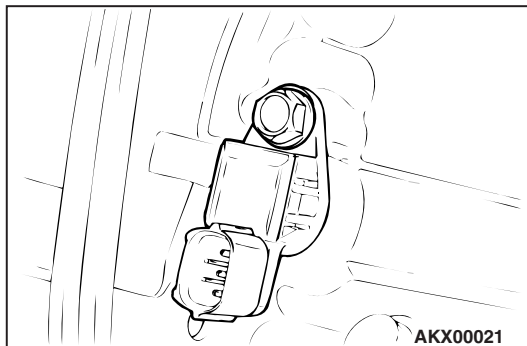

# REVERSE AND OVERDRIVE CLUTCHES

## DISASSEMBLY AND ASSEMBLY

M1233021200159

APPLY AUTOMATIC TRANSMISSION FLUID TO ALL MOVING PARTS BEFORE INSTALLATION.

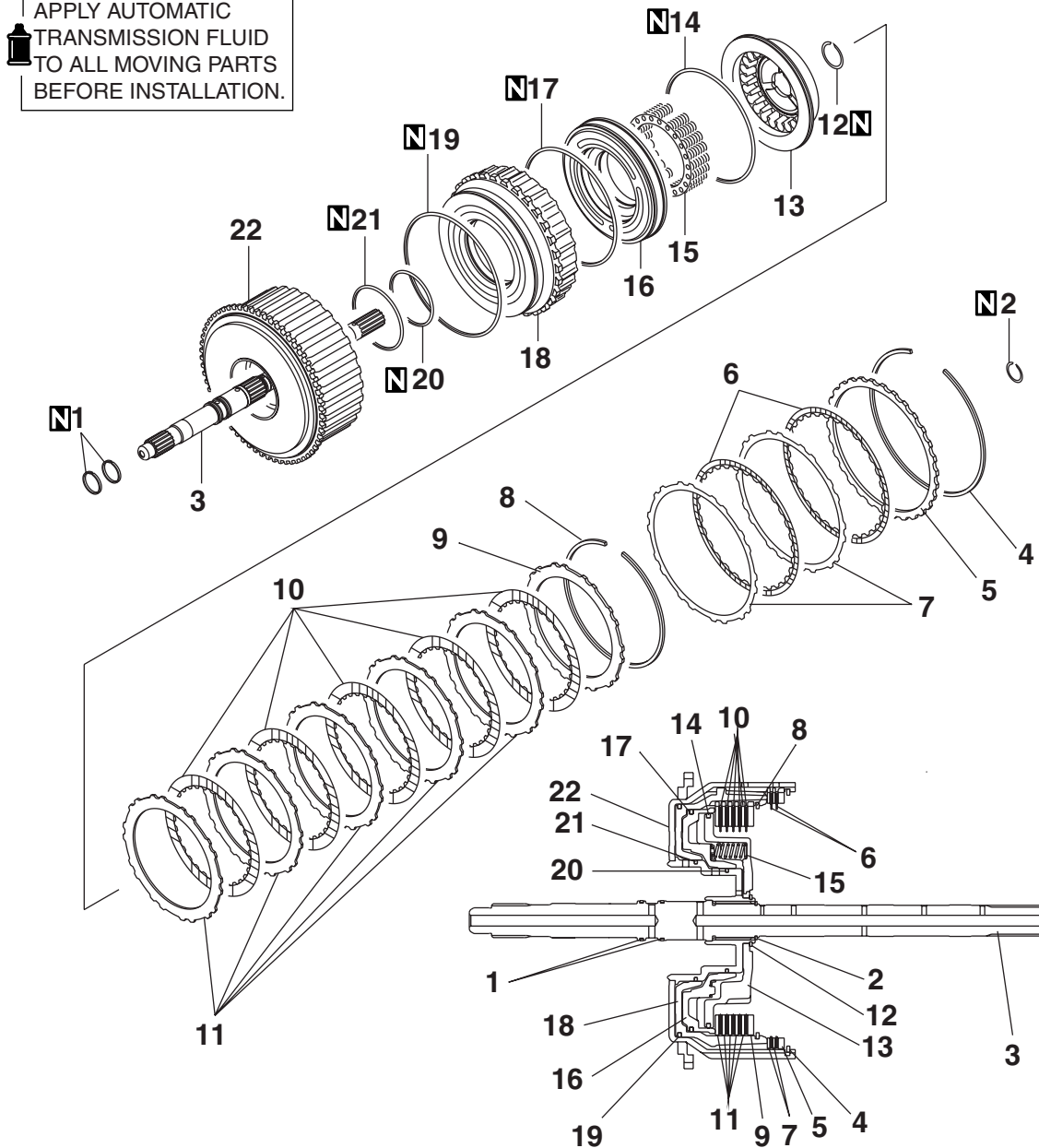

- DISASSEMBLY STEPS**
- 1. SEAL RING
  - 2. SNAP RING
  - 3. INPUT SHAFT
  - >>H<< 4. SNAP RING
  - >>G<< 5. REACTION PLATE
  - >>G<< 6. CLUTCH DISC
  - >>G<< 7. CLUTCH PLATE

- DISASSEMBLY STEPS**
- >>F<< 8. SNAP RING
  - >>E<< 9. REACTION PLATE
  - >>E<< 10. CLUTCH DISC
  - >>E<< 11. CLUTCH PLATE
  - <<A>> >>D<< 12. SNAP RING
  - >>A<< 13. SPRING RETAINER
  - >>A<< 14. D-RING

AKX00121AB

**DISASSEMBLY STEPS**

- >>C<< 15. RETURN SPRING
- 16. OVERDRIVE CLUTCH PISTON
- >>A<< 17. D-RING
- >>B<< 18. REVERSE CLUTCH PISTON
- >>A<< 19. D-RING
- >>A<< 20. D-RING
- >>A<< 21. D-RING
- 22. REVERSE CLUTCH RETAINER

**Required Special Tools:**

- MB991629: Spring Compressor
- MB991789: Spring Compressor
- MD998924: Spring Compressor Retainer
- MD999590: Spring Compressor

**DISASSEMBLY SERVICE POINT**

**<<A>> SNAP RING REMOVAL**

1. Set special tools MD999590 and MD998924 as shown in the illustration.
2. Compress the return spring, and remove the snap ring.

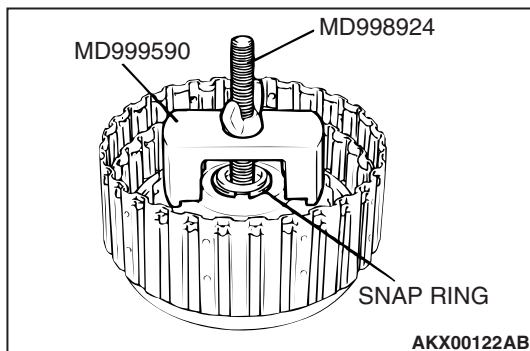

**ASSEMBLY SERVICE POINTS**

**>>A<< D-RING INSTALLATION**

1. Apply ATF to the D-ring.
2. Install the D-ring in the reverse clutch retainer, piston, overdrive clutch piston and spring retainer grooves. Make sure that the D-ring is not twisted or damaged when installing.

**>>B<< REVERSE CLUTCH PISTON INSTALLATION**

Align the reverse clutch piston and reverse clutch retainer holes (A and B), and then assemble.

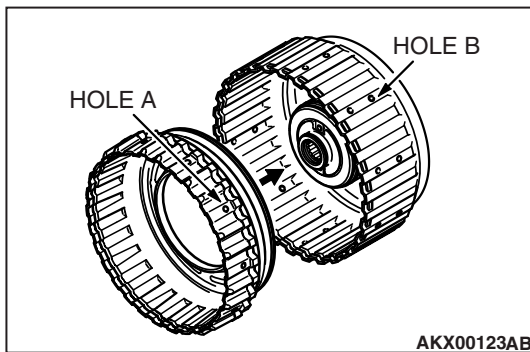

**>>C<< RETURN SPRING INSTALLATION**

Align the two return spring holes with the two projections on the override clutch piston, and then assemble.

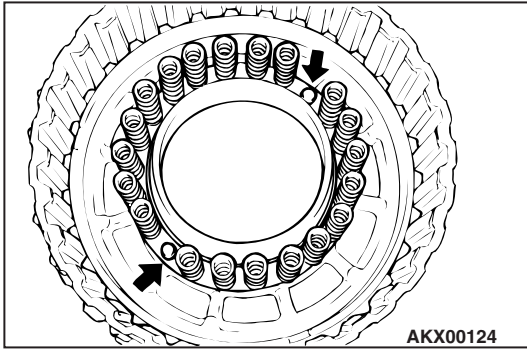

**>>D<< SNAP RING INSTALLATION**

1. Set special tools MD999590 and MD998924 as shown in the illustration.
2. Tighten the special tool nut, and press the spring retainer against the reverse clutch retainer.
3. Install the thickest snap ring that can be fitted in the snap ring groove of reverse clutch retainer.
4. Confirm that clearance between the snap ring and spring retainer is the standard value.

**Standard value: 0 – 0.09 mm (0 – 0.004 inch)**

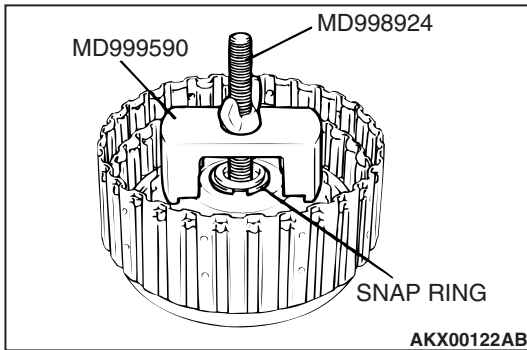

**>>E<< CLUTCH PLATE/CLUTCH DISC/REACTION PLATE INSTALLATION**

1. Alternately assemble the clutch disc and clutch plate in the reverse clutch piston.
2. Install the reaction plate so that it is oriented as shown in the illustration.

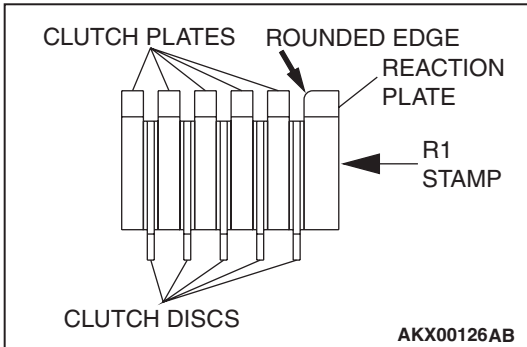

**>>F<< SNAP RING INSTALLATION**

1. Install the snap ring in the reverse clutch piston groove.
2. Set special tools MB991629 and MD998924 as shown in the illustration, and compress the clutch element.

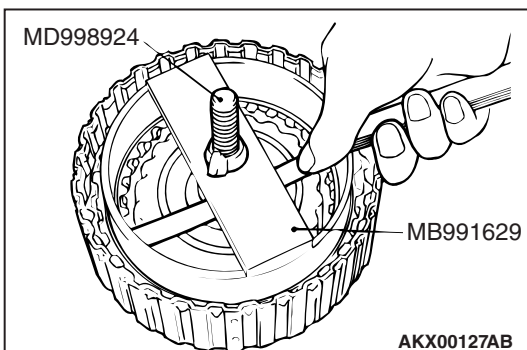

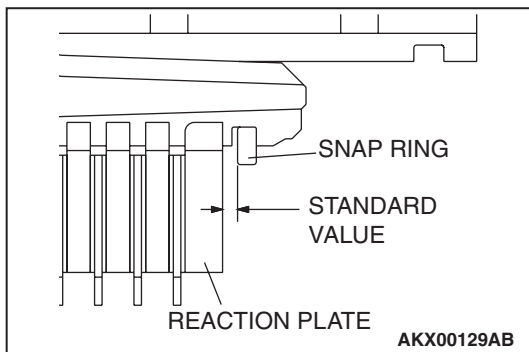

3. Confirm that the clearance (overdrive clutch end play) of the snap ring and reaction plate is the standard value. If the clearance is not at the standard value, select the snap ring and adjust so that the clearance is within the standard value.

**Standard value: 2.0 – 2.2 mm (0.079 – 0.087 inch)**

**>>G<< CLUTCH PLATE/CLUTCH DISC/REACTION PLATE INSTALLATION**

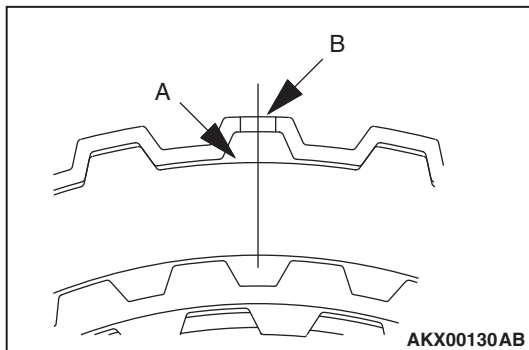

1. Alternately assemble the clutch plate and clutch disc in the reverse clutch retainer. Align and assemble both clutch plates (where there are no teeth) (A in the illustration) with the reverse clutch retainer hole (B in the illustration).

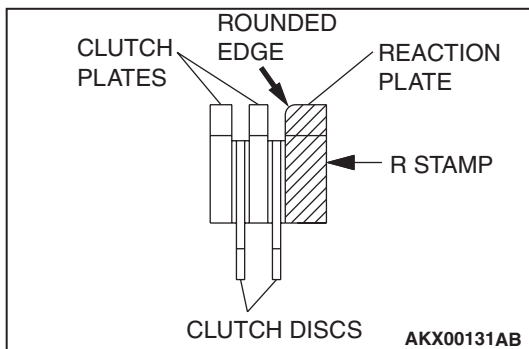

2. Install the reaction plate so that it is oriented as shown in the illustration. Assemble in the same manner as the clutch plate so the section with no teeth (A in the illustration) matches the retainer hole (B in the illustration).

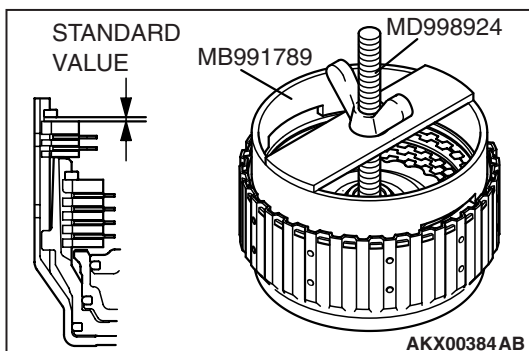

**>>H<< SNAP RING INSTALLATION**

1. Install the snap ring in the reverse clutch retainer groove.
2. Set special tools MB991789 and MD998924 as shown in the illustration, and compress the clutch element.
3. Check that the clearance between the snap ring and the clutch reaction plate is within the standard value. If not within the standard value, select a snap ring to adjust.

**Standard value: 1.5 – 1.7 mm (0.059 – 0.067 inch)**

**SECOND BRAKE****DISASSEMBLY AND ASSEMBLY**

M1233021800128

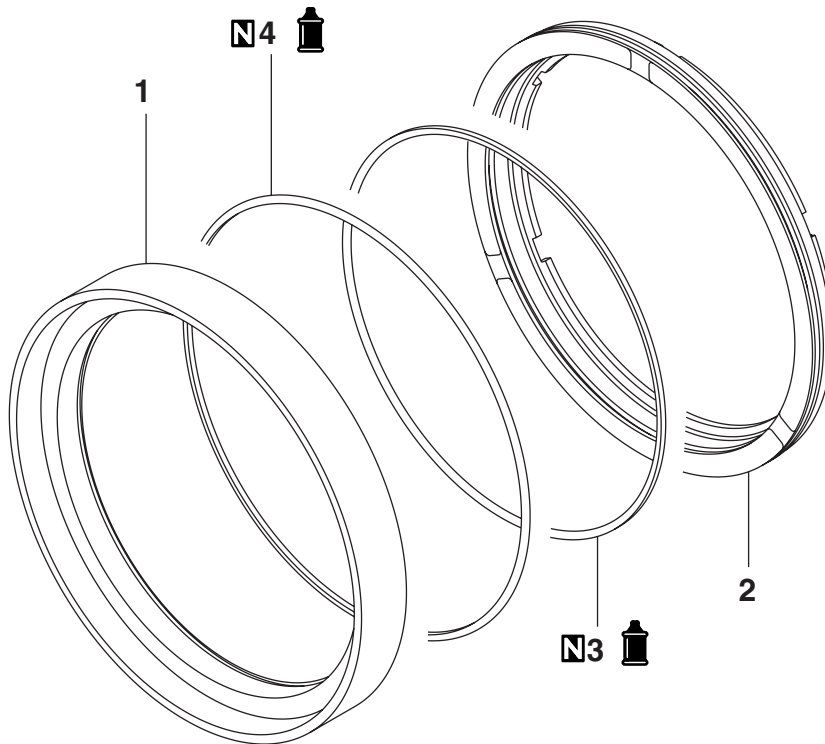

AKX00134AB

**DISASSEMBLY STEPS**

1. SECOND BRAKE RETAINER
2. SECOND BRAKE PISTON

**DISASSEMBLY STEPS**

- >>A<< 3. D-RING  
>>A<< 4. D-RING

**ASSEMBLY SERVICE POINT****>>A<<D-RING INSTALLATION**

1. Apply ATF to the D-ring.
2. Install the D-ring in the grooves on the outer and inner periphery of the piston. Make sure that the D-ring is not twisted or damaged when installing.

# LOW REVERSE ANNULUS GEAR

## DISASSEMBLY AND ASSEMBLY

M1233027100042

APPLY AUTOMATIC  
 TRANSMISSION FLUID  
 TO ALL MOVING PARTS  
 BEFORE INSTALLATION.

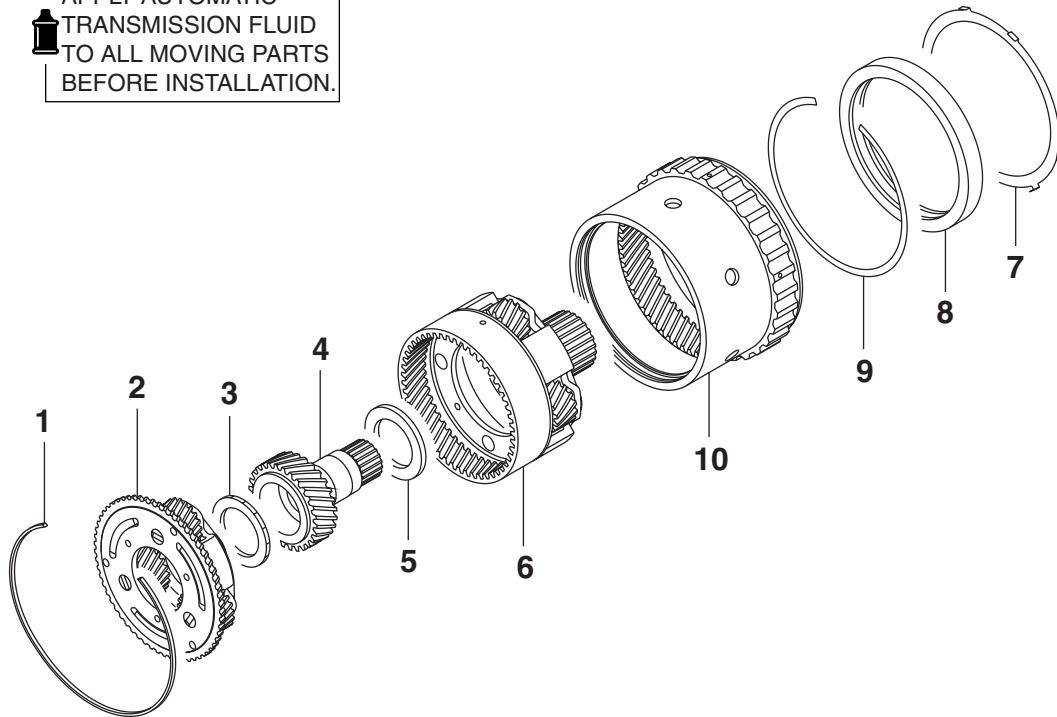

AKX00135AB

### DISASSEMBLY STEPS

1. SNAP RING
2. OVERDRIVE PLANETARY CARRIER
- >>D<< 3. THRUST BEARING NO.5
4. UNDERDRIVE SUN GEAR
- >>C<< 5. THRUST BEARING NO.6

### DISASSEMBLY STEPS

6. OUTPUT PLANETARY CARRIER
- >>B<< 7. STOPPER PLATE
- >>A<< 8. ONE-WAY CLUTCH
9. SNAP RING
10. LOW/REVERSE ANNULUS GEAR

## ASSEMBLY SERVICE POINTS

### >>A<< ONE-WAY CLUTCH INSTALLATION

Install the one-way clutch so that the arrow stamp is oriented as shown in the illustration.

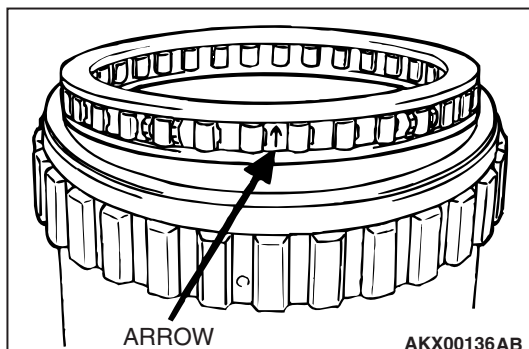

AKX00136AB

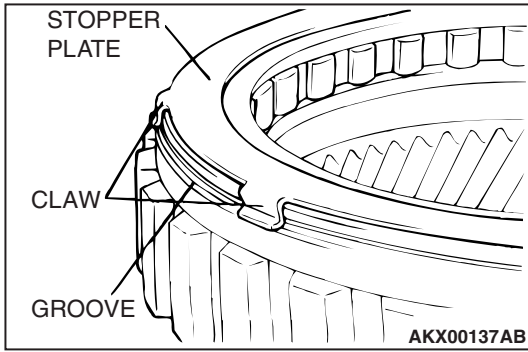

**>>B<< STOPPER PLATE INSTALLATION**

Install the stopper plate onto the low/reverse annulus gear. Make sure that the stopper plate claw is securely engaged in the annulus gear groove.

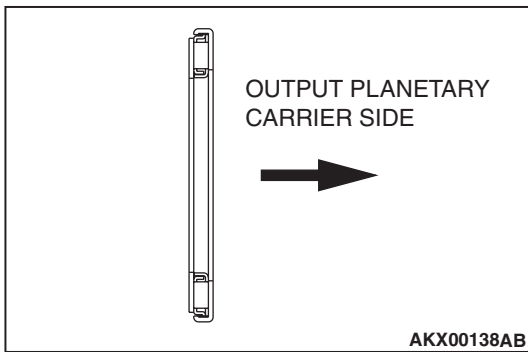

**>>C<< THRUST BEARING NUMBER 6 INSTALLATION**

**CAUTION**

Make sure thrust bearing number 6 is mounted in the correct direction.

Apply Vaseline or petroleum jelly on the thrust bearing number 6, and then install onto the output planetary carrier.

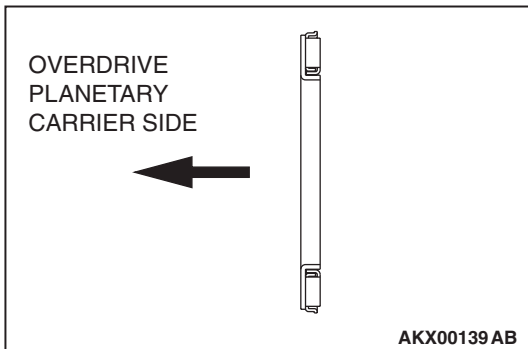

**>>D<< THRUST BEARING NUMBER 5 INSTALLATION**

**CAUTION**

Make sure thrust bearing number 5 is mounted in the correct direction.

Apply Vaseline or petroleum jelly on the thrust bearing number 5, and then install on the overdrive planetary carrier.



# CENTER SUPPORT

## DISASSEMBLY AND ASSEMBLY

M1233010000054

APPLY AUTOMATIC  
TRANSMISSION FLUID  
TO ALL MOVING PARTS  
BEFORE INSTALLATION.

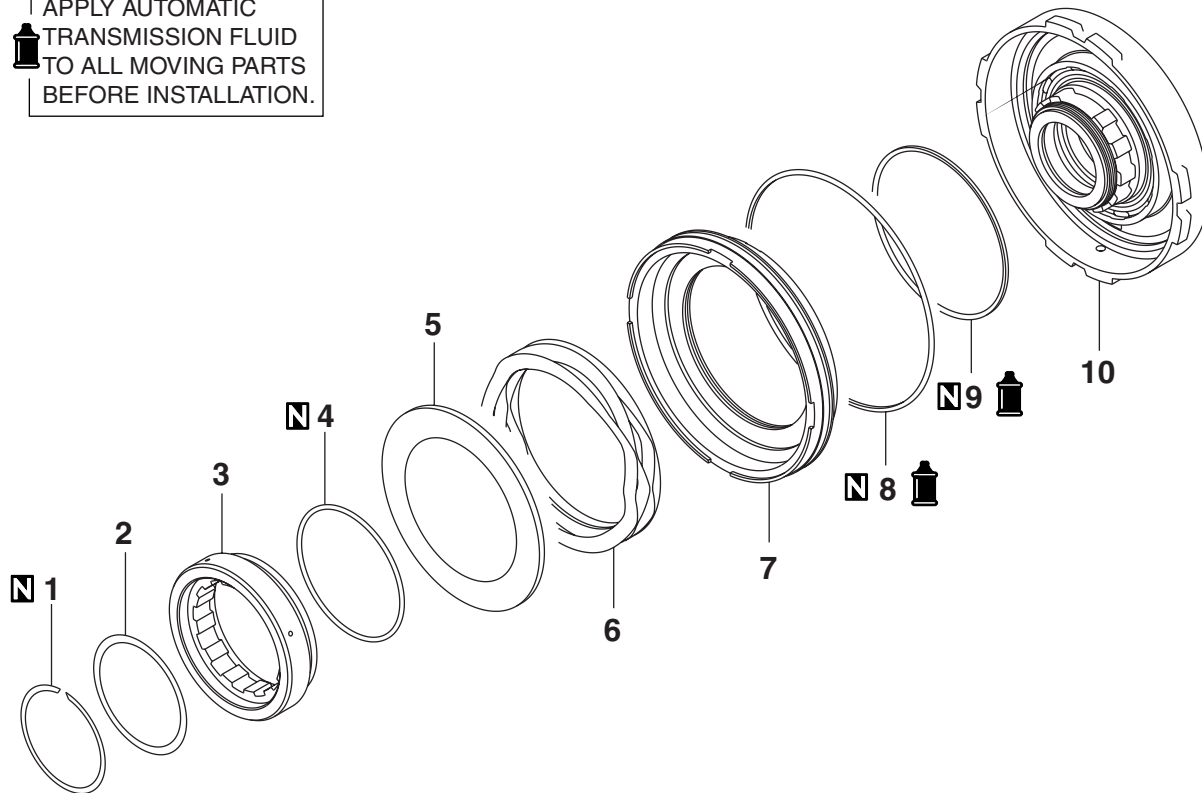

AKX00140AB

- DISASSEMBLY STEPS**
- <<A>> >>C<< 1. SNAP RING  
2. PLATE  
>>B<< 3. ONE-WAY CLUTCH INNER RACE  
4. O-RING  
5. SPRING RETAINER

- DISASSEMBLY STEPS**
6. RETURN SPRING  
7. LOW/REVERSE BRAKE PISTON  
>>A<< 8. D-RING  
>>A<< 9. D-RING  
10. CENTER SUPPORT

### Required Special Tools:

- MB991630: Spring Compressor
- MD998924: Spring Compressor Retainer

### DISASSEMBLY SERVICE POINT

#### <<A>> SNAP RING REMOVAL

1. Set special tools MD998924 and MB991630 as shown in the illustration so that they are pressed against the inner race of the one-way clutch.
2. Screw in the special tool nut, and lightly press against the inner race of the one-way clutch.
3. Remove the snap ring.

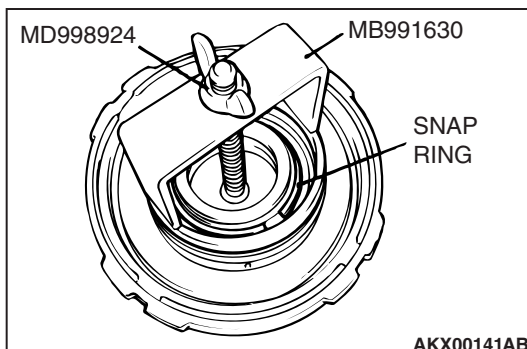

AKX00141AB

**ASSEMBLY SERVICE POINTS****>>A<< D-RING INSTALLATION**

1. Apply ATF to the D-ring.
2. Install the D-ring in the grooves on the outer and inner periphery of the piston. Make sure that the D-ring is not twisted or damaged when installing.

**>>B<< O-RING INSTALLATION**

Install the O-ring onto the center support at the position shown in the illustration.

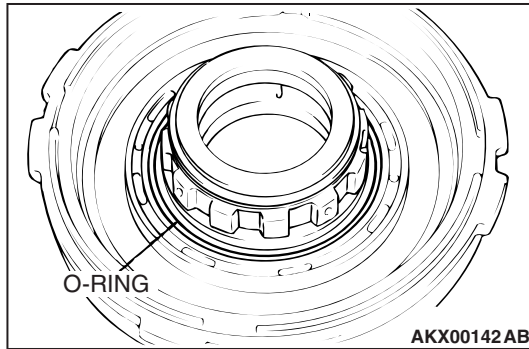
**>>C<< SNAP RING INSTALLATION**

1. Set special tools MD998924 and MB991630 as shown in the illustration.
2. Screw in the special tool nut, and lightly press against the inner race of the one-way clutch.
3. Install the snap ring.

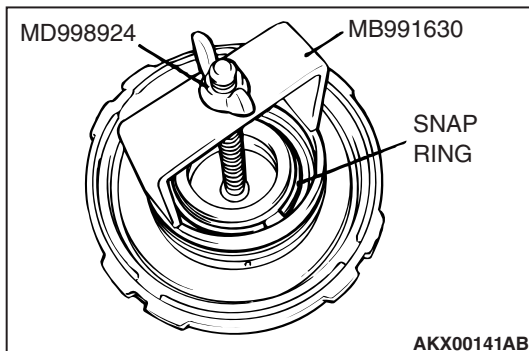

# UNDERDRIVE CLUTCH

## DISASSEMBLY AND ASSEMBLY

M1233027300046

APPLY AUTOMATIC  
TRANSMISSION FLUID  
TO ALL MOVING PARTS  
BEFORE INSTALLATION.

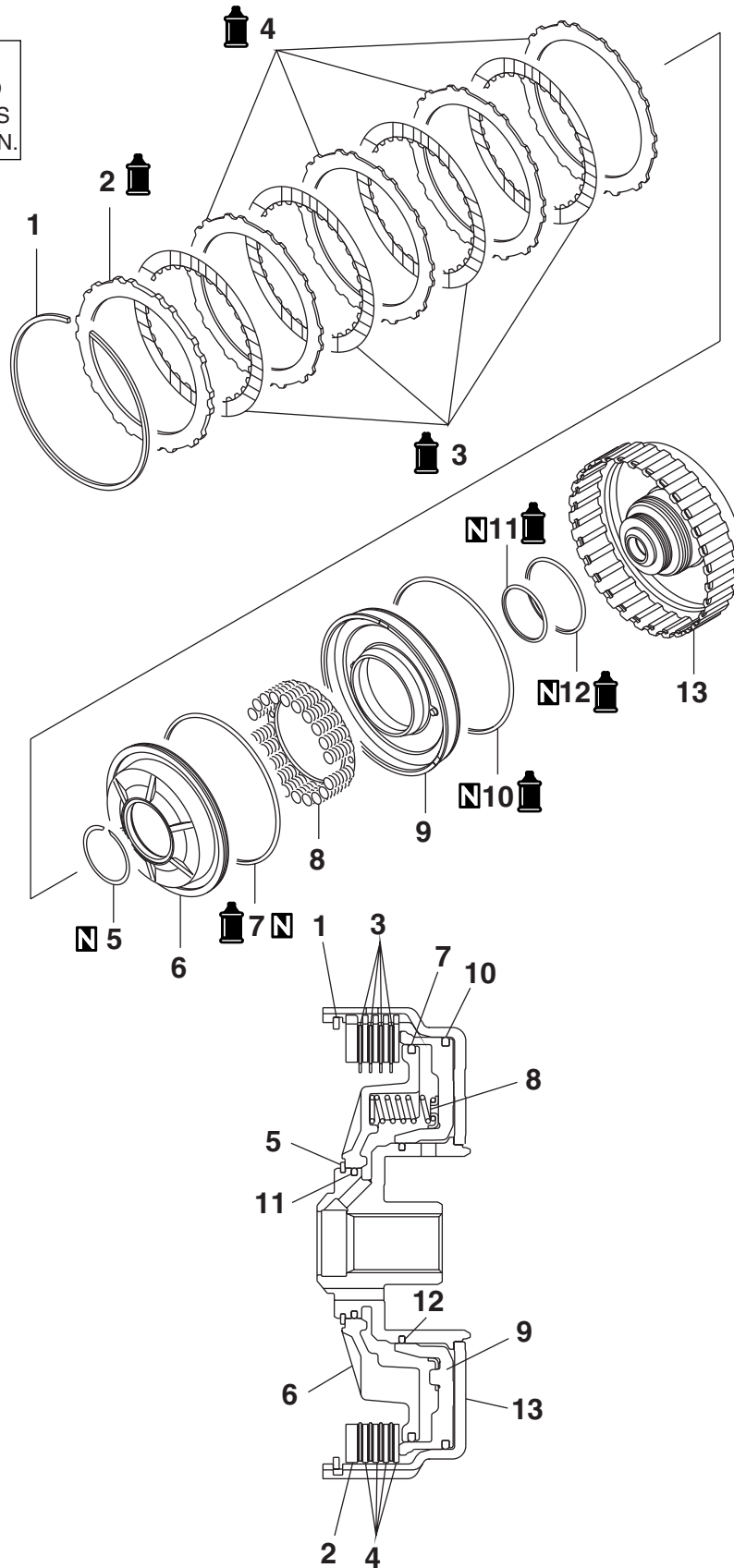

AKX00143AB

<b>DISASSEMBLY STEPS</b>	
>>E<<	1. SNAP RING
>>D<<	2. REACTION PLATE
>>D<<	3. CLUTCH DISC
>>D<<	4. CLUTCH PLATE
<<A>>	>>C<<
	5. SNAP RING
	6. SPRING RETAINER
	>>A<<
	7. D-RING

<b>DISASSEMBLY STEPS</b>	
>>B<<	8. RETURN SPRING
	9. UNDERDRIVE CLUTCH PISTON
>>A<<	10. D-RING
>>A<<	11. D-RING
>>A<<	12. D-RING
	13. UNDERDRIVE CLUTCH RETAINER

**Required Special Tools:**

- MB991629: Spring Compressor
- MD998907: Spring Compressor
- MD998924: Spring Compressor Retainer

**DISASSEMBLY SERVICE POINT****<<A>> SNAP RING REMOVAL**

1. Set special tools MD998924 and MD998907 as shown in the illustration.
2. Compress the return spring, and remove the snap ring.

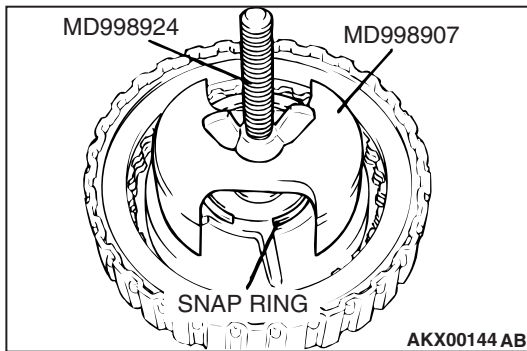
**ASSEMBLY SERVICE POINTS****>>A<< D-RING INSTALLATION**

1. Apply ATF to the D-ring.
2. Install the D-ring in the grooves of the underdrive clutch retainer and spring retainer. Make sure that the D-ring is not twisted or damaged when installing.

**>>B<< RETURN SPRING INSTALLATION**

Align the two return spring holes with the two projections on the underdrive clutch piston, and then assemble.

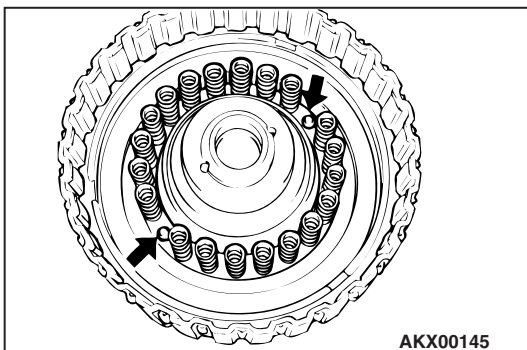

**>>C<< SNAP RING INSTALLATION**

1. Set special tools MD998924 and MD998907 as shown in the illustration.
2. Compress the return spring, and install the snap ring.

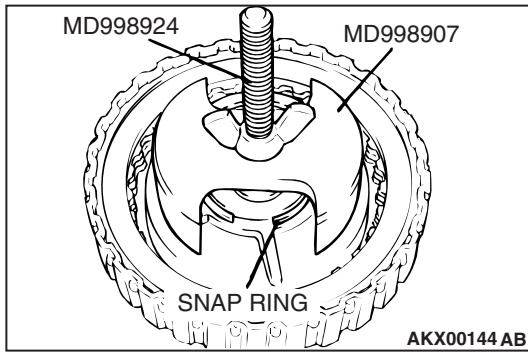

**>>D<< CLUTCH PLATE/CLUTCH DISC/REACTION PLATE  
INSTALLATION**

1. Alternately assemble the clutch plate and clutch disc in the underdrive clutch retainer. Align and assemble the four clutch plates (where there are no teeth) (A in the illustration) with the underdrive clutch retainer hole (B in the illustration).
2. Install the reaction plate so that it is oriented as shown in the illustration. Assemble in the same manner as the clutch plate so that the section with no teeth (A in the illustration) matches the retainer hole (B in the illustration).

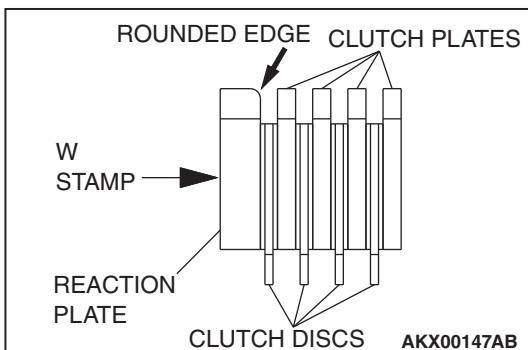
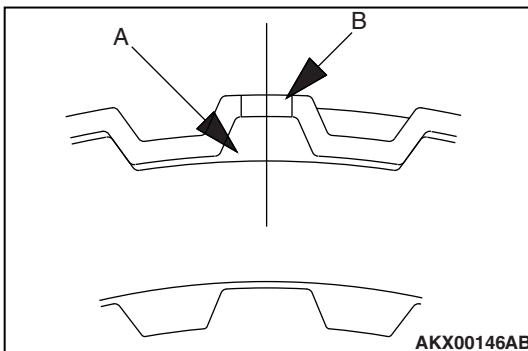

## &gt;&gt;E&lt;&lt; SNAP RING INSTALLATION

1. Install the snap ring in the groove of the underdrive clutch retainer.
2. Set special tools MB991629 and MD998924 as shown in the illustration, and compress the clutch element.

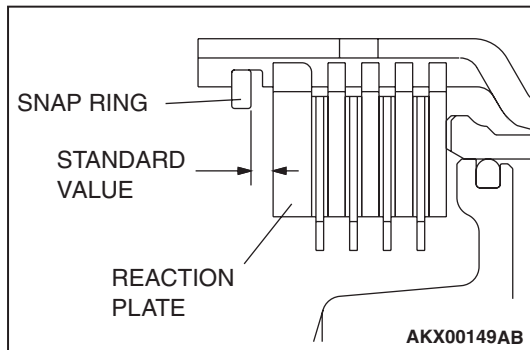
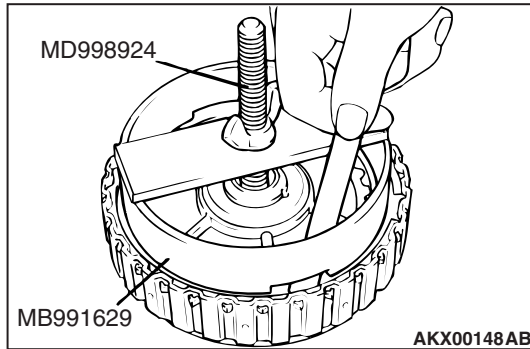

3. Confirm that the clearance (underdrive clutch end play) between the snap ring and reaction plate is the standard value. If the clearance is not at the standard value, select the snap ring and adjust so that the clearance is within the standard value.

**Standard value: 1.6 – 1.8 mm (0.063 – 0.071 inch)**

# VALVE BODY

## DISASSEMBLY AND ASSEMBLY

M1233012100079

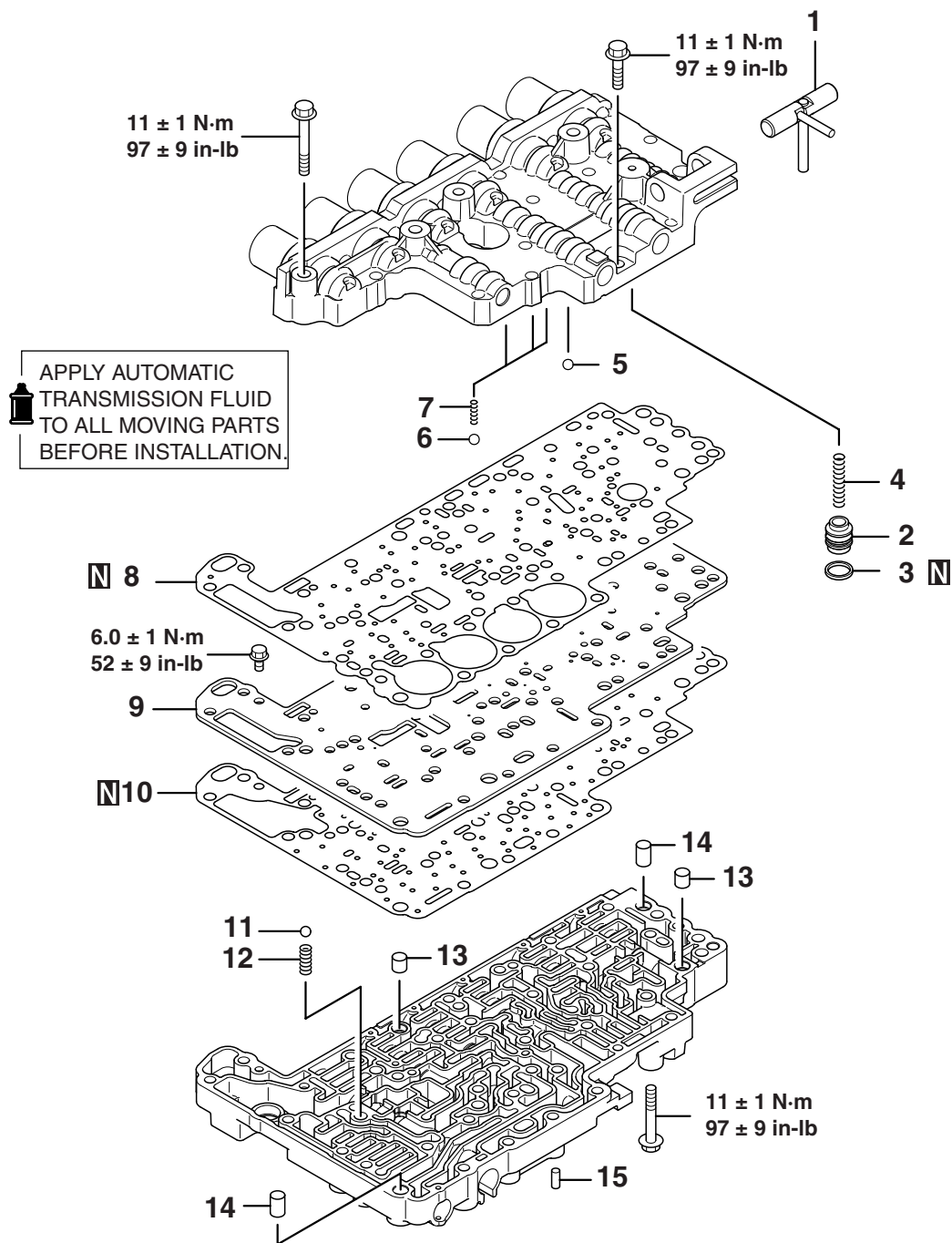

AKX00386AB

- DISASSEMBLY STEPS**
- >>G<< 1. MANUAL VALVE PIN
  - >>F<< 2. DAMPING VALVE
  - >>F<< 3. SEAL RING
  - >>F<< 4. DAMPING VALVE SPRING
  - >>F<< 5. BALL (ORIFICE CHECK BALL)

- DISASSEMBLY STEPS**
- >>F<< 6. STEEL BALL (ORIFICE CHECK BALL)
  - >>F<< 7. SPRING
  - 8. UPPER VALVE BODY GASKET
  - 9. SEPARATING PLATE
  - 10. LOWER VALVE BODY GASKET

**DISASSEMBLY STEPS**

- >>E<< 11. STEEL BALL (LINE RELIEF)
- >>E<< 12. SPRING
- >>D<< 13. KNOCK BUSHING
- >>C<< 14. KNOCK BUSHING
- >>B<< 15. DOWEL PIN

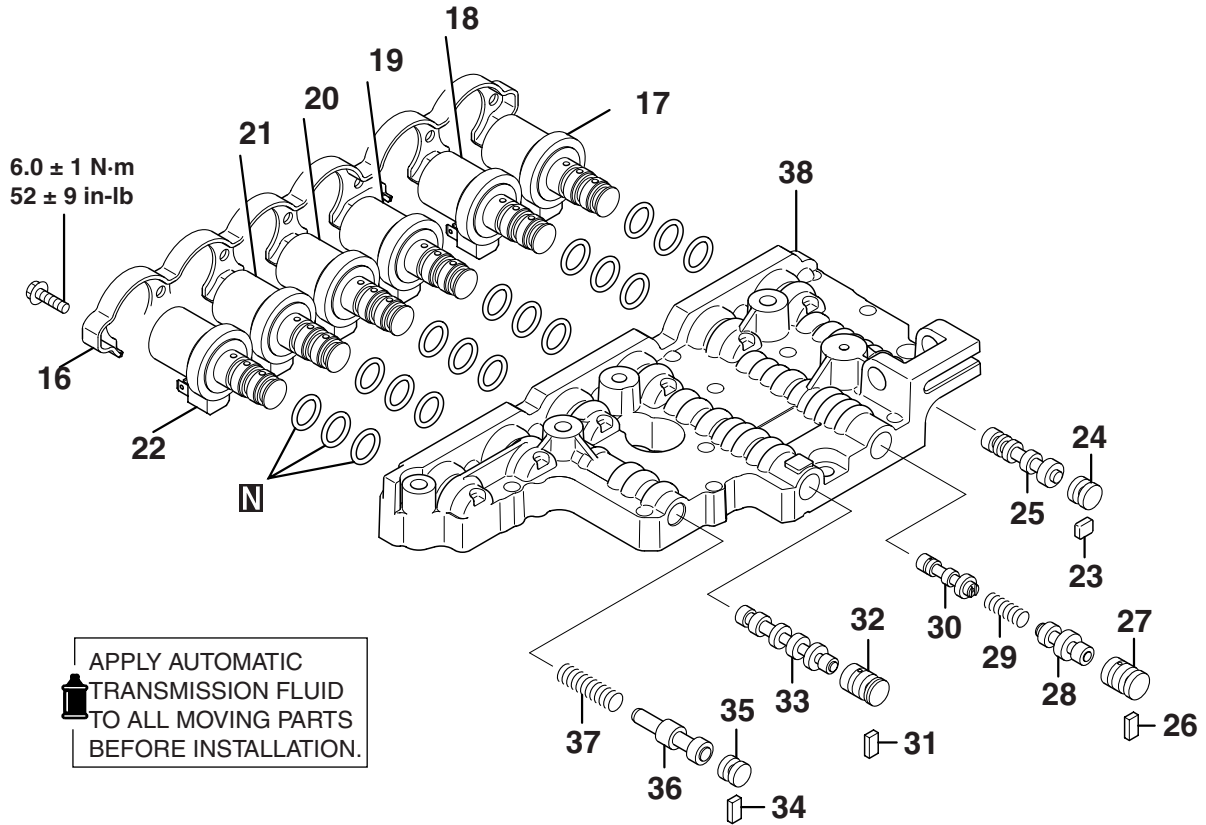

AKX00387AB

**DISASSEMBLY STEPS**

- <<A>> >>A<< 16. SOLENOID SUPPORT
- <<A>> >>A<< 17. LOW/REVERSE BRAKE SOLENOID VALVE
- <<A>> >>A<< 18. REDUCTION BRAKE SOLENOID VALVE
- <<A>> >>A<< 19. SECOND BRAKE SOLENOID VALVE
- <<A>> >>A<< 20. UNDERDRIVE CLUTCH SOLENOID VALVE
- <<A>> >>A<< 21. OVERDRIVE CLUTCH SOLENOID VALVE
- <<A>> >>A<< 22. TORQUE CONVERTER CLUTCH CONTROL SOLENOID VALVE
- 23. STOPPER PLATE
- 24. STOPPER PLUG
- 25. SWITCHING VALVE

**DISASSEMBLY STEPS**

- 26. STOPPER PLATE
- 27. FAIL-SAFE VALVE A SLEEVE
- 28. FAIL-SAFE VALVE A2
- 29. FAIL-SAFE VALVE A SPRING
- 30. FAIL-SAFE VALVE A1
- 31. STOPPER PLATE
- 32. FAIL-SAFE VALVE B SLEEVE
- 33. FAIL-SAFE VALVE B
- 34. STOPPER PLATE
- 35. STOPPER PLUG
- 36. TORQUE CONVERTER PRESSURE CONTROL VALVE
- 37. TORQUE CONVERTER PRESSURE CONTROL VALVE SPRING
- 38. UPPER VALVE BODY



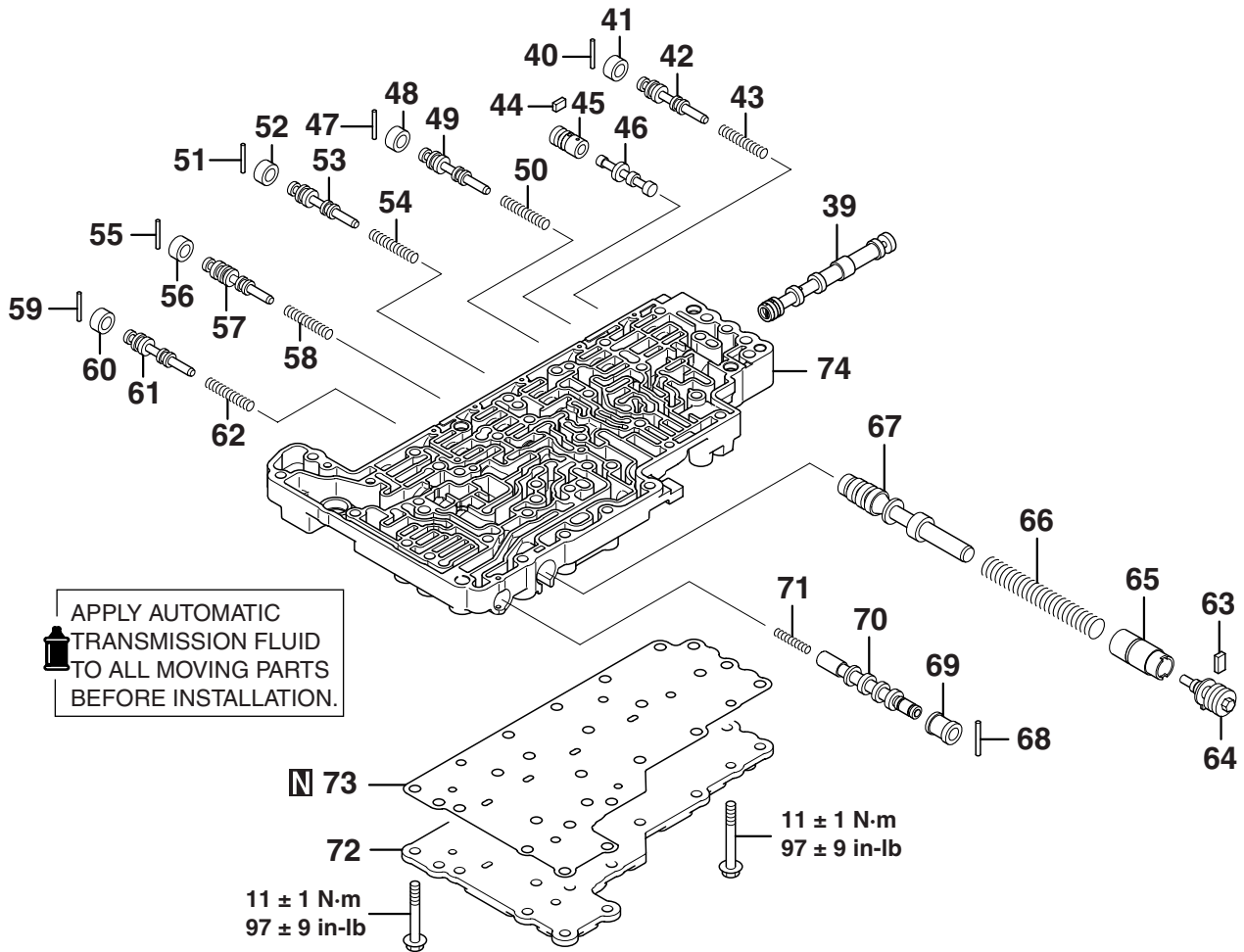

AKX00388AB

**DISASSEMBLY STEPS**

- 39. MANUAL VALVE
- 40. ROLLER
- 41. LOW/REVERSE BRAKE PRESSURE CONTROL VALVE SLEEVE
- 42. LOW/REVERSE BRAKE PRESSURE CONTROL VALVE
- 43. LOW/REVERSE BRAKE PRESSURE CONTROL VALVE SPRING
- 44. STOPPER PLATE
- 45. FAIL-SAFE VALVE C SLEEVE
- 46. FAIL-SAFE VALVE C
- 47. ROLLER
- 48. REDUCTION BRAKE PRESSURE CONTROL VALVE SLEEVE
- 49. REDUCTION BRAKE PRESSURE CONTROL VALVE
- 50. REDUCTION BRAKE PRESSURE CONTROL VALVE SPRING
- 51. ROLLER

**DISASSEMBLY STEPS**

- 52. SECOND BRAKE PRESSURE CONTROL VALVE SLEEVE
- 53. SECOND BRAKE PRESSURE CONTROL VALVE
- 54. SECOND BRAKE PRESSURE CONTROL VALVE SPRING
- 55. ROLLER
- 56. UNDERDRIVE CLUTCH PRESSURE CONTROL VALVE SLEEVE
- 57. UNDERDRIVE CLUTCH PRESSURE CONTROL VALVE
- 58. UNDERDRIVE CLUTCH PRESSURE CONTROL VALVE SPRING
- 59. ROLLER
- 60. OVERDRIVE CLUTCH PRESSURE CONTROL VALVE SLEEVE
- 61. OVERDRIVE CLUTCH PRESSURE CONTROL VALVE

**DISASSEMBLY STEPS**

62. OVERDRIVE CLUTCH  
PRESSURE CONTROL VALVE  
SPRING
63. STOPPER PLATE
64. REGULATOR VALVE ADJUSTING  
SCREW
65. REGULATOR VALVE SLEEVE
66. REGULATOR VALVE SPRING
67. REGULATOR VALVE

**DISASSEMBLY STEPS**

68. ROLLER
69. TORQUE CONVERTER CLUTCH  
CONTROL VALVE SLEEVE
70. TORQUE CONVERTER CLUTCH  
CONTROL VALVE
71. TORQUE CONVERTER CLUTCH  
CONTROL VALVE SPRING
72. COVER
73. COVER GASKET
74. LOWER VALVE BODY

**DISASSEMBLY SERVICE POINT****<<A>> SOLENOID VALVE REMOVAL**

Before removing the solenoid valves, make marks with white paint, etc., so that these valves can be reinstalled in the original positions.

**ASSEMBLY SERVICE POINTS****>>A<< SOLENOID VALVE INSTALLATION**

1. Apply ATF, petroleum jelly or Vaseline to O-ring, and install it to solenoid valves.
2. Following the marks made when removing, install each solenoid valve in its proper position.

**>>B<< DOWEL PIN INSTALLATION**

Install the dowel pin at the specified position on the lower valve body.

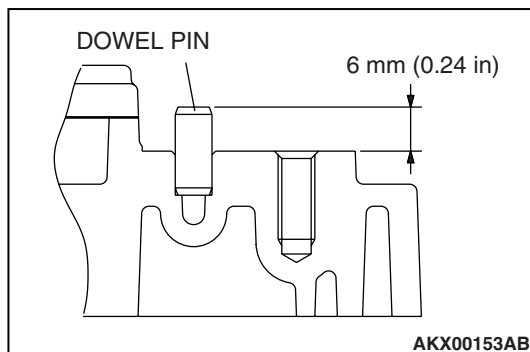

**>>C<< KNOCK BUSHING INSTALLATION**

Install the knock bushing onto the lower valve body position shown in the illustration.

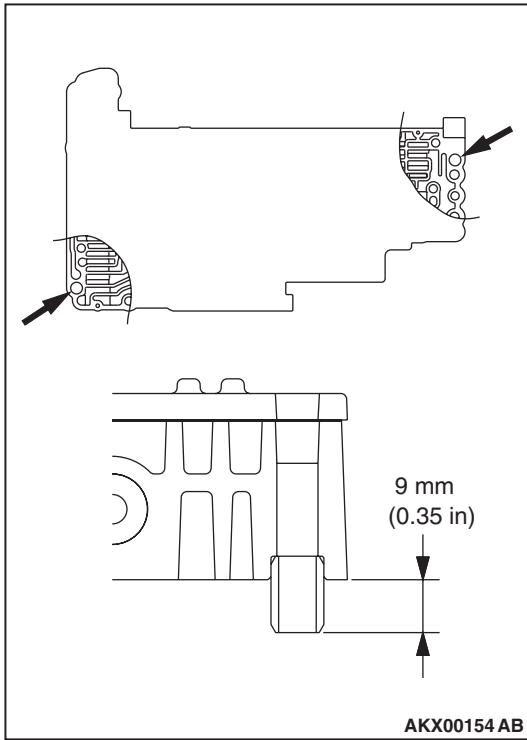

**>>D<< KNOCK BUSHING INSTALLATION**

Install the knock bushing onto the lower valve body position shown in the illustration.

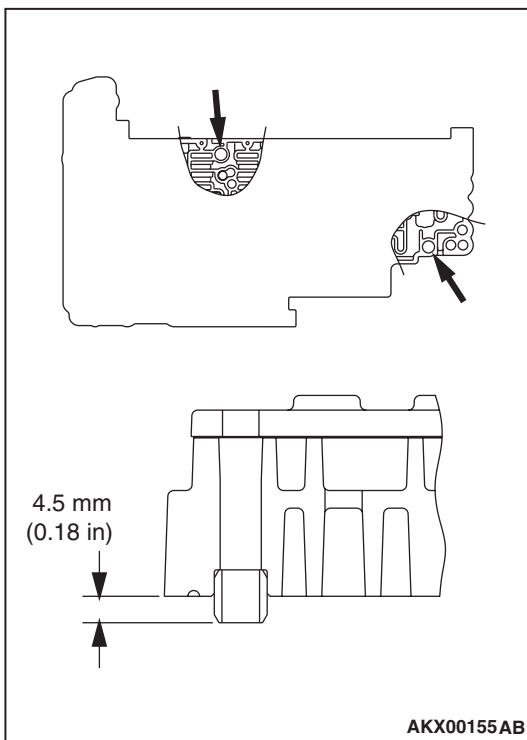

**>>E<< SPRING/STEEL BALL (LINE RELIEF)  
INSTALLATION**

Install the spring [7 mm (0.276 inch) diameter, 17.3 mm (0.681 inch) length] and the steel ball [6.4 mm (0.25 inch) diameter] onto the lower valve body position shown in the illustration.

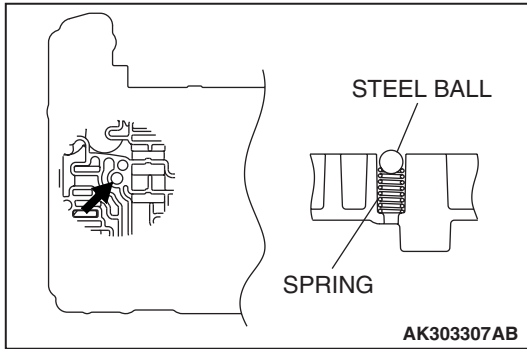
**>>F<< SPRING/STEEL BALL (ORIFICE CHECK BALL)/  
BALL (ORIFICE CHECK BALL)/DAMPING VALVE SPRING/  
SEAL RING/DAMPING VALVE INSTALLATION**

1. Install the spring [4.5 mm (0.177 inch) diameter, 15.4 mm (0.606 inch) length] and the steel ball [6.4 mm (0.25 inch) diameter] onto the upper valve body position shown in the illustration.
2. Install the ball (rubber) [6.4 mm (0.25 inch) diameter] onto the upper valve body position shown in the illustration.
3. After installing the seal ring onto the damping valve, install together with the damping valve spring [7.7 mm (0.303 inch) diameter, 35.8 mm (1.409 inch) length] onto the upper valve body position shown in the illustration.

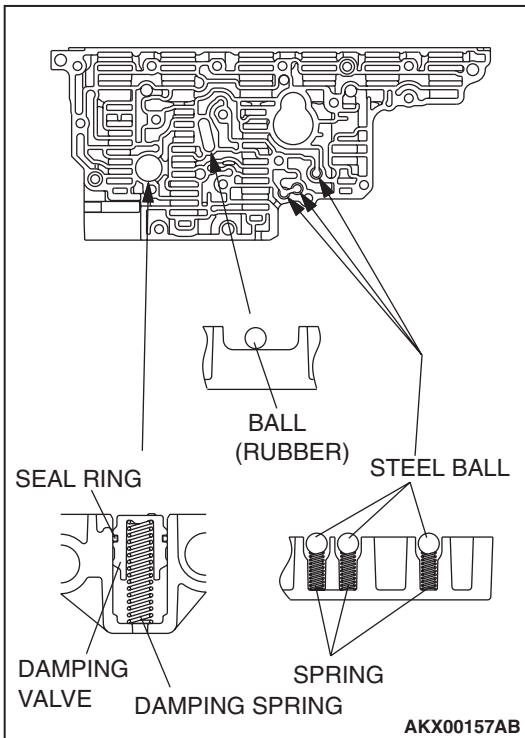
**>>G<< MANUAL VALVE INSTALLATION**

Fit and install the manual valve pin into the groove of the manual valve.

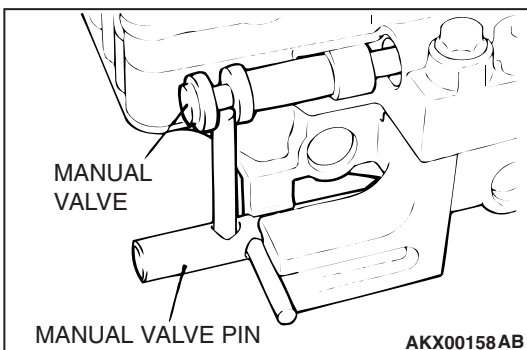

# DIRECT ANNULUS GEAR

## DISASSEMBLY AND ASSEMBLY

M1233028000026

<V5A51>

APPLY AUTOMATIC  
TRANSMISSION FLUID  
TO ALL MOVING PARTS  
BEFORE INSTALLATION.

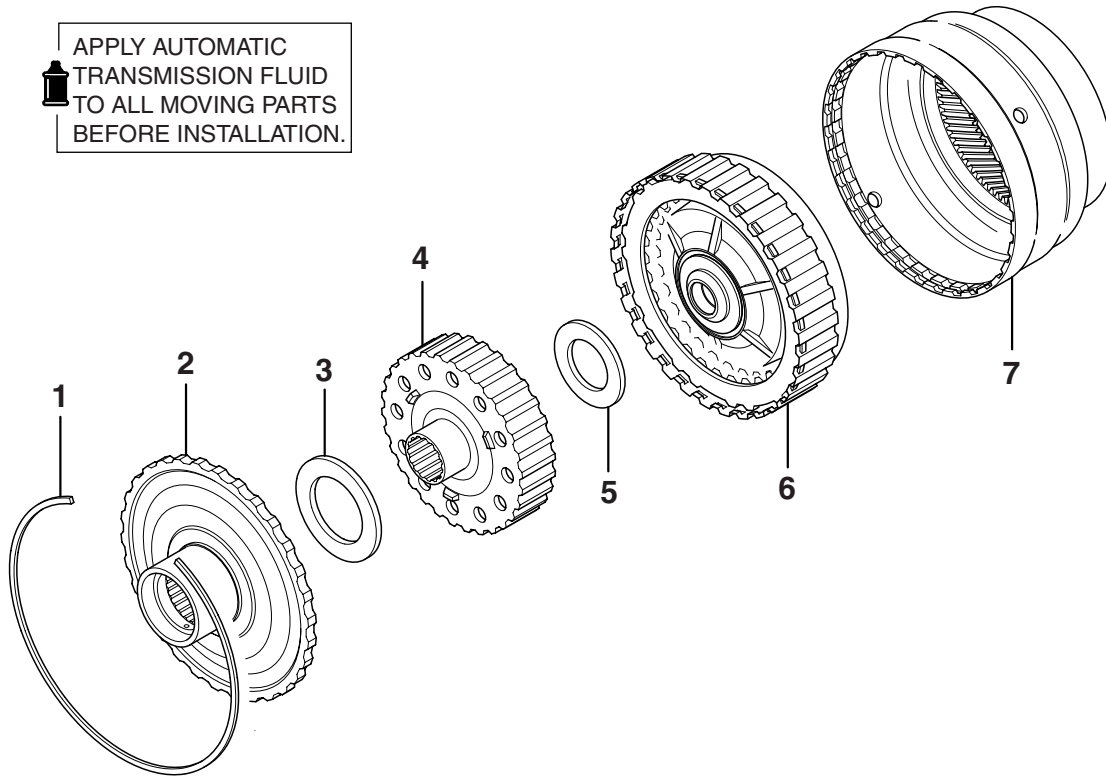

AKX00389AB

### DISASSEMBLY STEPS

1. SNAP RING
2. OUTPUT FLANGE
- >>B<< 3. THRUST BEARING NUMBER 10
4. UNDERDRIVE CLUTCH HUB

### DISASSEMBLY STEPS

- >>A<< 5. THRUST BEARING NUMBER 11
6. UNDERDRIVE CLUTCH
7. DIRECT ANNULUS GEAR

## ASSEMBLY SERVICE POINTS

## &gt;&gt;A&lt;&lt; THRUST BEARING NUMBER 11 INSTALLATION

**⚠ CAUTION**

**Make sure thrust bearing number 11 is mounted in the correct direction.**

Apply Vaseline or petroleum jelly on the thrust bearing number 11, and then install on the underdrive clutch.

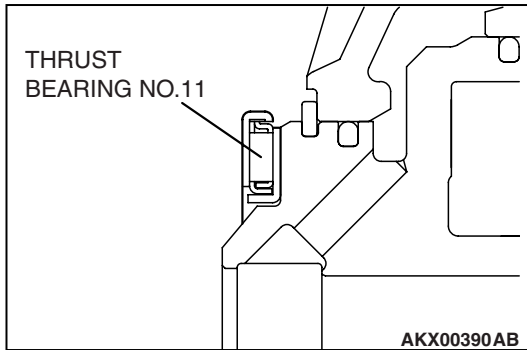

## &gt;&gt;B&lt;&lt; THRUST BEARING NUMBER 10 INSTALLATION

**⚠ CAUTION**

**Make sure thrust bearing number 10 is mounted in the correct direction.**

Apply Vaseline or petrolatum jelly on the thrust bearing number 10, and then install on the underdrive clutch hub.

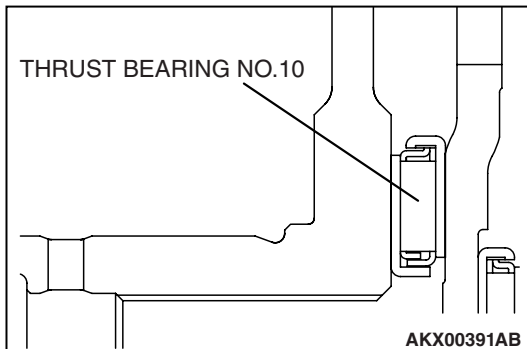

# DIRECT CLUTCH

## DISASSEMBLY AND ASSEMBLY

M1233009700048

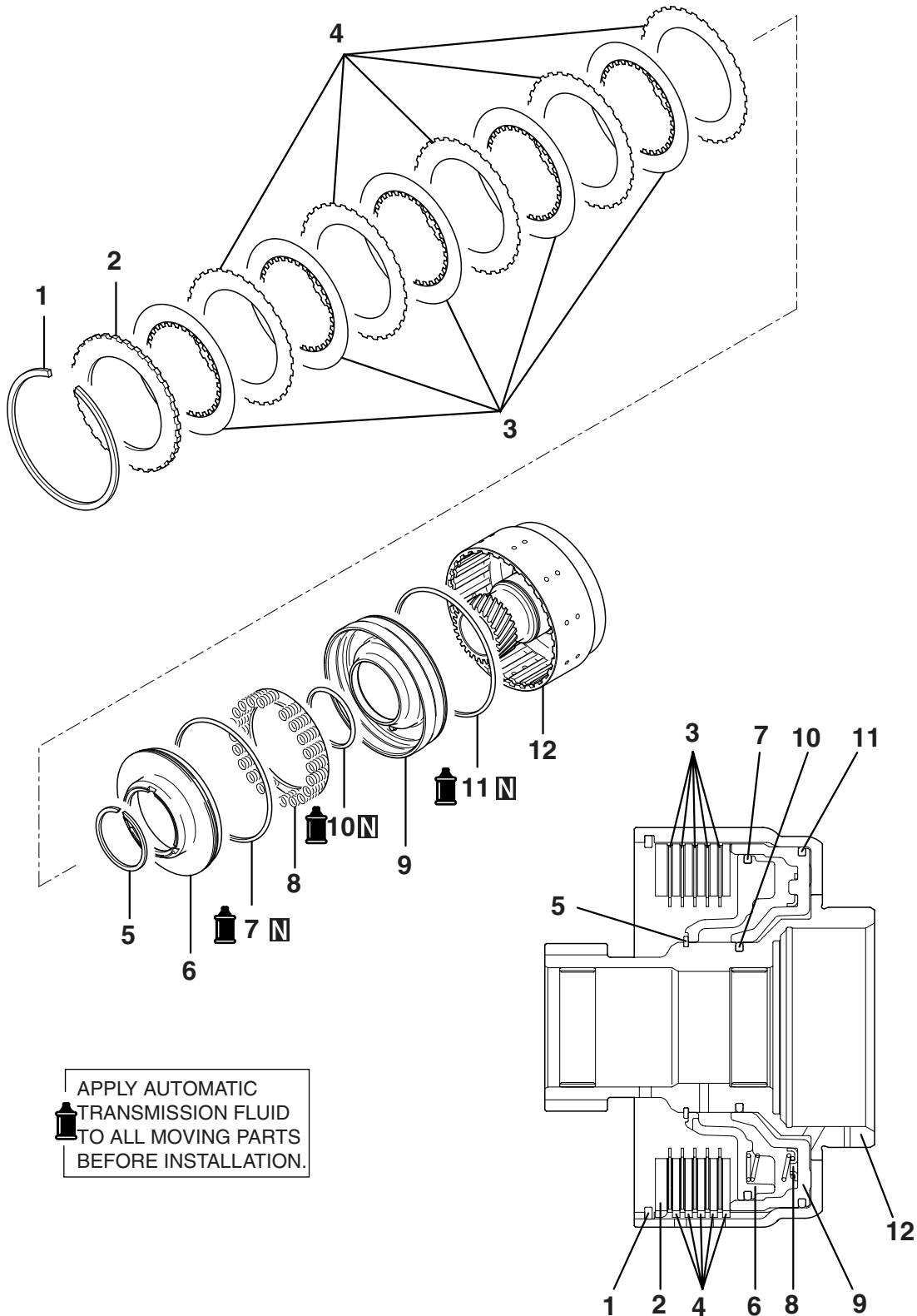

APPLY AUTOMATIC  
TRANSMISSION FLUID  
TO ALL MOVING PARTS  
BEFORE INSTALLATION.

- DISASSEMBLY STEPS**
- >>D<< 1. SNAP RING
  - >>C<< 2. REACTION PLATE
  - >>C<< 3. CLUTCH DISC
  - >>C<< 4. CLUTCH PLATE
  - <<A>> >>B<< 5. SNAP RING
  - 6. SPRING RETAINER

- DISASSEMBLY STEPS**
- >>A<< 7. D-RING
  - 8. RETURN SPRING
  - 9. DIRECT CLUTCH PISTON
  - >>A<< 10. D-RING
  - >>A<< 11. D-RING
  - 12. DIRECT CLUTCH RETAINER

**Required Special Tools:**

- MB991630: Spring Compressor
- MD998924: Spring Compressor Retainer

**DISASSEMBLY SERVICE POINT**

**<<A>> SNAP RING REMOVAL**

1. Set special tools MB991630 and MD998924 as shown in the illustration.
2. Compress the return spring, and remove the snap ring.

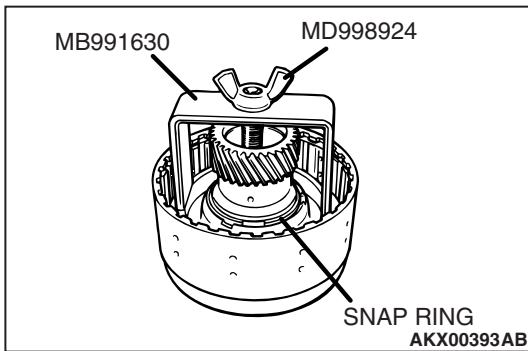

**ASSEMBLY SERVICE POINTS**

**>>A<< D-RING INSTALLATION**

1. Apply ATF to the D-ring.
2. Install the D-ring in the direct clutch piston and spring retainer groove. Make sure that the D-ring is not twisted or damaged when installing.

**>>B<< SNAP RING INSTALLATION**

1. Set special tools MB991630 and MD998924 as shown in the illustration.
2. Compress the return spring, and install the snap ring.

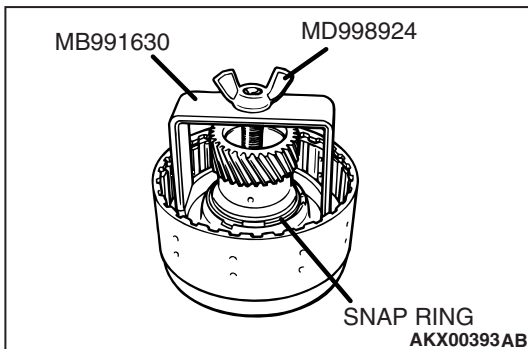



**>>C<< CLUTCH PLATE/CLUTCH DISC/REACTION PLATE  
INSTALLATION**

1. Alternately assemble the clutch plate and clutch disc in the reverse clutch retainer. Align and assemble both clutch plates (where there are no teeth) (A in the illustration) with the reverse clutch retainer hole (B in the illustration).

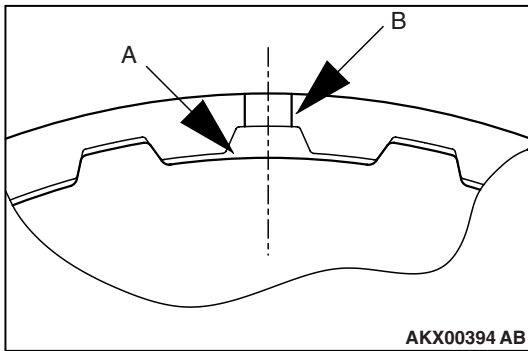

2. Install the reaction plate so that it is oriented as shown in the illustration. Assemble in the same manner as the clutch plate so that the section with no teeth (A in the illustration) matches the retainer hole (B in the illustration).

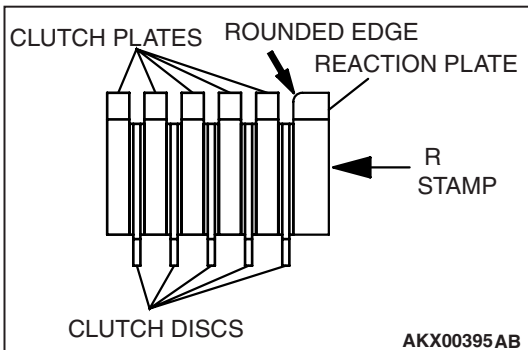

**>>D<< SNAP RING INSTALLATION**

1. Install the snap ring in the direct clutch retainer groove.  
2. Press the entire periphery of the reaction plate with a force of 49 N (11 pound), and confirm that the clearance (direct clutch end play) between the snap ring and reaction plate is the standard value. If the clearance is not at the standard value, select the snap ring and adjust so that the clearance is within the standard value.

**standard value: 1.0 – 1.2 mm (0.037 – 0.047 inch)**

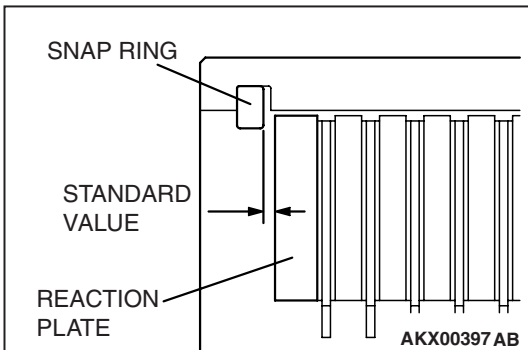
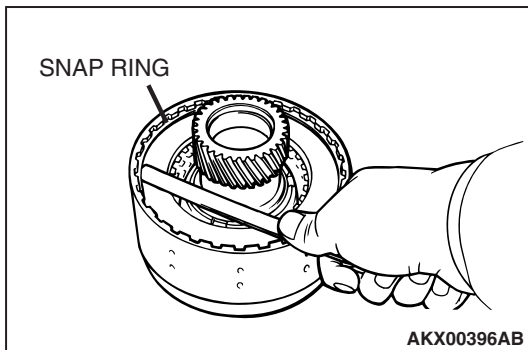

# OUTPUTSHAFT SUPPORT

## DISASSEMBLY AND ASSEMBLY

M1233029000030

APPLY AUTOMATIC TRANSMISSION FLUID TO ALL MOVING PARTS BEFORE INSTALLATION.

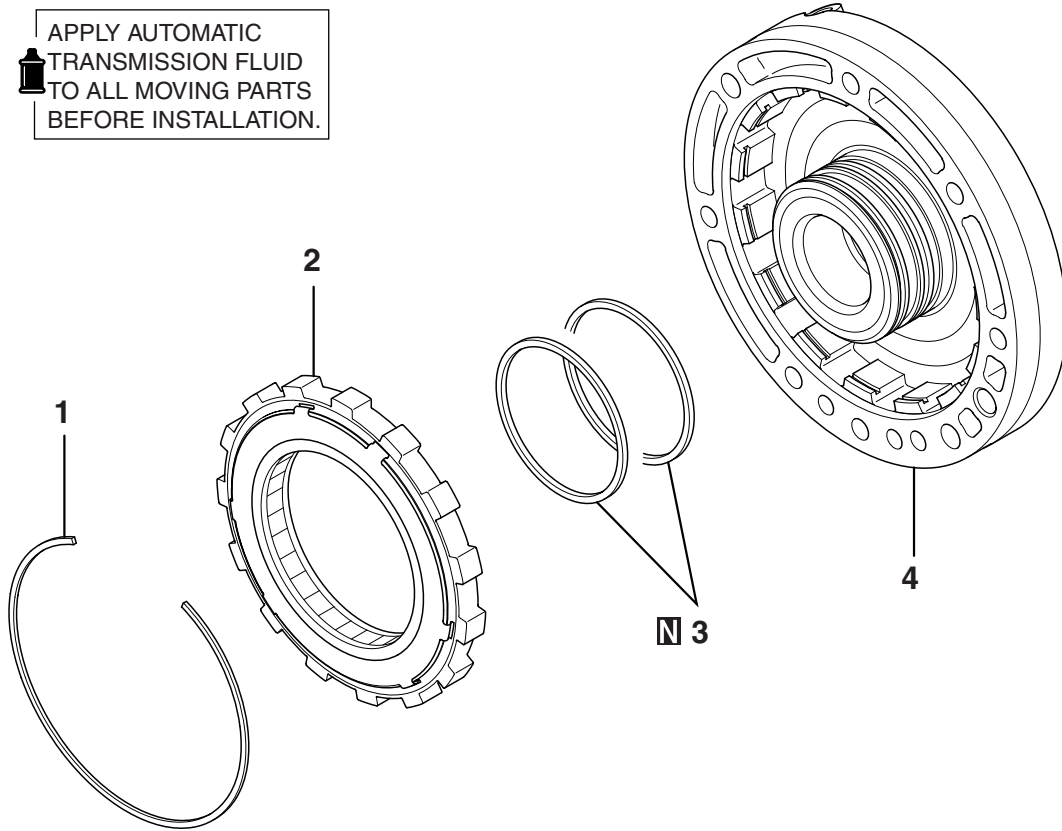

### DISASSEMBLY STEPS

- >>A<<
1. SNAP RING
  2. ONE-WAY CLUTCH

AKX00398AB

### DISASSEMBLY STEPS

3. SEAL RING
4. OUTPUT SHAFT SUPPORT

## ASSEMBLY SERVICE POINT

### >>A<< ONE-WAY CLUTCH INSTALLATION

Install the one-way clutch in such a way that it will be oriented in the direction shown.

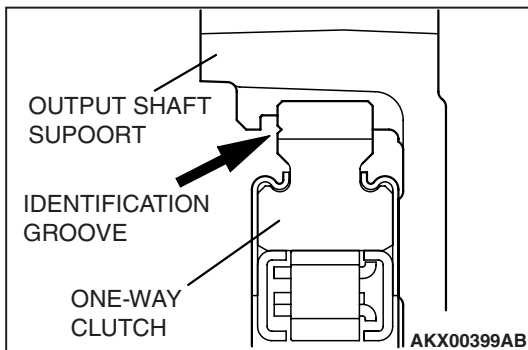

AKX00399AB

# TRANSFER

## DISASSEMBLY AND ASSEMBLY

M1233013300139

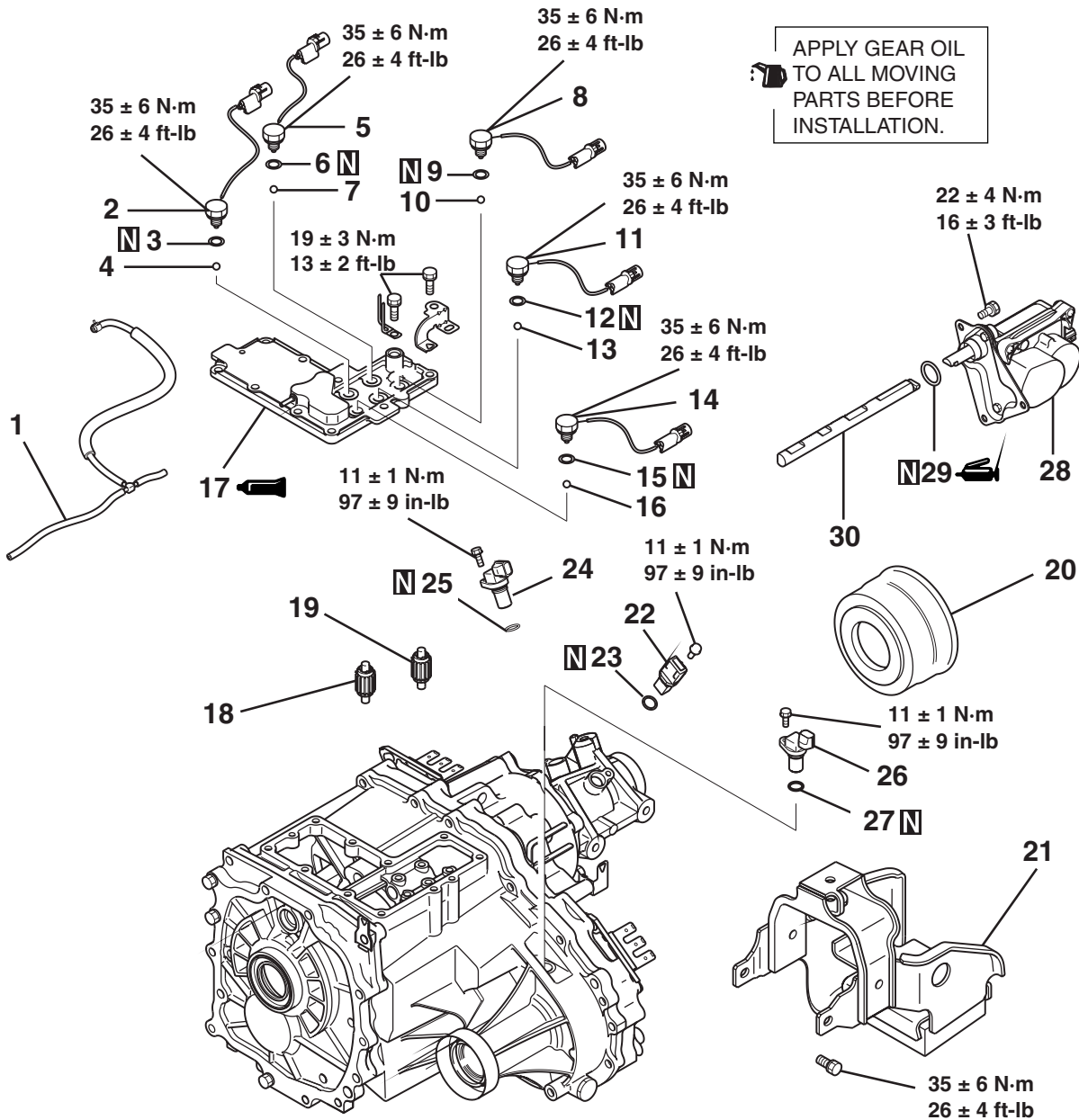

AKX00205AB

**DISASSEMBLY STEPS**

- 1. VACUUM HOSE
- >>W<< 2. 4LLC DETECTION SWITCH
- 3. GASKET
- 4. STEEL BALL
- >>W<< 5. 2WD DETECTION SWITCH
- 6. GASKET
- 7. STEEL BALL
- >>W<< 8. CENTER DIFFERENTIAL LOCK SWITCH
- 9. GASKET
- 10. STEEL BALL

**DISASSEMBLY STEPS**

- >>W<< 11. 4H DETECTION SWITCH
- 12. GASKET
- 13. STEEL BALL
- >>W<< 14. 2-4WD DETECTION SWITCH
- 15. GASKET
- 16. STEEL BALL
- >>V<< 17. TRANSFER CASE COVER
- >>U<< 18. SHIFT RAIL DRIVE GEAR
- >>U<< 19. SHIFT RAIL DRIVE GEAR
- 20. DUST SEAL GUARD
- 21. DYNAMIC DAMPER

**DISASSEMBLY STEPS**

- 22. VEHICLE SPEED SENSOR
- 23. O-RING
- 24. REAR OUTPUT SENSOR
- 25. O-RING

**DISASSEMBLY STEPS**

- 26. FRONT OUTPUT SENSOR
- 27. O-RING
- >>T<< 28. SIFT ACTUATOR
- 29. O-RING
- >>T<< 30. MAIN SHIFT RAIL

APPLY GEAR OIL  
TO ALL MOVING  
PARTS BEFORE  
INSTALLATION.

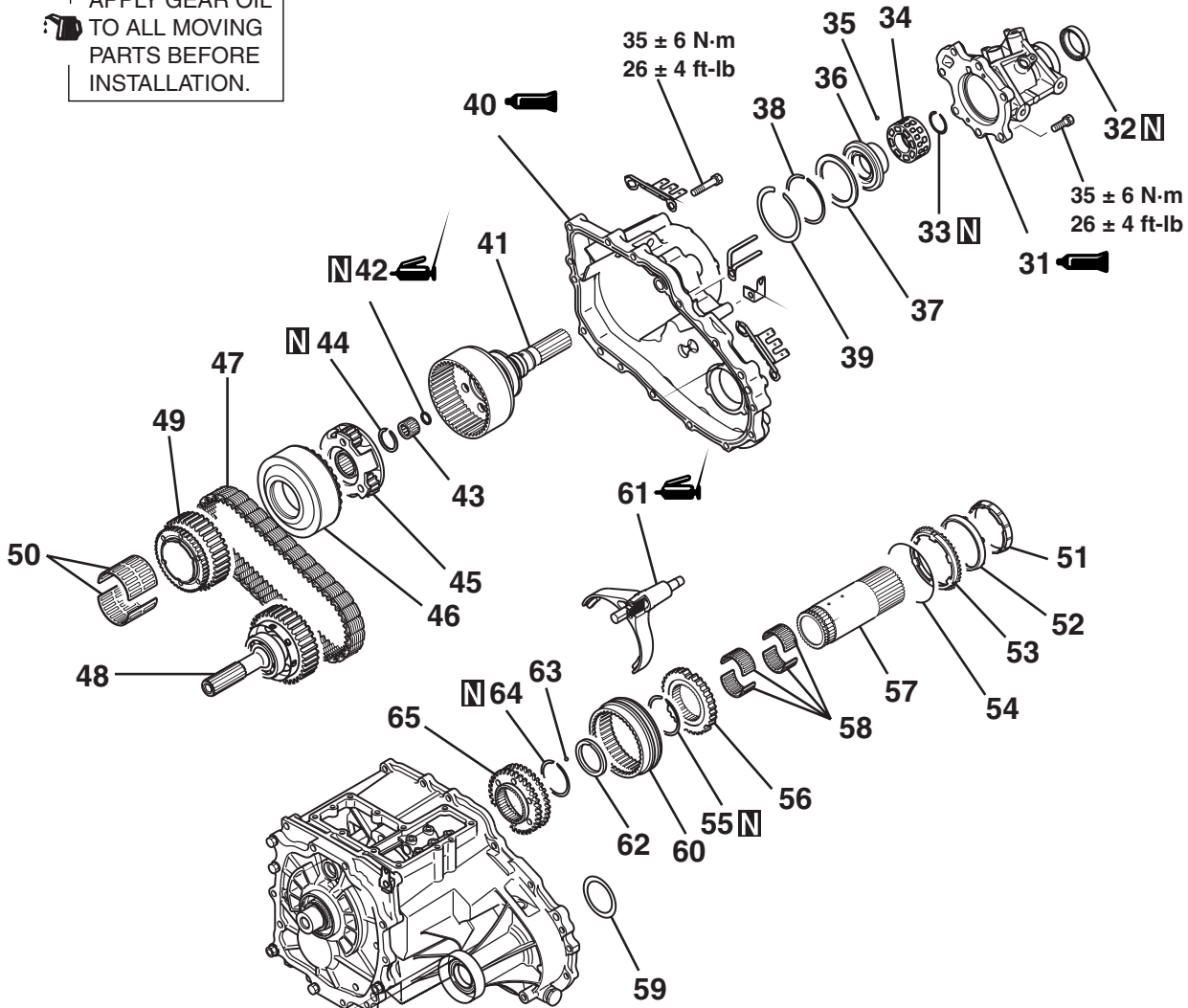

AKX00206AB

**DISASSEMBLY STEPS**

- >>S<< 31. REAR COVER
- >>R<< 32. OIL SEAL
- 33. SNAP RING
- 34. SENSOR ROTOR
- 35. STEEL BALL
- 36. OIL GUIDE
- >>Q<< 37. SPACER
- 38. SNAP RING
- >>P<< 39. SNAP RING
- >>O<< 40. CHAIN COVER
- >>N<< 41. REAR OUTPUT SHAFT
- 42. O-RING
- 43. BEARING
- 44. SNAP RING

**DISASSEMBLY STEPS**

- 45. CENTER DIFFERENTIAL PLANETARY CARRIER
- 46. VISCOUS COUPLING
- <<A>> >>M<< 47. CHAIN
- <<A>> >>M<< 48. FRONT OUTPUT SHAFT
- >>M<< 49. DRIVE SPROCKET
- 50. BEARING
- >>L<< 51. SYNCHRONIZER INNER RING
- >>L<< 52. SYNCHRONIZER CONE
- >>L<< 53. SYNCHRONIZER OUTER RING
- 54. SYNCHRONIZER SPRING
- >>K<< 55. SNAP RING
- 56. 2-4WD CLUTCH HUB
- 57. SUN GEAR
- 58. BEARING

**DISASSEMBLY STEPS**

- >>J<< 59. WAVE SPRING
- >>J<< 60. 2-4WD CLUTCH SLEEVE
- >>J<< 61. 2-4WD SHIFT FORK
- >>I<< 62. SPACER
- >>I<< 63. STEEL BALL
- >>H<< 64. SNAP RING
- 65. DIFFERENTIAL LOCK HUB

 APPLY GEAR OIL TO ALL MOVING PARTS BEFORE INSTALLATION.

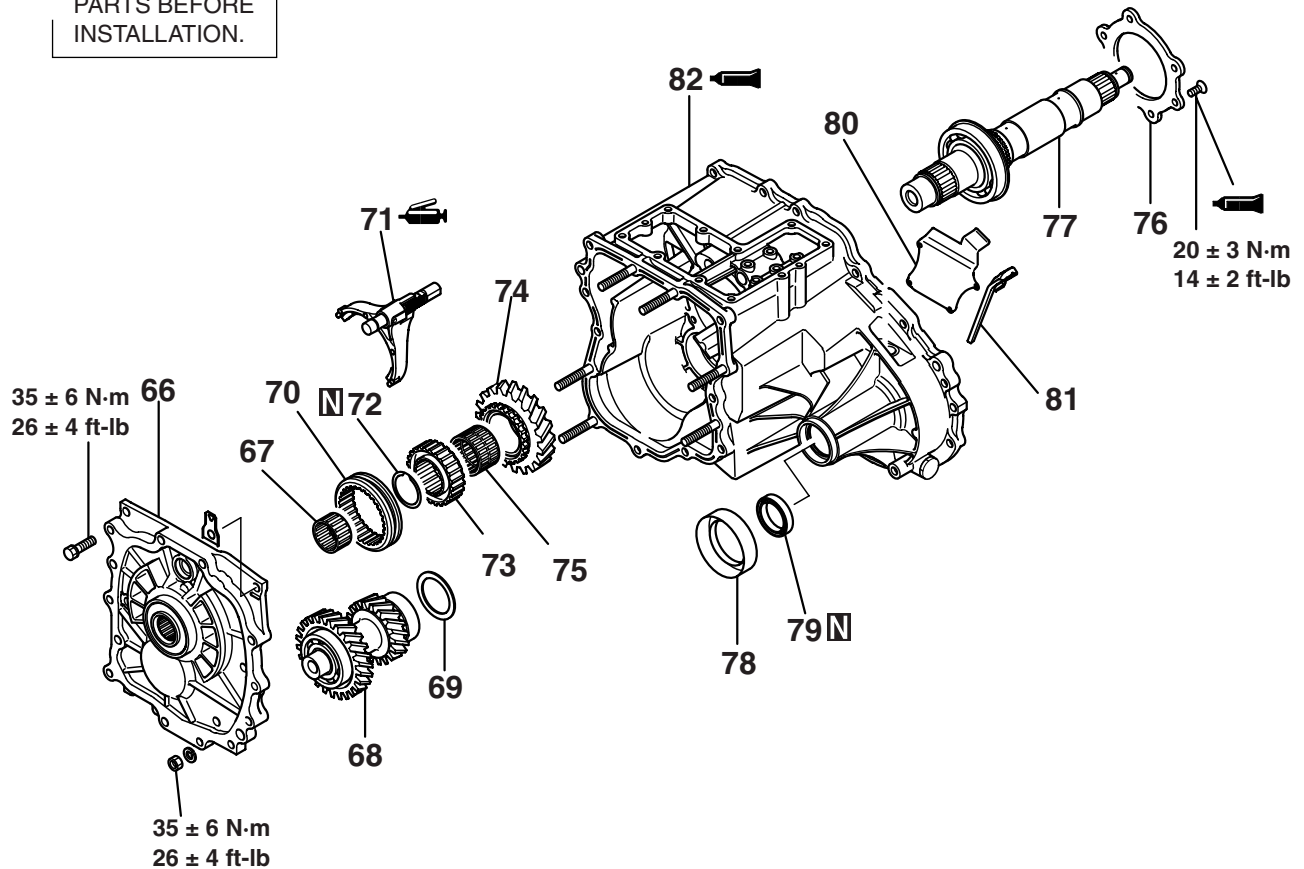

AKX00207AB

**DISASSEMBLY STEPS**

- >>G<< 66. TRANSFER CASE PLATE
- 67. BEARING
- 68. COUNTER SHAFT GEAR
- >>F<< 69. SPACER
- >>E<< 70. H-L CLUTCH SLEEVE
- >>E<< 71. H-L SHIFT FORK
- >>D<< 72. SNAP RING
- 73. H-L CLUTCH HUB
- 74. LOW SPEED GEAR

**DISASSEMBLY STEPS**

- 75. BEARING
- >>C<< 76. REAR BEARING RETAINER
- 77. TRANSFER DRIVE SHAFT
- 78. DUST SEAL GUARD
- >>B<< 79. OIL SEAL
- <<B>> >>A<< 80. OIL GUIDE
- 81. OIL GUIDE
- 82. TRANSFER CASE

**Required special tools:**

- MB990932: Installer Adapter
- MB990936: Installer Adapter
- MB990938: Handle

**DISASSEMBLY SERVICE POINTS****<<A>> CHAIN/FRONT OUTPUT SHAFT/SUN GEAR  
REMOVAL**

Remove the sun gear, chain and front output shaft as a set.

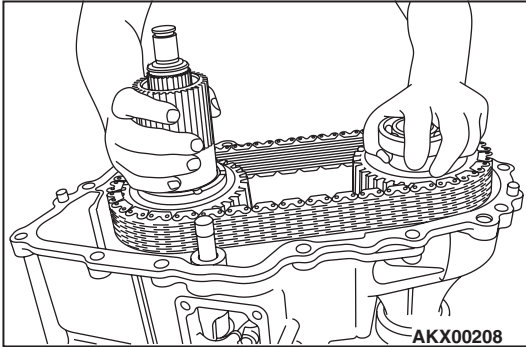
**<<B>> OIL GUIDE REMOVAL****⚠ CAUTION**

Usually no disassembly is necessary for the oil guide.  
After removal, the transfer case can not be reused.  
Remove the caulking part and disassemble the oil guide.

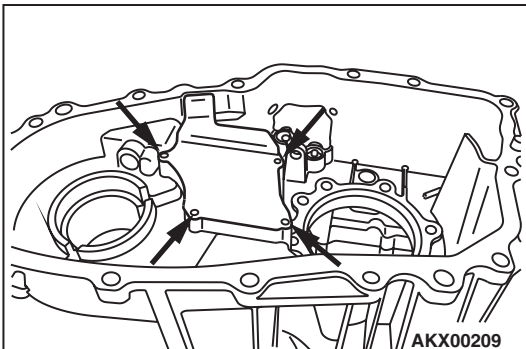
**ASSEMBLY SERVICE POINTS****>>A<< OIL GUIDE INSTALLATION**

Mount the oil guide on new transfer case, and caulk so that the dimension of protruded part (4 places) is as shown to fix the oil guide.

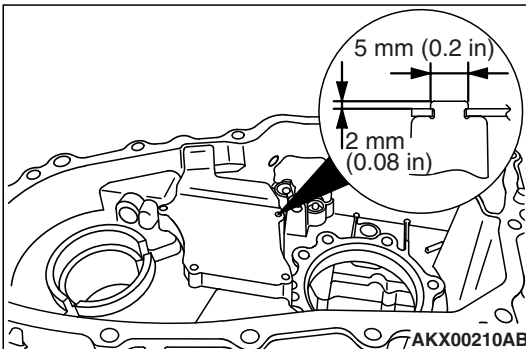

**>>B<< OIL SEAL INSTALLATION**

1. Use special tools MB990929 and MB990938 to install the oil seal.
2. Apply MITSUBISHI genuine grease Part number 0101011 or equivalent to the lip of the oil seal.

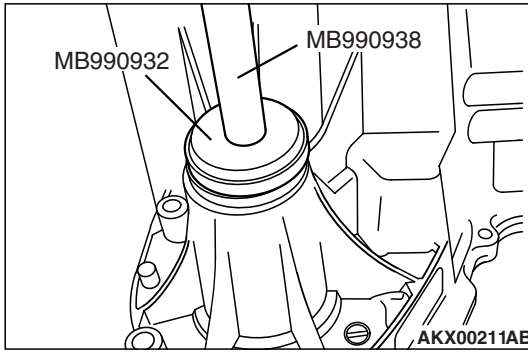

**>>C<< REAR BEARING RETAINER INSTALLATION**

Apply MITSUBISHI genuine sealant part number MD997740 or equivalent to the threads.

*NOTE: The new bolt is precoated with sealant, so sealant does not need to be applied.*

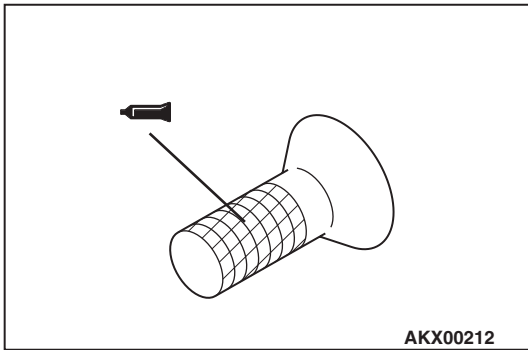

**>>D<< SNAP RING INSTALLATION**

Select and install the snap ring which adjusts the H-L clutch hub end play to the standard value.

**Standard value: 0 – 0.08 mm (0 – 0.003 inch)**

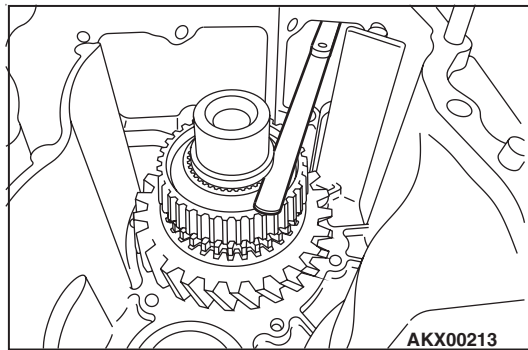

**>>E<< H-L SHIFT FORK/H-L CLUTCH SLEEVE  
INSTALLATION**

Apply MITSUBISHI genuine grease Part number 0101011 or equivalent to the high-low shift fork lift inserting part at indicated in drawing. Install the high-low shift fork and the high low clutch sleeve in the combined state onto the transfer case.

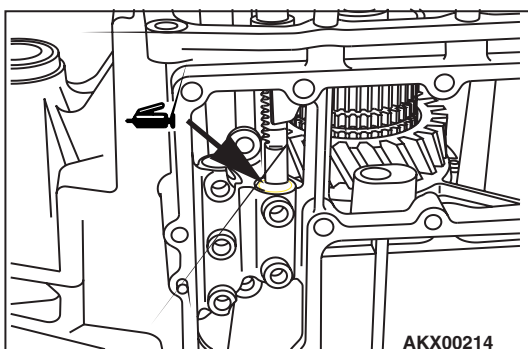

## &gt;&gt;F&lt;&lt; SPACER INSTALLATION

1. Place pieces of solder [approximately 10 mm (0.4 inch) in length and 1.6 mm (0.06 inch) in diameter] in the transfer case housing as shown.
2. Install the countershaft gear into the transfer case.
3. Install the transfer case plate and tighten the bolts.

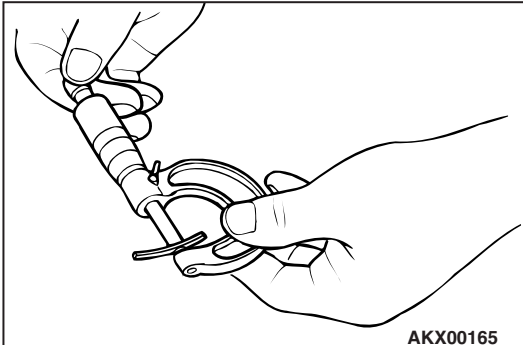
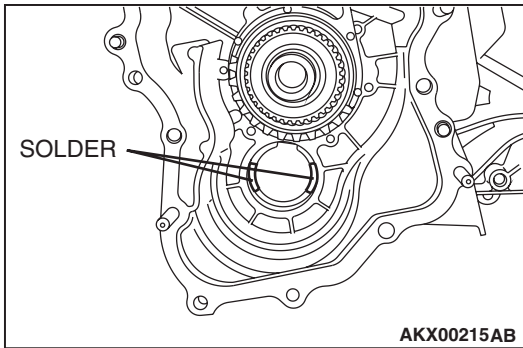

4. Using a micrometer, measure the thickness of the crushed solder. Based on the result, select a spacer which adjusts the end play to the standard value shown below.

**Standard value: 0 – 0.15 mm (0 – 0.006 inch)**

*NOTE: If the solder is not crushed, repeat steps 1 and 2 using thicker solder.*

## &gt;&gt;G&lt;&lt; TRANSFER CASE PLATE INSTALLATION

1. Apply MITSUBISHI genuine grease Part number 0101011 or equivalent to the high-low shift rail inserting part indicated in the drawing.

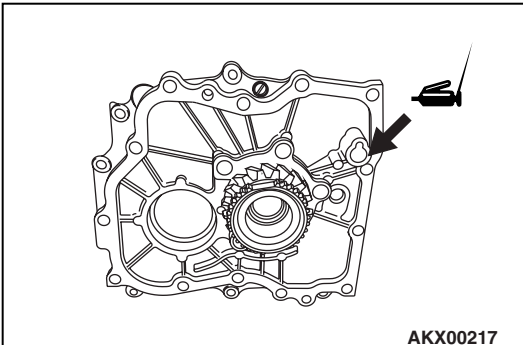

2. Face the notched section of the input gears in the direction shown in the illustration.

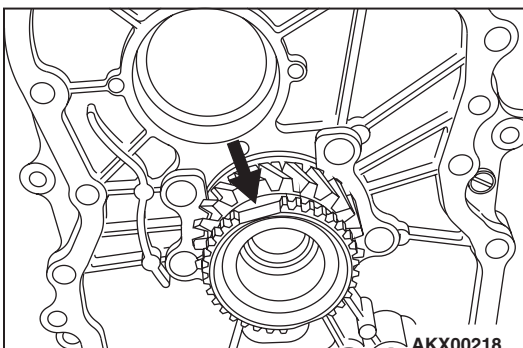



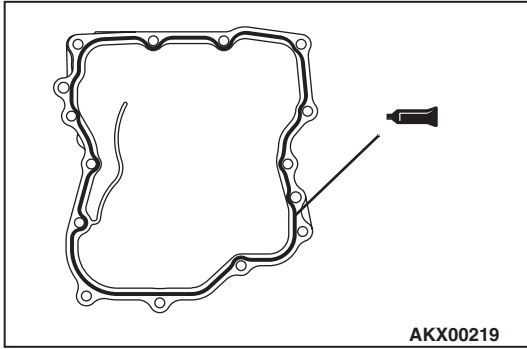

**⚠ CAUTION**

Squeeze the sealant out evenly to apply it in an unbroken, non-excessive quantity.

3. Apply MITSUBISHI genuine sealant Part number MD997740 or equivalent to the transfer case.

**⚠ CAUTION**

In case the sub-gear is difficult to engage the counter shaft gear, install securely by rotating the transfer drive shaft and such.

4. Install the transfer case plate together with the input gear. Slide the input gear tooth aligned in Step 2 along the tooth space of the countershaft gear.

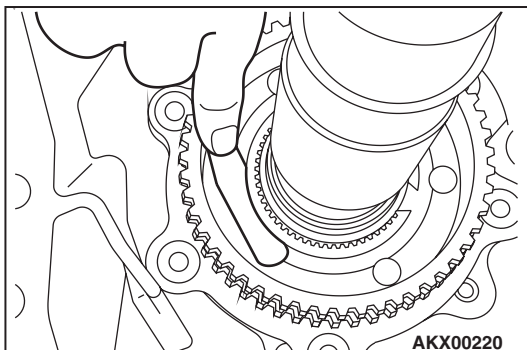

**>>H<< SNAP RING INSTALLATION**

Select and install the snap ring which adjusts the differential lock hub end play to the standard value.

**Standard value: 0 – 0.08 mm (0 – 0.003 inch)**

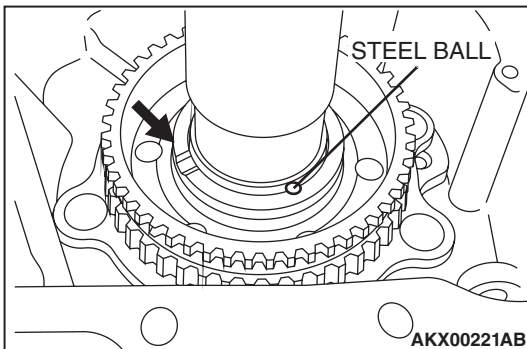

**>>I<< STEEL BALL/SPACER INSTALLATION**

Install the steel ball at the indicated location on the transfer drive shaft, and then install so that the oil groove of spacer is the chain cover side.

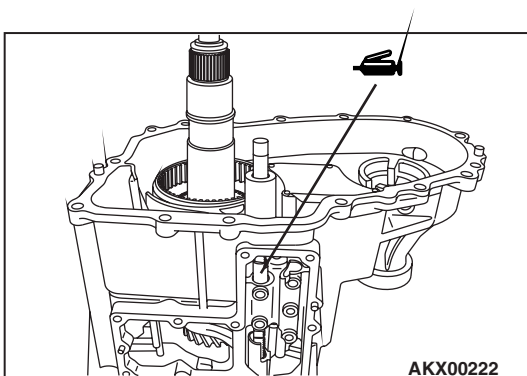

**>>J<< 2-4WD SHIFT FORK/2-4WD CLUTCH SLEEVE INSTALLATION**

Apply MITSUBISHI genuine grease Part number 0101011 or equivalent to 2-4WD shift fork shaft inserting part indicated in drawing, and then install the 2-4WD shift fork and the 2-4WD clutch sleeve in combined state on the transfer case.

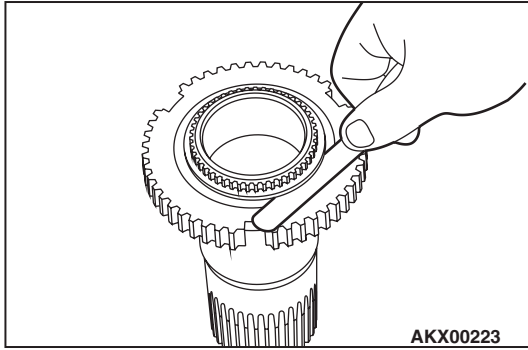
**>>K<< SNAP RING INSTALLATION**

Select and install the snap ring which adjusts the 2-4WD clutch hub end play to the standard value.

**Standard value: 0 – 0.08 mm (0 – 0.003 inch)**

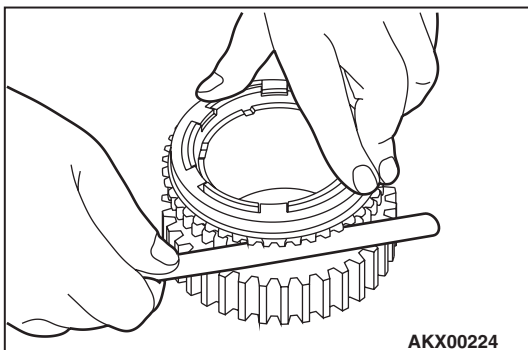
**>>L<< SYNCHRONIZER OUTER RING/SYNCHRONIZER CONE/SYNCHRONIZER INNER RING INSTALLATION**

1. Push the synchronizer outer ring, synchronizer cone and the synchronizer inner ring into the drive sprocket in combined state, and then measure the indicated dimension of the drive sprocket and synchronizer outer ring.

**LIMIT: 0.3 mm (0.012 inch)**

2. In case that the value is out of limit, exchange as the synchronizer ring set.

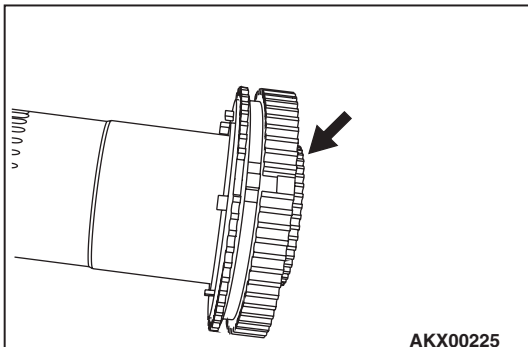

3. Combine the synchronizer outer ring, the synchronizer cone and the synchronizer inner ring, and install them by mating the notch of 2-4WD clutch hub and protrusion of the synchronizer outer ring.

**>>M<< DRIVE SPROCKET/FRONT OUTPUT SHAFT/CHAIN INSTALLATION**

1. Engage the chain to the drive sprocket and the sprocket of front output shaft.

**⚠ CAUTION**

Then engage the indicated hole of drive sprocket to the protrusion of the synchronizer cone.

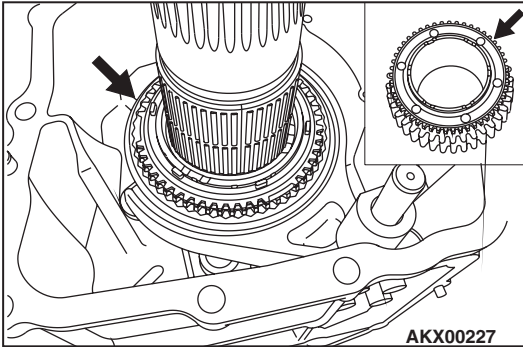

2. Install the chain, the drive sprocket and the front output shaft onto the transfer case in combined state.

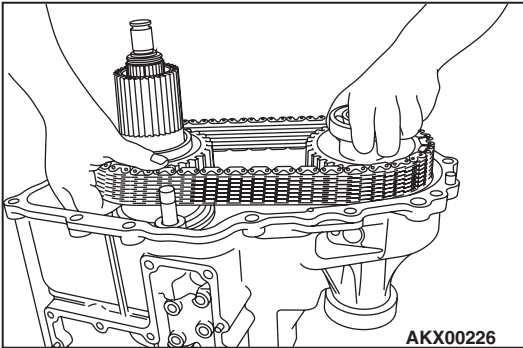

**>>N<< REAR OUTPUT SHAFT INSTALLATION**

Apply MITSUBISHI genuine grease Part number 0101011 or equivalent to the indicated O-ring, and then install the rear output shaft.

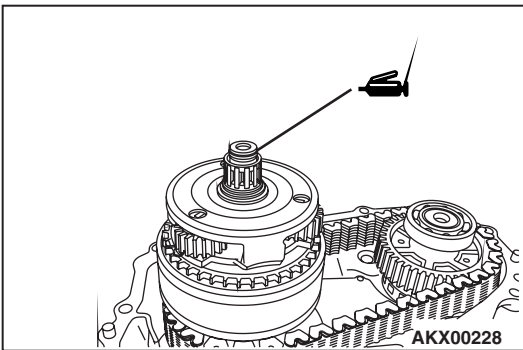

**>>O<< CHAIN COVER INSTALLATION**

1. Apply MITSUBISHI genuine grease Part number 0101011 or equivalent to the indicated 2-4WD shift rail insertion part.
2. Apply sealant MITSUBISHI genuine sealant Part number MD997740 or equivalent to the chain cover, and then install the chain cover.

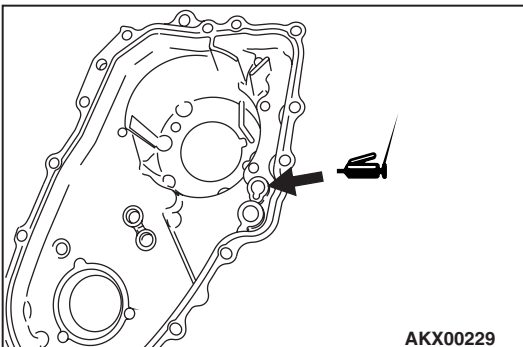

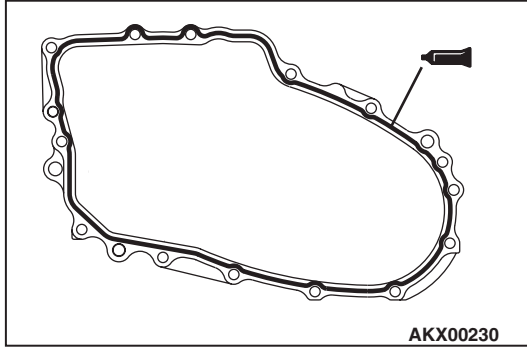

**⚠ CAUTION**

Squeeze the sealant out evenly to apply it in an unbroken, non-excessive quantity.

**>>P<< SNAP RING INSTALLATION**

1. Install the snap ring onto the bearing groove of the rear output shaft.
2. Measure the clearance between the chain cover and snap ring while pushing the rear output shaft to chain cover side.
3. Select the snap ring of a value which the standard value is added to the measured clearance value.

**Standard value: 0 – 12 – 0.24 mm (0.005 – 0.009 inch)**

4. Remove the snap ring of the bearing groove of the rear output shaft, and install the selected snap ring. Then install again the snap ring on the bearing groove of the rear output shaft.

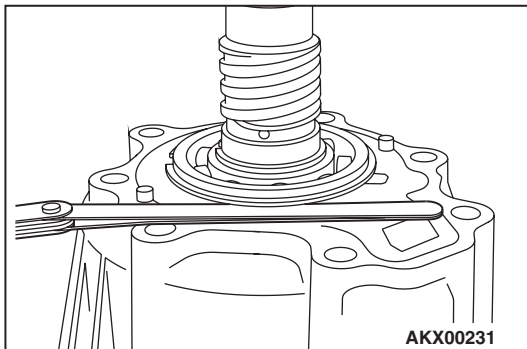

**>>Q<< SPACER INSTALLATION**

**⚠ CAUTION**

Then, measure it with the snap ring installed.

1. Measure the protrusion amount A of bearing from the chain cover while pushing the rear output shaft to the chain cover side.

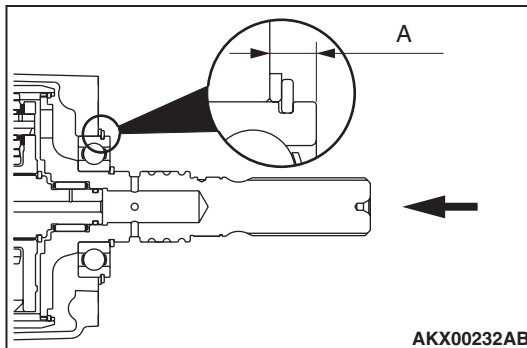

2. Measure the depression B at indicated part of the rear cover.
3. Calculate the clearance between the bearing and rear cover by subtracting the measurement value A from measurement value B of the procedure 2, and then select and install the spacer so that the clearance is the standard value.

**Standard value: 0 – 0.12 mm (0 – 0.005 inch)**

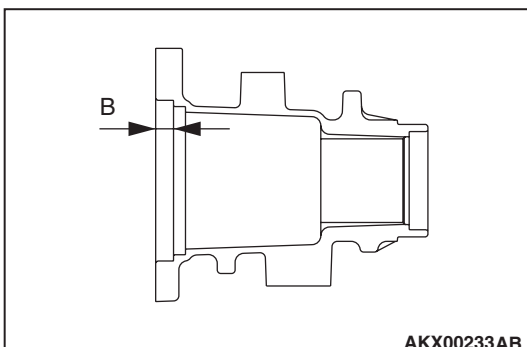

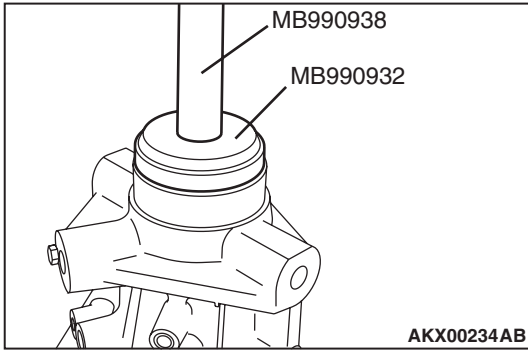

**>>R<< OIL SEAL INSTALLATION**

1. Use special tools MB990932 and MB990938 to install the oil seal.
2. Apply MITSUBISHI genuine grease Part number 0101011 or equivalent to the lip of the oil seal.

**>>S<< REAR COVER INSTALLATION**

**⚠ CAUTION**

**Squeeze the sealant out evenly to apply it in an unbroken, non-excessive quantity.**

Apply sealant Mitsubishi genuine sealant Part number MD997740 or equivalent to the chain cover, and then install the rear cover.

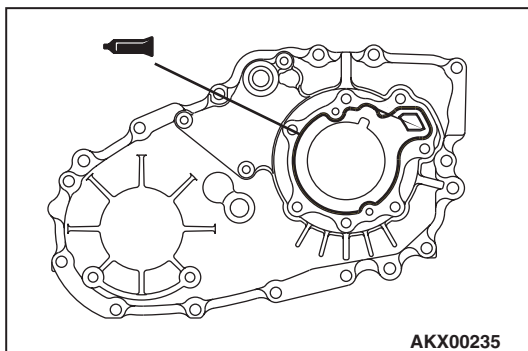

**>>T<< MAIN SHIFT RAIL/SHIFT ACTUATOR INSTALLATION**

1. Connect a 12V power supply across the terminals of the actuator connector in a polarity appropriate for causing the actuator motor to move in the rod extending direction or retracting direction until the amount of extension of the rod is as indicated in the drawing.

TERMINAL A	TERMINAL B	ROD MOVEMENT
Power supply (+)	Power supply (-)	Extension
Power supply (-)	Power supply (+)	Retraction

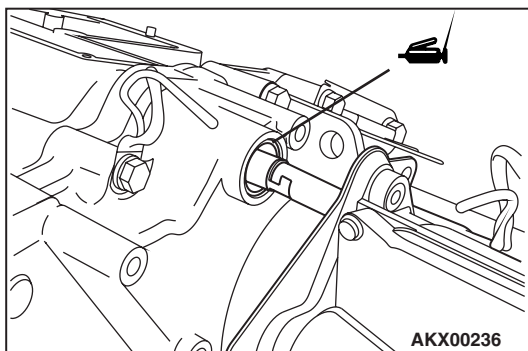
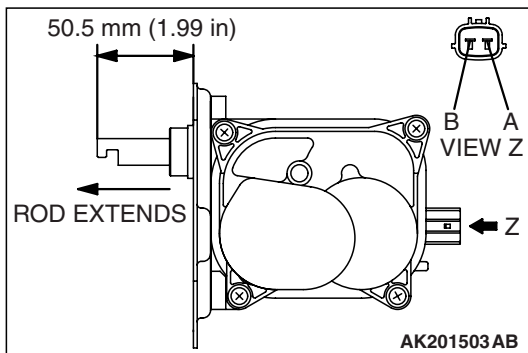

2. Apply MITSUBISHI genuine grease Part number 0101011 or equivalent to the O-ring at indicated location.
3. Insert the combination of the key of the main shift rail and the key of the actuator into the transfer case.

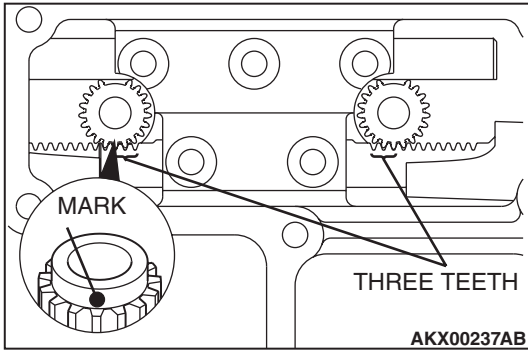

**>>U<< SHIFT RAIL DRIVE GEAR INSTALLATION**

Install so that the mating mark of the shift rail drive gear engages 3 teeth of each shift rail drive gear.

**>>V<< TRANSFER CASE COVER INSTALLATION**

**⚠ CAUTION**

Squeeze the sealant out evenly to apply it in an unbroken, non-excessive quantity.

Apply sealant MITSUBISHI genuine sealant Part number MD997740 or equivalent to the transfer case, and then install the transfer case cover.

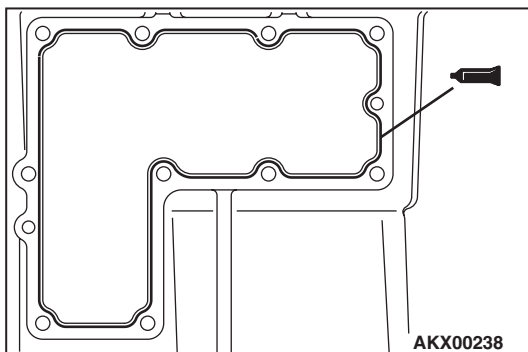

**>>W<< 2-4WD DETECTION SWITCH/4H DETECTION SWITCH/CENTER DIFFERENTIAL LOCK DETECTION SWITCH/2WD DETECTION SWITCH/4LLC DETECTION SWITCH INSTALLATION**

Install with care. Do not make a mistake when locating each switch.

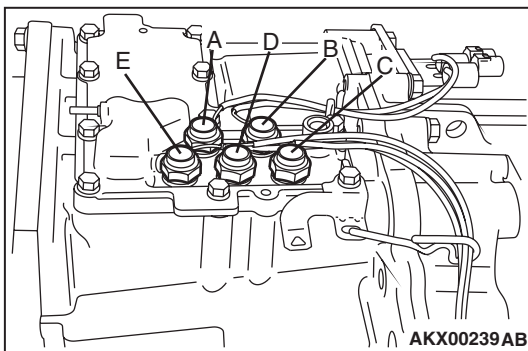

	DETECTION SWITCH NAME	TUBE COLOR	CONNECTOR COLOR
A	4LLC	Black	Brown
B	2WD	Black	Black
C	CENTER DIFFERENTIAL LOCK	Blue	Brown
D	4H	Green	White
E	2-4WD	Blue	Black

**INSPECTION**

M1233013400084

**2-4WD, H-L, 4LLC, 2WD, CENTER DIFFERENTIAL LOCK,  
4H DETECTION SWITCH**

Check for the continuity between the connector terminal and switch body.

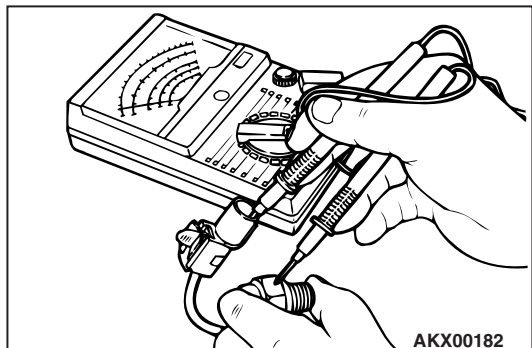

SWITCH STATE	CONTINUITY
Switch end pressed	No
Switch end released	Yes

**LOW RANGE OPERATION DETECTION SWITCH**

Check for the continuity between the connector terminal and switch body.

SWITCH STATE	CONTINUITY
Switch end pressed	Yes
Switch end released	No

**TRANSFER CASE PLATE**

**DISASSEMBLY AND ASSEMBLY**

M1233024200062

 APPLY GEAR OIL TO ALL MOVING PARTS BEFORE INSTALLATION.

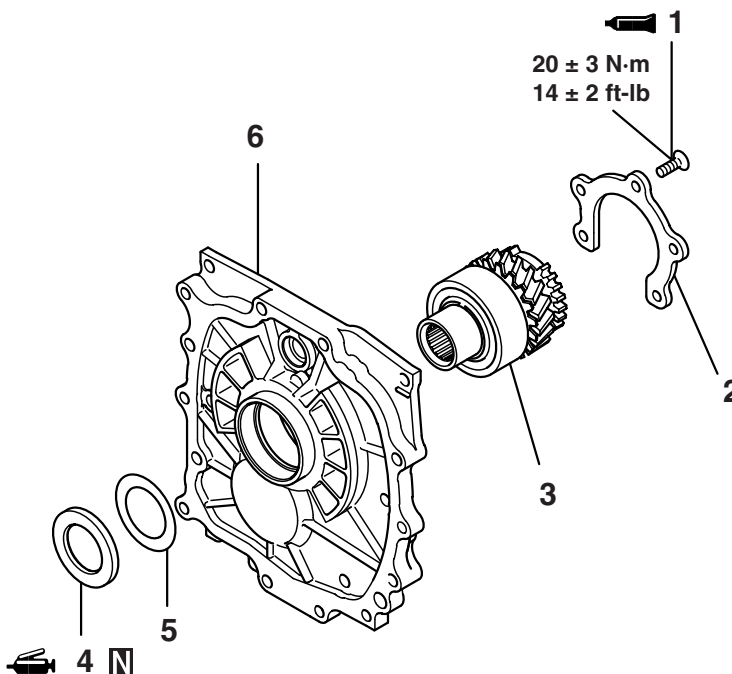

AKX00438 AD

- >>B<<**
- DISASSEMBLY STEPS**
1. BOLT
  2. BEARING RETAINER
  3. TRANSFER INPUT GEAR

- >>A<<**
- DISASSEMBLY STEPS**
4. OIL SEAL
  5. BAFFLE PLATE
  6. TRANSFER CASE PLATE

**Required Special Tools:**

- MB990938: Handle
- MB990936: Installer Adapter

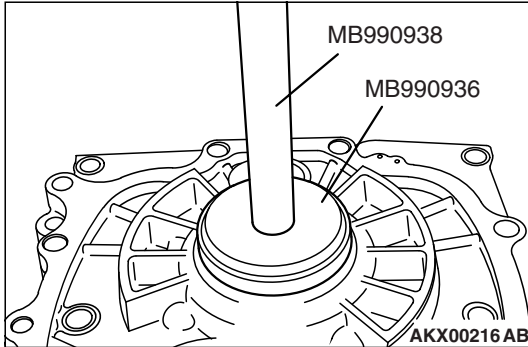
**ASSEMBLY SERVICE POINTS****>>A<< OIL SEAL INSTALLATION**

1. Use special tools MB990938 and MB990936 to install the oil seal.
2. Apply Mitsubishi genuine grease part number 0101011 or equivalent to the lip of the oil seal.

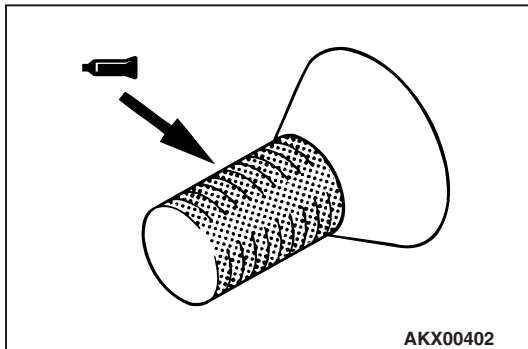
**>>B<< BOLT INSTALLATION**

Apply Mitsubishi genuine sealant part number MD997740 or equivalent to the threads.

*NOTE: The new bolt is pre-coated with sealant, so sealant does not need to be applied.*



# INPUT GEAR

## DISASSEMBLY AND ASSEMBLY

M1233015100078

 APPLY GEAR OIL  
TO ALL MOVING  
PARTS BEFORE  
INSTALLATION.

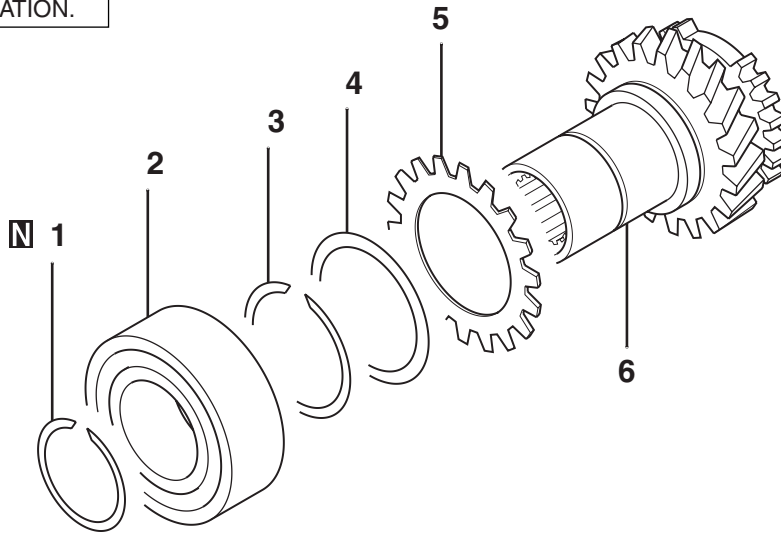

AKX00252AB

- DISASSEMBLE STEPS**
- >>B<< 1. SNAP RING
- <<A>> >>A<< 2. BALL BEARING
3. SNAP RING

- DISASSEMBLE STEPS**
4. CONE SPRING
5. SUB GEAR
6. TRANSFER INPUT GEAR

### Required special tools:

- MD998801: Bearing Remover
- MD998812: Installer Cap
- MD998826: Installer Adapter

### DISASSEMBLY SERVICE POINT

#### <<A>> BALL BEARING REMOVAL

Use special tool MD998801 to remove the ball bearing.

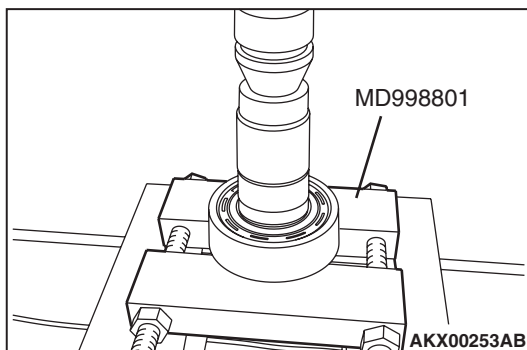

AKX00253AB

**ASSEMBLY SERVICE POINTS**

**>>A<< BALL BEARING INSTALLATION**

Use special tools MD998812 and MD998826 to install the ball bearing.

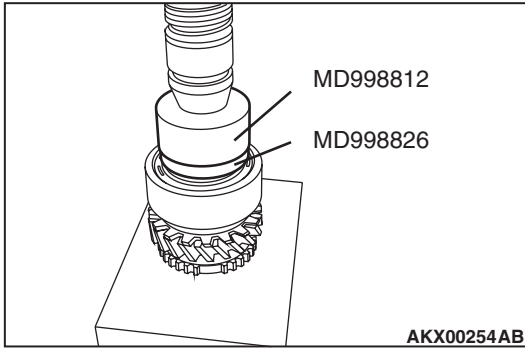

**>>B<< SNAP RING INSTALLATION**

1. Install the thickest snap ring that can be fitted in the snap ring groove of the transfer input gear.
2. Make sure that the transfer input gear bearing end play meets the standard value.

**Standard value: 0 – 0.06 mm (0 – 0.002 inch)**

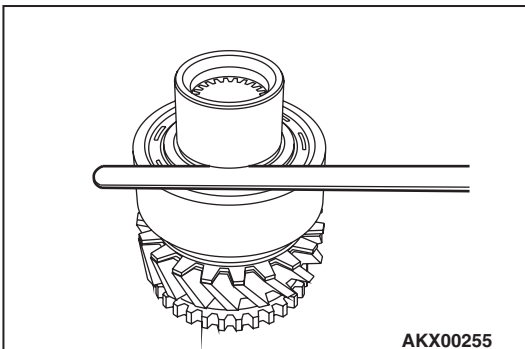

**COUNTERSHAFT GEAR**

**DISASSEMBLY AND ASSEMBLY**

M1233024000079

APPLY GEAR OIL  
TO ALL MOVING  
PARTS BEFORE  
INSTALLATION.

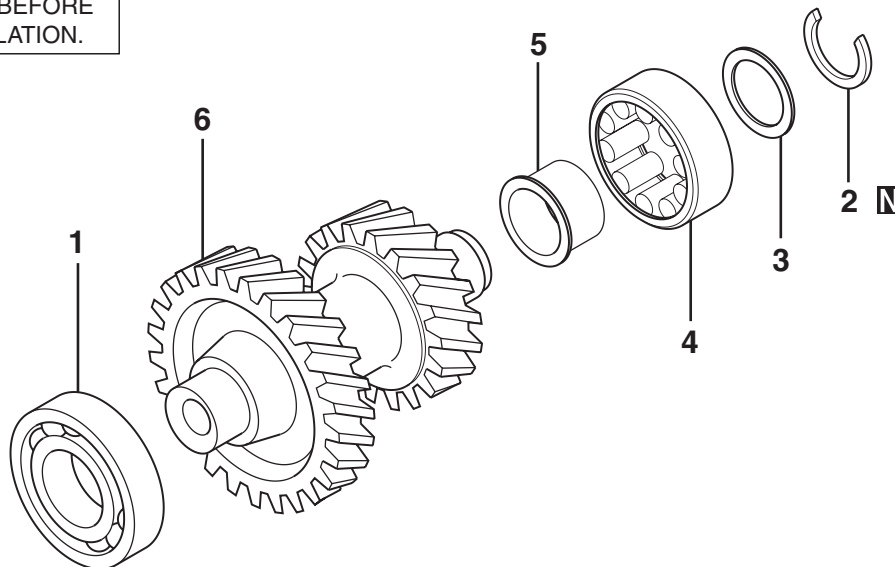

AKX00256AB

- DISASSEMBLY STEPS**
- <<A>> >>C<< 1. BALL BEARING  
 >>B<< 2. SNAP RING  
 <<B>> >>A<< 3. SPACER

- DISASSEMBLY STEPS**
- <<B>> >>A<< 4. ROLLER BEARING  
 <<B>> >>A<< 5. INNER RACE  
 6. COUNTER SHAFT GEAR

**Required special tools:**

- MD998801: Bearing Remover
- MD998368: Bearing Installer
- MD998812: Installer Cap
- MD998818: Installer Adapter

**DISASSEMBLY SERVICE POINT**

**<<A>> BALL BEARING REMOVAL**

Use special tool MD998801 to remove the ball bearing.

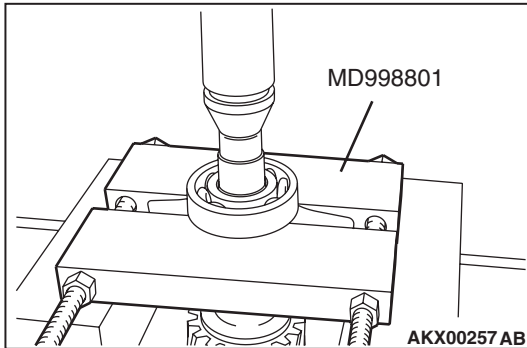

**<<B>> SPACER/ROLLER BEARING/INNER RACE REMOVAL**

1. Remove the spacer and roller bearing.
2. Use special tools MD998801 and MD998368 to remove the inner race.

*NOTE: In the case that the installation of the spacer, roller bearing, and inner race is in reverse order according to the vehicle, then remove the inner race, roller bearing and spacer at the same time.*

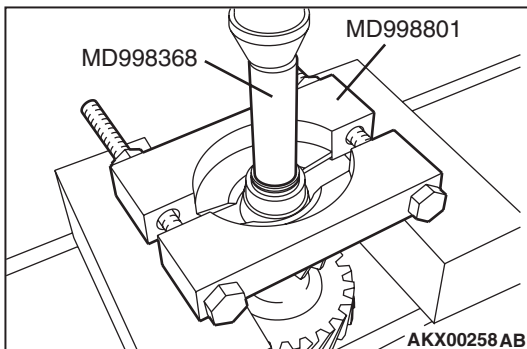

**ASSEMBLY SERVICE POINTS**

**>>A<< INNER RACE/ROLLER BEARING/SPACER INSTALLATION**

1. Use special tools MD998812 and MD998818 to install the inner race.
2. Install the roller bearing and spacer.

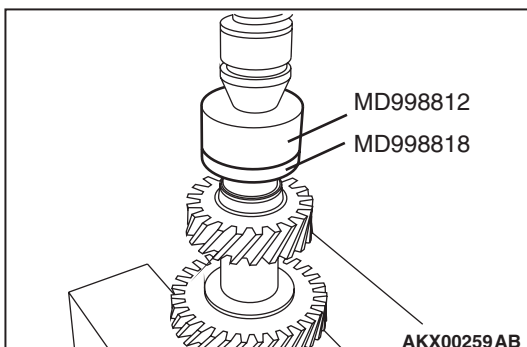

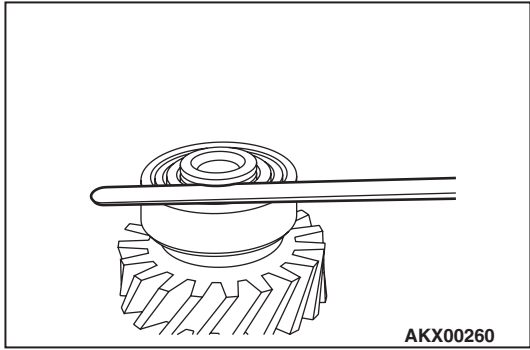

**>>B<< SNAP RING INSTALLATION**

1. Install the thickest snap ring that can be fitted into the snap ring groove of the counter shaft gear.
2. Make sure that the counter shaft gear roller bearing end play meets the standard value.

**Standard value: 0 – 0.08 mm (0 – 0.003 inch)**

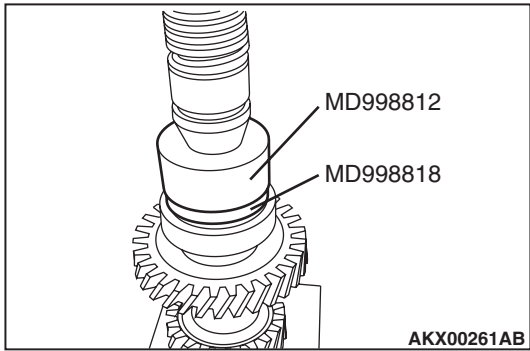

**>>C<< BALL BEARING INSTALLATION**

Use special tools MD998812 and MD998818 to install the ball bearing.

**REAR OUTPUT SHAFT**

**DISASSEMBLY AND ASSEMBLY**

M1233013600107

 APPLY GEAR OIL TO ALL MOVING PARTS BEFORE INSTALLATION.

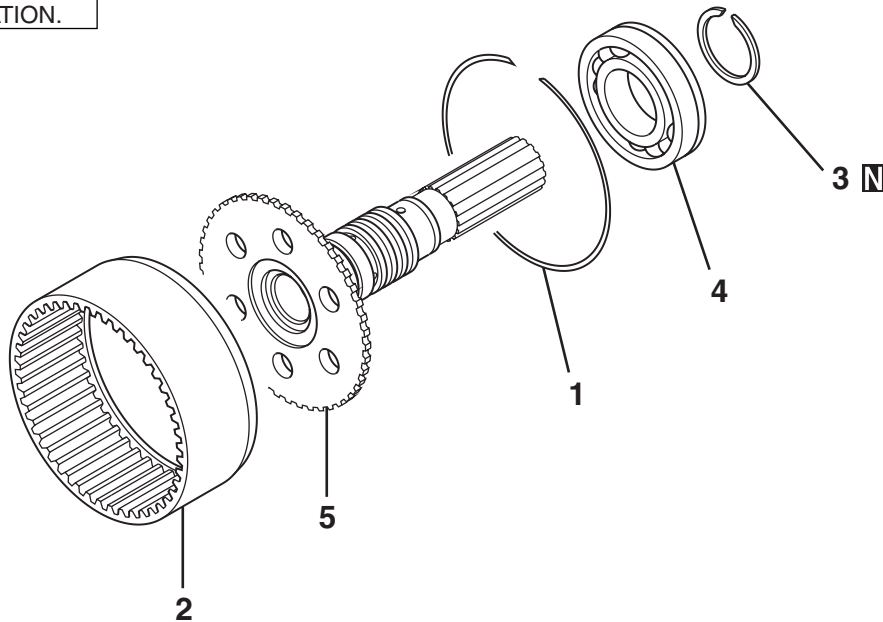

AKX00242AB

- DISASSEMBLY STEPS**
- >>C<< 1. SNAP RING  
2. ANNULUS GEAR
- >>B<< 3. SNAP RING

- DISASSEMBLY STEPS**
- <<A>> >>A<< 4. BALL BEARING  
5. REAR OUTPUT SHAFT

**Required special tools**

- MD998812: Installer Cap
- MD998814: Installer-200
- MD998824: Installer Adapter
- MD998917: Bearing Remover

**DISASSEMBLY SERVICE POINT**

**<<A>> BALL BEARING REMOVAL**

Use special tool MD998917 to remove the ball bearing.

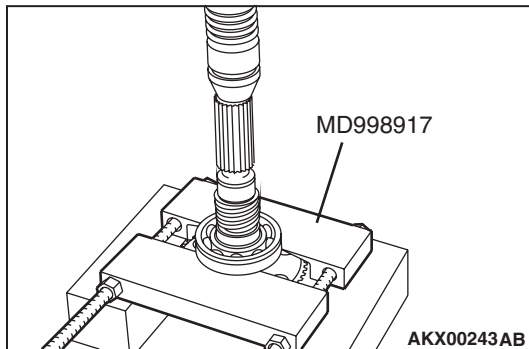

**ASSEMBLY SERVICE POINTS**

**>>A<< BALL BEARING INSTALLATION**

Use special tools MD998812, MD998814 and MD998824 to install the ball bearing.

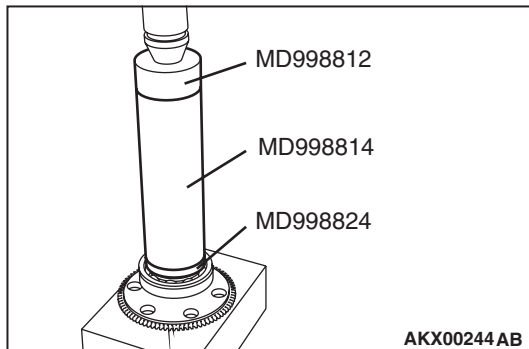

**>>B<< SNAP RING INSTALLATION**

1. Install the thickest snap ring that can be fitted in the snap ring groove of the rear output shaft.
2. Make sure that the rear output shaft bearing end play meets the standard value.

**Standard value: 0 – 0.08 mm (0 – 0.003 inch)**

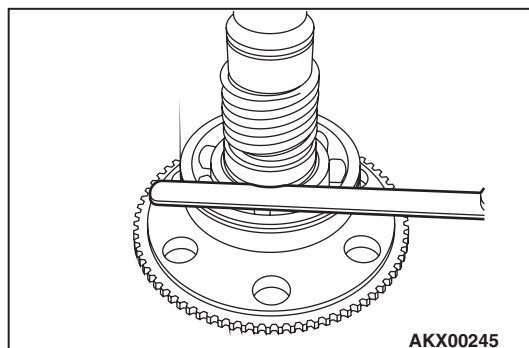

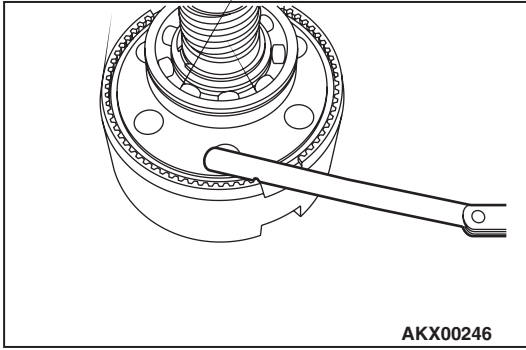

**>>C<< SNAP RING INSTALLATION**

1. Install the thickest snap ring that can be fitted in the snap ring groove of the annulus gear.
2. Make sure that the annulus gear end play meets the standard value.

**Standard value: 0 – 0.08 mm (0 – 0.003 inch)**

**FRONT OUTPUT SHAFT**

**DISASSEMBLY AND ASSEMBLY**

M1233014800096

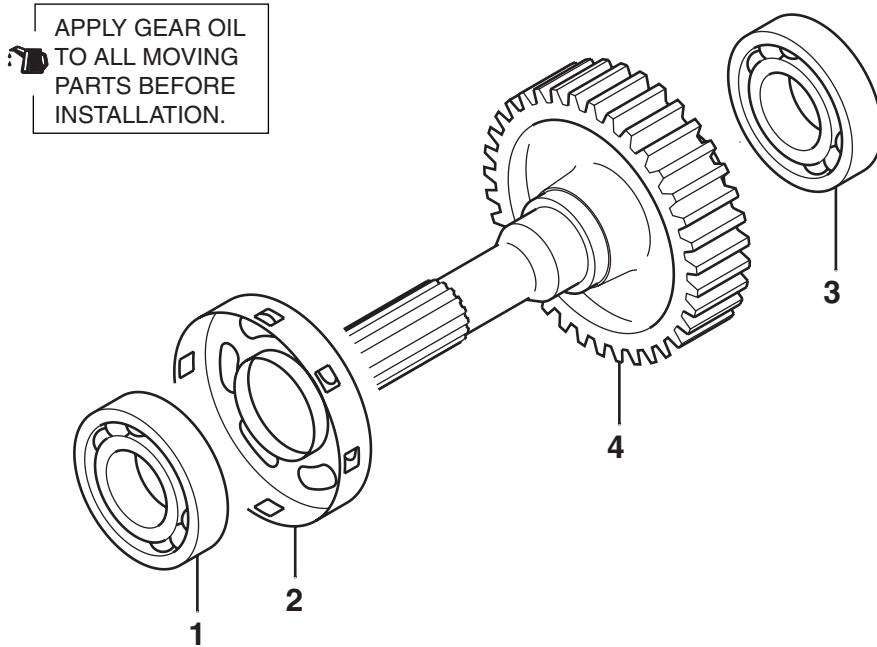

AKX00247AB

- <<A>> >>B<<**
- DISASSEMBLY STEPS**
1. BALL BEARING
  2. SENSOR ROTOR

- <<B>> >>A<<**
- DISASSEMBLY STEPS**
3. BALL BEARING
  4. FRONT OUTPUT SHAFT

**Required Special tools:**

- MD998801: Bearing Remover
- MD998812: Installer Cap
- MD998813: Installer-100
- MD998818: Installer Adapter

**DISASSEMBLY SERVICE POINT**

**<<A>> BALL BEARING REMOVAL**

Use special tool MD998801 to remove the ball bearing.

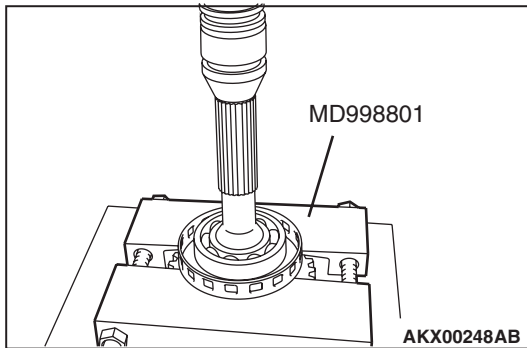

**<<B>> BALL BEARING REMOVAL**

Use special tool MD998801 to remove the ball bearing.

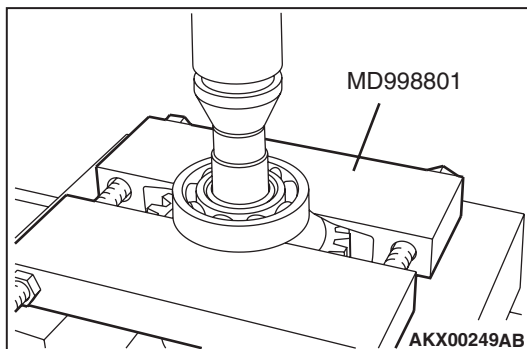

**ASSEMBLY SERVICE POINTS**

**>>A<< BALL BEARING INSTALLATION**

Use special tools MD998812 and MD998818 to install the ball bearing.

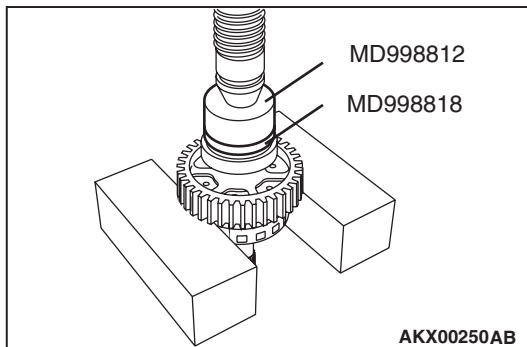

**>>B<< BALL BEARING INSTALLATION**

Use special tools MD998812, MD998813 and MD998818 to install the ball bearing.

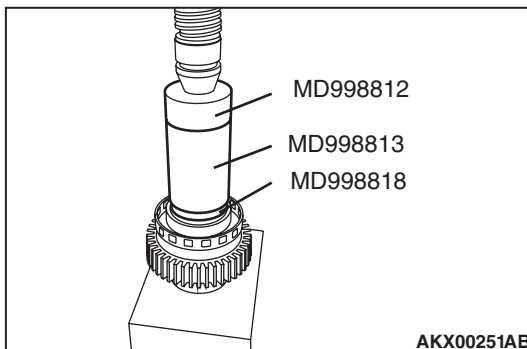

**TRANSFER DRIVE SHAFT****DISASSEMBLY AND ASSEMBLY**

M1233014500040

APPLY GEAR OIL  
TO ALL MOVING  
PARTS BEFORE  
INSTALLATION.

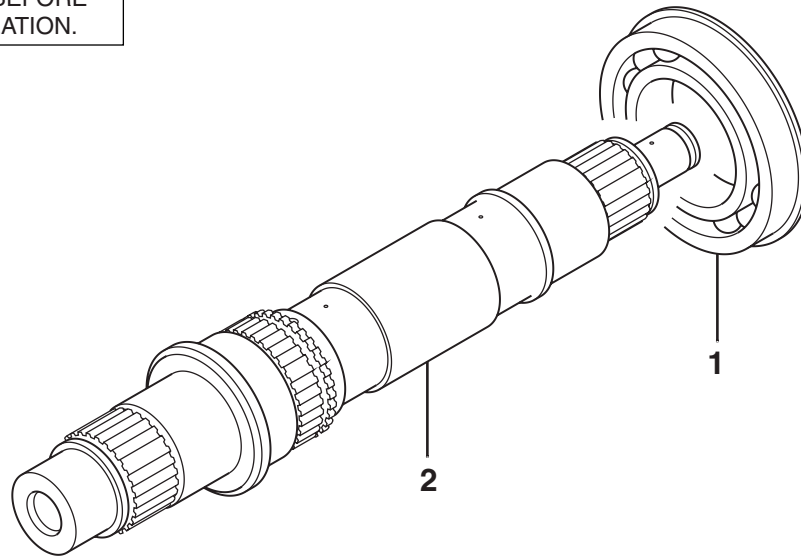

AKX00262AB

**DISASSEMBLY STEPS**

- <<A>> >>A<< 1. BALL BEARING  
2. TRANSFER DRIVE SHAFT

**Required special tools**

- MD998192: Bearing puller
- MD998812: Installer Cap
- MD998814: Installer-200
- MD998830: Installer Adapter
- MD998917: Bearing Remover

**DISASSEMBLY SERVICE POINT****<<A>> BALL BEARING REMOVAL**

Use special tool MD9988917 to remove the ball bearing.

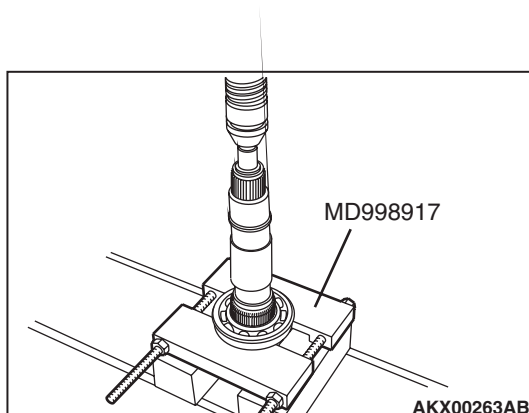

AKX00263AB



**ASSEMBLY SERVICE POINTS**

**>>A<< INNER RACE/ROLLER BEARING/SPACER INSTALLATION**

Use special tools MD998812, MD998814, MD998830 and MD998192 to install the inner race.

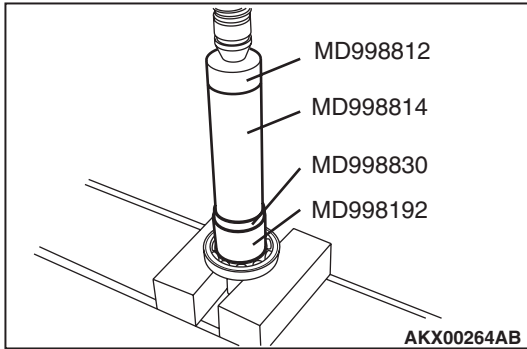

**SHIFTRAIL DRIVE GEAR**

**DISASSEMBLY AND ASSEMBLY**

M1233030500028

 APPLY GEAR OIL TO ALL MOVING PARTS BEFORE INSTALLATION.

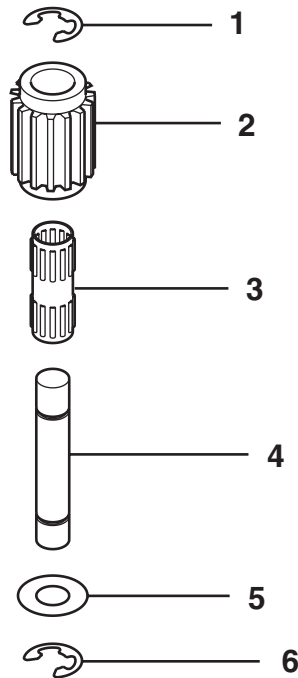

AKX00240AB

**DISASSEMBLY STEPS**

- >>A<<
1. SNAP RING
  2. SHIFTRAIL DRIVE GEAR
  3. BEARING

**DISASSEMBLY STEPS**

4. SHIFTRAIL DRIVE GEAR SHAFT
5. WASHER
6. SNAP RING

**ASSEMBLY SERVICE POINT**

**>>A<< SHIFT RAIL DRIVE GEAR INSTALLATION**

Install so that the mating mark of the shift rail drive gear is opposite side of the washer.

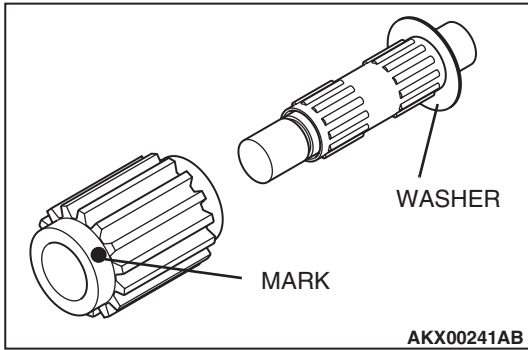

**2-4 SHIFT RAIL/H-L SHIFT RAIL**

**DISASSEMBLY AND ASSEMBLY**

M1233031500021

APPLY GEAR OIL TO ALL MOVING PARTS BEFORE INSTALLATION.

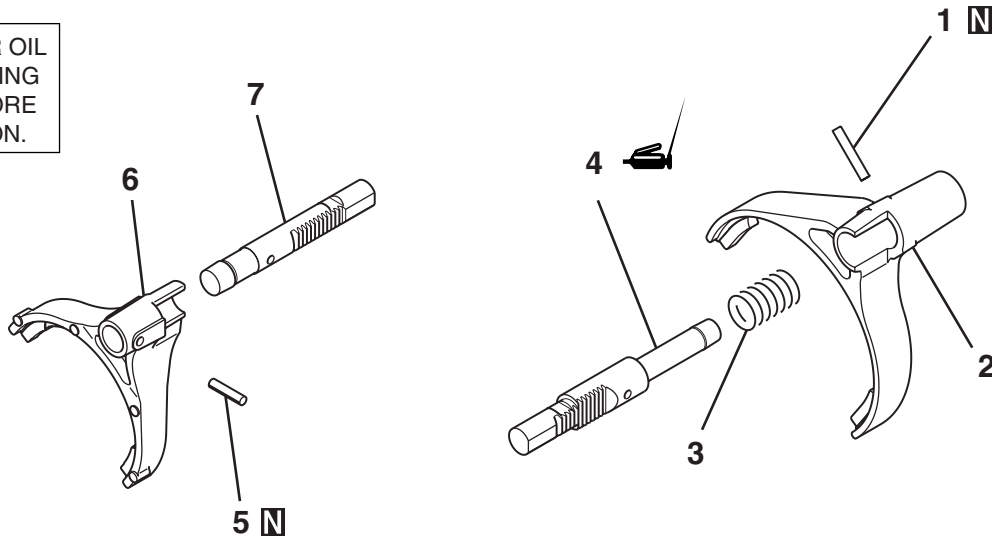

AKX00265AB

- DISASSEMBLY STEPS**
- >>A<< 1. SPRING PIN
  - 2. 2-4WD SHIFT FORK
  - 3. SPRING
  - >>B<< 4. 2-4WD SHIFT RAIL

- DISASSEMBLY STEPS**
- >>A<< 5. SPRING PIN
  - 6. H-L SHIFT FORK
  - 7. H-L SHIFT RAIL

### ASSEMBLY SERVICE POINTS

#### >>A<< SPRING PIN INSTALLATION

Install the spring pin so that the slit of spring pin faces forward of the transfer.

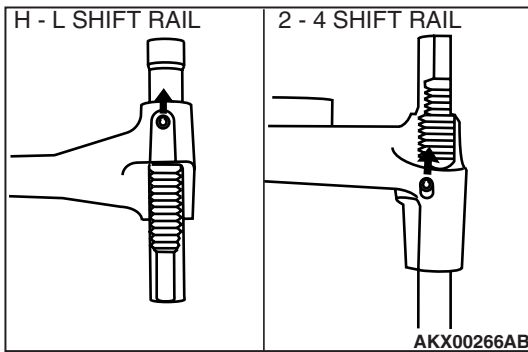

#### >>B<< 2-4WD SHIFT RAIL INSTALLATION

Apply Mitsubishi genuine grease Part number 0101011 or equivalent to the contact part between 2-4WD shift rail and 2-4 WD shift fork, and install.

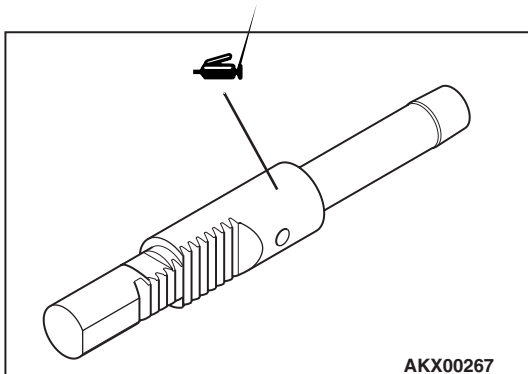

**SPECIFICATIONS****TORQUE SPECIFICATION**

M1233023100426

**Transmission**

ITEMS	SPECIFICATIONS
Anchor plug	98 ± 15 N·m (71 ± 11 ft-lb)
Cable end bracket mounting bolt	48 ± 6 N·m (35 ± 4 ft-lb)
Converter housing to transmission case tightening bolts	48 ± 6 N·m (35 ± 4 ft-lb)
Detent spring mounting bolt	6.0 ± 1 N·m (52 ± 9 in-lb)
Input shaft speed sensor mounting bolt	11 ± 1 N·m (97 ± 9 in-lb)
Lower valve body cover mounting bolt	11 ± 1 N·m (97 ± 9 in-lb)
Lower valve body mounting bolt	11 ± 1 N·m (97 ± 9 in-lb)
Manual control lever mounting nut	22 ± 3 N·m (16 ± 2 ft-lb)
Oil filter mounting bolt	6.0 ± 1 N·m (52 ± 9 in-lb)
Oil pan mounting bolt	11 ± 1 N·m (97 ± 9 in-lb)
Oil pump mounting bolt	23 ± 3 N·m (17 ± 2 ft-lb)
Output shaft speed sensor mounting bolt	11 ± 1 N·m (97 ± 9 in-lb)
Output shaft support mounting bolt	23 ± 3 N·m (17 ± 2 ft-lb)
Park/neutral position switch mounting bolt	11 ± 1 N·m (97 ± 9 in-lb)
Reduction brake piston adjust rod	5.0 N·m (44 in-lb)
Reduction brake piston nut	18 ± 3 N·m (13 ± 2 ft-lb)
Separating plate mounting bolt	6.0 ± 1 N·m (52 ± 9 in-lb)
Solenoid support mounting bolt	6.0 ± 1 N·m (52 ± 9 in-lb)
Transfer to transfer case adapter tightening bolt	35 ± 6 N·m (26 ± 4 ft-lb)
Transmission case to transfer case adapter tightening bolt	48 ± 6 N·m (35 ± 4 ft-lb)
Upper valve body mounting bolt	11 ± 1 N·m (97 ± 9 in-lb)
Valve body mounting bolt	11 ± 1 N·m (97 ± 9 in-lb)

**Transfer**

ITEMS	SPECIFICATIONS
2WD switch	35 ± 6 N·m (26 ± 4 ft-lb)
2-4WD switch	35 ± 6 N·m (26 ± 4 ft-lb)
4H switch	35 ± 6 N·m (26 ± 4 ft-lb)
4LL switch	35 ± 6 N·m (26 ± 4 ft-lb)
Center differential lock switch	35 ± 6 N·m (26 ± 4 ft-lb)
Control housing to transfer case tightening bolt	19 ± 3 N·m (13 ± 2 ft-lb)
Output sensor mounting bolt	11 ± 1 N·m (97 ± 9 in-lb)
Rear cover to chain cover tightening bolt	35 ± 6 N·m (26 ± 4 ft-lb)
Sift actuator mounting bolt	22 ± 4 N·m (16 ± 3 ft-lb)
Speedometer sensor mounting bolt	11 ± 1 N·m (97 ± 9 in-lb)
Transfer case plate to bearing retainer mounting bolt	20 ± 2 N·m (14 ± 1 ft-lb)
Transfer case plate to transfer case tightening bolt and nut	35 ± 6 N·m (26 ± 4 ft-lb)
Transfer case to bearing retainer mounting bolt	20 ± 2 N·m (14 ± 1 ft-lb)

ITEMS	SPECIFICATIONS
Transfer case to chain cover tightening bolt	35 ± 6 N·m (26 ± 4 ft-lb)

**GENERAL SPECIFICATION(S)**

M1233000200455

TRANSMISSION MODEL		V5A51-7-HCB
Applicable engine		3.8L
Transmission type		Electronically controlled 4-speed full-automatic
Torque converter type		3-element with torque converter clutch
Transmission gear ratio	1st	3.789
	2nd	2.057
	3rd	1.421
	4th	1.000
	5th	0.731
	Reverse	3.865
Transfer type		SUPER SELECT 4WD
Transfer gear ratio	High	1.000
	Low	1.900

**SERVICE SPECIFICATION(S)**

M1233000300322

**Transmission**

ITEMS	STANDARD VALUE
Direct planetary carrier end play mm (in)	0.25 – 0.71 (0.0098 – 0.0278)
Underdrive clutch end play mm (in)	1.6 – 1.8 (0.063 – 0.071)
Input shaft end play mm (in)	0.25 – 0.81 (0.0098 – 0.0319)
Overdrive clutch end play mm (in)	2.0 – 2.2 (0.079 – 0.087)
Overdrive clutch return spring retainer end play mm (in)	0 – 0.09 (0 – 0.004)
Second brake end play mm (in)	1.49 – 1.95 (0.0587 – 0.0768)
Center support end play mm (in)	0 – 0.16 (0 – 0.0063)
Brake reaction plate end play mm (in)	0 – 0.16 (0 – 0.0063)
Reverse clutch end play mm (in)	1.5 – 1.7 (0.059 – 0.067)
Low/reverse brake end play mm (in)	1.65 – 2.11 (0.0650 – 0.0831)
Direct clutch end play mm (in)	1.0 – 1.2(0.039 – 0.047)

**Transfer**

ITEMS	STANDARD VALUE
Countershaft gear end play mm (in)	0 – 0.15 (0 – 0.006)
H-L clutch hub end play mm (in)	0 – 0.08 (0 – 0.003)
Differential lock hub end play mm (in)	0 – 0.08 (0 – 0.003)
2-4WD clutch hub end play mm (in)	0 – 0.08 (0 – 0.003)
Synchronizer outer ring to drive sprocket clearance mm (in)	Limit 0.3 (0.01)
Rear output shaft bearing snap ring to chain cover preload mm (in)	0.12 – 0.24 (0.005 – 0.009)
Rear output shaft bearing to rear cove clearance mm (in)	0 – 0.12 (0 – 0.005)
Input gear bearing end play mm (in)	0 – 0.06 (0 – 0.002)

ITEMS	STANDARD VALUE
Countershaft gear bearing end play mm (in)	0 – 0.08 (0 – 0.003)
Rear output shaft bearing end play mm (in)	0 – 0.08 (0 – 0.003)
Annulus gear end play mm (in)	0 – 0.08 (0 – 0.003)

**VALVE BODY SPRING IDENTIFICATION**

M1233022900162

ITEM	WIRE DIAMETER mm (in)	OUTSIDE DIAMETER mm (in)	FREE HEIGHT mm (in)	NUMBER OF LOOPS
Orifice check ball spring	0.5 (0.02)	4.5 (0.18)	15.4 (0.61)	15
Torque converter clutch control valve spring	0.7 (0.03)	5.9 (0.23)	28.1 (1.11)	19
Damping valve spring	1.0 (0.04)	7.7 (0.30)	35.8 (1.41)	17
Torque converter pressure control valve spring	1.6 (0.06)	11.2 (0.44)	29.4 (1.16)	9.5
Fail-safe valve a spring	0.7 (0.03)	8.9 (0.35)	21.9 (0.86)	9.5
Pressure control valve spring	0.7 (0.03)	7.6 (0.30)	37.7 (1.48)	25
Line relief valve spring	1.0 (0.04)	7.0 (0.28)	17.3 (0.68)	10
Regulator valve spring	1.8 (0.07)	13.3 (0.52)	44.6 (1.76)	12.5

**ADJUSTING PLATE, SNAP RING AND SPACERS**

M1233023000300

**Transmission****Thrust race (For adjustment of direct planetary carrier end play)**

THICKNESS mm (in)	IDENTIFICATION SYMBOL	PART NO.
1.6 (0.063)	None	MR276705
1.8 (0.071)	None	MR276706
2.0 (0.079)	None	MR276707
2.2 (0.087)	None	MR276708
2.4 (0.094)	None	MR276709

**Snap ring (For adjustment of underdrive clutch and overdrive clutch end play)**

THICKNESS mm (in)	IDENTIFICATION SYMBOL	PART NO.
1.6 (0.063)	Brown	MD759960
1.7 (0.067)	None	MD759961
1.8 (0.071)	Blue	MD759962
1.9 (0.075)	Brown	MD758892
2.0 (0.079)	None	MD750841
2.1 (0.083)	Blue	MD750842
2.2 (0.087)	Brown	MD750843
2.3 (0.091)	None	MD750844
2.4 (0.094)	Blue	MD750845
2.5 (0.098)	Brown	MD750846
2.6 (0.102)	None	MD750847
2.7 (0.106)	Blue	MD750848

<b>THICKNESS mm (in)</b>	<b>IDENTIFICATION SYMBOL</b>	<b>PART NO.</b>
2.8 (0.110)	Brown	MD750849
2.9 (0.114)	None	MD750850
3.0 (0.118)	Blue	MD750851

**Thrust race (For adjustment of input shaft end play)**

<b>THICKNESS mm (in)</b>	<b>IDENTIFICATION SYMBOL</b>	<b>PART NO.</b>
1.4 (0.055)	None	MD723063
1.6 (0.063)	None	MD707267
1.8 (0.071)	None	MD723064
2.0 (0.079)	None	MD707268
2.2 (0.087)	None	MD723065
2.4 (0.094)	None	MD724358
2.6 (0.102)	None	MD754798

**Snap ring (For adjustment of overdrive clutch return spring retainer end play)**

<b>THICKNESS mm (in)</b>	<b>IDENTIFICATION SYMBOL</b>	<b>PART NO.</b>
1.48 (0.058)	Brown	MR336158
1.53 (0.060)	Black	MR336159
1.58 (0.062)	None	MR336160
1.63 (0.064)	Brown	MR336161

**Pressure plate (For adjustment of second brake end play)**

<b>THICKNESS mm (in)</b>	<b>IDENTIFICATION SYMBOL</b>	<b>PART NO.</b>
1.6 (0.063)	F	MR336390
1.8 (0.071)	E	MR336391
2.0 (0.079)	D	MR336392
2.2 (0.087)	C	MR336393
2.4 (0.094)	B	MR336394
2.6 (0.102)	A	MR336395
2.8 (0.110)	0	MR336396
3.0 (0.118)	1	MR336397

**Snap ring (For adjustment of center support and brake reaction plate end play)**

<b>THICKNESS mm (in)</b>	<b>IDENTIFICATION SYMBOL</b>	<b>PART NO.</b>
2.2 (0.087)	None	MD756784
2.3 (0.091)	Blue	MD756785
2.4 (0.094)	Brown	MD758552
2.5 (0.098)	None	MD758553

**Snap ring (For adjustment of reverse clutch end play)**

<b>THICKNESS mm (in)</b>	<b>IDENTIFICATION SYMBOL</b>	<b>PART NO.</b>
1.6 (0.063)	None	MD761088
1.7 (0.067)	Blue	MD761089
1.8 (0.071)	Brown	MD761090

THICKNESS mm (in)	IDENTIFICATION SYMBOL	PART NO.
1.9 (0.075)	None	MD758947
2.0 (0.079)	Blue	MD756690
2.1 (0.083)	Brown	MD756691
2.2 (0.087)	None	MD756692
2.3 (0.091)	Blue	MD756693
2.4 (0.094)	Brown	MD756694
2.5 (0.098)	None	MD756695
2.6 (0.102)	Blue	MD756696
2.7 (0.106)	Brown	MD756697
2.8 (0.110)	None	MD756698

**Snap ring (For adjustment of direct clutch end play)**

THICKNESS mm (in)	IDENTIFICATION SYMBOL	PART NO.
1.9 (0.075)	Brown	MD758946
2.0 (0.079)	None	MD753397
2.1 (0.083)	Blue	MD753398
2.2 (0.087)	Brown	MD753399
2.3 (0.091)	None	MD753400
2.4 (0.094)	Blue	MD753401
2.5 (0.098)	Brown	MD753402
2.6 (0.102)	None	MD753403
2.7 (0.106)	Blue	MD753404
2.8 (0.110)	Brown	MD753405
2.9 (0.114)	None	MD753406
3.0 (0.118)	Blue	MD753407

**Pressure plate (For adjustment low/reverse brake end play)**

THICKNESS mm (in)	IDENTIFICATION SYMBOL	PART NO.
1.8 (0.071)	E	MD759425
2.0 (0.079)	D	MD759426
2.2 (0.087)	C	MD759427
2.4 (0.094)	B	MD759428
2.6 (0.102)	A	MD759429
2.8 (0.110)	0	MD759430
3.0 (0.118)	1	MD759431

**Transfer****Snap ring (For adjustment input gear bearing end play)**

THICKNESS mm (in)	IDENTIFICATION SYMBOL	PART NO.
2.30 (0.091)	None	MD704199
2.35 (0.093)	Red	MD704200



<b>THICKNESS mm (in)</b>	<b>IDENTIFICATION SYMBOL</b>	<b>PART NO.</b>
2.40 (0.094)	White	MD704201
2.45 (0.096)	Blue	MD704202
2.50 (0.098)	Green	MD704203

**Spacer (For adjustment of countershaft gear end play)**

<b>THICKNESS mm (in)</b>	<b>IDENTIFICATION SYMBOL</b>	<b>PART NO.</b>
1.77 (0.070)	None	MB896728
1.91 (0.075)	Blue	MB896729
2.05 (0.081)	Brown	MB896730
2.19 (0.086)	White	MB896731
2.33 (0.091)	Red	MB896732

**Snap ring (For adjustment of countershaft gear bearing end play)**

<b>THICKNESS mm (in)</b>	<b>IDENTIFICATION SYMBOL</b>	<b>PART NO.</b>
1.48 (0.058)	Blue	MB919176
1.62 (0.064)	None	MB919177

**Snap ring (For adjustment of H-L clutch hub end play)**

<b>THICKNESS mm (in)</b>	<b>IDENTIFICATION SYMBOL</b>	<b>PART NO.</b>
2.18 (0.086)	–	MR410928
2.25 (0.089)	–	MR410929
2.32 (0.091)	–	MR410930
2.39 (0.094)	–	MR410931

**Spacer (For adjustment of rear output shaft to chain cover preload)**

<b>THICKNESS mm (in)</b>	<b>IDENTIFICATION SYMBOL</b>	<b>PART NO.</b>
1.57 (0.062)	–	MR486340
1.63 (0.064)	–	MR486341
1.69 (0.067)	–	MR486342
1.75 (0.069)	–	MR486343
1.81 (0.071)	–	MR486344
1.87 (0.074)	–	MR486345
1.93 (0.076)	–	MR486346
1.99 (0.078)	–	MR486347
2.05 (0.081)	–	MR477935
2.11 (0.083)	–	MR477936
2.17 (0.085)	–	MR477937
2.23 (0.088)	–	MR477938
2.29 (0.090)	–	MR477939
2.35 (0.093)	–	MR477940
2.41 (0.095)	–	MR477941
2.47 (0.097)	–	MR477942

THICKNESS mm (in)	IDENTIFICATION SYMBOL	PART NO.
2.53 (0.100)	–	MR477943
2.59 (0.102)	–	MR477944
2.65 (0.104)	–	MR477945
2.71 (0.107)	–	MR477946
2.77 (0.109)	–	MR477947

**Spacer (For adjustment of rear output shaft to rear cover clearance)**

THICKNESS mm (in)	IDENTIFICATION SYMBOL	PART NO.
2.57 (0.101)	–	MR477950
2.63 (0.104)	–	MR477951
2.69 (0.106)	–	MR477952
2.75 (0.108)	–	MR477953
2.81 (0.111)	–	MR477954
2.87 (0.113)	–	MR477955
2.93 (0.115)	–	MR477956
2.99 (0.118)	–	MR477957
3.05 (0.120)	–	MR477958
3.11 (0.122)	–	MR477959
3.17 (0.125)	–	MR477960
3.23 (0.127)	–	MR477961
3.29 (0.129)	–	MR477962
3.35 (0.132)	–	MR477963
3.41 (0.134)	–	MR477964
3.47 (0.137)	–	MR477965
3.53 (0.139)	–	MR477966
3.59 (0.141)	–	MR477967
3.65 (0.144)	–	MR477968
3.71 (0.146)	–	MR486348
3.77 (0.148)	–	MR486349
3.83 (0.151)	–	MR486350
3.89 (0.153)	–	MR486351
3.95 (0.156)	–	MR486352

**Snap ring (For adjustment annulus gear end play)**

<b>THICKNESS mm (in)</b>	<b>IDENTIFICATION SYMBOL</b>	<b>PART NO.</b>
1.90 (0.075)	–	MR305024
1.94 (0.076)	–	MR305025
1.98 (0.078)	–	MR305026
2.02 (0.080)	–	MR305027
2.06 (0.081)	–	MR305028
2.10 (0.083)	–	MR305029

**SEALANTS AND ADHESIVES**

M1233000500274

**Transmission**

<b>ITEMS</b>	<b>SPECIFIED SEALANTS</b>
Transfer case adapter	mitsubishi genuine sealant part No. MR166584 or equivalent
Sealing cap	3M™ ADD part No.8672 or equivalent
Converter housing	mitsubishi genuine sealant part No. MR166584 or equivalent
Oil pan	mitsubishi genuine sealant part No. MR166584 or equivalent

**Transfer**

<b>ITEMS</b>	<b>SPECIFIED SEALANTS AND ADHESIVE</b>
Chain cover	mitsubishi genuine sealant part No. MD997740 or equivalent
Rear cover	mitsubishi genuine sealant part No. MD997740 or equivalent
Support pin insertion	3M™ AAD part No.8672 or equivalent
Support pin thread	mitsubishi genuine adhesive part No. MD160450 or equivalent
Control housing	mitsubishi genuine sealant part No. MD997740 or equivalent
H-L shift rail plug	3M™ AAD part No.8672 or equivalent
Plug	3M™ AAD part No.8672 or equivalent
Transfer case plate	mitsubishi genuine sealant part No. MD997740 or equivalent
Bearing retainer mounting bolt	mitsubishi genuine sealant part No. MD997740 or equivalent

---

## NOTES