

GROUP 51

EXTERIOR

CONTENTS

FRONT BUMPER ASSEMBLY	51-2	SIDE STEP	51-19
SPECIAL TOOL	51-2	REMOVAL AND INSTALLATION	51-19
FRONT BUMPER ASSEMBLY	51-3	SIDE STEP DISASSEMBLY AND	
REMOVAL AND INSTALLATION	51-3	ASSEMBLY	51-21
DISASSEMBLY AND ASSEMBLY	51-5	WINDSHIELD WIPER AND WASHER	51-22
REAR BUMPER ASSEMBLY	51-6	GENERAL DESCRIPTION	51-22
REMOVAL AND INSTALLATION	51-6	WINDSHIELD WIPER AND WASHER	
DISASSEMBLY AND ASSEMBLY	51-7	DIAGNOSIS	51-22
ROOF RAIL	51-9	WINDSHIELD WIPER AND WASHER	51-23
REMOVAL AND INSTALLATION	51-9	REMOVAL AND INSTALLATION	51-23
MOLDINGS	51-9	INSPECTION	51-24
SPECIAL TOOL	51-9	REAR WIPER AND WASHER	51-28
MOLDINGS	51-10	GENERAL DESCRIPTION	51-28
REMOVAL AND INSTALLATION	51-10	REAR WIPER AND WASHER DIAGNOSIS	51-28
GARNISHES	51-15	REAR WIPER AND WASHER	51-29
REMOVAL AND INSTALLATION	51-15	REMOVAL AND INSTALLATION	51-29
MUD GUARD	51-17	INSPECTION	51-30
REMOVAL AND INSTALLATION	51-17	MARK	51-32
REAR DEFLECTOR	51-17	REMOVAL AND INSTALLATION	51-32
SPECIAL TOOL	51-17	OUTSIDE MIRROR	51-34
REAR DEFLECTOR	51-18	REMOVAL AND INSTALLATION	51-34
REMOVAL AND INSTALLATION	51-18	INSPECTION	51-37
		SPECIFICATIONS	51-38
		FASTENER TIGHTENING SPECIFICATIONS	51-38
		SERVICE SPECIFICATIONS	51-38
		ADHESIVES	51-39

FRONT BUMPER ASSEMBLY**SPECIAL TOOL**

M1511000600058

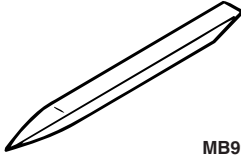
TOOL	TOOL NUMBER AND NAME	SUPERSESSION	APPLICATION
 MB990784	MB990784 Ornament remover	General service tool	Removal of clip

**FRONT BUMPER ASSEMBLY
REMOVAL AND INSTALLATION**

M1511001400574

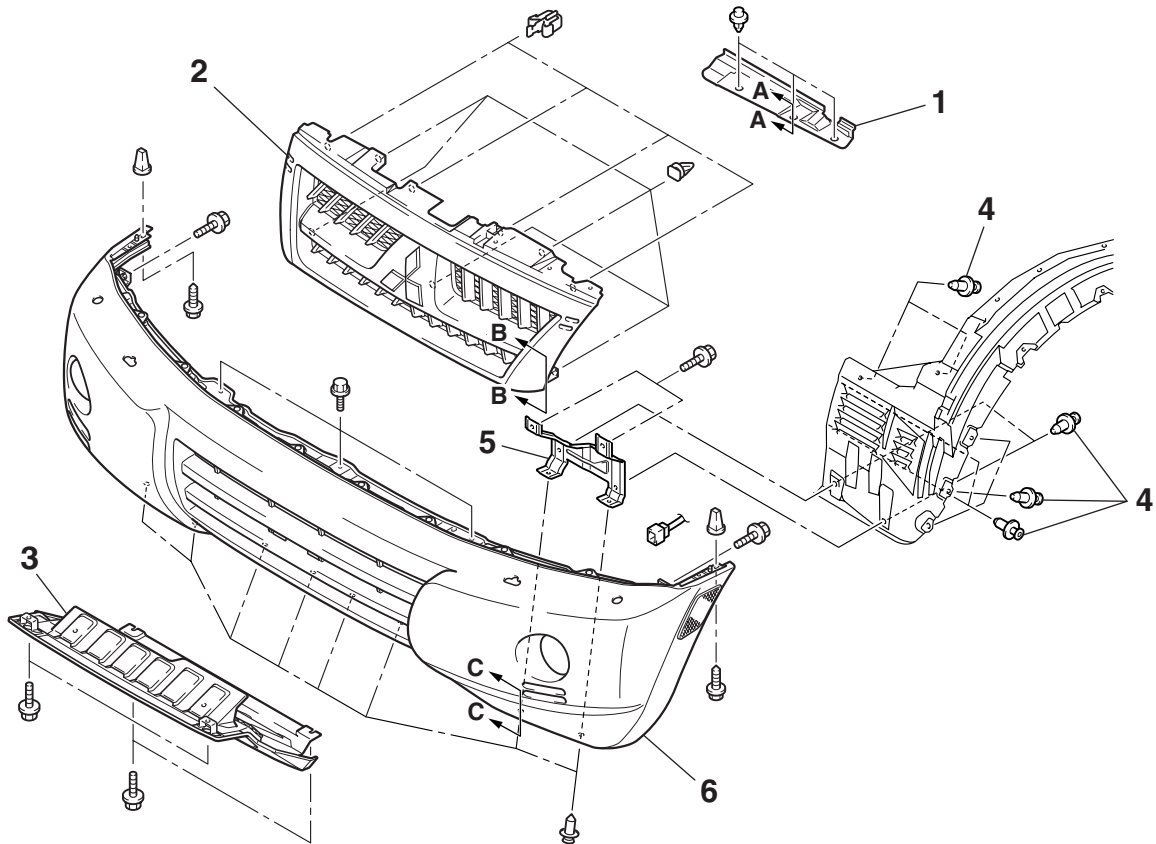
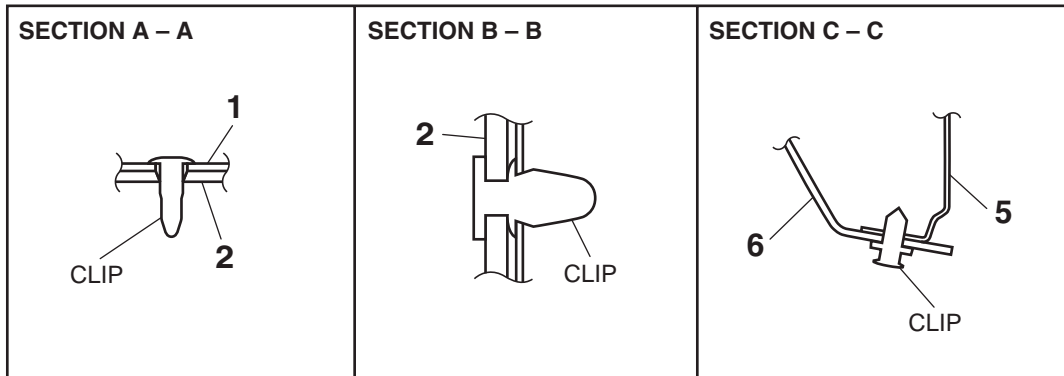

AC203563AB

REMOVAL STEPS

1. RADIATOR COVER
2. RADIATOR GRILL
3. SKID PLATE
4. SPLASH SHIELD MOUNTING CLIP
5. FRONT BUMPER LOWER STAY

REMOVAL STEPS (Continued)

- FOG LIGHT CONNECTOR CONNECTION
- 6. FRONT BUMPER FACE ASSEMBLY

Required Special Tool:

- MB990784: Ornament Remover

<<A>>

REMOVAL SERVICE POINT**<<A>> RADIATOR GRILL REMOVAL**

While pulling the radiator grille gently towards you, push the tab of the clip in the direction of the arrow with a flat-tipped screwdriver to remove the radiator grille.

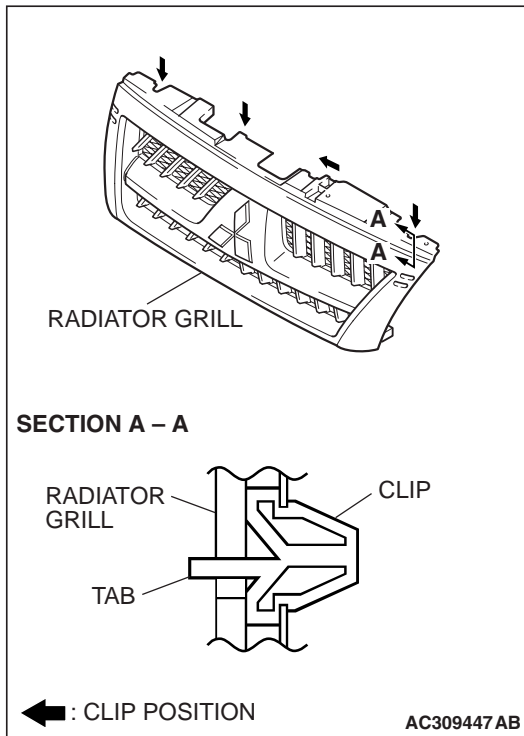

DISASSEMBLY AND ASSEMBLY

M1511001600589

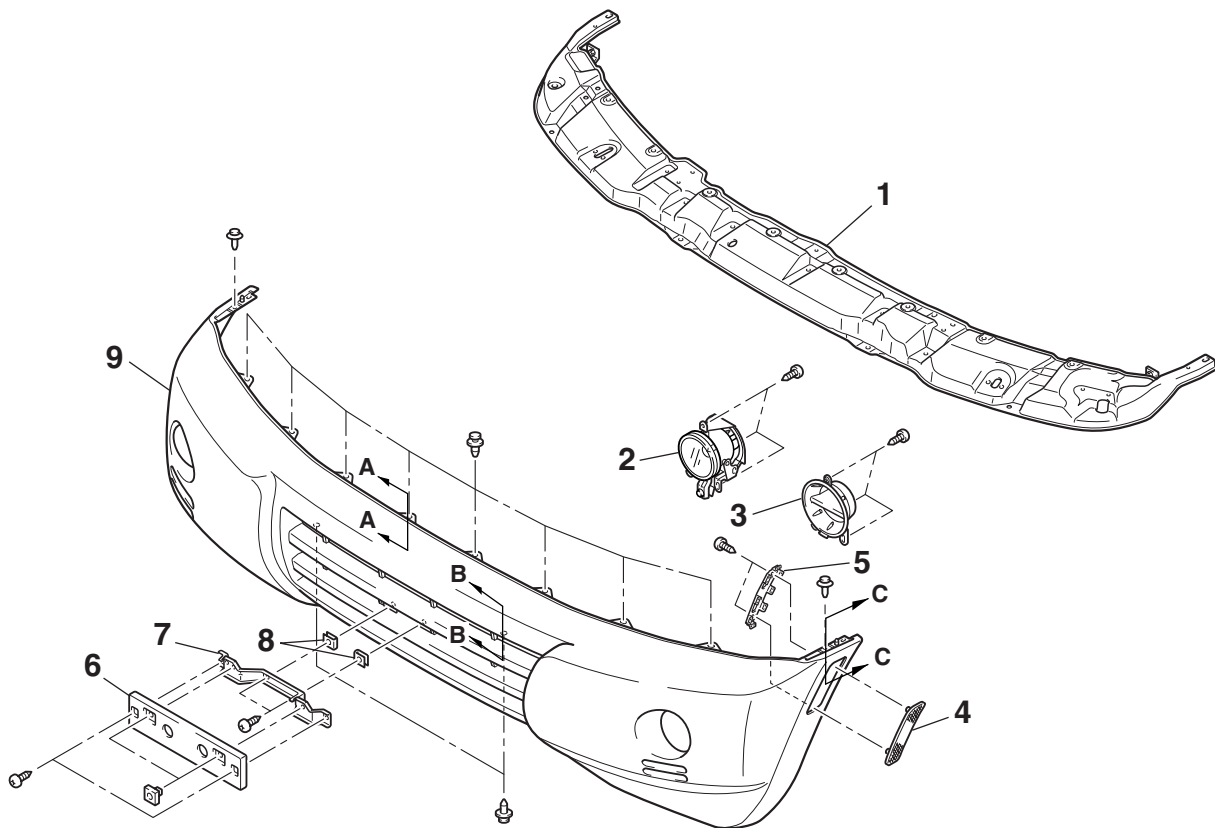
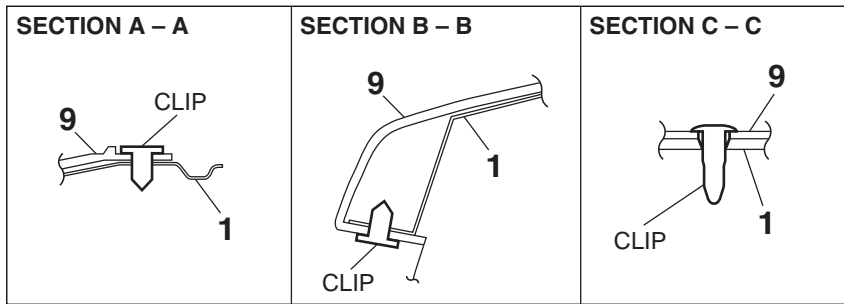

AC203564 AB

<<A>>

DISASSEMBLY STEPS

1. FRONT BUMPER REINFORCEMENT ASSEMBLY
2. FOG LIGHT
3. AIR BLOWER GARNISH
<VEHICLES WITHOUT FOG LIGHT>
4. REFLEX REFLECTOR
5. REFLEX REFLECTOR BRACKET
6. LICENSE PLATE GARNISH

DISASSEMBLY STEPS (Continued)

7. LICENSE PLATE GARNISH BRACKET
8. LICENSE PLATE BRACKET
9. FRONT BUMPER FACE

Required Special Tool:

- MB990784: Ornament Remover

DISASSEMBLY SERVICE POINT

<<A>> FRONT BUMPER REINFORCEMENT REMOVAL

1. Use special tool MB990784 to pull up the center pin in the clip.
2. Remove the clip.

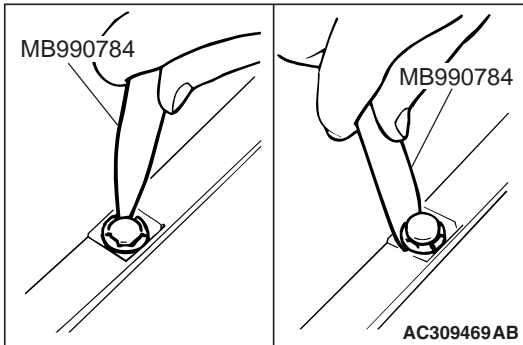

REAR BUMPER ASSEMBLY

REMOVAL AND INSTALLATION

M1511001900494

Pre-removal and Post-installation Operation

- Mud Guard Removal and Installation (Refer to P.51-17).
- Rear Combination Light Removal and Installation (Refer to GROUP 54A, Rear Combination Light P.54A-86).

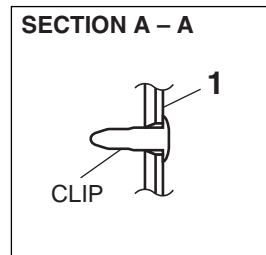
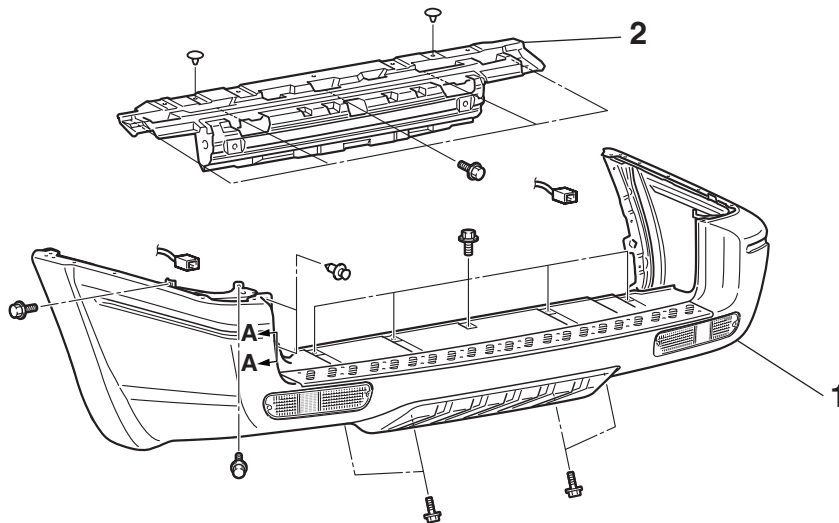

AC203641AB

REAR BUMPER ASSEMBLY REMOVAL
STEPS

1. REAR BUMPER ASSEMBLY
2. REAR BUMPER REINFORCEMENT

Required Special Tool:

- MB990784: Ornament Remover

DISASSEMBLY AND ASSEMBLY

M1511002100402

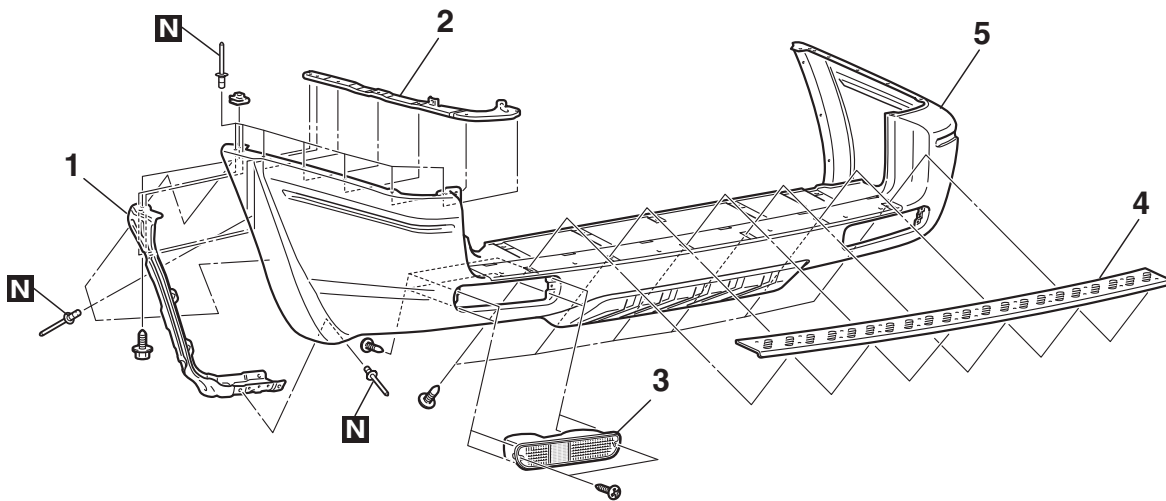
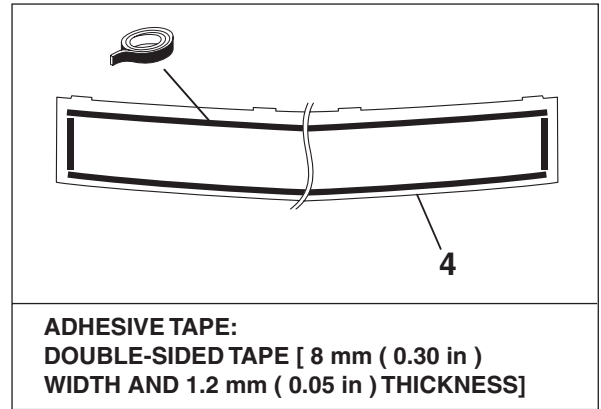

AC203642AC

**REAR BUMPER ASSEMBLY
DISASSEMBLY STEPS**

- <<A>> >>A<< 1. REAR MUDGUARD
REINFORCEMENT
- <<A>> >>A<< 2. REAR BUMPER SIDE RETAINER
- <<A>> >>A<< 3. REAR LIGHT

**REAR BUMPER ASSEMBLY
DISASSEMBLY STEPS (Continued)**

4. REAR BUMPER STEP COVER
5. REAR BUMPER FACE

Required Special Tool:

- MB990784: Ornament Remover

DISASSEMBLY SERVICE POINT**<<A>> REAR MUDGUARD REINFORCEMENT, REAR BUMPER SIDE RETAINER REMOVAL**

Use a drill [4.5 mm (0.18 inch)] to make a hole in the rivet to break it, and then remove the rivet.

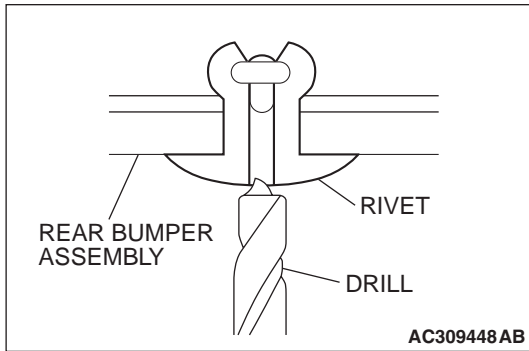
**ASSEMBLY SERVICE POINT****>>A<< REAR MUDGUARD REINFORCEMENT, REAR BUMPER SIDE RETAINER**

Use the rivet tool shown in the illustration to attach the rivet by the following procedure.

1. Insert the rivet into the base material (rear mudguard reinforcement, rear bumper side retainer).
2. Place the recommended tool over section A of the rivet.
3. While pushing the flange surface of the rivet with the recommended tool, press the handle of the tool.
4. The thin part of section A of the rivet will break and the rivet will then be attached.

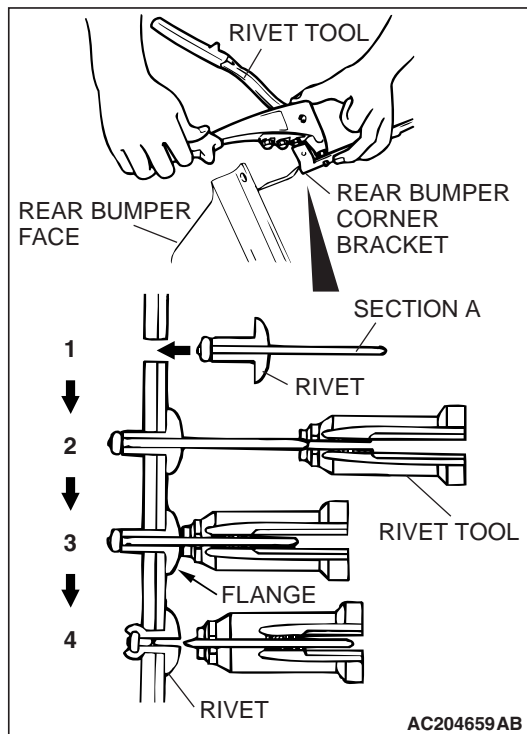

ROOF RAIL

REMOVAL AND INSTALLATION

M1511016600198

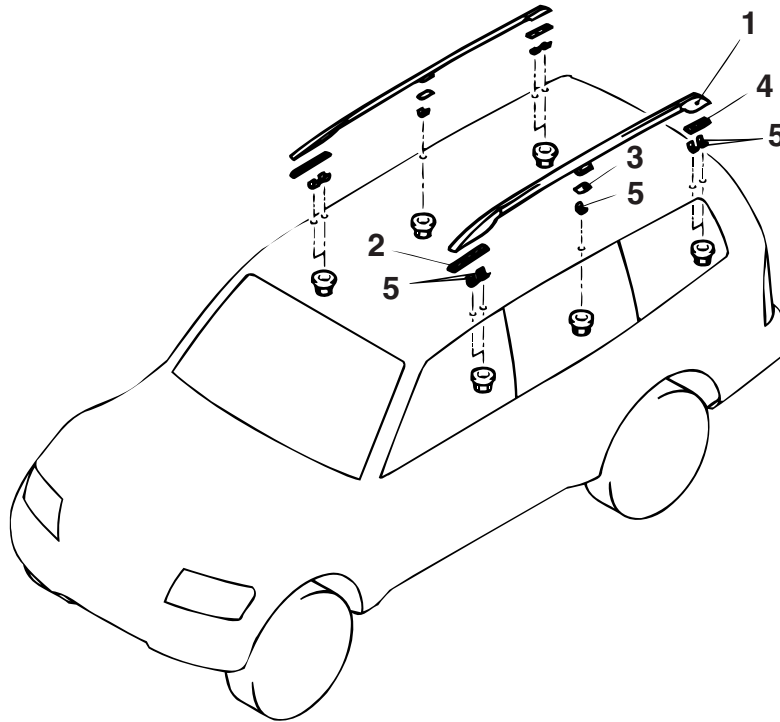

ACX00429 AB

REMOVAL STEPS

- HEADLINING (REFER TO GROUP 52A, HEADLINING [P.52A-10](#)).
- SET BRACKET (REFER TO GROUP 42, SUNROOF [P.42-66](#)).
- 1. ROOF RAIL ASSEMBLY

REMOVAL STEPS (Continued)

- 2. ROOF RAIL FRONT SEAL
- 3. ROOF RAIL CENTER SEAL
- 4. ROOF RAIL REAR SEAL
- 5. ROOF RAIL SEAL

MOLDINGS

SPECIAL TOOL

M1511000601244

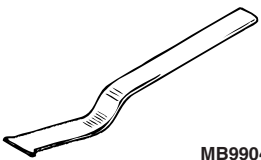
TOOL	TOOL NUMBER AND NAME	SUPERSESSON	APPLICATION
 <p>MB990449</p>	MB990449 Window molding remover	General service tool	Removal of roof drip molding

MOLDINGS
REMOVAL AND INSTALLATION

M1511004700176

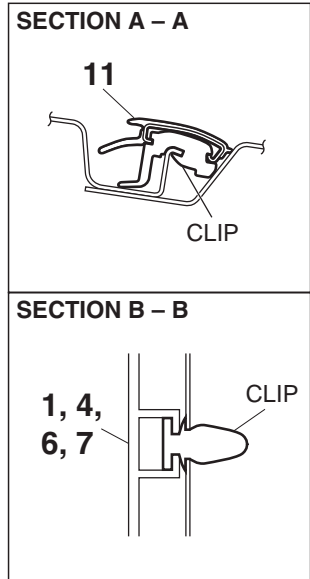
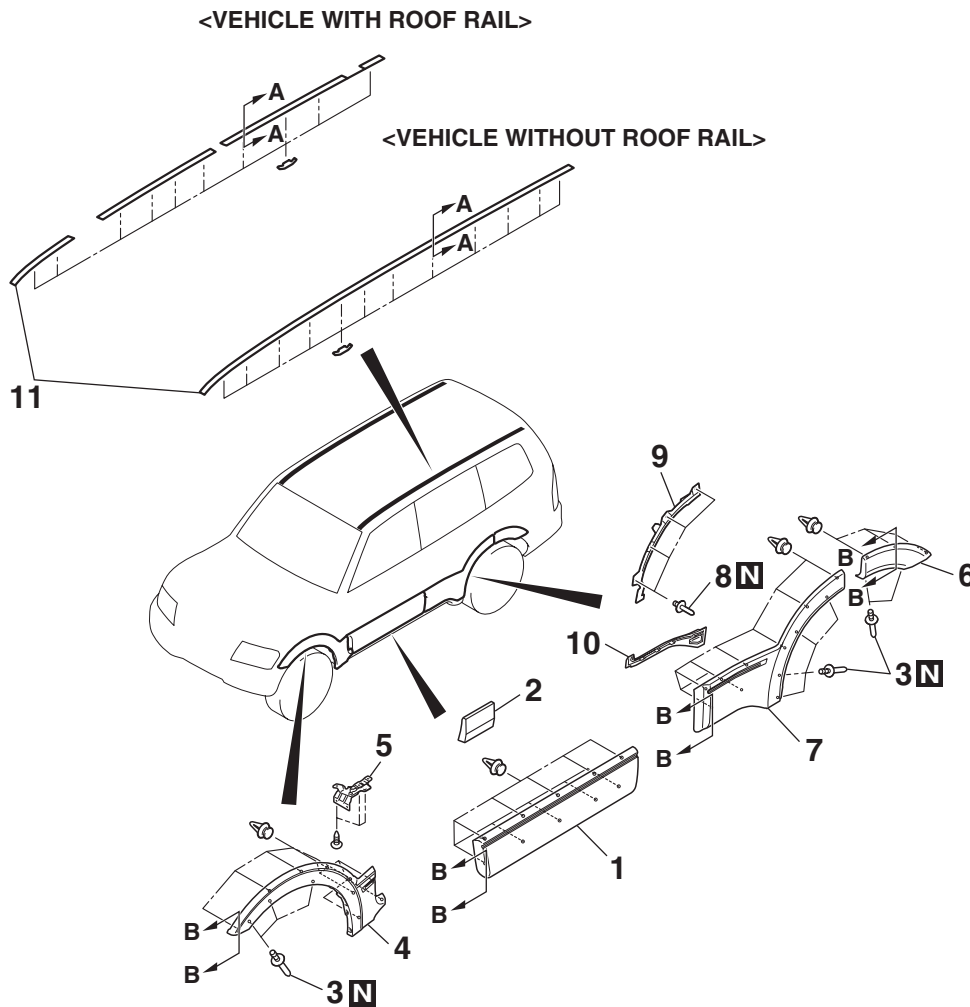

AC309453AB

- <<A>> >>A<< 1. FRONT DOOR MOLDING
2. FRONT DOOR CORE
**FRONT WHEEL CUT MOLDING
REMOVAL STEPS**
- <> >>B<< 3. RIVET A
<<A>> >>A<< 4. FRONT WHEEL CUT MOLDING
5. WHEEL CUT MOLDING BRACKET
**REAR WHEEL CUT MOLDING
REMOVAL STEPS**
- <> >>B<< 3. RIVET A
<<A>> >>A<< 6. REAR WHEEL CUT MOLDING

**REAR DOOR MOLDING
REMOVAL
STEPS**

- <> >>B<< 3. RIVET A
<<A>> >>A<< 7. REAR DOOR MOLDING
<> >>C<< 8. RIVET B
9. REAR DOOR MOLDING BRACKET
10. LOWER COVER

**ROOF DRIP MOLDING
REMOVAL
STEPS**

- ROOF RAIL ASSEMBLY
- 11. ROOF DRIP MOLDING

Required Special Tools:

- MB990449: Window Molding Remover
- MB990784: Ornament Remover

ADHESIVE TAPE POSITION

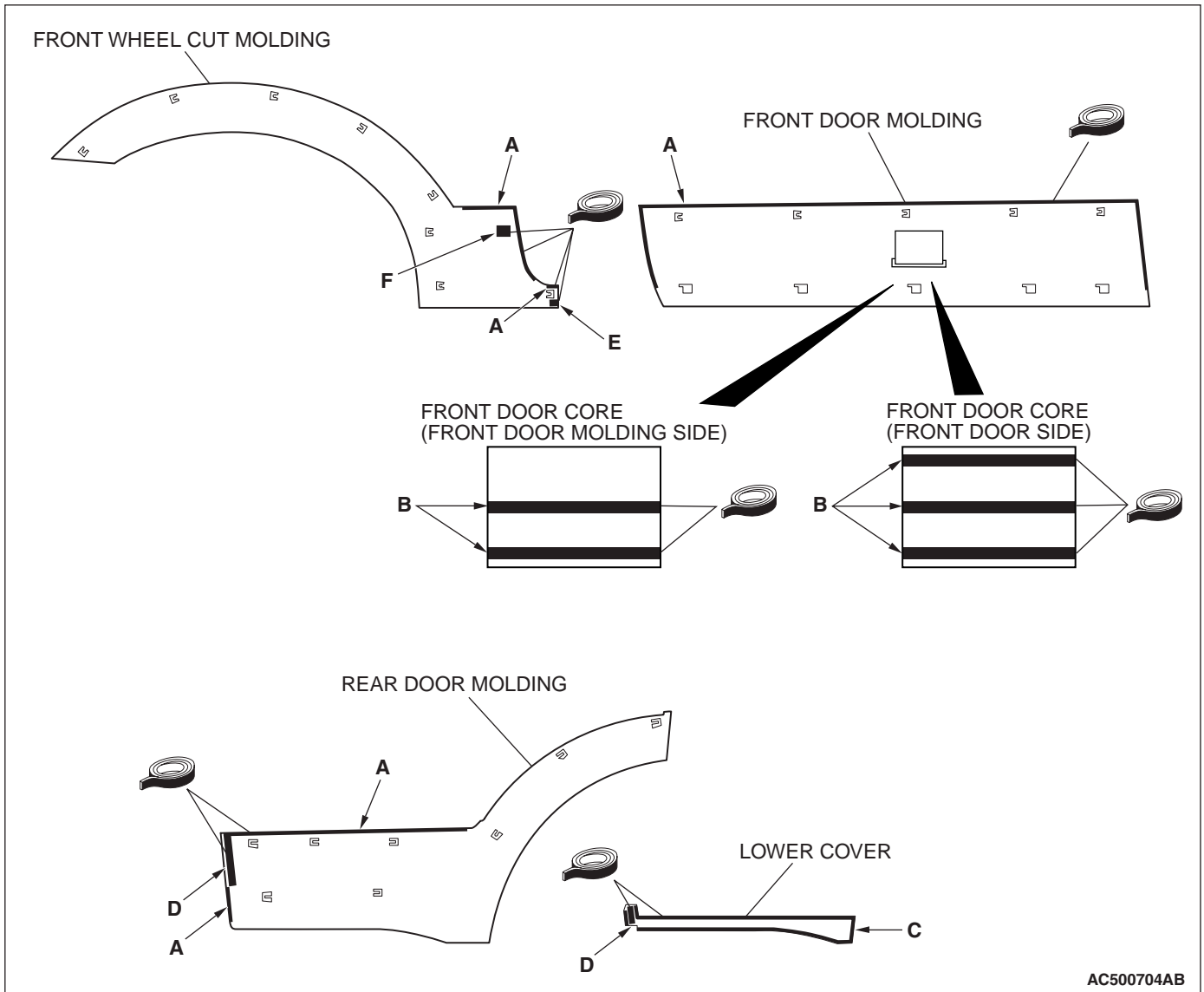

AC500704AB

- ADHESIVE TAPE: DOUBLE-SIDED TAPE**
- A : 4.0 mm (0.16 in) WIDTH AND 1.2 mm (0.05 in) THICKNESS**
 - B : 5.0 mm (0.20 in) WIDTH AND 2.0 mm (0.08 in) THICKNESS**
 - C : 10.0 mm (0.39 in) WIDTH AND 1.2 mm (0.05 in) THICKNESS**
 - D : 24.0 mm (0.95 in) WIDTH AND 1.2 mm (0.05 in) THICKNESS**
 - E : 30.0 mm (1.18 in) WIDTH AND 0.8 mm (0.03 in) THICKNESS**
 - F : 35.0 mm (1.38 in) WIDTH AND 1.2 mm (0.05 in) THICKNESS**

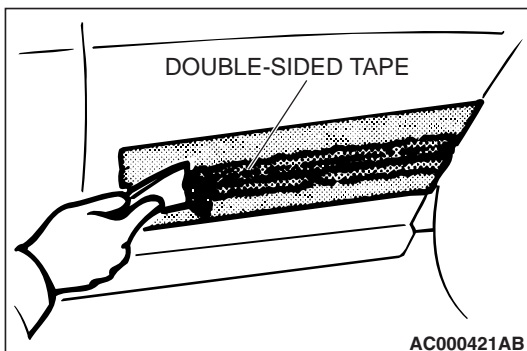
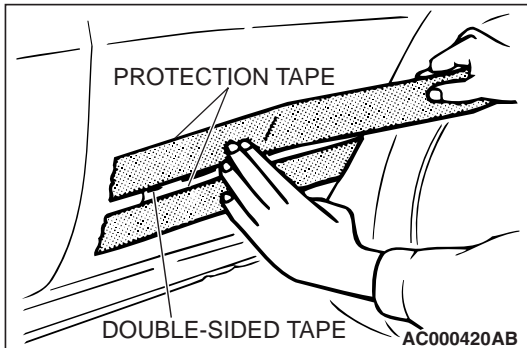
REMOVAL SERVICE POINTS**<<A>> FRONT DOOR MOLDING, FRONT WHEEL CUT MOLDING, REAR WHEEL CUT MOLDING AND REAR DOOR MOLDING REMOVAL**

1. Attach protection tape all the way along the edges of the double-sided tape which is still adhering to the body.

2. Use a resin spatula to scrape off the double-sided tape.
3. Peel off the protection tape.
4. Wipe the body surface and clean it with a rag moistened with isopropyl alcohol.

<> RIVET A AND RIVET B REMOVAL

Use a drill [with a 4.0 mm (0.16 inch) bit for rivet A, or a 6.5 mm (0.25 inch) bit for rivet B] to make a hole in the rivet to break it, and then remove the rivets.

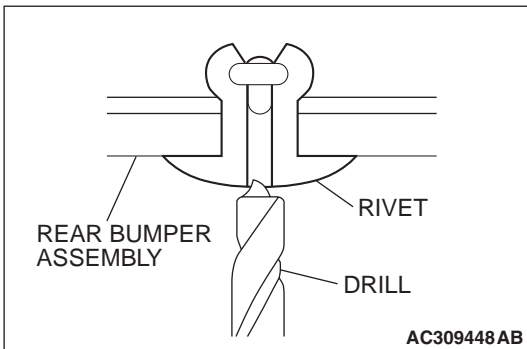

<<C>> ROOF DRIP MOLDING REMOVAL

⚠ CAUTION

If the molding becomes deformed, it should not be re-used.

Use special tool MB990449 to pry out the molding.

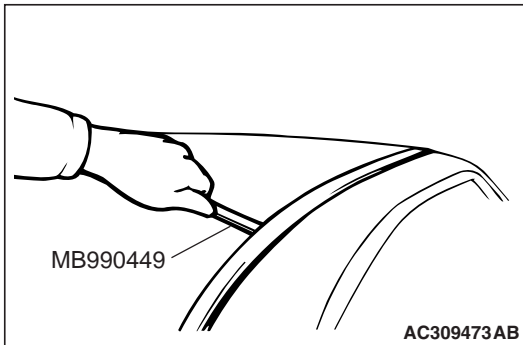

INSTALLATION SERVICE POINTS

>>A<< FRONT DOOR MOLDING, FRONT WHEEL CUT MOLDING, REAR WHEEL CUT MOLDING AND REAR DOOR MOLDING INSTALLATION.

1. Scrape off the double-sided tape with a resin spatula or gasket scraper.
2. Use a shop towel moistened with 3M™ AAD Part number 8906 or equivalent to wipe the rear pillar garnish surface.

⚠ CAUTION

Do not remove all of the residual adhesive.

3. Remove only a small portion of the residual adhesive.

⚠ CAUTION

- Always apply it evenly on the entire surface, because a lot or little will reduce its strength.
- Do not touch the painted surface.

4. Affix the specified double-sided tape to the moldings (Refer to P.51-10).

5. Tear off the double-sided tape backing paper.

NOTE: If you attach the adhesive tape to the edge of the backing paper, it will be easy to tear off.

6. Install the moldings.

NOTE: If the double-sided tape is difficult to affix in cold temperature, etc., warm the bonding surfaces of the body and molding to about 40 – 60 °C (104 – 140 °F) before affixing the tape.

7. Firmly press in the moldings.

NOTE: When a new part is used, observe Steps 5 to 7.

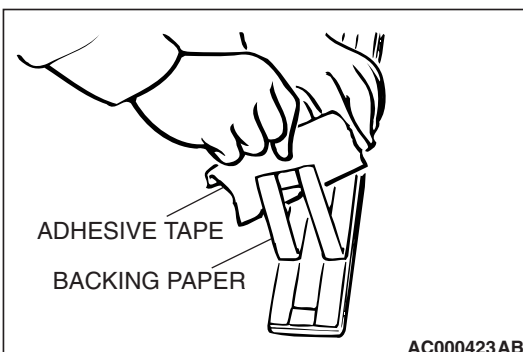
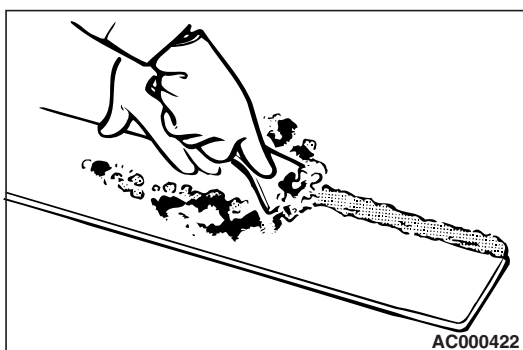

>>B<< RIVET A INSTALLATION

Install by the same procedure described previously for REAR MUD GUARD REINFORCEMENT, REAR BUMPER SIDE RETAINER, REAR BUMPER CORNER BRACKET INSTALLATION (Refer to [P.51-7](#)).

>>C<< RIVET B INSTALLATION

1. Insert the rivet [4.8 mm (0.19 inch)] into the body panel and wide fender.
2. Insert "A" of the rivet into the rivet tool.
3. Pressing the flange surface of the rivet, move the handle of the rivet tool.
4. The thinnest point of "A" is cut and the rivet is held in position.

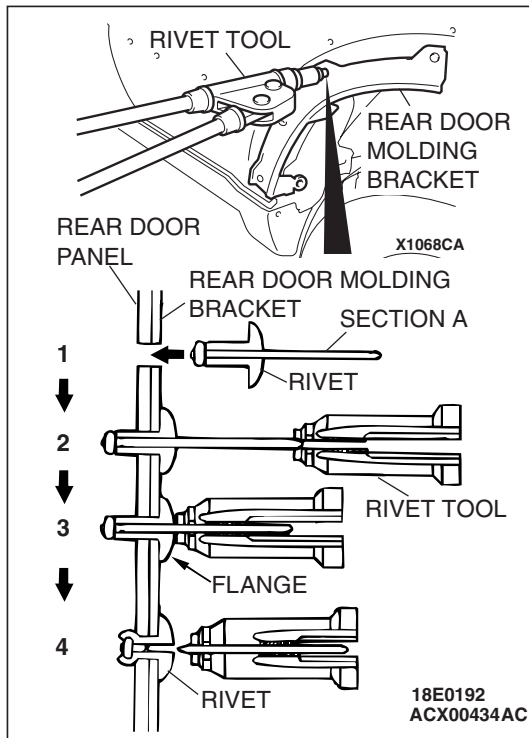

GARNISHES

REMOVAL AND INSTALLATION

M1511004100130

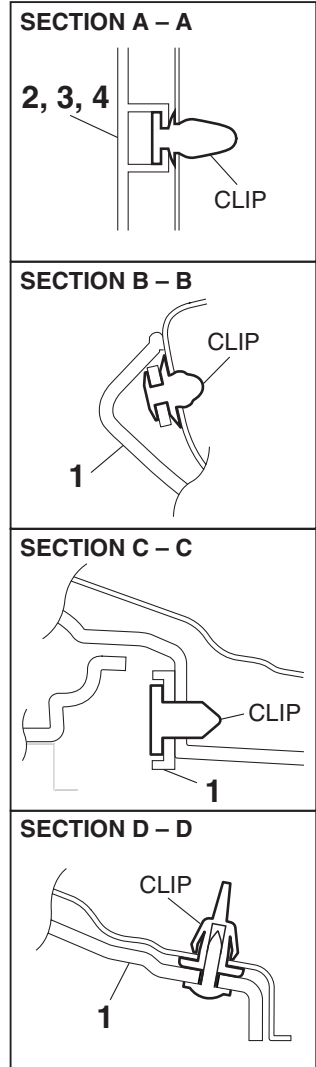
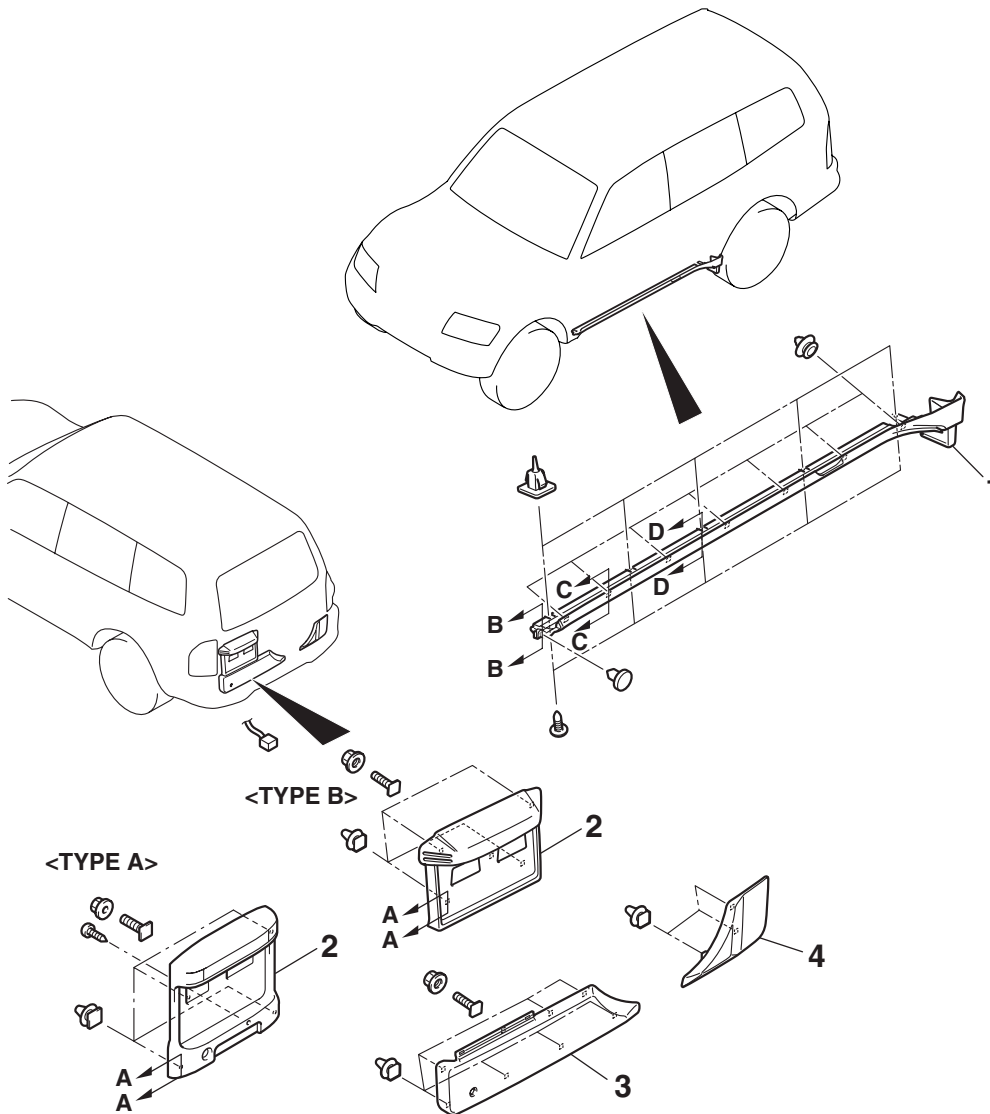

AC309234AB

SIDE SILL GARNISH REMOVAL STEPS

- SIDE STEP (REFER TO P.51-19).
- FRONT MUD GUARD (REFER TO P.51-17).

<<A>> >>A<< 1. SIDE SILL GARNISH

LICENSE PLATE GARNISH REMOVAL STEPS

- TOOLBOX BRACKET, UPPER (REFER TO GROUP 42, BACK DOOR TRIM AND WATERPROOF FILM P.42-53).
- LICENSE PLATE LIGHT (REFER TO GROUP 54A, REAR COMBINATION LIGHT P.54A-86).

<<A>> >>A<< 2. LICENSE PLATE GARNISH
<<A>> >>A<< 3. BACK DOOR LEFT GARNISH
<<A>> >>A<< 4. BACK DOOR GARNISH

ADHESIVE TAPE POSITION

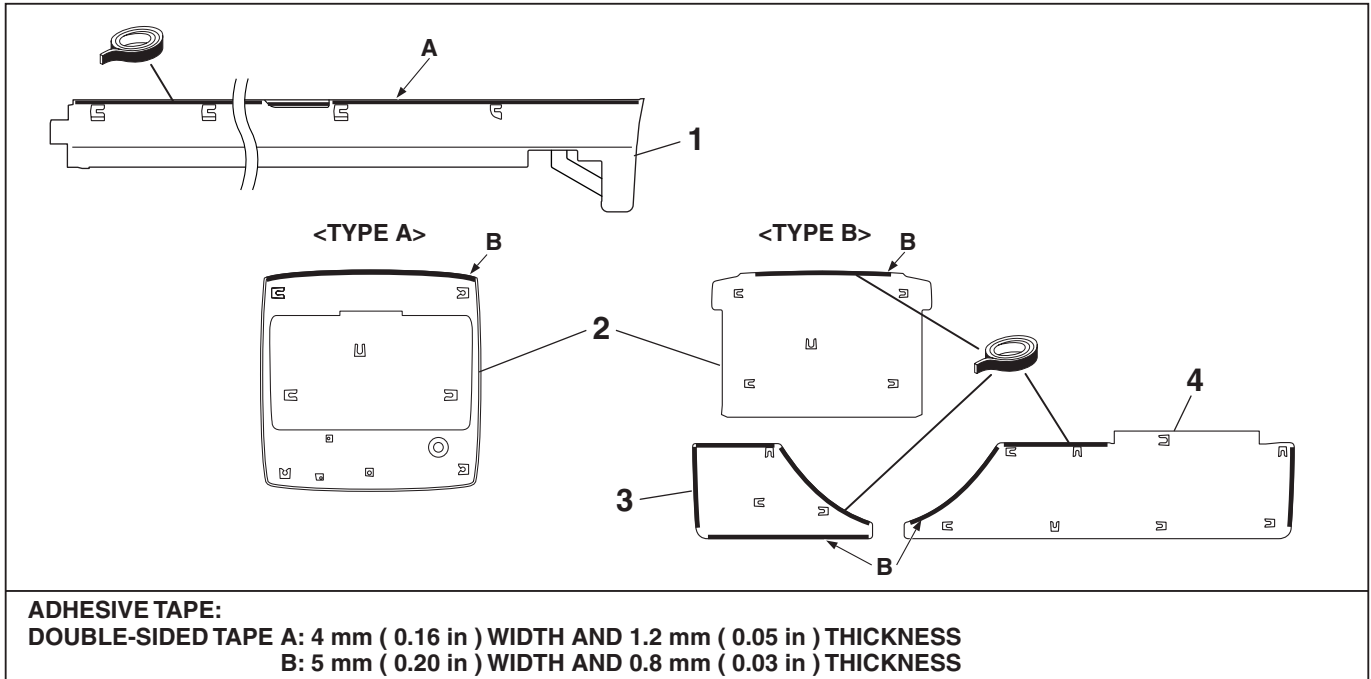

AC309235AC

REMOVAL SERVICE POINT

<<A>> SIDE SILL GARNISH, LICENSE PLATE GARNISH,
BACK DOOR LEFT GARNISH, BACK DOOR GARNISH
REMOVAL

Remove by the same procedure as described in FRONT DOOR MOLDING, FRONT WHEEL CUT MOLDING, REAR WHEEL CUT MOLDING AND REAR DOOR MOLDING REMOVAL (Refer to P.51-10).

INSTALLATION SERVICE POINT

>>A<< SIDE SILL GARNISH, LICENSE PLATE GARNISH,
BACK DOOR LEFT GARNISH, BACK DOOR GARNISH
INSTALLATION

Install by the same procedure as described in FRONT DOOR MOLDING, FRONT WHEEL CUT MOLDING, REAR WHEEL CUT MOLDING AND REAR DOOR MOLDING INSTALLATION (Refer to P.51-10).

MUD GUARD

REMOVAL AND INSTALLATION

M1511011200076

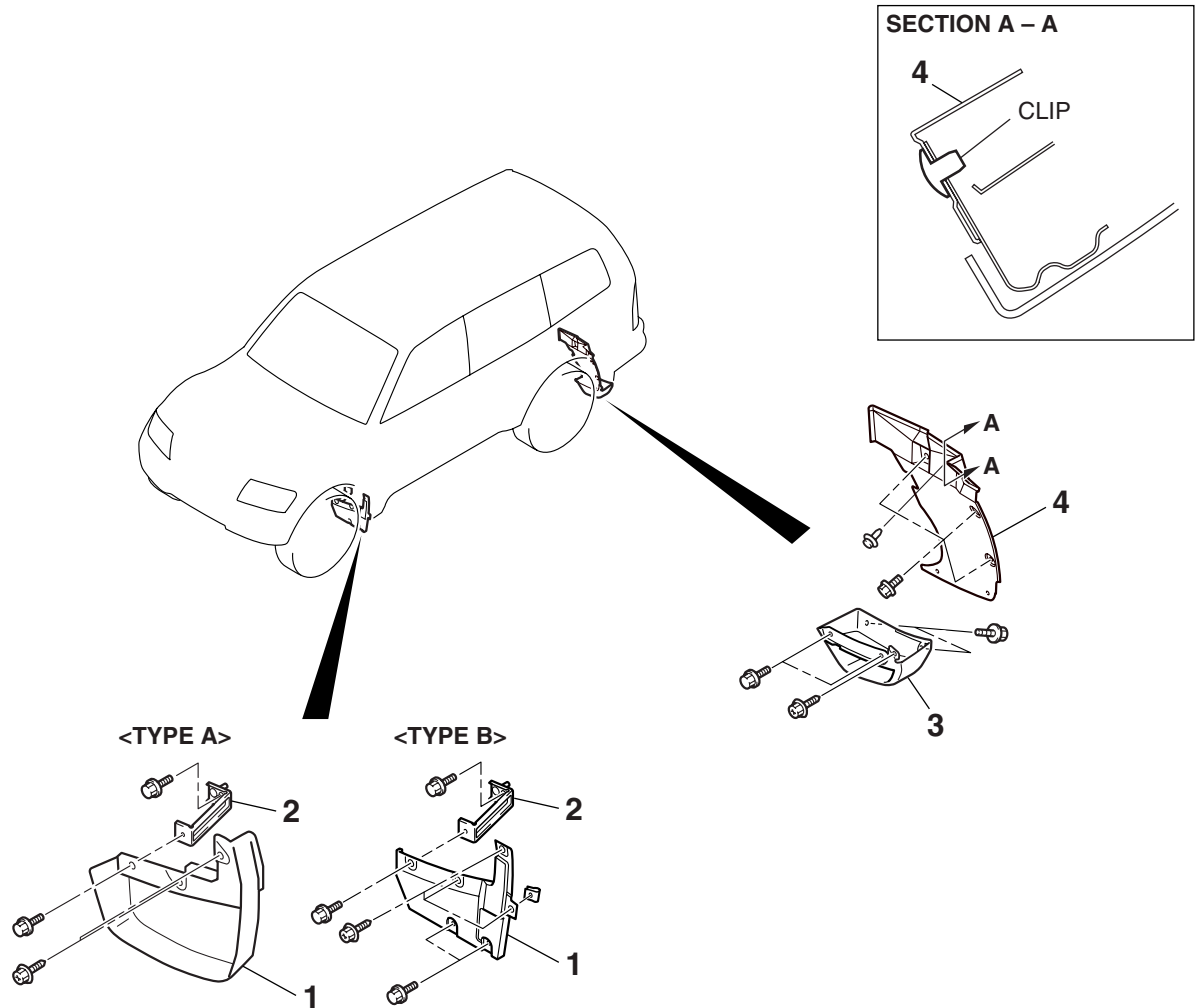

FRONT MUD GUARD REMOVAL STEPS

1. FRONT MUD GUARD
2. FRONT MUD GUARD BRACKET

REAR MUD GUARD REMOVAL STEPS

3. REAR MUD GUARD
4. REAR MUD GUARD PROTECTOR

AC309356AB

REAR DEFLECTOR

SPECIAL TOOL

M1511000600865

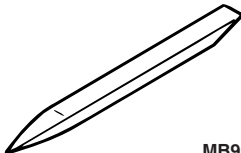
TOOL	TOOL NUMBER AND NAME	SUPERSESSION	APPLICATION
 MB990784	MB990784 Ornament remover	General service tool	Removal of rear deflector cover

REAR DEFLECTOR
REMOVAL AND INSTALLATION

M1511017500042

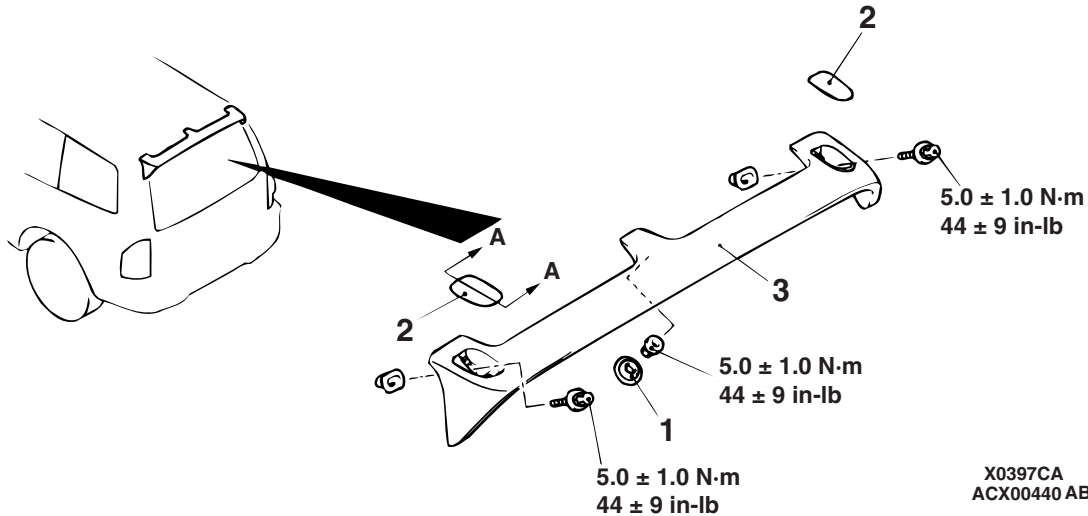
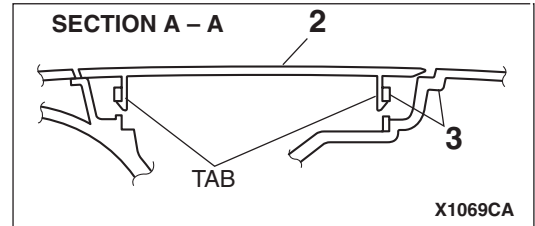

REMOVAL STEPS

<<A>>

1. RESIN PLUG
2. REAR DEFLECTOR COVER
3. REAR DEFLECTOR

Required Special Tool:

- MB990784: Ornament Remover

REMOVAL SERVICE POINT

<<A>> **REAR DEFLECTOR COVER REMOVAL**

1. Insert the special tool MB990784 into the slit on the rear deflector cover.
2. Release the tab by prying it towards the front of the vehicle.

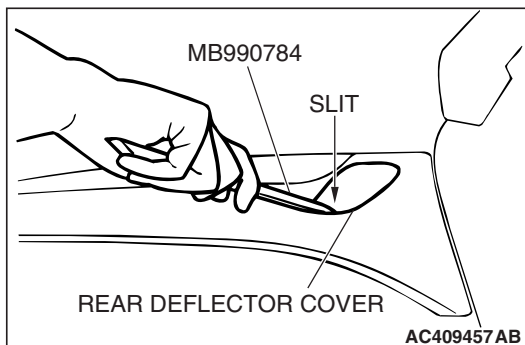

SIDE STEP

REMOVAL AND INSTALLATION

M1511011500129

<TYPE A>

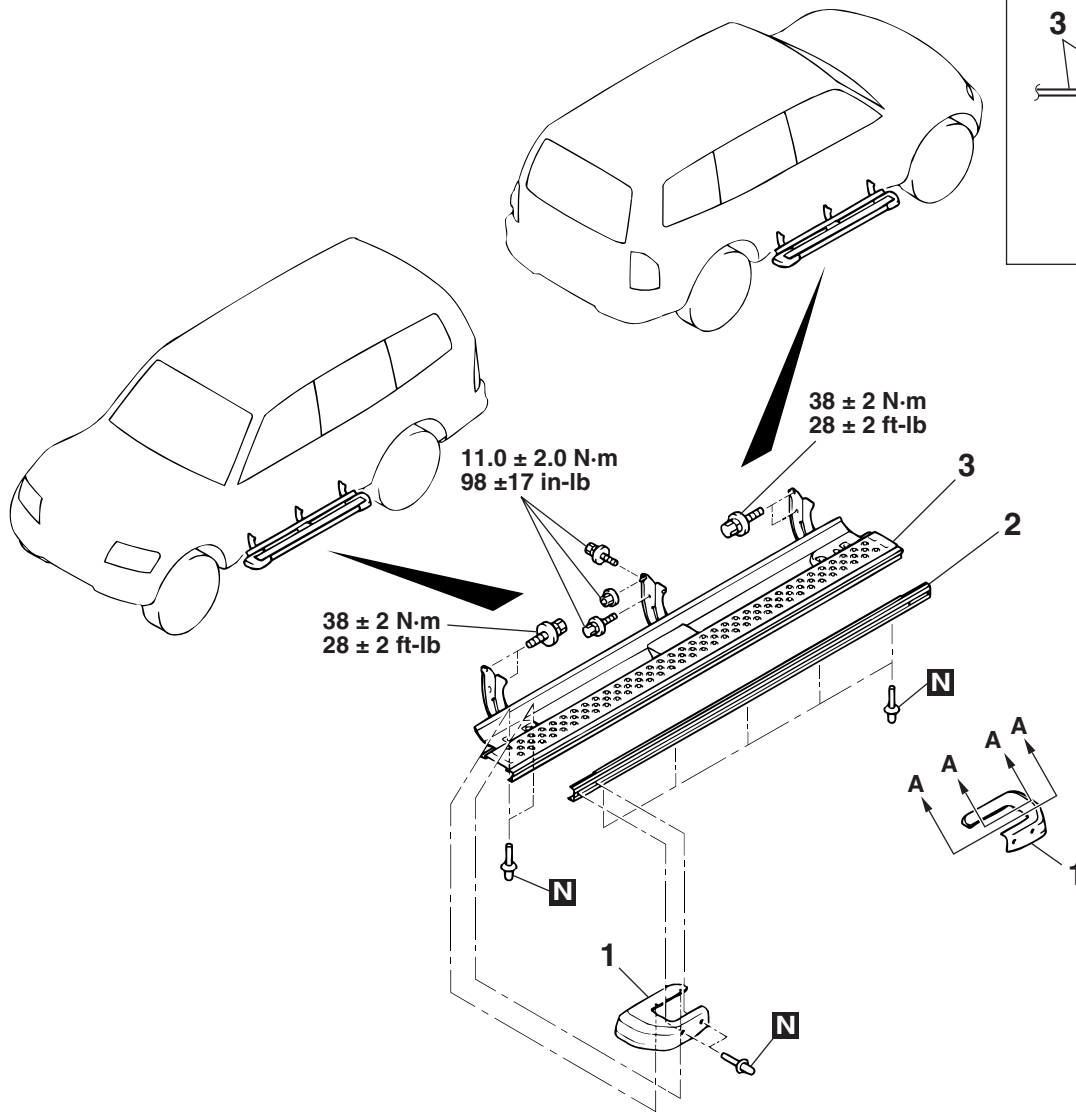
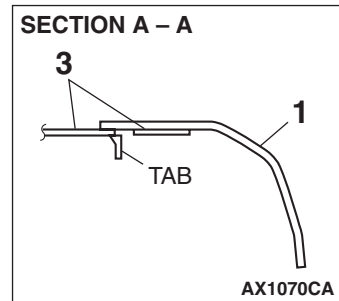

AC309216AB

REMOVAL STEPS

<<A>> >>A<< 1. SIDE STEP COVER

REMOVAL STEPS (Continued)

<<A>> >>A<< 2. NON-SLIP COVER
3. SIDE STEP ASSEMBLY

<TYPE B>

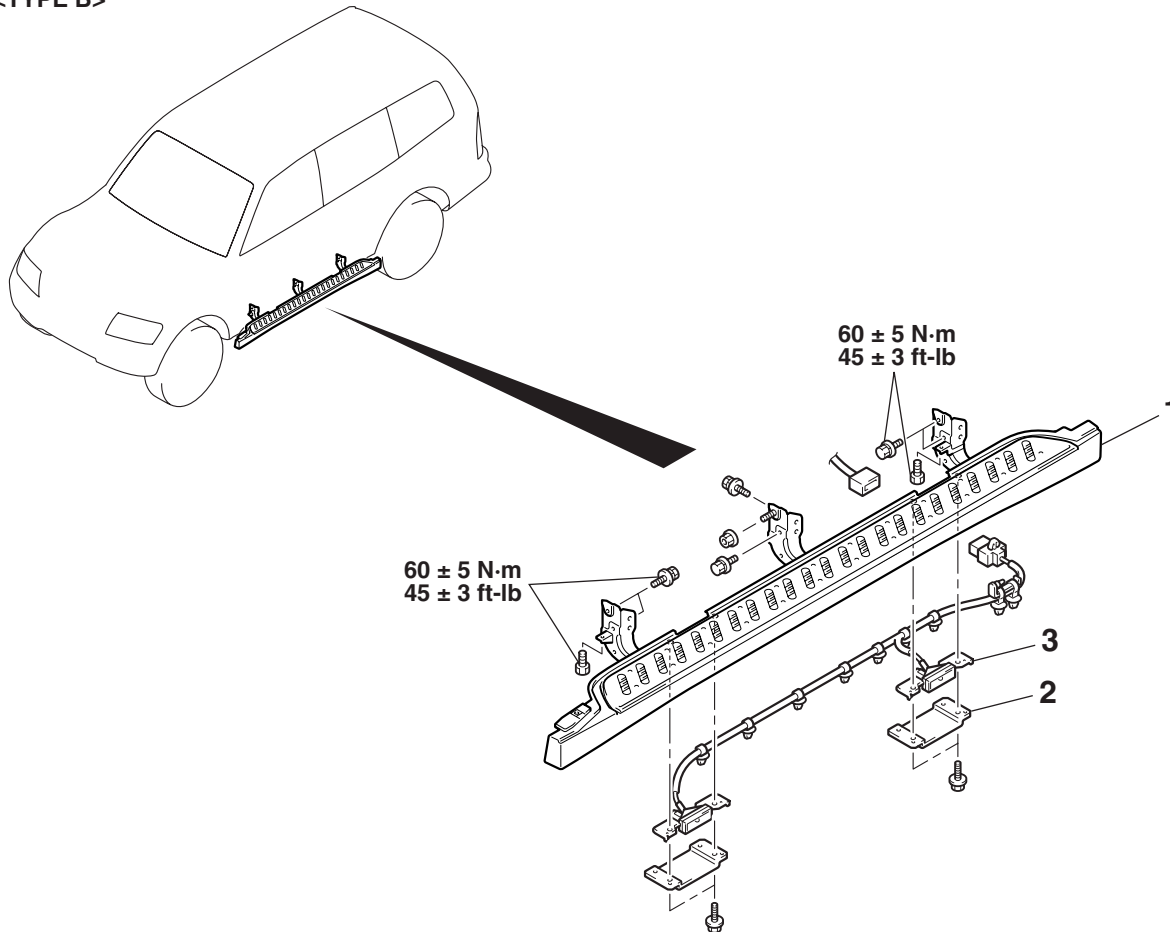

AC309062AB

REMOVAL STEPS

- SIDE STEP LIGHT ASSEMBLY CONNECTOR CONNECTION
- 1. SIDE STEP ASSEMBLY

REMOVAL STEPS (Continued)

2. SIDE STEP LIGHT BRACKET PROTECTOR
3. SIDE STEP LIGHT ASSEMBLY

REMOVAL SERVICE POINT**<<A>> SIDE STEP COVER, NON-SLIP COVER REMOVAL**

Remove by the same procedure as for REAR MUD GUARD REINFORCEMENT, REAR BUMPER SIDE RETAINER, REAR BUMPER CORNER BRACKET REMOVAL (Refer to [P.51-7](#)).

INSTALLATION SERVICE POINTS**>>A<< SIDE STEP COVER, NON-SLIP COVER INSTALLATION**

Install by the same procedure as for REAR MUD GUARD REINFORCEMENT, REAR BUMPER SIDE RETAINER, REAR BUMPER CORNER BRACKET INSTALLATION (Refer to [P.51-7](#)).

SIDE STEP DISASSEMBLY AND ASSEMBLY

M1511014300038

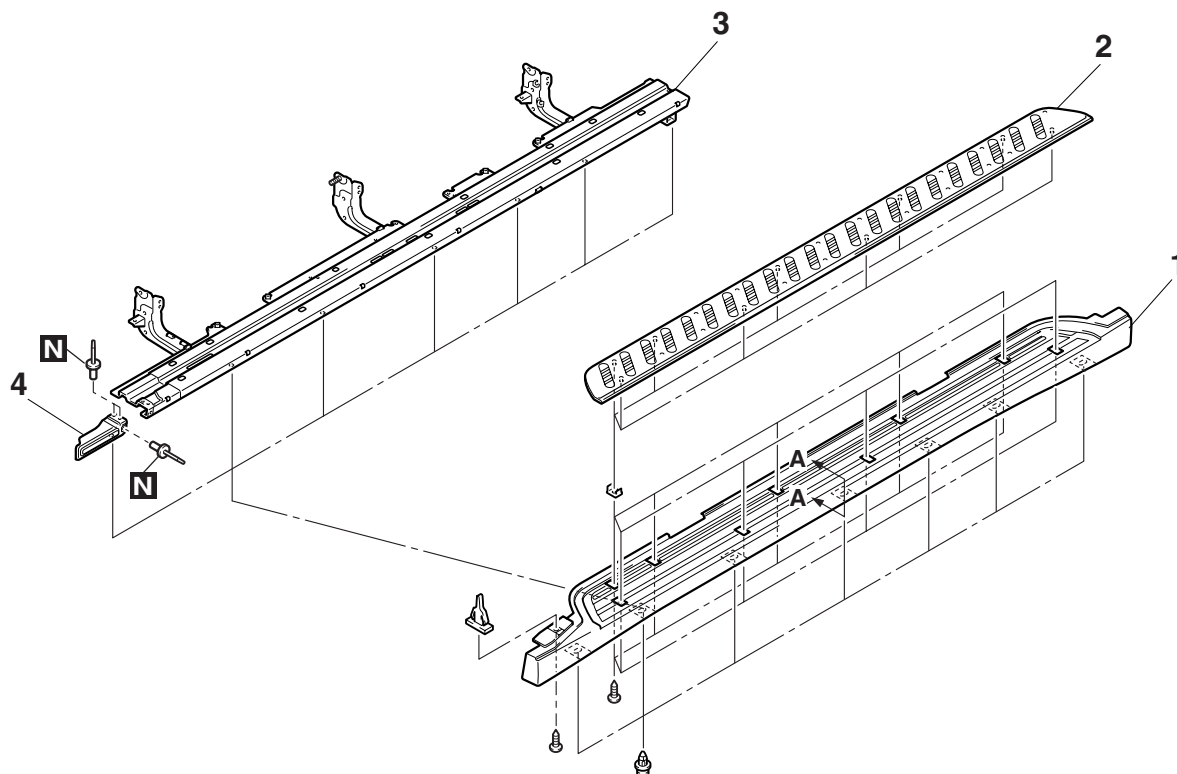
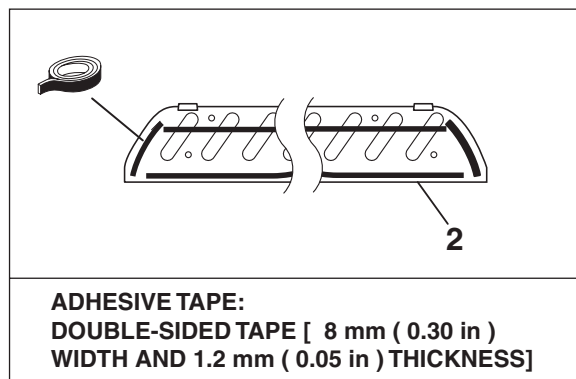
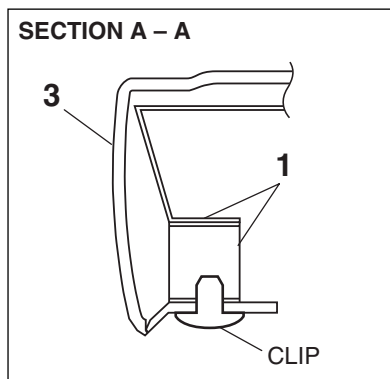

AC203469AC

- DISASSEMBLY STEPS**
1. SIDE STEP GARNISH
 2. SIDE STEP COVER

- DISASSEMBLY STEPS (Continued)**
3. SIDE STEP
 4. SIDE STEP GARNISH BRACKET

WINDSHIELD WIPER AND WASHER

GENERAL DESCRIPTION

WINDSHIELD WIPER AND WASHER OPERATION

WINDSHIELD LOW-SPEED (AND HIGH-SPEED) WIPER OPERATION

- If the wiper switch is turned to the "LO" position with the ignition switch at the "ACC" or "ON" position, the column switch sends a low-speed wiper ON and high-speed wiper OFF signals to the front-ECU. This turns the wiper signal on and the wiper speed switching relay off (low-speed), causing the wipers to operate at low-speed.
- If the wiper switch is turned to the "HI" position, the column switch sends a low-speed wiper OFF and high-speed wiper ON signals to the front-ECU. This turns both the wiper signal and the wiper speed switching relay on (high-speed), causing the wipers to operate at high-speed.

WINDSHIELD INTERMITTENT WIPER OPERATION

- The ETACS-ECU calculates the wiper operation interval according to the voltage signal sent from the column switch. Then the ETACS-ECU sends a signal to the front-ECU. The front-ECU determines the wiper operation interval and turns on the wiper signal relay. This causes the wiper auto stop relay to turn on. Then the wiper auto stop relay will turn off after the wipers reach the park

WINDSHIELD WIPER AND WASHER DIAGNOSIS

The windshield wiper and washer are controlled by the Simplified Wiring System (SWS). For troubleshooting, refer to GROUP 54B, SWS Diagnosis [P.54B-22](#).

M1511000100666

position. This causes the wiper signal relay and then the wipers to turn off. If the wiper signal relay remains off for the wiper operation interval, the relay turns on again, causing the wipers to operate in intermittent mode.

WINDSHIELD MIST WIPER OPERATION

- If the wiper switch is turned to the "MIST" position with the ignition switch at "ACC" or "ON" position, the mist wiper high-speed operation signal is sent to the front-ECU. This signal turns on the wiper speed switching relay, causing the wipers to work at high-speed while the mist switch is on.
- While the mist wiper switch remains turned on when the intermittent mode is still working, the wipers work as the mist wiper. However, the wipers return to the intermittent mode again when the wiper auto stop signal turns on after the mist wiper switch is turned off.

WINDSHIELD WASHER OPERATION

- If the wiper switch is turned to the "WASHER" position with the ignition switch at "ACC" or "ON" position, the washer ON signal is sent to the front-ECU, causing the wiper signal to turn on after 0.3 second. After the washer switch signal turns off, the wiper signal turns off in three seconds. If the wiper switch is turned the "WASHER" position while the wiper is at intermittent mode, the washer works for that period when the washer switch remains on. Then the wipers return to the intermittent mode.

M1511000700419

**WINDSHIELD WIPER AND WASHER
REMOVAL AND INSTALLATION**

M1511008200300

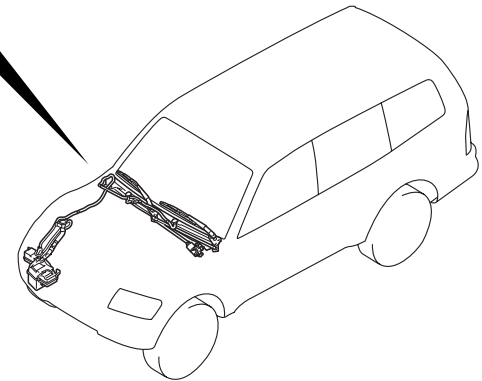
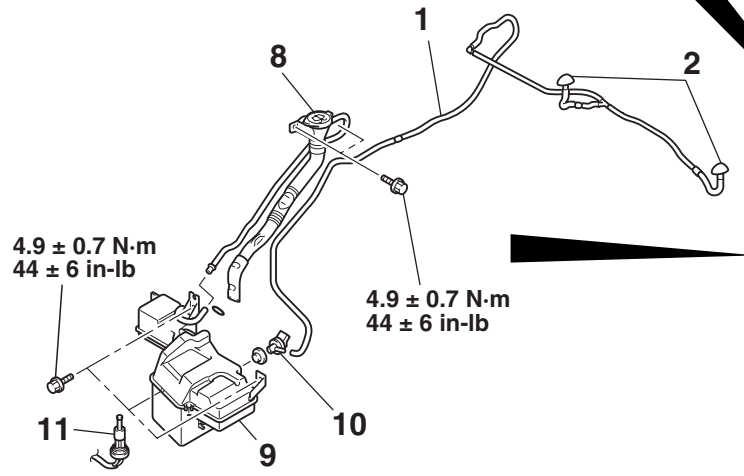
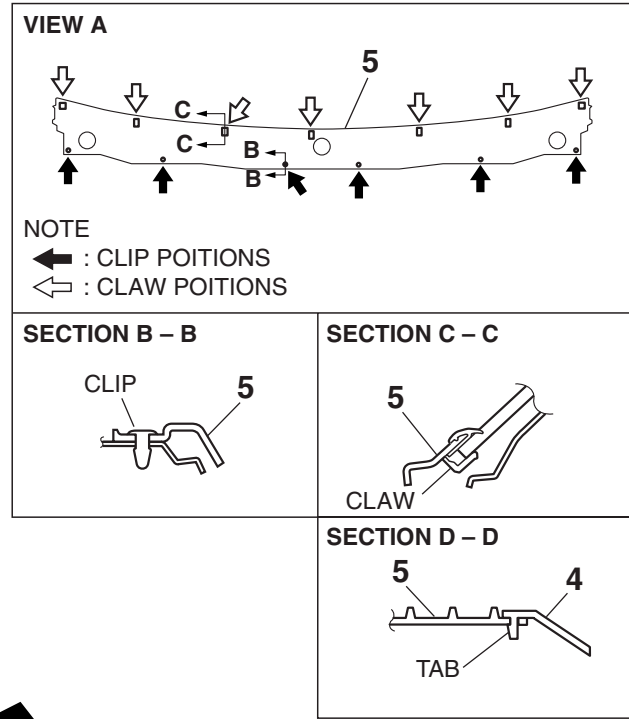
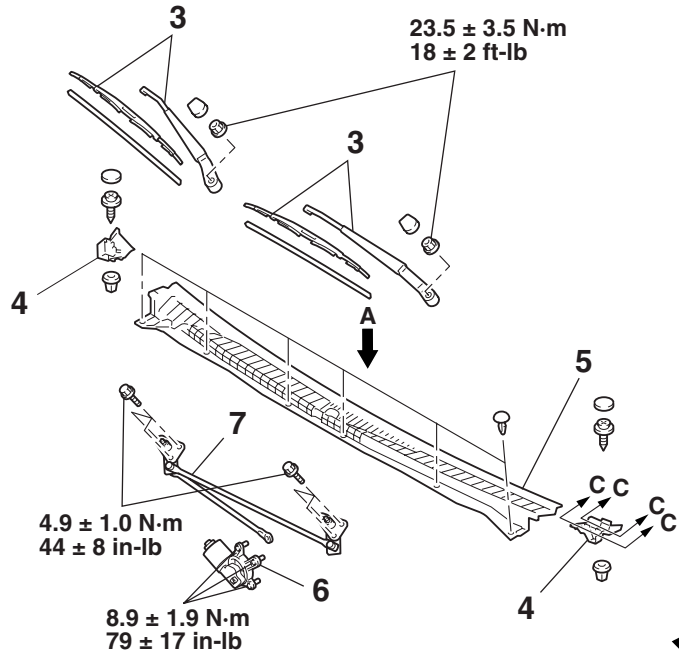

AC203576 AB

1. WASHER HOSE
 2. WASHER NOZZLE
- WIPER MOTOR AND LINK ASSEMBLY
REMOVAL STEPS**
- >>A<<
3. WIPER ARM AND BLADE ASSEMBLY
 4. FRONT DECK SIDE GARNISH
 5. FRONT DECK GARNISH
 6. WIPER MOTOR ASSEMBLY
 7. LINK ASSEMBLY

<<A>>

WASHER TANK REMOVAL STEPS

- FRONT BUMPER ASSEMBLY (REFER TO P.51-3).
- HEADLIGHT (REFER TO GROUP 54A, HEADLIGHT AND FRONT COMBINATION LIGHT P.54A-80).
- 8. INLET ASSEMBLY
- 9. WASHER TANK ASSEMBLY
- 10. WINDSHIELD WASHER MOTOR
- 11. WASHER FLUID LEVEL SENSOR

NOTE: For removal and installation of the wiper and washer switch, refer to GROUP 54A, Column switch P.54A-119.

REMOVAL SERVICE POINT

<<A>> WIPER MOTOR ASSEMBLY REMOVAL

⚠ CAUTION

Be careful not to damage the windshield glass when removing the wiper motor and link assembly.

1. Remove the five mounting bolts of the wiper motor and link assembly and disconnect the connector.
2. To protect the windshield, apply duct tape to the entire circumference of the glass near the wiper motor and link assembly installation position.

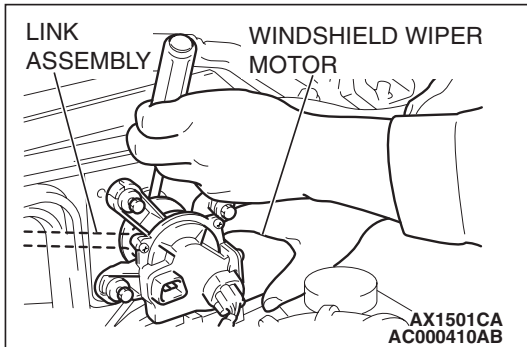

INSTALLATION SERVICE POINT

>>A<< WIPER ARM AND BLADE ASSEMBLY INSTALLATION

Install the wiper blade at the specified position (standard value).

Standard value: Driver's side(A): 20 – 30mm (0.8 – 1.2 inches)

Passenger's side(B): 25 – 35mm (1.0 – 1.4 inches)

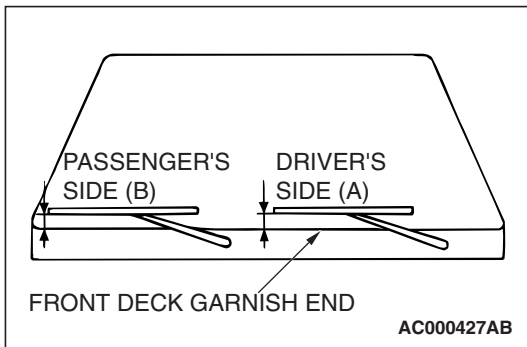

INSPECTION

M1511019100244

WINDSHIELD WIPER MOTOR CHECK

The windshield wiper motor assembly should be installed to the vehicle body and the harness connector should be disconnected when checking the wiper motor.

Wiper Motor at Low-Speed and High-Speed Operation

Connect the battery to the wiper motor as shown in the illustration, and then check the operation of the wiper motor at low speed and at high speed.

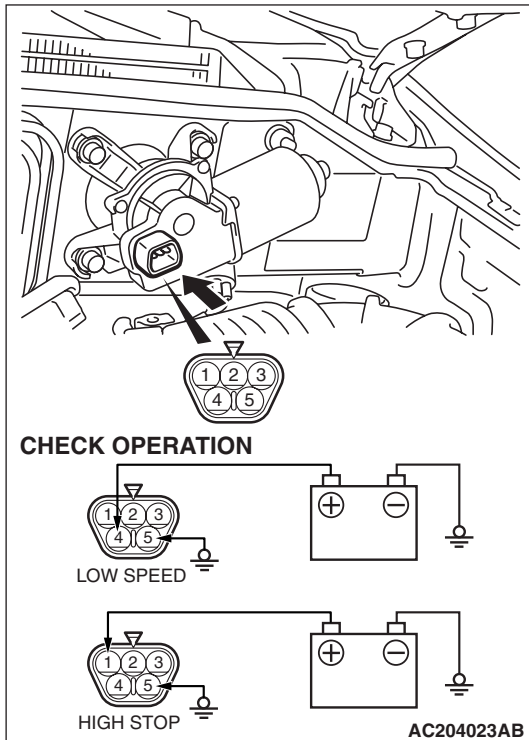

Wiper Motor at Stop Position Operation

1. Connect the battery to the wiper motor as shown in illustration (A), and then run the wiper motor at low speed. Then, while the motor is operating, disconnect the battery to make the wiper motor stop.
2. Connect the terminals and the battery as shown in illustration (B), and then check whether the wiper motor automatically stops in the correct stop position after it has been running at low speed.

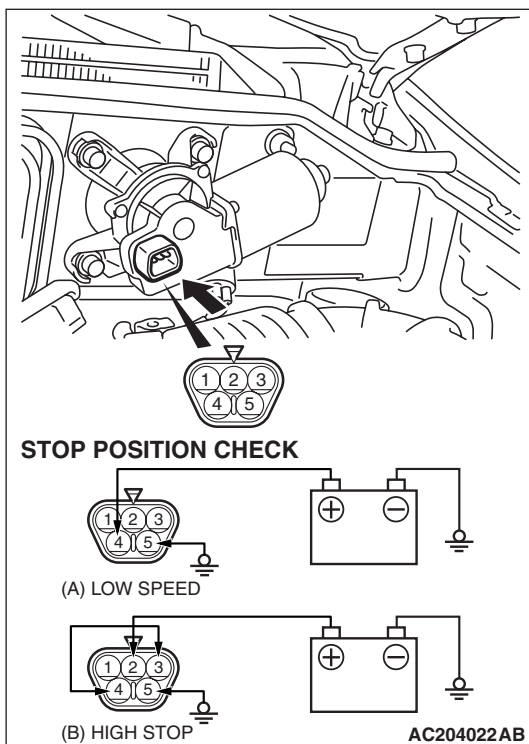

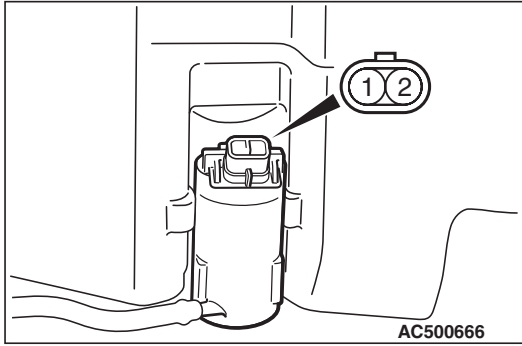
WINDSHIELD WASHER MOTOR CHECK

1. The windshield washer tank assembly should be installed and the windshield washer tank should be filled with water when checking the washer motor.
2. Check that water is sprayed out strongly when battery positive voltage is applied to terminal (1) and terminal (2) is grounded.

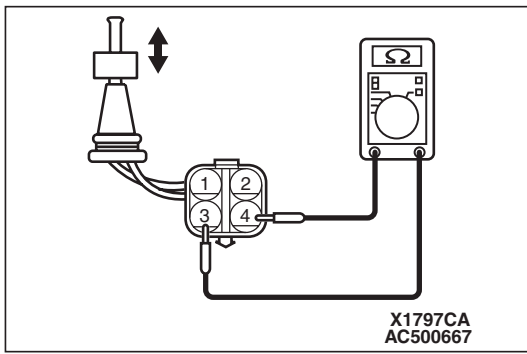
WINDSHIELD WASHER FLUID LEVEL SWITCH CHECK

1. Connect a circuit tester to the connector of the level sensor as shown.
2. Check that when the float is moved down, the circuit is closed and that when the float is moved up, the circuit is opened.

**WINDSHIELD WASHER NOZZLE SPRAY
POSITION CHECK**

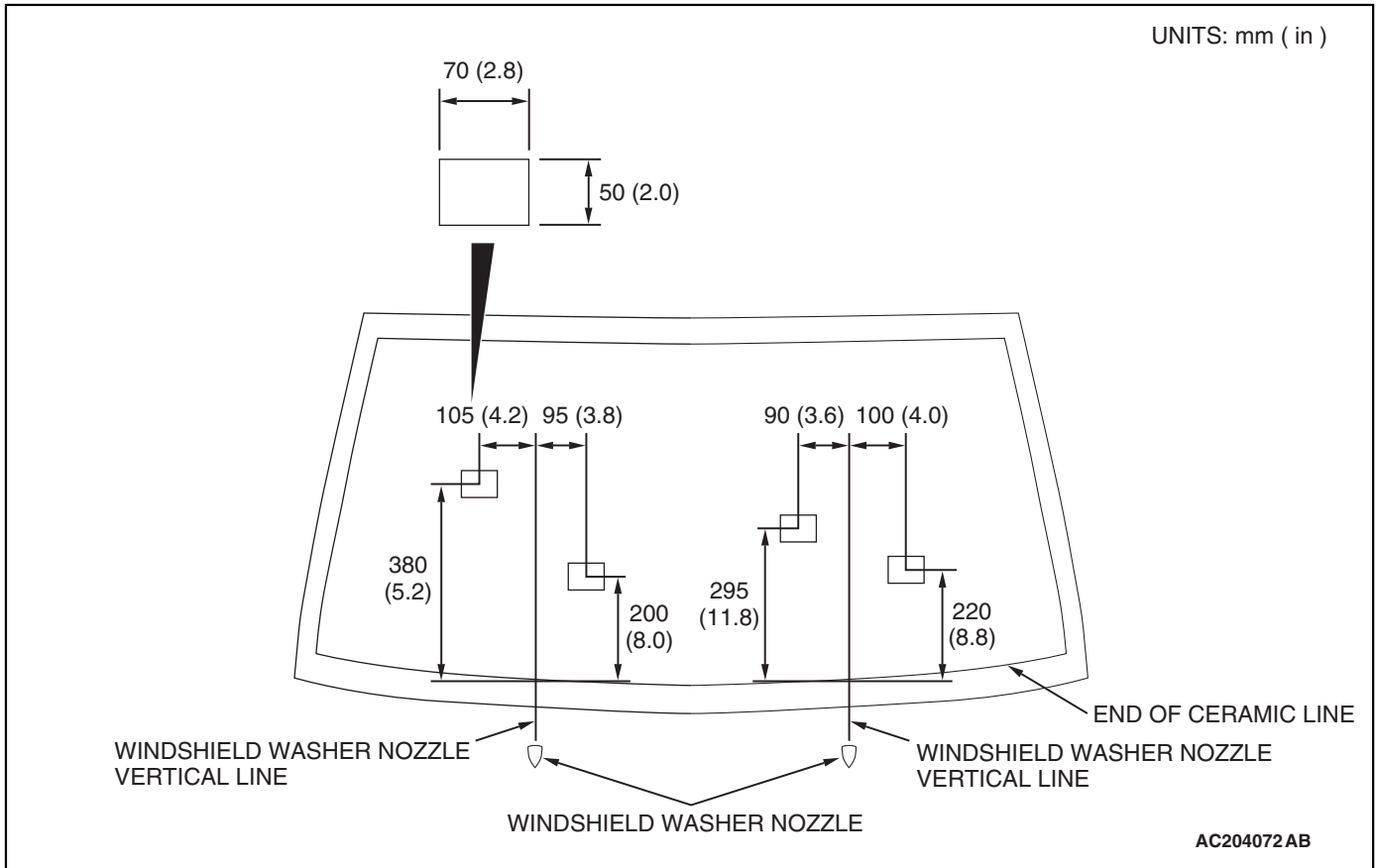

Move the nozzle to adjust so that the water is sprayed out within the range shown in the illustration.

**WINDSHIELD WIPER AND WINDSHIELD WASHER
SWITCH CHECK**

1. Windshield wiper and washer switch

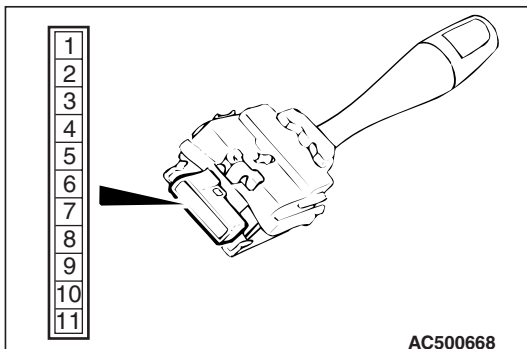

SWITCH POSITION	TERMINAL CONNECTION	SPECIFIED CONDITION
OFF	6 – 7, 6 – 8, 6 – 9, 6 – 10, 6 – 11	Open circuit
Windshield wiper mist switch ON	6 – 11	Less than 2 ohms
Windshield intermittent wiper switch ON	6 – 10	
Windshield low-speed wiper switch ON	6 – 9	
Windshield high-speed wiper switch ON	6 – 8	
Windshield washer switch ON	6 – 7	

2. Windshield intermittent wiper interval adjusting knob
Measure the resistance value between terminal numbers 3 and 6. The resistance value should rise smoothly from approximately 0 ohm ("FAST" position) to approximately 1 k Ω ("SLOW" position).

REAR WIPER AND WASHER

GENERAL DESCRIPTION

M1511000100677

REAR WIPER AND WASHER OPERATION

REAR WIPER OPERATION

- If the rear wiper switch of the column switch assembly is turned ON with the ignition switch in the ACC or ON position, the ETACS-ECU turns ON the rear wiper drive signal for three seconds (approx. two operations). 7.4 seconds later, the wiper begins the intermittent operation with eight seconds' cycle. If the selector lever is moved to the R position when the rear wiper switch of the column switch assembly is turned ON and the ignition switch is in any position other than OFF, transmission range switch (reverse) turns ON. One second later, the ETACS-ECU turns ON the rear wiper drive signal for three seconds (approx. two operations) to clear the rear field of view. 7.4 seconds later, the wiper returns to the intermittent operation of eight seconds' cycle.

REAR WIPER AND WASHER DIAGNOSIS

The rear wiper and washer are controlled by the Simplified Wiring System (SWS). For troubleshooting, refer to GROUP 54B, SWS Diagnosis [P.54B-22](#).

REAR WASHER OPERATION

- If the washer switch at the steering column is placed in the ON position when the ignition switch is in the ACC or ON position, the rear washer switch signal to the ETACS-ECU is set to high. Then the wiper drive signal turns ON 0.3 second and turns OFF three seconds after the rear washer switch signal has become low. If the rear wiper is in intermittent operation when the rear washer switch is turned ON, the rear wiper again continues the intermittent operation with eight seconds' cycle from 7.4 seconds after the rear wiper drive signal is turned OFF.

M1511000700420

REAR WIPER AND WASHER
REMOVAL AND INSTALLATION

M1511008800120

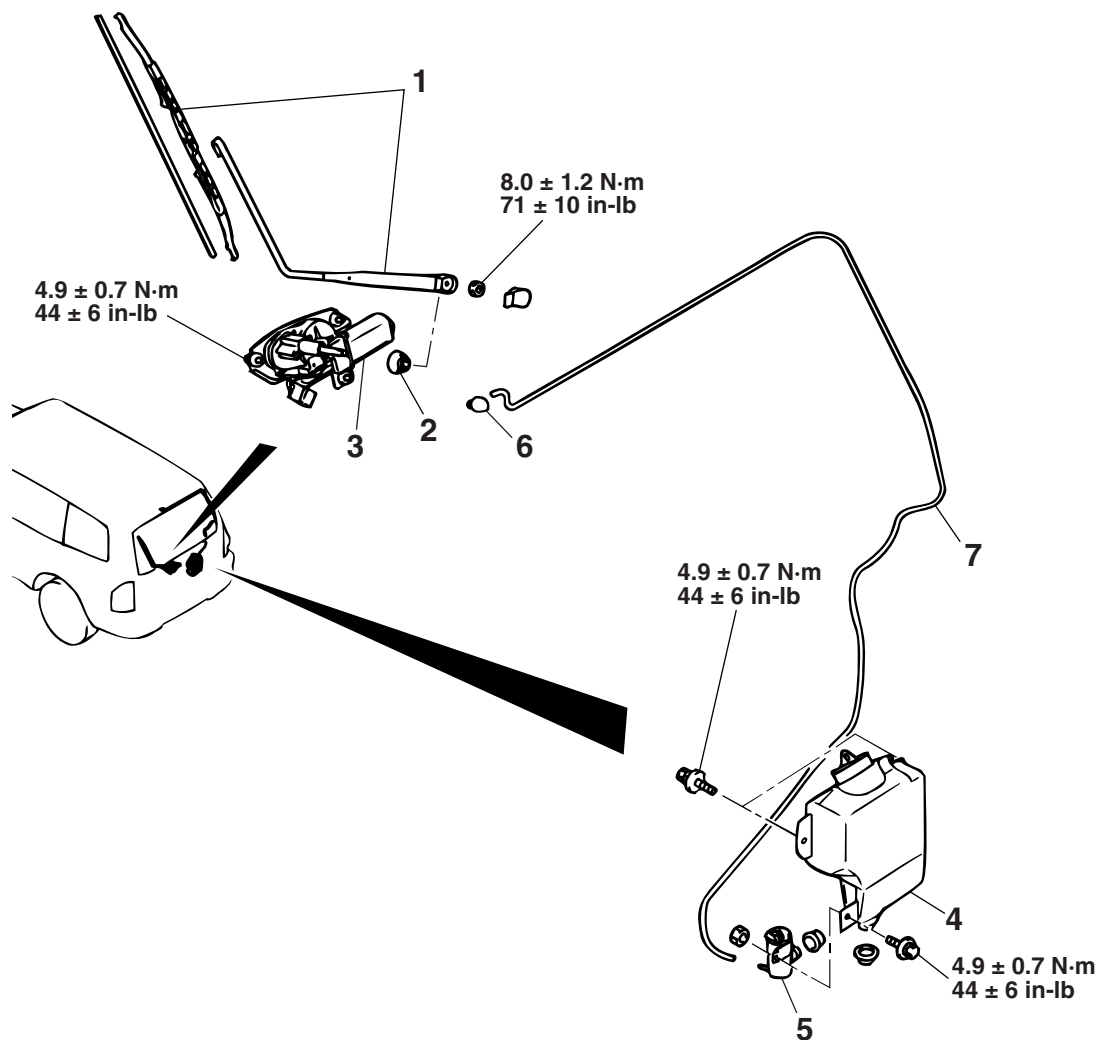

AC309462AB

**REAR WIPER MOTOR ASSEMBLY
REMOVAL STEPS**

- TOOLBOX BRACKET, UPPER (REFER TO GROUP 42, DOOR TRIM AND WATERPROOF FILM [P.42-53](#)).

- >>B<< 1. REAR WIPER ARM AND BLADE ASSEMBLY
- >>A<< 2. GROMMET
- 3. REAR WIPER MOTOR ASSEMBLY

**REAR WASHER TANK ASSEMBLY
AND REAR WASHER MOTOR
REMOVAL STEPS**

- WATERPROOF FILM (REFER TO GROUP 42, DOOR TRIM AND WATERPROOF FILM [P.42-53](#)).

**REAR WASHER TANK ASSEMBLY
AND REAR WASHER MOTOR
REMOVAL STEPS (Continued)**

- 4. REAR WASHER TANK ASSEMBLY
- 5. REAR WASHER MOTOR

**REAR WASHER HOSE REMOVAL
STEPS**

- 6. WASHER NOZZLE
- WATERPROOF FILM (REFER TO GROUP 42, DOOR TRIM AND WATERPROOF FILM [P.42-53](#)).
- 7. REAR WASHER HOSE

NOTE: For removal and installation of the wiper and washer switch, refer to GROUP 54A, Column switch [P.54A-119](#).

INSTALLATION SERVICE POINTS

>>A<< GROMMET INSTALLATION

Install so that the matching mark on the grommet is aligned with the notch in the mounting hole.

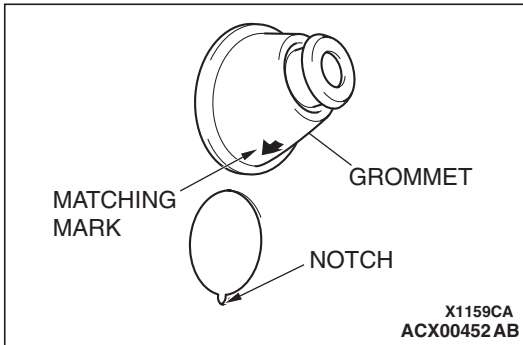

>>B<< REAR WIPER ARM AND BLADE ASSEMBLY INSTALLATION

Install so that the end of the wiper blade stops at the specified position (standard value).

Standard value (A): 25 – 35 mm (1.0 – 1.4 inches)

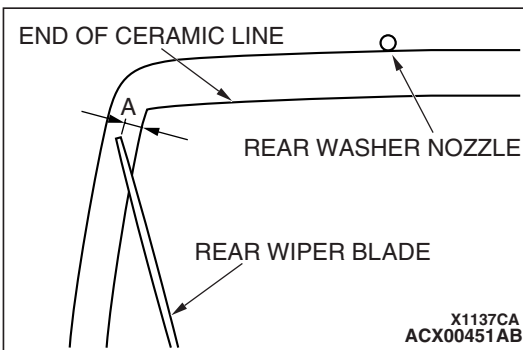

INSPECTION

M1511019100255

REAR WIPER MOTOR CHECK

The rear wiper motor assembly should be installed to the vehicle body and the harness connector should be disconnected when checking the wiper motor.

Wiper Motor Operation

Connect the battery to the wiper motor as shown in the illustration, and then check the operation of the wiper motor.

Wiper Motor at Stop Position Operation

1. Operate the wiper motor by the same method as described in the check procedure above. Then, while the motor is operating, disconnect the battery to make the wiper motor stop.
2. Reconnect the battery as shown in the illustration, and then check whether the wiper motor automatically stops in the correct stop position after it has been running.

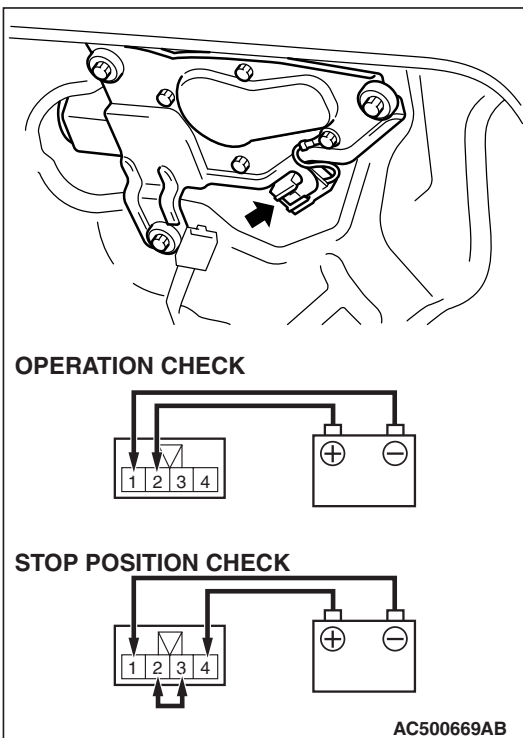

REAR WASHER MOTOR CHECK

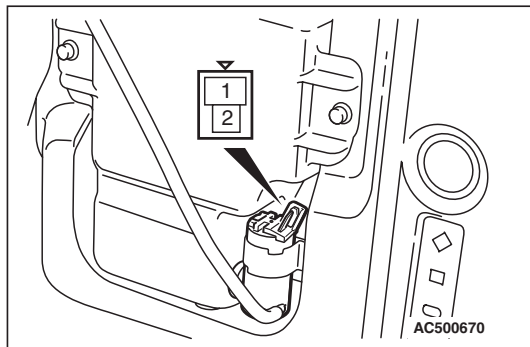

1. The rear washer tank assembly should be installed and the rear washer tank should be filled with water when checking the washer motor.
2. Check that water is sprayed out strongly when system voltage is applied to terminal (2) and terminal (1) is grounded.

REAR WASHER NOZZLE SPRAY DIRECTION CHECK

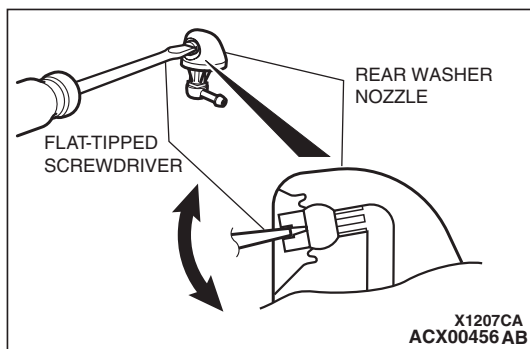
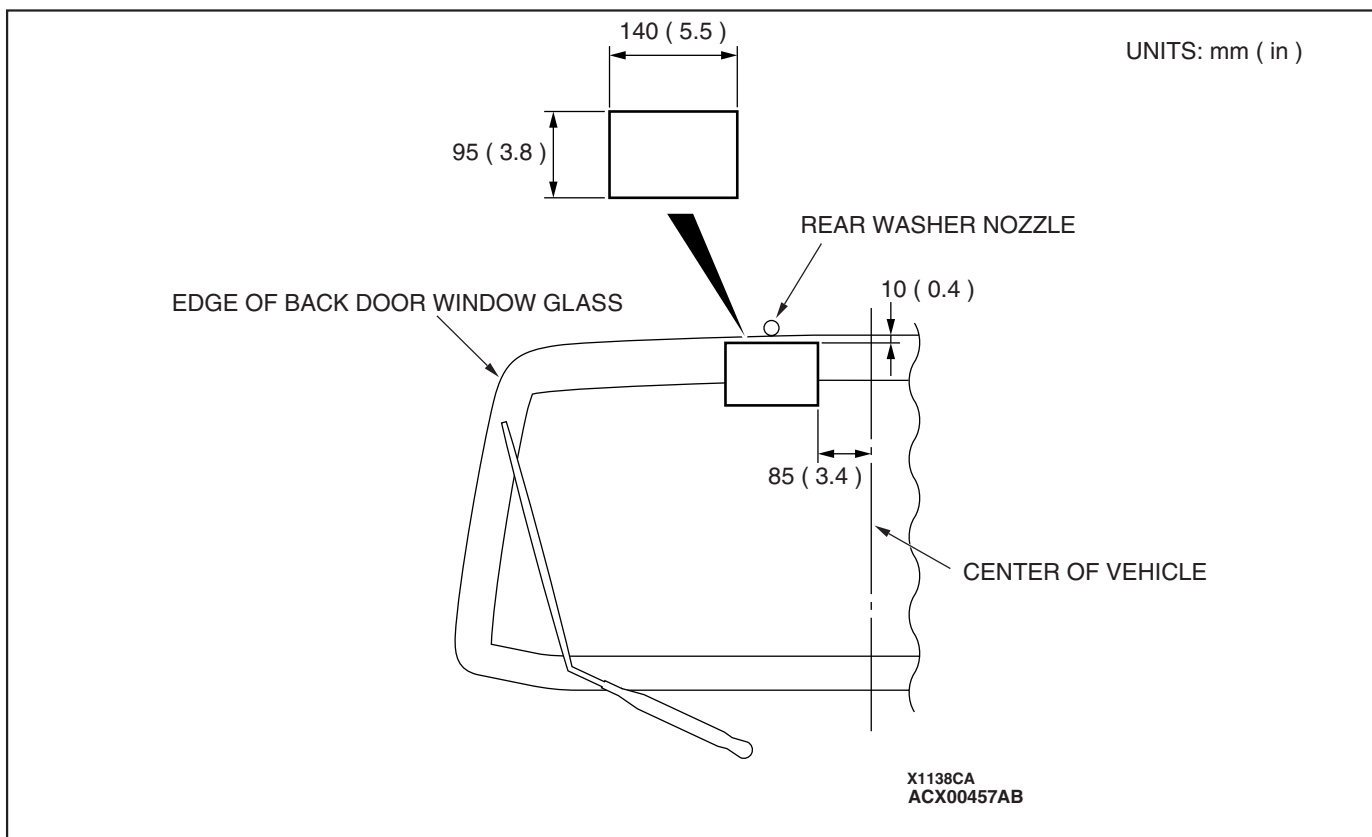

Move the nozzle to adjust so that the water is sprayed out within the range shown in the illustration.

CAUTION

Be careful not to damage the spray hole of the nozzle when inserting the flat-tipped screwdriver into the spray hole of the nozzle.

- To adjust the vertical direction of the rear washer nozzle spray position, insert a flat-tipped screwdriver into the spray hole of the rear washer nozzle and move it in the direction of the arrow.

REAR WIPER AND WASHER SWITCH CHECK

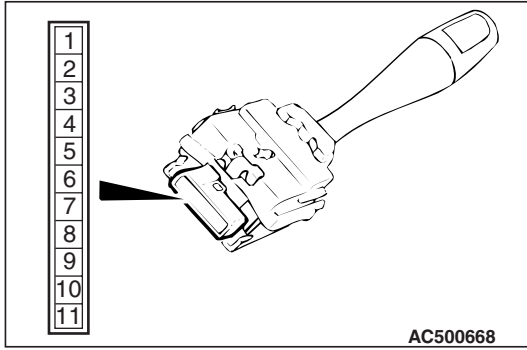

SWITCH POSITION	TERMINAL CONNECTION	SPECIFIED CONDITION
OFF	4 – 6, 5 – 6	Open circuit
Rear washer switch ON	5 – 6	Less than 2 ohms
Rear wiper switch ON	4 – 6	

MARK

REMOVAL AND INSTALLATION

M1511011800852

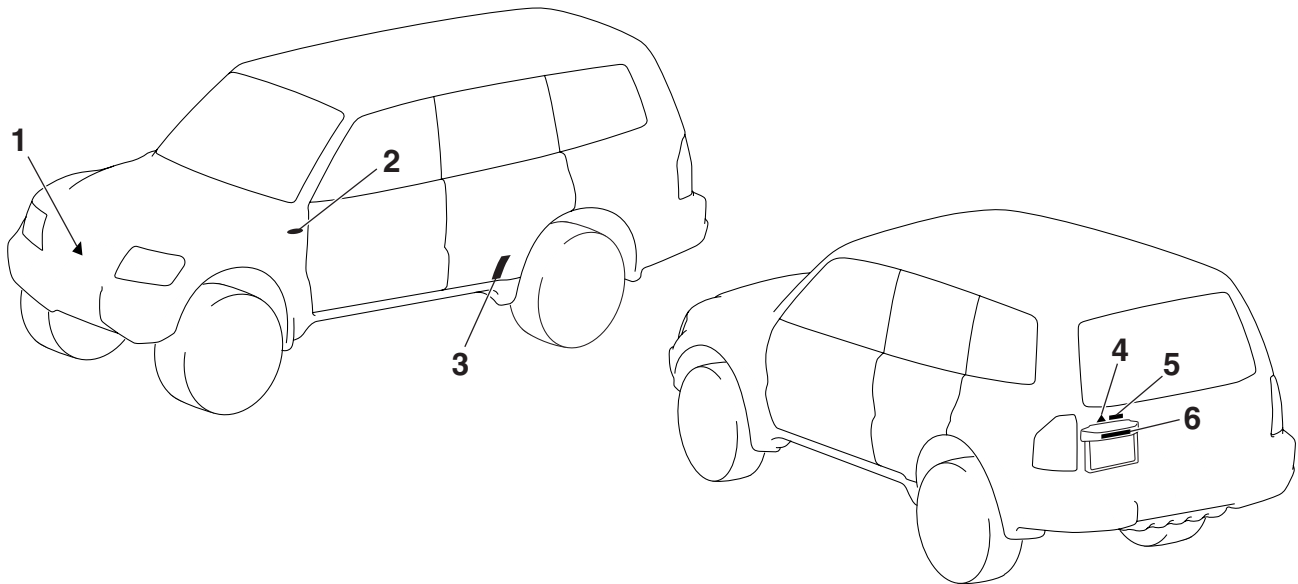

AC400227AB

- 1. FRONT THREE-DIAMOND MARK
- 2. MONTERO MARK
- >>A<< 3. PROTECTOR FILM
- >>A<< 4. REAR THREE-DIAMOND MARK
- >>A<< 5. GRADE MARK
- >>A<< 6. MONTERO MARK

Required Special Tool:

- MB990528: Stripe Tape Spatula

INSTALLATION SERVICE POINT

>>A<< MARK INSTALLATION

1. Installation position
Attach to the position shown in the illustration.

PROTECTOR FILM

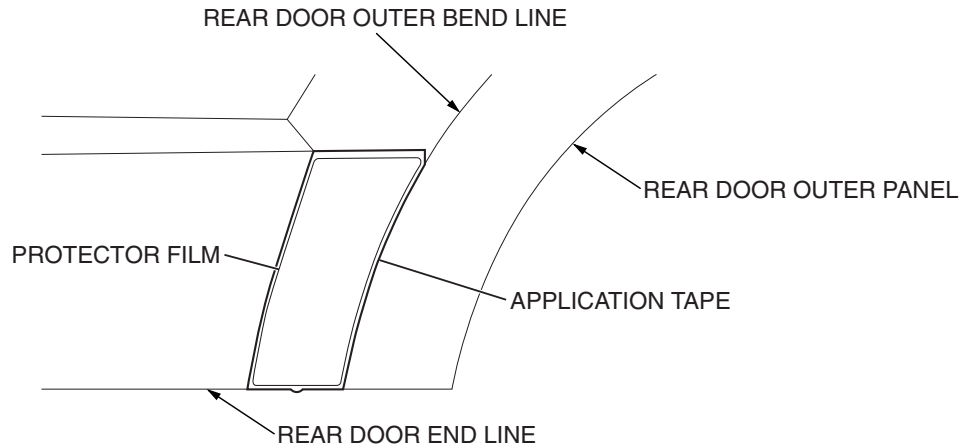

AC309357AC

THREE-DIAMOND MARK, GRADE MARK (XLS, LIMITED), MONTERO MARK

UNITS: mm (in)

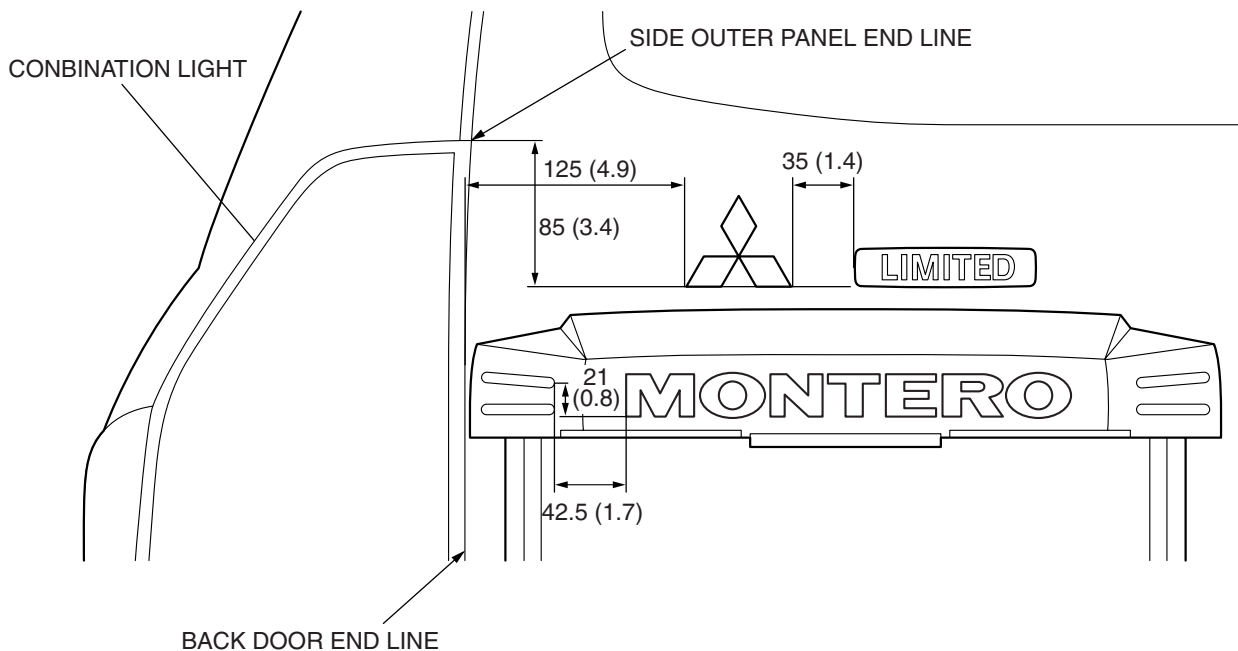

AC400226AB

2. Installation procedure
 - (1) Use 3M™ AAD Part number 8906 or equivalent to clean the mark installation surfaces on the body.

⚠ CAUTION

When attaching the marks, the ambient temperature should be 20 – 38°C (60 – 100°F) and the air should be completely free of dust. If the ambient temperature is lower than 20°C (60°F), the marks and the places on the vehicle body where the marks are to be attached should be heated to 20 – 38°C (60 – 100°F).

- (2) Peel off the backing paper from the reverse side of the marks, carefully attach the marks to the vehicle body in the exact position shown.

OUTSIDE MIRROR**REMOVAL AND INSTALLATION**

M1511024400014

<DOOR MIRROR>

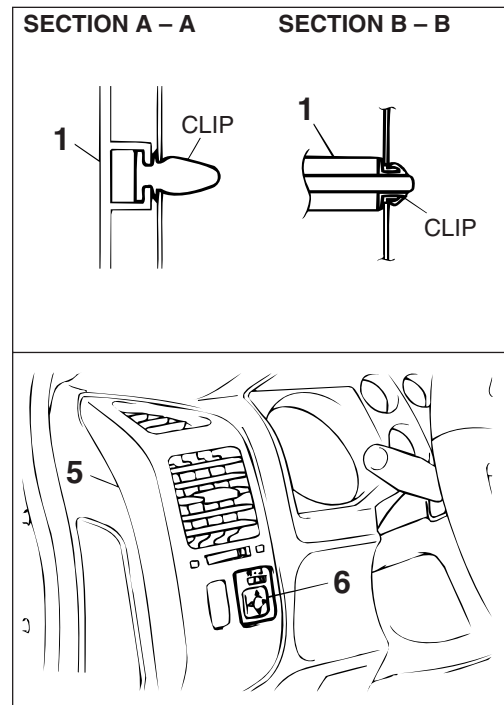
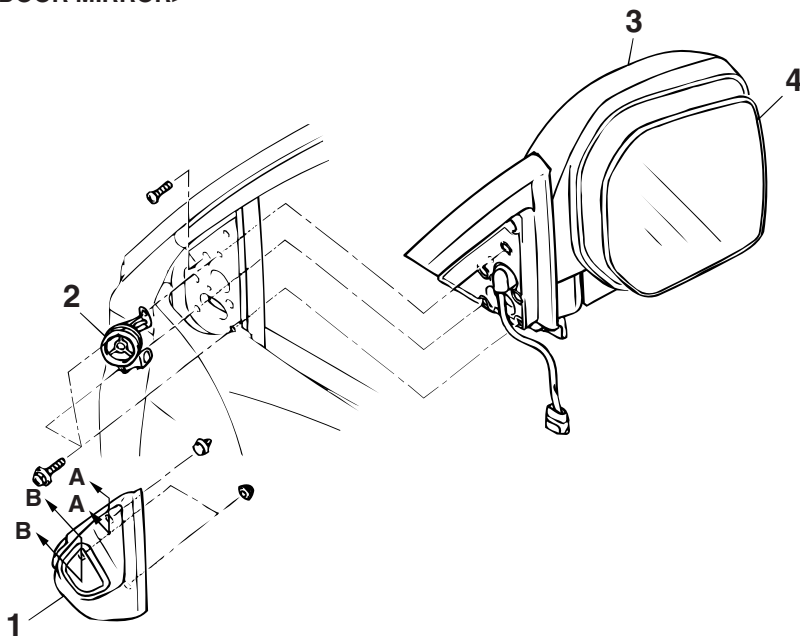

AC309201AB

<REAR UNDER MIRROR>

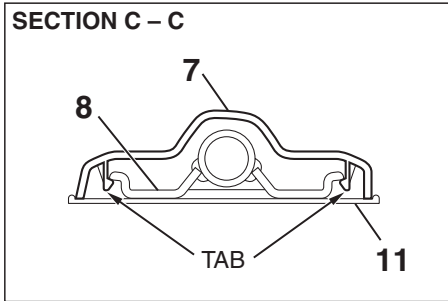
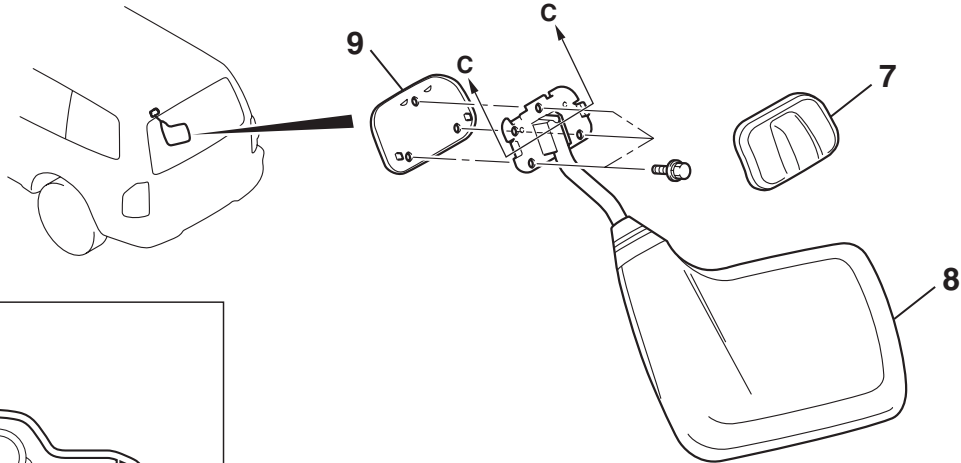

AC309189AB

DOOR MIRROR REMOVAL STEPS

1. DELTA COVER, INNER
2. TWEETER COVER
3. DOOR MIRROR ASSEMBLY
4. MIRROR

<<A>> >>A<<

**REMOTE CONTROLLED MIRROR
SWITCH REMOVAL STEPS**

5. AIR OUTLET ASSEMBLY (REFER TO GROUP 52A, INSTRUMENT PANEL P.52A-3).
6. REMOTE CONTROLLED MIRROR SWITCH

**REAR UNDER MIRROR REMOVAL
STEPS**

7. REAR UNDER MIRROR COVER
8. REAR UNDER MIRROR
9. REAR UNDER MIRROR GASKET

REMOVAL SERVICE POINT**<<A>> MIRROR REMOVAL**

Push the top of the mirror with your hand to tilt it and attach the protective tape as shown in the illustration. Then insert a flat-tipped screwdriver in between the notch at the rear of the mirror and the pivot plate, and disengage the bottom of the mirror.

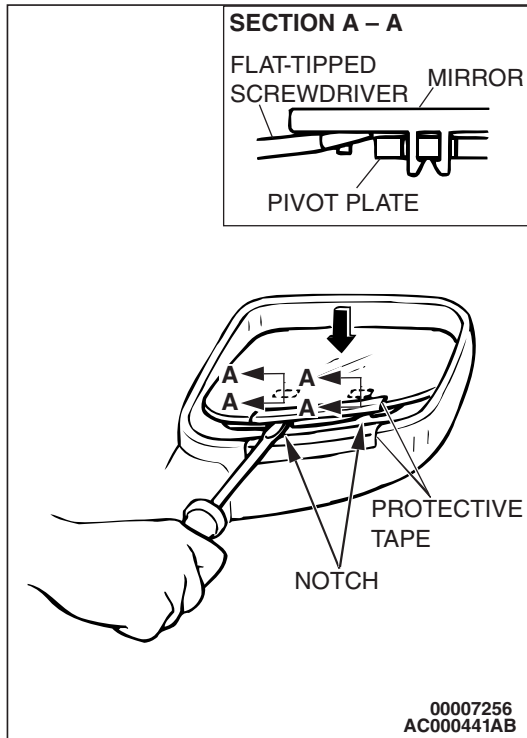
**INSTALLATION SERVICE POINT****>>A<< MIRROR INSTALLATION**

While supporting the clip position on the underside of the pivot plate with a flat-tipped screwdriver, press the clip at the front of the mirror to engage the bottom of the mirror.

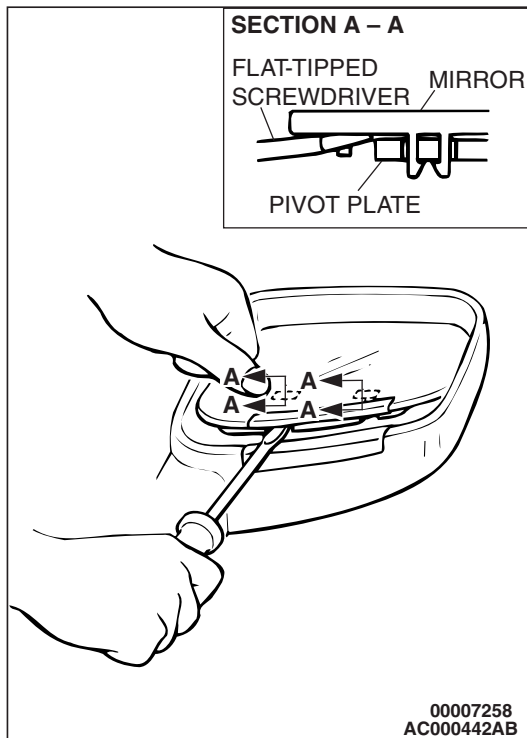

INSPECTION

M1511019100608

REMOTE CONTROLLED MIRROR ASSEMBLY
CHECK

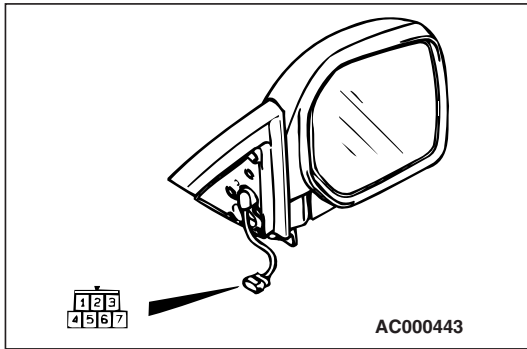

BATTERY CONNECTION	SPECIFIED CONDITION
<ul style="list-style-type: none"> Connect terminal 6 to the negative battery terminal Connect terminal 4 to the positive battery terminal 	Mirror glass should face upward
<ul style="list-style-type: none"> Connect terminal 4 to the negative battery terminal Connect terminal 6 to the positive battery terminal 	Mirror glass should face downward
<ul style="list-style-type: none"> Connect terminal 5 to the negative battery terminal Connect terminal 6 to the positive battery terminal 	Mirror glass should face to the right
<ul style="list-style-type: none"> Connect terminal 6 to the negative battery terminal Connect terminal 5 to the positive battery terminal 	Mirror glass should face to the left

REMOTE CONTROLLED MIRROR SWITCH
CONTINUITY CHECK

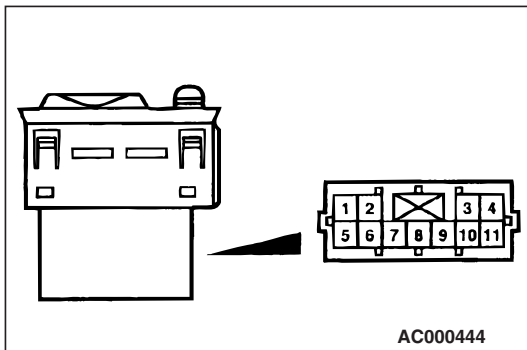

SWITCH POSITION		TESTER CONNECTION	SPECIFIED CONDITION
Left side	Up	1 - 6, 9 - 11	Less than 2 ohms
	Down	1 - 11, 6 - 9	
	Right	1 - 6, 9 - 10	
	Left	1 - 10, 6 - 9	
Right side	Up	1 - 6, 3 - 9	
	Down	1 - 3, 6 - 9	
	Right	1 - 6, 2 - 9	
	Left	1 - 2, 6 - 9	

HEATING ELEMENT FUNCTION CHECK

For vehicles with heated door mirrors, check that there is continuity between terminals (3) and (7).

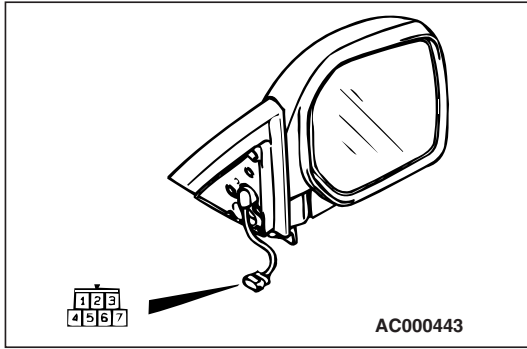

SPECIFICATIONS

FASTENER TIGHTENING SPECIFICATIONS

M1511015300310

ITEM	SPECIFICATION
Rear deflector	
Rear deflector bolt	5.0 ± 1.0 N·m (44 ± 9 in-lb)
Rear deflector nut	5.0 ± 1.0 N·m (44 ± 9 in-lb)
Side step <Type A>	
Side step assembly bolt and nut	11.0 ± 2.0 N·m (98 ± 17 in-lb)
Side step assembly bolt	38 ± 2 N·m (28 ± 2 ft-lb)
Side step <Type B>	
Side step assembly bolt	60 ± 5 N·m (45 ± 3 ft-lb)
Windshield wiper and washer	
Wiper arm and blade assembly nut	23.5 ± 3.5 N·m (18 ± 2 ft-lb)
Wiper link assembly bolt	4.9 ± 1.0 N·m (44 ± 8 in-lb)
Wiper motor assembly bolt	8.9 ± 1.9 N·m (79 ± 17 in-lb)
Inlet assembly bolt	4.9 ± 0.7 N·m (44 ± 6 in-lb)
Washer tank assembly bolt	4.9 ± 0.7 N·m (44 ± 6 in-lb)
Rear wiper and washer	
Wiper arm and blade assembly nut	8.0 ± 1.2 N·m (71 ± 10 in-lb)
Wiper motor assembly bolt	4.9 ± 0.7 N·m (44 ± 6 in-lb)
Washer tank assembly bolt	4.9 ± 0.7 N·m (44 ± 6 in-lb)
Washer motor bolt	4.9 ± 0.7 N·m (44 ± 6 in-lb)

SERVICE SPECIFICATIONS

M1511000300240

ITEM	STANDARD VALUE	
Windshield wiper blade position installation mm (in)	Driver's side	20 – 30 (0.8 – 1.2)
	Passenger's side	25 – 35 (1.0 – 1.4)
Rear wiper blade position installation mm (in)	25 – 35 (1.0 – 1.4)	

ADHESIVES

M1511000500482

ITEM	SPECIFICATION
Rear bumper step cover	Adhesive tape: Double-sided tape 8.0 mm (0.30 in) width and 1.2 mm (0.05 in) thickness
Front wheel cut molding	Adhesive tape: Double-sided tape 4.0 mm (0.16 in) width and 1.2 mm (0.05 in) thickness, and 30.0 mm (1.18 in) width and 0.8 mm (0.03 in) thickness, and 35.0 mm (1.38 in) width and 1.2 mm (0.05 in) thickness
Front door molding	Adhesive tape: Double-sided tape 4.0 mm (0.16 in) width and 1.2 mm (0.05 in) thickness
Front door core (front door molding side, front door side)	Adhesive tape: Double-sided tape 5.0 mm (0.20 in) width and 2.0 mm (0.08 in) thickness
Rear door molding	Adhesive tape: Double-sided tape 4.0 mm (0.16 in) width and 1.2 mm (0.05 in) thickness, and 24.0 mm (0.95 in) width and 1.2 mm (0.05 in) thickness
Lower cover	Adhesive tape: Double-sided tape 10.0 mm (0.39 in) width and 1.2 mm (0.05 in) thickness, and 24.0 mm (0.95 in) width and 1.2 mm (0.05 in) thickness
Side sill garnish	Adhesive tape: Double-sided tape 4.0 mm (0.16 in) width and 1.2 mm (0.05 in) thickness
License plate garnish	Adhesive tape: Double-sided tape 5.0 mm (0.20 in) width and 0.8 mm (0.03 in) thickness
Back door garnish	Adhesive tape: Double-sided tape 5.0 mm (0.20 in) width and 0.8 mm (0.03 in) thickness
Back door left garnish	Adhesive tape: Double-sided tape 5.0 mm (0.20 in) width and 0.8 mm (0.03 in) thickness
Side step cover	Adhesive tape: Double-sided tape 8.0 mm (0.30 in) width and 1.2 mm (0.05 in) thickness

NOTES