

GROUP 36

PARKING BRAKES

CONTENTS

GENERAL DESCRIPTION	36-2	PARKING BRAKE CABLE	36-7
		REMOVAL AND INSTALLATION	36-7
PARKING BRAKE DIAGNOSIS	36-2	PARKING BRAKE LINING AND DRUM	36-8
INTRODUCTION.....	36-2	REMOVAL AND INSTALLATION	36-8
TROUBLESHOOTING STRATEGY	36-2	INSPECTION.....	36-10
SYMPTOM CHART.....	36-2		
SYMPTOM PROCEDURES	36-3	SPECIFICATIONS	36-11
ON-VEHICLE SERVICE	36-4	FASTENER TIGHTENING	
PARKING BRAKE LEVER STROKE CHECK		SPECIFICATIONS.....	36-11
AND ADJUSTMENT	36-4	SERVICE SPECIFICATIONS	36-11
PARKING BRAKE SWITCH CHECK	36-5	LUBRICANT	36-11
PARKING BRAKE LINING SEATING		SEALANT	36-11
PROCEDURE.....	36-5		
PARKING BRAKE LEVER	36-6		
REMOVAL AND INSTALLATION.....	36-6		

GENERAL DESCRIPTION

M1361000100236

The parking brake is of a mechanical control type acting on the rear wheels. A lever is used to apply the parking brake. The operation method utilizes a parking brake lever which is in an offset position at the driver's side.

CONSTRUCTION DIAGRAM

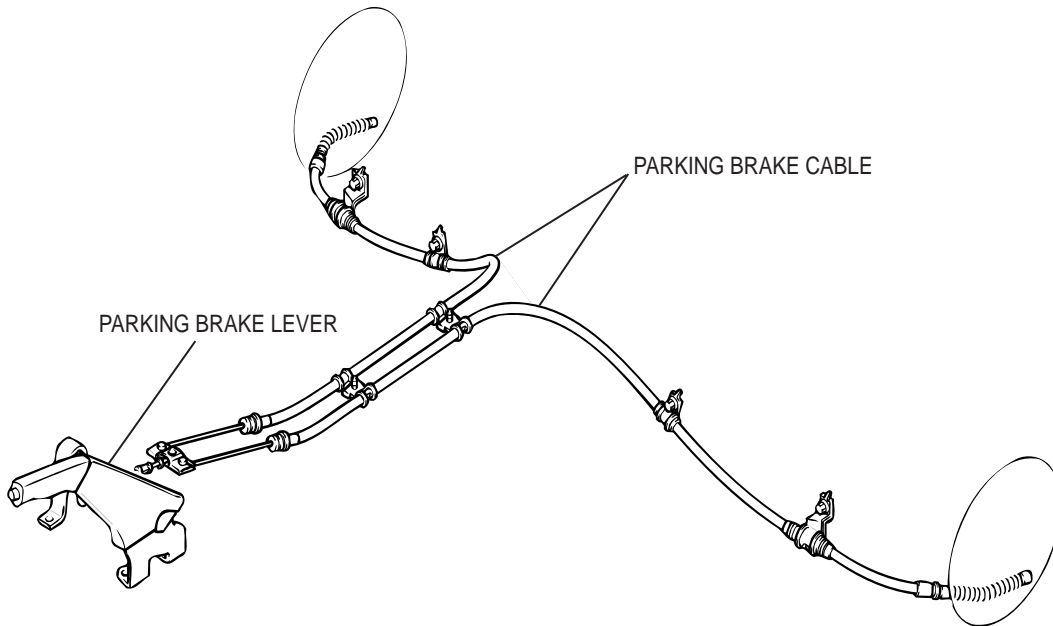

AC204057AB

PARKING BRAKE DIAGNOSIS

INTRODUCTION

M1361003700196

If the parking brake is faulty, parking brake effort will become insufficient. The cause may be a malfunction of parking brake parts or the parking brake lever being out of adjustment.

TROUBLESHOOTING STRATEGY

M1361003800201

Use these steps to plan your diagnostic strategy. If you follow them carefully, you will be sure that you have exhausted most of the possible ways to find a parking brakes fault.

1. Gather Information from the customer.

2. Verify that the condition described by the customer exists.
3. Find the malfunction by following the Symptom Chart.
4. Verify malfunction is eliminated.

SYMPTOM CHART

M1361004100205

SYMPTOMS	INSPECTION PROCEDURE	REFERENCE PAGE
Parking brake does not fully release	1	P.36-3
Parking brake does not hold	2	P.36-3

SYMPTOM PROCEDURES

INSPECTION PROCEDURE 1: Parking Brake does not Fully Release

DIAGNOSIS

STEP 1. Check that the parking brake can be released correctly.

Q: Is the parking brake released correctly?

YES : Correct the parking brake. Then go to Step 5.

NO : Go to Step 2.

STEP 2. Check that the parking brake is adjusted correctly (Refer to P.36-4).

Q: Is the parking brake adjusted correctly?

YES : Adjust the parking brake. Then go to Step 5.

NO : Go to Step 3.

STEP 3. Check the parking brake cable routing.

Q: Is the parking brake routing correct?

YES : Correct the cable routing. Then go to Step 5.

NO : Go to Step 4.

STEP 4. Check the rear brake's shoes and linings (Refer to P.36-10).

Q: Are the rear brake shoes and linings in good condition?

YES : Correct the rear brake shoe(s) and lining(s). Then go to Step 5.

NO : Go to Step 5.

STEP 5. Retest the system.

Q: Is the malfunction eliminated?

YES : The procedure is complete.

NO : Recheck from Step 1.

INSPECTION PROCEDURE 2: Parking Brake does not Hold

DIAGNOSIS

STEP 1. Check the parking brake lever for excessive stroke.

Q: Is the parking brake lever stroke excessive?

YES : Adjust the parking brake lever stroke (Refer to P.36-4.) or check the parking brake cable routing. (Refer to P.36-7.) Then go to Step 5.

NO : Go to Step 2.

STEP 2. Check for a sticking parking brake cable.

Q: Does the parking brake cable bind?

YES : Replace the cable. Then go to Step 5.

NO : Go to Step 3.

STEP 3. Check lining surface for grease or oil contamination.

Q: Is the lining surface contaminated with oil or grease?

YES : Replace the lining. Then go to Step 5.

NO : Go to Step 4.

STEP 4. Check the rear brake's shoe and lining.

Q: Is there a fault?

YES : Correct the shoe and lining. Then go to Step 5.

NO : Go to Step 5.

STEP 5. Retest the system.

Q: Is the malfunction eliminated?

YES : The procedure is complete.

NO : Recheck from Step 1.

ON-VEHICLE SERVICE

PARKING BRAKE LEVER STROKE CHECK AND
ADJUSTMENT

M1361000900221

1. Pull the parking brake lever with a force of approximately 200 N (45 pounds) and count the number of notches.

Standard value: 5 – 7 notches

2. If the parking brake lever stroke is not within the standard value, adjust as described below.

- (1) Remove the cup holder, and then loosen the adjusting nut to move it to the cable rod end so that the cable will be free.

- (2) Remove the rear wheels.

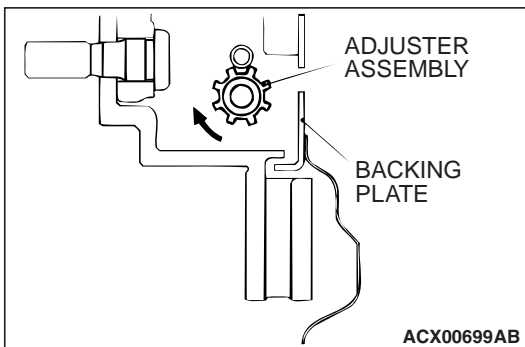
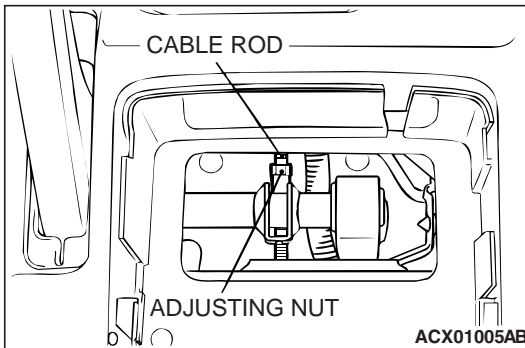

- (3) Remove the adjustment hole plug on the rear brake backing plate, and then use a flat-tip screwdriver to turn the adjuster in the direction of the arrow (the direction which expands the shoe) so that the disc will not rotate. Return the adjuster three or four notches in the direction opposite to the direction of the arrow.

CAUTION

If the parking brake lever stroke is below the standard value and the braking is too firm, the rear brakes may drag.

- (4) Turn the adjusting nut to adjust the parking brake lever stroke to the standard value. After adjusting, check that there is no space between the adjusting nut and the parking brake lever.

- (5) Release the parking brake and turn the rear wheels to check that the rear brakes are not dragging.

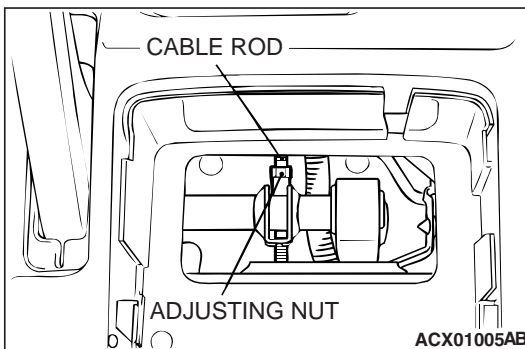

PARKING BRAKE SWITCH CHECK

M1361003300251

1. Remove the cup holder and indicator panel (Refer to GROUP 52A, Floor Console P.52A-7).
2. Check for continuity between the parking brake switch terminal and the switch mounting bolt.

When parking brake lever is pulled	2 ohm or less
When parking brake lever is released	Open circuit

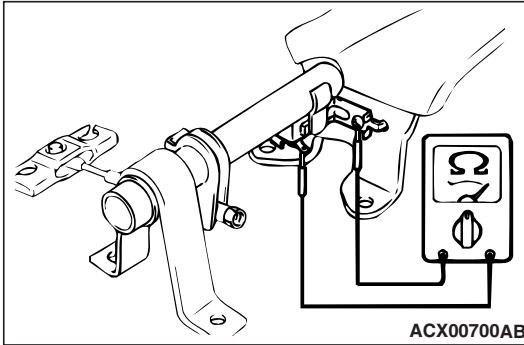

PARKING BRAKE LINING SEATING PROCEDURE

M1361001100198

⚠ CAUTION

Perform lining seating in a place with good visibility, and pay careful attention to safety.

Perform lining seating by the following procedure when replacing the parking brake linings or the rear brake disc rotors, or when brake performance is insufficient.

1. Adjust the parking brake stroke to the specified value (Refer to P.36-4).
2. Hook a spring scale onto the center of the parking brake lever grip and pull it with a force of 100 – 150 N (23 – 34 pounds) in a direction perpendicular to the handle.
3. Drive the vehicle at a constant speed of 35 – 50 km/h (22 – 31 mph) for 100 meters (328 feet).
4. Release the parking brake and let the brakes cool for five to ten minutes.
5. Repeat the procedure in steps 2. to 4. four to five times.

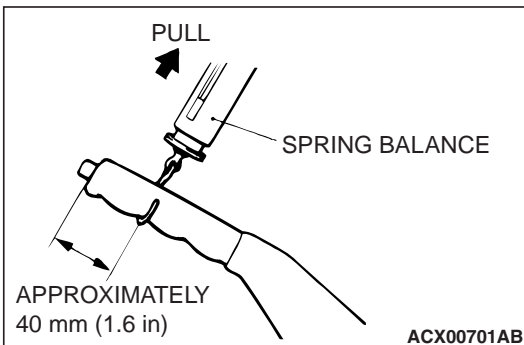

PARKING BRAKE LEVER

REMOVAL AND INSTALLATION

M1361001300211

Pre-removal Operation

- Floor Console Removal (Refer to GROUP 52A, Floor Console P.52A-7.)

Post-installation Operation

- Parking Brake Lever Stroke Adjustment (Refer to P.36-4.)
- Floor Console Installation (Refer to GROUP 52A, Floor Console P.52A-7.)

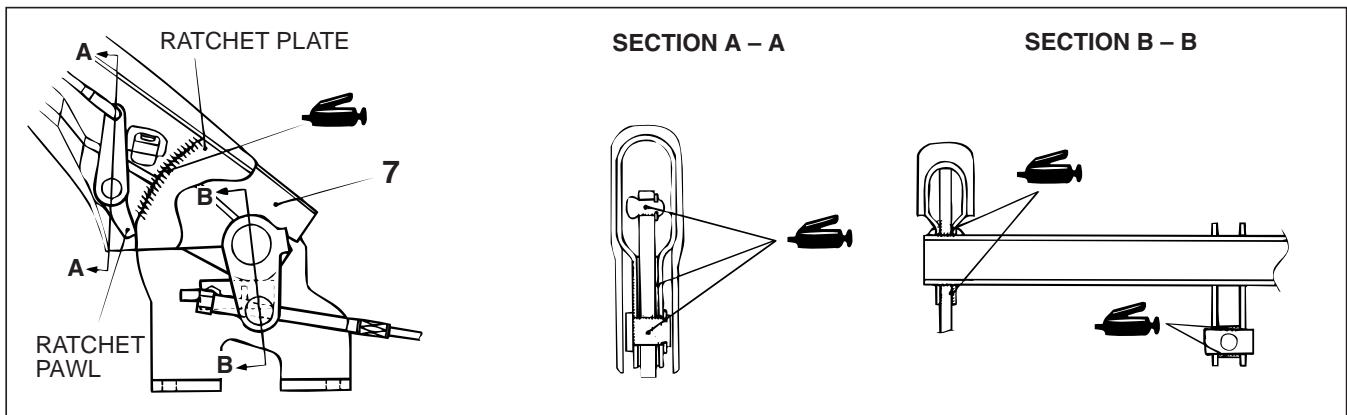
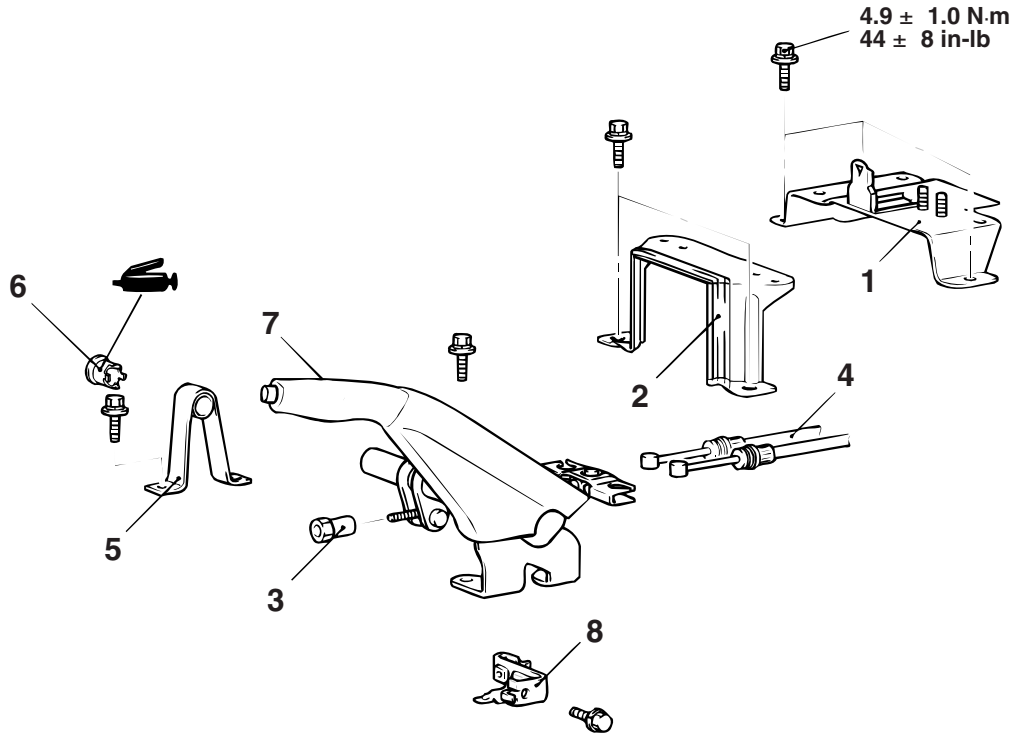

ACX00702 AB

REMOVAL STEPS

1. G-SENSOR BRACKET
2. FLOOR CONSOLE BRACKET
3. ADJUSTING NUT
4. PARKING BRAKE CABLE ASSEMBLY
5. PARKING BRAKE STAY

REMOVAL STEPS (Continued)

6. BUSHING
7. PARKING BRAKE LEVER ASSEMBLY
8. PARKING BRAKE SWITCH

PARKING BRAKE CABLE

REMOVAL AND INSTALLATION

M1361001900365

Pre-removal Operation

- Floor Console Removal (Refer to GROUP 52A, Floor Console [P.52A-7.](#))

Post-installation Operation

- Parking Brake Lever Stroke Check and Adjustment (Refer to [P.36-4.](#))
- Floor Console Installation (Refer to GROUP 52A, Floor Console [P.52A-7.](#))

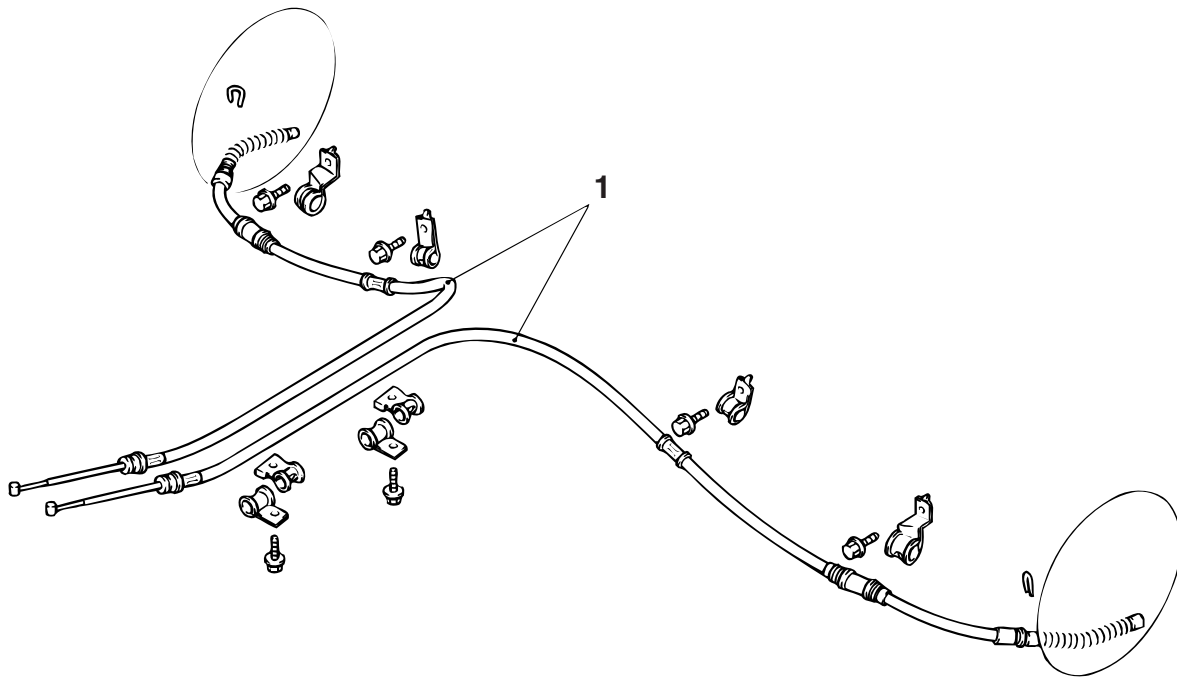

ACX00703 AB

REMOVAL STEPS

- SHOE AND LINING ASSEMBLY (REFER TO [P.36-8.](#))
 - PARKING BRAKE CABLE ASSEMBLY CONNECTION (REFER TO [P.36-6.](#))
1. PARKING BRAKE CABLE

PARKING BRAKE LINING AND DRUM

REMOVAL AND INSTALLATION

M1361002500371

Post-installation Operation

- Parking Brake Lever Stroke Check and Adjustment (Refer to P.36-4).
- Parking Brake Lining Seating (Refer to P.36-5).
- Floor Console Installation (Refer to GROUP 52A, Floor Console P.52A-7).

142 ± 14 N·m
105 ± 10 ft·lb

100 ± 10 N·m
74 ± 7 ft·lb

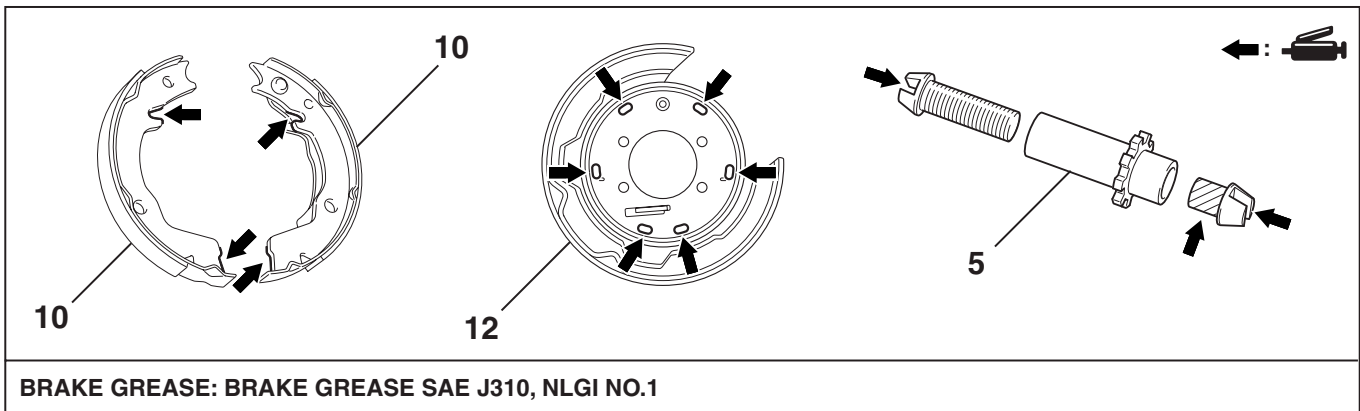
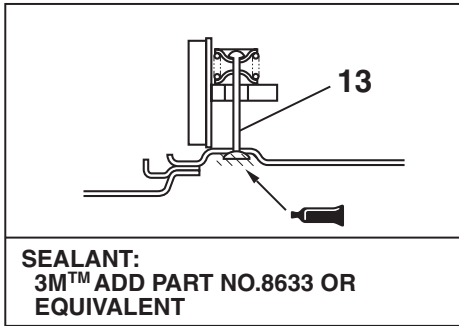
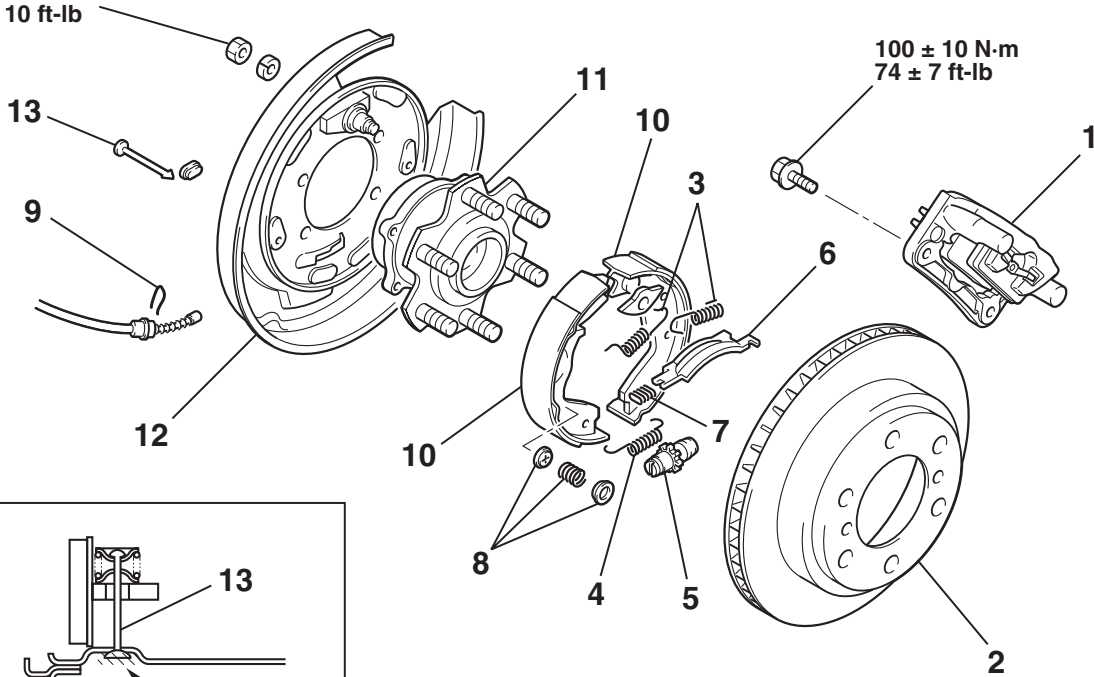

AC204052AC

<<A>>

- REMOVAL STEPS**
1. REAR BRAKE CALIPER ASSEMBLY
 2. REAR BRAKE DISC
 - >>B<< 3. SHOE-TO-ANCHOR SPRING
 4. ADJUSTING WHEEL SPRING
 - >>A<< 5. ADJUSTER ASSEMBLY
 6. STRUT

- REMOVAL STEPS (Continued)**
7. SHOE-TO- SHOE SPRING
 8. SHOE HOLD-DOWN CUP AND SHOE HOLD-DOWN SPRING
 9. CLIP
 10. SHOE AND LINING ASSEMBLY

REMOVAL STEPS (Continued)

11. REAR HUB ASSEMBLY (REFER TO GROUP 27, REAR HUB ASSEMBLY P.27-14).
12. BACKING PLATE
13. SHOE HOLD-DOWN PIN

REMOVAL SERVICE POINT

<<A>> REAR BRAKE CALIPER ASSEMBLY REMOVAL

Remove the rear brake caliper assembly and support it with wire or something similar.

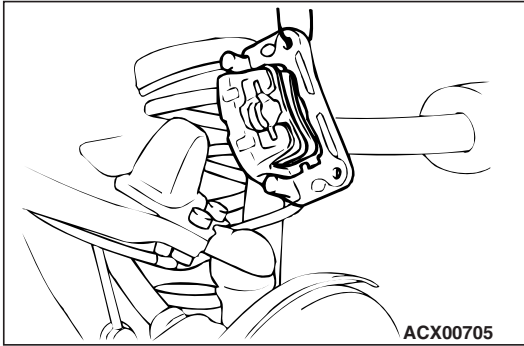

INSTALLATION SERVICE POINTS

>>A<< ADJUSTER ASSEMBLY INSTALLATION

Install the adjuster so that the shoe adjusting bolt for the left hand wheel is attached towards the rear of the vehicle, and the shoe adjusting bolt for the right hand wheel is towards the front of the vehicle.

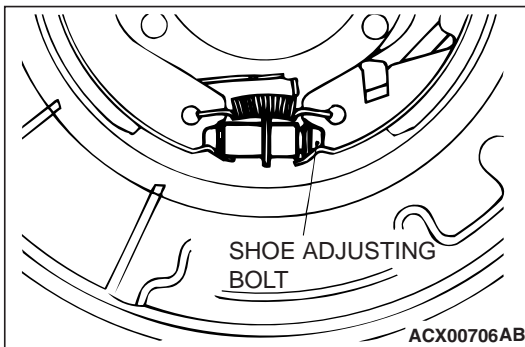

>>B<< SHOE-TO-ANCHOR SPRING INSTALLATION

⚠ CAUTION

The front and rear shoe-to-anchor springs are not interchangeable, so the spring with the paint mark must be installed at the rear side.

Install the shoe-to-anchor springs in the order shown in the illustration.

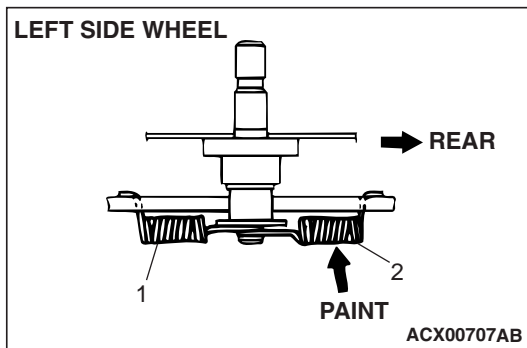
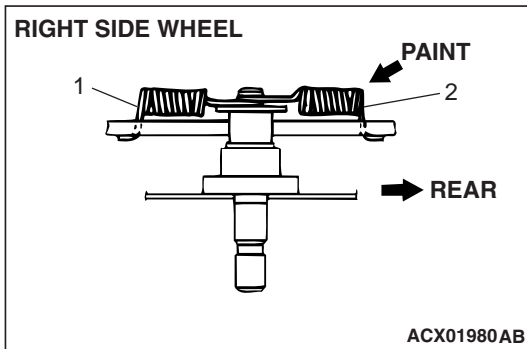

INSPECTION

M1361002600185

PARKING BRAKE LINING AND BRAKE DRUM CHECK

1. Measure the thickness of the brake lining at several places.
Standard value: 3.0 mm (0.12 inch)
Minimum Limit: 1.0 mm (0.04 inch)
2. If the thickness of the brake lining is below the limit, replace the shoe and lining assemblies on both sides of the vehicle. Never replace only one side.

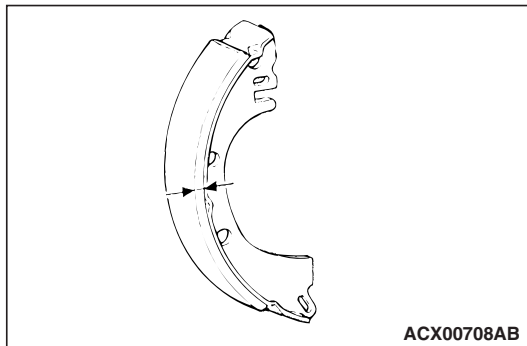

3. Measure the inside diameter of the brake disc in two places or more.

Standard value: 199.0 mm (7.8 inch)

Limit: 200.0 mm (7.9 inch)

4. If the inside diameter exceeds the limit, or if it is excessively worn on one side, replace the brake disc.

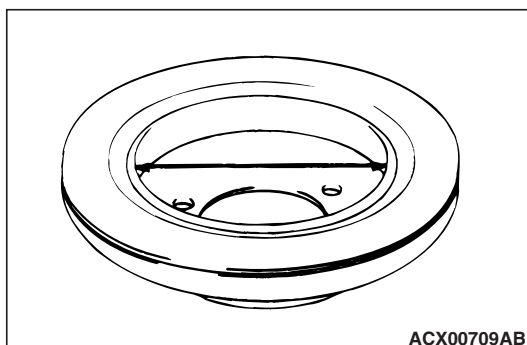

SPECIFICATIONS

FASTENER TIGHTENING SPECIFICATIONS

M1361003500211

ITEM	SPECIFICATION
Parking brake lever	
G-sensor bracket mounting bolt	4.9 ± 1.0 N·m (44 ± 8 in-lb)
Parking brake lining and drum	
Anchor to shoe spring attaching nut	142 ± 14 N·m (105 ± 10 ft-lb)
Rear brake caliper assembly mounting bolt	100 ± 10 N·m (74 ± 7 ft-lb)

SERVICE SPECIFICATIONS

M1361000300661

ITEM	STANDARD VALUE	LIMIT
Parking brake lever stroke [Parking brake lever pull force: Approximately 200 N (45 lb)]	5 – 7 notches	–
Rear brake lining thickness mm (in)	3.0 (0.12)	Minimum 1.0 (0.04)
Brake drum inside diameter mm (in)	199.0 (7.8)	200.0 (7.9)

LUBRICANT

M1361000400237

ITEM	SPECIFIED LUBRICANT
Adjuster	Brake grease SAE J310, NLGI No.1
Backing plate	
Shoe and lining assembly	

SEALANT

M1361000500085

ITEM	SPECIFIED SEALANT	REMARK
Shoe hold-down pin	3M™ ATD Part No. 8633 or equivalent	Drying sealant

NOTES