

# **MITSUBISHI SPACE RUNNER SPACE WAGON**

## **WORKSHOP MANUAL ELECTRICAL WIRING**

### **FILING INSTRUCTION**

Please keep these manual pages in the binder which is keeping the manual PHDE9214.

File these pages according to the signs "ADDED" and "REVISED" on the "List of effective pages" which are interpreted below.

ADDED: File the pages with this sign additionally in your manual.

REVISED: Replace the existing pages with the corresponding pages with this sign.

Missing sheets will be supplied upon request.

Group/ Page	Revision code	Date	Remarks	Group/ Page	Revision code	Date	Remarks
<b>LIST OF EFFECTIVE PAGES</b>				16	B	May 1993	REVISED
1 thru 2	B	May 1993	ADDED	17 thru 19	A	Jan. 1993	
<1993 models>				19-1 thru 19-4	B	May 1993	ADDED
Foreword		Jun. 1992		20	B	May 1993	REVISED
<b>1-HOW TO READ THE WIRING DIAGRAMS</b>				21 thru 22	A	Jan. 1993	
1	B	May 1993	REVISED	23		Jun. 1992	
2 thru 3		Jun. 1992		23-1 thru 23-4	B	May 1993	ADDED
4 thru 7	B	May 1993	REVISED	24	B	May 1993	REVISED
8		Jun. 1992		25 thru 28	A	Jan. 1993	
9 thru 12	B	May 1993	REVISED	28-1 thru 28-6	B	May 1993	ADDED
13	B	May 1993	ADDED	29	B	May 1993	REVISED
<b>2-WIRING HARNESS CONFIGURATION DIAGRAMS</b>				30 thru 33	A	Jan. 1993	
1 thru 12		Jun. 1992		33-1 thru 33-6	B	May 1993	ADDED
13	A	Jan. 1993		34 thru 37		Jun. 1992	
14 thru 15		Jun. 1992		38	A	Jan. 1993	
16	A	Jan. 1993		39		Jun. 1992	
17 thru 19	B	May 1993	REVISED	40 thru 43	A	Jan. 1993	
20 thru 21		Jun. 1992		44 thru 45		Jun. 1992	
22 thru 23	A	Jan. 1993		46 thru 49	A	Jan. 1993	
24 thru 25		Jun. 1992		50 thru 51		Jun. 1992	
26 thru 27	A	Jan. 1993		52	A	Jan. 1993	
28 thru 30		Jun. 1992		53		Jun. 1992	
<b>3-SINGLE PART INSTALLATION POSITION</b>				54	A	Jan. 1993	
1	A	Jan. 1993		55 thru 56		Jun. 1992	
2 thru 6		Jun. 1992		57	A	Jan. 1993	
7 thru 11	A	Jan. 1993		58		Jun. 1992	
11-1 thru 11-2	A	Jan. 1993		59 thru 60	A	Jan. 1993	
12	A	Jan. 1993		61		Jun. 1992	
13 thru 18		Jun. 1992		62	A	Jan. 1993	
<b>4-CIRCUIT DIAGRAM</b>				63 thru 64		Jun. 1992	
1 thru 2	B	May 1993	REVISED	65 thru 66	A	Jan. 1993	
3 thru 6		Jun. 1992		67		Jun. 1992	
7	A	Jan. 1993		68	A	Jan. 1993	
8 thru 9		Jun. 1992		69 thru 70		Jun. 1992	
10	A	Jan. 1993		71 thru 76	A	Jan. 1993	
11 thru 12		Jun. 1992		77 thru 78		Jun. 1992	
13 thru 14	A	Jan. 1993		79	A	Jan. 1993	
15		Jun. 1992		80		Jun. 1992	

**LIST OF EFFECTIVE PAGES**

<b>Group/ Page</b>	<b>Revision code</b>	<b>Date</b>	<b>Remarks</b>	<b>Group/ Page</b>	<b>Revision code</b>	<b>Date</b>	<b>Remarks</b>
81 thru 83	A	Jan. 1993		<1994 models>			
84 thru 85		Jun. 1992		<b>Foreword</b>	<b>B</b>	<b>May 1993</b>	<b>ADDED</b>
86 thru 87	A	Jan. 1993		<b>1A-HOW TO READ THE WIRING DIAGRAMS</b>			
88 thru 89		Jun. 1992		<b>1 thru 2</b>	<b>B</b>	<b>May 1993</b>	<b>ADDED</b>
90 thru 92	A	Jan. 1993		<b>2A-WIRING HARNESS CONFIGURATION DIAGRAMS</b>			
93 thru 94		Jun. 1992		<b>1 thru 30</b>	<b>B</b>	<b>May 1993</b>	<b>ADDED</b>
95 thru 97	A	Jan. 1993		<b>3A-SINGLE PART INSTALLATION POSITION</b>			
98 thru 99		Jun. 1992		<b>1 thru 24</b>	<b>B</b>	<b>May 1993</b>	<b>ADDED</b>
100 thru 103	A	Jan. 1993		<b>4A-CIRCUIT DIAGRAM</b>			
104 thru 105		Jun. 1992		<b>1 thru 193</b>	<b>B</b>	<b>May 1993</b>	<b>ADDED</b>
106 thru 113	A	Jan. 1993		<b>WIRING DIAGRAM &lt;L.H. drive vehicles&gt;</b>			
114 thru 115		Jun. 1992		<b>1 thru 4</b>	<b>B</b>	<b>May 1993</b>	<b>ADDED</b>
116	A	Jan. 1993		<b>WIRING DIAGRAM &lt;R.H. drive vehicles&gt;</b>			
117 thru 118		Jun. 1992		<b>5 thru 8</b>	<b>B</b>	<b>May 1993</b>	<b>ADDED</b>
119 thru 120	A	Jan. 1993					
121 thru 122		Jun. 1992					
123 thru 126	A	Jan. 1993					
127 thru 137		Jun. 1992					
138 thru 140	A	Jan. 1993					
141		Jun. 1992					
142	A	Jan. 1993					
143		Jun. 1992					
144 thru 145	A	Jan. 1993					
145-1 thru 145-4	A	Jan. 1993					
146 thru 147	A	Jan. 1993					
147-1 thru 147-4	A	Jan. 1993					
148	A	Jan. 1993					
149 thru 151		Jun. 1992					
152	A	Jan. 1993					
153 thru 156		Jun. 1992					
<b>WIRING DIAGRAM &lt;L.H. drive vehicles&gt;</b>							
<b>A thru D</b>		Jun. 1992					
<b>WIRING DIAGRAM &lt;R.H. drive vehicles&gt;</b>							
<b>E thru H</b>		Jun. 1992					

RJCR306008-310  
 RJCR301008-162  
 RJCR207008-220  
**ADDED**

# MITSUBISHI SPACE RUNNER SPACE WAGON ELECTRICAL WIRING

## GROUP INDEX

### FOREWORD

This Electrical Wiring Manual contains information necessary for inspection and servicing of electrical wiring in the Mitsubishi SPACE RUNNER and SPACE WAGON edited in the form of wiring harness configuration diagrams and function-separated circuit diagrams.

It is recommended that all service mechanics engaged in the servicing of the vehicle refer to the following publications as well as this manual.

WORKSHOP MANUAL      PWDE9104  
(Loose-leaf edition)

WORKSHOP MANUAL  
Engine Group      PWEE□□□□  
(Loose-leaf edition)

PARTS CATALOGUE      B608D501A□  
   B608E501A□

All information, illustrations and product descriptions contained in this manual are current as of time of publication. We, however, reserve the right to make changes at any time without prior notice or obligation.

HOW TO READ THE WIRING DIAGRAMS .....	<b>1</b>
WIRING HARNESS CONFIGURATION DIAGRAMS .....	<b>2</b>
SINGLE PART INSTALLATION POSITION .....	<b>3</b>
CIRCUIT DIAGRAM .....	<b>4</b>



# HOW TO USE THIS MANUAL

## CONTENTS

The preceding page contains GROUP INDEX which lists the group title and group number.

## PAGE NUMBERS

All page numbers consist of two sets of digits separated by a dash. The digits preceding the dash identify the number of the group. The digits following the dash represent the consecutive page number within the group. The page numbers can be found on the top left or right of each page.

## OPERATION AND TROUBLESHOOTING HINTS

In the GROUP 4 circuit diagrams, the operation and troubleshooting hints are given on the previous page or following page for each circuit where necessary.

# MITSUBISHI SPACE RUNNER SPACE WAGON

## ELECTRICAL WIRING

### GROUP INDEX

HOW TO READ THE WIRING DIAGRAMS .....	<b>1A</b>
WIRING HARNESS CONFIGURATION DIAGRAMS .....	<b>2A</b>
SINGLE PART INSTALLATION POSITION .....	<b>3A</b>
CIRCUIT DIAGRAM .....	<b>4A</b>

### FOREWORD

This Electrical Wiring Manual contains information necessary for inspection and servicing of electrical wiring in the Mitsubishi SPACE RUNNER and SPACE WAGON edited in the form of wiring harness configuration diagrams and function-separated circuit diagrams.

It is recommended that all service mechanics engaged in the servicing of the vehicle refer to the following publications as well as this manual.

TECHNICAL INFORMATION MANUAL	PYDE9107
WORKSHOP MANUAL	PWDE9104 (Loose-leaf edition)
WORKSHOP MANUAL Engine Group	PWEE□□□□ (Loose-leaf edition)
PARTS CATALOGUE	B608D504A□ B608E504A□

All information, illustrations and product descriptions contained in this manual are current as of time of publication. We, however, reserve the right to make changes at any time without prior notice or obligation.



# HOW TO USE THIS MANUAL

## **CONTENTS**

The preceding page contains GROUP INDEX which lists the group title and group number.

## **PAGE NUMBERS**

All page numbers consist of two sets of digits separated by a dash. The digits preceding the dash identify the number of the group. The digits following the dash represent the consecutive page number within the group. The page numbers can be found on the top left or right of each page.

## **OPERATION AND TROUBLESHOOTING HINTS**

In the GROUP 4A circuit diagrams, the operation and troubleshooting hints are given on the previous page or following page for each circuit where necessary.

# 1 HOW TO READ THE WIRING DIAGRAMS

MODELS .....	1-3
COMPOSITION AND CONTENTS OF WIRING DIAGRAMS .....	1-4
HOW TO READ CONFIGURATION DIAGRAMS .....	1-5
HOW TO READ CIRCUIT DIAGRAMS .....	1-6
MARKINGS FOR CONNECTOR EARTHING .....	1-8
WIRE COLOUR CODES .....	1-10
ABBREVIATION SYMBOLS .....	1-11
HOW TO READ WIRING DIAGRAM .....	1-13





**MODELS**

Model code	Engine model	Transmission model
N11WSNJEL6	4G93	F5M22 (5M/T)
N11WSNJER6	4G93	F5M22 (5M/T)
N11WSNUEL6	4G93	F5M22 (5M/T)
N11WSNUER6	4G93	F5M22 (5M/T)
N11WSRUEL6	4G93	F4A22 (4A/T)
N11WSRUER6	4G93	F4A22 (4A/T)
N21WSNUEL6	4G93	W5M31 (5M/T)
N21WSNUER6	4G93	W5M31 (5M/T)
N18WSNJTL6	4D68-TURBOCHARGER	F5M31 (5M/T)
N18WSNJTR6	4D68-TURBOCHARGER	F5M31 (5M/T)
N33WLNUEL6	4G63	F5M22 (5M/T)
N33WLNUER6	4G63	F5M22 (5M/T)
N33WLRUEL6	4G63	F4A22 (4A/T)
N33WLRUER6	4G63	F4A22 (4A/T)
N38WLNUTL6	4D68-TURBOCHARGER	F5M31 (5M/T)
N38WLNUTR6	4D68-TURBOCHARGER	F5M31 (5M/T)
N43WLNUEL6	4G63	W5M31 (5M/T)
N43WLNUER6	4G63	W5M31 (5M/T)
N43WLRUEL6	4G63	W4A32 (4A/T)
N43WLRUER6	4G63	W4A32 (4A/T)
N33WLNSEL6	4G63	F5M22 (5M/T)
N33WLRSEL6	4G63	F4A22 (4A/T)
N43WLNSEL6	4G63	W5M31 (5M/T)
N43WLRSEL6	4G63	W4A32 (4A/T)
N34WLNUEL6	4G64	F5M22 (5M/T)
N34WLRUEL6	4G64	F4A22 (4A/T)

## COMPOSITION AND CONTENTS OF WIRING DIAGRAMS

- (1) This manual consists of wiring harness diagrams, installation locations of individual parts, circuit diagrams and wiring diagram.
- (2) In each of the sections, all specifications are listed, including optional specifications. Accordingly, some specifications may not be applicable for individual vehicles.

Section	Basic contents
Wiring harness configuration diagrams	Connector locations and harness wiring configurations on actual vehicles are illustrated.
Single part installation position	Locations are shown for earth points of relays, control units, sensors, diodes, check terminals, spare terminals, fusible links, fuses, etc. In the parts lists, parts are listed in alphabetical order.
Circuit diagrams	<p>Circuits from power supply to earth are shown completely, classified according to system. There is a main division into power circuits, and circuits classified by system. The circuits classified by system also include operation and troubleshooting hints.</p> <ul style="list-style-type: none"> <li>• Power supply circuits Circuits from the battery to fusible link, dedicated fuses, ignition switch, general purpose fuses, etc.</li> <li>• Circuits classified by system For each system, the circuits are shown from fuse to earth, excluding the power supply sections.</li> <li>• Operation The normal operation of each system is briefly described, following the route of current flow.</li> <li>• Troubleshooting hints This is a brief explanation of the inspection points that serve as hints when troubleshooting. Explanations of the circuits controlled by the electronic control unit are omitted. Refer to the related publications as required.</li> <li>• Junction block/Jumper connector Here is the circuit for the entire junction block or jumper connector since only the part of the junction block or jumper connector needed is normally show in each circuit diagram.</li> </ul>
Wiring diagram	All the harnesses and connectors are shown together so that the circuit diagrams and wiring harnesses of the entire vehicle can be seen at a glance.

## HOW TO READ CONFIGURATION DIAGRAMS

The wiring harness diagrams clearly show the connector locations and harness routings at each site in actual vehicles.

Denotes connector No.  
 The same connector No. is used throughout the circuit diagrams to facilitate connector location searches.  
 The first alphabetical symbol indicates the location site of the connector and a number that follows is the unique number. Numbers are assigned to parts in clockwise order on the diagram.  
 When the connectors are centralized in one place, the connector colors are shown for easy identification.

Example: A-12 (black)

- Connector colour
- Number specific to connector (serial number)
- Connector location site symbol
- A: Engine compartment
- B: Engine and transmission
- C: Dash panel
- D: Instrument panel
- E: Interior
- F: Under rear floor

The mark ★ shows the standard mounting position of wiring harness.

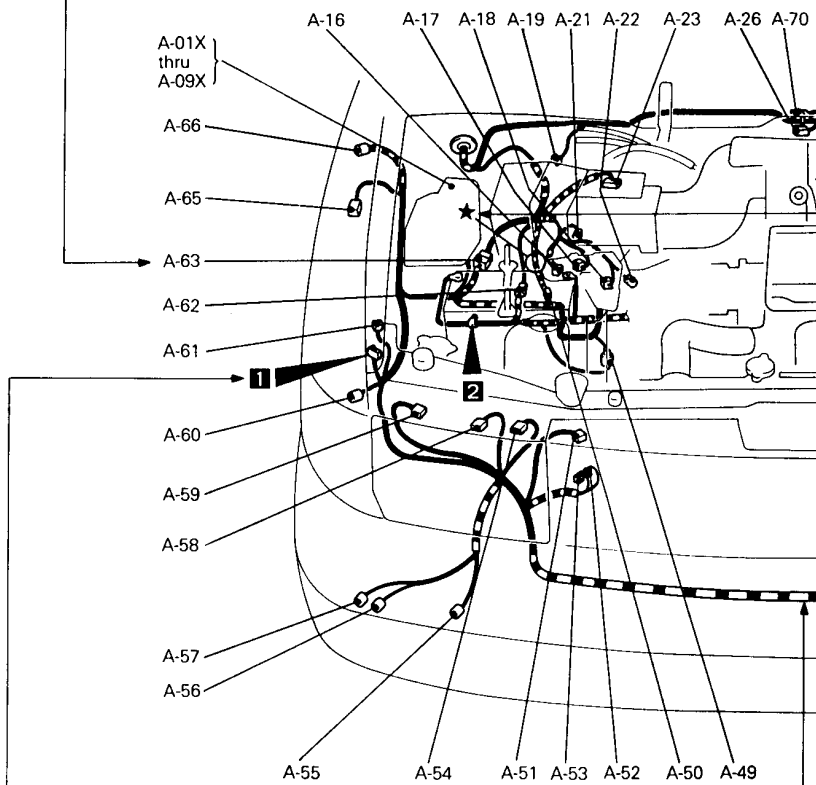

Denotes earth point.  
 Same earth number is used throughout circuit diagrams to facilitate search of earth point. Refer to GROUP 3 SINGLE PART INSTALLATION POSITION-EARTH MOUNTING LOCATIONS for details of earth points.

Denotes a section covered by a corrugated tube.

# 1-6 HOW TO READ THE WIRING DIAGRAMS — How to Read Circuit Diagrams

## HOW TO READ CIRCUIT DIAGRAMS

The circuit of each system from fuse (or fusible link) to earth is shown. The power supply is shown at the top and the earth at the bottom to facilitate understanding of the current flow.

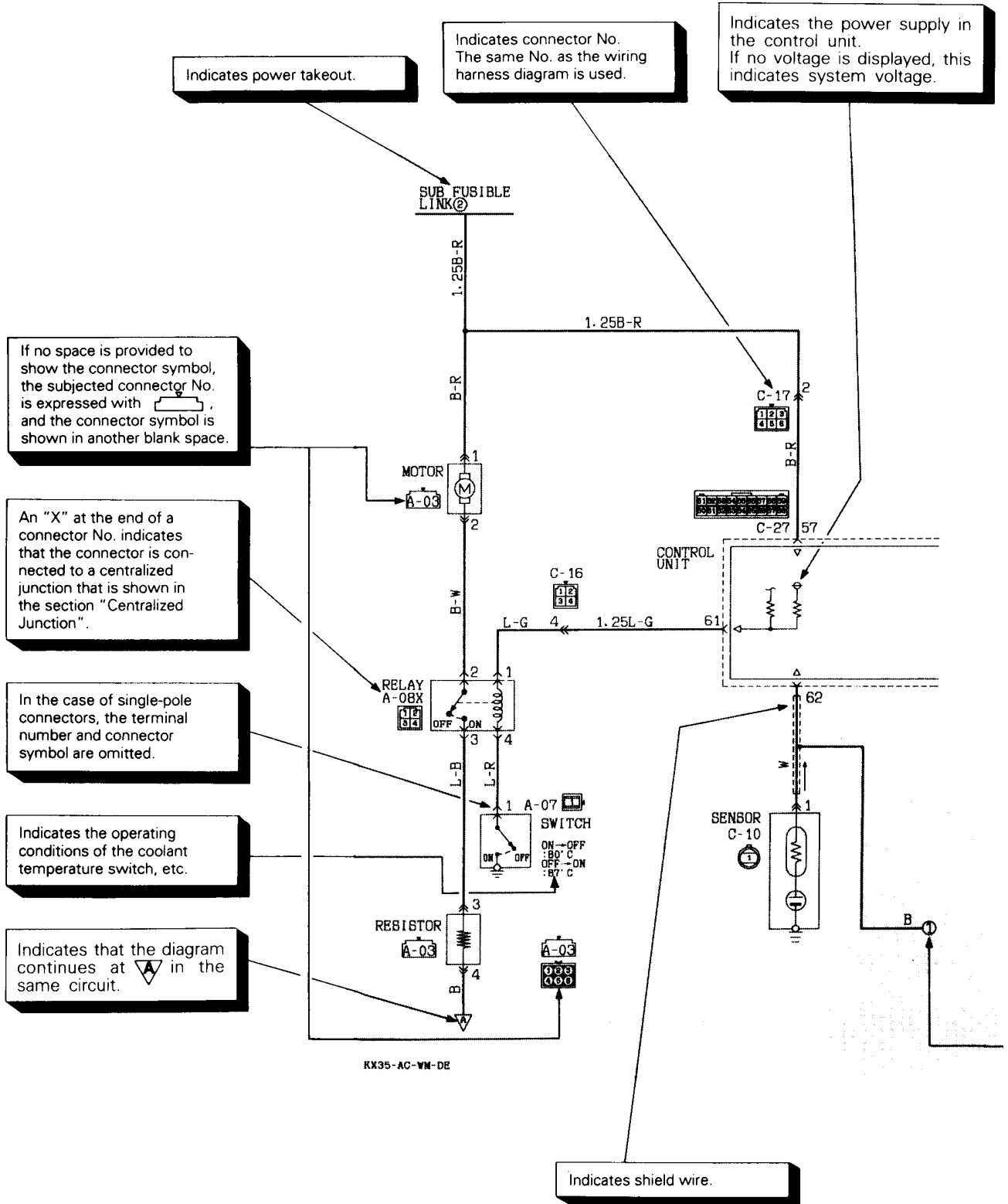

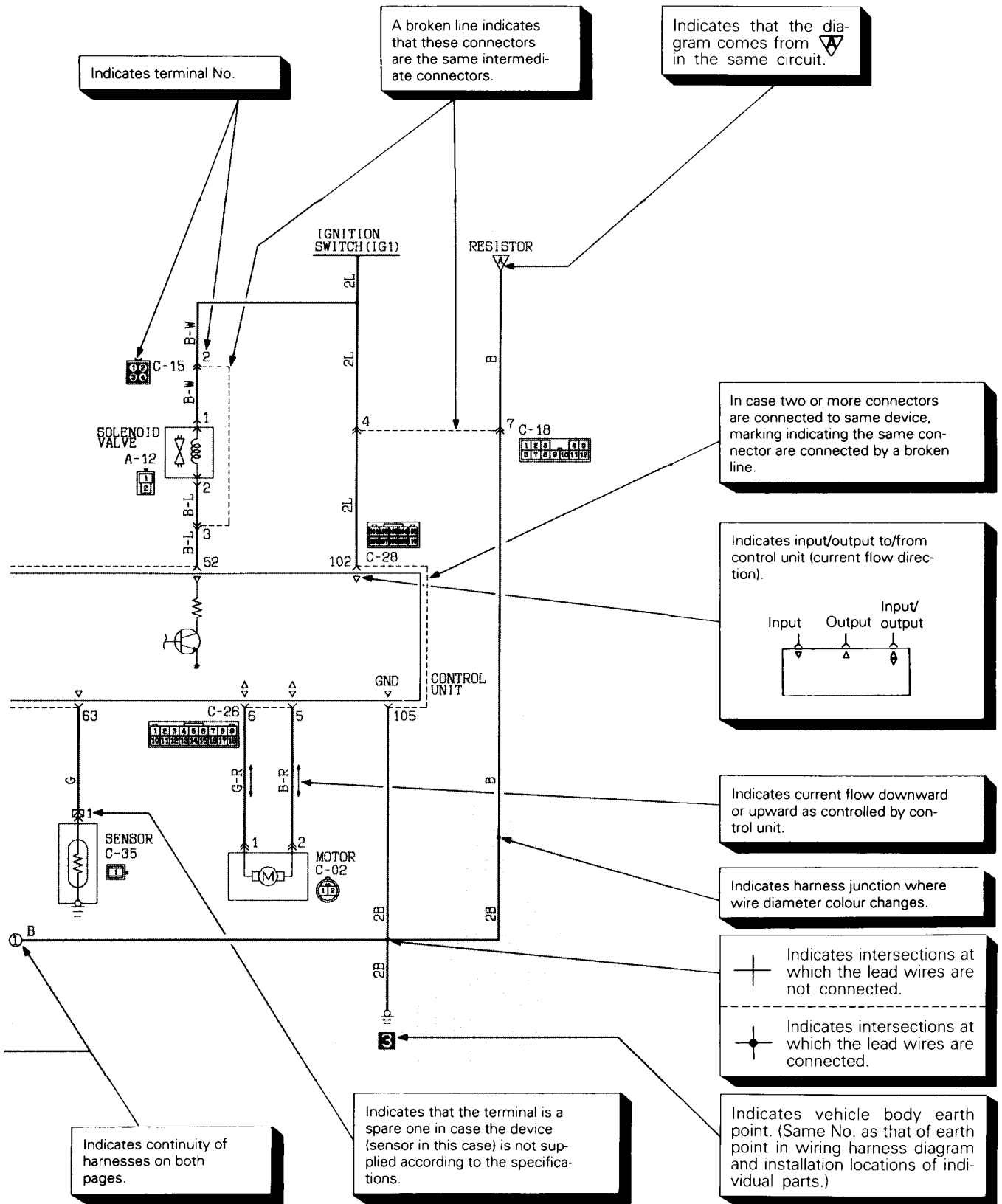





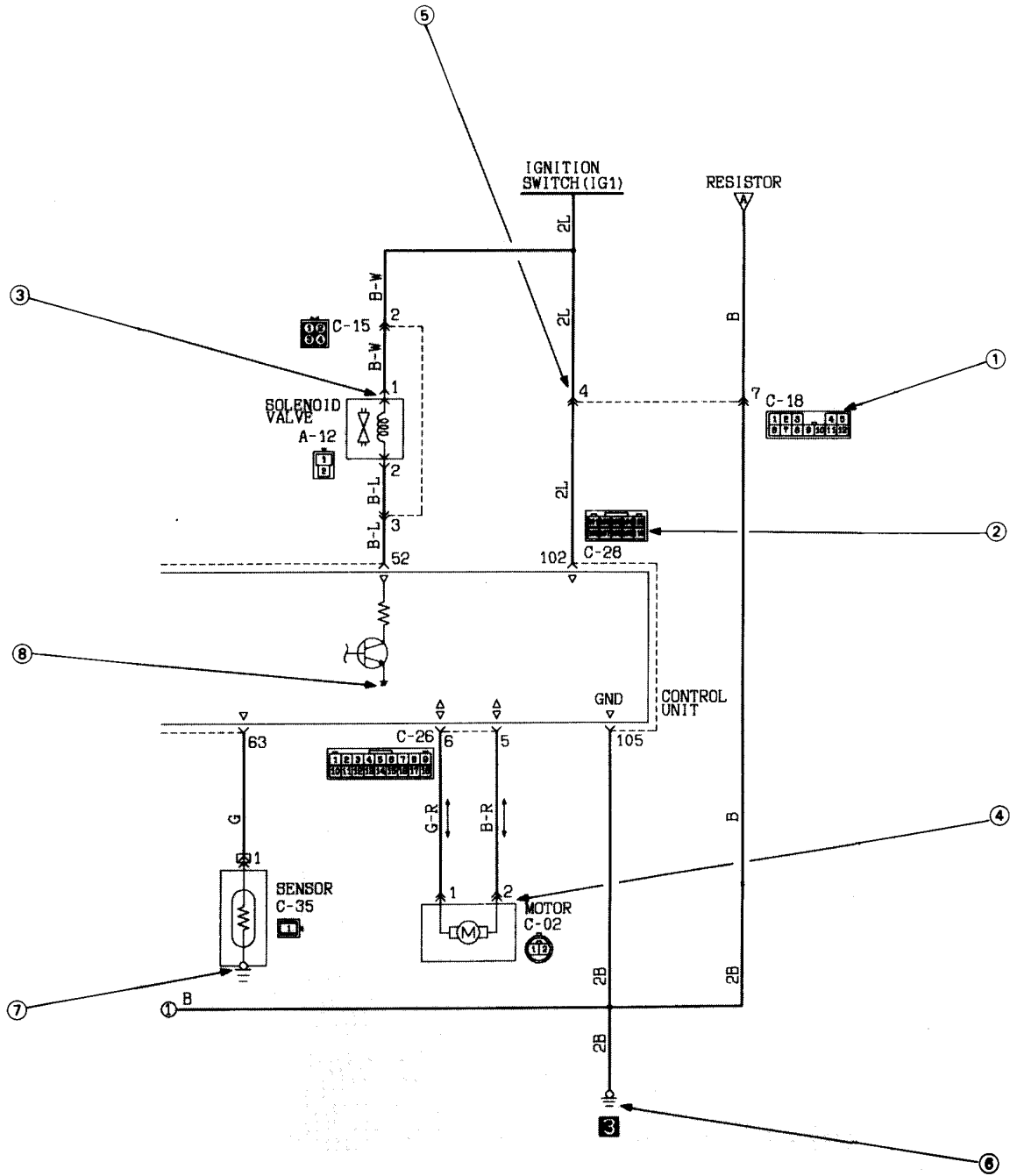

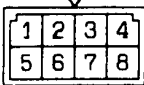
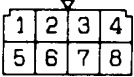
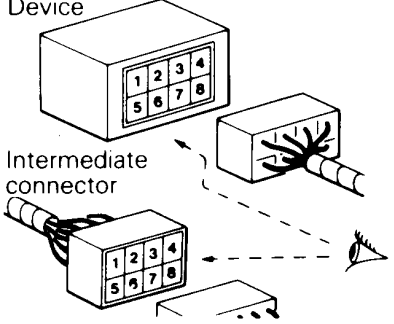
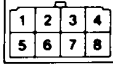
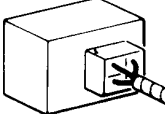
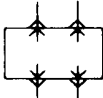
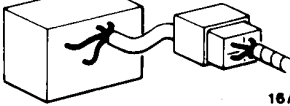
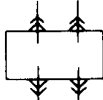
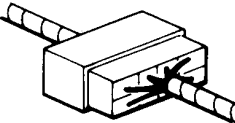

# 1-8 HOW TO READ THE WIRING DIAGRAMS — Markings for Connector Earthing

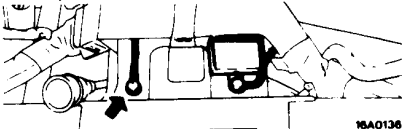
## MARKINGS FOR CONNECTOR EARTHING

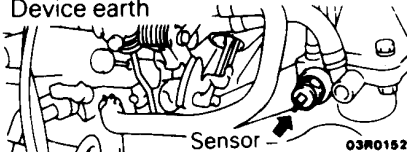

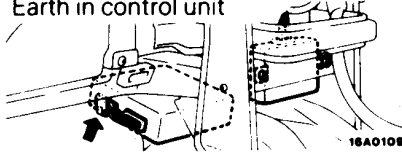
# HOW TO READ THE WIRING DIAGRAMS — Markings for Connector Earthing 1-9

No	Item	Symbol	Contents
Connector marking	① Male 	↓	Double connector contour lines indicate male connector terminals and single contour line indicates female terminals as illustrated here.
	Female 	Y	
Connector symbol marking	② Device  Intermediate connector <span style="float: right;">16A0333</span>		The symbol indicates the connector as viewed from illustrated direction. At the connection with a device, the connector symbol on the device side is shown, and for an intermediate connector, male connector symbol is shown. However, this does not apply for the diagnosis connector. For details of the diagnosis connector, refer to "MUT-II OPERATING INSTRUCTIONS."
Connector connection marking	③ Direct connection type 		A connection between a device and connector on the harness side is either by direct insertion in the device (direct connection type) or by connection with a harness connector on the device side furnished (harness connection type). The two types are indicated as illustrated.
	④ Harness connection type  <span style="float: right;">16A0334</span>		
	⑤ Intermediate connector  <span style="float: right;">16A0339</span>		
Earth markings	⑥ Body earth  <span style="float: right;">16A0136</span>		Earth is either by body earth, device earth or control unit interior earth. These are indicated as illustrated.
	⑦ Device earth  Sensor <span style="float: right;">03R0152</span>		
	⑧ Earth in control unit  <span style="float: right;">16A0108</span>		



# 1-10 HOW TO READ THE WIRING DIAGRAMS — Wire Colour Codes

## WIRE COLOUR CODES

Wire colours are identified by the following colour codes.

Code	Wire colour	Code	Wire colour
B	Black	P	Pink
BR	Brown	R	Red
G	Green	SB	Sky blue
GR	Gray	V	Violet
L	Blue	W	White
LG	Light green	Y	Yellow
O	Orange		

### NOTE

If a cable has two colours, the first of the two colour code characters indicates the basic colour (colour of the cable coating) and the second indicates marking colour.

Example: <F> 1.25 G - B

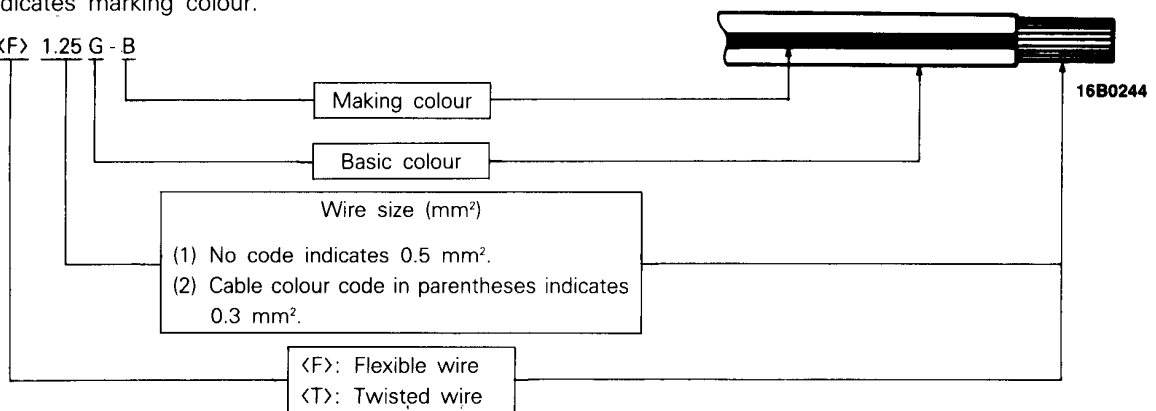

## ABBREVIATION SYMBOLS

The abbreviation symbols used in wiring diagrams are defined below.

Abbreviation symbol	Meaning	Abbreviation symbol	Meaning
ABS	Anti-lock brake system	J/B	Junction block
A/C	Air conditioner	J/C	Jumper connector
A/T	Automatic transmission	LHD	L.H. drive vehicles
DIESEL	Diesel-powered vehicles	MPI	Multi-point injection
DRL	Daytime running lamp	M/T	Manual transmission
EGR	Exhaust gas recirculation	PETROL	Petrol-powered vehicles
ELC-4A/T	Electronic control 4-speed automatic transmission	RHD	R.H. drive vehicles
		SOHC	Single overhead camshaft engine
GND	Earth	SRS	Supplemental restraint system
ILL	Illumination lamp	2WD	Front wheel-drive vehicles
IND	Indicator lamp	4WD	4 wheel-drive vehicles

### Abbreviation symbols used for combination meters

Abbreviation symbol	Meaning	Abbreviation symbol	Meaning
ABS	Anti-lock brake system warning lamp	OIL	Oil pressure warning lamp
A/T TEMP	Automatic fluid temperature warning lamp	OIL LEVEL	Engine oil level warning lamp
		R/FOG	Rear fog lamp indicator lamp
BEAM	Upper beam indicator lamp	REED	Reed switch (vehicle speed sensor)
BRAKE	Brake warning lamp	SPEED	Speedometer
CHECK ENGINE	Check engine warning lamp	SRS	Supplemental restraint system warning lamp
CHG	Charging warning lamp		
DOOR	Door-ajar warning lamp	TACHO	Tachometer
F/GA	Fuel gauge	T/GA	Engine coolant temperature gauge
FILTER	Fuel filter warning lamp	TURN (LH)	Turn signal indicator lamp (L.H.)
FUEL	Low fuel warning lamp	TURN (RH)	Turn signal indicator lamp (R.H.)
GLOW	Glow warning lamp	WASHER	Headlamp washer fluid warning lamp
HAZARD	Hazard warning indicator lamp	WATER TEMP ALARM	Engine coolant temperature warning lamp

## 1-12 HOW TO READ THE WIRING DIAGRAMS — Abbreviation Symbols

### Abbreviation symbols used for switches and relays

Name of switches and relays	Abbreviation symbol	Operation	Name of switches and relays	Abbreviation symbol	Operation		
Ignition switch	ACC	When turned to the ACC (ACCESSORY) or ON position, the power circuit starts functioning.	Blower switch	LO	Blower operates at low speed		
				ML	Blower operates at medium speed		
	IG1	Even when at the ST (START) position, the power circuit starts functioning.		MH	Blower operates at medium high speed		
				HI	Blower operates at high speed		
	IG2	When at the ST (START) position, the power circuit does not start functioning.	A/C switch	ECONO	1st position (economical operation)		
				A/C	2nd position (full load operation)		
Dimmer passing switch	LO	Low beams ON	Wiper switch	LO	Wipers operate at low speed		
	HI	High beams ON		HI	Wipers operate at high speed		
	PASS	Passing beams ON		INT	Wipers operate intermittently		
Lighting switch	TAIL	Position, tail, licence-plate and instrument panel lamps ON	Remote control mirror switch	LH	L.H. mirror operates		
	HEAD	Headlamps ON		RH	R.H. mirror operates		
Room lamp switch	DOOR	Room lamp ON when a door is open	Sunroof switch	UP	Sunroof tilted up		
Turn signal switch				LH	L.H. turn signal lamps ON	DOWN	Sunroof tilted down
				RH	R.H. turn signal lamps ON	OPEN	Sunroof slides open
						CLOSE	Sunroof slides to close
Power window switch	UP	Window closed	Heated seat switch	LO	Normal heating		
	DOWN	Window opened		HI	Rapid heating		
Door lock actuator	LOCK	Door locked	Others	ON	Switched on		
	UNLOCK	Door unlocked					
Door lock relay	LOCK	Door locked		OFF	Switched off		
	UNLOCK	Door unlocked					

HOW TO READ WIRING DIAGRAM

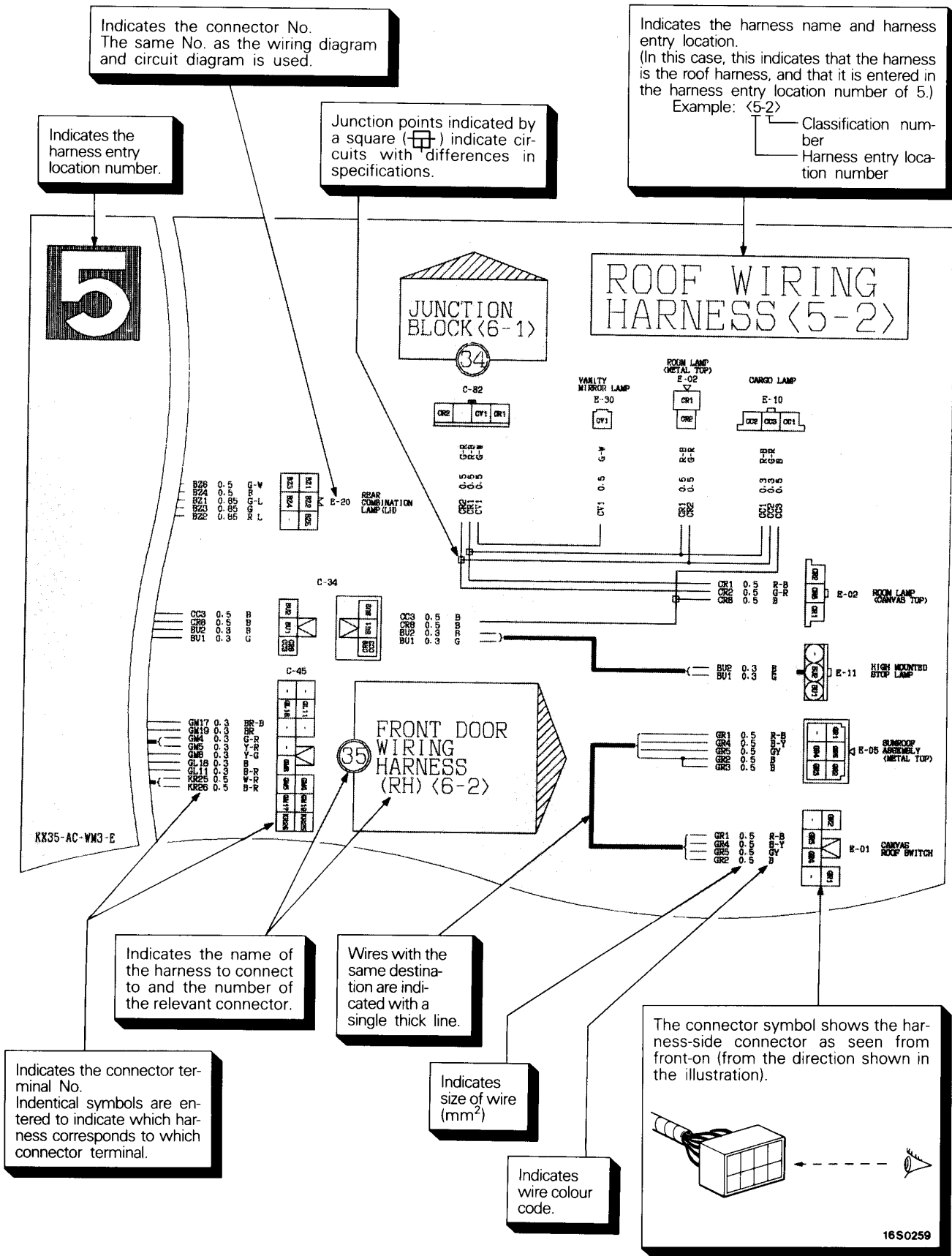

# 1A HOW TO READ THE WIRING DIAGRAMS

<b>MODELS .....</b>	<b>1A-2</b>
<b>COMPOSITION AND CONTENTS OF WIRING DIAGRAMS</b>	} Refer to '93 models' Electrical wiring
<b>HOW TO READ CONFIGURATION DIAGRAMS</b>	
<b>HOW TO READ CIRCUIT DIAGRAMS</b>	
<b>MARKINGS FOR CONNECTOR EARTHING</b>	
<b>WIRE COLOUR CODES</b>	
<b>ABBREVIATION SYMBOLS</b>	
<b>HOW TO READ WIRING DIAGRAM</b>	

**MODELS****<SPACE RUNNER>**

Model code		Engine model	Transmission model	Fuel supply system
N11W	SNJEL6/R6	4G93 SOHC-16 valve [1,834 cm <sup>3</sup> ]	F5M22 (2WD-5M/T)	MPI
	SNUEL6/R6		F4A22 (2WD-4A/T)	
	SRUEL6/R6			
N18W	SNJTL6/R6	4D68 with a turbocharger [1,998 cm <sup>3</sup> ]	F5M31 (2WD-5M/T)	Fuel Injection Pump
N21W	SNUEL6/R6	4G93 SOHC-16 valve [1,834 cm <sup>3</sup> ]	W5M31 (4WD-5M/T)	MPI

**<SPACE WAGON>**

Model code		Engine model	Transmission model	Fuel supply system
N33W	LNUEL6/R6	4G63 SOHC-16 valve [1,997 cm <sup>3</sup> ]	F5M22 (2WD-5M/T)	MPI
	LRUEL6/R6		F4A22 (2WD-4A/T)	
	LNSEL6		F5M22 (2WD-5M/T)	
	LRSEL6		F4A22 (2WD-4A/T)	
N34W	LNUEL6	4G64 SOHC-16 valve [2,350 cm <sup>3</sup> ]	F5M31 (2WD-5M/T)	
	LRUEL6		F4A23 (2WD-4A/T)	
N38W	LNUTL6/R6	4D68 with a turbocharger [1,998 cm <sup>3</sup> ]	F5M31 (2WD-5M/T)	Fuel Injection Pump
N43W	LNUEL6/R6	4G63 SOHC-16 valve [1,997 cm <sup>3</sup> ]	W5M31 (4WD-5M/T)	MPI
	LRUEL6/R6		W4A32 (4WD-4A/T)	
	LNSEL6		W5M31 (4WD-5M/T)	
	LRSEL6		W4A32 (4WD-4A/T)	

## 2 WIRING HARNESS CONFIGURATION DIAGRAMS

### 1 OVERALL WIRING DIAGRAM

1-1 L.H. drive vehicles .....	2-2
1-2 R.H. drive vehicles .....	2-3

### 2 ENGINE COMPARTMENT **A**

2-1 L.H. drive vehicles with MPI engine .....	2-4
2-2 R.H. drive vehicles with MPI engine .....	2-6
2-3 L.H. drive vehicles with Diesel engine .....	2-8
2-4 R.H. drive vehicles with Diesel engine .....	2-10

### 3 ENGINE AND TRANSMISSION **B**

3-1 4G93 MPI engine .....	2-12
3-2 4G63 and 4G64 MPI engine .....	2-13
3-3 Diesel engine .....	2-14

### 4 DASH PANEL **C**

4-1 L.H. drive vehicles .....	2-16
4-2 R.H. drive vehicles .....	2-18

### 5 INSTRUMENT PANEL **D**

5-1 L.H. drive vehicles .....	2-20
5-2 R.H. drive vehicles .....	2-21

### 6 INTERIOR **E**

6-1 L.H. drive vehicles <SPACE RUNNER> .....	2-22
6-2 R.H. drive vehicles <SPACE RUNNER> .....	2-24
6-3 L.H. drive vehicles <SPACE WAGON> .....	2-26
6-4 R.H. drive vehicles <SPACE WAGON> .....	2-28

### 7 REAR UNDER FLOOR **F** ..... 2-30

## 2-2 WIRING HARNESS CONFIGURATION DIAGRAMS — Overall Wiring Diagram

### 1 OVERALL WIRING DIAGRAM

#### 1-1 L.H. drive vehicles

##### <SPACE RUNNER>

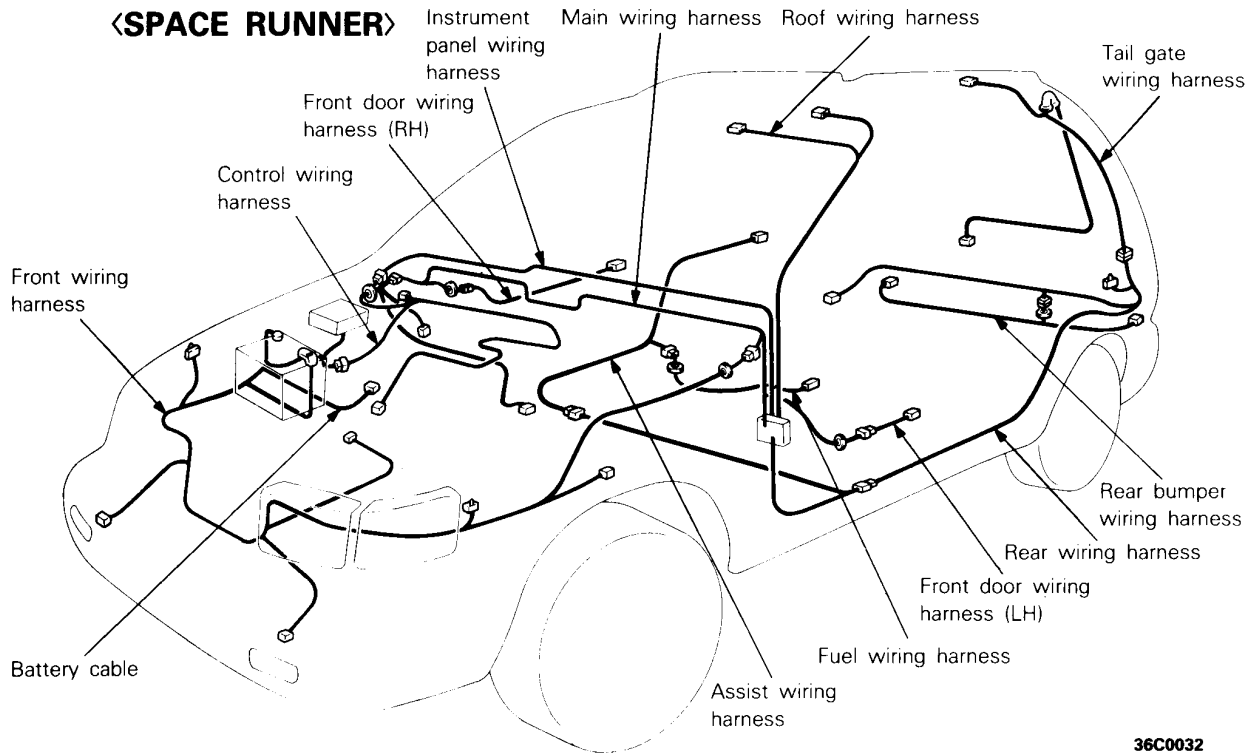

##### <SPACE WAGON>

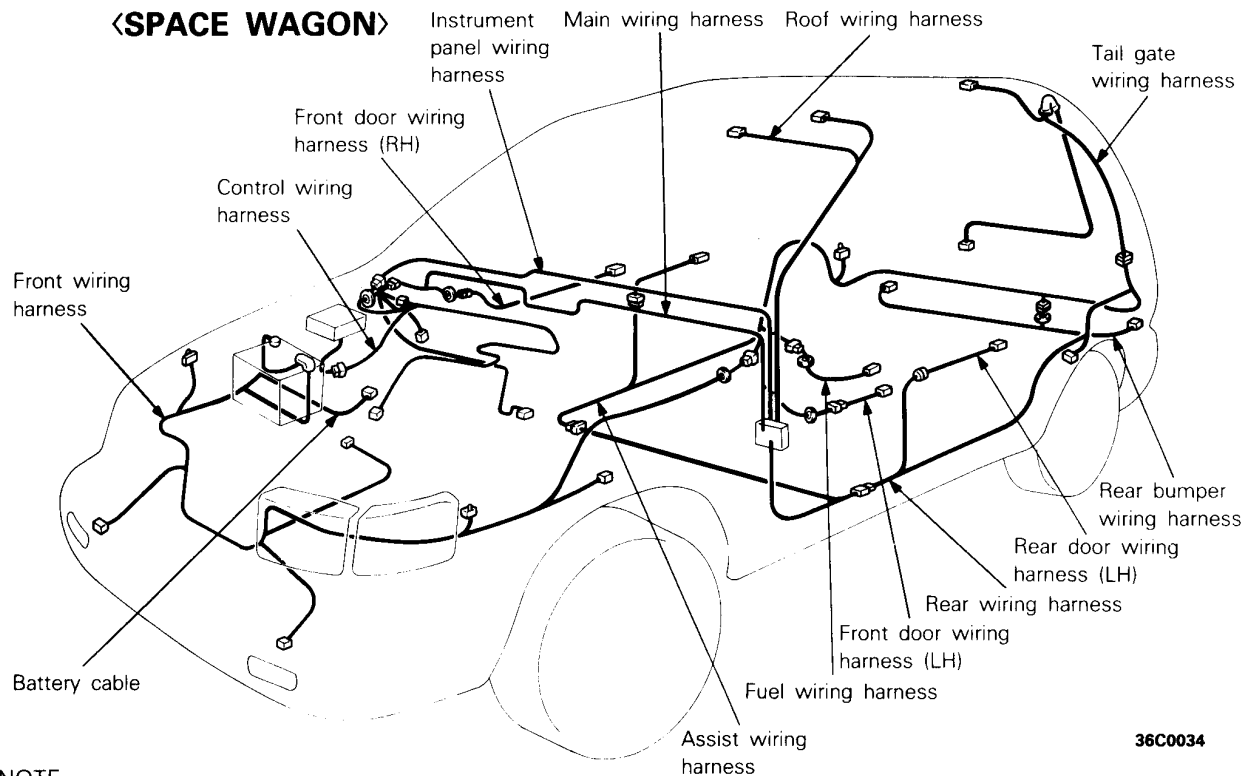

NOTE  
This illustration shows only the major wiring harness.



1-2 R.H. drive vehicles

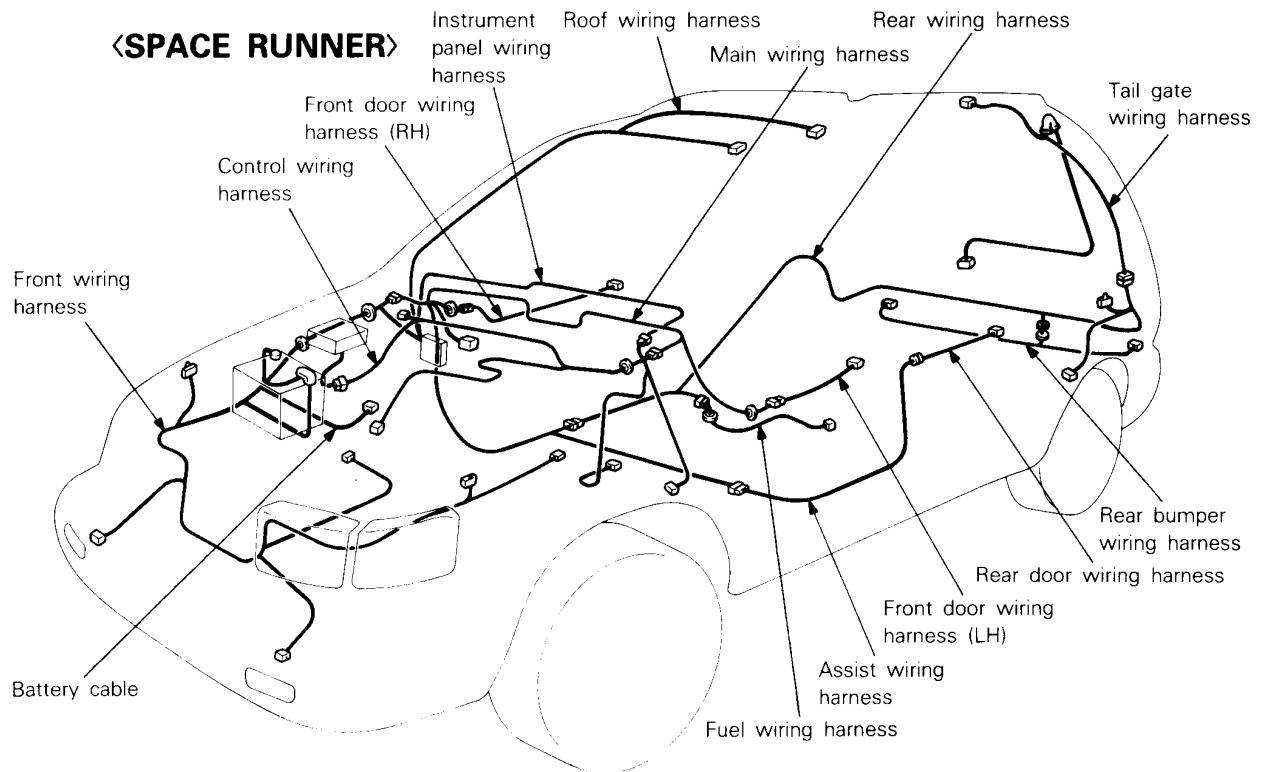

36C0033

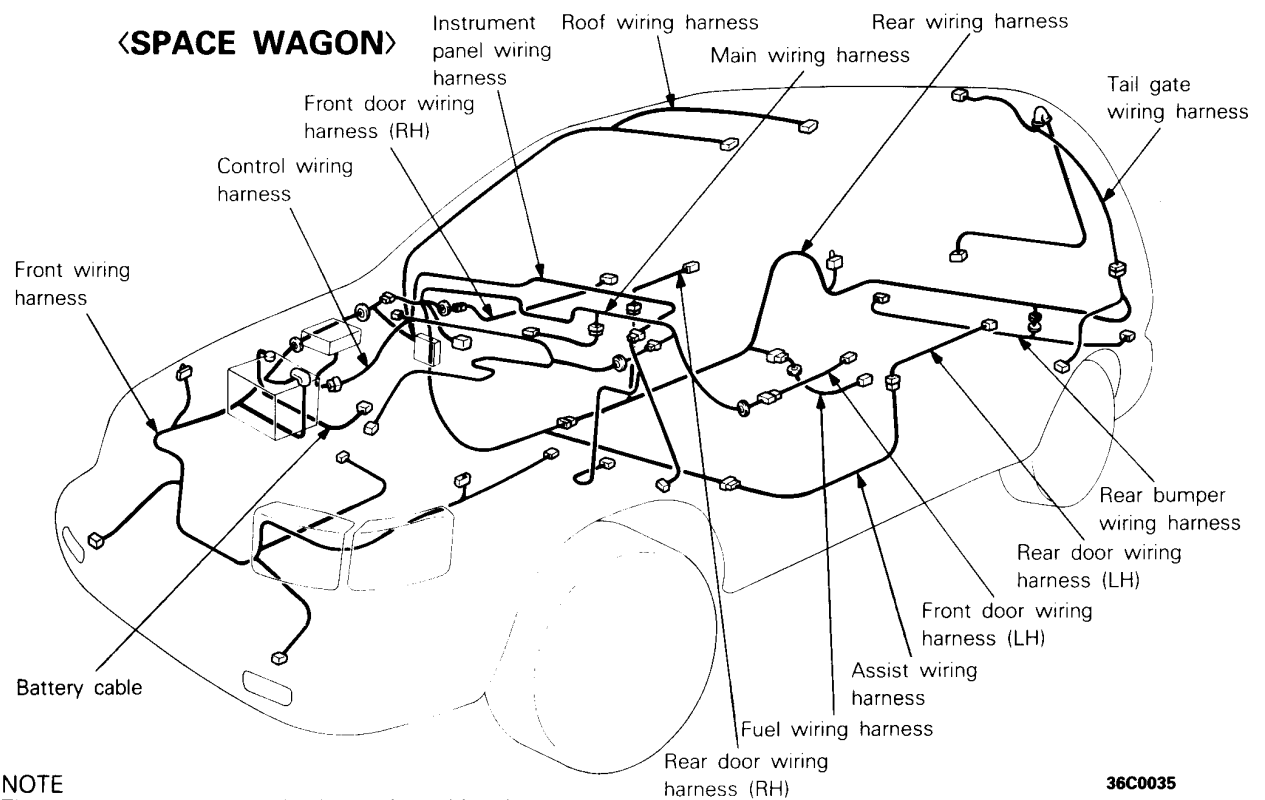

36C0035

NOTE  
This illustration shows only the major wiring harness.

## 2 ENGINE COMPARTMENT

### 2-1 L.H. drive vehicles with MPI engine

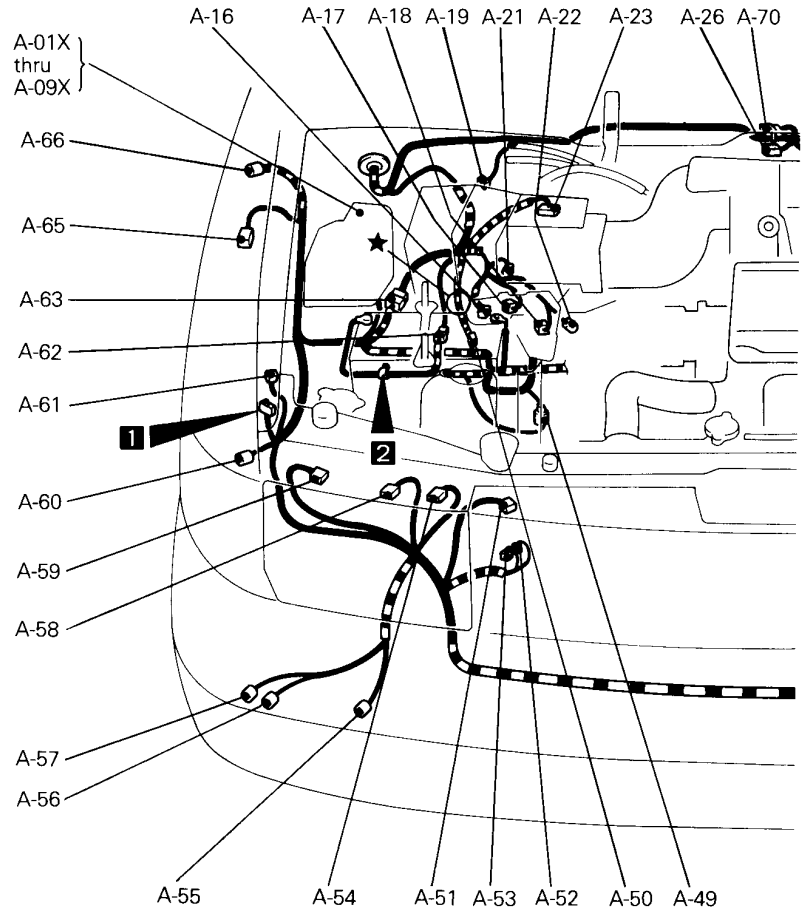
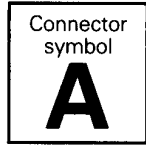

- A-01X } Refer to CENTRALIZED JUNCTION
- A-02X }
- A-03X }
- A-04X }
- A-05X }
- A-06X }
- A-07X }
- A-08X }
- A-09X }
- A-10 } —
- thru }
- A-15 }
- A-16 ELC 4A/T solenoid <A/T>
- A-17 Inhibitor switch <A/T>
- A-18 A/T fluid temperature sensor <A/T>
- A-19 Brake fluid level sensor
- A-20 —
- A-21 Pulse generator <A/T>

- A-22 Kickdown servo switch <A/T>
- A-23 Air flow sensor
- A-24 —
- A-25 —
- A-26 Fuel pump check connector
- A-27 —
- A-28 —
- A-29 EGR solenoid valve
- A-30 Purge control solenoid valve
- A-31 Ignition timing adjustment connector
- A-32 —
- A-33 Front wiper motor
- A-34 } —
- A-35 }
- A-36 }
- A-37 Side turn signal lamp (LH)
- A-38 ABS speed sensor (Front: LH)

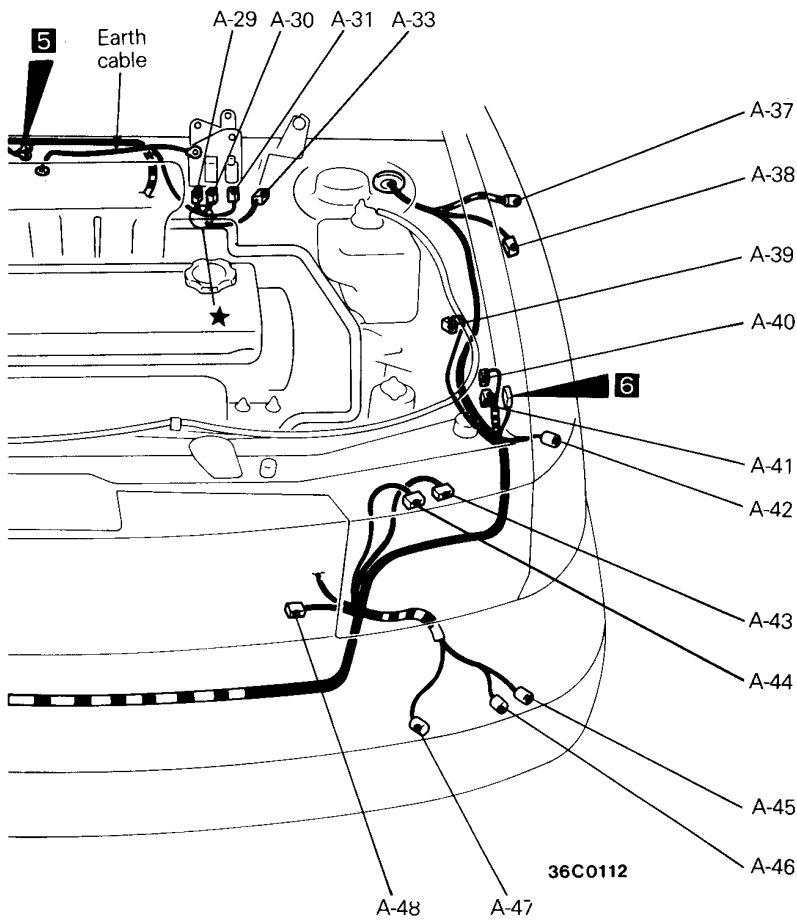

**Vehicles with daytime running lamp**

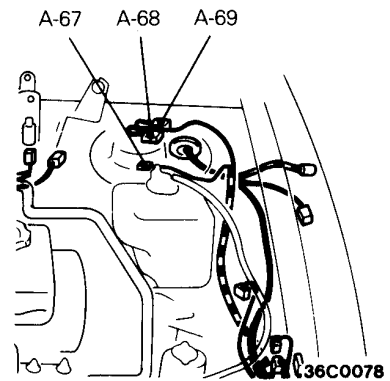

- |        |   |                  |   |
|--------|---|------------------|---|
| A-39   | Dual pressure switch <4G93> or triple pressure switch <4G63 and 4G64> | A-56 } Horn (RH) |   |
| A-40 } | ABS hydraulic unit  | A-57 }           |   |
| A-41 } |   |                  |   |
| A-42   | Front combination lamp (LH)   | A-58             | Headlamp leveling unit (RH)                                 |
| A-43   | Headlamp leveling unit (LH)   | A-59             | Headlamp washer motor                                       |
| A-44   | Headlamp (LH)   | A-60             | Front combination lamp (RH)                                 |
| A-45 } | Horn (LH)   | A-61             | Headlamp washer relay                                       |
| A-46 } |   |                  |   |
| A-47   | Front turn signal lamp (LH)   | A-62             | Control wiring harness and battery cable combination        |
| A-48   | Condenser fan motor   | A-63             | Front wiring harness and control wiring harness combination |
| A-49   | Front wiring harness and battery cable combination                    | A-64             | —   |
| A-50   | Back-up lamp switch <M/T>   | A-65             | ABS speed sensor (Front: RH)                                |
| A-51   | Radiator fan motor  | A-66             | Side turn signal lamp (RH)                                  |
| A-52   | Front washer motor  | A-67             | Daytime running lamp control unit                           |
| A-53   | Rear washer motor   | A-68             | Daytime running lamp relay 1                                |
| A-54   | Headlamp (RH)   | A-69             | Daytime running lamp relay 2                                |
| A-55   | Front turn signal lamp (RH)   | A-70             | Engine speed detection connector                            |
|        |   | A-71 }           | —   |
|        |   | A-72 }           |   |
|        |   | A-73 }           |   |

2-2 R.H. drive vehicles with MPI engine

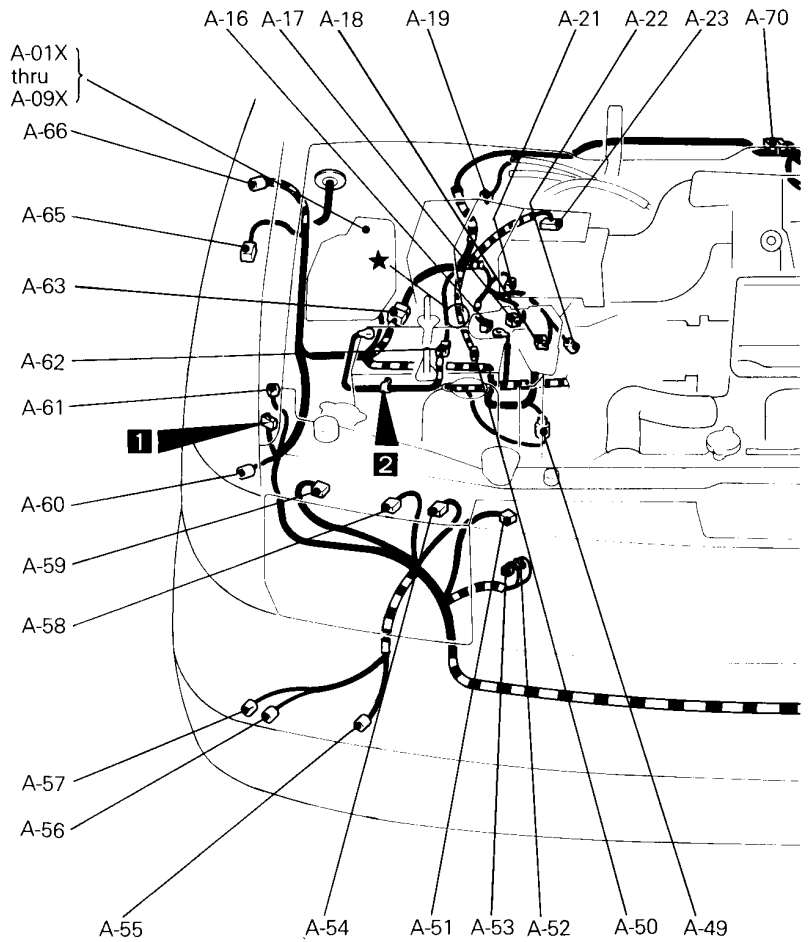
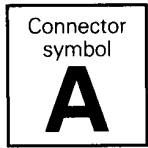

- A-01X } Refer to CENTRALIZED JUNCTION
- A-02X }
- A-03X }
- A-04X }
- A-05X }
- A-06X }
- A-07X }
- A-08X }
- A-09X }
- A-10 } —
- thru }
- A-15 }
- A-16 ELC 4A/T solenoid <A/T>
- A-17 Inhibitor switch <A/T>
- A-18 A/T fluid temperature sensor <A/T>
- A-19 Brake fluid level sensor
- A-20 —
- A-21 Pulse generator <A/T>
- A-22 Kickdown servo switch <A/T>

- A-23 Air flow sensor
- A-24 —
- A-25 —
- A-26 Fuel pump check connector
- A-27 —
- A-28 —
- A-29 EGR solenoid valve
- A-30 Purge control solenoid valve
- A-31 Ignition timing adjustment connector
- A-32 Resistor
- A-33 Front wiper motor
- A-34 Dim-dip lamp relay 1
- A-35 Dim-dip lamp relay 2
- A-36 Dim-dip lamp relay 3
- A-37 Side turn signal lamp (LH)
- A-38 ABS speed sensor (Front: LH)
- A-39 Dual pressure switch <4G93> or triple pressure switch <4G63>

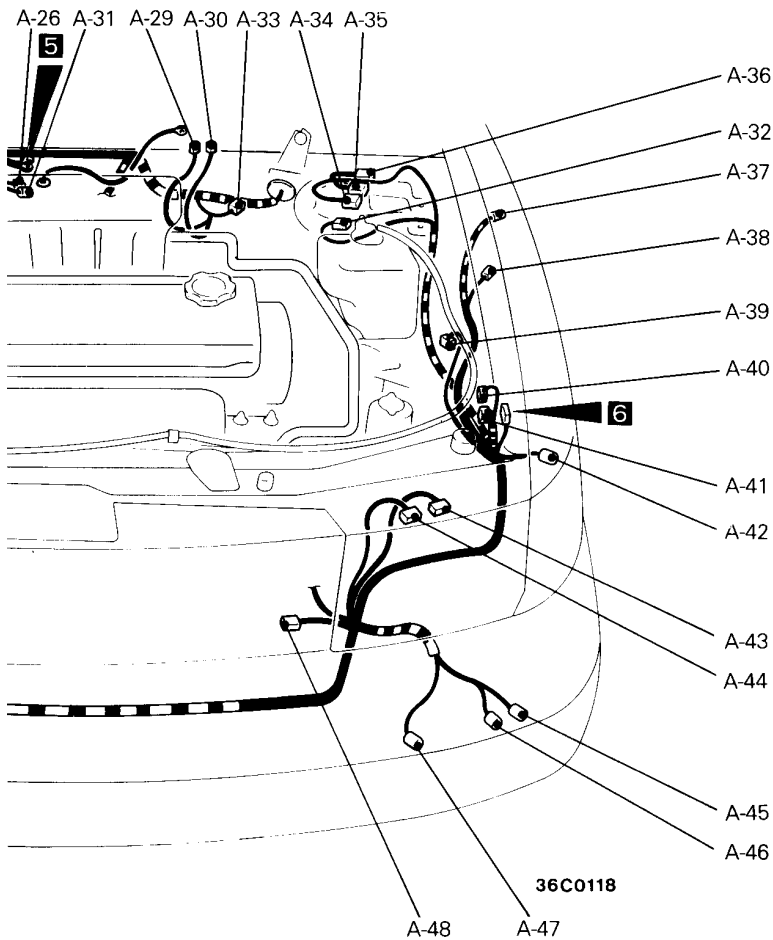

- A-40 } ABS hydraulic unit
- A-41 }
- A-42 Front combination lamp (LH)
- A-43 Headlamp leveling unit (LH)
- A-44 Headlamp (LH)
- A-45 } Horn (LH)
- A-46 }
- A-47 Front turn signal lamp (LH)
- A-48 Condenser fan motor
- A-49 Front wiring harness and battery cable combination
- A-50 Back-up lamp switch (M/T)
- A-51 Radiator fan motor
- A-52 Front washer motor
- A-53 Rear washer motor
- A-54 Headlamp (RH)
- A-55 Front turn signal lamp (RH)
- A-56 } Horn (RH)
- A-57 }

- A-58 Headlamp leveling unit (RH)
- A-59 Headlamp washer motor
- A-60 Front combination lamp (RH)
- A-61 Headlamp washer relay
- A-62 Control wiring harness and battery cable combination
- A-63 Front wiring harness and control wiring harness combination
- A-64 —
- A-65 ABS speed sensor (Front: RH)
- A-66 Side turn signal lamp (RH)
- A-67 } —
- A-68 }
- A-69 }
- A-70 Engine speed detection connector
- A-71 } —
- A-72 }
- A-73 }

2-3 L.H. drive vehicles with Diesel engine

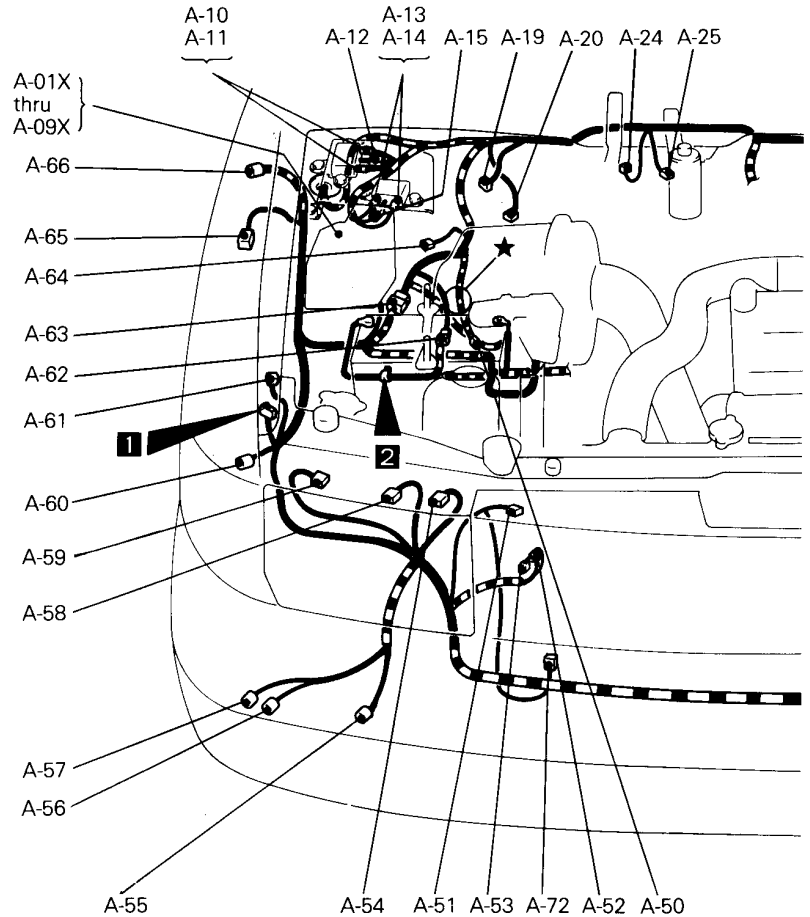
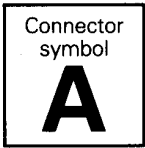

- A-01X }
  - A-02X } Refer to CENTRALIZED JUNCTION
  - A-03X }
  - A-04X }
  - A-05X }
  - A-06X }
  - A-07X }
  - A-08X }
  - A-09X }
- A-10 }
  - A-11 } Glow plug relay 1
  - A-12 }
  - A-13 }
  - A-14 } Glow plug relay 2
  - A-15 }
  - A-16 }
  - A-17 } —
  - A-18 }
  - A-19 } Brake fluid level sensor

- A-20 } Vacuum switch
- A-21 }
- A-22 } —
- A-23 }
- A-24 } Starter relay
- A-25 } Water level switch
- A-26 } —
- A-27 } Idle-up solenoid valve (A/C)
- A-28 } EGR solenoid valve No. 1
- A-29 } EGR solenoid valve No. 2
- A-30 }
- A-31 }
- A-32 }
- A-33 } Front wiper motor
- A-34 }
- A-35 }
- A-36 }
- A-37 } Side turn signal lamp (LH)

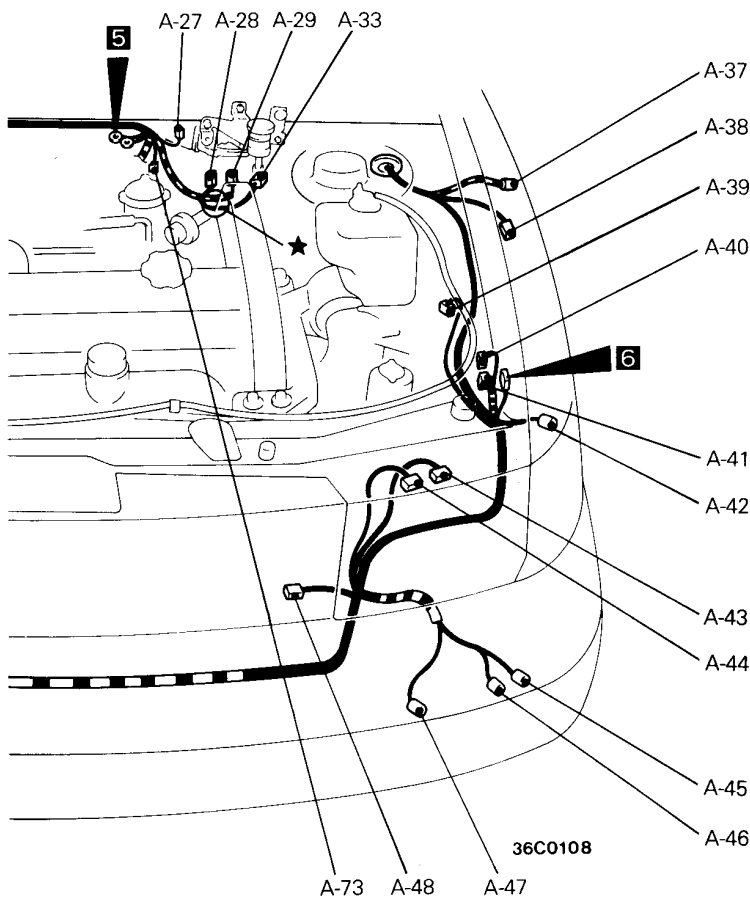

**Vehicles with daytime running lamp**

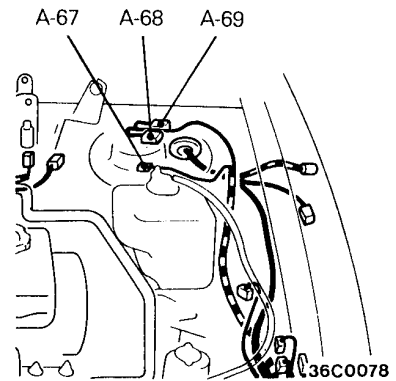

- A-38 ABS speed sensor (Front: LH)
- A-39 Triple pressure switch
- A-40 } ABS hydraulic unit
- A-41 }
- A-42 Front combination lamp (LH)
- A-43 Headlamp leveling unit (LH)
- A-44 Headlamp (LH)
- A-45 } Horn (LH)
- A-46 }
- A-47 Front turn signal lamp (LH)
- A-48 Condenser fan motor
- A-49 —
- A-50 Back-up lamp switch <M/T>
- A-51 Radiator fan motor
- A-52 Front washer motor
- A-53 Rear washer motor
- A-54 Headlamp (RH)
- A-55 Front turn signal lamp (RH)
- A-56 } Horn (RH)
- A-57 }

- A-58 Headlamp leveling unit (RH)
- A-59 Headlamp washer motor
- A-60 Front combination lamp (RH)
- A-61 Headlamp washer relay
- A-62 Control wiring harness and battery cable combination
- A-63 Front wiring harness and control wiring harness combination
- A-64 Dropping resistor
- A-65 ABS speed sensor (Front: RH)
- A-66 Side turn signal lamp (RH)
- A-67 Daytime running lamp control unit
- A-68 Daytime running lamp relay 1
- A-69 Daytime running lamp relay 2
- A-70 } —
- A-71 }
- A-72 Thermo sensor and resistor (Radiator fan)
- A-73 A/C refrigerant capacity control solenoid valve

## 2-10 WIRING HARNESS CONFIGURATION DIAGRAMS — Engine Compartment

### 2-4 R.H. drive vehicles with Diesel engine

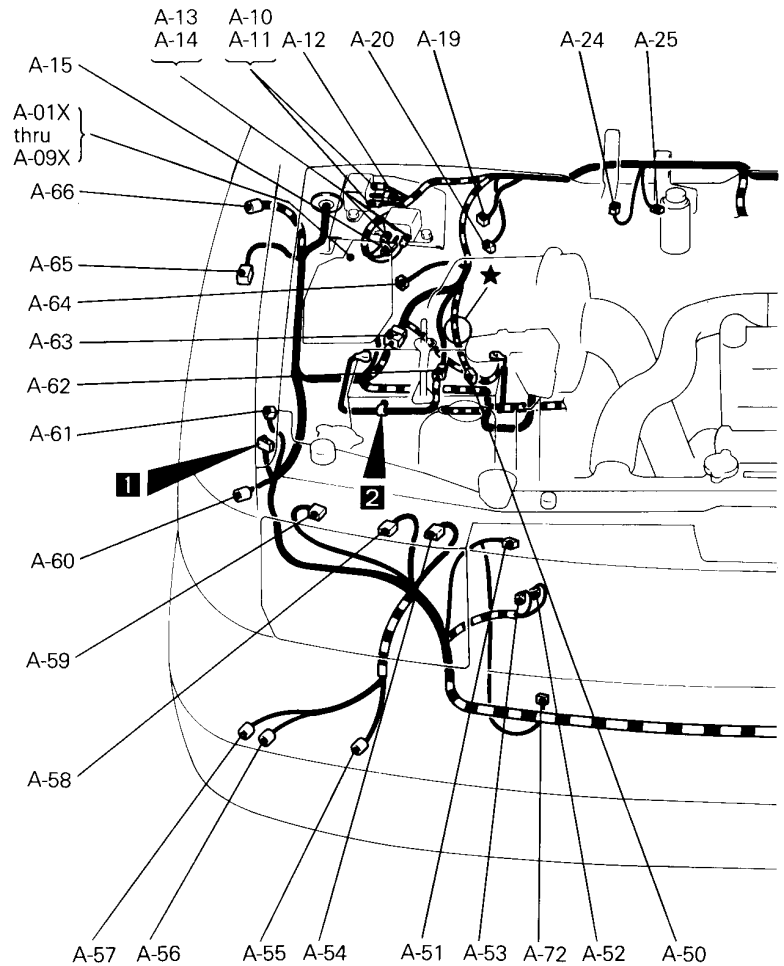
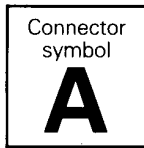

A-01X	} Refer to CENTRALIZED JUNCTION
A-02X	
A-03X	
A-04X	
A-05X	
A-06X	
A-07X	
A-08X	
A-09X	
A-10	
A-11	} Glow plug relay 1
A-12	
A-13	
A-14	} Glow plug relay 2
A-15	
A-16	
A-17	} —
A-18	

A-19	Brake fluid level sensor
A-20	Vacuum switch
A-21	} —
A-22	
A-23	
A-24	Starter relay
A-25	Water level switch
A-26	—
A-27	Idle-up solenoid valve <A/C>
A-28	EGR solenoid valve No. 1
A-29	EGR solenoid valve No. 2
A-30	} —
A-31	
A-32	Resistor
A-33	Front wiper motor
A-34	Dim-dip lamp relay 1
A-35	Dim-dip lamp relay 2
A-36	Dim-dip lamp relay 3



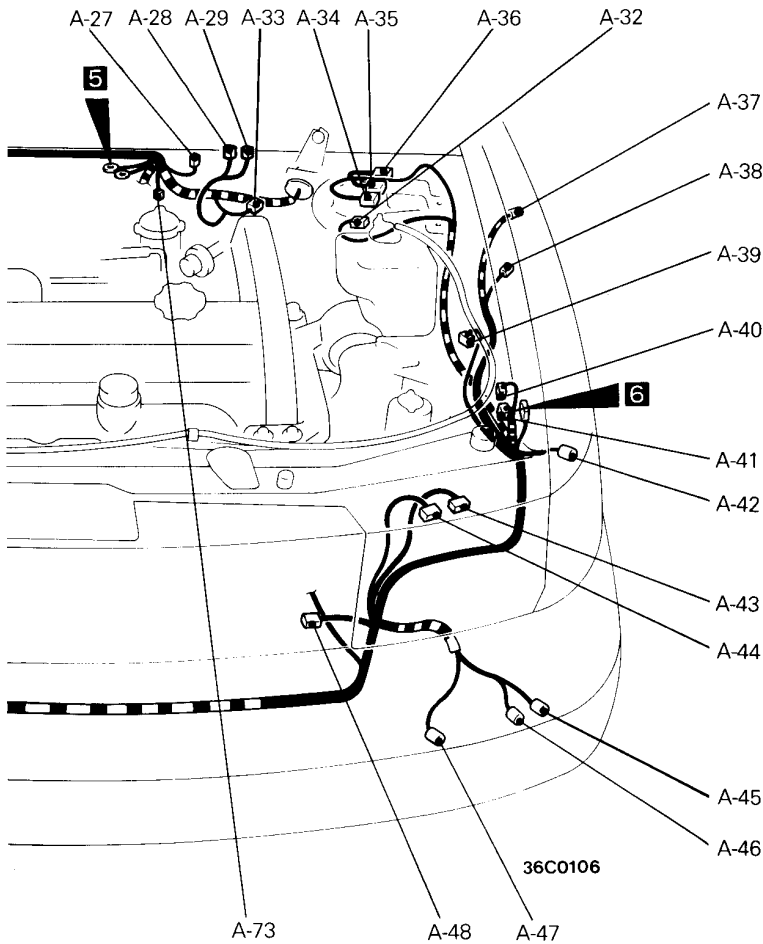

- A-37 Side turn signal lamp (LH)
- A-38 ABS speed sensor (Front: LH)
- A-39 Triple pressure switch
- A-40 } ABS hydraulic unit
- A-41 }
- A-42 Front combination lamp (LH)
- A-43 Headlamp leveling unit (LH)
- A-44 Headlamp (LH)
- A-45 } Horn (LH)
- A-46 }
- A-47 Front turn signal lamp (LH)
- A-48 Condenser fan motor
- A-49 —
- A-50 Back-up lamp switch <M/T>
- A-51 Radiator fan motor
- A-52 Front washer motor
- A-53 Rear washer motor
- A-54 Headlamp (RH)

- A-55 Front turn signal lamp (RH)
- A-56 } Horn (RH)
- A-57 }
- A-58 Headlamp leveling unit (RH)
- A-59 Headlamp washer motor
- A-60 Front combination lamp (RH)
- A-61 Headlamp washer relay
- A-62 Control wiring harness and battery cable combination
- A-63 Front wiring harness and control wiring harness combination
- A-64 Dropping resistor
- A-65 ABS speed sensor (Front: RH)
- A-66 Side turn signal lamp (RH)
- A-67 } —
- A-71 }
- A-72 Thermo sensor and resistor (Radiator fan)
- A-73 A/C refrigerant capacity control solenoid valve

### 3 ENGINE AND TRANSMISSION

#### 3-1 4G93 MPI engine

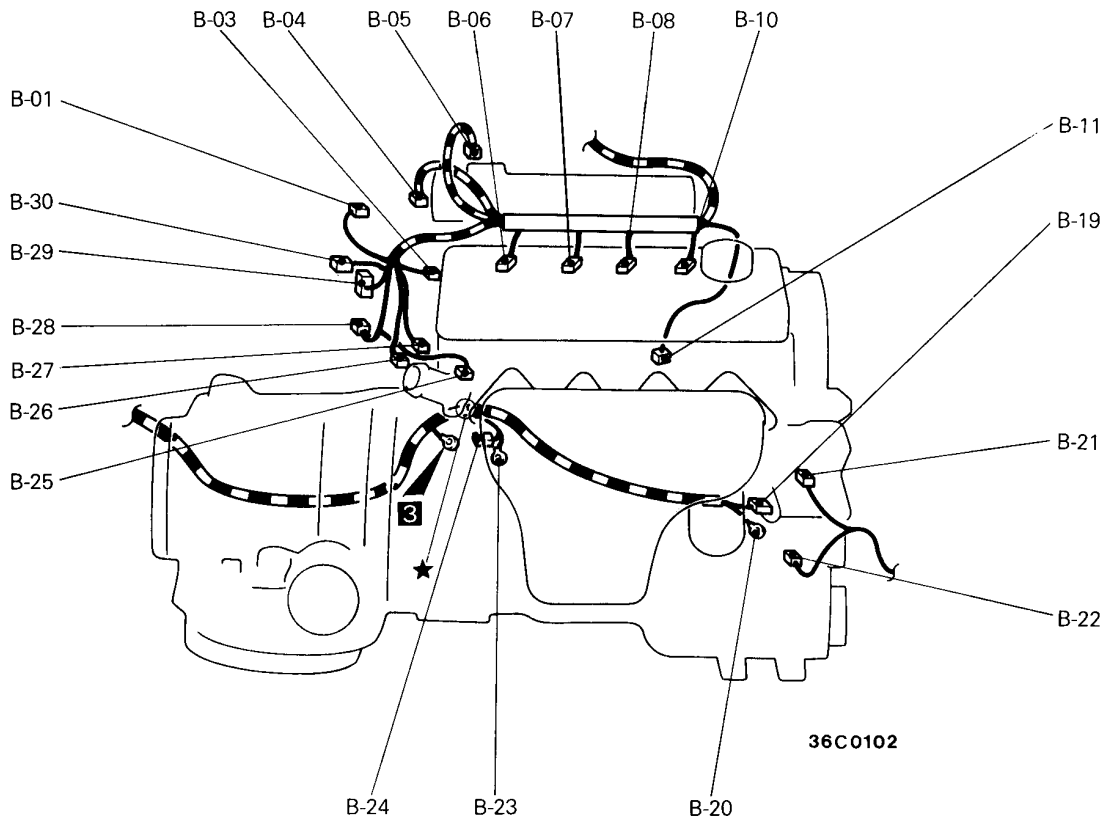
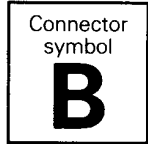

- |      |                                       |      |  |
|------|---------------------------------------|------|--|
| B-01 | Engine coolant temperature sensor     | B-19 | } Alternator   |
| B-02 | —                                     | B-20 |  |
| B-03 | Engine coolant temperature gauge unit | B-21 | Power steering oil pressure switch                     |
| B-04 | Idle speed control actuator           | B-22 | Magnetic clutch <A/C> and revolution pick-up sensor    |
| B-05 | Throttle position sensor              | B-23 | } Starter  |
| B-06 | Injector No. 4                        | B-24 |  |
| B-07 | Injector No. 3                        | B-25 | Engine coolant temperature switch (for engine control) |
| B-08 | Injector No. 2                        | B-26 | Oxygen sensor  |
| B-09 | —                                     | B-27 | Oil pressure switch                                    |
| B-10 | Injector No. 1                        | B-28 | } Distributor assembly                                 |
| B-11 | Detonation sensor                     | B-29 |  |
| B-12 | } —                                   | B-30 | Condenser  |
| thru |                                       | B-31 | } —  |
| B-18 |                                       | B-32 |  |
|      |                                       | B-33 |  |

3-2 4G63 and 4G64 MPI engine

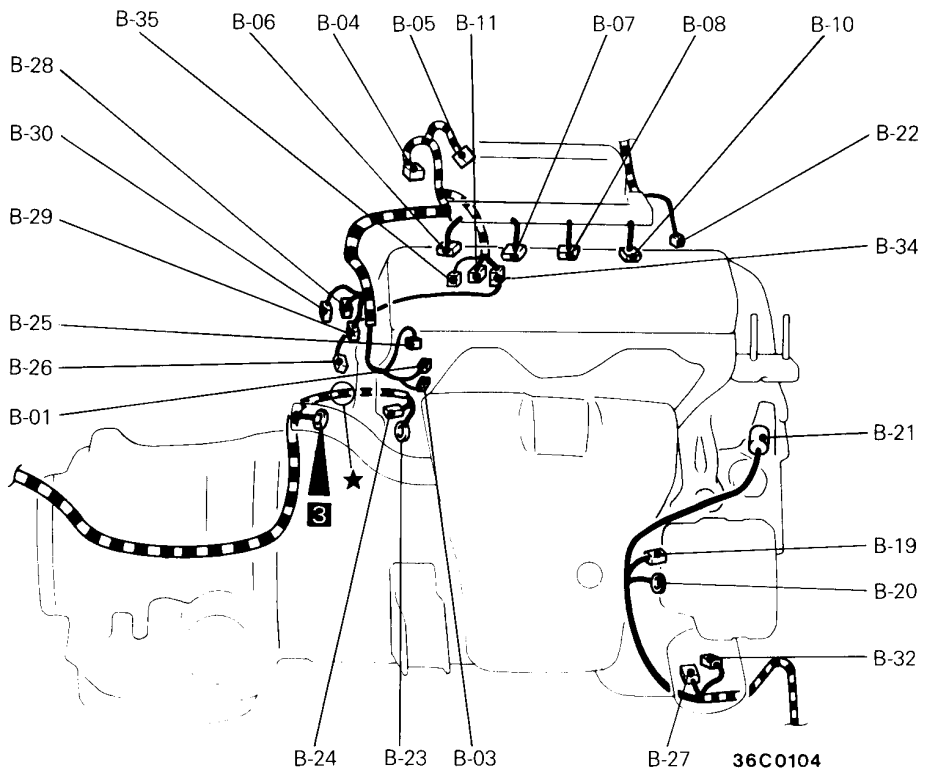
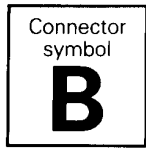

- |                   |                                       |                             |   |
|-------------------|---------------------------------------|-----------------------------|---|
| B-01              | Engine coolant temperature sensor     | B-21                        | Power steering oil pressure switch                                      |
| B-02              | —                                     | B-22                        | Magnetic clutch <A/C>   |
| B-03              | Engine coolant temperature gauge unit | B-23 } Starter              |   |
| B-04              | Idle speed control actuator           | B-24 }                      |   |
| B-05              | Throttle position sensor              | B-25                        | Engine coolant temperature switch (for engine control)                  |
| B-06              | Injector No. 4                        | B-26                        | Oxygen sensor   |
| B-07              | Injector No. 3                        | B-27                        | Oil pressure switch   |
| B-08              | Injector No. 2                        | B-28 } Distributor assembly |   |
| B-09              | —                                     | B-29 }                      |   |
| B-10              | Injector No. 1                        | B-30                        | Condenser   |
| B-11              | Detonation sensor                     | B-31                        | —   |
| B-12 } —          |                                       | B-32                        | Engine oil level sensor   |
| thru } —          |                                       | B-33                        | —   |
| B-18 } —          |                                       | B-34                        | Oxygen sensor sub wiring harness and control wiring harness combination |
| B-19 } Alternator |                                       | B-35                        | EGR temperature sensor <4G64>   |
| B-20 }            |                                       |                             |   |



NOTES

## 4 DASH PANEL

### 4-1 L.H. drive vehicles

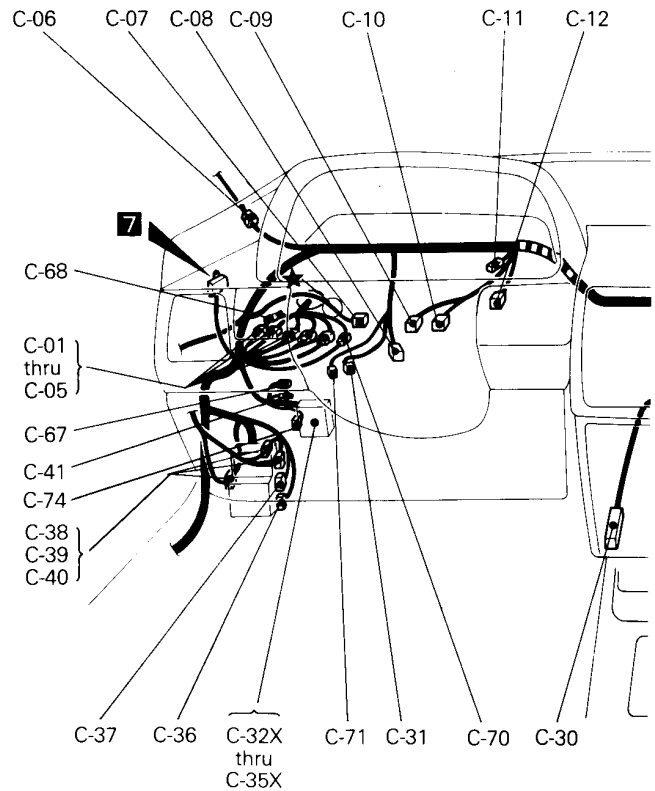
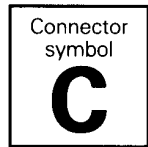

- C-01 } Front wiring harness and main wiring harness combination
- C-05 }
- C-06 } Main wiring harness and roof wiring harness combination
- C-07 } Ignition switch
- C-08 } Stop lamp switch
- C-09 } Column switch
- C-10 }
- C-11 } Diode (Daytime running lamp)
- C-12 } No connection
- C-13 } Air conditioner switch
- C-14 } Heater control illumination lamp
- C-15 } Blower switch
- C-16 } Resistor
- C-17 } Control wiring harness and main wiring harness combination
- C-18 }
- C-19 }
- C-20 }
- C-21 } Engine control unit or glow control unit
- C-22 }
- C-23 } Engine control relay
- C-24 } Fuel octane ratio selection connector

- C-25 } Blower motor
- C-26 }
- C-27 }
- C-28 } —
- C-29 } Overdrive switch
- C-30 } ABS control unit
- C-31 } Lighting monitor buzzer
- C-32X } ABS relay
- C-33X } Power window relay
- C-34X } Central door lock control unit
- C-35X } Rear fog lamp relay
- C-36 } Diagnosis connector
- C-37 } Turn signal and hazard flasher unit
- C-38 } Main wiring harness and instrument panel wiring harness combination
- C-39 }
- C-40 }
- C-41 } Diode (ABS)
- C-42 } Air thermo sensor
- C-43 } Air inlet sensor
- C-44 } Automatic compressor control unit
- C-45 } Main wiring harness and air conditioner wiring harness combination
- C-46 }
- C-47 } A/C belt lock controller (petrol)
- C-48 } Defogger relay

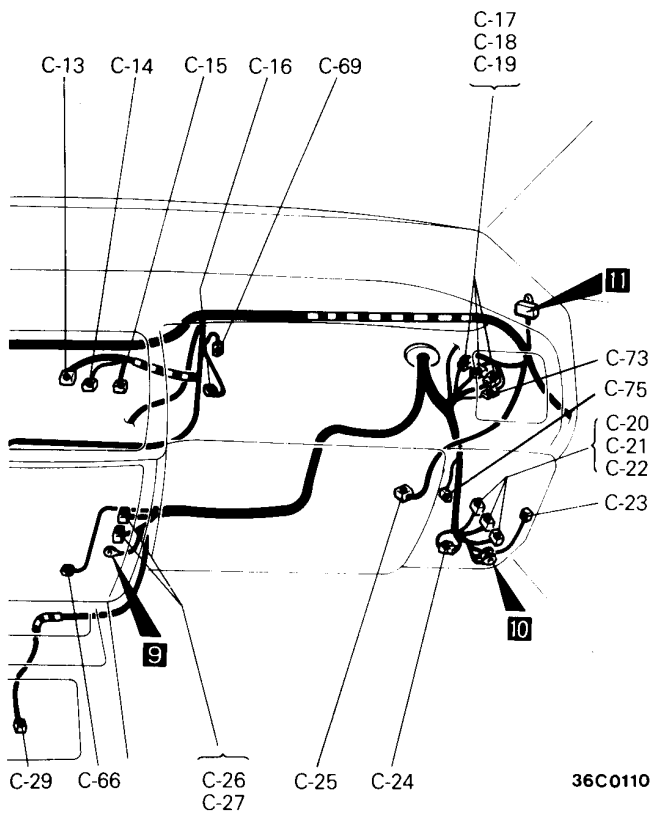

36C0110

**Vehicles with air conditioner  
<Vehicles with 4G93 MPI engine>**

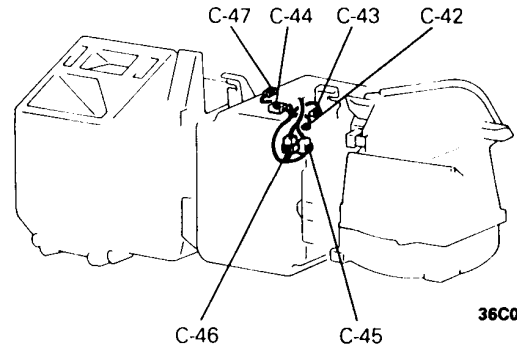

36C0038

**<Vehicles with 4G63, 4G64 MPI  
and diesel engine>**

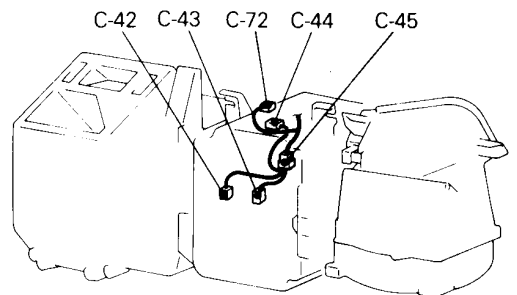

36C0095

- C-49 Roof wiring harness and junction block combination
- C-50 } Front wiring harness and junction block combination
- C-51 }
- C-52 }
- C-53 Instrument panel wiring harness and junction block combination
- C-54 Heater relay
- C-55 } Main wiring harness and junction block combination
- thru }
- C-61 }
- C-62 } —
- thru }
- C-65 }
- C-66 Kick down switch <A/T>
- C-67 Diode (for engine control)
- C-68 A/C diode <Diesel (A/C)>
- C-69 ABS resistor
- C-70 Front wiring harness and main wiring harness combination <Diesel (A/C)>
- C-71 Engine oil level relay
- C-72 A/C relay <Diesel (A/C)>
- C-73 Control wiring harness and main wiring harness combination <4G64>
- C-74 } J/C (Jumper connector)
- C-75 }

**Junction block**

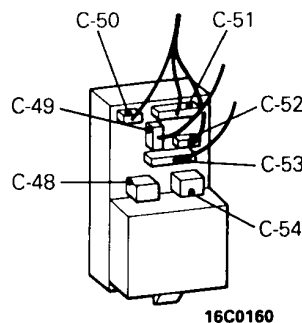

16C0160

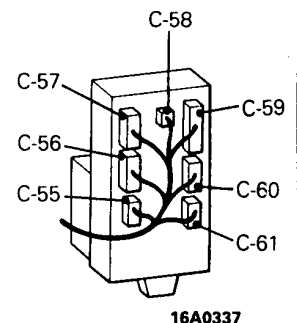

16A0337

4-2 R.H. drive vehicles

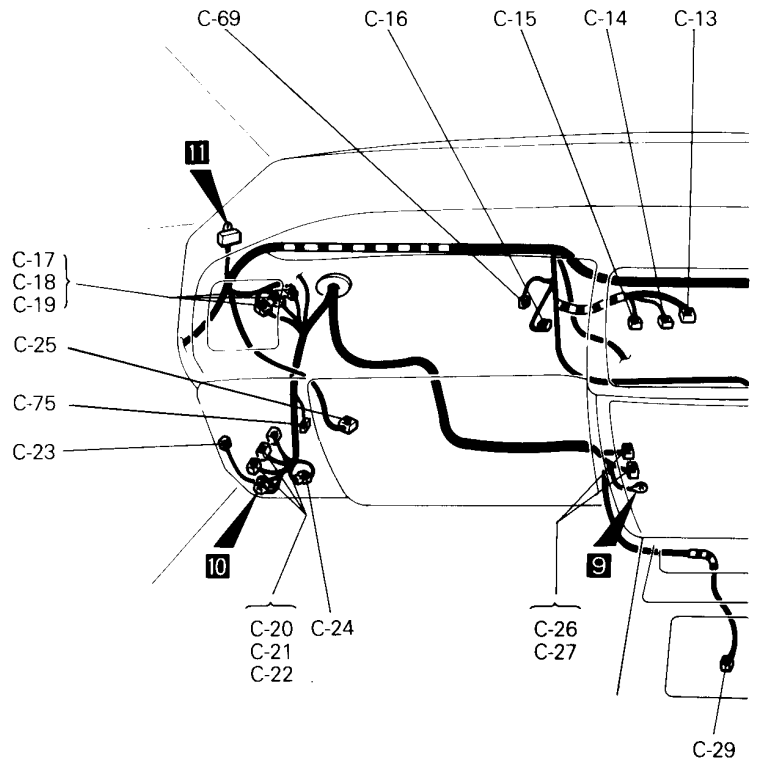
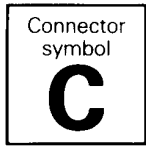

- C-01 } Front wiring harness and main wiring harness
- thru } combination
- C-05 }
- C-06 Main wiring harness and roof wiring harness
- combination
- C-07 Ignition switch
- C-08 Stop lamp switch
- C-09 } Column switch
- C-10 }
- C-11 —
- C-12 No connection
- C-13 Air conditioner switch
- C-14 Heater control illumination lamp
- C-15 Blower switch
- C-16 Resistor
- C-17 } Control wiring harness and main wiring harness com-
- C-18 } bination
- C-19 }
- C-20 } Engine control unit or glow control unit
- C-21 }
- C-22 }

- C-23 Engine control relay
- C-24 Fuel octane ratio selection connector
- C-25 Blower motor
- C-26 } ELC 4A/T control unit
- C-27 }
- C-28 —
- C-29 Overdrive switch
- C-30 ABS control unit
- C-31 Lighting monitor buzzer
- C-32X ABS relay
- C-33X Power window relay
- C-34X Central door lock control unit
- C-35X Rear fog lamp relay
- C-36 Diagnosis connector
- C-37 Turn signal and hazard flasher unit
- C-38 }
- C-39 } Main wiring harness and instrument panel wiring
- C-40 } harness combination
- C-41 Diode <ABS>
- C-42 Air thermo sensor
- C-43 Air inlet sensor



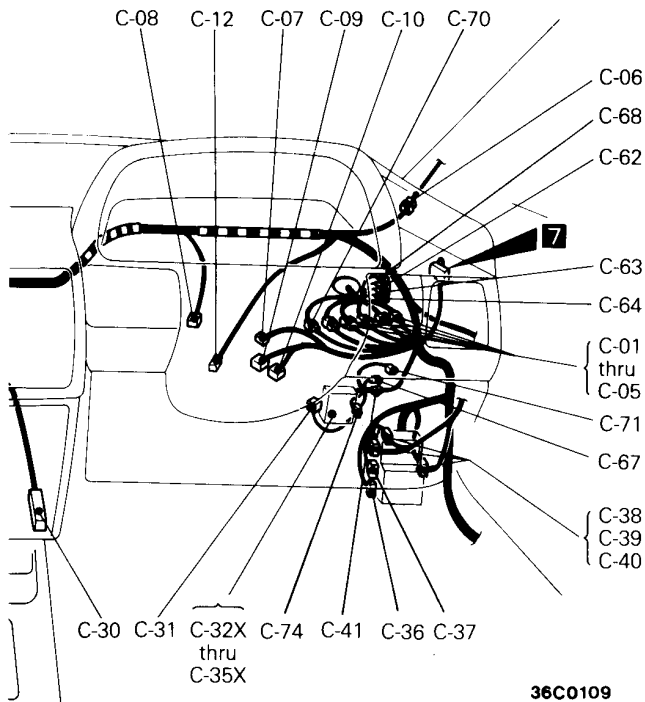

36C0109

**Vehicles with air conditioner  
<Vehicles with 4G93 MPI engine>**

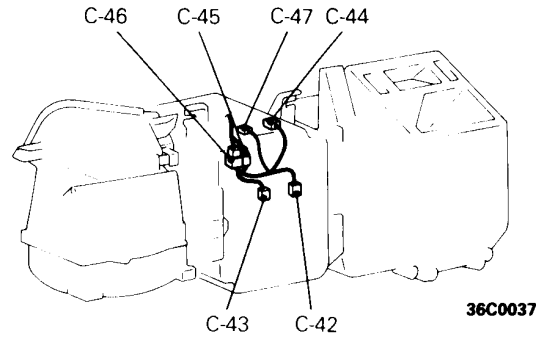

36C0037

**<Vehicles with 4G63 MPI and diesel engine>**

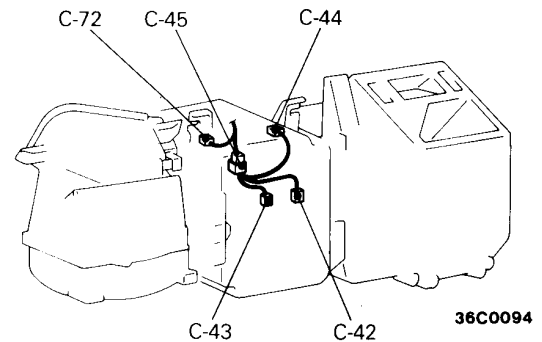

36C0094

**Junction block**

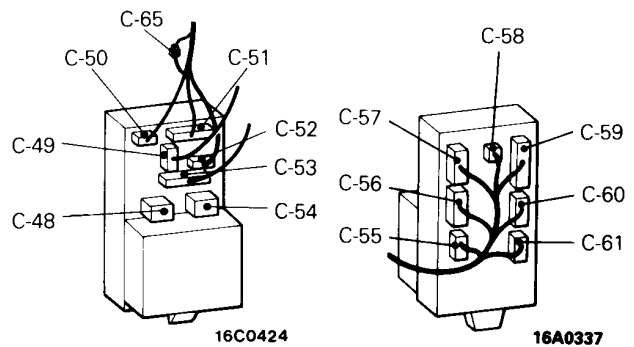

16C0424

16A0337

- C-44 Automatic compressor control unit
- C-45 } Main wiring harness and air conditioner wiring harness combination
- C-46 }
- C-47 A/C belt lock controller <petrol>
- C-48 Defogger relay
- C-49 Roof wiring harness and junction block combination
- C-50 }
- C-51 } Front wiring harness and junction block combination
- C-52 }
- C-53 Instrument panel wiring harness and junction block combination
- C-54 Heater relay
- C-55 }
- thru } Main wiring harness and junction block combination
- C-61 }
- C-62 }
- C-63 } Diode (dim-dip lamp)
- C-64 }
- C-65 Rear fog lamp connector
- C-66 —

- C-67 Diode (for engine control)
- C-68 A/C diode <Diesel (A/C)>
- C-69 ABS resistor
- C-70 Front wiring harness and main wiring harness combination <Diesel (A/C)>
- C-71 Engine oil level relay
- C-72 A/C relay <Diesel (A/C)>
- C-73 —
- C-74 }
- C-75 } J/C (Jumper connector)

## 5 INSTRUMENT PANEL

### 5-1 L.H. drive vehicles

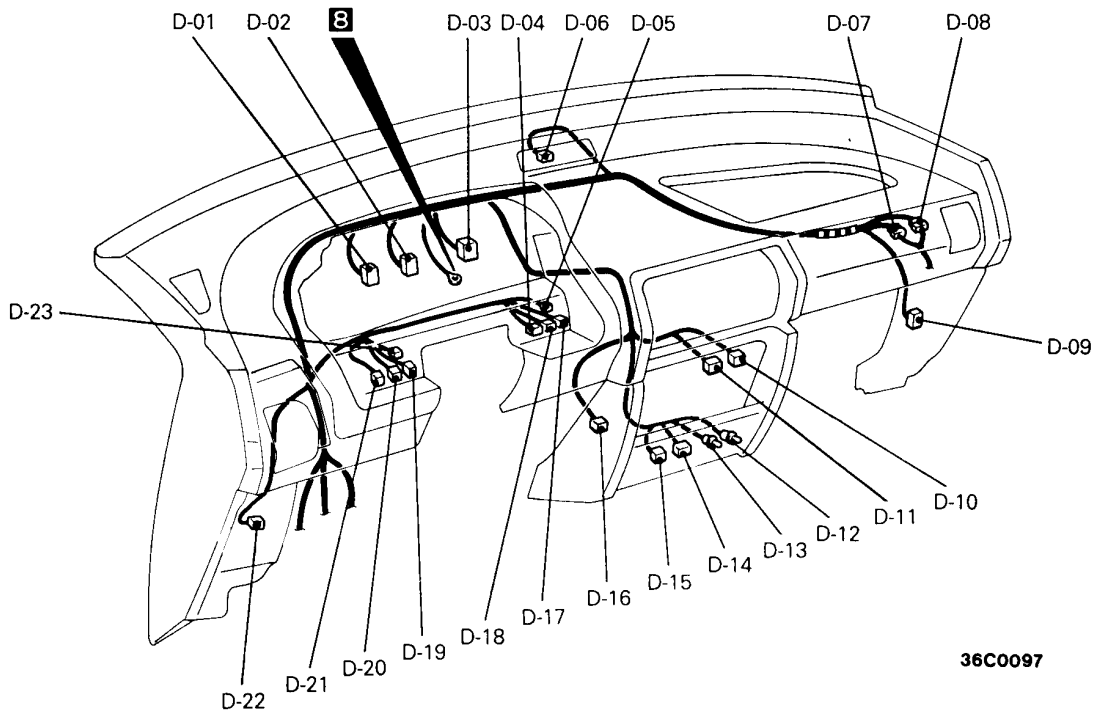
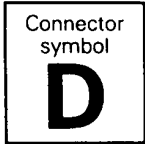

36C0097

D-01	} Combination meter	D-13	Cigarette lighter illumination lamp
D-02		D-14	} Cigarette lighter
D-03		D-15	
D-04	Rear wiper and washer switch	D-16	Headlamp leveling switch
D-05	Cluster switch illumination lamp (RH)	D-17	Hazard switch
D-06	Clock	D-18	Defogger switch
D-07	} Instrument panel wiring harness and control wiring	D-19	Rear fog lamp switch
D-08		} harness combination	D-20
D-09	Front speaker (RH)		D-21
D-10	} Radio	D-22	Front speaker (LH)
D-11		} Ashtray illumination lamp	D-23
D-12			

5-2 R.H. drive vehicles

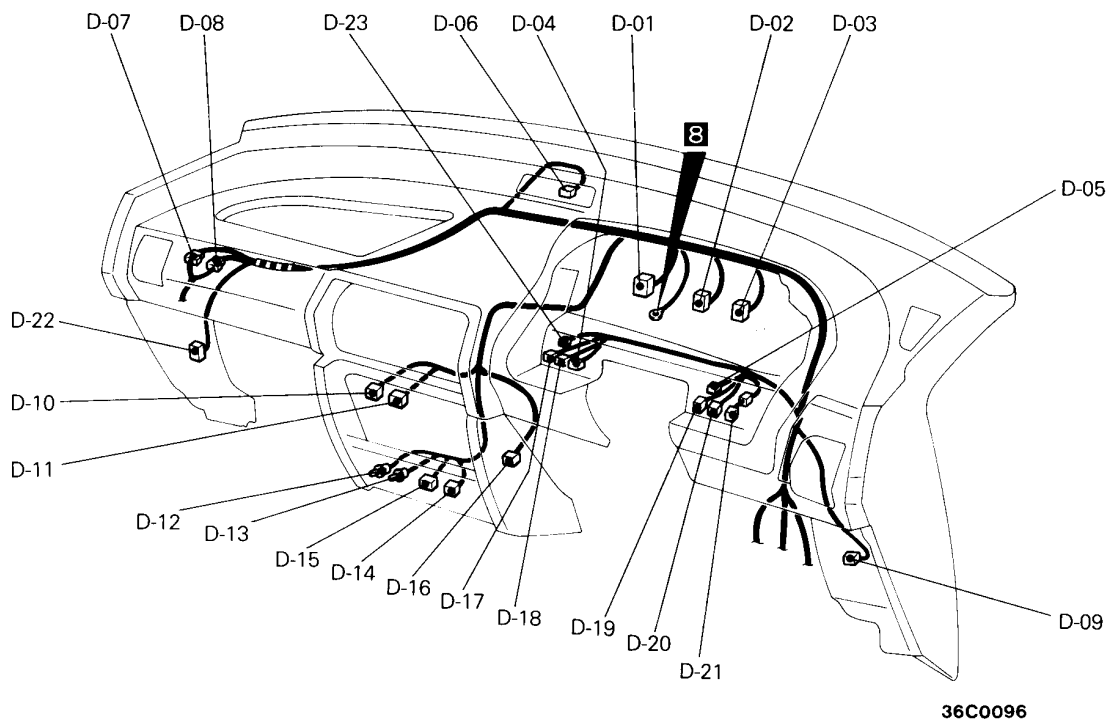
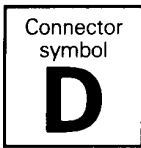

- |      |  |                          |  |
|------|--|--------------------------|--|
| D-01 | } Combination meter                                  | D-13                     | Cigarette lighter illumination lamp  |
| D-02 |  | D-14                     | } Cigarette lighter  |
| D-03 |  | D-15                     |  |
| D-04 | Rear wiper and washer switch                         | D-16                     | Headlamp leveling switch   |
| D-05 | Cluster switch illumination lamp (RH)                | D-17                     | Hazard switch  |
| D-06 | Clock  | D-18                     | Defogger switch  |
| D-07 | } Instrument panel wiring harness and control wiring | D-19                     | Rear fog lamp switch   |
| D-08 |  | harness combination      | D-20   |
| D-09 | Front speaker (RH)                                   | D-21                     | Tailgate lock switch <GLX> or door lock switch <vehicles with central door locking system> |
| D-10 | } Radio  | D-22                     | Front speaker (LH)   |
| D-11 |  | Ashtay illumination lamp | D-23   |

# 6 INTERIOR

## 6-1 L.H. drive vehicles <SPACE RUNNER>

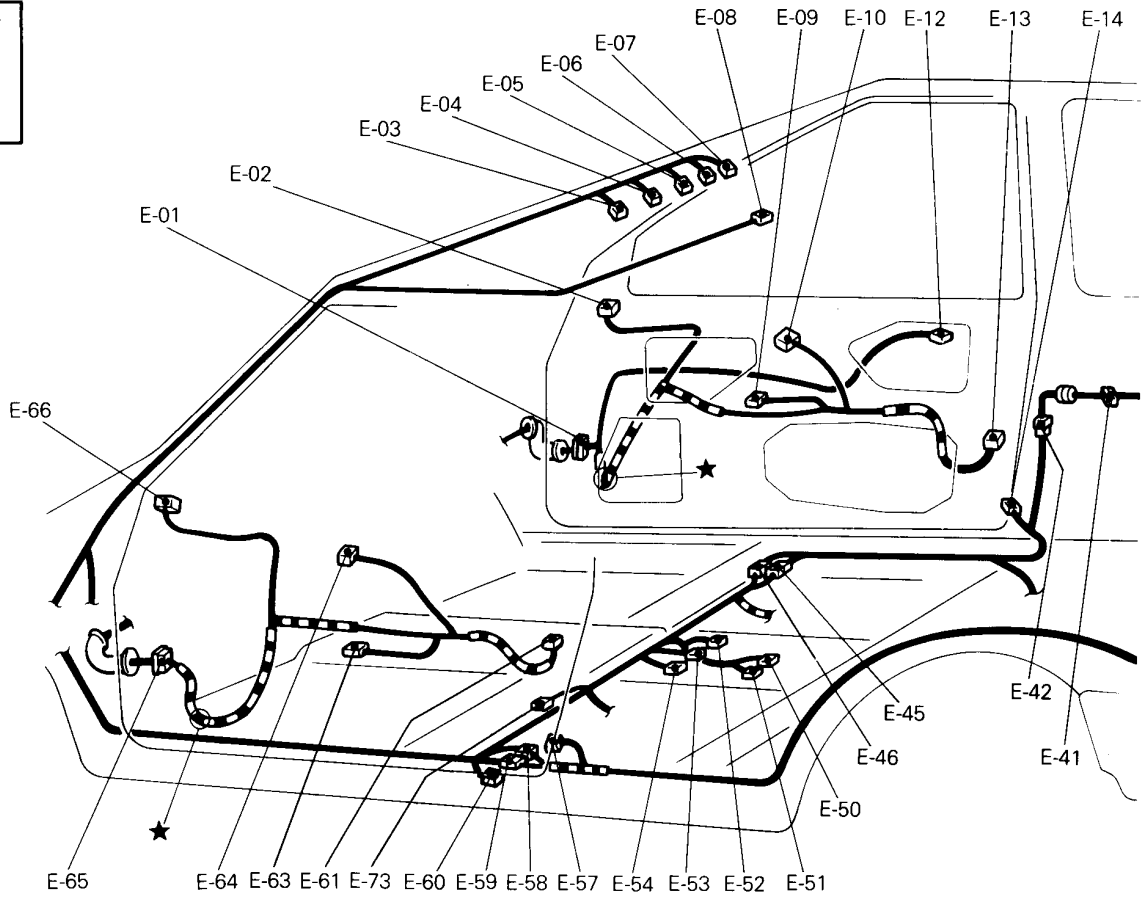
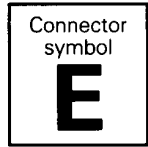

- |                            |  |                  |   |
|----------------------------|--|------------------|---|
| E-01                       | Front door wiring harness (RH) and main wiring harness combination | E-20             | Rear door lock actuator (RH)  |
| E-02                       | Remote controlled mirror (RH)                                      | E-21             | Defogger (+)  |
| E-03                       | Sunroof control relay  | E-22             | —   |
| E-04                       | Sunroof relay  | E-23             | Cargo room lamp   |
| E-05                       | Room lamp <vehicles with sunroof>                                  | E-24             | Defogger (—)  |
| E-06                       | Limit switch <vehicles with sunroof>                               | E-25 }<br>E-26 } | Rear combination lamp (RH)  |
| E-07                       | Sunroof motor  | E-27             | —   |
| E-08                       | Room lamp <vehicles without sunroof>                               | E-28             | Back-up lamp  |
| E-09                       | Power window motor (RH)  | E-29             | License plate lamp  |
| E-10                       | Power window sub switch (front)                                    | E-30             | Tailgate switch   |
| E-11                       | —  | E-31             | Rear wiper motor  |
| E-12                       | Door lock key cylinder switch                                      | E-32             | Tailgate lock actuator  |
| E-13                       | Front door lock actuator (RH)                                      | E-33             | Tailgate wiring harness and tailgate sub wiring harness combination |
| E-14                       | Front door switch (passenger's side)                               | E-34             | Rear wiring harness and rear bumper wiring harness combination      |
| E-15 }<br>thru }<br>E-18 } | —  | E-35             | Rear fog lamp   |
| E-19                       | Rear door switch (RH)  | E-36             | —   |

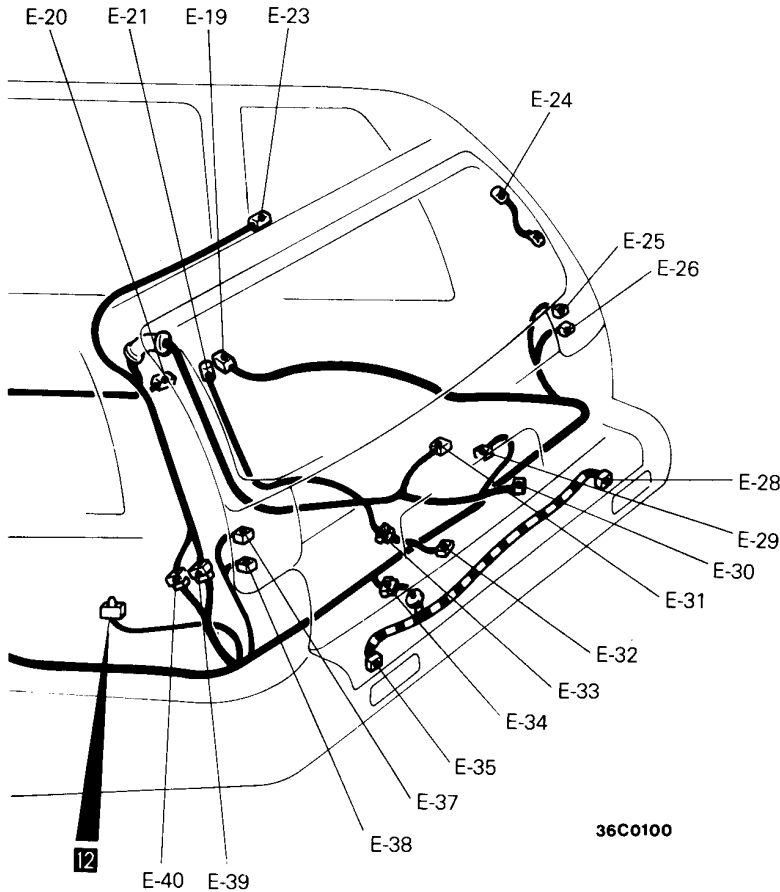

Vehicles with heated seat

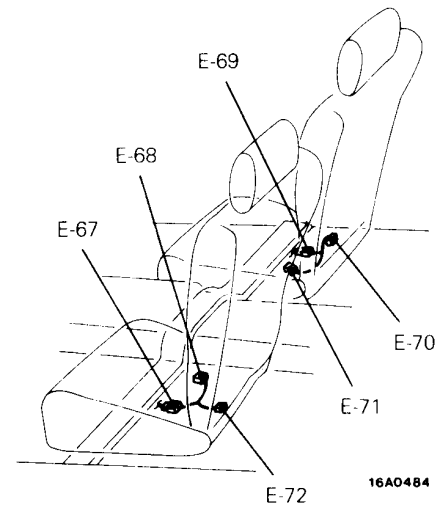

36C0100

- |      |   |      |   |
|------|---|------|---|
| E-37 | Rear combination lamp (LH)                                  | E-57 | Front door switch (driver's side)                                   |
| E-38 |   | E-58 | Main wiring harness and rear wiring harness combination             |
| E-39 | Rear wiring harness and tailgate wiring harness combination | E-59 | No connection   |
| E-40 |   | E-60 |   |
| E-41 | Contact switch (door side)                                  | E-61 | Front door lock actuator (LH)                                       |
| E-42 | Contact switch (body side)                                  | E-62 | —   |
| E-43 | —   | E-63 | Power window motor (LH)   |
| E-44 | —   | E-64 | Power window main switch  |
| E-45 | Main wiring harness and assist wiring harness combination   | E-65 | Front door wiring harness (LH) and main wiring harness combination  |
| E-46 |   | E-66 | Remote controlled mirror (LH)                                       |
| E-47 | —   | E-67 | Main wiring harness and heated seat wiring harness (LH) combination |
| E-48 |   | E-68 | Seat cushion heater (LH)  |
| E-49 |   | E-69 | Main wiring harness and heated seat wiring harness (RH) combination |
| E-50 | Heated seat switch (RH)                                     | E-70 | Seat back heater (RH)   |
| E-51 | Heated seat switch (LH)                                     | E-71 | Seat cushion heater (RH)  |
| E-52 | Remote controlled mirror switch                             | E-72 | Seat back heater (LH)   |
| E-53 | ABS G sensor <4WD>  | E-73 | No connection   |
| E-54 | Parking brake switch  |      |   |
| E-55 | —   |      |   |
| E-56 | —   |      |   |

6-2 R.H. drive vehicles <SPACE RUNNER>

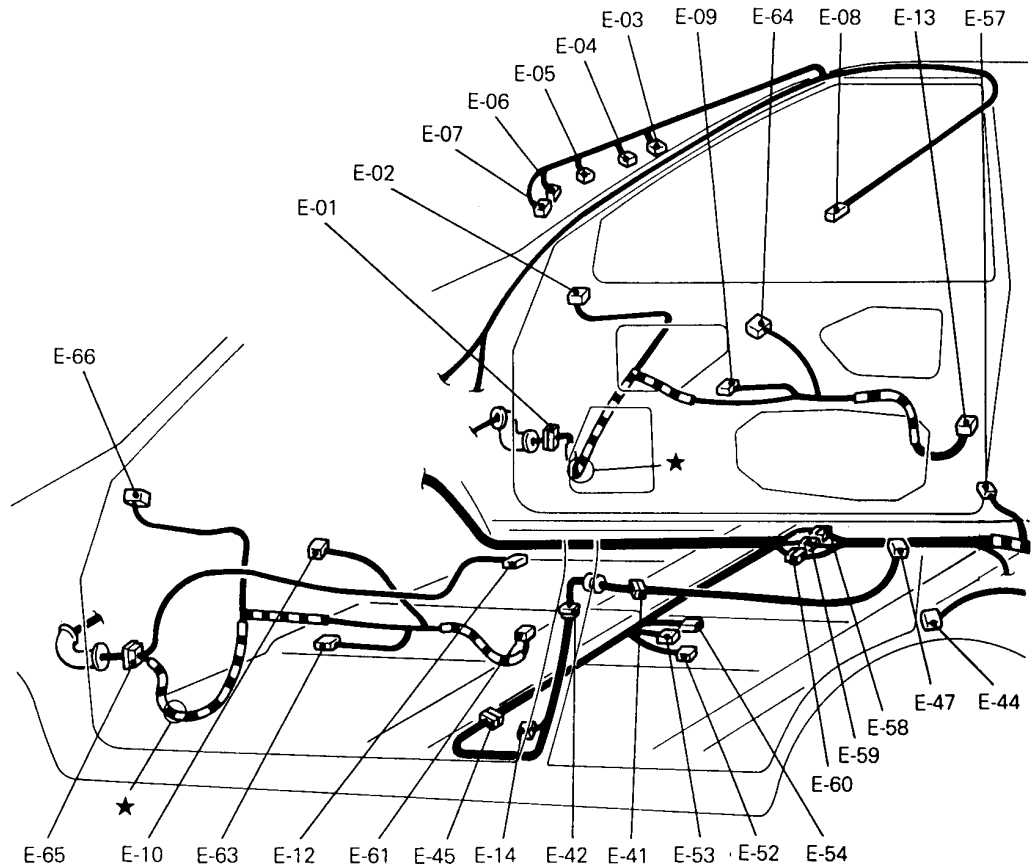
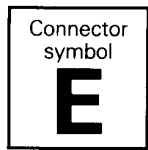

- |                            |  |                  |   |
|----------------------------|--|------------------|---|
| E-01                       | Front door wiring harness (RH) and main wiring harness combination | E-21             | Defogger (+)  |
| E-02                       | Remote controlled mirror (RH)                                      | E-22             | —   |
| E-03                       | Sunroof control relay  | E-23             | Cargo room lamp   |
| E-04                       | Sunroof relay  | E-24             | Defogger (—)  |
| E-05                       | Room lamp <vehicles with sunroof>                                  | E-25 }<br>E-26 } | Rear combination lamp (RH)  |
| E-06                       | Limit switch <vehicles with sunroof>                               | E-27             | —   |
| E-07                       | Sunroof motor  | E-28             | Back-up lamp  |
| E-08                       | Room lamp <vehicles without sunroof>                               | E-29             | License plate lamp  |
| E-09                       | Power window motor (RH)  | E-30             | Tailgate switch   |
| E-10                       | Power window sub switch (front)                                    | E-31             | Rear wiper motor  |
| E-11                       | —  | E-32             | Tailgate lock actuator  |
| E-12                       | Door lock key cylinder switch                                      | E-33             | Tailgate wiring harness and tailgate sub wiring harness combination |
| E-13                       | Front door lock actuator (RH)                                      | E-34             | Rear wiring harness and rear bumper wiring harness combination      |
| E-14                       | Front door switch (passenger's side)                               | E-35             | Rear fog lamp   |
| E-15 }<br>thru }<br>E-20 } | —  |                  |   |

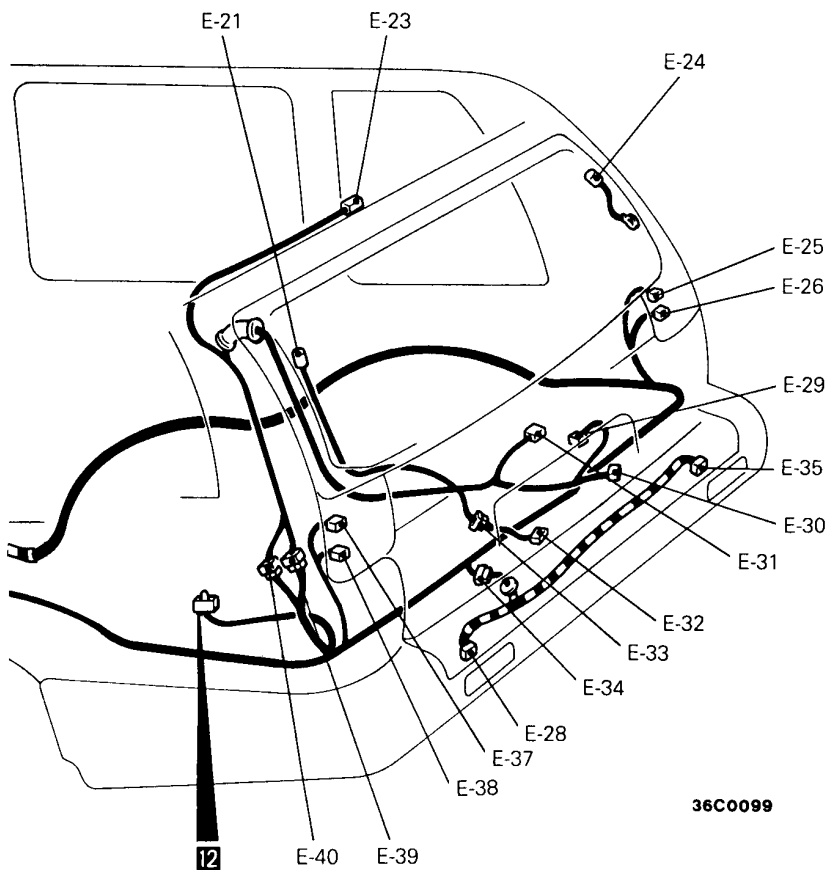

36C0099

- |      |   |      |  |
|------|---|------|--|
| E-36 | —   | E-54 | Parking brake switch   |
| E-37 | } Rear combination lamp (LH)                                  | E-55 | —  |
| E-38 |   | E-56 | —  |
| E-39 |   | E-57 | Front door switch (driver's side)                                  |
| E-40 | } Rear wiring harness and tailgate wiring harness combination | E-58 | } Main wiring harness and rear wiring harness combination          |
| E-41 |   | E-59 |  |
| E-42 | Contact switch (door side)                                    | E-60 | —  |
| E-43 | —   | E-61 | Front door lock actuator (LH)                                      |
| E-44 | Rear door switch (LH)   | E-62 | —  |
| E-45 | Main wiring harness and assist wiring harness combination     | E-63 | Power window motor (LH)  |
| E-46 | —   | E-64 | Power window main switch   |
| E-47 | Rear door lock actuator (LH)                                  | E-65 | Front door wiring harness (LH) and main wiring harness combination |
| E-48 | } —   | E-66 | Remote controlled mirror (LH)                                      |
| thru |   | E-67 | } —  |
| E-51 |   | E-72 |  |
| E-52 |   |      |  |
| E-53 | Remote controlled mirror switch                               |      |  |
|      | ABS G sensor <4WD>  |      |  |

6-3 L.H. drive vehicles <SPACE WAGON>

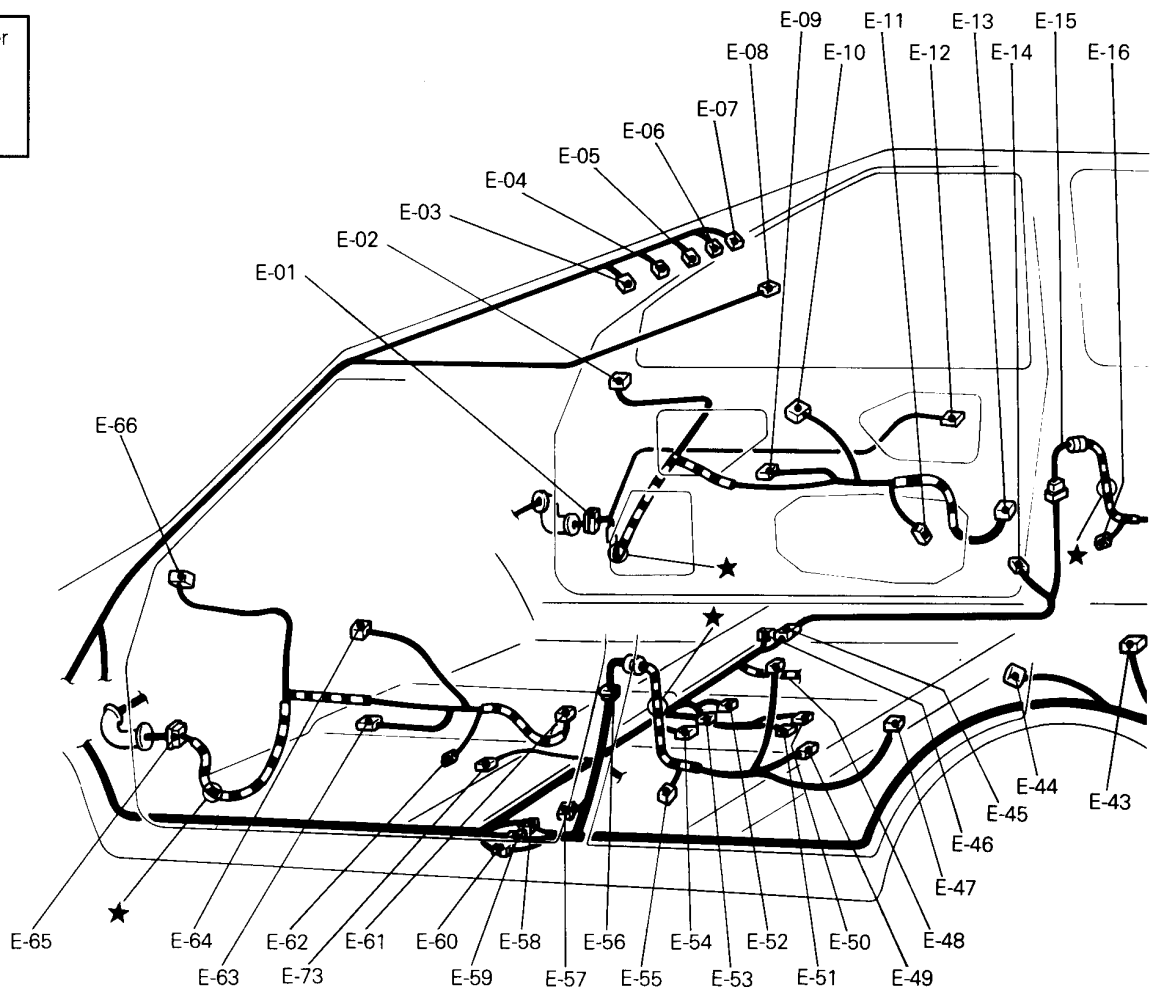
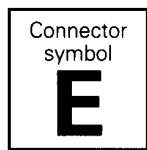

- |      |  |                                   |   |
|------|--|-----------------------------------|---|
| E-01 | Front door wiring harness (RH) and main wiring harness combination | E-19                              | Rear door switch (RH)   |
| E-02 | Remote controlled mirror (RH)                                      | E-20                              | Rear door lock actuator (RH)  |
| E-03 | Sunroof control relay  | E-21                              | Defogger (+)  |
| E-04 | Sunroof relay  | E-22                              | Rear speaker (RH)   |
| E-05 | Room lamp <vehicles with sunroof>                                  | E-23                              | Cargo room lamp   |
| E-06 | Limit switch <vehicles with sunroof>                               | E-24                              | Defogger (-)  |
| E-07 | Sunroof motor  | E-25 } Rear combination lamp (RH) |   |
| E-08 | Room lamp <vehicles without sunroof>                               | E-26 }                            |   |
| E-09 | Power window motor (RH)  | E-27                              | Tailgate lamp (RH)  |
| E-10 | Power window sub switch (front)                                    | E-28                              | Back-up lamp  |
| E-11 | Front door lamp (passenger's side)                                 | E-29                              | License plate lamp  |
| E-12 | Door lock key cylinder switch                                      | E-30                              | Tailgate switch   |
| E-13 | Front door lock actuator (RH)                                      | E-31                              | Rear wiper motor  |
| E-14 | Front door switch (passenger's side)                               | E-32                              | Tailgate lock actuator  |
| E-15 | Assist wiring harness and rear door wiring harness combination     | E-33                              | Tailgate wiring harness and tailgate sub wiring harness combination |
| E-16 | Power window motor (rear: RH)                                      | E-34                              | Rear wiring harness and rear bumper wiring harness combination      |
| E-17 | Power window sub switch (rear: RH)                                 | E-35                              | Rear fog lamp   |
| E-18 | Rear door lamp (RH)  |                                   |   |



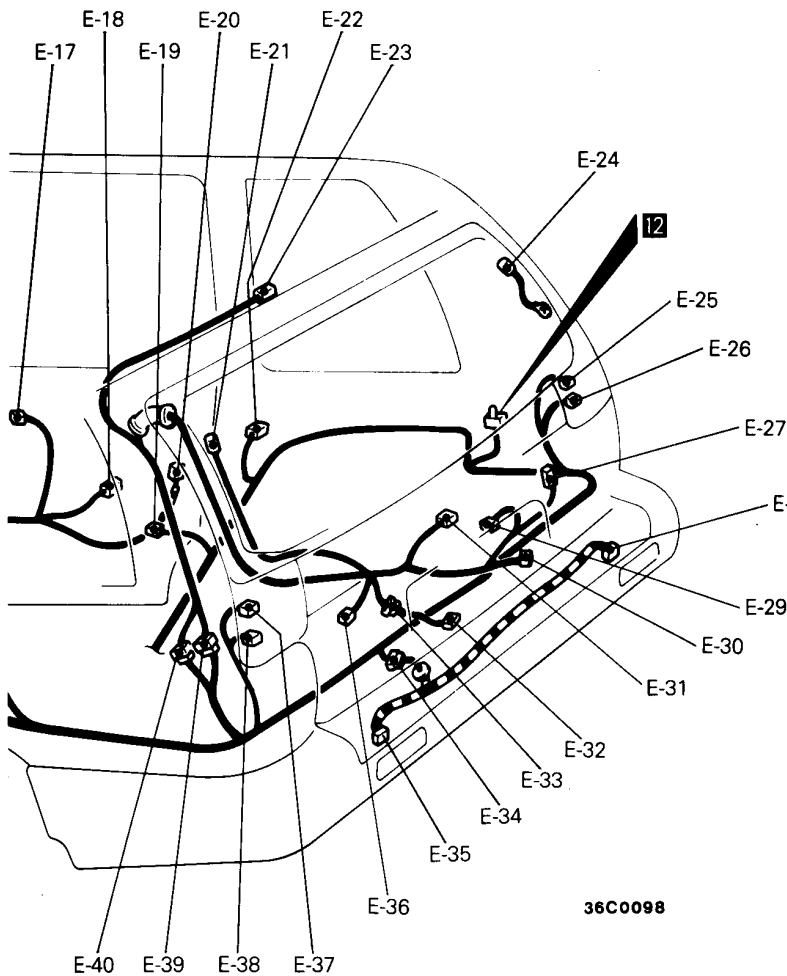

Vehicles with heated seat

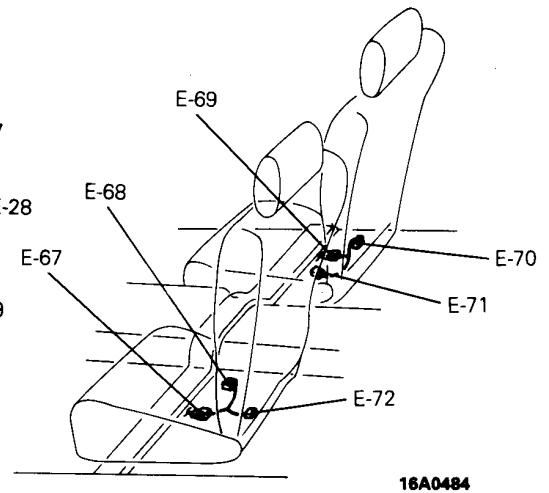

- E-36 Tailgate lamp (LH)
- E-37 } Rear combination lamp (LH)
- E-38 } Rear combination lamp (LH)
- E-39 } Rear wiring harness and tailgate wiring harness combination
- E-40 } Rear wiring harness and tailgate wiring harness combination
- E-41 —
- E-42 —
- E-43 Rear speaker (LH)
- E-44 Rear door switch (LH)
- E-45 Main wiring harness and assist wiring harness combination
- E-46 No connection
- E-47 Rear door lock actuator (LH)
- E-48 Power window sub switch (rear: LH)
- E-49 Rear door lamp (LH)
- E-50 Heated seat switch (RH)
- E-51 Heated seat switch (LH)
- E-52 Remote controlled mirror switch
- E-53 ABS G sensor <4WD>
- E-54 Parking brake switch
- E-55 Power window motor (rear: LH)

- E-56 Assist wiring harness and rear door (LH) wiring harness combination
- E-57 Front door switch (driver's side)
- E-58 } Main wiring harness and rear wiring harness combination
- E-59 } Main wiring harness and rear wiring harness combination
- E-60 } Main wiring harness and rear wiring harness combination
- E-61 Front door lock actuator (LH)
- E-62 Front door lamp (driver's side)
- E-63 Power window motor (LH)
- E-64 Power window main switch
- E-65 Front door wiring harness (LH) and main wiring harness combination
- E-66 Remote controlled mirror (LH)
- E-67 Main wiring harness and heated seat wiring harness (LH) combination
- E-68 Seat cushion heater (LH)
- E-69 Main wiring harness and heated seat wiring harness (RH) combination
- E-70 Seat back heater (RH)
- E-71 Seat cushion heater (RH)
- E-72 Seat back heater (LH)
- E-73 Rear oxygen sensor <4G64> or no connection

6-4 R.H. drive vehicles <SPACE WAGON>

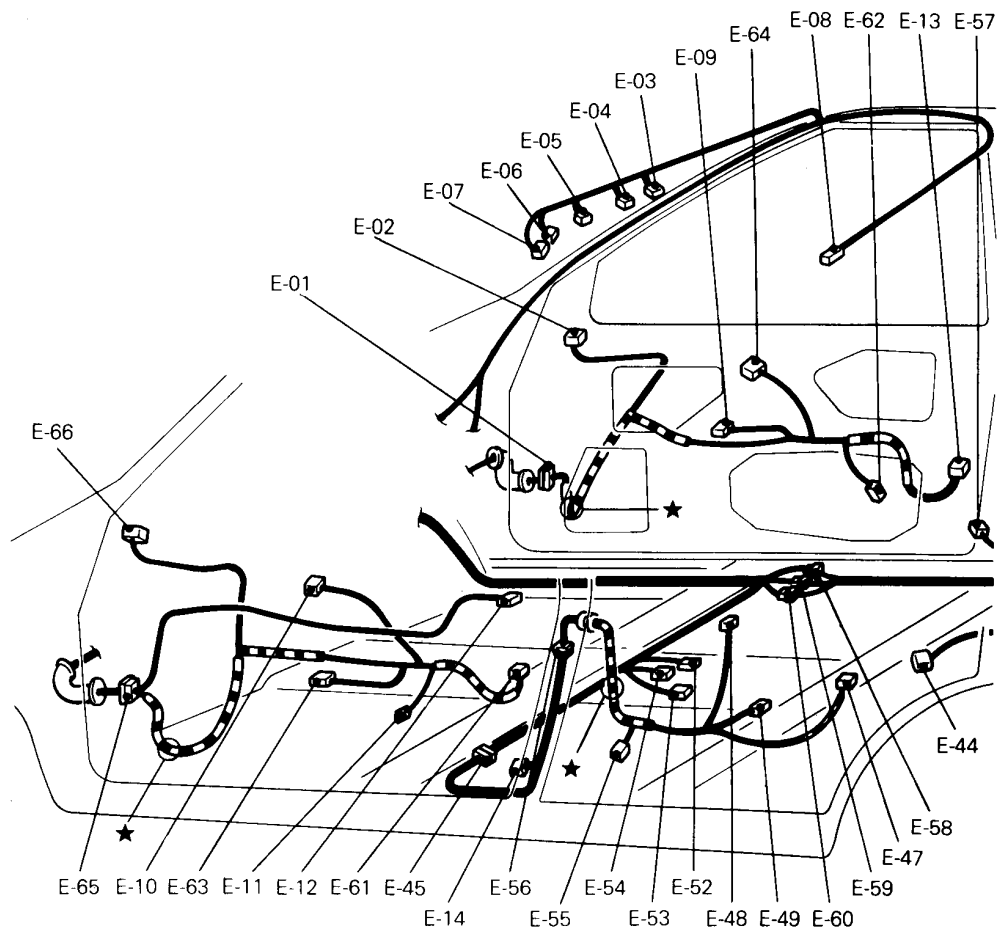
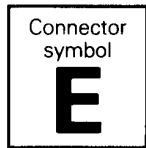

- |      |  |                  |   |
|------|--|------------------|---|
| E-01 | Front door wiring harness (RH) and main wiring harness combination | E-18             | Rear door lamp (RH)   |
| E-02 | Remote controlled mirror (RH)                                      | E-19             | Rear door switch (RH)   |
| E-03 | Sunroof control relay  | E-20             | Rear door lock actuator (RH)  |
| E-04 | Sunroof relay  | E-21             | Defogger (+)  |
| E-05 | Room lamp <vehicles with sunroof>                                  | E-22             | Rear speaker (RH)   |
| E-06 | Limit switch <vehicles with sunroof>                               | E-23             | Cargo room lamp   |
| E-07 | Sunroof motor  | E-24             | Defogger (-)  |
| E-08 | Room lamp <vehicles without sunroof>                               | E-25 }<br>E-26 } | Rear combination lamp (RH)  |
| E-09 | Power window motor (RH)  | E-27             | Tailgate lamp (RH)  |
| E-10 | Power window sub switch (front)                                    | E-28             | Back-up lamp  |
| E-11 | Front door lamp (passenger's side)                                 | E-29             | License plate lamp  |
| E-12 | Door lock key cylinder switch                                      | E-30             | Tailgate switch   |
| E-13 | Front door lock actuator (RH)                                      | E-31             | Rear wiper motor  |
| E-14 | Front door switch (passenger's side)                               | E-32             | Tailgate lock actuator  |
| E-15 | Assist wiring harness and rear door wiring harness combination     | E-33             | Tailgate wiring harness and tailgate sub wiring harness combination |
| E-16 | Power window motor (rear: RH)                                      | E-34             | Rear wiring harness and rear bumper wiring harness combination      |
| E-17 | Power window sub switch (rear: RH)                                 |                  |   |

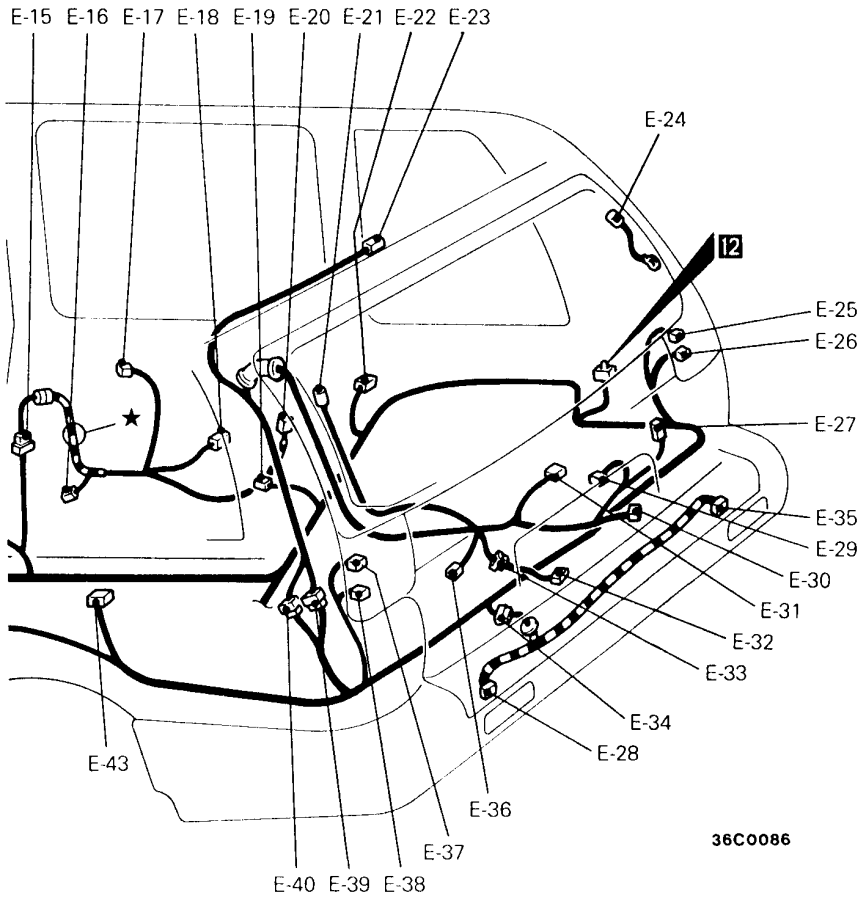

36C0086

- |                  |   |                  |   |
|------------------|---|------------------|---|
| E-35             | Rear fog lamp   | E-53             | ABS G sensor <4WD>  |
| E-36             | Tailgate lamp (LH)  | E-54             | Parking brake switch  |
| E-37 }<br>E-38 } | Rear combination lamp (LH)                                  | E-55             | Power window motor (rear: LH)                                       |
| E-39 }<br>E-40 } | Rear wiring harness and tailgate wiring harness combination | E-56             | Assist wiring harness and rear door (LH) wiring harness combination |
| E-41             | —   | E-57             | Front door switch (driver's side)                                   |
| E-42             | —   | E-58 }<br>E-59 } | Main wiring harness and rear wiring harness combination             |
| E-43             | Rear speaker (LH)   | E-60             | —   |
| E-44             | Rear door switch (LH)                                       | E-61             | Front door lock actuator (LH)                                       |
| E-45             | Main wiring harness and assist wiring harness combination   | E-62             | Front door lamp (driver's side)                                     |
| E-46             | —   | E-63             | Power window motor (LH)   |
| E-47             | Rear door lock actuator (LH)                                | E-64             | Power window main switch  |
| E-48             | Power window sub switch (rear: LH)                          | E-65             | Front door wiring harness (LH) and main wiring harness combination  |
| E-49             | Rear door lamp (LH)   | E-66             | Remote controlled mirror (LH)                                       |
| E-50             | —   | E-67 }<br>E-72 } | —   |
| E-51             | —   |                  |   |
| E-52             | Remote controlled mirror switch                             |                  |   |

## 7 REAR UNDER FLOOR

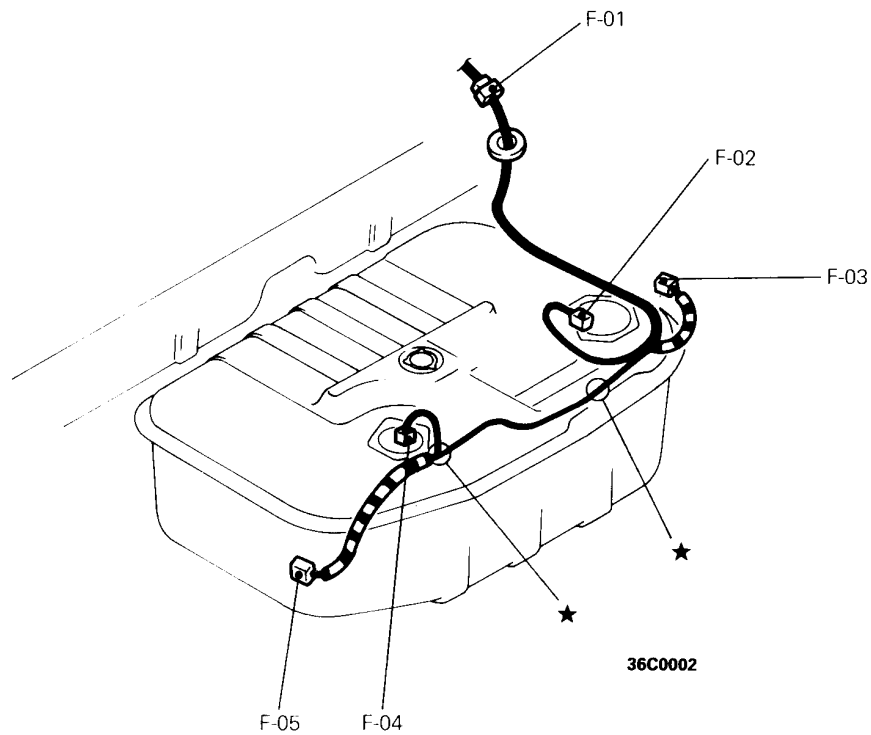
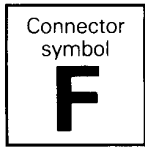

- F-01 Rear wiring harness\*<sup>1</sup> or assist wiring harness\*<sup>2</sup> and fuel wiring harness combination
- F-02 Fuel pump <2WD> or fuel pump and gauge assembly <4WD>
- F-03 ABS speed sensor (rear: RH)
- F-04 Fuel gauge unit
- F-05 ABS speed sensor (rear: LH)

Remarks

- \*1: SPACE RUNNER <RHD> and SPACE WAGON
- \*2: SPACE RUNNER <LHD>

## 2A WIRING HARNESS CONFIGURATION DIAGRAMS

### OVERALL WIRING DIAGRAM

L.H. drive vehicles .....	2A-2
R.H. drive vehicles .....	2A-3

### ENGINE COMPARTMENT **A**

L.H. drive vehicles with MPI engine .....	2A-4
R.H. drive vehicles with MPI engine .....	2A-6
L.H. drive vehicles with Diesel engine .....	2A-8
R.H. drive vehicles with Diesel engine .....	2A-10

### ENGINE AND TRANSMISSION **B**

4G93 MPI engine .....	2A-12
4G63 and 4G64 MPI engine .....	2A-13
Diesel engine .....	2A-14

### DASH PANEL **C**

L.H. drive vehicles .....	2A-16
R.H. drive vehicles .....	2A-18

### INSTRUMENT PANEL **D**

L.H. drive vehicles .....	2A-20
R.H. drive vehicles .....	2A-21

### INTERIOR **E**

L.H. drive vehicles <SPACE RUNNER> .....	2A-22
R.H. drive vehicles <SPACE RUNNER> .....	2A-24
L.H. drive vehicles <SPACE WAGON> .....	2A-26
R.H. drive vehicles <SPACE WAGON> .....	2A-28

### UNDER REAR FLOOR **F** ..... 2A-30

## OVERALL WIRING DIAGRAM

L.H. drive vehicles  
 <SPACE RUNNER>

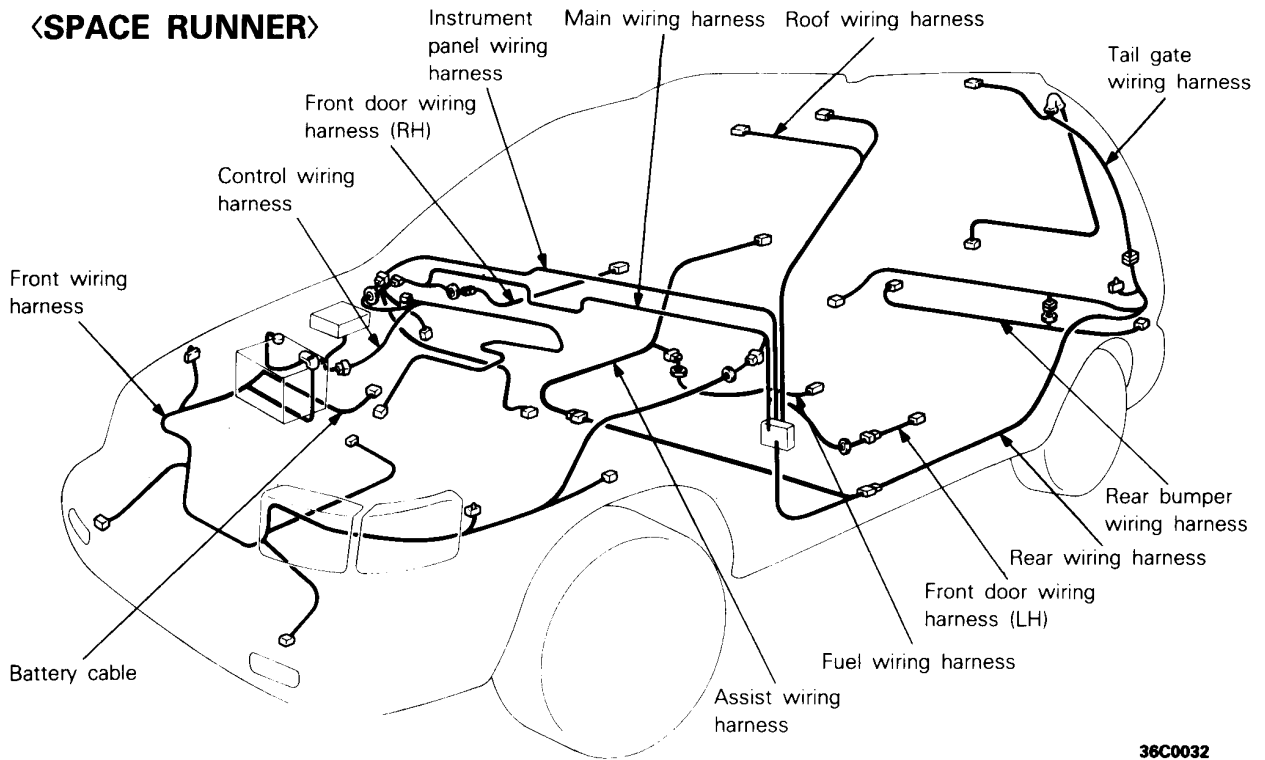

36C0032

<SPACE WAGON>

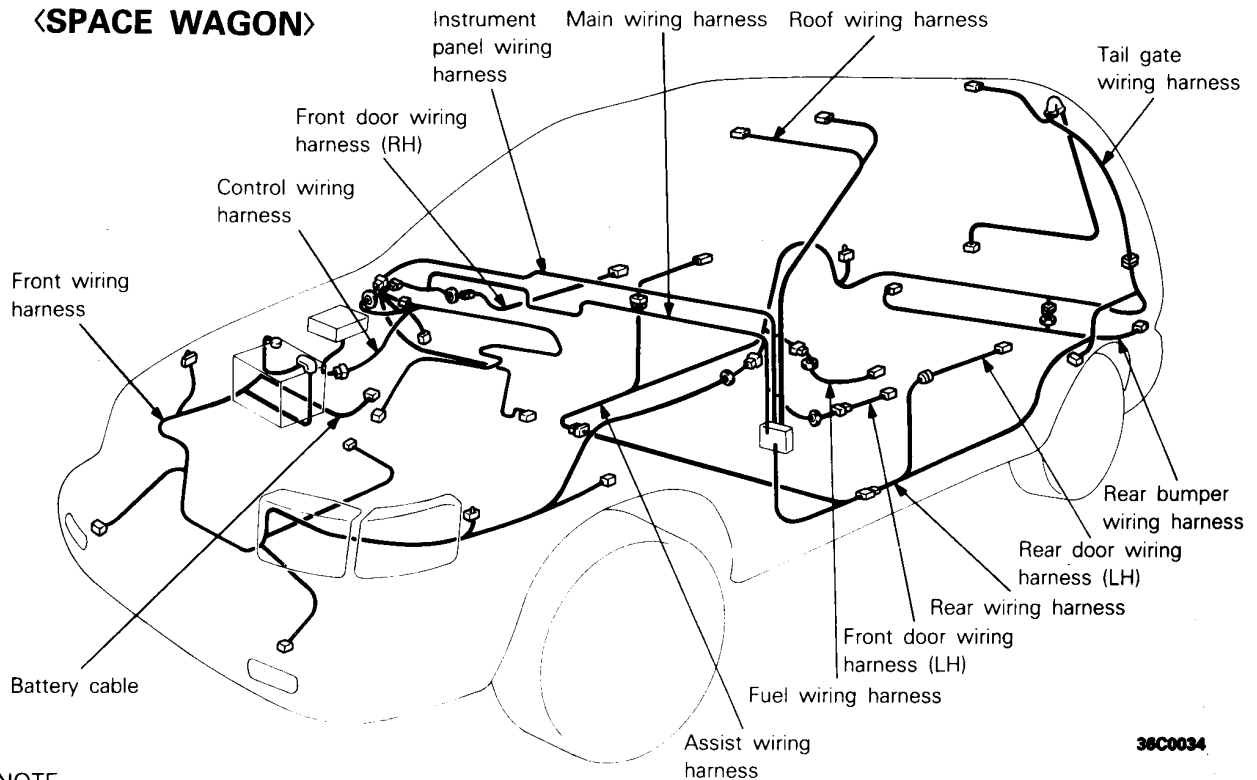

36C0034

NOTE  
 This illustration shows only the major wiring harness.

# OVERALL WIRING DIAGRAM

**R.H. drive vehicles  
<SPACE RUNNER>**

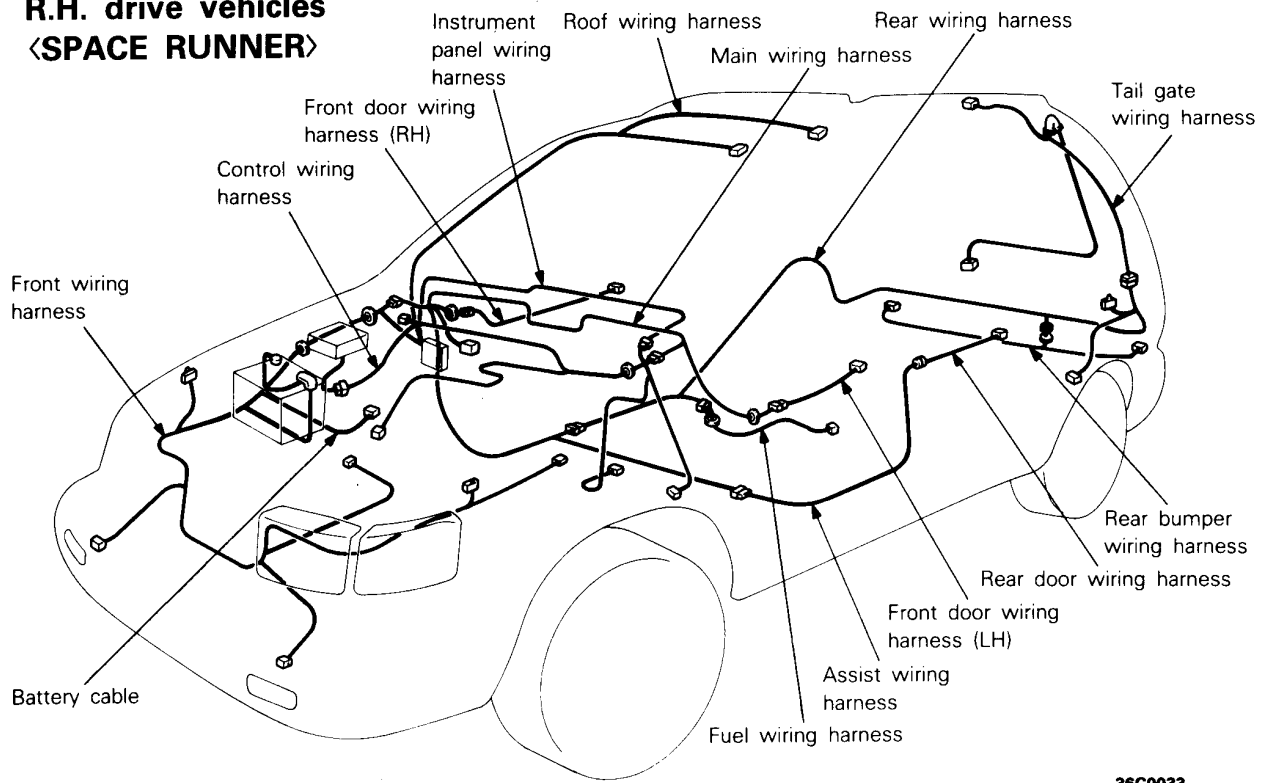

36C0033

**<SPACE WAGON>**

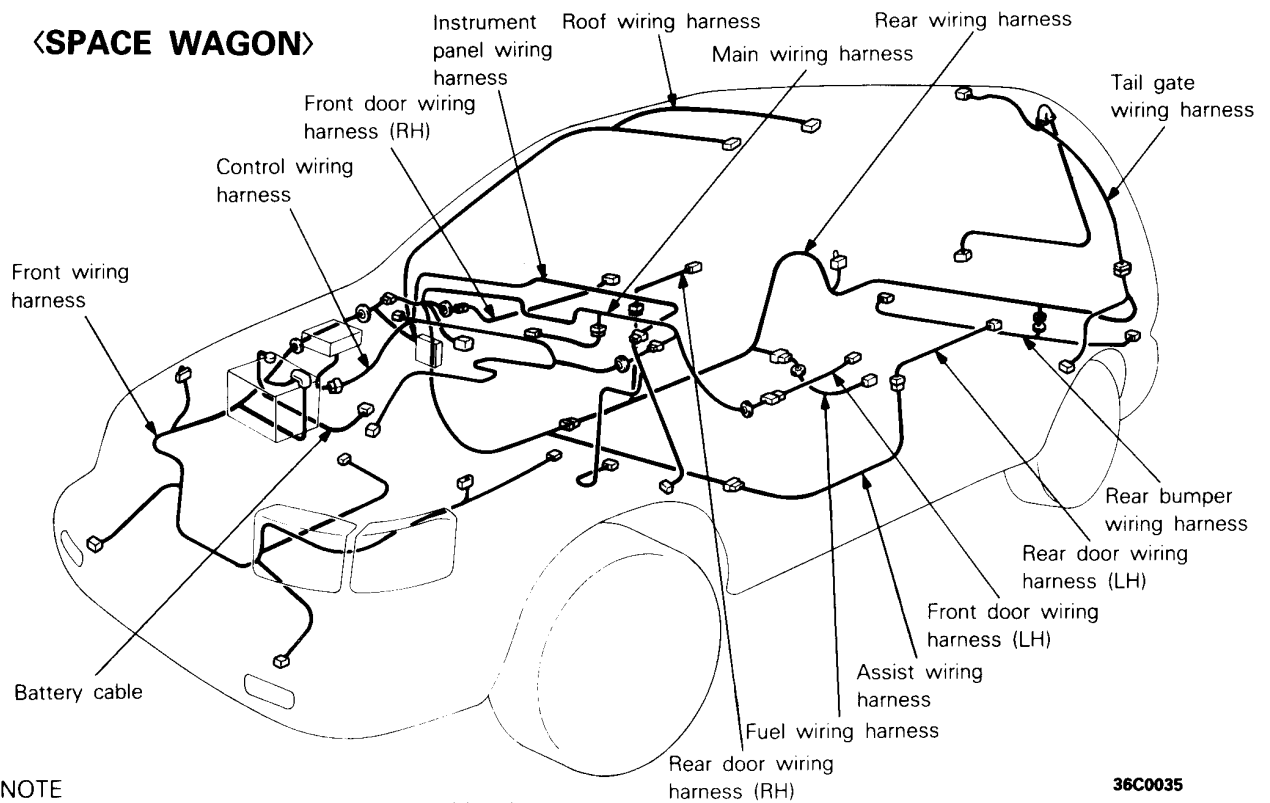

36C0035

**NOTE**  
This illustration shows only the major wiring harness.

# ENGINE COMPARTMENT

L.H. drive vehicles with MPI engine

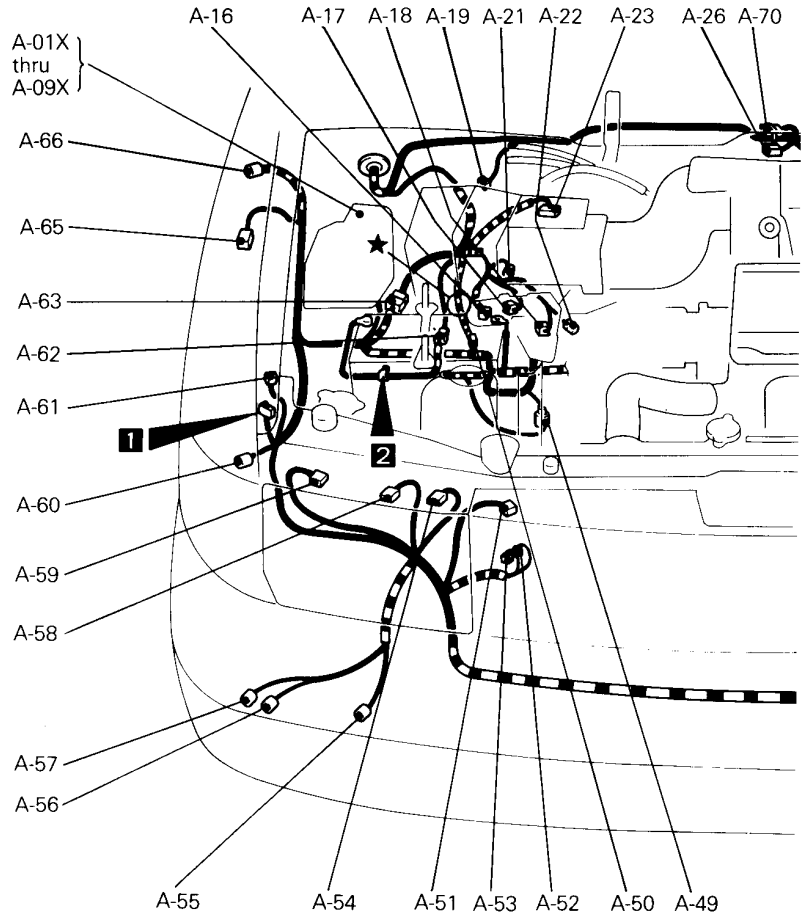
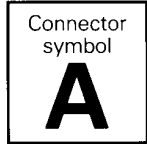

- A-01X } Refer to CENTRALIZED JUNCTION
- thru }
- A-09X }
- A-10 } —
- thru }
- A-15 }
- A-16 ELC-4A/T solenoid <A/T>
- A-17 Inhibitor switch <A/T>
- A-18 A/T fluid temperature sensor <A/T>
- A-19 Brake fluid level sensor
- A-20 —
- A-21 Pulse generator <A/T>
- A-22 Kickdown servo switch <A/T>
- A-23 Air flow sensor
- A-24 —
- A-25 —

- A-26 Fuel pump check connector
- A-27 —
- A-28 —
- A-29 EGR solenoid valve
- A-30 Purge control solenoid valve
- A-31 Ignition timing adjustment connector
- A-32 —
- A-33 Windshield wiper motor
- A-34 } —
- A-35 }
- A-36 }
- A-37 Side turn signal lamp (LH)
- A-38 ABS speed sensor (Front: LH)
- A-39 Dual pressure switch <4G93> or triple pressure switch <4G63 and 4G64>



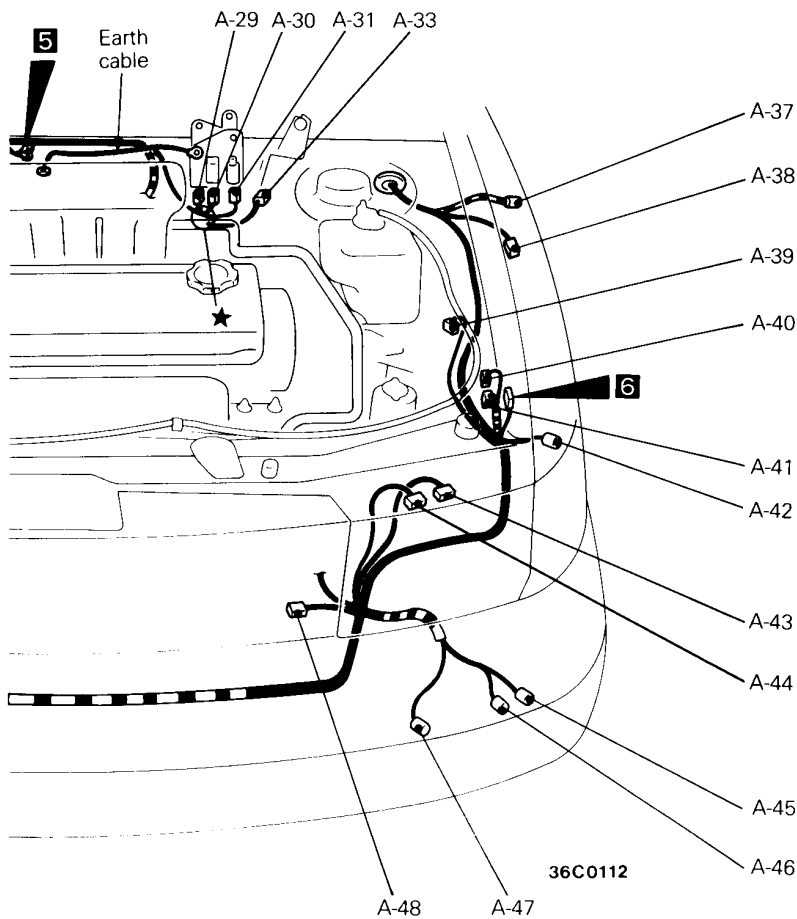

**Vehicles with daytime running lamp**

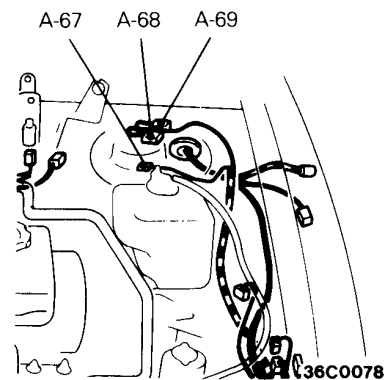

- |        |  |        |   |
|--------|--|--------|---|
| A-40 } | ABS hydraulic unit                                 | A-56 } | Horn (RH)   |
| A-41 } |  | A-57 } |   |
| A-42   | Front combination lamp (LH)                        | A-58   | Headlamp leveling unit (RH)                                 |
| A-43   | Headlamp leveling unit (LH)                        | A-59   | Headlamp washer motor                                       |
| A-44   | Headlamp (LH)                                      | A-60   | Front combination lamp (RH)                                 |
| A-45 } |  | A-61   | Headlamp washer relay                                       |
| A-46 } | Horn (LH)  | A-62   | Control wiring harness and battery cable combination        |
| A-47   | Front turn signal lamp (LH)                        | A-63   | Front wiring harness and control wiring harness combination |
| A-48   | Condenser fan motor                                | A-64   | —   |
| A-49   | Front wiring harness and battery cable combination | A-65   | ABS speed sensor (Front: RH)                                |
| A-50   | Back-up lamp switch (M/T)                          | A-66   | Side turn signal lamp (RH)                                  |
| A-51   | Radiator fan motor                                 | A-67   | Daytime running lamp control unit                           |
| A-52   | Windshield washer motor                            | A-68   | Daytime running lamp relay 1                                |
| A-53   | Rear washer motor                                  | A-69   | Daytime running lamp relay 2                                |
| A-54   | Headlamp (RH)                                      | A-70   | Engine speed detection connector                            |
| A-55   | Front turn signal lamp (RH)                        |        |   |

# ENGINE COMPARTMENT

R.H. drive vehicles with MPI engine

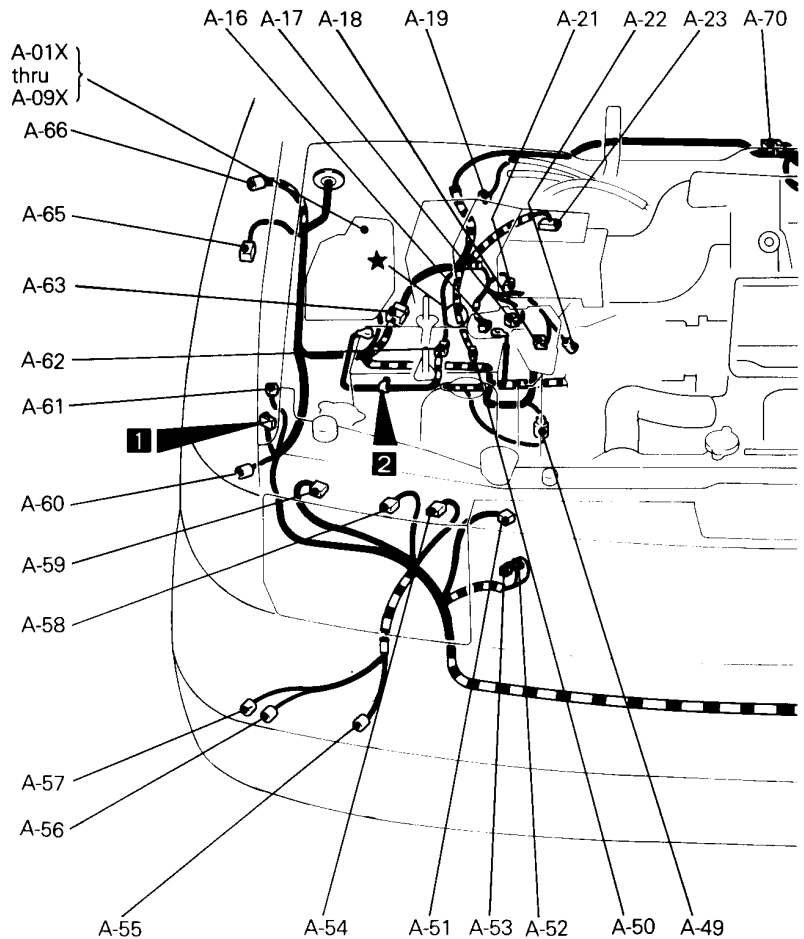
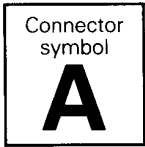

- A-01X } Refer to CENTRALIZED JUNCTION
- thru }
- A-09X }
- A-10 } —
- thru }
- A-15 }
- A-16 ELC-4A/T solenoid <A/T>
- A-17 Inhibitor switch <A/T>
- A-18 A/T fluid temperature sensor <A/T>
- A-19 Brake fluid level sensor
- A-20 —
- A-21 Pulse generator <A/T>
- A-22 Kickdown servo switch <A/T>
- A-23 Air flow sensor
- A-24 —
- A-25 —

- A-26 Fuel pump check connector
- A-27 —
- A-28 —
- A-29 EGR solenoid valve
- A-30 Purge control solenoid valve
- A-31 Ignition timing adjustment connector
- A-32 Resistor
- A-33 Windshield wiper motor
- A-34 Dim-dip lamp relay 1
- A-35 Dim-dip lamp relay 2
- A-36 Dim-dip lamp relay 3
- A-37 Side turn signal lamp (LH)
- A-38 ABS speed sensor (Front: LH)
- A-39 Dual pressure switch <4G93> or triple pressure switch <4G63>

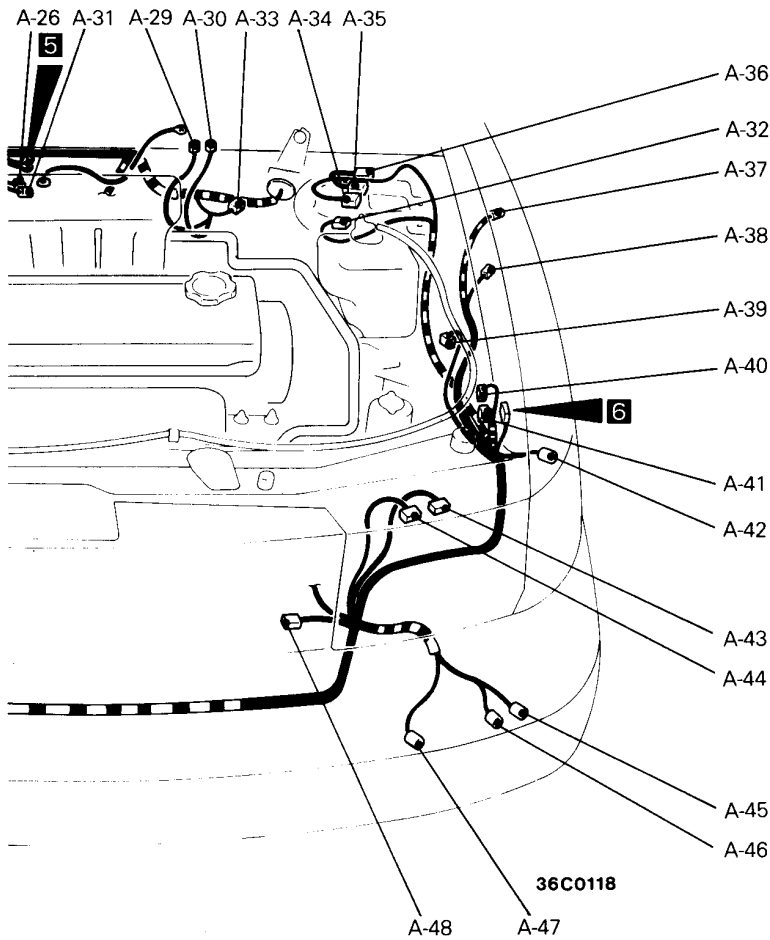

- A-40 } ABS hydraulic unit
- A-41 } Front combination lamp (LH)
- A-42 } Headlamp leveling unit (LH)
- A-43 } Headlamp (LH)
- A-44 } Horn (LH)
- A-45 } Front turn signal lamp (LH)
- A-46 } Condenser fan motor
- A-47 } Front wiring harness and battery cable combination
- A-48 } Back-up lamp switch (M/T)
- A-49 } Radiator fan motor
- A-50 } Windshield washer motor
- A-51 } Rear washer motor
- A-52 } Headlamp (RH)
- A-53 } Front turn signal lamp (RH)

- A-54 } Horn (RH)
- A-55 } Headlamp leveling unit (RH)
- A-56 } Headlamp washer motor
- A-57 } Front combination lamp (RH)
- A-58 } Headlamp washer relay
- A-59 } Control wiring harness and battery cable combination
- A-60 } Front wiring harness and control wiring harness combination
- A-61 } —
- A-62 } ABS speed sensor (Front: RH)
- A-63 } Side turn signal lamp (RH)
- A-64 } —
- A-65 } —
- A-66 } —
- A-67 } —
- A-68 } —
- A-69 } —
- A-70 } Engine speed detection connector

# ENGINE COMPARTMENT

L.H. drive vehicles with Diesel engine

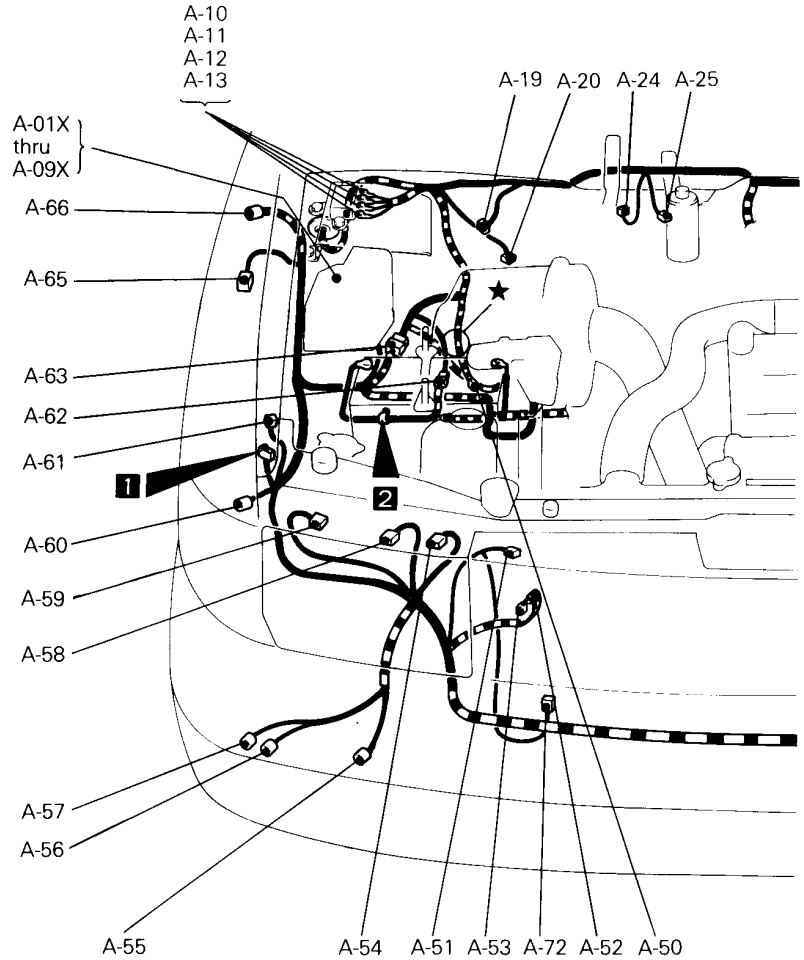
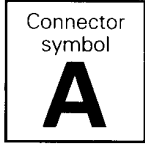

- A-01X } Refer to CENTRALIZED JUNCTION
- thru }
- A-09X }
- A-10 } Glow plug relay
- thru }
- A-13 }
- A-14 } —
- thru }
- A-18 } —
- A-19 } Brake fluid level sensor
- A-20 } Vacuum switch
- A-21 } —
- A-22 } —
- A-23 } —
- A-24 } Starter relay
- A-25 } Water level switch

- A-26 } —
- A-27 } Idle-up solenoid valve (A/C)
- A-28 } EGR solenoid valve No. 1
- A-29 } EGR solenoid valve No. 2
- A-30 } —
- A-31 } —
- A-32 } —
- A-33 } Windshield wiper motor
- A-34 } —
- A-35 } —
- A-36 } —
- A-37 } Side turn signal lamp (LH)
- A-38 } ABS speed sensor (Front: LH)
- A-39 } Triple pressure switch
- A-40 } ABS hydraulic unit
- A-41 } —

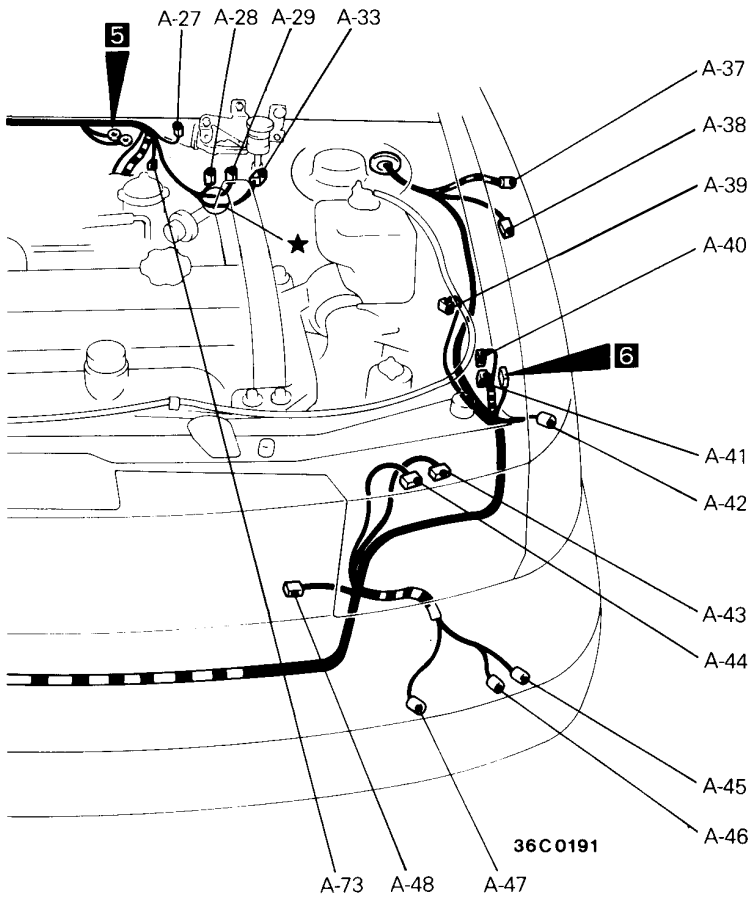

**Vehicles with daytime running lamp**

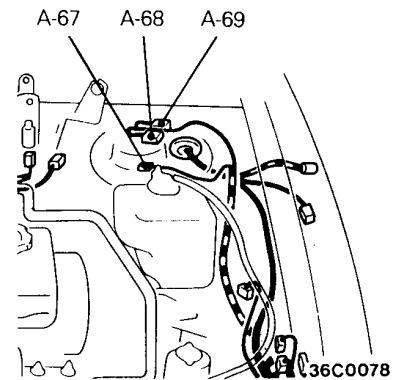

- |                  |                             |      |   |
|------------------|-----------------------------|------|---|
| A-42             | Front combination lamp (LH) | A-58 | Headlamp leveling unit (RH)                                 |
| A-43             | Headlamp leveling unit (LH) | A-59 | Headlamp washer motor                                       |
| A-44             | Headlamp (LH)               | A-60 | Front combination lamp (RH)                                 |
| A-45 }<br>A-46 } | Horn (LH)                   | A-61 | Headlamp washer relay                                       |
| A-47             | Front turn signal lamp (LH) | A-62 | Control wiring harness and battery cable combination        |
| A-48             | Condenser fan motor         | A-63 | Front wiring harness and control wiring harness combination |
| A-49             | —                           | A-64 | —   |
| A-50             | Back-up lamp switch <M/T>   | A-65 | ABS speed sensor (Front: RH)                                |
| A-51             | Radiator fan motor          | A-66 | Side turn signal lamp (RH)                                  |
| A-52             | Windshield washer motor     | A-67 | Daytime running lamp control unit                           |
| A-53             | Rear washer motor           | A-68 | Daytime running lamp relay 1                                |
| A-54             | Headlamp (RH)               | A-69 | Daytime running lamp relay 2                                |
| A-55             | Front turn signal lamp (RH) | A-70 | —   |
| A-56 }<br>A-57 } | Horn (RH)                   | A-71 | —   |
|                  |                             | A-72 | Thermo switch and resistor (Radiator fan)                   |
|                  |                             | A-73 | A/C refrigerant capacity control solenoid valve             |

# ENGINE COMPARTMENT

R.H. drive vehicles with Diesel engine

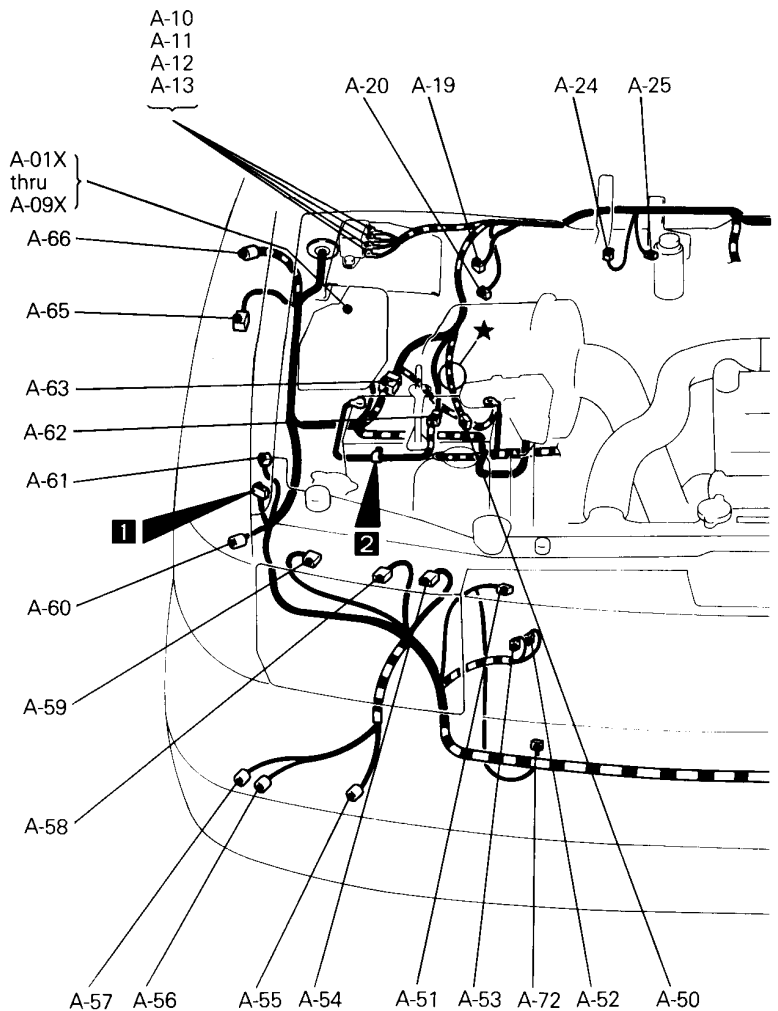
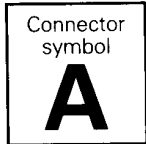

- A-01X } Refer to CENTRALIZED JUNCTION
- thru }
- A-09X }
- A-10 } Glow plug relay
- thru }
- A-13 }
- A-14 } —
- thru }
- A-18 }
- A-19 } Brake fluid level sensor
- A-20 } Vacuum switch
- A-21 } —
- A-22 }
- A-23 }
- A-24 } Starter relay
- A-25 } Water level switch

- A-26 } —
- A-27 } Idle-up solenoid valve <A/C>
- A-28 } EGR solenoid valve No. 1
- A-29 } EGR solenoid valve No. 2
- A-30 } —
- A-31 } —
- A-32 } Resistor
- A-33 } Windshield wiper motor
- A-34 } Dim-dip lamp relay 1
- A-35 } Dim-dip lamp relay 2
- A-36 } Dim-dip lamp relay 3
- A-37 } Side turn signal lamp (LH)
- A-38 } ABS speed sensor (Front: LH)
- A-39 } Triple pressure switch
- A-40 } ABS hydraulic unit
- A-41 }

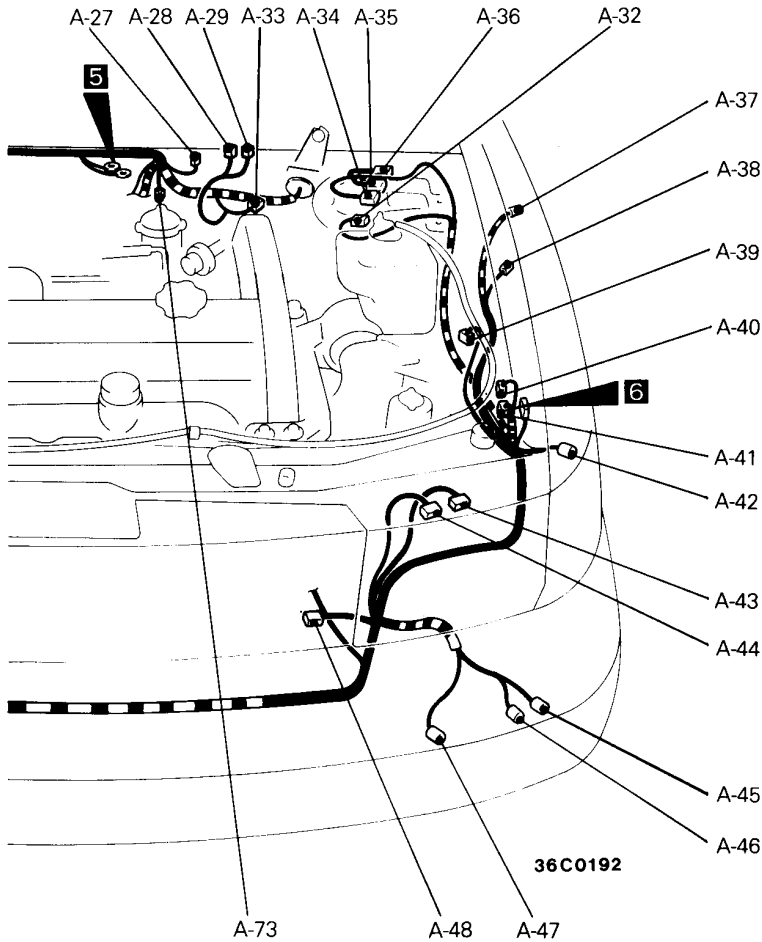

- A-42 Front combination lamp (LH)
- A-43 Headlamp leveling unit (LH)
- A-44 Headlamp (LH)
- A-45 } Horn (LH)
- A-46 }
- A-47 Front turn signal lamp (LH)
- A-48 Condenser fan motor
- A-49 —
- A-50 Back-up lamp switch <M/T>
- A-51 Radiator fan motor
- A-52 Windshield washer motor
- A-53 Rear washer motor
- A-54 Headlamp (RH)
- A-55 Front turn signal lamp (RH)
- A-56 } Horn (RH)
- A-57 }

- A-58 Headlamp leveling unit (RH)
- A-59 Headlamp washer motor
- A-60 Front combination lamp (RH)
- A-61 Headlamp washer relay
- A-62 Control wiring harness and battery cable combination
- A-63 Front wiring harness and control wiring harness combination
- A-64 —
- A-65 ABS speed sensor (Front: RH)
- A-66 Side turn signal lamp (RH)
- A-67 } —
- thru }
- A-71 }
- A-72 Thermo switch and resistor (Radiator fan)
- A-73 A/C refrigerant capacity control solenoid valve

# ENGINE AND TRANSMISSION

## 4G93 MPI engine

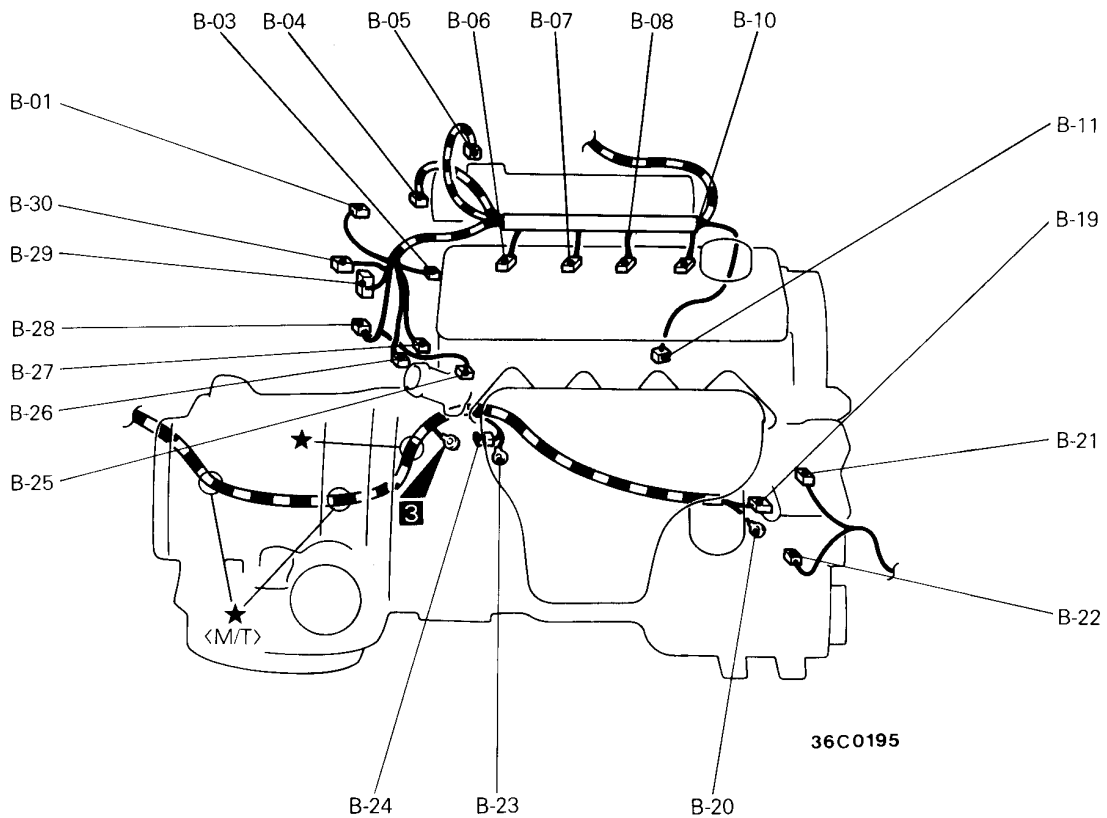
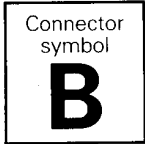

- |                            |  |        |   |
|----------------------------|--|--------|---|
| B-01                       | Engine coolant temperature sensor (for engine control) | B-19 } | Alternator  |
| B-02                       | —  | B-20 } | Alternator  |
| B-03                       | Engine coolant temperature gauge unit                  | B-21   | Power steering oil pressure switch                  |
| B-04                       | Idle speed control actuator                            | B-22   | Magnetic clutch and revolution pick-up sensor <A/C> |
| B-05                       | Throttle position sensor                               | B-23 } | Starter   |
| B-06                       | Injector No. 4   | B-24 } |   |
| B-07                       | Injector No. 3   | B-25   | Engine coolant temperature switch (for A/C)         |
| B-08                       | Injector No. 2   | B-26   | Oxygen sensor                                       |
| B-09                       | —  | B-27   | Oil pressure switch                                 |
| B-10                       | Injector No. 1   | B-28 } | Distributor assembly                                |
| B-11                       | Detonation sensor                                      | B-29 } |   |
| B-12 }<br>thru }<br>B-18 } | —  | B-30   | Capacitor   |



## ENGINE AND TRANSMISSION

### 4G63 and 4G64 MPI engine

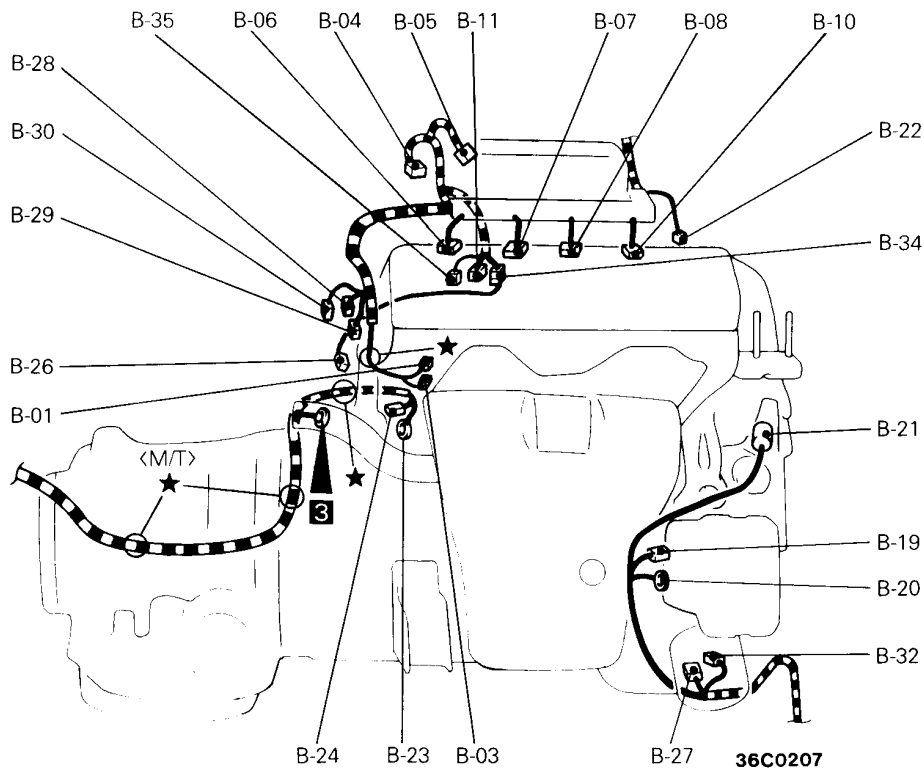
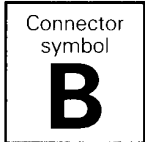

B-01	Engine coolant temperature sensor (for engine control)	B-21	Power steering oil pressure switch
B-02	—	B-22	Magnetic clutch <A/C>
B-03	Engine coolant temperature gauge unit	B-23 } Starter	
B-04	Idle speed control actuator	B-24 }	
B-05	Throttle position sensor	B-25	—
B-06	Injector No. 4	B-26	Oxygen sensor
B-07	Injector No. 3	B-27	Oil pressure switch
B-08	Injector No. 2	B-28 } Distributor assembly	
B-09	—	B-29 }	
B-10	Injector No. 1	B-30	Capacitor
B-11	Detonation sensor <4G63>	B-31	—
B-12 } —		B-32	Engine oil level sensor
thru } —		B-33	—
B-18 } —		B-34	Oxygen sensor sub wiring harness and control wiring harness combination
B-19 } Alternator		B-35	EGR temperature sensor <4G64>
B-20 }			

# ENGINE AND TRANSMISSION

## Diesel engine

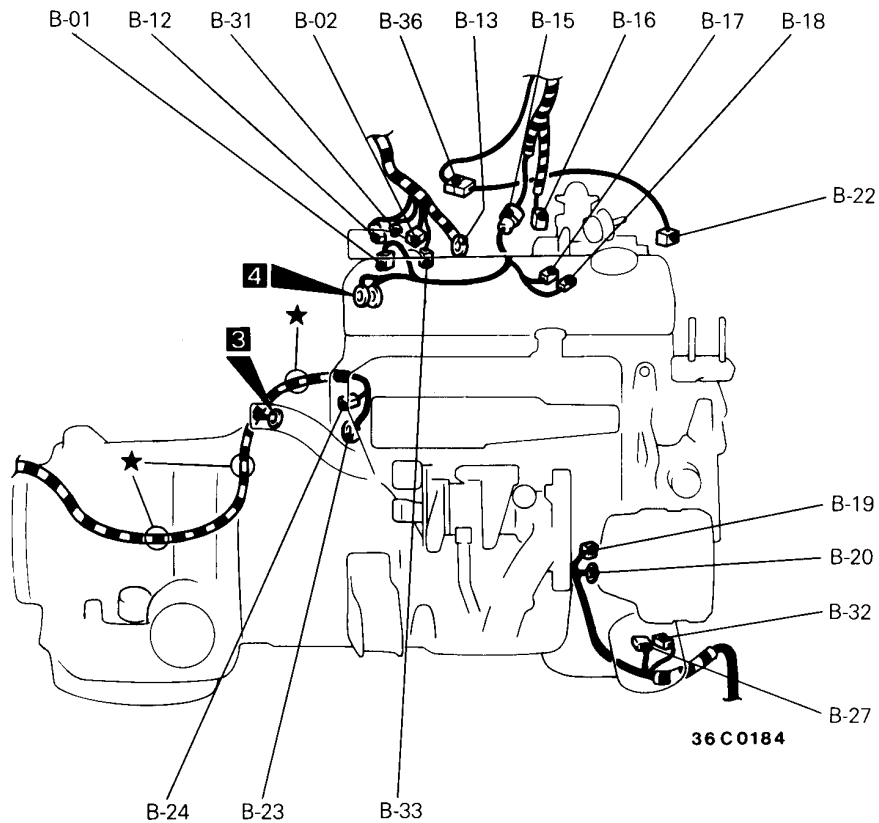
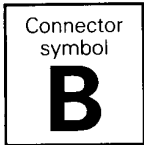

B-01	Engine coolant temperature sensor and gauge unit	B-22	Magnetic clutch <A/C>
B-02	Engine coolant temperature switch (for condenser fan)	B-23	Starter
B-03 } thru B-11	—	B-24	
		B-25	
B-12	Engine coolant temperature switch <A/C>	B-26	—
B-13	Glow plug	B-27	Oil pressure switch
B-14	—	B-28	—
B-15	Control wiring harness and fuel injection pump wiring harness combination	B-29	—
B-16	Lever (throttle) position sensor	B-30	—
B-17	Fuel cut solenoid valve	B-31	Engine coolant temperature sensor (for water temperature alarm lamp)
B-18	Revolution pick up sensor	B-32	Engine oil level sensor <SPACE WAGON>
B-19 } Alternator		B-33	Engine coolant temperature switch <EGR>
B-20 } —		B-34	—
B-21	—	B-35	—
		B-36	Control wiring harness and magnetic clutch joint wiring harness combination

NOTES

## DASH PANEL

L.H. drive vehicles

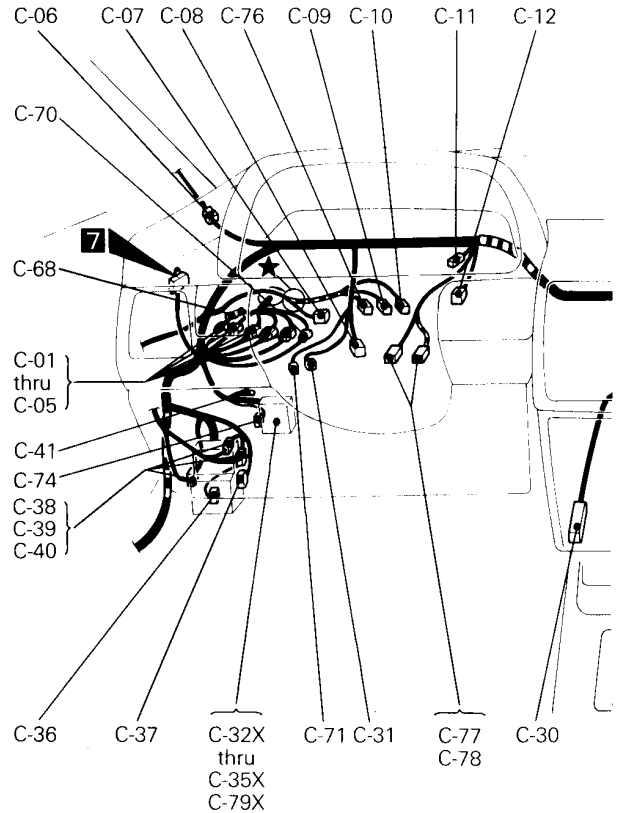
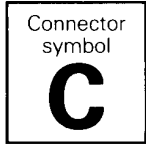

- C-01 } Front wiring harness and main wiring harness combination
- C-05 }
- C-06 Main wiring harness and roof wiring harness combination
- C-07 Ignition switch
- C-08 Stop lamp switch
- C-09 } Column switch
- C-10 }
- C-11 Diode (for headlamp circuit)
- C-12 No connection
- C-13 A/C switch
- C-14 Heater control illumination lamp
- C-15 Blower switch
- C-16 Resistor
- C-17 } Control wiring harness and main wiring harness combination
- C-18 }
- C-19 }
- C-20 Engine control unit or glow control unit
- C-21 } Engine control unit
- C-22 }
- C-23 Engine control relay
- C-24 Fuel octane ratio selection connector
- C-25 Blower motor

- C-26 } ELC-4A/T control unit
- C-27 }
- C-28 —
- C-29 Overdrive switch
- C-30 ABS control unit
- C-31 Lighting monitor buzzer
- C-32X ABS power relay
- C-33X Power windows relay
- C-34X Central door lock control unit or jumper connector
- C-35X Rear fog lamp relay
- C-36 Diagnosis connector
- C-37 Turn signal and hazard flasher unit
- C-38 } Main wiring harness and instrument panel wiring harness combination
- C-39 }
- C-40 }
- C-41 Diode (for ABS circuit)
- C-42 Air thermo sensor
- C-43 Air inlet sensor
- C-44 Automatic compressor control unit
- C-45 } Main wiring harness and A/C wiring harness combination
- C-46 }
- C-47 A/C belt lock controller <4G93>
- C-48 Defogger relay
- C-49 Roof wiring harness and junction block combination

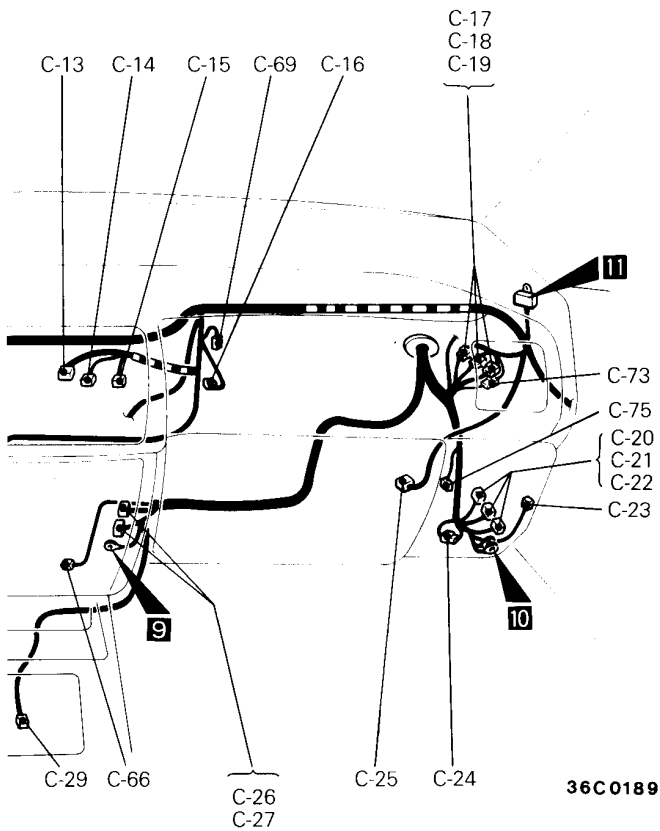

36C0189

**Vehicles with air conditioner  
<Vehicles with 4G93 MPI engine>**

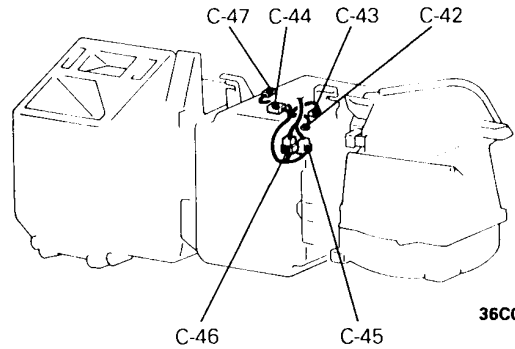

36C0038

**<Vehicles with 4G63, 4G64 MPI  
and diesel engine>**

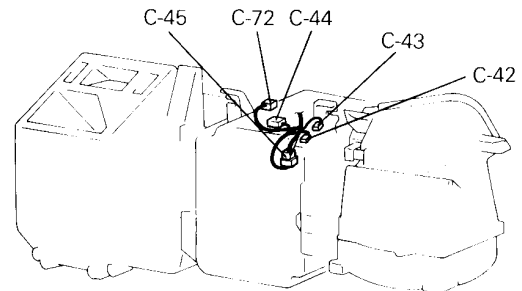

36C0194

- C-50 } Front wiring harness and junction block combination
- C-51 }
- C-52 }
- C-53 } Instrument panel wiring harness and junction block combination
- C-54 } Heater relay
- C-55 } Main wiring harness and junction block combination
- thru }
- C-61 }
- C-62 } —
- thru }
- C-65 }
- C-66 } Kick down switch <A/T>
- C-67 } —
- C-68 } Diode <Diesel (for A/C circuit)>
- C-69 } ABS resistor
- C-70 } Front wiring harness and main wiring harness combination <Diesel (A/C)>
- C-71 } Engine oil level relay
- C-72 } A/C relay <Diesel (A/C)>
- C-73 } Control wiring harness and main wiring harness combination <4G64>
- C-74 } J/C (Jumper connector)
- C-75 } J/C (Jumper connector)

**Junction block**

**(Front side)**

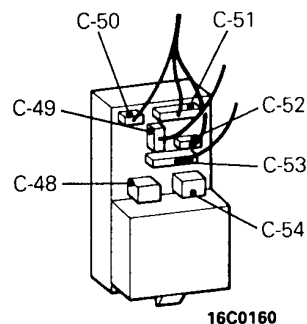

16C0160

**(Rear side)**

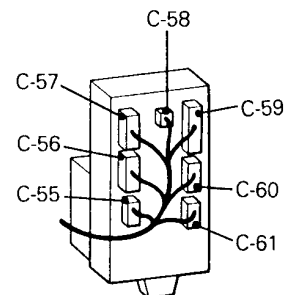

16A0337

- C-76 } Column switch <SRS>
- C-77 } Clock spring <SRS>
- C-78 }
- C-79X } Horn relay <SRS>

# DASH PANEL

R.H. drive vehicles

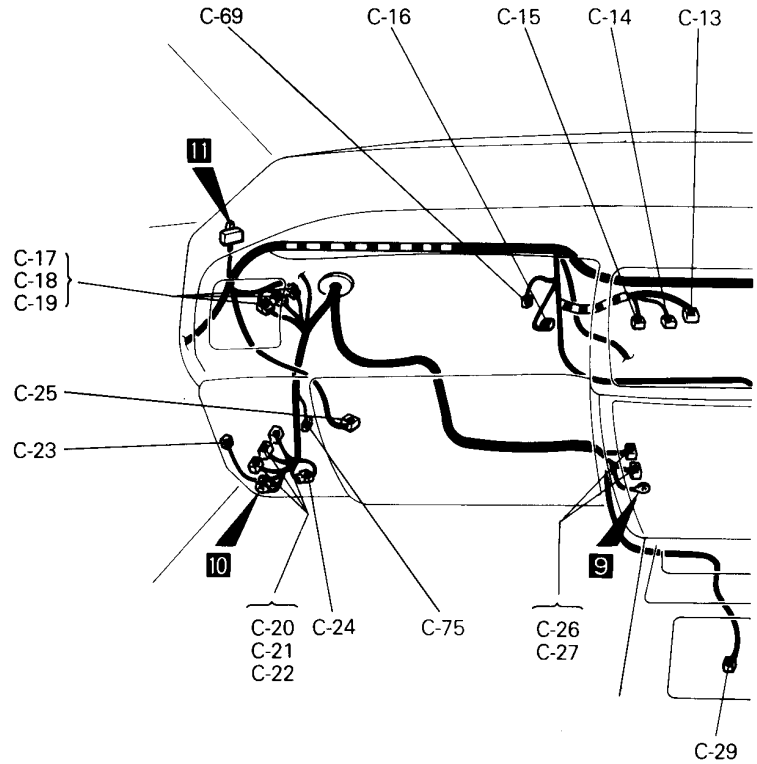
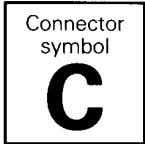

- |                            |  |        |   |
|----------------------------|--|--------|---|
| C-01 }<br>thru }<br>C-05 } | Front wiring harness and main wiring harness combination   | C-23   | Engine control relay  |
| C-06                       | Main wiring harness and roof wiring harness combination    | C-24   | Fuel octane ratio selection connector                               |
| C-07                       | Ignition switch  | C-25   | Blower motor  |
| C-08                       | Stop lamp switch   | C-26 } | ELC-4A/T control unit   |
| C-09 }                     | Column switch  | C-27 } |   |
| C-10 }                     |  | C-28   | —   |
| C-11                       | —  | C-29   | Overdrive switch  |
| C-12                       | No connection  | C-30   | ABS control unit  |
| C-13                       | A/C switch   | C-31   | Lighting monitor buzzer   |
| C-14                       | Heater control illumination lamp                           | C-32X  | ABS power relay   |
| C-15                       | Blower switch  | C-33X  | Power windows relay   |
| C-16                       | Resistor   | C-34X  | Central door lock control unit or jumper connector                  |
| C-17 }                     | Control wiring harness and main wiring harness combination | C-35X  | Rear fog lamp relay   |
| C-18 }                     |  | C-36   | Diagnosis connector   |
| C-19 }                     |  | C-37   | Turn signal and hazard flasher unit                                 |
| C-20                       | Engine control unit or glow control unit                   | C-38 } | Main wiring harness and instrument panel wiring harness combination |
| C-21 }                     | Engine control unit  | C-39 } |   |
| C-22 }                     |  | C-40 } | C-41  |
|                            |  | C-42   | Air thermo sensor   |
|                            |  | C-43   | Air inlet sensor  |

**Vehicles with air conditioner**  
**<Vehicles with 4G93 MPI engine>**

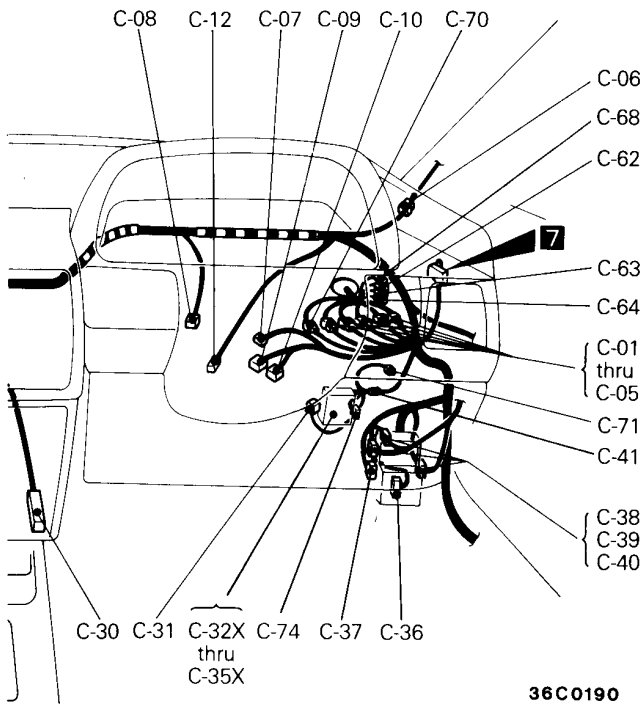

36C0190

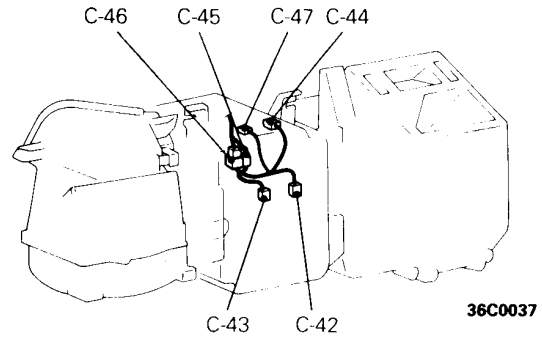

36C0037

**<Vehicles with 4G63 MPI and diesel engine>**

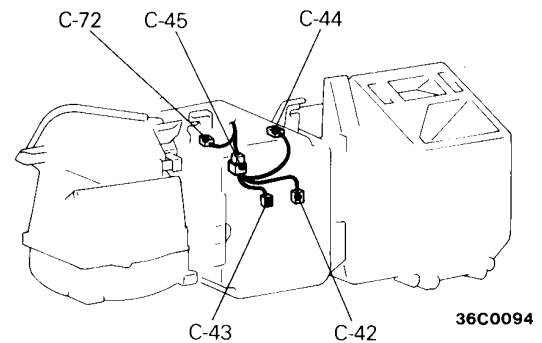

36C0094

**Junction block**  
**(Front side)**

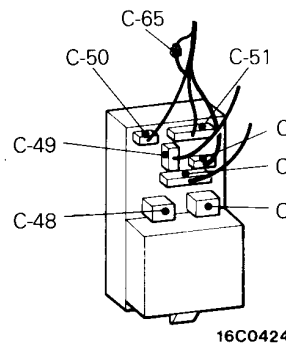

16C0424

**(Rear side)**

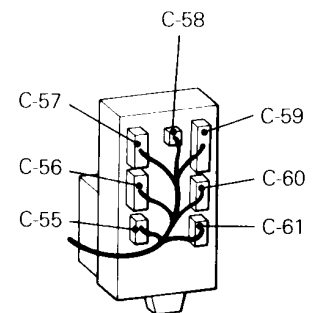

16A0337

- C-44 Automatic compressor control unit
- C-45 } Main wiring harness and A/C wiring harness combination
- C-46 }
- C-47 A/C belt lock controller <4G93>
- C-48 Defogger relay
- C-49 Roof wiring harness and junction block combination
- C-50 }
- C-51 } Front wiring harness and junction block combination
- C-52 }
- C-53 Instrument panel wiring harness and junction block combination
- C-54 Heater relay
- C-55 } Main wiring harness and junction block combination
- C-56 }
- C-57 }
- C-58 }
- C-59 }
- C-60 }
- C-61 }
- C-62 } Diode (for dim-dip lamp circuit)
- C-63 }
- C-64 }
- C-65 Rear fog lamp connector
- C-66 —
- C-67 —

- C-68 Diode <Diesel (for A/C circuit)>
- C-69 ABS resistor
- C-70 Front wiring harness and main wiring harness combination <Diesel (A/C)>
- C-71 Engine oil level relay
- C-72 A/C relay <Diesel (A/C)>
- C-73 —
- C-74 J/C (Jumper connector)
- C-75 J/C (Jumper connector)

# INSTRUMENT PANEL

L.H. drive vehicles

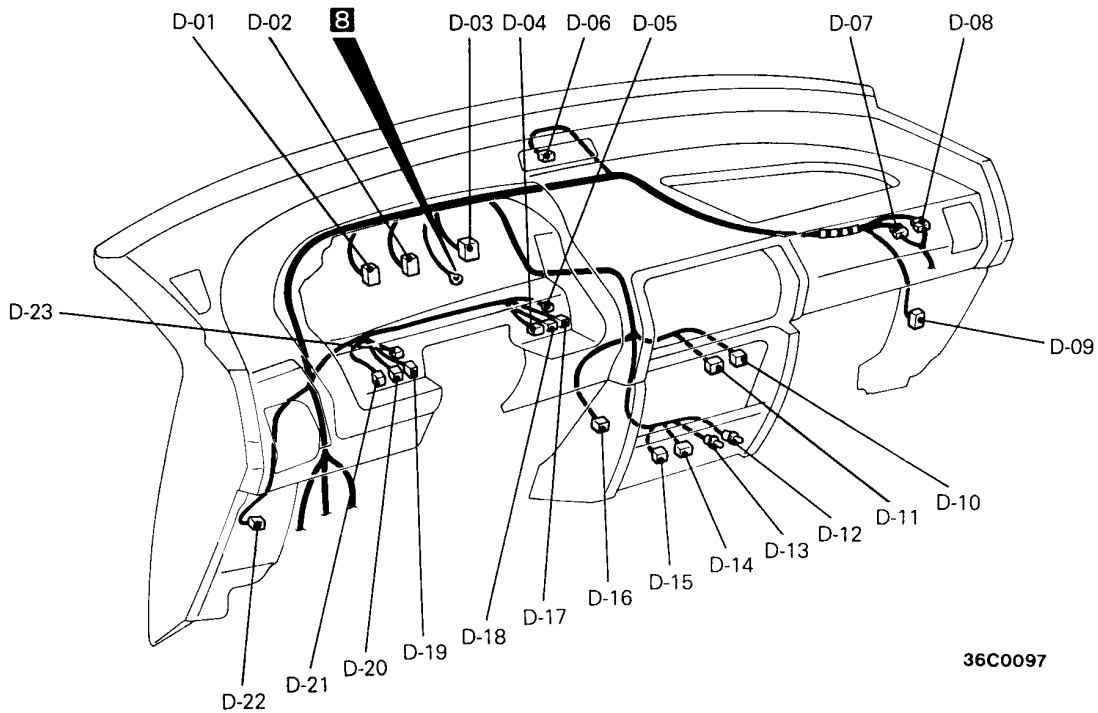
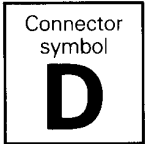

36C0097

- |      |  |                           |  |
|------|--|---------------------------|--|
| D-01 | } Combination meter                                  | D-13                      | Cigarette lighter illumination lamp      |
| D-02 |  | D-14                      | } Cigarette lighter                      |
| D-03 |  | D-15                      |  |
| D-04 | Rear wiper and washer switch                         | D-16                      | Headlamp leveling switch                 |
| D-05 | Cluster switch illumination lamp (RH)                | D-17                      | Hazard switch                            |
| D-06 | Clock  | D-18                      | Defogger switch                          |
| D-07 | } Instrument panel wiring harness and control wiring | D-19                      | Rear fog lamp switch                     |
| D-08 |  | harness combination       | D-20                                     |
| D-09 | Front speaker (RH)                                   | D-21                      | Door lock switch or tailgate lock switch |
| D-10 | } Radio and tape player                              | D-22                      | Front speaker (LH)                       |
| D-11 |  | Ashtray illumination lamp | D-23                                     |



# INSTRUMENT PANEL

R.H. drive vehicles

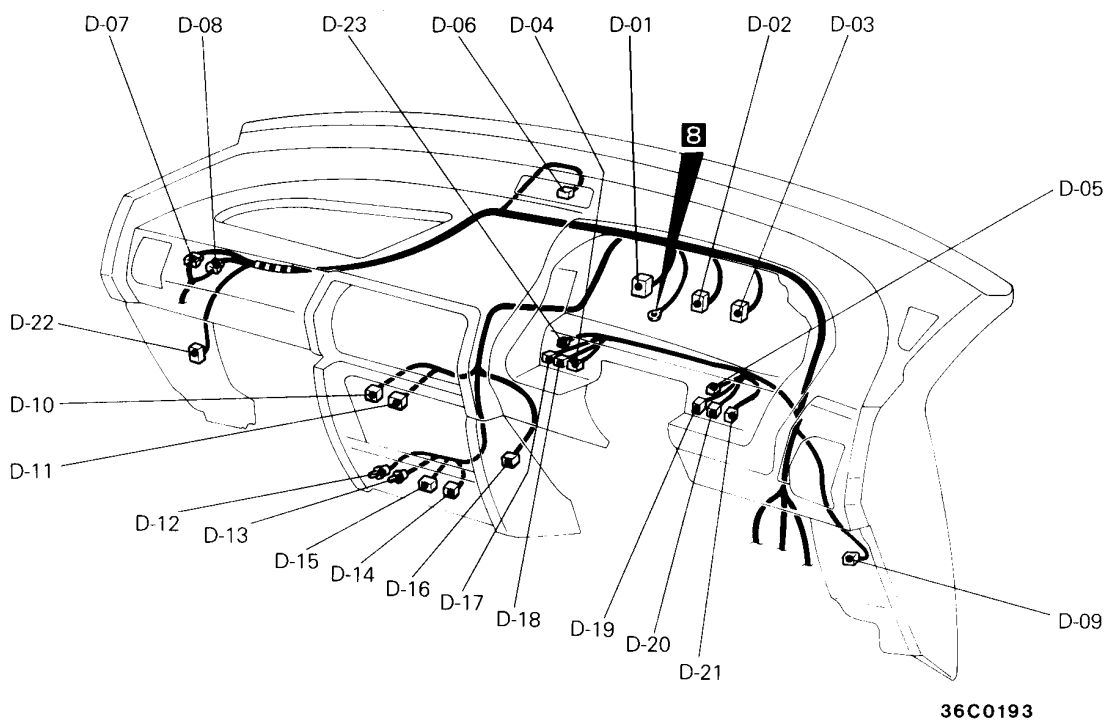
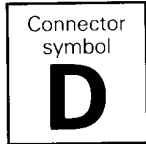

36C0193

- |      |  |                           |  |
|------|--|---------------------------|--|
| D-01 | } Combination meter                                  | D-13                      | Cigarette lighter illumination lamp      |
| D-02 |  | D-14                      | } Cigarette lighter                      |
| D-03 |  | D-15                      |  |
| D-04 | Rear wiper and washer switch                         | D-16                      | Headlamp leveling switch                 |
| D-05 | Cluster switch illumination lamp (RH)                | D-17                      | Hazard switch                            |
| D-06 | Clock  | D-18                      | Defogger switch                          |
| D-07 | } Instrument panel wiring harness and control wiring | D-19                      | Rear fog lamp switch                     |
| D-08 |  | harness combination       | D-20                                     |
| D-09 | Front speaker (RH)                                   | D-21                      | Door lock switch or tailgate lock switch |
| D-10 | } Radio and tape player                              | D-22                      | Front speaker (LH)                       |
| D-11 |  | Ashtray illumination lamp | D-23                                     |

# INTERIOR

## L.H. drive vehicles <SPACE RUNNER>

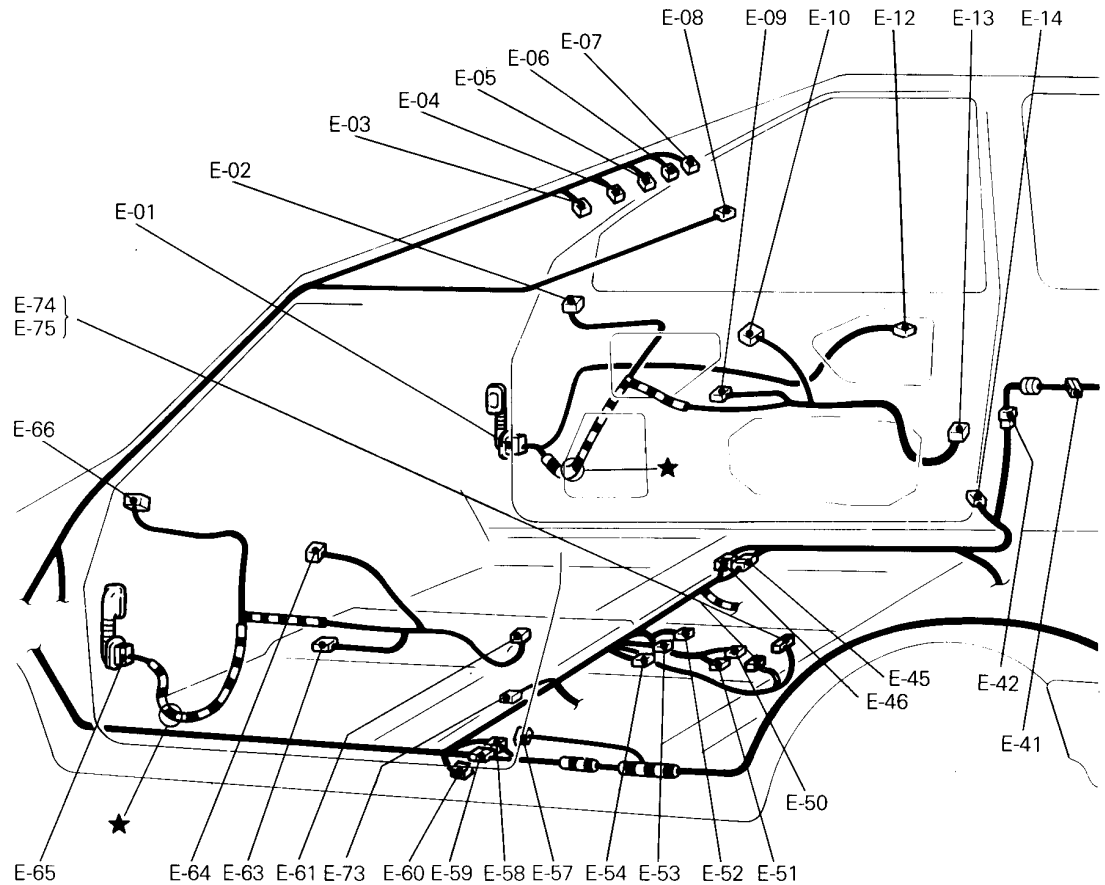
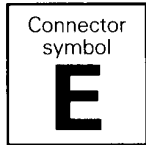

E-01	Front door wiring harness (RH) and main wiring harness combination	E-21	Defogger (+)
E-02	Remote controlled mirror (RH)	E-22	—
E-03	Sunroof control relay	E-23	Cargo room lamp
E-04	Sunroof relay	E-24	Defogger (—)
E-05	Room lamp <vehicles with sunroof>	E-25 }	Rear combination lamp (RH)
E-06	Limit switch <vehicles with sunroof>	E-26 }	
E-07	Sunroof motor	E-27	—
E-08	Room lamp <vehicles without sunroof>	E-28	Back-up lamp
E-09	Power window motor (RH)	E-29	License plate lamp
E-10	Power window sub switch (front)	E-30	Tailgate switch
E-11	—	E-31	Rear wiper motor
E-12	Door lock key cylinder switch	E-32	Tailgate lock actuator
E-13	Front door lock actuator (RH)	E-33	Tailgate wiring harness and tailgate sub wiring harness combination
E-14	Front door switch (passenger's side)	E-34	Rear wiring harness and rear bumper wiring harness combination
E-15 } thru } E-18 }	—	E-35	Rear fog lamp
E-19	Rear door switch (RH)	E-36	—
E-20	Rear door lock actuator (RH)	E-37 } E-38 }	Rear combination lamp (LH)

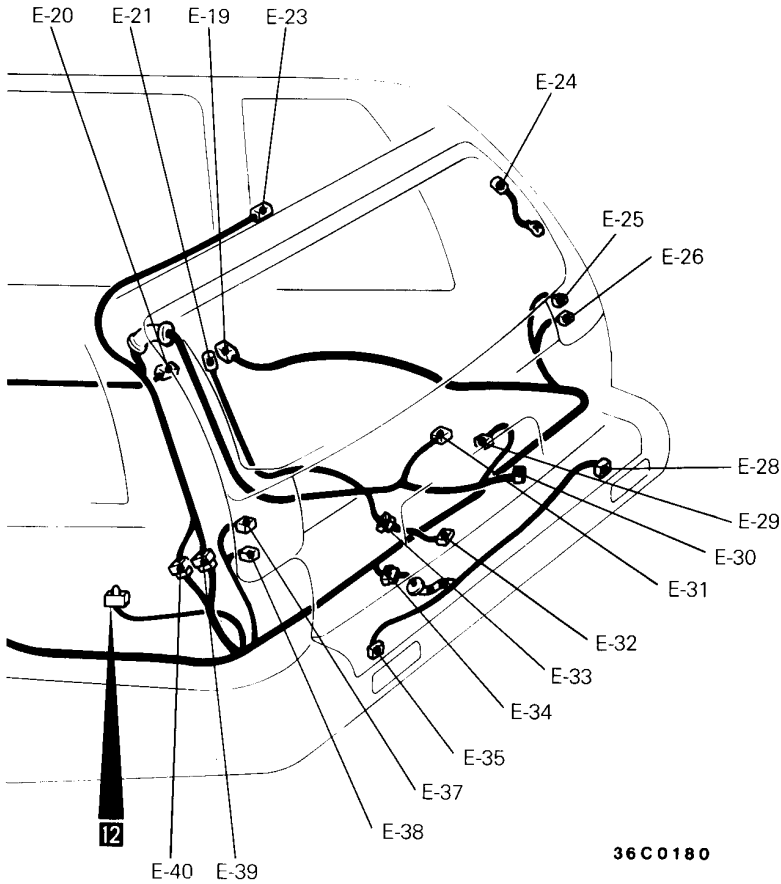

**Vehicles with heated seat**

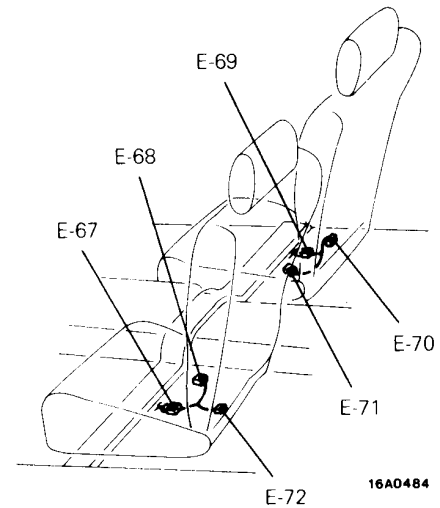

36C0180

E-39 } Rear wiring harness and tailgate wiring harness combination	E-58 } Main wiring harness and rear wiring harness combination
E-40 } combination	E-59 } combination
E-41 Contact switch (door side)	E-60 No connection
E-42 Contact switch (body side)	E-61 Front door lock actuator (LH)
E-43 —	E-62 —
E-44 —	E-63 Power window motor (LH)
E-45 } Main wiring harness and assist wiring harness combination	E-64 Power window main switch
E-46 } combination	E-65 Front door wiring harness (LH) and main wiring harness combination
E-47 —	E-66 Remote controlled mirror (LH)
E-48 —	E-67 Main wiring harness and heated seat wiring harness (LH) combination
E-49 —	E-68 Seat cushion heater (LH)
E-50 Heated seat switch (RH)	E-69 Main wiring harness and heated seat wiring harness (RH) combination
E-51 Heated seat switch (LH)	E-70 Seat back heater (RH)
E-52 Remote controlled mirror switch	E-71 Seat cushion heater (RH)
E-53 ABS G sensor <4WD>	E-72 Seat back heater (LH)
E-54 Parking brake switch	E-73 No connection
E-55 —	E-74 } SRS diagnosis unit
E-56 —	E-75 }
E-57 Front door switch (driver's side)	

# INTERIOR

R.H. drive vehicles <SPACE RUNNER>

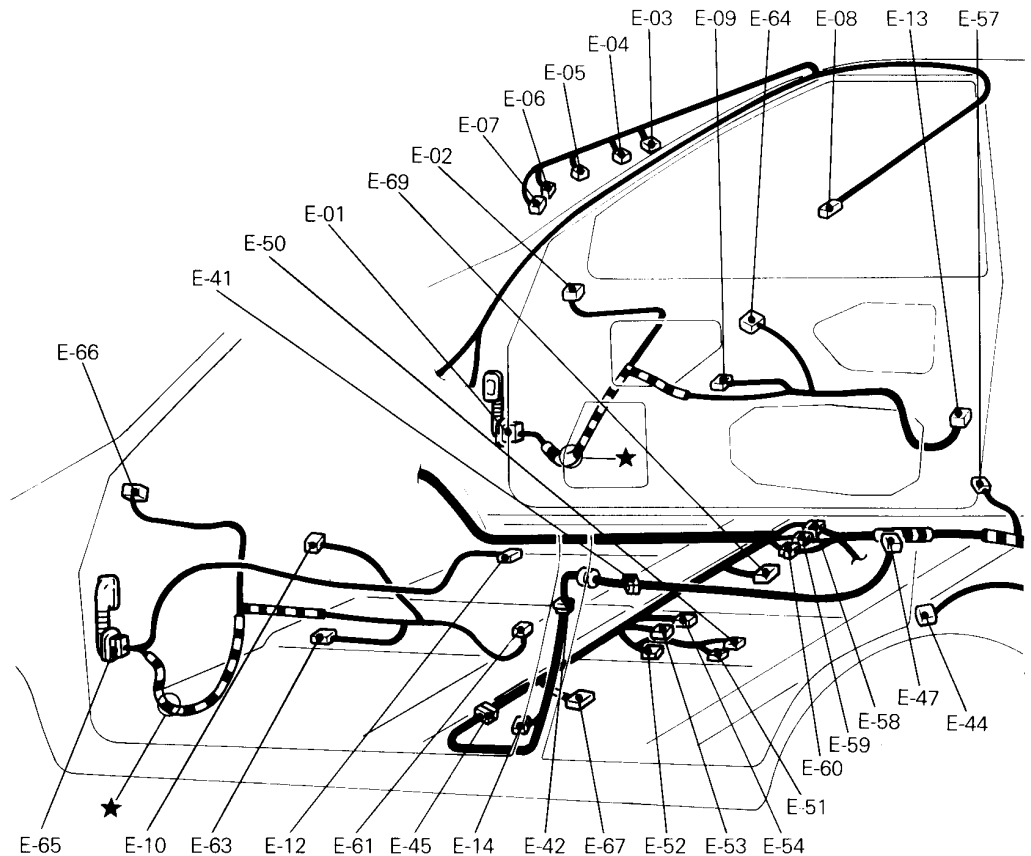
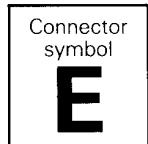

- |          |  |                                   |   |
|----------|--|-----------------------------------|---|
| E-01     | Front door wiring harness (RH) and main wiring harness combination | E-21                              | Defogger (+)  |
| E-02     | Remote controlled mirror (RH)                                      | E-22                              | —   |
| E-03     | Sunroof control relay  | E-23                              | Cargo room lamp   |
| E-04     | Sunroof relay  | E-24                              | Defogger (—)  |
| E-05     | Room lamp <vehicles with sunroof>                                  | E-25 } Rear combination lamp (RH) |   |
| E-06     | Limit switch <vehicles with sunroof>                               | E-26 }                            |   |
| E-07     | Sunroof motor  | E-27                              | —   |
| E-08     | Room lamp <vehicles without sunroof>                               | E-28                              | Back-up lamp  |
| E-09     | Power window motor (RH)  | E-29                              | License plate lamp  |
| E-10     | Power window sub switch (front)                                    | E-30                              | Tailgate switch   |
| E-11     | —  | E-31                              | Rear wiper motor  |
| E-12     | Door lock key cylinder switch                                      | E-32                              | Tailgate lock actuator  |
| E-13     | Front door lock actuator (RH)                                      | E-33                              | Tailgate wiring harness and tailgate sub wiring harness combination |
| E-14     | Front door switch (passenger's side)                               | E-34                              | Rear wiring harness and rear bumper wiring harness combination      |
| E-15 } — |  | E-35                              | Rear fog lamp   |
| E-16 }   |  |                                   |   |
| E-17 }   |  |                                   |   |
| E-18 }   |  |                                   |   |
| E-19 }   |  |                                   |   |
| E-20 }   |  |                                   |   |

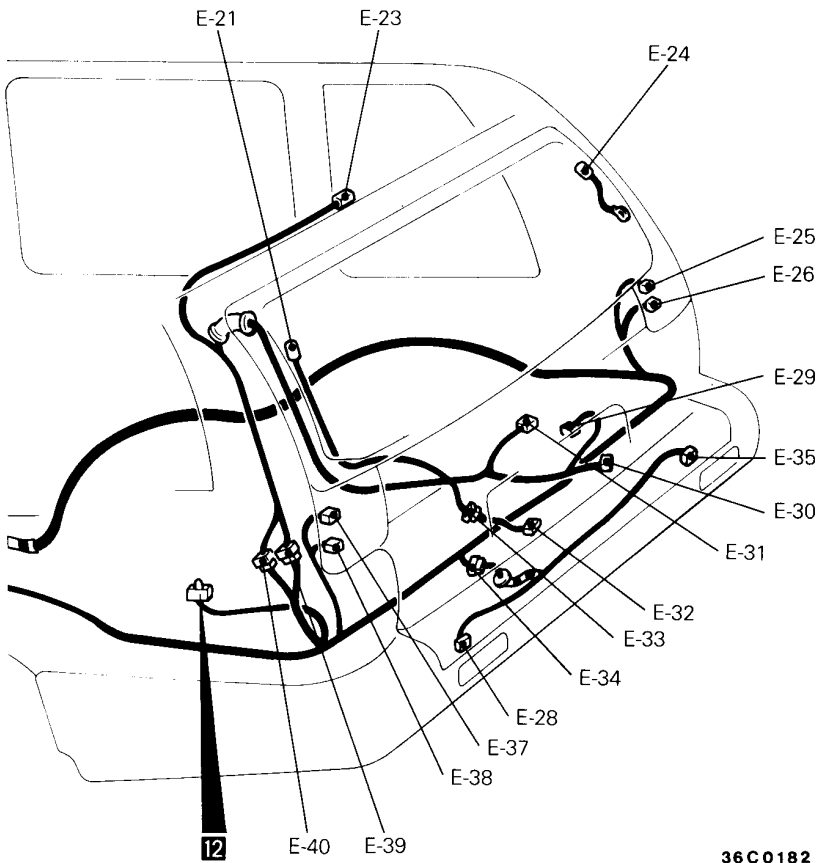

36C0182

E-36	—	E-53	ABS G sensor <4WD>
E-37	} Rear combination lamp (LH)	E-54	Parking brake switch
E-38		E-55	—
E-39		E-56	—
E-40	} Rear wiring harness and tailgate wiring harness combination	E-57	Front door switch (driver's side)
E-41		E-58	} Main wiring harness and rear wiring harness combination
E-42	E-59		
E-43	E-60		
E-44	Contact switch (door side)	E-61	Front door lock actuator (LH)
E-45	Contact switch (body side)	E-62	—
E-46	—	E-63	Power window motor (LH)
E-47	Rear door switch (LH)	E-64	Power window main switch
E-48	Main wiring harness and assist wiring harness combination	E-65	Front door wiring harness (LH) and main wiring harness combination
E-49	—	E-66	Remote controlled mirror (LH)
E-50	—	E-67	No connection
E-51	} No connection	E-68	—
E-52		Remote controlled mirror switch	E-69

# INTERIOR

## L.H. drive vehicles <SPACE WAGON>

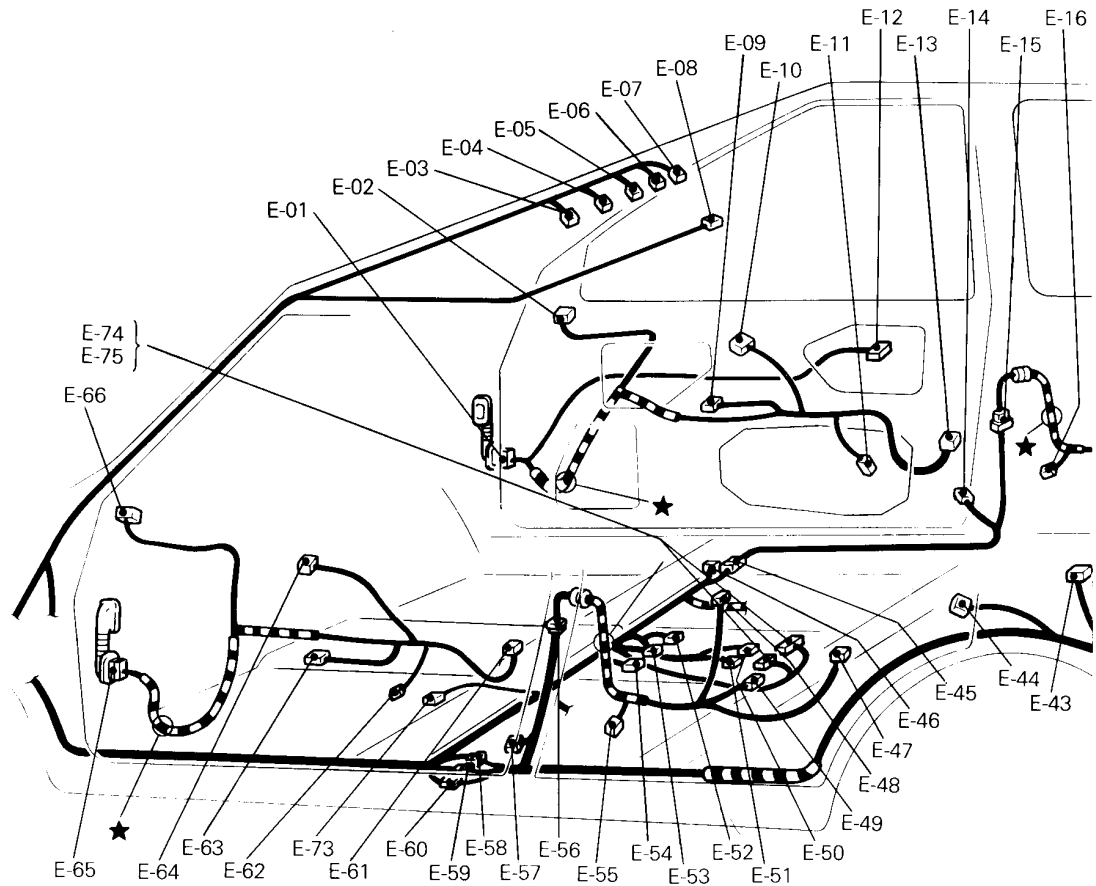
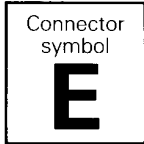

- |      |  |        |   |
|------|--|--------|---|
| E-01 | Front door wiring harness (RH) and main wiring harness combination | E-20   | Rear door lock actuator (RH)  |
| E-02 | Remote controlled mirror (RH)                                      | E-21   | Defogger (+)  |
| E-03 | Sunroof control relay  | E-22   | Rear speaker (RH)   |
| E-04 | Sunroof relay  | E-23   | Cargo room lamp   |
| E-05 | Room lamp <vehicles with sunroof>                                  | E-24   | Defogger (-)  |
| E-06 | Limit switch <vehicles with sunroof>                               | E-25 } | Rear combination lamp (RH)  |
| E-07 | Sunroof motor  | E-26 } |   |
| E-08 | Room lamp <vehicles without sunroof>                               | E-27   | Tailgate lamp (RH)  |
| E-09 | Power window motor (RH)  | E-28   | Back-up lamp  |
| E-10 | Power window sub switch (front)                                    | E-29   | License plate lamp  |
| E-11 | Front door lamp (passenger's side)                                 | E-30   | Tailgate switch   |
| E-12 | Door lock key cylinder switch                                      | E-31   | Rear wiper motor  |
| E-13 | Front door lock actuator (RH)                                      | E-32   | Tailgate lock actuator  |
| E-14 | Front door switch (passenger's side)                               | E-33   | Tailgate wiring harness and tailgate sub wiring harness combination |
| E-15 | Assist wiring harness and rear door wiring harness combination     | E-34   | Rear wiring harness and rear bumper wiring harness combination      |
| E-16 | Power window motor (rear: RH)                                      | E-35   | Rear fog lamp   |
| E-17 | Power window sub switch (rear: RH)                                 | E-36   | Tailgate lamp (LH)  |
| E-18 | Rear door lamp (RH)  | E-37 } | Rear combination lamp (LH)  |
| E-19 | Rear door switch (RH)  | E-38 } |   |

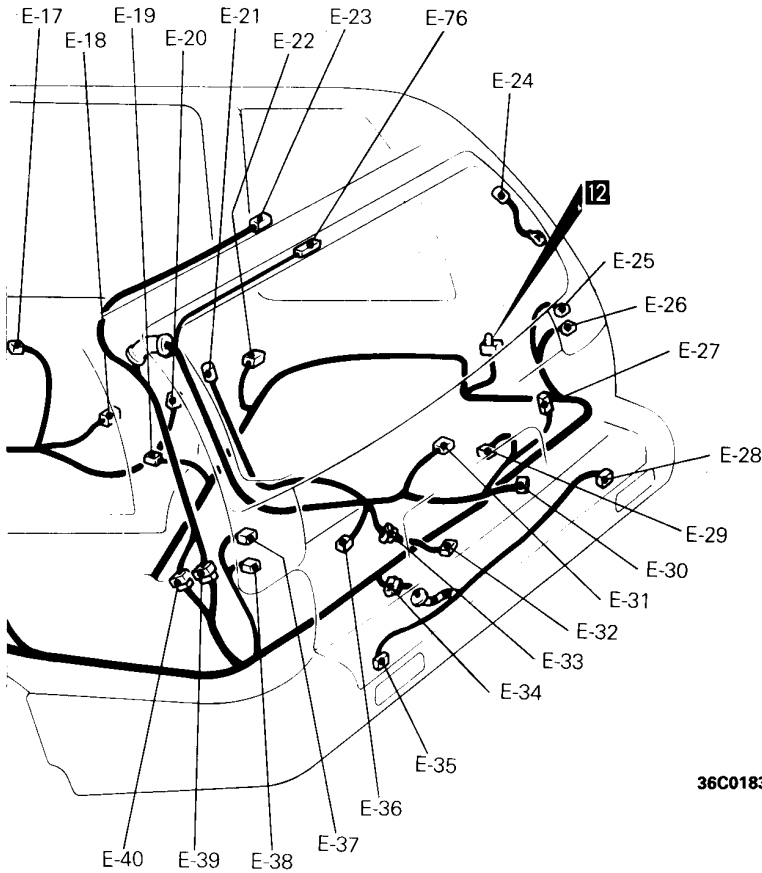

Vehicles with heated seat

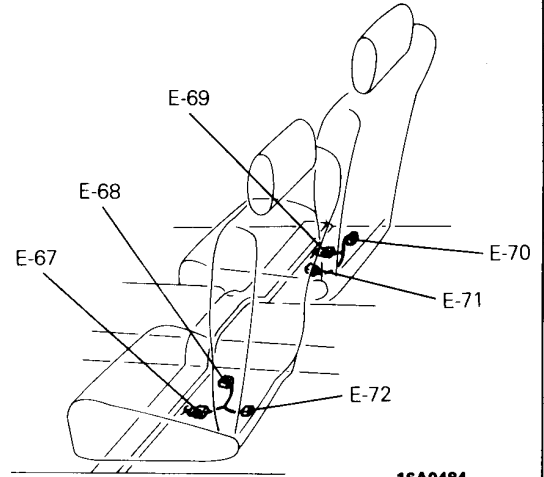

16A0484

36C0183

E-39 } Rear wiring harness and tailgate wiring harness combination	E-58 } Main wiring harness and rear wiring harness combination
E-40 } —	E-59 } —
E-41 } —	E-60 } —
E-42 } —	E-61 Front door lock actuator (LH)
E-43 Rear speaker (LH)	E-62 Front door lamp (driver's side)
E-44 Rear door switch (LH)	E-63 Power window motor (LH)
E-45 Main wiring harness and assist wiring harness combination	E-64 Power window main switch
E-46 No connection	E-65 Front door wiring harness (LH) and main wiring harness combination
E-47 Rear door lock actuator (LH)	E-66 Remote controlled mirror (LH)
E-48 Power window sub switch (rear: LH)	E-67 Main wiring harness and heated seat wiring harness (LH) combination
E-49 Rear door lamp (LH)	E-68 Seat cushion heater (LH)
E-50 Heated seat switch (RH)	E-69 Main wiring harness and heated seat wiring harness (RH) combination
E-51 Heated seat switch (LH)	E-70 Seat back heater (RH)
E-52 Remote controlled mirror switch	E-71 Seat cushion heater (RH)
E-53 ABS G sensor <4WD>	E-72 Seat back heater (LH)
E-54 Parking brake switch	E-73 Rear oxygen sensor <4G64> or no connection
E-55 Power window motor (rear: LH)	E-74 } SRS diagnosis unit
E-56 Assist wiring harness and rear door (LH) wiring harness combination	E-75 } —
E-57 Front door switch (driver's side)	E-76 High-mounted stop lamp

# INTERIOR

## R.H. drive vehicles <SPACE WAGON>

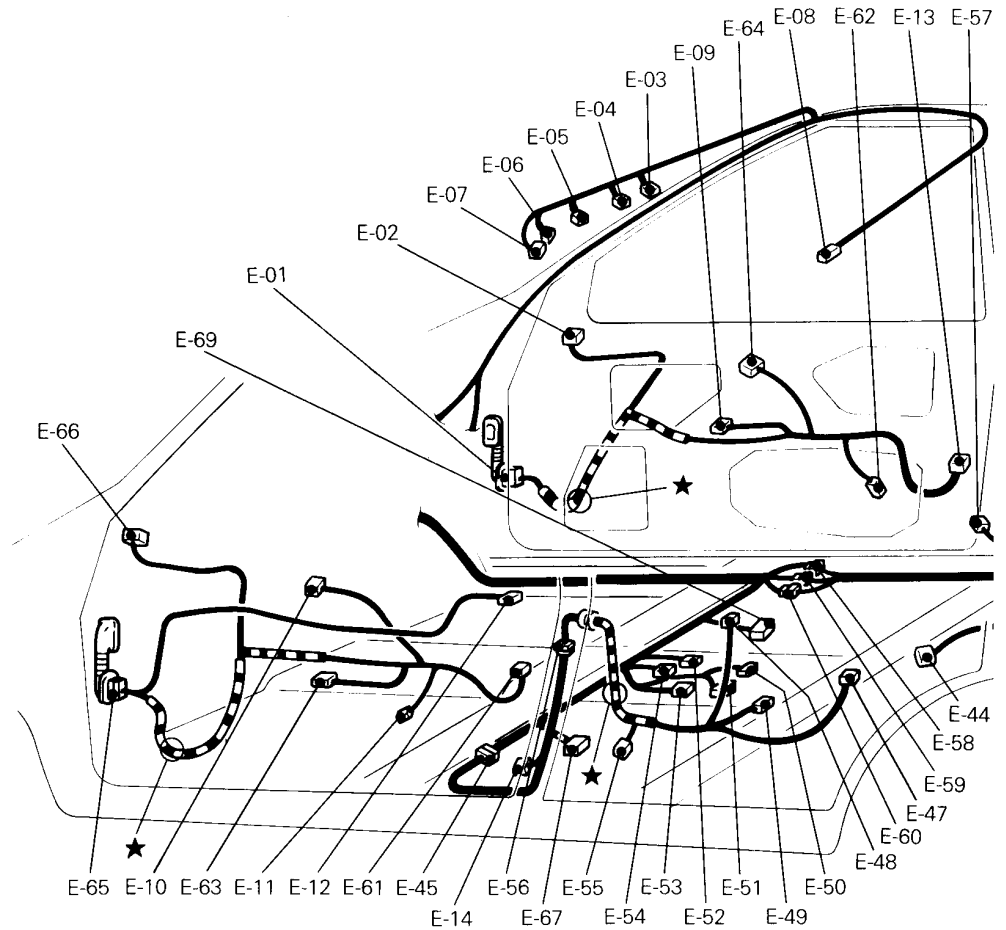
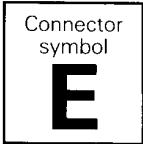

- |      |  |                  |   |
|------|--|------------------|---|
| E-01 | Front door wiring harness (RH) and main wiring harness combination | E-18             | Rear door lamp (RH)   |
| E-02 | Remote controlled mirror (RH)                                      | E-19             | Rear door switch (RH)   |
| E-03 | Sunroof control relay  | E-20             | Rear door lock actuator (RH)  |
| E-04 | Sunroof relay  | E-21             | Defogger (+)  |
| E-05 | Room lamp <vehicles with sunroof>                                  | E-22             | Rear speaker (RH)   |
| E-06 | Limit switch <vehicles with sunroof>                               | E-23             | Cargo room lamp   |
| E-07 | Sunroof motor  | E-24             | Defogger (-)  |
| E-08 | Room lamp <vehicles without sunroof>                               | E-25 }<br>E-26 } | Rear combination lamp (RH)  |
| E-09 | Power window motor (RH)  | E-27             | Tailgate lamp (RH)  |
| E-10 | Power window sub switch (front)                                    | E-28             | Back-up lamp  |
| E-11 | Front door lamp (passenger's side)                                 | E-29             | License plate lamp  |
| E-12 | Door lock key cylinder switch                                      | E-30             | Tailgate switch   |
| E-13 | Front door lock actuator (RH)                                      | E-31             | Rear wiper motor  |
| E-14 | Front door switch (passenger's side)                               | E-32             | Tailgate lock actuator  |
| E-15 | Assist wiring harness and rear door wiring harness combination     | E-33             | Tailgate wiring harness and tailgate sub wiring harness combination |
| E-16 | Power window motor (rear: RH)                                      | E-34             | Rear wiring harness and rear bumper wiring harness combination      |
| E-17 | Power window sub switch (rear: RH)                                 |                  |   |



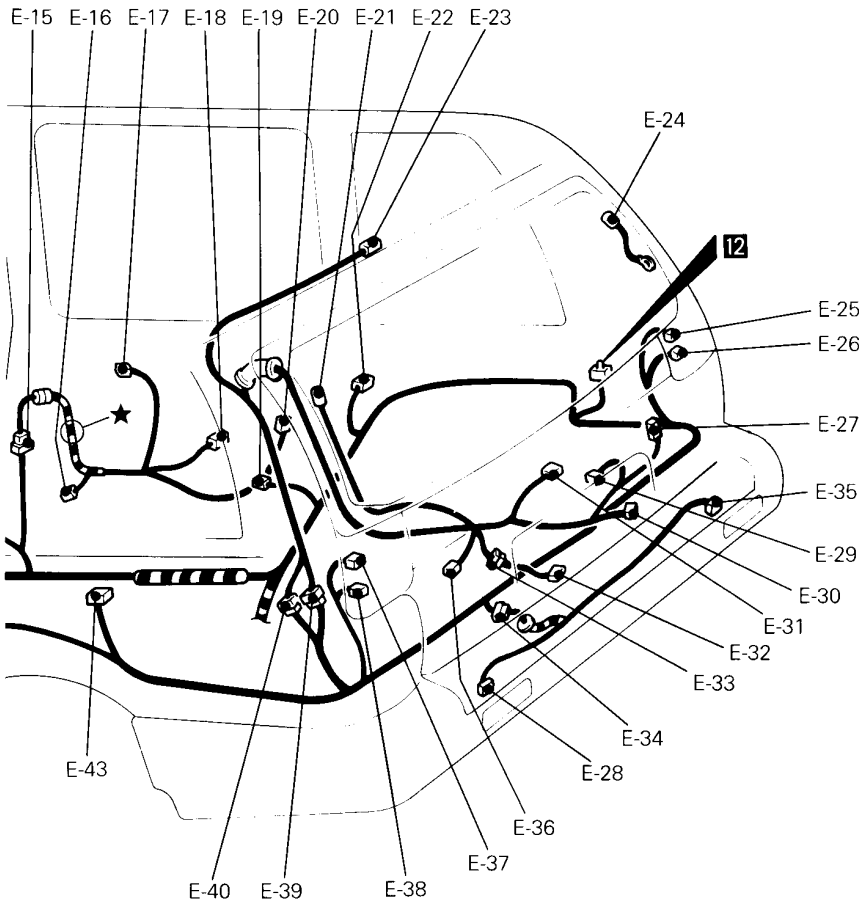

36C0181

E-35	Rear fog lamp	E-53	ABS G sensor <4WD>
E-36	Tailgate lamp (LH)	E-54	Parking brake switch
E-37	Rear combination lamp (LH)	E-55	Power window motor (rear: LH)
E-38		E-56	Assist wiring harness and rear door (LH) wiring harness combination
E-39	Rear wiring harness and tailgate wiring harness combination	E-57	Front door switch (driver's side)
E-40		E-58	Main wiring harness and rear wiring harness combination
E-41	—	E-59	
E-42	—	E-60	
E-43	Rear speaker (LH)	E-61	Front door lock actuator (LH)
E-44	Rear door switch (LH)	E-62	Front door lamp (driver's side)
E-45	Main wiring harness and assist wiring harness combination	E-63	Power window motor (LH)
E-46	—	E-64	Power window main switch
E-47	Rear door lock actuator (LH)	E-65	Front door wiring harness (LH) and main wiring harness combination
E-48	Power window sub switch (rear: LH)	E-66	Remote controlled mirror (LH)
E-49	Rear door lamp (LH)	E-67	No connection
E-50	No connection	E-68	—
E-51		E-69	No connection
E-52	Remote controlled mirror switch		

## UNDER REAR FLOOR

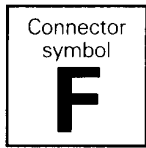

### SPACE RUNNER

<2WD>

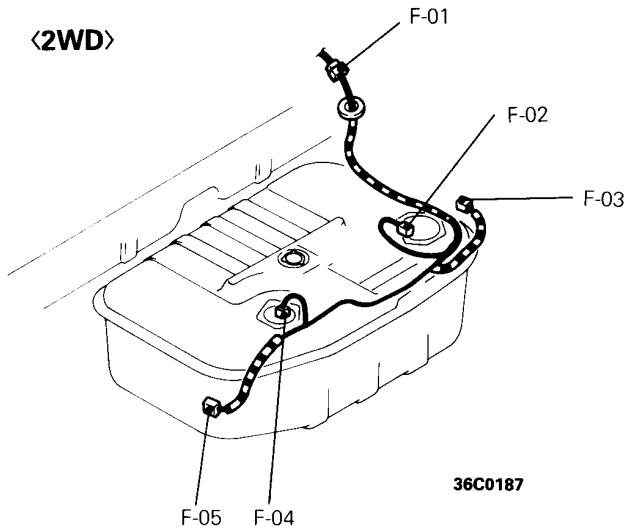

<4WD>

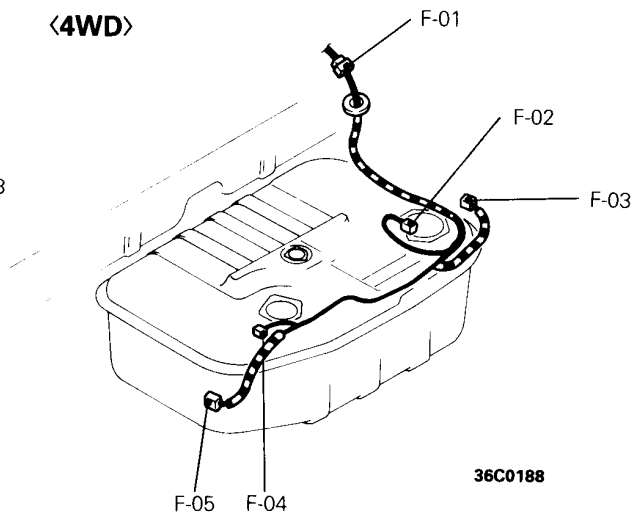

### SPACE WAGON

<2WD>

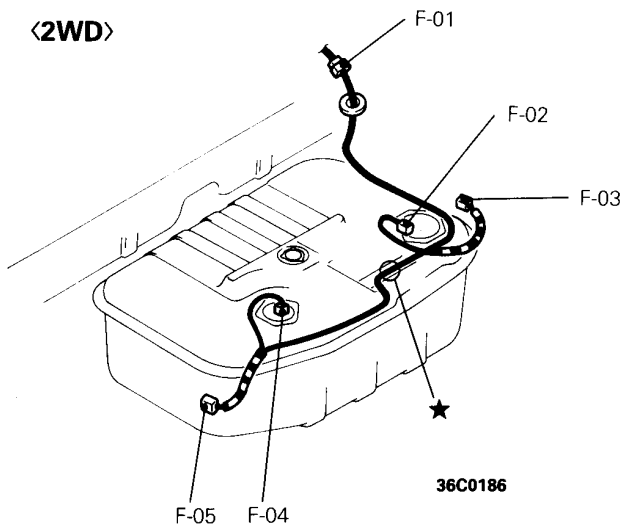

<4WD>

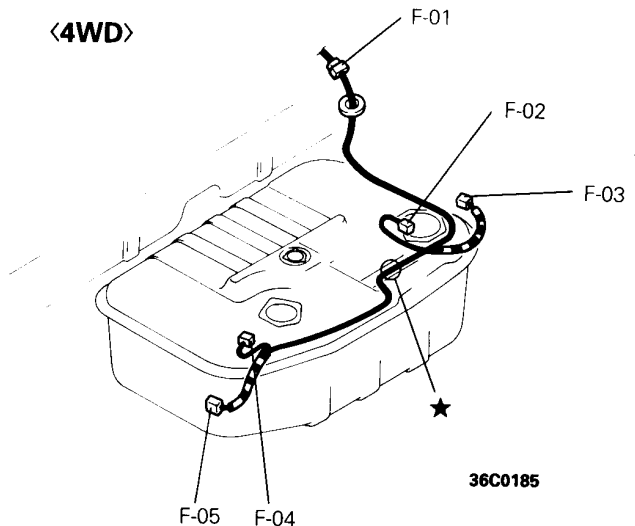

F-01 Rear wiring harness\*<sup>1</sup> or assist wiring harness\*<sup>2</sup> and fuel wiring harness combination  
 F-02 Fuel pump <2WD> or fuel pump and gauge assembly <4WD>

F-03 ABS speed sensor (Rear: RH)  
 F-04 Fuel gauge unit  
 F-05 ABS speed sensor (Rear: LH)

Remarks

- \*1: SPACE RUNNER <RHD> and SPACE WAGON
- \*2: SPACE RUNNER <LHD>

### 3 SINGLE PART INSTALLATION POSITION

<b>RELAY</b> .....	<b>3- 2</b>
<b>CONTROL UNIT</b> .....	<b>3- 5</b>
<b>SENSOR</b>	
<MPI> .....	3- 7
<Diesel> .....	3-11
<b>DIODE</b> .....	<b>3-12</b>
<b>INSPECTION TERMINAL</b> .....	<b>3-13</b>
<b>FUSIBLE LINK AND FUSE</b> .....	<b>3-14</b>
<b>EARTH CABLE</b> .....	<b>3-15</b>
<b>EARTH</b> .....	<b>3-15</b>

## RELAY

Name	Symbol	Name	Symbol
ABS motor relay	F	Glow relay 1 <Diesel-powered vehicles>	C
ABS relay	H	Glow relay 2 <Diesel-powered vehicles>	C
ABS valve relay	F	Headlamp relay	B
A/C compressor relay	B	Headlamp washer relay	A
A/C relay <Diesel-powered vehicles>	L	Heater relay	G
Alternator relay	B	Intermittent wiper relay (windshield wiper)	I
Condenser fan motor relay (High)	B	Intermittent wiper relay (rear wiper)	J
Condenser fan motor relay (Low)	B	Power window relay	H
Daytime running lamp relay 1 <Vehicles for Norway and Sweden>	E	Radiator fan motor relay (High)	B
		Radiator fan motor relay (Low)	B
Daytime running lamp relay 2 <Vehicles for Norway and Sweden>	E	Rear fog lamp relay	H
Defogger relay	G	Starter relay <Diesel-powered vehicles>	D
Dim-dip lamp relay 1 <R.H. drive vehicles>	E	Sunroof control relay	N
Dim-dip lamp relay 2 <R.H. drive vehicles>	E	Sunroof relay	N
Dim-dip lamp relay 3 <R.H. drive vehicles>	E	Tail lamp relay	B
Engine control relay	K	Turn and hazard flasher unit	G
Engine oil level relay <Petrol-powered vehicles (4G63, 4G64) and diesel-powered vehicles (SPACE WAGON)>	M		

## NOTE

Names are listed in alphabetical order.

Engine compartment

<Petrol-powered vehicles>

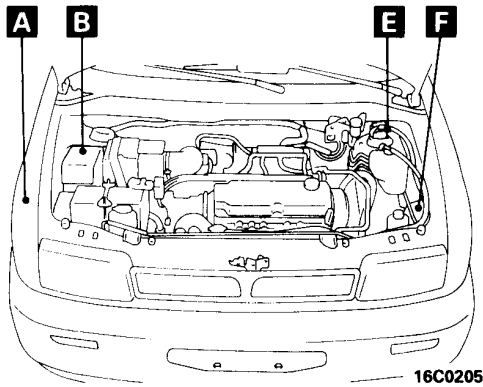

<Diesel-powered vehicles>

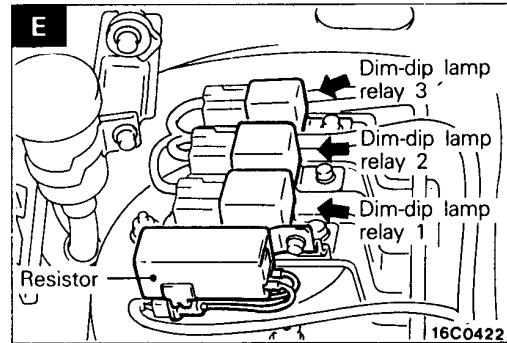
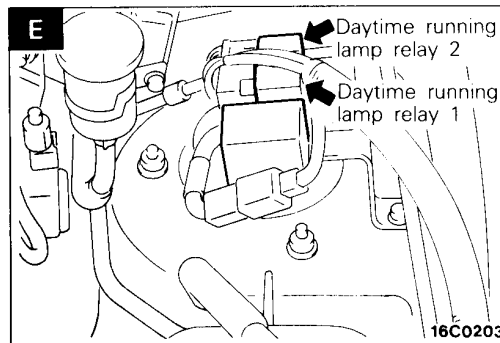
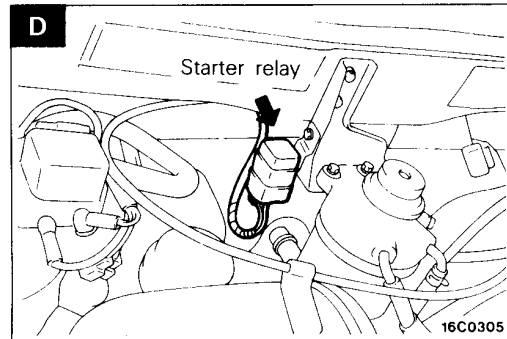
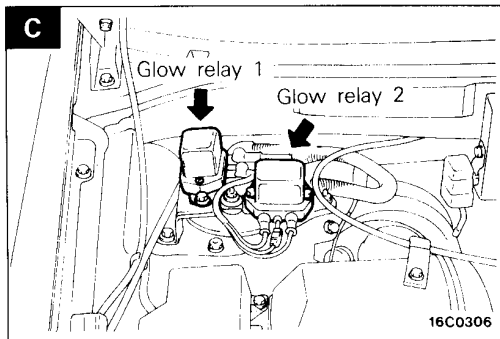
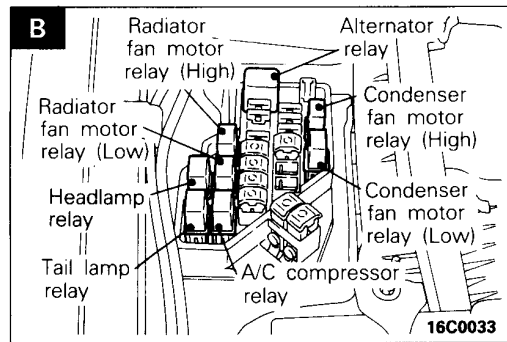
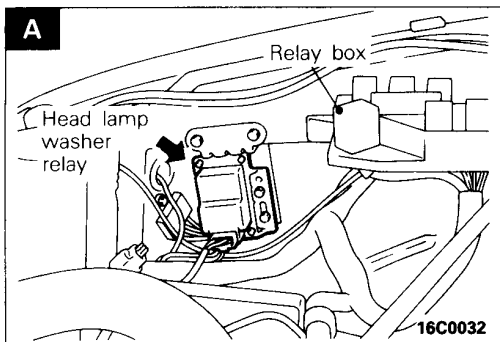
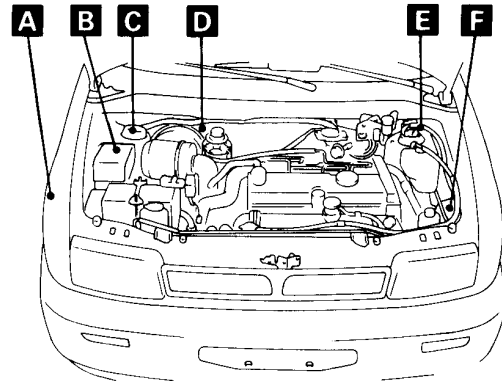

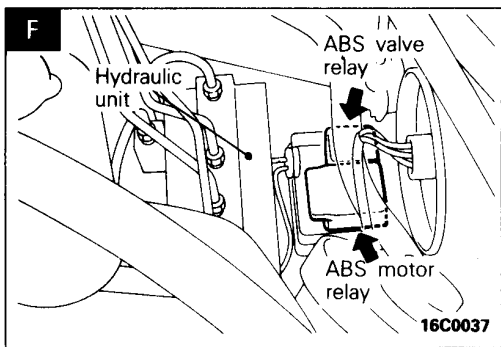

Instrument panel

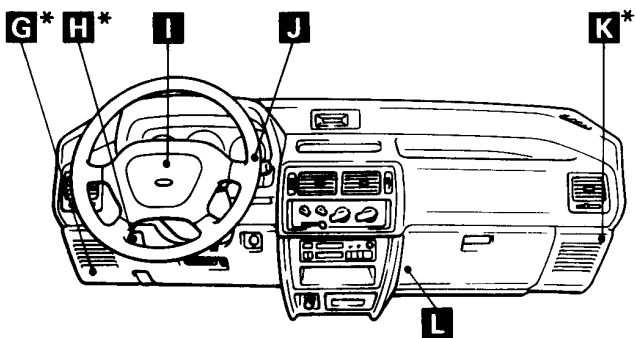

16C0172

NOTE  
For R.H. drive vehicles, only the positions indicated by the \* are symmetrical.

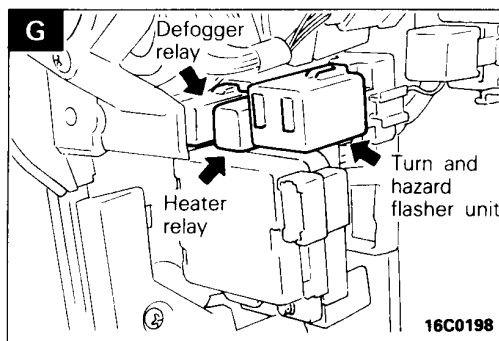

16C0198

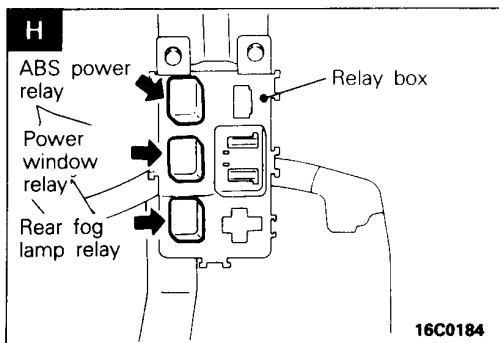

16C0184

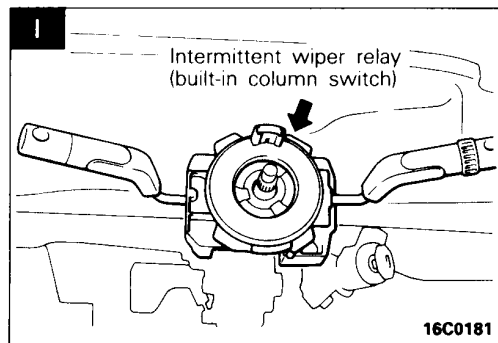

16C0181

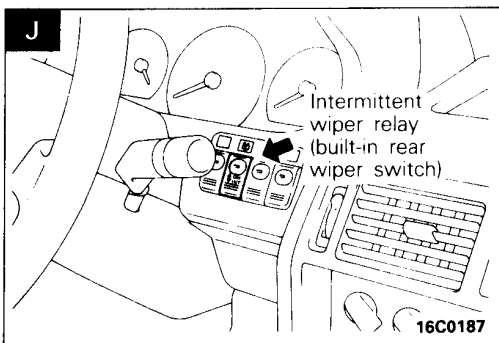

16C0187

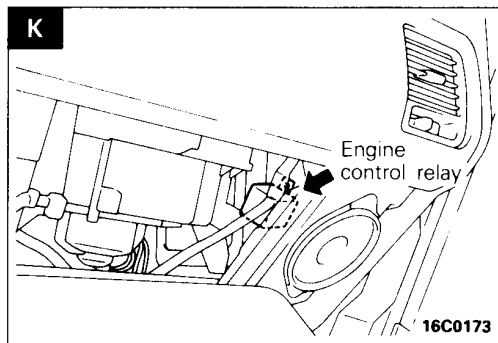

16C0173

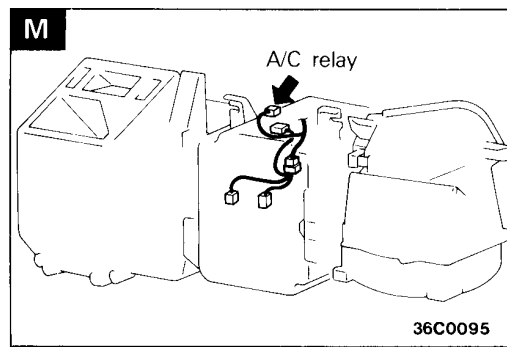
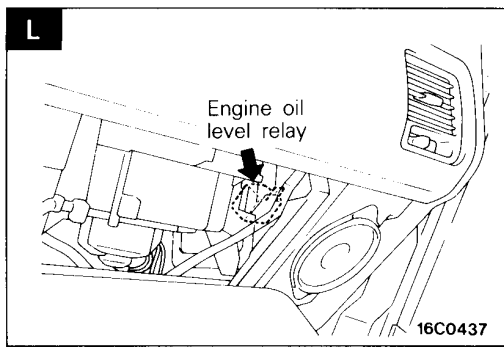

**Roof**

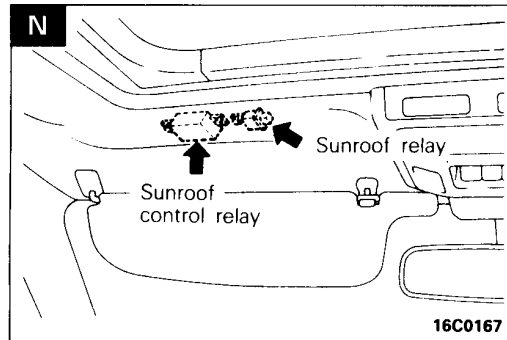
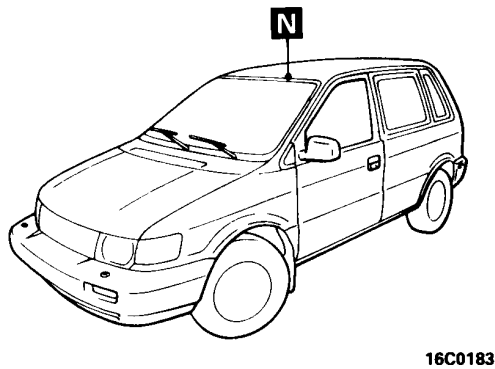

**CONTROL UNIT**

Name	Symbol	Name	Symbol
ABS control unit	D	Door lock control unit	B
A/C belt lock controller	E	ELC-4 A/T control unit	C
Automatic compressor control unit (for A/C)	E	Engine control unit <MPI>	F
Daytime running lamp control unit <Vehicles for Norway and Sweden>	A	Glow control unit <Diesel-powered vehicles>	F

NOTE  
Names are listed in alphabetical order.

**Engine compartment**

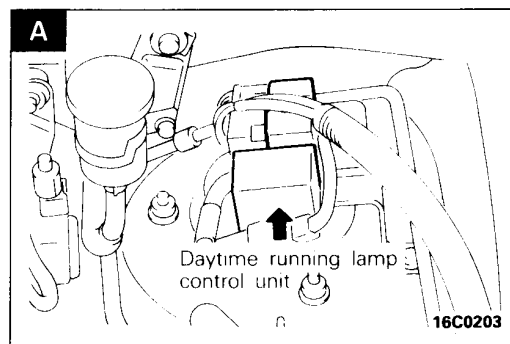
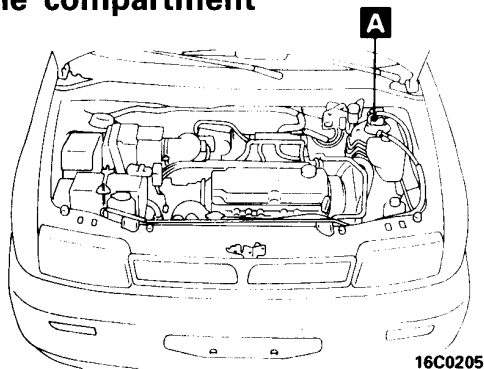

Instrument panel

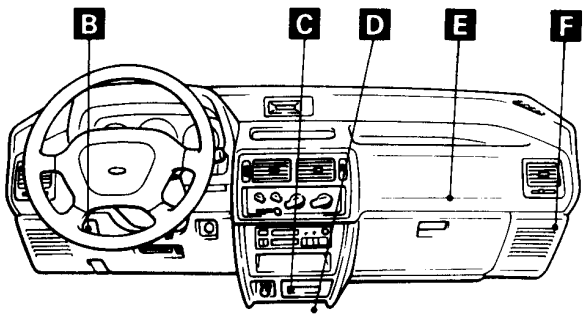

16C0172

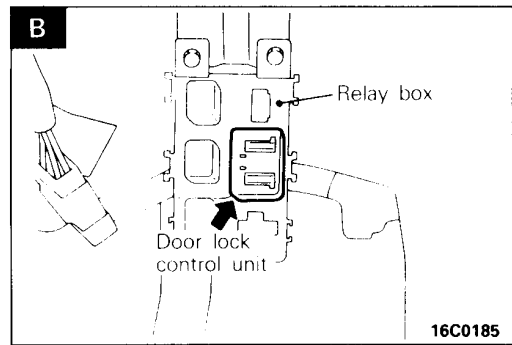

16C0185

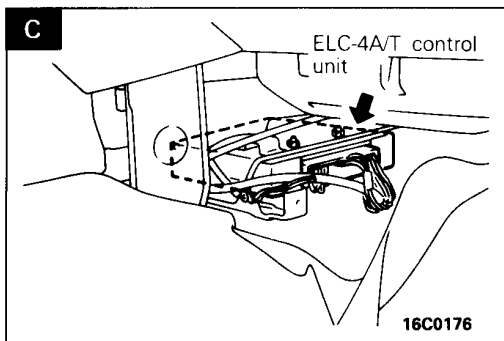

16C0176

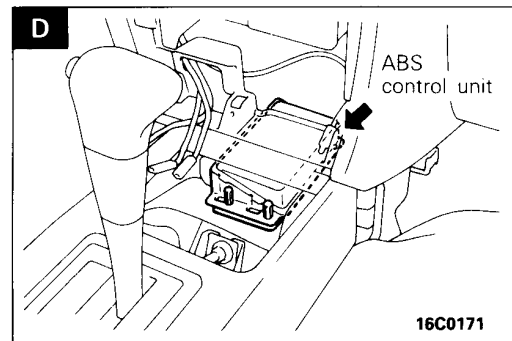

16C0171

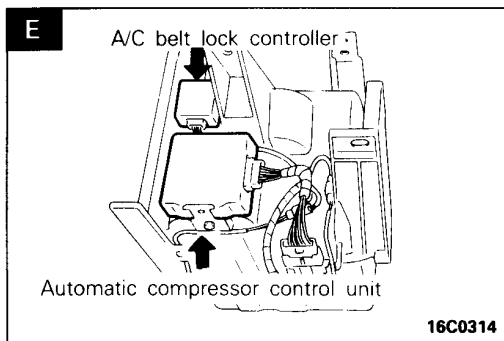

16C0314

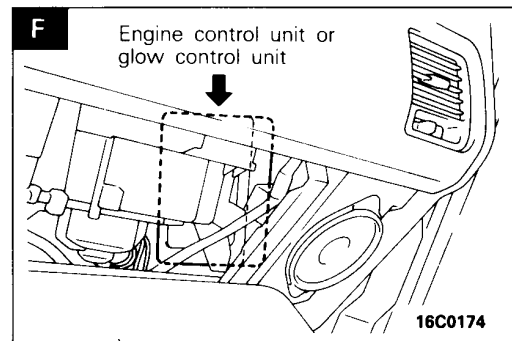

16C0174



**SENSOR**

〈MPI〉

Name	Symbol	Name	Symbol
ABS speed sensor (front)	P	Engine coolant temperature sensor	D
ABS speed sensor (rear)	Q	Engine coolant temperature switch (for A/C)	4G93 C
Air-flow sensor (with built-in barometric pressure sensor, intake air temperature sensor)	B		4G63, 4G64 D
		Engine oil level sensor <4G63 and 4G64>	J
Air inlet sensor (for A/C)	N	G sensor (for ABS) <4WD>	L
Air thermo sensor (for A/C)	M	Kick down servo switch	A
Automatic transmission fluid temperature sensor	A	Oxygen sensor	4G93 H
			4G63, 4G64 O
Crank angle sensor and top dead center sensor	C	Rear oxygen sensor <4G64>	O
Detonation sensor	F	Revolution pick-up sensor	I
EGR temperature sensor <4G64>	G	Throttle position sensor	E
Engine coolant temperature gauge unit	D	Vehicle speed sensor (Reed switch)	K

NOTE

Names are listed in alphabetical order.

**Engine compartment**

〈4G93 engine〉

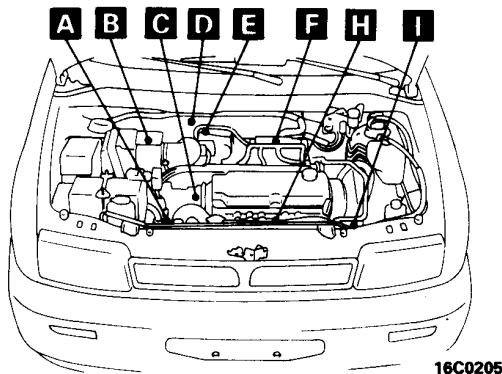

〈4G63 and 4G64 engine〉

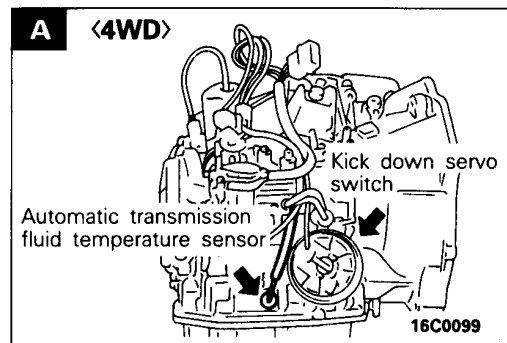
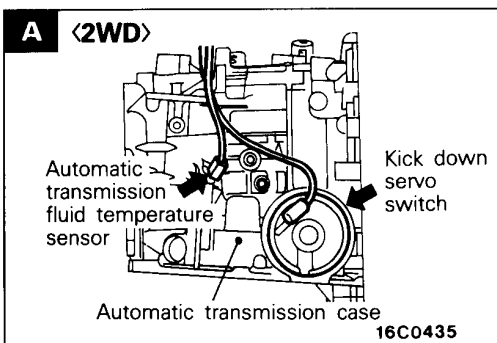
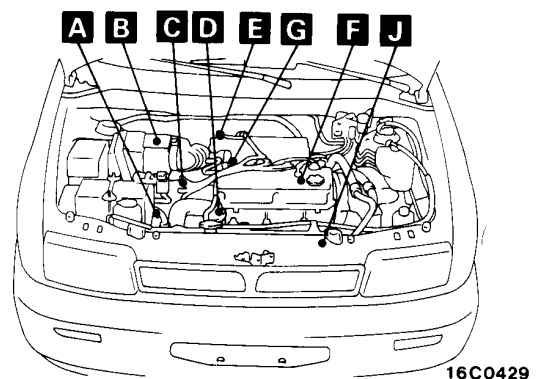

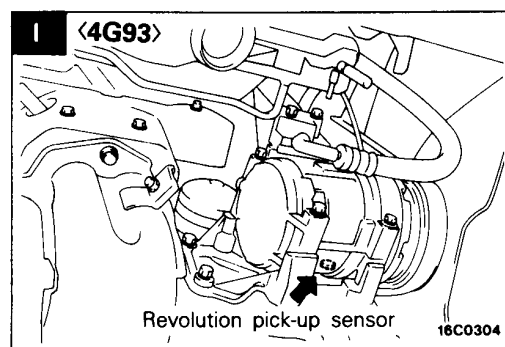
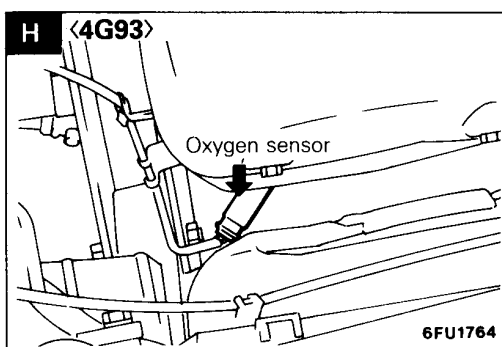
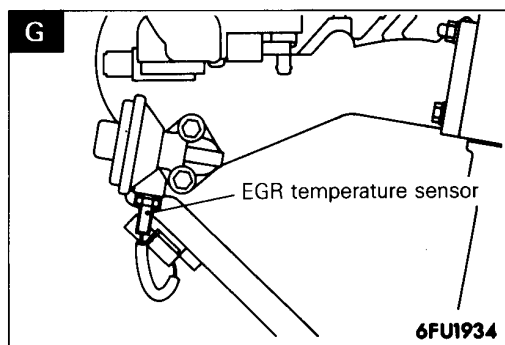
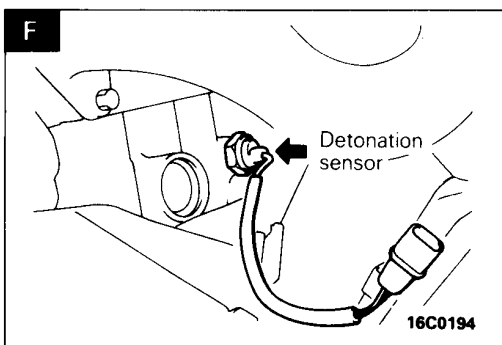
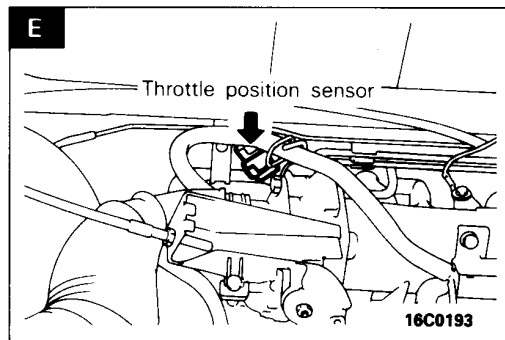
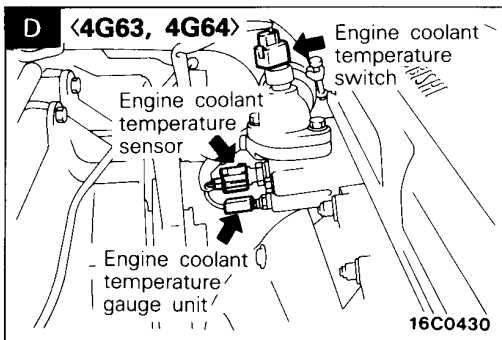
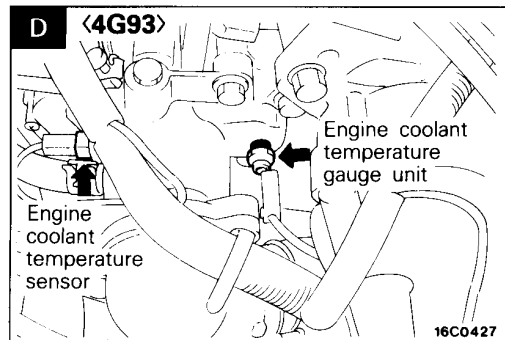
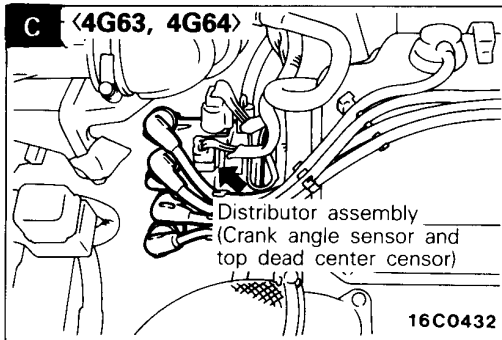
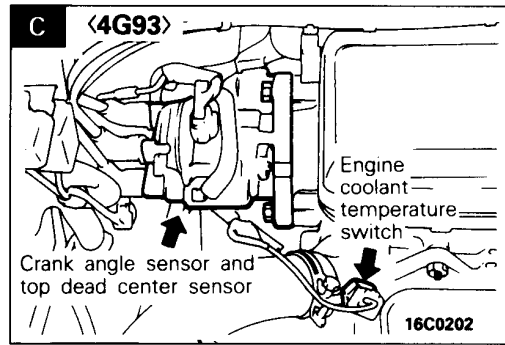
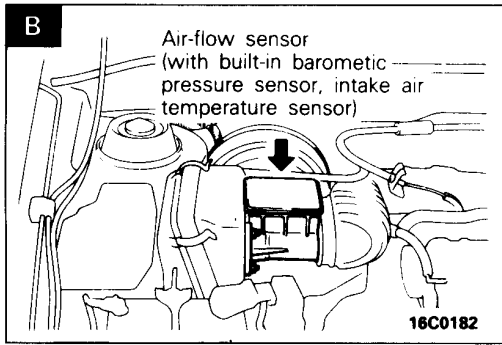

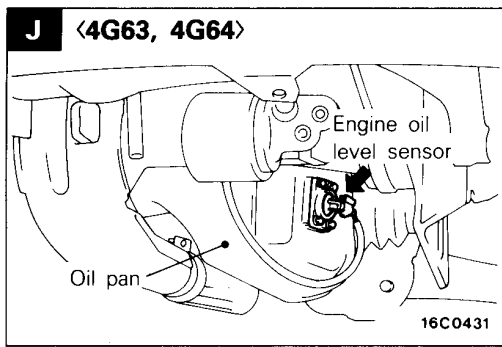

Instrument panel

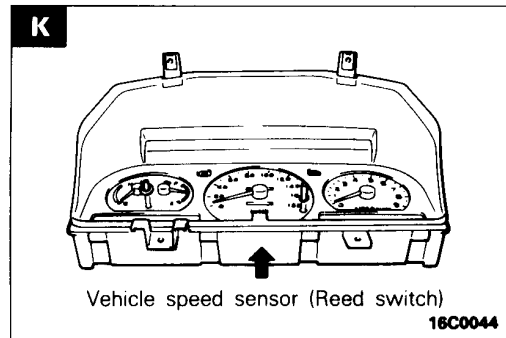
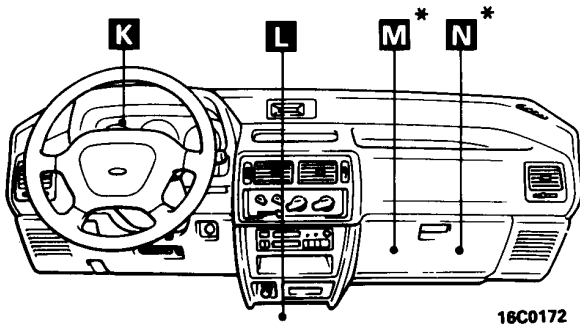

NOTE  
For R.H. drive vehicles, only the positions indicated by the \* are symmetrical.

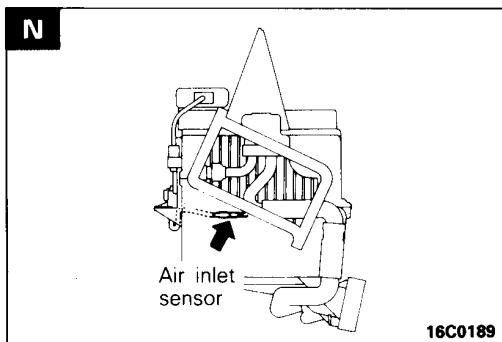
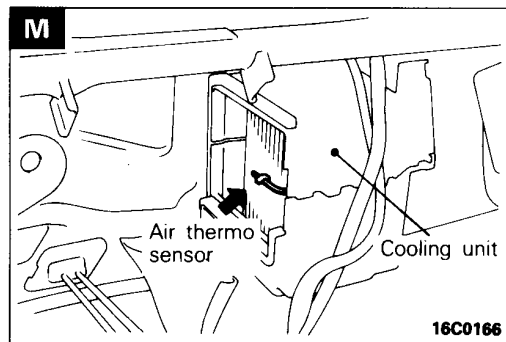
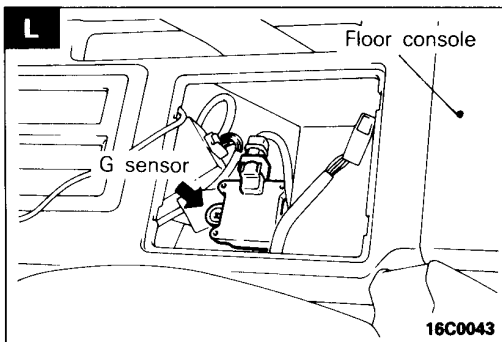

Front under floor

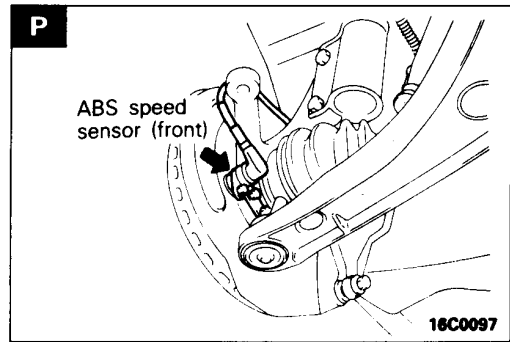
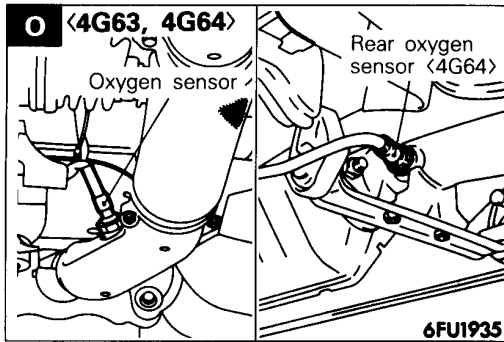
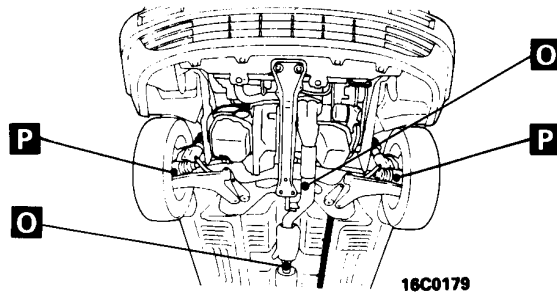

Rear under floor

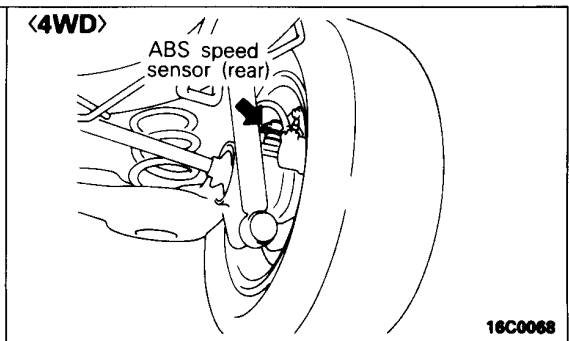
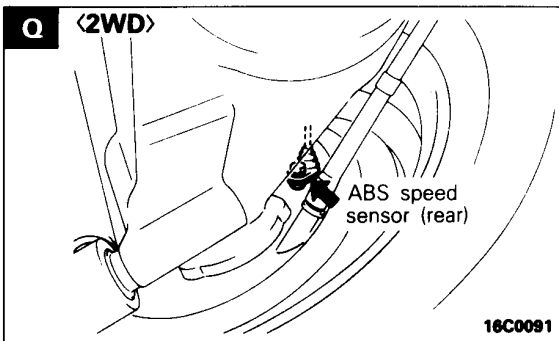
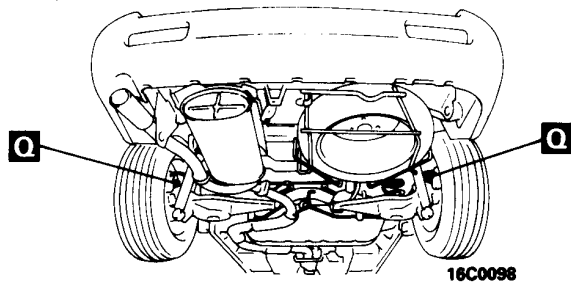

**SENSOR**

<Diesel>

Name	Symbol	Name	Symbol
ABS speed sensor (front)	G	Engine coolant temperature switch (for condenser fan)	A
ABS speed sensor (rear)	H	Engine coolant temperature switch (for A/C)	A
Air inlet sensor (for A/C)	F	Engine oil level sensor	C
Air thermo sensor (for A/C)	E	Lever (throttle) position sensor	B
Engine coolant temperature sensor	A	Revolution pick up	B
Engine coolant temperature sensor (for water temperature alarm lamp)	A	Vehicle speed sensor (Reed switch)	D
Engine coolant temperature switch (for EGR)	A		

**NOTE**

Names are listed in alphabetical order.

**Engine compartment**

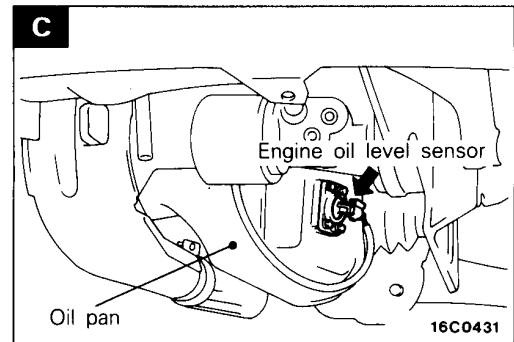
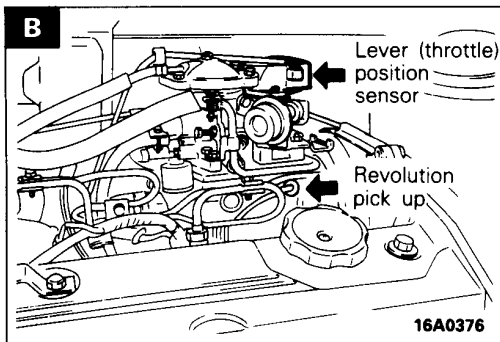
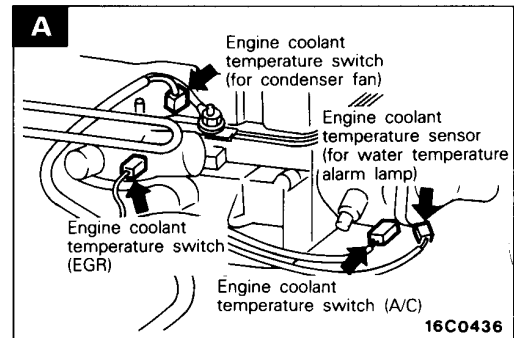
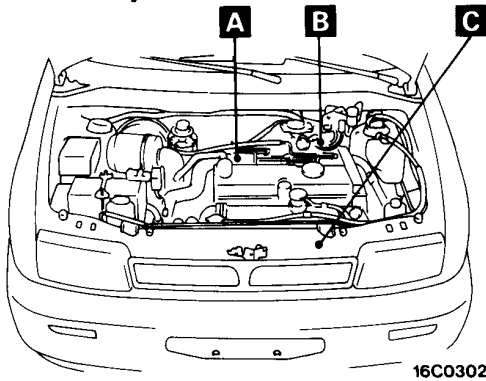

Instrument panel

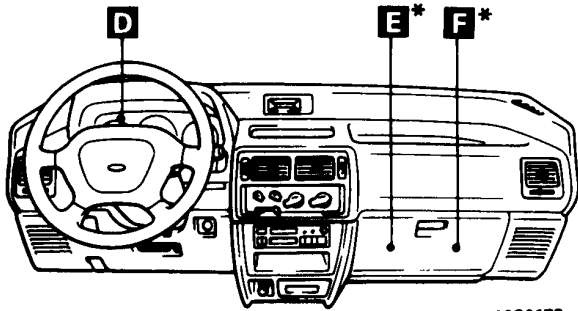

16C0172

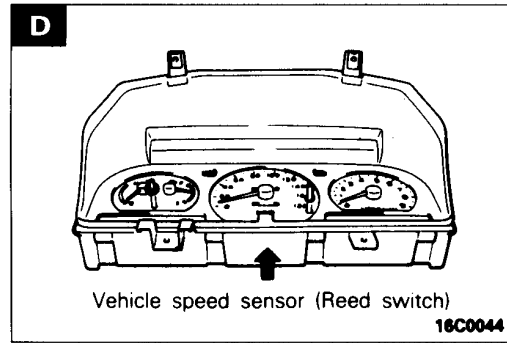

Vehicle speed sensor (Reed switch)

16C0044

NOTE

For R.H. drive vehicles, only the positions indicated by the \* are symmetrical.

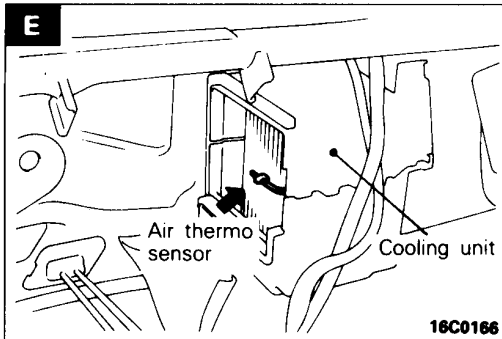

16C0186

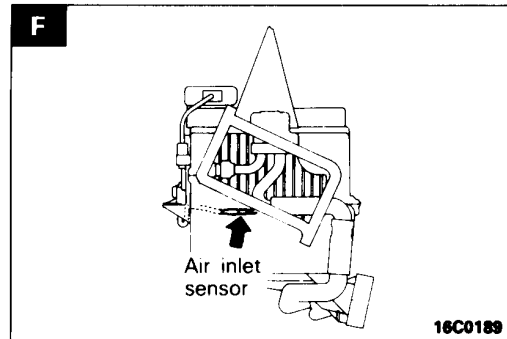

16C0189

Front under floor

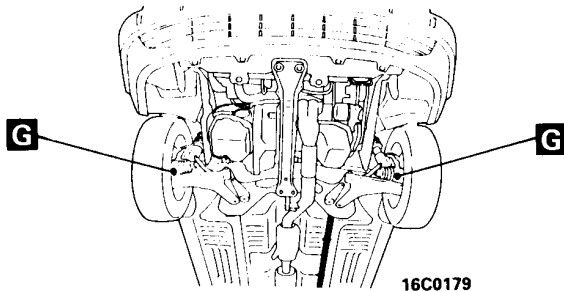

16C0179

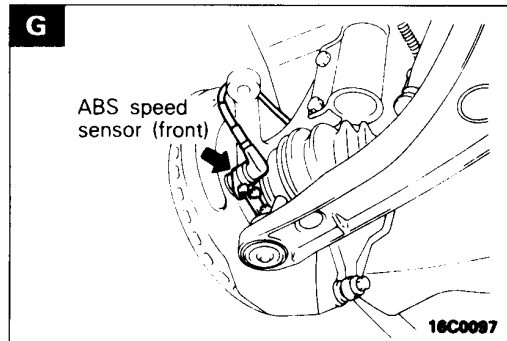

ABS speed sensor (front)

16C0097

Rear under floor

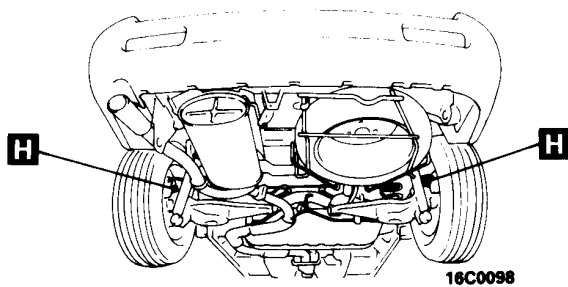

16C0098

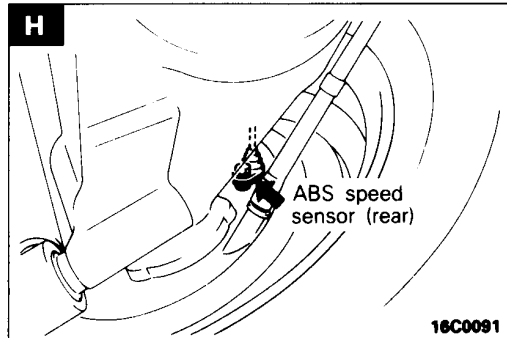

ABS speed sensor (rear)

16C0091

NOTES

**DIODE**

**Instrument panel**

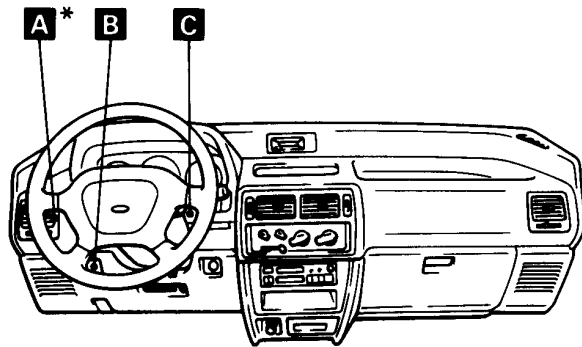

16C0172

Name	Symbol
Diode (for A/C circuit) <Diesel-powered vehicles>	A
Diode (for ABS circuit)	B
Diode (for daytime running lamp circuit)	C
Diode (for dim-dip lamp circuit)	A
Diode (for engine control circuit)	B

NOTE  
Names are listed in alphabetical order.

NOTE  
For R.H. drive vehicles, only the positions indicated by the\* are symmetrical.

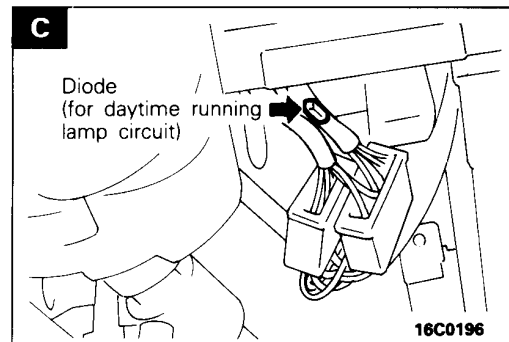
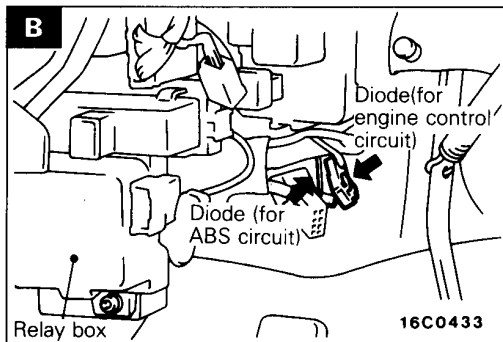
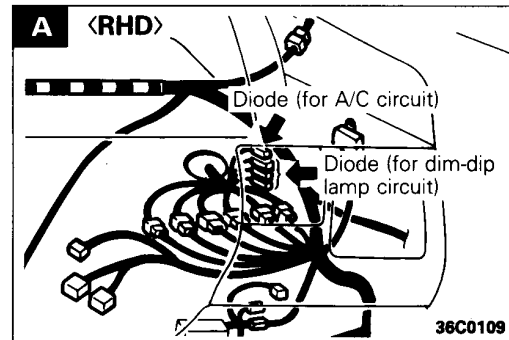
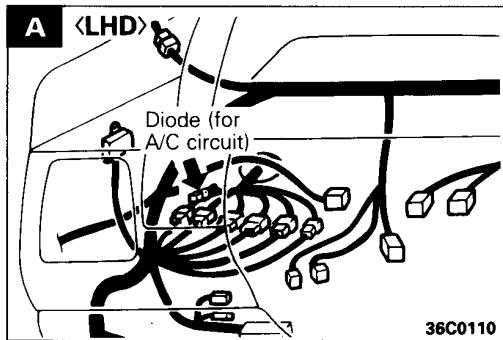



# INSPECTION TERMINAL

Name	Symbol	Name	Symbol
Engine speed detection connector	A	Ignition timing adjustment connector	B
Fuel pump check connector	A	Self-diagnosis connector	C

NOTE  
Names are listed in alphabetical order.

## Engine compartment

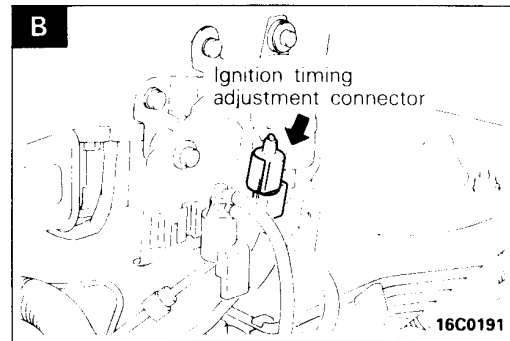
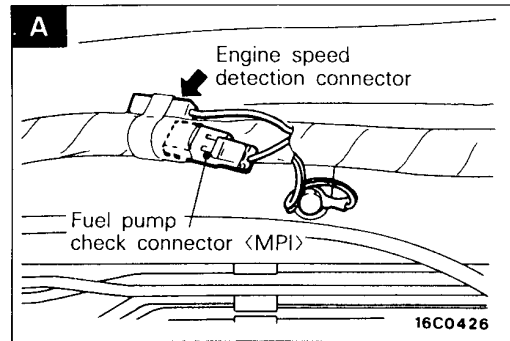
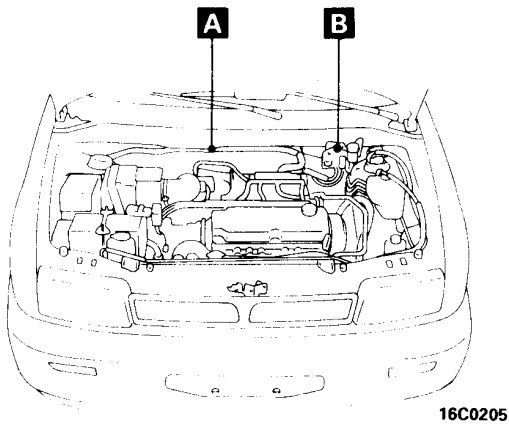

## Instrument panel

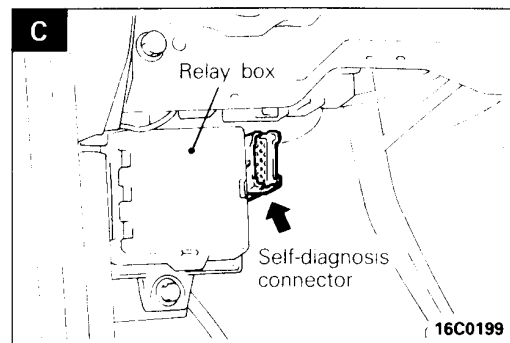
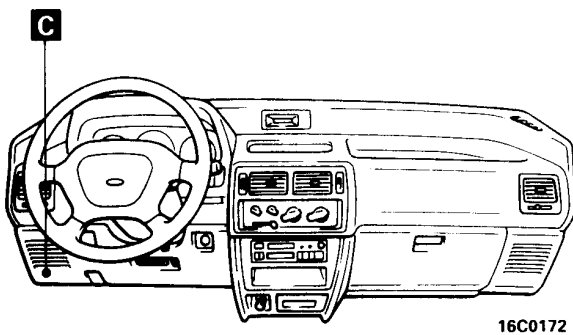

### 3-14 SINGLE PART INSTALLATION POSITION — Fusible Link and Fuse

## FUSIBLE LINK AND FUSE

### Engine compartment

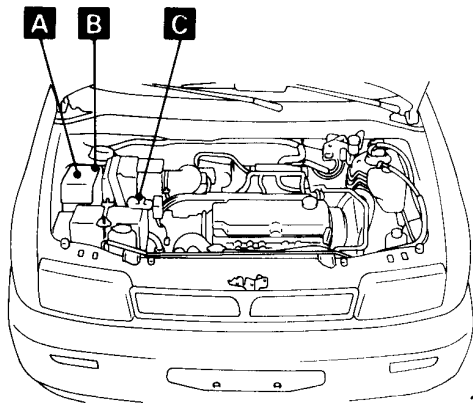

16C0205

Name	Symbol
Dedicated fuses	B
Main fusible links	C
Multi-purpose fuses	D
Sub fusible links	A

NOTE  
Names are listed in alphabetical order.

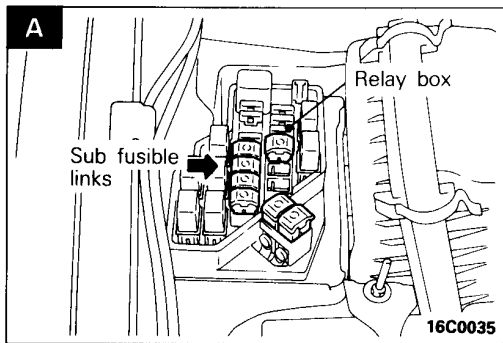

16C0035

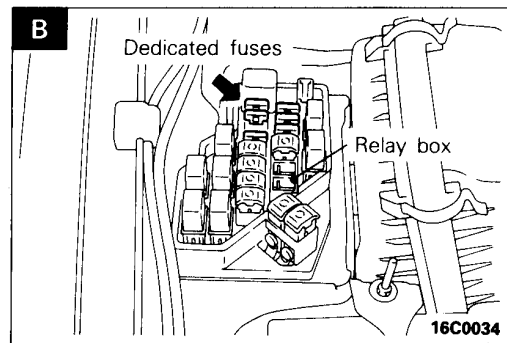

16C0034

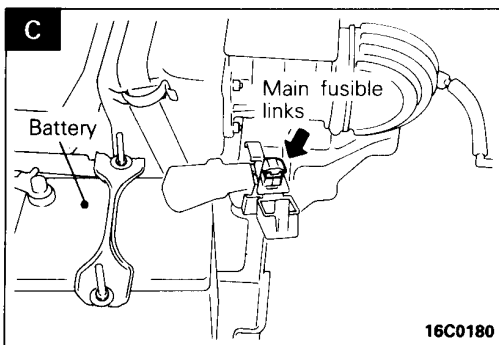

16C0180

### Instrument panel

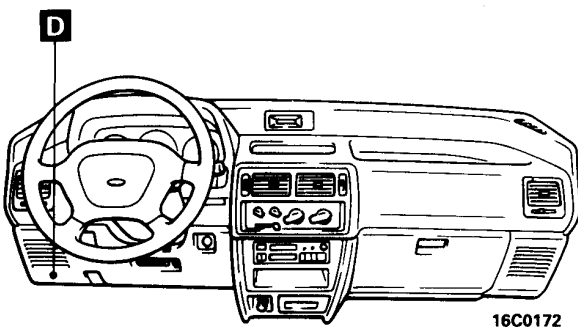

16C0172

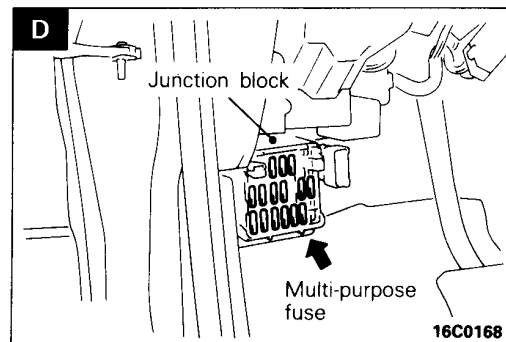

16C0168

**EARTH CABLE**

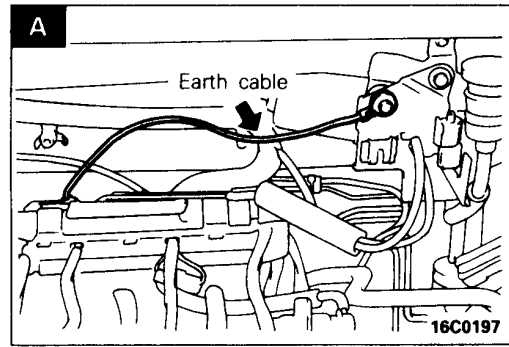
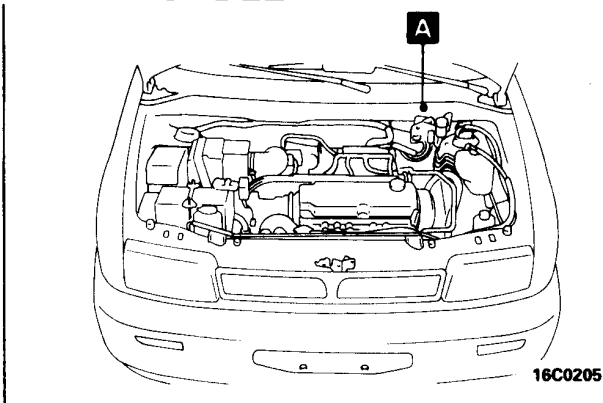

**EARTH**

Engine compartment  
 <Petrol-powered vehicles>

<Diesel-powered vehicles>

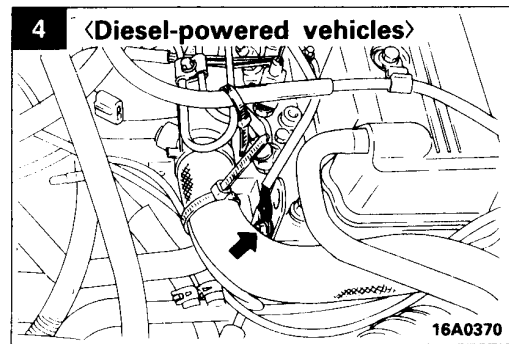
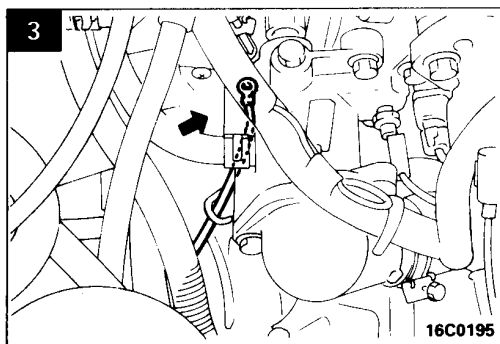
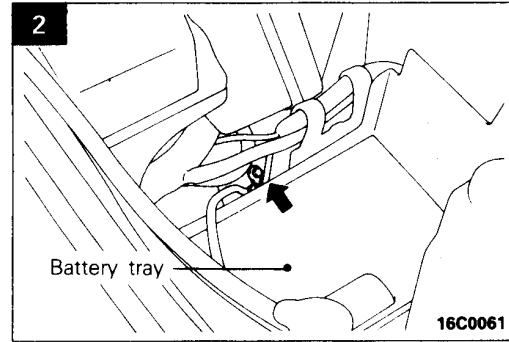
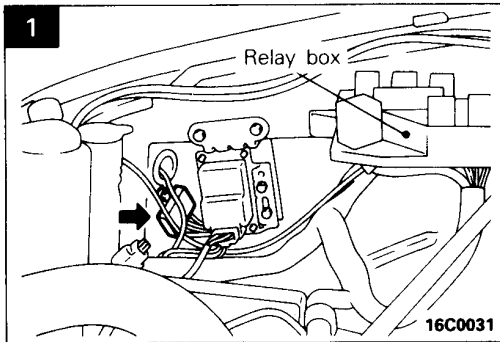
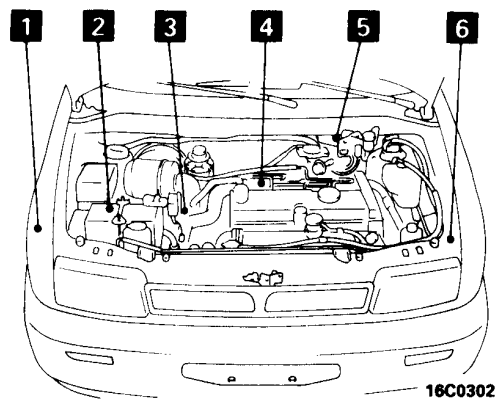
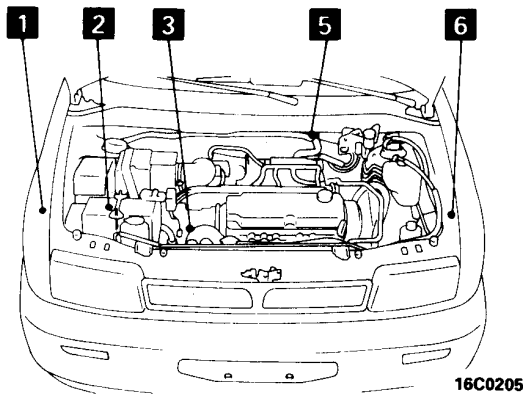

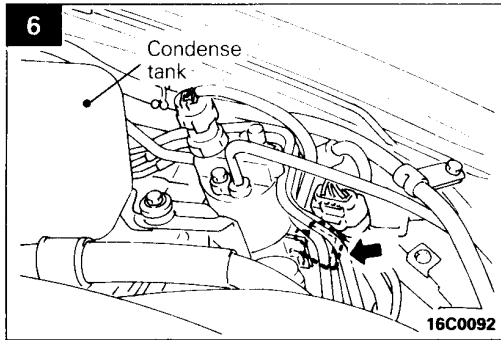
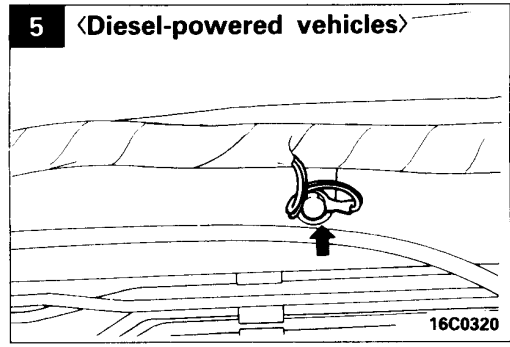
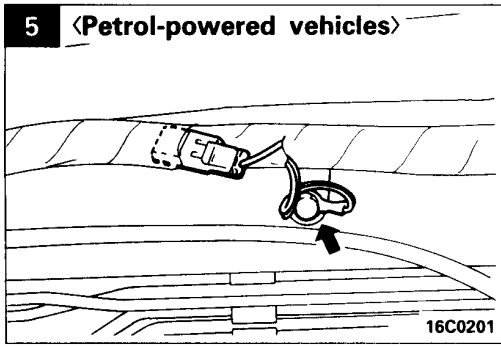

**Instrument panel**

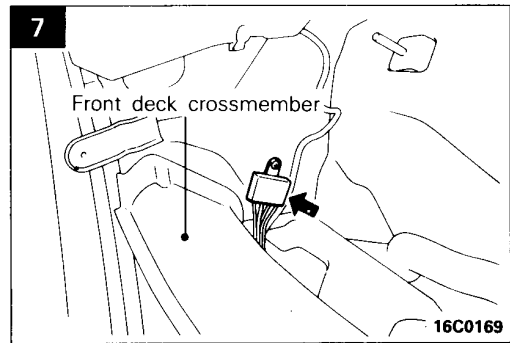
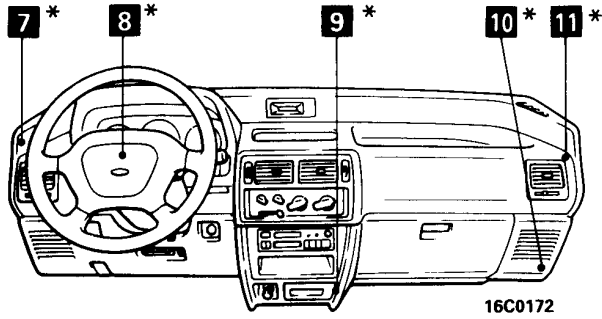

NOTE  
For R.H. drive vehicles, only the positions indicated by the \* are symmetrical.

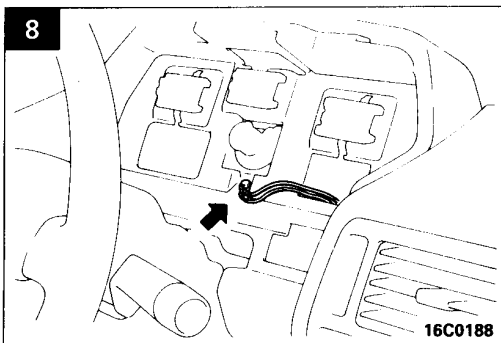

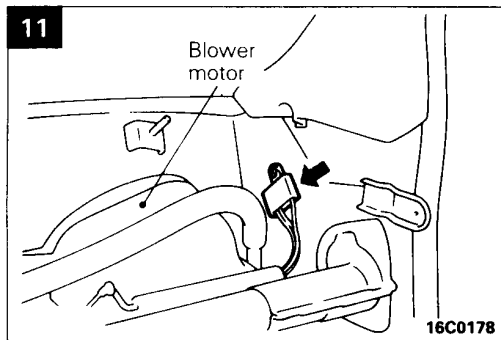
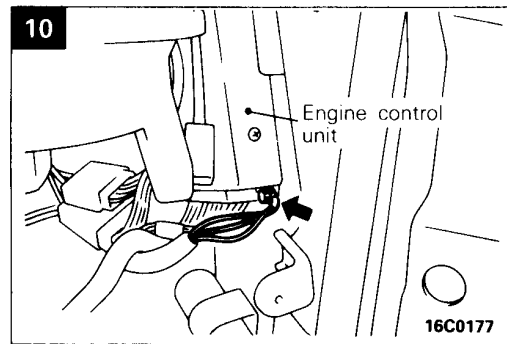
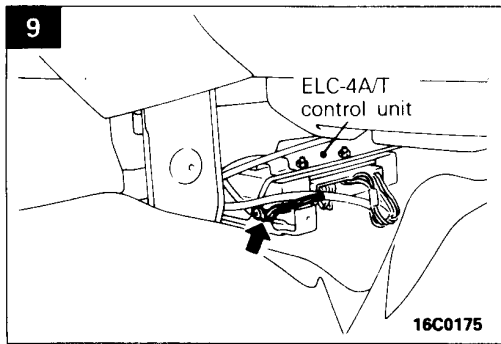

Rear

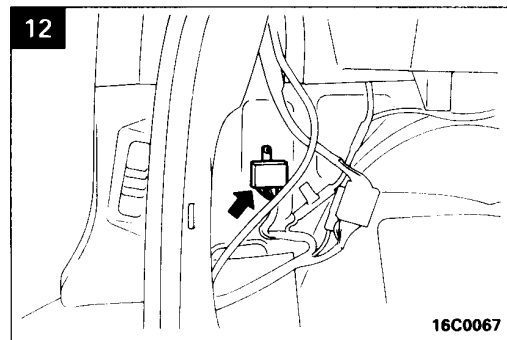
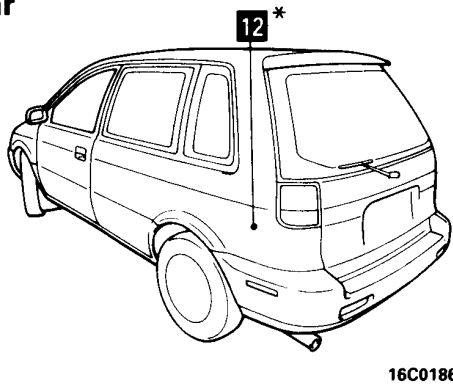

NOTE  
For SPACE WAGON, only the positions indicated by the \* are symmetrical.

## 3A SINGLE PART INSTALLATION POSITION

<b>RELAY</b> .....	<b>3A-2</b>
<b>CONTROL UNIT</b> .....	<b>3A-5</b>
<b>SENSOR</b>	
<4G93> .....	3A-7
<4G63 and 4G64> .....	3A-10
<4D68> .....	3A-14
<b>SOLENOID VALVE</b> .....	<b>3A-16</b>
<b>DIODE</b> .....	<b>3A-17</b>
<b>INSPECTION TERMINAL</b> .....	<b>3A-18</b>
<b>FUSIBLE LINK AND FUSE</b> .....	<b>3A-19</b>
<b>EARTH CABLE</b> .....	<b>3A-20</b>
<b>EARTH</b> .....	<b>3A-21</b>

RELAY

Name	Symbol	Name	Symbol
ABS motor relay	F	Glow plug relay <Diesel>	C
ABS power relay	H	Headlamp relay	B
ABS valve relay	F	Headlamp washer relay	A
A/C compressor relay	B	Heater relay	G
A/C relay <Diesel>	L	Horn relay <SRS>	H
Alternator relay	B	Intermittent wiper relay (windshield wiper)	I
Condenser fan motor relay (HI)	B	Intermittent wiper relay (rear wiper)	J
Condenser fan motor relay (LO)	B	Power windows relay	H
Daytime running lamp relay 1	E	Radiator fan motor relay (HI)	B
Daytime running lamp relay 2	E	Radiator fan motor relay (LO)	B
Defogger relay	G	Rear fog lamp relay	H
Dim-dip lamp relay 1 <R.H. drive vehicles>	E	Starter relay <Diesel>	D
Dim-dip lamp relay 2 <R.H. drive vehicles>	E	Sunroof control relay	M
Dim-dip lamp relay 3 <R.H. drive vehicles>	E	Sunroof relay	M
Engine control relay	K	Tail lamp relay	B
Engine oil level relay <SPACE WAGON>	K	Turn signal and hazard flasher unit	G

Engine compartment

<Petrol-powered vehicles>

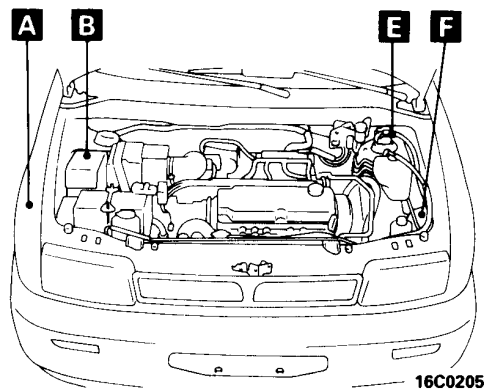

<Diesel-powered vehicles>

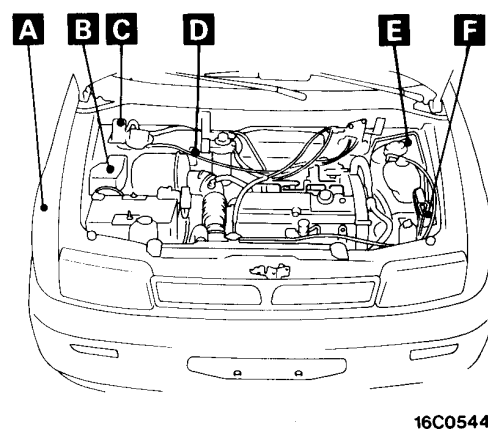

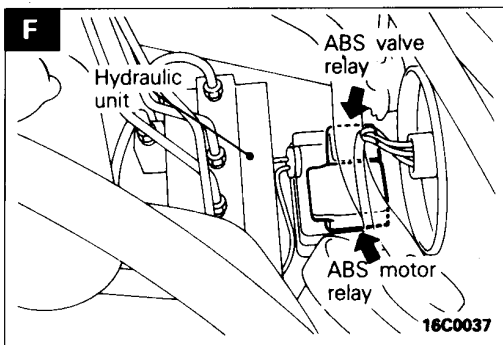
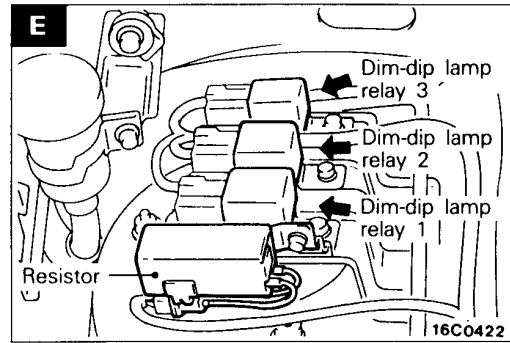
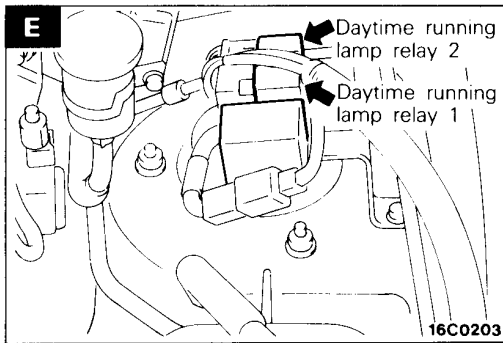
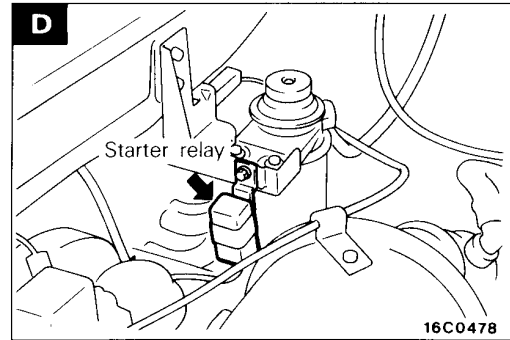
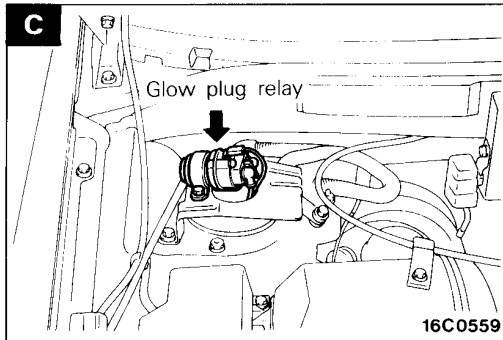
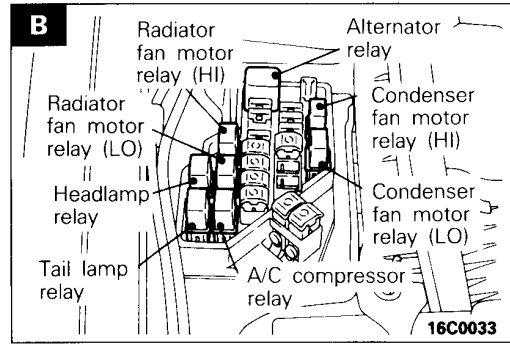
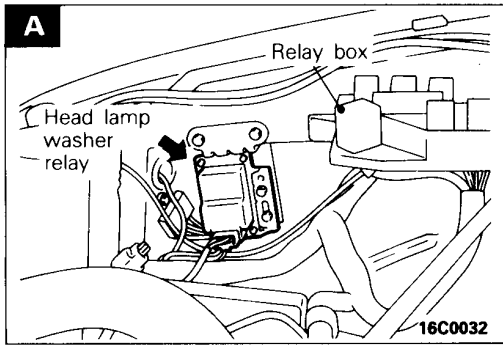



# 3A-4

# SINGLE PART INSTALLATION POSITION — Relay

## Instrument panel

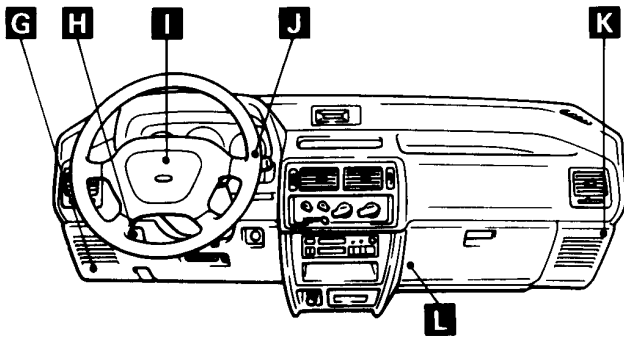

16C0172

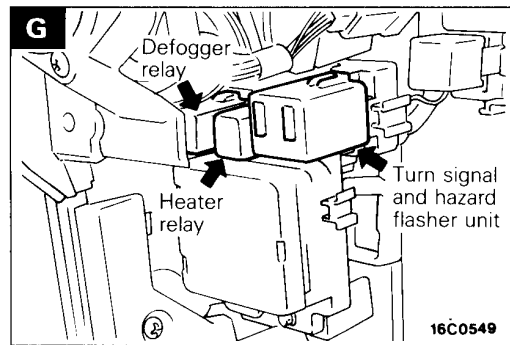

16C0549

**NOTE**

For R.H. drive vehicles, part installation positions are symmetrical.

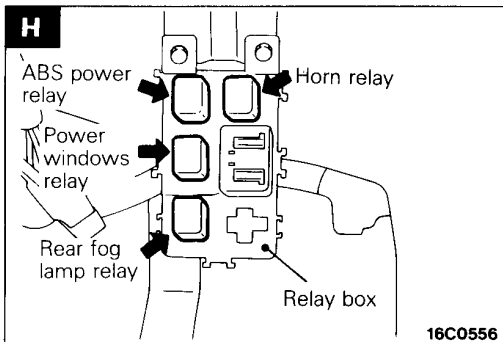

16C0556

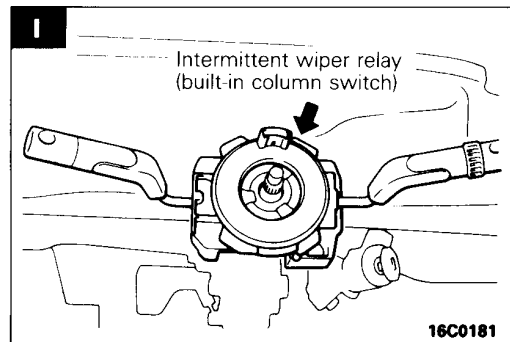

16C0181

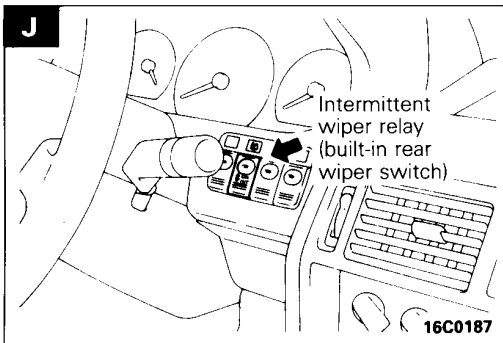

16C0187

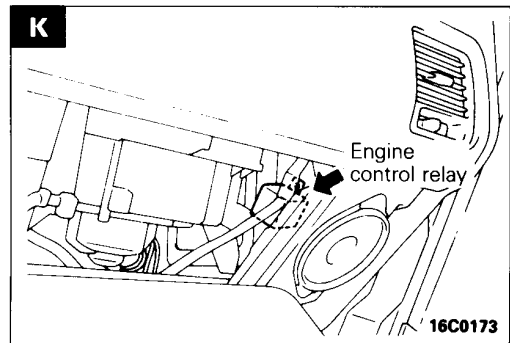

16C0173

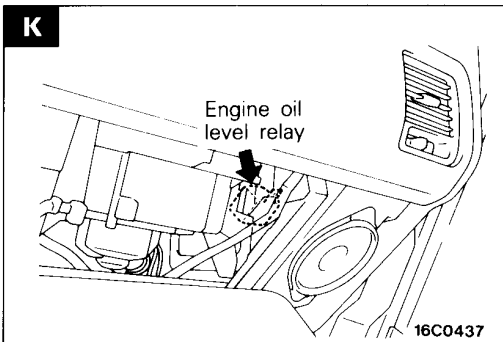

16C0437

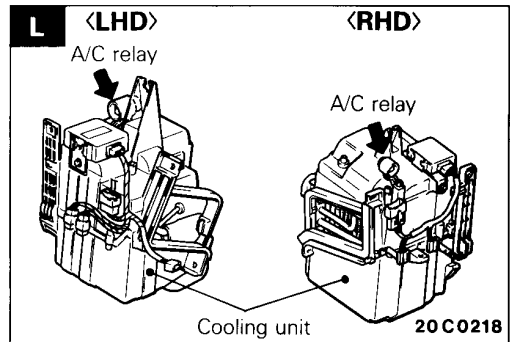

20C0218

Roof

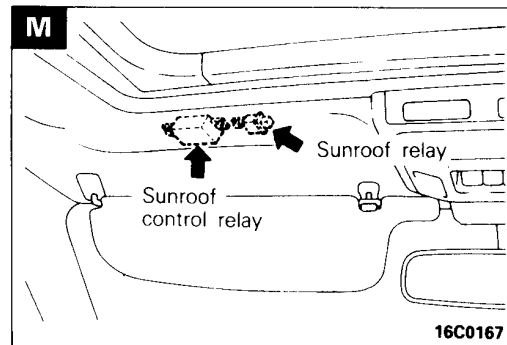
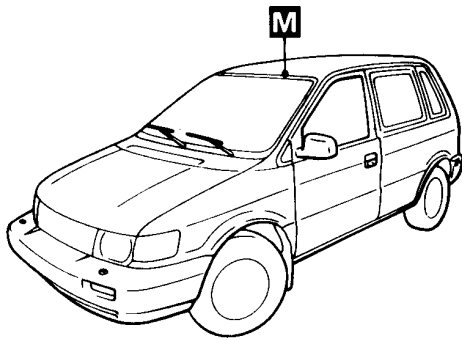

NOTE  
For R.H. drive vehicles, part installation position is symmetrical.

16C0183

CONTROL UNIT

Name	Symbol	Name	Symbol
ABS control unit	D	ELC-4A/T control unit	C
A/C belt lock controller <4G93>	E	Engine control unit <MPI>	F
Automatic compressor control unit <A/C>	E	Glow control unit <Diesel>	F
Central door lock control unit	B	SRS diagnosis unit	G
Daytime running lamp control unit	A		

Engine compartment

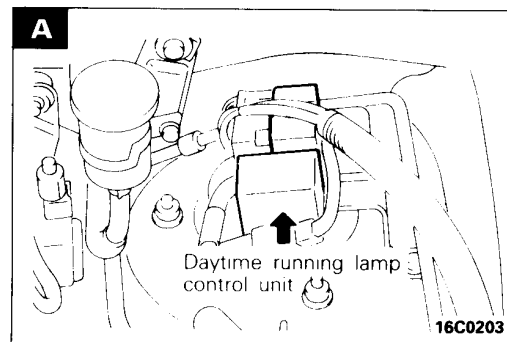
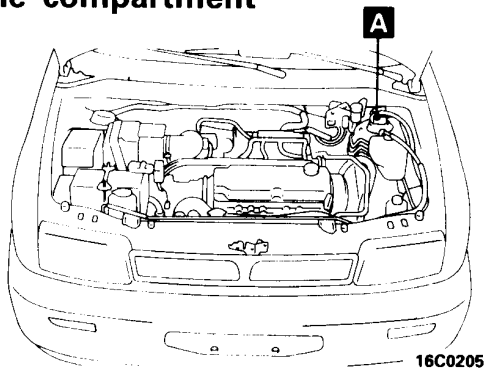

Instrument panel

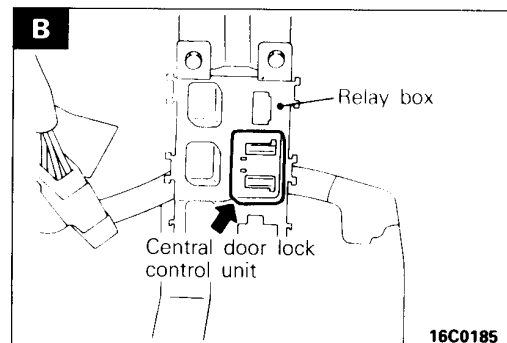
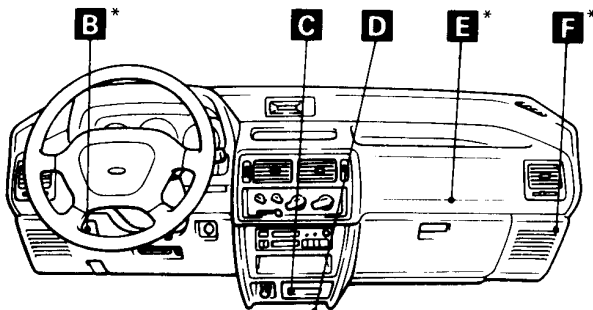

NOTE  
For R.H. drive vehicles, only the positions indicated by the \* are symmetrical.

16C0172

16C0185

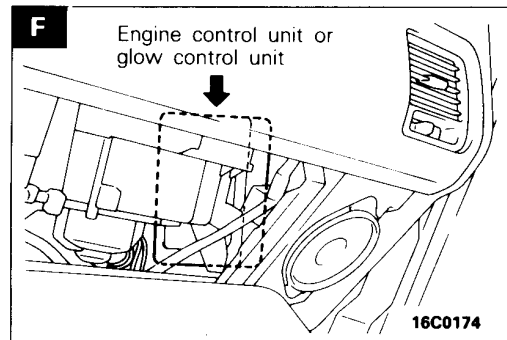
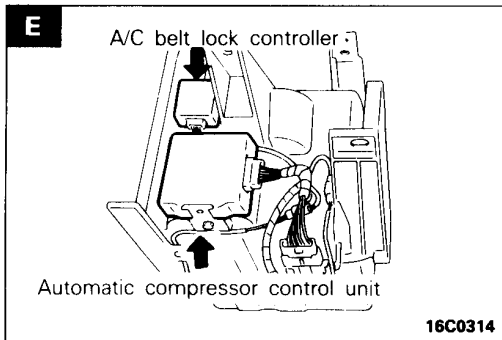
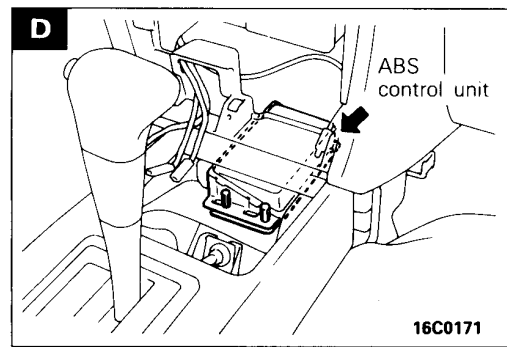
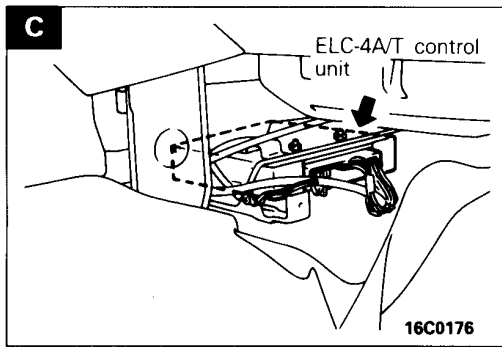

Floor console

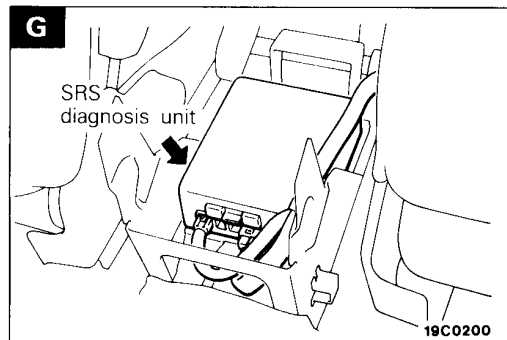
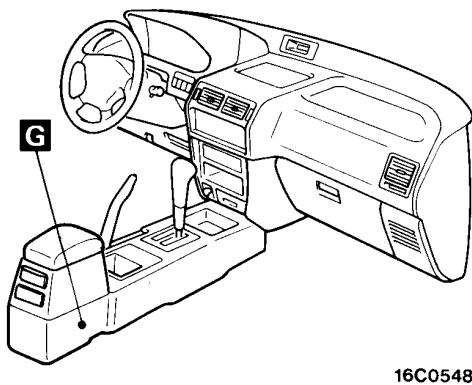

**SENSOR**

<4G93>

Name	Symbol	Name	Symbol
ABS speed sensor (front)	N	Engine coolant temperature sensor (for engine control)	D
ABS speed sensor (rear)	O	Engine coolant temperature switch (for A/C)	C
Air-flow sensor (with built-in barometric pressure sensor, intake air temperature sensor)	B	G sensor (for ABS) <4WD>	M
Air inlet sensor <A/C>	L	Idle speed control servo valve position sensor	F
Air thermo sensor <A/C>	K	Oxygen sensor	G
A/T fluid temperature sensor	A	Revolution pick-up sensor <A/C>	I
Crank angle sensor and top dead center sensor	C	Throttle position sensor	E
Detonation sensor	H	Vehicle speed sensor (Reed switch)	J
Engine coolant temperature gauge unit	D		

**Engine compartment**

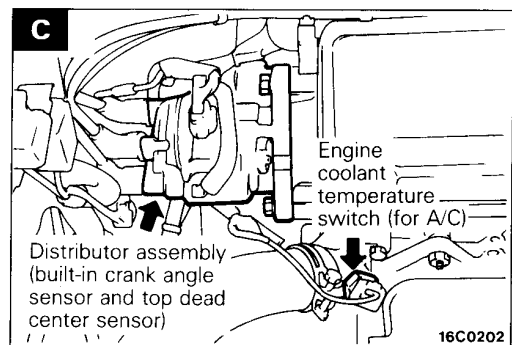
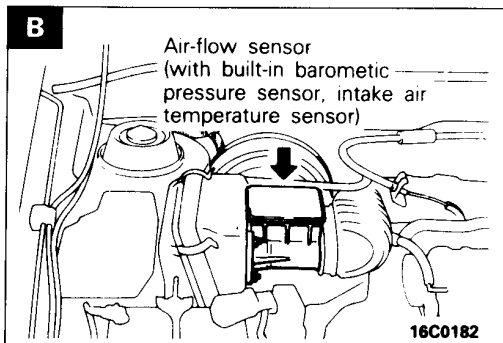
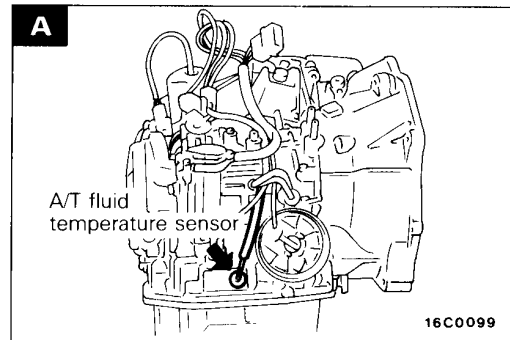
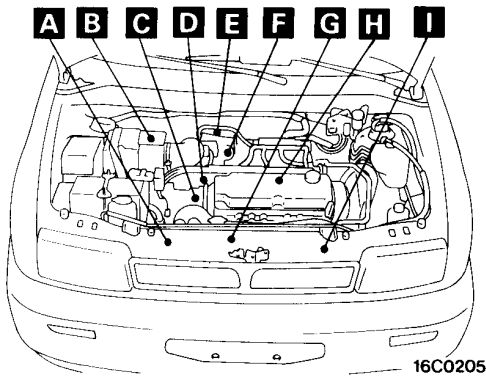

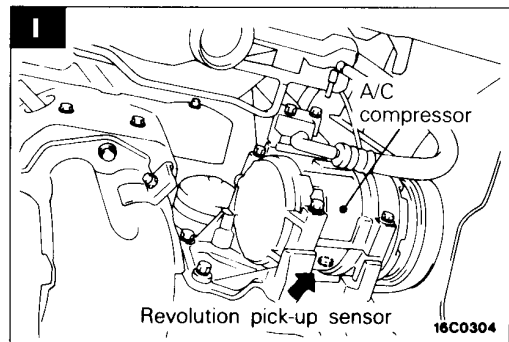
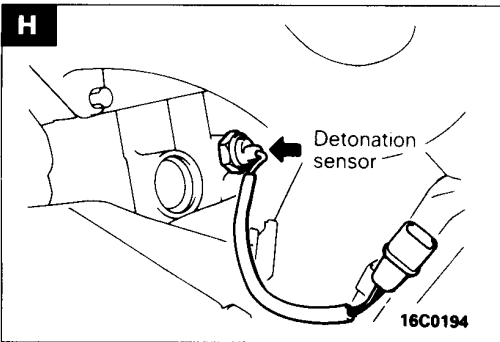
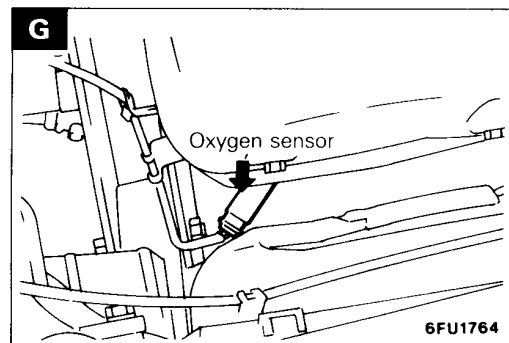
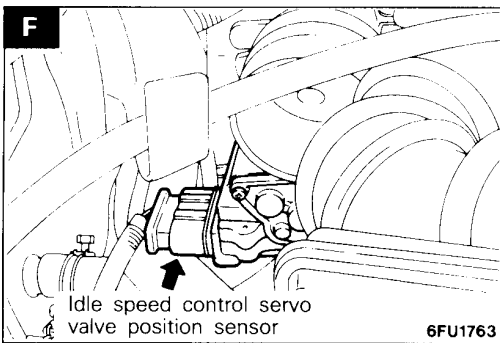
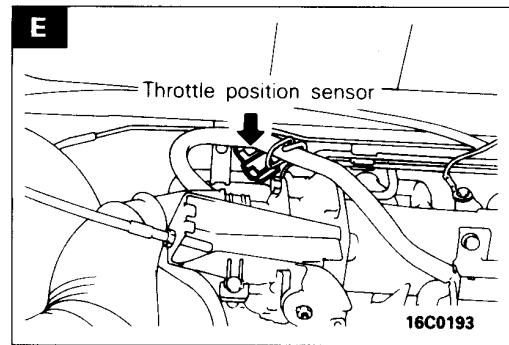
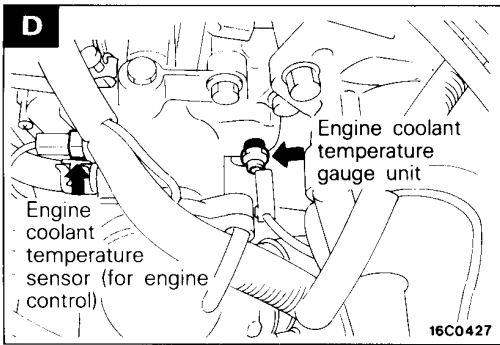

**Instrument panel**

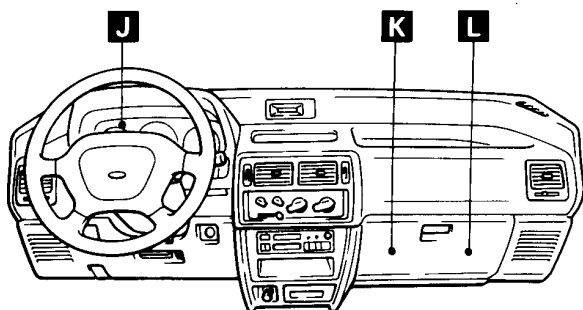

16C0172

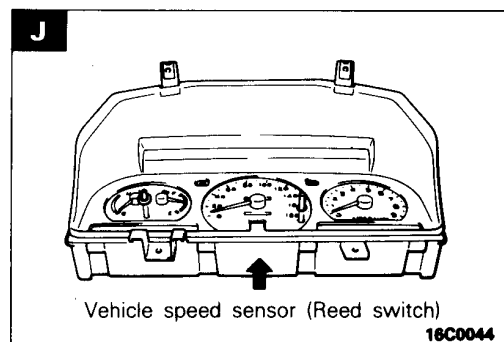

**NOTE**  
For R.H. drive vehicles, part installation positions are symmetrical.

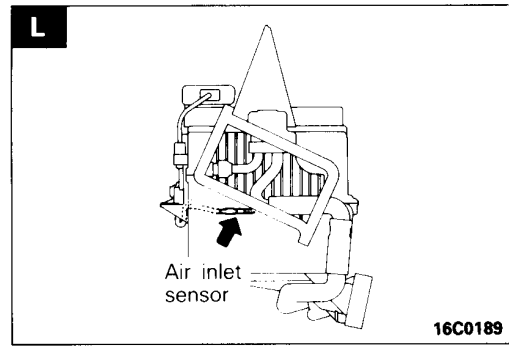
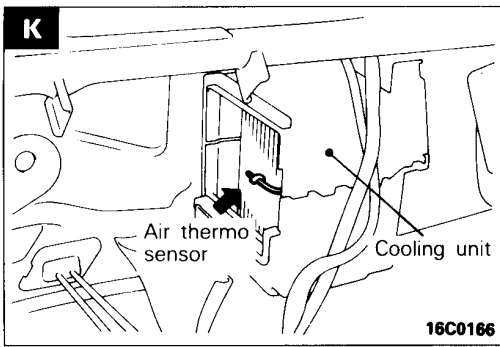

Floor console

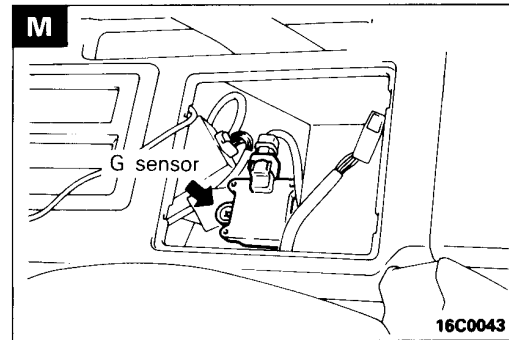
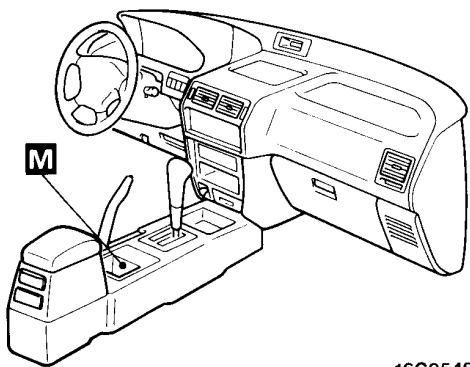

Front under floor

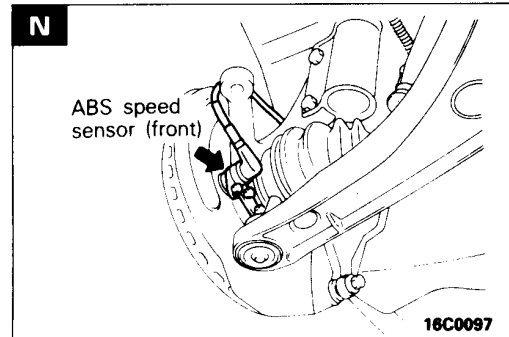
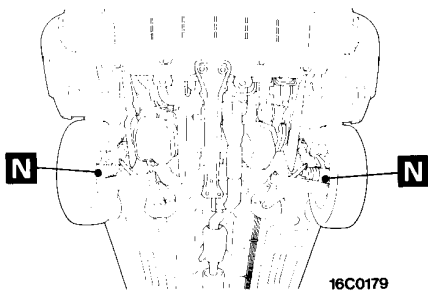

Rear under floor

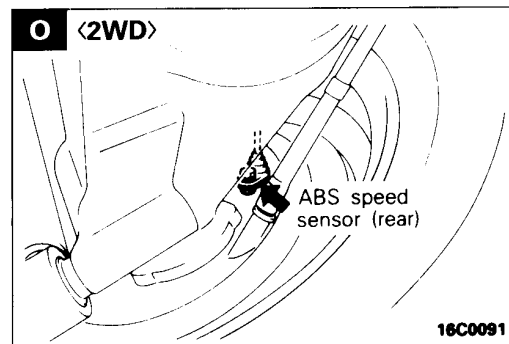
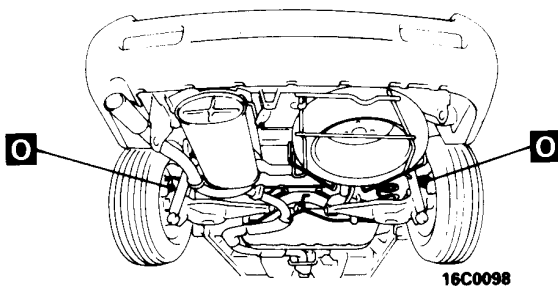

### 3A-10 SINGLE PART INSTALLATION POSITION — Sensor <4G93>/<4G63 and 4G64>

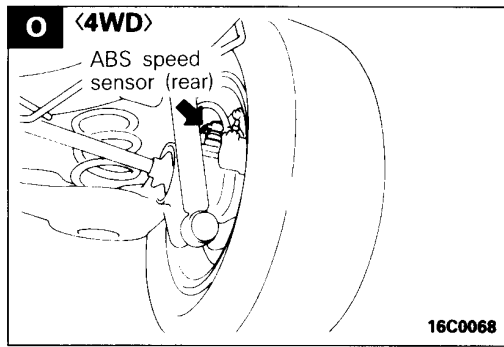

## SENSOR

### <4G63 and 4G64>

Name	Symbol	Name	Symbol
ABS speed sensor (front)	O	Engine coolant temperature sensor (for engine control)	D
ABS speed sensor (rear)	P	Engine oil level sensor	I
Air-flow sensor (with built-in barometric pressure sensor, intake air temperature sensor)	B	G sensor (for ABS) <4WD>	M
Air inlet sensor <A/C>	L	Idle speed control servo valve position sensor	F
Air thermo sensor <A/C>	K	Oxygen sensor	N
A/T fluid temperature sensor	A	Rear oxygen sensor <4G64>	N
Crank angle sensor and top dead center sensor	C	Throttle position sensor	E
Detonation sensor <4G63>	H	Vehicle speed sensor (Reed switch)	J
EGR temperature sensor <4G64>	G		
Engine coolant temperature gauge unit	D		

### Engine compartment

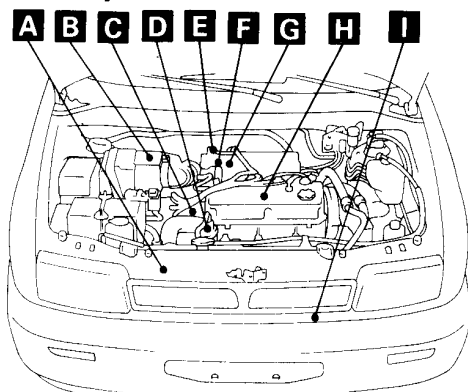

16C0429

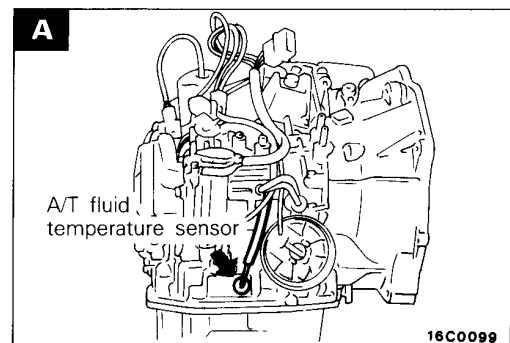

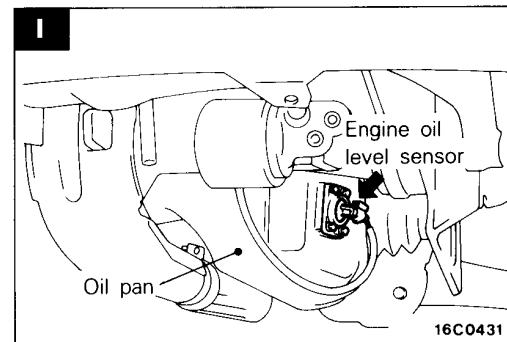
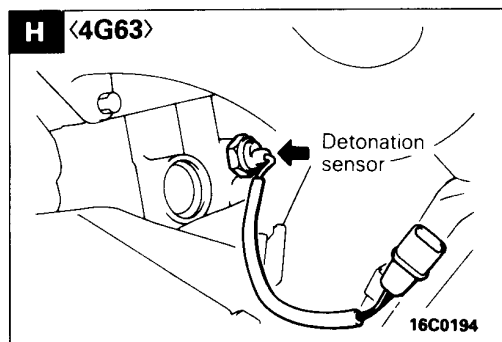
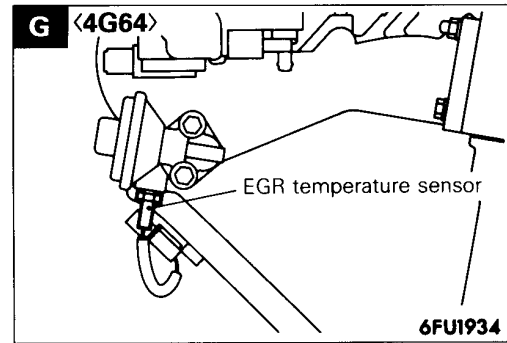
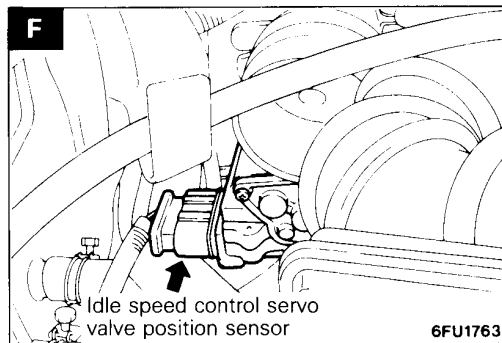
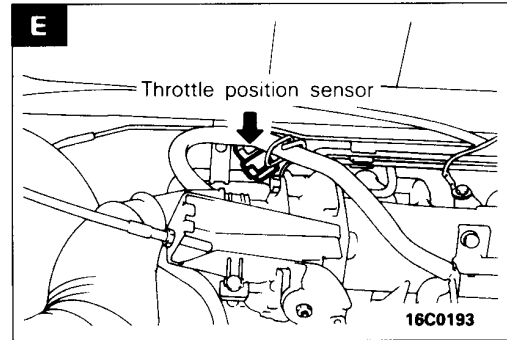
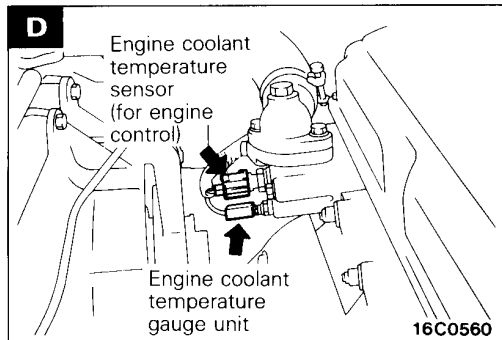
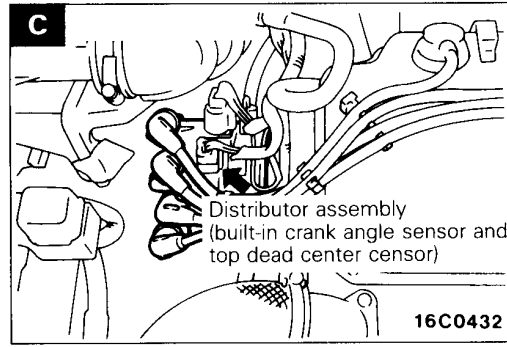
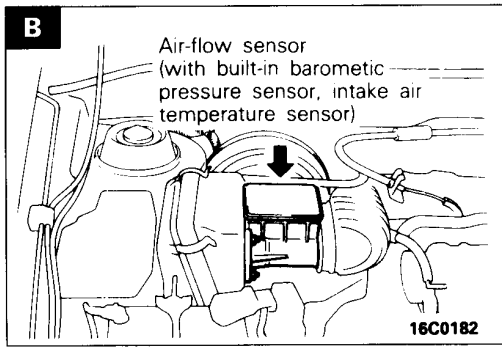



# 3A-12 SINGLE PART INSTALLATION POSITION — Sensor <4G63 and 4G64>

## Instrument panel

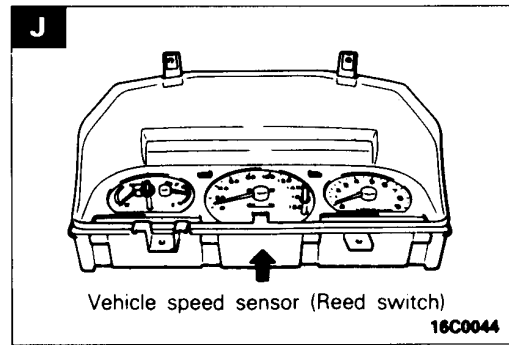
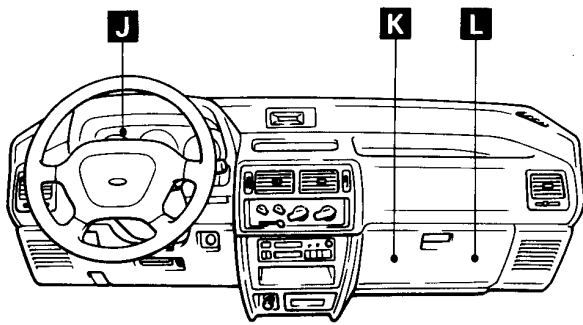

16C0172

NOTE  
For R.H. drive vehicles, part installation positions are symmetrical.

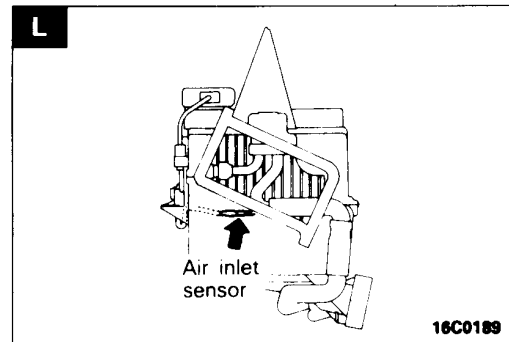
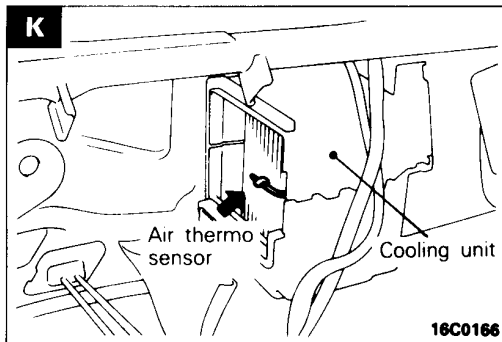

## Floor console

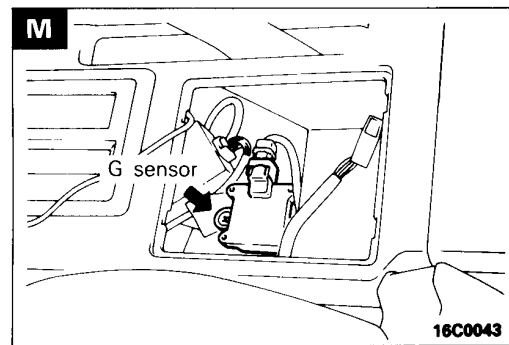
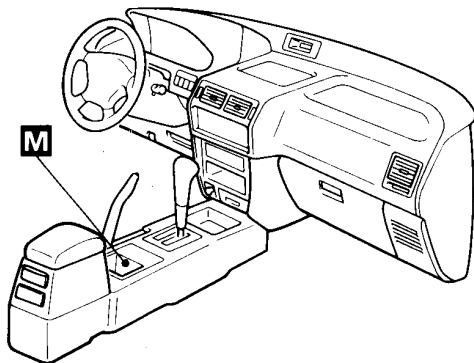

## Front under floor

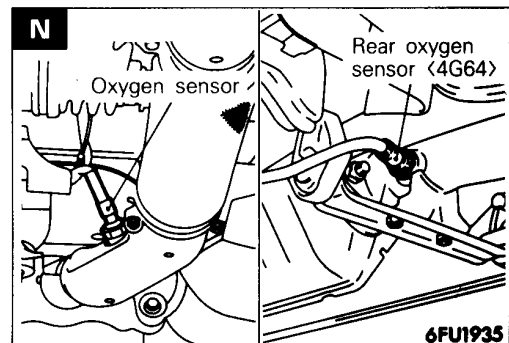
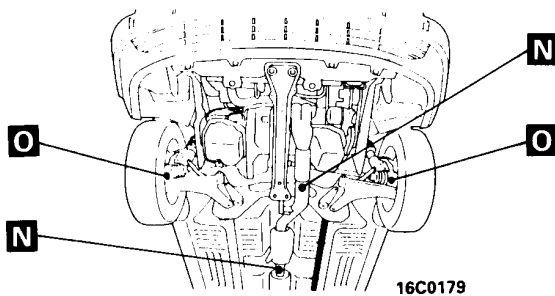

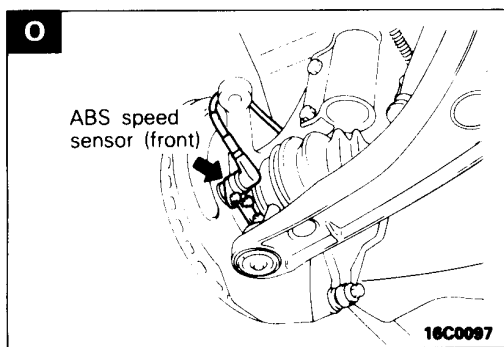

Rear under floor

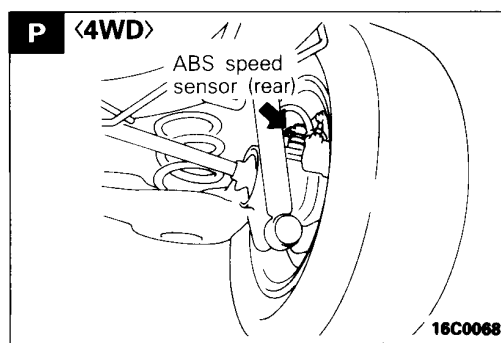
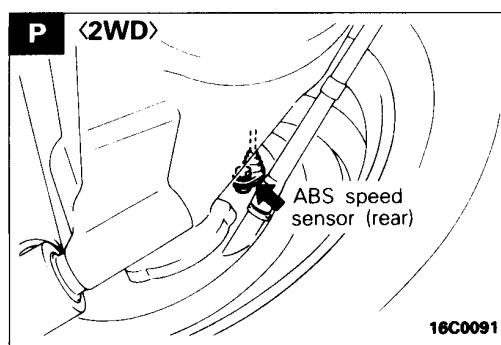
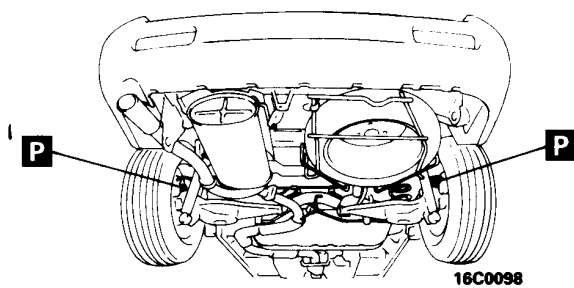

# 3A-14 SINGLE PART INSTALLATION POSITION — Sensor <4D68>

## SENSOR <4D68>

Name	Symbol	Name	Symbol
ABS speed sensor (front)	H	Engine coolant temperature switch (for condenser fan)	B
ABS speed sensor (rear)	I	Engine coolant temperature switch (for A/C)	A
Air inlet sensor <A/C>	G	Engine oil level sensor	D
Air thermo sensor <A/C>	F	Lever (throttle) position sensor	C
Engine coolant temperature sensor and gauge unit	B	Revolution pick up sensor	C
Engine coolant temperature sensor (for water temperature alarm lamp)	A	Vehicle speed sensor (Reed switch)	E
Engine coolant temperature switch (for EGR)	A		

### Engine compartment

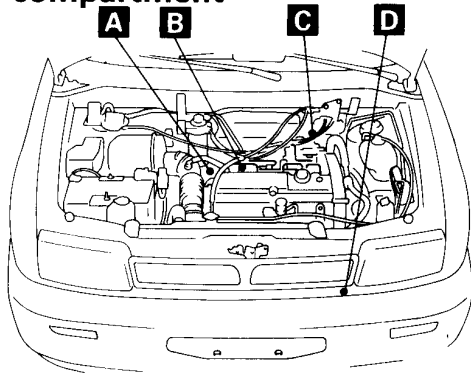

16C0544

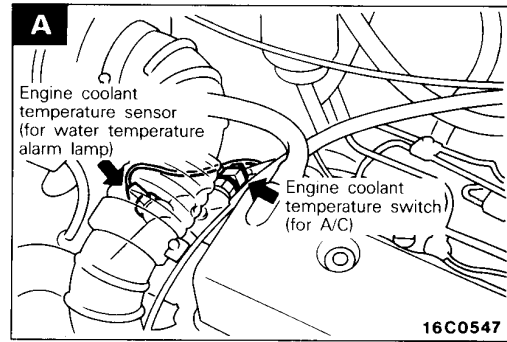

16C0547

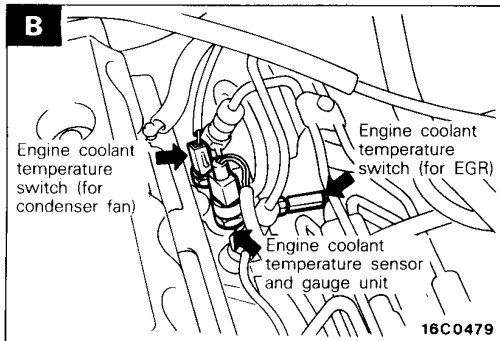

16C0479

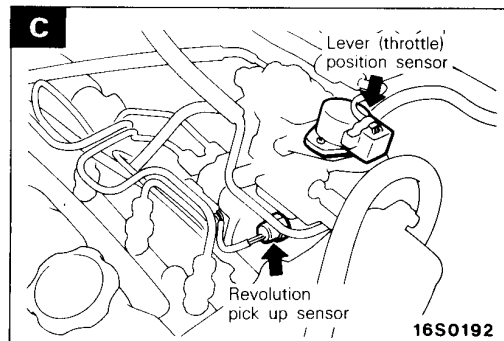

16S0192

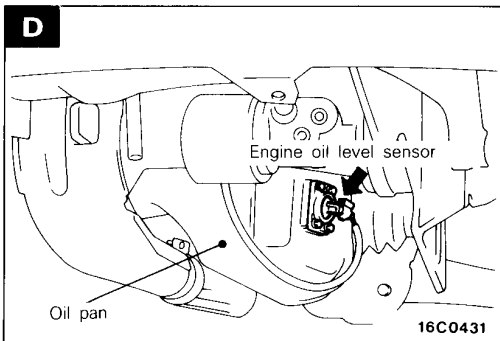

16C0431

Instrument panel

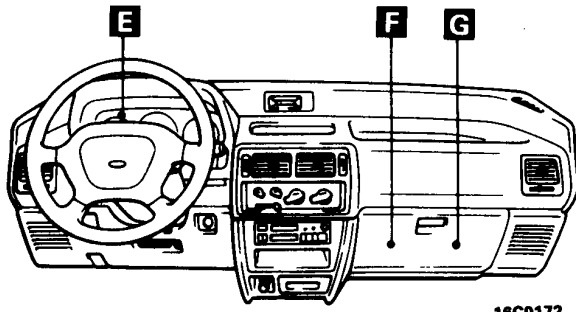

16C0172

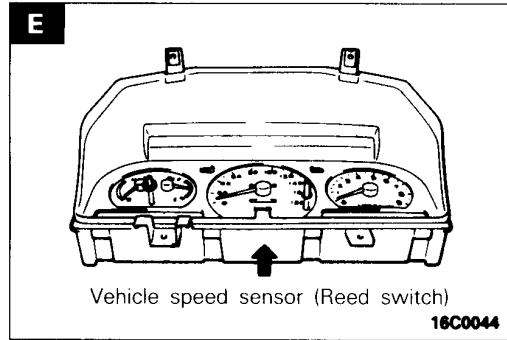

Vehicle speed sensor (Reed switch)

16C0044

NOTE  
For R.H. drive vehicles, part installation positions are symmetrical.

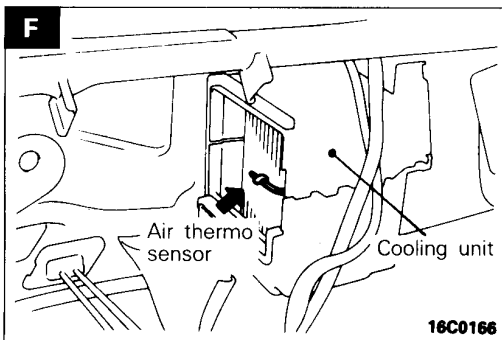

16C0166

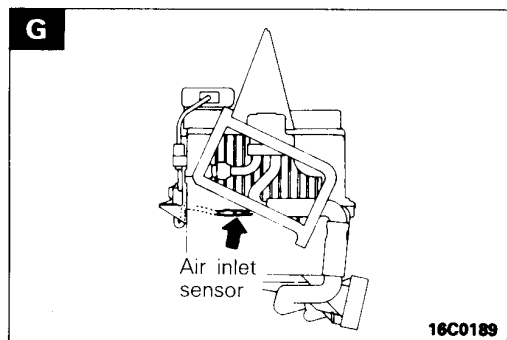

16C0189

Front under floor

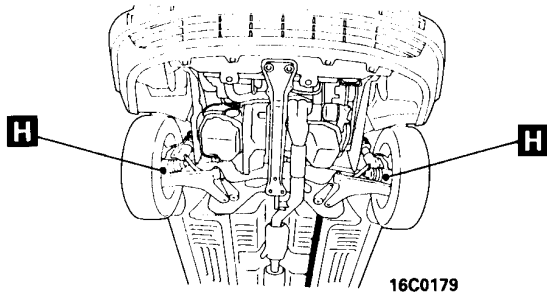

16C0179

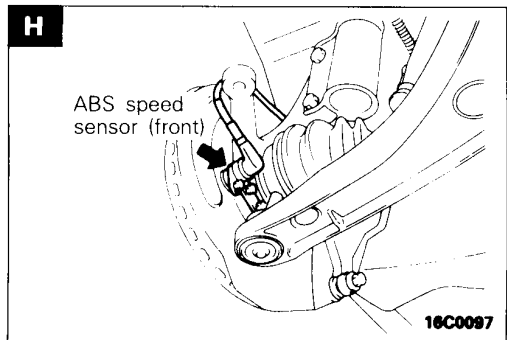

16C0097

Rear under floor

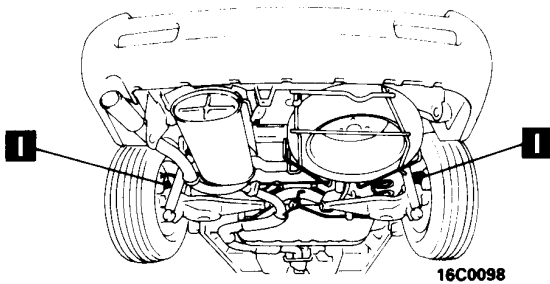

16C0098

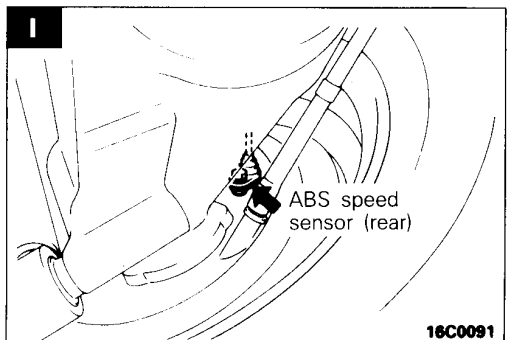

16C0091

# 3A-16 SINGLE PART INSTALLATION POSITION — Solenoid Valve

## SOLENOID VALVE

Name	Symbol	Name	Symbol
ABS solenoid valve	E	EGR solenoid valve I <Diesel>	D
A/C refrigerant capacity control solenoid valve	C	EGR solenoid valve II <Diesel>	D
ELC-4A/T control solenoid valve	A	Fuel cut solenoid valve <Diesel>	B
<ul style="list-style-type: none"> <li>• Damper clutch control solenoid valve</li> <li>• Oil pressure control solenoid valve</li> <li>• Shift control solenoid valve A, B</li> </ul>		Idle up solenoid valve <Diesel (A/C)>	D
EGR solenoid valve <4G63 and 4G64>	D	Purge control solenoid valve <Petrol>	D

### Engine compartment

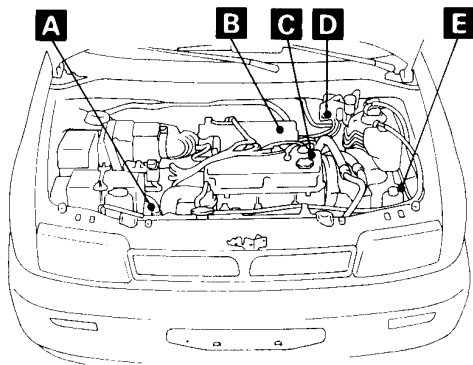

16C0429

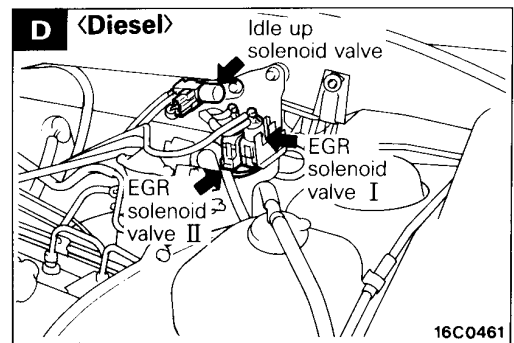
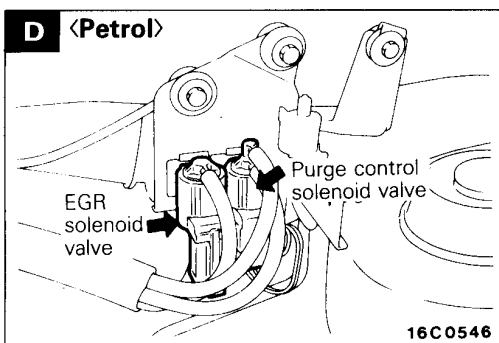
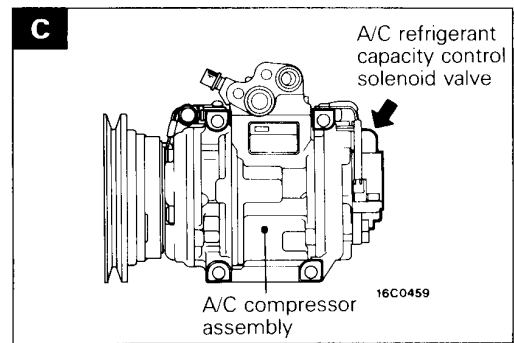
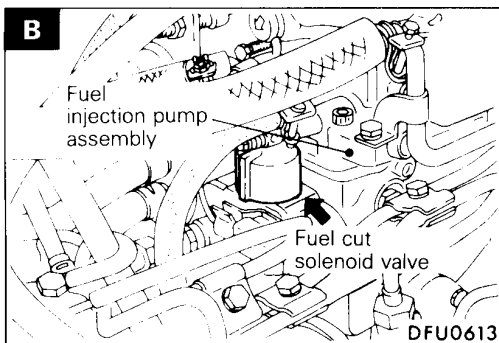
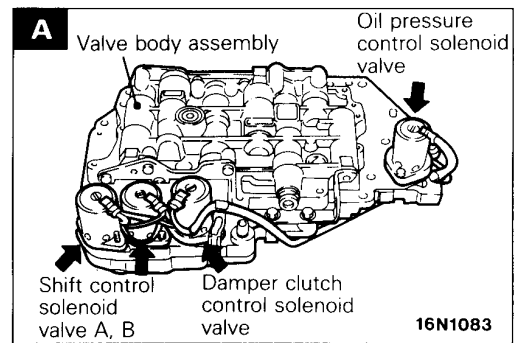

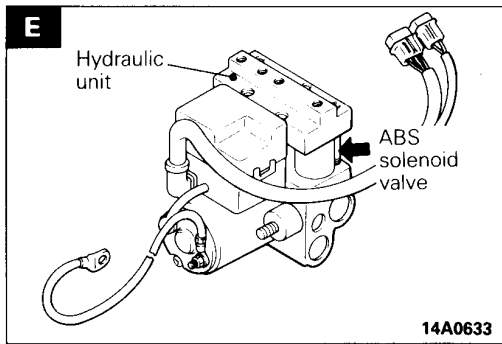

## DIODE

Name	Symbol
Diode (for A/C circuit) <Diesel>	A
Diode (for ABS circuit)	B
Diode (for headlamp circuit) <LHD>	C
Diode (for dim-dip lamp circuit)	A

### Instrument panel

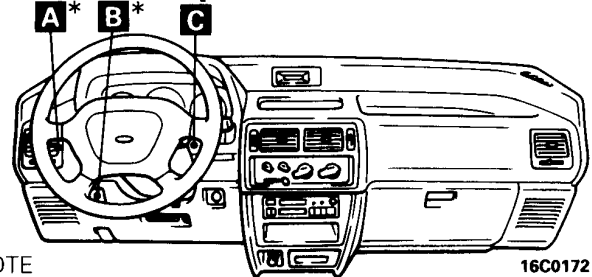

NOTE  
For R.H. drive vehicles, only the positions indicated by the\* are symmetrical.

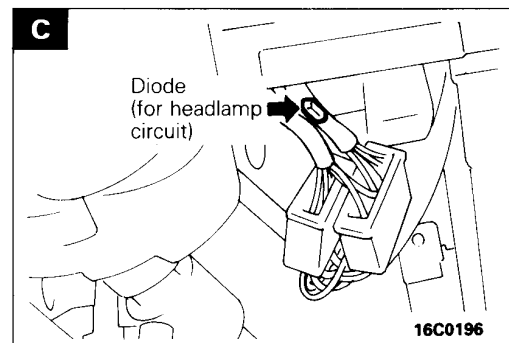
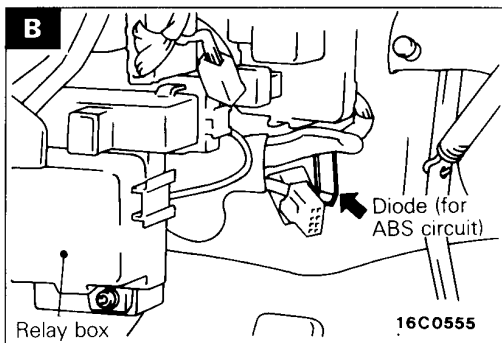
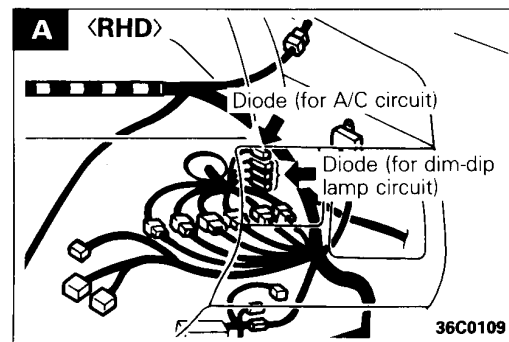
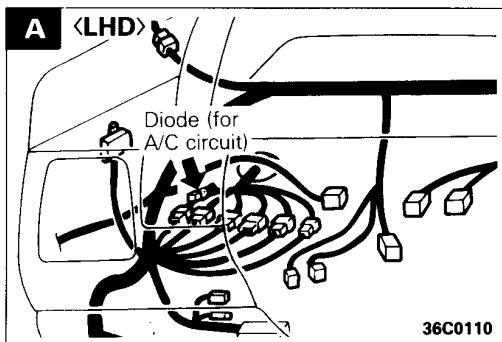

# 3A-18 SINGLE PART INSTALLATION POSITION — Inspection Terminal

## INSPECTION TERMINAL

Name	Symbol	Name	Symbol
Diagnosis connector	C	Ignition timing adjustment connector <MPI>	LHD
Engine speed detection connector <MPI>	A		RHD
Fuel pump check connector <MPI>	A		

### Engine compartment

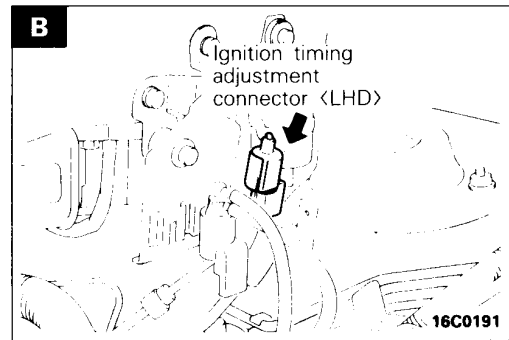
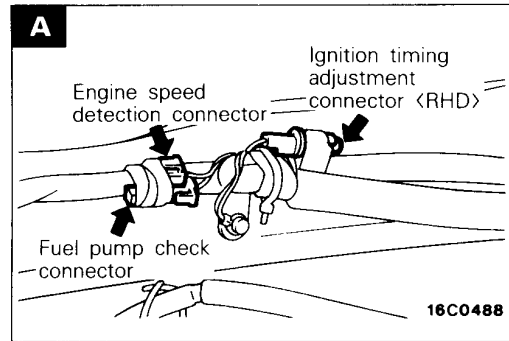
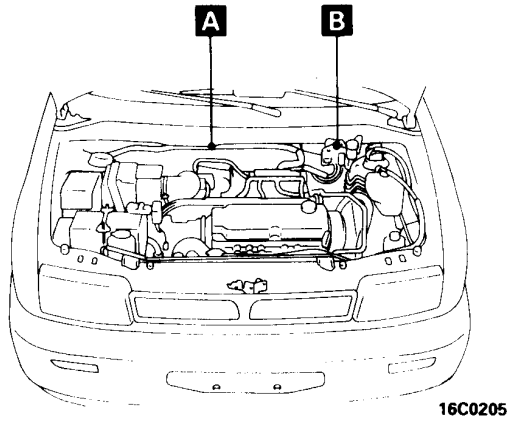

### Instrument panel

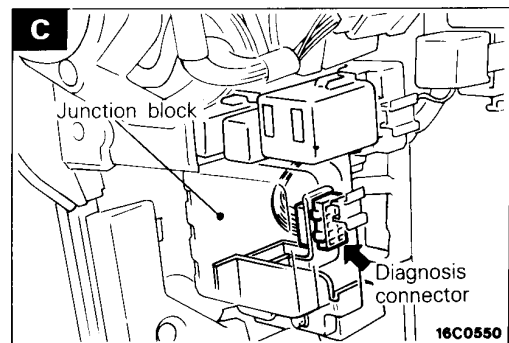
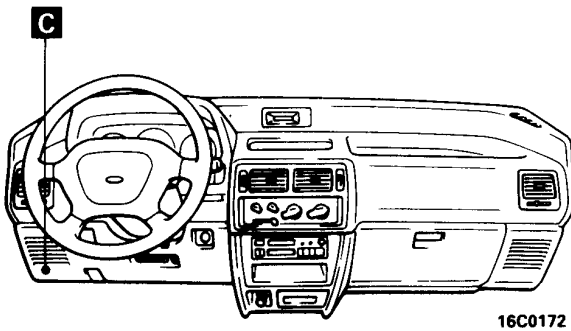

NOTE  
For R.H. drive vehicles, part installation position is symmetrical.

**FUSIBLE LINK AND FUSE**

Name	Symbol	Name	Symbol
Dedicated fuses	B	Multi-purpose fuses	D
Main fusible links	C	Sub fusible links	A

**Engine compartment**

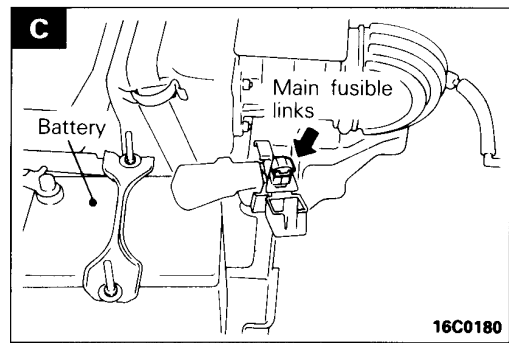
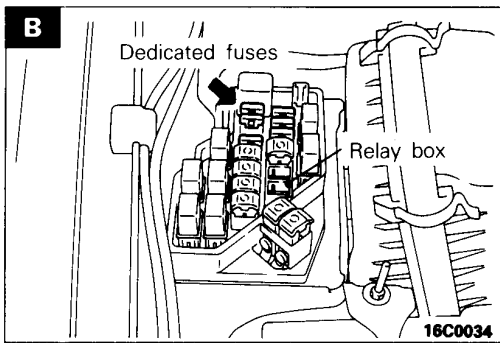
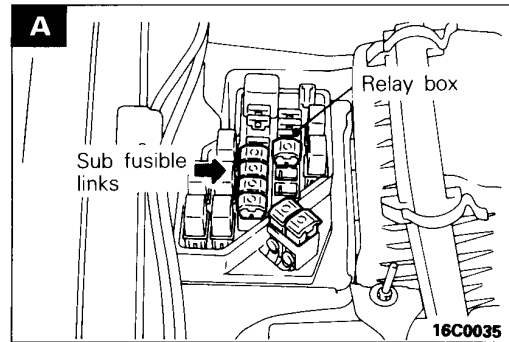
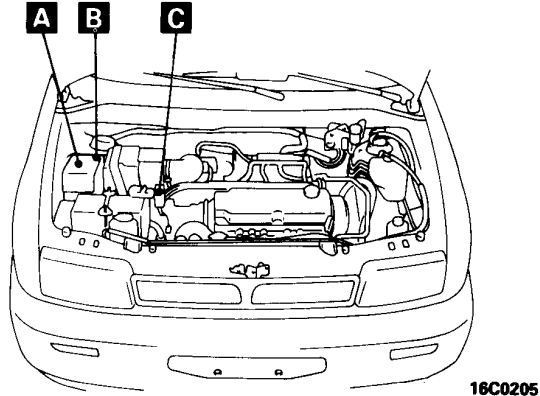

**Instrument panel**

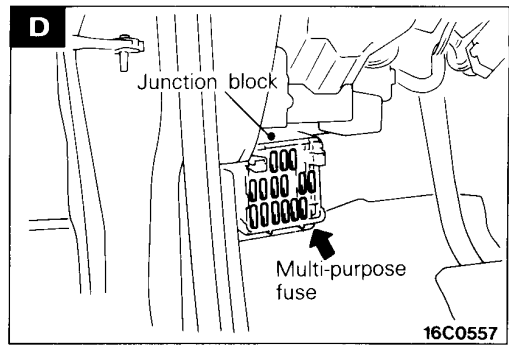
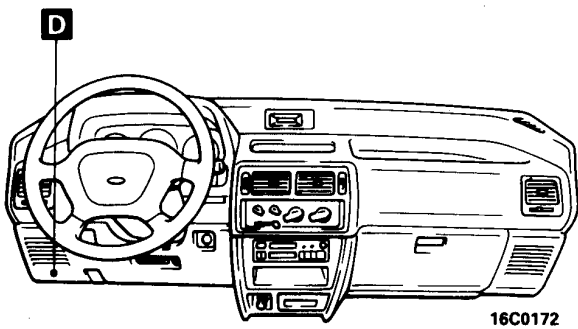

NOTE  
For R.H. drive vehicles, part installation position is symmetrical.



**3A-20 SINGLE PART INSTALLATION POSITION — Earth Cable**

**EARTH CABLE**

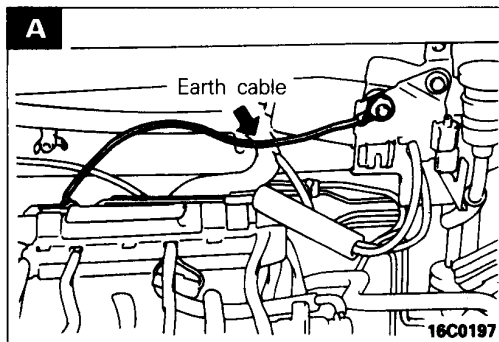
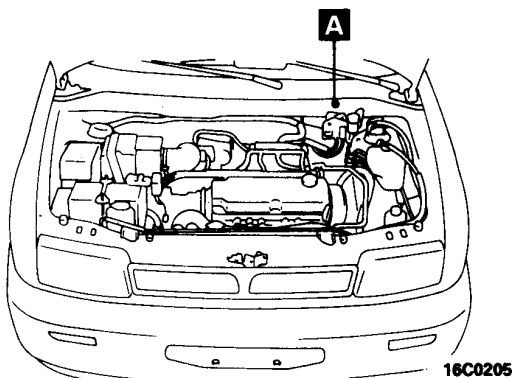

# EARTH

## L.H. drive vehicles <SPACE RUNNER>

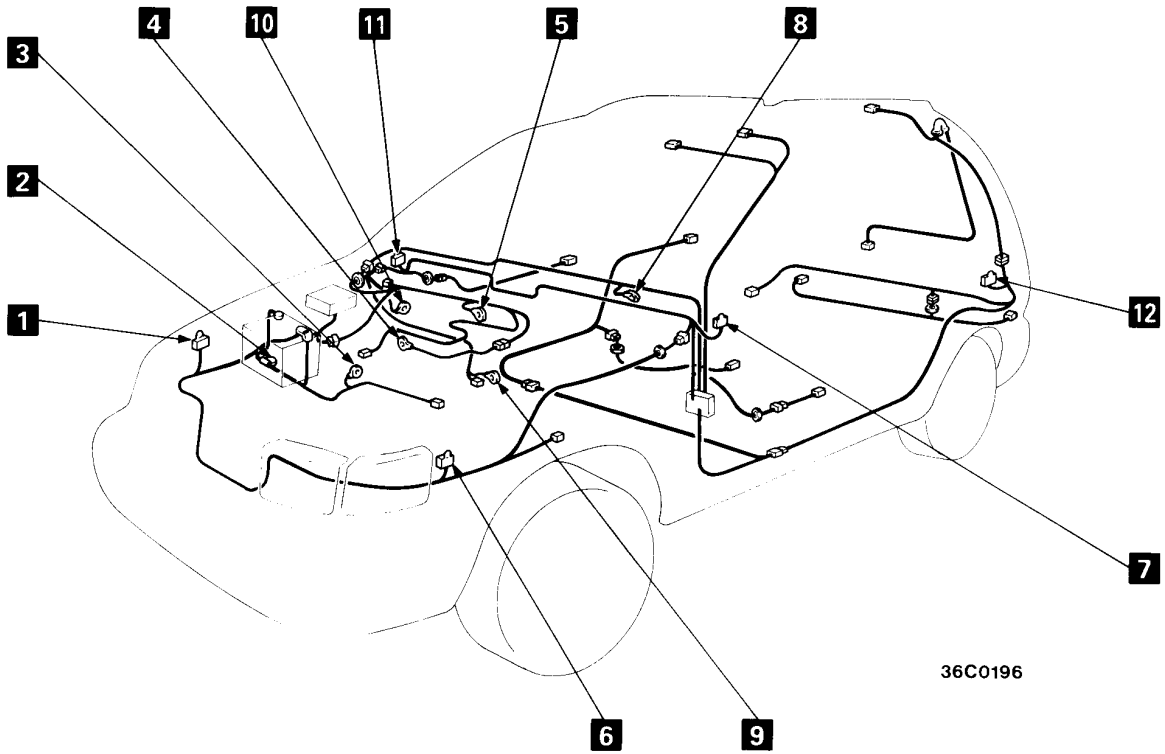

## L.H. drive vehicles <SPACE WAGON>

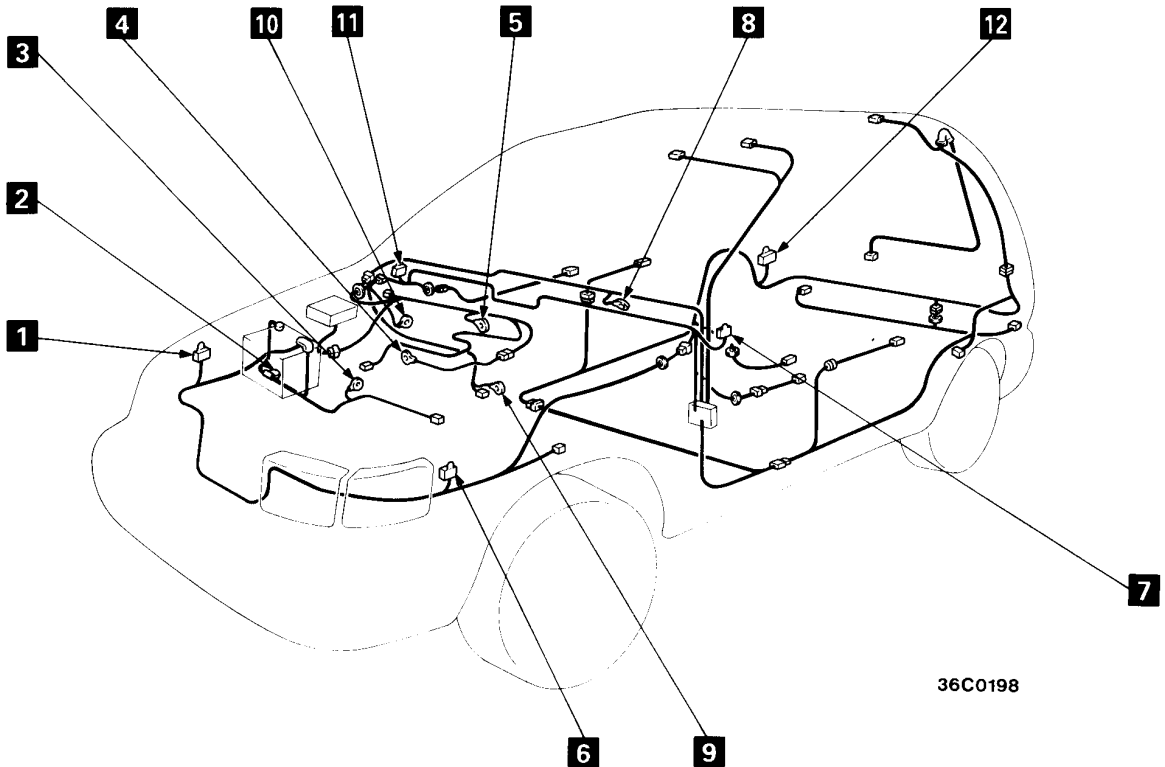

R.H. drive vehicles <SPACE RUNNER>

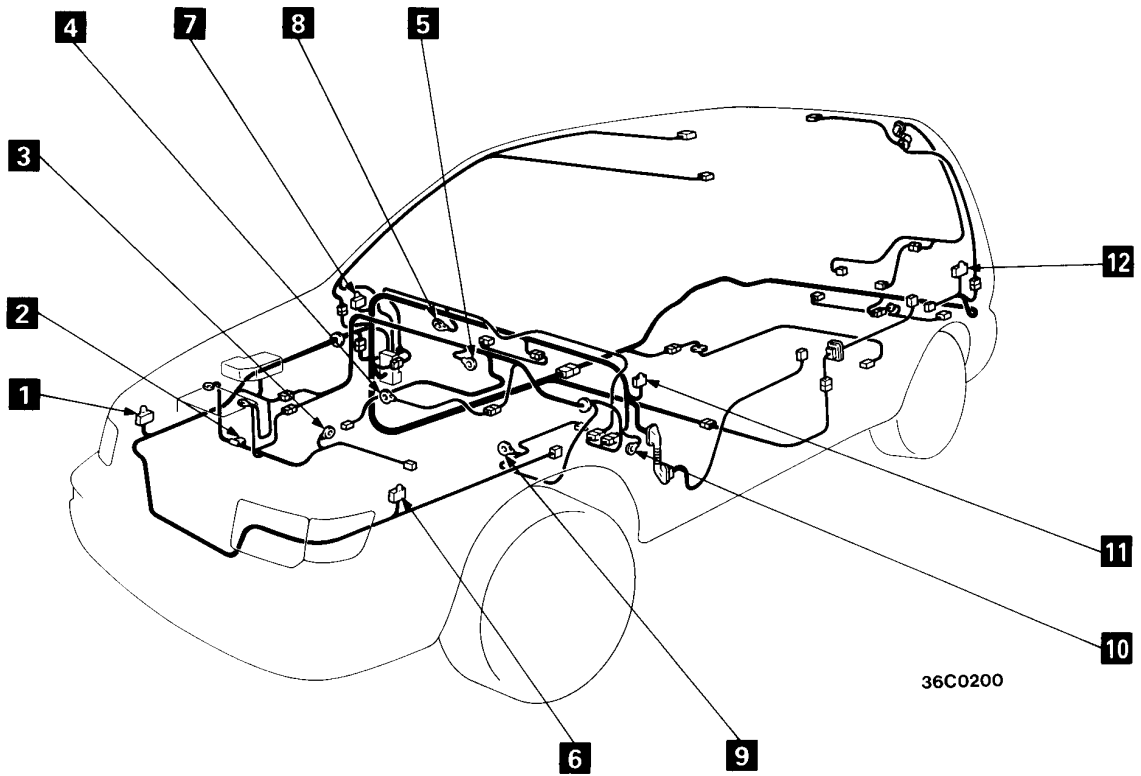

R.H. drive vehicles <SPACE WAGON>

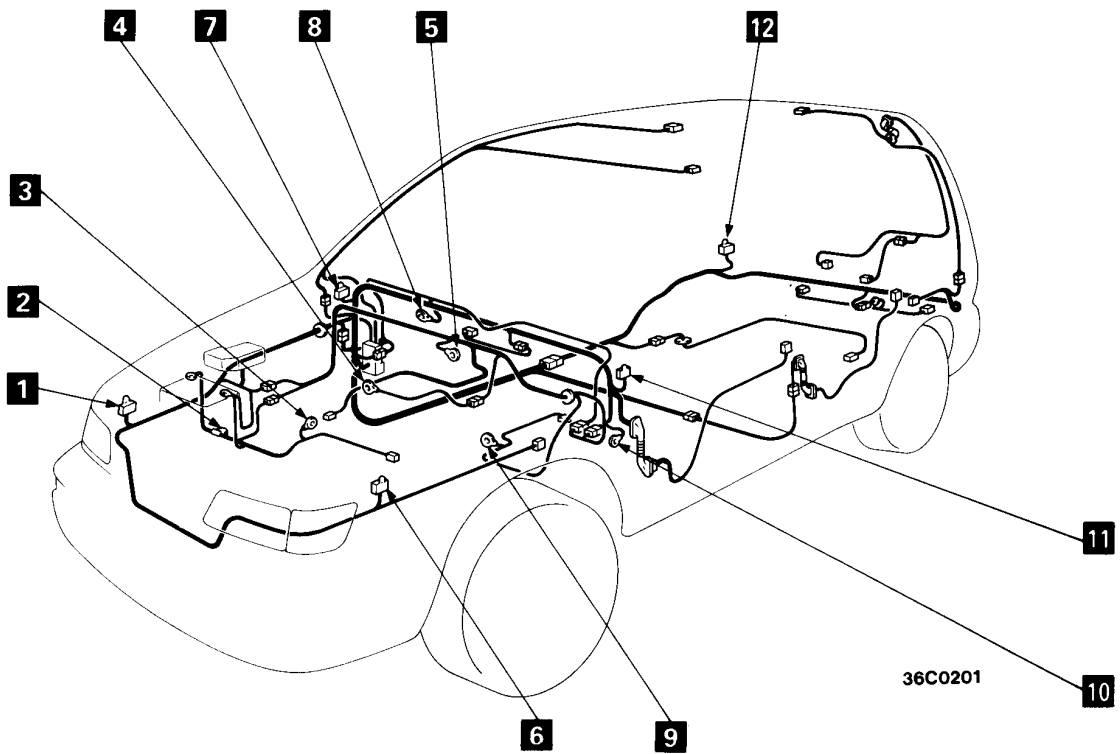

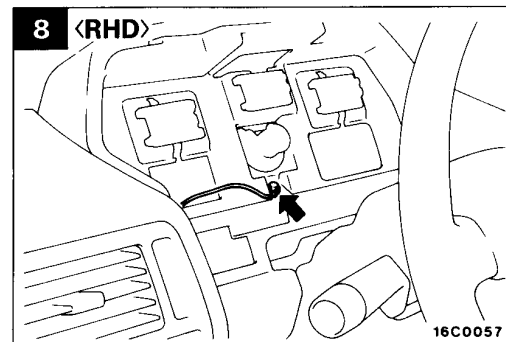
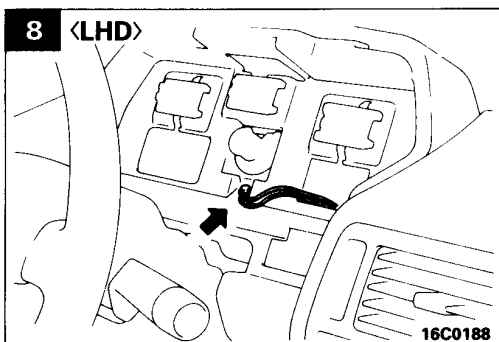
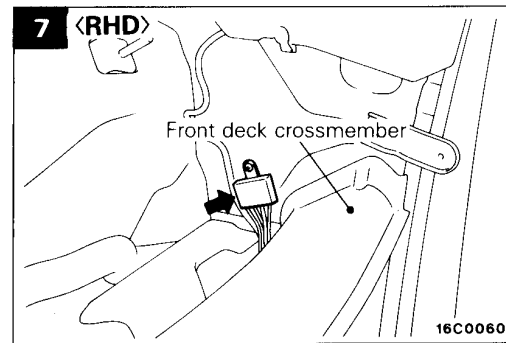
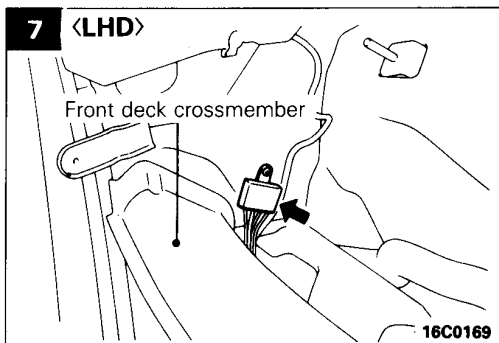
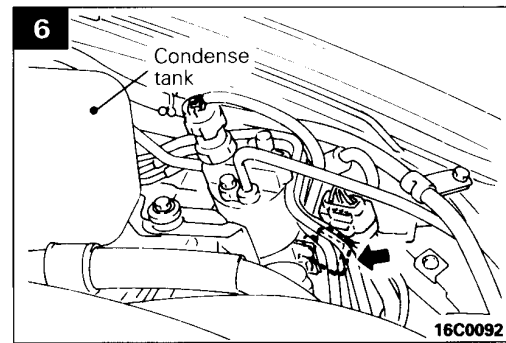
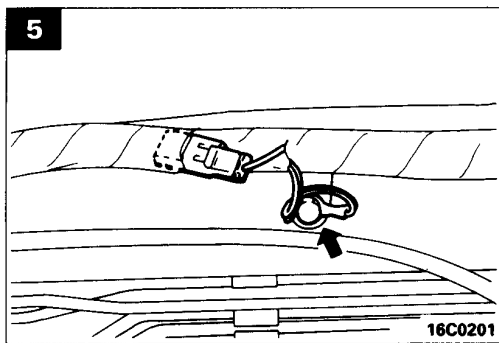
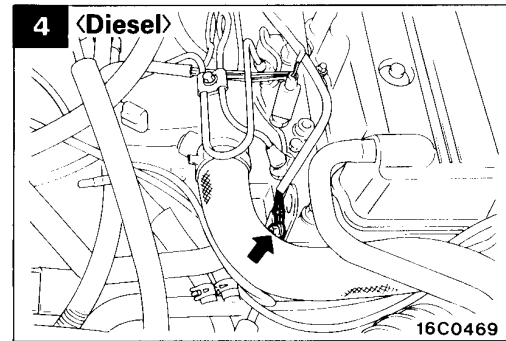
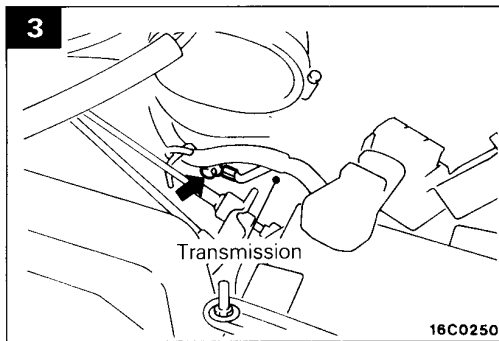
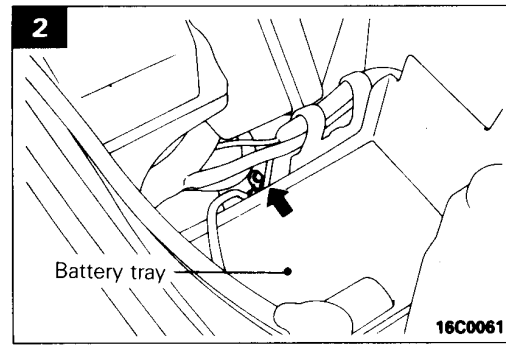
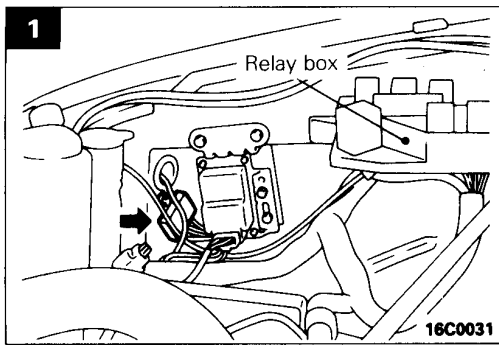

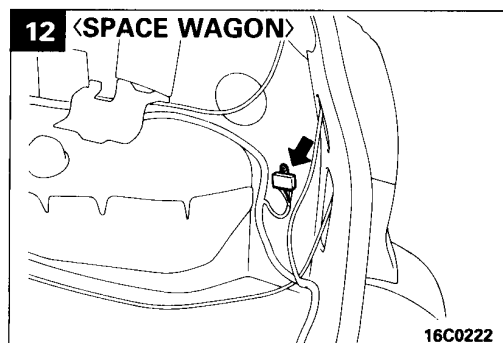
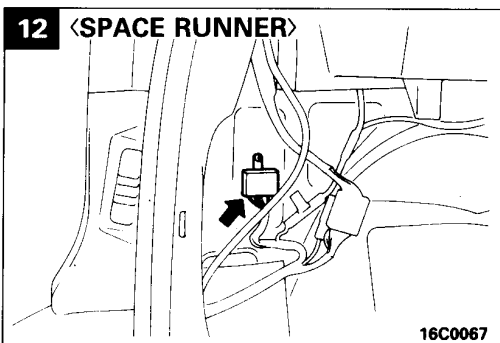
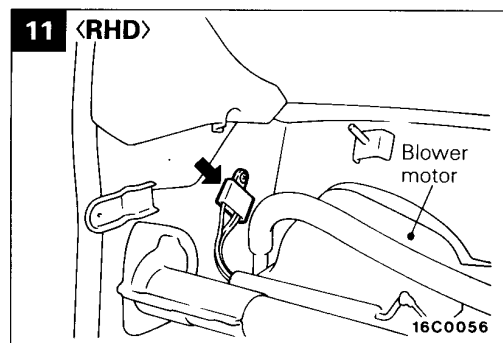
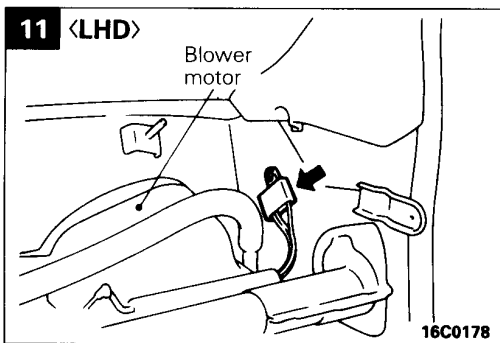
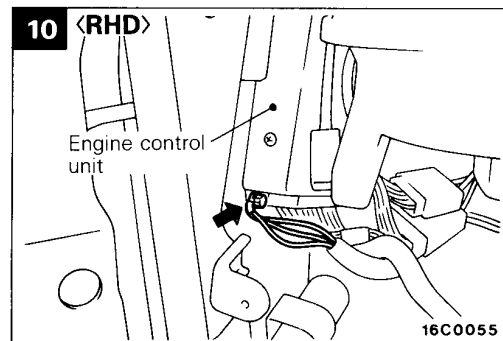
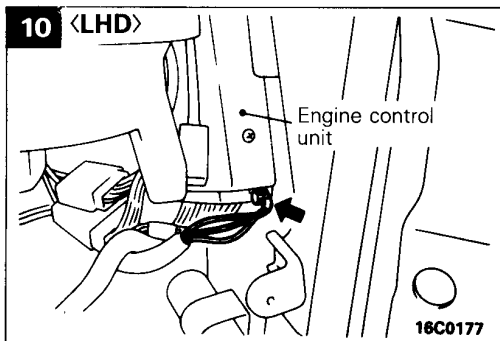
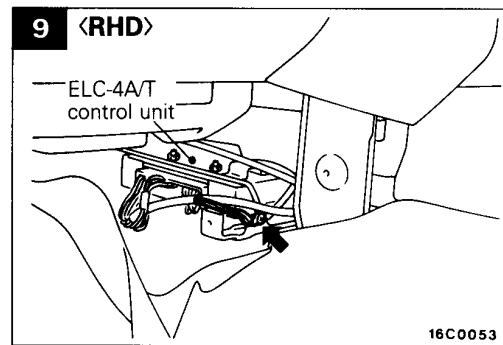
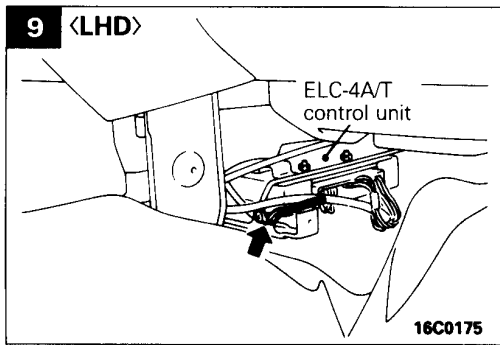

## 4 CIRCUIT DIAGRAM

<b>1 POWER DISTRIBUTION SYSTEM</b> .....	<b>4-3</b>
<b>2 STARTING SYSTEM</b>	
2-1 Petrol-powered vehicles .....	4-7
2-2 Diesel-powered vehicles .....	4-8
<b>3 IGNITION SYSTEM</b> .....	<b>4-10</b>
<b>4 CHARGING SYSTEM</b>	
4-1 Petrol-powered vehicles <4G93> .....	4-12
4-2 Petrol-powered vehicles <4G63 and 4G64> and diesel-powered vehicles .....	4-13
<b>5 GLOW SYSTEM</b> .....	<b>4-14</b>
<b>6 MPI SYSTEM</b>	
6-1 4G93 <L.H. drive vehicles> Vehicles without Jumper connector C-75 .....	4-16
6-2 4G93 <L.H. drive vehicles> Vehicles with Jumper connector C-75 .....	4-19-1
6-3 4G93 <R.H. drive vehicles> Vehicles without Jumper connector C-75 .....	4-20
6-4 4G93 <R.H. drive vehicles> Vehicles with Jumper connector C-75 .....	4-23-1
6-5 4G63 and 4G64 <L.H. drive vehicles> Vehicles without Jumper connector C-75 .....	4-24
6-6 4G63 and 4G64 <L.H. drive vehicles> Vehicles with Jumper connector C-75 .....	4-28-2
6-7 4G64 <R.H. drive vehicles> Vehicles without Jumper connector C-75 .....	4-29
6-8 4G64 <R.H. drive vehicles> Vehicles with Jumper connector C-75 .....	4-33-1
<b>7 COOLING SYSTEM</b>	
7-1 Petrol-powered vehicles <4G93> .....	4-34
7-2 Petrol-powered vehicles <4G63 and 4G64> .....	4-36
7-3 Diesel-powered vehicles .....	4-38
<b>8 ELC 4-SPEED AUTOMATIC TRANSMISSION</b>	
8-1 L.H. drive vehicles .....	4-40
8-2 R.H. drive vehicles .....	4-46
<b>9 HEADLAMP</b>	
9-1 Vehicles with daytime running lamp .....	4-52
9-2 Vehicles with dim-dip lamp .....	4-56
9-3 Vehicles without daytime running lamp .....	4-60
9-4 Headlamp leveling system .....	4-62
<b>10 TAIL LAMP, POSITION LAMP AND LICENCE PLATE LAMP</b> .....	<b>4-64</b>
<b>11 REAR FOG LAMP</b>	
11-1 L.H. drive vehicles with daytime running lamp .....	4-66
11-2 L.H. drive vehicles without daytime running lamp .....	4-68
11-3 R.H. drive vehicles .....	4-69
<b>12 ROOM LAMP AND CARGO ROOM LAMP</b>	
12-1 L.H. drive vehicles without door lamp .....	4-71
12-2 R.H. drive vehicles without door lamp .....	4-72
12-3 L.H. drive vehicles with door lamp .....	4-73
12-4 R.H. drive vehicles with door lamp .....	4-74
<b>13 DOOR LAMP</b>	
13-1 L.H. drive vehicles .....	4-75
13-2 R.H. drive vehicles .....	4-76
<b>14 CLUSTER SWITCH ILLUMINATION LAMP</b> .....	<b>4-77</b>
<b>15 TURN-SIGNAL LAMP AND HAZARD LAMP</b> ....	<b>4-78</b>
<b>16 STOP LAMP</b> .....	<b>4-81</b>
<b>17 BACK-UP LAMP</b> .....	<b>4-82</b>
<b>18 LIGHTING MONITOR BUZZER</b> .....	<b>4-83</b>
<b>19 HORN</b> .....	<b>4-85</b>
<b>20 METER AND GAUGE</b> .....	<b>4-86</b>
<b>21 WARNING LAMP</b>	
21-1 Petrol-powered vehicles .....	4-90
21-2 Diesel-powered vehicles .....	4-92
21-3 Low engine oil level warning lamp <Petrol-powered vehicles (4G63 and 4G64) and diesel-powered vehicles (SPAC WAGON)> .....	4-95
<b>22 INDICATOR LAMP</b> .....	<b>4-96</b>
<b>23 POWER WINDOW</b>	
23-1 SPACE RUNNER .....	4-99
23-2 SPACE WAGON <L.H. drive vehicles> .....	4-100
23-3 SPACE WAGON <R.H. drive vehicles> .....	4-102
<b>24 TAILGATE LOCKING SYSTEM &lt;Vehicles without central door locking system (GLX)&gt;</b> .....	<b>4-104</b>
<b>25 CENTRAL DOOR LOCKING SYSTEM</b>	
25-1 SPACE RUNNER <L.H. drive vehicles> .....	4-106
25-2 SPACE RUNNER <R.H. drive vehicles> .....	4-108
25-3 SPACE WAGON <L.H. drive vehicles> .....	4-110
25-4 SPACE WAGON <R.H. drive vehicles> .....	4-112
<b>26 HEATER AND AIR CONDITIONER</b>	
26-1 Petrol-powered vehicles <4G93> .....	4-116
26-2 Petrol-powered vehicles <4G63 and 4G64> .....	4-120
26-3 Diesel-powered vehicles .....	4-123
<b>27 WIPER AND WASHER</b>	
27-1 Windshield wiper and washer .....	4-128
27-2 Rear wiper and washer .....	4-130

<b>28 HEADLAMP WASHER .....</b>	<b>4-132</b>
<b>29 DEFOGGER AND DOOR MIRROR HEATER .....</b>	<b>4-134</b>
<b>30 REMOTE CONTROLLED MIRROR</b>	
30-1 Vehicles with door mirror heater .....	4-136
30-2 Vehicles without door mirror heater ....	4-137
<b>31 RADIO AND TAPE PLAYER .....</b>	<b>4-138</b>
<b>32 CLOCK .....</b>	<b>4-140</b>
<b>33 CIGARETTE LIGHTER .....</b>	<b>4-141</b>
<b>34 SUNROOF .....</b>	<b>4-142</b>
<b>35 ANTI-LOCK BRAKE SYSTEM</b>	
35-1 2WD .....	4-144
35-2 4WD .....	4-146
<b>36 HEATED SEAT .....</b>	<b>4-148</b>
<b>37 JUNCTION BLOCK .....</b>	<b>4-150</b>
<b>38 CENTRALIZED JUNCTION .....</b>	<b>4-152</b>

1. POWER DISTRIBUTION SYSTEM

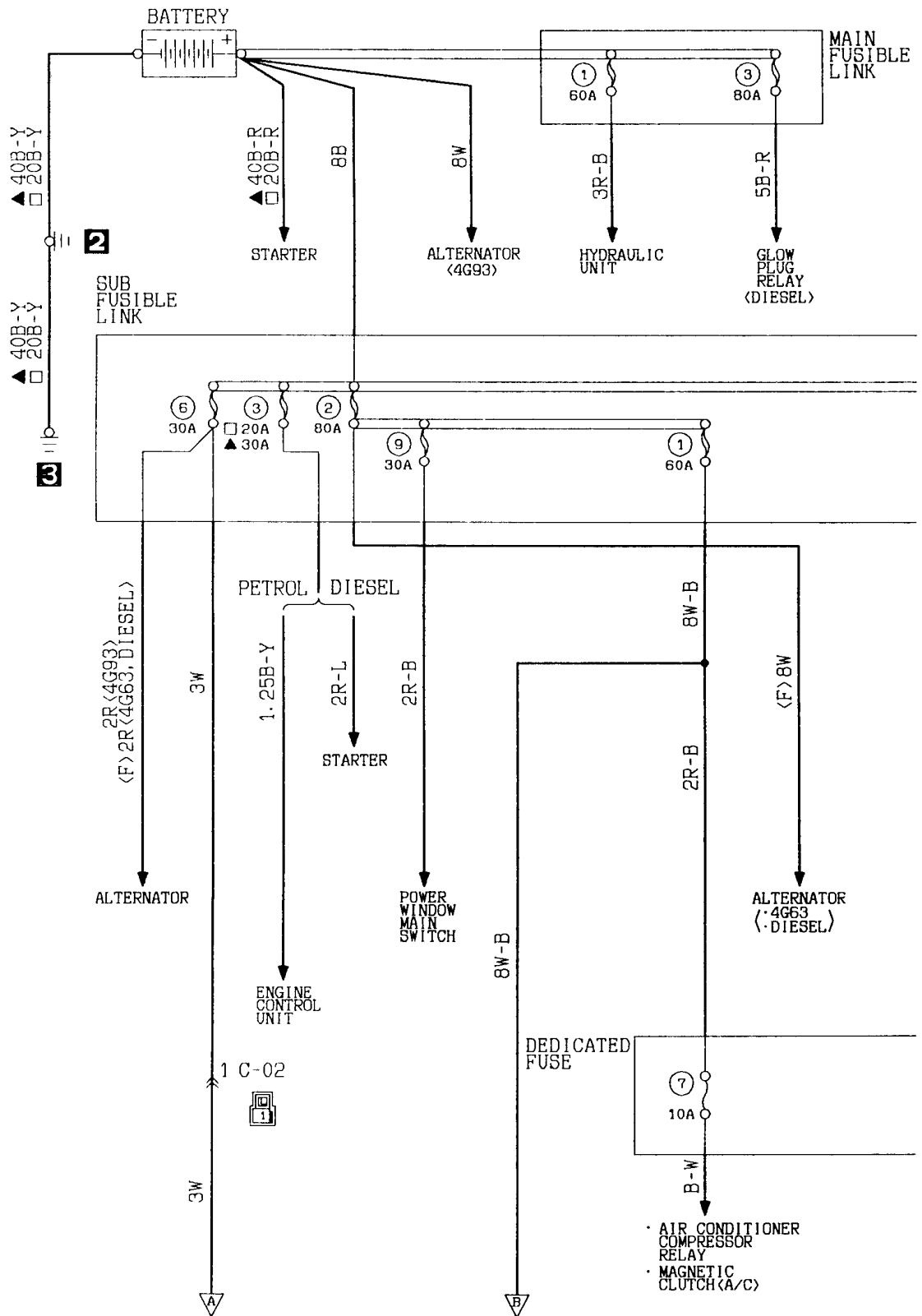

Wire colour code  
 B:Black LG:Light green G:Green L:Blue W:White Y:Yellow SB:Sky blue  
 BR:Brown O:Orange GR:Gray R:Red P:Pink V:Violet



Remarks  
 □: Petrol-powered vehicles.  
 ▲: Diesel-powered vehicles.

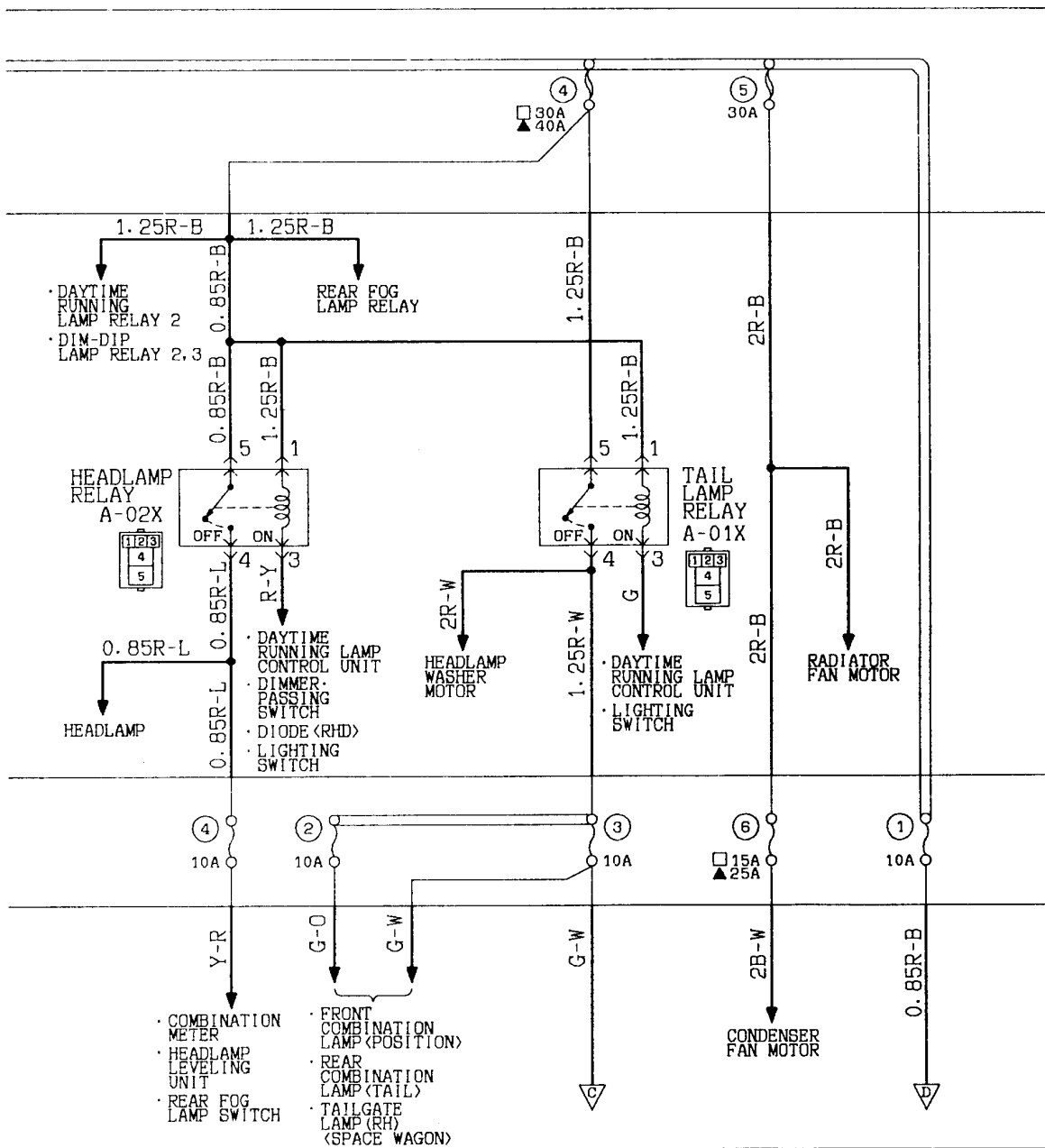

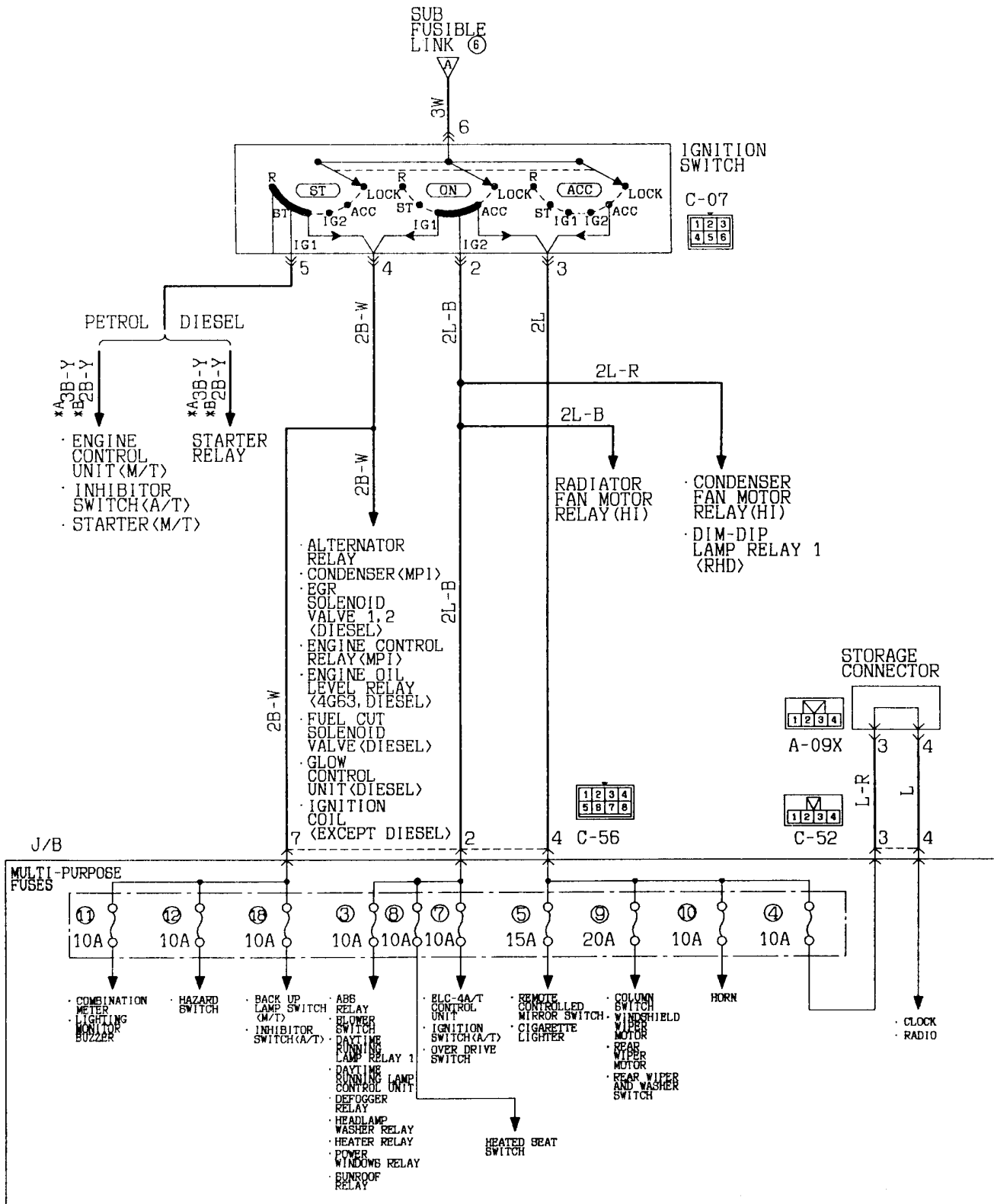

- Remarks
- (1) The above circuit diagram shows the current flow at the ignition key position "ACC", "ON" and "ST" combined.
  - (2) Be sure trace the appropriate circuit depending on the ignition key position.
  - (3) \*A: L. H. drive vehicles.
  - (4) \*B: R. H. drive vehicles.

KX35-AC-Z0102A-EC

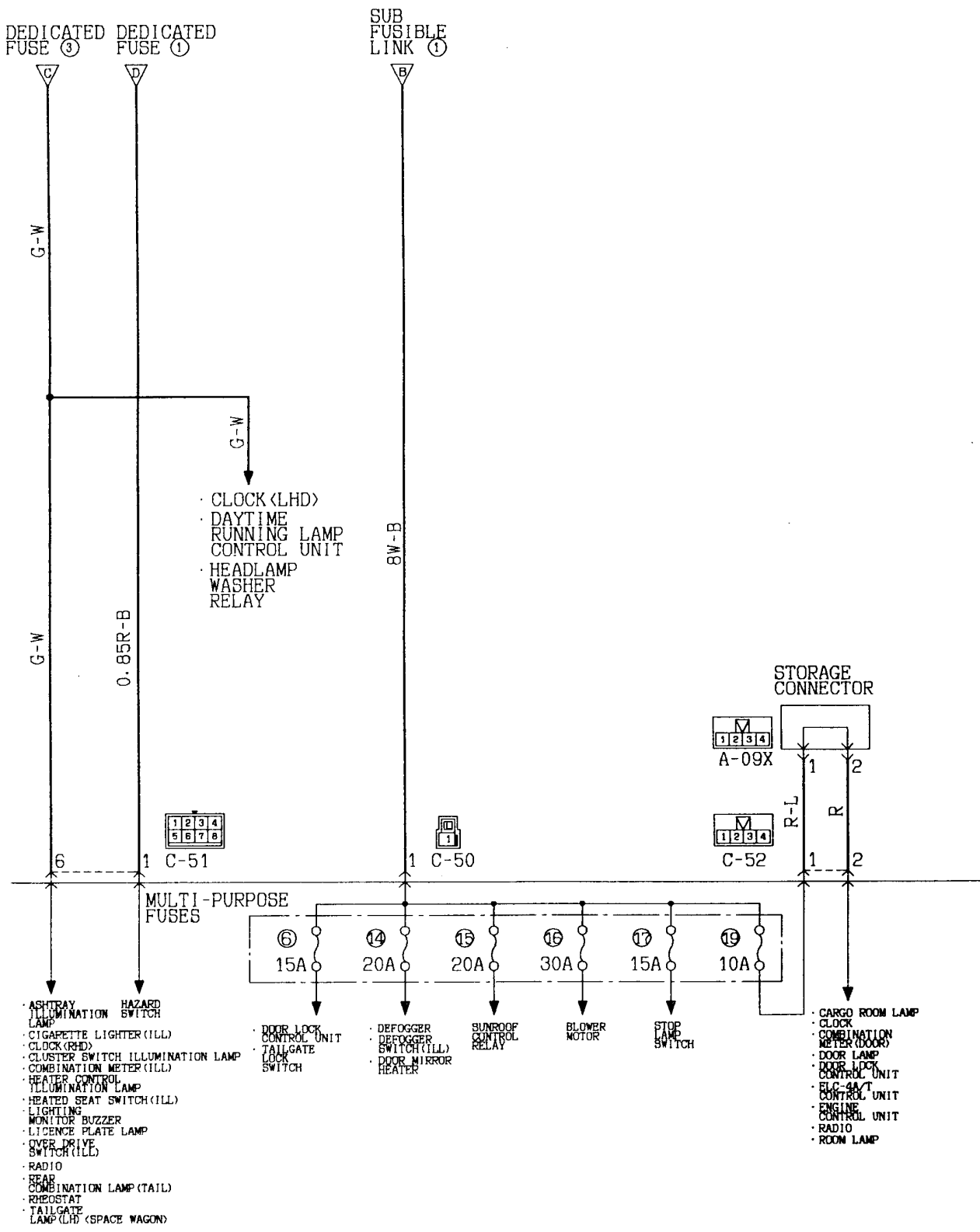

Wire colour code  
 B:Black LG:Light green G:Green L:Blue W:White Y:Yellow SB:Sky blue  
 BR:Brown O:Orange GR:Gray R:Red P:Pink V:Violet

2 STARTING SYSTEM  
2-1 Petrol-powered vehicles

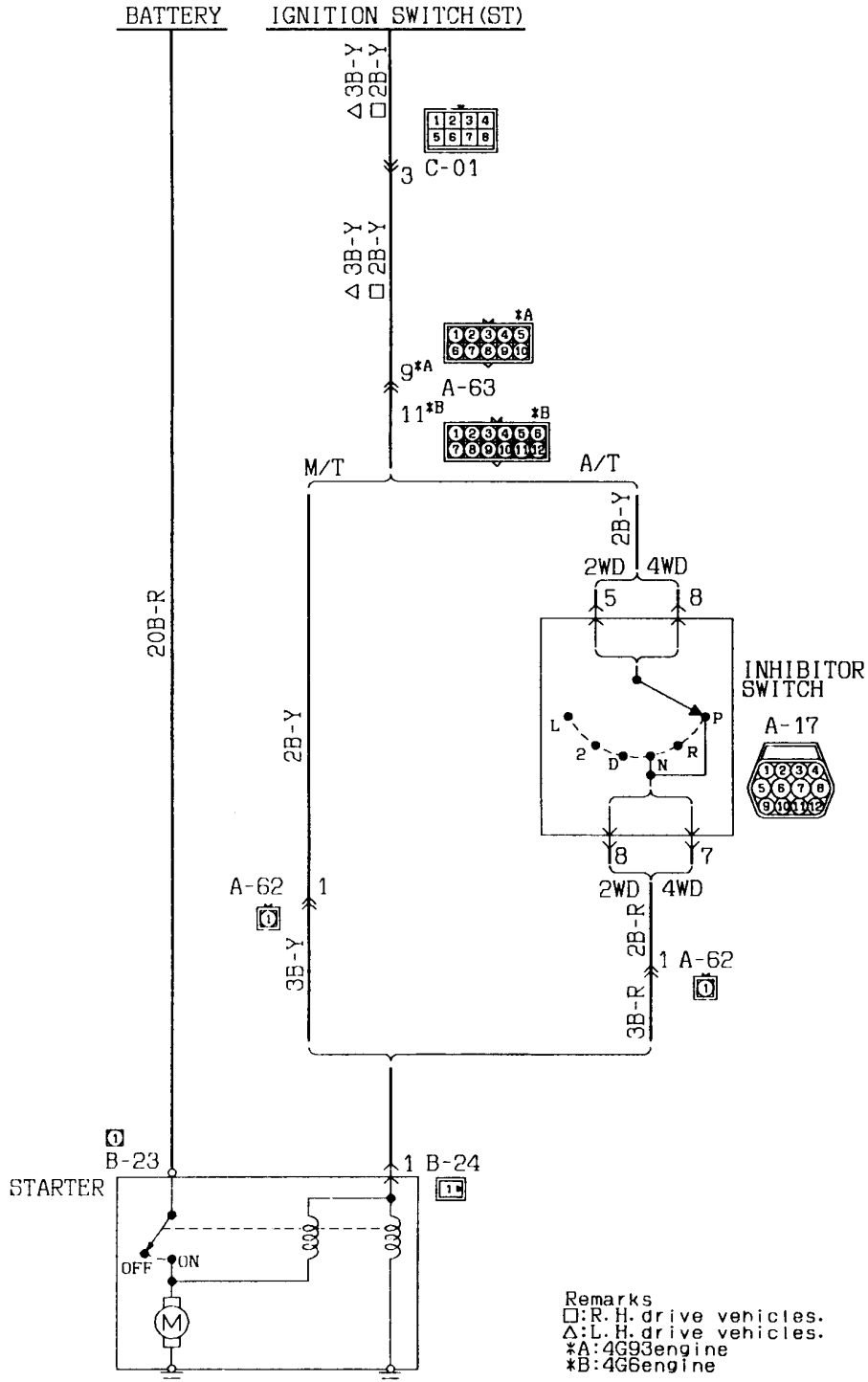

Remarks  
 □: R. H. drive vehicles.  
 △: L. H. drive vehicles.  
 \*A: 4G93 engine  
 \*B: 4G6 engine

Wire colour code  
 B:Black LG:Light green G:Green L:Blue W:White Y:Yellow SB:Sky blue  
 BR:Brown O:Orange GR:Gray R:Red P:Pink V:Violet

2-2 Diesel-powered vehicles

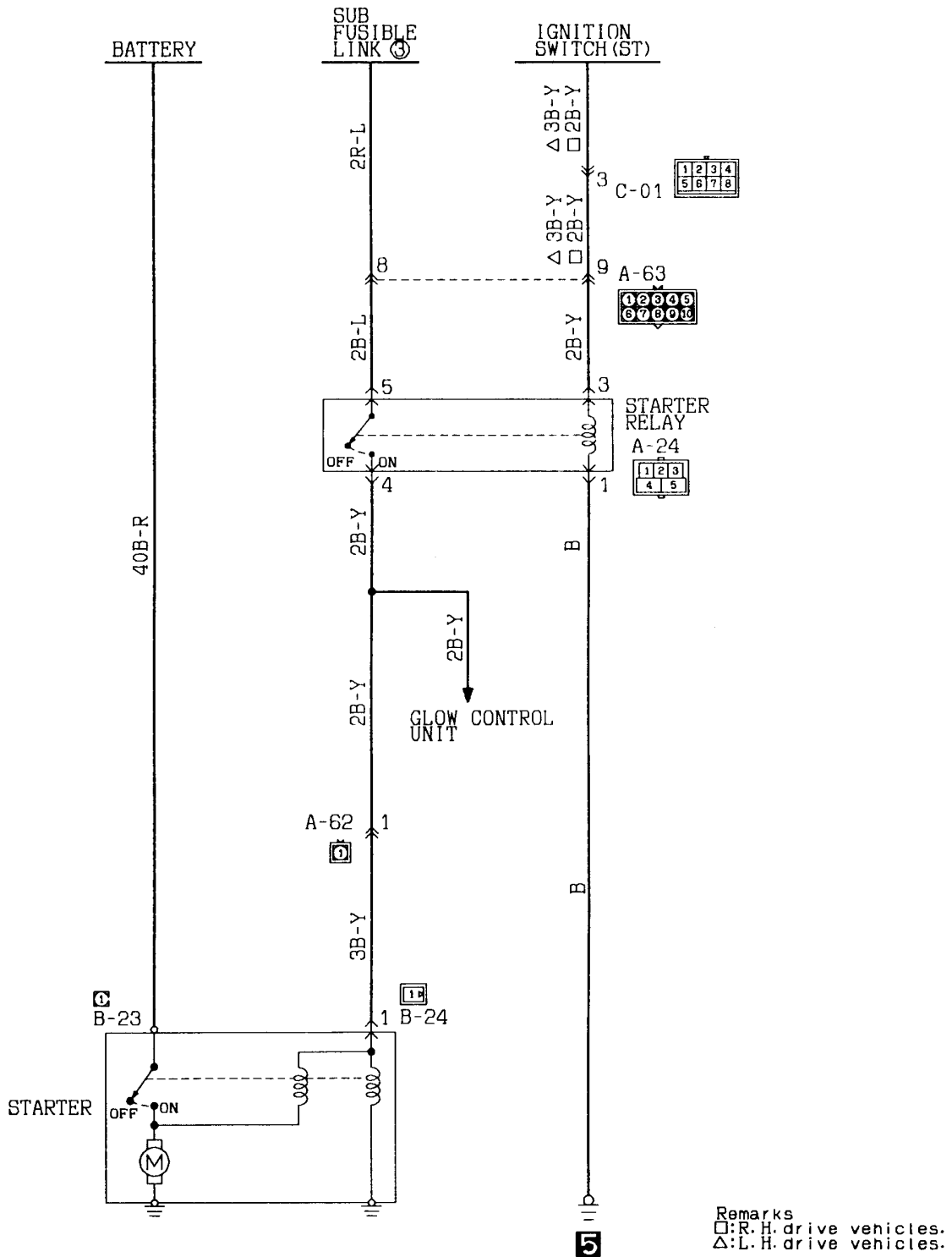

Wire colour code  
 B:Black LG:Light green G:Green L:Blue W:White Y:Yellow SB:Sky blue  
 BR:Brown O:Orange GR:Gray R:Red P:Pink V:Violet

**STARTING SYSTEM (See P. 4-7, 8.)****OPERATION****<Petrol-powered vehicles>**

- On vehicles with automatic transmission, Placing the ignition switch in the ST position with the selector lever in P or N position causes the starter contacts (magnet switch) to close energizing the starter motor.

**<Diesel-powered vehicles>**

- When the ignition switch is turned to the "ST" position, the starter relay becomes on. This will turn on the contacts of the starter (magnetic switch) to revolve the starter motor.

**TROUBLESHOOTING HINTS**

1. Starter motor does not turn over at all.
  - Check starter (coil).
  - Check battery terminals for proper contact.
  - Starter relay inspection (diesel-powered vehicle)
2. Starter motor does not stop rotating.
  - Check starter (magnet switch).

3 IGNITION SYSTEM

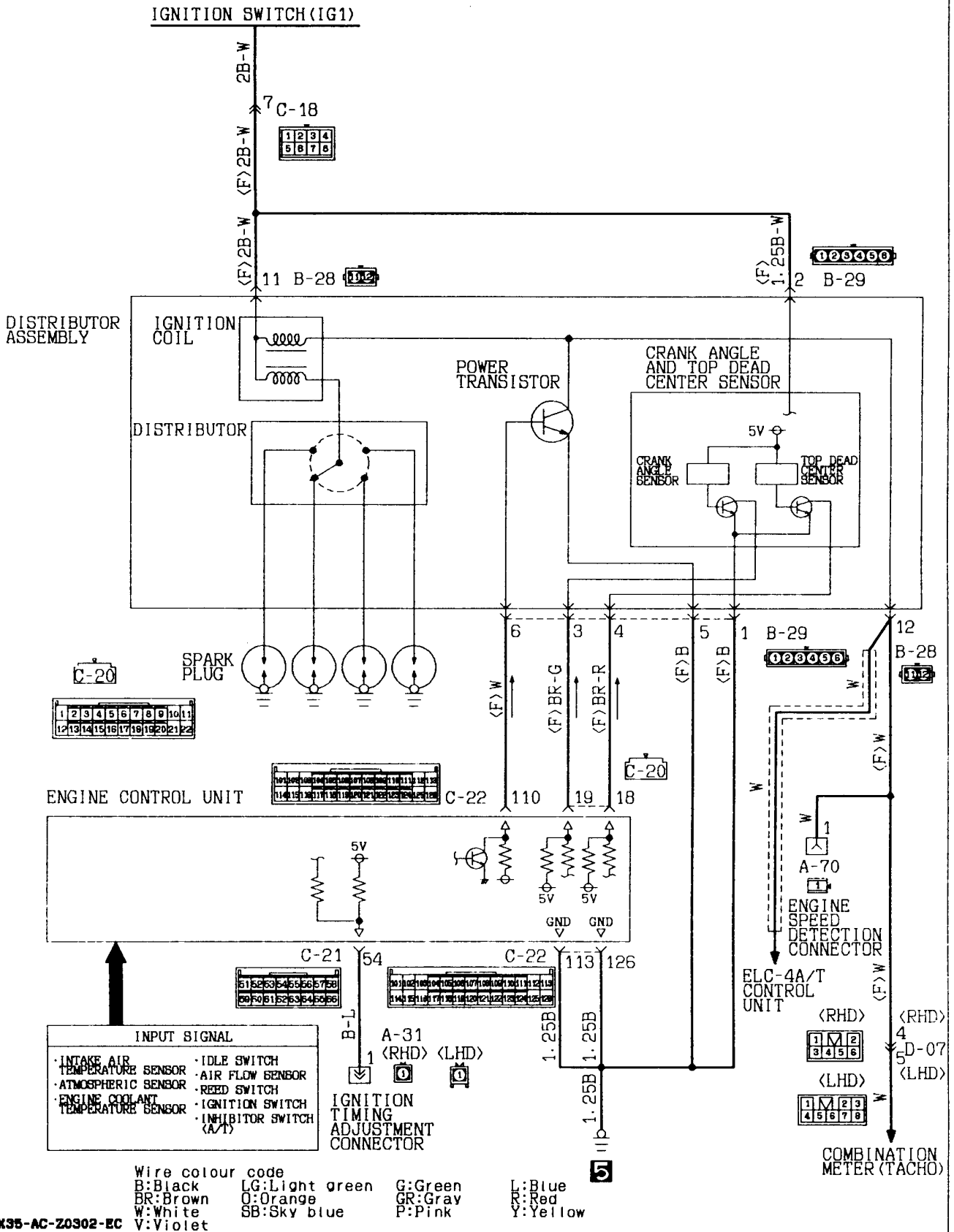

**CHARGING SYSTEM (See P. 4-12, 13.)****OPERATION****When engine is stationary**

- When the ignition switch is turned to the ON position, current flows the alternator L terminal to the field coil and, at the same time, the charge warning lamp lights up.

**When engine is started and after engine has started**

- When the engine is started, the charge warning lamp goes out because of the charging voltage being applied to the alternator L terminal.
- The battery voltage being applied to the alternator S terminal is monitored by the IC voltage regulator. Hence, the amount of electricity produced by the alternator is controlled by allowing and cutting off the current flowing to the field coil.
- The alternator B terminal supplies power to each load.

**Remarks**

- The alternator relay is provided to back up the flow of current to the field coil when the charge warning lamp is open.

**TROUBLESHOOTING HINTS**

1. Charging indicator lamp does not go on when the ignition switch is turned to "ON", before the engine starts.
  - Check the bulb.
2. Charging indicator lamp fails to go off once the engine starts.
  - Check IC voltage regulator of alternator.
3. Discharged or overcharged battery.
  - Check IC voltage regulator of alternator.
4. Charge warning lamp lights up dimly.
  - Check combination meter diode (for short).



4 CHARGING SYSTEM  
4-1 Petrol-powered vehicles <4G93>

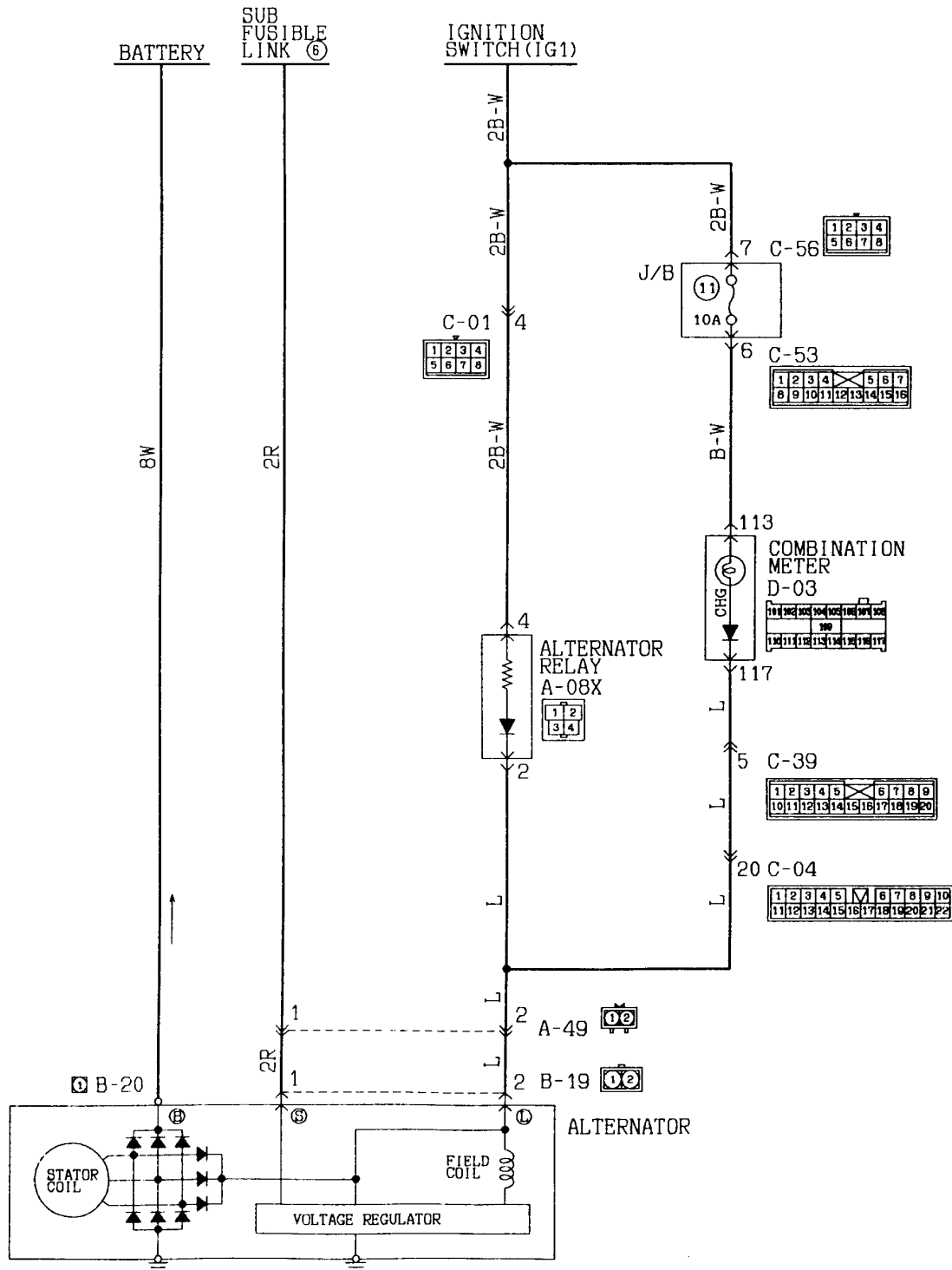

Wire colour code  
 B:Black LG:Light green G:Green L:Blue W:White Y:Yellow SB:Sky blue  
 BR:Brown O:Orange GR:Gray R:Red P:Pink V:Violet

4-2 Petrol-powered vehicles (4G63 and 4G64) and diesel-powered vehicles

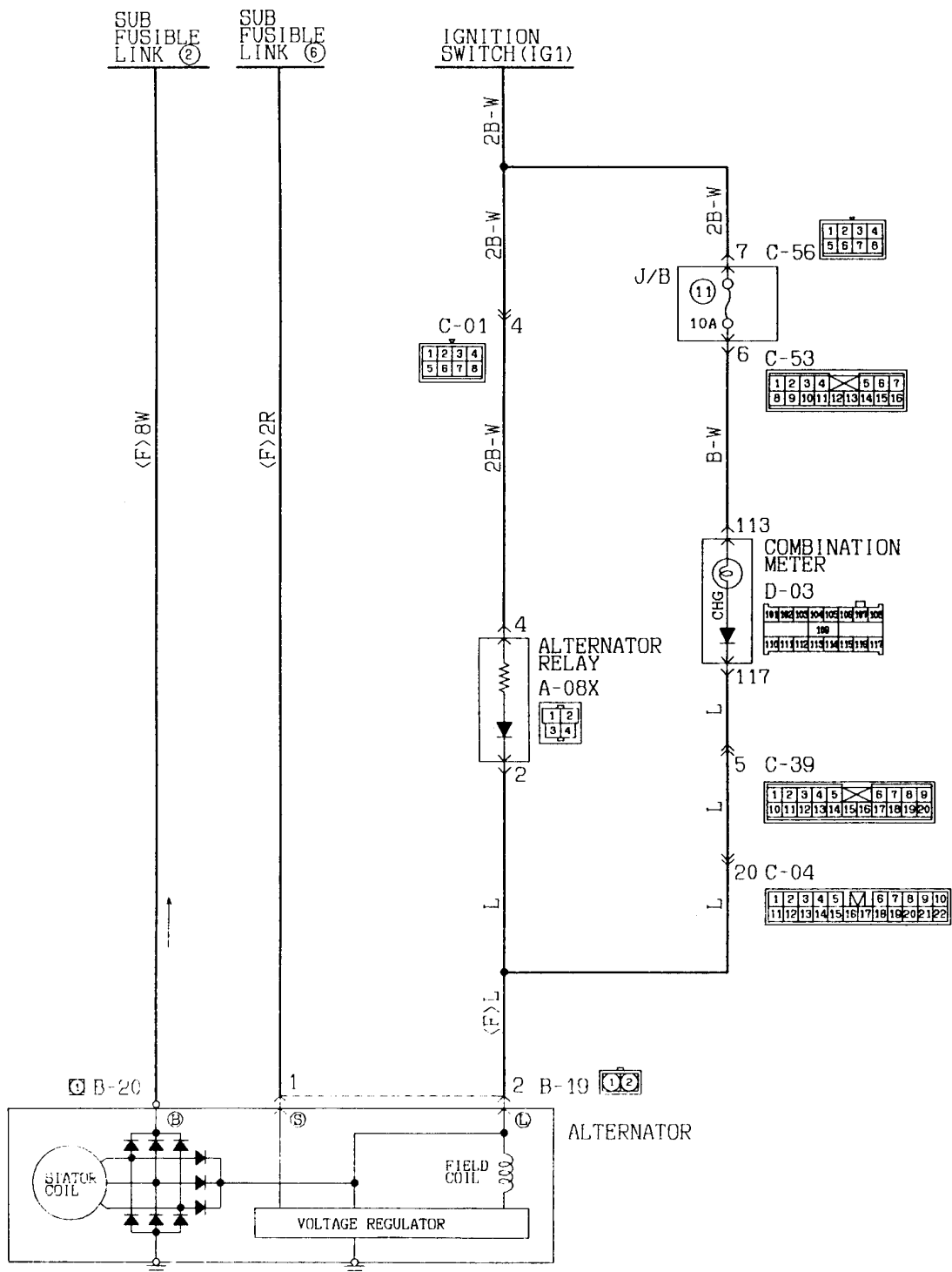

Wire colour code

B:Black LG:Light green  
BR:Brown O:Orange

G:Green GR:Gray

L:Blue R:Red

W:White P:Pink

Y:Yellow V:Violet

SB:Sky blue

5 GLOW SYSTEM

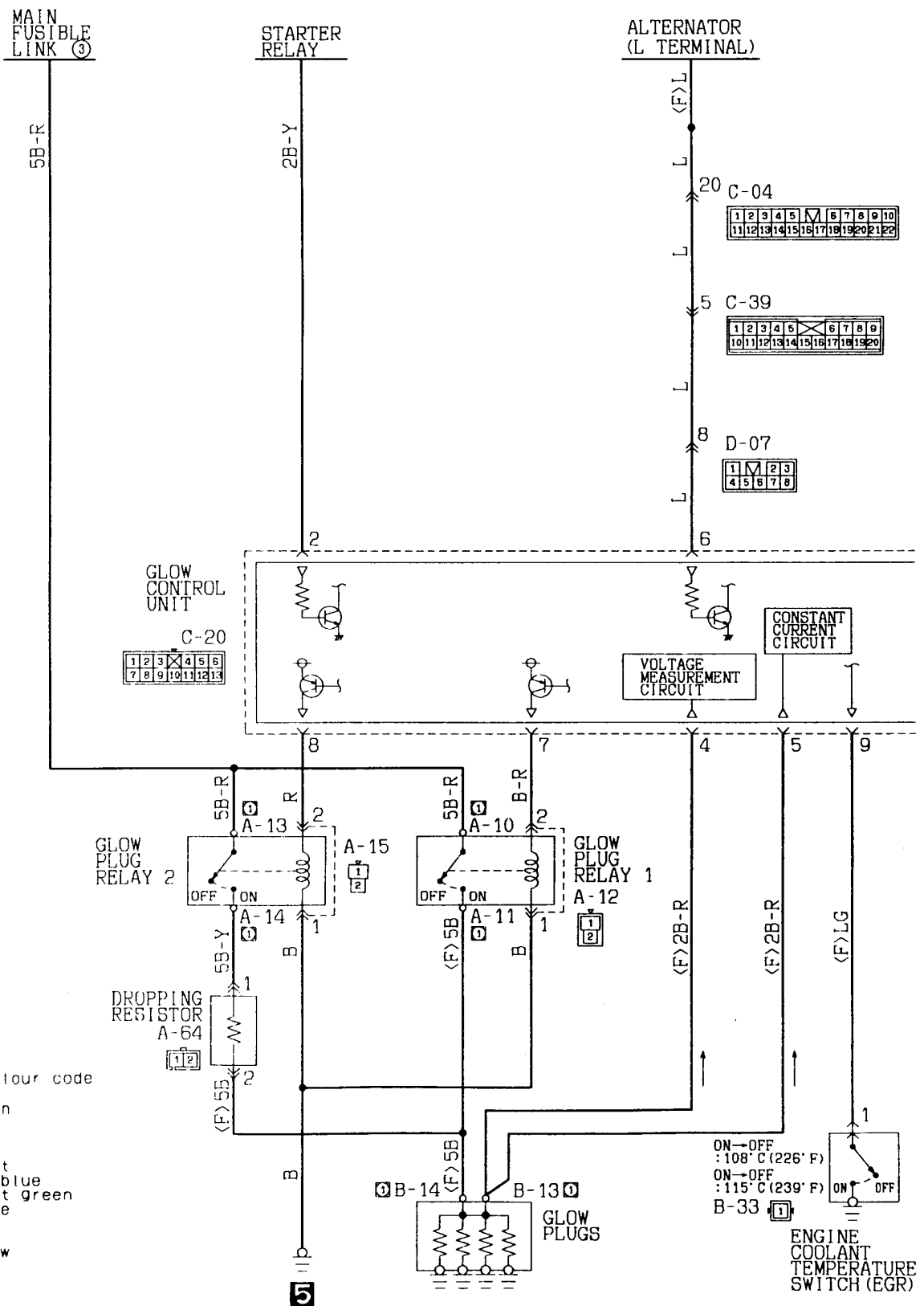

Wire colour code  
 B:Black  
 BR:Brown  
 G:Green  
 GR:Gray  
 L:Blue  
 V:Violet  
 SB:Sky blue  
 LG:Light green  
 O:Orange  
 P:Pink  
 R:Red  
 Y:Yellow  
 W:White

ON-OFF  
 : 108° C (226° F)  
 ON-OFF  
 : 115° C (239° F)  
 B-33

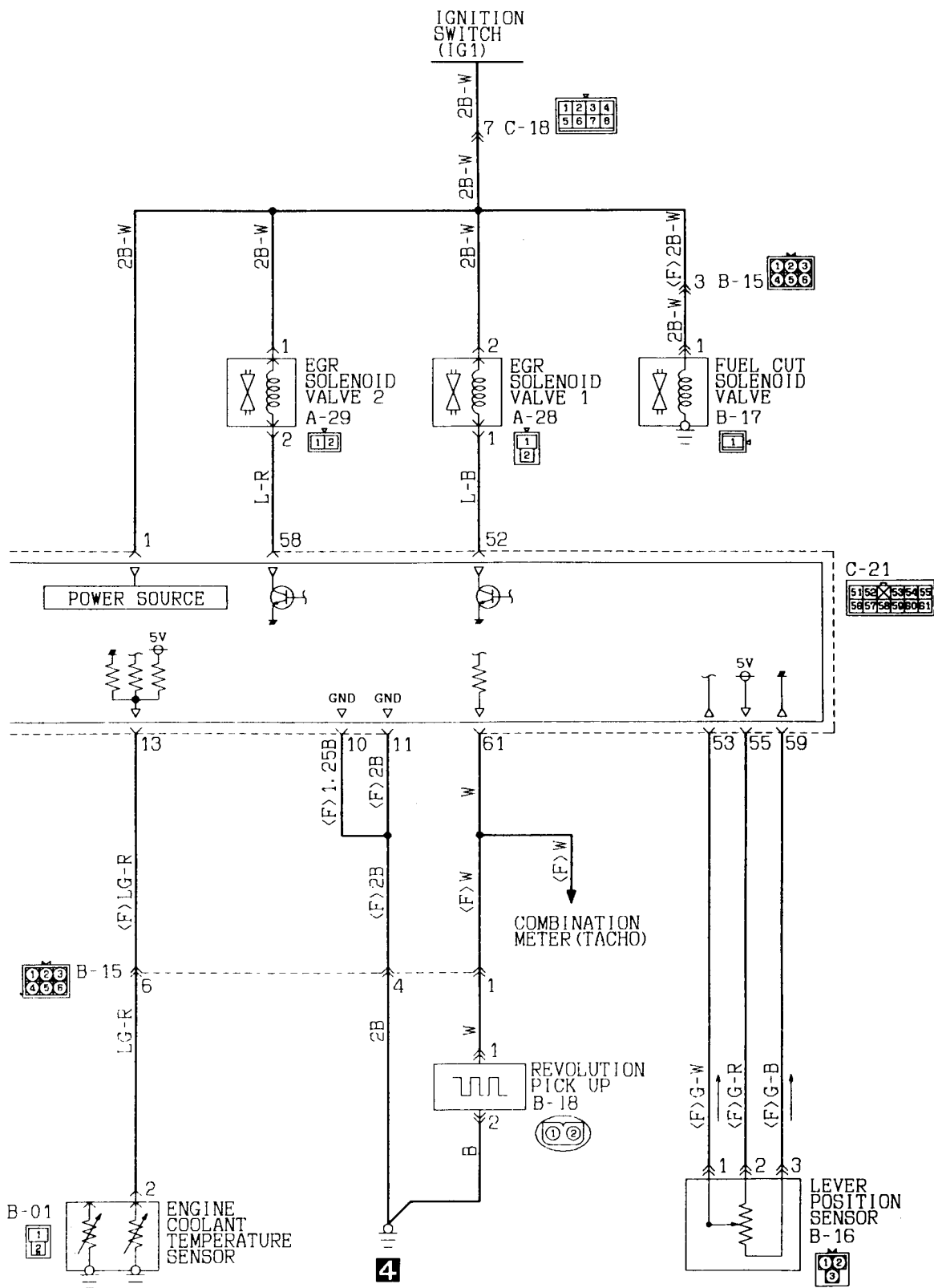

6 MPI SYSTEM

6-1 4G93<L.H. drive vehicles>

Vehicles without Jumper connector C-75

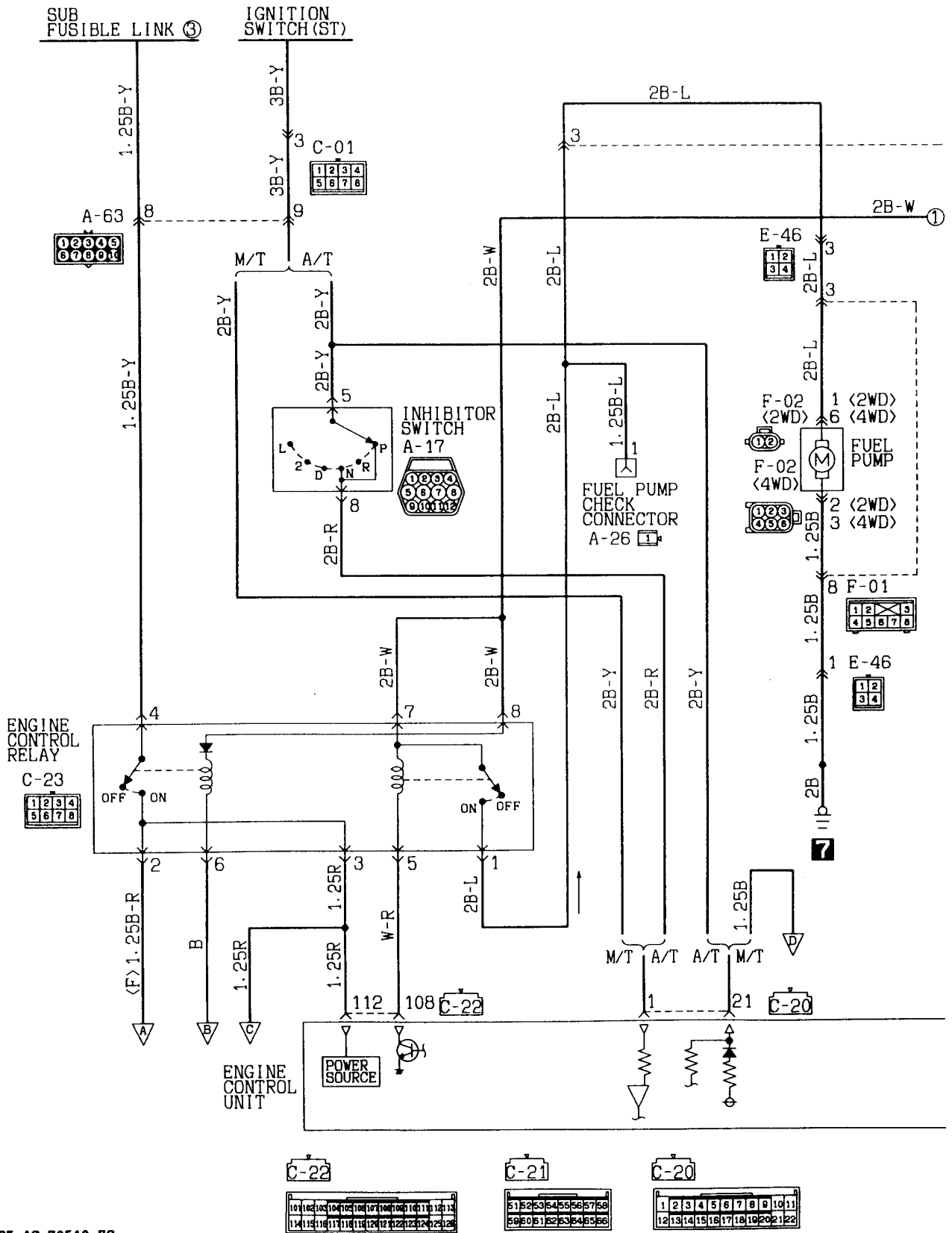

KX35-AC-Z0510-EC

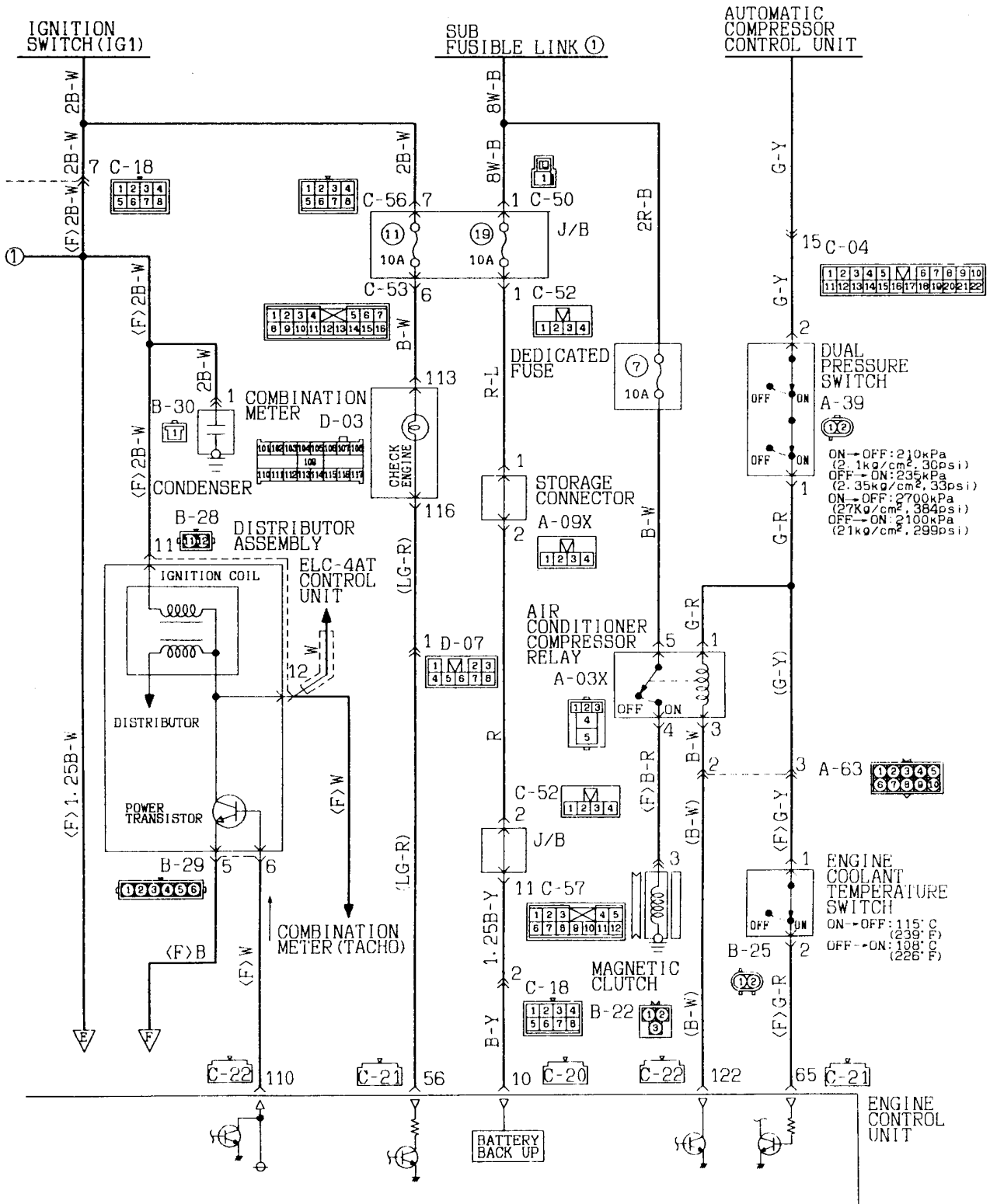

Wire colour code  
 B:Black LG:Light green G:Green L:Blue  
 BR:Brown O:Orange GR:Gray R:Red  
 W:White SB:Sky blue P:Pink Y:Yellow  
 V:Violet

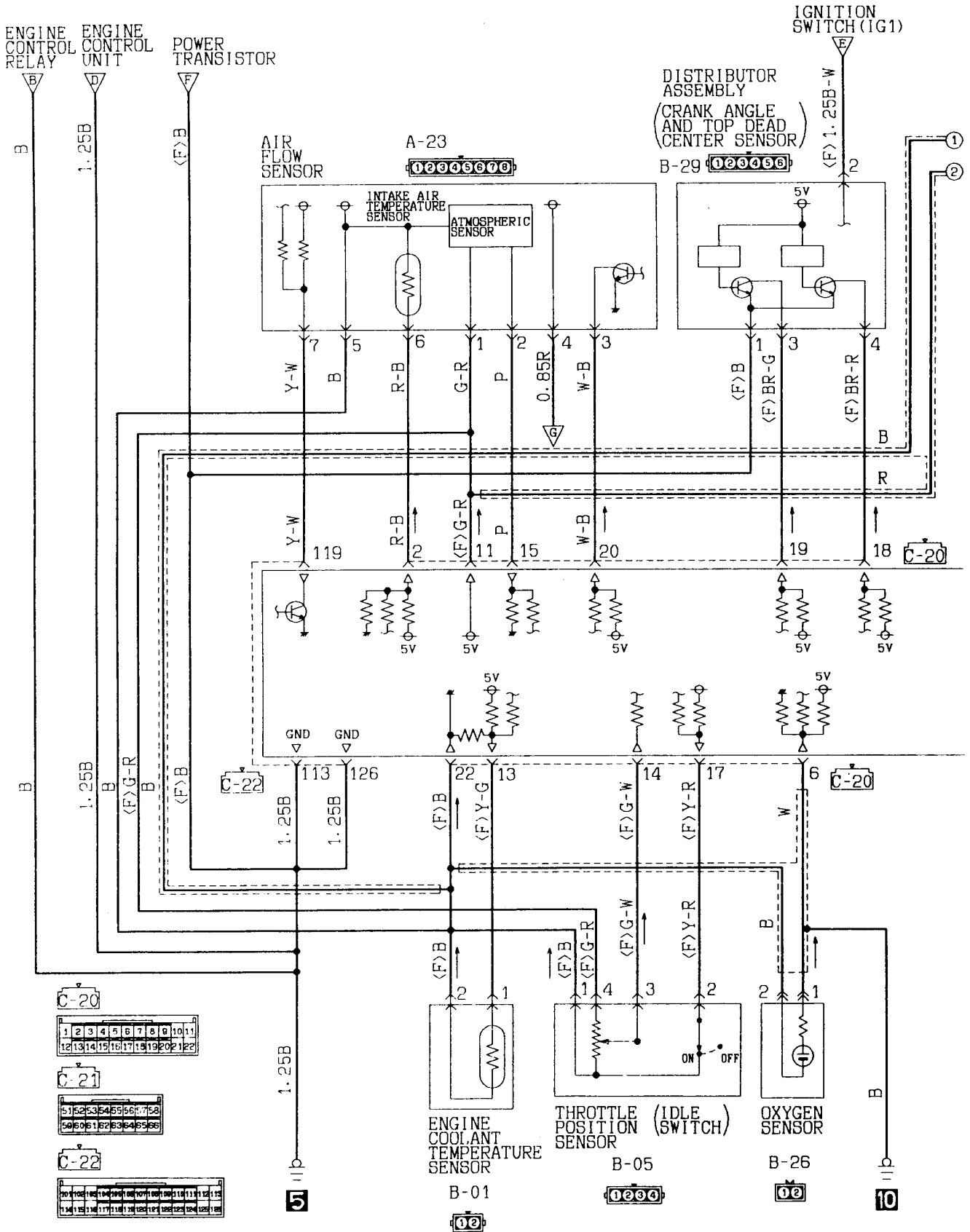

KX35-AC-Z0510A-EC

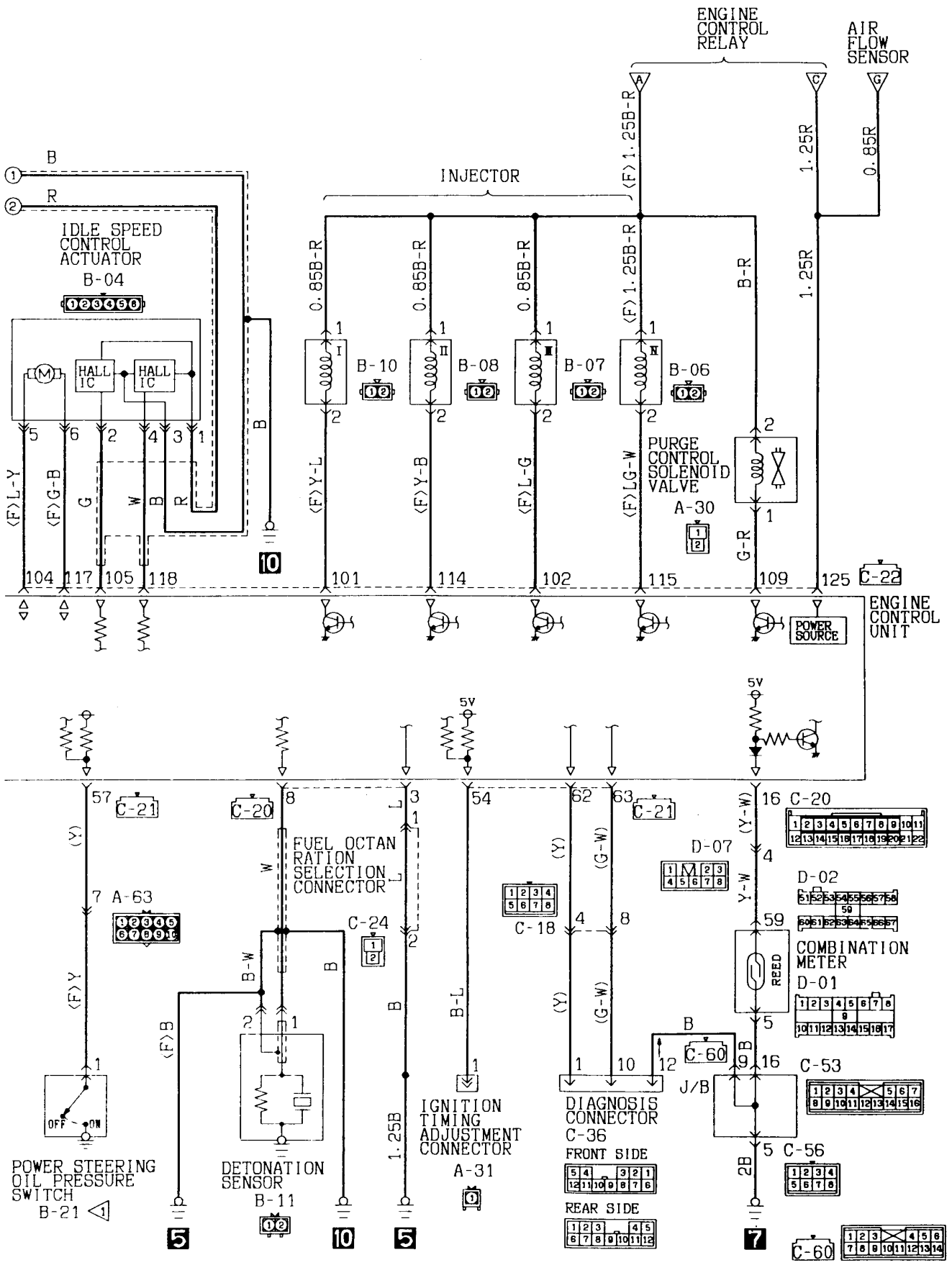



6-2 4G93<L.H. drive vehicles>  
Vehicles with Jumper connector C-75

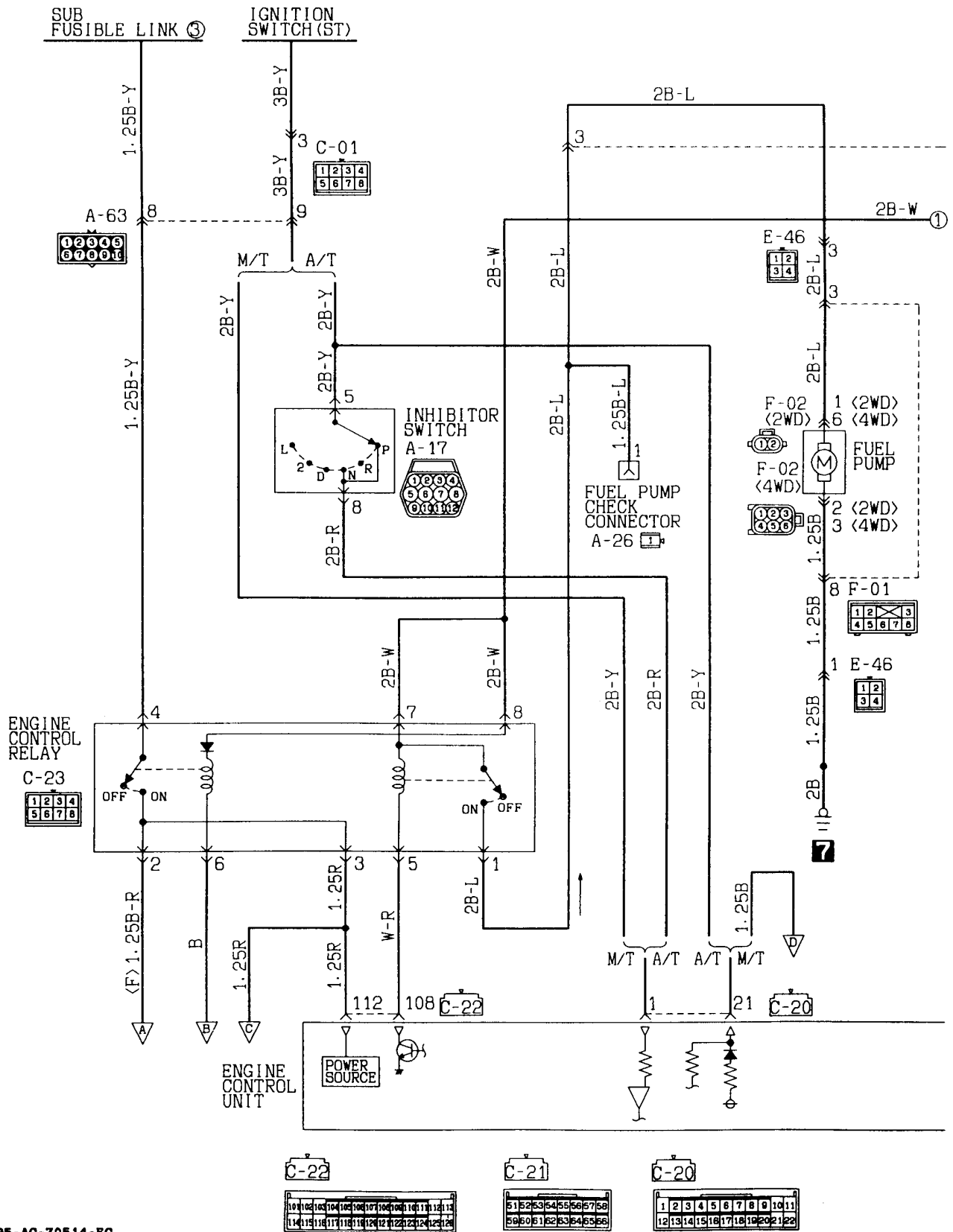

KX35-AC-Z0514-EC

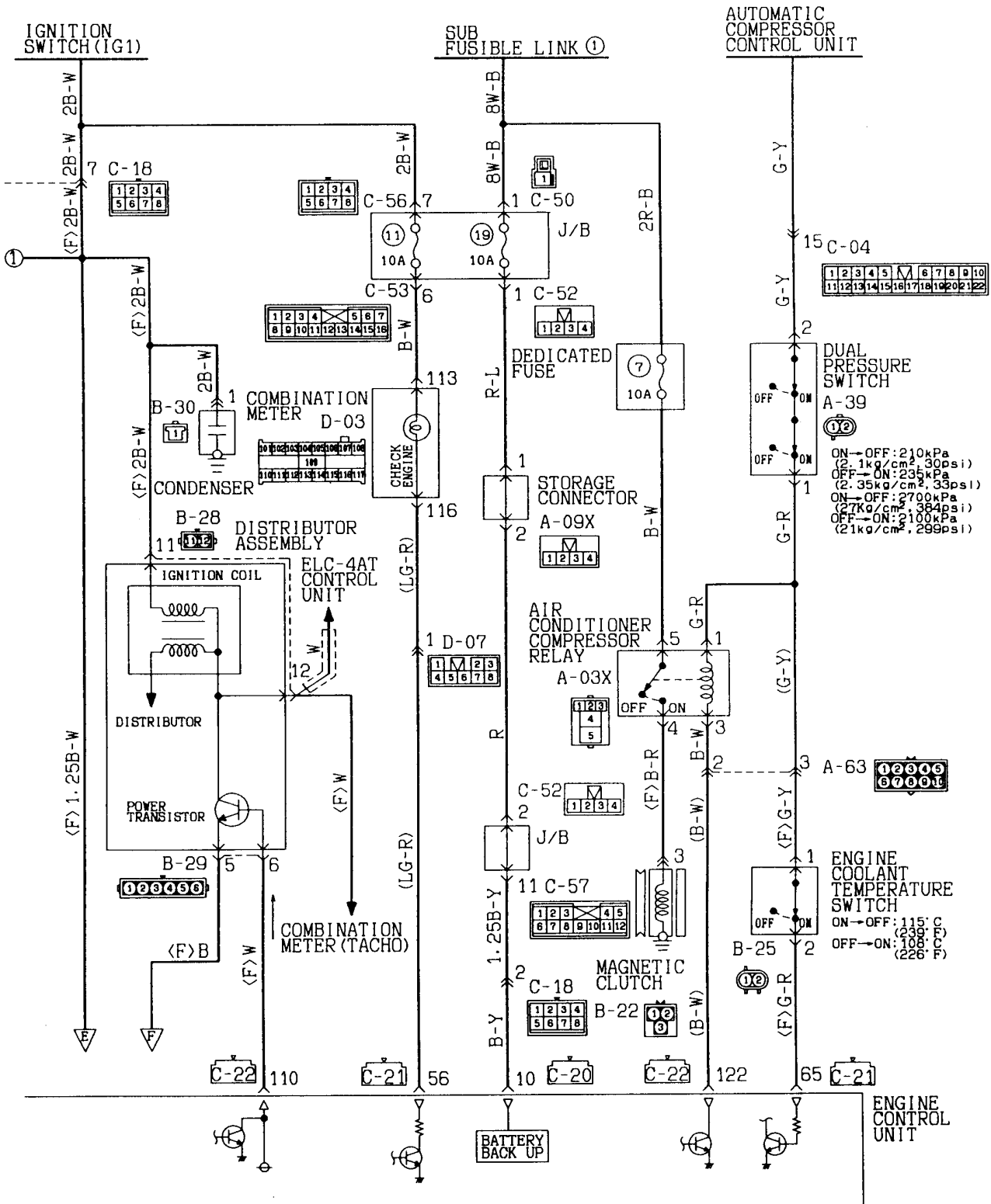

Wire colour code  
 B:Black LG:Light green G:Green L:Blue  
 BR:Brown O:Orange GR:Gray R:Red  
 W:White SB:Sky blue P:Pink Y:Yellow  
 V:Violet

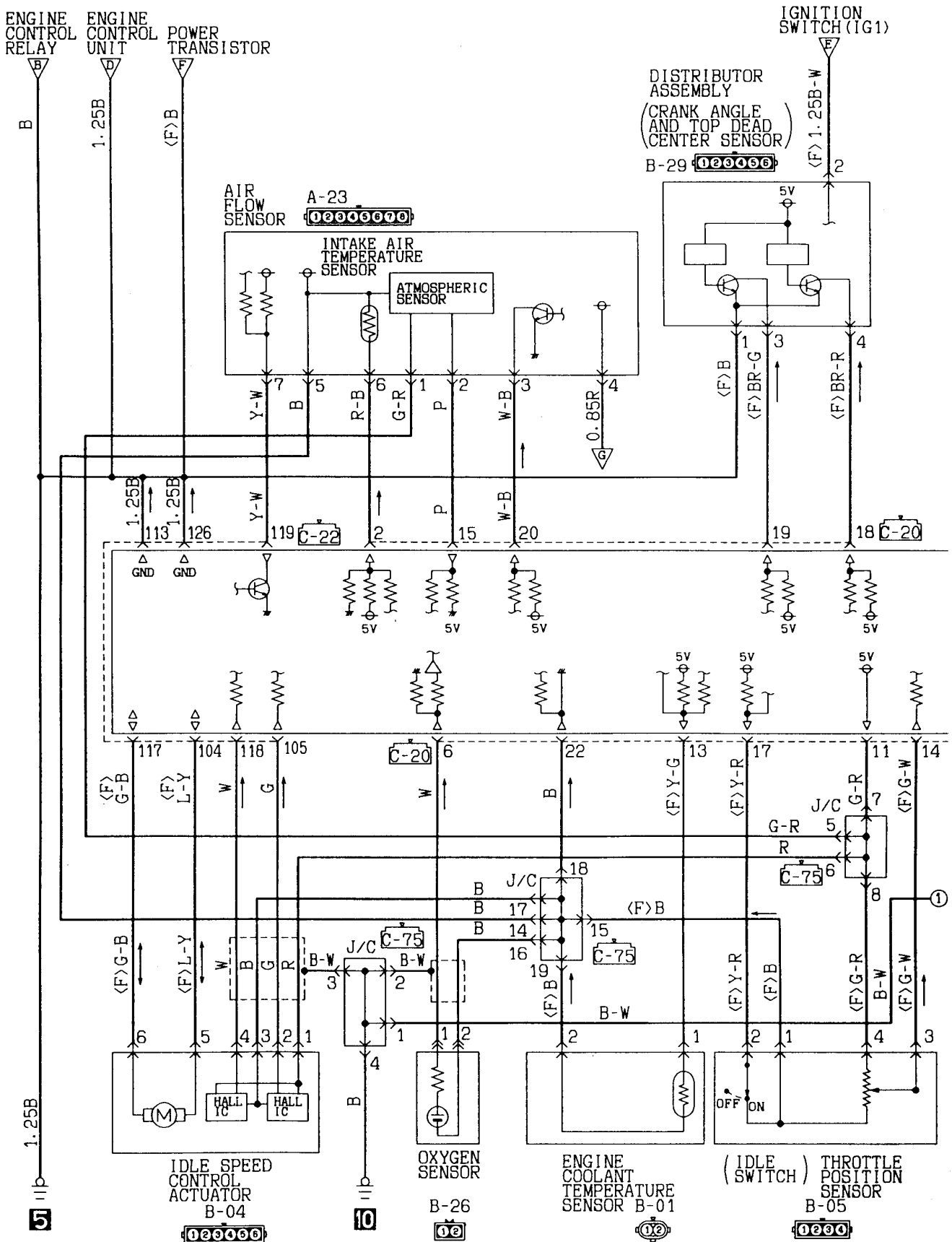

KX35-AC-Z0514A-EC

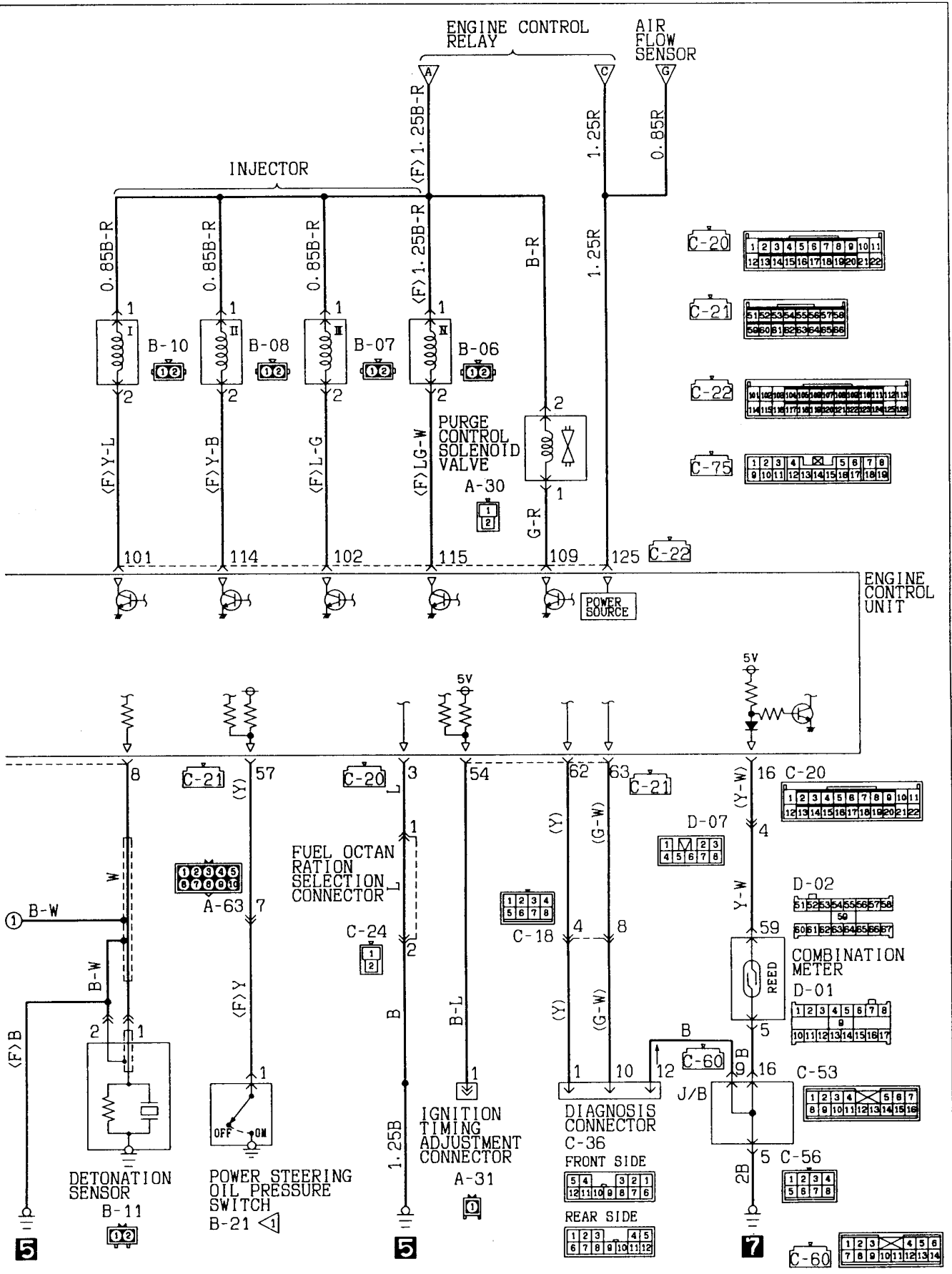

6-3 4G93<R. H. drive vehicles>  
Vehicles without Jumper connector C-75

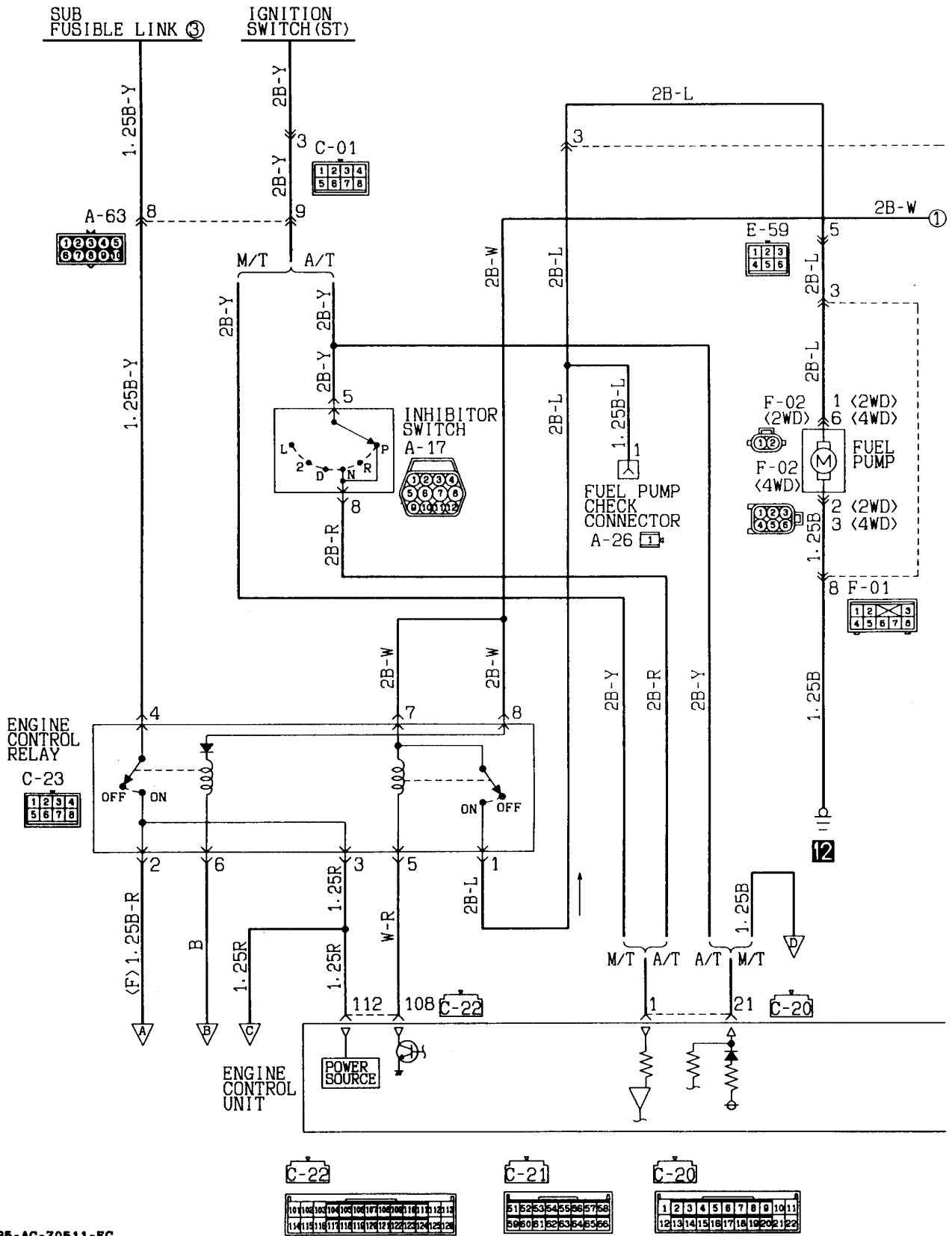

KX35-AC-Z0511-EC

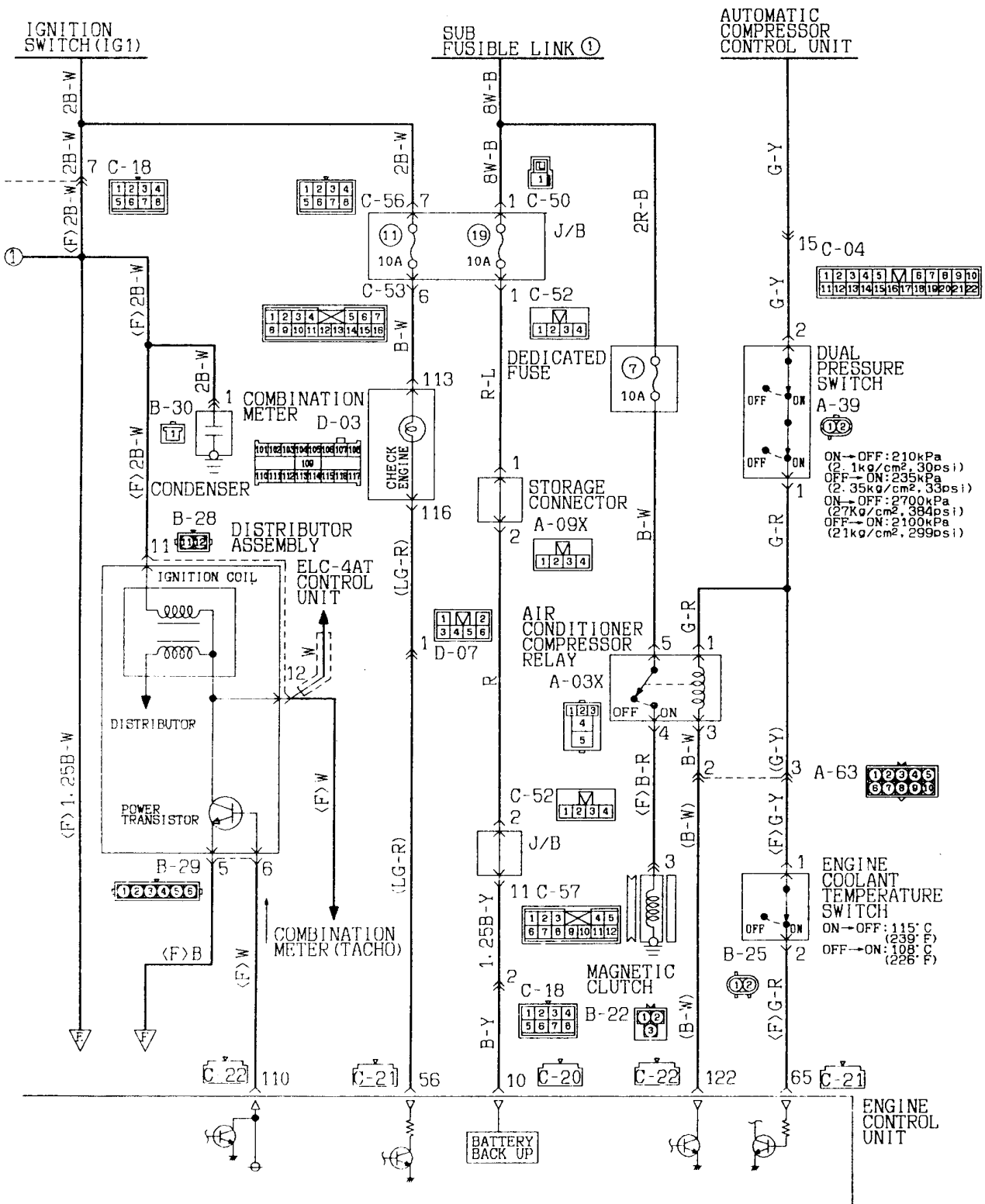

Wire colour code  
 B:Black    LG:Light green    G:Green    L:Blue  
 BR:Brown    O:Orange    GR:Gray    R:Red  
 W:White    SB:Sky blue    P:Pink    Y:Yellow  
 V:Violet

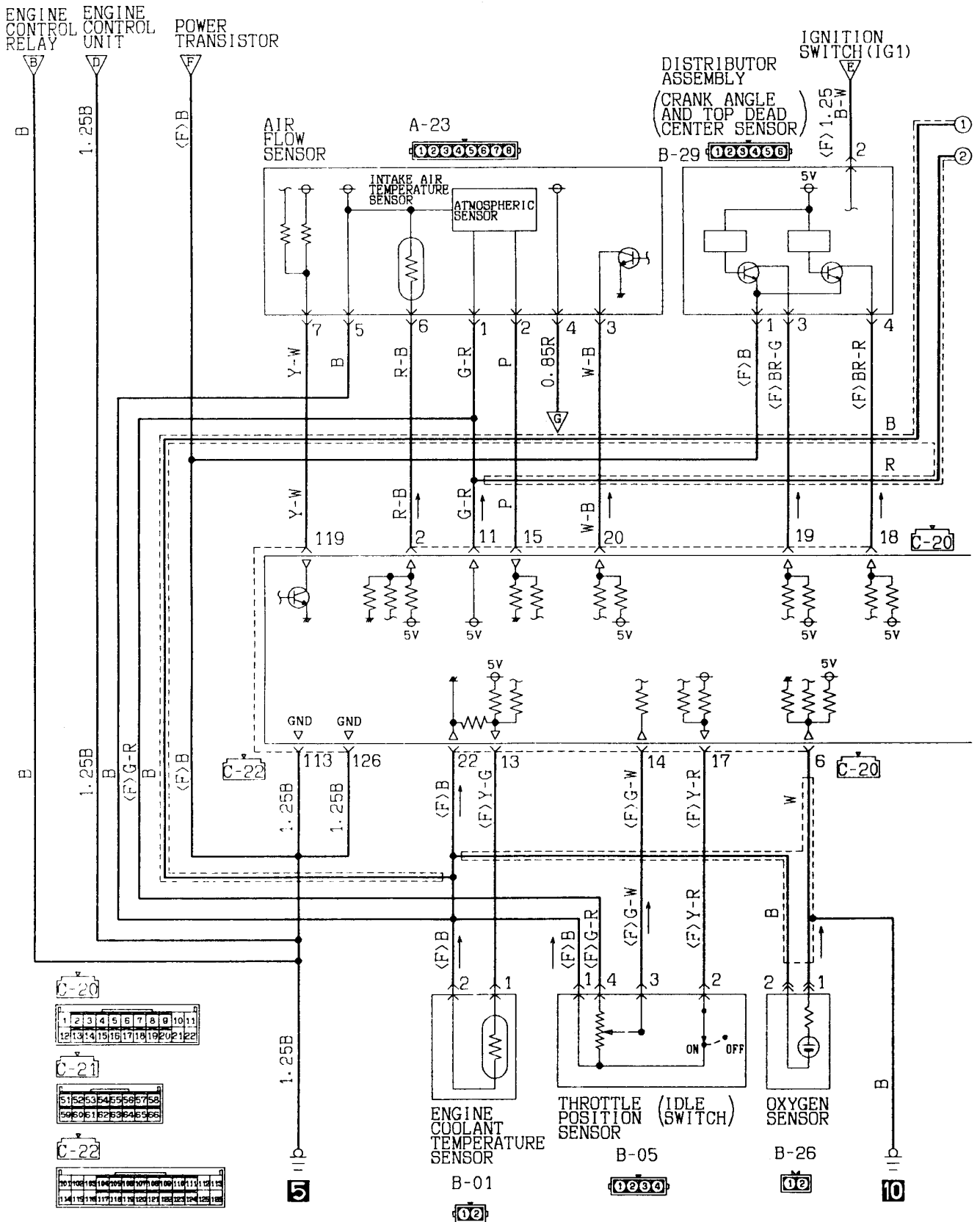

KX35-AC-Z0511A-EC

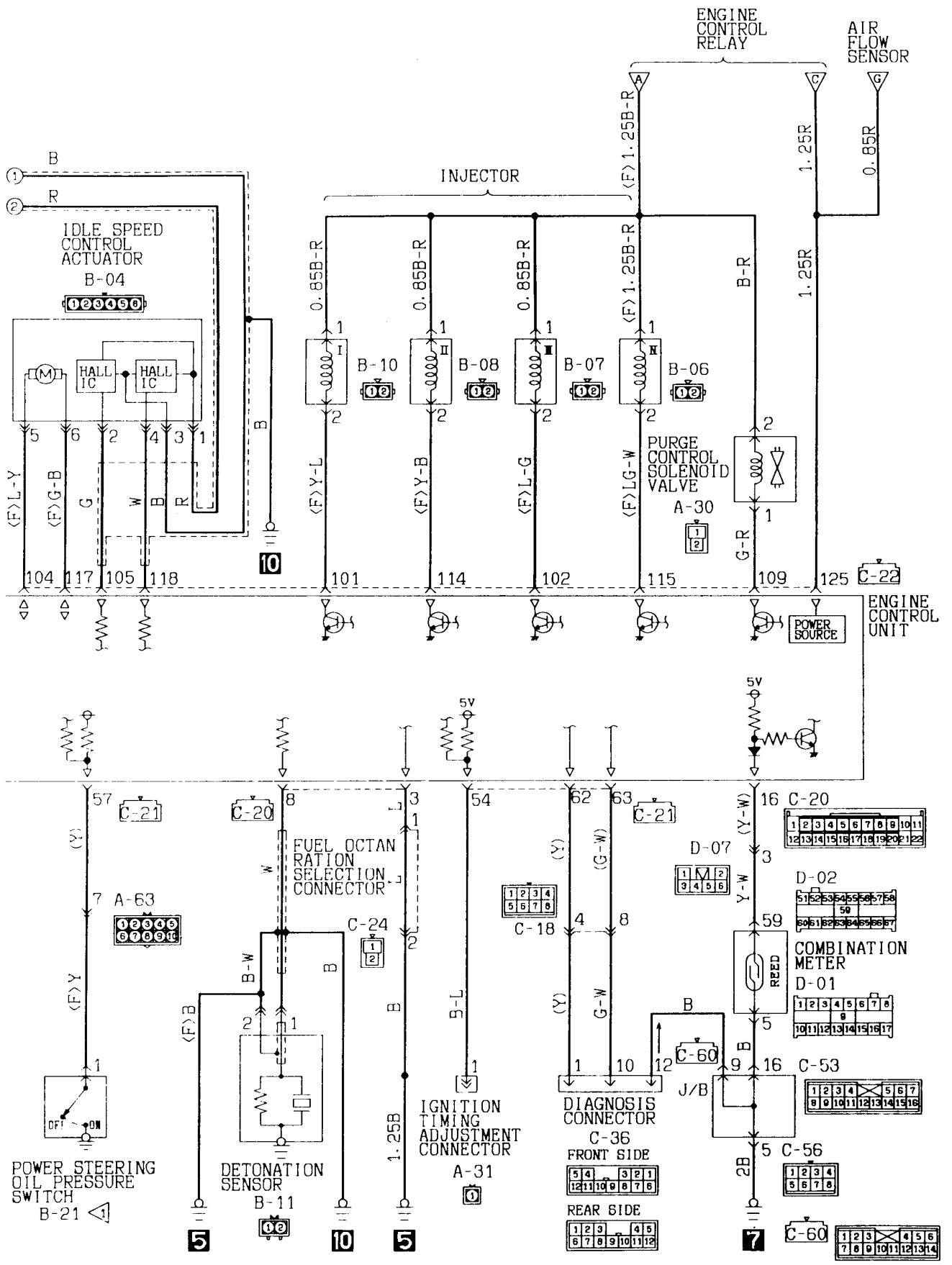



6-4 4G93 <R. H. drive vehicles>  
Vehicles with Jumper connector C-75

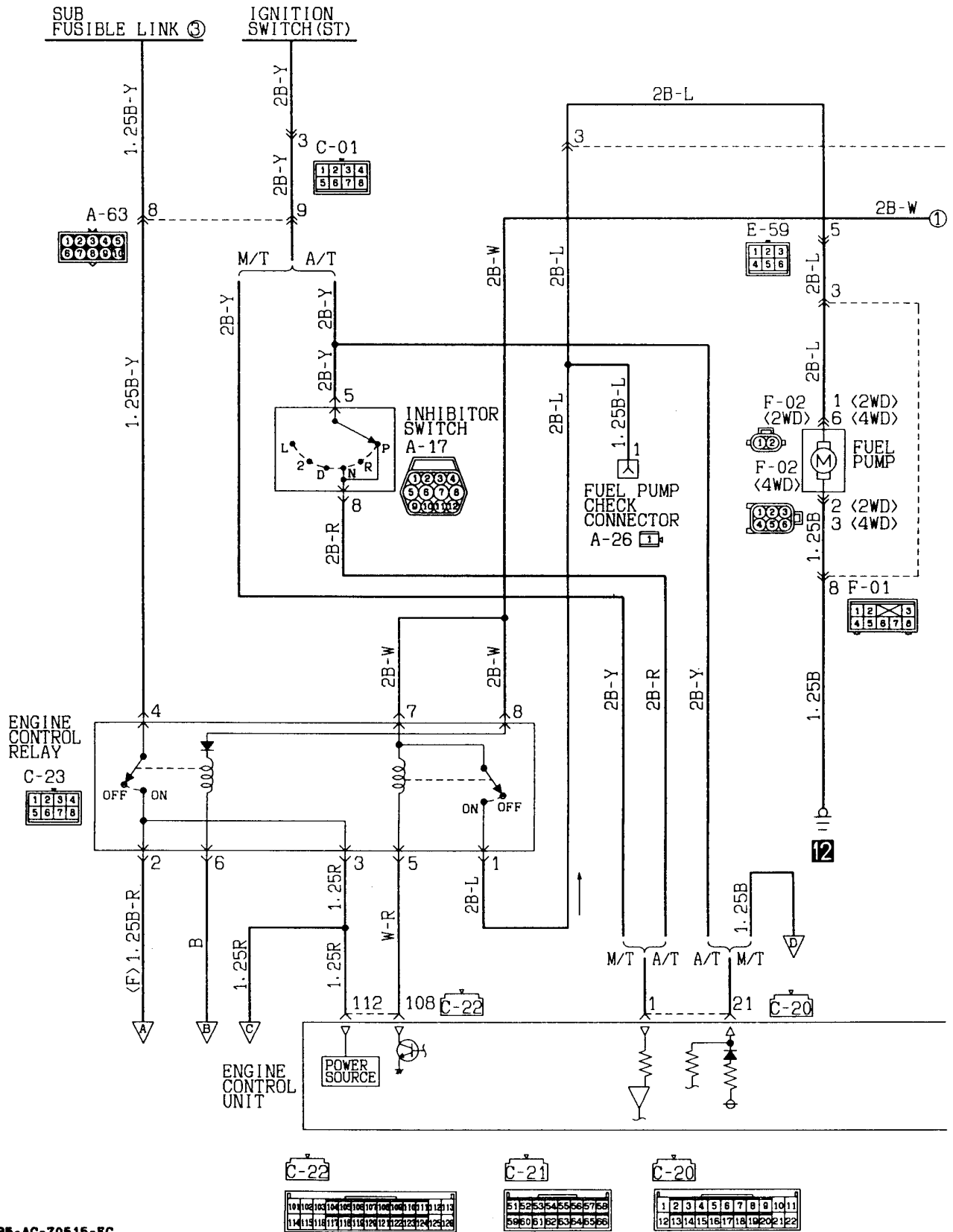

KX35-AC-Z0515-EC

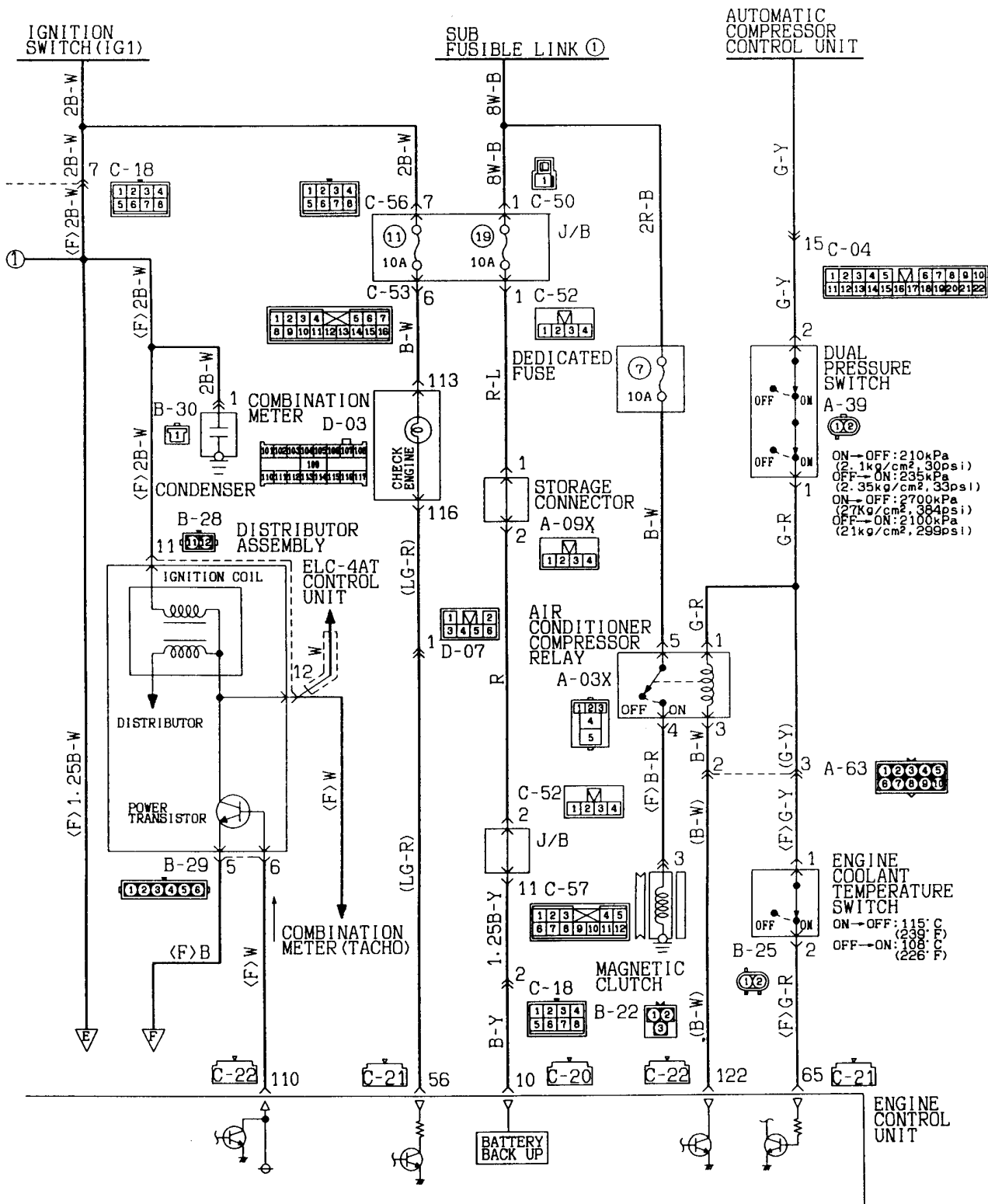

Wire colour code  
 B:Black    LG:Light green    G:Green    L:Blue  
 BR:Brown    O:Orange    GR:Gray    R:Red  
 W:White    SB:Sky blue    P:Pink    Y:Yellow  
 V:Violet

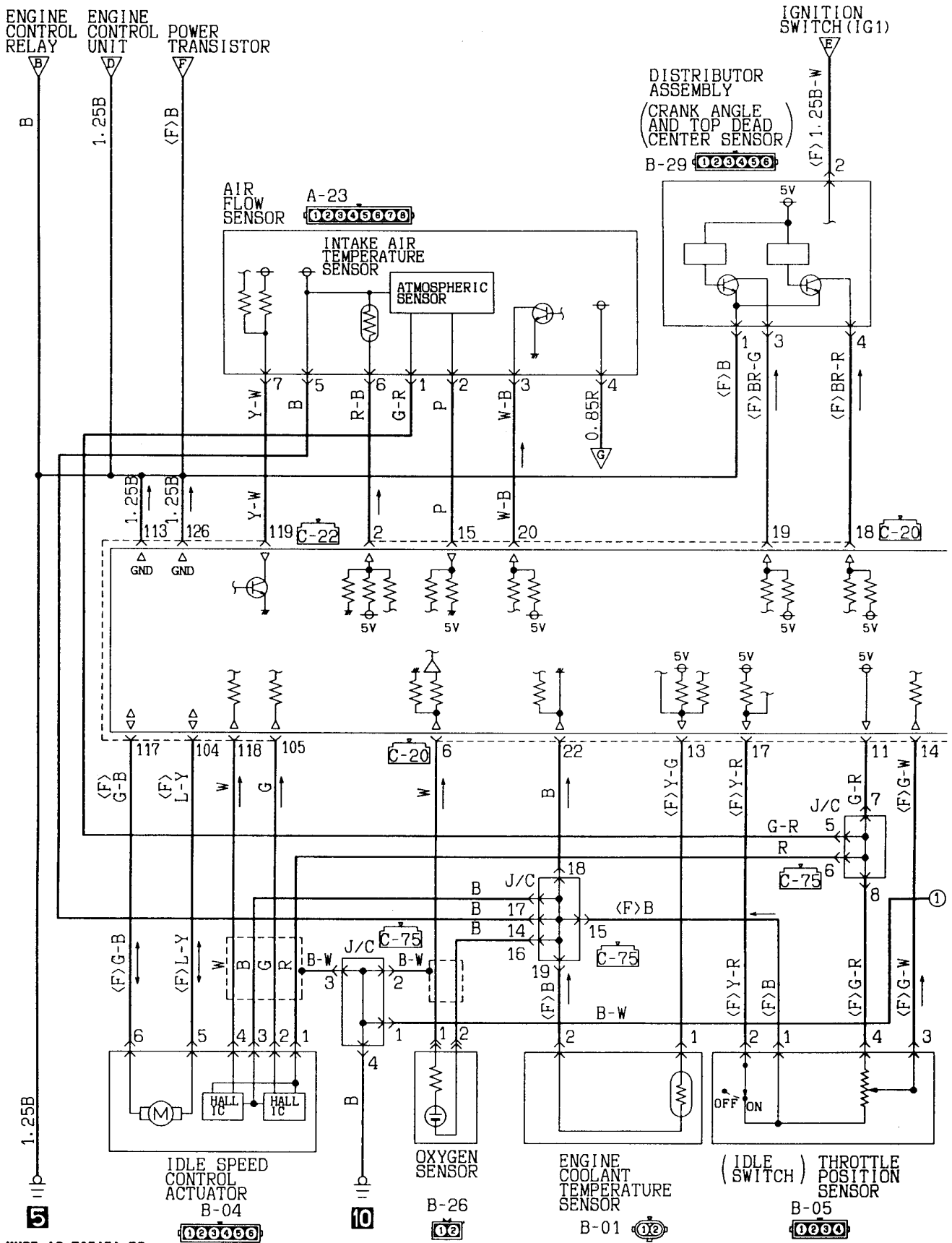

KX35-AC-Z0515A-EC

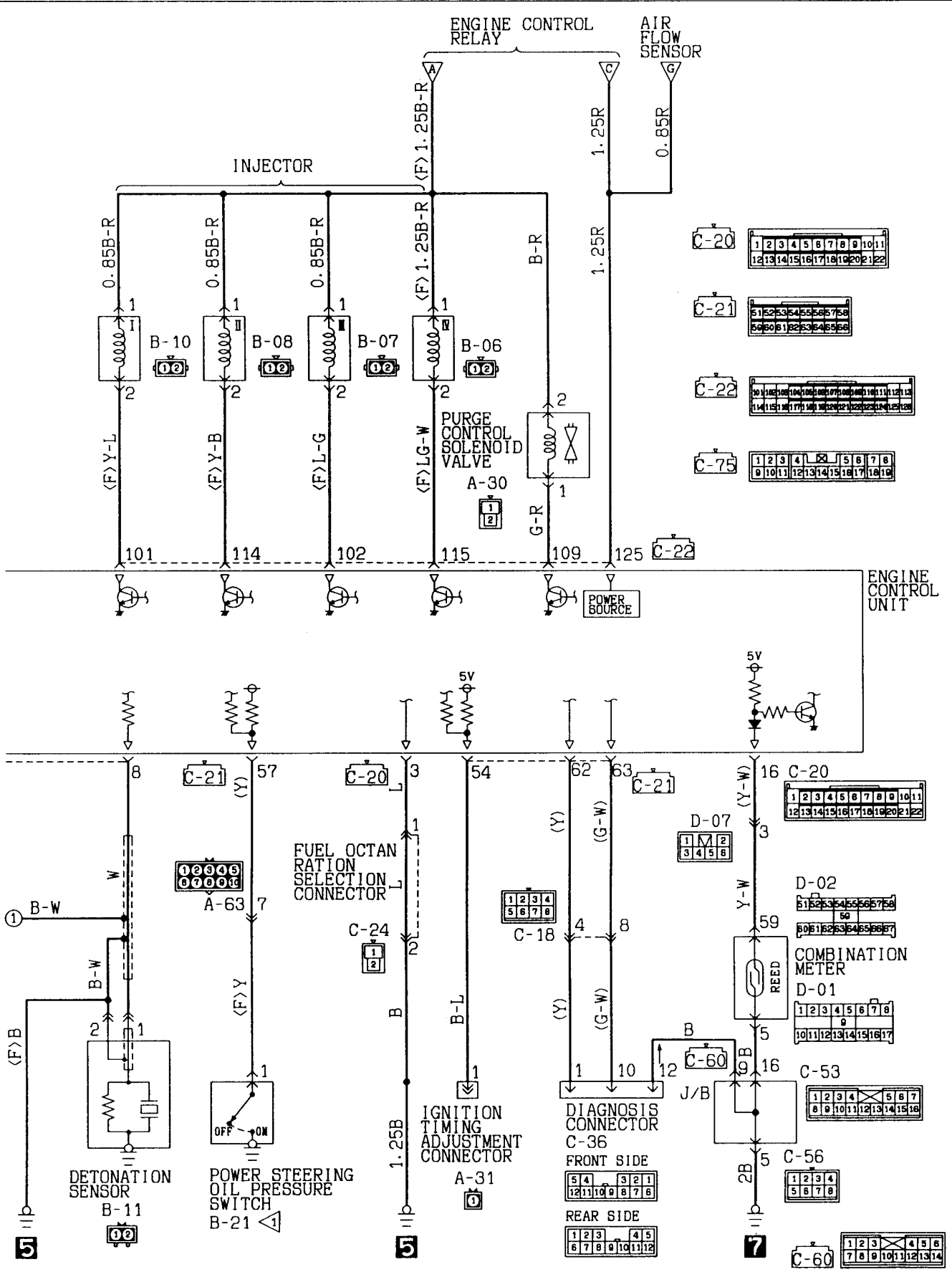

6-5 4G63 and 4G64 (L.H. drive vehicles)  
Vehicles without Jumper connector C-75

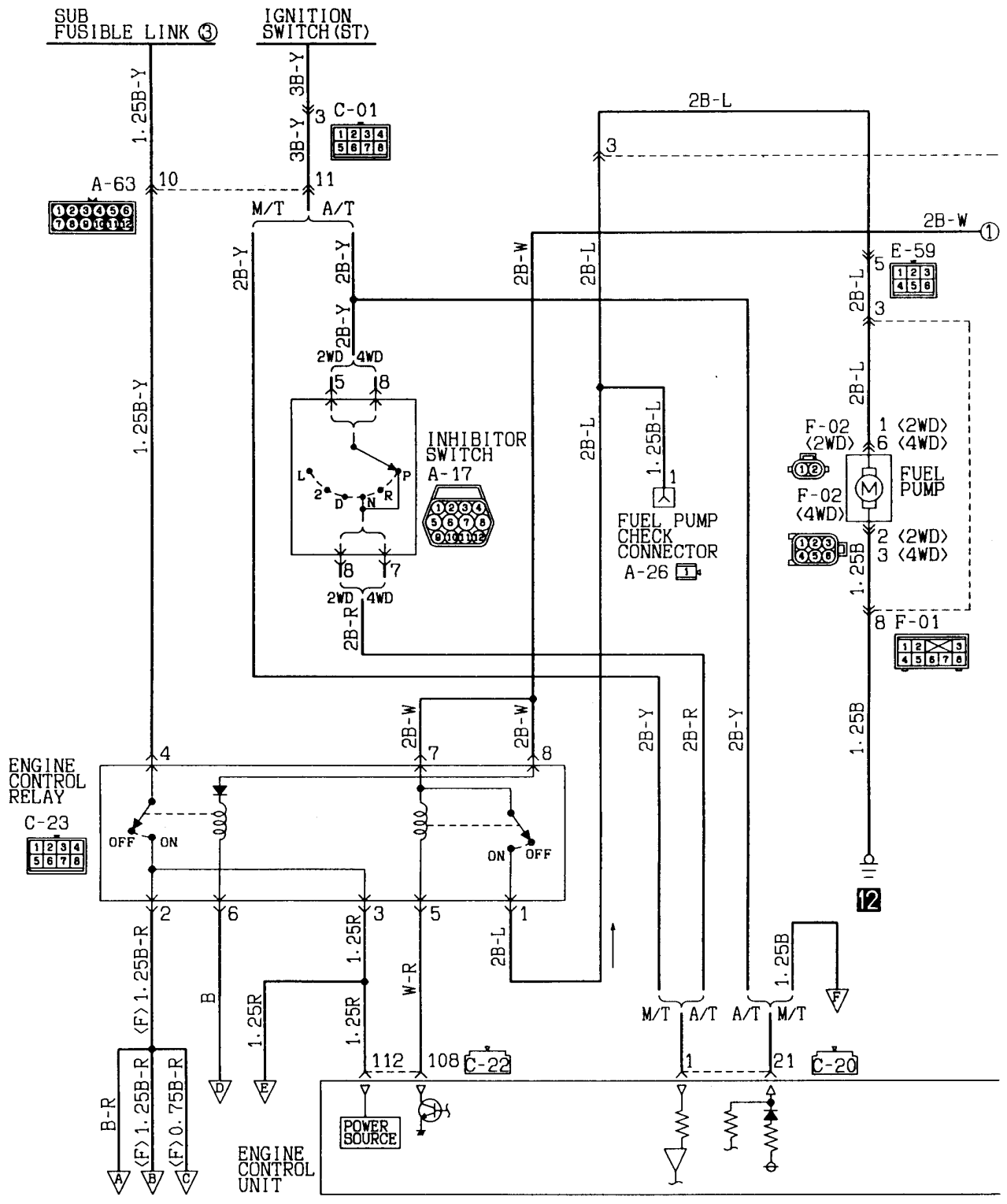

KX35-AC-Z0512-EC

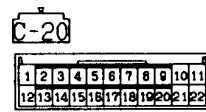
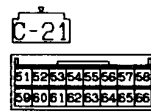
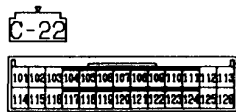

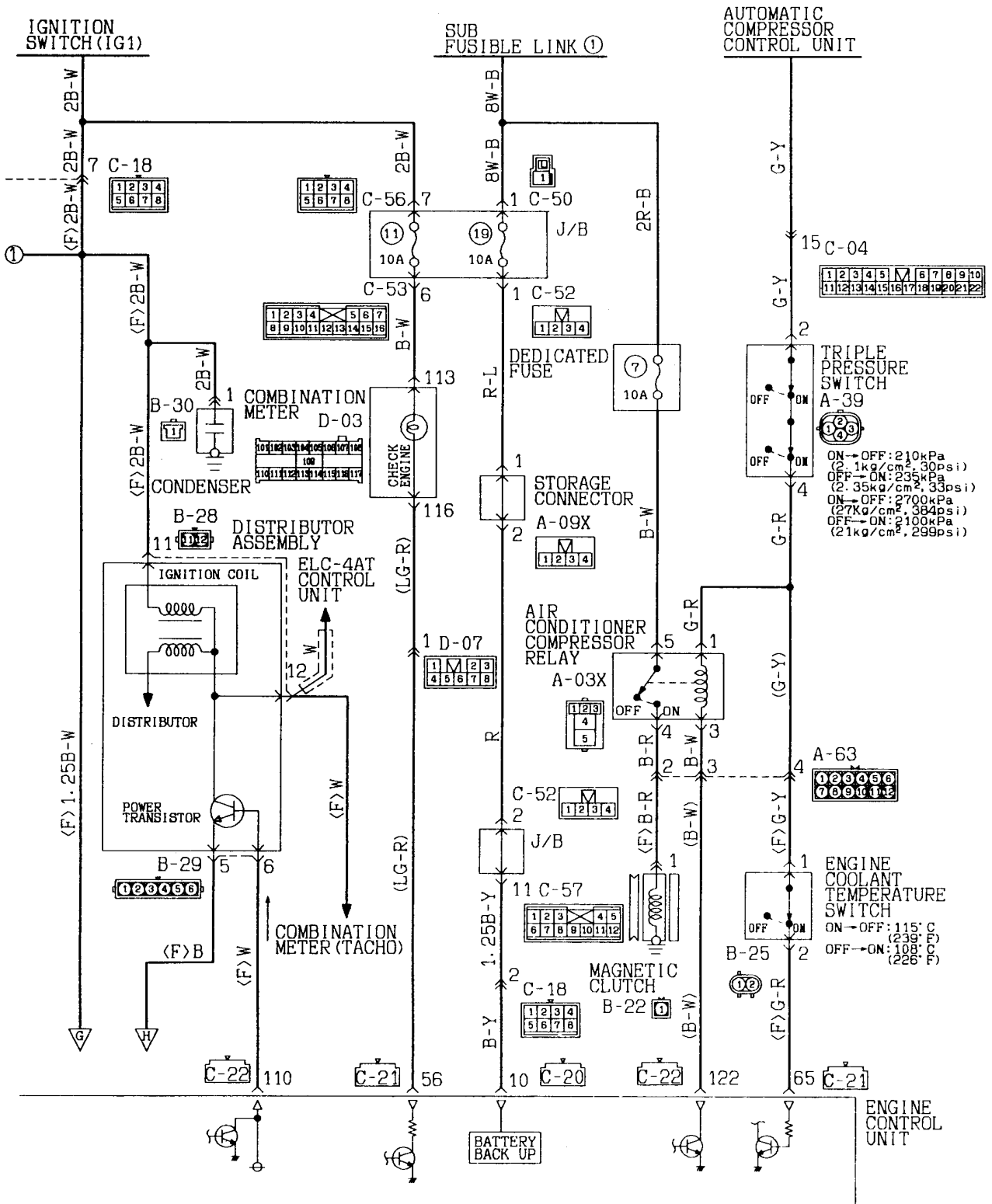

Wire colour code  
 B:Black LG:Light green G:Green L:Blue  
 BR:Brown O:Orange GR:Gray R:Red  
 W:White SB:Sky blue P:Pink Y:Yellow  
 V:Violet

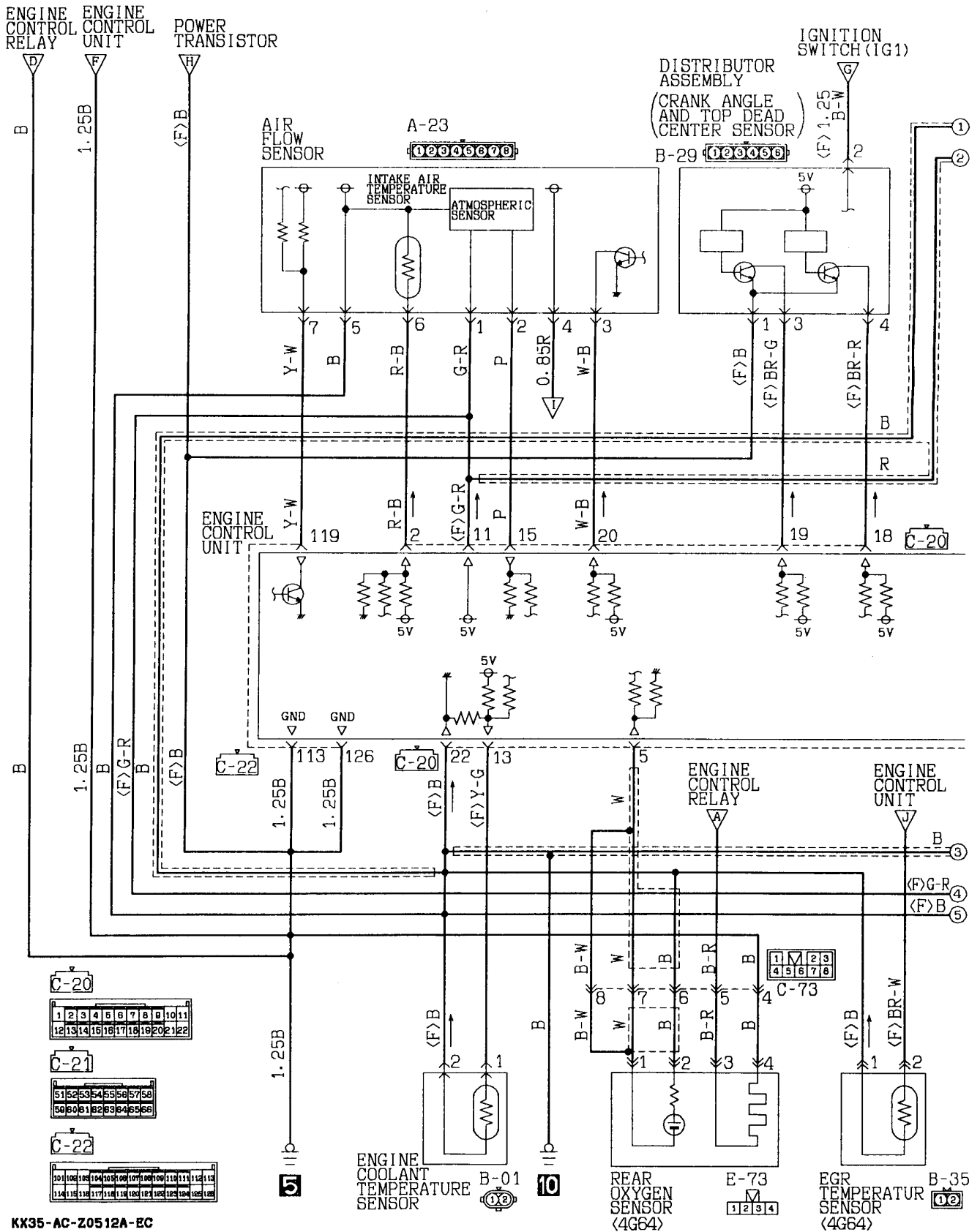

KX35-AC-Z0512A-EC

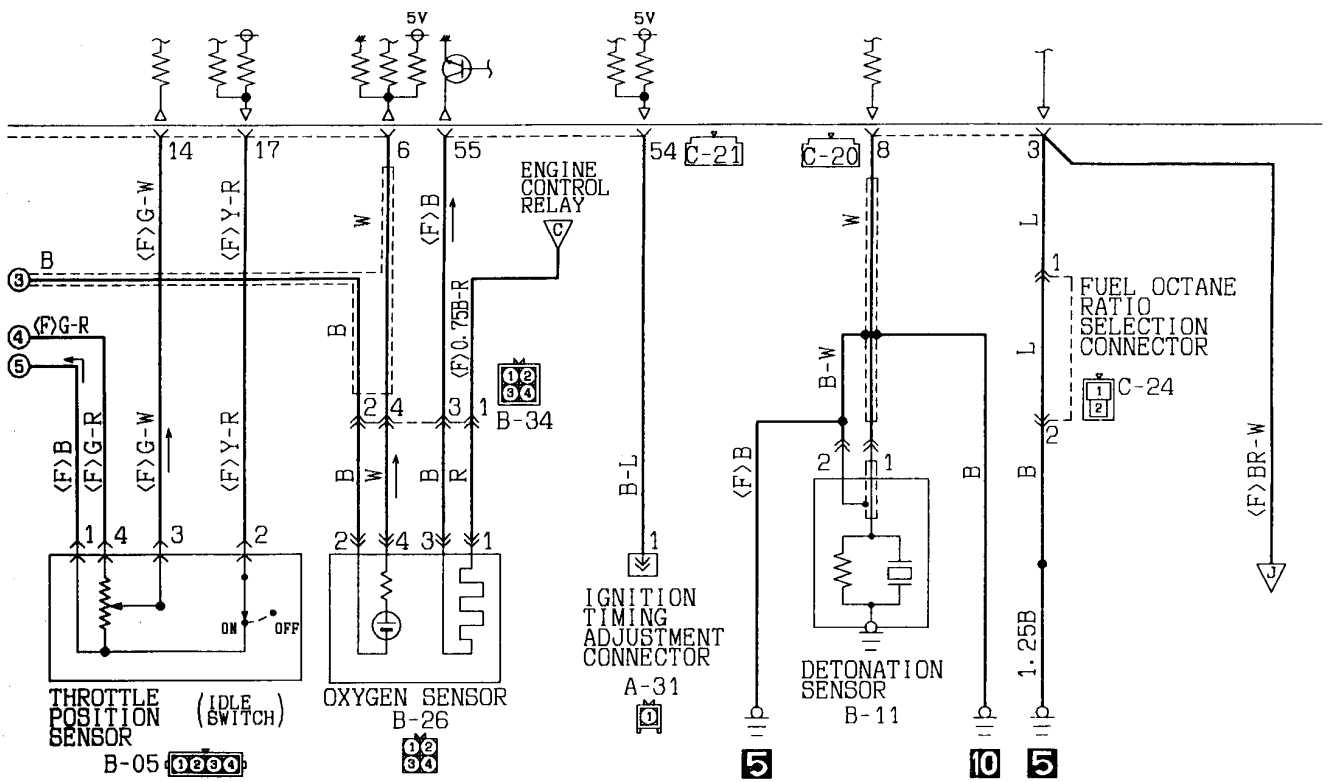
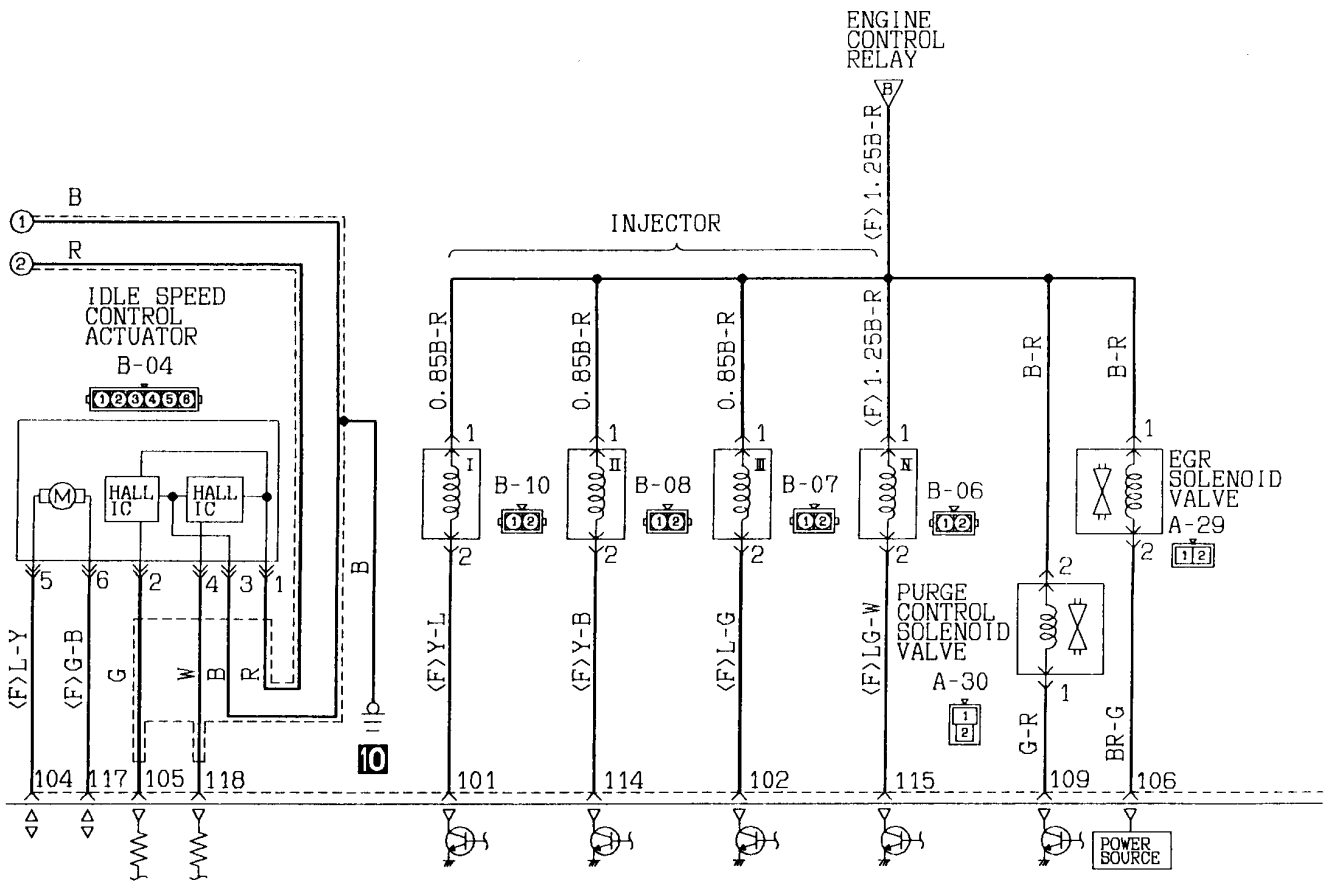



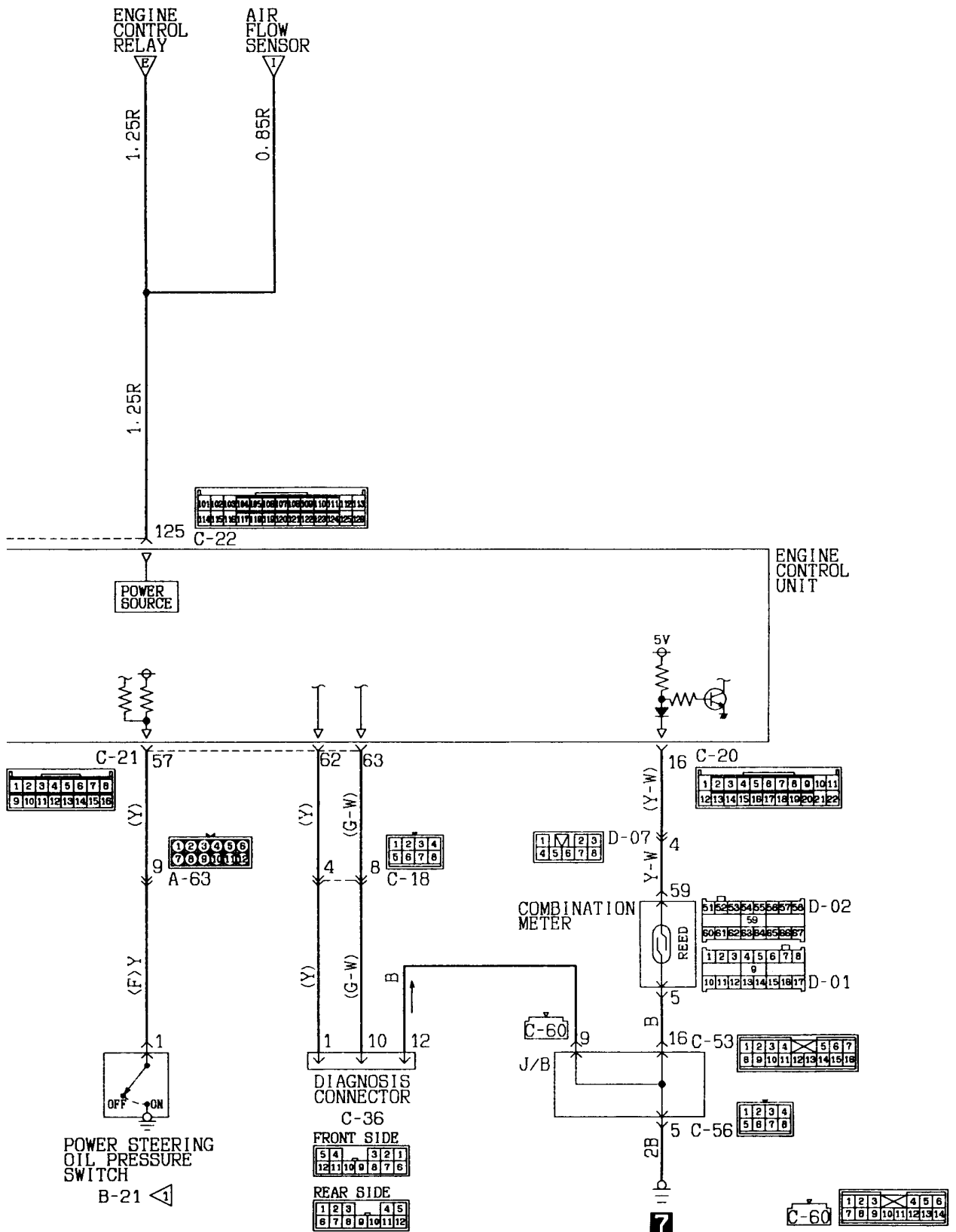

KX35-AC-Z0512B-EC

**NOTES**

6-6 4G63 and 4G64 (L.H. drive vehicles)  
Vehicles with Jumper connector C-75

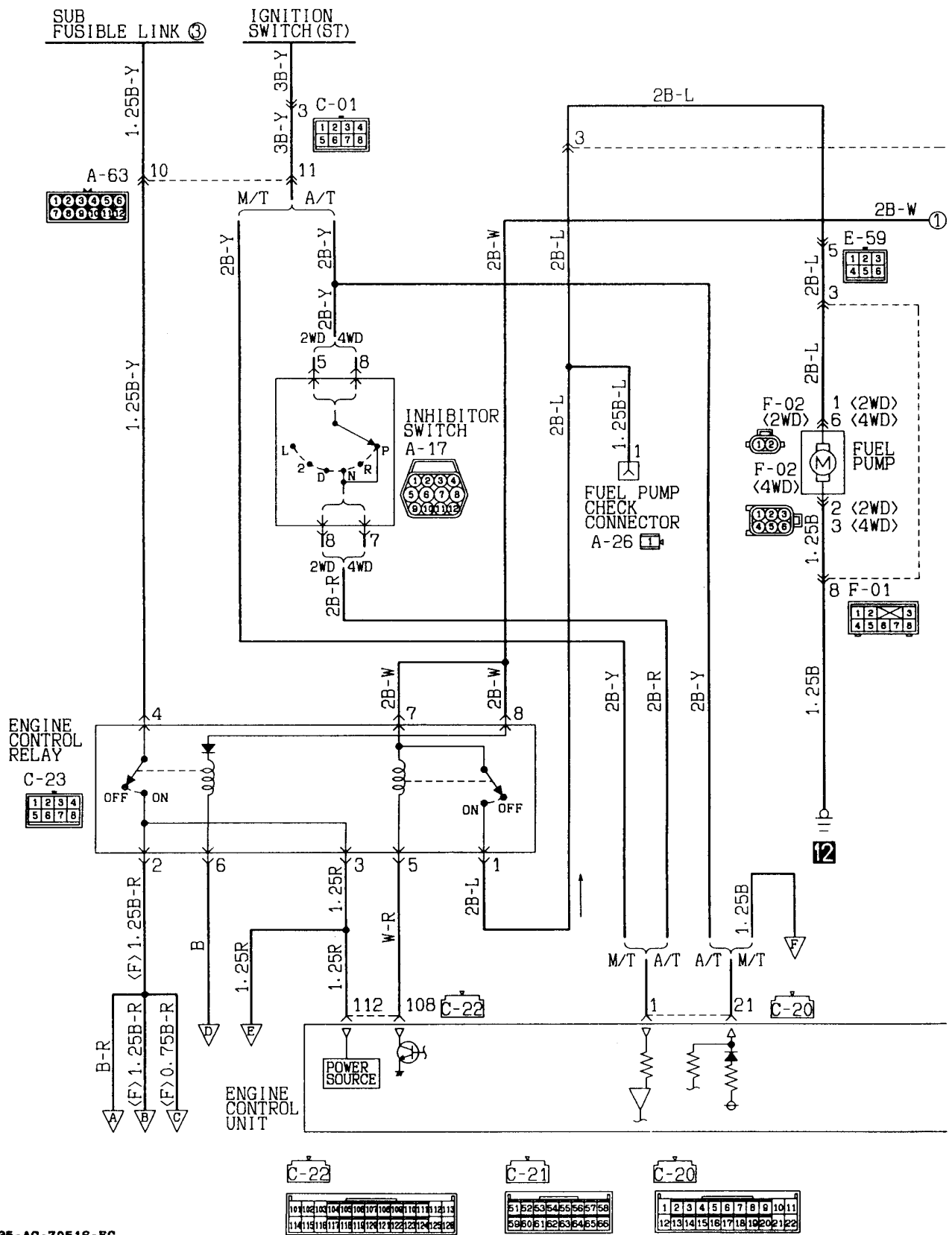

KX35-AC-Z0518-EC

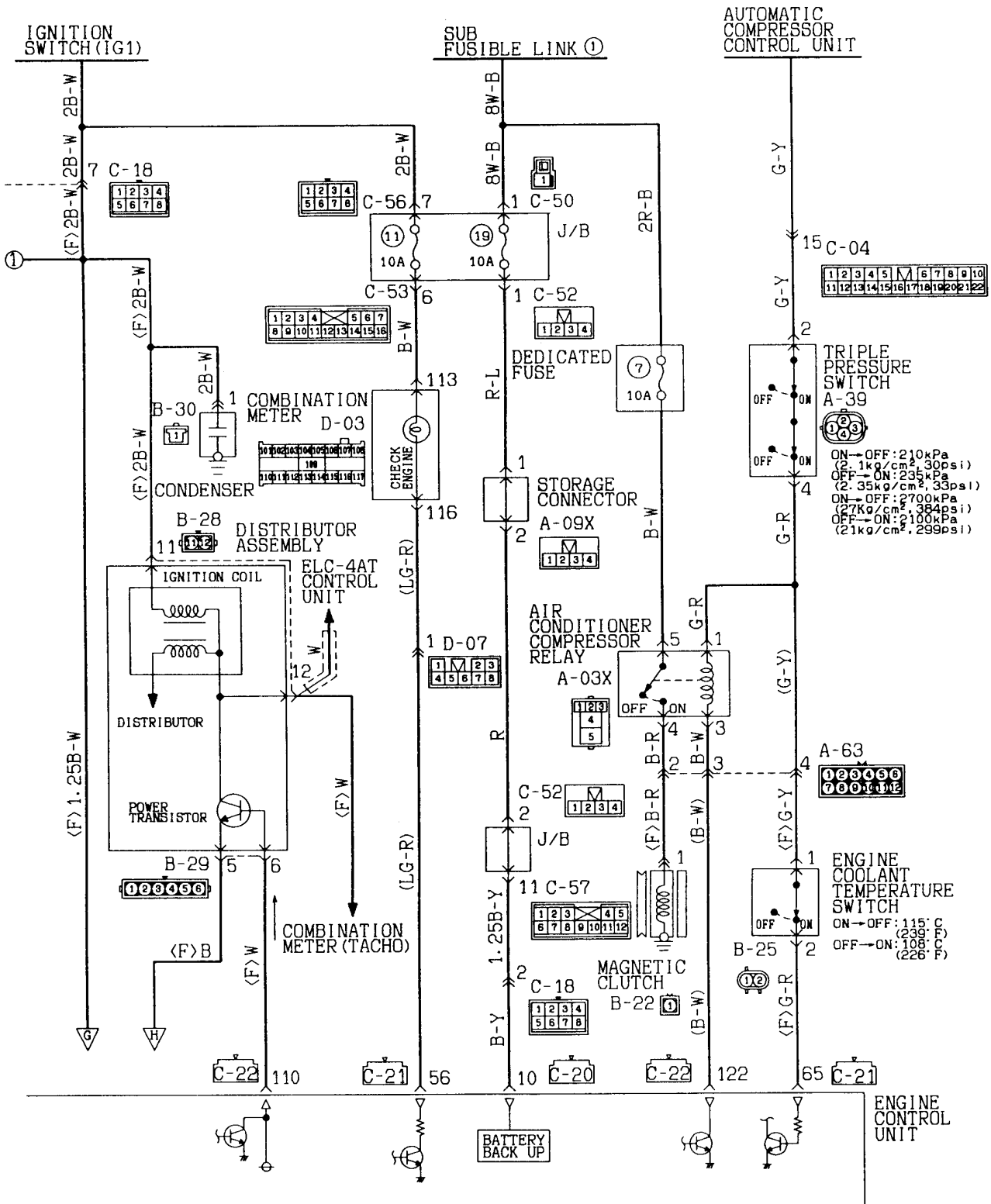

Wire colour code  
 B:Black LG:Light green G:Green L:Blue  
 BR:Brown O:Orange GR:Gray R:Red  
 W:White SB:Sky blue P:Pink Y:Yellow  
 V:Violet

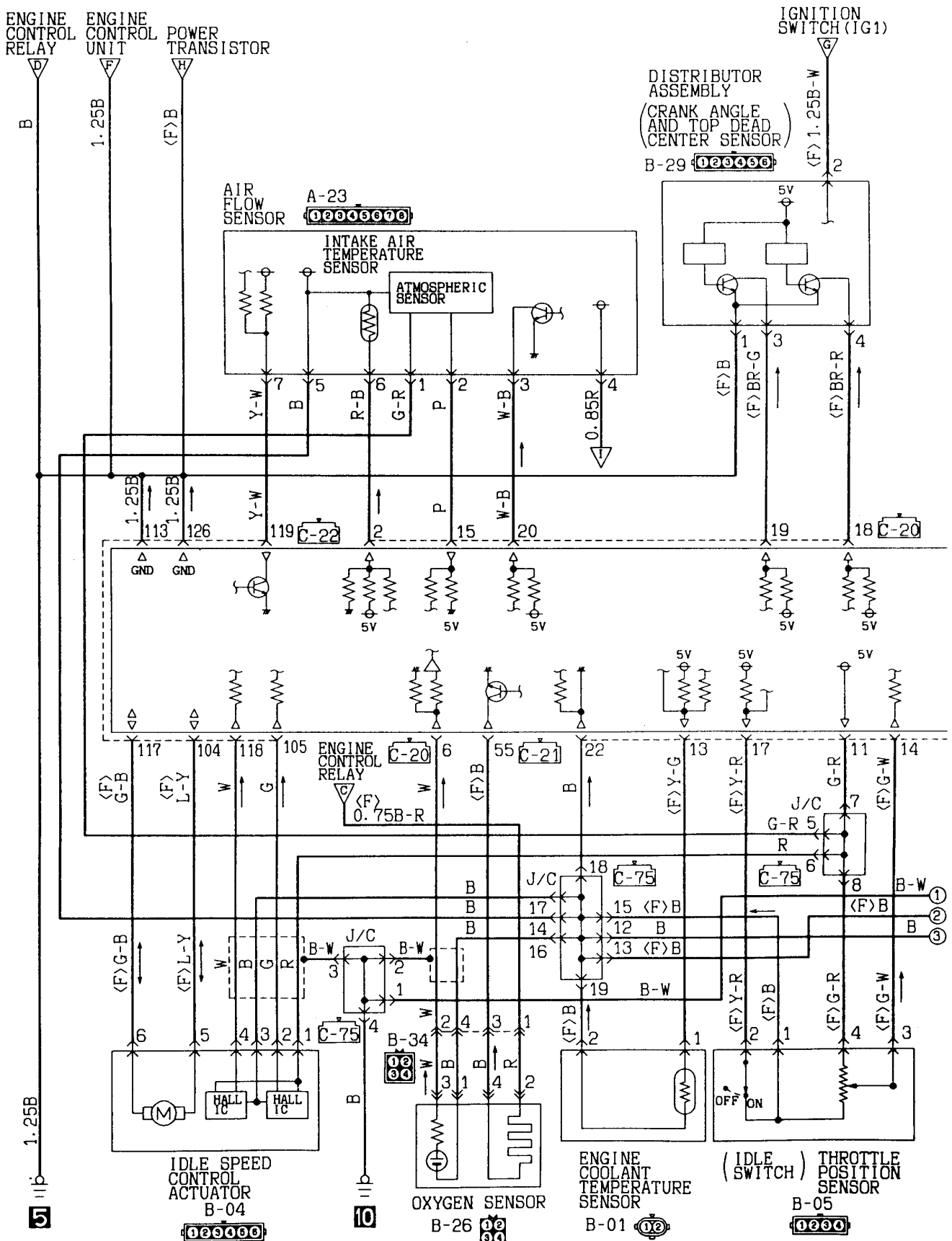

KX35-AC-Z0516A-EC

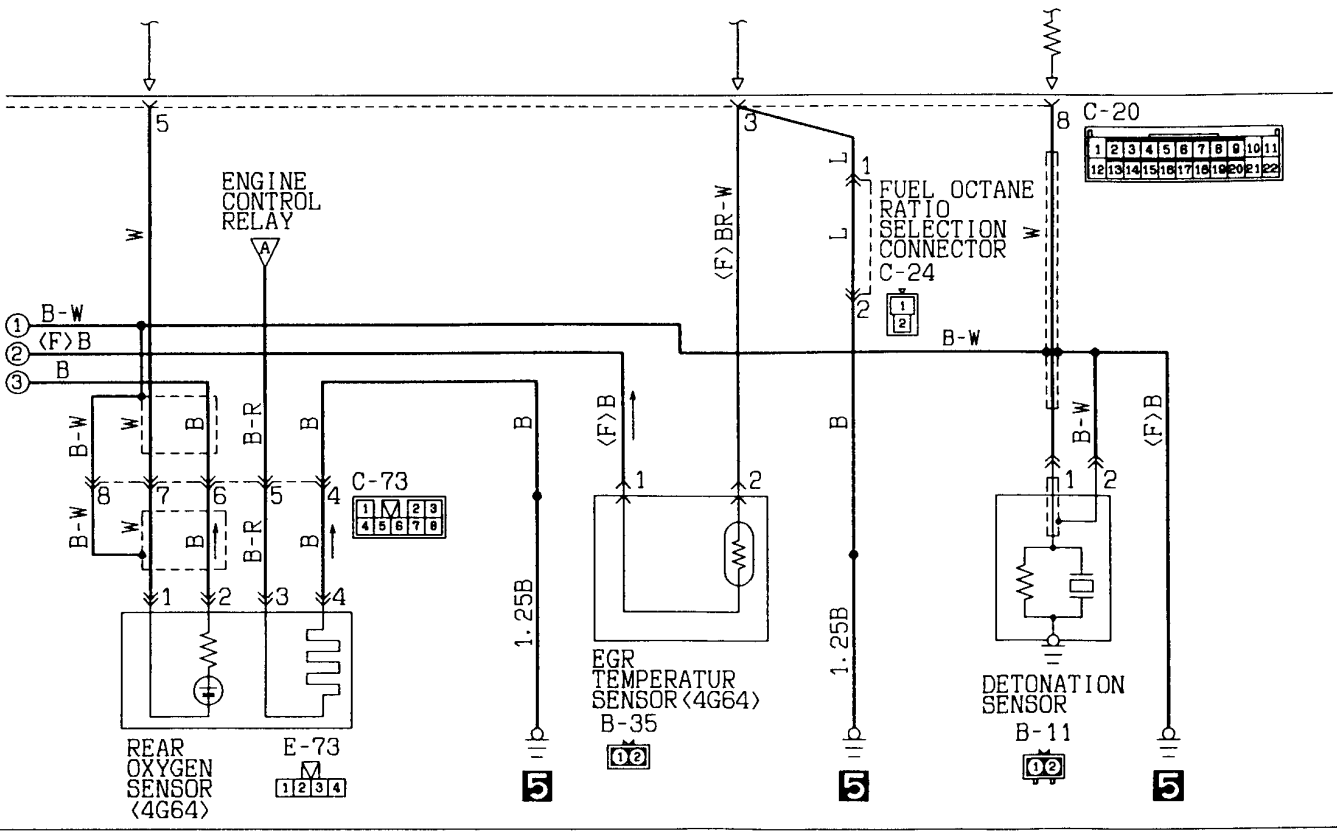
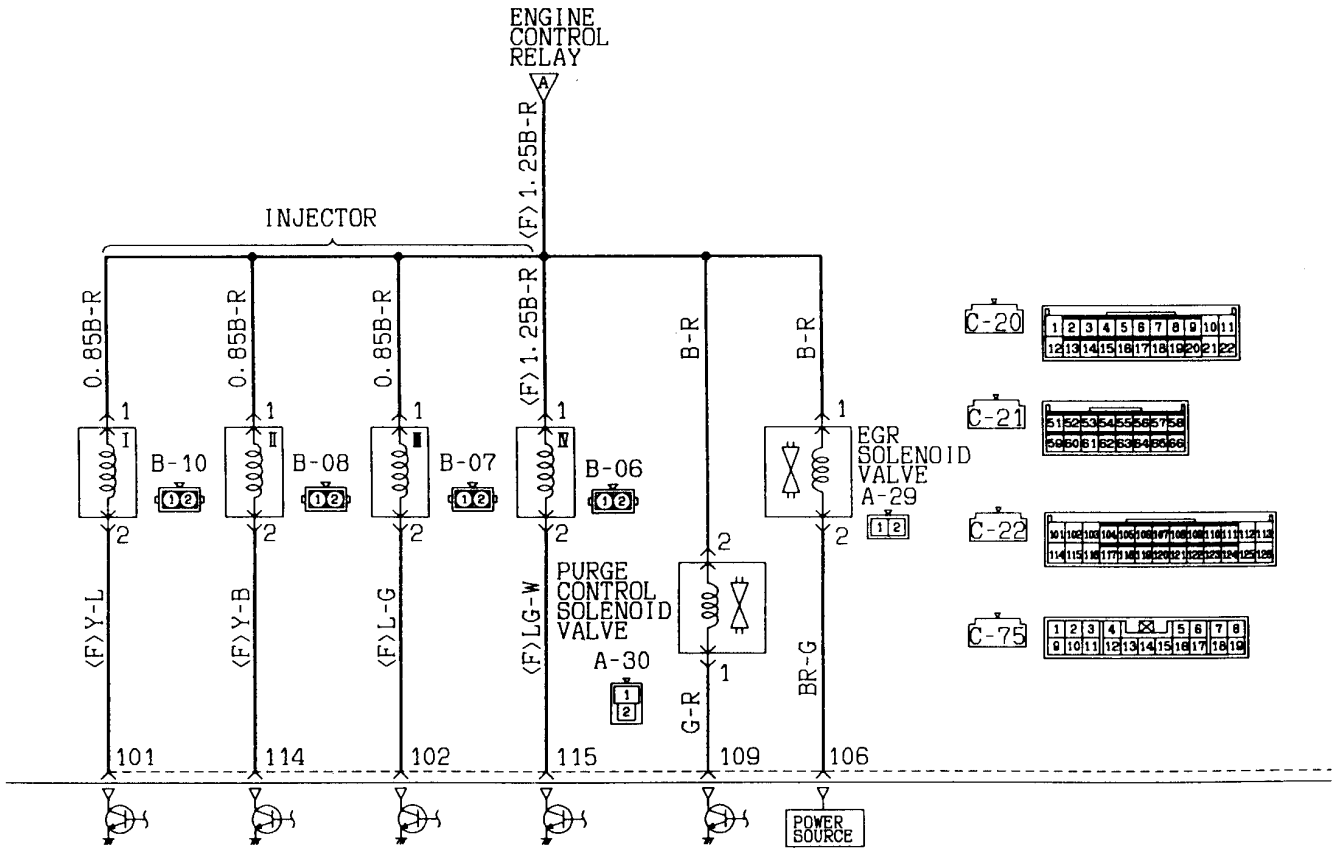

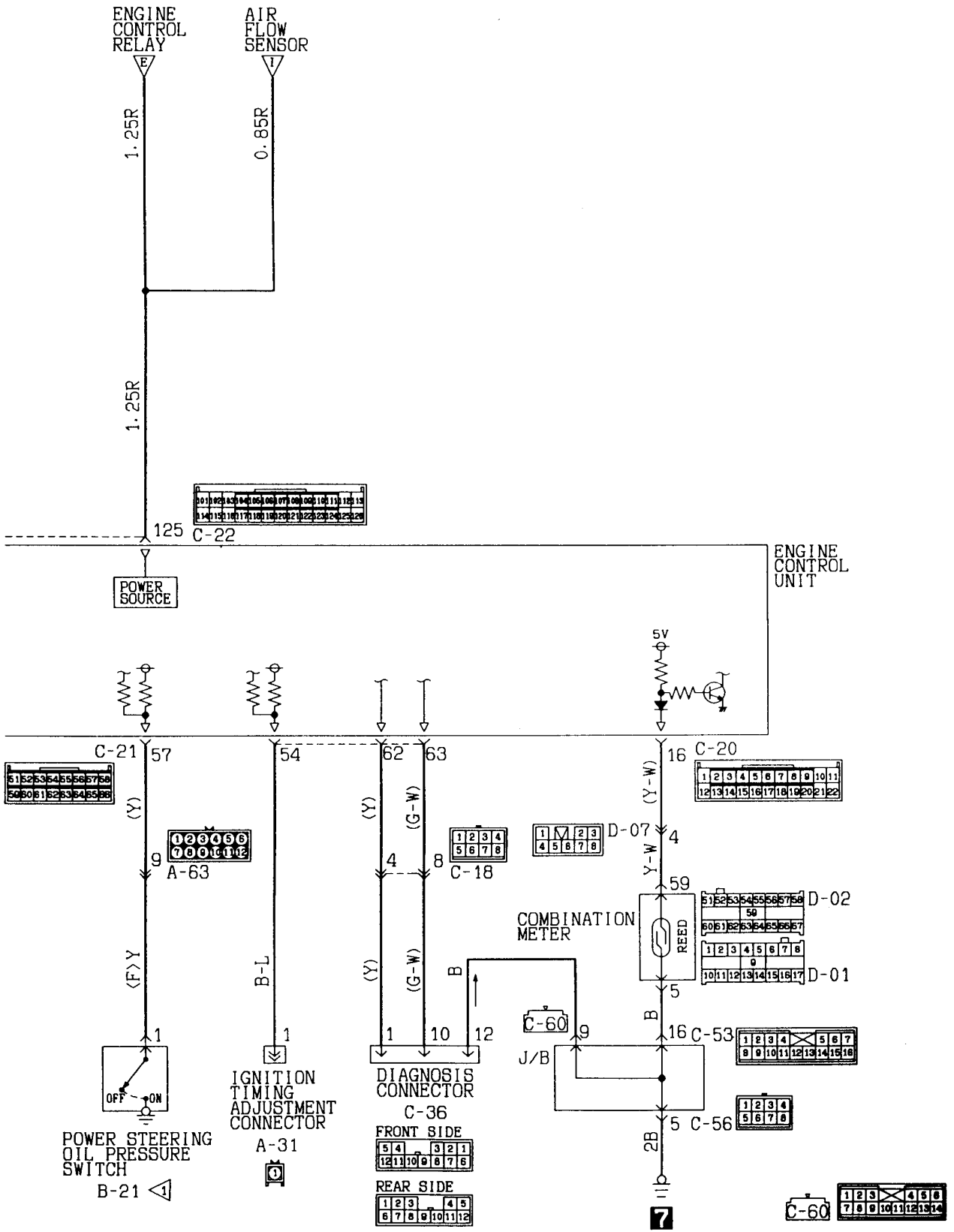

6-7 4G63 (R.H. drive vehicles)  
 Vehicles without Jumper connector C-75

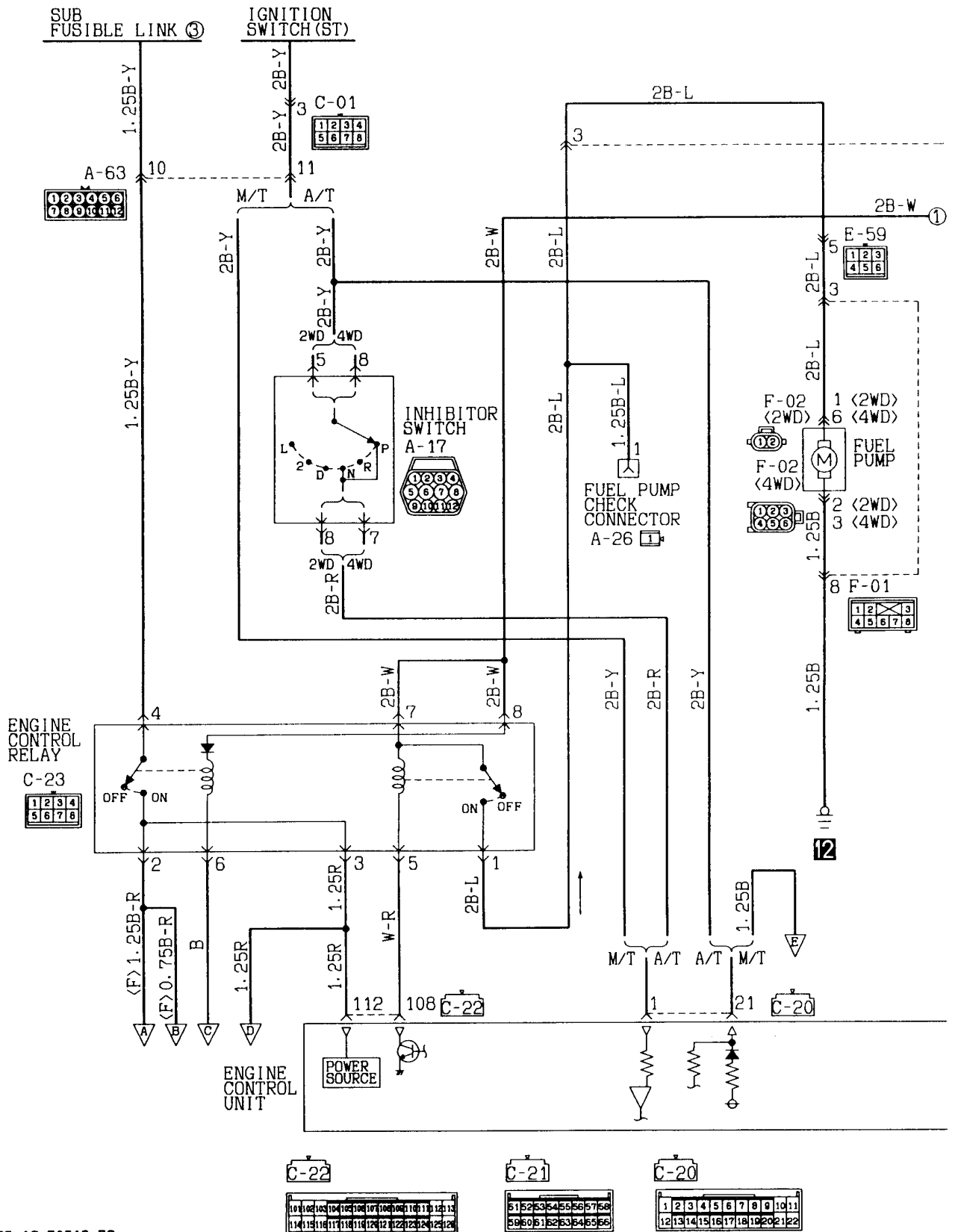

KX35-AC-Z0513-EC



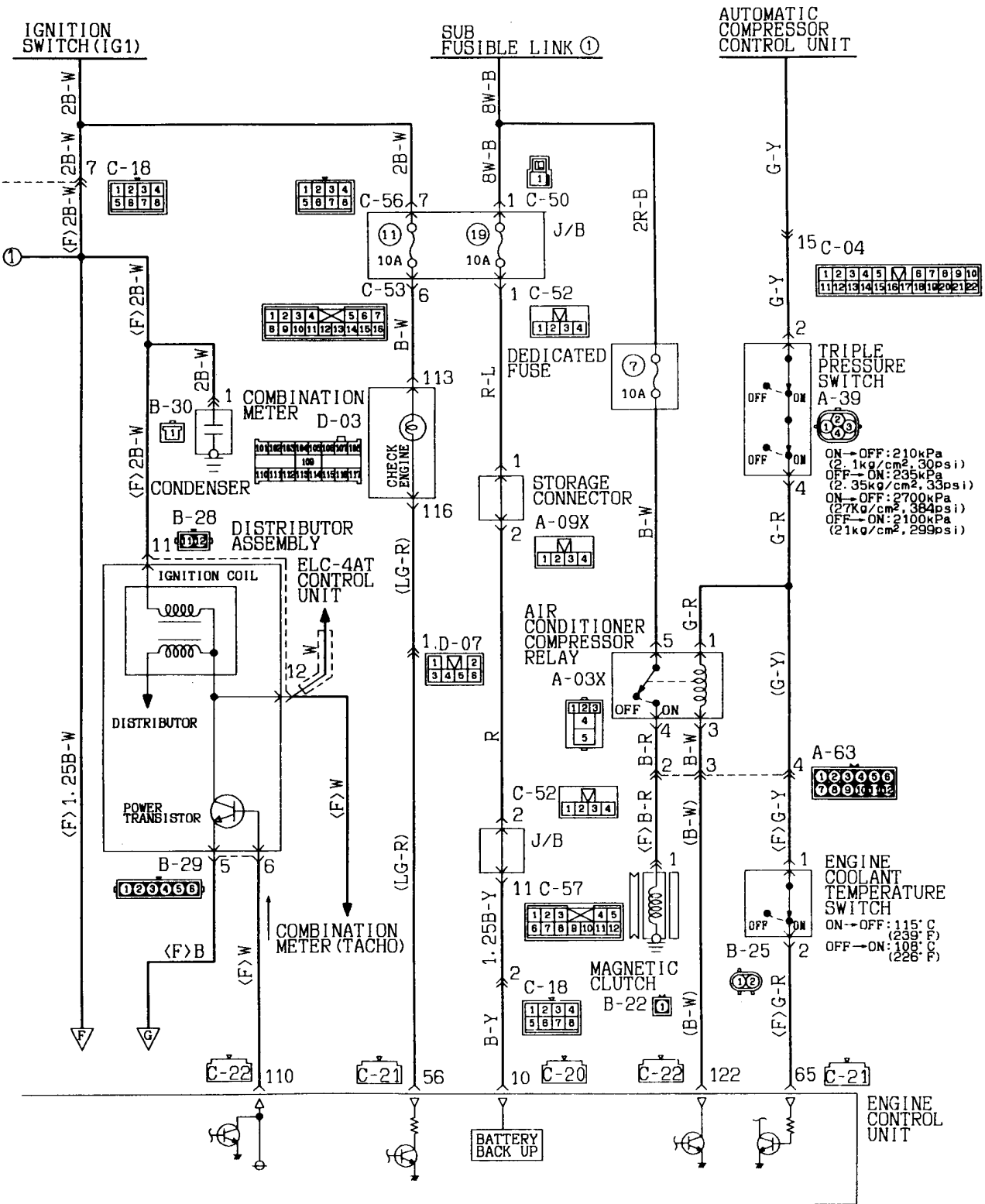

Wire colour code  
 B:Black LG:Light green G:Green L:Blue W:White Y:Yellow SB:Sky blue  
 BR:Brown O:Orange GR:Gray R:Red P:Pink V:Violet

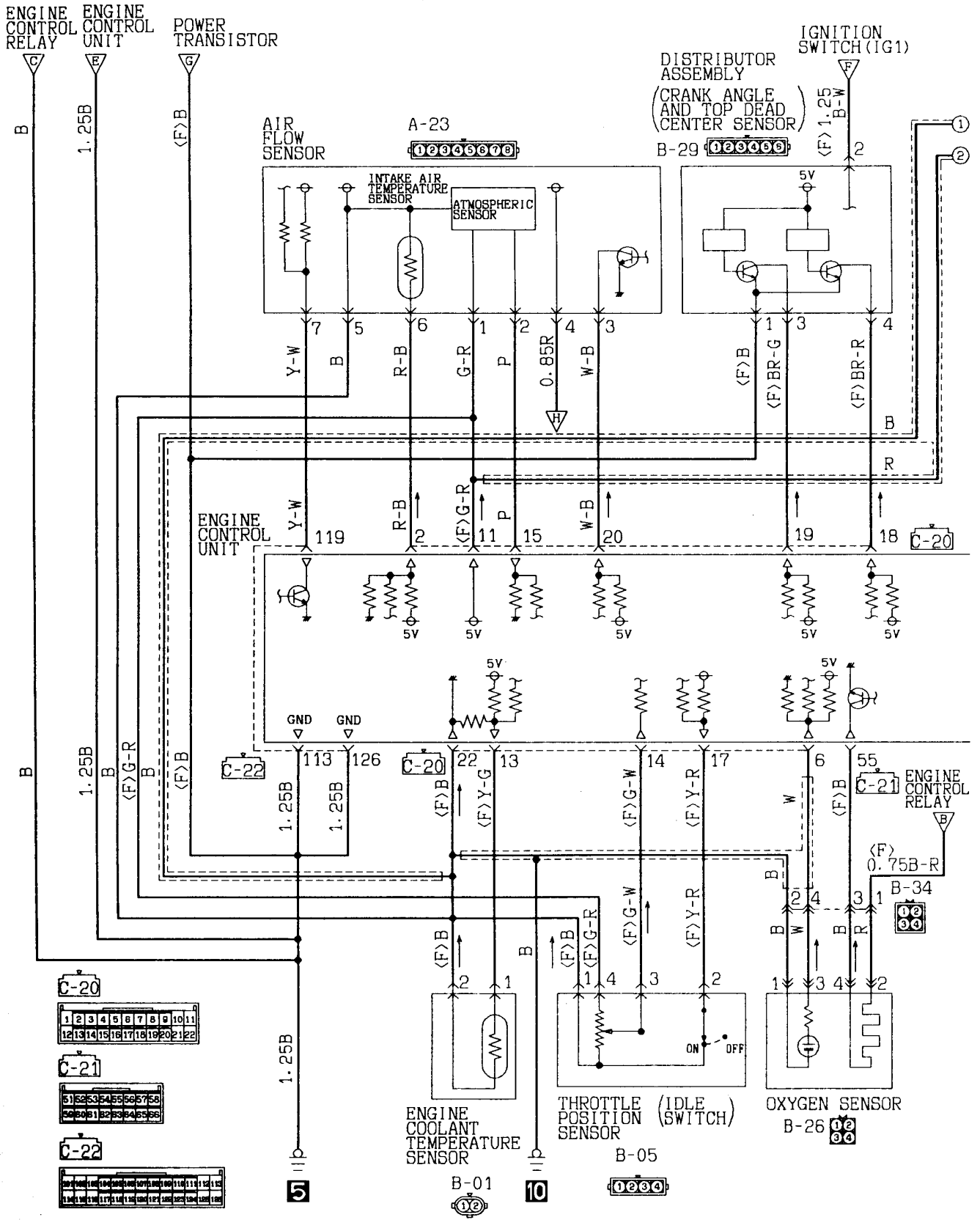

KX35-AC-Z0513A-EC

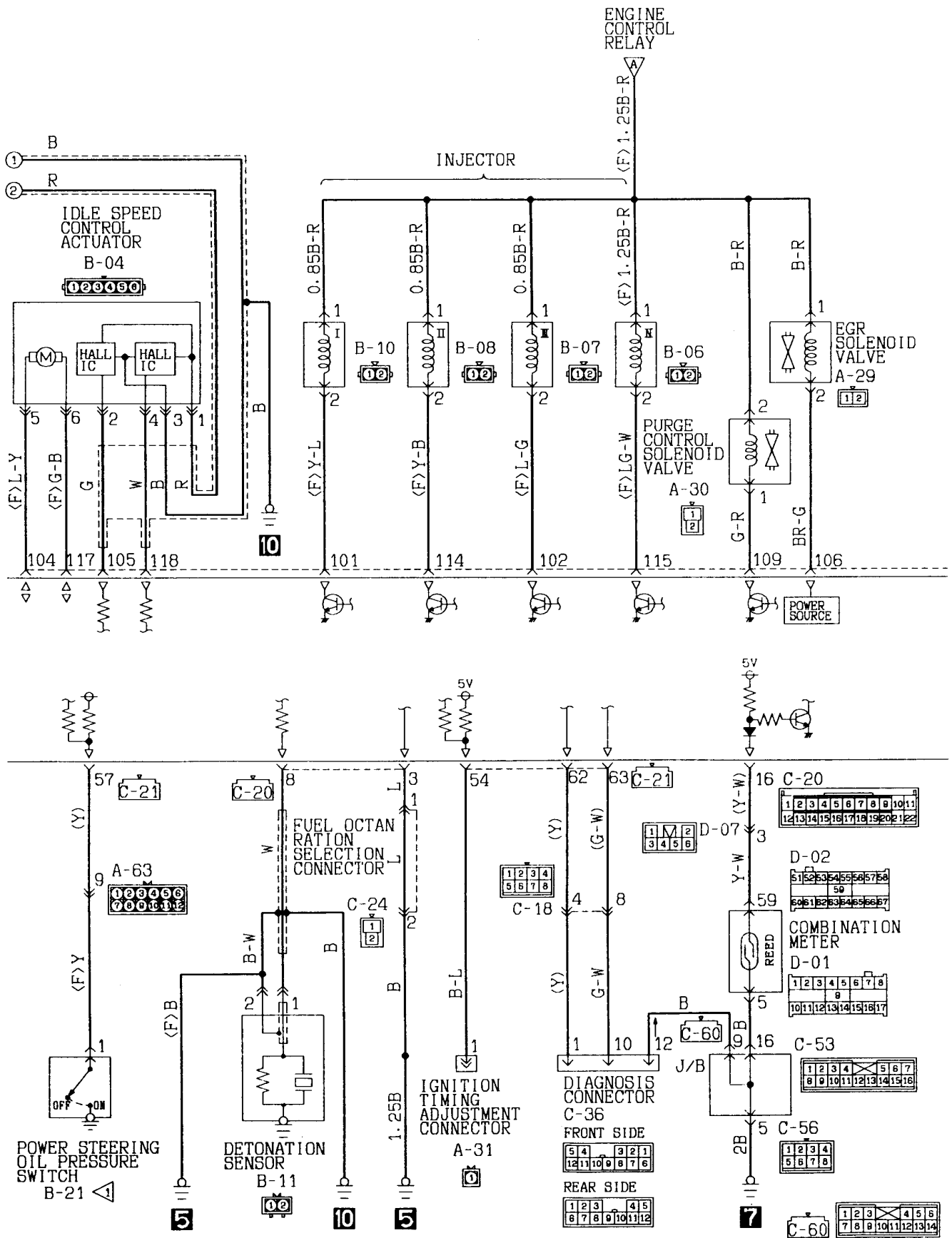

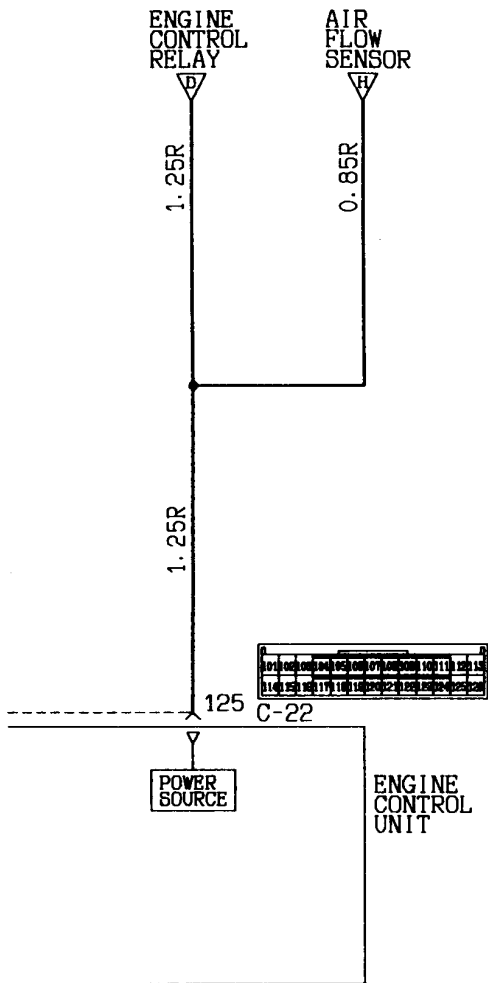

1	2	3	4	5	6	7	8	9	10	11	12	13
14	15	16	17	18	19	20	21	22	23	24	25	26

**KX35-AC-Z0513B-EC**

Wire colour code						
B:Black	LG:Light green	G:Green	L:Blue	W:White	Y:Yellow	SB:Sky blue
BR:Brown	O:Orange	GR:Gray	R:Red	P:Pink	V:Violet	

6-8 4G63<R. H. drive vehicles>  
Vehicles with Jumper connector C-75

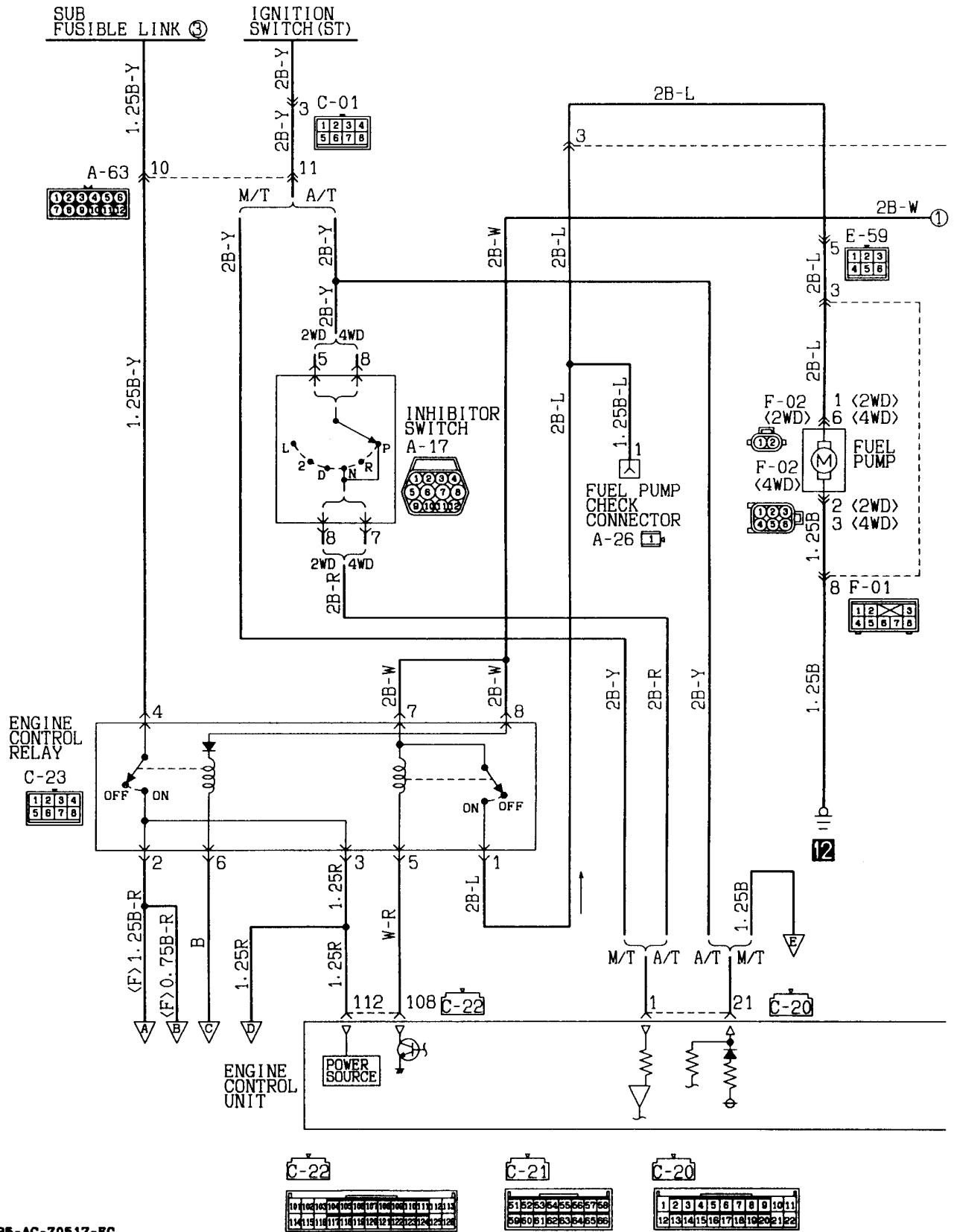

KX35-AC-Z0517-EC

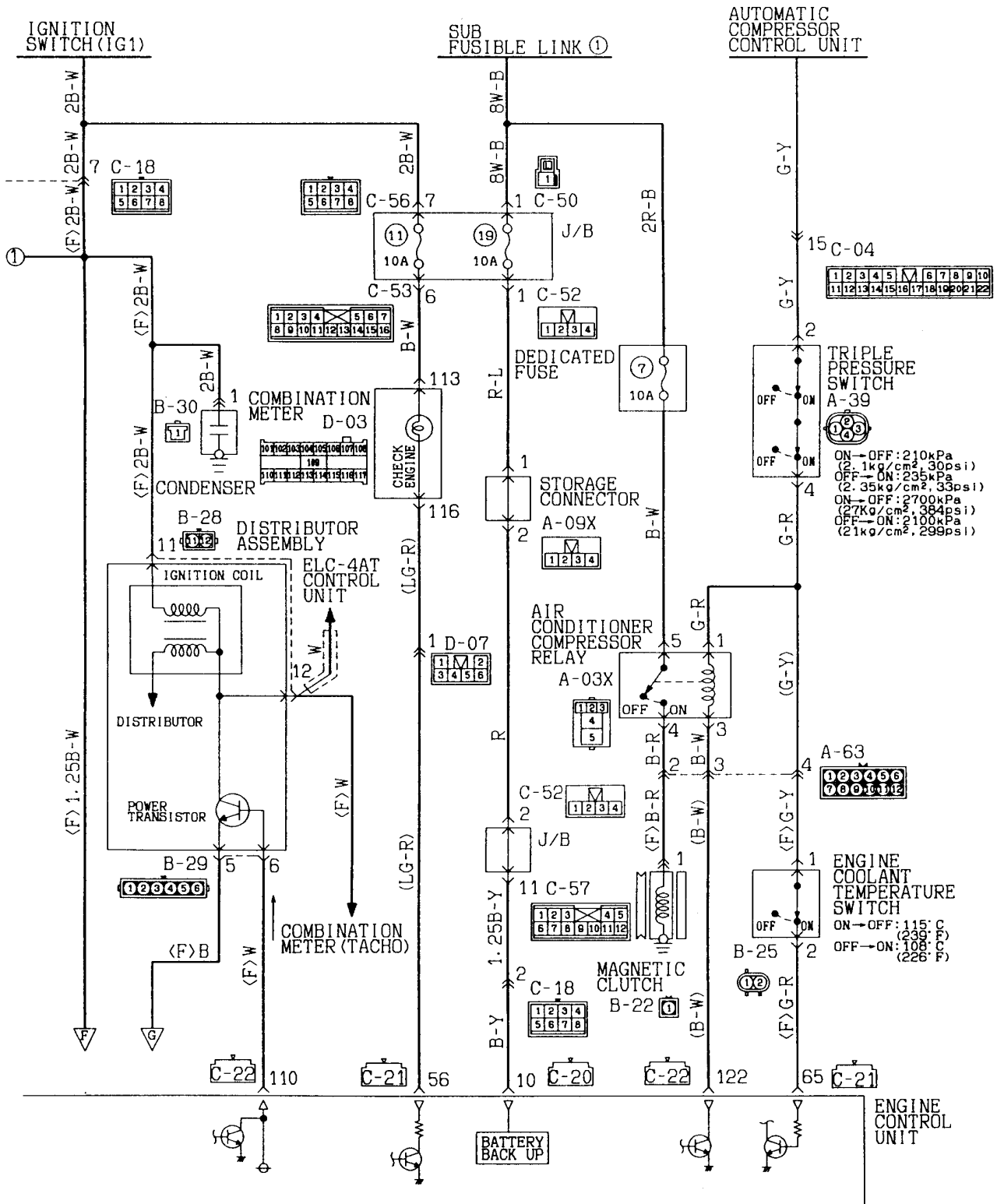

Wire colour code  
 B:Black LG:Light green G:Green L:Blue W:White Y:Yellow SB:Sky blue  
 BR:Brown O:Orange GR:Gray R:Red P:Pink V:Violet

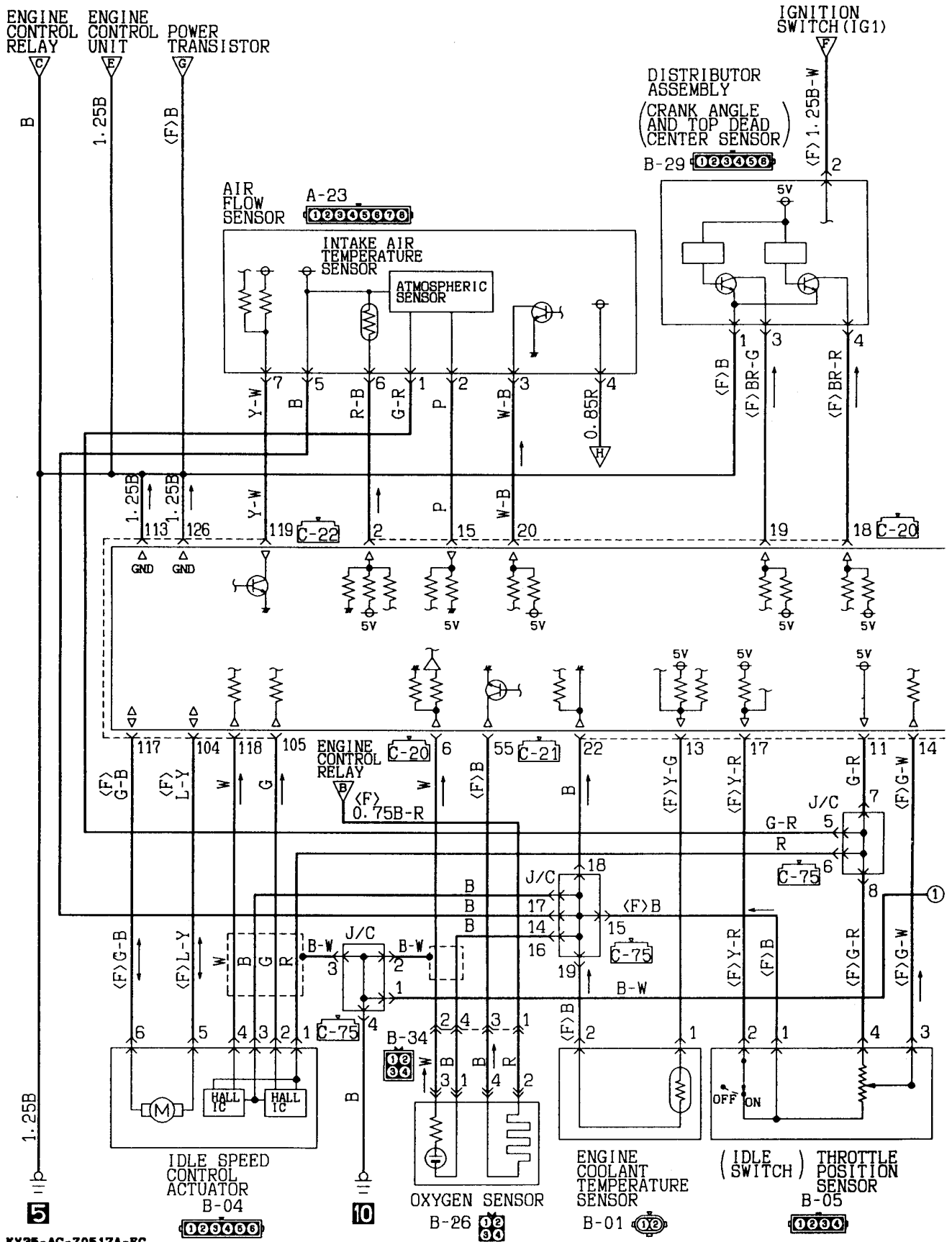

KX35-AC-Z0517A-EC

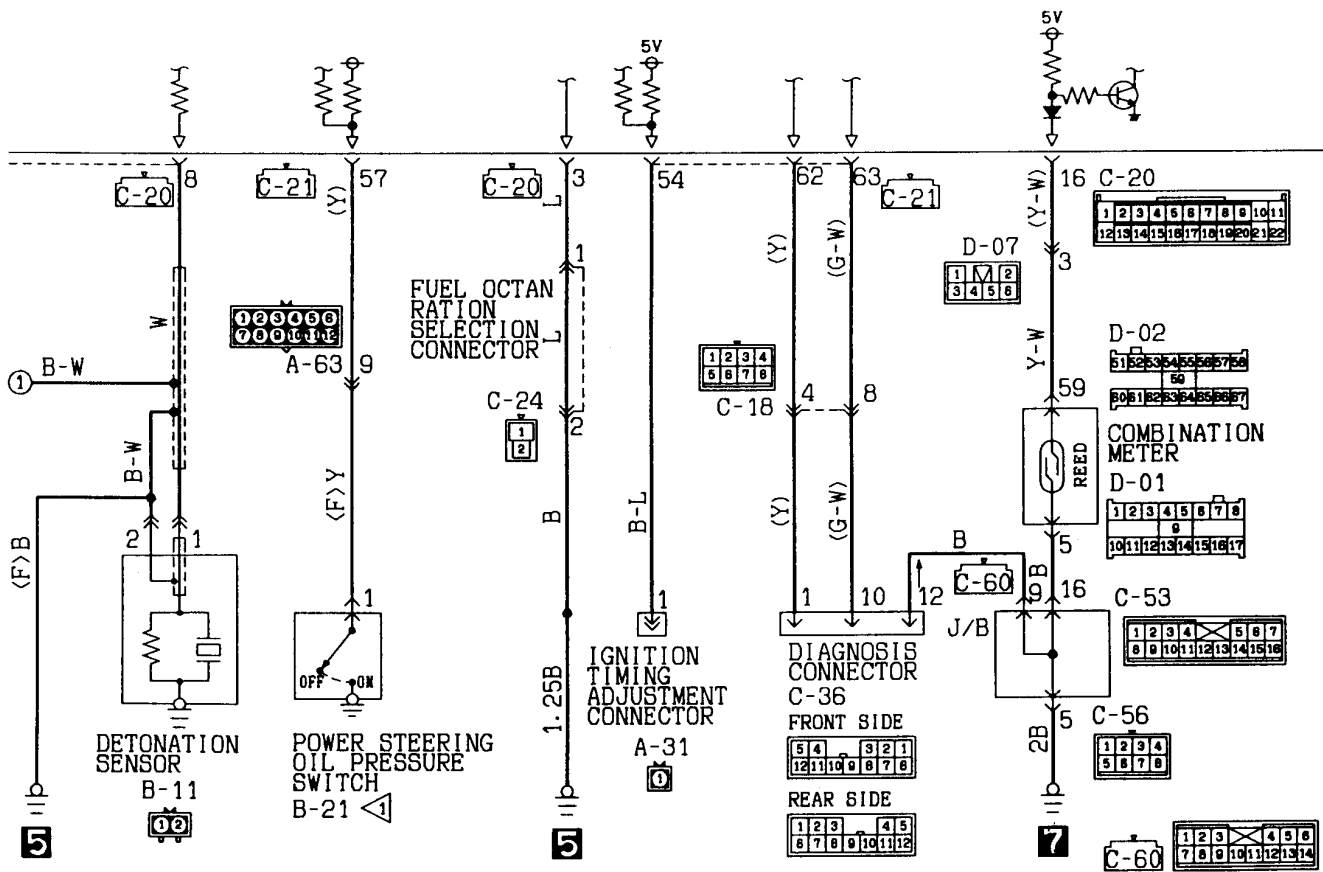
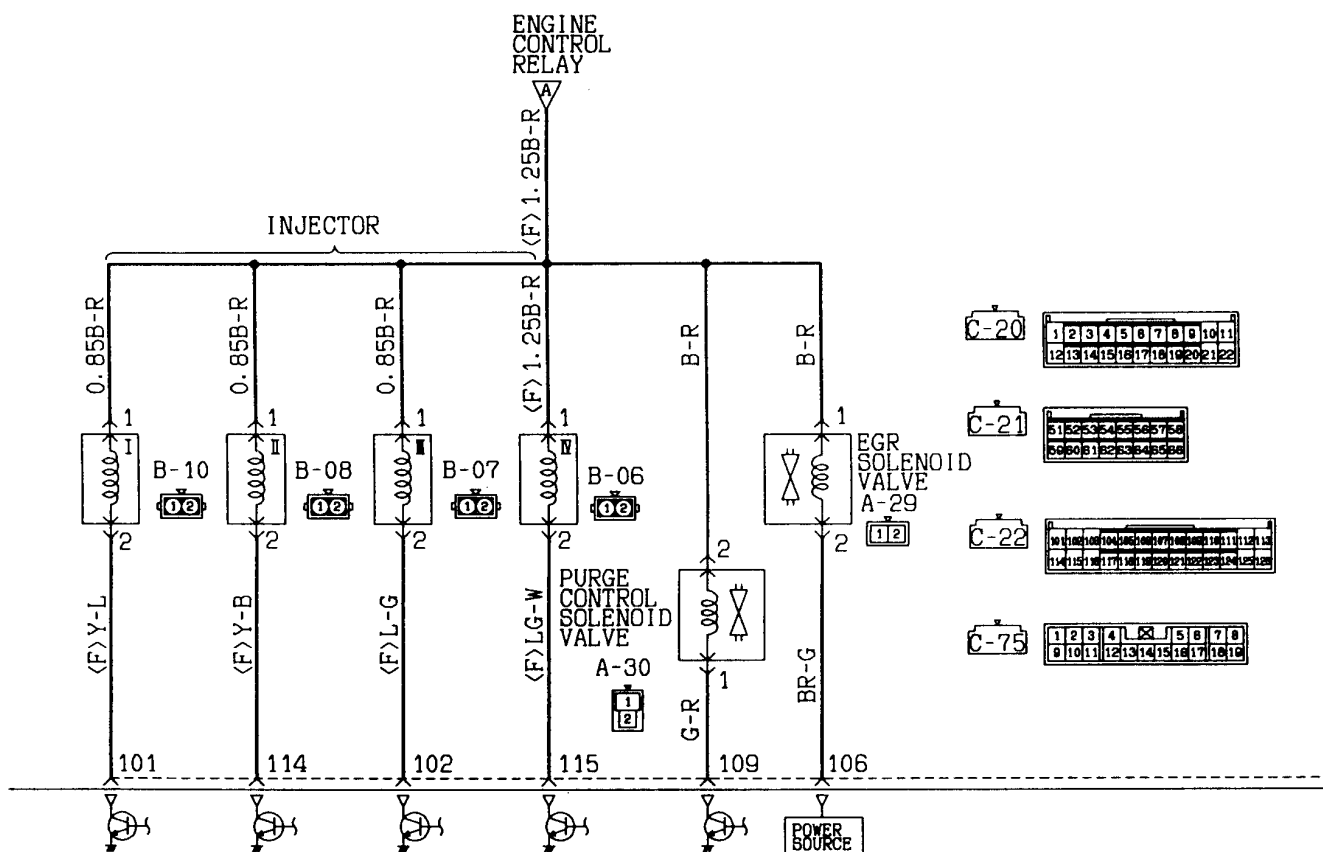



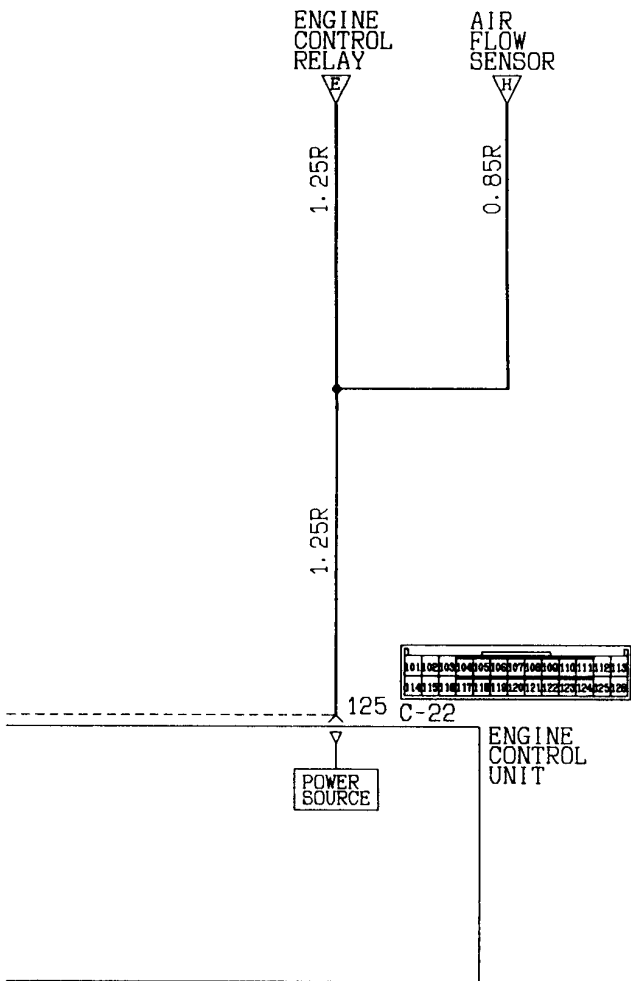

NOTES

7 COOLING SYSTEM  
7-1 Petrol-powered Vehicles <4G93>

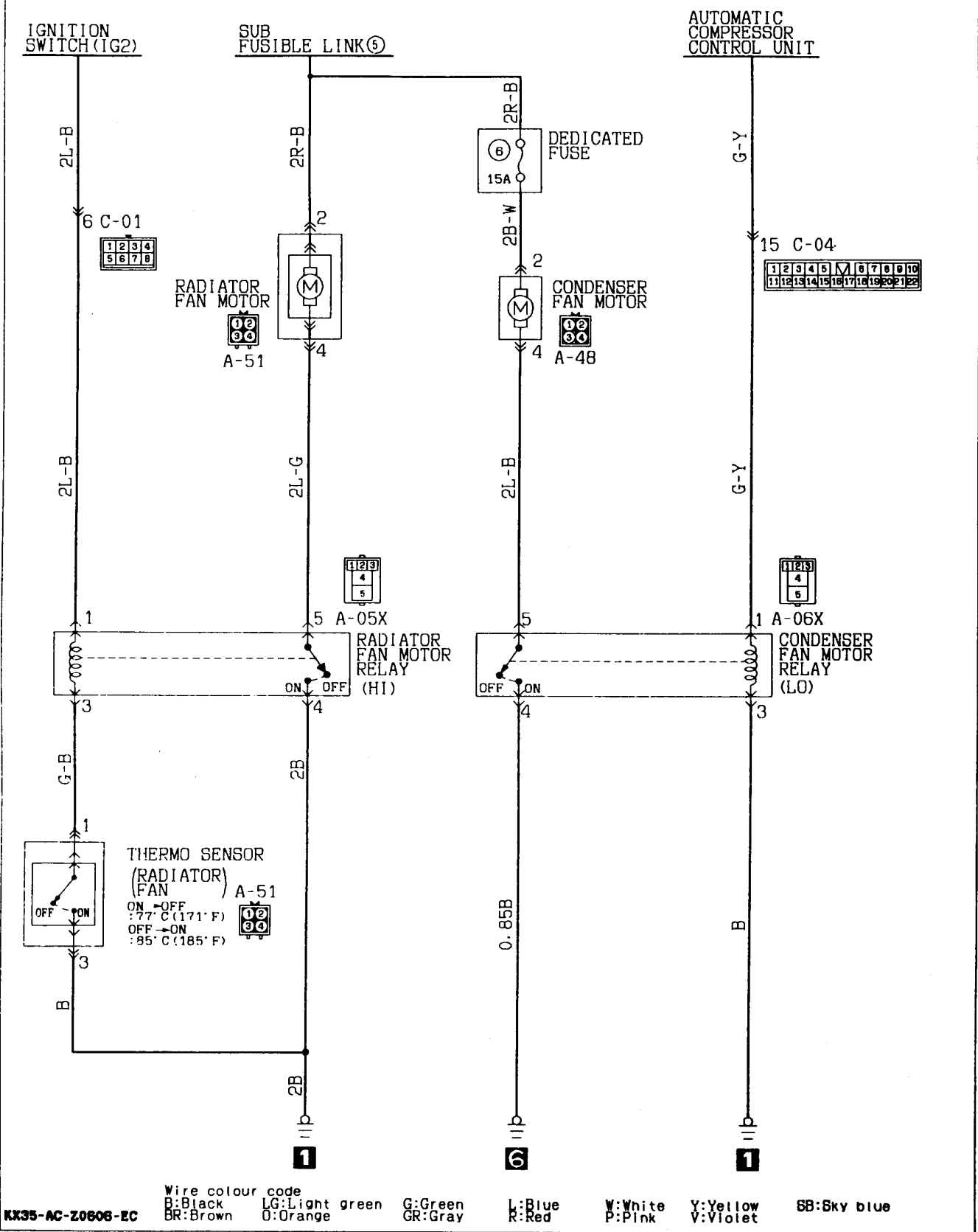

**COOLING SYSTEM <Petrol-powered vehicles (4G93)> (See P. 4-34.)**

**OPERATION**

**1. When auto compressor control unit outputs LO signal (0 V)**

- When the engine coolant temperature goes up to 85°C (185°F), the thermo sensor of radiator is activated.
- This energizes the radiator fan motor relay, causing the radiator fan to start rotating.

**2. When auto compressor control unit outputs HI signal (approx. 12 V)**

- The condenser fan motor relay (LO) is energized by the power supplied from the auto compressor control unit causing the condenser fan to start rotating.
- As the engine coolant temperature rises up to 85°C (185°F), the thermo sensor is activated, just as in 1 above, causing the radiator fan to start rotating.

**TROUBLESHOOTING HINTS**

1. Neither radiator fan nor condenser fan operates.
  - Check the sub-fusible link No. ⑤.
2. Condenser fan only does not operate at all.
  - Check the dedicated fuse No. ⑥.
  - Check to see if auto compressor control unit outputs a signal.

Remarks

- For troubleshooting the auto compressor control unit, see the Troubleshooting in Group 55 Heater and Air Conditioner of the separate WORKSHOP MANUAL (Pub. No. PWDE9104).

Auto Compressor Control Unit HI Signal Output Conditions

Ignition switch (IG <sub>2</sub> )	ON	Remarks (1) The auto compressor control unit outputs a LO signal (0 V) if any one of the switches and sensors is deactivated. (2) The * marked device measures the temperature of the intake air, and according to the control characteristics of the the magnetic clutch for the compressor, the automatic compressor control unit outputs the "HI" signal (12 V).
Blower switch	ON	
Air conditioner switch	ON (ECONO or A/C)	
Air inlet sensor	*	
Air thermo sensor	*	

7-2 Petrol-powered vehicles (4G63 and 4G64)

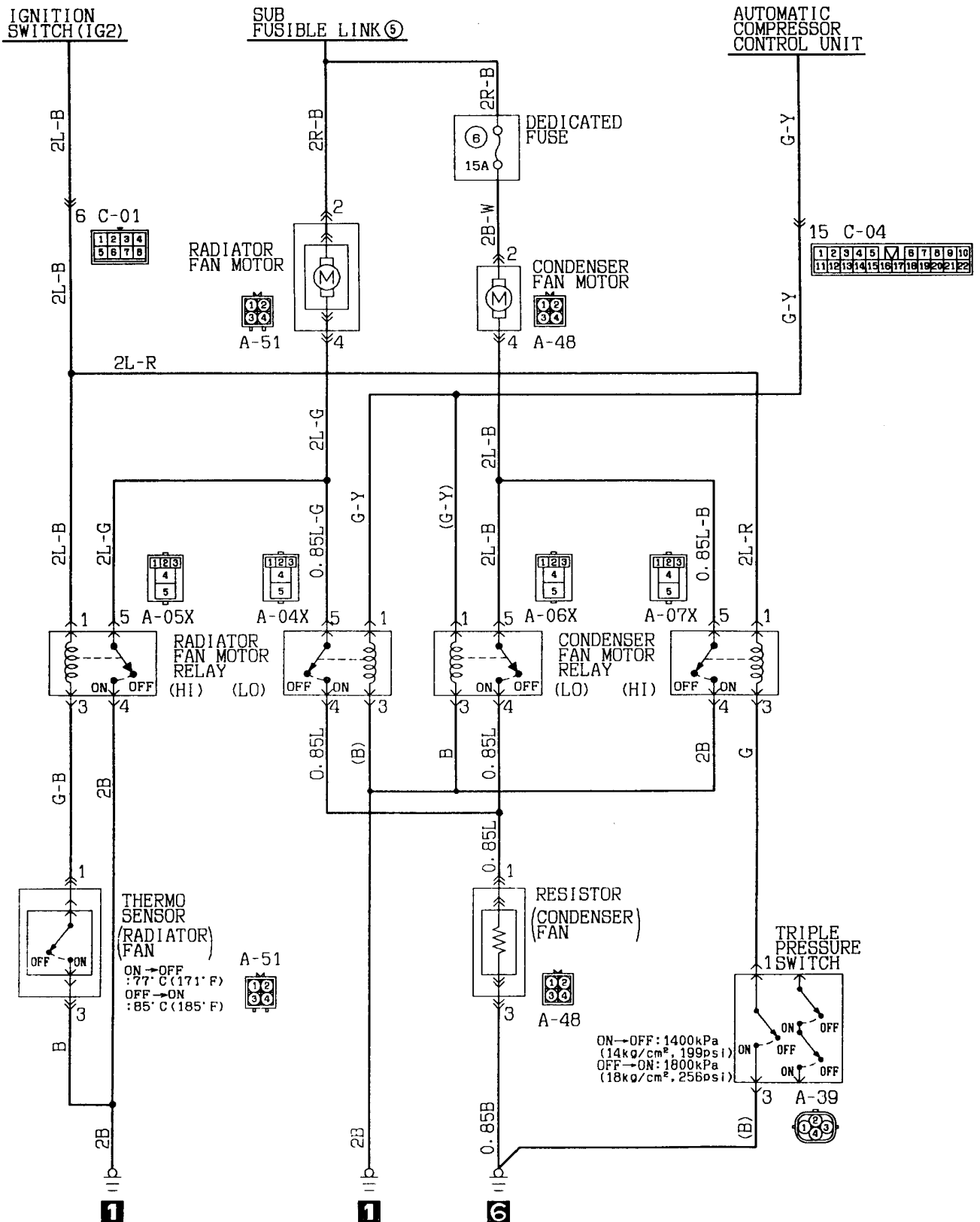

Wire colour code  
 B:Black LG:Light green G:Green L:Blue W:White Y:Yellow SB:Sky blue  
 BR:Brown O:Orange GR:Gray R:Red P:Pink V:Violet

**COOLING SYSTEM <Petrol-powered vehicles (4G63 and 4G64)> (See P. 4-36.)**

**OPERATION**

**1. When automatic compressor control unit outputs LO signal (0 V)**

- When the engine coolant temperature reaches 85°C (185°F), the thermo sensor of radiator is activated.
- This energizes the radiator fan motor relay (HI), causing the radiator fan to rotate at high speed.

**2. When automatic compressor control unit outputs HI signal (approx. 12 V)**

- The radiator fan motor relay (LO) and condenser fan motor relay (LO) are both energized by the power from the automatic compressor control unit. As a result, the radiator fan and condenser fan are rotated unconditionally at low speed by the circuit completed with the resistor.
- As in 1 above, when the engine coolant temperature reaches 85°C (185°F), the thermo sensor is activated causing the radiator fan to rotate at high speed.
- When either the pressure switch turns ON as a result of the refrigerant line pressure on the middle-pressure side building up in hot weather, the condenser fan motor relay (HI) is also energized causing the condenser fan to rotate at high speed.

**TROUBLESHOOTING HINTS**

- Neither radiator fan nor condenser fan operates.
  - Check the sub-fusible link No. ⑤.
- Condenser fan does not operate at all.
  - Check the dedicated fuse No. ⑥.
- Radiator fan and condenser fan do not operate at low speed.
  - Compressor magnetic clutch is not activated.
    - Check the automatic compressor control unit for output.

**Remarks**

- For troubleshooting the automatic compressor control unit, see the Troubleshooting in Group 55 Heater and Air Conditioner of the separate WORKSHOP MANUAL (Pub. No. PWDE9104).
- (2) Compressor magnetic clutch is activated.
  - Check relay and resistor on the low-speed side.

Automatic Compressor Control Unit HI Signal Output Conditions

Ignition switch (IG <sub>2</sub> )	ON	Remarks (1) The automatic compressor control unit outputs a LO signal (0 V) when any one of the switches and sensors is deactivated. (2) The * marked device measures the temperature of the intake air, and according to the control characteristics of the magnetic clutch for the compressor, the automatic compressor control unit outputs the "HI" signal (12 V).
Blower switch	ON	
Air conditioner switch	ON (ECONO or A/C)	
Air inlet sensor	*	
Air thermo sensor	*	

Fan Operating Conditions

Automatic compressor control unit output	Switch position		Fan operating condition	
	Pressure switch [ON with 1,800 kPa (18 kg/cm <sup>2</sup> , 256 psi) or higher]	Thermo sensor (for radiator fan) [ON with 85°C (185°F) or higher]	Radiator fan	Condenser fan
LO (0 V)	OFF	OFF	OFF	OFF
LO (0 V)	OFF	ON	HIGH	OFF
HI (12 V)	OFF	OFF	LOW	LOW
HI (12 V)	ON	OFF	LOW	HIGH
HI (12 V)	OFF	ON	HIGH	LOW
HI (12 V)	ON	ON	HIGH	HIGH

7-3 Diesel-powered vehicles

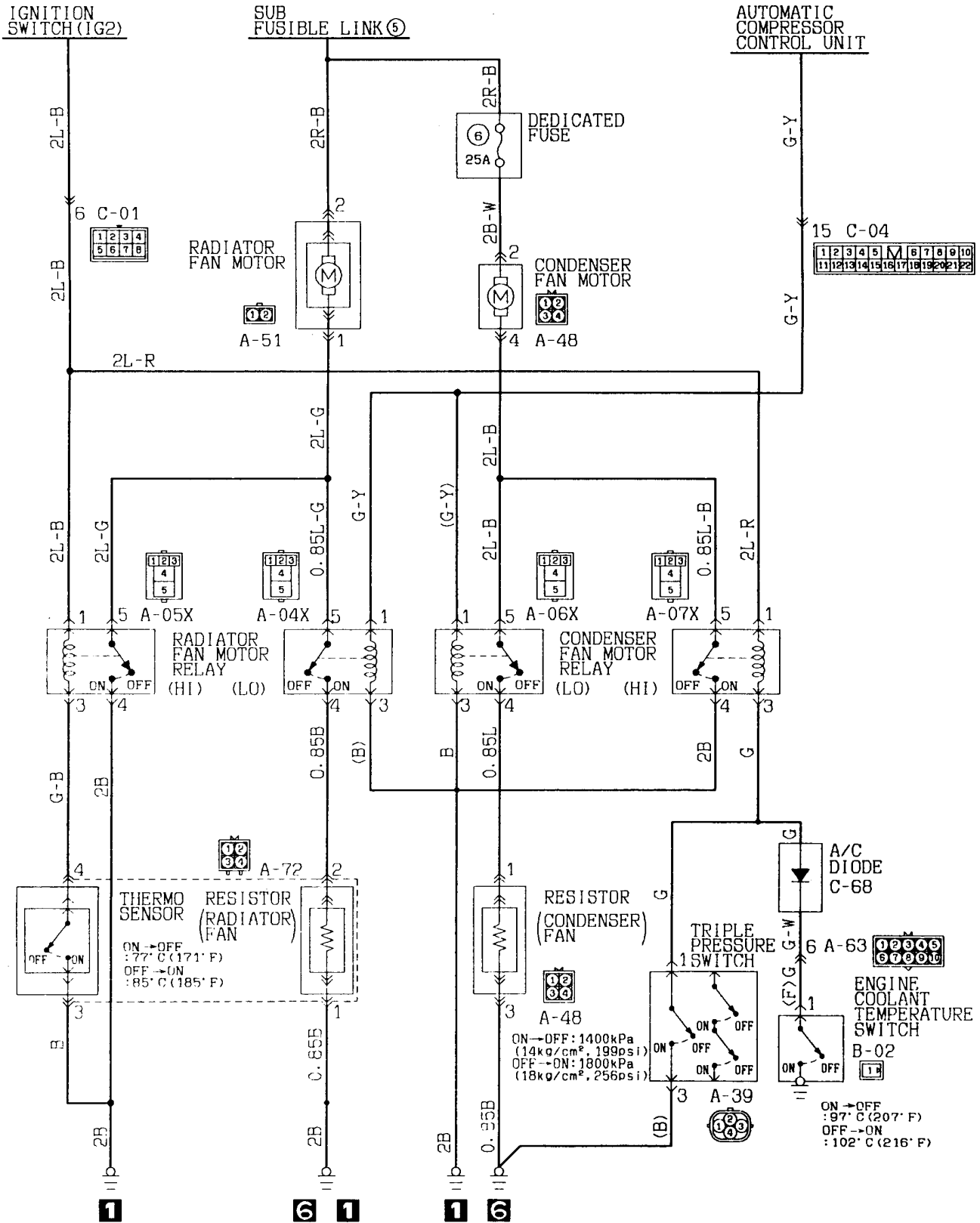

Wire colour code  
 B:Black LG:Light green G:Green L:Blue W:White Y:Yellow SB:Sky blue  
 BR:Brown O:Orange GR:Gray R:Red P:Pink V:Violet

**COOLING SYSTEM <Diesel-powered vehicles> (See P. 4-38.)**

**OPERATION**

**1. When automatic compressor control unit outputs LO signal (0 V)**

- When the engine coolant temperature reaches 85°C (185°F), the thermo sensor of radiator is activated.
- This energizes the radiator fan motor relay (HI), causing the radiator fan to rotate at high speed.

**2. When automatic compressor control unit outputs HI signal (approx. 12 V)**

- The radiator fan motor relay (LO) and condenser fan motor relay (LO) are both energized by the power from the automatic compressor control unit. As a result, the radiator fan is rotated unconditionally at low speed by the circuit completed with each resistor.
- As in 1 above, when the engine coolant temperature reaches 85°C (185°F), the thermo sensor is activated causing the radiator fan to rotate at high speed.
- When either the pressure switch turns ON as a result of the refrigerant line pressure on the middle-pressure side building up in hot weather, or the engine coolant temperature switch turns ON as a result of engine coolant temperature further increasing, the condenser fan motor relay (HI) is also energized causing the condenser fan to rotate at high speed.

**TROUBLESHOOTING HINTS**

1. Neither radiator fan nor condenser fan operates.
  - Check the sub-fusible link No. ⑤.
2. Condenser fan does not operate at all.
  - Check the dedicated fuse No. ⑥.
3. Radiator fan and condenser fan do not operate at low speed.
  - (1) Compressor magnetic clutch is not activated.
    - Check the automatic compressor control unit for output.

Remarks

- For troubleshooting the automatic compressor control unit, see the Troubleshooting in Group 55 Heater and Air Conditioner of the separate WORKSHOP MANUAL (Pub. No. PWDE9104).
- (2) Compressor magnetic clutch is activated.
  - Check relay and resistor on the low-speed side.

Automatic Compressor Control Unit HI Signal Output Conditions

Ignition switch (IG <sub>2</sub> )	ON	Remarks (1) The automatic compressor control unit outputs a LO signal (0 V) when any one of the switches and sensors is deactivated. (2) The * marked device measures the temperature of the intake air, and according to the control characteristics of the magnetic clutch for the compressor, the automatic compressor control unit outputs the "HI" signal (12 V).
Blower switch	ON	
Air conditioner switch	ON (ECONO or A/C)	
Air inlet sensor	*	
Air thermo sensor	*	

Fan Operating Conditions

Automatic compressor control unit output	Switch position			Fan operating condition	
	Pressure switch [ON with 1,800 kPa (18 kg/cm <sup>2</sup> . 256 psi) or higher]	Thermo sensor (for radiator fan) [ON with 85°C (185°F) or higher]	Coolant temperature switch (for condenser fan) [ON with 102°C (216°F) or higher]	Radiator fan	Condenser fan
LO (0 V)	OFF	OFF	OFF	OFF	OFF
LO (0 V)	OFF	ON	OFF	HIGH	OFF
LO (0 V)	OFF	ON	ON	HIGH	HIGH
HI (12 V)	OFF	OFF	OFF	LOW	LOW
HI (12 V)	ON	OFF	OFF	LOW	HIGH
HI (12 V)	OFF	ON	OFF	HIGH	LOW
HI (12 V)	ON	ON	OFF	HIGH	HIGH
HI (12 V)	ON	ON	ON	HIGH	HIGH
HI (12 V)	OFF	ON	ON	HIGH	HIGH



# 8 ELC 4-SPEED AUTOMATIC TRANSMISSION

8-1 L.H. drive vehicles

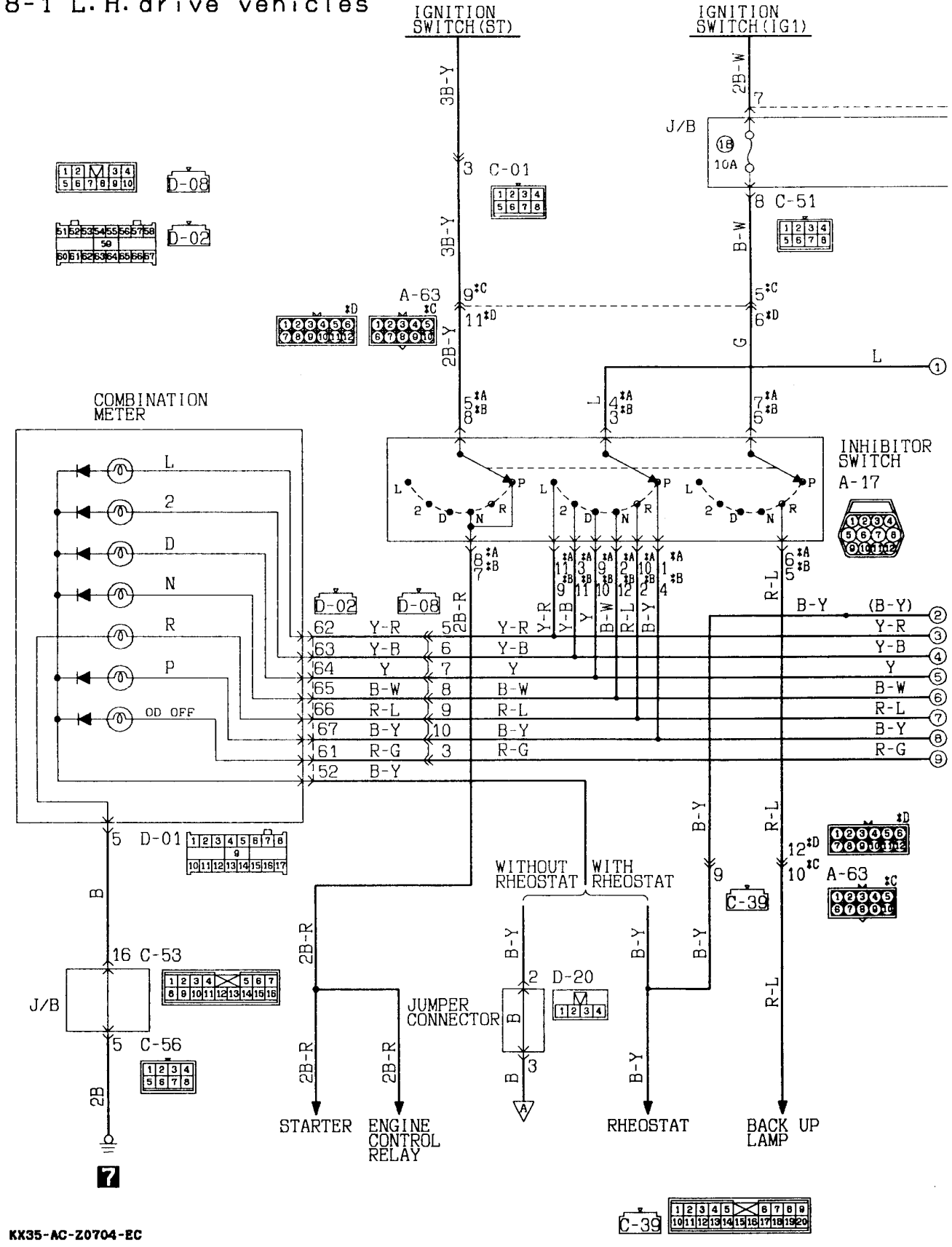

KX35-AC-Z0704-EC

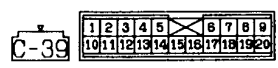

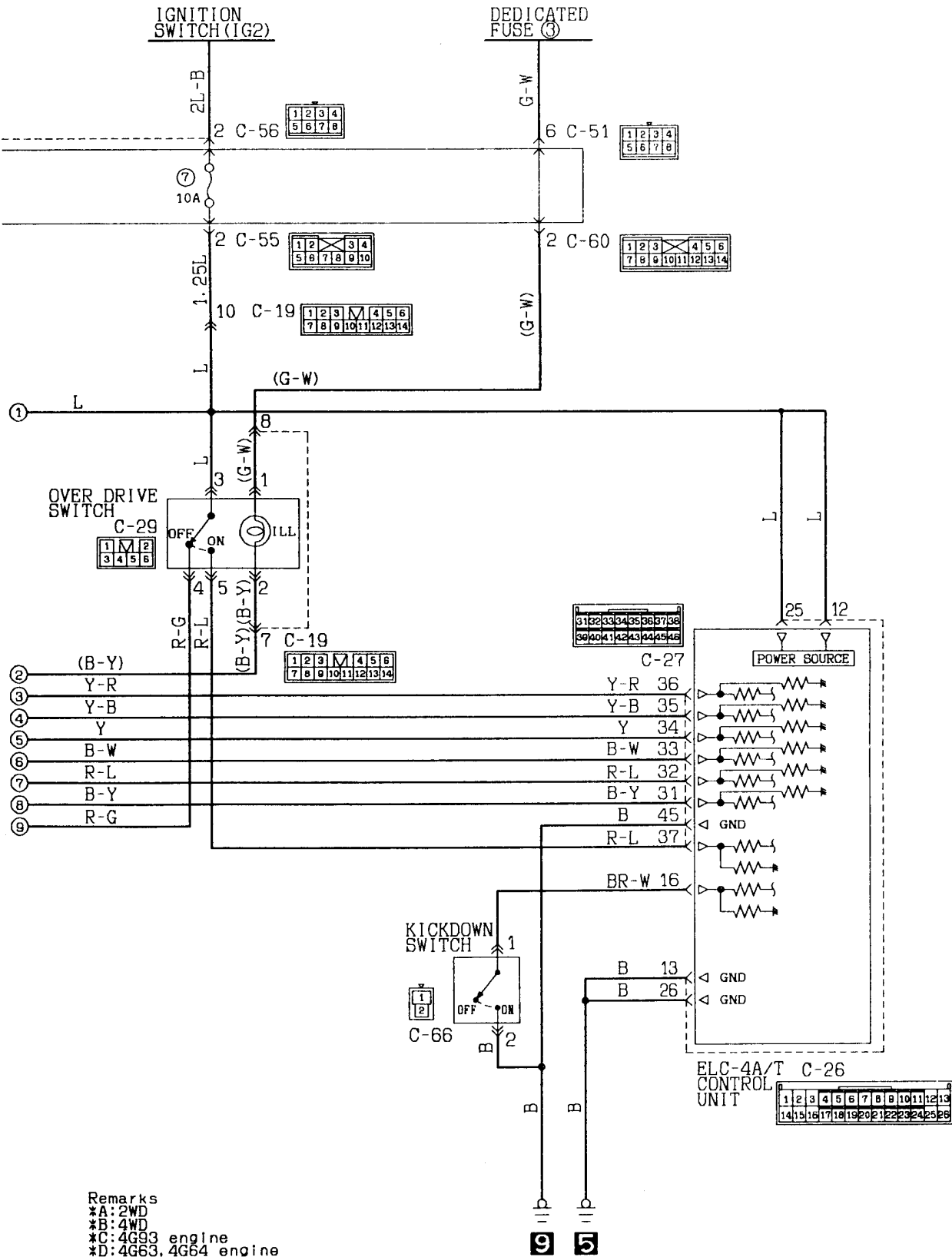

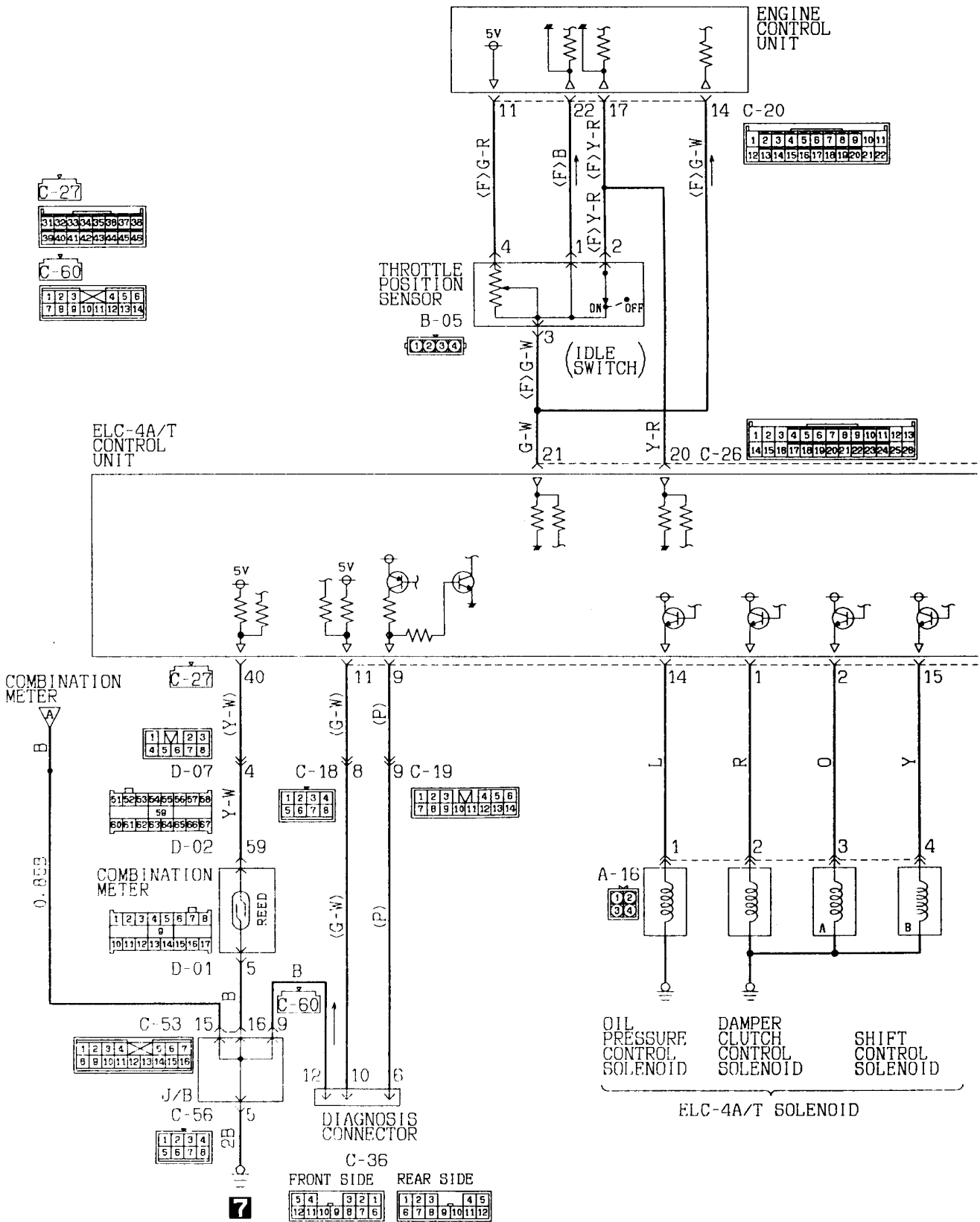

Wire colour code  
 B:Black LG:Light green G:Green L:Blue W:White Y:Yellow SB:Sky blue  
 BR:Brown O:Orange GR:Gray R:Red P:Pink V:Violet

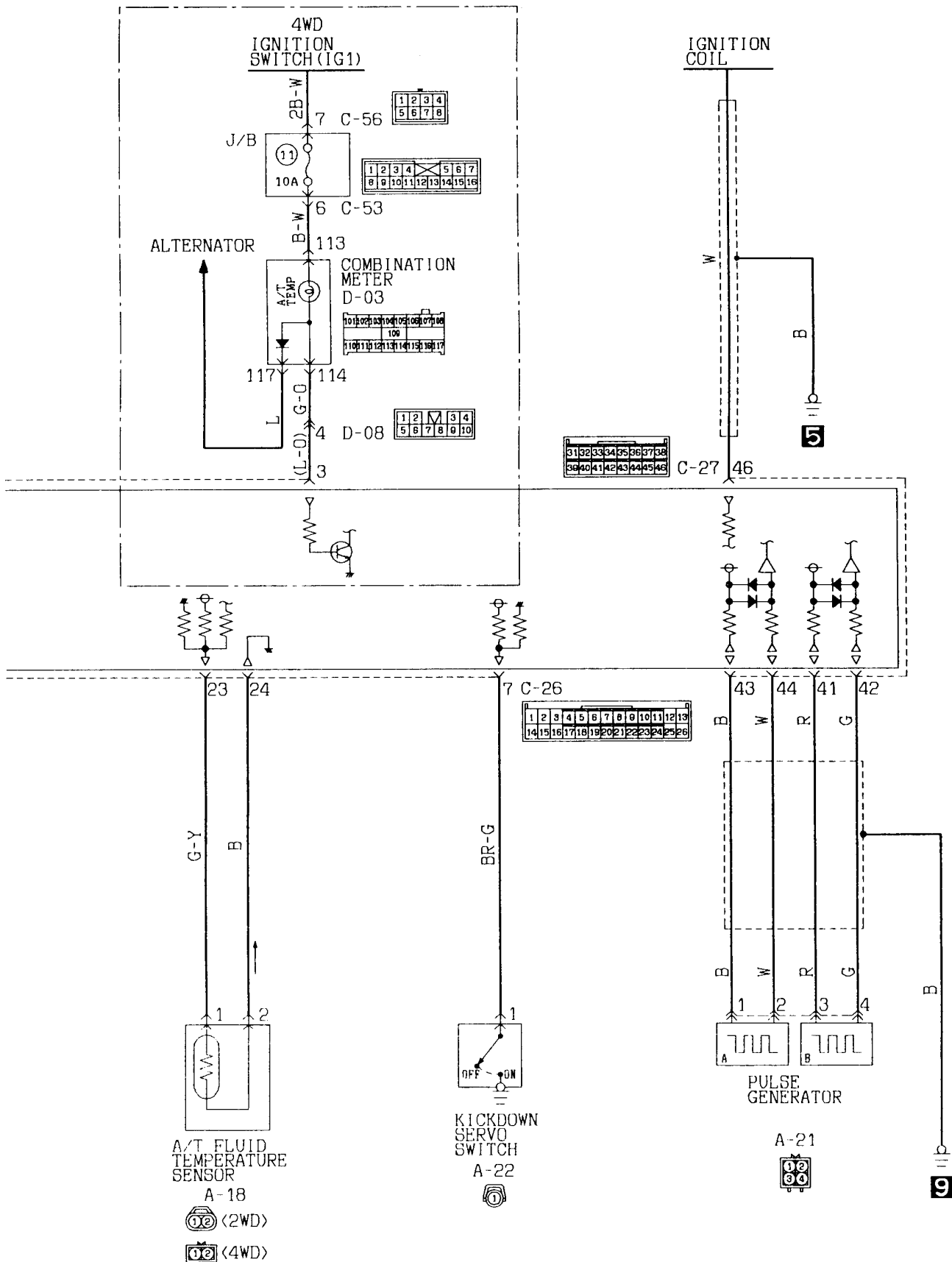

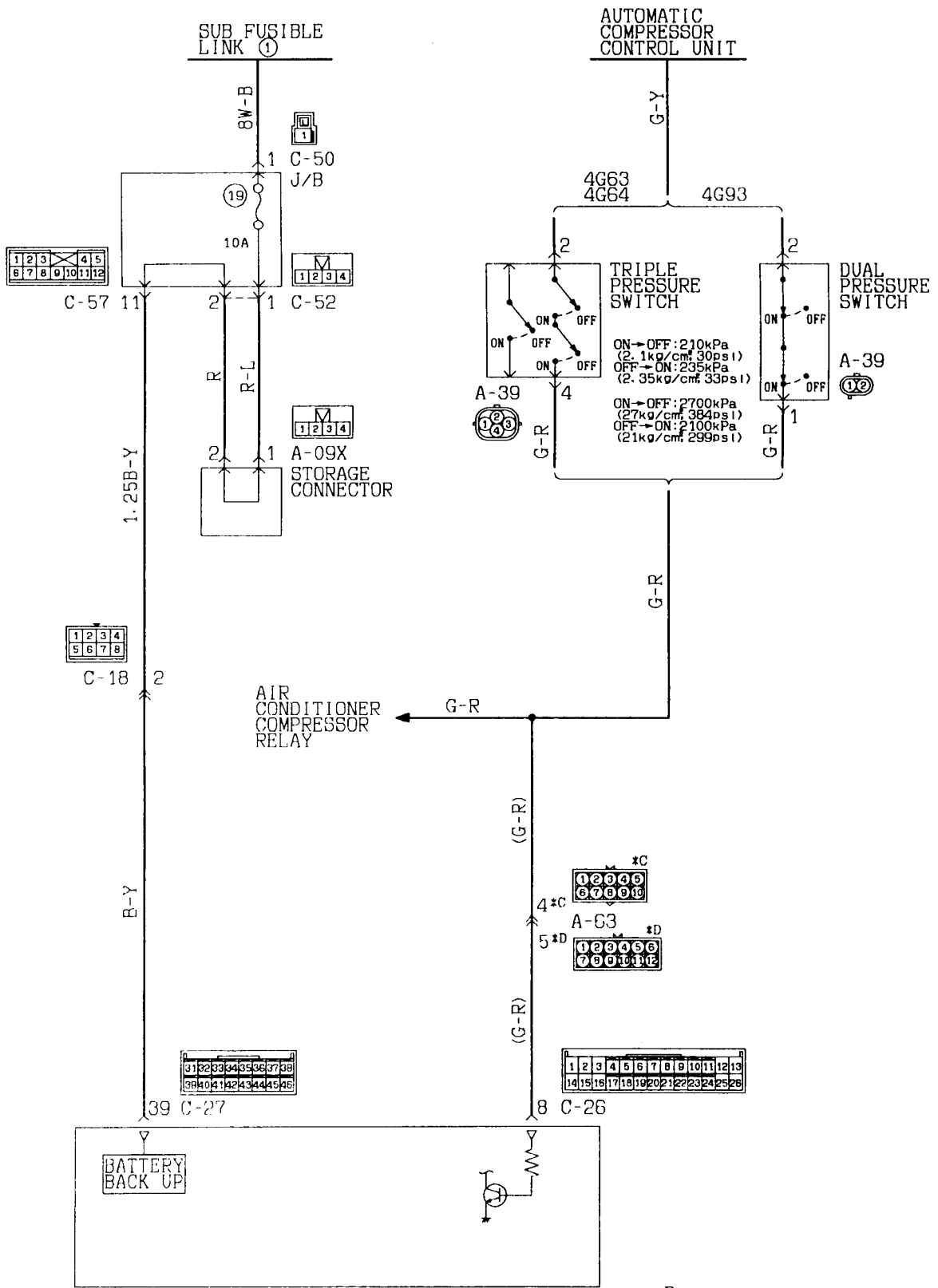

Remarks  
 \*C: 4G93 engine  
 \*D: 4G63, 4G64 engine

Wire colour code  
 B: Black LG: Light green G: Green L: Blue W: White Y: Yellow SB: Sky blue  
 BR: Brown O: Orange GR: Gray R: Red P: Pink V: Violet

**ELC 4-SPEED AUTOMATIC TRANSMISSION (See P. 4-40, 46.)****OPERATION****<Selector lever position indicator lamp>**

- When the selector lever is operated with the ignition switch in the ON position, the corresponding indicator lamp on the combination meter lights up according to the position of the lever.

**<OD OFF indicator lamp>**

- When the OD switch is depressed and latched (OD ON position) with the ignition switch in the ON position, the indicator lamp goes out; When it is depressed a second time to release from the latched position (OD OFF position), the lamp comes on.

8-2 R.H. drive vehicles

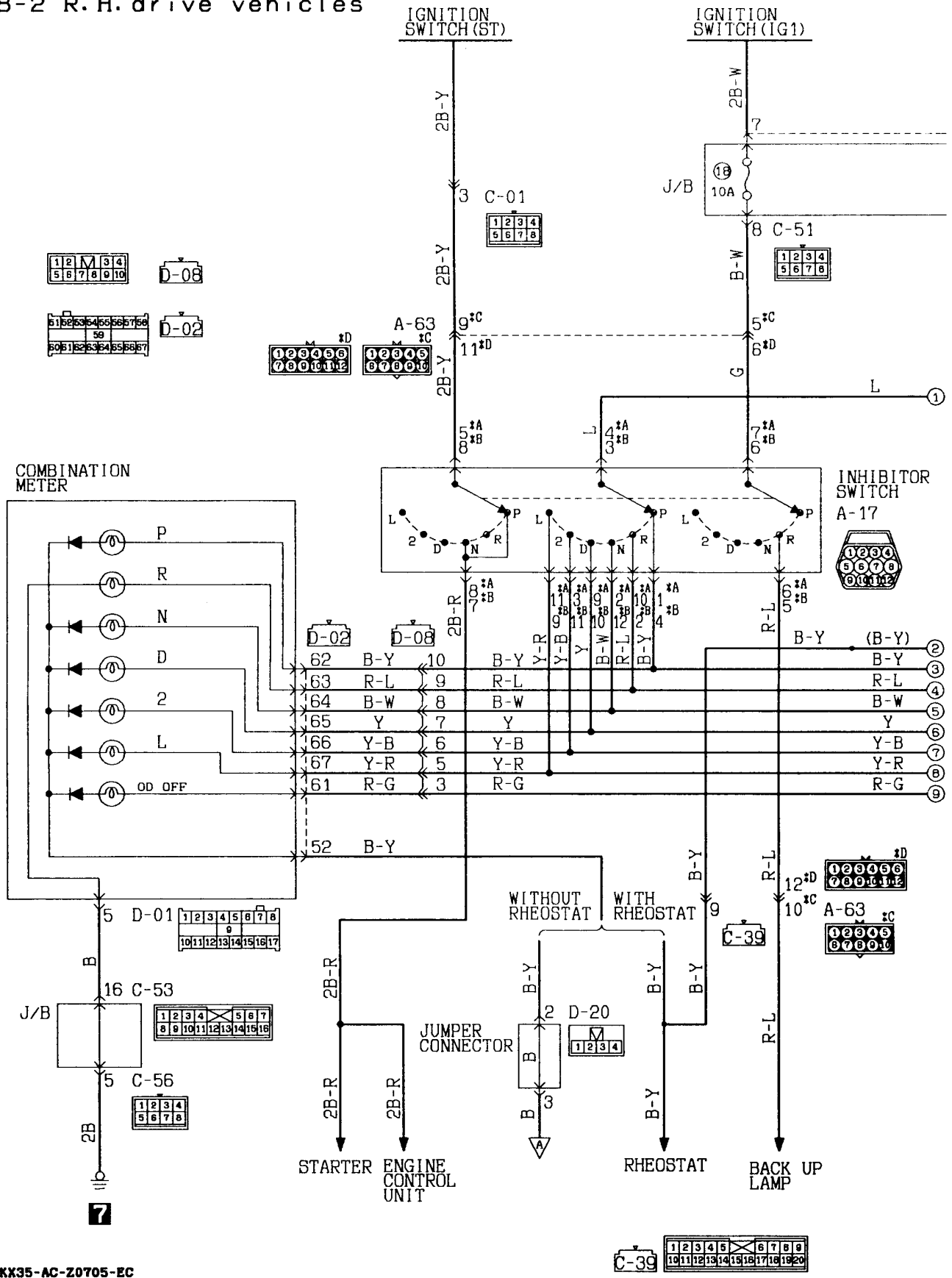

KX35-AC-Z0705-EC

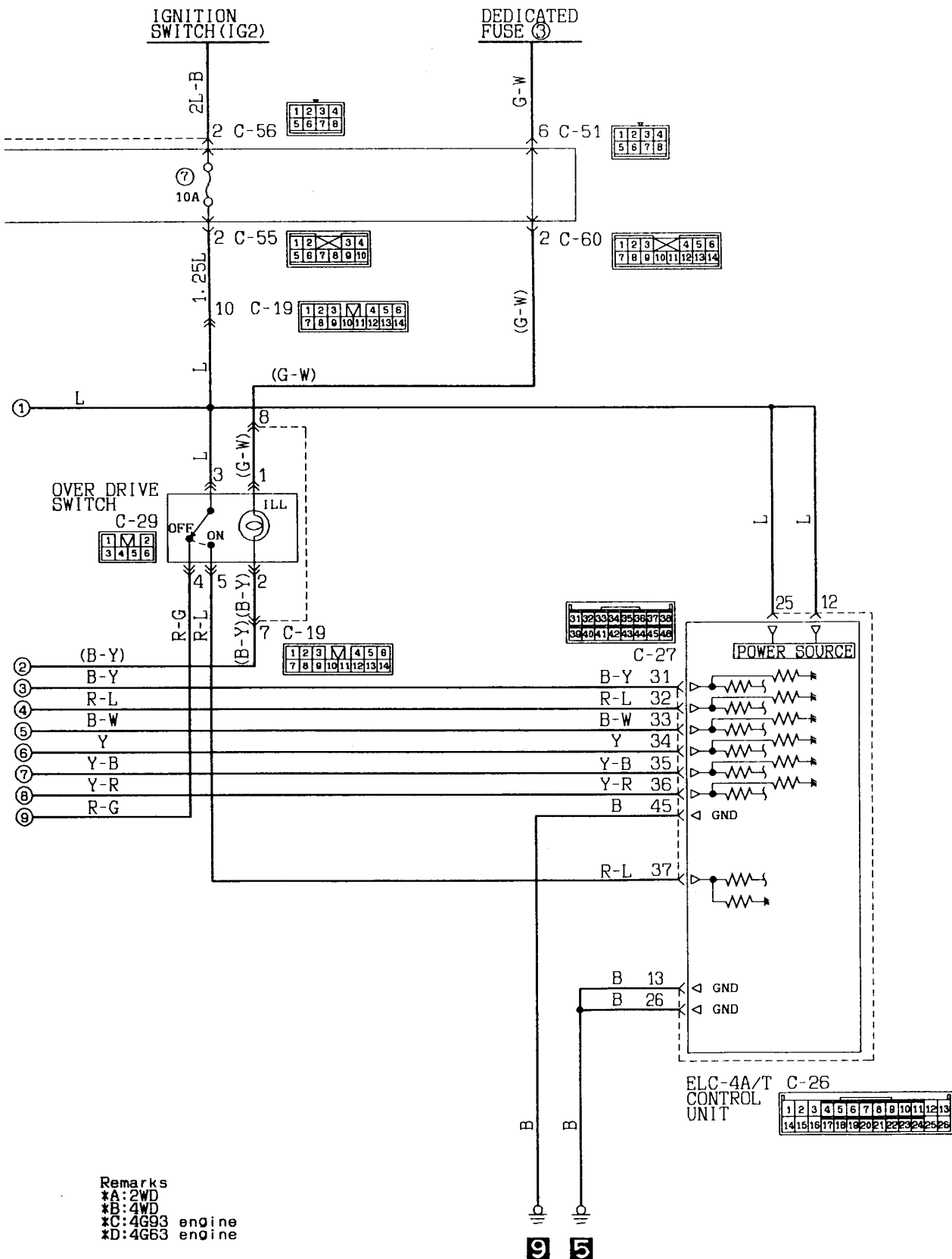

Remarks  
 \*A: 2WD  
 \*B: 4WD  
 \*C: 4G93 engine  
 \*D: 4G63 engine

Wire colour code  
 B: Black LG: Light green G: Green L: Blue W: White Y: Yellow SB: Sky blue  
 BR: Brown O: Orange GR: Gray R: Red P: Pink V: Violet



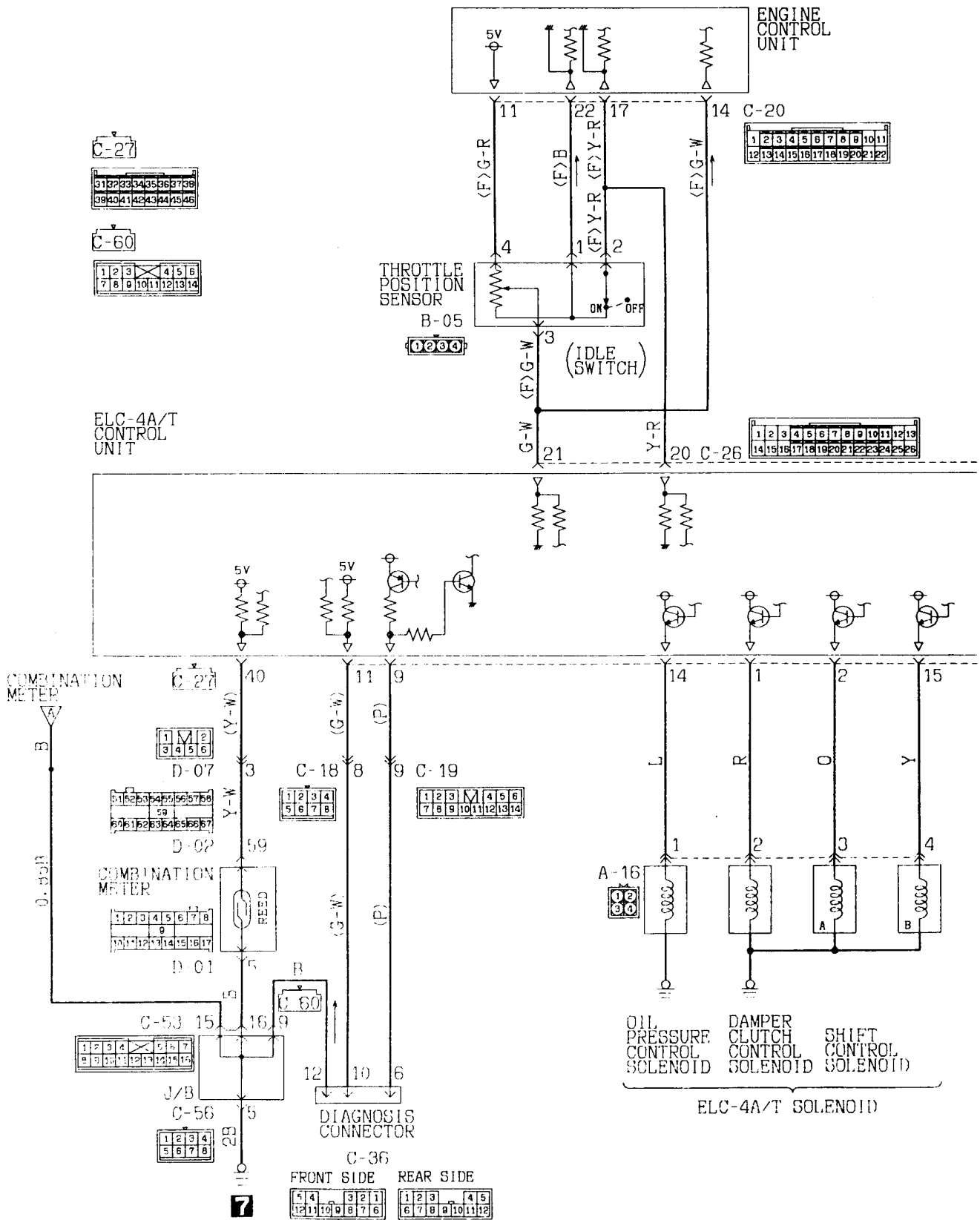

Wire colour code  
 B:Black LG:Light green G:Green L:Blue W:White Y:Yellow SB:Sky blue  
 BR:Brown O:Orange GR:Gray R:Red P:Pink V:Violet

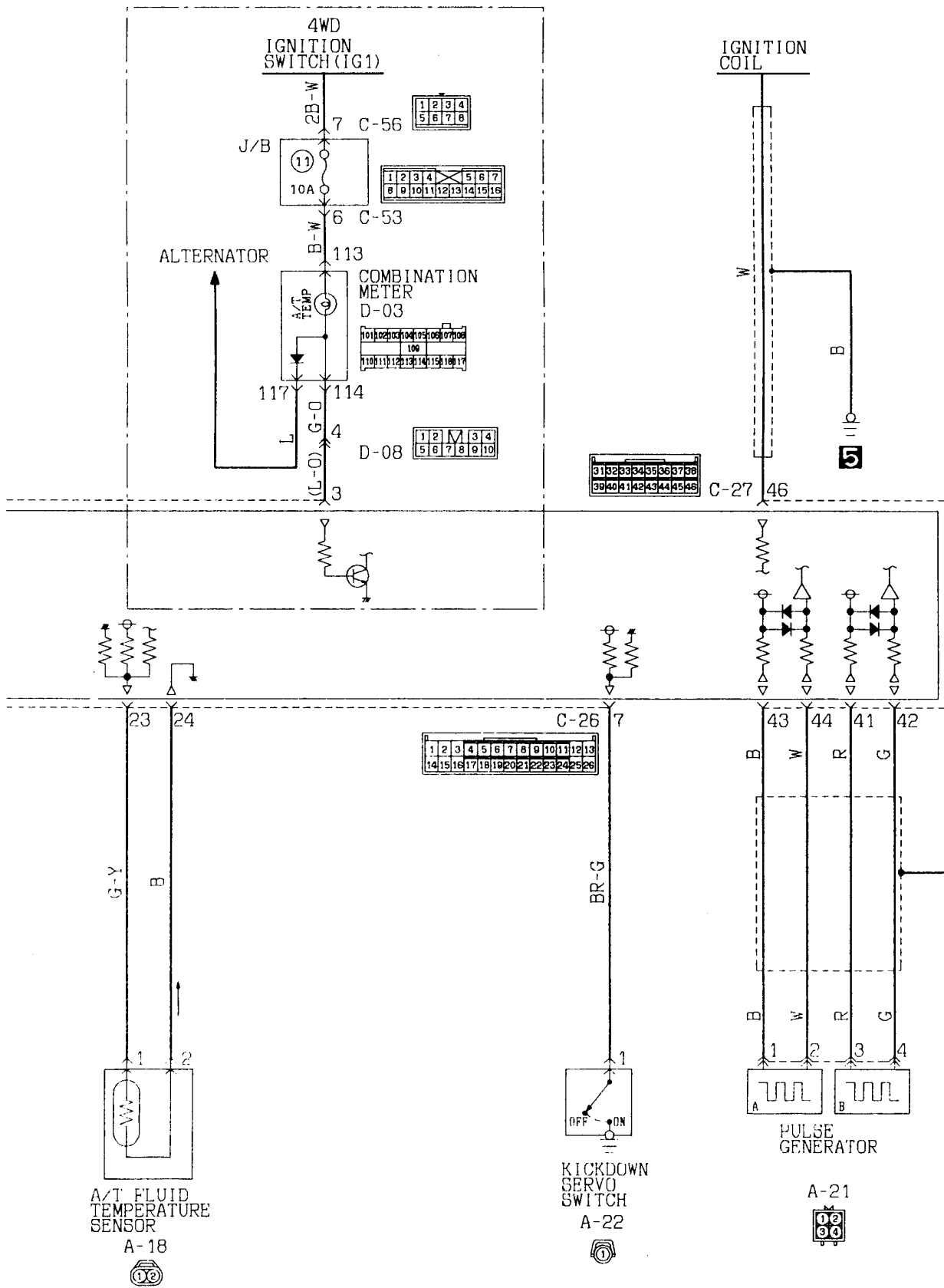

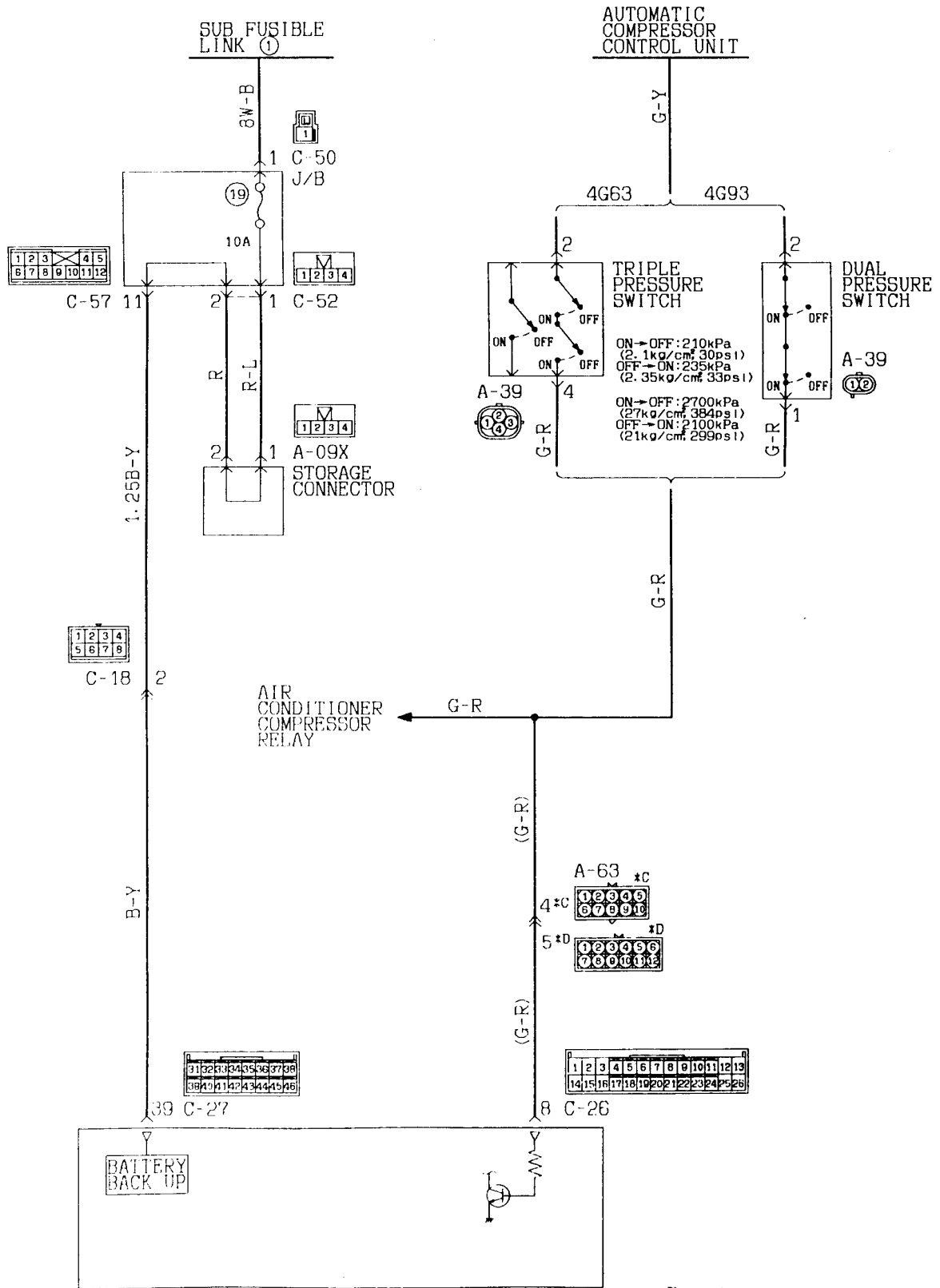

Remarks  
 \*C:4G93 engine  
 \*D:4G63 engine

Wire colour code  
 B:Black LG:Light green G:Green L:Blue W:White Y:Yellow SB:Sky blue  
 BR:Brown O:Orange GR:Gray R:Red P:Pink V:Violet

**HEADLAMP** <Vehicles with daytime running lamp> (See P. 4-52.)**OPERATION**

Headlamp Relay ON Conditions

Ignition switch	Lighting switch	Dimmer/passing switch	Headlamp relay
"ON"	—	—	ON
—	"HEAD"	—	ON
—	—	"PASS"	ON

**<Daytime running lamp operation>**

- Turning the ignition switch to the ON position causes the headlamp relay, daytime running lamp relay 1, and tail lamp relay to be energized, which causes the headlamps, tail lamps, etc. to come on.

**<Low-beam operation>**

- Placing the lighting switch in the HEAD position causes the headlamp relay and daytime running lamp relay 2 to be energized.
- If the dimmer/passing switch is placed in the LO position at this time, the headlamps light up in low beam.

**<Upper-beam operation>**

- Placing the lighting switch in the HEAD position causes the headlamp relay and daytime running lamp relay 2 to be energized.
- If the dimmer/passing switch is placed in the HI position at this time, the headlamps light up in upper beam.

**<Upper-beam indicator lamp>**

- This lamp lights up when the upper/passing beams are on, indicating that the headlamps are on in upper beam.

**TROUBLESHOOTING HINTS**

- Headlamps don't come on.
  - But the tail lamps do illuminate.
    - Check the headlamp relay.
    - Check the lighting switch.
  - The tail lamps also don't illuminate.
    - Check the sub fusible link No. ④.
- The low beam at both sides doesn't illuminate.
  - Check the dimmer switch LO contacts.
- The upper beam at both sides doesn't illuminate.
  - The passing signal functions OK.
    - Check the dimmer switch HI contacts.
  - The passing signal doesn't function.
    - Check the dimmer switch.
    - Check the daytime running lamp relay 2.
    - Check the daytime running lamp control unit.
- One headlamp doesn't illuminate.
  - Check the bulb.
- Can't switch from low to upper beam or vice-versa.
  - Check the dimmer switch.
- With the ignition switch at the "ON" position, the headlamps' low beam does not illuminate.
  - Check the daytime running lamp relay 1.
  - Check the daytime running lamp control unit.
- Upper-beam indicator lamp does not come on.
  - Headlamp upper beams are operational.
    - Check the dedicated fuse No. ④.
    - Check the indicator lamp bulb.

**Remark**

- The head lamp circuit has a lighting monitor buzzer system. For operation and troubleshooting hints, refer to LIGHTING MONITOR BUZZER (P. 4-84).

# 9 HEADLAMP

9-1 Vehicles with daytime running lamp

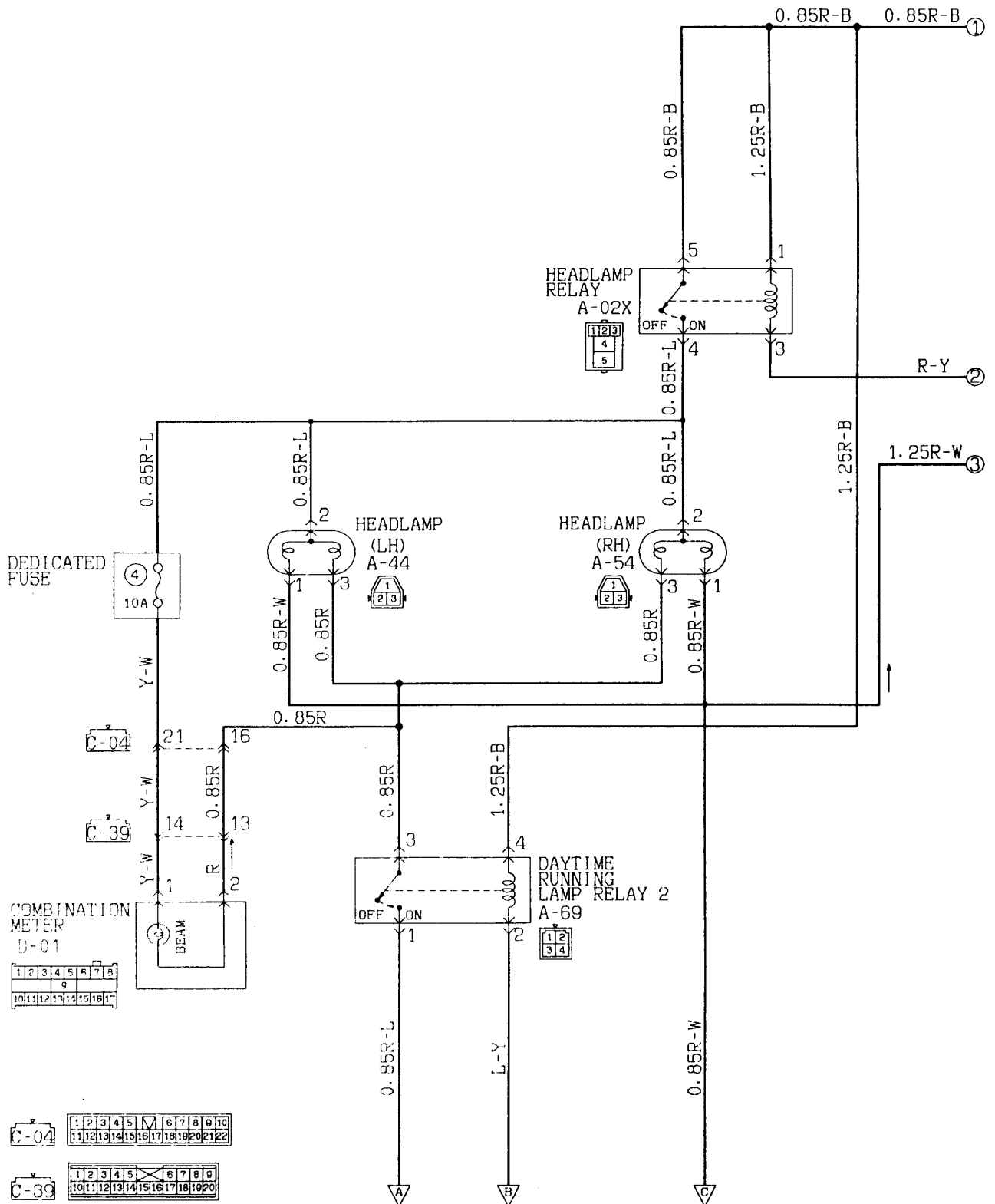

**KX35-AC-Z0820-EC** Wire colour code  
 B:Black LG:Light green G:Green L:Blue W:White Y:Yellow SB:Sky blue  
 BR:Brown O:Orange GR:Gray R:Red P:Pink V:Violet

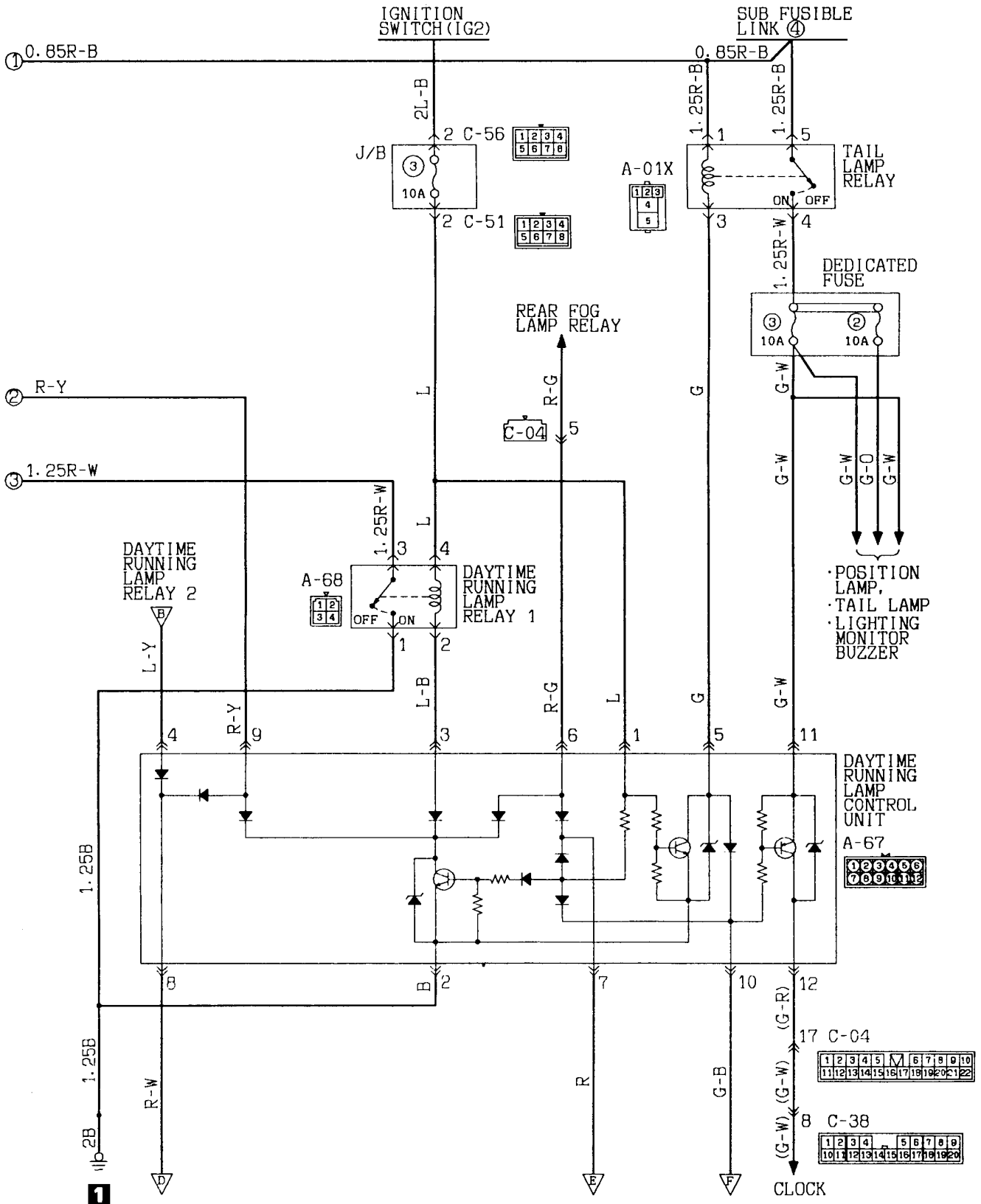

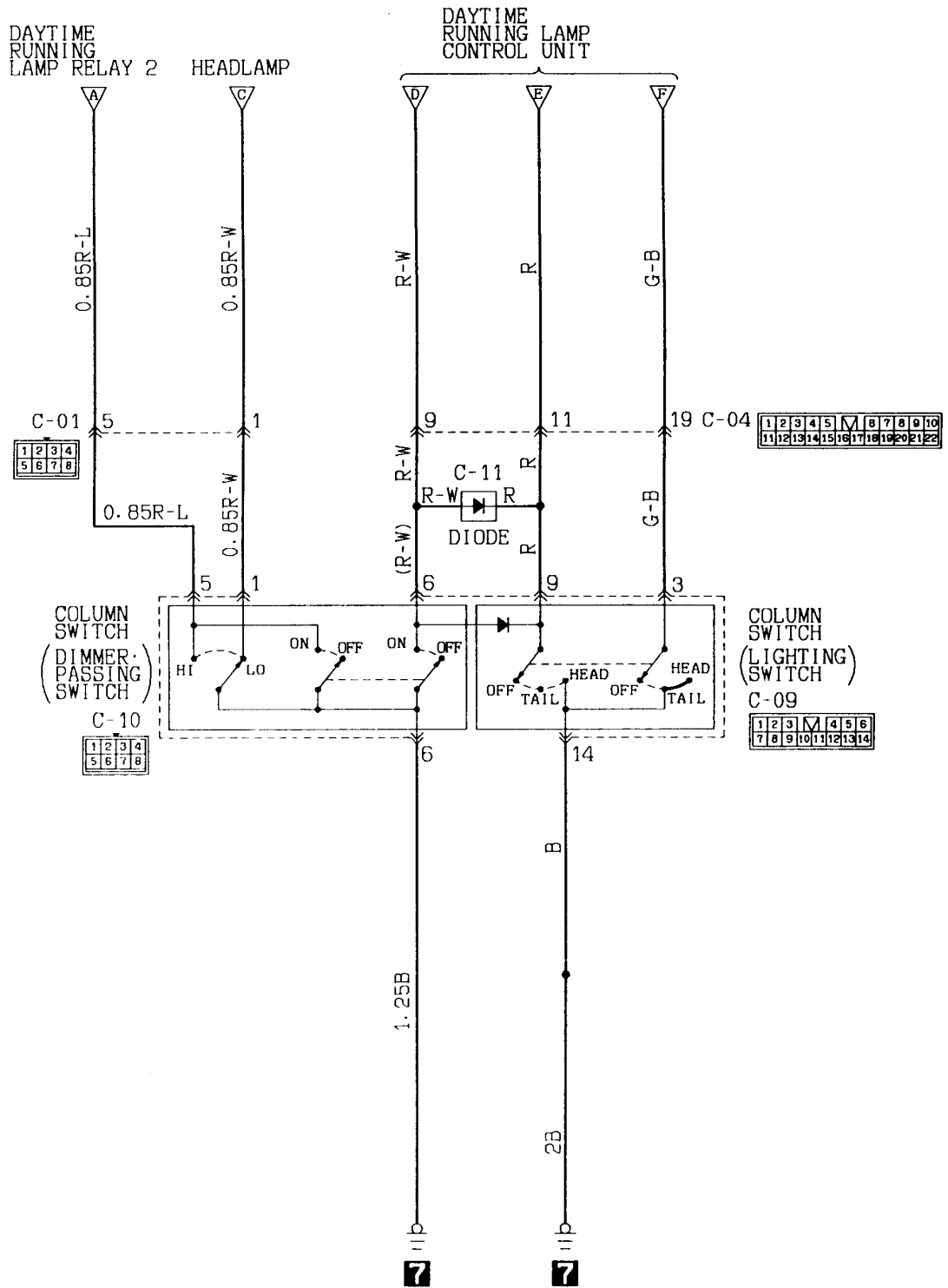

Wire colour code  
 B:Black LG:Light green G:Green L:Blue W:White Y:Yellow SB:Sky blue  
 BR:Brown O:Orange GR:Gray R:Red P:Pink V:Violet

**HEADLAMP <Vehicles with dim-dip lamp> (See P. 4-56.)****OPERATION**

Headlamp Relay ON Conditions

Ignition switch	Lighting switch	Dimmer/passing switch	Headlamp relay
"ON"	"TAIL"	—	ON
—	"HEAD"	—	ON
—	—	"PASS"	ON

**<Dim-dip lamp operation>**

- Placing the lighting switch in the TAIL position causes dim-dip lamp relay 1 to be energized.
- This causes the headlamp relay to be also energized resulting in the headlamps being lit up dimly through the circuit by way of resistor.

**<Low-beam operation>**

- Placing the lighting switch in the HEAD position causes the headlamp relay, dim-dip lamp relay 2 and dim-dip lamp relay 3 to be energized.
- If the dimmer/passing switch is placed in the LO position at this time, the headlamps light up in low beam.

**<Upper-beam operation>**

- Placing the lighting switch in the HEAD position causes the headlamp relay, dim-dip lamp relay 2 and dim-dip lamp relay 3 to be energized.
- If the dimmer/passing switch is placed in the HI position at this time, the headlamps light up in upper beam.

**<Upper-beam indicator lamp>**

- This lamp lights up when the upper/passing beams are on, indicating that the headlamps are on in upper beam.

**TROUBLESHOOTING HINTS**

1. Headlamps don't come on.
  - (1) But the tail lamps do illuminate.
    - Check the headlamp relay.
    - Check the lighting switch.
    - Check the dim-dip lamp relay 2 and 3.
  - (2) The tail lamps also don't illuminate.
    - Check the sub fusible link No. ④.
2. The low beam at both sides doesn't illuminate.
  - Check the dimmer switch LO contacts.
3. The upper beam at both sides doesn't illuminate.
  - (1) The passing signal functions OK.
    - Check the dimmer switch HI contacts.
  - (2) The passing signal doesn't function.
    - Check the dimmer switch.
4. One headlamp doesn't illuminate.
  - Check the bulb.
5. Can't switch from low to upper beam or vice-versa.
  - Check the dimmer switch.
6. The headlamps' low beam does not illuminate at the "HEAD" position of the lighting switch.
  - (1) The low beam does illuminate, however, when, with lighting switch at the "HEAD" position, the dimmer switch is set to "LO".
    - Check the dim-dip lamp relay 1.
    - Check the resistor.
    - Check the diode.
7. Upper-beam indicator lamp does not come on.
  - (1) Headlamp upper beams are operational.
    - Check the dedicated fuse No. ④.
    - Check the indicator lamp bulb.

**Remark**

- The head lamp circuit has a lighting monitor buzzer system. For operation and troubleshooting hints, refer to LIGHTING MONITOR BUZZER (P. 4-84).



9-2 Vehicles with dim-dip lamp

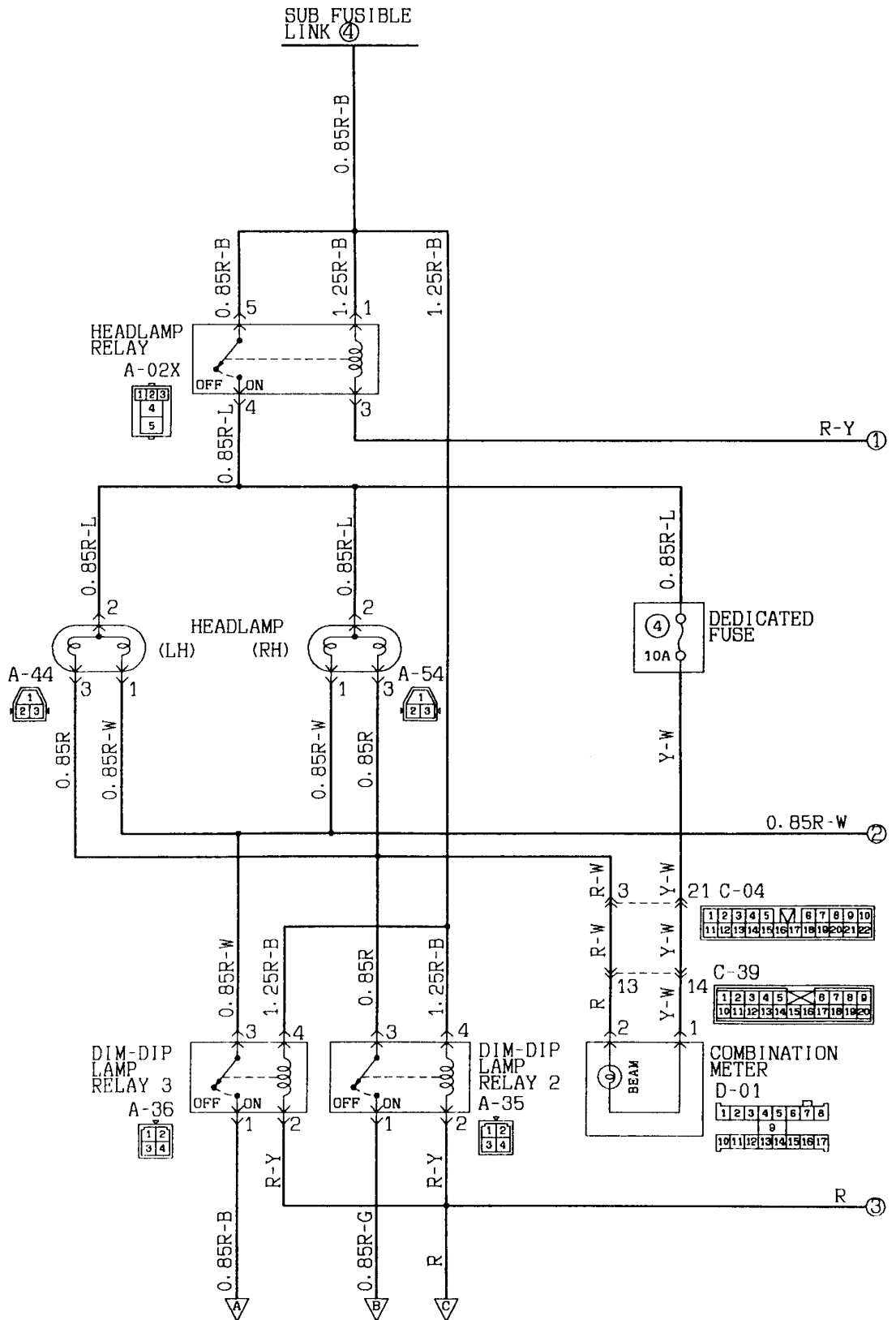

KX35-AC-Z0821-EC

Wire colour code  
 B:Black LG:Light green G:Green L:Blue W:White Y:Yellow SB:Sky blue  
 BR:Brown O:Orange GR:Gray R:Red P:Pink V:Violet

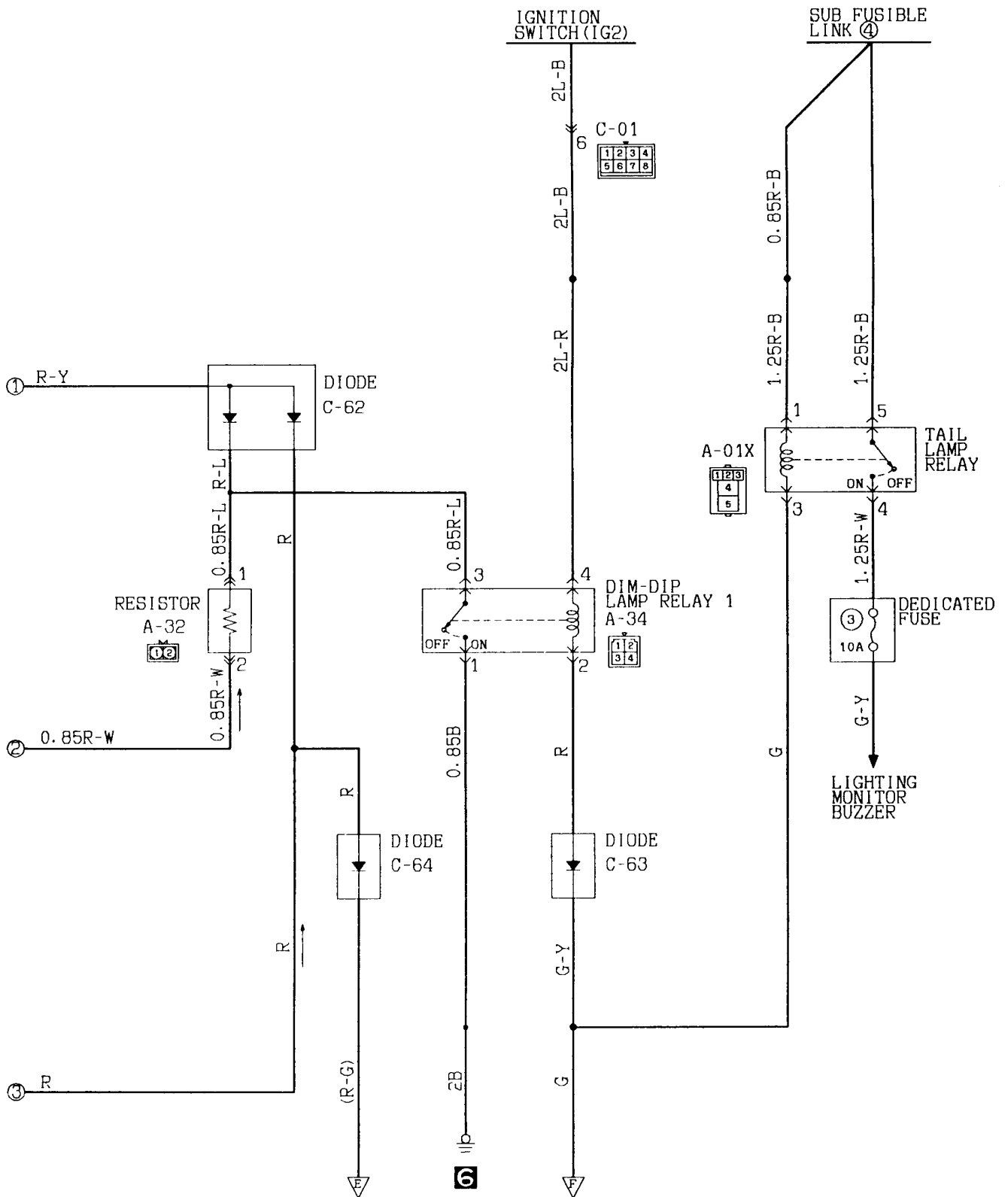

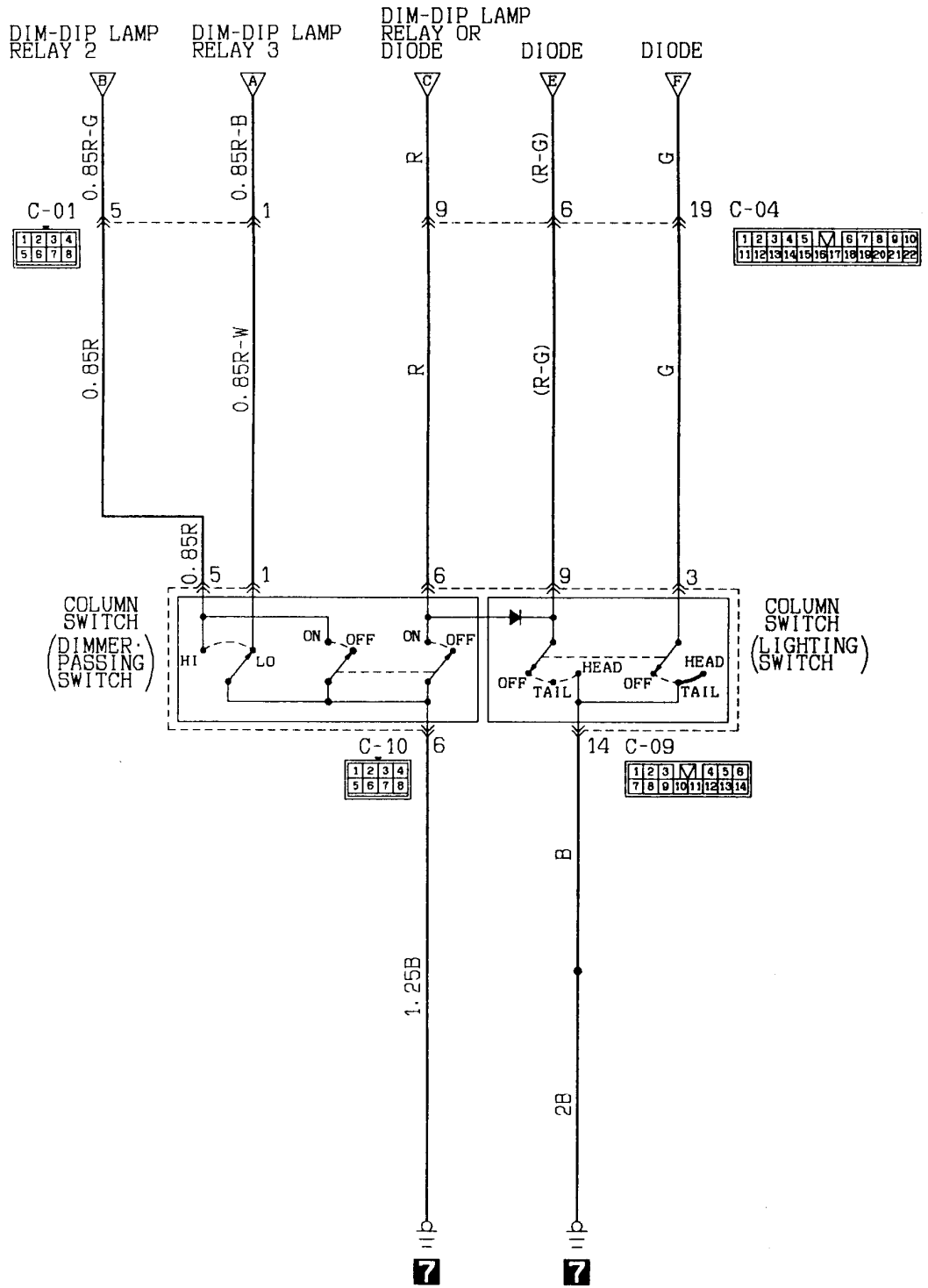

Wire colour code  
 B:Black LG:Light green G:Green L:Blue W:White Y:Yellow SB:Sky blue  
 BR:Brown O:Orange GR:Gray R:Red P:Pink V:Violet

**HEADLAMP <Vehicles without daytime running lamp > (See P. 4-60.)****OPERATION**

Headlamp Relay ON Conditions

Ignition switch	Lighting switch	Dimmer/passing switch	Headlamp relay
—	"HEAD"	—	ON
—	—	"PASS"	ON

**<Low-beam operation>**

- Placing the lighting switch in the HEAD position causes the headlamp relay to be energized.
- If the dimmer/passing switch is placed in the LO position at this time, then the headlamps light up in low beam.

**<Upper-beam operation>**

- Placing the lighting switch in the HEAD position causes the headlamp relay to be energized.
- If the dimmer/passing switch is placed in the HI position at this time, the headlamps light up in upper beam.

**<Upper-beam indicator lamp>**

- This lamp lights up when the upper/passing beams are on, indicating that the headlamps are on in upper beam.

**<Passing operation>**

- When the dimmer/passing switch is set to the "ON" position, the headlamp relay is switched ON and the upper beam of the headlamps illuminates.

**TROUBLESHOOTING HINTS**

1. Headlamps don't come on.
  - (1) But the tail lamps do illuminate.
    - Check the headlamp relay.
    - Check the lighting switch.
  - (2) The tail lamps also don't illuminate.
    - Check the sub fusible link No. ④.
2. The low beam at both sides doesn't illuminate.
  - Check the dimmer switch LO contacts.
3. The upper beam at both sides doesn't illuminate.
  - (1) The passing signal functions OK.
    - Check the dimmer switch HI contacts.
  - (2) The passing signal doesn't function.
    - Check the dimmer switch.
4. One headlamp doesn't illuminate.
  - Check the bulb.
5. Can't switch from low to upper beam or vice-versa.
  - Check the dimmer switch.
6. Upper-beam indicator lamp does not come on.
  - (1) Headlamp upper beams are operational. Upper-beams are operational.
    - Check the dedicated fuse No. ④.
    - Check the indicator lamp bulb.

**Remark**

- The head lamp circuit has a lighting monitor buzzer system. For operation and troubleshooting hints, refer to LIGHTING MONITOR BUZZER (P. 4-84).

9-3 Vehicles without daytime running lamp

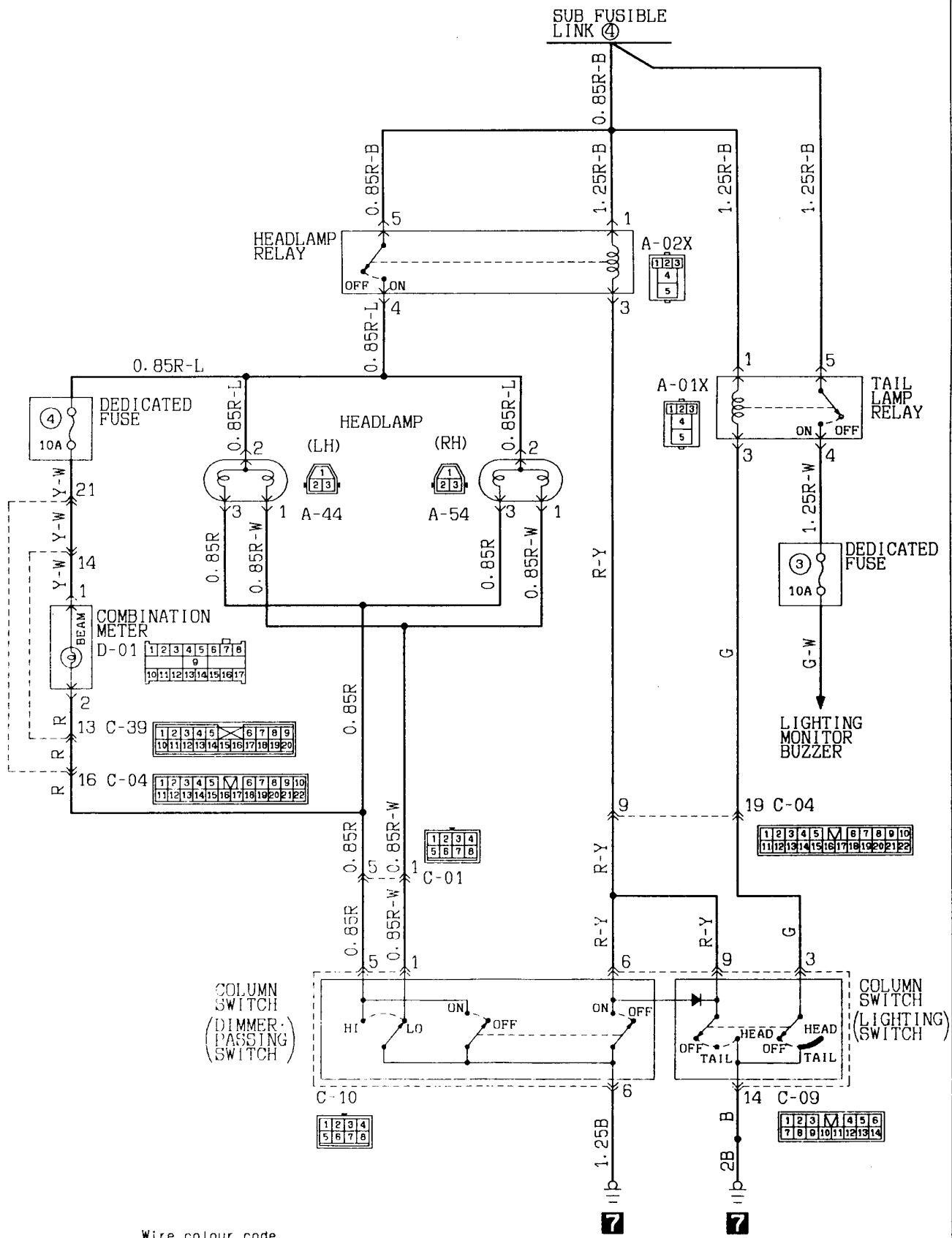

Wire colour code  
 B:Black LG:Light green G:Green L:Blue W:White Y:Yellow SB:Sky blue  
 BR:Brown O:Orange GR:Gray R:Red P:Pink V:Violet

**HEADLAMP (Headlamp leveling system) (See P. 4-62.)****Downtilt operation**

- When the headlamps are switched ON, battery voltage is applied, through dedicated fuse no. ④ (10A), from the headlamp relay to the headlamp leveling unit.
- When the headlamp leveling switch setting is changed from the "0" position to the "1" position, electricity flows from Relay 2 to print base 1 to the headlamp leveling switch and to earth; the Relay 2 contacts are thus switched ON and the motor is activated. As a result, the headlamp leveling unit's shaft is pushed outward, the reflector tilts downward, and the optical axis of the headlamps is tilted in the downward direction.
- At the same time, the contacts of the sensor switch, which are interlocked with the movement of the motor, also turn in the "DOWN" direction, and, at the position where there is no longer contact of print base 1 and the brush contact, Relay 2 is switched OFF and the motor stops.
- In the same way as described above, when the headlamp leveling switch setting is changed from the "1" position to the "2" position and further to the "3" position and the "4" position, the motor continues to rotate so that the headlamp leveling unit's shaft is pushed outward, tilting the reflector further downward; the optical axis of the headlamps is at the maximum downward tilt at the "4" position of the headlamp leveling switch.

**Return operation**

- When the setting of the headlamp leveling switch is changed from the "4" position to the "3" position, electricity flows from Relay 1 to print base 3 to the headlamp leveling switch and to earth; the Relay 1 contacts are thus switched ON, and the motor rotates in the direction opposite to that for downtilt.  
As a result, the headlamp leveling unit's shaft is drawn inward, the tilt of the reflector is reduced, and the optical axis of the headlamps is changed in the upward direction.
- At the same time, the contacts of the sensor switch turn in the "UP" direction, and, at the position where there is no longer contact of print base 3 and the brush contact, Relay 1 is switched OFF and the motor stops.
- When the setting of the headlamp leveling switch is further changed from the "3" position to the "2" position and to the "1" position, the motor continues to rotate, and the optical axis of the headlamps returns to the minimum tilt position at the "0" setting of the switch.
- In order to prevent overheat damage to the motor as a result of frequent operation of the headlamp leveling system, a thermistor is provided in the circuitry within the headlamp leveling unit.

1. No operation of the headlamp leveling system.
  - (1) The upper beam indicator lamp also does not illuminate.
    - Check the dedicated fuse No. ④.
  - (2) The upper beam indicator lamp illuminates.
    - Check the headlamp leveling switch.
    - Check the headlamp leveling unit.
2. Either the left or right part of the headlamp leveling system does not operate.
  - Check the headlamp leveling unit for the side the does not operate.
3. Either the downtilt operation or the return operation does not function.
  - Check the headlamp leveling unit.

9-4 Headlamp leveling system

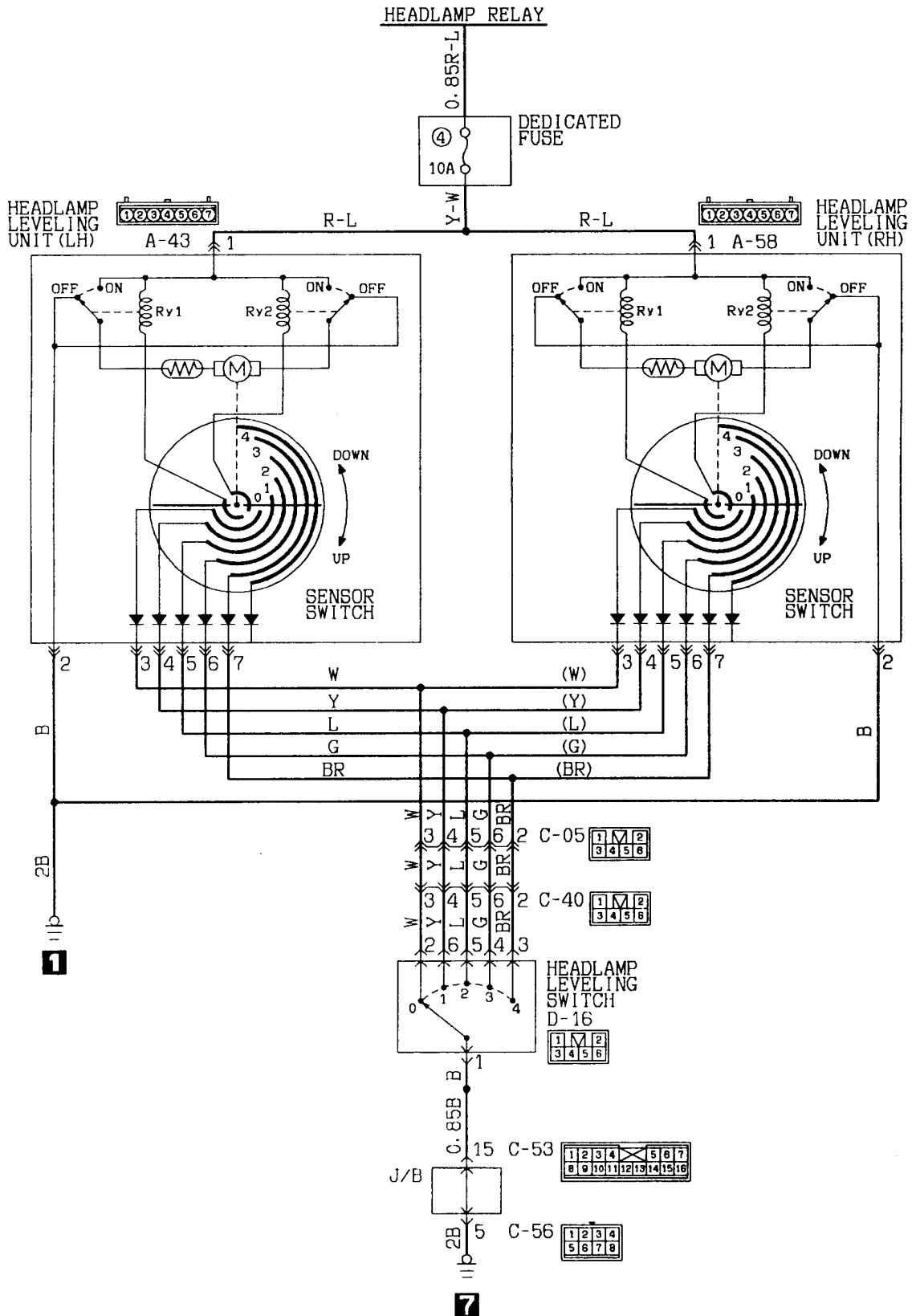

Wire colour code  
 B:Black LG:Light green G:Green L:Blue W:White Y:Yellow SB:Sky blue  
 BR:Brown O:Orange GR:Gray R:Red P:Pink V:Violet

**TAIL LAMP, POSITION LAMP AND LICENCE PLATE LAMP (See P. 4-64.)**

**OPERATION**

- Placing the lighting switch in the TAIL or HEAD position causes the tail lamp relay to be energized.
- As a result, current flows by way of dedicated fuse No. ② and No. ③ to each lamp, causing the lamp to come on.

**TROUBLESHOOTING HINTS**

1. No lamp come on.
  - (1) Headlamps do not come on, either.
    - Check the sub-fusible link No. ④.
  - (2) Headlamps do come on.
    - Check the tail lamp relay.
    - Check dedicated fuse No. ② and No. ③.

**Remark**

- The tail lamp circuit has a lighting monitor buzzer system. For operation and troubleshooting hints, refer to LIGHTING MONITOR BUZZER (P. 4-84).



**4-64 CIRCUIT DIAGRAM — Tail Lamp, Position Lamp and Licence Plate Lamp**

**10 TAIL LAMP, POSITION LAMP AND LICENCE PLATE LAMP**

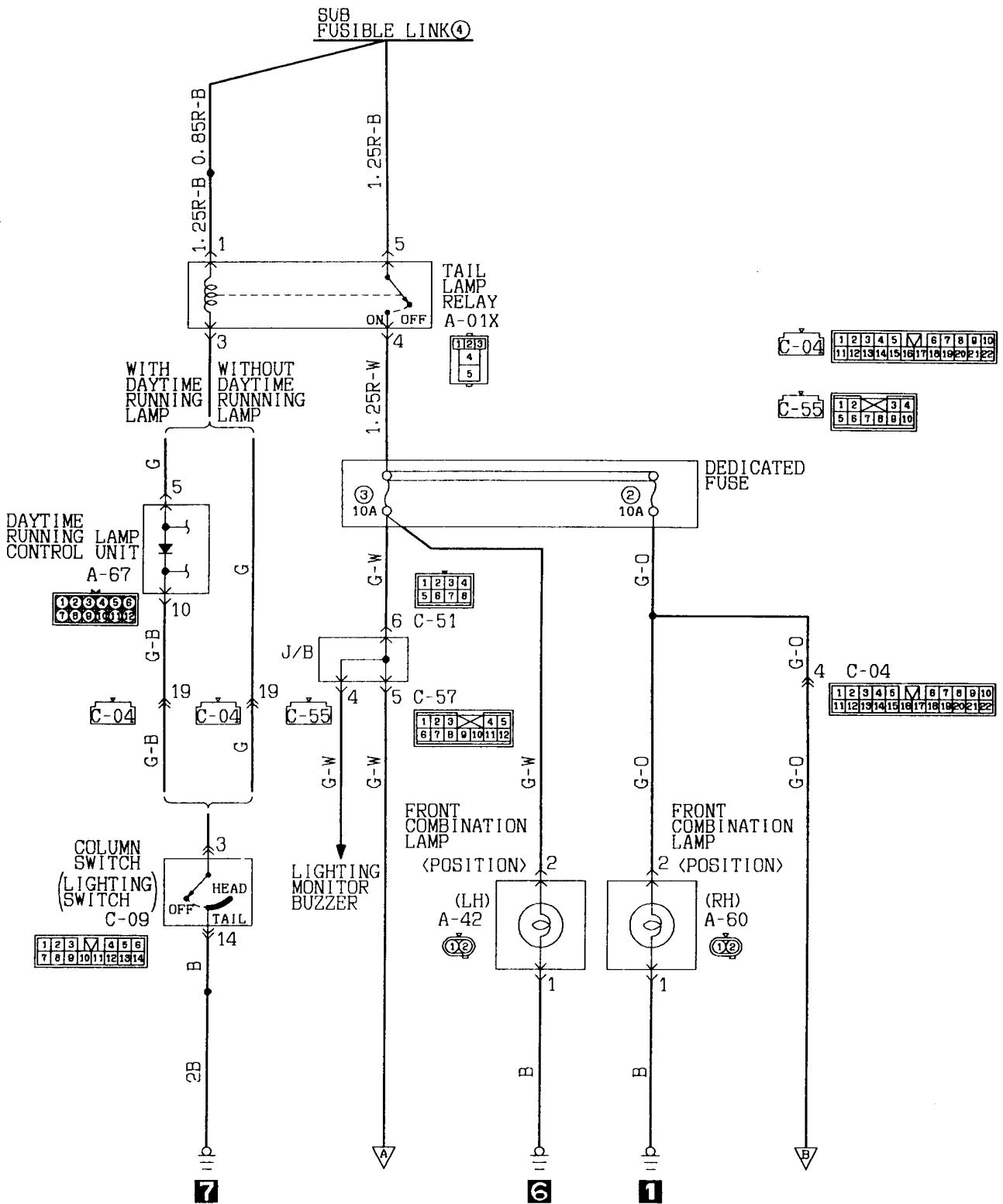

Wire colour code  
 B:Black LG:Light green G:Green L:Blue W:White Y:Yellow SB:Sky blue  
 BR:Brown O:Orange GR:Gray R:Red P:Pink V:Violet

KX35-AC-Z0824-EC

© Mitsubishi Motors Corporation Jun. 1992

PHDE9214

**CIRCUIT DIAGRAM — Tail Lamp, Position Lamp and Licence Plate Lamp 4-65**

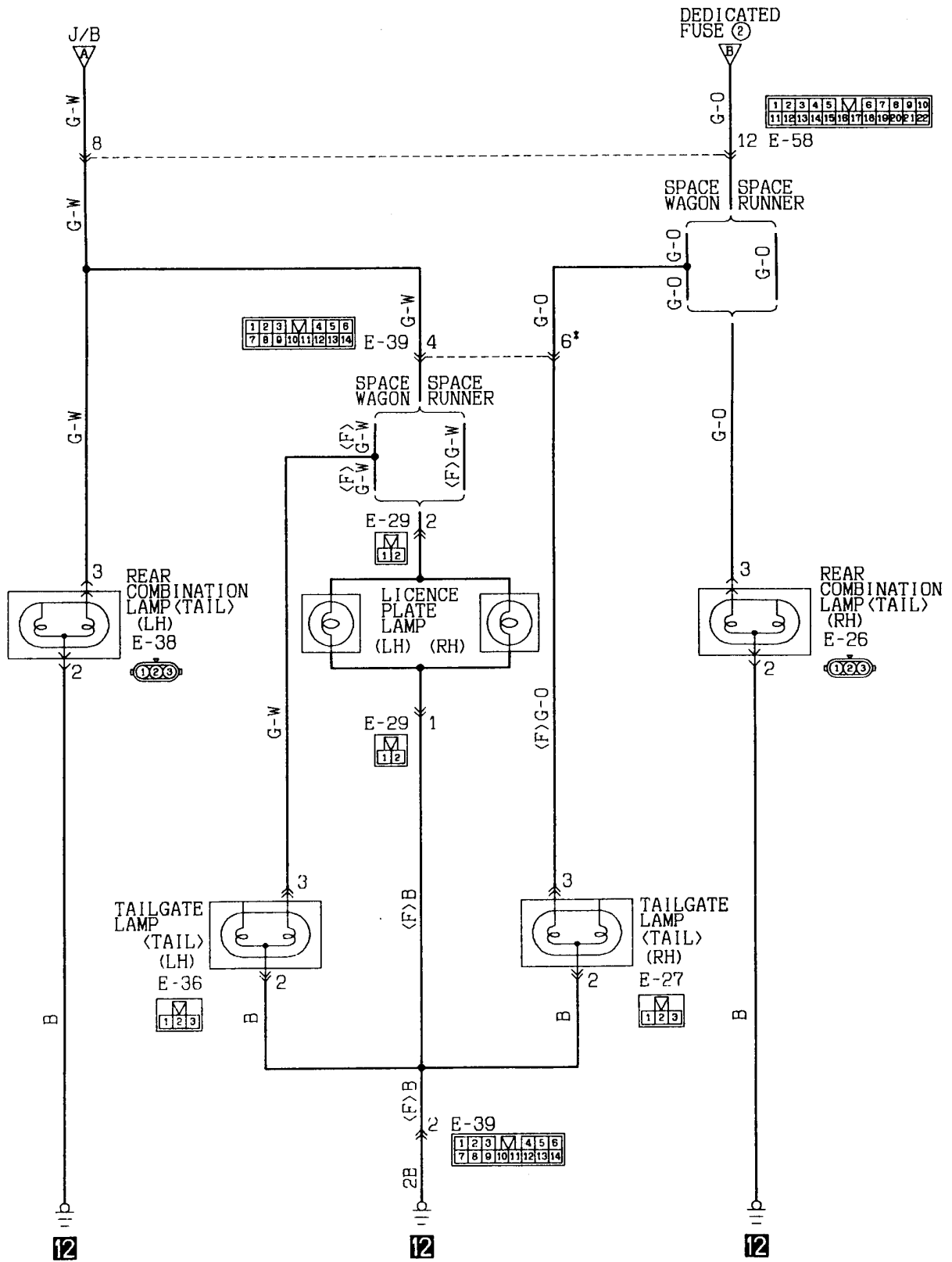

Remark  
\*: SPACE WAGON

11 REAR FOG LAMP

11-1 L.H. drive vehicles with daytime running lamp

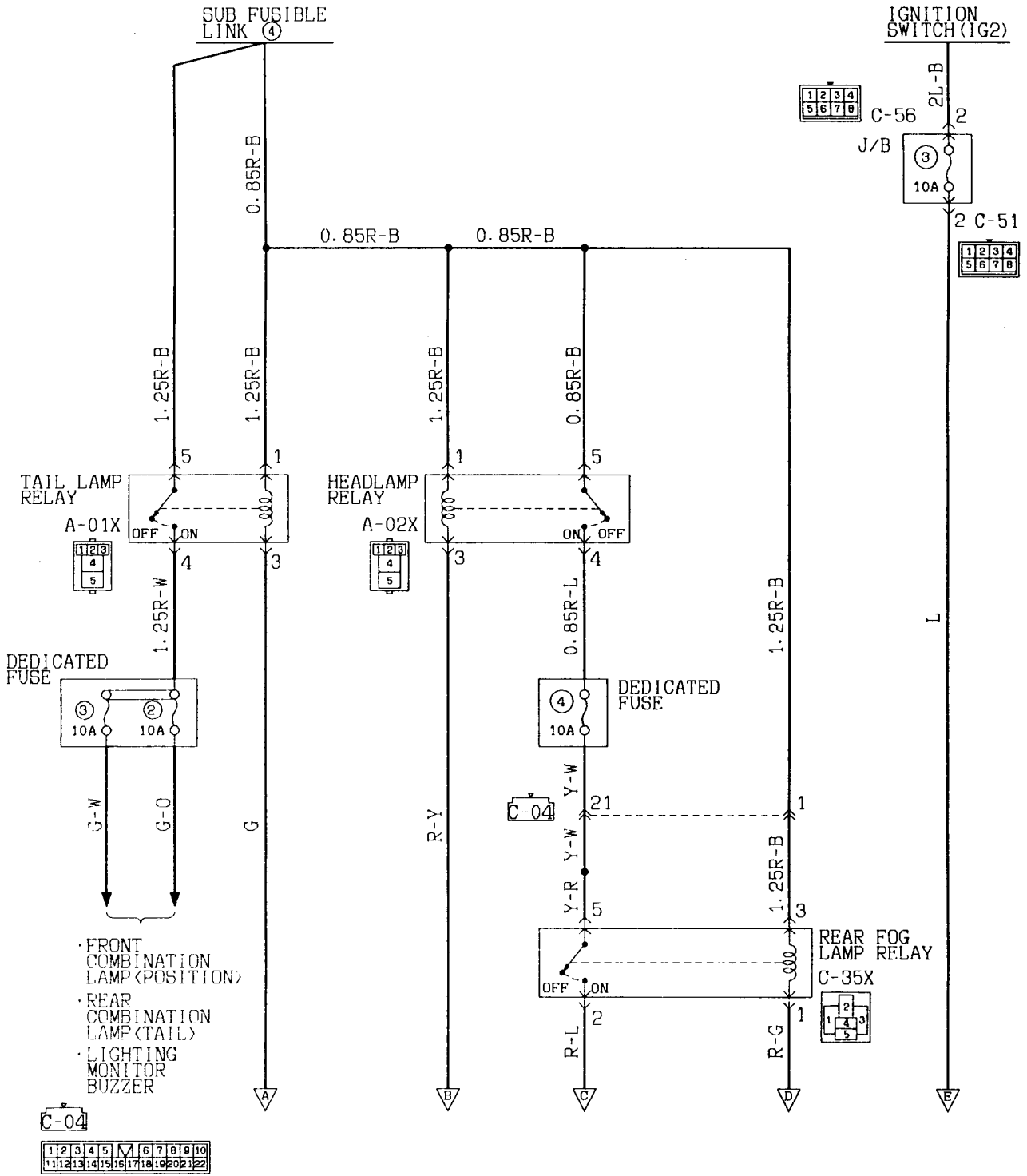

- FRONT COMBINATION LAMP (POSITION)
- REAR COMBINATION LAMP (TAIL)
- LIGHTING MONITOR BUZZER

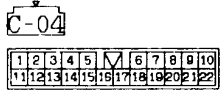

Wire colour code  
 B:Black LG:Light green G:Green L:Blue W:White Y:Yellow SB:Sky blue  
 BR:Brown O:Orange GR:Gray R:Red P:Pink V:Violet

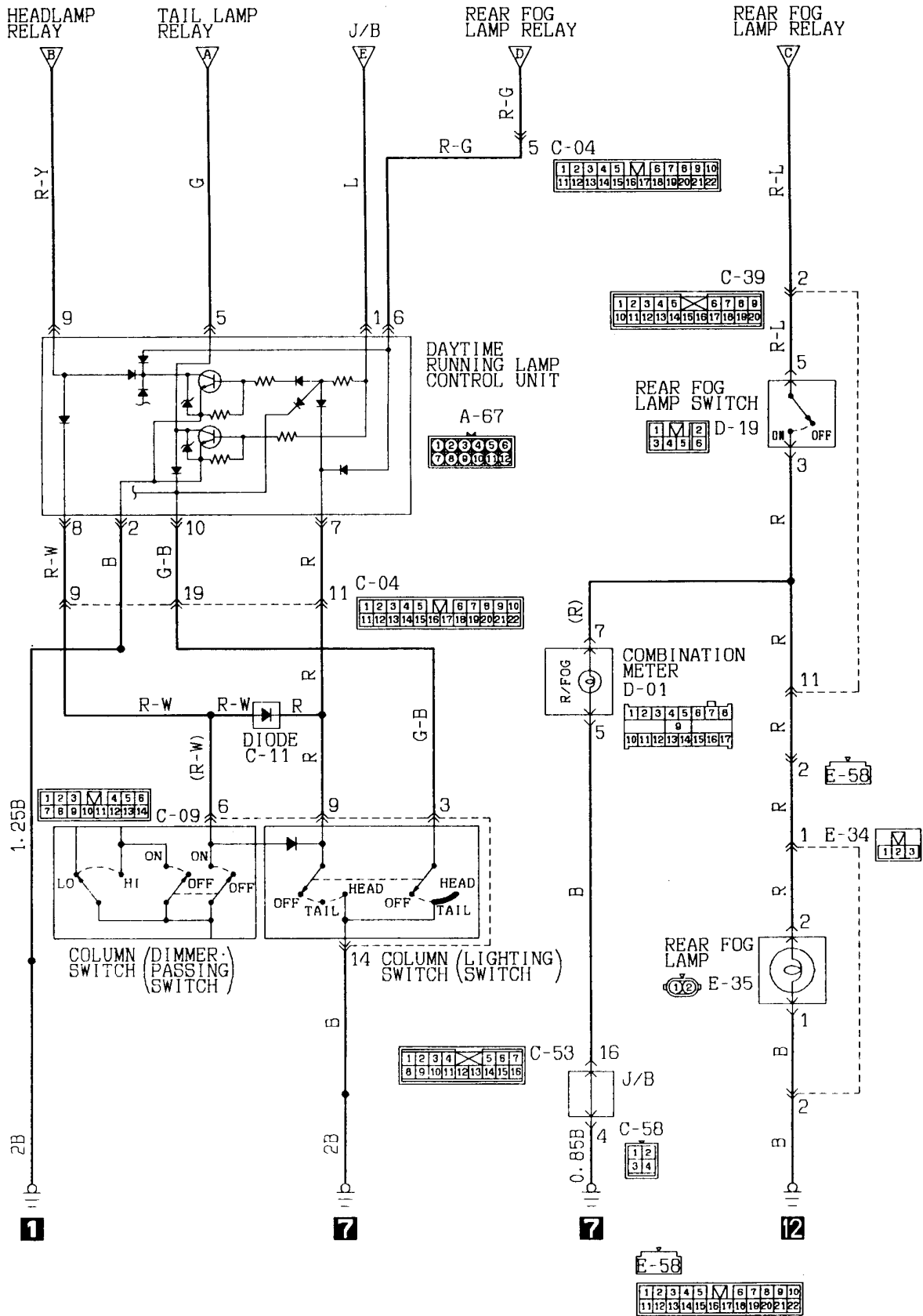

11-2 L.H. drive vehicles without daytime running lamp

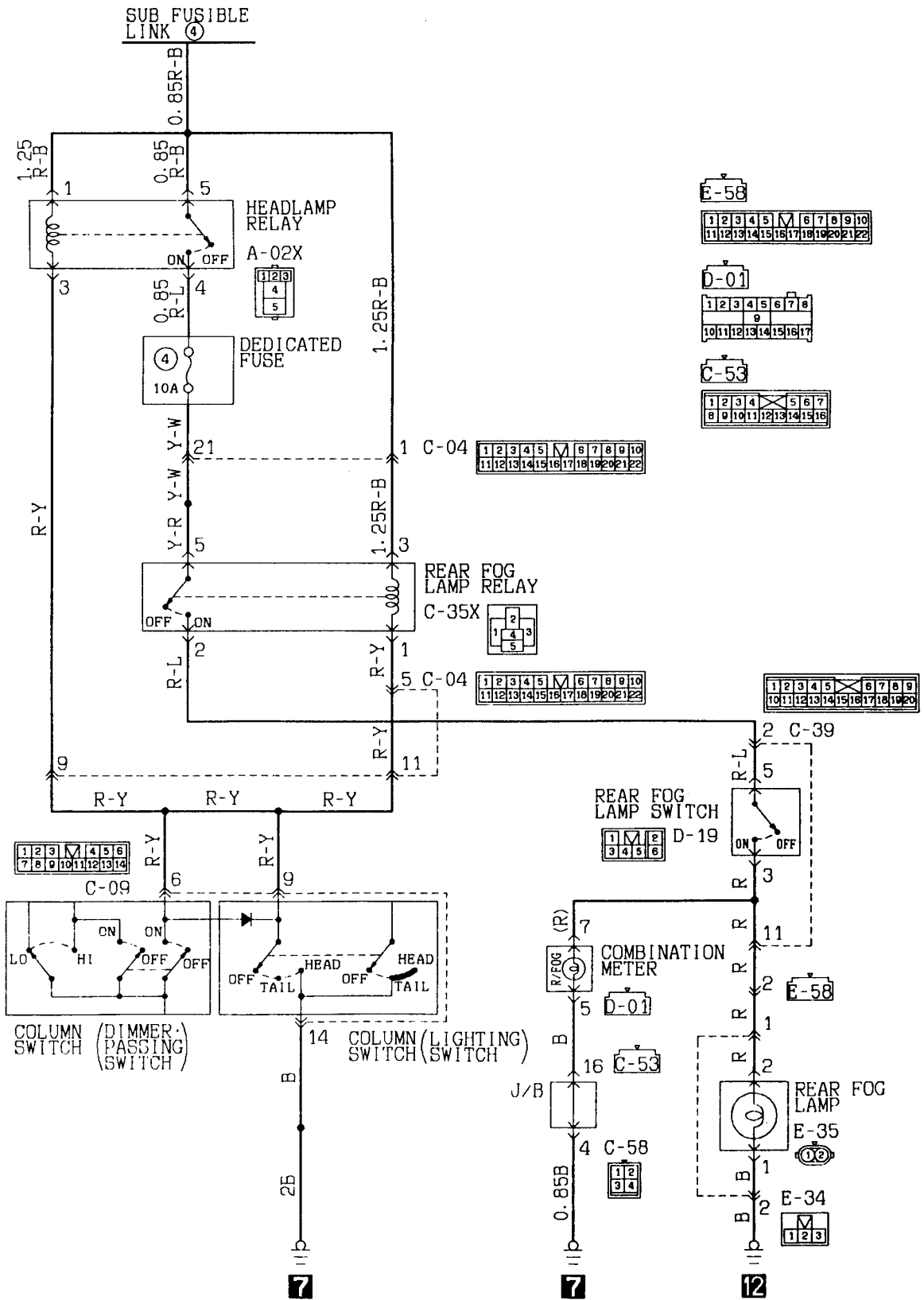

Wire colour code  
 B:Black LG:Light green G:Green L:Blue W:White Y:Yellow SB:Sky blue  
 BR:Brown O:Orange GR:Gray R:Red P:Pink V:Violet

11-3 R.H. drive vehicles

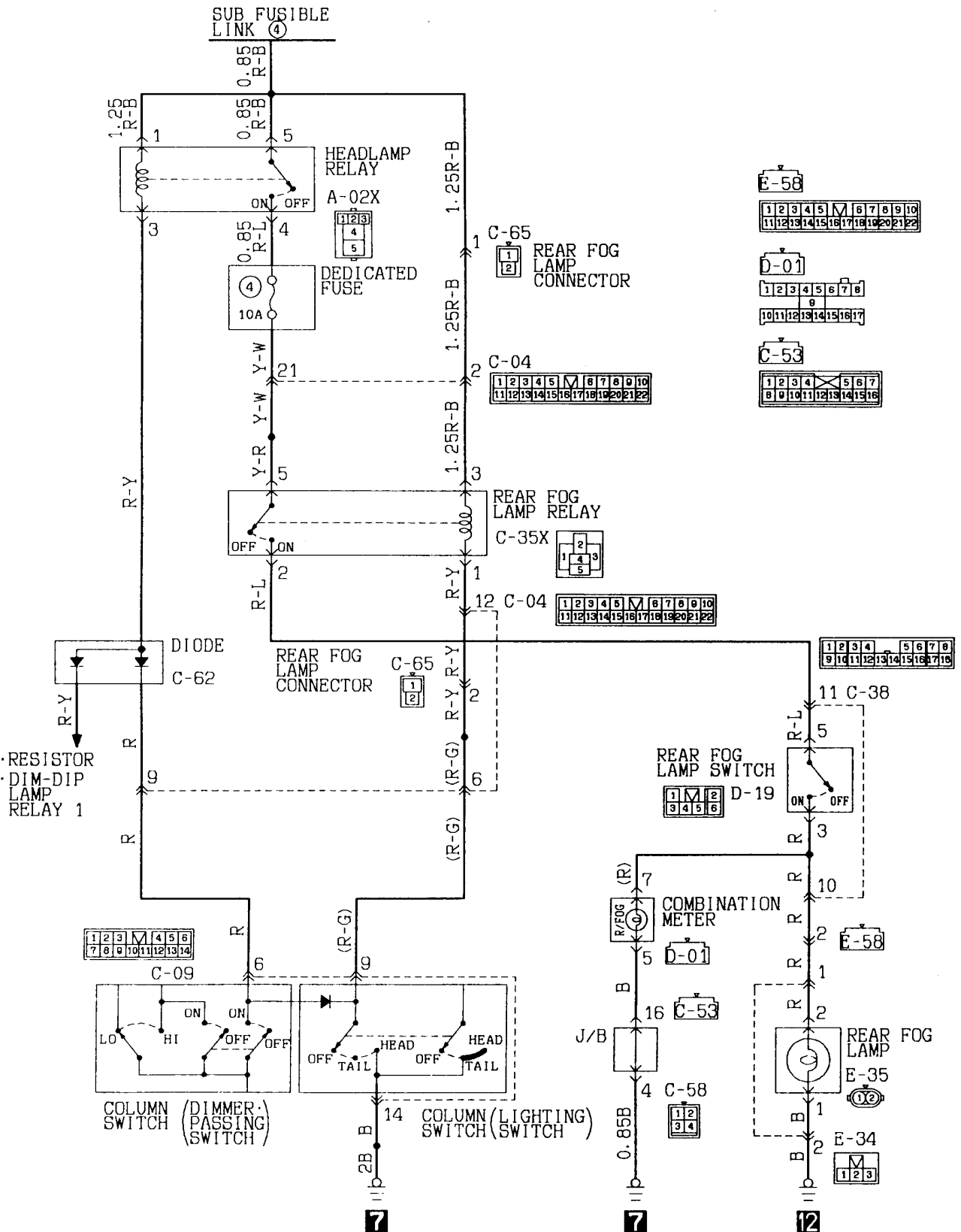

Wire colour code  
 B:Black LG:Light green G:Green L:Blue W:White Y:Yellow SB:Sky blue  
 BR:Brown O:Orange GR:Gray R:Red P:Pink V:Violet

**REAR FOG LAMP (See P. 4-66, 68, 69.)****OPERATION**

Rear Fog Lamp Relay ON Conditions

Ignition switch	Lighting switch	Rear fog lamp relay
—	"HEAD"	ON

- Placing the lighting switch in the HEAD position causes the rear fog lamp relay to be energized.
- When the rear fog lamp switch is turned ON in this condition, the rear fog lamp comes on.

**TROUBLESHOOTING HINTS**

1. The rear fog lamp doesn't illuminate.
  - (1) Headlamps come on.
    - Check the rear fog lamp relay.
    - Check the rear fog lamp switch.
    - Check the dedicated fuse No. ④.
  - (2) Headlamps do not come on, either.
    - Check the lighting switch.
    - Check the sub fusible link No. ④.
2. The rear fog lamp at the one side doesn't illuminate.
  - Check the bulb.

**ROOM LAMP AND CARGO ROOM LAMP (See P. 4-71, 72, 73, 74.)****OPERATION****<Room lamp>**

- Placing the room lamp switch in the ON position causes the room lamp to come on at all times.
- Opening any one of the doors with the room lamp switch in the DOOR position causes the room lamp to come on.
- Closing all doors causes the room lamp to go out.

**<Cargo room lamp>**

- Placing the cargo room lamp switch in the ON position causes the cargo room lamp to come on at all times.
- Opening the tailgate with the cargo room lamp switch in the DOOR position causes the cargo room lamp to come on.
- Closing the tailgate causes the cargo room lamp to go out.

**TROUBLESHOOTING HINTS**

1. Room lamp does not come on.
  - (1) Clock is not operating, either.
    - Check the multi-purpose fuse No. ⑱.
  - (2) Room lamp does not come on when any door is opened with the room lamp switch in the DOOR position.
    - Check the bulb.
    - Check the room lamp switch.
  - (3) Room lamp does not come on when a door is opened with the room lamp switch in the DOOR position.
    - Check the door switch (of the suspected door).
2. Cargo room lamp does not come on.
  - (1) Clock is not operating, either.
    - Check the multi-purpose fuse No. ⑱.
  - (2) Cargo room lamp does not come on when the tailgate is opened with the cargo room lamp switch in the DOOR position.
    - Check the bulb.
    - Check the cargo room lamp switch.
    - Check the latch switch.

12 ROOM LAMP AND CARGO ROOM LAMP  
 12-1 L.H. drive vehicles without door lamp

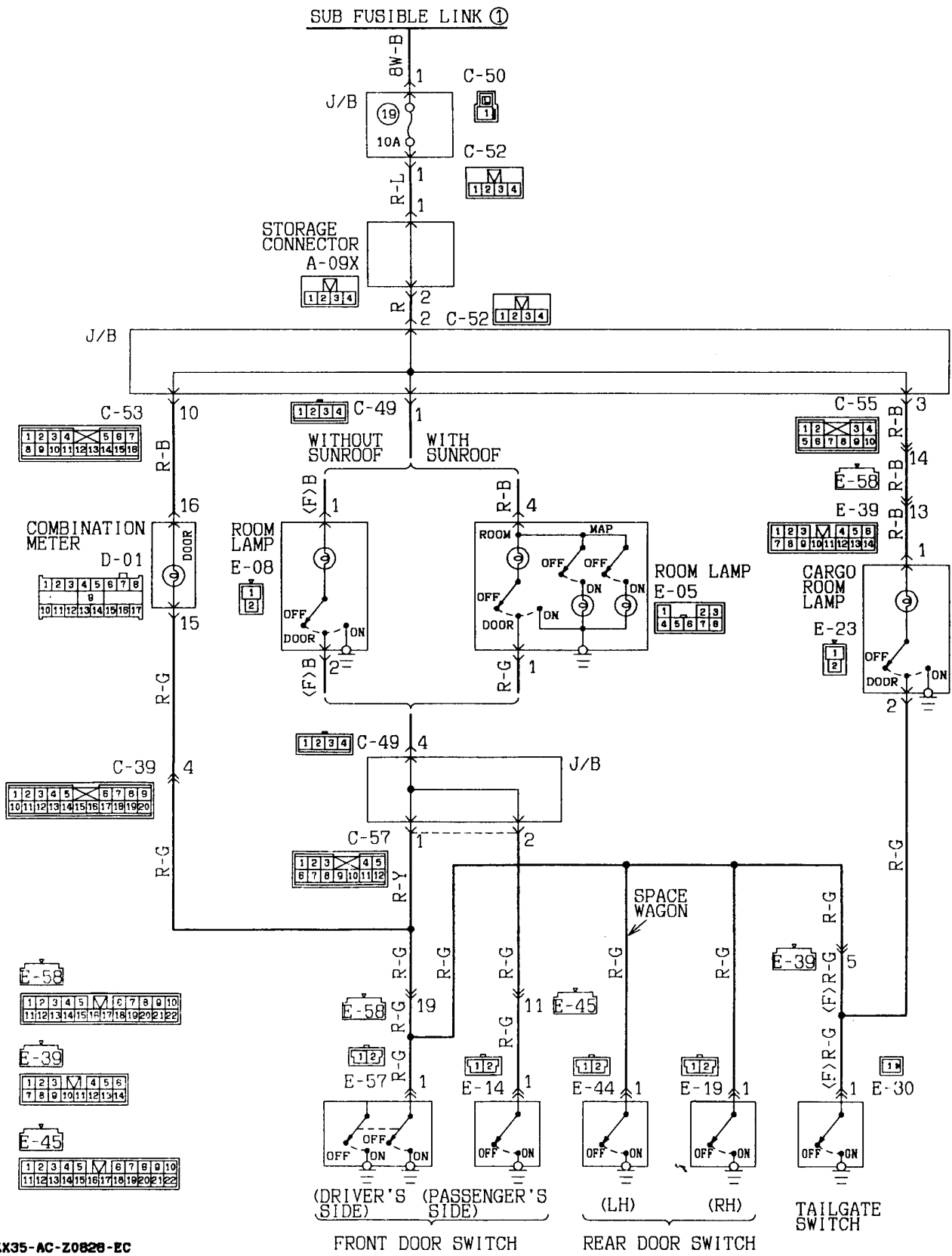

KX35-AC-Z0828-EC



12-2 R.H. drive vehicles without door lamp

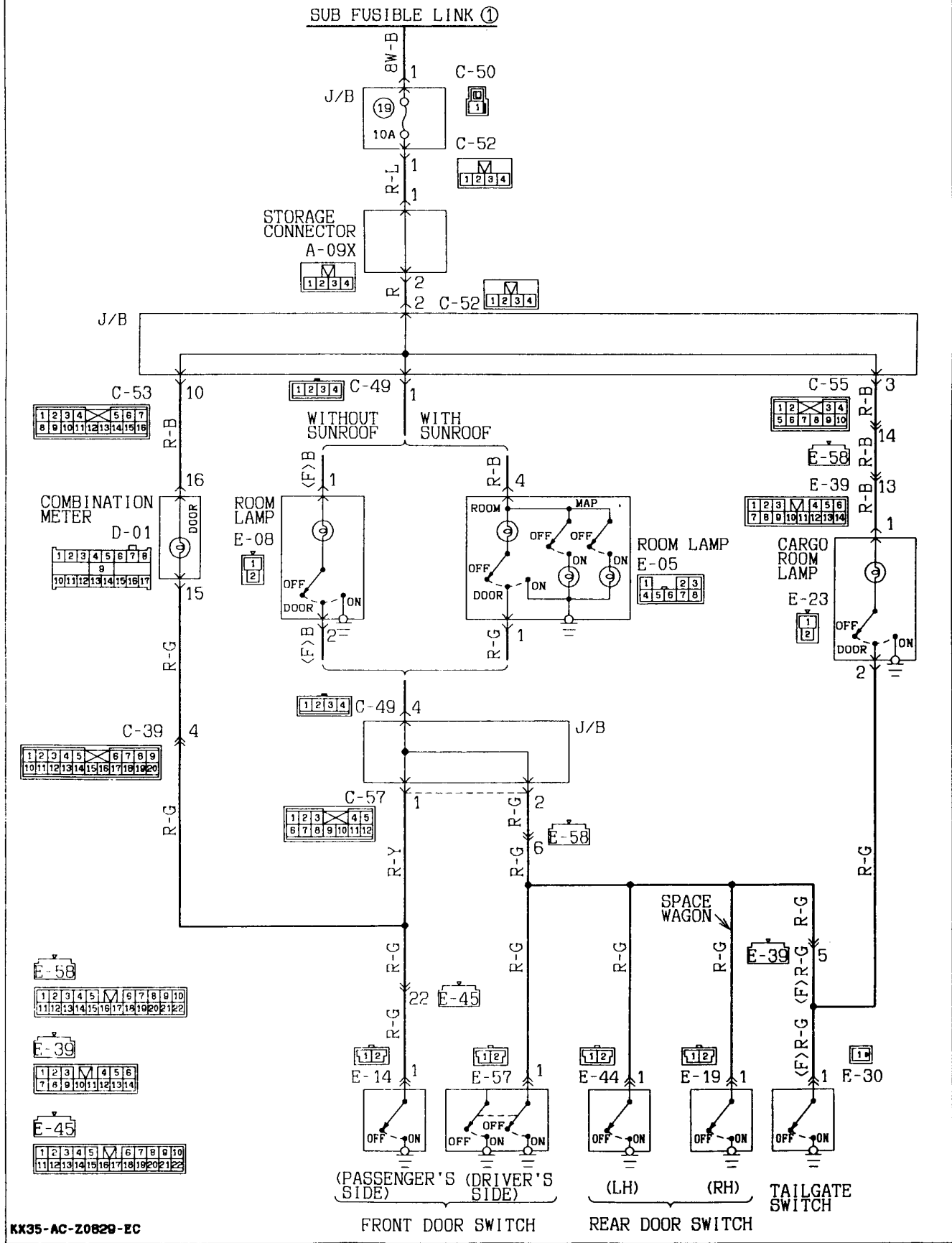

KX35-AC-Z0820-EC

12-3 L.H. drive vehicles with door lamp

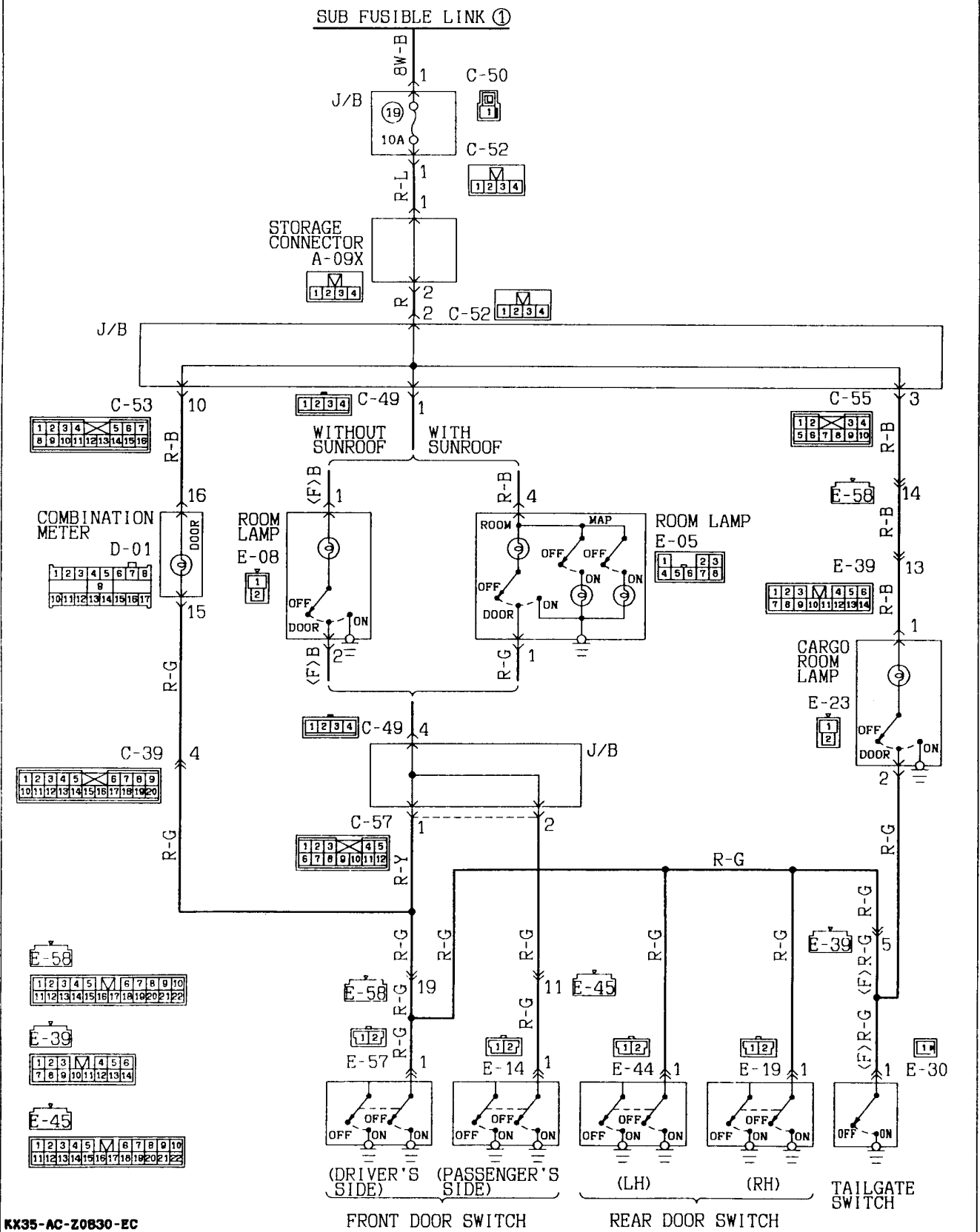

KX35-AC-Z0830-EC

12-4 R.H. drive vehicles with door lamp

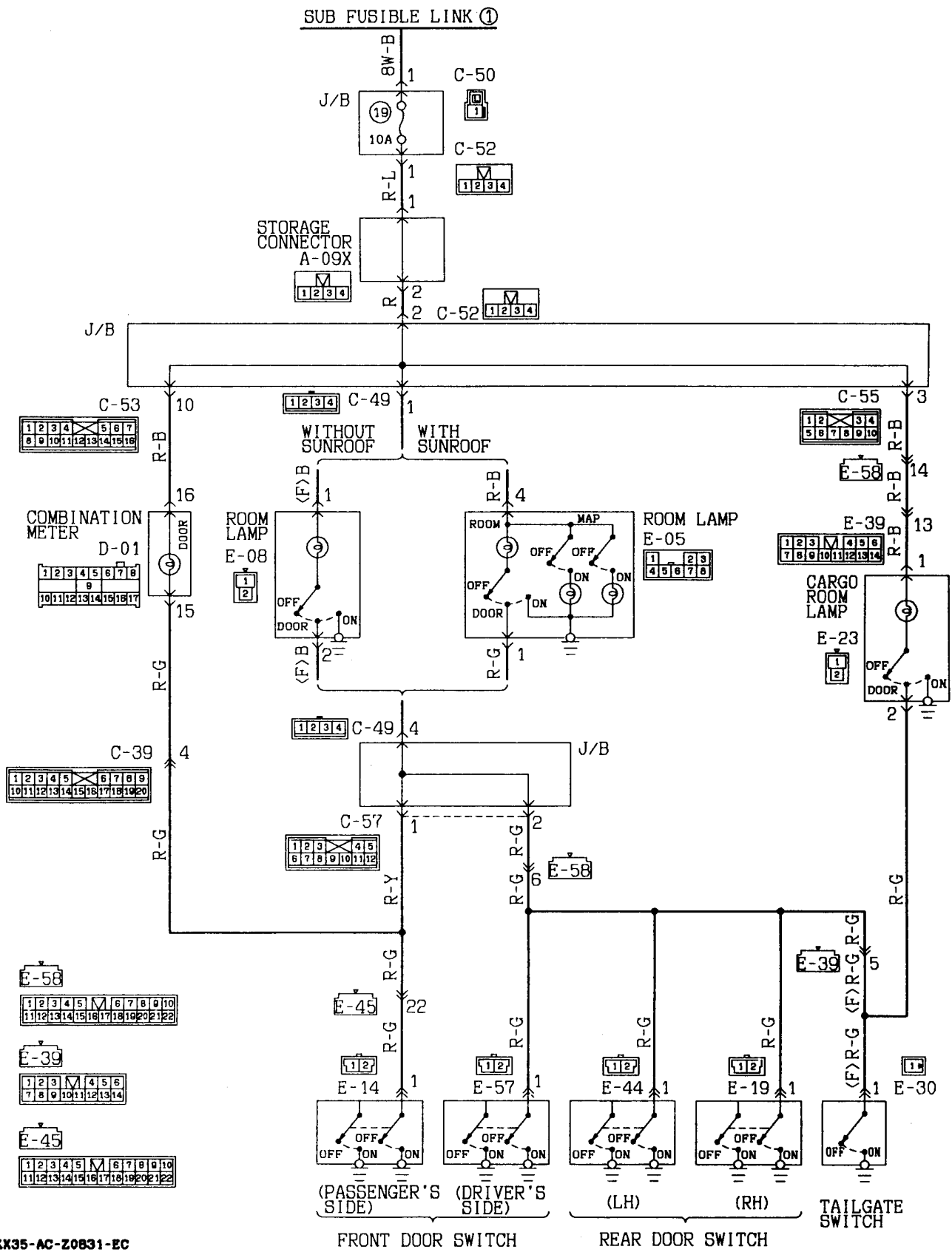

KX35-AC-Z0831-EC

13 DOOR LAMP  
13-1 L.H. drive vehicles

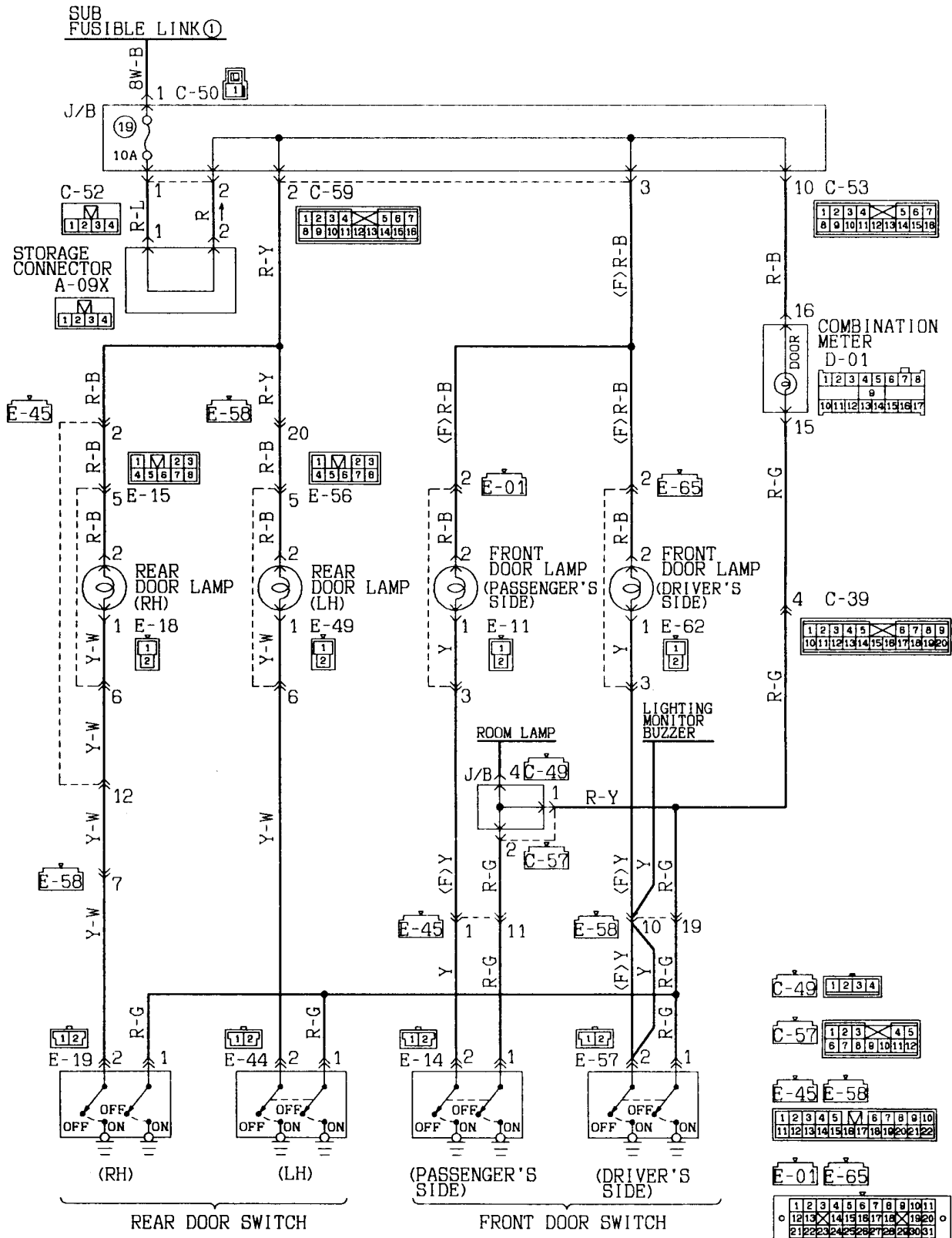

Wire colour code  
B:Black LG:Light green G:Green L:Blue W:White Y:Yellow  
BR:Brown O:Orange GR:Gray R:Red P:Pink V:Violet

13-2 R. H. drive vehicles

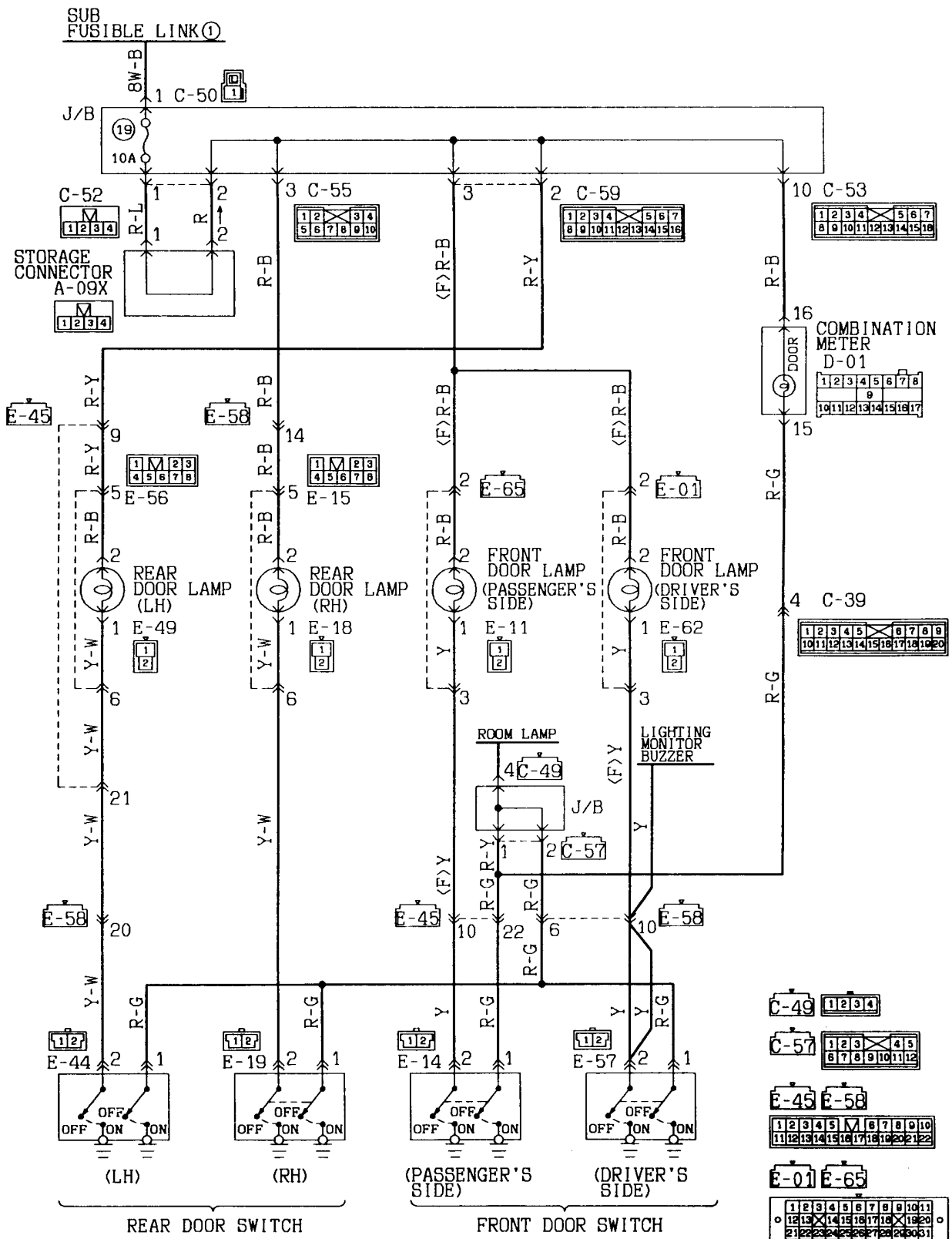

Wire colour code  
 B:Black L:Light green G:Green L:Blue W:White Y:Yellow Sb:Sky blue  
 Br:Brown O:Orange Gr:Gray R:Red P:Pink V:Violet

14 CLUSTER SWITCH ILLUMINATION LAMP

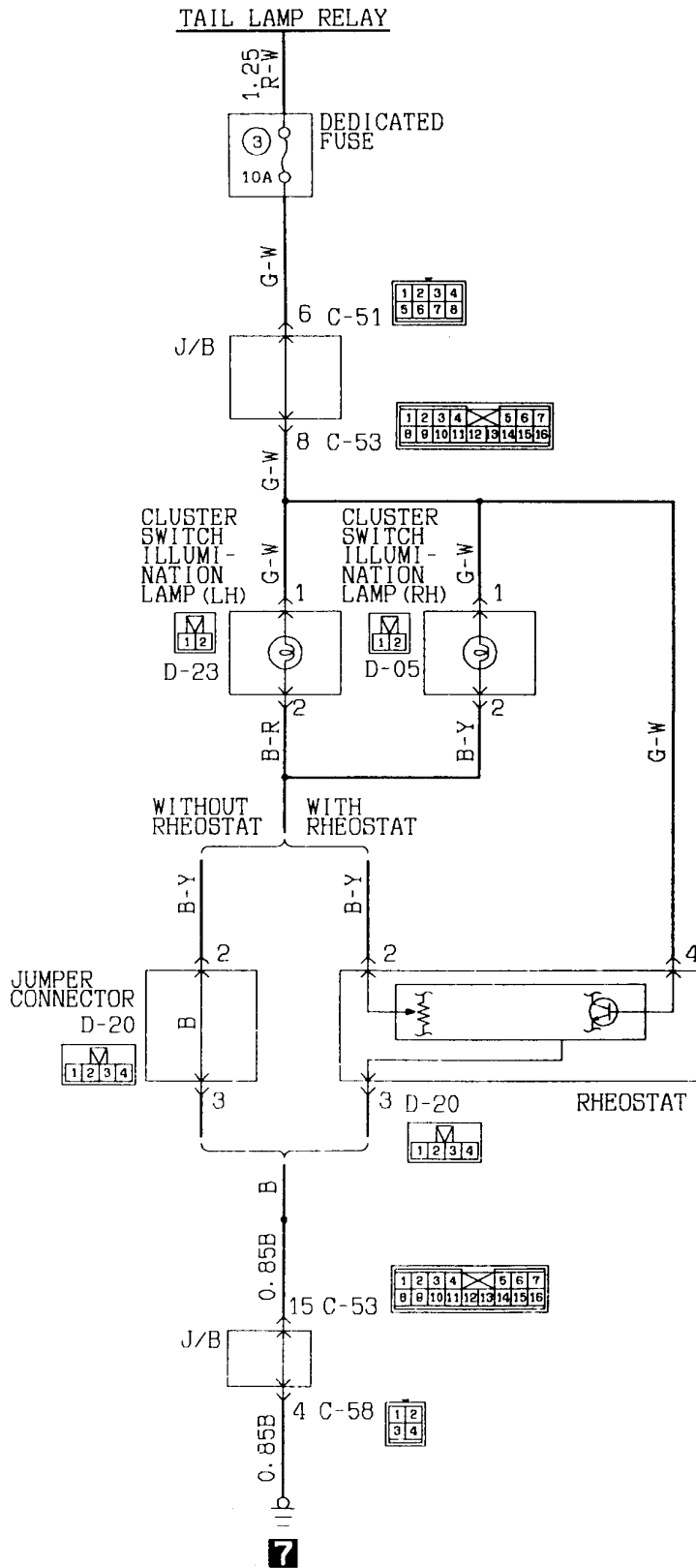

Wire colour code  
 B:Black LG:Light green G:Green L:Blue W:White Y:Yellow SB:Sky blue  
 BR:Brown O:Orange GR:Gray R:Red P:Pink V:Violet

KX35-AC-Z0908-EC

15 TURN SIGNAL LAMP AND HAZARD LAMP

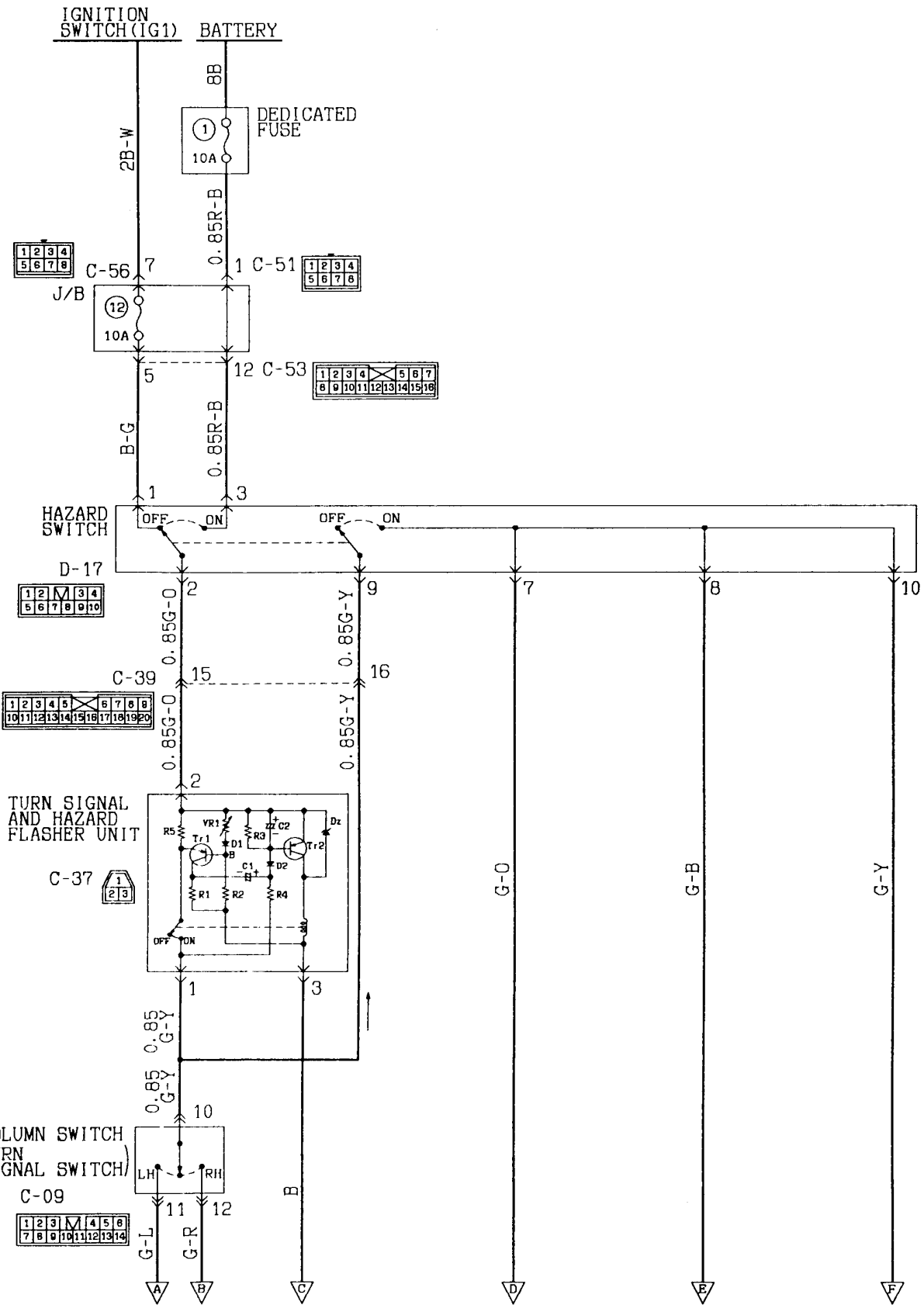

KX35-AC-Z0909-2C

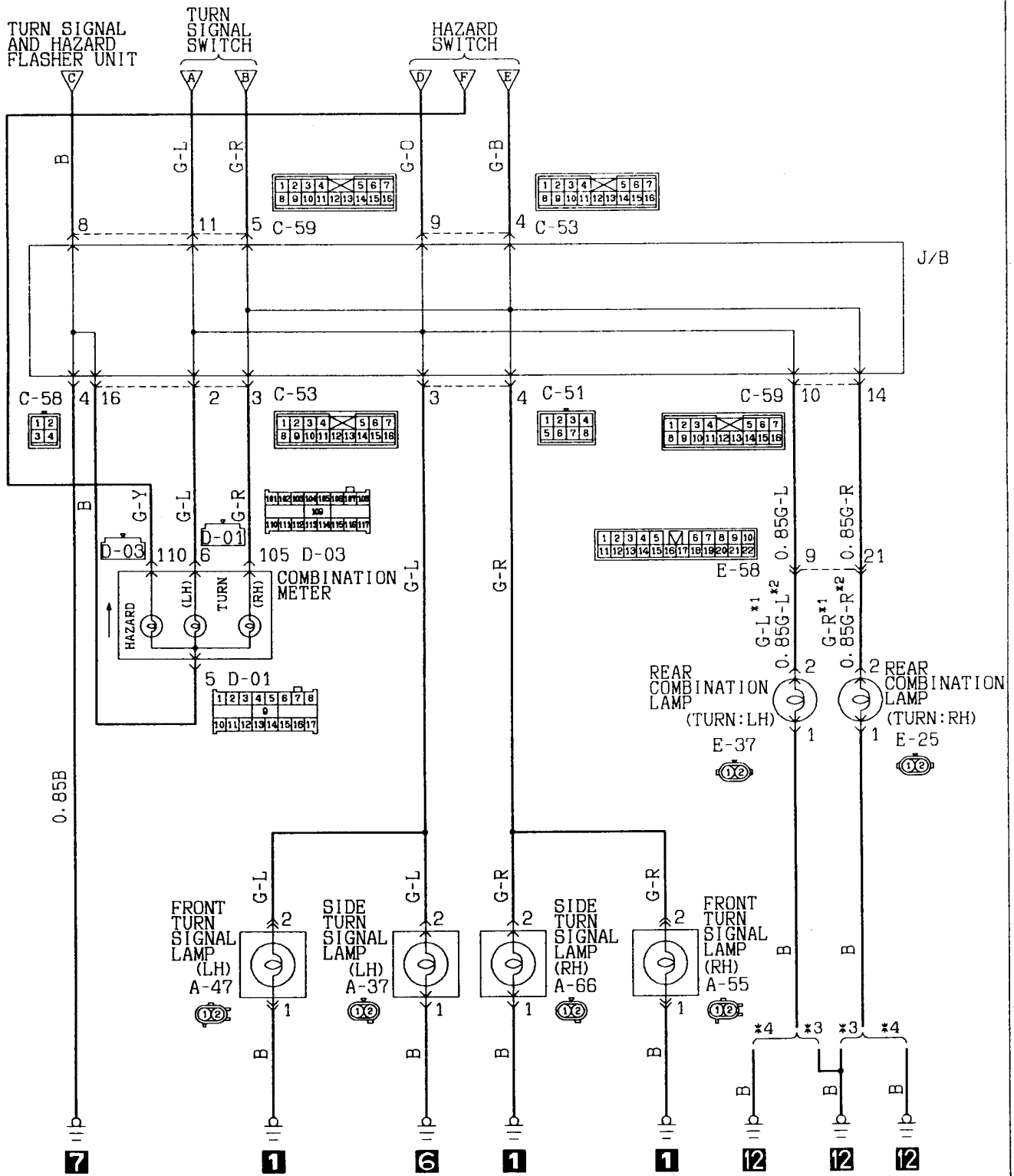

Remarks  
 (1) \*1: SPACE RUNNER (LHD)  
 (2) \*2: SPACE RUNNER (RHD) and SPACE WAGON  
 (3) \*3: SPACE RUNNER (RHD)  
 (4) \*4: SPACE RUNNER (LHD) and SPACE WAGON

Wire colour code  
 B:Black LG:Light green G:Green L:Blue W:White Y:Yellow SB:Sky blue  
 BR:Brown O:Orange GR:Gray R:Red P:Pink V:Violet



**TURN-SIGNAL LAMP AND HAZARD LAMP (See P. 4-78.)****OPERATION****<Turn-signal lamp>****1. In normal operating condition**

- When the ignition switch is turned to the "ON" position, current flows to the flasher unit via the hazard lamp switch, and the Tr1 in the flasher unit turns "ON" (Tr2 remains "OFF").
- When the turn signal switch is moved to the "LH" (or "RH") position, the base current in Tr2 flows to D2, R4, the turn signal switch, the turn signal lamp and the earth. The relay coil operates to close the relay contact, turning Tr2 "ON", and the turn signal lamp illuminates.
- When the relay contact closes, the emitter-side voltage in Tr1 drops and Tr1 turns "OFF". However, Tr2 stays "ON" so that the charge current in C2 flows to D2, C1, R1 and to the earth.
- When C1 is fully charged, the current from C2 stops flowing and Tr2 turns "OFF". The relay contact opens and the lamp switches off.
- When the relay contact opens, C1 discharges electricity through the R4, switch, lamp, earth, power, R5 and Tr1 closed circuit to increase the emitter-side voltage in Tr1 and turn Tr1 "ON". At this time, the lamp does not illuminate due to the large resistance in R4.
- When the electrical discharge from C1 is completed, Tr2 turns "ON". The relay contact closes, and the lamp illuminates.
- By repetition of the above operations, the turn signal lamps and the turn signal indicator for "LH" (or "RH") continues to flash.

**2. When one bulb is burnt out**

- When any one of the turn signal lamps is burnt out the resistance in the whole of the lamp circuit increases, so even if the relay contact closes, Tr1 will not turn completely "OFF".
- Because of this, a small amount of collector current will flow through Tr1, and so C1 will become completely charged in a quicker time than normal, and the illumination time for the lamps will become shorter.
- The relay contact will open and C1 will discharge electricity, but the charge voltage will be low, so the discharge time will be shorter than normal.
- Because of the above operation, the lamps will flash continuously at a faster frequency than normal.

**<Hazard lamp>**

- When the hazard switch is placed in the ON position, the flasher unit relay contacts repeatedly close and open, which results in the RH and LH turn-signal lamps, turn-signal indicator lamps, and hazard warning indicator lamps flashing on and off at the same time.

**Remarks**

- The number of times the hazard lamps flash on and off does not change even when one bulb is out.

**TROUBLESHOOTING HINTS**

1. Neither the turn-signal lamps nor hazard lamps operate.
  - Check hazard switch contacts (on power source end).
  - Check the flasher unit.
2. All LH or RH turn-signal lamps do not operate.
  - (1) Hazard lamp is fully operational.
    - Check hazard switch contacts (on turn-signal end).
    - Check the turn-signal switch.
3. Flashing cycle of turn signal lamps is shorter.
  - Check bulb.
4. Hazard lamp does not operate.
  - (1) Turn-signal lamps are operational.
    - Check hazard switch contacts (on hazard lamp end).

16 STOP LAMP

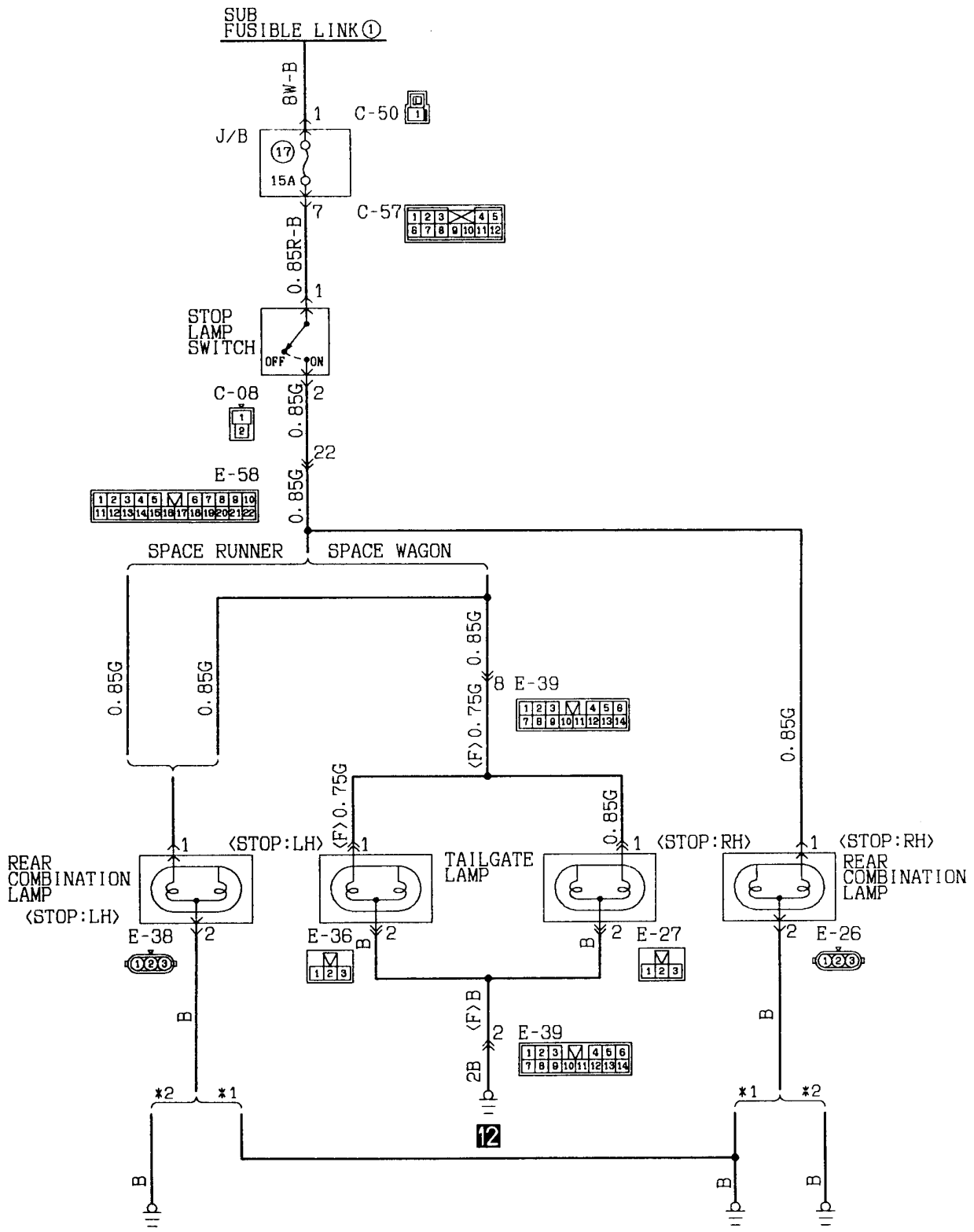

Remarks  
 (1) \*1: SPACE RUNNER (RHD)  
 (2) \*2: SPACE RUNNER (LHD) and SPACE WAGON

Wire colour code  
 B:Black LG:Light green G:Green L:Blue W:White Y:Yellow SB:Sky blue  
 BR:Brown O:Orange GR:Gray R:Red P:Pink V:Violet

KX35-AC-Z0910-EC

17 BACK-UP LAMP

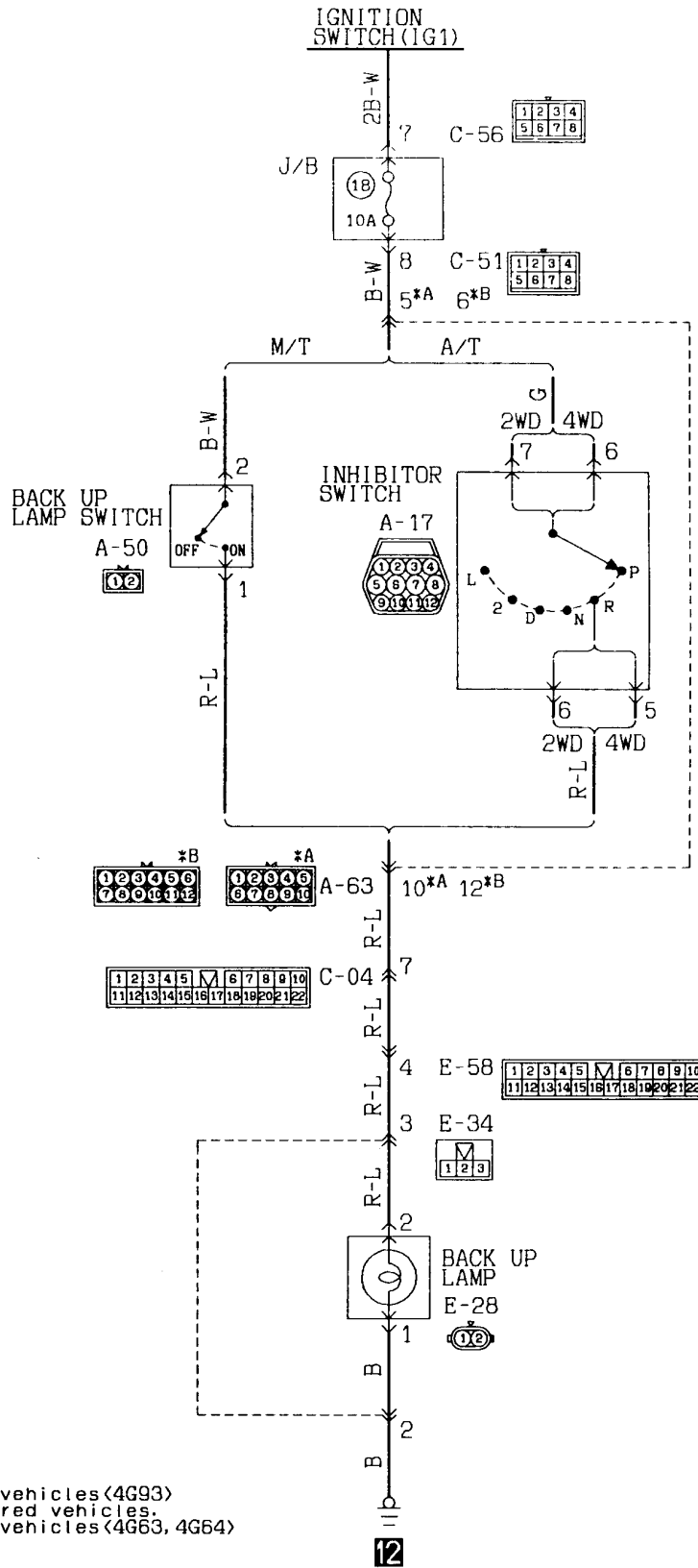

Remarks  
 \*A: Petrol-powered vehicles (4G93) and diesel-powered vehicles.  
 \*B: Petrol-powered vehicles (4G63, 4G64)

Wire colour code  
 B: Black LG: Light green G: Green L: Blue W: White Y: Yellow SB: Sky blue  
 BR: Brown O: Orange GR: Gray R: Red P: Pink V: Violet

18 LIGHTING MONITOR BUZZER

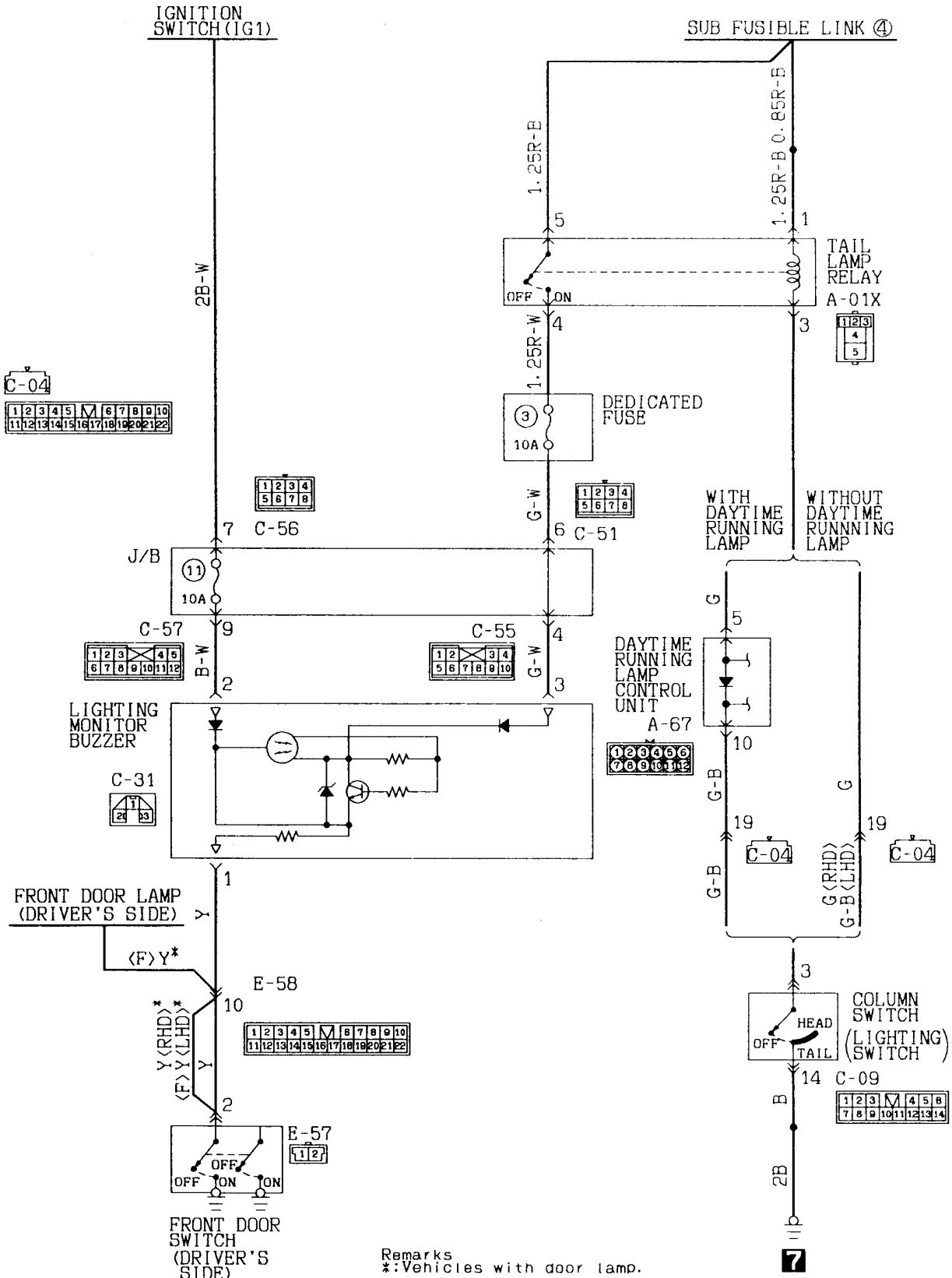

Remarks  
\*: Vehicles with door lamp.

Wire colour code  
 B: Black    LG: Light green    G: Green    L: Blue    W: White    Y: Yellow    SB: Sky blue  
 BR: Brown    O: Orange    GR: Gray    R: Red    P: Pink    V: Violet

**LIGHTING MONITOR BUZZER (See P. 4-83.)****OPERATION**

- Placing the lighting switch in the TAIL or HEAD position causes the tail lamp relay to be energized.
- When the ignition switch is in the "OFF" position in this condition, if the driver's side door is opened and the front door switch turns "ON", the buzzer sounds to indicate that the lamps are not switched off.

**TROUBLESHOOTING HINTS**

1. Lighting monitor buzzer doesn't sound.
  - (1) But the tail lamps do illuminate.
    - Check the lighting monitor buzzer.
    - Check the front door switch (driver's side).
  - (2) The tail lamps also don't illuminate.
    - Check the sub fusible link No. ④.
    - Check the dedicated fuse No. ③.

19 HORN

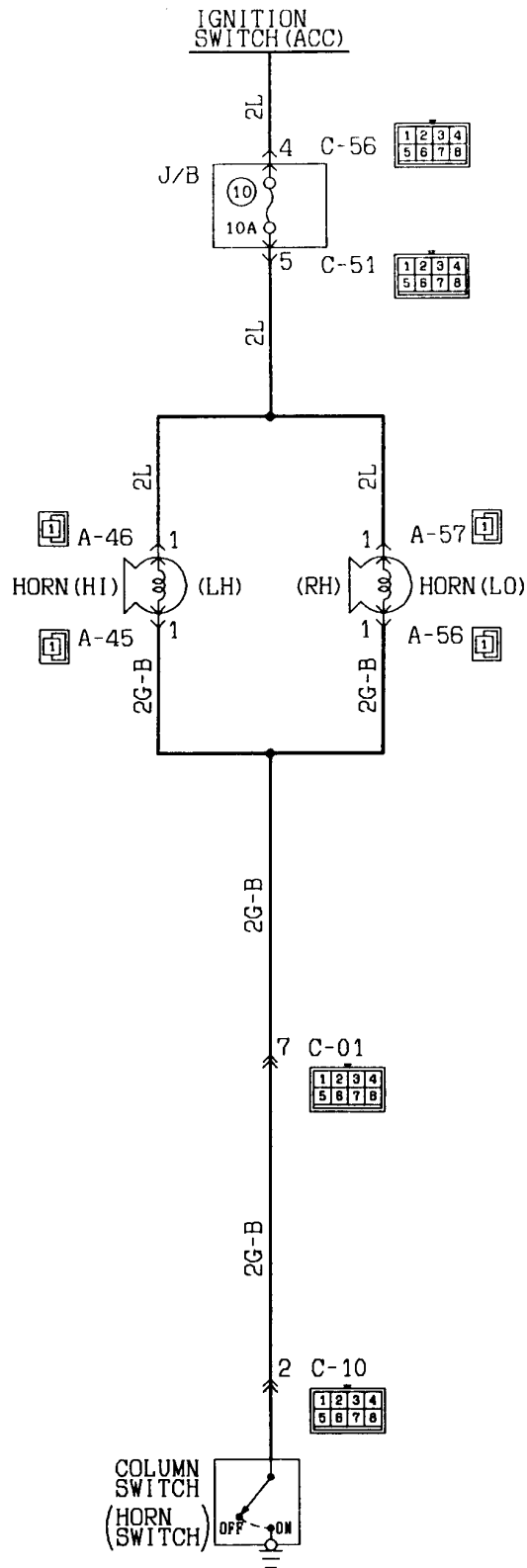

Wire colour code  
 B:Black LG:Light green G:Green L:Blue W:White Y:Yellow SB:Sky blue  
 BR:Brown O:Orange GR:Gray R:Red P:Pink V:Violet

20 METER AND GAUGE

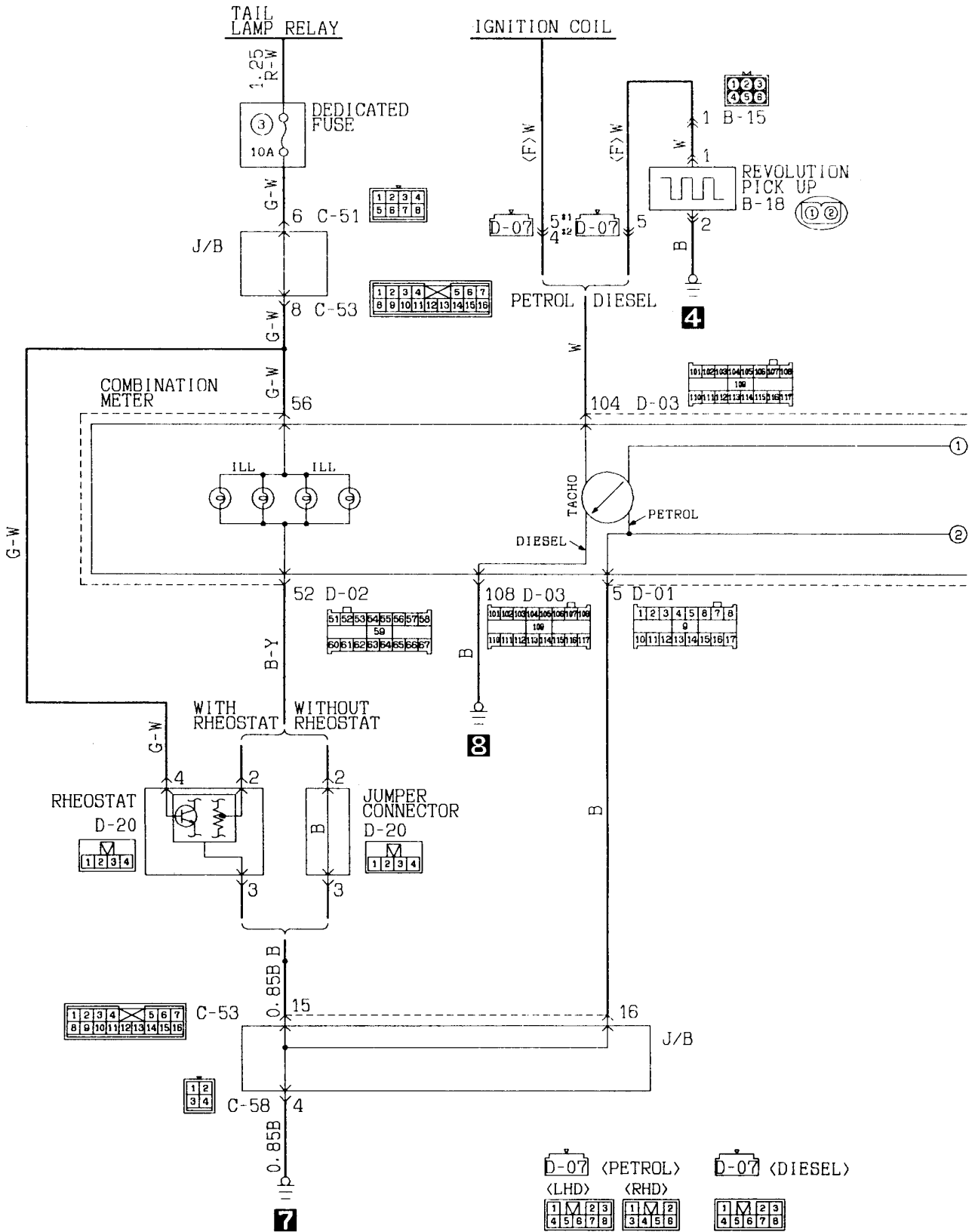

Wire colour code  
 B:Black LG:Light green G:Green L:Blue W:White Y:Yellow SB:Sky blue  
 BR:Brown O:Orange GR:Gray R:Red P:Pink V:Violet

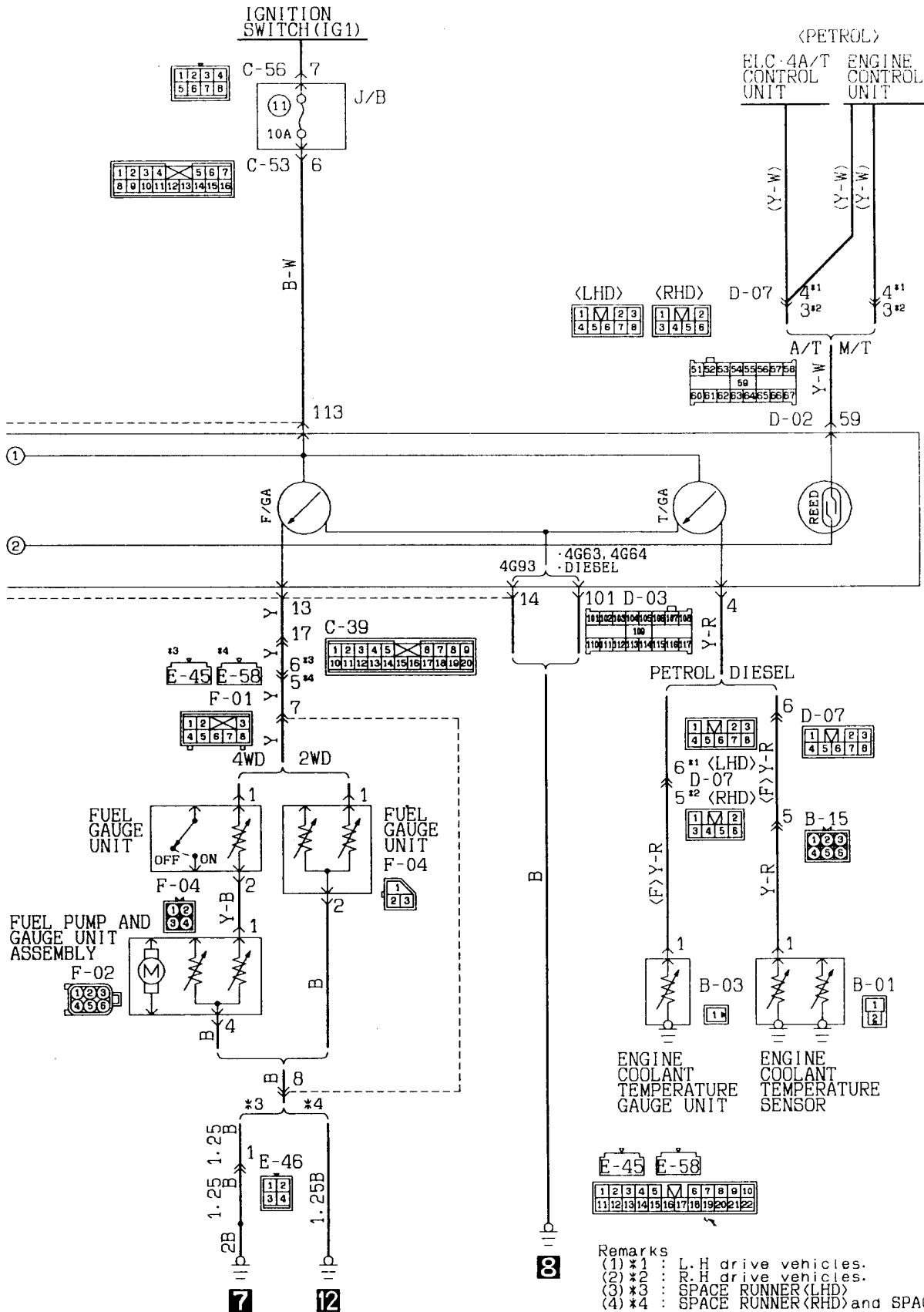

Remarks

- (1) \*1 : L.H drive vehicles.
- (2) \*2 : R.H drive vehicles.
- (3) \*3 : SPACE RUNNER <LHD>
- (4) \*4 : SPACE RUNNER <RHD> and SPACE WAGON



**METER AND GAUGE (See P. 4-86.)****OPERATION****<Fuel gauge>**

- When the ignition switch is at the "ON" position, the fuel gauge is activated.
- When there is much fuel, the unit's resistance is small and the current flowing in the circuit is great, so the gauge's indicator indicates in the "F" area.
- When there is little fuel, the unit's resistance is high and the current flowing in the circuit is small, so the gauge's indicator indicates in the "E" area.

**<Engine coolant temperature gauge>**

- When the ignition switch is at the "ON" position, the engine coolant temperature gauge is activated.
- When the engine coolant temperature is high, the unit's resistance is low and there is a great flow of current in the circuit, so the gauge's indicator indicates in the "H" area.
- When the engine coolant temperature is low, the unit's resistance is high and there is a small flow of current in the circuit, so the gauge's indicator indicates in the "C" area.

**<Reed switch>**

- This switch generates pulses according to the current vehicle speed and provides a vehicle-speed signal for the control systems using vehicle speeds as an input source (such as transmission control system).

**TROUBLESHOOTING HINTS**

1. Fuel gauge does not operate, or registers incorrectly.
  - (1) The fuel gauge indicates "F" when the fuel gauge unit connector is disconnected and the "1" terminal is earthed.
    - Check fuel gauge.
2. Engine coolant temperature gauge does not operate, or registers incorrectly.
  - (1) The engine coolant temperature gauge indicates "H" when the engine coolant temperature gauge unit (PETROL) or the engine coolant temperature sensor (DIESEL) connector is disconnected and the "1" terminal is earthed.
    - Check the engine coolant temperature gauge unit (PETROL) or the engine coolant temperature sensor (DIESEL).
3. Vehicle-speed-dependent control systems do not operate.
  - Check the reed switch of speedometer.
4. Meter illumination lamp does not come on.
  - (1) Tail lamps do come on.
    - Check the rheostat.
    - Check earth.

NOTES

# 21 WARNING LAMP

21-1 Petrol-powered vehicles

SUB FUSIBLE LINK ①

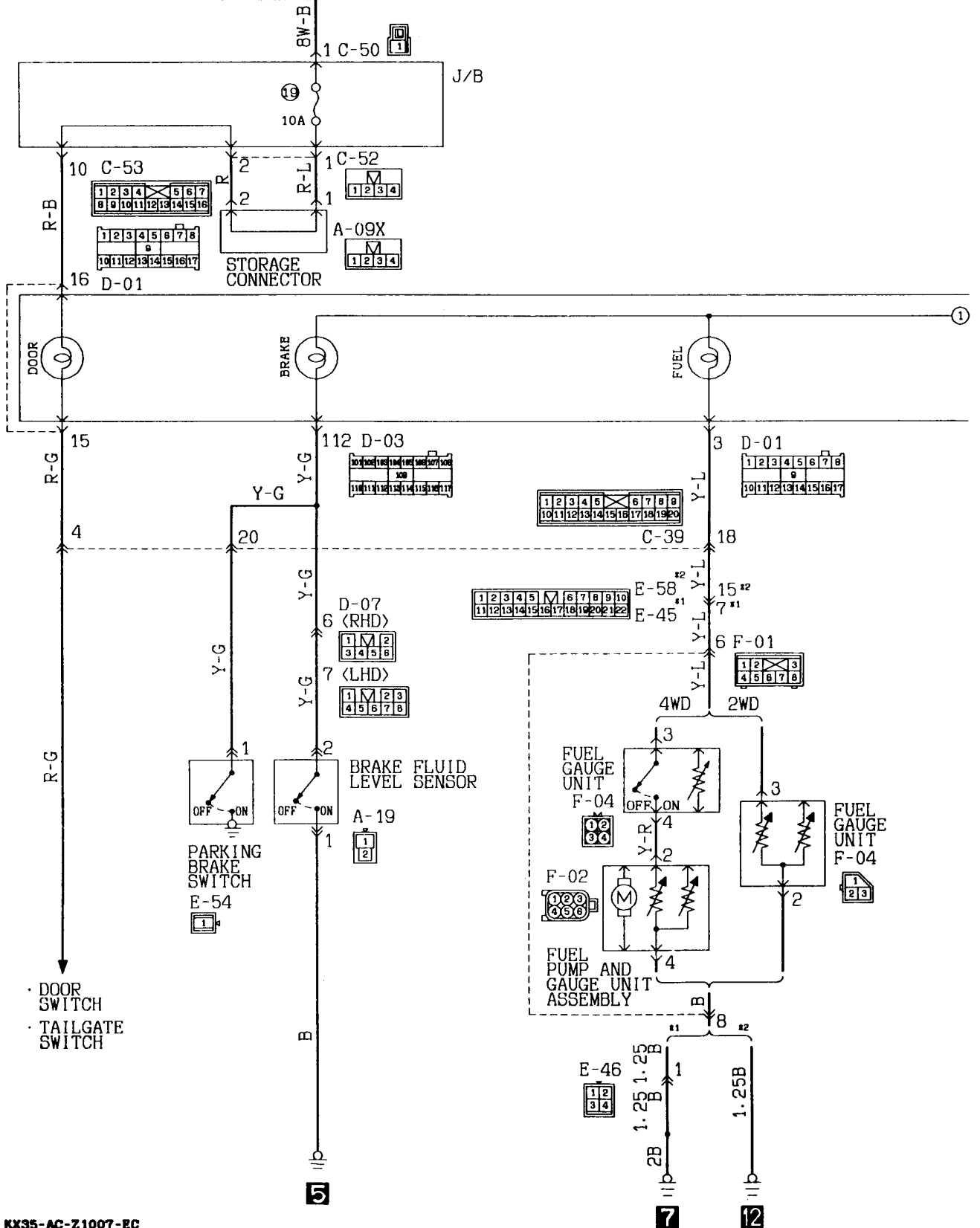

KX35-AC-Z1007-EC

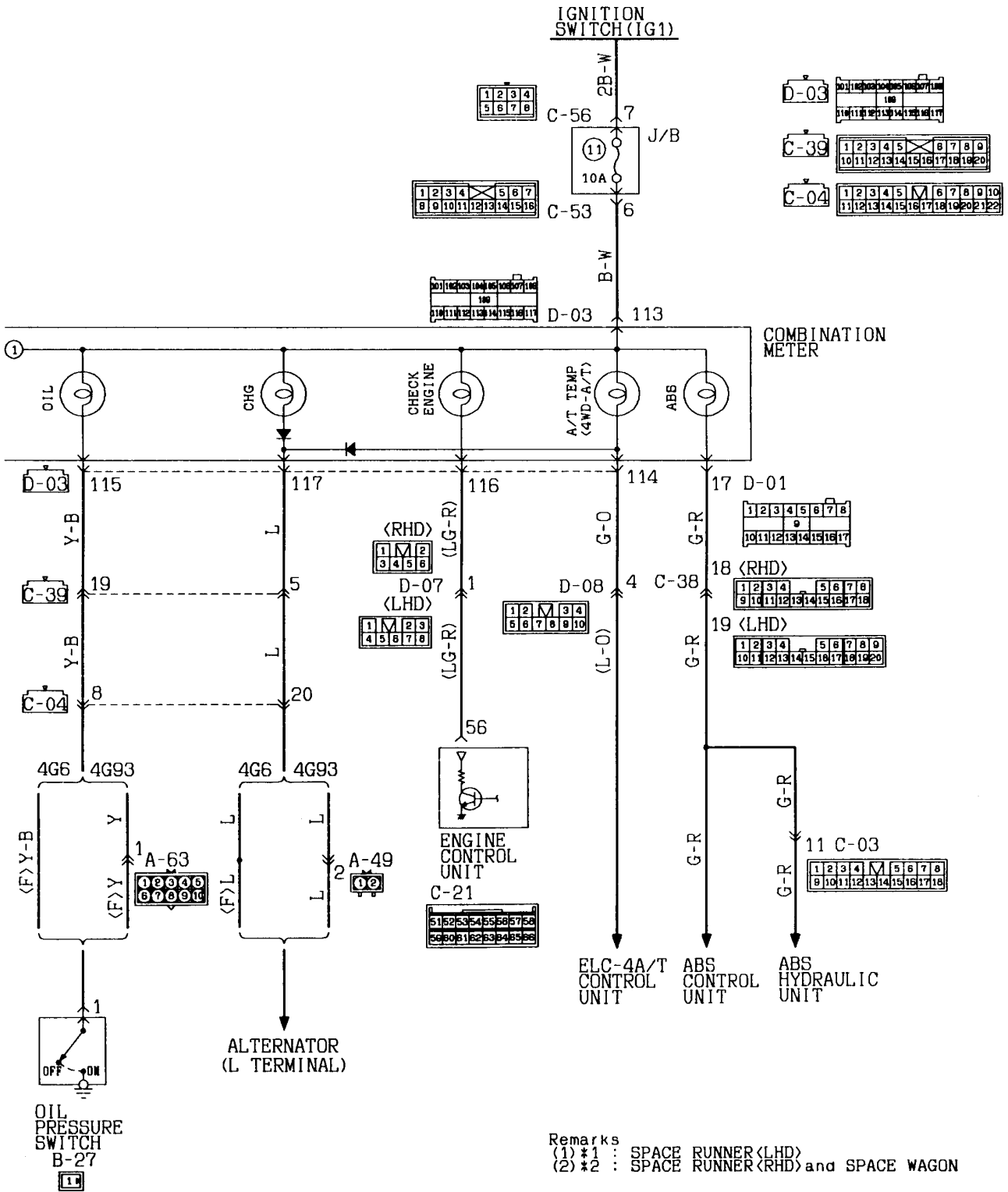

Remarks  
 (1) \*1 : SPACE RUNNER <LHD>  
 (2) \*2 : SPACE RUNNER <RHD> and SPACE WAGON

Wire colour code  
 B:Black LG:Light green G:Green L:Blue W:White Y:Yellow SB:Sky blue  
 BR:Brown O:Orange GR:Gray R:Red P:Pink V:Violet

21-2 Diesel-powered vehicles

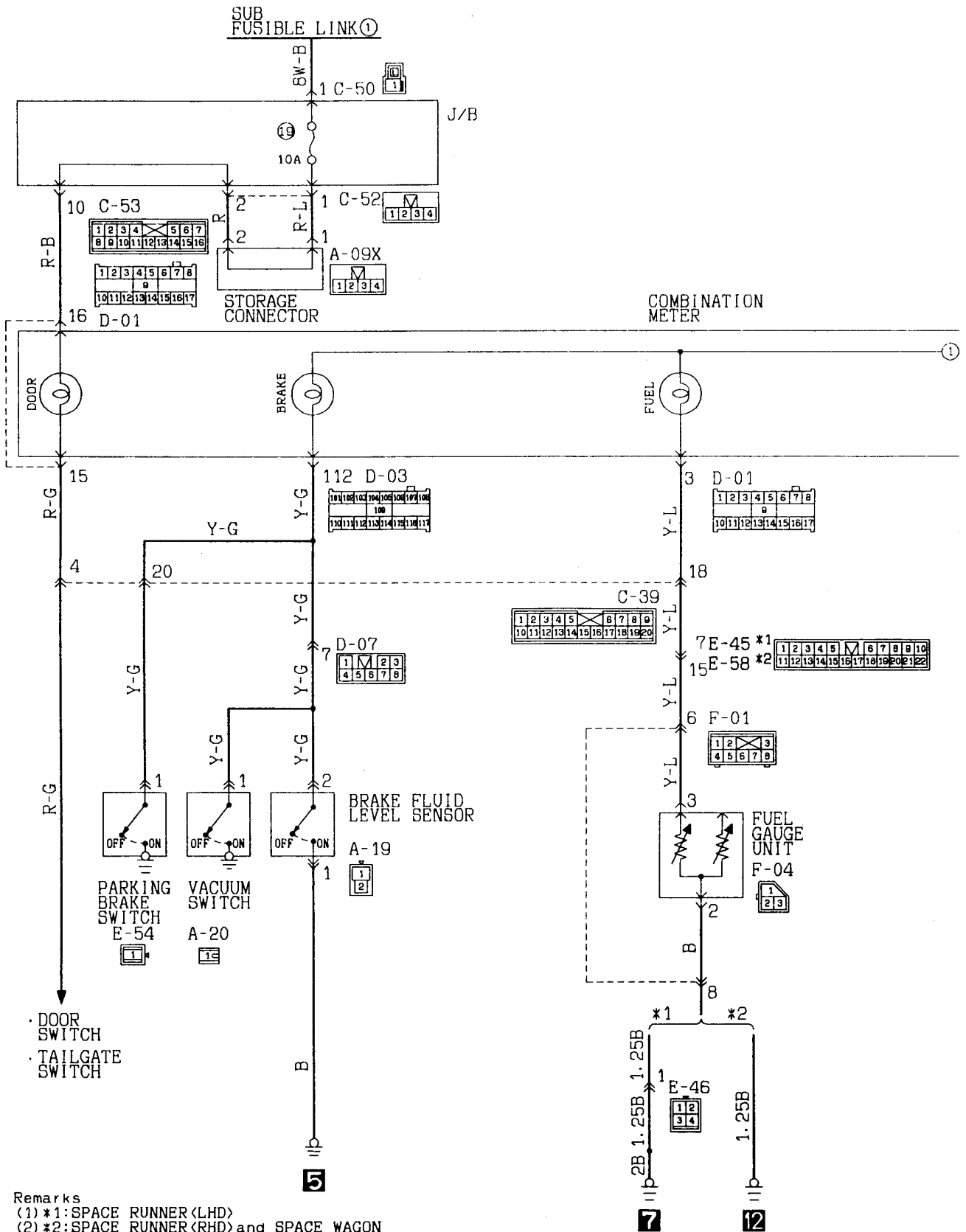

KX35-AC-Z1008-EC

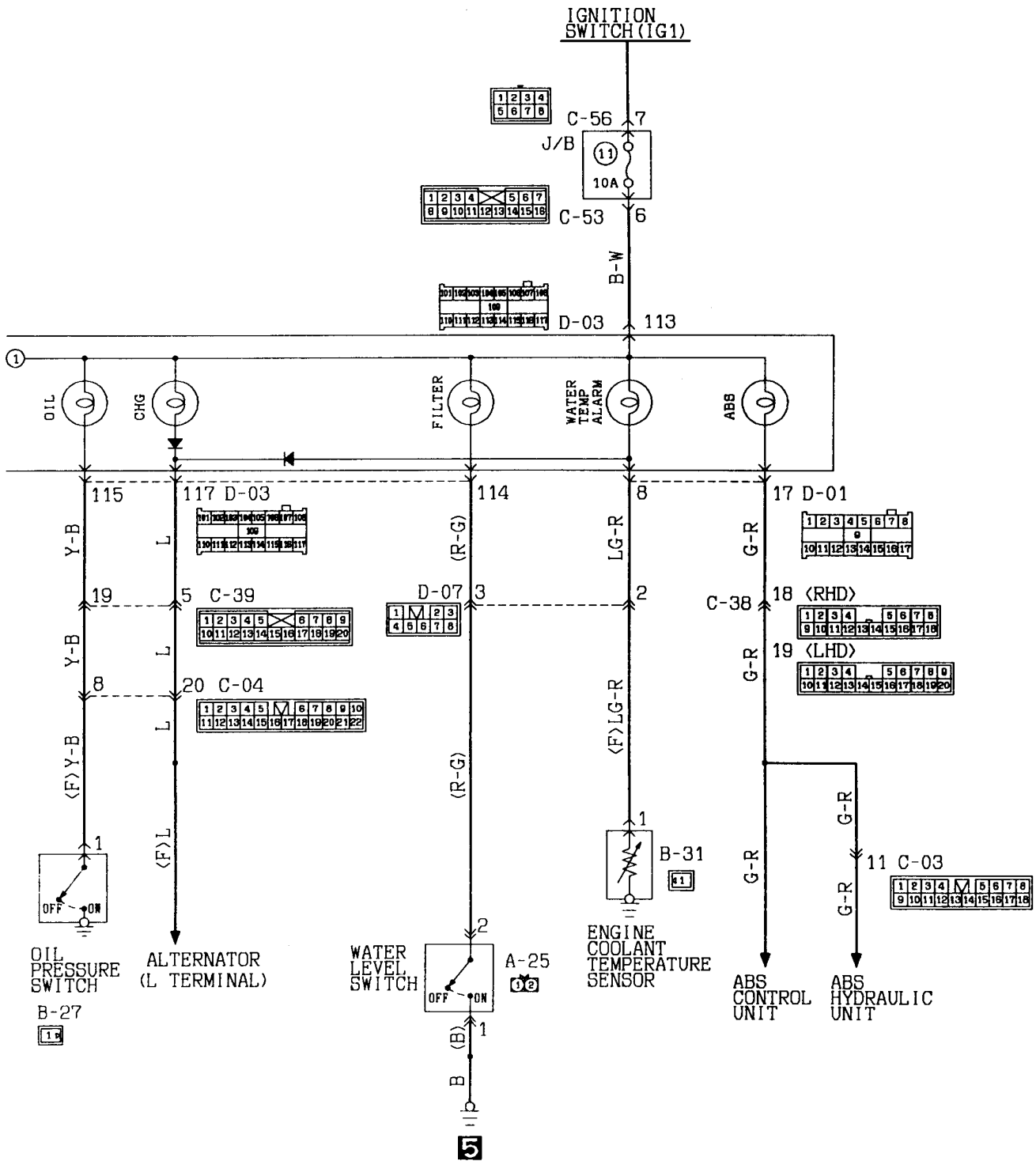

Wire colour code  
 B:Black LG:Light green G:Green L:Blue W:White Y:Yellow SB:Sky blue  
 BR:Brown O:Orange GR:Gray R:Red P:Pink V:Violet

**WARNING LAMP (See P. 4-90, 92.)****OPERATION****<Brake warning lamp>**

- When the brake fluid level goes down below a predetermined level or parking brake lever is pulled, with the ignition switch in the ON position, the brake fluid level sensor is activated or the parking brake switch is turned ON, causing the brake warning lamp to light up.
- On diesel-powered vehicles, when the brake booster vacuum line fails, the vacuum switch is turned ON causing the brake warning lamp to light up.

**<Fuel warning lamp>**

- When the fuel level goes down causing the level sensor to be exposed, with the ignition switch in the ON position, the resistance of level sensor becomes small. When this resistance goes down below the predetermined level, the fuel warning lamp lights up to warn the driver that the amount of fuel still available for use is small.

**<Oil pressure warning lamp>**

- When the lubrication system fails with the ignition switch in the ON position resulting in the oil pressure failing to build up, the oil pressure switch turns ON causing the oil pressure warning lamp to light up.

**<Charge warning lamp>**

- See CHARGING SYSTEM (P. 4-11.)

**<Check engine warning lamp>**

- See the Service Adjustment Procedure, in Group 11 of the separate WORKSHOP MANUAL (Pub. No. PWDE9104.)

**<Fuel filter warning lamp>  
(Diesel-powered vehicles)**

- When the ignition switch is turned to the "ON" position (with the engine stopped), the fuel filter warning lamp comes on and the lamp switches OFF when the engine is started. This feature can be used to check for a failure of the lamp's bulb.
- When condensate has accumulated in the fuel filter, the water level switch turns ON causing the fuel filter warning lamp to light up.

**<ABS warning lamp>  
(Vehicles with ABS system)**

- See the Troubleshooting of Anti-skid Brake in Group 35 of the separate WORKSHOP MANUAL (Pub. No. PWDE9104.)

**<Engine coolant temperature warning lamp>  
(Diesel-powered vehicles)**

- When the engine coolant temperature reaches 110°C (230°F), the engine coolant temperature switch is switched ON and the warning lamp illuminates.

**<Automatic transmission oil temperature warning lamp (A/T TEMP)>  
(4WD A/T)**

- When the ignition switch is in the "ON" position, the A/T fluid temperature sensor detects the temperature of the A/T fluid, and when it reaches the abnormal high temperature (approx. 150°C), the signal from the ELC-4A/T control unit causes the A/T fluid temperature warning lamp to illuminate as a warning.

21-3 LOW ENGINE OIL LEVEL WARNING LAMP  
 (Petrol-powered vehicles (4G63 and 4G64) and Diesel-powered vehicles (SPACE WAGON))

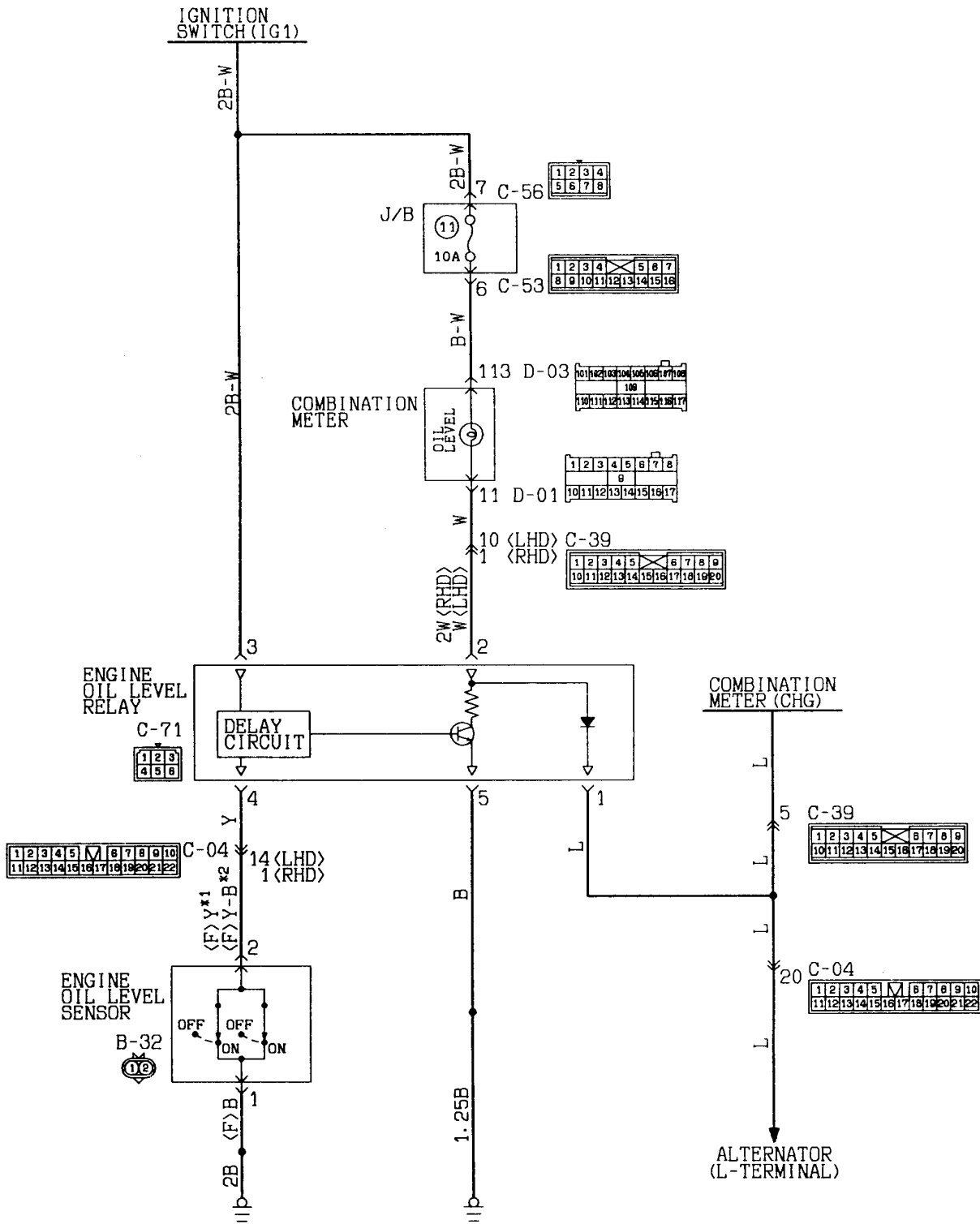

Remarks  
 (1) \*1: 4G6 (LHD)  
 (2) \*2: 4G6 (RHD) and 4D68

Wire colour code  
 B:Black LG:Light green G:Green L:Blue W:White Y:Yellow SB:Sky blue  
 BR:Brown O:Orange GR:Gray R:Red P:Pink V:Violet



22 INDICATOR LAMP

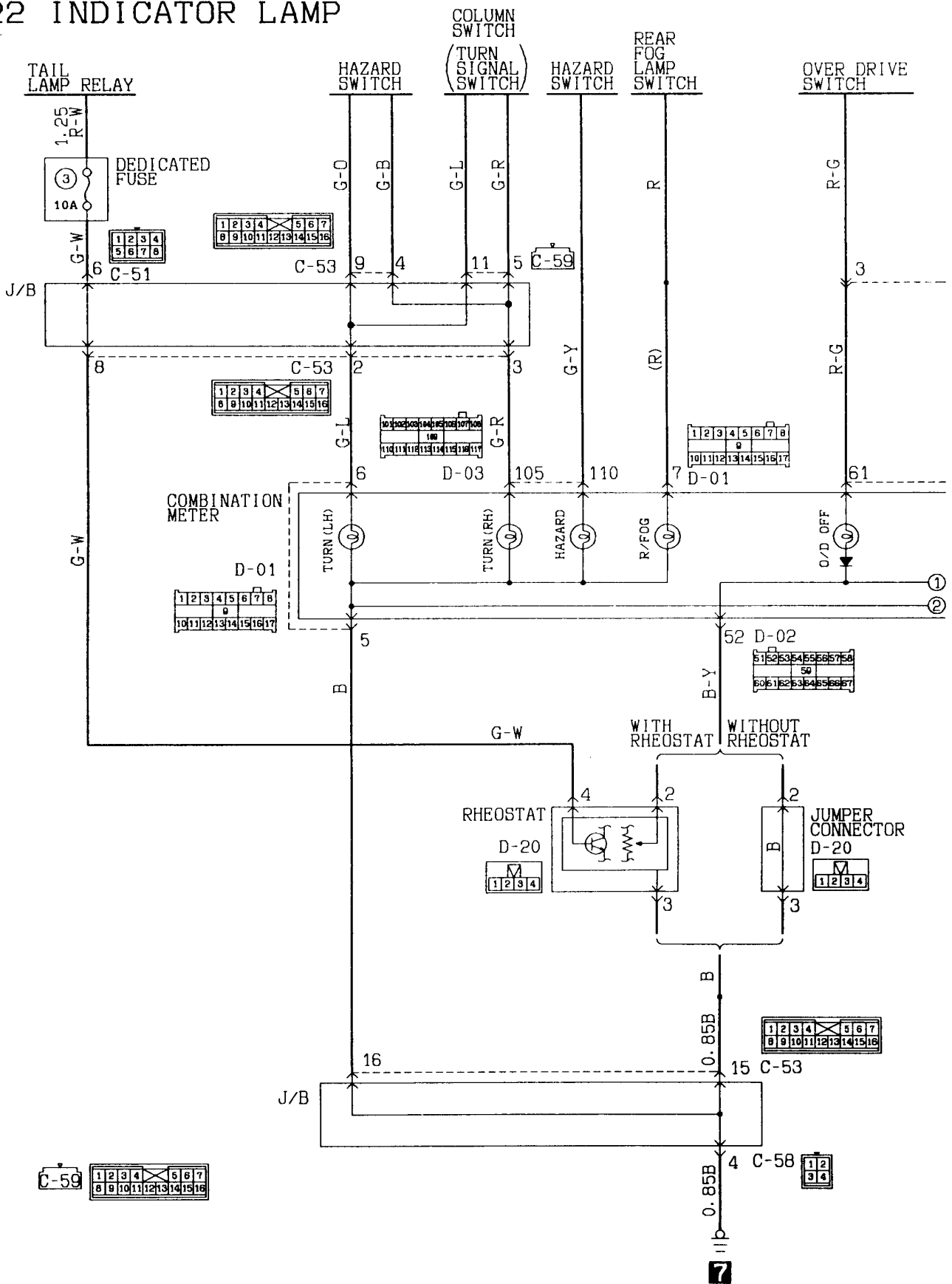

KX35-AC-Z1010-EC

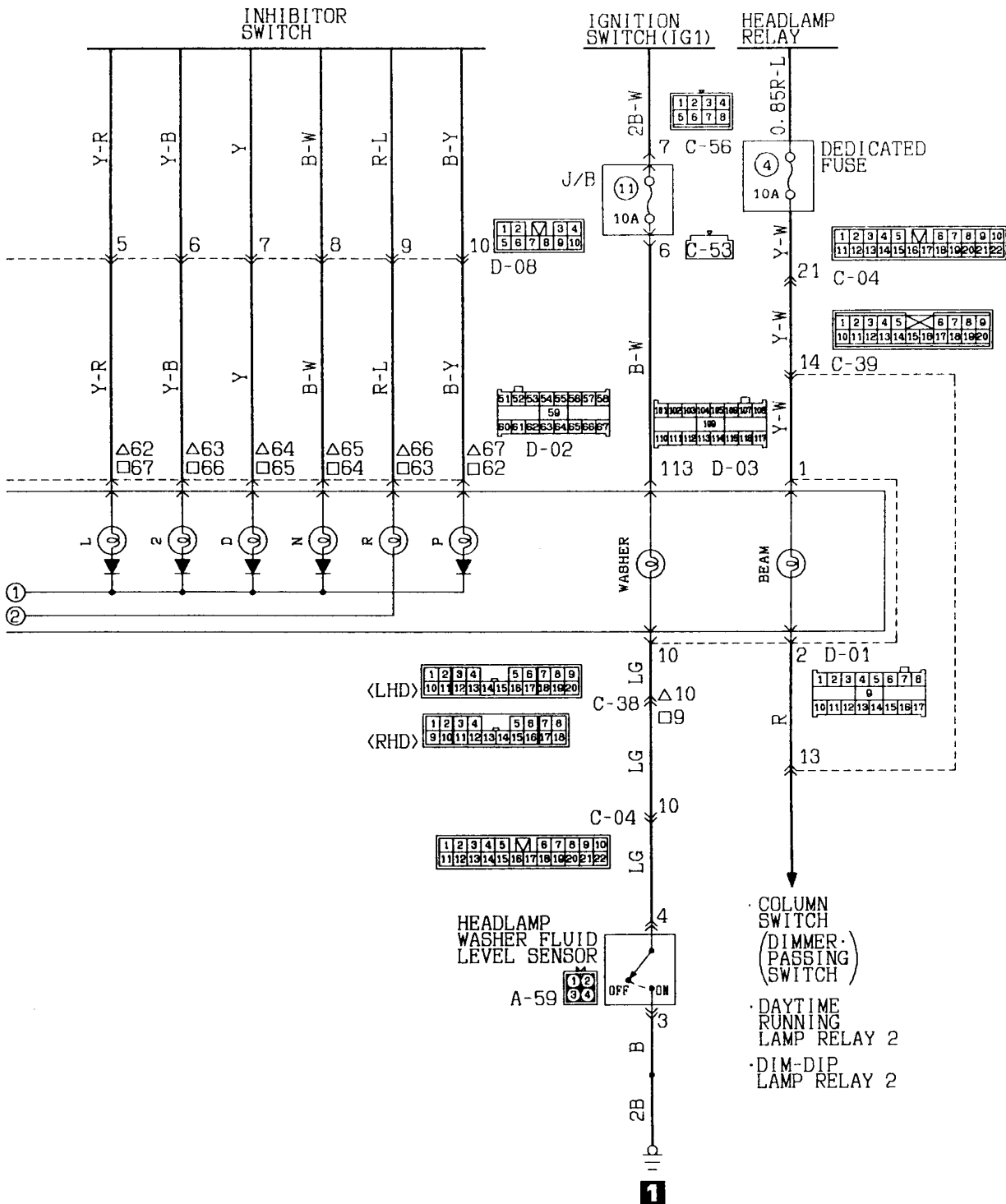

Remarks  
 (1)  $\Delta$ : L.H. drive vehicles.  
 (2)  $\square$ : R.H. drive vehicles.

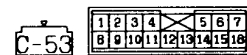

Wire colour code  
 B:Black LG:Light green G:Green L:Blue W:White Y:Yellow SB:Sky blue  
 BR:Brown O:Orange GR:Gray R:Red P:Pink V:Violet

**POWER WINDOW (See P. 4-99, 100, 102.)****OPERATION**

- When the power window (main or sub) switch is depressed (UP or DOWN) with the ignition switch in the ON position, current flows through sub-fusible link No. ⑨ to the power window motor. This energizes the power window motor causing the door window glass to open or close.
- When the DOWN side the power window main switch (driver's seat side switch) is depressed all the way, it is locked in the depressed position and the power window motor is operated until the door glass is fully opened.
- When the power window lock switch is placed in the LOCK (OFF) position, operating a switch other than the ones for the driver's and front passenger's side window (both main and sub) does not cause the power window motor to be operated.
- The power window motor is provide with a circuit breaker that protects the motor from damage caused by overcurrent.  
Reference: Circuit breaker characteristics Restricts the motor at room temperature [20 to 25°C (68 to 77°F)];  
Opens following 4-to-40sec. initial energization time;  
Resets within 60 seconds if left open thereafter.

**TROUBLESHOOTING HINTS**

1. All door glasses cannot be opened or closed.
  - Check the sub-fusible link No. ⑨.
  - Check the multi-purpose fuse No. ③.
  - Check the power window relay.
  - Check the power window main switch.
2. Some door glass cannot be opened or closed.
  - (1) Neither power window main nor sub switch is activated.
    - Check the power window main switch.
    - Check the defective power window motor.
  - (2) Either power window main or sub switch is inoperative.
    - Check the inoperative power window switch.
3. One-touch switch function is not operational.
  - Replace the power window main switch.

23 POWER WINDOW  
23-1 SPACE RUNNER

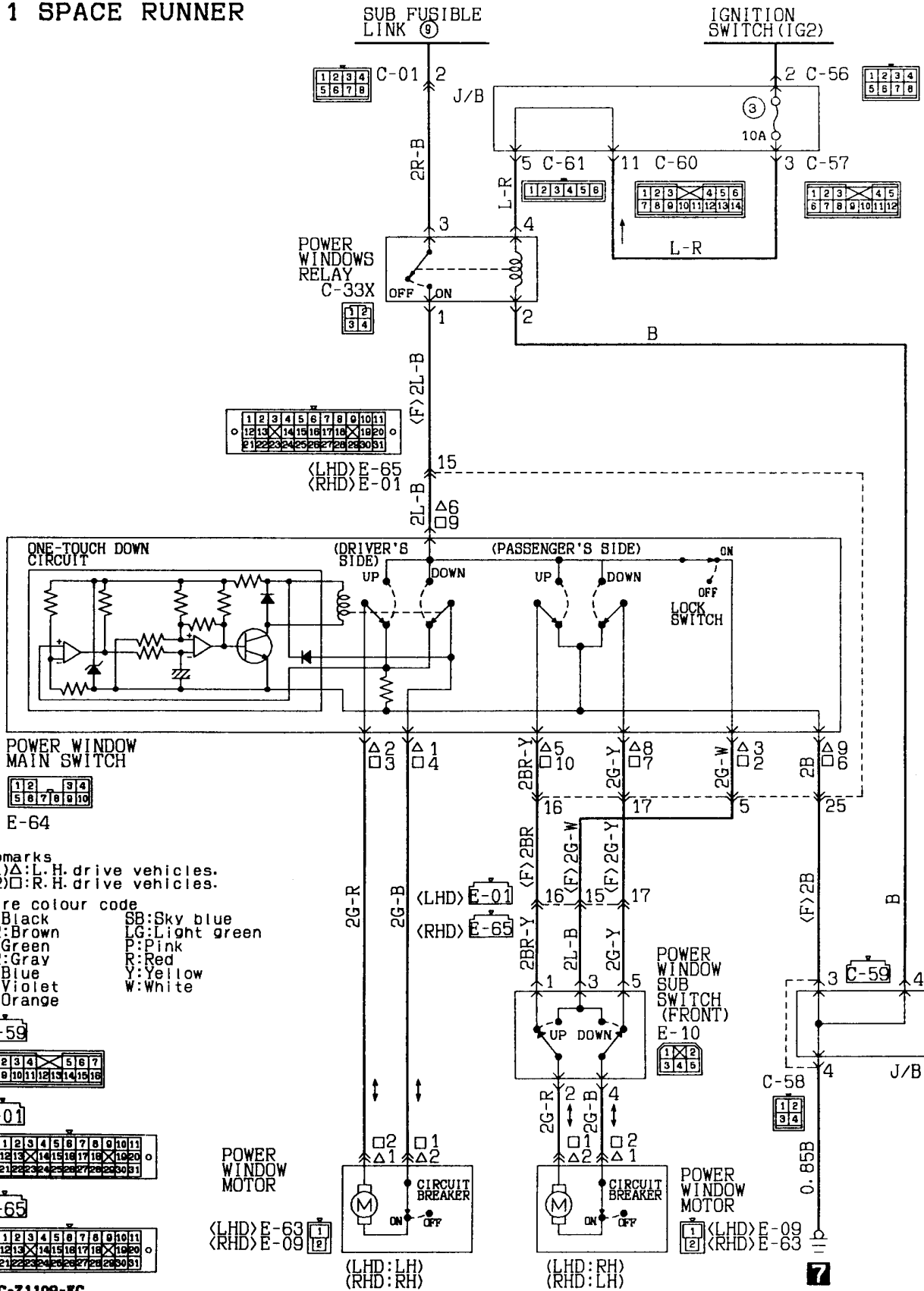

Remarks  
(1)Δ: L.H. drive vehicles.  
(2)□: R.H. drive vehicles.

Wire colour code  
B: Black  
BR: Brown  
G: Green  
GR: Gray  
L: Blue  
V: Violet  
O: Orange  
SB: Sky blue  
LG: Light green  
P: Pink  
R: Red  
Y: Yellow  
W: White

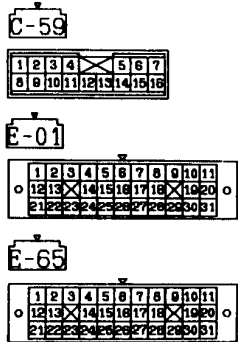

KX35-AC-Z1109-EC

23-2 SPACE WAGON<L.H. drive vehicles>

E-45

1	2	3	4	5	M	6	7	8	9	10	
11	12	13	14	15	16	17	18	19	20	21	22

1	2	3	4	M	5	6	7	8	9	
10	11	12	13	14	15	16	17	18	19	20

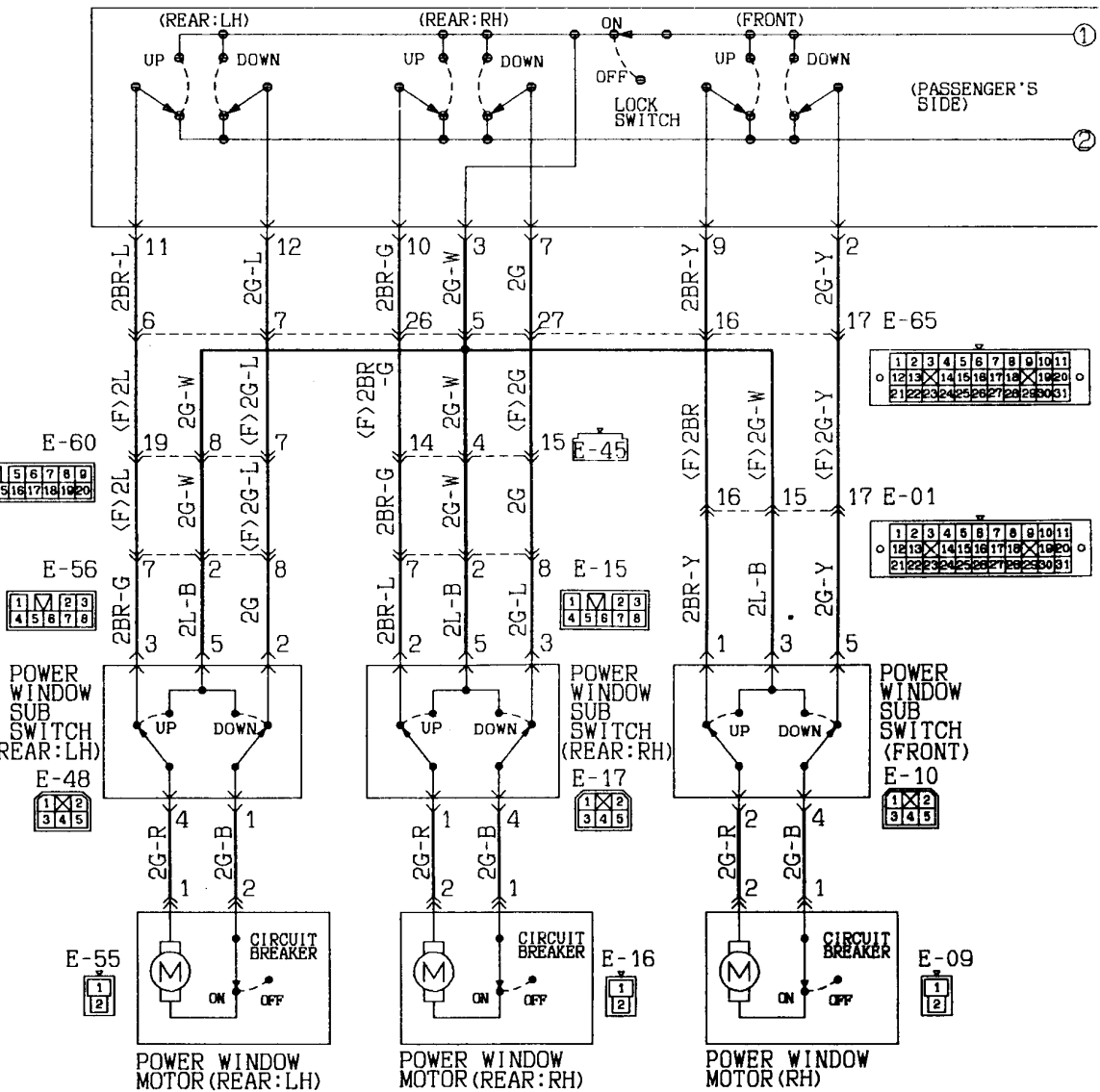

1	2	3	4	5	6	7	8	9	10	11
12	13	14	15	16	17	18	19	20	21	22

1	2	3	4	5	6	7	8	9	10	11
12	13	14	15	16	17	18	19	20	21	22

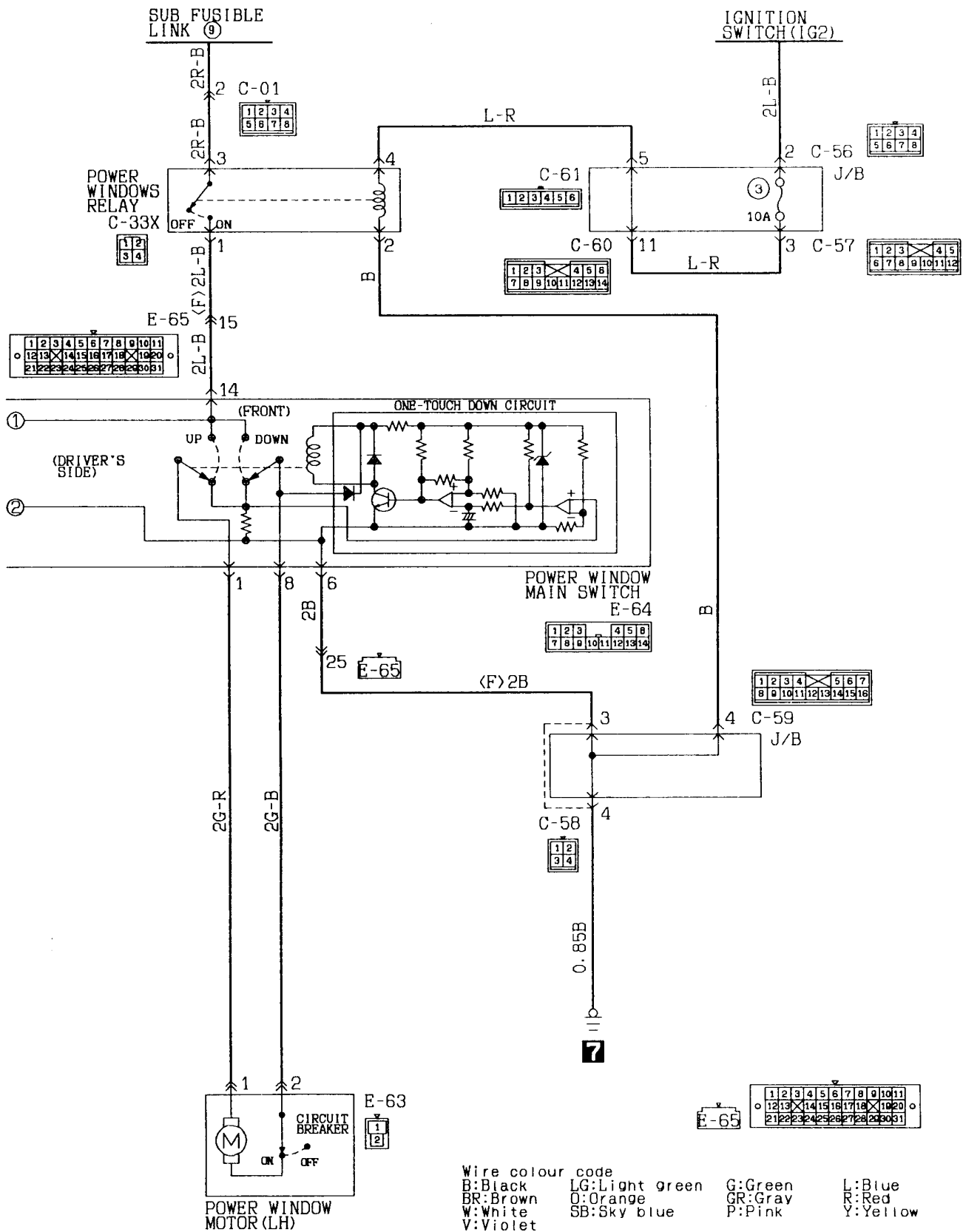

23-3 SPACE WAGON (R. H. drive vehicles)

E-45

1	2	3	4	5	M	6	7	8	9	10	
11	12	13	14	15	16	17	18	19	20	21	22

1	2	3	4	M	5	6	7	8	9	
10	11	12	13	14	15	16	17	18	19	20

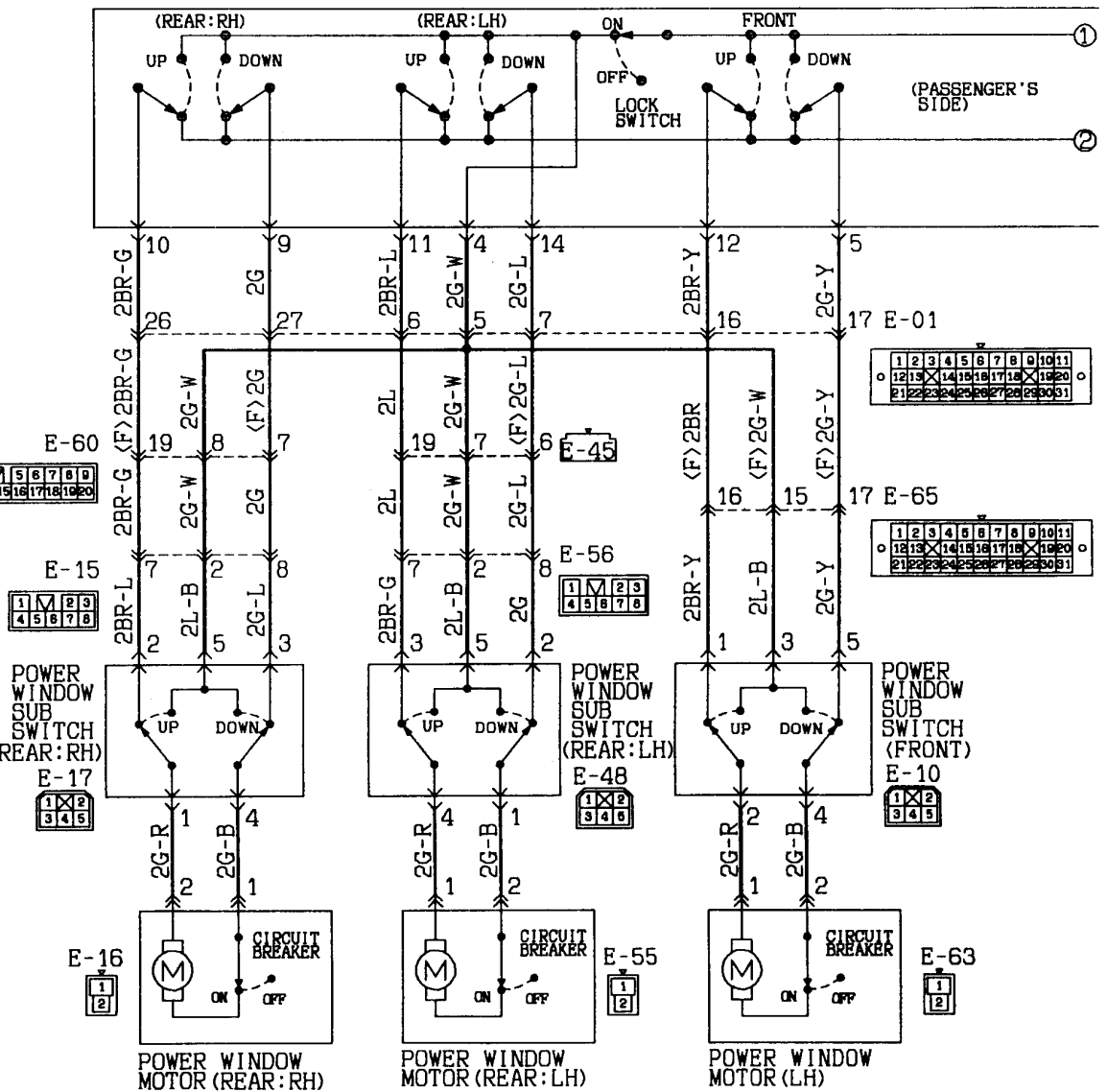

1	2	3	4	5	6	7	8	9	10	11
12	13	14	15	16	17	18	19	20	21	22

1	2	3	4	5	6	7	8	9	10	11
12	13	14	15	16	17	18	19	20	21	22

KX35-AC-Z1111-EC

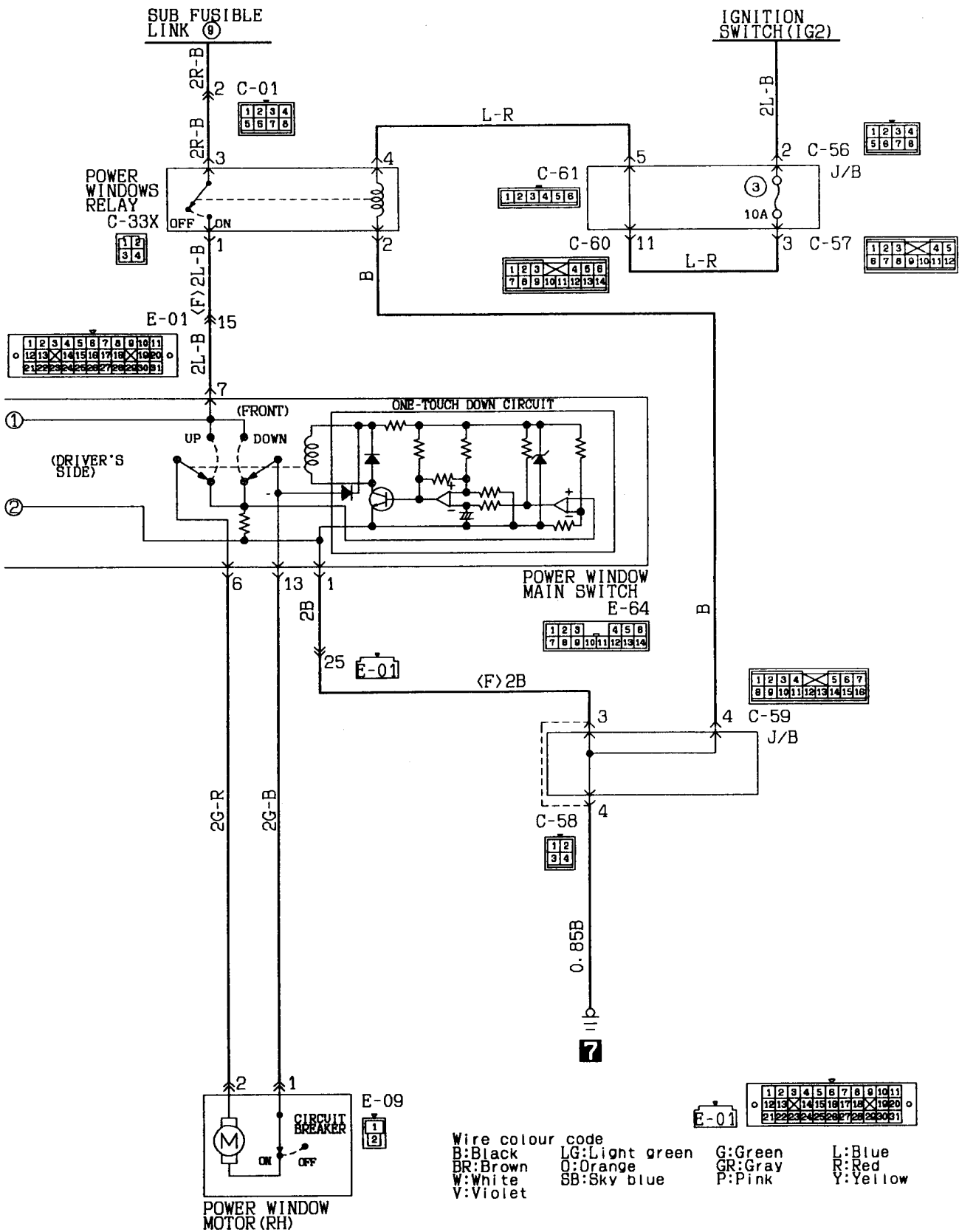



24 TAILGATE LOCKING SYSTEM  
 (Vehicles without central door locking system (GLX))

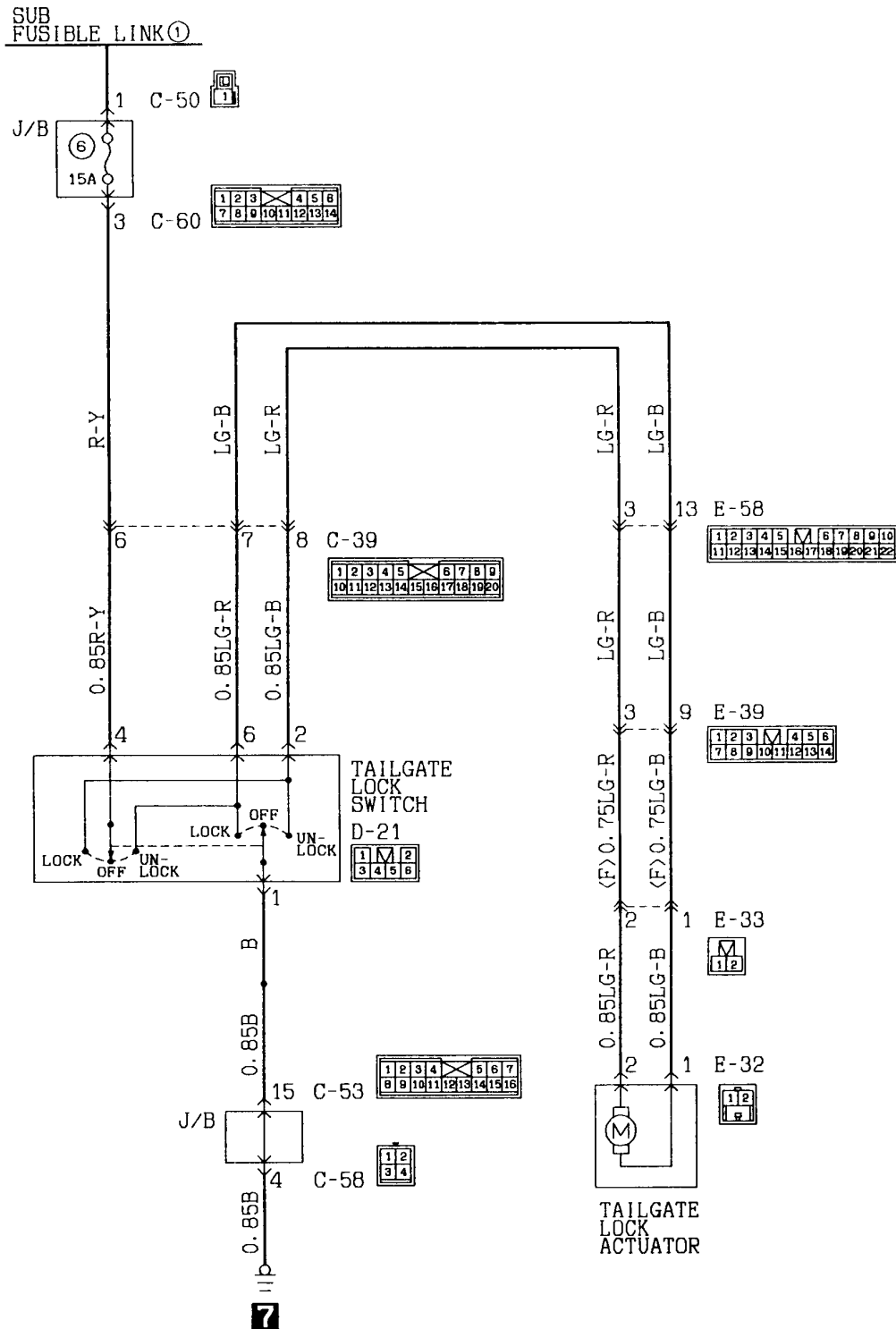

Wire colour code  
 B:Black LG:Light green G:Green L:Blue W:White Y:Yellow SB:Sky blue  
 BR:Brown O:Orange GR:Gray R:Red P:Pink V:Violet

**TAILGATE LOCKING SYSTEM (See P. 4-104.)****OPERATION**

- Battery voltage is always available, through multi-purpose fuse No. ⑥, to the tailgate lock switch.
- When the tailgate lock switch is switched ON or OFF, current flows to multi-purpose fuse No. ⑥, the tailgate lock switch, the tailgate lock actuator, the tailgate lock switch, and earth; the tailgate lock actuator's motor is then activated, thus locking or unlocking the tailgate.

**TROUBLESHOOTING HINTS**

1. Does not lock or unlock.
  - Check the tailgate lock switch.
  - Check the tailgate lock actuator.

25 CENTRAL DOOR LOCKING SYSTEM  
25-1 SPACE RUNNER (L.H. drive vehicles)

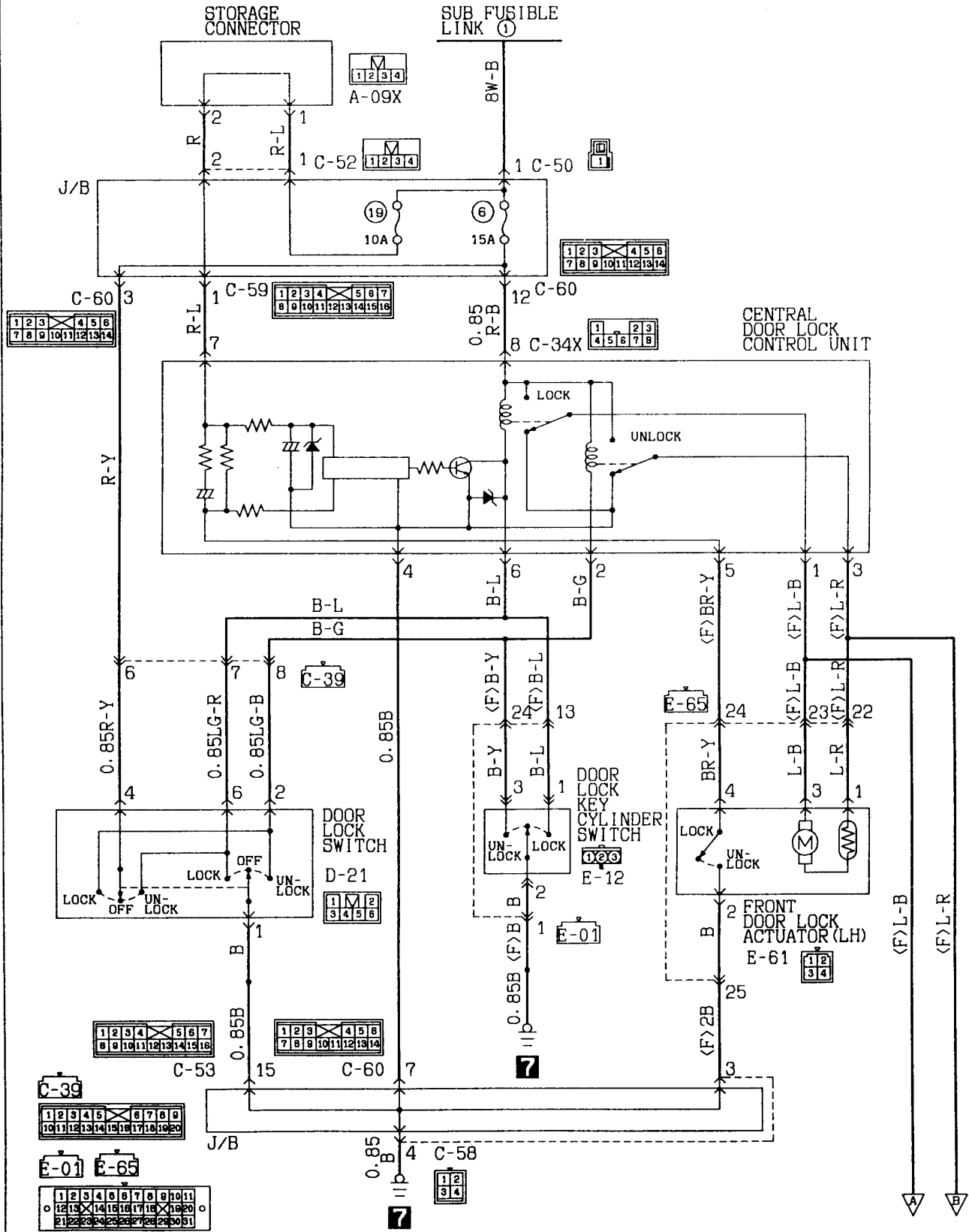

KX35-AC-Z1113-EC

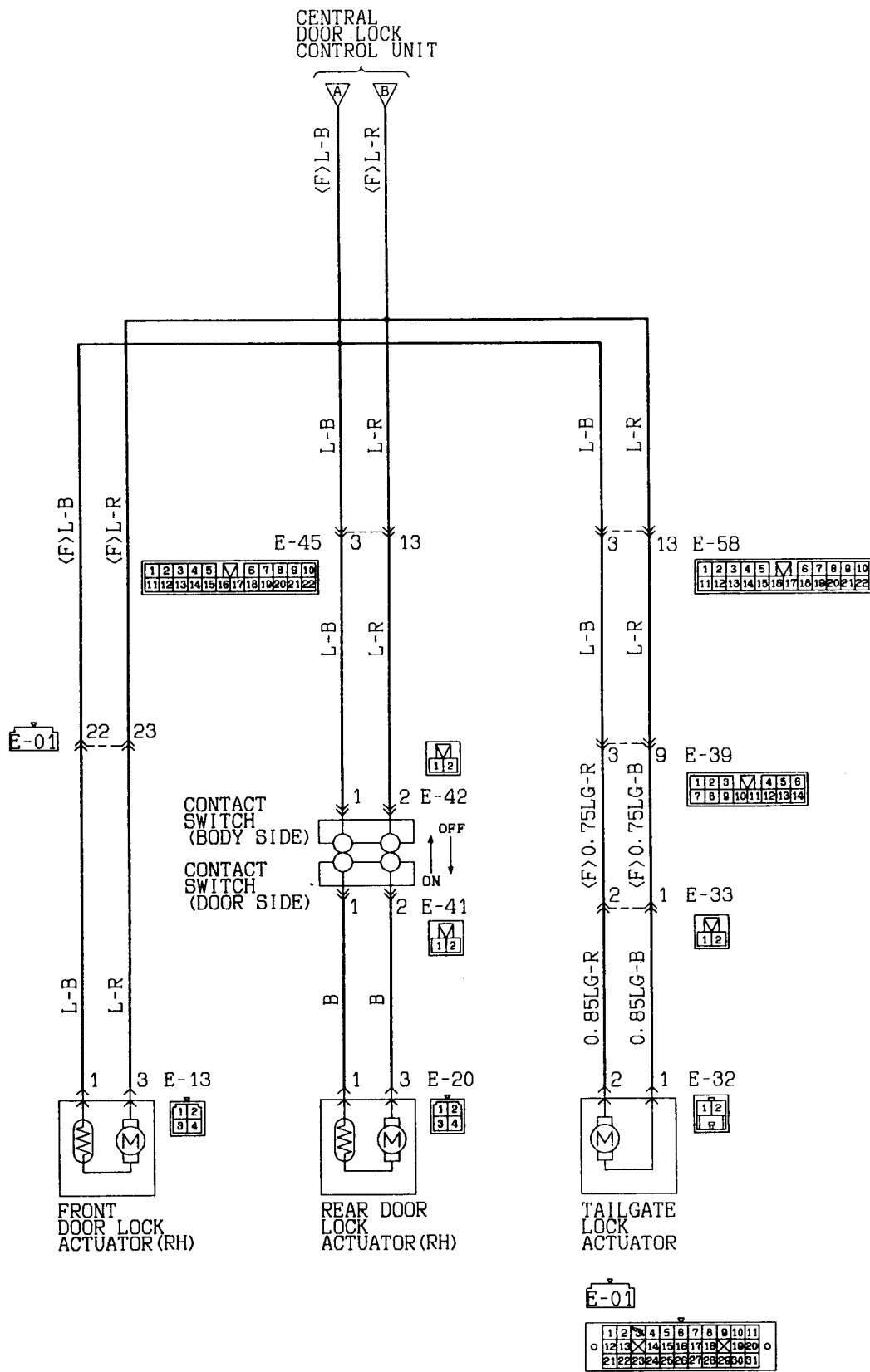

Wire colour code  
 B:Black    LG:Light green    G:Green    L:Blue    W:White    Y:Yellow    SB:Sky blue  
 BR:Brown    O:Orange    GR:Gray    R:Red    P:Pink    V:Violet

25-2 SPACE RUNNER (R. H. drive vehicles)

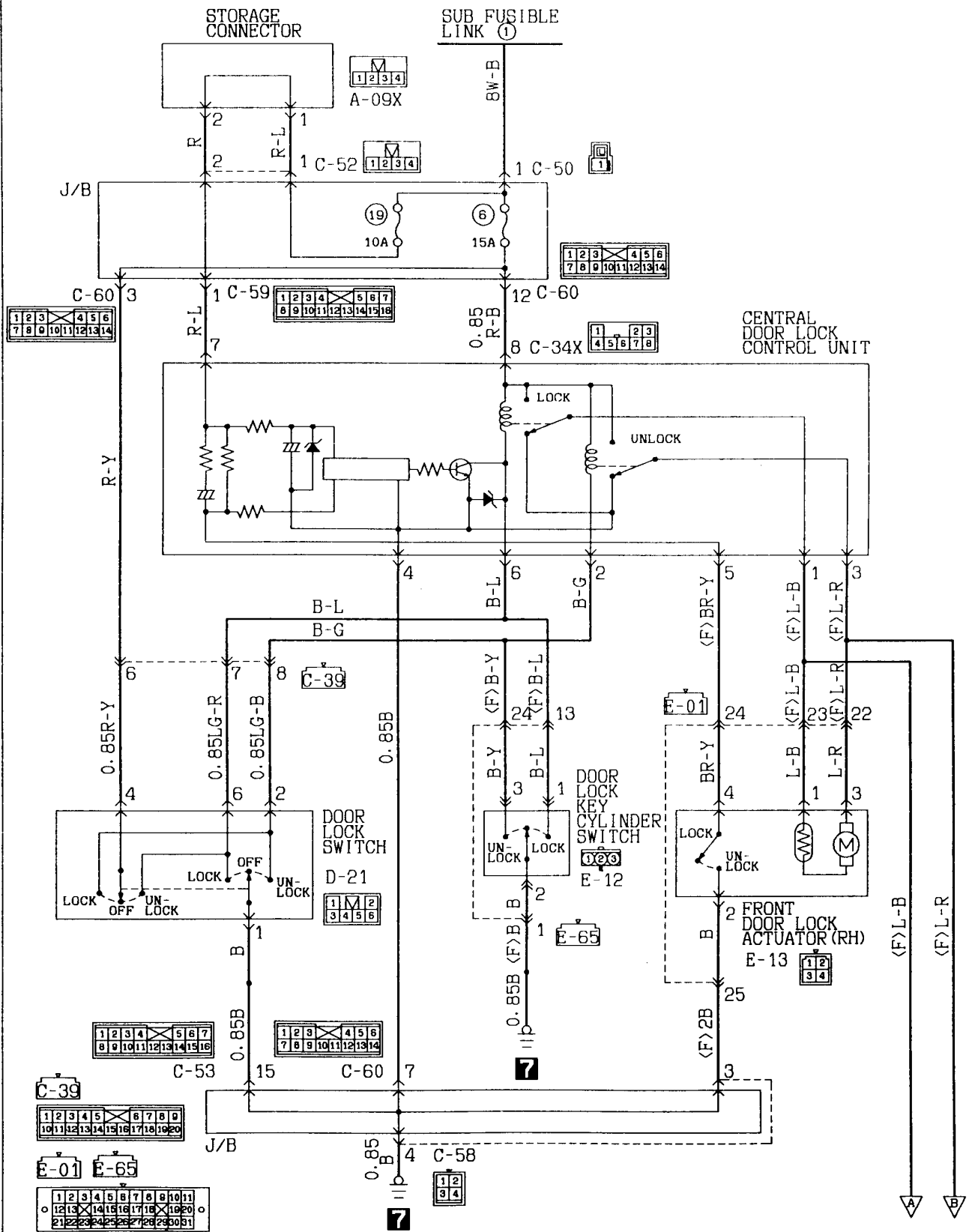

KK35-AC-Z1114-EC

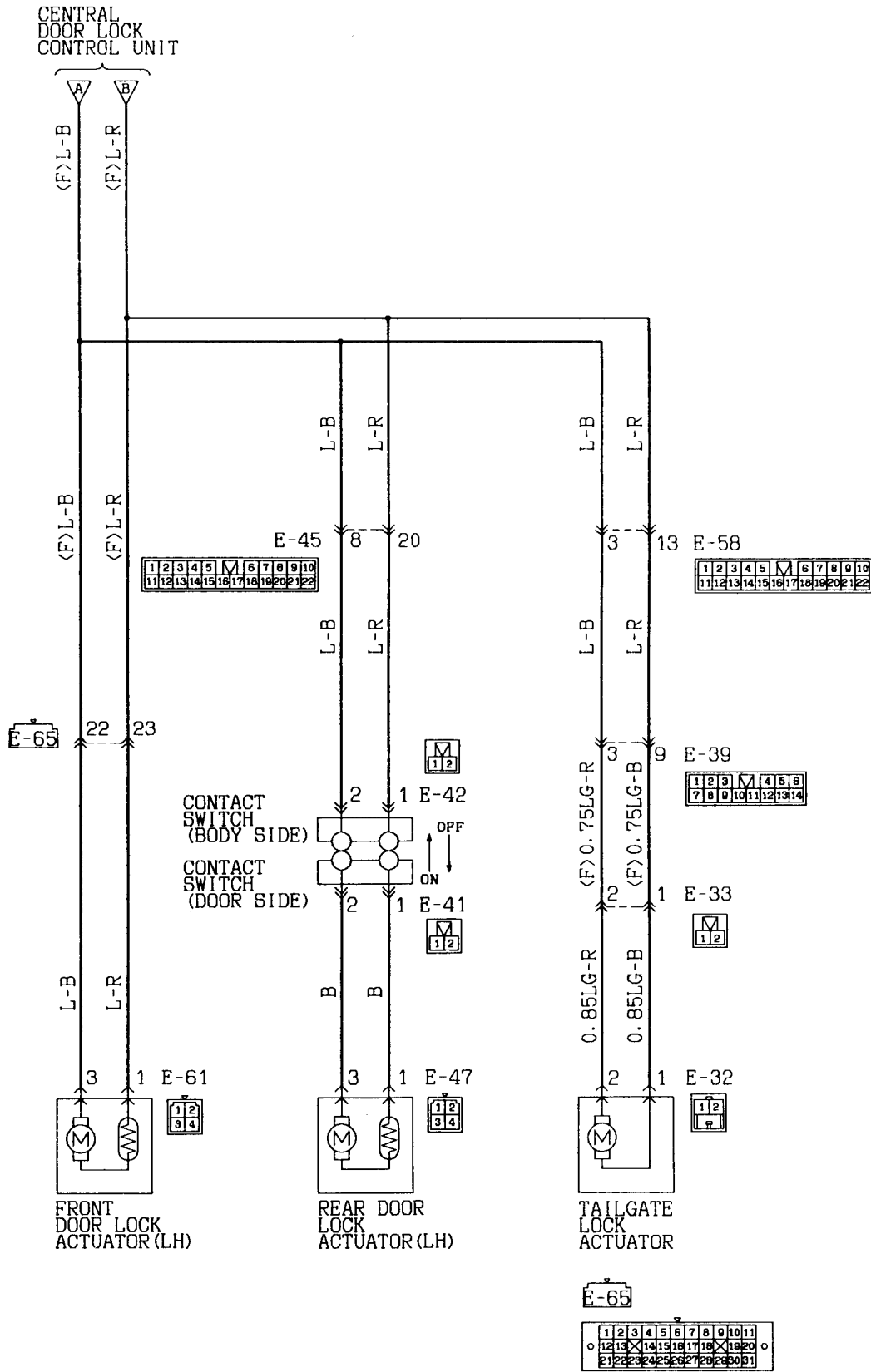

Wire colour code  
 B:Black LG:Light green G:Green L:Blue W:White Y:Yellow SB:Sky blue  
 BR:Brown O:Orange GR:Gray R:Red P:Pink V:Violet

25-3 SPACE WAGON <L.H. drive vehicles>

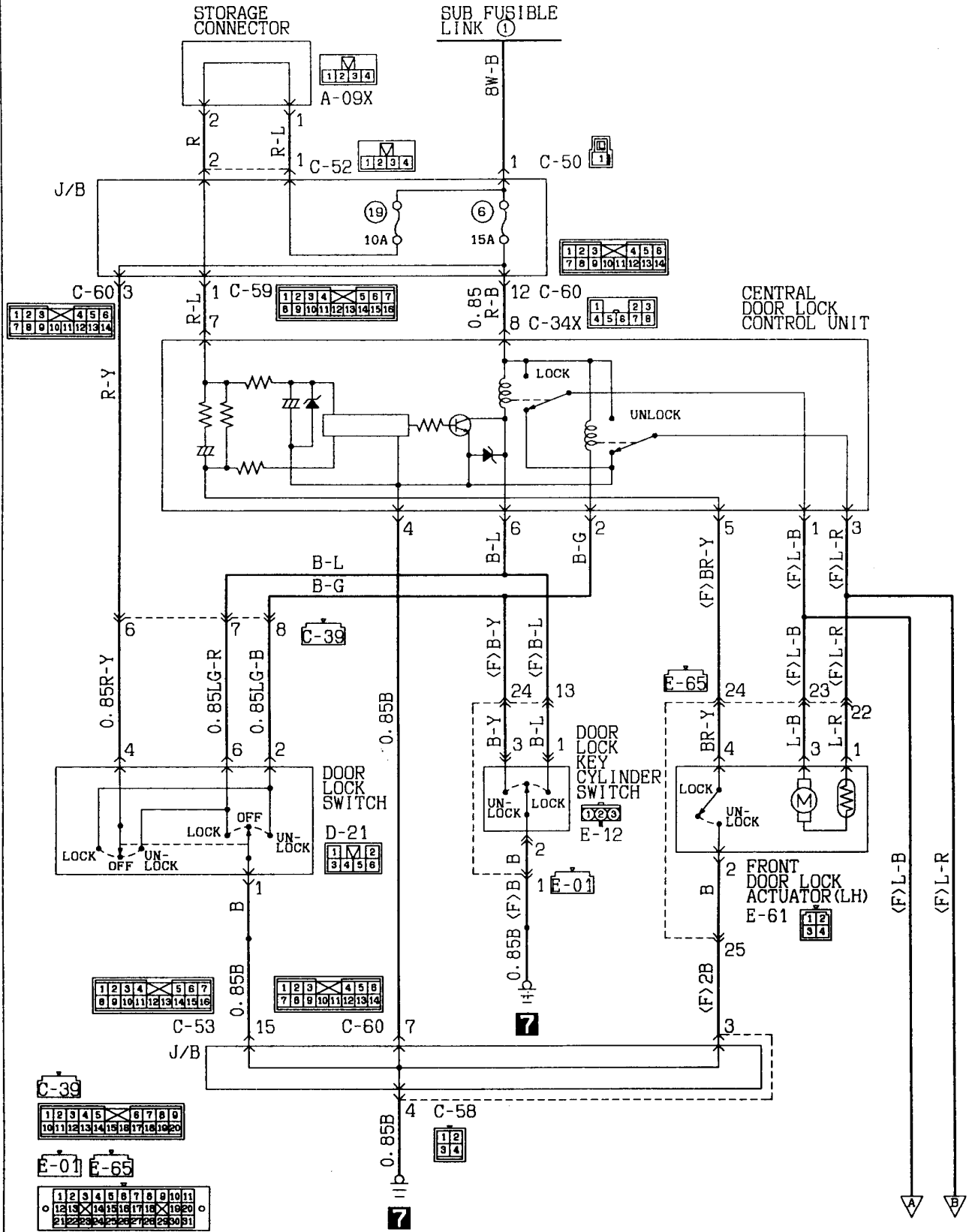

KX35-AC-Z1115-EC

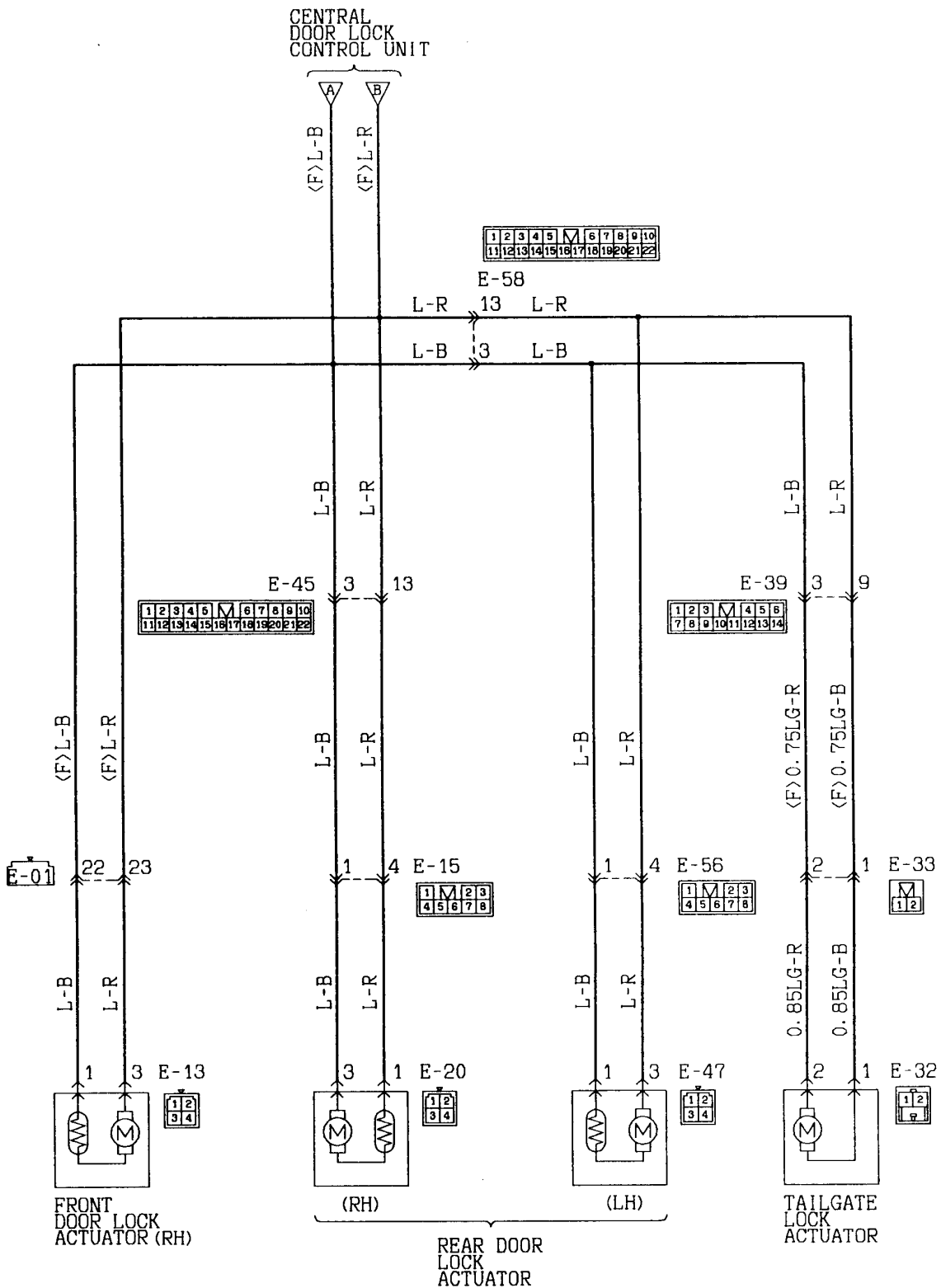

E-01

1	2	3	4	5	6	7	8	9	10	11
12	13	14	15	16	17	18	19	20		
21	22	23	24	25	26	27	28	29	30	31

Wire colour code  
 B:Black LG:Light green G:Green L:Blue  
 BR:Brown O:Orange GR:Gray R:Red  
 W:White SB:Sky blue P:Pink Y:Yellow  
 V:Violet



25-4 SPACE WAGON <R.H. drive vehicles>

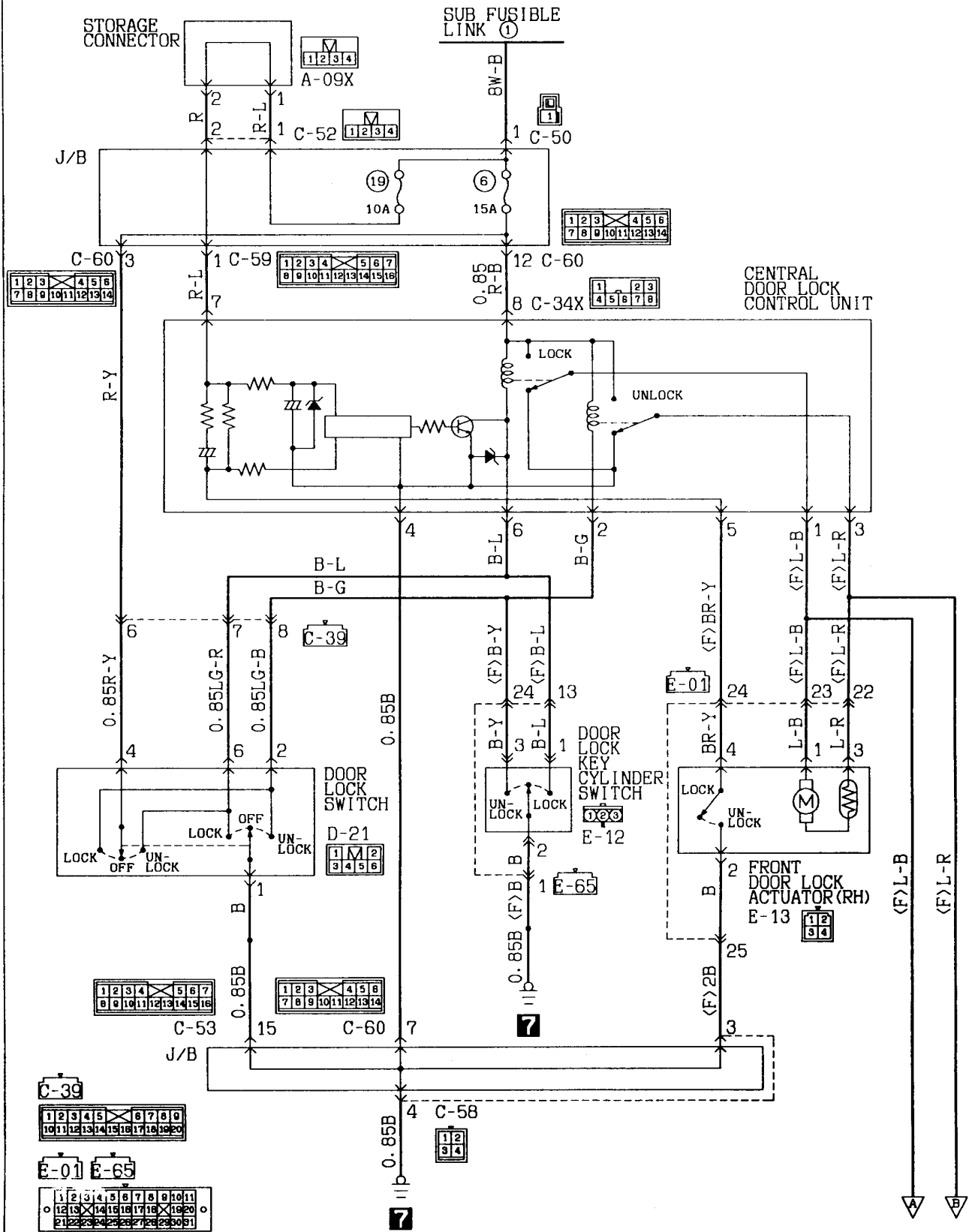

KX35-AC-Z1118-EC

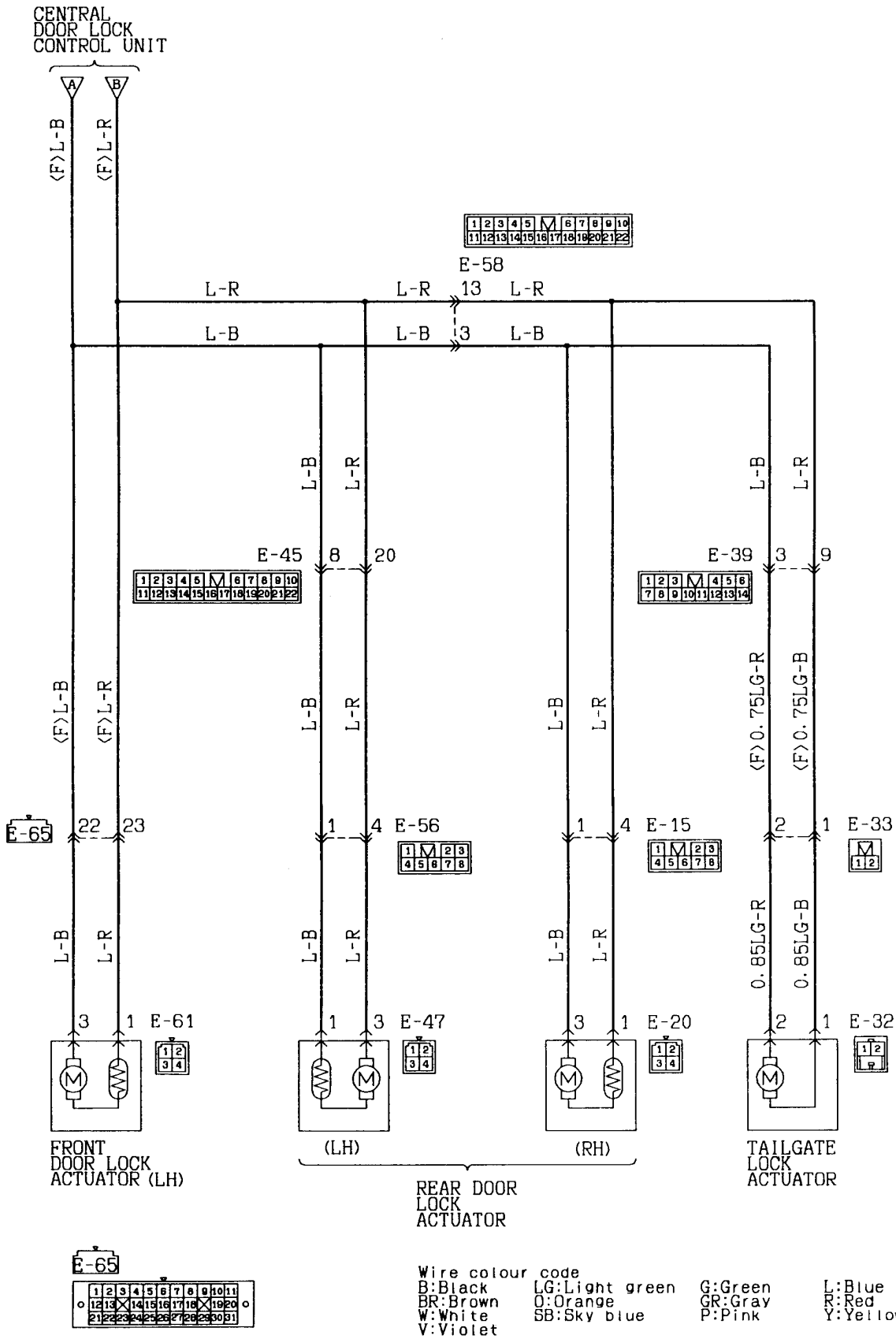

**CENTRAL DOOR LOCKING SYSTEM (See P. 4-106, 108, 110, 112.)****OPERATION****1. Operation with the inside lock knob on the driver's side (including door lock key operation).**

- If the inside lock knob on the driver's side is locked (or unlocked), the switch in the front door lock actuator (driver's side) goes off (or on) and the lock side (or unlock side) relay in the door lock control unit goes on for 0.5 second and the actuators for all doors (including tailgate) function.

**2. Operation with the door lock key.**

- If the door lock key (passenger's side) is turned to the lock side (or unlock side), the lock side (or unlock side) relay in the door lock control unit goes on for 0.5 second and the actuators for all doors (including tailgate) function.

**3. Operation with door lock switch**

- If the door lock switch is locked (or unlocked), the lock side (or unlock side) relay in the door lock control unit goes on for 0.5 second and the actuators for all doors (including tailgate) function.

**Remark**

- Each door lock actuator is provided with a PTC thermistor to prevent the motor from being damaged by overheating. This results in the actuator not properly operating at times when the central door lock is frequently used; the actuator is operational if it resumes normal operation within several minutes.

**TROUBLESHOOTING HINTS**

1. Any one of the door lock actuators is inoperative.
  - Check the defective door actuator.
2. Locking (or unlocking) is possible with the door lock key (passenger's side) but locking (or unlocking) is not possible with the inside lock knob on the driver's side (including door lock key operation).
  - Inspect the front door lock actuator (driver's side)
  - Inspect the door lock control unit.
3. Locking (or unlocking) is possible with the inside lock knob (including door lock key operation) on the driver's side but locking (or unlocking) is not possible with the door lock key (passenger's side).
  - Inspect the door lock key cylinder (passenger's side).
  - Inspect the door lock control unit.

**HEATER AND AIR CONDITIONER (See P. 4-116, 120, 123.)**

**OPERATION**

**<Blower control>**

- When the ignition switch is turned ON, the heater relay is energized. If the blower switch is turned ON (LO, ML, MH, or HI position) in this condition, the blower is activated through the circuit via resistor at a speed corresponding to the blower switch position.

**<Condenser fan and radiator fan control>**

- For the operation of each fan, see COOLING SYSTEM (P. 4-35, 37, 39.)

**<Compressor control>**

- The air inlet sensor which senses the temperature of the air sent to the evaporator, and the air thermo sensor, which senses the temperature of the air flowing out of the evaporator, are deactivated with temperature 3.2°C (38°F) or below. Here, the engine coolant temperature switch senses the temperature of engine coolant, and it is turned off at 115°C (239°F) or higher temperatures. Also, after it has turned off, the engine coolant temperature will drop, and when it becomes 108°C or lower, the switch turns ON.
- The dual pressure switch (or triple pressure switch) turns OFF when the refrigerant pressure becomes excessively high or low, thus protecting the compressor circuit.
- When these sensors are all activated, the dual pressure switch (or triple pressure switch) is ON, and the ignition switch, blower switch, and air conditioner switch are ON, the air conditioner compressor relay is energized.

- To prevent the engine from stalling and oscillating and to ensure good acceleration, the engine control unit (vehicles with MPI) turns OFF the air conditioner compressor relay driving transistor, and thus the air conditioner compressor relay, when the engine is started, when it runs at low speed, and when the vehicle is quickly accelerated.

**TROUBLESHOOTING HINTS**

**<Blower control>**

1. Blower motor is energized at one switch position and not energized at another.
  - Check harness and connectors between defective switch position and resistor (or blower motor in HI position).
2. Blower motor is energized only when switch is positioned in HI.
  - Check the resistor.
3. Blower motor speed does not represent the switch position.
  - Check the blower switch.

**<Condenser fan and radiator fan control>**

- See COOLING SYSTEM (P. 4-35, 37, 39.)

**<Compressor control>**

- See the Troubleshooting in Group 55 of the separate WORKSHOP MANUAL (Pub. No. PWDE9104.)

**Air Conditioner Compressor Relay ON Conditions**

Ignition switch (IG <sub>2</sub> )	ON	Remarks (1) Air compressor relay is deenergized when any one switch, sensor or control unit shown on the left turns OFF (HI). (2) The * marked device measures the temperature of the intake air, and according to the control characteristics of the magnetic clutch for the compressor, the auto compressor control unit outputs the "HI" signal (12V).
Blower switch	ON	
Air conditioner switch	ON (ECONO or A/C)	
Air inlet sensor	*	
Air thermo sensor	*	
Engine coolant temperature switch (Diesel-powered vehicles)	ON	
Triple pressure switch (Diesel-powered vehicles)	Low-pressure side ON [235 kPa (2.35 kg/cm <sup>2</sup> , 33 psi) or higher]	
Dual pressure switch (Petrol-powered vehicles)	High-pressure side ON [2,100 kPa (21 kg/cm <sup>2</sup> , 299 psi) or higher]	
Air conditioner compressor relay driving transistor (within engine control unit)	ON	

26 HEATER AND AIR CONDITIONER  
26-1 Petrol-powered vehicles <4G93>

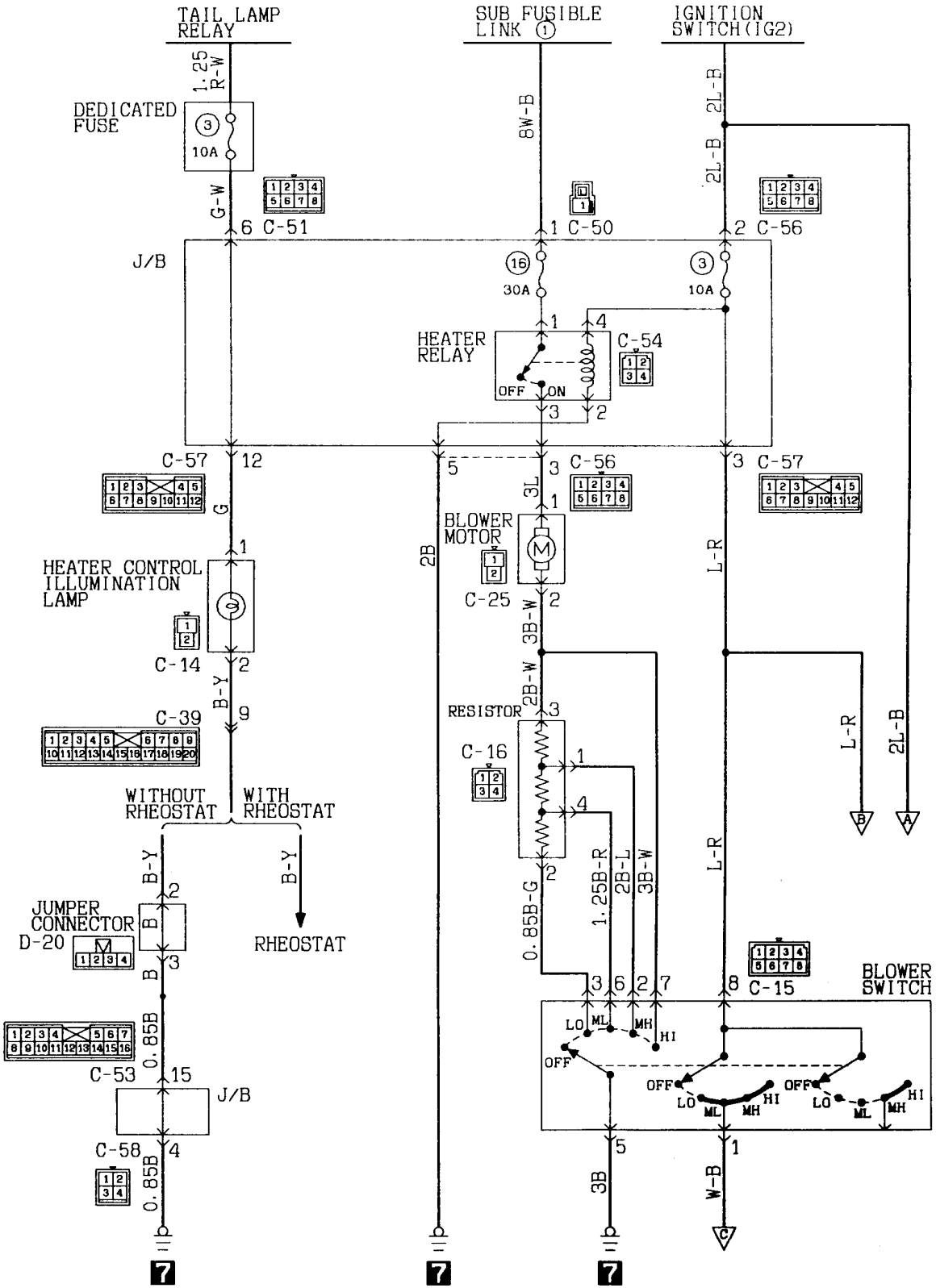

Wire colour code  
 B:Black LG:Light green G:Green L:Blue W:White Y:Yellow BB:Sky blue  
 BR:Brown O:Orange GR:Gray R:Red P:Pink V:Violet

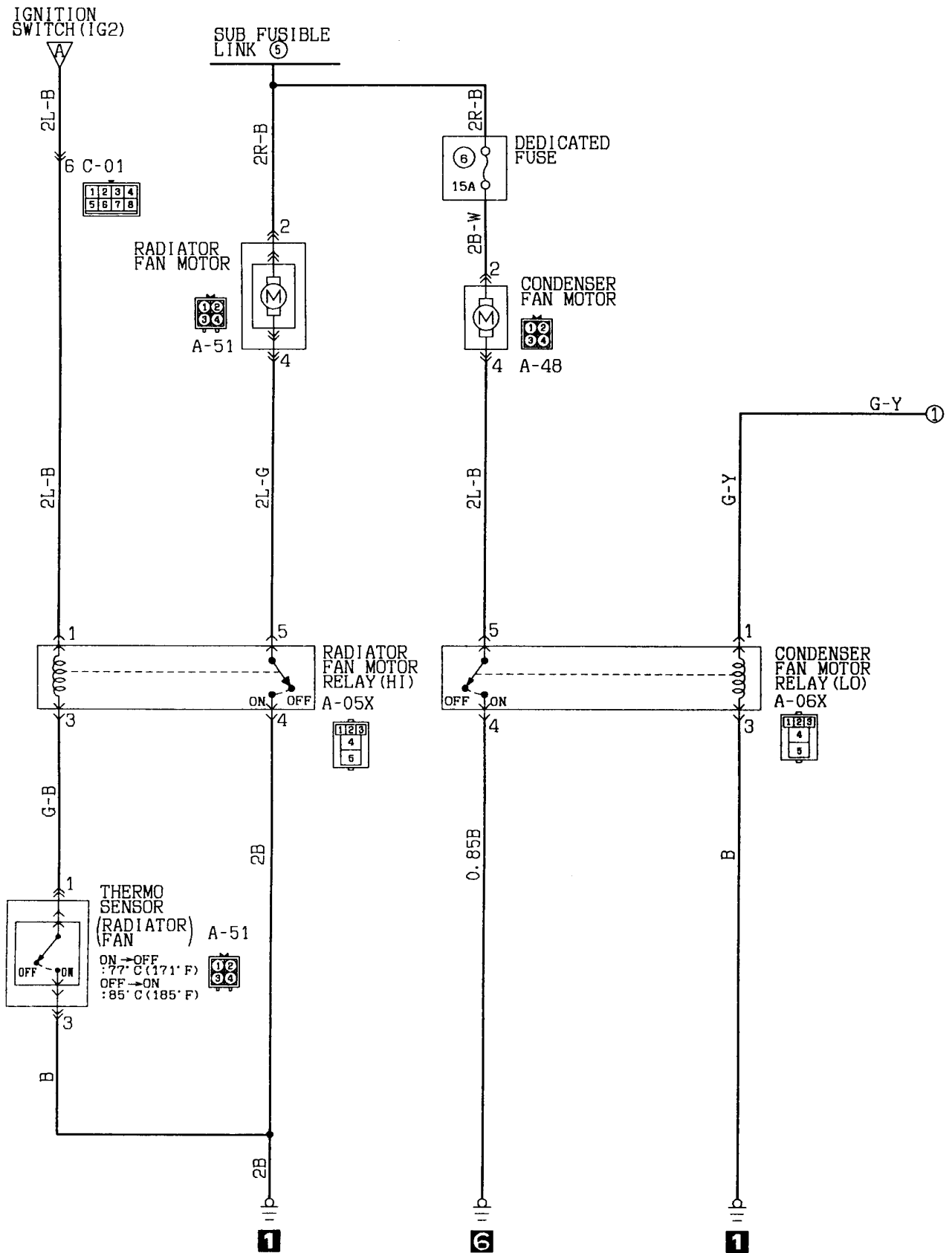

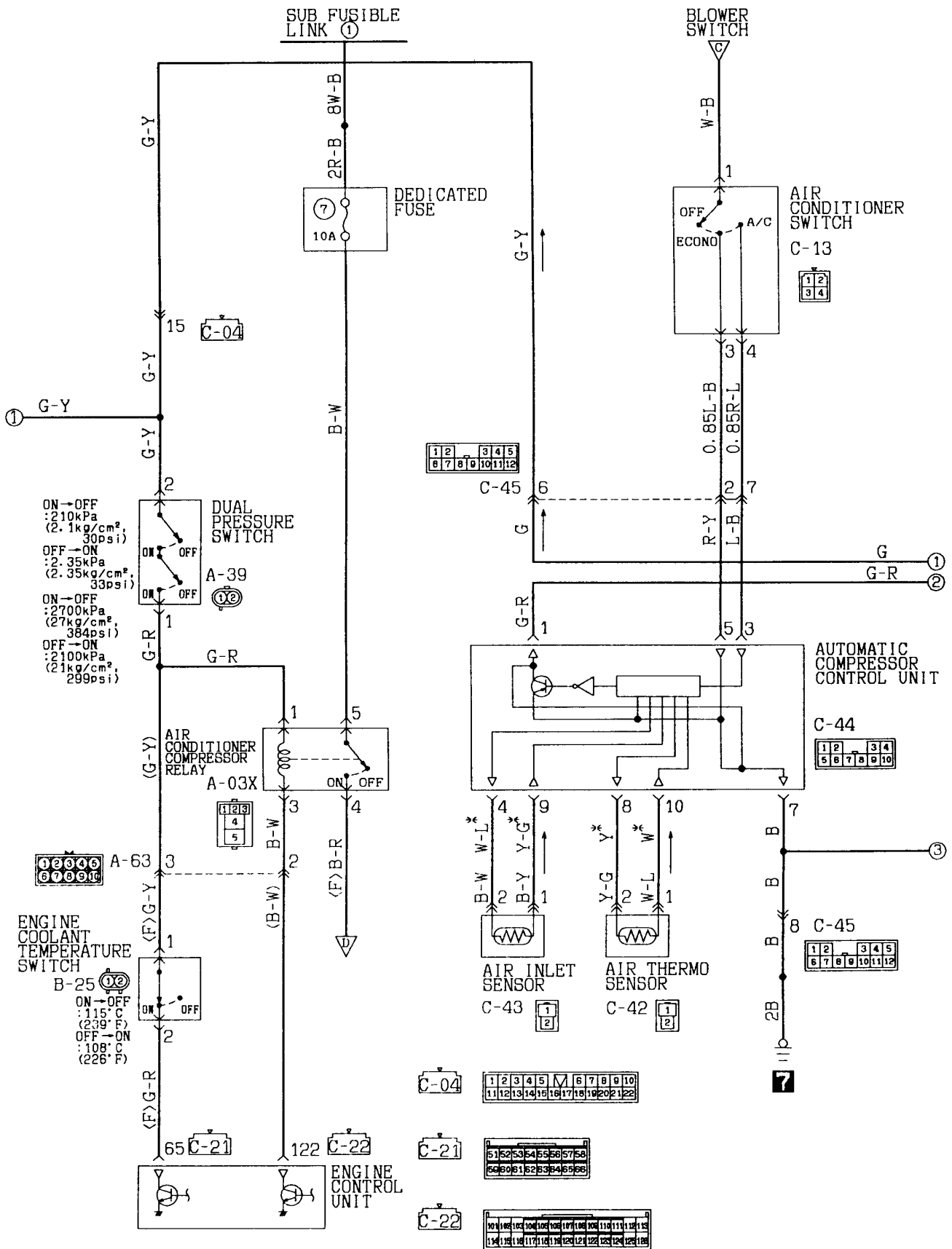

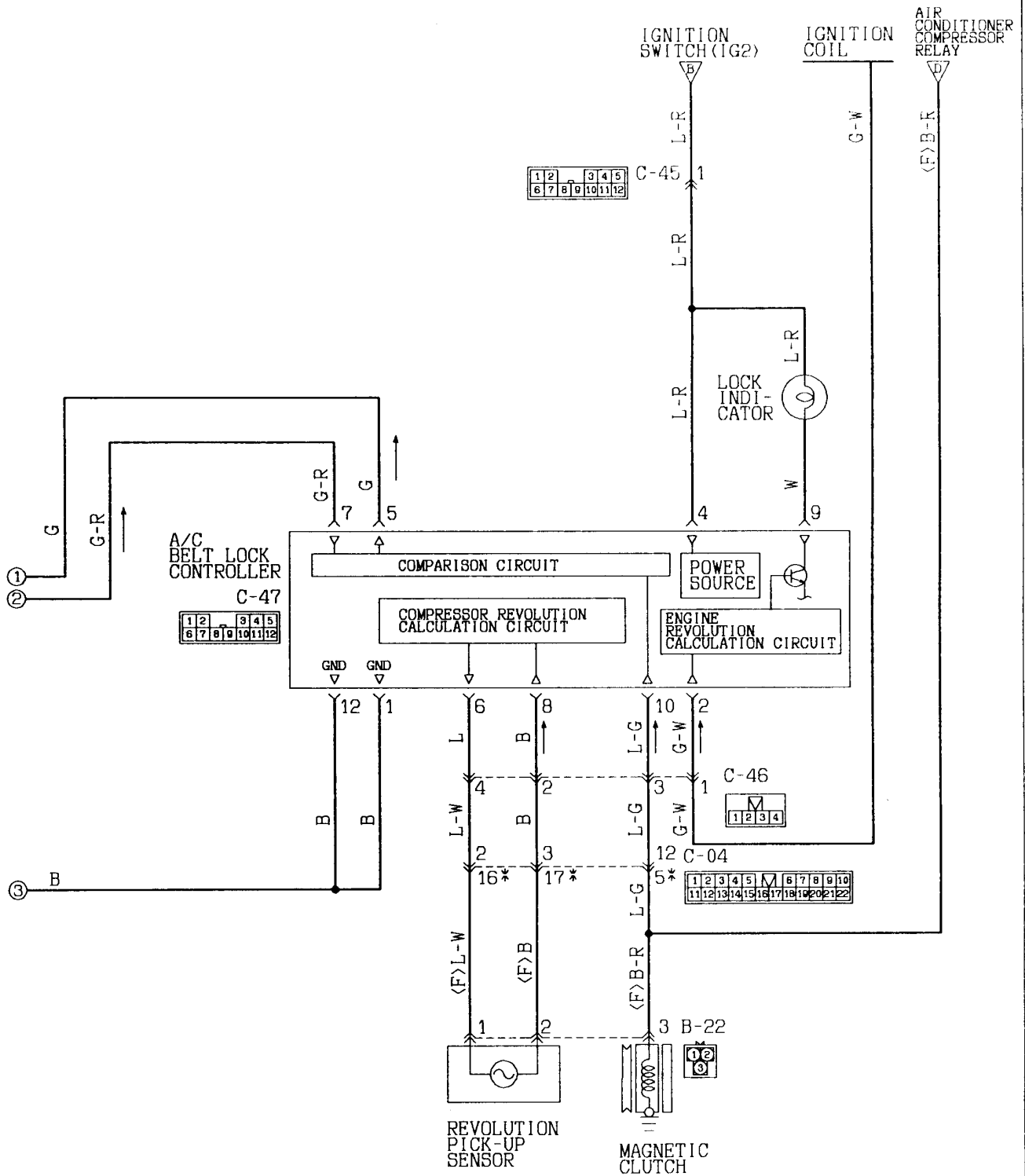

Remark  
\*: R. H. drive vehicles.

Wire colour code  
 B:Black LG:Light green G:Green L:Blue W:White Y:Yellow SB:Sky blue  
 BR:Brown O:Orange GR:Gray R:Red P:Pink V:Violet



26-2 Petroi-powered vehicles (4G63 and 4G64)

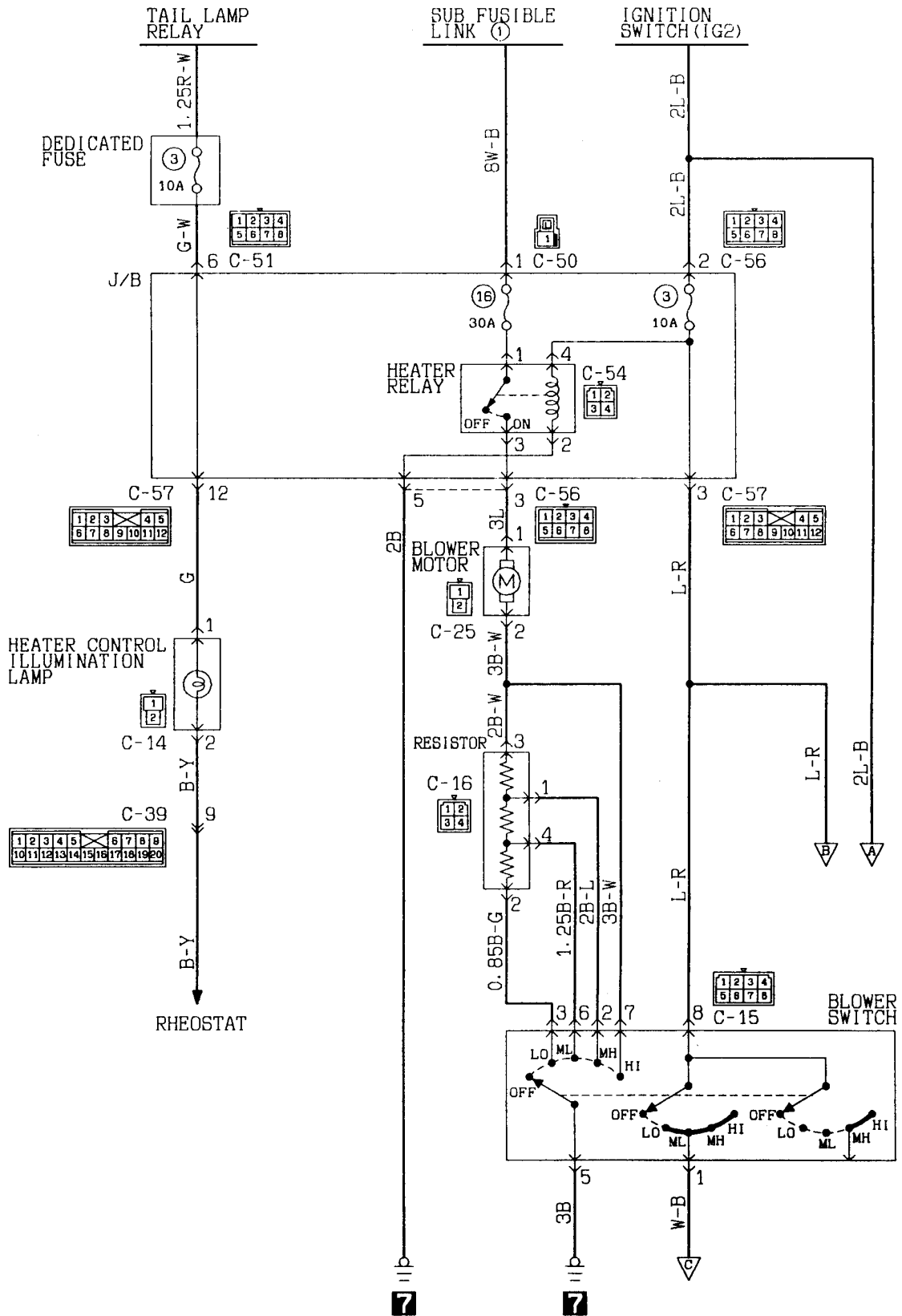

Wire colour code  
 B:Black LG:Light green G:Green L:Blue W:White Y:Yellow SB:Sky blue  
 BR:Brown O:Orange GR:Gray R:Red P:Pink V:Violet

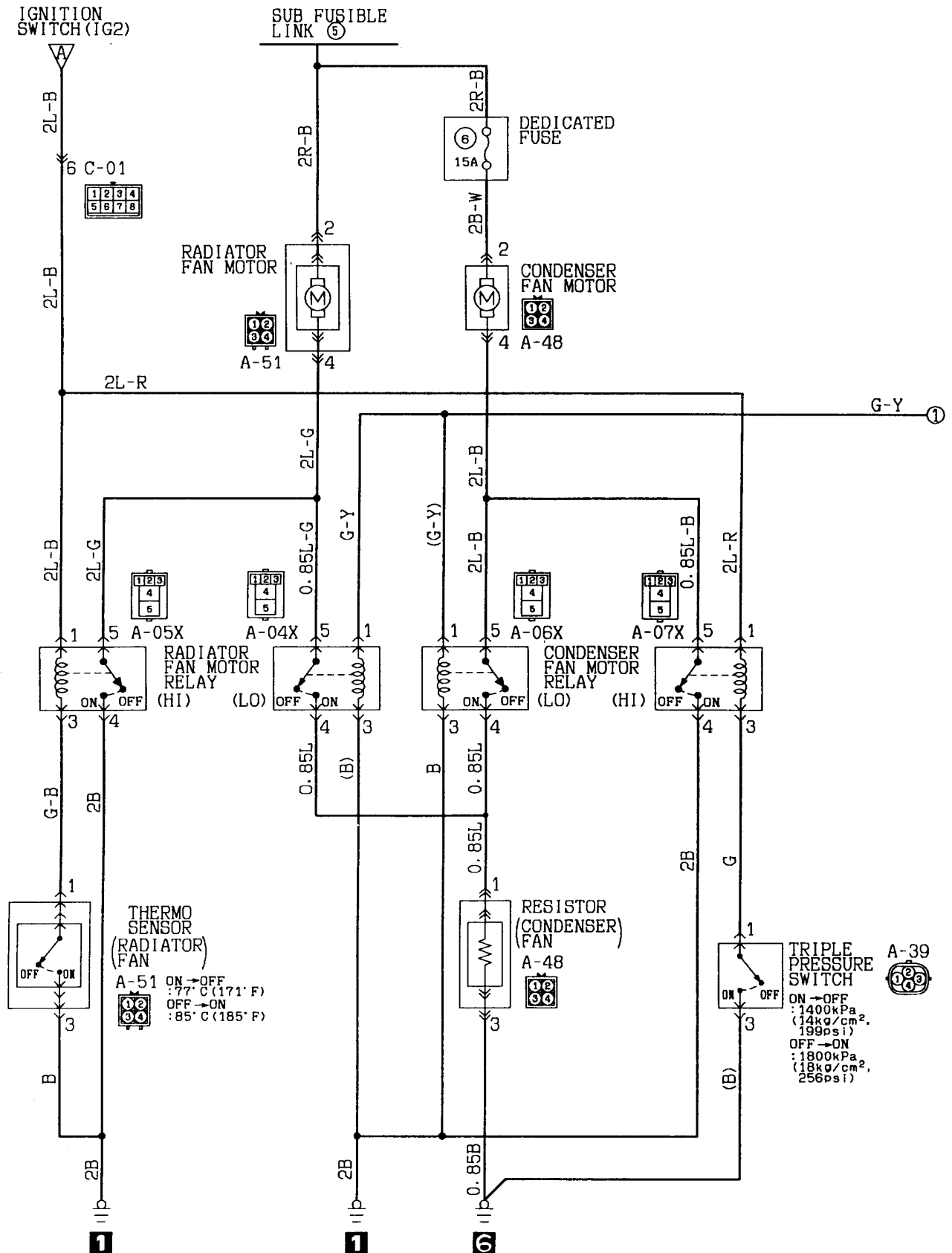

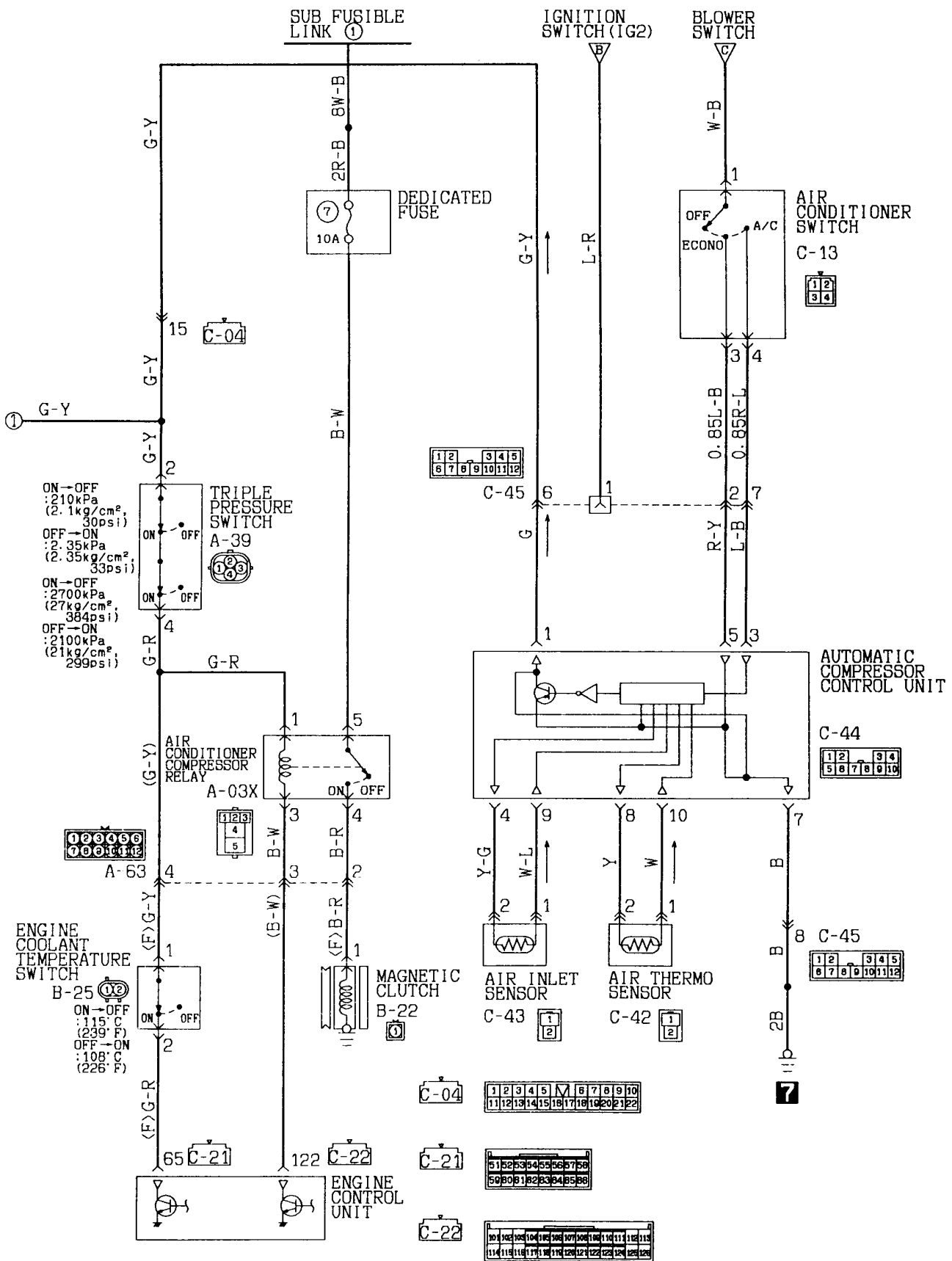

KX35-AC-Z1203A-EC

26-3 Diesel-powered vehicles

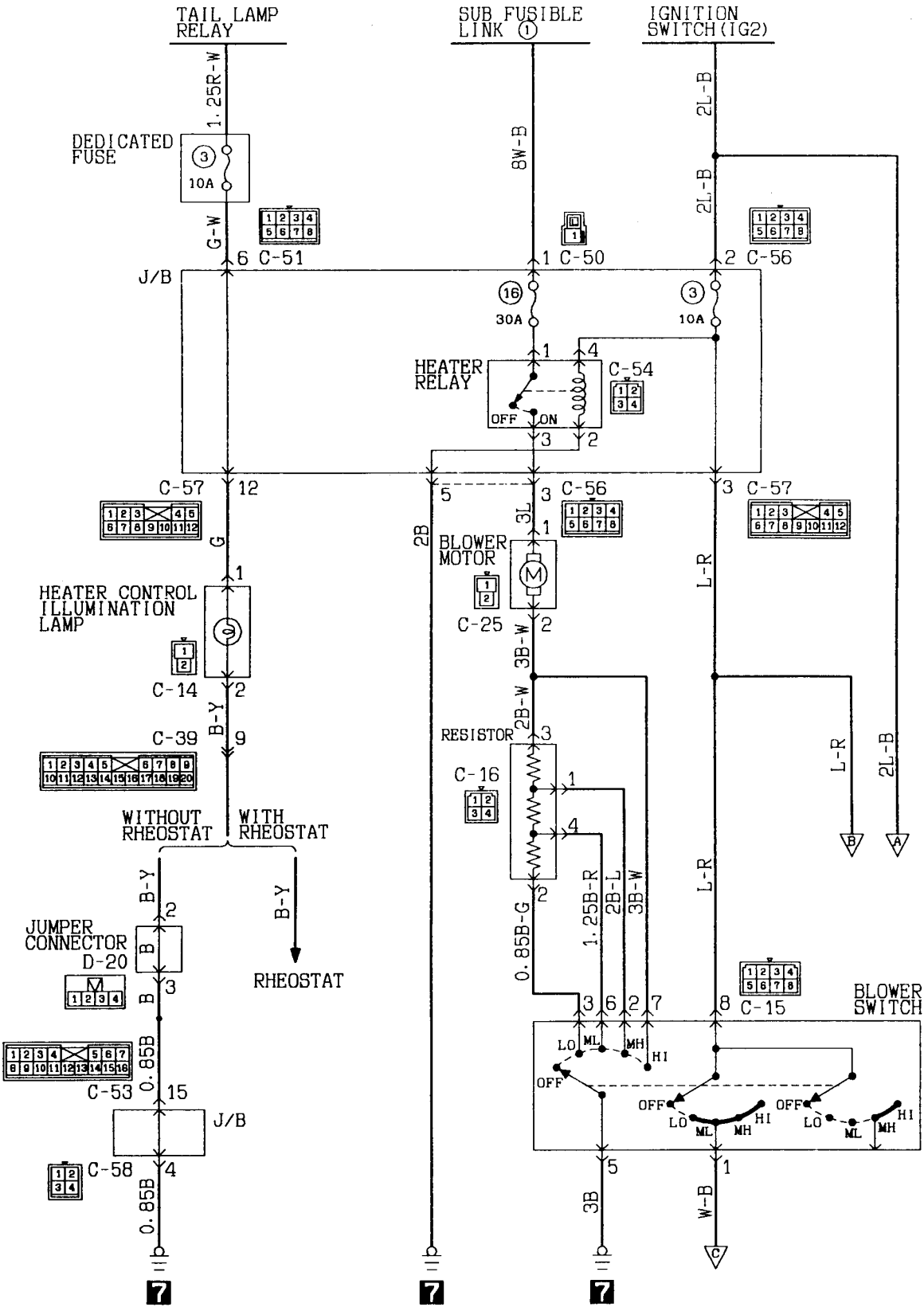

Wire colour code  
 B:Black LG:Light green G:Green L:Blue W:White Y:Yellow SB:Sky blue  
 BR:Brown O:Orange GR:Gray R:Red P:Pink V:Violet

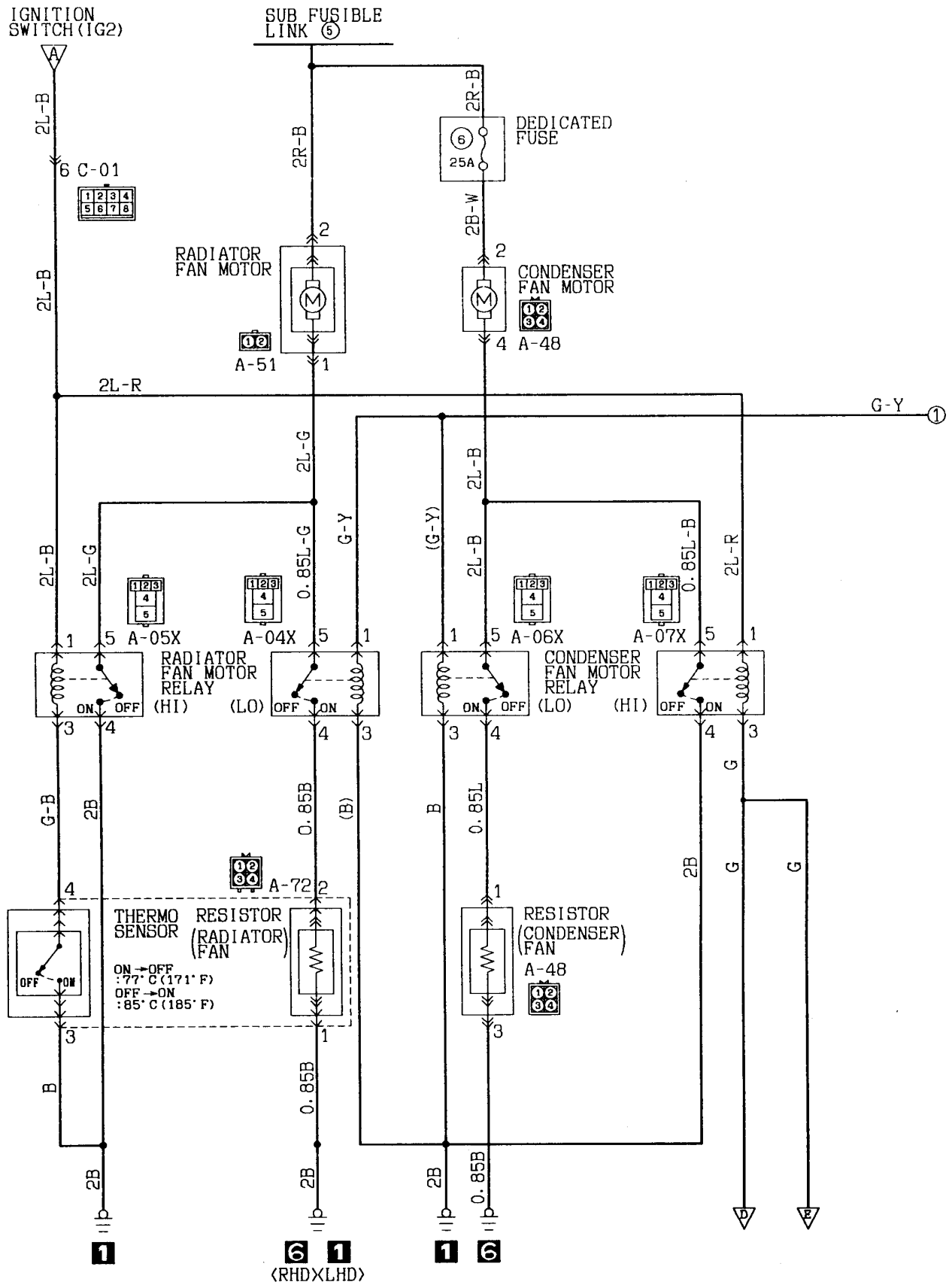

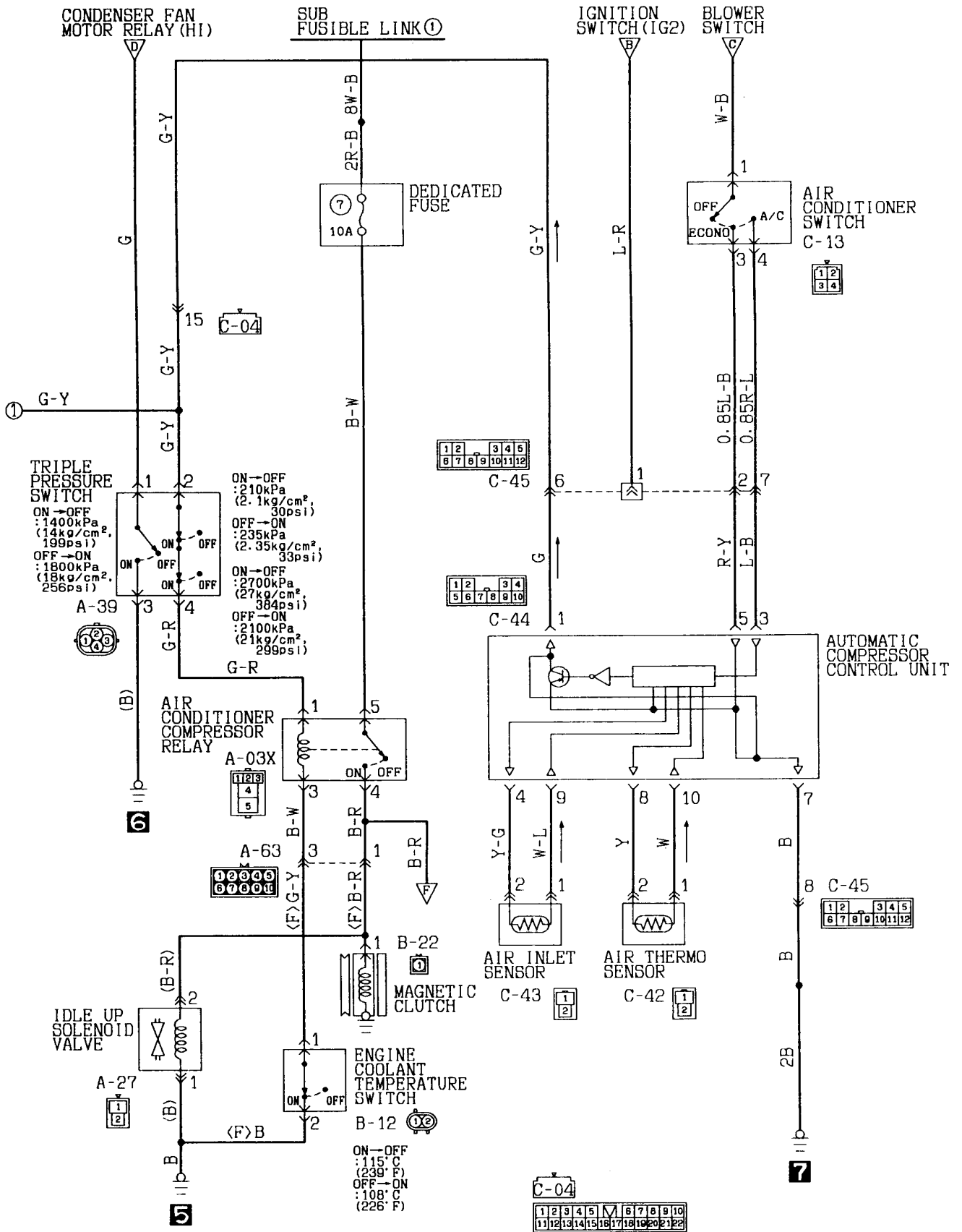

KX35-AC-Z1204A-EC

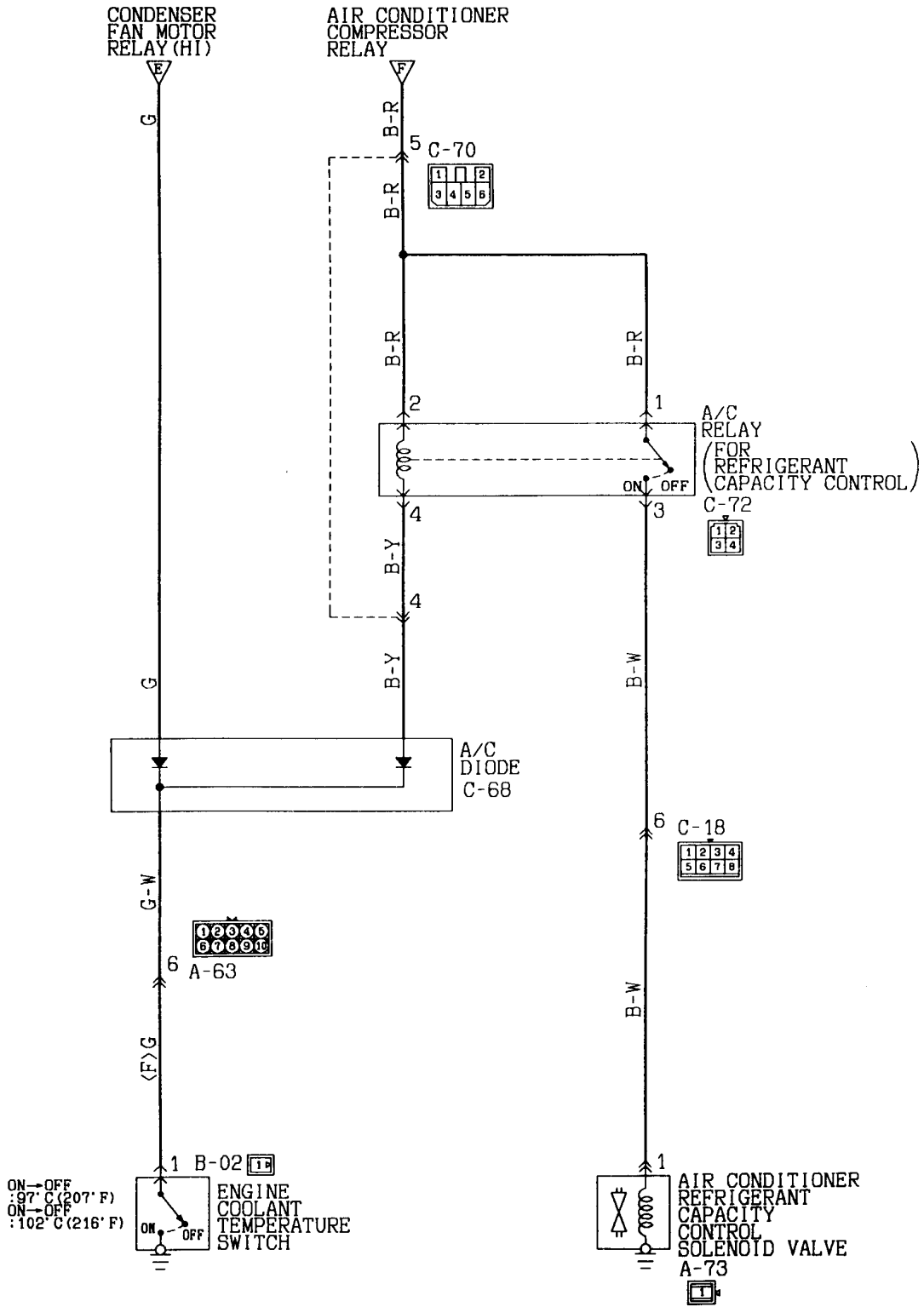

Wire colour code  
 B:Black LG:Light green G:Green L:Blue W:White Y:Yellow SB:Sky blue  
 BR:Brown O:Orange GR:Gray R:Red P:Pink V:Violet

NOTES



# 27 WIPER AND WASHER

27-1 Windshield wiper and washer

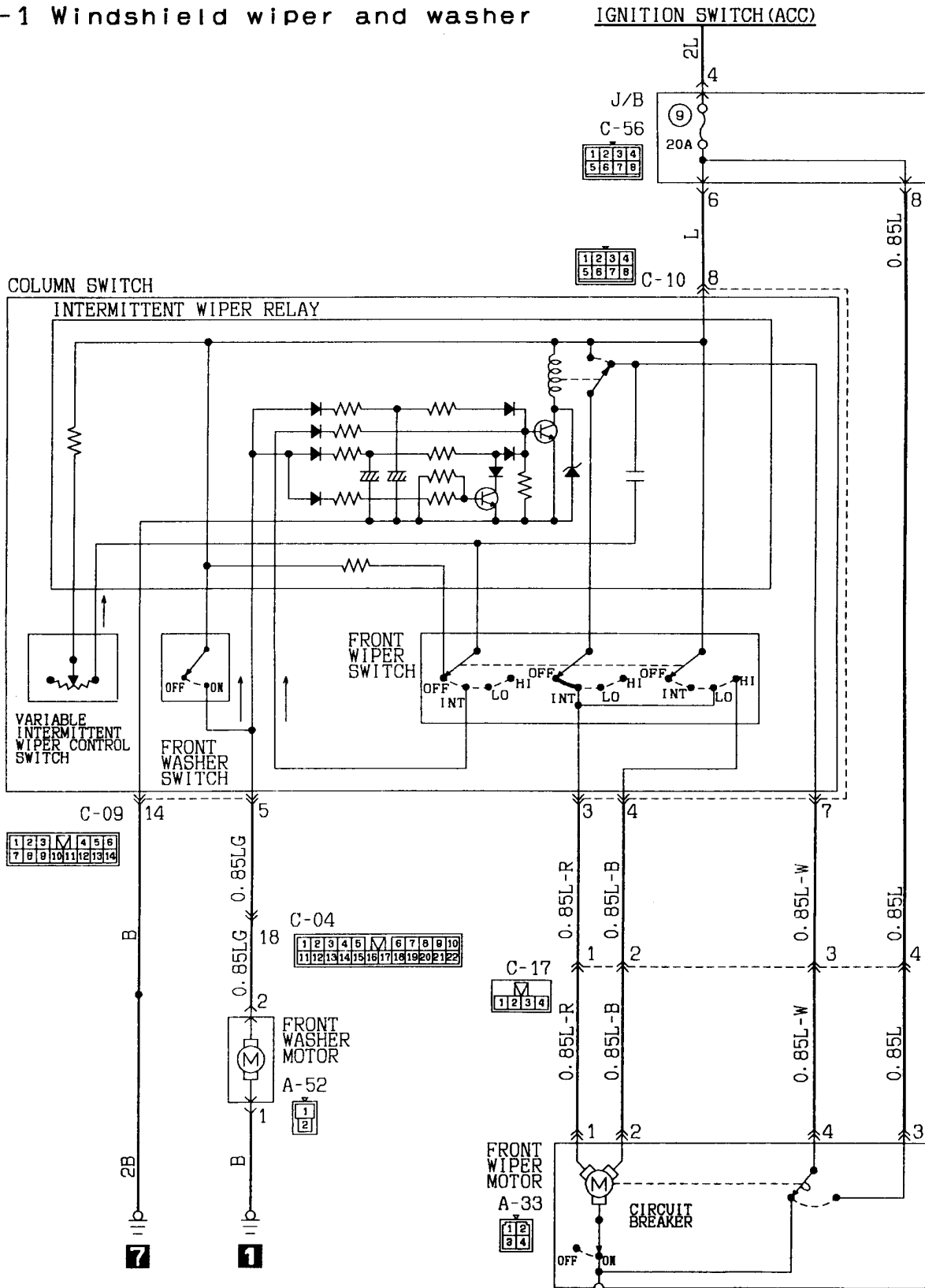

Wire colour code  
 B:Black LG:Light green G:Green L:Blue W:White Y:Yellow SB:Sky blue  
 BR:Brown O:Orange GR:Gray R:Red P:Pink V:Violet

**WIPER AND WASHER <Windshield wiper and washer> (See P. 4-128.)**

**OPERATION**

**<Low-speed (and high-speed) wiper operation>**

- When the wiper switch is placed in the LO position with ignition switch in the ACC or ON position, wipers operate continuously at low speed.
- Placing the wiper switch in the HI position causes the wipers to operate at high speed.

**<Auto wiper stop operation>**

- When the wiper switch is placed in the OFF position, the cam contacts of wiper motor caused current to flow through the auto wiper stop circuit, allowing the wiper blades to cycle before they reach to the stop positions.

**<Intermittent wiper operation>**

- When the wiper switch is placed in the INT position with the ignition switch in ACC or ON position, the intermittent wiper relay is energized causing the intermittent wiper relay contacts to close and open repeatedly.
- When the contacts are closed, the wiper motor is energized.
- When the wiper motor is energized, the relay contacts open; however, the cam contacts keep the wiper motor energized until the wiper blades return to their stop position.

**<Washer-Wiper operation>**

- When the washer switch is turned ON, the intermittent wiper relay contacts close causing wipers to cycle two to three times.

**TROUBLESHOOTING HINTS**

1. Wipers do not operate.
  - (1) Washer is not operative, either.
    - Check the multi-purpose fuse No. ⑨.
    - Check the earth.
2. Low-speed (or high-speed) wiper operation only is inoperative.
  - Check the wiper switch.
3. Wipers do not stop.
  - Check the wiper motor.
  - Check the intermittent wiper relay.
  - Check the wiper switch.
4. Intermittent wiper operation is inoperative.
  - Check terminal voltage of steering-column switch (with a built-in intermittent wiper relay) with the intermittent wiper relay energized.

Terminal No.	Voltage	Check
3	0V	Intermittent wiper relay or wiper switch
	12V	Intermittent wiper relay
	0V ↔ 12V (alternating)	— (Normal)

5. The length of pause for intermittent operation cannot be varied.
  - Check the variable intermittent wiper control switch.
  - Check the intermittent wiper relay.
6. Washer is inoperative.
  - (1) Wiper is operative on washer-wiper operation.
    - Check the washer motor.
  - (2) Washer-wiper operation is inoperative also.
    - Check the washer switch.
7. Washer-wiper operation is inoperative.
  - Check the intermittent wiper relay.

27-2 Rear wiper and washer

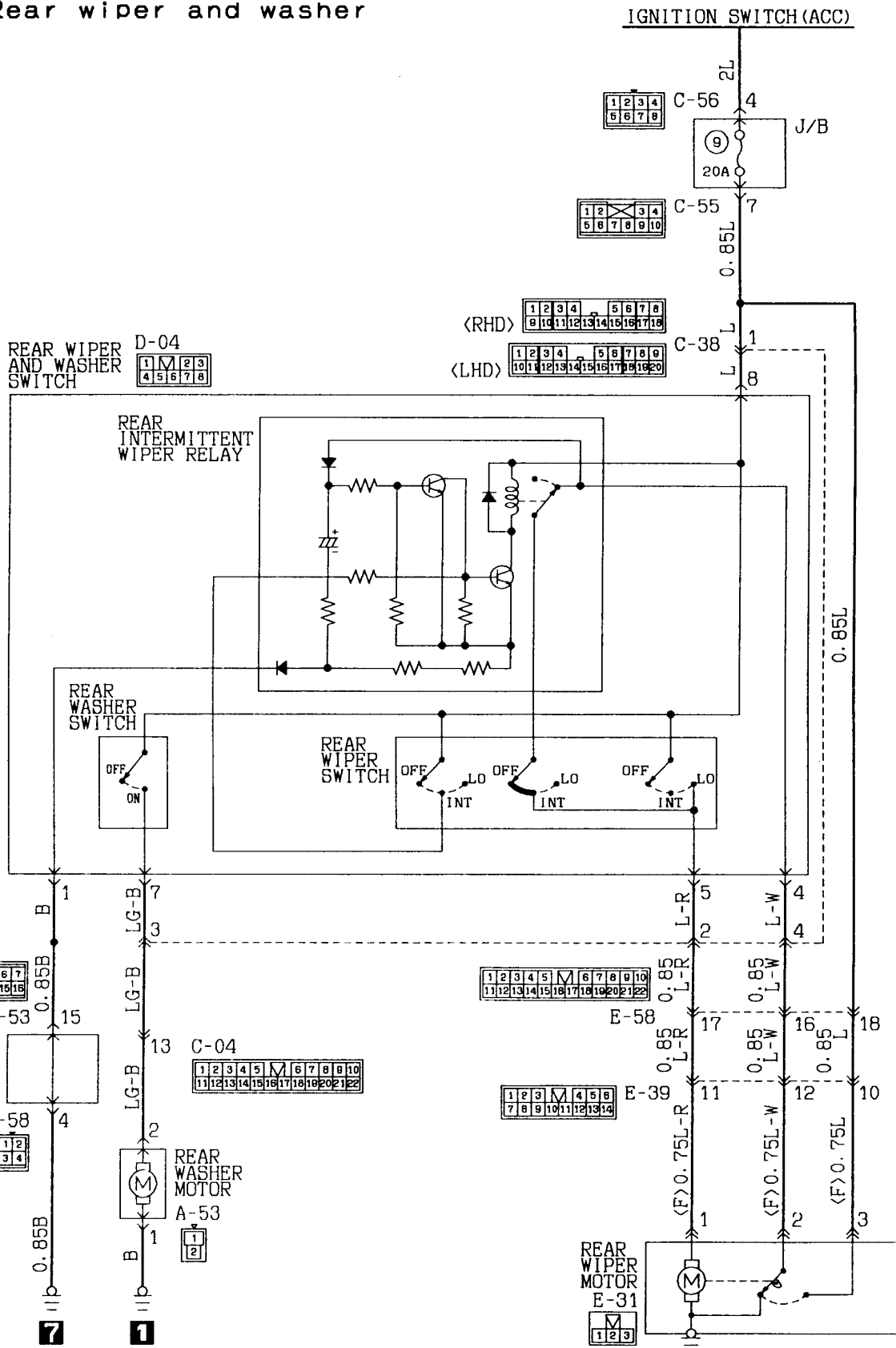

Wire colour code  
 B:Black LG:Light green G:Green L:Blue W:White Y:Yellow SB:Sky blue  
 BR:Brown O:Orange GR:Gray R:Red P:Pink V:Violet

**WIPER AND WASHER <Rear wiper and washer> (See P. 4-130.)****OPERATION****<Low-speed wiper operation>**

- When the wiper switch is placed in the LO position with the ignition switch in the ACC or ON position, wipers operate continuously at low speed.

**<Auto wiper stop operation>**

- When the wiper switch is placed in the OFF position, the cam contacts of wiper motor causes current to flow through the auto wiper stop circuit, allowing the wiper blades to cycle before they reach to the stop positions.

**<Intermittent wiper operation>**

- When the wiper switch is placed in the INT position with the ignition switch in ACC or ON position, the intermittent wiper relay is energized causing the intermittent wiper relay contacts to close and open repeatedly.
- When the contacts are closed, the wiper motor is energized.
- When the wiper motor is energized, the relay contacts open; however, the cam contacts keep the wiper motor energized until the wiper blades return to their stop position.

**TROUBLESHOOTING HINTS**

1. Wipers do not operate.
  - (1) Washer is not operative, either.
    - Check the multi-purpose fuse No. ⑨.
    - Check the earth.
    - Check the wiper switch.
2. Wipers do not stop.
  - Check the wiper motor.
  - Check the intermittent wiper relay.
  - Check the wiper switch.
3. Intermittent wiper operation is inoperative.
  - Check terminal voltage of the intermittent wiper relay energized.

Terminal No.	Voltage	Check
5	0V	Intermittent wiper relay or wiper switch
	12V	Intermittent wiper relay
	0V ↔ 12V (alternating)	— (Normal)

4. Washer is inoperative,
  - Check the washer motor.
  - Check the washer switch.

28 HEADLAMP WASHER

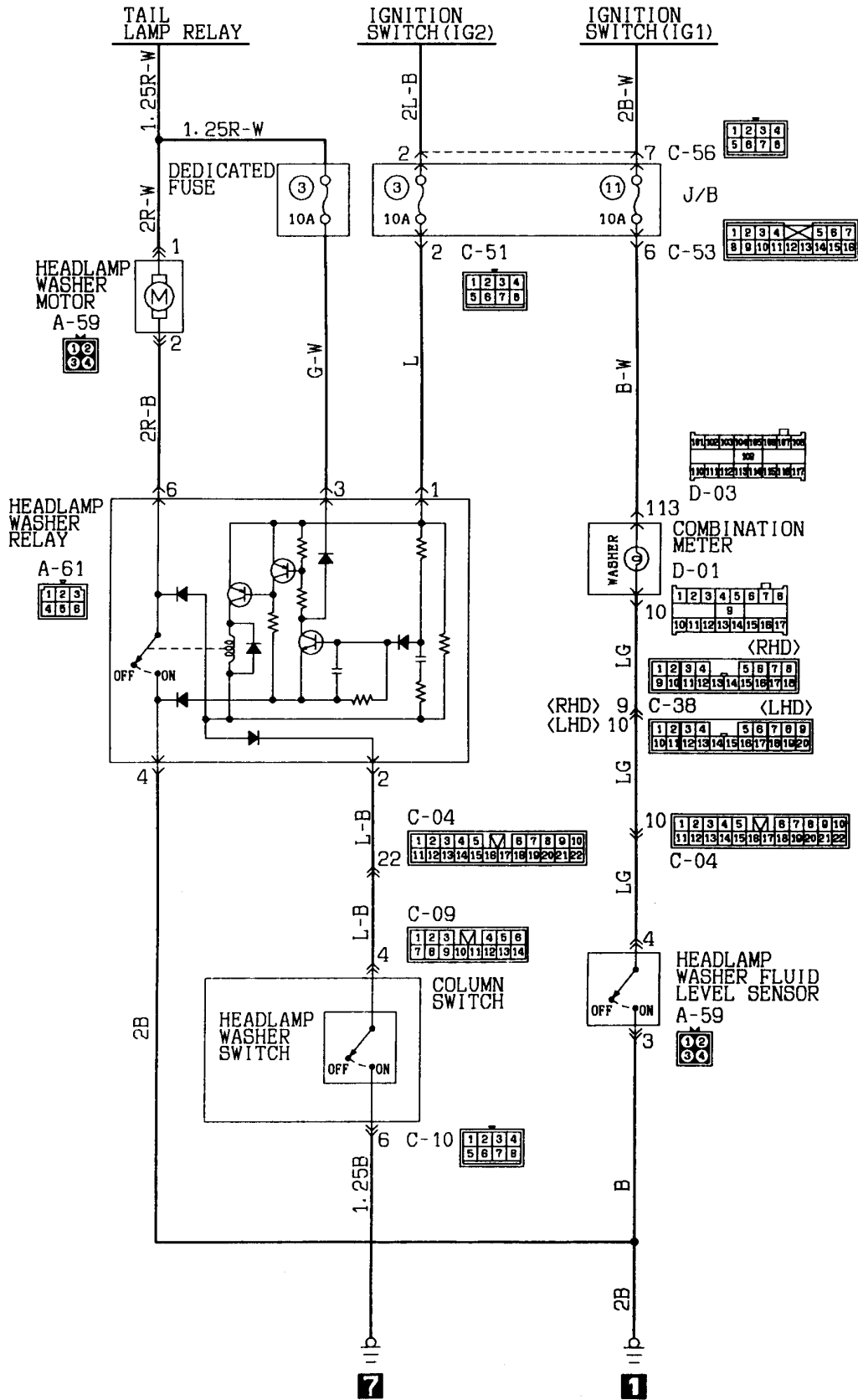

KX35-AC-Z1311-EC

**HEADLAMP WASHER (See P. 4-132.)****OPERATION**

- When the headlamp washer switch is turned ON with ignition switch in ON and lighting switch in TAIL or HEAD position, the headlamp washer relay is energized causing the headlamp washer motor to start.

**<Headlamp washer fluid level indicator lamp>**

- When the headlamp washer fluid level goes down below a predetermined level with the ignition switch in ON position, the headlamp washer level sensor is activated causing the headlamp washer fluid level indicator to light up.

**TROUBLESHOOTING HINTS**

1. Headlamp washer motor does not start.
  - (1) Blower motor does not start, either.
    - Check the multi-purpose fuse No. ③.
  - (2) Blower motor does start.
    - Check the headlamp washer motor.
    - Check the headlamp washer relay.
    - Check the headlamp washer switch.

**DEFOGGER AND DOOR MIRROR HEATER (See P. 4-134.)****OPERATION**

- When the defogger switch is turned ON with the ignition switch in ON position, the defogger relay is energized causing defogger and mirror heater to operate.
- At the same time, the defogger indicator lamp lights up indicating that the defogger is in operation.

**TROUBLESHOOTING HINTS**

1. Defogger (or mirror heater )is inoperative.
  - (1) Indicator does not come on, either.
    - Check the multi-purpose fuse No. ⑭.
    - Check the defogger relay.
  - (2) Indicator comes on.
    - Check the defogger.

29 DEFOGGER AND DOOR MIRROR HEATER

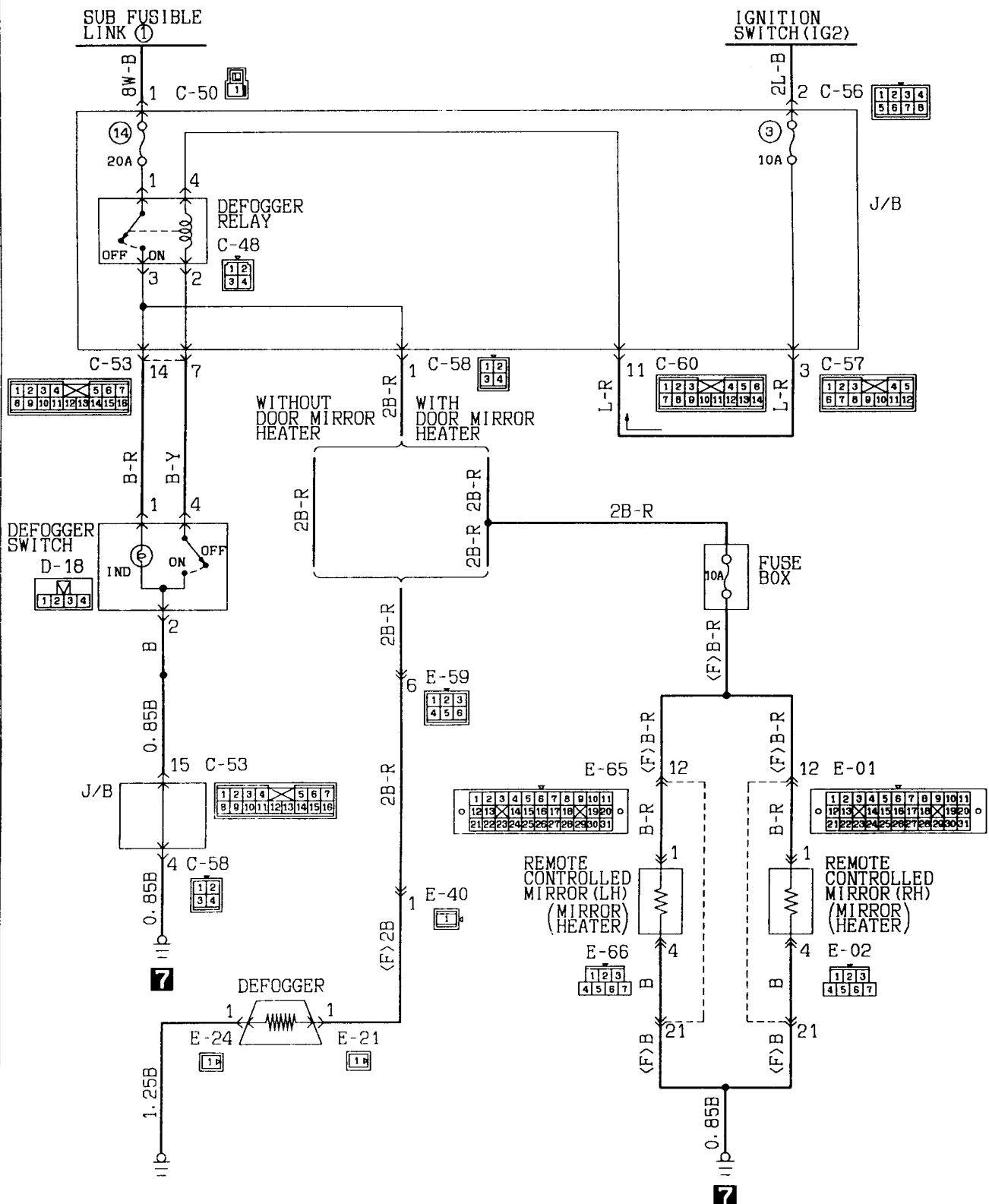

Wire colour code  
 B:Black LG:Light green G:Green L:Blue W:White Y:Yellow SB:Sky blue  
 BR:Brown O:Orange GR:Gray R:Red P:Pink V:Violet

KX35-AC-Z1312-EC

**REMOTE CONTROLLED MIRROR (See P. 4-136, 137.)****OPERATION**

- When the remote controlled mirror switch is operated with the ignition switch in ACC or ON position, the motor is started allowing the driver to adjust the orientation of the mirror surface.

**TROUBLESHOOTING HINTS**

1. LH and RH mirrors do not move.
  - (1) Cigarette lighter is also inoperative.
    - Check the multi-purpose fuse No. ⑤.
  - (2) Cigarette lighter is operative.
    - Check the remote controlled mirror switch.



30 REMOTE CONTROLLED MIRROR  
 30-1 Vehicles with door mirror heater

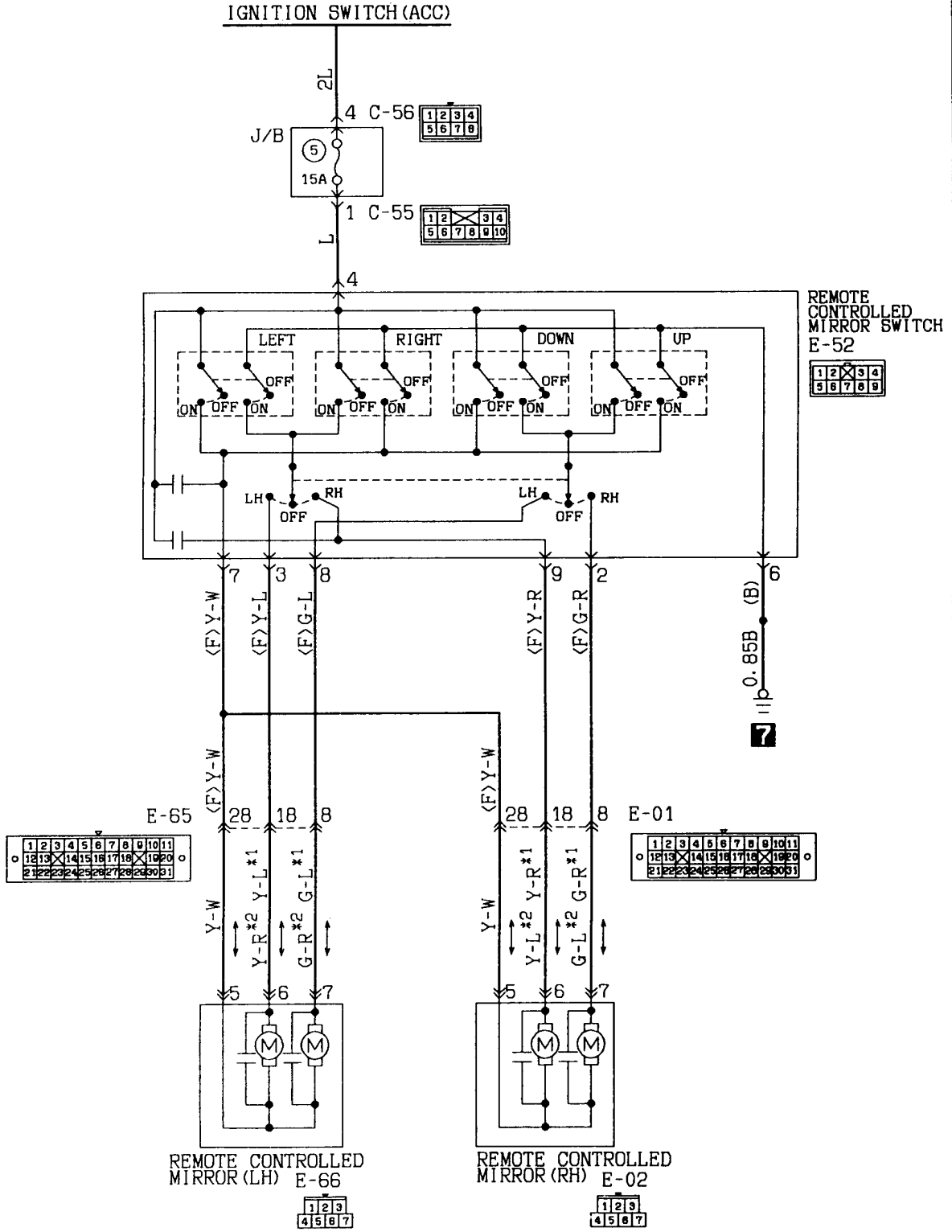

Remarks  
 (1)\*1:R.H.drive vehicles.  
 (2)\*\*2:L.H.drive vehicles.

30-2 Vehicles without door mirror heater

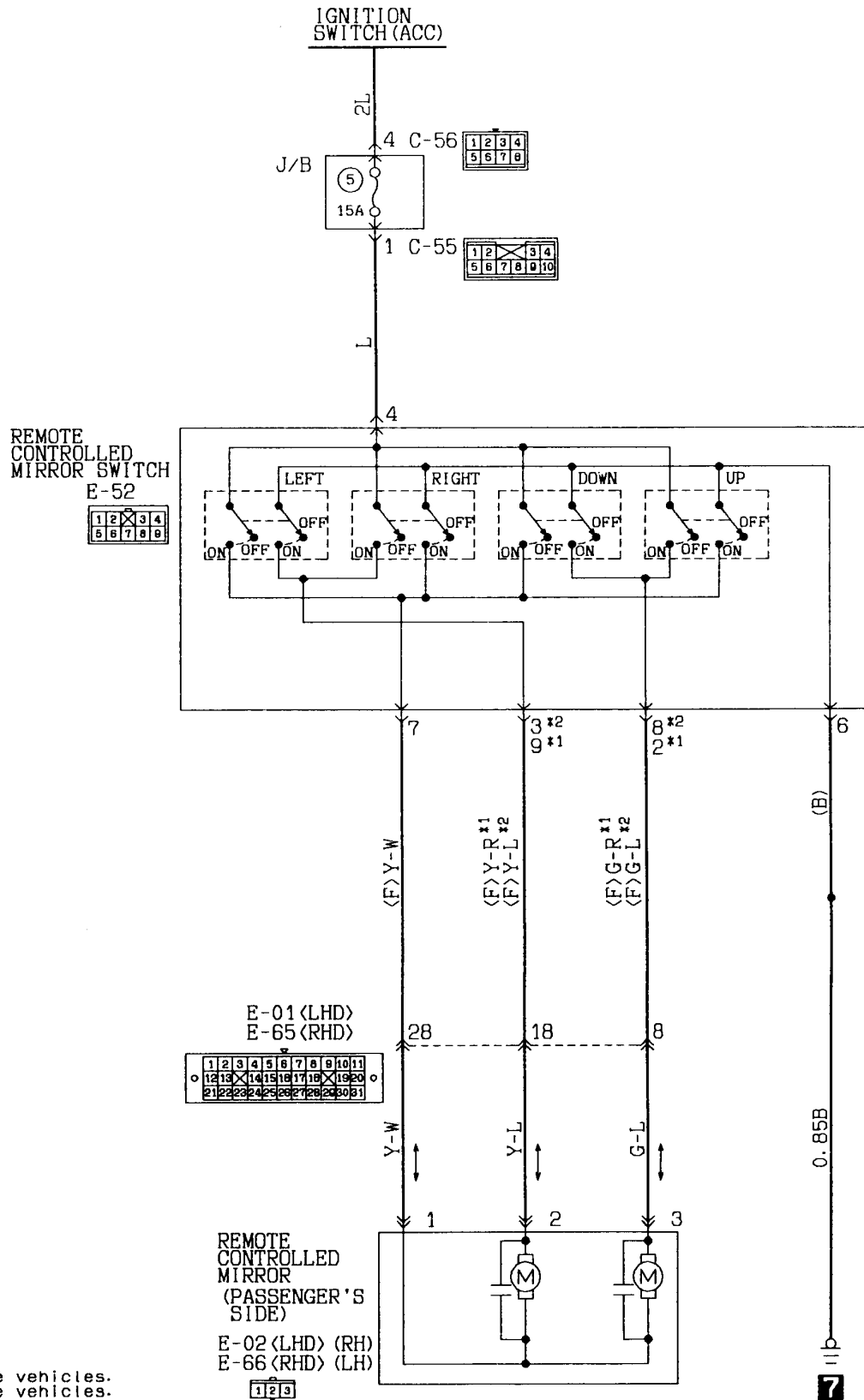

Remarks  
(1) \*1: L. H. drive vehicles.  
(2) \*2: R. H. drive vehicles.

Wire colour code  
B:Black LG:Light green G:Green L:Blue W:White Y:Yellow SB:Sky blue  
BR:Brown O:Orange GR:Gray R:Red P:Pink V:Violet

31 RADIO AND TAPE PLAYER

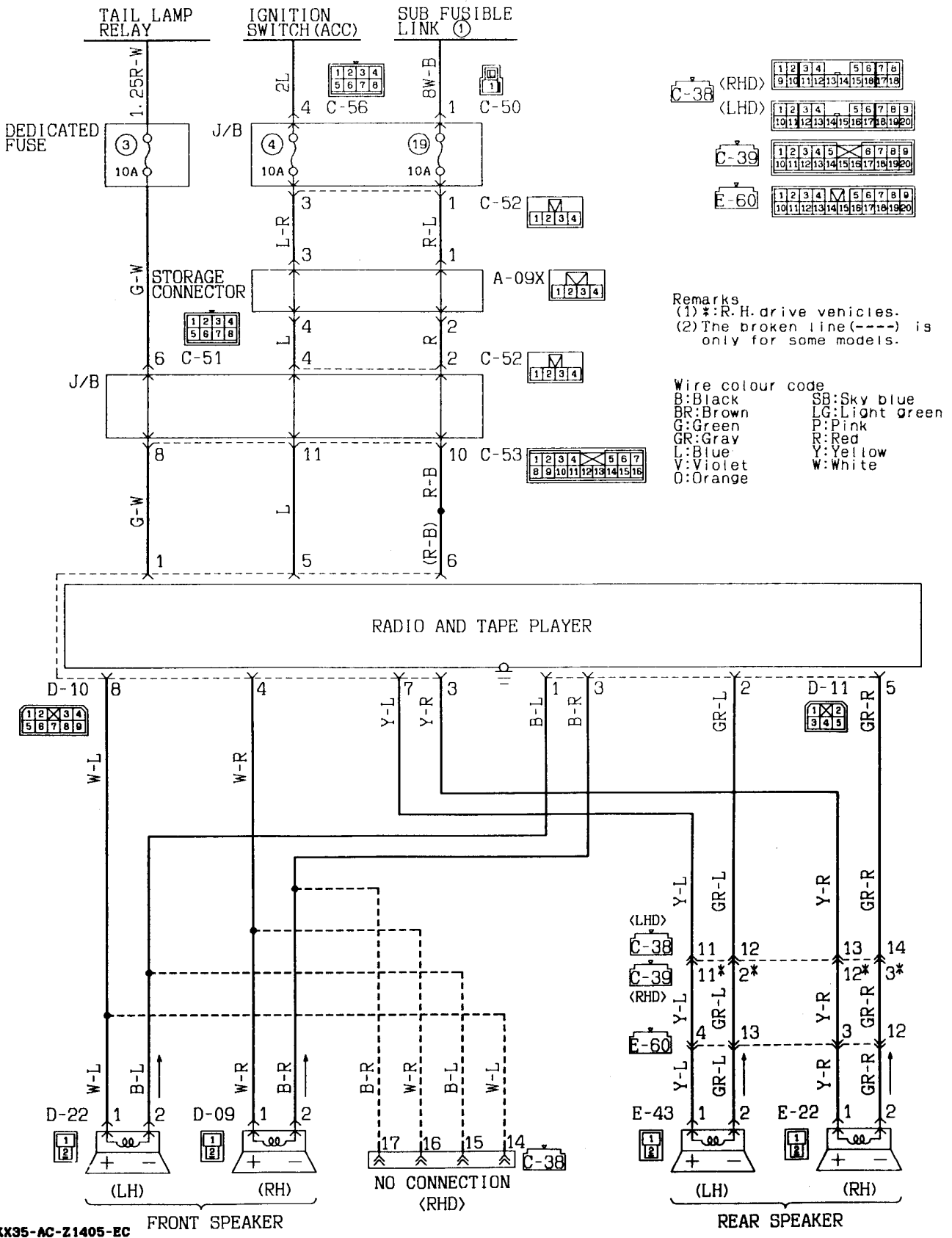

KX35-AC-Z1405-EC

**NOTES**

32 CLOCK

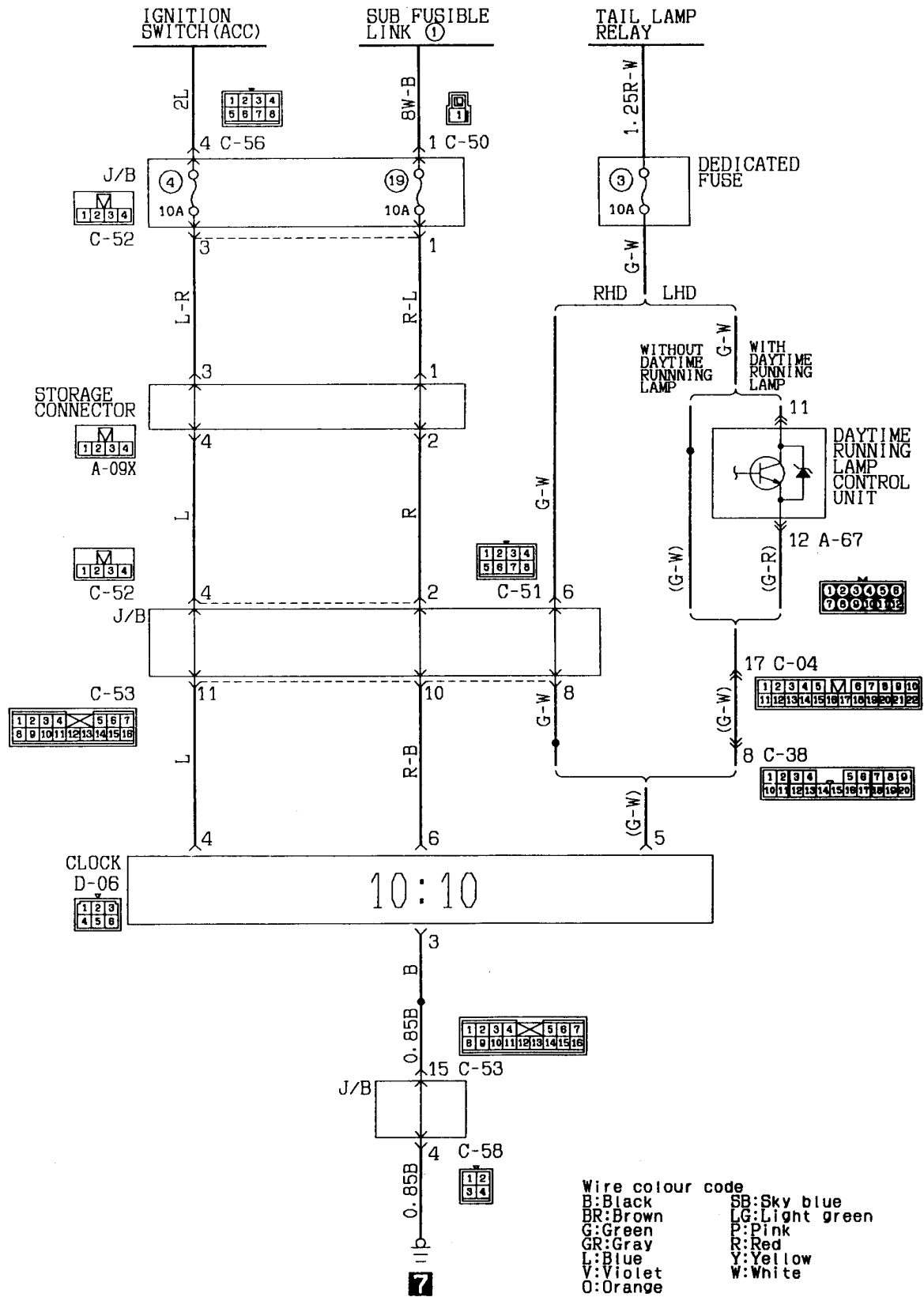

Wire colour code  
 B:Black  
 BR:Brown  
 G:Green  
 GR:Gray  
 L:Blue  
 V:Violet  
 O:Orange  
 SB:Sky blue  
 LG:Light green  
 P:Pink  
 R:Red  
 Y:Yellow  
 W:White

33 CIGARETTE LIGHTER

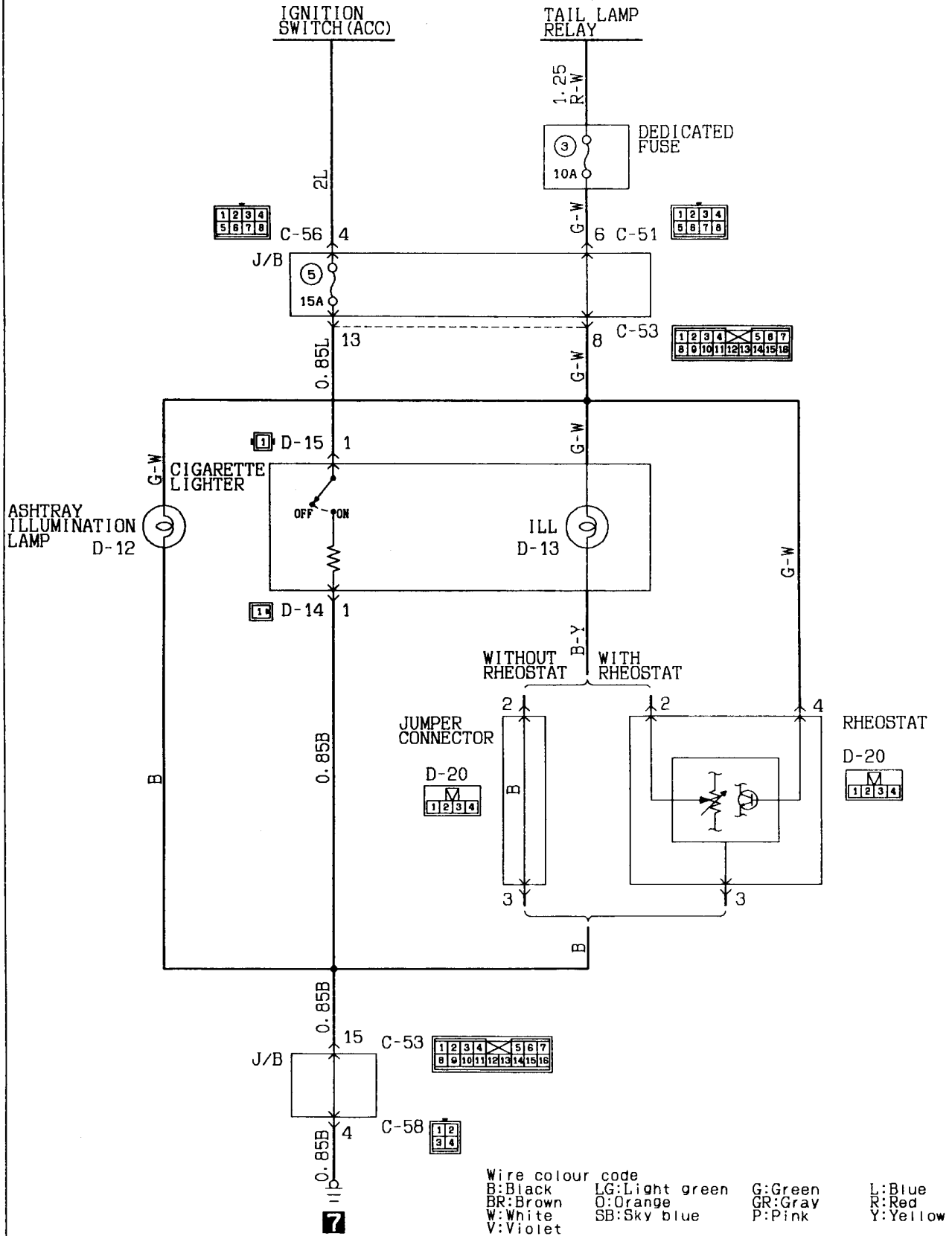

Wire colour code  
 B:Black LG:Light green G:Green L:Blue  
 BR:Brown O:Orange GR:Gray R:Red  
 W:White SB:Sky blue P:Pink Y:Yellow  
 V:Violet

KX35-AC-21408-EC

# 34 SUNROOF

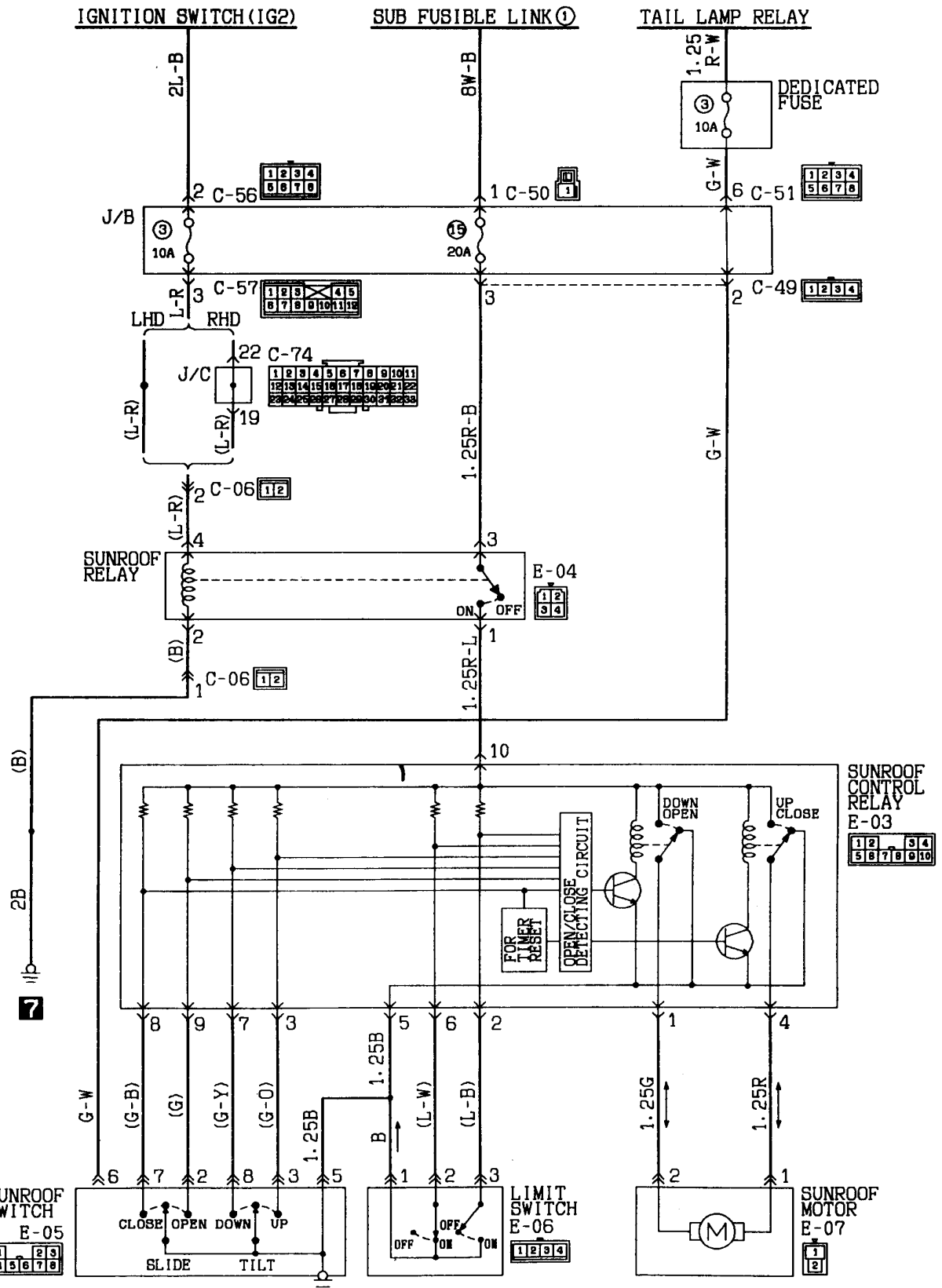

KX95-AC-Z1507-EC

**SUNROOF (See P. 4-142.)****OPERATION****<Tilt operation>**

- When the UP side of the tilt switch is depressed with the roof lid in fully-closed position and ignition switch in ON, the open/close position detecting circuit of the sunroof control relay turns ON Tr<sub>2</sub> causing relay 2 to be energized. This results in the sunroof motor being rotated causing the rear end to raise approx. 30 mm (1.18 in.).
- When the DOWN side of the tilt switch is depressed, relay 1 is energized causing the roof lid to close down.
- When the roof lid is fully closed, limit switch 1 turns ON causing relay 1 to deenergized. As a result, the motor stops rotating.

**<Slide operation>**

- When the OPEN side of the slide switch is depressed with the ignition switch in ON position, the open/close position detecting circuit of the sunroof control relay turns ON Tr<sub>1</sub> causing relay 1 to be energized. This results in the sunroof motor being rotated and the roof lid opens as long as the switch is held down.
- As when the OPEN side is held down, holding down the CLOSE side energizes relay 2 causing the roof lid to close. If the switch is held down with the roof lid opened more than half, the limit switch turns OFF just before the lid is fully closed, which deenergizes relay 2. As a result, the motor stops rotating and the roof lid stops in mid-motion. If the switch is released and then depressed and held down, the restart timer turns ON Tr<sub>2</sub> causing relay 2 to be energized. This in turn causes the sunroof motor to start.
- When the roof lid is fully closed, limit switch 2 turns OFF, deenergizing relay 2. Then, the motor stops rotating.

**TROUBLESHOOTING HINTS**

1. Sunroof is not operative at all.
  - (1) Power window is inoperative also.
    - Check the multi-purpose fuse No. ③.
  - (2) Power window is operative.
    - Check the multi-purpose fuse No. ⑮.
    - Check the sunroof relay.



35 ANTI-LOCK BRAKE SYSTEM (ABS)  
35-1 2WD

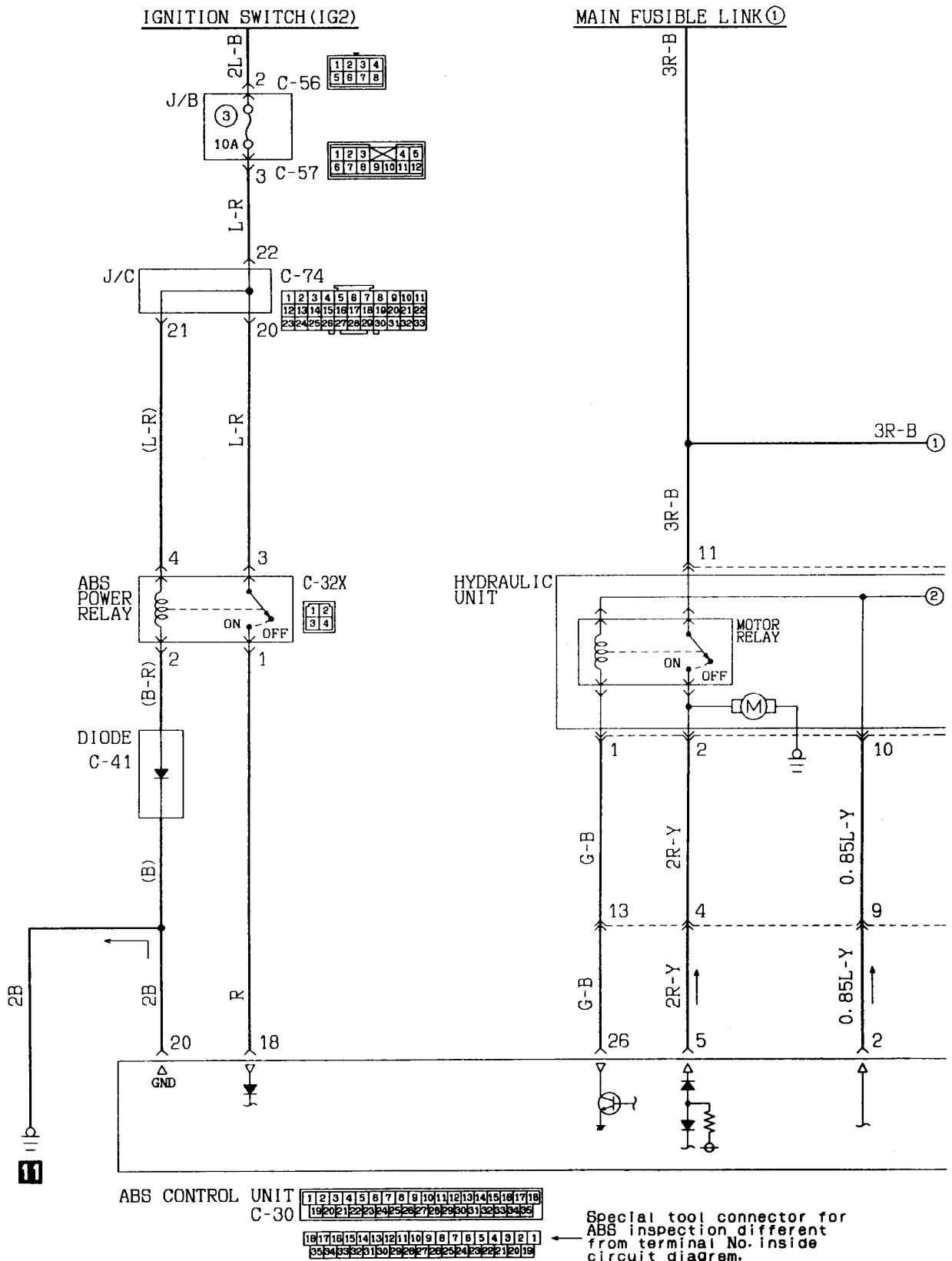

KX35-AC-Z1508-EC

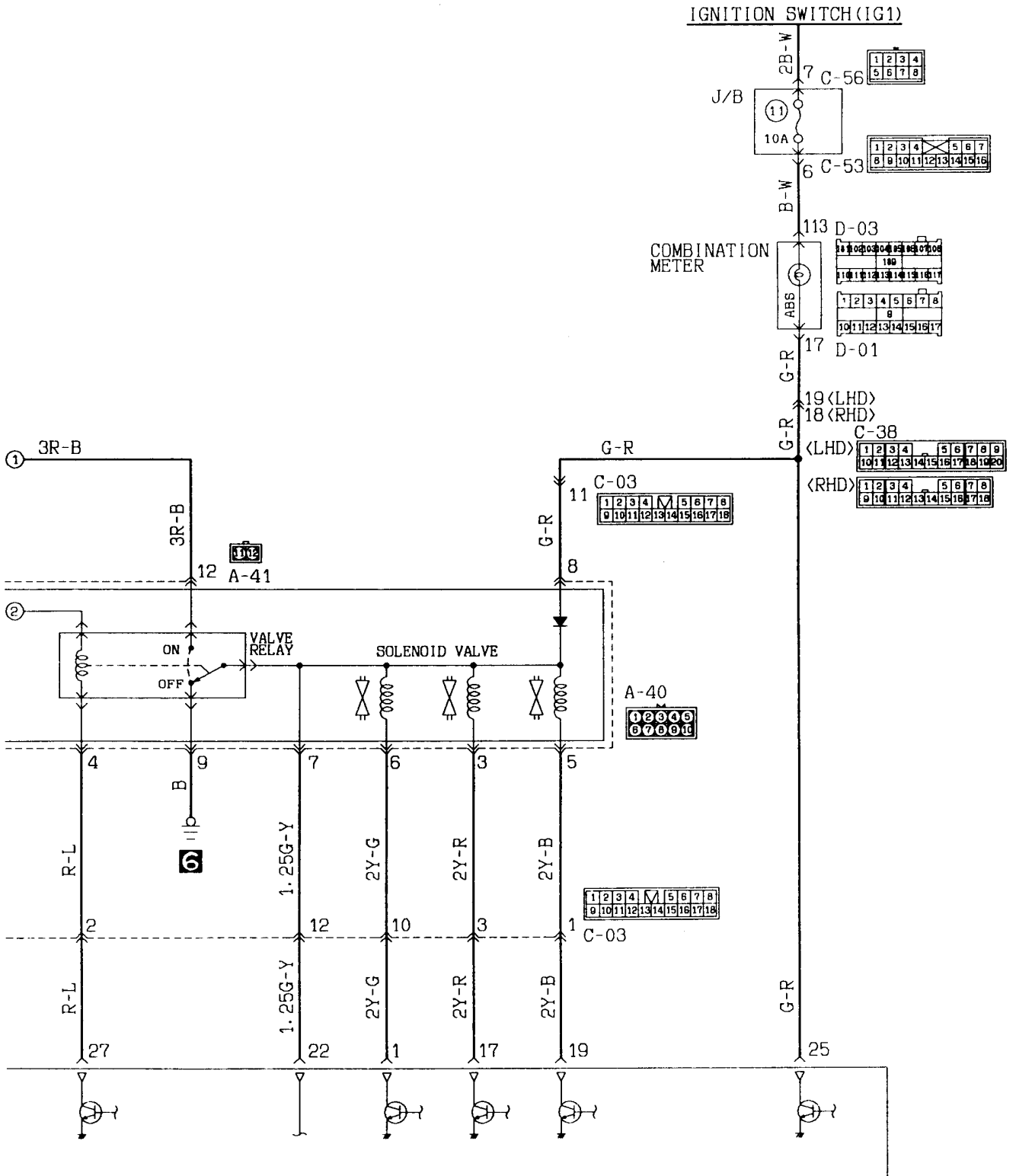

Wire colour code  
 B:Black LG:Light green G:Green L:Blue W:White Y:Yellow SB:Sky blue  
 BR:Brown O:Orange GR:Gray R:Red P:Pink V:Violet

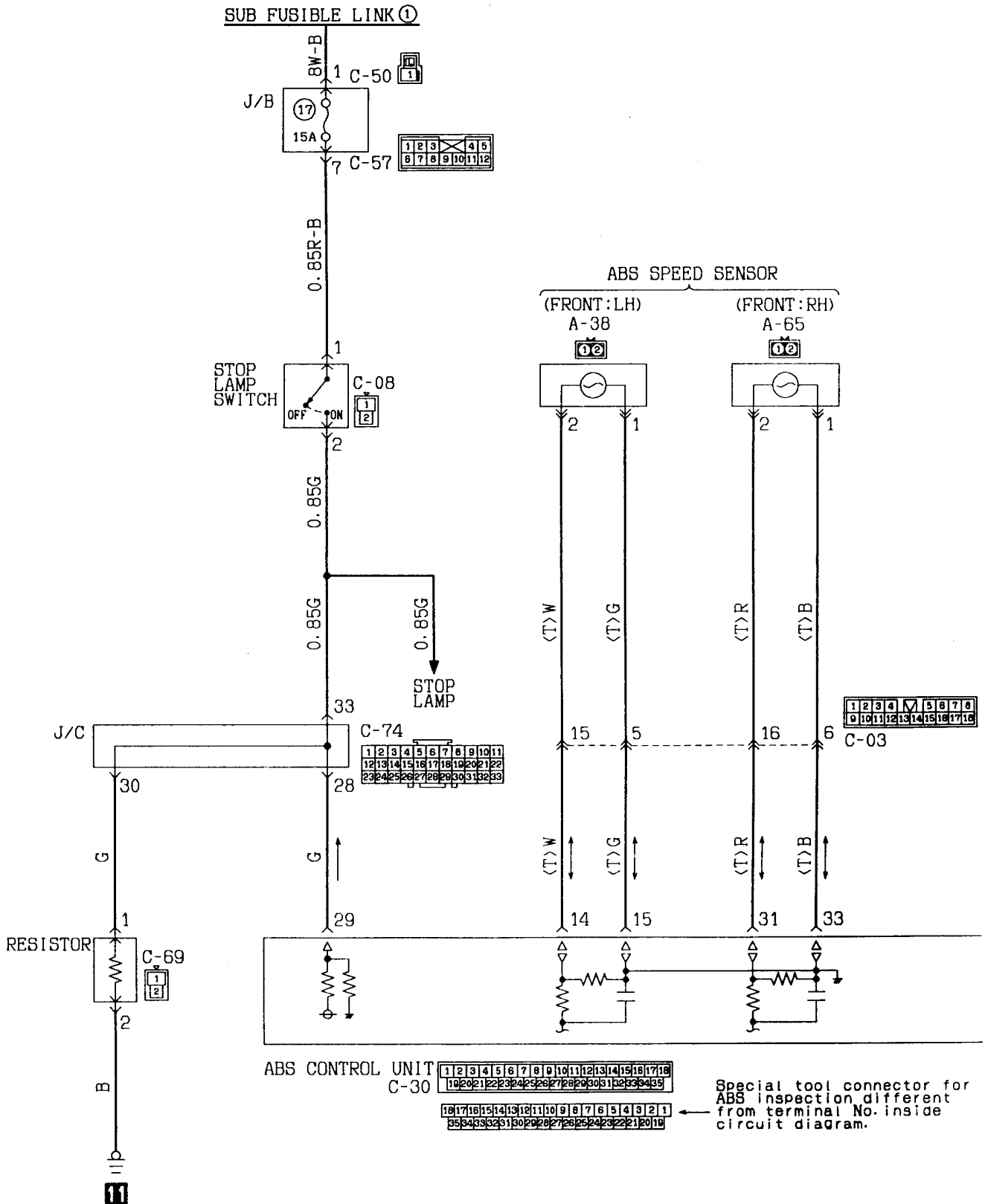

Wire colour code  
 B:Black LG:Light green G:Green L:Blue W:White Y:Yellow SB:Sky blue  
 BR:Brown O:Orange GR:Gray R:Red P:Pink V:Violet

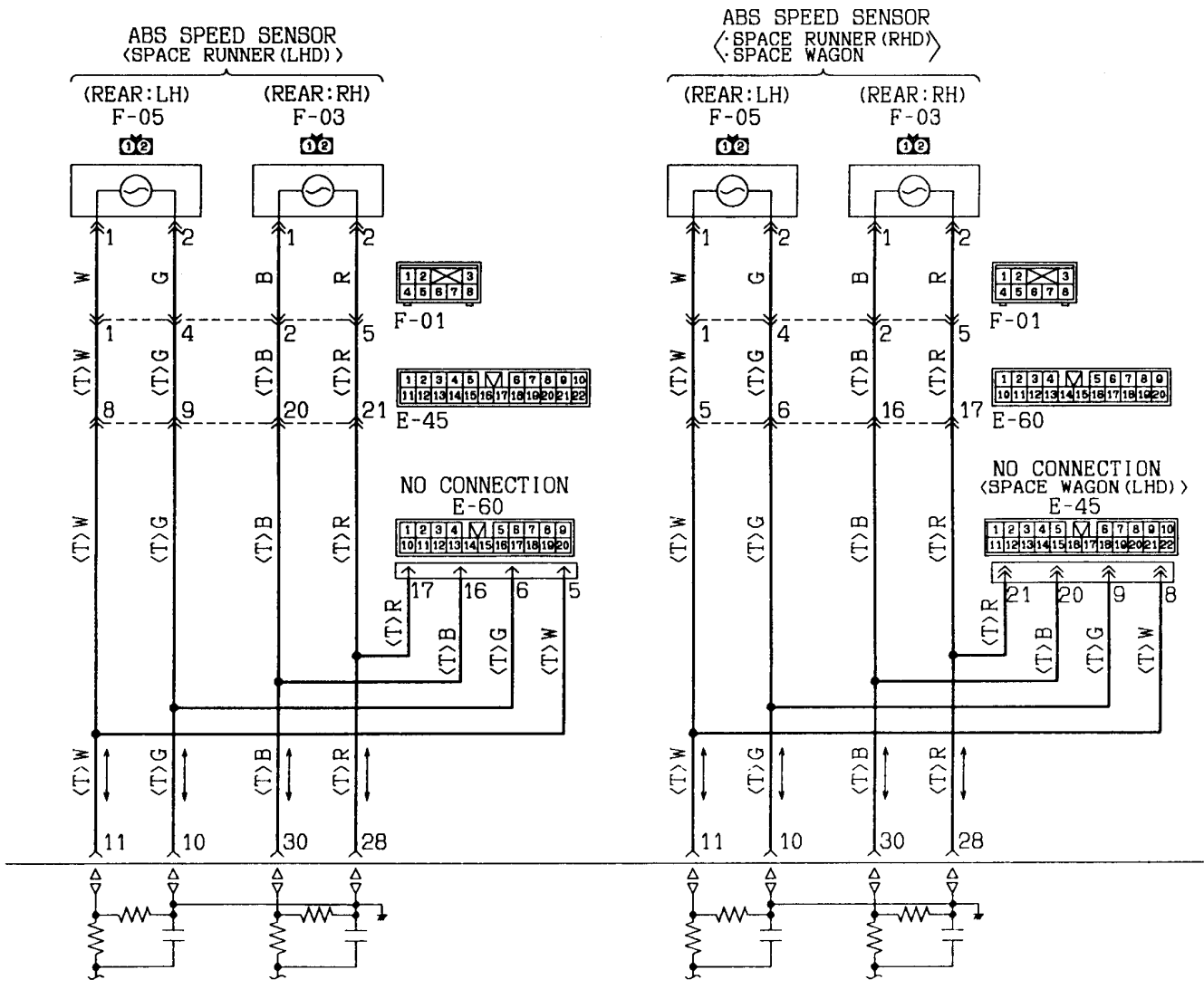

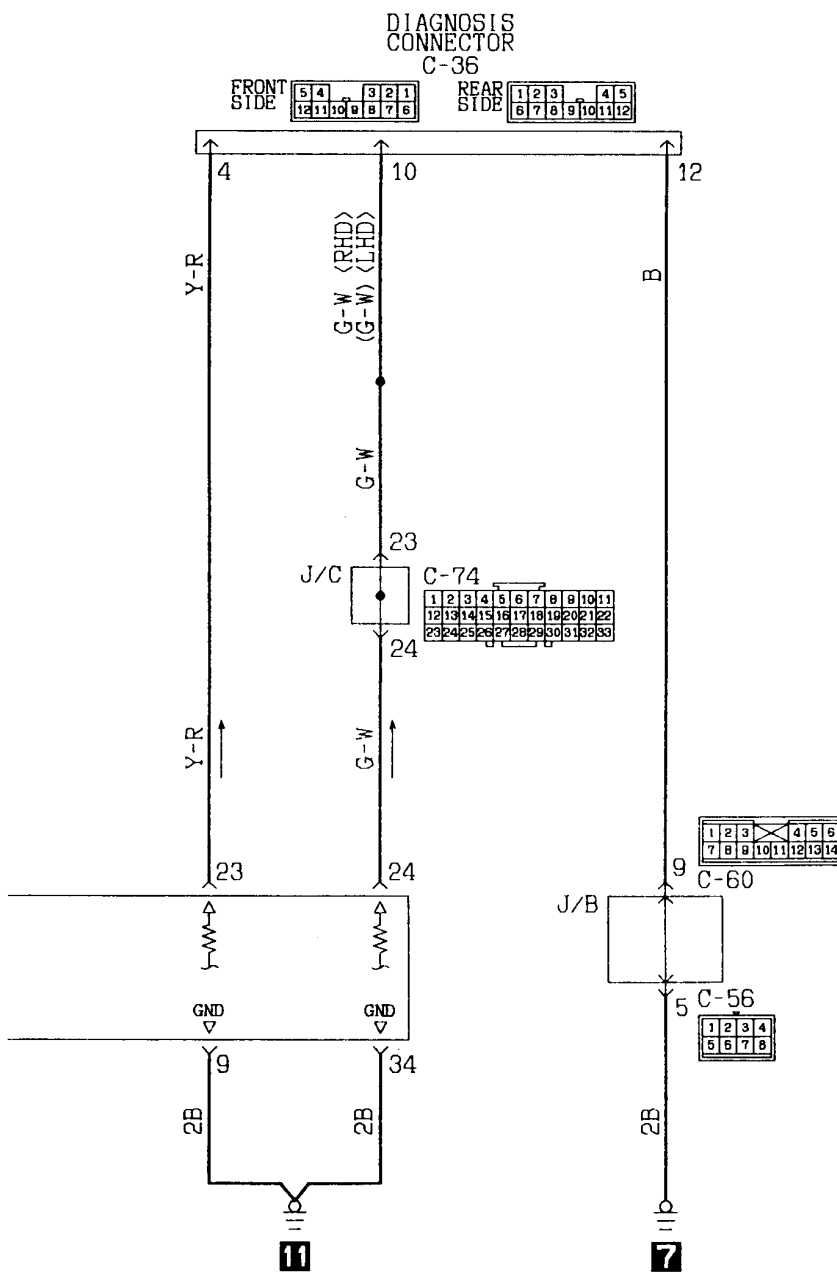

**NOTES**

35-2 4WD

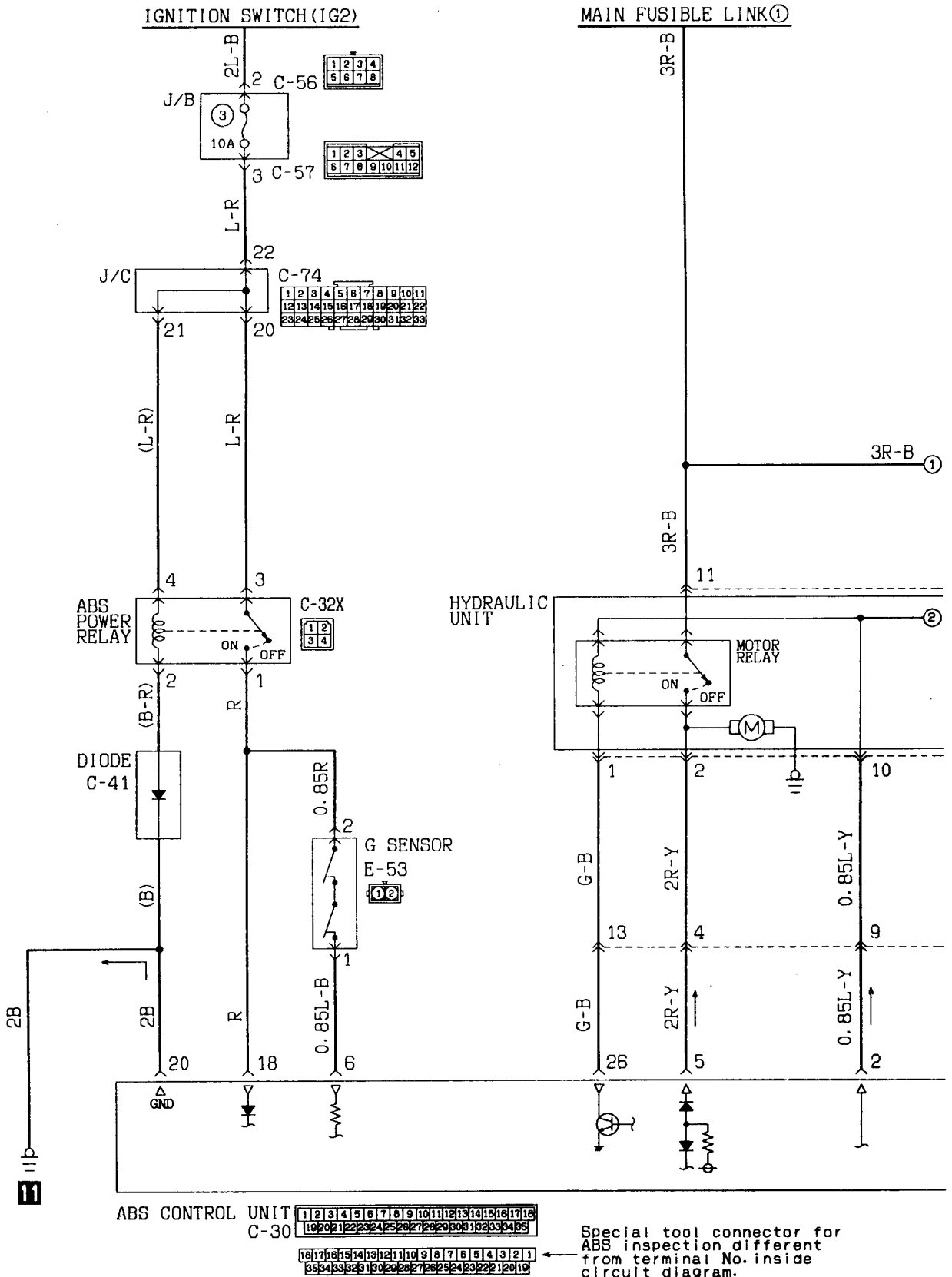

KX35-AC-Z1509-EC

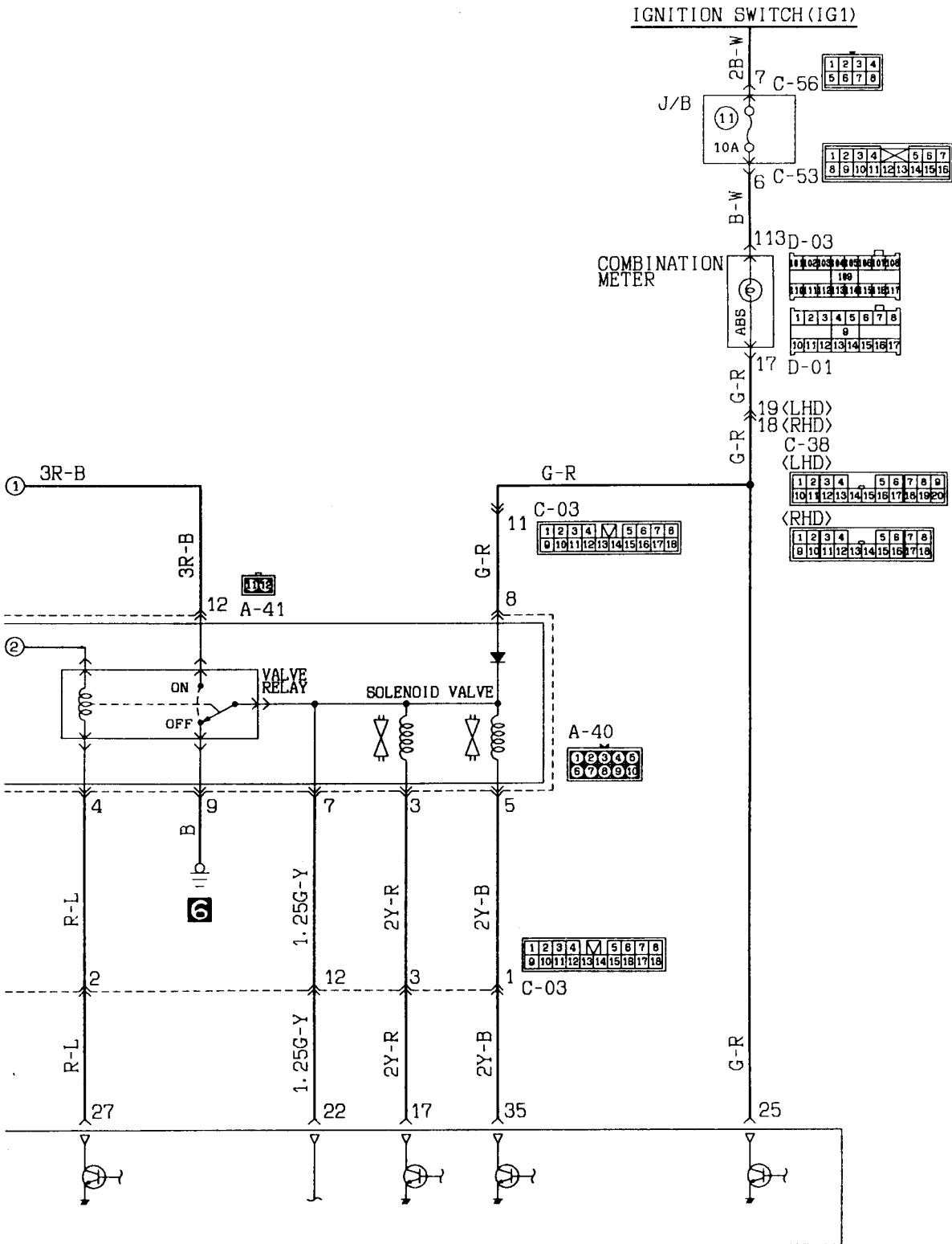



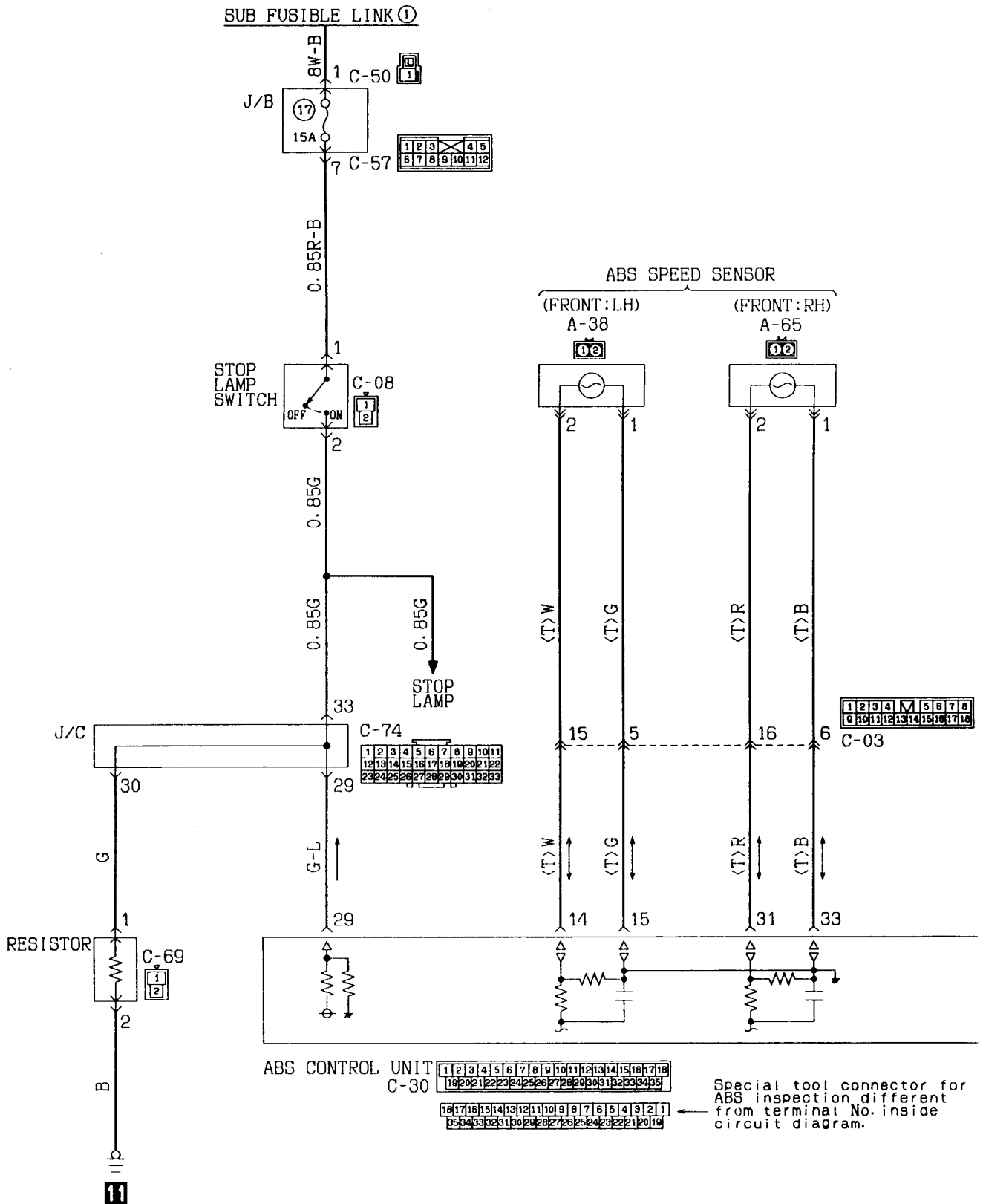

Wire colour code  
 B:Black LG:Light green G:Green L:Blue W:White Y:Yellow SB:Sky blue  
 BR:Brown O:Orange GR:Gray R:Red P:Pink V:Violet

KX35-AC-Z1509A-EC

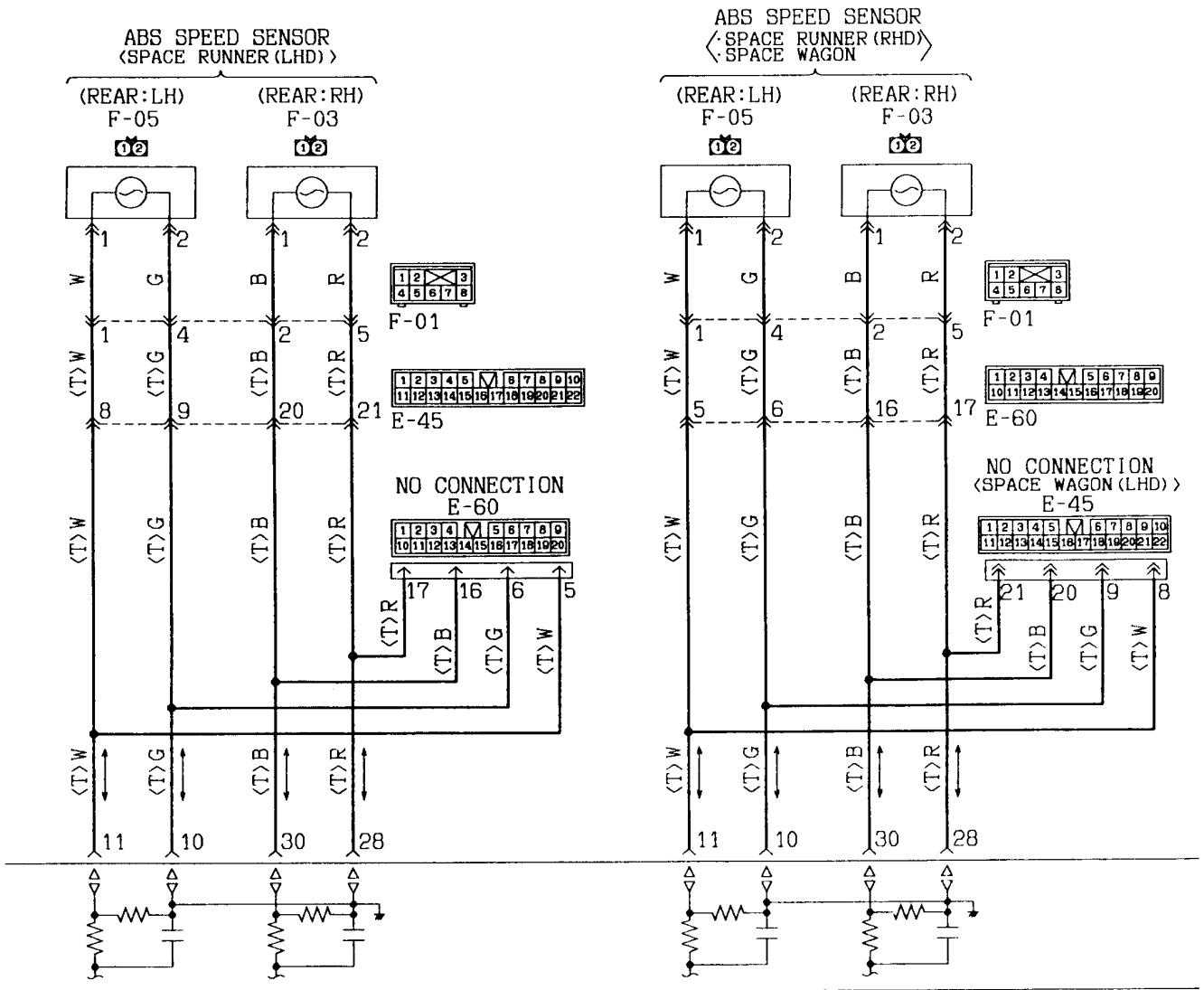

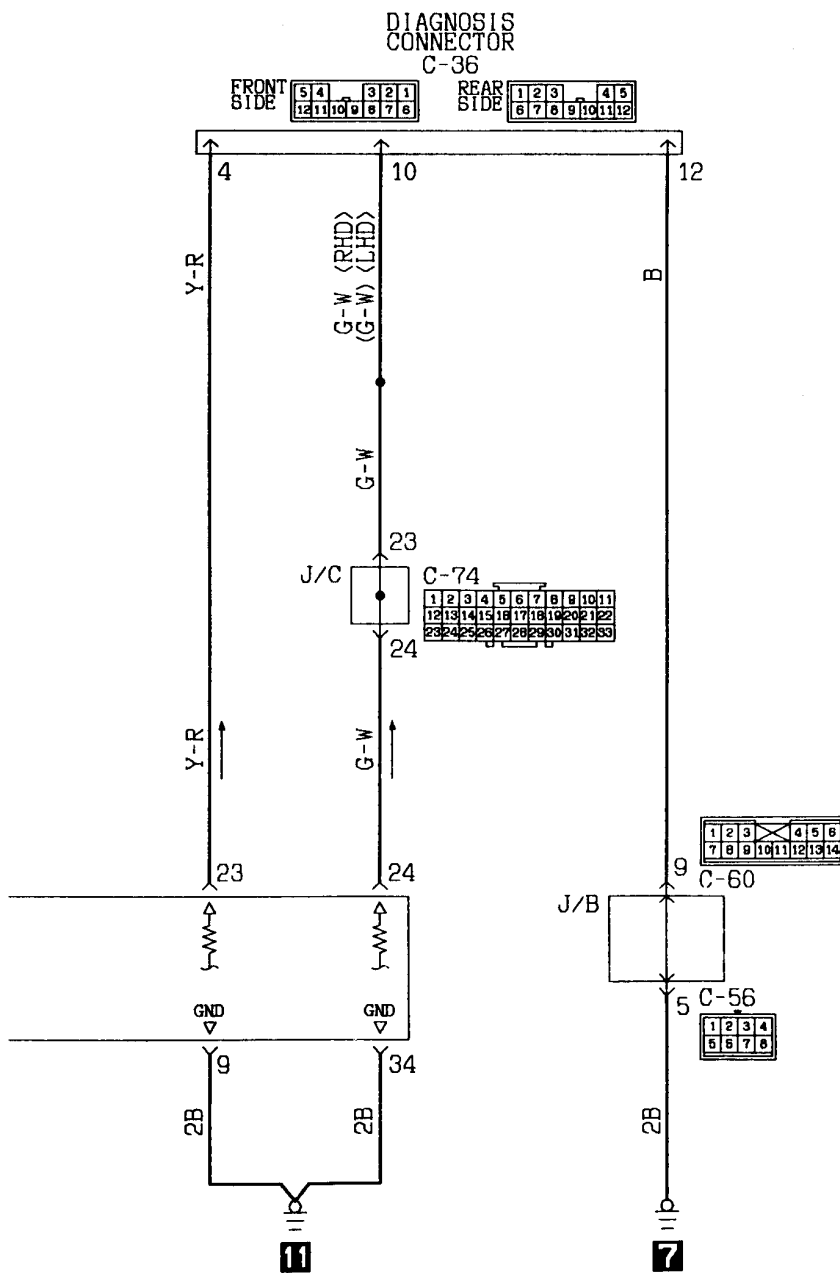

NOTES

36 HEATED SEAT

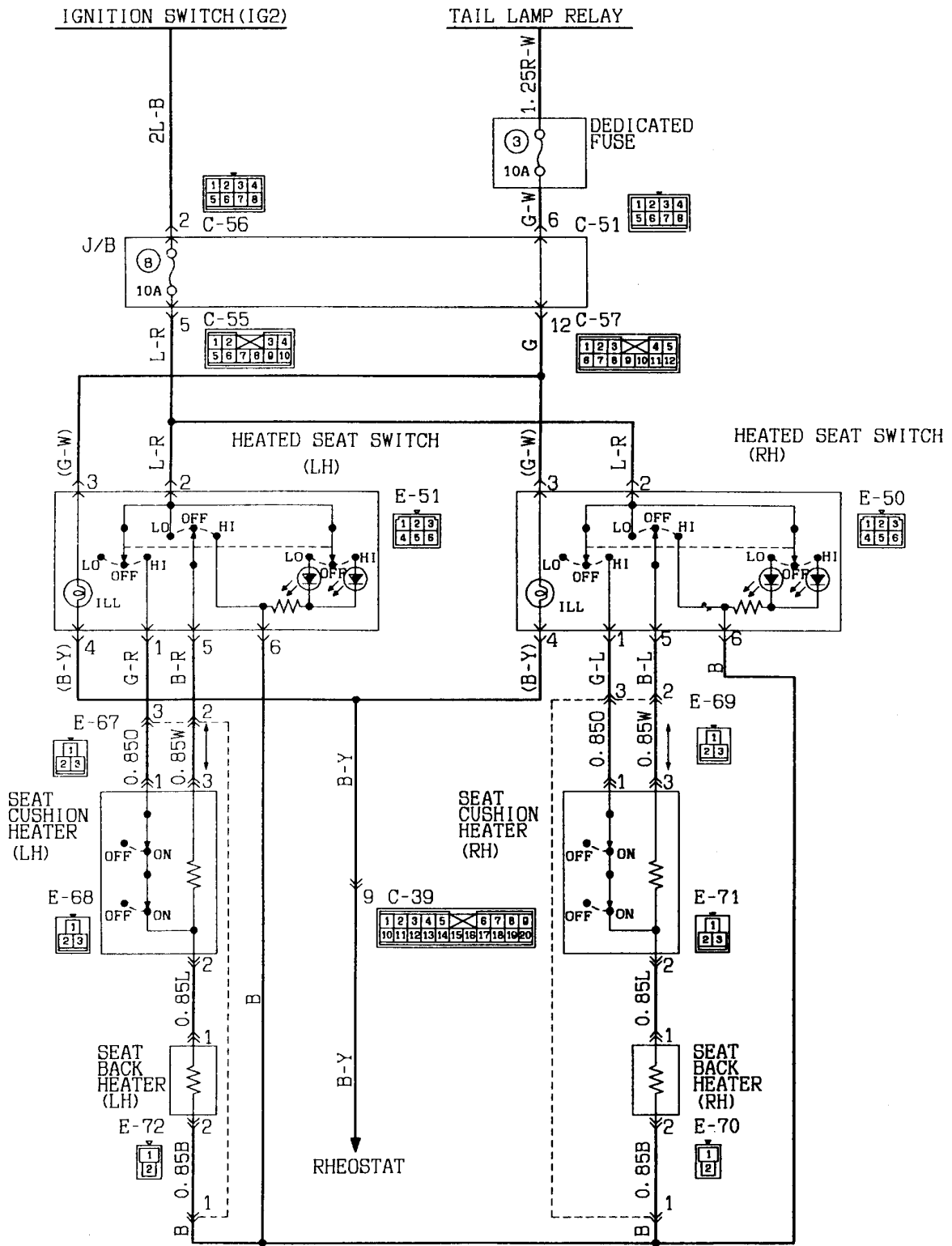

Wire colour code  
 B:Black LG:Light green G:Green L:Blue  
 BR:Brown O:Orange GR:Gray R:Red  
 W:White SB:Sky blue P:Pink Y:Yellow  
 V:Violet

**HEATED SEAT (See P. 4-148.)****OPERATION**

- When the heated seat switch is turned ON (either in LO or HI) with the ignition switch in ON position, the heated seat is activated with operation corresponding to the switch position.

**TROUBLESHOOTING HINTS**

1. The heated seat warms at one place only.
  - Check the heated seat.
2. The heated seat doesn't become warm.
  - Check the multi-purpose fuse No. ⑧.
  - Check the heated seat switch.

# 37 JUNCTION BLOCK

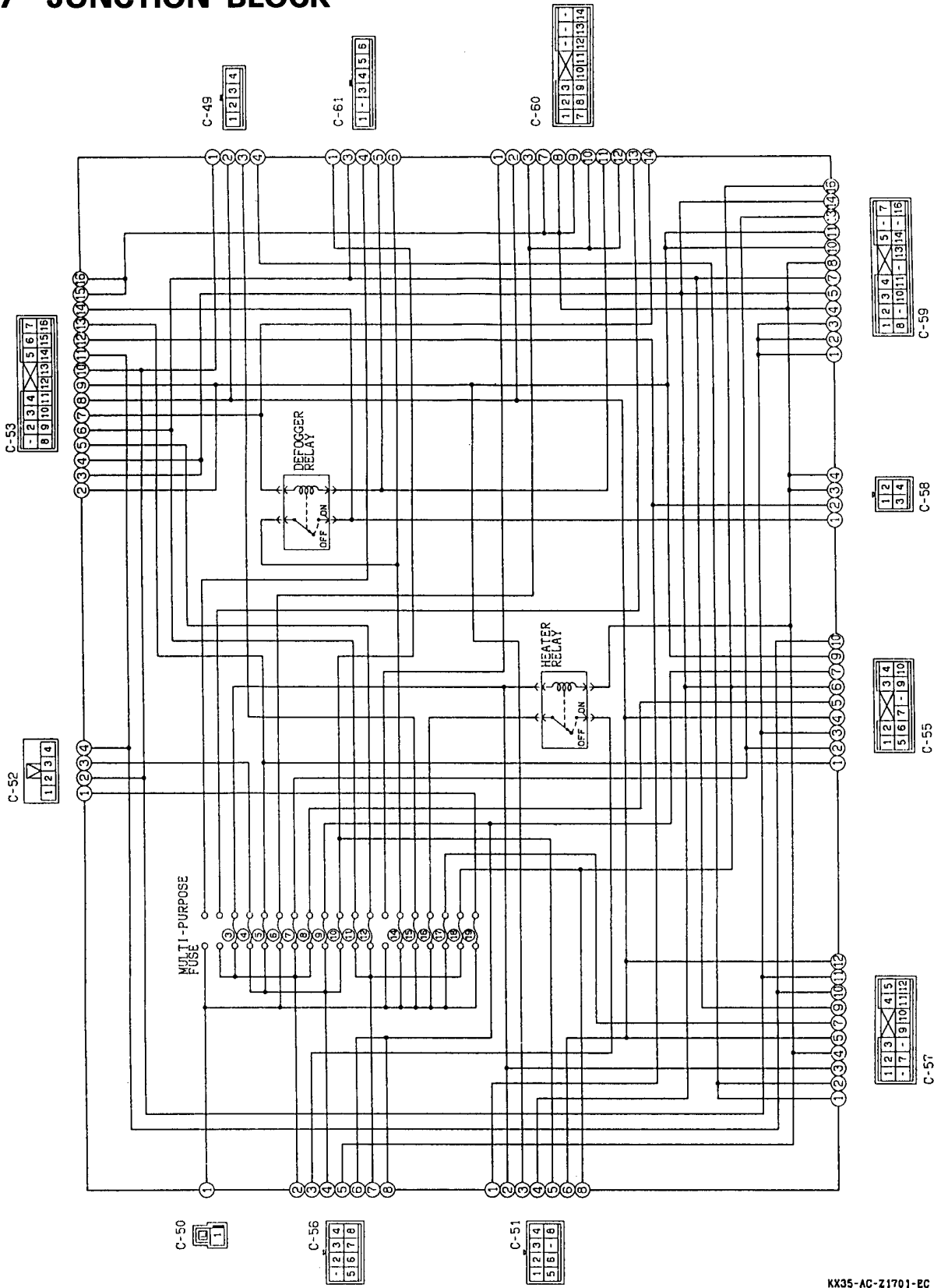

**Remark**

- Connector numbers are keyed to the configuration diagram (dashboard panel) and each circuit diagram.

KX35-AC-Z1701-EC

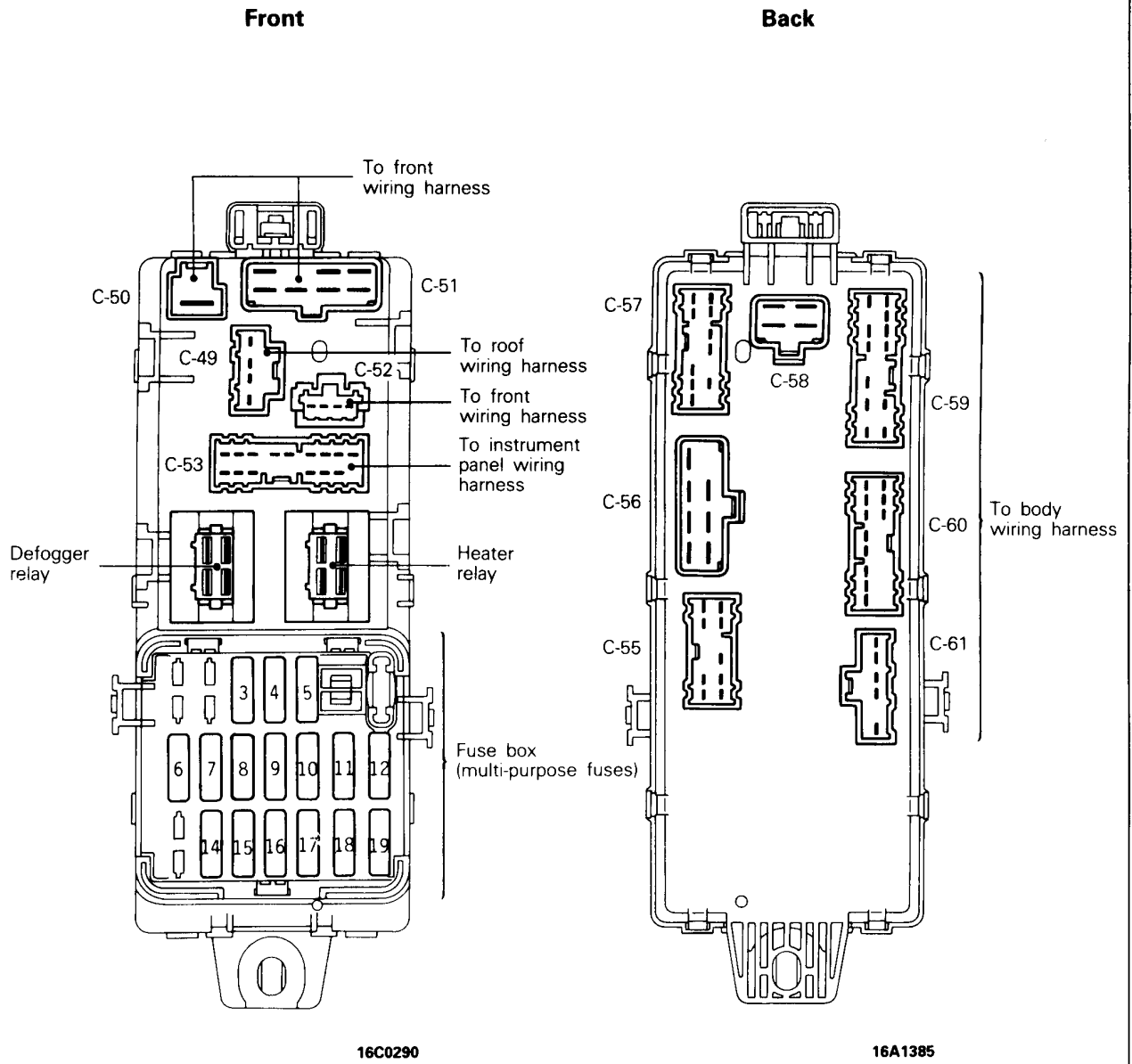



### 38 CENTRALIZED JUNCTION

#### MAIN FUSIBLE LINK (Connected directly to battery positive terminal)

No.	Circuit	Housing colour	Rated capacity (A)
1	ABS circuit (hydraulic unit power source)	Yellow	60
2	—	—	—
3	Grow circuit	Black	80

<Petrol-powered vehicles with ABS and Diesel-powered vehicles without ABS>

<Diesel-powered vehicles with ABS>

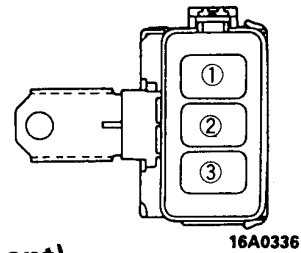
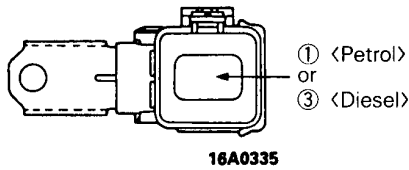

#### SUB-FUSIBLE LINK (Relay box in engine compartment)

No.	Circuit	Housing colour	Rated capacity (A)
1	Junction block (Multi-purpose fuse ⑥, ⑭, ⑮, ⑯, ⑰, ⑲), A/C circuit	Yellow	60
2	Sub-fusible link No. ①, ⑨, alternator circuit	Black	80
3	MPI circuit* <sup>1</sup>	Blue* <sup>1</sup>	20* <sup>1</sup>
	Starting circuit* <sup>2</sup>	Green* <sup>2</sup>	30* <sup>2</sup>
4	Headlamp and tail lamp circuit	Pink	30
5	Radiator fan motor and condenser fan motor circuit	Pink	30* <sup>1</sup> 40* <sup>2</sup>
6	Ignition switch and alternator circuit	Pink	30
7	—	—	—
8	—	—	—
9	Power window circuit	Pink	30

NOTE

- (1) \*1: Petrol-powered vehicles
- (2) \*2: Diesel-powered vehicles

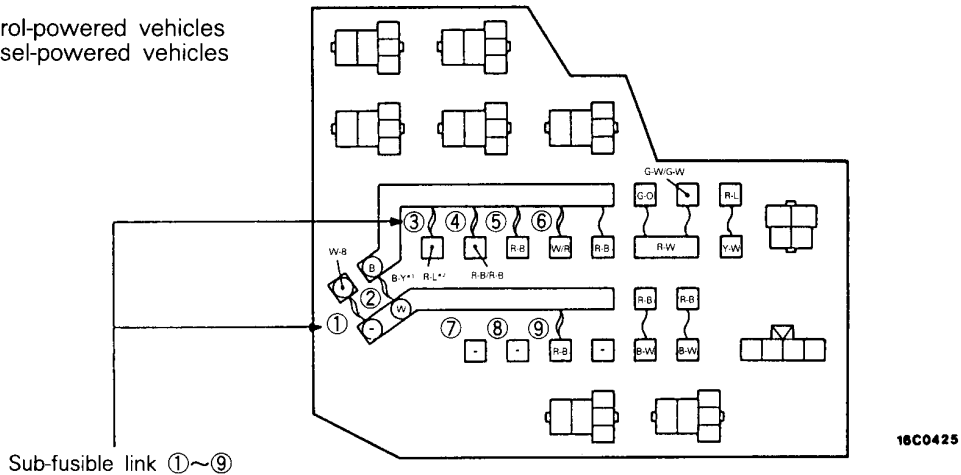

**DEDICATED FUSE (Relay box in engine compartment)**

Power supply circuit	No.	Rated capacity (A)	Housing Colour	Circuit
Battery	1	10	Red	Hazard lamp circuit
Tail lamp relay (Battery)	2	10	Red	Tail lamp circuit
	3	10	Red	Tail lamp circuit Illumination circuit Lighting monitor buzzer circuit Headlamp washer circuit
Headlamp relay (Battery)	4	10	Red	Upper beam indicator circuit Rear fog lamp circuit Headlamp leveling circuit
—	5	—	—	—
Battery	6	15 <sup>*1, *3</sup>	Blue <sup>*1, *3</sup>	Condenser fan motor circuit
		25 <sup>*2</sup>	Transparent <sup>*2</sup>	
	7	10	Red	A/C compressor circuit

NOTE

- (1) \*1: Petrol-powered vehicles
- (2) \*2: Diesel-powered vehicles
- (3) \*3: Diesel-powered vehicles without air conditioner

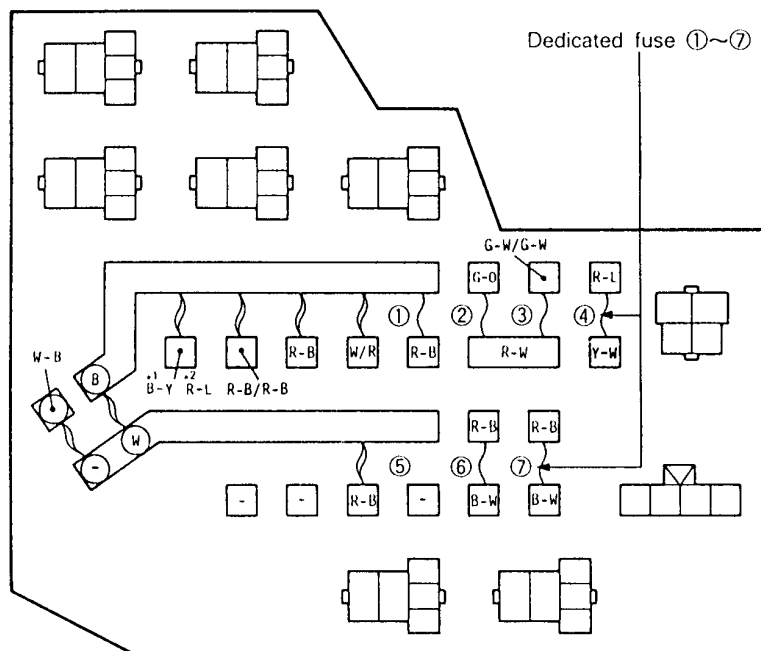

16C0425

**MULTI-PURPOSE FUSES (In junction block)**

Power supply circuit		No.	Rated capacity (A)	Load circuit
—		1	—	—
—		2	—	—
Ignition switch	IG <sub>2</sub>	3	10	Heater relay, defogger relay, headlamp washer relay, ABS relay, daytime running lamp control unit, sunroof relay, power window relay, daytime running lamp relay 1 and blower switch
		4	10	Radio and clock
	ACC	5	15	Cigarette lighter and remote controlled mirror switch
Battery		6	15	Door lock control unit and taigate lock switch
Ignition switch	IG <sub>2</sub>	7	10	OD switch, inhibitor switch and ELC-4A/T control unit
		8	10	Heated seat switch
	ACC	9	20	Front wiper relay, front wiper motor, rear wiper and washer switch and rear wiper motor
		10	10	Horn
	IG <sub>1</sub>	11	10	Combination meter, Lighting monitor buzzer
		12	10	Hazard switch
—		13	—	—
Battery		14	20	Defogger, defogger switch and door mirror heater
		15	20	Sunroof control relay
		16	30	Blower motor
		17	15	Stop lamp switch
Ignition switch	IG <sub>1</sub>	18	10	Back-up lamp switch and inhibitor switch
Battery		19	10	Clock, radio, door lamp, room lamp, cargo room lamp, engine control unit, door-ajar warning lamp, door lock control unit and ELC-4 A/T control unit

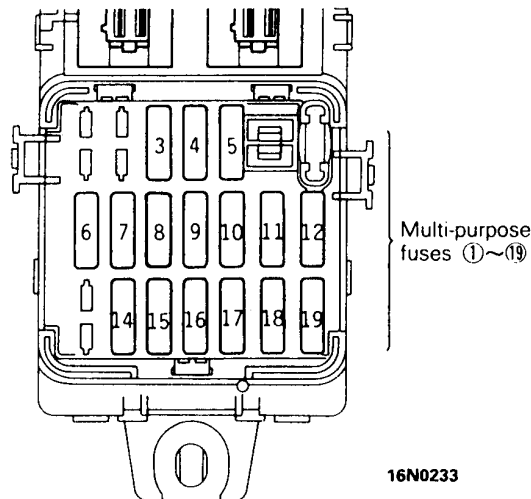

16N0233

**CENTRALIZED RELAY**

Classification		Name	Classification		Name
Relay box in engine compartment	A-01X	Tail lamp relay	Interior relay box	C-32X	ABS relay
	A-02X	Headlamp relay		C-33X	Power window relay
	A-03X	A/C compressor relay		C-34X	Central door lock control unit
	A-04X	Radiator fan motor relay (LO)		C-35X	Rear fog lamp relay
	A-05X	Radiator fan motor relay (HI)			
	A-06X	Condenser fan motor relay (LO)			
	A-07X	Condenser fan motor relay (HI)			
	A-08X	Alternator relay			
	A-09X	Storage connector			

<Relay box in engine compartment>

<Interior relay box>

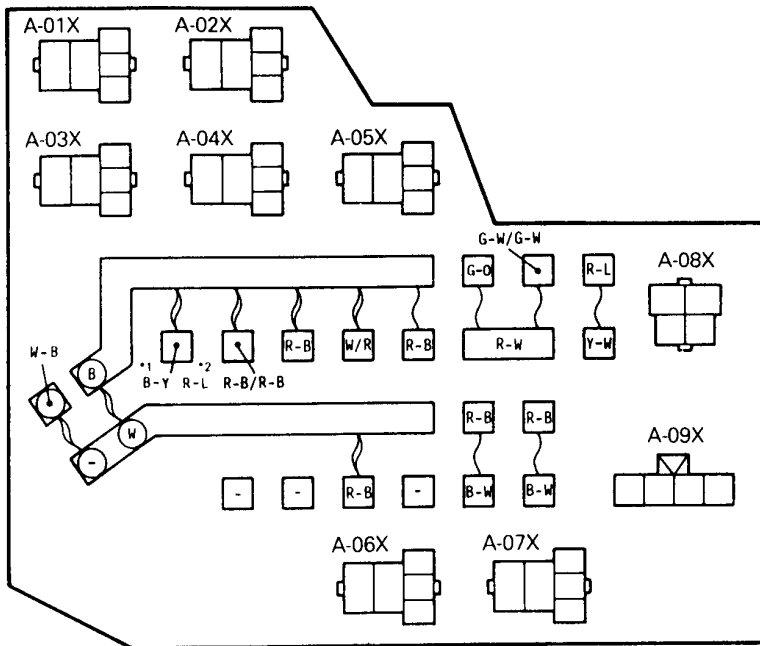

16C0425

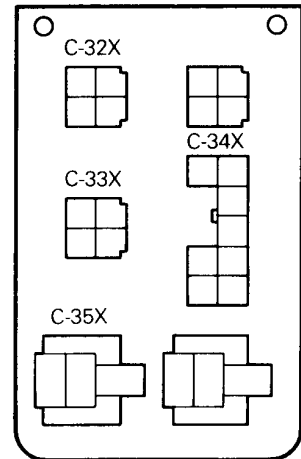

16C0070

NOTE

- (1) \*1: Petrol-powered vehicles
- (2) \*2: Diesel-powered vehicles

## 4A CIRCUIT DIAGRAM

<b>JUNCTION BLOCK (J/B)</b> .....	<b>4A-4</b>	<b>ROOM LAMP AND CARGO ROOM LAMP</b>	
<b>JUMPER CONNECTOR (J/C)</b> .....	<b>4A-6</b>	• L.H. drive vehicles with door lamp .....	4A-102
<b>CENTRALIZED JUNCTION</b> .....	<b>4A-8</b>	• L.H. drive vehicles without door lamp .....	4A-103
<b>POWER DISTRIBUTION SYSTEM</b> .....	<b>4A-14</b>	• R.H. drive vehicles with door lamp .....	4A-104
<b>STARTING SYSTEM</b>		• R.H. drive vehicles without door lamp .....	4A-105
• Petrol-powered vehicles .....	4A-20	<b>DOOR LAMP</b>	
• Diesel-powered vehicles .....	4A-21	• L.H. drive vehicles .....	4A-106
<b>IGNITION SYSTEM</b> .....	<b>4A-22</b>	• R.H. drive vehicles .....	4A-107
<b>CHARGING SYSTEM</b>		<b>CLUSTER SWITCH ILLUMINATION LAMP</b> .....	<b>4A-108</b>
• 4G93 .....	4A-24	<b>TURN-SIGNAL LAMP AND HAZARD LAMP</b>	
• 4G63, 4G64 and 4D68 .....	4A-25	• Vehicles with SRS .....	4A-110
<b>GLOW SYSTEM</b> .....	<b>4A-26</b>	• Vehicles without SRS .....	4A-112
<b>MPI SYSTEM</b>		<b>STOP LAMP</b>	
• 4G93 <L.H. drive vehicles> .....	4A-29	• Vehicles with high-mounted stop lamp ....	4A-114
• 4G93 <R.H. drive vehicles> .....	4A-35	• Vehicles without high-mounted stop lamp ....	4A-115
• 4G63 and 4G64 <L.H. drive vehicles> .....	4A-41	<b>BACK-UP LAMP</b> .....	<b>4A-116</b>
• 4G63 <R.H. drive vehicles> .....	4A-47	<b>LIGHTING MONITOR BUZZER</b>	
<b>COOLING SYSTEM</b>		• Vehicles with SRS .....	4A-117
• 4G93 .....	4A-54	• Vehicles without SRS .....	4A-118
• 4G63 and 4G64 .....	4A-56	<b>HORN</b>	
• 4D68 .....	4A-58	• Vehicles with SRS .....	4A-120
<b>ELC 4A-SPEED AUTOMATIC TRANSMISSION</b>		• Vehicles without SRS .....	4A-121
• L.H. drive vehicles .....	4A-60	<b>METER AND GAUGE</b> .....	<b>4A-122</b>
• R.H. drive vehicles .....	4A-66	<b>BRAKE WARNING LAMP</b> .....	<b>4A-126</b>
<b>HEADLAMP</b>		<b>FUEL WARNING LAMP</b> .....	<b>4A-126</b>
• Vehicles with daytime running lamp <with SRS> .....	4A-72	<b>OIL PRESSURE WARNING LAMP</b> .....	<b>4A-127</b>
• Vehicles with daytime running lamp <without SRS> .....	4A-76	<b>ENGINE COOLANT TEMPERATURE WARNING LAMP</b>	
• L.H. drive vehicles without daytime running lamp <with SRS> .....	4A-79	• 4D68 .....	4A-127
• L.H. drive vehicles without daytime running lamp <without SRS> .....	4A-80	<b>LOW ENGINE OIL LEVEL WARNING LAMP</b>	
• R.H. drive vehicles .....	4A-82	• SPACE WAGON .....	4A-128
<b>HEADLAMP LEVELING SYSTEM</b> .....	<b>4A-86</b>	<b>POWER WINDOW</b>	
<b>TAIL LAMP, POSITION LAMP AND LICENCE PLATE LAMP</b>		• SPACE RUNNER <L.H. drive vehicles> .....	4A-130
• Vehicles with SRS .....	4A-88	• SPACE RUNNER <R.H. drive vehicles> .....	4A-131
• Vehicles without SRS .....	4A-90	• SPACE WAGON <L.H. drive vehicles> .....	4A-132
<b>REAR FOG LAMP</b>		• SPACE WAGON <R.H. drive vehicles> .....	4A-134
• Vehicles with daytime running lamp <with SRS> .....	4A-94	<b>CENTRAL DOOR LOCKING SYSTEM</b>	
• Vehicles with daytime running lamp <without SRS> .....	4A-96	• SPACE RUNNER <L.H. drive vehicles> .....	4A-138
• L.H. drive vehicles without daytime running lamp <with SRS> .....	4A-98	• SPACE RUNNER <R.H. drive vehicles> .....	4A-140
• L.H. drive vehicles without daytime running lamp <without SRS> .....	4A-99	• SPACE WAGON <L.H. drive vehicles> .....	4A-142
• R.H. drive vehicles .....	4A-100	• SPACE WAGON <R.H. drive vehicles> .....	4A-144

**TAILGATE LOCKING SYSTEM**

- SPACE RUNNER ..... 4A-146
- SPACE WAGON ..... 4A-148

**HEATER AND AIR CONDITIONER**

- 4G93 ..... 4A-150
- 4G63 and 4G64 ..... 4A-154
- 4D68 ..... 4A-158

**WINDSHIELD WIPER AND WASHER**

- Vehicles with SRS ..... 4A-164
- Vehicles without SRS ..... 4A-165

**REAR WIPER AND WASHER ..... 4A-168****HEADLAMP WASHER ..... 4A-169****DEFOGGER AND DOOR MIRROR****HEATER ..... 4A-171****REMOTE CONTROLLED MIRROR**

- Vehicles with door mirror heater ..... 4A-172
- Vehicles without door mirror heater ..... 4A-173

**CIGARETTE LIGHTER ..... 4A-175****CLOCK ..... 4A-176****RADIO AND TAPE PLAYER ..... 4A-177****SUNROOF ..... 4A-178****HEATED SEAT ..... 4A-180****ANTI-LOCK BRAKE SYSTEM (ABS)**

- 2WD ..... 4A-182
- 4WD ..... 4A-188

**SUPPLEMENTAL RESTRAINT SYSTEM****(SRS) ..... 4A-193**

NOTES

# JUNCTION BLOCK (J/B)

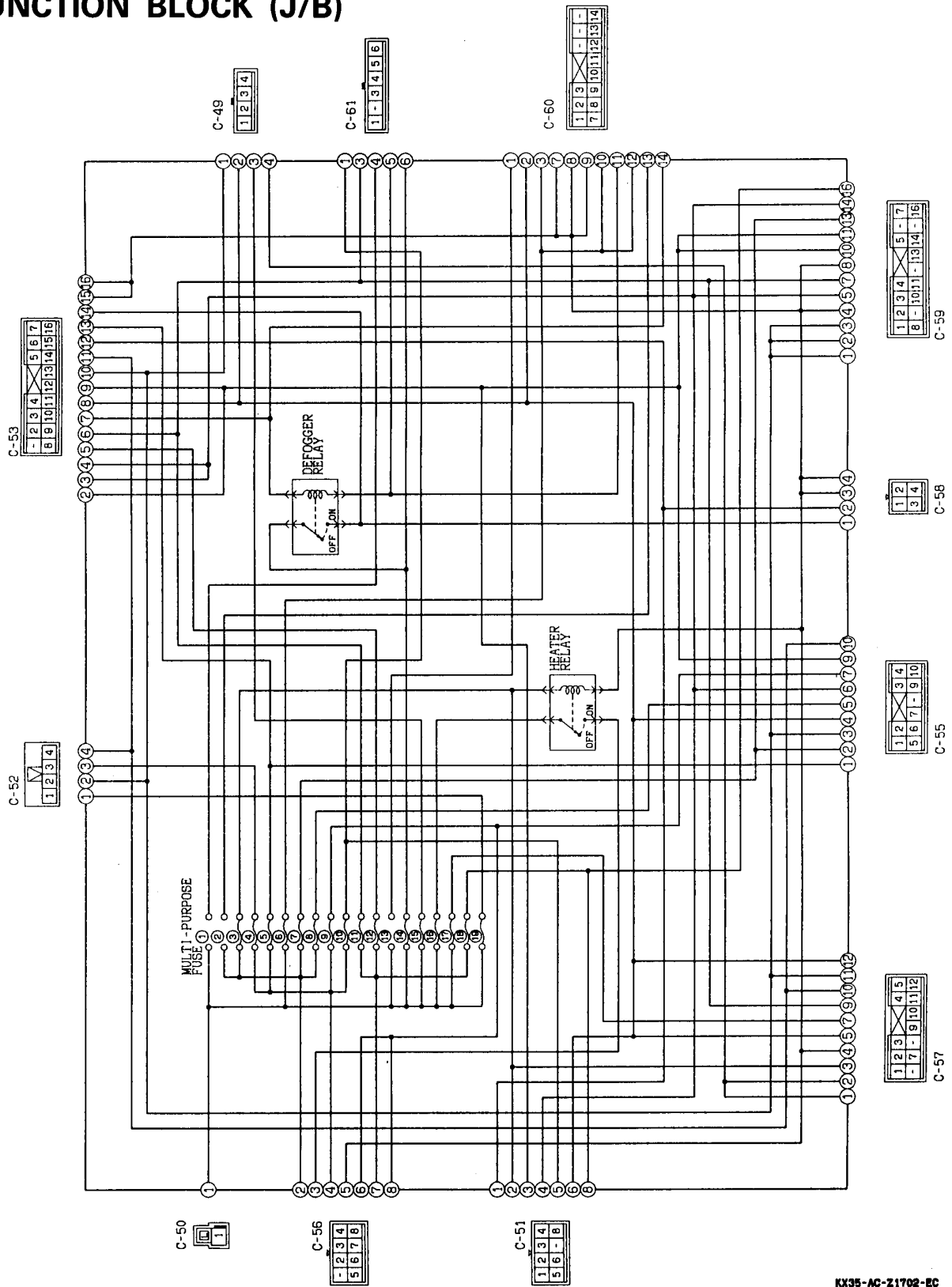

**Remark**

- Connector numbers are keyed to the configuration diagram (dashboard panel) and each circuit diagram.

KX35-AC-21702-EC



Front

Back

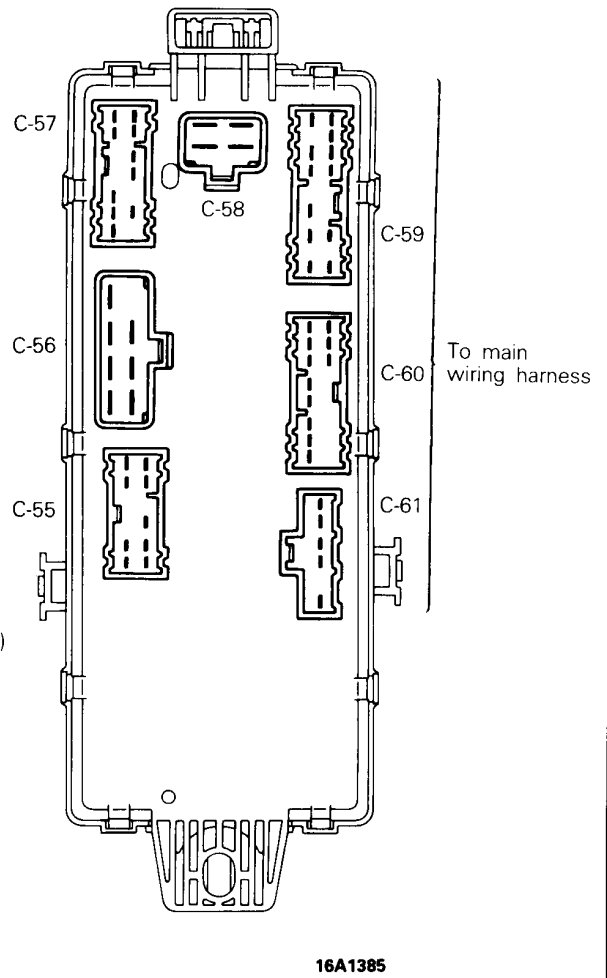
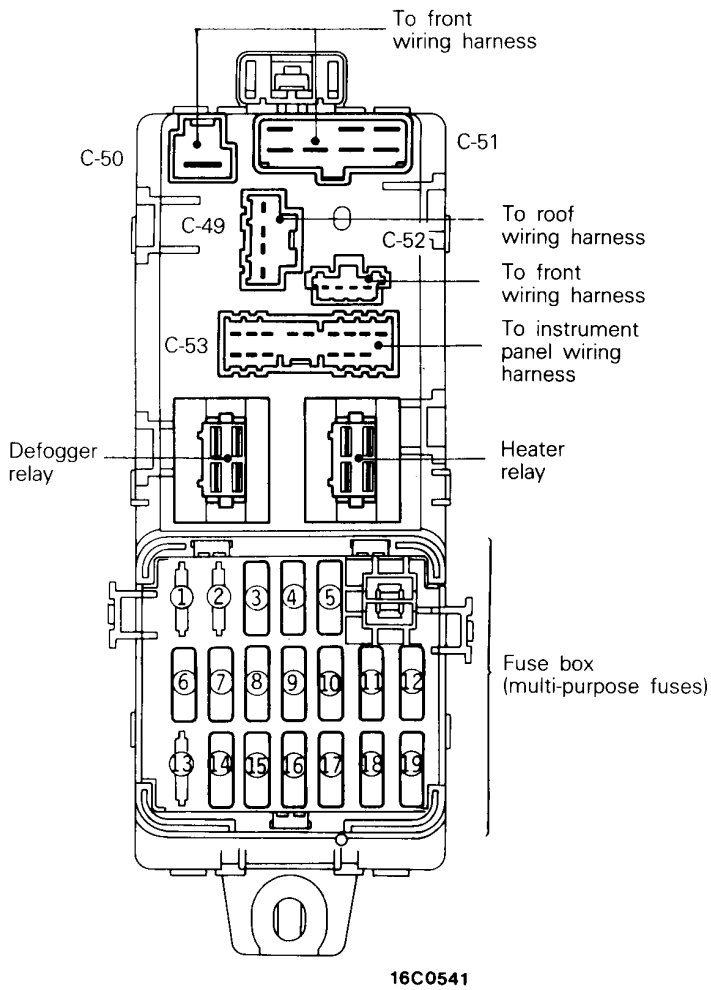

JUMPER CONNECTOR (J/C)

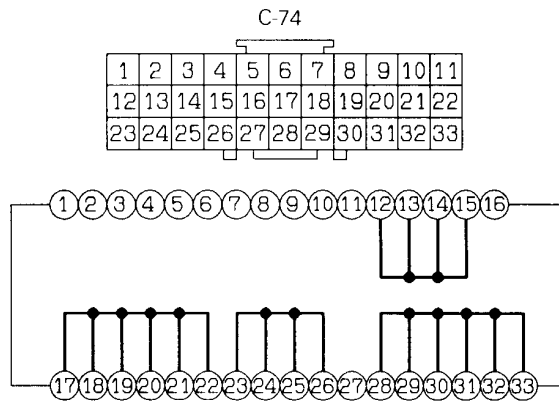

KX35-AC-Z1701-E

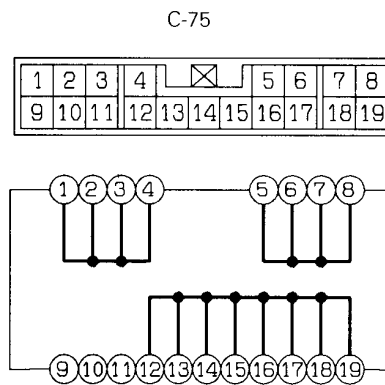

KX35-AC-Z1702-E

NOTES

**CENTRALIZED JUNCTION**

**MAIN FUSIBLE LINK (Connected directly to battery positive terminal)**

No.	Circuit	Housing colour	Rated capacity (A)
1	ABS circuit (hydraulic unit power source)	Yellow	60
2	—	—	—
3	Grow circuit	Black	80

〈Petrol-powered vehicles with ABS and Diesel-powered vehicles without ABS〉

〈Diesel-powered vehicles with ABS〉

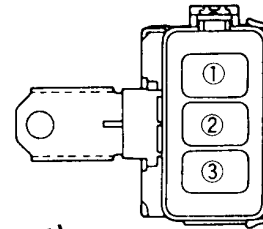
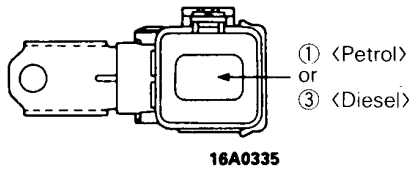

**SUB-FUSIBLE LINK (Relay box in engine compartment)**

No.	Circuit	Housing colour	Rated capacity (A)
1	Junction block (Multi-purpose fuse ⑥, ⑭, ⑮, ⑯, ⑰, ⑲), A/C compressor circuit	Yellow	60
2	Sub-fusible link No. ①, ⑨, alternator circuit	Black	80
3	MPI circuit <Petrol>	Blue	20
	Starting circuit <Diesel>	Pink	30
4	Headlamp and tail lamp circuit	Pink	30
		Pink	30 <Petrol>
5	Radiator fan motor and condenser fan motor circuit	Green	40 <Diesel>
		Pink	30 <Petrol>
6	Ignition switch and alternator circuit	Pink	30
7	—	—	—
8	—	—	—
9	Power window circuit	Pink	30

NOTE

- (1) \*1: Petrol-powered vehicles
- (2) \*2: Diesel-powered vehicles

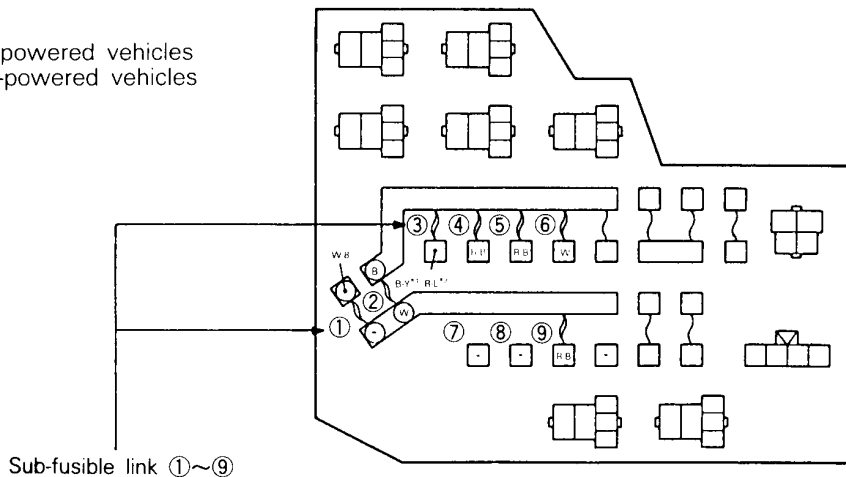

**DEDICATED FUSE (Relay box in engine compartment)**

Power supply circuit	No.	Rated capacity (A)	Housing Colour	Circuit
Battery	1	10	Red	Hazard lamp circuit
Tail lamp relay (Battery)	2	10	Red	Tail lamp circuit
	3	10	Red	Tail lamp circuit Illumination circuit Lighting monitor buzzer circuit Headlamp washer circuit
Headlamp relay (Battery)	4	10	Red	Upper beam indicator circuit Rear fog lamp circuit Headlamp leveling circuit
Battery	5	—	—	—
	6	15 <sup>*1</sup>	Blue	Condenser fan motor circuit
		25 <sup>*2</sup>	Transparent	
7	10	Red	A/C compressor circuit	

NOTE

- (1) \*1: A/T <except 4G63 (2WD-A/T)>
- (2) \*2: M/T and 4G63 <2WD-A/T>

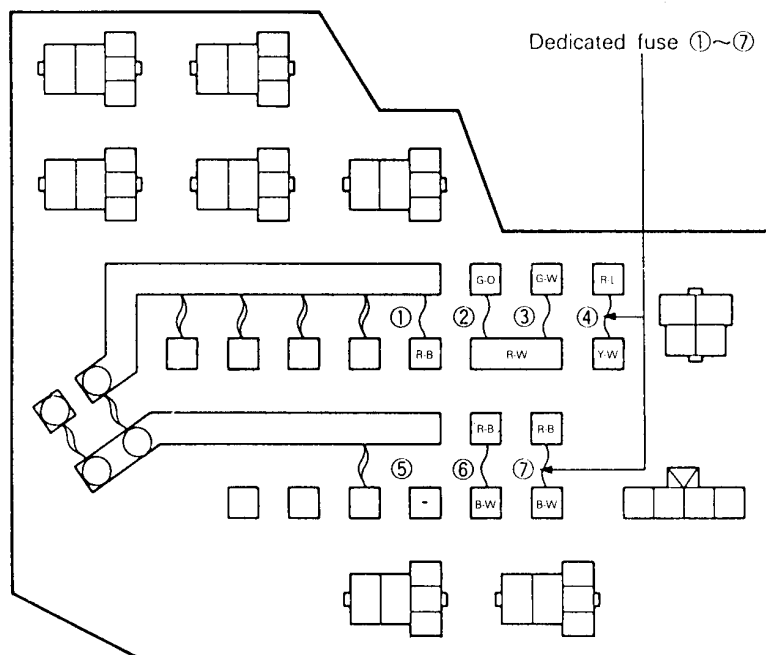

16C0425

**MULTI-PURPOSE FUSE (In junction block)**

Power supply circuit	No.	Rated capacity (A)	Housing colour	Load circuit	
Battery	1	—	—	—	
Ignition switch	2	—	—	—	
	IG2	3	10	Red	Heater relay, defogger relay, headlamp washer relay, ABS power relay, daytime running lamp control unit, sunroof relay, power windows relay, daytime running lamp relay 1, A/C belt lock controller <4G93>, automatic compressor control unit and ABS control unit
		ACC	4	10	Red
	5		15	Blue	Cigarette lighter and remote controlled mirror
	Battery	6	15	Blue	Central door lock control unit
Ignition switch	IG2	7	10	Red	Combination meter <4A/T> and ELC-4A/T control unit
		8	10	Red	Heated seat switch
	ACC	9	20	Yellow	Intermittent wiper relay, wiper and washer motor
		10	10	Red	Horn and horn relay <SRS>
	IG1	11	10	Red	Combination meter, lighting monitor buzzer and SRS diagnosis unit
		12	10	Red	Turn signal and hazard flasher unit
Battery	13	—	—	—	
	14	20	Yellow	Defogger, defogger switch and door mirror heater	
	15	20	Yellow	Sunroof control relay	
	16	30	Pink	Blower motor	
	17	15	Blue	Stop lamp	
Ignition switch	IG1	18	10	Red	Back-up lamp and SRS diagnosis unit
Battery	19	10	Red	Room lamp, cargo room lamp, door lamp, clock, radio and tape player, combination meter, central door lock control unit, engine control unit, ELC-4A/T control unit and MUT-II (diagnosis connector)	

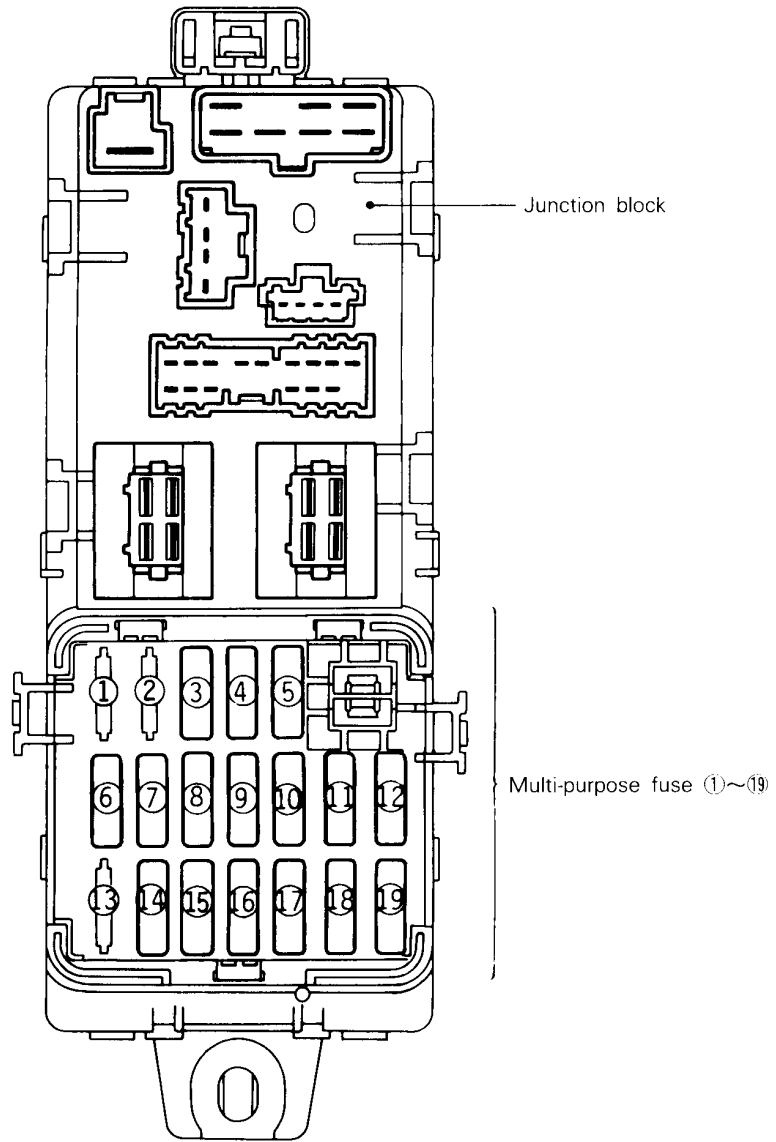

16C0541

# 4A-12

# CIRCUIT DIAGRAM — Centralized Junction

## CENTRALIZED RELAY

(Relay box in engine compartment)

Connector No.	Name	Connector No.	Name
A-01X	Tail lamp relay	A-06X	Condenser fan motor relay (LO)
A-02X	Headlamp relay	A-07X	Condenser fan motor relay (HI)
A-03X	A/C compressor relay	A-08X	Alternator relay
A-04X	Radiator fan motor relay (LO)	A-09X	Storage connector
A-05X	Radiator fan motor relay (HI)		

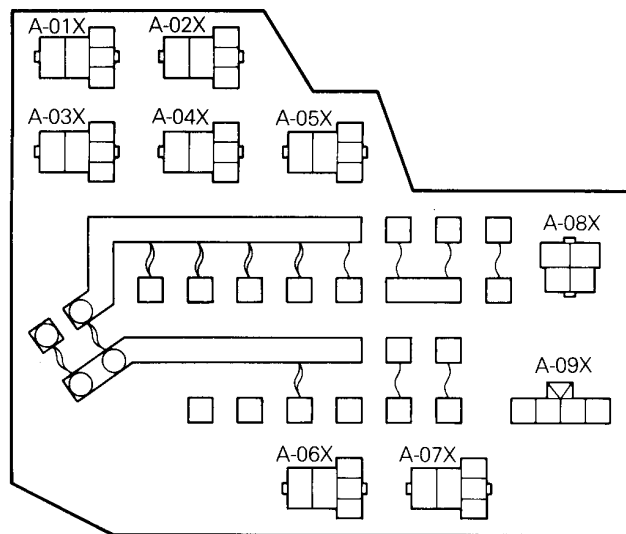

16C0425

(Interior relay box)

Connector No.	Name	Connector No.	Name
C-32X	ABS power relay	C-35X	Rear fog lamp relay
C-33X	Power windows relay	C-79X	Horn relay <SRS>
C-34X	Central door lock control unit or jumper connector		

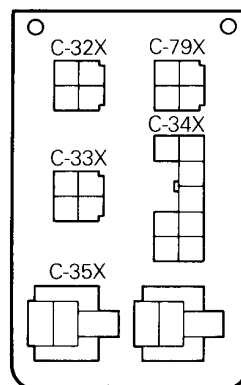

16C0070



---

NOTES

POWER DISTRIBUTION SYSTEM

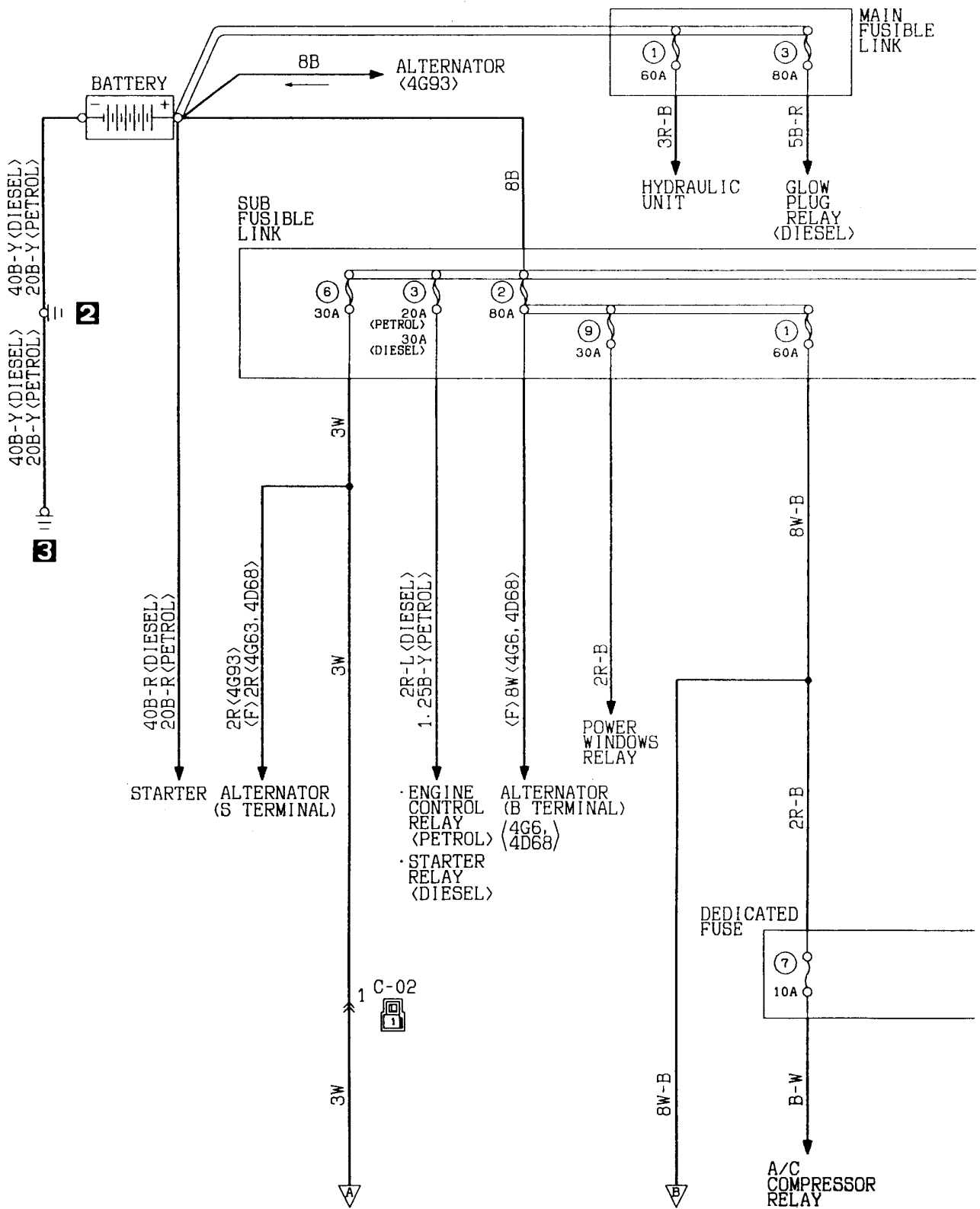

Wire colour code  
 B:Black LG:Light green G:Green L:Blue W:White Y:Yellow SB:Sky blue  
 BR:Brown O:Orange GR:Gray R:Red P:Pink V:Violet

Remarks  
 \*1: A/T (except 4G63 (2WD-A/T))  
 \*2: M/T and 4G63 (2WD-A/T)

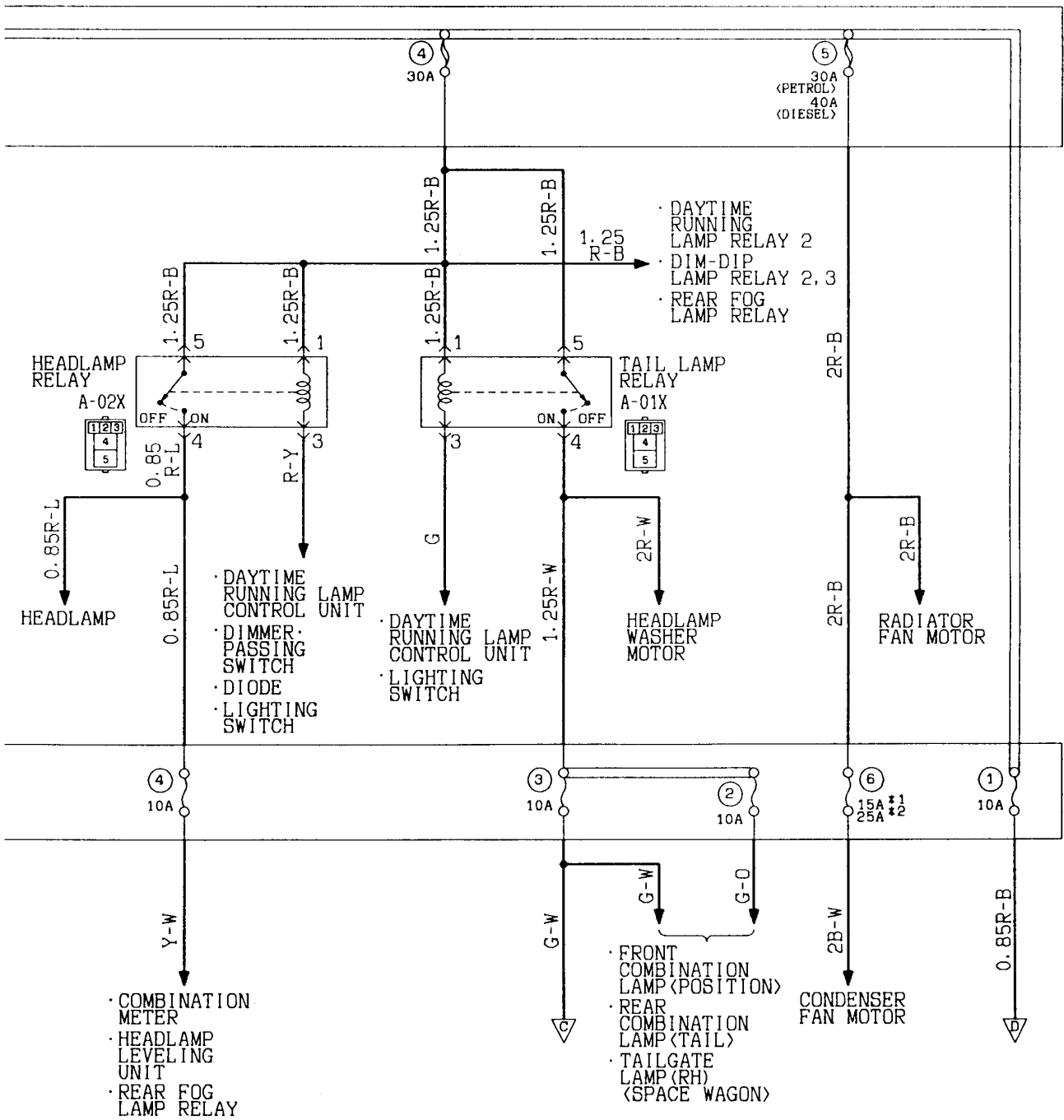

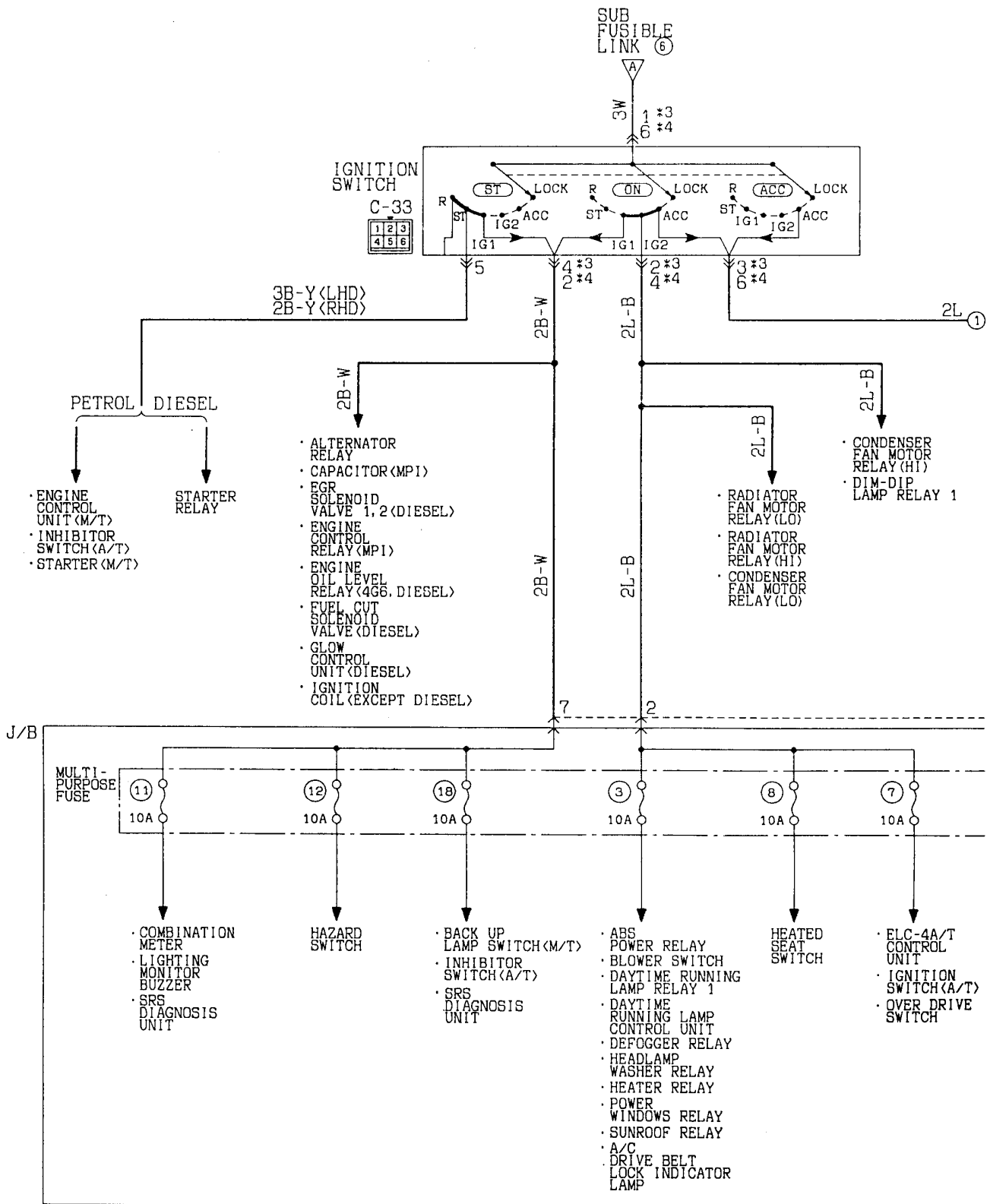

Remarks  
 (1) The above circuit diagram shows the current flow at the ignition key position "ACC", "ON" and "ST" combined. Be sure to trace the appropriate circuit depending on the ignition key position.  
 (2) \*3: Vehicles with SRS.  
 (3) \*4: Vehicles without SRS.

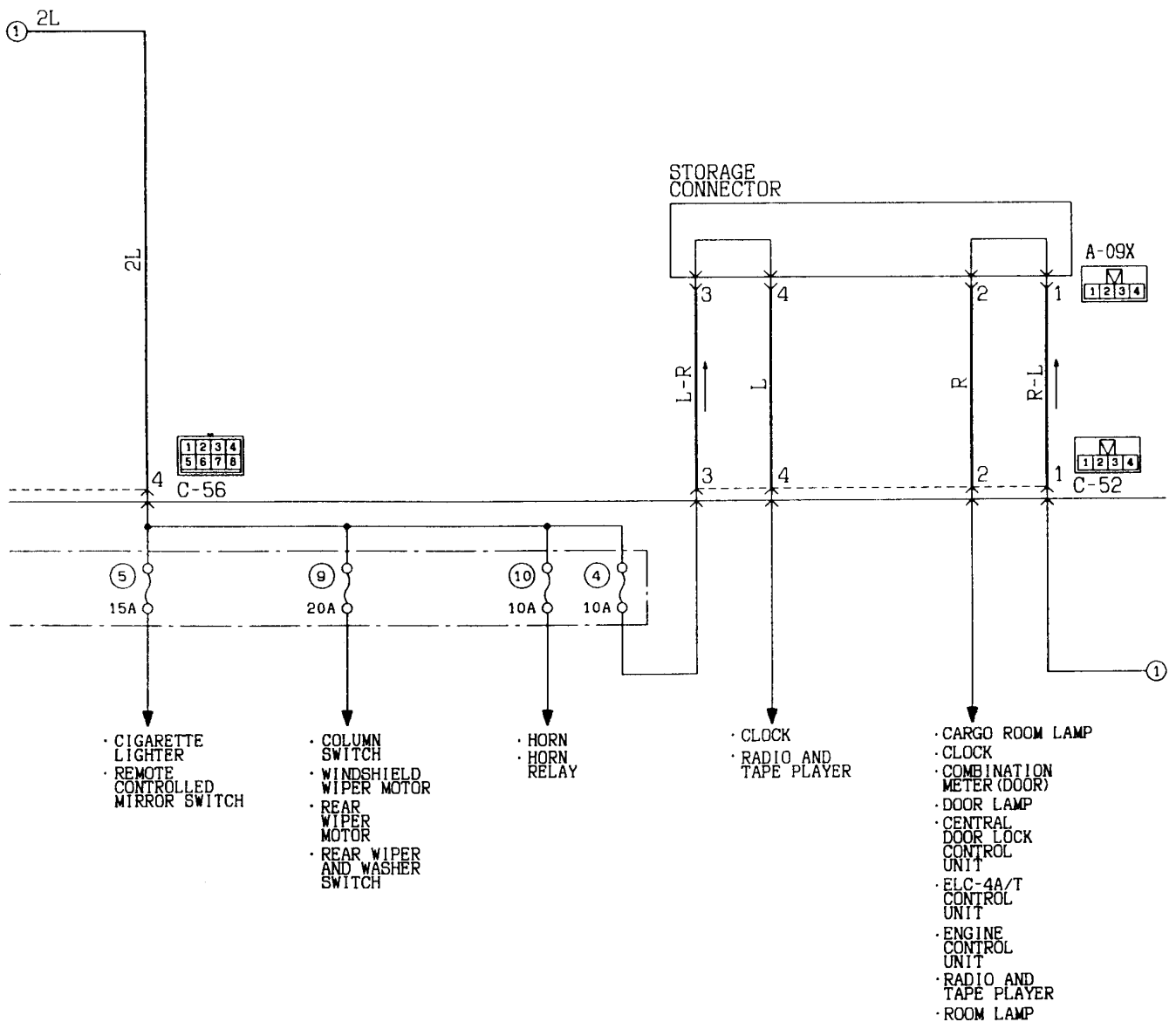

Wire colour code  
 B:Black LG:Light green G:Green L:Blue W:White Y:Yellow SB:Sky blue  
 BR:Brown O:Orange GR:Gray R:Red P:Pink V:Violet

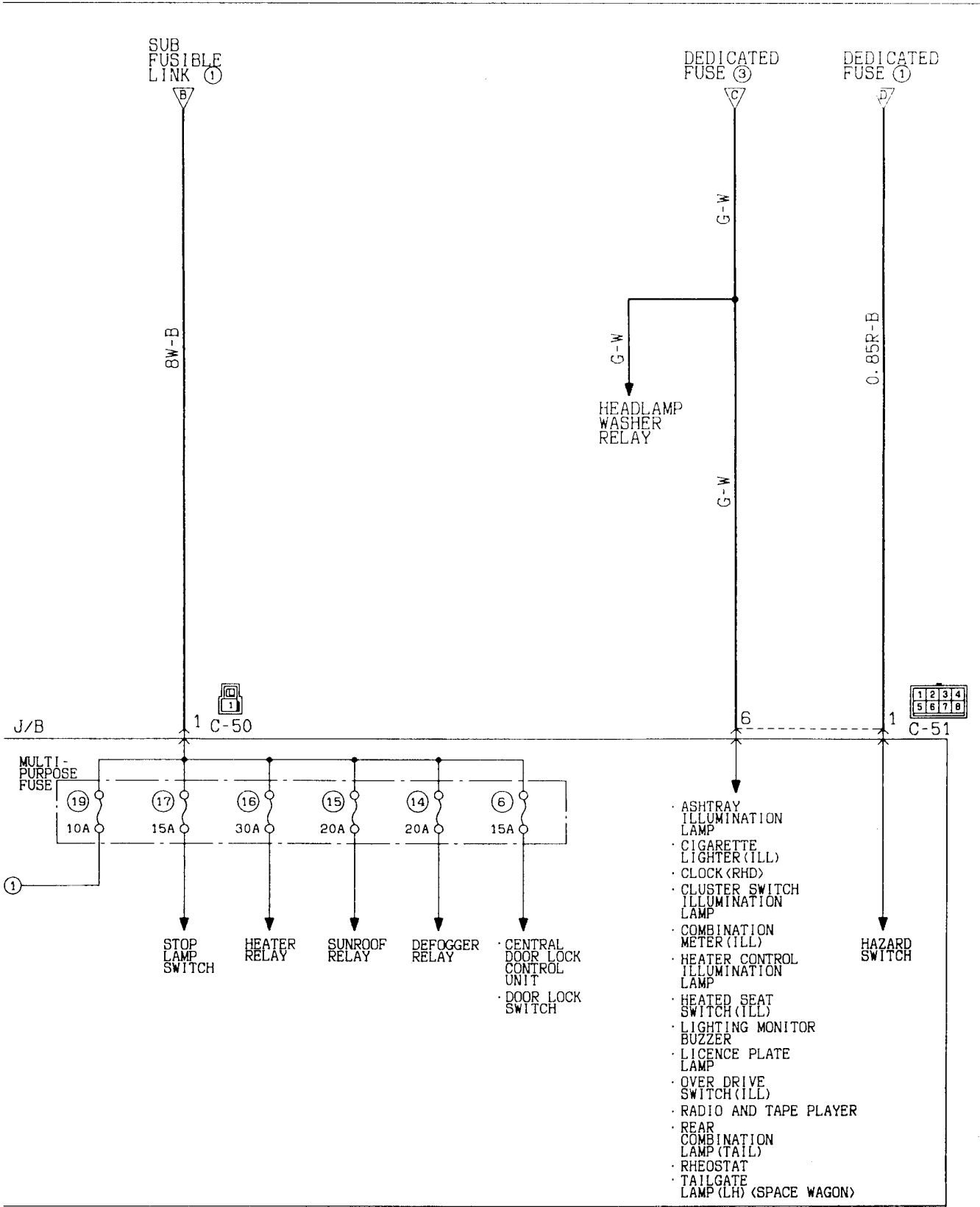

Wire colour code  
 B:Black LG:Light green G:Green L:Blue W:White Y:Yellow SB:Sky blue  
 BR:Brown O:Orange GR:Gray R:Red P:Pink V:Violet

**STARTING SYSTEM (See P. 4A-20, 21.)****OPERATION****<Petrol-powered vehicles>**

- On vehicles with automatic transmission, Placing the ignition switch in the ST position with the selector lever in P or N position causes the starter contacts (magnet switch) to close energizing the starter motor.

**<Diesel-powered vehicles>**

- When the ignition switch is turned to the "ST" position, the starter relay becomes on. This will turn on the contacts of the starter (magnetic switch) to revolve the starter motor.

**TROUBLESHOOTING HINTS**

1. Starter motor does not turn over at all.
  - Check starter (coil).
  - Check battery terminals for proper contact.
  - Starter relay inspection (diesel-powered vehicle)
2. Starter motor does not stop rotating.
  - Check starter (magnet switch).

STARTING SYSTEM  
Petrol-powered vehicles

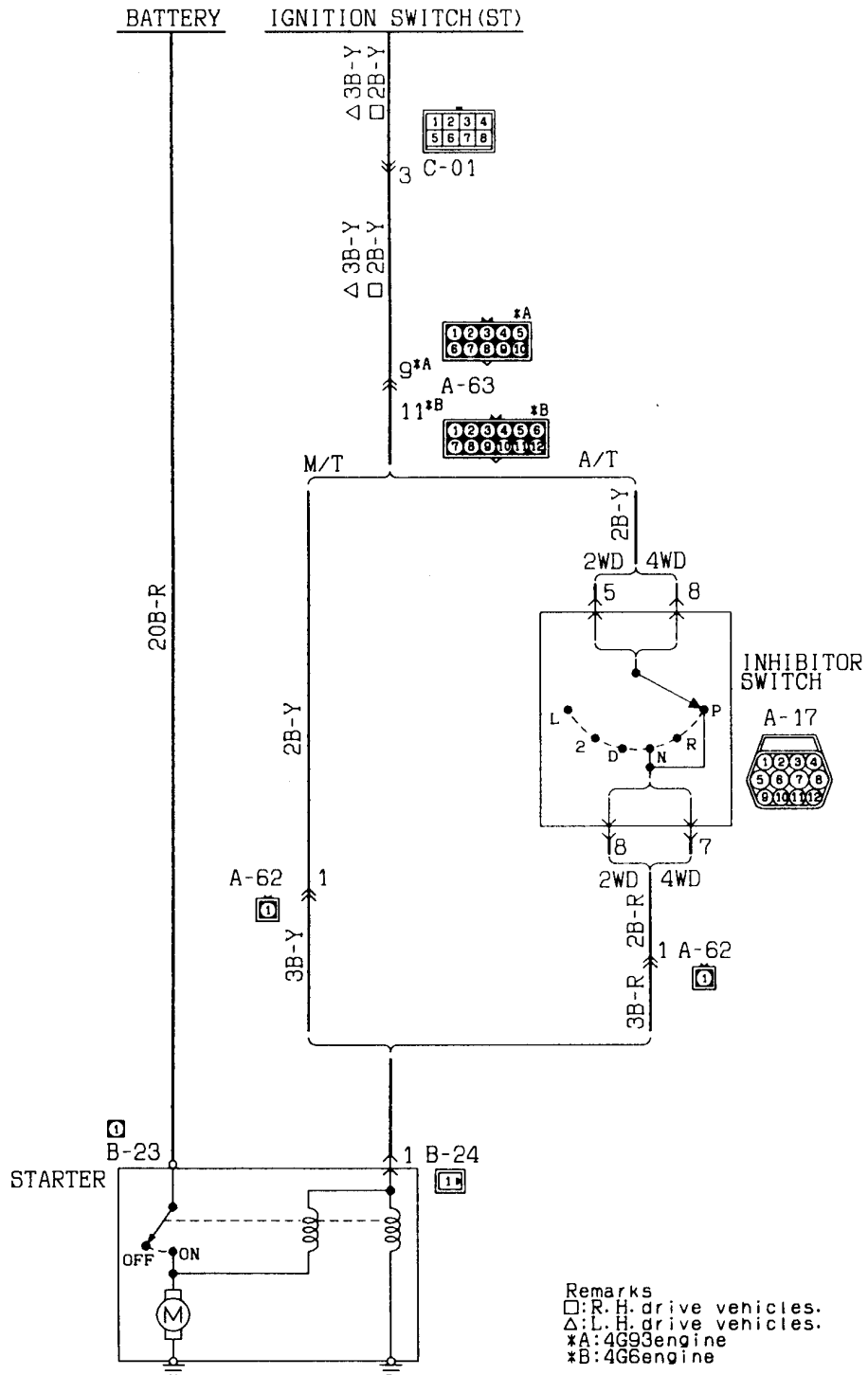

Remarks  
 □: R. H. drive vehicles.  
 △: L. H. drive vehicles.  
 \*A: 4G93 engine  
 \*B: 4G6 engine

Wire colour code  
 B:Black LG:Light green G:Green L:Blue W:White Y:Yellow SB:Sky blue  
 BR:Brown O:Orange GR:Gray R:Red P:Pink V:Violet



STARTING SYSTEM  
Diesel-powered vehicles

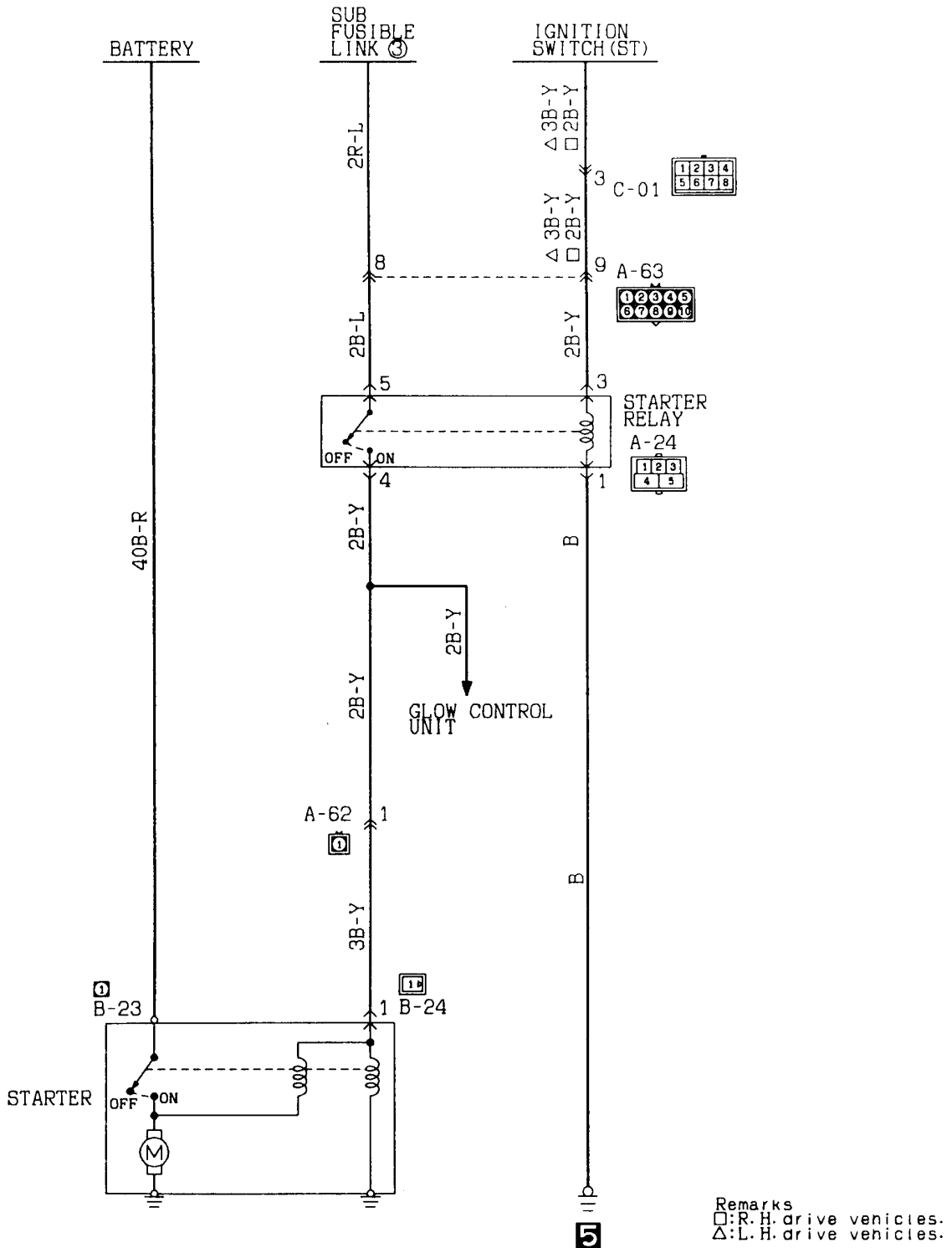

Wire colour code  
 B:Black LG:Light green G:Green L:Blue W:White Y:Yellow SB:Sky blue  
 BR:Brown O:Orange GR:Gray R:Red P:Pink V:Violet

IGNITION SYSTEM

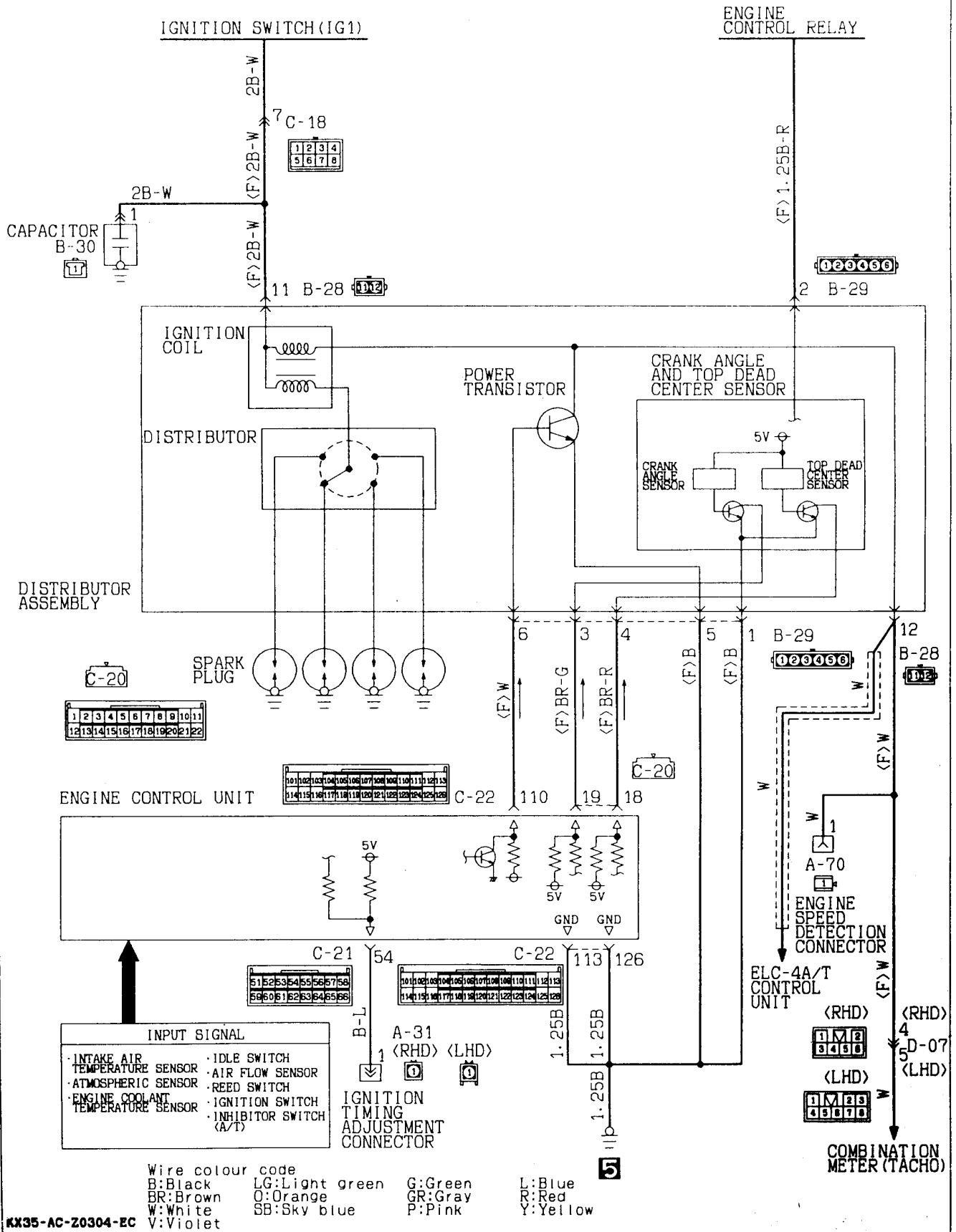

KX35-AC-Z0304-EC

**CHARGING SYSTEM (See P. 4A-24, 25.)****OPERATION****When engine is stationary**

- When the ignition switch is turned to the ON position, current flows the alternator L terminal to the field coil and, at the same time, the charge warning lamp lights up.

**When engine is started and after engine has started**

- When the engine is started, the charge warning lamp goes out because of the charging voltage being applied to the alternator L terminal.
- The battery voltage being applied to the alternator S terminal is monitored by the IC voltage regulator. Hence, the amount of electricity produced by the alternator is controlled by allowing and cutting off the current flowing to the field coil.
- The alternator B terminal supplies power to each load.

**Remarks**

- The alternator relay is provided to back up the flow of current to the field coil when the charge warning lamp is open.

**TROUBLESHOOTING HINTS**

1. Charging indicator lamp does not go on when the ignition switch is turned to "ON", before the engine starts.
  - Check the bulb.
2. Charging indicator lamp fails to go off once the engine starts.
  - Check IC voltage regulator of alternator.
3. Discharged or overcharged battery.
  - Check IC voltage regulator of alternator.
4. Charge warning lamp lights up dimly.
  - Check combination meter diode (for short).

CHARGING SYSTEM  
4G93

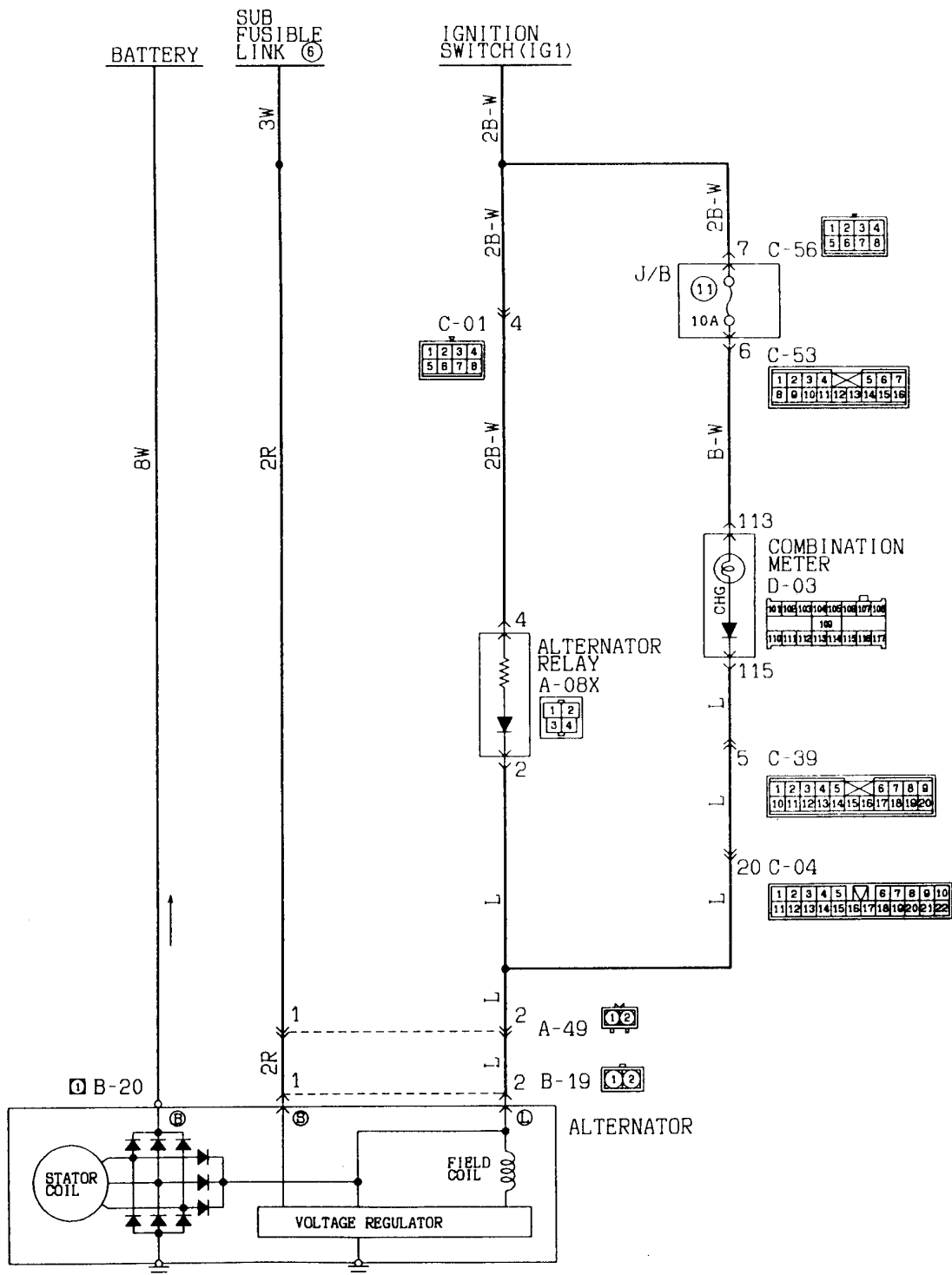

Wire colour code  
 B:Black LG:Light green G:Green L:Blue W:White Y:Yellow SB:Sky blue  
 BR:Brown O:Orange GR:Gray R:Red P:Pink V:Violet

CHARGING SYSTEM  
4G63, 4G64 and 4D68

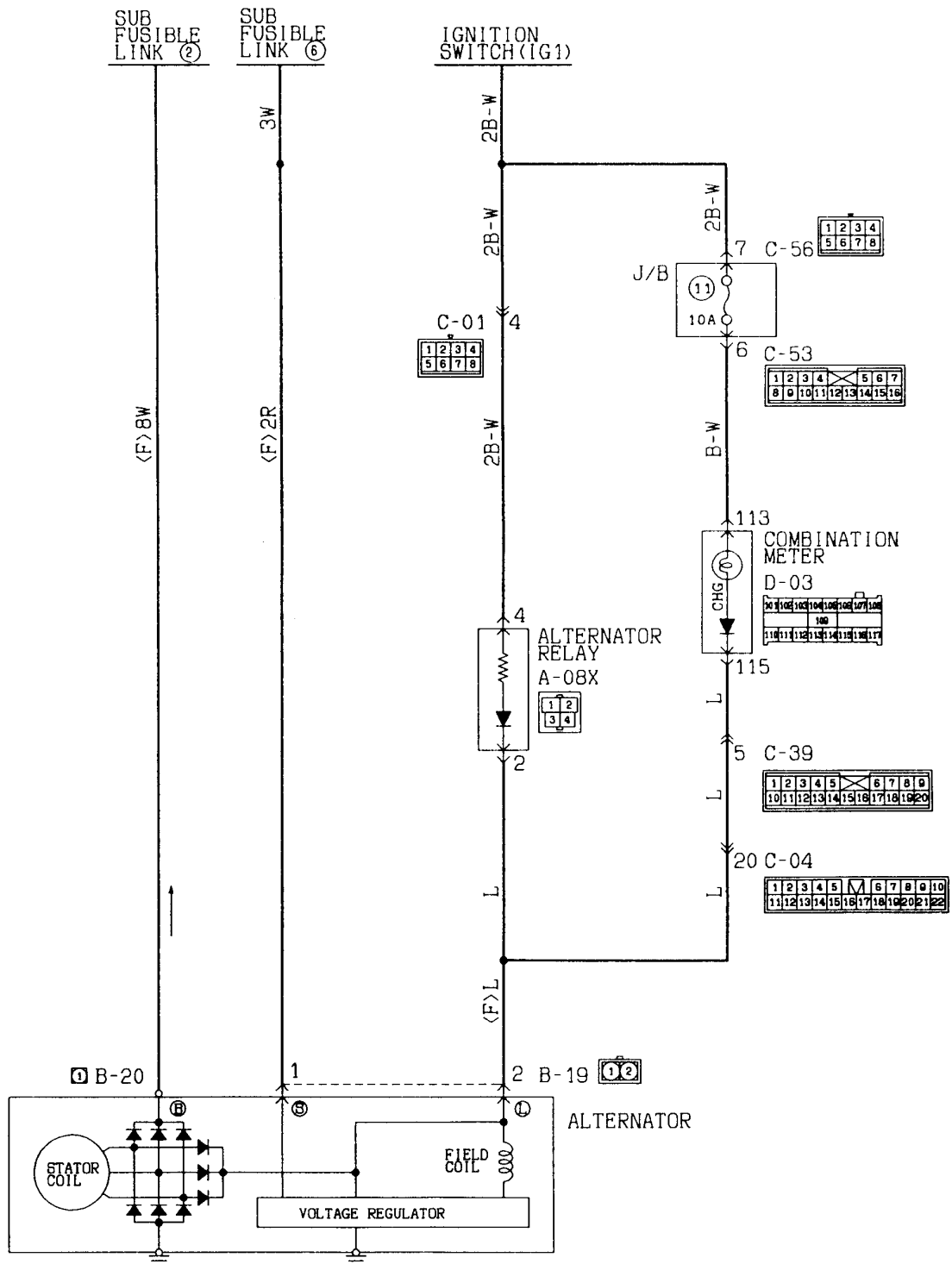

Wire colour code  
 B:Black LG:Light green G:Green L:Blue W:White Y:Yellow SB:Sky blue  
 BR:Brown O:Orange GR:Gray R:Red P:Pink V:Violet

GLOW SYSTEM

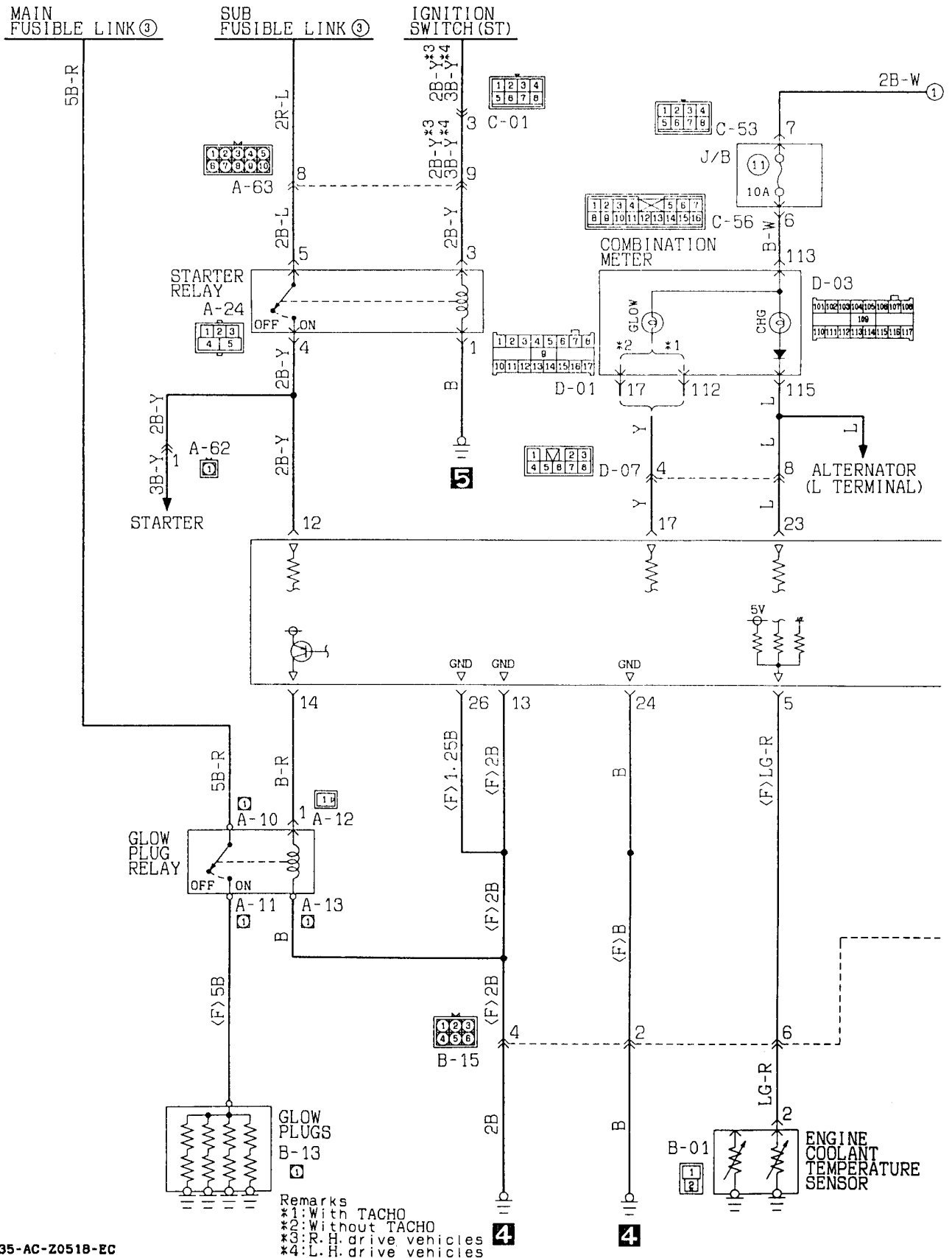

KX35-AC-Z0518-EC

Remarks  
 \*1: With TACHO  
 \*2: Without TACHO  
 \*3: R. H. drive vehicles  
 \*4: L. H. drive vehicles

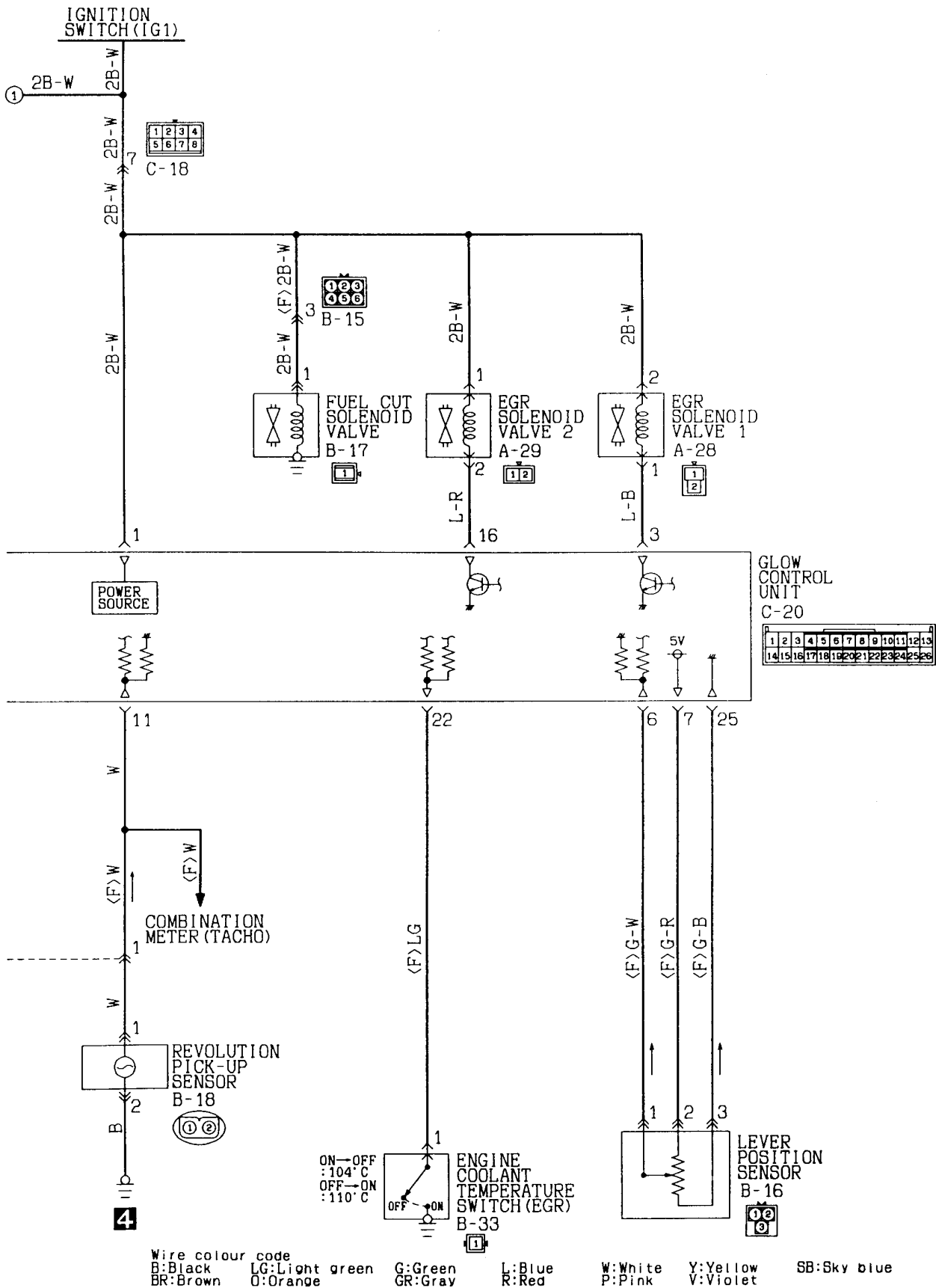

**NOTES**



MPI SYSTEM  
4G93 <L. H. drive vehicles>

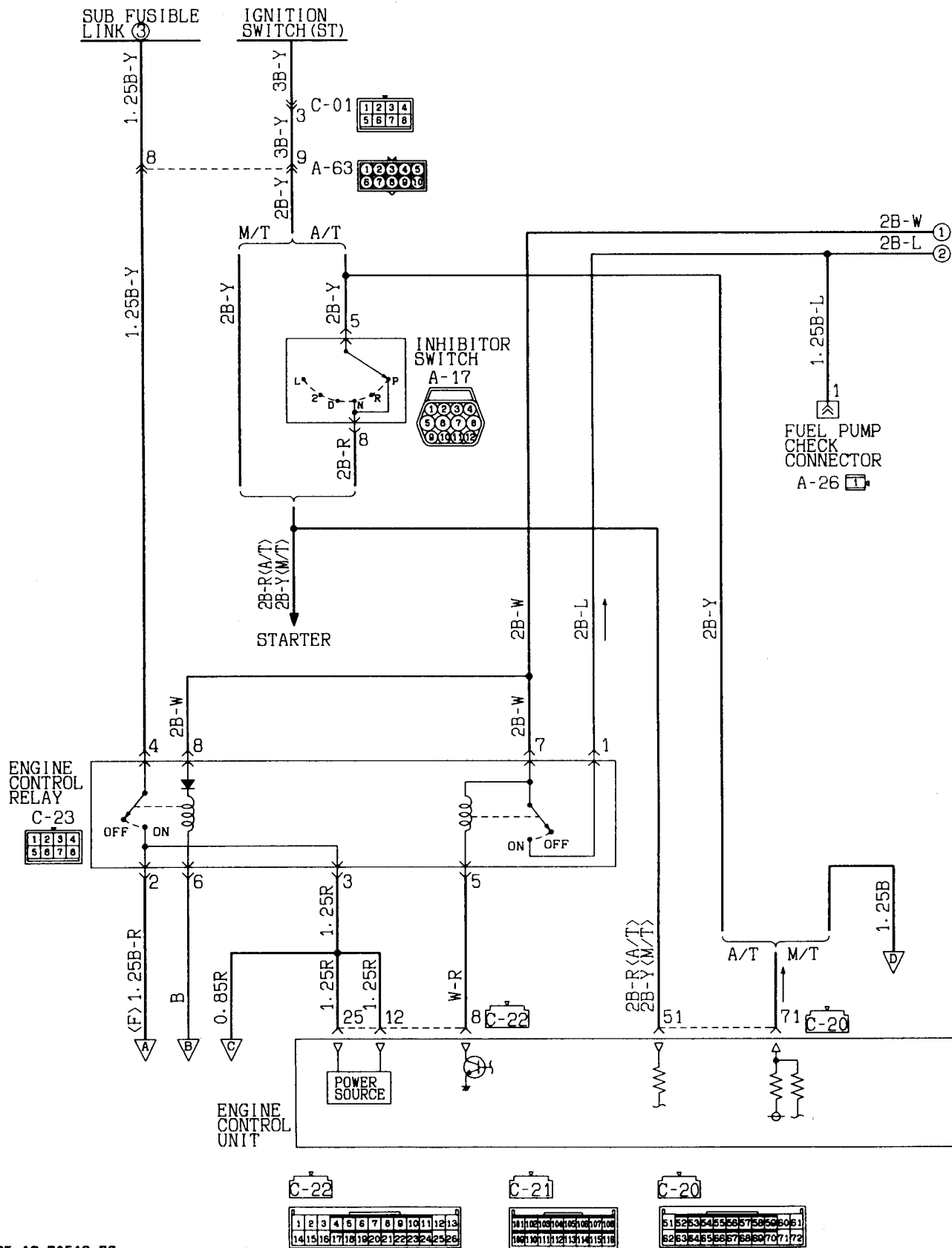

KX35-AC-Z0519-EC

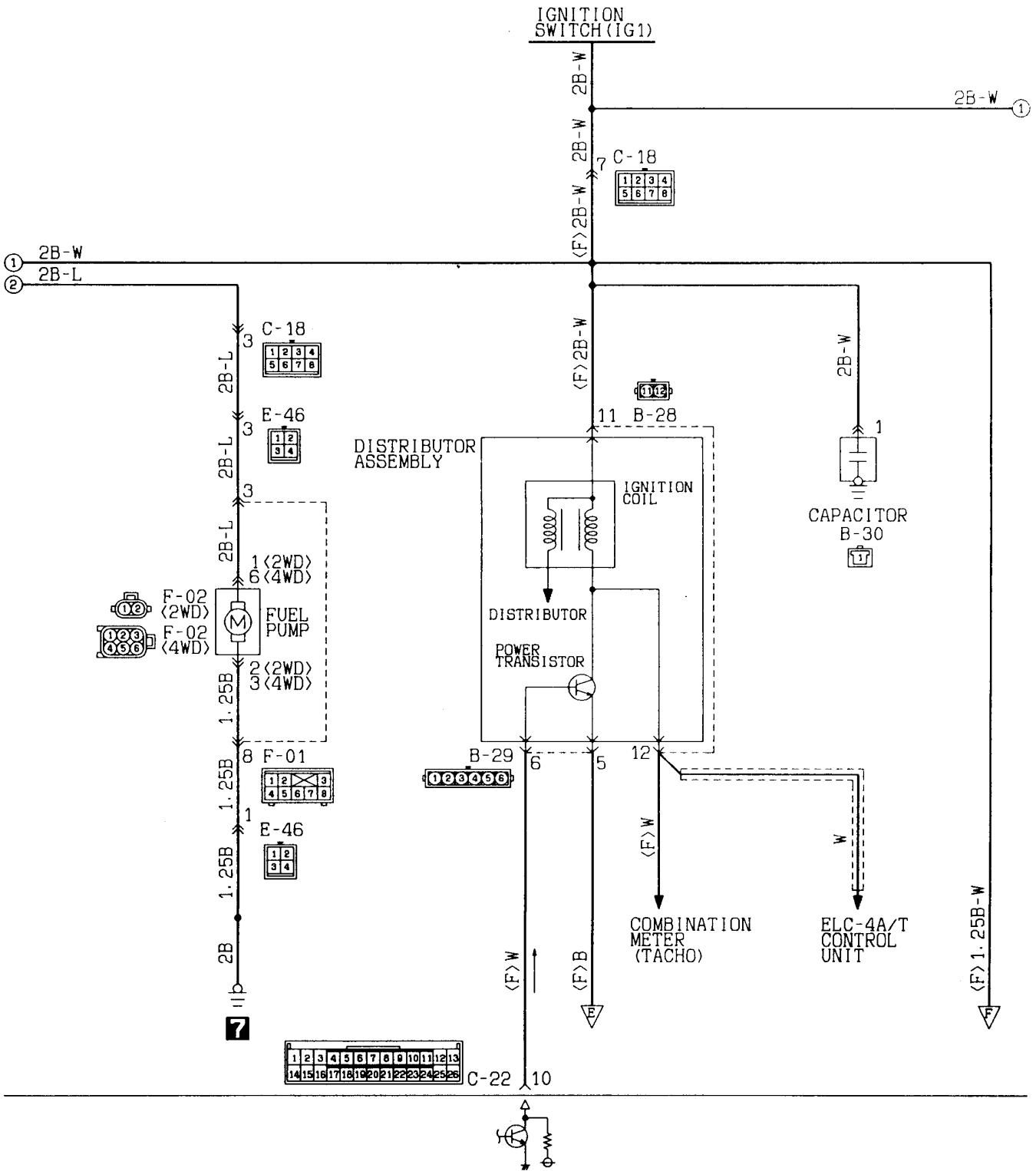

Wire colour code  
 B:Black LG:Light green G:Green L:Blue W:White Y:Yellow SB:Sky blue  
 BR:Brown O:Orange GR:Gray R:Red P:Pink V:Violet

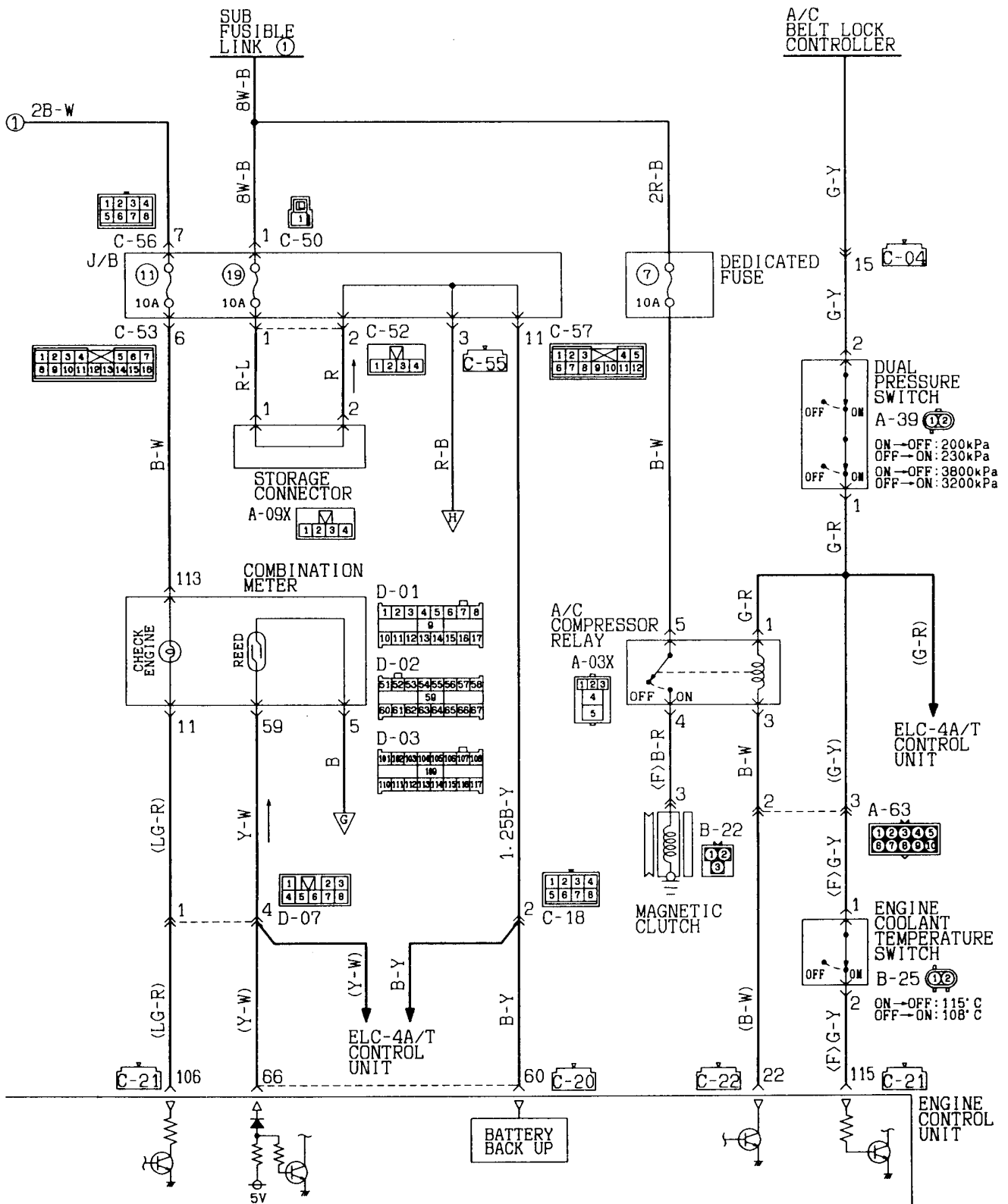

KX35-AC-Z0519A-EC

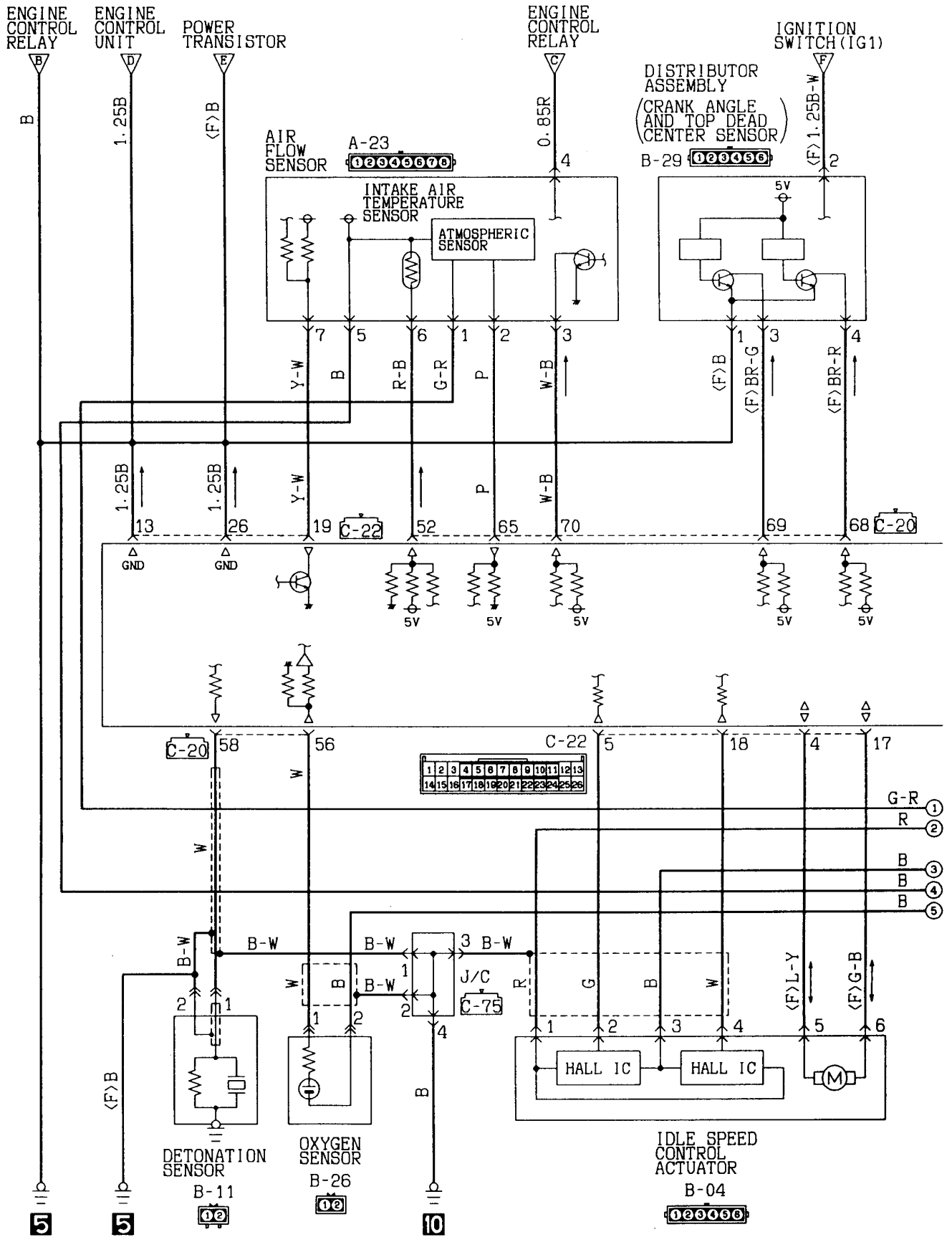

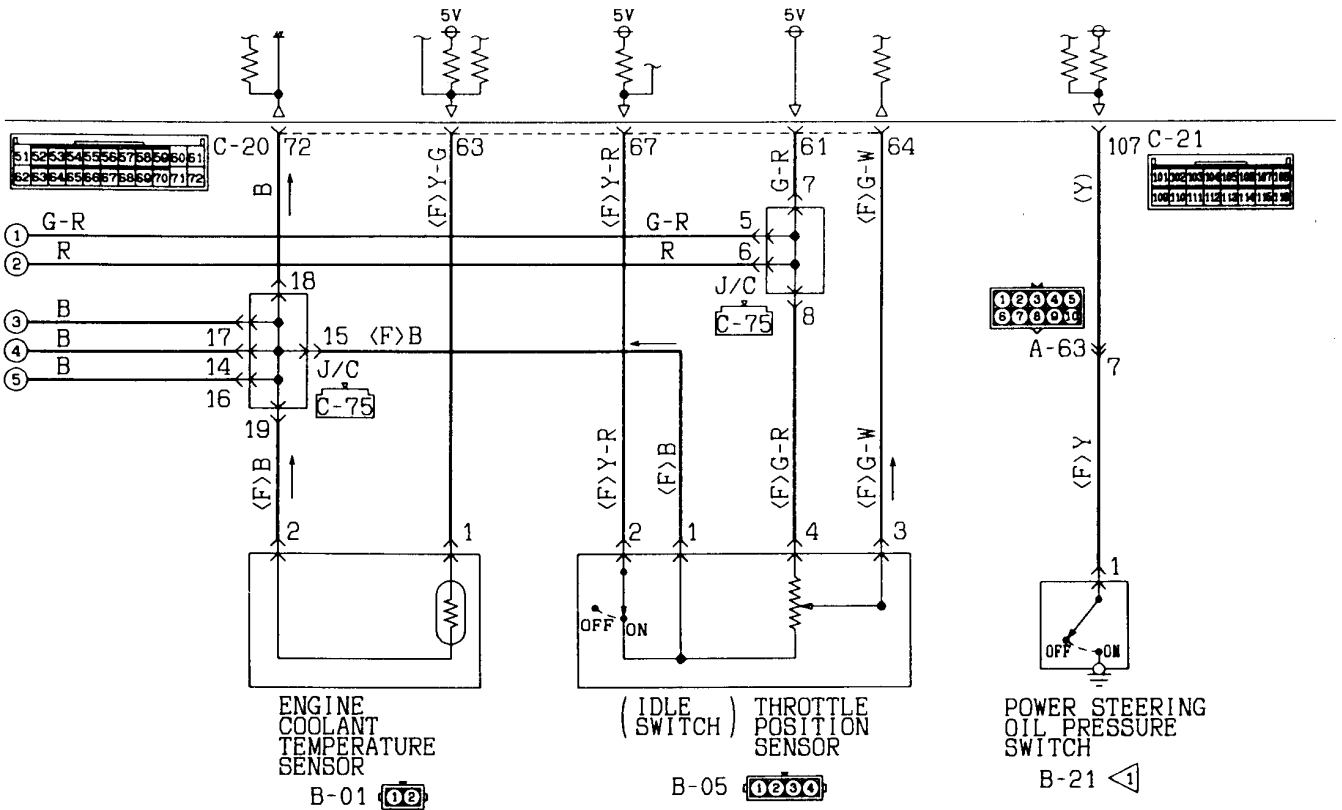
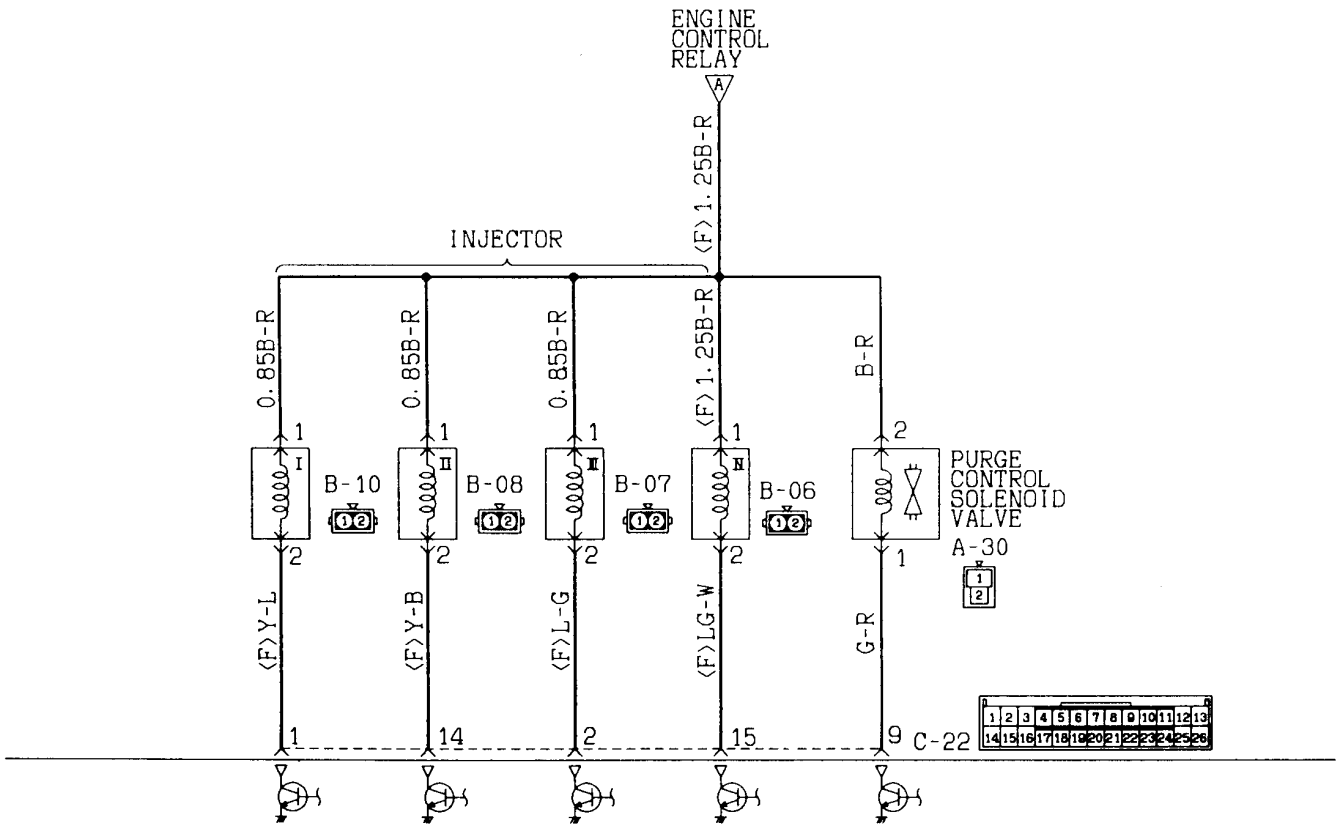

KX35-AC-Z0519B-EC

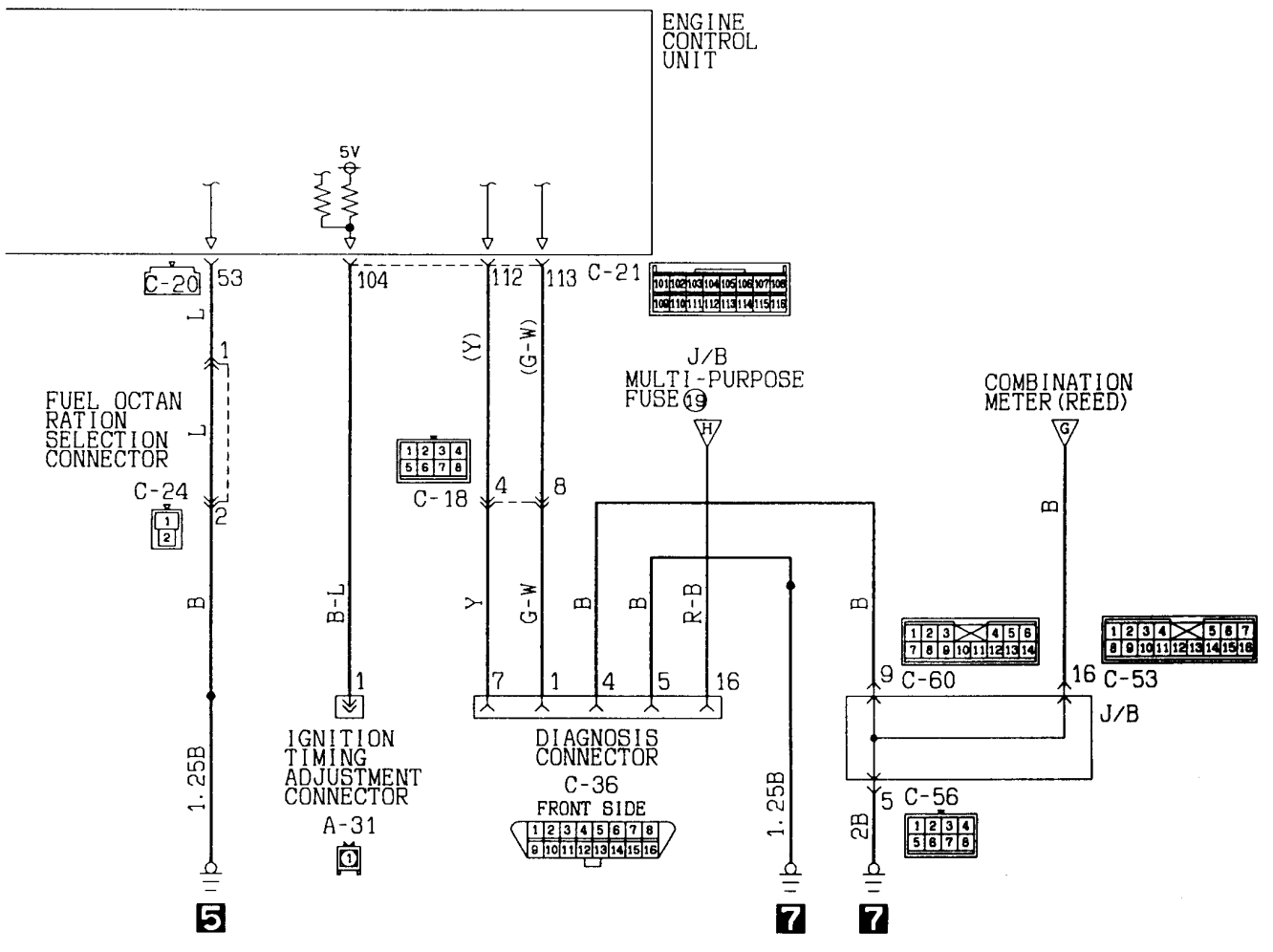
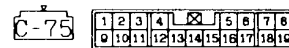
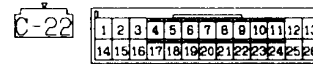
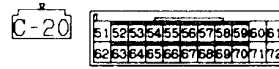

**MPI SYSTEM**  
4G93 (R. H. drive vehicles)

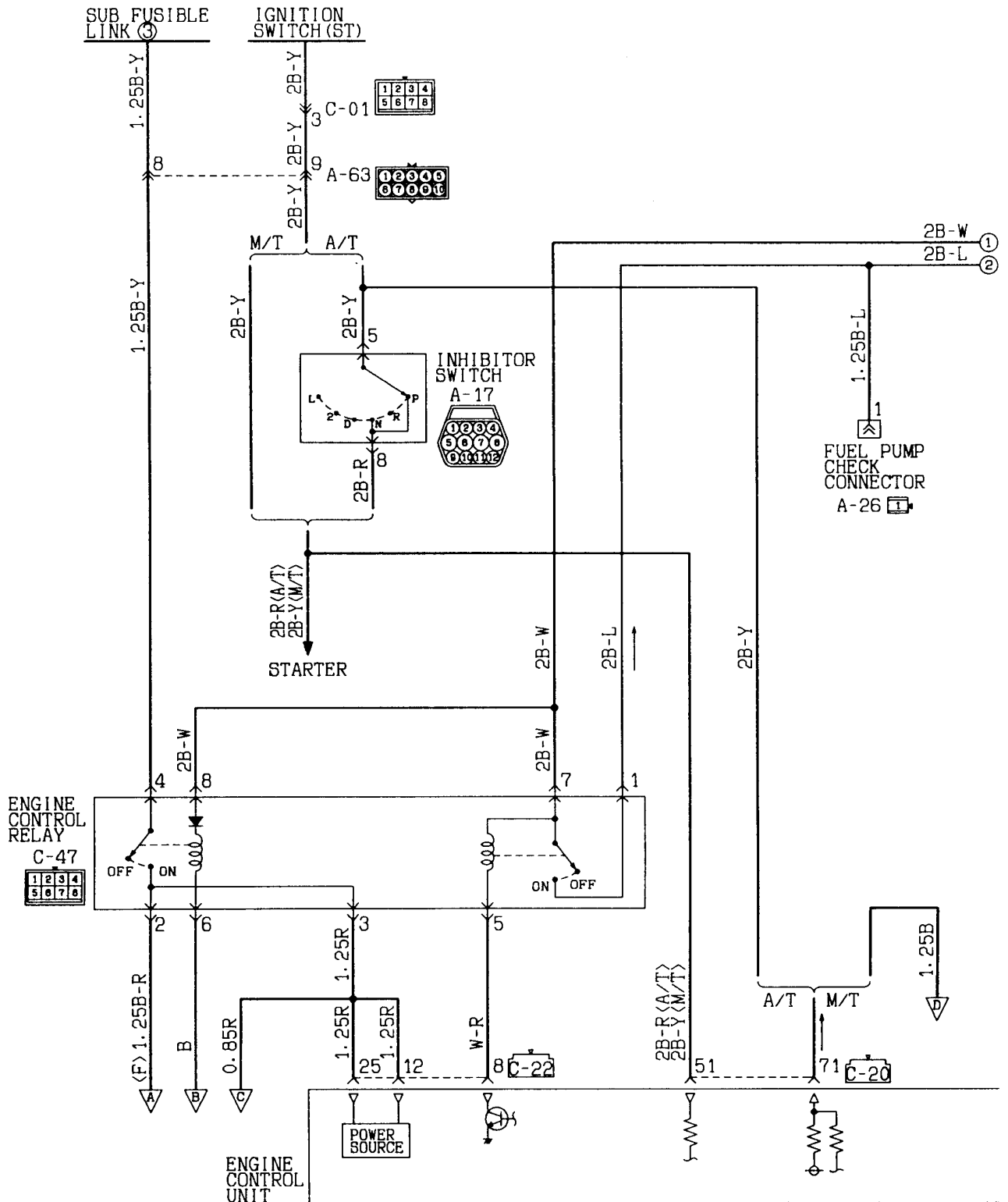

C-22

1	2	3	4	5	6	7	8	9	10	11	12	13
14	15	16	17	18	19	20	21	22	23	24	25	26

C-21

1	2	3	4	5	6	7	8	9	10	11	12	13	14	15	16	17	18
19	20	21	22	23	24	25	26	27	28	29	30	31	32	33	34	35	36

C-20

51	52	53	54	55	56	57	58	59	60	61
62	63	64	65	66	67	68	69	70	71	72

KX35-AC-Z0520-EC

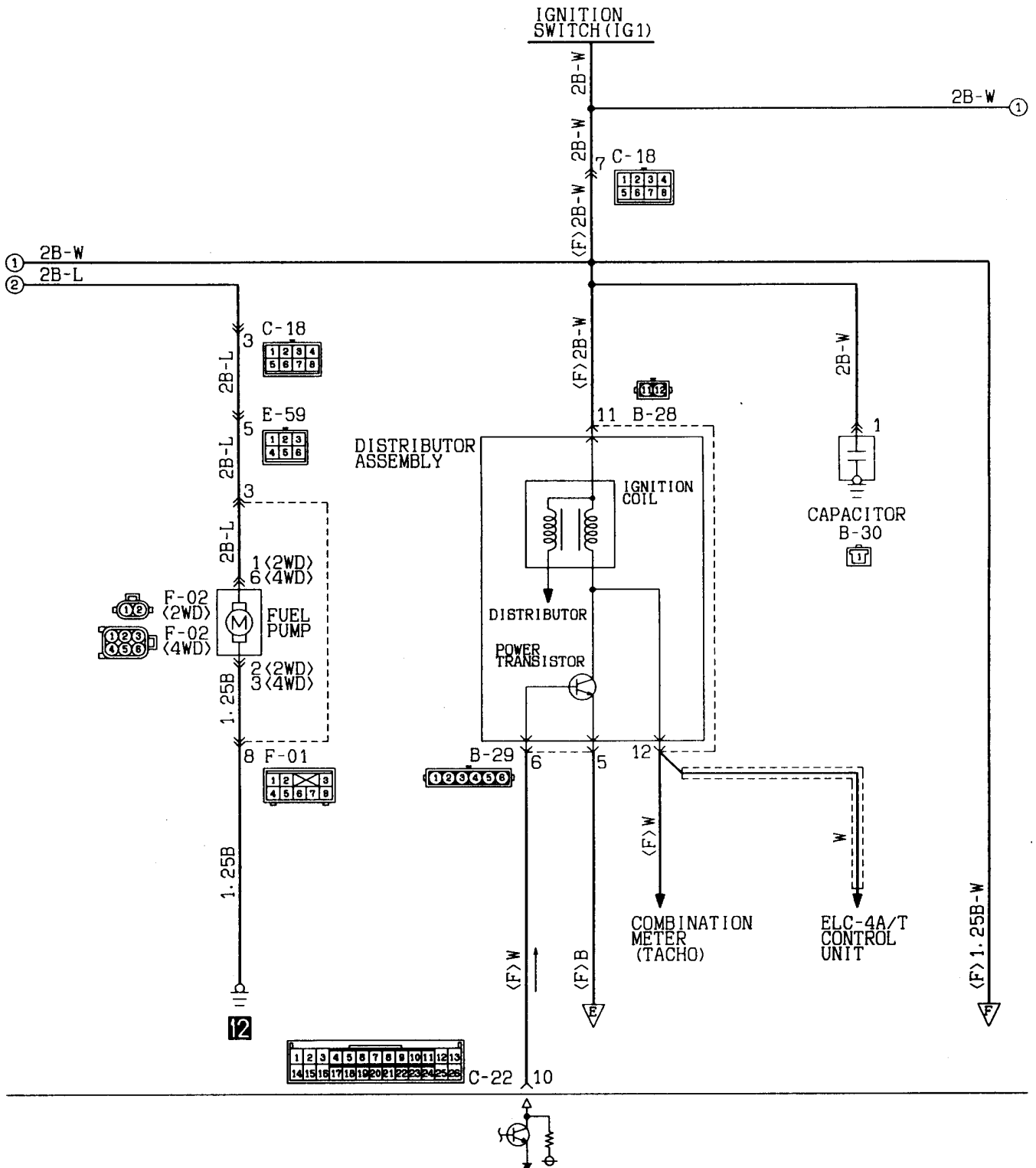

Wire colour code  
 B:Black LG:Light green G:Green L:Blue W:White Y:Yellow SB:Sky blue  
 BR:Brown O:Orange GR:Gray R:Red P:Pink V:Violet



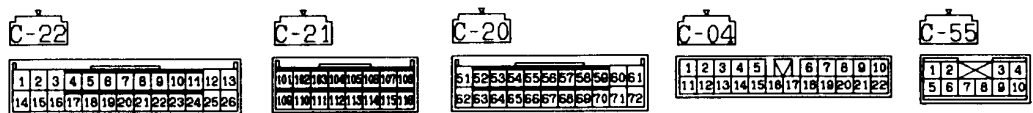
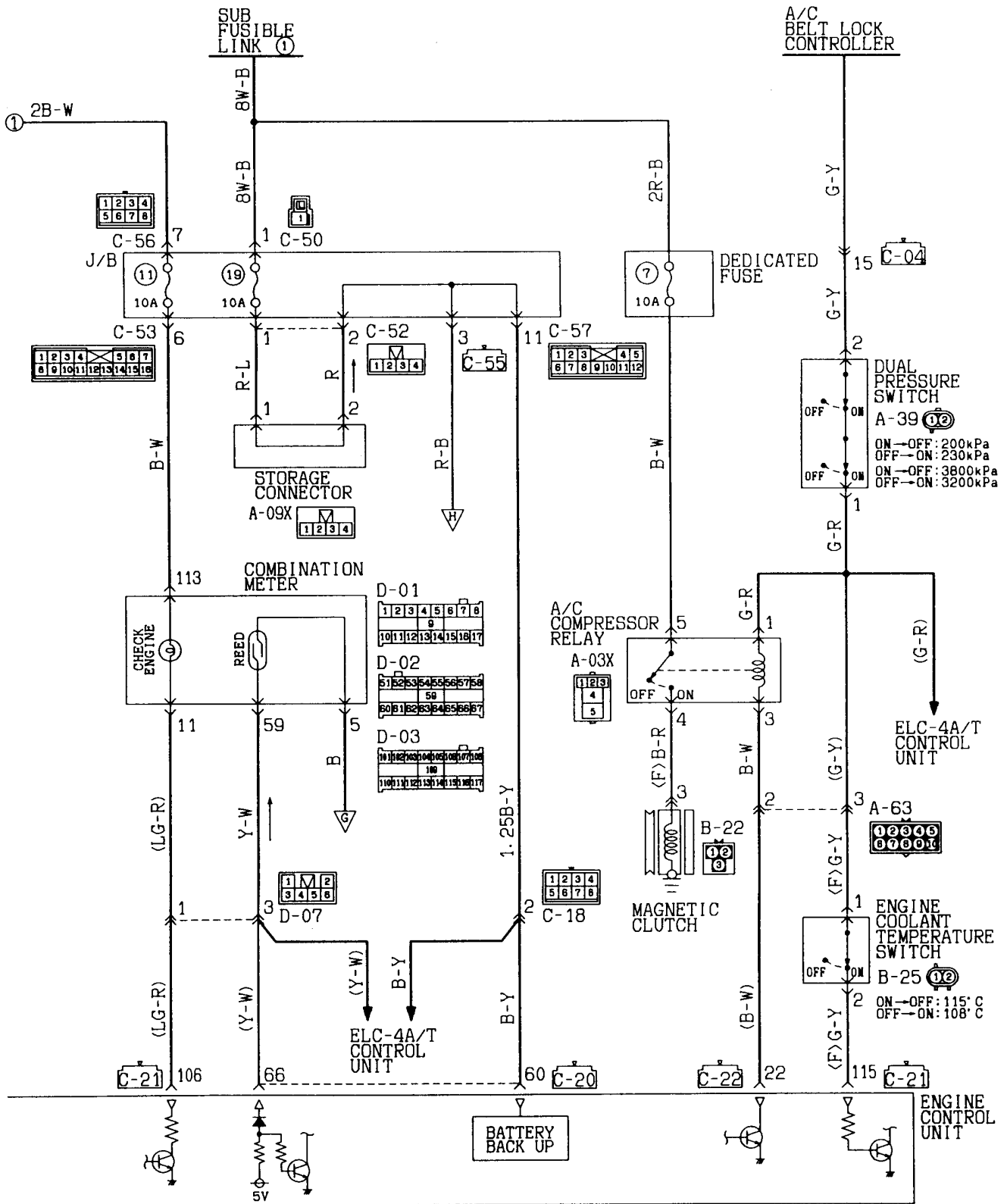

KX35-AC-Z0520A-EC

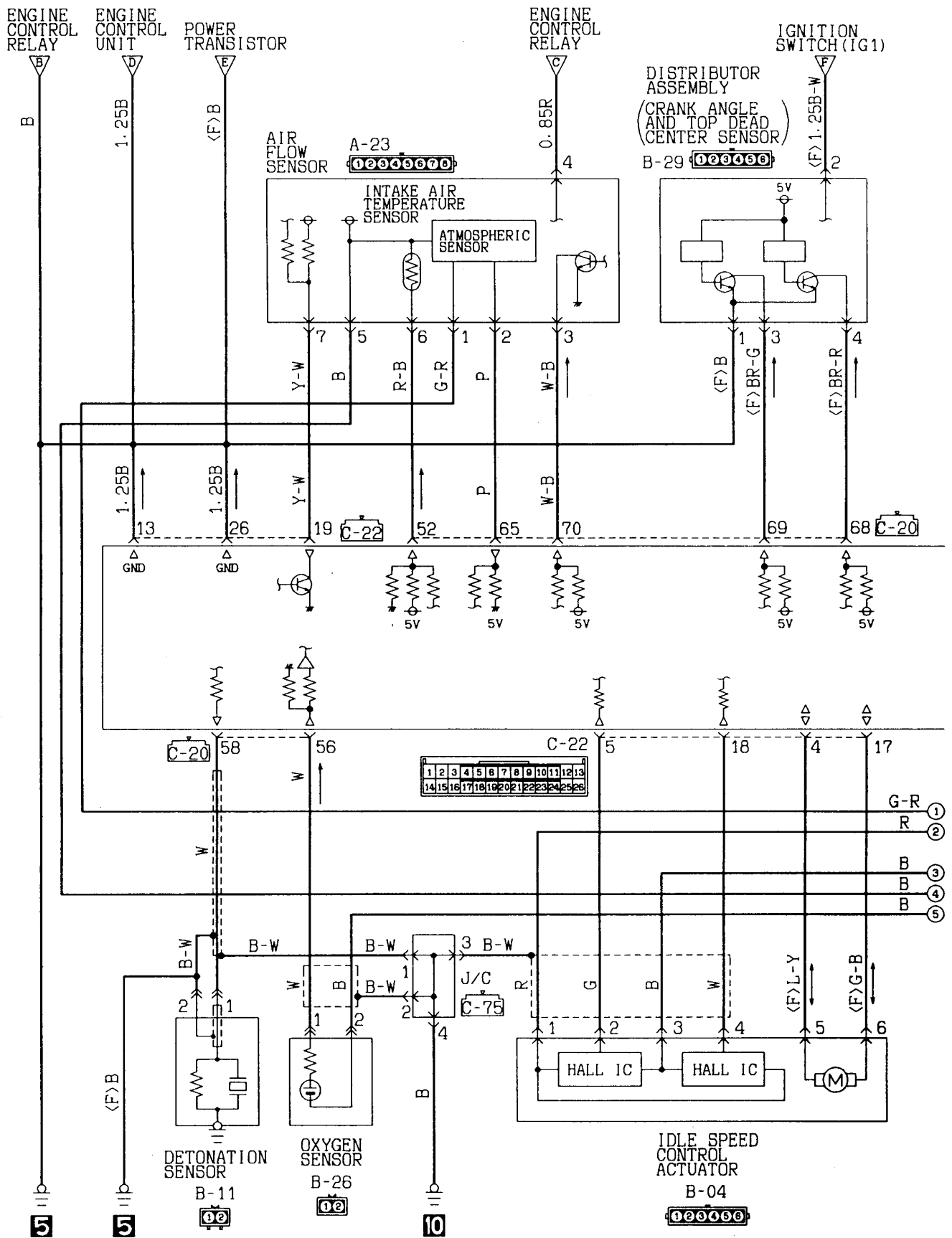

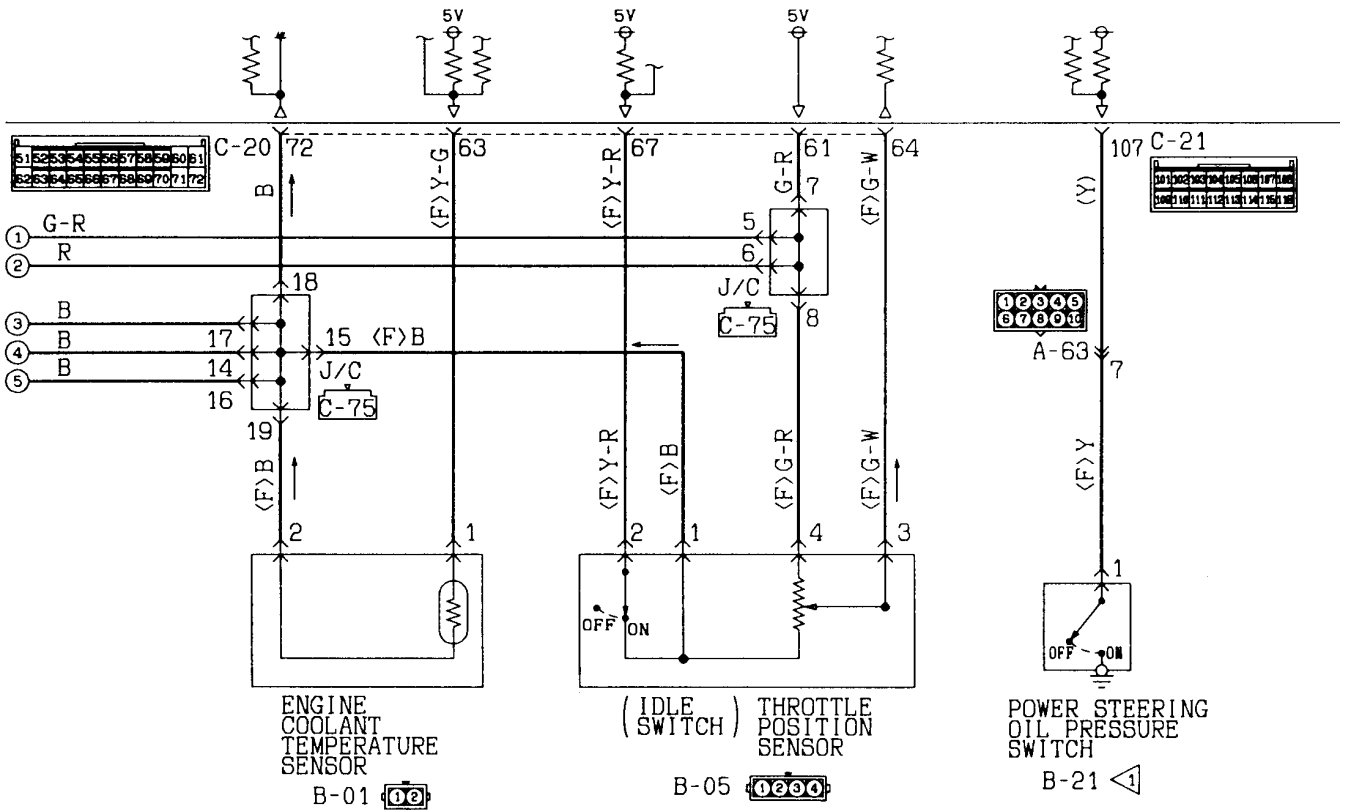
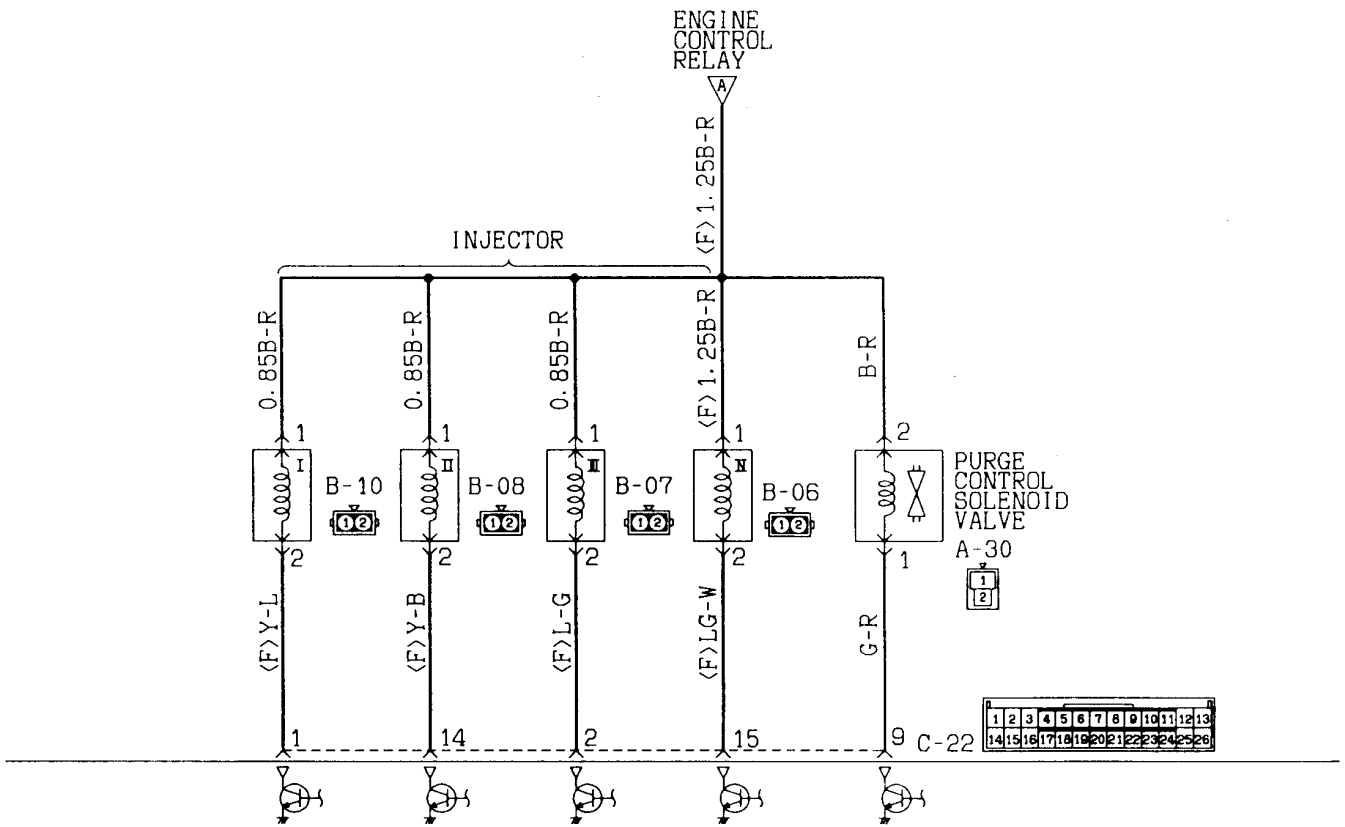

KX35-AC-Z0520B-EC

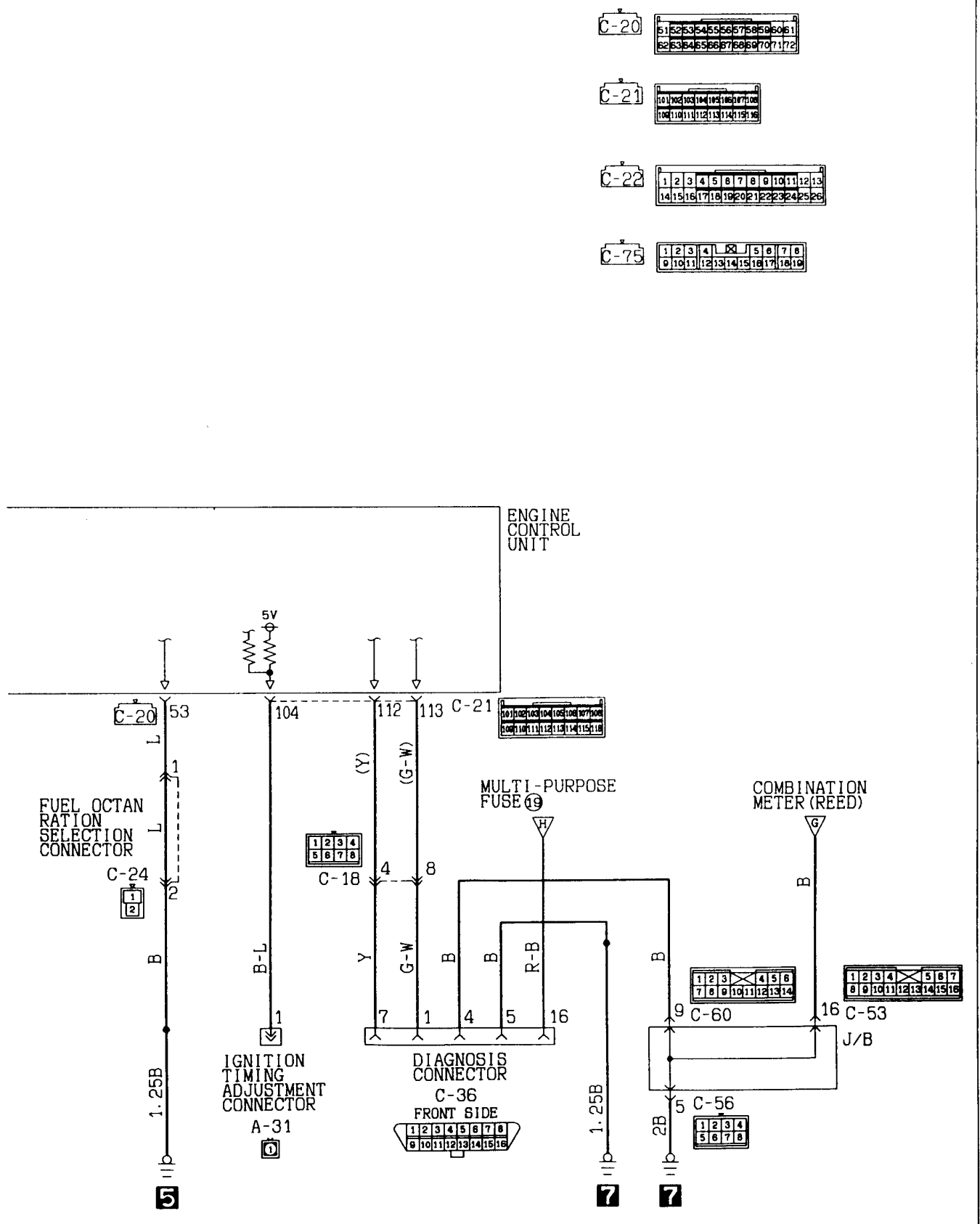

MPI SYSTEM  
4G63 and 4G64 (L.H. drive vehicles)

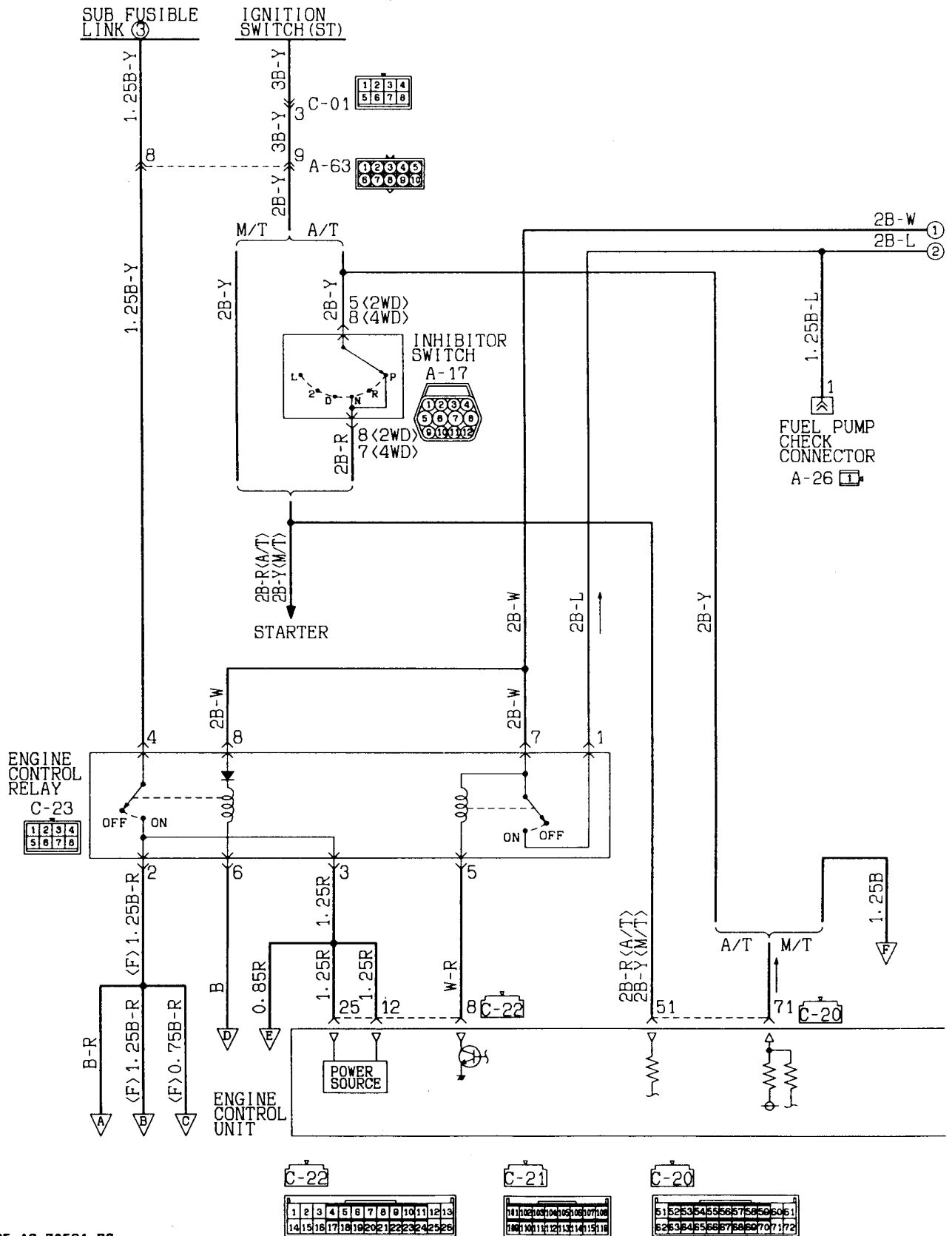

KX35-AC-Z0521-EC

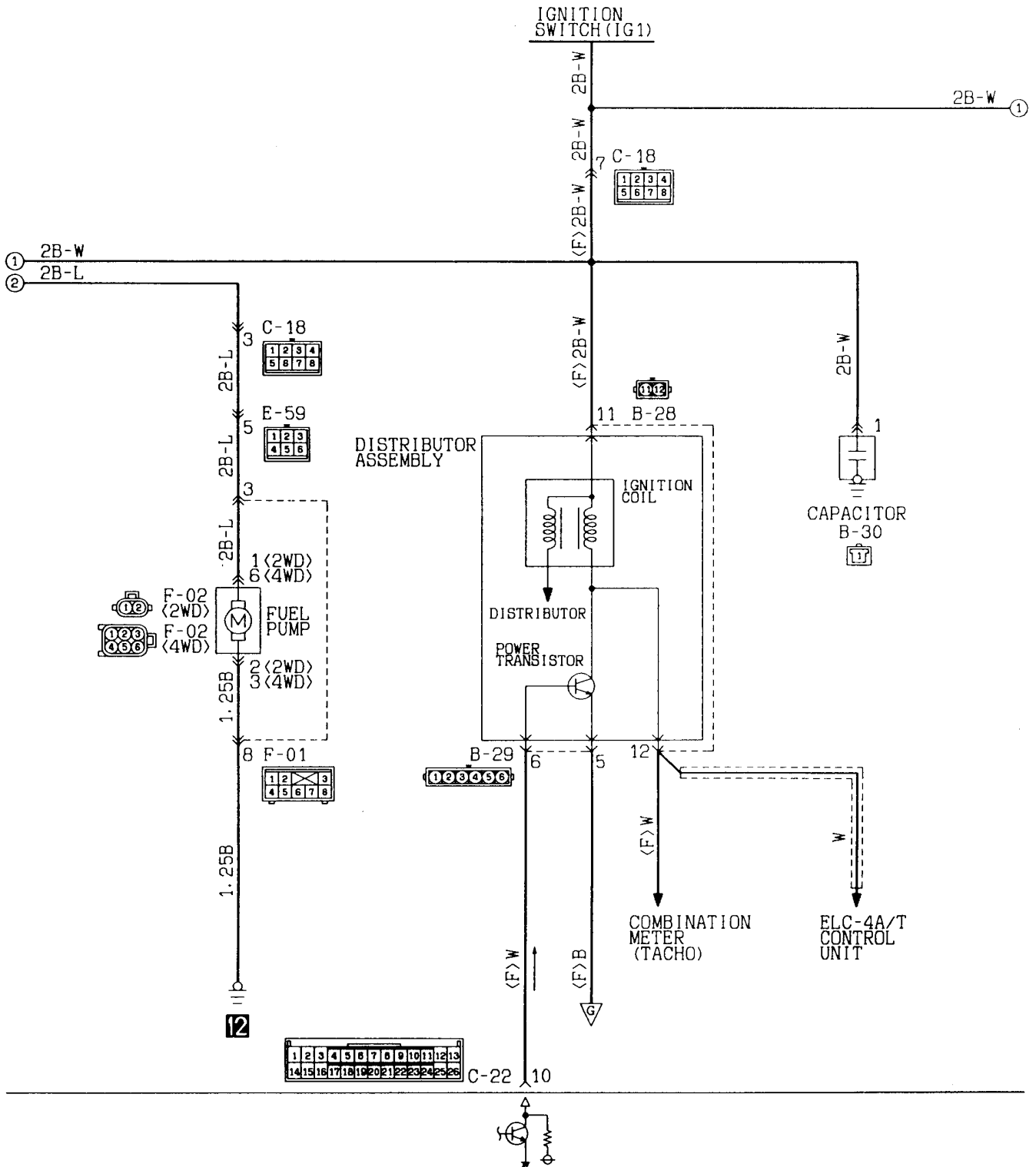

Wire colour code  
 B:Black LG:Light green G:Green L:Blue W:White Y:Yellow SB:Sky blue  
 BR:Brown O:Orange GR:Gray R:Red P:Pink V:Violet

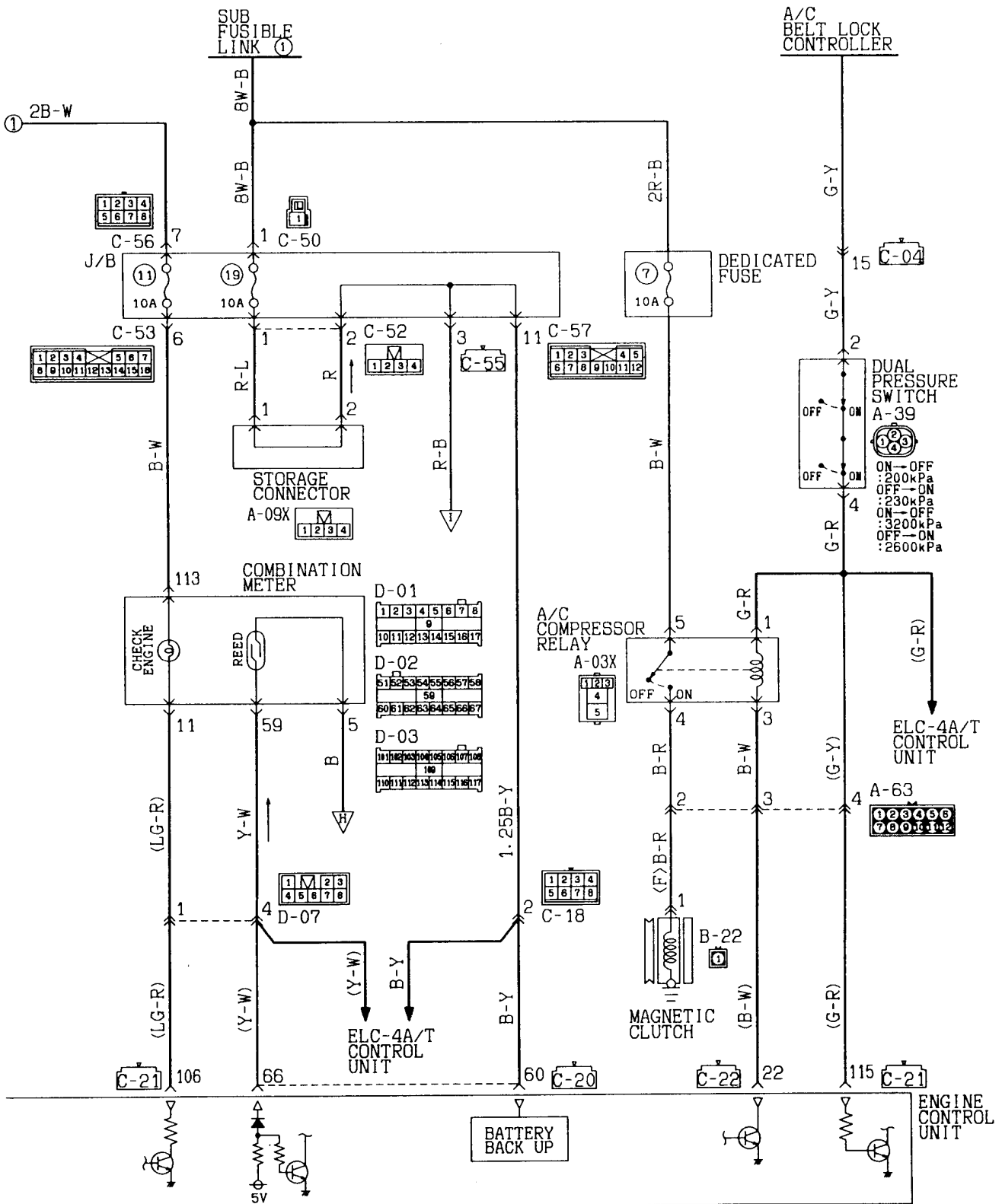

KX35-AC-20521A-EC

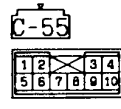
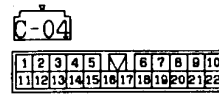
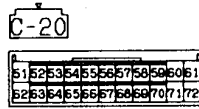
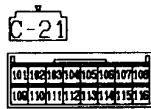
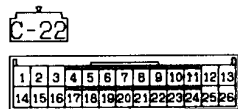

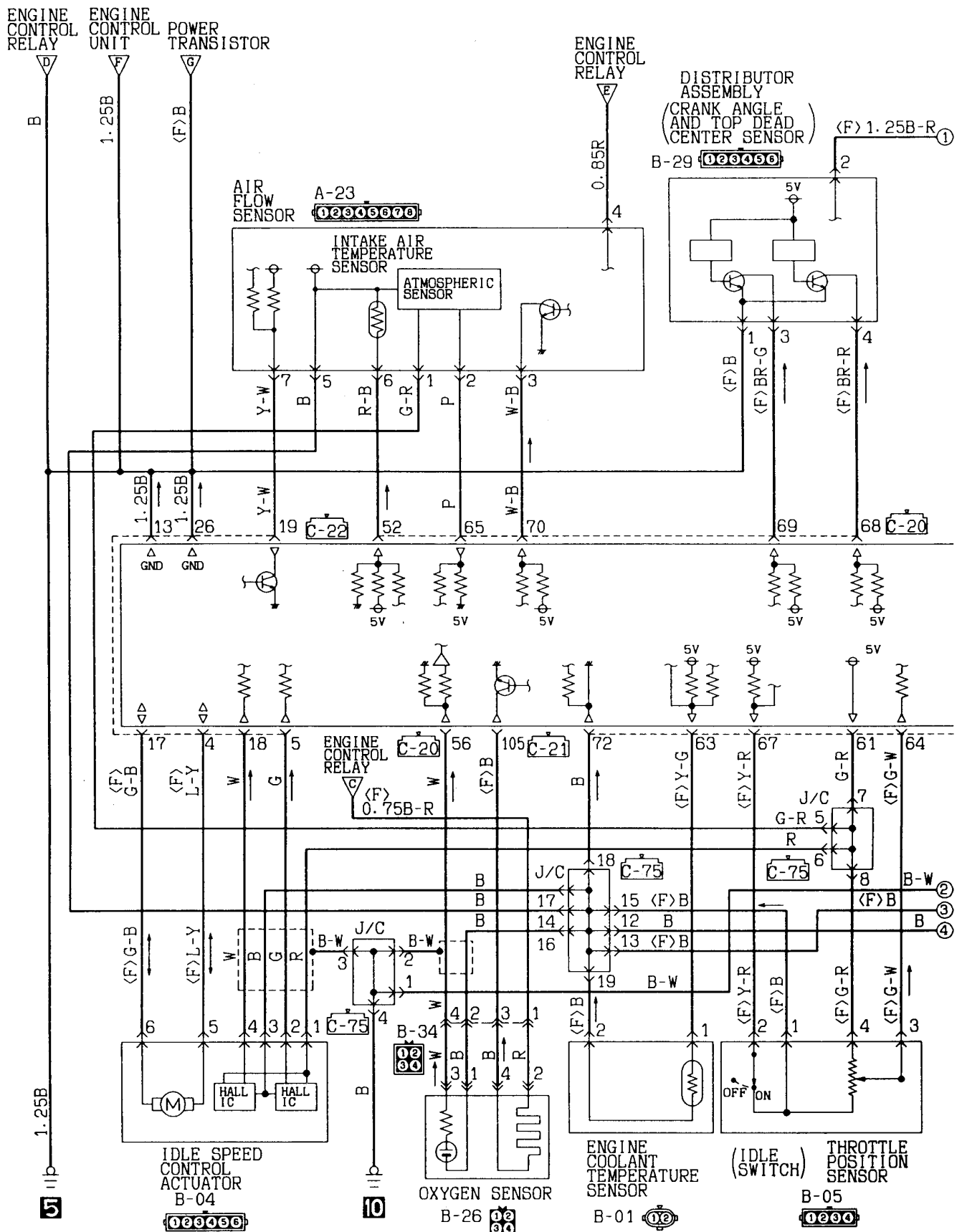



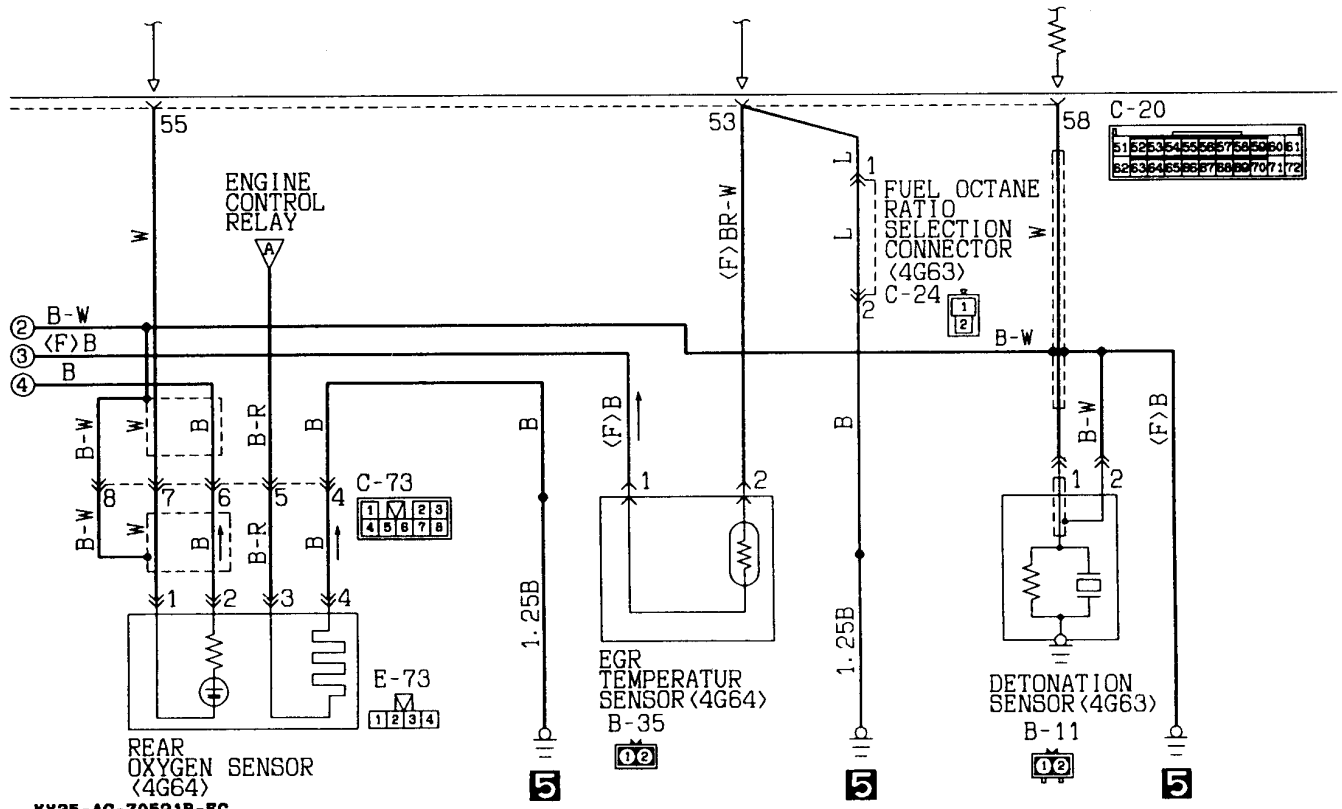
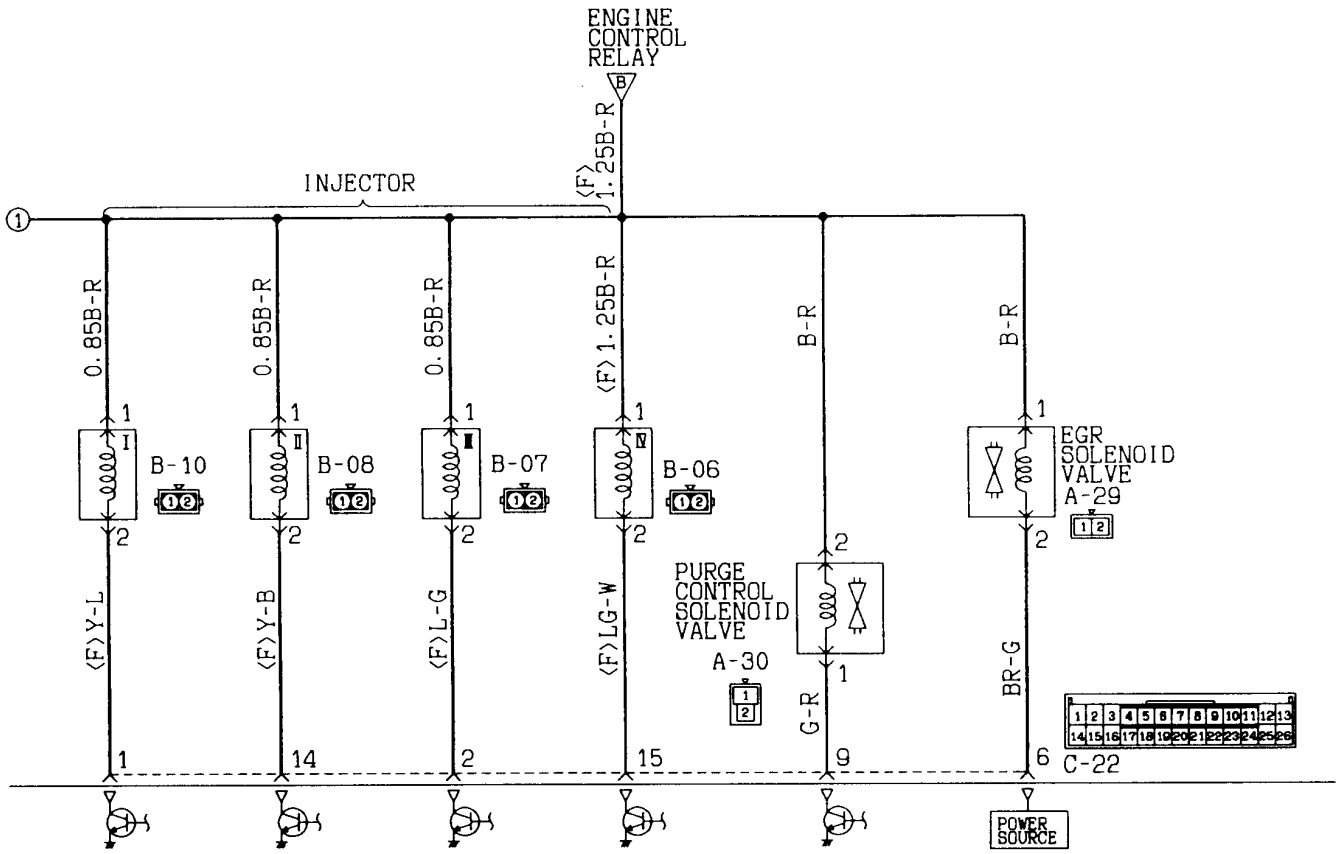

KX35-AC-20521B-EC

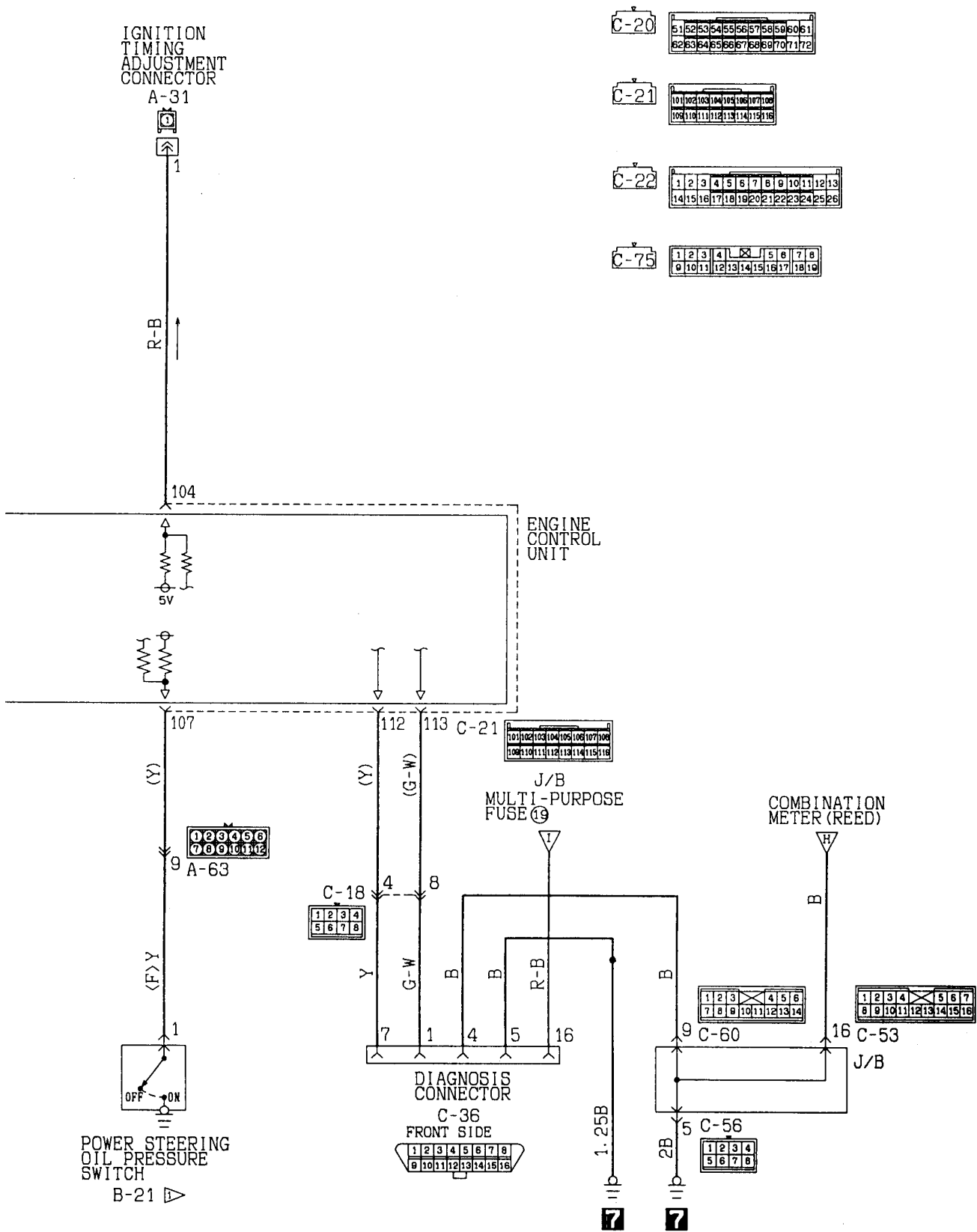

MPI SYSTEM  
4G63 (R. H. drive vehicles)

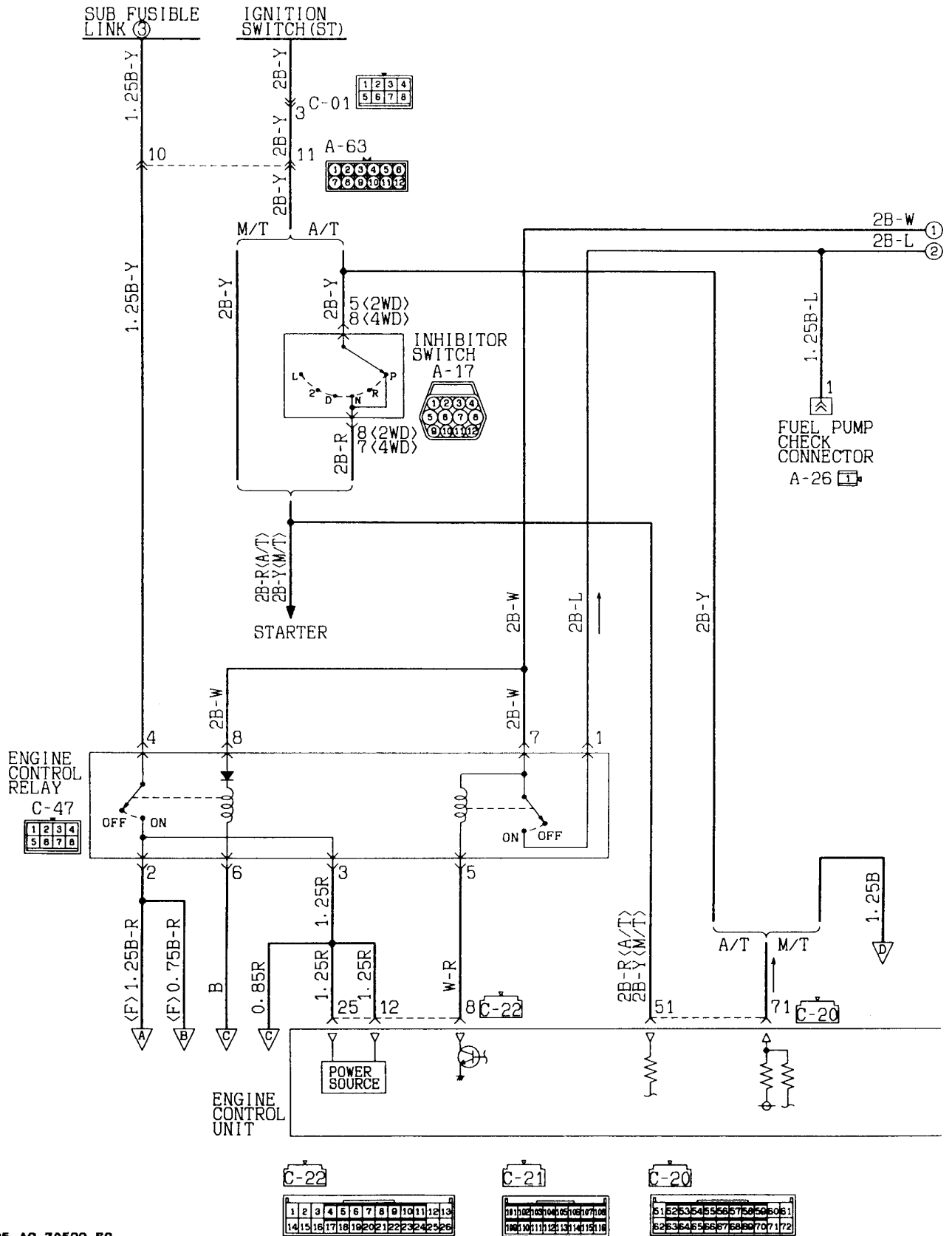

KX35-AC-Z0522-EC

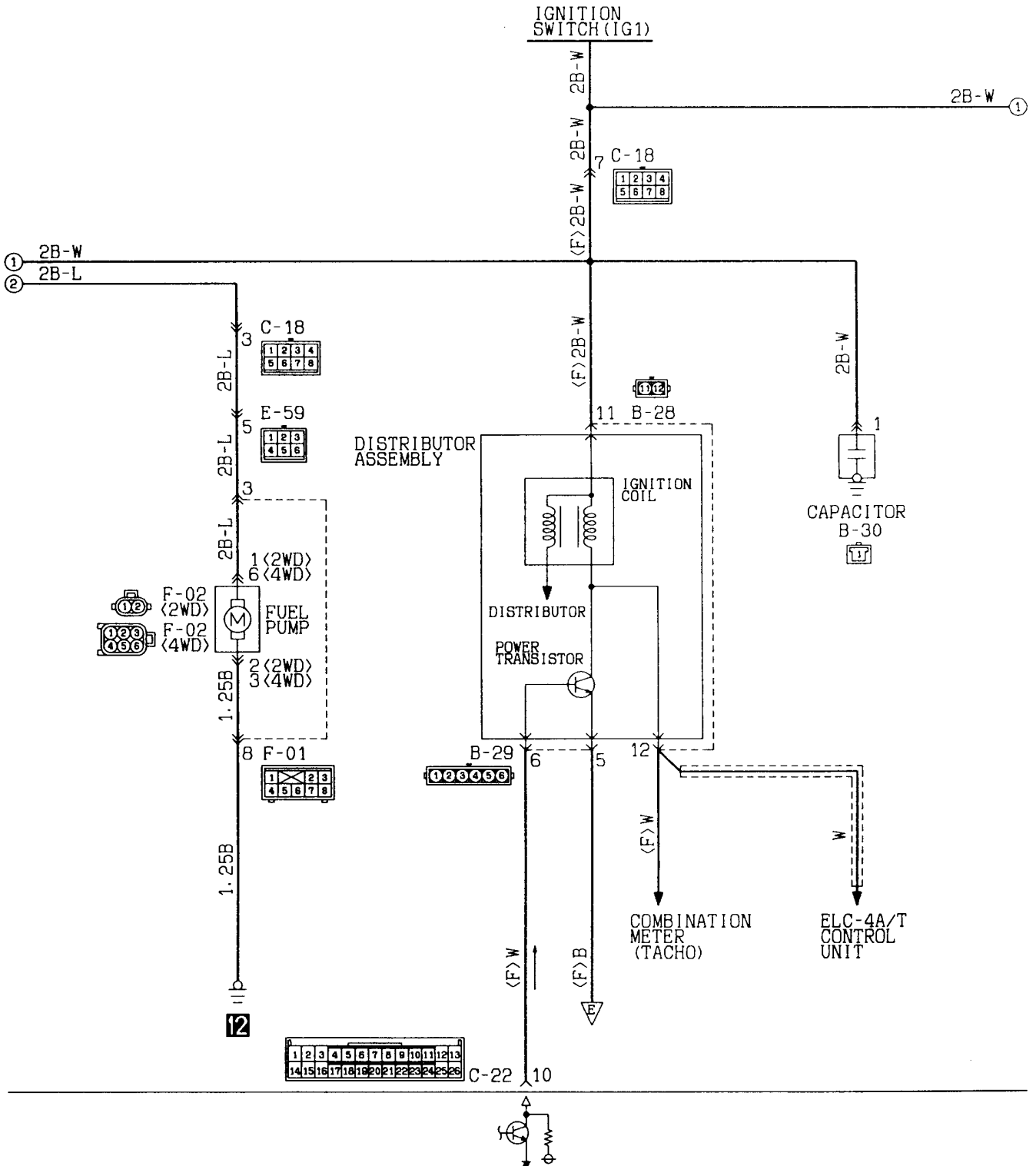

Wire colour code  
 B:Black LG:Light green G:Green L:Blue W:White Y:Yellow SB:Sky blue  
 BR:Brown O:Orange GR:Gray R:Red P:Pink V:Violet

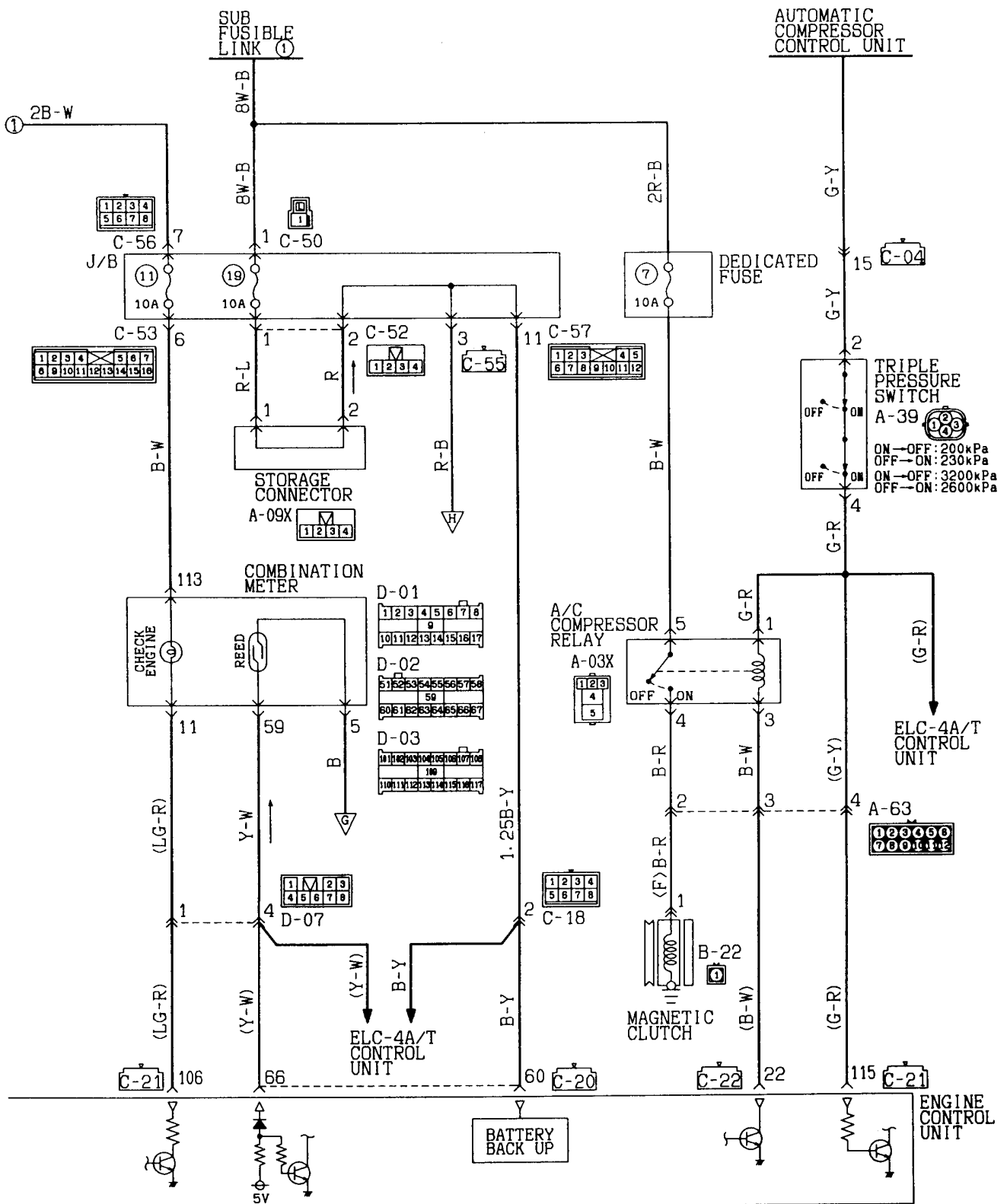

KX35-AC-Z0522A-EC

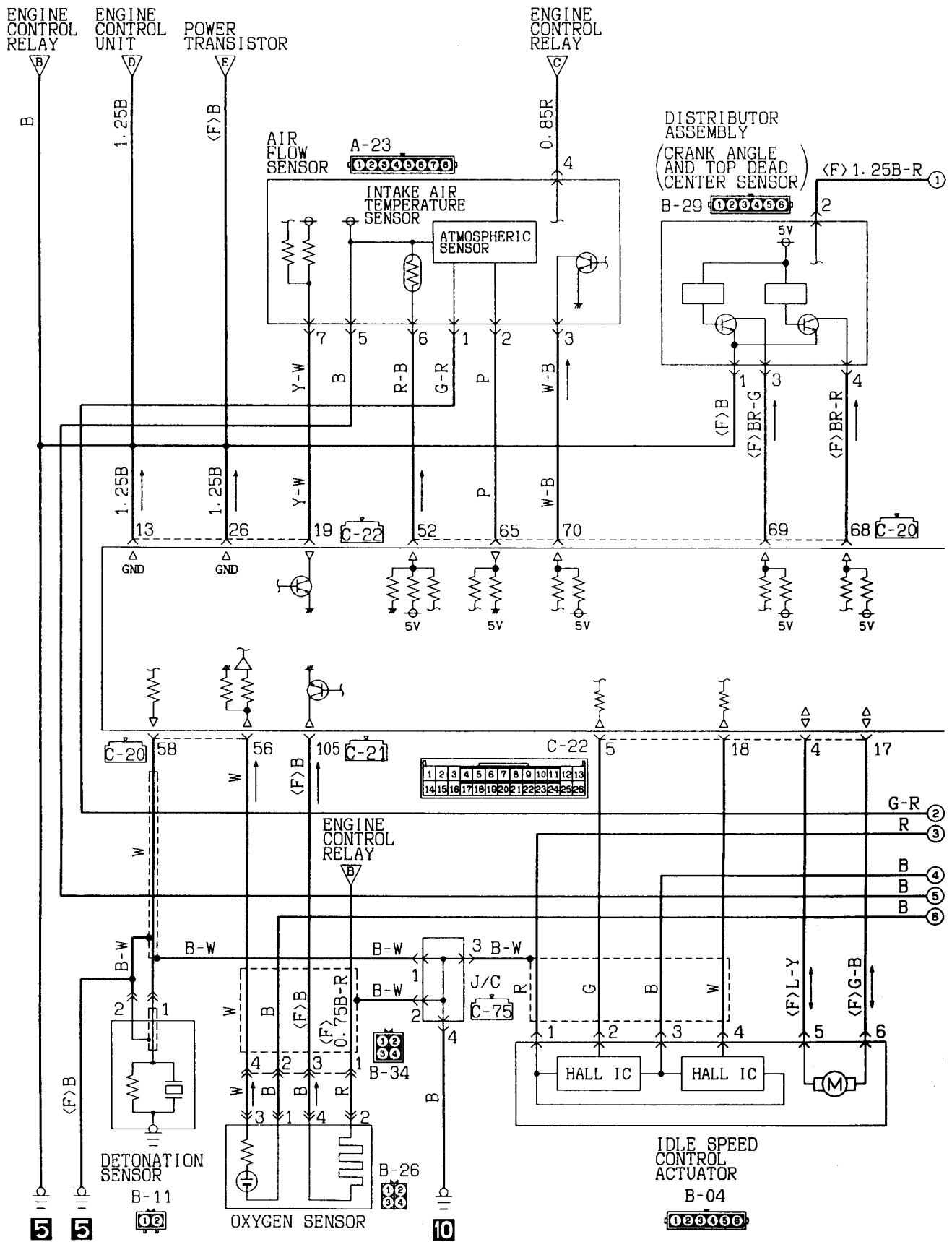

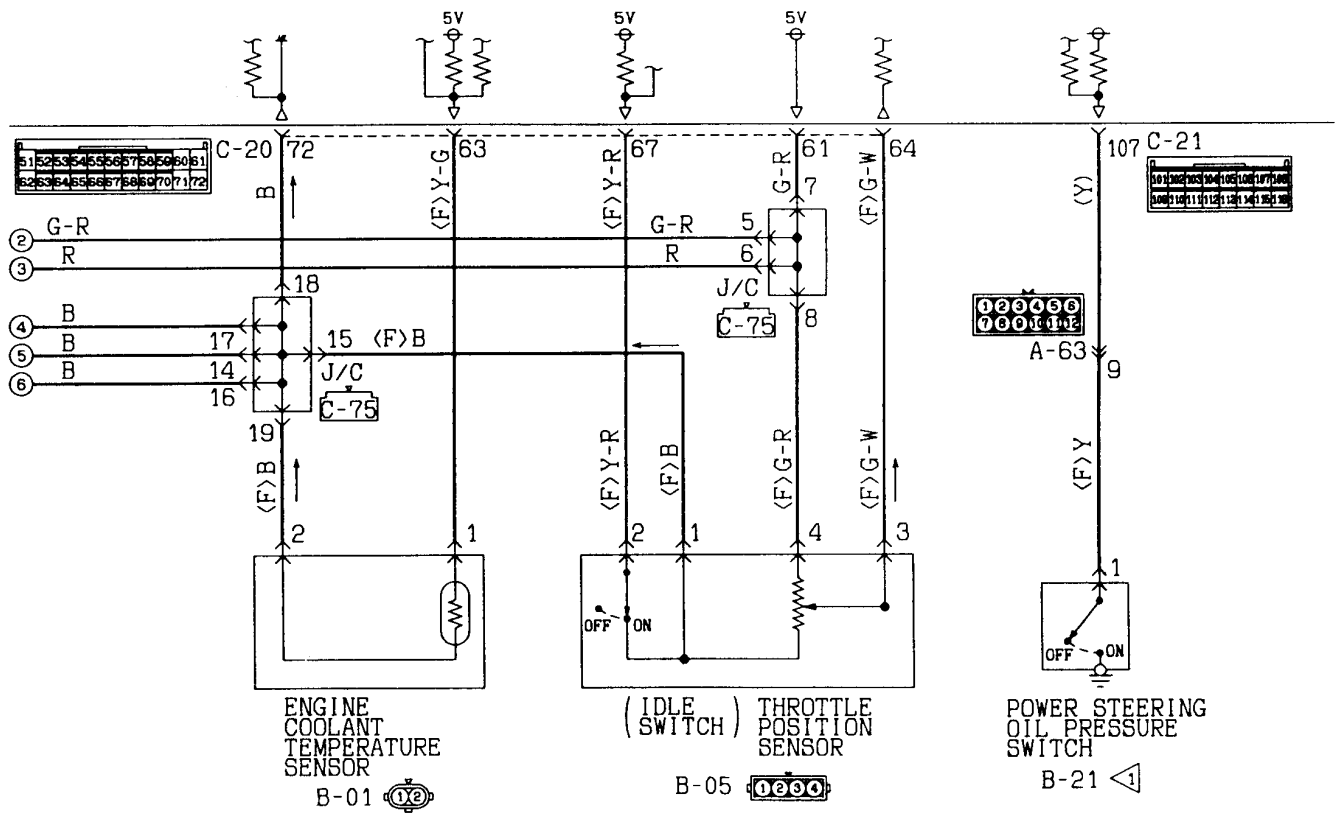
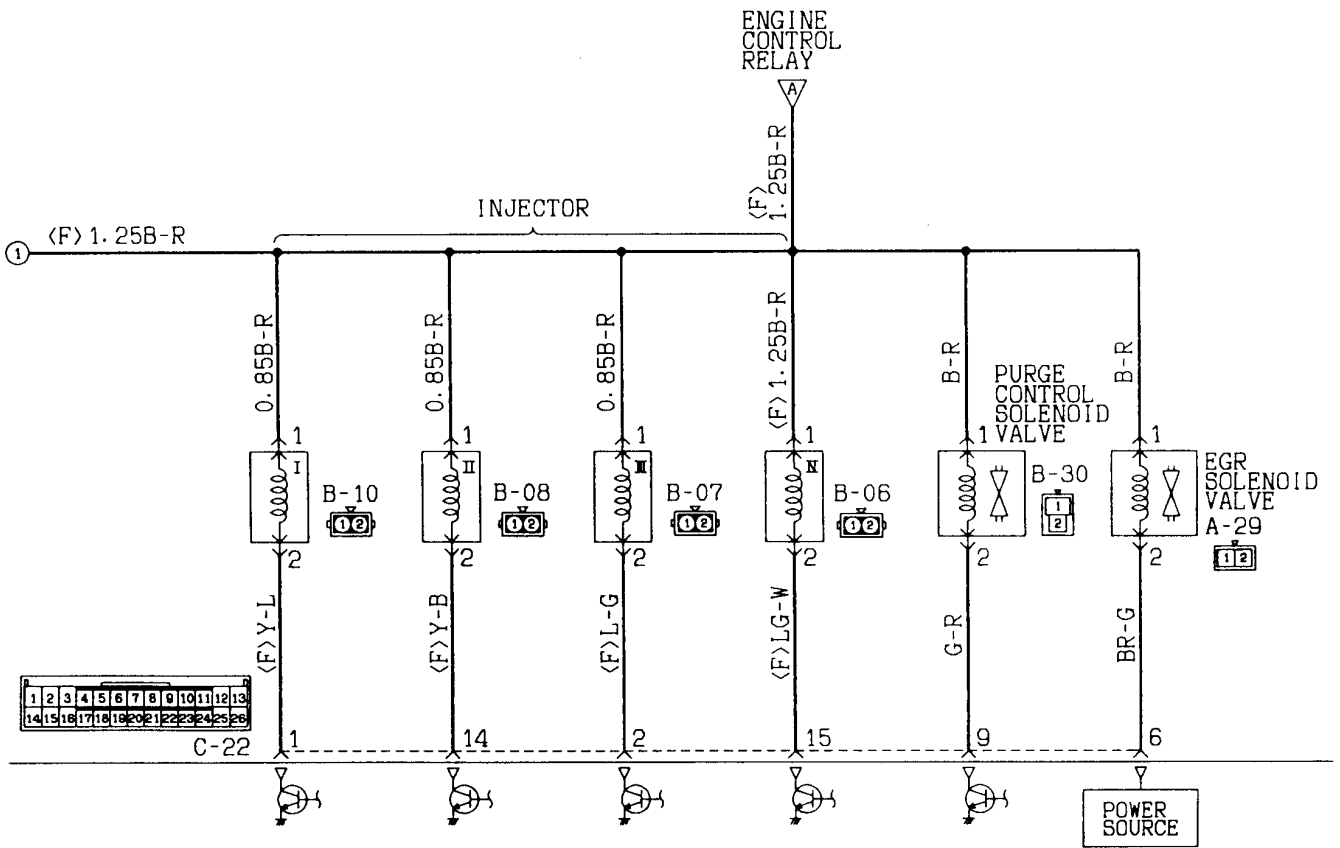

KX35-AC-20522B-EC

C-20	5	6	7	8	9	10	11	12	13	14	15	16	17	18
	51	52	53	54	55	56	57	58	59	60	61			
	62	63	64	65	66	67	68	69	70	71	72			

C-21	10	11	12	13	14	15	16	17	18
	101	102	103	104	105	106	107	108	
	109	110	111	112	113	114	115	116	

C-22	1	2	3	4	5	6	7	8	9	10	11	12	13
	14	15	16	17	18	19	20	21	22	23	24	25	26

C-75	1	2	3	4	5	6	7	8
	9	10	11	12	13	14	15	16
	17	18	19	20	21	22	23	24

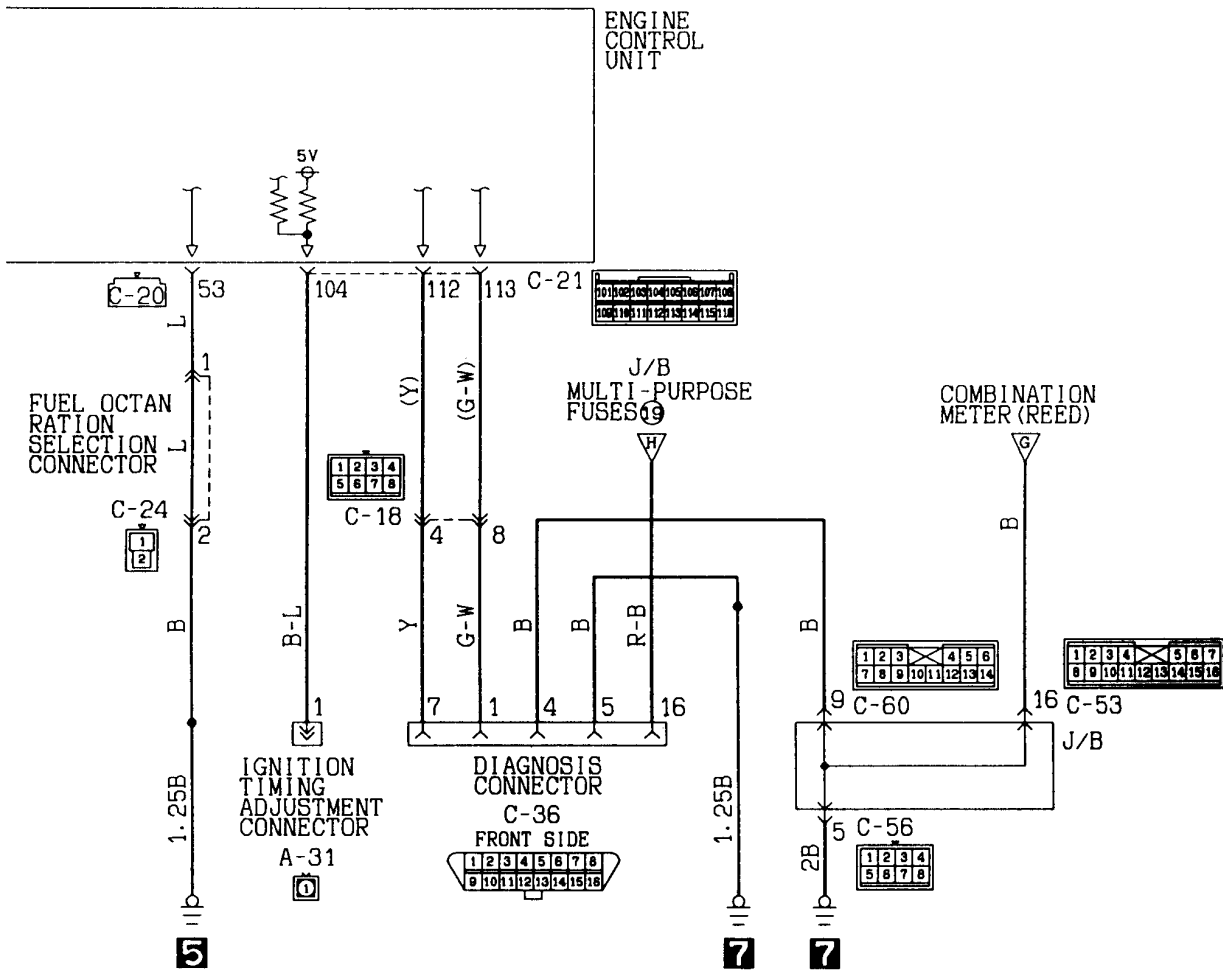



NOTES

COOLING SYSTEM  
4G93

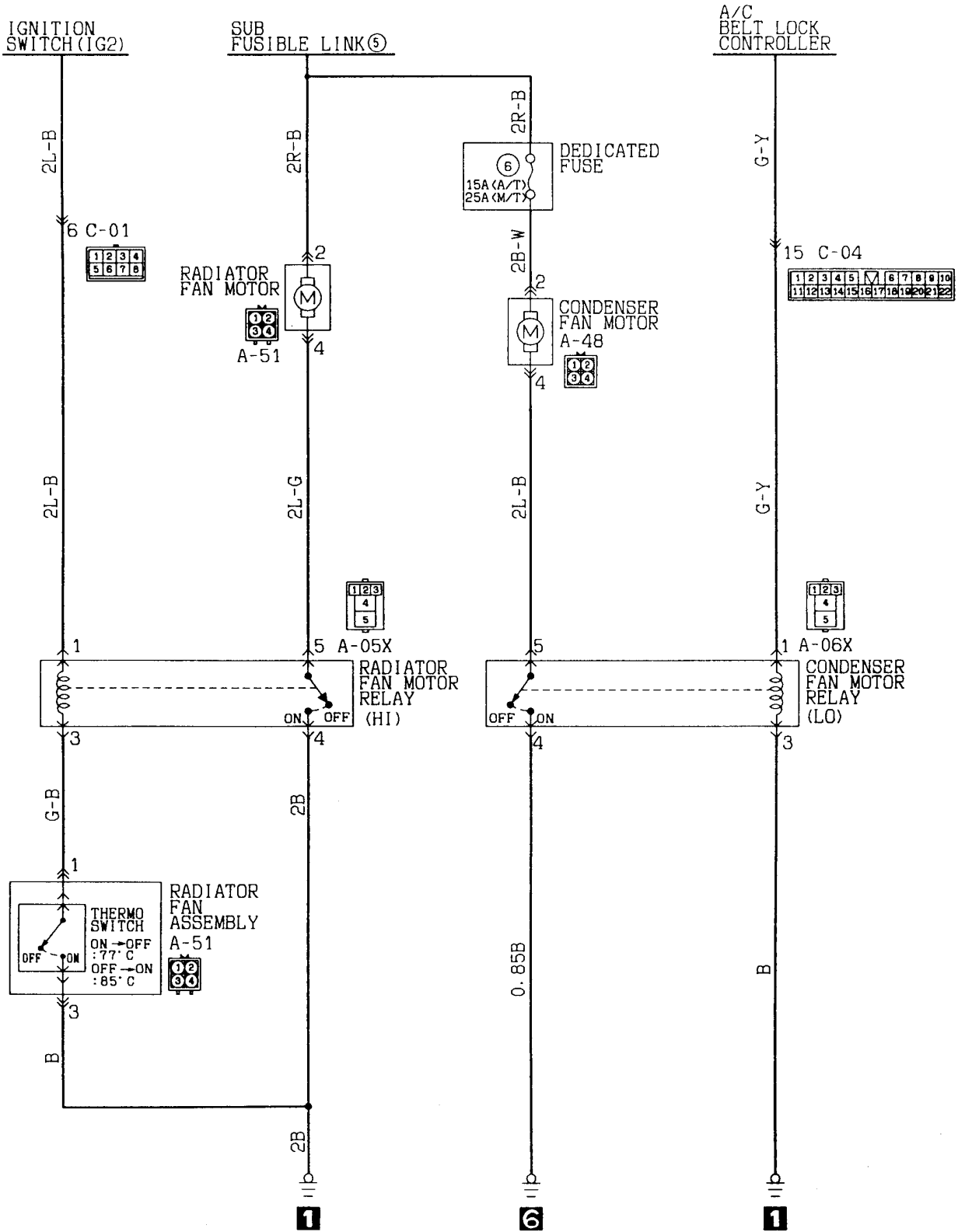

Wire colour code  
 B:Black LG:Light green G:Green L:Blue W:White Y:Yellow SB:Sky blue  
 BR:Brown O:Orange GR:Gray R:Red P:Pink V:Violet

**COOLING SYSTEM <4G93> (See P. 4A-54.)**

**OPERATION**

**1. When A/C belt lock controller outputs LO signal (0 V)**

- When the engine coolant temperature goes up to 85°C, the thermo switch of radiator is activated.
- This energizes the radiator fan motor relay, causing the radiator fan to start rotating.

**2. When A/C belt lock controller outputs HI signal (System voltage)**

- The condenser fan motor relay (LO) is energized by the power supplied from the auto compressor control unit causing the condenser fan to start rotating.
- As the engine coolant temperature rises up to 85°C, the thermo switch is activated, just as in 1 above, causing the radiator fan to start rotating.

**TROUBLESHOOTING HINTS**

1. Neither radiator fan nor condenser fan operates.
  - Check the sub-fusible link No. (5).
2. Condenser fan only does not operate at all.
  - Check the dedicated fuse No. (6).
  - Check to see if auto compressor control unit outputs a signal.

Remarks

- For troubleshooting the automatic compressor control unit, see the Troubleshooting in Group 55 Heater and Air Conditioner of the separate WORKSHOP MANUAL (Pub. No. PWDE9104).

A/C Belt Lock Controller HI Signal Output Conditions

Ignition switch (IG <sub>2</sub> )	ON	Remarks (1) The A/C belt lock controller outputs a LO signal (0 V) if any one of the switches and sensors is deactivated. (2) The * marked device measures the temperature of the intake air, and according to the control characteristics of the the magnetic clutch for the compressor, the automatic compressor control unit outputs the "HI" signal (System voltage).
Blower switch	ON	
Air conditioner switch	ON (ECONO or A/C)	
Air inlet sensor	*	
Air thermo sensor	*	

Fan Operating Conditions

Automatic compressor control unit output	Switch position	Fan operating condition	
	Thermo sensor (for radiator fan) [ON with 85°C or higher]	Radiator fan	Condenser fan
LO (0V)	OFF	OFF	OFF
	ON	HIGH	OFF
HI (System voltage)	OFF	OFF	HIGH
	ON	HIGH	HIGH

COOLING SYSTEM  
4G63 and 4G64

IGNITION SWITCH(IG2)

SUB FUSIBLE LINK ⑤

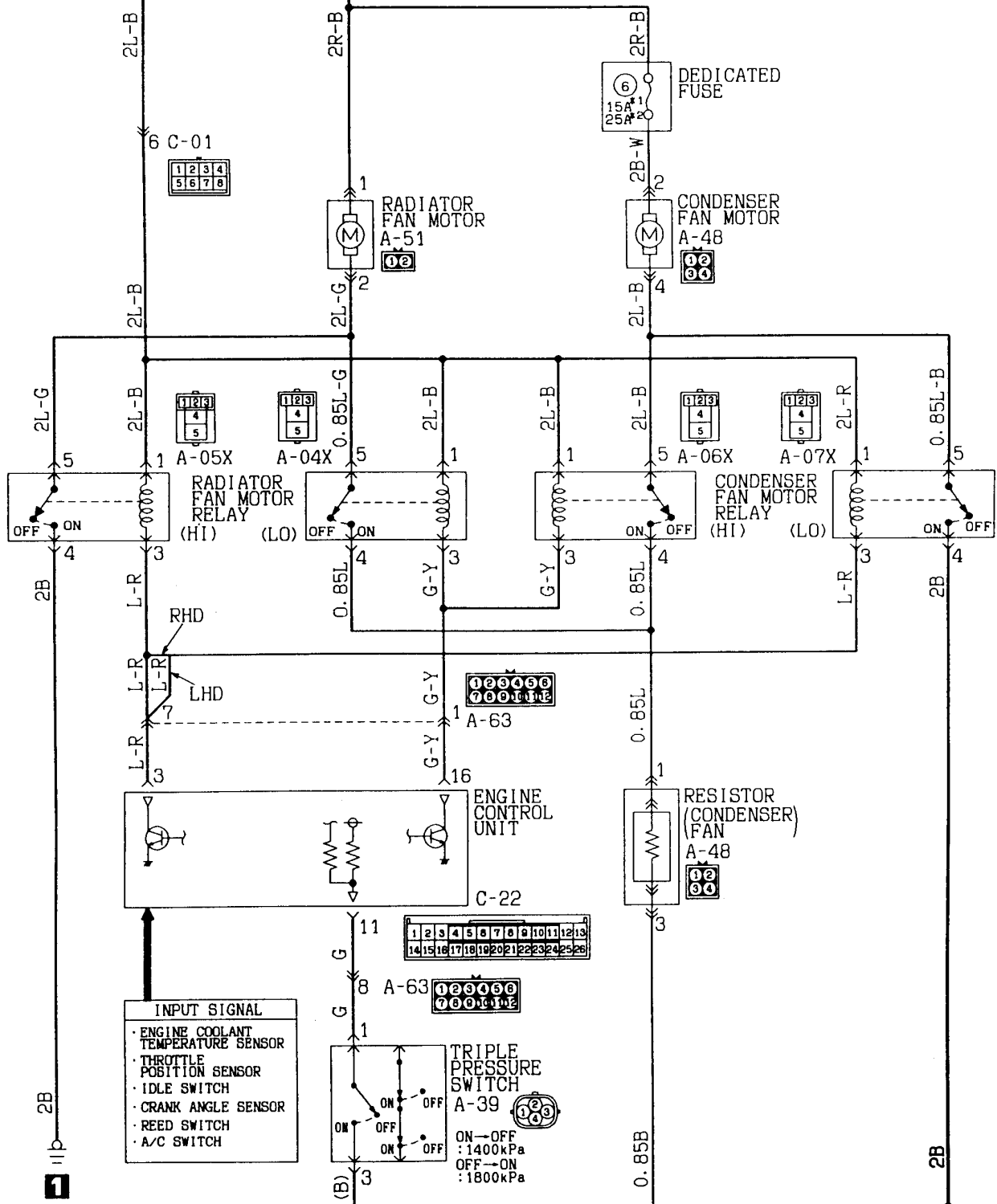

Remarks

- \*1: A/T(except 4G63(2WD-A/T))
- \*2: M/T and 4G63(2WD-A/T)

Wire colour code  
B:Black LG:Light green  
BR:Brown O:Orange

green G:Green L:Blue  
GR:Gray R:Red

W:White Y:Yellow  
P:Pink V:Violet

SB:Sky blue

**COOLING SYSTEM <4G63 and 4G64> (See P. 4A-56.)**

**OPERATION**

- The engine control unit controls the operation speed of the radiator fan motor and condenser fan motor in accordance with the engine coolant temperature, vehicle speed and engine operating conditions by controlling the power transistors (low-speed side and high-speed side) for driving the fan motors inside the engine control unit.
- When the low-speed side (or high-speed side) power transistor inside the engine control unit turns ON, the LO (or HI) sides of the radiator fan motor relay and condenser fan motor relay turn ON, and the fan motors operate at low (or high) speed.

**TROUBLESHOOTING HINTS**

1. Neither radiator fan nor condenser fan operates.
  - Check the sub-fusible link No. ⑤.
2. Condenser fan does not operate at all.
  - Check the dedicated fuse No. ⑥.
3. Radiator fan and condenser fan do not operate at low speed.
  - Check resistor.

Remarks

- For troubleshooting the engine control unit, see the Troubleshooting in Group 13 Fuel of the separate WORKSHOP MANUAL (Pub. No. PWDE9104).
- For troubleshooting the automatic compressor control unit, see the Troubleshooting in Group 55 Heater and Air Conditioner of the separate WORKSHOP MANUAL (Pub. No. PWDE9104).

Fan Operating Conditions

A/C switch	Vehicle speed	Engine coolant temperature	Power transistors inside engine control unit		Fan operation conditions	
			Low-speed side	High-speed side	Radiator fan	Condenser fan
OFF	79 km/h or less	94°C or less	OFF	OFF	Stopped	Stopped
		95°C or more	ON	OFF	Low speed	Stopped
		105°C or more	ON	ON	High speed	High speed
	80 km/h or more	104°C or less	OFF	OFF	Stopped	Stopped
		105°C or more	ON	ON	High speed	High speed
ON	—	104°C or less	ON	OFF	Low speed	Low speed
		105°C or more	ON	ON	High speed	High speed

NOTE

- (1) When the A/C switch and triple pressure switch (medium pressure) are both ON, the radiator fan and condenser fan will both operate at high speed irrespective of the vehicle speed and the engine coolant temperature.
- (2) If there is a malfunction of the engine coolant temperature sensor, the radiator fan and condenser fan will operate at high speed.

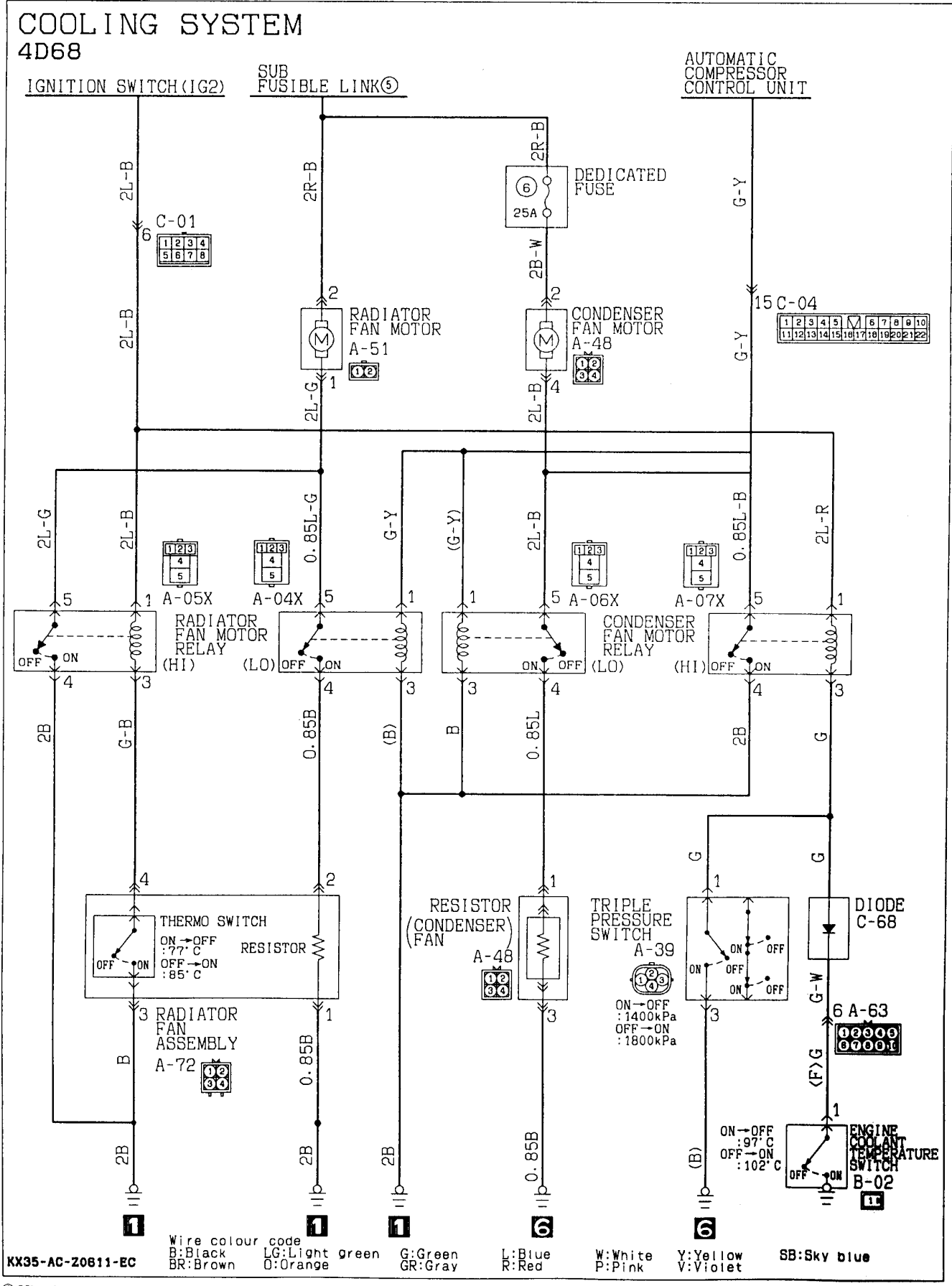

**COOLING SYSTEM <4D68> (See P. 4A-58.)**

**OPERATION**

**1. When automatic compressor control unit outputs LO signal (0 V)**

- When the engine coolant temperature reaches 85°C, the thermo switch of radiator is activated.
- This energizes the radiator fan motor relay (HI), causing the radiator fan to rotate at high speed.

**2. When automatic compressor control unit outputs HI signal (System voltage)**

- The radiator fan motor relay (LO) and condenser fan motor relay (LO) are both energized by the power from the automatic compressor control unit. As a result, the radiator fan is rotated unconditionally at low speed by the circuit completed with each resistor.
- As in 1 above, when the engine coolant temperature reaches 85°C, the thermo switch is activated causing the radiator fan to rotate at high speed.
- When either the pressure switch turns ON as a result of the refrigerant line pressure on the middle-pressure side building up in hot weather, or the engine coolant temperature switch turns ON as a result of engine coolant temperature further increasing, the condenser fan motor relay (HI) is also energized causing the condenser fan to rotate at high speed.

**TROUBLESHOOTING HINTS**

- Neither radiator fan nor condenser fan operates.
  - Check the sub-fusible link No. ⑤.
- Condenser fan does not operate at all.
  - Check the dedicated fuse No. ⑥.
- Radiator fan and condenser fan do not operate at low speed.
  - Compressor magnetic clutch is not activated.
    - Check the automatic compressor control unit for output.
  - Compressor magnetic clutch is activated.
    - Check relay and resistor on the low-speed side.

Remarks

- For troubleshooting the automatic compressor control unit, see the Troubleshooting in Group 55 Heater and Air Conditioner of the separate WORKSHOP MANUAL (Pub. No. PWDE9104).

Automatic Compressor Control Unit HI Signal Output Conditions

Ignition switch (IG <sub>2</sub> )	ON	Remarks (1) The automatic compressor control unit outputs a LO signal (0 V) when any one of the switches and sensors is deactivated. (2) The * marked device measures the temperature of the intake air, and according to the control characteristics of the magnetic clutch for the compressor, the automatic compressor control unit outputs the "HI" signal (System voltage).
Blower switch	ON	
Air conditioner switch	ON (ECONO or A/C)	
Air inlet sensor	*	
Air thermo sensor	*	

Fan Operating Conditions

Automatic compressor control unit output	Switch position			Fan operating condition	
	Pressure switch [ON with 1,800 kPa or higher]	Thermo sensor (for radiator fan) [ON with 85°C or higher]	Coolant temperature switch (for condenser fan) [ON with 102°C or higher]	Radiator fan	Condenser fan
LO (0 V)	OFF	OFF	OFF	OFF	OFF
	OFF	ON	OFF	HIGH	OFF
	OFF	ON	ON	HIGH	HIGH
HI (System voltage)	OFF	OFF	OFF	LOW	LOW
	ON	OFF	OFF	LOW	HIGH
	OFF	ON	OFF	HIGH	LOW
	ON	ON	OFF	HIGH	HIGH
	ON	ON	ON	HIGH	HIGH
	OFF	ON	ON	HIGH	HIGH

# ELC 4-SPEED AUTOMATIC TRANSMISSION

L.H. drive vehicles

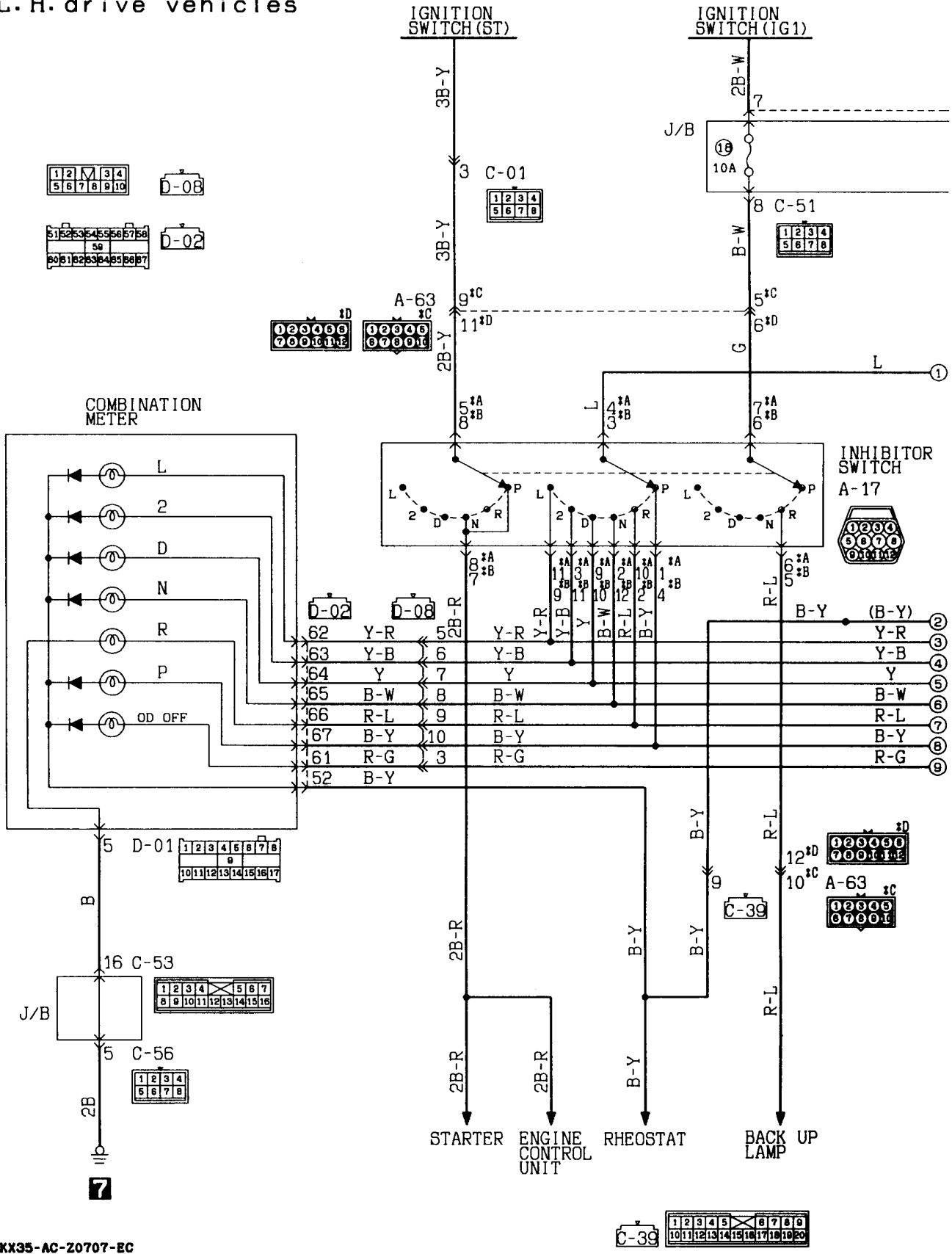

KX35-AC-Z0707-EC



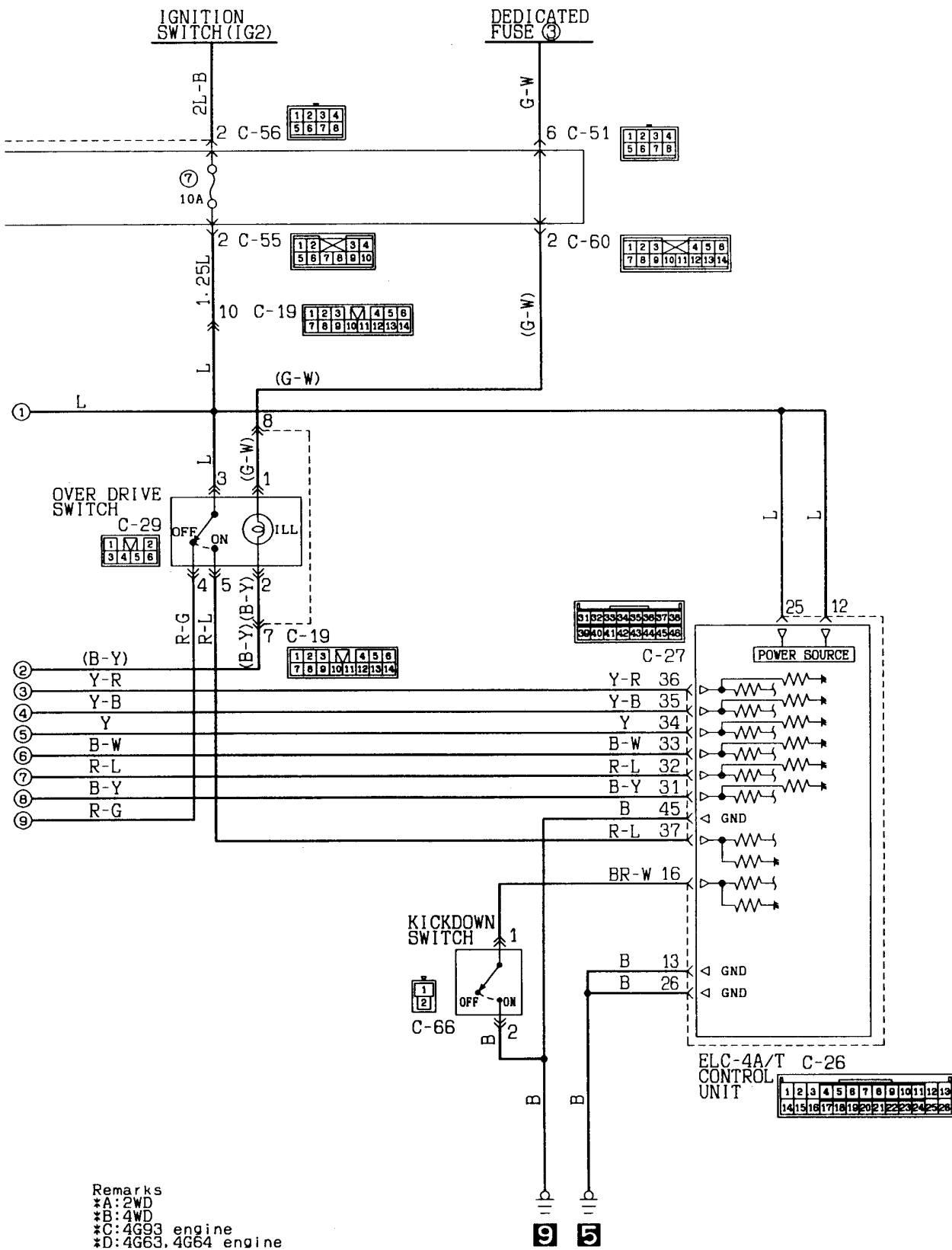

Remarks  
 \*A: 2WD  
 \*B: 4WD  
 \*C: 4G93 engine  
 \*D: 4G63, 4G64 engine

Wire colour code  
 B: Black LG: Light green G: Green L: Blue W: White Y: Yellow SB: Sky blue  
 BR: Brown O: Orange GR: Gray R: Red P: Pink V: Violet

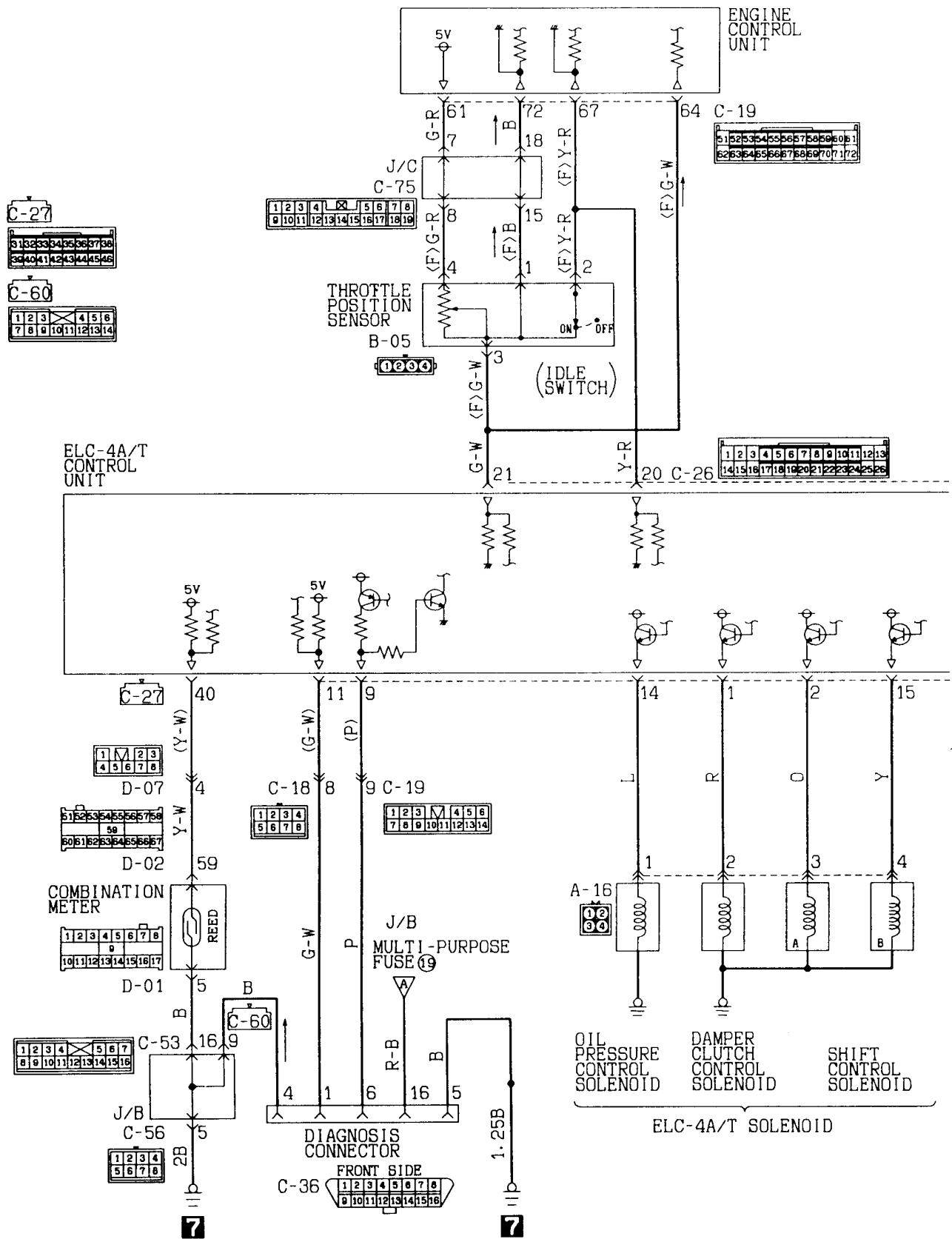

Wire colour code  
 B:Black LG:Light green G:Green L:Blue W:White Y:Yellow SB:Sky blue  
 BR:Brown O:Orange GR:Gray R:Red P:Pink V:Violet

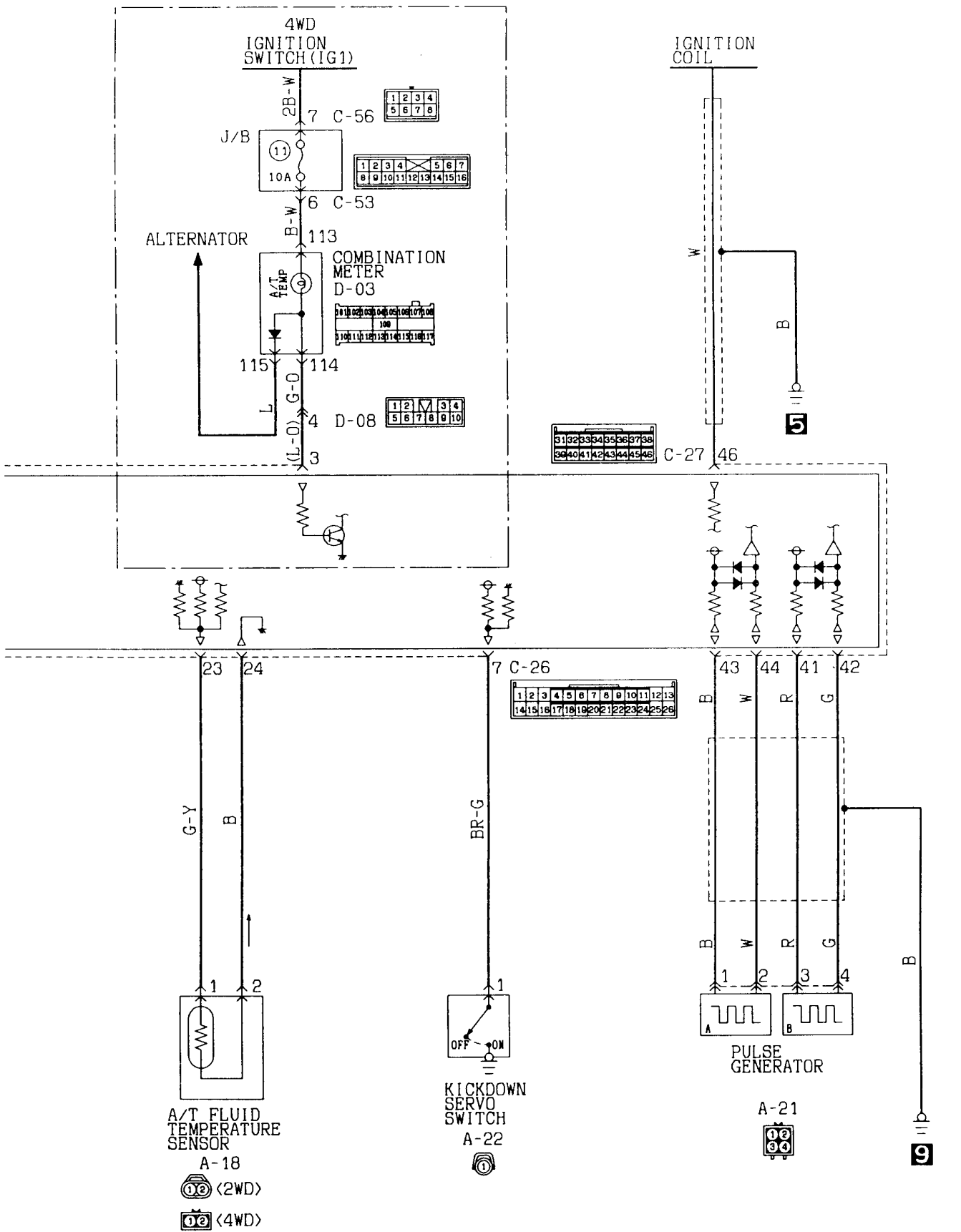

# 4A-64 CIRCUIT DIAGRAM — ELC 4-Speed Automatic Transmission

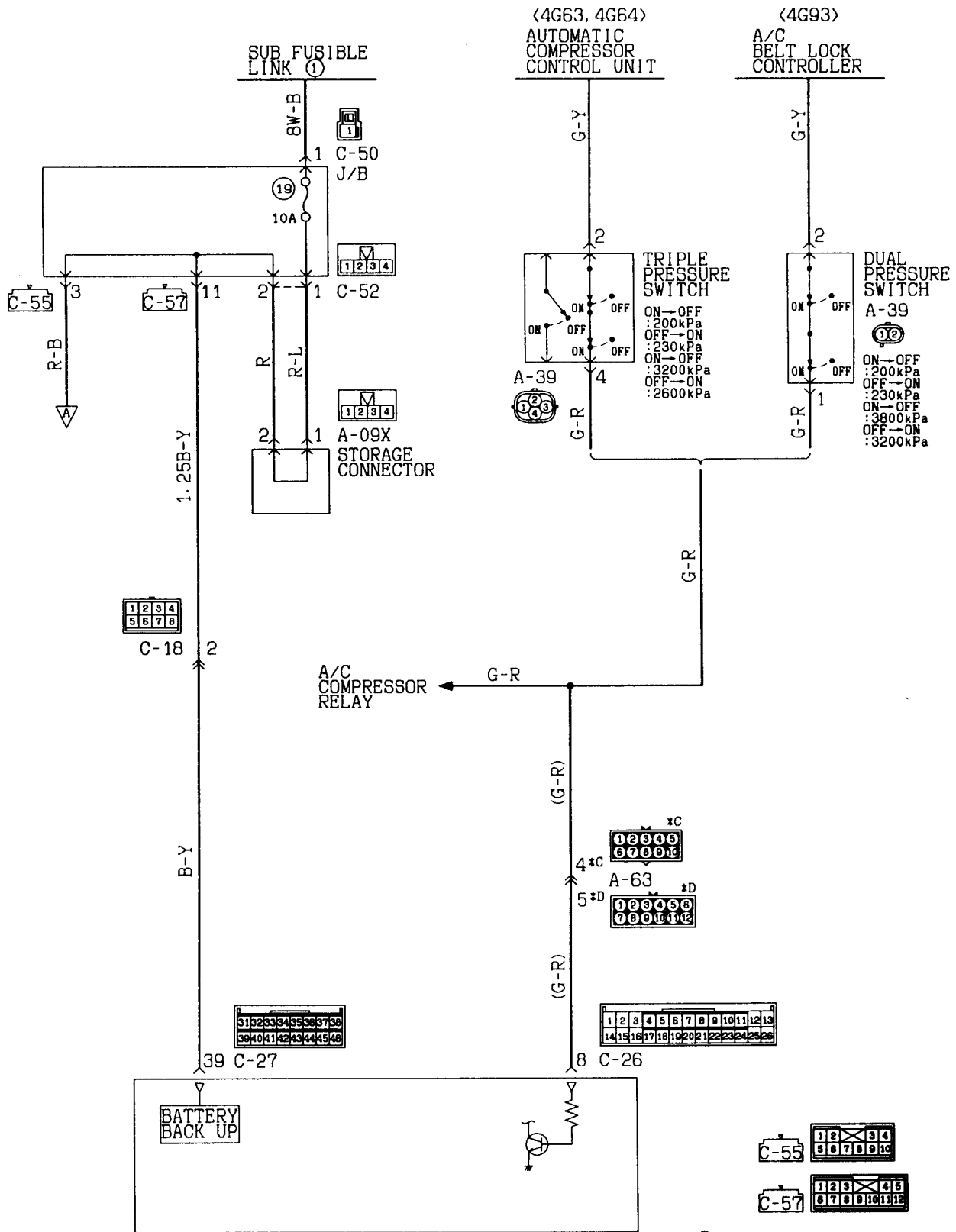

Wire colour code  
 B:Black LG:Light green G:Green L:Blue W:White Y:Yellow SB:Skv blue  
 BR:Brown O:Orange GR:Gray R:Red P:Pink V:Violet

NOTES

# ELC 4-SPEED AUTOMATIC TRANSMISSION

R. H. drive vehicles

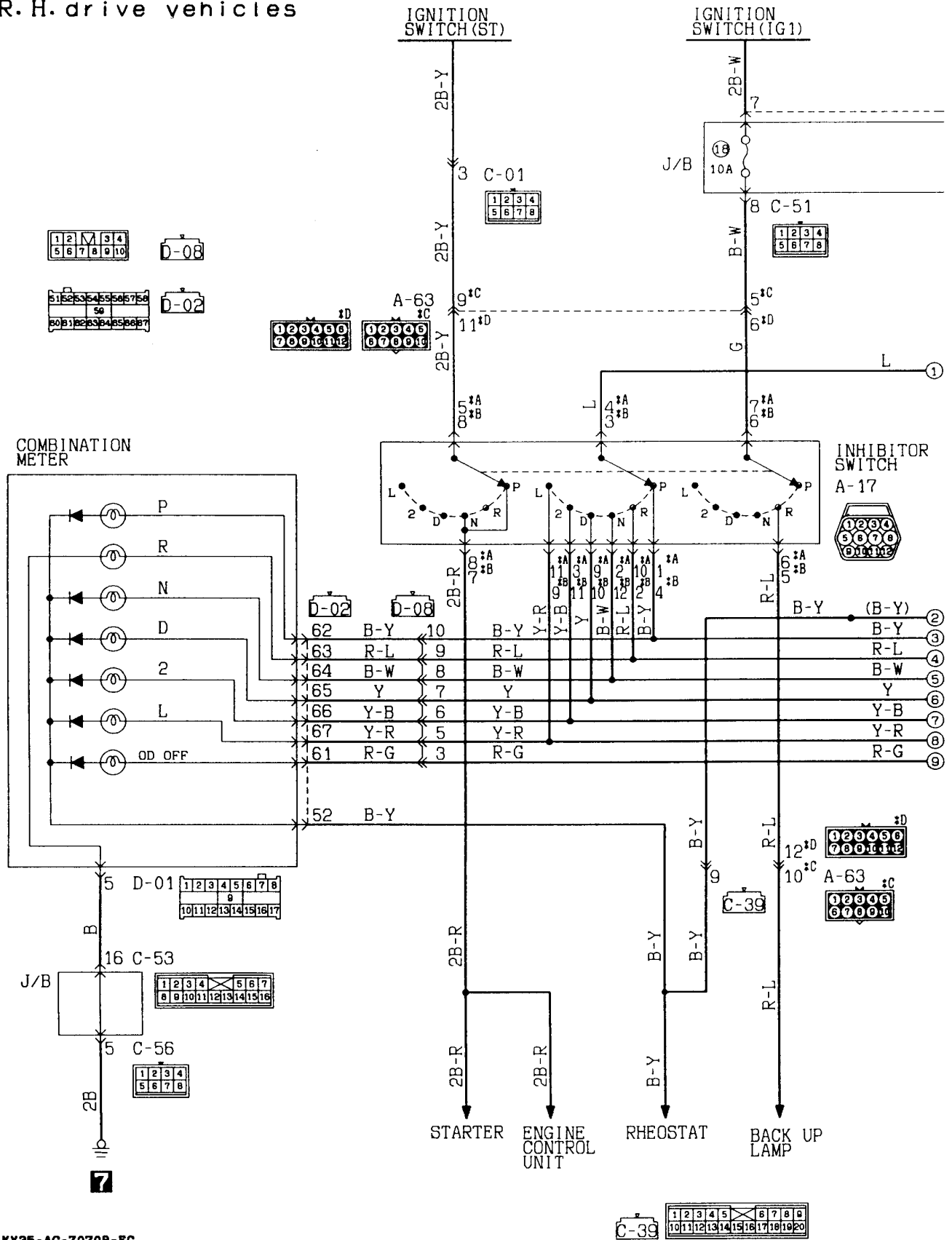

KX35-AC-Z0708-EC



# 4A-68 CIRCUIT DIAGRAM — ELC 4-Speed Automatic Transmission

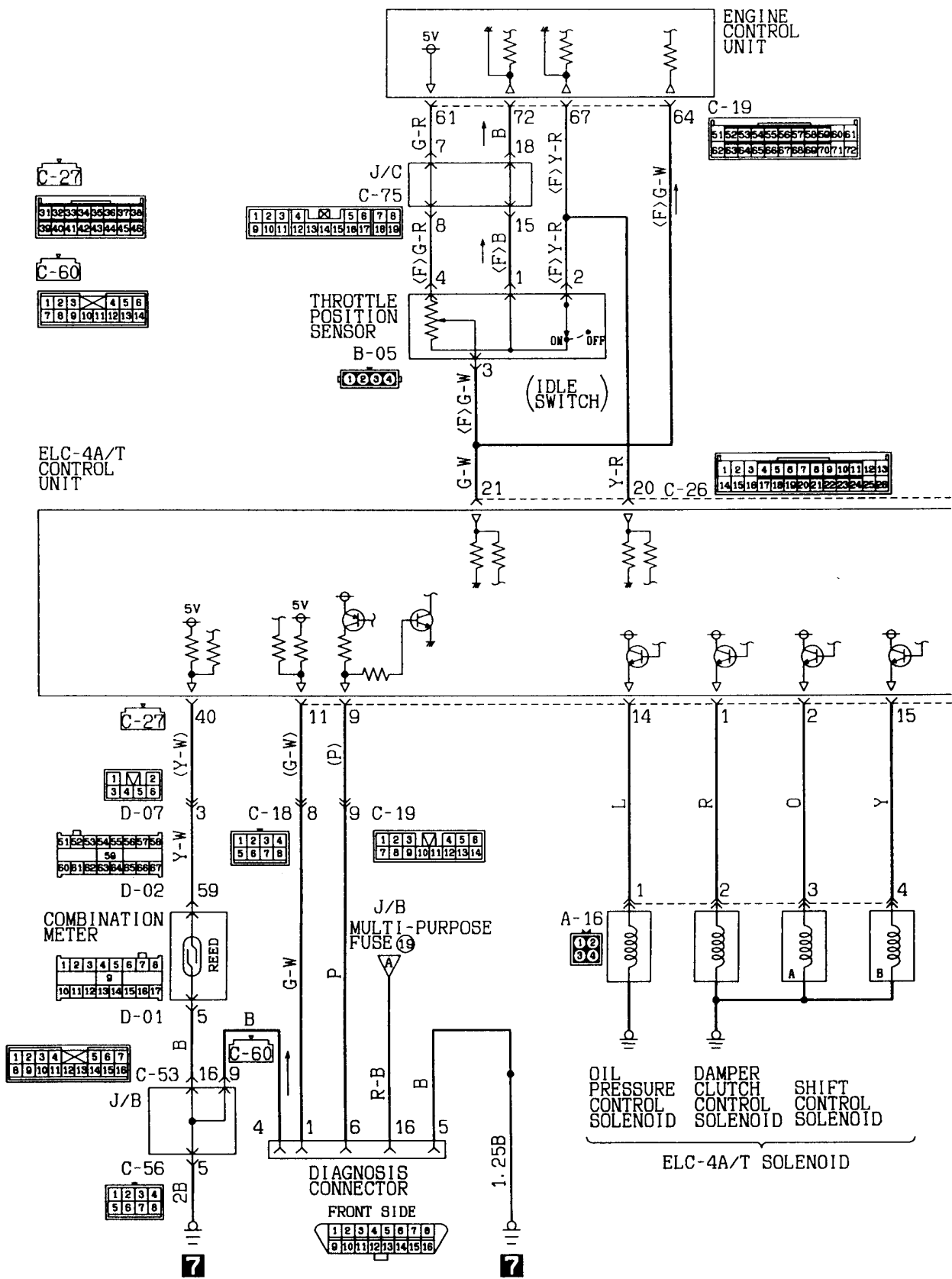

Wire colour code  
 B:Black LG:Light green G:Green L:Blue W:White Y:Yellow SB:Sky blue  
 BR:Brown O:Orange GR:Gray R:Red P:Pink V:Violet



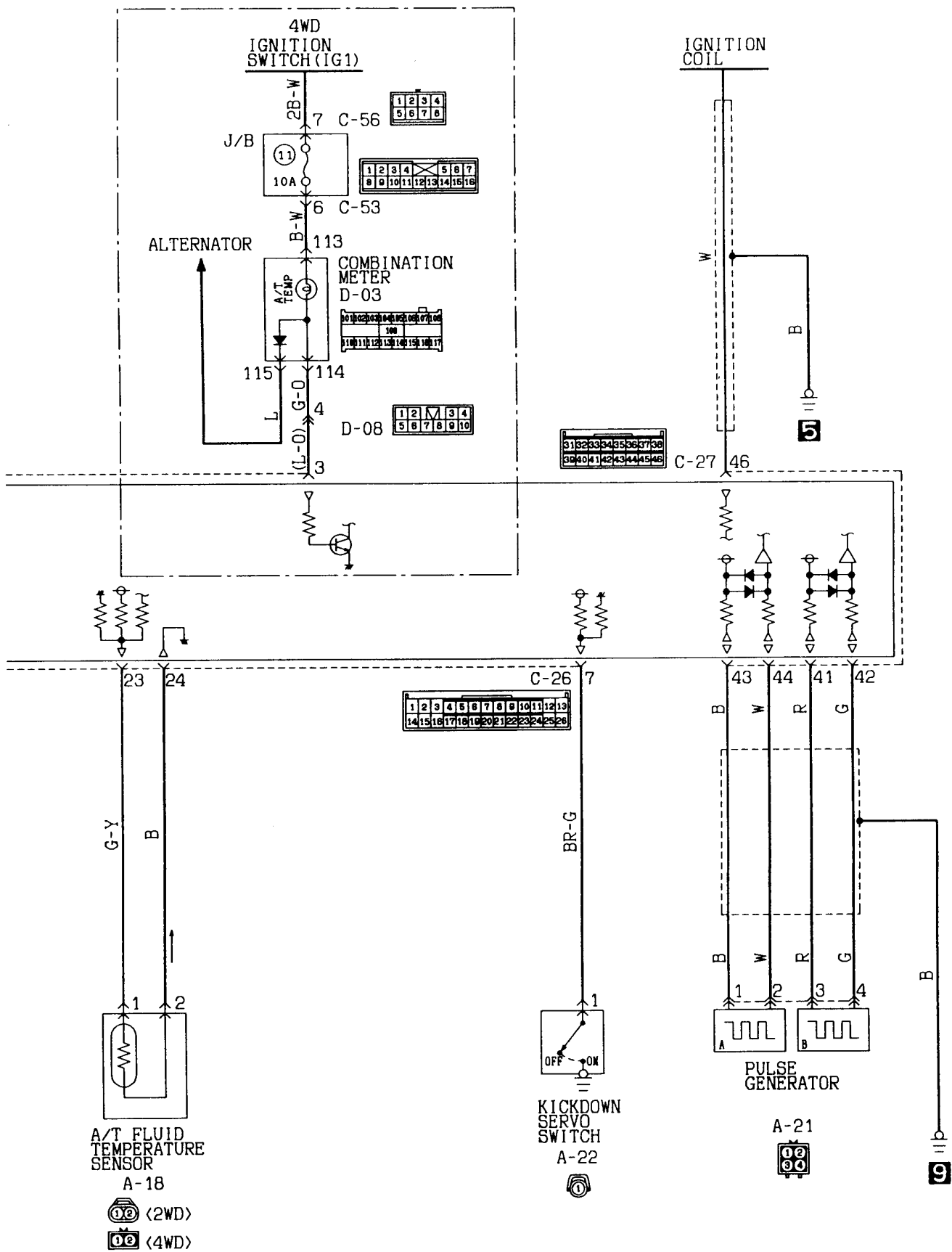

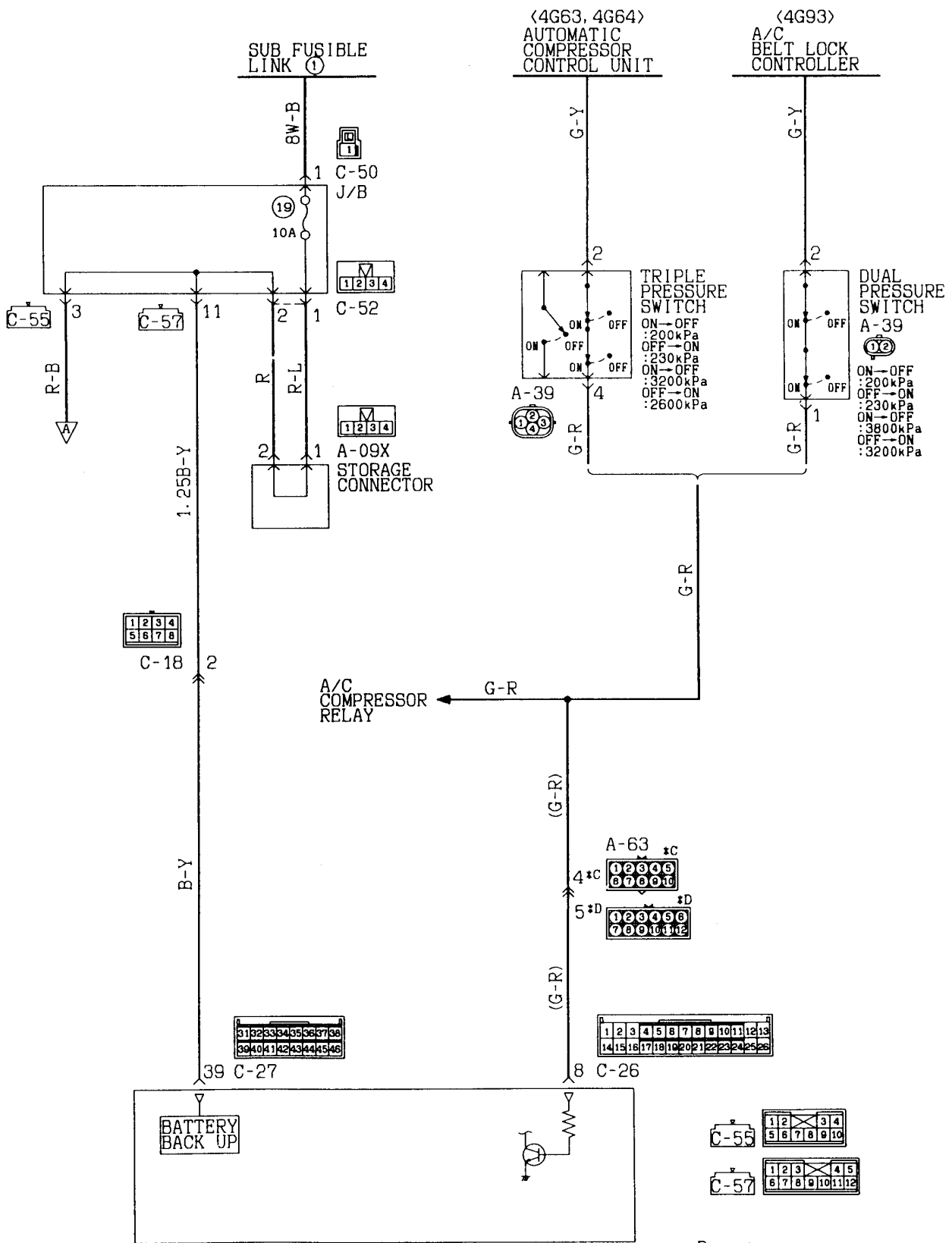

ELC-4A/T CONTROL UNIT

Remarks  
 \*C: 4G93 engine  
 \*D: 4G63 engine

Wire colour code  
 B:Black LG:Light green G:Green L:Blue W:White Y:Yellow SB:Sky blue  
 BR:Brown O:Orange GR:Gray R:Red P:Pink V:Violet

NOTES

HEADLAMP

Vehicles with daytime running lamp (with SRS)

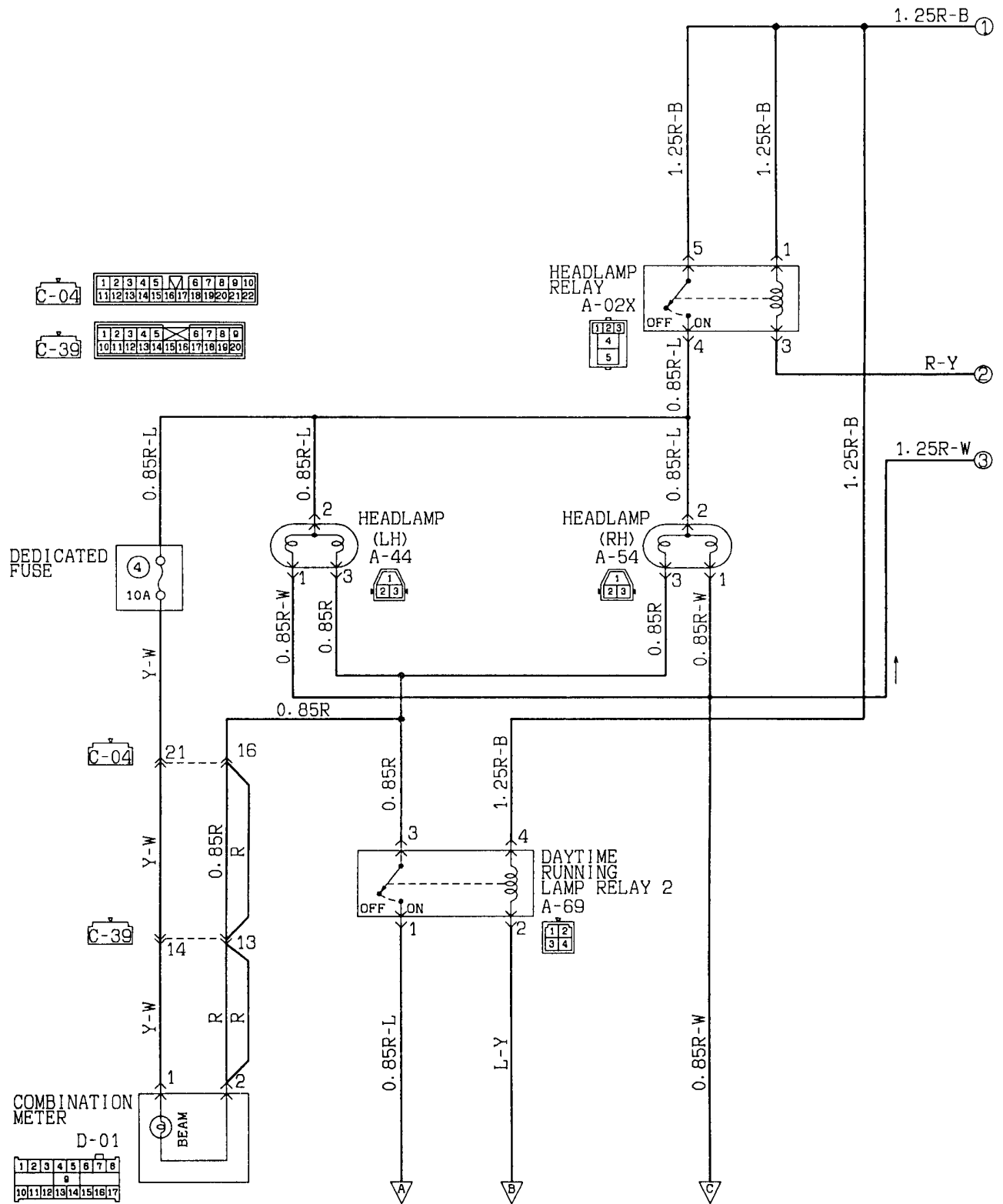

Wire colour code  
 B:Black LG:Light green G:Green L:Blue W:White Y:Yellow SB:Sky blue  
 BR:Brown O:Orange GR:Gray R:Red P:Pink V:Violet

KX35-AC-Z0834-EC

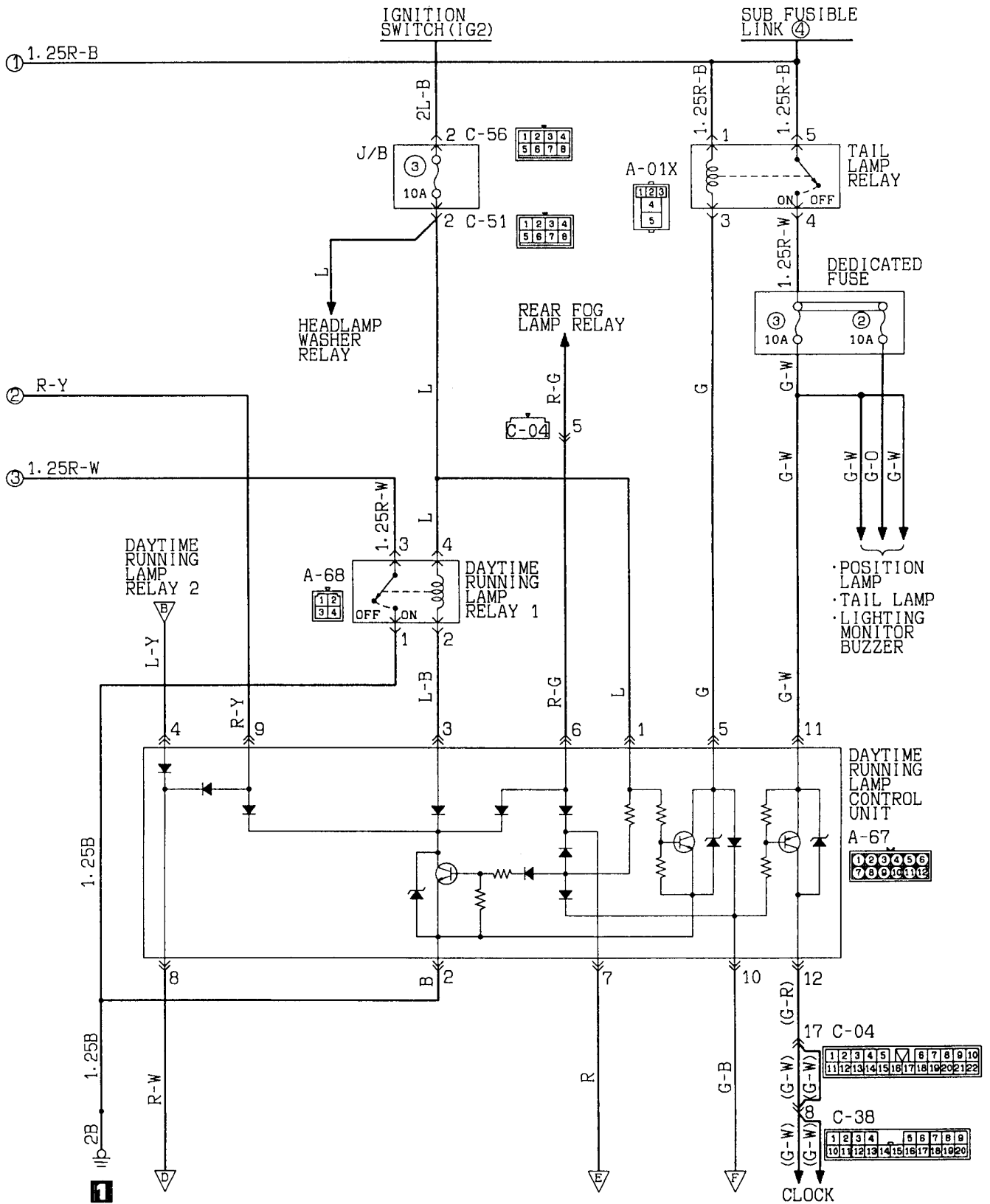

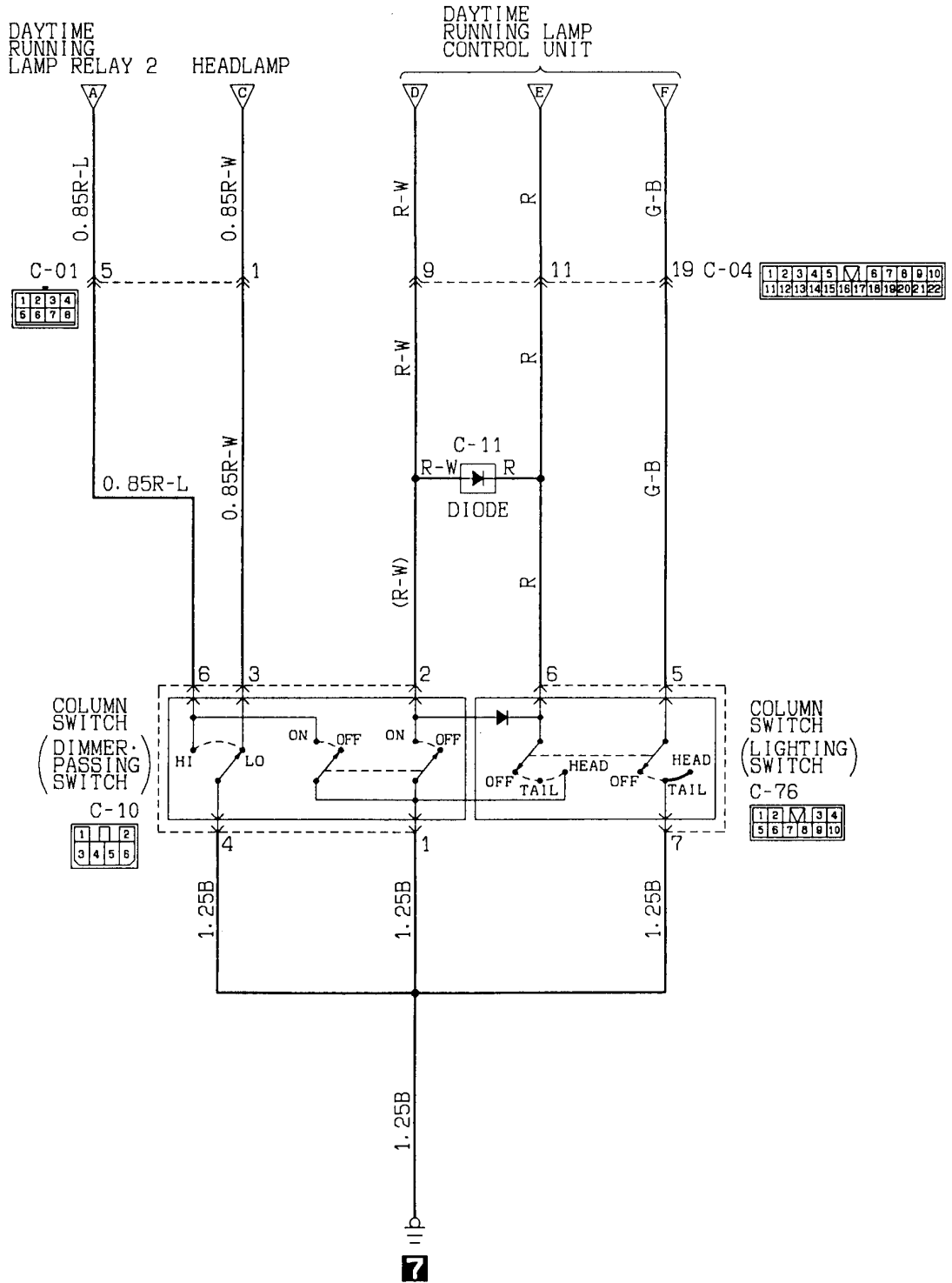

Wire colour code  
 B:Black LG:Light green G:Green L:Blue W:White Y:Yellow SB:Sky blue  
 BR:Brown O:Orange GR:Gray R:Red P:Pink V:Violet

**HEADLAMP <Vehicles with daytime running lamp> (See P. 4A-72, 76.)****OPERATION**

Headlamp Relay ON Conditions

Ignition switch	Lighting switch	Dimmer/passing switch	Headlamp relay
"ON"	—	—	ON
—	"HEAD"	—	ON
—	—	"PASS"	ON

**<Daytime running lamp operation>**

- Turning the ignition switch to the ON position causes the headlamp relay, daytime running lamp relay 1, and tail lamp relay to be energized, which causes the headlamps, tail lamps, etc. to come on.

**<Low-beam operation>**

- Placing the lighting switch in the HEAD position causes the headlamp relay and daytime running lamp relay 2 to be energized.
- If the dimmer/passing switch is placed in the LO position at this time, the headlamps light up in low beam.

**<Upper-beam operation>**

- Placing the lighting switch in the HEAD position causes the headlamp relay and daytime running lamp relay 2 to be energized.
- If the dimmer/passing switch is placed in the HI position at this time, the headlamps light up in upper beam.

**<Upper-beam indicator lamp>**

- This lamp lights up when the upper/passing beams are on, indicating that the headlamps are on in upper beam.

**TROUBLESHOOTING HINTS**

1. Headlamps don't come on.
  - (1) But the tail lamps do illuminate.
    - Check the headlamp relay.
    - Check the lighting switch.
  - (2) The tail lamps also don't illuminate.
    - Check the sub fusible link No. ④.
2. The low beam at both sides doesn't illuminate.
  - Check the dimmer switch LO contacts.
3. The upper beam at both sides doesn't illuminate.
  - (1) The passing signal functions OK.
    - Check the dimmer switch HI contacts.
  - (2) The passing signal doesn't function.
    - Check the dimmer switch.
    - Check the daytime running lamp relay 2.
    - Check the daytime running lamp control unit.
4. One headlamp doesn't illuminate.
  - Check the bulb.
5. Can't switch from low to upper beam or vice-versa.
  - Check the dimmer switch.
6. With the ignition switch at the "ON" position, the headlamps' low beam does not illuminate.
  - Check the daytime running lamp relay 1.
  - Check the daytime running lamp control unit.
7. Upper-beam indicator lamp does not come on.
  - (1) Headlamp upper beams are operational.
    - Check the dedicated fuse No. ④.
    - Check the indicator lamp bulb.

**Remark**

- The head lamp circuit has a lighting monitor buzzer system. For operation and troubleshooting hints, refer to LIGHTING MONITOR BUZZER (P. 4A-119).

HEADLAMP

Vehicles with daytime running lamp (without SRS)

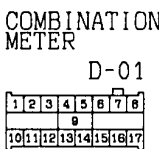
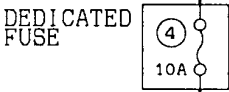
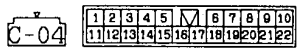
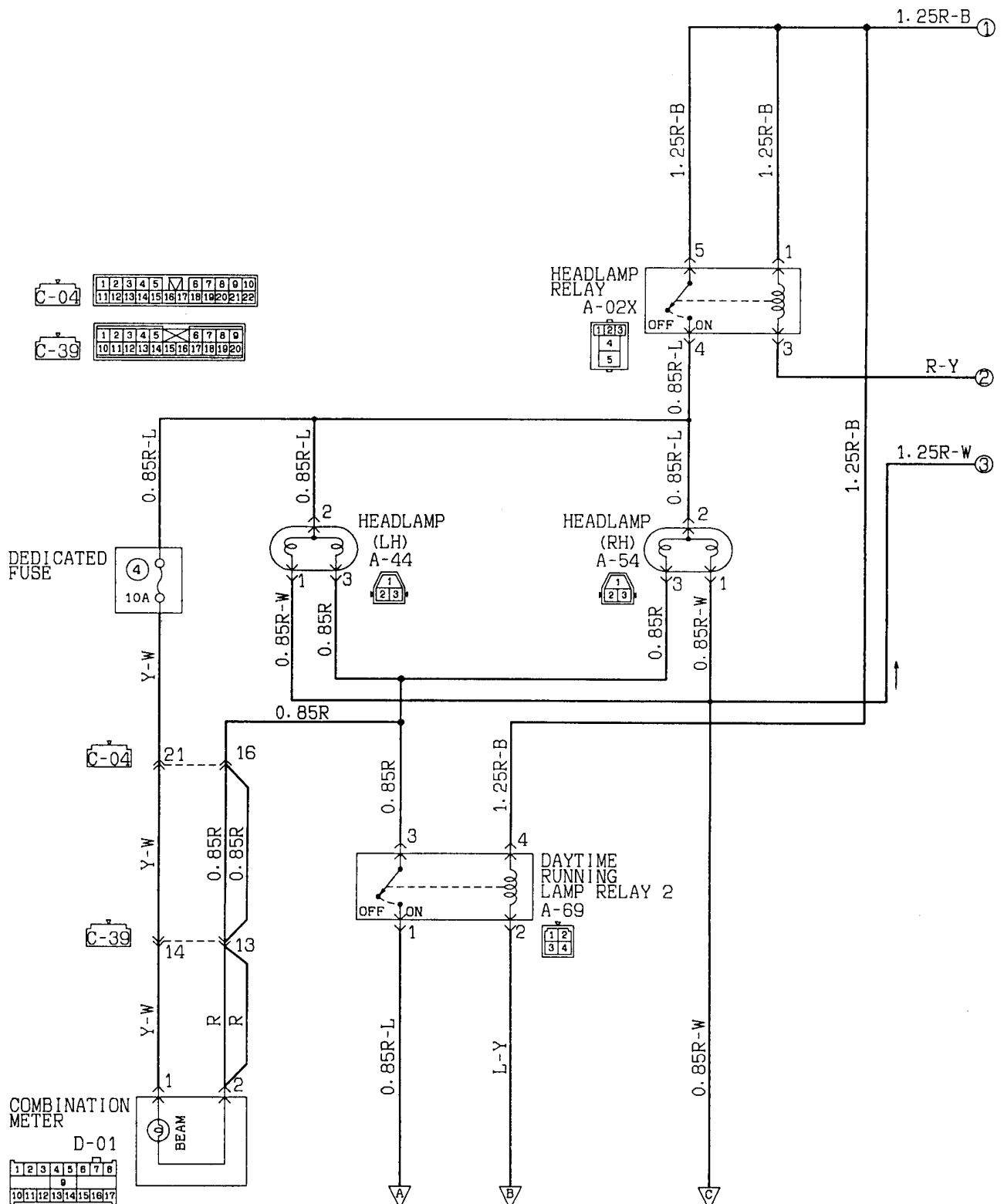

Wire colour code  
 B:Black LG:Light green G:Green L:Blue W:White Y:Yellow SB:Sky blue  
 BR:Brown O:Orange GR:Gray R:Red P:Pink V:Violet

KX35-AC-Z0B35-EC



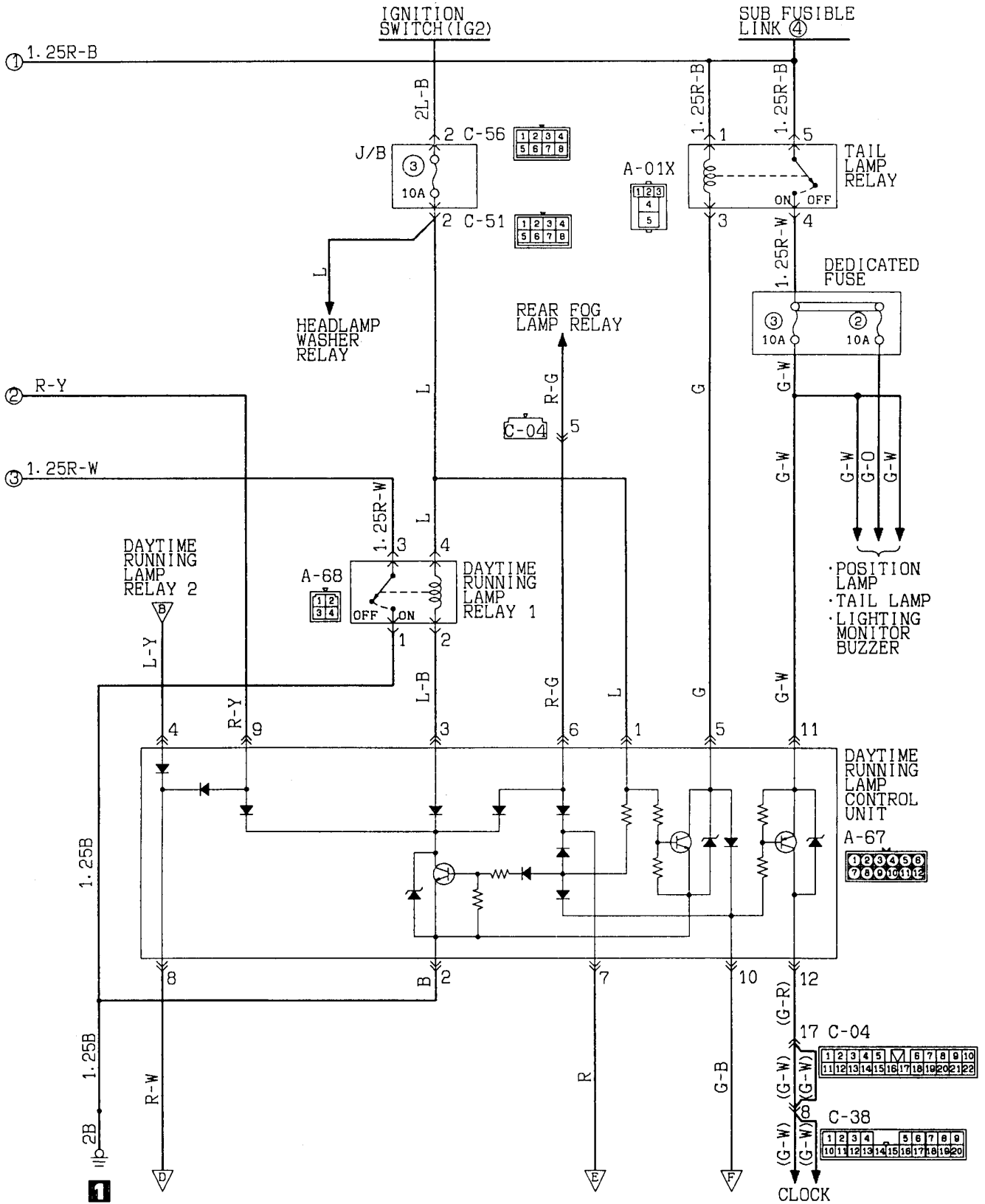

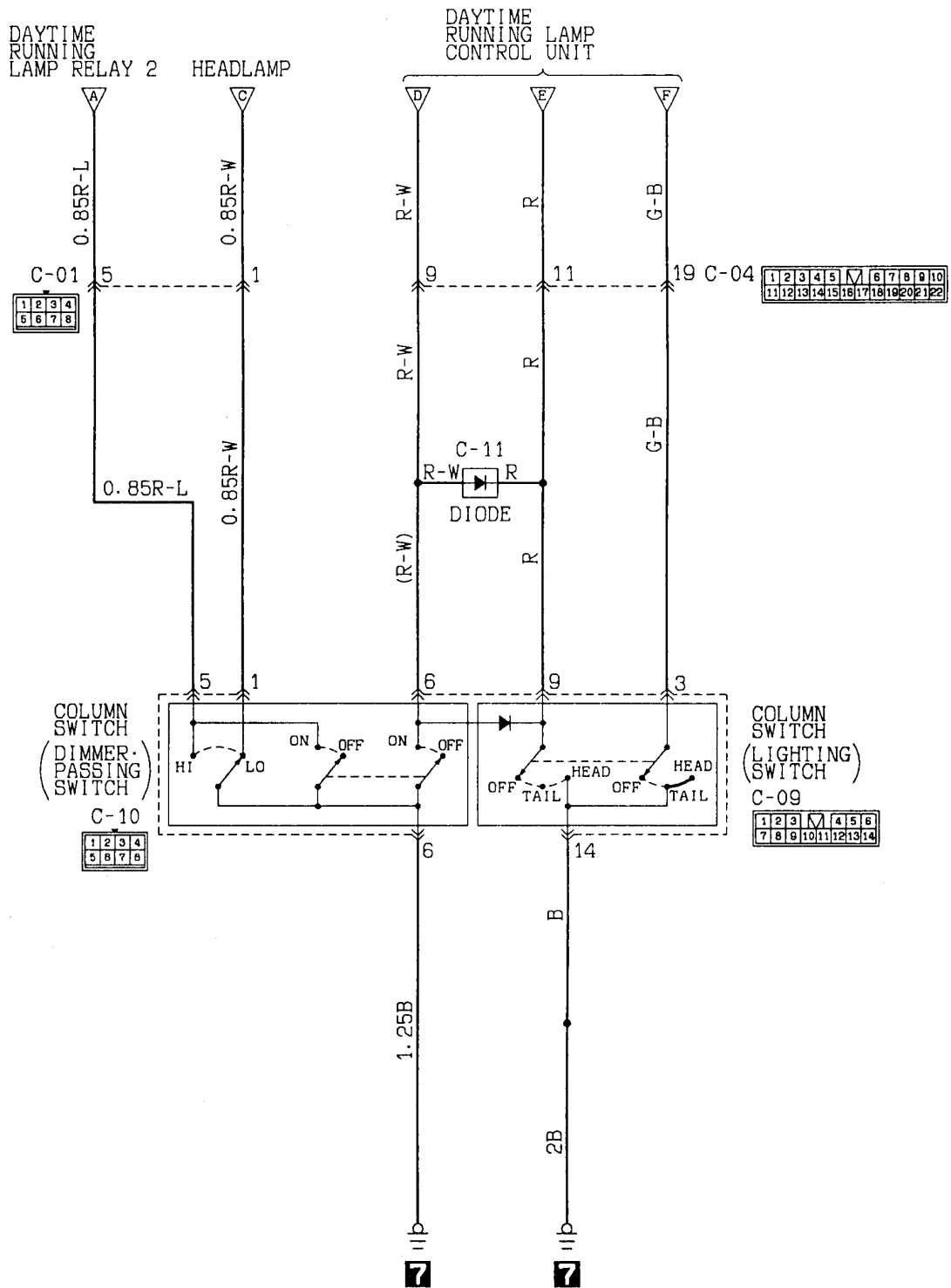

Wire colour code

B:Black LG:Light green G:Green L:Blue W:White Y:Yellow SB:Sky blue  
 BR:Brown O:Orange GR:Gray R:Red P:Pink V:Violet

HEADLAMP

L.H. drive vehicles without daytime running lamp  
(with SRS)

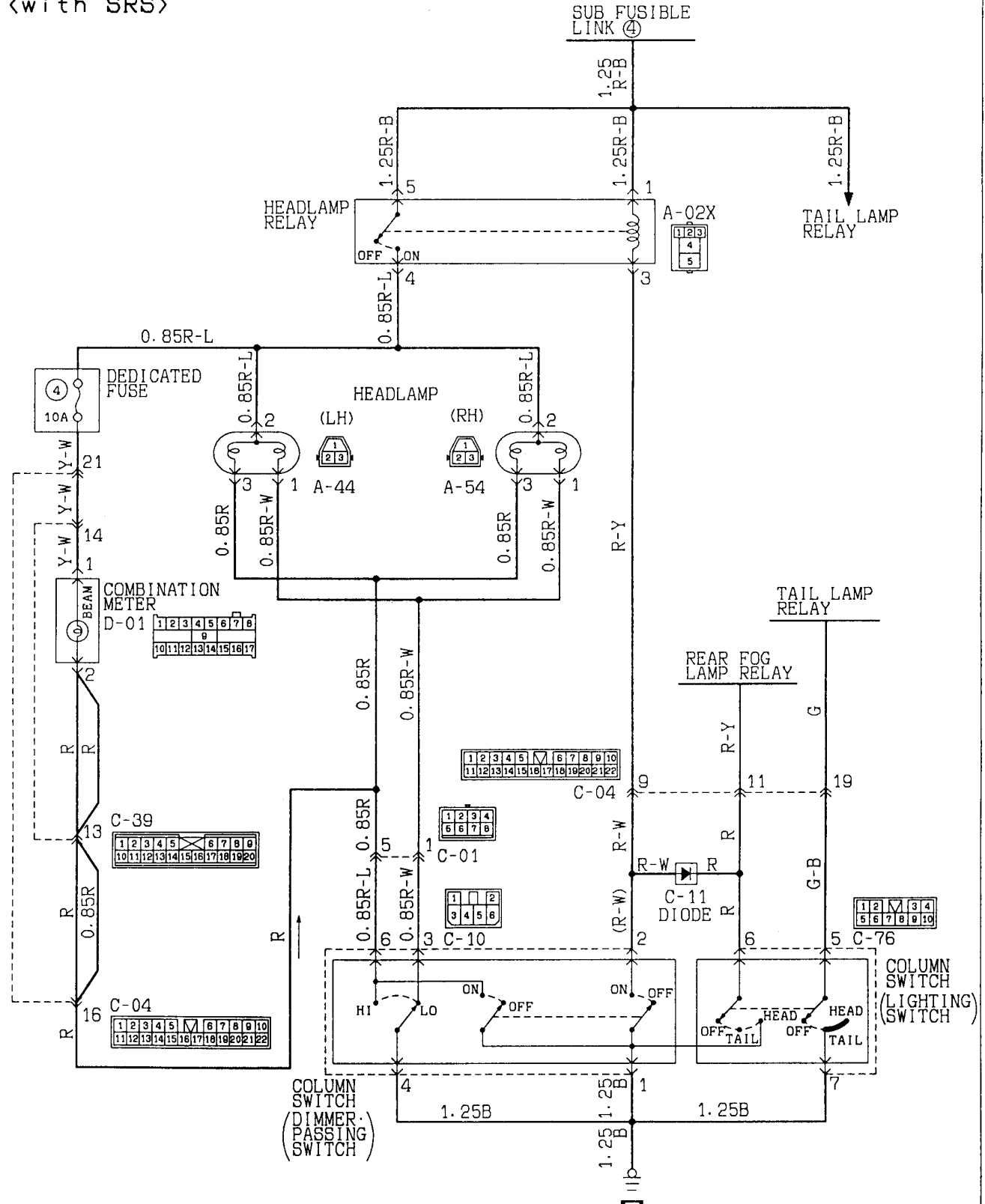

Wire colour code  
 B:Black LG:Light green G:Green L:Blue W:White Y:Yellow SB:Sky blue  
 BR:Brown O:Orange GR:Gray R:Red P:Pink V:Violet

KX35-AC-Z0838-EC

© Mitsubishi Motors Corporation May 1993

PHDE9214-B

ADDED

HEADLAMP

L.H. drive vehicles without daytime running lamp  
(without SRS)

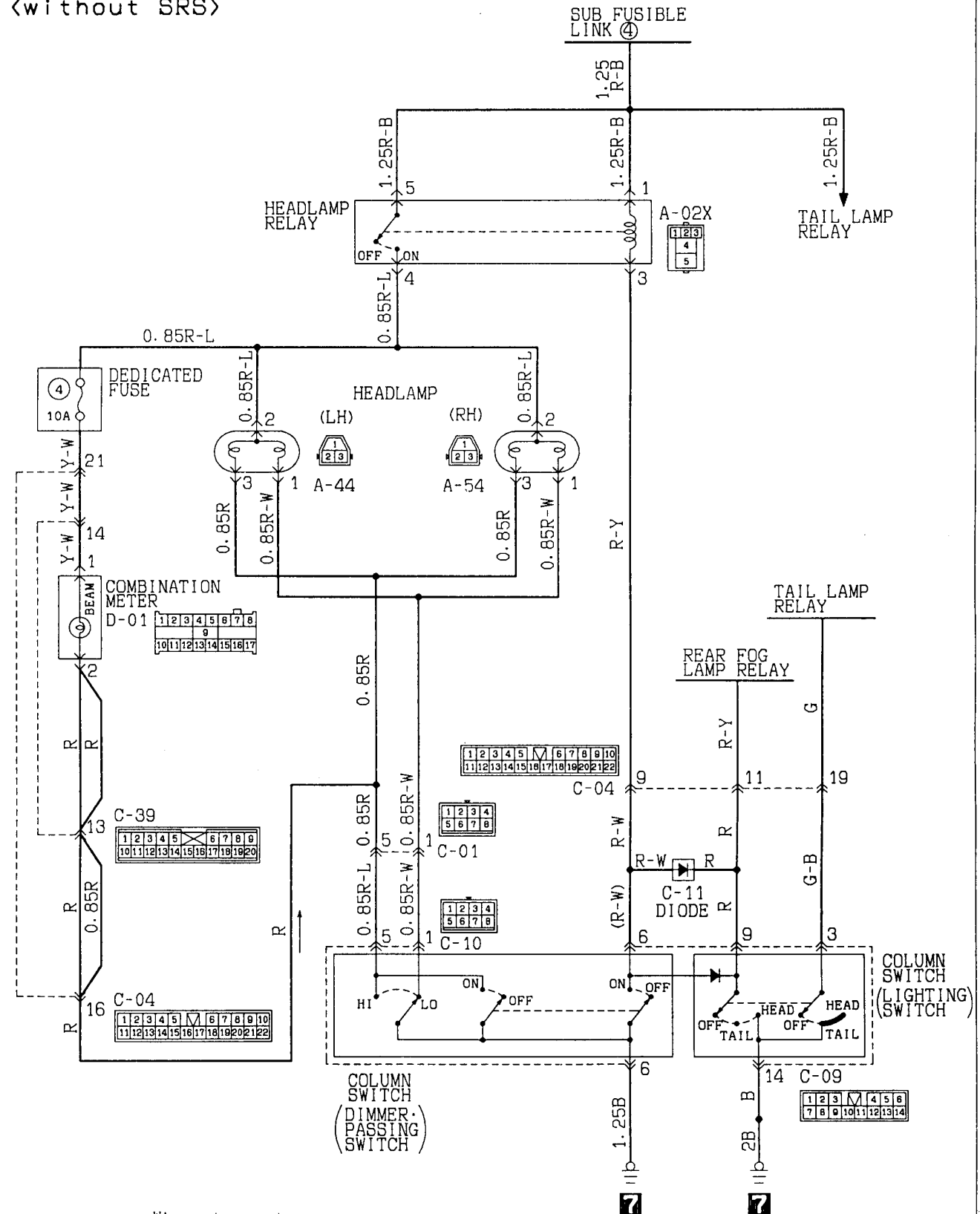

Wire colour code  
 B:Black LG:Light green G:Green L:Blue W:White Y:Yellow SB:Sky blue  
 BR:Brown O:Orange GR:Gray R:Red P:Pink V:Violet

**HEADLAMP <L.H. drive vehicles without daytime running lamp> (See P. 4A-79, 80.)**

Headlamp Relay ON Conditions

Ignition switch	Lighting switch	Dimmer/passing switch	Headlamp relay
—	"HEAD"	—	ON
—	—	"PASS"	ON

**<Low-beam operation>**

- Placing the lighting switch in the HEAD position causes the headlamp relay to be energized.
- If the dimmer/passing switch is placed in the LO position at this time, then the headlamps light up in low beam.

**<Upper-beam operation>**

- Placing the lighting switch in the HEAD position causes the headlamp relay to be energized.
- If the dimmer/passing switch is placed in the HI position at this time, the headlamps light up in upper beam.

**<Upper-beam indicator lamp>**

- This lamp lights up when the upper/passing beams are on, indicating that the headlamps are on in upper beam.

**<Passing operation>**

- When the dimmer/passing switch is set to the "ON" position, the headlamp relay is switched ON and the upper beam of the headlamps illuminates.

**TROUBLESHOOTING HINTS**

1. Headlamps don't come on.
  - (1) But the tail lamps do illuminate.
    - Check the headlamp relay.
    - Check the lighting switch.
  - (2) The tail lamps also don't illuminate.
    - Check the sub fusible link No. ④.
2. The low beam at both sides doesn't illuminate.
  - Check the dimmer switch LO contacts.
3. The upper beam at both sides doesn't illuminate.
  - (1) The passing signal functions OK.
    - Check the dimmer switch HI contacts.
  - (2) The passing signal doesn't function.
    - Check the dimmer switch.
4. One headlamp doesn't illuminate.
  - Check the bulb.
5. Can't switch from low to upper beam or vice-versa.
  - Check the dimmer switch.
6. Upper-beam indicator lamp does not come on.
  - (1) Headlamp upper beams are operational. Upper-beams are operational.
    - Check the dedicated fuse No. ④.
    - Check the indicator lamp bulb.

**Remark**

- The head lamp circuit has a lighting monitor buzzer system. For operation and troubleshooting hints, refer to LIGHTING MONITOR BUZZER (P. 4A-119).

HEADLAMP  
R.H. drive vehicles

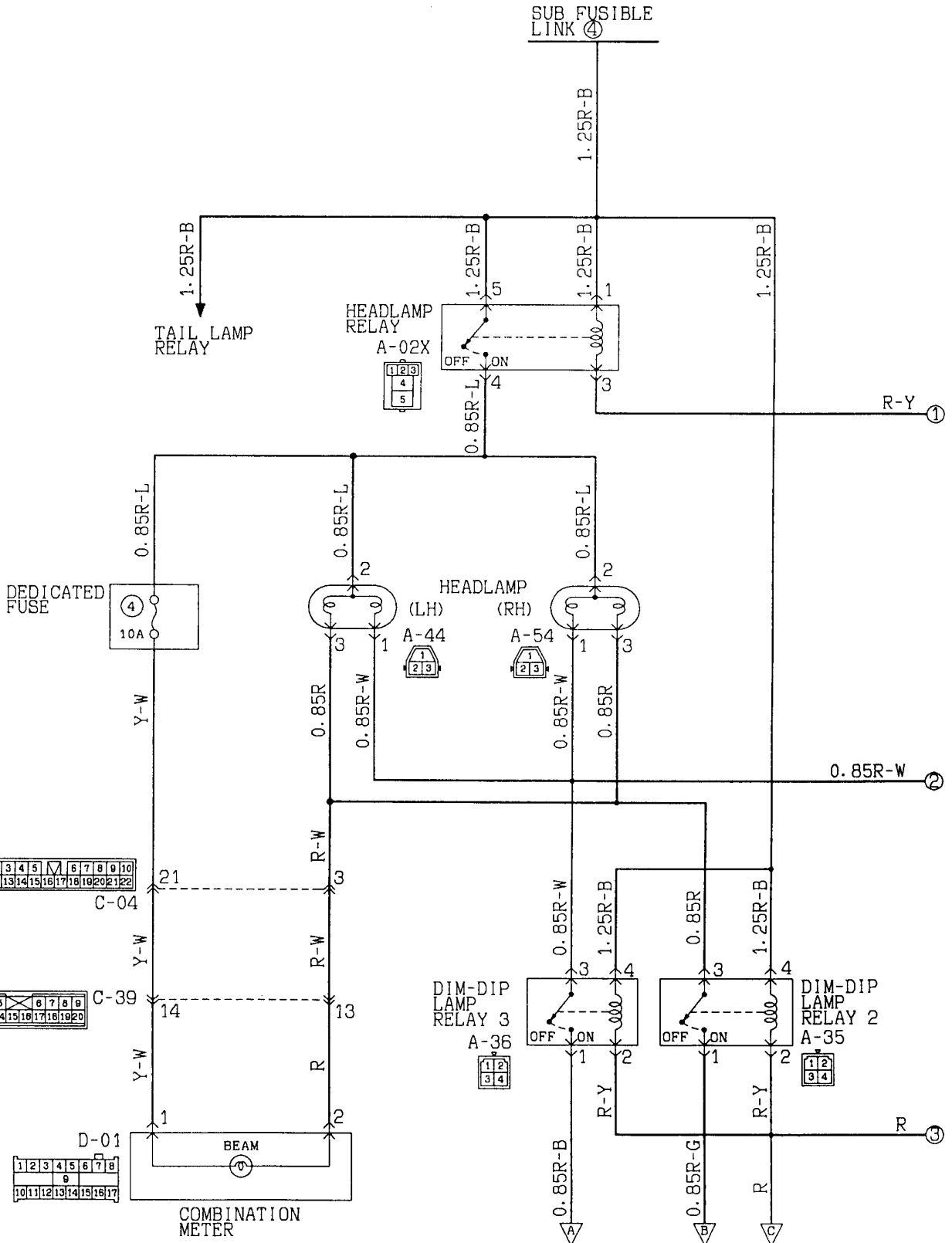

Wire colour code  
 B:Black LG:Light green G:Green L:Blue W:White Y:Yellow SB:Sky blue  
 BR:Brown O:Orange GR:Gray R:Red P:Pink V:Violet

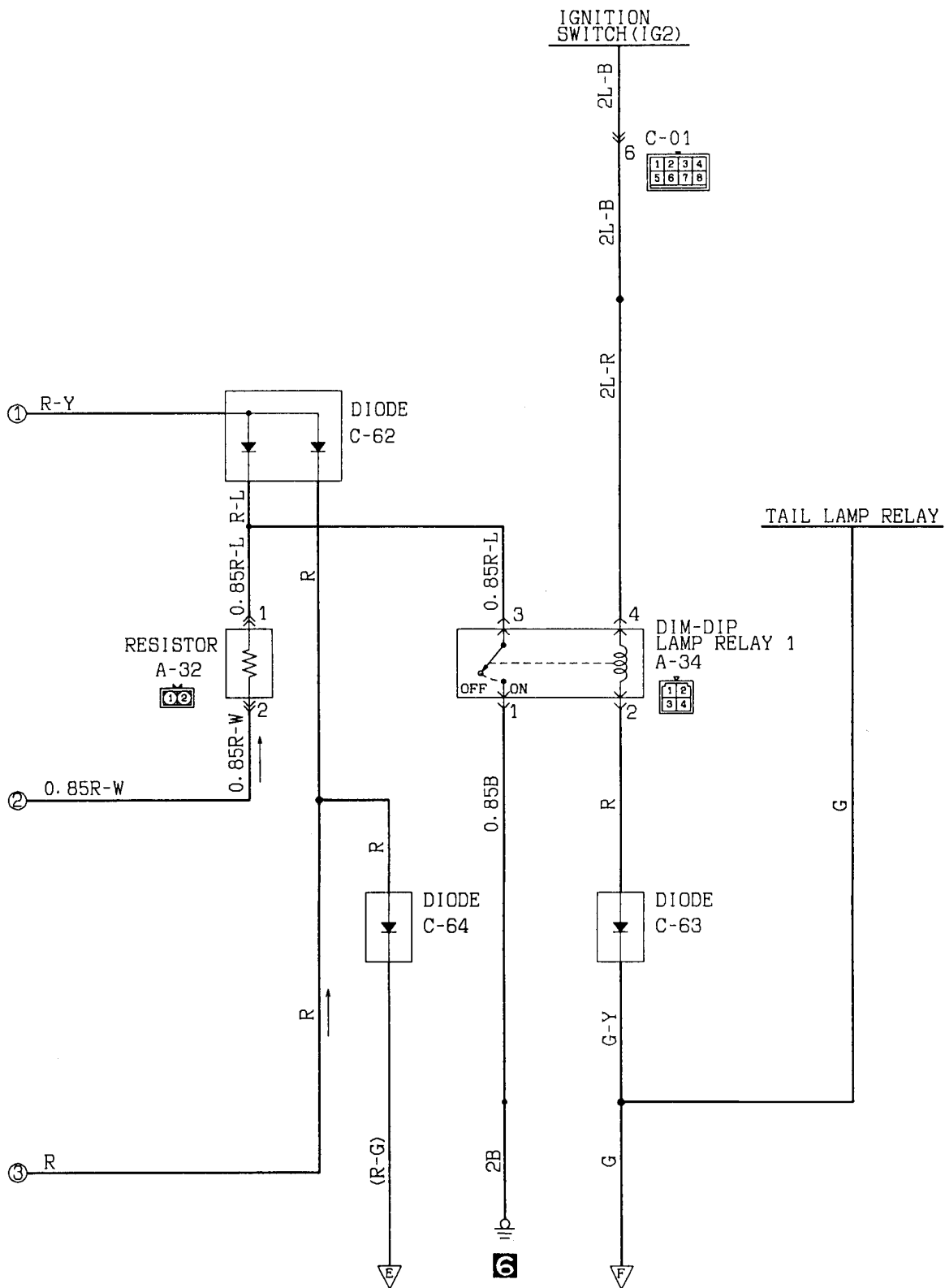

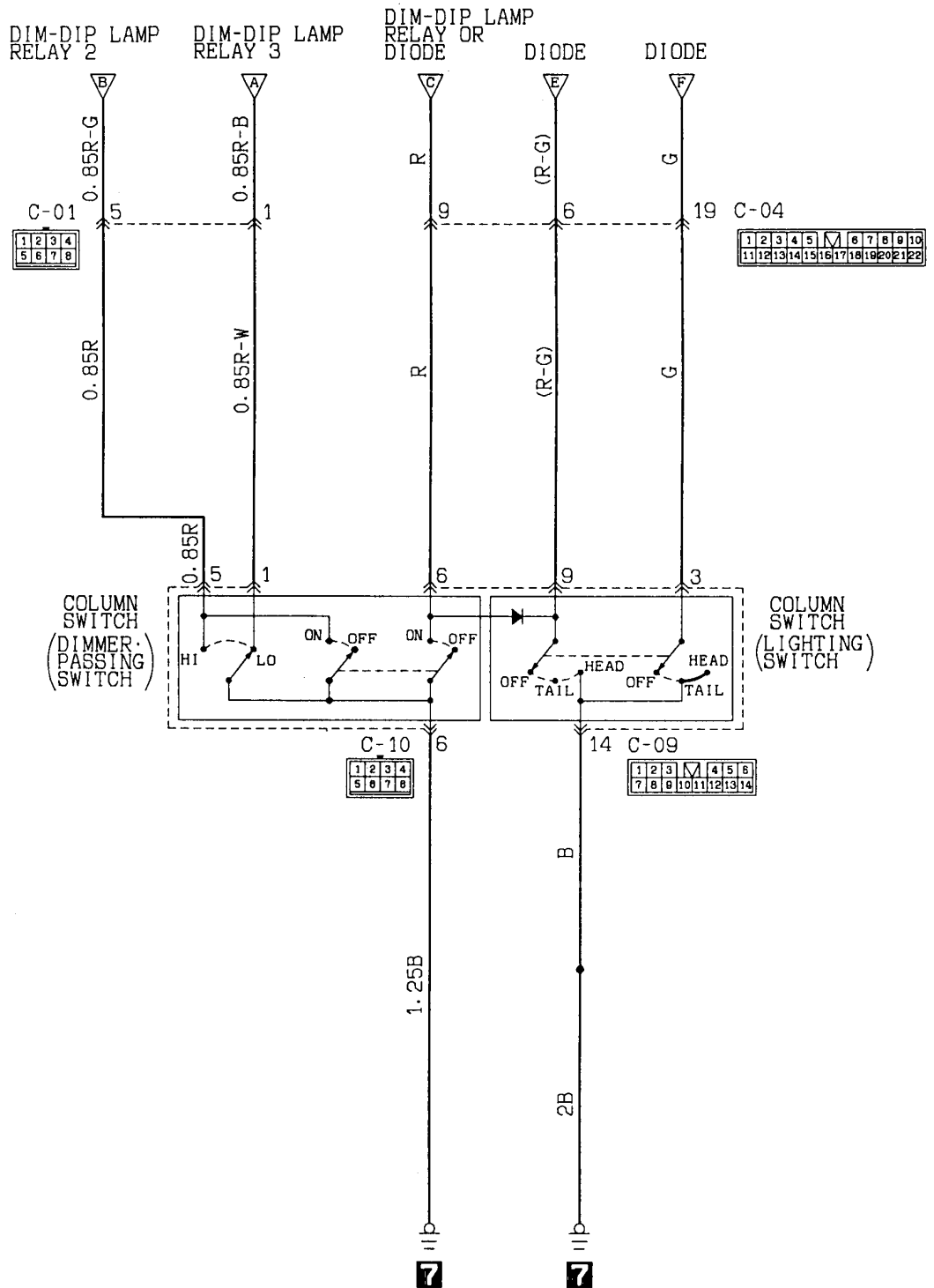

Wire colour code  
 B:Black LG:Light green G:Green L:Blue W:White Y:Yellow SB:Sky blue  
 BR:Brown O:Orange GR:Gray R:Red P:Pink V:Violet



**HEADLAMP <R.H. drive vehicles> (See P. 4A-82.)****OPERATION**

Headlamp Relay ON Conditions

Ignition switch	Lighting switch	Dimmer/passing switch	Headlamp relay
"ON"	"TAIL"	—	ON
—	"HEAD"	—	ON
—	—	"PASS"	ON

**<Dim-dip lamp operation>**

- Placing the lighting switch in the TAIL position causes dim-dip lamp relay 1 to be energized.
- This causes the headlamp relay to be also energized resulting in the headlamps being lit up dimly through the circuit by way of resistor.

**<Low-beam operation>**

- Placing the lighting switch in the HEAD position causes the headlamp relay, dim-dip lamp relay 2 and dim-dip lamp relay 3 to be energized.
- If the dimmer/passing switch is placed in the LO position at this time, the headlamps light up in low beam.

**<Upper-beam operation>**

- Placing the lighting switch in the HEAD position causes the headlamp relay, dim-dip lamp relay 2 and dim-dip lamp relay 3 to be energized.
- If the dimmer/passing switch is placed in the HI position at this time, the headlamps light up in upper beam.

**<Upper-beam indicator lamp>**

- This lamp lights up when the upper/passing beams are on, indicating that the headlamps are on in upper beam.

**TROUBLESHOOTING HINTS**

- Headlamps don't come on.
  - But the tail lamps do illuminate.
    - Check the headlamp relay.
    - Check the lighting switch.
    - Check the dim-dip lamp relay 2 and 3.
  - The tail lamps also don't illuminate.
    - Check the sub fusible link No. ④.
- The low beam at both sides doesn't illuminate.
  - Check the dimmer switch LO contacts.
- The upper beam at both sides doesn't illuminate.
  - The passing signal functions OK.
    - Check the dimmer switch HI contacts.
  - The passing signal doesn't function.
    - Check the dimmer switch.
- One headlamp doesn't illuminate.
  - Check the bulb.
- Can't switch from low to upper beam or vice-versa.
  - Check the dimmer switch.
- The headlamps' low beam does not illuminate at the "HEAD" position of the lighting switch.
  - The low beam does illuminate, however, when, with lighting switch at the "HEAD" position, the dimmer switch is set to "LO".
    - Check the dim-dip lamp relay 1.
    - Check the resistor.
    - Check the diode.
- Upper-beam indicator lamp does not come on.
  - Headlamp upper beams are operational.
    - Check the dedicated fuse No. ④.
    - Check the indicator lamp bulb.

**Remark**

- The head lamp circuit has a lighting monitor buzzer system. For operation and troubleshooting hints, refer to LIGHTING MONITOR BUZZER (P. 4A-119).

HEADLAMP LEVELING SYSTEM

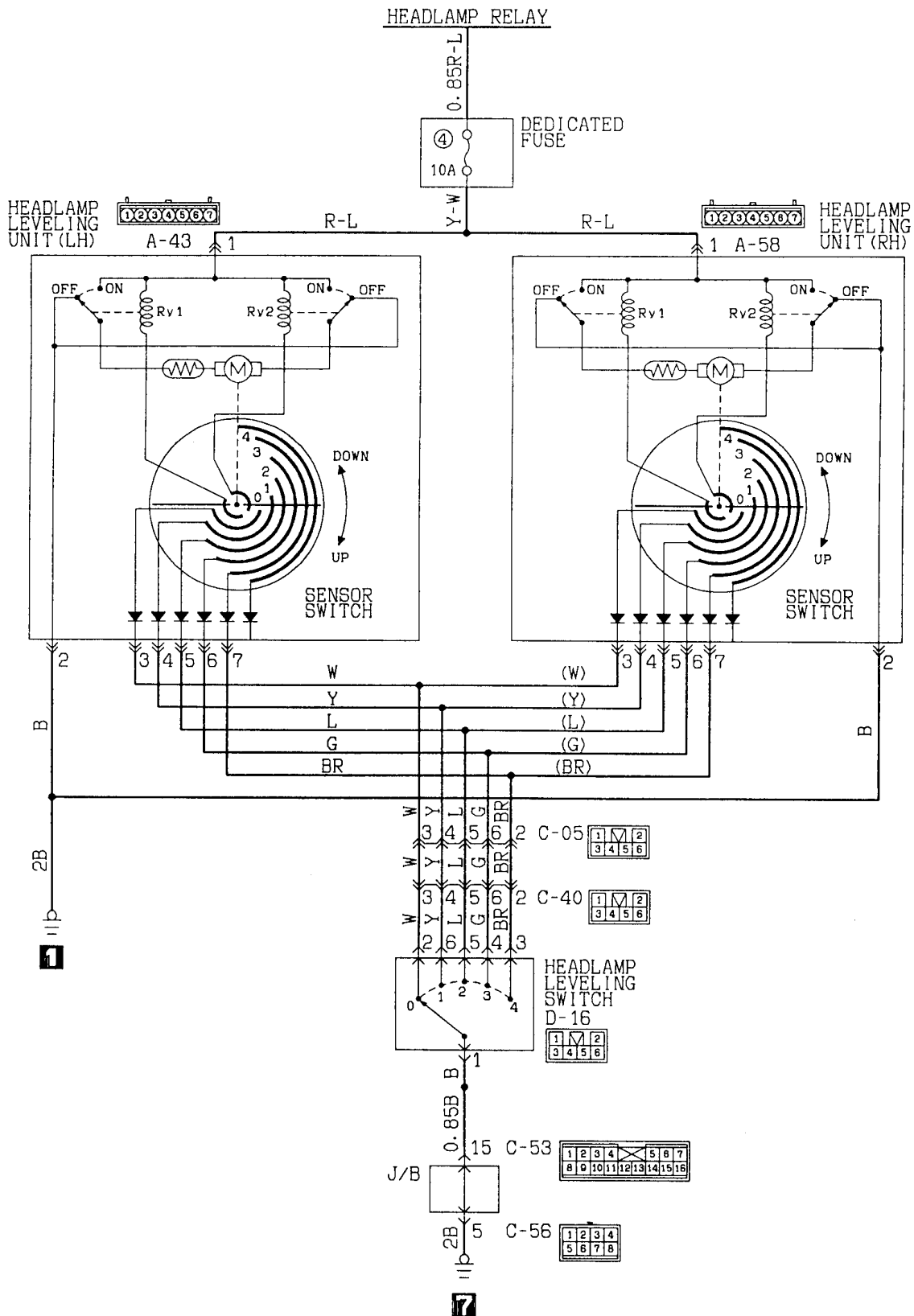

Wire colour code  
 B:Black LG:Light green G:Green L:Blue W:White Y:Yellow SB:Sky blue  
 BR:Brown O:Orange GR:Gray R:Red P:Pink V:Violet

**HEADLAMP LEVELING SYSTEM (See P. 4A-86.)****OPERATION****Downtilt operation**

- When the headlamps are switched ON, battery voltage is applied, through dedicated fuse no. ④ (10A), from the headlamp relay to the headlamp leveling unit.
- When the headlamp leveling switch setting is changed from the "0" position to the "1" position, electricity flows from Relay 2 to print base 1 to the headlamp leveling switch and to earth; the Relay 2 contacts are thus switched ON and the motor is activated. As a result, the headlamp leveling unit's shaft is pushed outward, the reflector tilts downward, and the optical axis of the headlamps is tilted in the downward direction.
- At the same time, the contacts of the sensor switch, which are interlocked with the movement of the motor, also turn in the "DOWN" direction, and, at the position where there is no longer contact of print base 1 and the brush contact, Relay 2 is switched OFF and the motor stops.
- In the same way as described above, when the headlamp leveling switch setting is changed from the "1" position to the "2" position and further to the "3" position and the "4" position, the motor continues to rotate so that the headlamp leveling unit's shaft is pushed outward, tilting the reflector further downward; the optical axis of the headlamps is at the maximum downward tilt at the "4" position of the headlamp leveling switch.

**Return operation**

- When the setting of the headlamp leveling switch is changed from the "4" position to the "3" position, electricity flows from Relay 1 to print base 3 to the headlamp leveling switch and to earth; the Relay 1 contacts are thus switched ON, and the motor rotates in the direction opposite to that for downtilt.  
As a result, the headlamp leveling unit's shaft is drawn inward, the tilt of the reflector is reduced, and the optical axis of the headlamps is changed in the upward direction.
- At the same time, the contacts of the sensor switch turn in the "UP" direction, and, at the position where there is no longer contact of print base 3 and the brush contact, Relay 1 is switched OFF and the motor stops.
- When the setting of the headlamp leveling switch is further changed from the "3" position to the "2" position and to the "1" position, the motor continues to rotate, and the optical axis of the headlamps returns to the minimum tilt position at the "0" setting of the switch.
- In order to prevent overheat damage to the motor as a result of frequent operation of the headlamp leveling system, a thermistor is provided in the circuitry within the headlamp leveling unit.

**TROUBLESHOOTING HINTS**

1. No operation of the headlamp leveling system.
  - (1) The upper beam indicator lamp also does not illuminate.
    - Check the dedicated fuse No. ④.
  - (2) The upper beam indicator lamp illuminates.
    - Check the headlamp leveling switch.
    - Check the headlamp leveling unit.
2. Either the left or right part of the headlamp leveling system does not operate.
  - Check the headlamp leveling unit for the side the does not operate.
3. Either the downtilt operation or the return operation does not function.
  - Check the headlamp leveling unit.

# 4A-88 CIRCUIT DIAGRAM — Tail Lamp, Position Lamp and Licence Plate Lamp

## TAIL LAMP, POSITION LAMP AND LICENCE PLATE LAMP Vehicles with SRS

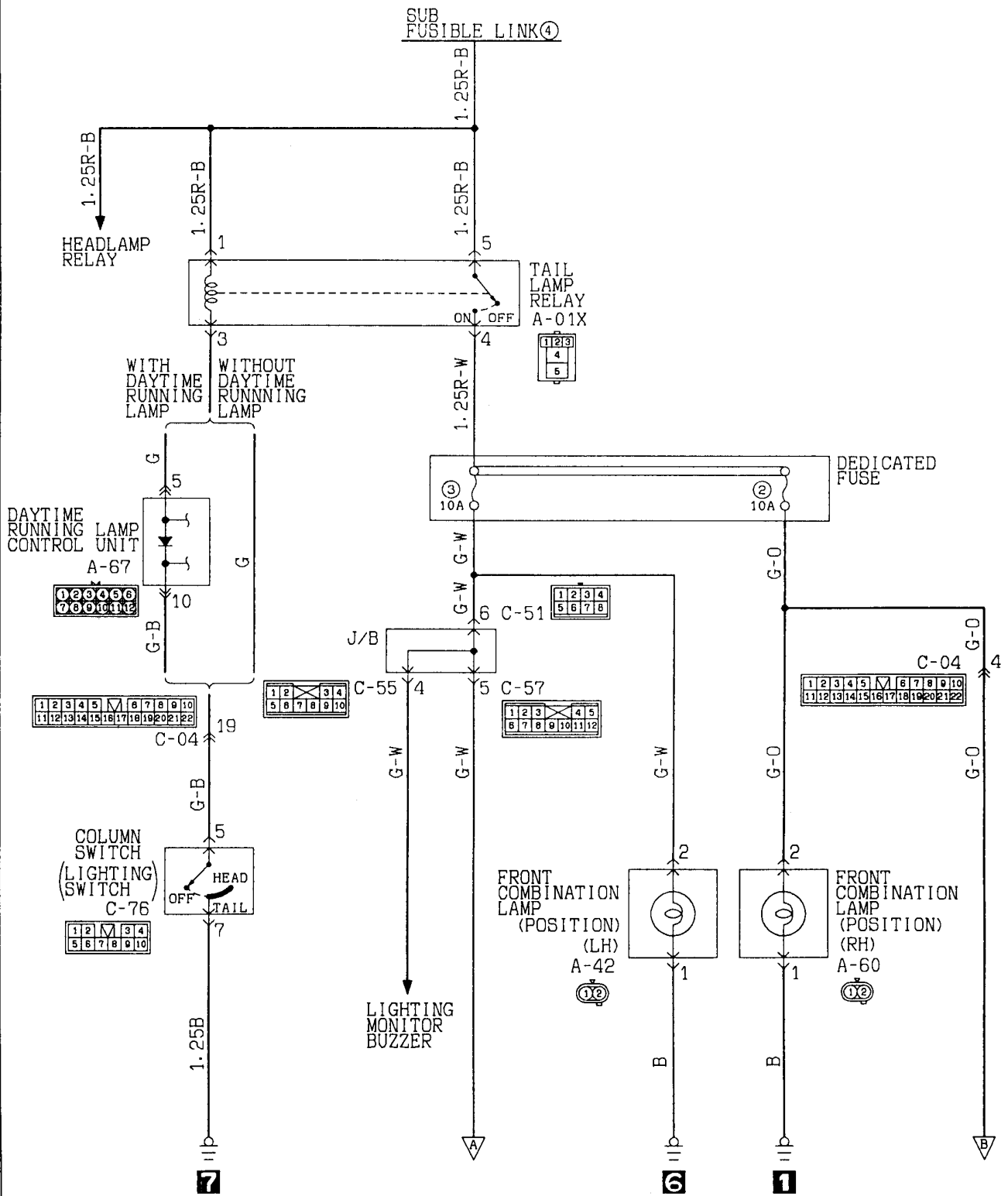

Wire colour code  
 B:Black LG:Light green G:Green L:Blue W:White Y:Yellow SB:Sky blue  
 BR:Brown O:Orange GR:Gray R:Red P:Pink V:Violet

# CIRCUIT DIAGRAM — Tail Lamp, Position Lamp and Licence Plate Lamp 4A-89

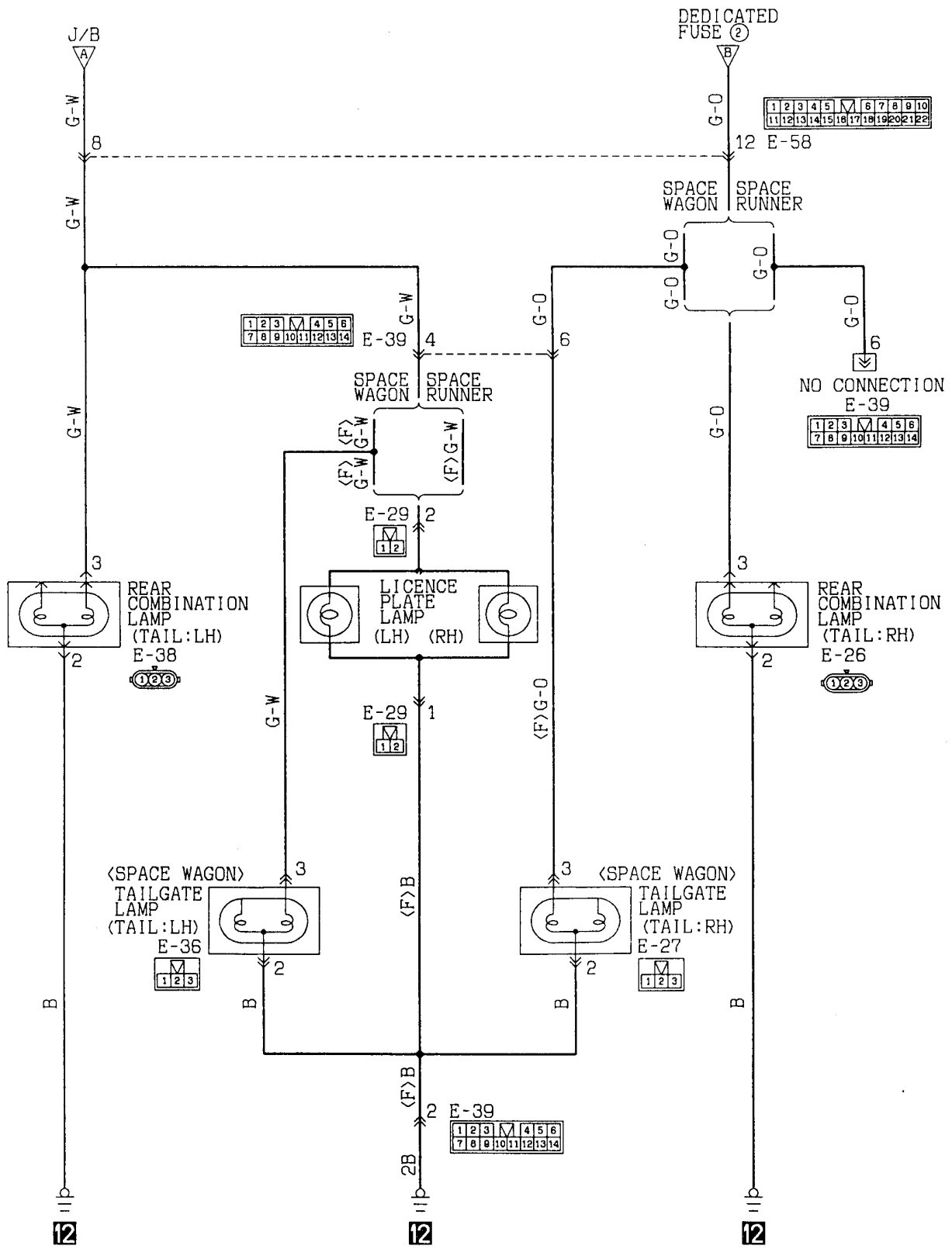

# 4A-90 CIRCUIT DIAGRAM — Tail Lamp, Position Lamp and Licence Plate Lamp

## TAIL LAMP, POSITION LAMP AND LICENCE PLATE LAMP Vehicles without SRS

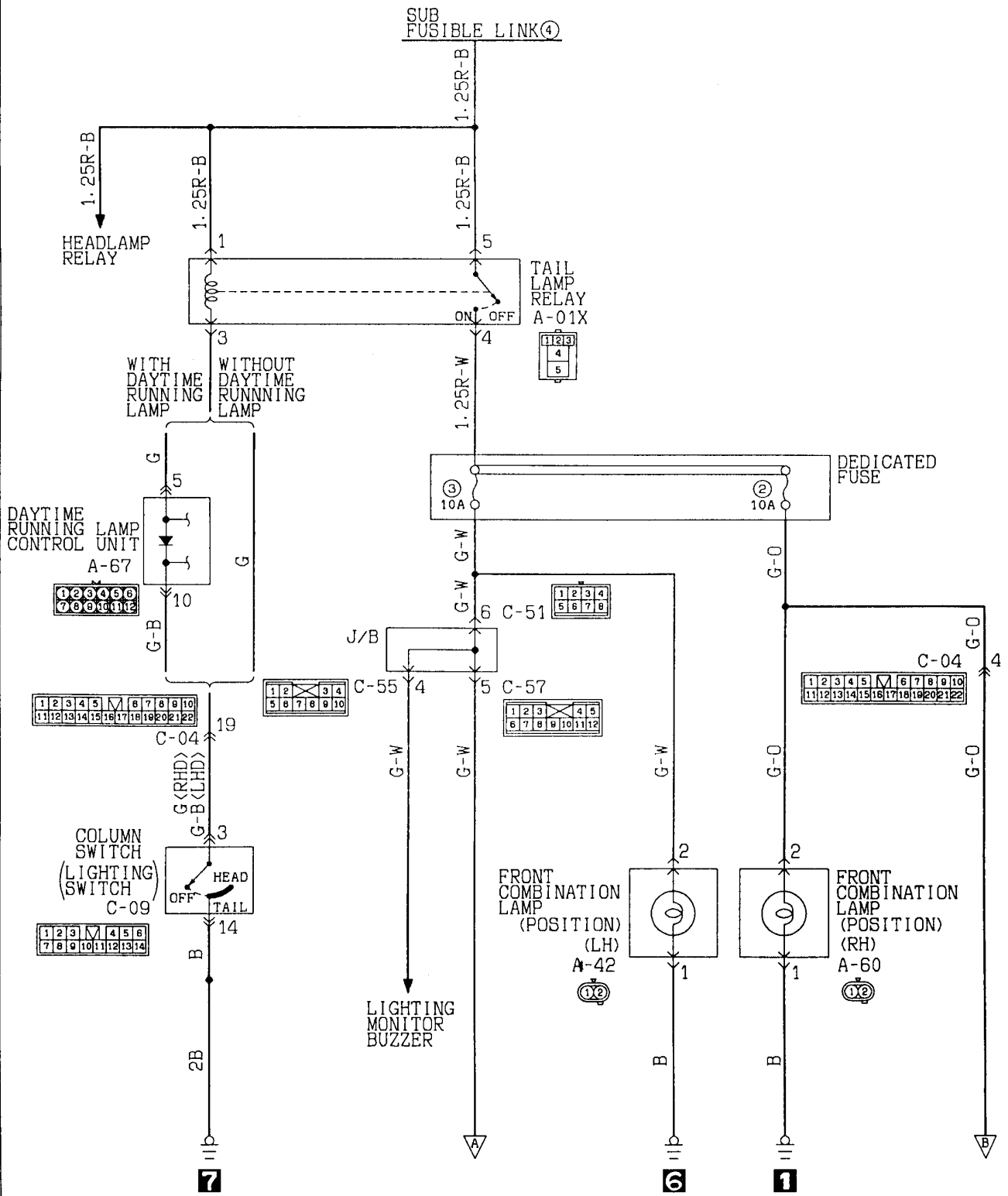

Wire colour code  
 B:Black LG:Light green G:Green L:Blue W:White Y:Yellow SB:Sky blue  
 BR:Brown O:Orange GR:Gray R:Red P:Pink V:Violet

KX35-AC-Z0841-EC

© Mitsubishi Motors Corporation May 1993

PHDE9214-B

ADDED

# CIRCUIT DIAGRAM — Tail Lamp, Position Lamp and Licence Plate Lamp 4A-91

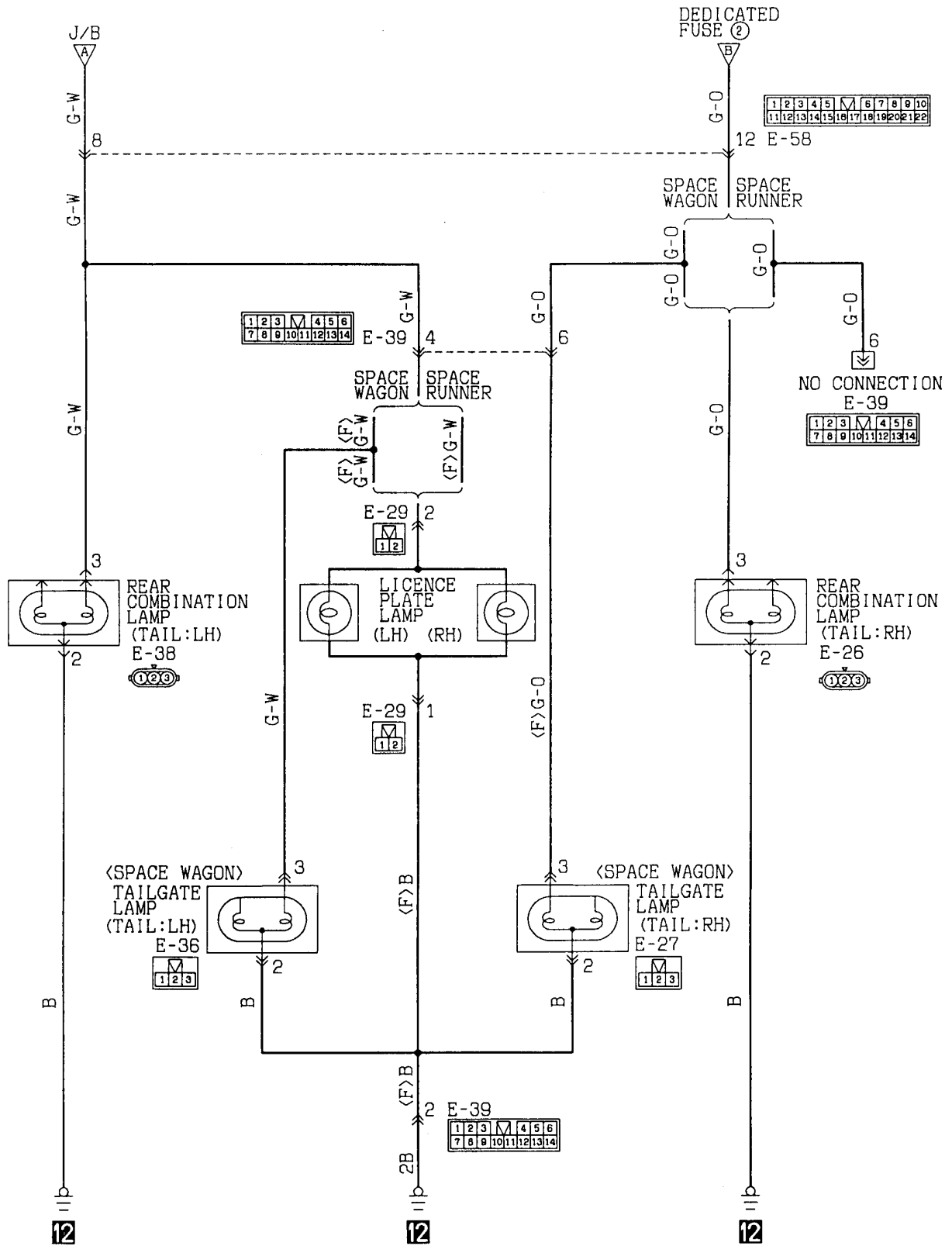

## **4A-92 CIRCUIT DIAGRAM — Tail Lamp, Position Lamp and License Plate Lamp**

---

### **TAIL LAMP, POSITION LAMP AND LICENCE PLATE LAMP (See P. 4A-88, 90.)**

#### **OPERATION**

- Placing the lighting switch in the TAIL or HEAD position causes the tail lamp relay to be energized. For vehicles with daytime running lamps, if the ignition switch is turned to the "ON" position, the tail lamp relay normally is always "ON".
- As a result, current flows by way of dedicated fuse No. ② and No. ③ to each lamp, causing the lamp to come on.

#### **TROUBLESHOOTING HINTS**

1. No lamp come on.
  - (1) Headlamps do not come on, either.
    - Check the sub-fusible link No. ④.
  - (2) Headlamps do come on.
    - Check the tail lamp relay.
    - Check dedicated fuse No. ② and No. ③.

#### **Remark**

- The tail lamp circuit has a lighting monitor buzzer system. For operation and troubleshooting hints, refer to LIGHTING MONITOR BUZZER (P. 4A-119).



NOTES

REAR FOG LAMP

Vehicles with daytime running lamp (with SRS)

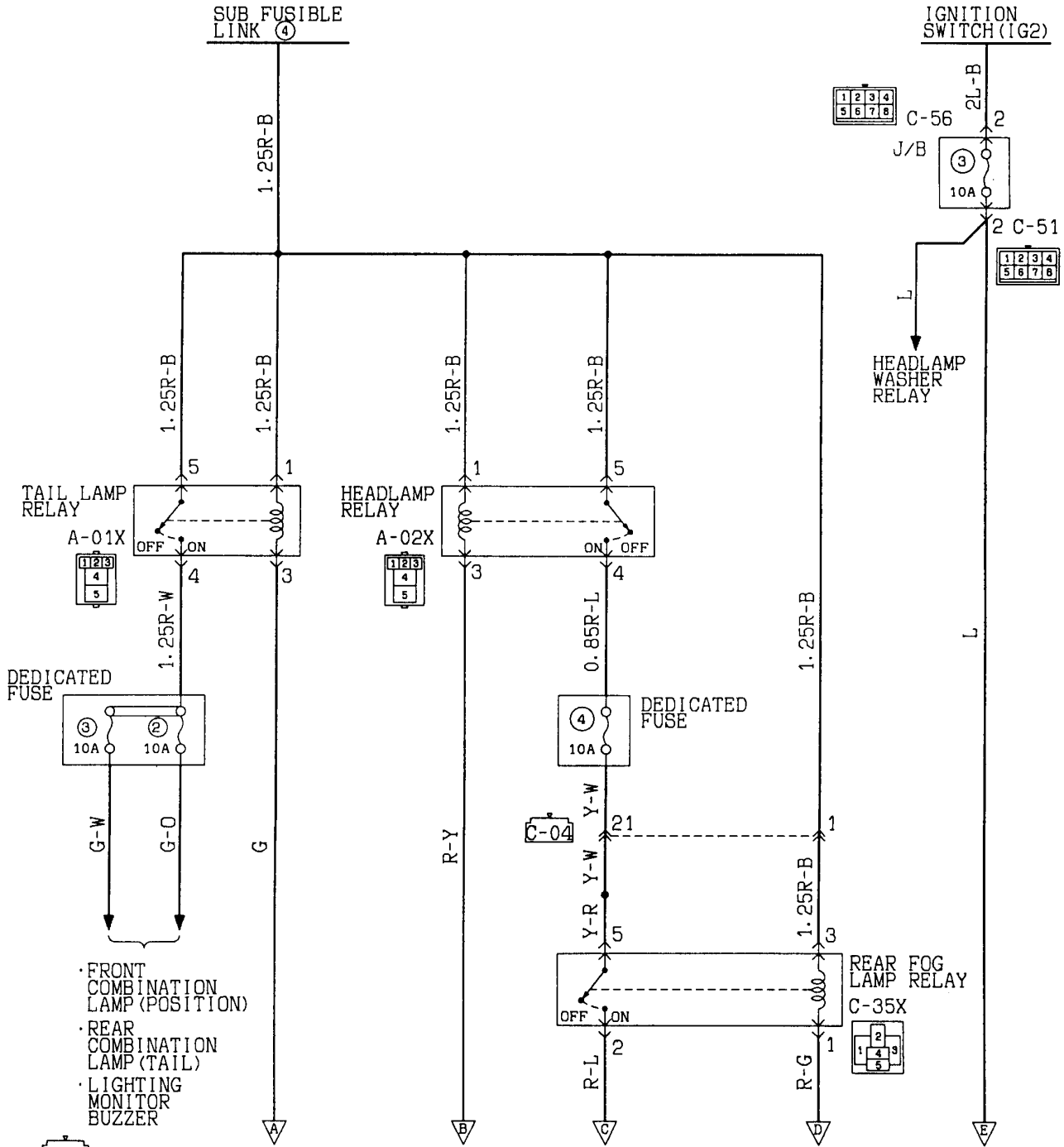

- FRONT COMBINATION LAMP (POSITION)
- REAR COMBINATION LAMP (TAIL)
- LIGHTING MONITOR BUZZER

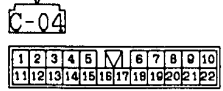

Wire colour code  
 B:Black LG:Light green G:Green L:Blue W:White Y:Yellow SB:Sky blue  
 BR:Brown O:Orange GR:Gray R:Red P:Pink V:Violet

# CIRCUIT DIAGRAM — Rear Fog lamp

4A-95

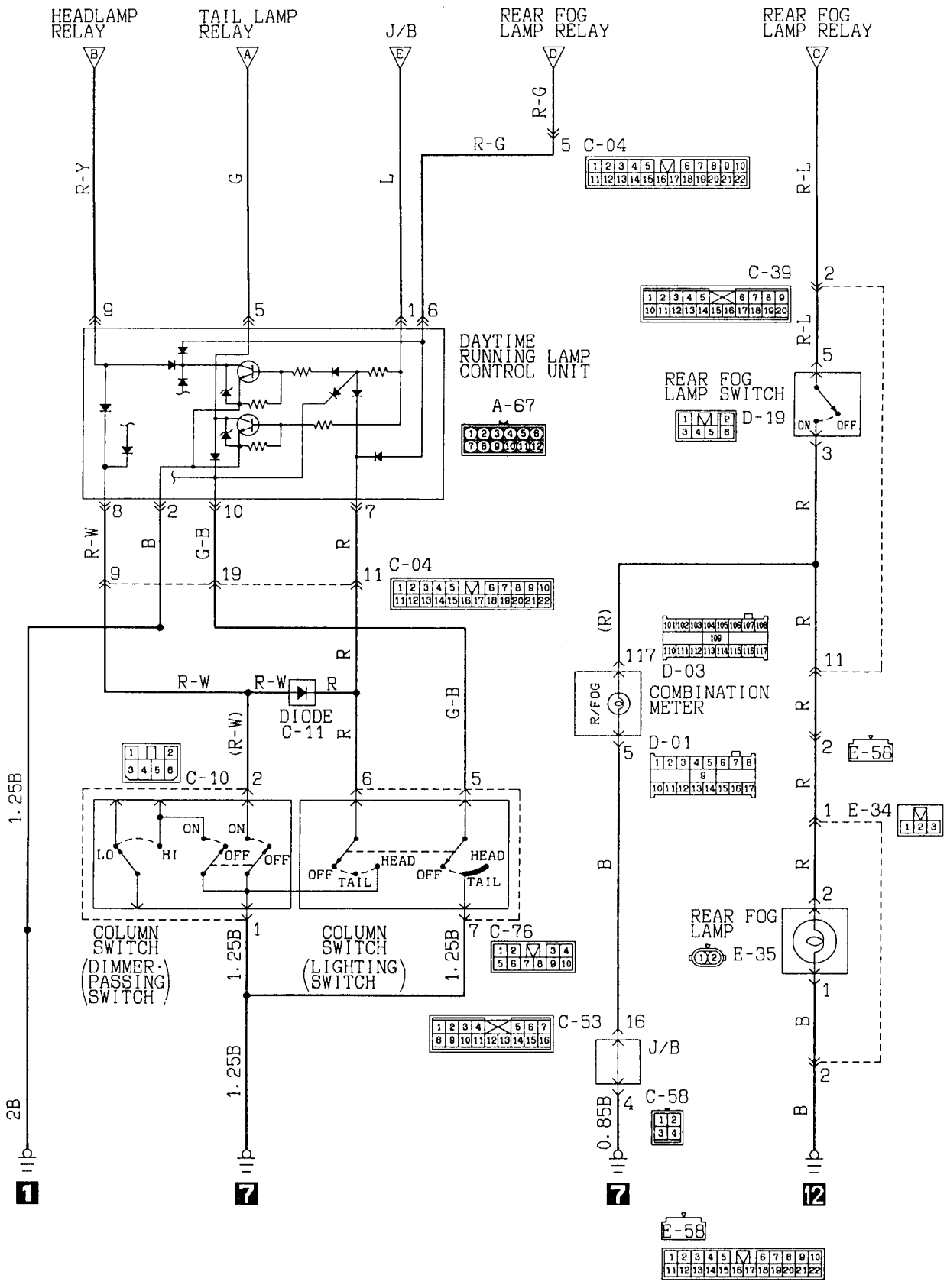

REAR FOG LAMP

Vehicles with daytime running lamp (without SRS)

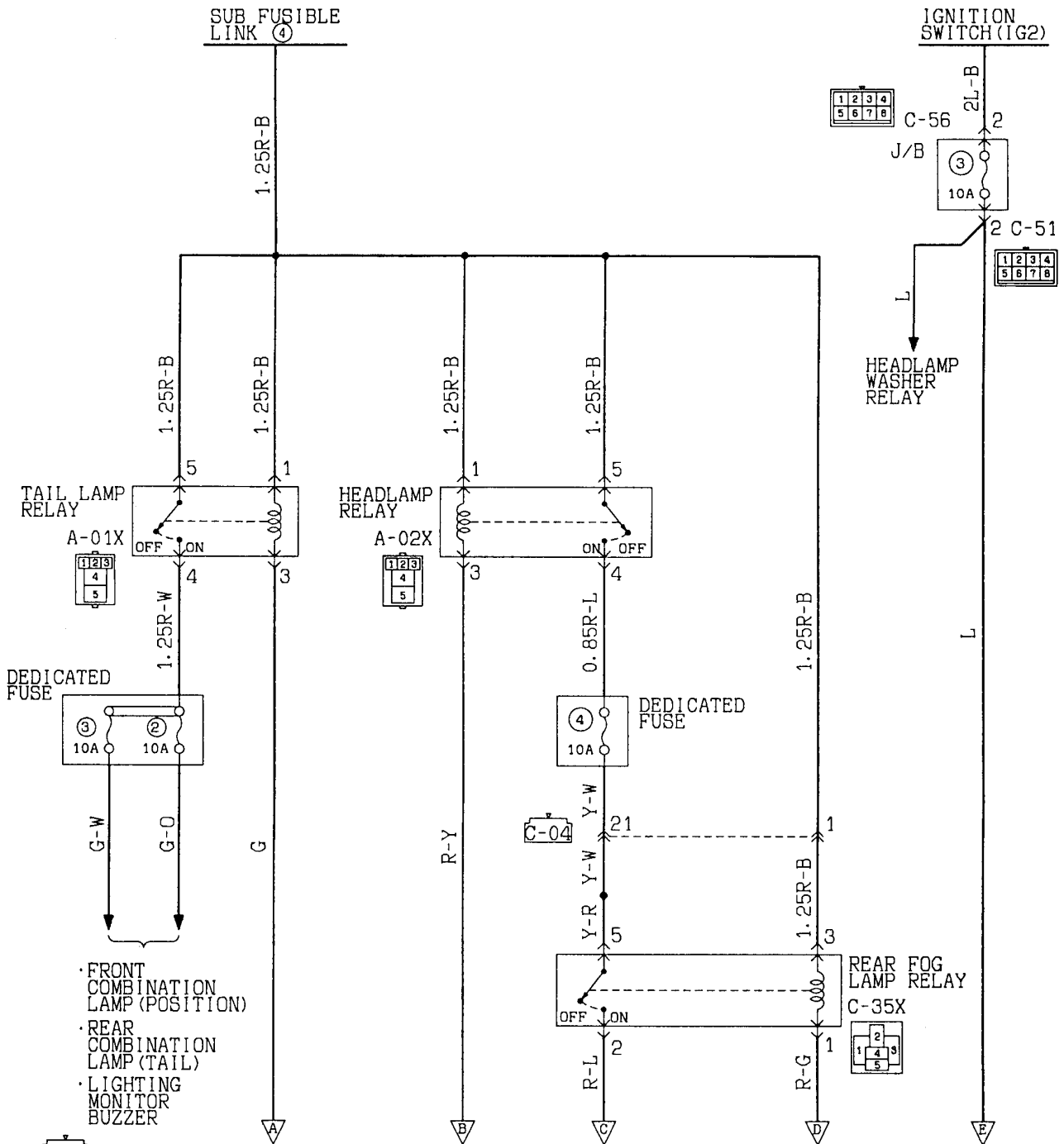

- FRONT COMBINATION LAMP (POSITION)
- REAR COMBINATION LAMP (TAIL)
- LIGHTING MONITOR BUZZER

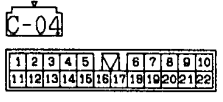

Wire colour code  
 B:Black LG:Light green G:Green L:Blue W:White Y:Yellow SB:Sky blue  
 BR:Brown O:Orange GR:Gray R:Red P:Pink V:Violet



REAR FOG LAMP

L.H. drive vehicles without daytime running lamp<with SRS>

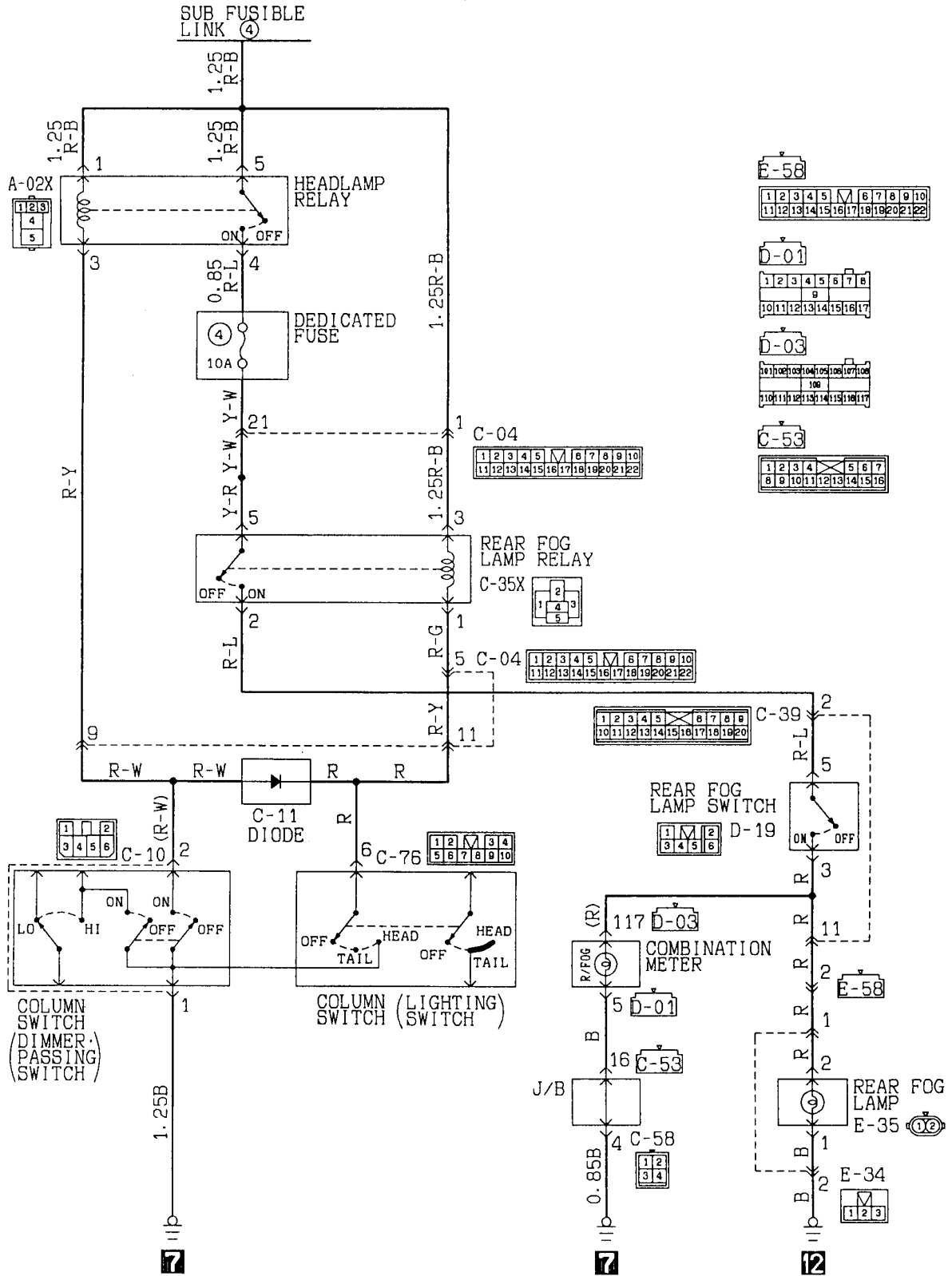

Wire colour code  
 B:Black LG:Light green G:Green L:Blue W:White P:Pink SB:Sky blue  
 BR:Brown O:Orange GR:Gray R:Red Y:Yellow V:Violet

KX35-AC-Z0844-EC

REAR FOG LAMP

L.H. drive vehicles without daytime running lamp (without SRS)

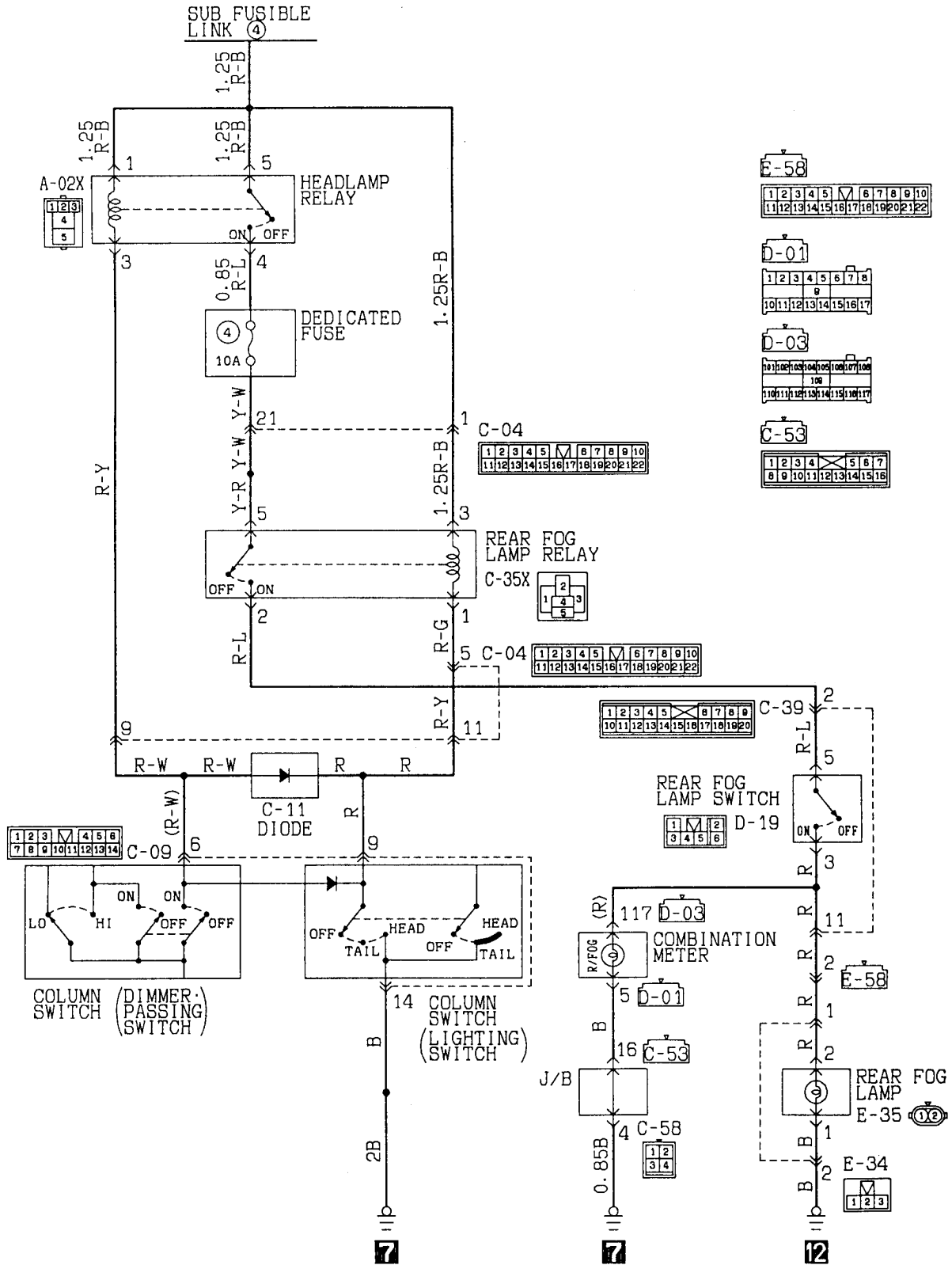

Wire colour code  
 B:Black LG:Light green G:Green L:Blue W:White Y:Yellow SB:Sky blue  
 BR:Brown O:Orange GR:Gray R:Red P:Pink V:Violet

KX35-AC-20845-EC

© Mitsubishi Motors Corporation May 1993

PHDE9214-B

ADDED

REAR FOG LAMP  
R.H. drive vehicles

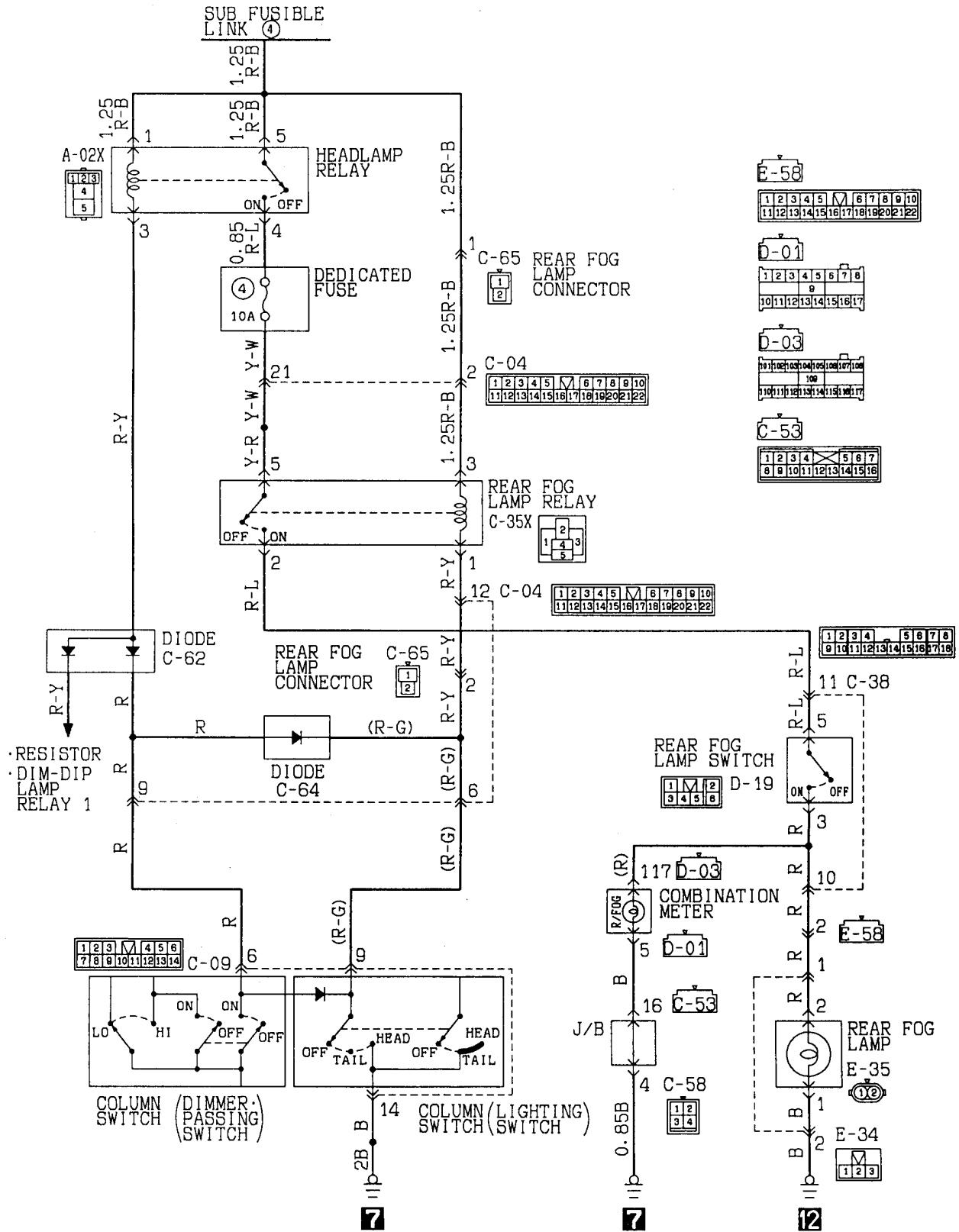

Wire colour code  
 B:Black LG:Light green G:Green L:Blue W:White Y:Yellow SB:Sky blue  
 BR:Brown O:Orange GR:Gray R:Red P:Pink V:Violet



**REAR FOG LAMP (See P. 4A-94, 96, 98, 99, 100.)**

**OPERATION**

Rear Fog Lamp Relay ON Conditions

〈Vehicles without daytime running lamp〉

Ignition switch	Lighting switch	Rear fog lamp relay
—	"HEAD"	ON

〈Vehicles with daytime running lamp〉

Ignition switch	Lighting switch	Rear fog lamp relay
—	"HEAD"	ON
"ON"	"OFF" or "HEAD"	ON

- Placing the lighting switch in the HEAD position causes the rear fog lamp relay to be energized. For vehicles with daytime running lamps, if the ignition switch is in the "ON" position and the lighting switch is in the "OFF" position, the rear fog lamp relay will be energized.
- When the rear fog lamp switch is turned ON in this condition, the rear fog lamp comes on.

**TROUBLESHOOTING HINTS**

1. The rear fog lamp doesn't illuminate.
  - (1) Headlamps come on.
    - Check the rear fog lamp relay.
    - Check the rear fog lamp switch.
    - Check the dedicated fuse No. ④.
  - (2) Headlamps do not come on, either.
    - Check the lighting switch.
    - Check the sub fusible link No. ④.
2. The rear fog lamp at the one side doesn't illuminate.
  - Check the bulb.

**ROOM LAMP AND CARGO ROOM LAMP (See P. 4A-102, 103, 104, 105.)**

**OPERATION**

〈Room lamp〉

- Placing the room lamp switch in the ON position causes the room lamp to come on at all times.
- Opening any one of the doors with the room lamp switch in the DOOR position causes the room lamp to come on.
- Closing all doors causes the room lamp to go out.

〈Cargo room lamp〉

- Placing the cargo room lamp switch in the ON position causes the cargo room lamp to come on at all times.
- Opening the tailgate with the cargo room lamp switch in the DOOR position causes the cargo room lamp to come on.
- Closing the tailgate causes the cargo room lamp to go out.

**TROUBLESHOOTING HINTS**

1. Room lamp does not come on.
  - (1) Clock is not operating, either.
    - Check the multi-purpose fuse No. ⑱.
  - (2) Room lamp does not come on when any door is opened with the room lamp switch in the DOOR position.
    - Check the bulb.
    - Check the room lamp switch.
  - (3) Room lamp does not come on when a door is opened with the room lamp switch in the DOOR position.
    - Check the door switch (of the suspected door).
2. Cargo room lamp does not come on.
  - (1) Clock is not operating, either.
    - Check the multi-purpose fuse No. ⑱.
  - (2) Cargo room lamp does not come on when the tailgate is opened with the cargo room lamp switch in the DOOR position.
    - Check the bulb.
    - Check the cargo room lamp switch.
    - Check the latch switch.

ROOM LAMP AND CARGO ROOM LAMP  
L.H. drive vehicles with door lamp

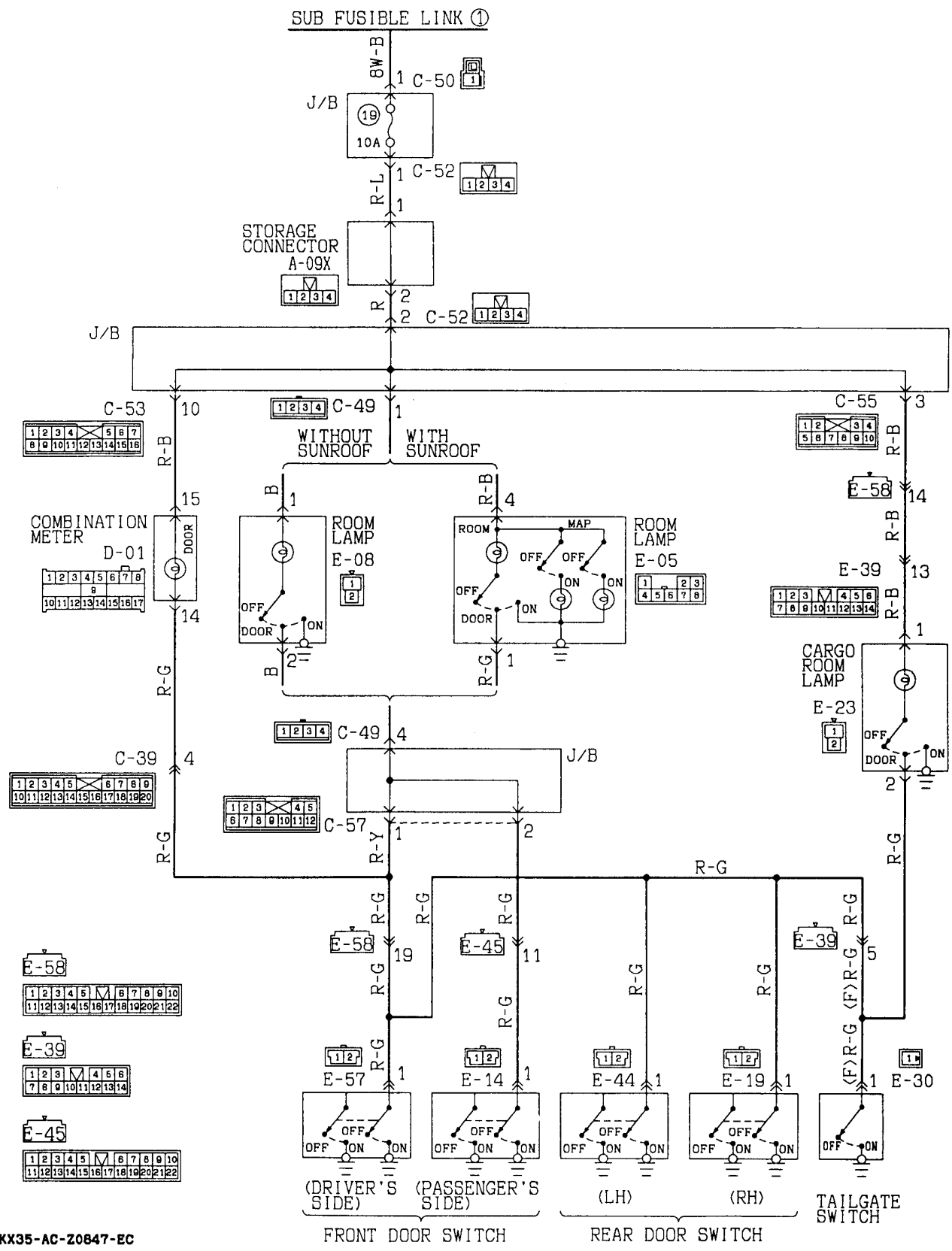

KX35-AC-Z0847-EC





ROOM LAMP AND CARGO ROOM LAMP  
R.H. drive vehicles without door lamp

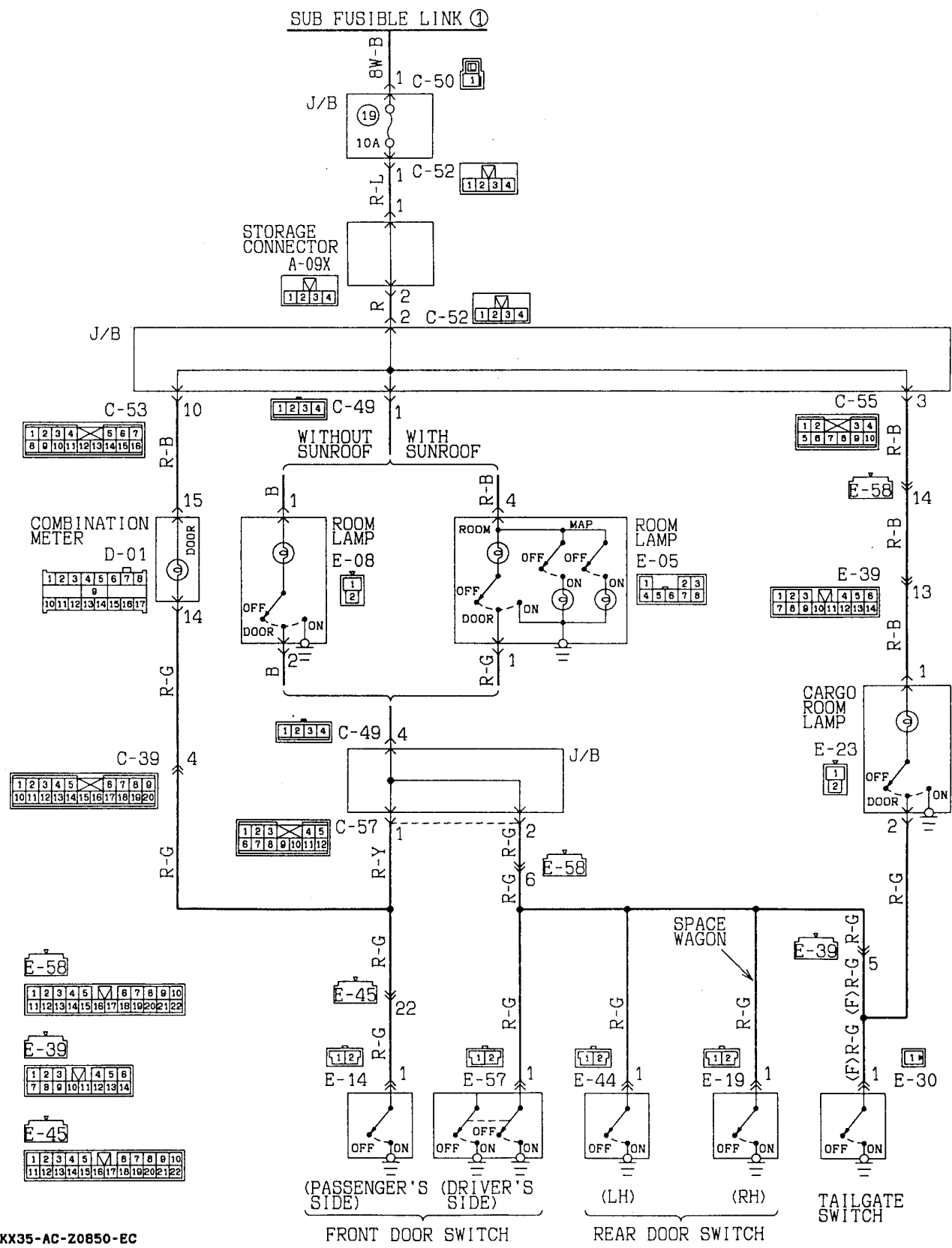

KX35-AC-Z0850-EC



DOOR LAMP  
R. H. drive vehicles

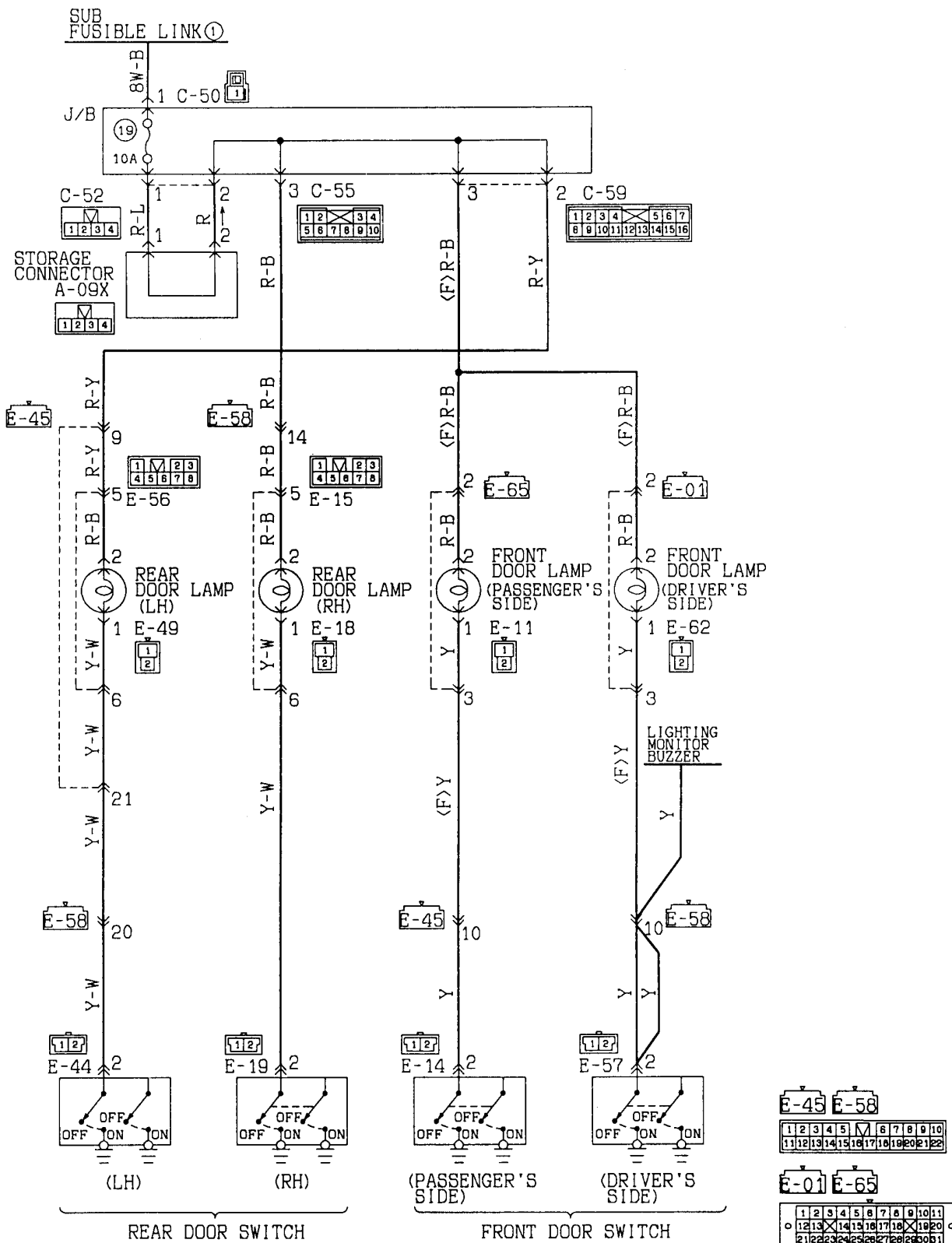

Wire colour code  
 B:Black L:Light green G:Green L:Blue W:White Y:Yellow Sb:Sky blue  
 Br:Brown O:Orange Gr:Gray R:Red P:Pink V:Violet

CLUSTER SWITCH ILLUMINATION LAMP

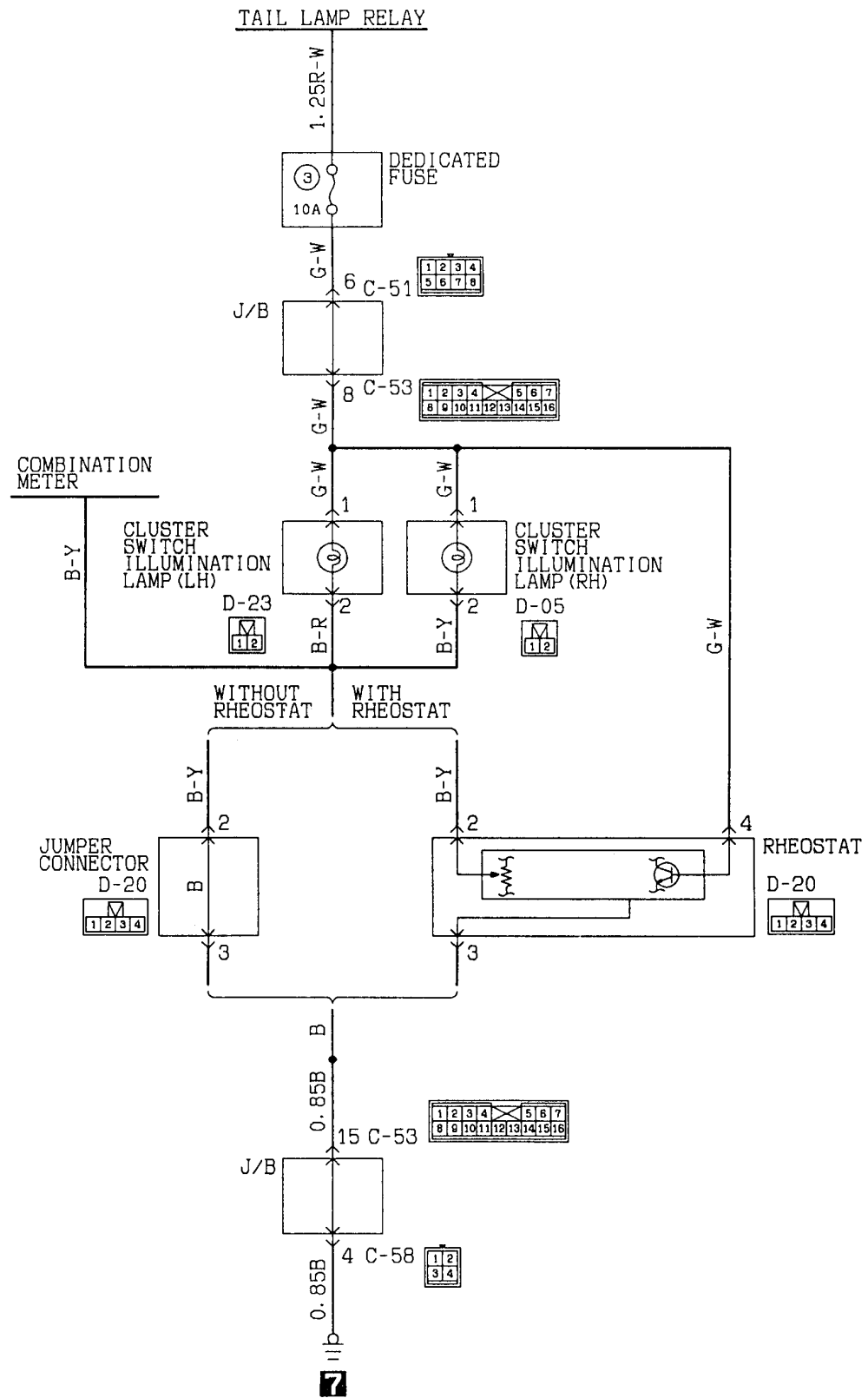

Wire colour code  
 B:Black LG:Light green G:Green L:Blue W:White Y:Yellow SB:Sky blue  
 BR:Brown O:Orange GR:Gray R:Red P:Pink V:Violet



**TURN-SIGNAL LAMP AND HAZARD LAMP (See P. 4A-110, 112.)**

**OPERATION**

**<Turn-signal lamp>**

**1. In normal operating condition**

- When the ignition switch is turned to the "ON" position, current flows to the flasher unit via the hazard lamp switch, and the Tr1 in the flasher unit turns "ON" (Tr2 remains "OFF").
- When the turn signal switch is moved to the "LH" (or "RH") position, the base current in Tr2 flows to D2, R4, the turn signal switch, the turn signal lamp and the earth. The relay coil operates to close the relay contact, turning Tr2 "ON", and the turn signal lamp illuminates.
- When the relay contact closes, the emitter-side voltage in Tr1 drops and Tr1 turns "OFF". However, Tr2 stays "ON" so that the charge current in C2 flows to D2, C1, R1 and to the earth.
- When C1 is fully charged, the current from C2 stops flowing and Tr2 turns "OFF". The relay contact opens and the lamp switches off.
- When the relay contact opens, C1 discharges electricity through the R4, switch, lamp, earth, power, R5 and Tr1 closed circuit to increase the emitter-side voltage in Tr1 and turn Tr1 "ON". At this time, the lamp does not illuminate due to the large resistance in R4.
- When the electrical discharge from C1 is completed, Tr2 turns "ON". The relay contact closes, and the lamp illuminates.
- By repetition of the above operations, the turn signal lamps and the turn signal indicator for "LH" (or "RH") continues to flash.

**2. When one bulb is burnt out**

- When any one of the turn signal lamps is burnt out the resistance in the whole of the lamp circuit increases, so even if the relay contact closes, Tr1 will not turn completely "OFF".
- Because of this, a small amount of collector current will flow through Tr1, and so C1 will become completely charged in a quicker time than normal, and the illumination time for the lamps will become shorter.
- The relay contact will open and C1 will discharge electricity, but the charge voltage will be low, so the discharge time will be shorter than normal.
- Because of the above operation, the lamps will flash continuously at a faster frequency than normal.

**<Hazard lamp>**

- When the hazard switch is placed in the ON position, the flasher unit relay contacts repeatedly close and open, which results in the RH and LH turn-signal lamps, turn-signal indicator lamps, and hazard warning indicator lamps flashing on and off at the same time.

Remarks

- The number of times the hazard lamps flash on and off does not change even when one bulb is out.

**TROUBLESHOOTING HINTS**

1. Neither the turn-signal lamps nor hazard lamps operate.
  - Check hazard switch contacts (on power source end).
  - Check the flasher unit.
2. All LH or RH turn-signal lamps do not operate.
  - (1) Hazard lamp is fully operational.
    - Check hazard switch contacts (on turn-signal end).
    - Check the turn-signal switch.
3. Flashing cycle of turn signal lamps is shorter.
  - Check bulb.
4. Hazard lamp does not operate.
  - (1) Turn-signal lamps are operational.
    - Check hazard switch contacts (on hazard lamp end).

**4A-110 CIRCUIT DIAGRAM — Turn-signal Lamp and Hazard Lamp**

**TURN SIGNAL LAMP AND HAZARD LAMP**  
Vehicles with SRS

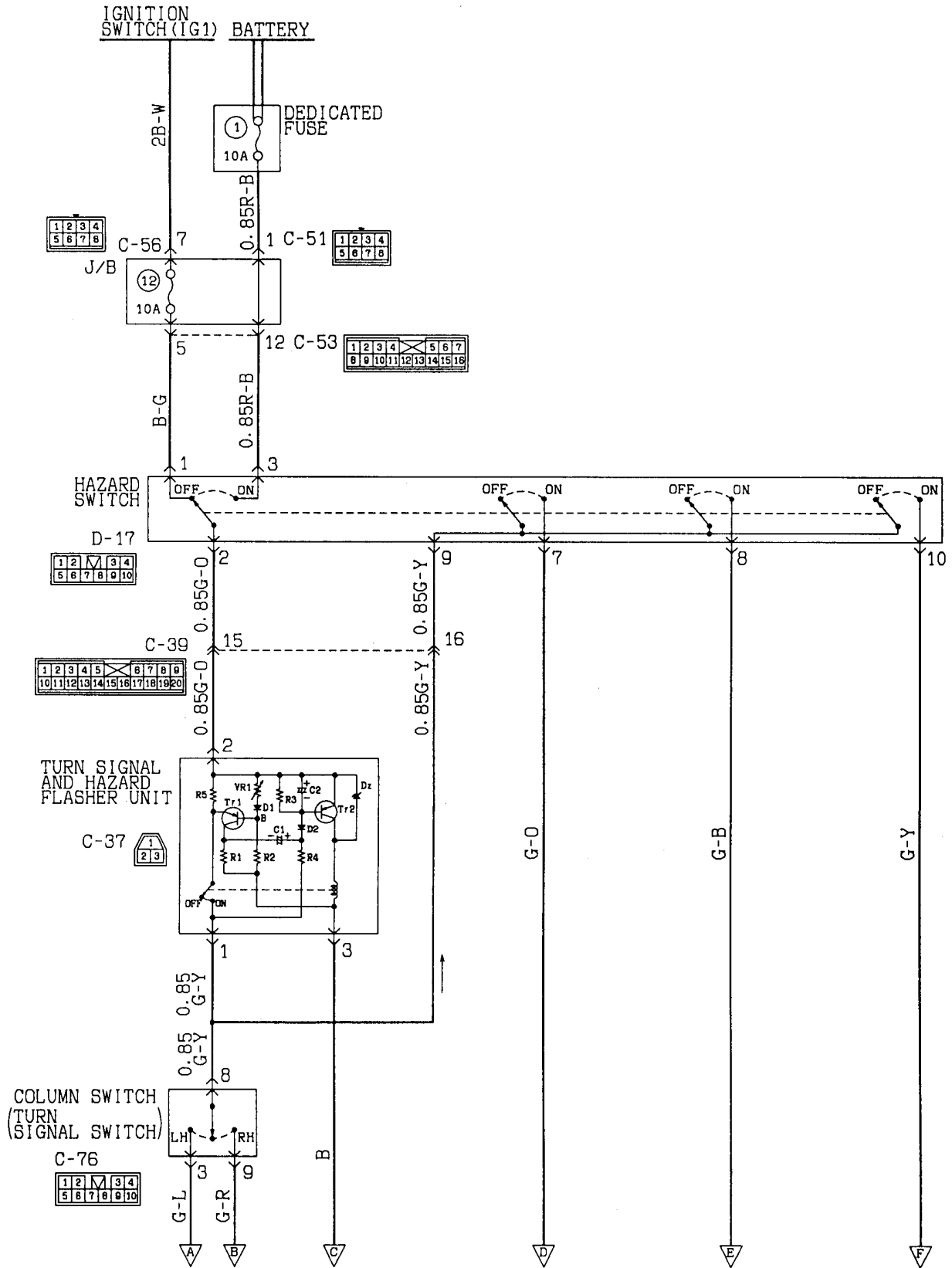

KX35-AC-Z0914-EC

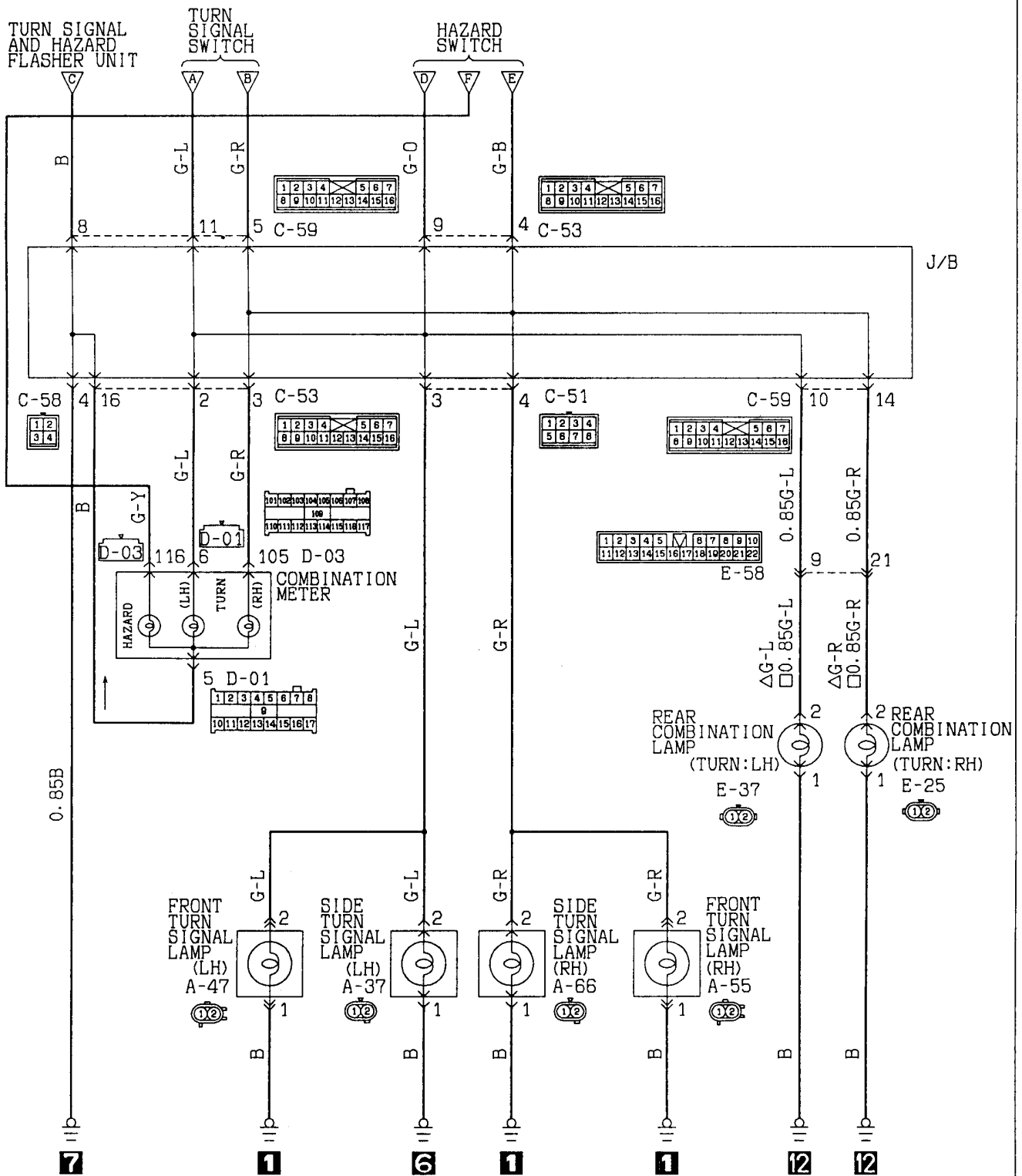

Remarks  
 (1) Δ: SPACE RUNNER  
 (2) □: SPACE WAGON

Wire colour code  
 B:Black LG:Light green G:Green L:Blue W:White Y:Yellow SB:Sky blue  
 BR:Brown O:Orange GR:Gray R:Red P:Pink V:Violet

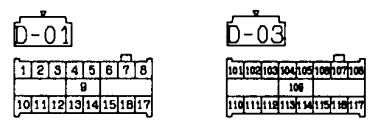

**4A-112 CIRCUIT DIAGRAM — Turn-signal Lamp and Hazard Lamp**

**TURN SIGNAL LAMP AND HAZARD LAMP**  
Vehicles without SRS

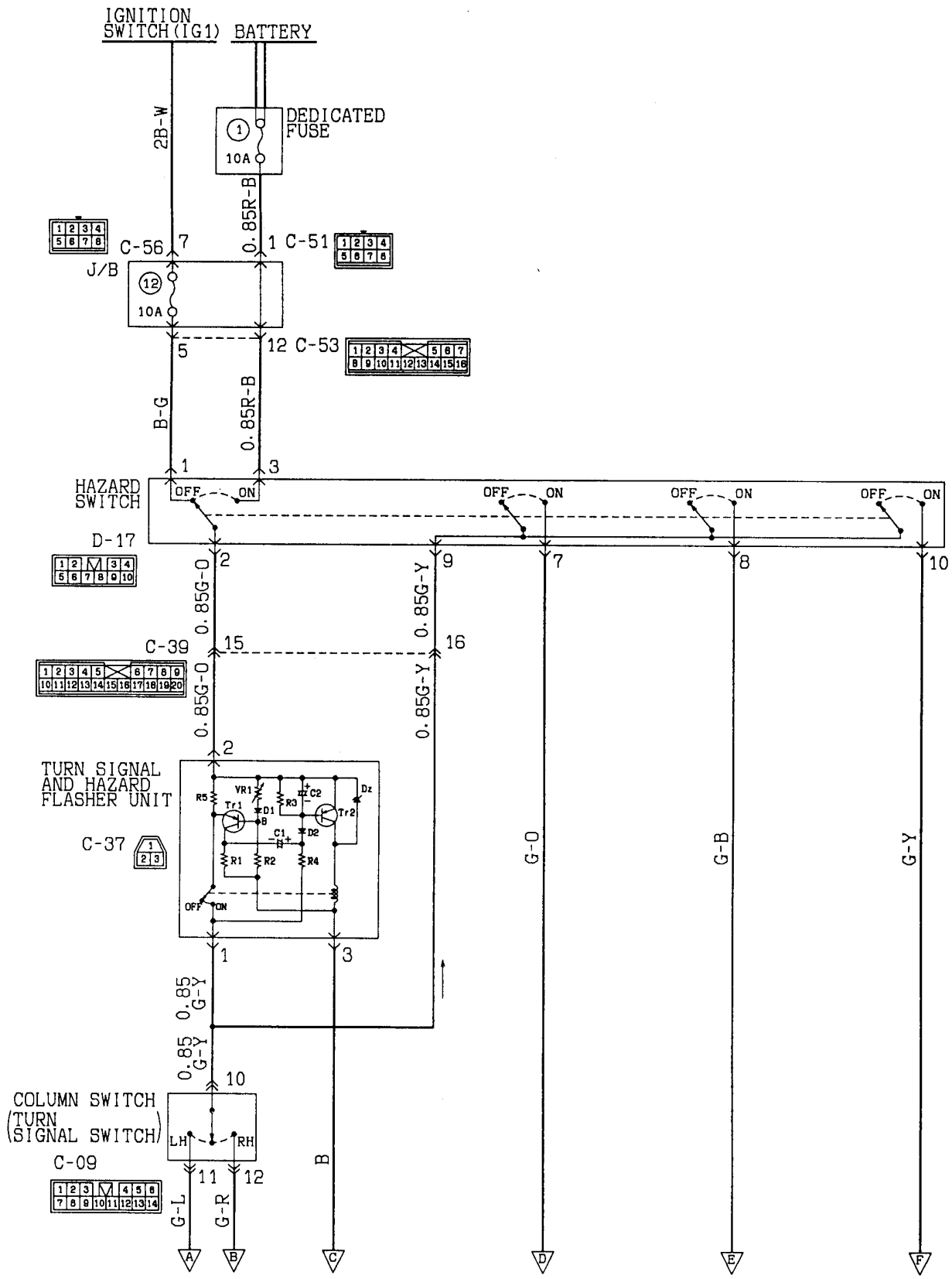

KX35-AC-Z0915-EC

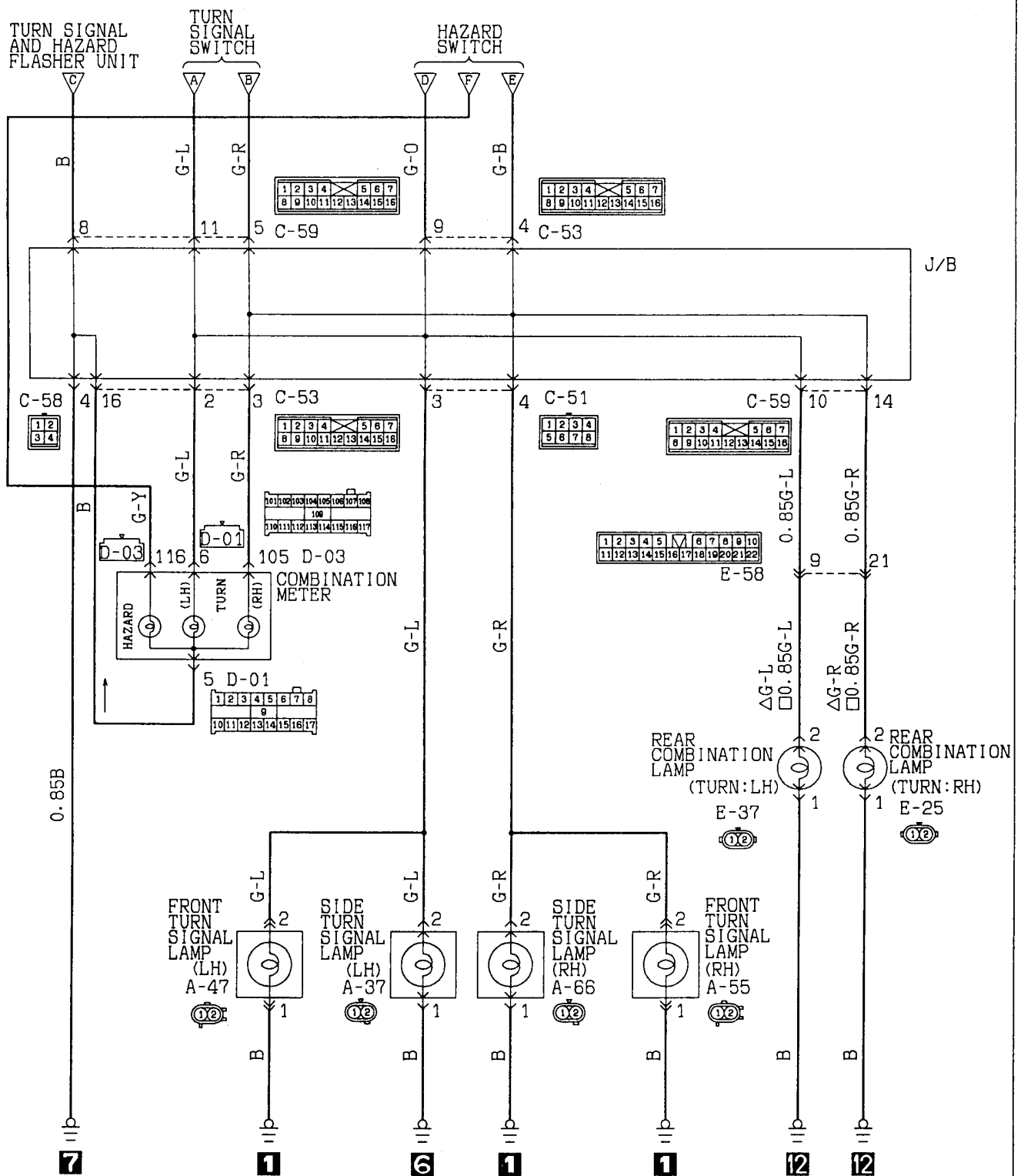

Remarks  
 (1) Δ: SPACE RUNNER (LHD)  
 (2) □: SPACE RUNNER (RHD) and SPACE WAGON

Wire colour code  
 B:Black LG:Light green G:Green L:Blue W:White Y:Yellow SB:Sky blue  
 BR:Brown O:Orange GR:Gray R:Red P:Pink V:Violet

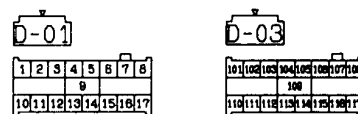

STOP LAMP

Vehicles with higt-mounted stop lamp

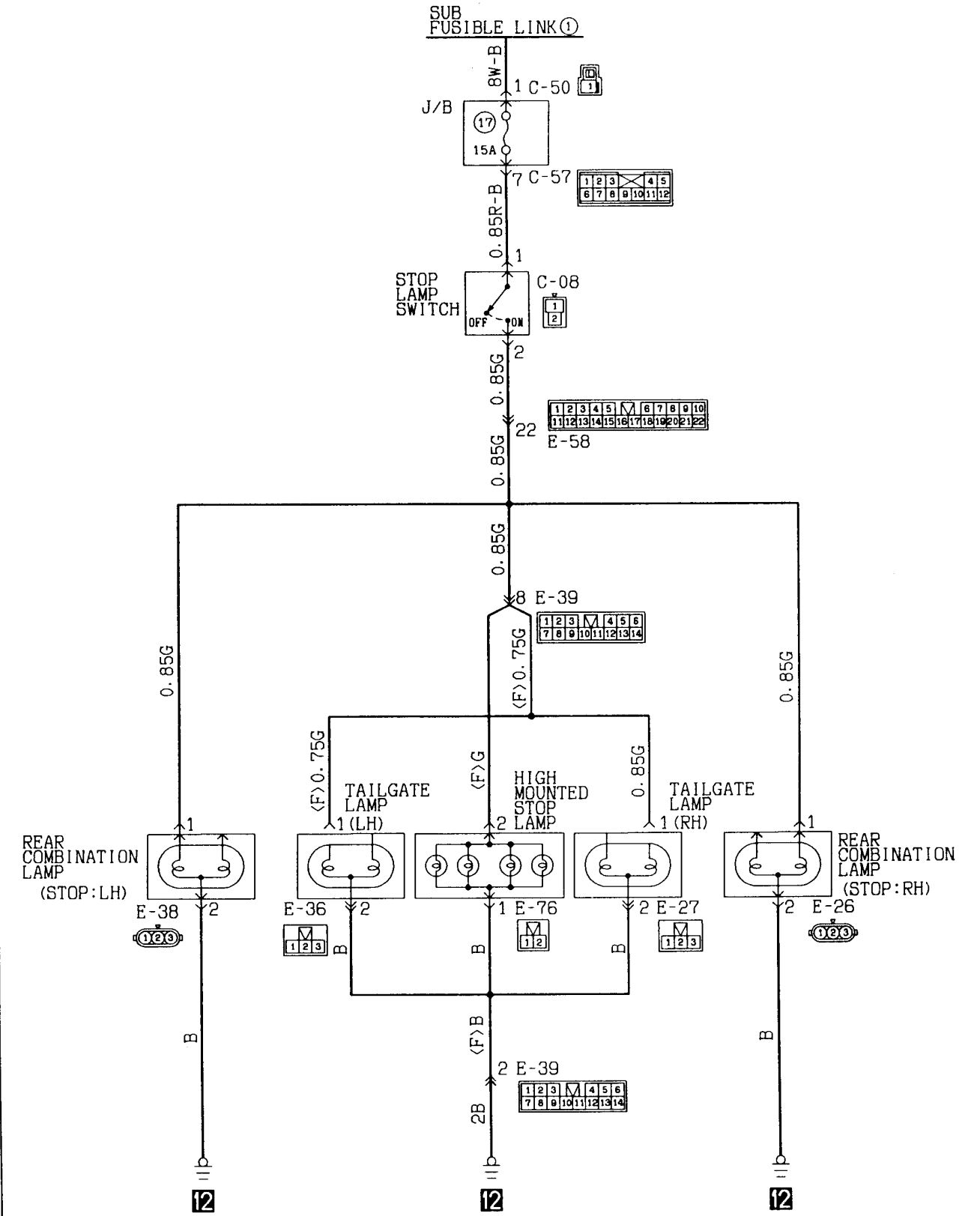

Wire colour code  
 B:Black LG:Light green G:Green L:Blue W:White Y:Yellow SB:Sky blue  
 BR:Brown O:Orange GR:Gray R:Red P:Pink V:Violet

KX35-AC-20922-EC

STOP LAMP

Vehicles without higt-mounted stop lamp

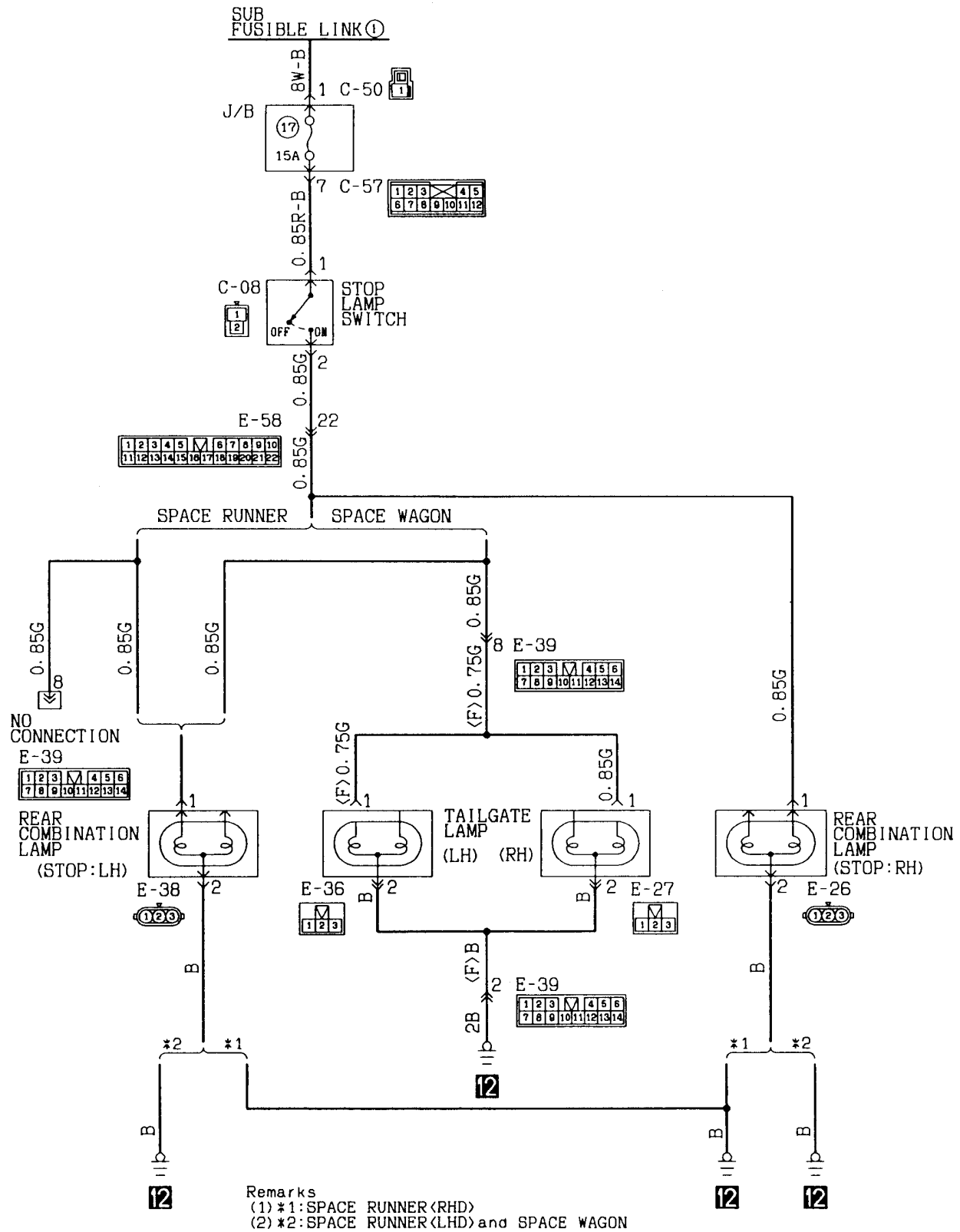

Wire colour code

B:Black LG:Light green G:Green L:Blue W:White Y:Yellow SB:Skv blue  
 BR:Brown O:Orange GR:Gray R:Red P:Pink V:Violet

BACK-UP LAMP

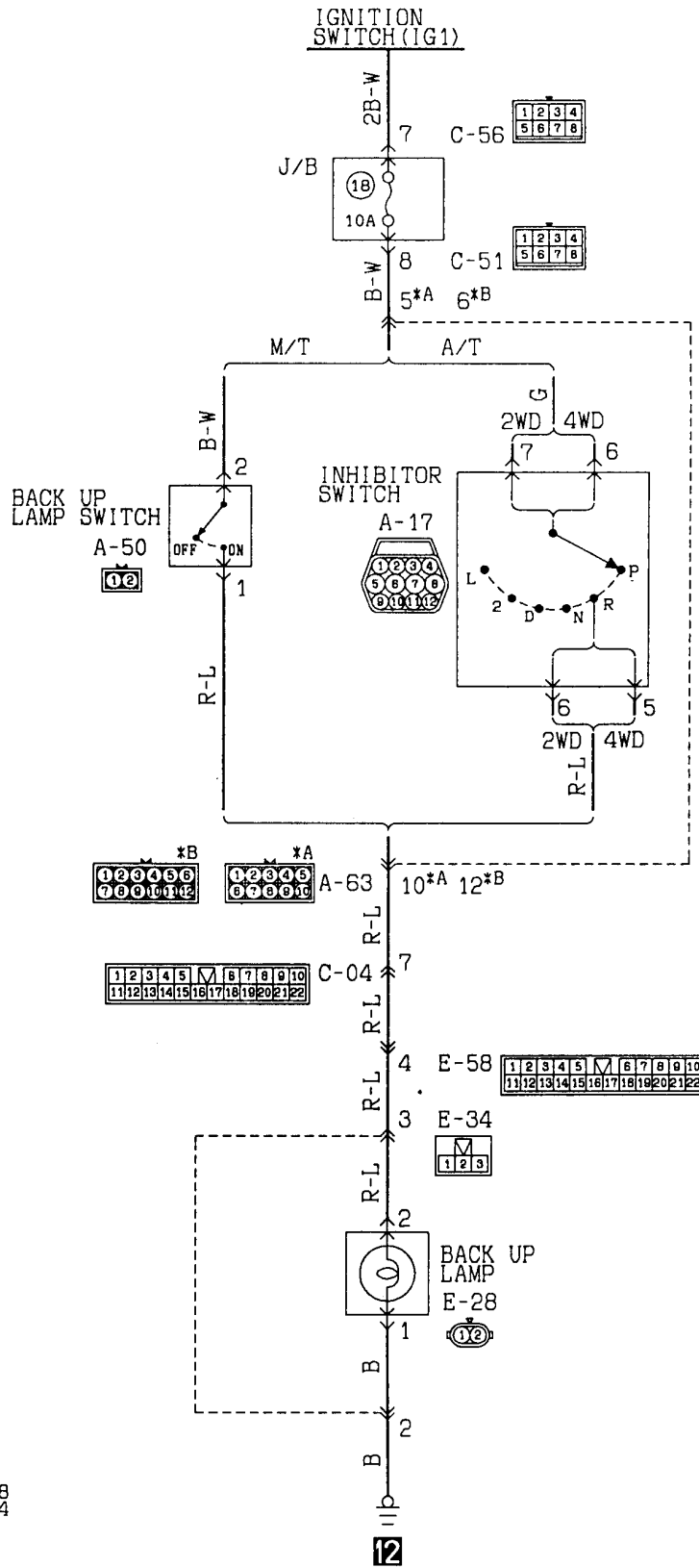

Remarks  
 (1)\*A:4G93 and 4D68  
 (2)\*B:4G63 and 4G64

Wire colour code  
 B:Black LG:Light green G:Green L:Blue W:White Y:Yellow SB:Sky blue  
 BR:Brown O:Orange GR:Gray R:Red P:Pink V:Violet





# LIGHTING MONITOR BUZZER

Vehicles without SRS

IGNITION SWITCH (IG1)

SUB FUSIBLE LINK ④

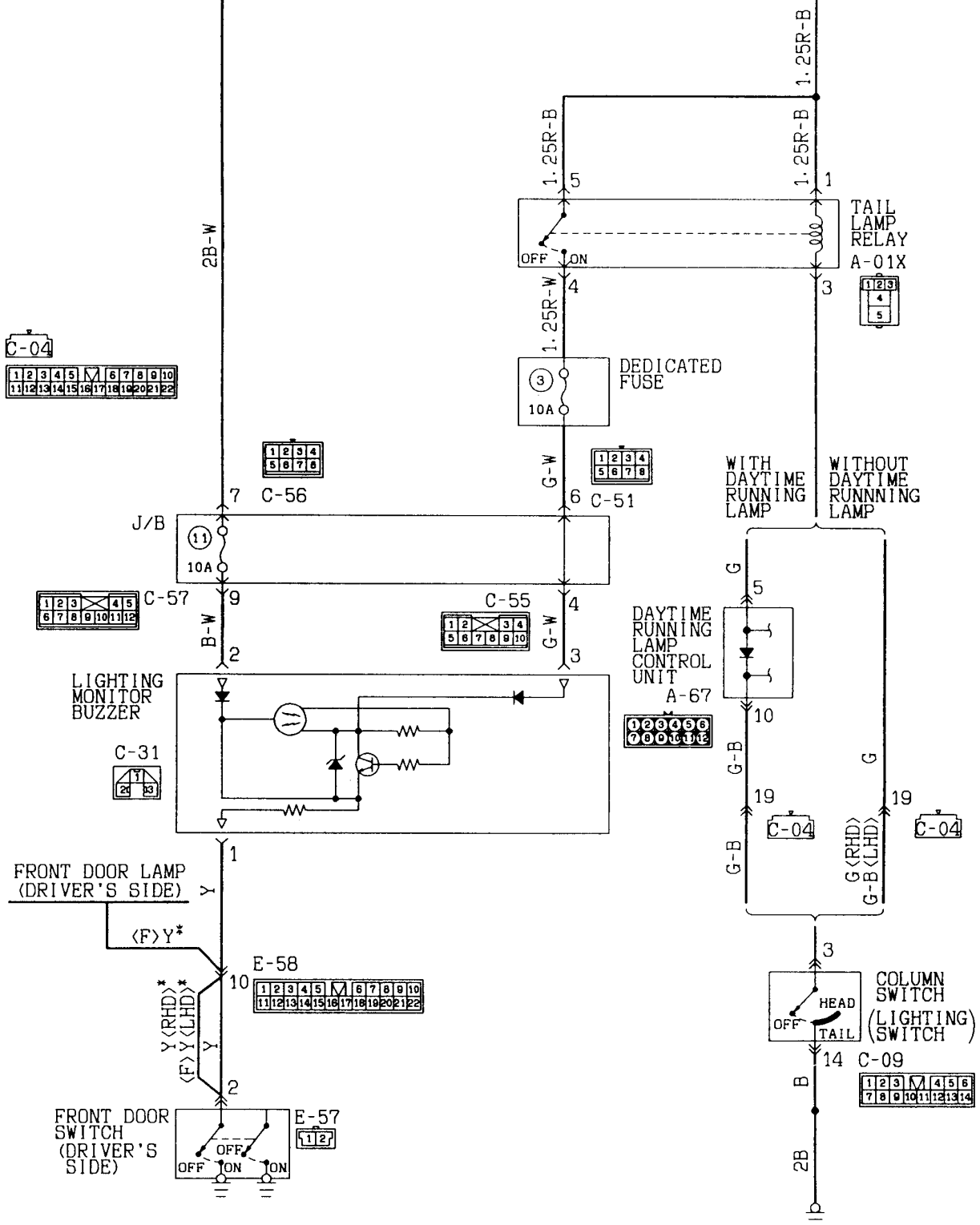

Remarks  
\*: Vehicles with door lamp.

Wire colour code  
 B:Black LG:Light green G:Green L:Blue W:White Y:Yellow SB:Sky blue  
 BR:Brown O:Orange GR:Gray R:Red P:Pink V:Violet

**LIGHTING MONITOR BUZZER (See P. 4A-117, 118.)****OPERATION**

- Placing the lighting switch in the TAIL or HEAD position causes the tail lamp relay to be energized.
- When the ignition switch is in the "OFF" position in this condition, if the driver's side door is opened and the front door switch turns "ON", the buzzer sounds to indicate that the lamps are not switched off.

**TROUBLESHOOTING HINTS**

1. Lighting monitor buzzer doesn't sound.
  - (1) But the tail lamps do illuminate.
    - Check the lighting monitor buzzer.
    - Check the front door switch (driver's side).
  - (2) The tail lamps also don't illuminate.
    - Check the sub fusible link No. ④.
    - Check the dedicated fuse No. ③.

HORN  
Vehicles with SRS

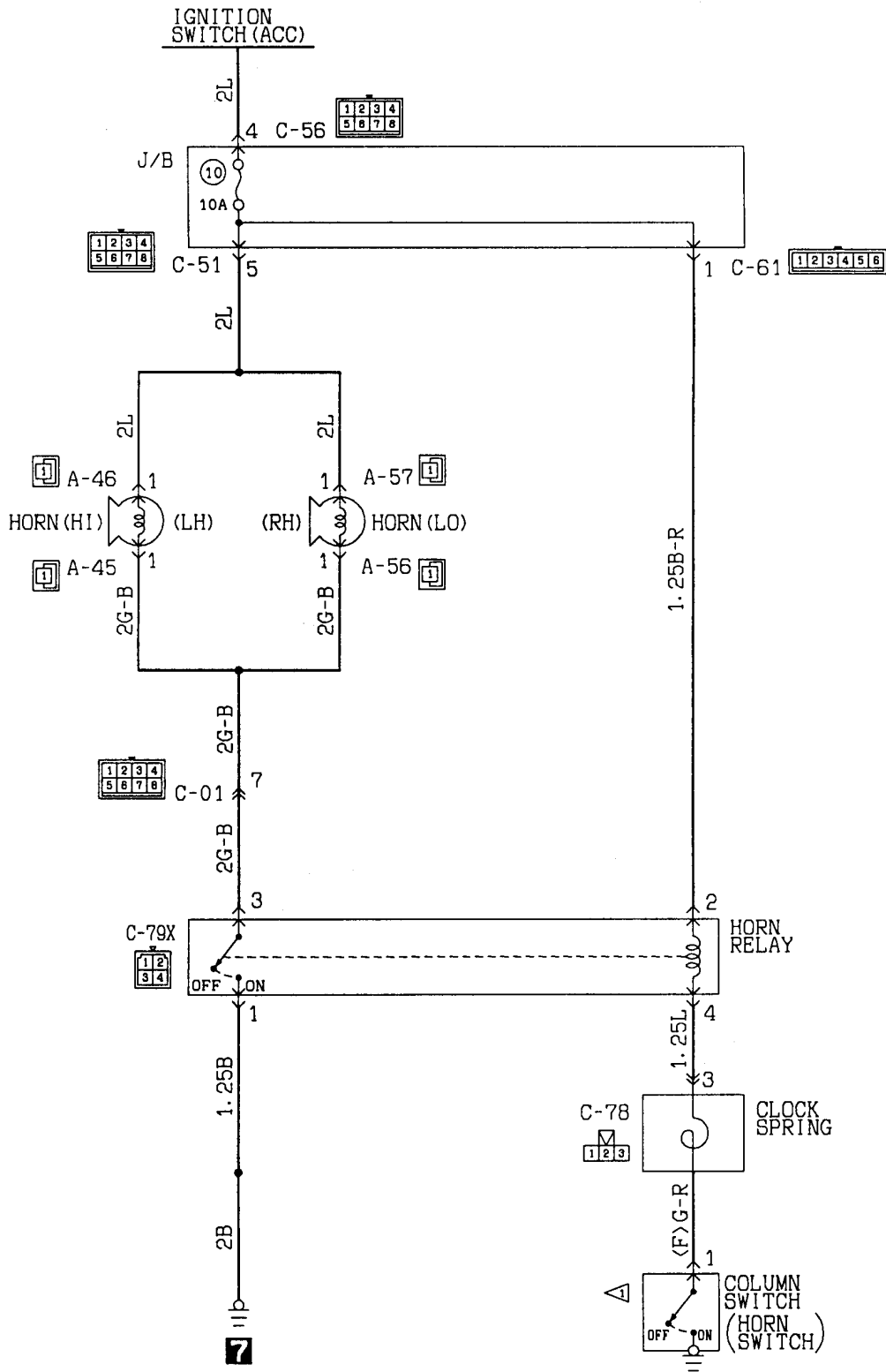

Wire colour code  
 B:Black LG:Light green G:Green L:Blue W:White Y:Yellow SB:Sky blue  
 BR:Brown O:Orange GR:Gray R:Red P:Pink V:Violet

HORN

Vehicles without SRS

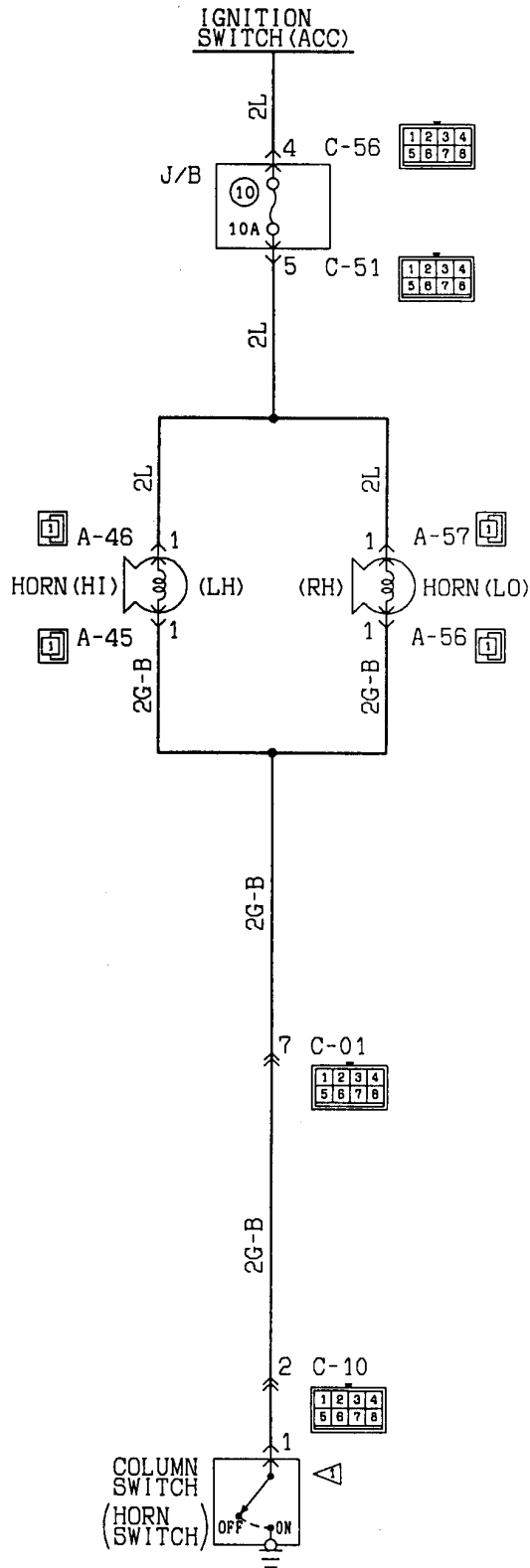

Wire colour code  
 B:Black LG:Light green G:Green L:Blue W:White Y:Yellow SB:Sky blue  
 BR:Brown O:Orange GR:Gray R:Red P:Pink V:Violet

METER AND GAUGE

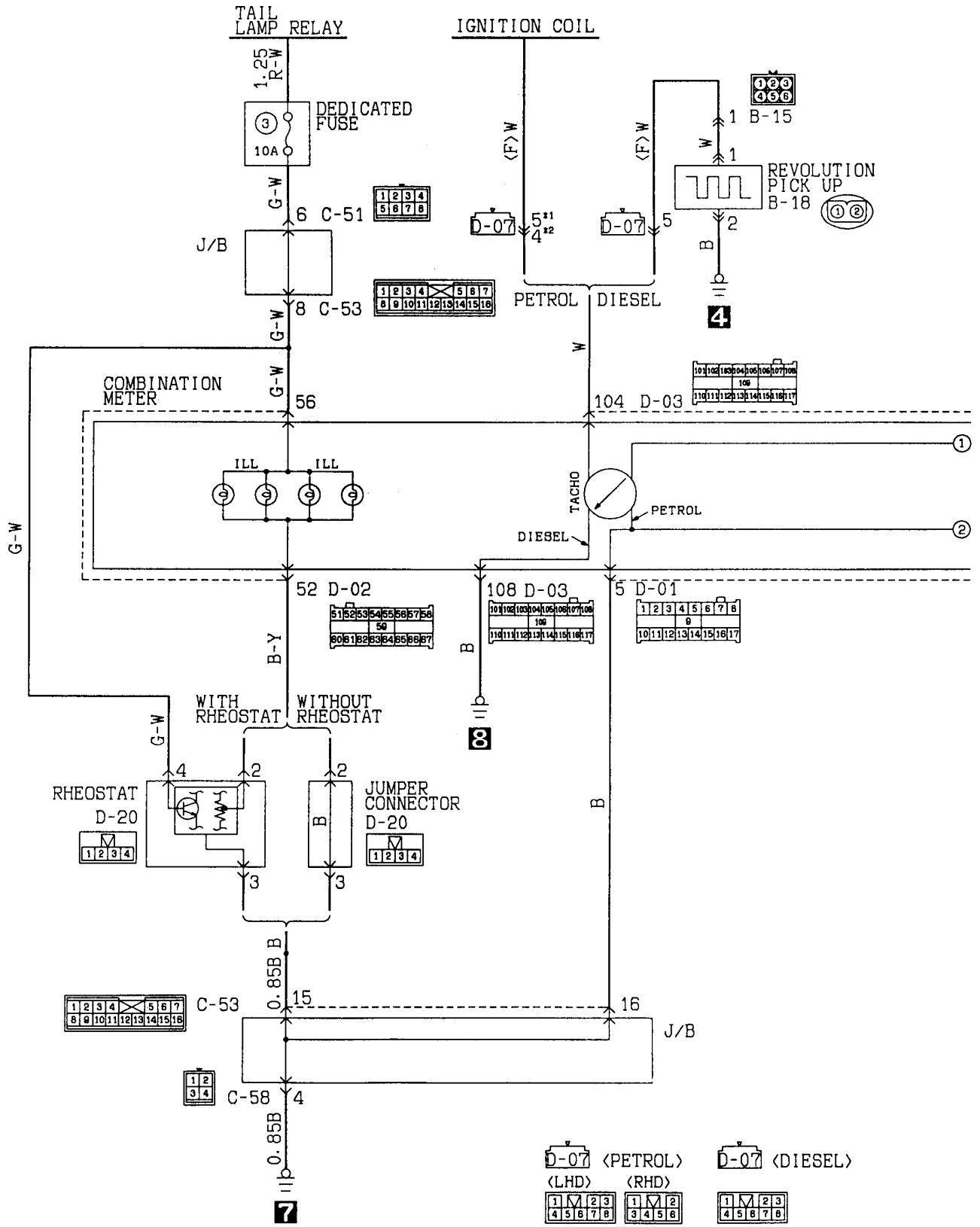

Wire colour code  
 B:Black LG:Light green G:Green L:Blue W:White Y:Yellow SB:Sky blue  
 BR:Brown O:Orange GR:Gray R:Red P:Pink V:Violet



**METER AND GAUGE (See P. 4A-122.)****OPERATION****<Fuel gauge>**

- When the ignition switch is at the "ON" position, the fuel gauge is activated.
- When there is much fuel, the unit's resistance is small and the current flowing in the circuit is great, so the gauge's indicator indicates in the "F" area.
- When there is little fuel, the unit's resistance is high and the current flowing in the circuit is small, so the gauge's indicator indicates in the "E" area.

**<Engine coolant temperature gauge>**

- When the ignition switch is at the "ON" position, the engine coolant temperature gauge is activated.
- When the engine coolant temperature is high, the unit's resistance is low and there is a great flow of current in the circuit, so the gauge's indicator indicates in the "H" area.
- When the engine coolant temperature is low, the unit's resistance is high and there is a small flow of current in the circuit, so the gauge's indicator indicates in the "C" area.

**<Reed switch>**

- This switch generates pulses according to the current vehicle speed and provides a vehicle-speed signal for the control systems using vehicle speeds as an input source (such as transmission control system).

**TROUBLESHOOTING HINTS**

1. Fuel gauge does not operate, or registers incorrectly.
  - (1) The fuel gauge indicates "F" when the fuel gauge unit connector is disconnected and the "1" terminal is earthed.
    - Check fuel gauge.
2. Engine coolant temperature gauge does not operate, or registers incorrectly.
  - (1) The engine coolant temperature gauge indicates "H" when the engine coolant temperature gauge unit (PETROL) or the engine coolant temperature sensor (DIESEL) connector is disconnected and the "1" terminal is earthed.
    - Check the engine coolant temperature gauge unit (PETROL) or the engine coolant temperature sensor (DIESEL).
3. Vehicle-speed-dependent control systems do not operate.
  - Check the reed switch of speedometer.
4. Meter illumination lamp does not come on.
  - (1) Tail lamps do come on.
    - Check the rheostat.
    - Check earth.



**BRAKE WARNING LAMP (See P. 4A-126.)****FUEL WARNING LAMP (See P. 4A-126.)****OIL PRESSURE WARNING LAMP (See P. 4A-127.)****ENGINE COOLANT TEMPERATURE WARNING LAMP (See P. 4A-127.)****OPERATION****<Brake warning lamp>**

- When the brake fluid level goes down below a predetermined level or parking brake lever is pulled, with the ignition switch in the ON position, the brake fluid level sensor is activated or the parking brake switch is turned ON, causing the brake warning lamp to light up.
- On diesel-powered vehicles, when the brake booster vacuum line fails, the vacuum switch is turned ON causing the brake warning lamp to light up.

**<Fuel warning lamp>**

- When the fuel level goes down causing the level sensor to be exposed, with the ignition switch in the ON position, the resistance of level sensor becomes small. When this resistance goes down below the predetermined level, the fuel warning lamp lights up to warn the driver that the amount of fuel still available for use is small.

**<Oil pressure warning lamp>**

- When the lubrication system fails after engine starting resulting in the oil pressure failing to build up, the oil pressure switch turns ON causing the oil pressure warning lamp to light up.

**<Engine coolant temperature warning lamp>**

- When the engine coolant temperature reaches 115°C, the engine coolant temperature switch is switched ON and the warning lamp illuminates.

**4A-126 CIRCUIT DIAGRAM — Brake Warning Lamp/Fuel Warning Lamp**

**BRAKE WARNING LAMP**

**FUEL WARNING LAMP**

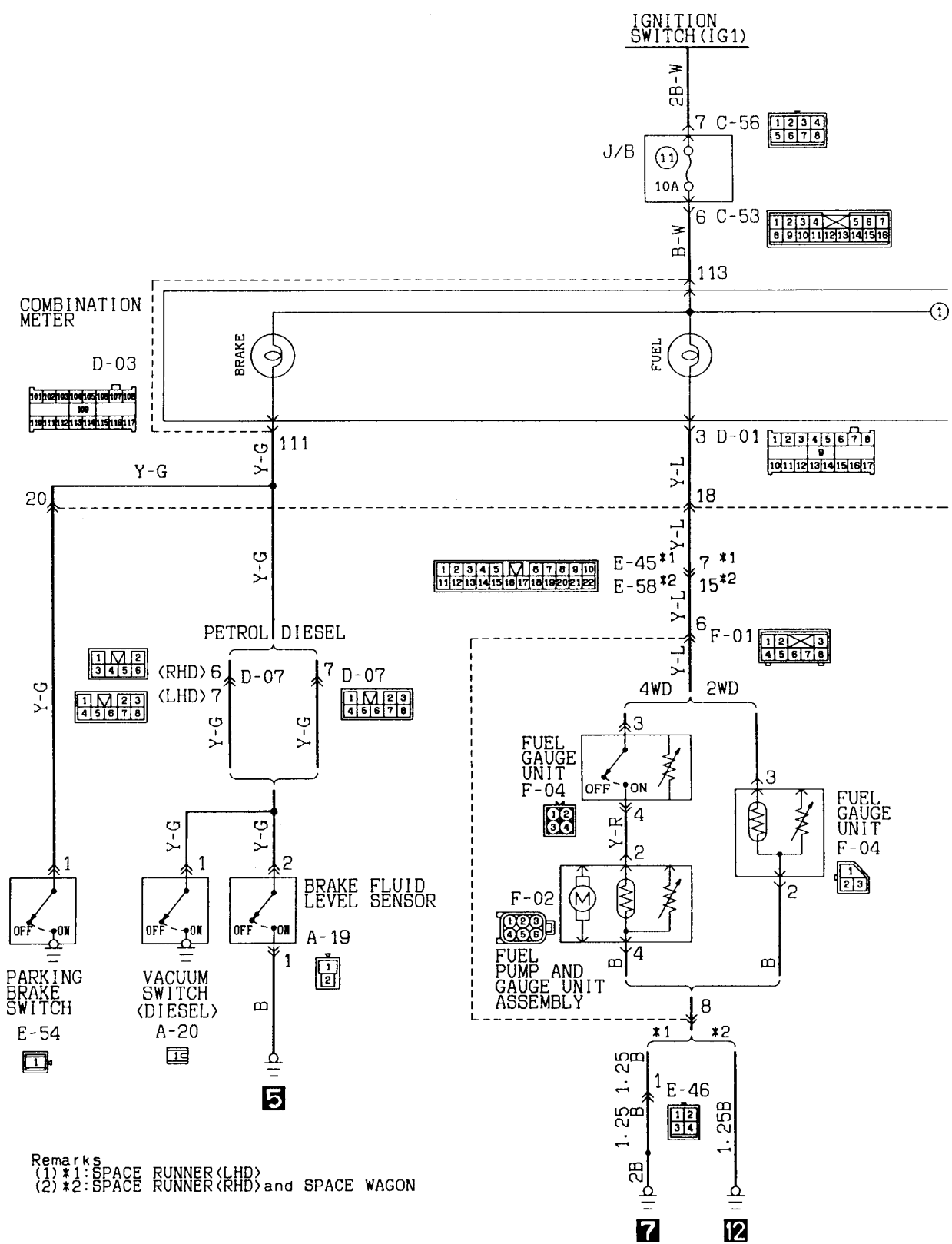

Remarks  
 (1) \*1: SPACE RUNNER (LHD)  
 (2) \*2: SPACE RUNNER (RHD) and SPACE WAGON

Wire colour code  
 B:Black LG:Light green G:Green L:Blue W:White Y:Yellow SB:Sky blue  
 BR:Brown O:Orange GR:Gray R:Red P:Pink V:Violet

KX35-AC-Z1012-EC

OIL PRESSURE WARNING LAMP

ENGINE COOLANT TEMPERATURE WARNING LAMP  
4D68

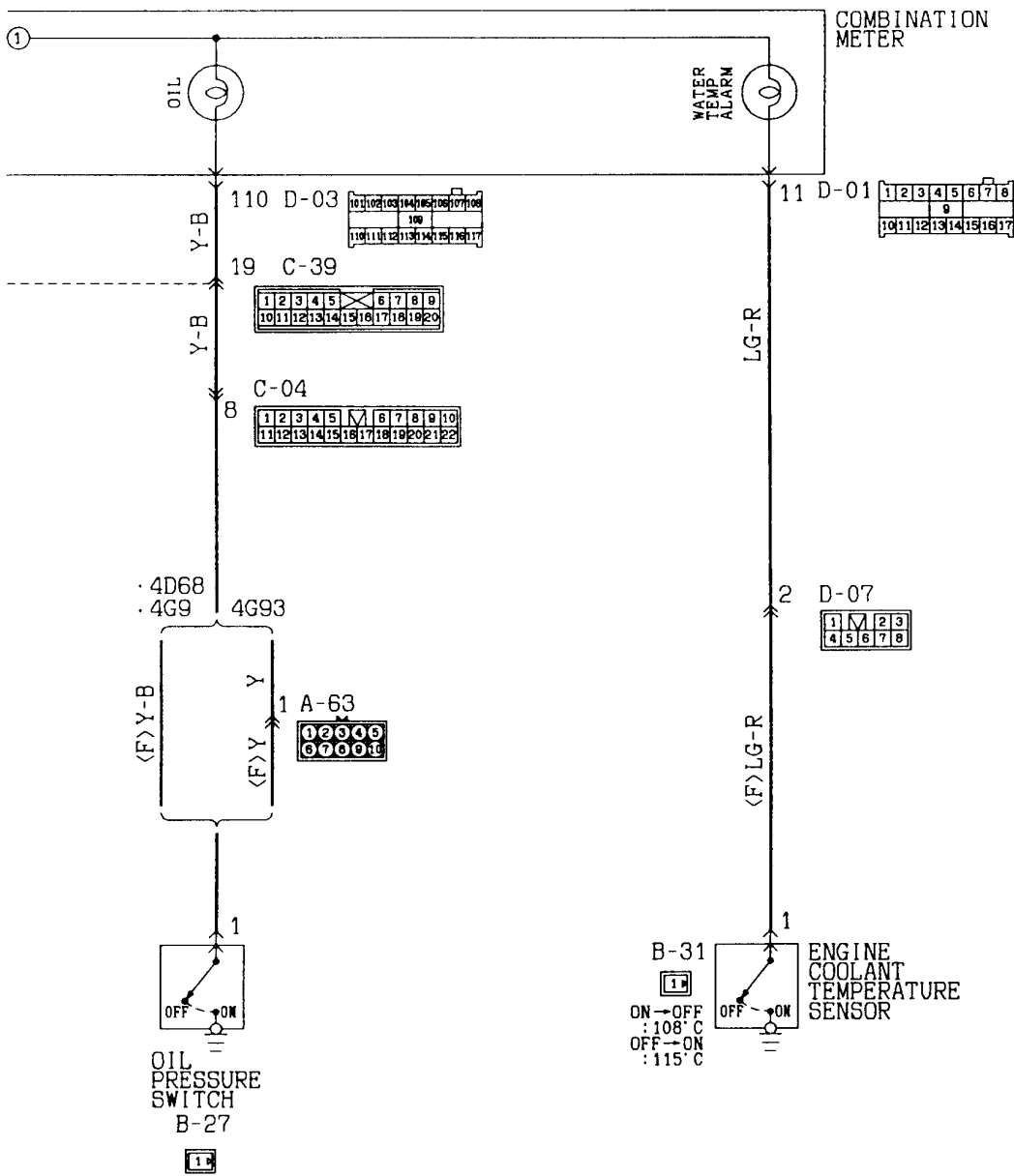

LOW ENGINE OIL LEVEL WARNING LAMP  
SPACE WAGON

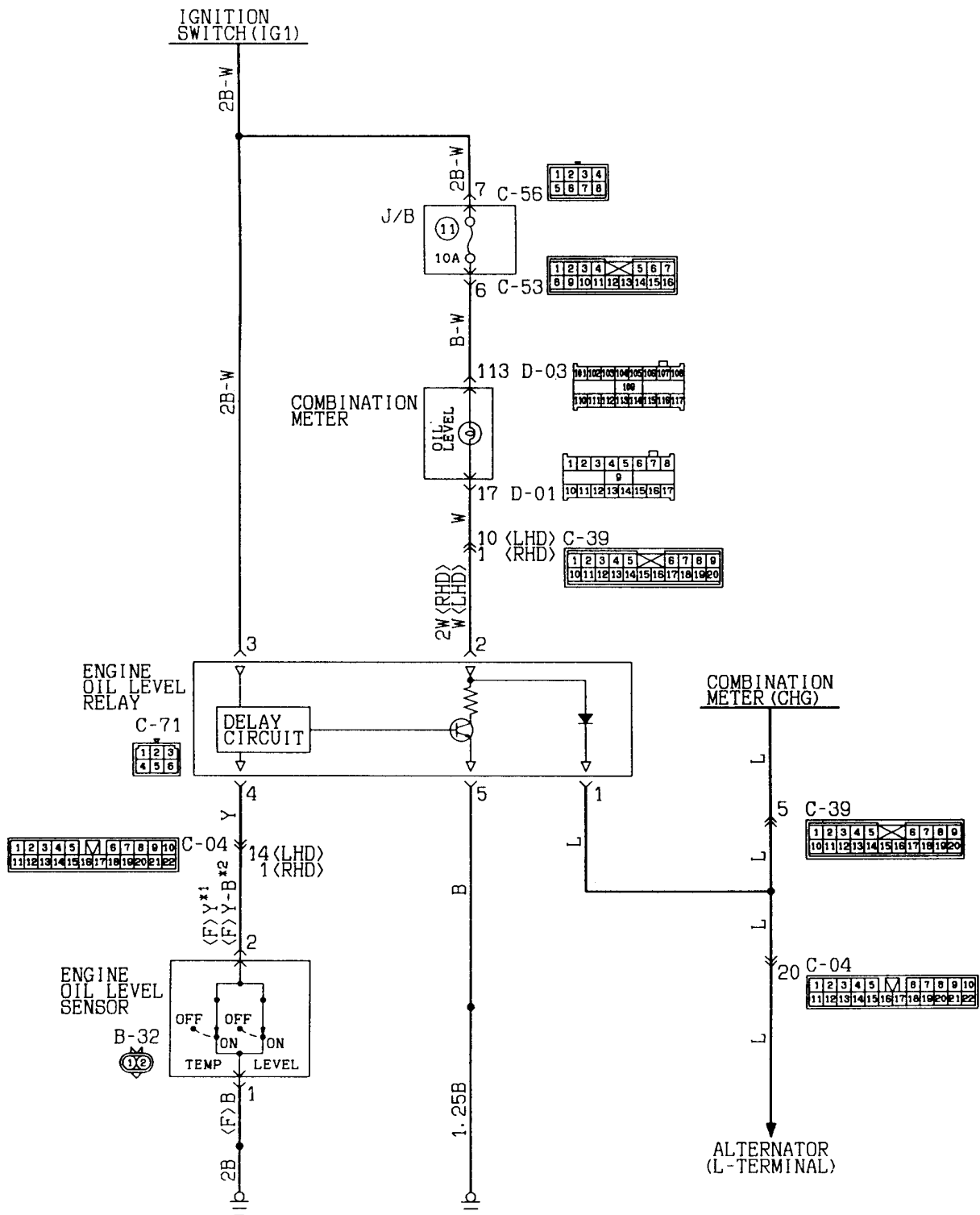

**1** **6**  
(LHD) (RHD)

Remarks  
(1) \*1: 4G6 (LHD)  
(2) \*2: 4G6 (RHD) and 4D68

Wire colour code  
B: Black LG: Light green G: Green L: Blue W: White Y: Yellow SB: Sky blue  
BR: Brown O: Orange GR: Gray R: Red P: Pink V: Violet

**LOW ENGINE OIL LEVEL WARNING LAMP (See P. 4A-128.)**

**OPERATION**

- When the ignition switch is turned to the "ON" position (in the state where the engine is stopped), electric current will flow to terminal "L" of the alternator through the multi-purpose fuse No. ①, low engine oil level warning lamp and engine oil level relay and the low engine oil level warning lamp will also light up.
- When the engine starts, the charging voltage will be applied to the terminal "L" of the alternator. Therefore, the low engine oil level warning lamp will go out.
- When the engine oil temperature rises to approx. 55°C, the engine oil level sensor (TEMP) provided in the oil pan will be turned off.
- When the engine oil amount in the oil pan drops below the set level in this state, the engine oil level sensor (LEVEL) will be turned off to apply the voltage to the delay circuit.
- If the "OFF" state continues for approx. 40 seconds or more, the power transistor will be turned on to light the low engine oil level warning lamp to indicate a shortage of engine oil.

**Remark**

The delay circuit is provided to prevent the low engine oil level warning lamp from going on even if the engine oil level sensor is temporarily turned off due to cornering or other running conditions of the vehicle.

POWER WINDOW  
SPACE RUNNER (L.H. drive vehicles)

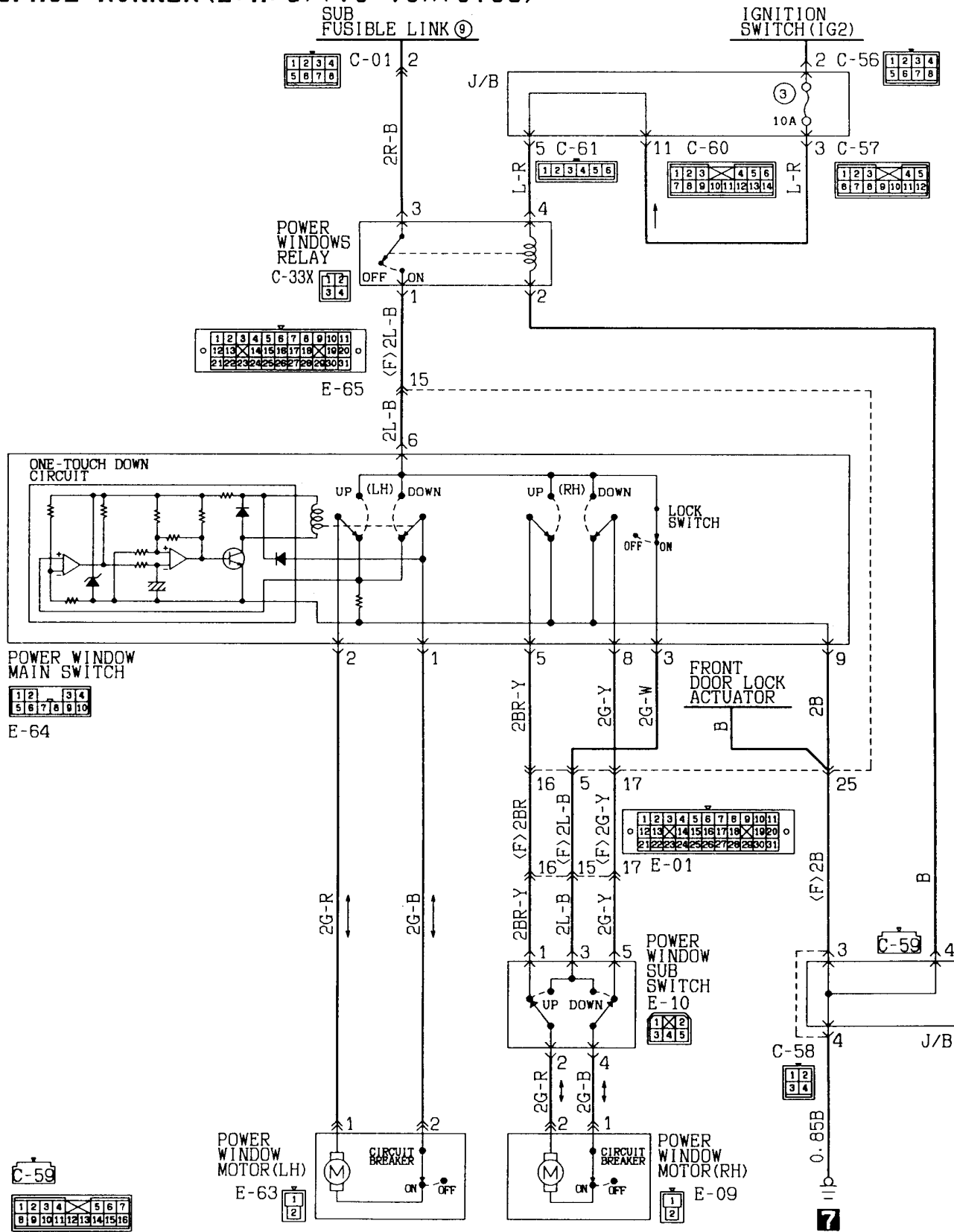

KX35-AC-Z1117-EC

POWER WINDOW  
SPACE RUNNER (R.H. drive vehicles)

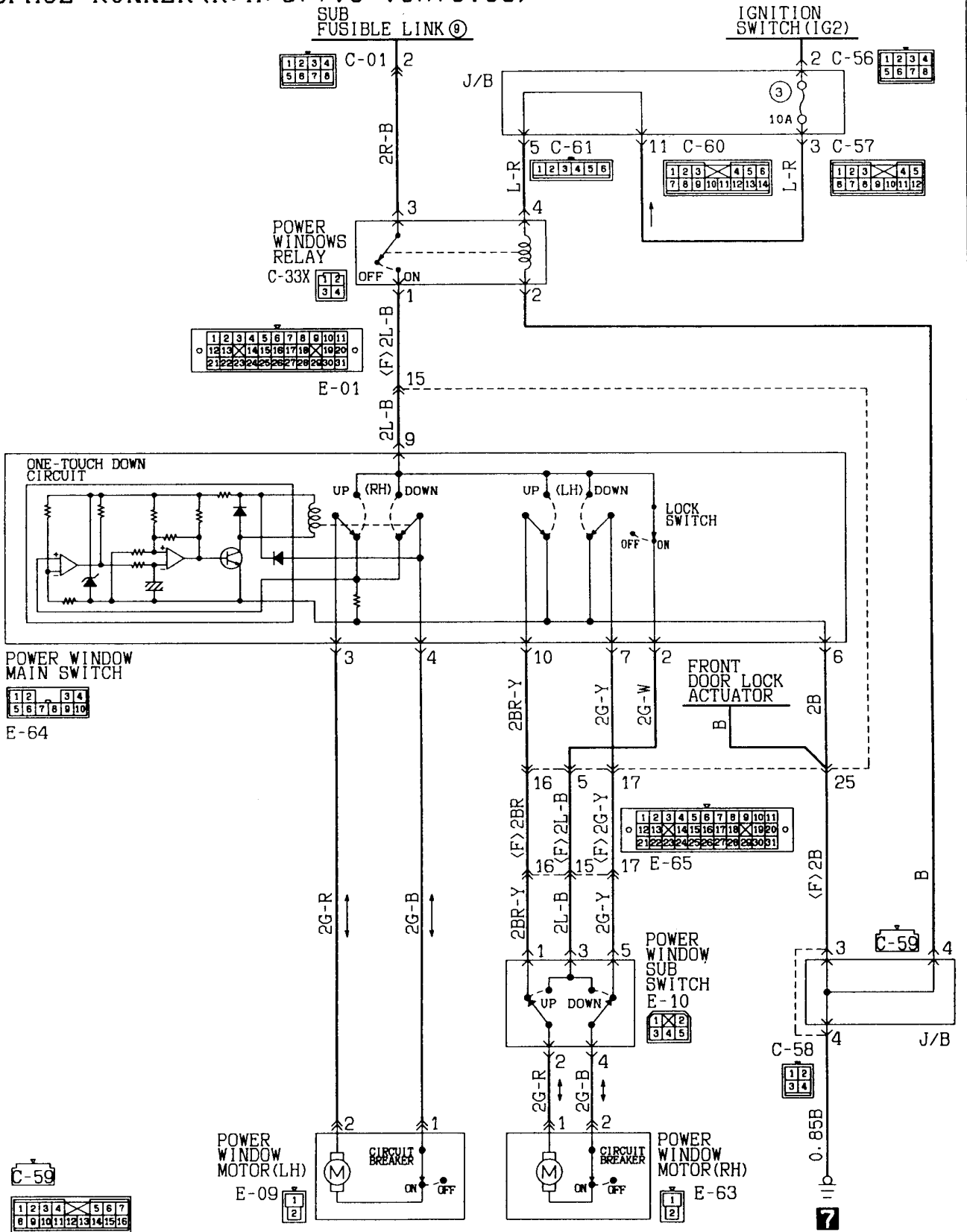

KX35-AC-Z1118-EC

POWER WINDOW  
SPACE WAGON (L. H. drive vehicles)

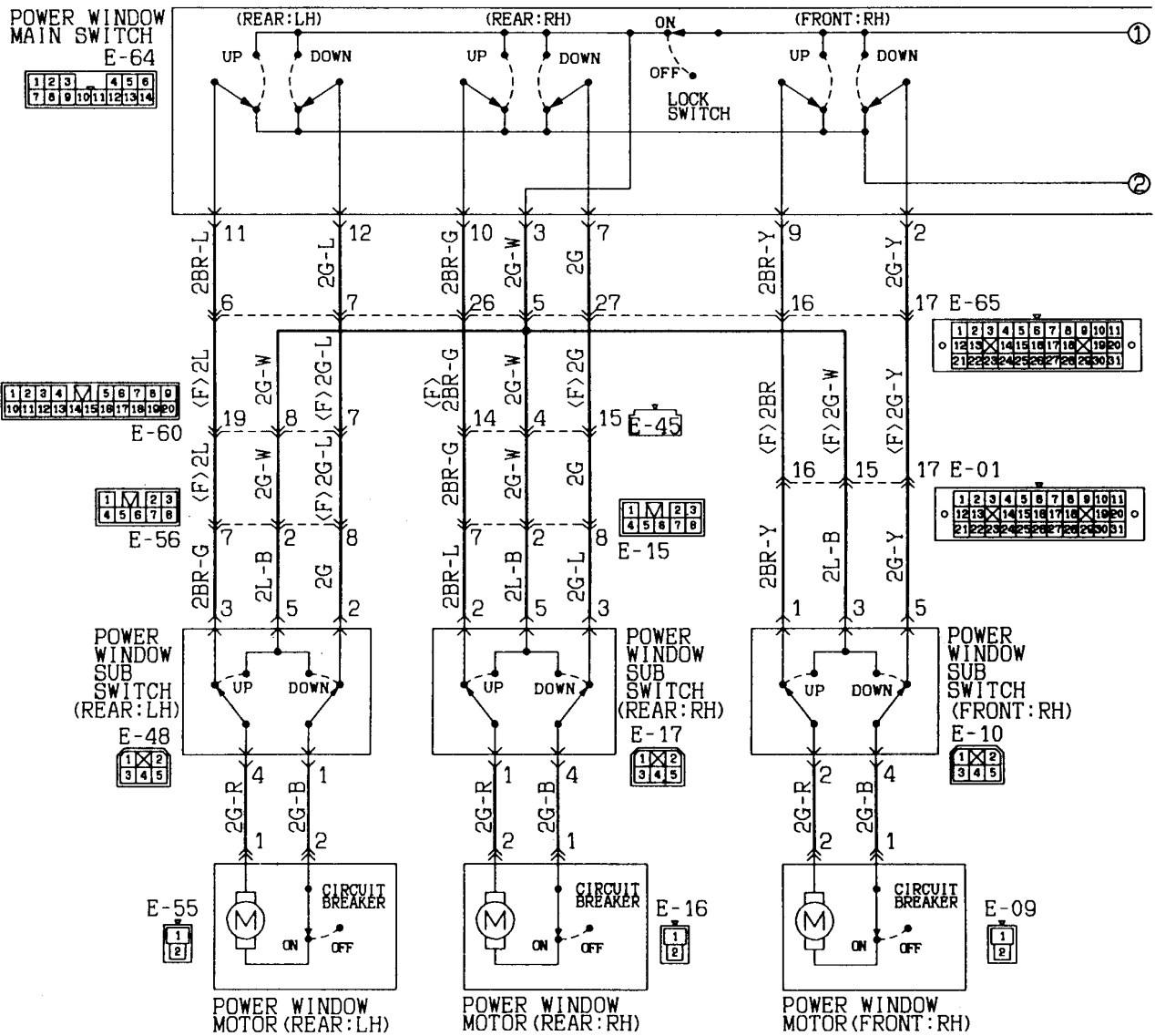

KX35-AC-Z1119-EC



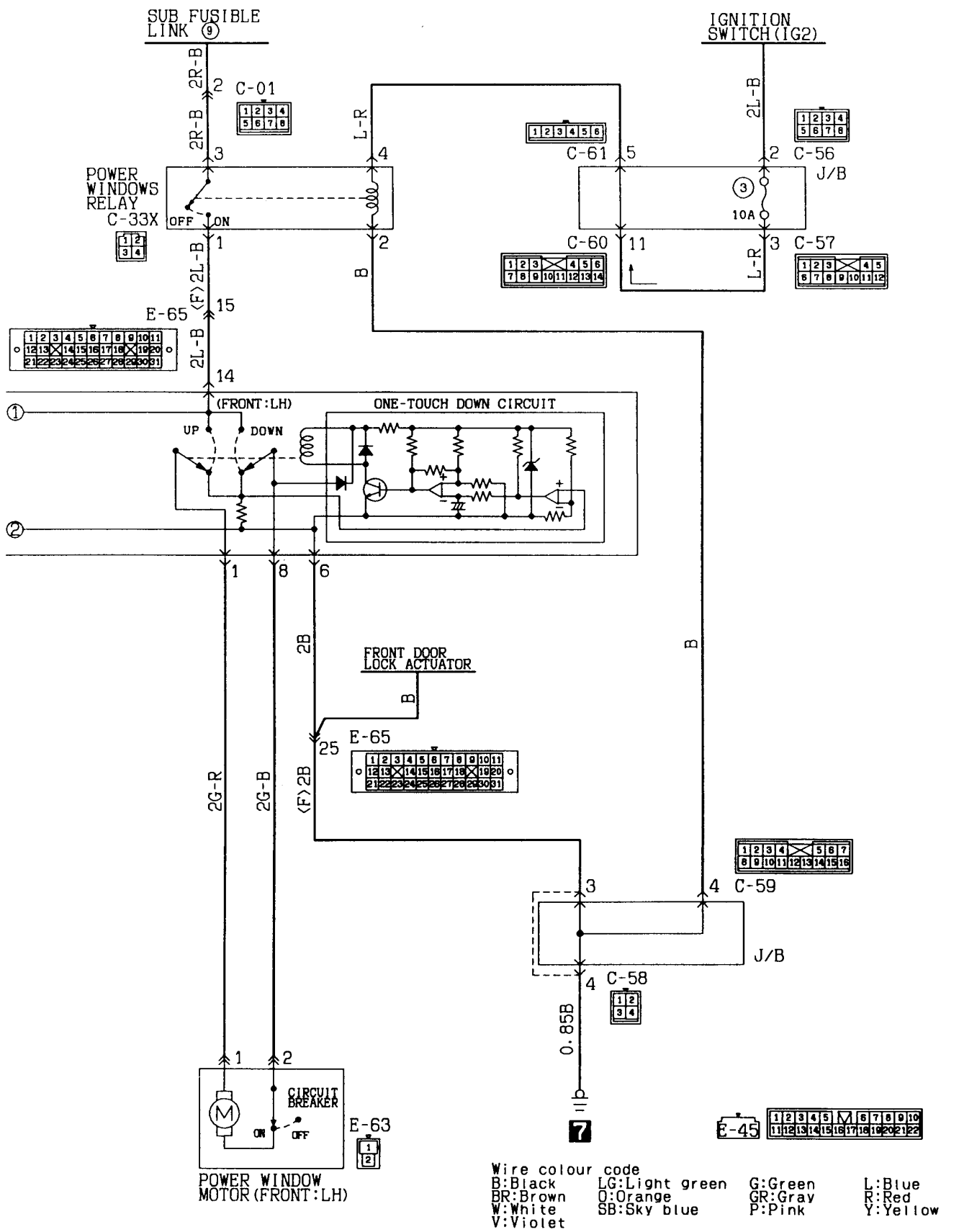

POWER WINDOW  
SPACE WAGON <R. H. drive vehicles>

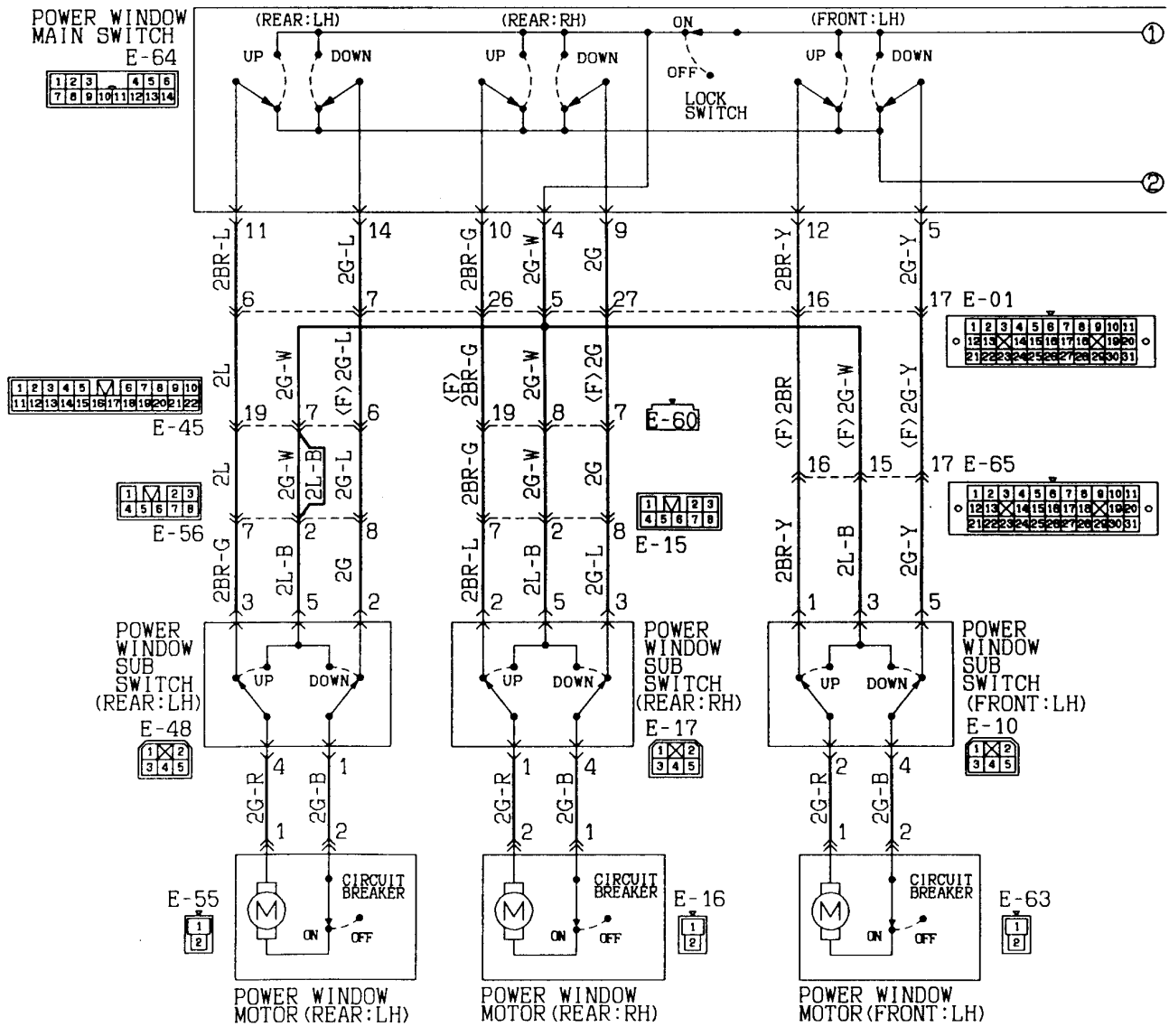

KX35-AC-Z1120-EC

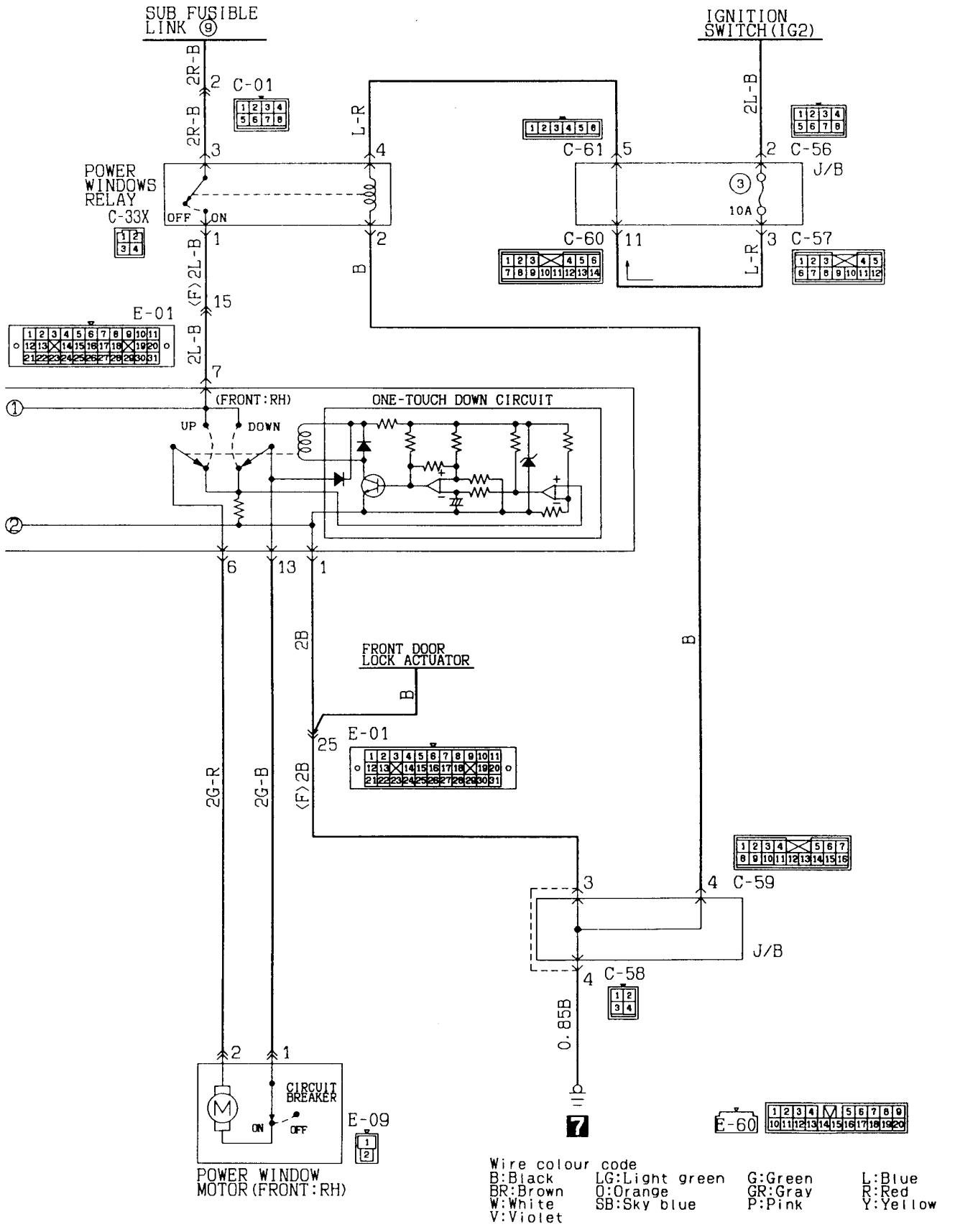

Wire colour code  
 B:Black LG:Light green G:Green L:Blue  
 BR:Brown O:Orange GR:Gray R:Red  
 W:White SB:Sky blue P:Pink Y:Yellow  
 V:Violet

**POWER WINDOW (See P. 4A-130, 131, 132, 134.)****OPERATION**

- When the power window (main or sub) switch is depressed (UP or DOWN) with the ignition switch in the ON position, current flows through sub-fusible link No. ⑨ to the power window motor. This energizes the power window motor causing the door window glass to open or close.
- When the DOWN side the power window main switch (driver's seat side switch) is depressed all the way, it is locked in the depressed position and the power window motor is operated until the door glass is fully opened.
- When the power window lock switch is placed in the LOCK (OFF) position, operating a switch other than the ones for the driver's and front passenger's side window (main) does not cause the power window motor to be operated.
- The power window motor is provide with a circuit breaker that protects the motor from damage caused by overcurrent.  
Reference: Circuit breaker characteristics Restricts the motor at room temperature [20 to 25°C]; Opens following 4-to-40sec. initial energization time;  
Resets within 60 seconds if left open thereafter.

**TROUBLESHOOTING HINTS**

1. All door glasses cannot be opened or closed.
  - Check the sub-fusible link No. ⑨.
  - Check the multi-purpose fuse No. ③.
  - Check the power window relay.
  - Check the power window main switch.
2. Some door glass cannot be opened or closed.
  - (1) Neither power window main nor sub switch is activated.
    - Check the power window main switch.
    - Check the defective power window motor.
  - (2) Either power window main or sub switch is inoperative.
    - Check the inoperative power window switch.
3. One-touch switch function is not operational.
  - Replace the power window main switch.

**CENTRAL DOOR LOCKING SYSTEM (See P. 4A-138, 140, 142, 144.)****OPERATION****1. Operation with the inside lock knob on the driver's side (including door lock key operation).**

- If the inside lock knob on the driver's side is locked (or unlocked), the switch in the front door lock actuator (driver's side) goes off (or on) and the lock side (or unlock side) relay in the door lock control unit goes on for 0.5 second and the actuators for all doors (including tailgate) function.

**2. Operation with the door lock key.**

- If the door lock key (passenger's side) is turned to the lock side (or unlock side), the lock side (or unlock side) relay in the door lock control unit goes on for 0.5 second and the actuators for all doors (including tailgate) function.

**3. Operation with door lock switch**

- If the door lock switch is locked (or unlocked), the lock side (or unlock side) relay in the door lock control unit goes on for 0.5 second and the actuators for all doors (including tailgate) function.

**Remark**

- Each door lock actuator is provided with a PTC thermistor to prevent the motor from being damaged by overheating. This results in the actuator not properly operating at times when the central door lock is frequently used; the actuator is operational if it resumes normal operation within several minutes.

**TROUBLESHOOTING HINTS**

1. Any one of the door lock actuators is inoperative.
  - Check the defective door actuator.
2. Locking (or unlocking) is possible with the door lock key (passenger's side) but locking (or unlocking) is not possible with the inside lock knob on the driver's side (including door lock key operation).
  - Inspect the front door lock actuator (driver's side)
  - Inspect the door lock control unit.
3. Locking (or unlocking) is possible with the inside lock knob (including door lock key operation) on the driver's side but locking (or unlocking) is not possible with the door lock key (passenger's side).
  - Inspect the door lock key cylinder (passenger's side).
  - Inspect the door lock control unit.



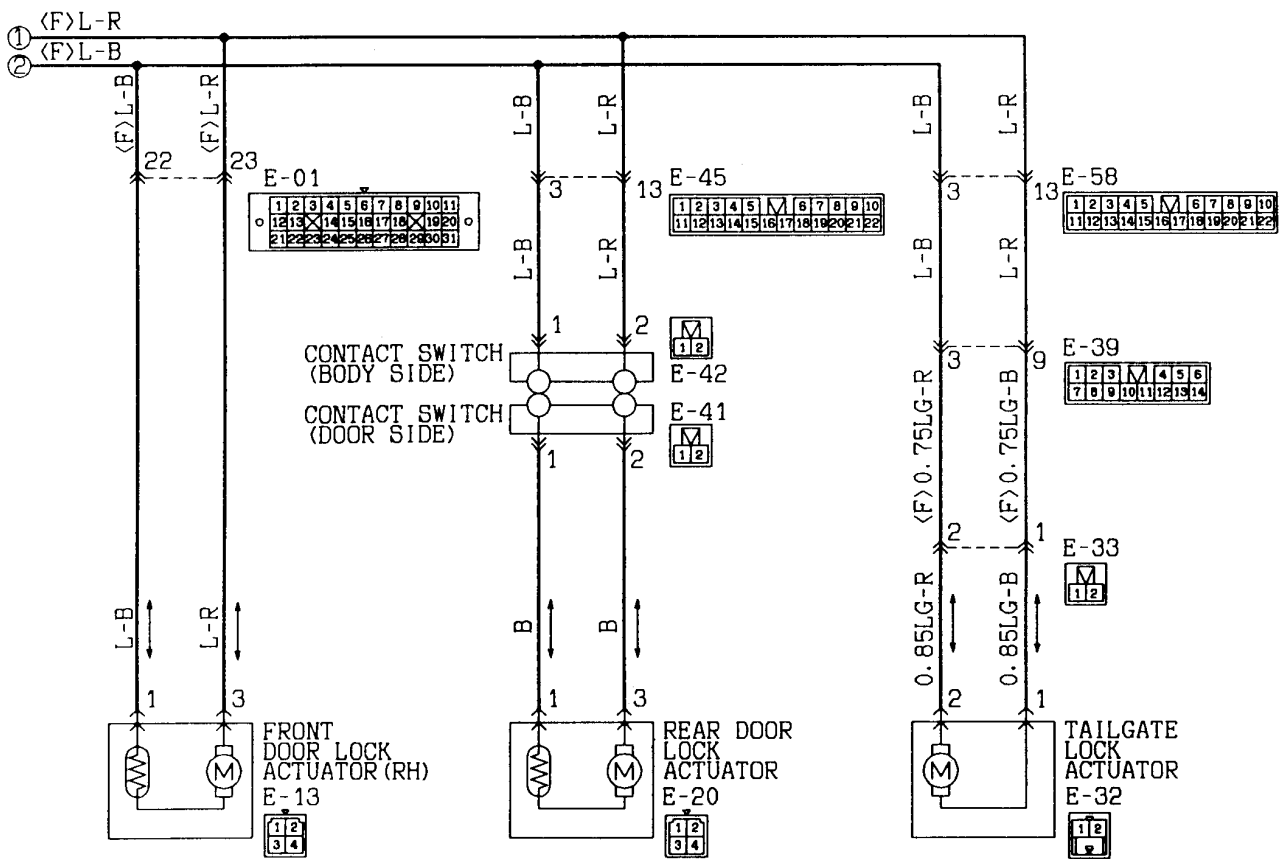

Wire colour code  
 B:Black LG:Light green G:Green L:Blue W:White Y:Yellow SB:Sky blue  
 BR:Brown O:Orange GR:Gray R:Red P:Pink V:Violet

# CENTRAL DOOR LOCKING SYSTEM SPACE RUNNER (R.H. drive vehicles)

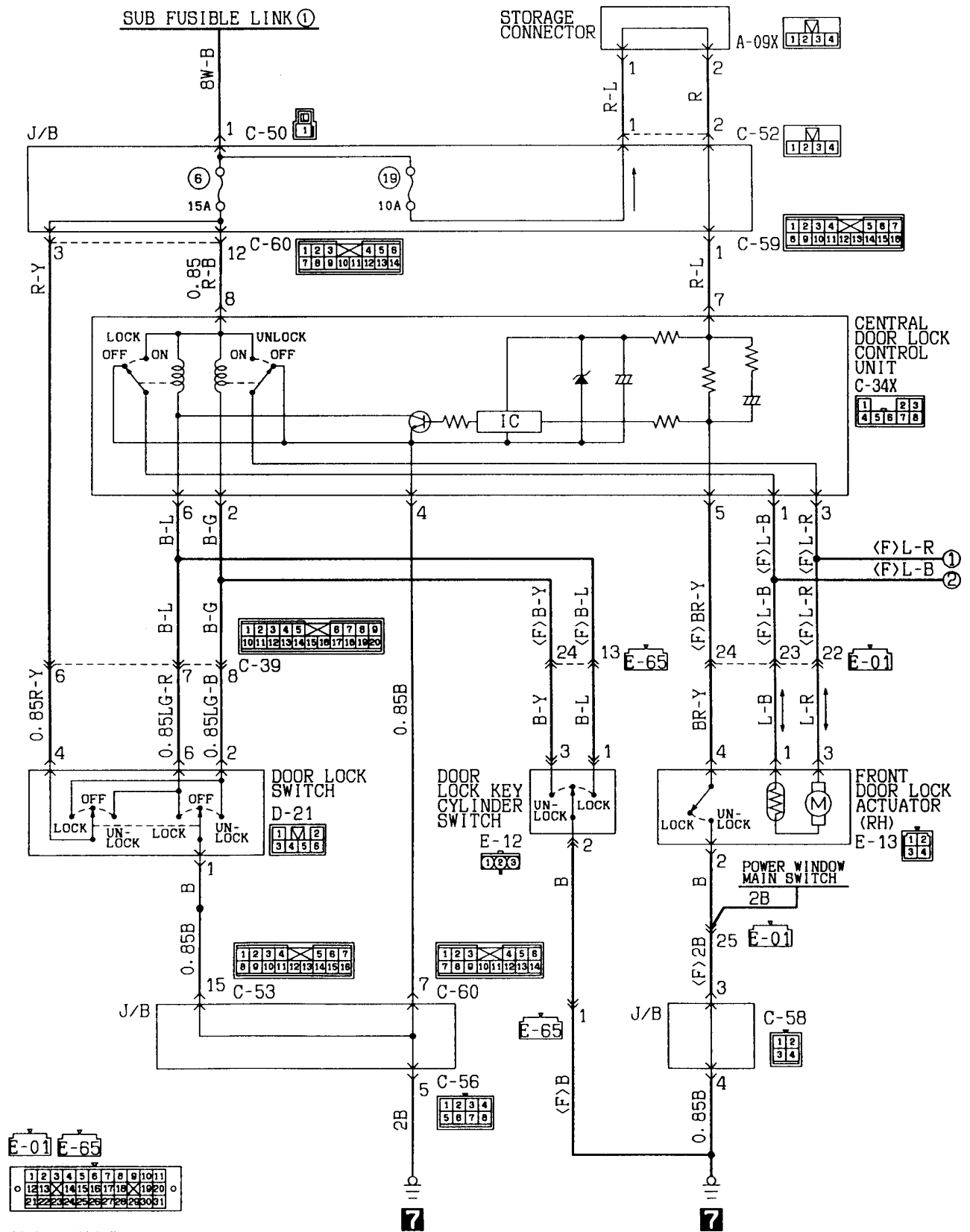

KX35-AC-Z1122-EC



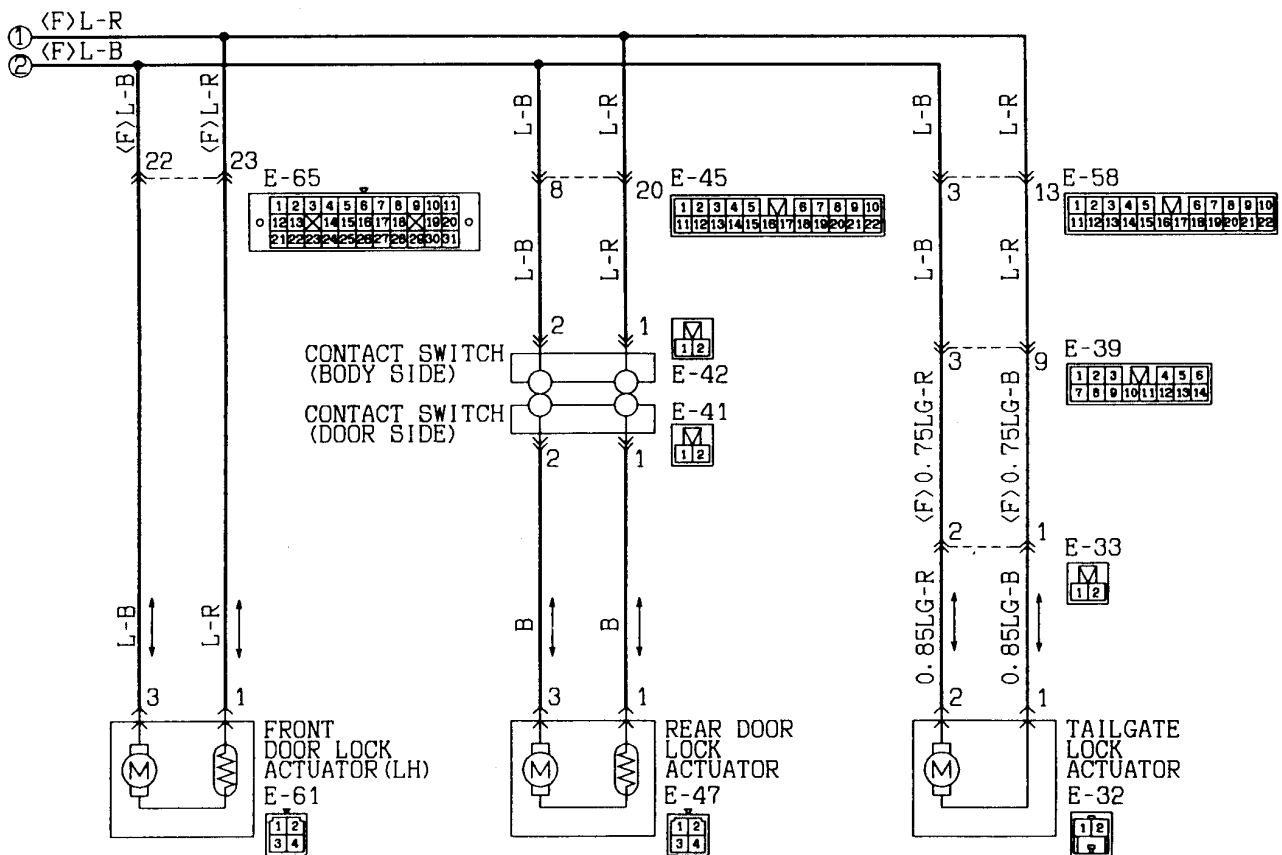

Wire colour code  
 B:Black LG:Light green G:Green L:Blue W:White Y:Yellow SB:Sky blue  
 BR:Brown O:Orange GR:Gray R:Red P:Pink V:Violet

CENTRAL DOOR LOCKING SYSTEM  
SPACE WAGON (L.H. drive vehicles)

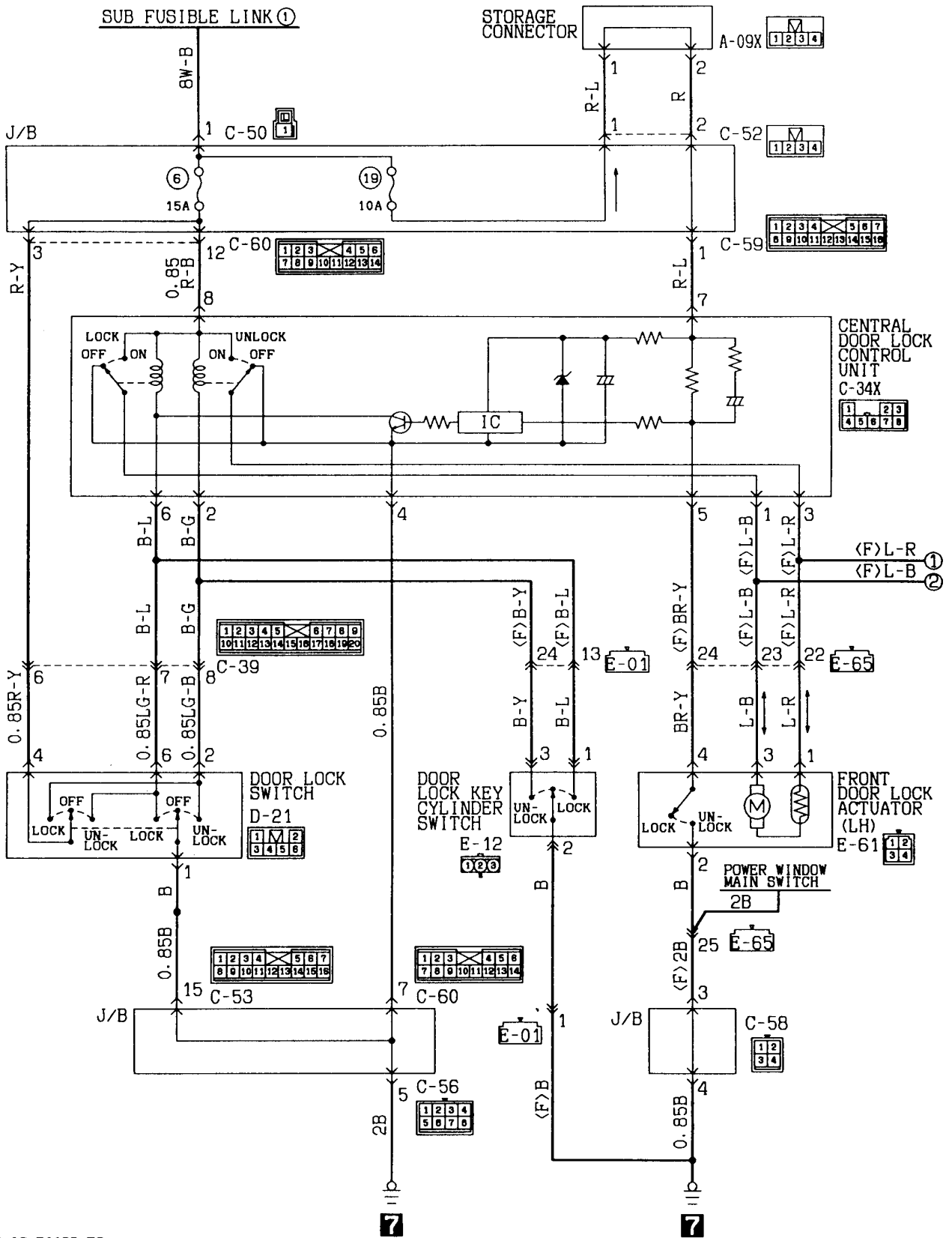

KX35-AC-Z1123-EC

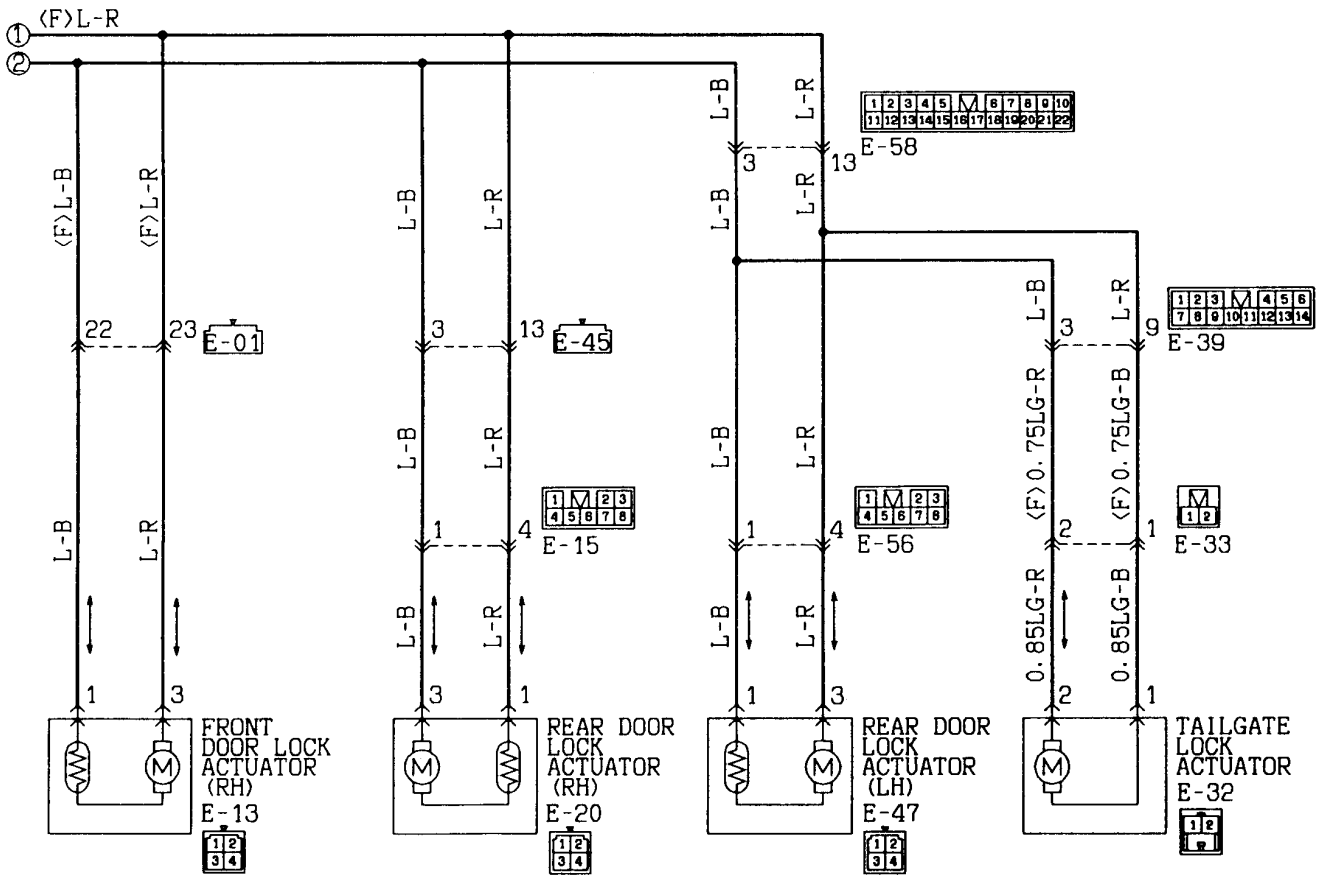
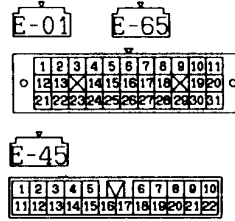

Wire colour code  
 B:Black    LG:Light green    G:Green    L:Blue    W:White    Y:Yellow    SB:Sky blue  
 BR:Brown    O:Orange    GR:Gray    R:Red    P:Pink    V:Violet

# CENTRAL DOOR LOCKING SYSTEM SPACE WAGON (R. H. drive vehicles)

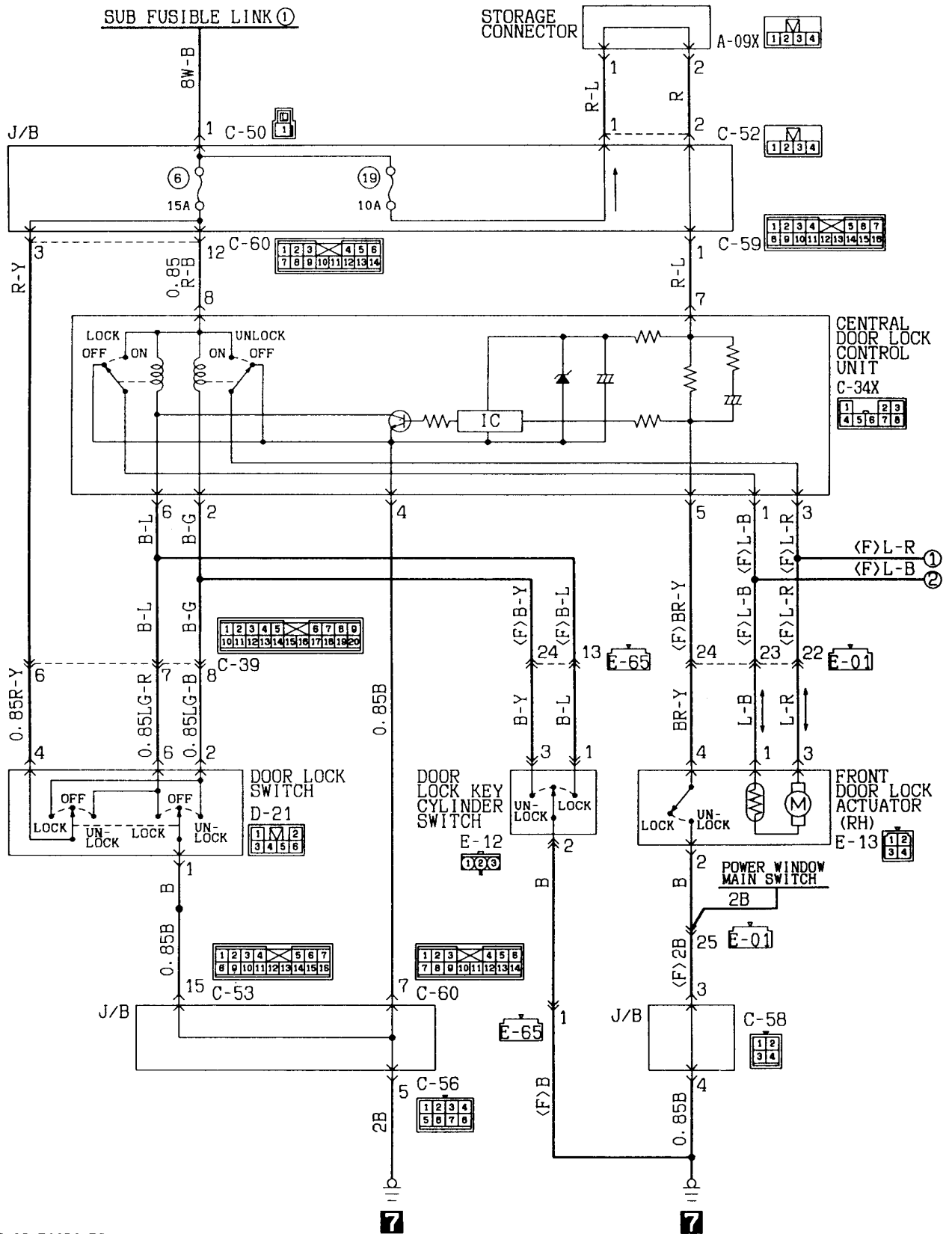

KX35-AC-Z1124-EC

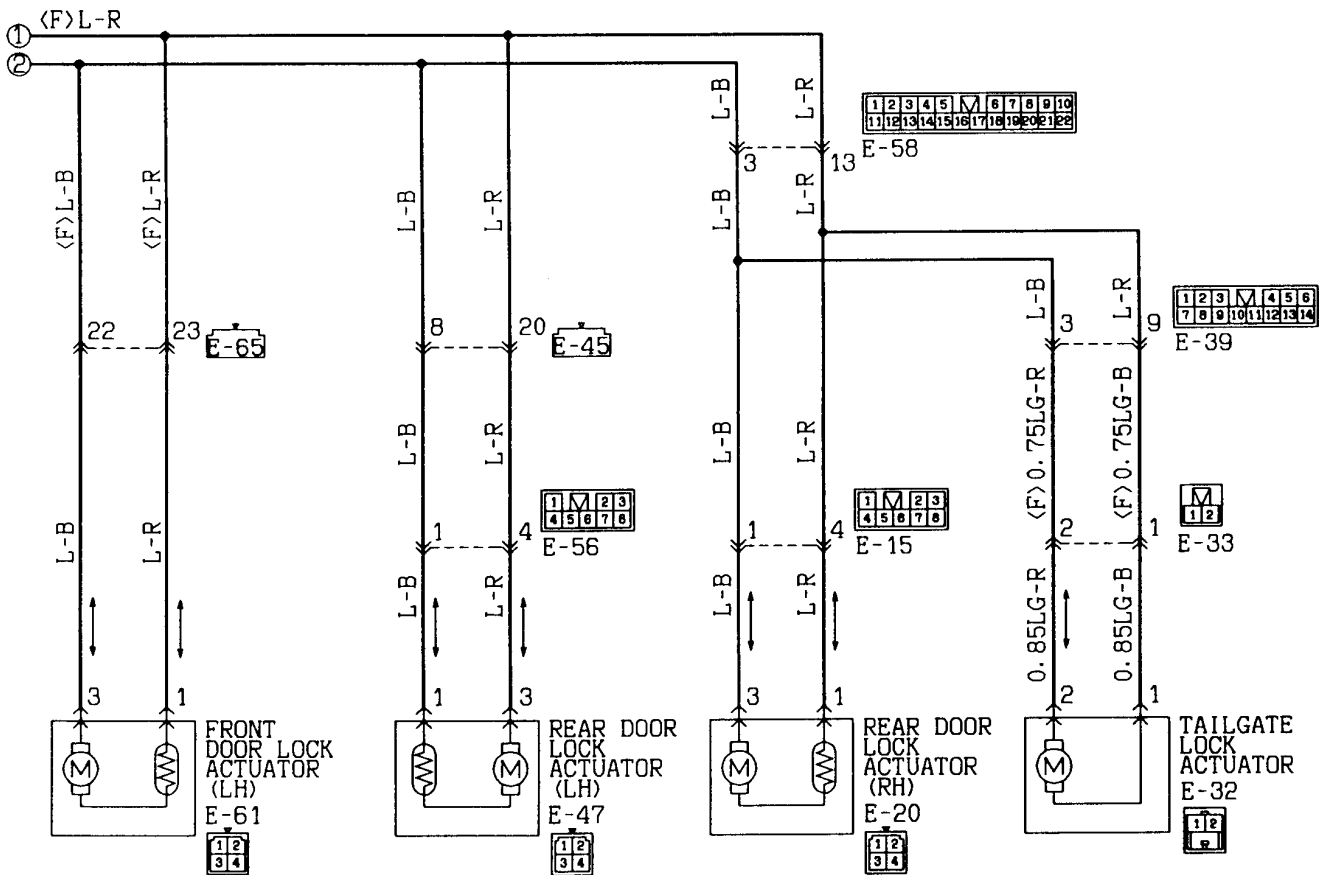
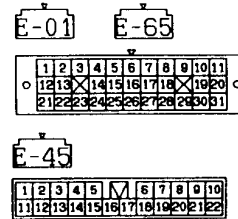

Wire colour code  
 B:Black LG:Light green G:Green L:Blue W:White Y:Yellow SB:Sky blue  
 BR:Brown O:Orange GR:Gray R:Red P:Pink V:Violet

TAILGATE LOCKING SYSTEM  
SPACE RUNNER

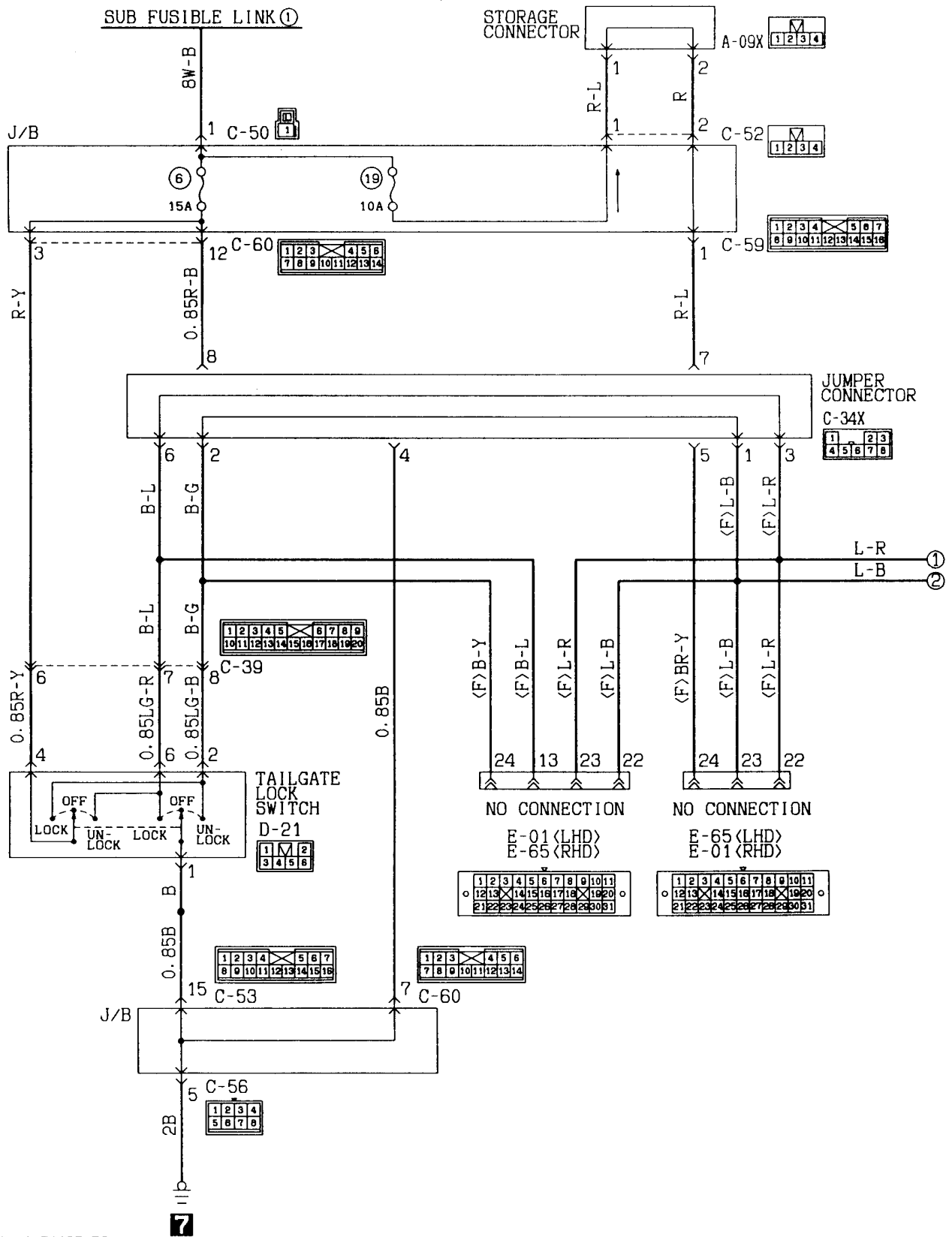

KX35-AC-21125-EC

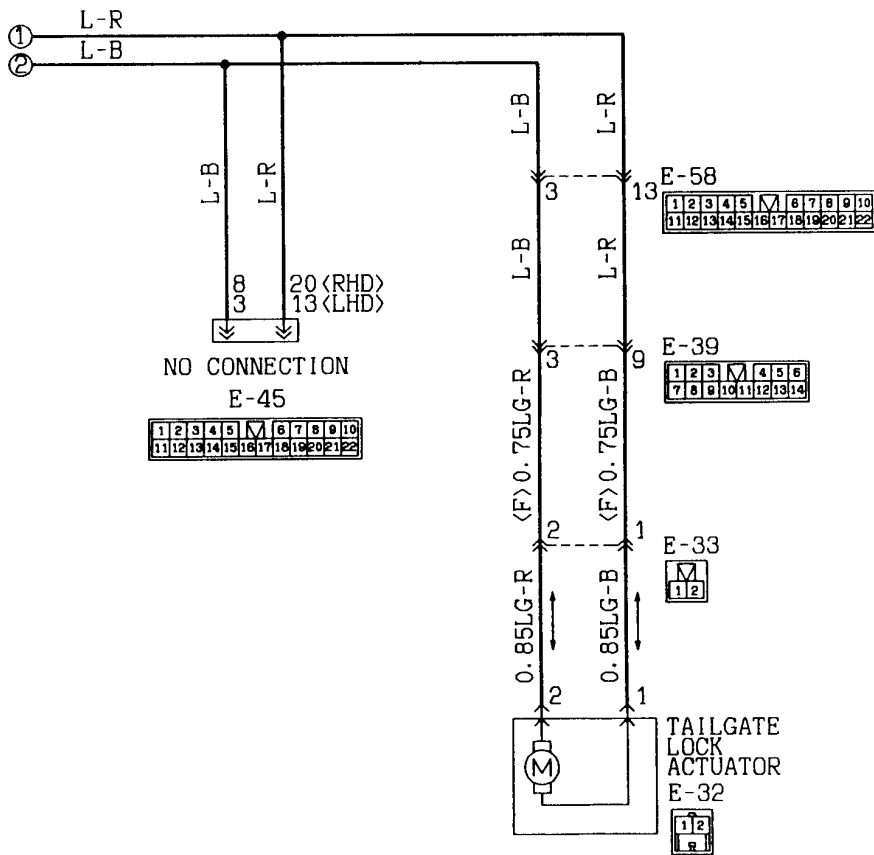

Wire colour code  
 B:Black LG:Light green G:Green L:Blue W:White Y:Yellow SB:Sky blue  
 BR:Brown O:Orange GR:Gray R:Red P:Pink V:Violet

TAILGATE LOCKING SYSTEM  
SPACE WAGON

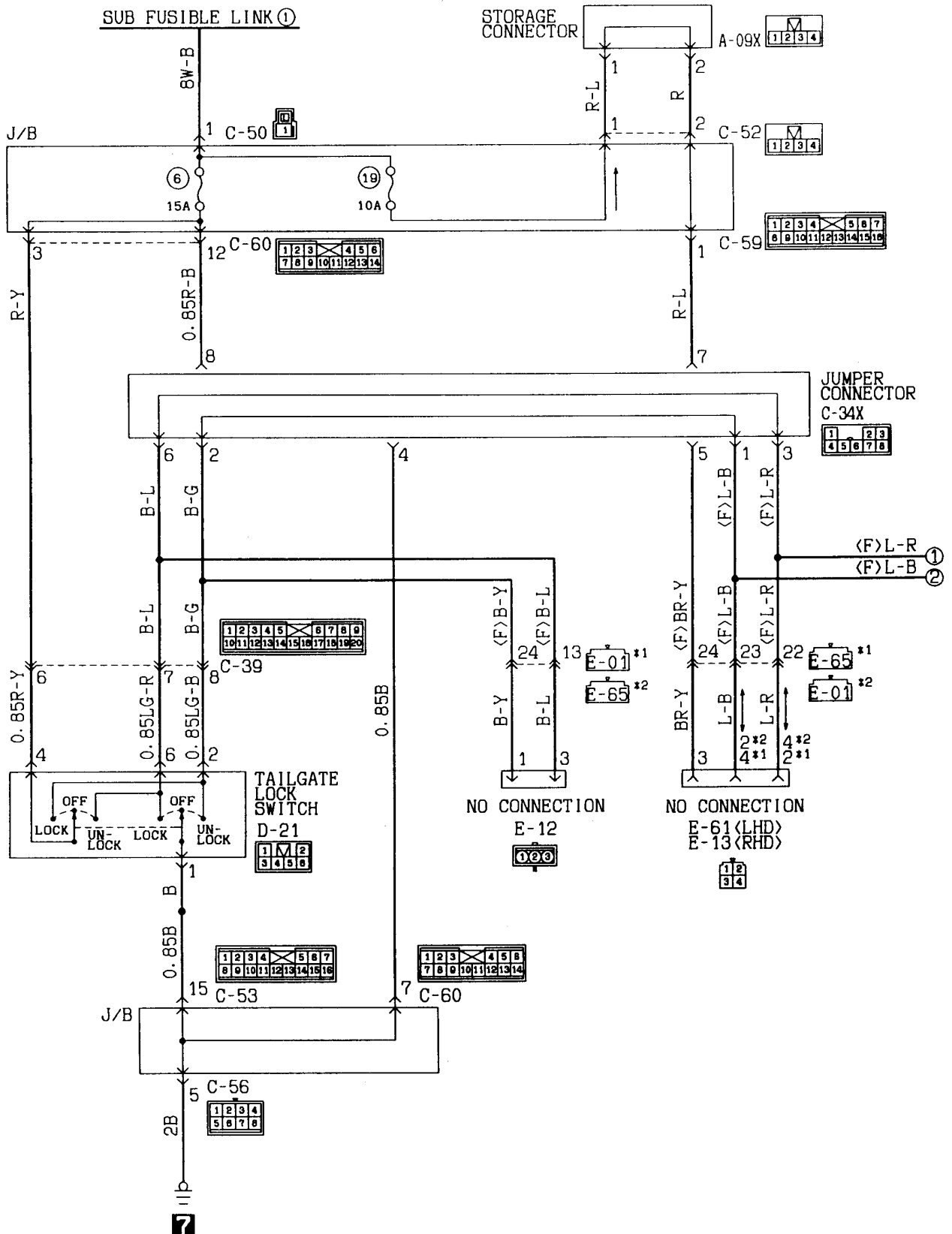

KX35-AC-Z1126-EC



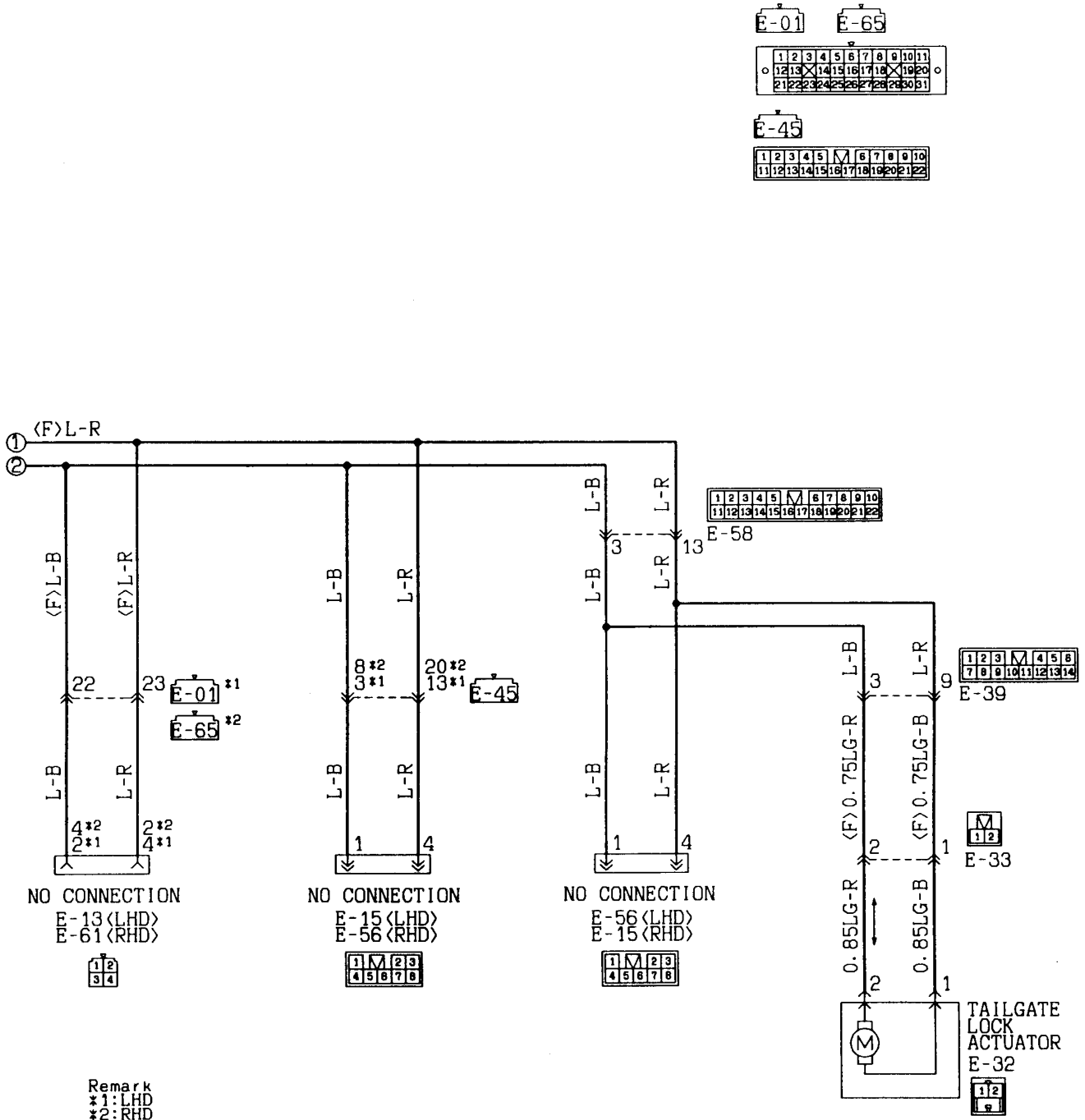

HEATER AND AIR CONDITIONER  
4G93

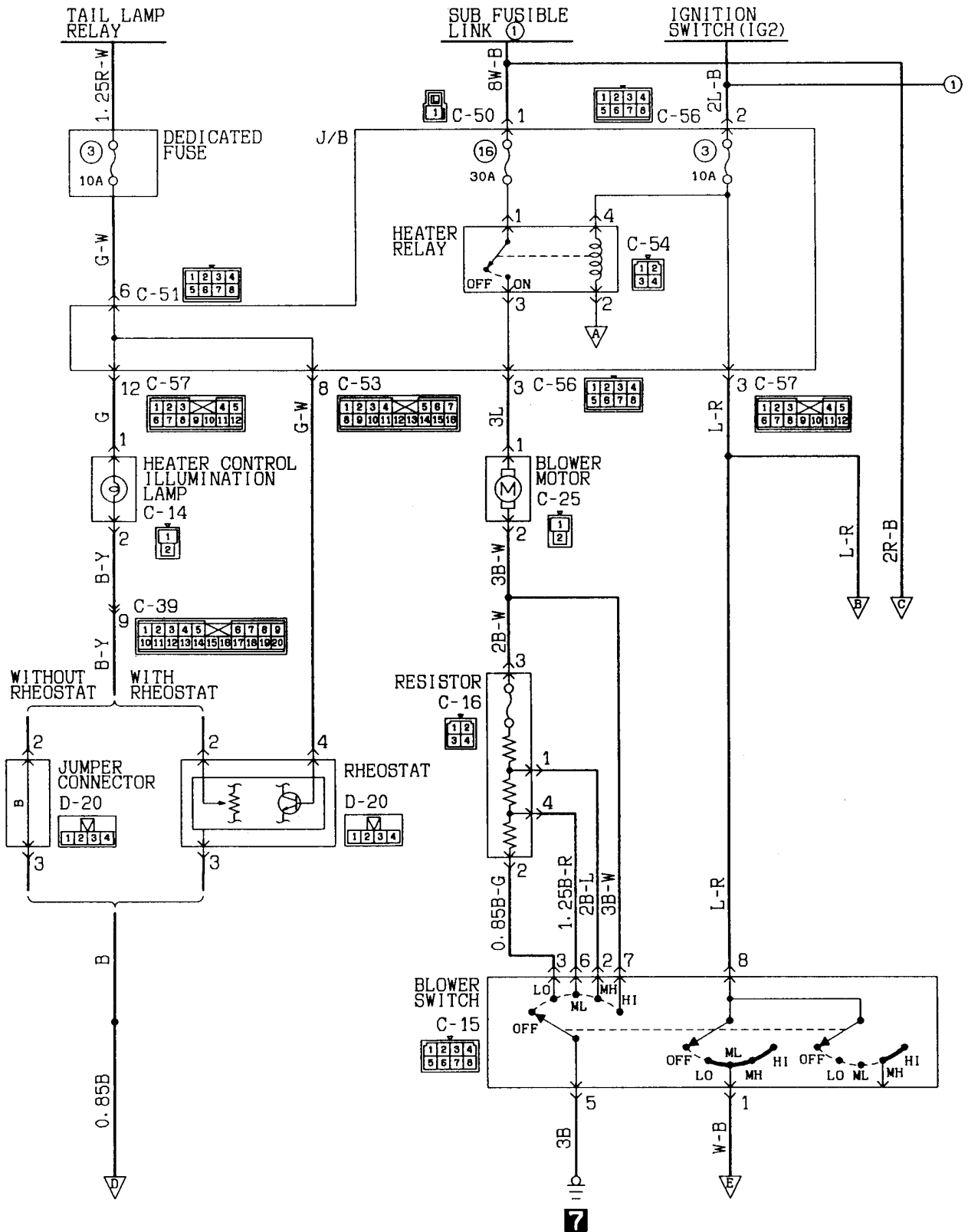

KX35-AC-Z1209-EC

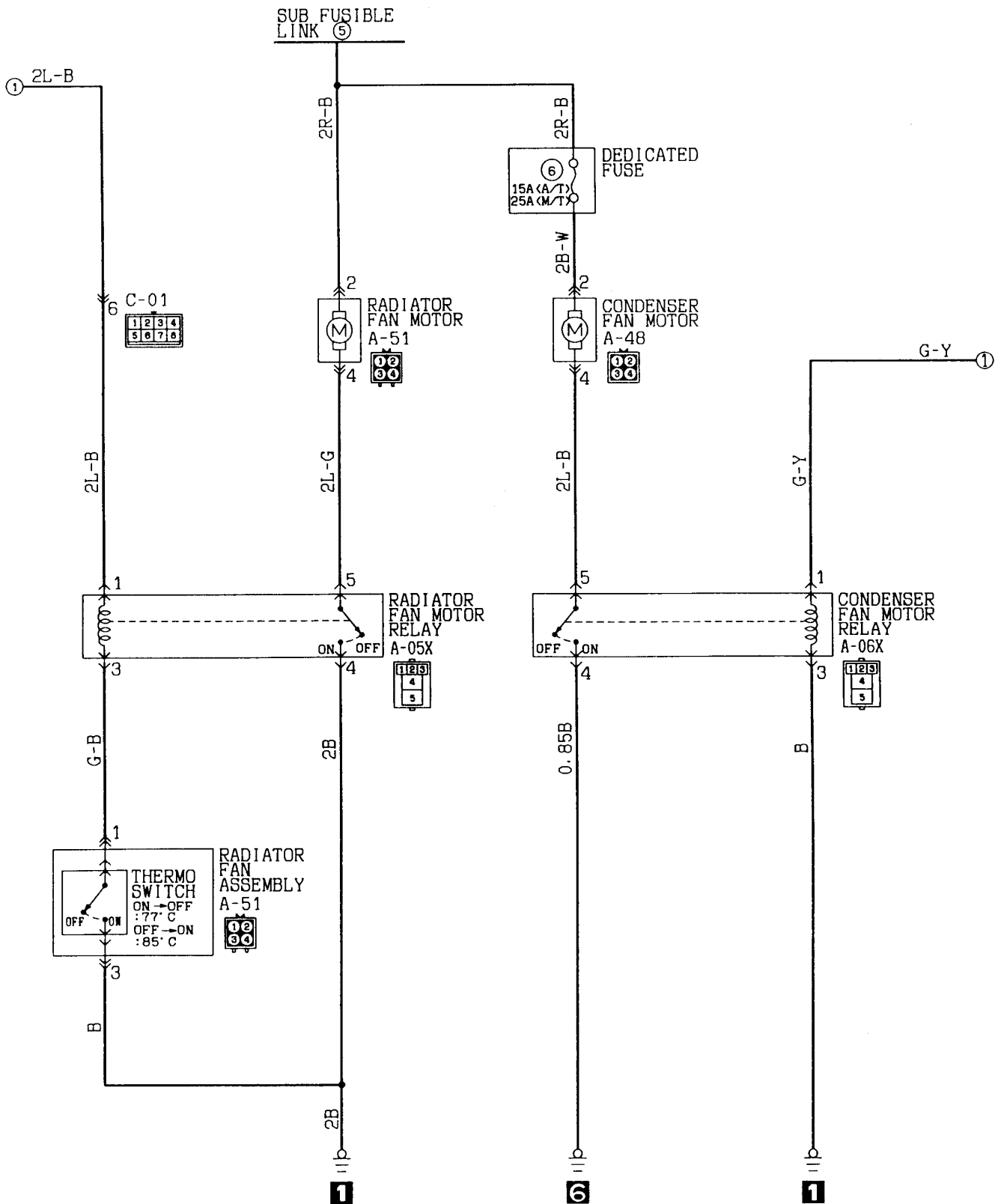

Wire colour code  
 B:Black LG:Light green G:Green L:Blue W:White Y:Yellow  
 BR:Brown O:Orange GR:Gray R:Red P:Pink V:Violet SB:Sky blue

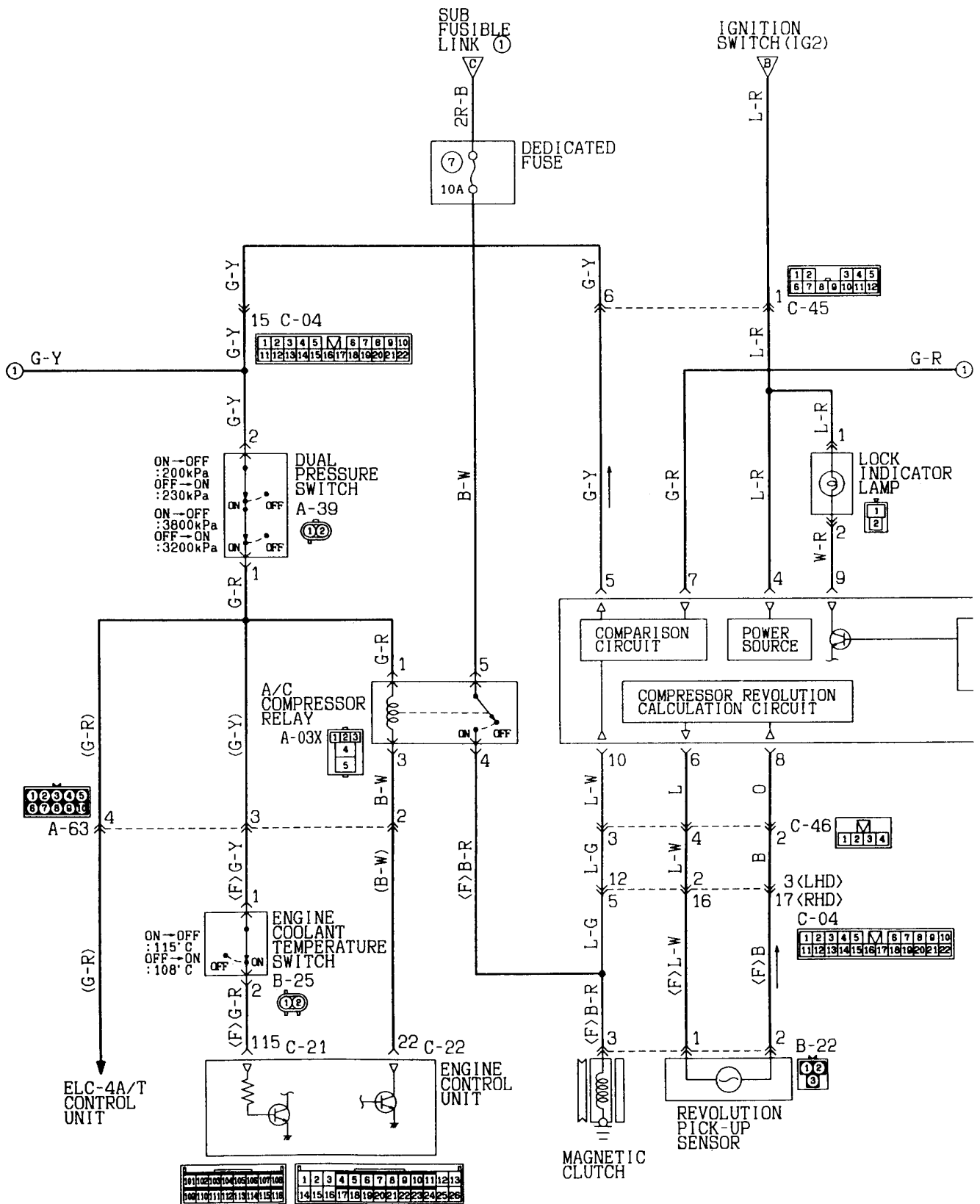

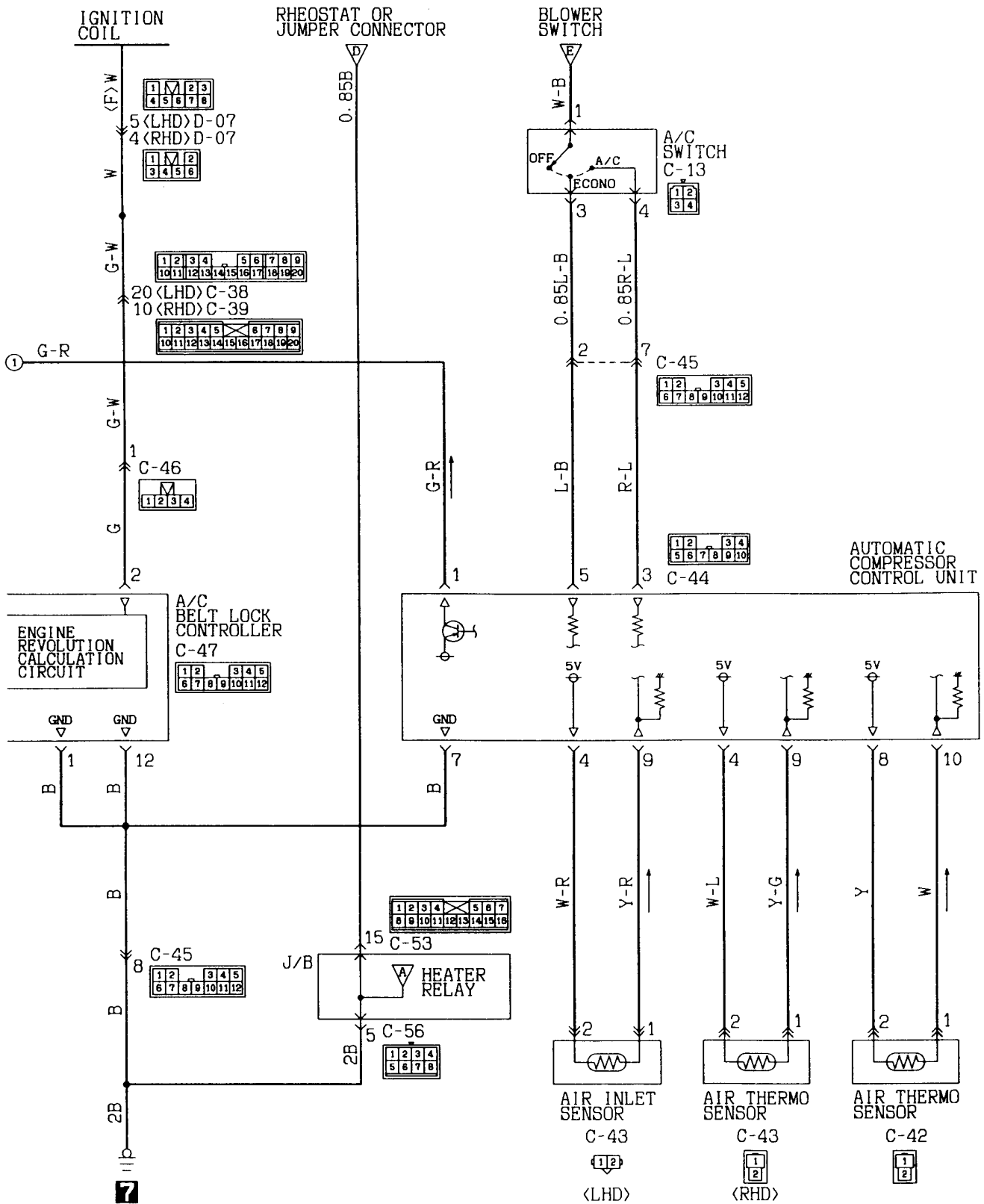

Wire colour code  
 B:Black LG:Light green G:Green L:Blue W:White Y:Yellow SB:Sky blue  
 BR:Brown O:Orange GR:Gray R:Red P:Pink V:Violet

HEATER AND AIR CONDITIONER  
4G63 and 4G64

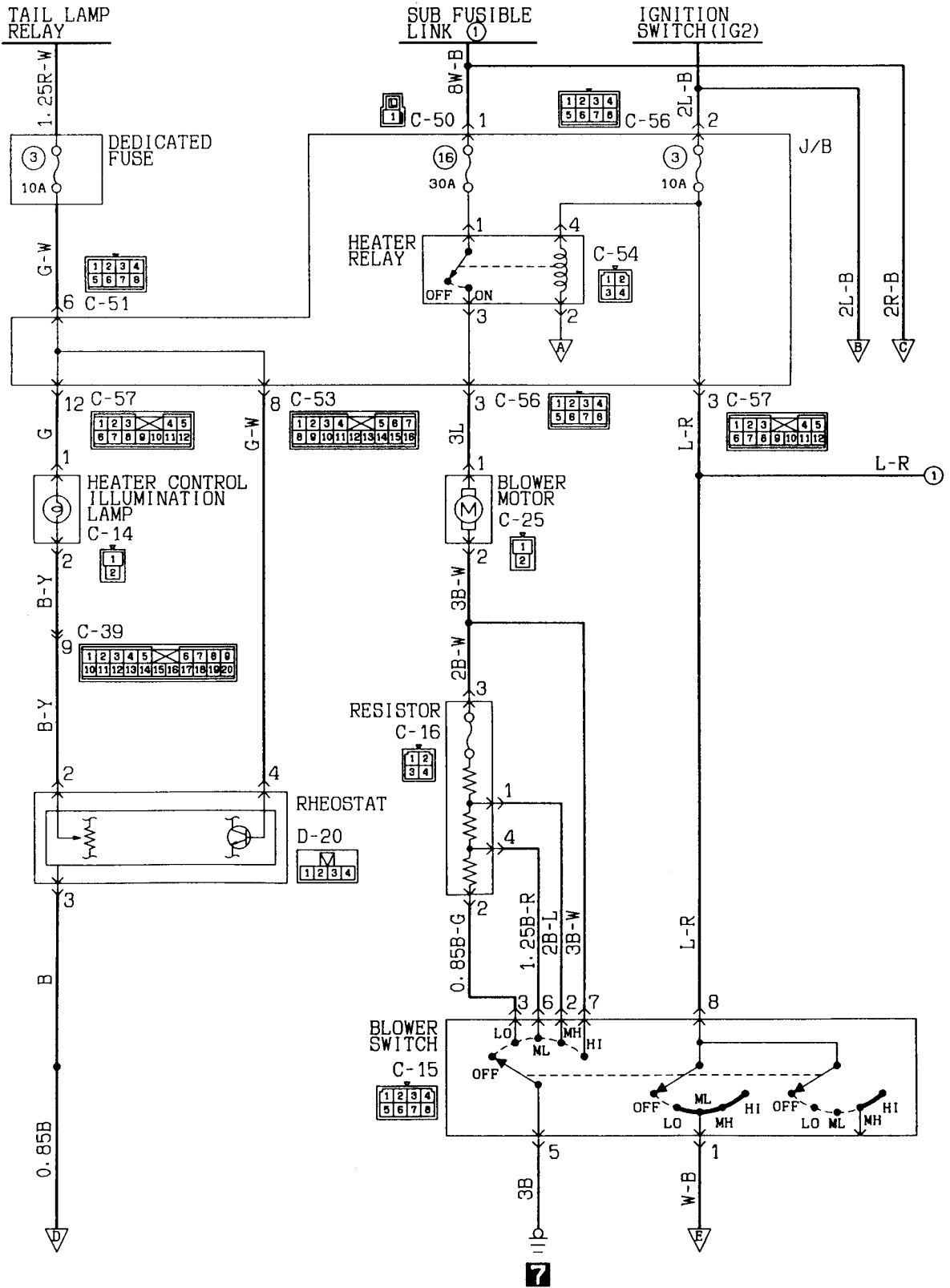

KX35-AC-Z1210-EC

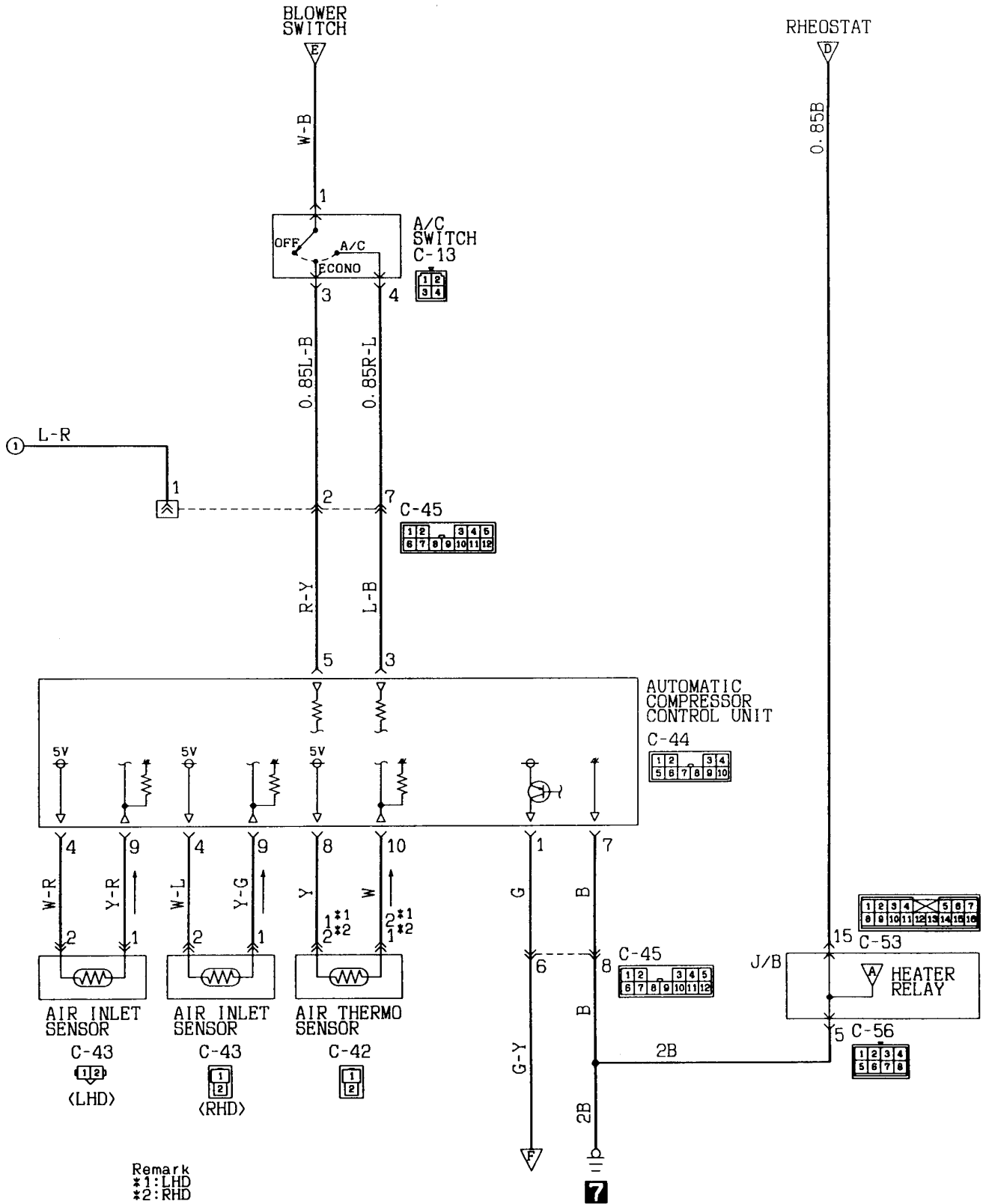

Remark  
\*1: LHD  
\*2: RHD

Wire colour code  
B:Black LG:Light green G:Green L:Blue W:White Y:Yellow SB:Sky blue  
BR:Brown O:Orange GR:Gray R:Red P:Pink V:Violet

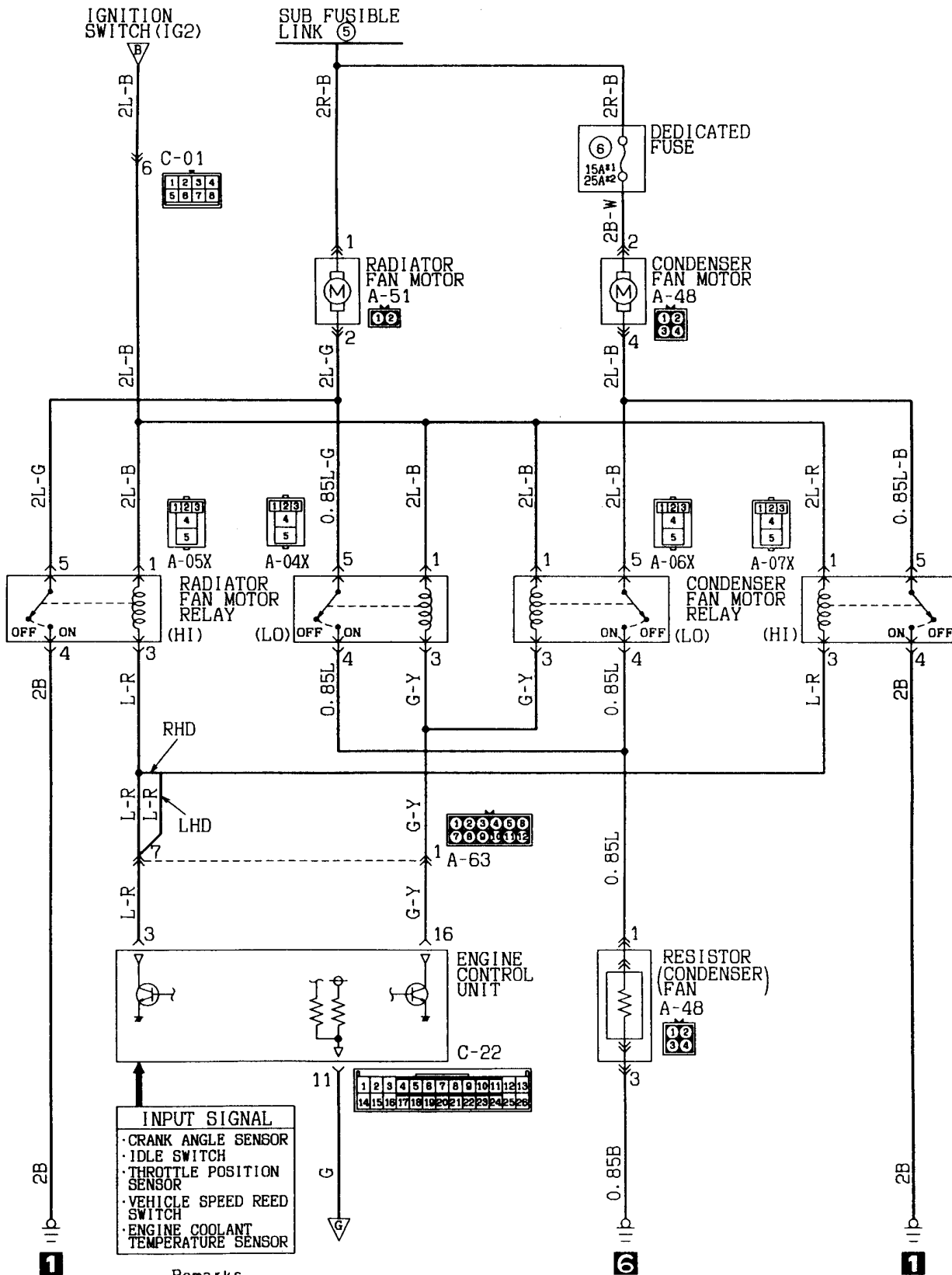

Remarks  
 \*1:4WD(A/T)  
 \*2:2WD and 4WD(M/T)



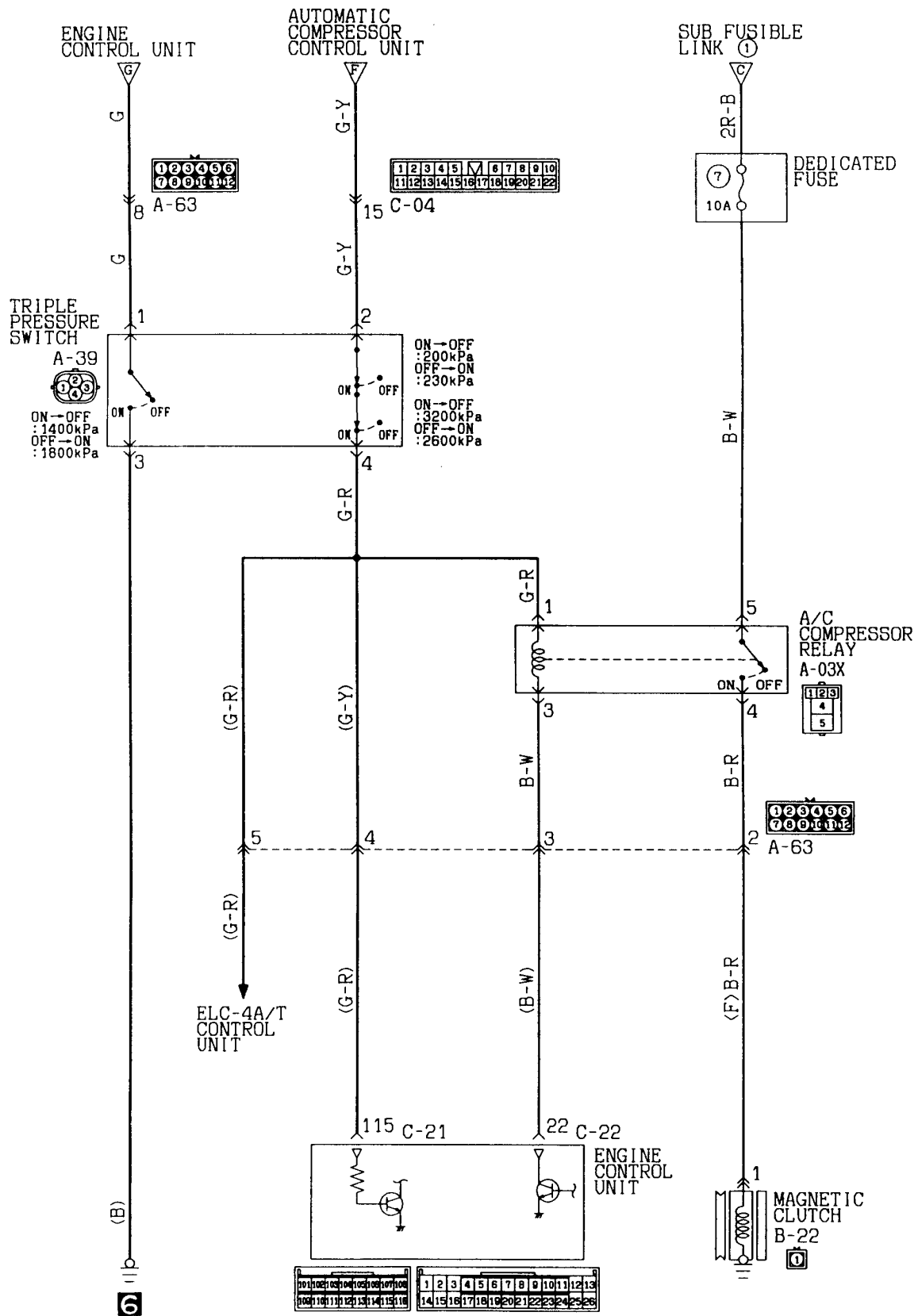

HEATER AND AIR CONDITIONER  
4D68

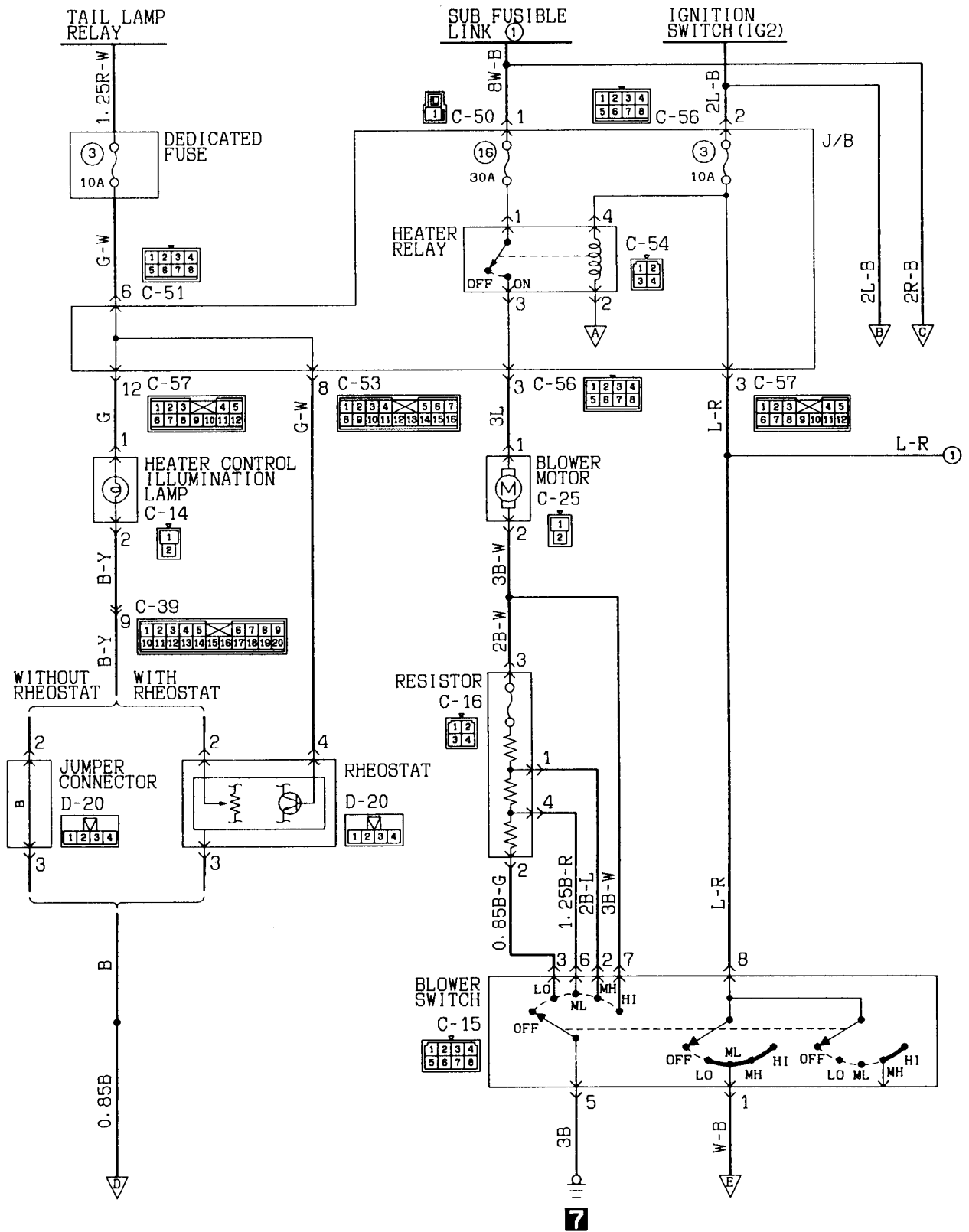

KX35-AC-Z1211-EC

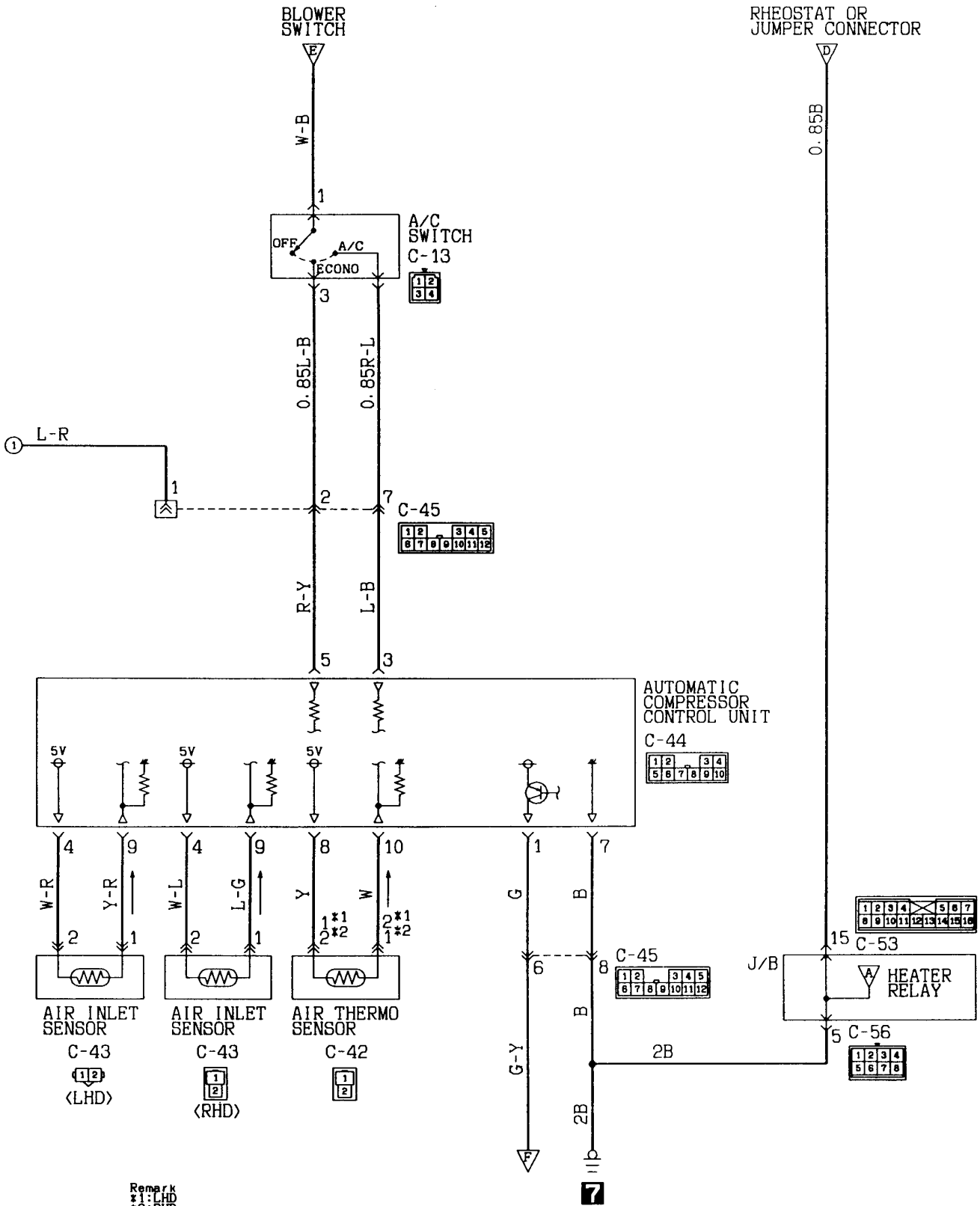

Remark  
 #1: LHD  
 #2: RHD

Wire colour code  
 B:Black LG:Light green G:Green L:Blue  
 BR:Brown O:Orange GR:Gray R:Red  
 W:White Y:Yellow P:Pink V:Violet  
 SB:Sky blue

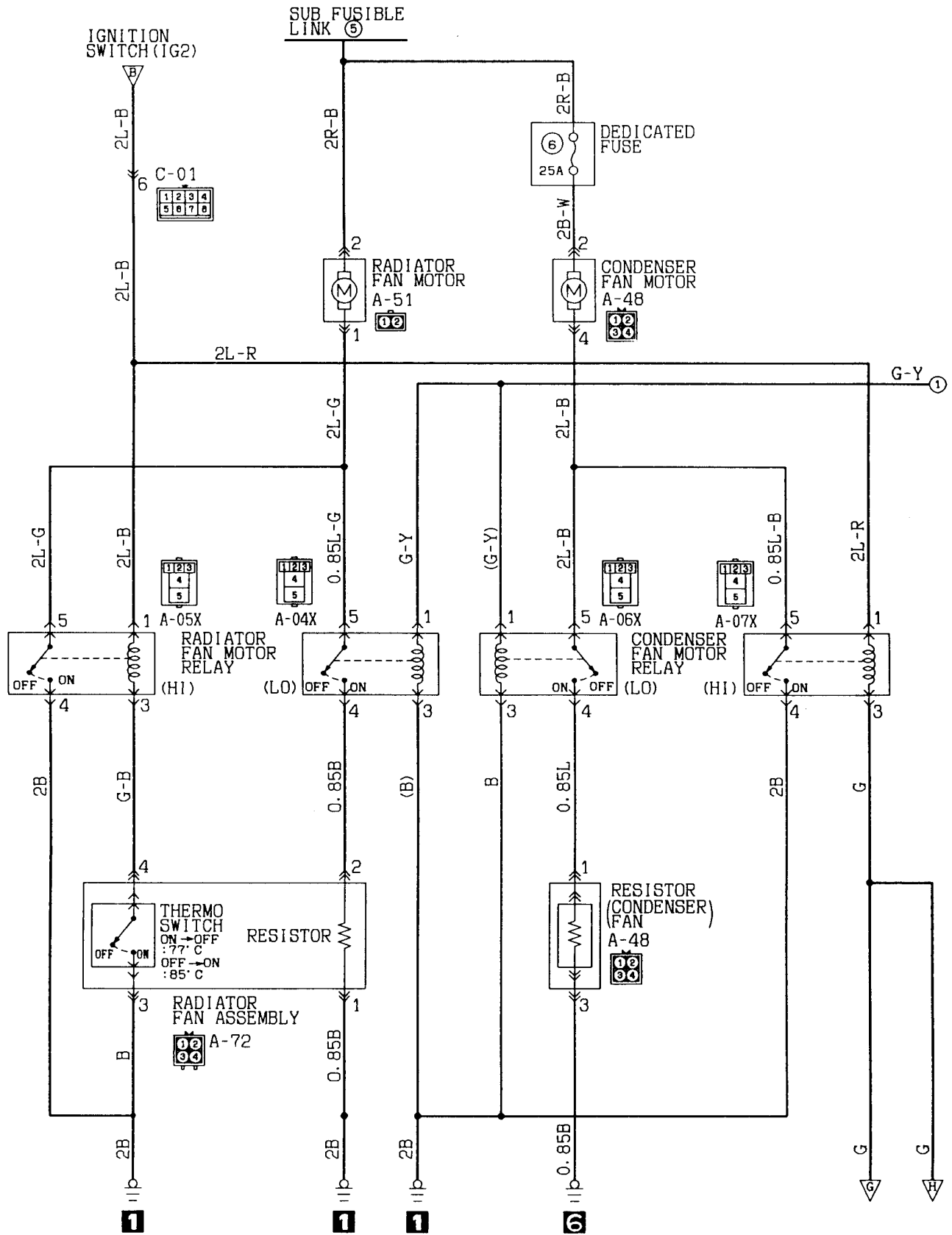

KX35-AC-Z1211A-EC

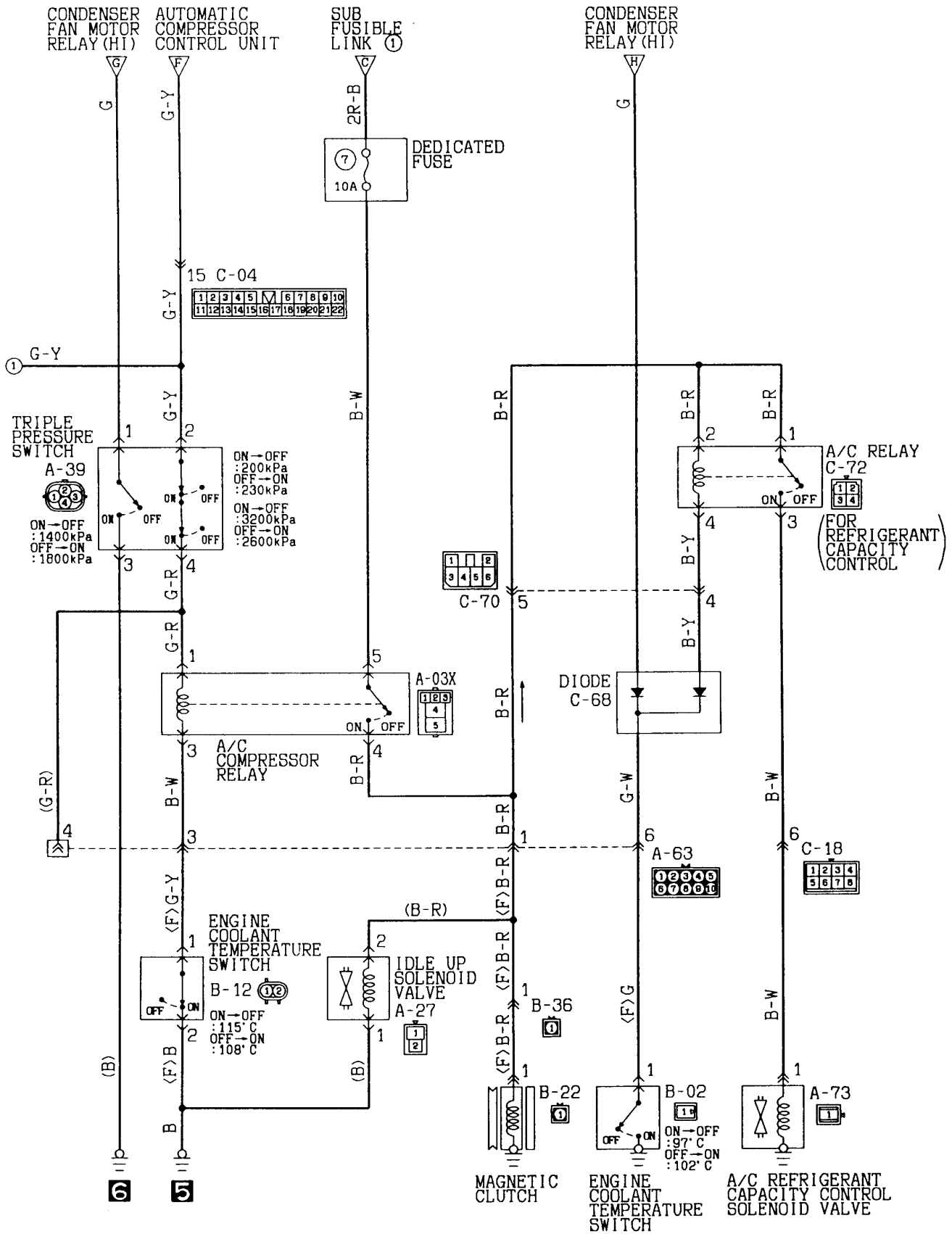

**HEATER AND AIR CONDITIONER (See P. 4A-150, 154, 158.)****OPERATION****<Blower control>**

- When the ignition switch is turned ON, the heater relay is energized. If the blower switch is turned ON (LO, ML, MH, or HI position) in this condition, the blower is activated through the circuit via resistor at a speed corresponding to the blower switch position.

**<Condenser fan and radiator fan control>**

- For the operation of each fan, see COOLING SYSTEM (P. 4A-55, 57, 59.)

**<Compressor control>**

- The air inlet sensor which senses the temperature of the air sent to the evaporator, and the air thermo sensor, which senses the temperature of the air flowing out of the evaporator, are deactivated with temperature 3.2°C or below.
- Here, the engine coolant temperature switch senses the temperature of engine coolant, and it is turned off at 115°C or higher temperatures. Also, after it has turned off, the engine coolant temperature will drop, and when it becomes 108°C or lower, the switch turns ON.<4G93 and 4D68>
- The dual pressure switch (or triple pressure switch) turns OFF when the refrigerant pressure becomes excessively high or low, thus protecting the compressor circuit.
- When these sensors are all activated, the dual pressure switch (or triple pressure switch) is ON, and the ignition switch, blower switch, and air conditioner switch are ON, the A/C compressor relay is energized.
- To prevent the engine from stalling and oscillating and to ensure good acceleration, the engine control unit (vehicles with MPI) turns OFF the A/C compressor relay driving transistor, and thus the A/C compressor relay, when the engine is started, when it runs at low speed, and when the vehicle is quickly accelerated.

**TROUBLESHOOTING HINTS****<Blower control>**

1. Blower motor is energized at one switch position and not energized at another.
  - Check harness and connectors between defective switch position and resistor (or blower motor in HI position).
2. Blower motor is energized only when switch is positioned in HI.
  - Check the resistor.
3. Blower motor speed does not represent the switch position.
  - Check the blower switch.

**<Condenser fan and radiator fan control>**

- See COOLING SYSTEM (P. 4A-55, 57, 59.)

**<Compressor control>**

- See the Troubleshooting in Group 55 of the separate WORKSHOP MANUAL (Pub. No. PWDE9104.)

A/C Compressor Relay ON Conditions

Ignition switch (IG <sub>2</sub> )		ON	Remarks (1) A/C compressor relay is deenergized when any one switch, sensor or control unit shown on the left turns OFF. (2) The * marked device measures the temperature of the intake air, and according to the control characteristics of the magnetic clutch for the compressor, the auto compressor control unit outputs the "HI" signal (System voltage).
Blower switch		ON	
A/C switch		ON (ECONO or A/C)	
Air inlet sensor		*	
Air thermo sensor		*	
Engine coolant temperature switch <4G93 and 4D68>		ON	
Triple pressure switch <4G63, 4G64 and 4D68>	Low-pressure side	ON [230 kPa or higher]	
	High-pressure side	ON [2,600 kPa or higher]	
Dual pressure switch <4G93>	Low-pressure side	ON [230 kPa or higher]	
	High-pressure side	ON [3,200 kPa or higher]	
A/C compressor relay driving transistor (within engine control unit) <MPI>		ON	

WINDSHIELD WIPER AND WASHER  
Vehicles with SRS

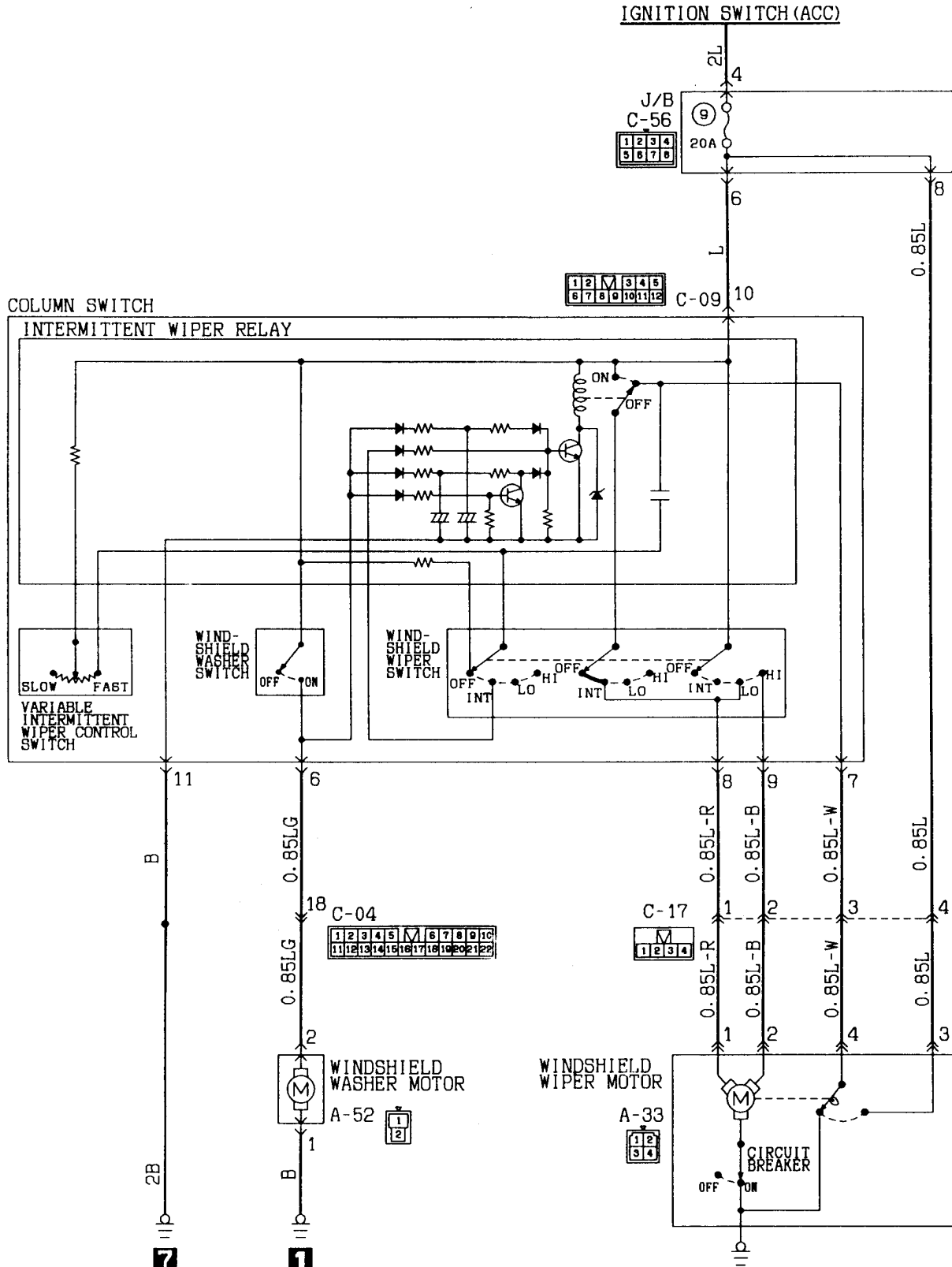

Wire colour code  
 B:Black LG:Light green G:Green L:Blue W:White Y:Yellow SB:Sky blue  
 BR:Brown O:Orange GR:Gray R:Red P:Pink V:Violet



WINDSHIELD WIPER AND WASHER  
Vehicles without SRS

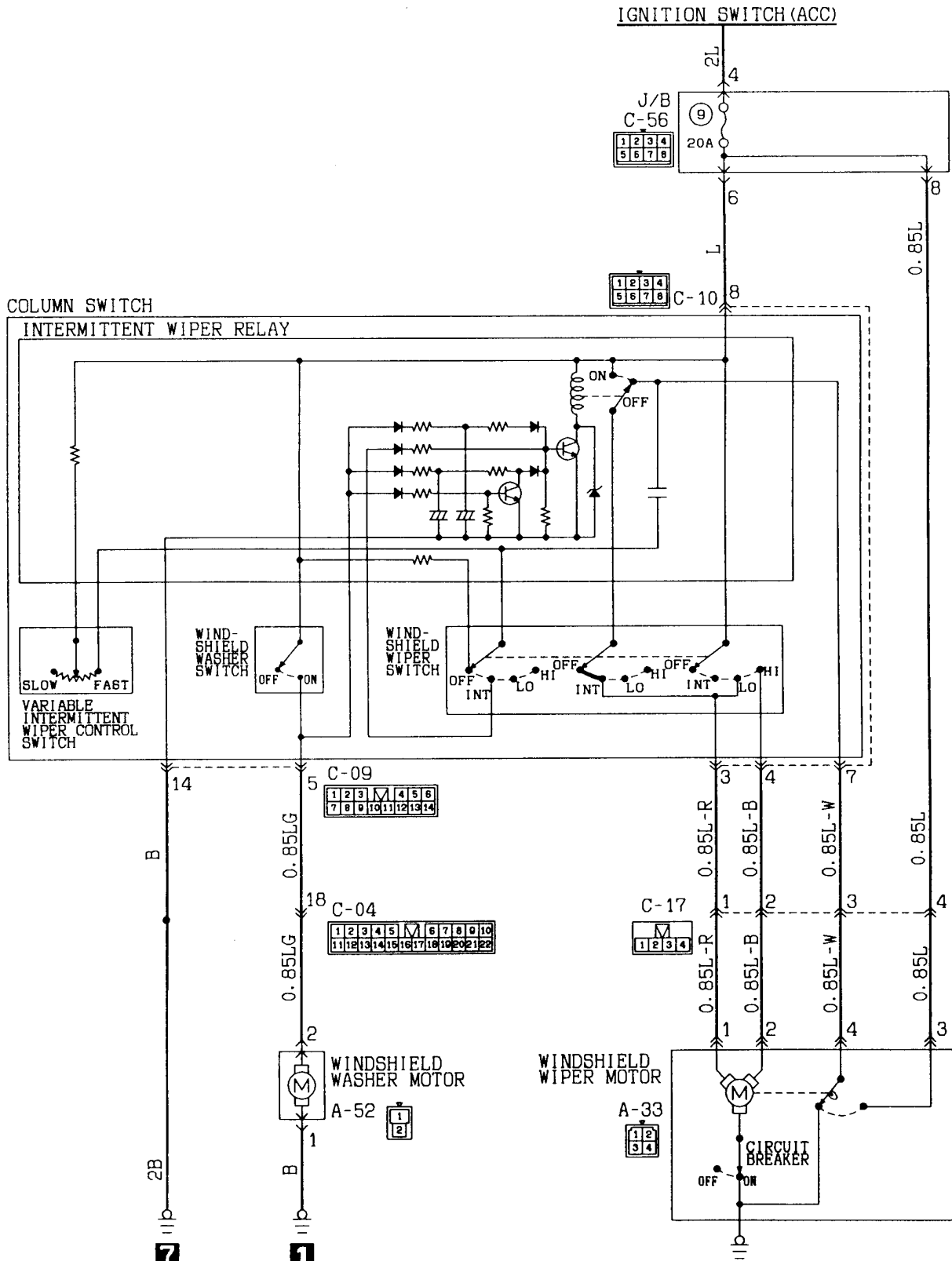

Wire colour code  
 B:Black LG:Light green G:Green L:Blue W:White Y:Yellow SB:Sky blue  
 BR:Brown O:Orange GR:Gray R:Red P:Pink V:Violet

KX35-AC-Z1316-EC

**WINDSHIELD WIPER AND WASHER (See P. 4A-164, 165.)****OPERATION****<Low-speed (and high-speed) wiper operation>**

- When the wiper switch is placed in the LO position with ignition switch in the ACC or ON position, wipers operate continuously at low speed.
- Placing the wiper switch in the HI position causes the wipers to operate at high speed.

**<Auto wiper stop operation>**

- When the wiper switch is placed in the OFF position, the cam contacts of wiper motor caused current to flow through the auto wiper stop circuit, allowing the wiper blades to cycle before they reach to the stop positions.

**<Intermittent wiper operation>**

- When the wiper switch is placed in the INT position with the ignition switch in ACC or ON position, the intermittent wiper relay is energized causing the intermittent wiper relay contacts to close and open repeatedly.
- When the contacts are closed, the wiper motor is energized.
- When the wiper motor is energized, the relay contacts open; however, the cam contacts keep the wiper motor energized until the wiper blades return to their stop position.

**<Washer-Wiper operation>**

- When the washer switch is turned ON, the intermittent wiper relay contacts close causing wipers to cycle two to three times.

**Remark**

- The washer-wiper operates in the priority even during intermittent operation of the wiper.

**TROUBLESHOOTING HINTS**

1. Wipers do not operate.
  - (1) Washer is not operative, either.
    - Check the multi-purpose fuse No. ⑨.
    - Check the earth.
2. Low-speed (or high-speed) wiper operation only is inoperative.
  - Check the wiper switch.
3. Wipers do not stop.
  - Check the wiper motor.
  - Check the intermittent wiper relay.
  - Check the wiper switch.
4. Intermittent wiper operation is inoperative.
  - Check terminal voltage of steering-column switch (with a built-in intermittent wiper relay) with the intermittent wiper relay energized.

Terminal No.	Voltage	Check
3	0V	Intermittent wiper relay or wiper switch
	System voltage	Intermittent wiper relay
	0V ↔ System voltage (alternating)	— (Normal)

5. The length of pause for intermittent operation cannot be varied.
  - Check the variable intermittent wiper control switch.
  - Check the intermittent wiper relay.
6. Washer is inoperative.
  - (1) Wiper is operative on washer-wiper operation.
    - Check the washer motor.
  - (2) Washer-wiper operation is inoperative also.
    - Check the washer switch.
7. Washer-wiper operation is inoperative.
  - Check the intermittent wiper relay.

**REAR WIPER AND WASHER (See P. 4A-168.)****OPERATION****<Low-speed wiper operation>**

- When the wiper switch is placed in the LO (or ON) position with the ignition switch in the ACC or ON position, wiper operates continuously at low speed.

**<Auto wiper stop operation>**

- When the wiper switch is placed in the OFF position, the cam contacts of wiper motor causes current to flow through the auto wiper stop circuit, allowing the wiper blades to cycle before they reach to the stop positions.

**<Intermittent wiper operation>**

- When the wiper switch is placed in the INT position with the ignition switch in ACC or ON position, the intermittent wiper relay is energized causing the intermittent wiper relay contacts to close and open repeatedly.
- When the contacts are closed, the wiper motor is energized.
- When the wiper motor is energized, the relay contacts open; however, the cam contacts keep the wiper motor energized until the wiper blades return to their stop position.

**TROUBLESHOOTING HINTS**

1. Wiper does not operate.
  - (1) Windshield wiper is not operative, either.
    - Check the multi-purpose fuse No. ⑨.
  - (2) Windshield wiper is operative.
    - Check the wiper motor.
    - Check the rear wiper switch.
    - Check the rear intermittent wiper relay.
2. Intermittent wiper operation is inoperative.
  - While the intermittent wiper relay is being operated, check the terminal voltage of the rear wiper switch (built into the intermittent wiper relay).

Terminal No.	Voltage	Check
5	0 V	Intermittent wiper relay or wiper switch
	System voltage	Intermittent wiper relay
	0 V ↔ System voltage (alternating)	— (Normal)

3. Wiper does not stop.
  - Check the wiper motor.
  - Check the rear intermittent wiper relay.
  - Check the rear wiper switch.
4. Washer is inoperative.
  - (1) Wiper is operative.
    - Check the rear washer motor.
    - Check the rear washer switch.

REAR WIPER AND WASHER

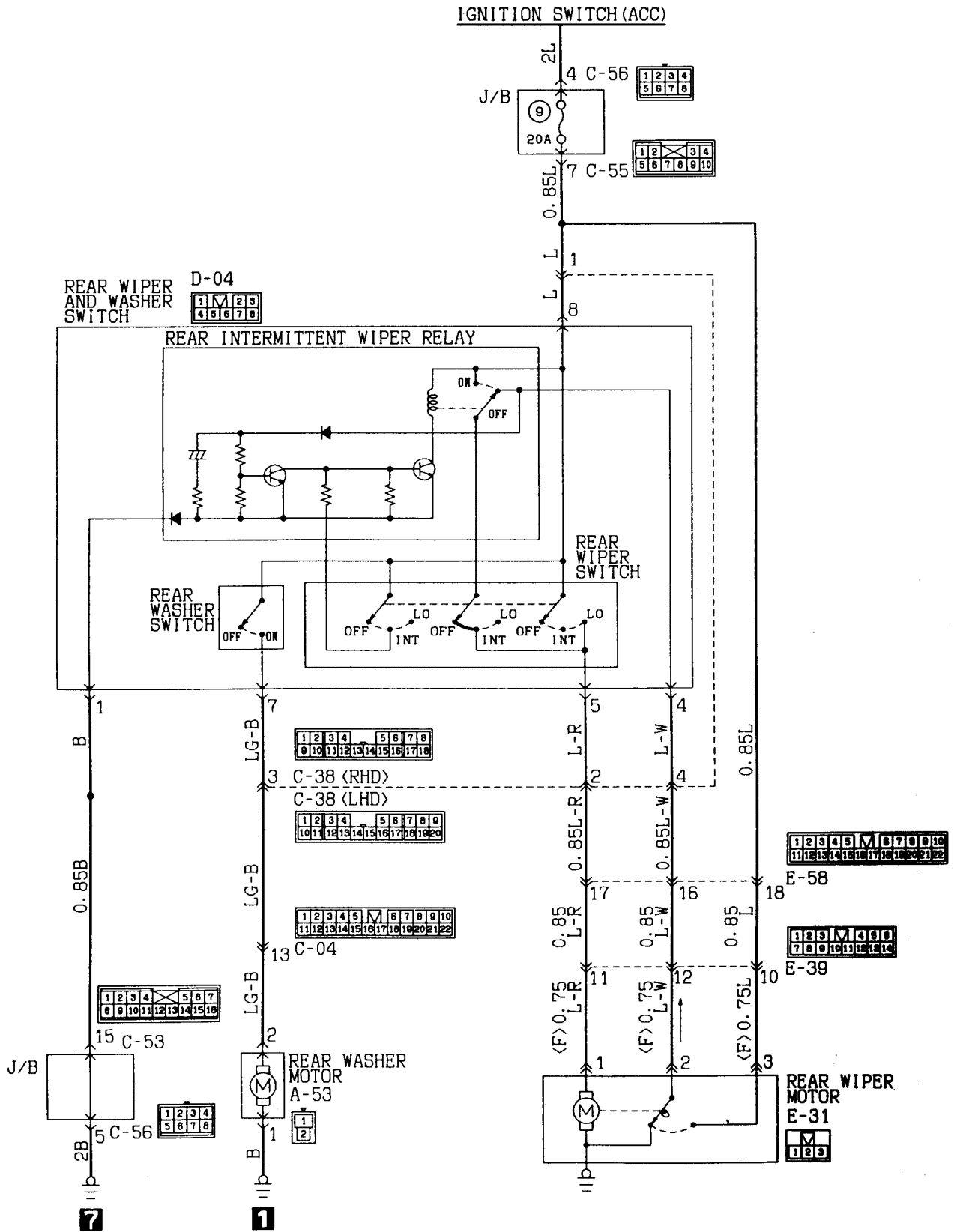

Wire colour code  
 B:Black LG:Light green G:Green L:Blue W:White Y:Yellow SB:Sky blue  
 BR:Brown O:Orange GR:Gray R:Red P:Pink V:Violet

HEADLAMP WASHER

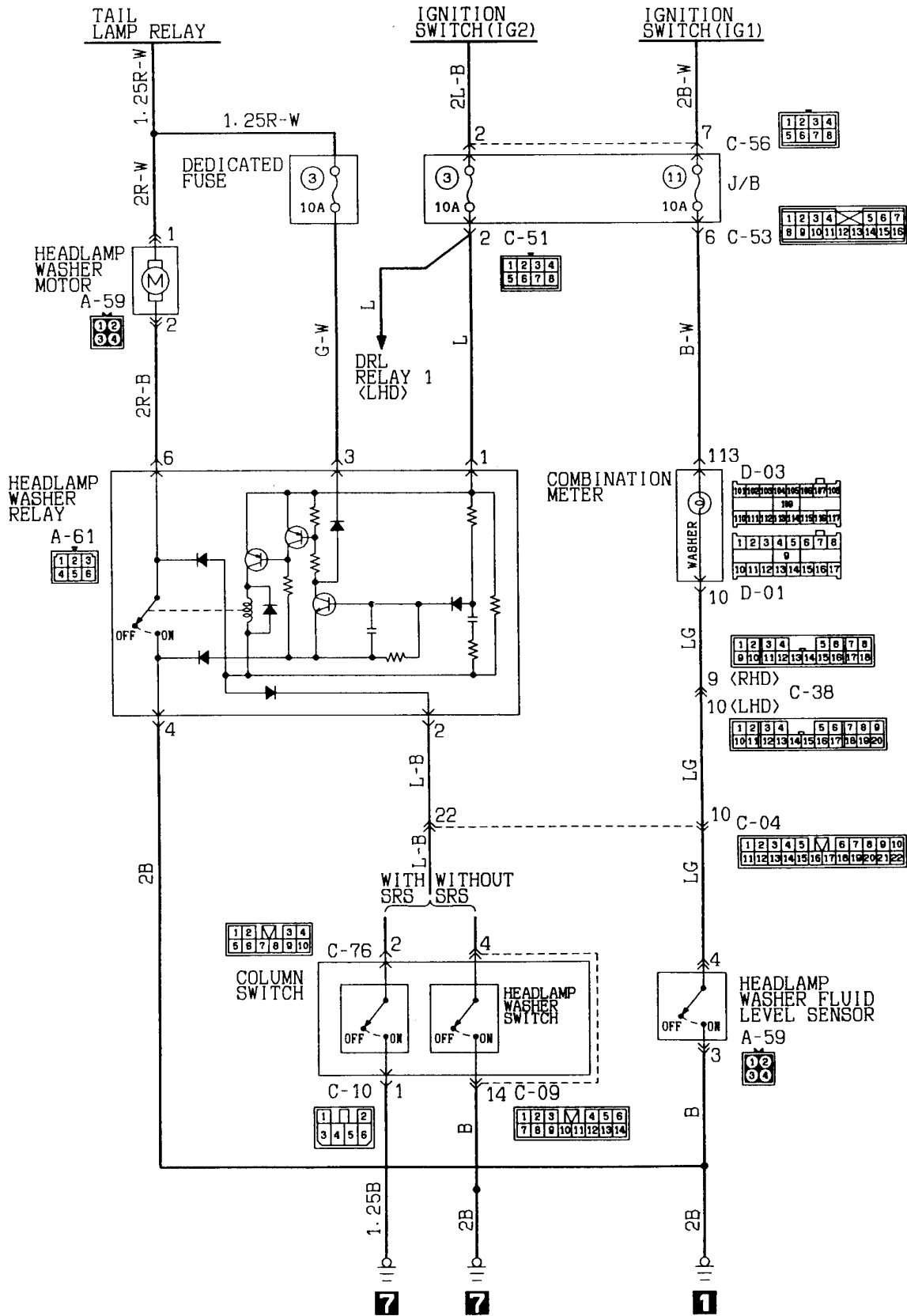

Wire colour code

KX35-AC-Z1318-EC

B:Black LG:Light green G:Green L:Blue W:White Y:Yellow SB:Sky blue  
 BR:Brown O:Orange GR:Gray R:Red P:Pink V:Violet

**HEADLAMP WASHER (See P. 4A-169.)****OPERATION**

- When the headlamp washer switch is turned ON with ignition switch in ON and lighting switch in TAIL or HEAD position, the headlamp washer relay is energized causing the headlamp washer motor to start.

**<Headlamp washer fluid level indicator lamp>**

- When the headlamp washer fluid level goes down below a predetermined level with the ignition switch in ON position, the headlamp washer level sensor is activated causing the headlamp washer fluid level indicator to light up.

**DEFOGGER AND DOOR MIRROR HEATER (See P. 4A-171.)****OPERATION**

- When the defogger switch is turned ON with the ignition switch in ON position, the defogger relay is energized causing defogger and mirror heater to operate.
- At the same time, the defogger indicator lamp lights up indicating that the defogger is in operation.

**TROUBLESHOOTING HINTS**

1. Headlamp washer motor does not start.
  - (1) Blower motor does not start, either.
    - Check the multi-purpose fuse No. ③.
  - (2) Blower motor does start.
    - Check the headlamp washer motor.
    - Check the headlamp washer relay.
    - Check the headlamp washer switch.

**TROUBLESHOOTING HINTS**

1. Defogger (or mirror heater )is inoperative.
  - (1) Indicator does not come on, either.
    - Check the multi-purpose fuse No. ⑭.
    - Check the defogger relay.
  - (2) Indicator comes on.
    - Check the defogger.

DEFOGGER AND DOOR MIRROR HEATER

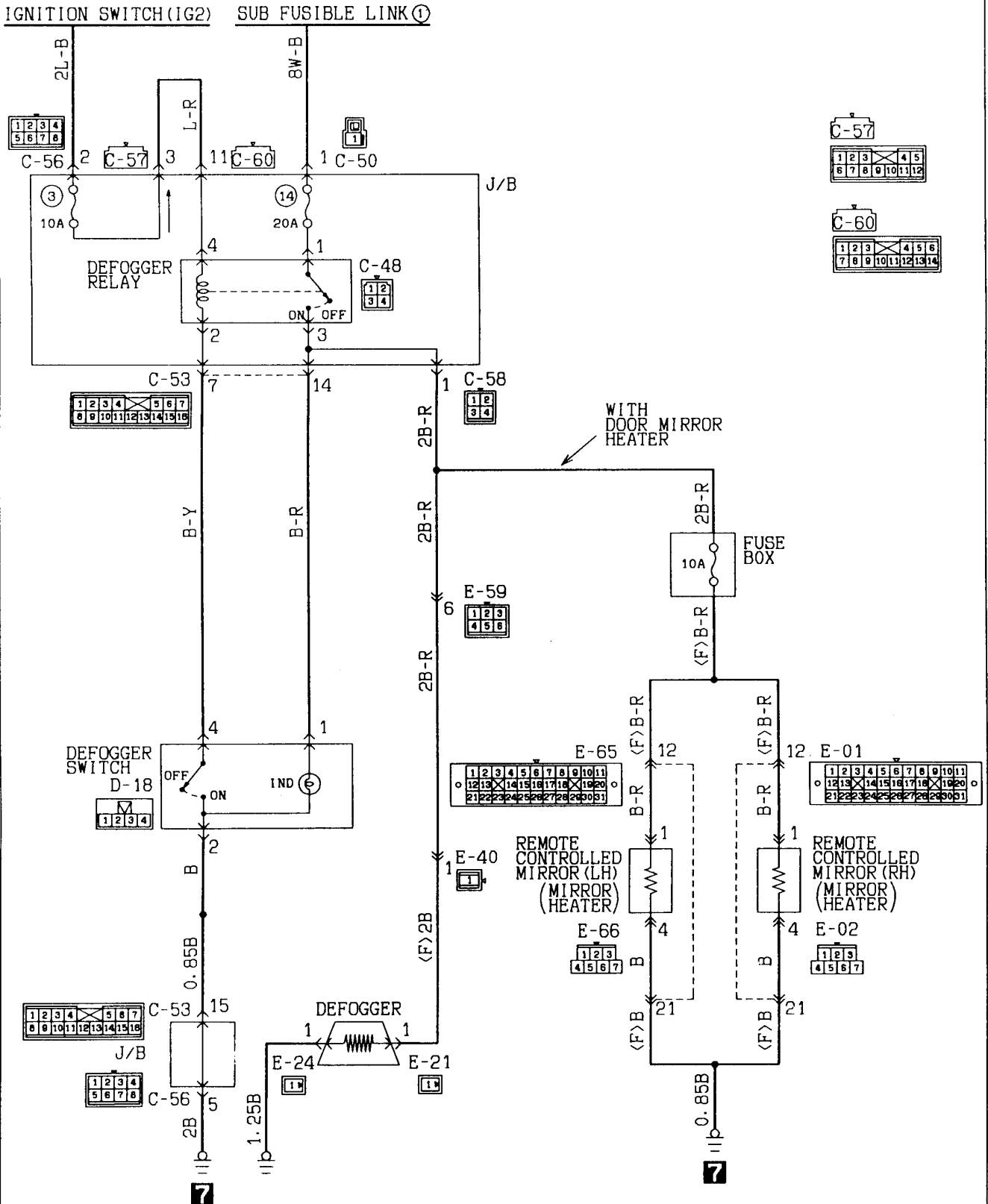

Wire colour code  
 B:Black LG:Light green G:Green L:Blue W:White Y:Yellow SB:Sky blue  
 BR:Brown O:Orange GR:Gray R:Red P:Pink V:Violet

KX35-AC-Z1319-EC

REMOTE CONTROLLED MIRROR  
Vehicles with door mirror heater

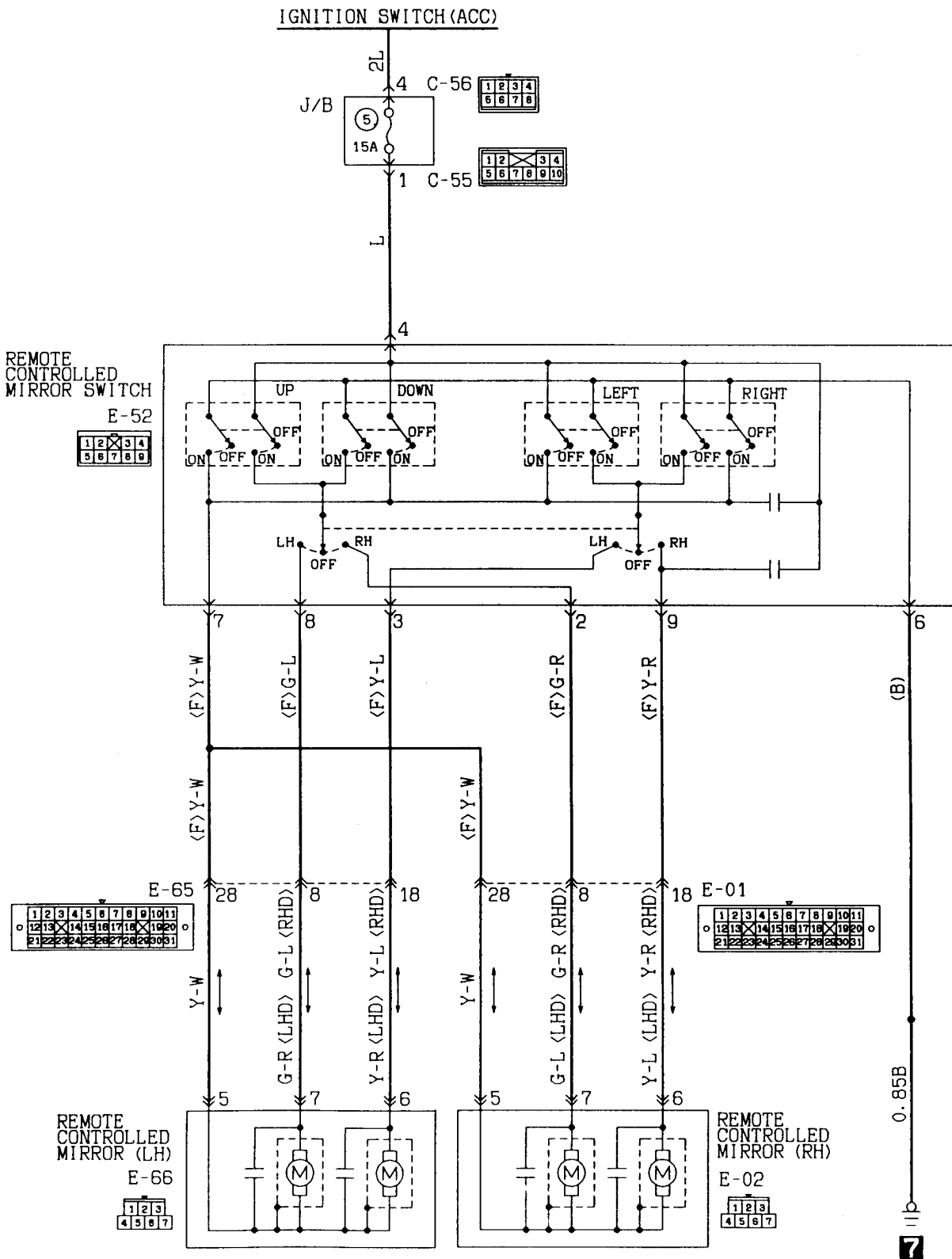

Wire colour code  
 B:Black LG:Light green G:Green L:Blue W:White Y:Yellow SB:Sky blue  
 BR:Brown O:Orange GR:Gray R:Red P:Pink V:Violet



REMOTE CONTROLLED MIRROR  
Vehicles without door mirror heater

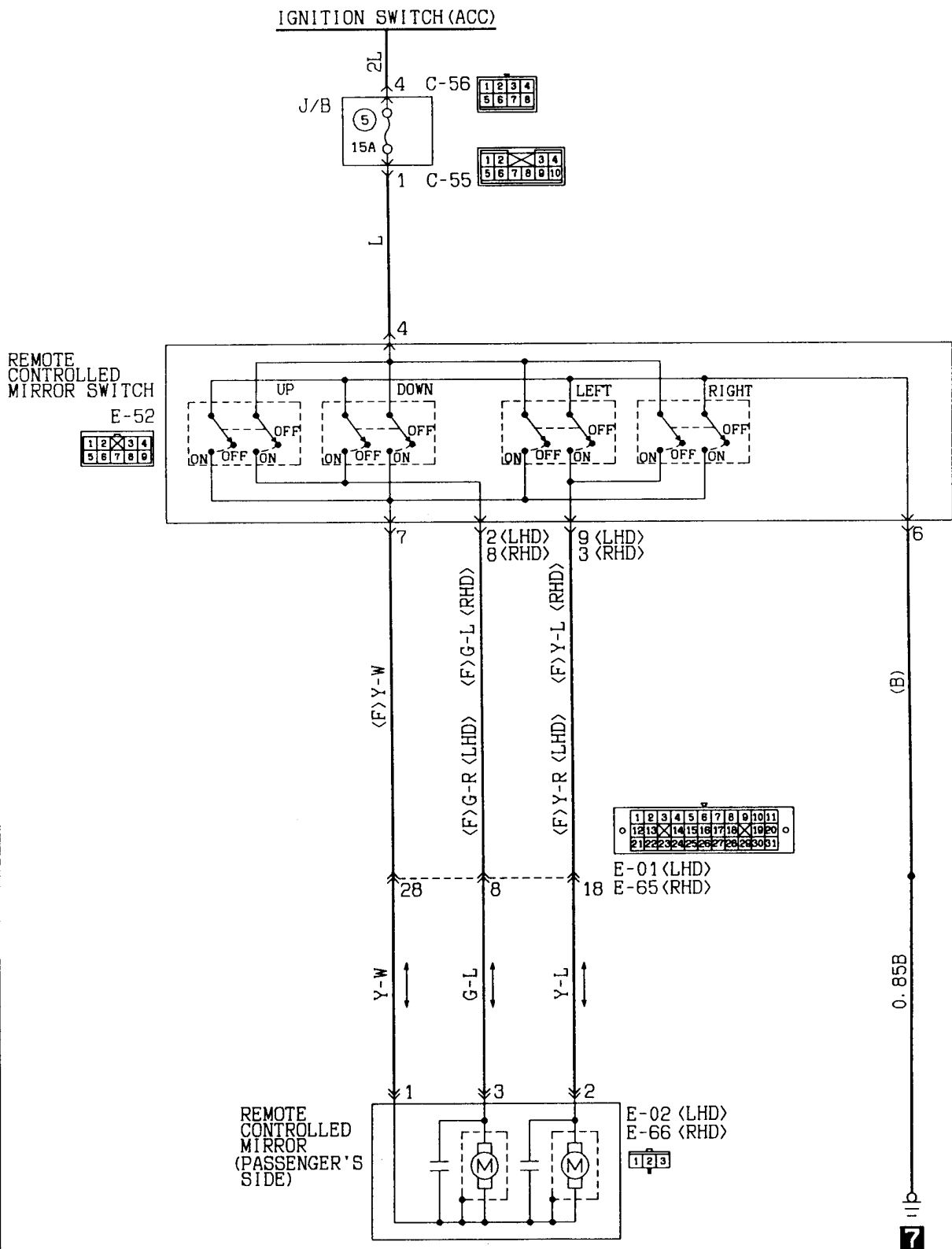

Wire colour code  
 B:Black LG:Light green G:Green L:Blue W:White Y:Yellow SB:Sky blue  
 BR:Brown O:Orange GR:Gray R:Red P:Pink V:Violet

**REMOTE CONTROLLED MIRROR (See P. 4A-172, 173.)****OPERATION**

- When the remote controlled mirror switch is operated with the ignition switch in ACC or ON position, the motor is started allowing the driver to adjust the orientation of the mirror surface.

**TROUBLESHOOTING HINTS**

1. LH and RH mirrors do not move.
  - (1) Cigarette lighter is also inoperative.
    - Check the multi-purpose fuse No. ⑤.
  - (2) Cigarette lighter is operative.
    - Check the remote controlled mirror switch.

CIGARETTE LIGHTER

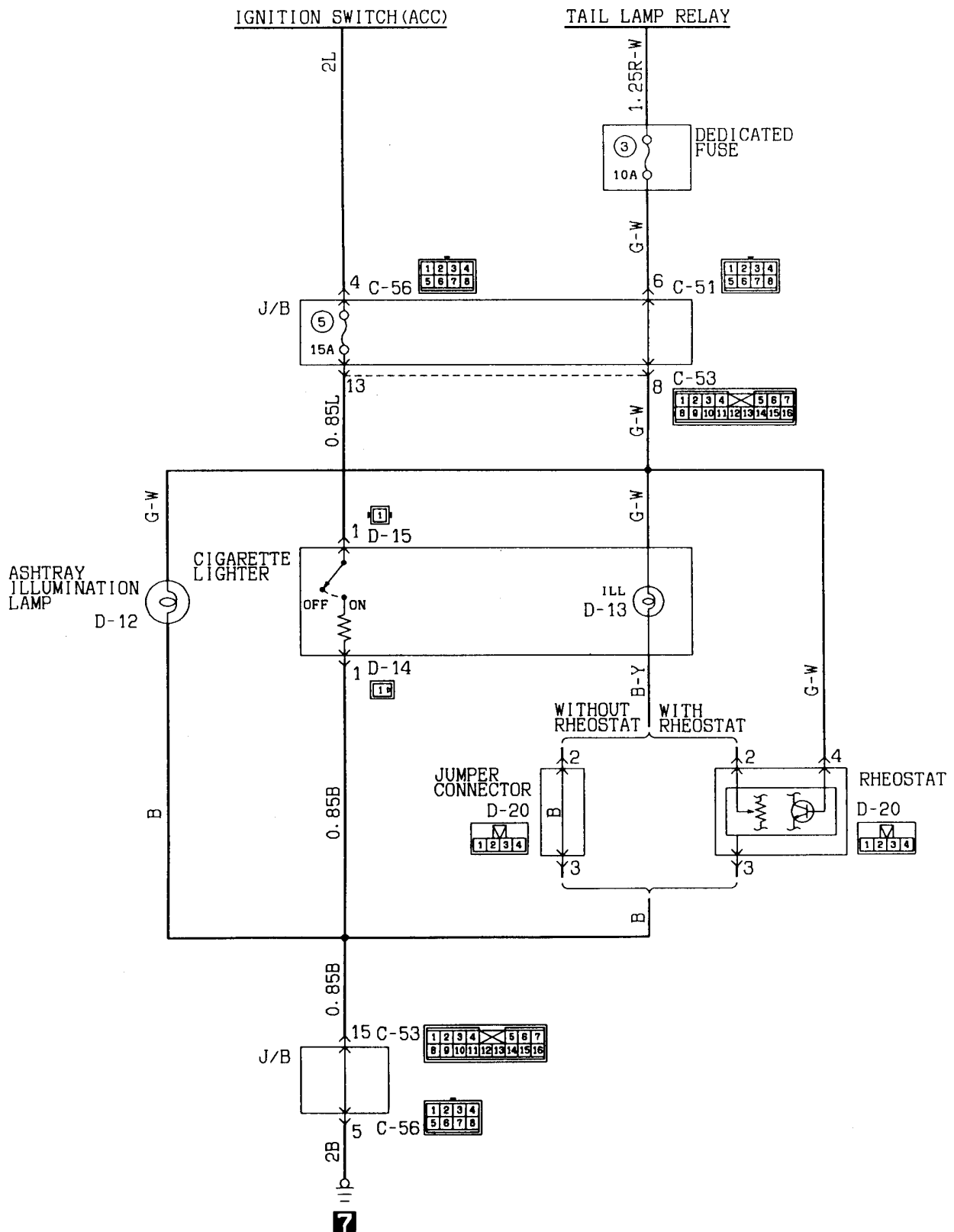

Wire colour code  
 B:Black LG:Light green G:Green L:Blue W:White Y:Yellow SB:Sky blue  
 BR:Brown O:Orange GR:Gray R:Red P:Pink V:Violet



RADIO AND TAPE PLAYER

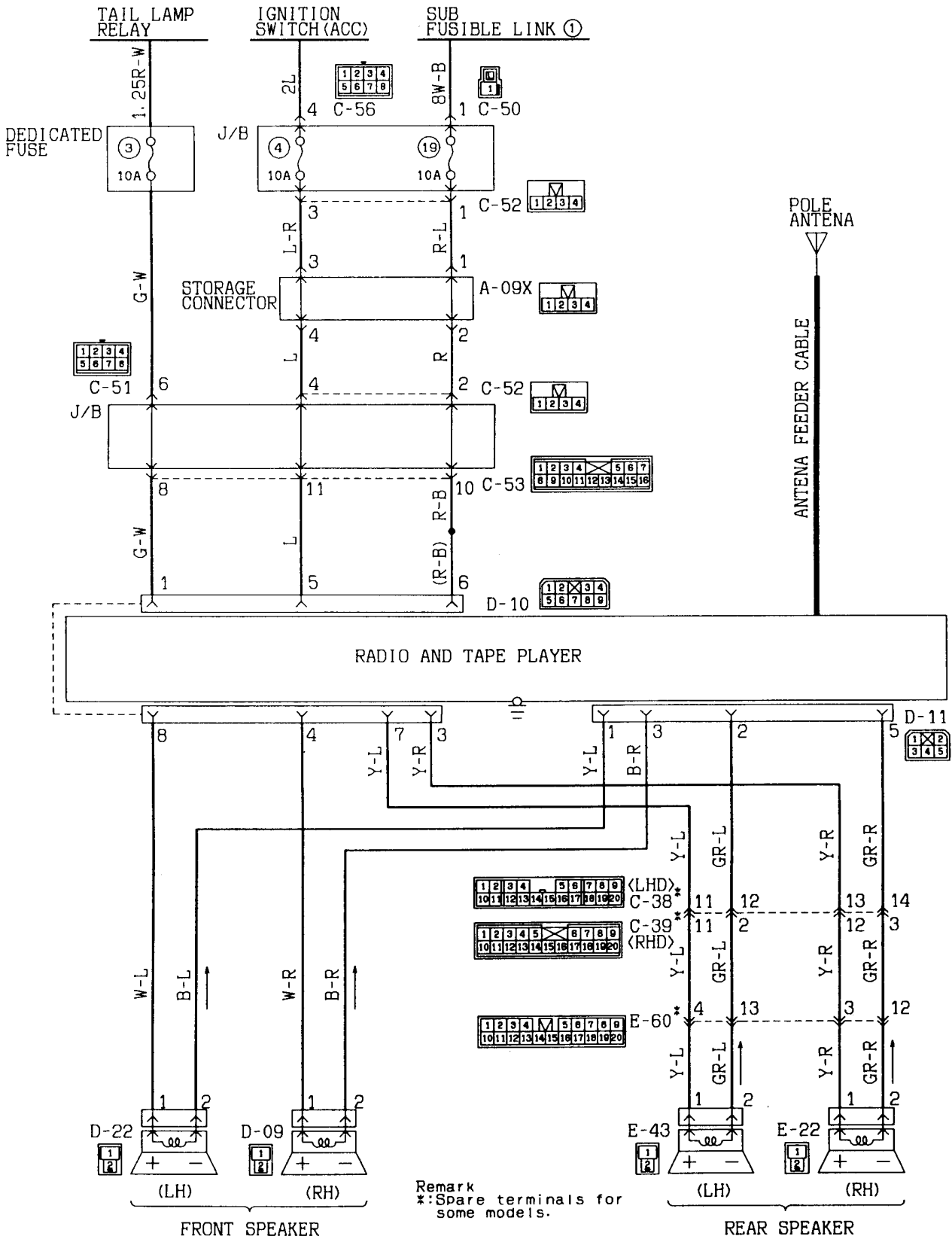

KX35-AC-Z1411-EC

Wire colour code  
 B:Black LG:Light green  
 BR:Brown O:Orange

G:Green L:Blue  
 GR:Gray R:Red

P:Pink Y:Yellow  
 V:Violet

SB:Sky blue

Remark  
 \*:Spare terminals for some models.

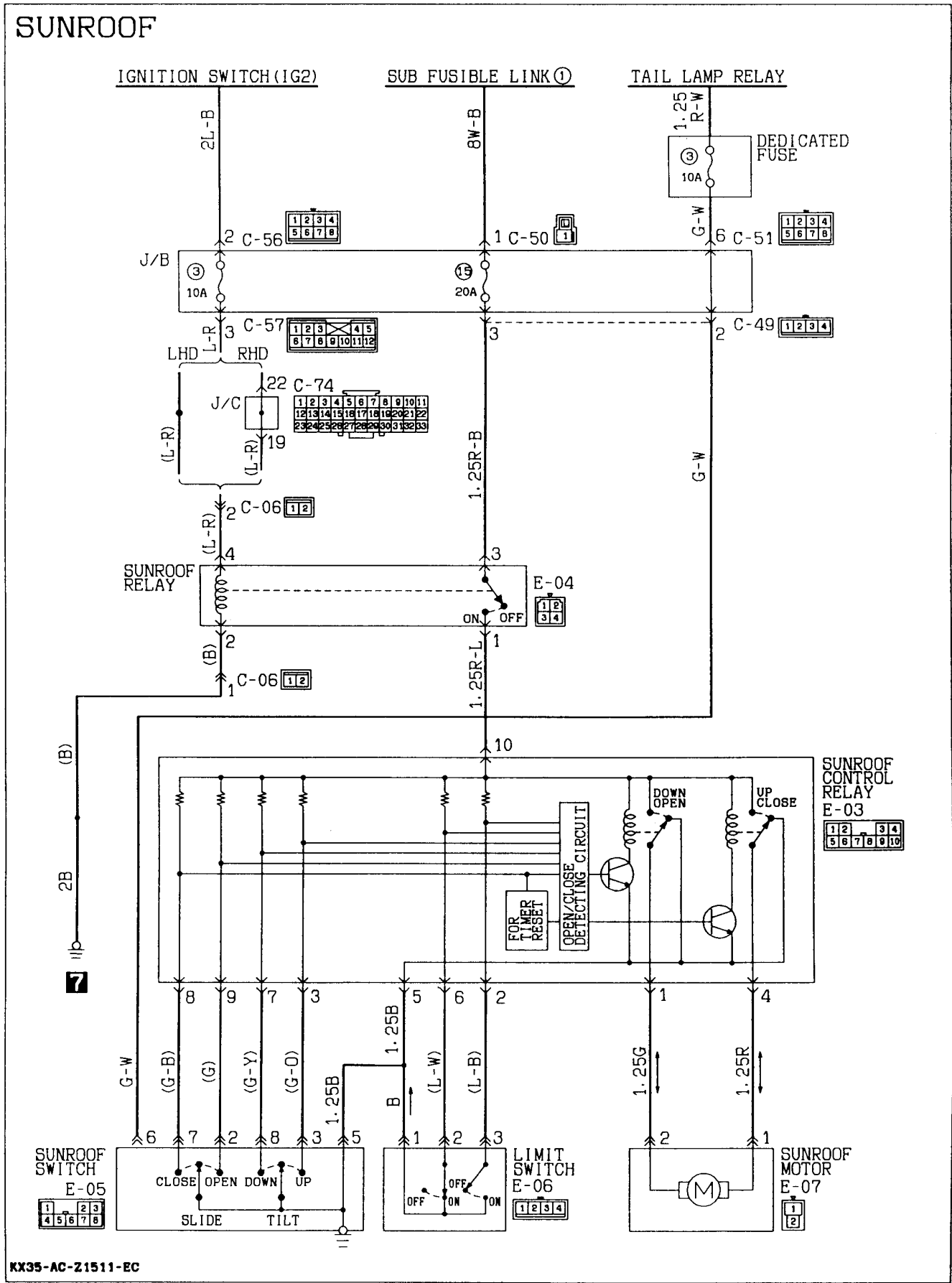

KX35-AC-Z1511-EC

**SUNROOF (See P. 4A-178.)****OPERATION****<Tilt operation>**

- If the UP side of the tilt switch is pressed while the sunroof is in the fully-closed position and the ignition switch is at the ON position, the rear edge of the sunroof opens by approximately 3 cm.
- When the DOWN side of the tilt switch is pressed, the sunroof closes.

**<Slide operation>**

- If the OPEN side of the slide switch is pressed while the ignition switch is at the ON position, the sunroof will open as long as the switch is being pressed.
- The sunroof will close as long as the CLOSE side of the slide switch is being pressed. If the switch is continuously pressed when the sunroof is opened more than half, the sunroof will stop just before it is fully closed and will not close any further. If the slide switch is first released and then pressed again continuously, the sunroof will close fully.

**HEATED SEAT (See P. 4A-180.)****OPERATION**

- When the heated seat switch is turned ON (either in LO or HI) with the ignition switch in ON position, the heated seat is activated with operation corresponding to the switch position.

**TROUBLESHOOTING HINTS**

1. Sunroof is not operative at all.
  - (1) Power window is inoperative also.
    - Check the multi-purpose fuse No. ③.
  - (2) Power window is operative.
    - Check the multi-purpose fuse No. ⑮.
    - Check the sunroof relay.

**TROUBLESHOOTING HINTS**

1. The heated seat warms at one place only.
  - Check the heated seat.
2. The heated seat doesn't become warm.
  - Check the multi-purpose fuse No. ⑧.
  - Check the heated seat switch.

# HEATED SEAT

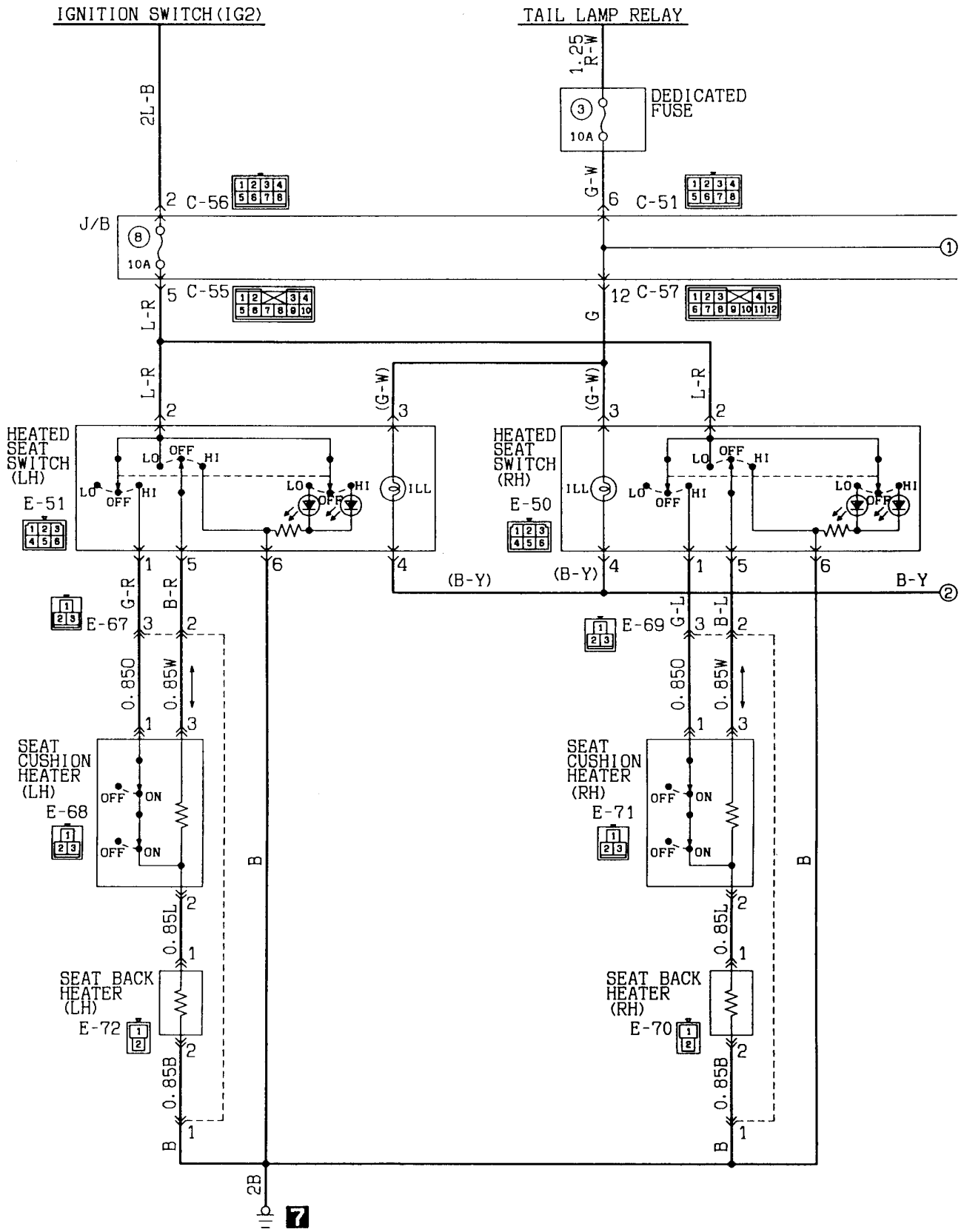

KX35-AC-Z1512-EC



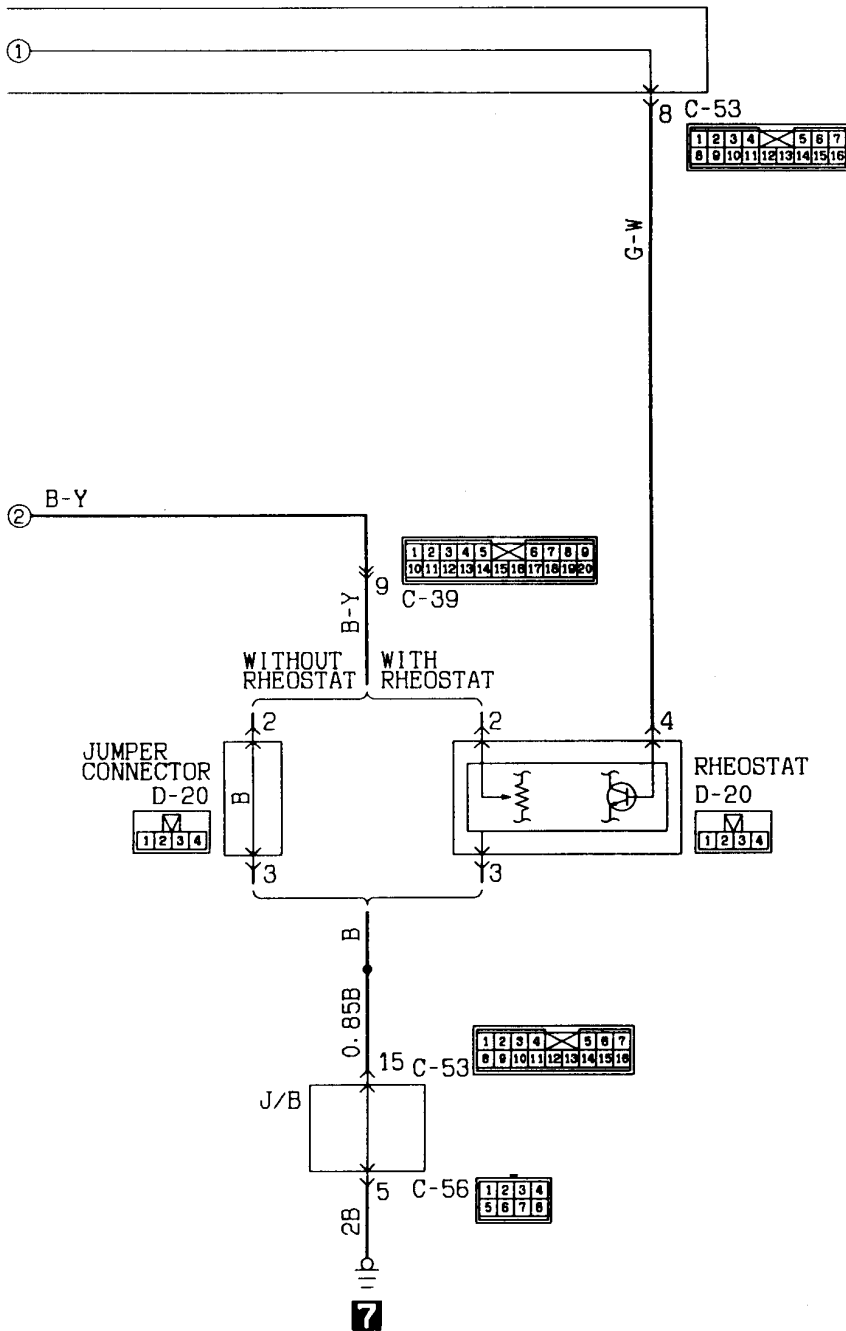

Wire colour code  
 B:Black    LG:Light green    G:Green    L:Blue    W:White    Y:Yellow    SB:Sky blue  
 BR:Brown    O:Orange    GR:Gray    R:Red    P:Pink    V:Violet

ANTI-LOCK BRAKE SYSTEM (ABS)  
2WD

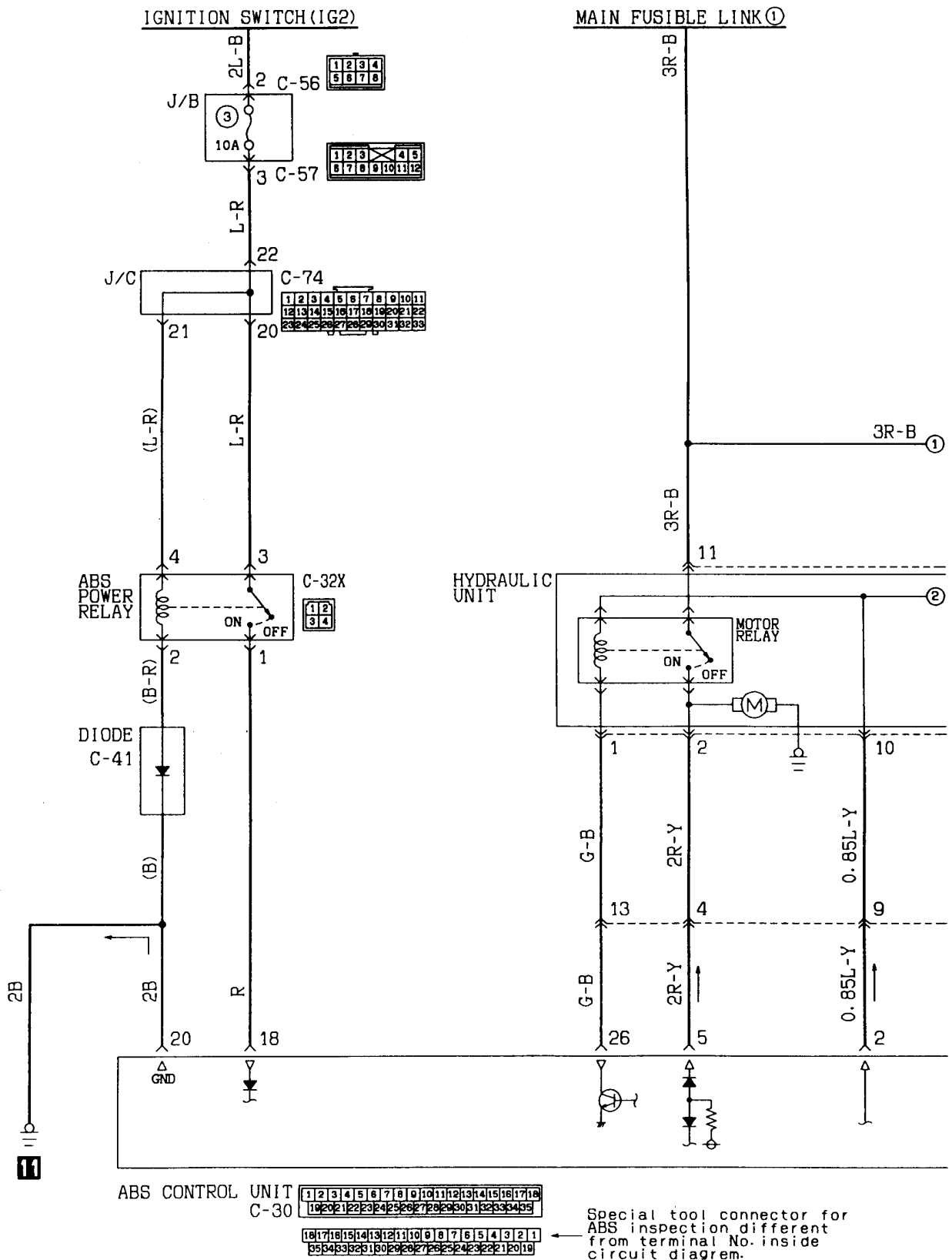

KX35-AC-Z1513-EC

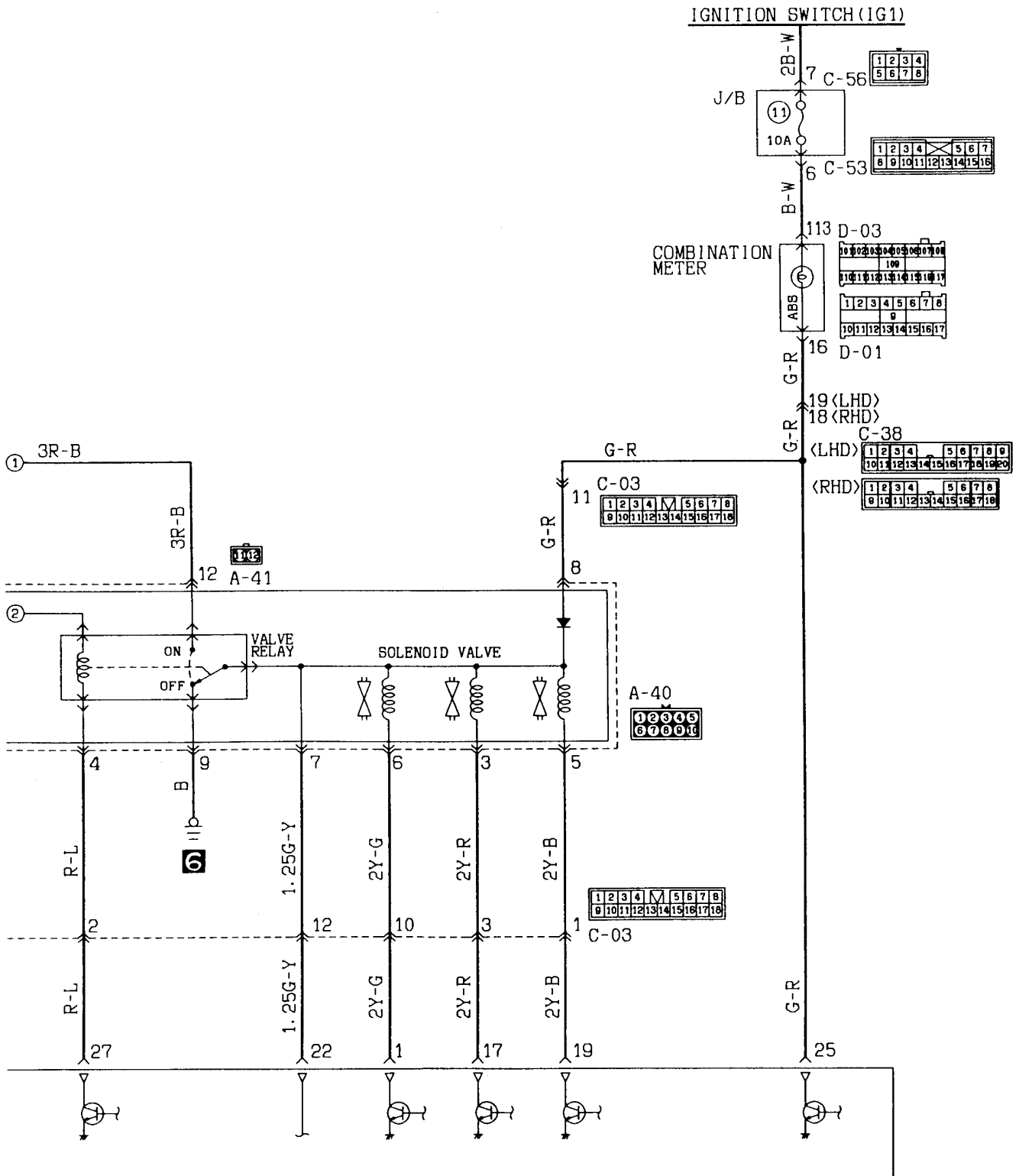

Wire colour code  
 B:Black LG:Light green G:Green L:Blue W:White Y:Yellow SB:Sky blue  
 BR:Brown O:Orange GR:Gray R:Red P:Pink V:Violet

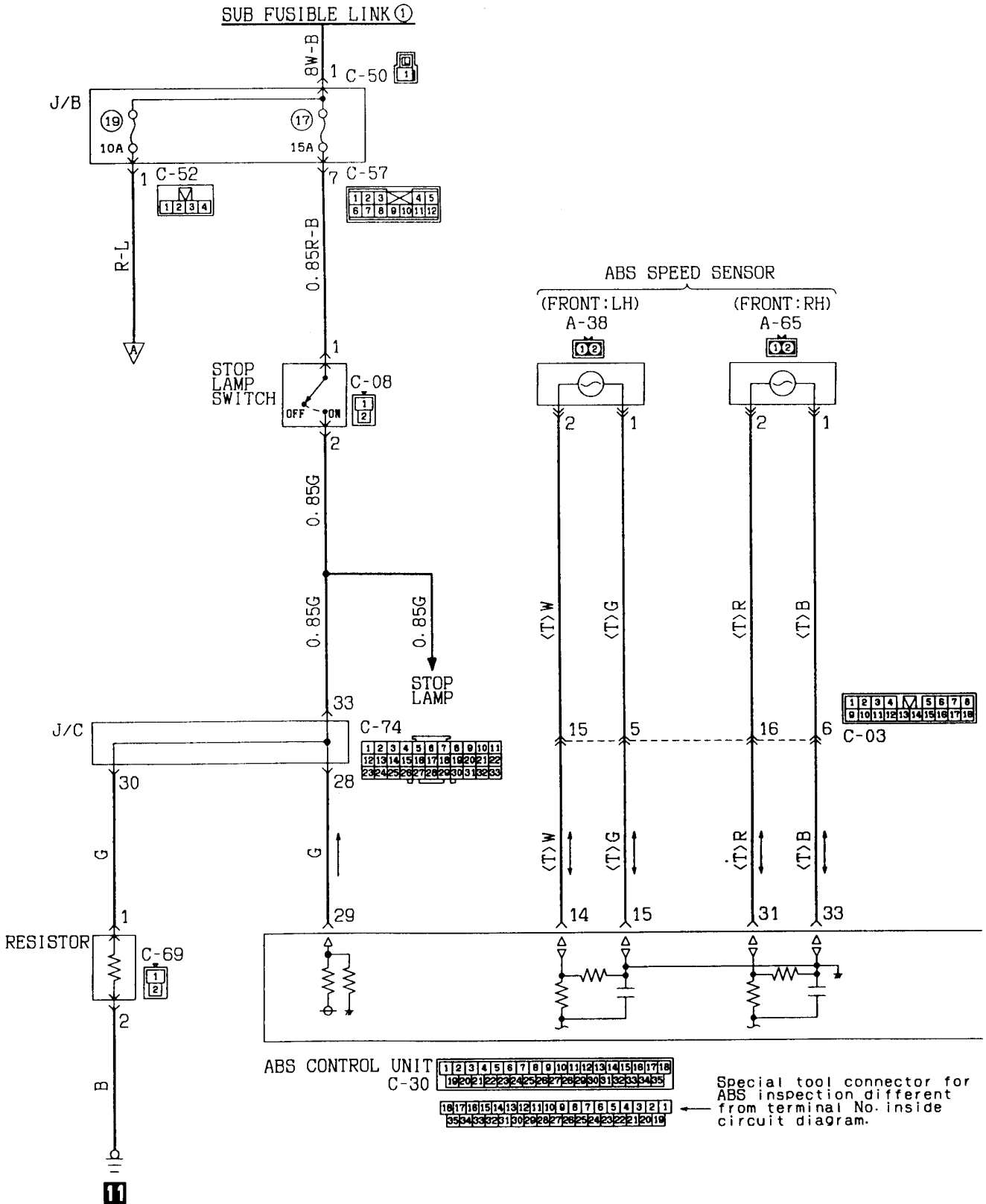

Wire colour code  
 B:Black LG:Light green G:Green L:Blue W:White Y:Yellow SB:Sky blue  
 BR:Brown O:Orange GR:Gray R:Red P:Pink V:Violet

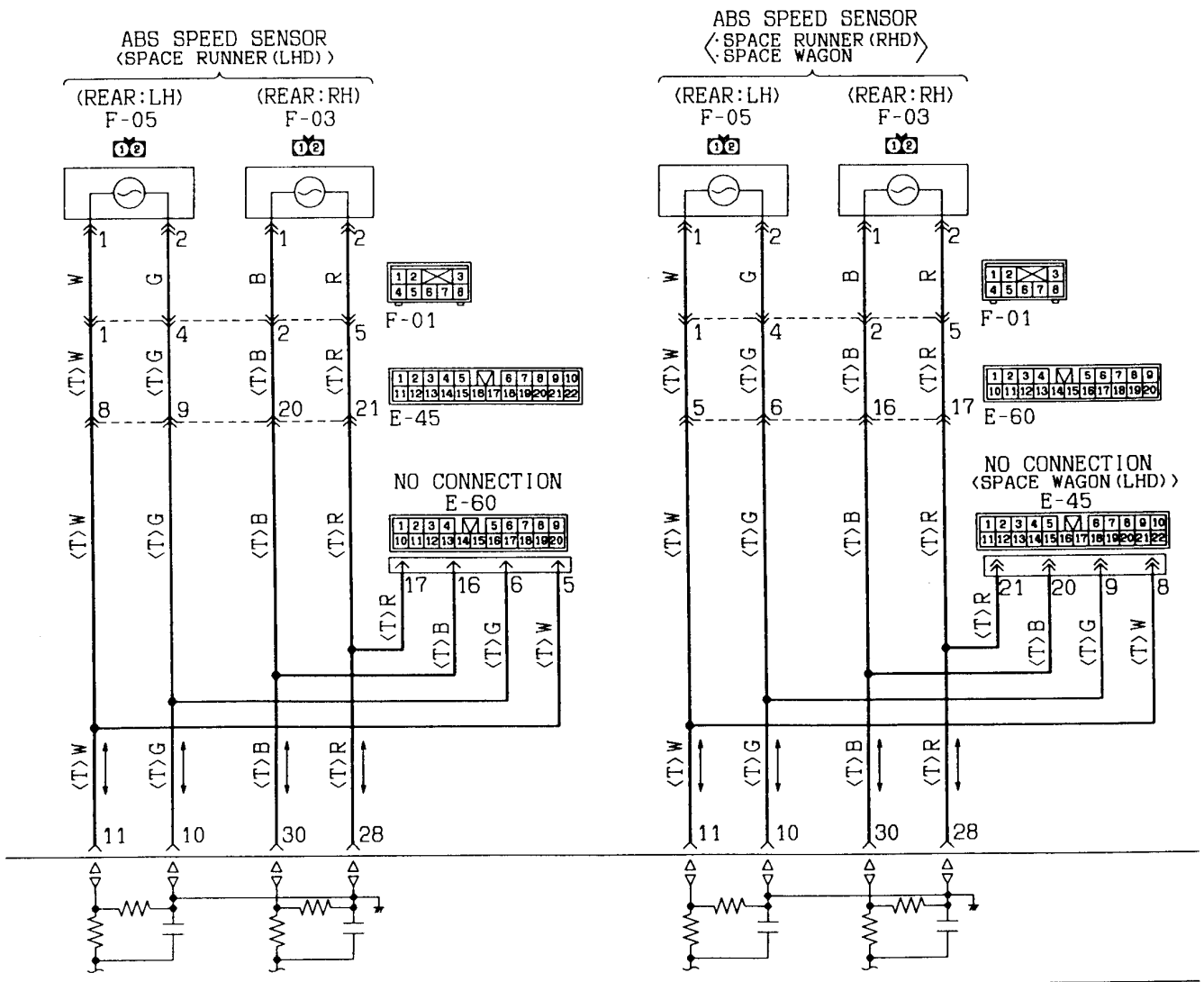

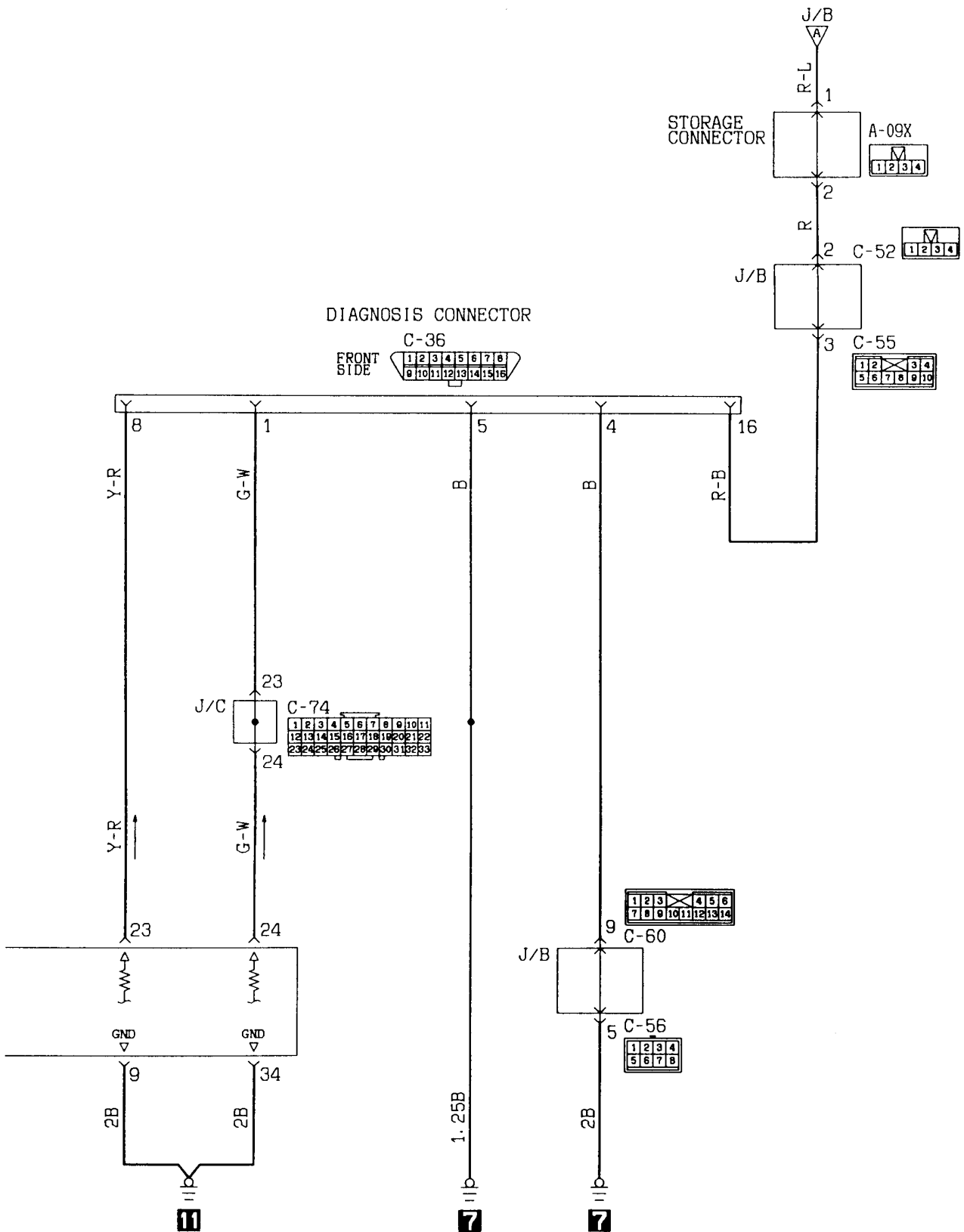

NOTES

ANTI-LOCK BRAKE SYSTEM (ABS)  
4WD

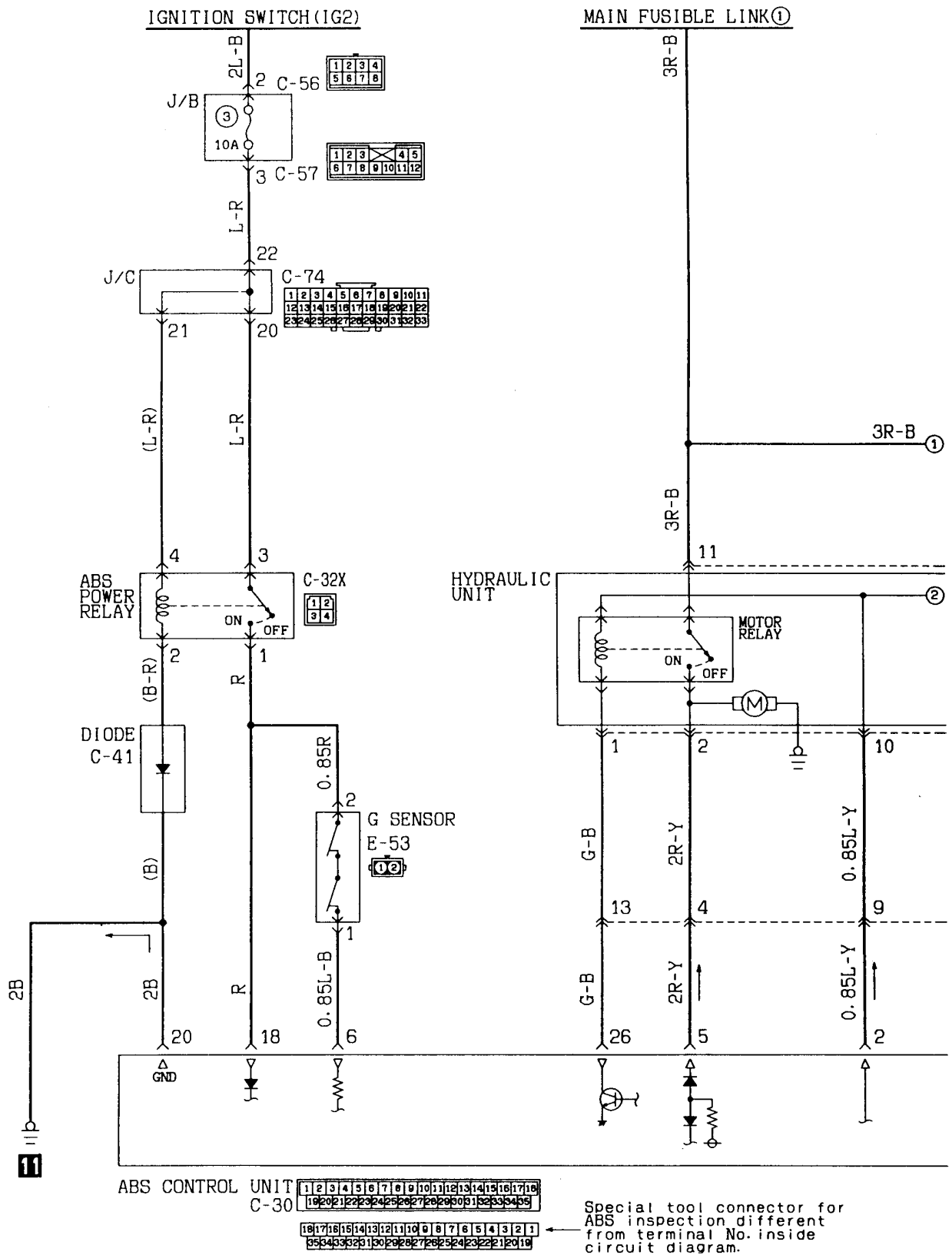

KX35-AC-Z1514-EC



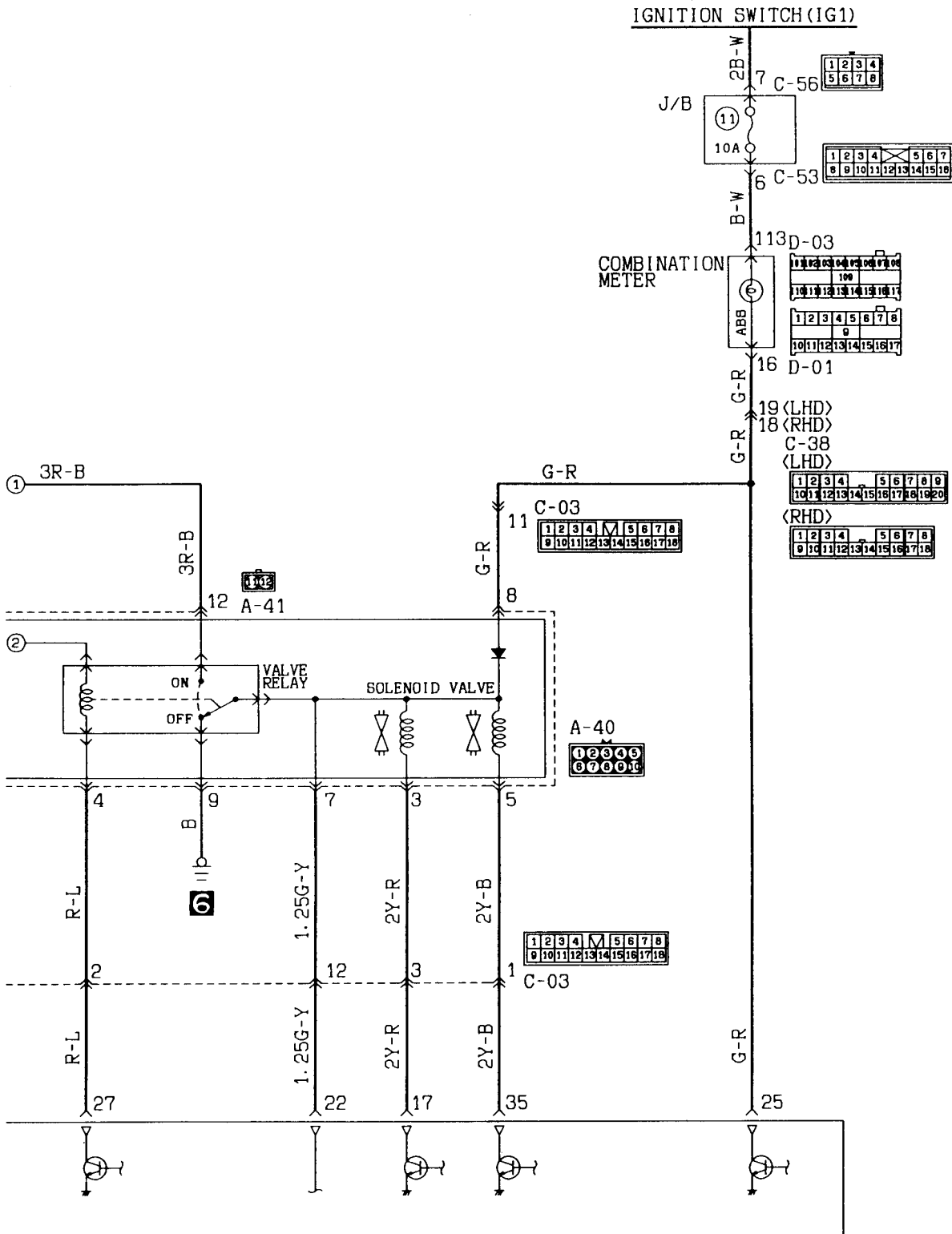

Wire colour code  
 B:Black LG:Light green G:Green L:Blue W:White Y:Yellow SB:Sky blue  
 BR:Brown O:Orange GR:Gray R:Red P:Pink V:Violet

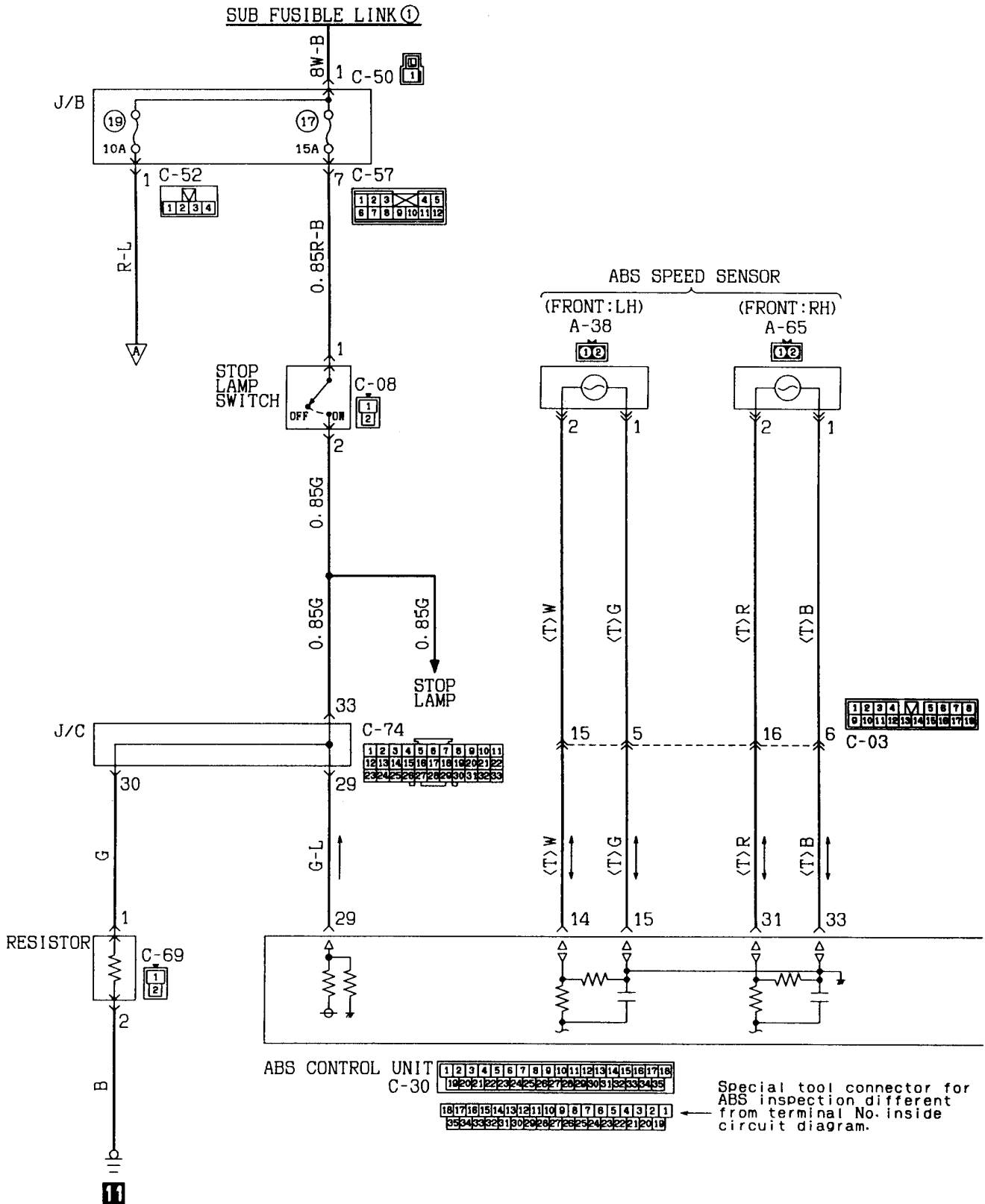

Wire colour code  
 B:Black LG:Light green G:Green L:Blue W:White Y:Yellow SB:Sky blue  
 BR:Brown O:Orange GR:Gray R:Red P:Pink V:Violet

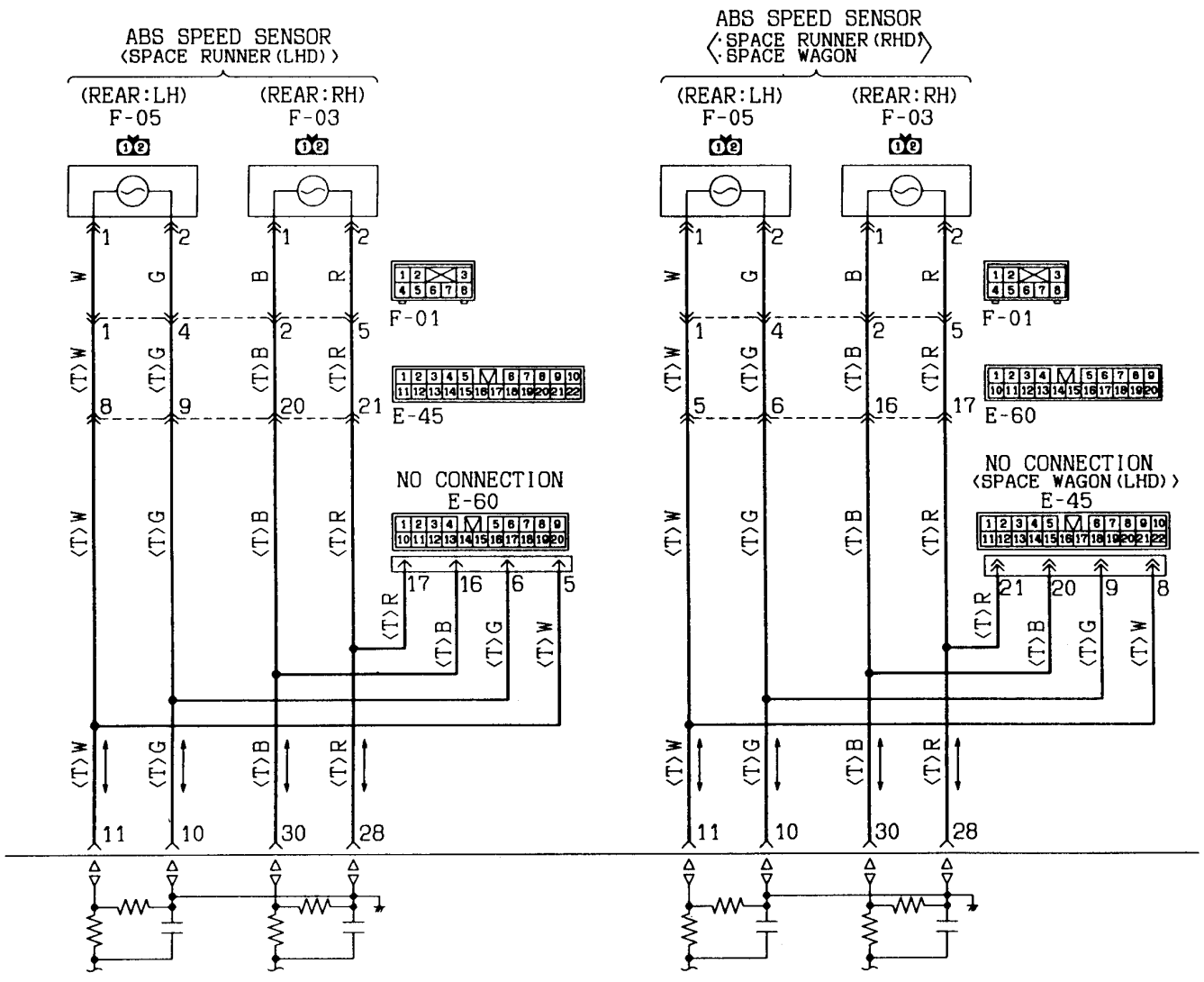

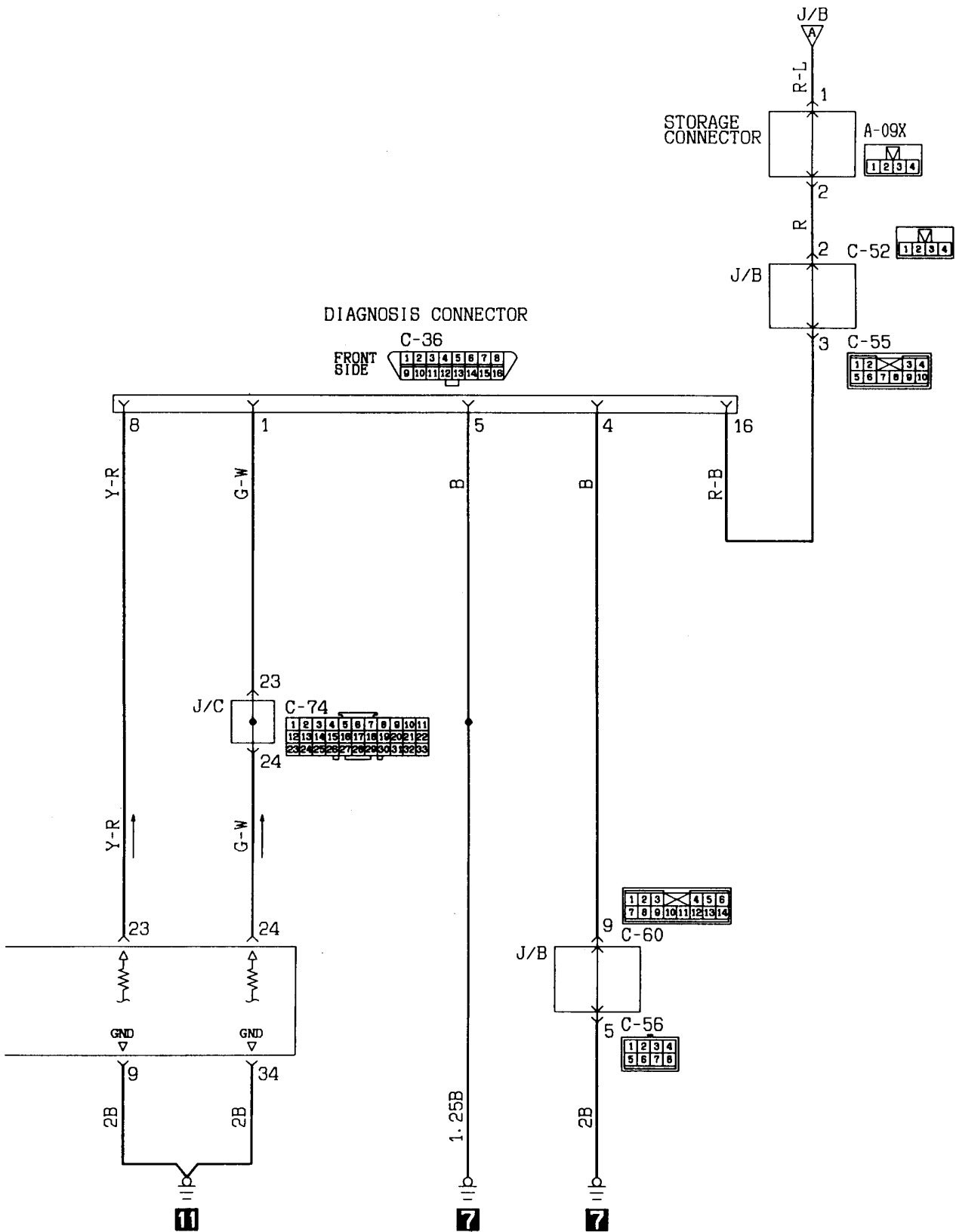

SUPPLEMENTAL RESTRAINT SYSTEM (SRS)

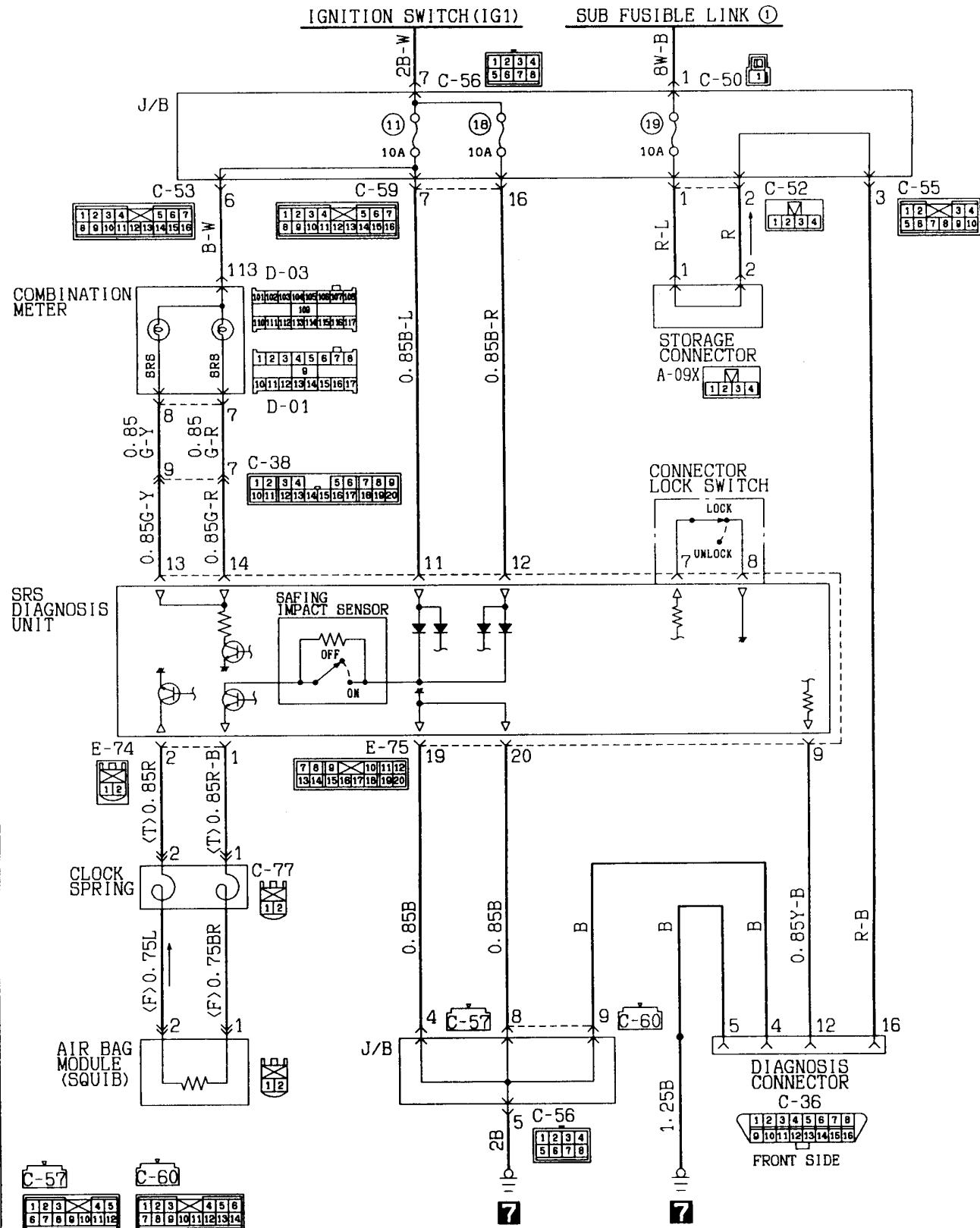

**CAUTION**  
 Carefully read and observe the SRS SERVICE PRECAUTIONS  
 (Refer to GROUP 52B SRS Service Precautions) prior to any service.

KX35-AC-21515-EC