LUBRICATION

CONTENTS

E12AA--

GENERAL INFORMATION	2	SERVICE ADJUSTMENT PROCEDURES	3
SPECIFICATIONS	3	Engine Oil Inspection	3
General Specifications	3	Engine Oil Replacement	4
Lubricants	3	Oil Filter Replacement	5
SPECIAL TOOL	3	ENGINE OIL COOLER <4D65>	6

GENERAL INFORMATION

E12BAAH

ENGINE OILS

Health Warning

Prolonged and repeated contact with mineral oil will result in the removal of natural fats from the skin, leading to dryness, irritation and dermatitis. In addition, used engine oil contains potentially harmful contaminants which may cause skin cancer. Adequate means of skin protection and washing facilities must be provided.

Recommended Precautions

The most effective precaution is to adapt working practices which prevent, as far as practicable, the risk of skin contact with mineral oils, for example by using enclosed systems for handling used engine oil and by degreasing components, where practicable, before handling them.

Other precautions:

- Avoid prolonged and repeated contact with oils, particularly used engine oils.
- Wear protective clothing, including impervious gloves where practicable.
- Avoid contaminating clothes, particularly underpants, with oil.
- Do not put oily rags in pockets, the use of overalls without pockets will avoid this.
- Do not wear heavily soiled clothing and oil-impregnated footwear. Overalls must be cleaned regularly and kept separate from personal clothing.
- Where there is a risk of eye contact, eye protection should be worn, for example, chemical goggles or face shields; in addition an eye wash facility should be provided.
- Obtain First Aid treatment immediately for open cuts and wounds.
- Wash regularly with soap and water to ensure all oil is removed, especially before meals (skin cleansers and nail brushes will help). After cleaning, the application of preparations containing lanolin to replace the natural skin oils is advised.
- Do not use petrol, kerosine, diesel fuel, gas oil, thinners or solvents for cleaning skin.
- Use barrier creams, applying them before each work period, to help the removal of oil from the skin after work.
- If skin disorders develop, obtain medical advice without delay.

SPECIFICATIONS

GENERAL SPECIFICATIONS

E12CA--

Items	4D65, 4D68
Engine oil cooler Performance	J/h (kcal/h, BTU/h) 20,930 × 10 ³ (5,000, 19,841)

LUBRICANTS

E12CD--

Items	Recommended lubricant	Quantity dm ³ (U.S.qts., Imp.qts.) [includes volume inside oil filter and oil cooler]
Engine oil (API classification)		
4G93	SG	3.8 (4.0, 3.3)
4G63, 4G64	SG	4.3 (4.5, 3.8)
4D65, 4D68	CD	5.1 (5.4, 4.5)

SPECIAL TOOL

E12CF--

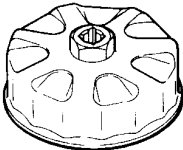
Tool	Number	Name	Use
	MB991396	Oil filter wrench	Removal and installation of engine oil filter <4G93>

SERVICE ADJUSTMENT PROCEDURES

ENGINE OIL INSPECTION

E12FCAE

1. Pull out the oil level gauge and remove oil adhered to the level gauge, wiping with clean cloth.
2. Insert the level gauge into the oil level gauge guide.
3. Pull out the level gauge slowly and check that the oil level is in the illustrated range.

NOTE

1. For this inspection, place the vehicle on a level surface.
2. Check while the engine is stationary. If the engine has been started, stop it and allow for some time before inspection.
4. If below the minimum level, supply with specified oil.

Specified oil: (API classification)

<4G93, 4G63, 4G64>

SG

<4D65, 4D68>

CD

Caution

Refilling beyond the maximum level has adverse effect on engine performance.

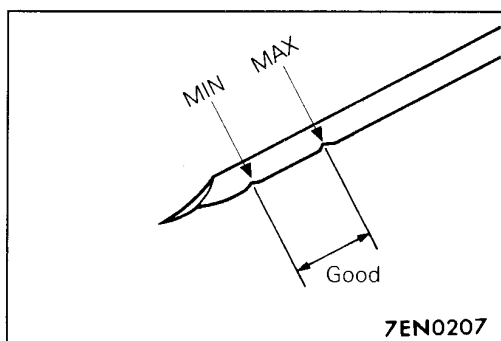

5. Run the engine at idle and stop. Then allow some time and check oil level again to make sure it is within the specified range.
6. Check that the oil is not excessively dirty, that there is no coolant or gasoline mixed in, and that it has sufficient viscosity.

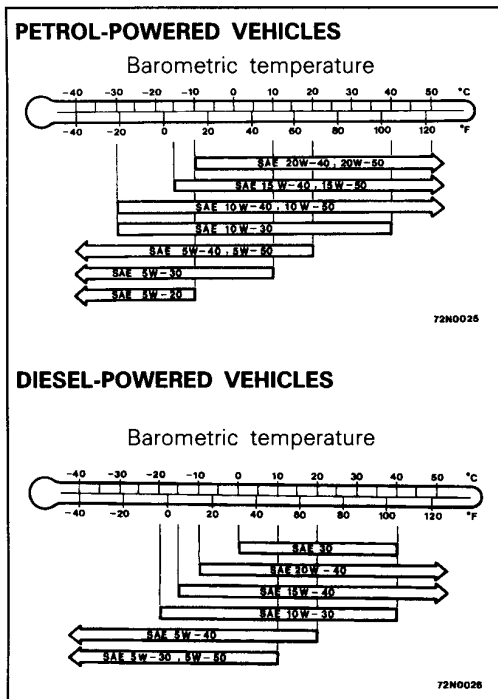

ENGINE OIL REPLACEMENT

E12FAAG

1. Start the engine and allow it to warm up until the temperature of the coolant reaches 80°C to 90°C (176°F to 194°F).
2. Remove the engine oil filler cap.
3. Remove the drain plug to drain oil.

Caution

Use care as oil could be hot.

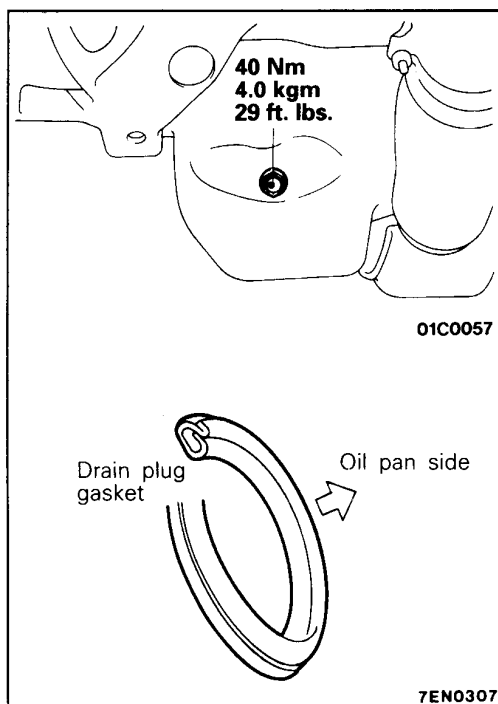

4. Fit the drain plug after oil has been drained completely.
- NOTE**
Install the drain plug gasket so it faces in the direction shown in the illustration.
5. Refill with specified quantity of oil.

Specified oil: (API classification)

4G93, 4G63, 4G64
4D65, 4D68

SG
CD

Oil quantity:

4G93 3.5 dm³ (3.7 U.S.qts., 3.1 Imp.qts.)
4G63, 4G64 4.0 dm³ (4.2 U.S.qts., 3.5 Imp.qts.)
4D65, 4D68 4.0 dm³ (4.2 U.S.qts., 3.5 Imp.qts.)

[Excludes volume inside oil filter and oil cooler]

6. Install the engine oil filler cap.
7. Check oil level. (Refer to P.12-3.)

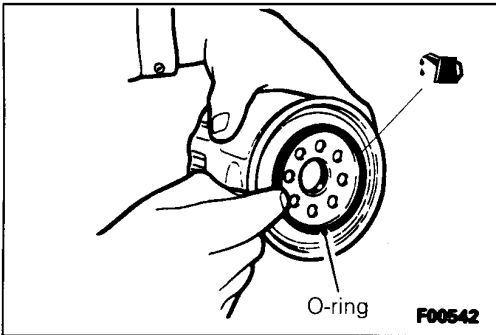
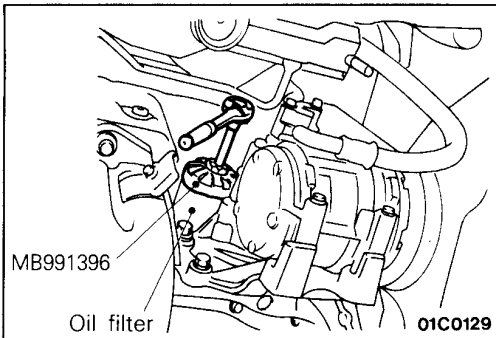
**OIL FILTER REPLACEMENT**

E12FBAF

<4G93>

- (1) After removing the engine oil filler cap, remove the engine oil drain plug to drain the engine oil.
- (2) Use the special tool to remove the engine oil filter from the underside of the vehicle.
- (3) Clean the filter bracket side mounting surface.

- (4) Apply a small amount of engine oil to the O-ring of the new oil filter.
- (5) Use the special tool to install the engine oil filter.

NOTE

Tightening torque 14 Nm (1.4 kgm, 10 ft.lbs.)

- (6) Fill with engine oil.
- (7) Race the engine 2–3 times, and check to be sure that no engine oil leaks from the installation section of the oil filter.

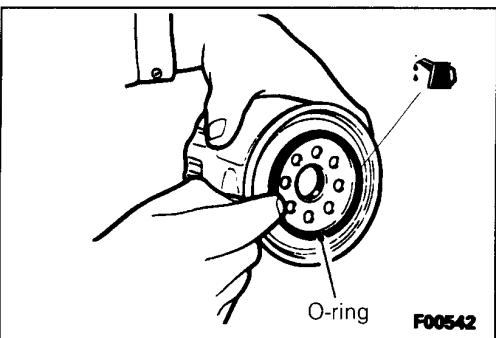
**<4G6, 4D6>**

- (1) After removing the engine oil filler cap, remove the engine oil drain plug to drain the engine oil.
- (2) Use an oil filter wrench to remove the engine oil filter.
- (3) Clean the filter bracket side mounting surface.
- (4) Apply a small amount of engine oil to the O-ring of the new oil filter.
- (5) Turn the oil filter by hand to install.

NOTE

Tightening torque 20 Nm (2.0 kgm, 14 ft.lbs.)

- (6) Fill with engine oil.
- (7) Race the engine 2–3 times, and check to be sure that no engine oil leaks from the installation section of the oil filter.

ENGINE OIL COOLER**REMOVAL AND INSTALLATION****Pre-removal and Post-installation Operation**

- Draining and Supplying Engine Oil (Refer to P. 12-4.)
- Removal and Installation of Radiator Grille (Refer to GROUP 51 – Front Grille.)
- Removal and Installation of Under Cover
- Removal and Installation of Front Bumper (Refer to GROUP 51 – Front Bumper.)

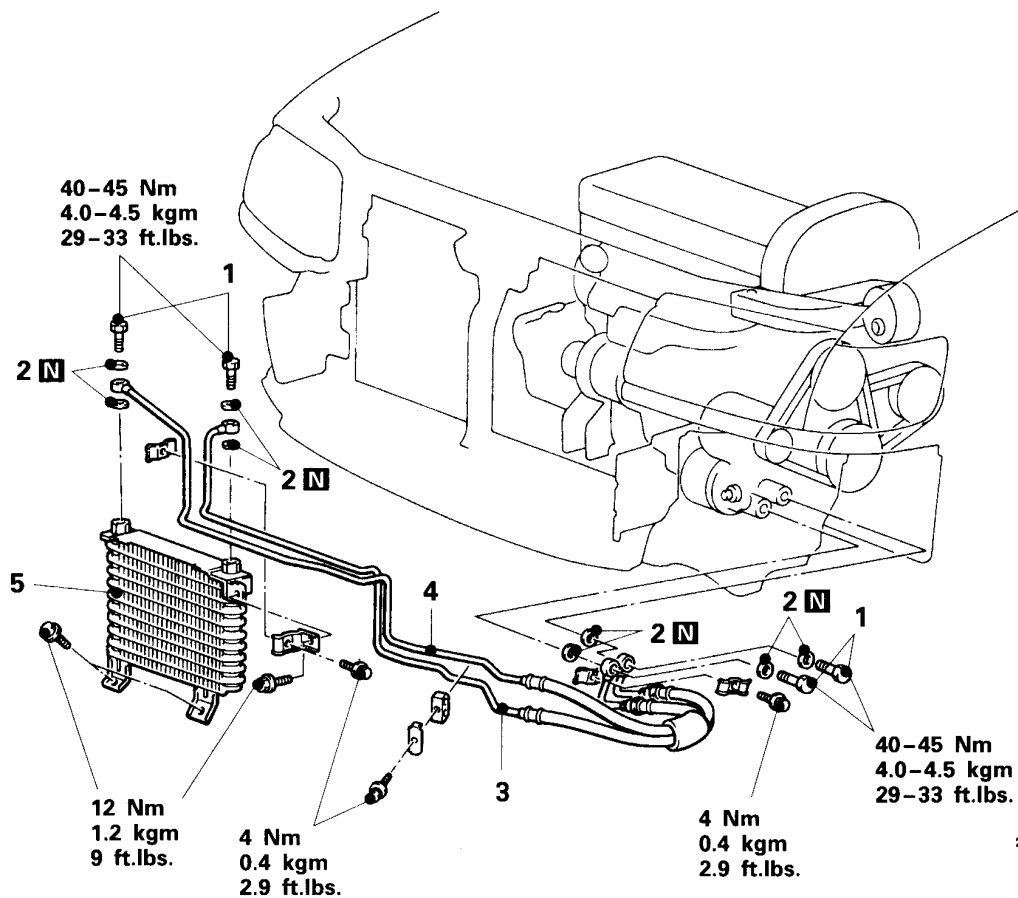

2D60001

Removal steps

1. Eye bolts
2. Gaskets
3. Engine oil feed hose and tube assembly
4. Engine oil return hose and tube assembly
5. Engine oil cooler