

STEERING

CONTENTS

E37AA--

SPECIFICATIONS	2	Checking Steering Wheel Return to Centre	9
General Specifications	2	Drive Belt Tension Check	9
Service Specifications	2	Fluid Level Check	11
Lubricants	3	Fluid Replacement	11
Sealant and Adhesives	3	Bleeding	12
SPECIAL TOOLS	4	Oil Pump Pressure Test	13
SERVICE ADJUSTMENT PROCEDURES	7	Power Steering Oil Pressure Switch Check	14
Steering Wheel Free Play Check	7	STEERING WHEEL AND SHAFT*	15
Steering Angle Check	7	POWER STEERING GEAR BOX*	19
Tie Rod End Ball Joint Variation Check	7	POWER STEERING OIL PUMP	30
Tie Rod End Ball Joint Starting Torque Check	8	POWER STEERING HOSES	35
Stationary Steering Effort Check	8		

WARNINGS REGARDING SERVICING OF SUPPLEMENTAL RESTRAINT SYSTEM (SRS) EQUIPPED VEHICLES

WARNING!

- (1) **Improper service or maintenance of any component of the SRS, or any SRS-related component, can lead to personal injury or death to service personnel (from inadvertent firing of the air bag) or to the driver (from rendering the SRS inoperative).**
- (2) **Service or maintenance of any SRS component or SRS-related component must be performed only at an authorized MITSUBISHI dealer.**
- (3) **MITSUBISHI dealer personnel must thoroughly review this manual, and especially its GROUP 52B—Supplemental Restraint System (SRS), before beginning any service or maintenance of any component of the SRS or any SRS-related component.**

NOTE

The SRS includes the following components: SRS diagnosis unit, SRS warning lamp, air bag module, clock spring, and interconnecting wiring. Other SRS-related components (that may have to be removed/installed in connection with SRS service or maintenance) are indicated in the table of contents by an asterisk (*).

SPECIFICATIONS

GENERAL SPECIFICATIONS

E37CA--

Items	Specifications
Gear box	
Steering gear type	Rack and pinion
Oil pump	
Oil pump type	Vane type
Displacement	9.6 (0.59) cm ³ /rev. (cu.in./rev.)
Relief set pressure	8 (80, 1,138) MPa (kg/cm ² , psi.)

SERVICE SPECIFICATIONS

E37CA--

Items	Specifications
Standard value	
Steering wheel free play (with engine stopped)	mm (in.) 15 (0.59) or less
Steering angle	
Inner wheel	36°30'±2°
Outer wheel	30°30'
Tie rod end ball joint starting torque	Nm (kgcm, in. lbs.) 0.5–2.5 (5–25, 4–22)
Stationary steering effort	N (kg, lbs.) 37 (3.7, 26.7)
Drive-belt tension	mm (in.)
When belt tension is readjusted	
Petrol-powered vehicles without A/C	9.5–11.5 (0.374–0.453)
Petrol-powered vehicles with A/C	6.8–7.6 (0.268–0.299)
Diesel-powered vehicles	6.5–9.0 (0.256–0.354)
When new belt is installed	
Petrol-powered vehicles without A/C	7.5–9.0 (0.295–0.354)
Petrol-powered vehicles with A/C	5.5–6.0 (0.217–0.236)
Diesel-powered vehicles	4.5–6.5 (0.177–0.256)
Oil pump pressure	Mpa (kg/cm ² , psi)
Oil pump relief pressure	7.5–8.2 (75–82, 1067–1166)
Pressure under no-load conditions	0.8–1.0 (8–10, 114–142)
Steering gear retention hydraulic pressure	7.5–8.2 (75–82, 1067–1166)
Oil pressure switch operating pressure	Mpa (kg/cm ² , psi) 1.5–2.0 (15–20, 213–284)
OFF ON	0.7–1.2 (7–12, 100–171)
ON OFF	0.6–1.3 (6–13, 5–11)
Total pinion preload	Nm (kgcm, in. lbs.)
Tie-rod joint swing torque	Nm (kgcm, in. lbs.)
<Vehicles built up to April, 1993>	2–5 (20–50, 17–43)
<Vehicles built from May, 1993>	1.5–5 (15–50, 13–43)
Limit	
Steering wheel free play (when hydraulic operation)	mm (in.) 30 (1.2)
Tie rod and ball joint variation (shaft direction)	mm (in.) 1.5 (0.059)

LUBRICANTS

E37CD-

Items	Specified lubricants	Quantity
Power steering gear box		
Bearing	Automatic transmission fluid DEXRON or DEXRON II	As required
O-ring	Automatic transmission fluid DEXRON or DEXRON II	As required
Oil seal	Automatic transmission fluid DEXRON or DEXRON II	As required
Special tool (MB991213)	Automatic transmission fluid DEXRON or DEXRON II	As required
Pinion and valve assembly seal ring part	Automatic transmission fluid DEXRON or DEXRON II	As required
Bellows	Silicone grease	As required
Oil pump		
Power steering fluid	Automatic transmission fluid DEXRON or DEXRON II	0.9 dm ³ (0.95 U.S.qt., 0.79 Imp.qt.)
Flow control valve	Automatic transmission fluid DEXRON or DEXRON II	As required
Friction surface of rotor, vane, cam ring and pump cover	Automatic transmission fluid DEXRON or DEXRON II	As required
O-ring	Automatic transmission fluid DEXRON or DEXRON II	As required





SEALANT AND ADHESIVES



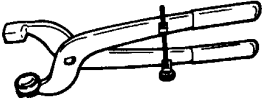
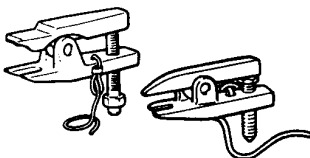

E37CE-

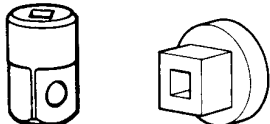
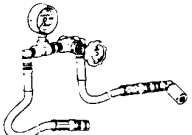
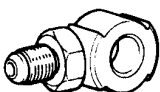
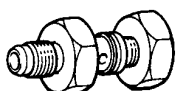
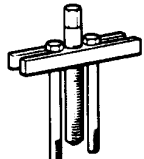
Items	Specified sealant and adhesive	Remarks
Power steering gear box		
End plug screw		
Power steering rack support cover screw	3M ATD Part No. 8661 or equivalent	Semi-drying sealant
Dust cover lip for tie rod end ball joint		

SPECIAL TOOLS

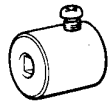
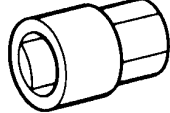
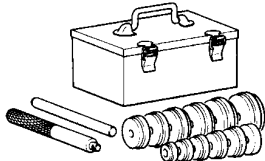
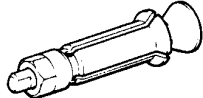
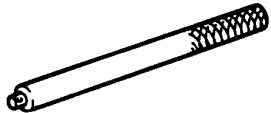





E37DA--

Tool	Number	Name	Use
	MB990948	Linkage joint gauge	Ball joint variation check for shaft direction
	MB991113 or MB990635	Steering linkage puller	Disconnection of tie-rod end
	MB990685	Torque wrench	Measurement of the ball joint starting torque Measurement of the pinion shaft preload
	MB990326 or CT-1046	Preload socket	Measurement of the ball joint starting torque
	MB990662	Oil pressure gauge assembly	Measurement of oil pressure
	MB990993 or MB991217	Power steering oil pressure gauge adapter (pump side)	Measurement of oil pressure
	MB990994	Power steering oil pressure gauge adapter (hose side)	Measurement of oil pressure
	MB990803	Steering wheel puller	Disconnection of the steering wheel
	MB990826	Torque wrench	Removal and installation of the tilt bracket or upper bracket

Tool	Number	Name	Use
	MB991006	Preload socket	Measurement of the pinion shaft preload
	MB991204	Torque wrench socket	Adjustment of rack support Removal of rack support cover
	MB990925	Bearing and oil seal installer set (Refer to GROUP 26)	Installation of the oil seal and bearing MB990927 MB990938 MB990939
	MB991120	Needle bearing puller	Removal of rack housing needle bearing
	MB991197	Bar (long type)	To press in the oil seal for the rack
	MB991199	Oil seal installer	To press in the oil seal for the rack
	MB991099	Oil seal installer attachment	Oil seal installer guide
	MB991202	Oil seal & bearing installer	Press fitting of rack housing bearing

37A-6

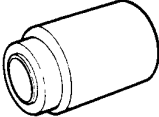
STEERING – Special Tools

Tool	Number	Name	Use
	MB991072	Lower arm bushing remover & installer	Press fitting of dust seal
	MB991213	Rack installer	Rack installation
	MB991203	Oil seal & bearing installer	To press in the valve housing oil seal and bearing
	MB991317	Seal ring installer	Compression of the seal rings after replacement of the pinion seal rings
	MB991152	Dust cover installer	To press in the column tube lower part bearing
	MB990776	Front axle base	Installation of dust cover for tie rod end ball joint
	MB990628	Snap ring pliers	To remove and install the snap ring of the pulley and shaft

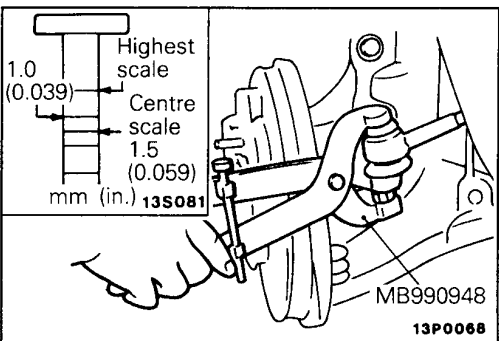
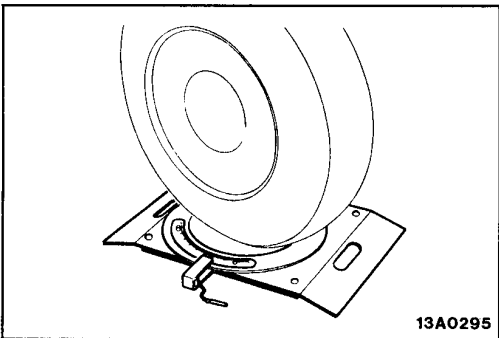
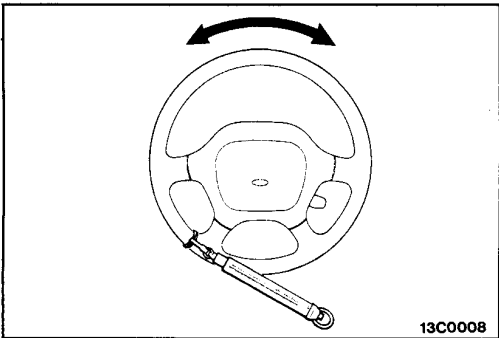
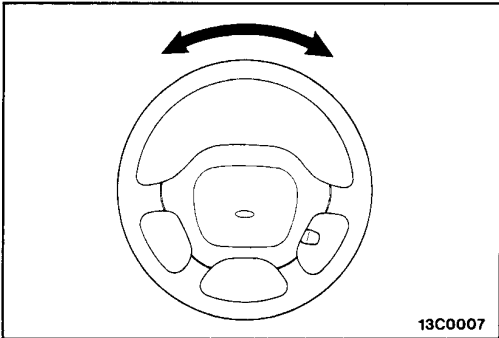

SERVICE ADJUSTMENT PROCEDURES E37FABC

STEERING WHEEL FREE PLAY CHECK

1. With engine running (hydraulic operation), set front wheels straight ahead.
2. Measure the play on steering wheel circumference before wheels start to move when slightly moving steering wheel in both directions.

Limit: 30 mm (1.2 in.)

3. When play exceeds the limit, check for play on steering shaft connection and steering linkage. Correct or replace.
4. If the free play still exceeds the limit value, set steering wheel straight ahead with engine stopped. Load 5 N (0.5 kg, 1 lb.) towards steering wheel circumference and check play.

Standard value (steering wheel play with engine stopped): 15 mm (0.59 in.) or less

If the play exceeds the standard value, remove steering gear box and check total pinion torque.

STEERING ANGLE CHECK E37FDAE

1. Locate front wheels on turning radius gauge and measure steering angle.

Standard value:

Inside wheel
Outside wheel

36°00' ± 2°
30°30'

2. When the angle is not within the standard value, the toe is probably incorrect. Adjust toe (Refer to GROUP 33A -- Service Adjustment Procedures) and recheck steering angle.

TIE ROD END BALL JOINT VARIATION CHECK (SHAFT DIRECTION) E37FVAA

1. Hold ball joint with the special tool.
2. Set special tool scale at its highest and measure variation with ball stud compressed. The variation should locate between the highest and centre scales.

Limit: 1.5 mm (0.059 in.)

3. When the variation exceeds the centre scale, replace the tie-rod end.

Caution

Even if the variation is within the limit, check ball joint starting torque.

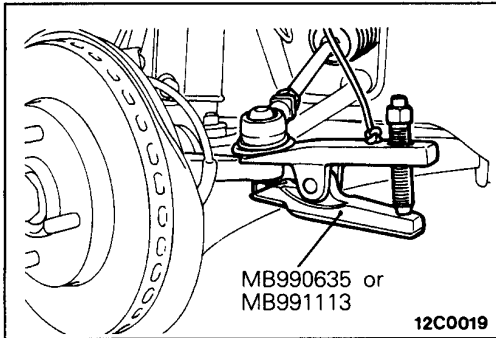

TIE ROD END BALL JOINT STARTING TORQUE CHECK

E37FMAA

1. Disconnect tie rod and knuckle with special tool.

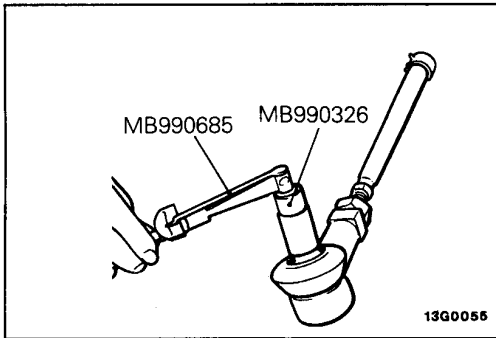

2. Move ball joint stud several times and install nut on stud. Measure ball joint starting torque with special tools.

Standard value: 0.5–2.5 Nm (5–25 kgcm, 4–22 in.lbs.)

3. When the starting torque exceeds the standard value, replace the rod end.
4. When the starting torque is under the standard value, check ball joint for end play or ratcheting. If none of these, the joint is still serviceable.

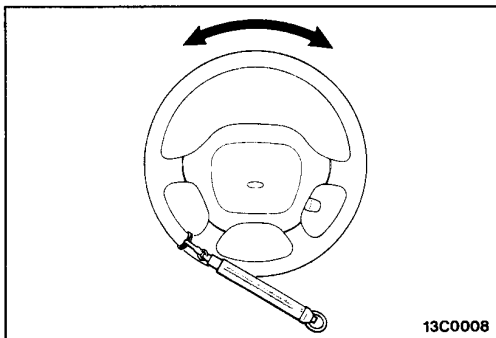

STATIONARY STEERING EFFORT CHECK

E37FFAH

1. With the vehicle stopped on a flat, paved surface, turn the steering wheel to the straight ahead position.
2. Start the engine and set it to $1,000 \pm 100$ r/min.

Caution

After checking the engine r/min., there must be a return to the standard idling r/min.

3. Attach a spring balance to the outer circumference of the steering wheel and measure the steering force required to turn the steering wheel from the straight ahead position to the left and right (within a range of 1.5 turns). Also check to be sure that there is no significant fluctuation of the required steering force.

Standard value:

Steering effort **37 N (3.7 kg, 26.7 lbs.) or less**
Fluctuation allowance **6 N (0.6 kg, 1.3 lbs.) or less**

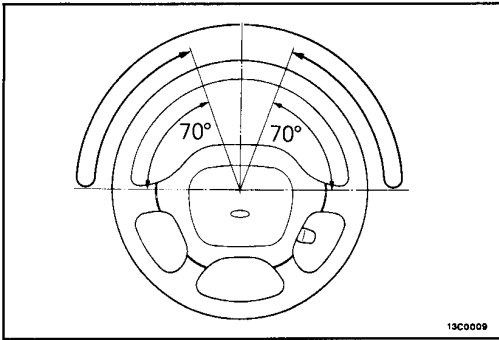

CHECKING STEERING WHEEL RETURN TO CENTRE

E37FGAA

- To make this test, conduct a road test and check as follows.
1. Make both gradual and sudden turns and check the steering "feeling" to be sure that there is no difference in the steering force required and the wheel return between left and right turns.
 2. At a speed of 35 km/h (22 mph), turn the steering wheel 90°, and release the steering wheel after 1 or 2 seconds. If the steering wheel then returns 70° or more, the return can be judged to be satisfactory.

NOTE

There will be a momentary feeling or "heaviness" when the wheel is turned quickly, but this is not abnormal. (This is because the oil pump discharge amount is especially apt to be insufficient during idling.)

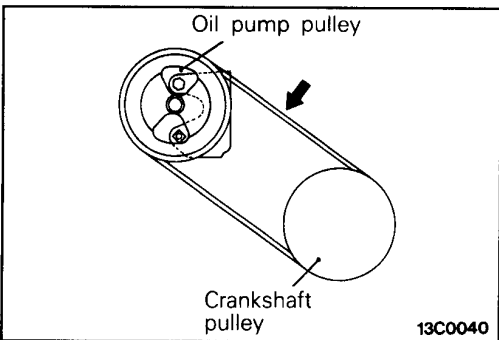

DRIVE BELT TENSION CHECK

E37FHAN

Check to be sure that the belt is not damaged and that the drive-belt is correctly attached to the groove of the pulley.

NOTE

If there is abnormal noise or belt slippage, check the belt tension and check for unusual wear or abrasion, or damage, of the pulley contact surface, and for scars or scratches on the pulley.

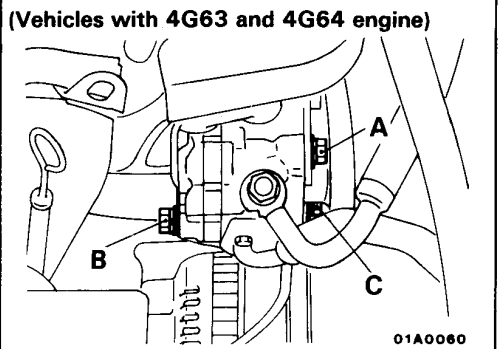
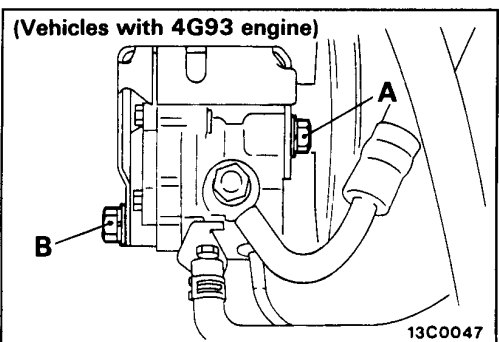

<Petrol-powered vehicles without A/C>

1. Press in drive-belt at the illustrated position with about 100 N (10 kg, 22 lbs.) and measure deflection. Use a belt tension gauge to check whether the belt tension is at the standard value.

Standard value

	Deflection mm (in.)	Tension N (kg, lbs.)
When belt tension is readjusted	9.5–11.5 (0.374–0.453)	400–600 (40–60, 88–132)
When new belt is installed	7.5–9.0 (0.295–0.354)	650–850 (65–85, 143–187)

2. If the deflection is out of the standard values, adjust the belt tension using the following procedure.
 - (1) Loosen bolts A and B or C (for holding the oil pump).

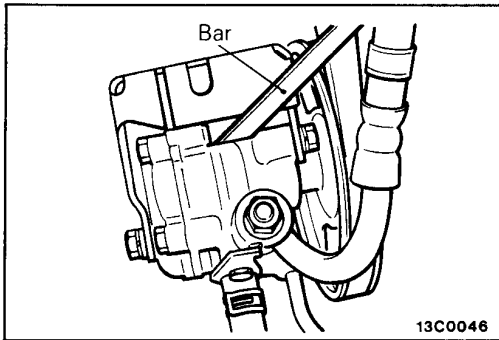

- (2) Place a bar or similar object against the body of the oil pump, and, while manually providing the suitable amount of tension, adjust the amount of flexion of the belt.
- (3) Tighten bolts A and B in that order.
- (4) Check the amount of flexion of the belt; readjust if necessary.

Caution

The check should be made after turning the engine one time or more in the regular direction of rotation (to the right).

<Petrol-powered vehicles with A/C>

1. Press in drive belt at the illustrated position with about 100 N (10 kg, 22 lbs.) and measure deflection.

Use a belt tension gauge to check whether the belt tension is at the standard value.

Standard value

	Deflection mm (in.)	Tension N (kg, lbs.)
When belt tension is readjusted	6.8–7.6 (0.268–0.299)	500–630 (50–63, 110–139)
When new belt is installed	5.5–6.0 (0.217–0.236)	750–800 (75–80, 165–176)

2. If the deflection is out of the standard values, loosen the tension pulley nut and adjust the belt tension with adjusting bolt.

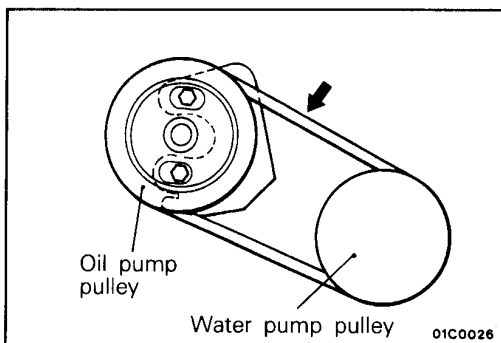
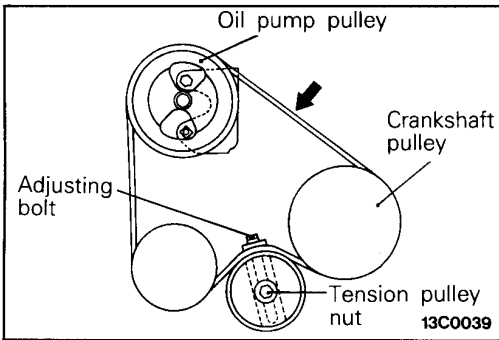

<Diesel-powered vehicles>

1. Press in drive belt at the illustrated position with about 100 N (10 kg, 22 lbs.) and measure deflection.

Standard value

mm (in.)

When belt tension is re-adjusted	6.5–9.0 (0.256–0.354)
When new belt is installed	4.5–6.5 (0.177–0.256)

2. If the deflection is out of the standard values, adjust the belt tension using the following procedure.
 - (1) Loosen bolts A, B and C (for holding the oil pump).

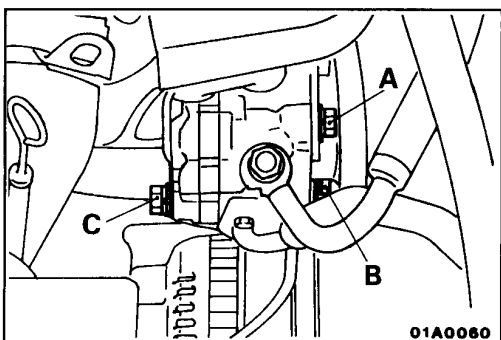

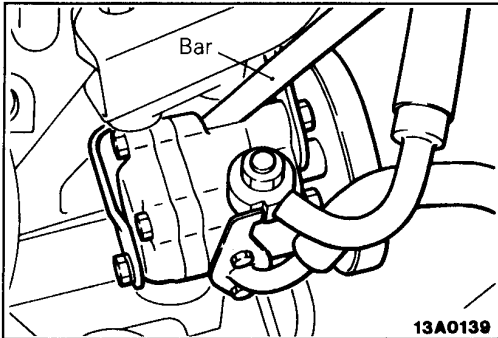

- (2) Place a bar or similar object against the body of the oil pump, and, while manually providing the suitable amount of tension, adjust the amount of flexion of the belt.
- (3) Tighten bolts A, B and C in that order.
- (4) Check the amount of flexion of the belt; readjust if necessary.

Caution

The check should be made after turning the engine one time or more in the regular direction of rotation (to the right).

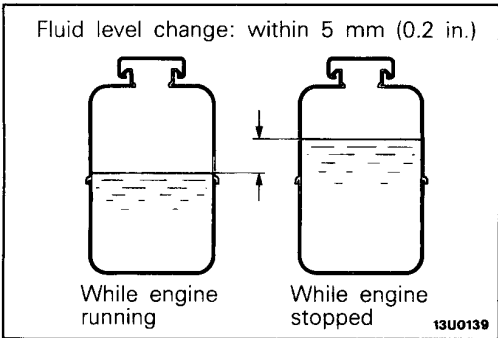

FLUID LEVEL CHECK

E37FIAD

1. Park the vehicle on a flat, level surface, start the engine, and then turn the steering wheel several times to raise the temperature of the fluid to approximately 50–60°C (122–140°F)
2. With the engine running, turn the wheel all the way to the left and right several times.
3. Check the fluid in the oil reservoir for foaming or milkiness.

Check the difference of the fluid level when the engine is stopped, and while it is running. If the fluid level changes considerably, air bleeding should be done.

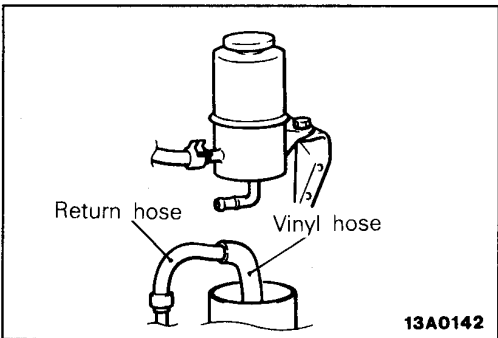

FLUID REPLACEMENT

E37FJAF

1. Raise the front wheels on a jack, and then support them with rigid racks.
2. Disconnect the return hose connection.
3. Connect a vinyl hose to the return hose, and drain the oil into a container.
4. On vehicles with a petrol engine, disconnect the high-tension cable. On vehicles with a diesel engine, remove the fuel cut valve connector attached to the injection pump.

While operating the starting motor intermittently, turn the steering wheel all the way to the left and right several times to drain all of the fluid.

Caution

Be careful not to position the high-tension cable near the carburettor or the delivery pipe.

5. Connect the return hoses securely, and then secure it with the clip.
6. Fill the oil reservoir with the specified fluid up to the lower position of the filter, and then bleed the air.

Specified fluid: Automatic transmission fluid DEXRON or DEXRON II

BLEEDING

1. Jack up the front wheels and support them by using a rigid rack.
2. Manually turn the oil pump pulley a few times.
3. Turn the steering wheel all the way to the left and to the right five or six times.
4. On vehicles with a petrol engine, disconnect the high-tension cable. On vehicles with a diesel engine, remove the fuel cut valve connector attached to the injection pump.

While operating the starting motor intermittently, turn the steering wheel all the way to the left and right five or six times (for 15 or 20 seconds).

Caution

1. **During air bleeding, replenish the fluid supply so that the level never falls below the lower position of the filter.**
2. **If air bleeding is done while engine is running, the air will be broken up and absorbed into the fluid; be sure to do the bleeding only while cranking.**
5. On vehicles with a petrol engine, connect the high-tension cable. On vehicles with a diesel engine, connect the fuel cut valve connector attached to the injection pump.
Start the engine (idling.)
6. Turn the steering wheel to the left and right until there are no air bubbles in the oil reservoir.
7. Confirm that the fluid is not milky, and that the level is up to the specified position on the level gauge.
8. Confirm that there is very little change in the fluid level when the steering wheel is turned left and right.
9. Check whether or not the change in the fluid level is within 5 mm (0.2 in.) when the engine is stopped and when it is running.

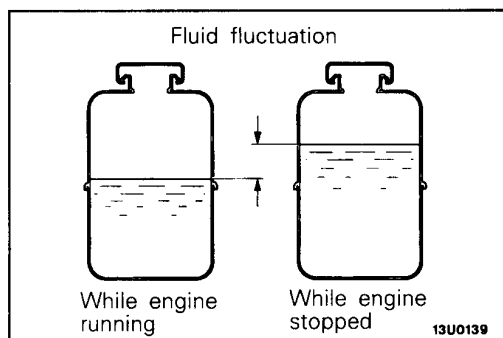
**Caution**

1. **If the change of the fluid level is 5 mm (0.2 in.) or more, the air has not been completely bled from the system, and thus must be bled completely.**
2. **If the fluid level rises suddenly after the engine is stopped, the air has not been completely bled.**
3. **If air bleeding is not complete, there will be abnormal noises from the pump and the flow-control valve, and this condition could cause a lessening of the life of the pump, etc.**

E37FLAE

OIL PUMP PRESSURE TEST**CHECKING THE OIL PUMP RELIEF PRESSURE**

1. Disconnect the pressure hose from the oil pump, and then connect the special tools.
2. Bleed the air, and then turn the steering wheel several times while the vehicle is not moving so that the temperature of the fluid rises to approximately 50–60°C (122–140°F).
3. Start the engine and idle it at 1,000±100 r/min.
4. Fully close the shut-off valve of the pressure gauge and measure the oil pump relief pressure to confirm that it is within the standard value range.

Standard value: 7.5–8.2 MPa
(75–82 kg/cm², 1,067–1,166 psi.)

Caution

Pressure gauge shut off valve must not remain closed for more than 10 seconds.

5. If it is not within the standard value, overhaul the oil pump.
6. Remove the special tools, and then tighten the pressure hose to the specified torque.
7. Bleed the system.

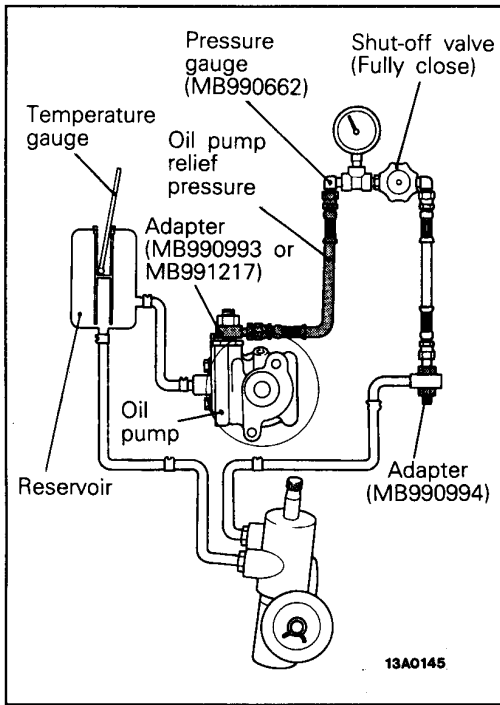
**CHECKING THE PRESSURE UNDER NO-LOAD CONDITIONS**

1. Disconnect the pressure hose from the oil pump, and then connect the special tools.
2. Bleed the air, and then turn the steering wheel several times while the vehicle is not moving so that the temperature of the fluid rises to approximately 50–60°C (122–140°F).
3. Start the engine and idle it at 1,000±100 r/min.
4. Check whether or not the hydraulic pressure is the standard value when no-load conditions are created by fully opening the shut-off valve of the pressure gauge.

Standard value: 0.8–1.0 MPa
(8–10 kg/cm², 114–142 psi.)

5. If it is not within the standard value, the probable cause is a malfunction of the oil line or steering gear box, so check these parts and repair as necessary.
6. Remove the special tools, and then tighten the pressure hose to the specified torque.
7. Bleed the system.

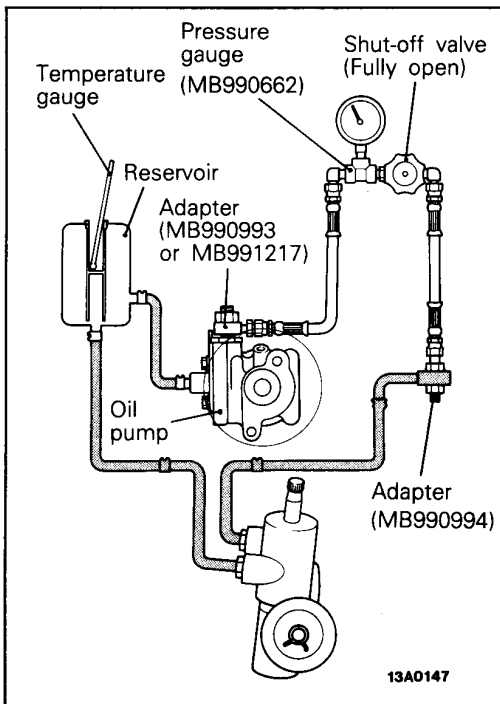

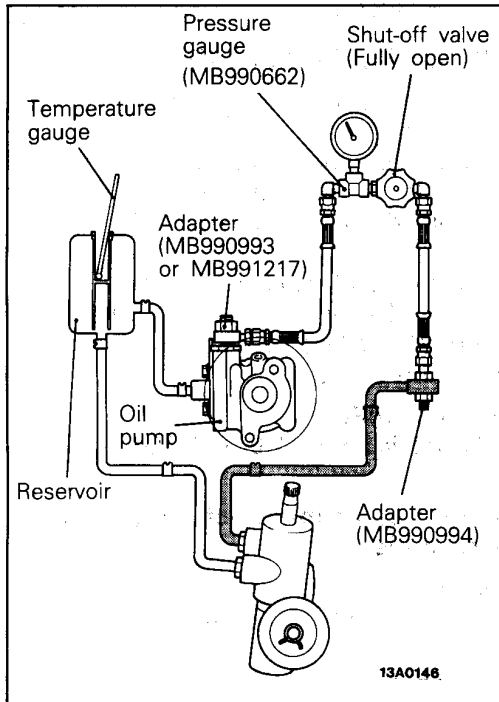

CHECKING THE STEERING GEAR RETENTION HYDRAULIC PRESSURE

1. Disconnect the pressure hose from the oil pump, and then connect the special tools.
2. Bleed the air, and then turn the steering wheel several times while the vehicle is not moving so that the temperature of the fluid rises to approximately 50–60°C (122–140°F).
3. Start the engine and idle it at 1,000±100 r/min.
4. Fully close and fully open the shut-off valve of the pressure gauge.
5. Turn the steering wheel all the way to the left or right; then check whether or not the retention hydraulic pressure is the standard value.

**Standard value: 7.5–8.2 MPa
(75–82 kg/cm², 1,067–1,166 psi.)**

6. When not within the standard value, overhaul the steering gear box.
Remeasure fluid pressure.
7. Remove the special tools, and then tighten the pressure hose to the specified torque.
8. Bleed the system.

POWER STEERING OIL PRESSURE SWITCH CHECK

E37FOAA

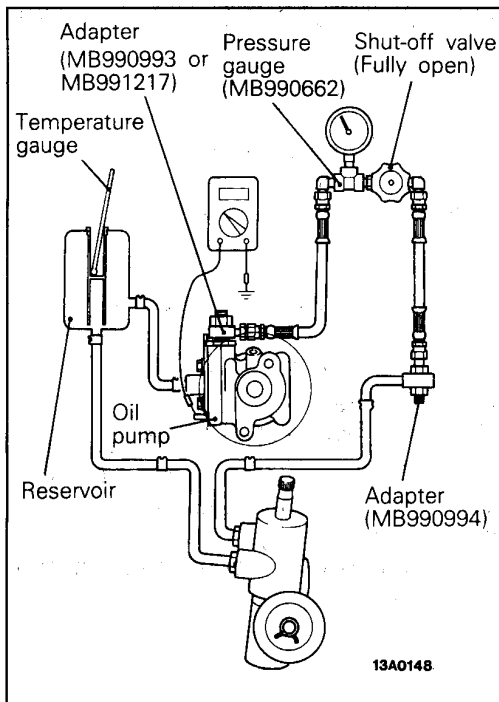

1. Disconnect the pressure hose from the oil pump, and then connect the special tools.
2. Bleed the air, and then turn the steering wheel several times while the vehicle is not moving so that the temperature of the fluid rises to approximately 50–60°C (122–140°F).
3. The engine should be idling.
4. Disconnect the connection of the connector for the oil pressure switch, and place an ohmmeter in position.
5. Gradually close the shut-off valve of the pressure gauge and increase the hydraulic pressure then check whether or not the hydraulic pressure that activates the switch is the standard value.

**Standard value: 1.5–2.0 MPa
(15–20 kg/cm², 213–284 psi.)**

6. Gradually open the shut-off valve and reduce the hydraulic pressure, then check whether or not the hydraulic pressure that deactivates the switch is the standard value.

**Standard value: 0.7–1.2 MPa
(7–12 kg/cm², 100–171 psi.)**

7. Remove the special tools, and then tighten the pressure hose to the specified torque.
8. Bleed the system.

STEERING WHEEL AND SHAFT

REMOVAL AND INSTALLATION

E37HA--

Post-installation Operation

- Inspection of Steering Wheel Centering.

Caution: SRS

Before removal of air bag module, refer to GROUP 52B – SRS Service Precautions and Air Bag Module and Clock Spring.

<Vehicles with SRS>

<Vehicles without SRS>

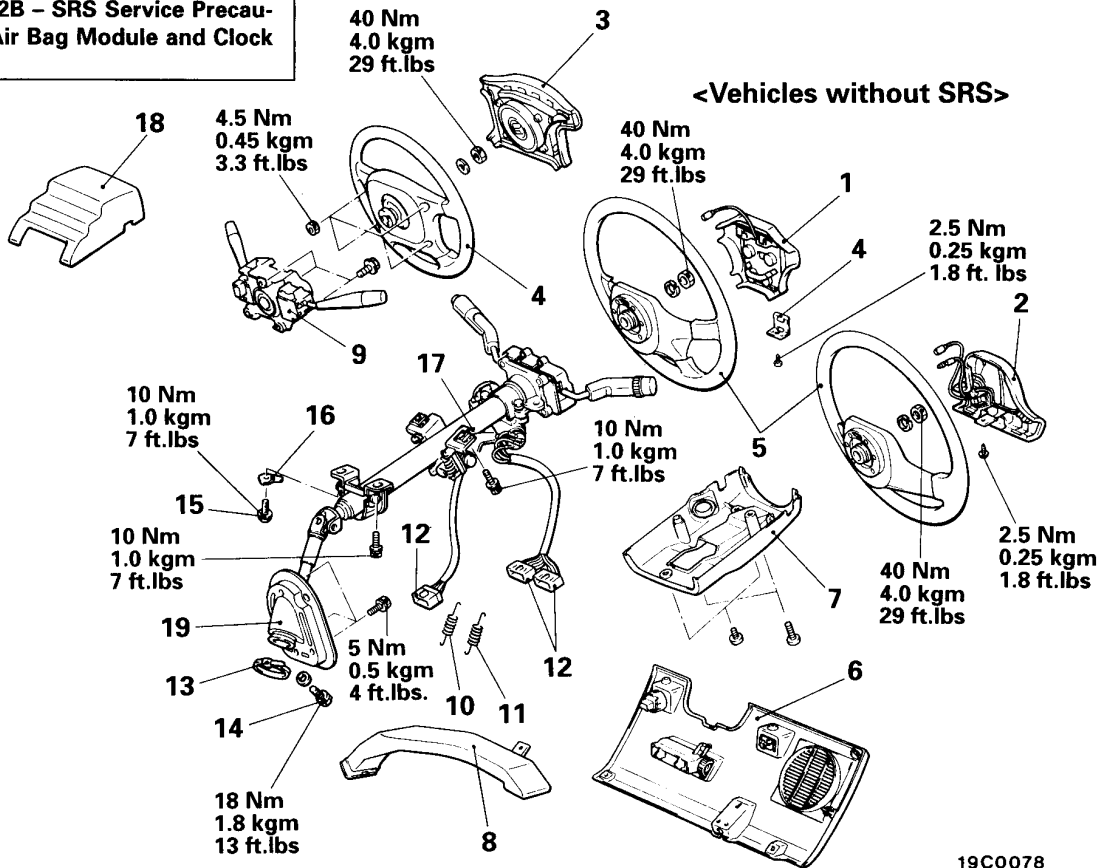

19C0078

Removal steps

- | | |
|---|---|
| <p>◆◆ 1. Horn pad (four spokes)</p> <p>2. Horn pad (two spokes)</p> <p>3. Air bag module (Refer to GROUP 52B – Air Bag Module and Clock Spring)</p> <p>◆◆ 4. Spring holder</p> <p>◆◆ 5. Steering wheel</p> <p>6. Instrument under cover (Refer to GROUP 52A – Instrument Panel.)</p> <p>7. Lower column cover</p> <p>8. Foot duct</p> <p>9. Clock spring and column switch assembly (Refer to GROUP 52B – Air Bag Module and Clock Spring)</p> <p>10. Brake pedal return spring</p> <p>11. Clutch pedal return spring <M/T></p> | <p>12. Harness connector</p> <p>13. Band</p> <p>14. Joint assembly and gear box connecting bolt</p> <p>◆◆ ◆◆ 15. Special screw</p> <p>16. Special washer</p> <p>17. Steering column assembly</p> <p>18. Upper column cover</p> <p>19. Steering joint cover assembly</p> |
|---|---|

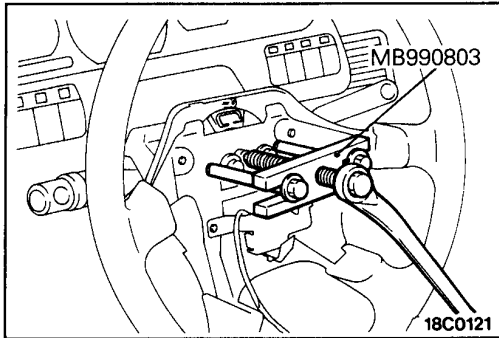
**SERVICE POINTS OF REMOVAL**

E37HBAW

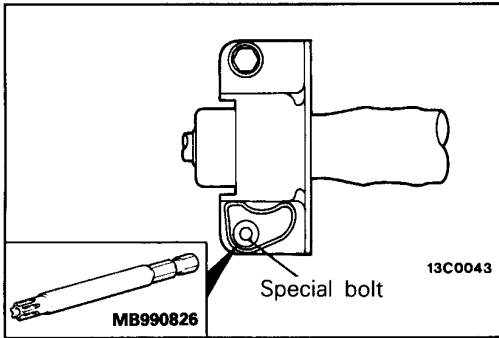
5. REMOVAL OF STEERING WHEEL**15. REMOVAL OF SPECIAL SCREW****SERVICE POINTS OF INSTALLATION**

E37HDAJ

15. INSTALLATION OF SPECIAL SCREW

Tighten the special screw using the special tool.

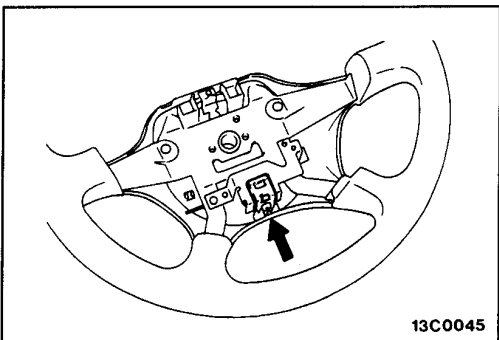
**1. INSTALLATION OF HORN PAD**

(1) Install the spring holder to the steering wheel.

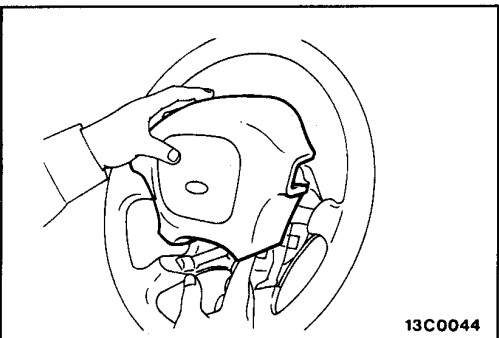

(2) Install the horn pad by pressing it down into the steering wheel.

DISASSEMBLY AND REASSEMBLY

E37HE-

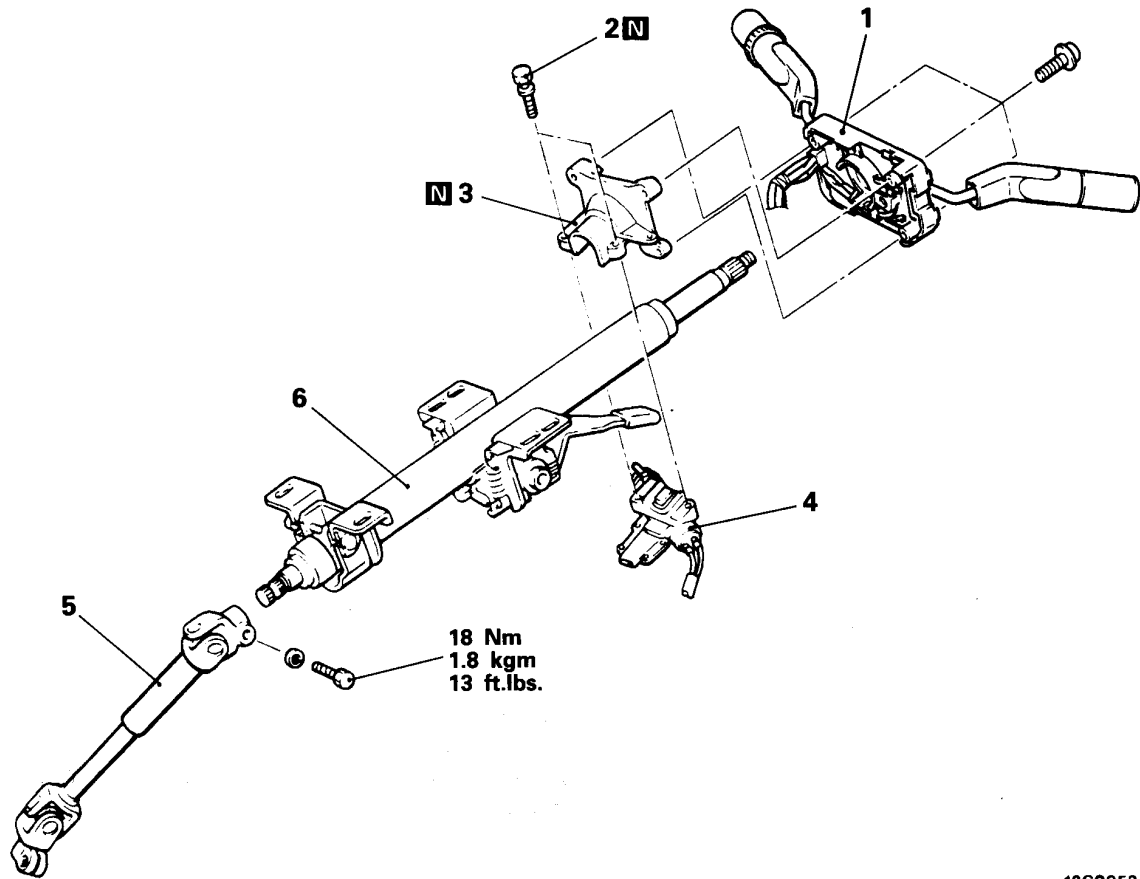

13C0053

Disassembly steps

- 1. Column switch assembly
- 2. Special bolt
- 3. Steering lock bracket
- 4. Steering lock
- 5. Joint assembly
- 6. Steering column assembly

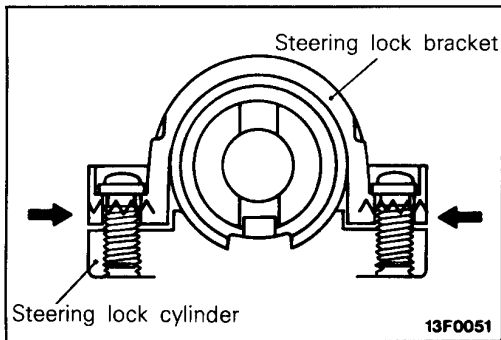
**SERVICE POINTS OF DISASSEMBLY**

E37HFAT

2. REMOVAL OF SPECIAL BOLT/3. STEERING LOCK BRACKET/4. STEERING LOCK

If it is necessary to remove the steering lock, use a hacksaw to cut the special bolts at the steering lock bracket side.

INSPECTION

E37HGAP

- Check the universal joint for end play.
- Check for bent steering column assembly.
- Check for damaged or defective steering column.

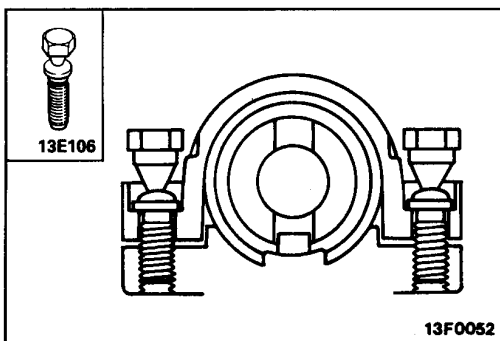
**SERVICE POINTS OF REASSEMBLY**

E37HHAS

4. INSTALLATION OF STEERING LOCK/3. STEERING LOCK BRACKET/2. SPECIAL BOLT

- (1) When installing the steering lock and steering lock bracket to the column tube, temporarily install the steering lock in alignment with the column boss.
- (2) After checking that the lock works properly, tighten the special bolts until the head twists off.

Caution

The steering lock bracket and bolts must be replaced with new ones when the steering lock is installed.

POWER STEERING GEAR BOX

REMOVAL AND INSTALLATION

E37PA-

Pre-removal Operation

- Draining of the Power Steering Fluid (Refer to P.37A-11.)
- Removal of Centermember (Refer to GROUP 32 – Engine Roll Stopper and Centermember.)

Post-installation Operation

- Installation of Centermember (Refer to GROUP 32 – Engine Roll Stopper and Centermember.)
- Supplying of the Power Steering Fluid (Refer to P.37A-11.)
- Bleeding of the Power Steering Fluid Line (Refer to P.37A-12.)
- Inspection of Steering Wheel Centering
- Adjustment of the Front Wheel Alignment (Refer to GROUP 33A – Service Adjustment Procedures.)

CAUTION: SRS

For vehicles with SRS, before removal of steering gear box, refer to GROUP 52B – SRS, center front wheels and remove ignition key. Failure to do so may damage SRS clock spring and render SRS system inoperative, risking serious driver injury.

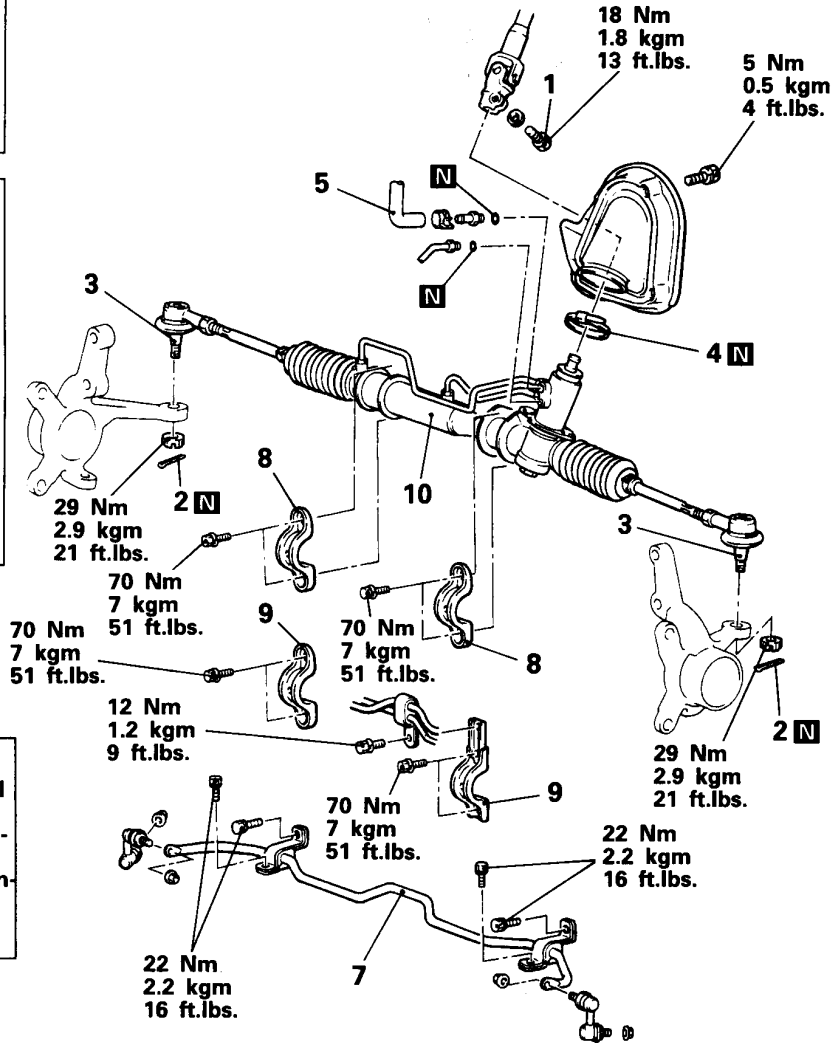

13C0056

Removal steps

1. Joint assembly and gear box connecting bolt
2. Split pin
3. Connection for tie-rod end and knuckle
4. Band
5. Connection for return tube
6. Bracket <4WD>
7. Stabilizer bar <Diesel-powered vehicles> (Refer to GROUP 33A – Stabilizer Bar.)
8. Clamp <L.H. drive vehicle>
9. Clamp <R.H. drive vehicle>
10. Gear box assembly

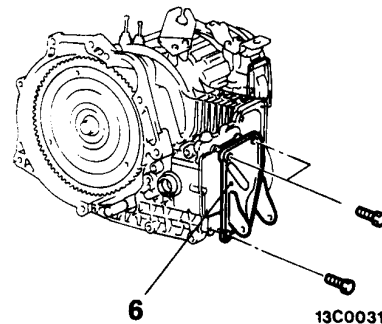

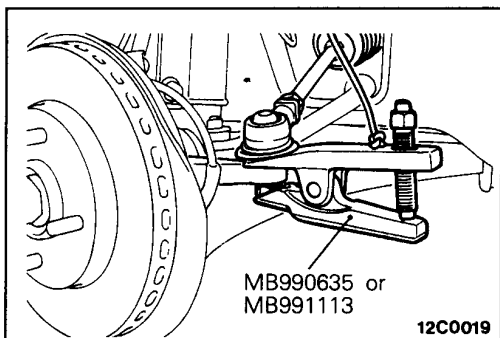
**SERVICE POINTS OF REMOVAL**

E37PBAF

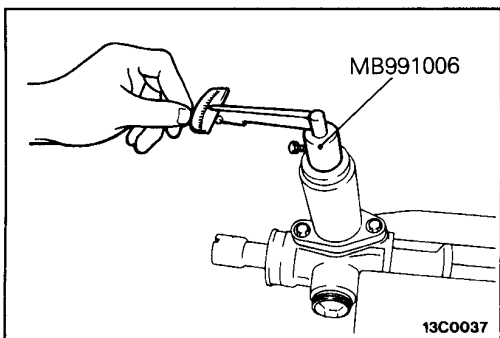
3. DISCONNECTION OF TIE-ROD END**INSPECTION**

E37PCA1

- Check the rubber parts for cracks and breakage.

GEAR BOX FOR TOTAL PINION PRELOAD

Using the special tools, rotate the pinion gear at the rate of one rotation in approximately 4 to 6 seconds to check the total pinion preload.

Standard value: 0.6–1.3 Nm (6–13 kgcm, 5–11 in.lbs.)

NOTE

Measure the pinion preload through the whole stroke of the rack.

If the measured value is not within the standard range, first adjust the rack support cover, and then check the total pinion starting torque again.

If the total pinion starting torque cannot be adjusted to within the standard range by adjusting the rack support cover, check the rack support cover, rack support spring, rack support and replace any parts necessary.

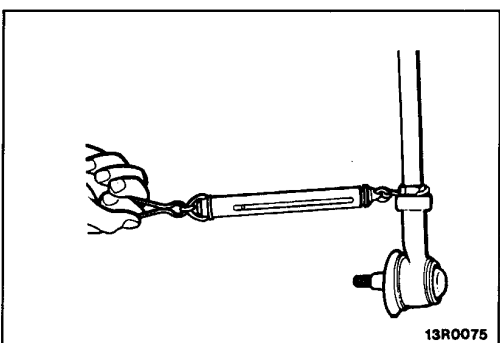
**CHECK THE TIE ROD FOR SWING RESISTANCE**

- (1) Give 10 hard swings to the tie rod.
- (2) Measure the tie rod swing resistance with a spring balance.

Standard value:

<Vehicles built up to April, 1993>

8–20 N (0.8–2.0 kg, 1.8–4.4 lbs.)

[2–5 Nm (20–50 kcm, 17–43 in. lbs.)]

<Vehicles built from May, 1993>

6–20 N (0.6–2.0 kg, 1.3–4.4 lbs.)

[1.5–5 Nm (15–50 kcm, 13–43 in. lbs.)]

- (3) If the measured value exceeds the standard value, replace tie rod assembly.

NOTE

Even if the measured value is below the standard value, the tie rod which swings smoothly without excessive play may be used.

DISASSEMBLY AND REASSEMBLY

E37PE-

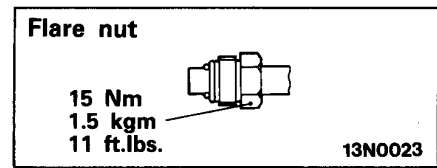
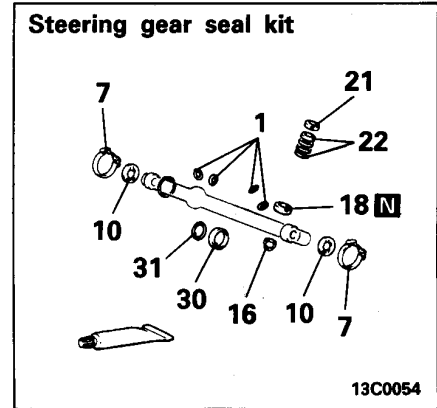
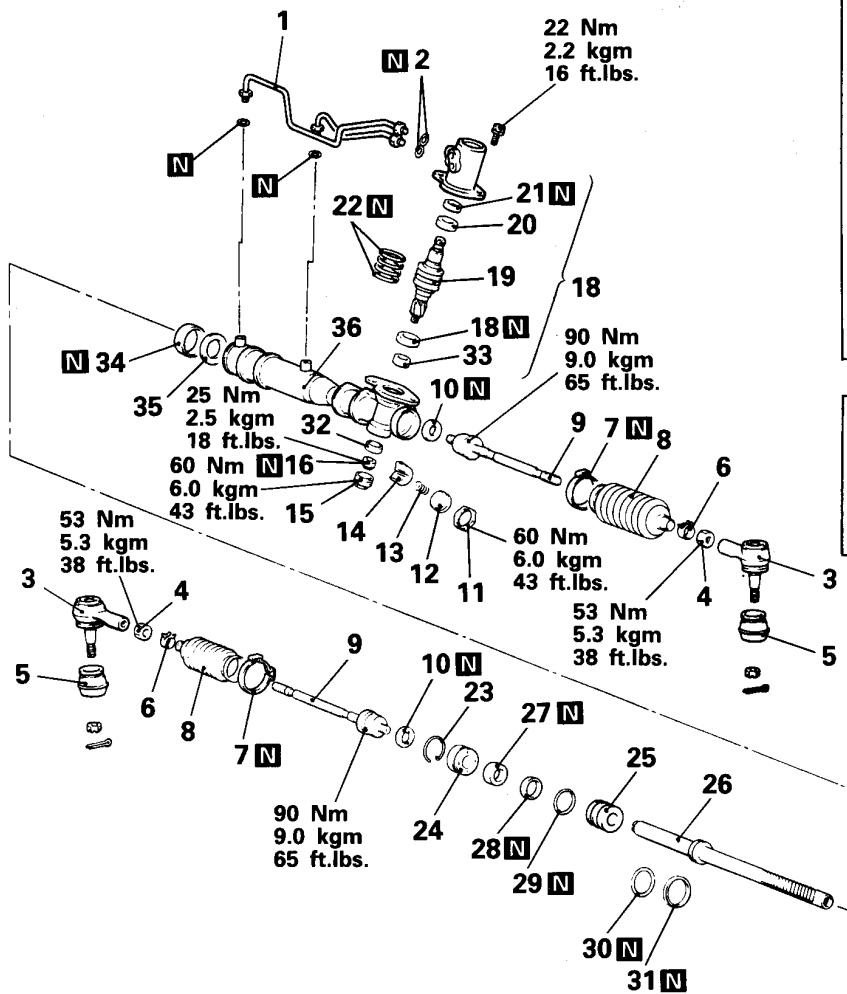

13C0054

Disassembly steps

- | | |
|--|-------------------------------|
| 1. Feed tube | 19. Pinion and valve assembly |
| 2. O-ring | 20. Ball bearing |
| 3. Tie-rod end | 21. Oil seal |
| 4. Tie-rod end locking nut | 22. Seal ring |
| 5. Dust cover | 23. Circlip |
| 6. Bellows clip | 24. Rack stopper |
| 7. Bellows band | 25. Rack bushing |
| 8. Bellows | 26. Rack |
| 9. Tie-rod | 27. Oil seal |
| 10. Tab washer | 28. Dust seal |
| ● Adjustment of total pinion torque | 29. O-ring |
| 11. Locking nut | 30. Seal ring |
| 12. Rack support cover | 31. O-ring |
| 13. Rack support spring | 32. Ball bearing |
| 14. Rack support (R.H. drive vehicles) | 33. Needle roller bearing |
| 15. End plug | 34. Oil seal |
| 16. Self-locking nut | 35. Back-up washer |
| 17. Valve housing assembly | 36. Rack housing |
| 18. Oil seal | |

LUBRICATION AND SEALING POINTS

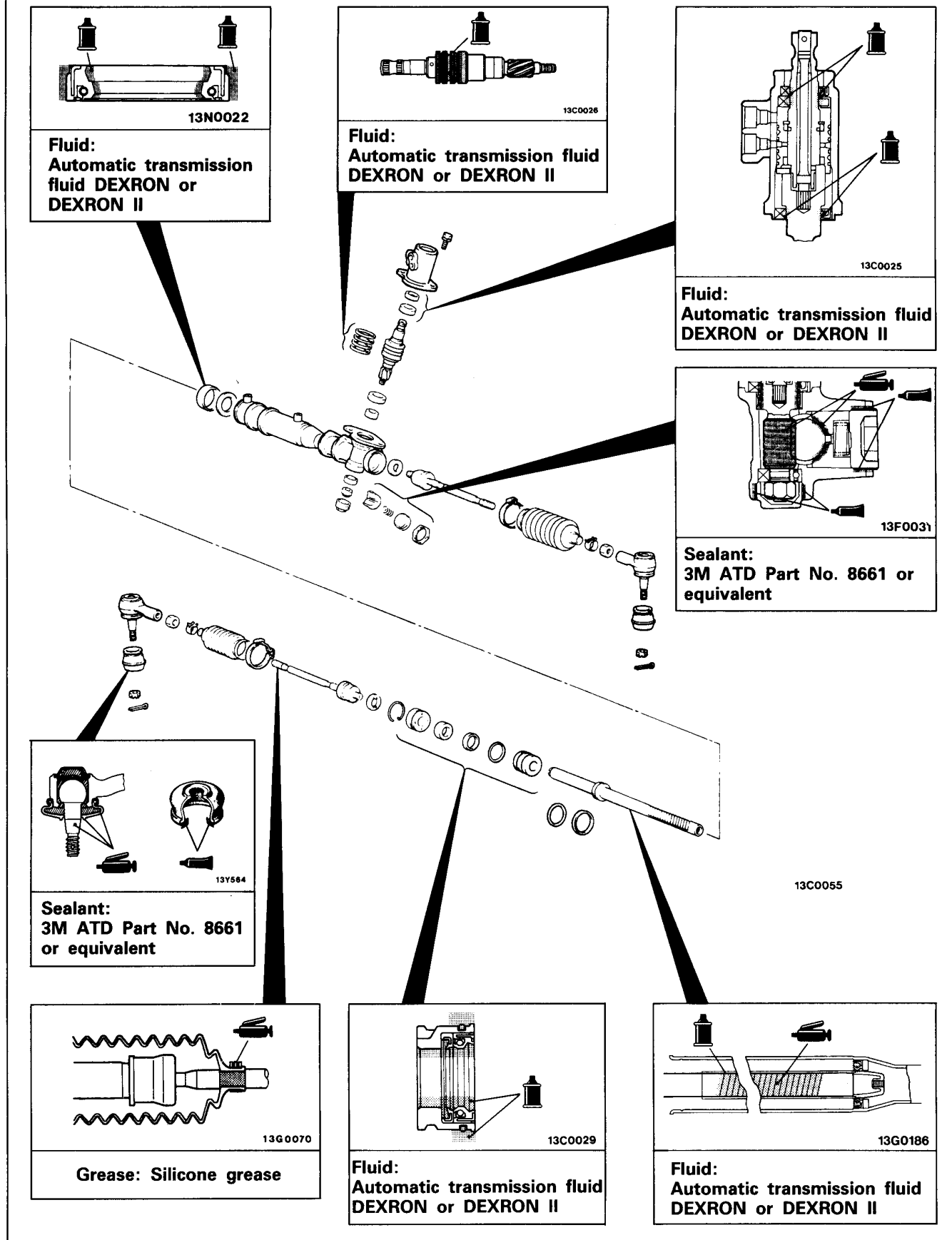

SERVICE POINTS OF DISASSEMBLY

12. REMOVAL OF RACK SUPPORT COVER

Using the special tool, remove the rack support cover from the gear box.

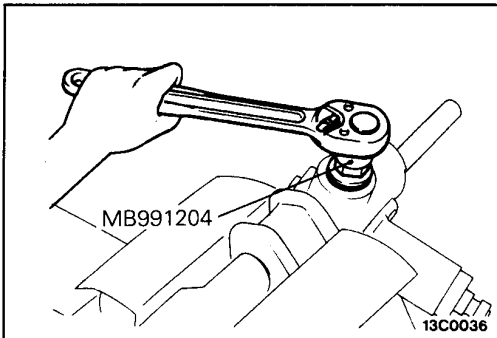

18. REMOVAL OF OIL SEAL/19. PINION AND VALVE ASSEMBLY

Using a plastic hammer, gently tap the pinion to remove it.

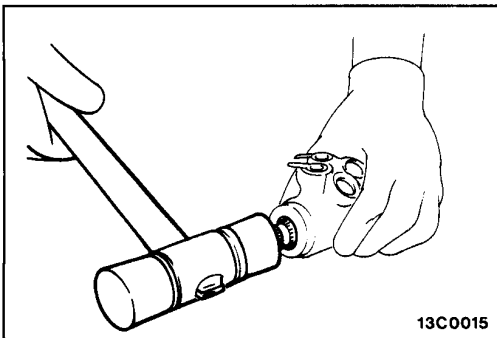

20. REMOVAL OF BALL BEARING/21. OIL SEAL

Using a socket, remove the oil seal and the ball bearing from the valve housing simultaneously.

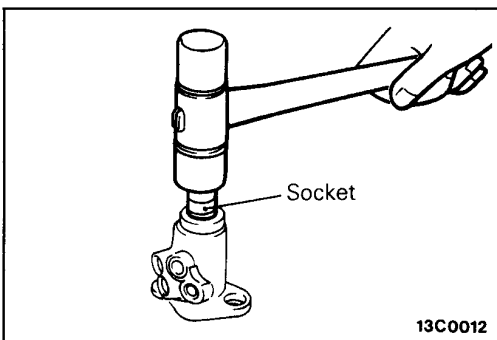

23. REMOVAL OF CIRCLIP

- (1) Turn the rack stopper clockwise until the end of the circlip comes out of the slot in the rack housing.
- (2) Turn the rack stopper anticlockwise to remove the circlip.

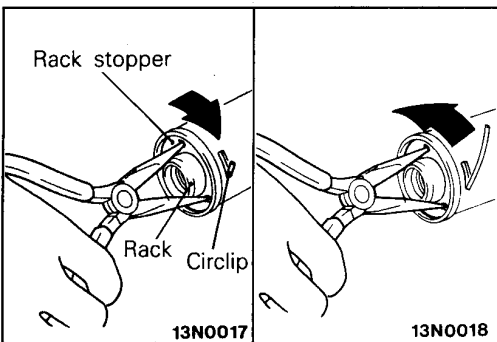

26. REMOVAL OF RACK

Pull out the rack slowly. At this time also take out the rack stopper and the rack bushing simultaneously.

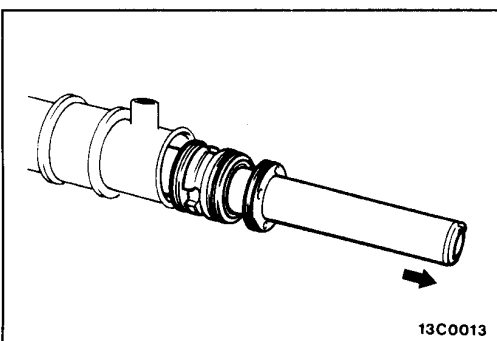

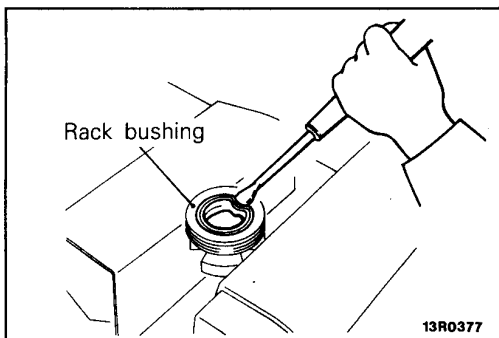
**27. REMOVAL OF OIL SEAL**

Partially bend oil seal and remove from rack bushing.

Caution

Do not damage oil seal press fitting surface.

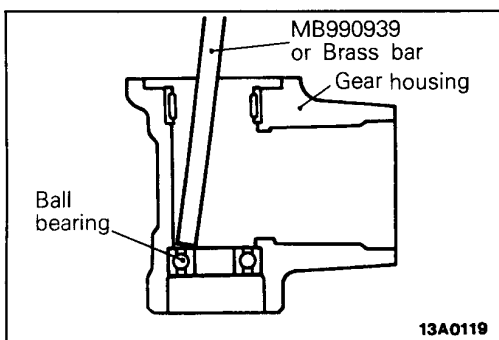
**32. REMOVAL OF BALL BEARING**

Use a brass bar or special tool to remove the ball bearing from the gear housing.

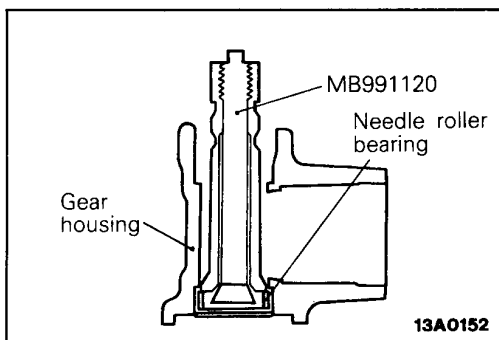
**33. REMOVAL OF NEEDLE ROLLER BEARING**

Use the special tool to remove the needle roller bearing from the rack housing.

Caution

Do not open special tool excessively to prevent damaging housing interior.

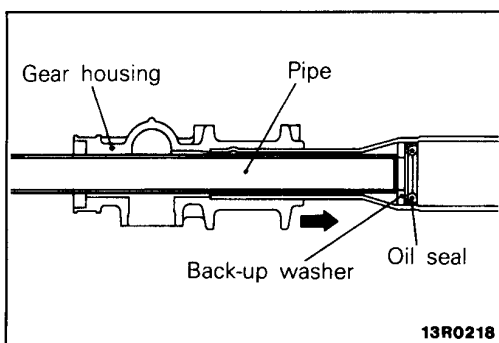
**34. REMOVAL OF OIL SEAL/35. BACK-UP WASHER**

Use a piece of pipe or similar tool to remove the back-up washer and oil seal from the gear housing.

Caution

Be careful not to damage the inner surface of the rack cylinder of the gear housing.

INSPECTION

E37PGAG

RACK

- Check the rack tooth surfaces for damage or wear.
- Check the oil seal contact surfaces for uneven wear.
- Check the rack for bends.

PINION AND VALVE ASSEMBLY

- Check the pinion gear tooth surfaces for damage or wear.
- Check for worn or defective seal ring.

BEARING

- Check for roughness or abnormal noise during bearing operation.
- Check the bearing for play.
- Check the needle roller bearings for roller slip-off.

OTHERS

- Check the cylinder inner surface of the rack housing for damage.
- Check the boots for damage, cracking or deterioration.
- Check the rack support for uneven wear or dents.
- Check the rack bushing for uneven wear or damage.

SERVICE POINTS OF REASSEMBLY

E37PHAQ

35. INSTALLATION OF BACK-UP WASHER/34. OIL SEAL

- (1) Apply a coating of the specified fluid to the outside of the oil seal.

**Specified fluid: Automatic transmission fluid
DEXRON or DEXRON II**

- (2) Using the special tools, press the back-up washer and the oil seal into the rack housing to the specified position (where the upper surface of press-in guide coincides with the stepped part of the press-in tool)

33. INSTALLATION OF NEEDLE ROLLER BEARING

- (1) Apply specified fluid to housing, bearing and oil seal press fitting surface.

**Specified fluid: Automatic transmission fluid
DEXRON or DEXRON II**

- (2) Press fit needle roller bearing with special tools.

Caution

Press fit straight as valve housing is aluminium.

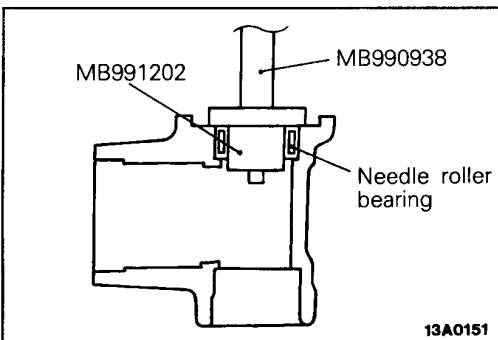
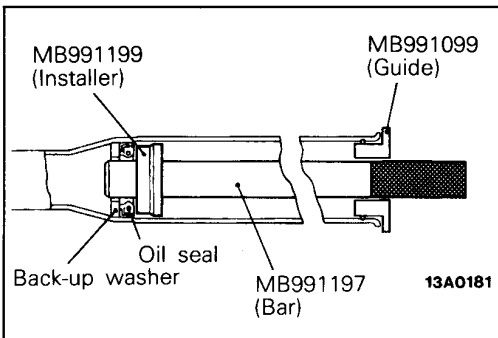

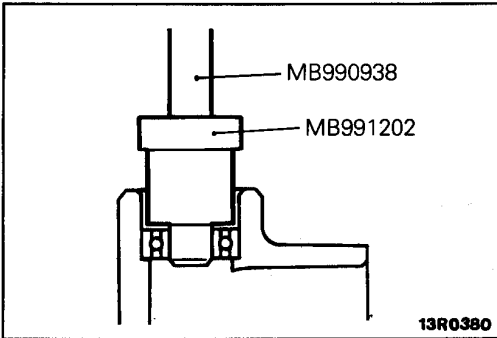

32. INSTALLATION OF BALL BEARING

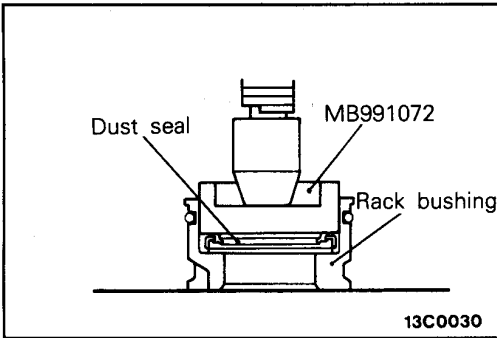

28. INSTALLATION OF DUST SEAL/27. OIL SEAL

- (1) Apply a coating of the specified fluid to the outside of the dust seal, oil seal and O-ring.

Specified fluid: Automatic transmission fluid DEXRON or DEXRON II

- (2) Use special tool to press fit oil seal until touches rack bush end.

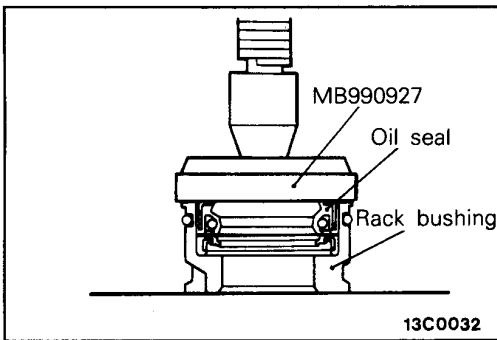

26. INSTALLATION OF RACK

- (1) Apply a coating of multipurpose grease to the rack teeth face.

Caution

Do not close the vent hole in the rack with grease.

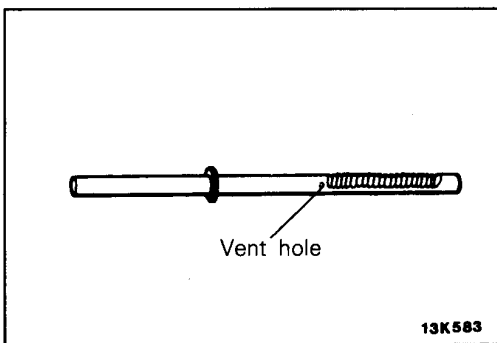

- (2) Cover rack serrations with special tool.
- (3) Apply specified fluid on special tool.

Specified fluid: Automatic transmission fluid DEXRON or DEXRON II

- (4) Match oil seal centre with rack to prevent retainer spring from slipping and slowly insert rack from power cylinder side.

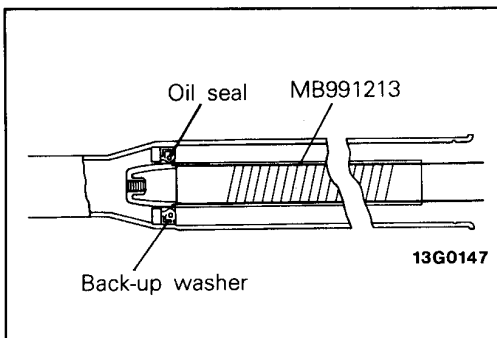

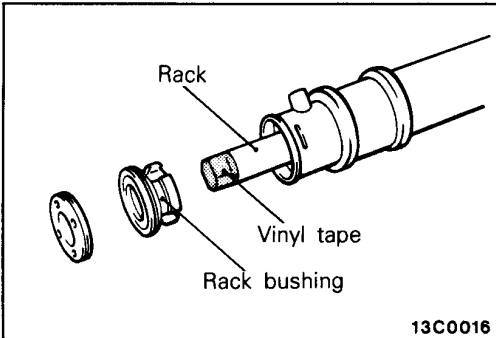

25. INSTALLATION OF RACK BUSHING ASSEMBLY

Wrap the rack end with vinyl tape, apply a coating of the specified fluid, and then install the rack bushing and rack stopper.

Specified fluid: Automatic transmission fluid DEXRON or DEXRON II

Caution

Do not allow oil seal retainer spring to slip out.

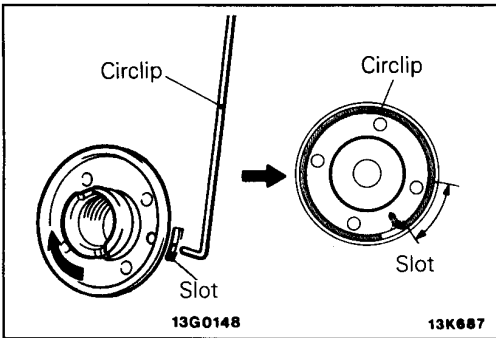

23. INSTALLATION OF CIRCLIP

Insert circlip to rack stopper hole through cylinder hole. Turn rack stopper clockwise and insert circlip firmly.

Caution

Insert circlip to rack stopper hole whilst turning rack stopper clockwise.

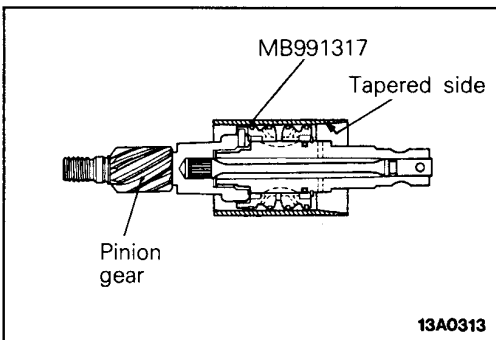

22. INSTALLATION OF SEAL RING

- (1) Knead the seal ring to soften it.
- (2) Apply the specified fluid to the seal ring, and install to the rack groove.

Specified fluid: Automatic transmission fluid DEXRON or DEXRON II

- (3) Insert the tapered side of the special tool from the pinion gear side, and compress the seal ring.

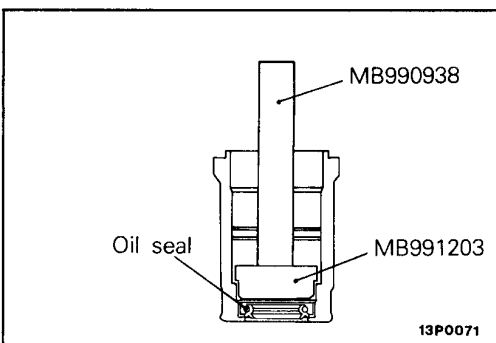

21. INSTALLATION OF OIL SEAL

Apply a coating of the specified fluid to the outside of the oil seal. Using the special tools, press the oil seal into the valve housing.

Specified fluid: Automatic transmission fluid DEXRON or DEXRON II

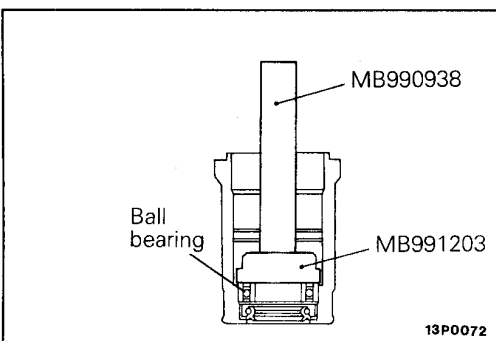

20. INSTALLATION OF BALL BEARING

Apply a coating of the specified fluid to the outside of the ball bearing. Using the special tools, press the ball bearing into the valve housing.

Specified fluid: Automatic transmission fluid DEXRON or DEXRON II

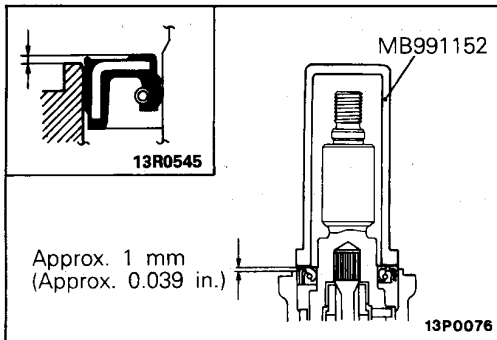

18. INSTALLATION OF OIL SEAL

Using the special tool, press the oil seal into the valve housing.

Caution

In order to eliminate a seal malfunction at the valve housing alignment surface, the upper surface of the oil seal should project outward approximately 1 mm (0.039 in.) from the housing edge surface.

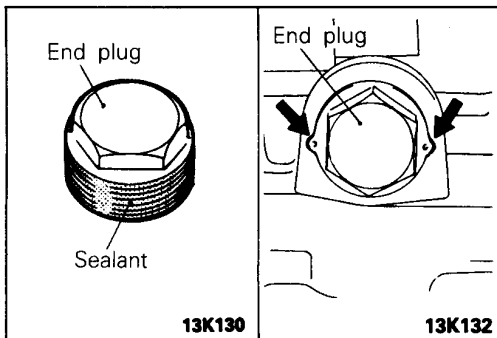

15. INSTALLATION OF END PLUG

- (1) Apply the specified sealant to the threaded part of the end plug.

Specified sealant: 3M ATD Part No. 8661 or equivalent

- (2) Secure the threaded portion of the end plug at two places by using a punch.

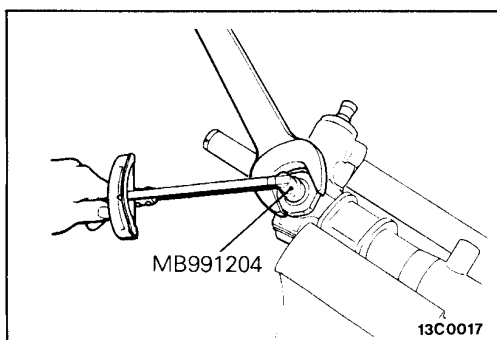

• ADJUSTMENT OF TOTAL PINION PRELOAD

- (1) Position rack at its centre. With special tool, tighten rack support cover to 15 Nm (1.5 kgm, 11 ft.lbs.)
- (2) In neutral position, rotate pinion shaft clockwise one turn/4–6 seconds with special tool. Return rack support cover 30°–60° and adjust torque to the standard value.

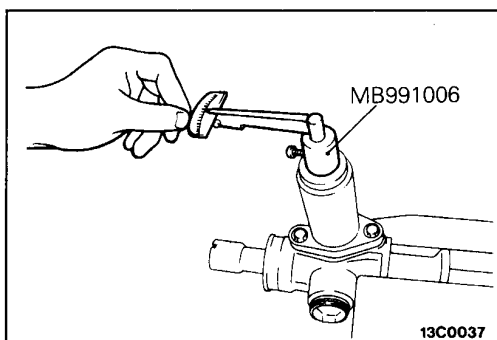

- (3) Using the special tools, rotate the pinion gear at the rate of one rotation in approximately 4 to 6 seconds to check the total pinion preload.

Standard value: 0.6–1.3 Nm

(6–13 kgcm, 5–11 in.lbs.)

Change in torque: 0.4 Nm (4 kgcm, 3 in.lbs.)

Caution

1. **When adjusting, set the standard value at its highest value.**
2. **Assure no ratcheting or catching when operating rack towards the shaft direction.**

NOTE

When it cannot be adjusted within the specified return angle, check rack support cover components or replace.

- (4) After adjusting, lock rack support cover with lock nut.

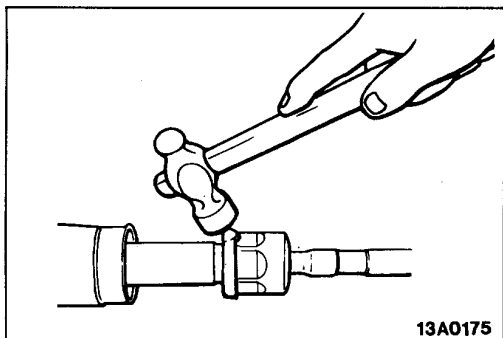

10. INSTALLATION OF TAB WASHER/9. TIE ROD

After installing tie-rod to rack, fold tab washer end (2 locations) to tie rod notch.

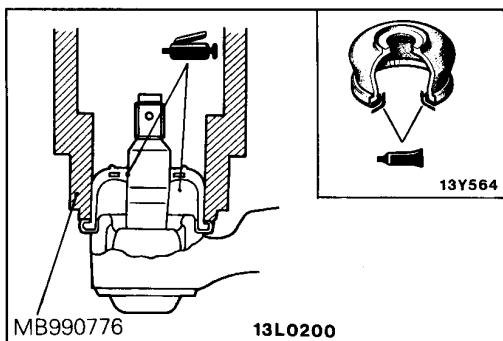

5. INSTALLATION OF DUST COVER

- (1) Pack dust cover interior with multipurpose grease.
- (2) Apply specified sealant to dust cover lip.

Specified sealant: 3M ATD Part No. 8661 or equivalent

- (3) Using the special tool, install the dust cover to the tie rod end ball joint.

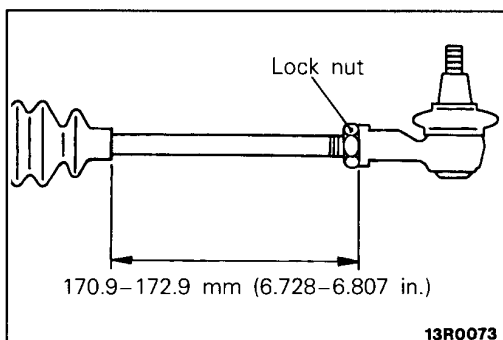

4. INSTALLATION OF TIE ROD END LOCKING NUT/3. TIE ROD END

Screw in tie-rod end to have its right and left length as illustrated. Lock with lock nut.

Caution

Fully tighten the lock nut after installing the gearbox and adjusting the toe-in.

POWER STEERING OIL PUMP

REMOVAL AND INSTALLATION

E37RA--

Pre-removal Operation

- Draining of the Power Steering Fluid (Refer to P.37A-11.)

Post-installation Operation

- Supplying of the Power Steering Fluid
- Adjusting Drive-belt Tension (Refer to P.37A-9.)
- Bleeding of the Power Steering Fluid Line (Refer to P.37A-12.)
- Check the Oil Pump Pressure (Refer to P.37A-13.)

<Petrol-powered vehicles>

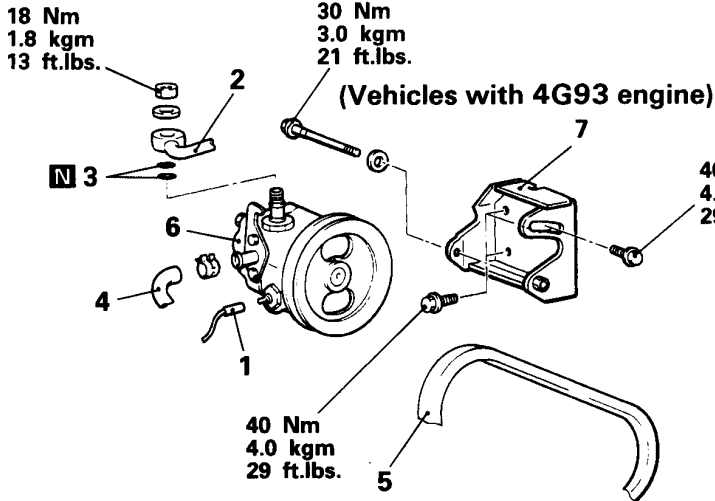

(Vehicles with 4G63 and 4G64 engine)

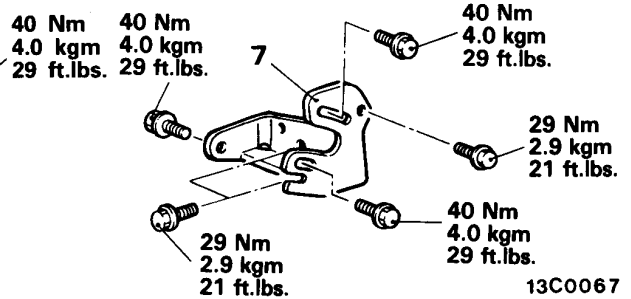

<Diesel-powered vehicles>

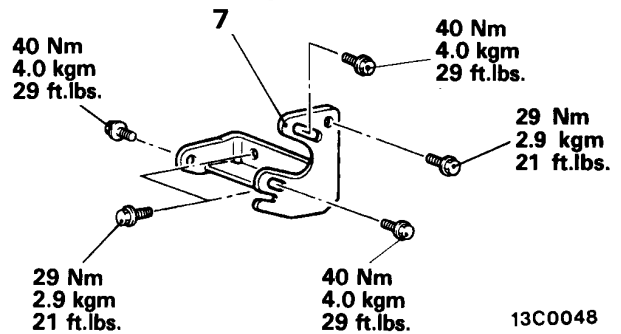

Removal steps

1. Pressure switch connector
<Petrol-powered vehicles>
2. Pressure hose
3. O-ring
4. Suction hose
5. Drive-belt
6. Oil pump
7. Oil pump bracket

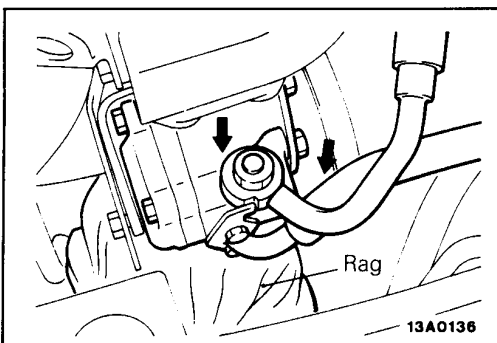

SERVICE POINTS OF REMOVAL

E37RBAJ

2. REMOVAL OF PRESSURE HOSE/4. SUCTION HOSE

Caution

In diesel-powered vehicles, the alternator is below the oil pump, so cover the alternator with a rag before removing any of the hoses.

INSPECTION

E37RCAAB

- Check the drive-belt for cracks.
- Check the pulley assembly for uneven rotation.

SERVICE POINTS OF INSTALLATION

E37RDAJ

2. INSTALLATION OF PRESSURE HOSE

Connect the pressure hose so that its notch part contacts the suction connector.

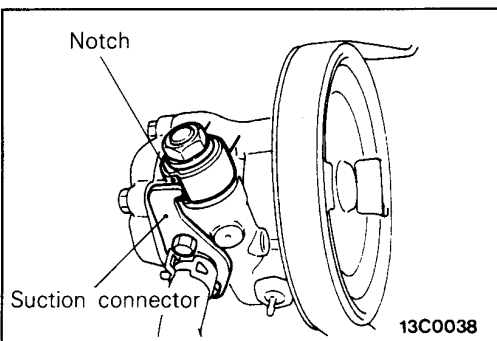

DISASSEMBLY AND REASSEMBLY

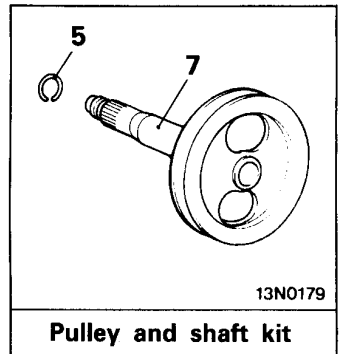
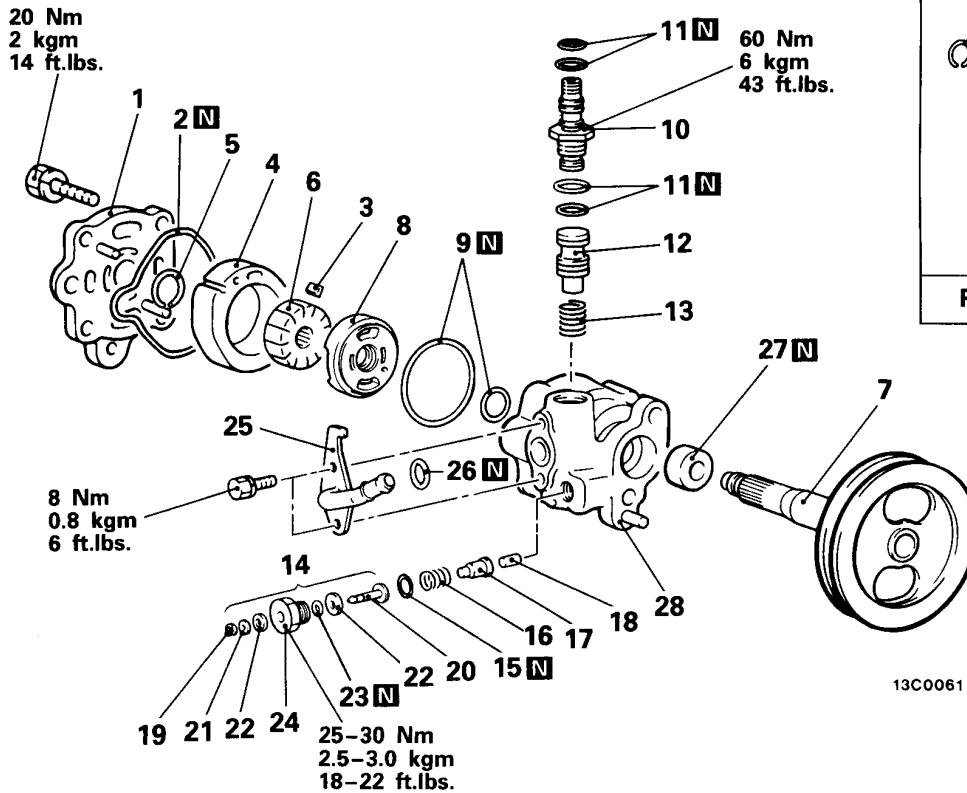
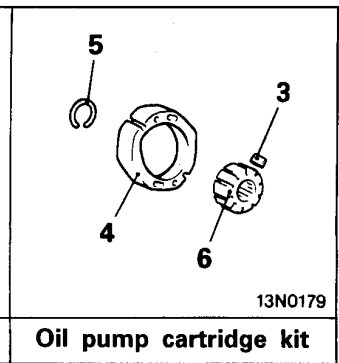
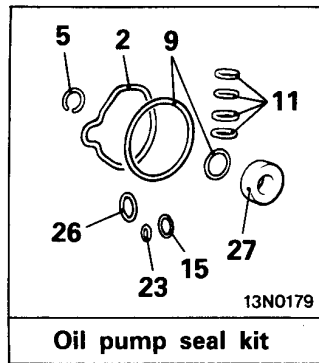
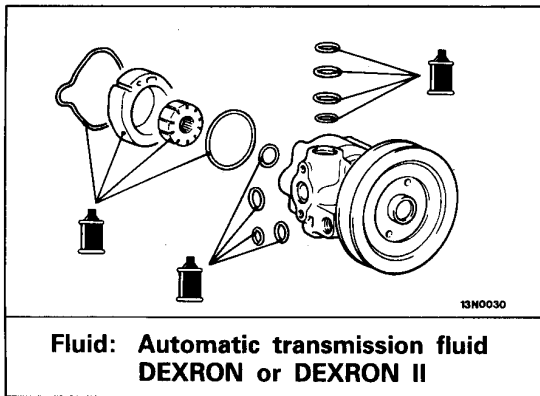

Disassembly steps

- 1. Pump cover
 - 2. O-ring
 - 3. Vanes
 - 4. Cam ring
 - 5. Snap ring
 - 6. Rotor
 - 7. Pulley assembly
 - 8. Side plate
 - 9. O-ring
 - 10. Connector
 - 11. O-ring
 - 12. Flow control valve
 - 13. Flow control spring
 - 14. Terminal assembly
 - 15. O-ring
- Petrol-powered vehicles

- 16. Spring
 - 17. Plunger
 - 18. Piston rod
 - 19. Snap ring
 - 20. Terminal
 - 21. Washer
 - 22. Insulator
 - 23. O-ring
 - 24. Plug
 - 25. Suction connector
 - 26. O-ring
 - 27. Oil seal
 - 28. Oil pump body
- Petrol-powered vehicles

Caution
Do not disassemble the flow control valve.

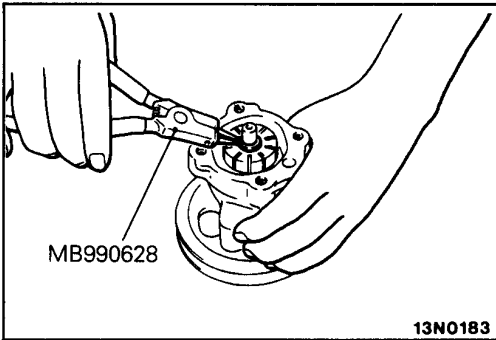
**SERVICE POINTS OF DISASSEMBLY**

E37RFAH

5. REMOVAL OF SNAP RING**INSPECTION**

E37RGAH

- Check the flow control valve for clogging.
- Check the pulley assembly for wear or damage.
- Check the groove of rotor and vane for "Stepped" wear.
- Check the contact surface of cam ring and vanes for "stepped" wear.
- Check the vanes for damage.

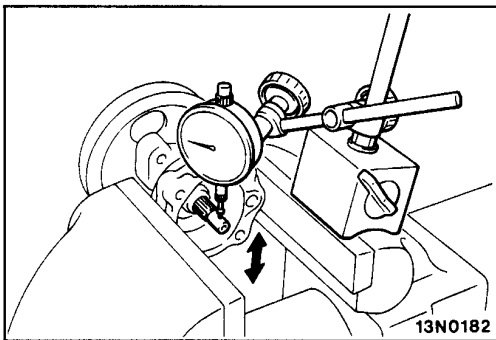
**CLEARANCE BETWEEN SHAFT AND PUMP BODY**

- (1) Place the dial gauge against the end of the pulley assembly's shaft.
- (2) Move the pulley assembly up and down and measure the play.

Limit: 0.1 mm (0.004 in.)

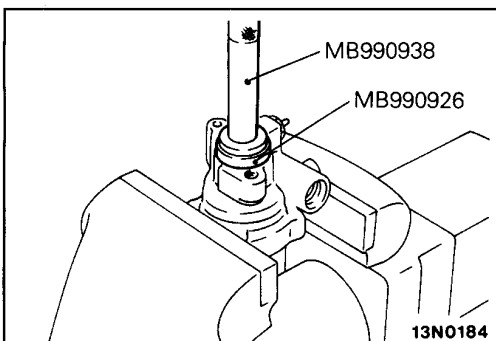
**SERVICE POINTS OF REASSEMBLY**

E37RHAL

27. INSTALLATION OF OIL SEAL

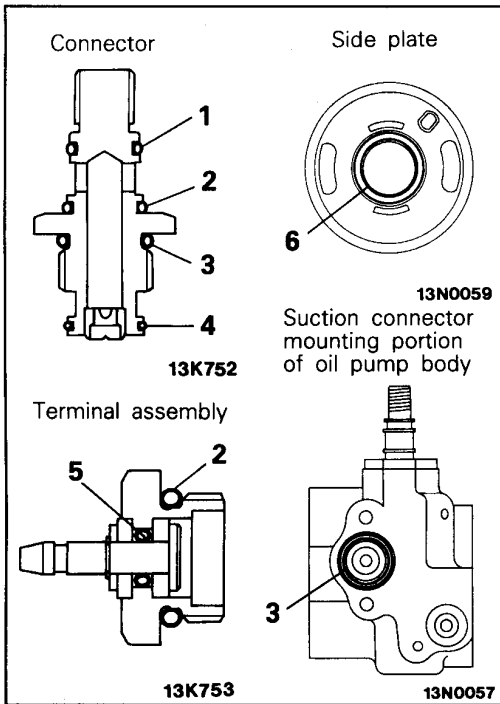

26. 23. 15. 11. 9. INSTALLATION OF O-RINGS

Apply specified fluid on O-rings to install.

No.	I.D. × Width	mm (in.)
1	11 × 1.9	(0.433 × 0.075)
2	13 × 1.9	(0.512 × 0.075)
3	17.8 × 2.4	(0.701 × 0.094)
4	13.5 × 1.5	(0.531 × 0.059)
5	3.8 × 1.9	(0.150 × 0.075)
6	16.8 × 2.4	(0.661 × 0.094)

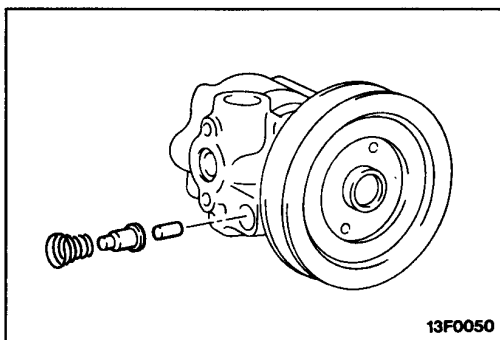

16. INSTALLATION OF SPRING

Fit the spring to the oil pump body with the larger-diameter end at the terminal assembly side.

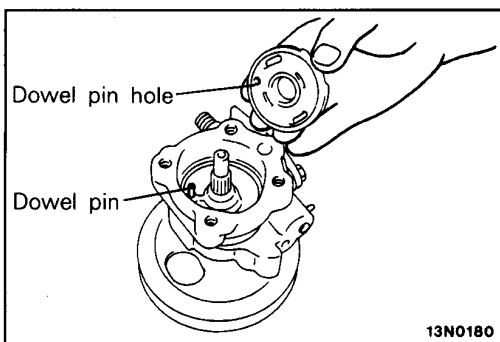

8. INSTALLATION OF SIDE PLATE

Line up the dowel pin hole of the side plate with the dowel pin of the pump body when installing the side plate.

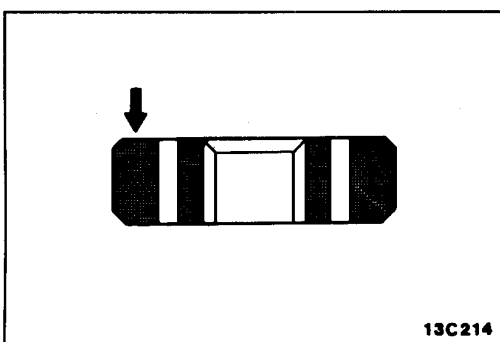

6. INSTALLATION OF ROTOR

Install the rotor to the pulley assembly so that the rotor's punch mark is at the pump cover side.

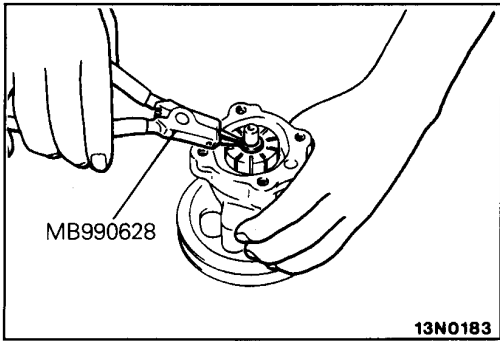

5. INSTALLATION OF SNAP RING

After installation of the snap ring, lift the rotor and check that the snap ring has entered the countersunk part.

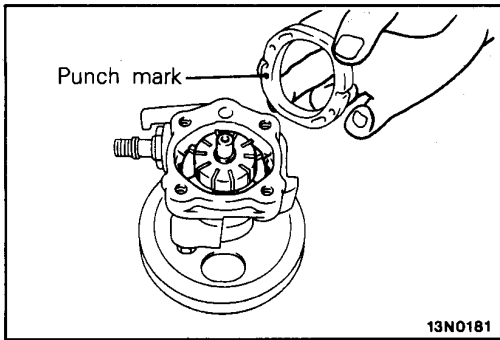
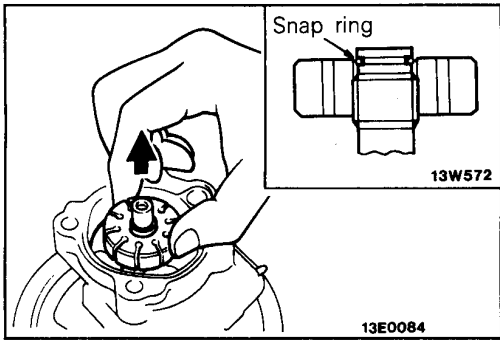

4. INSTALLATION OF CAM RING

Install the cam ring with the punch mark facing the side plate.

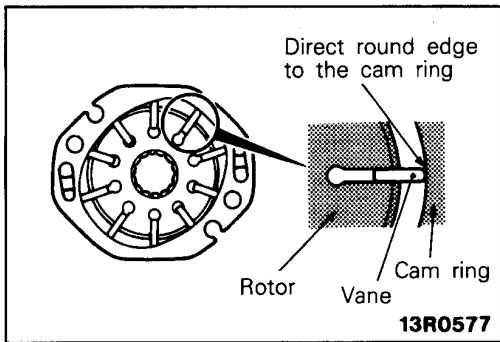

3. INSTALLATION OF VANES

Install the vanes on the rotor, paying close attention to the installation direction.

POWER STEERING HOSES

REMOVAL AND INSTALLATION

E37TA--

Pre-removal Operation

- Draining of the Power Steering Fluid
- Removal of Front Bumper (Refer to GROUP 51 – Front Bumper.)

Post-installation Operation

- Installation of Front Bumper (Refer to GROUP 51 – Front Bumper.)
- Supplying of the Power Steering Fluid
- Bleeding of the Power Steering Fluid Line (Refer to P.37A-12.)

<L.H. drive vehicles>

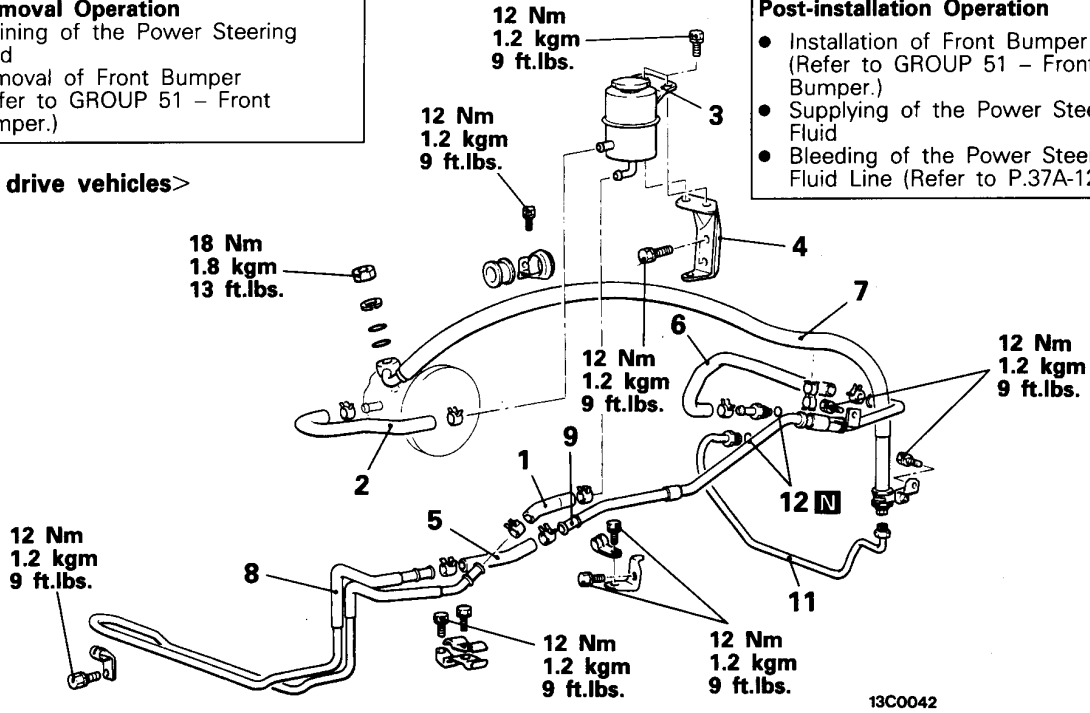

<R.H. drive vehicles>

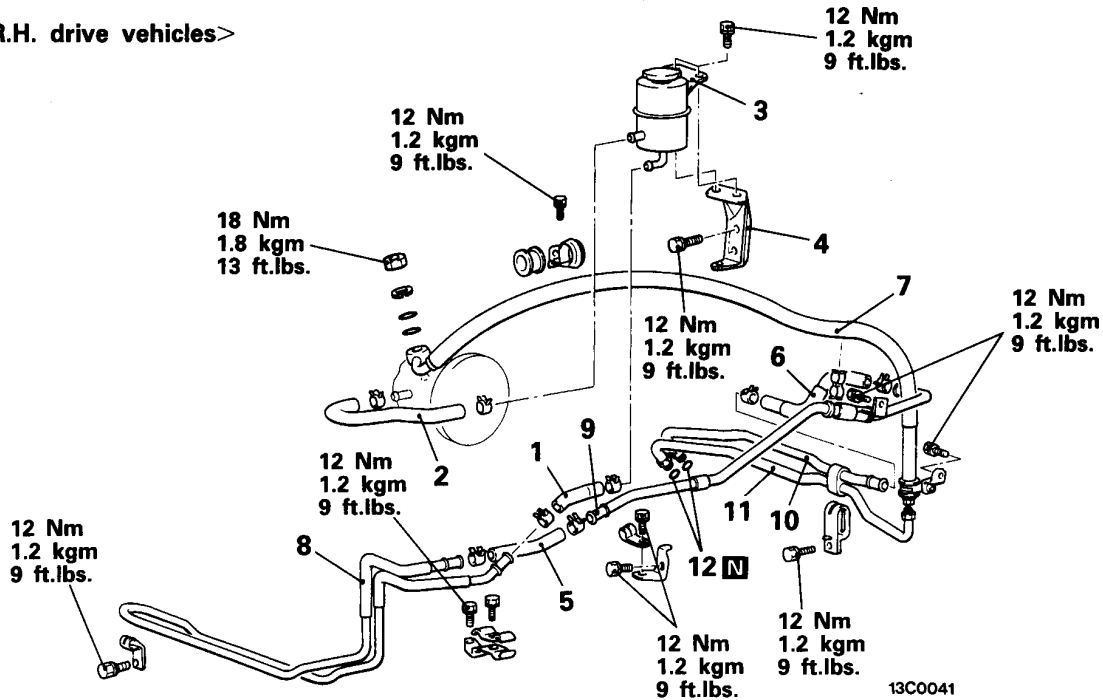

- | | |
|--|-------------------|
| 1. Return hose | 7. Pressure hose |
| 2. Suction hose | 8. Cooler tube |
| 3. Oil reservoir | 9. Return tube |
| 4. Oil reservoir bracket | 10. Return tube |
| <Diesel-powered vehicles built up to May 1992> | 11. Pressure tube |
| 5. Return hose | 12. O-ring |
| 6. Return hose | |

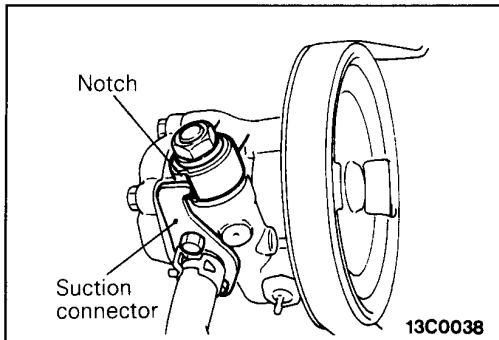
**SERVICE POINT OF INSTALLATION**

E37TDAF

7. INSTALLATION OF PRESSURE HOSE

- (1) Connect the pressure hose so that its notch part contacts the suction connector.

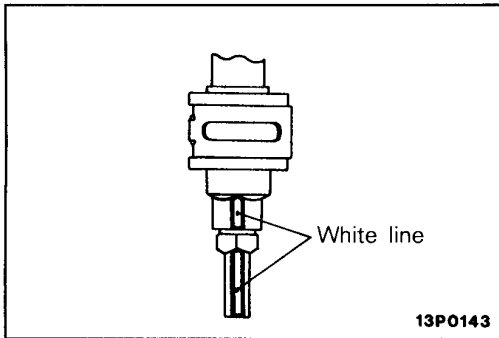

- (2) When the pressure hose is installed, align the white line on the pressure hose with the white line on the pressure tube so that together they form a straight line.