

# BODY

## CONTENTS

E42AA--

<b>SPECIFICATIONS</b> .....	<b>2</b>	<b>REAR QUARTER WINDOW GLASS</b>	
General Specifications .....	2	<SPACE RUNNER> .....	<b>33</b>
Service Specifications.....	4	<b>QUARTER WINDOW GLASS</b>	
Sealant and Adhesive.....	4	<SPACE WAGON> .....	<b>36</b>
<b>SPECIAL TOOLS</b> .....	<b>5</b>	<b>TAILGATE WINDOW GLASS</b> .....	<b>40</b>
<b>TROUBLESHOOTING</b> .....	<b>6</b>	<b>FRONT DOOR ASSEMBLY</b> .....	<b>45</b>
<b>SERVICE ADJUSTMENT PROCEDURES</b> .....	<b>10</b>	<b>REAR DOOR ASSEMBLY</b>	
Door Fit Adjustment.....	10	<SPACE RUNNER> .....	<b>46</b>
Rear Door Fit Adjustment		<b>REAR DOOR ASSEMBLY</b>	
<SPACE RUNNER> .....	10	<SPACE WAGON> .....	<b>52</b>
Door Glass Adjustment .....	16	<b>TAILGATE ASSEMBLY</b> .....	<b>53</b>
Inside handle play adjustment		<b>DOOR TRIM AND WATERPROOF FILM</b> .....	<b>55</b>
<except rear door of SPACE RUNNER> .....	16	<b>TAILGATE TRIM AND</b>	
Outside handle play adjustment		<b>WATERPROOF FILM</b> .....	<b>57</b>
<except rear door of SPACE RUNNER> .....	16	<b>DOOR GLASS AND REGULATOR</b> .....	<b>58</b>
Water Test.....	17	<b>DOOR HANDLE AND LATCH</b>	
Sunroof Fit Adjustment .....	17	<FRONT DOOR> .....	<b>63</b>
<b>HOOD</b> .....	<b>19</b>	<b>DOOR HANDLE AND LATCH</b>	
<b>FENDER</b> .....	<b>20</b>	<REAR DOOR> .....	<b>65</b>
<b>FUEL TANK FILLER DOOR</b> .....	<b>21</b>	<b>TAILGATE HANDLE AND LATCH</b> .....	<b>67</b>
<b>WINDSHIELD GLASS</b> .....	<b>25</b>	<b>DOOR RUNCHANNEL</b> .....	<b>68</b>
<b>FRONT QUARTER WINDOW GLASS</b>		<b>WEATHERSTRIP</b> .....	<b>69</b>
<SPACE RUNNER> .....	<b>31</b>	<b>SUNROOF</b> .....	<b>71</b>
<b>REAR DOOR WINDOW GLASS</b>			
<SPACE RUNNER> .....	<b>32</b>		

## SPECIFICATIONS

## GENERAL SPECIFICATIONS

E42CA--

Items	Specifications
Hood Type	Rear hinged front opening type
Front door Construction Regulator system Locking system	Front-hinged, sash construction Wire type Pin-fork type
Rear door <SPACE RUNNER> Construction Open/close window <SPACE WAGON> Construction Regulator system Locking system	Slide type Front-hinged, rear opening type  Front-hinged, sash construction Wire type Pin-fork type
Tailgate Type	Single unit lift type
Glass installation method Windshield glass Tailgate window glass Front quarter window glass (one door side) <SPACE RUNNER> Rear quarter window glass (two door side) <SPACE RUNNER> Quarter window glass <SPACE WAGON>	Adhesive type Adhesive type Front hinged, rear opening type  Adhesive type Adhesive type
Glass thickness Windshield glass Tailgate window glass Front door glass Rear door glass Quarter window glass Sunroof glass	mm (in.) 5.3 (0.21) mm (in.) 3.5 (0.14) mm (in.) 3.5 (0.14) mm (in.) 3.5 (0.14) mm (in.) 3.5 (0.14) mm (in.) 4.0 (0.16)
Sunroof motor Type Speed at no load Speed at load At 1 Nm (0.1 kgm, 0.72 ft.lbs.) Bound current Turning direction	DC ferrite (with built-in circuit breaker) r/min 140 or more r/min 120–160 A 35 or less Both clockwise and anti-clockwise

Item	Specifications	
Power window motor		
Type	Permanent magnet type (built-in circuit breaker)	
Revolutions under no load	<Front> r/min	80 or more
	<Rear> r/min	75 or more
Revolutions under load	r/min	
At 1 Nm (0.1 kgm, 0.72 ft.lbs.)		65–95
At 2 Nm (0.2 kgm, 1.45 ft.lbs.)		5 –80
Bound current	A	34 or less
Direction of rotation	Clockwise and anti-clockwise	
Power window main switch		
Type	Automatic reset type	
Rated load current	A	
Lock switch	20	
Power window switch	7	
Power window sub switch		
Type	Automatic reset type	
Rated load current	A	10
Power window relay		
Maximum contact current	A	22
Rated coil current	A	0.135–0.215
Voltage drop between terminals (At 12 V and the rated load current)	V	0.2 or less
Door lock control unit		
Effective voltage	V	10–16
Current consumption (when not in operation)	mA	3 or less
Door lock power relay		
Range of voltage used	V	8–16
Rated load current (at 13.5 V)	A	10
Rated coil current	A	Max. 0.2
Voltage drop between terminals	V	0.2 or less
Front door lock actuator		
Bound current (at 12 V)	A	2.5–4.5
Operating voltage range	V	9–15
Tripping time (at 12 V)*	second	5–30
Rear door lock actuator		
Bound current (at 12 V)	A	2.5–4.5
Operating voltage range	V	9–15
Tripping time (at 12 V)*	second	5–30
Tailgate lock actuator		
Bound current (at 12 V)	A	2.5–4.5
Operating voltage range	V	9–15
Tripping time (at 12 V)*	Second	5–30

NOTE

\*Tripping time is the time consumed until current reaches 0.5A after power connection.

## SERVICE SPECIFICATIONS

E42CB--

Items	Standard value
Door inside handle play (except rear door of SPACE RUNNER) mm (in.)	4–10 (0.16–0.40)
Door outside handle play (except rear door of SPACE RUNNER) mm (in.)	4–10 (0.16–0.40)
Sunroof sliding resistance N (kg. lbs.)	120 (12, 26)
Slipping force of sunroof motor clutch N (kg. lbs.)	35–44 (3.5–4.4, 8–10)



## SEALANT AND ADHESIVE

E42CE--

Items	Specified sealant and adhesive	Remarks
Door window glass rear runchannel	3M ATD Part No. 8001, 8011 or equivalent	Drying adhesive
Fender to body panel Splash shield to fender Waterproof film Guide rail to sliding roof cable guide casing	3M ATD Part No. 8625 or equivalent	Ribbon sealer
Windshield glass Tailgate window glass	3M Super Fast Urethan Auto Glass sealant Part No. 8609 or equivalent	–
	3M Super Fast Urethan Primer Part No. 8608 or equivalent	–
Quarter window glass	3M ATD Part No. 8513 or equivalent	Drying sealant
	3M ATD Part No. 8509 or equivalent	Non-drying sealant

**SPECIAL TOOLS**

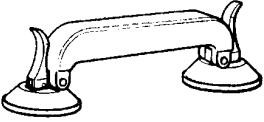
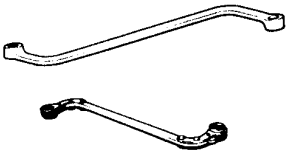
E42DA--

Tool	Number	Name	Use
	MB990480	Glass holder	Removal and installation of windshield
	MB990900 or MB991164	Door adjusting wrench	Adjustment of door fit
	MB990784	Ornament remover	Removal of the window moulding and interior parts

**TROUBLESHOOTING**

E42EF--

**REAR DOOR <SPACE RUNNER>**

Lock mechanism does not lock or unlock at the same time when the door is fully open  
Refer to Trouble Symptom 1

Door opening and closing is heavy, or if it feels like there is something inside the rail (noise comes from the upper rail)  
Refer to Trouble Symptom 5.

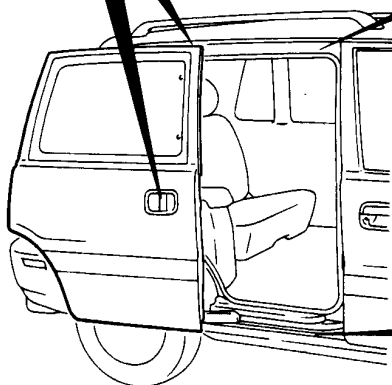

18C0438

Door opening and closing is heavy, or if it feels like there is something inside the rail (noise comes from the lower rail)  
Refer to Trouble Symptom 6.

Door assembly touches the quarter panel while sliding (when closed)  
Refer to Trouble Symptom 4

Door assembly is buoyed up and does not close (center roller arm does not move)  
Refer to Trouble Symptom 2

If door is not closed firmly, the door assembly cannot be fully closed (door latch half latches without fully linking)  
Refer to Trouble Symptom 3

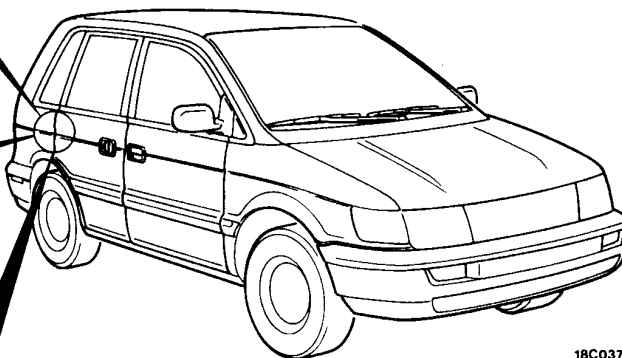

18C0376

**TROUBLE SYMPTOM 1**

Lock mechanism (upper roller arm side and center roller arm side) does not lock or unlock at the same time when the door is fully open

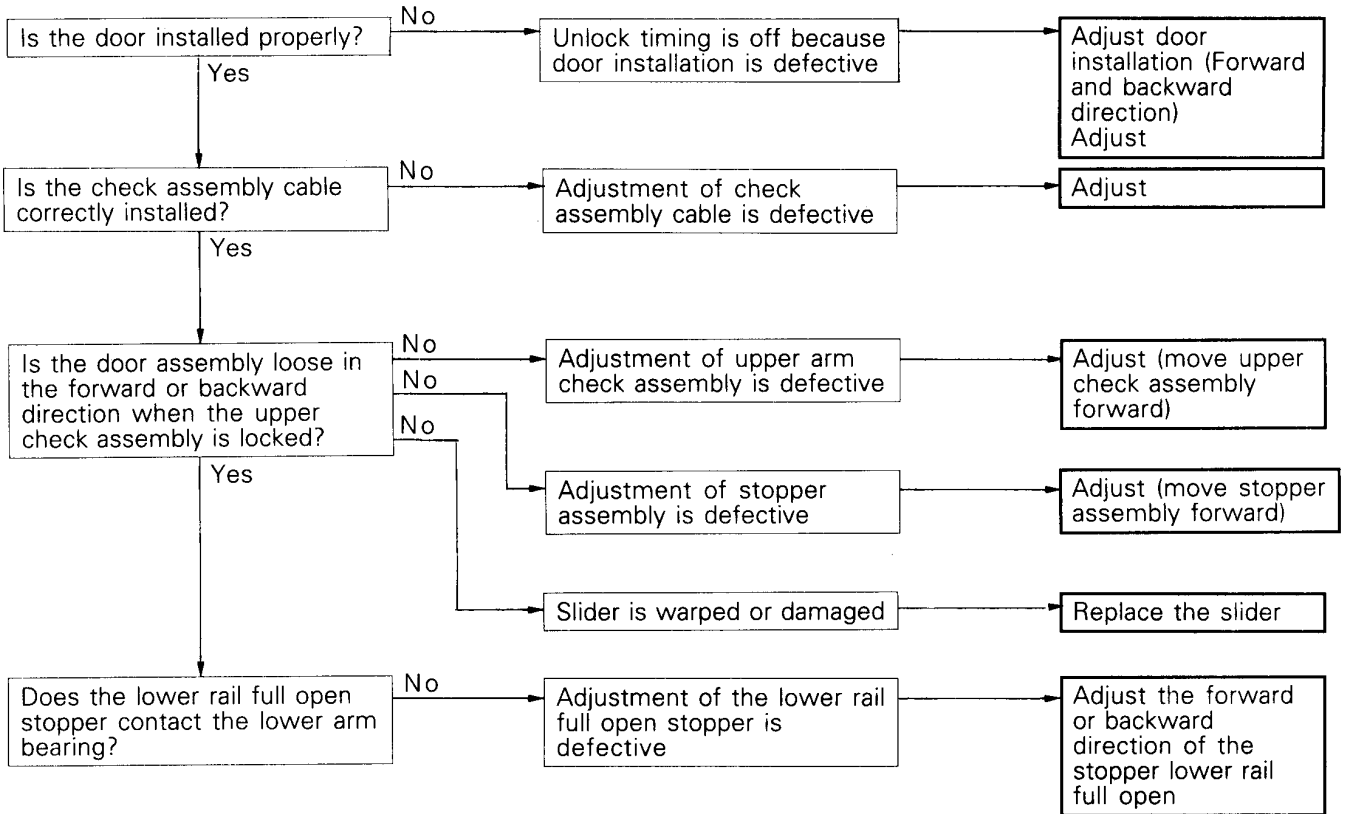

**TROUBLE SYMPTOM 2**

Door assembly is buoyed up and does not close (center roller arm does not move)

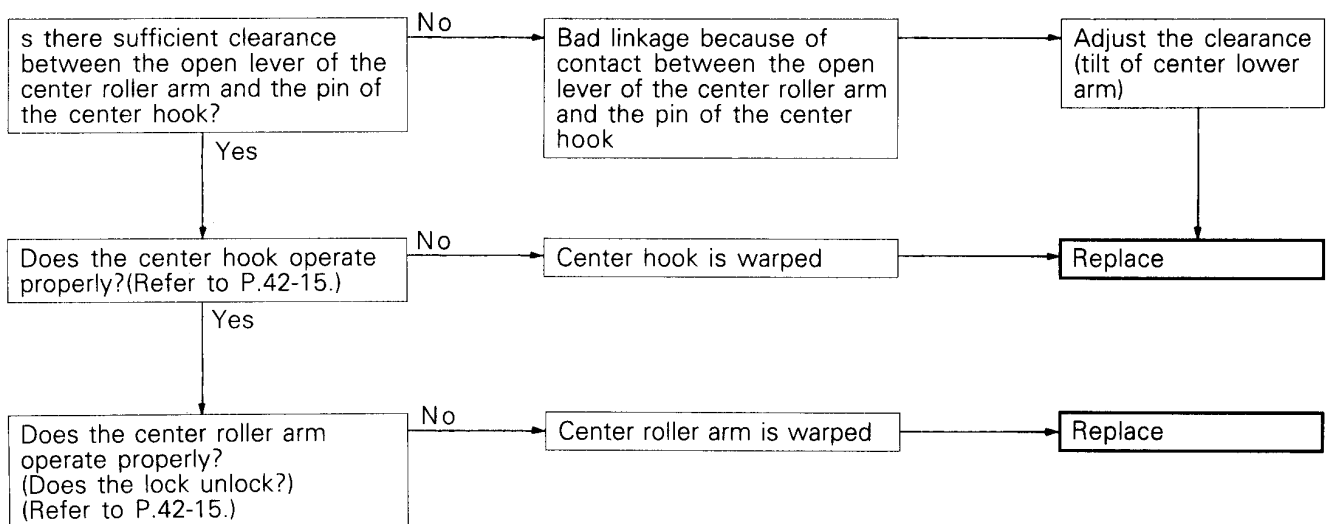

**TROUBLE SYMPTOM 3**

If door is not closed firmly, the door assembly cannot be fully closed. (Door latch half latches without fully linking)

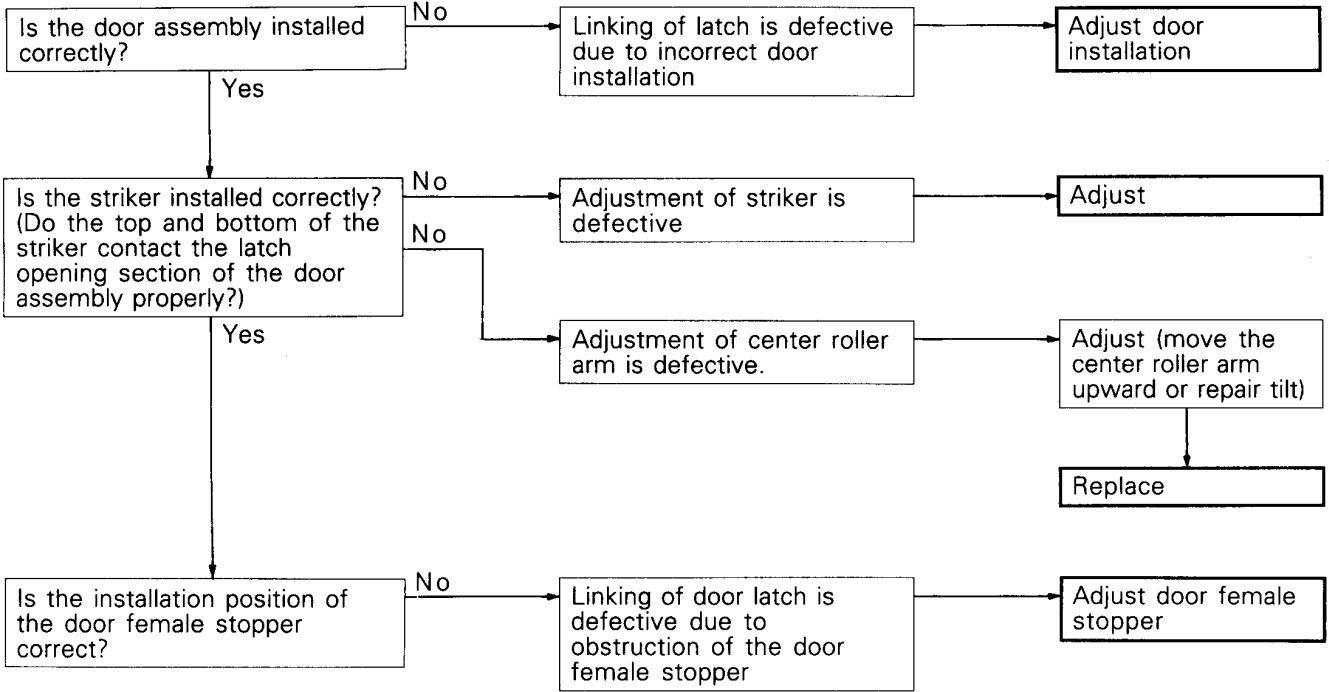

**TROUBLE SYMPTOM 4**

Door assembly touches the quarter panel while sliding (when closed)

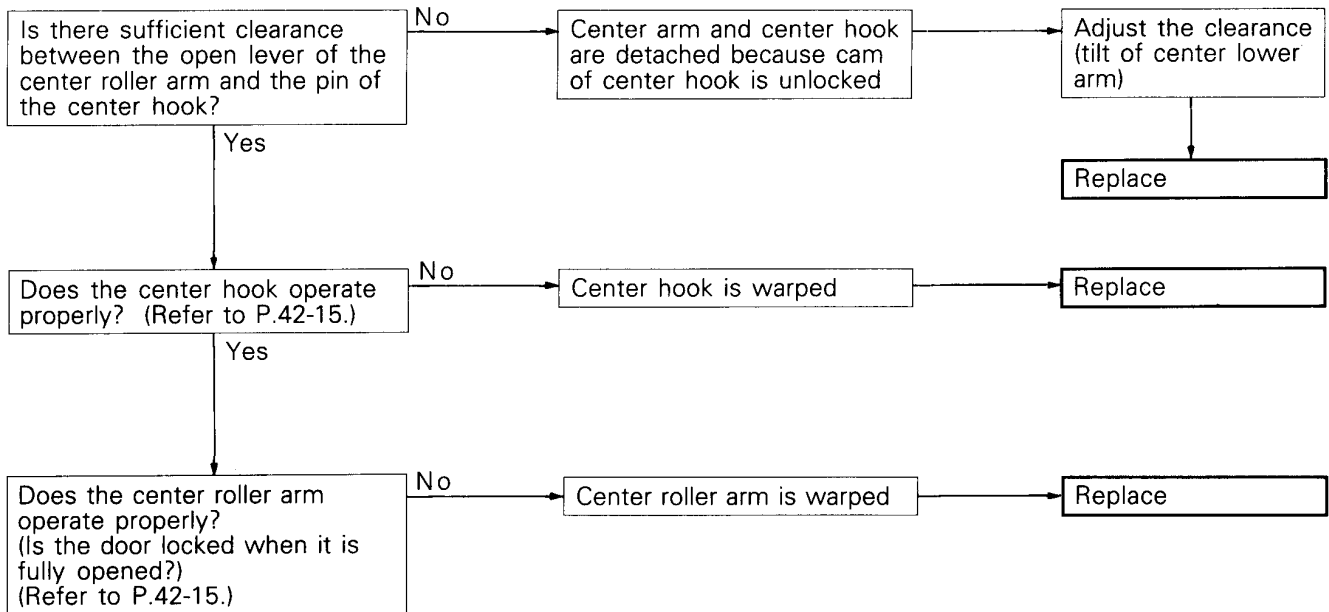



**TROUBLE SYMPTOM 5**

Door opening and closing is heavy, or if it feels like there is something inside the rail (noise comes from the upper rail)

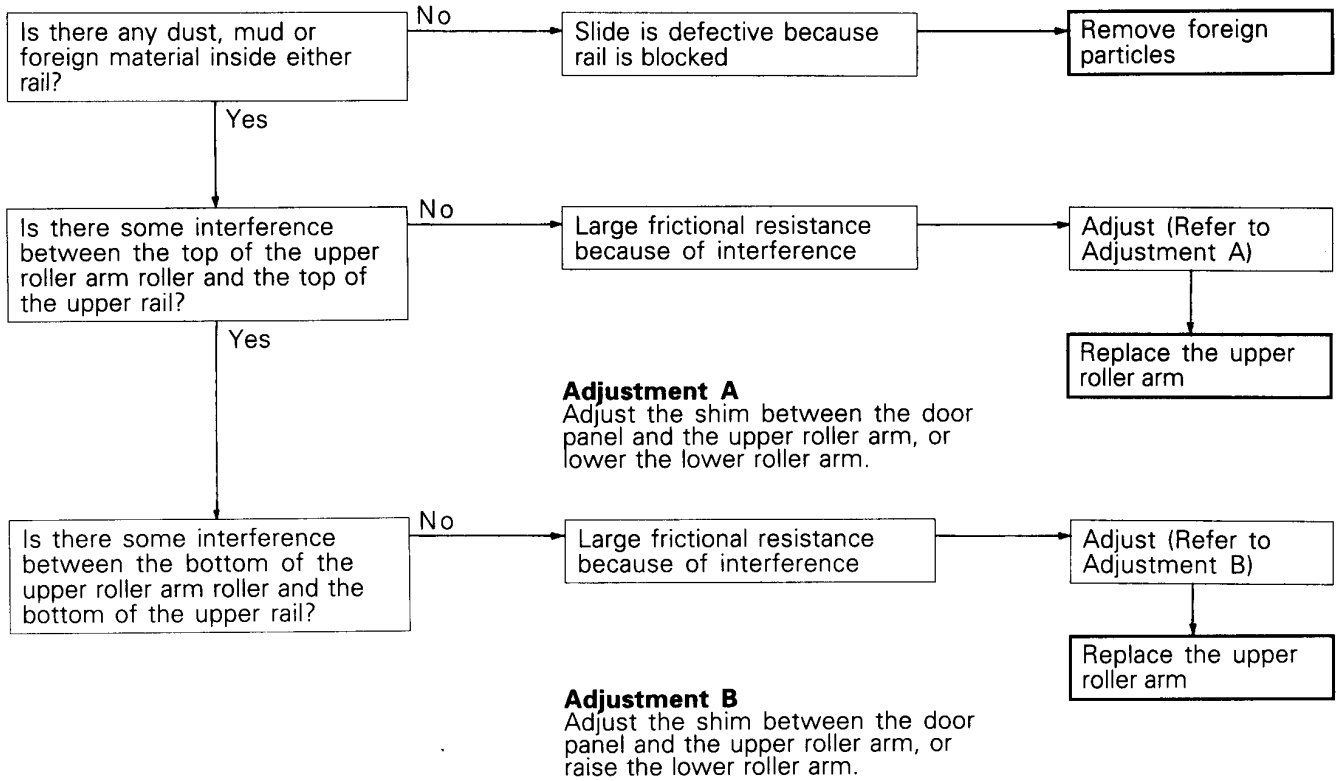

**TROUBLE SYMPTOM 6**

Door opening and closing is heavy, or if it feels like there is something inside the rail (noise comes from the lower rail)

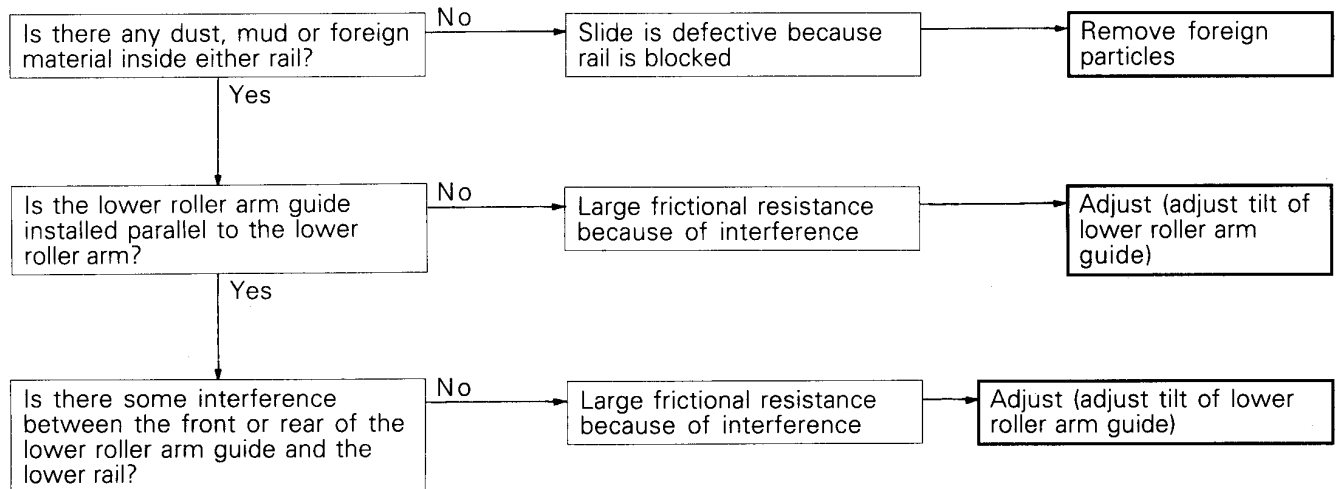

**SERVICE ADJUSTMENT PROCEDURES**

**DOOR FIT ADJUSTMENT**

E42FDAG

1. Use the special tool to loosen the hinge mounting bolts on the body side, and then adjust the clearance around the door so that it is uniform on all sides.
2. When there is a stepped section in the door and body, use the special tool to loosen the door hinge mounting bolt on the door side and adjust the door fit.

**Caution**

**Attach protection tape to the fender edges where the hinge is installed.**

3. If the door opening and closing is stiff, adjust the linking of the striker and the door latch using the shim, while moving the striker up and down, or left and right.

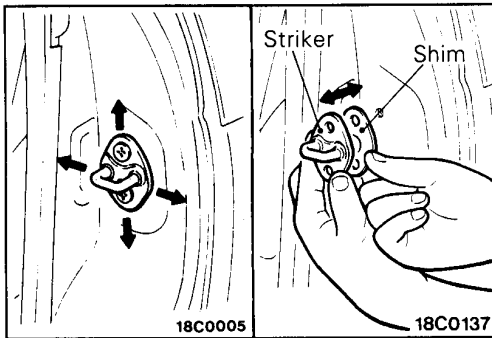
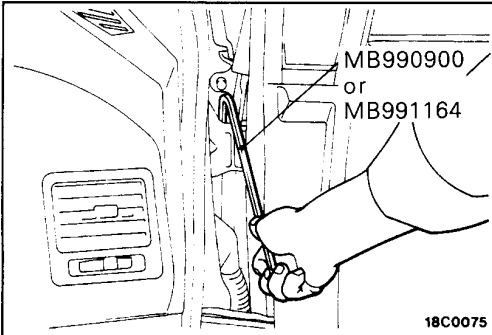

**REAR DOOR FIT ADJUSTMENT <SPACE RUNNER>**

E42FDAJ

**OPENING DIMENSIONS FOR EACH SECTION**

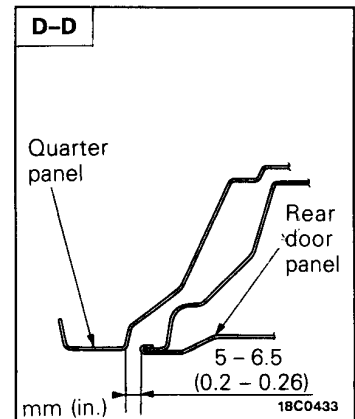
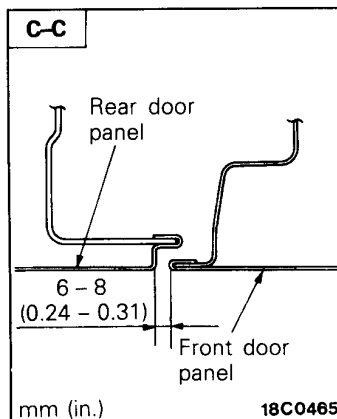
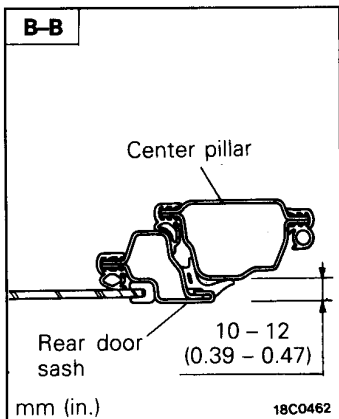
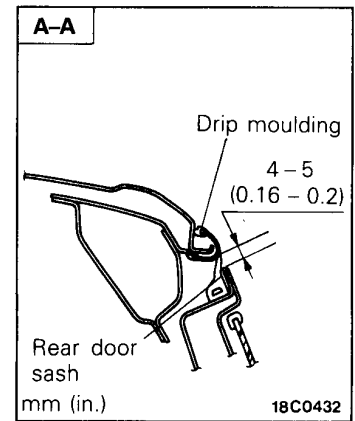
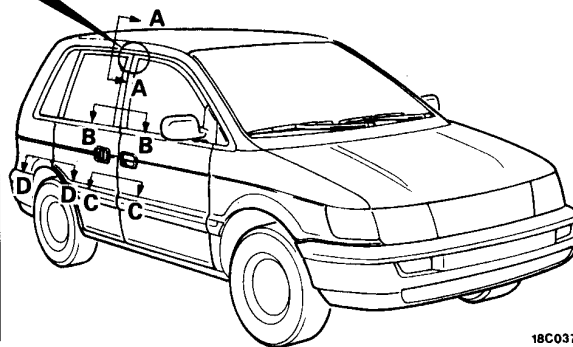
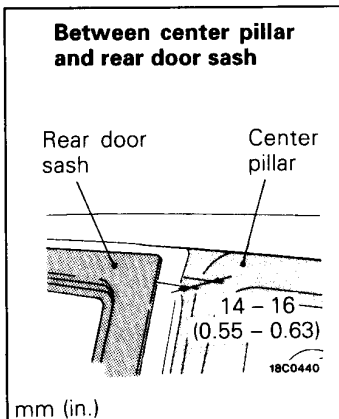

ADJUSTMENT LOCATIONS FOR EACH SECTION

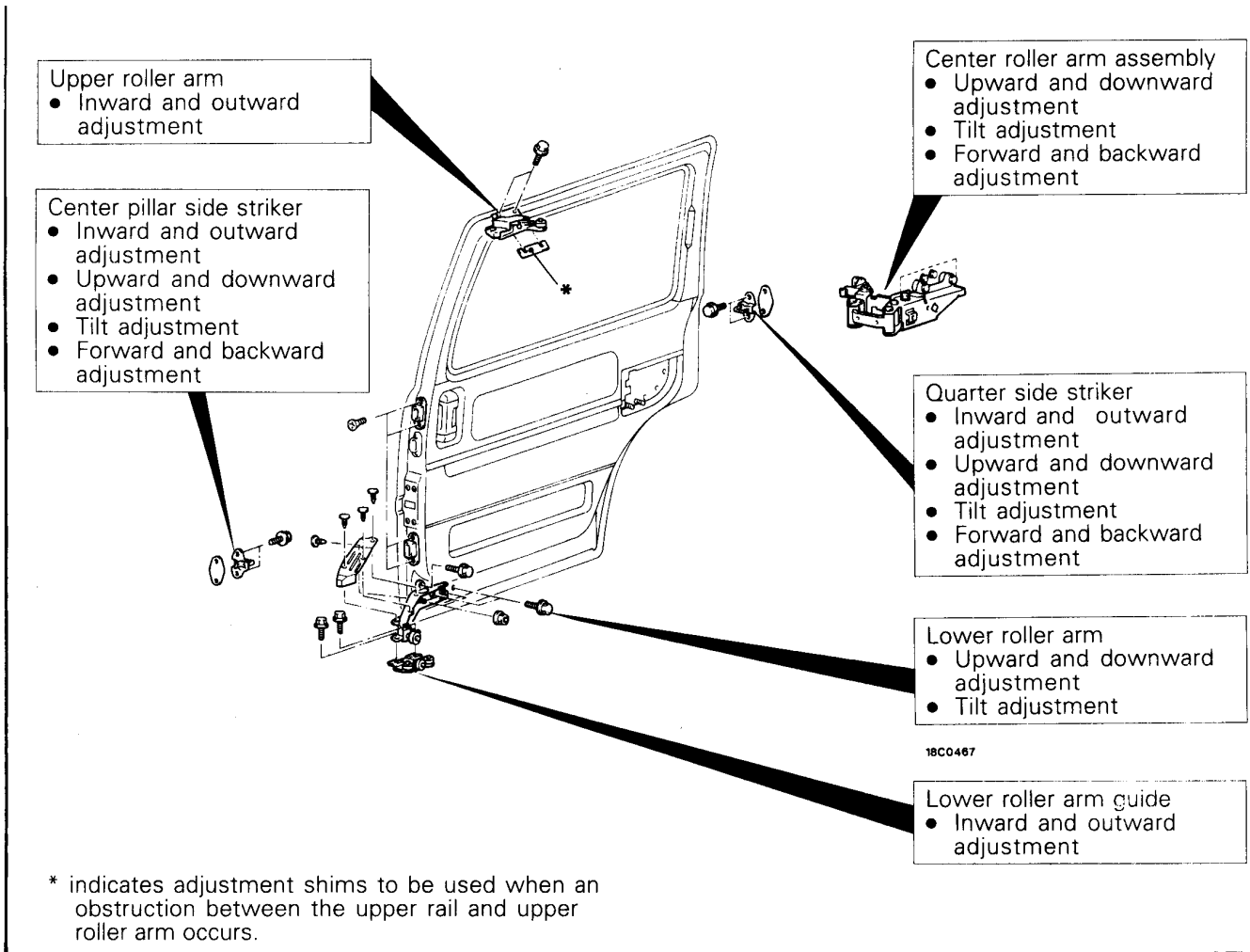

Item	Adjustment procedure				
	①	②	③	④	⑤
Inward and outward stepping	Adjust quarter side striker (Inward and outward direction)	Adjust upper roller arm (Inward and outward direction)	Adjust lower roller arm guide (Inward and outward direction)	Adjust center pillar side striker (Inward and outward direction)	Adjust female stopper
Upward and downward installation is defective	Adjust quarter side striker (Upward and downward directions)	Adjust lower roller arm (Upward and downward directions)	Adjust center pillar side striker (Upward and downward directions)	Adjust female stopper	Adjust center roller arm assembly (Upward and downward directions)
Door tilt	Adjust quarter side striker (Upward and downward directions)	Adjust tilt of lower roller arm	Adjust center pillar side striker (Upward and downward directions)	Adjust female stopper	Adjust center roller arm assembly (Upward and downward directions)
Forward and backward installation is defective	Adjust the center roller arm assembly	Adjust the shim of the center pillar side striker	Adjust the shim of the quarter side striker	—	—

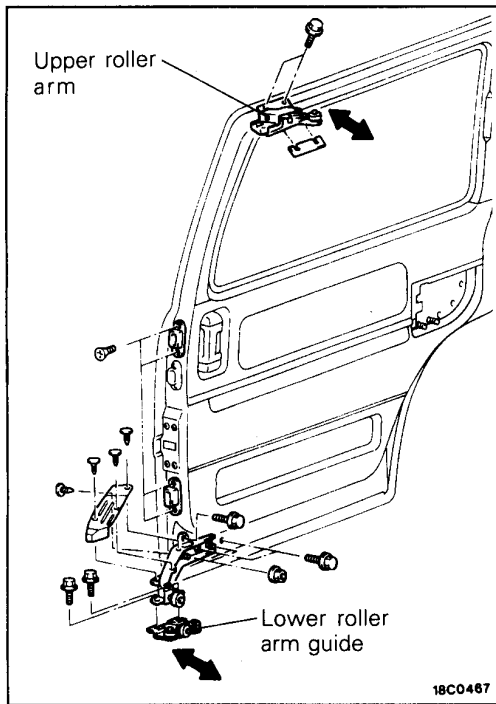

### INWARD AND OUTWARD ADJUSTMENT USING THE UPPER ROLLER ARM AND LOWER ROLLER ARM GUIDES

When the door is protruding into the body, adjust by loosening the mounting bolts of the upper roller arm and lower roller arm guides, and moving the upper roller arm and lower roller arm guides towards the inside of the vehicle. If the door is sticking out of the body, move the upper roller arm and lower roller arm guides in the opposite direction towards the outside of the vehicle.

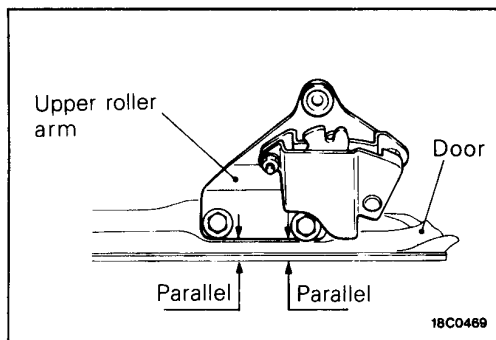

### Caution

The upper roller arm should be moved so that it is parallel to the door.

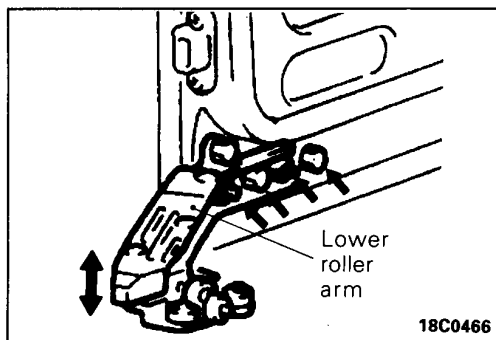

### UPWARD AND DOWNWARD ADJUSTMENT USING LOWER ROLLER ARM

When the whole door is low, loosen the lower roller arm bolts and nuts, and lower the arm. If the whole door is high, adjust by raising the arm.

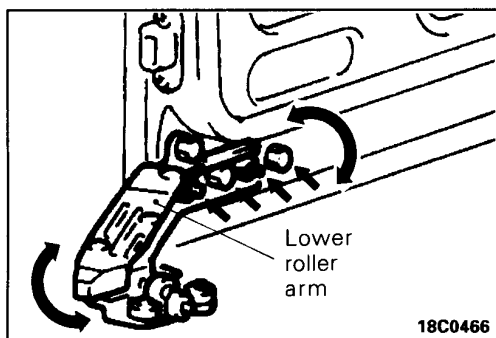

### TILT ADJUSTMENT USING LOWER ROLLER ARM

If the door is tilted, adjust by loosening the mounting bolt and nut of the lower roller arm and changing the installation angle of the arm.

### Caution

After adjustment, the front and rear of the lower roller arm guide should not interfere with the lower rail.

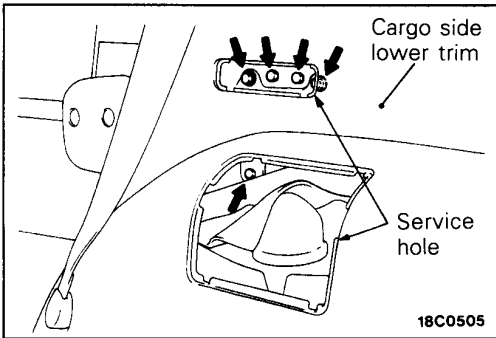

**UPWARD AND DOWNWARD AND FORWARD AND BACKWARD ADJUSTMENT USING THE CENTER ROLLER ARM**

If the door is tilted, or if the up and down or forward and backward installation is defective, adjust by the following procedure.

- (1) Adjust the linking of the door latch.
- (2) Fully close the door, loosen the center roller arm mounting bolt and adjust by moving the arm forward and backward and also upward and downward.

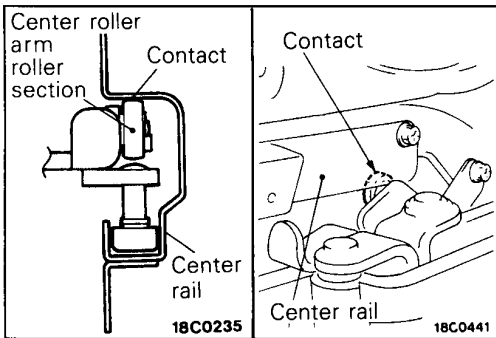

**NOTE**

After adjustment, remove the rear door upper trim, and check to be sure that the roller part of the center roller arm comes in contact with the center rail.

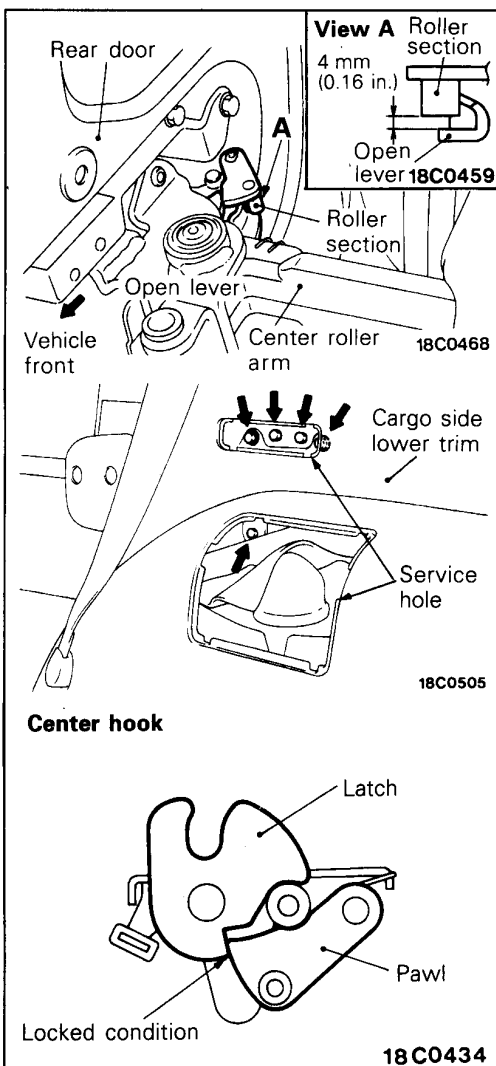

**CENTER ROLLER ARM AND CENTER HOOK LINKAGE ADJUSTMENT**

Immediately after the door is opened, adjust by the following procedures so that the open lever of the center roller arm and the roller section of the center hook should be in the positions shown in the figure.

- (1) Remove the rear door upper trim. (Refer to P.42-56.)
- (2) Adjust by loosening the mounting bolt of the center roller arm and changing the arm mounting angle (tilt).

**Caution**

**After adjustment, when the door is fully closed, the latch in the door center arm hook assembly should be in the locked condition.**

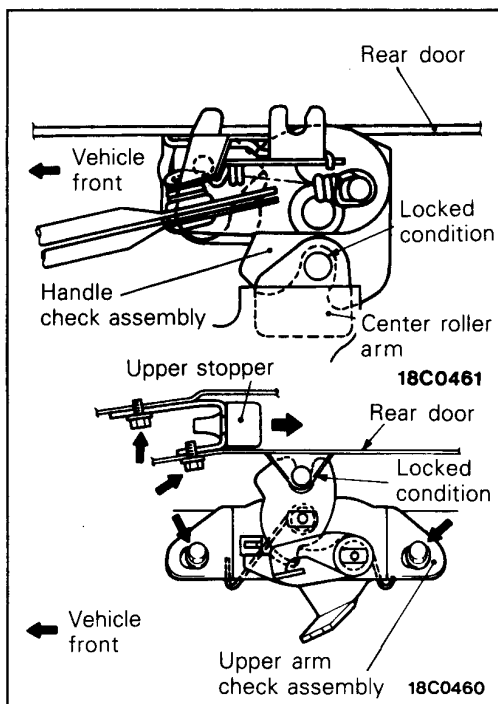
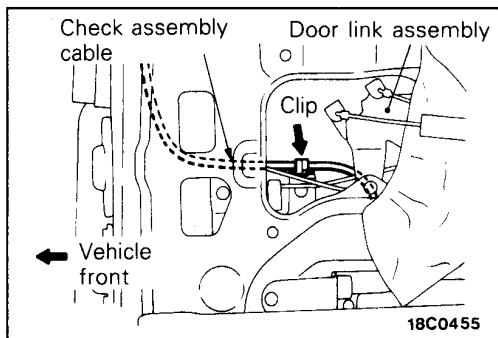
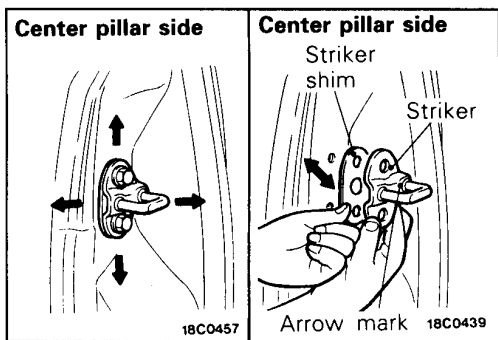
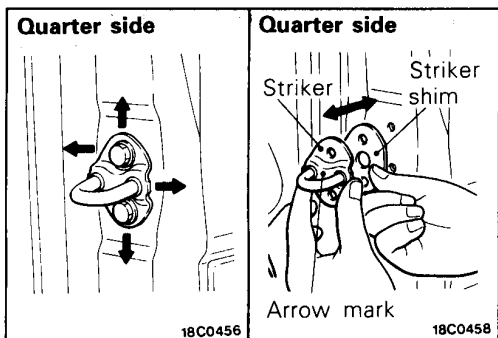

**DOOR LATCH LINKAGE ADJUSTMENT**

If the door opening and closing is stiff, adjust the linking of the striker and the door latch using the shim, while moving the striker up and down, or left and right.

**Caution**

1. Use up to 2 shims for adjusting the quarter side, and 1 for the center pillar side.
2. When installing the striker, install so that the arrow in the position shown in the illustration is facing towards the inside of the vehicle.

**DOOR CHECK ADJUSTMENT**

When the door is fully opened, and at the same time the handle check assembly and the upper check assembly are not locked, adjust by the following procedure.

- (1) Remove the rear door upper trim and check to be sure that the position of the check assembly cable marking and the clip shown in the illustration are aligned.
- (2) With the door fully opened, check to be sure that the handle check assembly locks.
- (3) Loosen the mounting bolt of the upper arm check assembly, lock the check assembly to the upper rail and secure it by lightly pushing it towards the rear of the vehicle.
- (4) Loosen the upper stopper mounting bolt and secure the stopper by lightly pushing it towards the front of the vehicle.

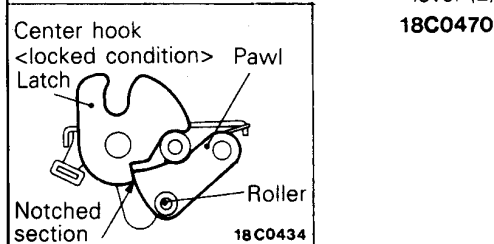
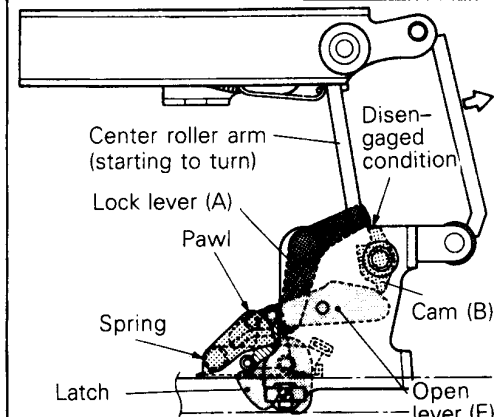
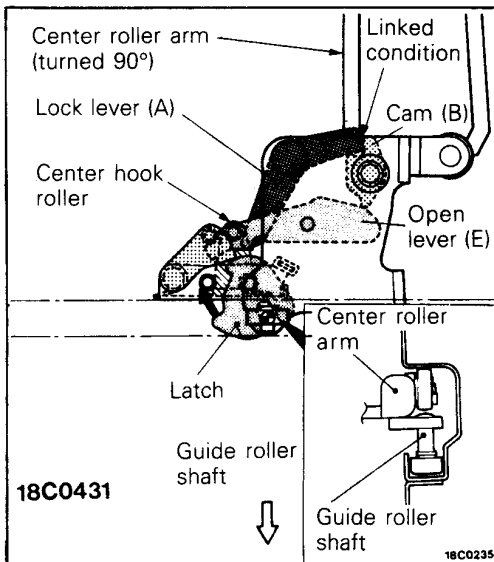
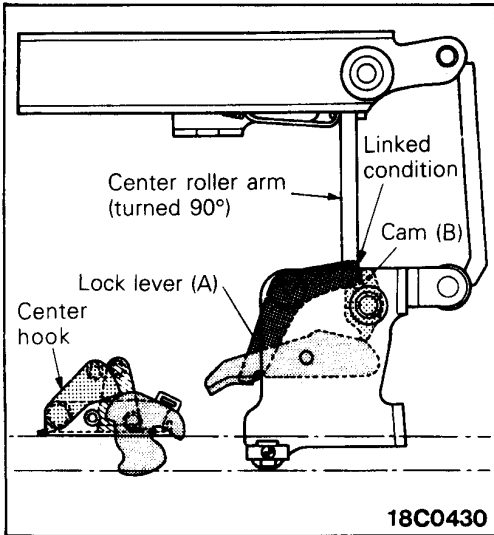

**CENTER ROLLER ARM AND CENTER HOOK OPERATION INSPECTION**

Remove the rear door upper trim and inspect the movement of the center roller arm and center hook.

- (1) When the door assembly is sliding from directly after the door is opened (center roller arm is turned 90°) until the door is fully opened
  - Lock lever (A) and cam (B) of the center roller arm should be linked. At this time, check to be sure that the center roller arm does not swing when the door assembly is lightly pushed toward the centre of the vehicle from the outside of the vehicle.
- (2) When the door assembly is made to slide forward from the fully opened condition, just before the door closes (center roller arm turns 90°)
  - ① Check to be sure that the lock lever (A) and cam (B) are linked when the center hook roller is contacting the lock lever (A).
  - ② At this time, check to be sure that the center hook latch is linked to the guide roller shaft of the center roller arm, and that it starts to turn.
- (3) When the door assembly is made to slide forward and the center roller arm begins to swing
  - ① Check to be sure that lock lever (A) and cam (B) disengage when the center hook roller pushes lock lever (A).
  - ② Check to be sure that the roller of the center hook pawl and the open lever (E) of the center roller arm are contacting.
  - ③ Check the following operation when the door assembly is made to slide again.
    - The center hook latch that is linked to the guide roller shaft of the center roller arm turns. In addition, the open lever (E) turns by means of cam (B) that turns at the same time as the center roller arm starts to swing. Check to be sure that the pawl that contacts the open lever (E) moves into the notched section in the latch by spring force, and that the latch locks.

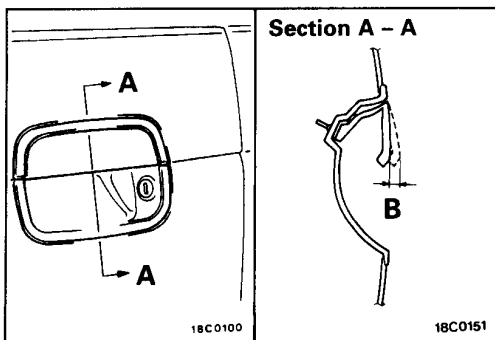
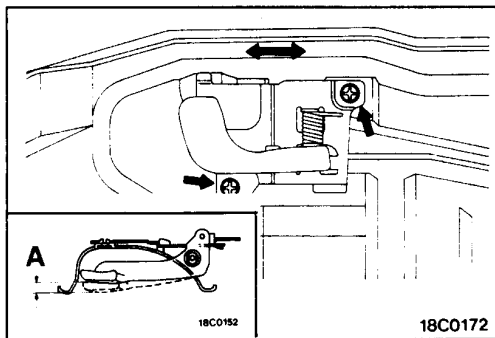
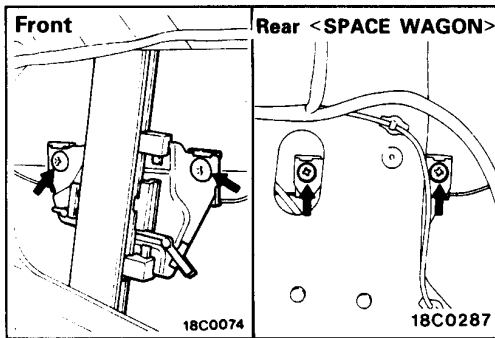
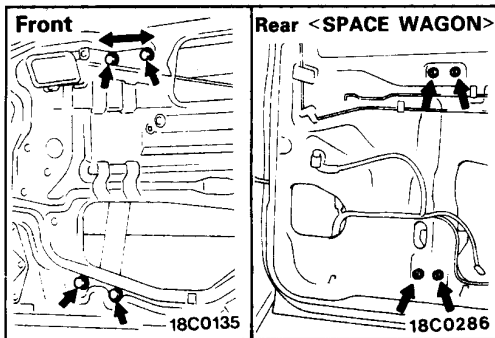

## DOOR GLASS ADJUSTMENT

E42FEAH

1. Remove the door trim and waterproof film. (Refer to P.42-55, 56.)
2. Loosen the installation bolt of the window regulator assembly; then move the upper installation back and forth and adjust the tilted angle of the glass.
3. Lower the door window glass to the position of the access hole.
4. Loosen the door glass installation screw, and adjust the forward/backward position of the glass.

## INSIDE HANDLE PLAY ADJUSTMENT <EXCEPT REAR DOOR OF SPACE RUNNER>

E42FGAC

1. Remove the door trim and waterproof film. (Refer to P.42-55, 56.)
2. Move the door inside handle installation position back agrees with the standard value.

**Standard value (A): 4–10 mm (0.16–0.40 in.)**

## OUTSIDE HANDLE PLAY CHECK <EXCEPT REAR DOOR OF SPACE RUNNER>

E42FHAD

If the door outside handle play does not conform to the standard value, check the door outside handle or door latch assembly, and replace if necessary.

**Standard value (B): 4–10 mm (0.16–0.40 in.)**



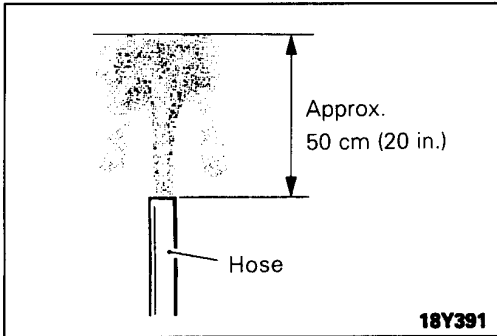

**WATER TEST**

E42FOAA

1. Close roof lid tightly.
2. Hold hose upward and adjust water fountain to about 50 cm (20 in.) high.

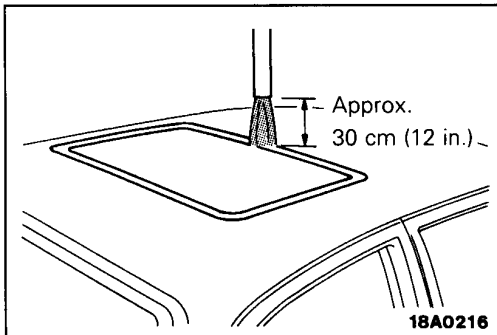

3. Pour water over the roof from about 30 cm (12 in.) above roof for more than 5 minutes.
4. While pouring water, check for leak around roof lid.
5. In the event of leakage, check drain pipe, weatherstrip contact and others.

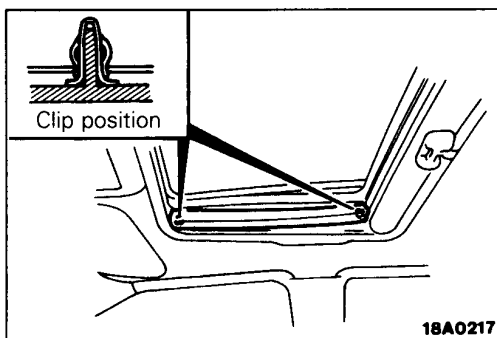

**SUNROOF FIT ADJUSTMENT**

E42FSAD

1. If the roof glass lid must be adjusted forward/backward or to right/left, do so as follows.
  - (1) Close the roof glass lid to the fully tilt closed position.

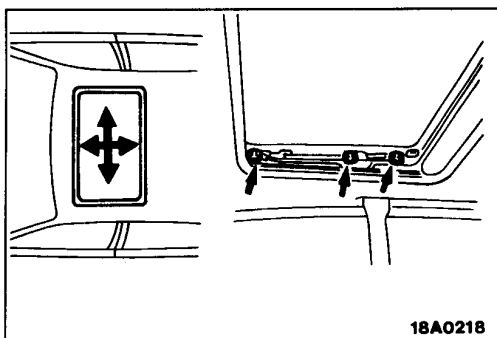

- (2) Loosen the nuts (six) and move the roof glass lid forward/backward or left/right.

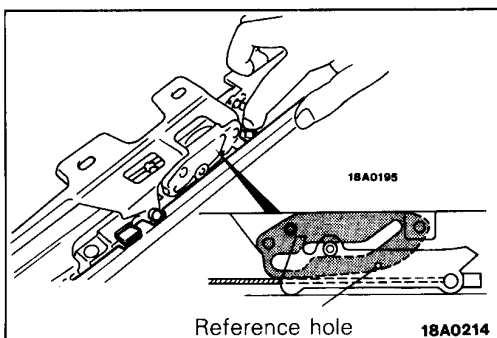

- (3) If a forward/backward adjustment has been made check to be sure that the sliding roof assembly's guide and the link's reference hole are positionally aligned.

**NOTE**

If the condition is not corrected by only an adjustment by the installation nut, there is a deviation of the fully closed position of the roof glass lid and the motor's fully closed position, so remove and check the motor.

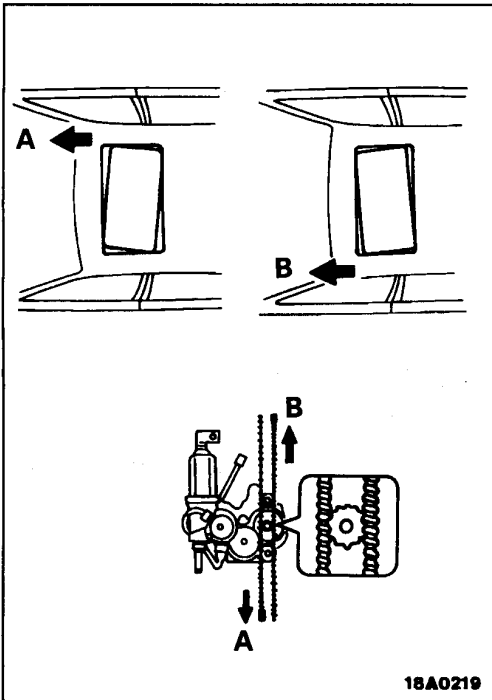

2. If the roof and roof glass lid are not parallel, correct as follows.

- (1) If the deviation is approximately 1 mm (0.04 in.), make the forward/backward or left/right adjustment by the same procedure.
- (2) If the deviation is approximately 2 mm (0.08 in.) remove the motor and advance the cable (at the side where the gap is larger) one pitch.

**NOTE**

There will be movement of 2.5 mm (0.098 in.) for one pitch of the cable.

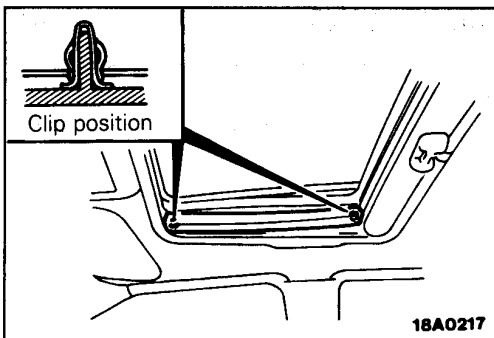

3. If the height of the roof and the roof glass lid must be adjusted, do so as follows.

- (1) Close the roof glass lid to the fully tilt closed position.

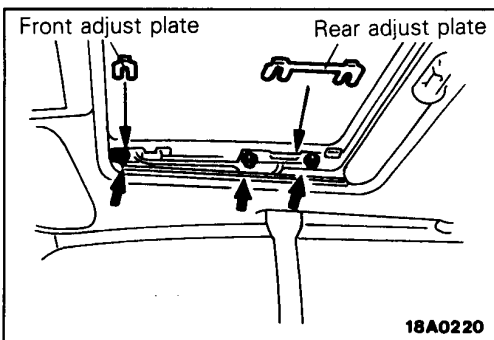

(2) Loosen the six nuts.

- (3) Adjust by increasing or decreasing the number of adjustment plates.

# HOOD

## REMOVAL AND INSTALLATION

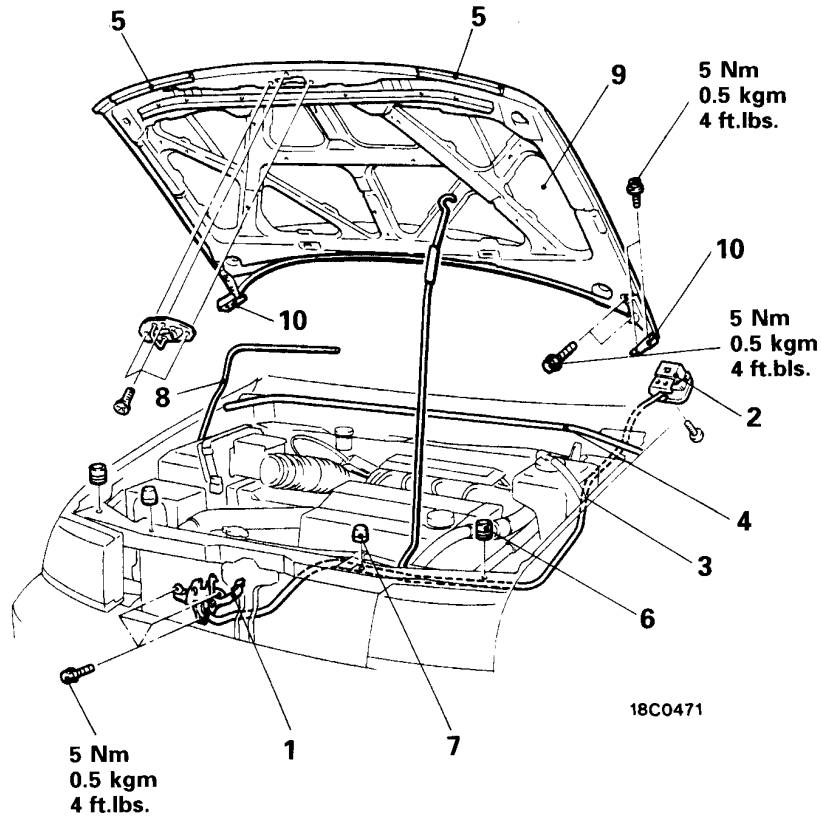

E42HAAM

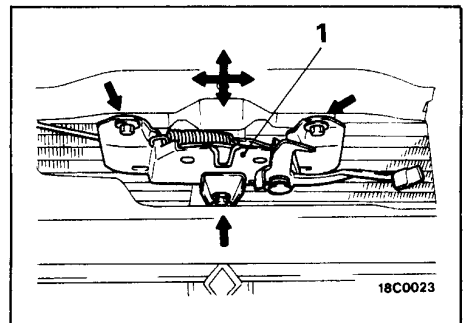
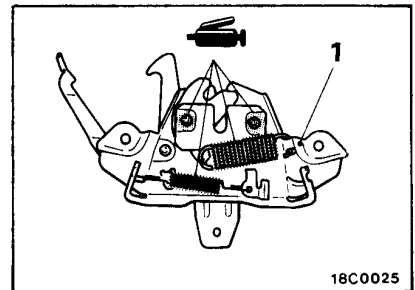
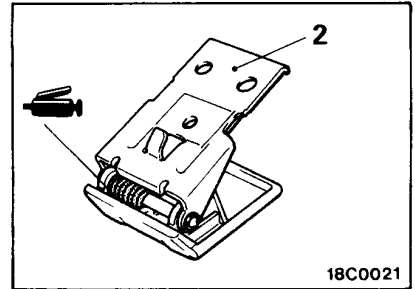
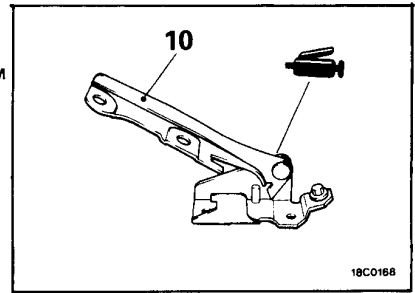

**Adjustment of engine hood step and hood striker linkage**

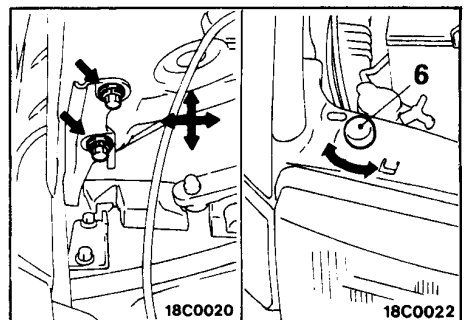

**Adjustment of clearance around hood and height**

### Removal steps

1. Hood latch
2. Hood lock release handle
3. Hood lock release cable
4. Hood weatherstrip
5. Hood front weatherstrip
6. Bumper
7. Bumper

### Hood and hood hinge removal steps

8. Washer tube
9. Hood
10. Hood hinge

FENDER

E42KAAV

REMOVAL AND INSTALLATION

- Pre-removal and Post-installation Operation**  
**Removal and Installation**
- Front Bumper Assembly (Refer to GROUP 51 – Front Bumper.)
  - Front Wiper Arm (Refer to GROUP 51 – Front Wiper, Washer.)
  - Air Inlet Grille (Refer to GROUP 51 – Front Wiper, Washer.)

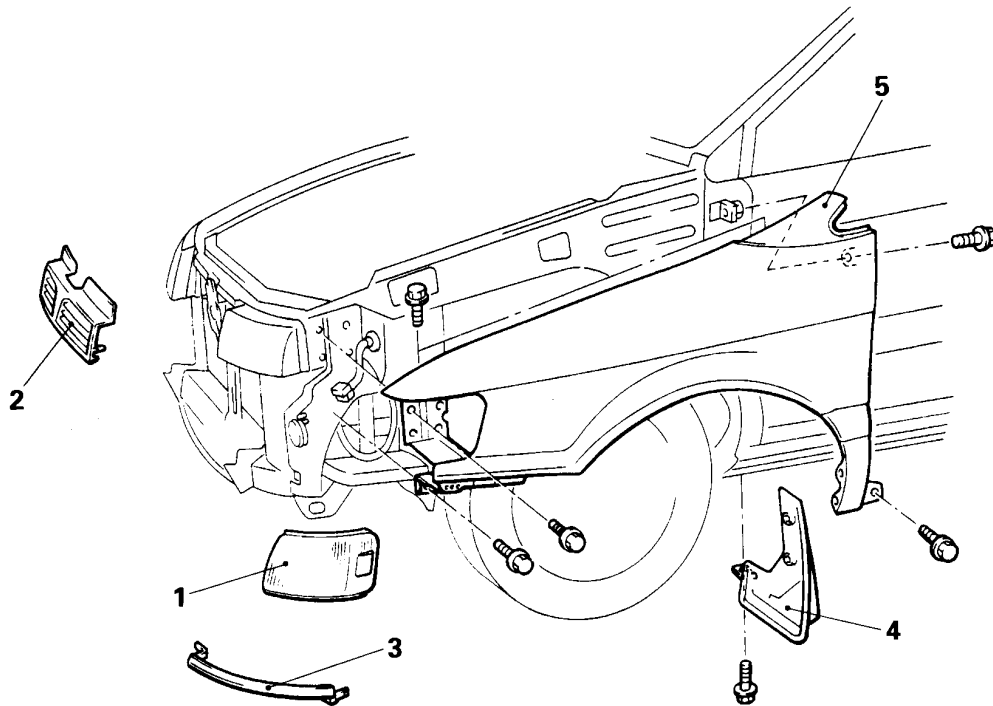

18C0502

**Removal steps**

1. Front combination lamp
2. Radiator grille
3. Grille filler garnish
4. Mud guard
5. Fender panel

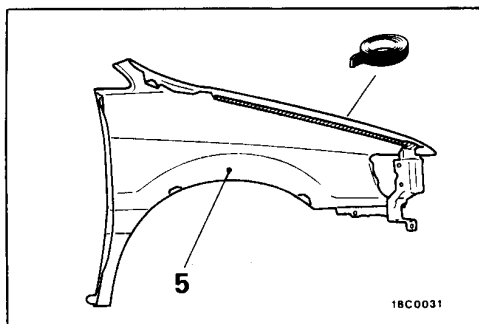

18C0031

**Sealant:**  
**3M ATD Part No. 8625 or equivalent**

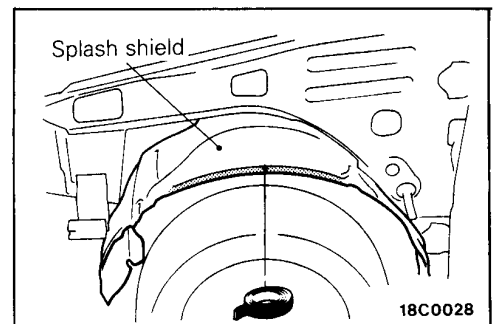

18C0028

**Sealant:**  
**3M ATD Part No. 8625 or equivalent**

**FUEL TANK FILLER DOOR**

E42JBAO

**REMOVAL AND INSTALLATION <R.H. DRIVE VEHICLES OF SPACE RUNNER, SPACE WAGON>**

**Pre-removal and Post-installation Operation**

- Removal and Installation of Front Seat <Driver's side> (Refer to GROUP 52A – Front Seat.)
- Removal and Installation of Second Seat and Third Seat <SPACE WAGON> (Refer to GROUP 52A – Second Seat, Third Seat.)
- Removal and Installation of Front Scuff Plate <Driver's side>, Quarter Lower Trim (R.H.), Cargo Side Lower Trim (R.H.)(Refer to GROUP 52A – Trims.)

**Adjustment**

- Fuel Filler Door Adjustment

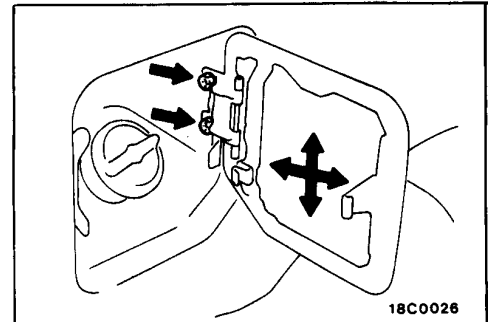

**Adjustment of step and clearance around fuel filler door.**

**<R.H. DRIVE VEHICLES OF SPACE RUNNER>**

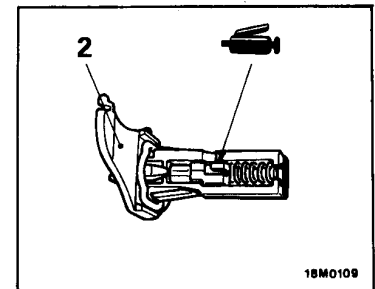
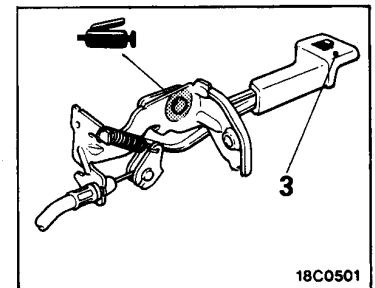
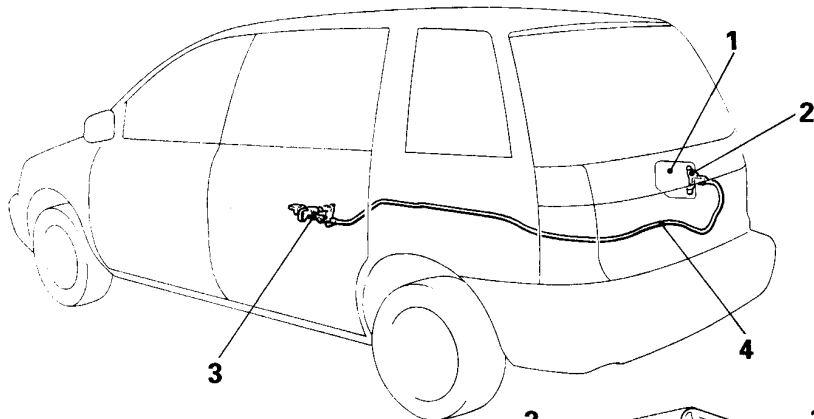

**<SPACE WAGON>**

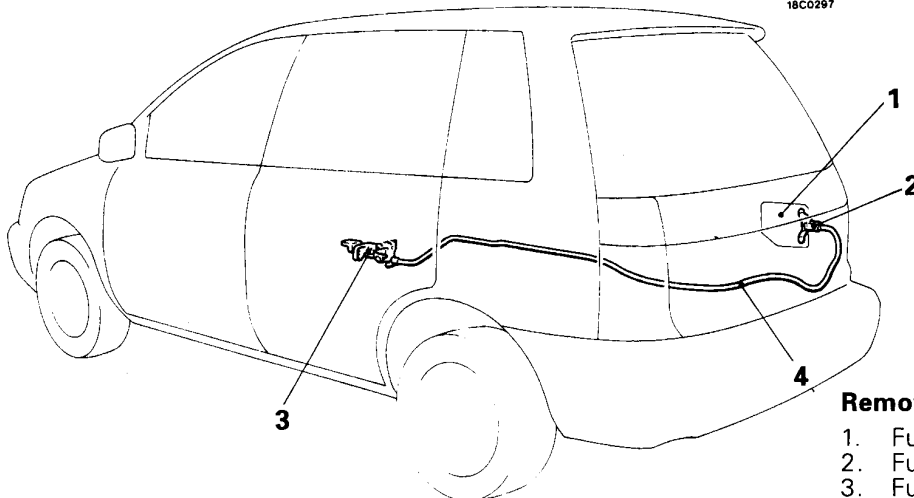
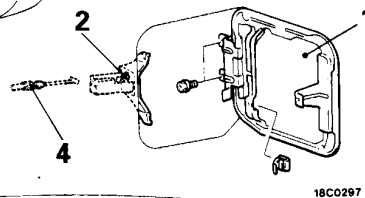

**Removal steps**

1. Fuel filler door
2. Fuel filler door hook
3. Fuel filler door lock release handle
4. Fuel filler door lock release cable

18C0297

REMOVAL AND INSTALLATION <L.H. DRIVE VEHICLES OF SPACE RUNNER>

**Pre-removal and Post-installation Operation**

- Removal and Installation of Front Seat <Driver's side>. (Refer to GROUP 52A – Seat.)
- Removal and Installation of Front Scuff Plate <Driver's side>, Quarter Lower Trim, Cargo Side Lower Trim, Rear End Trim. (Refer to GROUP 52A – Trims.)

**Adjustment**

- Fuel Filler Door Adjustment

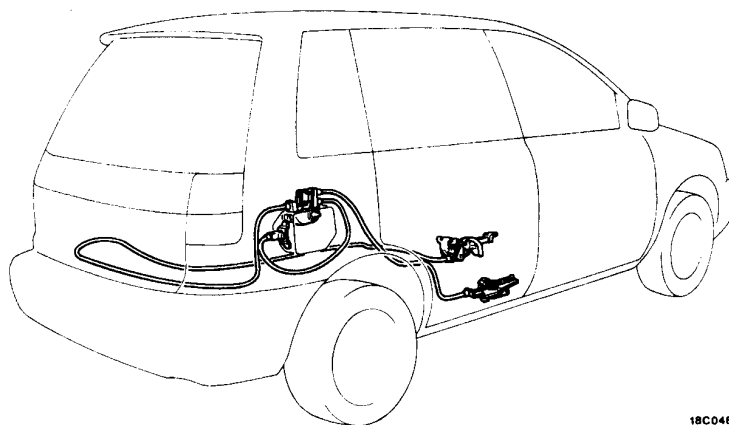

18C0480

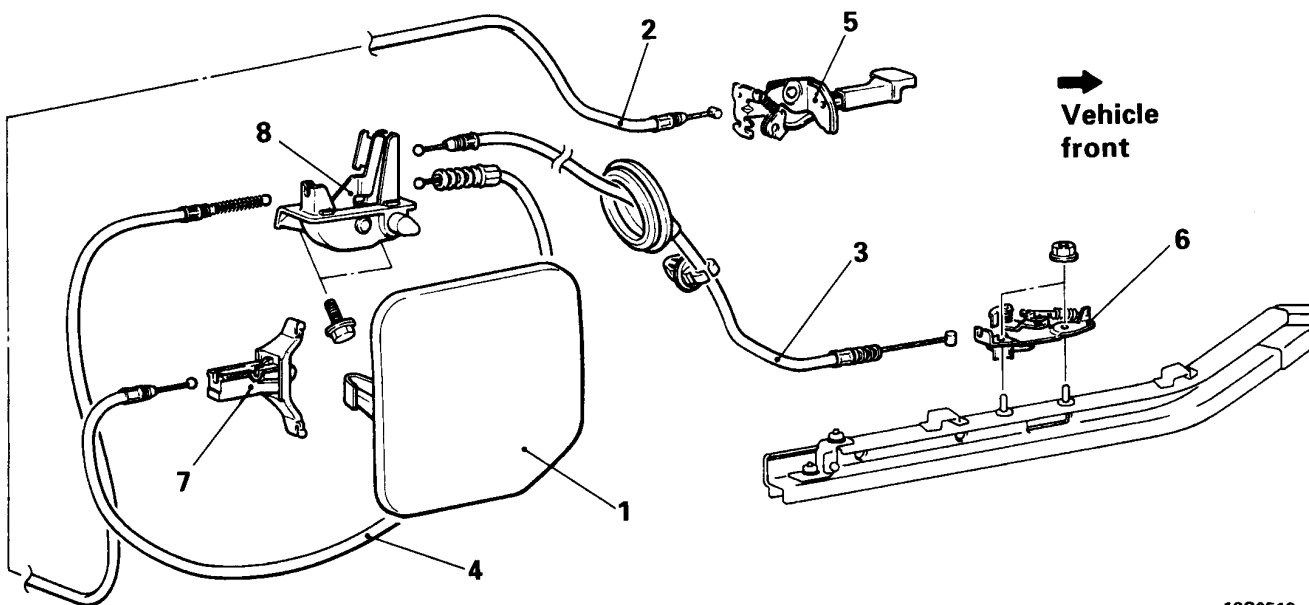

18C0512

1. Fuel filler door assembly

**Fuel filler door lock hook assembly removal steps**

- ◆◆ 2. Fuel filler door lock release cable
- 5. Fuel filler door lock release handle

**Fuel filler door safety stopper assembly removal steps**

- ◆◆◆◆ 3. Fuel filler door safety cable
- ◆◆◆◆ 6. Fuel filler door safety stopper assembly

**Fuel filler door hook removal steps**

- ◆◆ 4. Fuel filler door lock release cable
- 7. Fuel filler door hook

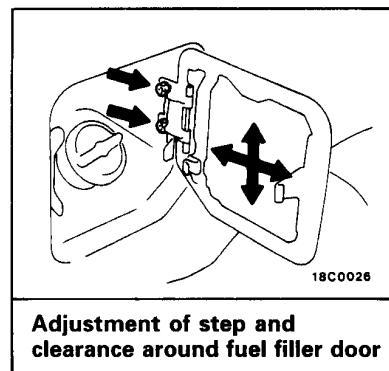

18C0026

**Adjustment of step and clearance around fuel filler door**

**Fuel filler door safety lever assembly removal steps**

- ◆◆ 2. Fuel filler door lock release cable
- 3. Fuel filler door safety cable
- ◆◆ 4. Fuel filler door lock release cable
- 8. Fuel filler door safety lever assembly

LUBRICATION POINTS

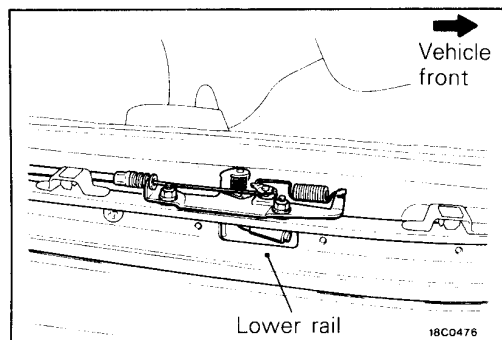
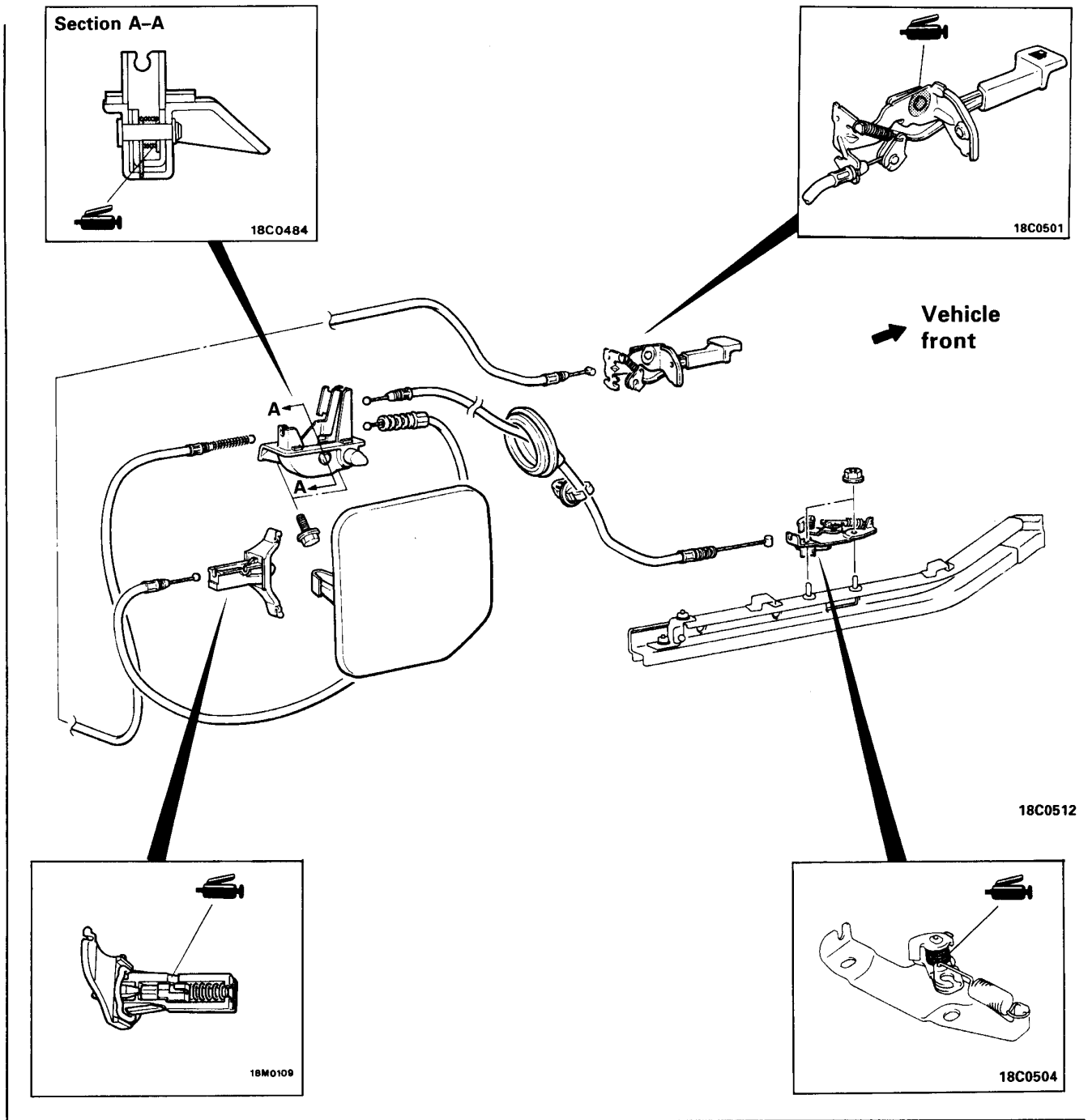

SERVICE POINTS OF REMOVAL

6. REMOVAL OF FUEL FILLER DOOR SAFETY STOPPER ASSEMBLY

- (1) Loosen the lower rail mounting screws and bolts.
- (2) Remove the nuts shown in the illustration, and remove the fuel filler door safety stopper assembly from the lower rail.

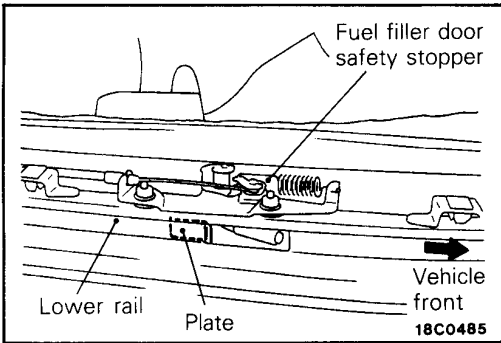

**SERVICE POINTS OF INSTALLATION**

**6. INSTALLATION OF FUEL FILLER DOOR SAFETY STOPPER ASSEMBLY**

Install the fuel filler door safety stopper assembly so that the plate shown in the illustration follows the line of the lower rail.

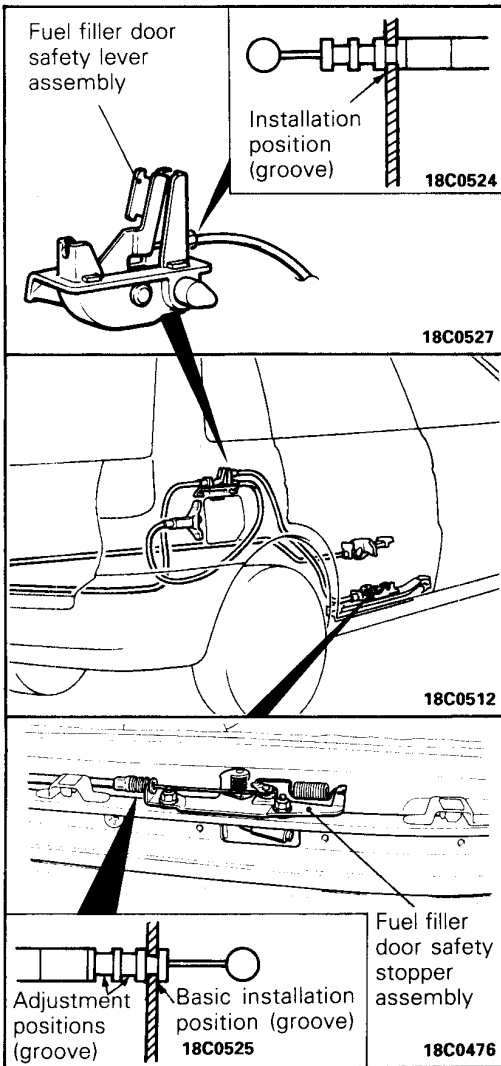

**4./2. INSTALLATION OF FUEL FILLER DOOR LOCK RELEASE CABLE**

The installation of the release cable differs on the fuel filler door safety lever assembly side and the fuel filler door safety stopper assembly side, so install as shown in the illustrations.

Carry out an operation inspection after installing, and if the fuel filler door does not open, adjust by changing the installation position (groove) of the release cable on the door safety stopper assembly side.



**WINDSHIELD GLASS**

E42LABP

**WINDSHIELD REPAIR**

<ul style="list-style-type: none"> <li>● Adhesive: 3M Super Fast Urethan Auto Glass Sealant Part No. 8609 or equivalent</li> <li>Primer: 3M Super Fast Urethan Primer Part No. 8608 or equivalent</li> <li>● Auto Window Sealer Kit TEROSON-127, 37V</li> </ul>	<ol style="list-style-type: none"> <li>1. Sealer</li> <li>2. Nozzle</li> <li>3. Primer container</li> <li>4. Primer container cap</li> <li>5. Piano wire</li> <li>6. Brush</li> <li>7. Cleaner</li> <li>8. Primer</li> <li>9. Filter</li> <li>10. Gauge</li> <li>11. Instruction manual</li> </ol>	<p>The diagram shows the components of the windshield repair kit. 1: A cylindrical adhesive dispenser with a nozzle. 2: A small nozzle. 3: A small primer container. 4: A cap for the primer container. 5: A circular piano wire. 6: A brush. 7: A small container of cleaner. 8: A small container of primer. 9: A filter. 10: A gauge. 11: An instruction manual.</p>
---	--	---

18P0466

**NOTE**

When using TEROSON-127, 37V, follow the instructions of the manual included in the kit.

Additional material required	
Spacers	Available as service part
Dam	Available as service part
Anti-rust solvent (or Tectyl 506T...Valvoline Oil Company)	For rust prevention
Isopropyl alcohol	For grease removal from bonded surface
Steel piano wire	Dia. x length...0.6 mm x 1 m (0.024 in. x 3 ft.)
	For cutting adhesive
Adhesive gun	For pressing-out adhesive

**HANDLING OF AUTO WINDOW SEALER**

Keep the sealant in a cool place, not exposed to the direct rays of the sun.

Do not place any heavy article on the sealant nor press it, otherwise it will become deformed.

Avoid storing the sealant for more than 6 months, because it will lose its sealing effect.

**BODY PINCH-WELD FLANGE SERVICING**

Before servicing the body pinch-weld flange, remove old adhesive completely.

If the flange requires painting, bake it after painting is completed.

WORKING PROCESS

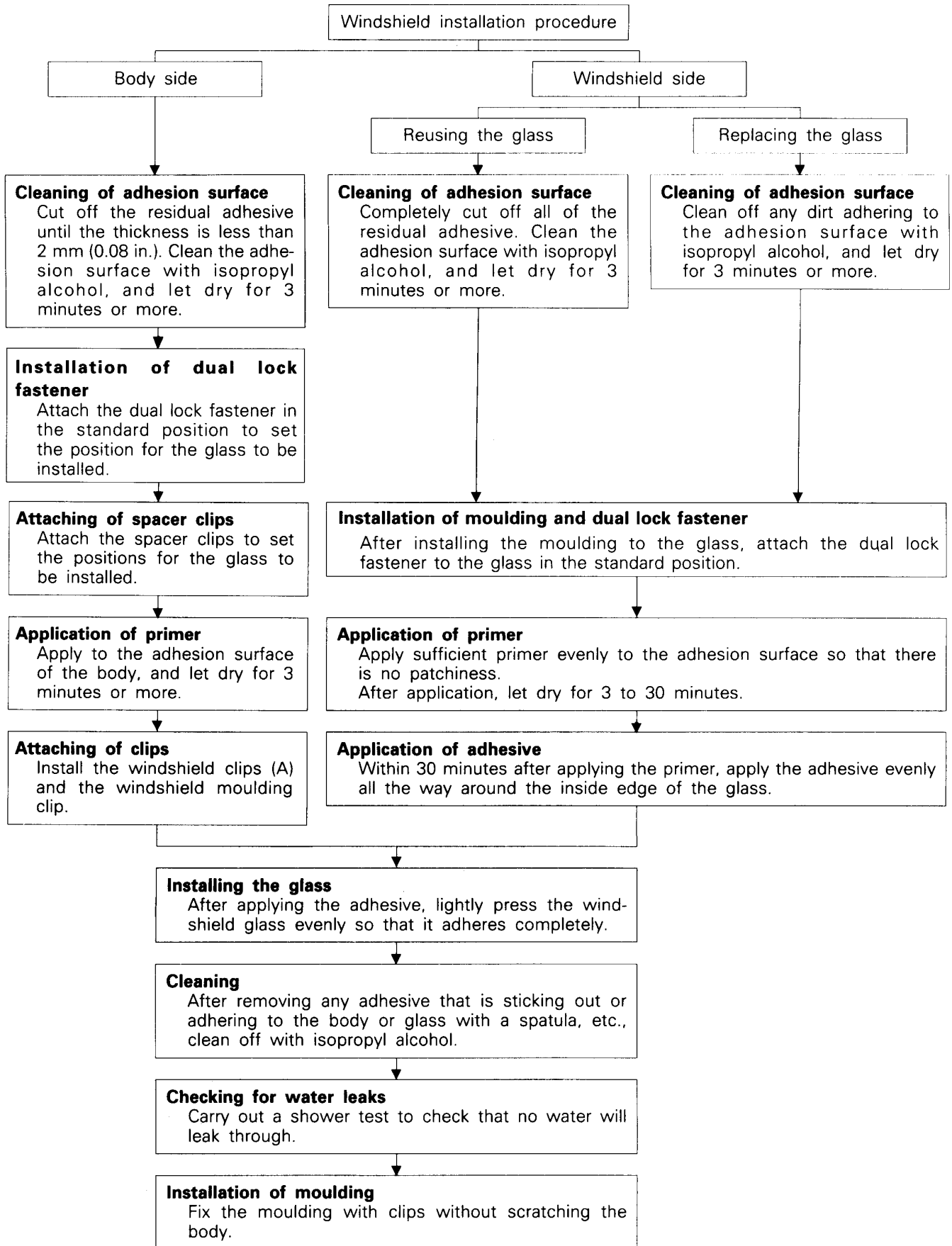

**REMOVAL AND INSTALLATION**

**Pre-removal and Post-installation Operation  
Removal and Installation**

- Front Deck Garnish (Refer to GROUP 51 – Garnish and Moulding.)
- Front Pillar Trim (Refer to GROUP 52A – Trims.)
- Headlining (Refer to GROUP 52A – Headlining.)

**Removal steps**

- ◆◆ ◆◆ 1. Windshield Glass
- ◆◆ ◆◆ 2. Glass spacer
- ◆◆ ◆◆ 3. Dual lock fastener
- ◆◆ ◆◆ 4. Moulding

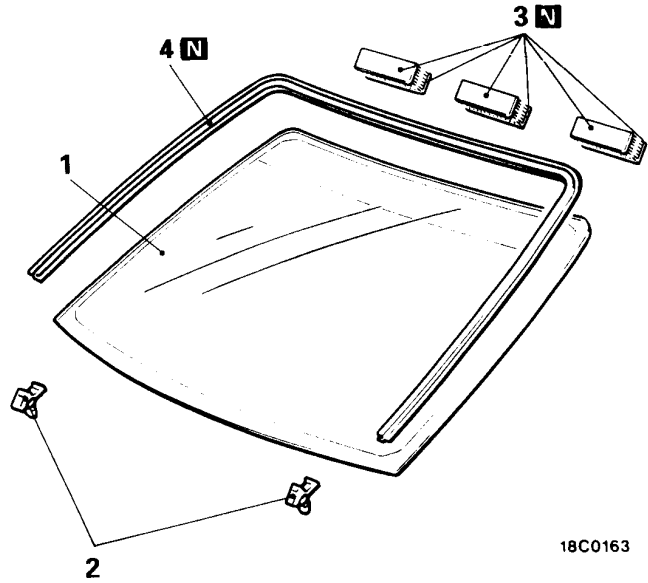

18C0163

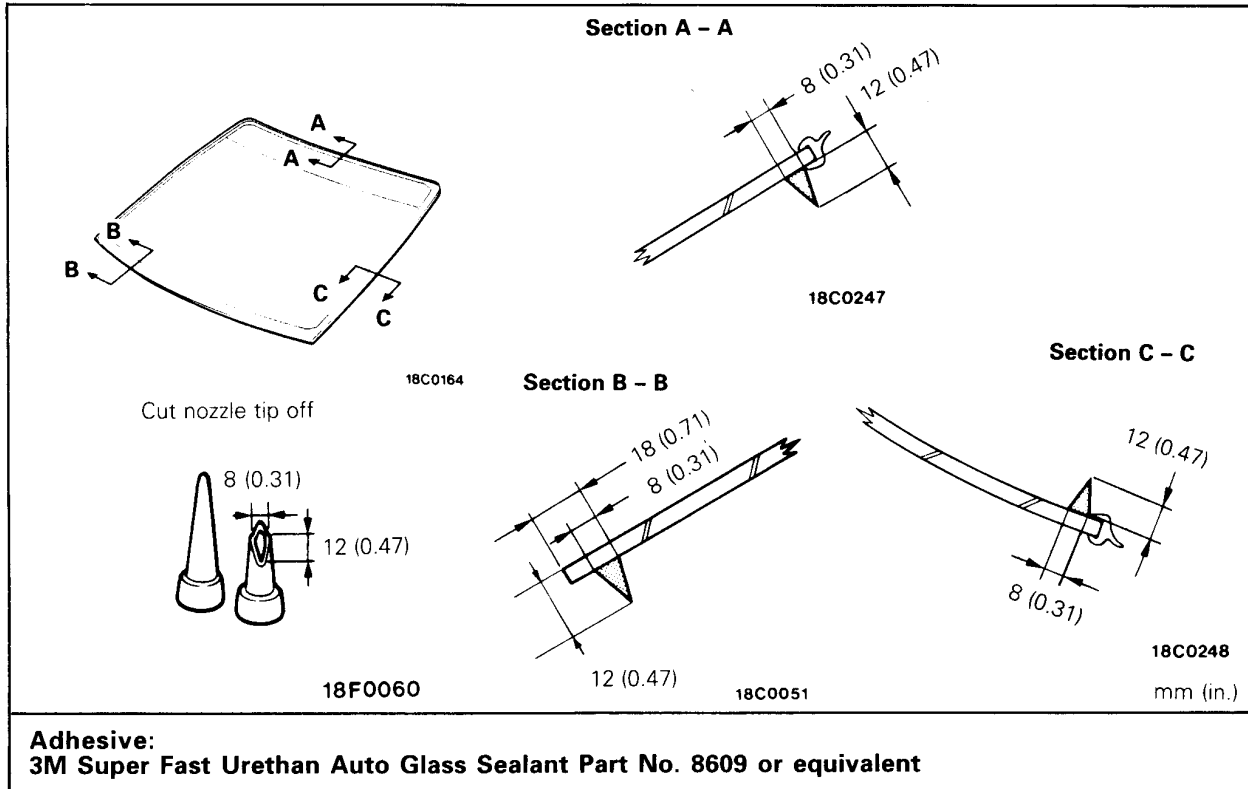

**Adhesive:**  
3M Super Fast Urethan Auto Glass Sealant Part No. 8609 or equivalent

18C0248  
mm (in.)

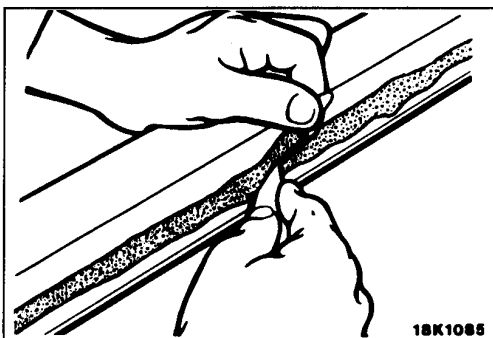
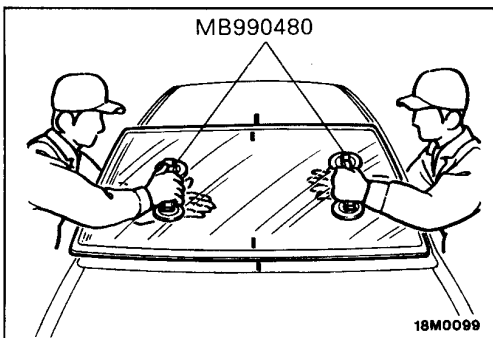
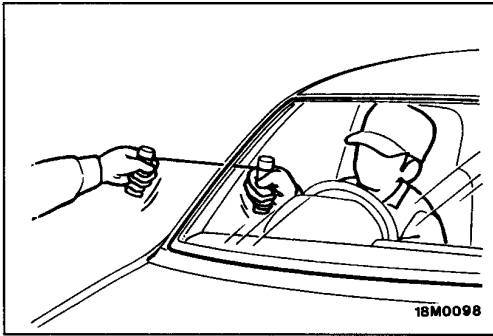
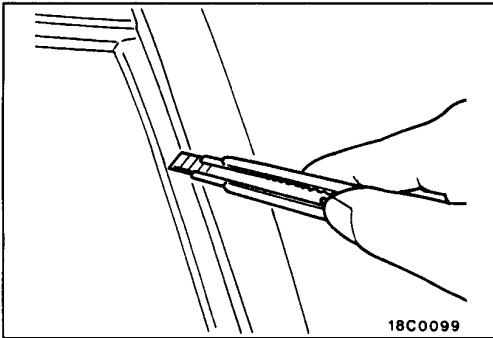

## SERVICE POINTS OF REMOVAL

### 1. REMOVAL OF WINDSHIELD GLASS

- (1) In order to protect the body (paint surface), apply cloth tape to all body areas around the installed windshield glass.
- (2) Cut the moulding with a cutter knife.

- (3) Using a sharp-point drill, make hole in the windshield glass adhesive.
- (4) Pass the piano wire from the inside of the vehicle through the hole.
- (5) Pull the piano wire alternately from the inside and outside along the windshield glass to cut the adhesive.

#### Caution

**Do not let the piano wire touch the edge of the windshield glass.**

- (6) Make mating marks on the windshield glass and body.
- (7) Use the special tool to remove the windshield glass.

- (8) Use a knife to cut away the remaining adhesive so that the thickness is within 2 mm (0.08 in.) around the entire circumference of the body flange.
- (9) Finish the flange surfaces so that they are smooth.

#### Caution

1. **Be careful not to remove more adhesive than is necessary.**
2. **Be careful also not damage the paintwork on the body surface with the knife. If the paintwork is damaged, repair the damaged area with repair paint or anti-rust agent.**

- (10) When reusing the glass, remove the adhesive and the chips of window spacer still adhering to the glass, and clean with isopropyl alcohol.
- (11) Clean the body side in the same way.

#### Caution

**Let the cleaned places stand for 3 minutes or more, and carry out the next procedures after they have dried. Also, do not touch any surface that has been cleaned.**

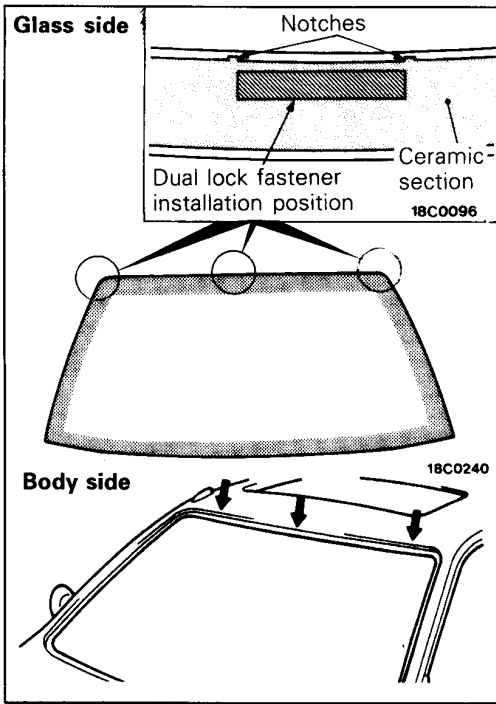

**SERVICE POINTS OF INSTALLATION**

**3. INSTALLATION OF DUAL LOCK FASTENER**

- (1) Wipe the windshield glass section in the figure with isopropyl alcohol to clean it and to remove all grease, etc.
- (2) Attach the dual lock fastener in the places shown in the illustration so that there are no bends or wrinkles on the inside of the windshield glass or the body.

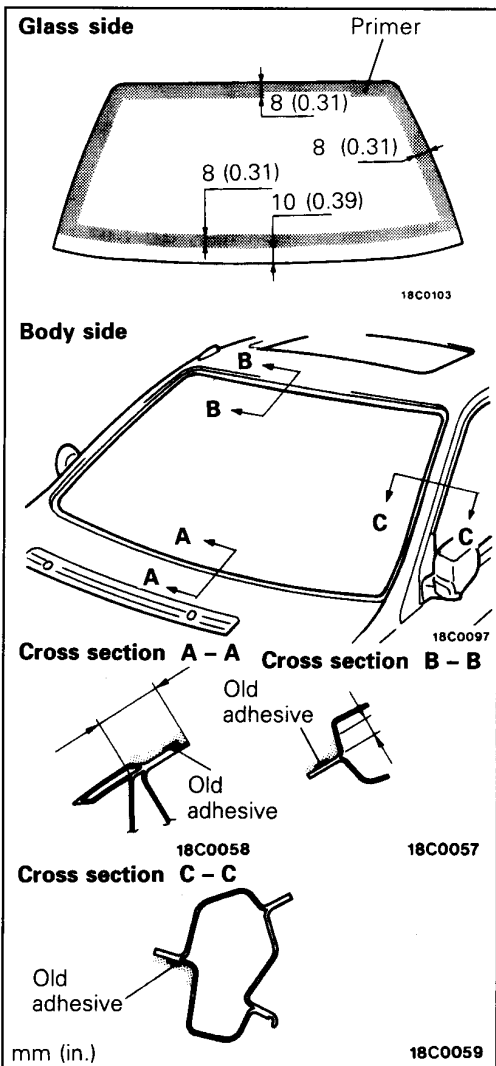

**1. INSTALLATION OF WINDSHIELD GLASS**

- (1) When replacing the glass, temporarily set the glass against the body, and mark the glass and body where they match.
- (2) Soak a sponge in the primer, and apply evenly to the glass and the body in the places shown in the figure.

**Specified primer: 3M Super Fast Urethan Primer Part No. 8608 or equivalent**

**Caution**

1. **The primer strengthens the adhesive strength, so be sure to apply it evenly around the entire circumference. But, a too thick application will cause lowering of the adhesive strength.**
2. **Do not touch the coated surface.**
- (3) After applying the primer, let it dry for 3 to 30 minutes.
- (4) Attach the spacer clip.

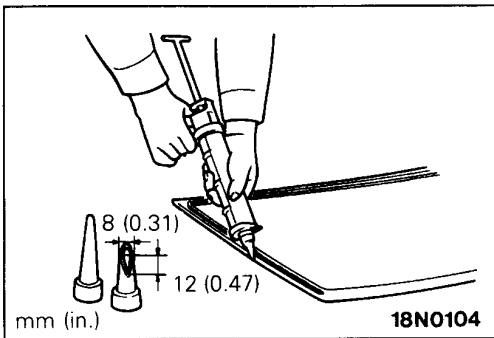

- (5) Within 30 minutes after applying the primer, fill the sealant gun with adhesive and apply the adhesive evenly around the entire circumference of the windshield.

**Specified adhesive: 3M Super Fast Urethan Auto Glass Sealant Part No. 8609 or equivalent**

**NOTE**

Cut the nozzle tip of the sealant gun into a V shape to facilitate adhesive application.

- (6) After applying the adhesive, match up the marks on the glass and the body.
- (7) After removing any adhesive that is sticking out or adhering to the body or glass with a spatula, etc., clean off with isopropyl alcohol.
- (8) After completion of this operation (after installing the glass), place it somewhere where it will not be disturbed, until the adhesive sets.

**Caution**

**If heat is applied with an infra-red lamp to shorten the setting time, keep the surface temperature of the adhesive below 100°C (212°F).**

- (9) After attaching the windshield glass to the body, let it stand for 30 minutes or more, and then test for water leakage.

**Caution**

1. If moving the vehicle, it should be done gently.
2. When testing for water leakage, do not pinch the end of the hose to spray the water.

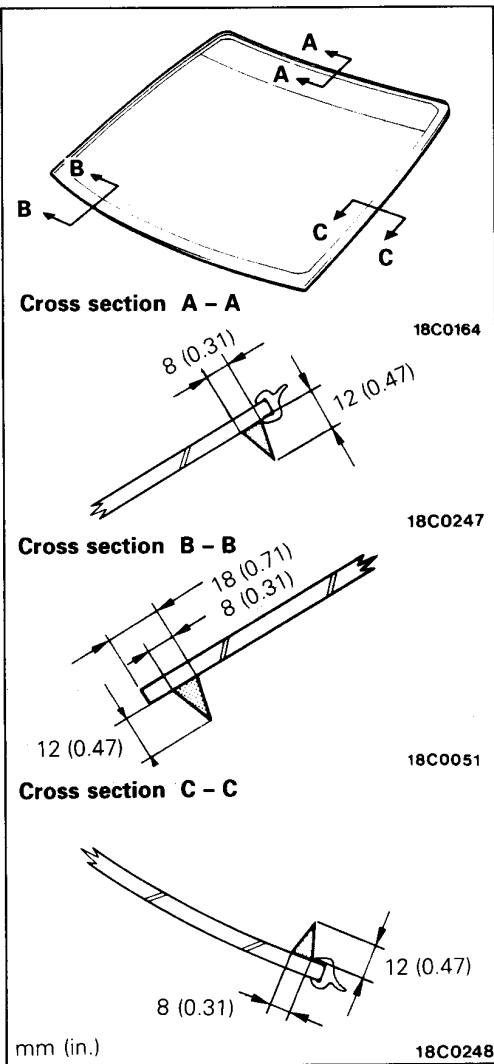

# FRONT QUARTER WINDOW GLASS (ONE DOOR SIDE) <SPACE RUNNER>

E42LBEA

## REMOVAL AND INSTALLATION

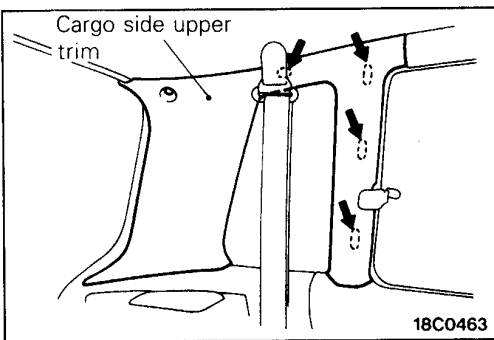
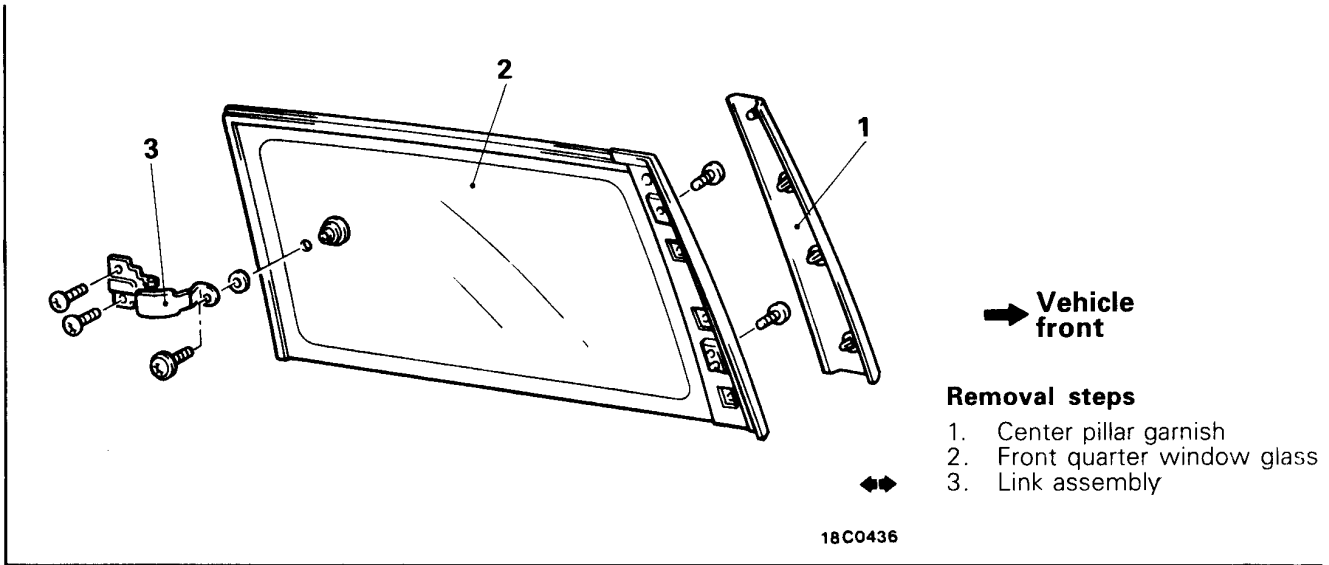

## SERVICE POINTS OF REMOVAL

### 3. REMOVAL OF LINK ASSEMBLY

(1) Remove the cargo side upper trim clips shown in the illustration.

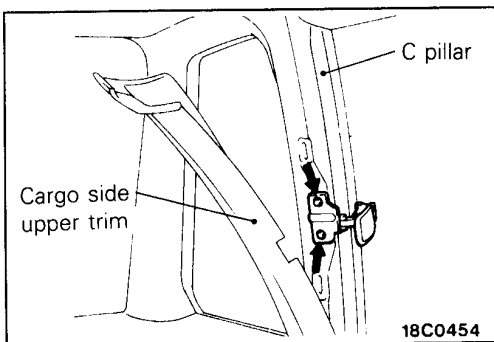

(2) Peel off the cargo side upper trim of the C pillar and remove the link assembly.

## 42-32 BODY – Rear Door Window Glass (Two Door Side) <SPACE RUNNER>

### REAR DOOR WINDOW GLASS (TWO DOOR SIDE) <SPACE RUNNER>

E42NCAN

#### REMOVAL AND INSTALLATION

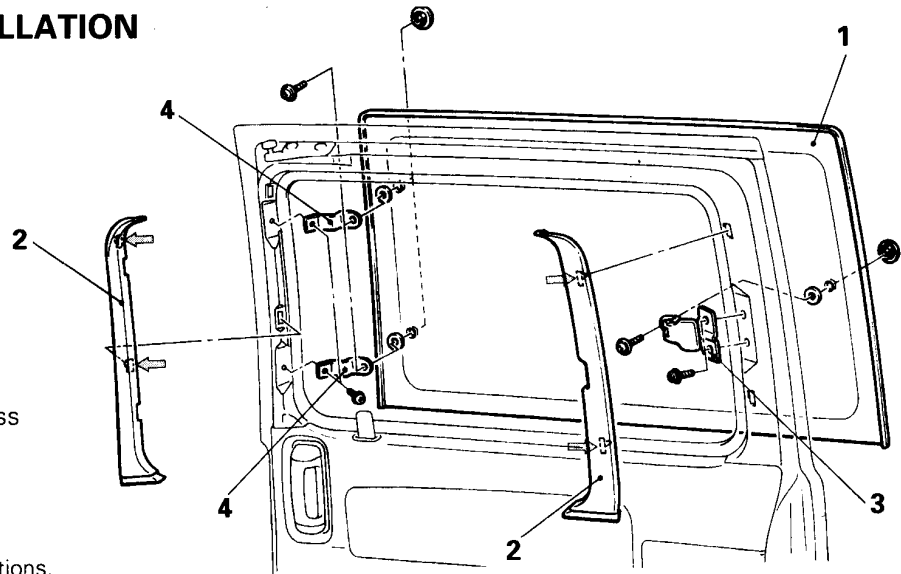

#### Removal steps

1. Rear door window glass
2. Rear door sash trim
3. Link assembly
4. Window hinge

#### NOTE

← indicates the clip positions.

18C0453



REAR QUARTER WINDOW GLASS <SPACE RUNNER>

E42LBDD

REMOVAL AND INSTALLATION

**Pre-removal and Post-installation Operation**

- Removal and installation of Cargo Side Upper Trim (Refer to GROUP 52A – Trims.)

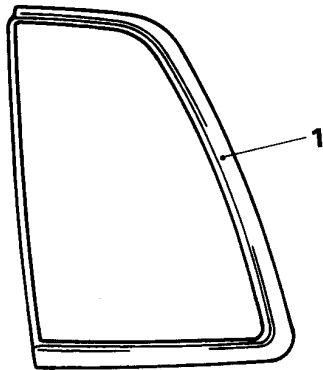

18C0105

◆◆ ◆◆ 1. Rear quarter window glass

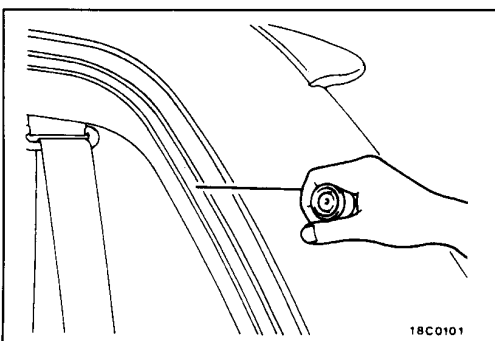
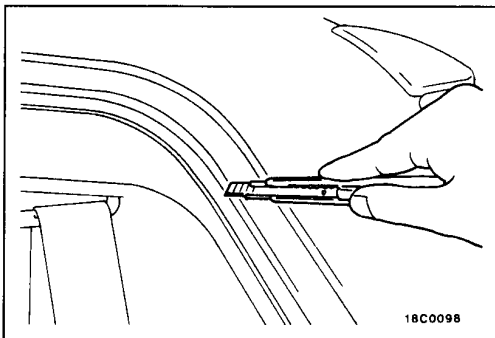
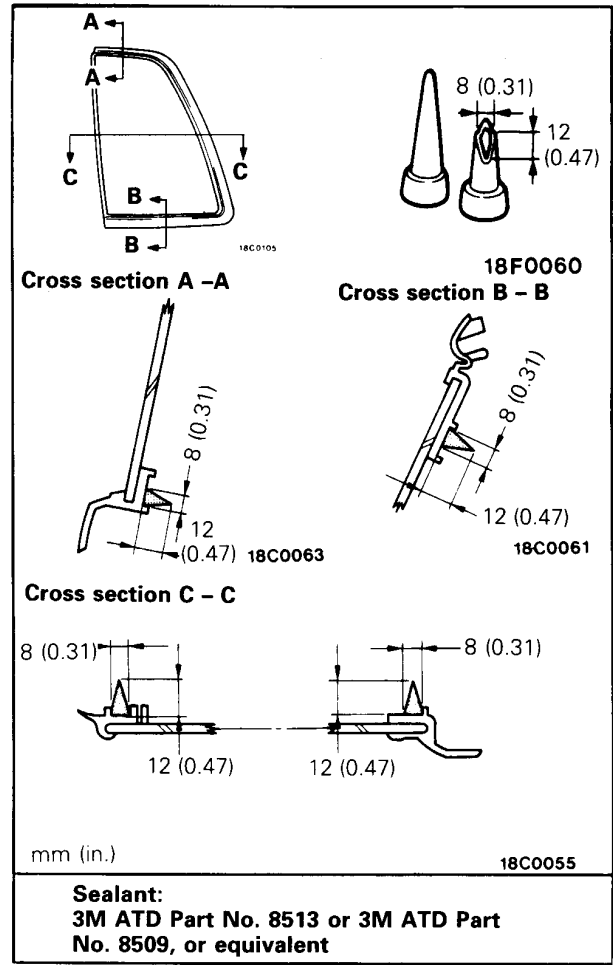

**SERVICE POINTS OF REMOVAL**

**1. REMOVAL OF REAR QUARTER WINDOW GLASS**

- (1) In order to protect the body (paint surface), apply cloth tape to all body areas around the installed rear quarter window glass.
- (2) Cut off the edge of the quarter window moulding with a cutter knife or similar tool.

- (3) Insert piano wire in between the body and the top of the quarter window glass, and pull both ends alternately so that the wire follows the line of the glass to cut the adhesive section, being careful of the clips.

**Caution**

**After cutting of the adhesive is finished, be sure to support the window glass so that it doesn't fall.**

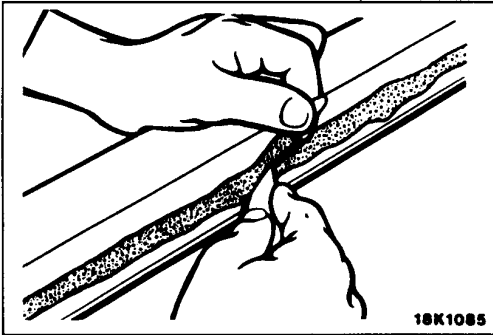

- (4) Use a knife to cut away the remaining adhesive so that the thickness is within 2 mm (0.08 in.) around the entire circumference of the body flange.
- (5) Finish the flange surfaces so that they are smooth.

**Caution**

1. Be careful not to remove more adhesive than is necessary.
2. Be careful also not to damage the paintwork on the body surface with the knife. If the paintwork is damaged, repair the damaged area with repair paint or anti-rust agent.

- (6) Clean with isopropyl alcohol.

**Caution**

Let the cleaned places stand for 3 minutes or more, and carry out the next procedures after they have dried. Also, do not touch any surface that has been cleaned.

**SERVICE POINTS OF INSTALLATION**

**1. INSTALLATION OF REAR QUARTER WINDOW GLASS**

- (1) Clean with isopropyl alcohol.
- (2) Soak a sponge in the primer, and apply evenly to the glass moulding and the body in the places shown in the illustration.

**Caution**

1. The primer strengthens the adhesive strength, so be sure to apply it evenly around the entire circumference. But, a too thick application will cause lowering of the adhesive strength.
2. Do not touch the coated surface.

- (3) After applying the primer, let it dry for 3 to 30 minutes.

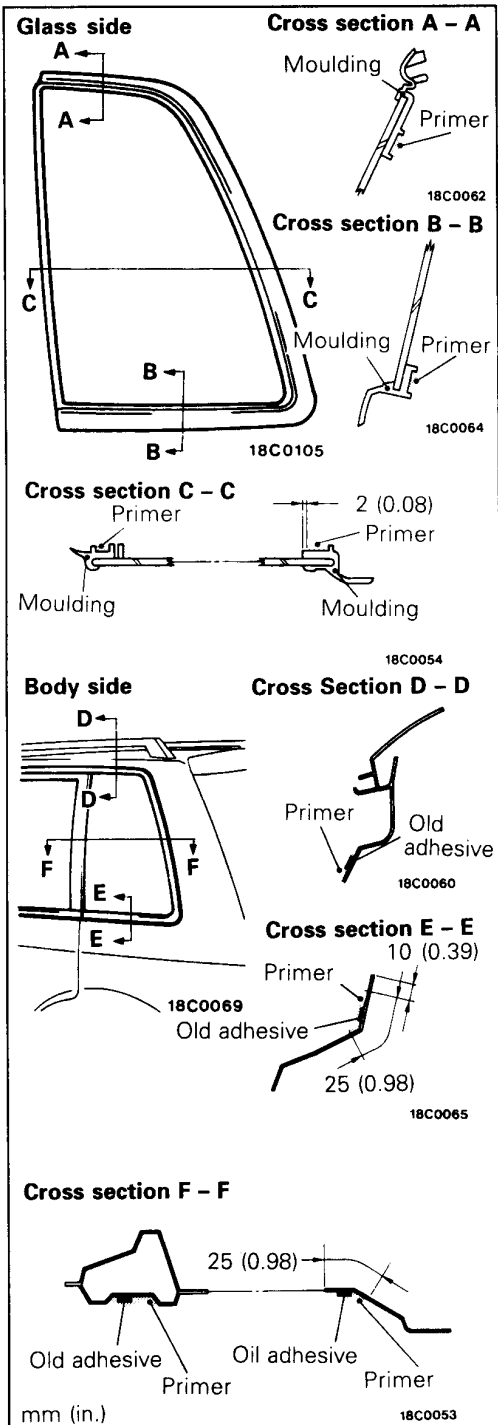

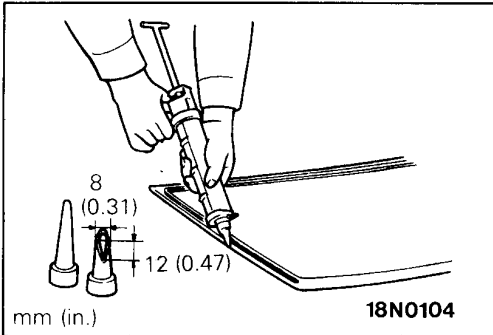

- (3) Within 30 minutes after applying the primer, fill the sealant gun with adhesive and apply the adhesive evenly around the entire circumference of the moulding.

**Specified sealant: 3M ATD Part No. 8513 or 3M ATD Part No. 8509, or equivalent**

**NOTE**

Cut the nozzle tip of the sealant gun into a V shape to facilitate adhesive application.

- (4) After applying the adhesive, lightly press the window glass evenly so that it adheres completely.

- (5) After removing any adhesive that is sticking out or adhering to the body or glass with a spatula, etc., clean off with isopropyl alcohol.

After completion of this operation (after installing the glass), place it somewhere where it will not be disturbed, until the adhesive sets.

**Caution**

**If heat is applied with an infra-red lamp to shorten the setting time, keep the surface temperature of the adhesive below 100°C (212°F).**

- (6) After attaching the rear quarter window glass to the body, let it stand for 30 minutes or more, and then test for water leakage.

**Caution**

1. If moving the vehicle, it should be done gently.
2. When testing for water leakage, do not pinch the end of the hose to spray the water.

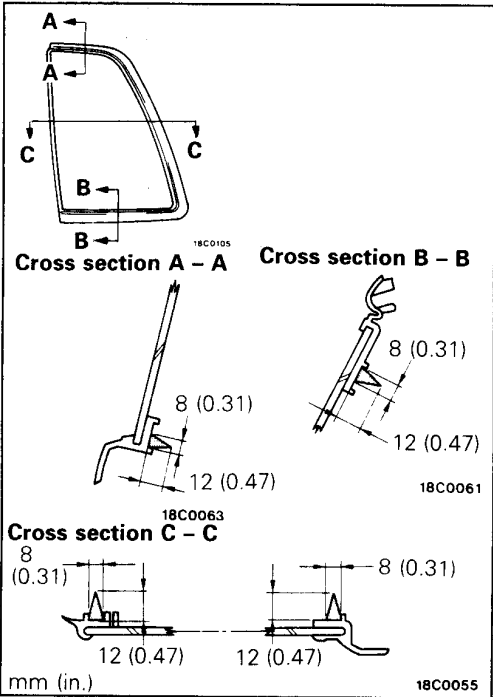

**QUARTER WINDOW GLASS <SPACE WAGON>**

**REMOVAL AND INSTALLATION**

**Pre-removal and Post-installation Operation**  
 • Removal and installation of Cargo Side Upper Trim (Refer to GROUP 52A - Trims.)

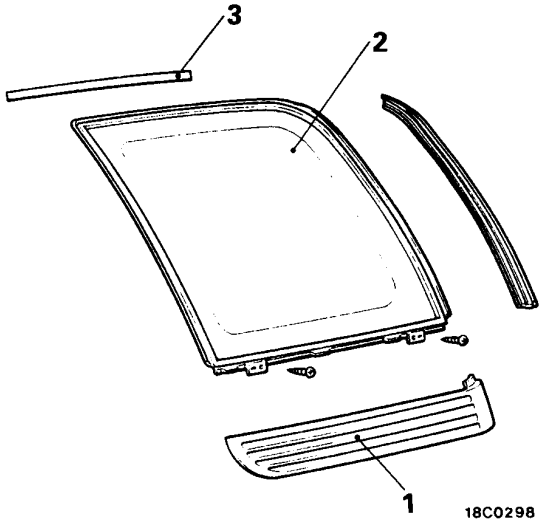

**Removal steps**

1. Quarter garnish (Refer to GROUP 51 - Garnish and Moulding.)
- ◆◆◆◆ 2. Quarter window glass
- ◆◆ 3. Window dam spacer

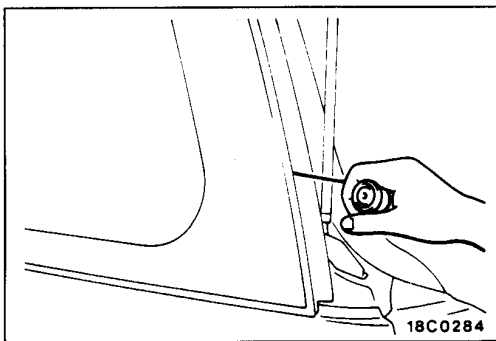
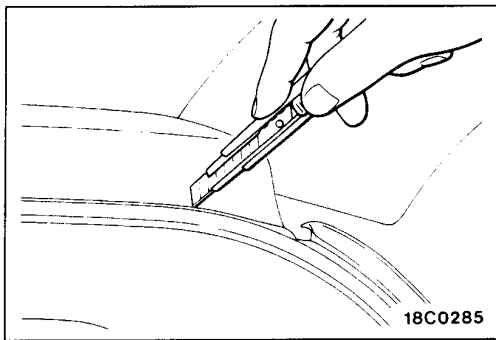
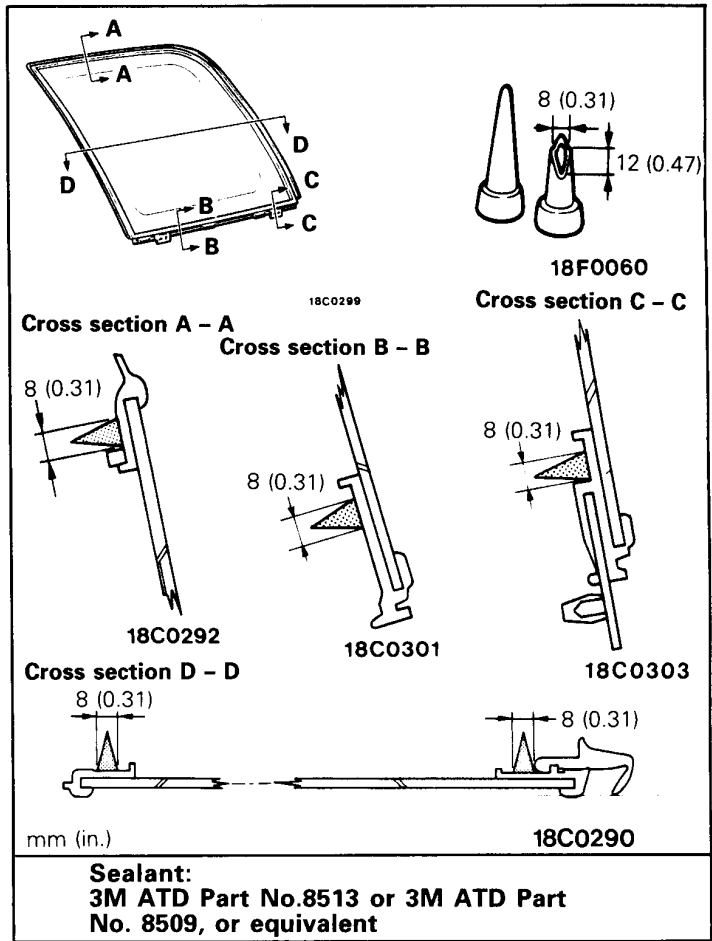

**SERVICE POINT OF REMOVAL**

**2. REMOVAL OF QUARTER WINDOW GLASS**

- (1) In order to protect the body (paint surface), apply cloth tape to all body areas around the installed quarter window glass.
- (2) Cut off the edge of the quarter window moulding with a cutter knife or similar tool.

- (3) Insert piano wire in between the body and the top of the quarter window glass, and pull both ends alternately so that the wire follows the line of the glass to cut the adhesive section, being careful of the clips.

**Caution**

**After cutting of the adhesive is finished, be sure to support the window glass so that it doesn't fall.**

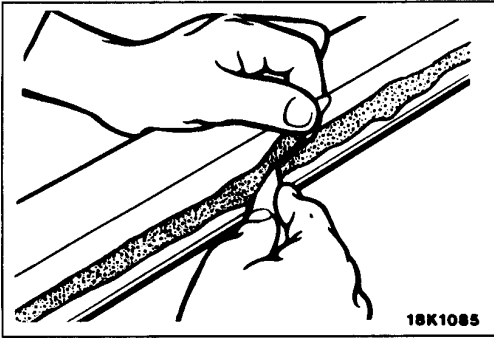

- (4) Use a knife to cut away the remaining adhesive so that the thickness is within 2 mm (0.08 in.) around the entire circumference of the body flange.
- (5) Finish the flange surfaces so that they are smooth.

**Caution**

1. Be careful not to remove more adhesive than is necessary.
2. Be careful also not to damage the paintwork on the body surface with the knife. If the paintwork is damaged, repair the damaged area with repair paint or anti-rust agent.

- (6) Clean with isopropyl alcohol.

**Caution**

Let the cleaned place stand for 3 minutes or more, and carry out the next procedures after they have dried. Also, do not touch any surface that has been cleaned.

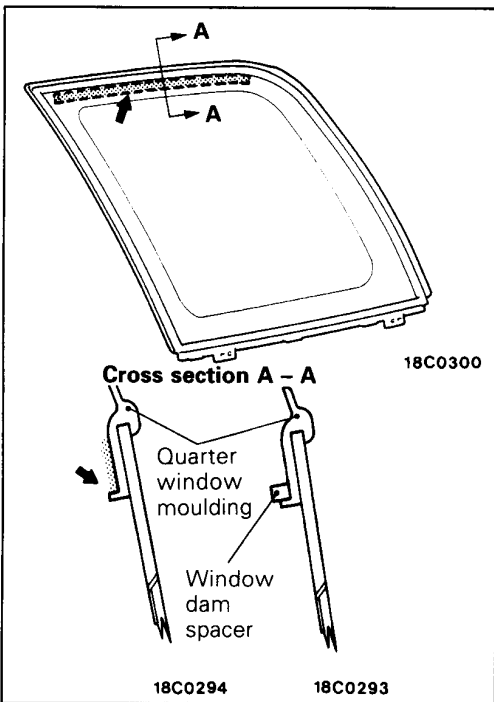

**SERVICE POINTS OF INSTALLATION**

**3. INSTALLATION OF WINDOW DAM SPACER**

- (1) Wipe the quarter window moulding section in the figure with isopropyl alcohol to clean it and to remove all grease, etc.
- (2) Glue the window dam correctly to the inside of the quarter window moulding so that it has no bends or raised sections.

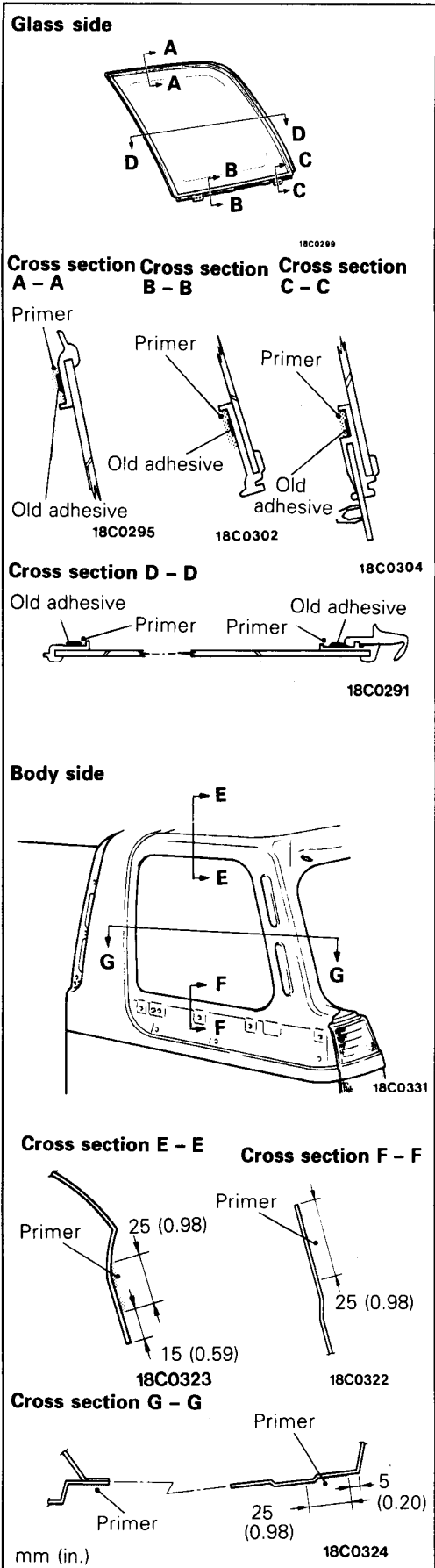

**2. INSTALLATION OF QUARTER WINDOW GLASS**

- (1) Soak a sponge in the primer, and apply evenly to the glass moulding and the body in the places shown in the illustration.

**Caution**

1. The primer strengthens the adhesive strength, so be sure to apply it evenly around the entire circumference. But, a too thick application will cause lowering of the adhesive strength.
2. Do not touch the coated surface.

- (2) After applying the primer, let it dry for 3 to 30 minutes.

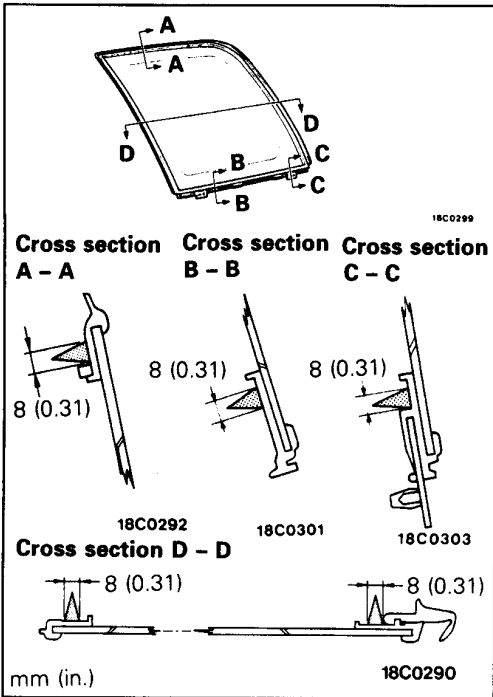
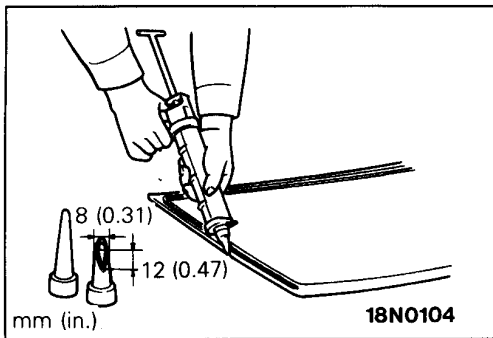

- (3) Within 30 minutes after applying the primer, fill the sealant gun with adhesive and apply the adhesive evenly around the entire circumference of the moulding.

**Specified sealant: 3M ATD Part No. 8513 or 3M ATD Part No. 8509, or equivalent**

**NOTE**

Cut the nozzle tip of the sealant gun into a V shape to facilitate adhesive application.

- (4) After applying the adhesive, lightly press the window glass evenly so that it adheres completely.
- (5) After removing any adhesive that is sticking out or adhering to the body or glass with a spatula, etc., clean off with isopropyl alcohol.
- After completion of this operation (after installing the glass), place it somewhere where it will not be disturbed, until the adhesive sets.

**Caution**

**If heat is applied with an infra-red lamp to shorten the setting time, keep the surface temperature of the adhesive below 100°C (212°F).**

- (6) After attaching the quarter window glass to the body, let it stand for 30 minutes or more, and then test for water leakage.

**Caution**

1. If moving the vehicle, it should be done gently.
2. When testing for water leakage, do not pinch the end of the hose to spray the water.

# TAILGATE WINDOW GLASS

## REMOVAL AND INSTALLATION

**Pre-removal and Post-installation Operation**  
 Removal and Installation

- Tailgate upper trim (Refer to P.42-57.)
- Tailgate upper side trim (Refer to P.42-57.)
- Tailgate lower trim (Refer to P.42-57.)
- Tailgate garnish (Refer to GROUP 51 – Tailgate Garnish.)

**Removal steps**

1. Rear defogger terminal
2. Tailgate glass spacer
3. Tailgate window glass
4. Dual lock fastener
5. Moulding

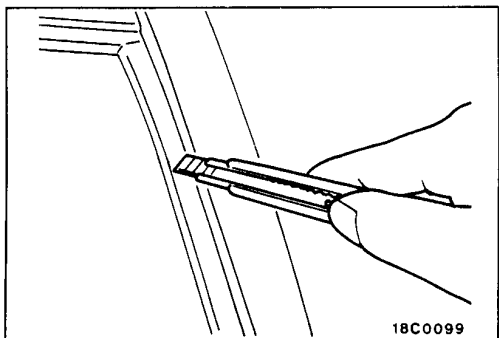
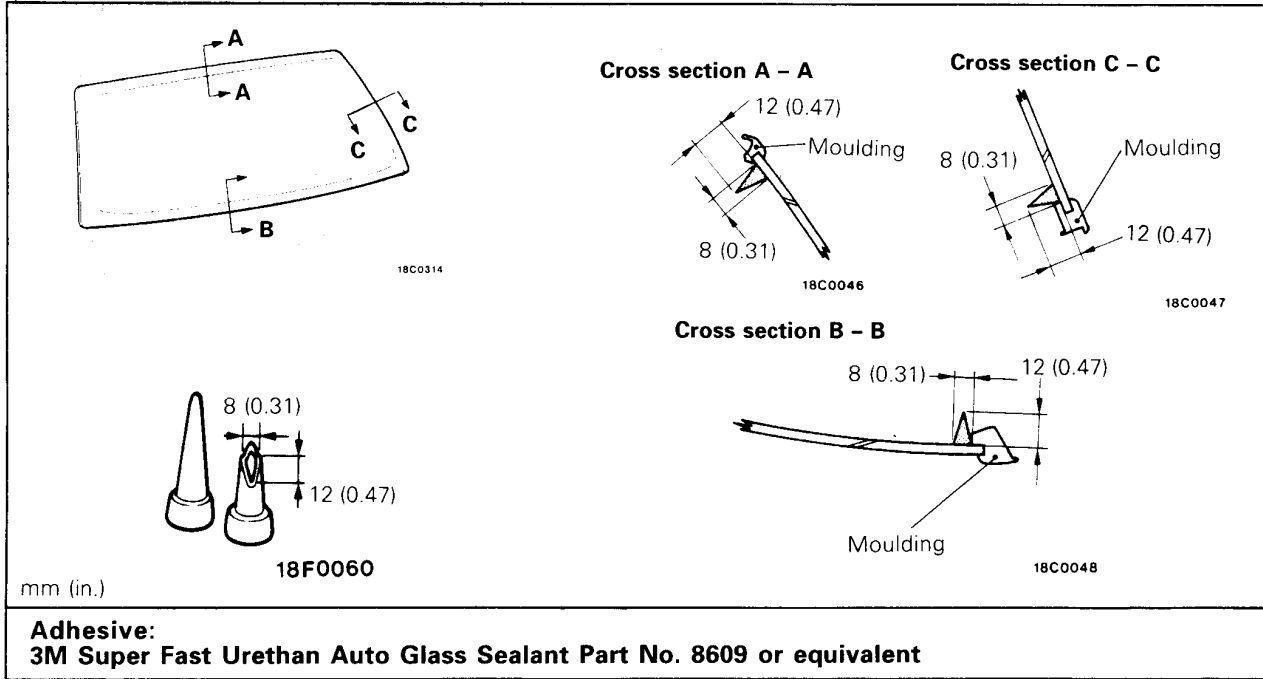
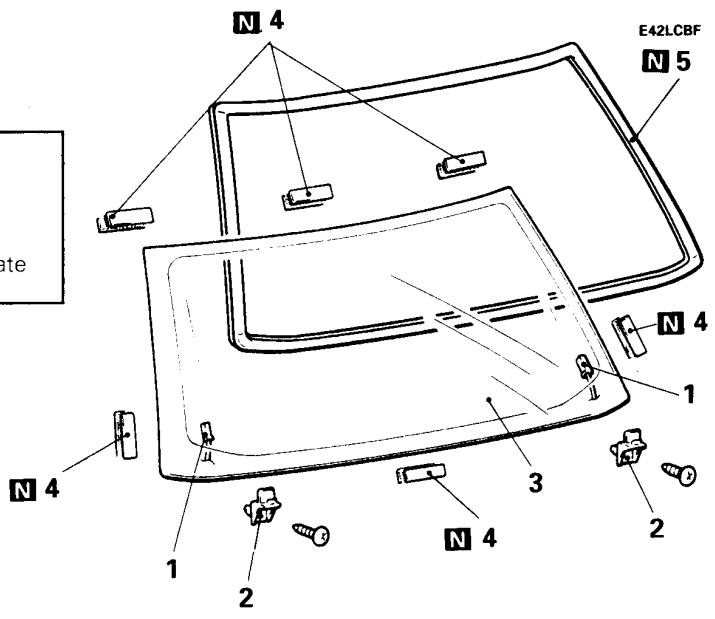

### SERVICE POINTS OF REMOVAL

#### 3. REMOVAL OF TAILGATE WINDOW GLASS

- (1) In order to protect the tailgate (paint surface), apply cloth tape to all tailgate areas around the installed tailgate window glass.
- (2) Cut the tailgate window glass moulding with a cutter knife.



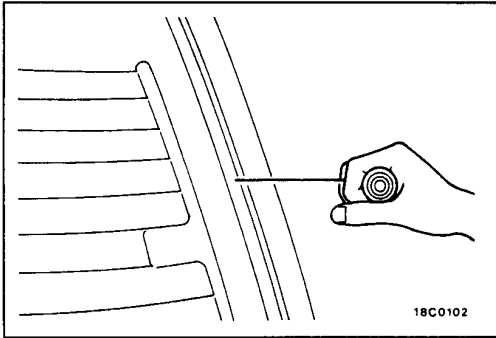

- (2) Using a sharp-point drill, make hole in the tailgate window glass adhesive.
- (3) Pass the piano wire from the inside of the vehicle through the hole.
- (4) Pull the piano wire alternately from the inside and outside along the tailgate window glass to cut the adhesive.

**Caution**

**Do not let the piano wire touch the edge of the tailgate window glass.**

- (5) Make mating marks on the tailgate window glass and body.
- (6) Use the special tool to remove the tailgate window glass.
- (7) Use a knife to cut away the remaining adhesive so that the thickness is within 2 mm (0.08 in.) around the entire circumference of the body flange.
- (8) Finish the flange surfaces so that they are smooth.

**Caution**

1. **Be careful not to remove more adhesive than is necessary.**
2. **Be careful also not to damage the paintwork on the body surface with the knife. If the paintwork is damaged, repair the damaged area with repair paint or anti-rust agent.**

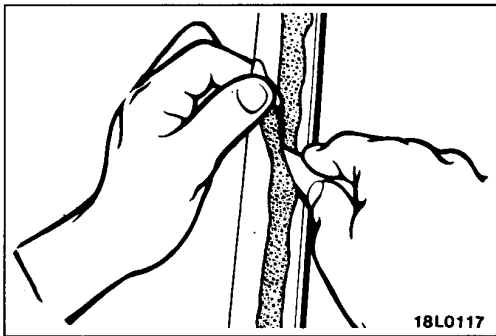

- (9) When re-using the glass, remove the adhesive still adhering to the glass, and clean with isopropyl alcohol.
- (10) Clean the body side in the same way.

**Caution**

**Let the cleaned places stand for 3 minutes or more, and carry out the next procedures after they have dried. Also, do not touch any surface that has been cleaned.**

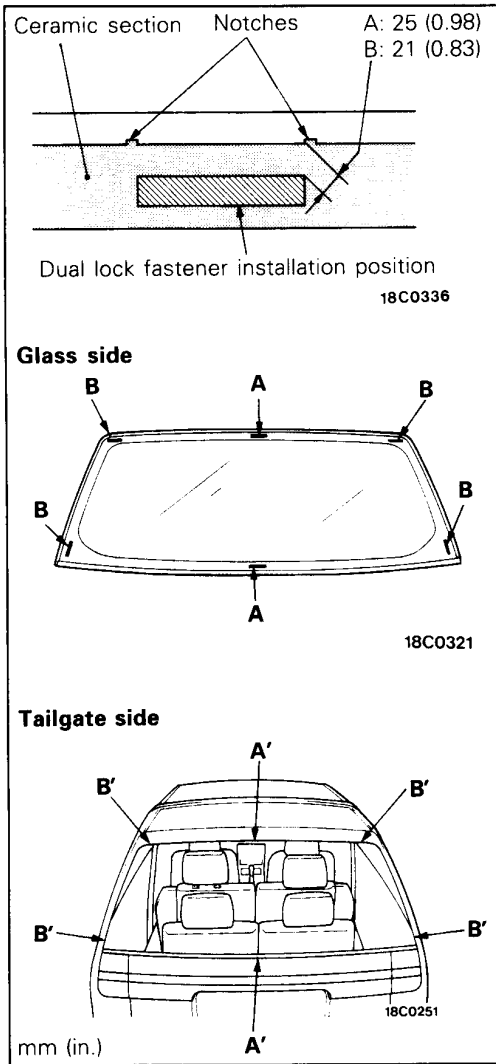

**SERVICE POINTS OF INSTALLATION**

**4. INSTALLATION OF DUAL LOCK FASTENER**

- (1) Clean off the dual lock fastener installation locations of the tailgate window glass and the tailgate with isopropyl alcohol.
- (2) Install the dual lock fastener so that the distances from the end of the ceramic section of the tailgate window glass to the installation position for the dual lock fastener are the same as at each position A and B on the tailgate window glass as shown in the illustration.
- (3) Install the dual lock fastener on the tailgate side so that there are no bends or wrinkles in the section that touches the glass side dual lock fastener.

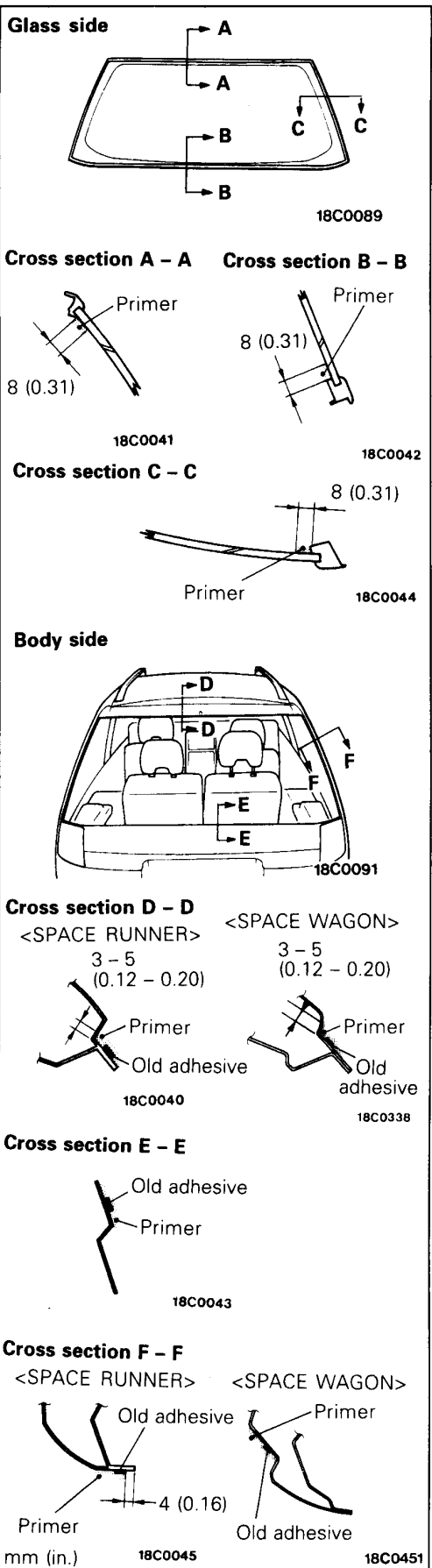

**3. INSTALLATION OF TAILGATE WINDOW GLASS**

- (1) Soak a sponge in the primer, and apply evenly to the glass and the body in the places shown in the figure.

**Specified primer: 3M Super Fast Urethan Primer Part No. 8608 or equivalent**

**Caution**

1. The primer strengthens the adhesive strength, so be sure to apply it evenly around the entire circumference. But, a too thick application will cause lowering of the adhesive strength.

2. Do not touch the coated surface.

- (2) After applying the primer, let it dry for 3 to 30 minutes.

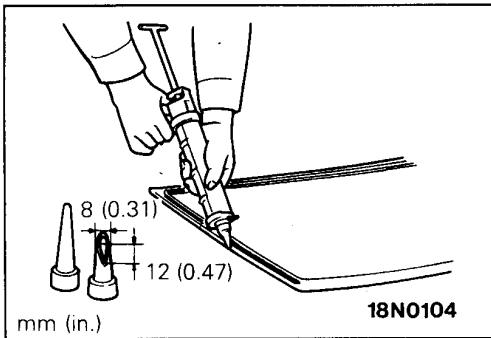

- (4) Within 30 minutes after applying the primer, fill the sealant gun with adhesive and apply the adhesive evenly around the entire circumference of the tailgate window glass.

**Specified adhesive: 3M Super Fast Urethan Auto Glass Sealant Part No. 8609 or equivalent**

**NOTE**

Cut the nozzle tip of the sealant gun into a V shape to facilitate adhesive application.

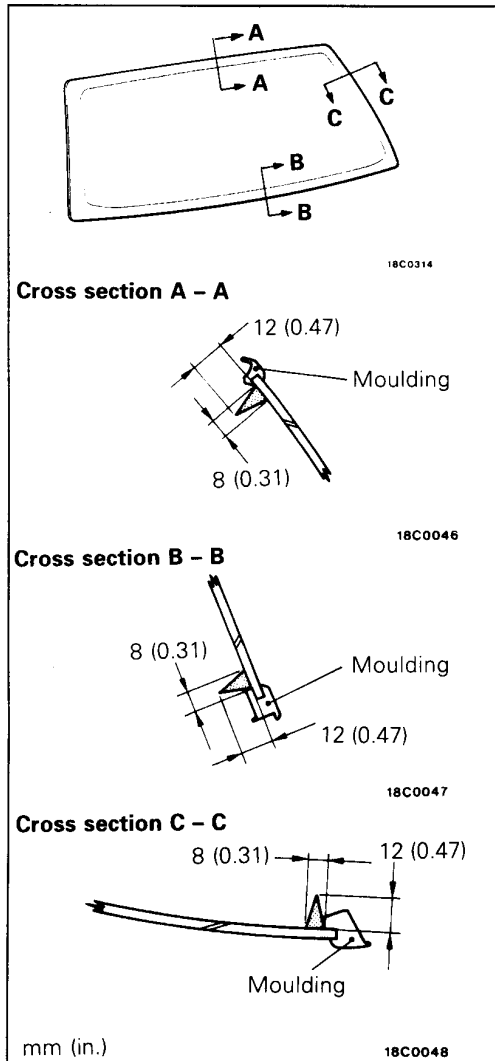

- (5) After applying the adhesive, match up the marks on the glass and the tailgate.
- (6) After removing any adhesive that is sticking out or adhering to the tailgate or glass with a spatula, etc., clean off with isopropyl alcohol.

After completion of this operation (after installing the glass), place it somewhere where it will not be disturbed, until the adhesive sets.

**Caution**

**If heat is applied with an infra-red lamp to shorten the setting time, keep the surface temperature of the adhesive below 100°C (212°F).**

- (7) After attaching the tailgate window glass to the tailgate, let it stand for 30 minutes or more, and then test for water leakage.

**Caution**

1. If moving the vehicle, it should be done gently.
2. When testing for water leakage, do not pinch the end of the hose spray the water.

# FRONT DOOR ASSEMBLY REMOVAL AND INSTALLATION

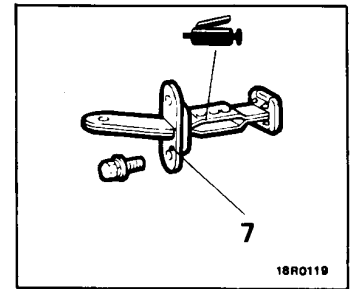
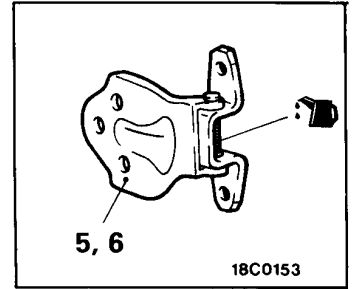
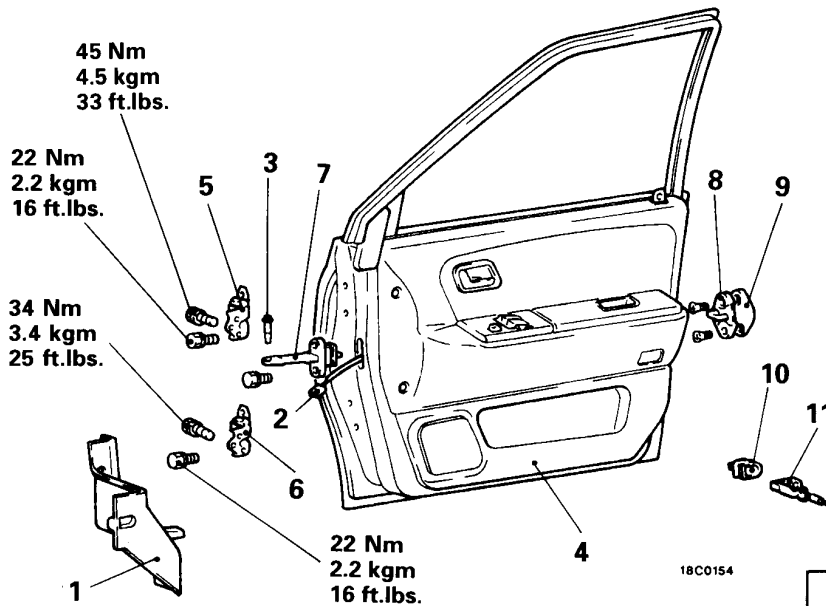

### Door assembly removal steps

1. Cowl side trim
2. Door harness connector
3. Pin
4. Front door assembly
5. Door upper hinge
6. Door lower hinge
- ◆◆ 7. Door check strap

### Striker removal steps

8. Striker
9. Striker shim

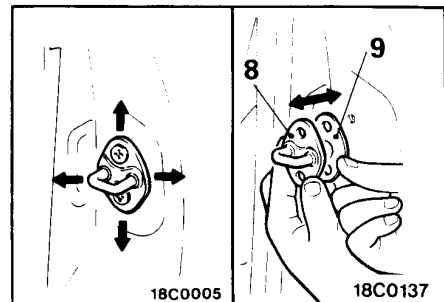

**Adjustment of the door stepping and the door latch linkage**

### Door switch removal steps

10. Door switch cap
11. Door switch

## INSPECTION

### DOOR SWITCH

Operate the switch, and check the continuity between the terminals.

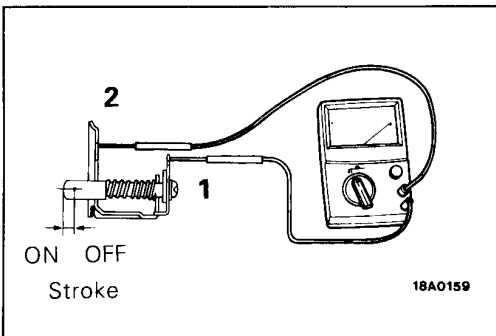

	Terminal	
	1	2
Switch position		
Open (ON)	○—○	○—○
Depressed (OFF)		

#### NOTE

○—○ indicates there is continuity between the terminals.

**SERVICE POINTS OF INSTALLATION**

**7. INSTALLATION OF DOOR CHECK STRAP**

Install the door check strap so that the identification mark faces upwards.

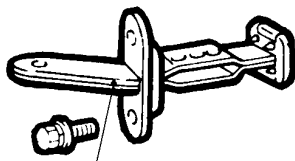

Identification mark

18R0119

Applicable location	identification mark
RH	KL
LH	KR

**REAR DOOR ASSEMBLY (TWO DOOR SIDE) <SPACE RUNNER>**

**REMOVAL AND INSTALLATION**

E42NAAB

**Post-installation Operation**  
 ● Door Adjustment (Refer to P.42-10.)

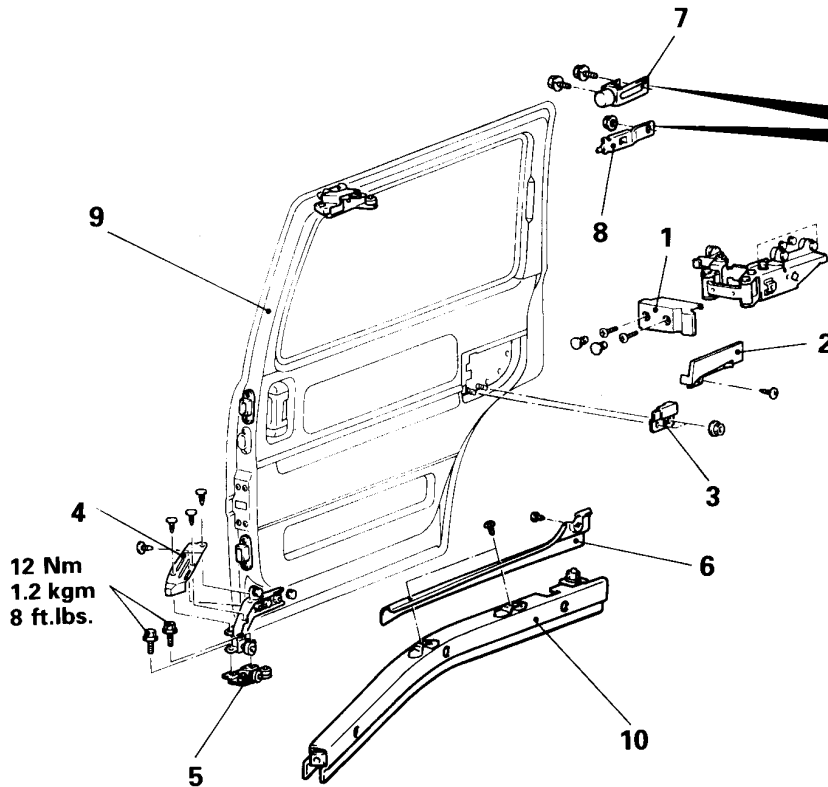

18C0452

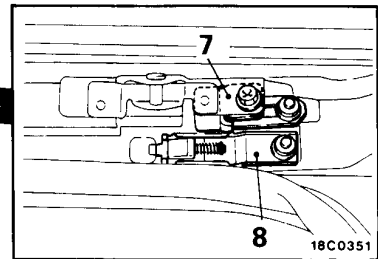

18C0351

**Removal steps**

- 1. Center roller arm cover
- 2. Rear door upper plate
- 3. Center rail cover
- 4. Lower roller arm cover
- 5. Lower roller arm guide
- 6. Lower rail cover
- 7. Upper open stopper
- 8. Upper arm slider
- 9. Door assembly
- 10. Lower rail

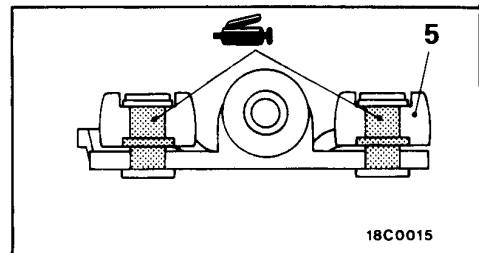

18C0015

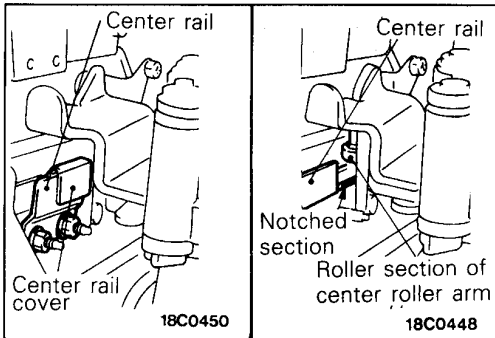

**SERVICE POINTS OF REMOVAL**

**3. REMOVAL OF CENTER RAIL COVER**

**Caution**

When the door is fully opened after the center rail cover has been removed, be careful that the door does not fall down when the roller section of the center roller arm is removed from the notched section of the center rail.

**4. REMOVAL OF LOWER ROLLER ARM COVER /5. LOWER ROLLER ARM GUIDE**

Fully open the door and remove the lower roller arm cover and the lower roller arm guide after securing the door by operating the lock mechanism.

**9. REMOVAL OF DOOR ASSEMBLY**

Remove the door assembly by the following procedure.

- (1) Slide the door forward to remove the roller section of the center roller arm from the notched section of the center rail.
- (2) Slide the door backwards to remove the roller section of the upper roller arm from the rear end of the upper rail.
- (3) While supporting the door with your hand, remove the roller section of the lower roller arm from the notched section of the lower rail, and then remove the door assembly.

**Caution**

Be careful not to damage the body and trims when removing the door assembly.

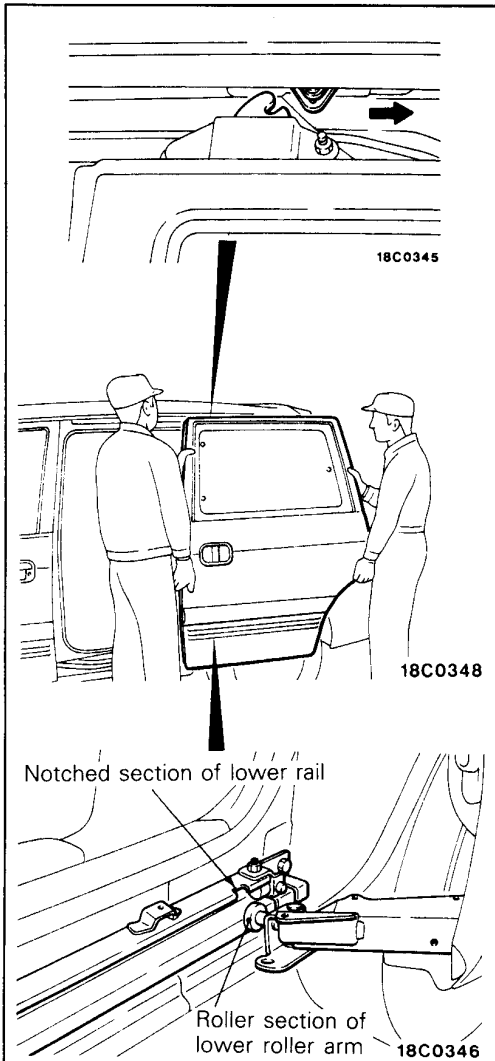

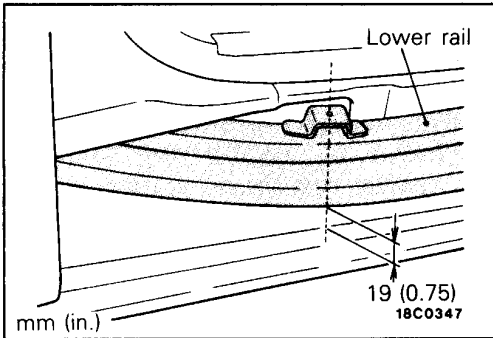

## SERVICE POINTS OF INSTALLATION

### 10. INSTALLATION OF LOWER RAIL

Install the lower rail so that the dimension between the body and the lower section of the lower rail (position shown in the illustration) is as shown in the illustration.

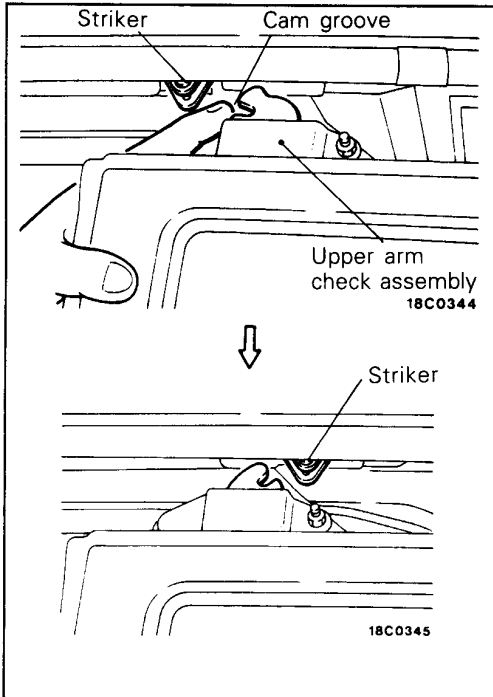

### 9. INSTALLATION OF DOOR ASSEMBLY

Install the door assembly by the following procedure.

- (1) Insert the roller section of the upper roller arm into the rear end of the upper rail by the following procedure.
  - ① Turn the cam of the upper check assembly in the direction of the arrow to insert the striker into the groove of the cam.
  - ② Next, keep the cam and the striker unlocked by operating the outside handle, and move the cam past the striker.
- (2) Insert the roller section of the lower roller arm into the notched section of the lower rail, and slide the door forward.
- (3) Insert the roller section of the center roller arm into the notched section of the center rail.

#### Caution

**Be careful not to damage the body and trims when removing the door assembly.**



**DISASSEMBLY AND REASSEMBLY**

**Pre-removal and Post-installation Operation**

- Removal and installation of door trim and waterproof film (Refer to P.42-56.)

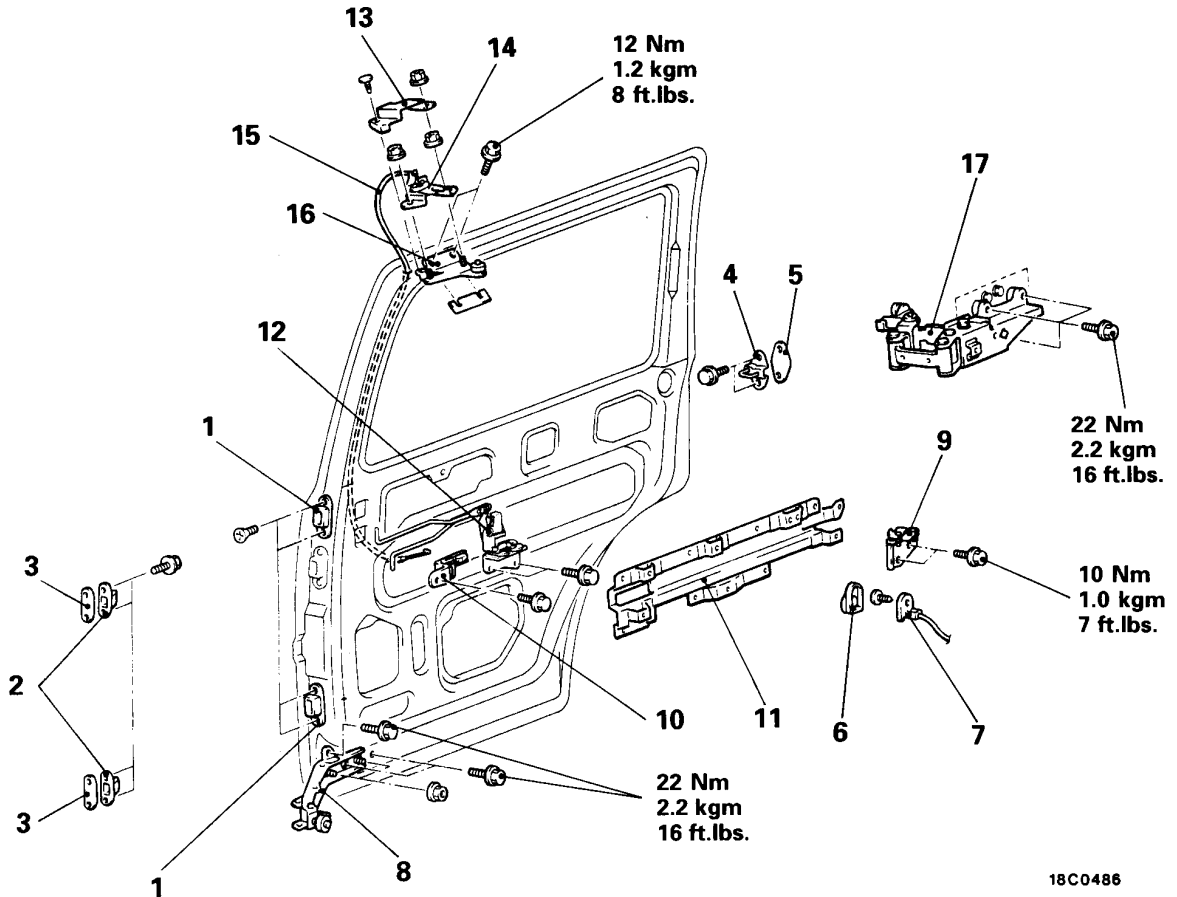

- ◆◆ 1. Door female stopper
- ◆◆ 2. Door mail stopper
- ◆◆ 3. Shim
- ◆◆ 4. Striker
- ◆◆ 5. Striker shim
- ◆◆ 6. Door switch cap
- ◆◆ 7. Door switch
- ◆◆ 8. Lower roller arm
- ◆◆ 9. Center hook
- ◆◆ 10. Center open stopper

**Handle check disassembly steps**

- ◆◆ 11. Center rail
- ◆◆ 12. Handle check assembly

**Upper arm check disassembly steps**

- ◆◆ 13. Upper arm check cover
- ◆◆ 14. Upper arm check assembly
- ◆◆ 15. Check assembly cable

**Upper roller arm disassembly steps**

- ◆◆ 14. Upper arm check assembly
- ◆◆ 16. Upper roller arm

**Center roller arm disassembly steps**

- Cargo side lower trim (Refer to GROUP 52A – Trim.)
- ◆◆ 17. Center roller arm

LUBRICATION POINTS

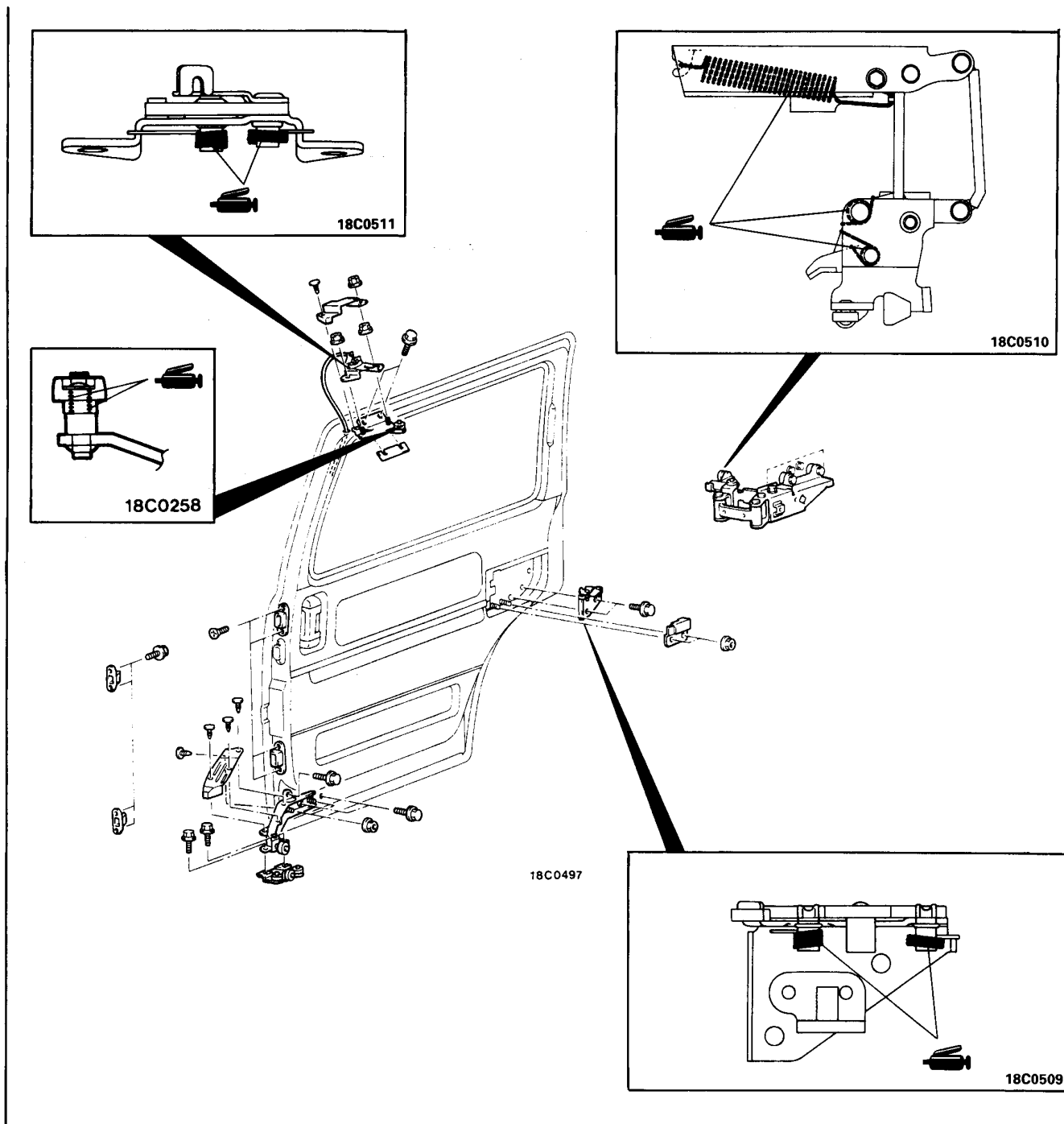

**INSPECTION**

**DOOR SWITCH**

Refer to P.42-45.

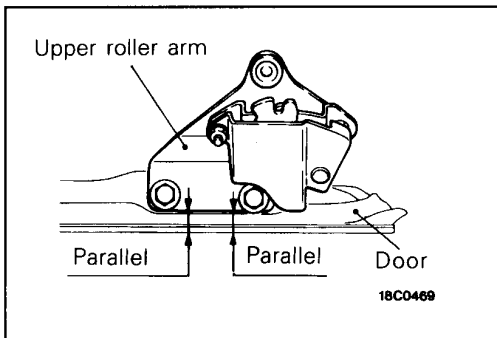

**SERVICE POINTS OF REASSEMBLY**

**16. INSTALLATION OF UPPER ROLLER ARM**

**Caution**

The upper roller arm should be installed so that it is parallel to the door.

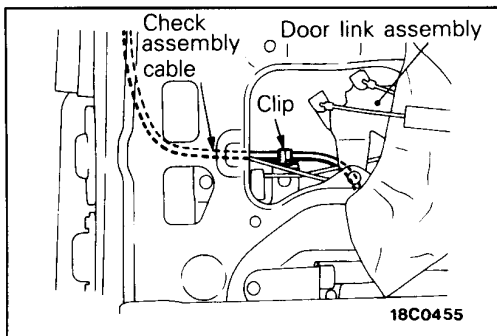

**15. INSTALLATION OF CHECK ASSEMBLY CABLE**

**Caution**

The position of the check assembly cable marking and the clip shown in the illustration should be aligned.

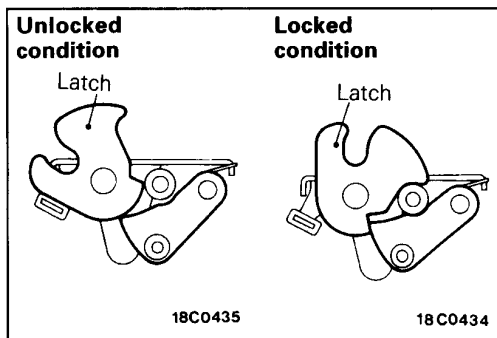

**9. INSTALLATION OF CENTER HOOK**

**Caution**

When installing the centre hook, install so that the latch shown in the illustration is in the unlocked position.

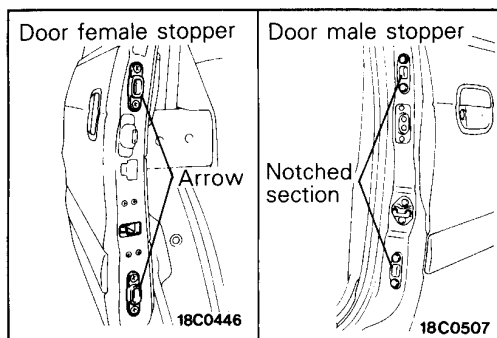

**2. INSTALLATION OF DOOR MALE STOPPER/1. DOOR FEMALE STOPPER**

**Caution**

1. The male stopper should be installed so that the notched section in the position shown in the illustration is on the inside of the vehicle.
2. The female stopper should be installed so that the direction of the arrow in the position shown in the illustration is on the inside of the vehicle.

**REAR DOOR ASSEMBLY <SPACE WAGON>**

**REMOVAL AND INSTALLATION**

**45 Nm**  
4.5 kgm  
33 ft.lbs.

**22 Nm**  
2.2 kgm  
16 ft.lbs.

**34 Nm**  
3.4 kgm  
25 ft.lbs.

**22 Nm**  
2.2 kgm  
16 ft.lbs.

**Door assembly removal steps**

1. Door harness connector
2. Pin
3. Door assembly
4. Door upper hinge
5. Door lower hinge
6. Door check strap

**Door switch removal steps**

9. Door switch cap
10. Door switch

**Striker removal steps**

7. Striker
8. Striker shim

**Adjustment of the door stepping and the door latch linkage**

**INSPECTION  
DOOR SWITCH**

Operate the switch, and check the continuity between the terminals.

	Terminal	
Switch position	1	2
Open (ON)	○—○	○—○
Depressed (OFF)		

NOTE  
○—○ indicates there is continuity between the terminals.

**SERVICE POINTS OF INSTALLATION  
6. INSTALLATION OF DOOR CHECK STRAP**

Install the door check strap so that the identification mark faces upwards.

Applicable location	Identification mark
R H	K L
L H	K R

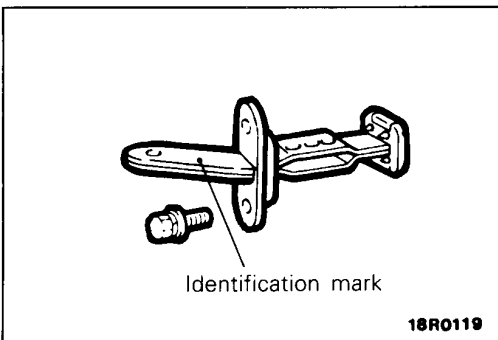
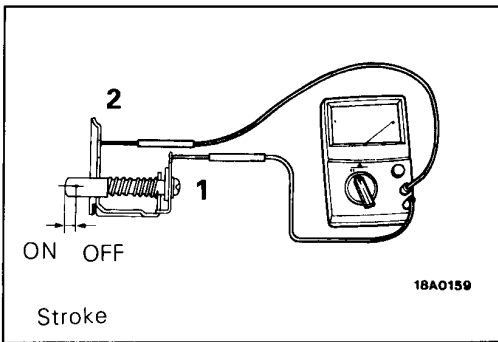

**TAILGATE ASSEMBLY  
REMOVAL AND INSTALLATION**

E420AAN

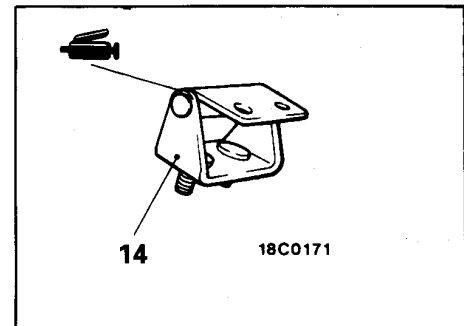
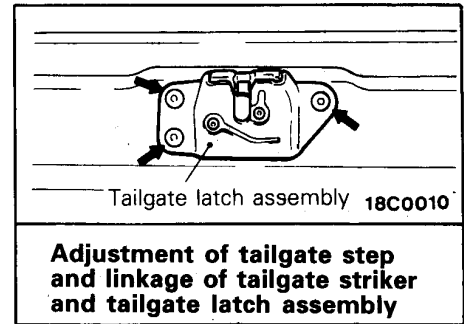
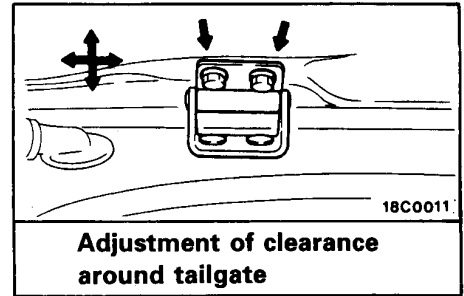
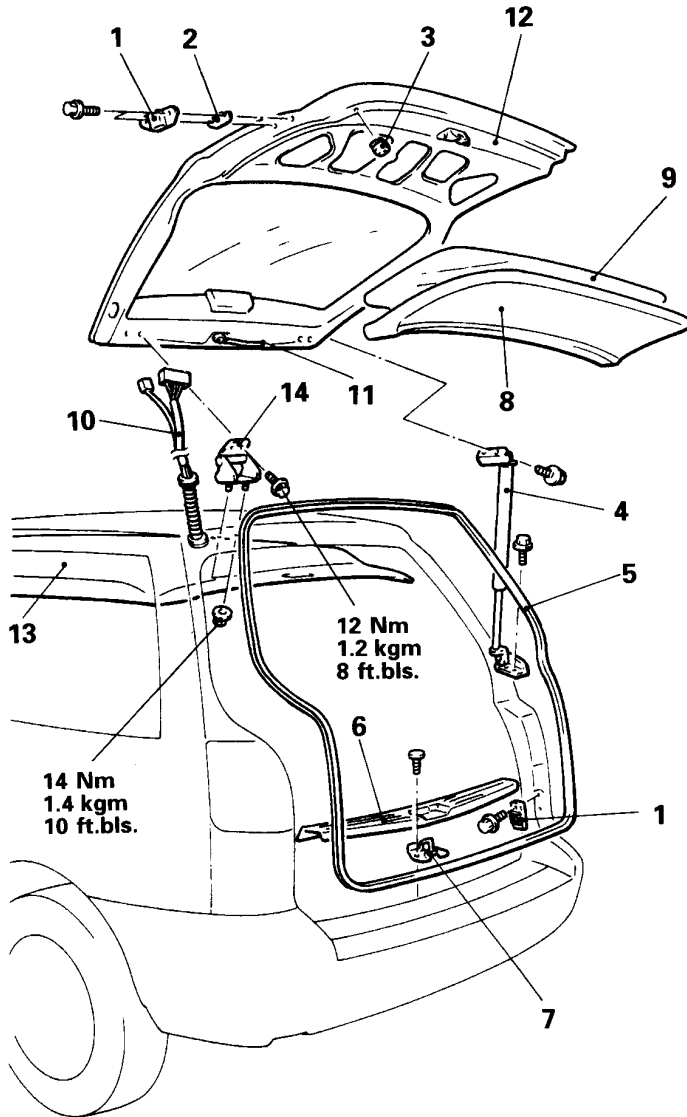

18C0134

- 1. Damper
- 2. Damper shim
- 3. Bumper
- 4. Tailgate gas spring
- 5. Weatherstrip

**Tailgate striker removal steps**

- 6. Rear end trim  
(Refer to GROUP 52A – Trims.)
- 7. Tailgate striker



**Tailgate hinge removal steps**

- 8. Tailgate lower trim
- 9. Waterproof film
- 10. Harness connector
- 11. Washer tube connection
- 12. Tailgate assembly
- 13. Headlining
- 14. Tailgate hinge

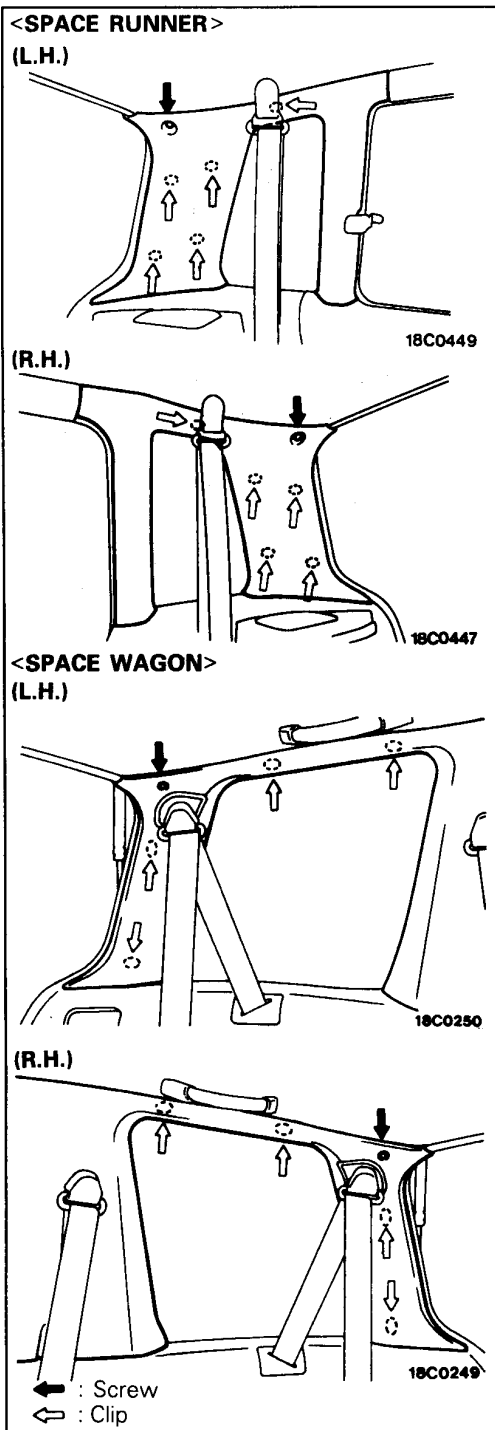

**SERVICE POINTS OF REMOVAL**

**13. REMOVAL OF HEADLINING/14. TAILGATE HINGE**

- (1) Remove the luggage compartment lamp assembly.
- (2) Remove the clips and screws of the luggage side upper trim from the places shown in the illustration.

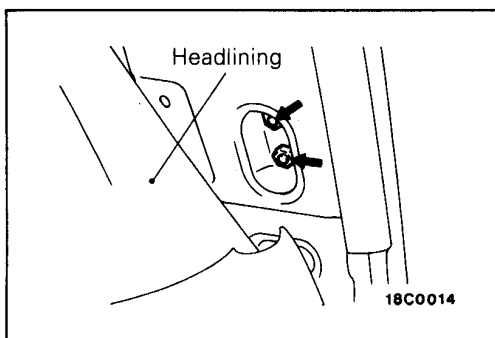

- (3) Lower the rear end of the head lining and remove the tailgate hinge.

**DOOR TRIM AND WATERPROOF FILM  
REMOVAL AND INSTALLATION <FRONT DOOR>**

E42MBBA

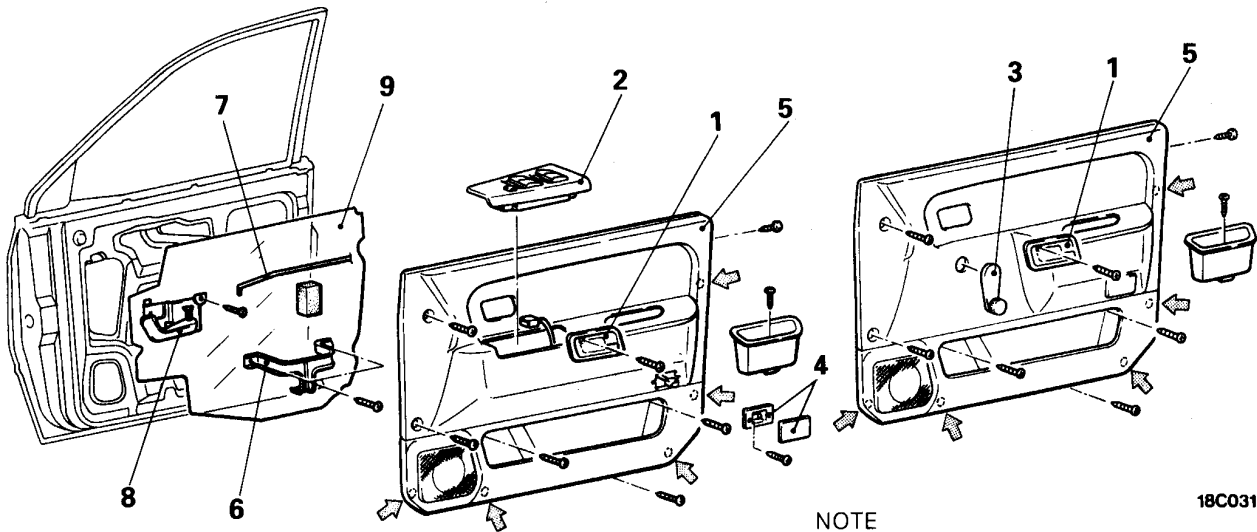

18C0312

NOTE

↔ : indicates the clip positions.

**Removal steps**

1. Inside handle cover
2. Power window switch assembly  
(Vehicles with power window)
3. Regulator handle  
(Vehicles without power window)
4. Door lamp
5. Door trim
6. Bracket
7. Rod
8. Inside handle
9. Waterproof film

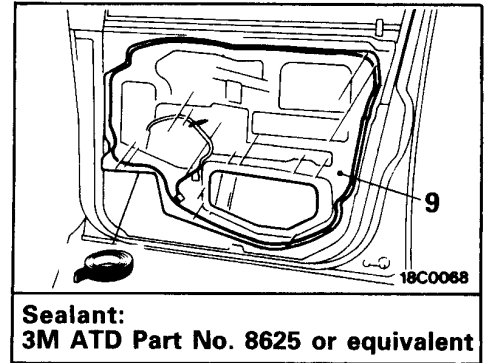

18C0068

**Sealant:  
3M ATD Part No. 8625 or equivalent**

REMOVAL AND INSTALLATION <REAR DOOR>

E42NBAE

<SPACE RUNNER>

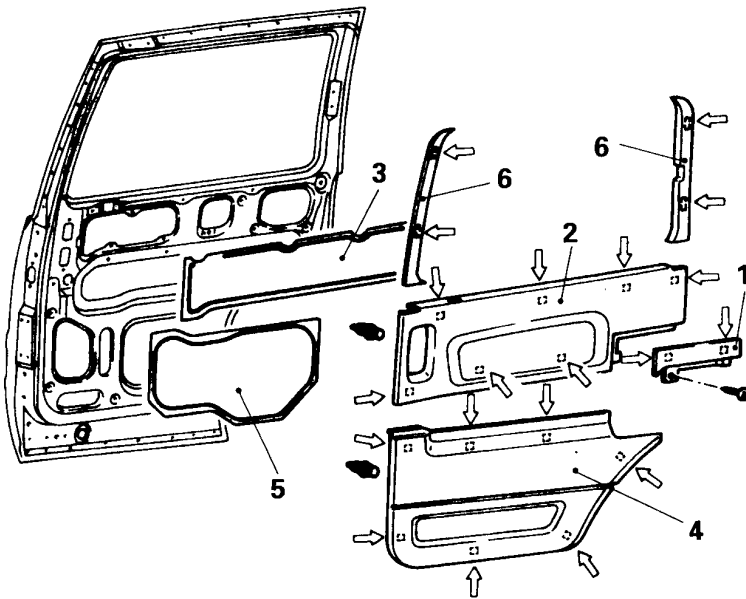

18C0443

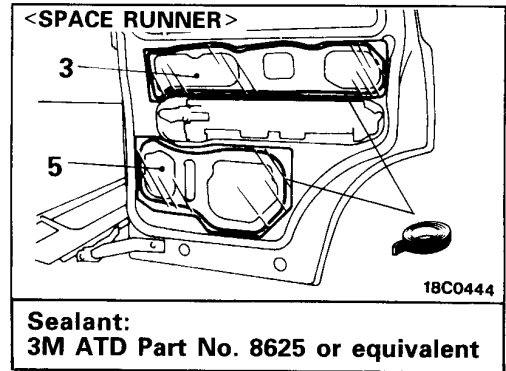

Sealant:  
3M ATD Part No. 8625 or equivalent

<SPACE WAGON>

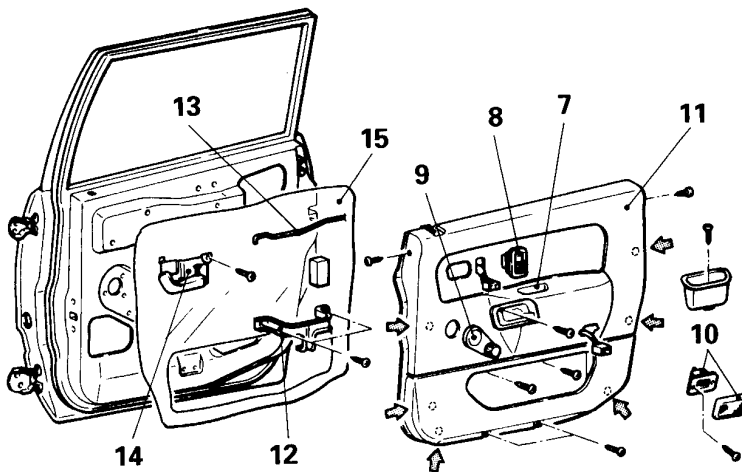

18C0320

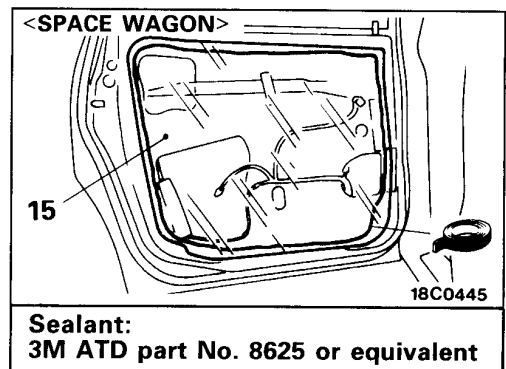

Sealant:  
3M ATD part No. 8625 or equivalent

Removal steps <SPACE RUNNER>

1. Upper plate
2. Door upper trim
3. Waterproof upper film
4. Door lower film
5. Waterproof lower film
6. Door sash trim

Removal steps <SPACE WAGON>

7. Inside handle cover
8. Power window switch assembly  
(Vehicles with power window)
9. Regulator handle  
(Vehicles without power window)
10. Door lamp
11. Door trim
12. Bracket
13. Rod
14. Inside handle
15. Waterproof film

NOTE

← : indicates the clip positions.



# TAILGATE TRIM AND WATERPROOF FILM

## REMOVAL AND INSTALLATION

<Up to April, 1993>

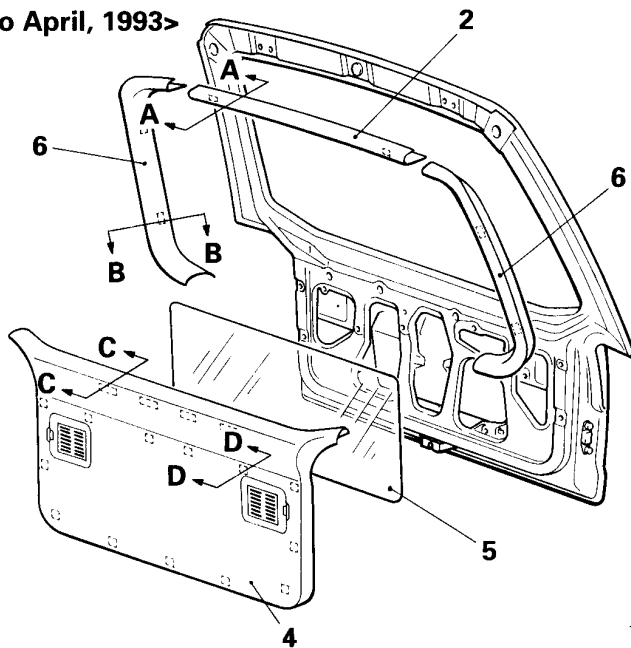

18C0508

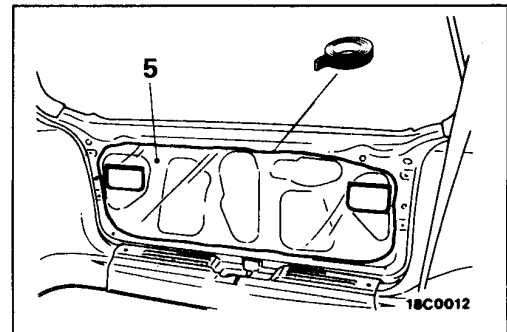

Sealant:  
3M ATD Part No. 8625 or equivalent

<From May, 1993>

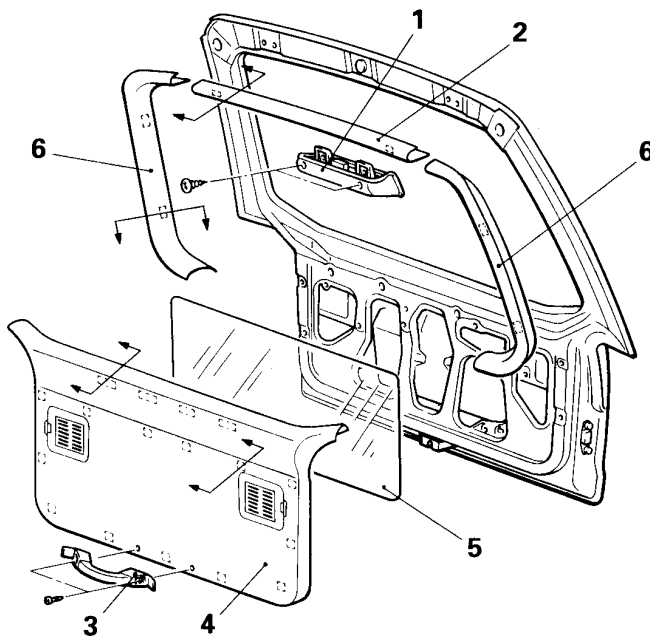

18C0698

Cross section A-A

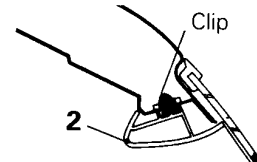

18C0006

Cross section B-B

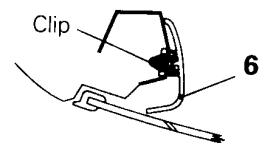

18C0007

Cross section C-C

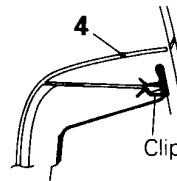

18C0009

Cross section D-D

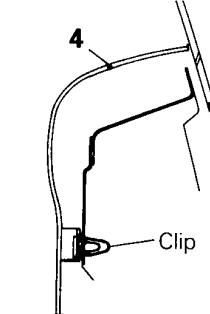

18C0008

### Tailgate upper trim removal steps

1. High mount stop lamp  
<Some models>
2. Tailgate upper trim

### Waterproof film removal steps

3. Assist grip
4. Tailgate lower trim
5. Waterproof film

### Tailgate side trim removal steps

1. High mount stop lamp  
<Some models>
2. Tailgate upper trim
3. Assist grip
4. Tailgate lower trim
6. Tailgate side trim

**DOOR GLASS AND REGULATOR**

**REMOVAL AND INSTALLATION**

E42MCAP

<Front door>

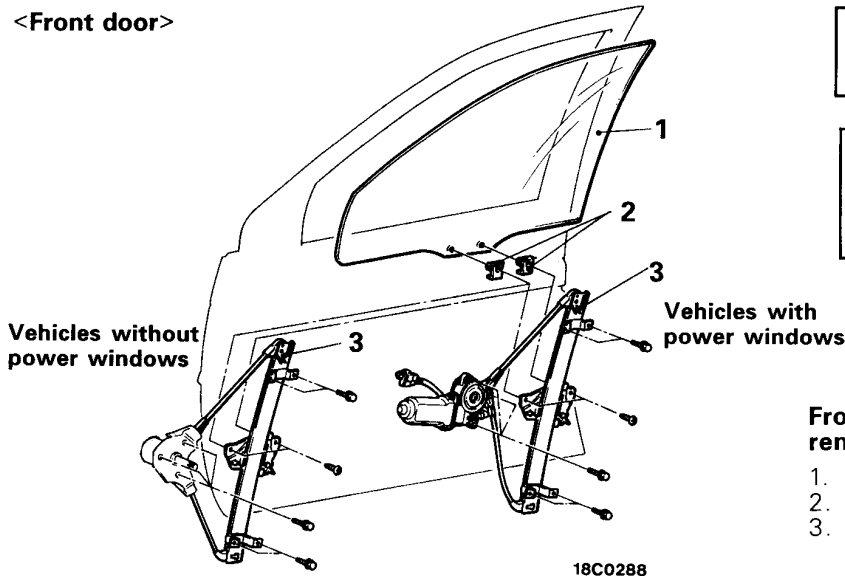

18C0288

**Pre-removal Operation**

- Removal of Door Trim and Waterproof Film (Refer to P.42-55, 56.)

**Post-installation Operation**

- Door Window Glass Adjustment (Refer to P.42-16.)
- Installation of Door Trim and Waterproof Film (Refer to P.42-55, 56.)

**Front window regulator assembly removal steps**

1. Door window glass
2. Door glass holder
3. Front window regulator assembly

<Rear door (SPACE WAGON)>

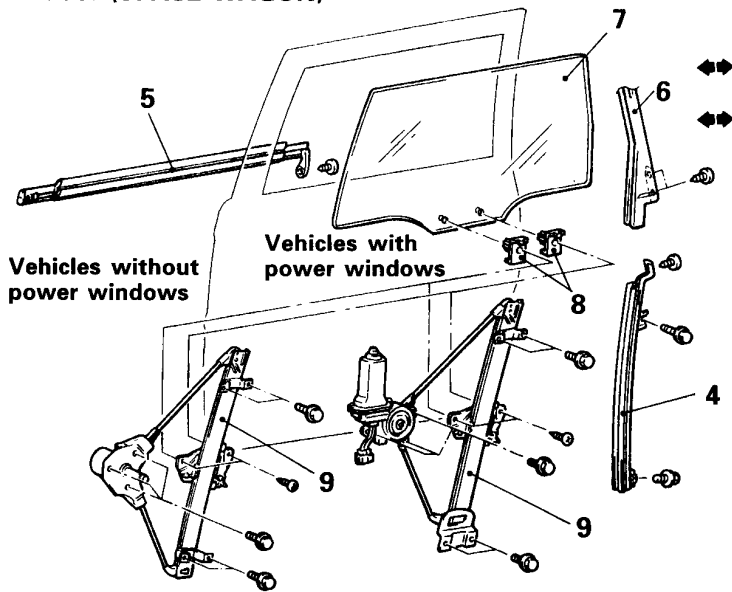

18C0330

**Rear window regulator assembly removal steps**

4. Door window rear lower sash assembly
5. Rear door belt outer weatherstrip
6. Rear door window glass runchannel
7. Door window glass
8. Door glass holder
9. Rear window regulator assembly

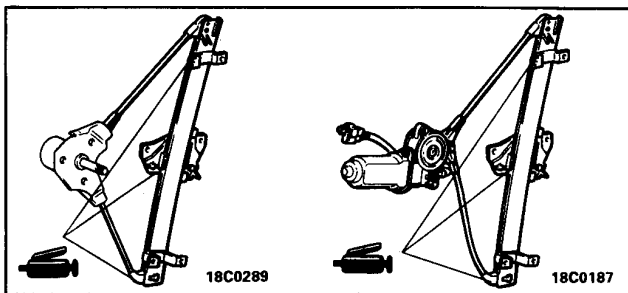

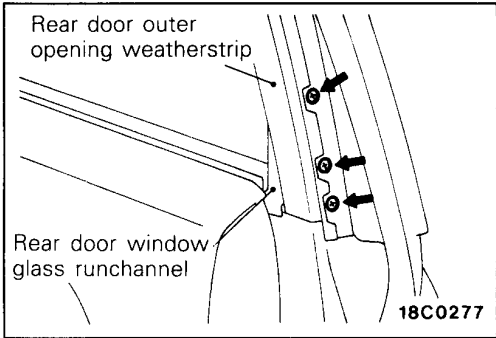

**SERVICE POINTS OF REMOVAL**

**4. REMOVAL OF DOOR WINDOW REAR LOWER SASH ASSEMBLY/ 6. REAR DOOR WINDOW GLASS RUNCHANNEL**

- (1) Remove the rear door outer opening weatherstrip from the rear door sash only.
- (2) Remove the door window rear lower sash assembly and the rear door window glass runchannel mounting screws, and then remove the sash assembly and window glass runchannel from the rear door panel.

**INSPECTION**

**POWER WINDOW RELAY**

- (1) Remove the instrument under cover (Refer to GROUP 52A – Instrument Panel.)
- (2) Remove the power window relay from the relay box.

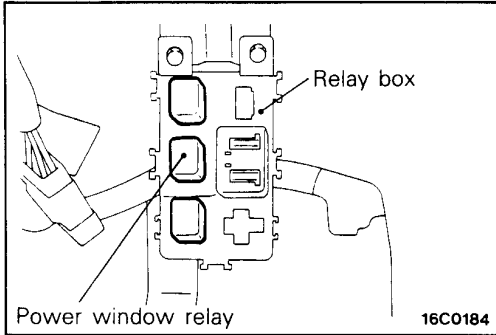

Terminal	1	2	3	4
Battery voltage				
Continuity no voltage		○—○		○—○
Continuity with voltage	○—○	⊕—○	○—○	○—○

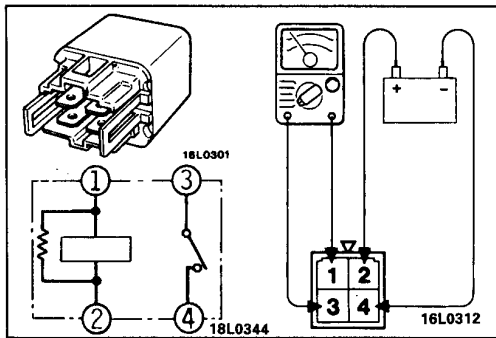

**NOTE**

- (1) ○—○ indicates that there is continuity between the terminals.
- (2) ⊕—○ Indicates connection of battery voltage.

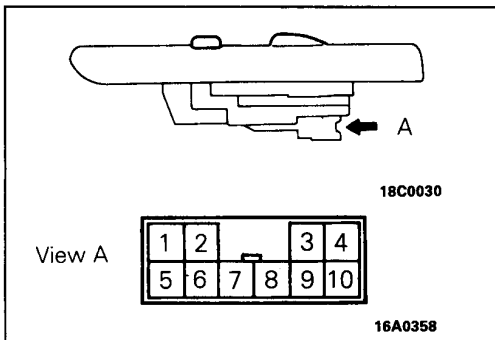

**POWER WINDOW SWITCH**

Operate the switch and check continuity between the terminals.

**MAIN SWITCH <SPACE RUNNER>**

Switch position		Power window switch (normal)			Power window switch (lock)		
		UP	OFF	DOWN	UP	OFF	DOWN
Front (Driver's side)	6 (9)	○		○	○		○
	2 (3)	○	○	○	○	○	○
	1 (4)	○	○	○	○	○	○
	9 (6)	○	○	○	○	○	○
Front (Passenger's side)	6 (9)	○		○	○		○
	5 (10)	○	○	○	○	○	○
	8 (7)	○	○	○		○	○
	9 (6)	○	○	○			

NOTE

- (1) ○—○ indicates that there is continuity between the terminals.
- (2) ( ) indicates power window switch terminals for R.H. drive vehicles.

MAIN SWITCH <SPACE WAGON>

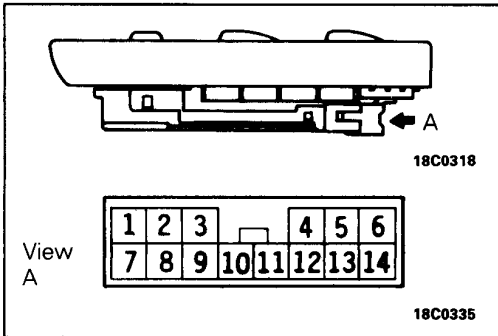

Switch Position		Power window switch (normal)			Power window switch (lock)		
		UP	OFF	DOWN	UP	OFF	DOWN
Front (Driver's side)	13 (8)	○		○	○		○
	1 (6)	○	○	○	○	○	○
	8 (13)	○	○	○	○	○	○
	5 (1)	○	○	○	○	○	○
Front (Passenger's side)	13 (8)	○		○	○		○
	9 (12)	○	○	○	○	○	○
	2 (5)	○	○	○	○	○	○
	5 (1)	○	○	○	○	○	○
Rear (R.H.)	13 (8)	○		○	○		
	10	○	○	○	○		○
	7 (9)	○	○	○		○	○
	5 (1)	○	○	○		○	○
Rear (L.H.)	13 (8)	○		○			
	11	○	○	○		○	○
	12 (14)	○	○	○	○	○	○
	5 (1)	○	○	○	○	○	○

NOTE

- (1) ○—○ indicates that there is continuity between the terminals.
- (2) ( ) indicates power window switch terminals for R.H. drive vehicles.

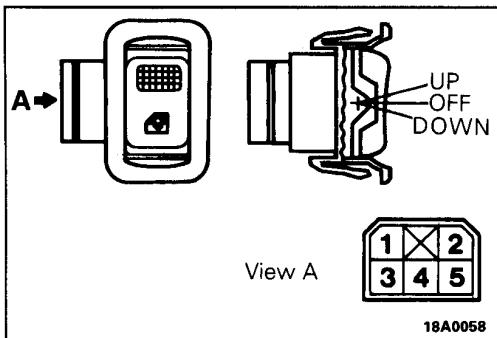
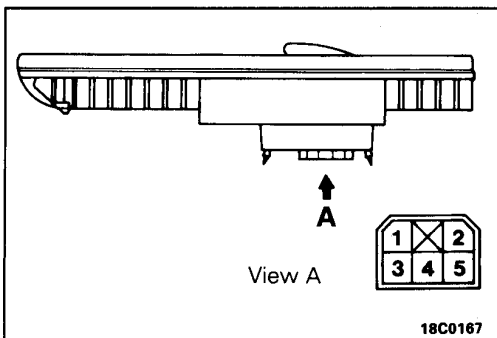

**SUB SWITCH <Front door>**

Terminal		Switch position	Sub Switch		
			UP	OFF	DOWN
Sub switch <Front door>	1			○	○
	2	○		○	○
	3	○			○
	4	○		○	○
	5	○		○	

NOTE

○—○ indicates that there is continuity between the terminals.

**SUB SWITCH <Rear door>**

Terminal		Switch position	LH			RH		
			UP	OFF	DOWN	UP	OFF	DOWN
Sub switch <Rear door>	5	○			○			○
	1	○	○	○	○			○
	4	○			○			○
	2		○	○			○	○
	3			○			○	

NOTE

○—○ indicates that there is continuity between the terminals.

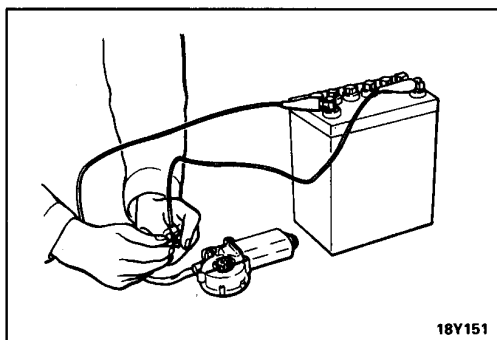

**POWER WINDOW MOTOR**

- (1) Check if the slider moves smoothly when the battery is directly connected to the motor terminals.
- (2) Check if the slider moves in the opposite direction when the battery is connected with the polarities reversed.

**DOOR HANDLE AND LATCH <FRONT DOOR>**

**REMOVAL AND INSTALLATION**

E42MDAY

**Pre-removal Operation**

- Removal of Door Trim and Waterproof Film (Refer to P.42-55.)

**Post-installation Operation**

- Door Inside Handle and Outside Handle Adjustment (Refer to P.42-16.)
- Installation of Door Trim and Waterproof Film (Refer to P.42-55.)

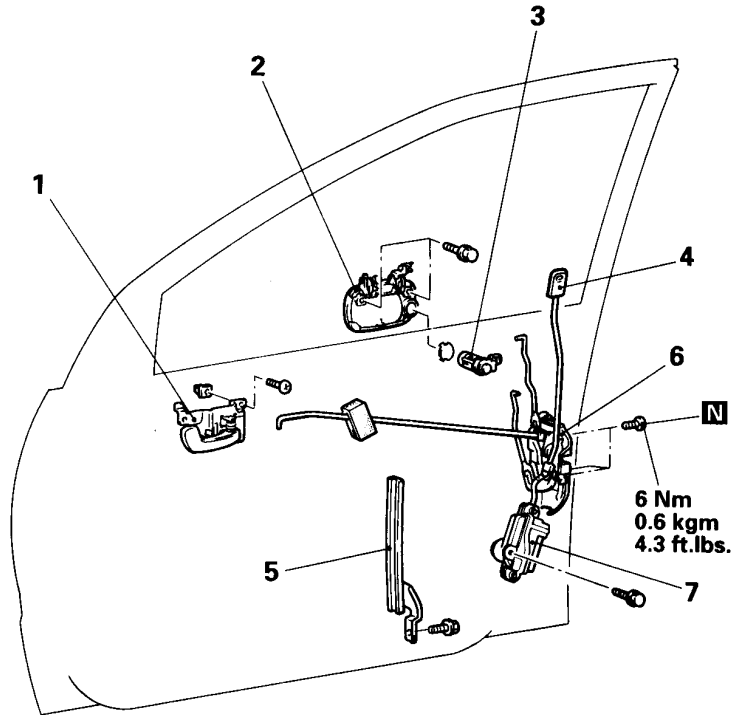
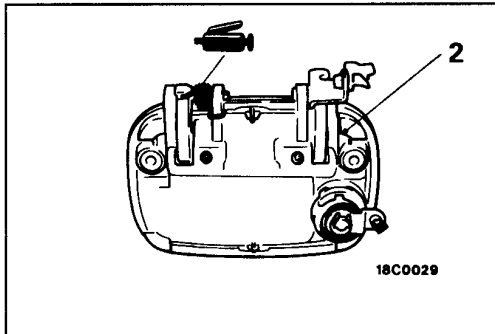
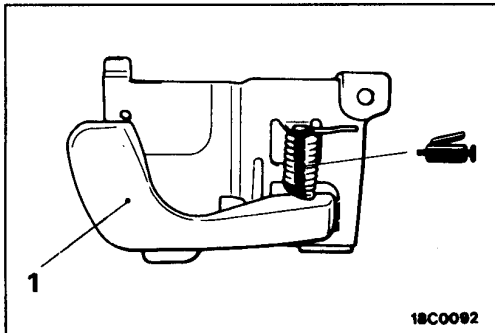

18C0636

1. Front door inside handle

**Front door outside handle and door lock actuator removal steps**

2. Front door outside handle
3. Door lock key cylinder
4. Door lock knob
5. Lower sash assembly
6. Front door latch assembly
7. Door lock actuator

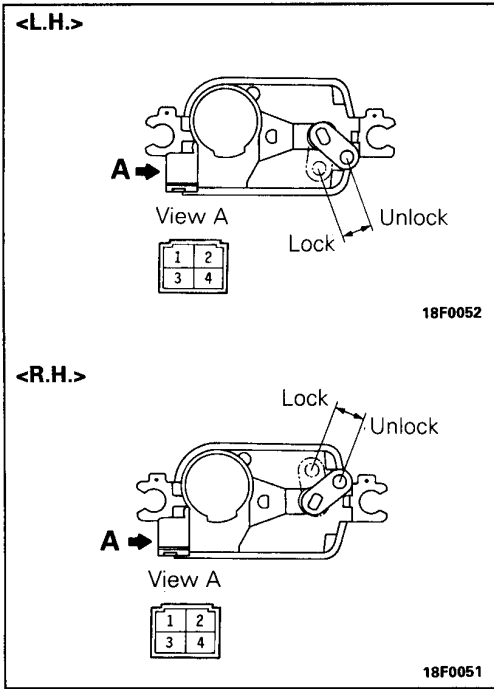

**INSPECTION**  
**FRONT DOOR LOCK ACTUATOR**

<L.H.>

- (1) After setting the rod to the UNLOCK position and applying battery voltage to terminal 3, check if the rod moves to the LOCK position when terminal 1 is earthed.
- (2) After setting the rod to the LOCK position, apply the battery voltage to terminal 1 and check if the rod moves to the UNLOCK position when terminal 3 is earthed.
- (3) For left-hand drive vehicles, when the actuator rod is set to the UNLOCK position, check if there is continuity between terminal 2 and terminal 4, and when the rod is set to the LOCK position, check if there is no continuity.

<R.H.>

- (1) After setting the rod to the UNLOCK position and applying battery voltage to terminal 1, check if the rod moves to the LOCK position when terminal 3 is earthed.
- (2) After setting the rod to the LOCK position and applying battery voltage to terminal 3, check if the rod moves to the UNLOCK position when terminal 1 is earthed.
- (3) For right-hand drive vehicles, when the actuator rod is set to the UNLOCK position, check if there is continuity between terminal 2 and terminal 4, and when the rod is set to the LOCK position, check if there is no continuity.

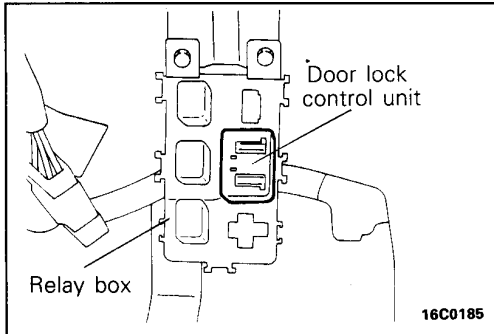

**DOOR LOCK CONTROL UNIT**

- (1) Remove the instrument under cover. (Refer to GROUP 52A – Instrument Panel.)
- (2) Remove the door lock control unit from the relay box.

Battery voltage	Terminal	1	2	3	4	5	6	7	8
Continuity no voltage		○	—	○	—	○		—	○
Continuity with voltage		○	—	○	⊖	—	⊖	⊕	⊖

NOTE

- (1) ○—○ indicates that there is continuity between the terminals.
- (2) ⊕—⊖ indicates connection of battery voltage.

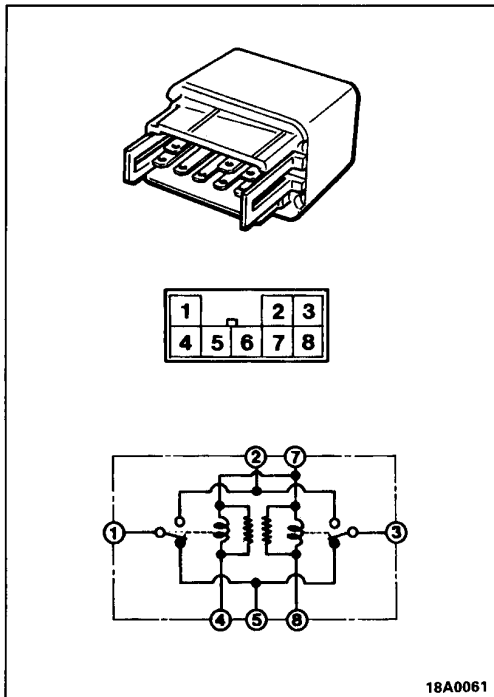



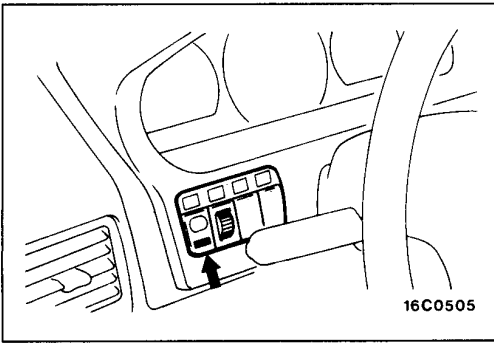

**CENTRAL DOOR LOCK SWITCH**

- (1) Remove the meter hood from the instrument panel. (Refer to GROUP 54 – Combination Meter)

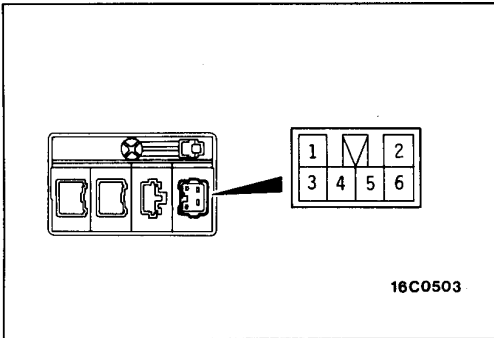

- (2) Operate the switch and check for continuity between the terminals.

Terminal No.	1	2	3	4	5	5
Switch position						
UNLOCK	○—○			○—○		○—○
LOCK	○—○	○—○		○—○		○—○

**NOTE**

○—○ indicates that there is continuity between the terminals.

**42-64-2**

---

**NOTES**

1

**DOOR HANDLE AND LATCH <REAR DOOR>**

**REMOVAL AND INSTALLATION**

E42NDAF

**Pre-removal Operation**

- Removal of Door Trim and Waterproof Film (Refer to P.42-56.)

**Post-installation Operation**

- Door Inside Handle and Outside Handle Adjustment (Refer to P.42-16.)
- Installation of Door Trim and Waterproof Film (Refer to P.42-56.)

**<SPACE RUNNER>**

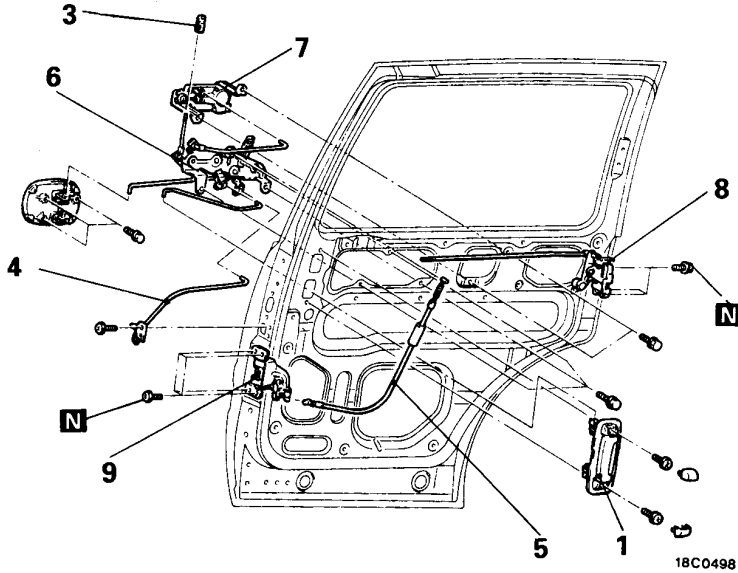

**<SPACE WAGON>**

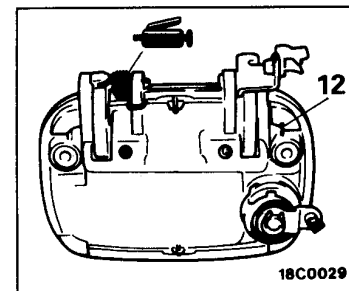
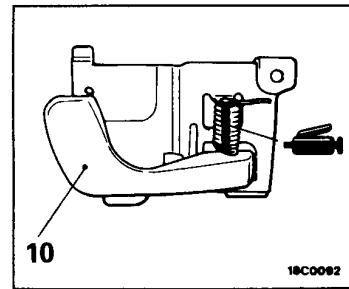
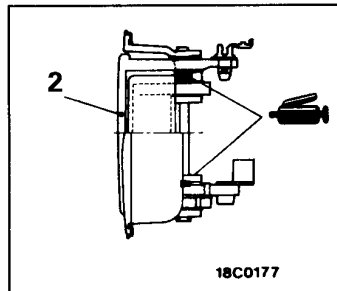
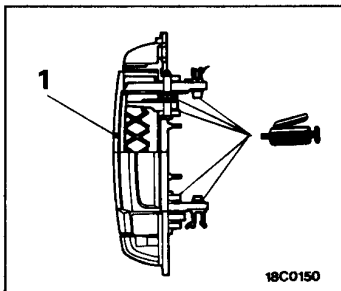
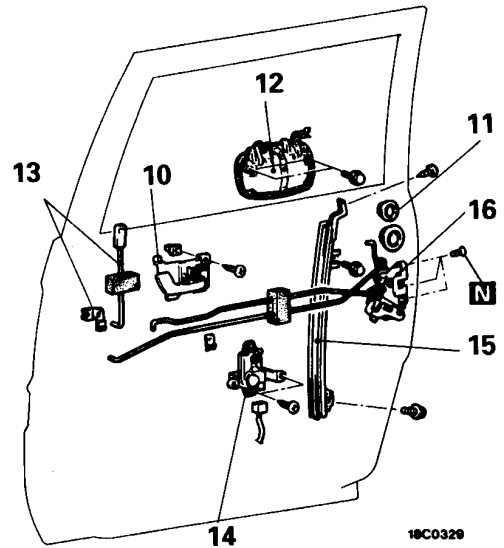

1. Rear door inside handle

**Rear door outside handle and door lock actuator removal steps <SPACE RUNNER>**

2. Rear door outside handle
3. Door lock knob
4. Rear door child protection assembly
5. Sub latch cable
6. Door link assembly
7. Door lock actuator

**Door latch assembly and sub latch assembly removal steps <SPACE RUNNER>**

8. Door latch assembly
5. Sub latch cable
9. Sub latch assembly
10. Rear door inside handle

**Rear door outside handle and rear door window latch assembly removal steps <SPACE WAGON>**

11. Grommet
12. Rear door outside handle
13. Rear door inside lock rod
14. Door lock actuator
15. Door window rear lower sash assembly (Refer to P.42-68.)
16. Door latch assembly

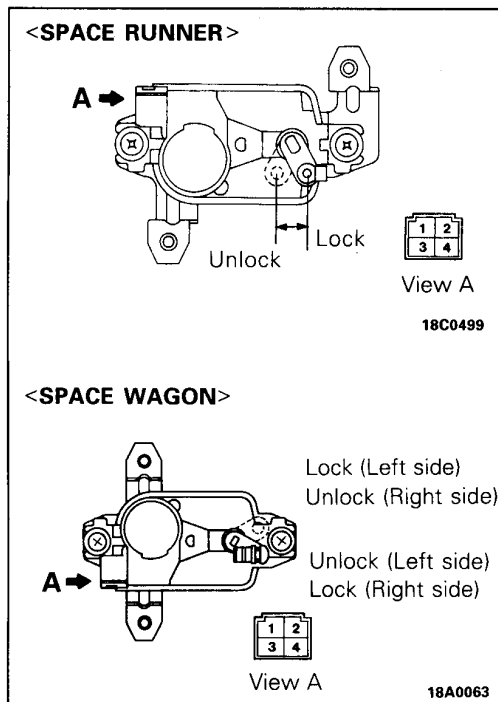
**INSPECTION****REAR DOOR LOCK ACTUATOR****<L.H.>**

- (1) After setting the rod to the LOCK position and applying battery voltage to terminal 3, check if the rod moves to the UNLOCK position when terminal 1 is earthed.
- (2) After setting the rod to the UNLOCK position and applying battery voltage to terminal 1, check if the rod moves to the LOCK position when terminal 3 is earthed.
- (3) For right-hand drive vehicles, when the actuator rod is set to the UNLOCK position, check if there is continuity between terminal 2 and terminal 4, and when the rod is set to the LOCK position, check if there is no continuity.

**<R.H.>**

- (1) After setting the rod to the LOCK position, apply the battery voltage to terminal 1 and check if the rod moves to the UNLOCK position when terminal 3 is earthed.
- (2) After setting the rod to the UNLOCK position and applying battery voltage to terminal 3, check if the rod moves to the LOCK position when terminal 1 is earthed.
- (3) For left-hand drive vehicles, when the actuator rod is set to the UNLOCK position, check if there is continuity between terminal 2 and terminal 4, and when the rod is set to the LOCK position, check if there is no continuity.

# TAILGATE HANDLE AND LATCH

## REMOVAL AND INSTALLATION

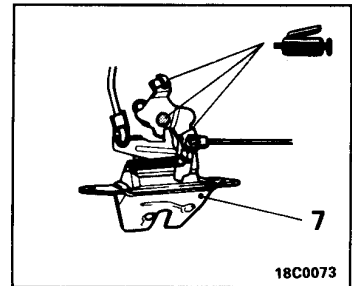
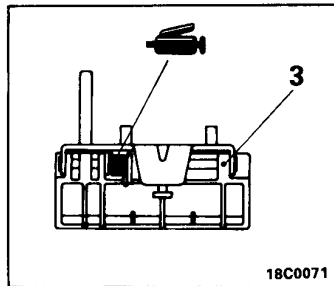
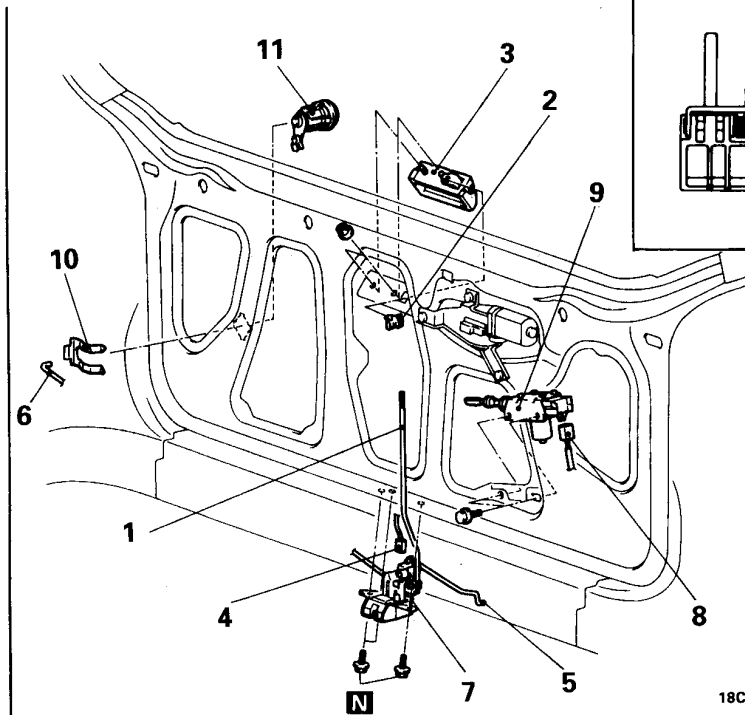

### Tailgate handle removal steps

1. Rod
2. Holder
3. Tailgate handle

### Tailgate latch assembly removal steps

1. Rod
4. Harness connector
5. Rod
6. Rod
7. Tailgate latch assembly

### Tailgate lock actuator removal steps

5. Rod
8. Harness connector
9. Tailgate lock actuator

### Tailgate lock cylinder removal steps

6. Rod
10. Cylinder lock retainer
11. Tailgate lock cylinder

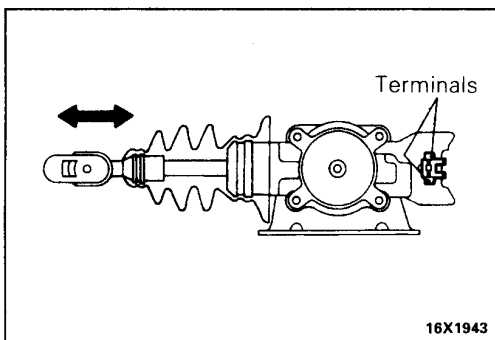

## INSPECTION

### TAILGATE LOCK ACTUATOR

Connect the battery source directly to the actuator terminals, and check the actuator plunger for operation. If the plunger moves in opposite direction when the connection polarity is changed, the plunger should be considered to be in normal condition.

**DOOR RUNCHANNEL**

**REMOVAL AND INSTALLATION**

E42MGAI

**Pre-removal Operation**  
 ● Removal of Door Trim and Waterproof Film (Refer to P.42-55, 56.)

**Post-installation Operation**  
 ● Door Window Glass Adjustment (Refer to P.42-16.)  
 ● Installation of Door Trim and Waterproof Film (Refer to P.42-55, 56.)

**<FRONT DOOR>**

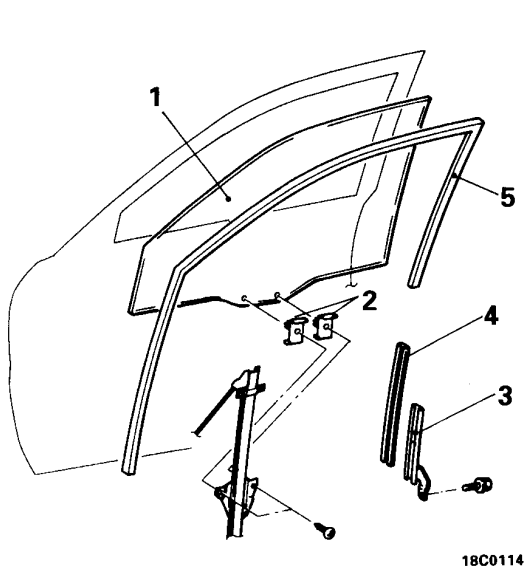

**<REAR DOOR (SPACE WAGON)>**

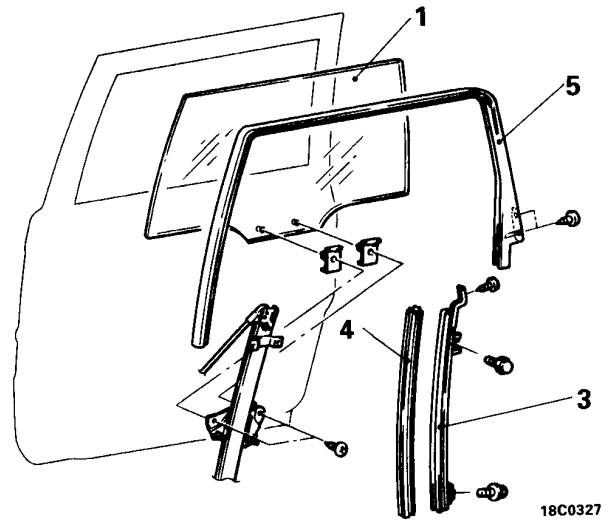

**Removal steps**

1. Door window glass
2. Door glass holder
3. Door window rear lower sash assembly (Refer to P.42-59.)
- ◆◆ 4. Door window glass rear runchannel
- ◆◆ 5. Door window glass runchannel

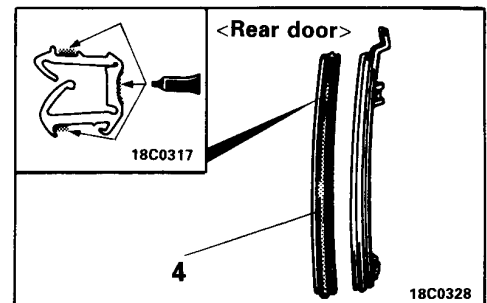

**Adhesive:**  
 3M ATD Part No. 8001 or 3M ATD Part No. 8011, or equivalent

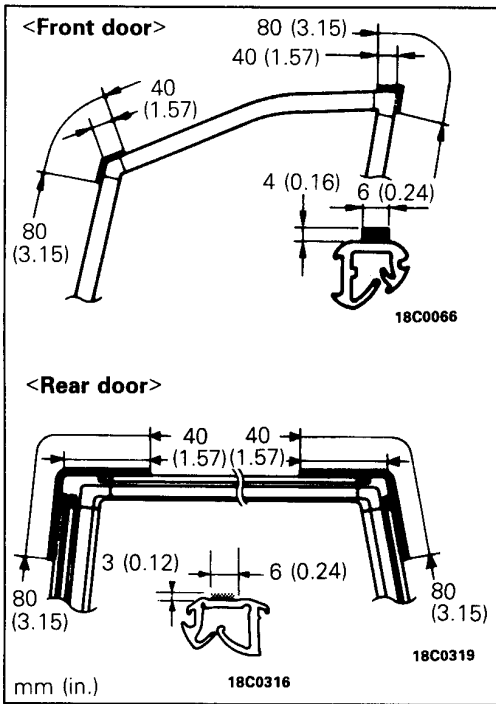

**SERVICE POINTS OF INSTALLATION**

**5. INSTALLATION OF DOOR WINDOW GLASS RUNCHANNEL**

Remove the dual-surface tape from the places shown in the figure. Then attach new dual-surface tape and install the runchannel to the door.

**WEATHERSTRIP**

**REMOVAL AND INSTALLATION**

**<FRONT DOOR>**

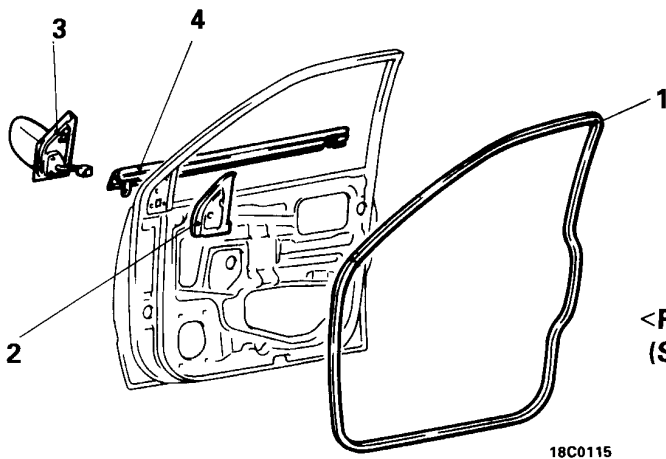

- ◆◆◆ 1. Front door outer opening weatherstrip

**Front door outer weatherstrip removal steps**

2. Delta inner cover
3. Door mirror assembly
4. Front door belt outer weatherstrip
5. Rear door outer opening weatherstrip
6. Rear door upper weatherstrip
7. Rear door lower weatherstrip
8. Rear door belt outer weatherstrip

**<REAR DOOR (SPACE RUNNER)>**

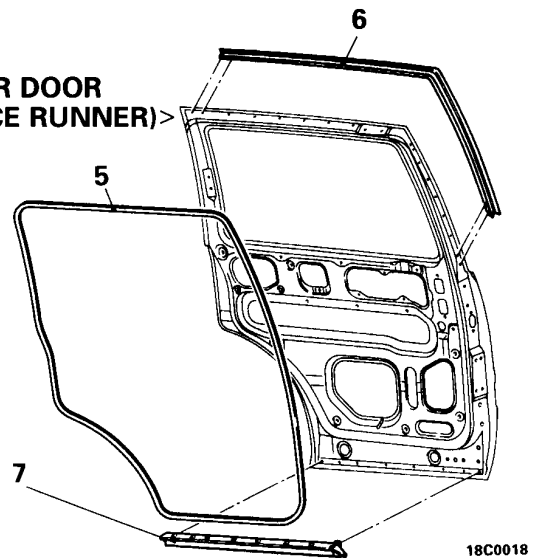

**<REAR DOOR (SPACE WAGON)>**

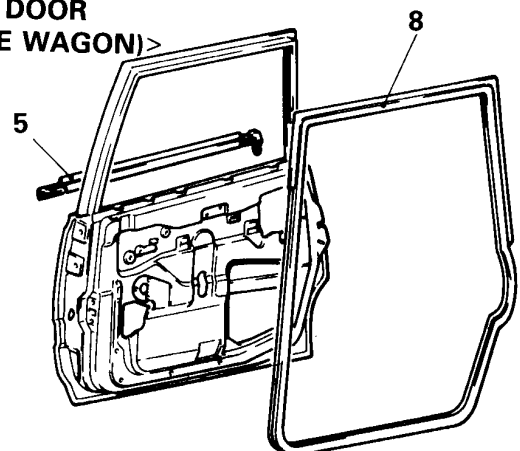

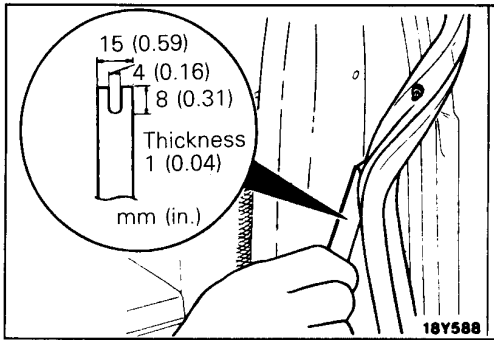

## SERVICE POINTS OF REMOVAL

### 1. REMOVAL OF DOOR OUTER OPENING WEATHERSTRIP

- (1) Remove the door check from the front door.
- (2) Make a tool as shown in the illustration to remove the door opening weatherstrip.

## SERVICE POINTS OF INSTALLATION

### 1. INSTALLATION OF FRONT DOOR OUTER OPENING WEATHERSTRIP

The clip colour identifies the left and right weatherstrips, so be sure to use the colours so as to install correctly.

Identification colour	Applicable side
White	Left door
Orange	Right door



# SUNROOF

## REMOVAL AND INSTALLATION

**Post-installation Operation**

- Sunroof Fit Adjustment (Refer to P.42-17.)
- Water Test (Refer to P.42-17.)

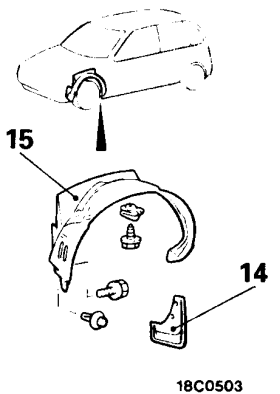
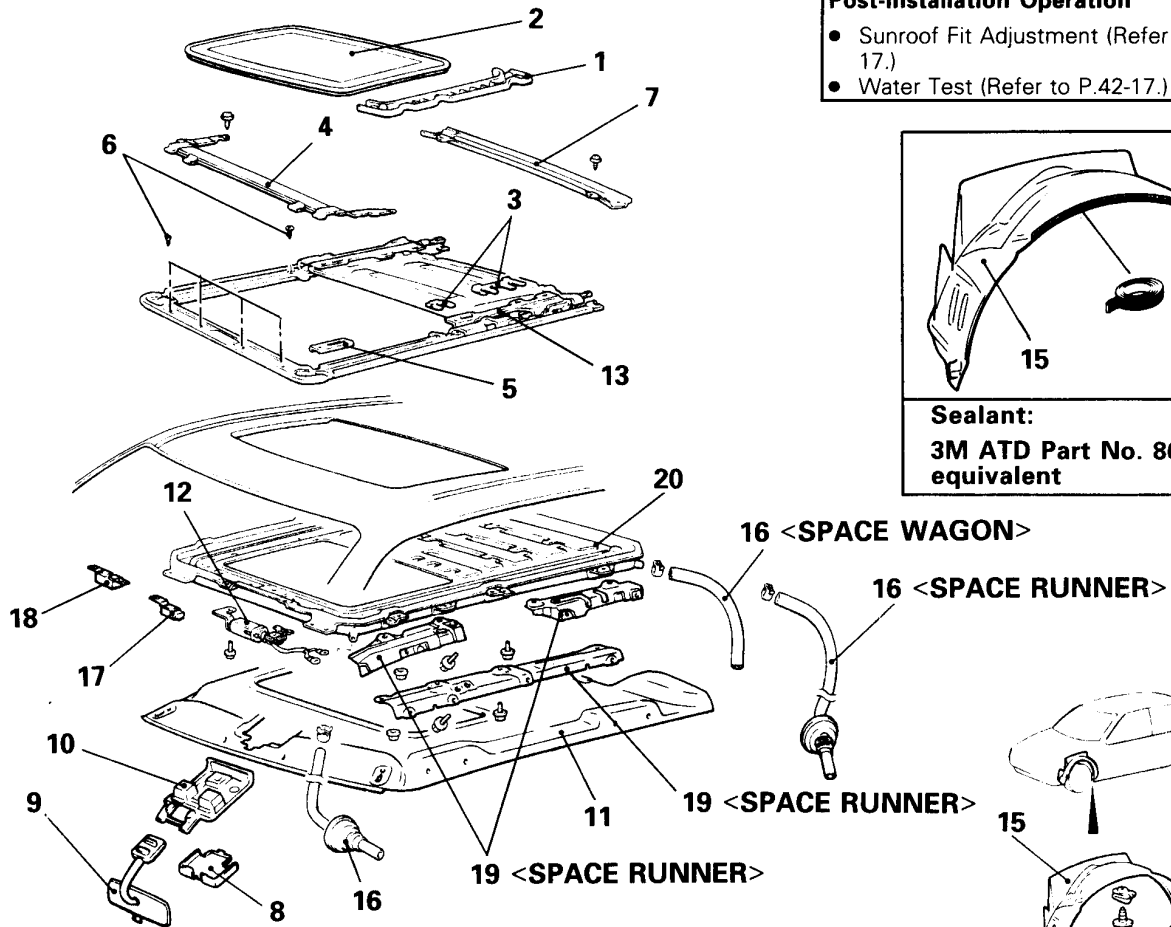
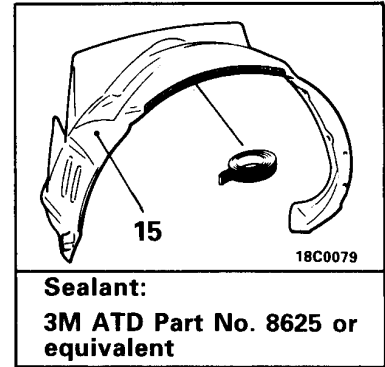

### Roof glass lid removal steps

- ◄◄ 1. Side garnish
- ◄◄ 2. Roof glass lid
- ◄◄ 3. Adjust plate

### Sliding roof assembly removal steps

- ◄◄ 1. Side garnish
- ◄◄ 2. Roof glass lid
- ◄◄ 3. Adjust plate
- ◄◄ 4. Deflector
- ◄◄ 5. Sliding roof guide rail cover
- ◄◄ 6. Screw
- ◄◄ 7. Roof drip rear channel
- ◄◄ 8. Cover
- ◄◄ 9. Inside rear view mirror
- ◄◄ 10. Sunroof switch and room lamp assembly
- ◄◄◄ 11. Headlining
- ◄◄◄ 12. Motor (Refer to GROUP 52A – Headlining)
- ◄◄◄ 13. Sliding roof assembly
- ◄◄◄ 16. Connection of the housing and drain hose
- ◄◄◄ 17. Power relay
- ◄◄◄ 18. Sunroof control relay
- ◄◄◄ 20. Housing assembly

### Motor removal steps

- ◄◄◄ 10. Sunroof switch and room lamp assembly
- ◄◄◄ 12. Motor

### Power relay and sunroof control relay removal steps

- ◄◄ 10. Sunroof switch and room lamp assembly
- ◄◄ 17. Power relay
- ◄◄ 18. Sunroof control relay

### Drain hose removal steps

- ◄◄◄ 10. Sunroof switch and room lamp assembly
- ◄◄◄ 11. Headlining (Refer to GROUP 52A – Headlining)
- ◄◄◄ 14. Mud guard
- ◄◄◄ 15. Splash shield
- ◄◄◄ 16. Drain hose

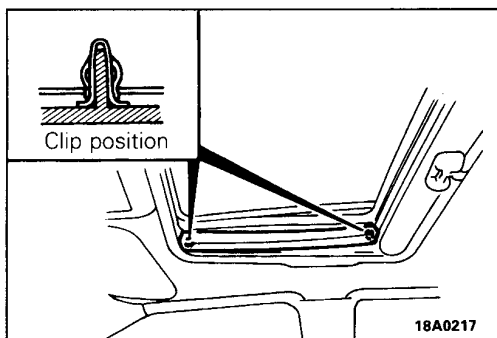

## SERVICE POINTS OF REMOVAL

### 1. REMOVAL OF SIDE GARNISH

Remove the side garnish.

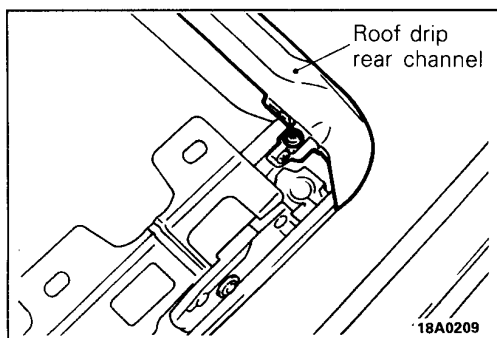

### 7. REMOVAL OF ROOF DRIP REAR CHANNEL

- (1) Operate the sunroof switch to bring the sliding roof drive cable assembly to the fully closed position.
- (2) Remove the roof drip rear channel.

### 12. REMOVAL OF MOTOR

#### Caution

- (1) If the motor is to be removed, be sure to first move the roof glass lid or the sliding roof drive cable assembly to the fully tilt closed position.
- (2) If the position of the roof glass lid and the motor's fully closed position do not correspond, the sunroof will not operate normally.

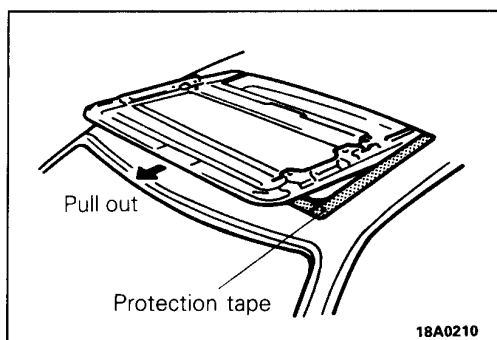

### 13. REMOVAL OF SLIDING ROOF ASSEMBLY

- (1) Attach protection tape around the opening of the roof panel.
- (2) Pull out, being careful not to strike the opening of the roof panel.

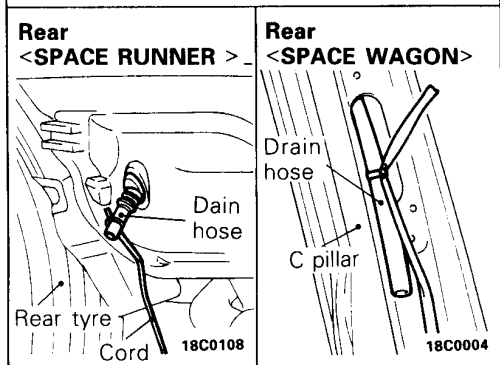
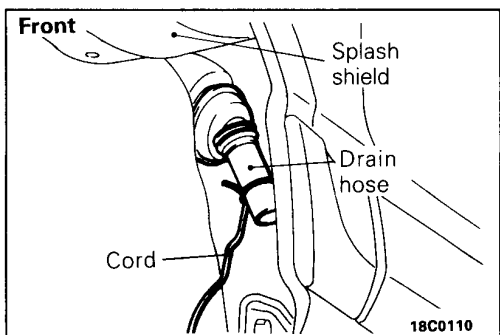

**16. REMOVAL OF DRAIN HOSE**

Tie a cord at the end of the drain hose and pull out the drain hose toward the vehicle interior.

**17. REMOVAL OF POWER RELAY/18. SUNROOF CONTROL RELAY**

Remove the front part of the right side of the head lining as much as possible by lowering it, and then remove the sunroof power relay and the sunroof control relay.

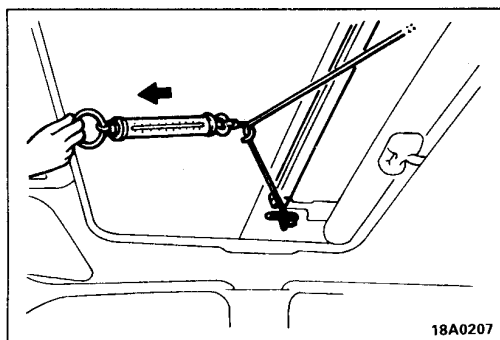
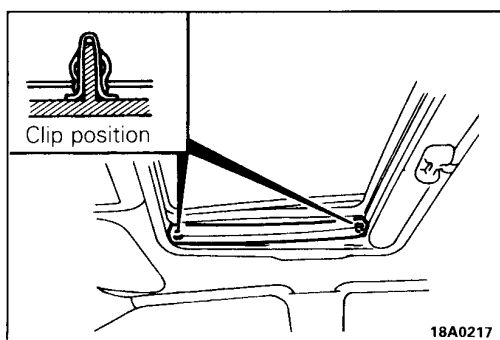

**INSPECTION**

**SLIDING RESISTANCE OF THE GLASS LID**

Check the sliding resistance of the roof glass lid by following the procedures below.

- (1) Remove the side garnish.
- (2) Loosen the nut at the front end of the roof glass lid installation, and then tie with a cord.
- (3) Remove the motor after opening the roof glass lid.
- (4) Using a spring scale, measure the sliding resistance of the roof glass lid.

**Standard value: 120 N (12 kg, 26 lbs.) or less**

- (5) If the sliding resistance of the roof glass lid exceeds the standard value, check for the following.
  - 1 Check the installation condition of the sliding roof assembly, and check for deformation or clogging by foreign material.
  - 2 Check for sticking of the drive cable.
  - 3 Check for an offset position of the roof glass lid.
- (6) When installing the motor, install after first aligning the fully tilt closed condition of the sliding roof assembly and of the motor.

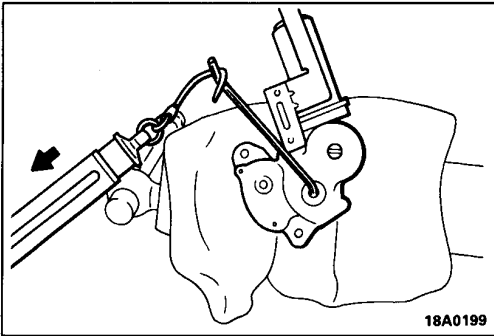

**SLIDING FORCE OF THE MOTOR'S CLUTCH**

- (1) Insert one end of an allen wrench (provided in the tool bag) into the motor gear hole and hook a spring scale to the other end, and measure the force when the clutch starts to slip (when the allen wrench begins to turn).

**Standard value: 35–44 N (3.5–4.4 kg, 8–10 ft.lbs.)**

**Caution**

**Pull the spring scale in a direction at right angles to the wrench. Note that if a wrench other than the one provided in the tool bag is used, the measured value may not coincide with the standard value.**

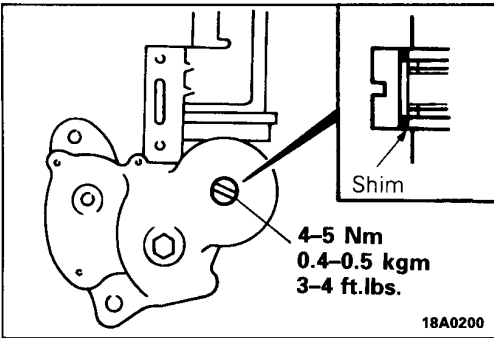

- (2) If the sliding force of the motor's clutch is not within the standard value range, adjust by following one or the other of the procedures described below.

- ① Adjust the tightening torque of the bolt within the tightening torque range indicated in the illustration.
- ② Remove the bolt and reduce the number of shims.

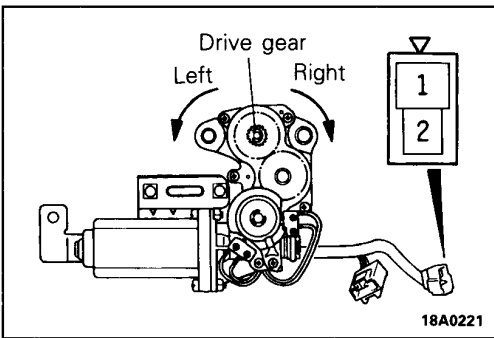

**MOTOR**

Check the direction of rotation of the drive gear when the battery is connected to the connector.

Terminal 1	Terminal 2	Drive gear rotation direction
+	-	Left
-	+	Right

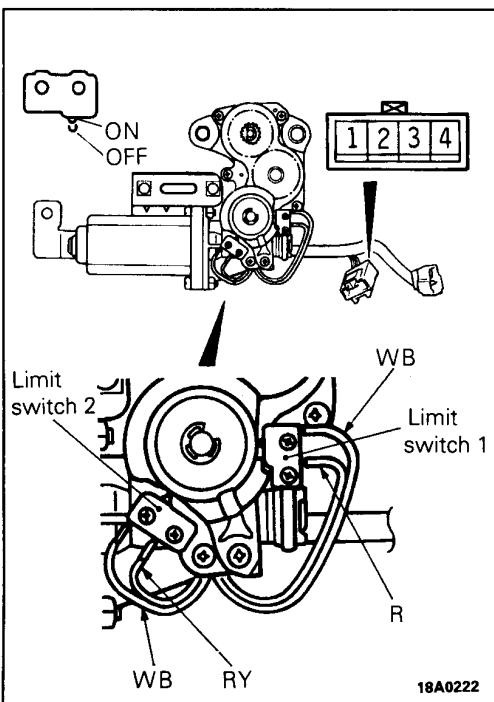

**LIMIT SWITCH**

- (1) Remove the limit switch from the motor; then operate the limit switch and check for continuity between the terminals.

		Terminal			
		1	2	3	4
Switch	ON	○—○			
	OFF				
Limit switch 1	ON	○—○			
	OFF				
Limit switch 2	ON	○—○			
	OFF				

**NOTE**

○—○ indicates that there is continuity between the terminals.

- (2) When installing the limit switch, install so that installation positions 1 and 2 and the inner and outer sides are as indicated in the illustration.

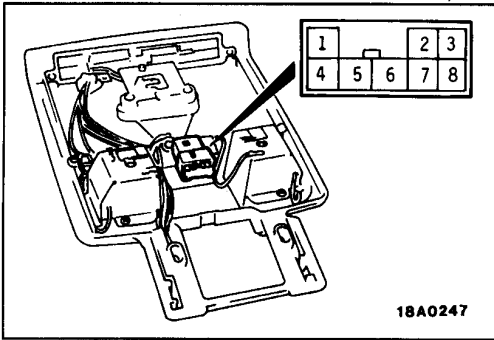

**SUNROOF SWITCH**

Switch		Terminal				
		2	3	5	7	8
Slide switch	Open	○—○				
	Closed			○—○		
Tilt switch	Up		○—○			
	Down			○—○		○—○

**NOTE**

○—○ indicates that there is continuity between the terminals.

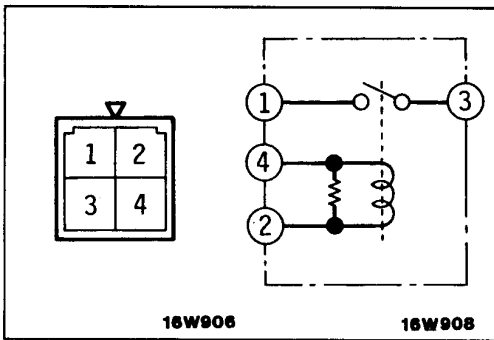

**POWER RELAY**

Terminal		1	2	3	4
		Battery voltage			
Continuity no voltage			○—○		○—○
Continuity with voltage		○—○	⊕---⊖	○—○	⊕---⊖

**NOTE**

- (1) ○—○ indicates that there is continuity between the terminals.
- (2) ⊕---⊖ indicates terminals to which battery voltage is applied.

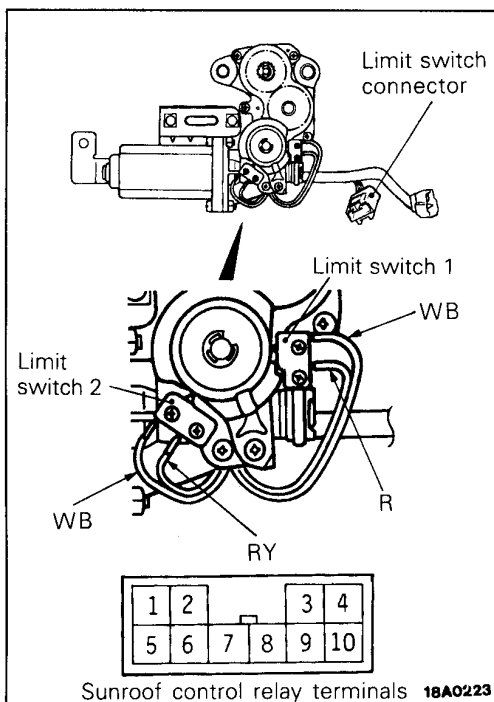

**SUNROOF CONTROL RELAY**

- (1) Remove the limit switch from the motor.
- (2) Connect the limit switch and the wiring harness' connector.
- (3) Switch ON the ignition switch.
- (4) Connect the tester to each terminal and to body earth (as shown in the table below), and then check the voltage and check for continuity.
- (5) When installing the limit switch, install so that installation positions 1 and 2 and the inner and outer sides are as indicated in the illustration.

Check sequence	Tester connection terminal	Checking conditions			Standard	Countermeasure if deviation from standard
		Always/Usually	Limit switch	Sunroof switch		
1	5	Always			Continuity	Check the harness (between the control relay and earth).
2	10	Always			Approx. 12 V	Check the harness (between the control relay and the battery).
3	6		No. 1 OFF		Approx. 12 V	Replace the control relay or the motor.
			No. 1 ON		0 V	Check the harness (between the control relay and earth).
4	2		No. 2 OFF		Approx. 12 V	Replace the control relay or the motor.
			No.2 ON		0 V	Check the harness (between the control relay and earth).
5	3	Usually			Approx. 12 V	Replace the control relay or the motor.
				Tilt up	0 V	Check the harness (between the control relay and earth). Check the tilt switch.
6	7	Usually			Approx. 12 V	Replace the control relay or the motor.
				Tilt down	0 V	Check the harness (between the control relay and earth). Check the tilt switch.
7	9	Usually			Approx. 12 V	Replace the control relay or the motor.
				Slide open	0 V	Check the harness (between the control relay and earth). Check the slide switch.
8	8	Usually			Approx. 12 V	Replace the control relay or the motor.
				Slide close	0 V	Check the harness (between the control relay and earth). Check the slide switch.
9	4		No. 2 OFF	Tilt up	Approx. 12 V	Replace the control relay.
10	1		① No. 2 OFF	② Tilt down	–	–
			③ No. 1 OFF → ON		Approx. 12 V → 0 V	Replace the control relay.
11	1		① No. 1 ON	② Slide open	–	–
			③ No. 2 ON		Approx. 12 V	Replace the control relay.
12	4		① No. 1 ON	② Slide close	–	–
			③ No. 2 ON → OFF		Approx. 12 V → 0 V	Replace the control relay.
13	4		① No. 1 OFF		–	–
			② No. 2 ON	③ Slide close	Approx. 12 V (for 0.5 sec.)	Replace the control relay.

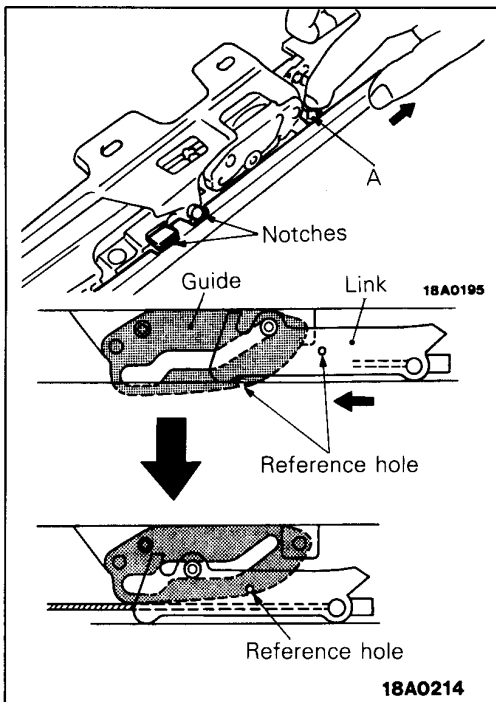
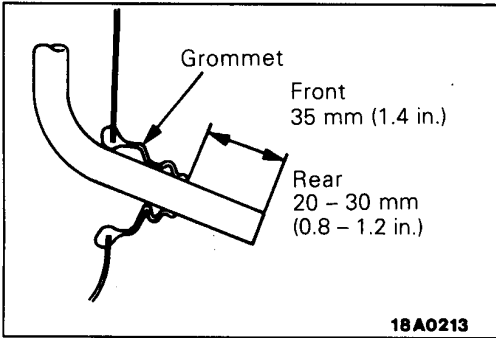
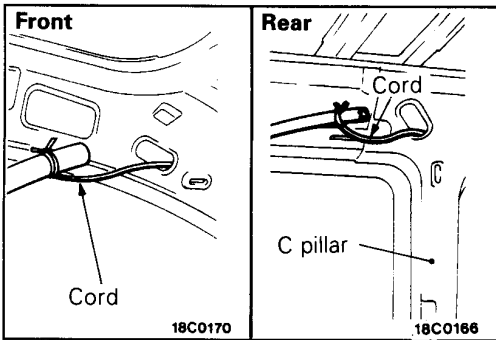

**SERVICE POINTS OF INSTALLATION**

**16. INSTALLATION OF DRAIN HOSE**

- (1) Tie the cord (passed through at the time of removal) to the end of the drain hose.
- (2) Pull the cord and pass the drain hose through.

- (3) Install the grommet, and install so that the amount of projection of the drain hose is as shown in the figure.

**13. INSTALLATION OF SLIDING ROOF ASSEMBLY**

Following the sequence described below, fully tilt close the left and right.

- (1) Slide the sliding roof drive cable assembly so that the notches in the guide rail are as indicated in the illustration.
- (2) With a finger at the place indicated by (A) in the illustration, slide the link forward and align the guide and the link's reference hole.

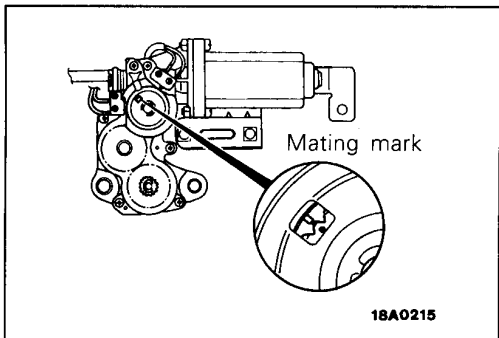

**12. INSTALLATION OF MOTOR**

Following the sequence described below, set to the fully tilt closed condition.

- (1) Remove the cam plate cover.
- (2) With the hexagonal wrench (included with the vehicle) attached at the hexagonal hole of the motor drive shaft, turn the cam and align with the mating mark.

**REASSEMBLY AND DISASSEMBLY**

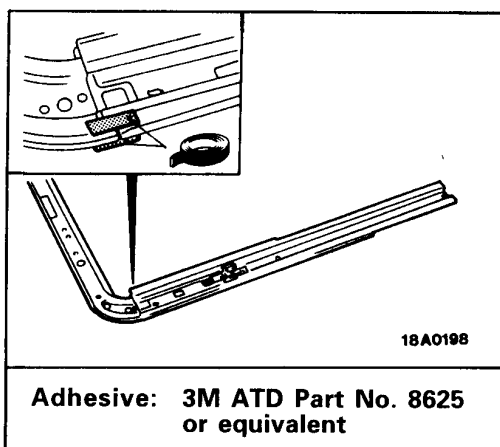
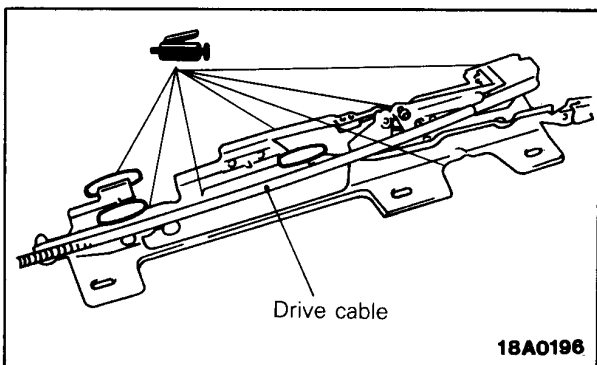
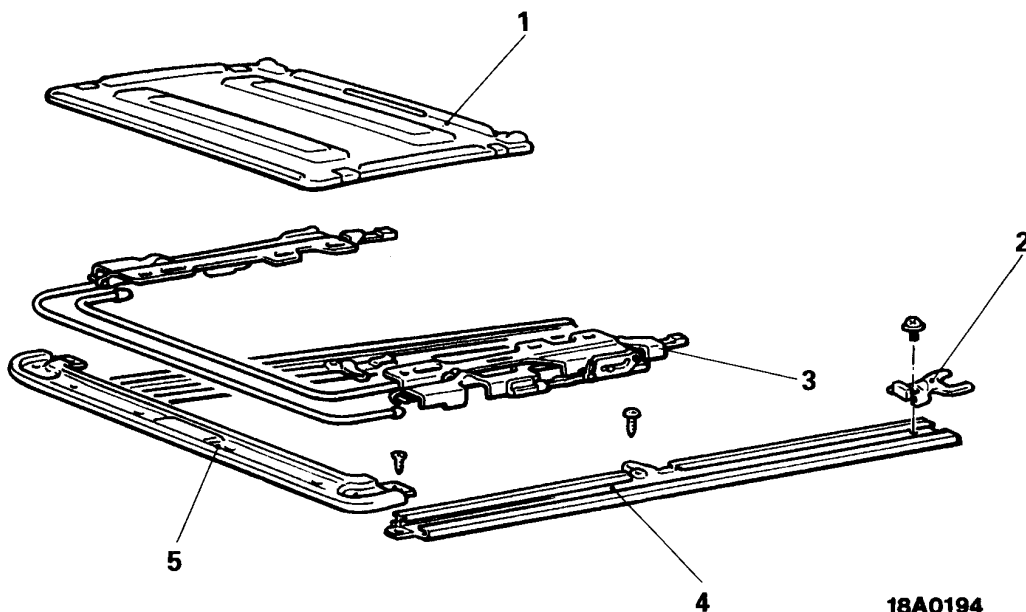

**Disassembly steps**

1. Sun shade
2. Stopper
- ◄◄ 3. Sliding roof drive cable assembly
- ◆◆ 4. Guide rail
- ◆◆ 5. Sliding roof cable guide casing



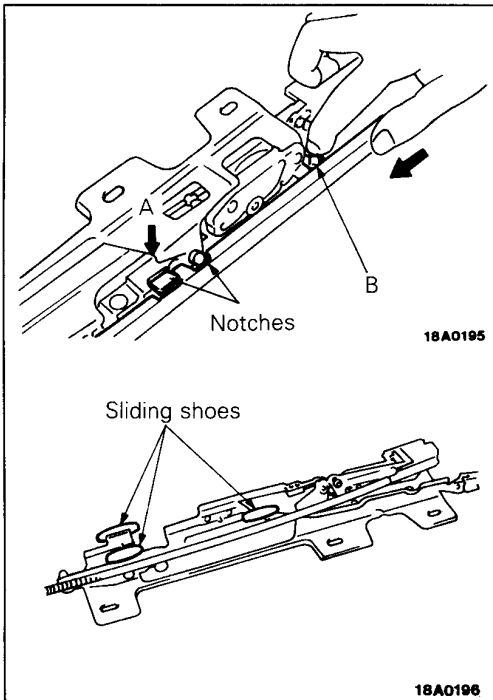

**SERVICE POINTS OF DISASSEMBLY**

**3. REMOVAL OF SLIDING ROOF DRIVE CABLE ASSEMBLY**

Pull out the sliding roof drive cable assembly from the rear part of the guide rail.  
If it won't slide (with the notches of the guide rail as indicated in the illustration), press the (A) part and, with a finger at the (B) part, slide toward the rear.

**Caution**

**Be careful not to lose the sliding shoes (plastic).**

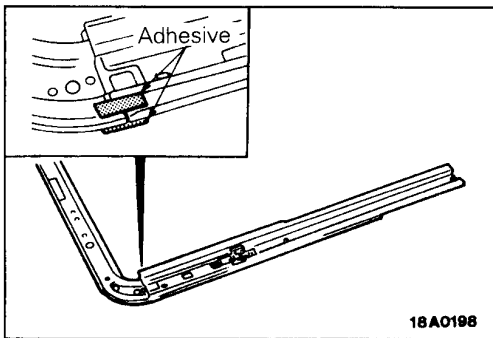

**SERVICE POINTS OF INSTALLATION**

**5. APPLICATION OF ADHESIVE TO SLIDING ROOF CABLE GUIDE CASING/4. GUIDE RAIL**

Apply a coating of adhesive to the seal at the coupling and to the cut part of the weatherstrip.

**Specified adhesive: 3M ATD Part No. 8625 or equivalent**

**Caution**

**If too much adhesive is applied, adhesive will adhere to the roof panel at the time of installation to body, so don't apply too much.**

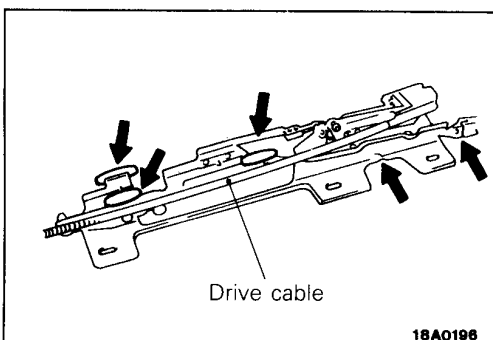

**3. APPLICATION OF GREASE TO SLIDING ROOF DRIVE CABLE ASSEMBLY**

Apply a coating of multipurpose grease to the drive cable link part and sliding part, and then insert the guide rail.