

GROUP 27 REAR AXLE

GENERAL

OUTLINE OF CHANGE

The service procedure of the rear axle has been established to correspond to the adoption of the disc brakes.

REAR AXLE HUB

REMOVAL AND INSTALLATION

Caution

1. The rear hub unit bearing should not be dismantled. When removing the rear hub assembly, the wheel bearing inner race may be left at the spindle side. In this case, always replace the rear hub assembly, otherwise the hub will damage the oil seal, causing oil leaks or excessive play.
2. Care must be taken not to scratch or otherwise damage the teeth of the ABS rotor. The ABS rotor must never be dropped. If the teeth of the ABS rotor are chipped, resulting in a deformation of the ABS rotor, it will not be able to accurately detect the wheel rotation speed, and the system will not function normally.

Post-installation Operation
Adjustment of Parking Brake (Refer to GROUP 36.)

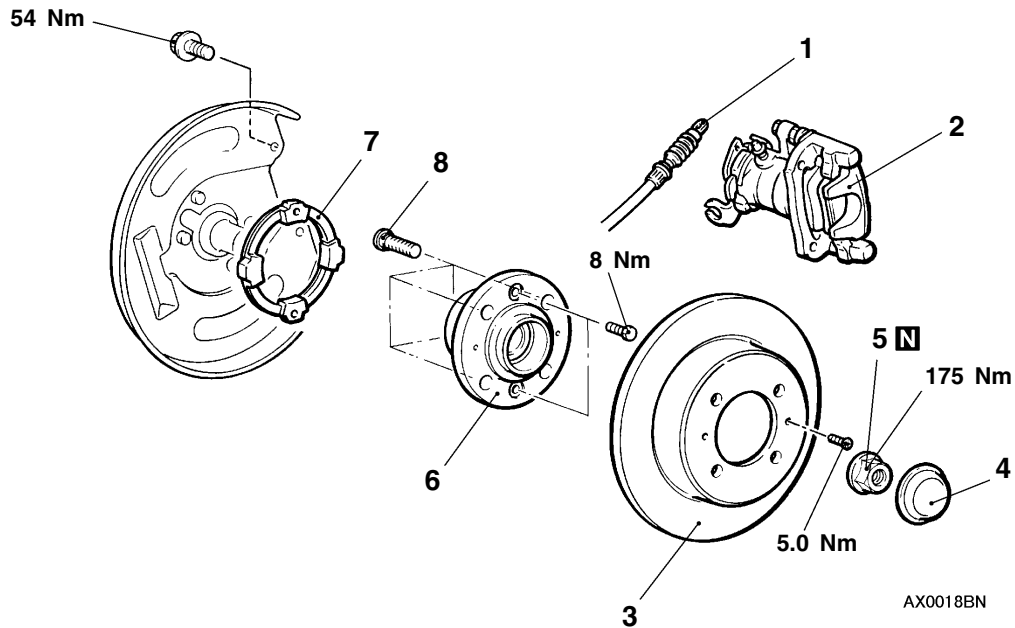

Removal steps



1. Parking brake cable connection
2. Caliper assembly
3. Brake disc
4. Hub cap



5. Flange nut
6. Rear hub assembly
7. ABS rotor
8. Hub bolt

REMOVAL SERVICE POINT**◀A▶ CALIPER ASSEMBLY REMOVAL**

Remove the caliper assembly and suspend it.

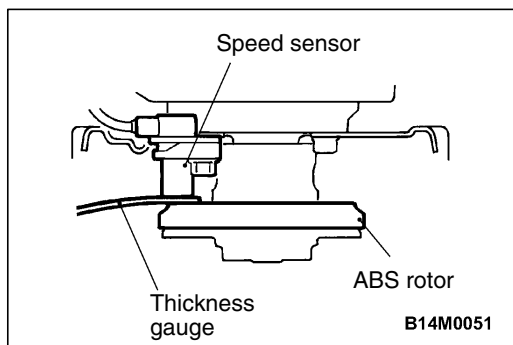
**INSTALLATION SERVICE POINT****▶A◀ REAR HUB ASSEMBLY INSTALLATION****Caution**

Be sure not to damage the pole piece at the tip the speed sensor by striking against other parts.

Insert a thickness gauge into the space between the speed sensor's pole piece and the ABS rotor's toothed surface, and check the clearance is the standard value all around.

Standard value: 0.1 – 1.9 mm

INSPECTION

- Check the oil seal for crack or damage.
- Check the rear hub unit bearing for wear or damage.
- Check the rear rotor for chipped teeth.