

GROUP 32

POWER PLANT MOUNT

GENERAL

OUTLINE OF CHANGES

The following service procedures have been established to correspond to the addition of the F9Q1 diesel engine.

ENGINE MOUNTING

REMOVAL AND INSTALLATION

Caution

Mounting locations marked by * should be provisionally tightened, and then fully tightened when the body is supporting the full weight of the engine.

Pre-removal Operation

Jack up the Engine and Transmission Assembly until There is no Weight on the Engine Mount Bracket Insulator.

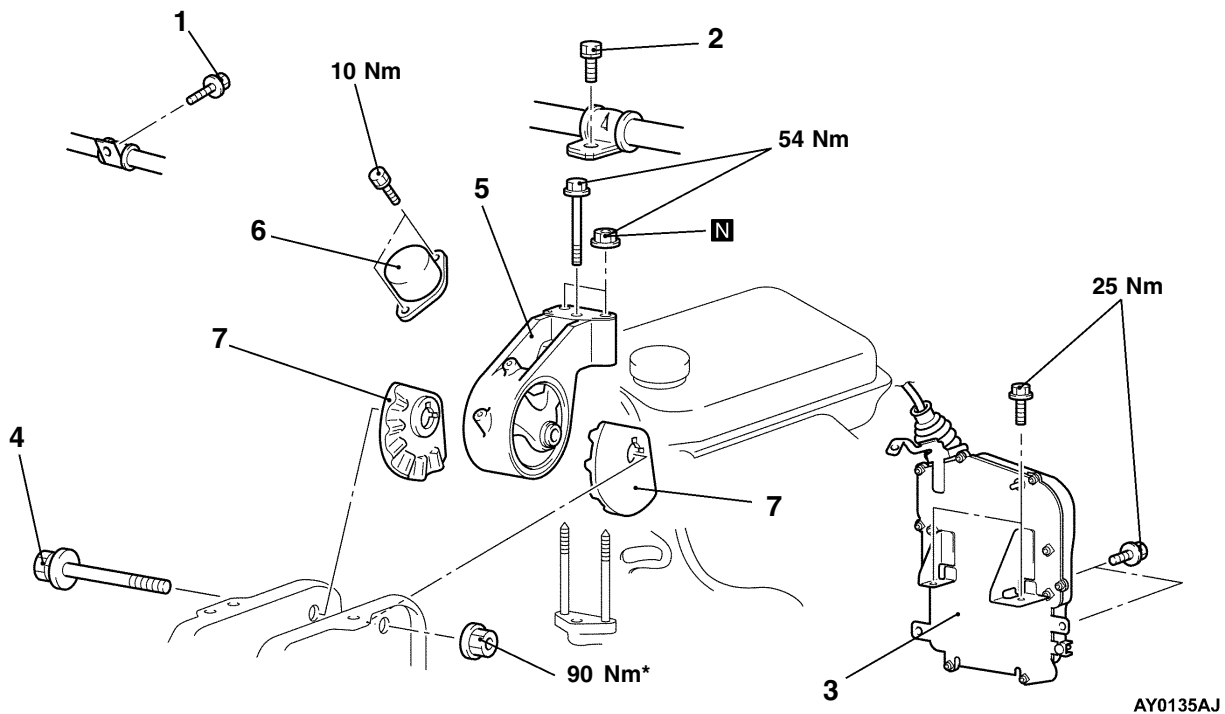

Removal steps

1. A/C suction hose clump
2. Power steering pressure hose clump
3. Engine-ECU assembly
4. Engine mount insulator mounting bolt



5. Engine mount bracket
6. Engine mount stopper
7. Dynamic damper



REMOVAL SERVICE POINT**◀A▶ ENGINE-ECU ASSEMBLY REMOVAL**

Disconnect the engine-ECU assembly, with its wiring harness attached, and move the ECU assembly aside so that it will not be in the way while removing the engine mount.

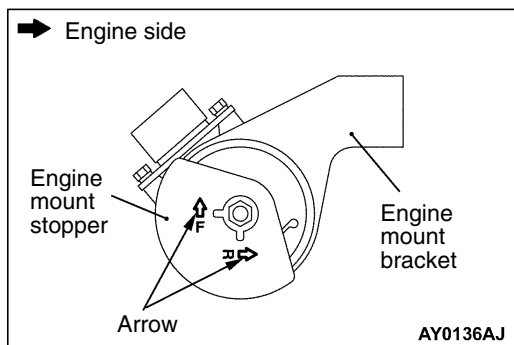
**INSTALLATION SERVICE POINT****▶A◀ ENGINE MOUNT STOPPER INSTALLATION**

Install the engine mount stopper so that the arrow marks point toward the shown direction.

TRANSMISSION MOUNTING

REMOVAL AND INSTALLATION

Caution

Mounting locations marked by * should be provisionally tightened, and then fully tightened when the body is supporting the full weight of the engine.

Pre-removal and Post-installation Operation
Air Cleaner Assembly Removal and Installation

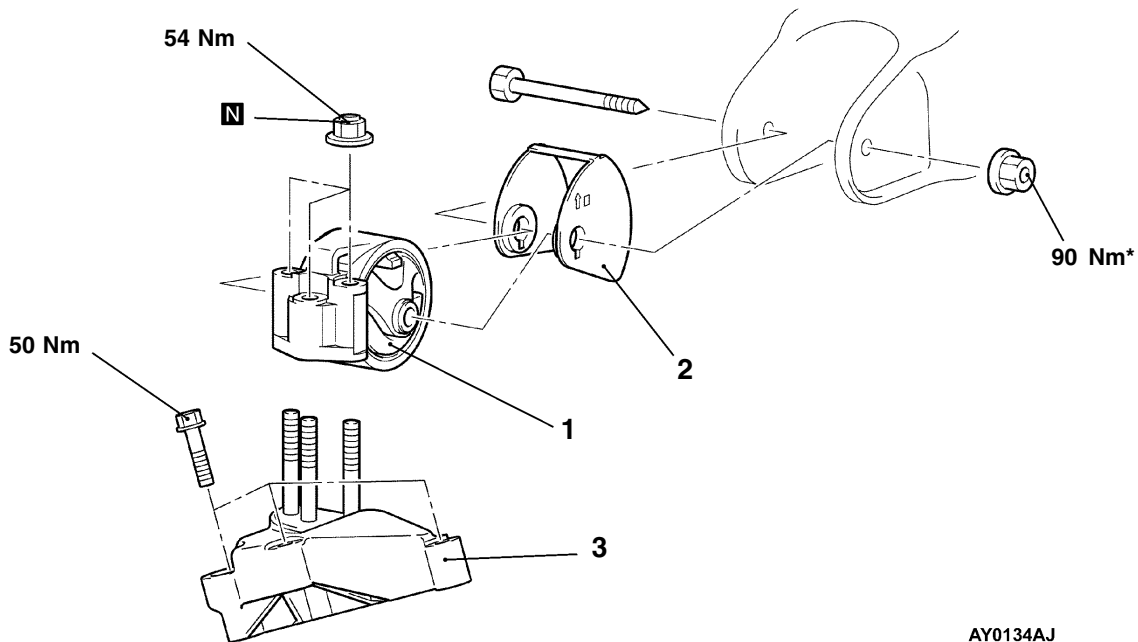

Removal steps

- Centermember mounting bolt
- 1. Transmission mount bracket

- ▶A◀ 2. Transmission mount stopper
- 3. Transmission mount lower bracket

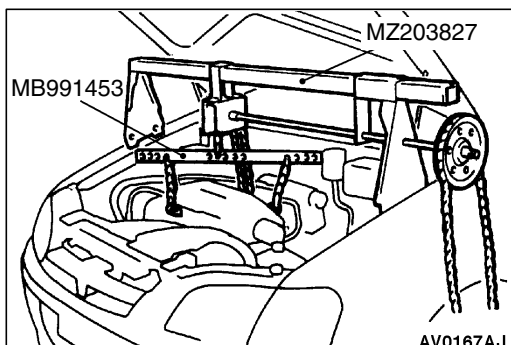

REMOVAL SERVICE POINT

◀A▶ TRANSMISSION MOUNT BRACKET REMOVAL

1. Install the special tool to the vehicle body to support the engine and transmission assembly.
2. Remove the centermember mounting bolts.
3. Remove the bolt and nuts of the transmission mount bracket.
4. After lowering the engine and transmission assembly, remove the transmission mount bracket.

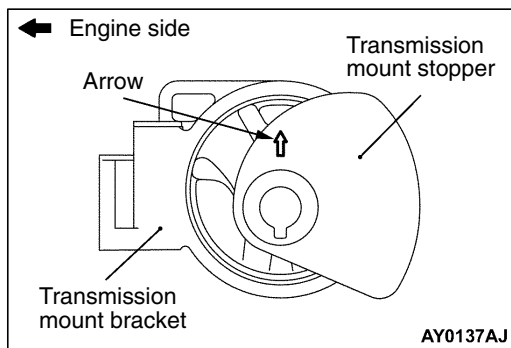
**INSTALLATION SERVICE POINT****▶◀ TRANSMISSION MOUNT STOPPER INSTALLATION**

Install the transmission mount stopper so that the arrow mark points toward the shown direction.

ENGINE ROLL STOPPER, CENTERMEMBER

REMOVAL AND INSTALLATION

Caution

Mounting locations marked by * should be provisionally tightened, and then fully tightened when the body is supporting the full weight of the engine.

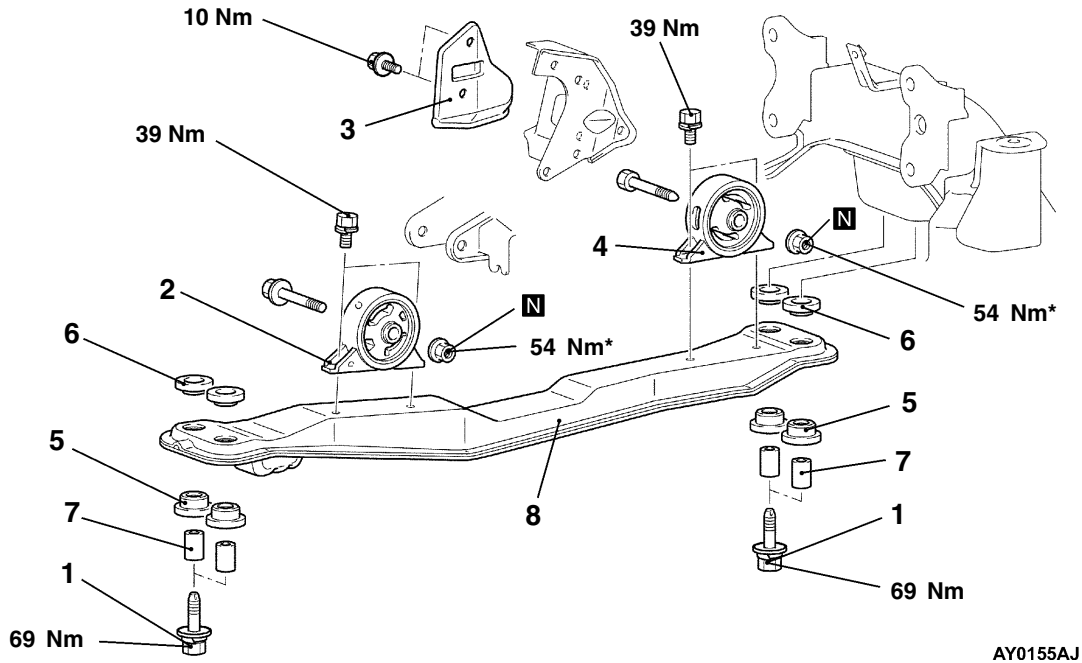

AY0155AJ

Removal steps

- 1. Bolt
- ▶B◀ 2. Front roll stopper bracket assembly
- ▶A◀ 3. Rear roll stopper heat protector
- ▶A◀ 4. Rear roll stopper bracket assembly

- 5. Bushing (lower)
- 6. Bushing (upper)
- 7. Collar
- 8. Centermember

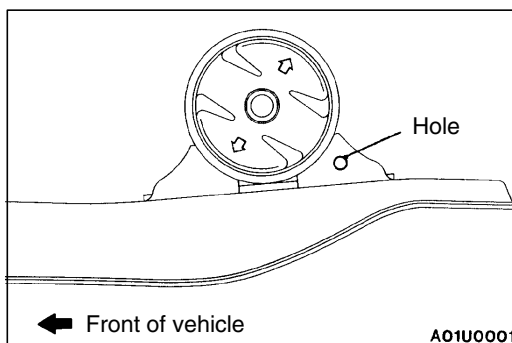

INSTALLATION SERVICE POINTS

▶A◀ REAR ROLL STOPPER BRACKET ASSEMBLY INSTALLATION

Install so that the hole in the rear roll stopper bracket is facing towards the rear of the vehicle.

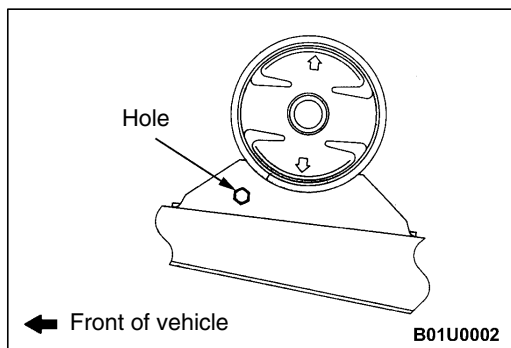
**▶B◀ FRONT ROLL STOPPER BRACKET ASSEMBLY
INSTALLATION**

Install so that the hole in the front roll stopper bracket is facing towards the front of the vehicle.