

GROUP 36

PARKING BRAKES

GENERAL

OUTLINE OF CHANGES

The service procedures of the parking brakes have been established to correspond to the adoption of the rear disc brakes.

ON-VEHICLE SERVICE

PARKING BRAKE LEVER STROKE CHECK

Check the parking brake lever stroke according to the previous procedure.

Standard value:

5–7 notches [Operation force: Approx. 196N]

If the parking brake lever stroke is not the standard value, adjust as described below.

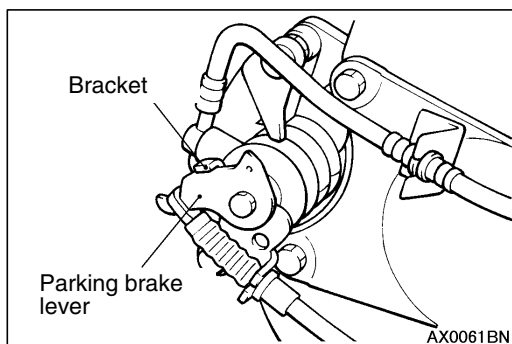
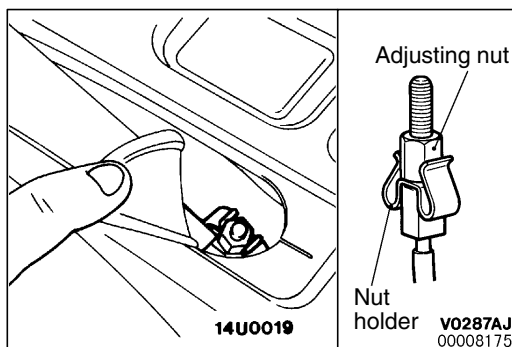

1. Loosen the adjusting nut to the end of the cable rod, thus freeing the parking brake cable.
2. With the engine idling, forcefully depress the brake pedal five or six times and confirm that the pedal stroke stops changing.

NOTE

If the pedal stroke stops changing, the automatic-adjustment mechanism is functioning normally, and the clearance between the pad and disc is correct.

3. Check that the parking brake lever on the caliper side is touching the bracket.

NOTE

If the parking brake lever is not touching the bracket, the parking brake cable might be stuck or routed incorrectly, or there might be a problem with the automatic adjustment mechanism inside the rear brake calipers. Therefore, it is necessary to check the parking brake cable and rear brake calipers.

4. Turn the adjusting nut to adjust the parking brake lever stroke to the standard value. After adjusting, check that there is no space between the adjusting nut and the parking brake lever. Check that the adjusting nut is also securely held by the nut holder.

Caution

If the parking brake lever stroke is below the standard value and the braking is too firm, the rear brakes may drag.

- After adjusting the parking brake lever stroke, jack up the rear of the vehicle. Release the parking brake and turn the rear wheels to check that the rear brakes are not dragging. In addition, check that the parking brake lever on the caliper side is touching the bracket.

PARKING BRAKE CABLE REMOVAL AND INSTALLATION

Pre-removal Operation Floor Console Removal

Post-installation Operation

- Parking Brake Lever Stroke Adjustment (Refer to P.36-1.)
- Floor Console Installation

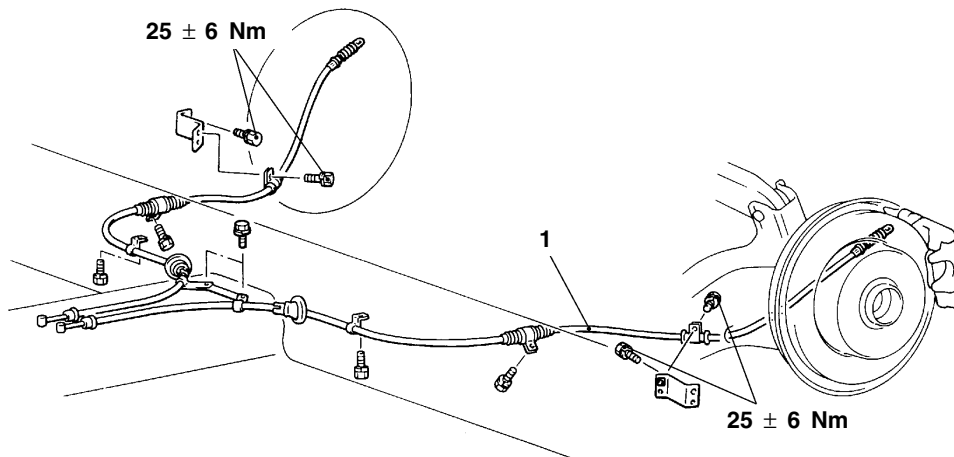

AX0019BN

▶A◀ 1. Parking brake cable

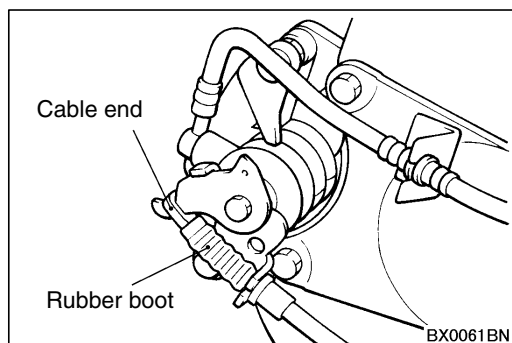

INSTALLATION SERVICE POINT

▶A◀ PARKING BRAKE CABLE INSTALLATION

Connect the parking brake cable, and then make sure that the rubber boot is securely engaged with the cable end.