

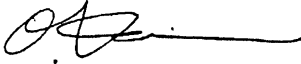

SERVICE BULLETIN

PUBLICATION GROUP, AFTER SALES SERVICE DEP.
MITSUBISHI MOTOR SALES EUROPE BV

SERVICE BULLETIN		No.: ESB-99E35-506	
		Date: 2000-04-15	<Model> (EC) CARISMA (EC) SPACE STAR
			<M/Y> 96-10
Subject:	ADDITION OF CAUTION ON READING OF DIAGNOSTIC TROUBLE CODES		
Group:	SERVICE BRAKE		
CORRECTION	 O. Kai - E.V.P. & G.M. After Sales Service Dept.		
1. Description:			
Caution has been added on reading of the diagnostic trouble codes by use of the ABS warning light.			
2. Applicable Manuals:			
Manual	Pub. No.	Language	Page(s)
'96 CARISMA Workshop Manual Chassis	PWDE9502	(English)	35B-7
	PWDS9503	(Spanish)	
	PWDF9504	(French)	
	PWDG9505	(German)	
	PWDD9506	(Dutch)	
	PWDW9507	(Swedish)	
	PWDI96E1	(Italian)	
'99 SPACE STAR Workshop Manual Chassis	CMXE99E1	(English)	35B-6
	CMXS99E1	(Spanish)	
	CMXF99E1	(French)	
	CMXG99E1	(German)	
	CMXD99E1	(Dutch)	
	CMXW99E1	(Swedish)	
	CMXI99E1	(Italian)	
3. Details:			
'96 CARISMA Workshop Manual chassis, page 2			
'99 SPACE STAR Workshop Manual chassis, page 3			

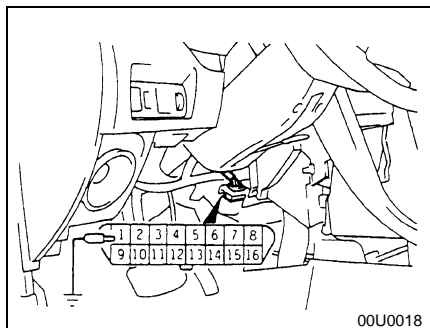

Without the MUT-II

1. Use the special tool to earth diagnosis connector terminal No. 1.

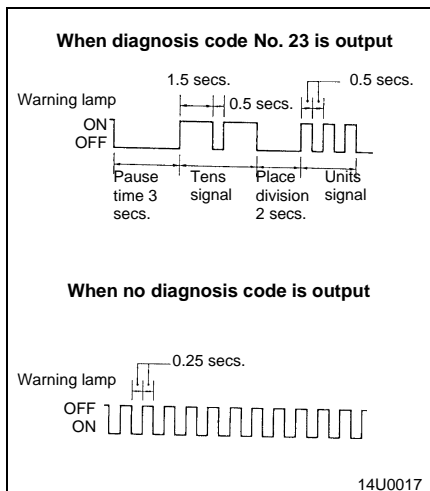

2. Turn the ignition switch to ON and then take a reading of the diagnosis codes from the flashing of the ABS warning lamp.

<Added>

Caution:

After placing the ignition switch in the ON position, do not press the brake pedal.

When an ABS fault occurs, if the brake pedal is depressed with the ignition switch in the ON position, the ABS warning light will remain illuminated.

This makes it impossible for the diagnostic trouble codes to be read.

ERASING DIAGNOSIS CODES

With the MUT-II

Connect the MUT-II to the diagnosis connector (16-pin), then erase the diagnosis codes.

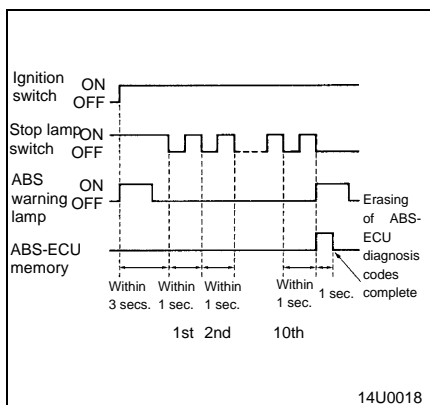

Without the MUT-II

The diagnosis codes can only be erased by operating the brake switch ten times according to the pattern shown in the illustration at left while the ABS is active and while driving at a speed of 10 km/h or less.

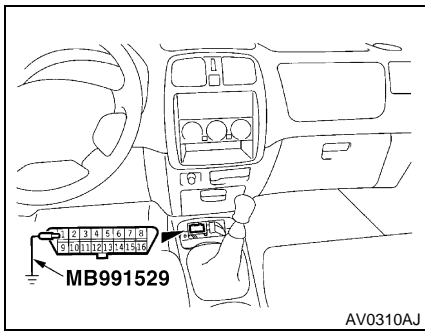

Without the MUT-II

1. Use the special tool to earth diagnosis connector terminal No. 1.

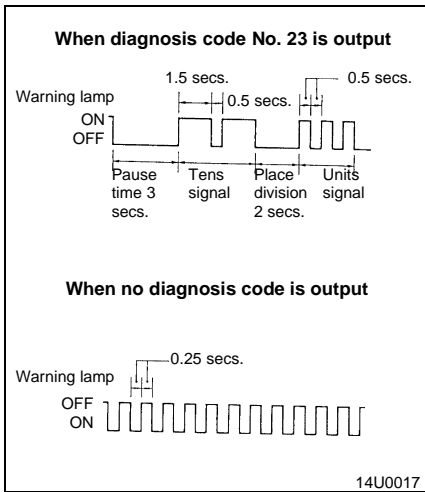

3. Turn the ignition switch to ON and then take a reading of the diagnosis codes from the flashing of the ABS warning lamp.

<Added>

Caution:

After placing the ignition switch in the ON position, do not press the brake pedal.

When an ABS fault occurs, if the brake pedal is depressed with the ignition switch in the ON position, the ABS warning light will remain illuminated.

This makes it impossible for the diagnostic trouble codes to be read.

ERASING DIAGNOSIS CODES

With the MUT-II

Connect the MUT-II to the diagnosis connector (16-pin), then erase the diagnosis codes.

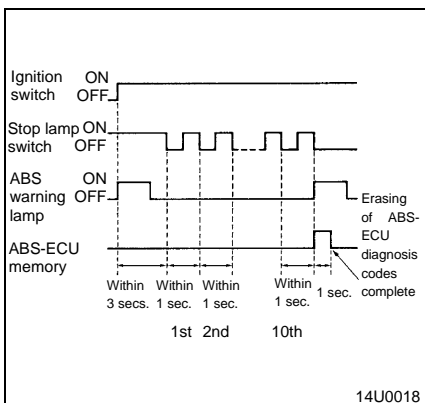

Without the MUT-II

The diagnosis codes can only be erased by operating the brake switch ten times according to the pattern shown in the illustration at left while the ABS is active and while driving at a speed of 10 km/h or less.