

---

# FRONT SUSPENSION

## CONTENTS

33109000094

<b>GENERAL INFORMATION</b> .....	<b>2</b>	<b>STRUT ASSEMBLY</b> .....	<b>6</b>
<b>SERVICE SPECIFICATIONS</b> .....	<b>2</b>	<b>LOWER ARM ASSEMBLY</b> .....	<b>10</b>
<b>SPECIAL TOOLS</b> .....	<b>3</b>	<b>STABILIZER BAR</b> .....	<b>14</b>
<b>ON-VEHICLE SERVICE</b> .....	<b>4</b>		
Wheel Alignment Check and Adjustment .....	4		
Ball Joint Dust Cover Check .....	5		



## 33A-2 FRONT SUSPENSION - General Information/Service Specifications

### GENERAL INFORMATION

33100010089

The front suspension is a McPherson strut with coil spring. The shock absorber is hydraulic double-acting type.

### COIL SPRING

Items	SPACE RUNNER	SPACE WAGON - 2WD	SPACE WAGON - 4WD
Wire diameter × average diameter × free length mm	13.6 × 160 × 368	14.0 × 160 × 371	14.1 × 160 × 381

### CONSTRUCTION DIAGRAM

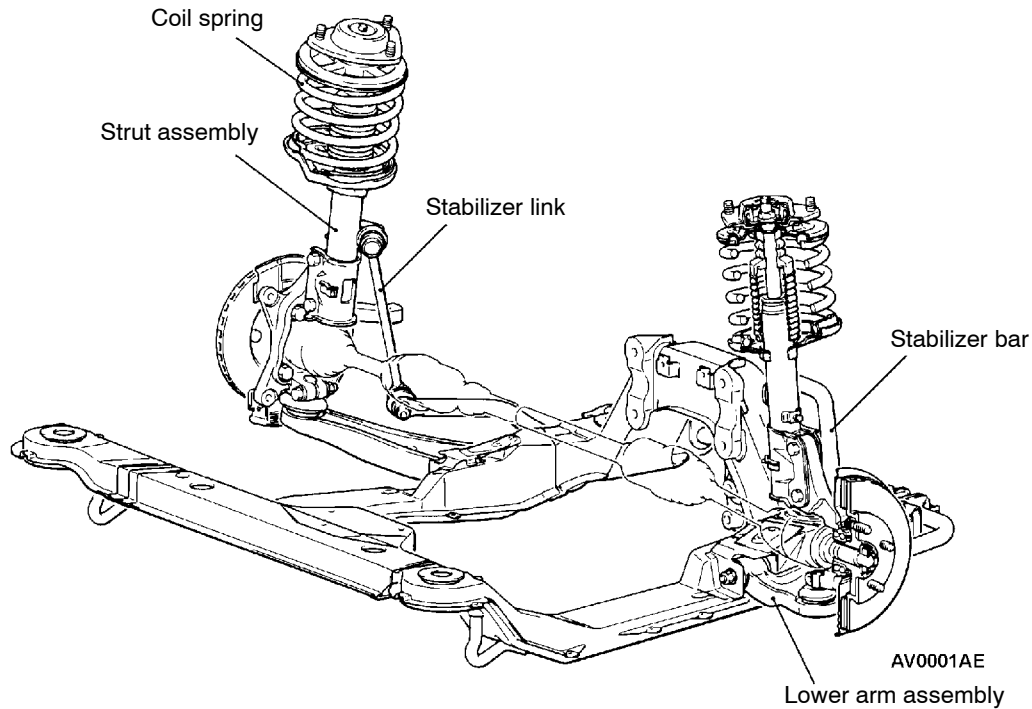

### SERVICE SPECIFICATIONS

33100030115

Items		SPACE RUNNER	SPACE WAGON
Toe-in	At the centre of tyre tread mm	0 ± 3	0 ± 3
	Toe-angle (per wheel)	0° 00' ± 08'	0° 00' ± 08'
Toe-out angle on turns (inner wheel when outer wheel at 20°)		22° 10'	21° 50'
Camber		0° 00' ± 30' *	-0° 10' ± 30' *
Caster		2° 45' ± 30' *	2° 50' ± 30' *
Kingpin inclination		11° 27'	12° 49'
Lower arm ball joint rotation starting torque Nm		2.0 - 8.8	2.0 - 8.8
Stabilizer link ball joint turning torque Nm		1.7 - 3.1	1.7 - 3.1

#### NOTE

\*: difference between right and left wheel: less than 30'

SPECIAL TOOLS

33100060077

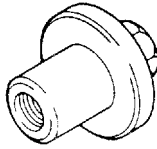
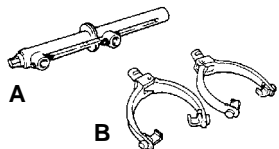
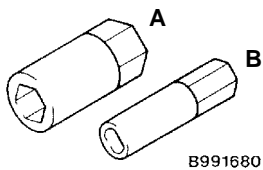
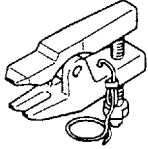
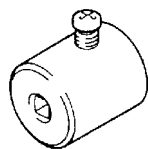
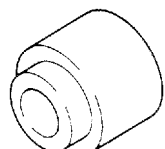
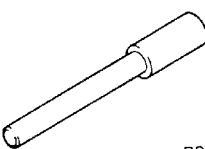
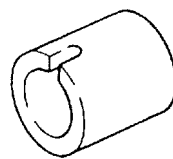
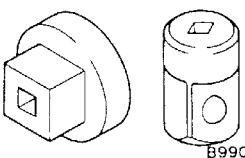
Tools	Number	Name	Use
 <p>B991004</p>	MB991004	Wheel alignment gauge attachment	Wheel alignment measurement <Vehicles with aluminium type wheelsd
 <p>A B 00003796</p>	A: MB991237 B: MB991238	A: Spring compressor body B: Arm set	Coil spring compression
 <p>A B B991680</p>	A: MB991619 B: MB991682	A: Wrench B: Socket	Strut assembly disassembly and reassembly
 <p>B991113</p>	MB991406, MB990635 or MB991113	Steering linkage puller	Tie rod end disconnection
 <p>B991006</p>	MB991006	Preload socket	Lower arm ball joint rotation starting torque measurement
 <p>B990800</p>	MB990800	Ball joint remover and installer	Lower arm ball joint dust cover installation
 <p>B990651</p>	MB990651	Bar	Driving out and press-fitting of lower arm bushing
	MB998716	Crankshaft wrench	
 <p>B990326</p>	MB990326	Preload socket	Stabilizer link ball joint turning torque measurement

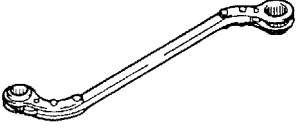
Tools	Number	Name	Use
 B991163	MB991164	Door adjusting wrench	Stabilizer bar bracket mounting bolt removal and installation

## ON-VEHICLE SERVICE

33100090267

### WHEEL ALIGNMENT CHECK AND ADJUSTMENT

Measure the wheel alignment with the vehicle parked on a level surface.

The front suspension, steering system, and wheels should be serviced to normal condition prior to measurement of wheel alignment.

#### TOE-IN

##### Standard value:

**At the centre of tyre tread  $0 \pm 3$  mm**

**Toe angle (per wheel)  $0^{\circ}00' \pm 08'$**

1. If the toe-in is not within the standard value, adjust the toe-in by undoing the clip and turning the left and right tie rod turnbuckles by the same amount (in opposite directions).

##### NOTE

The toe will move out as the left turnbuckle is turned toward the front of the vehicle and the right turnbuckle is turned toward the rear of the vehicle.

2. Use a turning radius gauge to check that the steering angle is at the standard value.  
(Refer to GROUP37A - On-vehicle Service.)

#### TOE-OUT ANGLE ON TURNS

To check the steering linkage, especially after the vehicle has been involved in an accident or if an accident is presumed, it is advisable to check the toe-out angle on turns in addition to the wheel alignment.

Conduct this test on the left turn as well as on the right turn.

**Standard value (inner wheel when outer wheel at  $20^{\circ}$ ) :**

**<SPACE RUNNER>  $22^{\circ}10'$**

**<SPACE WAGON>  $21^{\circ}50'$**

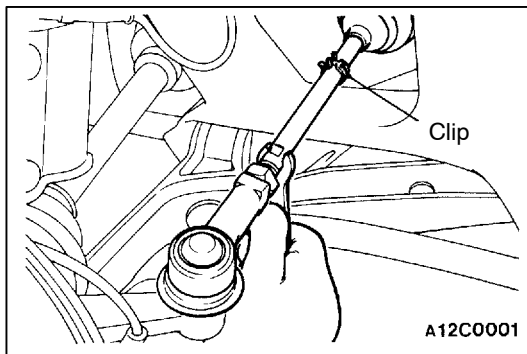

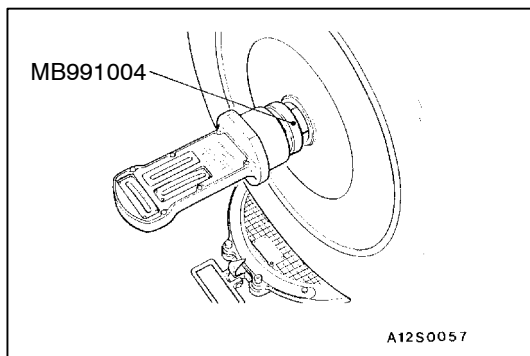
**CAMBER, CASTER AND KINGPIN INCLINATION****Standard value:**

Item	SPACE RUNNER	SPACE WAGON
Camber (difference between right and left wheel: less than 30')	0°00' ± 30'	-0°10' ± 30'
Caster (difference between right and left wheel: less than 30')	2°45' ± 30'	2°50' ± 30'
Kingpin inclination	11° 27'	12° 49'

**NOTE**

1. Camber and caster are preset at the factory and cannot be adjusted.
2. If camber is not within the standard value, check and replace bent or damaged parts.
3. For vehicles with aluminium type wheels, attach the camber/caster/kingpin gauge to the drive shaft by using the special tool. Tighten the special tool to the same torque 196 - 255 Nm as the drive shaft nut.

**Caution**

**To prevent the wheel bearing from damage, never subject the wheel bearings to the vehicle load when the drive shaft nuts are loosened.**

**BALL JOINT DUST COVER CHECK**

33200860090

1. Check the dust cover for cracks or damage by pushing it with finger.
2. If the dust cover is cracked or damaged, replace the upper arm assembly, compression lower arm assembly, lateral lower arm assembly or stabilizer link.

**NOTE**

Cracks or damage of the dust cover may cause damage of the ball joint.

## STRUT ASSEMBLY

33200110126

## REMOVAL AND INSTALLATION

**Pre-removal Operation**

Injector Driver Removal (Refer to GROUP 13.)

**Post-installation Operation**

- Injector Driver Installation (Refer to GROUP 13.)
- Check the Dust Cover for Cracks or Damage by Pushing it with Finger.
- Wheel Alignment Check and Adjustment (Refer to P.33A-4.)

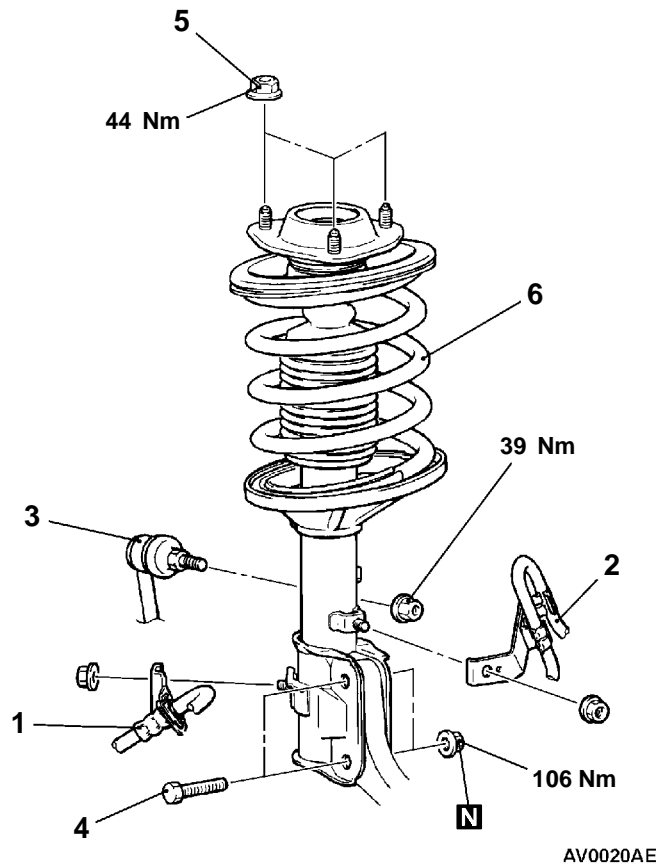
**Removal steps**

1. Brake hose bracket
2. Front wheel speed sensor harness  
<Vehicles with ABS>
3. Stabilizer link connection
4. Knuckle connection
5. Strut mounting nut
6. Strut assembly

**INSPECTION**

33200120020

- Check for oil leaks from the strut assembly.
- Check the strut assembly for damage or deformation

DISASSEMBLY AND REASSEMBLY

33200130139

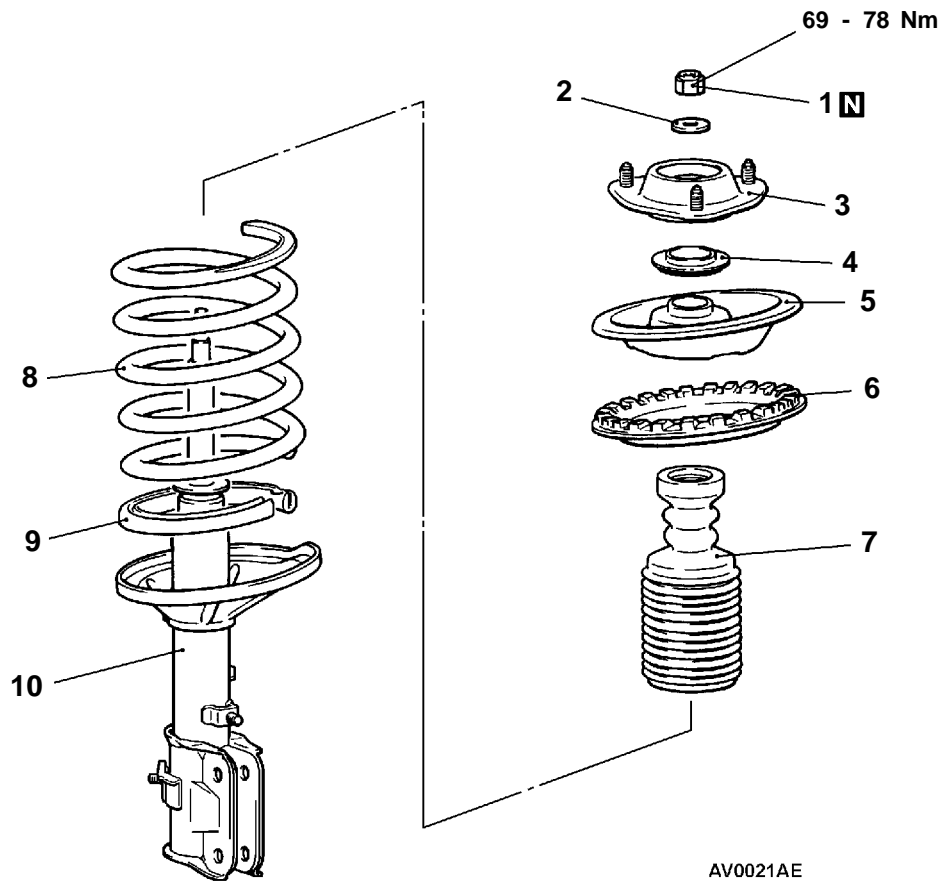

AV0021AE

**Disassembly steps**



1. Self-locking nut
2. Washer
3. Strut insulator assembly
4. Bearing
5. Upper spring seat

6. Upper spring pad
7. Bump rubber
8. Coil spring
9. Spring tube
10. Strut assembly

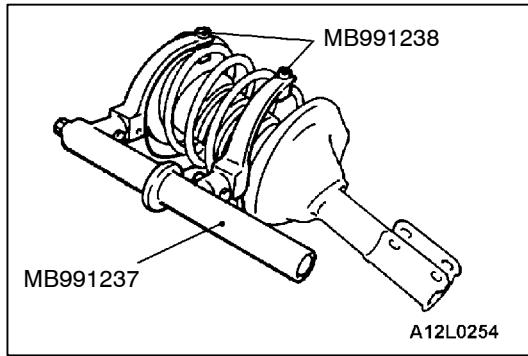

## DISASSEMBLY SERVICE POINT

### ◀A▶ SELF-LOCKING NUT REMOVAL

1. Use the special tools to compress the coil spring.

#### Caution

- (1) To compress the coil spring sufficiently, install the special tools evenly, and so that the maximum length will be attained within the installation range.
- (2) To prevent the special tool from damage, do not use an impact wrench to tighten the special tool bolt.

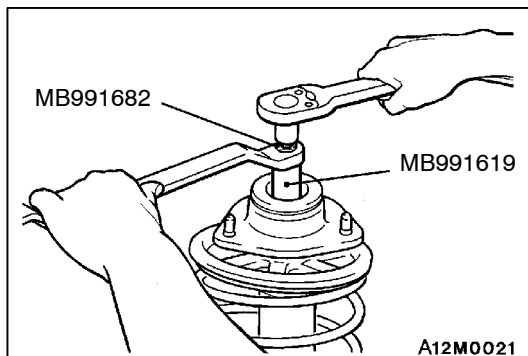

2. Use the special tools to remove the self-locking nut.

#### Caution

Do not use an impact wrench as internal parts of the strut assembly will be loosened.

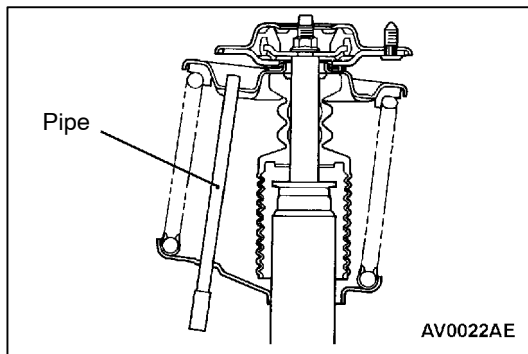

## REASSEMBLY SERVICE POINT

### ▶A◀ SELF-LOCKING NUT INSTALLATION

1. Check that the bearing is properly assembled.
2. With the coil spring held compressed by the special tools (MB991237 and MB991238), provisionally tighten the self-locking nut.

#### Caution

To prevent the special tool from damage, do not use an impact wrench to tighten the special tool bolt.

3. Line up the holes in the strut assembly lower spring seat with the hole in the upper spring seat.

#### NOTE

The job is easily accomplished with a pipe.

4. Correctly align both ends of the coil spring with the grooves in the spring seat, and then loosen the special tools (MB991237 and MB991238).



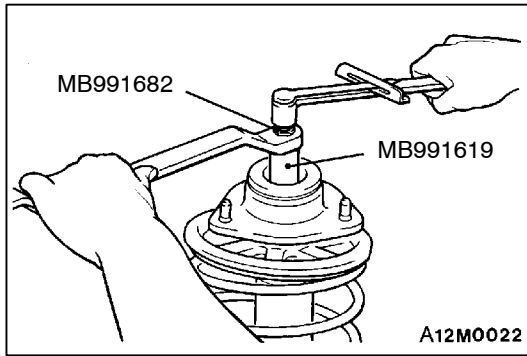

5. Using the special tool, tighten the self-locking nut to the specified torque.

**Specified torque: 69 - 78 Nm**

**Caution**

**Do not use an impact wrench as internal parts of the strut assembly will be loosened.**

**INSPECTION**

33200140064

- Check the bearing for wear or rust.
- Check the rubber parts for damage or deterioration.
- Check the spring for deformation, deterioration or damage.
- Check the shock absorber for deformation.

# LOWER ARM ASSEMBLY

## REMOVAL AND INSTALLATION

### Caution

\*: To prevent bushings from breakage the parts indicated by \* should be temporarily tightened, and then fully tightened with the vehicle on the ground in the unladen condition.

#### Post-installation Operation

- Check the Dust Cover for Cracks or Damage by Pushing it with Finger.
- Wheel Alignment Check and Adjustment (Refer to P.33A-4.)

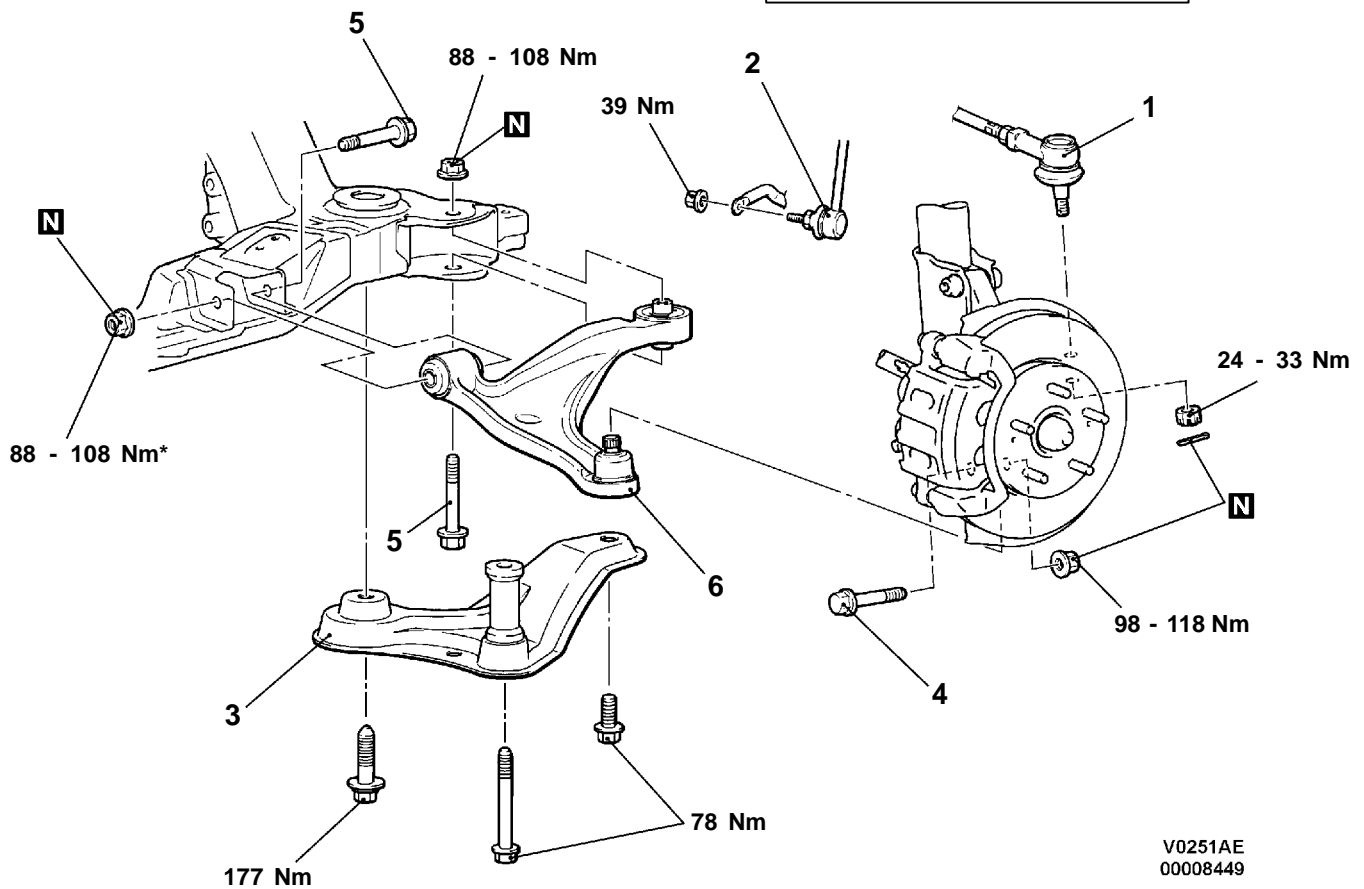
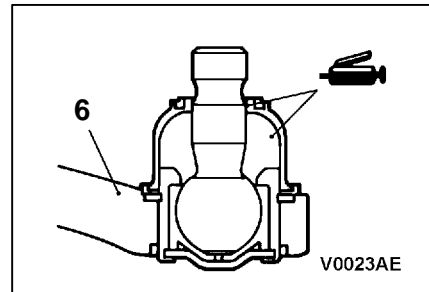

V0251AE  
00008449

### Removal steps



1. Tie rod end connection
2. Stabilizer link connection



3. Stay
4. Lower arm and knuckle connection



5. Lower arm and front member connection

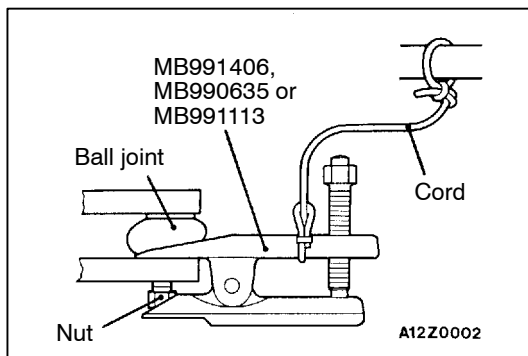

6. Lower arm assembly

**REMOVAL SERVICE POINTS****◀A▶ TIE ROD END DISCONNECTION****Caution**

1. Loosen the nut of the special tool, but do not remove it. If it is removed, the ball joint thread will be damaged.
2. Tie the special tool with a cord not to let it fall off.

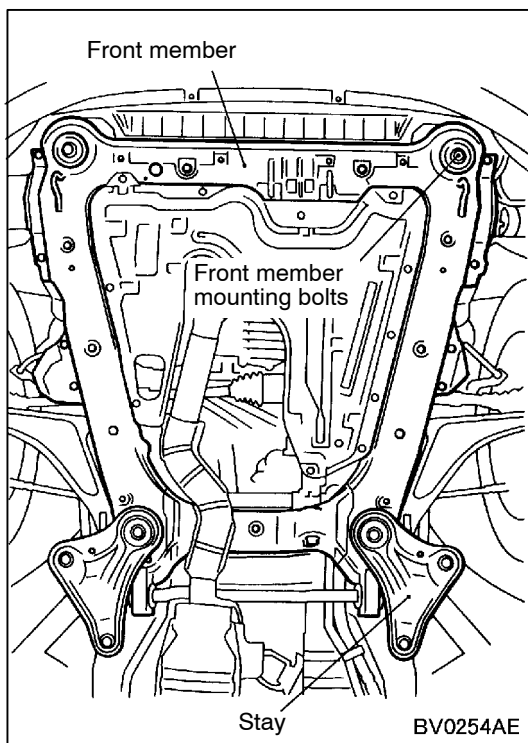
**◀B▶ STAY REMOVAL**

The stay is tightened together with the front member. After the stay is removed, tighten the bolts loosely to hold the front member.

**NOTE**

If the lower arm assembly has been removed, tighten the bolts loosely to hold the front member.

**◀C▶ LOWER ARM AND FRONT MEMBER DISCONNECTION**

To remove the connection bolts of the lower arm at the vehicle rear side, remove the front member mounting bolts, and then lower the front member.

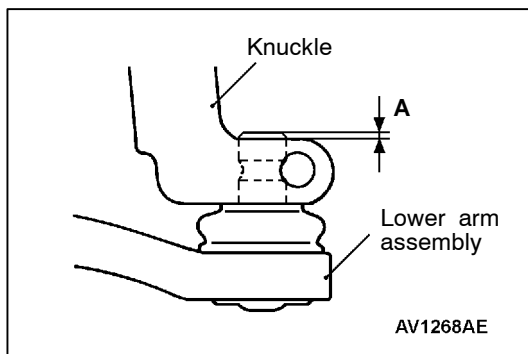
**INSTALLATION SERVICE POINT****▶A◀ LOWER ARM ASSEMBLY INSTALLATION**

1. Install the lower arm assembly to the knuckle.

**Caution**

When installing the lower arm assembly, make sure that the ball joint stud (A) does not protrude 4 mm or more from the knuckle in order to prevent grease from flowing out.

2. If grease has flown out of the dust cover by pushing the lower arm in the knuckle excessively, replace the dust cover. (Refer to P.33A-12.)
3. Check that there is no clearance between the knuckle and the dust cover.

**INSPECTION**

33200170117

- Check the bushing for wear and deterioration.
- Check the lower arm for bend or breakage.
- Check the stay for deterioration or damage.
- Check all bolts for condition and straightness.

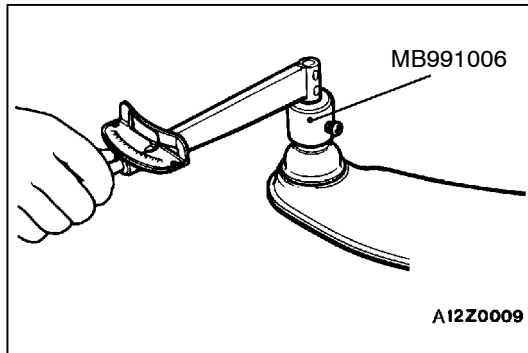
**LOWER ARM BALL JOINT ROTATION STARTING TORQUE CHECK**

1. After shaking the ball joint stud several times, install the nut to the stud and use the special tool to measure the rotation starting torque of the ball joint.

**Standard value: 2.0 - 8.8 Nm**

2. When the measured value exceeds the standard values, replace the lower arm assembly.
3. When the measured value is lower than the standard value, check that the ball joint turns smoothly without excessive play. If so, it is possible to use that ball joint.

**LOWER ARM BALL JOINT DUST COVER CHECK**

1. Check the dust cover for cracks or damage by pushing it with finger.
2. If the dust cover is cracked or damaged, replace the lower arm assembly.

**NOTE**

Cracks or damage of the dust cover may cause damage of the ball joint. When it is damaged during service work, replace the dust cover.

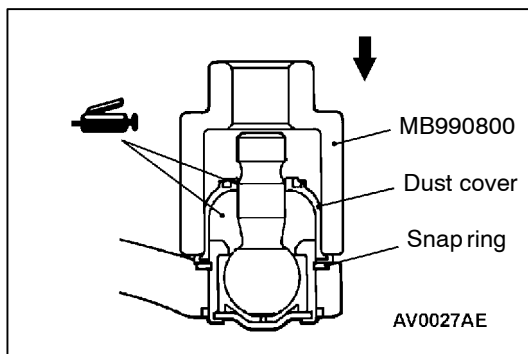
**LOWER ARM BALL JOINT DUST COVER REPLACEMENT**

33200820098

Only when the dust cover is damaged accidentally during service work, replace the dust cover as follows:

1. Remove the dust cover.
2. Apply multipurpose grease to the lip and inside of the dust cover.
3. Using the special tool, press the dust cover until it contacts the snap ring.
4. Check the dust cover for cracks or damage by pushing it with finger.

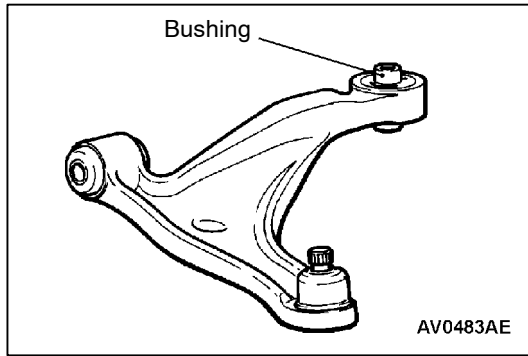
**BUSHING REPLACEMENT**

33200810118

Replace the rear bushing by the following procedure.

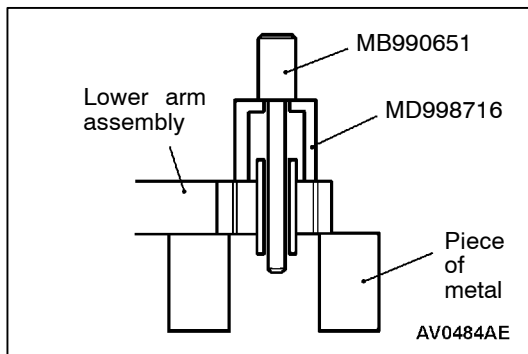

1. Use the special tools to drive out the bushing.

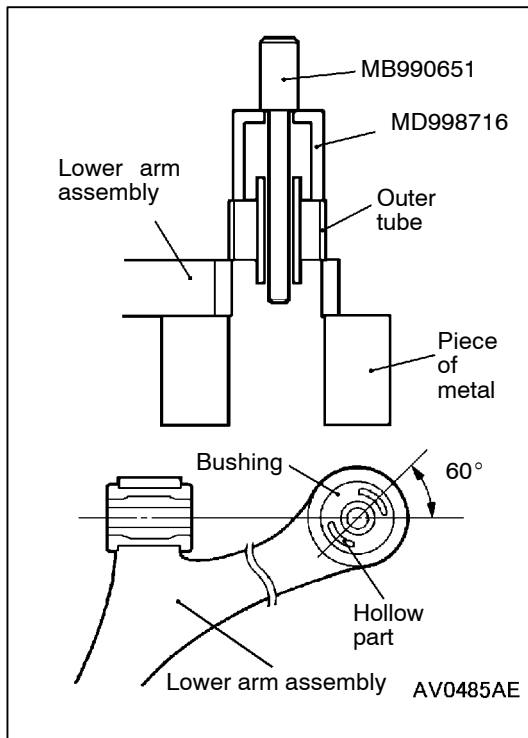

2. Use the special tools to press in the bushing.

3. Position the bushing so that its hollow part is as shown.

4. Press in the bushing until its outer tube top surface is lined up with the lower arm assembly.

## STABILIZER BAR

### REMOVAL AND INSTALLATION

#### Post-installation Operation

Check the Dust Cover for Cracks or Damage by Pushing it with Finger.

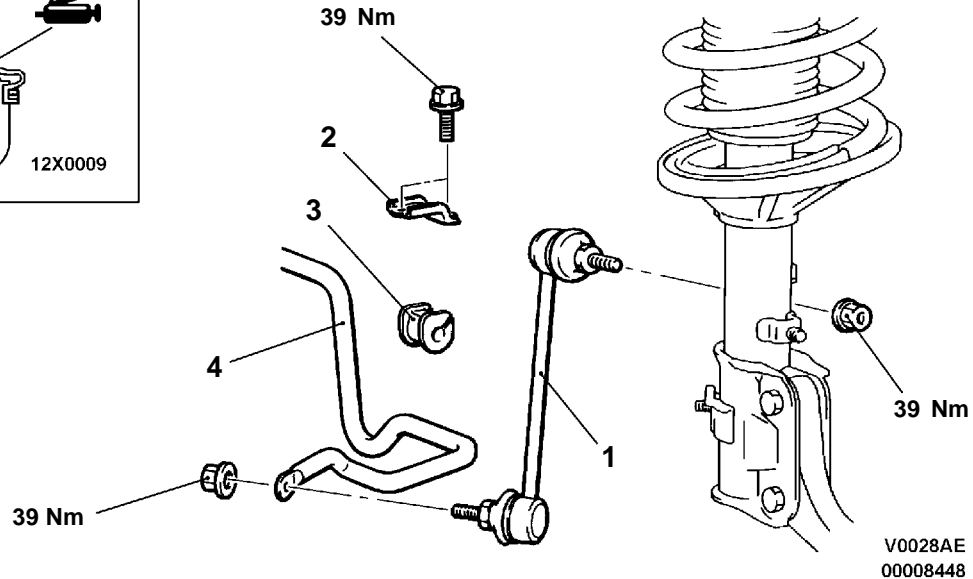
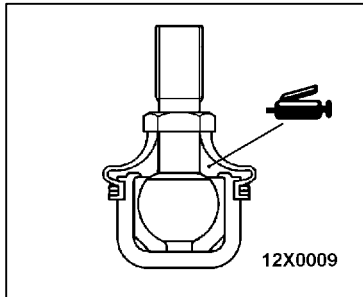

#### Removal steps

1. Stabilizer link
- Front member (Refer to GROUP 32.)
- ▶A▶ 2. Stabilizer bar bracket
- ▶A▶ 3. Bushing\*
- ▶A▶ 4. Stabilizer bar

#### NOTE

\*: If only the bushing is removed and installed, refer to P.33A-15.

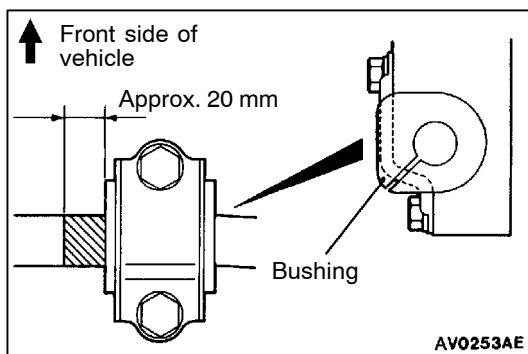

#### INSTALLATION SERVICE POINT

##### ▶A▶ STABILIZER BAR/BUSHING/STABILIZER BAR BRACKET INSTALLATION

1. Position the bushing so that its cut is aligned as shown.
2. Position the stabilizer at the left side of the vehicle so that its identification mark is as shown, and then tighten the stabilizer bar bracket mounting bolts.

**INSPECTION**

332000200076

- Check the bushing for wear and deterioration.
- Check the stabilizer bar for deterioration or damage.
- Check all bolts for condition and straightness.

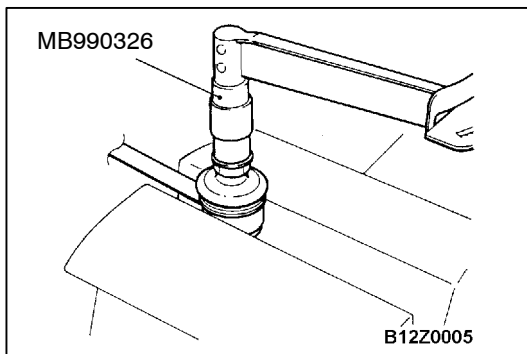
**STABILIZER LINK BALL JOINT TURNING TORQUE CHECK**

1. After shaking the ball joint stud several times, install the nut to the stud and use the special tool to measure the turning torque of the ball joint.

**Standard value: 1.7 - 3.1 Nm**

2. When the measured value exceeds the standard value, replace the stabilizer link.
3. When the measured value is lower than the standard value, check that the ball joint turns smoothly without excessive play. If so, it is possible to use that ball joint.

**STABILIZER LINK BALL JOINT DUST COVER CHECK**

1. Check the dust cover for cracks or damage by pushing it with finger.
2. If the dust cover is cracked or damaged, replace the stabilizer link.

**NOTE**

Cracks or damage of the dust cover may cause damage of the ball joint. When it is damaged during service work, replace the dust cover.

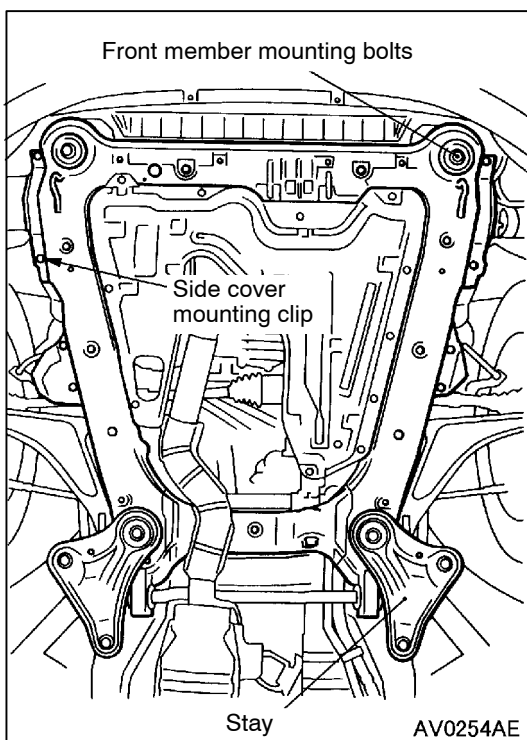
**BUSHING REPLACEMENT**

33201010012

1. Remove the side cover mounting clip.
2. Remove the front member mounting bolt and stay.

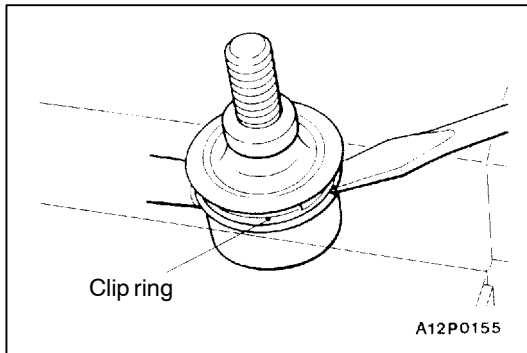
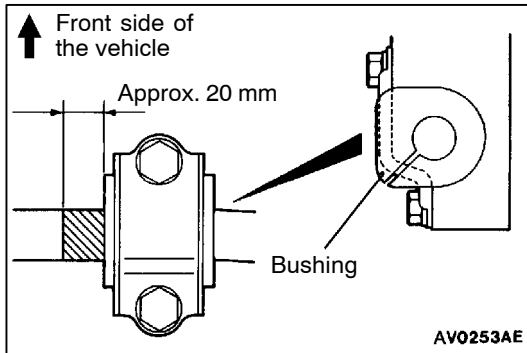
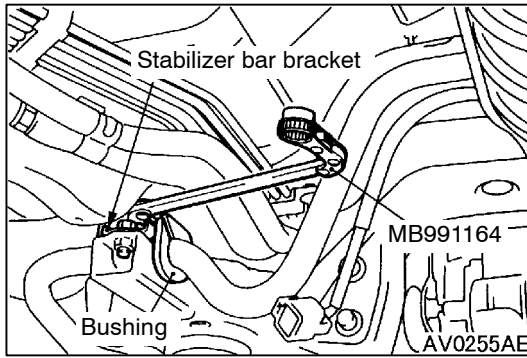

3. Use the special tool to remove the stabilizer bar bracket mounting bolt.
4. Remove the stabilizer bar bracket.

5. Position a new bushing so that its cut is as shown.
6. Position the stabilizer at the left side of the vehicle so that its identification mark is as shown, and then tighten the stabilizer bar bracket mounting bolts.
7. Install the stay, front member, side cover mounting clip in that order.

### STABILIZER LINK BALL JOINT DUST COVER REPLACEMENT

33201020015

Only when the dust cover is damaged accidentally during service work, replace the dust cover as follows:

1. Remove the clip ring and the dust cover.
2. Apply multipurpose grease to the inside of the dust cover.
3. Use plastic tape on the stabilizer link threads as shown in the illustration, and then install the dust cover to the stabilizer link.
4. Secure the dust cover by the clip ring.
5. Check the dust cover for cracks or damage by pushing it with finger.