

---

# REAR SUSPENSION

## CONTENTS

34109000206

<b>GENERAL INFORMATION</b> .....	<b>2</b>	<b>SHOCK ABSORBER ASSEMBLY</b> .....	<b>6</b>
<b>SERVICE SPECIFICATIONS</b> .....	<b>2</b>	<b>REAR SPRING</b> .....	<b>8</b>
<b>SPECIAL TOOLS</b> .....	<b>3</b>	<b>LOWER ARM ASSEMBLY</b> .....	<b>10</b>
<b>ON-VEHICLE SERVICE</b> .....	<b>4</b>	<b>SUSPENSION CROSSMEMBER</b> .....	<b>15</b>
Wheel Alignment Check and Adjustment .....	4	<b>STABILIZER BAR</b> .....	<b>18</b>
Wheel Bearing Axial Play Check <4WD> .....	5		



## GENERAL INFORMATION

34100010277

The rear suspension is a semi-trailing arm type suspension.

## COIL SPRING

Items	SPACE RUNNER	SPACE WAGON
Wire diameter × average diameter × free length mm	13 × 113 × 278	14 - 15 × 114 - 115 × 283 - 285

## CONSTRUCTION DIAGRAM

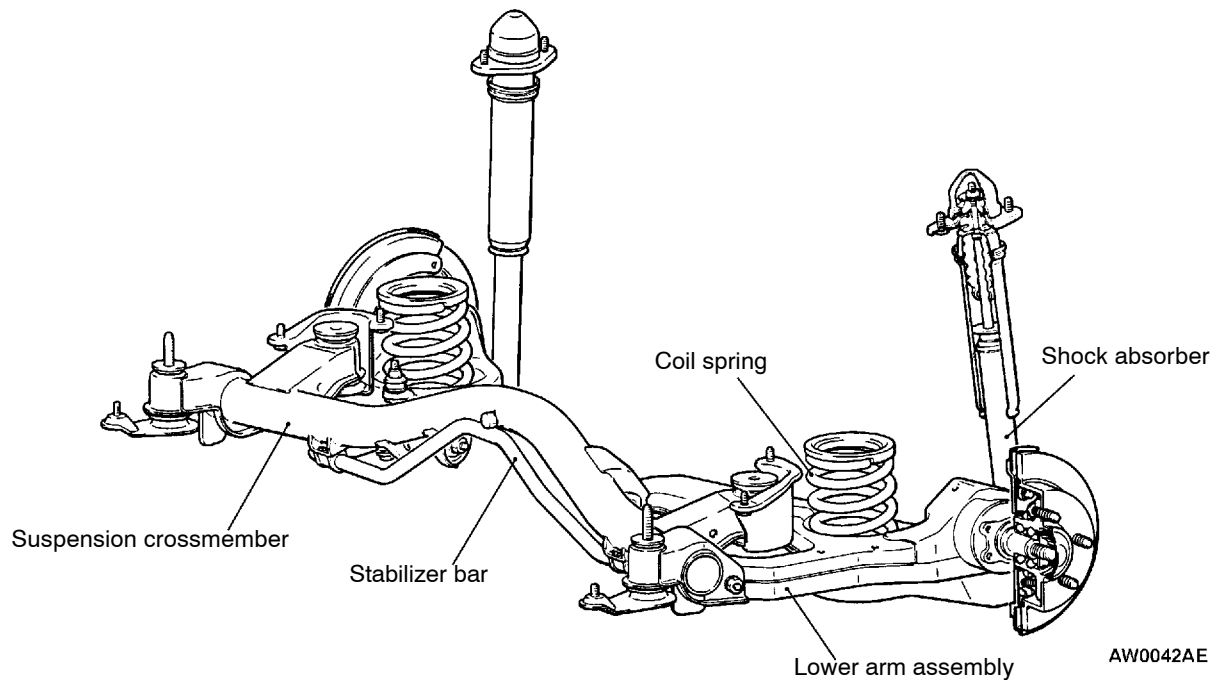

## SERVICE SPECIFICATIONS

34100030235

Items	Specifications
Toe-in	At the centre of tyre tread mm
	Toe-angle (per wheel)
Camber	
Wheel bearing axial play mm	
Wheel bearing rotation starting torque Nm	
Protruding length of stabilizer bar mounting bolt mm	

Specifications values:  
 Toe-in:  $3 \pm 2$  mm  
 Toe-angle:  $0^\circ 15' \pm 10'$   
 Camber:  $-0^\circ 45' \pm 30'$  (difference between right and left wheel: less than  $30'$ )  
 Wheel bearing axial play: 0.05 mm  
 Wheel bearing rotation starting torque: 1.0 or less Nm  
 Protruding length of stabilizer bar mounting bolt: 15 - 17 mm

**SPECIAL TOOLS**

34100060180

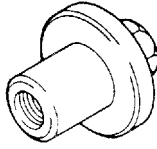
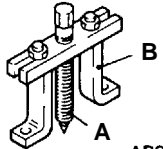
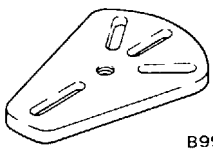
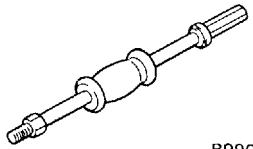
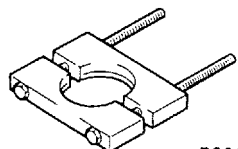
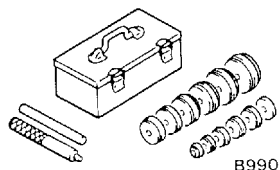
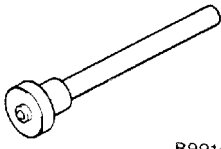
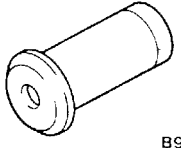
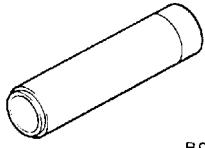
Tool	Number	Name	Use
 <p>B991004</p>	MB991004	Wheel alignment gauge attachment	Wheel alignment measurement cVehicles with aluminium type wheelsd
 <p>AB990241</p>	MB990241 A: MB990242 B: MB990244	Axle shaft puller A: Puller shaft B: Puller bar	Rear hub assembly removal <4WD>
 <p>B991354</p>	MB991354	Puller body	
 <p>B990211</p>	MB990211	Slide hammer	
 <p>B990560</p>	MB990560	Bearing remover	Wheel bearing inner race removal <4WD>
 <p>B990925</p>	MB990925	Bearing and oil seal installer set	Wheel bearing removal <4WD> For details of each installer, refer to GROUP 26 - Special Tools.
 <p>B991400</p>	MB991400	Rear wheel bearing and hub installer	<ul style="list-style-type: none"> <li>• Wheel bearing press-fitting &lt;4WD&gt;</li> <li>• Rear hub assembly press-fitting &lt;4WD&gt;</li> </ul>
 <p>B991401</p>	MB991401	Rear wheel bearing and hub installer base	
 <p>B991411</p>	MB991411	Rear wheel bearing and hub installer joint	

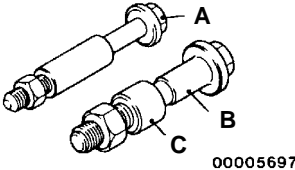
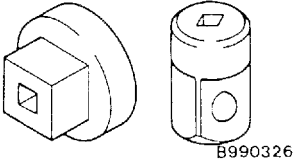
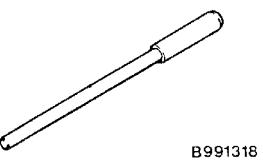
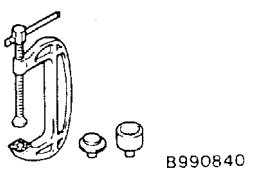
Tool	Number	Name	Use
 00005697	A: MB991017 B: MB990998 C: MB991000	A, B: Front hub remover and installer C: Spacer	Wheel bearing provisional holding MB991000, which belongs to MB990998, should be used as a spacer.
 B990326	MB990326	Preload socket	Wheel bearing rotation starting torque measurement
 B991318	MB991318	Lower arm bushing arbour	Driving out and press-fitting of suspension crossmember
 B990840	MB990840	Universal joint remover and installer	

## ON-VEHICLE SERVICE

33100100144

### WHEEL ALIGNMENT CHECK AND ADJUSTMENT

Measure the wheel alignment with the vehicle parked on level ground.

The rear suspension and wheels should be serviced to the normal condition prior to measurement of wheel alignment.

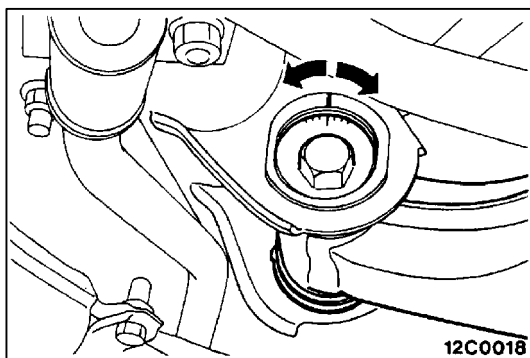

#### TOE-IN

Standard value:

At the centre of tyre tread  $3 \pm 2$  mm

Toe angle (per wheel)  $0^{\circ}15' \pm 10'$

Carry out adjustment by turning the mounting bolts inside the lower arm to the left and right by the same amounts.

LH: Turning clockwise → toe-out direction

RH: Turning clockwise → toe-in direction

Furthermore, toe adjustment can be made at graduations or approximately 2 mm.

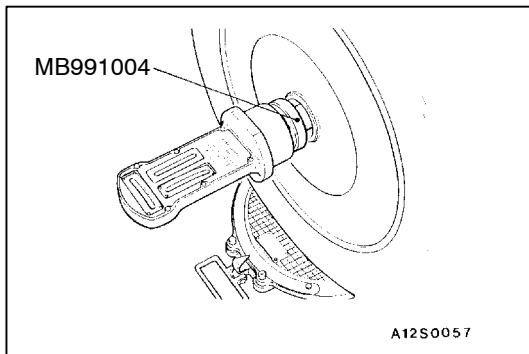

**CAMBER**

**Standard value:**

**-0°45' ± 30' (difference between right and left wheels: less than 30' )**

**NOTE**

1. Camber is preset at the factory and can not be adjusted.
2. For vehicles equipped with aluminium wheels, measure the camber after tightening the special tool (MB991004) to the specified torque 226 Nm.

**Caution**

**To prevent the wheel bearing from damage, never subject the wheel bearings to the full vehicle load when the flange nuts are loosened.**

**WHEEL BEARING AXIAL PLAY CHECK <4WD>**

34101140029

1. Remove the caliper assembly, and then hold it with a wire to prevent it from falling . Then remove the brake disc.

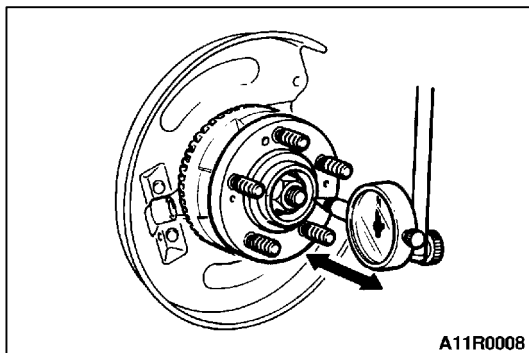

2. Check the bearing's axial play. Place a dial gauge against the hub surface; then move the hub in the axial direction and check whether or not there is axial play.

**Limit: 0.05 mm**

3. If the axial play exceeds the limit, replace the wheel bearing.

## SHOCK ABSORBER ASSEMBLY

34100510197

## REMOVAL AND INSTALLATION

## Caution

\*: To prevent a bushing from breakage, the part indicated by \* should be temporarily tightened, and then fully tightened with the vehicle on the ground in the unladen condition.

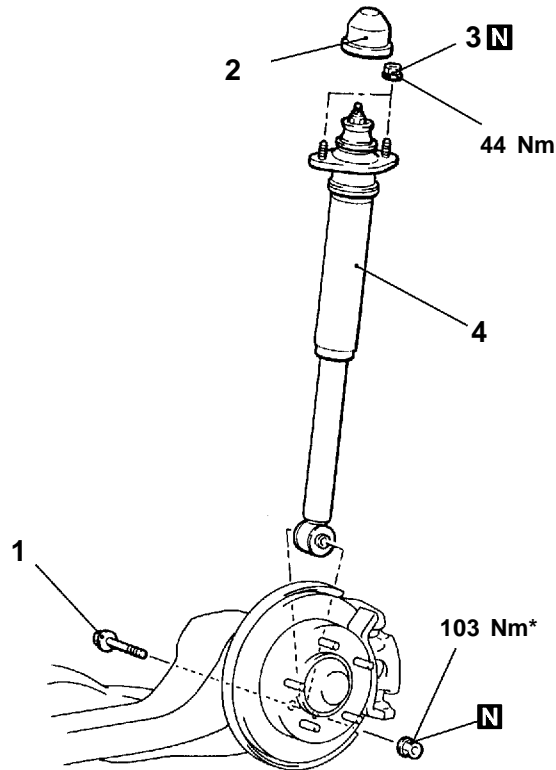

AW0139AE

## Removal steps



1. Shock absorber mounting bolt
  - Quarter armrest assembly  
(Refer to GROUP 52A - Trims.)
2. Cap

3. Shock absorber mounting nuts
4. Shock absorber assembly

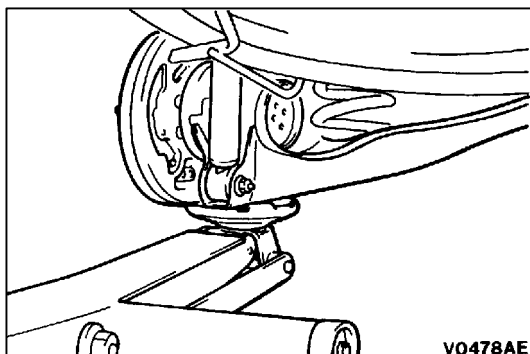

V0478AE

## REMOVAL SERVICE POINT

 SHOCK ABSORBER MOUNTING BOLT  
INSTALLATION

Support the lower arm assembly with a garage jack, and after compressing the coil spring, remove the shock absorber mounting bolt.

DISASSEMBLY AND REASSEMBLY

34100530155

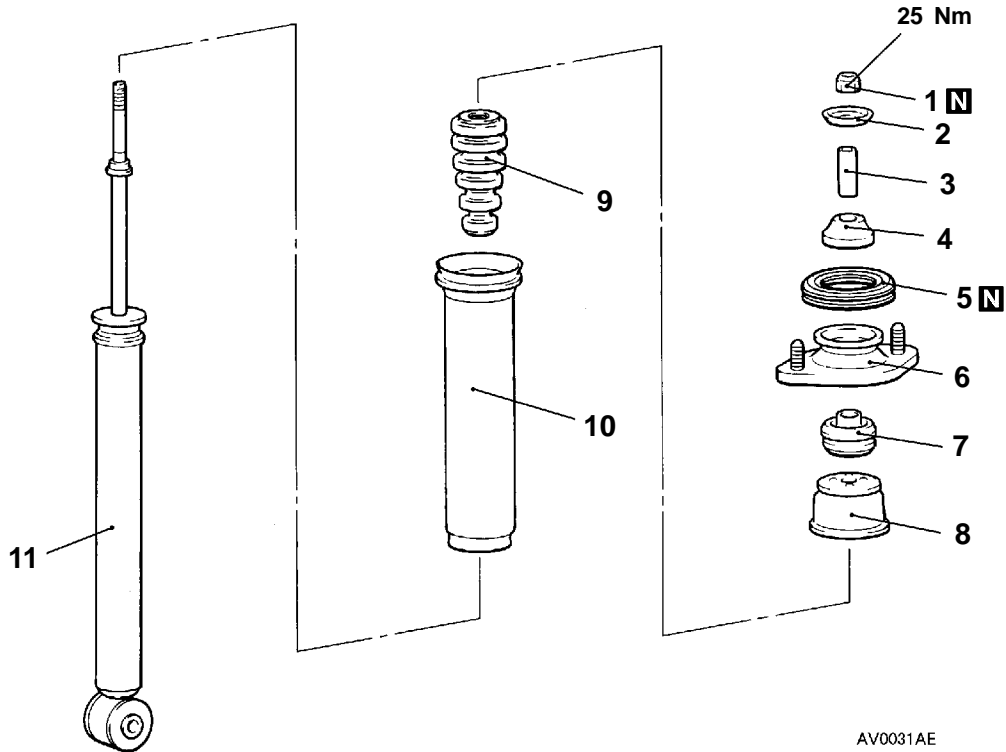

AV0031AE

**Disassembly steps**



1. Self-locking nut
2. Washer
3. Collar
4. Upper bushing
5. Gasket
6. Bracket assembly

7. Upper bushing
8. Cup assembly
9. Bump rubber
10. Dust cover
11. Shock absorber

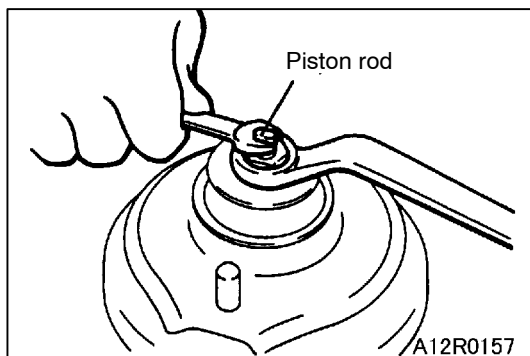

**DISASSEMBLY SERVICE POINT**

**◀A▶ SELF-LOCKING NUT REMOVAL**

Holding the piston rod, remove the self-locking nut.

**Caution**

Do not use an impact wrench as internal parts of the strut assembly will be loosened.

**REASSEMBLY SERVICE POINT**

**▶A◀ SELF-LOCKING NUT INSTALLATION**

**Caution**

Do not use an impact wrench as internal parts of the strut assembly will be loosened.

**INSPECTION**

- Check the rubber parts for damage.
- Check the shock absorber for deformation.

34100540066

# REAR SPRING

## REMOVAL AND INSTALLATION

### Caution

\*: To prevent bushings from breakage the parts indicated by \* should be temporarily tightened, and then fully tightened with the vehicle on the ground in the unladen condition.

#### Pre-removal Operation

- Main Muffler assembly Removal <4WD> (Refer to GROUP 15.)
- Load Sensing Spring Removal <SPACE WAGON - right side only> (Refer to GROUP 35A - Load Sensing Proportioning Valve.)

#### Post-installation Operation

- Load Sensing Spring Installation <SPACE WAGON - right side only> (Refer to GROUP 35A - Load Sensing Proportioning Valve.)
- Main Muffler assembly Installation <4WD> (Refer to GROUP 15.)
- Wheel Alignment Check and Adjustment (Refer to P.34-4.)

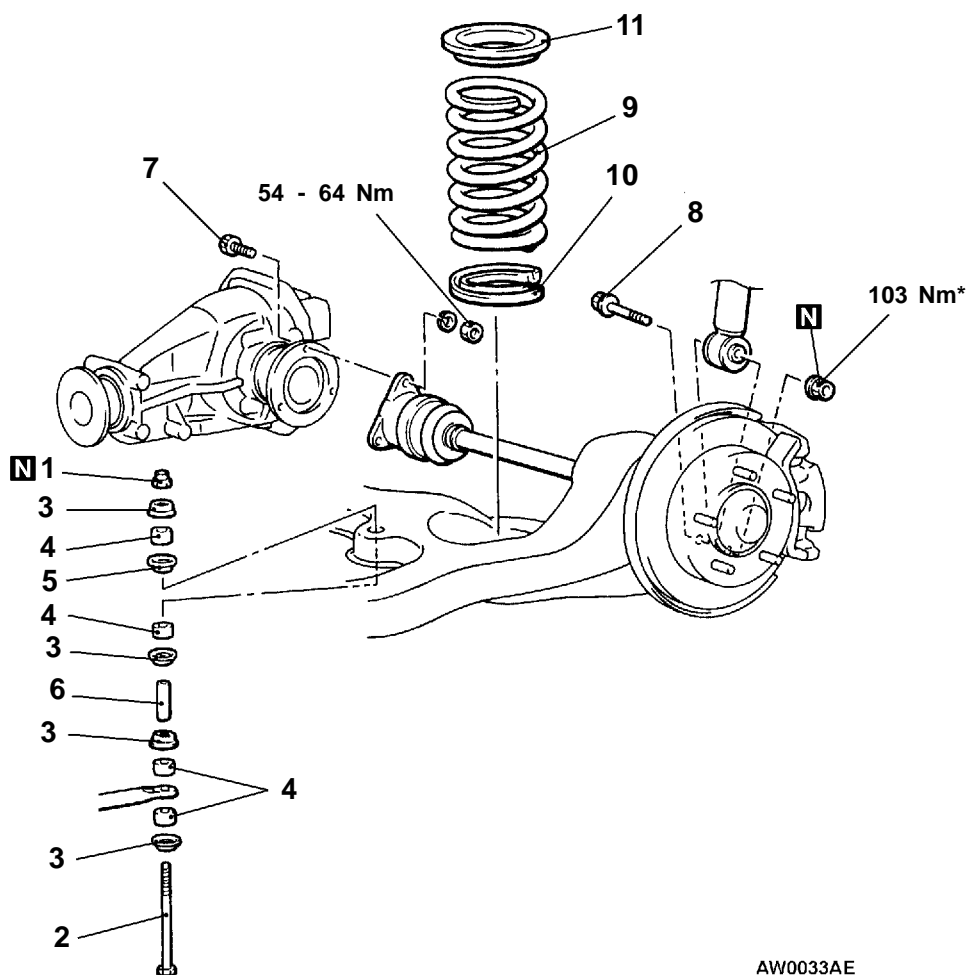

AW0033AE

### Removal steps



1. Self-locking nut
2. Bolt
3. Joint cup A
4. Stabilizer rubber
5. Joint cup B
6. Collar



7. Bolt <4WD>
8. Shock absorber mounting bolt
9. Coil spring
10. Tube pad
11. Spring pad



**REMOVAL SERVICE POINTS**

**◀A▶ BOLT REMOVAL <4WD>**

Remove the bolt, and then hold the drive shaft to the vehicle body with a wire.

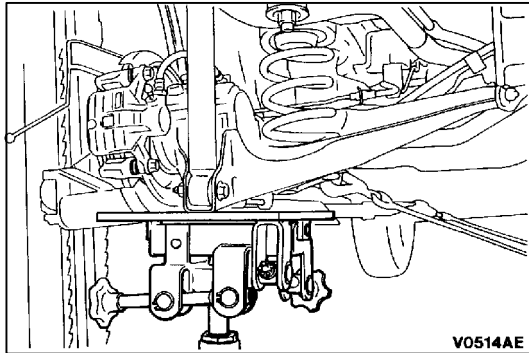

**◀B▶ SHOCK ABSORBER MOUNTING BOLT REMOVAL**

Support the lower arm assembly with a transmission jack, and after compressing the coil spring, remove the shock absorber mounting bolt.

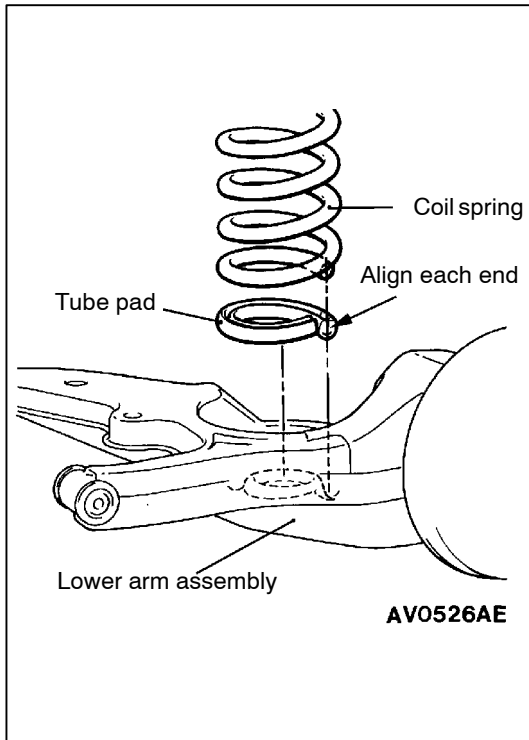

**INSTALLATION SERVICE POINTS**

**▶A◀ TUBE PAD/COIL SPRING INSTALLATION**

Install the tube pad to the coil spring while aligning the end of the pad with that of the spring. Then engage the bottom of the coil spring in the spring seat groove of the lower arm assembly properly.

**▶B◀ SELF-LOCKING NUT INSTALLATION**

Check that joint cups A and B face as shown, and then tighten the self-locking nut so that the shown dimension (A) is at the standard value.

**Standard value (A): 15 - 17 mm**

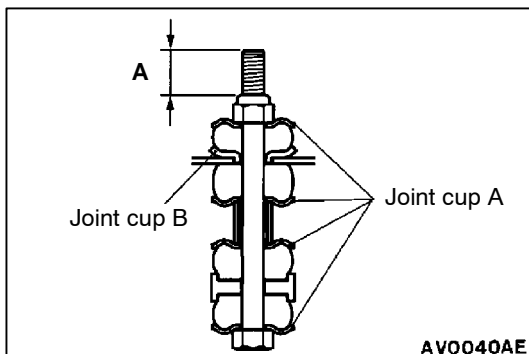

**INSPECTION**

34100630015

- Check the coil springs for crack, damage or deterioration.
- Check the spring seats for cracks and wear.

# LOWER ARM ASSEMBLY

## REMOVAL AND INSTALLATION

<2WD>

### Caution

\*: To prevent bushings from breakage the parts indicated by \* should be temporarily tightened, and then fully tightened with the vehicle on the ground in the unladen condition.

#### Pre-removal Operation

- Brake Fluid Draining
- Rear Hub Assembly Removal (Refer to GROUP 27A.)
- Coil Spring Removal (Refer to P.34-8.)

#### Post-installation Operation

- Coil Spring Installation (Refer to P.34-8.)
- Rear Hub Assembly Installation (Refer to GROUP 27A.)
- Brake Fluid Supplying
- Brake Line Bleeding (Refer to GROUP 35A - On-vehicle Service.)
- Parking Brake Lever Stroke Check and Adjustment (Refer to GROUP 36 - On-vehicle Service.)
- Wheel Alignment Check and Adjustment (Refer to P.34-4.)

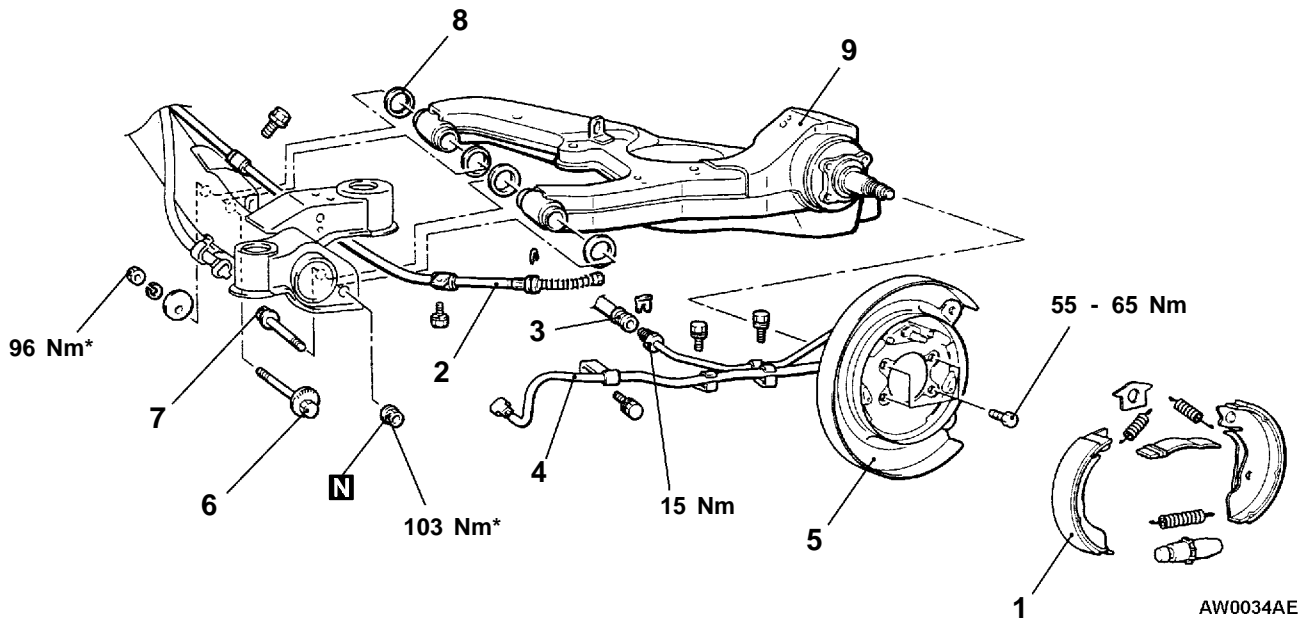

### Removal steps

1. Shoe and lining assembly (Refer to GROUP 36 - Parking brake cable.)
2. Parking brake cable connection
3. Brake hose connection
4. Rear wheel speed sensor harness connection <vehicles with ABS>



5. Rear brake assembly
6. Bolt assembly
7. Flange bolt
8. Stopper
9. Lower arm assembly

<4WD>

**Caution**

\*: To prevent bushings from breakage the parts indicated by \* should be temporarily tightened, and then fully tightened with the vehicle on the ground in the unladen condition.

**Pre-removal Operation**

- Brake Fluid Draining
- Drive Shaft Removal (Refer to GROUP 27B.)
- Coil Spring Removal (Refer to P.34-8.)

**Post-installation Operation**

- Coil Spring Installation (Refer to P.34-8.)
- Drive Shaft Installation (Refer to GROUP 27B.)
- Brake Fluid Supplying
- Brake Line Bleeding (Refer to GROUP 35A - On-vehicle Service.)
- Parking Brake Lever Stroke Check and Adjustment (Refer to GROUP 36 - On-vehicle Service.)
- Wheel Alignment Check and Adjustment (Refer to P.34-4.)

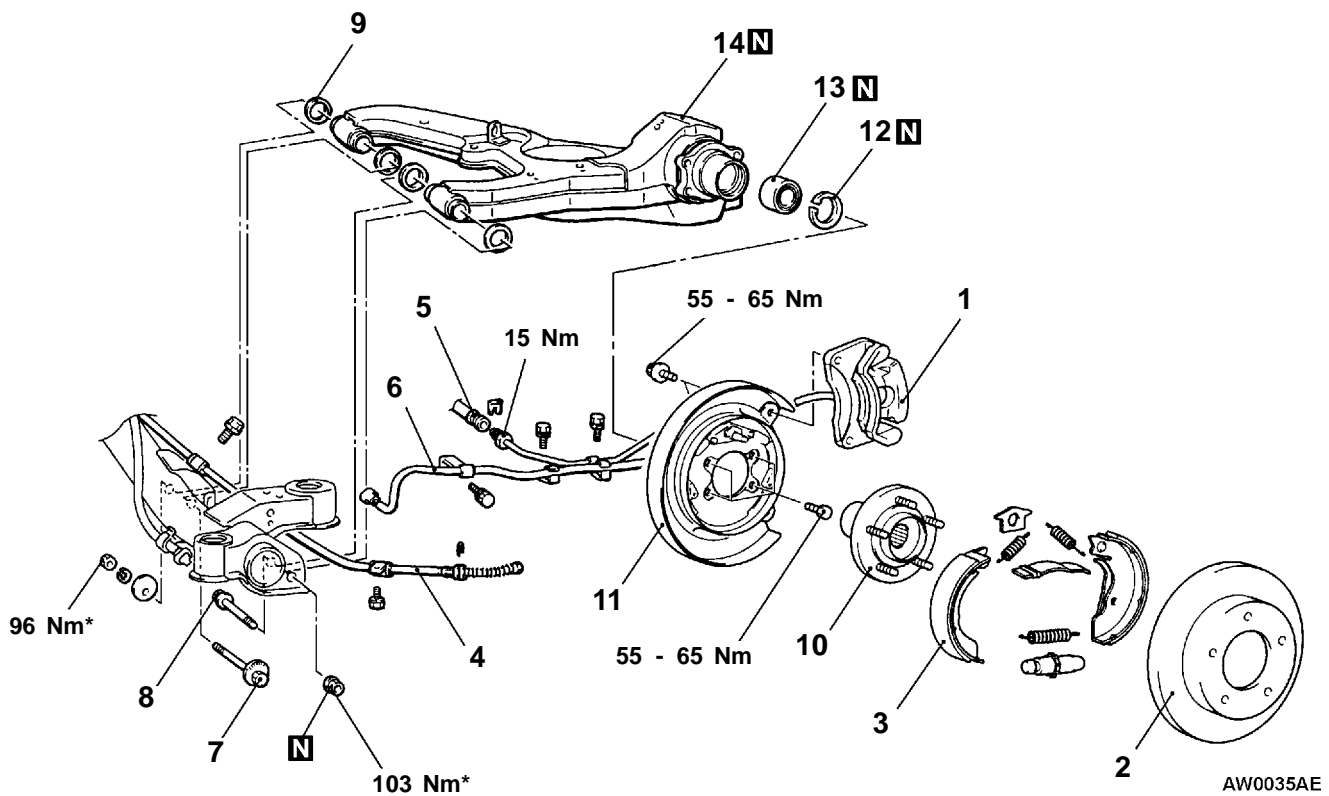

**Removal steps**

1. Caliper assembly
2. Brake disc
3. Shoe and lining assembly (Refer to GROUP 36 - Parking brake cable.)
4. Parking brake cable connection
5. Brake hose connection
6. Rear wheel speed sensor harness connection <vehicles with ABS>

- |         |                         |
|---------|-------------------------|
| ◀A▶ ▶C▶ | 7. Bolt assembly        |
|         | 8. Flange bolt          |
|         | 9. Stopper              |
| ◀B▶ ▶B▶ | 10. Rear hub assembly   |
|         | 11. Rear brake assembly |
|         | 12. Snap ring           |
| ◀C▶ ▶A▶ | 13. Wheel bearing       |
|         | 14. Lower arm assembly  |

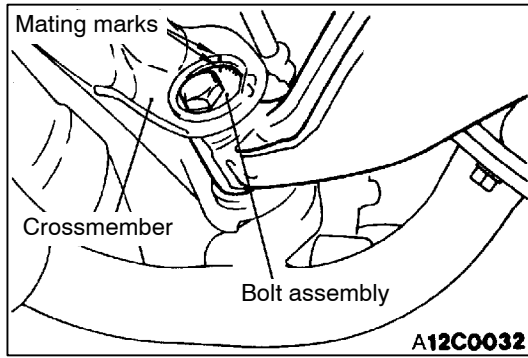
**REMOVAL SERVICE POINTS****◀A▶ BOLT ASSEMBLY REMOVAL**

Matchmark the lower arm bolt assembly and the crossmember, and remove the bolt assembly.

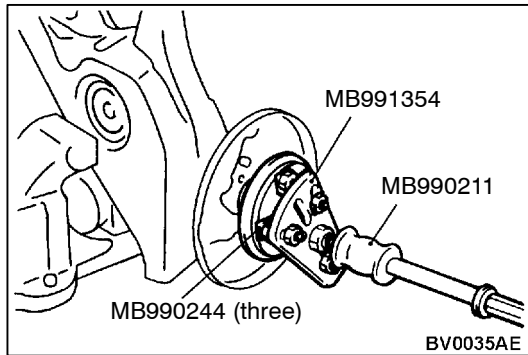
**◀B▶ REAR HUB ASSEMBLY REMOVAL <4WD>****Caution**

The ball bearing will be damaged when the rear hub is removed. If the rear hub has been removed, always replace the ball bearing.

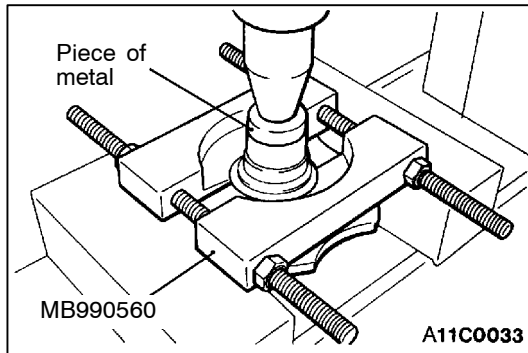
**◀C▶ WHEEL BEARING REMOVAL <4WD>**

1. Use the special tool to drive out the wheel bearing inner race.

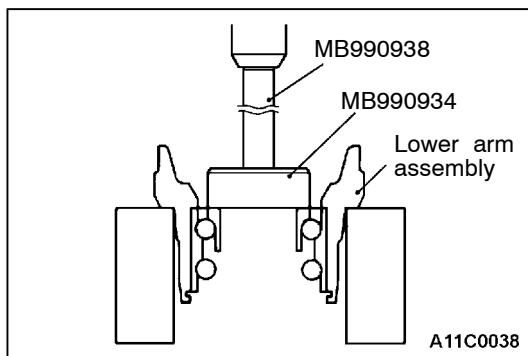

2. Use the special tools to remove the wheel bearing from the lower arm assembly.

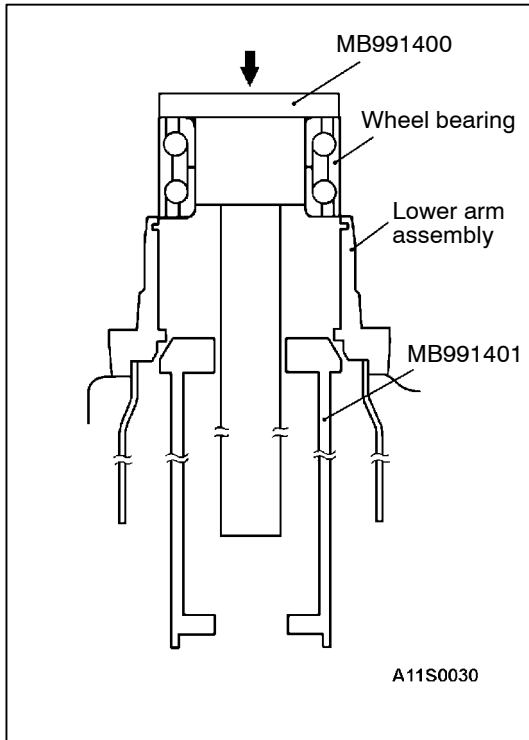

**INSTALLATION SERVICE POINTS**

**▶A◀ WHEEL BEARING INSTALLATION <4WD>**

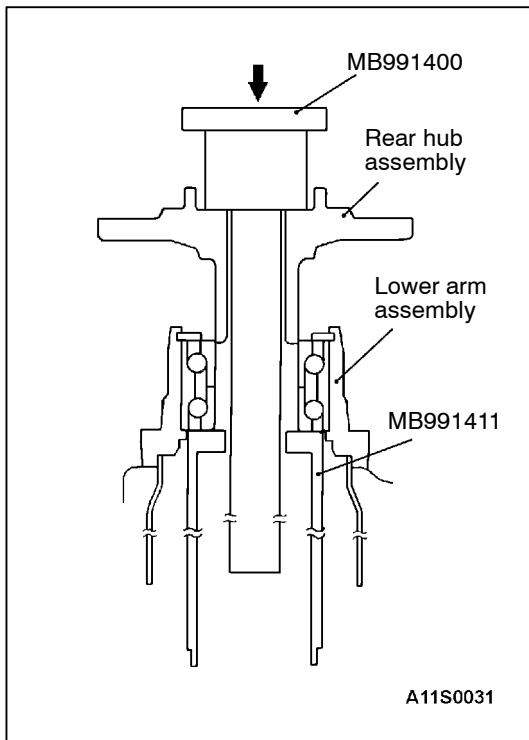

**▶B◀ REAR HUB ASSEMBLY INSTALLATION <4WD>**

**▶C◀ BOLT ASSEMBLY INSTALLATION**

Align the marks on the lower arm bolt assembly and the crossmember, and tighten the nut.

**INSPECTION**

34100660014

- Check the lower arm for deformation and deterioration.
- Check all bolts for condition and straightness.
- Check the spring seats for cracks and wear.

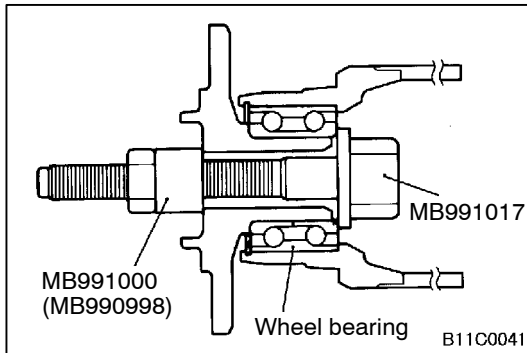
**WHEEL BEARING ROTATION STARTING TORQUE CHECK <4WD>**

1. Install the special tool to the rear hub assembly and tighten the nut to the specified torque 196 - 255 Nm.

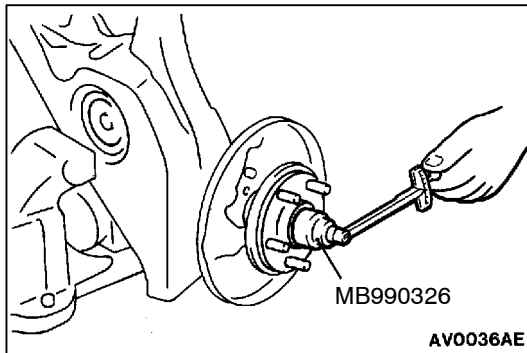

2. Use the special tool to measure the wheel bearing rotation starting torque.

**Limit: 1.0 Nm or less**

3. The wheel bearing rotation starting torque should be within the limit value range, and there should be no engagement or feeling of roughness.

# SUSPENSION CROSSMEMBER

34100680010

## REMOVAL AND INSTALLATION

### Caution

\*: To prevent bushings from breakage the parts indicated by \* should be temporarily tightened, and then fully tightened with the vehicle on the ground in the unladen condition.

**Pre-removal Operation**  
Brake Fluid Draining

### Post-installation Operation

- Brake Fluid Supplying
- Brake Line Bleeding  
(Refer to GROUP 35A - On-vehicle Service.)
- Parking Brake Lever Stroke Check and Adjustment  
(Refer to GROUP 36 - On-vehicle Service.)
- Wheel Alignment Check and Adjustment  
(Refer to P.34-4.)

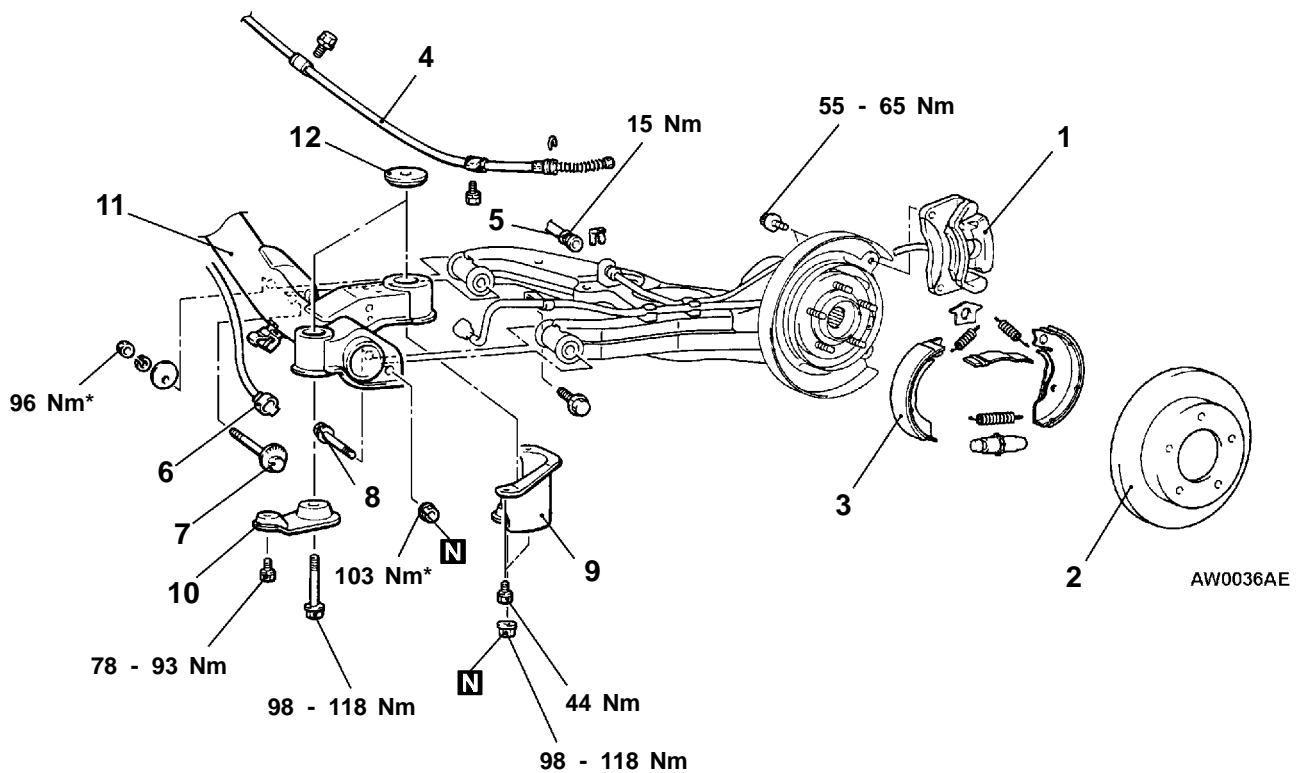

### Removal steps



- Lift supporting point
  - Coil spring (Refer to P.34-8.)
  - Center exhaust pipe (Refer to GROUP 15.)
  - Differential carrier assembly <4WD> (Refer to GROUP 27.)
  - Bracket assembly <4WD> (Refer to GROUP 27 - Differential mount.)
1. Caliper assembly
  2. Brake disc
  3. Shoe and lining assembly (Refer to GROUP 36 - Parking brake cable.)



4. Parking brake cable connection
5. Brake hose connection
6. Rear wheel speed sensor harness connection <vehicles with ABS>
7. Bolt assembly
8. Flange bolt
9. Crossmember bracket
10. Lower stopper
11. Suspension crossmember assembly
12. Upper stopper

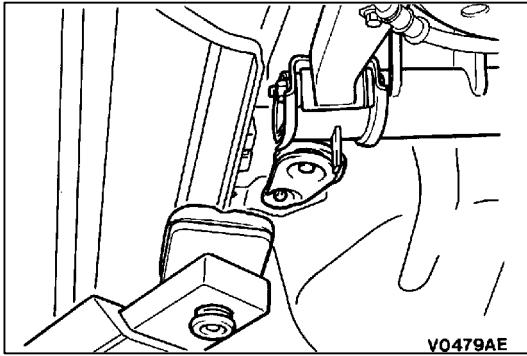

## REMOVAL SERVICE POINTS

### ◀A▶ LIFT SUPPORTING POINT

When the suspension crossmember is lowered from the vehicle, slide a lift arm to the front side of the vehicle slightly to make sure that the crossmember does not interfere with nearby parts.

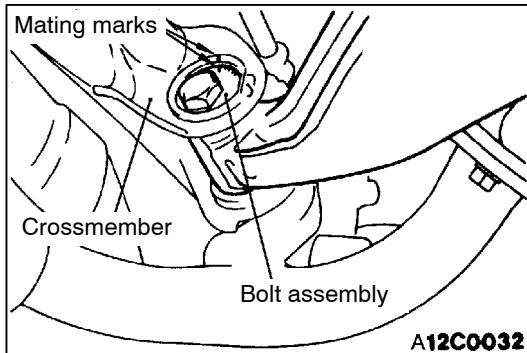

### ◀B▶ BOLT ASSEMBLY REMOVAL

Matchmark the lower arm bolt assembly and the crossmember, and then remove the bolt assembly.

## INSTALLATION SERVICE POINTS

### ▶A◀ LOWER STOPPER INSTALLATION

For the lower stopper bolts, first install the short (front) bolt loosely while no load is applied to it, and then tighten the long (rear) bolt to the specified torque. Finally, tighten the short bolt to the specified torque.

### ▶B◀ BOLT ASSEMBLY INSTALLATION

Align the marks on the lower arm bolt assembly and the crossmember, and then tighten the nut.

## INSPECTION

34100690013

- Check the crossmember for cracks or deformation.



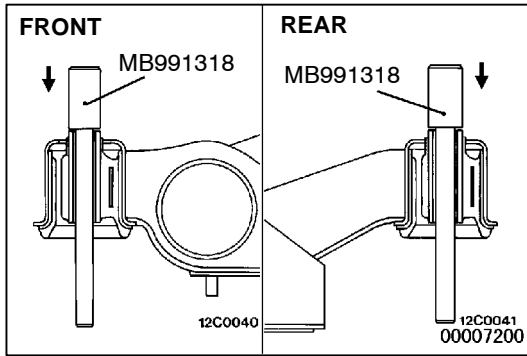

**SUSPENSION CROSSMEMBER BUSHING REPLACEMENT**

34101420017

1. Make a mark on the crossmember bracket to match the slits on the old bushing, and use these marks to position the new bushing.
2. Insert a flat-tipped screwdriver between the old bushing and the crossmember bracket, and lever around the bushing to break the seal.
3. Use the special tool to tap out the bushing from the crossmember bracket.

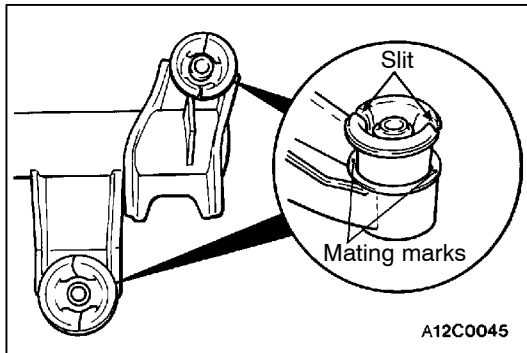

4. Align the slits on the new bushing with the mating marks on the crossmember bracket.

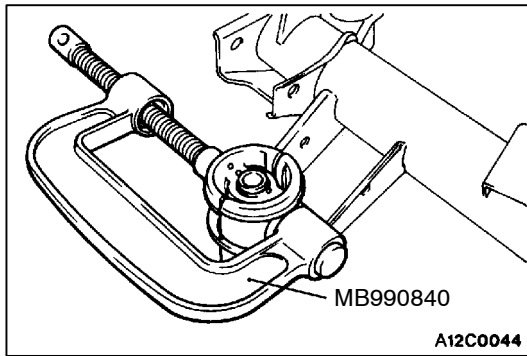

5. Use the special tool to reduce the size of the rear end of the bushing.

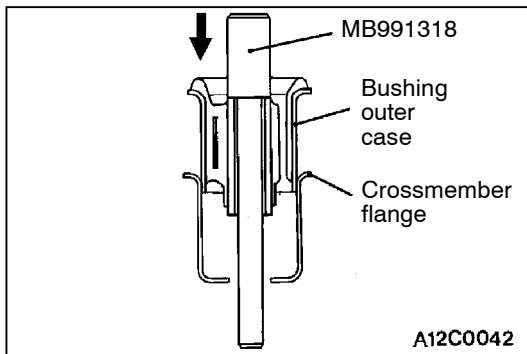

6. Use the special tool to press-fit the bushing until the outside case of the bushing is fitting securely in the crossmember flange.

# STABILIZER BAR

## REMOVAL AND INSTALLATION

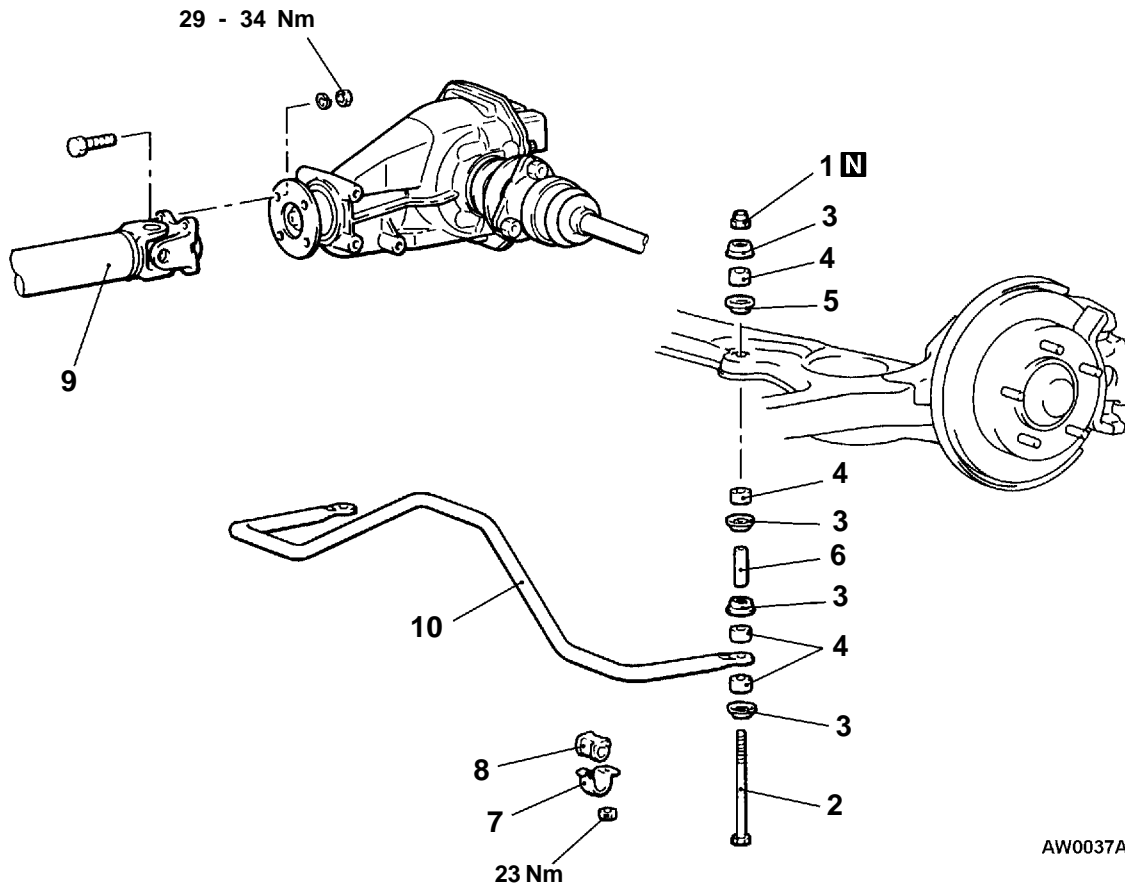

AW0037AE

### Removal steps



1. Self-locking nut
2. Bolt
3. Joint cap A
4. Stabilizer rubber
5. Joint cap B



6. Collar
7. Fixture
8. Bushing
9. Propeller shaft connection <4WD>
10. Stabilizer bar

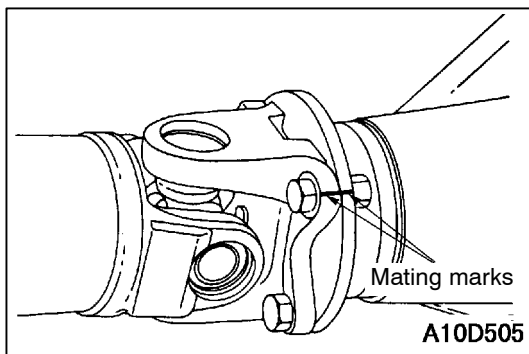

### REMOVAL SERVICE POINT

#### ◀A▶ PROPELLER SHAFT DISCONNECTION

1. Make mating marks on the differential companion flange and flange yoke, and then separate the differential carrier assembly and the propeller shaft.
2. Suspend the propeller shaft from the body with wire, etc, so that there are no sharp bends.

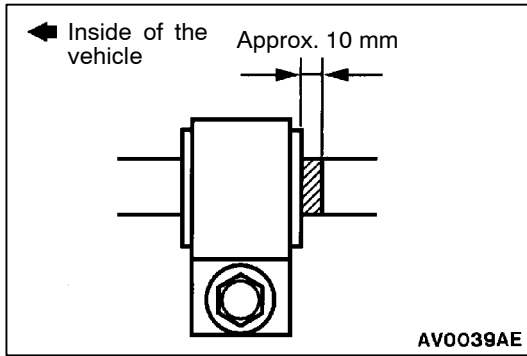

**INSTALLATION SERVICE POINTS**

**▶A◀ STABILIZER BAR/BUSHING/FIXTURE INSTALLATION**

Position the stabilizer bar at the left side of the vehicle so that its identification mark is as shown, and then tighten the fixture mounting nut assembly.

**▶B◀ PROPELLER SHAFT INSTALLATION**

Align the marks on the propeller shaft and the companion flange, and then install the propeller shaft.

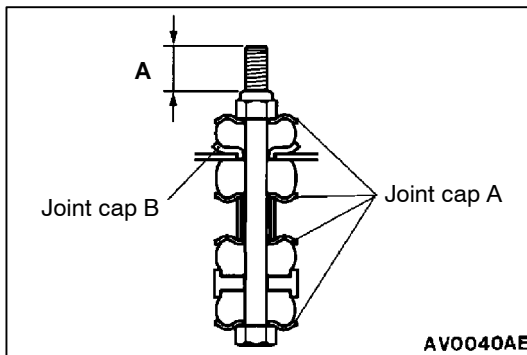

**▶C◀ SELF-LOCKING NUT INSTALLATION**

Check that joint cups A and B face as shown, and then tighten the self-locking nut so that the shown dimension (A) is at the standard value.

**Standard value (A): 15 - 17 mm**

**INSPECTION**

34100720019

- Check the bushing for wear and deterioration.
- Check the stabilizer bar for deterioration or damage.
- Check all bolts for condition and straightness.

---

## NOTES