

SECTION EM

GI

MA

EM

LC

EC

FE

CL

MT

AT

FA

RA

BR

ST

RS

BT

HA

EL

IDX

CONTENTS

PRECAUTIONS	2	CYLINDER HEAD	34
Parts Requiring Angular Tightening	2	Removal.....	35
Liquid Gasket Application Procedure	2	Disassembly	35
PREPARATION	3	Inspection	37
Special Service Tools	3	Assembly	41
Commercial Service Tools	5	Installation.....	41
OUTER COMPONENT PARTS	6	VALVE CLEARANCE	47
COMPRESSION PRESSURE	10	Checking.....	47
Measurement of Compression Pressure.....	10	Adjusting.....	48
OIL PAN	11	ENGINE REMOVAL	51
Removal.....	11	Removal.....	52
Installation.....	14	Installation.....	53
TIMING CHAIN	17	CYLINDER BLOCK	54
Removal.....	19	Disassembly	55
Inspection	26	Inspection	55
Installation.....	26	Assembly.....	62
OIL SEAL REPLACEMENT	31	SERVICE DATA AND SPECIFICATIONS (SDS)	65
		General Specifications.....	65
		Inspection and Adjustment.....	65

PRECAUTIONS

Parts Requiring Angular Tightening

- Use an angle wrench for the final tightening of the following engine parts:
 - (1) Cylinder head bolts
 - (2) Main bearing cap bolts
 - (3) Connecting rod cap nuts
 - (4) Crankshaft pulley bolt
- Do not use a torque value for final tightening.
- The torque value for these parts are for a preliminary step.
- Ensure thread and seat surfaces are clean and coated with engine oil.

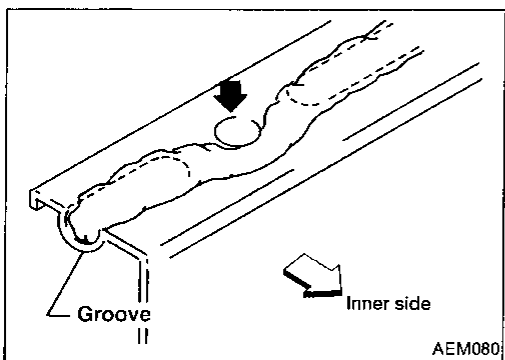
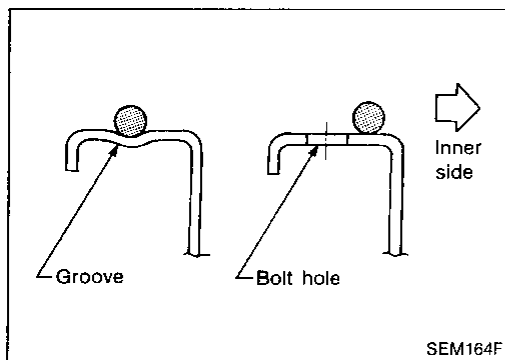

Liquid Gasket Application Procedure

- Use a scraper to remove all traces of old liquid gasket from mating surfaces and grooves. Also, completely clean any oil from these areas.
- Apply a continuous bead of liquid gasket to mating surfaces. (Use Genuine Liquid Gasket or equivalent.)
 - Be sure liquid gasket diameter is as specified.
- Apply liquid gasket around the inner side of bolt holes (unless otherwise specified).
- Assembly should be done within 5 minutes after coating.
- Wait at least 30 minutes before refilling engine oil and engine coolant.

PREPARATION

Special Service Tools

The actual shapes of Kent-Moore tools may differ from those of special service tools illustrated here.

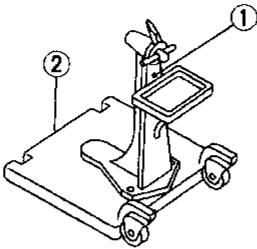
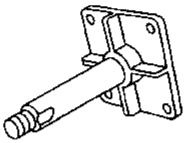
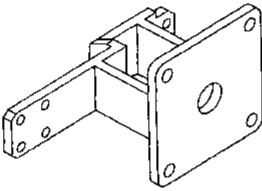
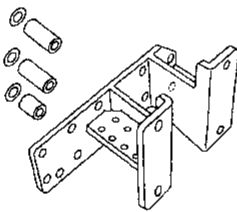
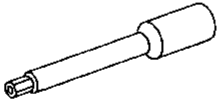
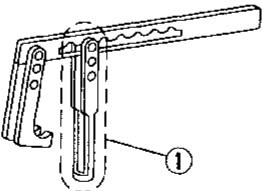
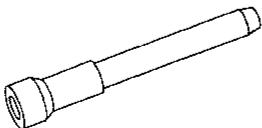
Tool number (Kent-Moore No.) Tool name	Description	
ST0501S000 (—) Engine stand assembly ① ST05011000 (—) Engine stand ② ST05012000 (—) Base	 NT042	Disassembling and assembling GI MA EM LC
KV10106500 (—) Engine stand shaft	 NT028	EC FE
KV10117000 (J41262) Engine sub-attachment	 NT373	KV10117000 has been replaced with KV10117001 (KV117000 is no longer in production, but it is usable). CL MT AT
KV10117001 (—) Engine sub-attachment	 NT372	Installing on the cylinder block FA RA BR
ST10120000 (J24239-01) Cylinder head bolt wrench	 NT019	Loosening and tightening cylinder head bolt ST RS
KV10116200 (J26336-A) Valve spring compressor ① KV10115900 (J26336-20) Attachment	 NT022	Disassembling valve mechanism BT HA
(J39386) Valve oil seal drift	 NT024	Installing valve oil seal EL IDX

PREPARATION

Special Service Tools (Cont'd)

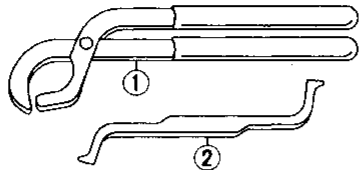
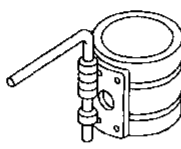
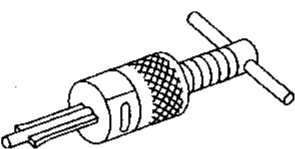
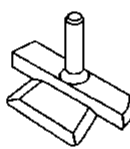
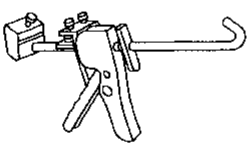
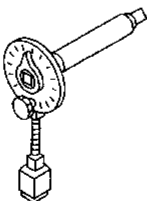
Tool number (Kent-Moore No.) Tool name	Description
KV101151S0 (J38972) Lifter stopper set ① KV10115110 (J38972-1) Camshaft pliers ② KV10115120 (J38972-2) Lifter stopper	<div style="display: flex; justify-content: space-between;"> <div data-bbox="430 525 487 546">NT041</div> <div data-bbox="998 262 1177 294" style="text-align: right;">Changing shims</div> </div> 
EM03470000 (J8037) Piston ring compressor	<div style="display: flex; justify-content: space-between;"> <div data-bbox="430 735 487 756">NT044</div> <div data-bbox="998 556 1421 619" style="text-align: right;">Installing piston assembly into cylinder bore</div> </div> 
ST16610001 (J23907) Pilot bushing puller	<div style="display: flex; justify-content: space-between;"> <div data-bbox="430 945 487 966">NT045</div> <div data-bbox="998 766 1372 798" style="text-align: right;">Removing crankshaft pilot bushing</div> </div> 
KV10111100 (J37228) Seal cutter	<div style="display: flex; justify-content: space-between;"> <div data-bbox="430 1155 487 1176">NT046</div> <div data-bbox="998 976 1421 1039" style="text-align: right;">Removing steel oil pan and rear timing chain case</div> </div> 
WS39930000 (—) Tube presser	<div style="display: flex; justify-content: space-between;"> <div data-bbox="430 1365 487 1386">NT052</div> <div data-bbox="998 1186 1356 1218" style="text-align: right;">Pressing the tube of liquid gasket</div> </div> 
KV10112100 (BT8653-A) Angle wrench	<div style="display: flex; justify-content: space-between;"> <div data-bbox="430 1617 487 1638">NT014</div> <div data-bbox="998 1396 1437 1459" style="text-align: right;">Tightening bolts for bearing cap, cylinder head, etc.</div> </div> 

PREPARATION

Commercial Service Tools

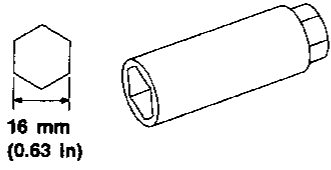
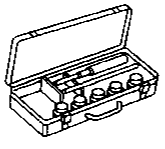
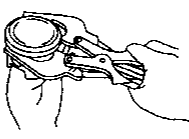
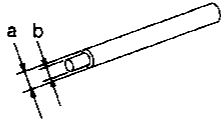
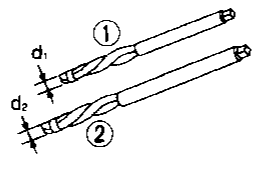
Tool name	Description	
Spark plug wrench	 <p style="text-align: center;">16 mm (0.63 in)</p> <p>NT047</p>	<p>Removing and installing spark plug</p> <p style="text-align: right;">GI MA</p>
Valve seat cutter set	 <p>NT048</p>	<p>Finishing valve seat dimensions</p> <p style="text-align: right;">EM LC</p>
Piston ring expander	 <p>NT030</p>	<p>Removing and installing piston ring</p> <p style="text-align: right;">EC FE</p>
Valve guide drift	 <p>NT015</p>	<p>Removing and installing valve guide</p> <p>Intake & Exhaust: a = 9.5 mm (0.374 in) dia. b = 5.5 mm (0.217 in) dia.</p> <p style="text-align: right;">MT AT</p>
Valve guide reamer	 <p>NT016</p>	<p>Reaming valve guide ① or hole for over-size valve guide ②</p> <p>Intake & Exhaust: d₁ = 6.0 mm (0.236 in) dia. d₂ = 10.2 mm (0.402 in) dia.</p> <p style="text-align: right;">FA RA BR ST RS BT HA EL IDX</p>

OUTER COMPONENT PARTS

SEC. 111-140-148-163-164-220-223

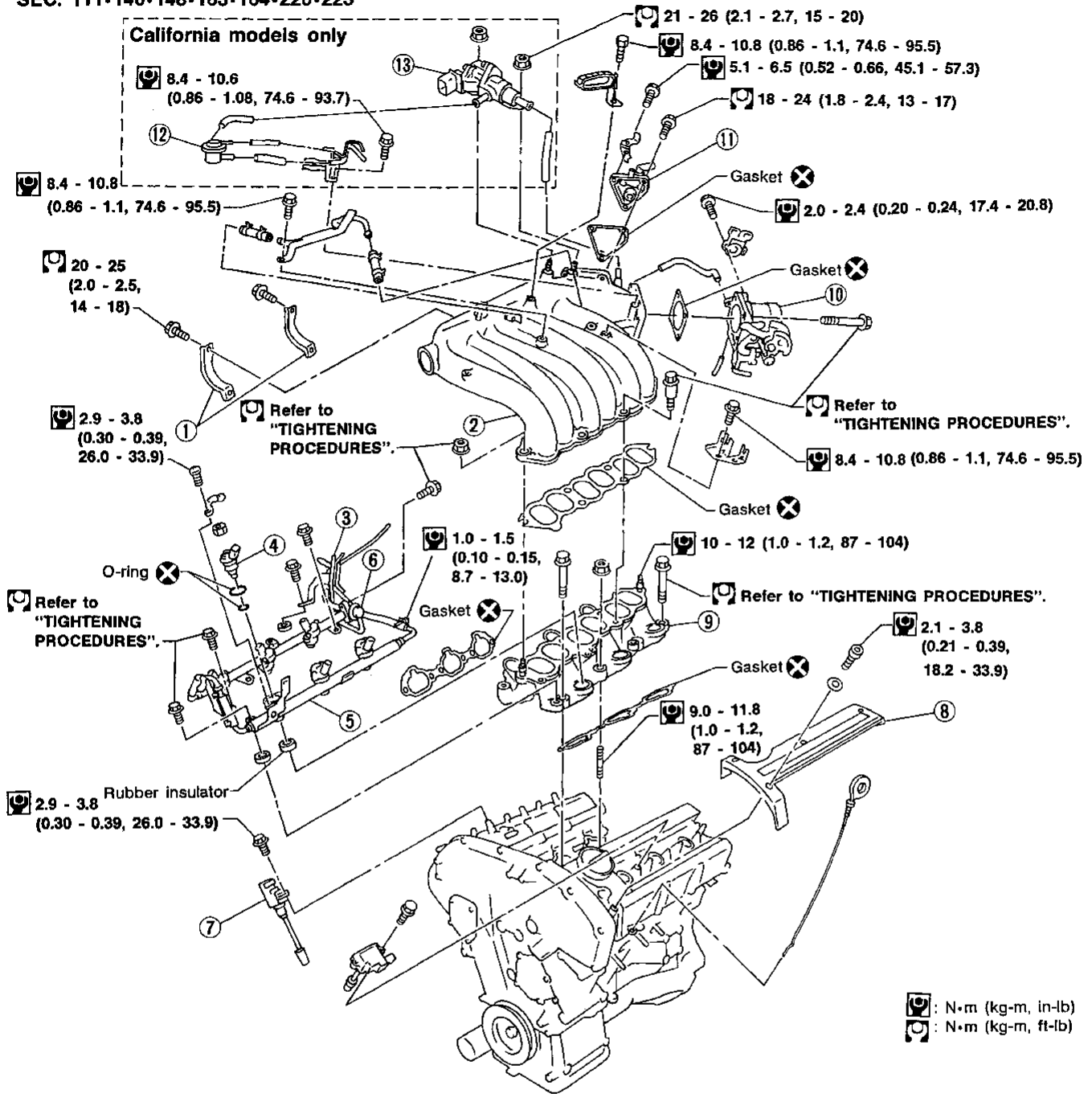

SEM182F

- | | | |
|-------------------------------------|---------------------------------------|--|
| ① Intake manifold collector support | ⑥ Fuel pressure regulator | ⑪ IACV-AAC valve |
| ② Intake manifold collector | ⑦ Ignition coil with power transistor | ⑫ EVAP canister purge control valve |
| ③ Sub-fuel tube | ⑧ Ornament cover | ⑬ EVAP canister purge volume control valve |
| ④ Injector | ⑨ Intake manifold | |
| ⑤ Fuel tube assembly | ⑩ Throttle body | |

OUTER COMPONENT PARTS

SEC. 140-147-210-211-221

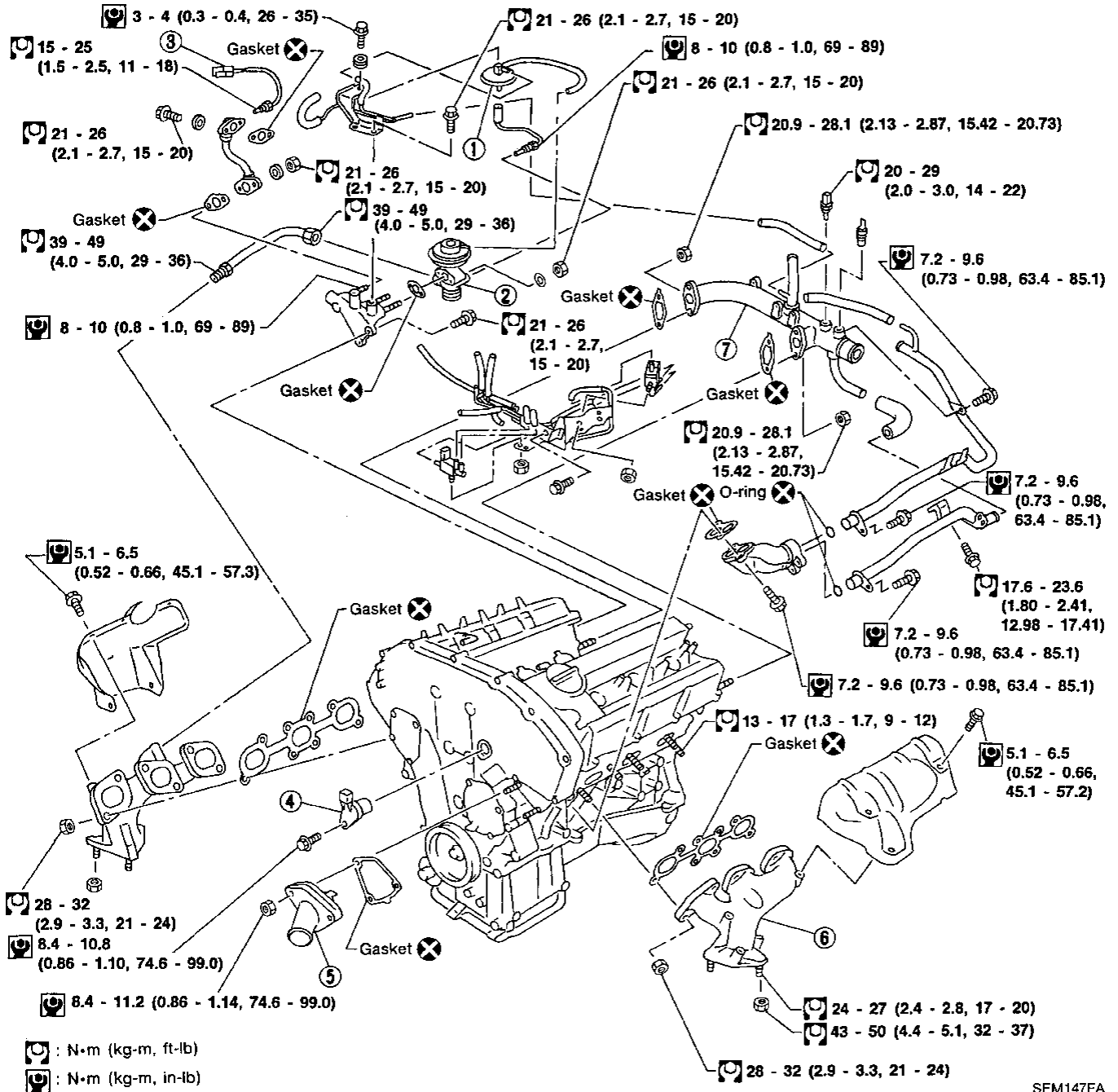

- | | | |
|--------------------------|------------------------------------|--------------------|
| ① EGRC-BPT valve | ④ Camshaft position sensor (PHASE) | ⑥ Exhaust manifold |
| ② EGR valve | ⑤ Thermostat with water inlet | ⑦ Water outlet |
| ③ EGR temperature sensor | | |

SEM147FA

GI
 MA
EM
 LC
 EC
 FE
 CL
 MT
 AT
 FA
 RA
 BR
 ST
 RS
 BT
 HA
 EL
 IDX

OUTER COMPONENT PARTS

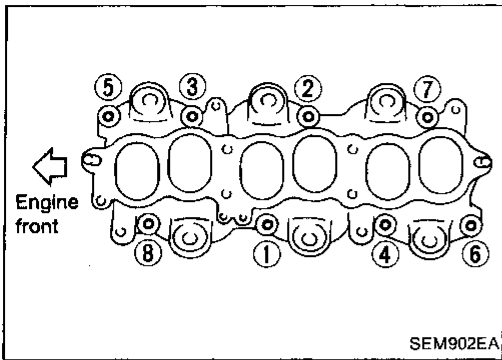

TIGHTENING PROCEDURES

Intake manifold

- Tighten in numerical order shown in the figure.

1. Tighten all bolts and nuts to 5 to 10 N·m (0.5 to 1.0 kg-m, 43 to 87 in-lb).
2. Tighten all bolts and nuts to 26 to 31 N·m (2.7 to 3.2 kg-m, 20 to 23 ft-lb).
3. Repeat step 2 at least five times to have all bolts and nuts tightened at a torque of 26 to 31 N·m (2.7 to 3.2 kg-m, 20 to 23 ft-lb).

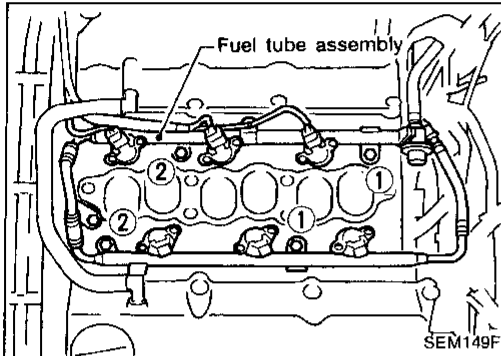

Fuel tube

- Tighten in numerical order shown in the figure.

1. Tighten all bolts to 9.3 to 10.8 N·m (0.95 to 1.1 kg-m, 82.5 to 95.5 in-lb).
2. Tighten all bolts to 21 to 26 N·m (2.1 to 2.7 kg-m, 15 to 20 ft-lb).

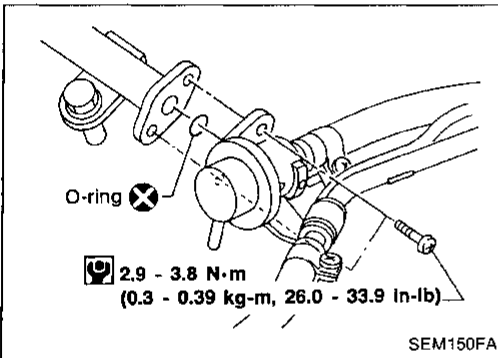

Fuel pressure regulator

Tighten fuel pressure regulator to 2.9 to 3.8 N·m (0.3 to 0.39 kg-m, 26.0 to 33.9 in-lb).

- Tighten screws evenly several times to have the fuel pressure regulator tightened at the specified torque.
- Always replace O-ring with new ones.
- Lubricate O-ring with new engine oil.

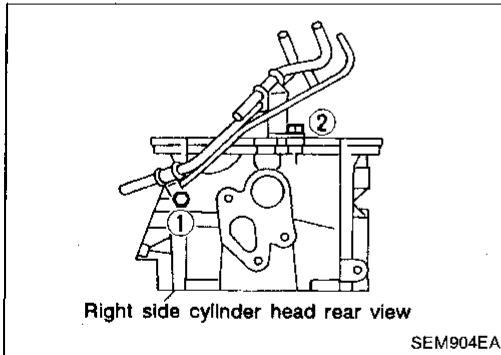

Sub-fuel tube

1. Temporarily tighten bolt ②.
2. Tighten bolt ① to 20.6 to 26.5 N·m (2.10 to 2.70 kg-m, 15.19 to 19.55 ft-lb).
3. Tighten bolt ② to 8.5 to 10.8 N·m (0.87 to 1.10 kg-m, 75.5 to 95.5 in-lb).

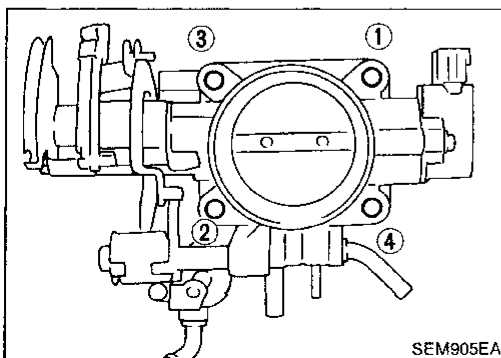

Throttle body

- Tighten in numerical order shown in the figure.

1. Tighten all bolts to 9 to 11 N·m (0.9 to 1.1 kg-m, 78 to 96 in-lb).
2. Tighten all bolts to 18 to 22 N·m (1.8 to 2.2 kg-m, 13 to 16 ft-lb).

OUTER COMPONENT PARTS

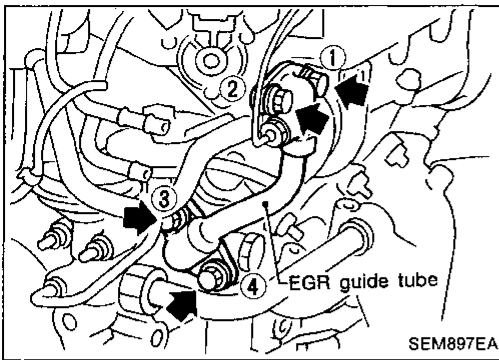

EGR guide tube

1. Tighten all bolts to 9 to 10 N·m (0.9 to 1.0 kg-m, 78 to 87 in-lb).
 2. Tighten all bolts to 21 to 26 N·m (2.1 to 2.7 kg-m, 15 to 20 ft-lb).
- **Before installing EGR guide tube, tighten intake manifold collector and collector bracket.**

GI

MA

EM

LC

EC

FE

CL

MT

AT

FA

RA

BR

ST

RS

BT

HA

EL

IDX

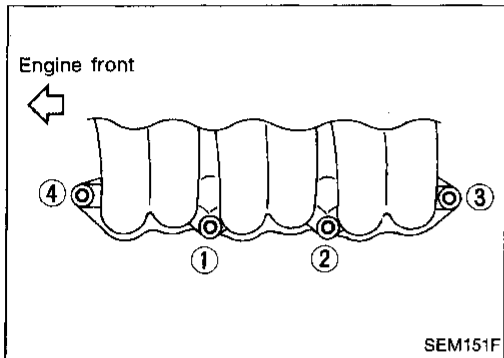

Intake manifold collector

Tighten bolts and nuts to 18 to 22 N·m (1.8 to 2.2 kg-m, 13 to 16 ft-lb) in numerical order shown in the figure.

COMPRESSION PRESSURE

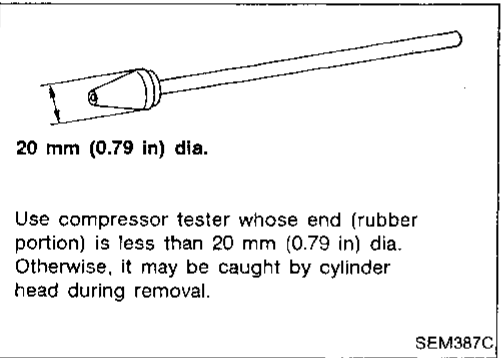
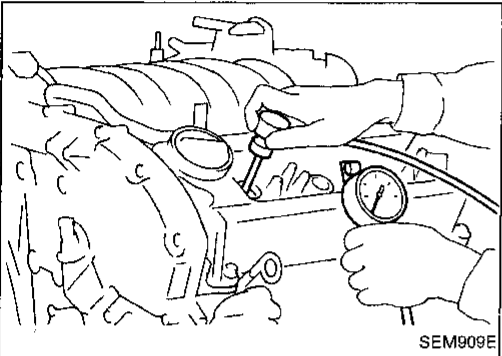
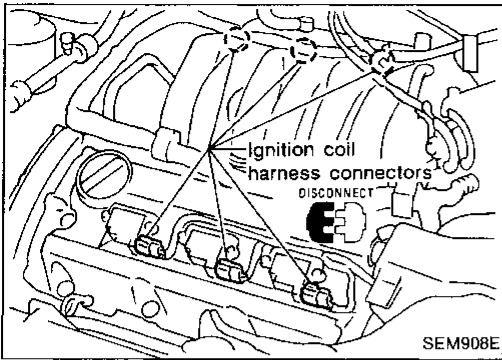

Measurement of Compression Pressure

1. Warm up engine.
 2. Turn ignition switch off.
 3. Release fuel pressure.
Refer to "Releasing Fuel Pressure" in EC section.
 4. Disconnect ignition coil with power transistor harness connectors, then remove ignition coils.
 5. Remove all spark plugs.
 6. Disconnect all injector harness connectors.
 7. Attach a compression tester to No. 1 cylinder.
 8. Depress accelerator pedal fully to keep throttle valve wide open.
 9. Crank engine and record highest gauge indication.
 10. Repeat the measurement on each cylinder as shown above.
- **Always use a fully-charged battery to obtain specified engine speed.**

Unit: kPa (kg/cm², psi)/rpm

Standard	Minimum	Difference limit between cylinders
1,275 (13.0, 185)/300	981. (10.0, 142)/300	98 (1.0, 14)/300

11. If compression in one or more cylinders is low:
 - a. Pour a small amount of engine oil into cylinders through spark plug holes.
 - b. Retest compression.
- **If adding oil helps compression, piston rings may be worn or damaged. If so, replace piston rings after checking piston.**
 - **If pressure stays low, a valve may be sticking or seating improperly. Inspect and repair valve and valve seat. (Refer to SDS, EM-65 and EM-68.) If valve or valve seat is damaged excessively, replace them.**
 - **If compression stays low in two cylinders that are next to each other:**
 - a. The cylinder head gasket may be leaking, or
 - b. Both cylinders may have valve component damage. Inspect and repair as necessary.

OIL PAN

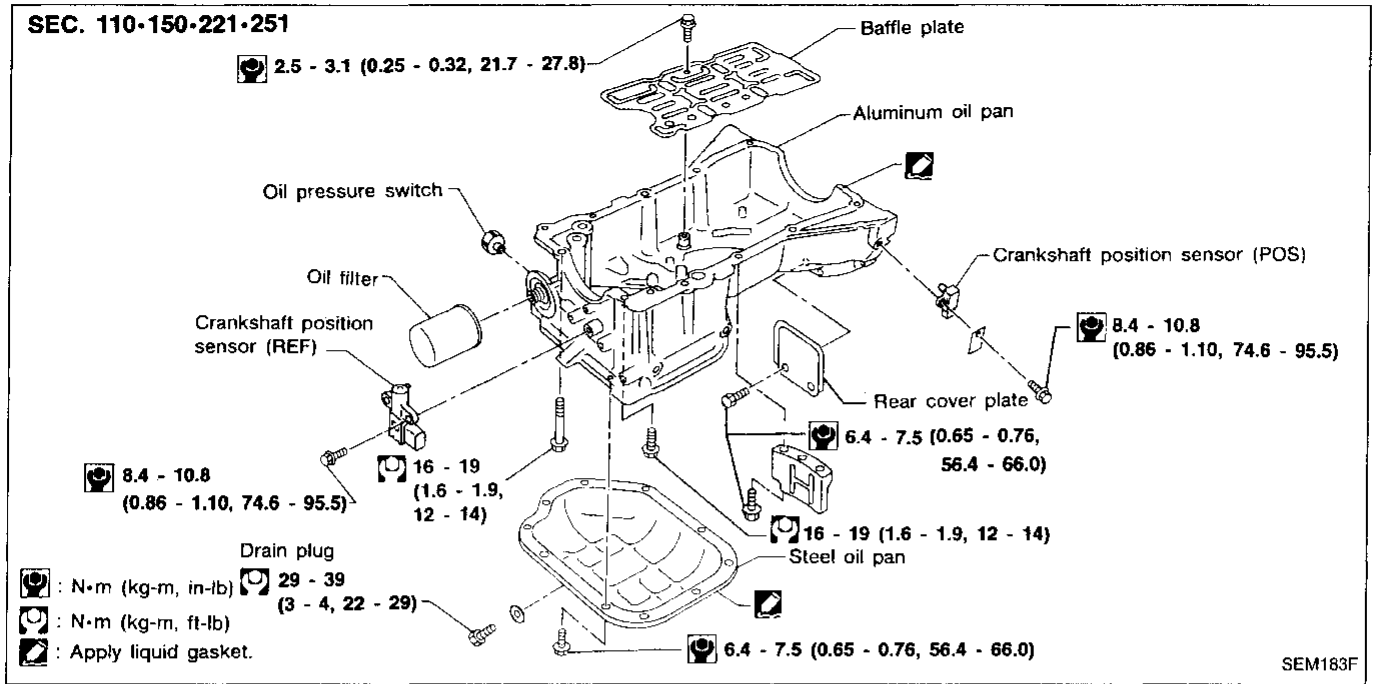

Removal

CAUTION:

When removing the aluminum oil pan from engine, first remove the crankshaft position sensors (POS and REF) from the assembly.

Be careful not to damage sensor edges and signal plate teeth.

1. Remove engine undercover.
2. Drain engine oil.

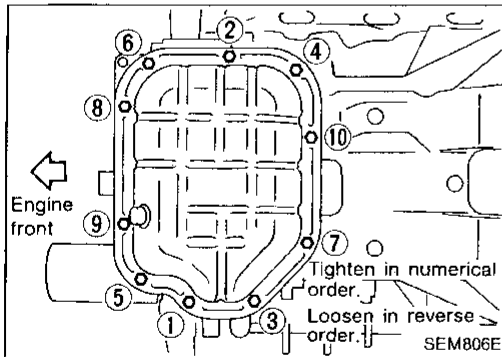

3. Remove steel oil pan bolts.

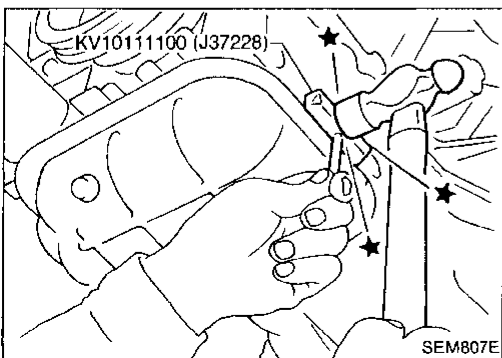

4. Remove steel oil pan.
 - a. Insert Tool between aluminum oil pan and steel oil pan.
 - Be careful not to damage aluminum mating surface.
 - Do not insert screwdriver, or oil pan flange will be deformed.

OIL PAN

Removal (Cont'd)

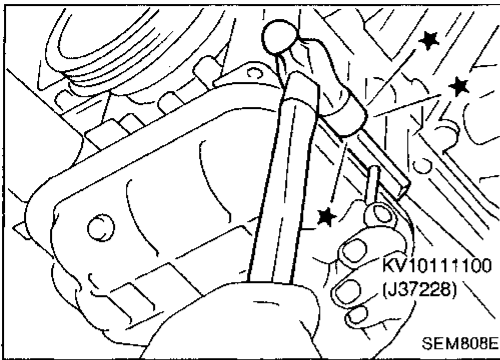

- b. Slide Tool by tapping on the side of the Tool with a hammer.
- c. Remove steel oil pan.

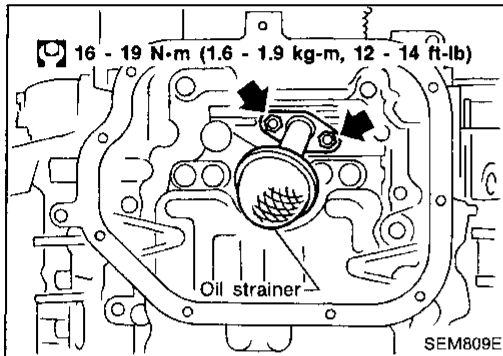

5. Remove oil strainer.

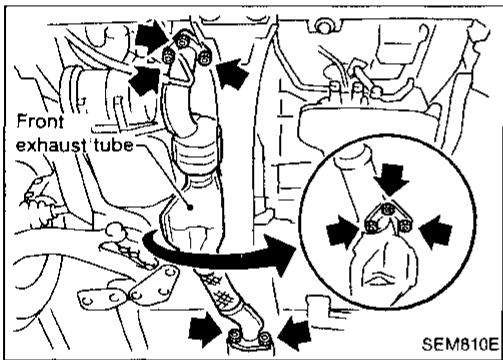

6. Remove front exhaust tube and its support.

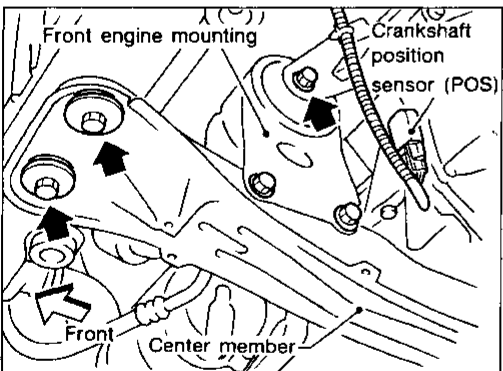

7. Set a suitable transmission jack under transaxle and hoist engine with engine slinger.
8. Remove crankshaft position sensors (POS and REF) from oil pan.
9. Remove front and rear engine mounting nuts and bolts.
10. Remove center member.

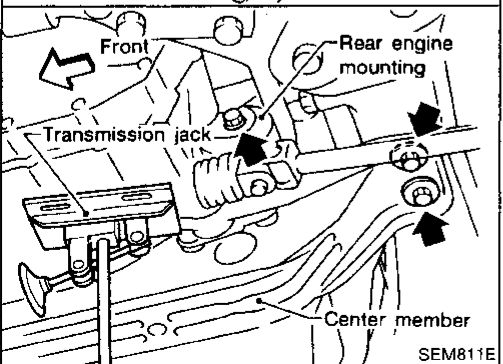

OIL PAN

Removal (Cont'd)

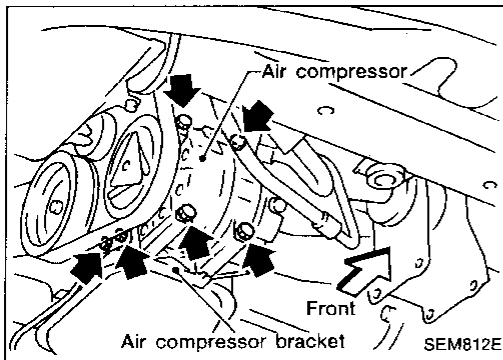

11. Remove drive belts.
12. Remove air compressor and bracket.

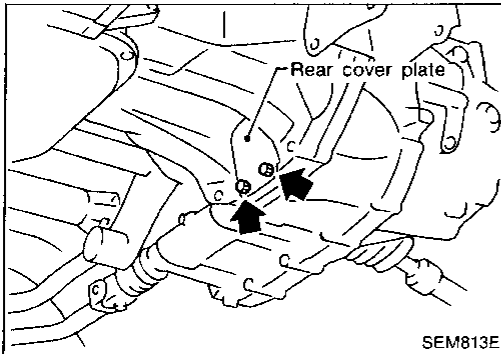

13. Remove rear cover plate.

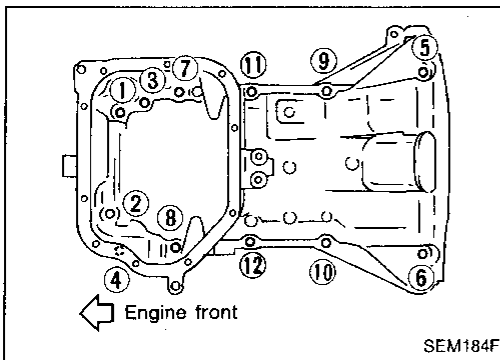

14. Remove aluminum oil pan bolts.

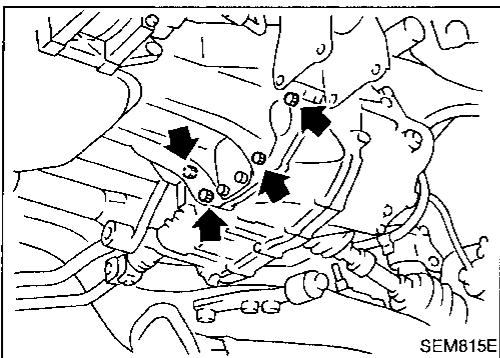

15. Remove transaxle bolts.

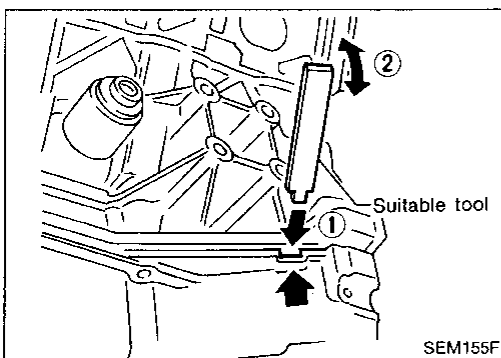

16. Remove aluminum oil pan.
 - a. Insert an appropriate size tool into the notch of aluminum oil pan as shown in the figure.
 - **Be careful not to damage aluminum mating surface.**
 - **Do not insert screwdriver, or oil pan flange will be deformed.**
 - b. Pry off aluminum oil pan by moving the tool up and down.
 - c. Remove aluminum oil pan.

GI

MA

EM

LC

EC

FE

CL

MT

AT

FA

RA

BR

ST

RS

BT

HA

EL

IDX

OIL PAN

Removal (Cont'd)

17. Remove O-rings from cylinder block and oil pump body.

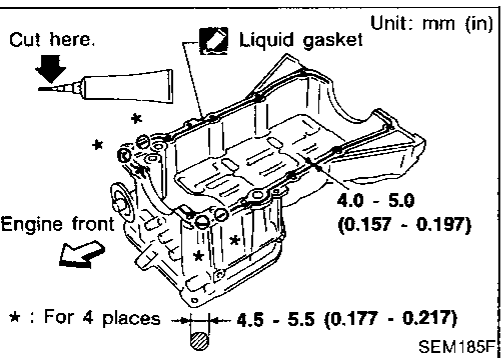
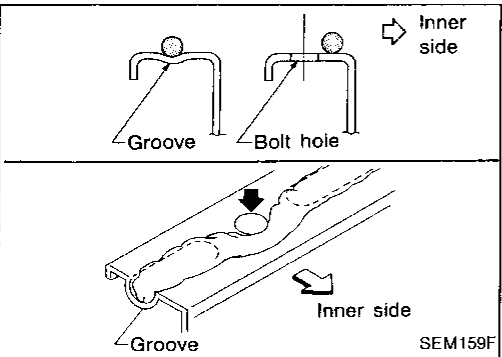
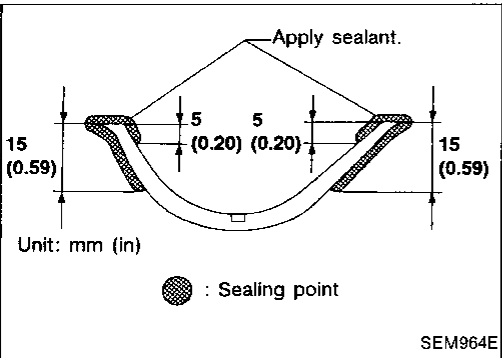
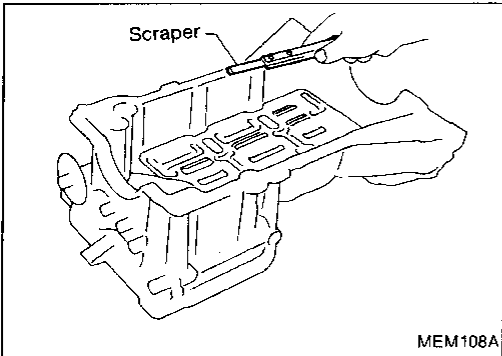
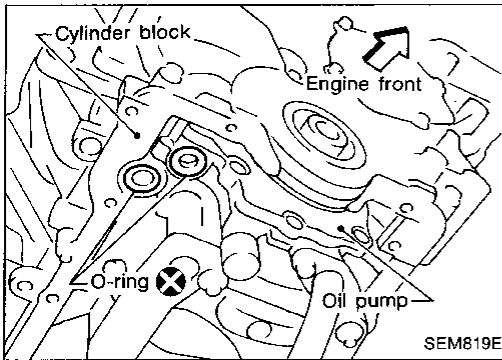

Installation

1. Install aluminum oil pan.
 - a. Use a scraper to remove all traces of liquid gasket from mating surfaces.
 - Also remove traces of liquid gasket from mating surface of cylinder block, front cover and steel oil pan.
 - **Remove old liquid gasket from the bolt hole and thread.**
 - b. Apply sealant to front cover gasket and rear oil seal retainer gasket.
 - c. Apply a continuous bead of liquid gasket to mating surface of aluminum oil pan.
 - **Use Genuine Liquid Gasket or equivalent.**
 - d. Apply liquid gasket to inner sealing surface as shown in figure.
 - **Be sure liquid gasket is 4.0 to 5.0 mm (0.157 to 0.197 in) or 4.5 to 5.5 mm (0.177 to 0.217 in) wide.**
 - **Attaching should be done within 5 minutes after coating.**

OIL PAN

Installation (Cont'd)

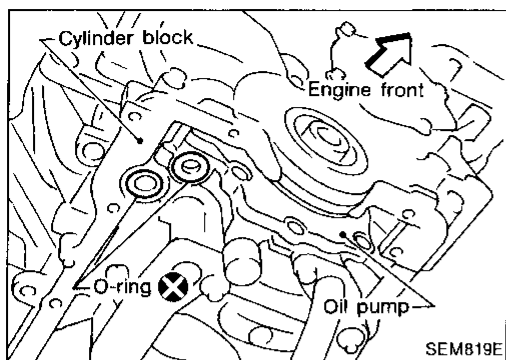

e. Install O-rings, cylinder block and oil pump body.

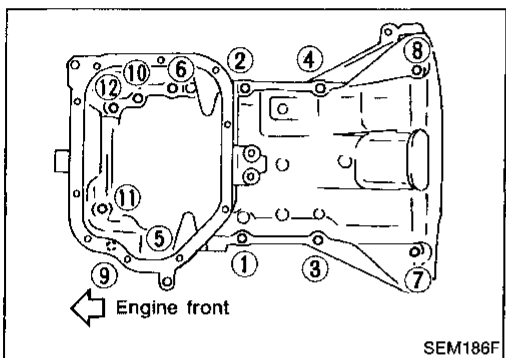

- f. Install aluminum oil pan.
- Tighten bolts in numerical order.
 - **Wait at least 30 minutes before refilling engine oil.**

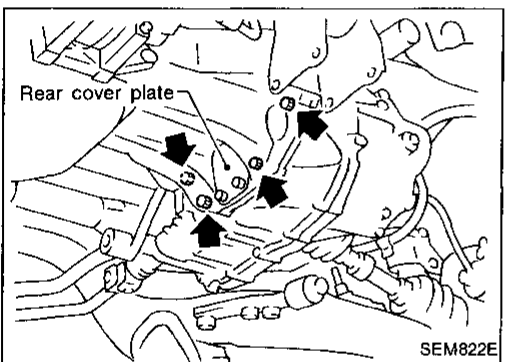

2. Install the transaxle bolts.
3. Install rear cover plate.

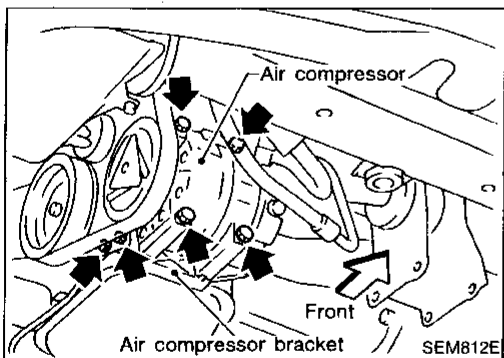

4. Install air compressor and bracket.
5. Install drive belts.
6. Install center member.
7. Install front and rear engine mounting insulator nuts and bolts.
8. Install crankshaft position sensors (POS and REF).
9. Install front exhaust tube and its support.
10. Install oil strainer.

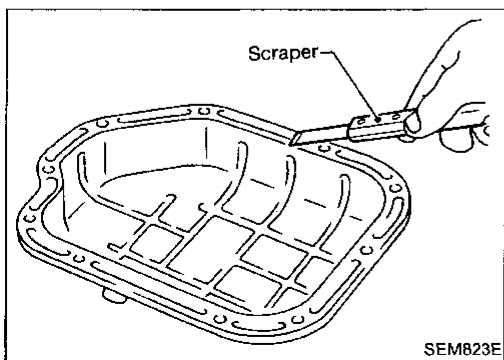

11. Install steel oil pan.
 - a. Use a scraper to remove all traces of liquid gasket from mating surfaces.
- Also remove traces of liquid gasket from mating surface of aluminum oil pan.

GI

MA

EM

LC

EC

FE

CL

MT

AT

FA

RA

BR

ST

RS

BT

HA

EL

IDX

OIL PAN

Installation (Cont'd)

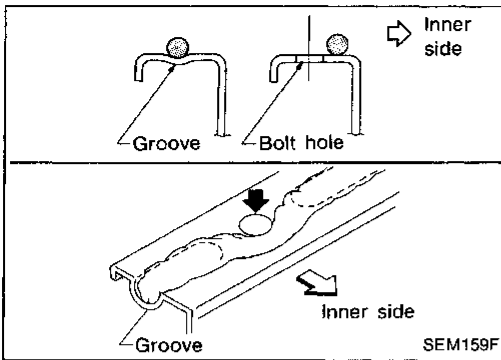

b. Apply a continuous bead of liquid gasket to mating surface of steel oil pan.

- Use Genuine Liquid Gasket or equivalent.
- Be sure liquid gasket is 4.0 to 5.0 mm (0.157 to 0.197 in) wide.
- Attaching should be done within 5 minutes after coating.

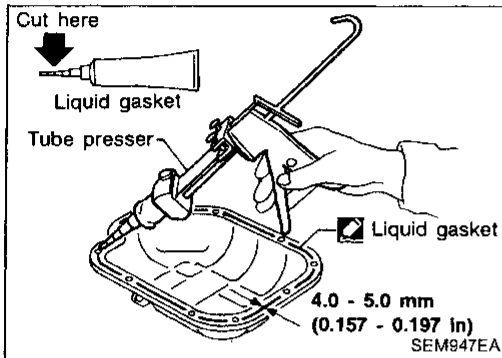

c. Install steel oil pan.

- Tighten in numerical order shown in the figure.
- Wait at least 30 minutes before refilling engine oil.

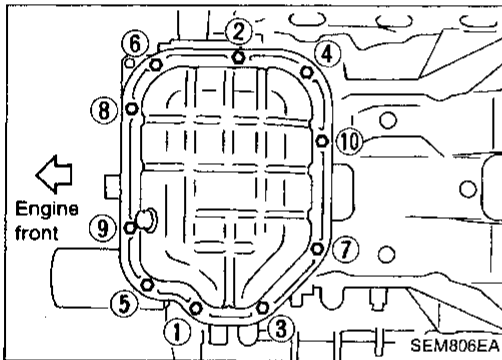

TIMING CHAIN

SEC. 120-130-135-150-210

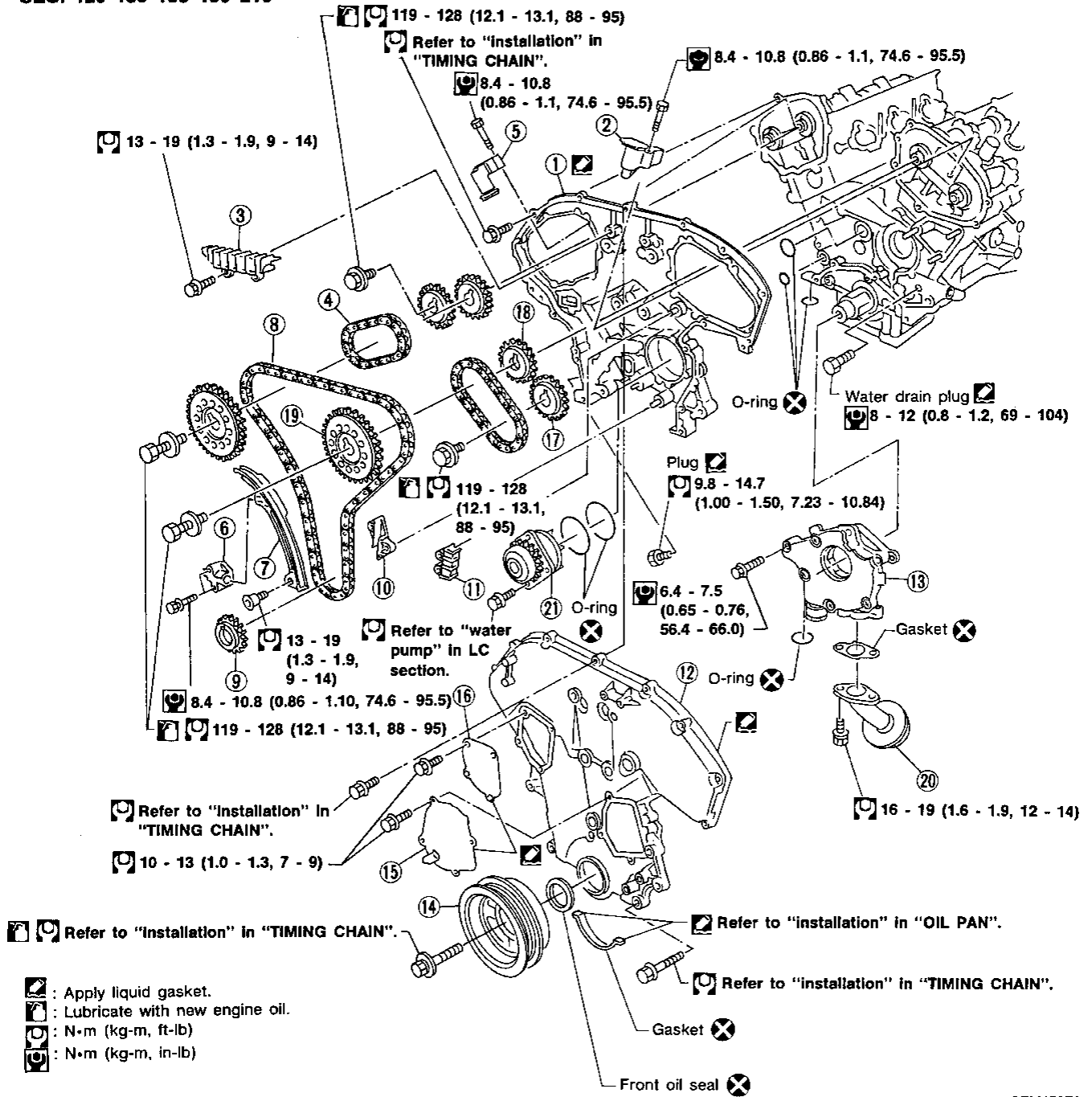

- | | | |
|----------------------------|---------------------------|---------------------------------|
| ① Rear timing chain case | ⑧ Timing chain | ⑮ Water pump cover |
| ② Left camshaft tensioner | ⑨ Crankshaft sprocket | ⑯ Chain tensioner cover |
| ③ Internal chain guide | ⑩ Lower chain guide | ⑰ Exhaust camshaft sprocket 2ND |
| ④ Camshaft chain | ⑪ Upper chain guide | ⑱ Intake camshaft sprocket 2ND |
| ⑤ Right camshaft tensioner | ⑫ Front timing chain case | ⑲ Camshaft sprocket 1ST |
| ⑥ Timing chain tensioner | ⑬ Oil pump assembly | ⑳ Oil strainer |
| ⑦ Slack side chain guide | ⑭ Crankshaft pulley | ㉑ Water pump |

SEM158FA

CI
 MA
EM
 LC
 EC
 FE
 CL
 MT
 AT
 FA
 RA
 BR
 ST
 RS
 BT
 HA
 EL
 IDX

TIMING CHAIN

POSITION FOR APPLYING LIQUID GASKET

Refer to "Installation" in "OIL PAN" for installing oil pan.

- Before installation, wipe off the protruding sealant.

Front timing chain case

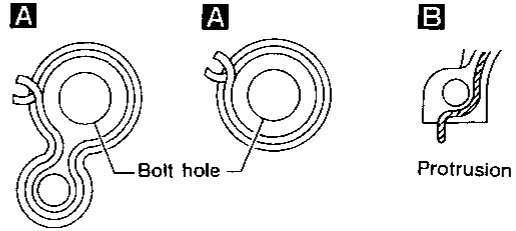
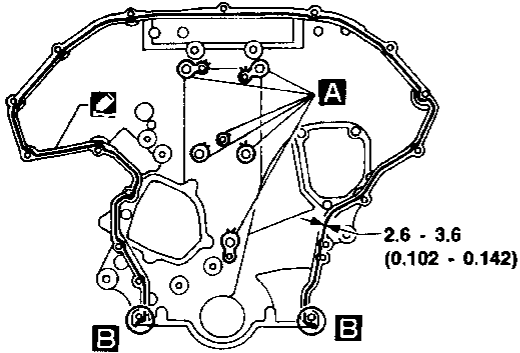

Sealant protrusion away from bolt hole

Rear timing chain case

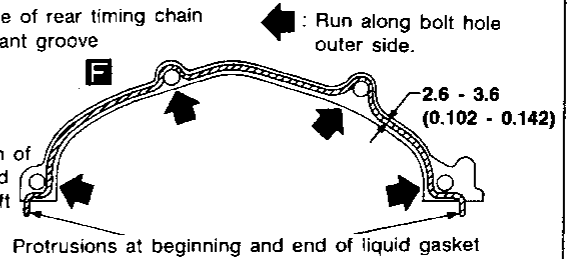
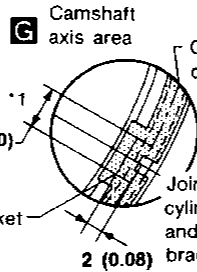
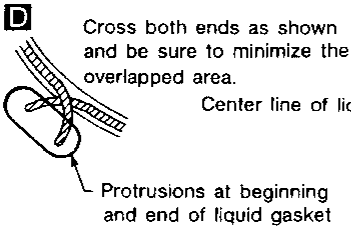
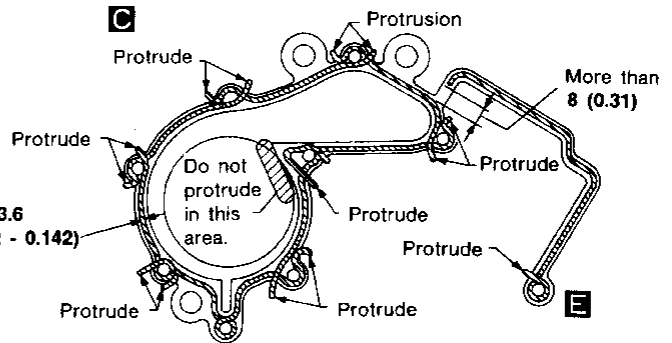
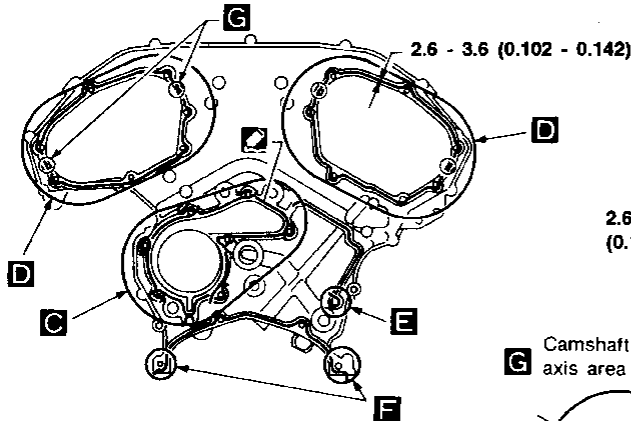

*1: Apply liquid gasket to the chamfered surface between camshaft bracket and cylinder head.

Camshaft bracket

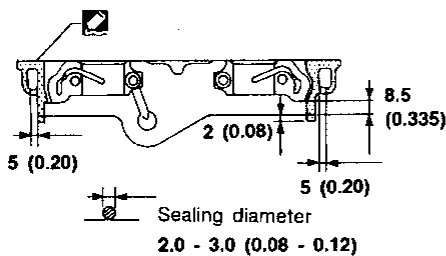

Rocker cover

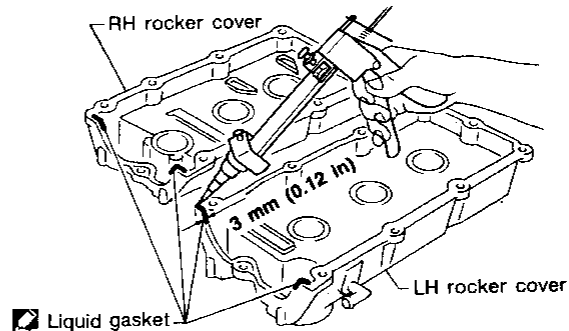

Unit: mm (in)

SEM189F

TIMING CHAIN

CAUTION:

- After removing timing chain, do not turn crankshaft and camshaft separately, or valves will strike piston heads.
- When installing camshafts, chain tensioners, oil seals, or other sliding parts, lubricate contacting surfaces with new engine oil.
- Apply new engine oil to bolt threads and seat surfaces when installing cylinder head, camshaft sprockets, crankshaft pulley, and camshaft brackets.
- Before disconnecting fuel hose, release fuel pressure. Refer to EC section ("Fuel Pressure Release", "BASIC SERVICE PROCEDURE").
- When removing the oil pans, oil pump assembly and timing chain from engine, first remove the camshaft position sensor (PHASE) and the crankshaft position sensors (REF) (POS) from the assembly.
Be careful not to damage sensor edges.
- Do not spill engine coolant on drive belts.

Removal

1. Drain engine oil.
2. Release fuel pressure.
Refer to "Fuel Pressure Release" in EC section.
3. Drain coolant by removing cylinder block drain plugs (refer to "Water pump" in LC section) and radiator drain cock.
4. Remove left side ornament cover.
5. Remove air duct to intake manifold, collector, blow-by hose, vacuum hoses, fuel hoses, wires, harness, connectors and so on.

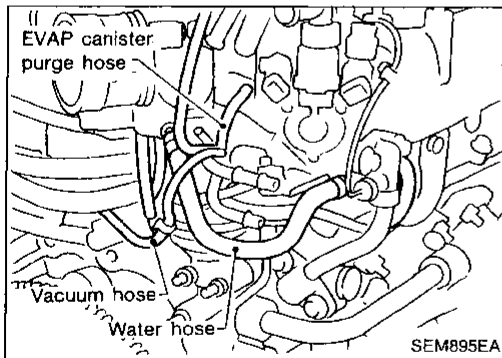

6. Remove the following.
 - Vacuum hoses
 - Water hoses
 - EVAP canister purge hose
 - Blow-by hose

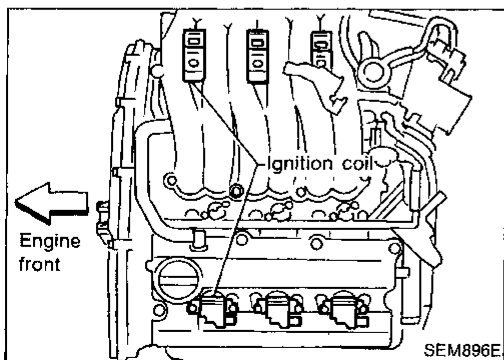

7. Remove RH and LH ignition coils.

TIMING CHAIN

Removal (Cont'd)

8. Remove EGR guide tube.

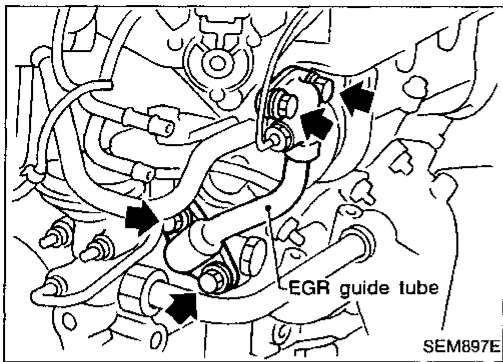

9. Remove intake manifold collector supports and intake manifold collector (RH cylinder head only).

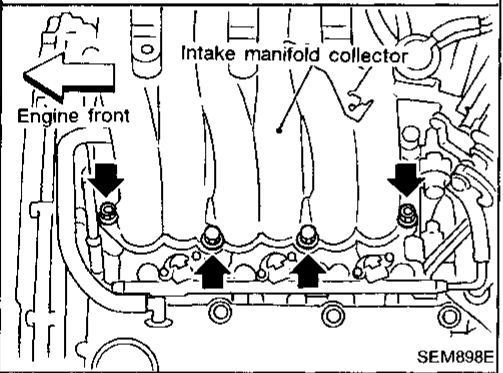
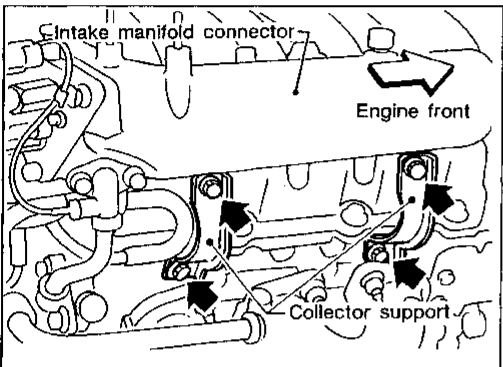

10. Remove fuel tube assembly. Refer to "TIGHTENING PROCEDURES" in "OUTER COMPONENT PARTS", (EM-8).

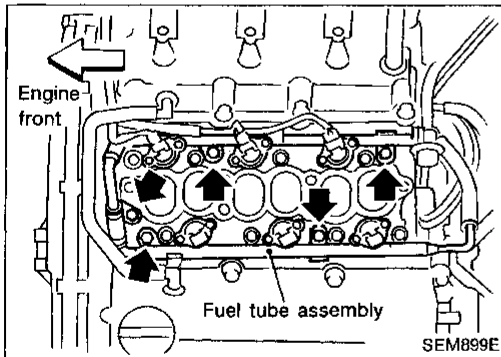

11. Remove intake manifold in reverse order of installation. Refer to "TIGHTENING PROCEDURES" in "OUTER COMPONENT PARTS", (EM-8).

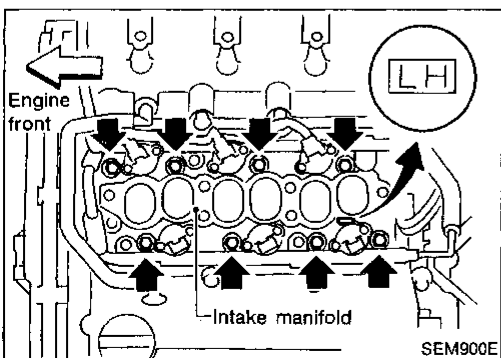

TIMING CHAIN

Removal (Cont'd)

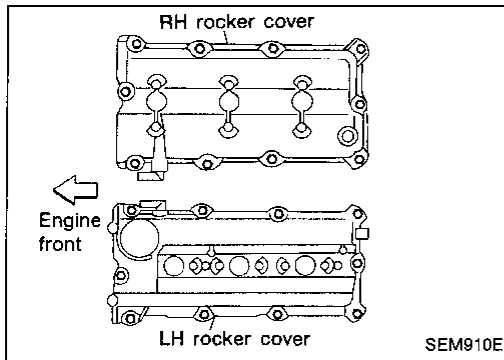

12. Remove RH and LH rocker covers from cylinder head.

13. Remove engine undercover.
14. Remove front RH wheel and engine side cover.
15. Remove drive belts and idler pulley bracket.

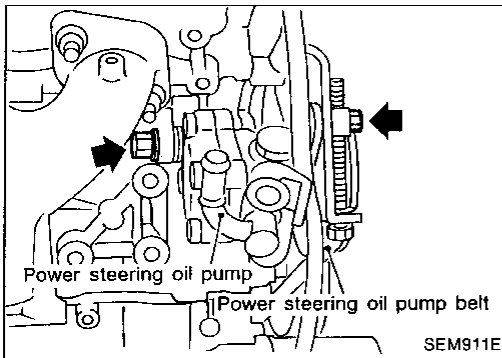

16. Remove power steering oil pump belt and power steering oil pump assembly.

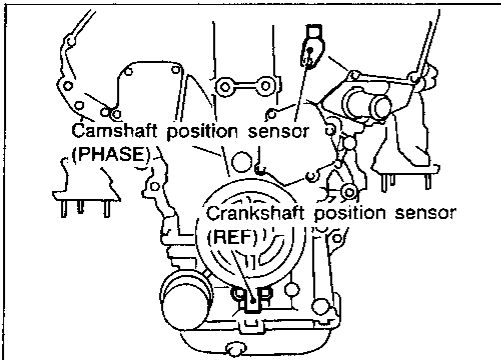

17. Remove camshaft position sensor (PHASE) and crankshaft position sensors (REF)/(POS).

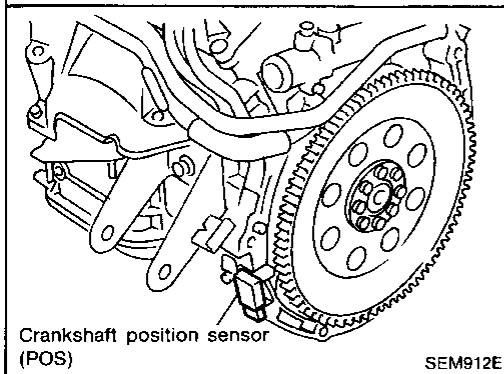

GI

MA

EM

LC

EC

FE

CL

MT

AT

FA

RA

BR

ST

RS

BT

HA

EL

IDX

TIMING CHAIN

Removal (Cont'd)

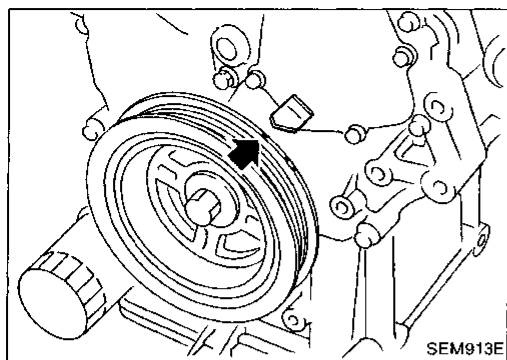

18. Set No. 1 piston at TDC on the compression stroke by rotating crankshaft.

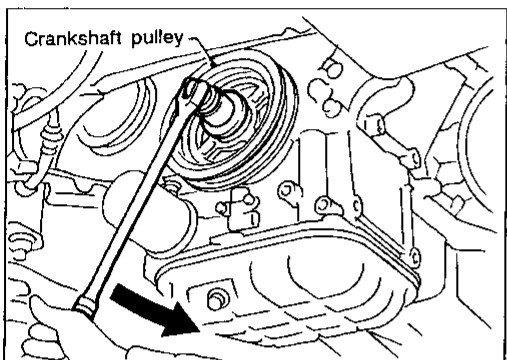

19. Loosen crankshaft pulley bolt. (At this time remove oil pan rear cover plate and set a suitable tool to ring gear so that crankshaft cannot rotate.)

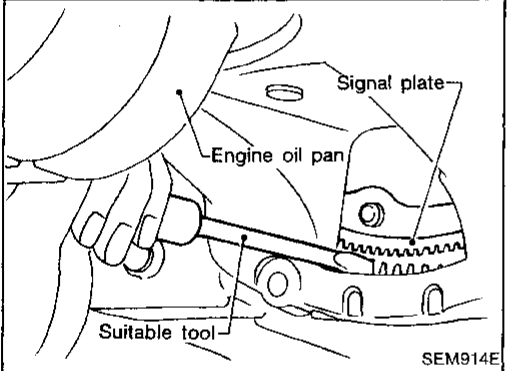

- Be careful not to damage the signal plate teeth.

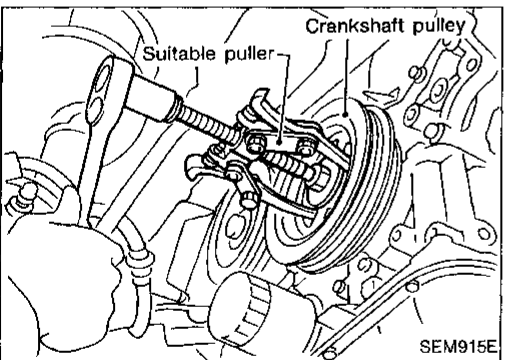

20. Remove crankshaft pulley with a suitable puller.

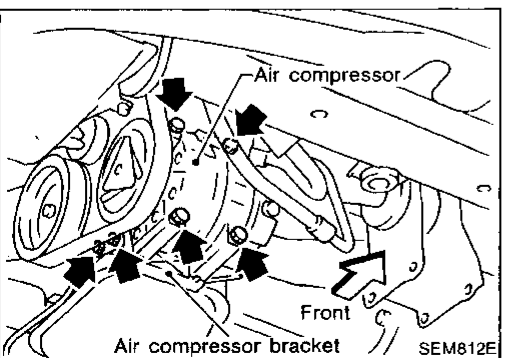

21. Remove air compressor and bracket.
 22. Remove front exhaust tube and its support.
 23. Hang engine at right and left side engine slingers with a suitable hoist.
 24. Remove right side engine mounting, mounting bracket and nuts.
 25. Remove center member assembly.
 26. Remove upper and lower oil pans.
- For procedures described in steps 21 through 26, refer to "Removal" in "OIL PAN".

TIMING CHAIN

Removal (Cont'd)

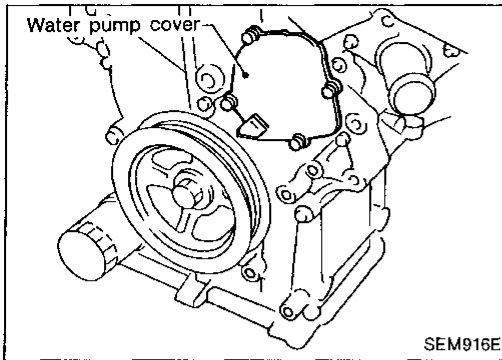

27. Remove water pump cover.

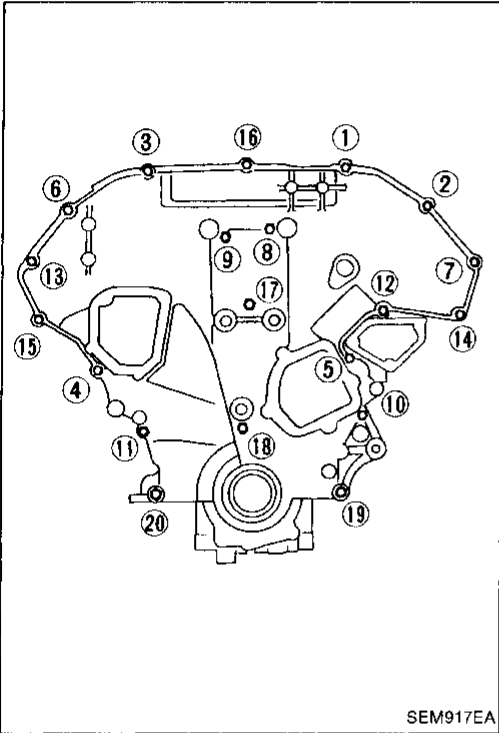

28. Remove front timing chain case bolts.

- Loosen bolts in numerical order as shown in the figure.

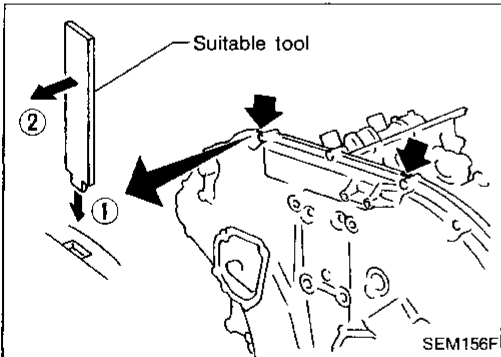

29. Remove front timing chain case.

- Do not scratch sealing surfaces.

GI

MA

EM

LC

EC

FE

CL

MT

AT

FA

RA

BR

ST

RS

BT

HA

EL

IDX

TIMING CHAIN

Removal (Cont'd)

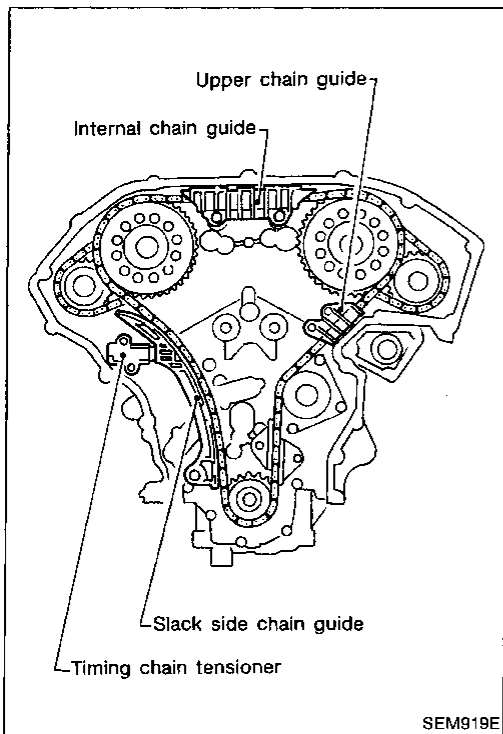

30. Remove internal timing chain guide.
31. Remove upper chain guide.
32. Remove timing chain tensioner and slack side chain guide.

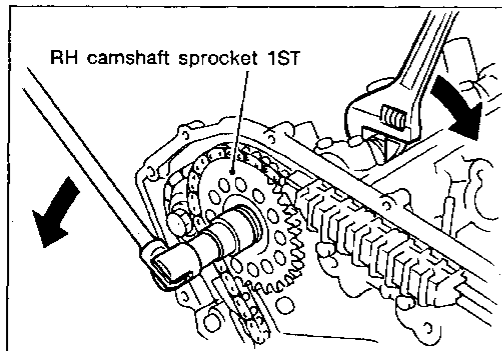

33. Remove RH & LH camshaft sprocket bolts 1ST.
34. Remove camshaft sprockets 1ST on both sides, crankshaft sprocket and timing chain.

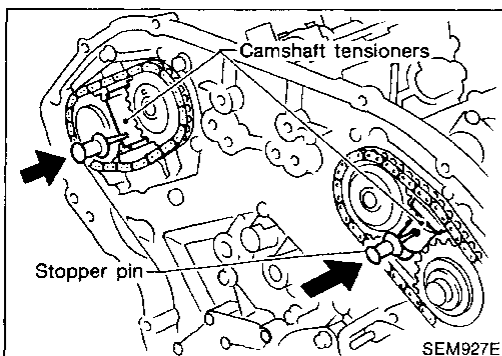
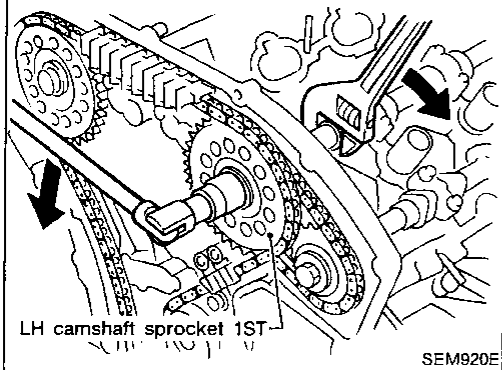

35. Attach a suitable stopper pin to RH and LH camshaft tensioners.

TIMING CHAIN

Removal (Cont'd)

36. Remove exhaust camshaft sprocket 2ND bolts on both sides.

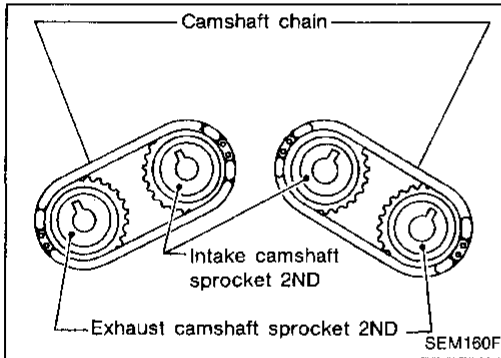
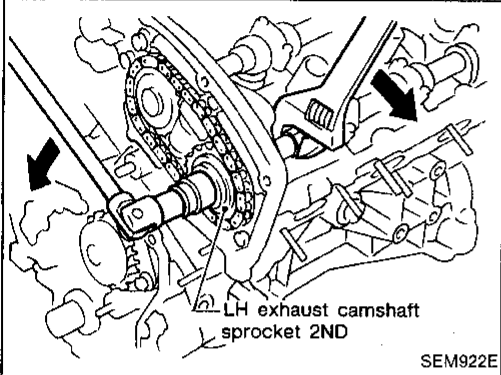
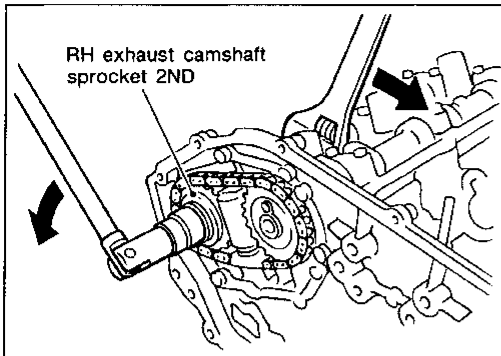

37. Remove exhaust camshaft sprockets 2ND, intake camshaft sprockets 2ND and camshaft chains on both sides.

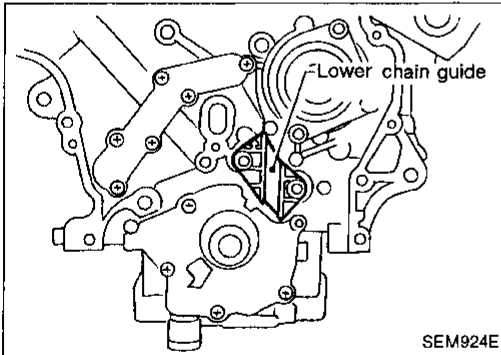

38. Remove lower chain guide.

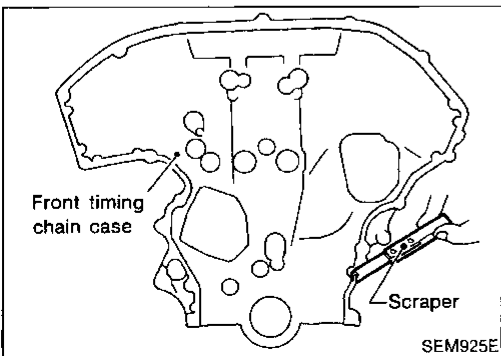

39. Use a scraper to remove all traces of liquid gasket from front timing chain case.

GI

MA

EM

LC

EC

FE

CL

WT

AT

FA

RA

BR

ST

RS

BT

HA

EL

IDX

TIMING CHAIN

Removal (Cont'd)

- Remove old liquid gasket from the bolt hole and thread.

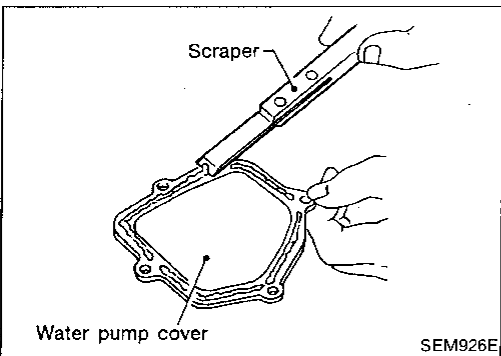
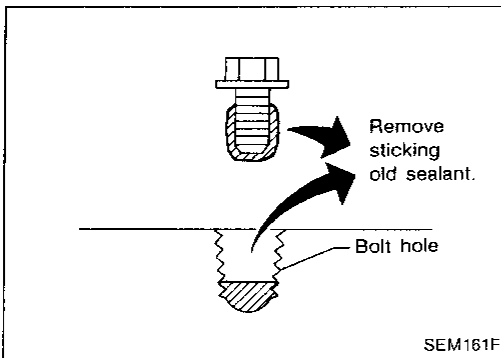

40. Use a scraper to remove all traces of liquid gasket from water pump cover.

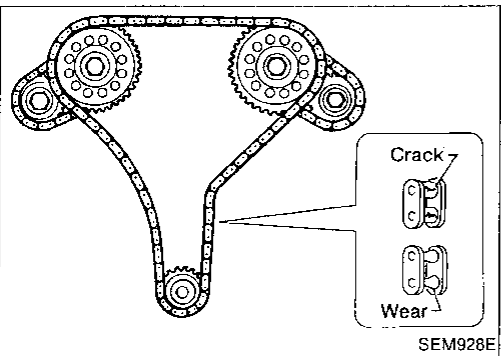

Inspection

Check for cracks and excessive wear at roller links. Replace chain if necessary.

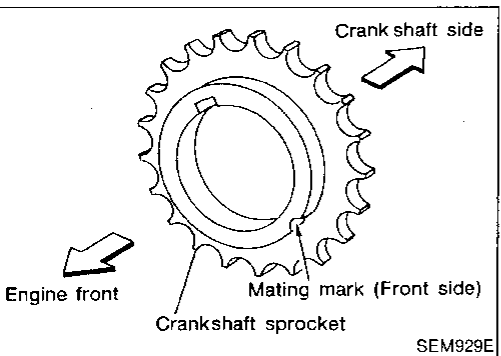

Installation

1. Install crankshaft sprocket on crankshaft.
 - Make sure that mating marks on crankshaft sprocket face front of engine.

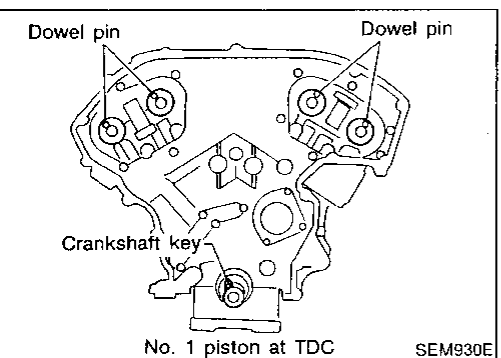

2. Position crankshaft so that No. 1 piston is set at TDC on compression stroke.

TIMING CHAIN

Installation (Cont'd)

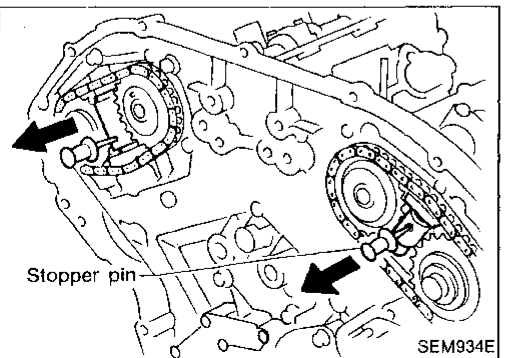
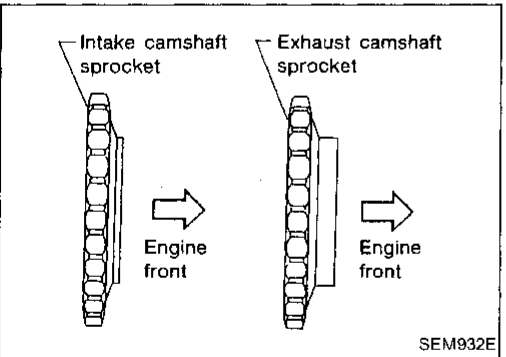
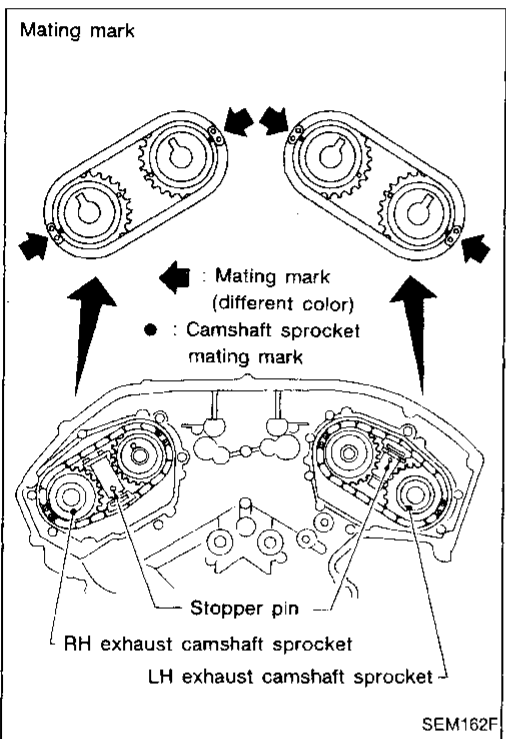
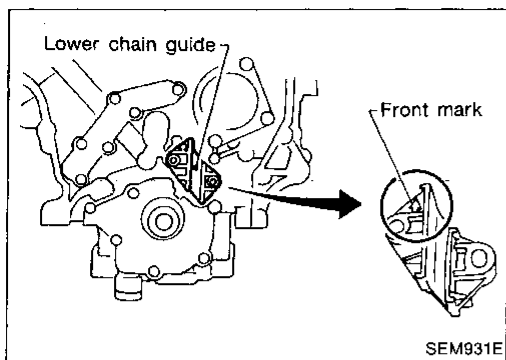

3. Install lower chain guide on dowel pin, with front mark on the guide facing upside.
 4. Align the marks on RH and LH intake camshaft sprockets (2ND), exhaust camshaft sprockets 2ND and camshaft chain, as shown.
 5. Put LH camshaft dowel pin into camshaft sprocket dowel groove and install these on camshaft. Tighten LH exhaust camshaft sprocket 2ND bolt.
 6. Put RH camshaft dowel pin in camshaft sprocket hole and install sprocket on camshaft.
 7. Tighten RH exhaust camshaft sprocket 2ND bolt.
- **Make sure that the timing marks on RH and LH intake camshaft sprockets (2ND) are aligned with the camshaft chain mark.**
 - **Lubricate threads and seat surfaces of camshaft sprocket bolts with new engine oil.**

8. Install intake and exhaust camshaft sprockets, being careful not to confuse the two (their thicknesses are different).
9. Remove RH and LH camshaft tensioner stopper pins.

TIMING CHAIN

Installation (Cont'd)

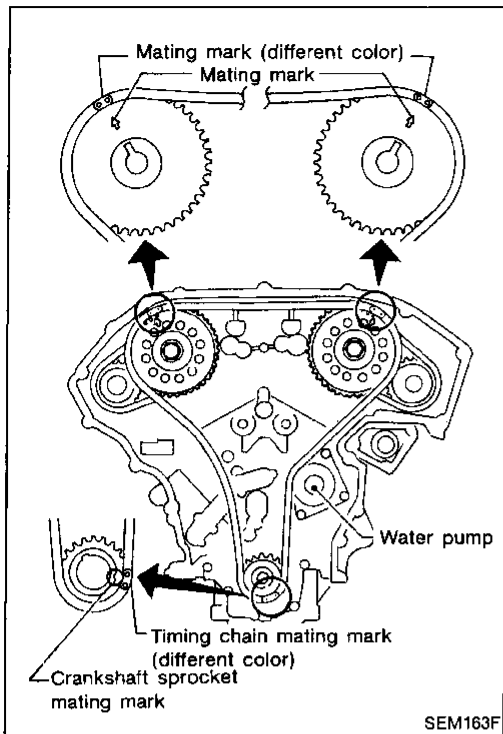

10. Align mating mark on crankshaft sprocket with matchmark on chain as shown.
11. Attach lower timing chain on the water pump sprocket.
12. Install RH and LH camshaft sprockets (1ST) onto timing chain by matching sprocket dowel grooves with camshaft.
13. Tighten RH and LH camshaft sprocket 1ST bolts.
 - **Lubricate threads and seat surfaces of the bolts with new engine oil.**
14. Install timing chain. Make sure that mating marks on crankshaft sprocket and RH and LH camshaft sprockets are aligned with matchmarks on timing chain.

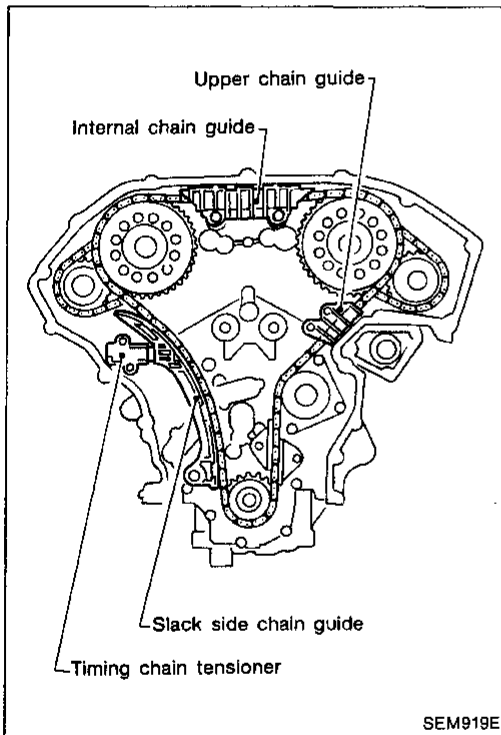

15. Install internal chain guide.
16. Install upper chain guide.
17. Install timing chain tensioner and slack side chain guide.
18. Apply liquid gasket to front timing chain case.
 - Refer to "POSITION FOR APPLYING LIQUID GASKET" (EM-18).
 - **Before installation, wipe off the protruding sealant.**

TIMING CHAIN

Installation (Cont'd)

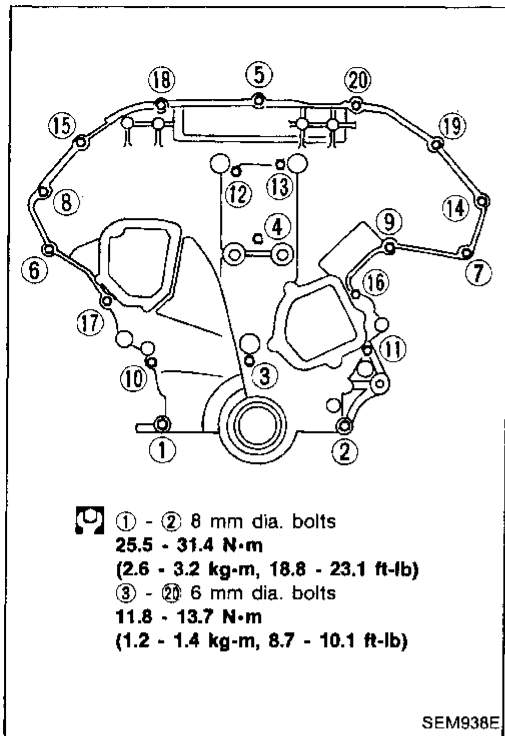

19. Install rear case pin into dowel pin hole on front timing chain case.
 20. Tighten bolts to the specified torque in order shown in the figure.
- **Leave the bolts unattended for 30 minutes or more after tightening.**

21. Apply liquid gasket to water pump cover.
22. Install water pump cover.
 - Apply a continuous bead of liquid gasket to mating surface of water pump cover. Refer to LC section ("Water Pump Installation").
23. Apply liquid gasket to RH and LH rocker covers.
 - Use genuine liquid gasket or equivalent.
 - Refer to "POSITION FOR APPLYING LIQUID GASKET" (EM-18).

24. Install RH and LH rocker covers.

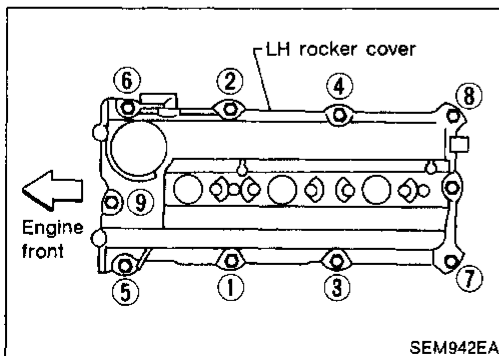
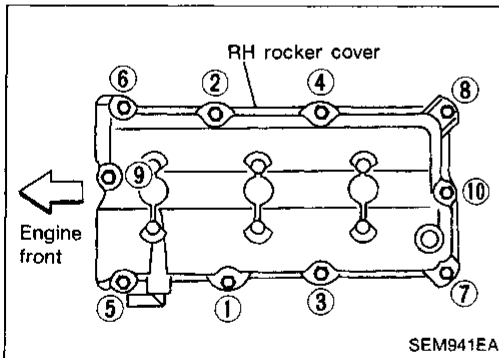

Rocker cover tightening procedure:

- **Tighten in numerical order as shown in the figure.**
- a. Tighten bolts ① to ⑩ in that order to 1 to 3 N·m (0.1 to 0.3 kg-m, 9 to 26 in-lb).
 - b. Tighten bolts ① to ⑩ as indicated in figure to 5.4 to 7.4 N·m (0.55 to 0.75 kg-m, 47.7 to 65.1 in-lb).

GI
MA
EM
LC
EC
FE
CL
MT
AT
FA
RA
BR
ST
RS
BT
HA
EL
IDX

TIMING CHAIN

Installation (Cont'd)

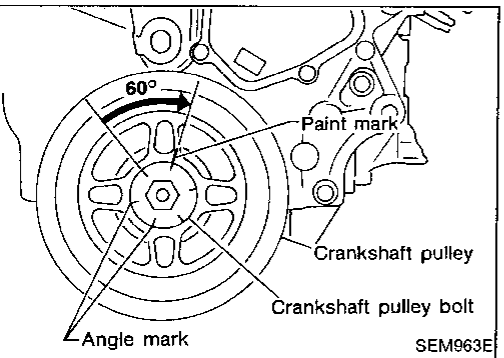
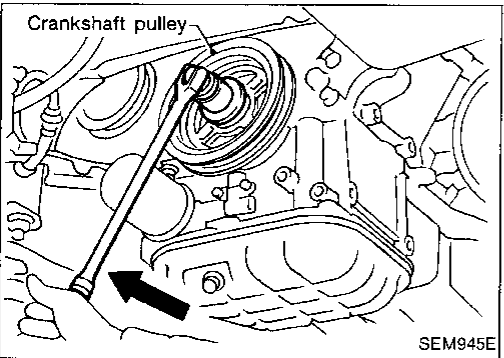
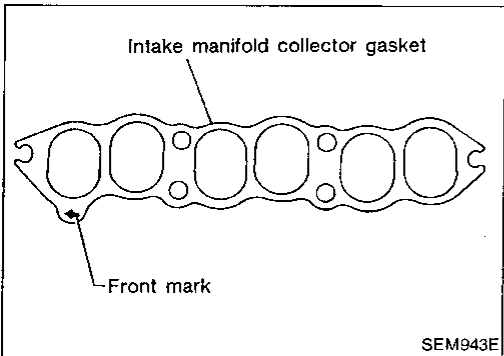
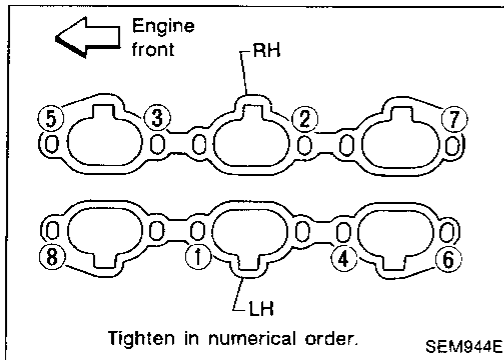

25. Install intake manifold. Tighten intake manifold nuts and bolts.

Refer to "TIGHTENING PROCEDURES" in "OUTER COMPONENT PARTS", (EM-8).

26. Install fuel tube assembly.

27. Install intake manifold collector gasket, with its front mark facing forwards.

28. Install intake manifold collector, supports and intake manifold collector bolt.

29. Install EGR guide tube.

Refer to "TIGHTENING PROCEDURES" in "OUTER COMPONENT PARTS", (EM-8).

30. Install RH and LH ignition coils.

31. Install rocker cover ornament on left side.

32. Install crankshaft pulley to crankshaft.

- Lubricate thread and seat surface of the bolt with new engine oil.

a. Tighten to 39 to 49 N·m (4.0 to 5.0 kg-m, 29 to 36 ft-lb).

b. Put a paint mark on the crankshaft pulley.

c. Again tighten by turning 60° to 66°, about the angle from one hexagon bolt head corner to another.

33. Install camshaft position sensor (PHASE) and crankshaft position sensors (REF)/(POS).

34. Reinstall removed parts in reverse order of removal.

- When installing fuel tube assembly, refer to "Injector Removal and Installation" in EC section.

- After installing the tensioner, race the engine at about 3,000 rpm under no load to purge air from the high-pressure chamber. The engine may produce a rattling noise. This indicates that air still remains in the chamber and is not a matter of concern.

OIL SEAL REPLACEMENT

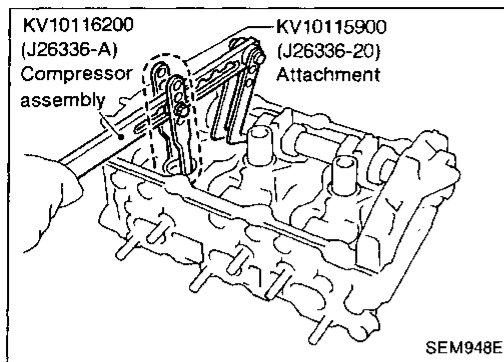

CAUTION:

When removing the oil pans, oil pump assembly and timing chain from engine, first remove the camshaft position sensor (PHASE) and the crankshaft position sensors (REF)/(POS) from the assembly.

Be careful not to damage sensor edges.

VALVE OIL SEAL

1. Remove LH ornament cover.
2. Remove RH and LH ignition coils.
3. Remove EGR guide tube.
4. Remove intake manifold collector supports and intake manifold collector (RH cylinder head only).
5. Remove RH and LH rocker covers from cylinder head.
6. Remove camshaft position sensor (PHASE) and crankshaft position sensors (REF)/(POS).
7. Remove oil pan. (Refer to "Removal" in "OIL PAN" EM-11.)
8. Remove timing chain. (Refer to "Removal" in "TIMING CHAIN" EM-19.)
9. Remove camshaft brackets and camshaft. (Refer to "Removal" in "CYLINDER HEAD" EM-35.)
10. Remove valve lifters and shims.
11. Remove valve spring with Tool.
12. Reinstall any parts removed in reverse order of removal.

Before removing valve spring, fix valve as follows.

Method A:

Piston concerned should be set at TDC to prevent valve from falling.

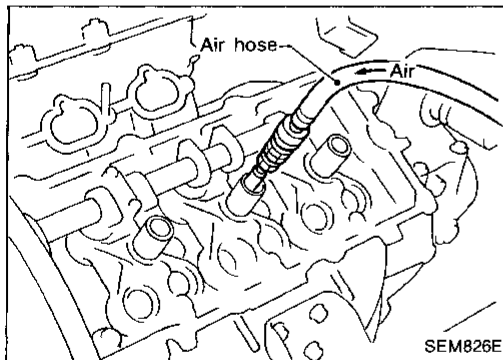

Method B:

Remove spark plug, then install air hose adapter into spark plug hole and apply air pressure to hold valves in place. Apply a pressure of 490 kPa (5 kg/cm², 71 psi).

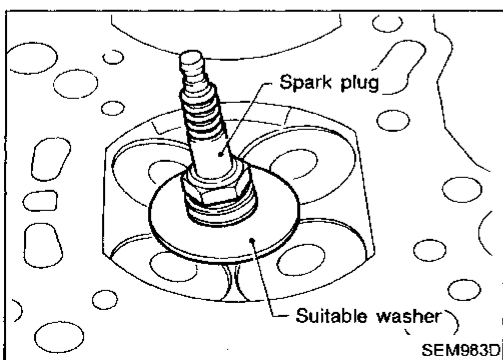

Method C:

Install spark plug with suitable washer into spark plug hole from combustion chamber side.

OIL SEAL REPLACEMENT

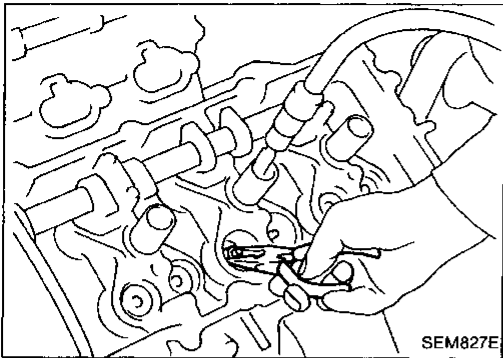

13. Remove valve oil seal.

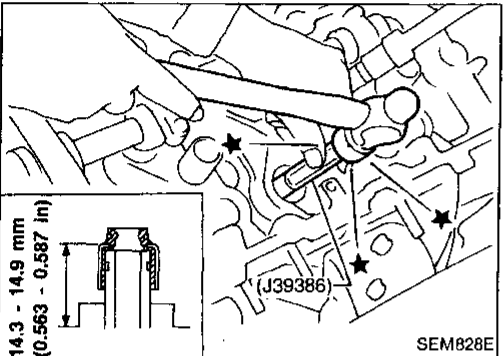

14. Apply engine oil to new valve oil seal and install it with Tool.

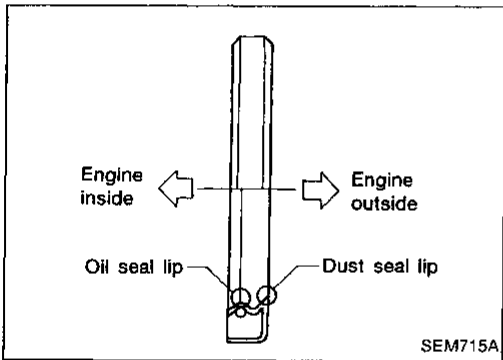

OIL SEAL INSTALLATION DIRECTION

- Install new oil seal in the direction shown in the figure.

FRONT OIL SEAL

1. Remove the following parts:
 - Engine undercover
 - Front RH wheel and engine side cover
 - Drive belts
 - Crankshaft position sensor (REF)
 - Crankshaft pulley

Be careful not to damage sensor edge.

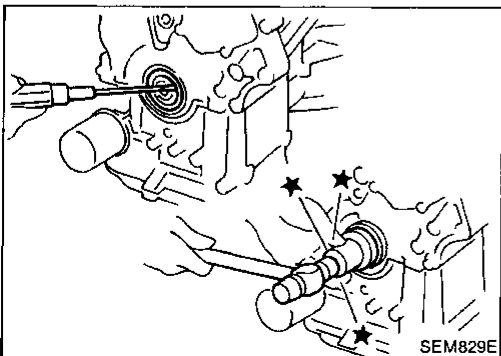

2. Remove front oil seal using a suitable tool.

Be careful not to scratch front cover.

3. Apply engine oil to new oil seal and install it using a suitable tool.

OIL SEAL REPLACEMENT

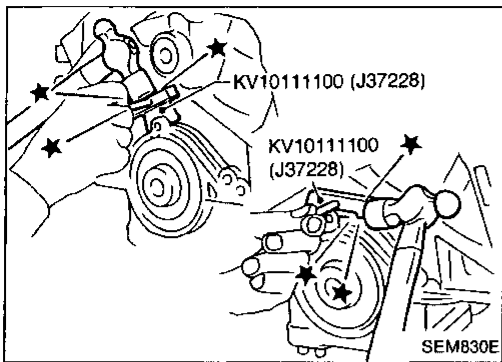

REAR OIL SEAL

1. Remove transaxle. (Refer to MT or AT section.)
2. Remove flywheel or drive plate.
3. Remove oil pan. (Refer to OIL PAN.)
4. Remove rear oil seal retainer.

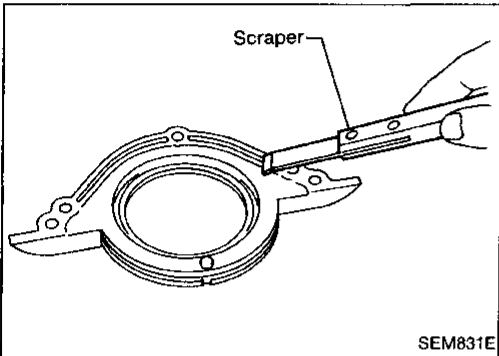

5. Remove traces of liquid gasket using scraper.
- Remove old liquid gasket from the bolt hole and thread.

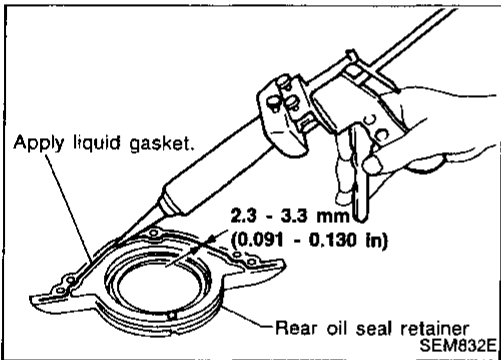

6. Apply liquid gasket to rear oil seal retainer.

GI

MA

EM

LC

EC

FE

CL

MT

AT

FA

RA

BR

ST

RS

BT

HA

EL

IDX

CYLINDER HEAD

SEC. 111-118-130-140-220

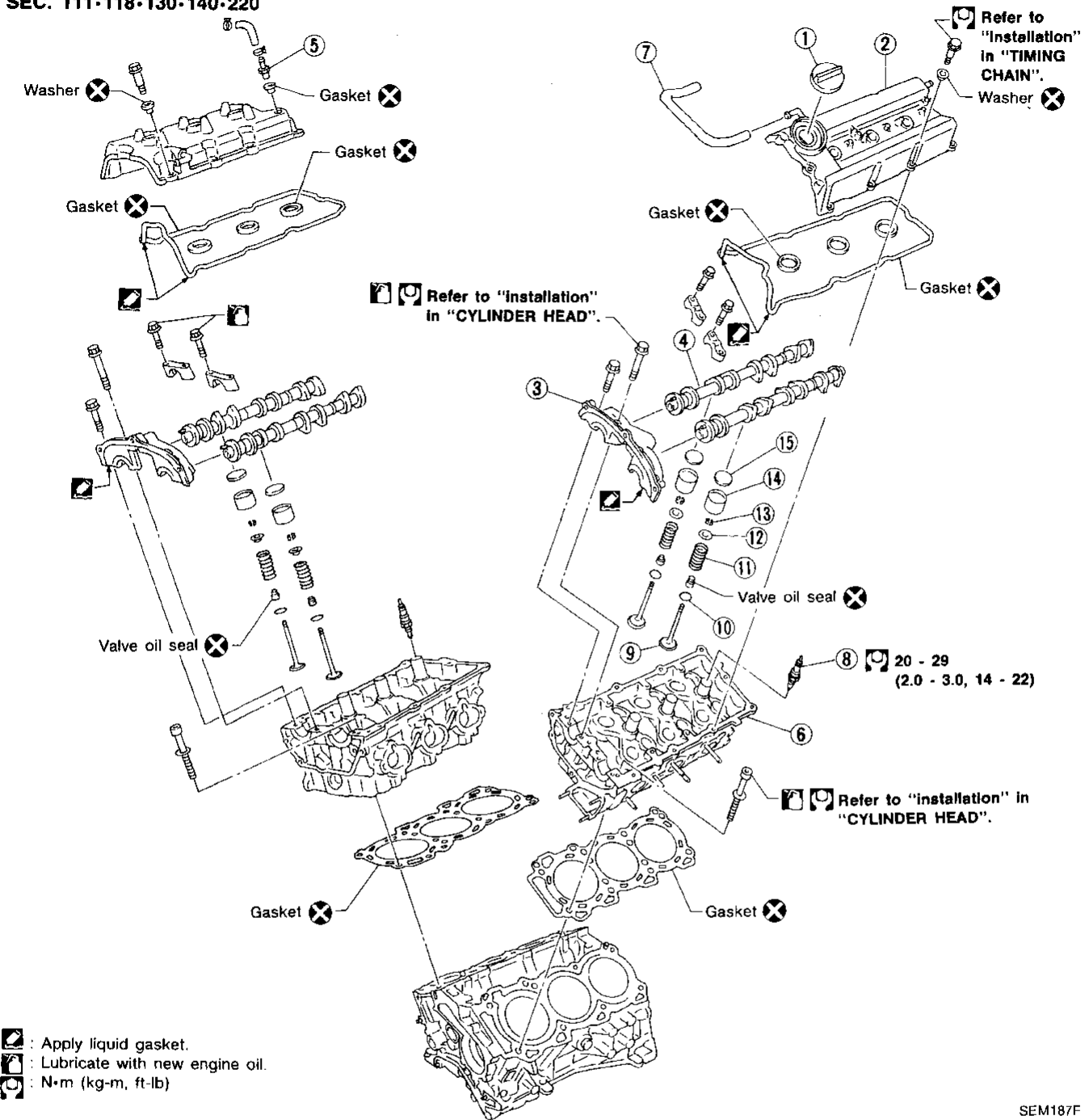

SEM187F

- | | | |
|--------------------|---------------------|-------------------------|
| ① Oil filler cap | ⑥ Cylinder head | ⑪ Valve spring |
| ② Rocker cover | ⑦ Blow by hose | ⑫ Valve spring retainer |
| ③ Camshaft bracket | ⑧ Spark plug | ⑬ Valve collet |
| ④ Camshaft | ⑨ Valve | ⑭ Valve lifter |
| ⑤ PCV valve | ⑩ Valve spring seat | ⑮ Shim |

CYLINDER HEAD

CAUTION:

- When installing camshafts, chain tensioners, oil seals, or other sliding parts, lubricate contacting surfaces with new engine oil.
- Apply new engine oil to threads and seat surfaces when installing cylinder head, camshaft sprocket, crankshaft pulley, and camshaft bracket.
- Attach tags to valve lifters so as not to mix them up.

Removal

This removal is the same procedure as that for timing chain. Refer to "Removal" in "TIMING CHAIN" (EM-19).

Disassembly

1. Remove rear timing chain case bolts.

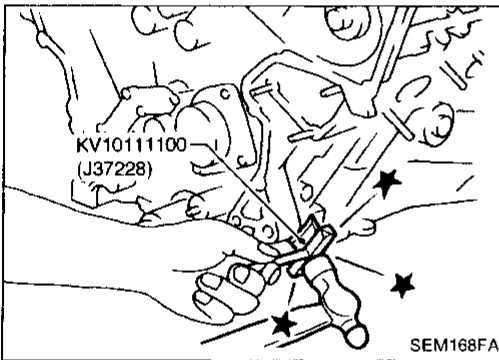
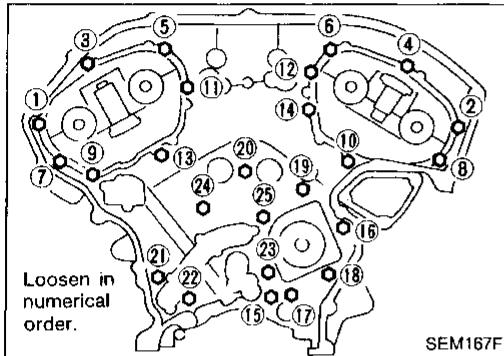

2. Remove rear timing chain case.

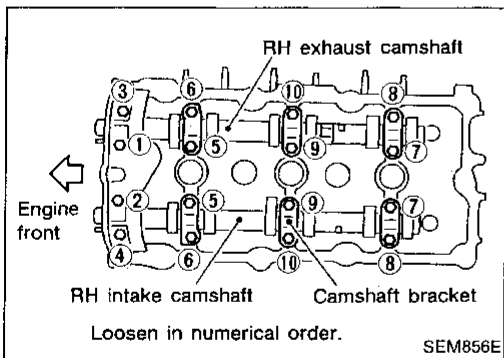

3. Remove intake and exhaust camshafts and camshaft brackets.

- Equally loosen camshaft bracket bolts in several steps in the numerical order shown in the figure.

For reinstallation, be sure to put marks on camshaft bracket before removal.

4. Remove valve component parts.

Refer to "VALVE OIL SEAL" in "OIL SEAL REPLACEMENT" (EM-31).

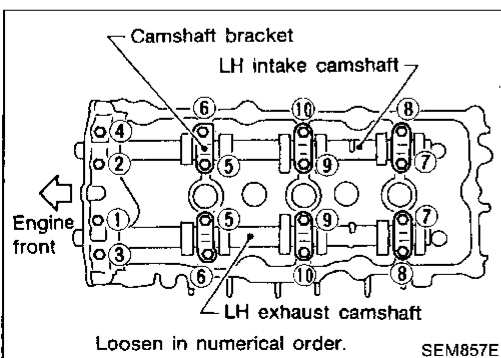

GI

MA

EM

LC

EC

FE

CL

MT

AT

FA

RA

BR

ST

RS

BT

HA

EL

IDX

CYLINDER HEAD

Disassembly (Cont'd)

5. Remove RH and LH camshaft tensioners from cylinder head.

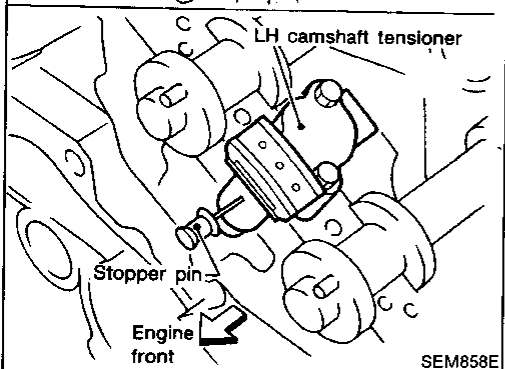
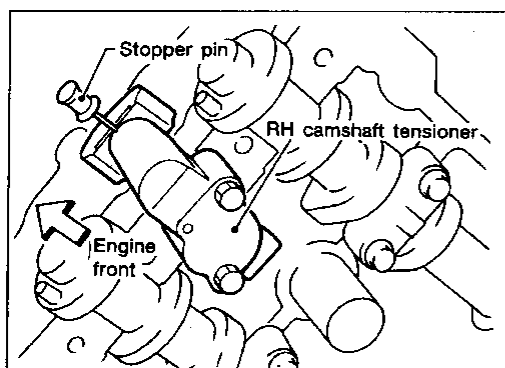

SEM858E

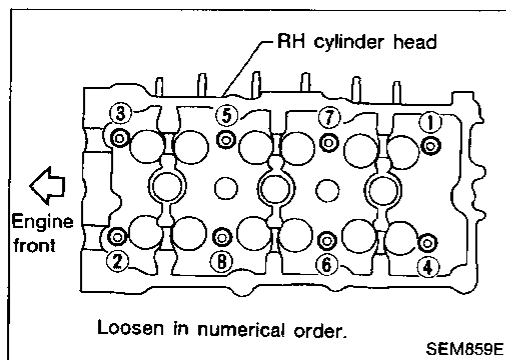

SEM859E

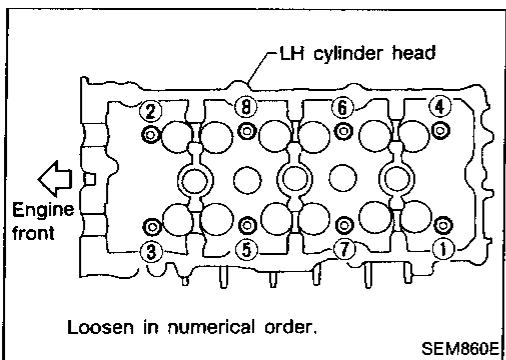

SEM860E

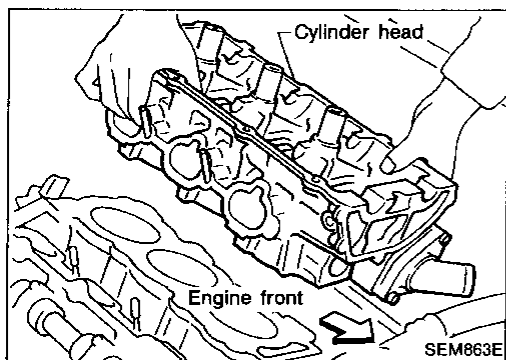

SEM863E

6. Remove cylinder head bolts.

- **Cylinder head bolts should be loosened in two or three steps.**
- **A warped or cracked cylinder head could result from removing in incorrect order.**

7. Remove cylinder head.

CYLINDER HEAD

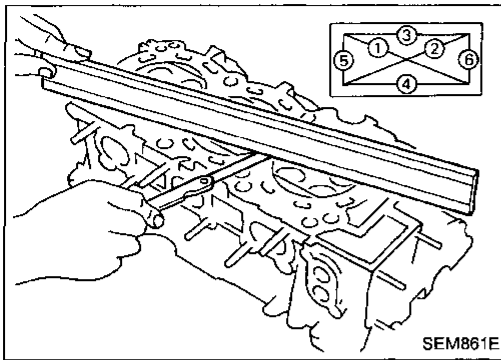

Inspection

CYLINDER HEAD DISTORTION

Clean surface of cylinder head.

Use a reliable straightedge and feeler gauge to check the flatness of cylinder head surface.

Check along six positions shown in the figure.

Head surface flatness: Limit 0.1 mm (0.004 in)

If beyond the specified limit, resurface or replace it.

The limit for cylinder head resurfacing is determined by the cylinder block resurfacing.

Resurfacing limit:

Amount of cylinder head resurfacing is "A".

Amount of cylinder block resurfacing is "B".

The maximum limit : $A + B = 0.2 \text{ mm (0.008 in)}$

After resurfacing cylinder head, check that camshaft rotates freely by hand. If resistance is felt, cylinder head must be replaced.

Nominal cylinder head height:

126.3 - 126.5 mm (4.972 - 4.980 in)

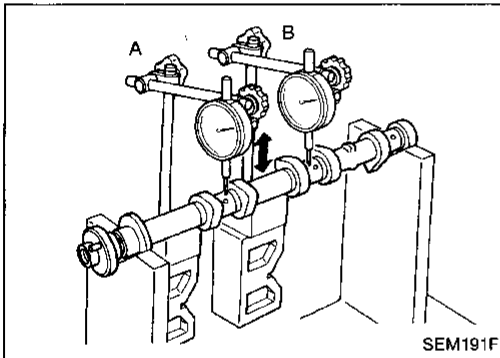

CAMSHAFT VISUAL CHECK

Check camshaft for scratches, seizure and wear.

CAMSHAFT RUNOUT

1. Measure camshaft runout at A and B as shown in the figure.

Runout (Total indicator reading):

Limit 0.05 mm (0.0020 in)

2. If it exceeds the limit, replace camshaft.

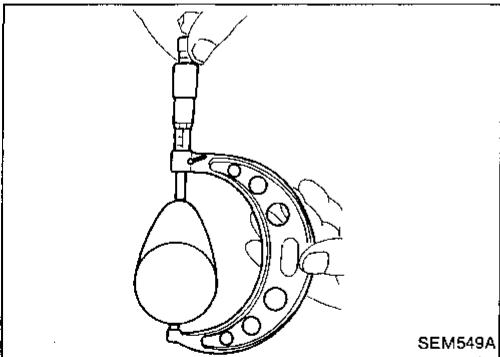

CAMSHAFT CAM HEIGHT

1. Measure camshaft cam height.

Standard cam height:

43.940 - 44.130 mm (1.7299 - 1.7374 in)

Cam wear limit:

0.2 mm (0.008 in)

2. If wear is beyond the limit, replace camshaft.

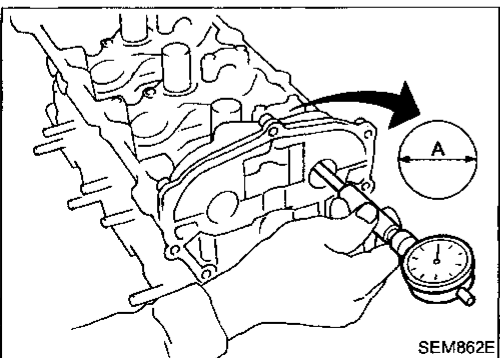

CAMSHAFT JOURNAL CLEARANCE

1. Install camshaft bracket and tighten bolts to the specified torque.

2. Measure inner diameter "A" of camshaft bearing.

Standard inner diameter:

No.1: 26.000 - 26.021 mm (1.0236 - 1.0244 in)

No. 2, 3, 4: 23.500 - 23.521 mm (0.9252 - 0.9260 in)

CYLINDER HEAD

Inspection (Cont'd)

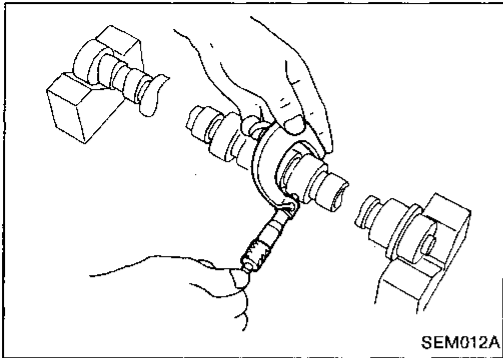

3. Measure outer diameter of camshaft journal.
Standard outer diameter:
No. 1: 25.935 - 25.955 mm (1.0211 - 1.0218 in)
No. 2, 3, 4: 23.435 - 23.455 mm (0.9226 - 0.9234 in)
4. If clearance exceeds the limit, replace camshaft and/or cylinder head.

Camshaft journal clearance:

Standard

0.045 - 0.086 mm (0.0018 - 0.0034 in)

Limit

0.15 mm (0.0059 in)

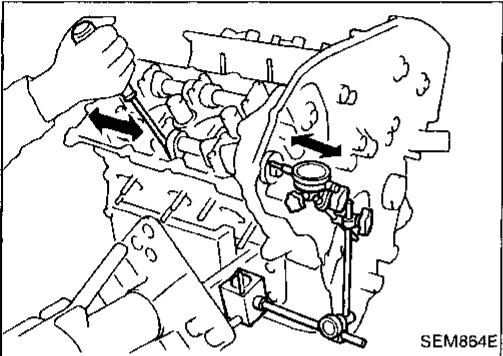

CAMSHAFT END PLAY

1. Install camshaft in cylinder head.
2. Measure camshaft end play.

Camshaft end play:

Standard

0.115 - 0.188 mm (0.0045 - 0.0074 in)

Limit

0.24 mm (0.0094 in)

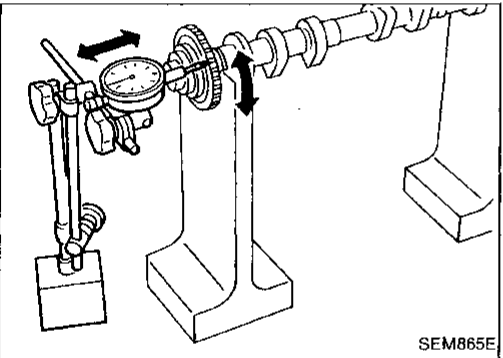

CAMSHAFT SPROCKET RUNOUT

1. Install sprocket on camshaft.
2. Measure camshaft sprocket runout.
Runout (Total indicator reading):
Less than 0.15 mm (0.0059 in)
3. If it exceeds the limit, replace camshaft sprocket.

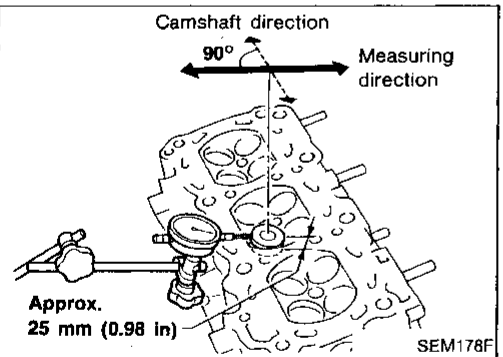

VALVE GUIDE CLEARANCE

1. Measure valve deflection as shown in the figure. (Valve and valve guide mostly wear in this direction.)

Valve deflection limit (Dial gauge reading):

Intake 0.24 mm (0.0094 in)

Exhaust 0.28 mm (0.0110 in)

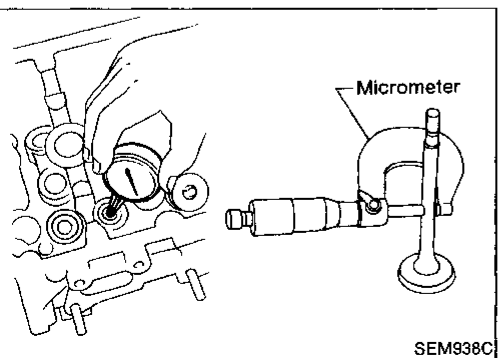

2. If it exceeds the limit, check valve to valve guide clearance.
 - a. Measure valve stem diameter and valve guide inner diameter.
 - b. Check that clearance is within specification.
Valve to valve guide clearance limit:
Intake 0.08 mm (0.0031 in)
Exhaust 0.1 mm (0.004 in)
 - c. If it exceeds the limit, replace valve or valve guide.

CYLINDER HEAD

Inspection (Cont'd)

VALVE GUIDE REPLACEMENT

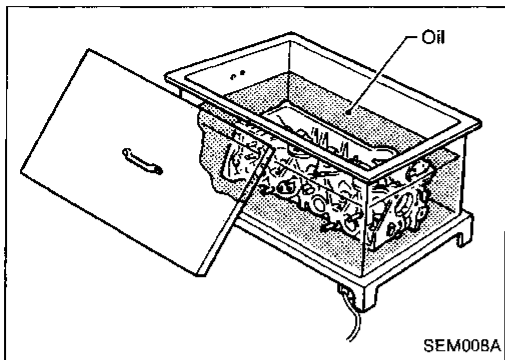

1. To remove valve guide, heat cylinder head to 110 to 130°C (230 to 266°F) by soaking in heated oil.

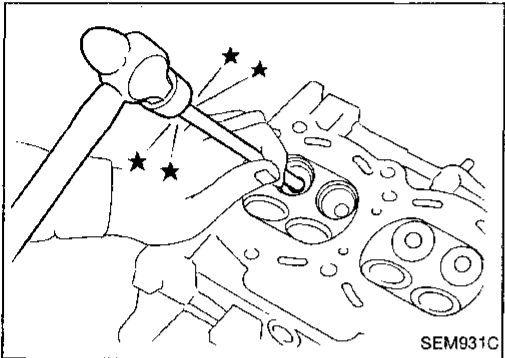

2. Drive out valve guide with a press [under a 20 kN (2 ton, 2.2 US ton, 2.0 Imp ton) pressure] or hammer and suitable tool.

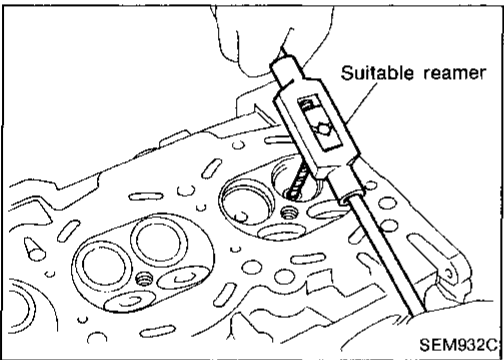

3. Ream cylinder head valve guide hole.
**Valve guide hole diameter
(for service parts):**
10.175 - 10.196 mm (0.4006 - 0.4014 in)

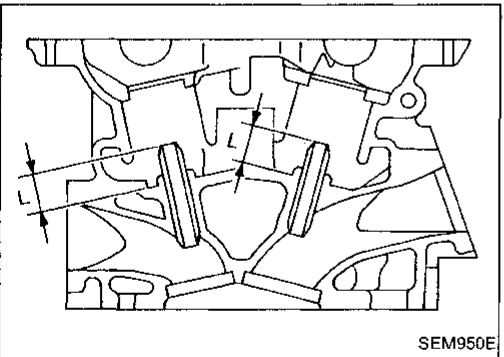

4. Heat cylinder head to 110 to 130°C (230 to 266°F) and press service valve guide onto cylinder head.

Projection "L":
12.6 - 12.8 mm (0.496 - 0.504 in)

5. Ream valve guide.
Finished size:
6.000 - 6.018 mm (0.2362 - 0.2369 in)

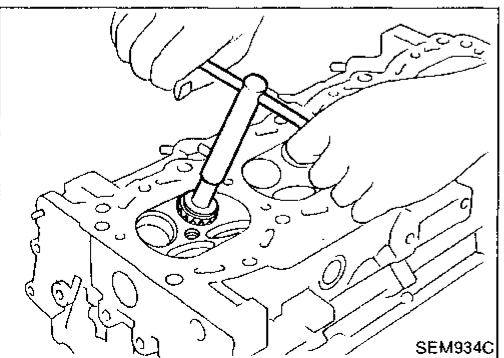

VALVE SEATS

Check valve seats for any evidence of pitting at valve contact surface, and reseat or replace if it has worn out excessively.

- Before repairing valve seats, check valve and valve guide for wear. If they have worn, replace them. Then correct valve seat.
- Use both hands to cut uniformly.

GI

MA

EM

LC

EC

FE

CL

MT

AT

FA

RA

BR

ST

RS

BT

HA

EL

IDX

CYLINDER HEAD

Inspection (Cont'd)

REPLACING VALVE SEAT FOR SERVICE PARTS

1. Bore out old seat until it collapses. Boring should not continue beyond the bottom face of the seat recess in cylinder head. Set the machine depth stop to ensure this.
2. Ream cylinder head recess for service valve seat.

Oversize [0.5 mm (0.020 in)]:

Intake 37.500 - 37.516 mm (1.4764 - 1.4770 in)

Exhaust 32.700 - 32.716 mm (1.2874 - 1.2880 in)

Be sure to ream in circles concentric to the valve guide center. This will enable valve seat to fit correctly.

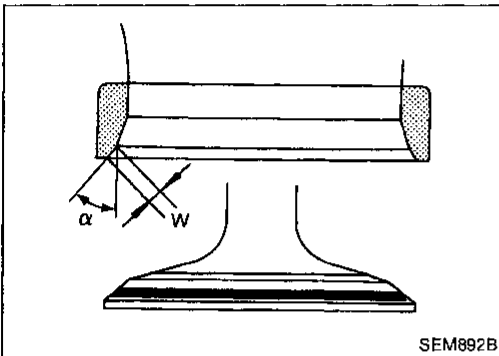
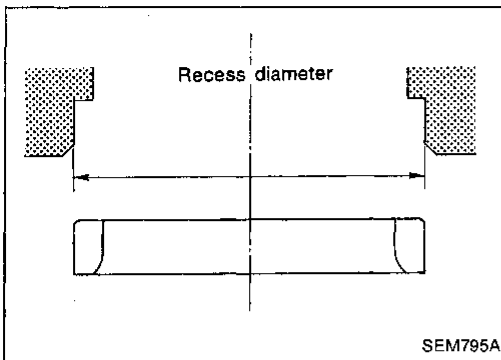

3. Heat cylinder head to 110 to 130°C (230 to 266°F) by soaking in heated oil.
4. Press fit valve seat until it seats on the bottom.
5. Cut or grind valve seat using suitable tool to the specified dimensions as shown in SDS (EM-68).
6. After cutting, lap valve seat with abrasive compound.
7. Check valve seating condition.

Seat face angle " α ": 44°53' - 45°07' deg.

Contacting width "W":

Intake: 1.09 - 1.31 mm (0.0429 - 0.0516 in)

Exhaust: 1.29 - 1.51 mm (0.0508 - 0.0594 in)

VALVE DIMENSIONS

Check dimensions of each valve. For dimensions, refer to SDS (EM-65).

When valve head has been worn down to 0.5 mm (0.020 in) in margin thickness, replace valve.

Grinding allowance for valve stem tip is 0.2 mm (0.008 in) or less.

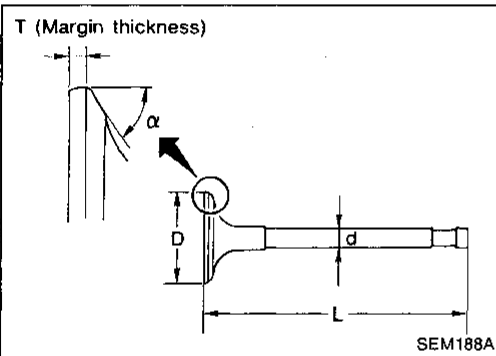

VALVE SPRING

Squareness

1. Measure dimension "S".

Out-of-square "S":

Less than 2.0 mm (0.079 in)

2. If it exceeds the limit, replace spring.

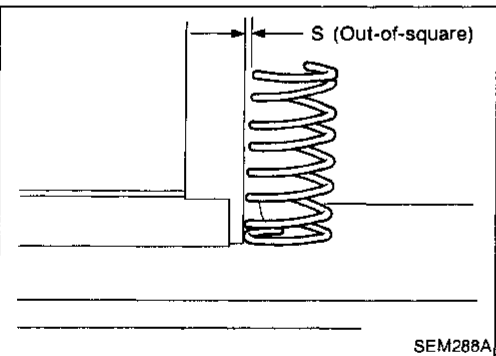

Pressure

Check valve spring pressure at specified spring height.

Pressure:

Standard

454 N (46.3 kg, 102.1 lb)

at height 27.55 mm (1.0846 in)

Limit

More than 428 N (43.7 kg, 96.2 lb)

at height 27.55 mm (1.0846 in)

If it exceeds the limit, replace spring.

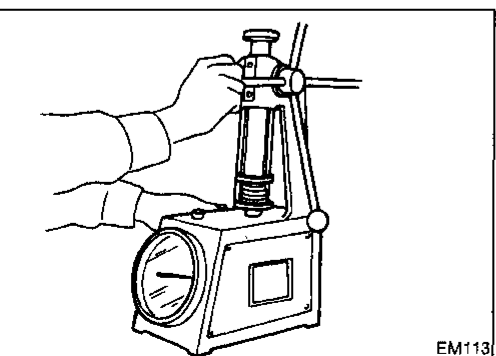

CYLINDER HEAD

Inspection (Cont'd)

VALVE LIFTER

1. Check contact and sliding surfaces for wear or scratches.

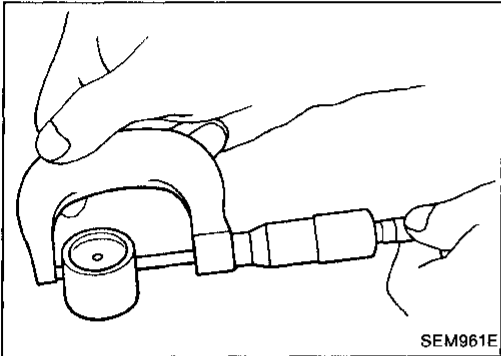
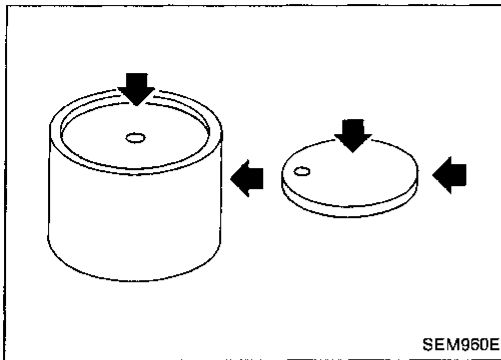

2. Check diameter of valve lifter and valve lifter guide bore.

Valve lifter outer diameter:

34.960 - 34.975 mm (1.3764 - 1.3770 in)

Lifter guide bore diameter:

35.000 - 35.021 mm (1.3780 - 1.3788 in)

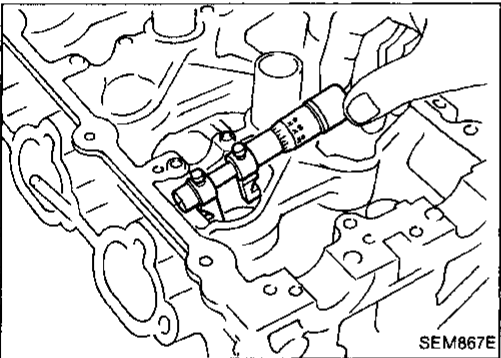

Assembly

1. Install valve component parts.
 - Always use new valve oil seal. Refer to **OIL SEAL REPLACEMENT (EM-31)**.
 - Before installing valve oil seal, install valve spring seat.
 - Install valve spring (uneven pitch type) with its narrow pitch side toward cylinder head side (paint mark).
 - After installing valve component parts, tap valve stem tip with plastic hammer to assure a proper fit.

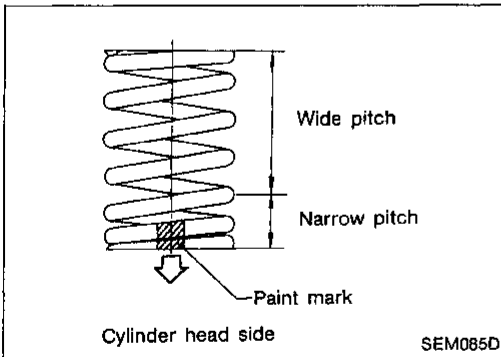

Installation

1. Before installing rear timing chain case, remove all traces of liquid gasket from mating surface using a scraper.
 - Also remove traces of liquid gasket from mating surface of cylinder block.

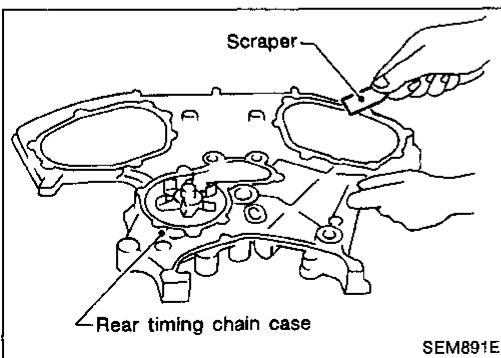

GI

MA

EM

LC

EC

FE

CL

MT

AT

FA

RA

BR

ST

RS

BT

HA

EL

IDX

CYLINDER HEAD

Installation (Cont'd)

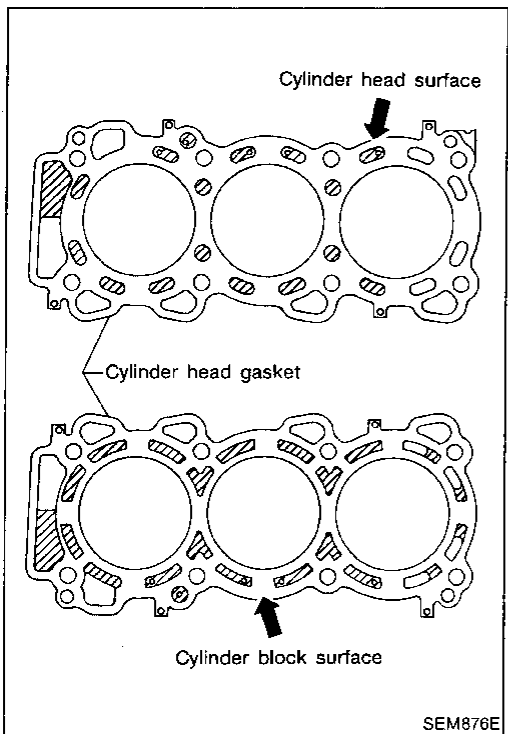
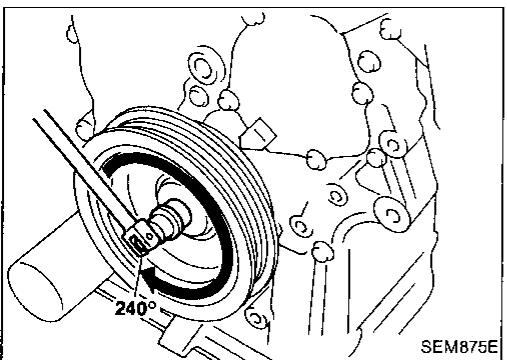
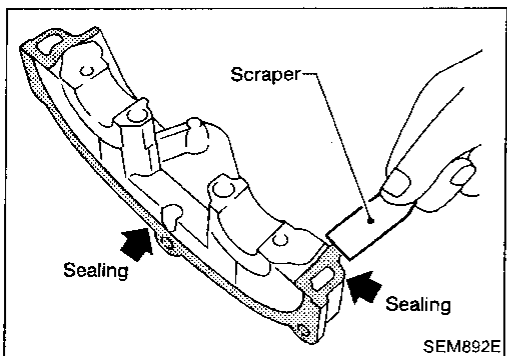
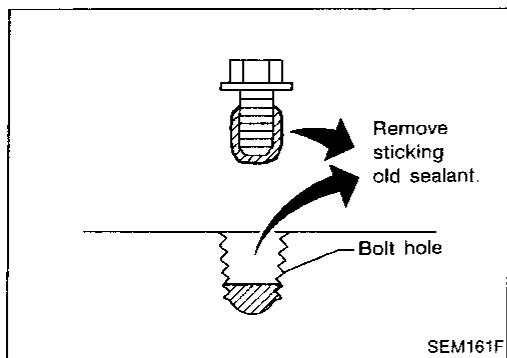

- Remove old liquid gasket from the bolt hole and thread.

2. Before installing cam bracket, remove all traces of liquid gasket from mating surface using a scraper.

3. Remove O-rings from cylinder block.

4. Turn crankshaft until No. 1 piston is set at approximately 240° before TDC on compression stroke to prevent interference of valves and pistons.

5. Install cylinder heads with new gaskets.

- Do not rotate crankshaft and camshaft separately, or valves will strike piston heads.

CYLINDER HEAD

Installation (Cont'd)

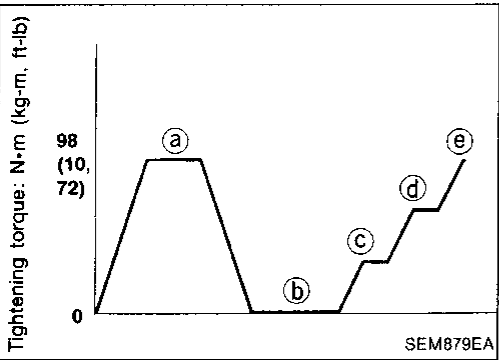
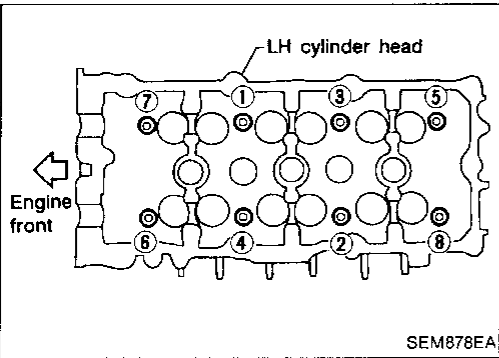
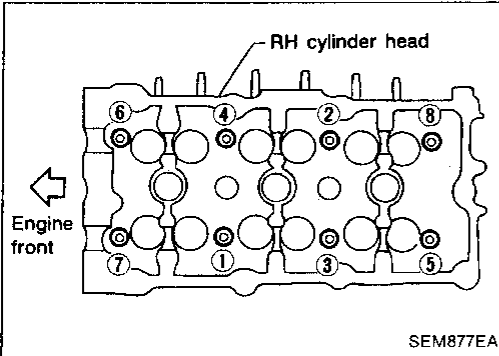
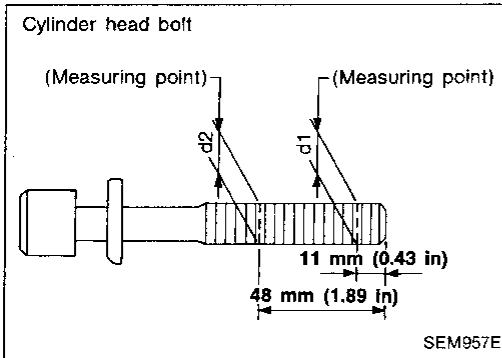

CAUTION:

Cylinder head bolts are tightened by plastic zone tightening method. Whenever the size difference between d1 and d2 exceeds the limit, replace them with new ones.

Limit (d1 - d2):

0.11 mm (0.0043 in)

- Lubricate threads and seat surfaces of the bolts with new engine oil.

● Tightening procedure:

- Tighten all bolts to 98 N·m (10 kg·m, 72 ft·lb).
 - Completely loosen all bolts.
 - Tighten all bolts to 34 to 44 N·m (3.5 to 4.5 kg·m, 25 to 33 ft·lb).
 - Turn all bolts 90 to 95 degrees clockwise.
 - Turn all bolts 90 to 95 degrees clockwise.
- Tighten in numerical order shown in the figure.

6. Install cylinder head outside bolts.

GI

MA

EM

LC

EC

FE

CL

MT

AT

FA

RA

BR

ST

RS

BT

HA

EL

IDX

CYLINDER HEAD

Installation (Cont'd)

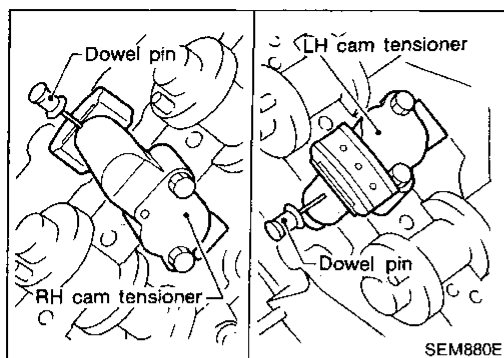

7. Install cam tensioners on both sides of cylinder head.

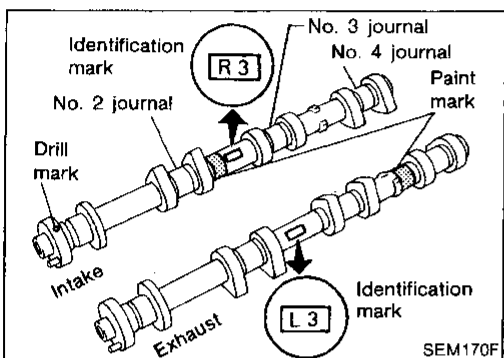

8. Install exhaust and intake camshafts and camshaft brackets.

● Identification marks are present on camshafts.

Camshaft		ID mark	Paint mark location
IN	LH	L3	Between No. 2 and No. 3 journals
	RH	R3	
EX	LH	L3	Between No. 3 and No. 4 journals
	RH	R3	

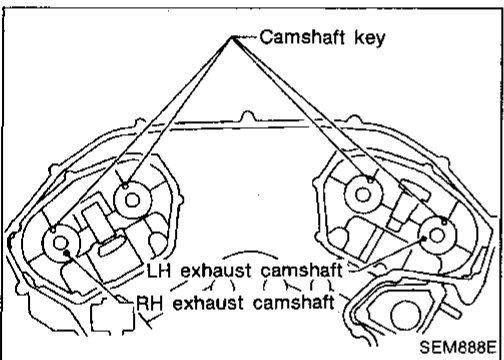

● Position camshaft

RH exhaust camshaft key at about 10 o'clock

LH exhaust camshaft key at about 2 o'clock

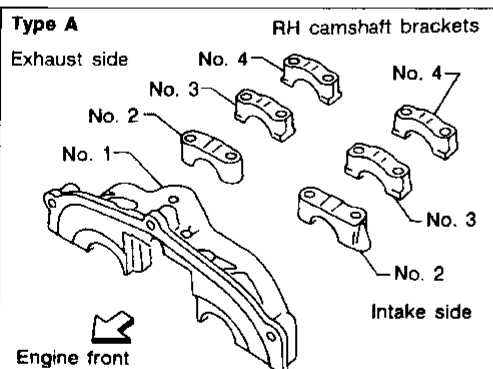

9. Before installing camshaft brackets, apply sealant to mating surface of No. 1 journal head.

● Use Genuine Liquid Gasket or equivalent.

● Refer to "POSITION FOR APPLYING LIQUID GASKET", (EM-18).

● Install camshaft brackets in their original positions.

● Tighten camshaft bracket bolts gradually in two or three stages.

● If any part of valve assembly or camshaft is replaced, check valve clearance according to reference data.

After completing assembly check valve clearance. Refer to "Checking" and "Adjusting" in "VALVE CLEARANCE" (EM-47 and 48).

Reference data valve clearance (Cold):

Intake

0.26 - 0.34 mm (0.010 - 0.013 in)

Exhaust

0.29 - 0.37 mm (0.011 - 0.015 in)

● Lubricate threads and seat surfaces of camshaft bracket bolts with new engine oil before installing them.

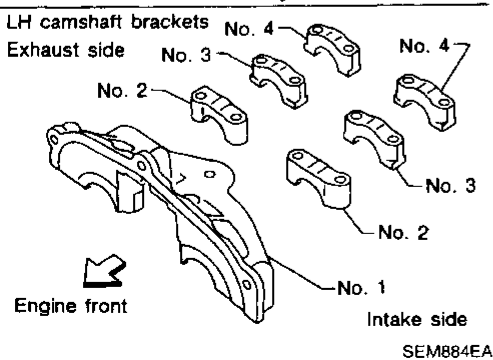

CYLINDER HEAD

Installation (Cont'd)

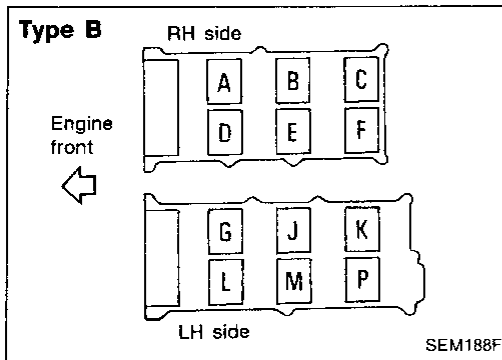

- Align stamp mark as shown in the figure.

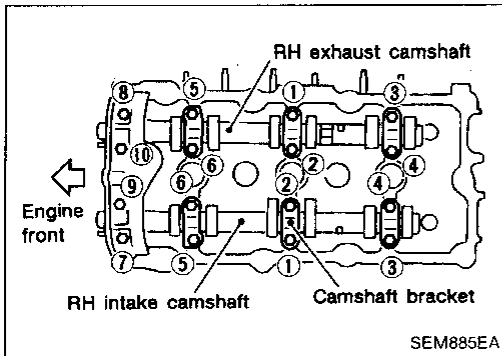

Tightening procedure

Tighten the camshaft brackets in the following steps.

Step	Tightening torque	Tightening order
1	1.96 N·m (0.2 kg-m, 17 in-lb)	Tighten in the order of ⑦ to ⑩, then tighten ① to ⑥.
2	6 N·m (0.6 kg-m, 52 in-lb)	Tighten in the numerical order.
3	9.02 - 11.8 N·m (0.92 - 1.20 kg-m, 79.9 - 104.2 in-lb)	Tighten in the numerical order.

- Tighten in numerical order shown in the figure.

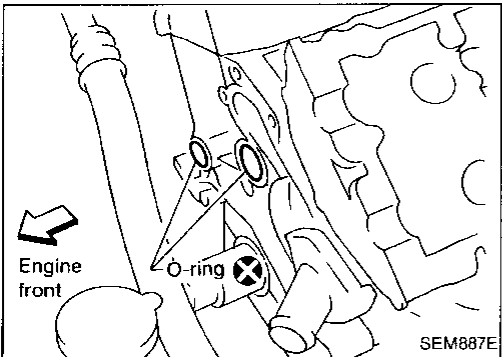
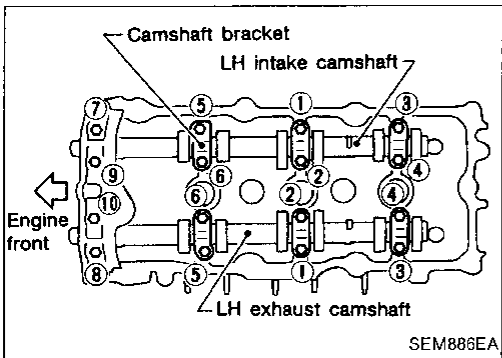

- Install O-rings to cylinder block.

- Apply sealant to the hatched portion of rear timing chain case.

- Apply continuous bead of liquid gasket to mating surface of rear timing chain case.

Refer to "POSITION FOR APPLYING LIQUID GASKET", (EM-18).

- Before installation, wipe off the protruding sealant.

CYLINDER HEAD

Installation (Cont'd)

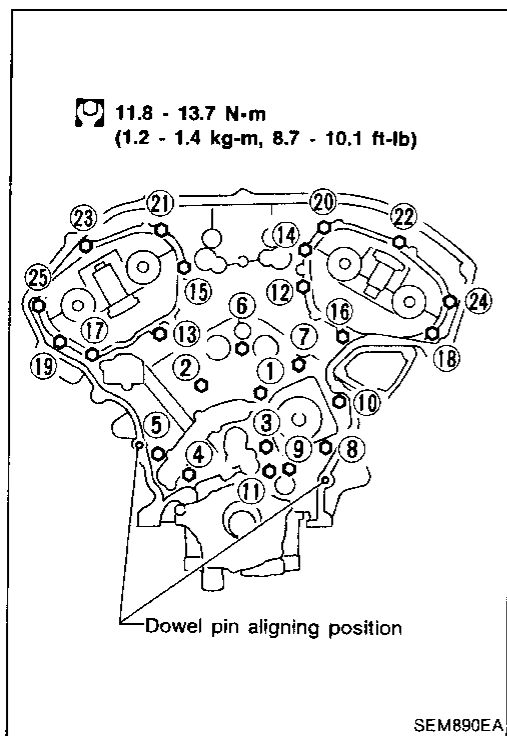

12. Align rear timing chain case with dowel pins, then install on cylinder head and block.
 13. Tighten rear chain case bolts.
 - (1) Tighten bolts in numerical order shown in the figure.
 - (2) Repeat above step (1).
- This installation is the same procedure as that for timing chain. Refer to "Installation" in "TIMING CHAIN" (EM-26).

VALVE CLEARANCE

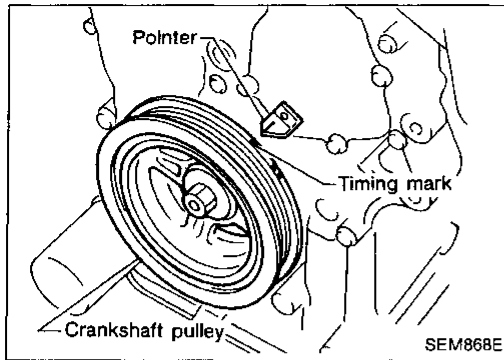

Checking

Check valve clearance while engine is cold and not running.

1. Remove intake manifold collector.
2. Remove rocker ornament covers.
3. Remove RH and LH rocker covers.
4. Remove all spark plugs.
5. Set No. 1 cylinder at TDC on its compression stroke.
 - Align pointer with TDC mark on crankshaft pulley.
 - Check that valve lifters on No. 1 cylinder are loose and valve lifters on No. 4 are tight.

If not, turn crankshaft one revolution (360°) and align as above.

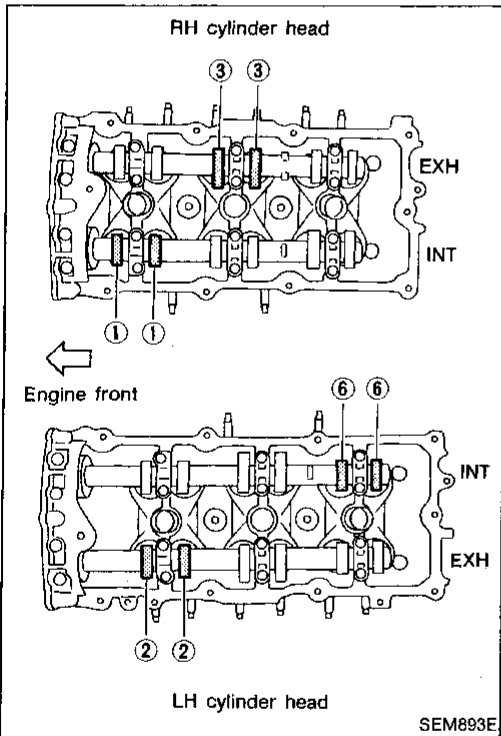

6. Check only those valves shown in the figure.

Valve Crank position	No. 1		No. 2		No. 3		No. 4		No. 5		No. 6	
	INT	EXH	INT	EXH	INT	EXH	INT	EXH	INT	EXH	INT	EXH
No. 1 TDC	○			○		○						○

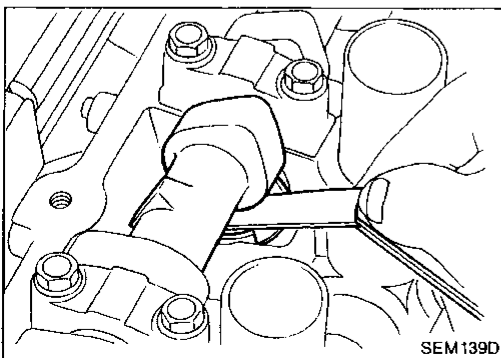

- Using a feeler gauge, measure clearance between valve lifter and camshaft.
- Record any valve clearance measurements which are out of specification. They will be used later to determine the required replacement adjusting shim.

Valve clearance for checking (Cold):

Intake

0.26 - 0.34 mm (0.010 - 0.013 in)

Exhaust

0.29 - 0.37 mm (0.011 - 0.015 in)

VALVE CLEARANCE

Checking (Cont'd)

7. Turn crankshaft 240° and align as above.
8. Set No. 3 cylinder at TDC on its compression stroke.
9. Check only those valves shown in the figure.

Valve Crank position	No. 1		No. 2		No. 3		No. 4		No. 5		No. 6	
	INT	EXH	INT	EXH	INT	EXH	INT	EXH	INT	EXH	INT	EXH
No. 3 TDC			○		○			○		○		

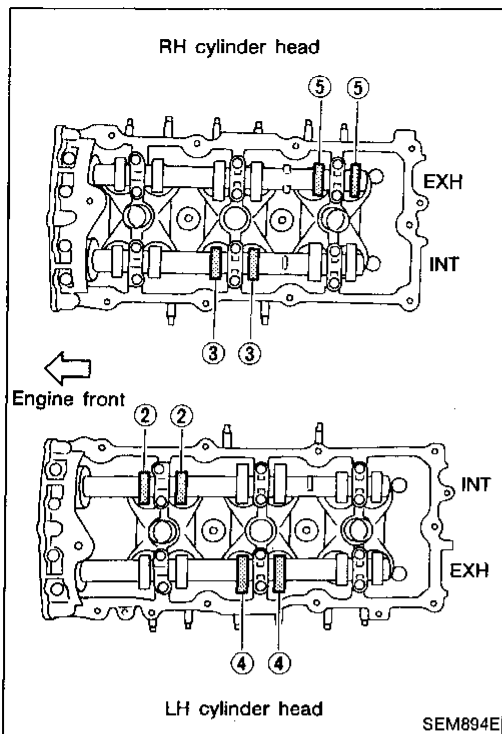

10. Turn crankshaft 240° and align as above.
11. Set No. 5 cylinder at TDC on its compression stroke.
12. Check only those valves shown in the figure.

Valve Crank position	No. 1		No. 2		No. 3		No. 4		No. 5		No. 6	
	INT	EXH	INT	EXH	INT	EXH	INT	EXH	INT	EXH	INT	EXH
No. 5 TDC		○					○		○			○

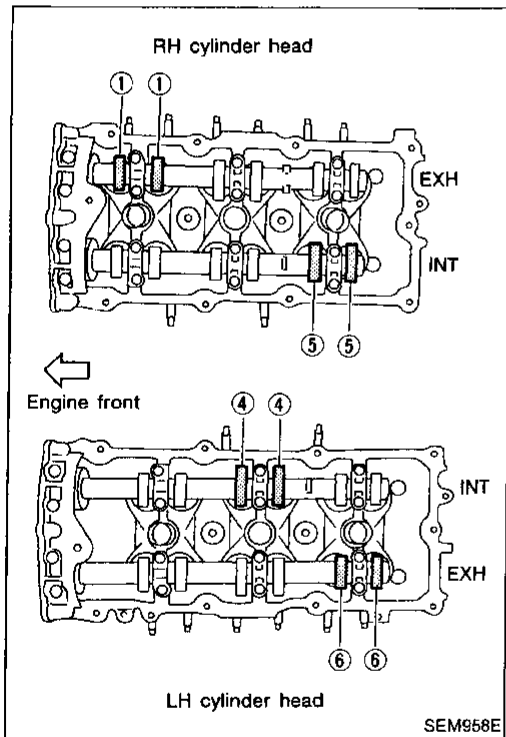

13. If all valve clearances are within specification, install the following parts.

- Intake manifold collector
- RH and LH rocker covers
- All spark plugs
- Rocker cover ornament

Adjusting

Adjust valve clearance while engine is cold.

1. Turn crankshaft, to position cam lobe on camshaft of valve that must be adjusted upward.
2. Place Tool (A) around camshaft as shown in figure.

Before placing Tool (A), rotate notch toward center of cylinder head (See figure.), to simplify shim removal later.

CAUTION:

Be careful not to damage cam surface with Tool (A).

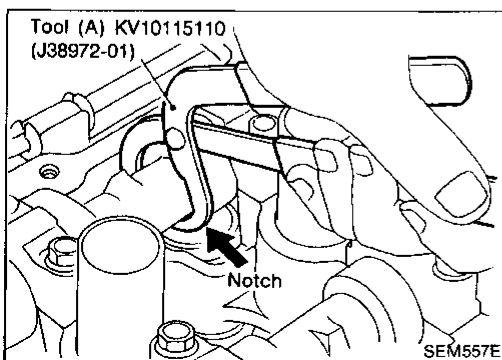

VALVE CLEARANCE

Adjusting (Cont'd)

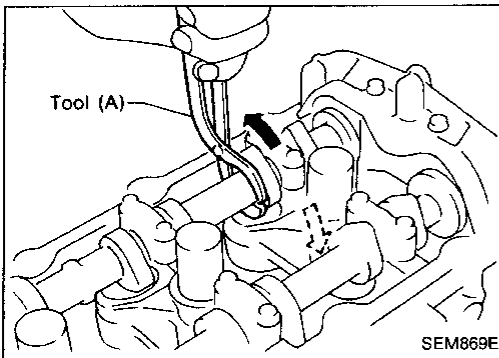

3. Rotate Tool (A) (See figure.) so that valve lifter is pushed down.

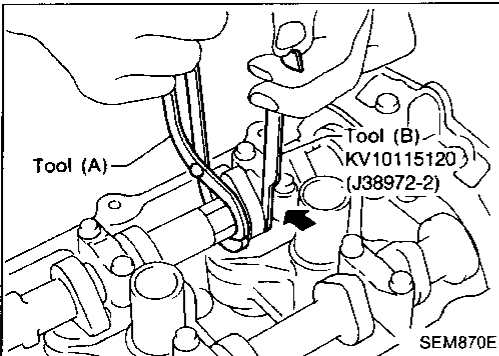

4. Place Tool (B) between camshaft and the edge of the valve lifter to retain valve lifter.

CAUTION:

- Tool (B) must be placed as close to camshaft bracket as possible.
 - Be careful not to damage cam surface with Tool (B).
5. Remove Tool (A).

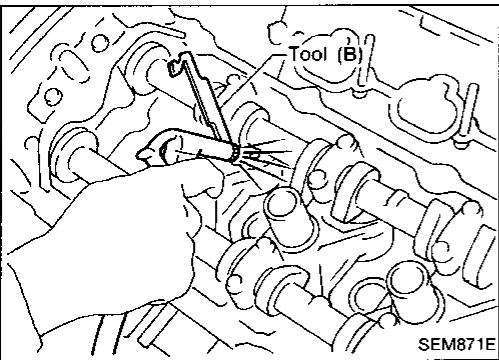

6. Blow air into the hole to separate adjusting shim from valve lifter.

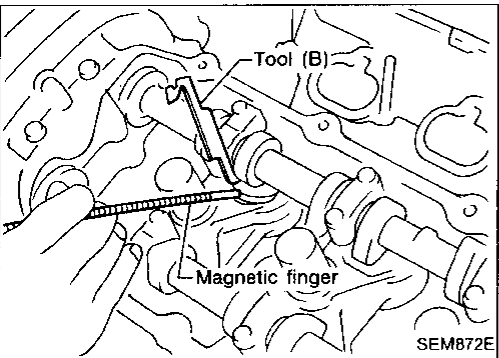

7. Remove adjusting shim using a small screwdriver and a magnetic finger.
8. Determine replacement adjusting shim size following formula.

- Using a micrometer determine thickness of removed shim.
 - Calculate thickness of new adjusting shim so valve clearance comes within specified values.
- R = Thickness of removed shim
N = Thickness of new shim
M = Measured valve clearance

Intake:

$$N = R + [M - 0.30 \text{ mm (0.0118 in)}]$$

Exhaust:

$$N = R + [M - 0.33 \text{ mm (0.0130 in)}]$$

Shims are available in 64 sizes from 2.32 mm (0.0913 in) to 2.95 mm (0.1161 in), in steps of 0.01 mm (0.0004 in).

- Select new shim with thickness as close as possible to calculated value.

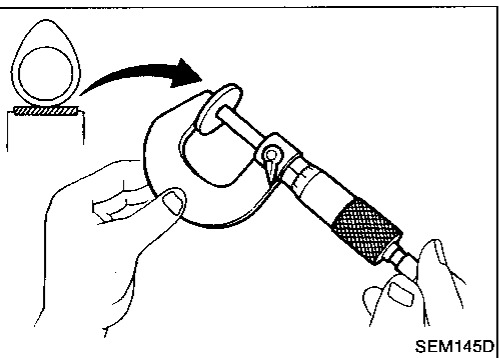

GI

MA

EM

LC

EC

FE

CL

MT

AT

FA

RA

BR

ST

RS

BT

HA

EL

IDX

VALVE CLEARANCE

Adjusting (Cont'd)

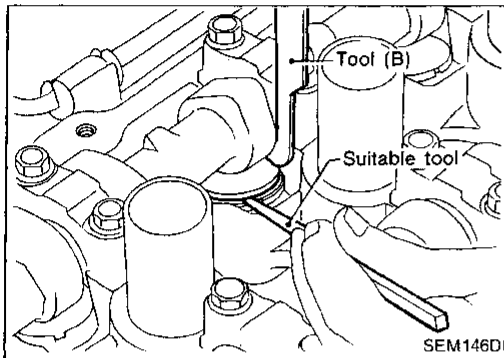
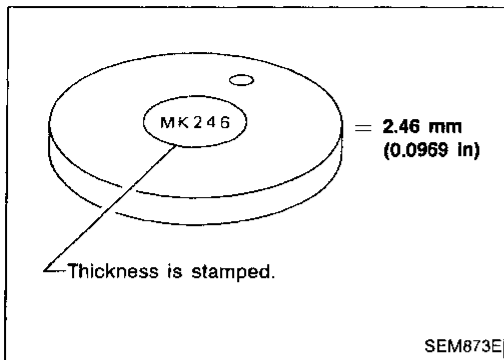

9. Install new shim using a suitable tool.
 - **Install with the surface on which the thickness is stamped facing down.**

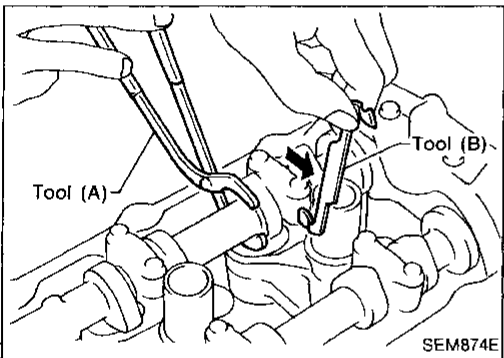

10. Place Tool (A) as mentioned in steps 2 and 3.
11. Remove Tool (B).
12. Remove Tool (A).
13. Recheck valve clearance.

Valve clearance:

Unit: mm (in)

	Cold	Hot* (reference data)
Intake	0.26 - 0.34 (0.010 - 0.013)	0.304 - 0.416 (0.012 - 0.016)
Exhaust	0.29 - 0.37 (0.011 - 0.015)	0.308 - 0.432 (0.012 - 0.017)

*: Approximately 80°C (176°F)

ENGINE REMOVAL

SEC. 112

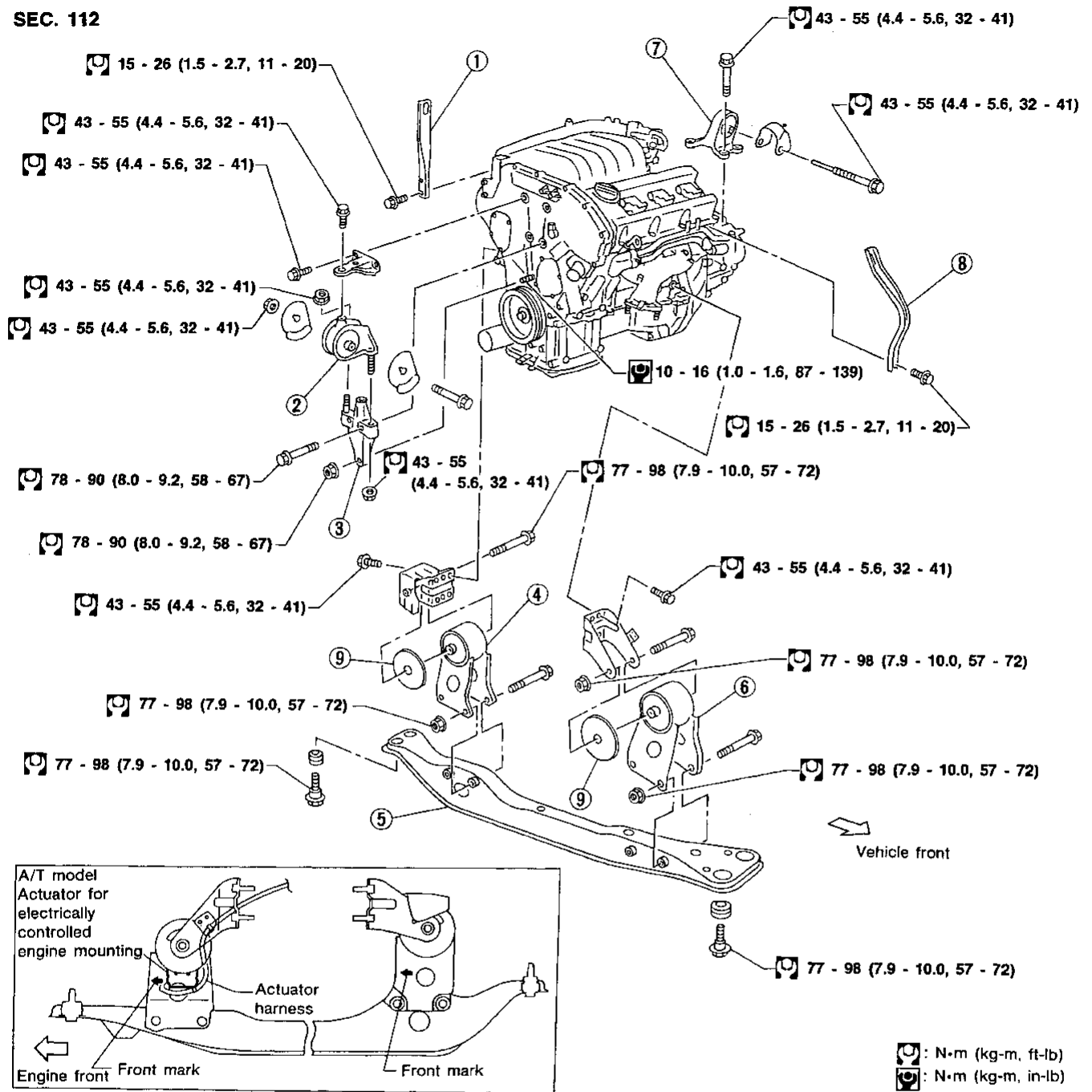

GI
MA
EM
LC
EC
FE
CL
MT
AT
FA
RA
BR
ST
RS
BT
HA
EL
IDX

MEM110A

- | | | |
|-------------------------------------|--------------------------------------|-----------------------|
| ① Front upper engine slinger | ⑤ Center member | ⑧ Rear engine slinger |
| ② RH engine mounting | ⑥ Front engine mounting (Fluid type) | ⑨ Insulator |
| ③ Mounting bracket | ⑦ LH engine mounting | |
| ④ Rear engine mounting (Fluid type) | | |

ENGINE REMOVAL

WARNING:

- Situate vehicle on a flat and solid surface.
- Place chocks at front and back of rear wheels.
- Do not remove engine until exhaust system has completely cooled off.

Otherwise, you may burn yourself and/or fire may break out in fuel line.

- For safety during subsequent steps, the tension of wires should be slacked against the engine.
- Before disconnecting fuel hose, release fuel pressure from fuel line.

Refer to "Fuel Pressure Release", "BASIC SERVICE PROCEDURE" in EC section.

- Before removing front axle from transaxle, place safety stands under designated front supporting points. Refer to GI section for lifting points and towing.
- Be sure to hoist engine and transaxle in a safe manner.
- For engines not equipped with engine slingers, attach proper slingers and bolts described in PARTS CATALOG.

CAUTION:

- When lifting engine, be careful not to strike adjacent parts, especially the following: Accelerator wire casing, brake lines, and brake master cylinder.
- In hoisting the engine, always use engine slingers in a safe manner.
- In removing drive shaft, be careful not to damage grease seal of transaxle.

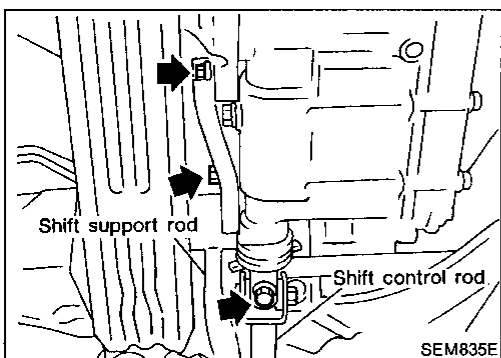
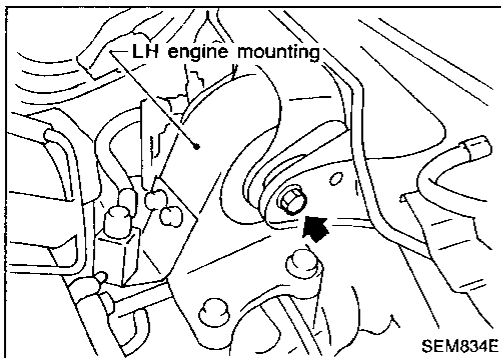

Removal

1. Remove engine undercover and hood.
2. Drain coolant from both cylinder block and radiator.
3. Remove vacuum hoses, fuel hoses, wires, harnesses, connectors and so on.
4. Remove front exhaust tubes, ball joints and drive shafts.
5. Remove radiator and fans.
6. Remove drive belts.
7. Remove alternator, compressor and power steering oil pump from engine.
8. Set a suitable transmission jack under transaxle. Hoist engine with engine slinger.
9. Remove rear engine mounting.
10. Disconnect control rod and support rod from transaxle (M/T model).
11. Disconnect control cable from transaxle (A/T model).

ENGINE REMOVAL

Removal (Cont'd)

12. Remove front engine mounting.

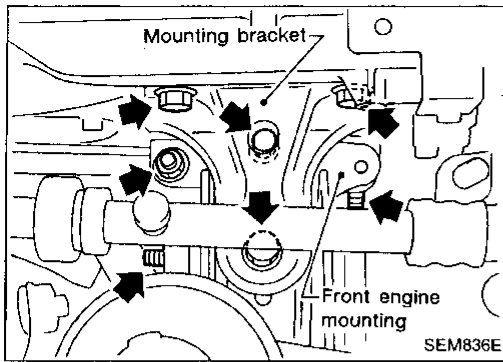

13. Remove center member and then slowly lower transmission jack.

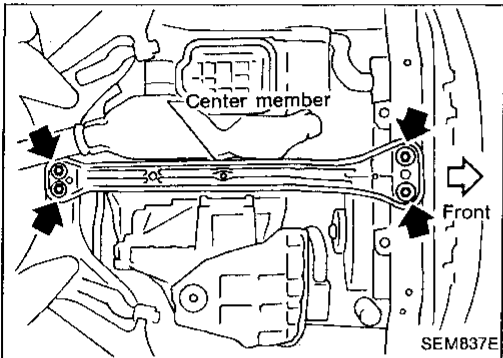

14. Remove engine with transaxle as shown.

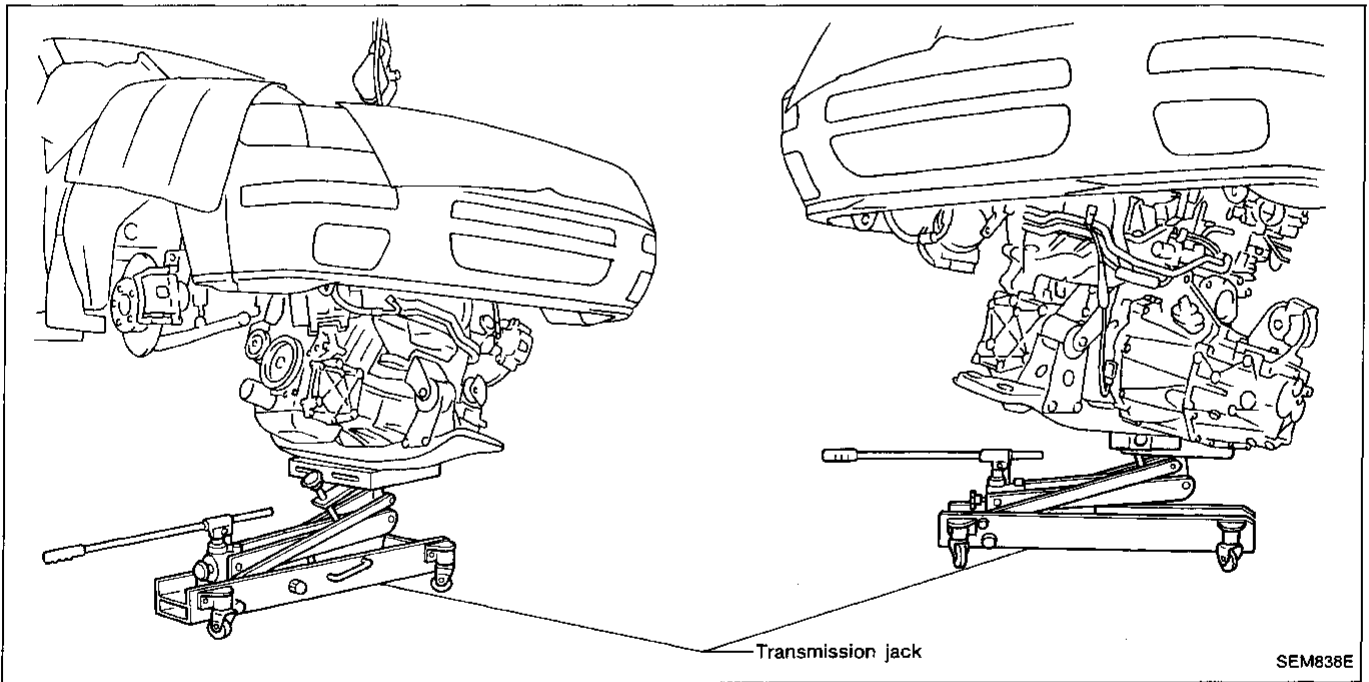

Installation

1. Installation is in the reverse order of removal.

GI

MA

EM

LC

EC

FE

CL

MT

AT

FA

RA

BR

ST

RS

BT

HA

EL

IDX

CYLINDER BLOCK

SEC. 110-120-226

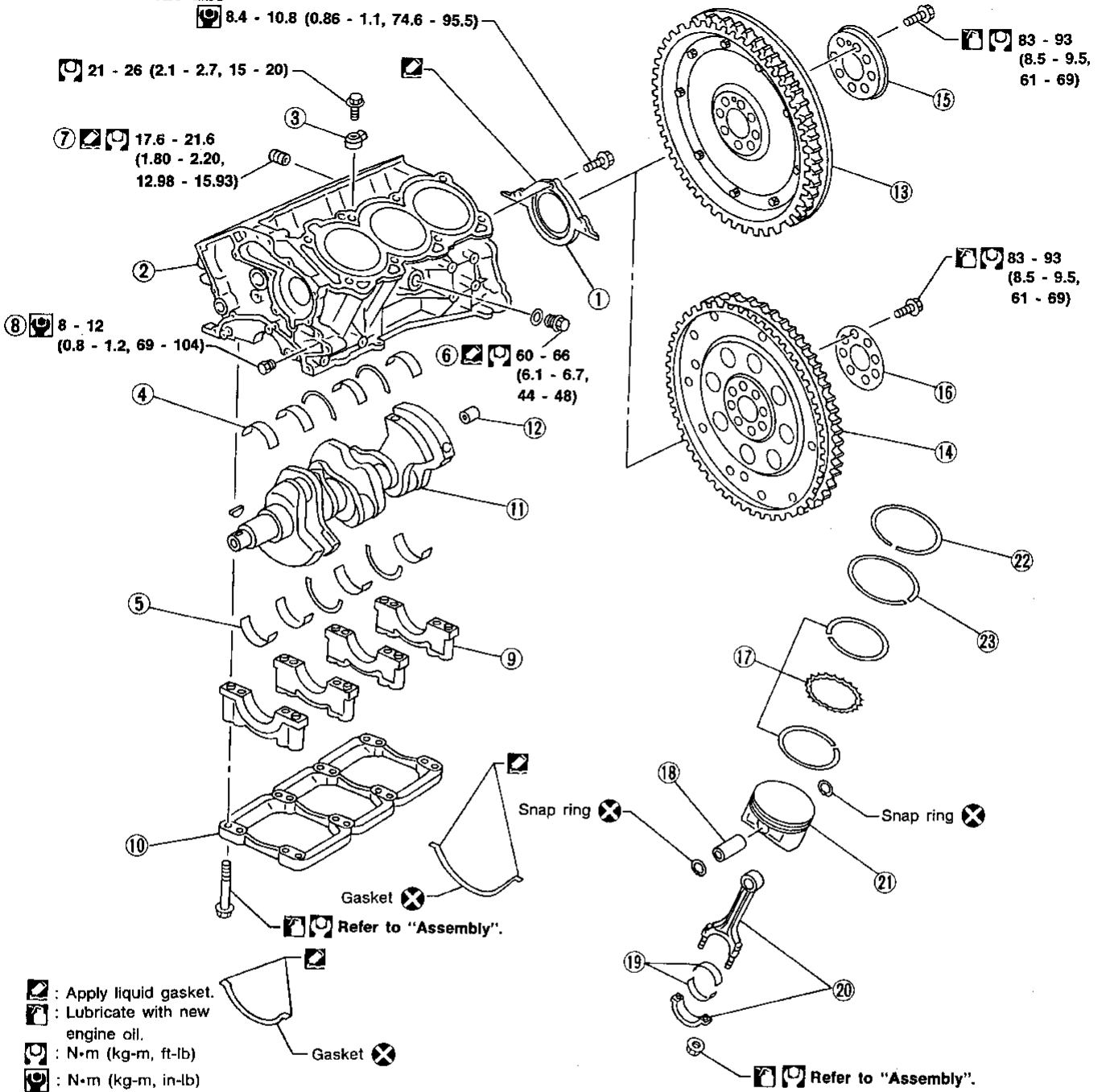

SEM173FA

- | | | |
|--------------------------------------|---|-----------------------------|
| ① Rear oil seal retainer | ⑨ Main bearing cap | ⑯ Drive plate reinforcement |
| ② Cylinder block | ⑩ Main bearing beam | ⑰ Oil ring |
| ③ Knock sensor | ⑪ Crankshaft | ⑱ Piston pin |
| ④ Upper main bearing | ⑫ Pilot bushing or pilot converter | ⑲ Connecting rod bearing |
| ⑤ Lower main bearing | ⑬ Flywheel with signal plate (M/T models) | ⑳ Connecting rod |
| ⑥ Water drain plug (LH side) | ⑭ Drive plate with signal plate (A/T model) | ㉑ Piston |
| ⑦ Water drain plug (RH side) | ⑮ Flywheel reinforcement | ㉒ Top ring |
| ⑧ Water drain plug (Water pump side) | | ㉓ 2nd ring |

CYLINDER BLOCK

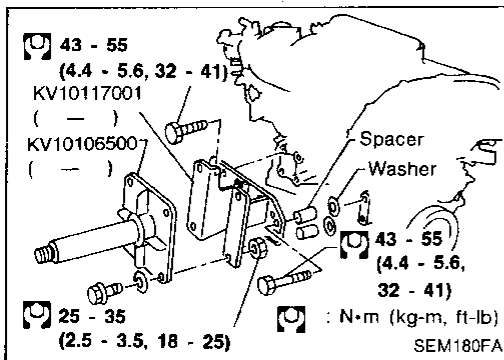

CAUTION:

- When installing bearings, pistons, or other sliding parts, lubricate contacting surfaces with new engine oil.
- Place removed parts such as bearings and bearing caps in their proper order and direction.
- When installing connecting rod nuts, and main bearing cap bolts, apply new engine oil to threads and seating surfaces.
- Do not allow any magnetic materials to contact the signal plate teeth of flywheel or drive plate.

GI

MA

EM

Disassembly

PISTON AND CRANKSHAFT

1. Remove engine. Refer to "ENGINE REMOVAL".
2. Place engine on a work stand.
3. Drain coolant and oil.
4. Remove cylinder head. Refer to "Removal" in "TIMING CHAIN".
5. Remove oil pan. Refer to "Removal" in "OIL PAN".
6. Remove timing chain. Refer to "Removal" in "TIMING CHAIN" (EM-19).
7. Remove pistons with connecting rods.
 - When disassembling piston and connecting rod, remove snap ring first, then heat piston to 60 to 70°C (140 to 158°F).
8. Remove rear oil seal retainer.

CAUTION:

- When piston rings are not replaced, make sure that piston rings are mounted in their original positions.
- When replacing piston rings, if there is no punchmark, install with either side up.

9. Remove main bearing beam, cap and crankshaft.

- Before removing bearing beam and bearing cap, measure crankshaft end play. Refer to EM-62.
- Bolts should be loosened in two or three steps.

LC

EC

FE

CL

MT

AT

FA

RA

BR

ST

RS

BT

HA

EL

IDX

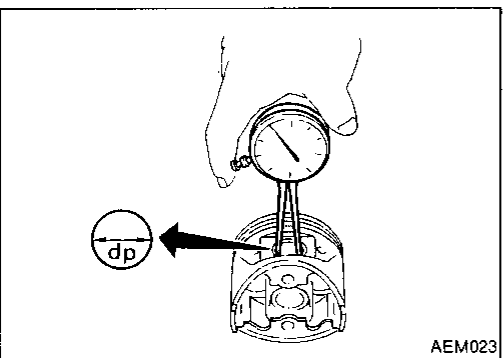
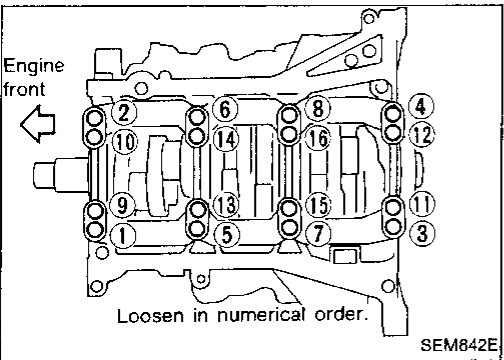
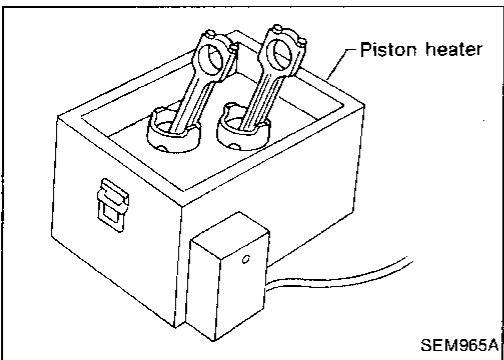
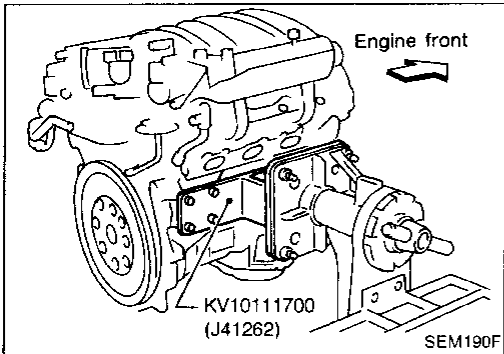

Inspection

PISTON AND PISTON PIN CLEARANCE

1. Measure inner diameter of piston pin hole "dp".
Standard diameter "dp":
21.993 - 22.005 mm (0.8659 - 0.8663 in)

CYLINDER BLOCK

Inspection (Cont'd)

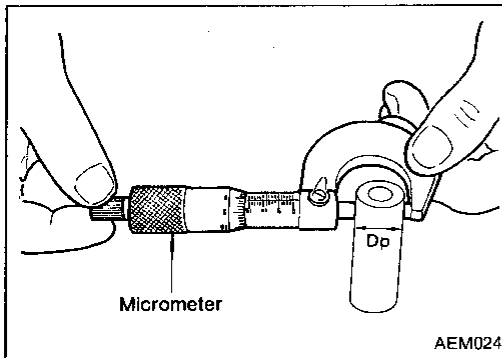

2. Measure outer diameter of piston pin "Dp".

Standard diameter "Dp":

21.989 - 22.001 mm (0.8657 - 0.8662 in)

3. Calculate piston pin clearance.

Dp - dp = 0.002 - 0.006 mm (0.0001 - 0.0002 in)

If it exceeds the above value, replace piston assembly with pin.

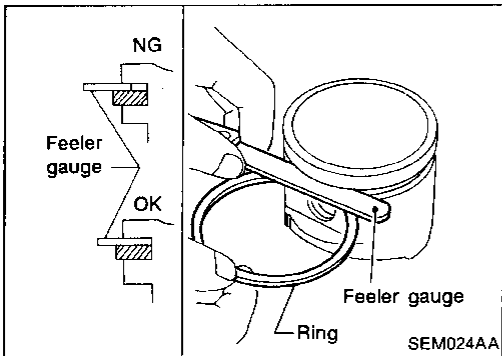

PISTON RING SIDE CLEARANCE

Side clearance:

Top ring

0.040 - 0.080 mm (0.0016 - 0.0031 in)

2nd ring

0.030 - 0.070 mm (0.0012 - 0.0028 in)

Max. limit of side clearance:

2nd ring 0.1 mm (0.004 in)

Top ring 0.11 mm (0.0043 in)

If out of specification, replace piston and/or piston ring assembly.

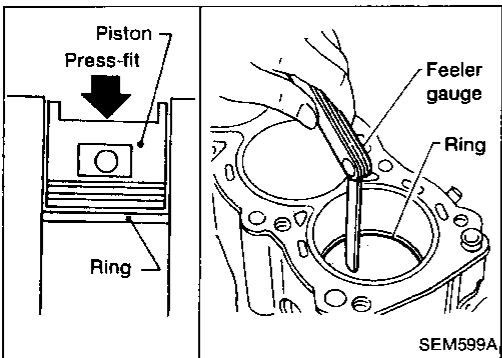

PISTON RING END GAP

End gap:

Top ring 0.22 - 0.41 mm (0.0087 - 0.0161 in)

2nd ring 0.50 - 0.74 mm (0.0197 - 0.0291 in)

Oil ring 0.20 - 0.69 mm (0.0079 - 0.0272 in)

Max. limit of ring gap:

Top ring 0.55 mm (0.0217 in)

2nd ring 0.85 mm (0.0335 in)

Oil ring 0.95 mm (0.0374 in)

If out of specification, replace piston ring. If gap still exceeds the limit even with a new ring, do the following. Rebore cylinder and use oversized piston and piston rings.

Refer to SDS (EM-70).

When replacing the piston, check the cylinder block surface for scratches or seizure. If scratches or seizure is found, hone or replace the cylinder block.

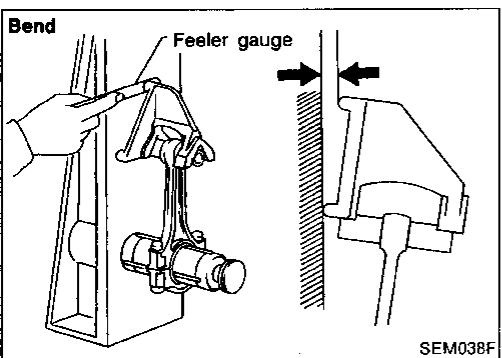

CONNECTING ROD BEND AND TORSION

Bend:

Limit 0.15 mm (0.0059 in)

per 100 mm (3.94 in) length

Torsion:

Limit 0.30 mm (0.0118 in)

per 100 mm (3.94 in) length

If it exceeds the limit, replace connecting rod assembly.

CYLINDER BLOCK

Inspection (Cont'd)

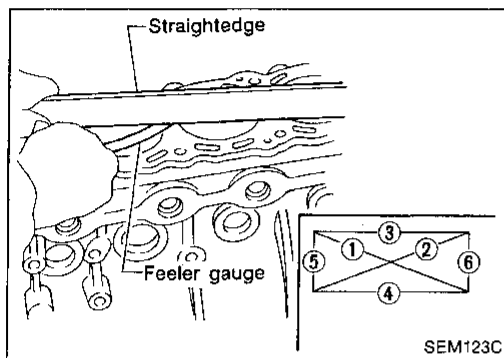
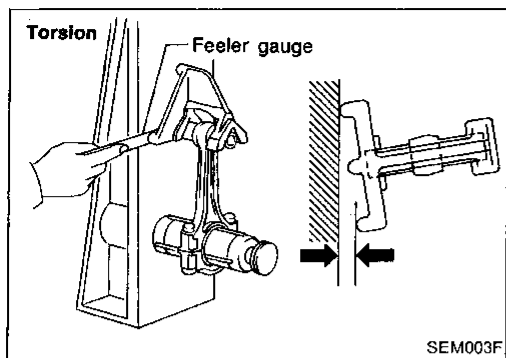

CYLINDER BLOCK DISTORTION AND WEAR

- Clean upper surface of cylinder block. Use a reliable straightedge and feeler gauge to check the flatness of cylinder block surface. Check along six positions shown in the figure.
Distortion limit: 0.10 mm (0.0039 in)
- If out of specification, resurface it. The limit for cylinder block resurfacing is determined by cylinder head resurfacing in engine.

Resurfacing limit:

Amount of cylinder head resurfacing is "A".
Amount of cylinder block resurfacing is "B".

The maximum limit is as follows:

$$A + B = 0.2 \text{ mm (0.008 in)}$$

Nominal cylinder block height from crankshaft center:
214.95 - 215.05 mm (8.4626 - 8.4665 in) Refer to SDS, (EM-69).

- If necessary, replace cylinder block.

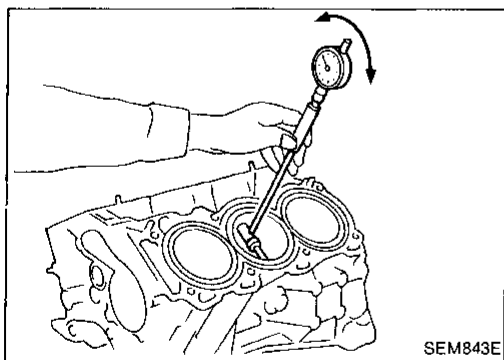

PISTON-TO-BORE CLEARANCE

- Using a bore gauge, measure cylinder bore for wear, out-of-round and taper.

Cylinder bore inner diameter

Grade No.	Standard inner diameter	Wear limit
No. 1	93.000 - 93.010 mm (3.6614 - 3.6618 in)	0.20 mm (0.0079 in)
No. 2	93.011 - 93.020 mm (3.6618 - 3.6622 in)	
No. 3	93.021 - 93.030 mm (3.6622 - 3.6626 in)	

If it exceeds the limit, rebore all cylinders. Replace cylinder block if necessary.

Out-of-round (X - Y):

Limit 0.015 mm (0.0006 in)

Taper (A - B - C):

Limit 0.010 mm (0.0004 in)

- Check for scratches and seizure. If seizure is found, hone it.

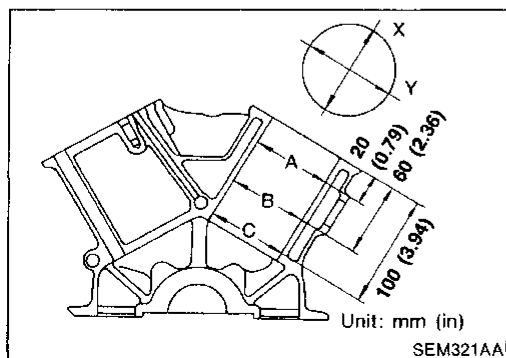

CYLINDER BLOCK

Inspection (Cont'd)

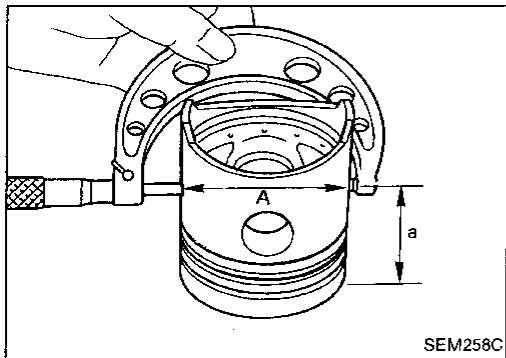
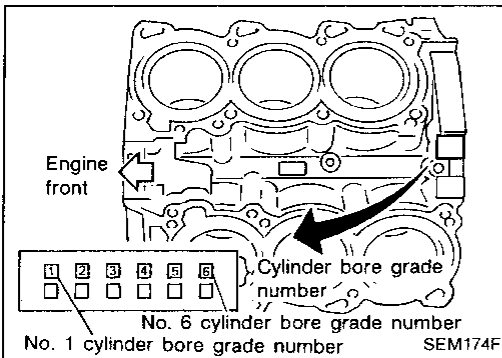

- If both cylinder block and piston are replaced with new ones, select piston of the same grade number punched on cylinder block rear position. These numbers are punched in either Arabic or Roman numerals.

3. Measure piston skirt diameter.
Piston diameter "A": Refer to SDS (EM-70).
Measuring point "a" (Distance from the top):
45.4 mm (1.787 in)
4. Check that piston-to-bore clearance is within specification.
Piston-to-bore clearance "B":
0.010 - 0.030 mm (0.0004 - 0.0012 in)
5. Determine piston oversize according to amount of cylinder wear.

Oversize pistons are available for service.
Refer to SDS (EM-70).

6. Cylinder bore size is determined by adding piston-to-bore clearance to piston diameter "A".

Rebored size calculation: $D = A + B - C$
where,

D: Bored diameter
A: Piston diameter as measured
B: Piston-to-bore clearance
C: Honing allowance 0.02 mm (0.0008 in)

7. Install main bearing caps, and tighten to the specified torque. Otherwise, cylinder bores may be distorted in final assembly.
8. Cut cylinder bores.
 - When any cylinder needs boring, all other cylinders must also be bored.
 - Do not cut too much out of cylinder bore at a time. Cut only 0.05 mm (0.0020 in) or so in diameter at a time.
- 9.hone cylinders to obtain specified piston-to-bore clearance.
10. Measure finished cylinder bore for out-of-round and taper.
 - Measurement should be done after cylinder bore cools down.

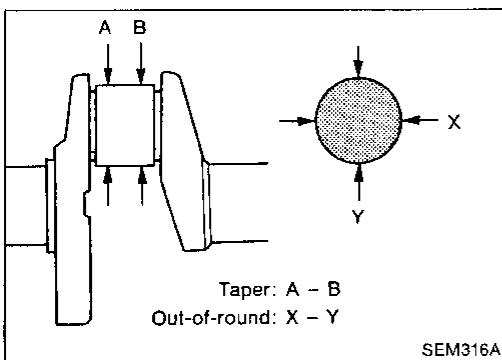

CRANKSHAFT

1. Check crankshaft main and pin journals for score, wear or cracks.
2. With a micrometer, measure journals for taper and out-of-round.

Out-of-round (X - Y):
Standard
0.002 mm (0.0001 in)

Taper (A - B):
Standard
0.002 mm (0.0001 in)

CYLINDER BLOCK

Inspection (Cont'd)

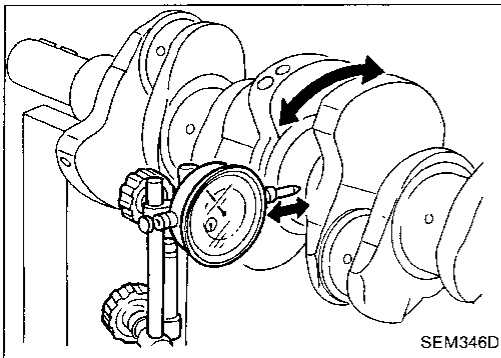

3. Measure crankshaft runout.
Runout (Total indicator reading):
Limit: 0.10 mm (0.0039 in)

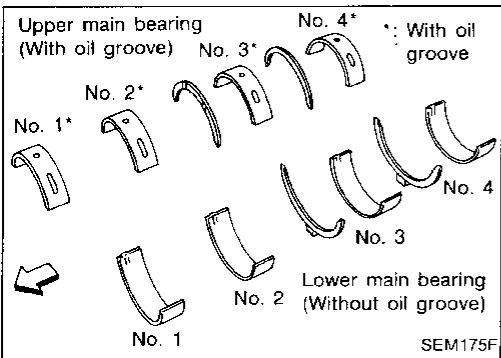

BEARING CLEARANCE

- Use either of the following two methods, however, method "A" gives more reliable results and is preferable.

Method A (Using bore gauge & micrometer)

Main bearing

1. Set main bearings in their proper positions on cylinder block and main bearing cap.

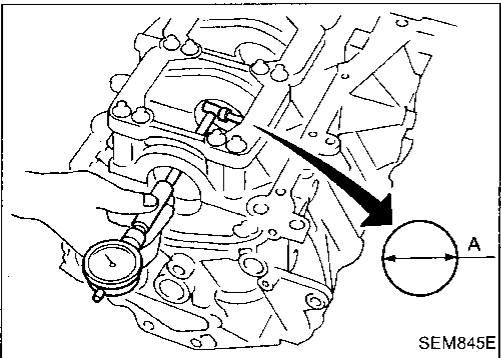

2. Install main bearing cap and bearing beam to cylinder block.

Tighten all bolts in correct order.

3. Measure inner diameters "A" of each main bearing.

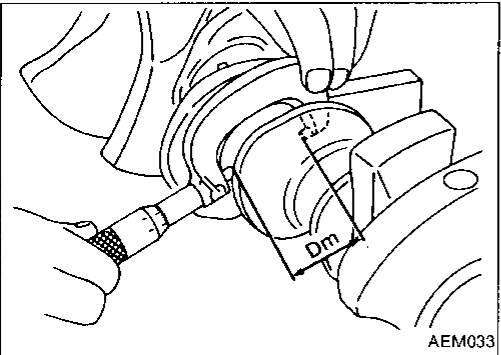

4. Measure outer diameters "Dm" of each crankshaft main journal.

5. Calculate main bearing clearance.

$$\text{Main bearing clearance} = A - Dm$$

Standard: 0.035 - 0.053 mm (0.0014 - 0.0021 in)

Limit: 0.065 mm (0.0026 in)

- If it exceeds the limit, replace bearing.
- If clearance cannot be adjusted using any standard bearing grade, grind crankshaft journal and use undersized bearing.

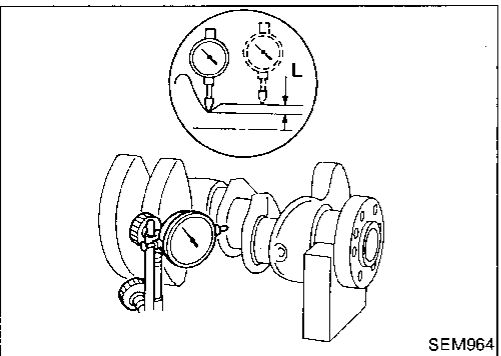

- a. When grinding crankshaft journal, confirm that "L" dimension in fillet roll is more than the specified limit.

"L": 0.1 mm (0.004 in)

- b. Refer to SDS for grinding crankshaft and available service parts.

CYLINDER BLOCK

Inspection (Cont'd)

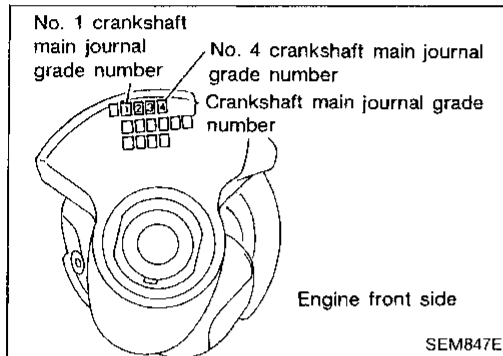
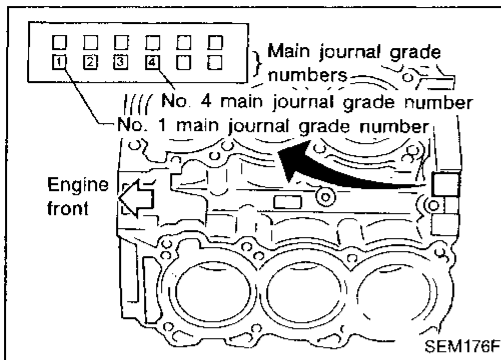

6. If crankshaft is reused, measure main bearing clearances and select thickness of main bearings. If crankshaft is replaced with a new one, select thickness of main bearings as follows:

- a. Grade number of each cylinder block main journal is punched on the respective cylinder block. These numbers are punched in either Arabic or Roman numerals.

- b. Grade number of each crankshaft main journal is punched on the respective crankshaft. These numbers are punched in either Arabic or Roman numerals.

- c. Select main bearing with suitable thickness according to the following calculation or table.

Example of calculation:

Cylinder block main journal grade number: 1

Crankshaft main journal grade number: 2

Main bearing grade number = 1 + 2 = 3 (Yellow)

Main bearing grade number (Identification color):

These numbers are punched in either Arabic or Roman numerals.

		Cylinder block main journal grade number			
		"0"	"1"	"2"	"3"
Crankshaft main journal grade number	"0"	0 (Black)	1 (Brown)	2 (Green)	3 (Yellow)
	"1"	1 (Brown)	2 (Green)	3 (Yellow)	4 (Blue)
	"2"	2 (Green)	3 (Yellow)	4 (Blue)	5 (pink)
	"3"	3 (Yellow)	4 (Blue)	5 (Pink)	6 (Purple)

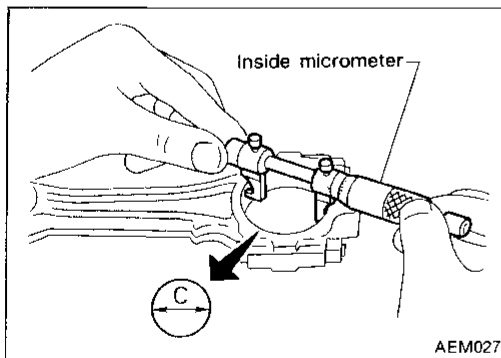

Connecting rod bearing (Big end)

1. Install connecting rod bearing to connecting rod and cap.
2. Install connecting rod cap to connecting rod.

Tighten bolts to the specified torque.

3. Measure inner diameter "C" of connecting rod.

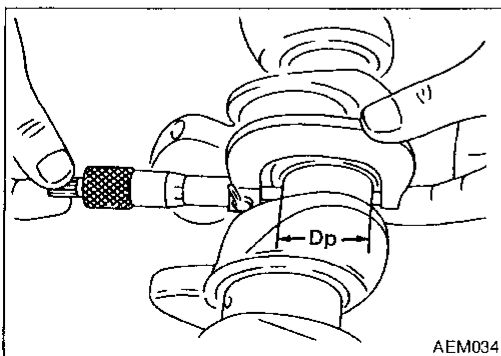

4. Measure outer diameter "Dp" of each crankshaft pin journal.

5. Calculate connecting rod bearing clearance.

Connecting rod bearing clearance = C - Dp

Standard: 0.034 - 0.059 mm (0.0013 - 0.0023 in)

Limit: 0.070 mm (0.0028 in)

6. If it exceeds the limit, replace bearing.

7. If clearance cannot be adjusted within the standard of any bearing, grind crankshaft journal and use undersized bearing. Refer to step 7 of "BEARING CLEARANCE — Main bearing" (EM-59).

CYLINDER BLOCK

Inspection (Cont'd)

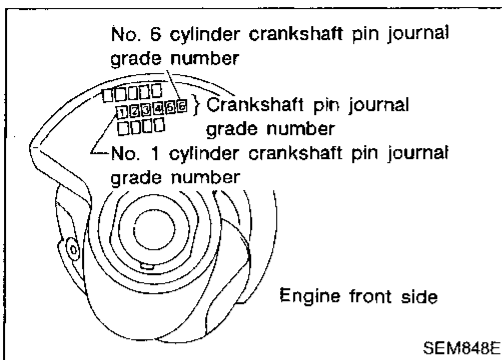

8. If crankshaft is replaced with a new one, select connecting rod bearing according to the following table.

Connecting rod bearing grade number (Identification color):

These numbers are punched in either Arabic or Roman numerals.

Crankshaft pin journal grade number	Connecting rod bearing grade number
0	0 (Black)
1	1 (Brown)
2	2 (Green)

Method B (Using plastigage)

CAUTION:

- Do not turn crankshaft or connecting rod while plastigage is being inserted.
- When bearing clearance exceeds the specified limit, ensure that the proper bearing has been installed. If incorrect bearing clearance exists, use a thicker or undersized main bearing to ensure specified clearance.

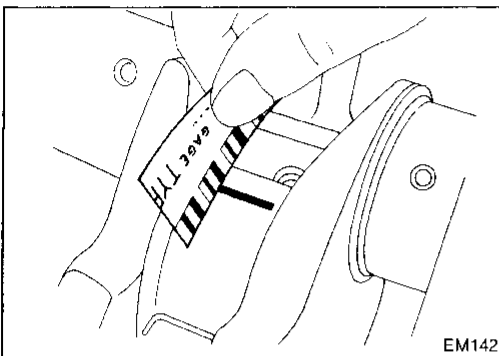

CONNECTING ROD BUSHING CLEARANCE (Small end)

1. Measure inner diameter "C" of bushing.
2. Measure outer diameter "Dp" of piston pin.
3. Calculate connecting rod bushing clearance.

$$\text{Connecting rod bushing clearance} = C - D_p$$

Standard: 0.005 - 0.017 mm (0.0002 - 0.0007 in)

Limit: 0.030 mm (0.0012 in)

If it exceeds the limit, replace connecting rod assembly or connecting rod bushing and/or piston set with pin.

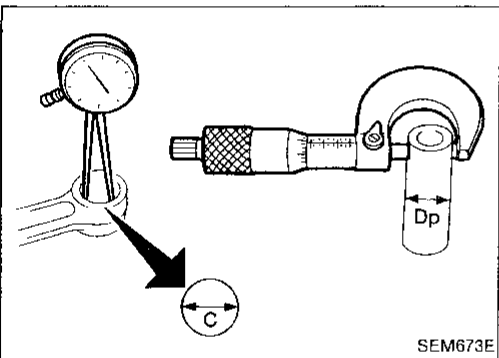

REPLACEMENT OF CONNECTING ROD BUSHING (Small end)

1. Drive in small end bushing until it is flush with end surface of rod.

Be sure to align the oil holes.

2. After driving in small end bushing, ream the bushing. This is to ensure the clearance between connecting rod bushing and piston pin is the specified value.

Clearance between connecting rod bushing and piston pin: 0.005 - 0.017 mm (0.0002 - 0.0007 in)

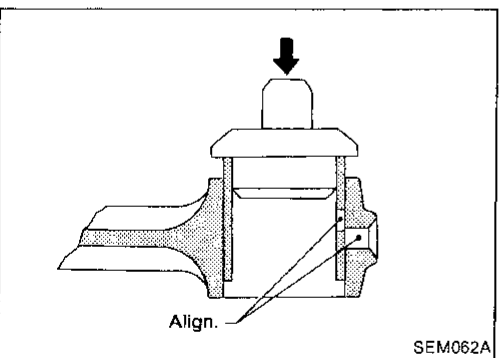

FLYWHEEL/DRIVE PLATE RUNOUT

Runout (Total indicator reading):

Flywheel (M/T model)★

Less than 0.15 mm (0.0059 in)

Drive plate (A/T model)

Less than 0.15 mm (0.0059 in)

★ **Measurement position:**

Approximately 145 mm (5.71 in) from the crankshaft center

CAUTION:

- The signal plate is built into the flywheel assembly. Be careful not to damage the signal plate, especially the teeth.

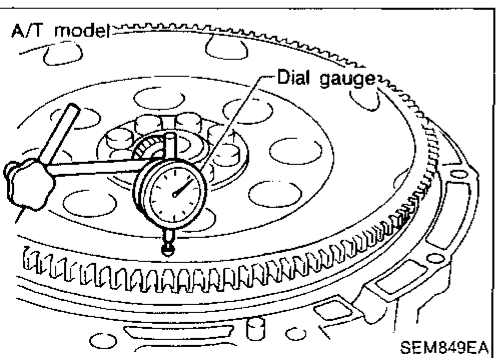

CYLINDER BLOCK

Inspection (Cont'd)

- Check the drive plate for deformation or cracks.
- Never place the flywheel assembly with the signal plate facing down.
- Keep any magnetized objects away from the signal plate.
- Do not allow any magnetic materials to contact the signal plate teeth.
- Do not surface flywheel. Replace as necessary.

Assembly

PISTON

1. Install new snap ring on one side of piston pin hole.
2. Heat piston to 60 to 70°C (140 to 158°F) and assemble piston, piston pin, connecting rod and new snap ring.
 - **Align the direction of piston and connecting rod.**
 - **Numbers stamped on connecting rod and cap correspond to each cylinder.**
 - **After assembly, make sure connecting rod swings smoothly.**
3. Set piston rings as shown.

CAUTION:

- **When piston rings are not replaced, make sure that piston rings are mounted in their original positions.**
- **When replacing piston rings, these without punchmarks, present, piston rings can be mounted with either side up.**

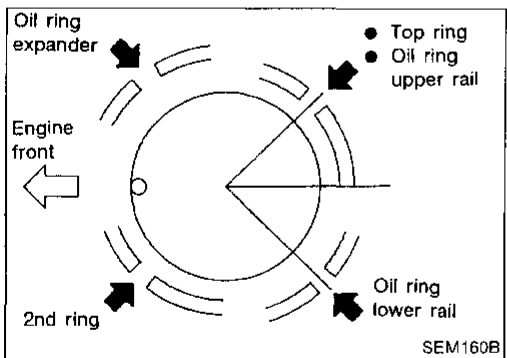
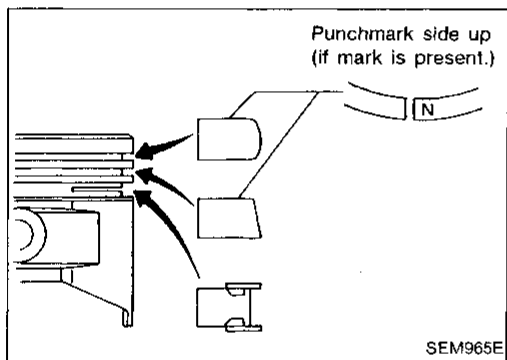
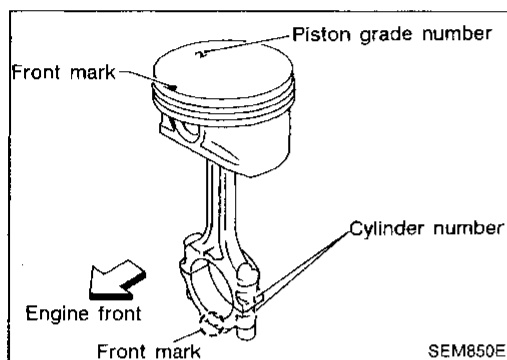

- **Align piston rings so that end gaps are positioned as shown in the figure.**

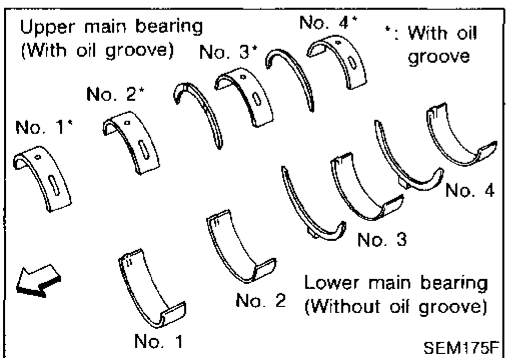

CRANKSHAFT

1. Set main bearings in their proper positions on cylinder block and main bearing beam.
 - **Confirm that correct main bearings are used. Refer to "Inspection" of this section.**

CYLINDER BLOCK

Assembly (Cont'd)

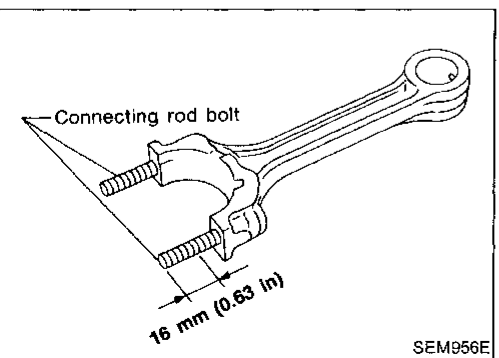
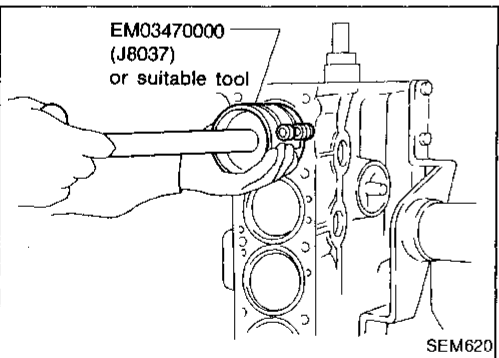
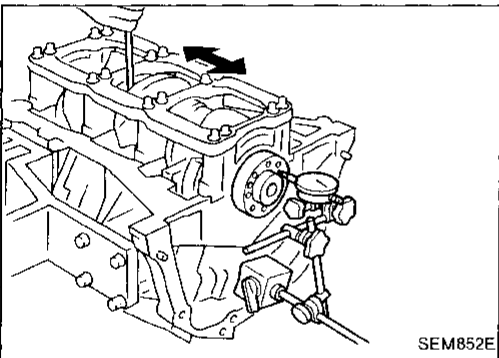
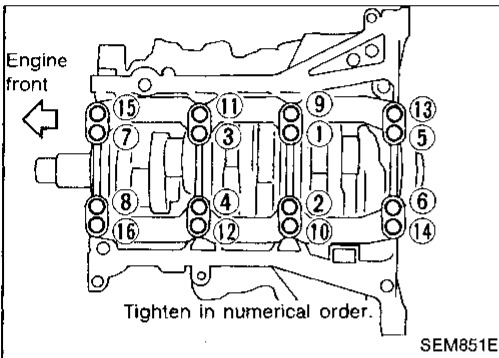
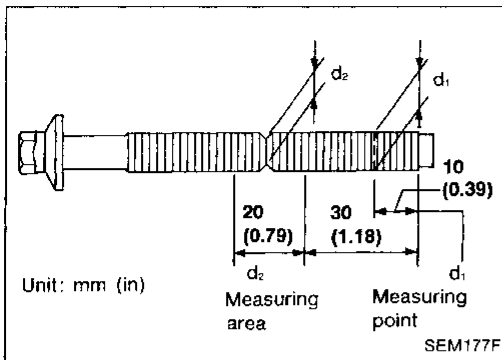

2. Instructions for re-use of main bearing cap bolts.
 - A plastic zone tightening method is used for tightening main bearing cap bolts. Measure d_1 and d_2 as shown in the figure.
 - d_2 : Select minimum diameter in the measuring area. If the difference between d_1 and d_2 exceeds the limit, replace the bolts with new ones.
 - Limit ($d_1 - d_2$): 0.11 mm (0.0043 in)
3. After installing crankshaft, main bearing cap, main bearing beam and bearing cap bolts, tighten bearing cap bolts in numerical order.
 - **Tightening procedure**
 - (1) Tighten all bolts to 32 to 38 N·m (3.3 to 3.9 kg-m, 24 to 28 ft-lb).
 - (2) Turn all bolts 90 to 95 degrees clockwise with angle wrench.
 - Prior to tightening bearing cap bolts, place bearing beam in its proper position by shifting crankshaft in the axial direction.
 - After securing bearing cap bolts, make sure crankshaft turns smoothly by hand.
 - Lubricate threads and seat surfaces of the bolts with new engine oil.
4. Measure crankshaft end play.
 - **Crankshaft end play:**
 - Standard: 0.10 - 0.25 mm (0.0039 - 0.0098 in)
 - Limit: 0.30 mm (0.0118 in)
 - If beyond the limit, replace bearing with a new one.
5. Install connecting rod bearings in connecting rods and connecting rod caps.
 - Confirm that correct bearings are used.
6. Install pistons with connecting rods.
 - a. Install them into corresponding cylinders with Tool.
 - Be careful not to scratch cylinder wall with the connecting rod.
 - Arrange so that front mark on piston head faces toward engine front.
 - b. A plastic zone tightening method is used for tightening connecting rod bolts and nuts. Check the old bolts for deformation before re-using them.
 - Ensure that the connecting rod nut can be screwed smoothly as far as the bolt thread end.
 - If this is not possible, use slide calipers to measure the outside diameter of the narrowest thread part of the bolt at 16 mm (0.63 in) from the thread end. Replace the connecting rod bolt and nut, if under the limit.
 - Standard: 7.90 - 8.00 mm (0.3110 - 0.3150 in)
 - Limit: 7.75 mm (0.3051 in)

CI

MA

EM

LC

EC

FE

CL

WT

AT

FA

RA

BR

ST

RS

BT

HA

EL

IDX

CYLINDER BLOCK

Assembly (Cont'd)

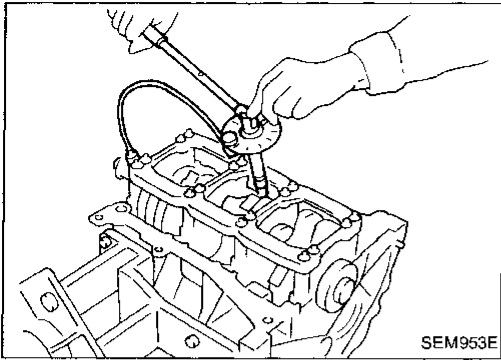

- c. Install connecting rod caps.
- **Lubricate threads and seat surfaces with new engine oil.** Tighten connecting rod bearing cap nuts to the specified torque.

Connecting rod bearing nut:

- (1) Tighten nuts to 19 to 21 N·m
(1.9 to 2.1 kg-m, 14 to 15 ft-lb).
- (2) Turn nuts 90 to 95 degrees clockwise with angle wrench

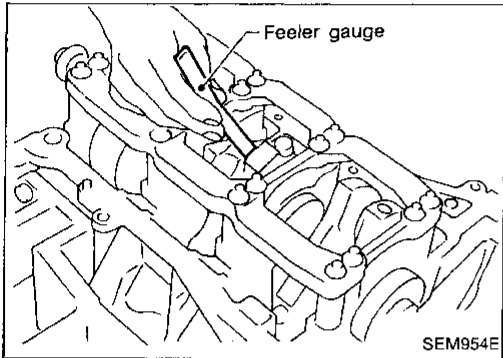

7. Measure connecting rod side clearance.

Connecting rod side clearance:

Standard

0.20 - 0.35 mm (0.0079 - 0.0138 in)

Limit

0.40 mm (0.0157 in)

If beyond the limit, replace connecting rod and/or crankshaft.

8. Install rear oil seal retainer.

SERVICE DATA AND SPECIFICATIONS (SDS)

General Specifications

Cylinder arrangement	V-6	
Displacement	cm ³ (cu in)	2,988 (182.33)
Bore and stroke	mm (in)	93 x 73.3 (3.66 x 2.886)
Valve arrangement	DOHC	
Firing order	1-2-3-4-5-6	
Number of piston rings		
Compression	2	
Oil	1	
Number of main bearings	4	
Compression ratio	10.0	

COMPRESSION PRESSURE

Unit: kPa (kg/cm², psi)/300 rpm

Compression pressure

Standard	1,275 (13.0, 185)
Minimum	981 (10.0, 142)
Differential limit between cylinders	98 (1.0, 14)

Cylinder number

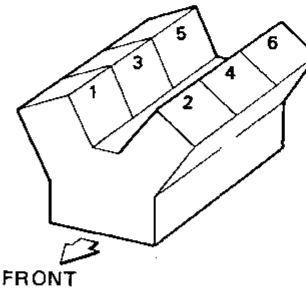

SEM713A

Inspection and Adjustment

CYLINDER HEAD

Unit: mm (in)

	Standard	Limit
Head surface distortion	Less than 0.03 (0.0012)	0.1 (0.004)

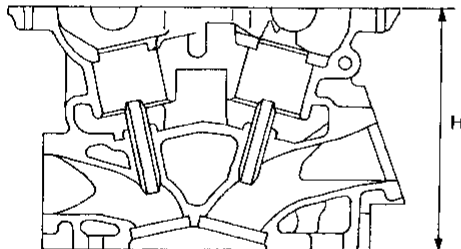

Nominal cylinder head height:
H = 126.3 - 126.5 mm (4.972 - 4.980 in)

SEM949E

VALVE

Unit: mm (in)

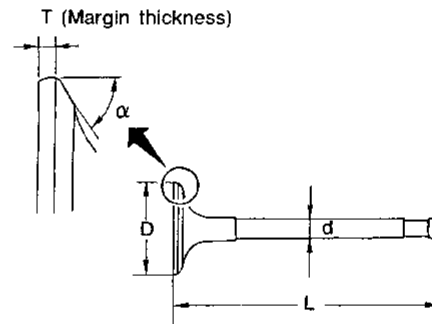

SEM188

Valve head diameter "D"

Intake	36.0 - 36.3 (1.417 - 1.429)
Exhaust	31.2 - 31.5 (1.228 - 1.240)

Valve length "L"

Intake	97.32 - 97.82 (3.8315 - 3.8512)
Exhaust	94.85 - 95.35 (3.7342 - 3.7539)

Valve stem diameter "d"

Intake	5.965 - 5.980 (0.2348 - 0.2354)
Exhaust	5.945 - 5.960 (0.2341 - 0.2346)

Valve seat angle "α"

Intake	45°15' - 45°45'
Exhaust	

Valve margin "T"

Intake	0.95 - 1.25 (0.0374 - 0.0492)
Exhaust	1.15 - 1.45 (0.0453 - 0.0571)

Valve margin "T" limit

More than 0.5 (0.020)

Valve stem end surface grinding limit

Less than 0.2 (0.008)

Valve clearance (Cold)

Intake	0.26 - 0.34 (0.010 - 0.013)
Exhaust	0.29 - 0.37 (0.011 - 0.015)

SERVICE DATA AND SPECIFICATIONS (SDS)

Inspection and Adjustment (Cont'd)

Valve clearance

Unit: mm (in)

	Cold	Hot* (reference data)
Intake	0.26 - 0.34 (0.010 - 0.013)	0.304 - 0.416 (0.012 - 0.016)
Exhaust	0.29 - 0.37 (0.011 - 0.015)	0.308 - 0.432 (0.012 - 0.017)

*: Approximately 80°C (176°F)

Available shims

Thickness mm (in)	Identification mark
2.32 (0.0913)	232
2.33 (0.0917)	233
2.34 (0.0921)	234
2.35 (0.0925)	235
2.36 (0.0929)	236
2.37 (0.0933)	237
2.38 (0.0937)	238
2.39 (0.0941)	239
2.40 (0.0945)	240
2.41 (0.0949)	241
2.42 (0.0953)	242
2.43 (0.0957)	243
2.44 (0.0961)	244
2.45 (0.0965)	245
2.46 (0.0969)	246
2.47 (0.0972)	247
2.48 (0.0976)	248
2.49 (0.0980)	249
2.50 (0.0984)	250
2.51 (0.0988)	251
2.52 (0.0992)	252
2.53 (0.0996)	253
2.54 (0.1000)	254
2.55 (0.1004)	255
2.56 (0.1008)	256
2.57 (0.1012)	257
2.58 (0.1016)	258
2.59 (0.1020)	259
2.60 (0.1024)	260
2.61 (0.1028)	261
2.62 (0.1031)	262
2.63 (0.1035)	263
2.64 (0.1039)	264

Thickness mm (in)	Identification mark
2.65 (0.1043)	265
2.66 (0.1047)	266
2.67 (0.1051)	267
2.68 (0.1055)	268
2.69 (0.1059)	269
2.70 (0.1063)	270
2.71 (0.1067)	271
2.72 (0.1071)	272
2.73 (0.1075)	273
2.74 (0.1079)	274
2.75 (0.1083)	275
2.76 (0.1087)	276
2.77 (0.1091)	277
2.78 (0.1094)	278
2.79 (0.1098)	279
2.80 (0.1102)	280
2.81 (0.1106)	281
2.82 (0.1110)	282
2.83 (0.1114)	283
2.84 (0.1118)	284
2.85 (0.1122)	285
2.86 (0.1126)	286
2.87 (0.1130)	287
2.88 (0.1134)	288
2.89 (0.1138)	289
2.90 (0.1142)	290
2.91 (0.1146)	291
2.92 (0.1150)	292
2.93 (0.1154)	293
2.94 (0.1157)	294
2.95 (0.1161)	295

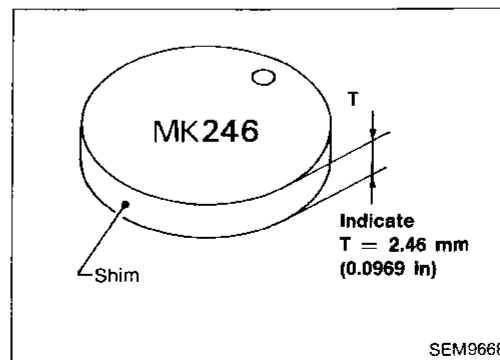

SERVICE DATA AND SPECIFICATIONS (SDS)

Inspection and Adjustment (Cont'd)

Valve spring

Free height	mm (in)	46.93 (1.8476)
Pressure N (kg, lb) at height mm (in)	Standard	454 (46.3, 102.1) at 27.55 (1.0846)
		Limit
Out-of-square	mm (in)	Less than 2.0 (0.079)

Valve lifter

Unit: mm (in)

Valve lifter outer diameter	34.960 - 34.975 (1.3764 - 1.3770)
Lifter guide inner diameter	35.000 - 35.021 (1.3780 - 1.3788)
Clearance between lifter and filter guide	0.025 - 0.061 (0.0010 - 0.0024)

Valve guide

Unit: mm (in)

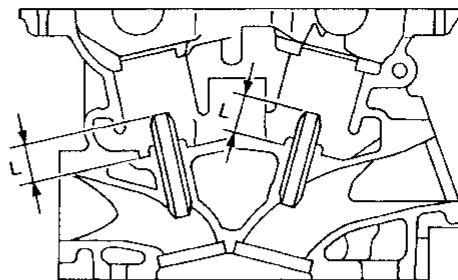

SEM950E

	Standard	Service
Valve guide		
Outer diameter	10.023 - 10.034 (0.3946 - 0.3950)	10.223 - 10.234 (0.4025 - 0.4029)
Valve guide		
Inner diameter (Finished size)	6.000 - 6.018 (0.2362 - 0.2369)	
Cylinder head valve guide hole diameter	9.975 - 9.996 (0.3927 - 0.3935)	10.175 - 10.196 (0.4006 - 0.4014)
Interference fit of valve guide	0.027 - 0.059 (0.0011 - 0.0023)	
	Standard	Max. tolerance
Stem to guide clearance	Intake	0.020 - 0.053 (0.008 - 0.0021)
	Exhaust	0.040 - 0.073 (0.0016 - 0.0029)
Valve deflec- tion limit	Intake	—
	Exhaust	—
Projection length "L"	12.6 - 12.8 (0.496 - 0.504)	

GI

MA

EM

LC

EC

FE

CL

MT

AT

FA

RA

BR

ST

RS

BT

HA

EL

DX

SERVICE DATA AND SPECIFICATIONS (SDS)

Inspection and Adjustment (Cont'd)

CAMSHAFT AND CAMSHAFT BEARING

Unit: mm (in)

	Standard	Limit
Camshaft journal to bearing clearance	0.045 - 0.086 (0.0018 - 0.0034)	0.15 (0.0059)
Inner diameter of camshaft bearing	No. 1 26.000 - 26.021 (1.0236 - 1.0244) No. 2,3,4 23.500 - 23.521 (0.9252 - 0.9260)	—
Outer diameter of camshaft journal	No. 1 25.935 - 25.955 (1.0211 - 1.0218) No. 2,3,4 23.435 - 23.455 (0.9226 - 0.9234)	—
Camshaft runout [TIR*]	Less than 0.02 (0.0008)	0.05 (0.0020)
Camshaft sprocket runout [TIR*]	Less than 0.15 (0.0059)	—
Camshaft end play	0.115 - 0.188 (0.0045 - 0.0074)	0.24 (0.0094)

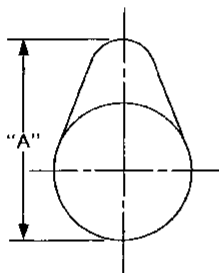

EM671

Cam height "A"	
Intake & Exhaust	43.940 - 44.130 (1.7299 - 1.7374)
Wear limit of cam height	0.2 (0.008)

*Total indicator reading

Valve timing

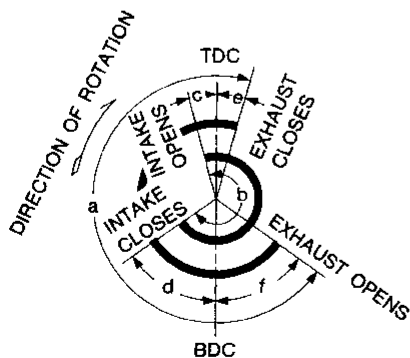

EM120
Unit: degree

a	b	c	d	e	f
232	232	3	49	3	49

CYLINDER BLOCK

Unit: mm (in)

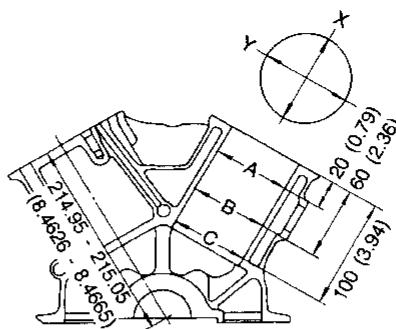

SEM022EA

Surface flatness

Standard	Less than 0.03 (0.0012)
Limit	0.10 (0.0039)

Cylinder bore

Inner diameter

Standard

Grade No. 1	93.000 - 93.010 (3.6614 - 3.6618)
Grade No. 2	93.011 - 93.020 (3.6618 - 3.6622)
Grade No. 3	93.021 - 93.030 (3.6622 - 3.6626)

Wear limit

0.20 (0.0079)

Out-of-round (X - Y)

Less than 0.015 (0.0006)

Taper (A - B - C)

Less than 0.010 (0.0004)

Main journal inner diameter

Grade No. 0	63.993 - 63.999 (2.5194 - 2.5196)
Grade No. 1	64.000 - 64.005 (2.5197 - 2.5199)
Grade No. 2	64.006 - 64.011 (2.5199 - 2.5201)
Grade No. 3	64.012 - 64.017 (2.5202 - 2.5203)

Difference in inner diameter between cylinders

Standard	Less than 0.03 (0.0012)
----------	-------------------------

SERVICE DATA AND SPECIFICATIONS (SDS)

Inspection and Adjustment (Cont'd)

PISTON, PISTON RING AND PISTON PIN

Available piston

Unit: mm (in)

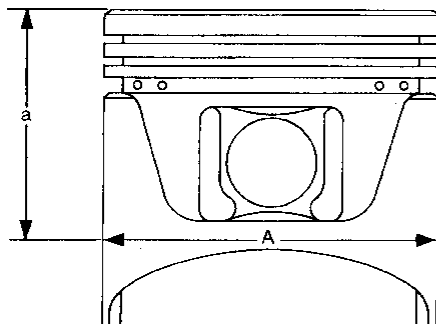

SEM882E

Piston skirt diameter "A"

Standard

Grade No. 1	92.980 - 92.990 (3.6606 - 3.6610)
Grade No. 2	92.990 - 93.000 (3.6610 - 3.6614)
Grade No. 3	93.000 - 93.010 (3.6614 - 3.6618)
0.20 (0.0079) oversize (Service)	93.180 - 93.210 (3.6685 - 3.6697)
"a" dimension	45.4 (1.787)
Piston pin hole diameter	21.993 - 22.005 (0.8659 - 0.8663)
Piston clearance to cylinder block	0.010 - 0.030 (0.0004 - 0.0012)

Piston ring

Unit: mm (in)

	Standard	Limit
Side clearance		
Top	0.040 - 0.080 (0.0016 - 0.0031)	0.11 (0.0043)
2nd	0.030 - 0.070 (0.0012 - 0.0028)	0.1 (0.004)
End gap		
Top	0.22 - 0.41 (0.0087 - 0.0161)	0.55 (0.0217)
2nd	0.50 - 0.74 (0.0197 - 0.0291)	0.85 (0.0335)
Oil (rail ring)	0.20 - 0.69 (0.0079 - 0.0272)	0.95 (0.0374)

Piston pin

Unit: mm (in)

Piston pin outer diameter	21.989 - 22.001 (0.8657 - 0.8662)
Interference fit of piston pin to piston	0.002 - 0.006 (0.0001 - 0.0002)
Piston pin to connecting rod bushing clearance	0.005 - 0.017 (0.0002 - 0.0007)

*Values measured at ambient temperature of 20°C (68°F)

CONNECTING ROD

Unit: mm (in)

Center distance	147.60 - 147.70 (5.8110 - 5.8149)
Bend [per 100 (3.94)]	
Limit	0.15 (0.0059)
Torsion [per 100 (3.94)]	
Limit	0.30 (0.0118)
Connecting rod small end inner diameter	23.980 - 24.000 (0.9441 - 0.9449)
Piston pin bushing inner diameter*	22.000 - 22.012 (0.8661 - 0.8666)
Connecting rod big end inner diameter	48.000 - 48.013 (1.8898 - 1.8903)
Side clearance	
Standard	0.20 - 0.35 (0.0079 - 0.0138)
Limit	0.40 (0.0157)

*After installing in connecting rod

SERVICE DATA AND SPECIFICATIONS (SDS)

Inspection and Adjustment (Cont'd)

CRANKSHAFT

Unit: mm (in)

Main journal dia. "Dm"	
Grade No. 0	59.969 - 59.975 (2.3610 - 2.3612)
Grade No. 1	59.963 - 59.969 (2.3607 - 2.3610)
Grade No. 2	59.957 - 59.963 (2.3605 - 2.3607)
Grade No. 3	59.951 - 59.957 (2.3603 - 2.3605)
Pin journal dia. "Dp"	
Grade No. 0	44.968 - 44.974 (1.7704 - 1.7706)
Grade No. 1	44.962 - 44.968 (1.7702 - 1.7704)
Grade No. 2	44.956 - 44.962 (1.7699 - 1.7702)
Center distance "r"	
36.61 - 36.69 (1.4413 - 1.4445)	
Out-of-round (X - Y)	
Standard	Less than 0.002 (0.0001)
Taper (A - B)	
Standard	Less than 0.002 (0.0001)
Runout [TIR]	
Limit	Less than 0.10 (0.0039)
Free end play	
Standard	0.10 - 0.25 (0.0039 - 0.0098)
Limit	0.30 (0.0118)

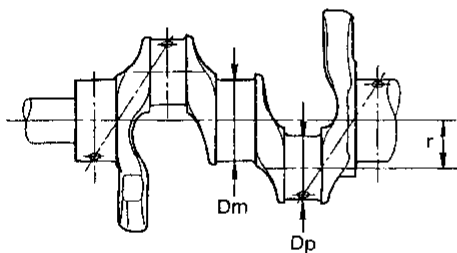

SEM645

Out-of-round (X) - (Y)
Taper (A) - (B)

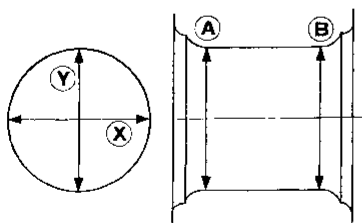

EM715

AVAILABLE MAIN BEARING

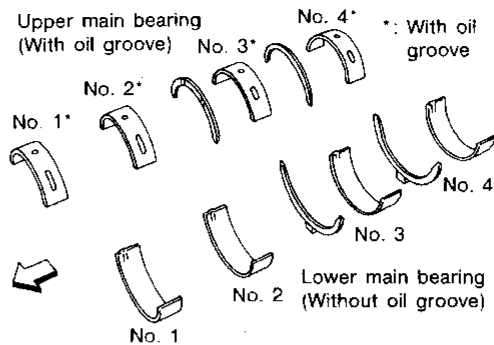

SEM175F

Grade number	Thickness "T" mm (in)	Width "W" mm (in)	Identification color
0	2.000 - 2.003 (0.0787 - 0.0789)	19.9 - 20.1 (0.783 - 0.791)	Black
1	2.003 - 2.006 (0.0789 - 0.0790)		Brown
2	2.006 - 2.009 (0.0790 - 0.0791)		Green
3	2.009 - 2.012 (0.0791 - 0.0792)		Yellow
4	2.012 - 2.015 (0.0792 - 0.0793)		Blue
5	2.015 - 2.018 (0.0793 - 0.0794)		Pink
6	2.018 - 2.021 (0.0794 - 0.0796)		Purple

Undersize

Unit: mm (in)

	Thickness	Main journal diameter "Dm"
0.25 (0.0098)	2.132 - 2.140 (0.0839 - 0.0843)	Grind so that bearing clearance is the specified value.

SERVICE DATA AND SPECIFICATIONS (SDS)

Inspection and Adjustment (Cont'd)

AVAILABLE CONNECTING ROD BEARING

MISCELLANEOUS COMPONENTS

Connecting rod bearing

Unit: mm (in)

Grade number	Thickness "T" mm (in)	Identification color (mark)
0	1.500 - 1.503 (0.0591 - 0.0592)	Black
1	1.503 - 1.506 (0.0592 - 0.0593)	Brown
2	1.506 - 1.509 (0.0593 - 0.0594)	Green

Flywheel runout [TIR]* Less than 0.15 (0.0059)

Drive plate runout [TIR]* Less than 0.15 (0.0059)

*Total indicator reading

Bearing clearance

Unit: mm (in)

Main bearing clearance

Standard 0.035 - 0.053 (0.0014 - 0.0021)

Limit 0.065 (0.0026)

Connecting rod bearing clearance

Standard 0.034 - 0.059 (0.0013 - 0.0023)

Limit 0.070 (0.0028)

Undersize

Unit: mm (in)

	Thickness	Crank pin journal diameter "Dp"
0.25 (0.0098)	1.626 - 1.634 (0.0640 - 0.0643)	Grind so that bearing clearance is the specified value.