

SECTION **MA**

GI

MA

EM

LC

EC

FE

CL

MT

AT

FA

RA

BR

ST

RS

BT

HA

EL

IDX

CONTENTS

PRECAUTIONS AND PREPARATION	2	Checking EVAP Vapor Lines	16
Supplemental Restraint System (SRS) "AIR BAG" and "SEAT BELT PRE-TENSIONER".....	2	CHASSIS AND BODY MAINTENANCE	17
Special Service Tool	2	Checking Exhaust System.....	17
Commercial Service Tool.....	2	Checking Clutch Fluid Level and Leaks.....	17
GENERAL MAINTENANCE	3	Checking M/T Oil.....	17
PERIODIC MAINTENANCE	5	Changing M/T Oil.....	17
Schedule 1.....	6	Checking A/T Fluid	18
Schedule 2.....	7	Changing A/T Fluid.....	18
RECOMMENDED FLUIDS AND LUBRICANTS	8	Balancing Wheels.....	19
Fluids and Lubricants	8	Tire Rotation	19
SAE Viscosity Number	8	Checking Brake Fluid Level and Leaks.....	19
Anti-freeze Coolant Mixture Ratio	9	Checking Brake Lines and Cables	19
ENGINE MAINTENANCE	10	Checking Disc Brake	19
Checking Drive Belts	10	Checking Steering Gear and Linkage	20
Changing Engine Coolant.....	11	Checking Power Steering Fluid and Lines.....	20
Checking Fuel Lines	12	Lubricating Locks, Hinges and Hood Latches.....	21
Changing Fuel Filter	13	Checking Seat Belts, Buckles, Retractors, Anchors and Adjusters.....	21
Changing Air Cleaner Filter	13	SERVICE DATA AND SPECIFICATIONS (SDS)	22
Changing Engine Oil.....	14	Engine Maintenance.....	22
Changing Oil Filter.....	14	Chassis and Body Maintenance.....	22
Changing Spark Plugs.....	15		

PRECAUTIONS AND PREPARATION

Supplemental Restraint System (SRS) “AIR BAG” and “SEAT BELT PRE-TENSIONER”

The Supplemental Restraint System “AIR BAG” and “SEAT BELT PRE-TENSIONER”, used along with a seat belt, help to reduce the risk or severity of injury to the driver and front passenger in a frontal collision. The Supplemental Restraint System consists of air bag modules (located in the center of the steering wheel and on the instrument panel on the passenger side), seat belt pre-tensioners, a diagnosis sensor unit, warning lamp, wiring harness and spiral cable.

In addition to the supplemental air bag modules for a frontal collision, the supplemental side air bag used along with the seat belt helps to reduce the risk or severity of injury to the driver and front passenger in a side collision. The supplemental side air bag consists of air bag modules (located in the outer side of front seats), satellite sensor, diagnosis sensor unit (which is one of components of supplemental air bags for a frontal collision), wiring harness, warning lamp (which is one of components of supplemental air bags for a frontal collision). Information necessary to service the system safely is included in the **RS** section of this Service Manual.

WARNING:

- To avoid rendering the SRS inoperative, which could increase the risk of personal injury or death in the event of a collision which would result in air bag inflation, all maintenance must be performed by an authorized INFINITI dealer.
- Improper maintenance, including incorrect removal and installation of the SRS, can lead to personal injury caused by unintentional activation of the system.
- Do not use electrical test equipment on any circuit related to the SRS unless instructed to in this Service Manual. SRS wiring harnesses (except “SEAT BELT PRE-TENSIONER” connector) can be identified with yellow harness connector (and with yellow harness protector or yellow insulation tape before the harness connectors).

Special Service Tool

The actual shapes of Kent-Moore tools may differ from these of special service tools illustrated here.

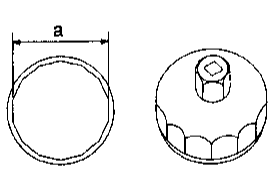
Tool number (Kent-Moore No.) Tool name	Description
KV10115801 (J38956) Oil filter wrench	 <p style="margin-top: 10px;">NT375 a: 64.3 mm (2.531 in)</p>

Commercial Service Tool

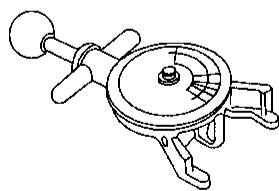
Tool name (Kent-Moore No.)	Description
Belt tension gauge (BT 3373-F)	 <p style="margin-top: 10px;">AMA126 Checking drive belt tension</p>

GENERAL MAINTENANCE

General maintenance includes those items which should be checked during normal day-to-day operation of the vehicle. They are essential if the vehicle is to continue operating properly. The owners can perform checks and inspections themselves or have their INFINITI dealers do them.

Item	Reference page	
OUTSIDE THE VEHICLE		
The maintenance items listed here should be performed from time to time, unless otherwise specified.		
Tires Check the pressure with a gauge periodically when at a service station, including the spare, and adjust to the specified pressure if necessary. Check carefully for damage, cuts or excessive wear.	—	GI MA
Wheel nuts When checking the tires, make sure no nuts are missing, and check for any loose nuts. Tighten if necessary.	—	EM
Tire rotation Tires should be rotated every 12,000 km (7,500 miles).	MA-19	LC
Wheel alignment and balance If the vehicle pulls to either side while driving on a straight and level road, or if you detect uneven or abnormal tire wear, there may be a need for wheel alignment. If the steering wheel or seat vibrates at normal highway speeds, wheel balancing may be needed.	MA-19 FA-7	EC
Windshield wiper blades Check for cracks or wear if they do not wipe properly.	—	FE
Doors and engine hood Check that all doors and the engine hood operate smoothly as well as the trunk lid or back hatch. Also make sure that all latches lock securely. Lubricate if necessary. Make sure that the secondary latch keeps the hood from opening when the primary latch is released.	MA-21	CL
When driving in areas using road salt or other corrosive materials, check lubrication frequently.		MT
INSIDE THE VEHICLE		
The maintenance items listed here should be checked on a regular basis, such as when performing periodic maintenance, cleaning the vehicle, etc.		
Lights Make sure that the headlights, stop lights, tail lights, turn signal lights, and other lights are all operating properly and installed securely. Also check headlight aim.	—	AT FA
Warning lights and buzzers/chimes Make sure that all warning lights and buzzers/chimes are operating properly.	—	RA
Windshield wiper and washer Check that the wipers and washer operate properly and that the wipers do not streak.	—	BR
Windshield defroster Check that air comes out of the defroster outlets properly and in good quantity when operating the heater or air conditioner.	—	ST
Steering wheel Check that it has the specified play. Be sure to check for changes in the steering condition, such as excessive play, hard steering or strange noises. Free play: Less than 35 mm (1.38 in)	—	RS
Seats Check seat position controls such as seat adjusters, seatback recliner, etc. to make sure they operate smoothly and that all latches lock securely in every position. Check that the head restraints move up and down smoothly and that the locks (if equipped) hold securely in all latched positions. Check that the latches lock securely for folding-down rear seatbacks.	—	BT
Seat belts Check that all parts of the seat belt system (e.g. buckles, anchors, adjusters and retractors) operate properly and smoothly, and are installed securely. Check the belt webbing for cuts, fraying, wear or damage.	MA-21 RS-6	HA
		EL
		IDX

GENERAL MAINTENANCE

Item	Reference page
Accelerator pedal Check the pedal for smooth operation and make sure the pedal does not catch or require uneven effort. Keep the floor mats away from the pedal.	—
Clutch pedal Make sure the pedal operates smoothly and check that it has the proper free play.	CL-5
Brakes Check that the brake does not pull the vehicle to one side when applied.	—
Brake pedal Check the pedal for smooth operation and make sure it has the proper distance under it when depressed fully. Check the brake booster function. Be sure to keep the floor mats away from the pedal.	BR-7, 10
Parking brake Check that the lever has the proper travel and make sure that the vehicle is held securely on a fairly steep hill when only the parking brake is applied.	BR-22
Automatic transmission "Park position" mechanism Check that the lock release button on the selector lever operates properly and smoothly. On a fairly steep hill check that the vehicle is held securely with the selector lever in the "P" position without applying any brakes.	—
UNDER THE HOOD AND VEHICLE	
The maintenance items listed here should be checked periodically (e.g. each time you check the engine oil or refuel).	
Windshield washer fluid Check that there is adequate fluid in the tank.	—
Engine coolant level Check the coolant level when the engine is cold.	MA-11
Radiator and hoses Check the front of the radiator and clean off any dirt, insects, leaves, etc., that may have accumulated. Make sure the hoses have no cracks, deformation, deterioration or loose connections.	—
Brake and clutch fluid levels Make sure that the brake and clutch fluid levels are between the "MAX" and "MIN" lines on the reservoir.	MA-17, 19
Battery Check the fluid level in each cell. It should be between the "MAX" and "MIN" lines.	—
Engine drive belts Make sure that no belt is frayed, worn, cracked or oily.	MA-10
Engine oil level Check the level on the dipstick after parking the vehicle on a level spot and turning off the engine.	MA-14
Power steering fluid level and lines Check the level in the reservoir tank with the engine off. Check the lines for proper attachment, leaks, cracks, etc.	MA-20
Automatic transmission fluid level Check the level on the dipstick after putting the selector lever in "P" with the engine idling.	MA-18
Exhaust system Make sure there are no loose supports, cracks or holes. If the sound of the exhaust seems unusual or there is a smell of exhaust fumes, immediately locate the trouble and correct it.	MA-17
Underbody The underbody is frequently exposed to corrosive substances such as those used on icy roads or to control dust. It is very important to remove these substances, otherwise rust will form on the floor pan, frame, fuel lines and around the exhaust system. At the end of winter, the underbody should be thoroughly flushed with plain water, being careful to clean those areas where mud and dirt can easily accumulate.	—
Fluid leaks Check under the vehicle for fuel, oil, water or other fluid leaks after the vehicle has been parked for a while. Water dripping from the air conditioner after use is normal. If you should notice any leaks or gasoline fumes are evident, check for the cause and correct it immediately.	—

PERIODIC MAINTENANCE

Two different maintenance schedules are provided, and should be used, depending upon the conditions in which the vehicle is mainly operated. **After 60,000 miles (96,000 km) or 48 months, continue the periodic maintenance at the same mileage/time intervals.**

SCHEDULE 1

Follow Periodic Maintenance Schedule 1 if your driving habits frequently includes one or more of the following driving conditions:

- Repeated short trips of less than 5 miles (8 km).
- Repeated short trips of less than 10 miles (16 km) with outside temperatures remaining below freezing.
- Operating in hot weather in stop-and-go "rush hour" traffic.
- Extensive idling and/or low speed driving for long distances, such as police, taxi or door-to-door delivery use.
- Driving in dusty conditions.
- Driving on rough, muddy, or salt spread roads.
- Towing a trailer, using a camper or a car-top carrier.

SCHEDULE 2

Follow Periodic Maintenance Schedule 2 if none of the driving conditions shown in Schedule 1 apply to your driving habits.

GI

MA

EM

LC

EC

FE

CL

MT

AT

FA

RA

BR

ST

RS

BT

HA

EL

IDX

PERIODIC MAINTENANCE

Schedule 1

[]: At the mileage intervals only

Abbreviations: R = Replace. I = Inspect. Correct or replace if necessary.

MAINTENANCE OPERATION	MAINTENANCE INTERVAL												Reference page				
	Miles x 1,000 (km x 1,000)	3.75 (6)	7.5 (12)	11.25 (18)	15 (24)	18.75 (30)	22.5 (36)	26.25 (42)	30 (48)	33.75 (54)	37.5 (60)	41.25 (72)		45 (84)	48.75 (90)	52.5 (96)	60 (96)
Perform at number of miles, kilometers or months, whichever comes first.	Months	3	6	9	12	15	18	21	24	27	30	33	36	39	42	45	48
Emission control system maintenance																	
Drive belts	See NOTE (1)															I*	MA-10
Air cleaner filter	See NOTE (2)								[R]							[R]	MA-13
EVAP vapor lines																I*	MA-16
Fuel lines																I*	MA-12
Fuel filter	See NOTE (3)*																MA-13
Engine coolant	See NOTE (4)																MA-11
Engine oil		R	R	R	R	R	R	R	R	R	R	R	R	R	R	R	MA-14
Engine oil filter (Use part No. 15208-31U00 or equivalent.)		R	R	R	R	R	R	R	R	R	R	R	R	R	R	R	MA-14
Spark plugs (Use PLATINUM-TIPPED type)																[R]	MA-15
Intake & exhaust valve clearance	See NOTE (5)*																EM-53
Chassis and body maintenance																	
Brake lines & cables																I	MA-19
Brake pads & discs																I	MA-19, 20
Manual transmission oil & automatic transmission fluid	See NOTE (6)															I	MA-17, 18
Steering gear & linkage, axle & suspension parts																I	MA-20, FA-6, RA-5
Exhaust system																I	MA-17
Front drive shaft boots																I	FA-8
Air bag system	See NOTE (7)																RS-11

NOTE: (1) After 60,000 miles (96,000 km) or 48 months, inspect every 15,000 miles (24,000 km) or 12 months.
 (2) If operating mainly in dusty conditions, more frequent maintenance may be required.
 (3) If vehicle is operated under extremely adverse weather conditions or in areas where ambient temperatures are either extremely low or extremely high, the filters might become clogged. In such an event, replace them immediately.
 (4) After 60,000 miles (96,000 km) or 48 months, replace every 30,000 miles (48,000 km) or 24 months.
 (5) If valve noise increases, inspect valve clearance.
 (6) If towing a trailer, using a camper or a car-top carrier, or driving on rough or muddy roads, change (not just inspect) oil at every 30,000 miles (48,000 km) or 24 months.
 (7) Inspect the air bag system 10 years after the date of manufacture noted on the FMVSS certification label.
 * Maintenance items and intervals with "*" are recommended by INFINTI for reliable vehicle operation. The owner need not perform such maintenance in order to maintain the emission warranty or manufacturer recall liability. Other maintenance items and intervals are required.

PERIODIC MAINTENANCE

Schedule 2

Abbreviations: R = Replace. I = Inspect. Correct or replace if necessary. []: At the mileage intervals only

MAINTENANCE OPERATION	MAINTENANCE INTERVAL											Reference page	
	Miles x 1,000 (km x 1,000)	7.5 (12)	15 (24)	22.5 (36)	30 (48)	37.5 (60)	45 (72)	52.5 (84)	60 (96)	Months			
Emission control system maintenance													
Drive belts	See NOTE (1)											I*	MA-10
Air cleaner filter				[R]								[R]	MA-13
EVAP vapor lines				I*								I*	MA-16
Fuel lines				I*								I*	MA-12
Fuel filter	See NOTE (2)*												MA-13
Engine coolant	See NOTE (3)											R*	MA-11
Engine oil		R	R	R	R	R	R	R	R	R	R	R	MA-14
Engine oil filter (Use part No. 15208-31U00 or equivalent.)		R	R	R	R	R	R	R	R	R	R	R	MA-14
Spark plugs (Use PLATINUM-TIPPED type)												[R]	MA-15
Intake & exhaust valve clearance	See NOTE (4)*												EM-53
Chassis and body maintenance													
Brake lines & cables		I	I	I	I	I	I	I	I	I	I	I	MA-19
Brake pads & discs		I	I	I	I	I	I	I	I	I	I	I	MA-19, 20
Manual transmission oil & automatic transmission fluid		I	I	I	I	I	I	I	I	I	I	I	MA-17, 18
Steering gear linkage, axle & suspension parts		I	I	I	I	I	I	I	I	I	I	I	MA-20, FA-6, RA-5
Exhaust system		I	I	I	I	I	I	I	I	I	I	I	MA-17
Front drive shaft boots		I	I	I	I	I	I	I	I	I	I	I	FA-8
Air bag system	See NOTE (5)												RS-11

NOTE: (1) After 60,000 miles (96,000 km) or 48 months, inspect every 15,000 miles (24,000 km) or 12 months.
 (2) If vehicle is operated under extremely adverse weather conditions or in areas where ambient temperatures are either extremely low or extremely high, the filters might become clogged. In such an event, replace them immediately.
 (3) After 60,000 miles (96,000 km) or 48 months, replace every 30,000 miles (48,000 km) or 24 months.
 (4) If valve noise increases, inspect valve clearance.
 (5) Inspect the air bag system 10 years after the date of manufacture noted on the FMVSS certification label.
 ★ Maintenance items and intervals with "*" are recommended by INFINTI for reliable vehicle operation. The owner need not perform such maintenance in order to maintain the emission warranty or manufacturer recall liability. Other maintenance items and intervals are required.

RECOMMENDED FLUIDS AND LUBRICANTS

Fluids and Lubricants

	Capacity (Approximate)			Recommended fluids and lubricants
	US measure	Imp measure	Liter	
Engine oil (Refill)				
With oil filter	4-1/4 qt	3-1/2 qt	4.0	<ul style="list-style-type: none"> • API Certification Mark*1 • API grade SG/SH, Energy Conserving II or API grade SJ, Energy Conserving*1 • ILSAC grade GF-II*1
Without oil filter	3-7/8 qt	3-1/4 qt	3.7	
Cooling system				
With reservoir	9 qt	7-1/2 qt	8.5	Genuine Nissan anti-freeze coolant or equivalent
Reservoir	7/8 qt	3/4 qt	0.8	
Manual transmission gear oil				
RS5F50V	9-1/8 - 9-1/2 pt	7-5/8 - 7-7/8 pt	4.3 - 4.5	API GL-4, Viscosity SAE 80W-90 only
RS5F50A	9-1/2 - 10-1/8 pt	7-7/8 - 8-1/2 pt	4.5 - 4.8	API GL-4, Viscosity SAE 80W-90 only
Automatic transmission fluid (RE4F04A/RE4F04V)				
	10 qt	8-1/4 qt	9.4	Nissan Matic "D" (Continental U.S. and Alaska) or Genuine Nissan Automatic Transmission Fluid (Canada)*2
Power steering fluid				
	—	—	—	Type DEXRON™ III or equivalent
Brake & Clutch fluid				
	—	—	—	Genuine Nissan Brake Fluid*3 or equivalent DOT 3 (US FMVSS No. 116)
Multi-purpose grease				
	—	—	—	NLGI No. 2 (Lithium soap base)

*1: For further details, see "SAE Viscosity Number".

*2: Dexron™ III/Mercon™ or equivalent may also be used. Outside the continental United States and Alaska contact an INFINITI dealership for more information regarding suitable fluids, including recommended brand(s) of Dexron™ III/Mercon™ Automatic Transmission Fluid.

*3: For more information regarding suitable fluids, contact an INFINITI dealership.

SAE Viscosity Number

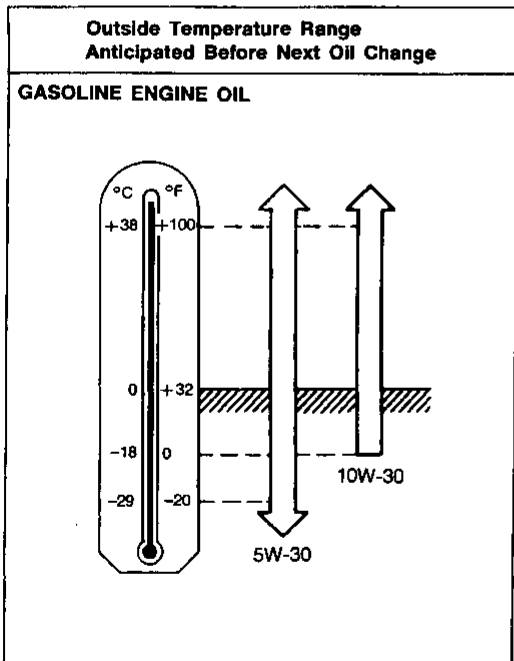

SAE 5W-30 viscosity oil is preferred for all temperatures. SAE 10W-30 viscosity oil may be used if the ambient temperature is above -18°C (0°F).

RECOMMENDED FLUIDS AND LUBRICANTS

Anti-freeze Coolant Mixture Ratio

The engine cooling system is filled at the factory with a high-quality, year-round, anti-freeze coolant solution. The anti-freeze solution contains rust and corrosion inhibitors. Therefore, additional cooling system additives are not necessary.

CAUTION:

When adding or replacing coolant, be sure to use only a Genuine Nissan anti-freeze coolant or equivalent with the proper mixture ratio of 50% anti-freeze and 50% demineralized water/distilled water.

Outside temperature down to		Anti- freeze	Demineralized water or distilled water
°C	°F		
-35	-30	50%	50%

Other types of coolant solutions may damage the cooling system.

GI

MA

EM

LC

EC

FE

GL

MT

AT

FA

RA

BR

ST

RS

BT

HA

EL

IDX

ENGINE MAINTENANCE

Checking Drive Belts

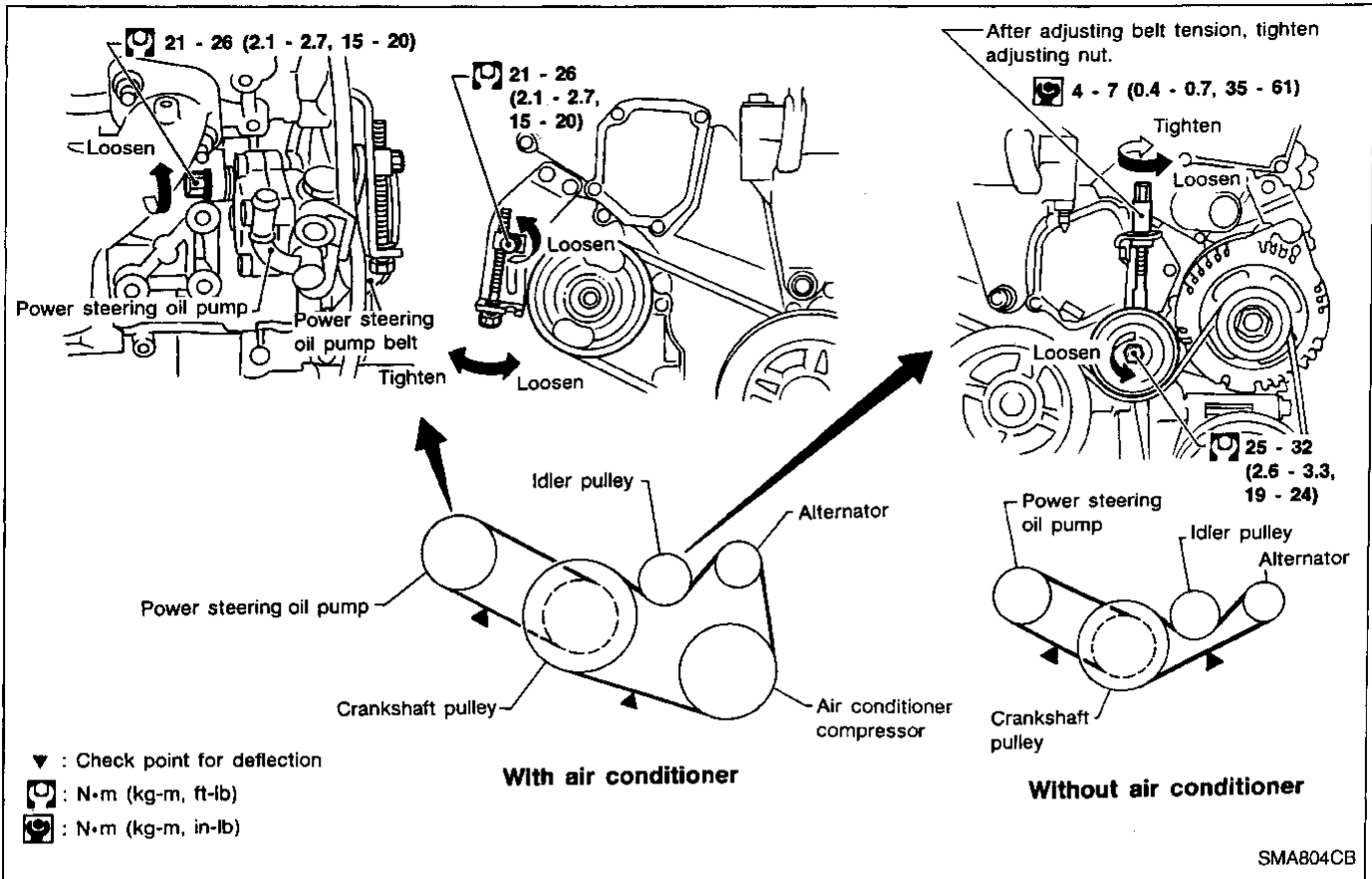

1. Inspect belts for cracks, fraying, wear and oil. If necessary, replace.
2. Inspect drive belt deflection or tension at a point on the belt midway between pulleys.
 - Check belt tension using belt tension gauge (BT 3373-F or equivalent).
 - Inspect drive belt deflection or tension when engine is cold.

Adjust if belt deflection exceeds the limit or if belt tension is not within specifications.

- Drive belt tension can also be checked at other points on the belts.

Belt deflection and tension:

	Deflection adjustment Unit: mm (in)			Tension adjustment*1 Unit: N (kg, lb)		
	Used belt		New belt	Used belt		New belt
	Limit	After adjustment		Limit	After adjustment	
Alternator						
With air conditioner compressor	7 (0.28)	4.2 - 4.6 (0.165 - 0.181)	3.8 - 4.1 (0.150 - 0.161)	294 (30, 66)	730 - 818 (74.5 - 83.5, 164 - 184)	794 - 892 (81 - 91, 179 - 201)
Without air conditioner compressor	10 (0.39)	6.3 - 6.9 (0.248 - 0.272)	5.8 - 6.2 (0.228 - 0.244)	294 (30, 66)	730 - 818 (74.5 - 83.5, 164 - 184)	882 - 980 (90 - 100, 198 - 221)
Power steering oil pump	11 (0.43)	7.3 - 8 (0.287 - 0.315)	6.5 - 7 (0.256 - 0.276)	196 (20, 44)	495 - 583 (50.5 - 59.5, 111 - 131)	755 - 853 (77 - 87, 170 - 192)
Applied pushing force	98 N (10 kg, 22 lb)			—		

*1: If the belt tension gauge cannot be installed at check points shown, check drive belt tension at a different location on the belt.

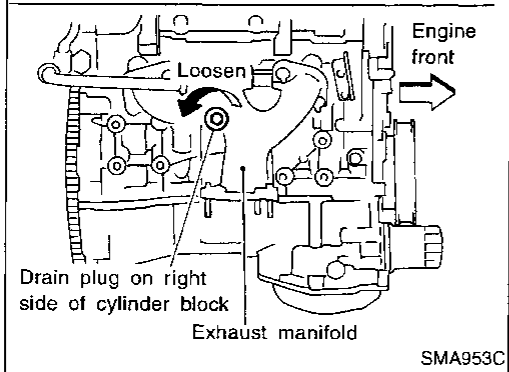
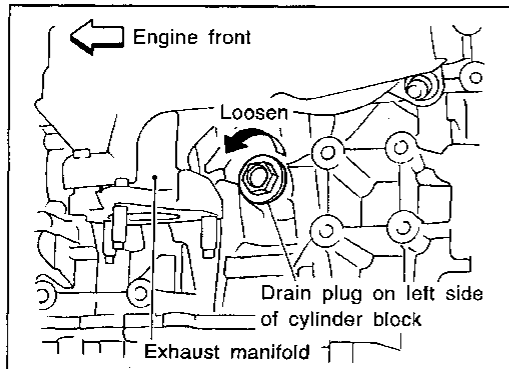
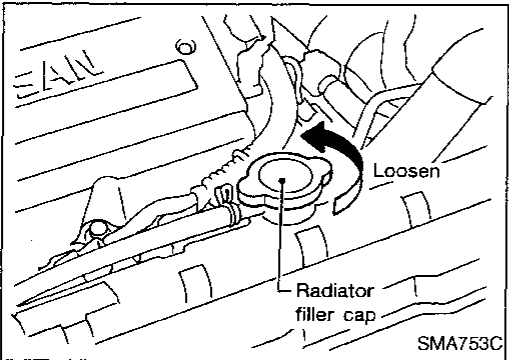
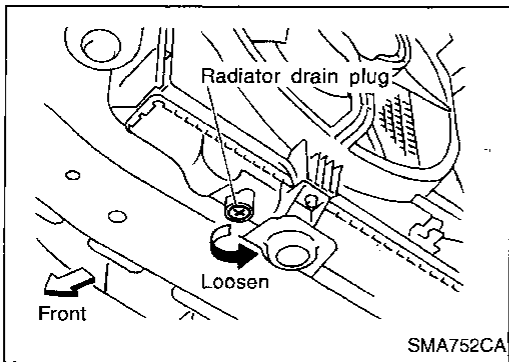

Changing Engine Coolant

WARNING:

To avoid the danger of being scalded, never change the coolant when the engine is hot.

— DRAINING ENGINE COOLANT —

1. Set air conditioner system as follows to prevent coolant from remaining in the system.
 - a. Turn ignition switch ON and set temperature controller to maximum hot position.
 - b. Wait 10 seconds before turning ignition switch OFF.
2. Open radiator drain plug at the bottom of radiator, and remove radiator filler cap.
3. Remove reservoir tank, drain coolant, then clean reservoir tank. Install it temporarily.
4. Remove drain plugs on both sides of cylinder block.
5. Check drained coolant for contaminants such as rust, corrosion or discoloration. If contaminated flush engine cooling system, refer to "FLUSHING COOLING SYSTEM" on next page.

● Be careful not to allow coolant to contact drive belts.

— REFILLING ENGINE COOLANT —

6. Install reservoir tank and radiator drain plug.
7. Close and tighten drain plugs securely.
- Apply sealant to the drain plug thread.
 - ⌚: 60 - 66 N·m (6.1 - 6.7 kg-m, 44 - 48 ft-lb) Left side
 - 18 - 22 N·m (1.8 - 2.2 kg-m, 13 - 16 ft-lb) Right side
- Use genuine Nissan anti-freeze coolant or equivalent mixed with water (distilled or demineralized).

ENGINE MAINTENANCE

Changing Engine Coolant (Cont'd)

Refer to "RECOMMENDED FLUIDS AND LUBRICANTS", MA-9.

Engine coolant capacity (With reservoir tank):

8.5 ℓ (9 US qt, 7-1/2 Imp qt)

Reservoir tank capacity:

0.8 ℓ (7/8 US qt, 3/4 Imp qt)

- Pour coolant through coolant filler neck slowly to allow air in system to escape.
- 8. Fill radiator and reservoir tank to specified level.
- 9. Warm up engine to normal operating temperature without radiator cap installed.
- 10. Run engine at 2,500 rpm for 10 seconds and return to idle speed.
- Repeat two or three times.

Watch coolant temperature gauge so as not to overheat the engine.

- 11. Stop engine and cool it down.
- Cool down using a fan to reduce the time.
- If necessary, refill radiator up to filler neck.
- 12. Refill reservoir tank to MAX level line.
- 13. Repeat steps 9 through 12 two or more times with radiator cap installed until coolant level no longer drops.
- 14. Check cooling system for leaks with engine running.
- 15. Warm up engine, and check for sound of coolant flow while running engine from idle up to 3,000 rpm with heater temperature control lever set at several positions between COOL and WARM.
- Sound may be noticeable at heater water cock.
- 16. If sound is heard, bleed air from cooling system by repeating steps 9 through 12 until coolant level no longer drops.
- Clean excess coolant from engine.

— FLUSHING COOLING SYSTEM —

1. Fill radiator and reservoir tank with water and reinstall radiator cap.
2. Run engine and warm it up to normal operating temperature.
3. Rev engine two or three times under no-load.
4. Stop engine and wait until it cools down.
5. Drain water.
6. Repeat steps 1 through 6 until clear water begins to drain from radiator.

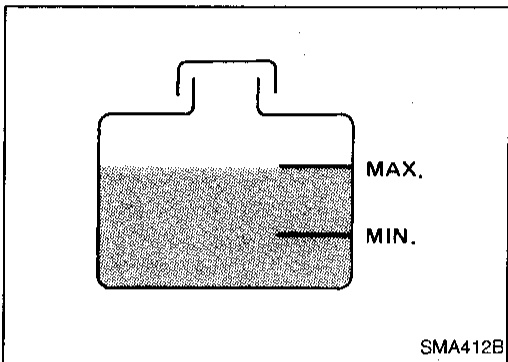
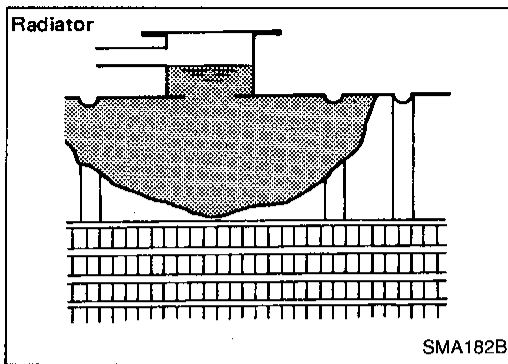

Checking Fuel Lines

Inspect fuel lines and tank for improper attachment, leaks, cracks, damage, chafing or deterioration.
If necessary, repair or replace.

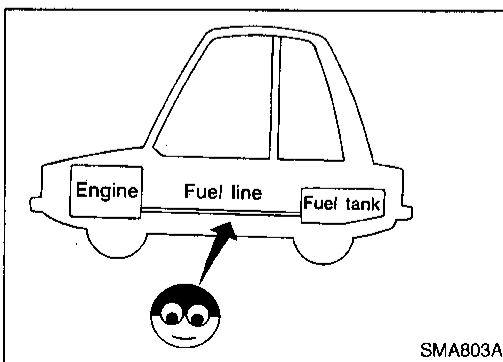

ENGINE MAINTENANCE

Checking Fuel Lines (Cont'd)

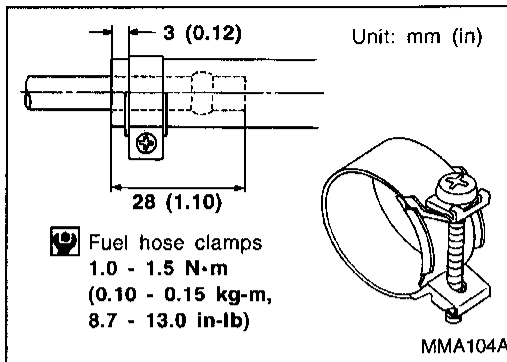

CAUTION:

Tighten high-pressure rubber hose clamp so that clamp end is 3 mm (0.12 in) from hose end.

Tightening torque specifications are the same for all rubber hose clamps.

Ensure that screw does not contact adjacent parts.

GI

MA

EM

Changing Fuel Filter

WARNING:

Before removing fuel filter, release fuel pressure from fuel line to eliminate danger.

LC

EC

FE

CL

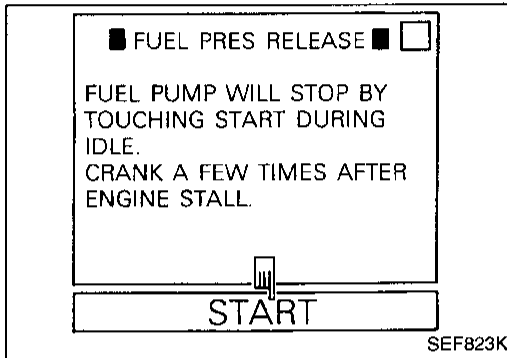

1. Start engine.
2. Perform "FUEL PRESSURE RELEASE" in "WORK SUPPORT" mode with CONSULT.
3. After engine stalls, crank engine two or three times to make sure that fuel pressure is released.
4. Turn ignition switch OFF.

OR

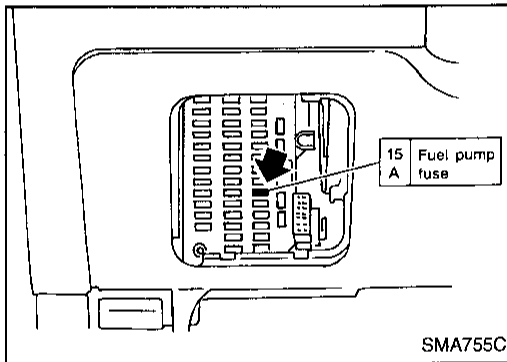

1. Remove fuel pump fuse.
2. Start engine.
3. After engine stalls, crank engine two or three times to make sure that fuel pressure is released.
4. Turn ignition switch off and install fuel pump fuse.

MT

AT

FA

RA

BR

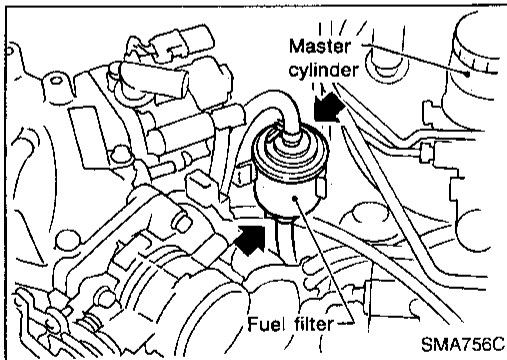

5. Loosen fuel hose clamps.
6. Replace fuel filter.
 - Be careful not to spill fuel over engine compartment. Place a shop towel to absorb fuel.
 - Use a high-pressure type fuel filter. Do not use a synthetic resinous fuel filter.
 - When tightening fuel hose clamps, refer to "Checking Fuel Lines".

ST

RS

BT

HA

Changing Air Cleaner Filter

Viscous paper type

The viscous paper type filter does not need cleaning.

EL

IDX

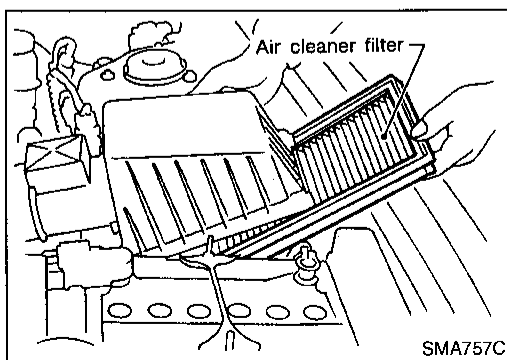

ENGINE MAINTENANCE

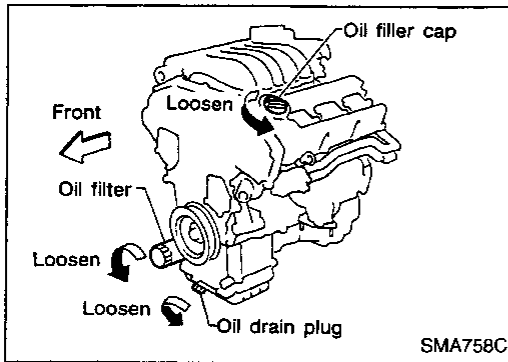

Changing Engine Oil

WARNING:

- Be careful not to burn yourself, as the engine oil is hot.
- Prolonged and repeated contact with used engine oil may cause skin cancer; try to avoid direct skin contact with used oil. If skin contact is made, wash thoroughly with soap or hand cleaner as soon as possible.

1. Warm up engine, and check for oil leakage from engine components.
2. Stop engine and wait more than 10 minutes.
3. Remove drain plug and oil filler cap.
4. Drain oil and refill with new engine oil.

Oil specification and viscosity:

- API Certification Mark
- API grade SG/SH, Energy Conserving II or API grade SJ, Energy Conserving
- ILSAC grade GF-II
- Refer to "RECOMMENDED FLUIDS AND LUBRICANTS", MA-8.

Oil capacity (Approximate):

Unit: liter (US qt, Imp qt)

Drain and refill	
With oil filter change	4.0 (4-1/4, 3-1/2)
Without oil filter change	3.7 (3-7/8, 3-1/4)
Dry engine (engine overhaul)	4.8 (5-1/8, 4-1/4)

CAUTION:

- Be sure to clean drain plug and install with new washer.

Drain plug:

: 29 - 39 N·m (3.0 - 4.0 kg·m, 22 - 29 ft·lb)

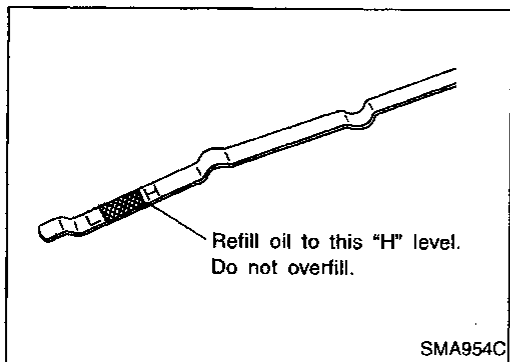

- The refill capacity depends on the oil temperature and drain time. Use these specifications for reference only. Always use the dipstick to determine when the proper amount of oil is in the engine.
 - Never pull out level gauge while filling engine oil.
5. Warm up engine and check area around drain plug and oil filter for oil leakage.
 6. Stop engine and wait more than 10 minutes.
 7. Check oil level.

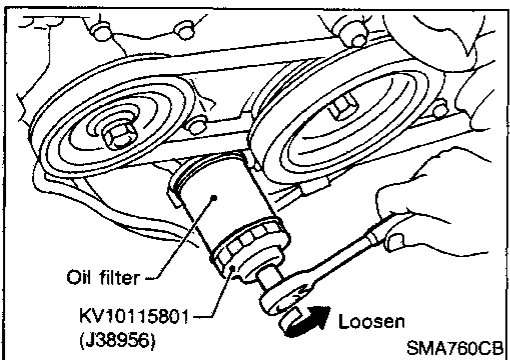

Changing Oil Filter

1. The oil filter is a small full-floating cartridge type and is provided with a relief valve.

Refer to LC section ("OIL FILTER").

2. Remove oil filter with Tool or suitable tool.

WARNING:

Be careful not to burn yourself, as the engine and the engine oil are hot.

ENGINE MAINTENANCE

Changing Oil Filter (Cont'd)

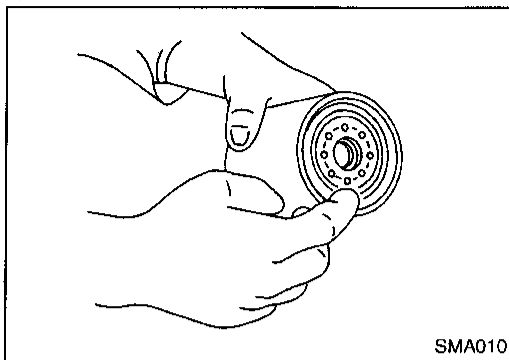

- Clean oil filter mounting surface on cylinder block. Coat rubber seal of new oil filter with engine oil.

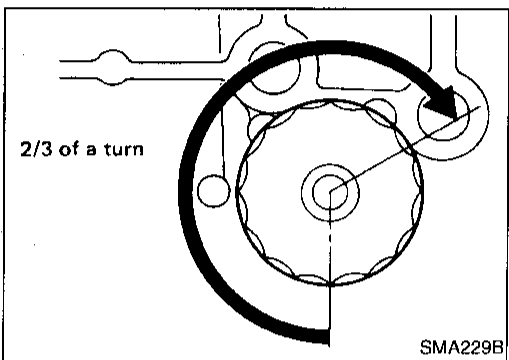

- Screw in the oil filter until a slight resistance is felt, then tighten additionally 2/3 turn.
- Add engine oil.

Oil filter:

: 14.7 - 20.5 N·m (1.5 - 2.1 kg-m, 11 - 15 ft-lb)

Refer to "Changing Engine Oil", MA-14.

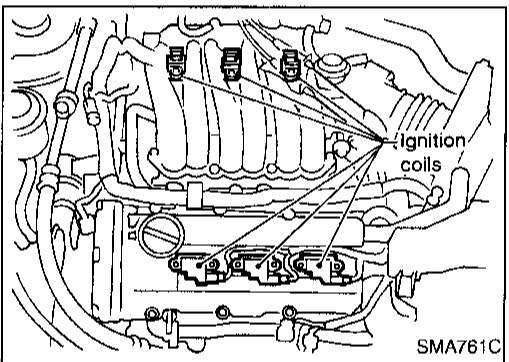

Changing Spark Plugs

- Remove left side rocker cover ornament.
- Disconnect ignition coil harness connectors.
- Loosen ignition coil fixing bolts and pull out coil from intake manifold connector.

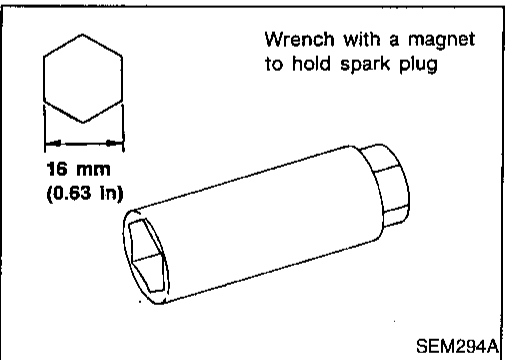

- Remove spark plugs with suitable spark plug wrench.

Spark plug (Platinum-tipped type):

Make	NGK
Standard type	PFR5G-11
Hot type	PFR4G-11
Cold type	PFR6G-11

Use standard type spark plug for normal condition.

The hot type spark plug is suitable when fouling may occur with the standard type spark plug such as:

- frequent engine starts
- low ambient temperatures

The cold type spark plug is suitable when spark knock may occur with the standard type spark plug such as:

- extended highway driving
- frequent high engine revolution

: 20 - 29 N·m
(2.0 - 3.0 kg-m, 14 - 22 ft-lb)

GI

MA

EM

LC

EC

FE

CL

MT

AT

FA

RA

BR

ST

RS

BT

HA

EL

IDX

ENGINE MAINTENANCE

Changing Spark Plugs (Cont'd)

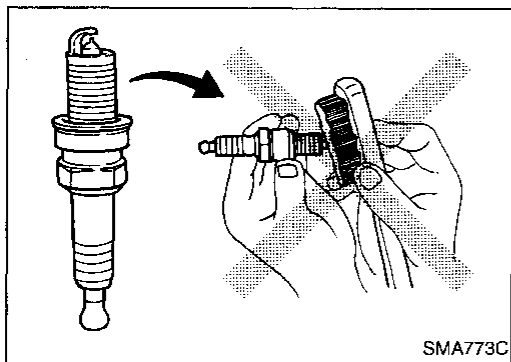

- Do not use a wire brush for cleaning.
- If plug tip is covered with carbon, spark plug cleaner may be used.

Cleaner air pressure:

Less than 588 kPa (6 kg/cm², 85 psi)

Cleaning time:

Less than 20 seconds

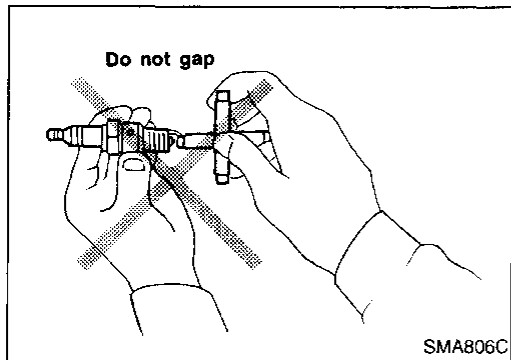

- Checking and adjusting plug gap is not required.

Checking EVAP Vapor Lines

1. Visually inspect EVAP vapor lines for improper attachment and for cracks, damage, loose connections, chafing and deterioration.
2. Inspect fuel tank filler cap vacuum relief valve for clogging, sticking, etc.

Refer to EVAPORATIVE EMISSION SYSTEM in EC section.

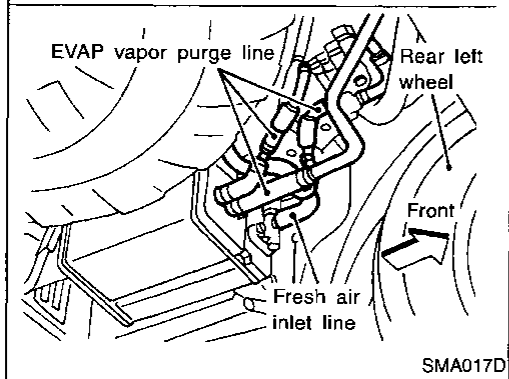
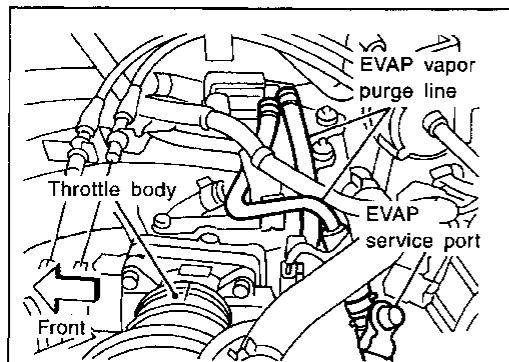

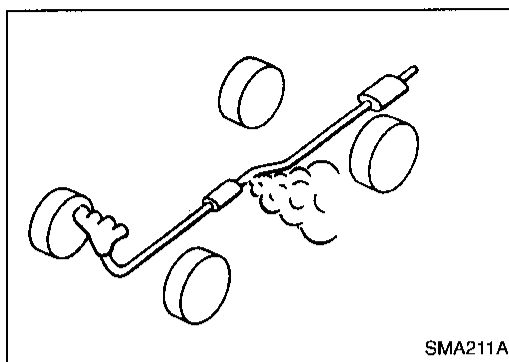

Checking Exhaust System

Check exhaust pipes, muffler and mounting for improper attachment, leaks, cracks, damage, chafing or deterioration.

GI

MA

EM

LC

EC

FE

CL

MT

AT

FA

RA

BR

ST

RS

BT

HA

EL

IDX

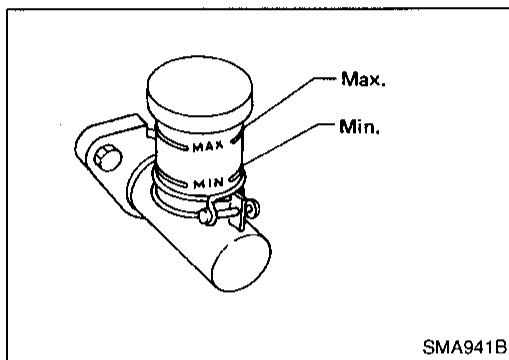

Checking Clutch Fluid Level and Leaks

If fluid level is extremely low, check clutch system for leaks.

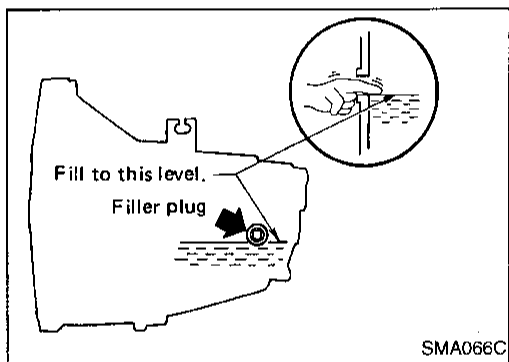

Checking M/T Oil

Check for oil leakage and oil level.

Never start engine while checking oil level.

Filler plug:

\square : 25 - 34 N·m (2.5 - 3.5 kg·m, 18 - 25 ft·lb)

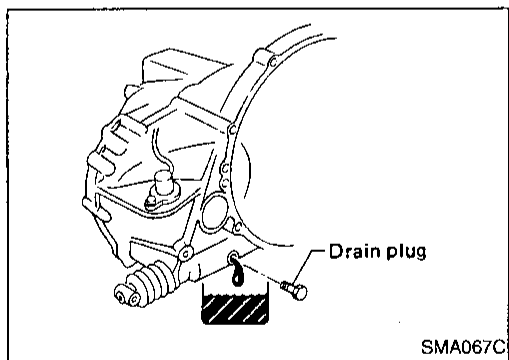

Changing M/T Oil

1. Drain oil from drain plug and refill with new gear oil.
2. Check oil level.

Oil grade:

API GL-4

Viscosity:

See "RECOMMENDED FLUIDS AND LUBRICANTS", MA-8.

Capacity:

RS5F50A

4.5 - 4.8ℓ

(9-1/2 - 10-1/8 US pt, 7-7/8 - 8-1/2 Imp pt)

RS5F50V

4.3 - 4.5ℓ

(9-1/8 - 9-1/2 US pt, 7-5/8 - 7-7/8 Imp pt)

Drain plug:

\square : 15 - 20 N·m (1.5 - 2.0 kg·m, 11 - 14 ft·lb)

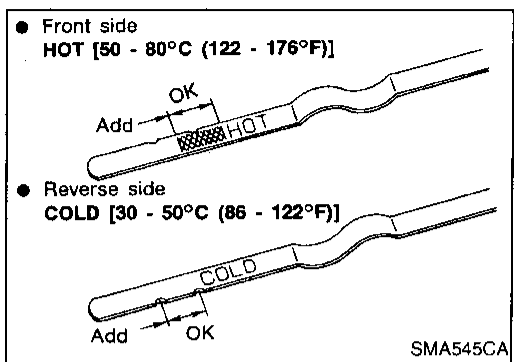

Checking A/T Fluid

1. Warm up engine.
2. Check for fluid leakage.
3. Before driving, fluid level can be checked at fluid temperatures of 30 to 50°C (86 to 122°F) using "COLD" range on dipstick.
 - a. Park vehicle on level surface and set parking brake.
 - b. Start engine and move selector lever through each gear position. Leave selector lever in "P" position.
 - c. Check fluid level with engine idling.
 - d. Remove dipstick and wipe clean with lint-free paper.
 - e. Re-insert dipstick into charging pipe as far as it will go.
 - f. Remove dipstick and note reading. If reading is at low side of range, add fluid to the charging pipe.

Do not overfill.

4. Drive vehicle for approximately 5 minutes in urban areas.
5. Re-check fluid level at fluid temperatures of 50 to 80°C (122 to 176°F) using "HOT" range on dipstick.

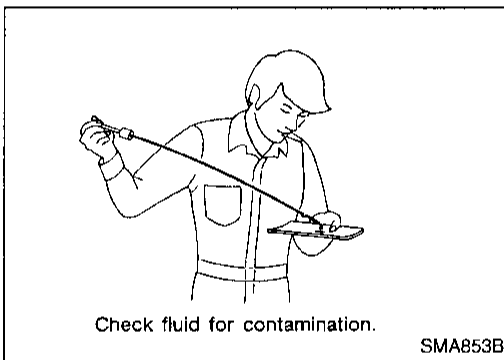

Check fluid for contamination.

SMA853B

6. Check fluid condition.
 - If fluid is very dark or smells burned, refer to AT section for checking operation of A/T. Flush cooling system after repair of A/T.
 - If A/T fluid contains frictional material (clutches, bands, etc.), replace radiator and flush cooler line using cleaning solvent and compressed air after repair of A/T. Refer to LC section ("Radiator", "ENGINE COOLING SYSTEM").

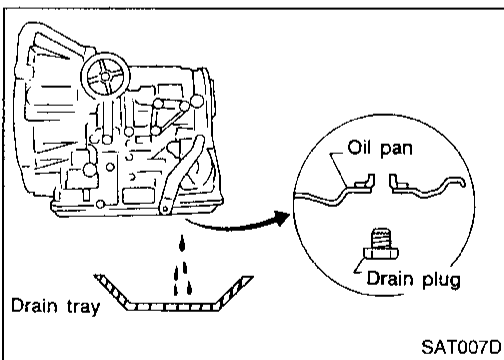

Drain tray

SAT007D

Changing A/T Fluid

1. Warm up A/T fluid.
2. Stop engine.
3. Drain A/T fluid from drain plug and refill with new A/T fluid. Always refill same volume with drained fluid.

Fluid grade:

Nissan Matic "D" (Continental U.S. and Alaska) or Genuine Nissan Automatic Transmission Fluid (Canada)

Refer to "RECOMMENDED FLUIDS AND LUBRICANTS", MA-8.

Fluid capacity (With torque converter):

9.4ℓ (10 US qt, 8-1/4 Imp qt)

Drain plug:

⌚: 29 - 39 N·m (3.0 - 4.0 kg·m, 22 - 29 ft·lb)

4. Run engine at idle speed for five minutes.
5. Check fluid level and condition. Refer to "Checking A/T Fluid". If fluid is still dirty, repeat step 2. through 5.

CHASSIS AND BODY MAINTENANCE

Balancing Wheels

Adjust wheel balance using road wheel center.

Wheel balance (Maximum allowable unbalance):

Maximum allowable unbalance	Dynamic (At rim flange)	10 (0.35) (one side)
	Static	20 (0.71)

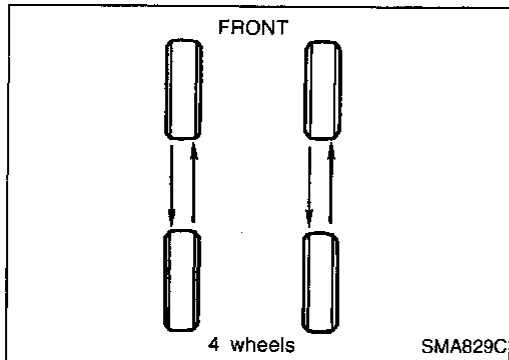

Tire Rotation

Do not include the T-type spare tire when rotating the tires.

Wheel nuts:

: 98 - 118 N·m
(10.0 - 12.0 kg·m, 72 - 87 ft·lb)

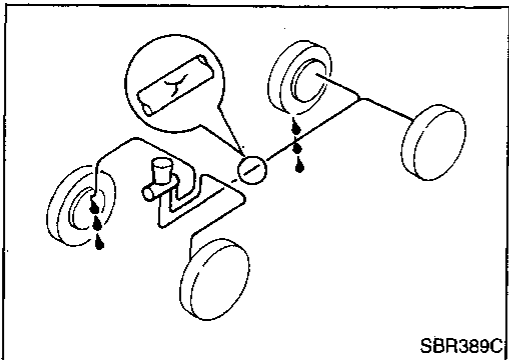

Checking Brake Fluid Level and Leaks

If fluid level is extremely low, check brake system for leaks.

Checking Brake Lines and Cables

Check brake fluid lines and parking brake cables for improper attachment, leaks, chafing, abrasions, deterioration, etc.

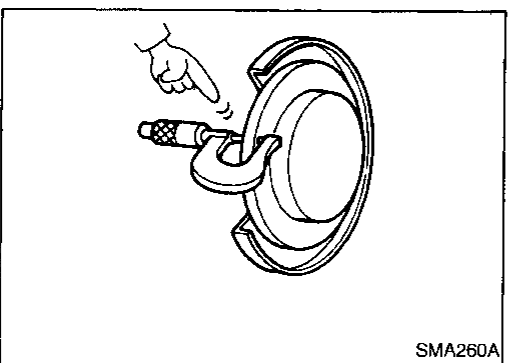

Checking Disc Brake

ROTOR

Check condition and thickness.

Unit: mm (in)

	Front	Rear
Brake model	CL25VB	CL9HA
Standard thickness	22 (0.87)	9 (0.35)
Maximum runout	0.07 (0.0028)	0.15 (0.0059)
Minimum thickness (Wear limit)	20.0 (0.787)	8.0 (0.315)

CHASSIS AND BODY MAINTENANCE

Checking Disc Brake (Cont'd)

CALIPER

Check for leakage.

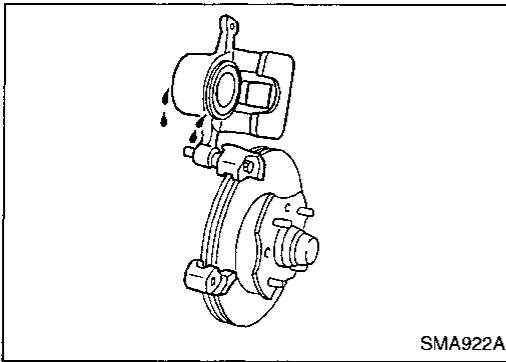

SMA922A

PAD

Check for wear or damage.

Unit: mm (in)

Brake model	CL25VB	CL9HA
Standard thickness	11 (0.43)	10 (0.39)
Minimum thickness (Wear limit)	2.0 (0.079)	1.5 (0.059)

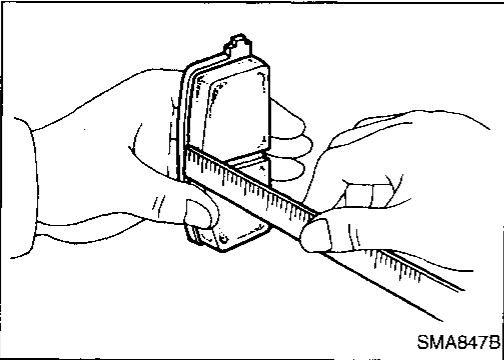

SMA947B

Checking Steering Gear and Linkage

STEERING GEAR

- Check gear housing and boots for looseness, damage and grease leakage.
- Check connection with steering column for looseness.

STEERING LINKAGE

Check ball joint, dust cover and other component parts for looseness, wear, damage and grease leakage.

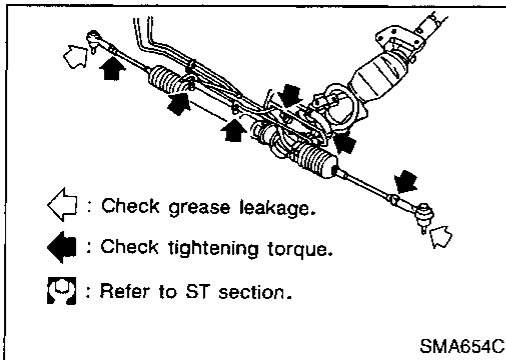

SMA654C

Checking Power Steering Fluid and Lines

Check fluid level in reservoir tank with engine off.

Use "HOT" range at fluid temperatures of 50 to 80°C (122 to 176°F) or "COLD" range at fluid temperatures of 0 to 30°C (32 to 86°F).

CAUTION:

- Do not overfill.
- Recommended fluid is Automatic Transmission Fluid type DEXRON™III or equivalent.

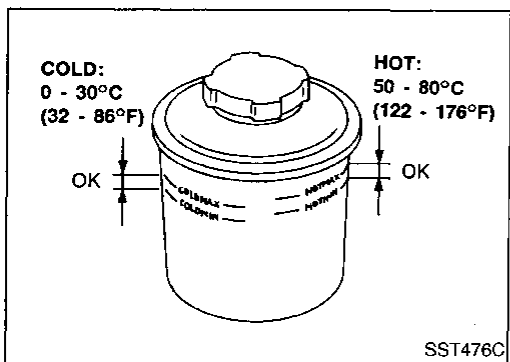

SST476C

- Check lines for improper attachment, leaks, cracks, damage, loose connections, chafing and deterioration.
- Check rack boots for accumulation of power steering fluid.

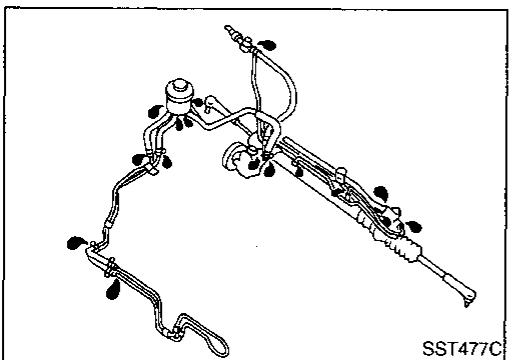

SST477C

Lubricating Locks, Hinges and Hood Latches

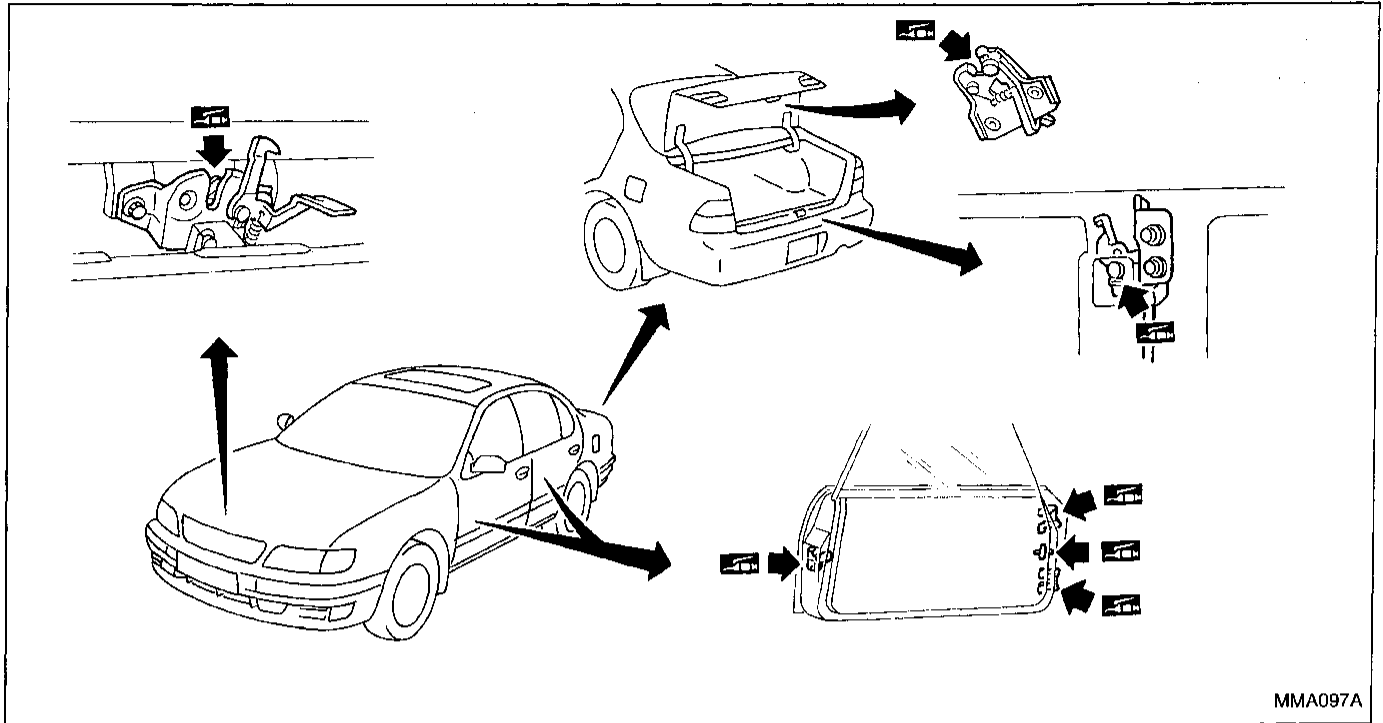

Checking Seat Belts, Buckles, Retractors, Anchors and Adjusters

CAUTION:

- After any collision, inspect all seat belt assemblies, including retractors and other attached hardware (i.e. guide rail set). Nissan recommends to replace all seat belt assemblies in use during a collision, unless not damaged and properly operating after minor collision. Also inspect seat belt assemblies not in use during a collision, and replace if damaged or improperly operating.
- If any component of seat belt assembly is questionable, do not repair. Replace as seat belt assembly.
- If webbing is cut, frayed, or damaged, replace belt assembly.
- Never oil tongue and buckle.
- Use a genuine seat belt assembly.

For details, refer to "Seat Belt Inspection", "SEAT BELTS" in RS section.

Anchor bolt

43 - 55 (4.4 - 5.6, 32 - 41)

: N·m (kg·m, ft·lb)

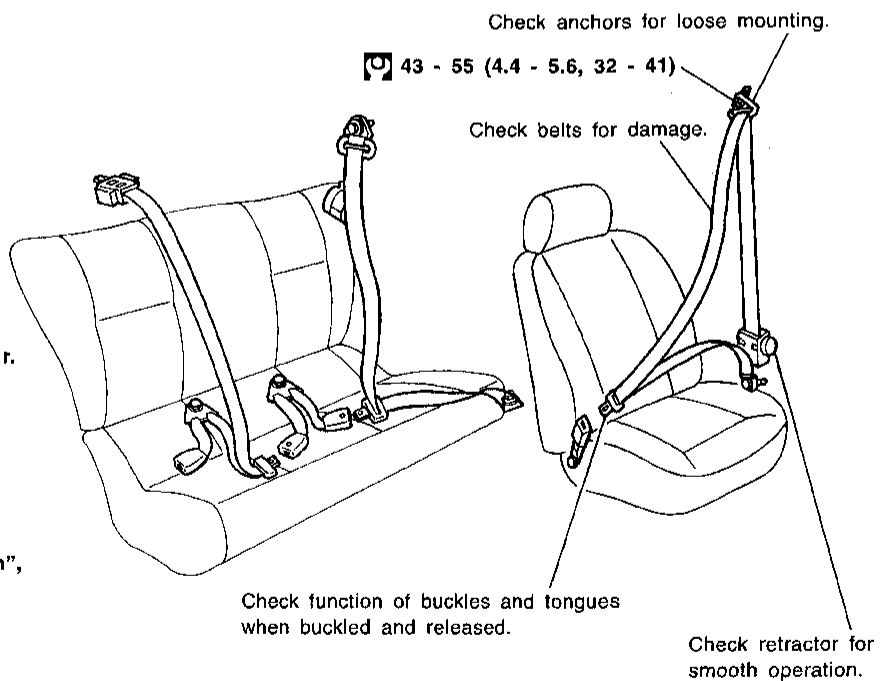

SMA025D

GI
MA
EM
LC
EC
FE
CL
MT
AT
FA
RA
BR
ST
RS
BT
HA
EL
IDX

SERVICE DATA AND SPECIFICATIONS (SDS)

Engine Maintenance

INSPECTION AND ADJUSTMENT

Belt deflection and tension

	Deflection adjustment Unit: mm (in)			Tension adjustment*1 Unit: N (kg, lb)		
	Used belt		New belt	Used belt		New belt
	Limit	After adjustment		Limit	After adjustment	
Alternator						
With air conditioner compressor	7 (0.28)	4.2 - 4.6 (0.165 - 0.181)	3.8 - 4.1 (0.150 - 0.161)	294 (30, 66)	730 - 818 (74.5 - 83.5, 164 - 184)	794 - 892 (81 - 91, 179 - 201)
Without air conditioner compressor	10 (0.39)	6.3 - 6.9 (0.248 - 0.272)	5.8 - 6.2 (0.228 - 0.244)	294 (30, 66)	730 - 818 (74.5 - 83.5, 164 - 184)	882 - 980 (90 - 100, 198 - 221)
Power steering oil pump	11 (0.43)	7.3 - 8 (0.287 - 0.315)	6.5 - 7 (0.256 - 0.276)	196 (20, 44)	495 - 583 (50.5 - 59.5, 111 - 131)	755 - 853 (77 - 87, 170 - 192)
Applied pushing force	98 N (10 kg, 22 lb)			—		

*1: If the belt tension gauge cannot be installed at check points, check drive belt tension at a different location on the belt.

Spark plug

	Platinum tipped type
Make	NGK
Type	
Standard	PFR5G-11
Hot	PFR4G-11
Cold	PFR6G-11

Chassis and Body Maintenance

INSPECTION AND ADJUSTMENT

Wheel balance

Maximum allowable unbalance	Dynamic (At rim flange)	10 (0.35) (one side)
	g (oz)	
	Static	20 (0.71)
	g (oz)	