

REAR AXLE & REAR SUSPENSION

SECTION **RA**

GI
MA
EM
LC
EC
FE
CL
MT
AT
FA
RA
BR
ST
RS
BT
HA
EL
IDX

CONTENTS

PRECAUTIONS AND PREPARATION2	Rear Wheel Alignment.....6
Precautions.....2	REAR AXLE7
Special Service Tool.....2	Wheel Hub.....7
Commercial Service Tools.....2	REAR SUSPENSION10
NOISE, VIBRATION AND HARSHNESS (NVH)	Components.....10
TROUBLESHOOTING3	Removal and Installation.....11
NVH Troubleshooting Chart.....3	Coil Spring and Shock Absorber.....11
REAR SUSPENSION SYSTEM4	Torsion Beam, Lateral Link and Control Rod.....13
Components.....4	SERVICE DATA AND SPECIFICATIONS (SDS)14
ON-VEHICLE SERVICE5	General Specifications.....14
Rear Axle and Rear Suspension Parts.....5	Inspection and Adjustment.....14
Rear Wheel Bearing.....5	

PRECAUTIONS AND PREPARATION

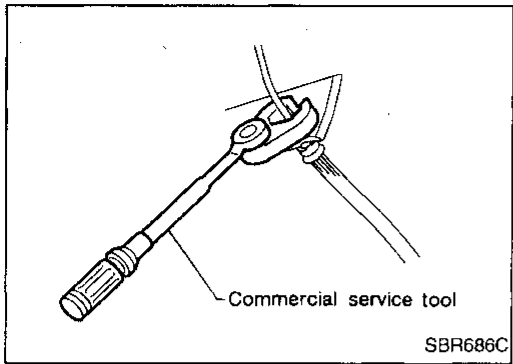

Precautions

- When installing each rubber part, final tightening must be carried out under unladen condition* with tires on ground.
*: Fuel, radiator coolant and engine oil full. Spare tire, jack, hand tools and mats in designated positions.
- Use flare nut wrench when removing or installing brake tubes.
- After installing removed suspension parts, check wheel alignment.
- Always torque brake lines when installing.

Special Service Tool

Tool number (Kent-Moore No.) Tool name	Description
ST15310000 (—) Drift	<p>NT607</p> <p>Install ABS sensor rotor</p> <p>a: 84 mm (3.31 in) dia. b: 96 mm (3.78 in) dia. c: 8 mm (0.31 in) d: 20 mm (0.79 in)</p>

Commercial Service Tools

Tool name	Description
① Flare nut crowfoot ② Torque wrench	<p>NT360</p> <p>Removing and installing brake piping</p> <p>a: 10 mm (0.39 in)</p>
Drift	<p>NT371</p> <p>Install ABS sensor rotor</p> <p>a: 75 mm (2.95 in) dia. b: 62 mm (2.44 in) dia.</p>
Spring compressor	<p>NT717</p> <p>Removing and installing coil spring</p>

NOISE, VIBRATION AND HARSHNESS (NVH) TROUBLESHOOTING

NVH Troubleshooting Chart

Use the chart below to help you find the cause of the symptom. If necessary, repair or replace these parts.

Symptom		Possible cause and SUSPECTED PARTS	Reference page													
			RA-4, 10	RA-12	RA-12	—	—	RA-12	RA-6	RA-5	NVH in FA section	NVH in FA section	NVH in FA section	NVH in FA section	NVH in BR section	NVH in ST section
REAR AXLE AND REAR SUSPENSION	Noise	Improper installation, looseness	X	X	X	X	X	X			X	X	X	X	X	X
	Shake	Shock absorber deformation, damage or deflection	X	X	X	X		X			X	X	X	X	X	X
	Vibration	Bushing or mounting deterioration	X	X	X	X	X				X	X	X			X
	Shimmy	Parts interference	X	X	X	X			X				X	X	X	X
	Judder	Spring fatigue	X	X	X								X	X	X	X
	Poor quality ride or handling	Suspension looseness	X	X	X	X				X	X		X	X	X	
		Incorrect wheel alignment														
		Wheel bearing damage														
		DRIVE SHAFT														
		FRONT AXLE AND FRONT SUSPENSION														
		TIRES														
		ROAD WHEEL														
		BRAKES														
		STEERING														

X: Applicable

GI
 MA
 EM
 LC
 EC
 FE
 CL
 MT
 AT
 FA
RA
 BR
 ST
 RS
 BT
 HA
 EL
 IDX

REAR SUSPENSION SYSTEM

Components

SEC. 431

When installing each rubber part, final tightening must be carried out under unladen condition* with tires on ground.

- * Fuel, radiator coolant and engine oil full.
- Spare tire, jack, hand tools and mats in designated positions.

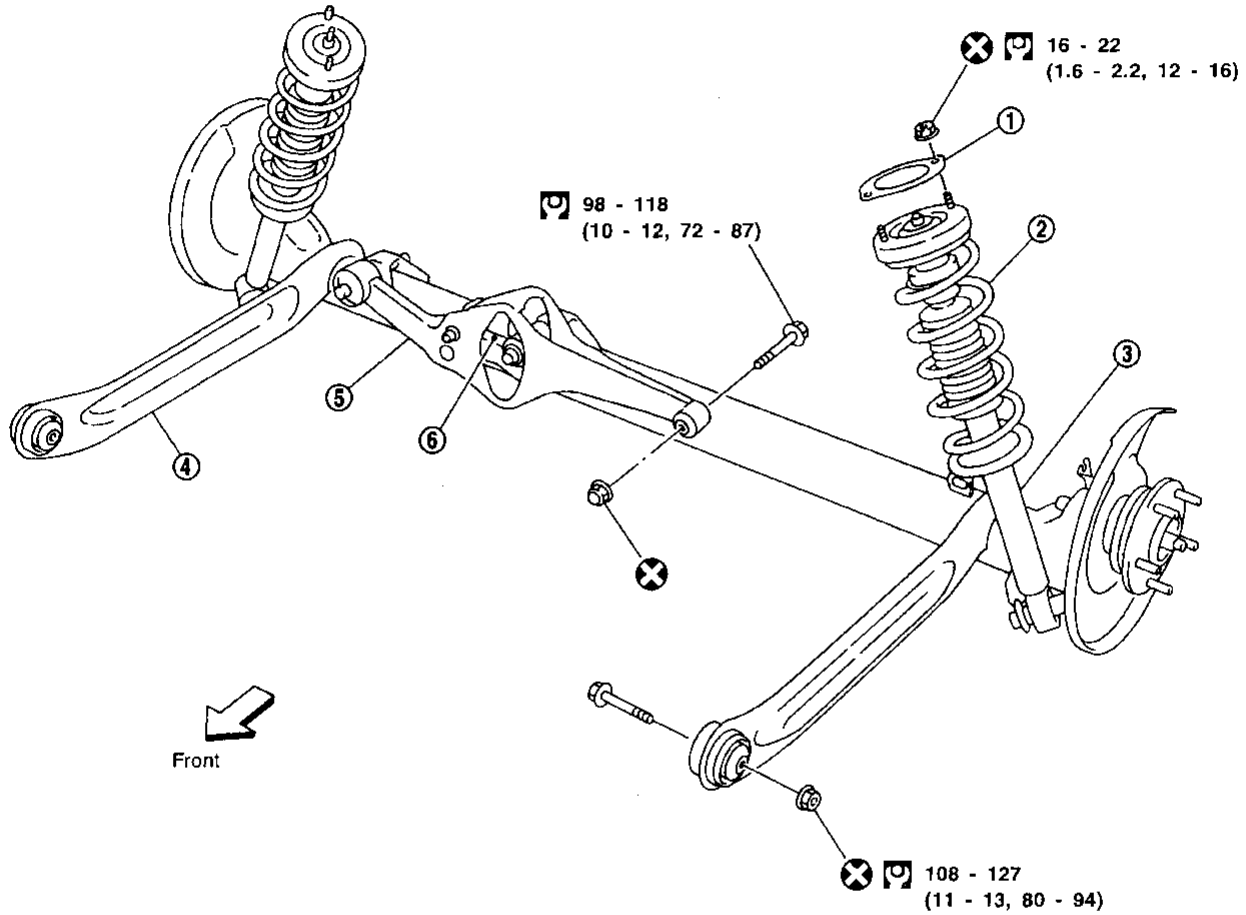

 : N·m (kg-m, ft-lb)

SRA807AA

- | | | |
|--------------------------------|------------------|----------------|
| ① Shock absorber mounting seal | ③ Shock absorber | ⑤ Lateral link |
| ② Coil spring | ④ Torsion beam | ⑥ Control rod |

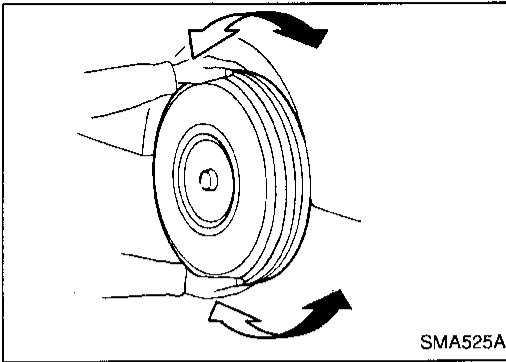

Rear Axle and Rear Suspension Parts

Check axle and suspension parts for looseness, wear or damage.

- Shake each rear wheel to check for excessive play.

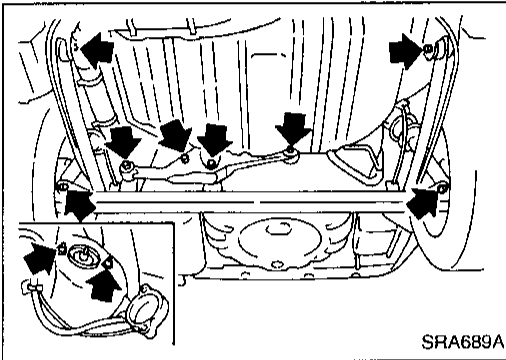

- Retighten all nuts and bolts to the specified torque.
Tightening torque:
Refer to REAR SUSPENSION (RA-10).

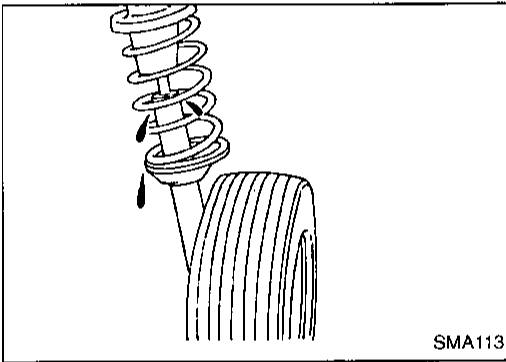

- Check shock absorber for oil leakage or other damage.
- Check wheelarch height. Refer to FA section ("Front Axle and Front Suspension", "ON-VEHICLE SERVICE").

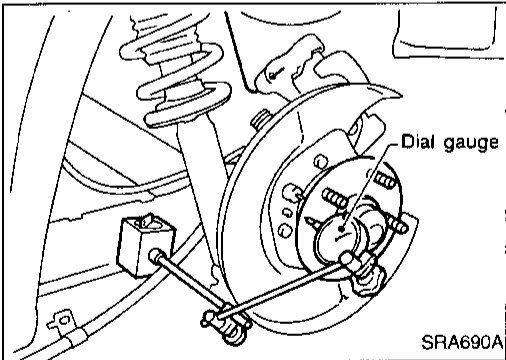

Rear Wheel Bearing

- Check axial end play.
Axial end play:
0.05 mm (0.0020 in) or less
- Check that wheel hub bearings operate smoothly.
- Check tightening torque of wheel bearing lock nut.
Ⓜ: 186 - 255 N·m
(19 - 26 kg-m, 137 - 188 ft-lb)
- Replace wheel bearing assembly if there is axial end play or wheel bearing does not turn smoothly. Refer to REAR AXLE — Wheel Hub (RA-7).

GI

MA

EM

LC

EC

FE

CL

MT

AT

FA

RA

BR

ST

RS

BT

HA

EL

IDX

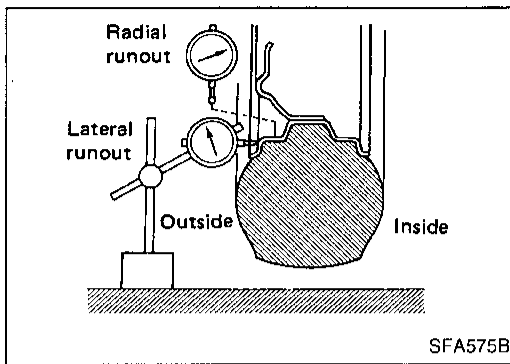

Rear Wheel Alignment

PRELIMINARY INSPECTION

Make following checks. Adjust, repair or replace if necessary.

- Check tires for wear and for improper inflation.
- Check rear wheel bearings for looseness.
- Check wheel runout.

Wheel runout: Refer to SDS in FA section.

- Check that rear shock absorber works properly.
- Check rear axle and rear suspension parts for looseness.
- Check vehicle posture (Unladen*).

*: Fuel, radiator coolant and engine oil full. Spare tire, jack, hand tools and mats in designated positions.

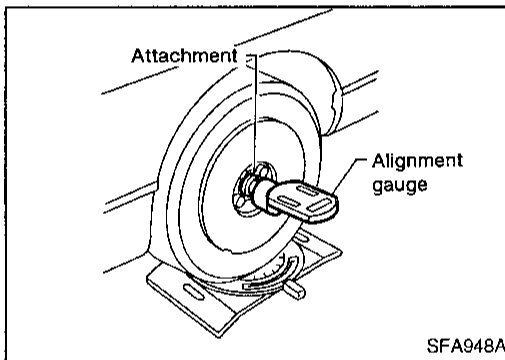

CAMBER

Camber is preset at factory and cannot be adjusted.

Camber:

Refer to SDS (RA-14).

- If the camber is not within specification, inspect and replace any damaged or worn rear suspension parts.

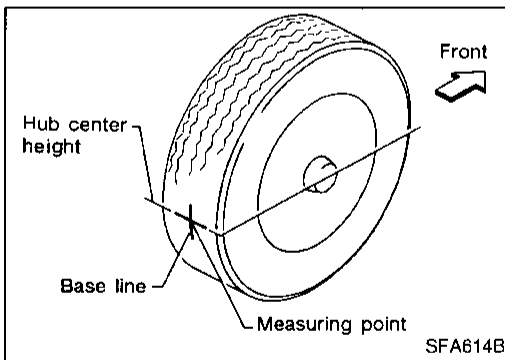

TOE-IN

Toe-in is preset at factory and cannot be adjusted.

Measure toe-in using following procedure. If out of specification, inspect and replace any damaged or worn rear suspension parts.

WARNING:

- Perform following procedure always on a flat surface.
- Make sure that no person is in front of the vehicle before pushing it.

1. Move rear of vehicle up and down to stabilize the posture.
2. Push the vehicle straight ahead about 5 m (196.9 in).
3. Put a mark on base line of the tread (rear side) at the same height of hub center to be a measuring point.
4. Measure distance "A" (rear side).
5. Push the vehicle slowly ahead to turn the wheels around 180 degrees.

If the wheels have passed 180 degrees, try the above procedure again from the beginning. Never push vehicle backward.

6. Measure distance "B" (front side).

Total toe-in (A - B):

Total toe-in angle:

Refer to SDS (RA-14).

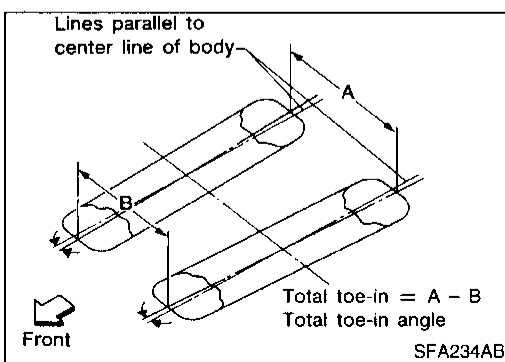

Wheel Hub

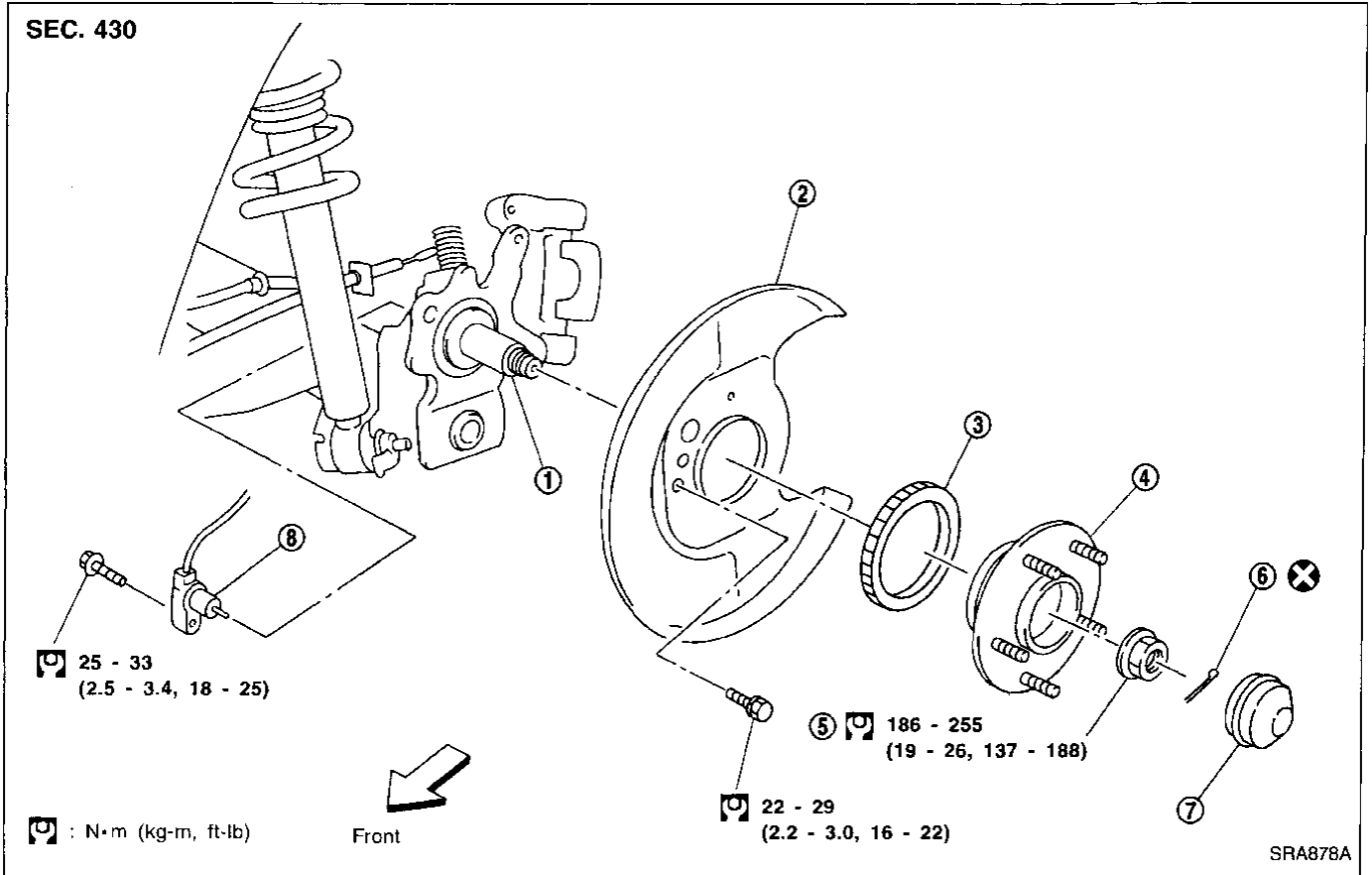

- ① Spindle
- ② Baffle plate
- ③ ABS sensor rotor

- ④ Wheel hub bearing
- ⑤ Wheel bearing lock nut
- ⑥ Cotter pin

- ⑦ Hub cap
- ⑧ ABS sensor

REMOVAL

CAUTION:

- Before removing the rear wheel hub assembly, disconnect the ABS wheel sensor from the assembly. Then move it away from the hub assembly. Failure to do so may result in damage to the sensor wires and the sensor becoming inoperative.
- Wheel hub bearing usually does not require maintenance. If any of the following symptoms are noted, replace wheel hub bearing assembly.
- Growling noise is emitted from wheel hub bearing during operation.
- Wheel hub bearing drags or turns roughly. This occurs when turning hub by hand after bearing lock nut is tightened to specified torque.

GI
MA
EM
LC
EC
FE
CL
MT
AT
FA
RA
BR
ST
RS
BT
HA
EL
IDX

REAR AXLE

Wheel Hub (Cont'd)

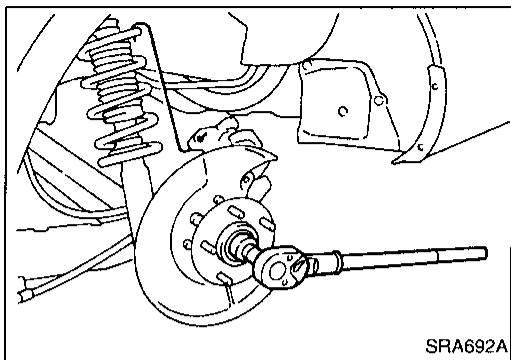

- 1) Remove brake caliper assembly.
 - 2) Remove wheel bearing lock nut.
- Remove brake caliper assembly and rotor.

Suspend caliper assembly with wire so as not to stretch brake hose.

**Be careful not to depress brake pedal, or piston will pop out.
Make sure brake hose is not twisted.**

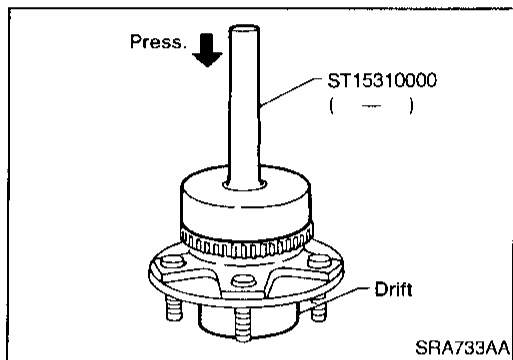

INSTALLATION

- With vehicles equipped with ABS, press-fit ABS sensor rotor into wheel hub bearing using a drift.

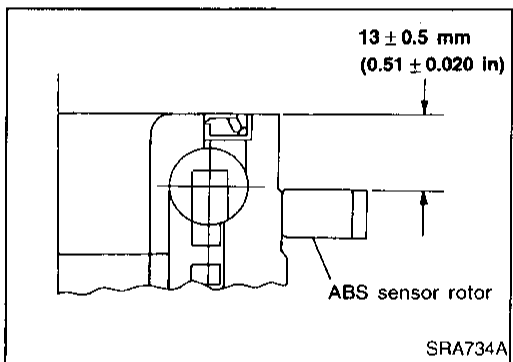

- Press-fit ABS sensor rotor as far as the location shown in figure at left.

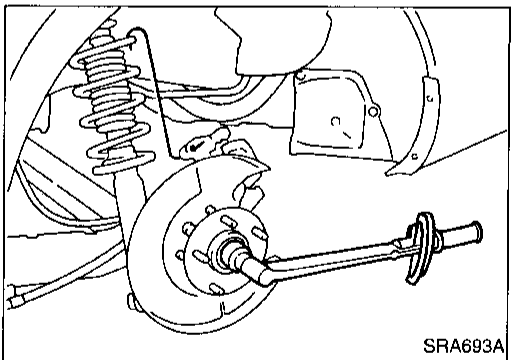

- Install wheel hub bearing.
- Tighten wheel bearing lock nut.
Before tightening, apply oil to threaded portion of rear spindle.
⊞: 186 - 255 N·m
(19 - 26 kg-m, 137 - 188 ft-lb)
- Check that wheel bearings operate smoothly.

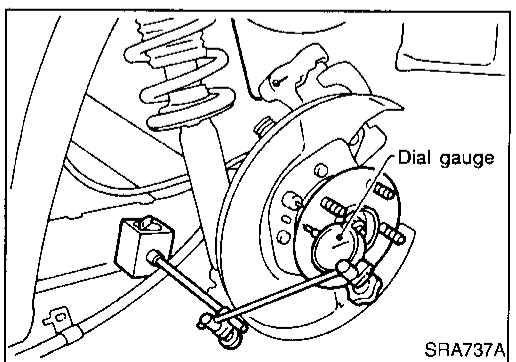

- Check wheel hub bearing axial end play.
Axial end play:
0.05 mm (0.0020 in) or less

REAR AXLE

Wheel Hub (Cont'd)

- Install hub cap using a suitable tool.
Do not reuse hub cap. When installing, replace it with a new one.

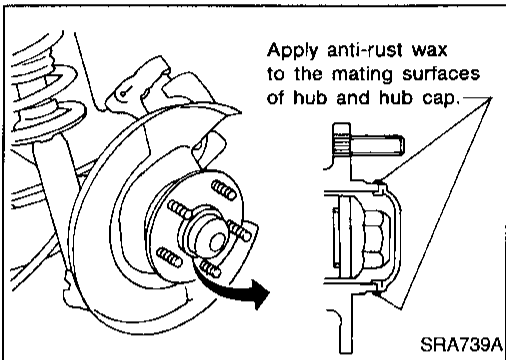
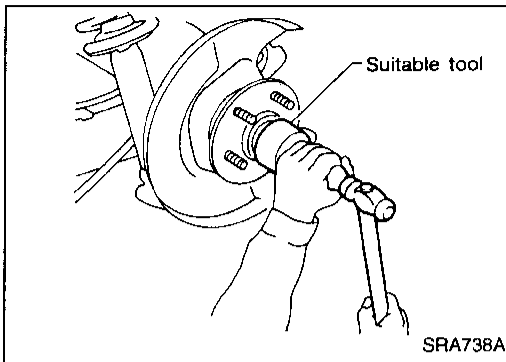

- Apply anti-rust wax to the mating surfaces of hub and hub cap.

GI

MA

EM

LC

EC

FE

CL

MT

AT

FA

RA

BR

ST

RS

BT

HA

EL

IDX

REAR SUSPENSION

Components

SEC. 431

When installing each rubber part, final tightening must be carried out under unladen condition* with tires on ground.

* Fuel, radiator coolant and engine oil full.
Spare tire, jack, hand tools and mats in designated positions.

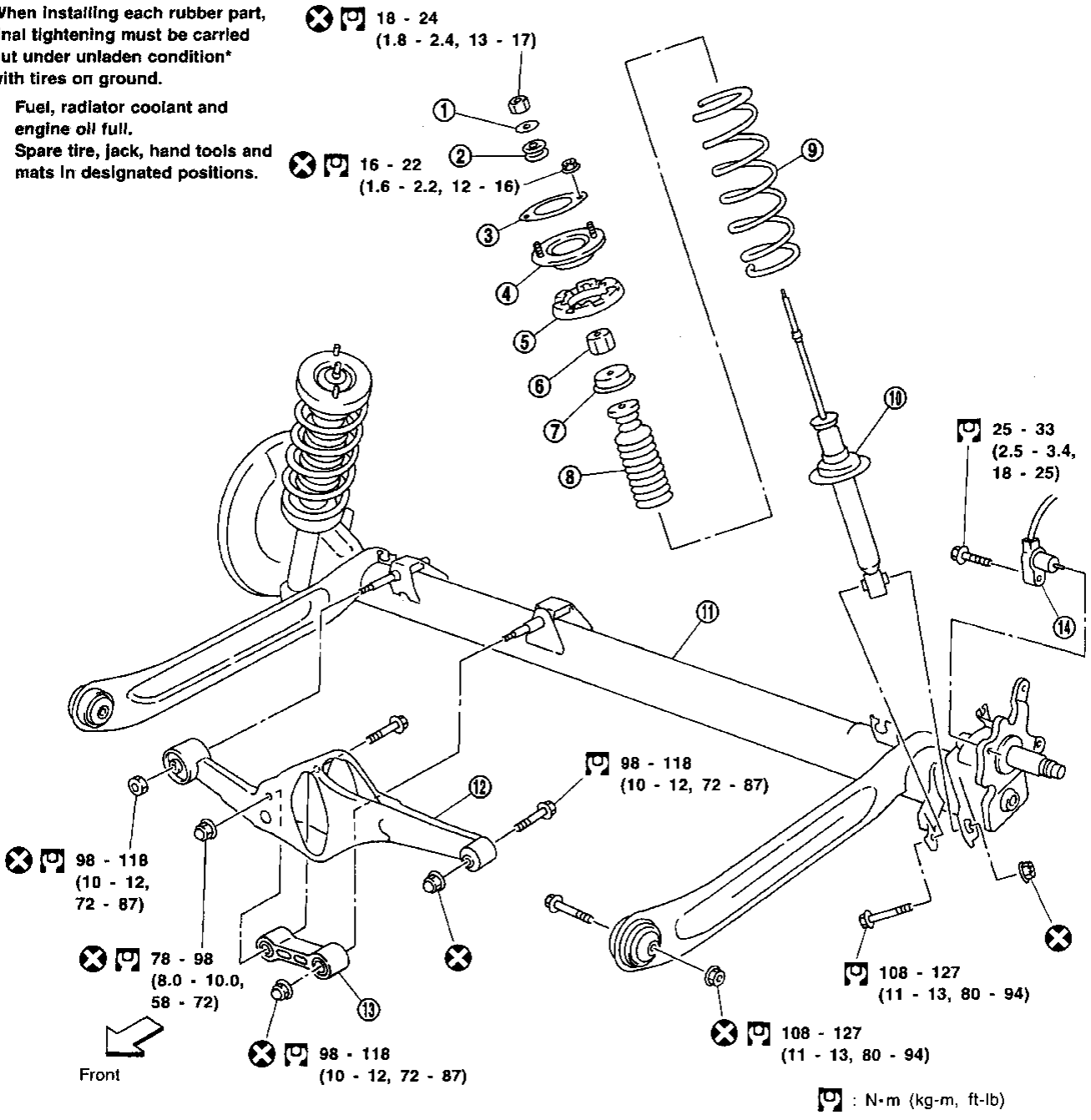

SRA879A

- | | | |
|-----------------------------------|----------------------|----------------|
| ① Washer | ⑥ Bushing | ⑪ Torsion beam |
| ② Bushing | ⑦ Bound bumper cover | ⑫ Lateral link |
| ③ Shock absorber mounting seal | ⑧ Bound bumper | ⑬ Control rod |
| ④ Shock absorber mounting bracket | ⑨ Coil spring | ⑭ ABS sensor |
| ⑤ Upper spring seat rubber | ⑩ Shock absorber | |

REAR SUSPENSION

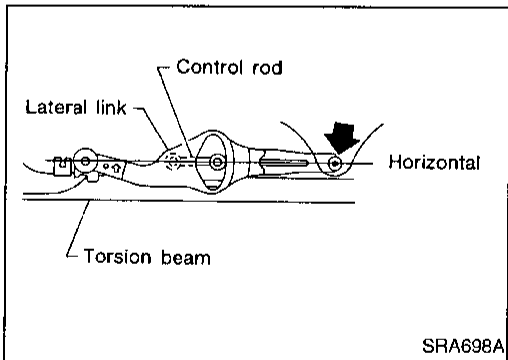
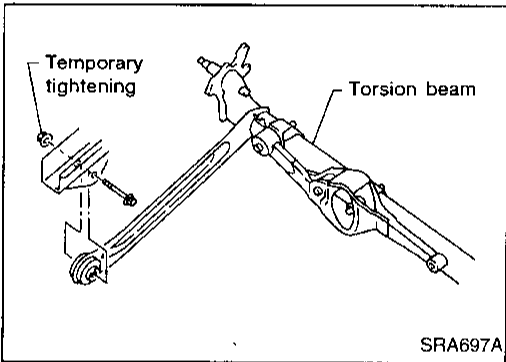
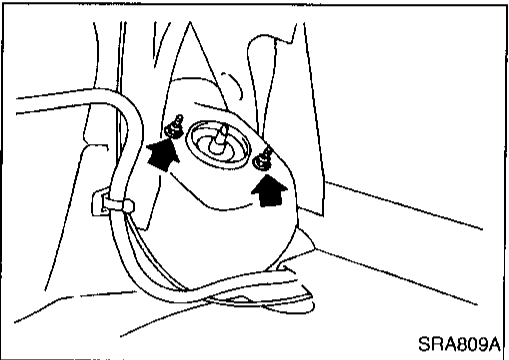
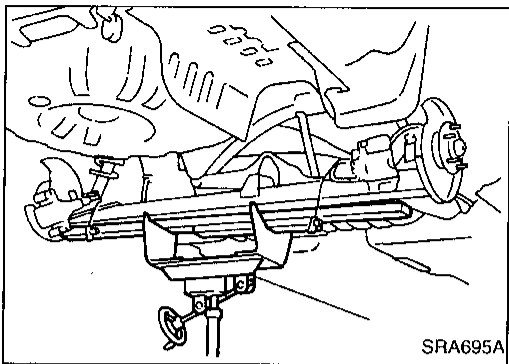

Removal and Installation

CAUTION:

- Before removing the rear suspension assembly, disconnect the ABS wheel sensor from the assembly. Failure to do so may result in damage to the sensor wires and the sensor becoming inoperative.

- Remove suspension assembly.

1. Remove brake caliper assembly and rotor.

Suspend caliper assembly with wire so as not to stretch brake hose.

Be careful not to depress brake pedal, or piston will pop out. Make sure brake hose is not twisted.

2. Using a transmission jack, raise torsion beam a little, and remove suspension fixing nuts and bolts.
3. Lower transmission jack, and remove suspension.
4. Remove trunk room trim. Refer to BT section ("Trunk Room Trim", "INTERIOR TRIM").
5. Remove strut securing nuts (upper side). Then pull out strut assembly.

- Install suspension assembly.

1. Temporarily attach torsion beam to vehicle.

2. Place lateral link and control rod horizontally against torsion beam. Tighten up lateral link on vehicle.

3. Attach shock absorber to vehicle. Then tighten up the lower side of shock absorber.

4. Tighten torsion beam in full rebound condition at the place indicated in step 1.

Coil Spring and Shock Absorber

REMOVAL

Remove shock absorber upper and lower fixing nuts.

Do not remove piston rod lock nut on vehicle.

GI

MA

EM

LC

EC

FE

CL

MT

AT

FA

RA

BR

ST

RS

BT

HA

EL

IDX

REAR SUSPENSION

Coil Spring and Shock Absorber (Cont'd)

DISASSEMBLY

1. Set shock absorber in vise, then **loosen** piston rod lock nut.

WARNING:

Do not remove piston rod lock nut.

2. Compress spring with tool so that the strut upper spring seat can be turned by hand.

WARNING:

Make sure that the pawls of the two spring compressors are firmly hooked on the spring. The spring compressors must be tightened alternately so as not to tilt the spring.

3. Remove piston rod lock nut.

INSPECTION

Shock absorber assembly

- Check for smooth operation through a full stroke, both compression and extension.
- Check for oil leakage on welded or gland packing portions.
- Check piston rod for cracks, deformation or other damage. Replace if necessary.

Upper rubber seat and bushing

Check rubber parts for deterioration or cracks. Replace if necessary.

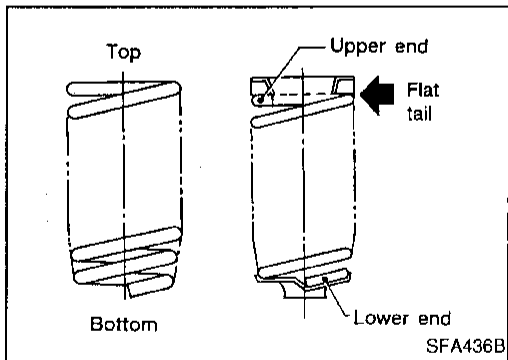
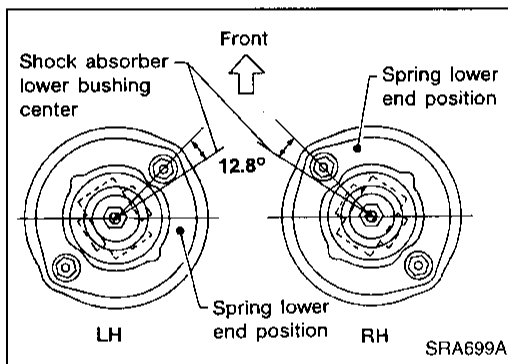
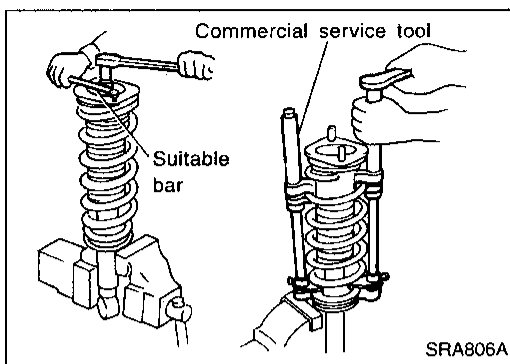

Coil spring

Check for cracks, deformation or other damage. Replace if necessary.

ASSEMBLY

- Locate upper spring seat as shown.

- When installing coil spring, be careful not to reverse top and bottom direction. (Top end is flat.)
- When installing coil spring on strut, it must be positioned as shown in figure at left.

REAR SUSPENSION

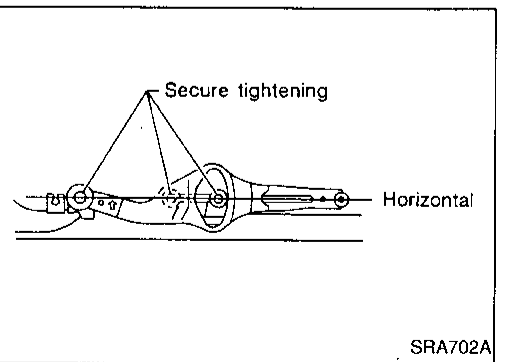
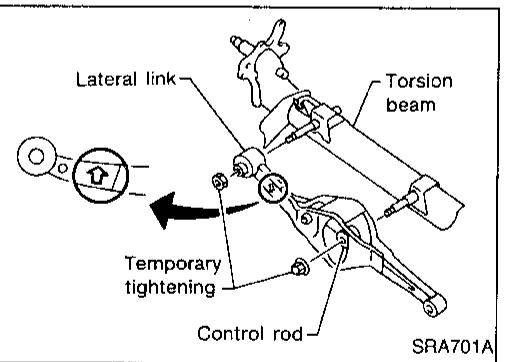
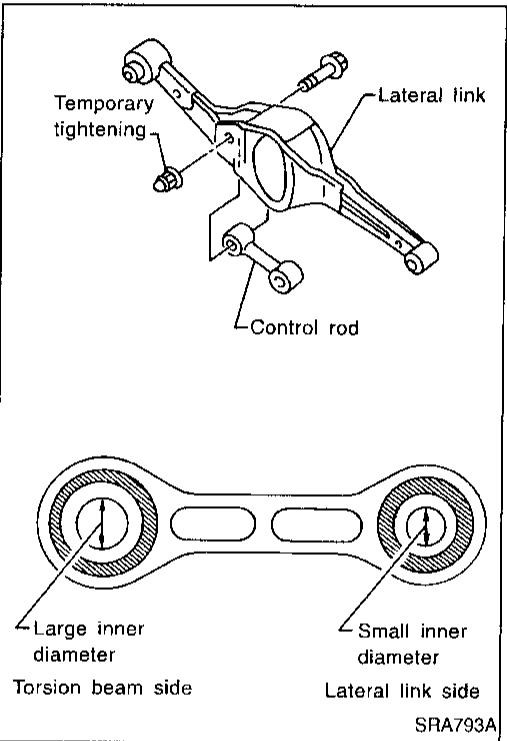
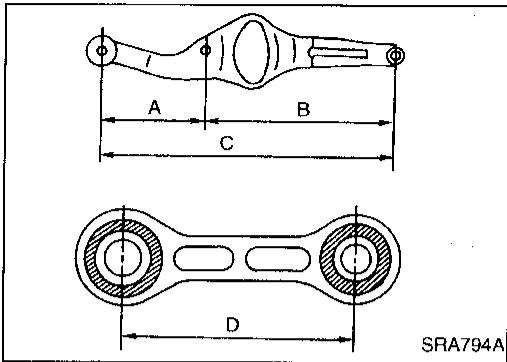

Torsion Beam, Lateral Link and Control Rod

DISASSEMBLY

- Remove torsion beam assembly. Refer to Removal and Installation in REAR SUSPENSION (RA-11).
- Remove lateral link and control rod from torsion beam.

INSPECTION

- Check for cracks, distortion or other damage. Replace if necessary.

Standard length:

- A 207 - 208 mm (8.15 - 8.19 in)
- B 394 - 395 mm (15.51 - 15.55 in)
- C 601 - 603 mm (23.66 - 23.74 in)
- D 106 - 108 mm (4.17 - 4.25 in)

- Check all rubber parts for wear, cracks or deformation. Replace if necessary.

ASSEMBLY

1. Temporarily assemble lateral link and control rod.
- When installing the control rod, connect the bush with the smaller inner diameter to the lateral link.

2. Temporarily install lateral link and control rod on torsion beam.
- When installing, place lateral link with the arrow topside.

3. Place lateral link and control rod horizontally against torsion beam, and tighten to the specified torque.
4. Install torsion beam assembly. Refer to Removal and Installation in REAR SUSPENSION (RA-11).

GI

MA

EM

LC

EC

FE

CL

MT

AT

FA

RA

BR

ST

RS

BT

HA

EL

IDX

SERVICE DATA AND SPECIFICATIONS (SDS)

General Specifications

Suspension type	Multi-link beam suspension
Shock absorber type	Double-acting hydraulic
Stabilizer	Standard equipment

Inspection and Adjustment

WHEEL ALIGNMENT (Unladen*)

Camber	Minimum	-1°45' (-1.75°)
	Nominal	-1°00' (-1.00°)
	Maximum	-0°15' (-0.25°)
Total toe-in	Minimum	-3 (-0.12)
	Nominal	1 (0.04)
	Maximum	5 (0.20)
Angle (left plus right)	Minimum	-16' (-0.27°)
	Nominal	5'30" (0.09°)
	Maximum	26' (0.43°)

WHEEL BEARING

Wheel bearing axial end play mm (in)	0.05 (0.0020)
Wheel bearing lock nut tightening torque N-m (kg-m, ft-lb)	186 - 255 (19 - 26, 137 - 188)

*: Fuel, radiator coolant and engine oil full. Spare tire, jack, hand tools and mats in designated positions.