

ENGINE LUBRICATION & COOLING SYSTEMS

SECTION LC

GI

MA

EM

LC

EC

FE

AT

AX

SU

BR

ST

RS

BT

HA

SC

EL

IDX

CONTENTS

ENGINE LUBRICATION SYSTEM2	CHECKING RADIATOR CAP10
Precautions2	CHECKING COOLING SYSTEM FOR LEAKS 11
SUPPLEMENTAL RESTRAINT SYSTEM (SRS)	Water Pump 11
“AIR BAG” AND “SEAT BELT PRE-TENSIONER”2	REMOVAL AND INSTALLATION 11
LIQUID GASKET APPLICATION PROCEDURE2	REMOVAL 11
Preparation3	INSPECTION 13
SPECIAL SERVICE TOOLS3	INSTALLATION 13
Lubrication Circuit4	Thermostat 15
Oil Pressure Check5	REMOVAL AND INSTALLATION 15
Oil Pump5	INSPECTION 15
REMOVAL AND INSTALLATION5	Water Control Valve 16
DISASSEMBLY AND ASSEMBLY6	REMOVAL AND INSTALLATION 16
OIL PUMP INSPECTION6	INSPECTION 16
REGULATOR VALVE INSPECTION7	Radiator 17
OIL FILTER7	REMOVAL AND INSTALLATION 17
Service Data and Specifications (SDS)7	Cooling Fan Control System 18
OIL PRESSURE7	Refilling Engine Coolant 18
REGULATOR VALVE7	Radiator (Aluminum type) 18
OIL PUMP7	PREPARATION 18
ENGINE COOLING SYSTEM8	DISASSEMBLY 19
Precautions8	ASSEMBLY 19
LIQUID GASKET APPLICATION PROCEDURE8	INSPECTION 21
Preparation8	Overheating Cause Analysis 22
SPECIAL SERVICE TOOLS8	Service Data and Specifications (SDS) 23
Cooling Circuit9	THERMOSTAT 23
System Check10	WATER CONTROL VALVE 23
CHECKING COOLING SYSTEM HOSES10	RADIATOR 23
CHECKING RADIATOR10	

ENGINE LUBRICATION SYSTEM

Precautions

Precautions

SUPPLEMENTAL RESTRAINT SYSTEM (SRS) “AIR BAG” AND “SEAT BELT PRE-TENSIONER”

NHLC0036

The Supplemental Restraint System such as “AIR BAG” and “SEAT BELT PRE-TENSIONER” used along with a seat belt, helps to reduce the risk or severity of injury to the driver and front passenger for certain types of collision. The SRS system composition which is available to NISSAN MODEL A33 is as follows (The composition varies according to optional equipment.):

- For a frontal collision
The Supplemental Restraint System consists of driver air bag module (located in the center of the steering wheel), front passenger air bag module (located on the instrument panel on passenger side), seat belt pre-tensioners, a diagnosis sensor unit, crash zone sensor, warning lamp, wiring harness and spiral cable.
- For a side collision
The Supplemental Restraint System consists of front side air bag module (located in the outer side of front seat), satellite sensor, diagnosis sensor unit (one of components of air bags for a frontal collision), wiring harness, warning lamp (one of components of air bags for a frontal collision).

Information necessary to service the system safely is included in the **RS section** of this Service Manual.

WARNING:

- To avoid rendering the SRS inoperative, which could increase the risk of personal injury or death in the event of a collision which would result in air bag inflation, all maintenance should be performed by an authorized NISSAN dealer.
- Improper maintenance, including incorrect removal and installation of the SRS, can lead to personal injury caused by unintentional activation of the system. For removal of Spiral Cable and Air Bag Module, see the RS section.
- Do not use electrical test equipment on any circuit related to the SRS unless instructed to in this Service Manual. SRS wiring harnesses can be identified with yellow harness connector (and with yellow harness protector or yellow insulation tape before the harness connectors).

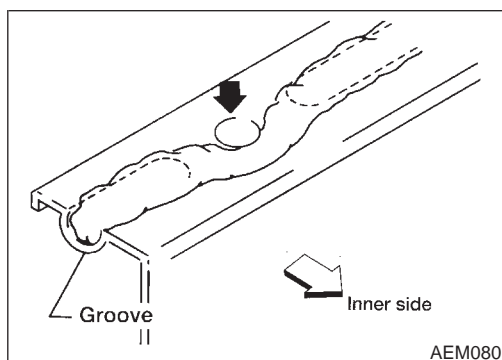
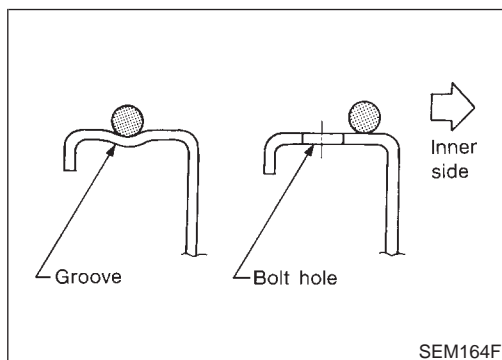

LIQUID GASKET APPLICATION PROCEDURE

NHLC0001

1. Use a scraper to remove all traces of old liquid gasket from mating surfaces and grooves. Also, completely clean any oil from these areas.
2. Apply a continuous bead of liquid gasket to mating surfaces. **(Use Genuine RTV silicone sealant Part No. 999MP-A7007 or equivalent.)**
 - For oil pan, be sure liquid gasket diameter is 3.5 to 4.5 mm (0.138 to 0.177 in) or 4.5 to 5.5 mm (0.177 to 0.217 in) as specified.
3. Apply liquid gasket around the inner side of bolt holes (unless otherwise specified).
4. Assembly should be done within 5 minutes after coating.
5. Wait at least 30 minutes before refilling engine oil and engine coolant.

ENGINE LUBRICATION SYSTEM

Preparation

Preparation SPECIAL SERVICE TOOLS

NHLC0002

The actual shapes of Kent-Moore tools may differ from those of special service tools illustrated here.

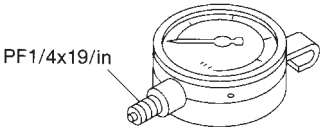
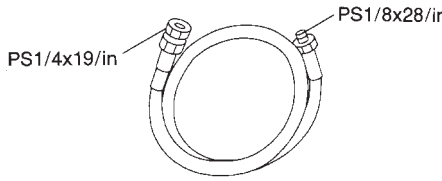
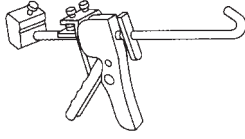
Tool number (Kent-Moore No.) Tool name	Description		GI
ST25051001 (J25695-1) Oil pressure gauge	 <p>PF1/4x19/in</p> <p>NT558</p>	Measuring oil pressure Maximum measuring range: 2,452 kPa (25 kg/cm², 356 psi)	MA EM LC
ST25052000 (J25695-2) Hose	 <p>PS1/4x19/in</p> <p>PS1/8x28/in</p> <p>NT559</p>	Adapting oil pressure gauge to upper oil pan	EC FE AT
WS39930000 (—) Tube pressure	 <p>NT052</p>	Pressing the tube of liquid gasket	AX SU

BR

ST

RS

BT

HA

SC

EL

IDX

ENGINE LUBRICATION SYSTEM

Lubrication Circuit

Lubrication Circuit

NHLC0003

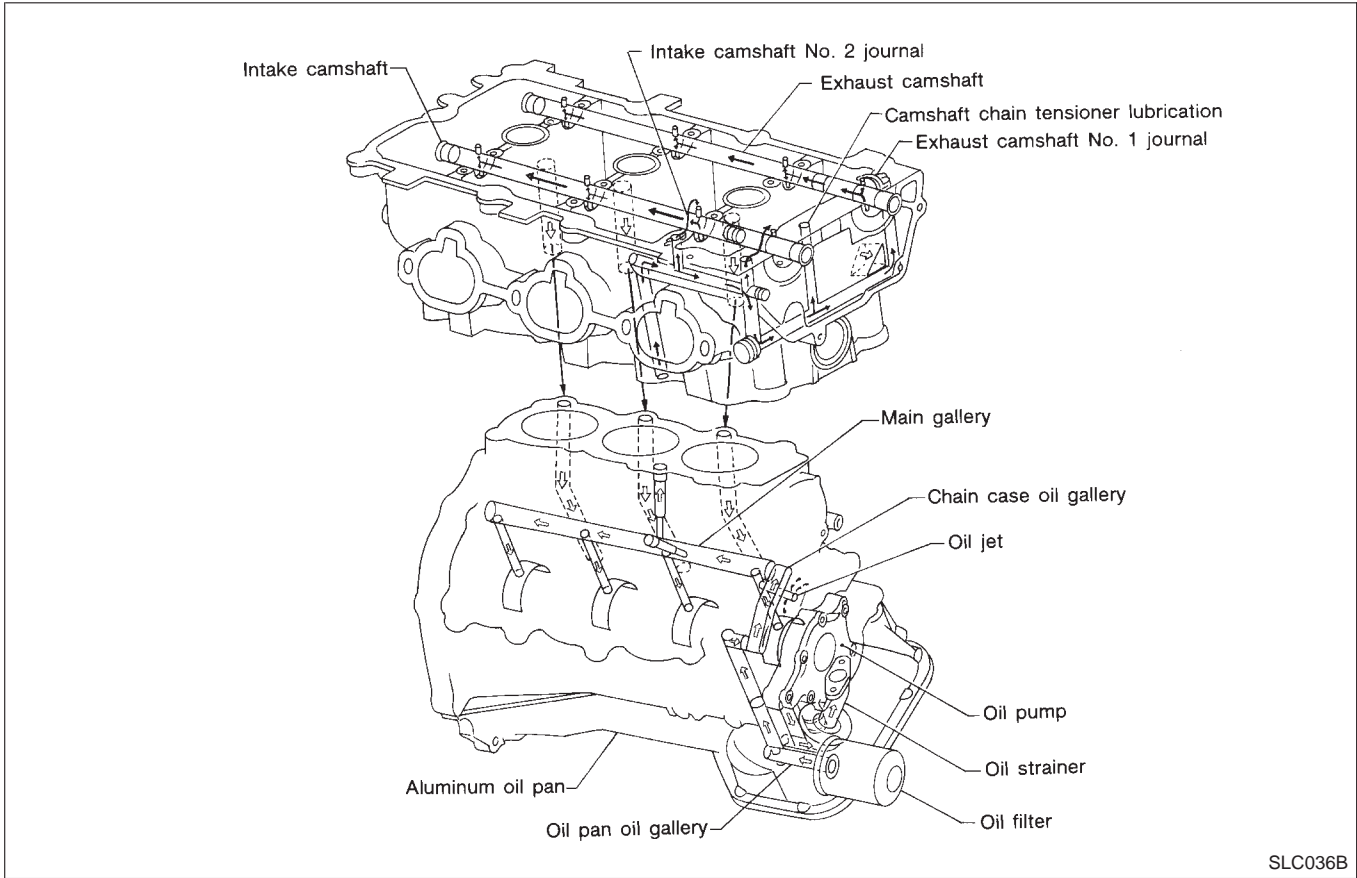

SLC036B

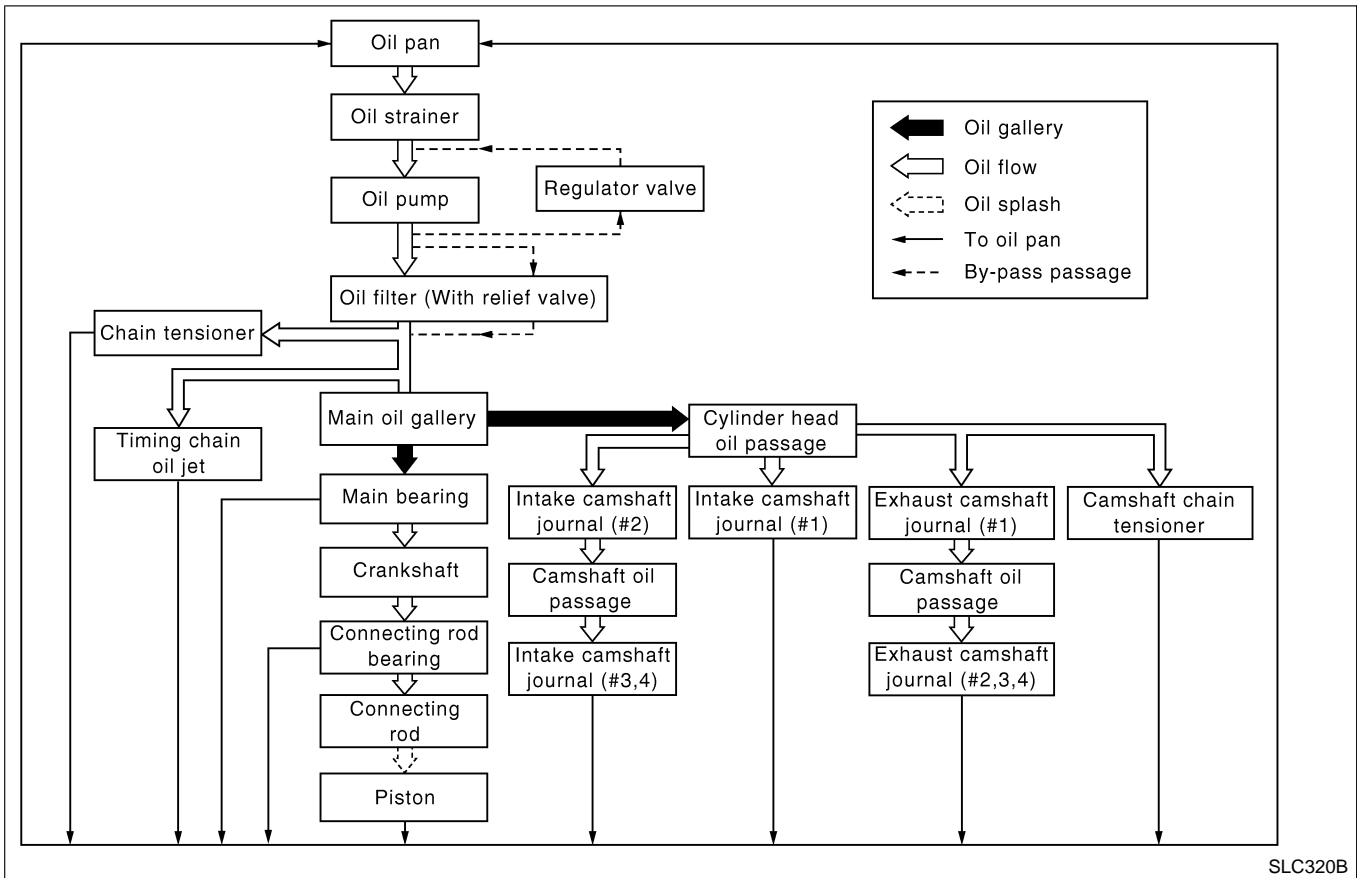

SLC320B

NHLC0004

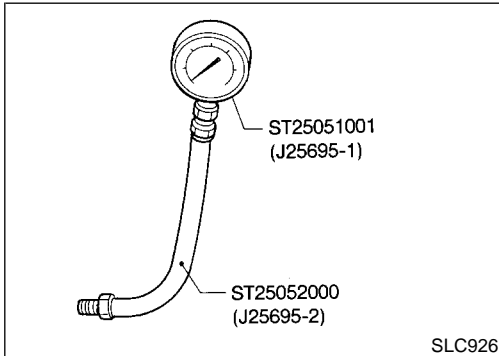
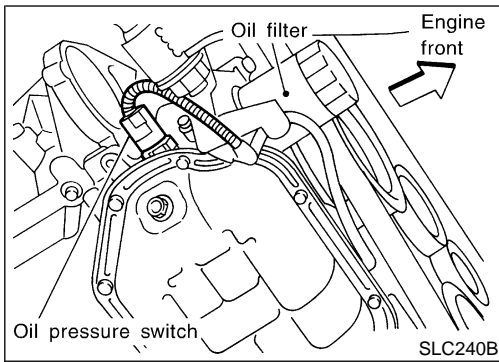

Oil Pressure Check

WARNING:

- Be careful not to burn yourself, as the engine and oil may be hot.
 - Oil pressure check should be done in “Parking position”.
1. Check oil level.
 2. Remove oil pressure switch.
 3. Install pressure gauge.
 4. Start engine and warm it up to normal operating temperature.
 5. Check oil pressure with engine running under no-load.

Engine speed rpm	Approximate discharge pressure kPa (kg/cm ² , psi)
Idle speed 2,000	More than 98 (1.0, 14) 390 (3.98, 56.6)

If difference is extreme, check oil passage and oil pump for oil leaks.

6. Install oil pressure switch with sealant.

Oil Pump

REMOVAL AND INSTALLATION

CAUTION:

When removing the oil pans, oil pump assembly and timing chain from engine, first remove the camshaft position sensor (PHASE) and the crankshaft position sensor (REF)/(POS) from the assembly.

Be careful not to damage sensor edge.

1. Drain engine oil.
2. Remove drive belts.
3. Remove camshaft position sensor (PHASE), and crankshaft position sensor (REF)/(POS).
4. Remove engine lower covers.
5. Remove crankshaft pulley.
6. Remove front exhaust tube and its support.
7. Support engine at right and left side engine slingers with a suitable hoist.
8. Remove engine right side mounting insulator and bracket bolts and nuts.
9. Remove center member assembly.
10. Remove air compressor assembly and bracket.
11. Remove oil pans. Refer to EM-13, “Removal”.
12. Remove water pump cover.
13. Remove front cover assembly.
14. Remove timing chain. Refer to EM-22, “Removal”.
15. Remove oil pump assembly.
16. Reinstall any parts removed in reverse order of removal.

GI

MA

EM

LC

EC

FE

AT

AX

SU

BR

ST

RS

BT

HA

SC

EL

IDX

ENGINE LUBRICATION SYSTEM

Oil Pump (Cont'd)

DISASSEMBLY AND ASSEMBLY

NHLC0006

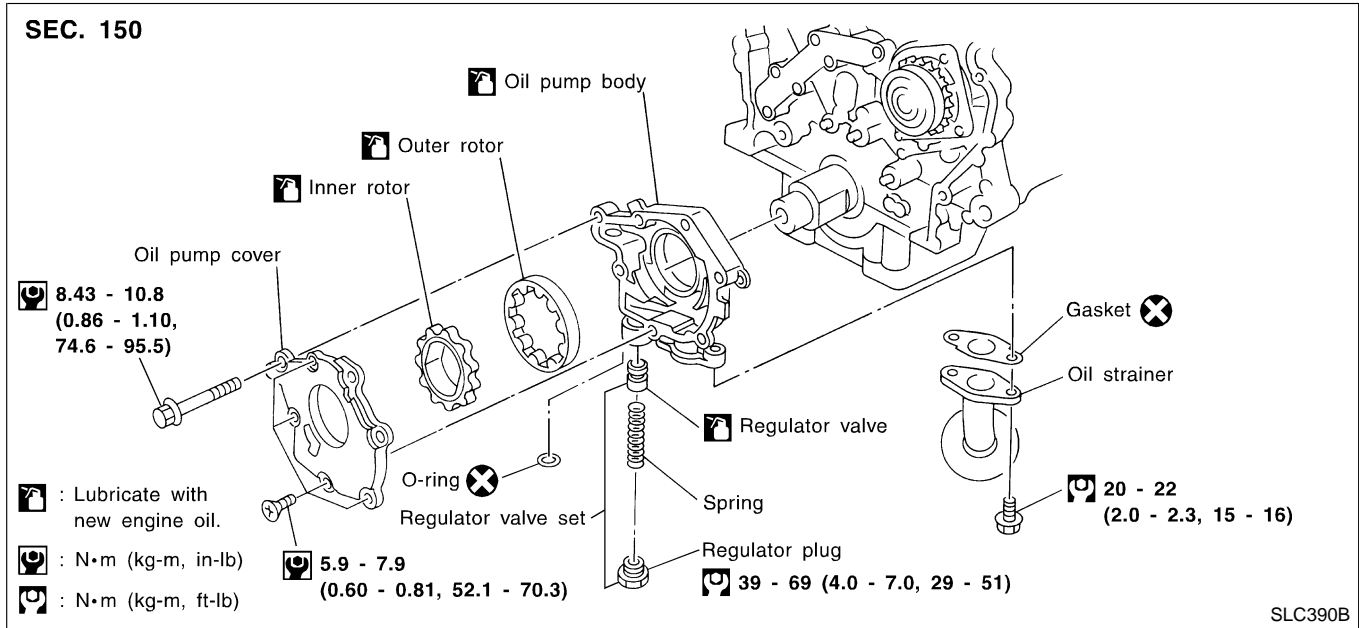

- When installing oil pump, apply engine oil to rotors.

OIL PUMP INSPECTION

NHLC0007

Using a feeler gauge, straightedge and micrometers, check the following clearances:

Unit: mm (in)

Body to outer rotor radial clearance 1	0.114 - 0.200 (0.0045 - 0.0079)
Inner rotor to outer rotor tip clearance 2	Below 0.18 (0.0071)
Body to inner rotor axial clearance 3	0.030 - 0.070 (0.0012 - 0.0028)
Body to outer rotor axial clearance 4	0.050 - 0.110 (0.0020 - 0.0043)
Inner rotor to brazed portion of housing clearance 5	0.045 - 0.091 (0.0018 - 0.0036)

- If the tip clearance (2) exceeds the limit, replace rotor set.
- If body to rotor clearances (1, 3, 4, 5) exceed the limit, replace oil pump body assembly.

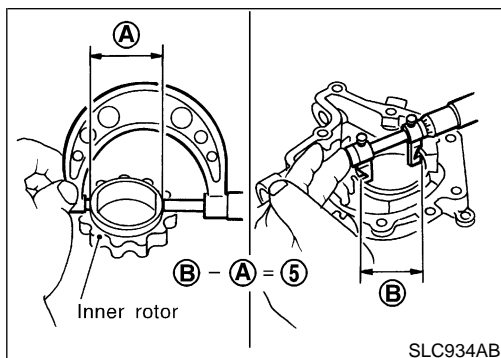
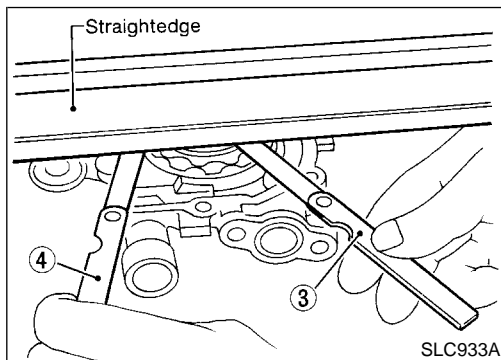
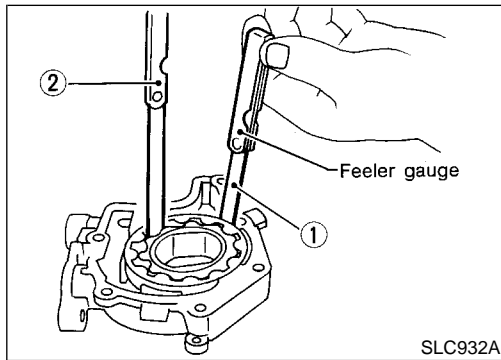

ENGINE LUBRICATION SYSTEM

Oil Pump (Cont'd)

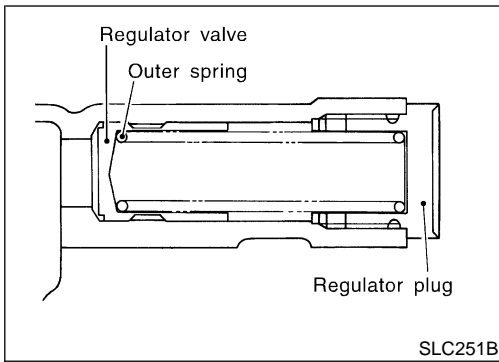

REGULATOR VALVE INSPECTION

NHLC0008

1. Visually inspect components for wear and damage.
2. Check oil pressure regulator valve sliding surface and valve spring.
3. Coat regulator valve with engine oil. Check that it falls smoothly into the valve hole by its own weight.

If damaged, replace regulator valve set or oil pump body.

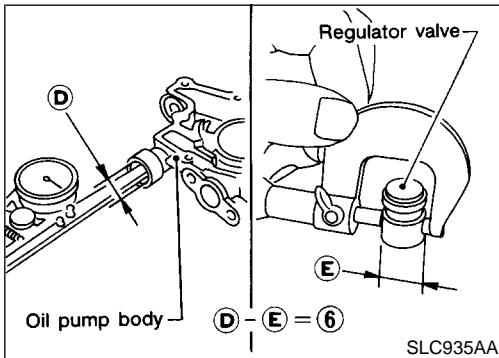

4. Check regulator valve to oil pump body clearance.

Clearance:

6 : 0.040 - 0.097 mm (0.0016 - 0.0038 in)

If it exceeds the limit, replace oil pump body.

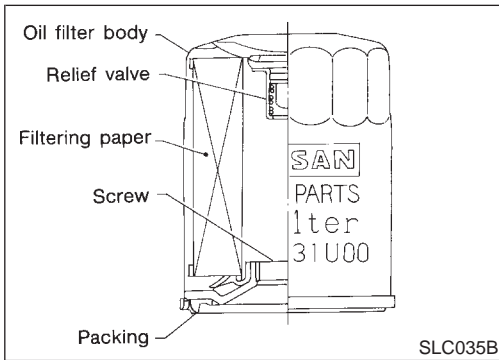

OIL FILTER

NHLC0009

The oil filter is a small, full-flow cartridge type and is provided with a relief valve.

- Use Tool specified in MA-18 for changing oil filter.

Service Data and Specifications (SDS)

OIL PRESSURE

NHLC0010

Engine speed rpm	Approximate discharge pressure kPa (kg/cm ² , psi)
Idle speed 2,000	More than 98 (1.0, 14) 390 (3.98, 56.6)

REGULATOR VALVE

NHLC0011

Unit: mm (in)

Regulator valve to oil pump cover clearance	0.040 - 0.097 (0.0016 - 0.0038)
---	---------------------------------

OIL PUMP

NHLC0012

Unit: mm (in)

Body to outer rotor radial clearance	0.114 - 0.200 (0.0045 - 0.0079)
Inner rotor to outer rotor tip clearance	Below 0.18 (0.0071)
Body to inner rotor axial clearance	0.030 - 0.070 (0.0012 - 0.0028)
Body to outer rotor axial clearance	0.050 - 0.110 (0.0020 - 0.0043)
Inner rotor to brazed portion of housing clearance	0.045 - 0.091 (0.0018 - 0.0036)

GI

MA

EM

LC

EC

FE

AT

AX

SU

BR

ST

RS

BT

HA

SC

EL

IDX

ENGINE COOLING SYSTEM

Precautions

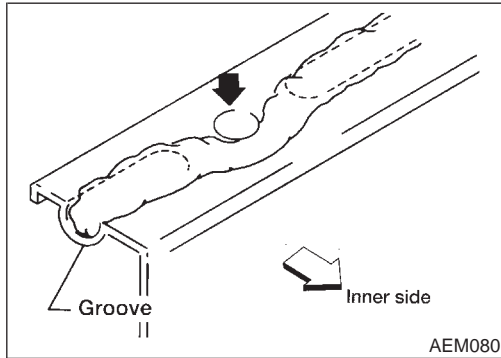
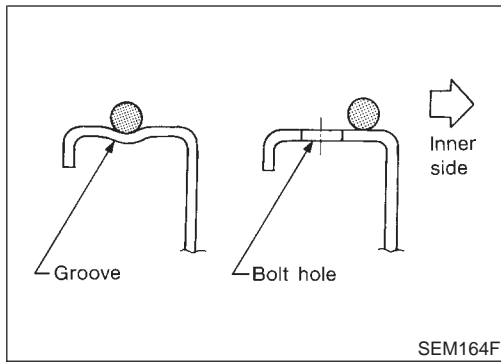

Precautions

LIQUID GASKET APPLICATION PROCEDURE

NHLC0013



1. Use a scraper to remove all traces of old liquid gasket from mating surfaces and grooves. Also, completely clean any oil from these areas.
2. Apply a continuous bead of liquid gasket to mating surfaces. **(Use Genuine RTV silicone sealant Part No. 999MP-A7007 or equivalent.)**
 - For areas except oil pan, be sure liquid gasket diameter is 2.3 to 3.3 mm (0.091 to 0.130 in).
3. Apply liquid gasket around the inner side of bolt holes (unless otherwise specified).
4. Assembly should be done within 5 minutes after coating.
5. Wait at least 30 minutes before refilling engine oil and engine coolant.

Preparation

SPECIAL SERVICE TOOLS

NHLC0014

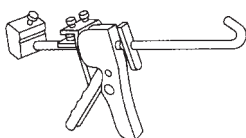
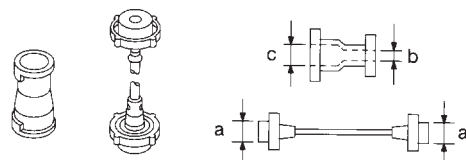
The actual shapes of Kent-Moore tools may differ from those of special service tools illustrated here.

Tool number (Kent-Moore No.) Tool name	Description
WS39930000 (—) Tube pressure	 Pressing the tube of liquid gasket NT052
EG17650301 (J33984-A) Radiator cap tester adapter	 Adapting radiator cap tester to radiator filler neck a: 28 (1.10) dia. b: 31.4 (1.236) dia. c: 41.3 (1.626) dia. Unit: mm (in) NT564
KV99103510 (—) Radiator plate pliers A	 Installing radiator upper and lower tanks NT224
KV99103520 (—) Radiator plate pliers B	 Removing radiator upper and lower tanks NT225

ENGINE COOLING SYSTEM

Cooling Circuit

Cooling Circuit

NHLC0015

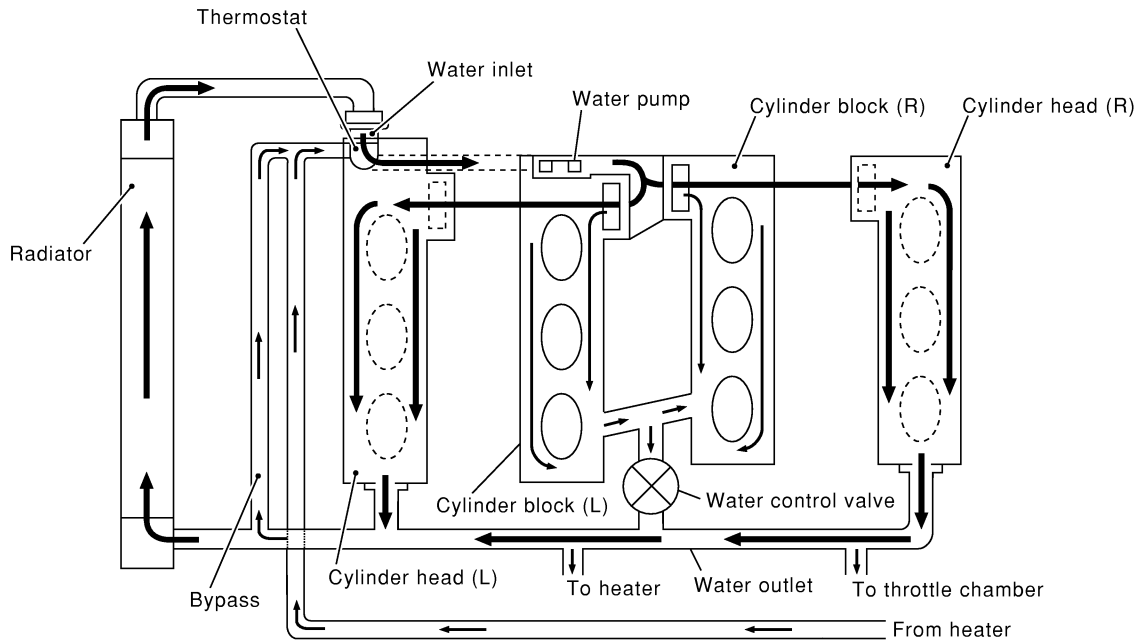

SLC391B

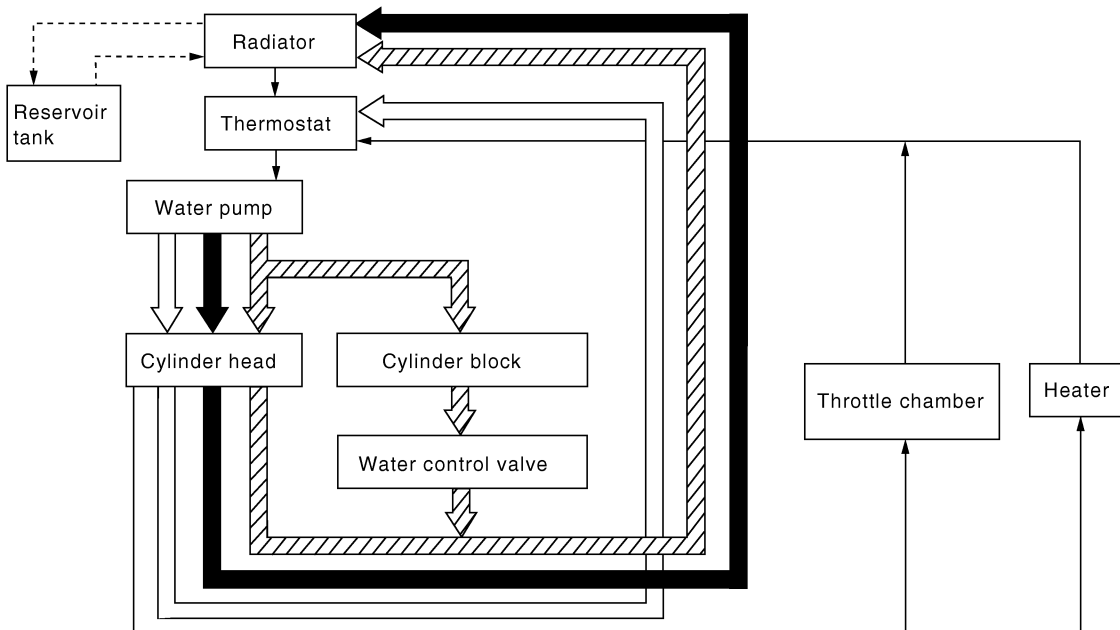

	Thermostat	Water control valve
←	Closed	Closed
←	Open	Closed
←	Open	Open

SLC392B

GI
MA
EM
LC
EC
FE
AT
AX
SU
BR
ST
RS
BT
HA
SC
EL
IDX

System Check

NHLC0016

WARNING:

Never remove the radiator cap when the engine is hot; serious burns could be caused by high pressure fluid escaping from the radiator.

Wrap a thick cloth around the cap and carefully remove it by turning it a quarter turn to allow built-up pressure to escape and then turn the cap all the way off.

CHECKING COOLING SYSTEM HOSES

NHLC0016S01

Check hoses for improper attachment, leaks, cracks, damage, loose connections, chafing and deterioration.

CHECKING RADIATOR

NHLC0016S02

Check radiator for mud or clogging. If necessary, clean radiator as follows.

- Be careful not to bend or damage the radiator fins.
 - When radiator is cleaned without removal, remove all surrounding parts such as cooling fan, radiator shroud and horns. Then tape the harness and connectors to prevent water from entering.
1. Apply water by hose to the back side of the radiator core vertically downward.
 2. Apply water again to all radiator core surfaces once per minute.
 3. Stop washing if any stains no longer flow out from the radiator.
 4. Blow air into the back side of radiator core vertically downward.
 - Use compressed air lower than 490 kPa (5 kg/cm², 71 psi) and keep distance more than 30 cm (11.8 in).
 5. Blow air again into all the radiator core surfaces once per minute until no water sprays out.

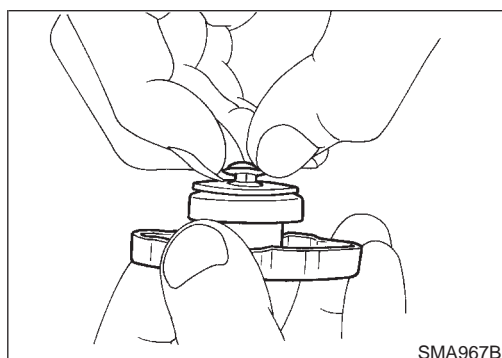
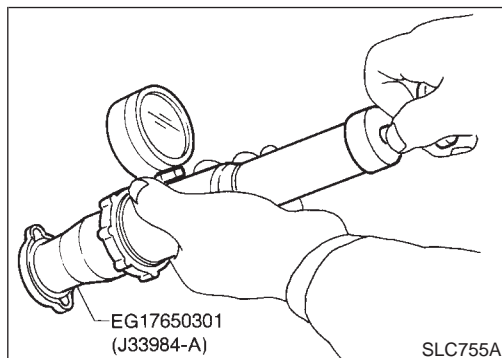

CHECKING RADIATOR CAP

NHLC0016S03

To check radiator cap, apply pressure to cap with a tester.

Radiator cap relief pressure:

Standard

78 - 98 kPa

(0.8 - 1.0 kg/cm², 11 - 14 psi)

Limit

59 - 98 kPa

(0.6 - 1.0 kg/cm², 9 - 14 psi)

Pull the negative pressure valve to open it. Check that it closes completely when released.

ENGINE COOLING SYSTEM

System Check (Cont'd)

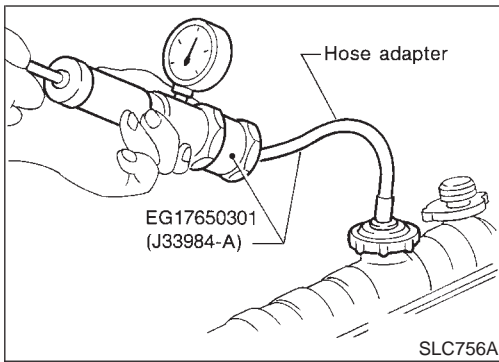

CHECKING COOLING SYSTEM FOR LEAKS

NHLC0016S04

To check for leakage, apply pressure to the cooling system with a tester.

Testing pressure:
157 kPa (1.6 kg/cm², 23 psi)

CAUTION:
Higher than the specified pressure may cause radiator damage.

GI

MA

EM

LC

Water Pump

REMOVAL AND INSTALLATION

NHLC0017

- CAUTION:**
- When removing water pump assembly, be careful not to get coolant on drive belt.
 - Water pump cannot be disassembled and should be replaced as a unit.
 - After installing water pump, connect hose and clamp securely, then check for leaks using radiator cap tester.

EC

FE

AT

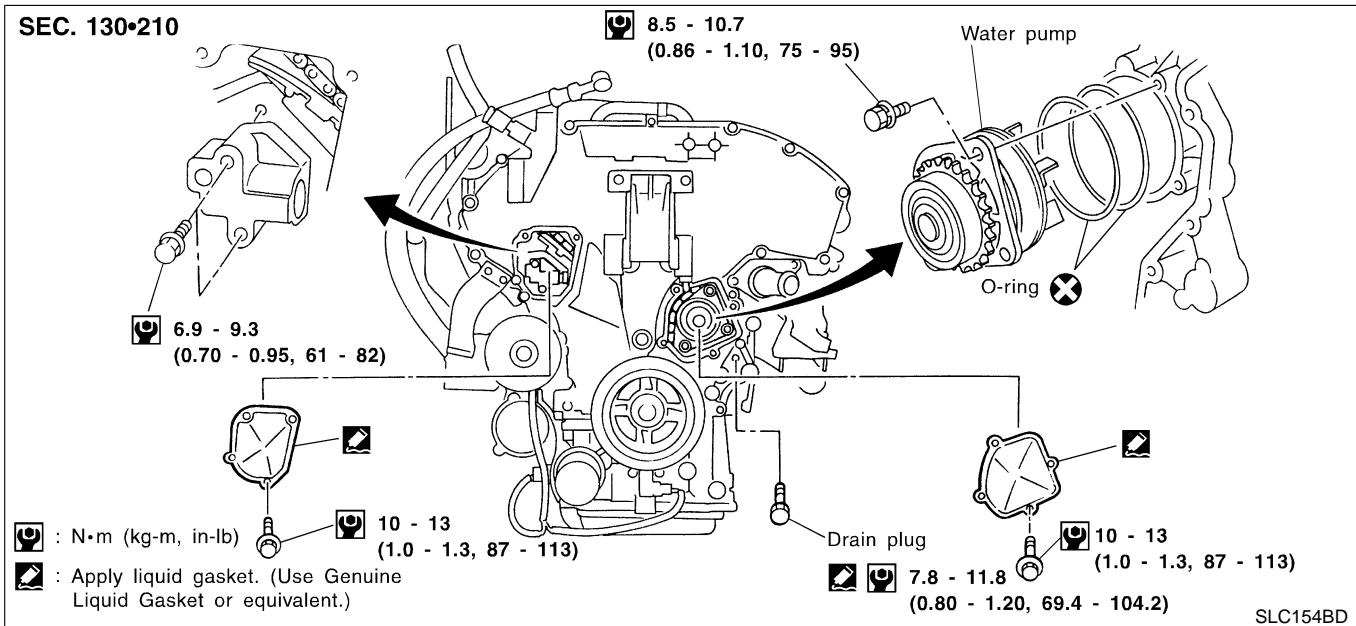

AX

SU

BR

ST

RS

BT

HA

SC

EL

IDX

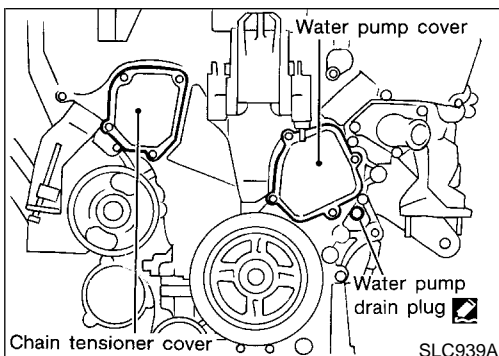

REMOVAL

NHLC0018

- Drain coolant from drain plugs on radiator and right side of cylinder block. Refer to MA-14, "Changing Engine Coolant".
- Remove right side engine mounting, mounting bracket and nuts.
- Remove drive belts and idler pulley bracket.
- Remove water pump drain plug.
- Remove chain tensioner cover and water pump cover.

ENGINE COOLING SYSTEM

Water Pump (Cont'd)

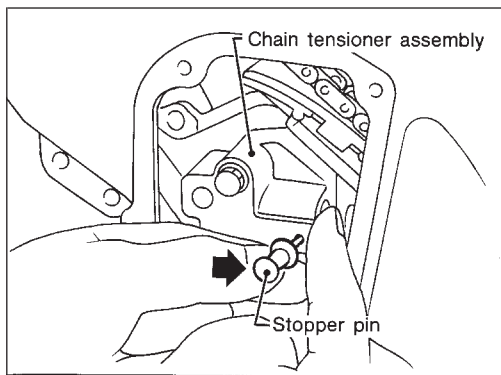

6. Pushing timing chain tensioner sleeve, apply a stopper pin so it does not return. Then remove the chain tensioner assembly.

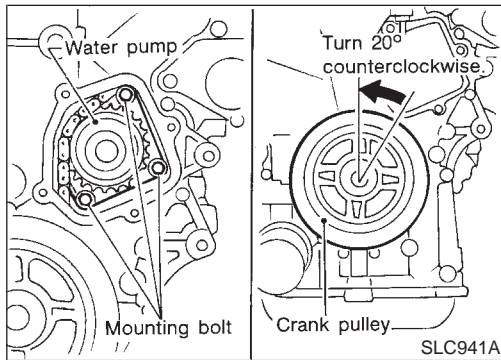
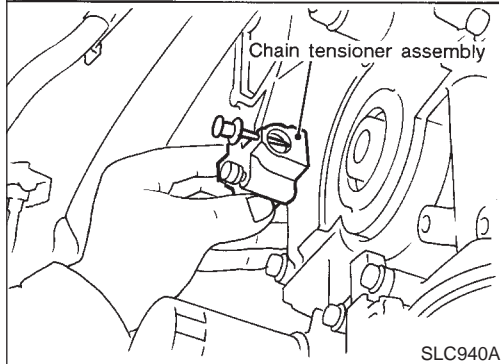

7. Remove the 3 water pump fixing bolts. Secure a gap between water pump gear and timing chain, by turning crankshaft pulley 20° backwards.

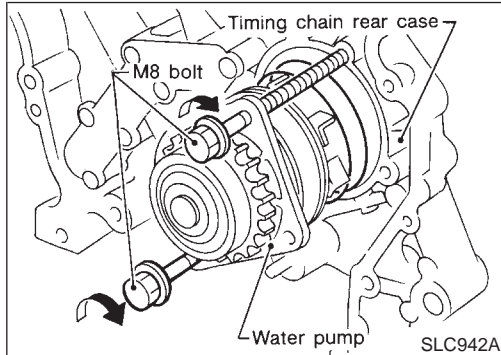

8. Put M8 bolts to two M8-threaded holes out of 3 water pump fixing bolt holes.

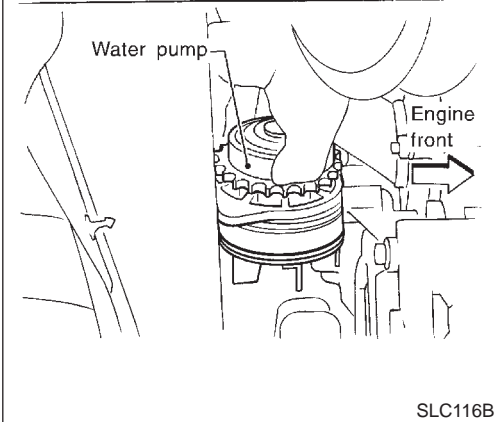
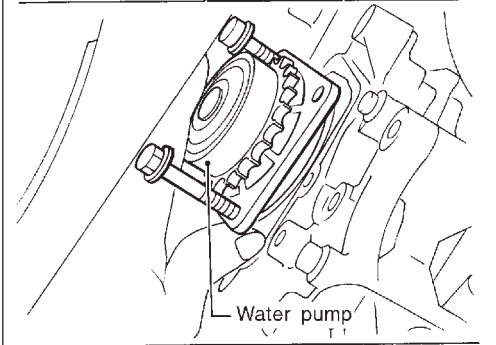
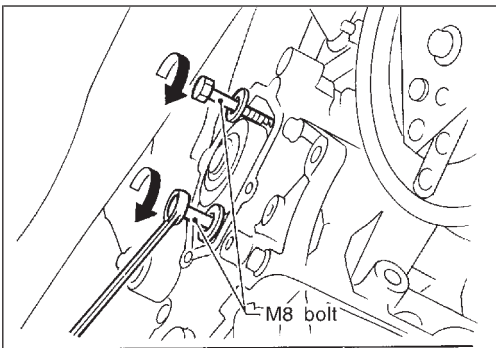

SLC116B

9. Tighten M8 bolts by turning half turn alternately until they reach timing chain rear case.
 - In order to prevent damages to water pump or timing chain rear case, do not tighten one bolt continuously. Always turn each bolt half turn each time.
10. Lift up water pump and remove it.
 - When lifting up water pump, do not allow water pump gear to hit timing chain.

GI

MA

EM

LC

EC

FE

AT

AX

SU

BR

ST

RS

NHLC0019

INSPECTION

1. Check for badly rusted or corroded body assembly.
2. Check for rough operation due to excessive end play.

BT

HA

SC

EL

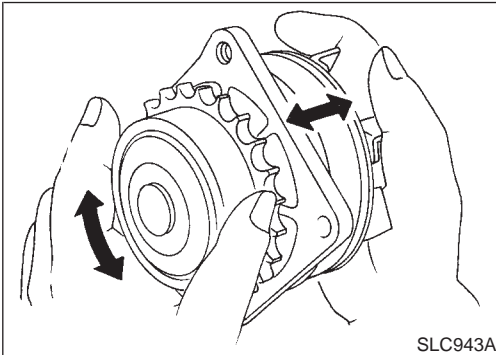

SLC943A

INSTALLATION

1. Apply engine oil and coolant to O-rings as shown in the figure.

NHLC0020

IDX

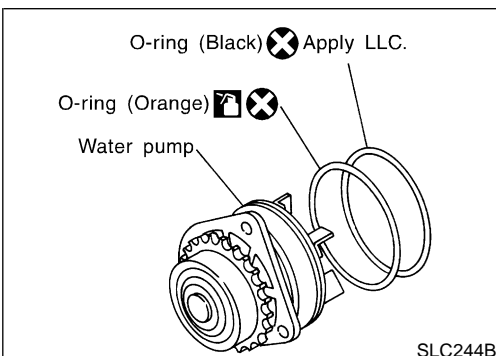

SLC244B

ENGINE COOLING SYSTEM

Water Pump (Cont'd)

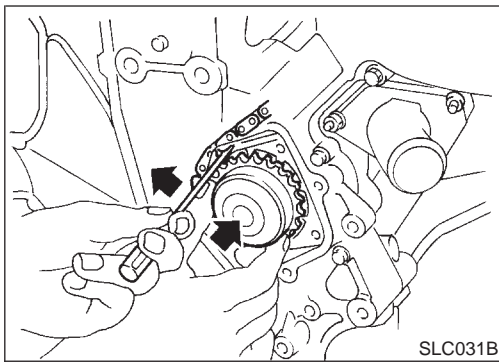

2. Install water pump.
 - Do not allow cylinder block to nip O-rings when installing water pump.

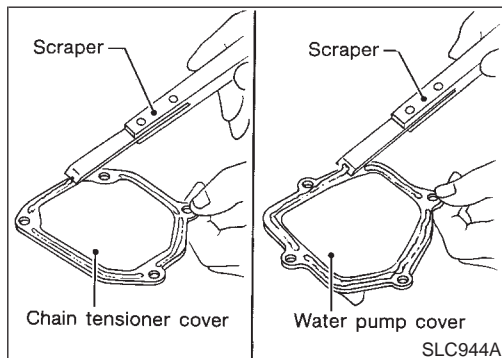

3. Before installing, remove all traces of liquid gasket from mating surface of water pump cover and chain tensioner cover using a scraper.
Also remove traces of liquid gasket from mating surface of front cover.

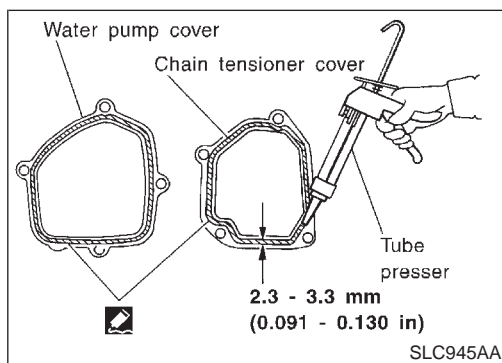

4. Apply a continuous bead of liquid gasket to mating surface of chain tensioner cover and water pump cover.

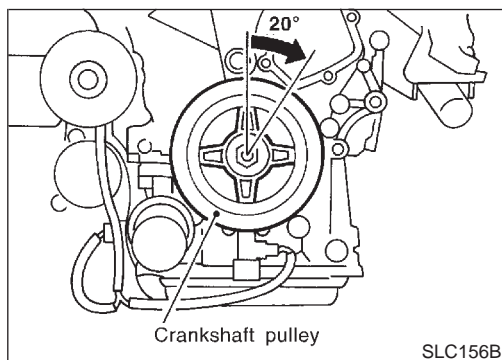

5. Return the crankshaft pulley to its original position by turning it 20° forward.

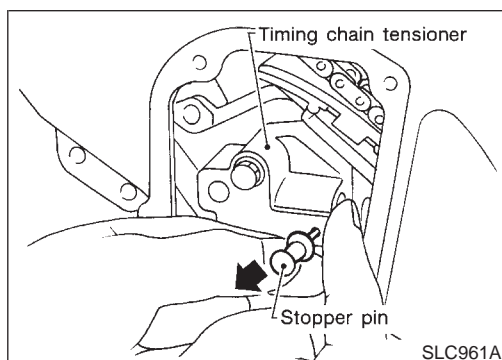

6. Install timing chain tensioner, then remove the stopper pin.
 - When installing the timing chain tensioner, engine oil should be applied to the oil hole and tensioner.
 - After starting engine, let idle for three minutes, then rev engine up to 3,000 rpm under no load to purge air from the high-pressure chamber of the chain tensioners. The engine may produce a rattling noise. This indicates that air still remains in the chamber and is not a matter of concern.
7. Install drain plug on cylinder block.
8. Reinstall any parts removed in reverse order of removal.

Thermostat REMOVAL AND INSTALLATION

NHLC0021

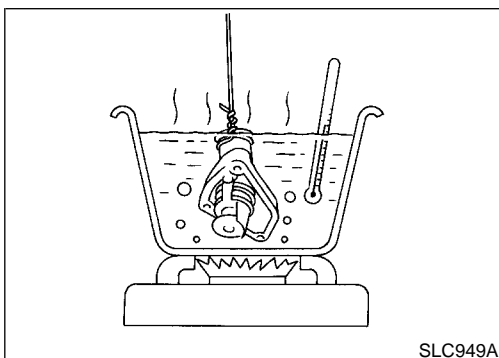
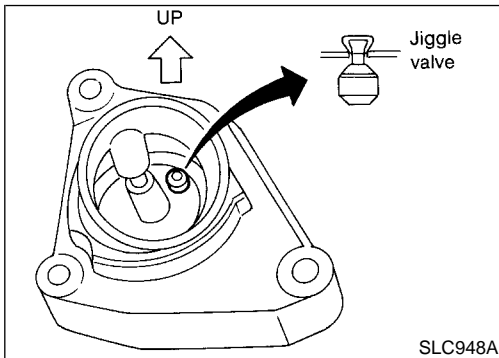
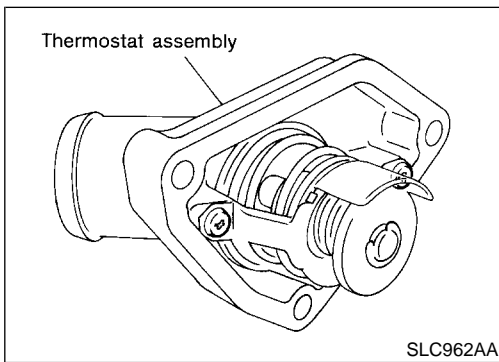
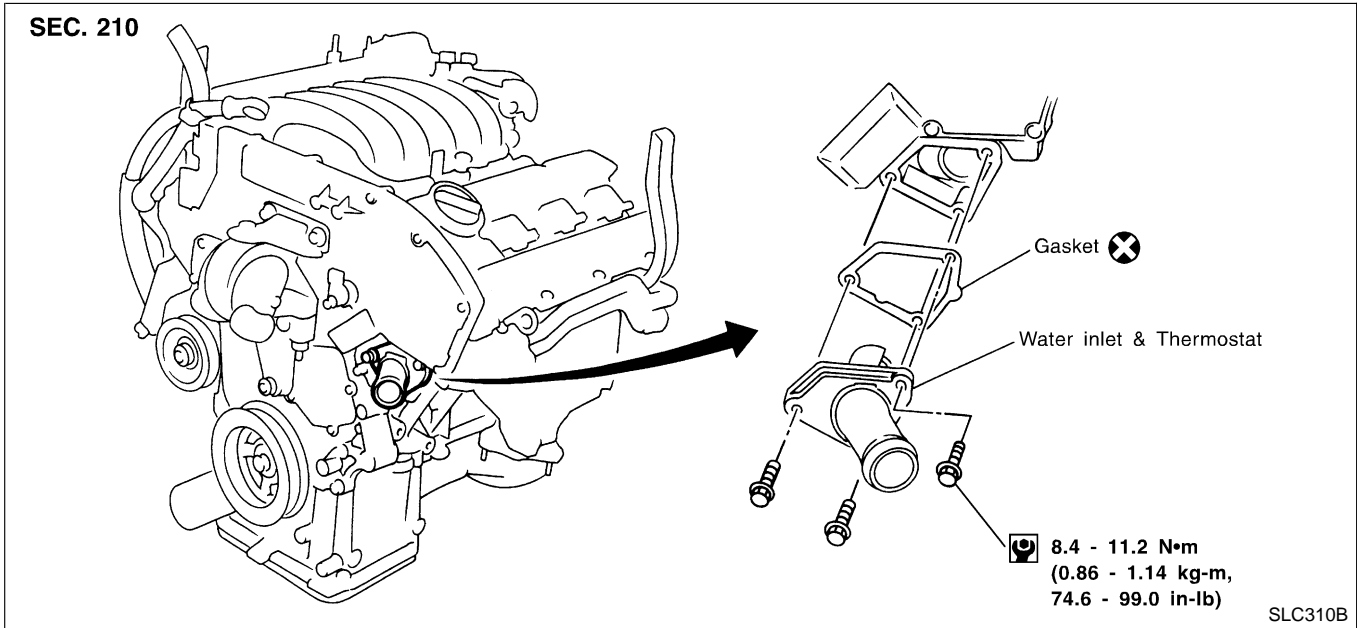

1. Drain coolant from drain plugs on radiator and both sides of cylinder block.
2. Remove drive belts and idler pulley bracket.
3. Remove water pump drain plug on pump side of cylinder block.
4. Remove lower radiator hose.
5. Remove water inlet and thermostat assembly.
 - **Do not disassemble water inlet and thermostat. Replace them as a unit, if necessary.**
6. Install thermostat with jiggle valve facing upward.
 - **After installation, run engine for a few minutes, and check for leaks.**
 - **Be careful not to spill coolant over engine compartment. Use a rag to absorb coolant.**

INSPECTION

NHLC0022

1. Check valve seating condition at ordinary room temperatures. It should seat tightly.
2. Check valve opening temperature and maximum valve lift.

	Standard
Valve opening temperature	82°C (180°F)
Valve lift	More than 8.6 mm/95°C (0.339 in/203°F)

ENGINE COOLING SYSTEM

Thermostat (Cont'd)

- Then check if valve closes at 5°C (9°F) below valve opening temperature.

Water Control Valve REMOVAL AND INSTALLATION

NHLC0032

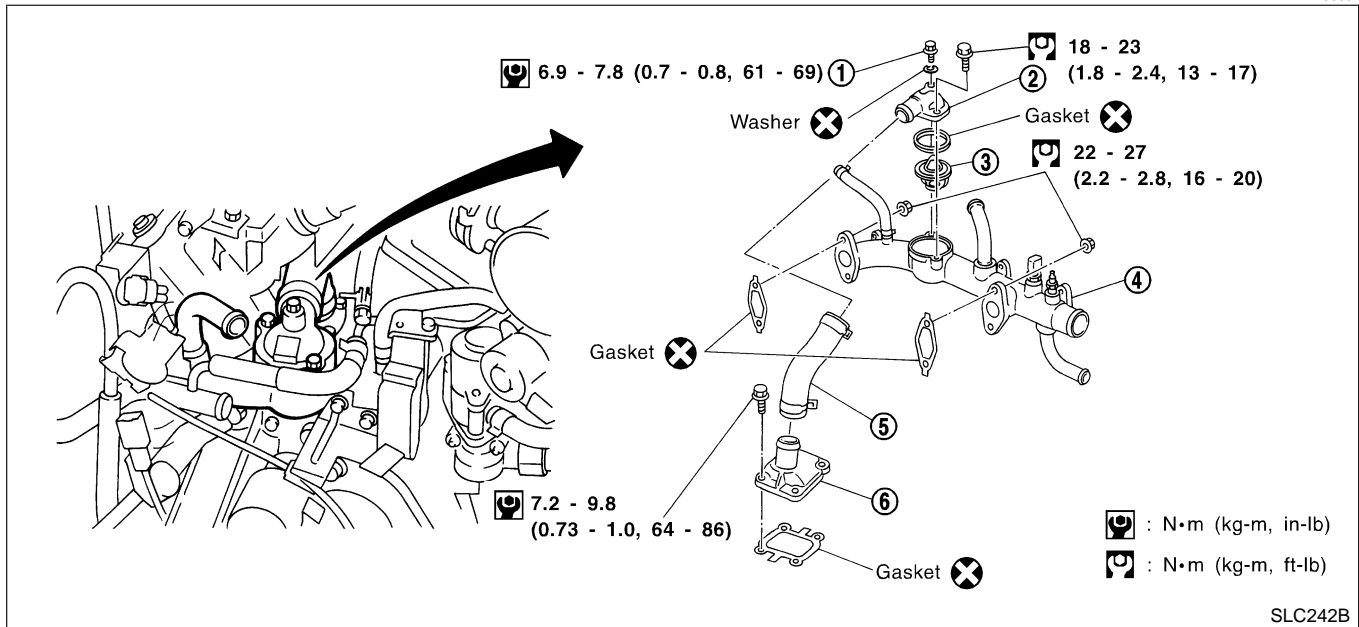

SLC242B

- | | | |
|--------------------|------------------------|--------------------------------|
| 1. Air relief plug | 3. Water control valve | 5. Water hose |
| 2. Water connector | 4. Water outlet | 6. Cylinder block water outlet |

- Drain coolant from drain plugs on radiator and both sides of cylinder block.
- Remove water connector and water control valve.
- Install water control valve and water connector.
 - After installation, run engine for a few minutes, and check for leaks.
 - Be careful not to spill coolant over engine compartment. Use a rag to absorb coolant.

INSPECTION

NHLC0033

- Check valve seating condition at ordinary room temperatures. It should seat tightly.
- Check valve opening temperature and maximum valve lift.

	Standard
Valve opening temperature	95°C (203°F)
Valve lift	More than 8.0 mm/108°C (0.315 in/226°F)

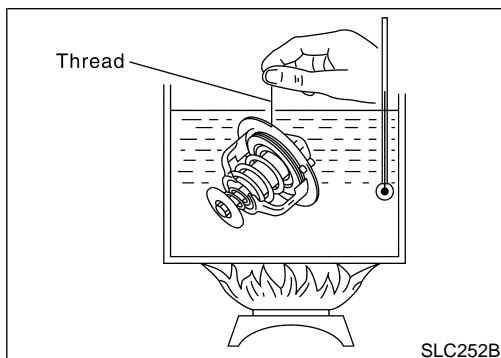

3. Then check if valve closes at 5°C (9°F) below valve opening temperature.

GI

MA

EM

LC

NHLC0023

EC

FE

AT

AX

SU

BR

ST

RS

BT

HA

SC

EL

IDX

Radiator

REMOVAL AND INSTALLATION

1. Remove under cover.
2. Drain coolant from radiator.
3. Disconnect radiator upper and lower hoses.
4. Remove radiator shroud.
5. Remove A/T oil cooler hoses.
6. Disconnect reservoir tank hose.
7. Remove radiator mounting bracket.
8. Remove radiator.
9. After repairing or replacing radiator, install any part removed in reverse order of removal.

When filling radiator with coolant, refer to MA-14, "Changing Engine Coolant".

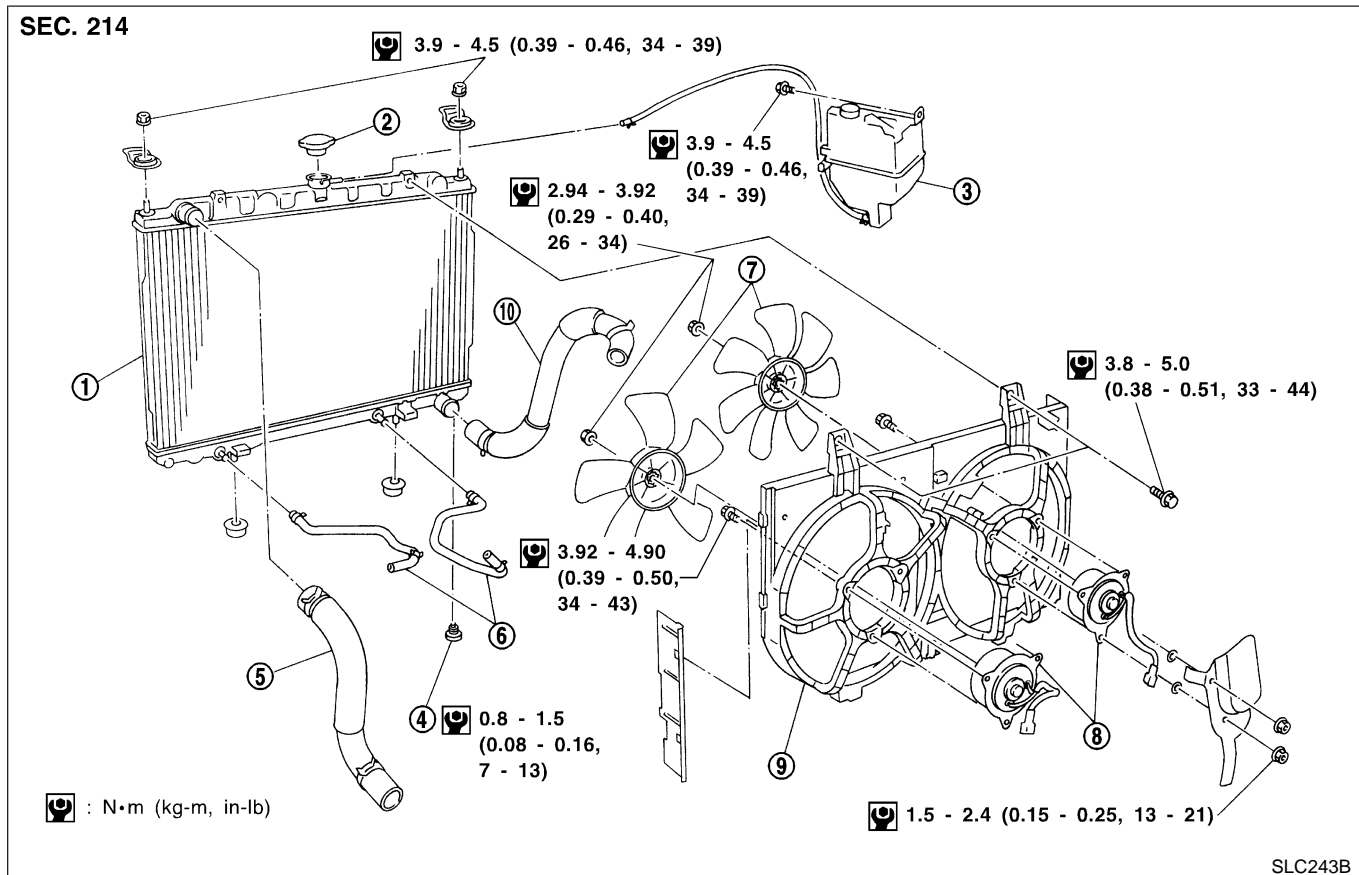

- | | | |
|------------------------|------------------------|-------------------------|
| 1. Radiator | 5. Upper radiator hose | 8. Cooling fan motors |
| 2. Radiator filler cap | 6. Oil cooler hoses | 9. Radiator shroud |
| 3. Reservoir tank | 7. Cooling fans | 10. Lower radiator hose |
| 4. Radiator drain cock | | |

ENGINE COOLING SYSTEM

Cooling Fan Control System

Cooling fans are controlled by ECM. For details, refer to EC-489. NHLC0024

Refilling Engine Coolant

For details on refilling engine coolant, refer to MA-15, "REFILLING ENGINE COOLANT". NHLC0034

Radiator (Aluminum type) PREPARATION

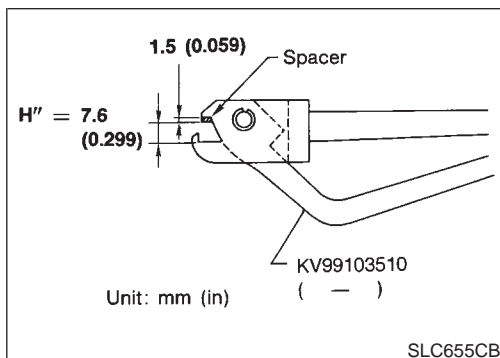
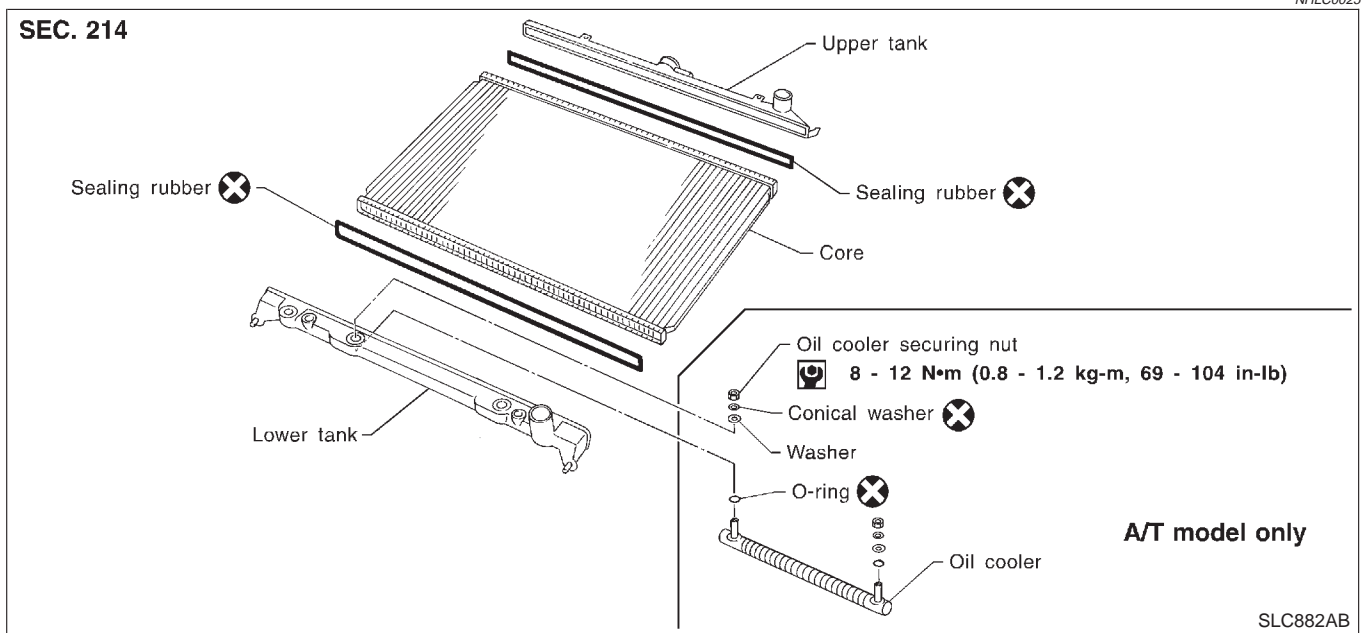

1. Attach the spacer to the tip of the radiator plate pliers A. Spacer specification: 1.5 mm (0.059 in) thick x 18 mm (0.71 in) wide x 8.5 mm (0.335 in) long.
2. Make sure that when radiator plate pliers A are closed dimension H'' is approx. 7.6 mm (0.299 in).
3. Adjust dimension H'' with the spacer, if necessary.

ENGINE COOLING SYSTEM

Radiator (Aluminum type) (Cont'd)

NHLC0026

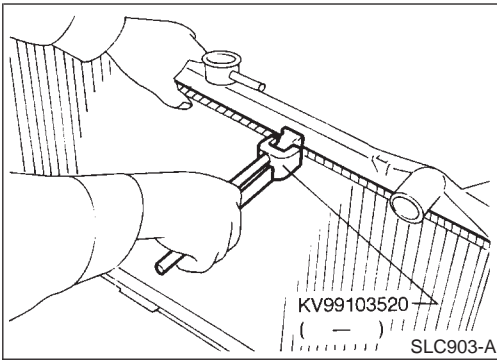

DISASSEMBLY

1. Remove tank with Tool.

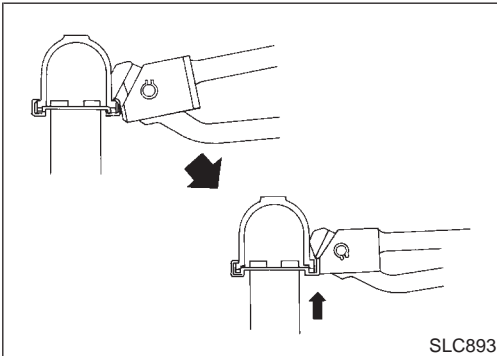

- Grip the crimped edge and bend it upwards so that Tool slips off.

Do not bend excessively.

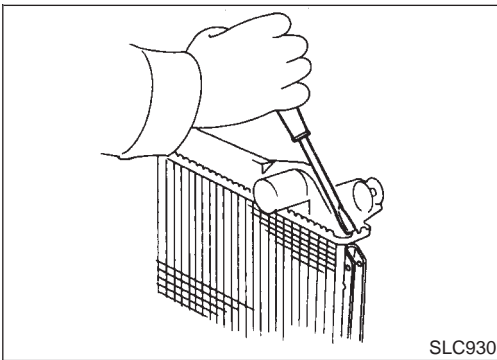

- In areas where Tool cannot be used, use a screwdriver to bend the edge up.

Be careful not to damage tank.

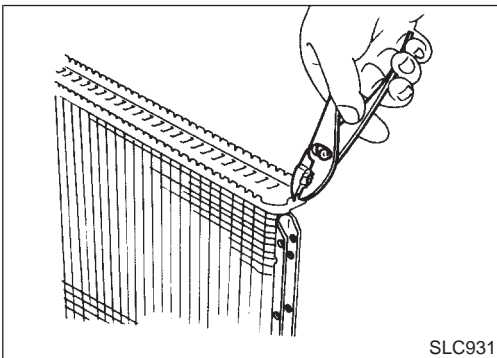

2. Make sure the edge stands straight up.
3. Remove oil cooler from tank.

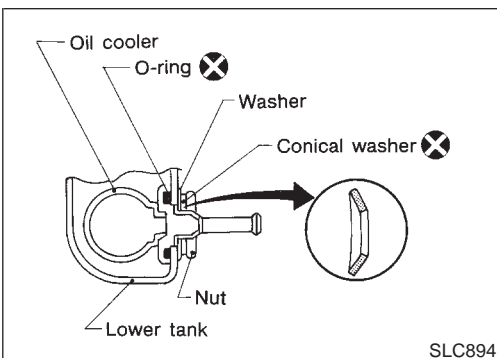

ASSEMBLY

1. Install oil cooler.

Pay attention to direction of conical washer.

NHLC0027

GI

MA

EM

LC

EC

FE

AT

AX

SU

BR

ST

RS

BT

HA

SC

EL

IDX

ENGINE COOLING SYSTEM

Radiator (Aluminum type) (Cont'd)

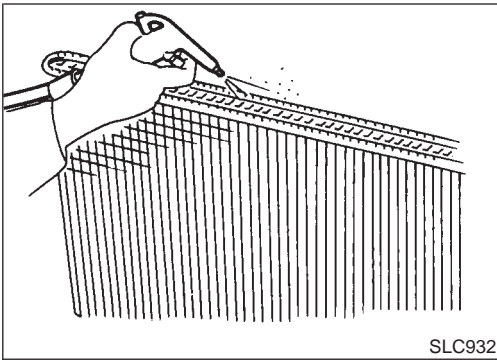

2. Clean contact portion of tank.

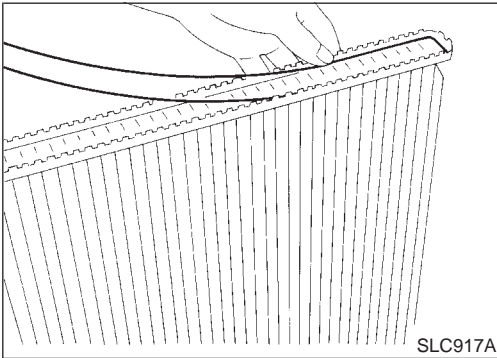

3. Install sealing rubber.
Push it in with fingers.
Be careful not to twist sealing rubber.

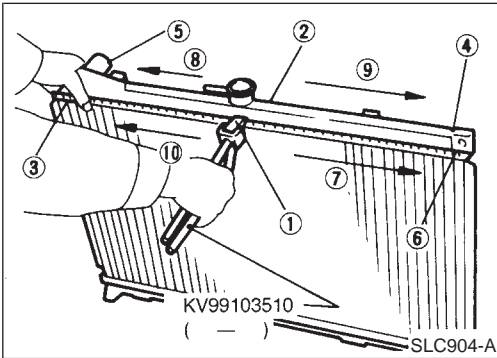

4. Caulk tank in specified sequence with Tool.

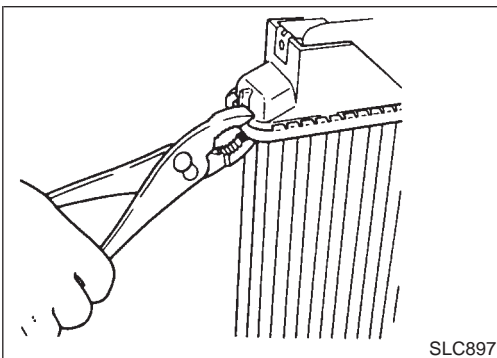
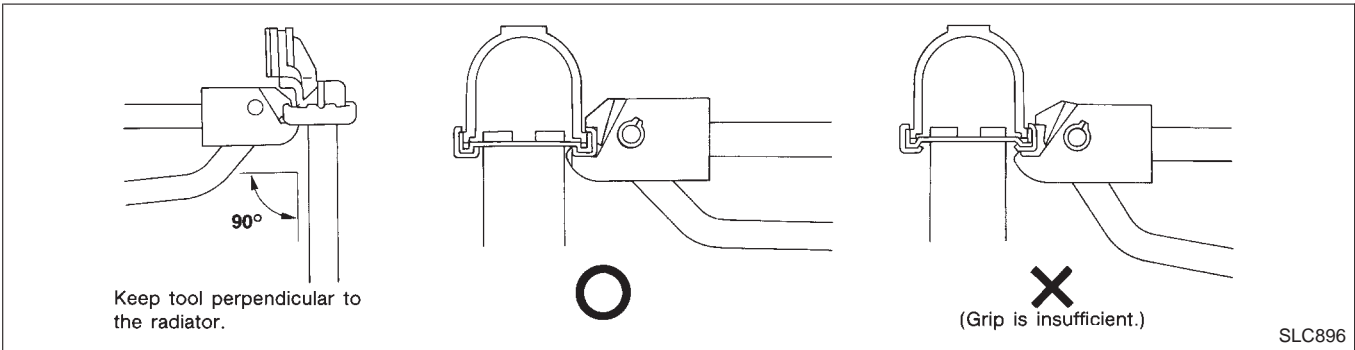

- Use pliers in the locations where Tool cannot be used.

ENGINE COOLING SYSTEM

Radiator (Aluminum type) (Cont'd)

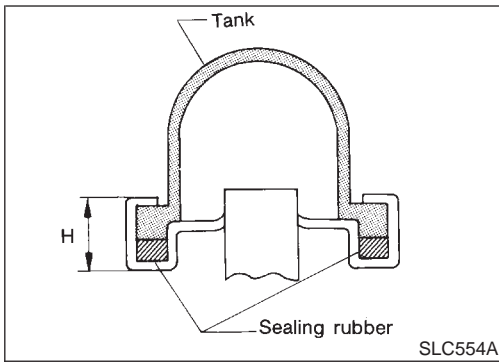

5. Make sure that the rim is completely crimped down.

Standard height "H":

8.0 - 8.4 mm (0.315 - 0.331 in)

6. Confirm that there is no leakage.

Refer to Inspection.

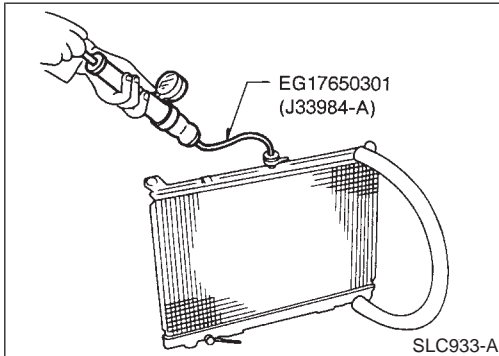

INSPECTION

Apply pressure with Tool.

Specified pressure value:

157 kPa (1.6 kg/cm², 23 psi)

WARNING:

To prevent the risk of the hose coming undone while under pressure, securely fasten it down with a hose clamp. Attach a hose to the oil cooler as well.

GI

MA

EM

LC

EC

FE

AT

AX

SU

BR

ST

RS

BT

HA

SC

EL

IDX

ENGINE COOLING SYSTEM

Overheating Cause Analysis

Overheating Cause Analysis

NHLC0029

		Symptom	Check items	
Cooling system parts malfunction	Poor heat transfer	Water pump malfunction	Worn or loose drive belt	—
		Thermostat stuck closed	—	
		Damaged fins	Dust contamination or paper clogging	
			Mechanical damage	
	Clogged radiator cooling tube	Excess foreign material (rust, dirt, sand, etc.)		
	Reduced air flow	Cooling fan does not operate	—	—
		High resistance to fan rotation		
		Damaged fan blades		
	Damaged radiator shroud	—	—	—
	Improper coolant mixture ratio	—	—	—
	Poor coolant quality	—	—	—
	Insufficient coolant	Coolant leaks	Cooling hose	Loose clamp
				Cracked hose
			Water pump	Poor sealing
			Radiator cap	Loose
				Poor sealing
Radiator			O-ring for damage, deterioration or improper fitting	
		Cracked radiator tank		
		Cracked radiator core		
Reservoir tank	Cracked reservoir tank			
Overflowing reservoir tank	Exhaust gas leaks into cooling system	Cylinder head deterioration		
		Cylinder head gasket deterioration		

ENGINE COOLING SYSTEM

Overheating Cause Analysis (Cont'd)

		Symptom		Check items	
Except cooling system parts malfunction	—	Overload on engine	Abusive driving	High engine rpm under no load	GI
				Driving in low gear for extended time	MA
				Driving at extremely high speed	EM
			Powertrain system malfunction	—	LC
			Installed improper size wheels and tires		EC
			Dragging brakes		
	Improper ignition timing				
	Blocked or restricted air flow	Blocked bumper	Blocked radiator grille	Installed car brassiere	FE
			Mud contamination or paper clogging	AT	
			Blocked radiator	—	AX
			Blocked condenser	—	
			Installed large fog lamp	—	

Service Data and Specifications (SDS)

THERMOSTAT

NHLC0030

Valve opening temperature	82°C (180°F)
Valve lift	More than 8.6 mm/95°C (0.339 in/203°F)

WATER CONTROL VALVE

NHLC0035

Valve opening temperature	95°C (203°F)
Valve lift	More than 8.0 mm/108°C (0.315 in/226°F)

RADIATOR

NHLC0031

Unit: kPa (kg/cm², psi)

Cap relief pressure	Standard	78 - 98 (0.8 - 1.0, 11 - 14)
	Limit	59 - 98 (0.6 - 1.0, 9 - 14)
Leakage test pressure		157 (1.6, 23)

NOTES