

GI
MA
EM
LC
EC
FE
CL
MT
AT
FA
RA
BR
ST
RS
BT
HA
EL
IDX

CONTENTS

| | | | |
|----------------------------------------------------------------------------|----|--------------------------------------------------|----|
| PRECAUTIONS | 2 | Circuit Inspection | 25 |
| Supplemental Restraint System (SRS) "AIR BAG" | 2 | HOW TO FOLLOW FLOW CHART IN TROUBLE | |
| General Precautions | 2 | DIAGNOSES | 31 |
| Precautions for Multiport Fuel Injection System or ECCS Engine | 4 | How to Follow This Flow Chart | 32 |
| Precautions for Three Way Catalyst | 5 | CONSULT CHECKING SYSTEM | 34 |
| Precautions for Engine Oils | 5 | Function and System Application | 34 |
| Precautions for Fuel | 6 | Lithium Battery Replacement | 34 |
| Precautions for Air Conditioning | 6 | Checking Equipment | 34 |
| HOW TO USE THIS MANUAL | 7 | Loading Procedure | 35 |
| HOW TO READ WIRING DIAGRAMS | 9 | CONSULT Data Link Connector (DLC) Circuit | 35 |
| Sample/Wiring Diagram — EXAMPL — | 9 | IDENTIFICATION INFORMATION | 36 |
| Description | 11 | Model Variation | 36 |
| HOW TO CHECK TERMINAL | 18 | Identification Number | 37 |
| Connector and Terminal Pin Kit | 18 | Dimensions | 39 |
| How to Probe Connectors | 18 | Wheels and Tires | 39 |
| How to Check Enlarged Contact Spring of Terminal | 19 | LIFTING POINTS AND TOW TRUCK TOWING | 40 |
| Waterproof Connector Inspection | 20 | Preparation | 40 |
| Terminal Lock Inspection | 20 | Board-on Lift | 40 |
| HOW TO PERFORM EFFICIENT DIAGNOSIS FOR AN ELECTRICAL INCIDENT | 21 | Garage Jack and Safety Stand | 41 |
| Work Flow | 21 | 2-pole Lift | 42 |
| Incident Simulation Tests | 22 | Tow Truck Towing | 43 |
| | | TIGHTENING TORQUE OF STANDARD BOLTS | 44 |
| | | SAE J1930 TERMINOLOGY LIST | 45 |
| | | SAE J1930 Terminology List | 45 |

PRECAUTIONS

Observe the following precautions to ensure safe and proper servicing. These precautions are not described in each individual section.

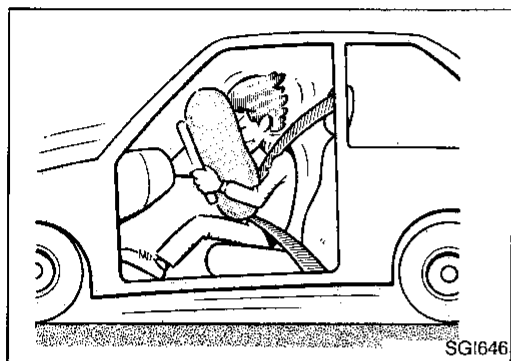

Supplemental Restraint System (SRS) "AIR BAG"

The Supplemental Restraint System "AIR BAG", used along with a seat belt, helps to reduce the risk or severity of injury to the driver and front passenger in a frontal collision. The Supplemental Restraint System consists of air bag modules (located in the center of the steering wheel and on the instrument panel on the passenger side), a diagnosis sensor unit, warning lamp, wiring harness and spiral cable. In addition to the supplemental air bags for a frontal collision, the supplemental side air bag (if so equipped) used along with the seat belt helps to reduce the risk or severity of injury to the driver and front passenger in a side collision. The supplemental side air bag consists of air bag modules (located in the outer side of front seats), satellite sensor, diagnosis sensor unit (which is one of components of supplemental air bags for a frontal collision), wiring harness, warning lamp (which is one of components of supplemental air bags for a frontal collision). Information necessary to service the system safely is included in the **RS section** in this Service Manual.

WARNING:

- To avoid rendering the SRS inoperative, which could increase the risk of personal injury or death in the event of a collision which would result in air bag inflation, all maintenance must be performed by an authorized NISSAN dealer.
- Improper maintenance, including incorrect removal and installation of the SRS, can lead to personal injury caused by unintentional activation of the system.
- Do not use electrical test equipment on any circuit related to the SRS unless instructed to in this Service Manual. SRS wiring harnesses can be identified with yellow harness protector or yellow insulation tape before the harness connectors.

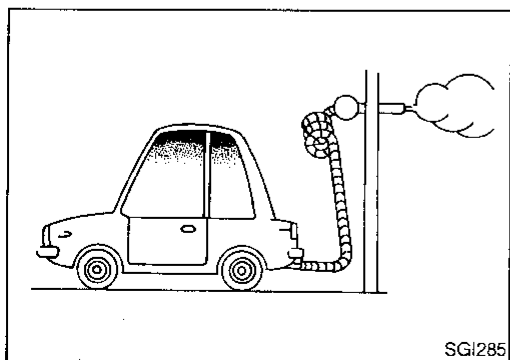

General Precautions

- Do not operate the engine for an extended period of time without proper exhaust ventilation. Keep the work area well ventilated and free of any inflammable materials. Special care should be taken when handling any inflammable or poisonous materials, such as gasoline, refrigerant gas, etc. When working in a pit or other enclosed area, be sure to properly ventilate the area before working with hazardous materials.
Do not smoke while working on the vehicle.

PRECAUTIONS

General Precautions (Cont'd)

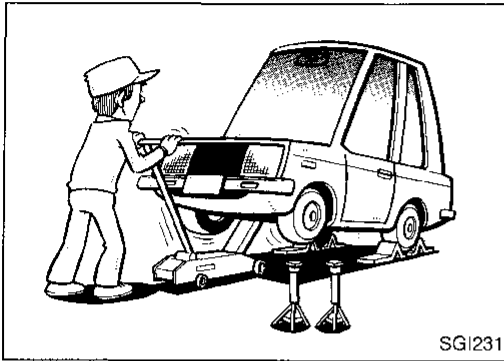

- Before jacking up the vehicle, apply wheel chocks or other tire blocks to the wheels to prevent the vehicle from moving. After jacking up the vehicle, support the vehicle weight with safety stands at the points designated for proper lifting before working on the vehicle.

These operations should be done on a level surface.

- When removing a heavy component such as the engine or transaxle, be careful not to lose your balance and drop them. Also, do not allow them to strike adjacent parts, especially the brake tubes and master cylinder.

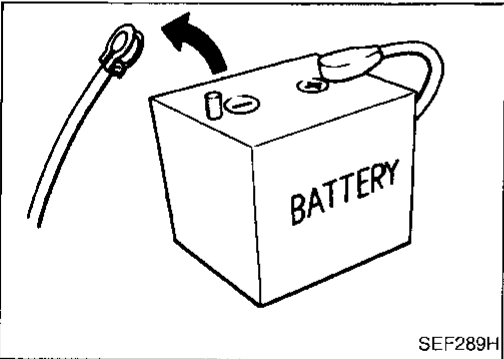

- Before starting repairs which do not require battery power:
Turn off ignition switch.
Disconnect the negative battery terminal.

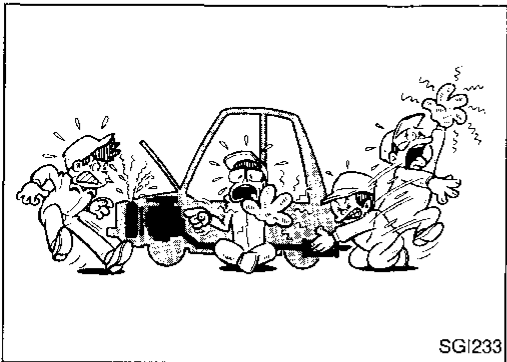

- To prevent serious burns:
Avoid contact with hot metal parts.
Do not remove the radiator cap when the engine is hot.

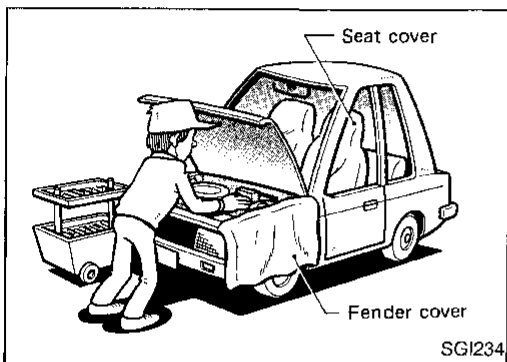

- Before servicing the vehicle:
Protect fenders, upholstery and carpeting with appropriate covers.
Take caution that keys, buckles or buttons do not scratch paint.

- Clean all disassembled parts in the designated liquid or solvent prior to inspection or assembly.
- Replace oil seals, gaskets, packings, O-rings, locking washers, cotter pins, self-locking nuts, etc. with new ones.
- Replace inner and outer races of tapered roller bearings and needle bearings as a set.
- Arrange the disassembled parts in accordance with their assembled locations and sequence.
- Do not touch the terminals of electrical components which use microcomputers (such as ECMs).
Static electricity may damage internal electronic components.

PRECAUTIONS

General Precautions (Cont'd)

- After disconnecting vacuum or air hoses, attach a tag to indicate the proper connection.
- Use only the fluids and lubricants specified in this manual.
- Use approved bonding agent, sealants or their equivalents when required.
- Use tools and recommended special tools where specified for safe and efficient service repairs.
- When repairing the fuel, oil, water, vacuum or exhaust systems, check all affected lines for leaks.
- Dispose of drained oil or the solvent used for cleaning parts in an appropriate manner.

WARNING:

To prevent ECM from storing the diagnostic trouble codes, do not carelessly disconnect the harness connectors which are related to the ECCS system and TCM (Transmission Control Module) system. The connectors should be disconnected only when working according to the WORK FLOW of TROUBLE DIAGNOSES in EC and AT sections.



Precautions for Multiport Fuel Injection System or ECCS Engine

- Before connecting or disconnecting any harness connector for the multiport fuel injection system or ECM (Engine Control Module):
Turn ignition switch to "OFF" position.
Disconnect negative battery terminal.
Otherwise, there may be damage to ECM.
- Before disconnecting pressurized fuel line from fuel pump to injectors, be sure to release fuel pressure.
- Be careful not to jar components such as ECM and mass air flow sensor.

PRECAUTIONS

Precautions for Three Way Catalyst

If a large amount of unburned fuel flows into the catalyst, the catalyst temperature will be excessively high. To prevent this, follow the instructions below:

- Use unleaded gasoline only. Leaded gasoline will seriously damage the three way catalyst.
- When checking for ignition spark or measuring engine compression, make tests quickly and only when necessary.
- Do not run engine when the fuel tank level is low, otherwise the engine may misfire, causing damage to the catalyst.

Do not place the vehicle on flammable material. Keep flammable material off the exhaust pipe and the three way catalyst.

Precautions for Engine Oils

Prolonged and repeated contact with used engine oil may cause skin cancer. Try to avoid direct skin contact with used oil.

If skin contact is made, wash thoroughly with soap or hand cleaner as soon as possible.

HEALTH PROTECTION PRECAUTIONS

- Avoid prolonged and repeated contact with oils, particularly used engine oils.
- Wear protective clothing, including impervious gloves where practicable.
- Do not put oily rags in pockets.
- Avoid contaminating clothes, particularly underclothing, with oil.
- Heavily soiled clothing and oil-impregnated footwear should not be worn. Overalls must be cleaned regularly.
- First Aid treatment should be obtained immediately for open cuts and wounds.
- Use barrier creams, applying them before each work period, to help the removal of oil from the skin.
- Wash with soap and water to ensure all oil is removed (skin cleansers and nail brushes will help). Preparations containing lanolin replace the natural skin oils which have been removed.
- Do not use gasoline, kerosine, diesel fuel, gas oil, thinners or solvents for cleaning skin.
- If skin disorders develop, obtain medical advice without delay.
- Where practicable, degrease components prior to handling.
- Where there is a risk of eye contact, eye protection should be worn, for example, chemical goggles or face shields; in addition an eye wash facility should be provided.

GI

MA

EM

LC

EC

FE

CL

MT

AT

FA

RA

BR

ST

RS

BT

HA

EL

IDX

PRECAUTIONS

Precautions for Engine Oils (Cont'd)

ENVIRONMENTAL PROTECTION PRECAUTIONS

Burning used engine oil in small space heaters or boilers can be recommended only for units of approved design. The heating system must meet the requirements of HM Inspectorate of Pollution for small burners of less than 0.4 MW. If in doubt, check with the appropriate local authority and/or manufacturer of the approved appliance.

Dispose of used oil and used oil filters through authorized waste disposal contractors to licensed waste disposal sites, or to the waste oil reclamation trade. If in doubt, contact the local authority for advice on disposal facilities.

It is illegal to pour used oil on to the ground, down sewers or drains, or into water courses.

The regulations concerning the pollution of the environment will vary between regions.

Precautions for Fuel

Use premium unleaded gasoline with an octane rating of at least 91 AKI (Anti-Knock Index) number (research octane number 96). If premium unleaded gasoline is not available, regular unleaded gasoline with an octane rating of at least 87 AKI (research octane number 91) can be used.

However, for maximum vehicle performance, the use of premium unleaded gasoline is recommended.

CAUTION:

Using a fuel other than that specified could adversely affect the emission control devices and systems, and could also affect the warranty coverage.

Under no circumstances should a leaded gasoline be used, since this will damage the three way catalyst.

Precautions for Air Conditioning

Use an approved refrigerant recovery unit any time the air conditioning system must be discharged. Refer to HA section ("HFC-134a (R-134a) Service Procedure", "SERVICE PROCEDURES") for specific instructions.

HOW TO USE THIS MANUAL



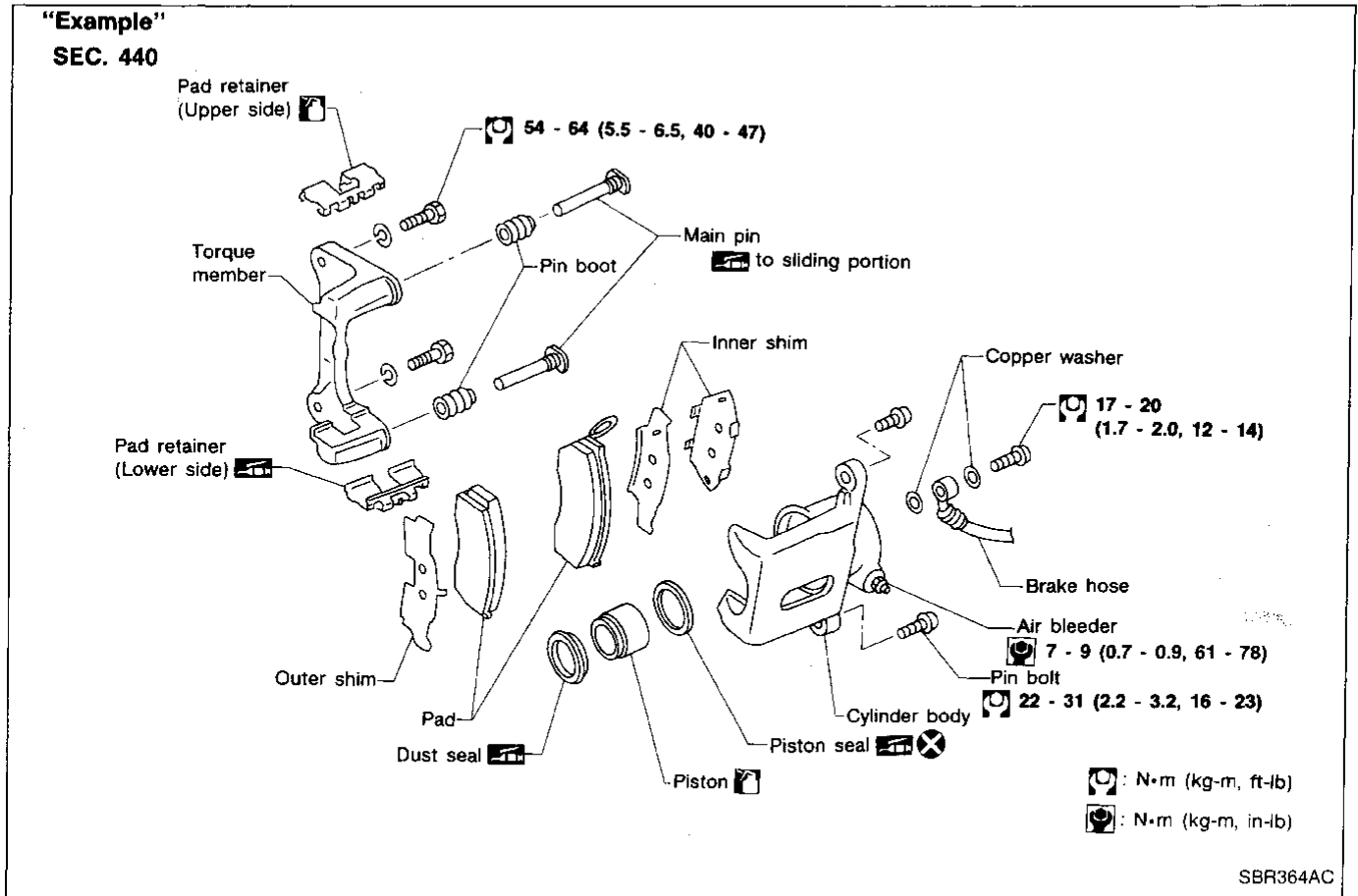





- **ALPHABETICAL INDEX** is provided at the end of this manual so that you can rapidly find the item and page you are searching for.
 - **A QUICK REFERENCE INDEX**, a black tab (e.g. **BR**) is provided on the first page. You can quickly find the first page of each section by mating it to the section's black tab.
 - **THE CONTENTS** are listed on the first page of each section.
 - **THE TITLE** is indicated on the upper portion of each page and shows the part or system.
 - **THE PAGE NUMBER** of each section consists of two letters which designate the particular section and a number (e.g. "BR-5").
 - **THE LARGE ILLUSTRATIONS** are exploded views (See below.) and contain tightening torques, lubrication points, section number of the **PARTS CATALOG** (e.g. SEC. 440) and other information necessary to perform repairs.
- The illustrations should be used in reference to service matters only. When ordering parts, refer to the appropriate **PARTS CATALOG**.



- **THE SMALL ILLUSTRATIONS** show the important steps such as inspection, use of special tools, knacks of work and hidden or tricky steps which are not shown in the previous large illustrations. Assembly, inspection and adjustment procedures for the complicated units such as the automatic transaxle or transmission, etc. are presented in a step-by-step format where necessary.

HOW TO USE THIS MANUAL

- The following **SYMBOLS AND ABBREVIATIONS** are used:

| | | | |
|-----------------------------------------------------------------------------------------|----------------------------------------------------------------------------------------------------------|----------------|-----------------------------------------|
|  | : Tightening torque | A/T | : Automatic Transaxle/Transmission |
|  | : Should be lubricated with grease. Unless otherwise indicated, use recommended multi-purpose grease. | A/C | : Air Conditioner |
|  | : Should be lubricated with oil. | P/S | : Power Steering |
|  | : Sealing point | SST | : Special Service Tools |
|  | : Checking point | SDS | : Service Data and Specifications |
|  | : Always replace after every disassembly. | SAE | : Society of Automotive Engineers, Inc. |
| LH, RH | : Left-Hand, Right-Hand | LHD | : Left-Hand Drive |
| FR, RR | : Front, Rear | RHD | : Right-Hand Drive |
| 2WD | : 2-Wheel Drive | ATF | : Automatic Transmission Fluid |
|  (P) | : Apply petroleum jelly. | D ₁ | : Drive range 1st gear |
|  (ATF) | : Apply ATF. | D ₂ | : Drive range 2nd gear |
| ★ | : Select with proper thickness. | D ₃ | : Drive range 3rd gear |
| ☆ | : Adjustment is required. | D ₄ | : Drive range 4th gear |
| M/T | : Manual Transaxle/Transmission | OD | : Overdrive |
| | | 2 ₂ | : 2nd range 2nd gear |
| | | 2 ₁ | : 2nd range 1st gear |
| | | 1 ₂ | : 1st range 2nd gear |
| | | 1 ₁ | : 1st range 1st gear |

- The **UNITS** given in this manual are primarily expressed as SI UNITS (International System of Unit), and alternatively expressed in the metric system and in the yard/pound system.

“Example”

Tightening torque:

59 - 78 N·m (6.0 - 8.0 kg-m, 43 - 58 ft-lb)

- TROUBLE DIAGNOSES** are included in sections dealing with complicated components.
- SERVICE DATA AND SPECIFICATIONS** are contained at the end of each section for quick reference of data.
- The captions **WARNING** and **CAUTION** warn you of steps that must be followed to prevent personal injury and/or damage to some part of the vehicle.

WARNING indicates the possibility of personal injury if instructions are not followed.

CAUTION indicates the possibility of component damage if instructions are not followed.

BOLD TYPED STATEMENTS except **WARNING** and **CAUTION** give you helpful information.

HOW TO READ WIRING DIAGRAMS

Sample/Wiring Diagram — EXAMPL —

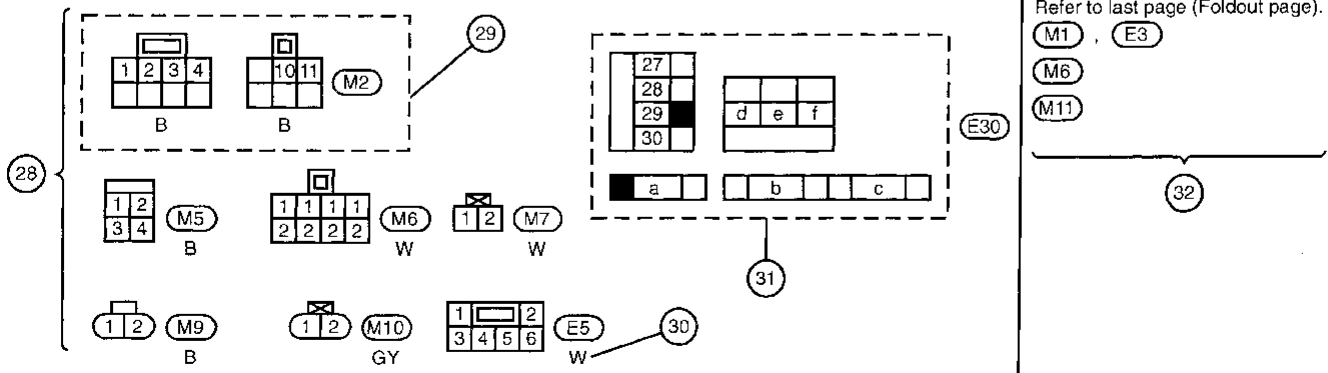
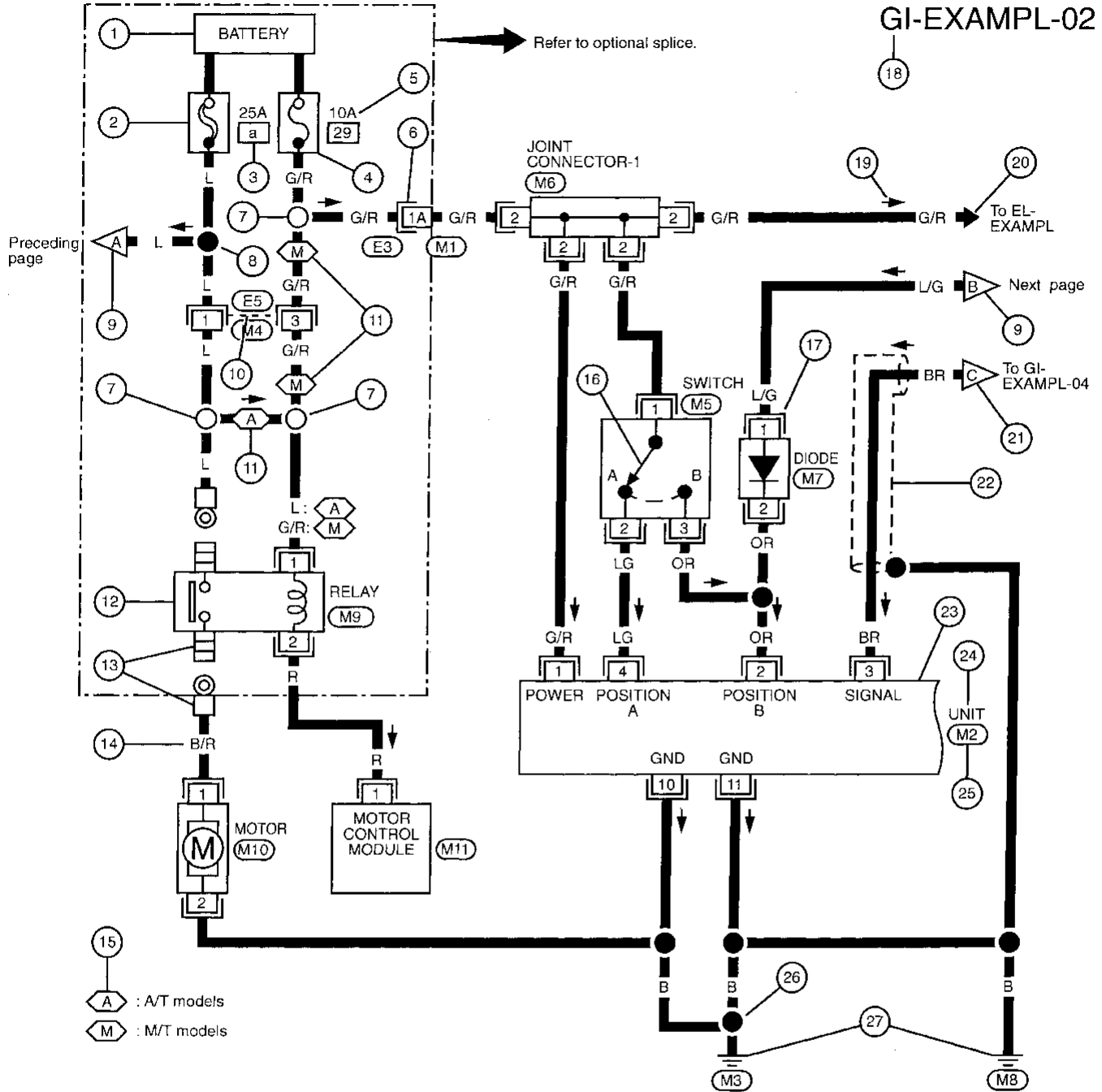

GI

MA

EM

LC

EC

FE

CL

MT

AT

FA

RA

BR

ST

RS

BT

HA

EL

IDX

HOW TO READ WIRING DIAGRAMS

Description

| Number | Item | Description | | | | | | | | | | | | | | | | |
|------------------|----------------------------|-----------------------------------------------------------------------------------------------------------------------------------------------------------------------------------------------------------------------------------------------------------------------------------------------------------------------------------------------------------------------------------------------------------------------------------------------------------------------------------------------------------------------------------------------------------------------------------------------------------------------------------------------------------------------------------------------------------------------------------------|-----------|------------|-----------|-------------|---------|----------|-----------|-------------|----------|-----------|------------|---------------|------------------|-----------------|--|-----------------|
| ① | Power condition | <ul style="list-style-type: none"> This shows the condition when the system receives battery positive voltage (can be operated). | | | | | | | | | | | | | | | | |
| ② | Fusible link | <ul style="list-style-type: none"> The double line shows that this is a fusible link. The open circle shows current flow in, and the shaded circle shows current flow out. | | | | | | | | | | | | | | | | |
| ③ | Fusible link/fuse location | <ul style="list-style-type: none"> This shows the location of the fusible link or fuse in the fusible link or fuse box. For arrangement, refer to EL section ("POWER SUPPLY ROUTING"). | | | | | | | | | | | | | | | | |
| ④ | Fuse | <ul style="list-style-type: none"> The single line shows that this is a fuse. The open circle shows current flow in, and the shaded circle shows current flow out. | | | | | | | | | | | | | | | | |
| ⑤ | Current rating | <ul style="list-style-type: none"> This shows the current rating of the fusible link or fuse. | | | | | | | | | | | | | | | | |
| ⑥ | Connectors | <ul style="list-style-type: none"> This shows that connector (E3) is female and connector (M1) is male. The G/R wire is located in the 1A terminal of both connectors. Terminal number with an alphabet (1A, 5B, etc.) indicates that the connector is SMJ connector. Refer to GI-17. | | | | | | | | | | | | | | | | |
| ⑦ | Optional splice | <ul style="list-style-type: none"> The open circle shows that the splice is optional depending on vehicle application. | | | | | | | | | | | | | | | | |
| ⑧ | Splice | <ul style="list-style-type: none"> The shaded circle shows that the splice is always on the vehicle. | | | | | | | | | | | | | | | | |
| ⑨ | Page crossing | <ul style="list-style-type: none"> This arrow shows that the circuit continues to an adjacent page. The A will match with the A on the preceding or next page. | | | | | | | | | | | | | | | | |
| ⑩ | Common connector | <ul style="list-style-type: none"> The dotted lines between terminals show that these terminals are part of the same connector. | | | | | | | | | | | | | | | | |
| ⑪ | Option abbreviation | <ul style="list-style-type: none"> This shows that the circuit is optional depending on vehicle application. | | | | | | | | | | | | | | | | |
| ⑫ | Relay | <ul style="list-style-type: none"> This shows an internal representation of the relay. For details, refer to EL section ("STANDARDIZED RELAY"). | | | | | | | | | | | | | | | | |
| ⑬ | Connectors | <ul style="list-style-type: none"> This shows that the connector is connected to the body or a terminal with bolt or nut. | | | | | | | | | | | | | | | | |
| ⑭ | Wire color | <ul style="list-style-type: none"> This shows a code for the color of the wire. <table style="width: 100%; border: none;"> <tr> <td>B = Black</td> <td>BR = Brown</td> </tr> <tr> <td>W = White</td> <td>OR = Orange</td> </tr> <tr> <td>R = Red</td> <td>P = Pink</td> </tr> <tr> <td>G = Green</td> <td>PU = Purple</td> </tr> <tr> <td>L = Blue</td> <td>GY = Gray</td> </tr> <tr> <td>Y = Yellow</td> <td>SB = Sky Blue</td> </tr> <tr> <td>LG = Light Green</td> <td>CH = Dark Brown</td> </tr> <tr> <td></td> <td>DG = Dark Green</td> </tr> </table> <p>When the wire color is striped, the base color is given first, followed by the stripe color as shown below: Example: L/W = Blue with White Stripe</p> | B = Black | BR = Brown | W = White | OR = Orange | R = Red | P = Pink | G = Green | PU = Purple | L = Blue | GY = Gray | Y = Yellow | SB = Sky Blue | LG = Light Green | CH = Dark Brown | | DG = Dark Green |
| B = Black | BR = Brown | | | | | | | | | | | | | | | | | |
| W = White | OR = Orange | | | | | | | | | | | | | | | | | |
| R = Red | P = Pink | | | | | | | | | | | | | | | | | |
| G = Green | PU = Purple | | | | | | | | | | | | | | | | | |
| L = Blue | GY = Gray | | | | | | | | | | | | | | | | | |
| Y = Yellow | SB = Sky Blue | | | | | | | | | | | | | | | | | |
| LG = Light Green | CH = Dark Brown | | | | | | | | | | | | | | | | | |
| | DG = Dark Green | | | | | | | | | | | | | | | | | |
| ⑮ | Option description | <ul style="list-style-type: none"> This shows a description of the option abbreviation used on the page. | | | | | | | | | | | | | | | | |
| ⑯ | Switch | <ul style="list-style-type: none"> This shows that continuity exists between terminals 1 and 2 when the switch is in the A position. Continuity exists between terminals 1 and 3 when the switch is in the B position. | | | | | | | | | | | | | | | | |
| ⑰ | Assembly parts | <ul style="list-style-type: none"> Connector terminal in component shows that it is a harness incorporated assembly. | | | | | | | | | | | | | | | | |
| ⑱ | Cell code | <ul style="list-style-type: none"> This identifies each page of the wiring diagram by section, system and wiring diagram page number. | | | | | | | | | | | | | | | | |

HOW TO READ WIRING DIAGRAMS



Description (Cont'd)

| Number | Item | Description |
|--------|----------------------------|-------------------------------------------------------------------------------------------------------------------------------------------------------------------------------------------------------------------------------------------------------------------------------------------------------------------------------------------------------------------------------------|
| ⑲ | Current flow arrow | <ul style="list-style-type: none"> • Arrow indicates electric current flow, especially where the direction of standard flow (vertically downward or horizontally from left to right) is difficult to follow. • A double arrow “\longleftrightarrow” shows that current can flow in either direction depending on circuit operation. |
| ⑳ | System branch | <ul style="list-style-type: none"> • This shows that the system branches to another system identified by cell code (section and system). |
| ㉑ | Page crossing | <ul style="list-style-type: none"> • This arrow shows that the circuit continues to another page identified by cell code. • The C will match with the C on another page within the system other than the next or preceding pages. |
| ㉒ | Shielded line | <ul style="list-style-type: none"> • The line enclosed by broken line circle shows shield wire. |
| ㉓ | Component box in wave line | <ul style="list-style-type: none"> • This shows that another part of the component is also shown on another page (indicated by wave line) within the system. |
| ㉔ | Component name | <ul style="list-style-type: none"> • This shows the name of a component. |
| ㉕ | Connector number | <ul style="list-style-type: none"> • This shows the connector number. • The letter shows which harness the connector is located in. Example: M: main harness. For detail and to locate the connector, refer to EL section (“Main Harness”, “HARNESS LAYOUT”). A coordinate grid is included for complex harnesses to aid in locating connectors. |
| ㉖ | Ground (GND) | <ul style="list-style-type: none"> • The line spliced and grounded under wire color shows that ground line is spliced at the grounded connector. |
| ㉗ | Ground (GND) | <ul style="list-style-type: none"> • This shows the ground connection. |
| ㉘ | Connector views | <ul style="list-style-type: none"> • This area shows the connector faces of the components in the wiring diagram on the page. |
| ㉙ | Common component | <ul style="list-style-type: none"> • Connectors enclosed in broken line show that these connectors belong to the same component. |
| ㉚ | Connector color | <ul style="list-style-type: none"> • This shows a code for the color of the connector. For code meaning, refer to wire color codes, Number ⑭ of this chart. |
| ㉛ | Fusible link and fuse box | <ul style="list-style-type: none"> • This shows the arrangement of fusible link(s) and fuse(s), used for connector views of “POWER SUPPLY ROUTING” in EL section. The open square shows current flow in, and the shaded square shows current flow out. |
| ㉜ | Reference area | <ul style="list-style-type: none"> • This shows that more information on the Super Multiple Junction (SMJ) and Joint Connectors (J/C) exists on the foldout page. Refer to GI-17 for details. |

HOW TO READ WIRING DIAGRAMS

Description (Cont'd) CONNECTOR SYMBOLS

Most of connector symbols in wiring diagrams are shown from the terminal side.

- Connector symbols shown from the terminal side are enclosed by a single line and followed by the direction mark  .
- Connector symbols shown from the harness side are enclosed by a double line and followed by the direction mark  .

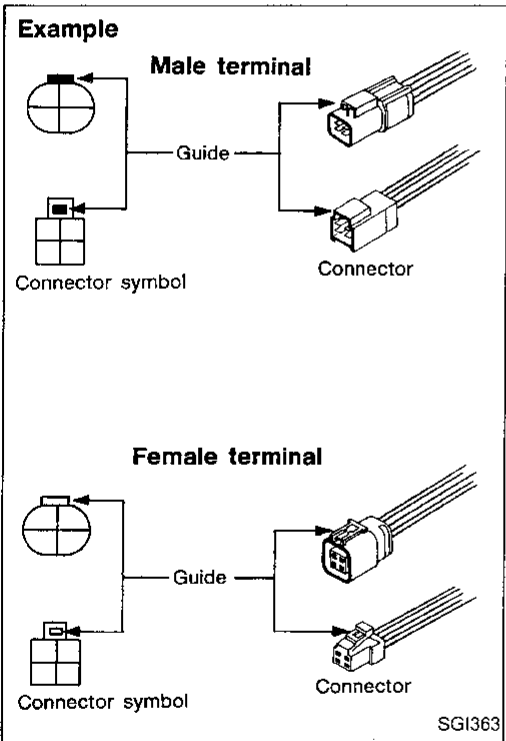
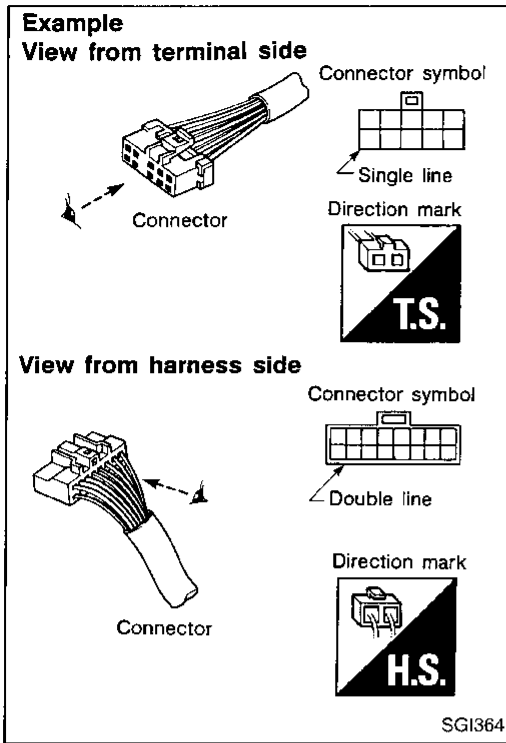

- Male and female terminals
Connector guides for male terminals are shown in black and female terminals in white in wiring diagrams.

GI

MA

EM

LC

EC

FE

CL

MT

AT

FA

RA

BR

ST

RS

BT

HA

EL

IDX

HOW TO READ WIRING DIAGRAMS

Description (Cont'd)

MULTIPLE SWITCH

The continuity of multiple switch is described in two ways as shown below.

- The switch chart is used in schematic diagrams.
- The switch diagram is used in wiring diagrams.

Example

(SWITCH CHART)

| WIPER SWITCH | | | | | |
|--------------|-----|-----|----|----|------|
| | OFF | INT | LO | HI | WASH |
| 1 | | | | | ○ |
| 2 | | | | ○ | |
| 3 | ○ | ○ | ○ | | |
| 4 | ○ | ○ | | | |
| 5 | | ○ | | | |
| 6 | | ○ | ○ | ○ | ○ |

(SWITCH DIAGRAM)

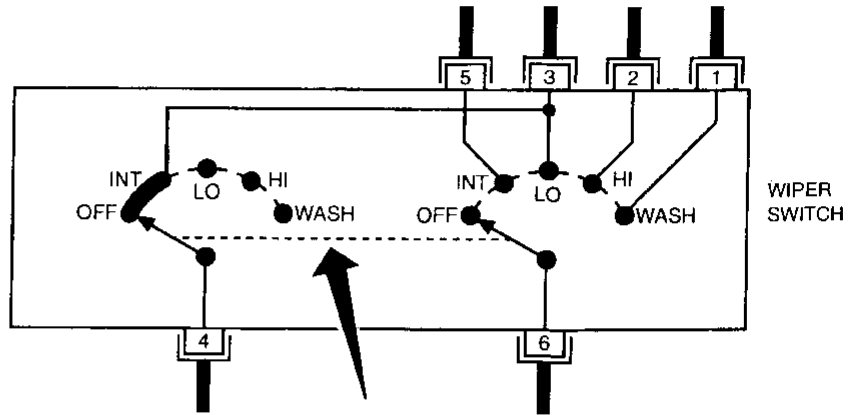

Continuity circuit of wiper switch

| SWITCH POSITION | CONTINUITY CIRCUIT |
|-----------------|--------------------|
| OFF | 3-4 |
| INT | 3-4, 5-6 |
| LO | 3-6 |
| HI | 2-6 |
| WASH | 1-6 |

SGI875

HOW TO READ WIRING DIAGRAMS

Description (Cont'd)

FOLDOUT PAGE

The foldout page should be opened when reading wiring diagram.

Super multiple junction (SMJ)

In wiring diagram, connectors consisting of terminals having terminal numbers with an alphabet (1B, 0D, etc.) are SMJ connectors.

If connector numbers are shown in Reference Area, these connector symbols are not shown in Connector Area. For terminal arrangement of these connectors, refer to the foldout page at the end of this manual.

Joint connector

Joint connector symbols are shown in Connector Area in the wiring diagram concerned. Foldout page also carries inside wiring layout together with such joint connector symbols.

GI
MA
EM
LC
EC
FE
CL
MT
AT
FA
RA
BR
ST
RS
BT
HA
EL
IDX

Example

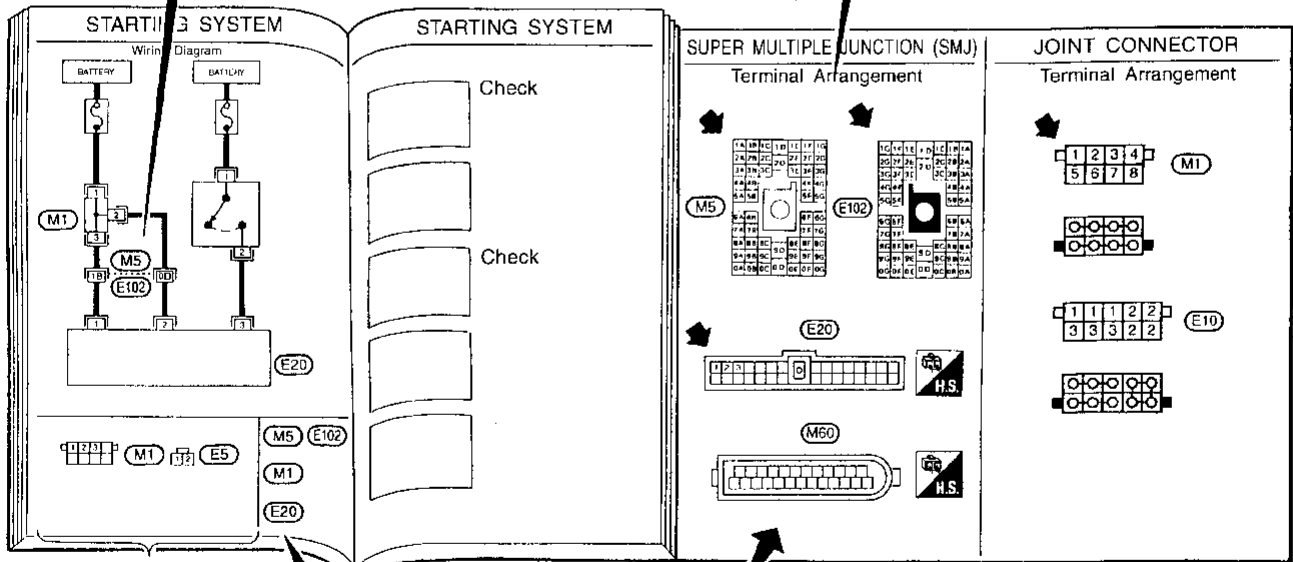
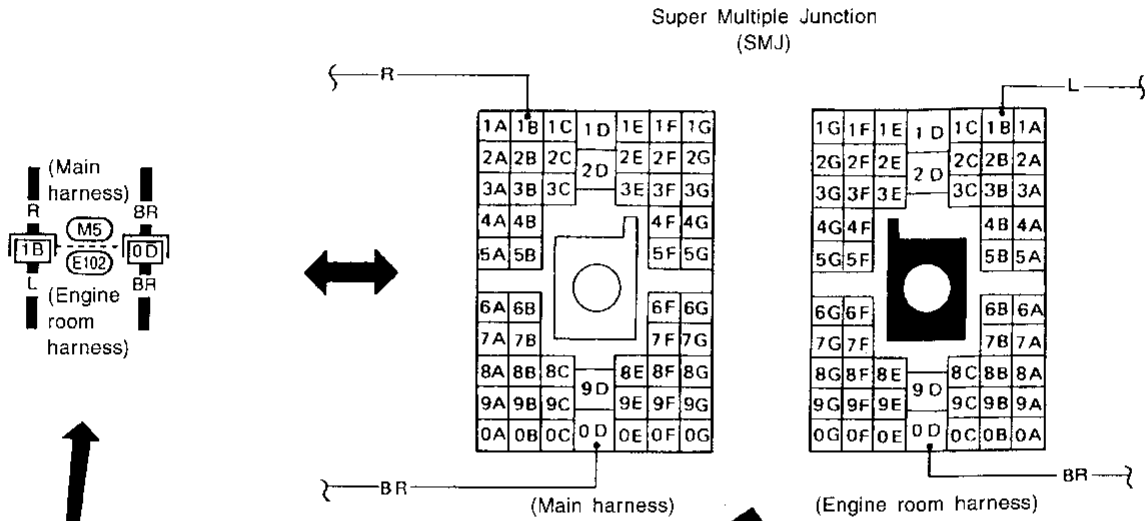

Reference Area:
Refer to the foldout page for the terminal arrangement of the connectors shown here in the "Reference Area".

SGI943

HOW TO CHECK TERMINAL

Connector and Terminal Pin Kit

Use the connector and terminal pin kit listed below when replacing connectors or terminals. The connector and terminal pin kit contains some of the most commonly used NISSAN connectors and terminals.

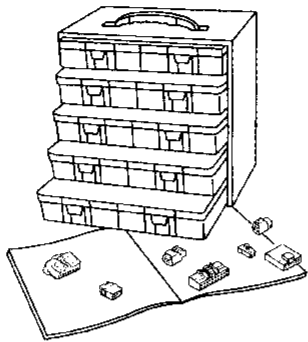
| Tool number (Kent-Moore No.) Tool name | Description |
|------------------------------------------------------|-------------------------------------------------------------------------------------------------|
| — (J38751-95NI) Connector and terminal pin kit |  <p>AGI063</p> |

How to Probe Connectors

Connector damage and an intermittent connection can result from improperly probing of the connector during circuit checks. The probe of a digital multimeter (DMM) may not correctly fit the connector cavity. To correctly probe the connector, follow the procedures below using a "T" pin. For the best contact grasp the "T" pin using an alligator clip.

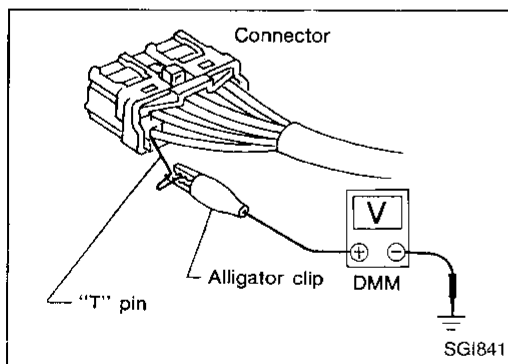

PROBING FROM HARNESS SIDE

Standard type (not waterproof type) connector should be probed from harness side with "T" pin.

- If the connector has a rear cover such as a ECM connector, remove the rear cover before probing the terminal.
- Do not probe waterproof connector from harness side. Damage to the seal between wire and connector may result.

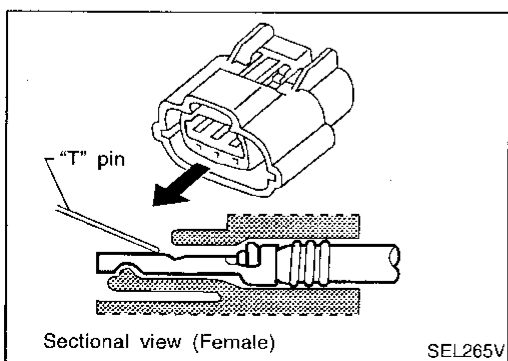

PROBING FROM TERMINAL SIDE

Female terminal

- There is a small notch above each female terminal. Probe each terminal with the "T" pin through the notch.

Do not insert any object other than the same type male terminal into female terminal.

HOW TO CHECK TERMINAL

How to Probe Connectors (Cont'd)

- Some connectors do not have a notch above each terminal. To probe each terminal, remove the connector retainer to make contact space for probing.

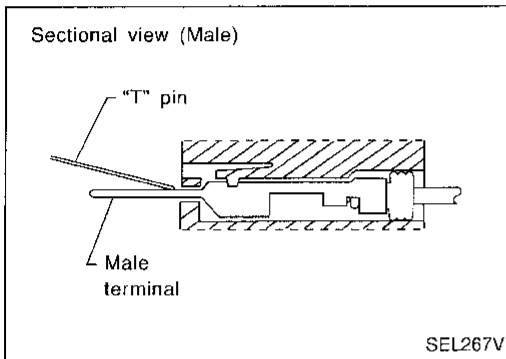
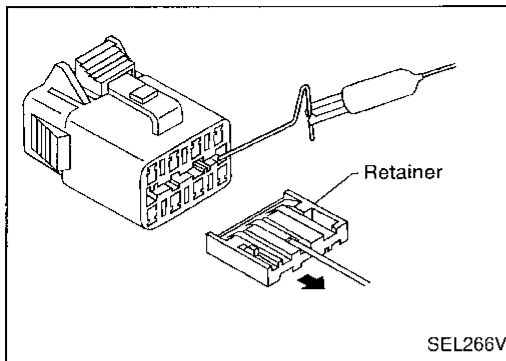

Male terminal

Carefully probe the contact surface of each terminal using a "T" pin.

Do not bend terminal.

How to Check Enlarged Contact Spring of Terminal

An enlarged contact spring of a terminal may create intermittent signals in the circuit.

If the intermittent open circuit occurs, follow the procedure below to inspect for open wires and enlarged contact spring of female terminal.

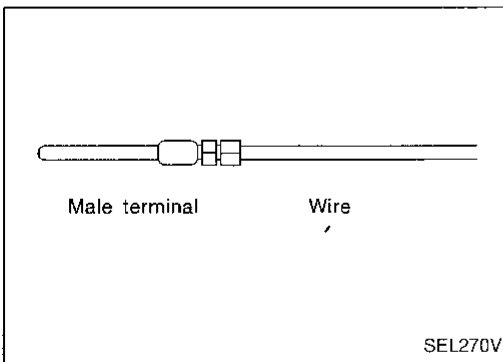

1. Assemble a male terminal and approx. 10 cm (3.9 in) of wire.

Use a male terminal which matches the female terminal.

2. Disconnect the suspected faulty connector and hold it terminal side up.

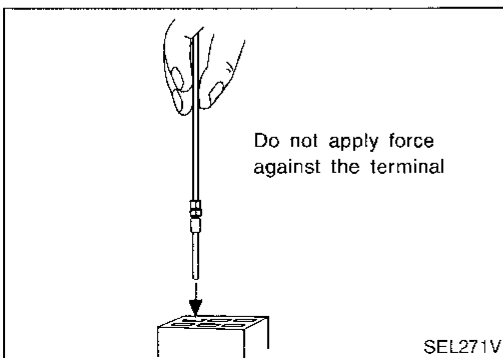

3. While holding the wire of the male terminal, try to insert the male terminal into the female terminal.

Do not force the male terminal into the female terminal with your hands.

GI

MA

EM

LC

EC

FE

CL

MT

AT

FA

RA

BR

ST

RS

BT

HA

EL

IDX

HOW TO CHECK TERMINAL

How to Check Enlarged Contact Spring of Terminal (Cont'd)

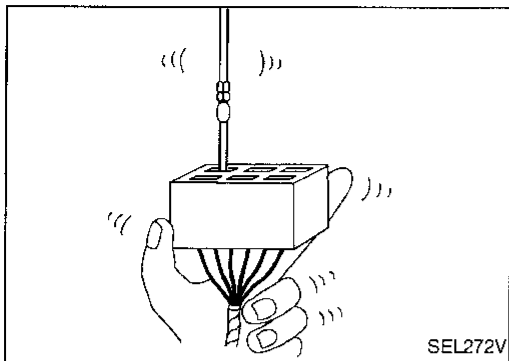

4. While moving the connector, check whether the male terminal can be easily inserted or not.

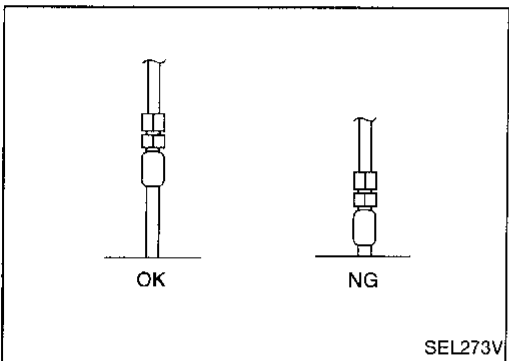

- If the male terminal can be easily inserted into the female terminal, replace the female terminal.

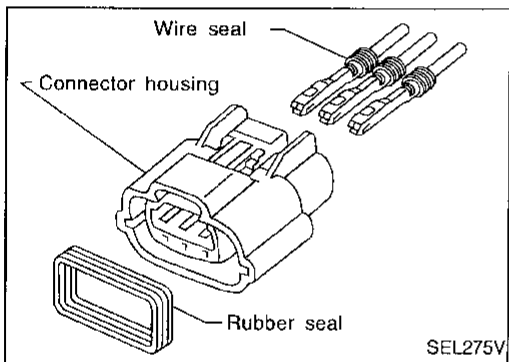

Waterproof Connector Inspection

If water enters the connector, it can short interior circuits. This may lead to intermittent problems.

Check the following items to maintain the original waterproof characteristics.

RUBBER SEAL INSPECTION

- Most waterproof connectors are provided with a rubber seal between the male and female connectors. If the seal is missing, the waterproof performance may not meet specifications.
- The rubber seal may come off when connectors are disconnected. Whenever connectors are reconnected, make sure the rubber seal is properly installed on either side of male or female connector.

WIRE SEAL INSPECTION

The wire seal must be installed on the wire insertion area of a waterproof connector. Be sure that the seal is installed properly.

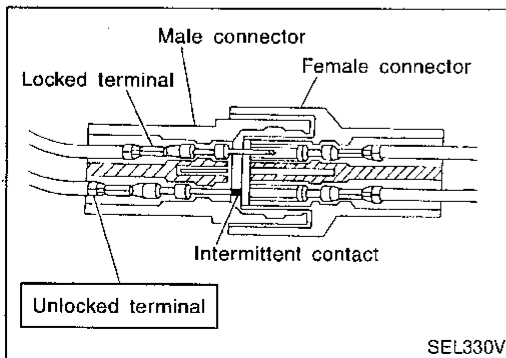

Terminal Lock Inspection

Check for unlocked terminals by pulling wire at the end of connector. An unlocked terminal may create intermittent signals in the circuit.

HOW TO PERFORM EFFICIENT DIAGNOSIS FOR AN ELECTRICAL INCIDENT

Work Flow

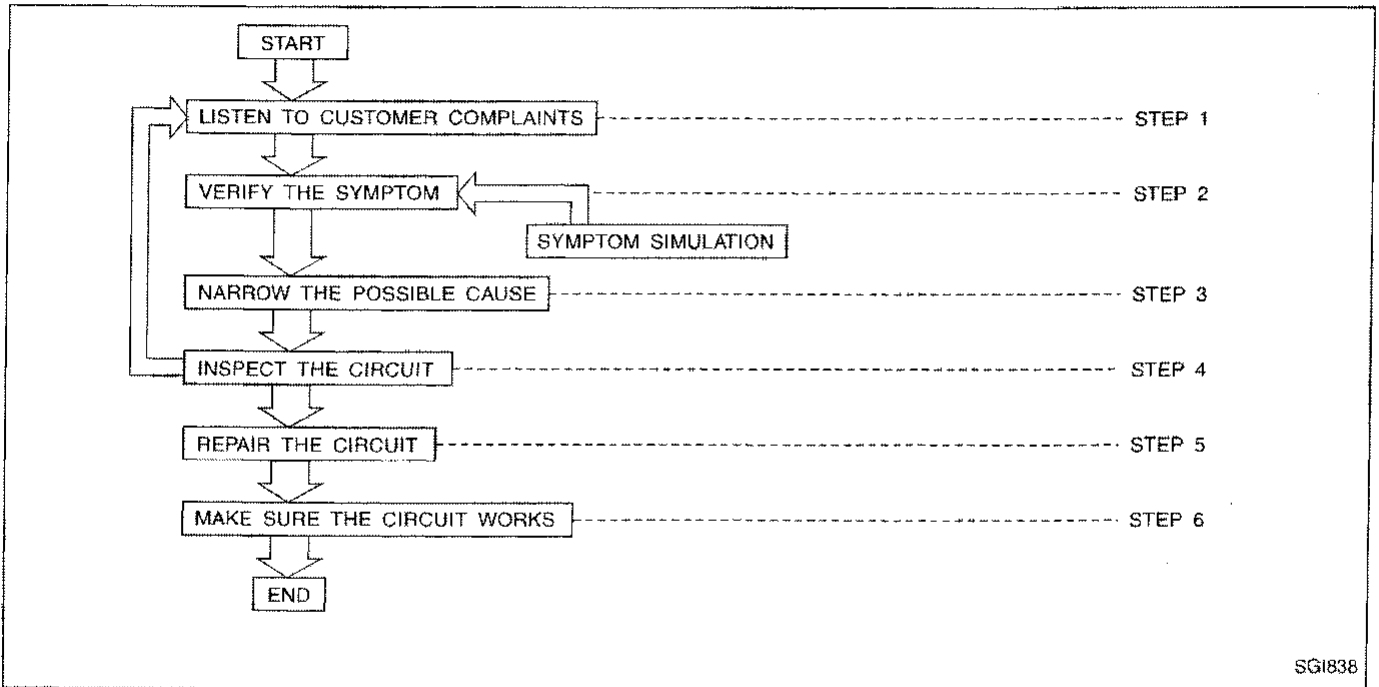

| STEP | DESCRIPTION |
|--------|------------------------------------------------------------------------------------------------------------------------------------------------------------------------------------------------------------------------------------------------------------------------------------------------------------------------------------------------------------------------------------------------------------------------------------------------------------------------------------------------------------------------------------------------------------------|
| STEP 1 | Get detailed information about the conditions and the environment when the incident occurred. The following are key pieces of information required to make a good analysis: WHAT Vehicle Model, Engine, Transmission and the System (i.e. Radio). WHEN Date, Time of Day, Weather Conditions, Frequency. WHERE Road Conditions, Altitude and Traffic Situation. HOW System Symptoms, Operating Conditions (Other Components Interaction). Service History and if any After Market Accessories have been installed. |
| STEP 2 | Operate the system, road test if necessary. Verify the parameter of the incident. If the problem can not be duplicated, refer to "Incident Simulation Tests" next page. |
| STEP 3 | Get the proper diagnosis materials together including: POWER SUPPLY ROUTING System Operation Descriptions Applicable Service Manual Sections Check For Any Service Bulletin* Identify where to begin diagnosis based upon your knowledge of the system operation and the customer comments. |
| STEP 4 | Inspect the system for mechanical binding, loose connectors or wiring damage. Determine which circuits and components are involved and diagnose using the Power Supply Routing and Harness Layouts. |
| STEP 5 | Repair or replace the incident circuit or component. |
| STEP 6 | Operate the system in all modes. Verify the system works properly under all conditions. Make sure you have not inadvertently created a new incident during your diagnosis or repair steps. |

Incident Simulation Tests

INTRODUCTION

Sometimes the symptom is not present when the vehicle is brought in for service. If possible, re-create the conditions present at the time of the incident. Doing so may help avoid a No Trouble Found Diagnosis. The following section illustrates ways to simulate the conditions/environment under which the owner experiences an electrical incident.

The section is broken into the six following topics:

- Vehicle vibration
- Heat sensitive
- Freezing
- Water intrusion
- Electrical load
- Cold or hot start up

Get a thorough description of the incident from the customer. It is important for simulating the conditions of the problem.

VEHICLE VIBRATION

The problem may occur or become worse while driving on a rough road or when engine is vibrating (idle with A/C on). In such a case, you will want to check for a vibration related condition. Refer to the illustration below.

Connectors & harness

Determine which connectors and wiring harness would affect the electrical system you are inspecting. **Gently** shake each connector and harness while monitoring the system for the incident you are trying to duplicate. This test may indicate a loose or poor electrical connection.

Hint

Connectors can be exposed to moisture. It is possible to get a thin film of corrosion on the connector terminals. A visual inspection may not reveal this without disconnecting the connector. If the problem occurs intermittently, perhaps the problem is caused by corrosion. It is a good idea to disconnect, inspect and clean the terminals on related connectors in the system.

Sensors & relays

Gently apply a slight vibration to sensors and relays in the system you are inspecting. This test may indicate a loose or poorly mounted sensor or relay.

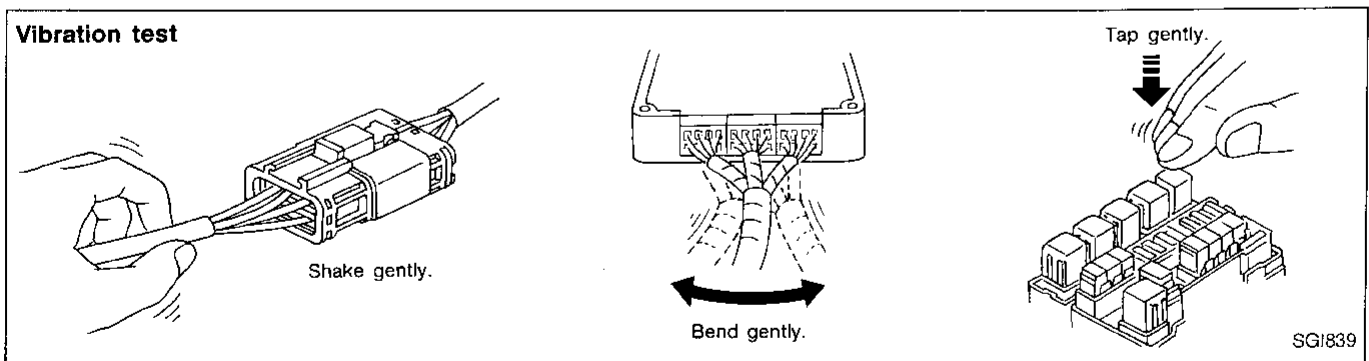

HOW TO PERFORM EFFICIENT DIAGNOSIS FOR AN ELECTRICAL INCIDENT

Incident Simulation Tests (Cont'd)

Engine compartment

There are several reasons a vehicle or engine vibration could cause an electrical complaint. Some of the things to check for are:

- Connectors not fully seated.
- Wiring harness not long enough and is being stressed due to engine vibrations or rocking.
- Wires laying across brackets or moving components.
- Loose, dirty or corroded ground wires.
- Wires routed too close to hot components.

To inspect components under the hood, start by verifying the integrity of ground connections. (Refer to GROUND INSPECTION described later.) First check that the system is properly grounded. Then check for loose connection by **gently shaking** the wiring or components as previously explained. Using the wiring diagrams inspect the wiring for continuity.

Behind the instrument panel

An improperly routed or improperly clamped harness can become pinched during accessory installation. Vehicle vibration can aggravate a harness which is routed along a bracket or near a screw.

Under seating areas

An unclamped or loose harness can cause wiring to be pinched by seat components (such as slide guides) during vehicle vibration. If the wiring runs under seating areas, inspect wire routing for possible damage or pinching.

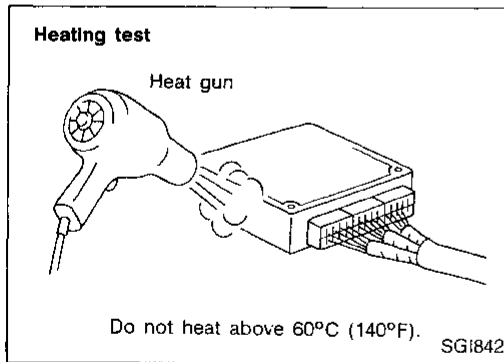

HEAT SENSITIVE

The owner's problem may occur during hot weather or after car has sat for a short time. In such cases you will want to check for a heat sensitive condition.

To determine if an electrical component is heat sensitive, heat the component with a heat gun or equivalent.

Do not heat components above 60°C (140°F). If incident occurs while heating the unit, either replace or properly insulate the component.

GI

MA

EM

LC

EC

FE

CL

MT

AT

FA

RA

BR

ST

RS

BT

HA

EL

IDX

HOW TO PERFORM EFFICIENT DIAGNOSIS FOR AN ELECTRICAL INCIDENT

Incident Simulation Tests (Cont'd)

FREEZING

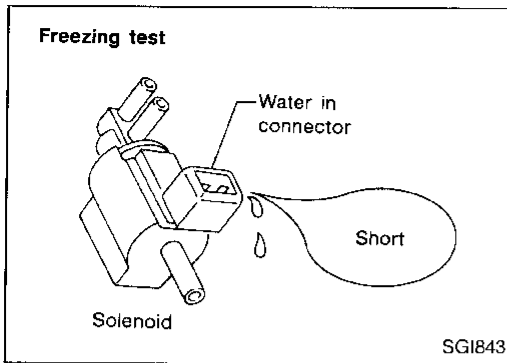

The customer may indicate the incident goes away after the car warms up (winter time). The cause could be related to water freezing somewhere in the wiring/electrical system.

There are two methods to check for this. The first is to arrange for the owner to leave his car overnight. Make sure it will get cold enough to demonstrate his complaint. Leave the car parked outside overnight. In the morning, do a quick and thorough diagnosis of those electrical components which could be affected.

The second method is to put the suspect component into a freezer long enough for any water to freeze. Reinstall the part into the car and check for the reoccurrence of the incident. If it occurs, repair or replace the component.

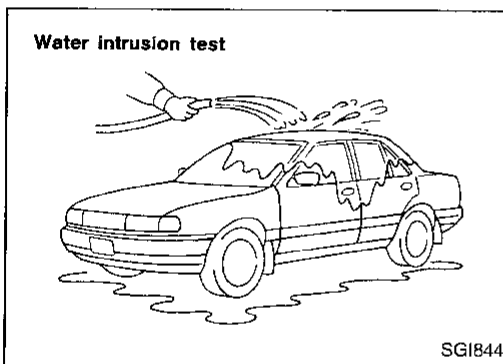

WATER INTRUSION

The incident may occur only during high humidity or in rainy/snowy weather. In such cases the incident could be caused by water intrusion on an electrical part. This can be simulated by soaking the car or running it through a car wash.

Do not spray water directly on any electrical components.

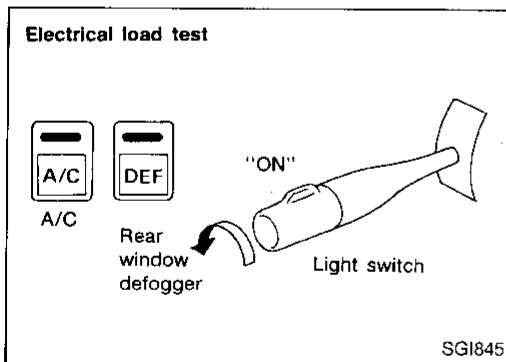

ELECTRICAL LOAD

The incident may be electrical load sensitive. Perform diagnosis with all accessories (including A/C, rear window defogger, radio, fog lamps) turned on.

COLD OR HOT START UP

On some occasions an electrical incident may occur only when the car is started cold. Or it may occur when the car is restarted hot shortly after being turned off. In these cases you may have to keep the car overnight to make a proper diagnosis.

Circuit Inspection

INTRODUCTION

In general, testing electrical circuits is an easy task if it is approached in a logical and organized method. Before beginning it is important to have all available information on the system to be tested. Also, get a thorough understanding of system operation. Then you will be able to use the appropriate equipment and follow the correct test procedure.

You may have to simulate vehicle vibrations while testing electrical components. **Gently shake** the wiring harness or electrical component to do this.

OPEN A circuit is open when there is no continuity through a section of the circuit.

SHORT There are two types of shorts.

- **SHORT CIRCUIT** When a circuit contacts another circuit and causes the normal resistance to change.
- **SHORT TO GROUND** When a circuit contacts a ground source and grounds the circuit.

Note: Refer to "HOW TO CHECK TERMINAL" in GI-18 to probe or check terminal.

TESTING FOR "OPENS" IN THE CIRCUIT

Before you begin to diagnose and test the system, you should rough sketch a schematic of the system. This will help you to logically walk through the diagnosis process. Drawing the sketch will also reinforce your working knowledge of the system.

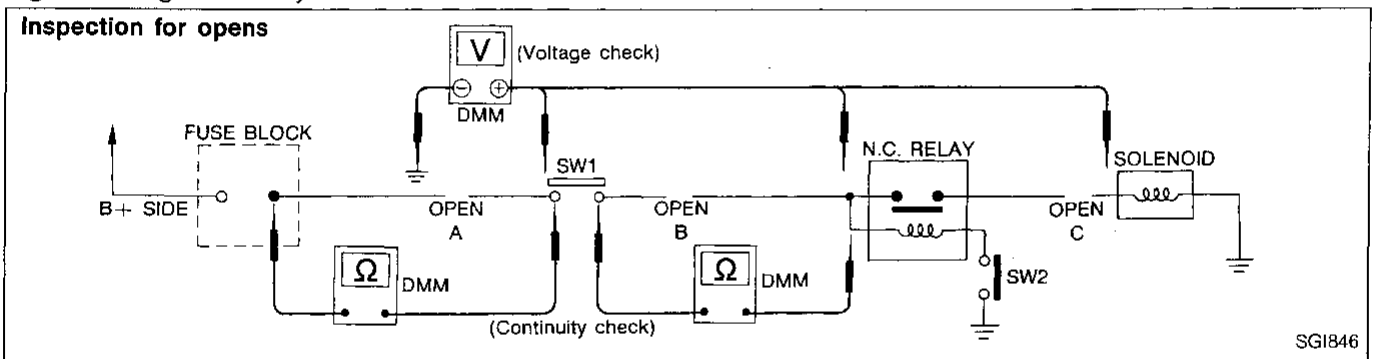

Continuity check method

The continuity check is used to find an open in the circuit. The Digital Multimeter (DMM) set on the resistance function will indicate an open circuit as over limit (OL, no beep tone or no ohms symbol). Make sure to always start with the DMM at the highest resistance level.

To help in understanding the diagnosis of open circuits please refer to the schematic above.

1. Disconnect the battery negative cable.
2. Start at one end of the circuit and work your way to the other end. (At the fuse block in this example)
3. Connect one probe of the DMM to the fuse block terminal on the load side.
4. Connect the other probe to the fuse block (power) side of SW1. Little or no resistance will indicate that portion of the circuit has good continuity. If there were an open in the circuit, the DMM would indicate an over limit or infinite resistance condition. (point A)
5. Connect the probes between SW1 and the relay. Little or no resistance will indicate that portion of the circuit has good continuity. If there were an open in the circuit, the DMM would indicate an over limit or infinite resistance condition. (point B)
6. Connect the probes between the relay and the solenoid. Little or no resistance will indicate that portion of the circuit has good continuity. If there were an open in the circuit, the DMM would indicate an over limit or infinite resistance condition. (point C)

Any circuit can be diagnosed using the approach in the above example.

HOW TO PERFORM EFFICIENT DIAGNOSIS FOR AN ELECTRICAL INCIDENT

Circuit Inspection (Cont'd)

Voltage check method

To help in understanding the diagnosis of open circuits please refer to the previous schematic.

In any powered circuit, an open can be found by methodically checking the system for the presence of voltage. This is done by switching the DMM to the voltage function.

1. Connect one probe of the DMM to a known good ground.
2. Begin probing at one end of the circuit and work your way to the other end.
3. With SW1 open, probe at SW1 to check for voltage.
voltage; open is further down the circuit than SW1.
no voltage; open is between fuse block and SW1 (point A).
4. Close SW1 and probe at relay.
voltage; open is further down the circuit than the relay.
no voltage; open is between SW1 and relay (point B).
5. Close the relay and probe at the solenoid.
voltage; open is further down the circuit than the solenoid.
no voltage; open is between relay and solenoid (point C).

Any powered circuit can be diagnosed using the approach in the above example.

TESTING FOR "SHORTS" IN THE CIRCUIT

To simplify the discussion of shorts in the system please refer to the schematic below.

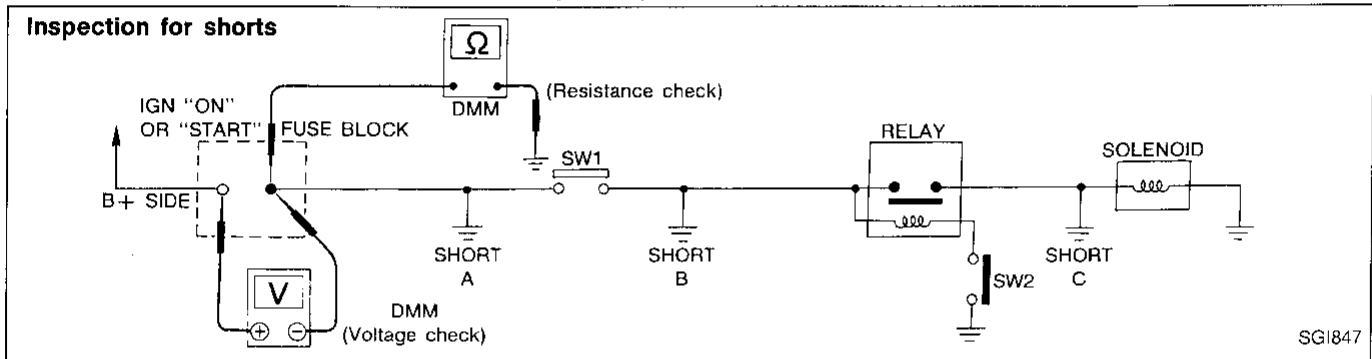

Resistance check method

1. Disconnect the battery negative cable and remove the blown fuse.
2. Disconnect all loads (SW1 open, relay disconnected and solenoid disconnected) powered through the fuse.
3. Connect one probe of the ohmmeter to the load side of the fuse terminal. Connect the other probe to a known good ground.
4. With SW1 open, check for continuity.
continuity; short is between fuse terminal and SW1 (point A).
no continuity; short is further down the circuit than SW1.
5. Close SW1 and disconnect the relay. Put probes at the load side of fuse terminal and a known good ground. Then, check for continuity.
continuity; short is between SW1 and the relay (point B).
no continuity; short is further down the circuit than the relay.
6. Close SW1 and jump the relay contacts with jumper wire. Put probes at the load side of fuse terminal and a known good ground. Then, check for continuity.
continuity; short is between relay and solenoid (point C).
no continuity; check solenoid, retrace steps.

HOW TO PERFORM EFFICIENT DIAGNOSIS FOR AN ELECTRICAL INCIDENT

Circuit Inspection (Cont'd)

Voltage check method

1. Remove the blown fuse and disconnect all loads (i.e. SW1 open, relay disconnected and solenoid disconnected) powered through the fuse.
2. Turn the ignition key to the ON or START position. Verify battery voltage at the B + side of the fuse terminal (one lead on the B + terminal side of the fuse block and one lead on a known good ground).
3. With SW1 open and the DMM leads across both fuse terminals, check for voltage.
voltage; short is between fuse block and SW1 (point A).
no voltage; short is further down the circuit than SW1.
4. With SW1 closed, relay and solenoid disconnected and the DMM leads across both fuse terminals, check for voltage.
voltage; short is between SW1 and the relay (point B).
no voltage; short is further down the circuit than the relay.
5. With SW1 closed, relay contacts jumped with fused jumper wire check for voltage.
voltage; short is down the circuit of the relay or between the relay and the disconnected solenoid (point C).
no voltage; retrace steps and check power to fuse block.

GI

MA

EM

LC

EC

FE

CL

MT

AT

FA

RA

BR

ST

RS

BT

HA

EL

IDX

GROUND INSPECTION

Ground connections are very important to the proper operation of electrical and electronic circuits. Ground connections are often exposed to moisture, dirt and other corrosive elements. The corrosion (rust) can become an unwanted resistance. This unwanted resistance can change the way a circuit works.

Electronically controlled circuits are very sensitive to proper grounding. A loose or corroded ground can drastically affect an electronically controlled circuit. A poor or corroded ground can easily affect the circuit. Even when the ground connection looks clean, there can be a thin film of rust on the surface.

When inspecting a ground connection follow these rules:

1. Remove the ground bolt screw or clip.
2. Inspect all mating surfaces for tarnish, dirt, rust, etc.
3. Clean as required to assure good contact.
4. Reinstall bolt or screw securely.
5. Inspect for "add-on" accessories which may be interfering with the ground circuit.
6. If several wires are crimped into one ground eyelet terminal, check for proper crimps. Make sure all of the wires are clean, securely fastened and providing a good ground path. If multiple wires are cased in one eyelet make sure no ground wires have excess wire insulation.

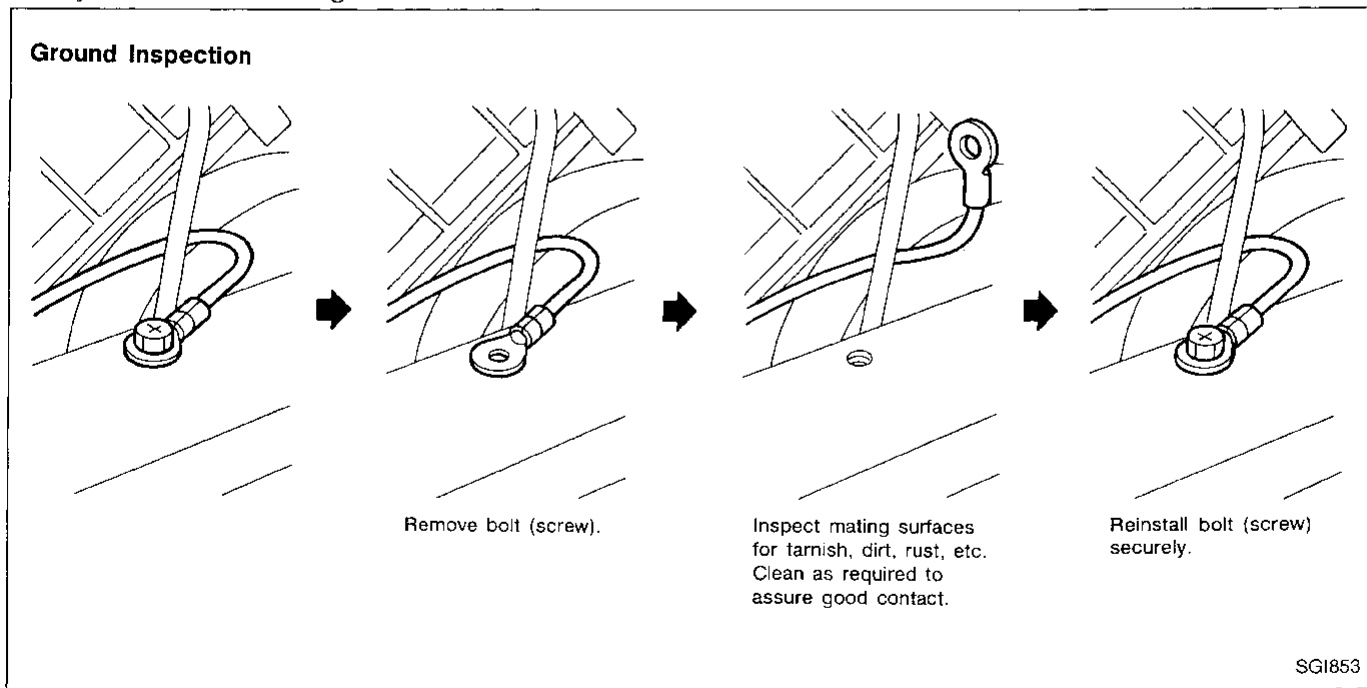

HOW TO PERFORM EFFICIENT DIAGNOSIS FOR AN ELECTRICAL INCIDENT

Circuit Inspection (Cont'd)

VOLTAGE DROP TESTS

Voltage drop tests are often used to find components or circuits which have excessive resistance. A voltage drop in a circuit is caused by a resistance **when the circuit is in operation**.

Check the wire in the illustration. When measuring resistance with ohmmeter, contact by a single strand of wire will give reading of 0 ohms. This would indicate a good circuit. When the circuit operates, this single strand of wire is not able to carry the current. The single strand will have a high resistance to the current. This will be picked up as a slight voltage drop.

Unwanted resistance can be caused by many situations as follows:

Undersized wiring (single strand example)

Corrosion on switch contacts

Loose wire connections or splices.

If repairs are needed always use wire that is of the same or larger gauge.

Measuring voltage drop — Accumulated method

1. Connect the voltmeter across the connector or part of the circuit you want to check. The positive lead of the voltmeter should be closer to power and the negative lead closer to ground.
2. Operate the circuit.
3. The voltmeter will indicate how many volts are being used to "push" current through that part of the circuit.

Note in the illustration that there is an excessive 4.1 volt drop between the battery and the bulb.

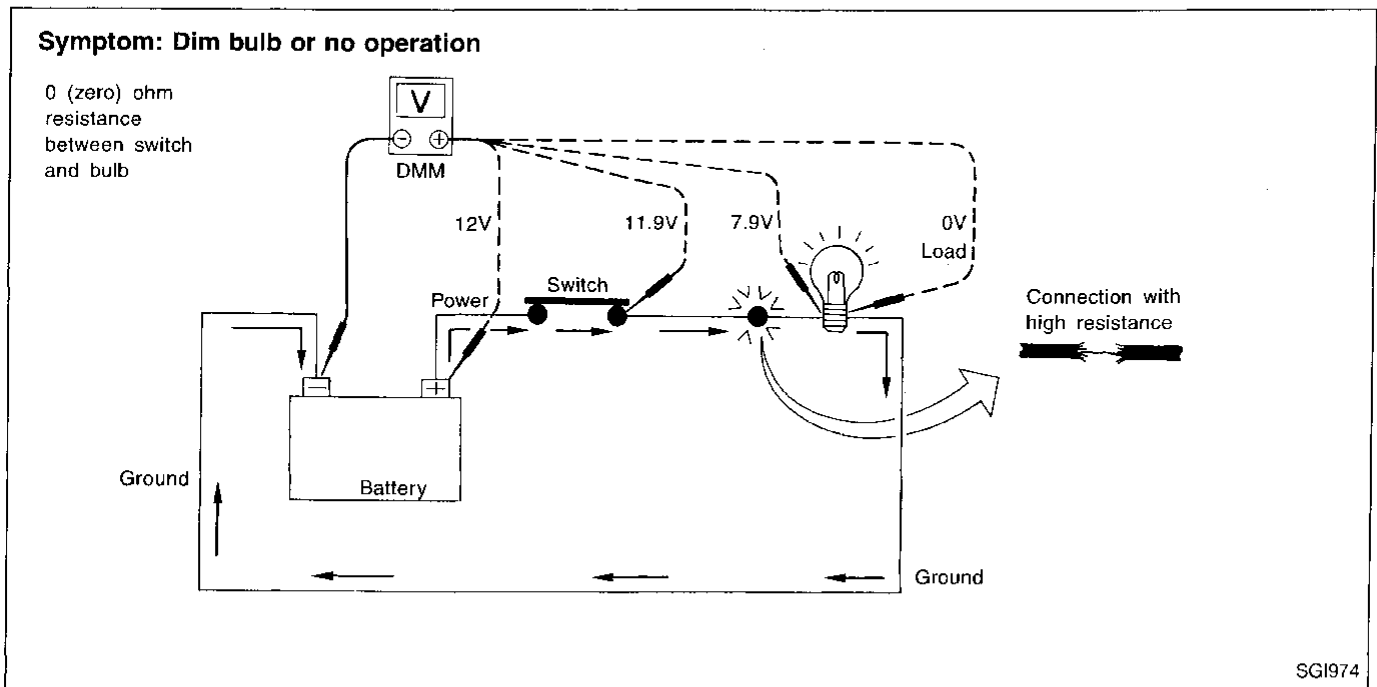

HOW TO PERFORM EFFICIENT DIAGNOSIS FOR AN ELECTRICAL INCIDENT

Circuit Inspection (Cont'd)

Measuring voltage drop — Step by step

The step by step method is most useful for isolating excessive drops in low voltage systems (such as those in "Computer Controlled Systems").

Circuits in the "Computer Controlled System" operate on very low amperage.

The (Computer Controlled) system operations can be adversely affected by any variation in resistance in the system. Such resistance variation may be caused by poor connection, improper installation, improper wire gauge or corrosion.

The step by step voltage drop test can identify a component or wire with too much resistance.

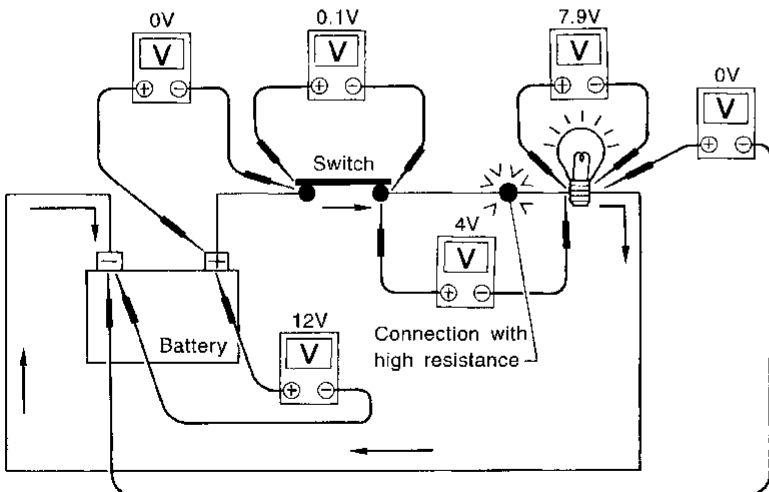

1. Connect the voltmeter as shown, starting at the battery and working your way around the circuit.
2. An unusually large voltage drop will indicate a component or wire that needs to be repaired. As you can see the illustration above, the poor connection causes a 4 volt drop.

The chart that follows illustrates some maximum allowable voltage drops. These values are given as a guideline, the exact value for each component may vary.

| COMPONENT | VOLTAGE DROP |
|--------------------|-------------------------|
| Wire | negligible < .001 volts |
| Ground Connections | Approx. 0.1 volts |
| Switch Contacts | Approx. 0.3 volts |

SGI854

GI
MA
EM
LC
EC
FE
CL
MT
AT
FA
RA
BR
ST
RS
BT
HA
EL
IDX

HOW TO PERFORM EFFICIENT DIAGNOSIS FOR AN ELECTRICAL INCIDENT

Circuit Inspection (Cont'd)

CONTROL UNIT CIRCUIT TEST

System Description: When the switch is ON, the control unit lights up the lamp.

Case 1

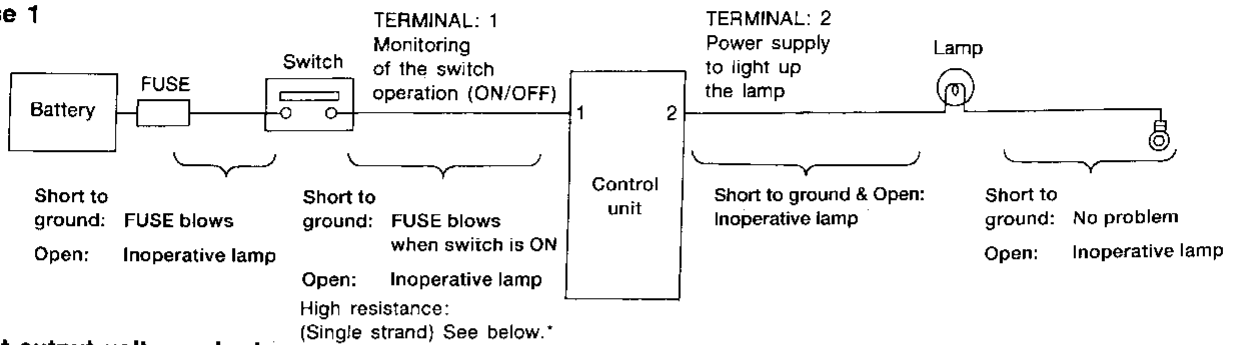

Input-output voltage chart

| Pin No. | Item | Condition | Voltage value [V] | In case of high resistance such as single strand [V] * |
|---------|--------|-----------|-------------------|--------------------------------------------------------|
| 1 | Switch | Switch ON | Battery voltage | Lower than battery voltage Approx. 8 (Example) |
| | | OFF | Approx. 0 | Approx. 0 |
| 2 | Lamp | Switch ON | Battery voltage | Approx. 0 (Inoperative lamp) |
| | | OFF | Approx. 0 | Approx. 0 |

The voltage value is based on the body ground.

*: If high resistance exists in the switch side circuit (caused by a single strand), terminal 1 does not detect battery voltage. Control unit does not detect the switch is ON even if the switch does turn ON. Therefore, the Control unit does not supply power to light up the lamp.

Case 2

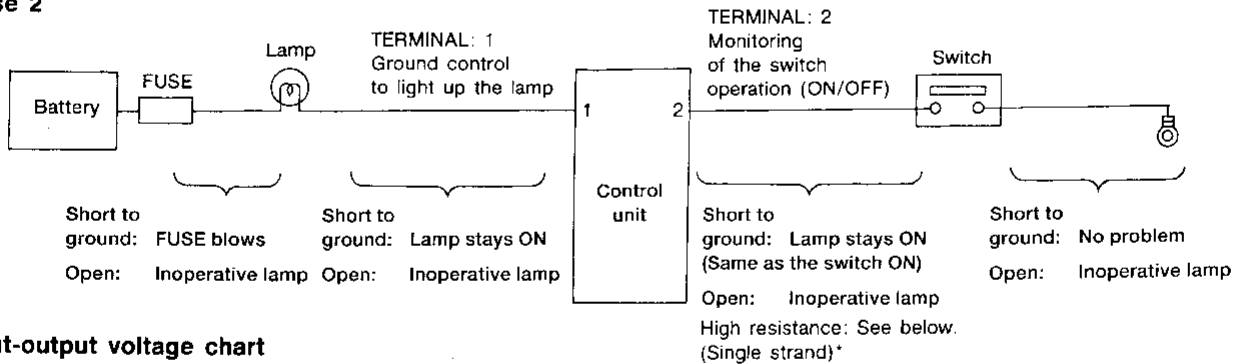

Input-output voltage chart

| Pin No. | Item | Condition | Voltage value [V] | In case of high resistance such as single strand [V] * |
|---------|--------|-----------|-------------------|--------------------------------------------------------|
| 1 | Lamp | Switch ON | Approx. 0 | Battery voltage (Inoperative lamp) |
| | | OFF | Battery voltage | Battery voltage |
| 2 | Switch | Switch ON | Approx. 0 | Higher than 0 Approx. 4 (Example) |
| | | OFF | Approx. 5 | Approx. 5 |

The voltage value is based on the body ground.

*: If high resistance exists in the switch side circuit (caused by a single strand), terminal 2 does not detect approx. 0V. Control unit does not detect the switch is ON even if the switch does turn ON. Therefore, the Control unit does not control ground to light up the lamp.

AGI059

HOW TO FOLLOW FLOW CHART IN TROUBLE DIAGNOSES

NOTICE

The flow chart indicates work procedures required to diagnose problems effectively. Observe the following instructions before diagnosing.

- 1) Use the flow chart after locating probable causes of a problem following the "Preliminary Check", the "Symptom Chart" or the "Work Flow".
- 2) After repairs, re-check that the problem has been completely eliminated.
- 3) Refer to Component Parts and Harness Connector Location for the Systems described in each section for identification/location of components and harness connectors.
- 4) Refer to the Circuit Diagram for Quick Pinpoint Check. If you must check circuit continuity between harness connectors in more detail, such as when a sub-harness is used, refer to Wiring Diagram in each individual section and Harness Layout in EL section for identification of harness connectors.
- 5) When checking circuit continuity, ignition switch should be "OFF".
- 6) Before checking voltage at connectors, check battery voltage.
- 7) After accomplishing the Diagnostic Procedures and Electrical Components Inspection, make sure that all harness connectors are reconnected as they were.

Example

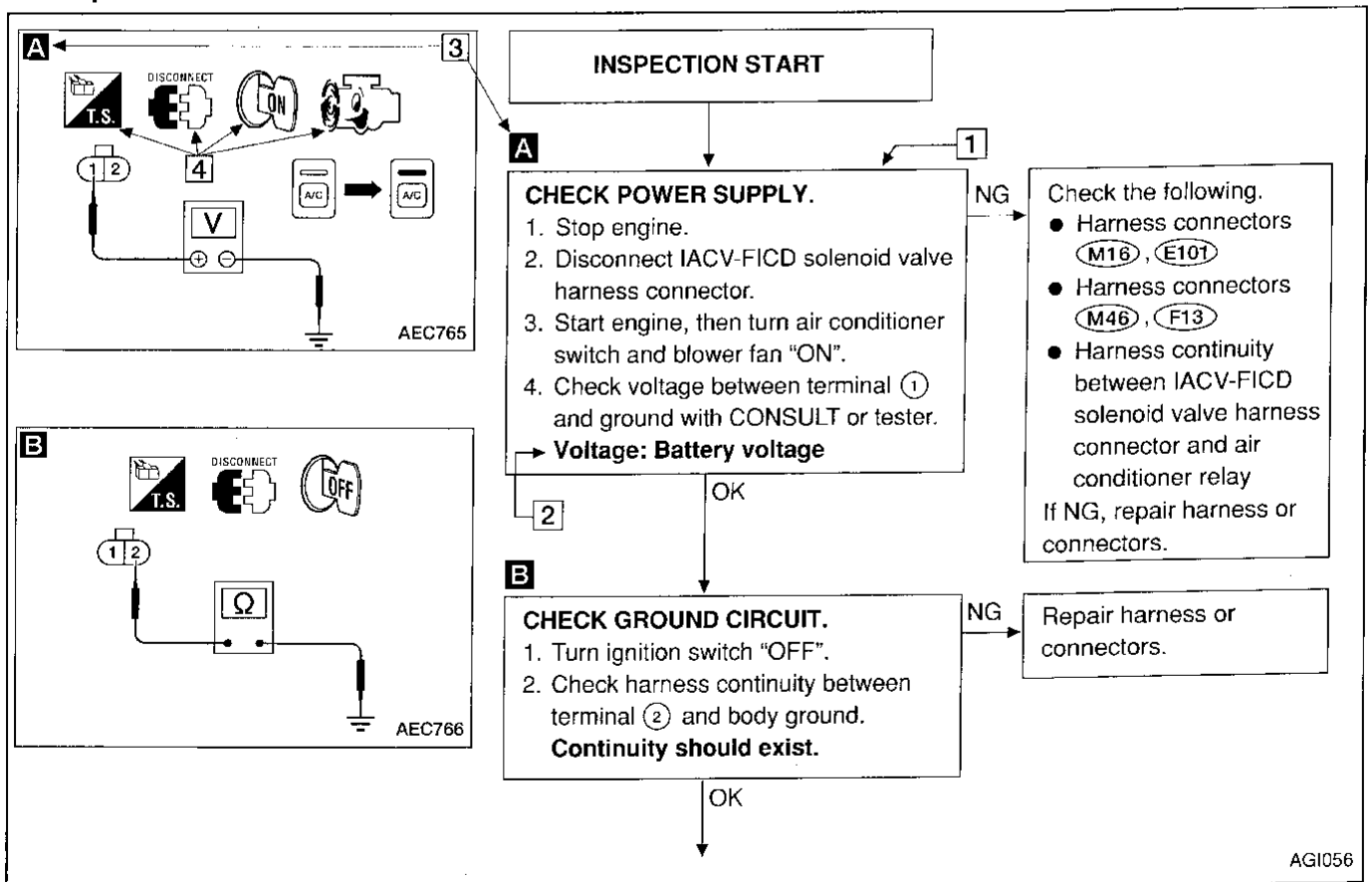

How to Follow This Flow Chart

1 Work and diagnostic procedure

Start to diagnose a problem using procedures indicated in enclosed blocks, as shown in the following example.

A

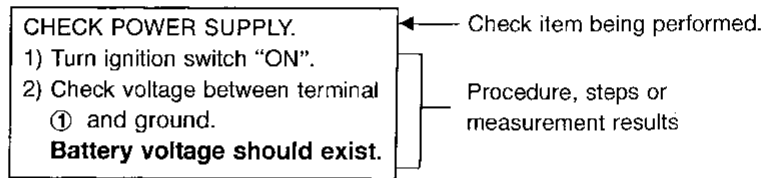

2 Measurement results

Required results are indicated in bold type in the corresponding block, as shown below:

These have the following meanings:

Battery voltage → 11 - 14V or approximately 12V

Voltage: Approximately 0V → Less than 1V

3 Cross reference of work symbols in the text and illustrations

Illustrations are provided as visual aids for work procedures. For example, symbol **A** indicated in the left upper portion of each illustration corresponds with the symbol in the flow chart for easy identification. More precisely, the procedure under the "CHECK POWER SUPPLY" outlined previously is indicated by illustration **A**.

4 Symbols used in illustrations

Symbols included in illustrations refer to measurements or procedures. Before diagnosing a problem, familiarize yourself with each symbol.

DIRECTION MARK

Refer to "CONNECTOR SYMBOLS" on GI-13.

HOW TO FOLLOW FLOW CHART IN TROUBLE DIAGNOSES

How to Follow This Flow Chart (Cont'd)

Key to symbols signifying measurements or procedures

| Symbol | Symbol explanation | Symbol | Symbol explanation |
|--------|---------------------------------------------------------|----------------------------------------------------------------------------------------------------------------------------------------------------------------------------------------------------|-----------------------------------------------------------------------|
| | Check after disconnecting the connector to be measured. | | Procedure with Generic Scan Tool (GST, OBD-II scan tool) |
| | Check after connecting the connector to be measured. | | Procedure without CONSULT or GST |
| | Insert key into ignition switch. | | A/C switch is "OFF". |
| | Remove key from ignition switch. | | A/C switch is "ON". |
| | Turn ignition switch to "OFF" position. | | REC switch is "ON". |
| | Turn ignition switch to "ON" position. | | REC switch is "OFF". |
| | Turn ignition switch to "START" position. | | DEF switch is "ON". |
| | Turn ignition switch from "OFF" to "ACC" position. | | Fan switch is "ON". (At any position except for "OFF" position) |
| | Turn ignition switch from "ACC" to "OFF" position. | | Fan switch is "OFF". |
| | Turn ignition switch from "OFF" to "ON" position. | | Apply positive voltage from battery with fuse directly to components. |
| | Turn ignition switch from "ON" to "OFF" position. | | Drive vehicle. |
| | Do not start engine, or check with engine stopped. | | Disconnect battery negative cable. |
| | Start engine, or check with engine running. | | Depress brake pedal. |
| | Apply parking brake. | | Release brake pedal. |
| | Release parking brake. | | Depress accelerator pedal. |
| | Check after engine is warmed up sufficiently. | | Release accelerator pedal. |
| | Voltage should be measured with a voltmeter. | <p>TCM CONNECTOR or ECM CONNECTOR</p> <p>Pin terminal check for SMJ type ECM and TCM connectors. For details regarding the terminal arrangement, refer to the foldout page.</p> | |
| | Circuit resistance should be measured with an ohmmeter. | | |
| | Current should be measured with an ammeter. | | |
| | Procedure with CONSULT | | |
| | Procedure without CONSULT | | |

GI
MA
EM
LC
EC
FE
CL
MT
AT
FA
RA
BR
ST
RS
BT
HA
EL
IDX

CONSULT CHECKING SYSTEM

Function and System Application

| Diagnostic test mode | Function | ECCS | A/T | Air bag | ABS | ASCD | *IVMS |
|---------------------------|---------------------------------------------------------------------------------------------------------------------------------------|------|-----|---------|-----|------|-------|
| Work support | This mode enables a technician to adjust some devices faster and more accurately by following the indications on CONSULT. | x | — | — | — | — | — |
| Self-diagnostic results | Self-diagnostic results can be read and erased quickly. | x | x | x | x | x | x |
| Trouble diagnostic record | Current self-diagnostic results and all trouble diagnostic records previously stored can be read. | — | — | x | — | — | — |
| ECU discriminated No. | Classification number of a replacement ECU can be read to prevent an incorrect ECU from being installed. | — | — | x | — | — | — |
| Data monitor | Input/Output data in the ECM can be read. | x | x | — | x | x | x |
| DTC work support | This mode enables a technician to set operating conditions to confirm self-diagnosis status/results. | — | x | — | — | — | — |
| Active test | Diagnostic Test Mode in which CONSULT drives some actuators apart from the ECMs and also shifts some parameters in a specified range. | x | — | — | x | — | x |
| ECM part number | ECM part number can be read. | x | x | — | x | — | x |
| Function test | Conducted by CONSULT instead of a technician to determine whether each system is "OK" or "NG". | x | — | — | — | — | — |
| DTC confirmation | The results of SRT (System Readiness Test) and the self-diagnosis status/results can be confirmed. | x | — | — | — | — | — |

x: Applicable

*IVMS: In-vehicle multiplexing system

Lithium Battery Replacement

CONSULT contains a lithium battery. When replacing the battery obey the following:

WARNING:

Replace the lithium battery with SANYO Electric Co., Ltd., CR2032 only. Use of another battery may present a risk of fire or explosion. The battery may present a fire or chemical burn hazard if mistreated. Do not recharge, disassemble or dispose of in fire.

Keep the battery out of reach of children and discard used battery conforming to the local regulations.

Checking Equipment

When ordering the below equipment, contact your NISSAN/INFINITI distributor.

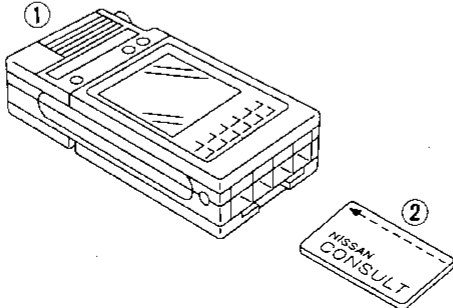
| Tool name | Description |
|--------------------------------------------------------------------------------------------------------------------------------------|-------------------------------------------------------------------------------------------------------------------------------|
| NISSAN CONSULT ① CONSULT unit and accessories ② Program card UE950, UE951 and UEOBD98 (For Engine and A/T System) |  <p style="text-align: center;">NT004</p> |

CONSULT CHECKING SYSTEM

Loading Procedure

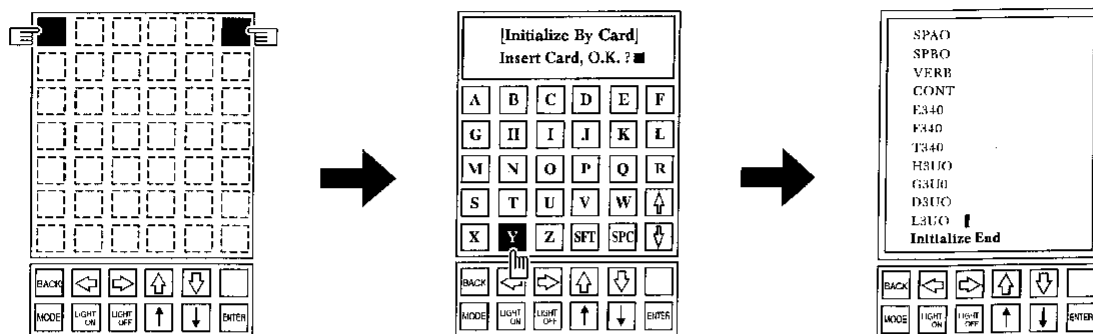

1. While holding down the upper left and right corner keys of the CONSULT touch panel, simultaneously press the power "ON" switch. While pushing the power "ON" switch, hold down both corner keys until the next screen appears.
2. If the initialization was done correctly, the following message will appear at the top of the display: "[Initialize By Card] Insert Card, O.K.?"
3. Insert the program card into the CONSULT program card reader.
4. Press "Y" on the touch panel.
5. Now the program will start to load.
6. After the "Initialize End" message appears, touch the "OFF" switch.

SGI983

CONSULT Data Link Connector (DLC) Circuit

Example

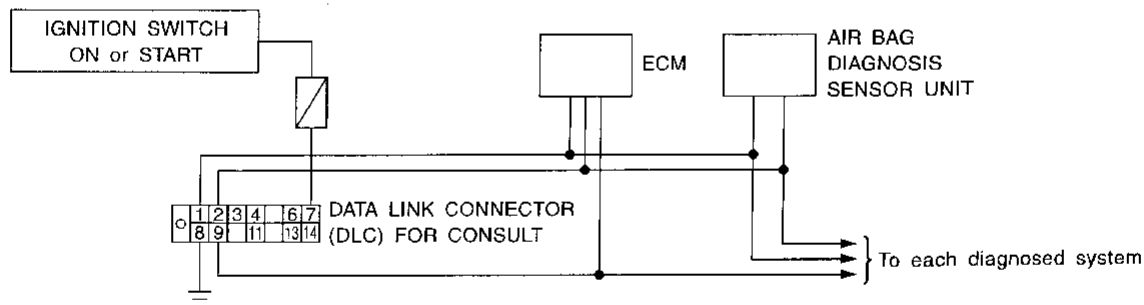

SGI984

INSPECTION PROCEDURE

If the CONSULT cannot diagnose the system properly, check the following items.

| Symptom | Check item |
|---------------------------------------------------------------------------|-------------------------------------------------------------------------------------------------------------------------------------------------------------------------------------------------------------------------------------------------------------------------------------------------------------------------------------------------------------------------------------------------------------------------------------------|
| CONSULT cannot access any system. | <ul style="list-style-type: none"> • CONSULT DLC power supply circuit (Terminal 7) and ground circuit (Terminal 8) (For detailed circuit, refer to "MIL & Data Link Connectors Wiring Diagram" in EC section.) • CONSULT DDL cable |
| CONSULT cannot access individual system. (Other systems can be accessed.) | <ul style="list-style-type: none"> • CONSULT program card (Check the appropriate CONSULT program card for the system. Refer to GI-34.) • Power supply and ground circuit for the control unit of the system (For detailed circuit, refer to wiring diagram for each system.) • Open or short circuit between the system and CONSULT DLC (For detailed circuit, refer to wiring diagram for each system.) |

IDENTIFICATION INFORMATION

Model Variation

| Body | Engine | Grade | Transaxle | Destination | | |
|-------|--------|----------------|-----------|------------------------|--------------------|---------------|
| | | | | Non-California, U.S.A. | California, U.S.A. | Canada |
| Sedan | VQ30DE | GXE | RE4F04A*1 | BLHULEA-EUA*3 | BLHULEA-EVA*3 | BLHULEA-ENA*3 |
| | | | RS5F50A*2 | BLHULEF-EUA | BLHULEF-EVA | BLHULEF-ENA |
| | | GLE | RE4F04A*1 | BLHULGA-EUA | BLHULGA-EVA | BLHULEA-ENA |
| | | SE, SE-S, SE-L | RE4F04A*1 | BLHULVA-EUA | BLHULVA-EVA | BLHULVA-ENA |
| | | | RS5F50A*2 | BLHULVF-EUA | BLHULVF-EVA | BLHULVF-ENA |

*1: The automatic transaxle with viscous LSD is "RE4F04V".

*2: The manual transaxle with viscous LSD is "RS5F50V".

*3: GXE or GXE-L grade

Prefix and suffix designations:

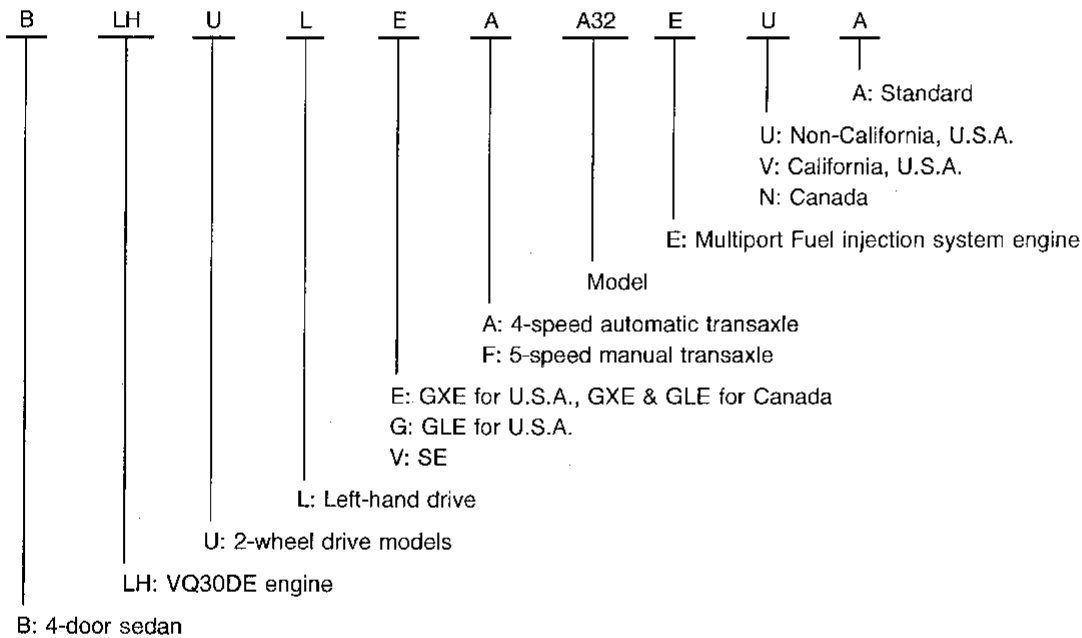

IDENTIFICATION INFORMATION

Identification Number (Cont'd)

IDENTIFICATION PLATE

| | | | |
|------------------------------|----------------------|---------------|--------|
| NISSAN MOTOR CO., LTD. JAPAN | | | |
| 型式 | TYPE | △ | |
| TIPO | | | |
| CHASSIS NO. | NO. DE CHASSIS | △ | |
| MODEL | MODELO | △ | |
| ○ | カラー-COLOR TRIM | △ | ○ |
| | トリム-COLOR GUARNICION | △ | |
| エン | ENGINE | △ | CC |
| ジン | MOTOR | △ | |
| ミッション | TRANS. AXLE | △ | |
| アックスル | TRANS. EJE | △ | |
| | 工場 | PLANT | PLANTA |
| 日産自動車株式会社 | | MADE IN JAPAN | |

- 1 Type
- 2 Vehicle identification number (Chassis number)
- 3 Model
- 4 Body color code
- 5 Trim color code
- 6 Engine model
- 7 Engine displacement
- 8 Transmission model
- 9 Axle model

SGI315

ENGINE SERIAL NUMBER

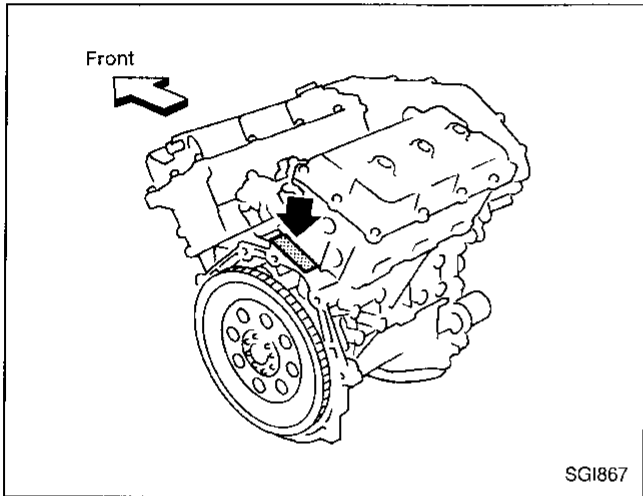

MANUAL TRANSAXLE NUMBER

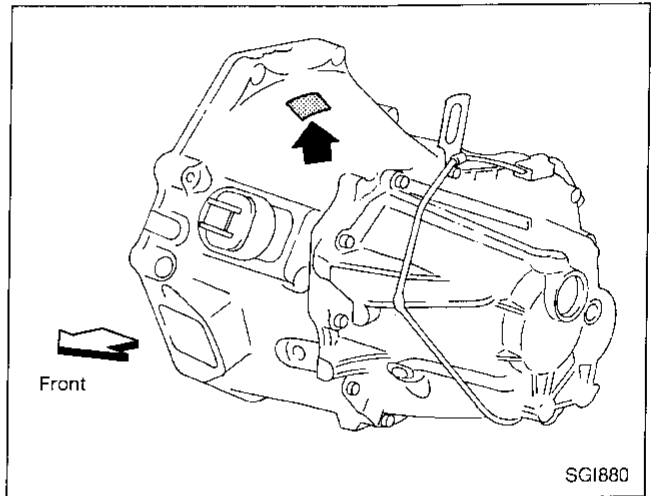

AUTOMATIC TRANSAXLE NUMBER

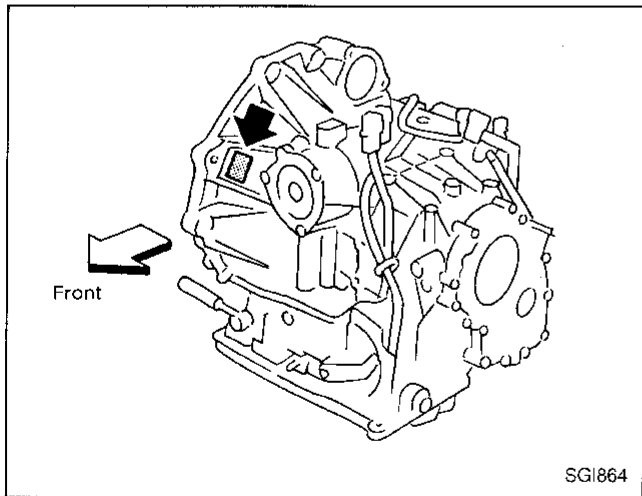

IDENTIFICATION INFORMATION

Dimensions

| | | | Sedan |
|-----------------------------|---------|--|-----------------------------------------------------------------------|
| Overall length | mm (in) | | 4,810 (189.4) |
| Overall width | mm (in) | | 1,770 (69.7) |
| Overall height | mm (in) | | 1,415 (55.7) |
| Front tread | mm (in) | | 1,530 (60.2)*1 |
| | | | 1,520 (59.8)*2 |
| Rear tread | mm (in) | | 1,510 (59.4)*1 |
| | | | 1,500 (59.1)*2 |
| Wheelbase | mm (in) | | 2,700 (106.3) |
| Gross vehicle weight rating | kg (lb) | | |
| Gross axle weight rating | | | See the "FMVSS certification label" on the driver's side lock pillar. |
| Front | kg (lb) | | |
| Rear | kg (lb) | | |

*1: For models with steel wheels

*2: For models with aluminum wheels

Wheels and Tires

| | | | |
|------------|--------------|---------|----------------------------------------------------|
| Road wheel | Steel | | 15 x 6JJ |
| | Offset | mm (in) | 40 (1.57) |
| | Aluminum | | 15 x 6.5JJ 16 x 6.5JJ |
| | Offset | mm (in) | 45 (1.77) |
| Tire size | Conventional | | P205/65R15 92S P205/65R15 92H P215/55R16 91H |
| | Spare | | Conventional*1 T125/70D16*2 T125/90D16*2, *3 |

*1: For Canada

*2: For U.S.A.

*3: For models with viscous LSD

GI
 MA
 EM
 LC
 EC
 PE
 CL
 MT
 AT
 FA
 RA
 BR
 ST
 RS
 BT
 HA
 EL
 IDX

LIFTING POINTS AND TOW TRUCK TOWING

Preparation

SPECIAL SERVICE TOOLS

The actual shapes of Kent-Moore tools may differ from those of special service tools illustrated here.

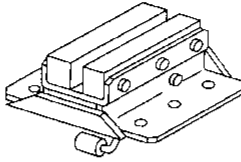
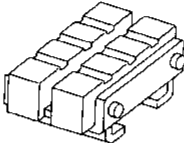
| Tool number (Kent-Moore number) Tool name | Description |
|-------------------------------------------------|---------------------------------------------------------------------------------------------|
| LM4086-0200 (—) Board on attachment |  NT001 |
| LM4519-0000 (—) Safety stand attachment |  NT002 |

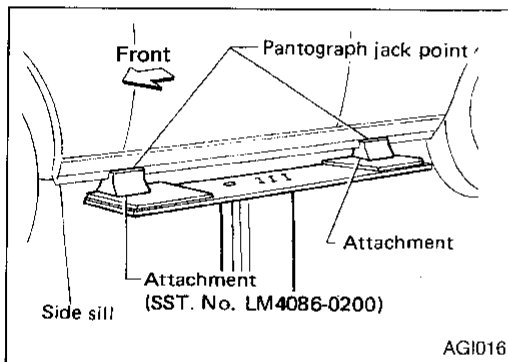

Board-on Lift

CAUTION:

Make sure vehicle is empty when lifting.

- The board-on lift attachment (LM4086-0200) set at front end of vehicle should be set on the front of the sill under the front door opening.
- Position attachments at front and rear ends of board-on lift.

LIFTING POINTS AND TOW TRUCK TOWING

Garage Jack and Safety Stand

WARNING:

- Never get under the vehicle while it is supported only by the jack. Always use safety stands when you have to get under the vehicle.
- Place wheel chocks at both front and back of the wheels on the ground.

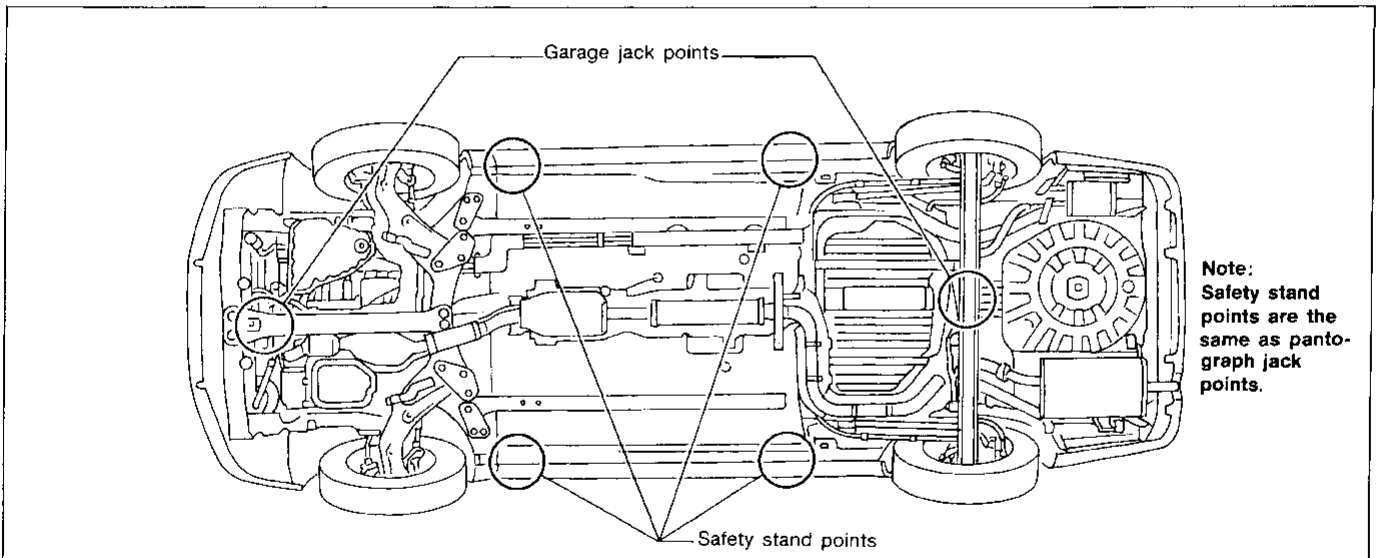

Use safety stand adapter as shown for stable support.

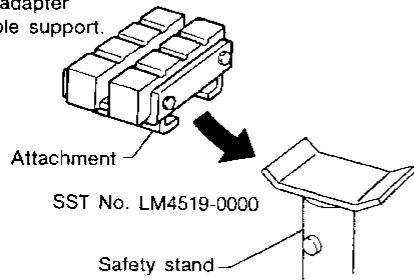

Fit the lower side sill into groove.

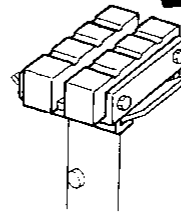

SGI902

LIFTING POINTS AND TOW TRUCK TOWING

2-pole Lift

WARNING:

When lifting the vehicle, open the lift arms as wide as possible and ensure that the front and rear of the vehicle are well balanced.

When setting the lift arm, do not allow the arm to contact the brake tubes and fuel lines.

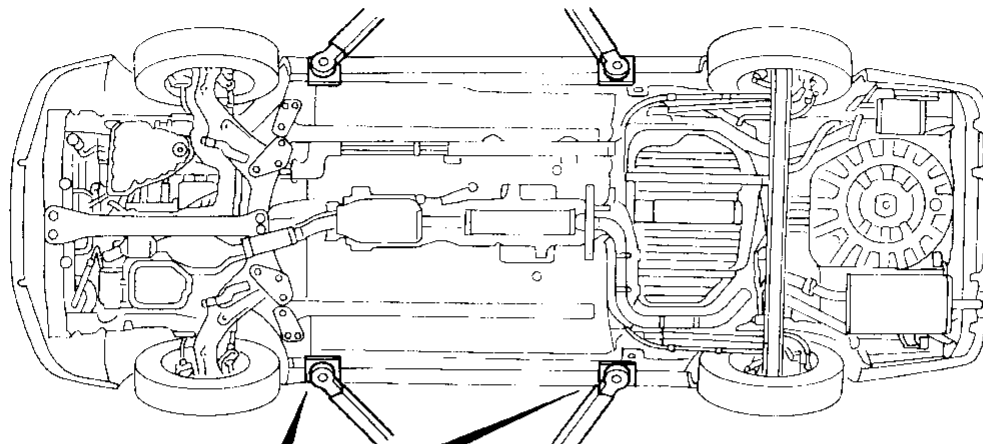

Note:
Lift-up points
are the same as
pantograph jack
points.



Put the sill in the groove of the lift pad to prevent the sill from deforming. If the pad does not have a groove, prepare a suitable attachment with one.

SGI903

Tow Truck Towing

CAUTION:

- When towing, make sure that the transaxle, axles, steering system, and powertrain are in working condition. If any unit is damaged, towing dollies, or a flat bed truck must be used.
- Always attach safety chains before towing.

NISSAN recommends that the vehicle be towed with the driving (front) wheels off the ground as illustrated.

CAUTION:

- Always release the parking brake when towing the vehicle with the front wheels raised with the rear wheels on the ground.
- When towing manual transaxle models with the front wheels on the ground (If a towing dollies does not be used), turn the ignition key to the OFF position, and secure the steering wheel in the straight-ahead position with a rope or similar device. Never place the ignition key in the LOCK position. This will result in damage to the steering lock mechanism. Move the shift lever to the N (Neutral) position.
- Never tow an automatic transaxle model with the rear wheels raised and the front wheels on the ground. This may cause serious and expensive damage to the transaxle. If it is necessary to tow the vehicle with the rear wheels raised, always use towing dollies under the front wheels.
- Never tow an automatic transaxle model from the rear (i.e., backward) with four wheels on the ground. This may cause serious and expensive damage to the transaxle.

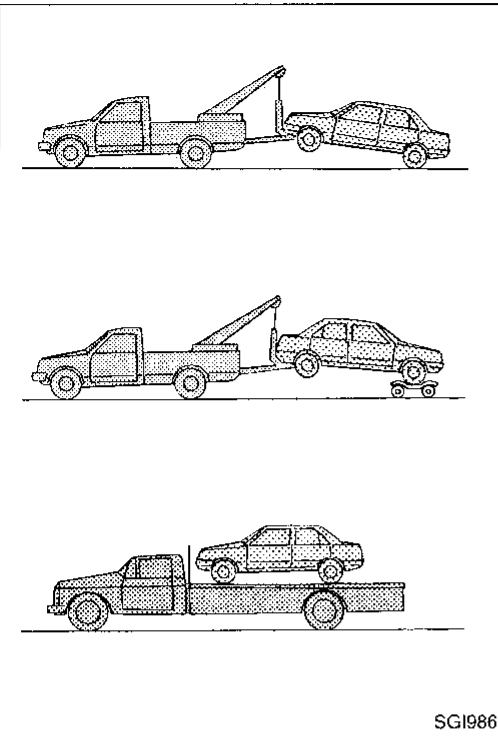

SGI986

Automatic transaxle model

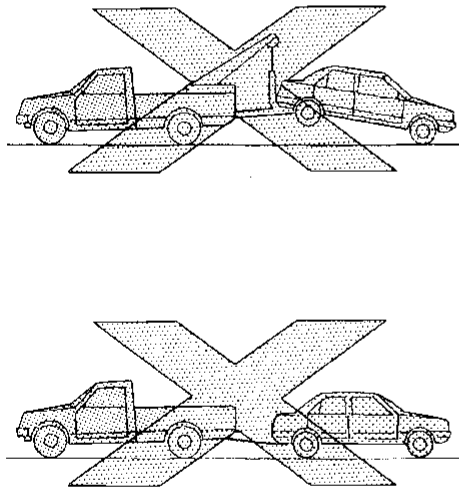

SGI987

VEHICLE RECOVERY (Freeing a stuck vehicle)

- Tow chains or cables must be attached only to the main structural members of the vehicle.
- Pulling devices should be routed so they do not touch any part of the suspension, steering, brake or cooling systems.
- Always pull the cable straight out from the front or rear of the vehicle. Never pull on the vehicle at a sideways angle.
- Pulling devices such as ropes or canvas straps are not recommended for use in vehicle towing or recovery.

GI

MA

EM

LC

EC

FE

CL

MT

AT

FA

RA

BR

ST

RS

BT

HA

EL

IDX

TIGHTENING TORQUE OF STANDARD BOLTS

| Grade | Bolt size | Bolt diameter* mm | Pitch mm | Tightening torque (Without lubricant) | | | | | | | |
|-------|-----------|-------------------|----------|---------------------------------------|------|-------|-------|---------------------|------|-------|-------|
| | | | | Hexagon head bolt | | | | Hexagon flange bolt | | | |
| | | | | N-m | kg-m | ft-lb | in-lb | N-m | kg-m | ft-lb | in-lb |
| 4T | M6 | 6.0 | 1.0 | 5.1 | 0.52 | 3.8 | 45.1 | 6.1 | 0.62 | 4.5 | 53.8 |
| | M8 | 8.0 | 1.25 | 13 | 1.3 | 9 | — | 15 | 1.5 | 11 | — |
| | | | 1.0 | 13 | 1.3 | 9 | — | 16 | 1.6 | 12 | — |
| | M10 | 10.0 | 1.5 | 25 | 2.5 | 18 | — | 29 | 3.0 | 22 | — |
| | | | 1.25 | 25 | 2.6 | 19 | — | 30 | 3.1 | 22 | — |
| | M12 | 12.0 | 1.75 | 42 | 4.3 | 31 | — | 51 | 5.2 | 38 | — |
| 1.25 | | | 46 | 4.7 | 34 | — | 56 | 5.7 | 41 | — | |
| M14 | 14.0 | 1.5 | 74 | 7.5 | 54 | — | 88 | 9.0 | 65 | — | |
| 7T | M6 | 6.0 | 1.0 | 8.4 | 0.86 | 6.2 | 74.6 | 10 | 1.0 | 7 | 87 |
| | M8 | 8.0 | 1.25 | 21 | 2.1 | 15 | — | 25 | 2.5 | 18 | — |
| | | | 1.0 | 22 | 2.2 | 16 | — | 26 | 2.7 | 20 | — |
| | M10 | 10.0 | 1.5 | 41 | 4.2 | 30 | — | 48 | 4.9 | 35 | — |
| | | | 1.25 | 43 | 4.4 | 32 | — | 51 | 5.2 | 38 | — |
| | M12 | 12.0 | 1.75 | 71 | 7.2 | 52 | — | 84 | 8.6 | 62 | — |
| 1.25 | | | 77 | 7.9 | 57 | — | 92 | 9.4 | 68 | — | |
| M14 | 14.0 | 1.5 | 127 | 13.0 | 94 | — | 147 | 15.0 | 108 | — | |
| 9T | M6 | 6.0 | 1.0 | 12 | 1.2 | 9 | — | 15 | 1.5 | 11 | — |
| | M8 | 8.0 | 1.25 | 29 | 3.0 | 22 | — | 35 | 3.6 | 26 | — |
| | | | 1.0 | 31 | 3.2 | 23 | — | 37 | 3.8 | 27 | — |
| | M10 | 10.0 | 1.5 | 59 | 6.0 | 43 | — | 70 | 7.1 | 51 | — |
| | | | 1.25 | 62 | 6.3 | 46 | — | 74 | 7.5 | 54 | — |
| | M12 | 12.0 | 1.75 | 98 | 10.0 | 72 | — | 118 | 12.0 | 87 | — |
| 1.25 | | | 108 | 11.0 | 80 | — | 137 | 14.0 | 101 | — | |
| M14 | 14.0 | 1.5 | 177 | 18.0 | 130 | — | 206 | 21.0 | 152 | — | |

1. Special parts are excluded.
2. This standard is applicable to bolts having the following marks embossed on the bolt head.

| Grade | Mark |
|----------|------|
| 4T | 4 |
| 7T | 7 |
| 9T | 9 |

*: Nominal diameter

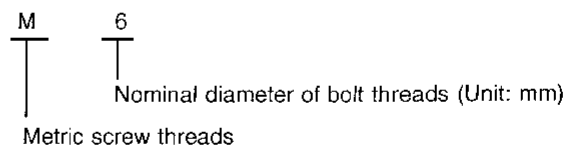

SAE J1930 TERMINOLOGY LIST

SAE J1930 Terminology List

All emission related terms used in this publication in accordance with SAE J1930 are listed. Accordingly, new terms, new acronyms/abbreviations and old terms are listed in the following chart.

***: Not applicable

| NEW TERM | NEW ACRONYM / ABBREVIATION | OLD TERM | GI |
|-----------------------------------------------------|-------------------------------|----------------------------------|-----|
| Air cleaner | ACL | Air cleaner | MA |
| Barometric pressure | BARO | *** | |
| Barometric pressure sensor-BCDD | BAROS-BCDD | BCDD | EM |
| Camshaft position | CMP | *** | |
| Camshaft position sensor | CMPS | Crank angle sensor | LC |
| Canister | *** | Canister | |
| Carburetor | CARB | Carburetor | EC |
| Charge air cooler | CAC | Intercooler | |
| Closed loop | CL | Closed loop | FE |
| Closed throttle position switch | CTP switch | Idle switch | |
| Clutch pedal position switch | CPP switch | Clutch switch | CL |
| Continuous fuel injection system | CFI system | *** | |
| Continuous trap oxidizer system | CTOX system | *** | |
| Crankshaft position | CKP | *** | MT |
| Crankshaft position sensor | CKPS | *** | |
| Data link connector | DLC | *** | AT |
| Data link connector for CONSULT | DLC for CONSULT | Diagnostic connector for CONSULT | |
| Diagnostic test mode | DTM | Diagnostic mode | FA |
| Diagnostic test mode selector | DTM selector | Diagnostic mode selector | |
| Diagnostic test mode I | DTM I | Mode I | RA |
| Diagnostic test mode II | DTM II | Mode II | |
| Diagnostic trouble code | DTC | Malfunction code | BR |
| Direct fuel injection system | DFI system | *** | |
| Distributor ignition system | DI system | Ignition timing control | ST |
| Early fuel evaporation-mixture heater | EFE-mixture heater | Mixture heater | |
| Early fuel evaporation system | EFE system | Mixture heater control | RS |
| Electrically erasable programmable read only memory | EEPROM | *** | |
| Electronic ignition system | EI system | Ignition timing control | BT |
| Engine control | EC | *** | |
| Engine control module | ECM | ECCS control unit | HA |
| Engine coolant temperature | ECT | Engine temperature | |
| Engine coolant temperature sensor | ECTS | Engine temperature sensor | EL |
| Engine modification | EM | *** | |
| Engine speed | RPM | Engine speed | IDX |
| Erasable programmable read only memory | EPROM | *** | |
| Evaporative emission canister | EVAP canister | Canister | |

SAE J1930 TERMINOLOGY LIST

SAE J1930 Terminology List (Cont'd)

***: Not applicable

| NEW TERM | NEW ACRONYM / ABBREVIATION | OLD TERM |
|-----------------------------------------------------------|-------------------------------------|-------------------------------------|
| Evaporative emission system | EVAP system | Evaporative emission control system |
| Exhaust gas recirculation valve | EGR valve | EGR valve |
| Exhaust gas recirculation control-BPT valve | EGRC-BPT valve | BPT valve |
| Exhaust gas recirculation control-solenoid valve | EGRC-solenoid valve | EGR control solenoid valve |
| Exhaust gas recirculation temperature sensor | EGRT sensor | Exhaust gas temperature sensor |
| EGR temperature sensor | | |
| Flash electrically erasable programmable read only memory | FEEPROM | *** |
| Flash erasable programmable read only memory | FEPPROM | *** |
| Flexible fuel sensor | FFS | *** |
| Flexible fuel system | FF system | *** |
| Fuel pressure regulator | *** | Pressure regulator |
| Fuel pressure regulator control solenoid valve | *** | PRVR control solenoid valve |
| Fuel trim | FT | *** |
| Heated Oxygen sensor | HO2S | Exhaust gas sensor |
| Idle air control system | IAC system | Idle speed control |
| Idle air control valve-air regulator | IACV-air regulator | Air regulator |
| Idle air control valve-auxiliary air control valve | IACV-AAC valve | Auxiliary air control (AAC) valve |
| Idle air control valve-FICD solenoid valve | IACV-FICD solenoid valve | FICD solenoid valve |
| Idle air control valve-idle up control solenoid valve | IACV-idle up control solenoid valve | Idle up control solenoid valve |
| Idle speed control-FI pot | ISC-FI pot | FI pot |
| Idle speed control system | ISC system | *** |
| Ignition control | IC | *** |
| Ignition control module | ICM | *** |
| Indirect fuel injection system | IFI system | *** |
| Intake air | IA | Air |
| Intake air temperature sensor | IAT sensor | Air temperature sensor |
| Knock | *** | Detonation |
| Knock sensor | KS | Detonation sensor |
| Malfunction indicator lamp | MIL | Check engine light |
| Manifold absolute pressure | MAP | *** |
| Manifold absolute pressure sensor | MAPS | *** |
| Manifold differential pressure | MDP | *** |
| Manifold differential pressure sensor | MDPS | *** |

SAE J1930 TERMINOLOGY LIST

SAE J1930 Terminology List (Cont'd)

***: Not applicable

| NEW TERM | NEW ACRONYM / ABBREVIATION | OLD TERM | |
|-------------------------------------------------------|-------------------------------|---------------------------------------|-----|
| Manifold surface temperature | MST | *** | |
| Manifold surface temperature sensor | MSTS | *** | GI |
| Manifold vacuum zone | MVZ | *** | |
| Manifold vacuum zone sensor | MVZS | *** | MA |
| Mass air flow sensor | MAFS | Air flow meter | |
| Mixture control solenoid valve | MC solenoid valve | Air-fuel ratio control solenoid valve | EM |
| Multiport fuel injection System | MFI system | Fuel injection control | |
| Neutral position switch | *** | Neutral switch | LC |
| Nonvolatile random access memory | NVRAM | *** | |
| On board diagnostic system | OBD system | Self-diagnosis | |
| Open loop | OL | Open loop | EC |
| Oxidation catalyst | OC | Catalyst | |
| Oxidation catalytic converter system | OC system | *** | FE |
| Oxygen sensor | O2S | Exhaust gas sensor | |
| Park position switch | *** | Park switch | CL |
| Park/neutral position switch | PNP switch | Park/neutral switch | |
| Periodic trap oxidizer system | PTOX system | *** | MT |
| Positive crankcase ventilation | PCV | Positive crankcase ventilation | |
| Positive crankcase ventilation valve | PCV valve | PCV valve | AT |
| Powertrain control module | PCM | *** | |
| Programmable read only memory | PROM | *** | |
| Pulsed secondary air injection control solenoid valve | PAIRC solenoid valve | AIV control solenoid valve | FA |
| Pulsed secondary air injection system | PAIR system | Air induction valve (AIV) control | |
| Pulsed secondary air injection valve | PAIR valve | Air induction valve | RA |
| Random access memory | RAM | *** | |
| Read only memory | ROM | *** | BR |
| Scan tool | ST | *** | |
| Secondary air injection pump | AIR pump | *** | ST |
| Secondary air injection system | AIR system | *** | |
| Sequential multiport fuel injection system | SFI system | Sequential fuel injection | RS |
| Service reminder indicator | SRI | *** | |
| Simultaneous multiport fuel injection system | *** | Simultaneous fuel injection | |
| Smoke puff limiter system | SPL system | *** | BT |
| Supercharger | SC | *** | |
| Supercharger bypass | SCB | *** | HA |
| System readiness test | SRT | *** | |
| Thermal vacuum valve | TVV | Thermal vacuum valve | EL |
| Three way catalyst | TWC | Catalyst | |
| Three way catalytic converter system | TWC system | *** | IDX |
| Three way + oxidation catalyst | TWC + OC | Catalyst | |

SAE J1930 TERMINOLOGY LIST

SAE J1930 Terminology List (Cont'd)

***: Not applicable

| NEW TERM | NEW ACRONYM / ABBREVIATION | OLD TERM |
|--------------------------------------------------|-------------------------------|---------------------------------------------|
| Three way + oxidation catalytic converter system | TWC + OC system | *** |
| Throttle body | TB | Throttle chamber SPI body |
| Throttle body fuel injection system | TBI system | Fuel injection control |
| Throttle position | TP | Throttle position |
| Throttle position sensor | TPS | Throttle sensor |
| Throttle position switch | TP switch | Throttle switch |
| Torque converter clutch solenoid valve | TCC solenoid valve | Lock-up cancel solenoid Lock-up solenoid |
| Transmission control module | TCM | A/T control unit |
| Turbocharger | TC | Turbocharger |
| Vehicle speed sensor | VSS | Vehicle speed sensor |
| Volume air flow sensor | VAFS | Air flow meter |
| Warm up oxidation catalyst | WU-OC | Catalyst |
| Warm up oxidation catalytic converter system | WU-OC system | *** |
| Warm up three way catalyst | WU-TWC | Catalyst |
| Warm up three way catalytic converter system | WU-TWC system | *** |
| Wide open throttle position switch | WOTP switch | Full switch |