

RESTRAINT SYSTEM

SECTION **RS**

GI

MA

EM

LC

EC

FE

CL

MT

AT

FA

RA

BR

ST

RS

BT

HA

EL

IDX

CONTENTS

PRECAUTION	2	Removal — Front Passenger Air Bag Module.....	15
Supplemental Restraint System (SRS) “AIR BAG”	2	Removal — Side Air Bag Module.....	16
SEAT BELTS	3	Installation — Air Bag Module and Spiral Cable.....	17
Front Seat Belt.....	3	Installation — Front Passenger Air Bag Module.....	18
Rear Seat Belt	4	Installation — Side Air Bag Module.....	19
Seat Belt Inspection.....	5	Disposal of Air Bag Module	19
SUPPLEMENTAL RESTRAINT SYSTEM (SRS)	8	TRouble DIAGNOSES — Supplemental Restraint System (SRS)	25
Precautions for SRS “AIR BAG”	8	Trouble Diagnoses Introduction.....	25
Special Service Tools	8	How to Perform Trouble Diagnoses for Quick and Accurate Repair	27
Description	9	Schematic	29
SRS Component Parts Location	10	Wiring Diagram — SRS —.....	30
Maintenance Items	10	Self-diagnosis	33
Removal and Installation — Diagnosis Sensor Unit and Satellite Sensor.....	12	Trouble Diagnoses for Air Bag Warning Lamp.....	51
Removal — Air Bag Module and Spiral Cable.....	14	COLLISION DIAGNOSIS	53

PRECAUTION

Supplemental Restraint System (SRS) "AIR BAG"

The Supplemental Restraint System "AIR BAG", used along with a seat belt, helps to reduce the risk or severity of injury to the driver and front passenger in a frontal collision. The Supplemental Restraint System consists of air bag modules (located in the center of the steering wheel and on the instrument panel on the passenger side), a diagnosis sensor unit, warning lamp, wiring harness and spiral cable.

If the vehicle is equipped with side air bag as the Supplemental Restraint System, the side air bag used along with the seat belt helps to reduce the risk or severity of injury to the driver and front passenger in a side collision. The side air bag consists of air bag modules (located in the outer side of front seats), satellite sensor, diagnosis sensor unit (which is one of components of air bags for a frontal collision), wiring harness, warning lamp (which is one of components of air bags for a frontal collision).

WARNING:

- **To avoid rendering the SRS inoperative, which could increase the risk of personal injury or death in the event of a collision which would result in air bag inflation, all maintenance must be performed by an authorized NISSAN dealer.**
- **Improper maintenance, including incorrect removal and installation of the SRS, can lead to personal injury caused by unintentional activation of the system.**
- **Do not use electrical test equipment on any circuit related to the SRS unless instructed to in this Service Manual. SRS wiring harnesses can be identified with yellow harness protector or yellow insulation tape before the harness connectors.**

SEAT BELTS

CAUTION:

- Do not disassemble buckle or seat belt assembly.
- Replace anchor bolts if they are deformed or worn out.
- Never oil tongue and buckle.
- If any component of seat belt assembly is questionable, do not repair. Replace the whole seat belt assembly.
- If webbing is cut, frayed, or damaged, replace seat belt assembly.
- When replacing seat belt assembly, use a genuine seat belt assembly.
- After any collision, inspect all seat belt assemblies, including retractors and other attached hardware (i.e., guide rail set).

Front Seat Belt

- ① Remove front seat. Refer to "SEAT" in BT section for details.
- ② Remove adjuster cover.
- ③ Slide the floor anchor cover.
- ④ Remove floor anchor bolt.
- ⑤ Remove shoulder anchor bolt.
- ⑥ Remove center pillar upper and lower garnish. Refer to "INTERIOR TRIM" in BT section for details.
- ⑦ Remove the bolt securing seat belt retractor, then remove seat belt and seat belt retractor.
- ⑧ Remove bolts securing seat belt adjuster, then remove seat belt adjuster.

SEC. 769-868

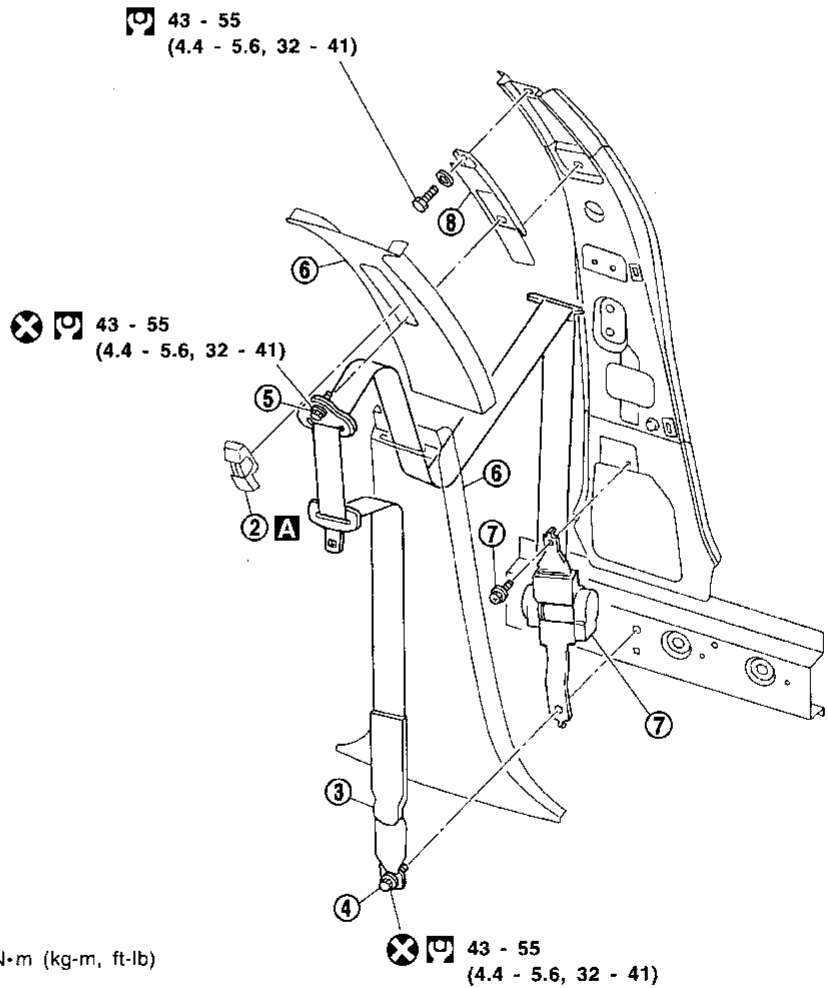
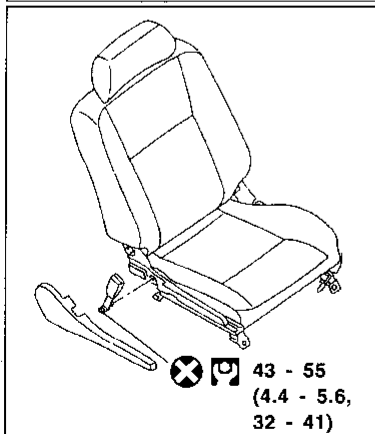
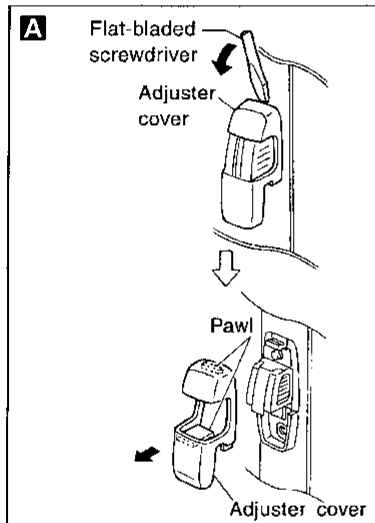

⊗ : N·m (kg·m, ft·lb)

GI

MA

EM

LC

EC

FE

CL

MT

AT

FA

RA

BR

ST

RS

BT

HA

EL

IDX

SEAT BELTS

Rear Seat Belt

- ① Remove rear seat. Refer to "SEAT" in BT section for details.
- ② Remove rear pillar garnish. Refer to "INTERIOR TRIM" in BT section for details.
- ③ Remove each anchor bolt.
- ④ Remove the bolt securing rear seat belt retractor, then remove seat belt retractor.

SEC. 869

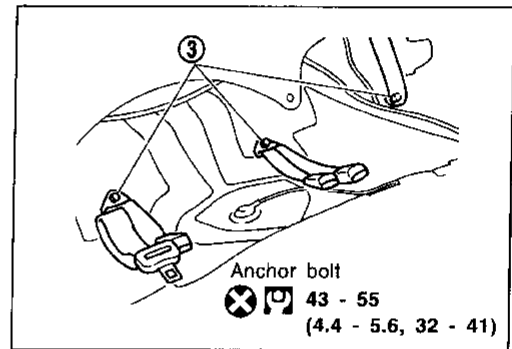
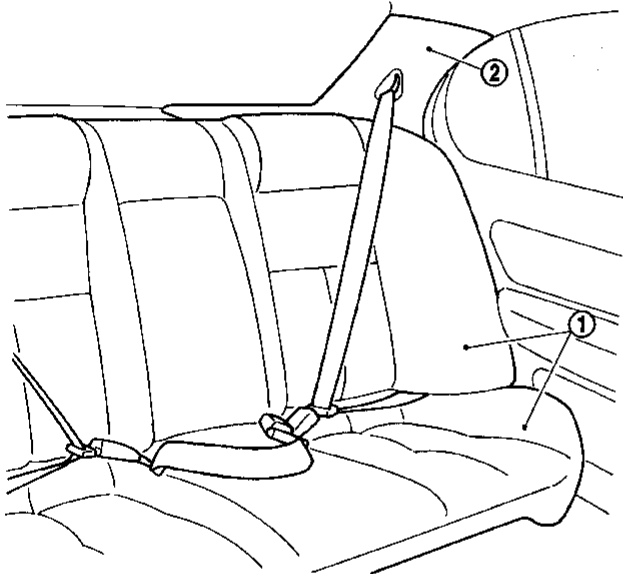
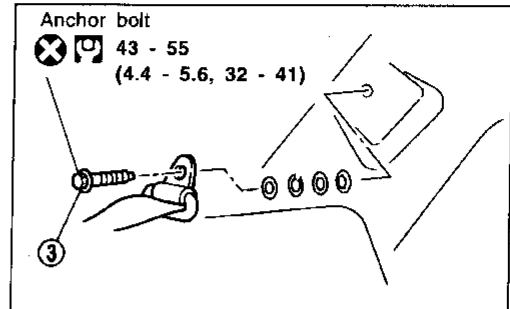
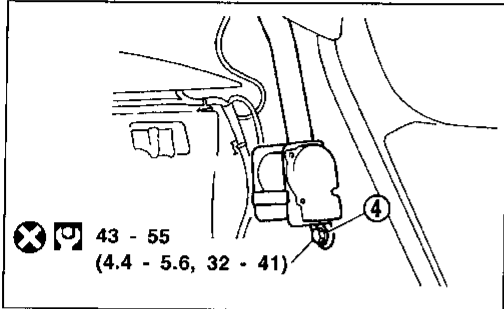

⊗ : N·m (kg-m, ft-lb)

SRS442

SEAT BELTS

Seat Belt Inspection

AFTER A COLLISION

WARNING:

Inspect all seat belt assemblies including retractors and attaching hardware after any collision. NISSAN recommends that all seat belt assemblies in use during a collision be replaced unless the collision was minor and the belts show no damage and continue to operate properly. Failure to do so could result in serious personal injury in an accident. Seat belt assemblies not in use during a collision should also be replaced if either damage or improper operation is noted.

Replace any seat belt assembly if:

- The seat belt was in use at the time of a collision (except for minor collisions and the belts, retractors and buckles show no damage and continue to operate properly).
- The seat belt was damaged in an accident (i.e. torn webbing, bent retractor or guide, etc.).
- The seat belt attaching point was damaged in an accident. Inspect the seat belt attaching area for damage or distortion and repair as necessary before installing a new seat belt assembly.

PRELIMINARY CHECKS

1. Check the seat belt warning lamp/chime for proper operation as follows:
 - a. Switch ignition ON. The seat belt warning lamp should illuminate. Also, the seat belt warning chime should sound for about seven seconds.
 - b. Fasten driver's seat belt. The seat belt warning lamp should go out and the chime (if sounding) should stop.
2. Check that the seat belt retractor, seat belt anchor and buckle bolts are securely attached.
3. Check the shoulder seat belt guide and shoulder belt height adjuster for front seats. Ensure guide swivels freely and that belt lays flat and does not bind in guide. Ensure height adjuster operates properly and holds securely.

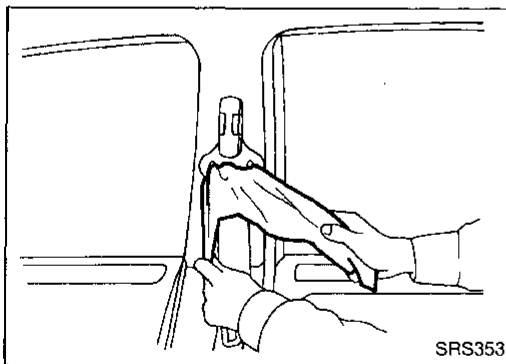

4. Check retractor operation:
 - a. Fully extend the seat belt webbing and check for twists, tears or other damage.
 - b. Allow the seat belt to retract. Ensure that belt returns smoothly and completely into the retractor. If the seat belt does not return smoothly, wipe the inside of the loops with a clean paper cloth etc. because dirt built up in the loops of the upper anchors can cause the seat belts to retract slowly.
 - c. Fasten the seat belt. Pull firmly on belt and buckle to ensure belt remains latched. Unfasten seat belt. Ensure belt releases freely and buckle button returns to original position.
5. For center (non-retractable) seat belt, check that the seat belt is accessible. Check seat belt webbing for twists, tears or other damage. Fasten the seat belt. Pull firmly on belt and buckle to ensure belt remains latched. Unfasten seat belts. Ensure belt releases freely and buckle button returns to original position.
6. Repeat steps above as necessary to check the other seat belts.

SEAT BELTS

Seat Belt Inspection (Cont'd)

ON-VEHICLE CHECK SEAT BELT RETRACTOR

Emergency Locking Retractors (ELR) and Automatic Locking Retractors (ALR)

NOTE:

All seat belt retractors are of the Emergency Locking Retractors (ELR) type. In an emergency (sudden stop) the retractor will lock and prevent the belt from extending any further. All outboard 3-point type seat belt retractors except the driver's seat belt also have an Automatic Locking Retractors (ALR) mode. The ALR mode (also called child restraint mode) is used when installing child seats in outboard seating positions. The ALR mode is activated when the seat belt is fully extended. When the belt is then retracted partially, the ALR mode automatically locks the seat belt in a specific position so the belt cannot be extended any further. To cancel the ALR mode, allow the seat belt to fully wind back into the retractor.

Check the seat belt retractors using the following test(s) to determine if a retractor assembly is operating properly.

ELR function stationary check

Grasp the shoulder belt and pull forward quickly. The retractor should lock and prevent the belt from extending further.

ALR function stationary check

1. Pull out entire length of seat belt from retractor until a click is heard.
2. Retract the belt partially. A clicking noise should be heard as the belt retracts indicating retractor is in the Automatic Locking Retractors (ALR) mode.
3. Grasp the seat belt and try to pull out of retractor. Belt must lock and not extend further. If NG, replace the retractor assembly.
4. Allow the entire length of belt to retract to cancel the ALR mode.

ELR function moving check (all outboard seating positions)

WARNING:

Perform the following test in a safe, open area clear of other vehicles and obstructions (for example, a large, empty parking lot). Road surface must be paved and dry. DO NOT perform the following test on wet or gravel roads or on public streets and highways. This could result in an accident and serious personal injury. The driver and passenger must be prepared to brace themselves in the event the retractor does not lock.

1. Fasten driver's seat belt. Buckle a passenger into the seat for the belt.
2. Proceed to the designated safe area.
3. Drive the vehicle at approximately 16 km/h (10 MPH). Notify any passengers of the pending sudden stop and the driver and passenger must be prepared to brace themselves in the event the retractor does not lock. Apply brakes firmly and make a very hard stop.

During the stop, seat belts should lock and not extend. If the seat belt retractor assembly does not lock, perform the retractor off-vehicle check.

SEAT BELTS

Seat Belt Inspection (Cont'd)

OFF-VEHICLE CHECK SEAT BELT RETRACTOR

1. Remove the seat belt retractor assembly.
2. Slowly pull out belt while tilting the retractor assembly forward from the mounted position without twisting the retractor assembly as shown in the illustration.

15 degrees or less tilt: Belt can be pulled out.

35 degrees or less tilt: Belt locks and cannot be pulled out.

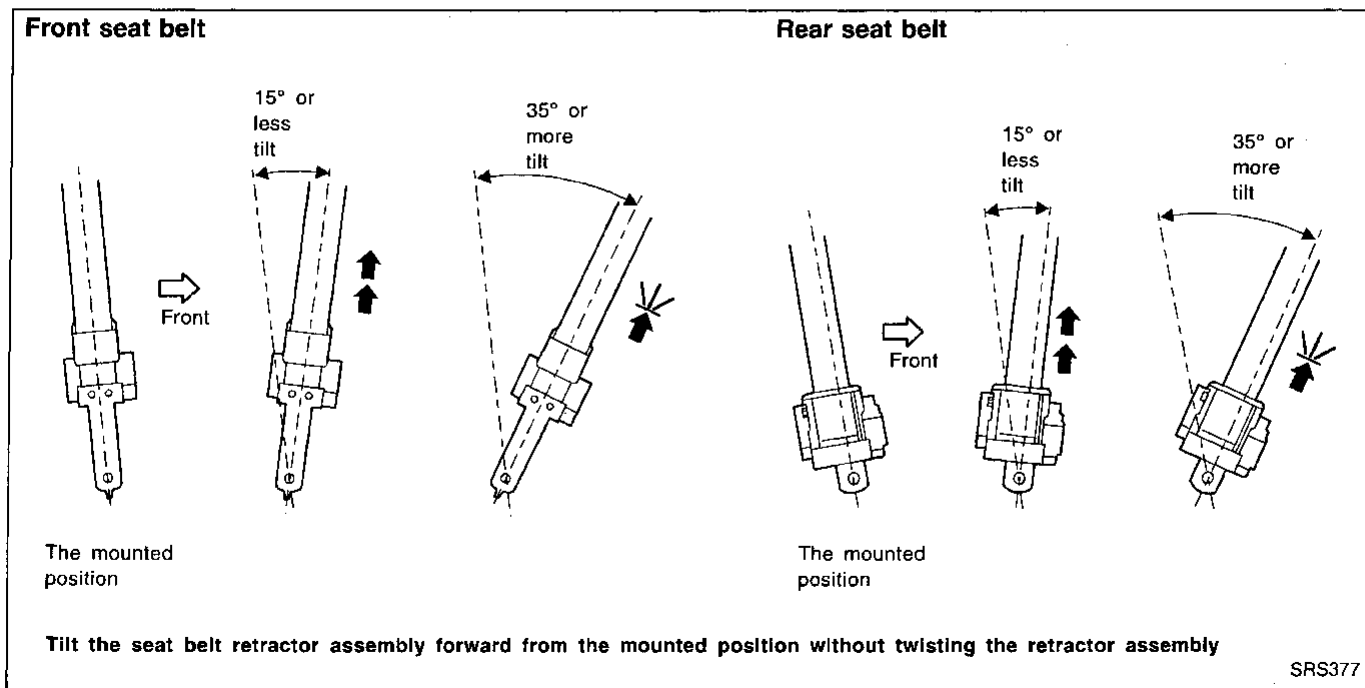

If NG, replace the retractor assembly.

GI

MA

EM

LC

EC

FE

CL

MT

AT

FA

RA

BR

ST

RS

BT

HA

EL

IDX

SUPPLEMENTAL RESTRAINT SYSTEM (SRS)

Precautions for SRS "AIR BAG"

- Do not use a circuit tester to check SRS circuits unless instructed to in this Service Manual.
- Before servicing the SRS, turn ignition switch "OFF", disconnect both battery cables and wait at least 3 minutes.
For approximately 3 minutes after the cables are removed, it is still possible for the air bag to deploy. Therefore, do not work on any SRS connectors or wires until at least 3 minutes have passed.
- Diagnosis sensor unit must always be installed with their arrow marks "↻" pointing towards the front of the vehicle for proper operation. Also check diagnosis sensor unit for cracks, deformities or rust before installation and replace as required.
- The spiral cable must be aligned with the neutral position since its rotations are limited. Do not attempt to turn steering wheel or column after removal of steering gear.
- Handle air bag module carefully. Always place it with the pad side facing upward.
- Conduct self-diagnosis to check entire SRS for proper function after replacing any components.
- After air bag inflates, the front instrument panel assembly should be replaced if damaged.

Special Service Tools

The actual shapes of Kent-Moore tools may differ from those of special service tools illustrated here.

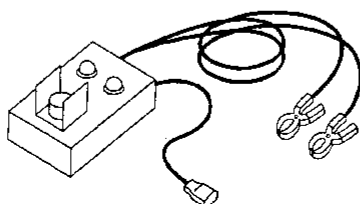
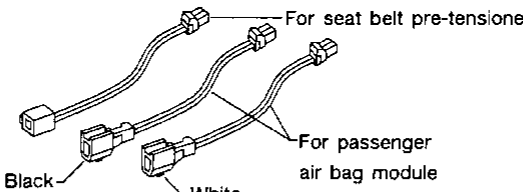
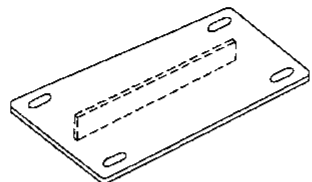
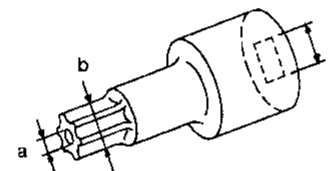
Tool number (Kent-Moore No.) Tool name	Description
KV991072S0 (J38381-KIT) Air bag deployment kit KV99106400 (J38381) Deployment tool	 <p style="text-align: right;">Disposing of air bag module</p> <p style="text-align: left;">NT357</p>
KV991065S0 (J38381-30) Deployment tool adapters	 <p style="text-align: right;">For seat belt pre-tensioner</p> <p style="text-align: right;">For passenger air bag module</p> <p style="text-align: left;">Black</p> <p style="text-align: left;">White</p> <p style="text-align: left;">NT353</p>
KV99105300 (J41246) Air bag module bracket	 <p style="text-align: right;">Anchoring air bag module</p> <p style="text-align: left;">NT354</p>
HT61961000 and HT62152000 combined (J38219) *Special torx bit	 <p style="text-align: right;">Use for special bolts [TAMPER RESISTANT TORX (Size T50)]</p> <p style="text-align: right;">a: 3.5 (0.138) dia. b: 8.5 - 8.6 (0.335 - 0.339) dia. c: approx. 10 (0.39) sq.</p> <p style="text-align: right;">Unit: mm (in)</p> <p style="text-align: left;">NT361</p>

*: Special tool or commercial equivalent

SUPPLEMENTAL RESTRAINT SYSTEM (SRS)

Description

The air bag deploys if the diagnosis sensor unit activates while the ignition switch is in "ON" or "START" position.

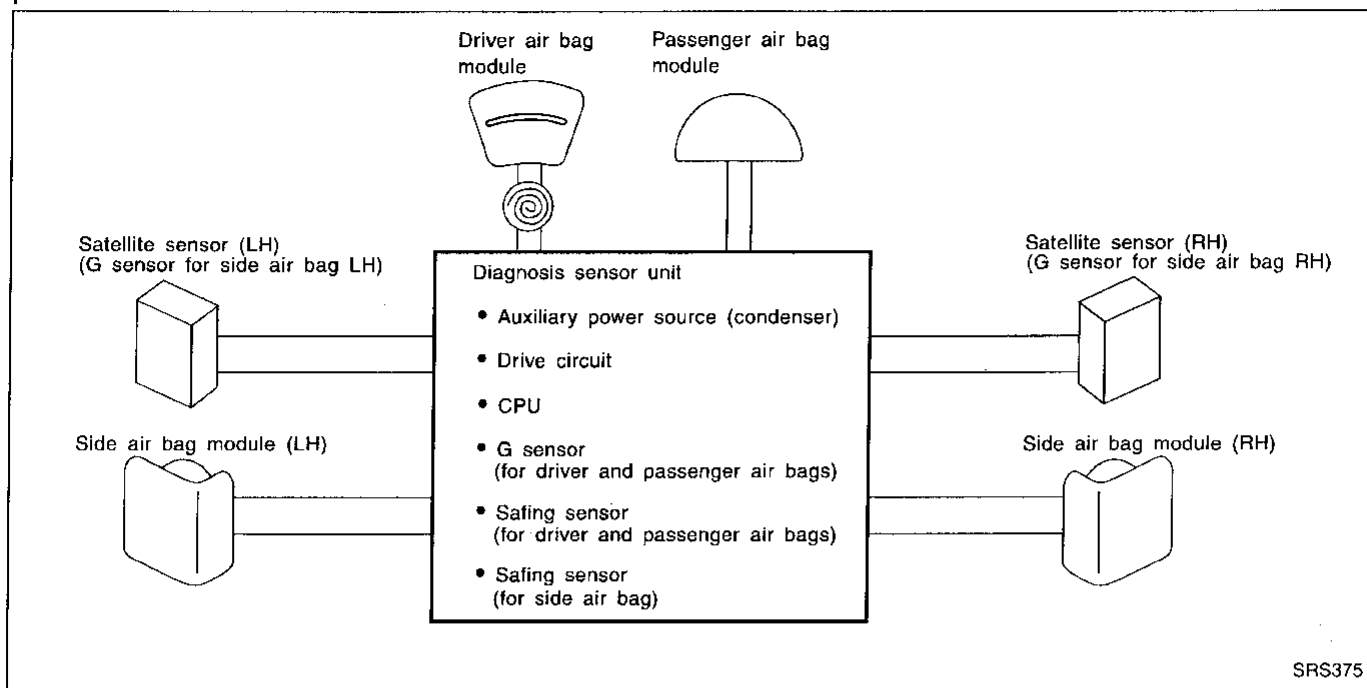

The collision modes for which supplemental restraint systems are activated are different among the SRS systems. For example, the driver air bag module and passenger air bag module are activated in a frontal collision but not in a side collision.

SRS configurations which are activated for some collision modes are as follows;

SRS configuration	Frontal collision	Left side collision	Right side collision
Driver air bag module	○	—	—
Passenger air bag module	○	—	—
Side air bag module (LH)	—	○	—
Side air bag module (RH)	—	—	○

GI
MA
EM
LC
EC
FE
CL
MT
AT
FA
RA
BR
ST
RS
BT
HA
EL
IDX

SRS Component Parts Location

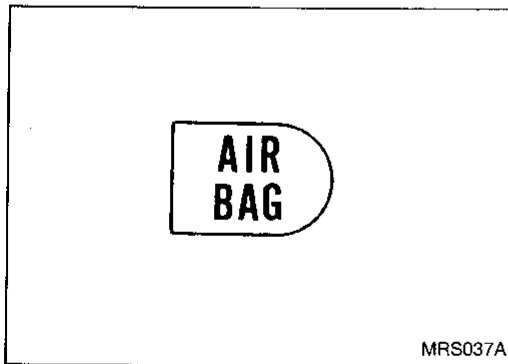
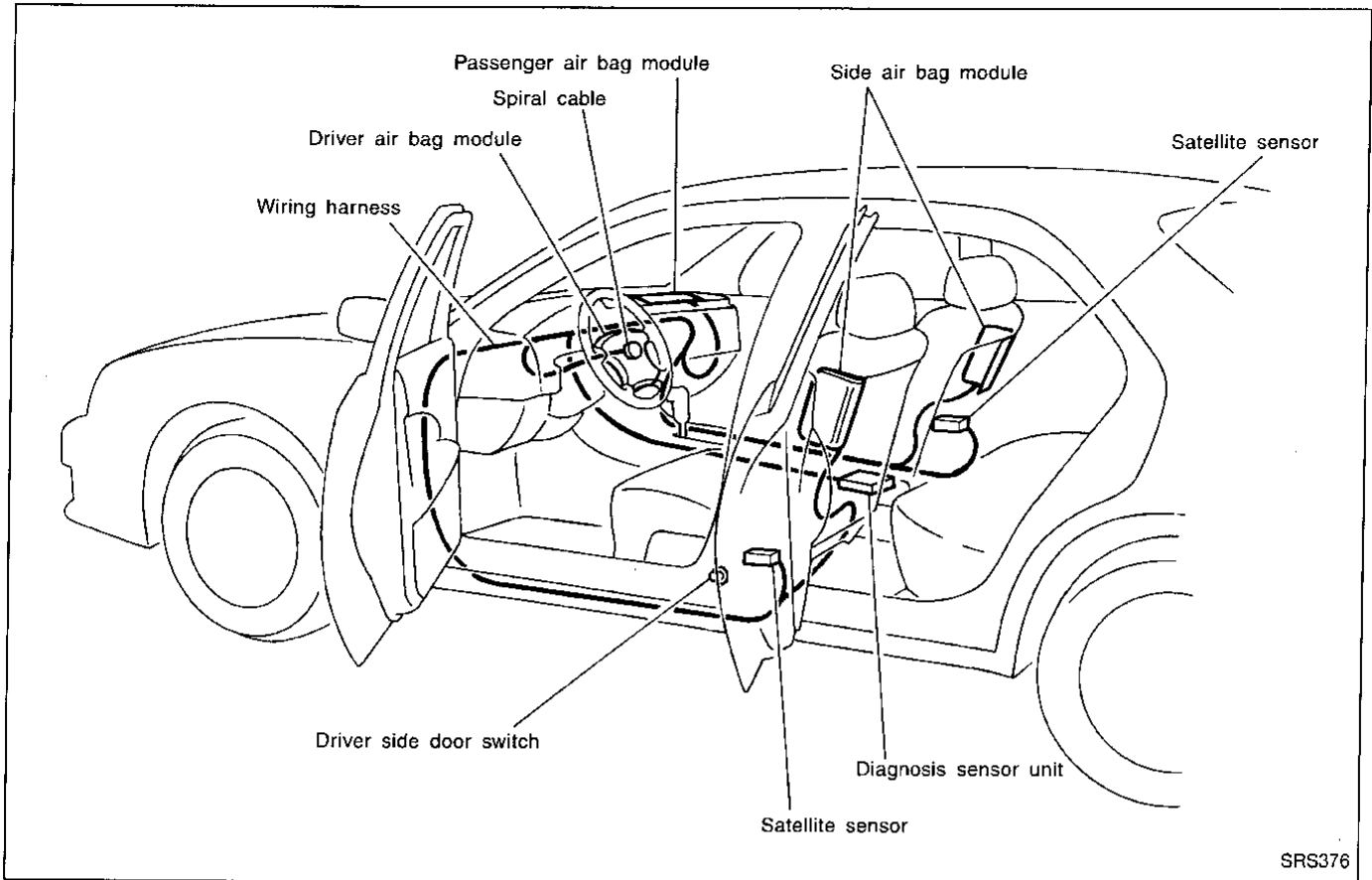

Maintenance Items

CAUTION:

Do not use a circuit tester to check SRS circuit.

1. Check operation of "AIR BAG" warning lamp.
After turning ignition key to "ON" position, "AIR BAG" warning lamp illuminates. The "AIR BAG" warning lamp will go off after about 7 seconds if no malfunction is detected.
If any of the following warning lamp conditions occur, immediately check the air bag system. Refer to RS-33 for details.
 - The "AIR BAG" warning lamp does not illuminate when the ignition switch is turned "ON".
 - The "AIR BAG" warning lamp does not go off about 7 seconds after the ignition switch is turned "ON".
 - The "AIR BAG" warning lamp blinks after about 7 seconds after the ignition switch is turned "ON".
2. Visually check SRS components.
 - (1) Diagnosis sensor unit
 - Check diagnosis sensor unit and bracket for dents, cracks or deformities.
 - Check connectors for damage and terminals for deformities.

SUPPLEMENTAL RESTRAINT SYSTEM (SRS)

Maintenance Items (Cont'd)

- (2) Air bag module and steering wheel
- Remove air bag module from steering wheel, instrument panel or seatback. Check harness cover and connectors for damage, terminals for deformities, and harness for binding.
 - Install driver air bag module to steering wheel to check fit or alignment with the wheel.
 - Check steering wheel for excessive free play.
 - Install passenger air bag module to instrument panel to check fit or alignment with the instrument panel.
 - Install side air bag module to seatback to check fit and alignment with the seat.

GI

MA

EM

- (3) Spiral cable
- Check spiral cable for dents, cracks, or deformities.
 - Check connectors and protective tape for damage.
 - Check steering wheel for noise, binding or heavy operation.

LC

- (4) Main harness, air bag harness, body harness
- Check connectors for poor connections, damage, and terminals for deformities.
 - Check harnesses for binding, chafing or cuts.

EC

FE

- (5) Satellite sensor
- Check satellite sensor (including bracket portion) for dents, cracks or deformities.
 - Check connectors for damage, and terminals for deformities.

CL

MT

CAUTION:

Replace previously used special bolts and ground bolt with new ones.

AT

FA

RA

BR

ST

RS

BT

HA

EL

IDX

Removal and Installation — Diagnosis Sensor Unit and Satellite Sensor

CAUTION:

- Before servicing SRS, turn the ignition switch off, disconnect both battery cables and wait at least 3 minutes.
- The special bolts are coated with bonding agent while the other bolt is for ground. Do not use old bolts after removal; replace with new ones.
- Check diagnosis sensor unit and satellite sensor for proper installation.
- Check diagnosis sensor unit and satellite sensor to ensure they are free of deformities, dents, cracks or rust. If they show any visible signs of damage, replace them with new ones.
- Check diagnosis sensor unit brackets to ensure they are free of deformities or rust.
- After replacement of diagnosis sensor unit and satellite sensor, check SRS function and perform self-diagnosis for SRS. Refer to “Self-diagnosis” for details. (RS-33)
- Do not attempt to disassemble diagnosis sensor unit and satellite sensor.
- Replace diagnosis sensor unit and satellite sensor if it has been dropped or sustained an impact.

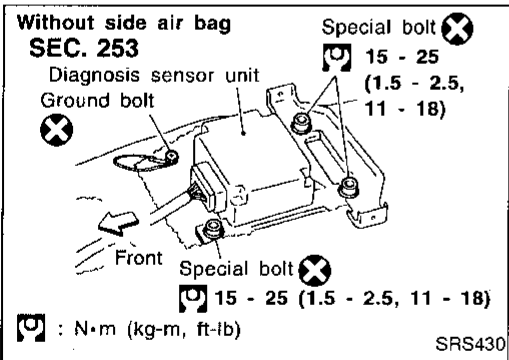
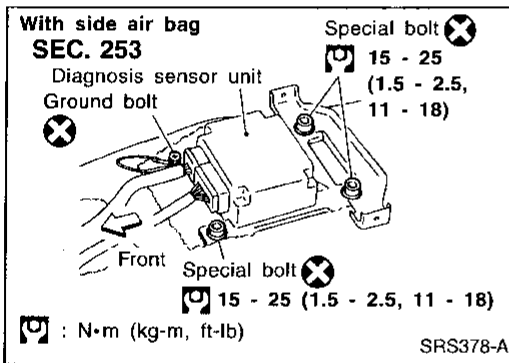

REMOVAL OF DIAGNOSIS SENSOR UNIT

1. Disconnect driver, passenger and side air bag module connectors.
2. Remove console box. Refer to “INSTRUMENT PANEL” in BT section.
3. Disconnect diagnosis sensor unit connector.
4. Remove ground bolt and also remove special bolts using the TAMPER RESISTANT TORX (Size T50), from diagnosis sensor unit.
Then remove the diagnosis sensor unit.

NOTE:

- To install, reverse the removal procedure sequence.

SUPPLEMENTAL RESTRAINT SYSTEM (SRS)

Removal and Installation — Diagnosis Sensor Unit and Satellite Sensor (Cont'd)

REMOVAL OF SATELLITE SENSOR

1. Remove seat belt retractor. Refer to "Front Seat Belt" for details. (RS-3)
2. Disconnect satellite sensor connector.
3. Remove bolt and special nuts from satellite sensor unit. Then remove the satellite sensor.

NOTE:

- To install, reverse the removal procedure sequence.

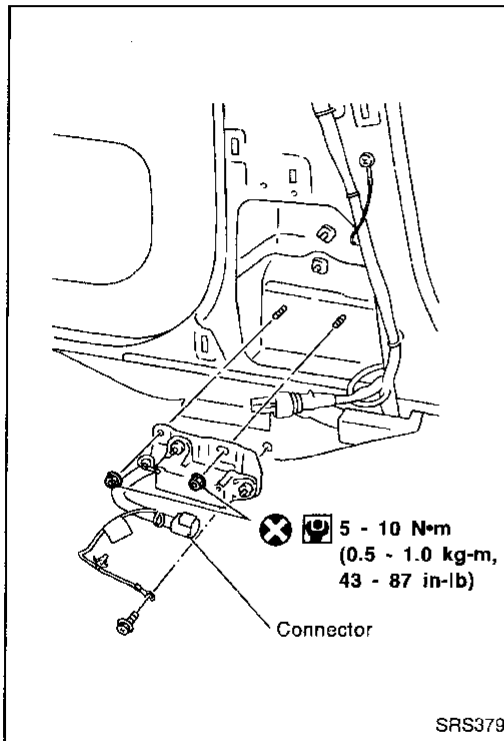

GI

MA

EM

LC

EC

FE

CL

MT

AT

FA

RA

BR

ST

RS

BT

HA

EL

IDX

SUPPLEMENTAL RESTRAINT SYSTEM (SRS)

Removal — Air Bag Module and Spiral Cable

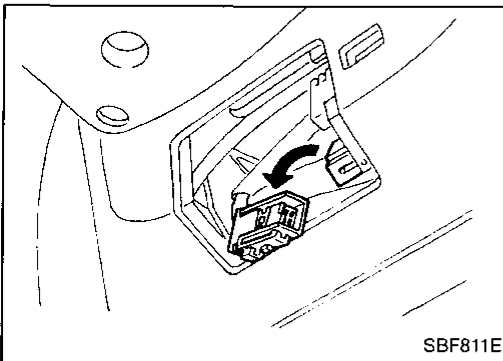
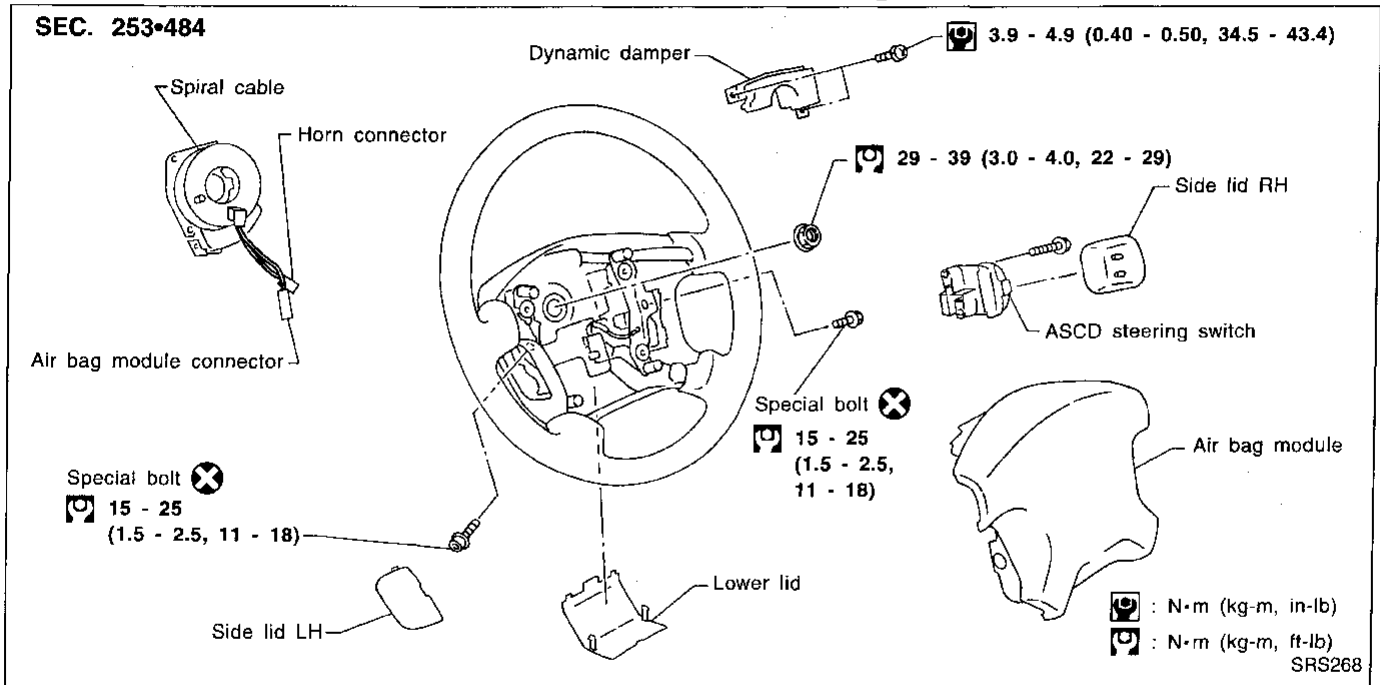

CAUTION:

- Before servicing SRS, turn the ignition switch off, disconnect both battery cables and wait at least 3 minutes.
 - Always work from the side of air bag module.
1. Remove lower lid from steering wheel, and disconnect air bag module connector.

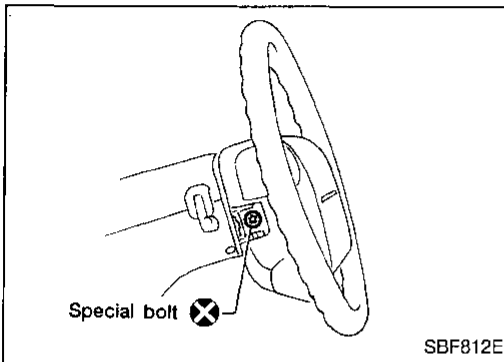

2. Remove side lid. Using the TAMPER RESISTANT TORX (Size T50), remove left and right special bolts. Air bag module can then be removed.

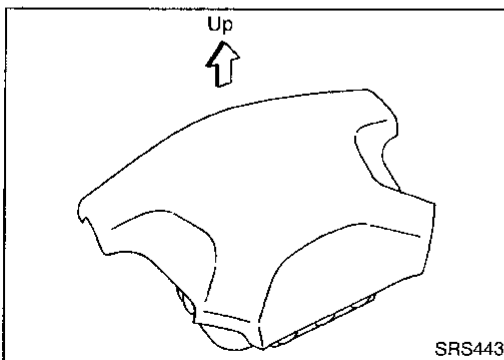

CAUTION:

- Always place air bag module with pad side facing upward.
- Do not attempt to disassemble air bag module.
- The special bolts are coated with bonding agent. Do not use old bolts after removal; replace with new ones.
- Do not insert any foreign objects (screwdriver, etc.) into air bag module connector.

SUPPLEMENTAL RESTRAINT SYSTEM (SRS)

Removal — Air Bag Module and Spiral Cable (Cont'd)

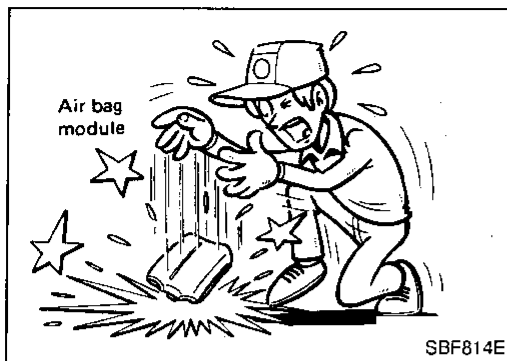

- Replace air bag module if it has been dropped or sustained an impact.
- Do not expose the air bag module to temperatures exceeding 90°C (194°F).
- Do not allow oil, grease or water to come in contact with the air bag module.

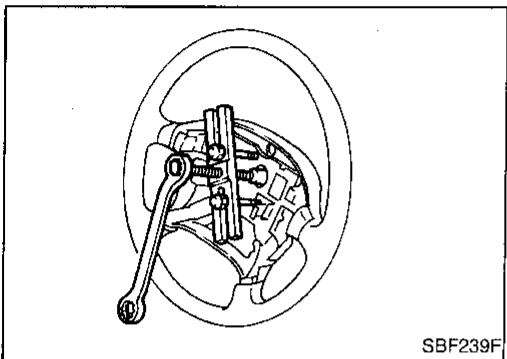

3. Set steering wheel in the neutral position.
4. Disconnect horn connector and remove nuts.
5. Remove dynamic damper. Then using steering wheel puller, remove steering wheel. Be careful not to over-tighten puller bolt on steering wheel.

CAUTION:

Do not tap or bump the steering wheel.

6. Remove steering column cover.

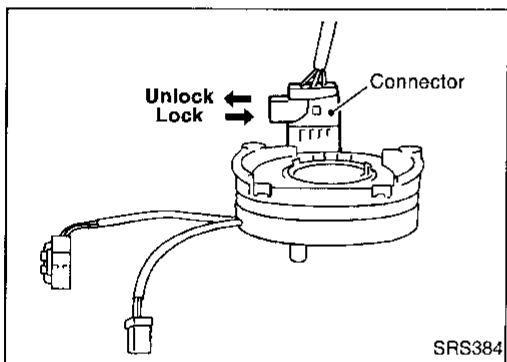

7. Unlock the spiral cable connector. Then, disconnect connector and remove the four screws. The spiral cable can then be removed.

CAUTION:

- Do not attempt to disassemble spiral cable.
- Do not apply lubricant to the spiral cable.

Removal — Front Passenger Air Bag Module

CAUTION:

- Before servicing SRS, turn the ignition switch off, disconnect both battery cables and wait at least 3 minutes.
- Always work from the side of or under air bag module.

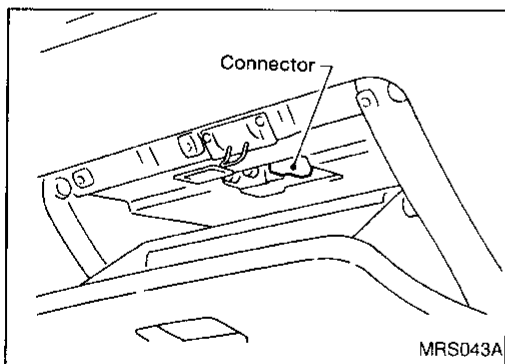

1. Open the glove box lid.
2. Disconnect air bag module connector from body harness air bag connector.
3. Remove glove box assembly. Refer to "INSTRUMENT PANEL" in BT section for details.

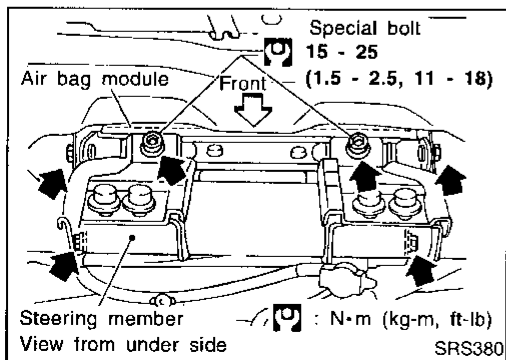

4. Remove the nuts and special bolts using the TAMPER RESISTANT TORX (Size T50) from front passenger air bag module. Take out the air bag module from the instrument panel.
- The air bag module is heavy and should be supported using both hands during removal.

SUPPLEMENTAL RESTRAINT SYSTEM (SRS)

Removal — Front Passenger Air Bag Module (Cont'd)

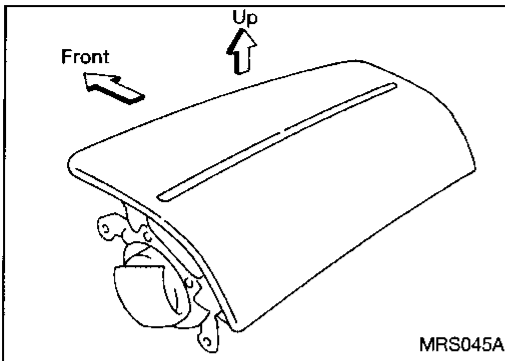

CAUTION:

- Always place air bag module with pad side facing upward.
- Do not attempt to disassemble air bag module.
- The special bolts are coated with bonding agent. Do not use old bolts after removal; replace with new coated bolts.
- Do not insert any foreign objects (screwdriver, etc.) into air bag module connector.

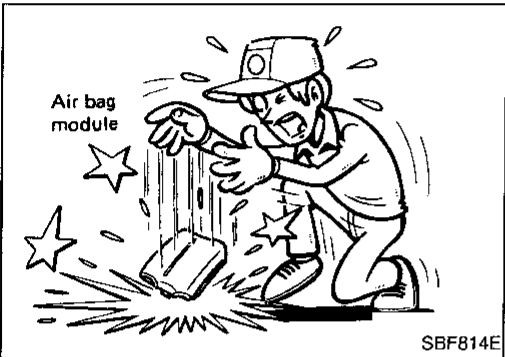

- Replace air bag module if it has been dropped or sustained an impact.
- Do not expose the air bag module to temperatures exceeding 90°C (194°F).
- Do not allow oil, grease or water to come in contact with the air bag module.
- After air bag inflates, the front instrument panel assembly should be replaced if damaged.

Removal — Side Air Bag Module

CAUTION:

- Before servicing SRS, turn the ignition switch off, disconnect both battery cables and wait at least 3 minutes.
 - Always work from the rear of air bag module.
1. Remove seatback finisher.
 - When using a clip removal tool to remove the seatback finisher, take care not to damage the air bag harness.
 2. Disconnect side air bag module connector.

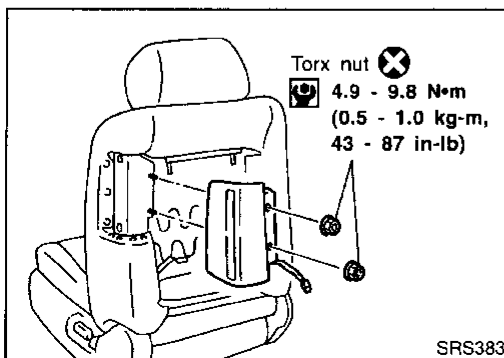
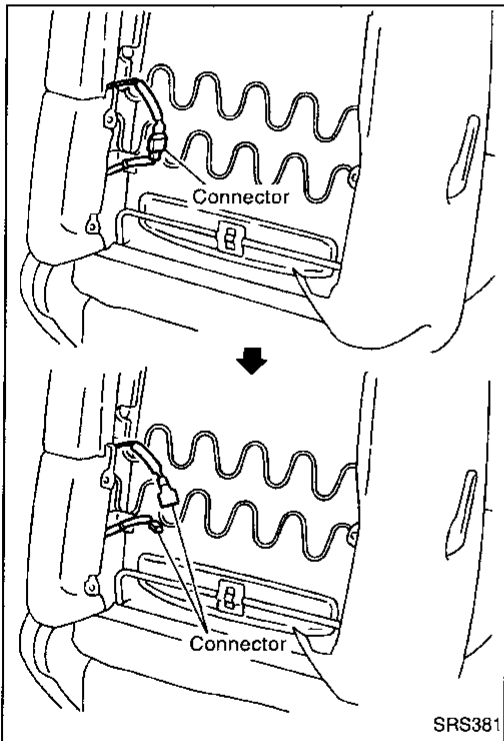

3. Remove torx nuts from air bag module. Air bag module can then be removed.

SUPPLEMENTAL RESTRAINT SYSTEM (SRS)

Removal — Side Air Bag Module (Cont'd)

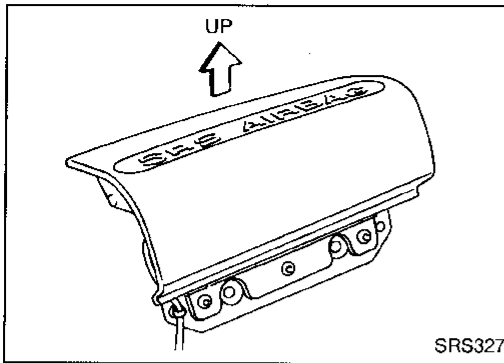

CAUTION:

- Always place air bag module with pad side facing upward.
- Do not attempt to disassemble air bag module.
- The torx nuts are coated with bonding agent. Do not use old nuts after removal; replace with new coated nuts.
- Do not insert any foreign objects (screwdriver, etc.) into air bag module connector.

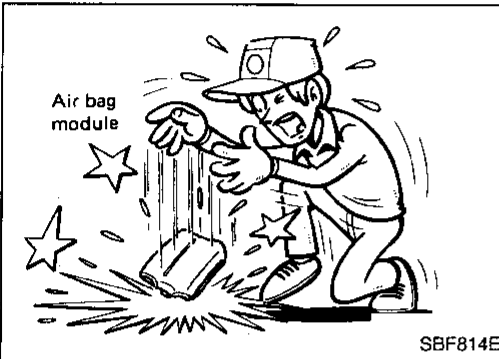

- Replace air bag module if it has been dropped or sustained an impact.
- Do not expose the air bag module to temperatures exceeding 90°C (194°F).
- Do not allow oil, grease or water to come in contact with the air bag module.
- After air bag inflates, the front seat should be replaced if damaged.

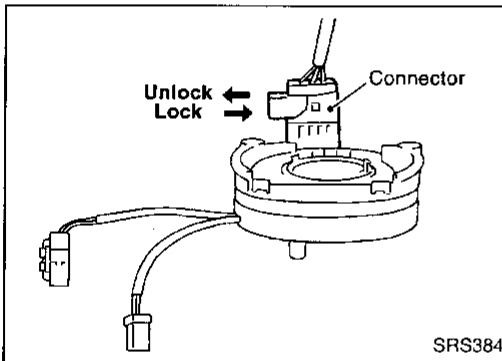

Installation — Air Bag Module and Spiral Cable

1. Set the front wheels in the straight-ahead position.
2. Connect spiral cable connector. Then, lock the connector and tighten with screws. Install steering column cover.

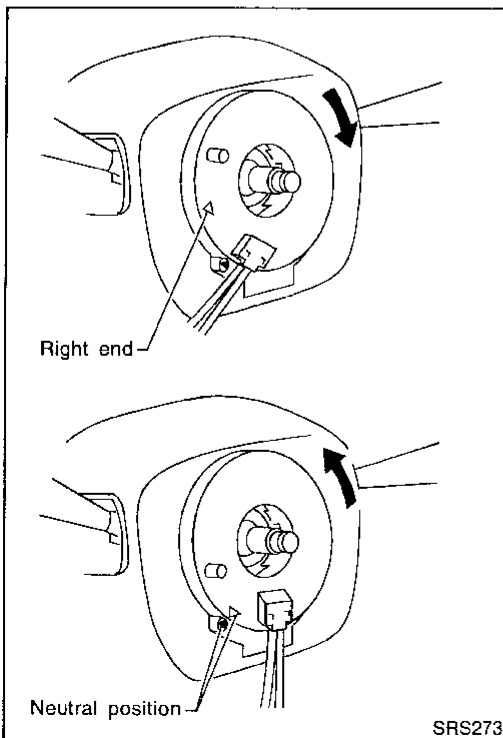

3. Make sure that the spiral cable is in the neutral position. The neutral position is detected by turning left about 2.5 revolutions from the right end position. Align the two marks (X).

CAUTION:

The spiral cable may snap due to steering operation if the cable is installed in an improper position.

Also, with the steering linkage disconnected, the cable may snap by turning the steering wheel beyond the limited number of turns.

The spiral cable can be turned up to about 2.5 turns from the neutral position to both the right and left.

SUPPLEMENTAL RESTRAINT SYSTEM (SRS)

Installation — Air Bag Module and Spiral Cable (Cont'd)

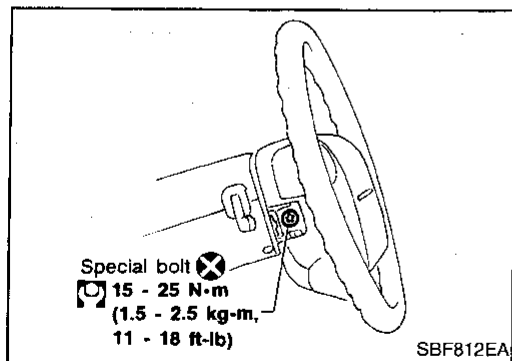
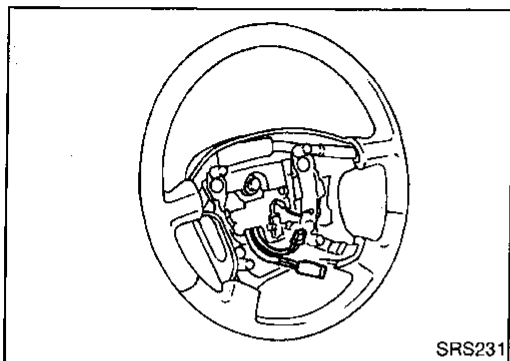

4. Install steering wheel setting spiral cable pin guides, and pull spiral cable through.
5. Connect horn connector and engage spiral cable with pawls in steering wheel. Move air bag module connector away from steering wheel lower lid opening.
6. Tighten nut.
 - : 29 - 39 N·m (3.0 - 4.0 kg-m, 22 - 29 ft-lb)
7. Install dynamic damper.
8. Position air bag module and tighten with new special bolts.
 - **Always service the air bag module from the side.**
9. Connect air bag module connector.
10. Install all lids.
11. Conduct self-diagnosis, RS-33, to ensure entire SRS operates properly. (Use CONSULT or warning lamp check.) Before performing self-diagnosis, connect both battery cables.
12. Turn steering wheel to the left end and then to the right end fully to make sure that spiral cable is set in the neutral position.

If air bag warning lamp blinks or stays ON (at the User mode), it shows the spiral cable may be snapped due to its improper position. Perform self-diagnosis again (use CONSULT or warning lamp). If a malfunction is detected, replace the spiral cable with a new one.
13. Perform self-diagnosis again to check that no malfunction is detected.

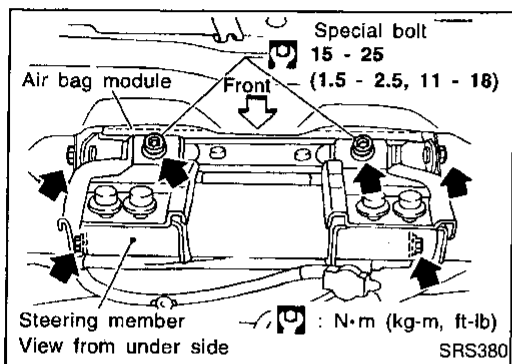

Installation — Front Passenger Air Bag Module

- **Always work from the side of or under air bag module.**
1. Install front passenger air bag module on steering member.
 - Ensure harness is not caught between rear of air bag module and steering member.
 2. Install glove box assembly. (Glove box lid is open.)
 3. Connect air bag module connector to body harness connector.
 4. Close the glove box lid.
 5. Connect both battery cables.
 6. Conduct self-diagnosis, RS-33, to ensure entire SRS operates properly. (Use CONSULT or warning lamp check.)

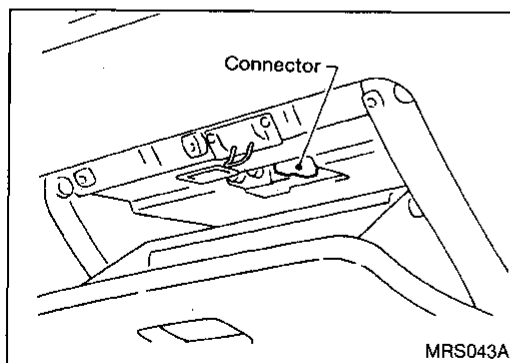

SUPPLEMENTAL RESTRAINT SYSTEM (SRS)

Installation — Side Air Bag Module

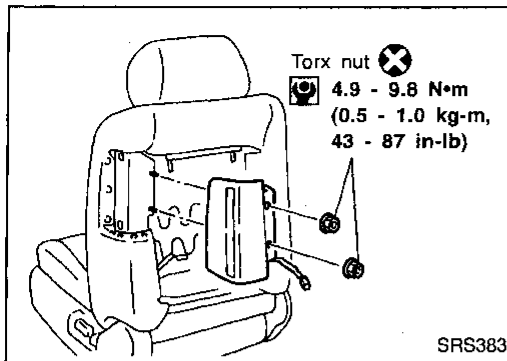

1. Install side air bag module on front seat with new torx nuts.

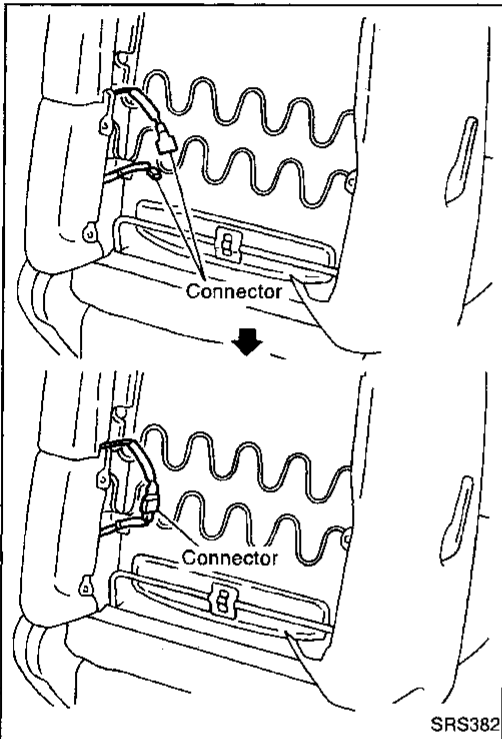

2. Connect side air bag module connector.
3. Install seatback finisher with new clips.
 - **Ensure harness is not caught between seatback finisher and seatback.**
4. Connect both battery cables.
5. Conduct self-diagnosis, RS-33, to ensure SRS operates properly. (Use CONSULT or air bag warning lamp.)

Disposal of Air Bag Module

- Before disposing of air bag module, or vehicles equipped with such systems, deploy the systems. If such systems have already been deployed due to an accident, dispose of them as indicated in "DISPOSING OF AIR BAG MODULE" (RS-24).
- When deploying the air bag module, always use the Special Service Tool; Deployment tool KV99106400 (Kent-Moore No. J38381).
- When deploying the air bag module, stand at least 5 m (16 ft) away from the deployment component.
- When deploying air bag module, a fairly loud noise is made, followed by smoke being released. The smoke is not poisonous, however, be careful not to inhale smoke since it irritates the throat and can cause choking.
- Always activate one air bag module at a time.
- Due to heat, leave air bag module unattended for more than 30 minutes after deployment.
- Be sure to wear gloves when handling a deployed air bag module.
- Never apply water to the deployed air bag module.
- Wash your hands clean after finishing work.
- Place the vehicle outdoors with an open space of at least 6 m (20 ft) on all sides when deploying air bag module while mounted in vehicle.
- Use a voltmeter to make sure the vehicle battery is fully charged.
- Do not dispose of the air bag module un-deployed.

GI

MA

EM

LC

EC

FE

CL

MT

AT

FA

RA

BR

ST

RS

BT

HA

EL

IDX

SUPPLEMENTAL RESTRAINT SYSTEM (SRS)

Disposal of Air Bag Module (Cont'd) CHECKING DEPLOYMENT TOOL

Connecting to battery

CAUTION:

The battery must show voltage of 9.6V or more.

Remove the battery from the vehicle and place it on dry wood blocks approximately 5 m (16 ft) away from the vehicle.

- Wait 3 minutes after the vehicle battery is disconnected before proceeding.
- Connect red clip of deployment tool to battery positive terminal and black clip to negative terminal.

Make sure the polarity is correct. The right side lamp in the tool, marked "deployment tool power", should glow with a green light. If the right side lamp glows red, reverse the connections to the battery.

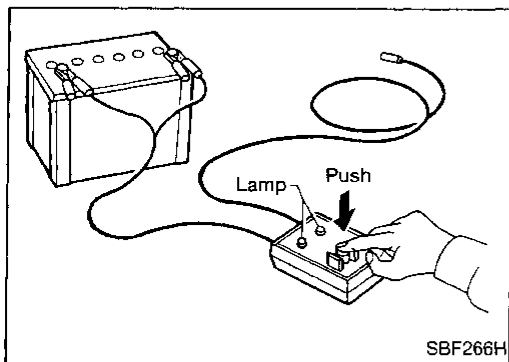
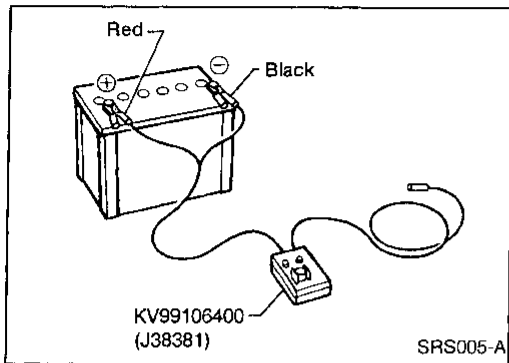

Deployment tool check

Press the deployment tool switch to the "ON" position. The left side lamp in the tool, marked "air bag connector voltage" should illuminate. If it does not illuminate, replace the tool.

Air bag deployment tool lamp illumination chart (Battery connected)

Switch operation	Left side lamp, green* "AIR BAG CONNECTOR VOLTAGE"	Right side lamp, green* "DEPLOYMENT TOOL POWER"
OFF	OFF	ON
ON	ON	ON

*: If this lamp glows red, the tool is connected to the battery incorrectly. Reverse the connections and make sure the lamp glows green.

SUPPLEMENTAL RESTRAINT SYSTEM (SRS)

Disposal of Air Bag Module (Cont'd)

DEPLOYMENT PROCEDURES FOR AIR BAG MODULE (OUTSIDE OF VEHICLE)

Unless the vehicle is being scrapped, deploying the air bag in the vehicle is not recommended. This may cause damage to the vehicle interior.

Anchor air bag module bracket [KV99105300 (J41246)] in a vise secured to a firm foundation during deployment.

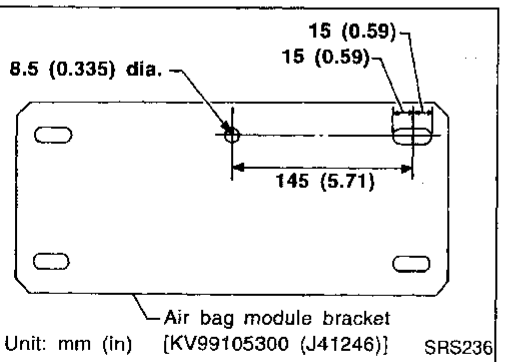
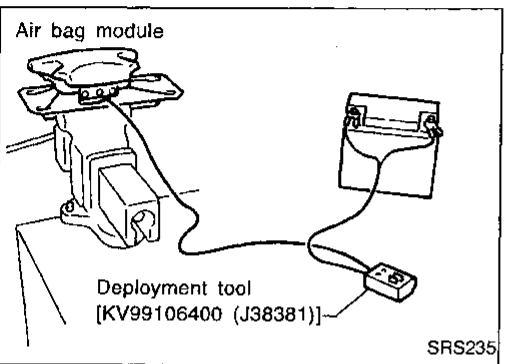
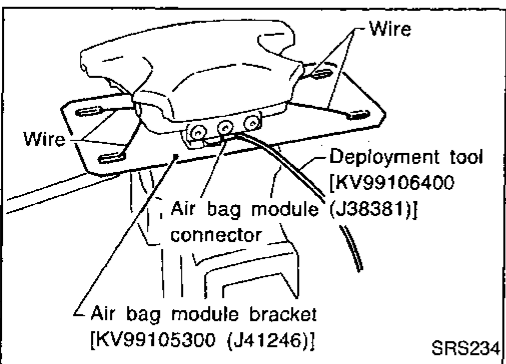
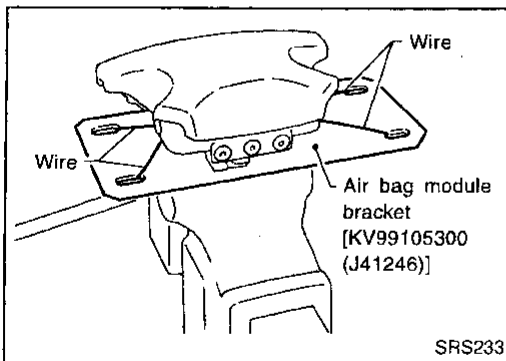
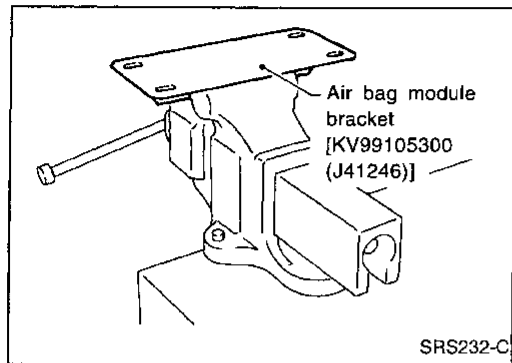

Deployment of driver's air bag module (outside of vehicle)

1. Using wire, secure air bag module to air bag module bracket [SST: KV99105300 (J41246)] at two places.

CAUTION:

Use wire of at least 1 mm (0.04 in) diameter.

2. Firmly secure air bag module bracket [SST: KV99105300 (J41246)] with air bag module attached, in a vise.

3. Connect deployment tool [SST: KV99106400 (J38381)] to air bag module connector.

4. Connect red clip of deployment tool to battery positive terminal and black clip to negative terminal.
5. The lamp on the right side of the tool, marked "deployment tool power", should glow green, not red.
6. Press the button on the deployment tool. The left side lamp on the tool, marked "air bag connector voltage", will illuminate and the air bag module will deploy.

CAUTION:

When deploying the air bag module, stand at least 5 m (16 ft) away from the air bag module.

Deployment of passenger air bag module (outside of vehicle)

1. Make an 8.5 mm (0.335 in) diameter hole in air bag module bracket [SST: KV99105300 (J41246)] at the position shown in figure at left.

GI

MA

EM

LC

EC

FE

CL

MT

AT

FA

RA

BR

ST

RS

BT

HA

EL

IDX

SUPPLEMENTAL RESTRAINT SYSTEM (SRS)

Disposal of Air Bag Module (Cont'd)

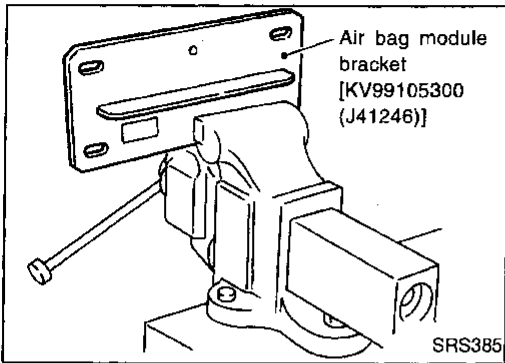

2. Firmly secure air bag module bracket [SST: KV99105300 (J41246)] in a vise.

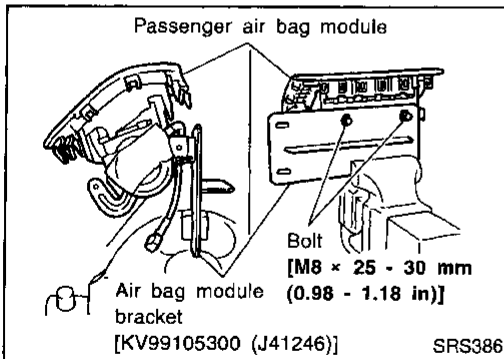

3. Match the two holes in air bag module bracket (held in vise) and passenger air bag module and fix them with two bolts [M8 x 25 - 30 mm (0.98 - 1.18 in)].

CAUTION:

If a gap exists between passenger air bag module and air bag module bracket, use a piece of wood inserted in the gap to stabilize the air bag module.

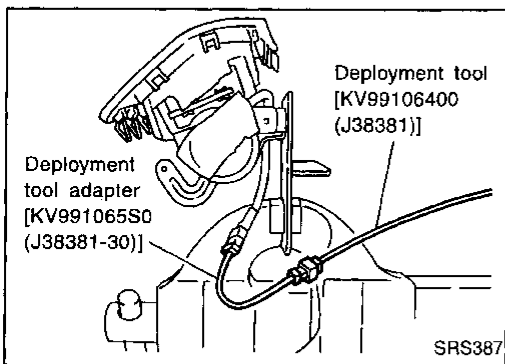

4. Connect deployment tool adapter [SST: KV991065S0 (J38381-30)] to deployment tool [SST: KV99106400 (J38381)] connector and connector on either side of air bag module.
5. Connect red clip of deployment tool to battery positive terminal and black clip to negative terminal.
6. The lamp on the right side of the tool, marked "deployment tool power", should glow green, not red.
7. Press the button on the deployment tool. The left side lamp on the tool, marked "air bag connector voltage", will illuminate and the air bag module will deploy.

CAUTION:

- When deploying the air bag module, do not stand on the deploying side.
- Stand at least 5 m (16 ft) away from the air bag module.

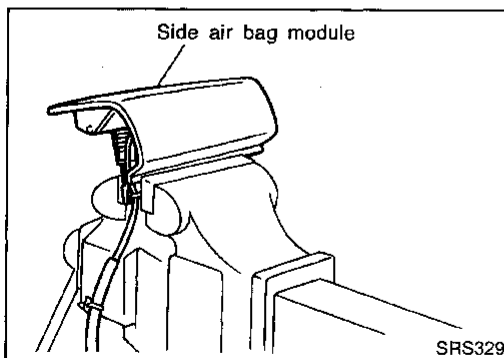
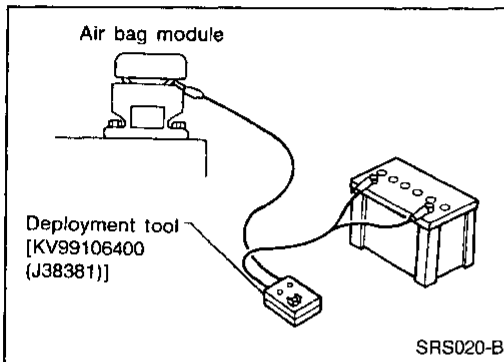

Deployment of side air bag module (outside of vehicle)

1. Firmly anchor side air bag module in a vise.

SUPPLEMENTAL RESTRAINT SYSTEM (SRS)

Disposal of Air Bag Module (Cont'd)

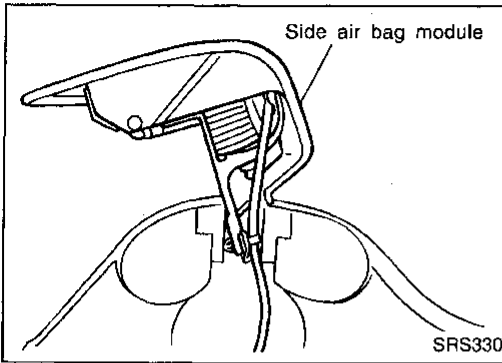

- The side air bag module must be installed in an oblique direction, not in a vertical direction. Refer to the figure at the left.
2. Connect deployment tool [SST: KV99106400 (J38381)] to side air bag module connector.

GI

MA

EM

LC

EC

FE

CL

MT

AT

FA

RA

BR

ST

RS

BT

HA

EL

IDX

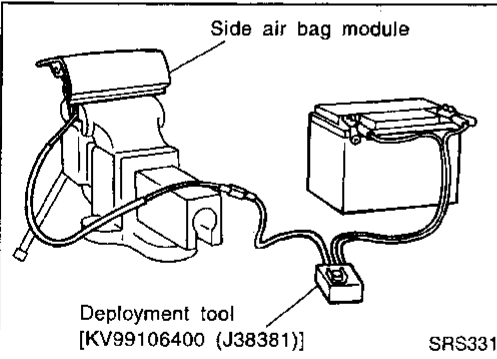

3. Connect red clip of deployment tool to battery positive terminal and black clip to negative terminal.
4. The lamp on the right side of the tool, marked "deployment tool power", should glow green, not red.
5. Press the button on the deployment tool. The left side lamp on the tool, marked "air bag module connector voltage", will illuminate and the air bag module will deploy.

CAUTION:

When deploying the air bag module, stand at least 5 m (16 ft) away from the air bag module.

DEPLOYMENT OF AIR BAG MODULE WHILE MOUNTED IN VEHICLE

When disposing of a vehicle, deploy air bag modules while they are mounted in vehicle.

CAUTION:

When deploying air bag module ensure vehicle is empty.

1. Disconnect both vehicle battery cables and wait 3 minutes.
2. Disconnect air bag modules connector.
3. Connect deployment tool [SST: KV99106400 (J38381)] to air bag module.

For front passenger air bag module, attach deployment tool adapter [SST: KV991065S0 (J38381-30)] to the tool connector.

4. Connect red clip of deployment tool to battery positive terminal and black clip to negative terminal.
5. The lamp on the right side of the tool, marked "deployment tool power", should glow green, not red.
6. Press the button on the deployment tool. The left side lamp on the tool, marked "air bag connector voltage", will illuminate and the air bag module will deploy.

CAUTION:

Activate only one air bag module at a time.

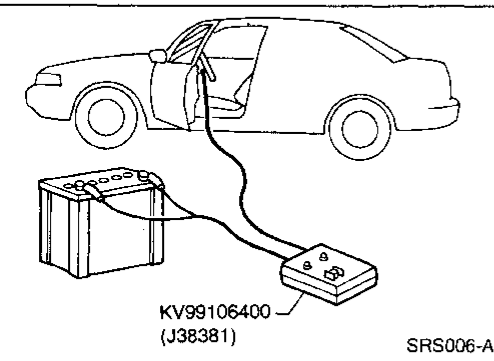

SUPPLEMENTAL RESTRAINT SYSTEM (SRS)

Disposal of Air Bag Module (Cont'd)

DISPOSING OF AIR BAG MODULE

Deployed air bag modules are very hot. Before disposing of air bag module, wait at least 30 minutes respectively. Seal them in a plastic bag before disposal.

CAUTION:

- Never apply water to a deployed air bag module.
- Be sure to wear gloves when handling a deployed air bag module.
- No poisonous gas is produced upon air bag module deployment. However, be careful not to inhale gas since it irritates throat and can cause choking.
- Do not attempt to disassemble air bag module.
- Air bag module cannot be reused.
- Wash your hands clean after finishing work.

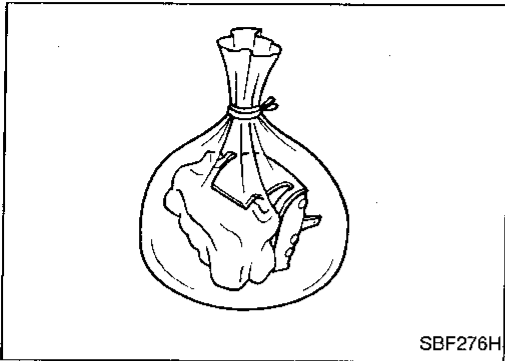

Trouble Diagnoses Introduction

CAUTION:

- Do not use a circuit tester to check SRS harness connectors unless instructed to in this Service Manual. SRS wiring harnesses can be identified with yellow harness protector or yellow insulation tape before the harness connectors.
- Do not attempt to repair, splice or modify the SRS wiring harness. If the harness is damaged, replace it with a new one.
- Keep ground portion clean.

DIAGNOSIS FUNCTION

The SRS self-diagnosis results can be read by using “AIR BAG” warning lamp and/or CONSULT. The reading of these results is accomplished using one of two modes — “User mode” and “Diagnosis mode”.

The User mode is exclusively prepared for the customer (driver). This mode warns the driver of a system malfunction through the operation of the “AIR BAG” warning lamp.

The Diagnosis mode allows the technician to locate and inspect the malfunctioning part.

The mode applications for the “AIR BAG” warning lamp and CONSULT are as follows:

	User mode	Diagnosis mode	Display type
“AIR BAG” warning lamp	X	X	ON-OFF operation
CONSULT	—	X	Monitoring

DIAGNOSIS MODE FOR CONSULT

- “SELF-DIAG [CURRENT]”
A current Self-diagnosis result (also indicated by the warning lamp flashes in the Diagnosis mode) is displayed on the CONSULT screen in real time. This refers to a malfunctioning part requiring repairs.
- “SELF-DIAG [PAST]”
Diagnosis results previously stored in the memory (also indicated by the warning lamp flashes in the Diagnosis mode) are displayed on the CONSULT screen. The stored results are not erased until memory erasing is executed.
- “TROUBLE DIAG RECORD”
With “TROUBLE DIAG RECORD”, diagnosis results previously erased by a reset operation can be displayed on the CONSULT screen.

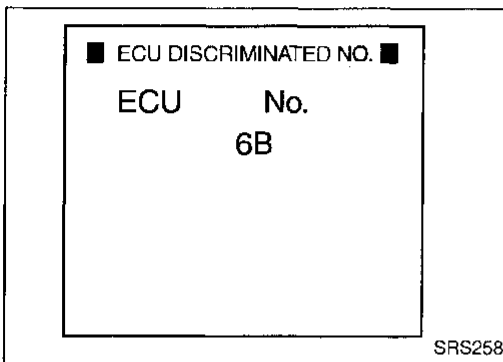

- “ECU DISCRIMINATED NO.”
The diagnosis sensor unit for each vehicle model is assigned with its own, individual classification number. This number will be displayed on the CONSULT screen, as shown at left. When replacing the diagnosis sensor unit, refer to the part number for the compatibility. After installation, replacement with a correct unit can be checked by confirming this classification number on the CONSULT screen.

For NISSAN MODEL A32, the diagnosis sensor unit classification number assigned is 6B.

TROUBLE DIAGNOSES — Supplemental Restraint System (SRS)

Trouble Diagnoses Introduction (Cont'd)

HOW TO CHANGE SELF-DIAGNOSIS MODE

With CONSULT

From User mode to Diagnosis mode

After selecting AIR BAG on the "SELECT SYSTEM" screen, User mode automatically changes to Diagnosis mode.

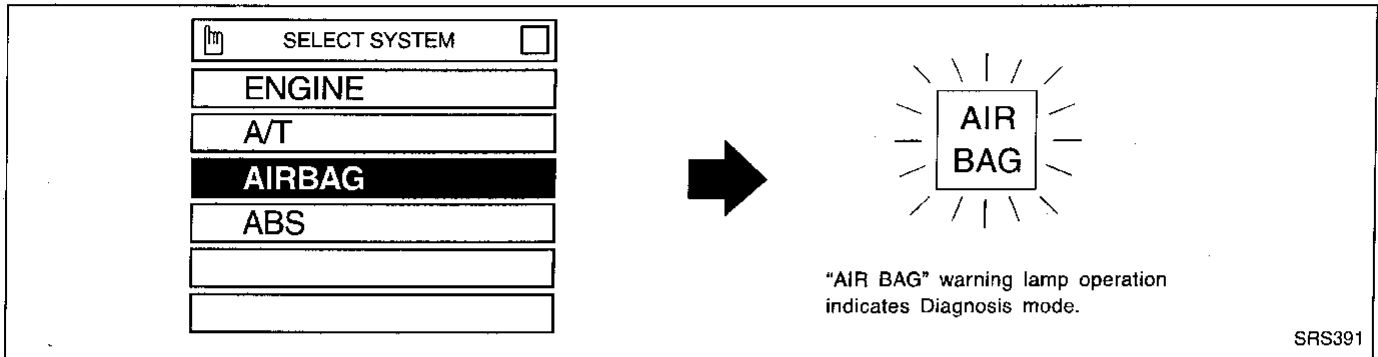

From Diagnosis mode to User mode

To return to User mode from diagnosis mode, touch "BACK" key of CONSULT until "SELECT SYSTEM" appears. Diagnosis mode automatically changes to User mode.

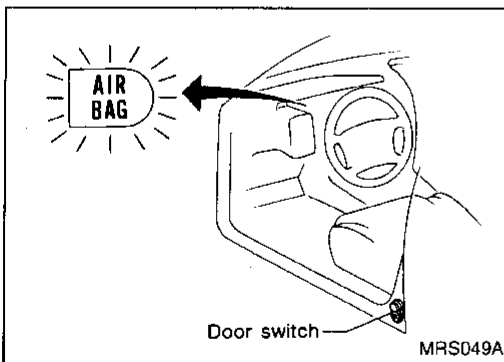
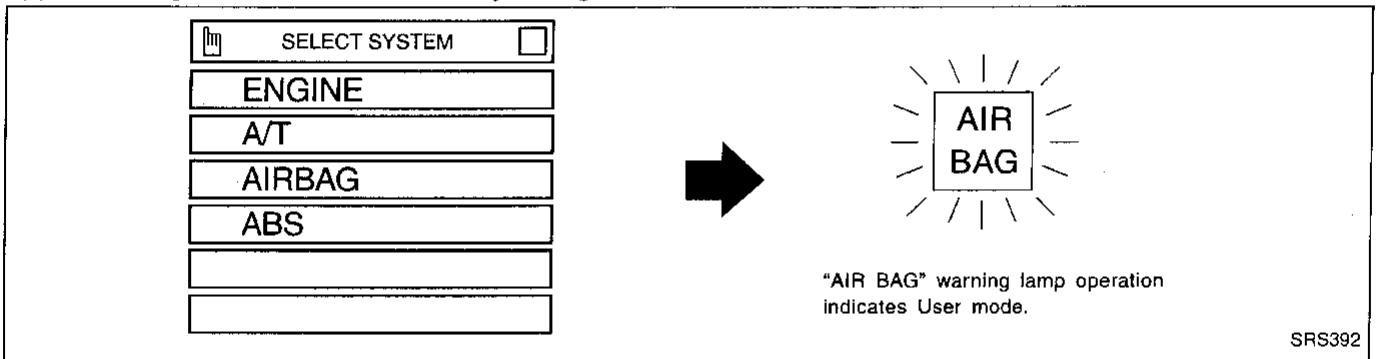

Without CONSULT

From User mode to Diagnosis mode

Diagnosis mode activates only when a malfunction is detected, by pressing the driver's door switch at least 5 times within 7 seconds after turning the ignition "ON". SRS will not enter Diagnosis mode if no malfunction is detected.

From Diagnosis mode to User mode

After a malfunction is repaired, switch the ignition "OFF" for at least 1 second, then back "ON". Diagnosis mode returns to User mode. If switching Diagnosis mode to User mode is required while malfunction is being detected, switch the ignition "OFF", then back "ON" and press the driver's door switch at least 5 times within 7 seconds.

HOW TO ERASE SELF-DIAGNOSIS RESULTS

With CONSULT

- "SELF-DIAG [CURRENT]"

A current Self-diagnosis result is displayed on the CONSULT screen in real time. After the malfunction is repaired completely, no malfunction is detected on "SELF-DIAG [CURRENT]".

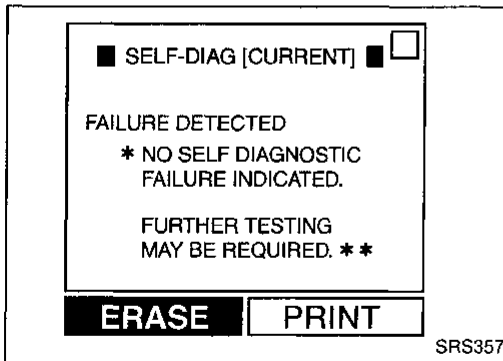

- "SELF-DIAG [PAST]"

Return to the "SELF-DIAG [CURRENT]" CONSULT screen by pushing "BACK" key of CONSULT and select "SELF-DIAG [CURRENT]" in "SELECT DIAG MODE". Touch "ERASE" in "SELF-DIAG [CURRENT]" mode.

NOTE:

If the memory of the malfunction in "SELF-DIAG [PAST]" is not erased, the User mode shows the system malfunction by the operation of the warning lamp even if the malfunction is repaired completely.

- "TROUBLE DIAG RECORD"

The memory of "TROUBLE DIAG RECORD" cannot be erased.

Without CONSULT

After a malfunction is repaired, return to User mode from Diagnosis mode by switching the ignition "OFF" for at least 1 second, then back "ON". At that time, the problem code is cleared.

How to Perform Trouble Diagnoses for Quick and Accurate Repair

A good understanding of the malfunction conditions can make troubleshooting faster and more accurate. In general, each customer feels differently about a problem. It is important to fully understand the symptoms or conditions for a customer complaint.

INFORMATION FROM CUSTOMER

WHAT Vehicle model
WHEN Date, Frequencies
WHERE Road conditions
HOW Operating conditions, Symptoms

PRELIMINARY CHECK

Check that the following parts are in good order.

- Battery [Refer to EL section ("BATTERY").]
- Fuse [Refer to EL section ("Fuse", "POWER SUPPLY ROUTING").]
- System component-to-harness connections

GI

MA

EM

LC

EC

FE

CL

MT

AT

FA

RA

BR

ST

RS

BT

HA

EL

IDX

TROUBLE DIAGNOSES — Supplemental Restraint System (SRS)

How to Perform Trouble Diagnoses for Quick and Accurate Repair (Cont'd)

WORK FLOW

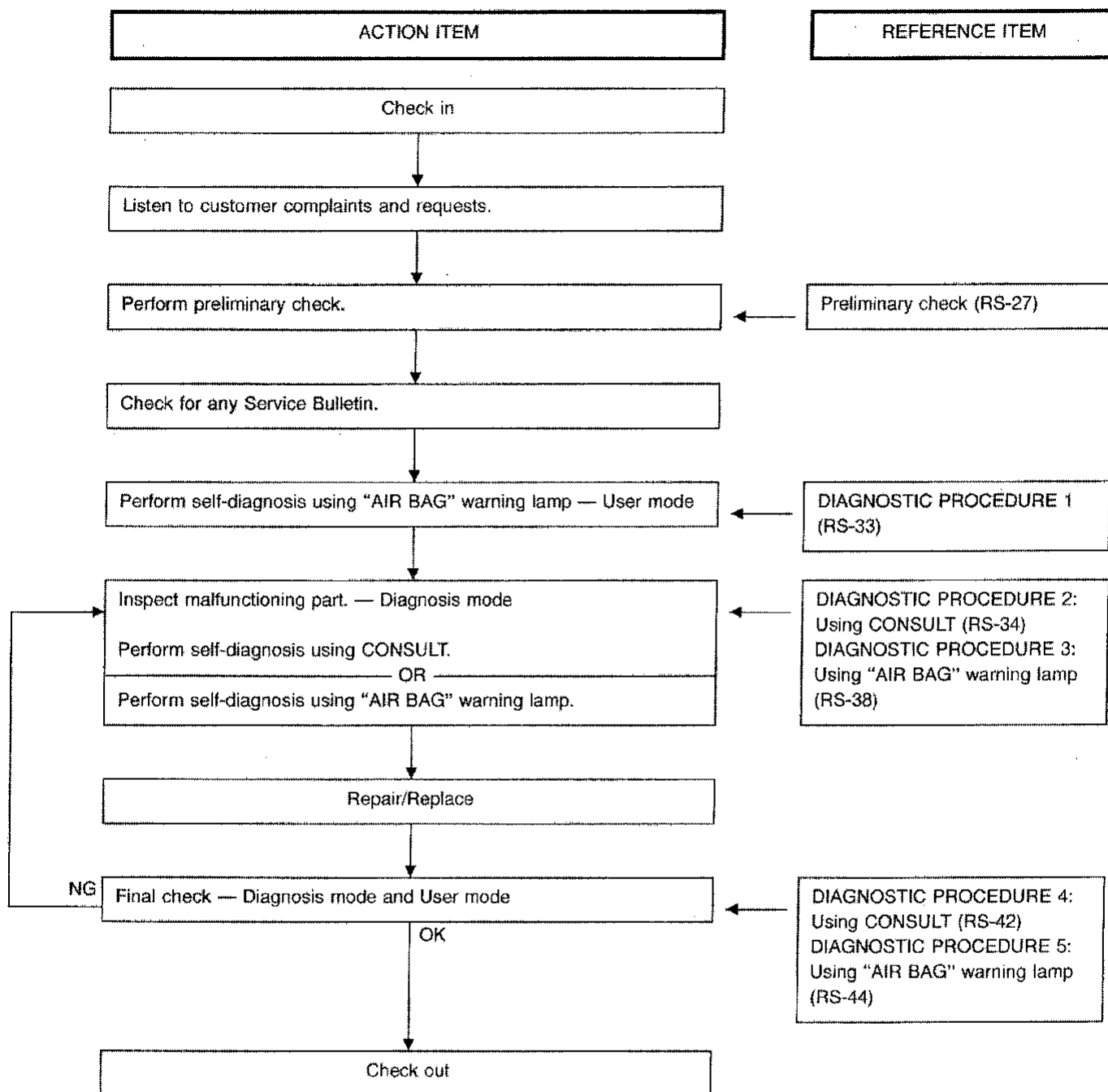

Schematic

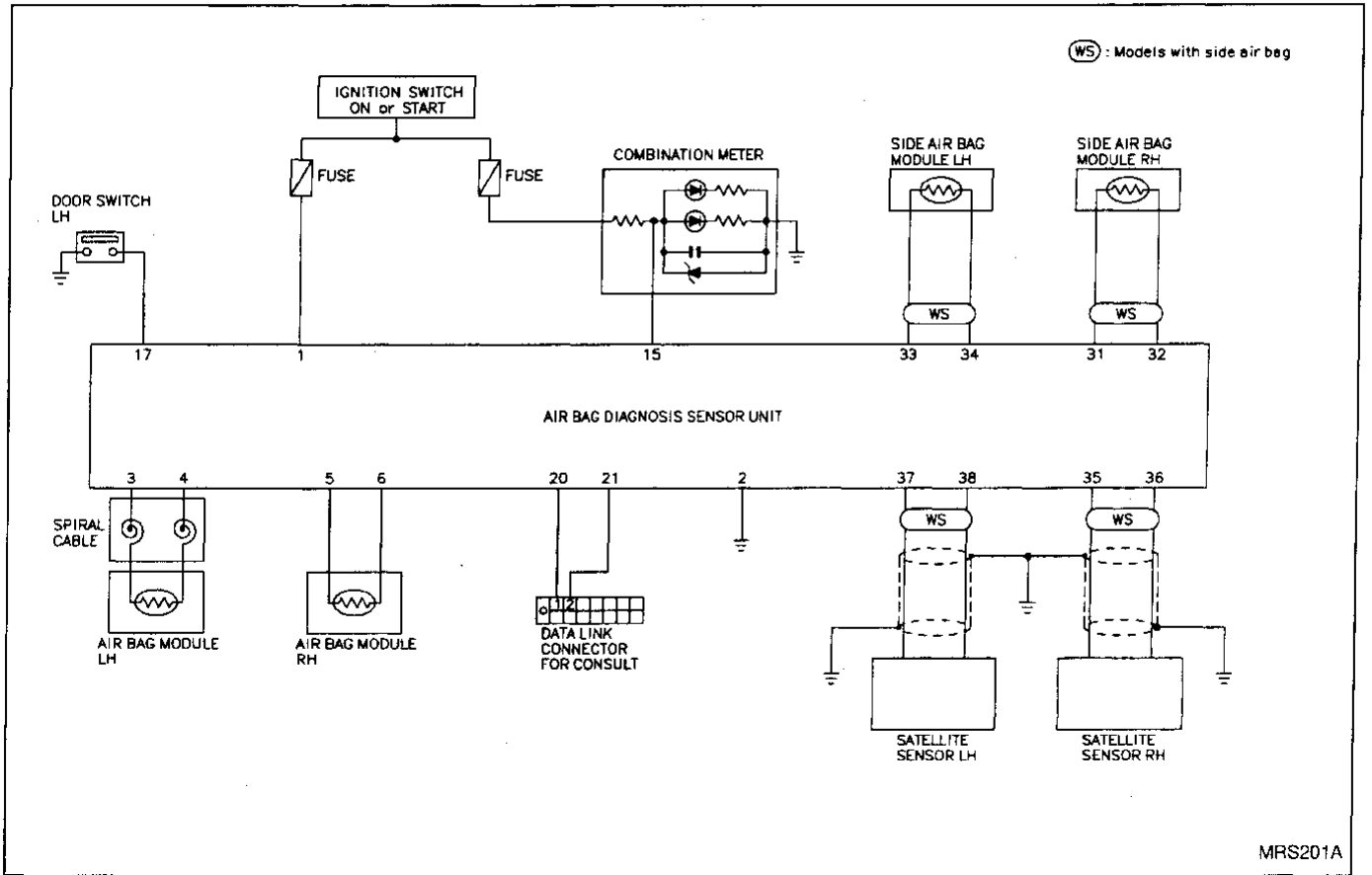

GI
MA
EM
LC
EC
FE
CL
MT
AT
FA
RA
BR
ST
RS
BT
HA
EL
IDX

Wiring Diagram — SRS —

RS-SRS-01

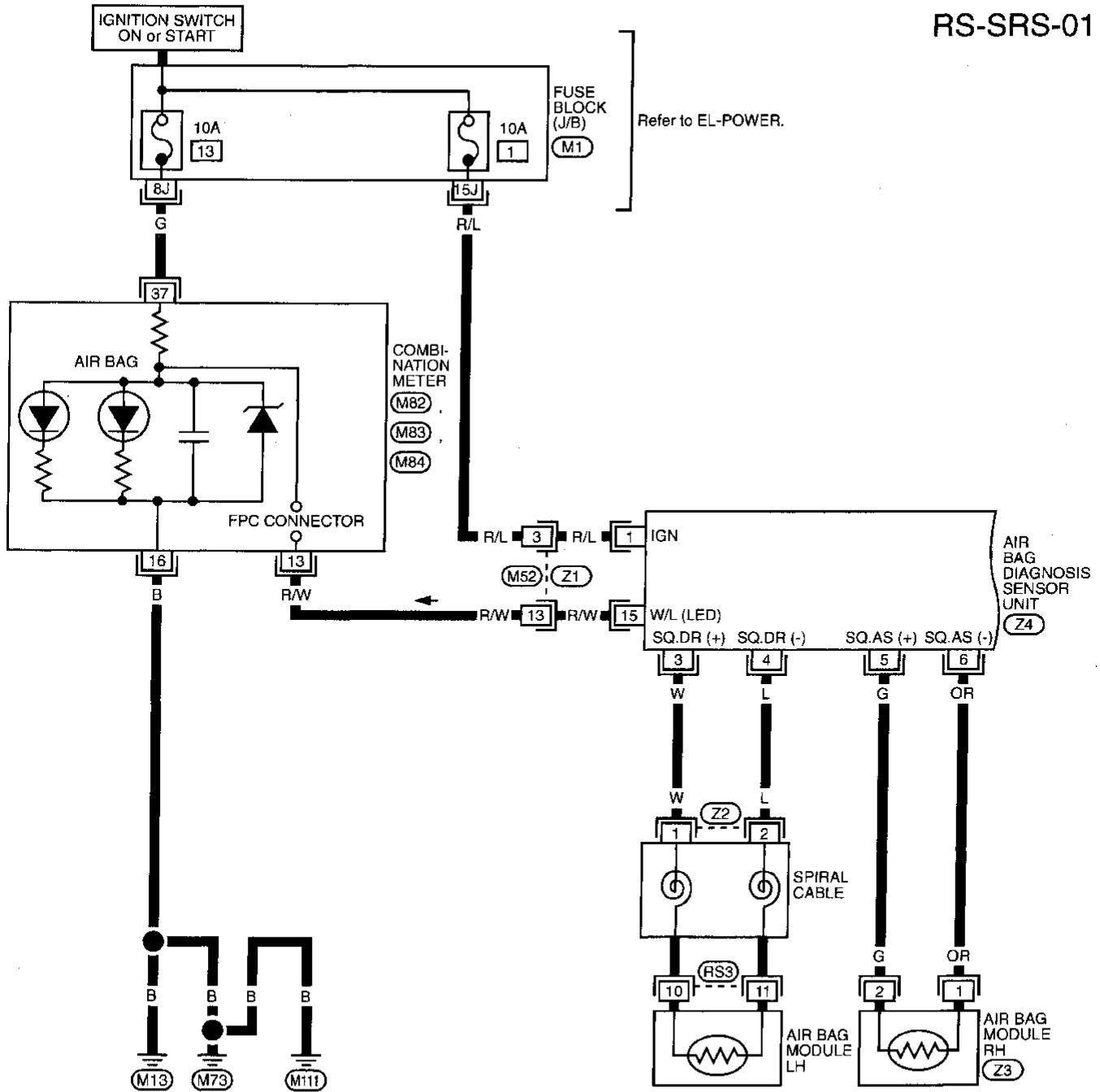

Refer to EL-POWER.

AIR BAG DIAGNOSIS SENSOR UNIT (Z4)

Refer to last page (Foldout page).

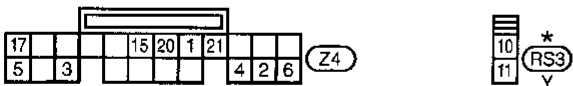
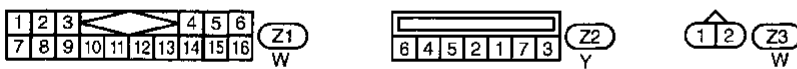
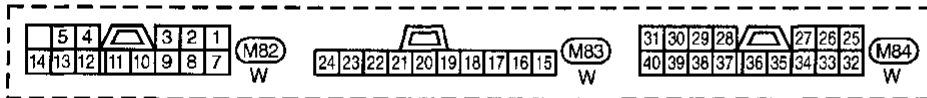

* : This connector is not shown in "HARNESS LAYOUT" of EL section.

(M1)

TROUBLE DIAGNOSES — Supplemental Restraint System (SRS)

Wiring Diagram — SRS — (Cont'd)

RS-SRS-02

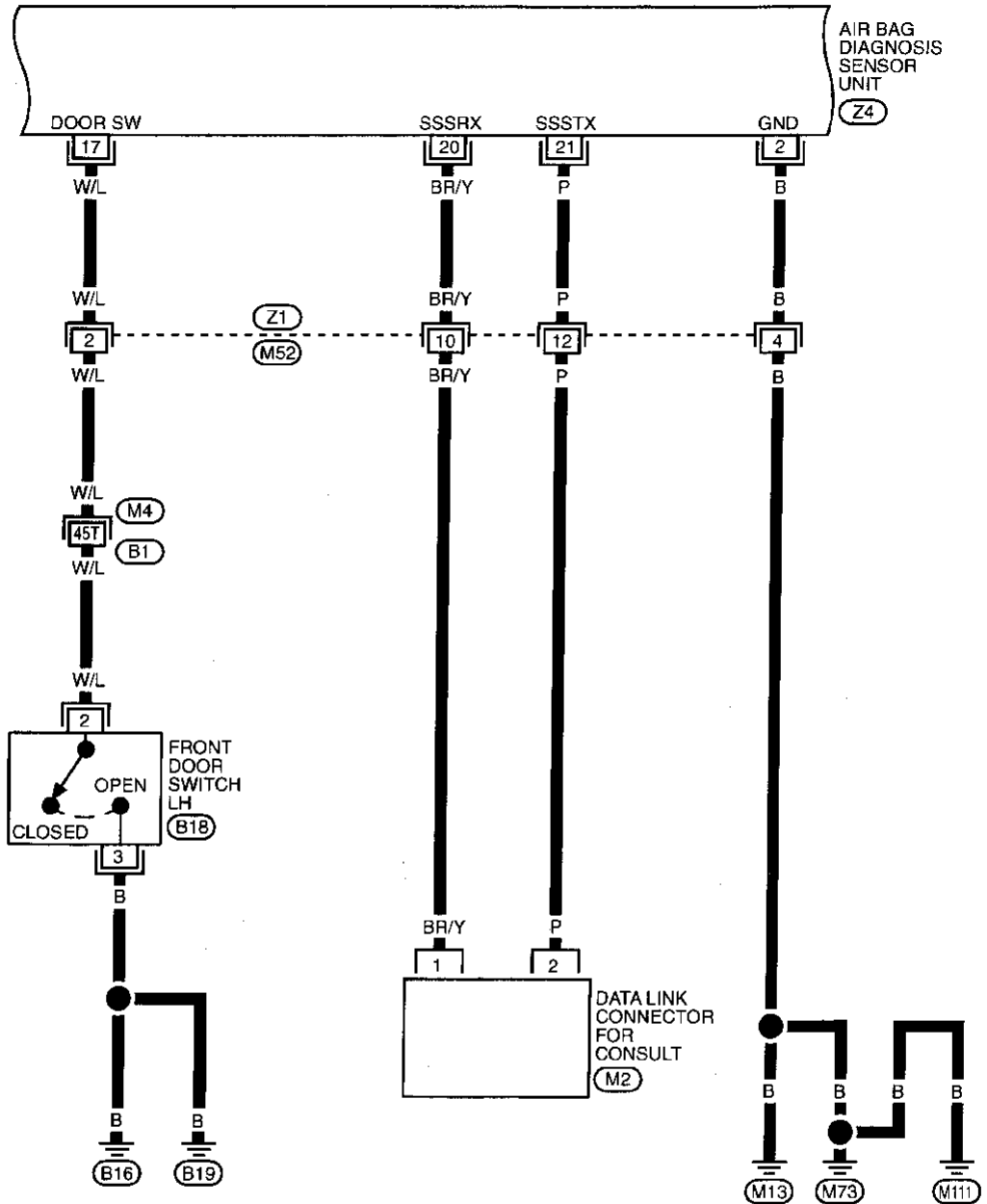

GI
 MA
 EM
 LC
 EC
 FE
 CL
 MT
 AT
 FA
 RA
 BR
 ST
RS

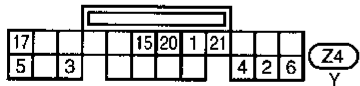
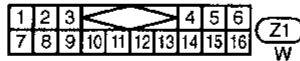
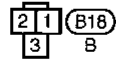
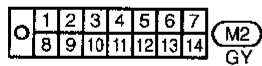

Refer to last page (Foldout page).
 (M4) . (B1)

BT
 HA
 EL
 IDX

TROUBLE DIAGNOSES — Supplemental Restraint System (SRS)

Wiring Diagram — SRS — (Cont'd)

MODELS WITH SIDE AIR BAG

RS-SRS-03

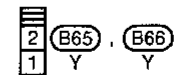
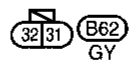
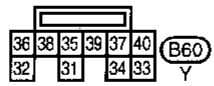
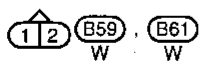
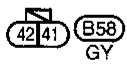
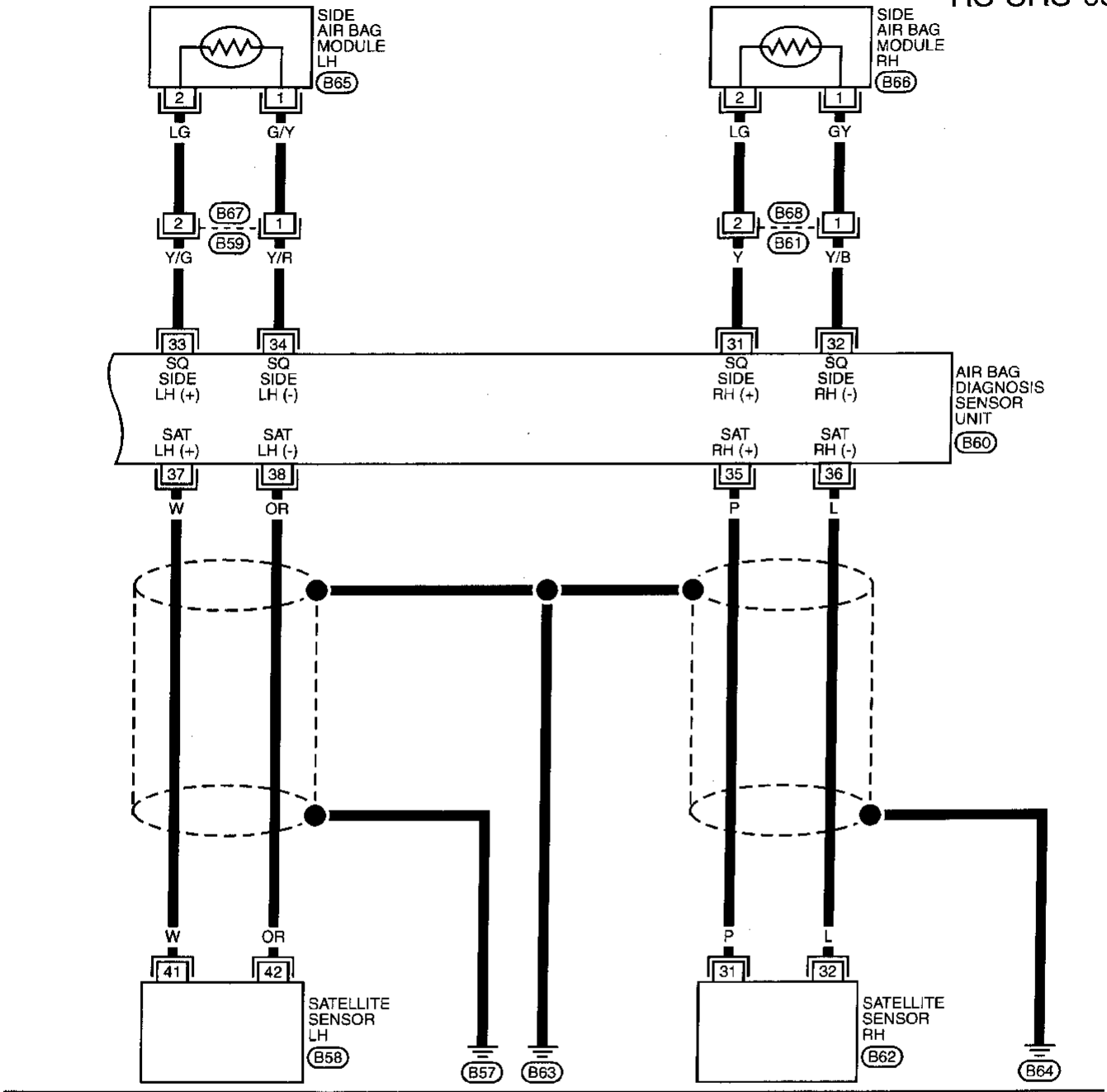

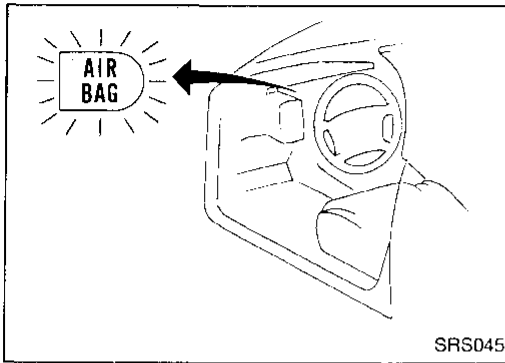

Self-diagnosis

DIAGNOSTIC PROCEDURE 1

Checking SRS operation by using "AIR BAG" warning lamp — User mode

1. After turning ignition switch from "OFF" to "ON", "AIR BAG" warning lamp operates.
2. Compare "AIR BAG" warning lamp operation to the chart below.

"AIR BAG" warning lamp operation — User mode —	SRS condition	Reference item
<p>MRS095A</p>	No malfunction is detected. No further action is necessary.	—
<p>MRS096A</p>	The system has problem and needs to be repaired as indicated.	Go to DIAGNOSTIC PROCEDURE 2 or 3 (RS-34 or 38).
<p>MRS097A</p>	Air bag is deployed. Air bag fuse, diagnosis sensor unit or harness is malfunctioning and needs to be repaired.	Go to COLLISION DIAGNOSIS (RS-53). Go to DIAGNOSTIC PROCEDURE 9 (RS-51).
<p>MRS098A</p>	One of the following has occurred and needs to be repaired. <ul style="list-style-type: none"> • Meter fuse is blown. • "AIR BAG" warning lamp circuit has open or short. • Diagnosis sensor unit is malfunctioning. 	Go to DIAGNOSTIC PROCEDURE 10 (RS-51).

NOTE:

If "AIR BAG" warning lamp operates differently from the operations shown above, refer to "AIR BAG" warning lamp operation — Diagnosis mode —, DIAGNOSTIC PROCEDURE 3 (step 4), RS-38.

TROUBLE DIAGNOSES — Supplemental Restraint System (SRS)

Self-diagnosis (Cont'd)

DIAGNOSTIC PROCEDURE 2 (CONSULT with CONSULT)

Inspecting SRS malfunctioning parts by using CONSULT —
Diagnosis mode

1. Turn ignition switch "OFF".
2. Connect "CONSULT" to Data link connector.

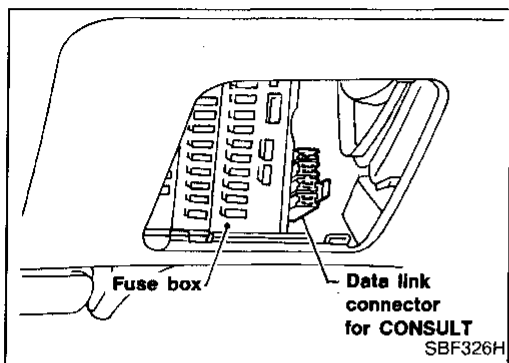

3. Turn ignition switch "ON".
4. Touch "START".

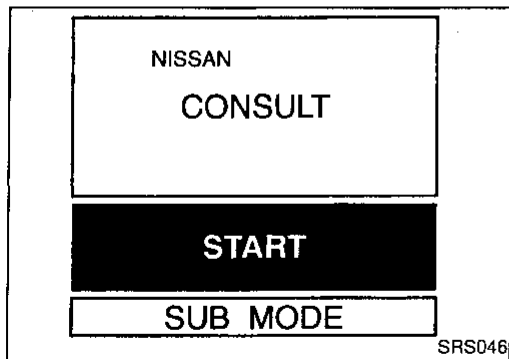

5. Touch "AIRBAG".

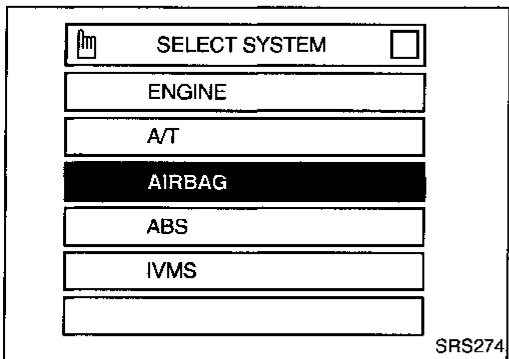

6. Touch "SELF-DIAG [CURRENT]".

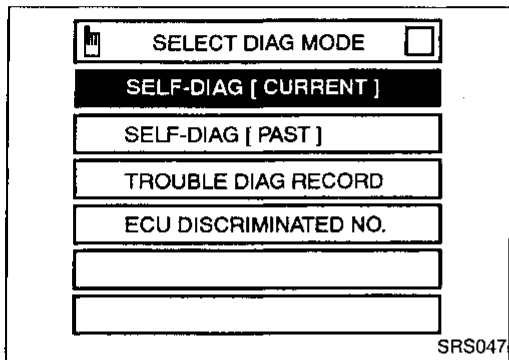

7. Diagnostic codes are displayed on "SELF-DIAG [CURRENT]".

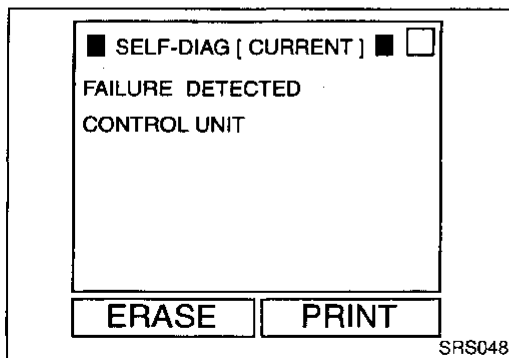

Self-diagnosis (Cont'd)

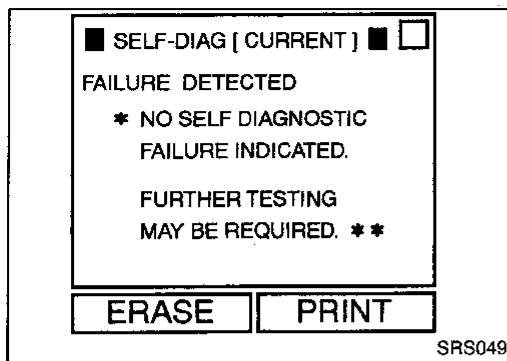

If no self-diagnostic failure is detected on "SELF-DIAG [CURRENT]" even though malfunction is detected in DIAGNOSTIC PROCEDURE 1, check the battery voltage. If the battery voltage is less than 9V, charge the battery. Then go to DIAGNOSTIC PROCEDURE 4 for final checking, page RS-42. If the battery voltage is OK, go to DIAGNOSTIC PROCEDURE 6, page RS-46, to diagnose the following situations:

- Self-diagnostic failure "SELF-DIAG [PAST]" (previously stored in the memory) might not be erased after repair.
- The SRS system malfunctions intermittently.

8. Touch "PRINT".
9. Compare diagnostic codes to the CONSULT DIAGNOSTIC CODE CHART, page RS-36.
10. Touch "BACK" key of CONSULT until SELECT SYSTEM appears in order to return to User mode from Diagnosis mode, then turn off CONSULT.
11. Turn ignition switch "OFF", then disconnect CONSULT and both battery cables.
12. Repair the system as outlined by the "Repair order" in CONSULT DIAGNOSTIC CODE CHART, that corresponds to the problem code. For replacement procedure of component parts, refer to RS-12.
13. After repairing the system, go to DIAGNOSTIC PROCEDURE 4 for final checking, page RS-42.

GI

MA

EM

LC

EC

FE

CL

MT

AT

FA

RA

BR

ST

RS

BT

HA

EL

IDX

TROUBLE DIAGNOSES — Supplemental Restraint System (SRS)

Self-diagnosis (Cont'd)

CONSULT DIAGNOSTIC CODE CHART ("SELF-DIAG [CURRENT]")

Diagnostic item	Explanation	Repair order Recheck SRS at each replacement.	
NO SELF DIAGNOSTIC FAILURE INDICATED	When malfunction is indicated by the "AIR BAG" warning lamp in User mode	<ul style="list-style-type: none"> ● Low battery voltage (Less than 9V) ● Self-diagnostic failure "SELF-DIAG [PAST]" (previously stored in the memory) might not be erased after repair. ● Intermittent problem has been detected in the past. 	<ul style="list-style-type: none"> ● Go to DIAGNOSTIC PROCEDURE 4 (RS-42) after charging battery. ● Go to DIAGNOSTIC PROCEDURE 6 (RS-46).
	● No malfunction is detected.	● Go to DIAGNOSTIC PROCEDURE 4 (RS-42).	
AIRBAG MODULE [OPEN]	● Driver's air bag module circuit is open. (including the spiral cable)	<ol style="list-style-type: none"> 1. Visually check the wiring harness connection. 2. Replace the harness if it has visible damage. 3. Replace the spiral cable. 4. Replace driver's air bag module. 5. Replace the diagnosis sensor unit. 	
AIRBAG MODULE [VB-SHORT]	● Driver's air bag module circuit is shorted to some power supply circuit. (including the spiral cable)	<ol style="list-style-type: none"> 1. Visually check the wiring harness connection. 2. Replace the harness if it has visible damage. 3. Replace the spiral cable. 4. Replace driver's air bag module. 5. Replace the diagnosis sensor unit. 	
AIRBAG MODULE [GND-SHORT]	● Driver's air bag module circuit is shorted to ground. (including the spiral cable)	<ol style="list-style-type: none"> 1. Visually check the wiring harness connection. 2. Replace the harness if it has visible damage. 3. Replace the spiral cable. 4. Replace driver's air bag module. (Before disposal of it, it must be deployed.) 5. Replace the diagnosis sensor unit. 	
AIRBAG MODULE [SHORT]	● Driver's air bag module circuits are shorted to each other.	<ol style="list-style-type: none"> 1. Visually check the wiring harness connection. 2. Replace the harness if it has visible damage. 3. Replace front passenger air bag module. (Before disposal of it, it must be deployed.) 4. Replace the diagnosis sensor unit. 	
ASSIST A/B MODULE [VB-SHORT]	● Front passenger air bag module circuit is shorted to some power supply circuit.	<ol style="list-style-type: none"> 1. Visually check the wiring harness connection. 2. Replace the harness if it has visible damage. 3. Replace front passenger air bag module. (Before disposal of it, it must be deployed.) 4. Replace the diagnosis sensor unit. 	
ASSIST A/B MODULE [OPEN]	● Front passenger air bag module circuit is open.	<ol style="list-style-type: none"> 1. Visually check the wiring harness connection. 2. Replace the harness if it has visible damage. 3. Replace front passenger air bag module. (Before disposal of it, it must be deployed.) 4. Replace the diagnosis sensor unit. 	
ASSIST A/B MODULE [GND-SHORT]	● Front passenger air bag module circuit is shorted to ground.	<ol style="list-style-type: none"> 1. Visually check the wiring harness connection. 2. Replace the harness if it has visible damage. 3. Replace front passenger air bag module. (Before disposal of it, it must be deployed.) 4. Replace the diagnosis sensor unit. 	
ASSIST A/B MODULE [SHORT]	● Front passenger air bag module circuits are shorted to each other.	<ol style="list-style-type: none"> 1. Visually check the wiring harness connection. 2. Replace the harness if it has visible damage. 3. Replace front passenger air bag module (LH). (Before disposal, it must be deployed.) 4. Replace the diagnosis sensor unit. 	
DA	● Side air bag module (LH) circuit is open.	<ol style="list-style-type: none"> 1. Visually check the wiring harness connection. 2. Replace the harness if it has visible damage. 3. Replace side air bag module (LH). (Before disposal, it must be deployed.) 4. Replace the diagnosis sensor unit. 	
DB	● Side air bag module (LH) circuit is shorted to some power supply circuits.	<ol style="list-style-type: none"> 1. Visually check the wiring harness connection. 2. Replace the harness if it has visible damage. 3. Replace side air bag module (LH). (Before disposal, it must be deployed.) 4. Replace the diagnosis sensor unit. 	
DC	● Side air bag module (LH) circuit is shorted to ground.	<ol style="list-style-type: none"> 1. Visually check the wiring harness connection. 2. Replace the harness if it has visible damage. 3. Replace side air bag module (RH). (Before disposal, it must be deployed.) 4. Replace the diagnosis sensor unit. 	
DD	● Side air bag module (LH) circuits are shorted to each other.	<ol style="list-style-type: none"> 1. Visually check the wiring harness connection. 2. Replace the harness if it has visible damage. 3. Replace side air bag module (RH). (Before disposal, it must be deployed.) 4. Replace the diagnosis sensor unit. 	
7A	● Side air bag module (RH) circuit is open.	<ol style="list-style-type: none"> 1. Visually check the wiring harness connection. 2. Replace the harness if it has visible damage. 3. Replace side air bag module (RH). (Before disposal, it must be deployed.) 4. Replace the diagnosis sensor unit. 	
7B	● Side air bag module (RH) circuit is shorted to some power supply circuits.	<ol style="list-style-type: none"> 1. Visually check the wiring harness connection. 2. Replace the harness if it has visible damage. 3. Replace side air bag module (RH). (Before disposal, it must be deployed.) 4. Replace the diagnosis sensor unit. 	
7C	● Side air bag module (RH) circuit is shorted to ground.	<ol style="list-style-type: none"> 1. Visually check the wiring harness connection. 2. Replace the harness if it has visible damage. 3. Replace side air bag module (RH). (Before disposal, it must be deployed.) 4. Replace the diagnosis sensor unit. 	
7D	● Side air bag module (RH) circuits are shorted to each other.	<ol style="list-style-type: none"> 1. Visually check the wiring harness connection. 2. Replace the harness if it has visible damage. 3. Replace side air bag module (RH). (Before disposal, it must be deployed.) 4. Replace the diagnosis sensor unit. 	

TROUBLE DIAGNOSES — Supplemental Restraint System (SRS)

Self-diagnosis (Cont'd)

Diagnostic item	Explanation	Repair order Recheck SRS at each replacement.	
91 92 93	<ul style="list-style-type: none"> ● Satellite sensor (LH) 	<ol style="list-style-type: none"> 1. Visually check the wiring harness connection. 2. Replace the harness if it has visible damage. 3. Replace the satellite sensor (LH). 4. Replace the diagnosis sensor unit. 	GI MA EM
81 82 83	<ul style="list-style-type: none"> ● Satellite sensor (RH) 	<ol style="list-style-type: none"> 1. Visually check the wiring harness connection. 2. Replace the harness if it has visible damage. 3. Replace the satellite sensor (RH). 4. Replace the diagnosis sensor unit. 	LC EC FE
CONTROL UNIT	<ul style="list-style-type: none"> ● Diagnosis sensor unit is malfunctioning. 	<ol style="list-style-type: none"> 1. Visually check the wiring harness connections. 2. Replace the diagnosis sensor unit. 	CL

* Follow the procedures in numerical order when repairing malfunctioning parts. Confirm whether malfunction is eliminated using the air bag warning lamp or CONSULT each time repair is finished. If malfunction is still observed, proceed to the next step. When malfunction is eliminated, further repair work is not required.

MT

AT

FA

RA

BR

ST

RS

BT

HA

EL

IDX

TROUBLE DIAGNOSES — Supplemental Restraint System (SRS)

Self-diagnosis (Cont'd)

DIAGNOSTIC PROCEDURE 3 ( without CONSULT)
Inspecting SRS malfunctioning parts by using "AIR BAG" warning lamp — Diagnosis mode

NOTE:

SRS will not enter Diagnosis mode if no malfunction is detected in User mode.

1. Open driver's door.
2. Turn ignition switch from "OFF" to "ON".
3. Press driver's door switch at least 5 times within 7 seconds after turning ignition switch "ON".
SRS is now in Diagnosis mode.
4. "AIR BAG" warning lamp operates in Diagnosis mode as follows:

NOTE:

If SRS does not enter Diagnosis mode even though malfunction is detected in User mode, go to **DIAGNOSTIC PROCEDURE 11**, page RS-52.

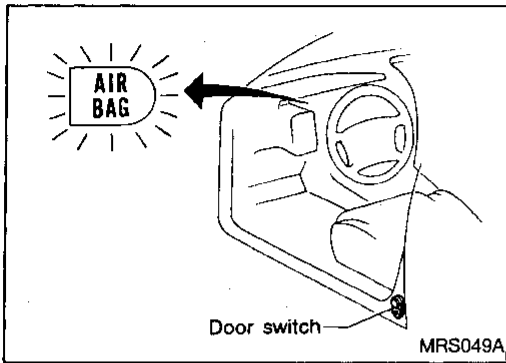

No.	"AIR BAG" warning lamp flash pattern — Diagnosis mode —	SRS condition
1	<p style="text-align: right;">(a) through (b) are repeated.</p> <p style="text-align: right;">SRS333</p>	<ul style="list-style-type: none"> • Diagnosis results (previously stored in the memory) might not be erased after repair. • Intermittent problem has been detected in the past. <p>Go to DIAGNOSTIC PROCEDURE 7 (RS-46).</p>
2	<p style="text-align: right;">(a) through (d) are repeated.</p> <p style="text-align: right;">SRS341</p> <p>(a) — Driver and passenger air bag marker (For identifying driver and/or passenger air bag malfunctioning) (d) — Indicates malfunctioning part. The number of flash varies with malfunctioning part (0.5 sec. ON and 0.5 sec. OFF is counted as one flash.)</p>	<p>The system has a problem and needs to be repaired.</p>
3	<p style="text-align: right;">(a) through (f) are repeated.</p> <p style="text-align: right;">SRS342-A</p> <p>(b), (c), (d) — Side air bag marker (For identifying side air bag malfunctioning) (f) — Indicates malfunctioning part. The number of flash varies with malfunctioning part (0.5 sec. ON and 0.5 sec. OFF is counted as one flash.)</p>	

TROUBLE DIAGNOSES — Supplemental Restraint System (SRS)

Self-diagnosis (Cont'd)

5. Malfunctioning part is indicated by the number of flashes (part ④ or ⑤). Compare the number of flashes to AIR BAG WARNING LAMP FLASH CODE CHART, page RS-39, and locate malfunctioning part.
6. Turn ignition switch "OFF", and disconnect both battery cables.
7. Repair the system as outlined by the "Repair order" in AIR BAG WARNING LAMP FLASH CODE CHART that corresponds to the flash code. For replacement procedure of component parts, refer to RS-12.
8. After repairing the system, go to DIAGNOSTIC PROCEDURE 5, page RS-44.

GI

MA

EM

LC

EC

FE

CL

MT

AT

FA

RA

BR

ST

RS

BT

HA

EL

IDX

AIR BAG WARNING LAMP FLASH CODE CHART (DIAGNOSIS MODE)

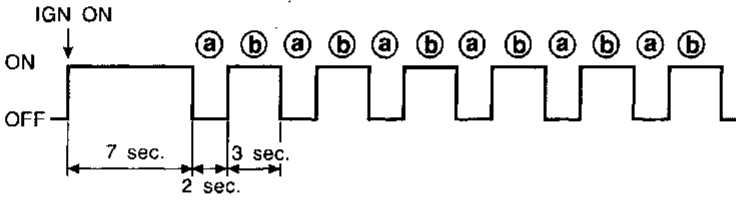
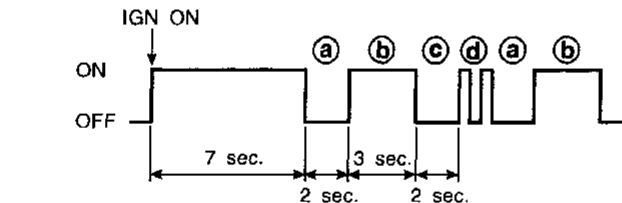
<ul style="list-style-type: none"> • Diagnosis results (previously stored in the memory) might not be erased after repair. • Intermittent problem has been detected in the past. 	<p style="text-align: center;">Flash pattern</p> <p style="text-align: right;">① through ⑥ are repeated.</p>  <p style="text-align: center;">SRS333</p> <p>Repair order</p> <ul style="list-style-type: none"> • Go to DIAGNOSTIC PROCEDURE 7 (RS-46).
<p>The driver's air bag module circuit is malfunctioning. (④: 2 flashes)</p>	<p style="text-align: center;">Flash pattern</p> <p style="text-align: right;">① through ⑥ are repeated. ④ — Two flashes indicate malfunctioning driver's air bag module circuit.</p>  <p style="text-align: center;">SRS334</p> <p>Repair order ("Recheck SRS at each replacement.")</p> <ol style="list-style-type: none"> 1. Visually check the wiring harness connection. 2. Replace the harness if it has visible damage. 3. Replace the spiral cable. 4. Replace driver's air bag module. (Before disposal, it must be deployed.) 5. Replace the diagnosis sensor unit.

TROUBLE DIAGNOSES — Supplemental Restraint System (SRS)

Self-diagnosis (Cont'd)

The diagnosis sensor unit is malfunctioning.
(④: 7 flashes)

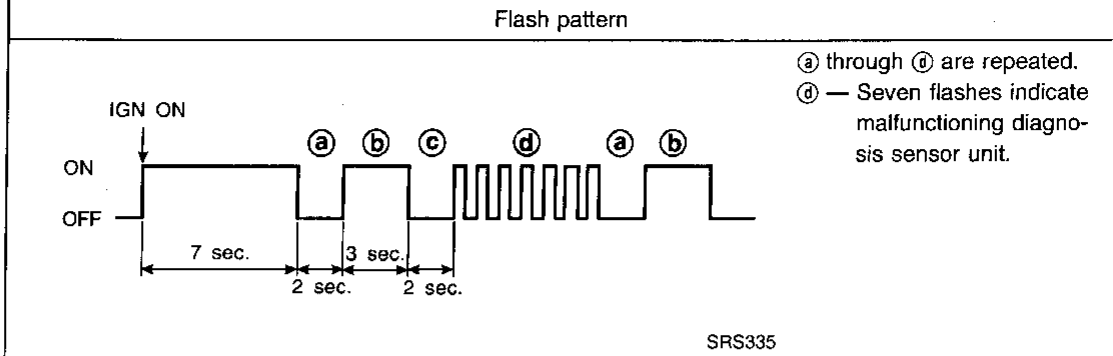

Repair order ("Recheck SRS at each replacement.")

1. Visually check the wiring harness connections.
2. Replace the diagnosis sensor unit.

The front passenger air bag module circuit is malfunctioning.
(④: 8 flashes)

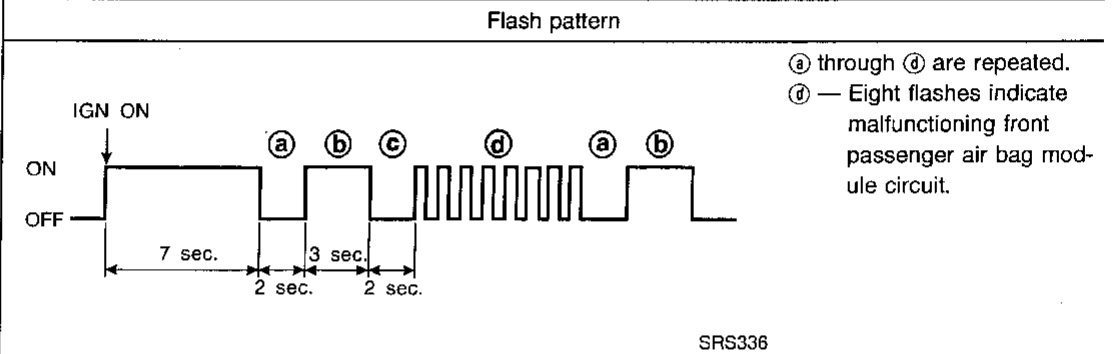

Repair order ("Recheck SRS at each replacement.")

1. Visually check the wiring harness connection.
2. Replace the harness if it has visible damage.
3. Replace front passenger air bag module.
(Before disposal, it must be deployed.)
4. Replace the diagnosis sensor unit.

The side air bag module (RH) circuit is malfunctioning.
(①: 1 flash)

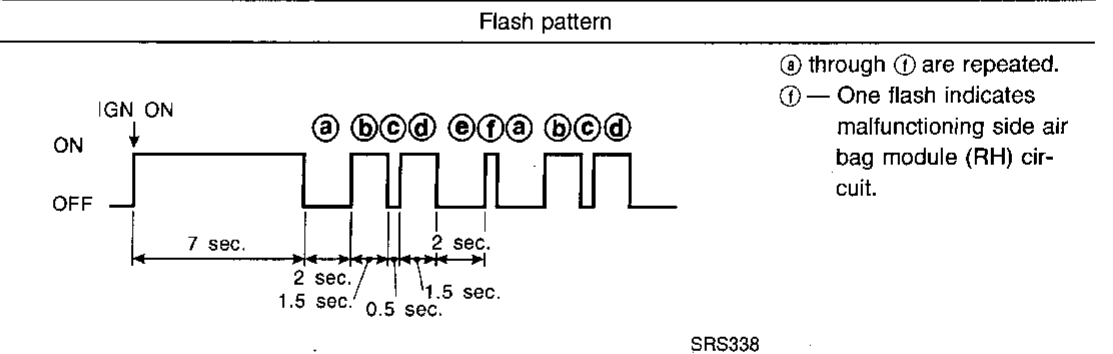

Repair order ("Recheck SRS at each replacement.")

1. Visually check the wiring harness connection.
2. Replace the harness if it has visible damage.
3. Replace side air bag module (RH).
(Before disposal, it must be deployed.)
4. Replace the diagnosis sensor unit.

TROUBLE DIAGNOSES — Supplemental Restraint System (SRS)

Self-diagnosis (Cont'd)

<p>The side air bag module (LH) circuit is malfunctioning. (①: 2 flashes)</p>	<p style="text-align: center;">Flash pattern</p> <p style="text-align: right;"> ⓐ through ① are repeated. ① — Two flashes indicate malfunctioning side air bag module (LH) circuit. </p> <p style="text-align: right;">SRS337</p>	GI MA EM	
<p>Repair order ("Recheck SRS at each replacement.")</p> <ol style="list-style-type: none"> 1. Visually check the wiring harness connection. 2. Replace the harness if it has visible damage. 3. Replace side air bag module (LH). (Before disposal, it must be deployed.) 4. Replace the diagnosis sensor unit. 			LC EC
<p>The satellite sensor (RH) is malfunctioning. (①: 3 flashes)</p>	<p style="text-align: center;">Flash pattern</p> <p style="text-align: right;"> ⓐ through ① are repeated. ① — Three flashes indicate malfunctioning satellite sensor (RH) circuit. </p> <p style="text-align: right;">SRS340</p>	FE CL MT AT	
<p>Repair order ("Recheck SRS at each replacement.")</p> <ol style="list-style-type: none"> 1. Visually check the wiring harness connection. 2. Replace the harness if it has visible damage. 3. Replace the satellite sensor (RH). 4. Replace the diagnosis sensor unit. 			FA RA
<p>The satellite sensor (LH) is malfunctioning. (①: 4 flashes)</p>	<p style="text-align: center;">Flash pattern</p> <p style="text-align: right;"> ⓐ through ① are repeated. ① — Four flashes indicate malfunctioning satellite sensor (LH) circuit. </p> <p style="text-align: right;">SRS339-A</p>	BR ST RS BT	
<p>Repair order ("Recheck SRS at each replacement.")</p> <ol style="list-style-type: none"> 1. Visually check the wiring harness connection. 2. Replace the harness if it has visible damage. 3. Replace the satellite sensor (LH). 4. Replace the diagnosis sensor unit. 			HA EL

* Follow the procedures in numerical order when repairing malfunctioning parts. Confirm whether malfunction is eliminated using the air bag warning lamp (in User mode) or CONSULT each time repair is finished. If malfunction is still observed, proceed to the next step. When malfunction is eliminated, further repair work is not required.

TROUBLE DIAGNOSES — Supplemental Restraint System (SRS)

Self-diagnosis (Cont'd)

DIAGNOSTIC PROCEDURE 4 (CONSULT with CONSULT)

Final checking after repairing SRS by using CONSULT — Diagnosis mode

1. After repairing SRS, connect both battery cables.
2. Connect CONSULT to Data link connector.
3. Turn ignition switch from "OFF" to "ON".

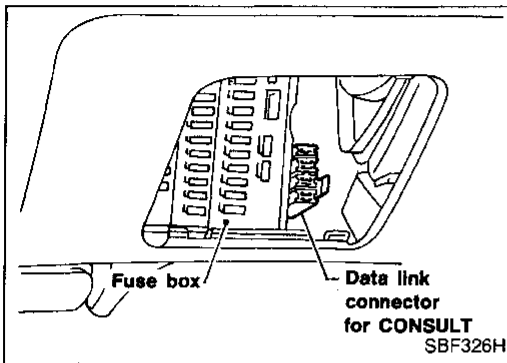

4. Touch "START".

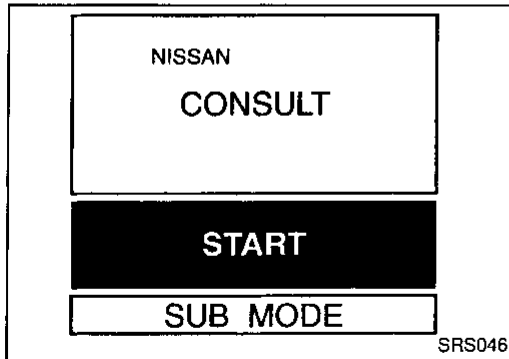

5. Touch "AIRBAG".

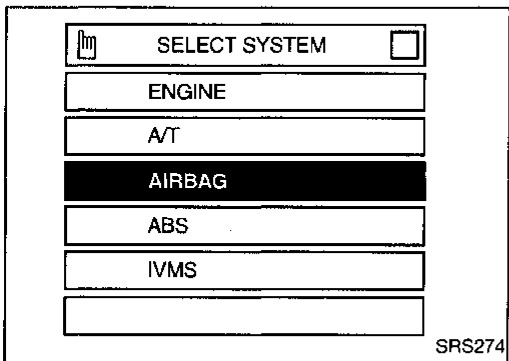

6. Touch "SELF-DIAG [CURRENT]".

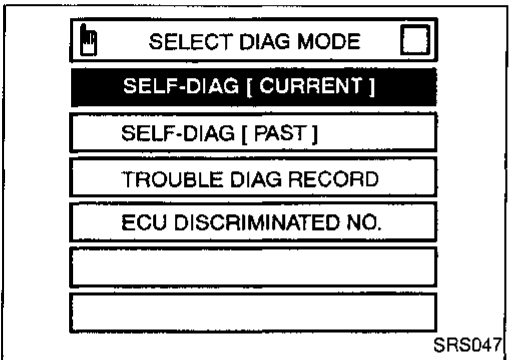

7. If no malfunction is detected on "SELF-DIAG [CURRENT]", repair of SRS is completed.

If any problem code is displayed on "SELF-DIAG [CURRENT]", the malfunctioning part is not repaired completely or another malfunctioning part is detected. Go to DIAGNOSTIC PROCEDURE 2, page RS-34, and repair malfunctioning part completely.

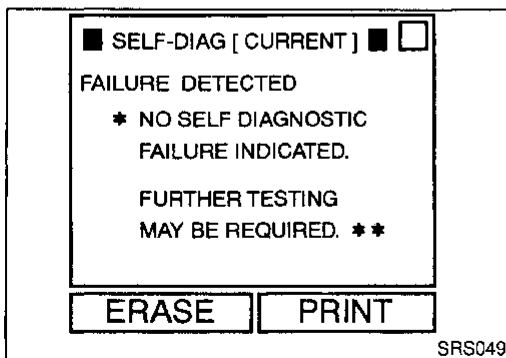

TROUBLE DIAGNOSES — Supplemental Restraint System (SRS)

Self-diagnosis (Cont'd)

8. Touch "ERASE".

NOTE:

Touch "ERASE" to clear the memory of the malfunction ("SELF-DIAG [PAST]").

If the memory of the malfunction is "SELF-DIAG [PAST]" is not erased, the User mode shows the system malfunction by the operation of the warning lamp even if the malfunction is repaired completely.

GI

MA

EM

LC

EC

FE

CL

MT

AT

FA

RA

BR

ST

RS

BT

HA

EL

IDX

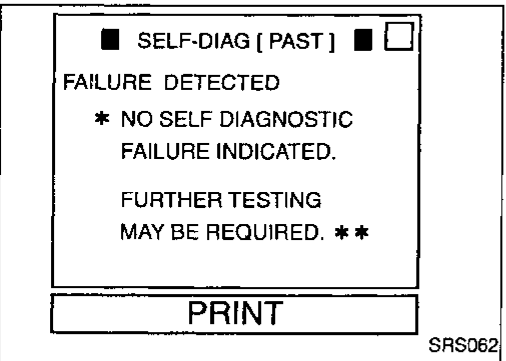
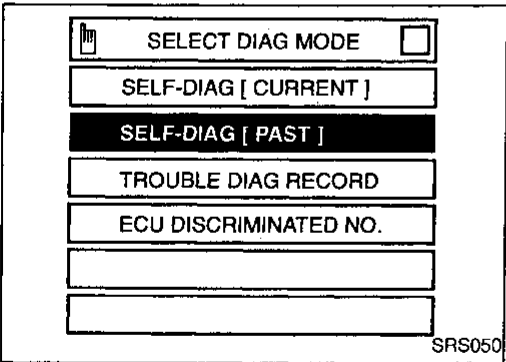
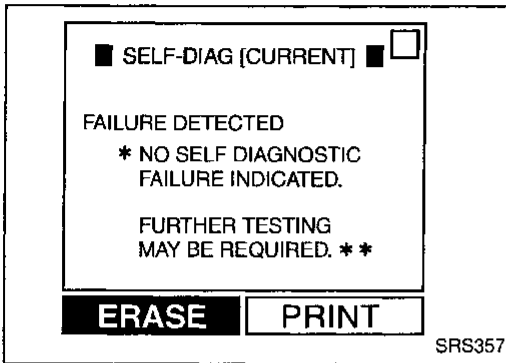

9. Touch "BACK" key of CONSULT to select "SELF-DIAG [PAST]" in the "SELECT DIAG MODE" screen. Touch "SELF-DIAG [PAST]".

10. Check that no self-diagnostic failure is detected on "SELF-DIAG [PAST]".

11. Touch "BACK" key of CONSULT until SELECT SYSTEM appears in order to return to User mode from Diagnosis mode, turn off CONSULT, then disconnect CONSULT.

12. Turn ignition switch "OFF".

13. Go to DIAGNOSTIC PROCEDURE 1, page RS-33 to check SRS operation by using "AIR BAG" warning lamp with User mode.

TROUBLE DIAGNOSES — Supplemental Restraint System (SRS)

Self-diagnosis (Cont'd)

DIAGNOSTIC PROCEDURE 5 (⌚ without CONSULT)

Final checking after repairing SRS by using "AIR BAG" warning lamp — Diagnosis mode and User mode

1. After repairing SRS connect both battery cables.
2. Open driver's door.
3. Turn ignition switch from "OFF" to "ON".
4. "AIR BAG" warning lamp operates in Diagnosis mode as follows:

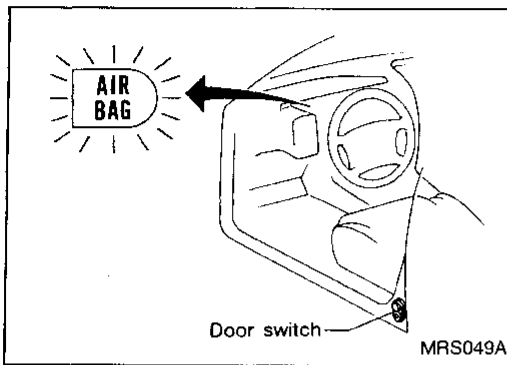

No.	"AIR BAG" warning lamp flash pattern — Diagnosis mode —	SRS condition
1	<p style="text-align: right;">SRS333</p>	<p>Ⓐ through Ⓑ are repeated.</p> <p>No malfunction is detected or repair is completed. No further action is necessary.</p>
2	<p style="text-align: right;">SRS341</p>	<p>Ⓐ through Ⓓ are repeated.</p> <p>Ⓑ — Driver and passenger air bag marker (For identifying driver and/or passenger air bag malfunctioning)</p> <p>Ⓓ — Indicates malfunctioning part. The number of flashes varies with malfunctioning part (0.5 sec. ON and 0.5 sec. OFF is counted as one flash.)</p> <p>The system has a problem and needs to be repaired.</p>
3	<p style="text-align: right;">SRS342-A</p>	<p>Ⓐ through Ⓕ are repeated.</p> <p>Ⓑ, Ⓒ, Ⓓ — Side air bag marker (For identifying side air bag malfunctioning)</p> <p>Ⓕ — Indicates malfunctioning part. The number of flashes varies with malfunctioning part (0.5 sec. ON and 0.5 sec. OFF is counted as one flash.)</p>

NOTE:

When diagnosis sensor unit is replaced with new one, "AIR BAG" warning lamp will operate in User mode. Checking "AIR BAG" warning lamp operation in Diagnosis mode is not required. Go to step 6.

TROUBLE DIAGNOSES — Supplemental Restraint System (SRS)

Self-diagnosis (Cont'd)

5. If "AIR BAG" warning lamp operates as shown in No. 1 in chart above, turn ignition switch "OFF" to reset from Diagnosis mode to User mode and to erase the memory of the malfunction. Then go to step 6.

If "AIR BAG" warning lamp operates as shown in No. 2 or No. 3 in chart above, the malfunctioning part is not repaired completely, or another malfunctioning part is detected. Go to DIAGNOSTIC PROCEDURE 3, page RS-38, and repair malfunctioning part completely.

6. Turn ignition switch "ON". "AIR BAG" warning lamp operates in User mode. Compare "AIR BAG" warning lamp operation to the chart below.

NOTE:

If switching Diagnosis mode to User mode is required while malfunction is being detected, turn ignition switch from "OFF" to "ON". Then press driver's door switch at least 5 times within 7 seconds after turning ignition switch "ON".

SRS is now in User mode.

"AIR BAG" warning lamp operation — User mode —	SRS condition	Reference item
<p>MRS095A</p>	<p>No malfunction is detected.</p> <p>No further action is necessary.</p>	—
<p>MRS096A</p>	<p>The system has problem and needs to be repaired as indicated.</p>	Go to DIAGNOSTIC PROCEDURE 2 or 3 (RS-34 or 38).
<p>MRS097A</p>	<p>Air bag is deployed.</p> <p>Air bag fuse, diagnosis sensor unit or harness is malfunctioning and needs to be repaired.</p>	<p>Go to COLLISION DIAGNOSIS (RS-53).</p> <p>Go to DIAGNOSTIC PROCEDURE 9 (RS-51).</p>
<p>MRS098A</p>	<p>One of the following has occurred and needs to be repaired.</p> <ul style="list-style-type: none"> • Meter fuse is blown. • "AIR BAG" warning lamp circuit has open or short. • Diagnosis sensor unit is malfunctioning. 	Go to DIAGNOSTIC PROCEDURE 10 (RS-51).

TROUBLE DIAGNOSES — Supplemental Restraint System (SRS)

Self-diagnosis (Cont'd)

DIAGNOSTIC PROCEDURE 6 (Continued from DIAGNOSTIC PROCEDURE 2) (📱 with CONSULT)

Inspecting SRS malfunctioning record

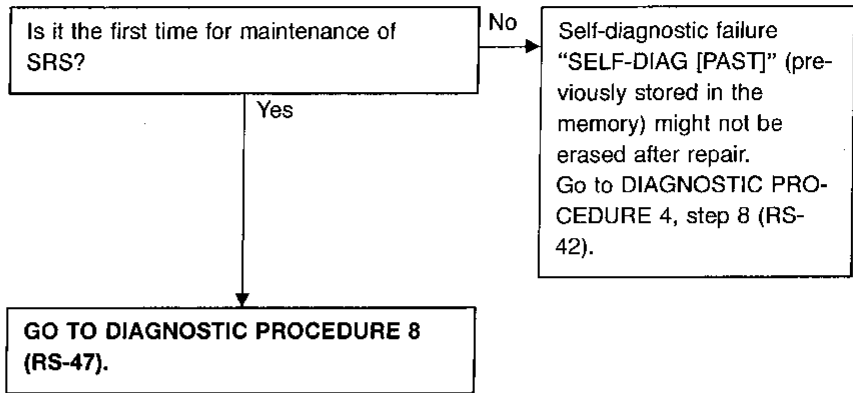

DIAGNOSTIC PROCEDURE 7 (Continued from DIAGNOSTIC PROCEDURE 3) (🕒 without CONSULT)

Inspecting SRS malfunctioning record

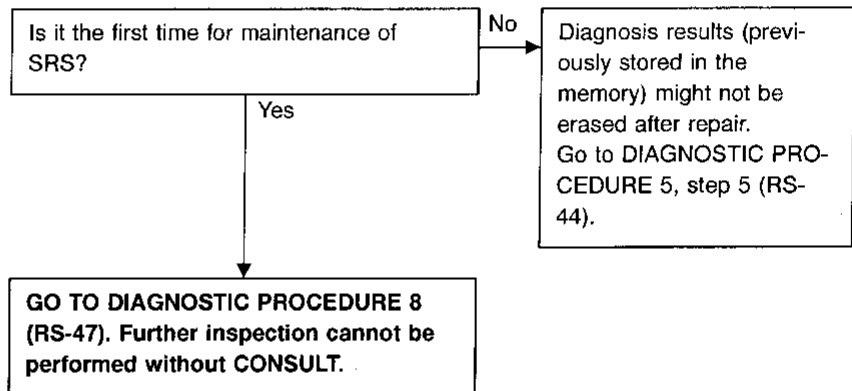

TROUBLE DIAGNOSES — Supplemental Restraint System (SRS)

Self-diagnosis (Cont'd)

DIAGNOSTIC PROCEDURE 8 (CONSULT) with CONSULT

Inspecting SRS intermittent problem by using CONSULT —
Diagnosis mode

1. Turn ignition switch "OFF".
2. Connect "CONSULT" to Data link connector.

GI

MA

EM

LC

EC

FE

CL

MT

AT

FA

RA

BR

ST

RS

BT

HA

EL

IDX

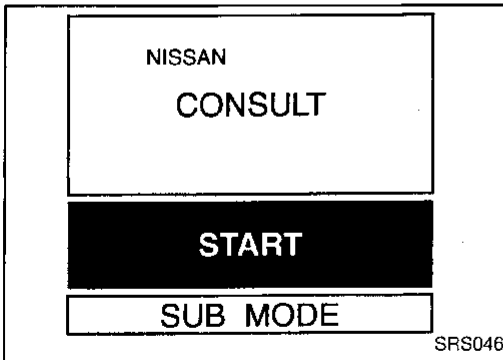
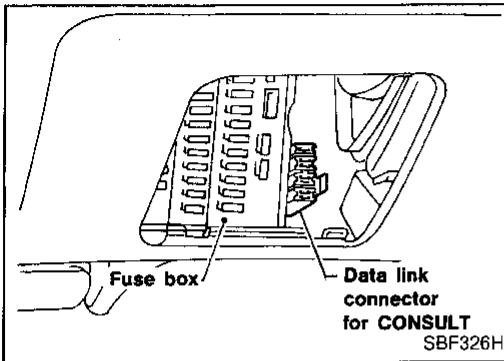

3. Turn ignition switch "ON".
4. Touch "START".

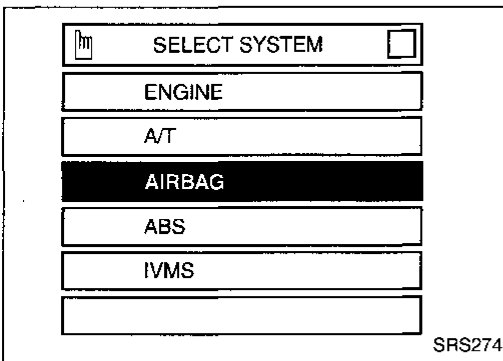

5. Touch "AIRBAG".

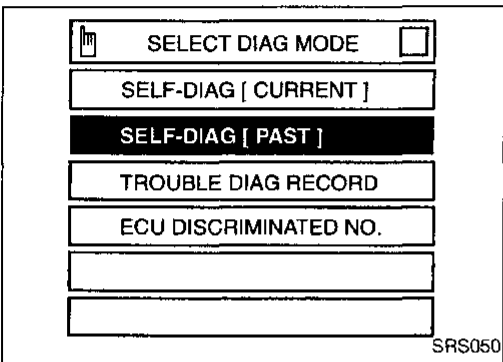

6. Touch "SELF-DIAG [PAST]".

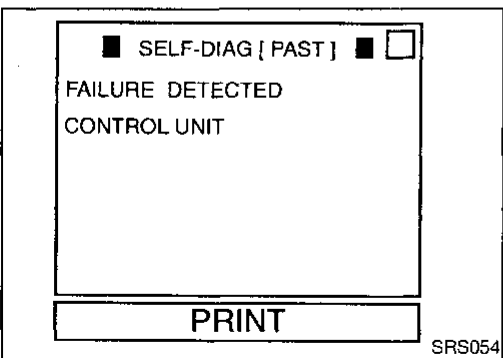

7. If diagnostic codes are displayed on "SELF-DIAG [PAST]", go to step 10.

TROUBLE DIAGNOSES — Supplemental Restraint System (SRS)

Self-diagnosis (Cont'd)

If no self-diagnostic failure is detected on "SELF-DIAG [PAST]", touch "BACK" and go back to "SELECT DIAG MODE".

■ SELF-DIAG [PAST] ■ □

FAILURE DETECTED

* NO SELF DIAGNOSTIC FAILURE INDICATED.

FURTHER TESTING MAY BE REQUIRED. **

PRINT

SRS062

SELECT DIAG MODE □

SELF-DIAG [CURRENT]

SELF-DIAG [PAST]

TROUBLE DIAG RECORD

ECU DISCRIMINATED NO.

SRS055

■ TROUBLE DIAG RECORD ■ □

FAILURE DETECTED

ASSIST A/B MODULE [OPEN]

PRINT

SRS056

8. Touch "TROUBLE DIAG RECORD".

NOTE:

With TROUBLE DIAG RECORD, diagnosis results previously erased by a reset operation can be displayed.

9. Diagnostic code is displayed on "TROUBLE DIAG RECORD".

10. Touch "PRINT".
11. Compare diagnostic codes to the INTERMITTENT PROBLEM DIAGNOSTIC CODE CHART, page RS-49.
12. Touch "BACK" key of CONSULT until SELECT SYSTEM appears, then turn off CONSULT.
13. Turn ignition switch "OFF", then disconnect CONSULT and both battery cables.
14. Repair the system as outlined by the "Repair order" in INTERMITTENT PROBLEM DIAGNOSTIC CODE CHART, that corresponds to the problem code. For replacement procedure of component parts, refer to RS-12.
15. Go to DIAGNOSTIC PROCEDURE 4, page RS-42, for final checking.

TROUBLE DIAGNOSES — Supplemental Restraint System (SRS)

Self-diagnosis (Cont'd)

INTERMITTENT PROBLEM DIAGNOSTIC CODE CHART ("SELF-DIAG [PAST]" or "TROUBLE DIAG RECORD")

Diagnostic item	Explanation		Repair order	
NO SELF DIAGNOSTIC FAILURE INDICATED.	When malfunction is indicated by the "AIR BAG" warning lamp in User mode	<ul style="list-style-type: none"> • Low battery voltage (Less than 9V) 	<ul style="list-style-type: none"> • Go to DIAGNOSTIC PROCEDURE 4 (RS-42) after charging battery. 	GI
	<ul style="list-style-type: none"> • No malfunction is detected. 		<ul style="list-style-type: none"> • Go to DIAGNOSTIC PROCEDURE 4 (RS-42). 	MA
AIRBAG MODULE [OPEN]	<ul style="list-style-type: none"> • Driver's air bag module circuit is open. (including the spiral cable) 		<ul style="list-style-type: none"> • Visually check the wiring harness connection. • Replace the harness if it has visible damage. • Replace driver's air bag module. (Before disposal of it, it must be deployed.) • Replace the spiral cable. • Replace the diagnosis sensor unit. 	EM
AIRBAG MODULE [VB-SHORT]	<ul style="list-style-type: none"> • Driver's air bag module circuit is shorted to some power supply circuit. (including the spiral cable) 			LC
AIRBAG MODULE [GND-SHORT]	<ul style="list-style-type: none"> • Driver's air bag module circuit is shorted to ground. (including the spiral cable) 			EC
AIRBAG MODULE [SHORT]	<ul style="list-style-type: none"> • Driver's air bag module circuits are shorted to each other. 			FE
ASSIST A/B MODULE [VB-SHORT]	<ul style="list-style-type: none"> • Front passenger air bag module circuit is shorted to some power supply circuit. 		<ul style="list-style-type: none"> • Visually check the wiring harness connection. • Replace the harness if it has visible damage. • Replace front passenger air bag module. (Before disposal of it, it must be deployed.) • Replace the diagnosis sensor unit. 	CL
ASSIST A/B MODULE [OPEN]	<ul style="list-style-type: none"> • Front passenger air bag module circuit is open. 			MT
ASSIST A/B MODULE [GND-SHORT]	<ul style="list-style-type: none"> • Front passenger air bag module circuit is shorted to ground. 			AT
ASSIST A/B MODULE [SHORT]	<ul style="list-style-type: none"> • Front passenger air bag module circuits are shorted to each other. 			FA
DA	<ul style="list-style-type: none"> • Side air bag module (LH) circuit is open. 		<ul style="list-style-type: none"> • Visually check the wiring harness connection. • Replace the harness if it has visible damage. • Replace side air bag module (LH). (Before disposal, it must be deployed.) • Replace the diagnosis sensor unit. 	RA
DB	<ul style="list-style-type: none"> • Side air bag module (LH) circuit is shorted to some power supply circuits. 			BR
DC	<ul style="list-style-type: none"> • Side air bag module (LH) circuit is shorted to ground. 			ST
DD	<ul style="list-style-type: none"> • Side air bag module (LH) circuits are shorted to each other. 			ST
7A	<ul style="list-style-type: none"> • Side air bag module (RH) circuit is open. 			RS
7B	<ul style="list-style-type: none"> • Side air bag module (RH) circuit is shorted to some power supply circuits. 			BT
7C	<ul style="list-style-type: none"> • Side air bag module (RH) circuit is shorted to ground. 			HA
7D	<ul style="list-style-type: none"> • Side air bag module (RH) circuits are shorted to each other. 		EL	

IDX

TROUBLE DIAGNOSES — Supplemental Restraint System (SRS)

Self-diagnosis (Cont'd)

Diagnostic item	Explanation	Repair order
91 92 93	<ul style="list-style-type: none">• Satellite sensor (LH)	<ul style="list-style-type: none">• Visually check the wiring harness connection.• Replace the harness if it has visible damage.• Replace the satellite sensor (LH).• Replace the diagnosis sensor unit.
81 82 83	<ul style="list-style-type: none">• Satellite sensor (RH)	<ul style="list-style-type: none">• Visually check the wiring harness connection.• Replace the harness if it has visible damage.• Replace the satellite sensor (RH).• Replace the diagnosis sensor unit.
CONTROL UNIT	<ul style="list-style-type: none">• Diagnosis sensor unit is malfunctioning.	<ul style="list-style-type: none">• Visually check the wiring harness connection.• Replace the diagnosis sensor unit.

* Intermittent problem areas cannot be easily located. For this reason, perform the procedures outlined under the repair order, then make the final system check.

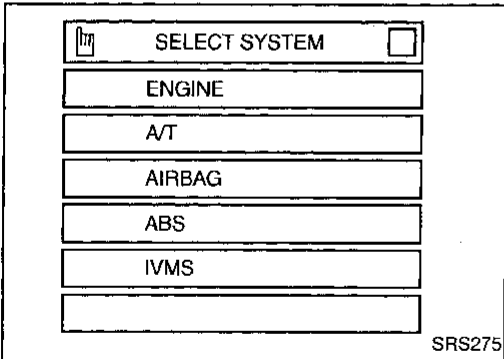
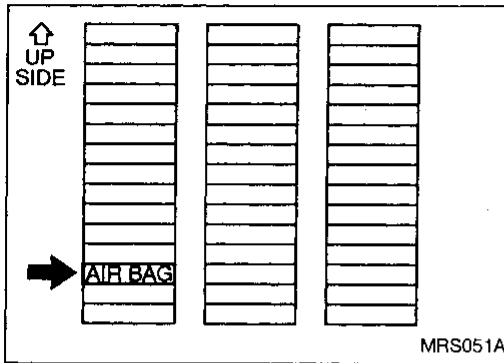

**Trouble Diagnoses for Air Bag Warning Lamp
DIAGNOSTIC PROCEDURE 9**

SYMPTOM: "AIR BAG" warning lamp does not turn off.

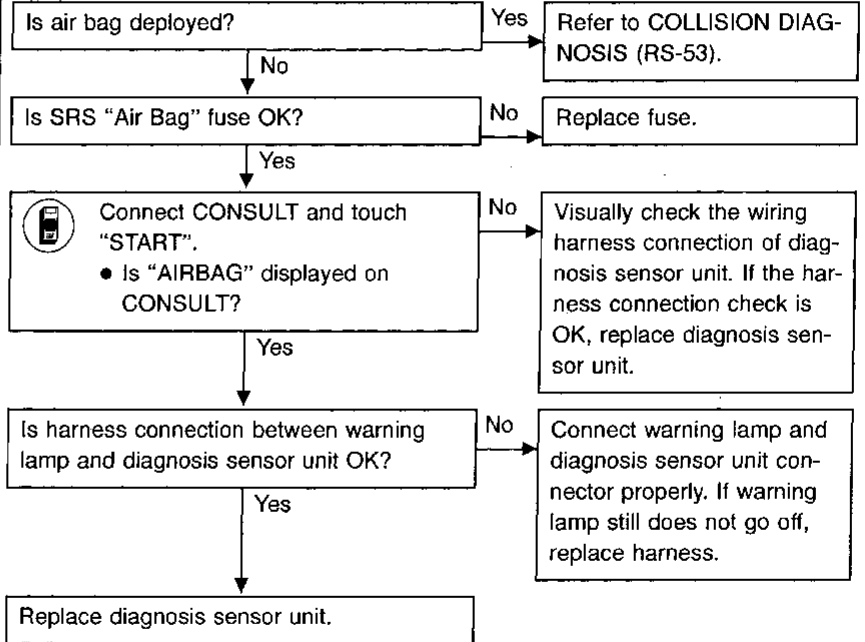

GI
MA
EM
LC
EC
FE
CL

MT
AT
FA

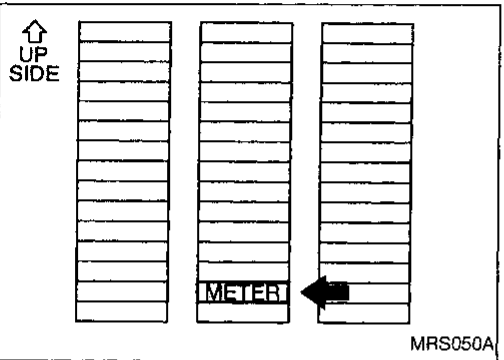

DIAGNOSTIC PROCEDURE 10

SYMPTOM: "AIR BAG" warning lamp does not turn on.

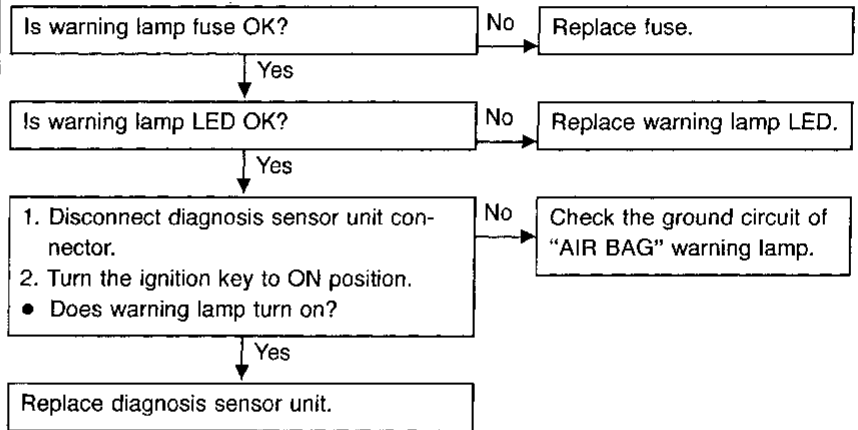

BR
ST
RS
BT
HA
EL
IDX

Trouble Diagnoses for Air Bag Warning Lamp (Cont'd)

DIAGNOSTIC PROCEDURE 11

SYMPTOM: SRS does not enter Diagnosis mode using door switch.

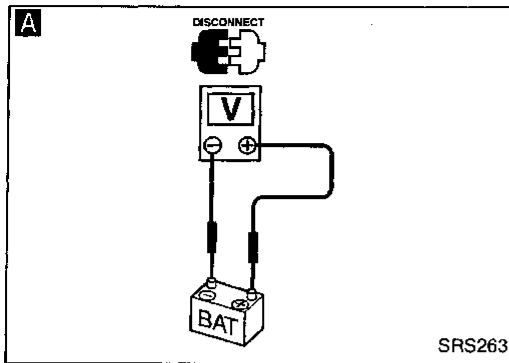

A
Disconnect both battery cables and check battery voltage using circuit tester.
• Is battery voltage more than 9V?

No → Charge battery.

Yes

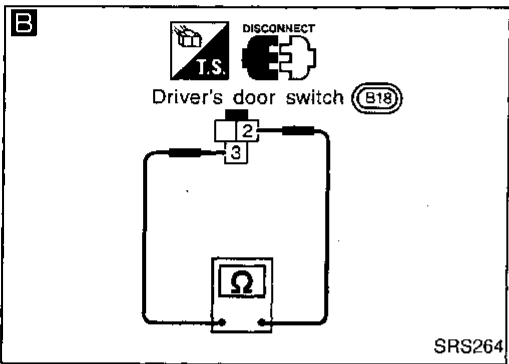

B
Remove driver's door switch and check continuity between driver's door switch connector terminals ② and ③ under the following conditions.

No → Replace driver's door switch.

Condition	Continuity
Door switch is depressed (Door is closed).	NO
Door switch is released (Door is open).	YES

Yes

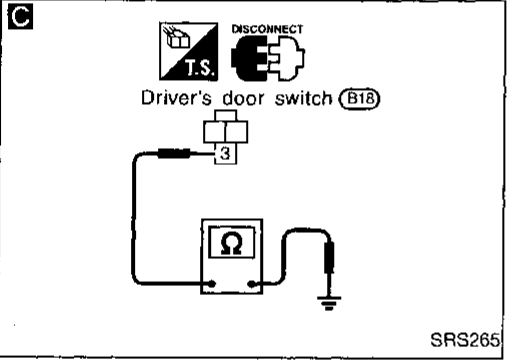

C
Check harness continuity between driver's door switch connector terminal ③ and body ground.
• Does continuity exist?

No → Replace or repair harness.

Yes

Replace diagnosis sensor unit.

Go to DIAGNOSTIC PROCEDURE 1 (RS-33).

COLLISION DIAGNOSIS

FOR FRONTAL COLLISION

To repair the SRS for a frontal collision, perform the following steps.

When SRS (except the side air bag) is activated in a collision:

- ① Replace the diagnosis sensor unit.
- ② Remove the air bag modules (except the side air bag module).
- ③ Check the SRS components using the table shown below:
 - Replace any SRS components showing visible signs of damage (dents, cracks, deformation).
- ④ Install new air bag modules (except the side air bag module).
- ⑤ Conduct self-diagnosis using CONSULT, and "AIR BAG" warning lamp. Refer to "Self-diagnosis" for details (RS-33). Ensure entire SRS operates properly.

When SRS is not activated in a collision:

- ① Check the SRS components using the table shown below:
 - Replace any SRS components showing visible signs of damage (dents, cracks, deformation).
- ② Conduct self-diagnosis using CONSULT, and "AIR BAG" warning lamp. Refer to "Self-diagnosis" for details (RS-33). Ensure entire SRS operates properly.

SRS inspection

Part	SRS (except the side air bag) is activated	SRS is NOT activated
Air bag module (driver and passenger side)	REPLACE Install air bag module with new bolts.	1. Remove air bag module. Check harness cover and connectors for damage, terminals for deformities, and harness for binding. 2-1. Install driver air bag module into the steering wheel to check fit and alignment with the wheel. 2-2. Install passenger air bag module into the instrument panel to check fit with the instrument panel. 3. No damage found, reinstall with new bolts. 4. If damaged—REPLACE. Air bag must be deployed before discarding.
Diagnosis sensor unit	REPLACE Install diagnosis sensor unit with new bolts.	1. Check case and bracket for dents, cracks or deformities. 2. Check connectors for damage, and terminals for deformities. 3. If no damage is found, reinstall with new bolts. 4. If damaged—REPLACE. Install diagnosis sensor unit with new bolts.
Steering wheel	1. Visually check steering wheel for deformities. 2. Check harness (built into steering wheel) and connectors for damage, and terminals for deformities. 3. Install air bag module to check fit or alignment with steering wheel. 4. Check steering wheel for excessive free play. 5. If no damage is found, reinstall the steering wheel. 6. If damaged—REPLACE.	
Spiral cable	1. Visually check spiral cable and combination switch for damage. 2. Check connectors, flat cable and protective tape for damage. 3. Check steering wheel for noise, binding or heavy operation. 4. If no damage is found, reinstall the spiral cable. 5. If damaged—REPLACE.	
Harness and Connectors	1. Check connectors for poor connection, damage, and terminals for deformities. 2. Check harness for binding, chafing, cuts, or deformities. 3. If no damage is found, reinstall harness and connectors. 4. Damaged—REPLACE damaged section of harness. Do not attempt to repair, splice or modify any SRS harness.	
Instrument panel	Refer to the table on the next page.	

COLLISION DIAGNOSIS

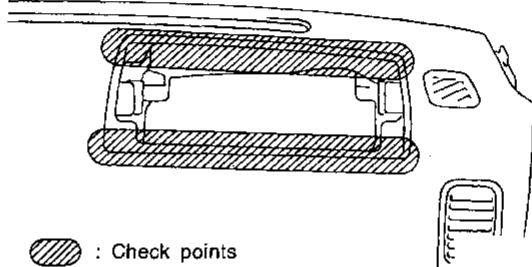
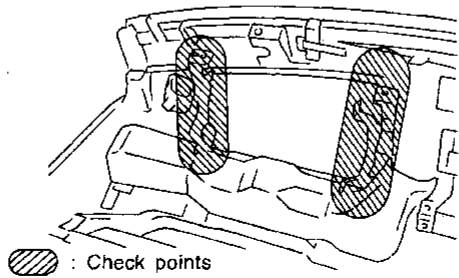
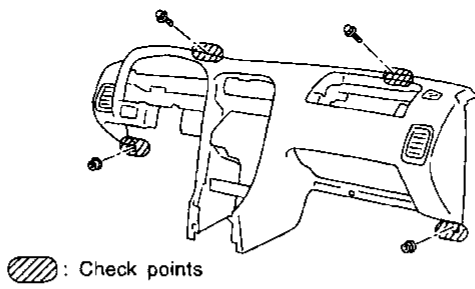
Part	SRS (except the side air bag) is activated	SRS is NOT activated
Instrument panel	<p>1. When passenger air bag inflates, check the following points for bending, deformities or cracks.</p> <ul style="list-style-type: none"> ● Opening portion for passenger air bag 	<p>1. When passenger air bag inflates, check the following points for bending, deformities or cracks.</p> <ul style="list-style-type: none"> ● Opening portion for passenger air bag
	<div style="text-align: center;">  <p>● : Check points</p> </div>	SRS388
	<ul style="list-style-type: none"> ● Passenger air bag module brackets 	<ul style="list-style-type: none"> ● Passenger air bag module brackets
	<div style="text-align: center;">  <p>● : Check points</p> </div>	SRS389
	<ul style="list-style-type: none"> ● The portions securing the instrument panel 	<ul style="list-style-type: none"> ● The portions securing the instrument panel
	<div style="text-align: center;">  <p>● : Check points</p> </div>	SRS390
	<p>2. If no damage is found, reinstall the instrument panel. 3. If damaged—REPLACE the instrument panel with bolts.</p>	

COLLISION DIAGNOSIS

FOR SIDE COLLISION

To repair the SRS for a side collision, perform the following steps.

When the side air bag is activated in the side collision:

- ① Replace the following component:
 - Diagnosis sensor unit
 - Satellite sensor (on the side on which side air bag is activated)
- ② Remove the deployed side air bag module.
- ③ Check the SRS components and the related parts using the table shown below.
 - Replace any SRS components and the related parts showing visible signs of damage (dents, cracks, deformation).
- ④ Install new side air bag module (on the side on which side air bag has been activated) with new nuts.
- ⑤ Conduct self-diagnosis using CONSULT, and "AIR BAG" warning lamp. Refer to "Self-diagnosis" for details (RS-33). Ensure entire SRS operates properly.

GI
MA
EM
LC

When SRS is not activated in the side collision:

- ① Check the SRS components and the related parts using the table shown below.
 - Replace any SRS components and the related parts showing visible signs of damage (dents, cracks, deformation).
- ② Conduct self-diagnosis using CONSULT, and "AIR BAG" warning lamp. Refer to "Self-diagnosis" for details (RS-33). Ensure entire SRS operates properly.

EC
FE

In the case of the side collision

Part	Side air bag is activated	SRS is NOT activated
Side air bag module (LH or RH)	REPLACE the deployed side air bag module with new nuts. (Repair or replace seatback, etc. before installing new one if damaged.)	1. Check for visible signs of damage (dents, cracks, deformation) of the side air bag module on the collision side. 2. Remove the side air bag module on the collision side. 3. Check harness and connectors for damage, and terminals for deformities. 4. Install side air bag module into the seat to check fit with the seat. 5. If no damage is found, reinstall the side air bag module with new special nuts. 6. If damaged—REPLACE it with the special nuts. Air bag must be deployed before disposing of it.
Satellite sensor (LH or RH)	REPLACE the satellite sensor on the collision side with new nuts. (Repair the center pillar inner, etc. before installing new one if damaged.)	1. Remove the satellite sensor on the collision side. Check harness connectors for damage, terminals for deformities, and harness for binding. 2. Check for visible signs of damage (dents, cracks, deformation) of the satellite sensor. 3. Install the satellite sensor to check fit. 4. If no damage is found, reinstall the satellite sensor with new special nuts. 5. If damaged—REPLACE the satellite sensor with the special nuts.
Diagnosis sensor unit	REPLACE the diagnosis sensor unit with the new bolts.	1. Check case and bracket for dents, cracks or deformities. 2. Check connectors for damage, and terminals for deformities. 3. If no damage is found, reinstall the diagnosis sensor unit with new special bolts and ground bolt. 4. If damaged—REPLACE the diagnosis sensor unit with the special bolts and ground bolt.
Seat	1. Visually check the seat on the collision side. 2. Remove the seat on the collision side and check the following for damage and deformities. <ul style="list-style-type: none"> ● Harness, connectors and terminals ● Frame, recliner, adjuster and slides 3. Install the side air bag module into the seat to check fit with the seat. 4. If no damage is found, reinstall the seat. 5. If damaged—REPLACE the damaged seat parts with new bolts.	
Center pillar inner	1. Check the center pillar inner on the collision side for damage (dents, cracks, deformation). 2. If damaged—REPAIR the center pillar inner.	

CL
MT
AT
FA
RA
BR
ST
RS
BT
HA
EL
IDX