

BRAKE SYSTEM

SECTION **BR**

CONTENTS

PRECAUTIONS	3	Removal.....	19
Supplemental Restraint System (SRS) "AIR BAG" and "SEAT BELT PRE-TENSIONER"	3	Disassembly.....	20
Precautions for Brake System.....	3	Inspection.....	20
Wiring Diagrams and Trouble Diagnosis.....	4	Assembly	20
PREPARATION	5	Installation.....	21
Commercial Service Tools	5	BRAKE BOOSTER	22
NOISE, VIBRATION AND HARSHNESS (NVH)		On-vehicle Service.....	22
TROUBLESHOOTING	6	Removal.....	22
NVH Troubleshooting Chart.....	6	Inspection.....	22
ON-VEHICLE SERVICE	7	Installation.....	23
Checking Brake Fluid Level.....	7	VACUUM HOSE	24
Checking Brake Line	7	Removal and Installation	24
Changing Brake Fluid.....	7	Inspection.....	24
Brake Burnishing Procedure.....	7	FRONT DISC BRAKE	25
Bleeding Brake System	8	Component	25
BRAKE HYDRAULIC LINE	9	Pad Replacement	25
Hydraulic Circuit.....	9	Removal.....	26
Removal.....	9	Disassembly.....	26
Inspection.....	9	Inspection.....	26
Installation.....	10	Assembly	28
DUAL PROPORTIONING VALVE	11	Installation.....	28
Inspection.....	11	REAR DISC BRAKE	29
BRAKE PEDAL AND BRACKET	12	Component	29
Removal and Installation	12	Pad Replacement	29
Inspection.....	12	Removal.....	31
Adjustment.....	12	Disassembly.....	32
MASTER CYLINDER (TOKICO)	14	Inspection.....	33
Removal.....	14	Assembly	34
Disassembly.....	15	Installation.....	36
Inspection.....	15	PARKING BRAKE CONTROL	38
Assembly	15	Components.....	38
Installation.....	16	Removal and Installation	38
MASTER CYLINDER (NABCO)	17	Inspection.....	38
Removal.....	17	Adjustment.....	39
Disassembly.....	17		
Inspection.....	18	<input type="checkbox"/> ABS <input type="checkbox"/>	
Assembly	18	DESCRIPTION	40
Installation.....	18	Purpose.....	40

CONTENTS (Cont'd)

ABS (Anti-Lock Brake System) Operation	40	Motor Relay or Motor.....	68
ABS Hydraulic Circuit	40	Low Voltage	70
System Components	41	Control Unit.....	72
System Description.....	41	TRUBLE DIAGNOSES FOR SYMPTOMS	73
Component Parts and Harness Connector		1. ABS Works Frequently	73
Location	43	2. Unexpected Pedal Action	73
Schematic	44	3. Long Stopping Distance	74
Wiring Diagram - ABS -	45	4. ABS Does Not Work.....	75
ON BOARD DIAGNOSTIC SYSTEM		5. Pedal Vibration and Noise.....	76
DESCRIPTION	48	6. ABS Warning Lamp Does Not Come On	
Self-diagnosis	48	When Ignition Switch Is Turned On.....	77
CONSULT-II	50	7. ABS Warning Lamp Stays On When Ignition	
CONSULT-II Inspection Procedure.....	50	Switch Is Turned On	79
TRUBLE DIAGNOSIS - INTRODUCTION	56	REMOVAL AND INSTALLATION	81
How to Perform Trouble Diagnoses for Quick		Wheel Sensors	81
and Accurate Repair	56	Sensor Rotor.....	81
TRUBLE DIAGNOSIS - BASIC INSPECTION	57	Actuator.....	82
Preliminary Check.....	57		
Ground Circuit Check	60		
TRUBLE DIAGNOSIS - GENERAL		SERVICE DATA AND SPECIFICATIONS (SDS)	83
DESCRIPTION	61	General Specifications.....	83
Malfunction Code/Symptom Chart.....	61	Disc Brake	83
TRUBLE DIAGNOSES FOR SELF-DIAGNOSTIC		Brake Pedal	83
ITEMS	62	Parking Brake	83
Wheel Sensor or Rotor.....	62	Control Valve	84
ABS Actuator Solenoid Valve or Solenoid Valve		Brake Booster	84
Relay.....	65	ABS Wheel Sensor.....	84

PRECAUTIONS

Supplemental Restraint System (SRS) "AIR BAG" and "SEAT BELT PRE-TENSIONER"

Supplemental Restraint System (SRS) "AIR BAG" and "SEAT BELT PRE-TENSIONER"

NFBR0112

The Supplemental Restraint System such as "AIR BAG" and "SEAT BELT PRE-TENSIONER" used along with a seat belt, helps to reduce the risk or severity of injury to the driver and front passenger for certain types of collision. The SRS system composition which is available to NISSAN MODEL A33 is as follows (The composition varies according to the destination and optional equipment.):

- For a frontal collision
The Supplemental Restraint System consists of driver air bag module (located in the center of the steering wheel), front passenger air bag module (located on the instrument panel on passenger side), seat belt pre-tensioners, a diagnosis sensor unit, warning lamp, wiring harness and spiral cable.
- For a side collision
The Supplemental Restraint System consists of front side air bag module (located in the outer side of front seat), satellite sensor, diagnosis sensor unit (one of components of air bags for a frontal collision), wiring harness, warning lamp (one of components of air bags for a frontal collision).

Information necessary to service the system safely is included in the **RS section** of this Service Manual.

WARNING:

- To avoid rendering the SRS inoperative, which could increase the risk of personal injury or death in the event of a collision which would result in air bag inflation, all maintenance should be performed by an authorized NISSAN dealer.
- Improper maintenance, including incorrect removal and installation of the SRS, can lead to personal injury caused by unintentional activation of the system. For removal of Spiral Cable and Air Bag Module, see the RS section.
- Do not use electrical test equipment on any circuit related to the SRS unless instructed to in this Service Manual. Spiral cable and wiring harnesses covered with yellow insulation tape either just before the harness connectors or for the complete harness are related to the SRS.

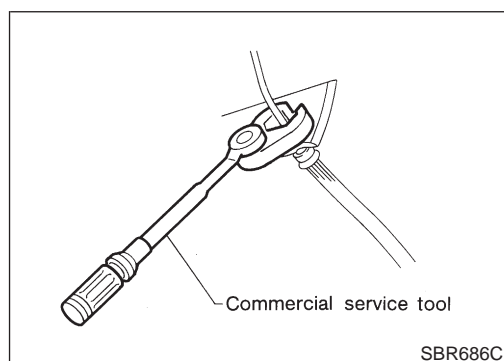

Precautions for Brake System

NFBR0113

- Recommended fluid is brake fluid "DOT 3".
- Never reuse drained brake fluid.
- Be careful not to splash brake fluid on painted areas.
- To clean or wash all parts of master cylinder, disc brake caliper and wheel cylinder, use clean brake fluid.
- Never use mineral oils such as gasoline or kerosene. They will ruin rubber parts of the hydraulic system.
- Use flare nut wrench when removing and installing brake tube.
- Always torque brake lines when installing.
- Burnish the brake contact surfaces after refinishing or replacing drums or rotors, after replacing pads or linings, or if a soft pedal occurs at very low mileage. Refer to "Brake Burnishing Procedure", "ON-VEHICLE SERVICE", BR-7.

WARNING:

- Clean brake pads and shoes with a waste cloth, then wipe with a dust collector.

PRECAUTIONS

Wiring Diagrams and Trouble Diagnosis

Wiring Diagrams and Trouble Diagnosis

NFBR0114

When you read wiring diagrams, refer to the following:

- GI-11, "HOW TO READ WIRING DIAGRAMS"
- EL-9, "POWER SUPPLY ROUTING" for power distribution circuit

When you perform trouble diagnosis, refer to the following:

- GI-32, "HOW TO FOLLOW TEST GROUP IN TROUBLE DIAGNOSIS"
- GI-21, "HOW TO PERFORM EFFICIENT DIAGNOSIS FOR AN ELECTRICAL INCIDENT"

PREPARATION

Commercial Service Tools

Commercial Service Tools

NFBR0115

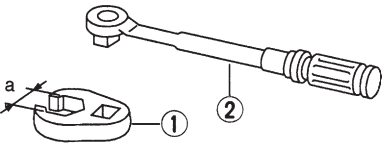
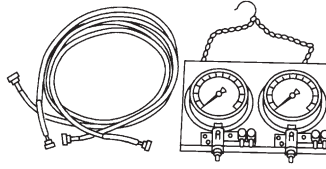
Tool name	Description
1 Flare nut crowfoot 2 Torque wrench	 <p>Removing and installing each brake piping a: 10 mm (0.39 in)</p> <p>NT360</p>
Brake fluid pressure gauge	 <p>Measuring brake fluid pressure</p> <p>NT151</p>

NOISE, VIBRATION AND HARSHNESS (NVH) TROUBLESHOOTING

NVH Troubleshooting Chart

NVH Troubleshooting Chart

NFBR0116S01

Use the chart below to help you find the cause of the symptom. If necessary, repair or replace these parts.

Symptom		BRAKE	Possible cause and SUSPECTED PARTS																
			Reference page	Pads - damaged	Pads - uneven wear	Shims damaged	Rotor imbalance	Rotor damage	Rotor runout	Rotor deformation	Rotor deflection	Rotor rust	Rotor thickness variation	DRIVE SHAFT	AXLE	SUSPENSION	TIRES	ROAD WHEEL	STEERING
Noise	Shake	Shimmy, Judder	BR-25, BR-29	BR-25, BR-29	BR-25, BR-29	—	—	BR-27, BR-33	—	—	—	BR-27, BR-33	AX-3	AX-3	SU-4	SU-4	SU-4	ST-5	
			X	X	X								X	X	X	X	X	X	X
						X								X	X	X	X	X	X
					X	X	X	X	X	X	X		X	X	X	X	X	X	

X: Applicable

ON-VEHICLE SERVICE

Checking Brake Fluid Level

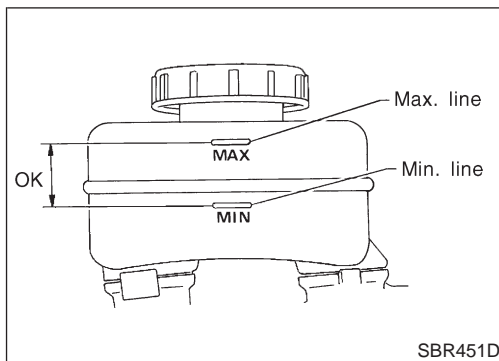

Checking Brake Fluid Level

NFBR0117

- Check fluid level in reservoir tank. It should be between Max and Min lines on reservoir tank.
- If fluid level is extremely low, check brake system for leaks.
- Release parking brake lever and see if brake warning lamp goes off. If not, check brake system for leaks.

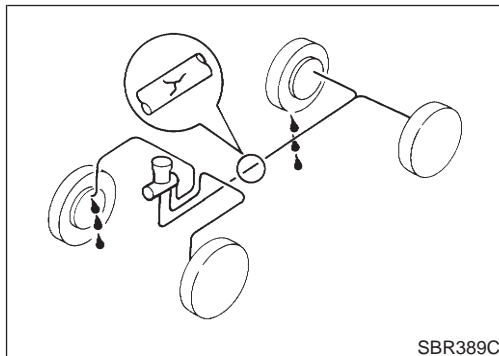

Checking Brake Line

NFBR0118

CAUTION:

If leakage occurs around joints, retighten or, if necessary, replace damaged parts.

1. Check brake lines (tubes and hoses) for cracks, deterioration or other damage. Replace any damaged parts.
2. Check for oil leakage by fully depressing brake pedal while engine is running.

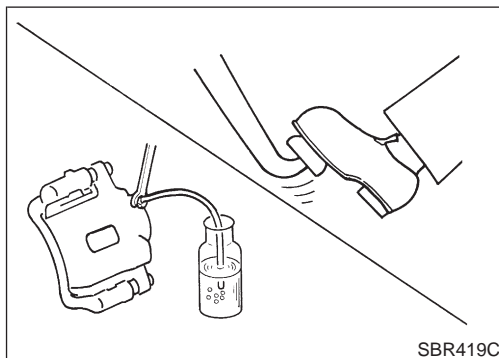

Changing Brake Fluid

NFBR0119

CAUTION:

- Refill with new brake fluid "DOT 3".
- Always keep fluid level higher than minimum line on reservoir tank.
- Never reuse drained brake fluid.
- Be careful not to splash brake fluid on painted areas; it may cause paint damage. If brake fluid is splashed on painted areas, wash it away with water immediately.

1. Clean inside of reservoir tank, and refill with new brake fluid.
2. Connect a vinyl tube to each air bleeder valve.
3. Drain brake fluid from each air bleeder valve by depressing brake pedal.
4. Refill until brake fluid comes out of each air bleeder valve. Use same procedure as in bleeding hydraulic system to refill brake fluid. Refer to "Bleeding Brake System", BR-8.

Brake Burnishing Procedure

NFBR0120

Burnish the brake contact surfaces according to the following procedure after refinishing or replacing drums or rotors, after replacing pads or linings, or if a soft pedal occurs at very low mileage.

CAUTION:

Only perform this procedure under safe road and traffic conditions. Use extreme caution.

1. Drive the vehicle on a straight smooth road at 50 km/h (31 MPH).
2. Use medium brake pedal/foot effort to bring the vehicle to a complete stop from 50 km/h (31 MPH). Adjust brake pedal/foot

ON-VEHICLE SERVICE

Brake Burnishing Procedure (Cont'd)

pressure such that vehicle stopping time equals 3 to 5 seconds.

3. To cool the brake system, drive the vehicle at 50 km/h (31 MPH) for 1 minute without stopping.
4. Repeat steps 1 to 3, 10 times or more to complete the burnishing procedure.

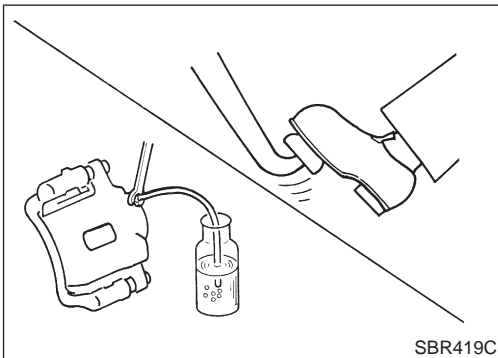
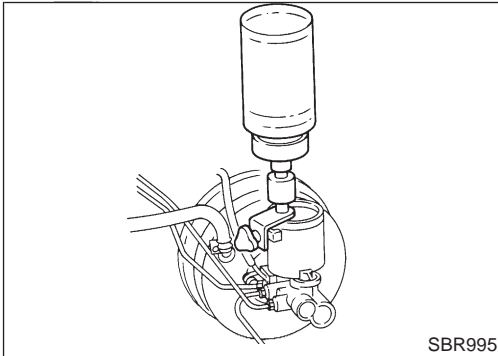

Bleeding Brake System

NFBR0121

CAUTION:

- Carefully monitor brake fluid level at master cylinder during bleeding operation.
 - Fill reservoir with new brake fluid "DOT 3". Make sure it is full at all times while bleeding air out of system.
 - Place a container under master cylinder to avoid spillage of brake fluid.
 - For models with ABS, turn ignition switch OFF and disconnect ABS actuator connectors or battery ground cable.
- Bleed air in the following order.
Right rear brake → Left front brake → Left rear brake → Right front brake
1. Connect a transparent vinyl tube to air bleeder valve.
 2. Fully depress brake pedal several times.
 3. With brake pedal depressed, open air bleeder valve to release air.
 4. Close air bleeder valve.
 5. Release brake pedal slowly.
 6. Repeat steps 2. through 5. until clear brake fluid comes out of air bleeder valve.

BRAKE HYDRAULIC LINE

Hydraulic Circuit

Hydraulic Circuit

NFBR0122

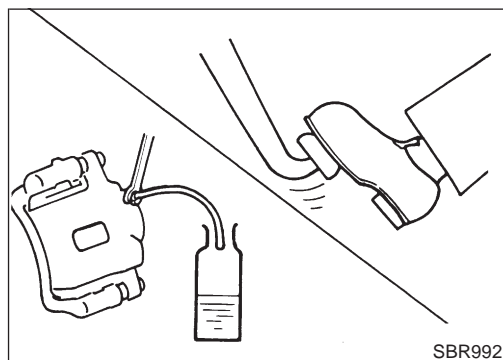
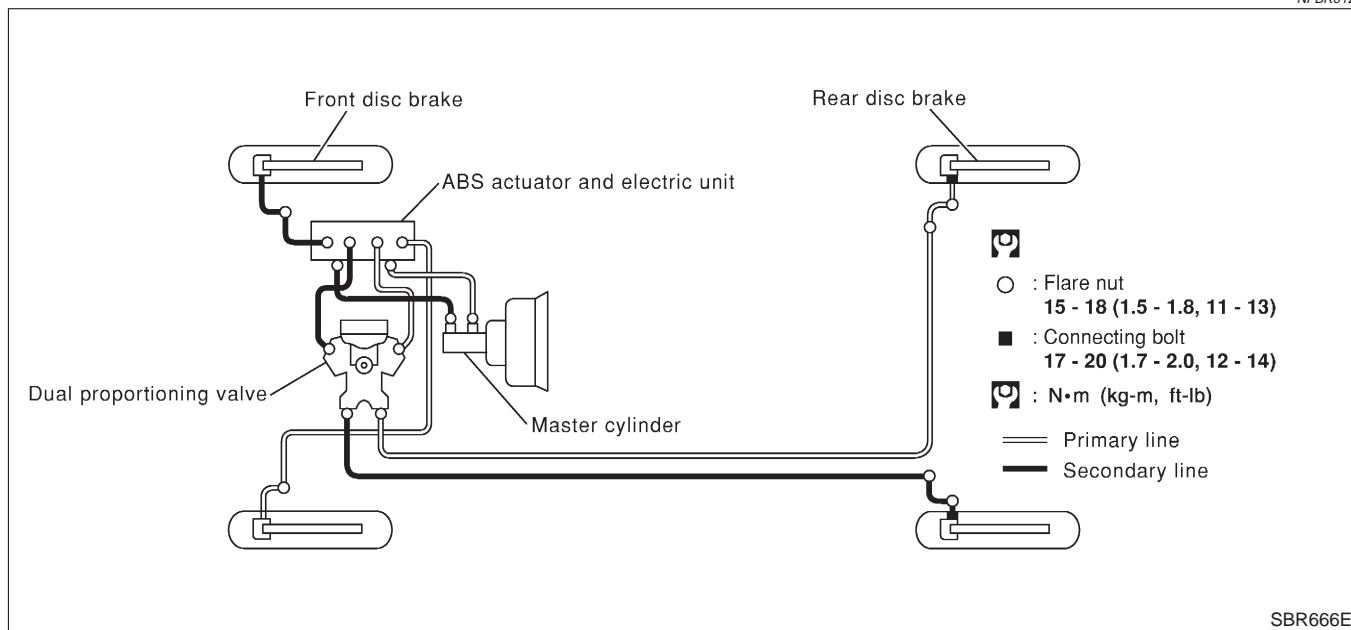

Removal

NFBR0123

CAUTION:

- Be careful not to splash brake fluid on painted areas; it may cause paint damage. If brake fluid is splashed on painted areas, wash it away with water immediately.
 - All hoses must be free from excessive bending, twisting and pulling.
1. Connect vinyl tube to air bleeder valve.
 2. Drain brake fluid from each air bleeder valve by depressing brake pedal.
 3. Remove flare nut connecting brake tube and hose, then withdraw lock spring.
 4. Cover openings to prevent entrance of dirt whenever disconnecting brake line.

Inspection

NFBR0124

Check brake lines (tubes and hoses) for cracks, deterioration or other damage. Replace any damaged parts.

BRAKE HYDRAULIC LINE

Installation

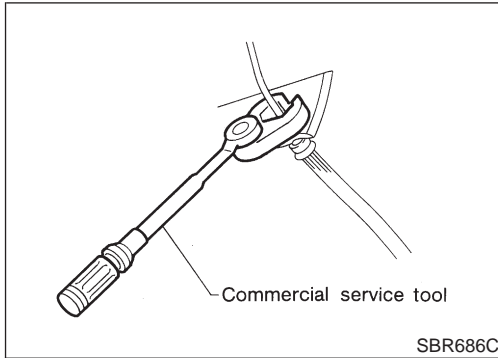

Installation

NFBR0125

CAUTION:

- Refill with new brake fluid "DOT 3".
 - Never reuse drained brake fluid.
1. Tighten all flare nuts and connecting bolts.

Specification:

Flare nut

15 - 18 N·m (1.5 - 1.8 kg-m, 11 - 13 ft-lb)

Connecting bolt

17 - 20 N·m (1.7 - 2.0 kg-m, 12 - 14 ft-lb)

2. Refill until new brake fluid comes out of each air bleeder valve.
3. Bleed air. Refer to "Bleeding Brake System", BR-8.

DUAL PROPORTIONING VALVE

Inspection

NFBR0126

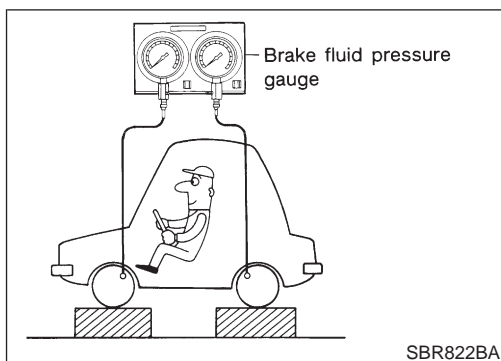

Inspection

CAUTION:

- Carefully monitor brake fluid level at master cylinder.
 - Use new brake fluid "DOT 3".
 - Be careful not to splash brake fluid on painted areas; it may cause paint damage. If brake fluid is splashed on paint areas, wash it away with water immediately.
1. Connect Tool to air bleeders of front and rear brakes on either LH and RH side.
 2. Bleed air from the Tool.
 3. Check fluid pressure by depressing brake pedal.

Unit: kPa (bar, kg/cm², psi)

Applied pressure (Front brake)	7,355 (73.6, 75, 1,067)
Output pressure (Rear brake)	5,100 - 5,492 (51.0 - 54.9, 52 - 56, 739 - 796)

If output pressure is out of specification, replace dual proportioning valve.

4. Bleed air after disconnecting the Tool. Refer to "Bleeding Brake System", BR-8.

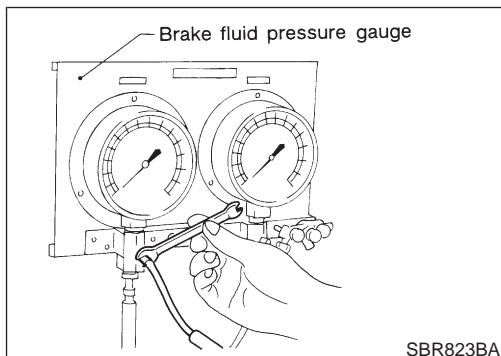

BRAKE PEDAL AND BRACKET

Removal and Installation

Removal and Installation

NFBR0127

SEC. 465•470

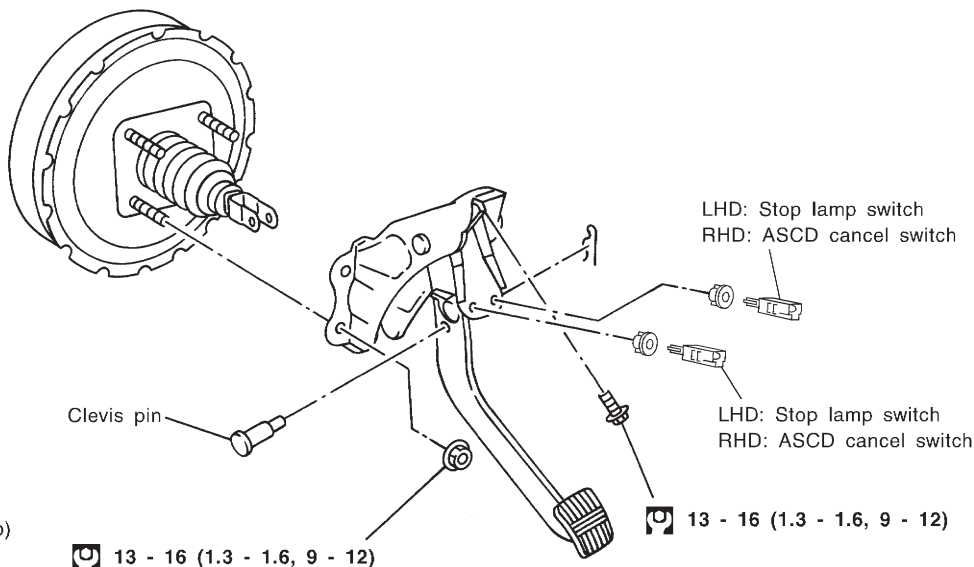

SBR525EA

Inspection

NFBR0128

Check brake pedal for following items.

- Brake pedal bend
- Clevis pin deformation
- Crack of any welded portion
- Crack or deformation of clevis pin stopper

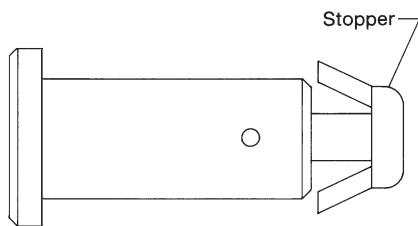

SBR997

Adjustment

NFBR0129

Check brake pedal free height from metal panel. Adjust if necessary.

H: Free height
Refer to SDS, BR-83.

D: Depressed height

LHD:

M/T 75.3 mm (2.965 in)

A/T 82.5 mm (3.248 in)

RHD:

M/T 80.8 mm (3.181 in)

A/T 88.4 mm (3.480 in)

Under force of 490 N (50 kg, 110 lb) with engine running

C₁, C₂: Clearance between pedal stopper and threaded end of stop lamp switch and ASCD switch

0.74 - 1.96 mm (0.0291 - 0.0772 in)

A: Pedal free play at pedal pad

1.0 - 3.0 mm (0.039 - 0.118 in)

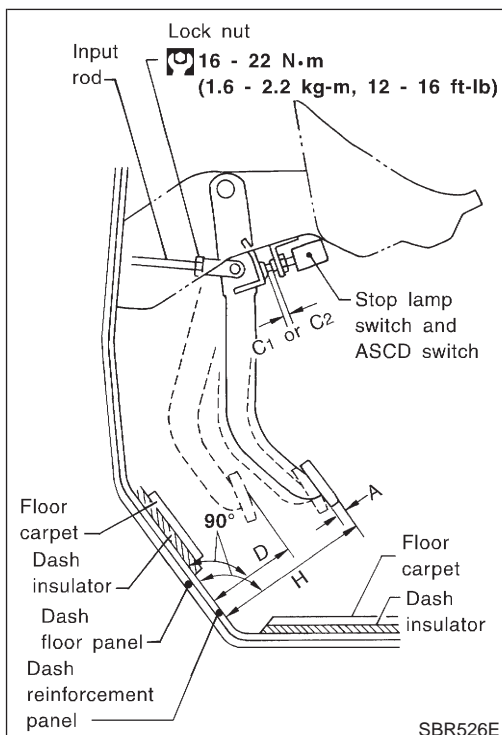

BRAKE PEDAL AND BRACKET

Adjustment (Cont'd)

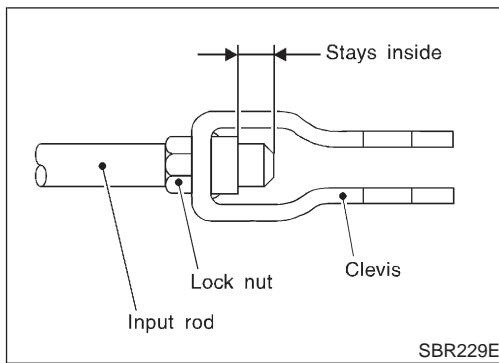

1. Loosen lock nut and adjust pedal free height by turning brake booster input rod. Then tighten lock nut.
2. Check pedal free play.
Make sure that stop lamps go off when pedal is released.
3. Check brake pedal's depressed height while engine is running. If lower than specification, check brake system for leaks, accumulation of air or any damage to components (master cylinder, wheel cylinder, etc.); then make necessary repairs.

MASTER CYLINDER (TOKICO)

Removal

Removal

NFBR0130

TOKICO make
SEC. 460

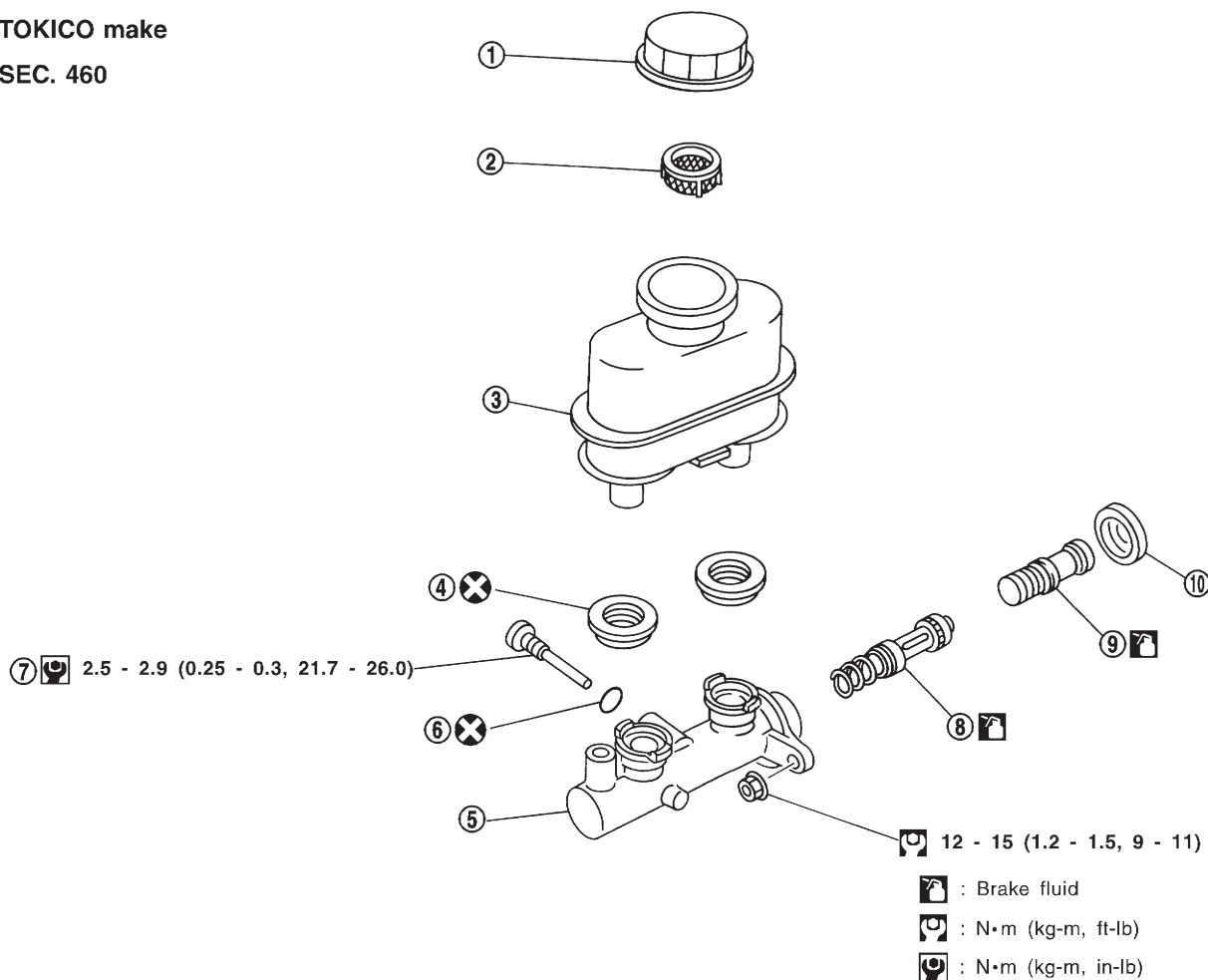

SBR554EA

- | | | |
|-------------------|-------------------|------------------------------|
| 1. Reservoir cap | 5. Cylinder body | 8. Secondary piston assembly |
| 2. Oil filter | 6. O-ring | 9. Primary piston assembly |
| 3. Reservoir tank | 7. Piston stopper | 10. Stopper cap |
| 4. Seal | | |

CAUTION:

Be careful not to splash brake fluid on painted areas; it may cause paint damage. If brake fluid is splashed on painted areas, wash it away with water immediately.

1. Connect a vinyl tube to air bleeder valve.
2. Drain brake fluid from each air bleeder valve, depressing brake pedal to empty fluid from master cylinder.
3. Remove brake pipe flare nuts.
4. Remove master cylinder mounting nuts.

MASTER CYLINDER (TOKICO)

Disassembly

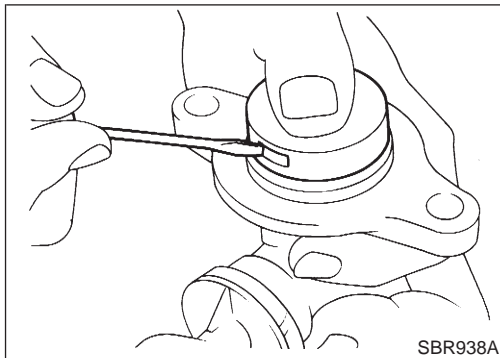

Disassembly

NFBR0131

1. Bend claws of stopper cap outward and remove stopper cap.

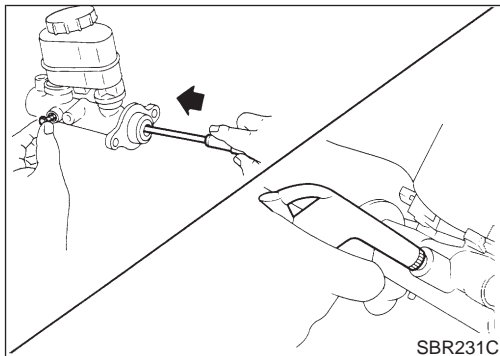

2. Remove valve stopper while piston is pushed into cylinder.
3. Remove piston assemblies.
If it is difficult to remove secondary piston assembly, gradually apply compressed air through fluid outlet.
4. Draw out reservoir tank.

Inspection

NFBR0132

Check for the following items.

Replace any part if damaged.

Master cylinder:

- Pin holes or scratches on inner wall.

Piston:

- Deformation of or scratches on piston cups.

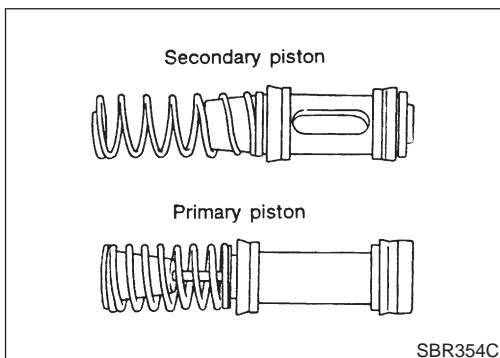

Assembly

NFBR0133

1. Insert secondary piston assembly. Then insert primary piston assembly.
 - Pay attention to alignment of secondary piston slit with valve stopper mounting hole of cylinder body.

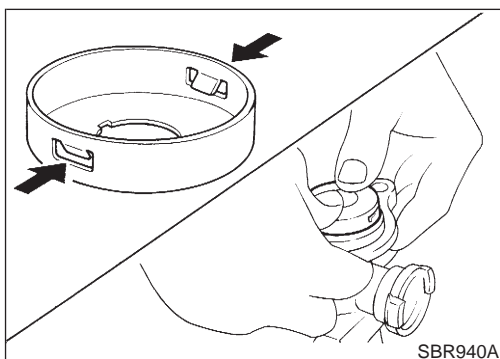

2. Install stopper cap.
Before installing stopper cap, ensure that claws are bent inward.
3. Push reservoir tank seals into cylinder body.
4. Push reservoir tank into cylinder body.

MASTER CYLINDER (TOKICO)

Assembly (Cont'd)

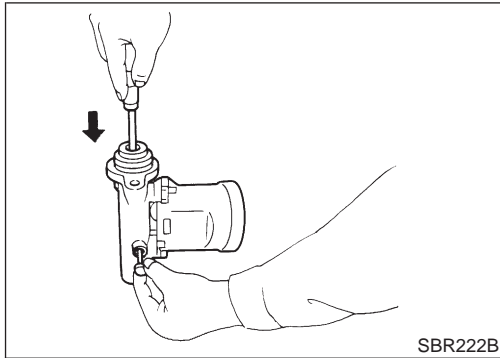

5. Install valve stopper while piston is pushed into cylinder.

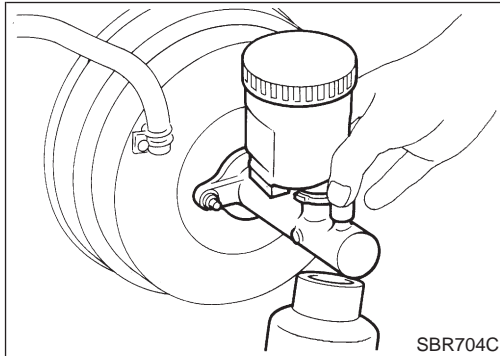

Installation

NFBR0134

CAUTION:

- Refill with new brake fluid "DOT 3".
 - Never reuse drained brake fluid.
1. Place master cylinder onto brake booster and secure mounting nuts lightly.
 2. Torque mounting nuts.
🔧 : 12 - 15 N·m (1.2 - 1.5 kg·m, 9 - 11 ft·lb)
 3. Fill up reservoir tank with new brake fluid.
 4. Plug all ports on master cylinder with fingers to prevent air suction while releasing brake pedal.
 5. Have driver depress brake pedal slowly several times until no air comes out of master cylinder.
 6. Fit brake lines to master cylinder.
 7. Tighten flare nuts.
🔧 : 15 - 18 N·m (1.5 - 1.8 kg·m, 11 - 13 ft·lb)
 8. Bleed air from brake system. Refer to "Bleeding Brake System", BR-8.

MASTER CYLINDER (NABCO)

Removal

Removal

NFBR0173

SEC. 460

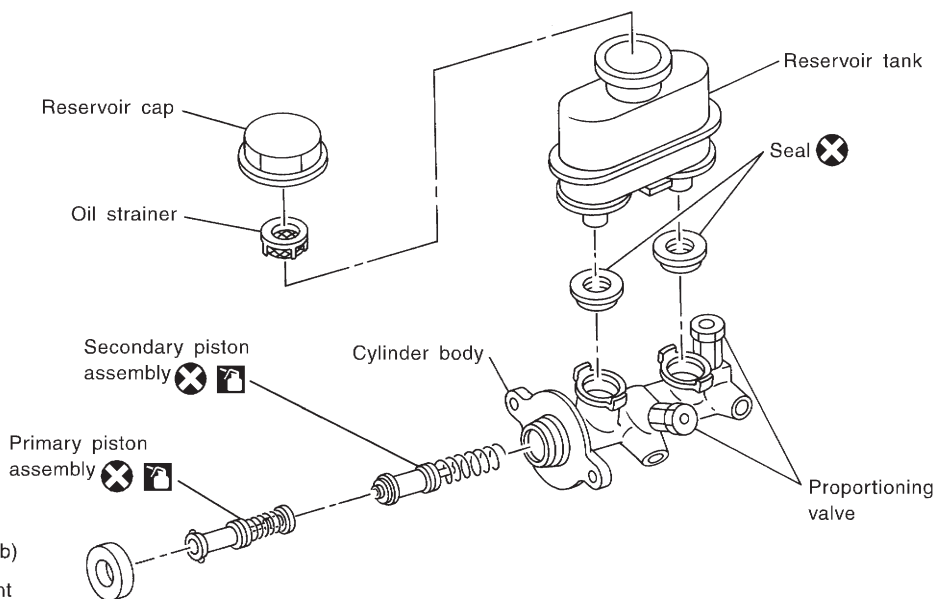

SBR643E

CAUTION:

Be careful not to splash brake fluid on painted areas; it may cause paint damage. If brake fluid is splashed on painted areas, wash it away with water immediately.

1. Connect a vinyl tube to air bleeder valve.
2. Drain brake fluid from each air bleeder valve, depressing brake pedal to empty fluid from master cylinder.
3. Remove brake pipe flare nuts.
4. Remove master cylinder mounting nuts.

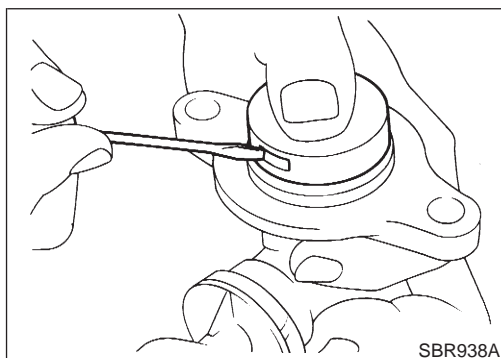

Disassembly

NFBR0174

1. Bend claws of stopper cap outward.

2. Remove valve stopper while piston is pushed into cylinder. (Models with ABS only)
3. Remove piston assemblies.

If it is difficult to remove secondary piston assembly, gradually apply compressed air through fluid outlet.

4. Draw out reservoir tank.

MASTER CYLINDER (NABCO)

Inspection

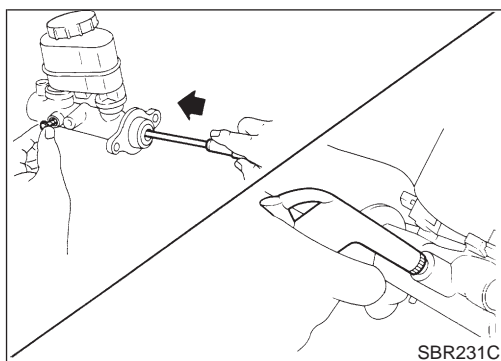

Inspection

NFBR0175

Check for the following items.
Replace any part if damaged.

Master cylinder:

- Pin holes or scratches on inner wall.

Piston:

- Deformation of or scratches on piston cups.

Assembly

NFBR0176

1. Insert secondary piston assembly. Then insert primary piston assembly.
 - Pay attention to alignment of secondary piston slit with valve stopper mounting hole of cylinder body.

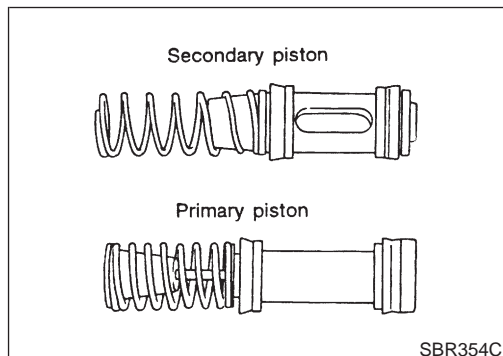

2. Install stopper cap.

Before installing stopper cap, ensure that claws are bent inward.

3. Push reservoir tank seals.
4. Push reservoir tank into master cylinder.

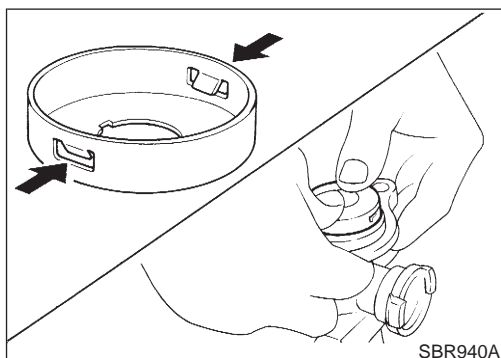

5. Install valve stopper while piston is pushed into cylinder.

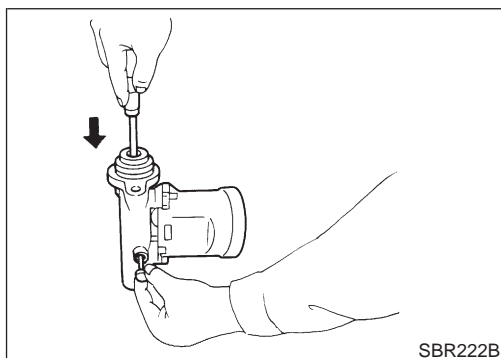

Installation

NFBR0177

CAUTION:

- Refill with new brake fluid “DOT 3” or “DOT 4”.
 - Never reuse drained brake fluid.
 - Do not mix different types of brake fluids (DOT 3, DOT 4).
1. Place master cylinder onto brake booster and secure mounting nuts lightly.
 2. Torque mounting nuts.
12 - 15 N·m (1.2 - 1.5 kg·m, 9 - 11 ft·lb)
 3. Fill up reservoir tank with new brake fluid.
 4. Plug all ports on master cylinder with fingers to prevent air

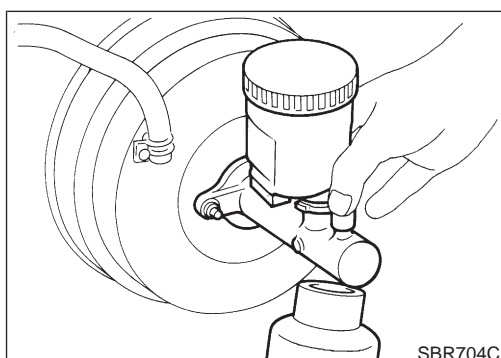

MASTER CYLINDER (NABCO)

Installation (Cont'd)

- suction while releasing brake pedal.
5. Have driver depress brake pedal slowly several times until no air comes out of master cylinder.
 6. Fit brake lines to master cylinder.
 7. Tighten flare nuts.
 : 15 - 18 N·m (1.5 - 1.8 kg-m, 11 - 13 ft-lb)
 8. Bleed air from brake system. Refer to "Bleeding Brake System", BR-8.

Removal

NFBR0135

NABCO make
SEC. 460

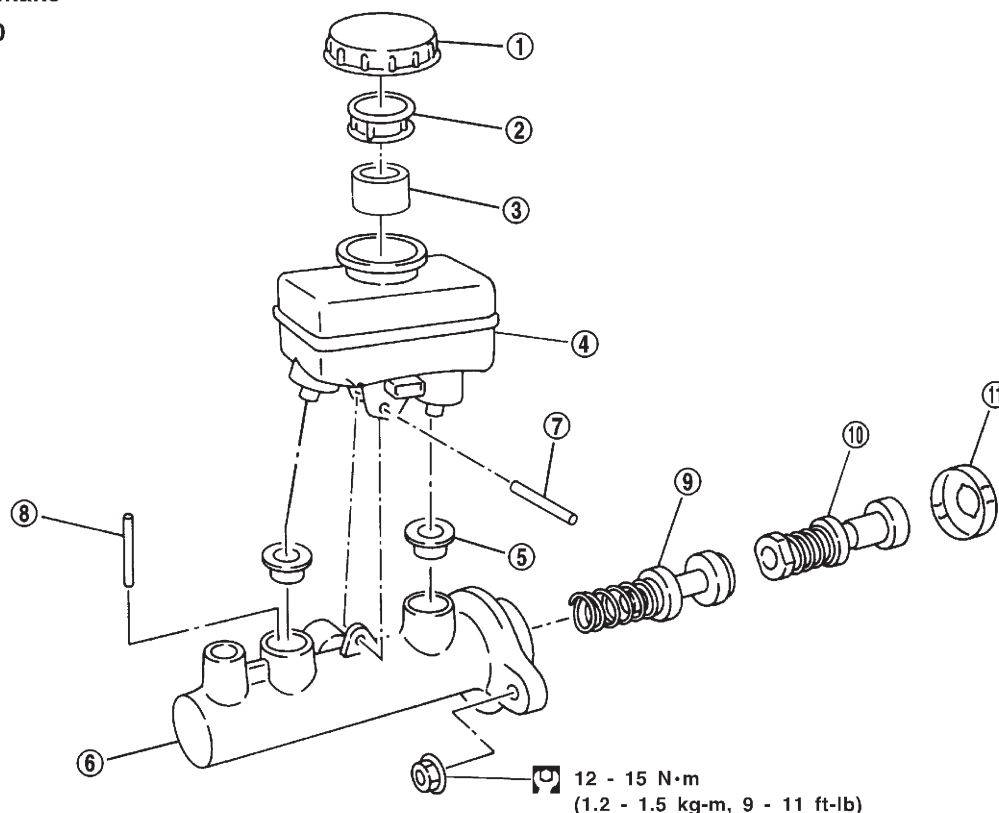

SBR555EA

- | | | |
|-------------------|-----------------------|------------------------------|
| 1. Reservoir cap | 5. Seal | 9. Secondary piston assembly |
| 2. Oil filter | 6. Cylinder body | 10. Primary piston assembly |
| 3. Float | 7. Spring pin | 11. Stopper cap |
| 4. Reservoir tank | 8. Piston stopper pin | |

CAUTION:

Be careful not to splash brake fluid on painted areas; it may cause paint damage. If brake fluid is splashed on painted areas, wash it away with water immediately.

1. Connect a vinyl tube to air bleeder valve.
2. Drain brake fluid from each air bleeder valve, depressing brake pedal to empty fluid from master cylinder.
3. Remove brake pipe flare nuts.
4. Remove master cylinder mounting nuts.

MASTER CYLINDER (NABCO)

Disassembly

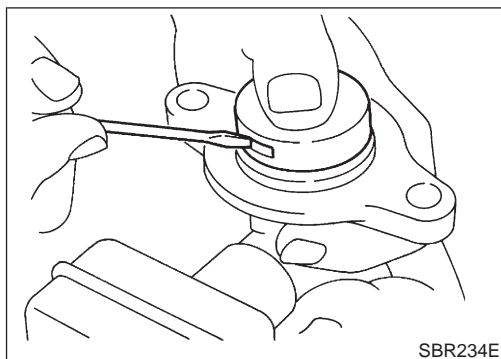

Disassembly

NFBR0136

1. Bend claws of stopper cap outward and remove stopper cap.

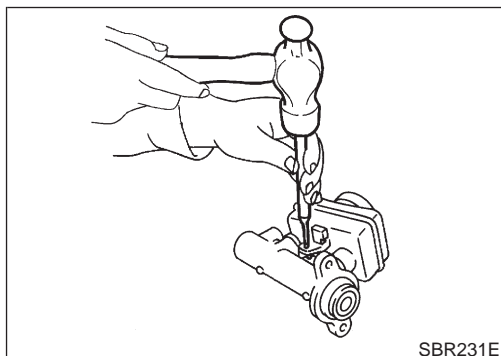

2. Drive out spring pin from cylinder body.
3. Draw out reservoir tank and seals.

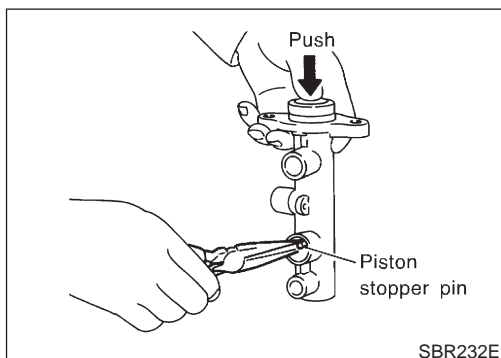

4. Remove piston stopper pin while piston is pushed into cylinder.
5. Remove piston assemblies.
If it is difficult to remove secondary piston assembly, gradually apply compressed air through fluid outlet.

Inspection

NFBR0137

Check for the following items.

Replace any part if damaged.

Master cylinder:

- Pin holes or scratches on inner wall.

Piston:

- Deformation of or scratches on piston cups.

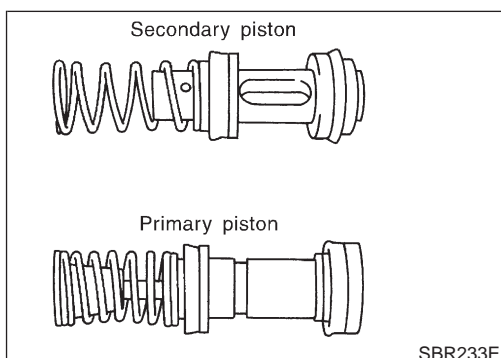

Assembly

NFBR0138

1. Insert secondary piston assembly. Then insert primary piston assembly.
 - **Pay attention to alignment of secondary piston slit with valve stopper mounting hole of cylinder body.**

MASTER CYLINDER (NABCO)

Assembly (Cont'd)

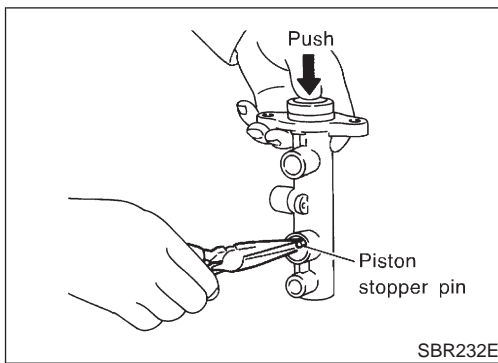

2. Install piston stopper pin while piston is pushed into cylinder.
3. Push reservoir tank seals and reservoir tank into cylinder body.
4. Install spring pin.

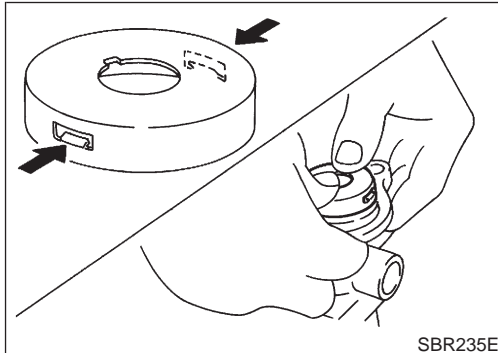

5. Install stopper cap.

Before installing stopper cap, ensure that claws are bent inward.

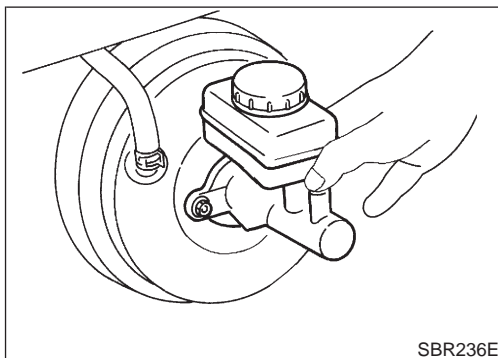

Installation

NFBR0139

CAUTION:

- Refill with new brake fluid "DOT 3".
 - Never reuse drained brake fluid.
1. Place master cylinder onto brake booster and secure mounting nuts lightly.
 2. Torque mounting nuts.
🔧 : 12 - 15 N-m (1.2 - 1.5 kg-m, 9 - 11 ft-lb)
 3. Fill up reservoir tank with new brake fluid.
 4. Plug all ports on master cylinder with fingers to prevent air suction while releasing brake pedal.
 5. Have driver depress brake pedal slowly several times until no air comes out of master cylinder.
 6. Fit brake lines to master cylinder.
 7. Tighten flare nuts.
🔧 : 15 - 18 N-m (1.5 - 1.8 kg-m, 11 - 13 ft-lb)
 8. Bleed air from brake system.

BRAKE BOOSTER

On-vehicle Service

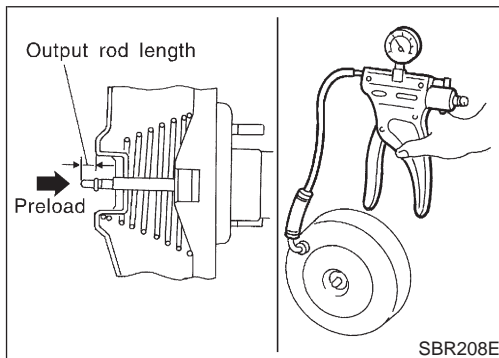
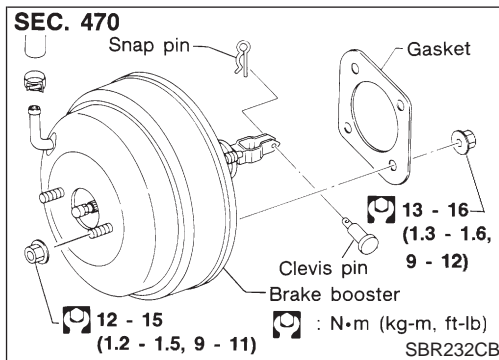
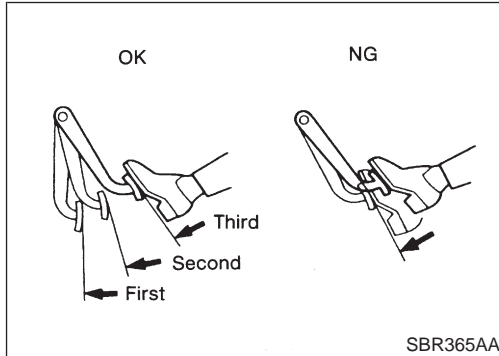
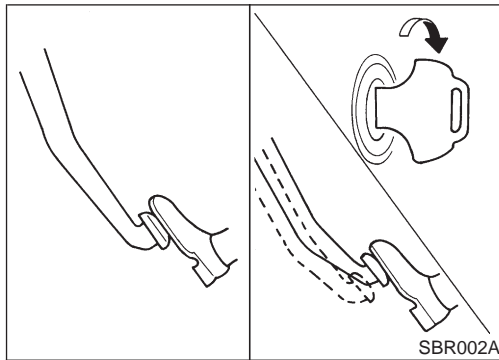

On-vehicle Service

NFBR0140

OPERATING CHECK

NFBR0140S01

1. Stop engine and depress brake pedal several times. Check that pedal stroke does not change.
2. Depress brake pedal, then start engine. If pedal goes down slightly, operation is normal.

AIRTIGHT CHECK

NFBR0140S02

1. Start engine, and stop it after one or two minutes. Depress brake pedal several times slowly. The pedal should go further down the first time, and then it should gradually rise thereafter.
2. Depress brake pedal while engine is running, and stop engine with pedal depressed. The pedal stroke should not change after holding pedal down for **30 seconds**.

Removal

NFBR0141

CAUTION:

- Be careful not to splash brake fluid on painted areas; it may cause paint damage. If brake fluid is splashed on painted areas, wash it away with water immediately.
- Be careful not to deform or bend brake pipes, during removal of booster.

Inspection

NFBR0142

OUTPUT ROD LENGTH CHECK

NFBR0142S01

1. Apply vacuum of -66.7 kPa (-667 mbar, -500 mmHg, -19.69 inHg) to brake booster with a handy vacuum pump.
2. Add preload of 19.6 N (2 kg, 4.4 lb) to output rod.
3. Check output rod length.

Specified length:

LHD	10.275 - 10.525 mm (0.4045 - 0.4144 in)
RHD	1.275 - 1.525 mm (0.0502 - 0.0600 in)

Installation

NFBR0143

CAUTION:

- Be careful not to deform or bend brake pipes, during installation of booster.
- Replace clevis pin if damaged.
- Refill with new brake fluid "DOT 3".
- Never reuse drained brake fluid.
- Take care not to damage brake booster mounting bolt thread when installing. Due to the acute angle of installation, the threads can be damaged with the dash panel.

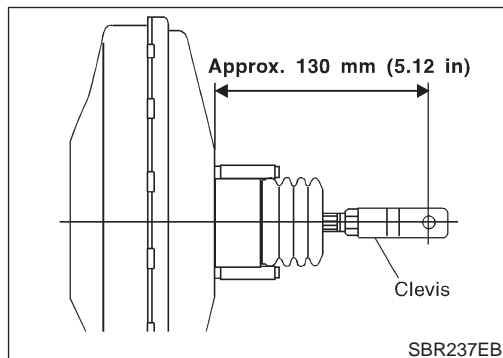

1. Before fitting booster, temporarily adjust clevis to dimension shown.
2. Fit booster, then secure mounting nuts (brake pedal bracket to master cylinder) lightly.
3. Connect brake pedal and booster input rod with clevis pin.
4. Secure mounting nuts.

Specification:

13 - 16 N·m (1.3 - 1.6 kg·m, 9 - 12 ft·lb)

5. Install master cylinder. Refer to "Installation" in "MASTER CYLINDER", BR-16 and BR-21.
6. Bleed air. Refer to "Bleeding Brake System", BR-8.

VACUUM HOSE

Removal and Installation

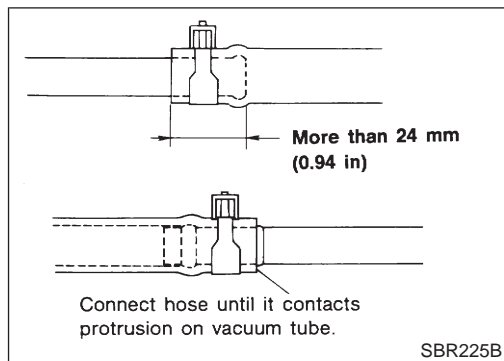

Removal and Installation

NFBR0144

CAUTION:

When installing vacuum hoses, pay attention to the following points.

- Do not apply any oil or lubricants to vacuum hose and check valve.
- Insert vacuum tube into vacuum hose as shown.
- Install check valve, paying attention to its direction.

Inspection

NFBR0145

HOSES AND CONNECTORS

NFBR0145S01

Check vacuum lines, connections and check valve for airtightness, improper attachment chafing and deterioration.

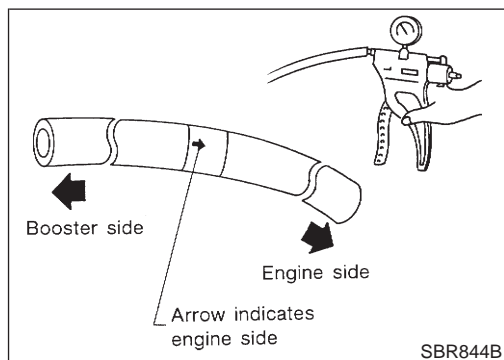

CHECK VALVE

NFBR0145S02

Check vacuum with a vacuum pump.

Connect to booster side	Vacuum should exist.
Connect to engine side	Vacuum should not exist.

FRONT DISC BRAKE

Component

Component

NFBR0146

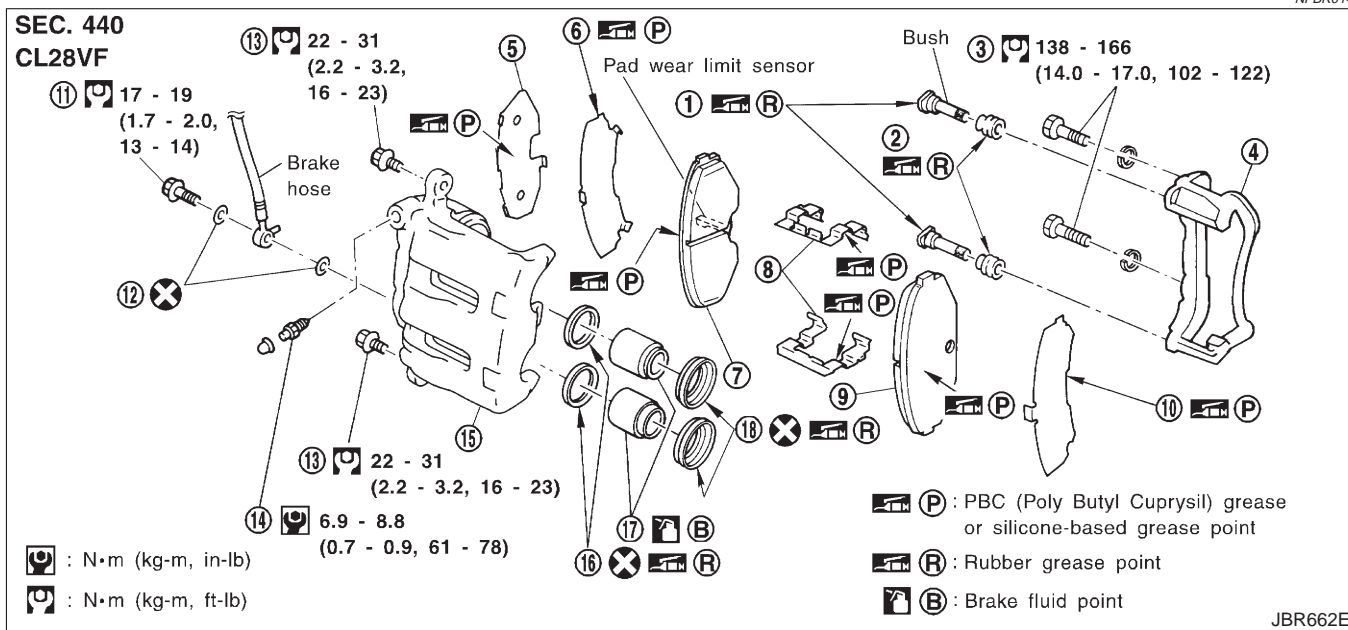

- | | | |
|------------------------------|---------------------|-------------------|
| 1. Main pin | 7. Inner pad | 13. Main pin bolt |
| 2. Pin boot | 8. Pad retainer | 14. Bleed valve |
| 3. Torque member fixing bolt | 9. Outer pad | 15. Cylinder body |
| 4. Torque member | 10. Outer shim | 16. Piston seal |
| 5. Shim cover | 11. Connecting bolt | 17. Piston |
| 6. Inner shim | 12. Copper washer | 18. Piston boot |

Pad Replacement

NFBR0147

WARNING:

Clean brake pads with a vacuum dust collector to minimize the hazard of airborne particles or other materials.

CAUTION:

- When cylinder body is open, do not depress brake pedal because piston will pop out.
- Be careful not to damage piston boot or get oil on rotor. Always replace shims when replacing pads.
- If shims are rusted or show peeling of the rubber coat, replace them with new shims.
- It is not necessary to remove connecting bolt except for disassembly or replacement of caliper assembly. In this case, suspend cylinder body with wire so as not to stretch brake hose.
- Burnish the brake contact surfaces after refinishing or replacing drums or rotors, after replacing pads or linings, or if a soft pedal occurs at very low mileage.

FRONT DISC BRAKE

Pad Replacement (Cont'd)

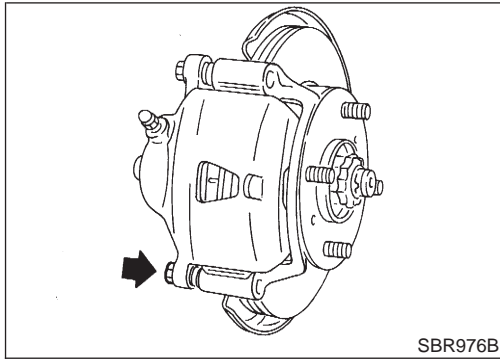

1. Remove master cylinder reservoir cap.
2. Remove pin bolt.
3. Open cylinder body upward. Then remove pad with retainers, inner and outer shims.

Standard pad thickness:

9.5 mm (0.374 in)

Pad wear limit:

2.0 mm (0.079 in)

Carefully monitor brake fluid level because brake fluid will return to reservoir when pushing back piston.

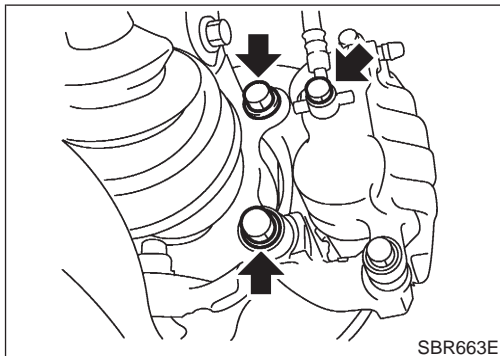
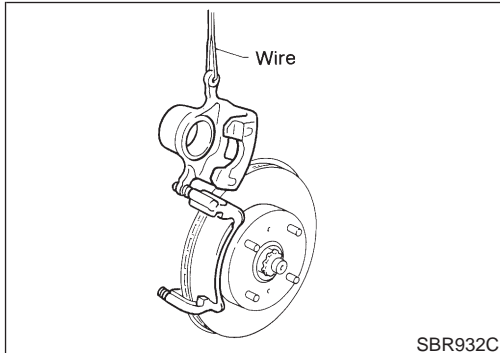

Removal

NFBR0148

WARNING:

Clean brake pads with a vacuum dust collector to minimize the hazard of airborne particles or other materials.

Remove torque member fixing bolts and connecting bolt.

It is not necessary to remove connecting bolt except for disassembly or replacement of caliper assembly. In this case, suspend caliper assembly with wire so as not to stretch brake hose.

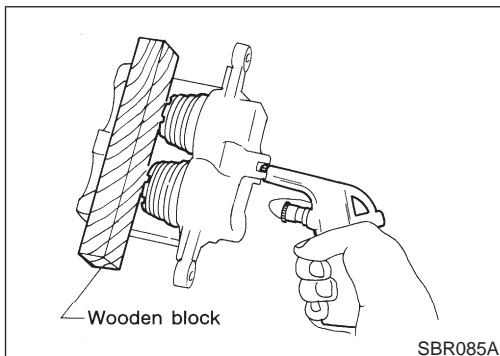

Disassembly

NFBR0149

WARNING:

Do not place your fingers in front of piston.

CAUTION:

Do not scratch or score cylinder wall.

1. Push out piston with piston boot with compressed air.
2. Remove piston seal with a suitable tool.

Inspection

NFBR0150

CALIPER

NFBR0150S01

Cylinder Body

NFBR0150S0101

- Check inside surface of cylinder for score, rust, wear, damage or presence of foreign materials. If any of the above conditions are observed, replace cylinder body.
- Minor damage from rust or foreign materials may be eliminated by polishing surface with a fine emery paper. Replace cylinder body if necessary.

CAUTION:

Use brake fluid to clean. Never use mineral oil.

FRONT DISC BRAKE

Inspection (Cont'd)

Piston

NFBR0150S0102

CAUTION:

Piston sliding surface is plated. Do not polish with emery paper even if rust or foreign materials are stuck to sliding surface.

Check piston for score, rust, wear, damage or presence of foreign materials. Replace if any of the above conditions are observed.

Slide Pin, Pin Bolt and Pin Boot

NFBR0150S0103

Check for wear, cracks or other damage. Replace if any of the above conditions are observed.

ROTOR

NFBR0150S02

Rubbing Surface

NFBR0150S0201

Check rotor for roughness, cracks or chips.

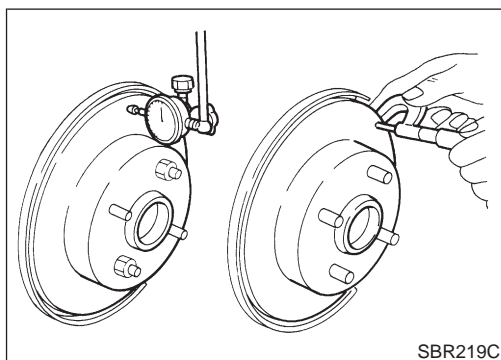

Runout

NFBR0150S0202

1. Secure rotor to wheel hub with at least two nuts (M12 x 1.25).
2. Check runout using a dial indicator.
Make sure that wheel bearing axial end play is within the specifications before measuring.

Maximum runout:

0.07 mm (0.0028 in)

3. If the runout is out of specification, find minimum runout position as follows:
 - a. Remove nuts and rotor from wheel hub.
 - b. Shift the rotor one hole and secure rotor to wheel hub with nuts.
 - c. Measure runout.
 - d. Repeat steps a. to c. so that minimum runout position can be found.
4. If the runout is still out of specification, turn rotor with on-car brake lathe ("MAD, DL-8700", "AMMCO 700 and 705" or equivalent).

Thickness

NFBR0150S0203

Thickness variation (At least 8 positions):

Maximum 0.01 mm (0.0004 in)

If thickness variation exceeds the specification, turn rotor with on-car brake lathe.

Rotor repair limit:

26.0 mm (1.024 in)

FRONT DISC BRAKE

Assembly

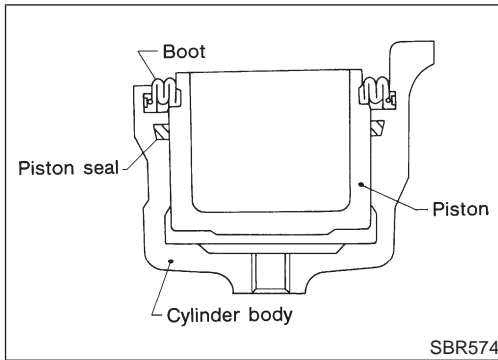

Assembly

NFBR0151

1. Insert piston seal into groove on cylinder body.
2. With piston boot fitted to piston, insert piston boot into groove on cylinder body and install piston.
3. Properly secure piston boot.

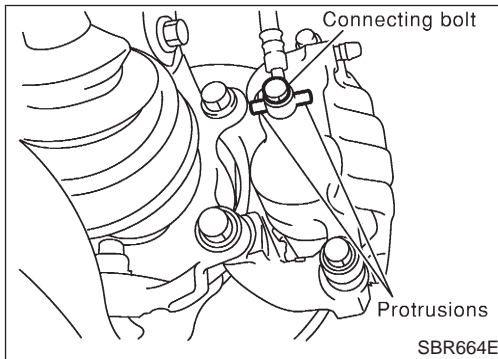

Installation

NFBR0152

CAUTION:

- Refill with new brake fluid "DOT 3".
 - Never reuse drained brake fluid.
1. Install brake hose to caliper securely.
 2. Install all parts and secure all bolts.
 3. Bleed air. Refer to "Bleeding Brake System", BR-8.

REAR DISC BRAKE

Component

Component

NFBR0153

SEC. 441

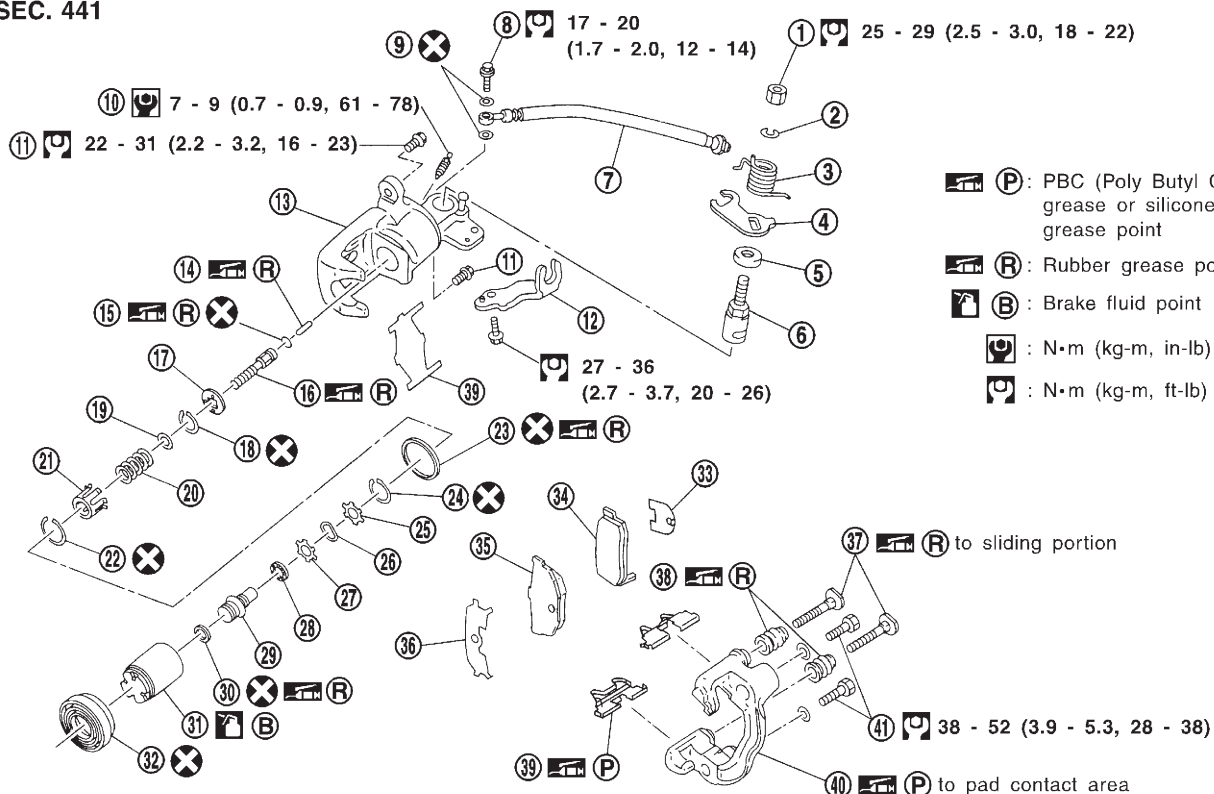

P: PBC (Poly Butyl Cuprysil) grease or silicone-based grease point

R: Rubber grease point

B: Brake fluid point

: N·m (kg-m, in-lb)

: N·m (kg-m, ft-lb)

SBR558E

- | | | |
|----------------------------|------------------|-------------------------------|
| 1. Nut | 15. O-ring | 29. Adjust nut |
| 2. Washer | 16. Push rod | 30. Cup |
| 3. Return spring | 17. Key plate | 31. Piston |
| 4. Parking brake lever | 18. Ring C | 32. Dust seal |
| 5. Cam boot | 19. Seat | 33. Inner shim |
| 6. Cam | 20. Spring | 34. Inner pad |
| 7. Brake hose | 21. Spring cover | 35. Outer pad |
| 8. Connecting bolt | 22. Ring B | 36. Outer shim |
| 9. Copper washer | 23. Piston seal | 37. Pin |
| 10. Bleed screw | 24. Ring A | 38. Pin boot |
| 11. Pin bolt | 25. Spacer | 39. Pad retainer |
| 12. Cable mounting bracket | 26. Wave washer | 40. Torque member |
| 13. Cylinder | 27. Spacer | 41. Torque member fixing bolt |
| 14. Strut | 28. Ball bearing | |

Pad Replacement

WARNING:

Clean brake pads with a vacuum dust collector to minimize the hazard of airborne particles or other materials.

CAUTION:

- When cylinder body is open, do not depress brake pedal because piston will pop out.
- Be careful not to damage piston boot or get oil on rotor. Always replace shims in replacing pads.
- If shims are rusted or show peeling of rubber coat, replace them with new shims.

NFBR0154

REAR DISC BRAKE

Pad Replacement (Cont'd)

- It is not necessary to remove connecting bolt except for disassembly or replacement of caliper assembly. In this case, suspend cylinder body with wire so as not to stretch brake hose.
- Burnish the brake contact surfaces after refinishing or replacing drums or rotors, after replacing pads or linings, or if a soft pedal occurs at very low mileage. Refer to "Brake Burnishing Procedure", "ON-VEHICLE SERVICE", BR-7.

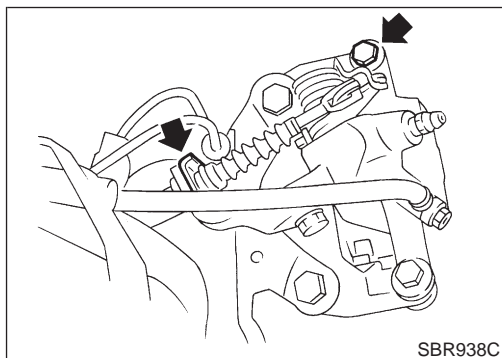

1. Remove master cylinder reservoir cap.
2. Remove brake cable mounting bolt and lock spring.
3. Release parking brake control lever, then disconnect cable from the caliper.
4. Remove upper pin bolt.
5. Open cylinder body downward. Then remove pad retainers, and inner and outer shims.

Standard pad thickness:

8 mm (0.31 in)

Pad wear limit:

2.0 mm (0.079 in)

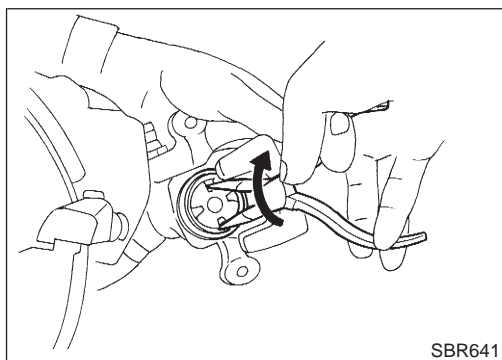
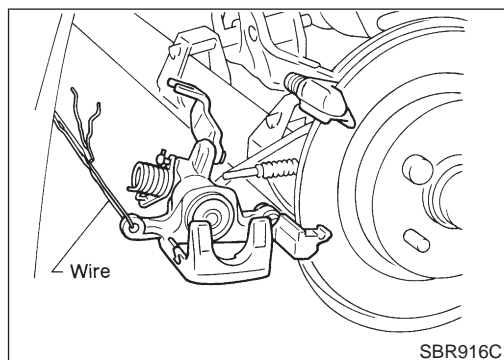

6. When installing new pads, push piston into cylinder body by gently turning piston clockwise, as shown. **Carefully monitor brake fluid level because brake fluid will return to reservoir when pushing back piston.**

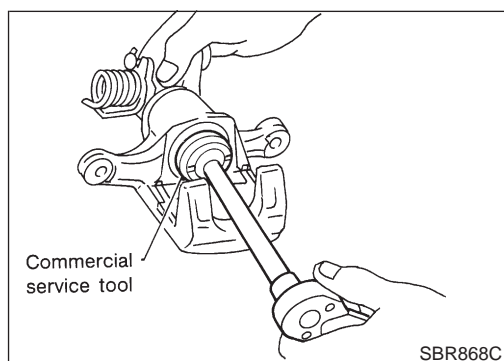

REAR DISC BRAKE

Pad Replacement (Cont'd)

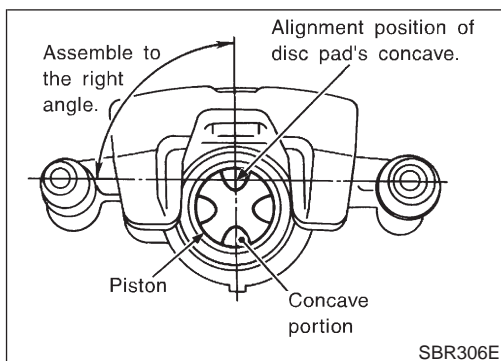

7. Adjust the piston to the right angle as shown in the figure.

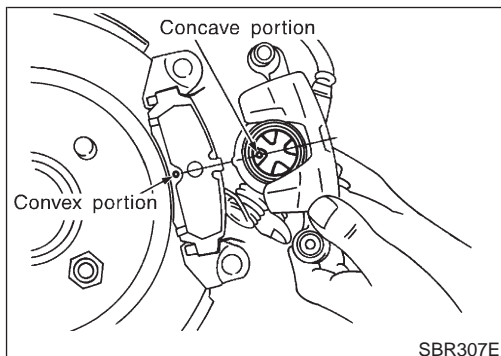

8. As shown in the figure, align the piston's concave to the pad's convex, then install the cylinder body to the torque member.

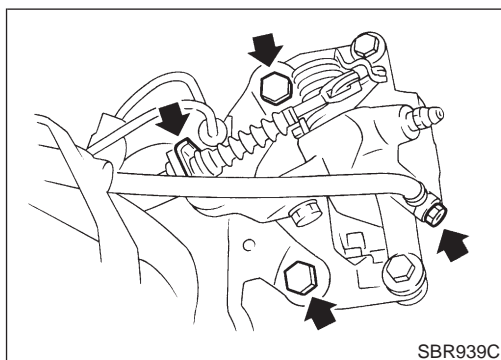

Removal

NFBR0155

WARNING:

Clean brake pads with a vacuum dust collector to minimize the hazard of airborne particles or other materials.

1. Remove brake cable mounting bolt and lock spring.
2. Release parking brake control lever, then disconnect cable from the caliper.
3. Remove torque member fixing bolts and connecting bolt.

It is not necessary to remove connecting bolt except for disassembly or replacement of caliper assembly. In this case, suspend caliper assembly with wire so as not to stretch brake hose.

REAR DISC BRAKE

Disassembly

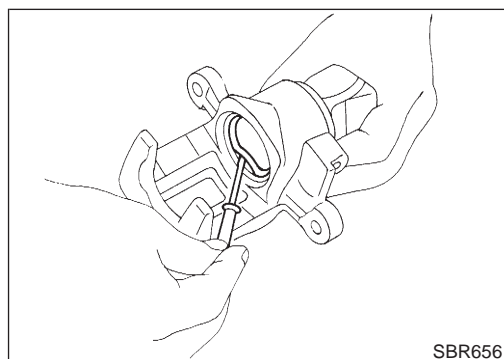
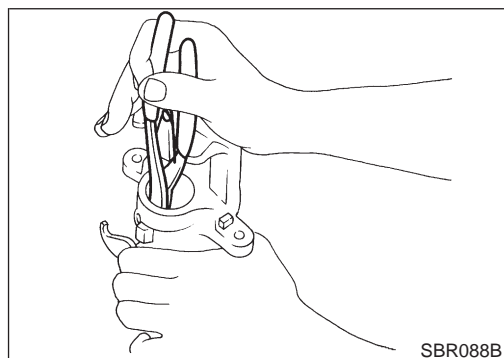
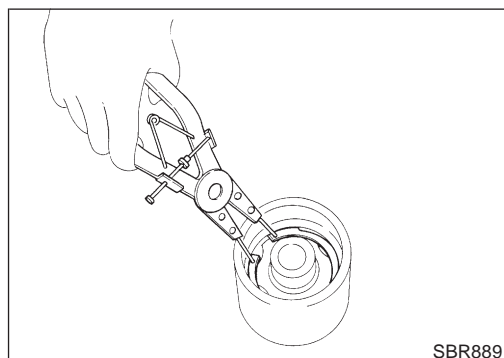
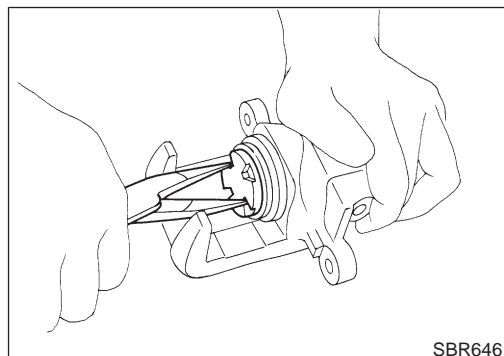
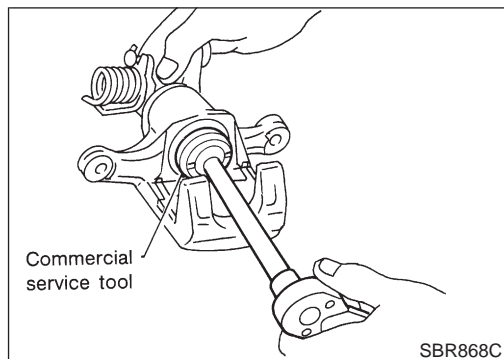

Disassembly

NFBR0156

1. Remove piston by turning it counterclockwise with suitable commercial service tool or long nose pliers.

2. Pry off ring A from piston with suitable pliers and remove adjusting nut.

3. Disassemble cylinder body.

- a. Pry off ring B with suitable pliers, then remove spring cover, spring and seat.
- b. Pry off ring C, then remove key plate, push rod and rod.

- c. Remove piston seal.
Be careful not to damage cylinder body.

REAR DISC BRAKE

Disassembly (Cont'd)

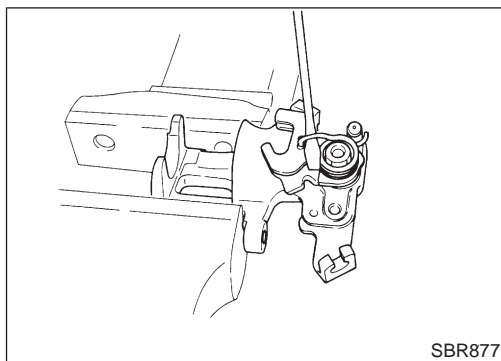

4. Remove return spring, toggle lever and cable guide.

Inspection

CALIPER

NFBR0157

NFBR0157S01

CAUTION:

Use brake fluid to clean cylinder. Never use mineral oil.

Cylinder Body

NFBR0157S0101

- Check inside surface of cylinder for score, rust, wear, damage or presence of foreign materials. If any of the above conditions are observed, replace cylinder body.
- Minor damage from rust or foreign materials may be eliminated by polishing surface with a fine emery paper. Replace cylinder body if necessary.

Torque Member

NFBR0157S0102

Check for wear, cracks or other damage. Replace if necessary.

Piston

NFBR0157S0103

CAUTION:

Piston sliding surface is plated. Do not polish with emery paper even if rust or foreign matter is stuck to sliding surface.

Check piston for score, rust, wear, damage or presence of foreign materials.

Replace if any of the above conditions are observed.

Pin and Pin Boot

NFBR0157S0104

Check for wear, cracks or other damage.

Replace if any of the above conditions are observed.

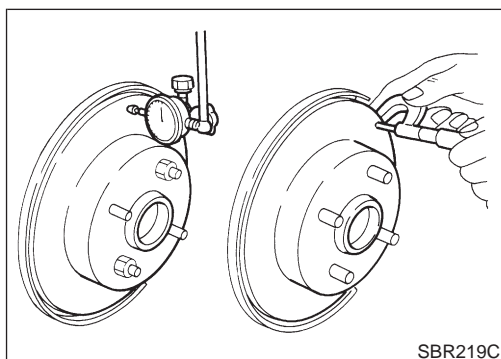

ROTOR

NFBR0157S02

Rubbing Surface

NFBR0157S0201

Check rotor for roughness, cracks or chips.

Runout

NFBR0157S0202

1. Secure rotor to wheel hub with two nuts (M12 x 1.25).
2. Check runout using a dial indicator.

Make sure that axial end play is within the specifications before measuring. Refer to AX-18, "REAR WHEEL BEARING".

3. Change relative positions of rotor and wheel hub so that runout is minimized.

REAR DISC BRAKE

Inspection (Cont'd)

Maximum runout:
0.07 mm (0.0028 in)

Thickness

Rotor repair limit:
Standard thickness
9 mm (0.35 in)
Minimum thickness
8 mm (0.31 in)

NFBR0157S0203

Thickness variation (At least 8 portions)
Maximum 0.02 mm (0.0008 in)

Assembly

1. Insert cam with depression facing towards open end of cylinder. NFBR0158

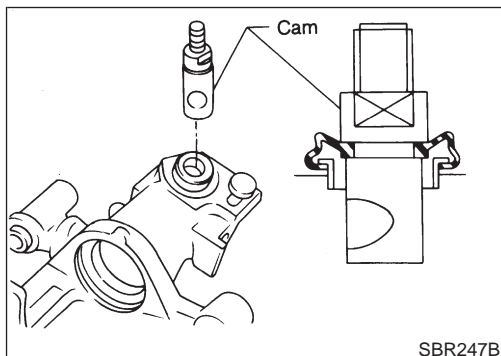

2. Generously apply rubber grease to strut and push rod to make insertion easy.

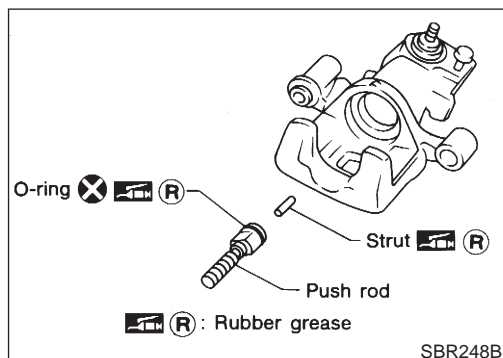

3. Fit push rod into square hole in key plate. Also match convex portion of key plate with concave portion of cylinder.

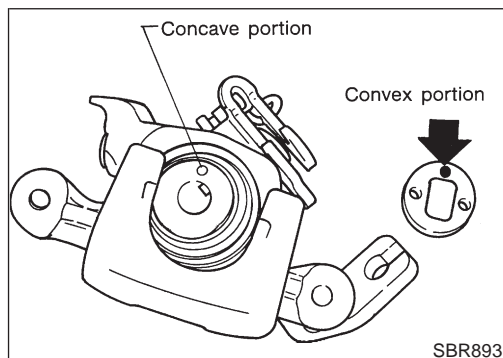

4. Install ring C with a suitable tool.

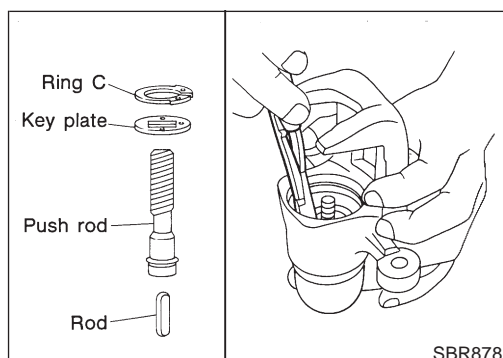

REAR DISC BRAKE

Assembly (Cont'd)

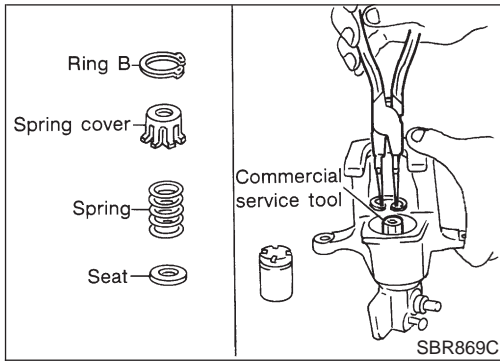

5. Install seat, spring, spring cover and ring B with suitable press and drift.

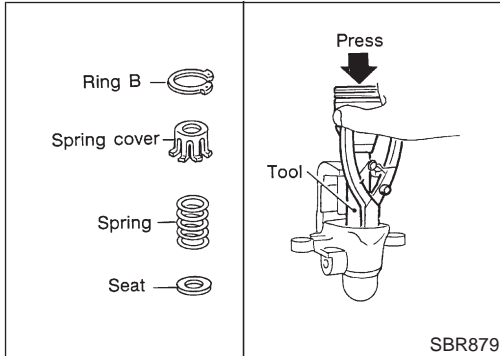

6. Install cup in the specified direction.

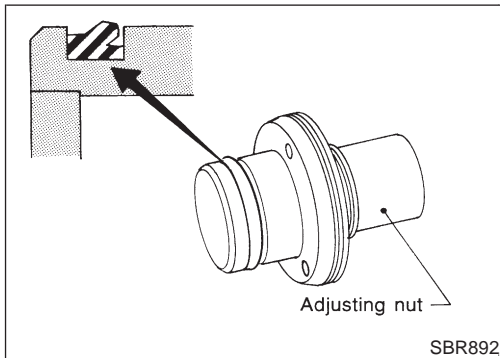

7. Install cup, adjuster, bearing, spacers, washers and ring A with a suitable tool.

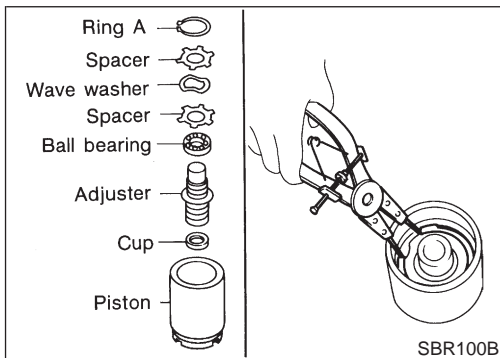

REAR DISC BRAKE

Assembly (Cont'd)

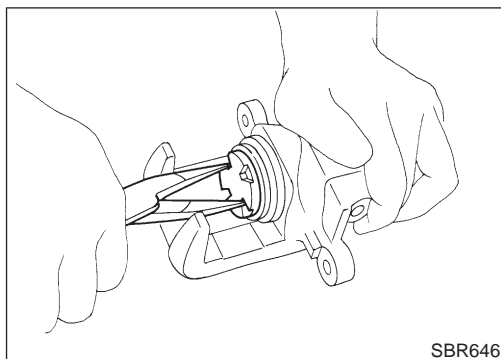

8. Insert piston seal into groove on cylinder body.
9. With piston boot fitted to piston, insert piston boot into groove on cylinder body and fit piston by turning it clockwise with long nose pliers, or suitable tool.

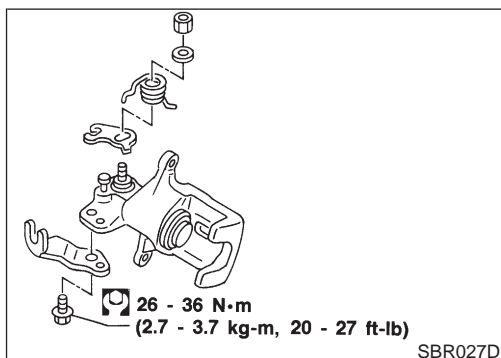
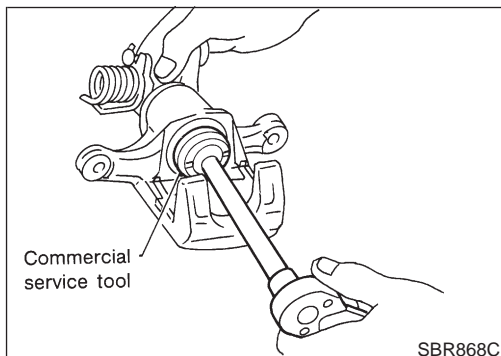

10. Fit toggle lever, return spring and cable guide.

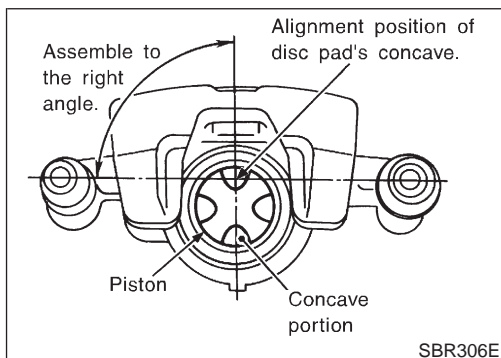

11. Adjust the piston to the right angle as shown in the figure.

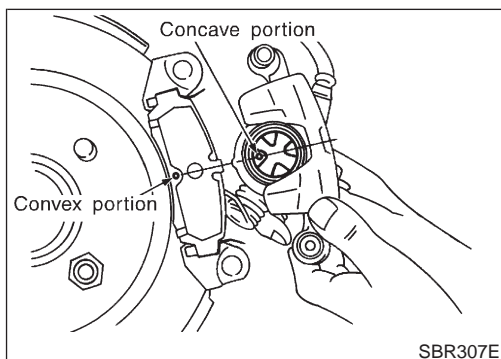

Installation

CAUTION:

- Refill with new brake fluid "DOT 3".
- Never reuse drained brake fluid.

1. Install caliper assembly.
- As shown in the figure, align the piston's concave to the pad's convex, then install the cylinder body to the torque member.
2. Install brake hose to caliper securely.
3. Install all parts and secure all bolts.
4. Bleed air. Refer to "Bleeding Brake System", BR-8.

NFBR0159

REAR DISC BRAKE

Installation (Cont'd)

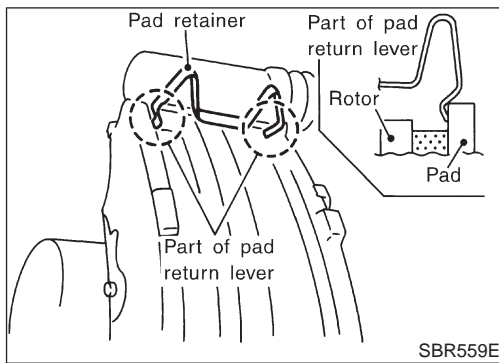

CAUTION:
The pad retainer is built so the pad returns to its original position. Be careful to install the pad so the pad-return lever is against the inner side of the pad, as shown in the left figure.

PARKING BRAKE CONTROL

Components

Components

NFBR0160

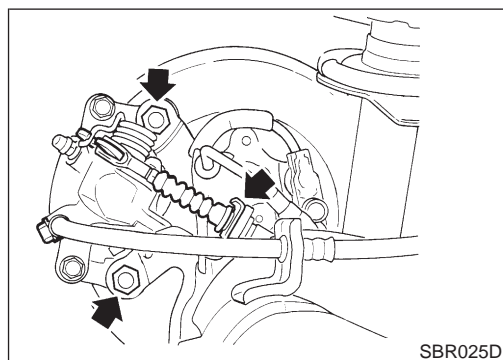
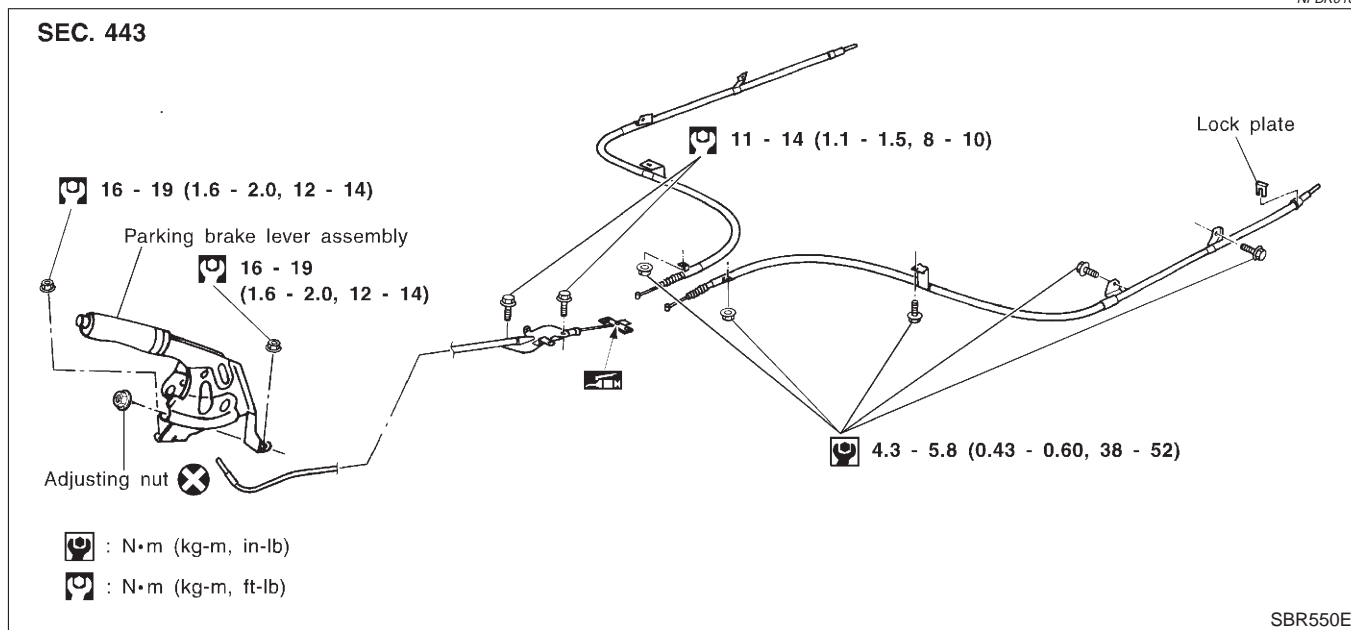

Removal and Installation

NFBR0161

1. To remove parking brake cable, first remove center console.
2. Disconnect warning switch connector.
3. Remove bolts, slacken off and remove adjusting nut.
4. Remove lock plate and disconnect cable.

Inspection

NFBR0162

1. Check control lever for wear or other damage. Replace if necessary.
2. Check wires for discontinuity or deterioration. Replace if necessary.
3. Check warning lamp and switch. Replace if necessary.
4. Check parts at each connecting portion and, if found deformed or damaged, replace.

PARKING BRAKE CONTROL

Adjustment

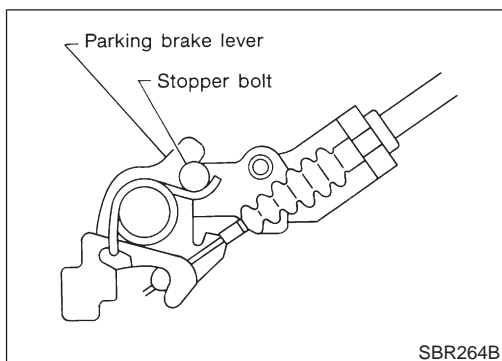

Adjustment

=NFBR0163

Pay attention to the following points after adjustment.

- 1) There is no drag when control lever is being released.
- 2) Be sure that toggle lever returns to stopper when parking brake lever or pedal is released.
 1. Loosen parking brake cable.
 2. Depress brake pedal fully more than five times.
 3. Operate control lever 10 times or more with a full stroke [203.5 mm (8.01 in)].
 4. Adjust control lever by turning adjusting nut.
 5. Pull control lever with specified amount of force. Check lever stroke and ensure smooth operation.

Number of notches:

10 - 11 [196 N (20 kg, 44 lb)]

6. Bend warning lamp switch plate. Warning lamp should come on when lever is pulled "A" notches. It should go off when the lever is fully released.

Number of "A" notches: 1

Purpose

Purpose

The ABS consists of electronic and hydraulic components. It allows for control of braking force so that locking of the wheels can be avoided.

NFBR0082

The ABS:

- 1) Ensures proper tracking performance through steering wheel operation.
- 2) Enables obstacles to be avoided through steering wheel operation.
- 3) Ensures vehicle stability by preventing flat spins.

ABS (Anti-Lock Brake System) Operation

NFBR0083

- When the vehicle speed is less than 10 km/h (6 MPH) this system does not work.
- The Anti-Lock Brake System (ABS) has self-test capabilities. The system turns on the ABS warning lamp for 1 second after turning the ignition switch ON. The system performs another test the first time the vehicle reaches 6 km/h (4 MPH). A mechanical noise may be heard as the ABS performs a self-test. This is a normal part of the self-test feature. If a malfunction is found during this check, the ABS warning lamp will come on.
- During ABS operation, a mechanical noise may be heard. This is a normal condition.

ABS Hydraulic Circuit

NFBR0084

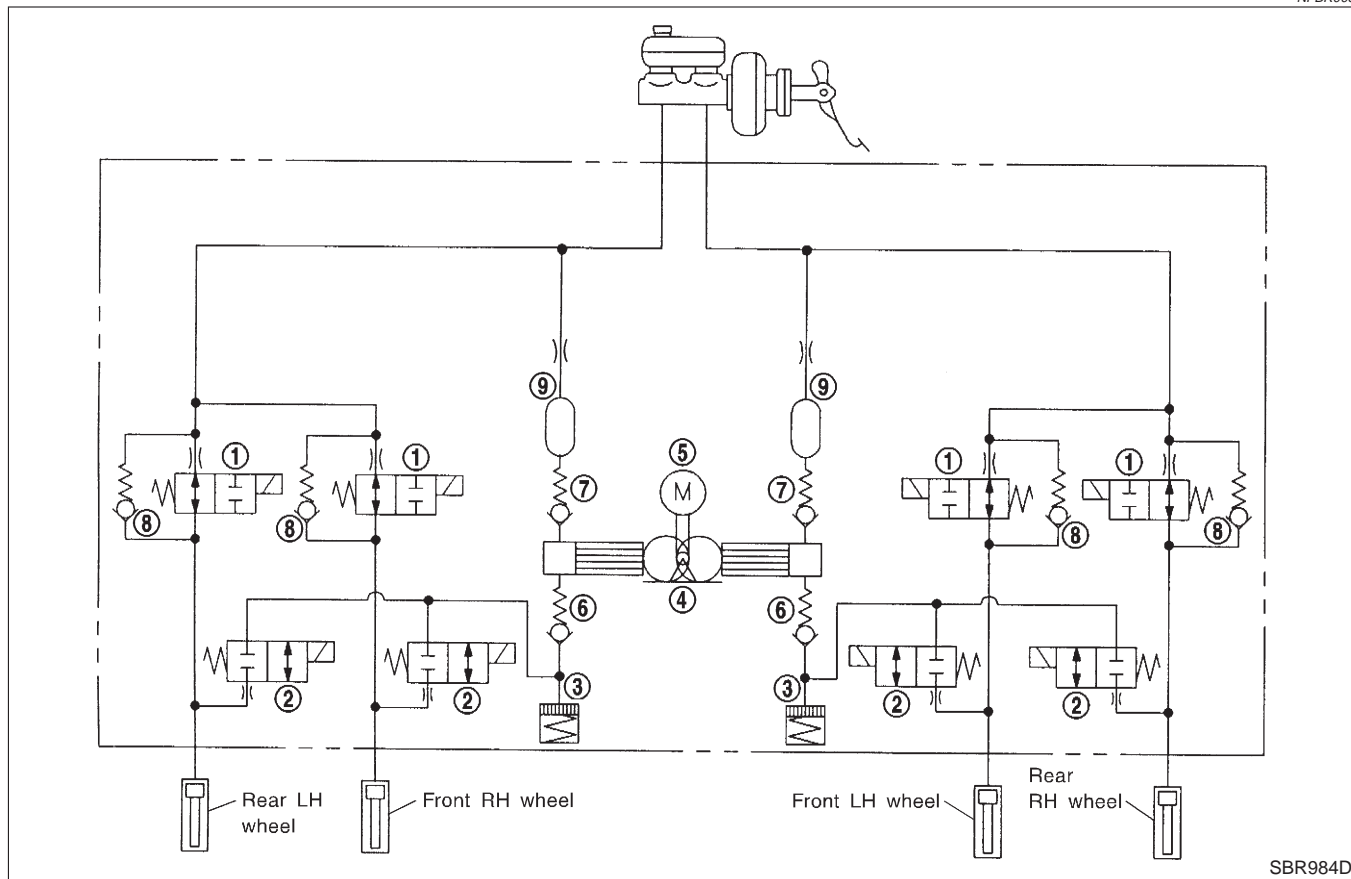

SBR984D

- | | | |
|--------------------------|----------------|-----------------------|
| 1. Inlet solenoid valve | 4. Pump | 7. Outlet valve |
| 2. Outlet solenoid valve | 5. Motor | 8. Bypass check valve |
| 3. Reservoir | 6. Inlet valve | 9. Damper |

System Components

NFBR0086

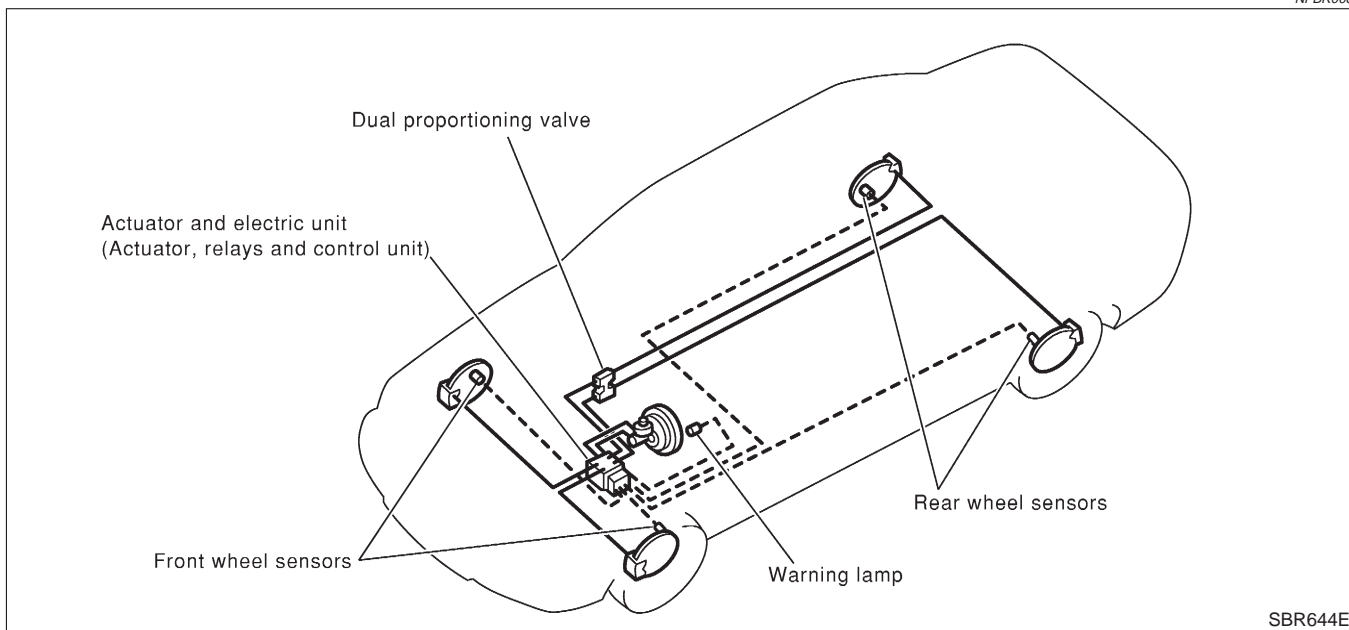

SBR644E

System Description

NFBR0087

SENSOR

NFBR0087S01

The sensor unit consists of a gear-shaped sensor rotor and a sensor element. The element contains a bar magnet around which a coil is wound. The sensor is installed on the back side of the brake rotor. Sine-wave current is generated by the sensor as the wheel rotates. The frequency and voltage increase(s) as the rotating speed increases.

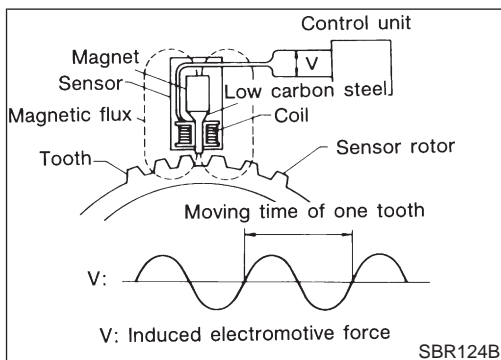

SBR124B

CONTROL UNIT

NFBR0087S02

The control unit computes the wheel rotating speed by the signal current sent from the sensor. Then it supplies a DC current to the actuator solenoid valve. It also controls ON-OFF operation of the valve relay and motor relay. If any electrical malfunction should be detected in the system, the control unit causes the warning lamp to light up. In this condition, the ABS will be deactivated by the control unit, and the vehicle's brake system reverts to normal operation.

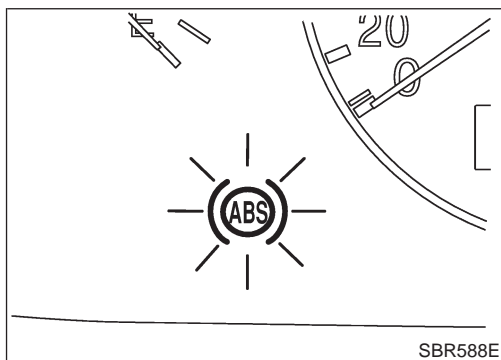

SBR588E

ABS ACTUATOR AND ELECTRIC UNIT

NFBR0087S03

The ABS actuator and electric unit contains:

- An electric motor and pump
- Two relays
- Eight solenoid valves, each inlet and outlet for
 - LH front
 - RH front
 - LH rear
 - RH rear
- ABS control unit

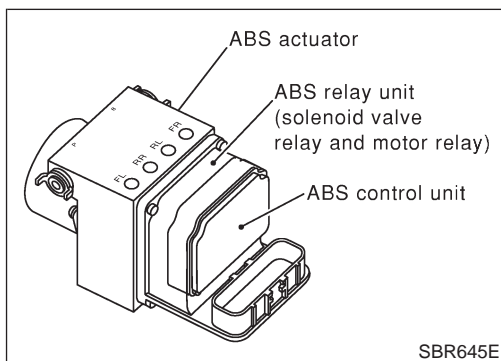

SBR645E

DESCRIPTION

ABS

System Description (Cont'd)

This components controls the hydraulic circuit and increases, holds or decreases hydraulic pressure to all or individual wheels. The ABS actuator and electric unit are not disassemble.

ABS Actuator Operation

NFBR0087S0301

		Inlet solenoid valve	Outlet solenoid valve	
Normal brake operation		OFF (Open)	OFF (Closed)	Master cylinder brake fluid pressure is directly transmitted to caliper via the inlet solenoid valve.
ABS operation	Pressure hold	ON (Closed)	OFF (Closed)	Hydraulic circuit is shut off to hold the caliper brake fluid pressure.
	Pressure decrease	ON (Closed)	ON (Open)	Caliper brake fluid is sent to reservoir via the outlet solenoid valve. Then it is pushed up to the master cylinder by pump.
	Pressure increase	OFF (Open)	OFF (Closed)	Master cylinder brake fluid pressure is transmitted to caliper.

DESCRIPTION

ABS

Component Parts and Harness Connector Location

Component Parts and Harness Connector Location

NFBR0088

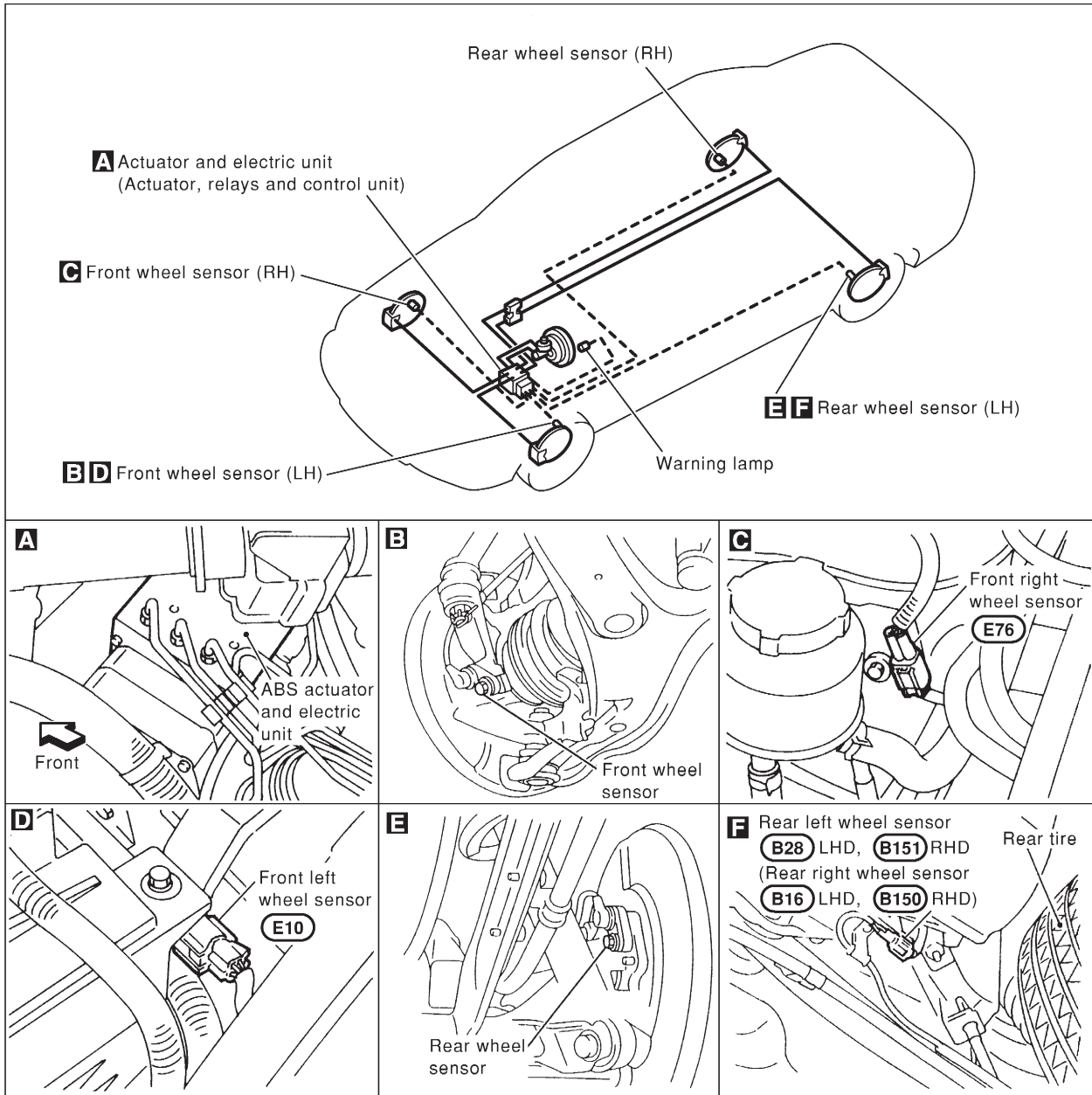

SBR646E

Schematic

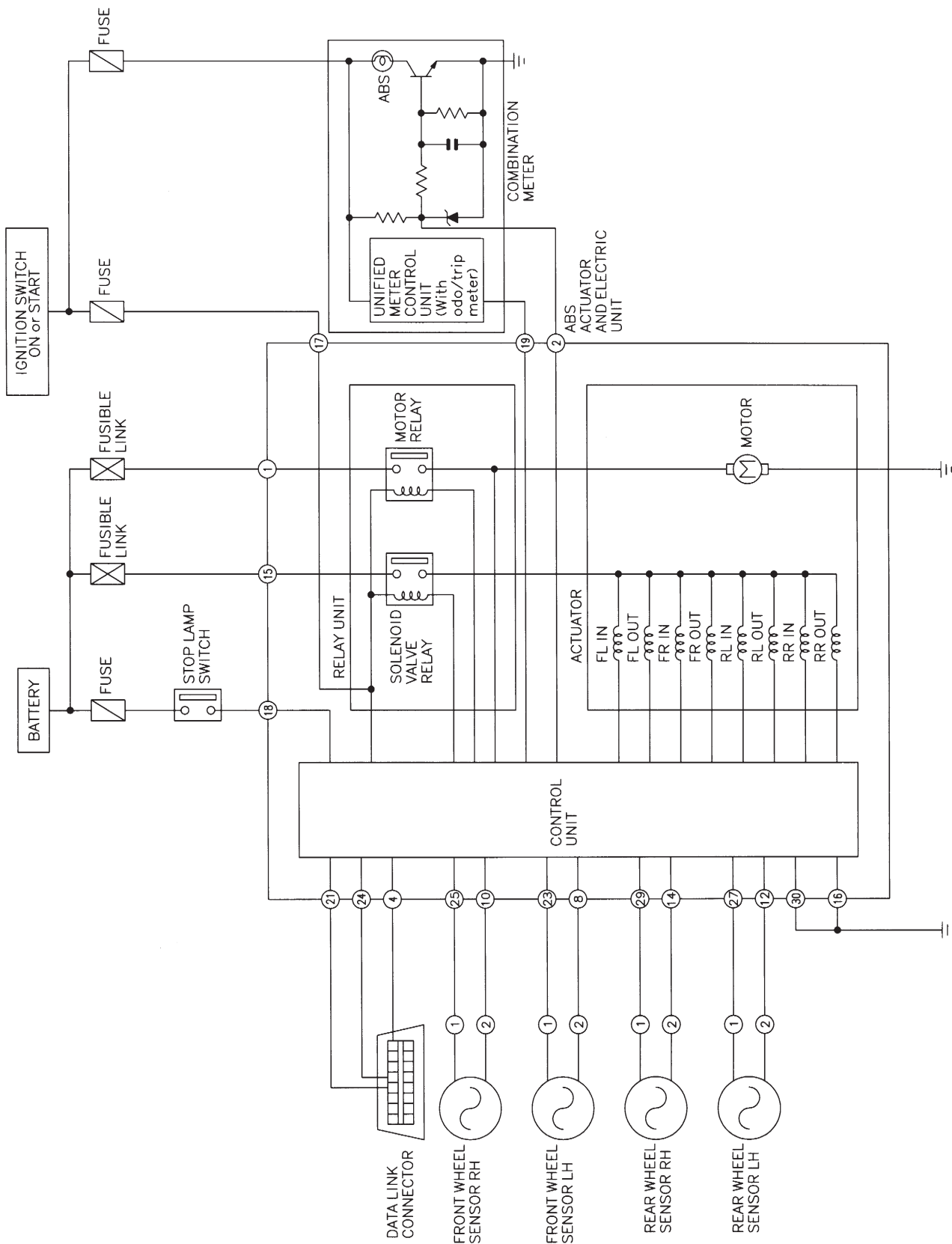

DESCRIPTION

ABS

Wiring Diagram — ABS —

Wiring Diagram — ABS —

NFBR0090

BR-ABS-01

REFER TO EL-POWER.

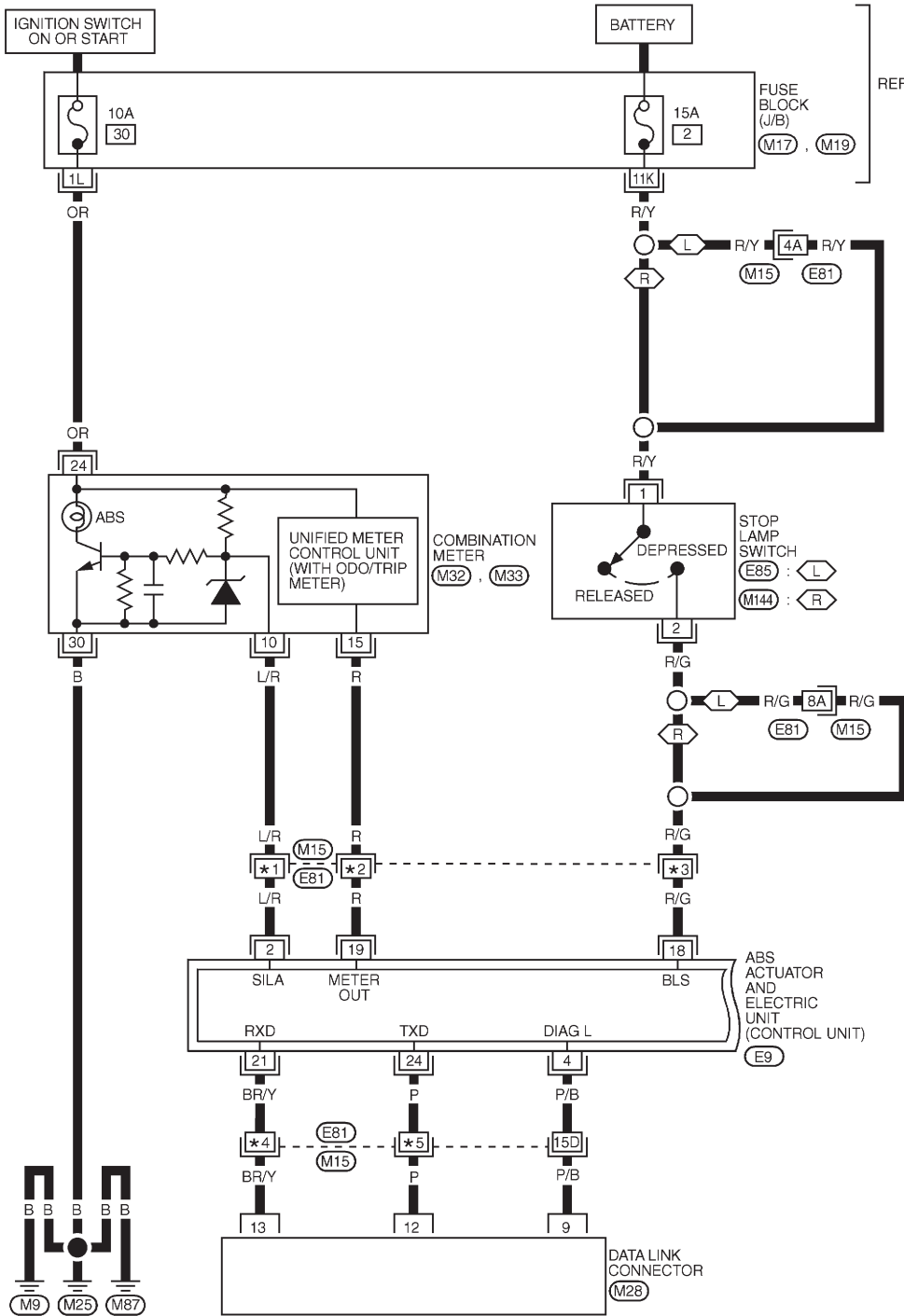

⬤ : LHD MODELS
⬤ : RHD MODELS

- * 1 14D : ⬤
- 10D : ⬤
- * 2 17D : ⬤
- 13D : ⬤
- * 3 3E : ⬤
- 4E : ⬤
- * 4 3D : ⬤
- 14D : ⬤
- * 5 16D : ⬤
- 2E : ⬤

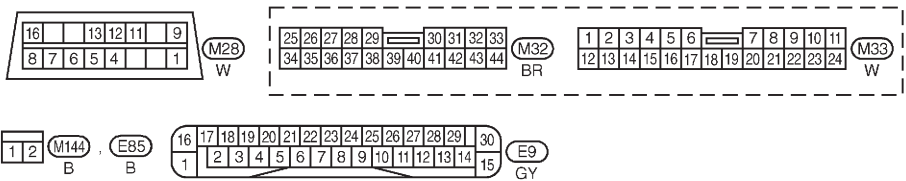

REFER TO THE FOLLOWING.
 (M15) -SUPER
 MULTIPLE JUNCTION (SMJ)
 (M17), (M19) -FUSE BLOCK-
 JUNCTION BOX (J/B)

MBR388A

DESCRIPTION

ABS

Wiring Diagram — ABS — (Cont'd)

BR-ABS-02

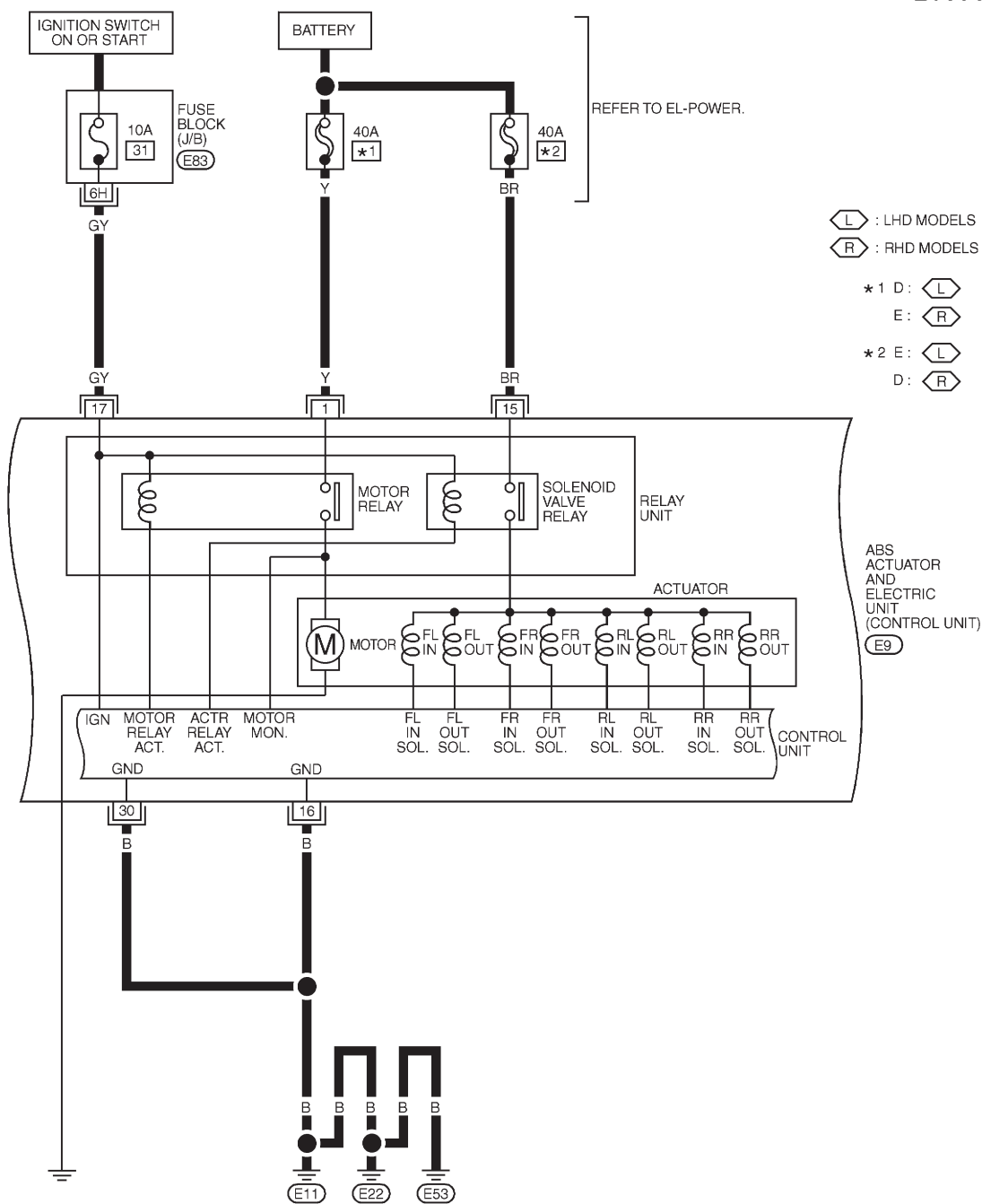

16	17	18	19	20	21	22	23	24	25	26	27	28	29	30	(E9)
1	2	3	4	5	6	7	8	9	10	11	12	13	14	15	GY

REFER TO THE FOLLOWING.
 (E83) - FUSE BLOCK-JUNCTION BOX (J/B)

MBR389A

DESCRIPTION

ABS

Wiring Diagram — ABS — (Cont'd)

BR-ABS-03

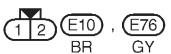
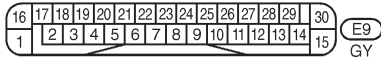
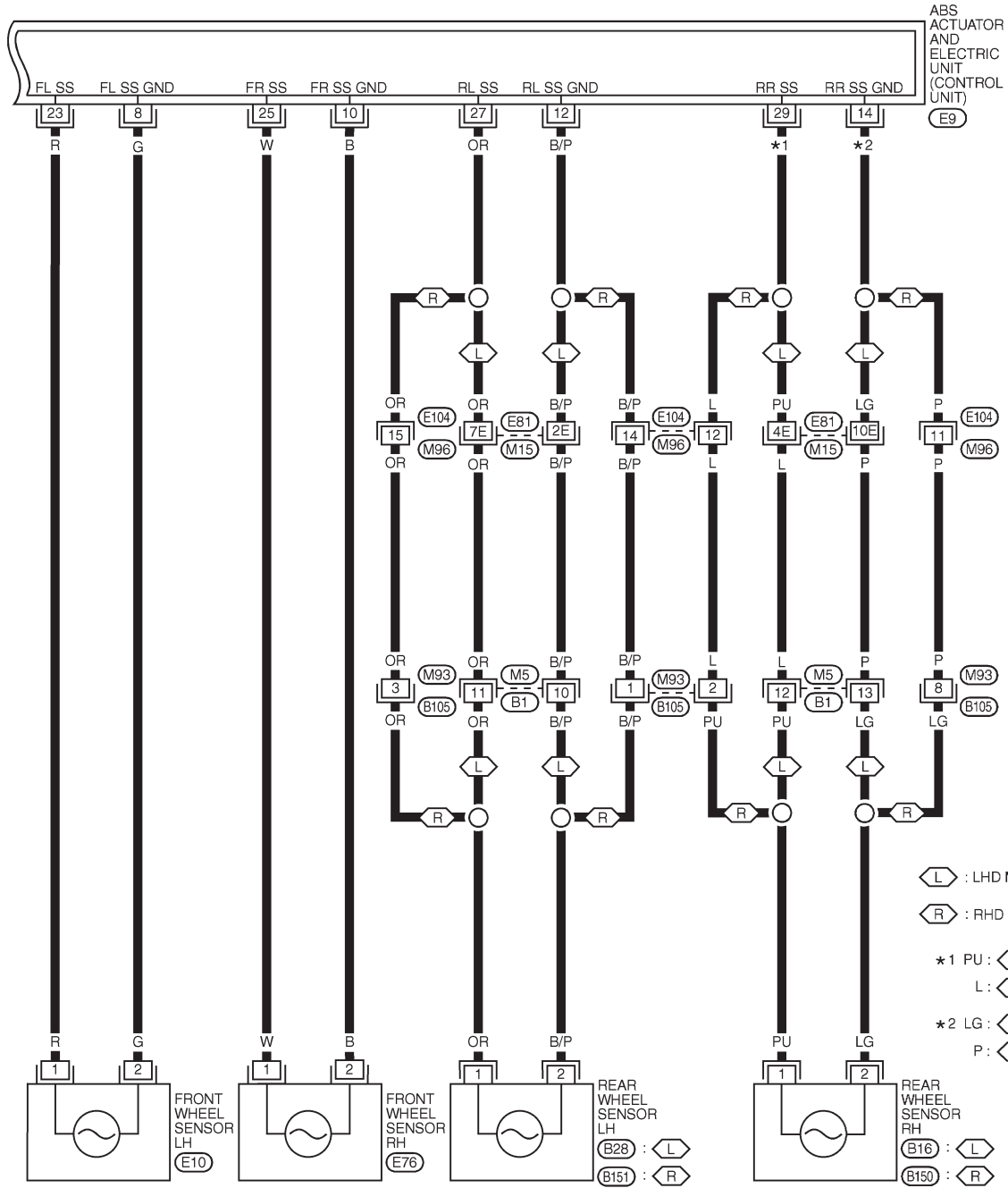

REFER TO THE FOLLOWING.
M15 -SUPER
 MULTIPLE JUNCTION (SMJ)

MBR390A

Self-diagnosis

NFBR0091

FUNCTION

NFBR0091S01

- When a problem occurs in the ABS, the ABS warning lamp on the instrument panel comes on. To start the self-diagnostic results mode, ground the self-diagnostic (check) terminal located on "Data link connector". The location of the malfunction is indicated by the ABS warning lamp flashing.

SELF-DIAGNOSIS PROCEDURE

NFBR0091S02

- Drive vehicle over 30 km/h (19 MPH) for at least one minute.
- Turn ignition switch "OFF".
- Ground terminal "8" of "Data link connector" with a suitable harness.
- Turn ignition switch "ON" while grounding terminal "8".
Do not depress brake pedal.
Do not start engine.

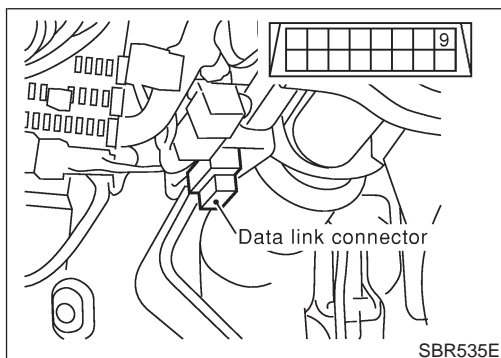
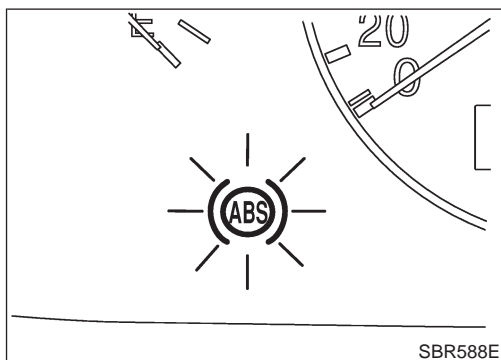
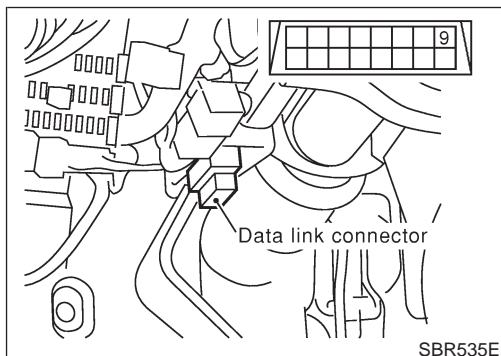

- After 3.0 seconds, the ABS warning lamp starts flashing to indicate the malfunction code No. (See NOTE.)
- Verify the location of the malfunction with the malfunction code chart. Refer to BR-61. Then make the necessary repairs following the diagnostic procedures.
- After the malfunctions are repaired, erase the malfunction codes stored in the control unit. Refer to BR-49.
- Rerun the self-diagnostic results mode to verify that the malfunction codes have been erased.
- Disconnect the check terminal from the ground. The self-diagnostic results mode is now complete.
- Check ABS warning lamp for deactivation after driving vehicle over 30 km/h (19 MPH) for at least one minute.
- After making certain that ABS warning lamp does not come on, test the ABS SELF-DIAGNOSIS in a safe area to verify that it functions properly.

NOTE:

The indication terminates after five minutes. However, when the ignition switch is turned from "OFF" to "ON", the indication starts flashing again.

HOW TO READ SELF-DIAGNOSTIC RESULTS (MALFUNCTION CODES)

NFBR0091S03

- Determine the code No. by counting the number of times the ABS warning lamp flashes on and off.
- When several malfunctions occur at one time, up to three code numbers can be stored; the latest malfunction will be indicated first.
- The indication begins with the start code 12. After that a maximum of three code numbers appear in the order of the latest one first. The indication then returns to the start code 12 to repeat (the indication will stay on for five minutes at the most).

4. The malfunction code chart is given on the BR-61 page.

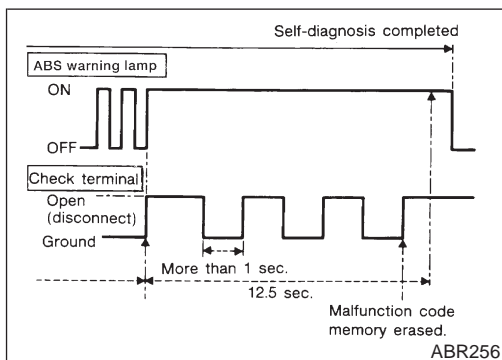
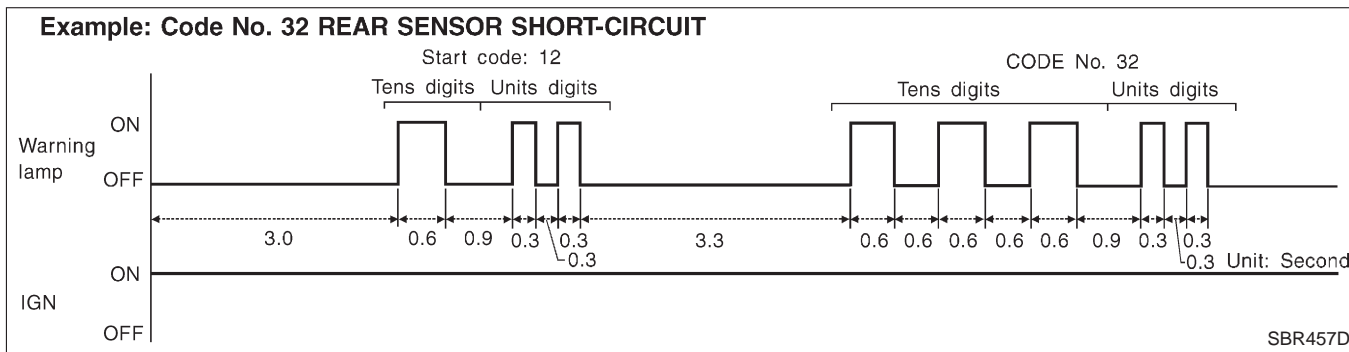

HOW TO ERASE SELF-DIAGNOSTIC RESULTS (MALFUNCTION CODES)

NFBR0091S04

1. Disconnect the check terminal from ground (ABS warning lamp will stay lit).
2. Within 12.5 seconds, ground the check terminal 3 times. Each terminal ground must last more than 1 second. The ABS warning lamp goes out after the erase operation has been completed.
3. Perform self-diagnosis again. Refer to BR-48. Only the start code should appear, no malfunction codes.

CONSULT-II

NFBR0092

CONSULT-II APPLICATION TO ABS

NFBR0092S01

ITEM	SELF-DIAGNOSTIC RESULTS	DATA MONITOR	ACTIVE TEST
Front right wheel sensor	X	X	—
Front left wheel sensor	X	X	—
Rear right wheel sensor	X	X	—
Rear left wheel sensor	X	X	—
Stop lamp switch	—	X	—
Front right inlet solenoid valve	X	X	X
Front right outlet solenoid valve	X	X	X
Front left inlet solenoid valve	X	X	X
Front left outlet solenoid valve	X	X	X
Rear right inlet solenoid valve	X	X	X
Rear right outlet solenoid valve	X	X	X
Rear left inlet solenoid valve	X	X	X
Rear left outlet solenoid valve	X	X	X
Actuator solenoid valve relay	X	X	—
Actuator motor relay (ABS MOTOR is shown on the ACTIVE TEST screen.)	X	X	X
ABS warning lamp	—	X	—
Battery voltage	X	X	—
Control unit	X	—	—

X: Applicable

—: Not applicable

ECU (ABS CONTROL UNIT) PART NUMBER MODE

NFBR0092S02

Ignore the ECU part number displayed in the ECU PART NUMBER MODE. Refer to parts catalog to order the ABS actuator and electric unit.

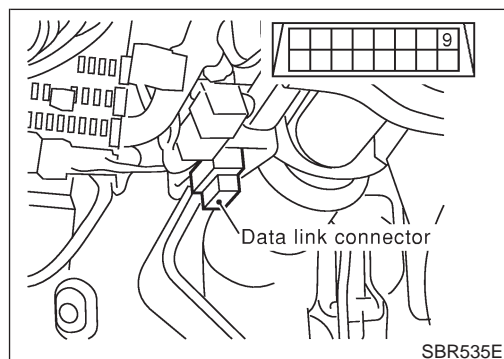

CONSULT-II Inspection Procedure SELF-DIAGNOSIS PROCEDURE

NFBR0093

NFBR0093S01

1. Turn ignition switch OFF.
2. Connect CONSULT-II to Data Link Connector.
3. Start engine.
4. Drive vehicle over 30 km/h (19 MPH) for at least one minute.

ON BOARD DIAGNOSTIC SYSTEM DESCRIPTION

ABS

CONSULT-II Inspection Procedure (Cont'd)

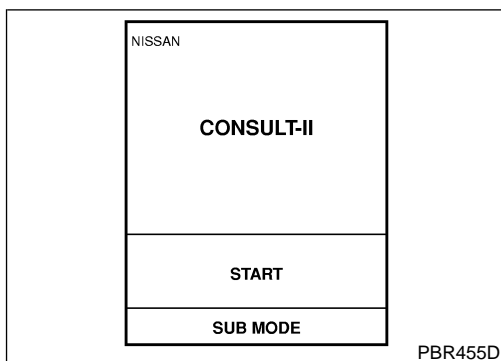

5. Stop vehicle with engine running and touch "START" on CONSULT-II screen.

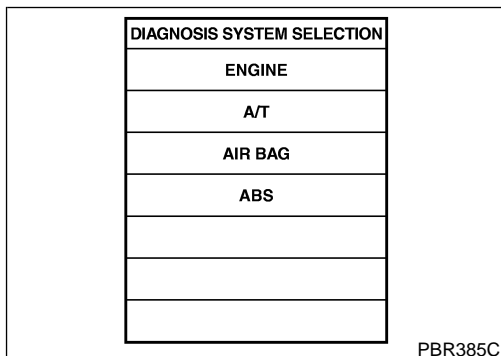

6. Touch "ABS".

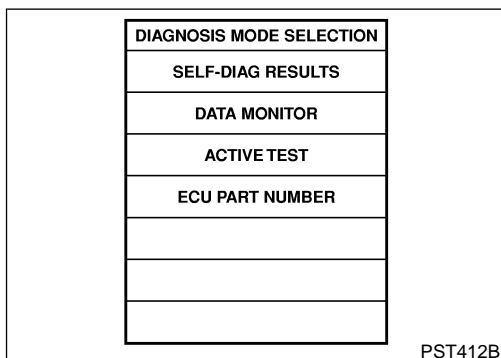

7. Touch "SELF-DIAG RESULTS".

- The screen shows the detected malfunction and how many times the ignition switch has been turned since the malfunction.

8. Make the necessary repairs following the diagnostic procedures.

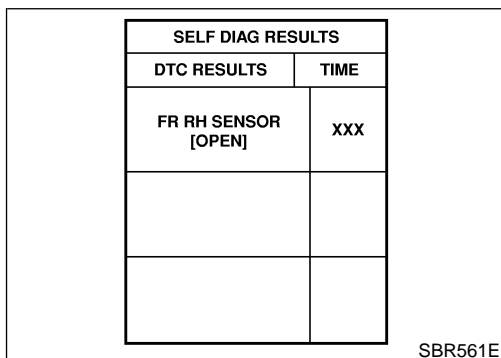

9. After the malfunctions are repaired, erase the self-diagnostic results stored in the control unit by touching "ERASE".

10. Check ABS warning lamp for deactivation after driving vehicle over 30 km/h (19 MPH) for at least one minute.

NOTE:
"SELF-DIAG RESULTS" screen shows the detected malfunction and how many times the ignition switch has been turned since the malfunction.

ON BOARD DIAGNOSTIC SYSTEM DESCRIPTION

ABS

CONSULT-II Inspection Procedure (Cont'd)

SELF-DIAGNOSTIC RESULTS MODE

=NFBR0093S02

Diagnostic item	Diagnostic item is detected when ...	Reference Page
FR RH SENSOR [OPEN]*1	<ul style="list-style-type: none"> ● Circuit for front right wheel sensor is open. (An abnormally high input voltage is entered.) 	BR-62
FR LH SENSOR [OPEN]*1	<ul style="list-style-type: none"> ● Circuit for front left wheel sensor is open. (An abnormally high input voltage is entered.) 	BR-62
RR RH SENSOR [OPEN]*1	<ul style="list-style-type: none"> ● Circuit for rear right sensor is open. (An abnormally high input voltage is entered.) 	BR-62
RR LH SENSOR [OPEN]*1	<ul style="list-style-type: none"> ● Circuit for rear left sensor is open. (An abnormally high input voltage is entered.) 	BR-62
FR RH SENSOR [SHORT]*1	<ul style="list-style-type: none"> ● Circuit for front right wheel sensor is shorted. (An abnormally low input voltage is entered.) 	BR-62
FR LH SENSOR [SHORT]*1	<ul style="list-style-type: none"> ● Circuit for front left wheel sensor is shorted. (An abnormally low input voltage is entered.) 	BR-62
RR RH SENSOR [SHORT]*1	<ul style="list-style-type: none"> ● Circuit for rear right sensor is shorted. (An abnormally low input voltage is entered.) 	BR-62
RR LH SENSOR [SHORT]*1	<ul style="list-style-type: none"> ● Circuit for rear left sensor is shorted. (An abnormally low input voltage is entered.) 	BR-62
ABS SENSOR [ABNORMAL SIGNAL]	<ul style="list-style-type: none"> ● Teeth damage on sensor rotor or improper installation of wheel sensor. (Abnormal wheel sensor signal is entered.) 	BR-62
FR RH IN ABS SOL [OPEN]	<ul style="list-style-type: none"> ● Circuit for front right inlet solenoid valve is open. (An abnormally low output voltage is entered.) 	BR-65
FR LH IN ABS SOL [OPEN]	<ul style="list-style-type: none"> ● Circuit for front left inlet solenoid valve is open. (An abnormally low output voltage is entered.) 	BR-65
RR RH IN ABS SOL [OPEN]	<ul style="list-style-type: none"> ● Circuit for rear right inlet solenoid valve is open. (An abnormally low output voltage is entered.) 	BR-65
RR LH IN ABS SOL [OPEN]	<ul style="list-style-type: none"> ● Circuit for rear left inlet solenoid valve is open. (An abnormally low output voltage is entered.) 	BR-65
FR RH IN ABS SOL [SHORT]	<ul style="list-style-type: none"> ● Circuit for front right inlet solenoid valve is shorted. (An abnormally high output voltage is entered.) 	BR-65
FR LH IN ABS SOL [SHORT]	<ul style="list-style-type: none"> ● Circuit for front left inlet solenoid valve is shorted. (An abnormally high output voltage is entered.) 	BR-65
RR RH IN ABS SOL [SHORT]	<ul style="list-style-type: none"> ● Circuit for rear right inlet solenoid valve is shorted. (An abnormally high output voltage is entered.) 	BR-65
RR LH IN ABS SOL [SHORT]	<ul style="list-style-type: none"> ● Circuit for rear left inlet solenoid valve is shorted. (An abnormally high output voltage is entered.) 	BR-65
FR RH OUT ABS SOL [OPEN]	<ul style="list-style-type: none"> ● Circuit for front right outlet solenoid valve is open. (An abnormally low output voltage is entered.) 	BR-65
FR LH OUT ABS SOL [OPEN]	<ul style="list-style-type: none"> ● Circuit for front left outlet solenoid valve is open. (An abnormally low output voltage is entered.) 	BR-65
RR RH OUT ABS SOL [OPEN]	<ul style="list-style-type: none"> ● Circuit for rear right outlet solenoid valve is open. (An abnormally low output voltage is entered.) 	BR-65
RR LH OUT ABS SOL [OPEN]	<ul style="list-style-type: none"> ● Circuit for rear left outlet solenoid valve is open. (An abnormally low output voltage is entered.) 	BR-65
FR RH OUT ABS SOL [SHORT]	<ul style="list-style-type: none"> ● Circuit for front right outlet solenoid valve is shorted. (An abnormally high output voltage is entered.) 	BR-65
FR LH OUT ABS SOL [SHORT]	<ul style="list-style-type: none"> ● Circuit for front left outlet solenoid valve is shorted. (An abnormally high output voltage is entered.) 	BR-65

ON BOARD DIAGNOSTIC SYSTEM DESCRIPTION

ABS

CONSULT-II Inspection Procedure (Cont'd)

Diagnostic item	Diagnostic item is detected when ...	Reference Page
RR RH OUT ABS SOL [SHORT]	<ul style="list-style-type: none"> ● Circuit for rear right outlet solenoid valve is shorted. (An abnormally high output voltage is entered.) 	BR-65
RR LH OUT ABS SOL [SHORT]	<ul style="list-style-type: none"> ● Circuit for rear left outlet solenoid valve is shorted. (An abnormally high output voltage is entered.) 	BR-65
ABS ACTUATOR RELAY [ABNORMAL]	<ul style="list-style-type: none"> ● Actuator solenoid valve relay is ON, even control unit sends off signal. ● Actuator solenoid valve relay is OFF, even control unit sends on signal. 	BR-65
ABS MOTOR RELAY [ABNORMAL]	<ul style="list-style-type: none"> ● Circuit for actuator motor is open or shorted. ● Actuator motor relay is stuck. 	BR-68
BATTERY VOLT [ABNORMAL]	<ul style="list-style-type: none"> ● Power source voltage supplied to ABS control unit is abnormally low. 	BR-70
CONTROL UNIT	<ul style="list-style-type: none"> ● Function of calculation in ABS control unit has failed. 	BR-72

*1: Be sure to confirm the ABS warning lamp illuminates when the ignition switch is turned ON after repairing the shorted sensor circuit, but the lamp goes out when driving the vehicle over 30 km/h (19 MPH) for one minute in accordance with SELF-DIAGNOSIS PROCEDURE.

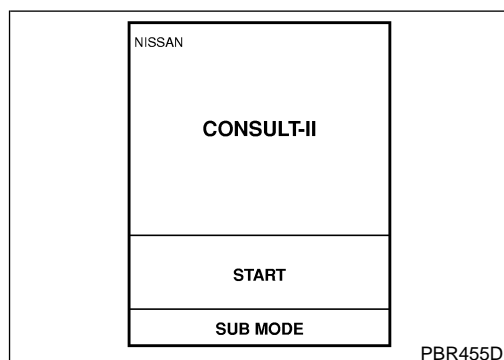

DATA MONITOR PROCEDURE

NFBR0093S03

1. Turn ignition switch OFF.
2. Connect CONSULT-II to data link connector.
3. Turn ignition switch ON.
4. Touch "START" on CONSULT-II screen.

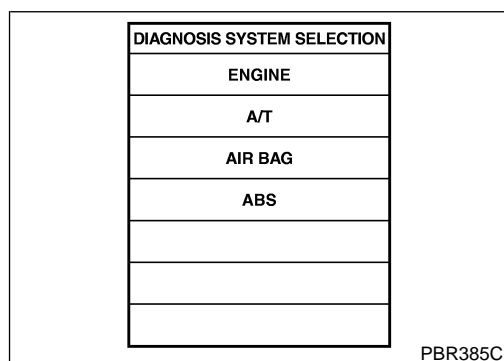

5. Touch "ABS".

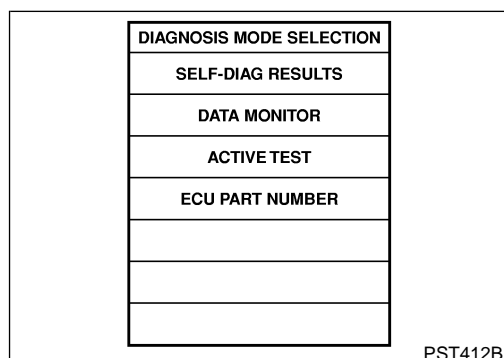

6. Touch "DATA MONITOR".
7. Touch "SETTING" on "SELECT MONITOR ITEM" screen.
8. Touch "LONG TIME" on "SET RECORDING COND" screen.
9. Touch "START" on "SELECT MONITOR ITEM".

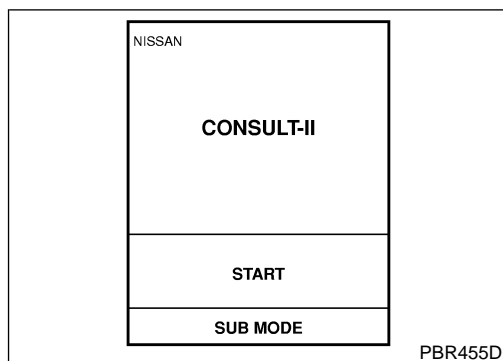

ACTIVE TEST PROCEDURE

NFBR0093S04

- When conducting Active test, vehicle must be stationary.
 - When ABS warning lamp stays on, never conduct Active test.
1. Turn ignition switch OFF.
 2. Connect CONSULT-II to Data Link Connector.
 3. Start engine.
 4. Touch "START" on CONSULT-II screen.

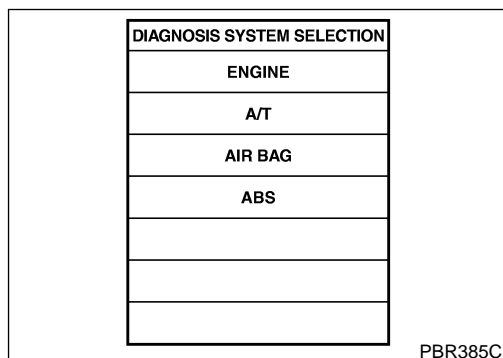

5. Touch "ABS".

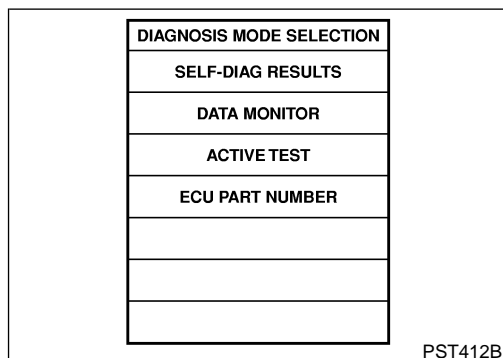

6. Touch "ACTIVE TEST".

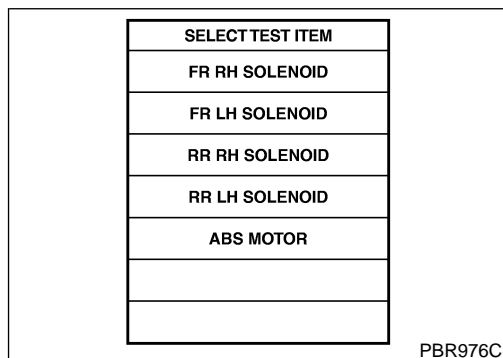

7. Select active test item by touching screen.

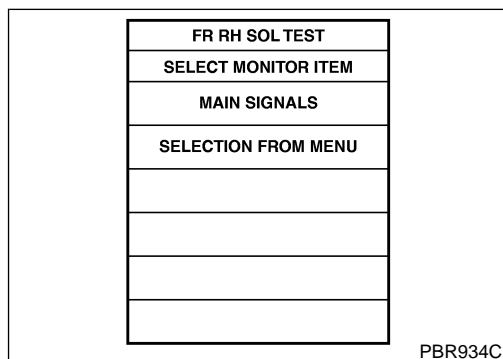

8. Touch "START".
9. Carry out the active test by touching screen key.

ON BOARD DIAGNOSTIC SYSTEM DESCRIPTION

ABS

CONSULT-II Inspection Procedure (Cont'd)

DATA MONITOR MODE

NFBR0093S05

MONITOR ITEM	CONDITION	SPECIFICATION
FR RH SENSOR FR LH SENSOR RR RH SENSOR RR LH SENSOR	Drive vehicle. (Each wheel is rotating.)	Displays computed vehicle speed from wheel sensor signal. Almost the same speed as speedometer.
STOP LAMP SW	Turn ignition switch ON and depress brake pedal.	Depress the pedal: ON Release the pedal: OFF
FR RH IN SOL FR RH OUT SOL FR LH IN SOL FR LH OUT SOL RR IN SOL RR OUT SOL RL IN SOL RL OUT SOL	Ignition switch is turned ON or engine is running.	Operating conditions for each solenoid valve are indicated. ABS is not operating: OFF
ACTUATOR RLY	Ignition switch is turned ON or engine is running.	Displays ON/OFF condition of ABS actuator relay. When turning ignition switch ON, ABS actuator relay is operated.
MOTOR RELAY		ABS is not operating: OFF ABS is operating: ON
WARNING LAMP		Warning lamp is turned on: ON Warning lamp is turned off: OFF
BATTERY VOLT		Power supply voltage for control unit

ACTIVE TEST MODE

NFBR0093S06

TEST ITEM	CONDITION	JUDGEMENT		
FR RH SOLENOID FR LH SOLENOID RR RH SOLENOID RR LH SOLENOID	Ignition switch is turned ON.	Brake fluid pressure control operation		
			IN SOL	OUT SOL
		UP (Increase):	OFF	OFF
		KEEP (Hold):	ON	OFF
		DOWN (Decrease):	ON	ON
ABS MOTOR		ABS actuator motor ON: Motor runs OFF: Motor stops		

NOTE:

Active test will automatically stop ten seconds after the test starts. (TEST IS STOPPED monitor shows ON.)

How to Perform Trouble Diagnoses for Quick and Accurate Repair

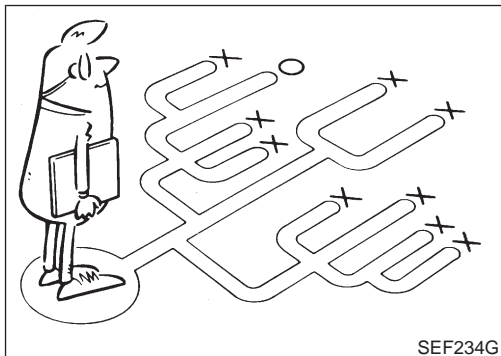
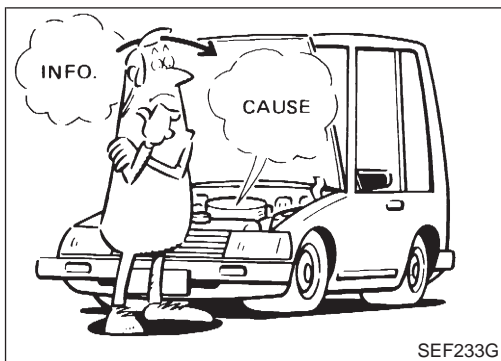

How to Perform Trouble Diagnoses for Quick and Accurate Repair

INTRODUCTION

NFBR0094

NFBR0094S01

The ABS system has an electronic control unit to control major functions. The control unit accepts input signals from sensors and instantly drives actuator. It is essential that both kinds of signals are proper and stable. It is also important to check for conventional problems: such as air leaks in the booster or lines, lack of brake fluid, or other problems with the brake system.

It is much more difficult to diagnose a problem that occurs intermittently rather than continuously. Most intermittent problems are caused by poor electric connections or faulty wiring. In this case, careful checking of suspicious circuits may help prevent the replacement of good parts.

A visual check only may not find the cause of the problems, so a road test should be performed.

Before undertaking actual checks, take just a few minutes to talk with a customer who approaches with a ABS complaint. The customer is a very good source of information on such problems; especially intermittent ones. Through the talks with the customer, find out what symptoms are present and under what conditions they occur.

Start your diagnosis by looking for "conventional" problems first. This is one of the best ways to troubleshoot brake problems on an ABS controlled vehicle. Also check related Service Bulletins for information.

Preliminary Check

NFBR0095

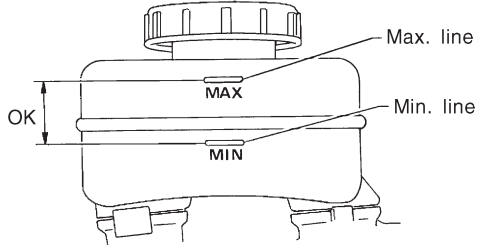
1	CHECK BRAKE FLUID LEVEL	
<p>Check brake fluid level in reservoir tank. Low fluid level may indicate brake pad wear or leakage from brake line.</p>		
		
SBR451D		
<p>Is brake fluid filled between MAX and MIN lines on reservoir tank and/or has brake fluid been contaminated?</p>		
Yes	▶	GO TO 2.
No	▶	Repair. GO TO 2.

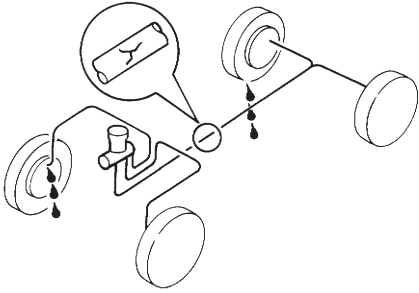
2	CHECK BRAKE LINE	
<p>Check brake line for leakage.</p>		
		
SBR389C		
<p>Is leakage present at or around brake lines, tubes or hoses or are any of these parts cracked or damaged?</p>		
Yes	▶	GO TO 3.
No	▶	Repair. GO TO 3.

Preliminary Check (Cont'd)

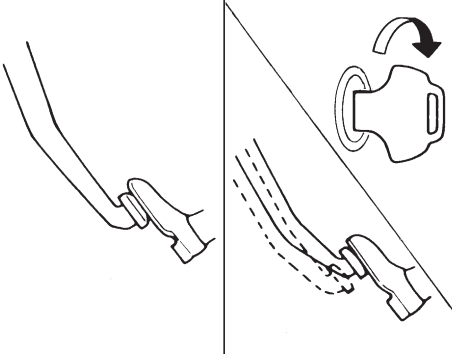
3	CHECK BRAKE BOOSTER OPERATION	
<p>Check brake booster for operation and air tightness. Refer to BR-22.</p> <div style="text-align: center;">  </div> <p style="text-align: right;">SBR058C</p>		
Is brake booster airtight and functioning properly?		
Yes	▶	GO TO 4.
No	▶	Replace. GO TO 4.

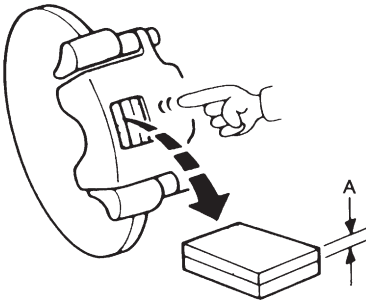
4	CHECK BRAKE PAD AND ROTOR	
<p>Check brake pad and rotor. Refer to BR-25, BR-27, BR-29, BR-33.</p> <div style="text-align: center;">  </div> <p style="text-align: right;">SBR059C</p>		
Are brake pads and rotors functioning properly?		
Yes	▶	GO TO 5.
No	▶	Replace.

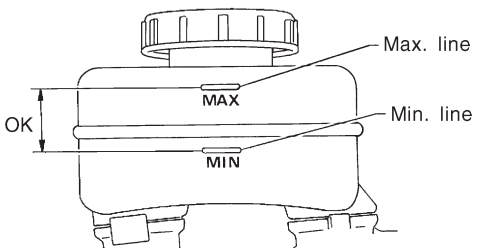
5	RECHECK BRAKE FLUID LEVEL	
Check brake fluid level in reservoir tank again.		
		
SBR451D		
Is brake fluid filled between MAX and MIN lines on reservoir tank and/or has brake fluid been contaminated?		
Yes	▶	GO TO 6.
No	▶	Fill up brake fluid.

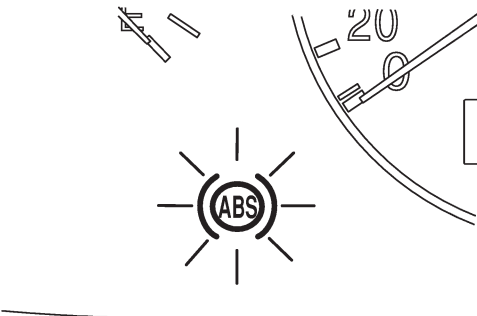
6	CHECK WARNING LAMP ACTIVATION	
Check warning lamp activation.		
		
SBR588E		
Does warning lamp turn on when ignition switch is turned "ON"?		
Yes	▶	GO TO 7.
No	▶	Check fuse, warning lamp bulb and warning lamp circuit.

7	CHECK WARNING LAMP DEACTIVATION	
Check warning lamp for deactivation after engine is started.		
Does warning lamp turn off when engine is started?		
Yes	▶	GO TO 8.
No	▶	Go to Self-diagnosis. Refer to BR-48, 50.

8	DRIVE VEHICLE	
Drive vehicle at speeds over 30 km/h (19 MPH) for at least one minute.		
Does warning lamp remain off after vehicle has been driven at 30 km/h (19 MPH) for at least one minute?		
Yes	▶	END
No	▶	Go to Self-diagnosis. Refer to BR-48, 50.

Ground Circuit Check

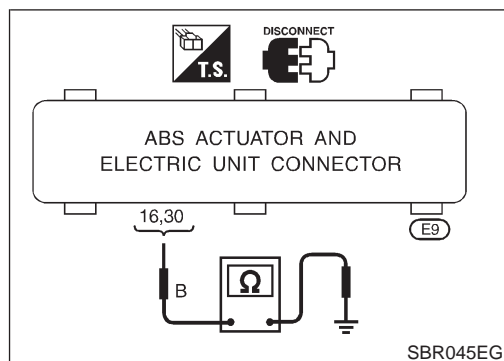

Ground Circuit Check

ABS ACTUATOR AND ELECTRIC UNIT GROUND

NFBR0096

NFBR0096S04

- Check continuity between ABS actuator and electric unit connector terminals and ground.

Continuity should exist.

TROUBLE DIAGNOSIS — GENERAL DESCRIPTION

ABS

Malfunction Code/Symptom Chart

Malfunction Code/Symptom Chart

NFB0097

Code No. (No. of LED flashes)	Malfunctioning part	Reference page
12	Self-diagnosis could not detect any malfunctions.	—
18	Sensor rotor	BR-62
21	Front right sensor (open-circuit)	BR-62
22	Front right sensor (short-circuit)	BR-62
25	Front left sensor (open-circuit)	BR-62
26	Front left sensor (short-circuit)	BR-62
31	Rear right sensor (open-circuit)	BR-62
32	Rear right sensor (short-circuit)	BR-62
35	Rear left sensor (open-circuit)	BR-62
36	Rear left sensor (short-circuit)	BR-62
41	Actuator front right outlet solenoid valve	BR-65
42	Actuator front right inlet solenoid valve	BR-65
45	Actuator front left outlet solenoid valve	BR-65
46	Actuator front left inlet solenoid valve	BR-65
51	Actuator rear right outlet solenoid valve	BR-65
52	Actuator rear right inlet solenoid valve	BR-65
55	Actuator rear left outlet solenoid valve	BR-65
56	Actuator rear left inlet solenoid valve	BR-65
57*	Power supply (Low voltage)	BR-70
61	Actuator motor or motor relay	BR-68
63	Solenoid valve relay	BR-65
71	Control unit	BR-72
ABS warning lamp stays on when ignition switch is turned on.	Control unit power supply circuit Warning lamp bulb circuit Control unit or control unit connector Solenoid valve relay stuck Power supply for solenoid valve relay coil	BR-79
ABS warning lamp stays on, during self-diagnosis.	Control unit	—
ABS warning lamp does not come on when ignition switch is turned on.	Fuse, warning lamp bulb or warning lamp circuit Control unit	BR-77
ABS warning lamp does not come on during self-diagnosis.	Control unit	—
Pedal vibration and noise	—	BR-76
Long stopping distance	—	BR-74
Unexpected pedal action	—	BR-73
ABS does not work.	—	BR-75
ABS works frequently.	—	BR-73

*: Under voltage that is too low, the control unit disable the ABS. It does not set the ABS in fail-safe condition. Instead, the ABS becomes a conventional brake system. After the power supply has resumed, the warning lamp goes off, making it possible for the ABS to be re-engaged.

Wheel Sensor or Rotor

DIAGNOSTIC PROCEDURE

Malfunction code No. 21, 22, 25, 26, 31, 32, 35, 36 or 18

NFBR0098

NFBR0098S01

NOTE:

Wheel position should be identified by code No. except code No. 18 (sensor rotor).

1	INSPECTION START
<p>Wheel sensor inspection</p> <div style="text-align: center;"> <p style="font-size: small;">Front RH Front LH Rear RH Rear LH</p> <p style="font-size: small;">25 10 23 8 29 14 27 12</p> <p style="font-size: small;">ABS actuator and electric unit</p> <p style="font-size: x-small;">Wheel sensor connectors (sensor side)</p> <p style="font-size: x-small;">Front RH Front LH Rear RH Rear LH</p> <p style="font-size: x-small;">(1) (2) (E76) (1) (2) (E10) (1) (2) (B16) LHD (1) (2) (B28) LHD</p> <p style="font-size: x-small;">(1) (2) (B150) RHD (1) (2) (B151) RHD</p> </div>	
<small>SBR590E</small>	
▶	GO TO 2.

2	CHECK CONNECTOR	
<p>1. Disconnect connectors from control unit and wheel sensor of malfunction code No. Check terminals for damage or loose connections. Then reconnect connectors.</p> <p>2. Carry out self-diagnosis again.</p> <p style="text-align: center;">Does warning lamp activate again?</p>		
Yes	▶	GO TO 3.
No	▶	INSPECTION END

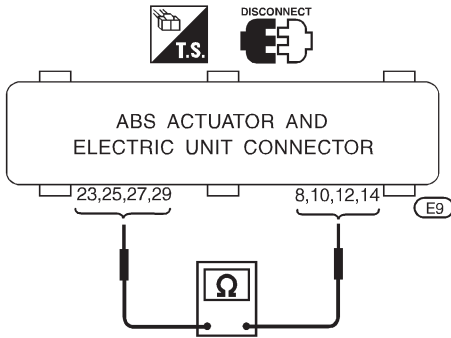
3	CHECK WHEEL SENSOR CIRCUIT
<p>1. Disconnect control unit connector. 2. Check resistance between control unit connector terminals. Code No. 21 or 22 (Front RH wheel) Terminals 10 and 25 Code No. 25 or 26 (Front LH wheel) Terminals 8 and 23 Code No. 31 or 32 (Rear RH wheel) Terminals 14 and 29 Code No. 35 or 36 (Rear LH wheel) Terminals 12 and 27</p> <p style="color: blue;">Resistance: 0.8 - 1.85 kΩ</p> <div style="text-align: center;">  </div> <p style="text-align: center;">Is resistance 1.44 - 1.76 kΩ?</p>	
Yes	▶ GO TO 5.
No	▶ GO TO 4.

SBR477EB

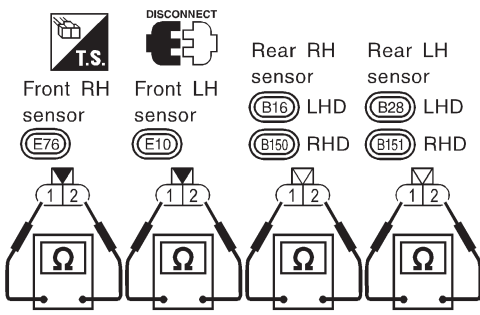
4	CHECK WHEEL SENSOR
<p>Check resistance of each sensor. (See NOTE.) Resistance: 0.8 - 1.85 kΩ</p> <div style="text-align: center;">  </div> <p style="text-align: center;">Is resistance 1.44 - 1.76 kΩ?</p>	
Yes	▶ Repair harness and connectors between control unit connector and wheel sensor connector.
No	▶ Replace wheel sensor.

SBR478EB

5	CHECK TIRE
<p>Check for inflation pressure, wear and size of each tire.</p> <p style="text-align: center;">Are tire pressure and size correct and is tire wear within specifications?</p>	
Yes	▶ GO TO 6.
No	▶ Adjust tire pressure or replace tire(s).

TROUBLE DIAGNOSES FOR SELF-DIAGNOSTIC ITEMS

ABS

Wheel Sensor or Rotor (Cont'd)

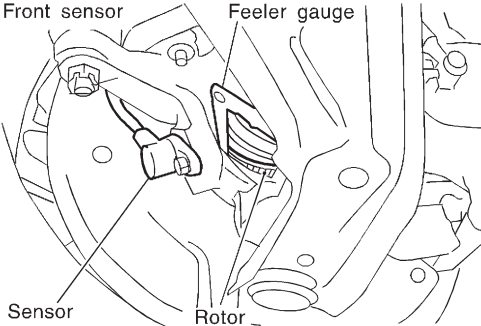
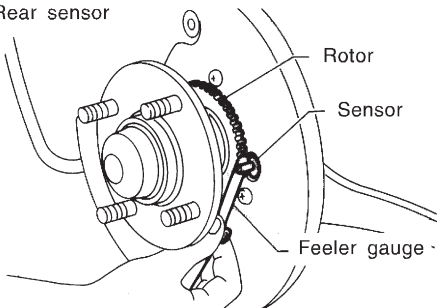
6	CHECK WHEEL BEARING	
<p>Check wheel bearing axial end play. Check clearance between sensor and rotor.</p> <p>Clearance: Front 0.273 - 0.925 mm (0.0107 - 0.0364 in) Rear 0.385 - 0.973 mm (0.0152 - 0.0383 in)</p>		
 <p style="text-align: right;">SBR333E</p>		
 <p style="text-align: right;">SBR069CA</p>		
Is axial end play and clearance within specifications?		
Yes	▶	GO TO 7.
No	▶	Clean sensor fixing portion, or replace sensor.

7	CHECK SENSOR ROTOR	
Check sensor rotor for teeth damage.		
Is sensor rotor free from damage?		
Yes	▶	Check control unit pin terminals for damage or the connection of control unit harness connector. Reconnect control unit harness connector. Then retest.
No	▶	Replace sensor rotor.

ABS Actuator Solenoid Valve or Solenoid Valve Relay

DIAGNOSTIC PROCEDURE

=NFBR0100

NFBR0100S01

Malfunction code No. 41, 45, 55, 42, 46, 56, 63, 51, 52

1	INSPECTION START
Solenoid valve relay inspection	
<p style="text-align: right;">SBR591E</p>	
▶ GO TO 2.	

2	CHECK SOLENOID VALVE POWER SUPPLY CIRCUIT
Check 40A [E] for LHD or [D] for RHD fusible link (ABS ACTR) for ABS solenoid valve relay. For fusible link layout, refer to POWER SUPPLY ROUTING in EL section.	
Is fusible link OK?	
Yes	▶ GO TO 3.
No	▶ GO TO 7.

3	CHECK FUSE
Check 10A fuse No. 31. For fuse layout, refer to "POWER SUPPLY ROUTING" in EL section.	
Is fuse OK?	
Yes	▶ GO TO 4.
No	▶ GO TO 9.

TROUBLE DIAGNOSES FOR SELF-DIAGNOSTIC ITEMS

ABS

ABS Actuator Solenoid Valve or Solenoid Valve Relay (Cont'd)

4	CHECK CONNECTOR	
1. Disconnect connectors from control unit and ABS actuator. Check terminals for damage or loose connection. Then reconnect connectors. 2. Carry out self-diagnosis again.		
Does warning lamp activate again?		
Yes	▶	GO TO 5.
No	▶	INSPECTION END

5	CHECK GROUND CIRCUIT	
Refer to ABS ACTUATOR AND ELECTRIC UNIT in Ground Circuit Check, BR-60.		
Is ground circuit OK?		
Yes	▶	GO TO 6.
No	▶	Repair harness and connectors.

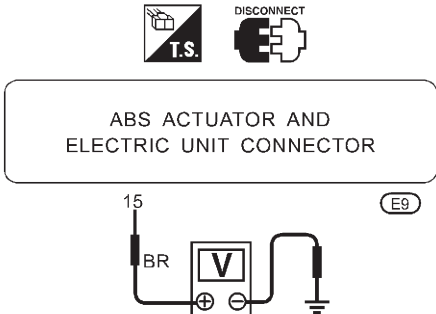
6	CHECK SOLENOID VALVE POWER SUPPLY CIRCUIT	
1. Disconnect ABS actuator and electric unit connector. 2. Check voltage between ABS actuator and electric unit connector terminal 15 and ground.		
		
SBR592E		
Does battery voltage exist?		
Yes	▶	Replace ABS actuator and electric unit.
No	▶	Check the following. <ul style="list-style-type: none"> ● Harness connector E9 ● Harness for open or short between ABS actuator and electric unit and fusible link If NG, repair harness or connectors.

7	REPLACE FUSIBLE LINK	
Replace fusible link.		
Does the fusible link blow out when ignition switch is turned "ON"?		
Yes	▶	GO TO 8.
No	▶	INSPECTION END

TROUBLE DIAGNOSES FOR SELF-DIAGNOSTIC ITEMS

ABS

ABS Actuator Solenoid Valve or Solenoid Valve Relay (Cont'd)

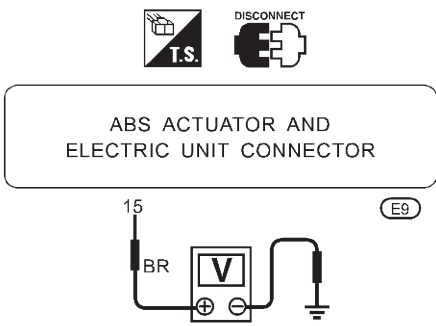
8	CHECK RELAY UNIT POWER SUPPLY CIRCUIT	
<p>1. Disconnect ABS actuator and electric unit connector. 2. Check continuity between ABS actuator and electric unit connector terminal 15 and ground.</p> <div style="text-align: center;">  </div> <p style="text-align: right;">SBR592E</p>		
Does continuity exist?		
Yes	▶	Replace ABS actuator and electric unit.
No	▶	Check the following. <ul style="list-style-type: none"> ● Harness connector E9 ● Harness for open or short between ABS actuator and electric unit and fusible link If NG, repair harness or connectors.

9	REPLACE FUSE	
Replace fuse.		
Does the fuse blow out when ignition switch is turned "ON"?		
Yes	▶	Check the following. <ul style="list-style-type: none"> ● Harness connector E9 ● Harness for open or short between ABS actuator and electric unit and fuse If NG, repair harness or connectors.
No	▶	INSPECTION END

Motor Relay or Motor DIAGNOSTIC PROCEDURE

Malfunction code No. 61

=NFBR0101

NFBR0101S01

1	INSPECTION START																														
<p>ABS motor relay inspection</p> <div style="text-align: center; margin: 10px 0;"> </div> <p style="margin-left: 20px;"> ABS actuator and electric unit connector (E9) <table border="1" style="display: inline-table; border-collapse: collapse; text-align: center;"> <tr> <td>16</td><td>17</td><td>18</td><td>19</td><td>20</td><td>21</td><td>22</td><td>23</td><td>24</td><td>25</td><td>26</td><td>27</td><td>28</td><td>29</td><td>30</td> </tr> <tr> <td>1</td><td>2</td><td>3</td><td>4</td><td>5</td><td>6</td><td>7</td><td>8</td><td>9</td><td>10</td><td>11</td><td>12</td><td>13</td><td>14</td><td>15</td> </tr> </table> </p>		16	17	18	19	20	21	22	23	24	25	26	27	28	29	30	1	2	3	4	5	6	7	8	9	10	11	12	13	14	15
16	17	18	19	20	21	22	23	24	25	26	27	28	29	30																	
1	2	3	4	5	6	7	8	9	10	11	12	13	14	15																	
SBR593E																															
▶ GO TO 2.																															

2	CHECK MOTOR POWER SUPPLY CIRCUIT
<p>Check 40A [D] LHD or [E] RHD fusible link (ABS MTR) for ABS motor relay. For fusible link layout, refer to POWER SUPPLY ROUTING in EL section.</p> <p style="text-align: center;">Is fusible link OK?</p>	
Yes	▶ GO TO 3.
No	▶ GO TO 6.

3	CHECK CONNECTOR
<p>1. Disconnect ABS actuator and electric unit connector. Check terminals for damage or loose connection. Then reconnect connectors.</p> <p>2. Carry out self-diagnosis again.</p> <p style="text-align: center;">Does warning lamp activate again?</p>	
Yes	▶ GO TO 4.
No	▶ INSPECTION END

TROUBLE DIAGNOSES FOR SELF-DIAGNOSTIC ITEMS

ABS

Motor Relay or Motor (Cont'd)

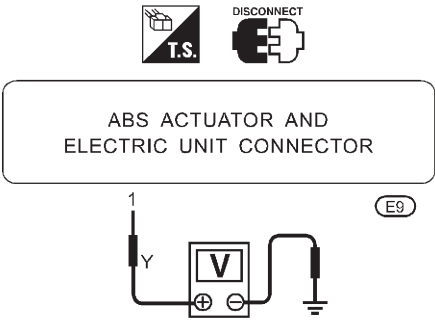
4	CHECK MOTOR RELAY POWER SUPPLY CIRCUIT	
<p>1. Disconnect ABS actuator and electric unit connector. 2. Check voltage between ABS actuator and electric unit connector terminal 1 and ground.</p> <div style="text-align: center;">  </div> <p style="text-align: right;">SBR594E</p>		
Does battery voltage exist?		
Yes	▶	GO TO 5.
No	▶	Check the following. <ul style="list-style-type: none"> ● Harness connector E9 ● Harness for open or short between ABS actuator and electric unit and fusible link If NG, repair harness or connectors.

5	CHECK ABS ACTUATOR AND ELECTRIC UNIT GROUND CIRCUIT	
<p>Refer to ABS ACTUATOR AND ELECTRIC UNIT GROUND in Ground Circuit Check, BR-60.</p> <p style="text-align: center;">Is ground circuit OK?</p>		
Yes	▶	Replace ABS actuator and electric unit.
No	▶	Check the following. <ul style="list-style-type: none"> ● Harness connector E9 ● Harness for open or short between ABS actuator and electric unit and ground If NG, repair harness or connectors.

6	REPLACE FUSIBLE LINK	
<p>Replace fusible link.</p> <p style="text-align: center;">Does the fusible link blow out when ignition switch is turned "ON"?</p>		
Yes	▶	GO TO 7.
No	▶	INSPECTION END

TROUBLE DIAGNOSES FOR SELF-DIAGNOSTIC ITEMS

ABS

Motor Relay or Motor (Cont'd)

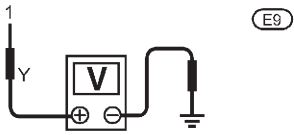
7	CHECK ABS ACTUATOR MOTOR POWER SUPPLY CIRCUIT	
<p>1. Disconnect battery cable and ABS actuator and electric unit connector. 2. Check continuity between ABS actuator and electric unit connector terminal 1 and ground.</p> <div style="text-align: center;">  <div style="border: 1px solid black; border-radius: 10px; padding: 5px; margin: 10px auto; width: fit-content;"> ABS ACTUATOR AND ELECTRIC UNIT CONNECTOR </div>  </div> <p style="text-align: right;">SBR594E</p> <p style="text-align: center;">Does continuity exist?</p>		
Yes	▶	Check ABS actuator and electric unit pin terminals for damage or the connection of ABS actuator and electric unit harness connector. Reconnect ABS actuator and electric unit harness connector. Then retest.
No	▶	<p>Check the following.</p> <ul style="list-style-type: none"> ● Harness connector E9 ● Harness for open or short between ABS actuator and electric unit and fusible link If NG, repair harness or connectors.

Low Voltage DIAGNOSTIC PROCEDURE Malfunction code No. 57

NFBR0102

NFBR0102S01

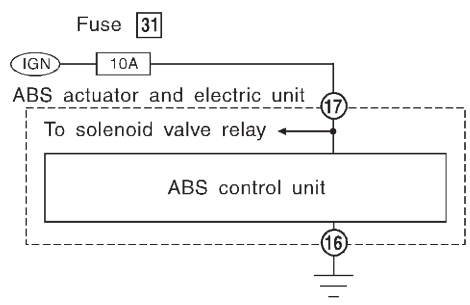
1	INSPECTION START	
<p>ABS actuator and electric unit power supply and ground circuit inspection</p> <div style="text-align: center;">  </div> <p style="text-align: right;">SBR595E</p>		
▶		GO TO 2.

2	CHECK CONNECTOR	
1. Disconnect ABS actuator and electric unit connector. Check terminals for damage or loose connections. Then reconnect connector. 2. Carry out self-diagnosis again.		
Does warning lamp activate again?		
Yes	▶	GO TO 3.
No	▶	INSPECTION END

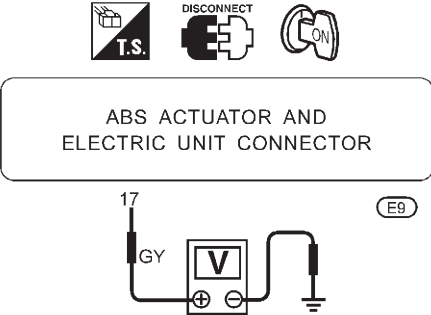
3	CHECK ABS ACTUATOR AND ELECTRIC UNIT POWER SUPPLY CIRCUIT	
1. Disconnect ABS actuator and electric unit connector. 2. Check voltage between ABS actuator and electric unit connector terminal 17 and ground.		
		
Does battery voltage exist when ignition switch is turned ON?		
Yes	▶	GO TO 4.
No	▶	GO TO 5.

SBR596E

4	CHECK ABS ACTUATOR AND ELECTRIC UNIT GROUND	
Refer to ABS ACTUATOR AND ELECTRIC UNIT GROUND in Ground Circuit Check, BR-60.		
Is ground circuit OK?		
OK	▶	Check ABS actuator and electric unit pin terminals for damage or the connection of ABS actuator and electric unit harness connector. Reconnect ABS actuator and electric unit harness connector. Then retest.
NG	▶	Check the following. <ul style="list-style-type: none"> ● Harness connector E9 ● Harness for open or short between ABS actuator and electric unit and ground If NG, repair harness or connectors.

5	CHECK FUSE	
Check 10A fuse 31 (Engine control) for control unit. Refer to POWER SUPPLY ROUTING in EL section.		
Is fuse OK?		
Yes	▶	GO TO 6.
No	▶	Replace fuse.

TROUBLE DIAGNOSES FOR SELF-DIAGNOSTIC ITEMS

ABS

Low Voltage (Cont'd)

6	CHECK ABS ACTUATOR AND ELECTRIC UNIT POWER SUPPLY CIRCUIT	
Check continuity between battery and ABS actuator and electric unit connector terminal 17.		
Does continuity exist?		
Yes	▶	Check battery. Refer to BATTERY in EL section.
No	▶	Check the following. <ul style="list-style-type: none"> ● Harness connector E9 ● Harness for open or short between ABS actuator and electric unit and fuse If NG, repair harness or connectors.

Control Unit DIAGNOSTIC PROCEDURE Malfunction code No. 71

NFBR0103
NFBR0103S01

1	INSPECTION START	
ABS actuator and electric unit power supply and ground circuit inspection		
<p style="text-align: center; font-size: small;">SBR597E</p>		
▶		GO TO 2.

2	CHECK CONNECTOR	
1. Disconnect ABS actuator and electric unit connector. Check terminals for damage or loose connections. Then reconnect connectors. 2. Carry out self-diagnosis again.		
Does warning lamp activate again?		
Yes	▶	GO TO 3.
No	▶	INSPECTION END

3	CHECK ABS ACTUATOR AND ELECTRIC UNIT POWER SUPPLY CIRCUIT	
Check voltage. Refer to "3. CHECK ABS ACTUATOR AND ELECTRIC UNIT POWER SUPPLY CIRCUIT" in "Low Voltage", BR-70.		
Does battery voltage exist when ignition switch is turned ON?		
Yes	▶	GO TO 4.
No	▶	Repair.

4	CHECK WARNING LAMP INDICATION	
Does warning lamp indicate code No. 71 again?		
Yes	▶	Replace ABS actuator and electric unit.
No	▶	Inspect the system according to the code No.

TROUBLE DIAGNOSES FOR SYMPTOMS

ABS

1. ABS Works Frequently

1. ABS Works Frequently

NFBR0104

1	CHECK BRAKE FLUID PRESSURE	
Check brake fluid pressure distribution. Refer to dual proportioning valve inspection in "DUAL PROPORTIONING VALVE", BR-11.		
Is brake fluid pressure distribution normal?		
Yes	▶	GO TO 2.
No	▶	Perform Preliminary Check. Refer to BR-57.

2	CHECK WHEEL SENSOR	
1. Check wheel sensor connector for terminal damage or loose connections. 2. Perform wheel sensor mechanical check. Refer to "Wheel Sensor or Rotor", BR-62.		
Are wheel sensors functioning properly?		
Yes	▶	GO TO 3.
No	▶	Repair.

3	CHECK FRONT AXLE	
Check front and rear axles for excessive looseness. Refer to AX section, "Front Wheel Bearing", "ON-VEHICLE SERVICE" and "Rear Wheel Bearing", "ON-VEHICLE SERVICE".		
Is front axle installed properly?		
Yes	▶	Go to "3. CHECK WARNING LAMP INDICATION" in "2. Unexpected Pedal Action", BR-73.
No	▶	Repair.

2. Unexpected Pedal Action

NFBR0105

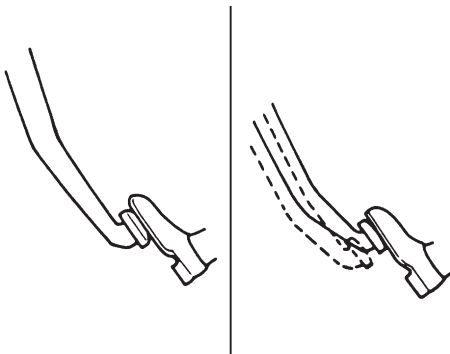
1	CHECK BRAKE PEDAL STROKE	
Check brake pedal stroke. Is stroke excessively large?		
		
SBR540A		
Yes	▶	Perform Preliminary Check. Refer to BR-57.
No	▶	GO TO 2.

TROUBLE DIAGNOSES FOR SYMPTOMS

ABS

2. Unexpected Pedal Action (Cont'd)

2	CHECK CONNECTOR AND PERFORMANCE	
1. Disconnect ABS actuator and electric unit connector. 2. Check whether brake is effective.		
OK or NG		
Yes	▶	GO TO 3.
No	▶	Perform Preliminary Check. Refer to BR-57.

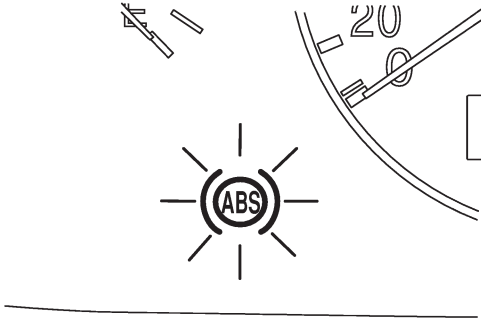
3	CHECK WARNING LAMP INDICATION	
Ensure warning lamp remains off while driving.		
		
Is warning lamp turned off?		
Yes	▶	GO TO 4.
No	▶	Carry out self-diagnosis. Refer to BR-48, BR-50.

SBR588E

4	CHECK WHEEL SENSOR	
1. Check wheel sensor connector for terminal damage or loose connection. 2. Perform wheel sensor mechanical check.		
Is wheel sensor mechanism OK?		
Yes	▶	Check ABS actuator and electric unit pin terminals for damage or the connection of ABS actuator and electric unit harness connector. Reconnect ABS actuator and electric unit harness connector. Then retest.
No	▶	Repair.

3. Long Stopping Distance

NFBR0106

1	CHECK CONNECTOR AND PERFORMANCE	
1. Cancel ABS by disconnecting ABS actuator and electric unit connector. 2. Check whether stopping distance is still long.		
OK or NG		
OK	▶	Perform Preliminary Check and air bleeding.
NG	▶	Go to "3. CHECK WARNING LAMP INDICATION" in "2. Unexpected Pedal Action", BR-73.

NOTE:

Stopping distance may be longer than vehicles without ABS when road condition is slippery.

4. ABS Does Not Work

NFBR0107

1	CHECK WARNING LAMP INDICATION
Does the ABS warning lamp activate?	
Yes	▶ Carry out self-diagnosis. Refer to BR-48, BR-50.
No	▶ Go to "3. CHECK WARNING LAMP INDICATION" in "2. Unexpected Pedal Action", BR-73.

NOTE:

ABS does not work when vehicle speed is under 10 km/h (6 MPH).

5. Pedal Vibration and Noise

=NFBR0108

1	INSPECTION START
Pedal vibration and noise inspection	
Brake pedal 	
SAT797A	
▶ GO TO 2.	

2	CHECK SYMPTOM
1. Apply brake. 2. Start engine.	
Does the symptom appear only when engine is started?	
Yes	▶ Carry out self-diagnosis. Refer to BR-48, BR-50.
No	▶ GO TO 3.

3	RECHECK SYMPTOM
Does the symptom appear when electrical equipment switches (such as headlamp) are operated?	
Yes	▶ GO TO 4.
No	▶ Go to "3. CHECK WARNING LAMP INDICATION" in "2. Unexpected Pedal Action", BR-73.

4	CHECK WHEEL SENSOR
Check wheel sensor shield ground. For location of shield ground, refer to wiring diagram and "HARNES LAYOUT" in EL section.	
Is wheel sensor shield grounded properly?	
Yes	▶ Check ABS actuator and electric unit pin terminals for damage or the connection of ABS actuator and electric unit harness connector. Reconnect ABS actuator and electric unit harness connector. Then retest.
No	▶ Repair.

NOTE:

ABS may operate and cause vibration under any of the following conditions.

- Applying brake gradually when shifting or operating clutch.
- Low friction (slippery) road.
- High speed cornering.
- Driving over bumps and pot holes.
- Engine speed is over 5,000 rpm with vehicle stopped.

TROUBLE DIAGNOSES FOR SYMPTOMS

ABS

6. ABS Warning Lamp Does Not Come On When Ignition Switch Is Turned On

6. ABS Warning Lamp Does Not Come On When Ignition Switch Is Turned On

=NFB0109

1	INSPECTION START
Warning lamp circuit inspection	
SBR598E	
▶	GO TO 2.

2	CHECK FUSE
Check 10A fuse No. 30 for warning lamp. For fuse layout, refer to "POWER SUPPLY ROUTING" in EL section.	
Is fuse OK?	
Yes	▶ GO TO 3.
No	▶ Replace fuse.

3	CHECK ABS CONTROL UNIT POWER SUPPLY CIRCUIT
<ol style="list-style-type: none"> 1. Install 10A fuse. 2. Remove solenoid valve relay. 3. Disconnect connectors from control unit and actuator. 4. Check voltage between control unit connector terminal 2 and ground after turning ignition switch "ON". 	
SBR599E	
Does battery voltage exist after turning ignition switch "ON"?	
Yes	▶ GO TO 5.
No	▶ GO TO 4.

TROUBLE DIAGNOSES FOR SYMPTOMS

ABS

6. ABS Warning Lamp Does Not Come On When Ignition Switch Is Turned On (Cont'd)

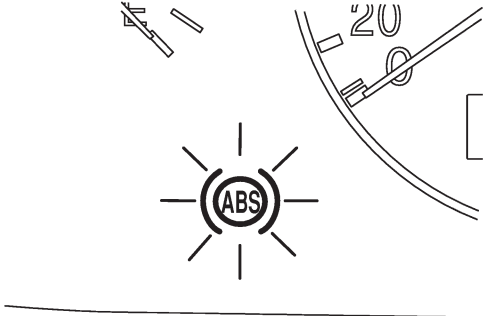
4	CHECK WARNING LAMP INDICATION	
Disconnect ABS actuator and electric unit connector.		
		
SBR588E		
Does the ABS warning lamp activate?		
Yes	▶	GO TO 6.
No	▶	GO TO 5.

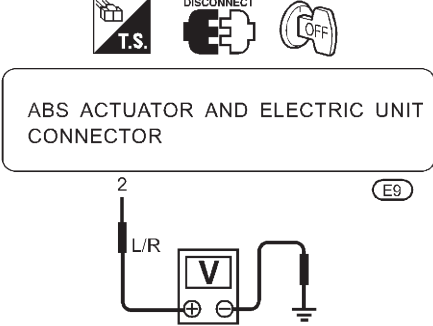
5	CHECK HARNESS FOR SHORT	
1. Disconnect ABS actuator and electric unit connector. 2. Check voltage between ABS actuator and electric unit connector terminal 2 and ground.		
		
SBR600E		
Does battery voltage exist?		
Yes	▶	Check combination meter. Refer to WARNING LAMPS in EL section.
No	▶	Repair harness and connectors between fuse and ABS actuator and electric unit connector terminal 2.

6	CHECK HARNESS CONNECTOR	
Check ABS actuator and electric unit pin terminals for damage or connection of ABS actuator and electric unit harness connector. Reconnect ABS actuator and electric unit harness connector. Then reset.		
OK	▶	INSPECTION END
NG	▶	Replace ABS actuator and electric unit.

7. ABS Warning Lamp Stays On When Ignition Switch Is Turned On

=NFBR0110

1	INSPECTION START
ABS control unit inspection	
SBR601E	
▶	GO TO 2.

2	CHECK WARNING LAMP
1. Disconnect ABS actuator and electric unit connector. 2. Connect suitable wire between ABS actuator and electric unit connector terminal 2 and ground.	
Does warning lamp activate?	
Yes	▶ GO TO 3.
No	▶ Repair combination meter. Check the following. <ul style="list-style-type: none"> ● Harness connector E9 ● Harness for open or short between ABS actuator and electric unit and fuse If NG, repair harness or connector.

SBR602E

3	CHECK HARNESS CONNECTOR
Check ABS actuator and electric unit pin terminals for damage or the connection of ABS actuator and electric unit harness connector. Reconnect ABS actuator and electric unit harness connector. Then retest.	
OK	▶ INSPECTION END
NG	▶ GO TO 4.

TROUBLE DIAGNOSES FOR SYMPTOMS

ABS

7. ABS Warning Lamp Stays On When Ignition Switch Is Turned On (Cont'd)

4	CHECK ABS MOTOR GROUND	
1. Turn ignition switch "OFF". 2. Check continuity between ABS motor and ground.		
Does continuity exist?		
Yes	▶	Replace ABS actuator and electric unit.
No	▶	Check the following. <ul style="list-style-type: none">● ABS motor ground harness● ABS motor ground harness for open or short between ABS motor and ground If NG, repair harness.

CAUTION:

Be careful not to damage sensor edge and sensor rotor teeth. When removing the front or rear wheel hub assembly, first remove the ABS wheel sensor from the assembly. Failure to do so may result in damage to the sensor wires making the sensor inoperative.

Wheel Sensors

NFBR0164S01

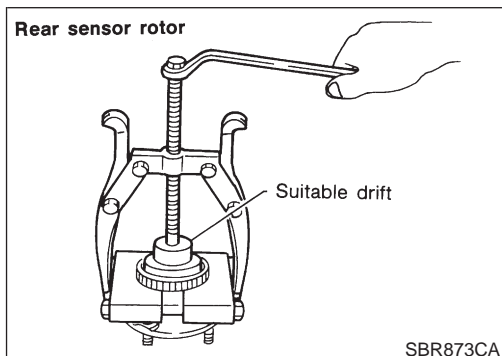
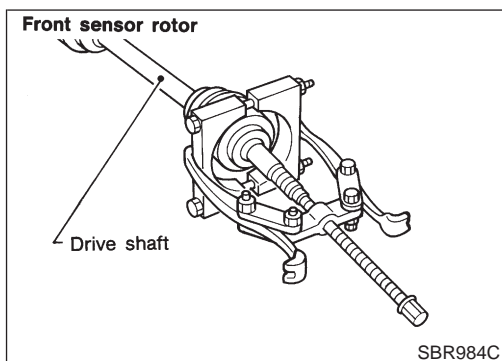
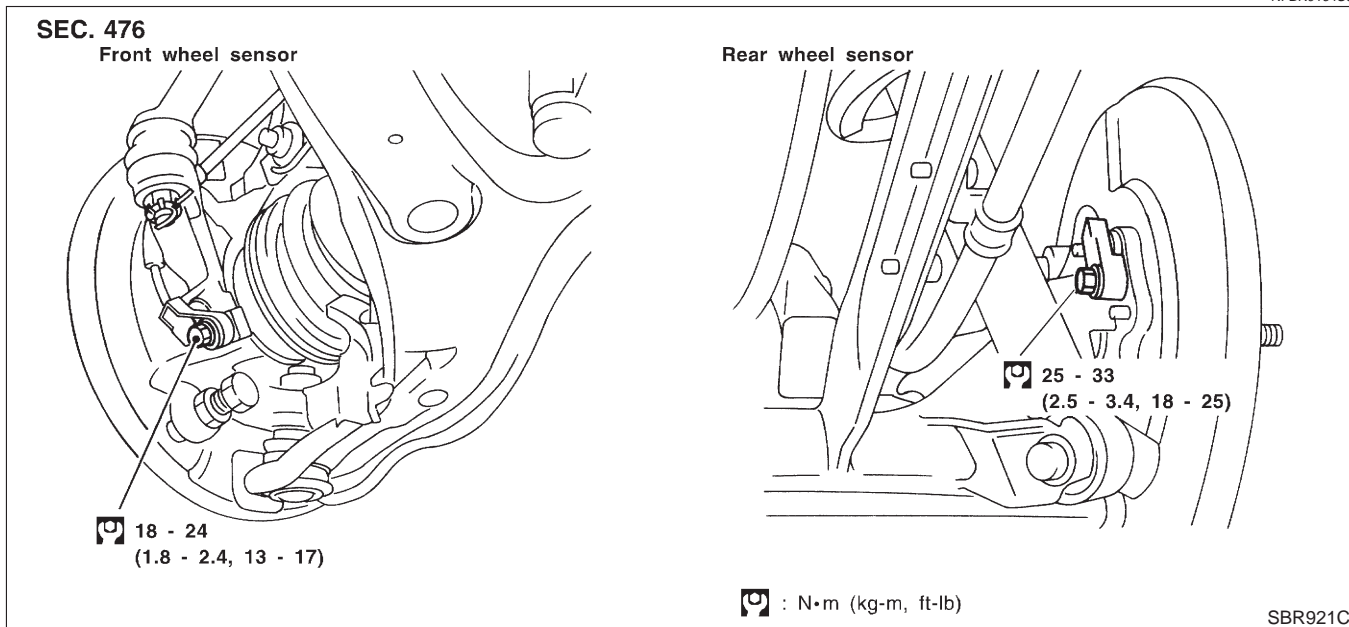

Sensor Rotor REMOVAL

NFBR0164S02

NFBR0164S0201

1. Remove the drive shaft and rear wheel hub. Refer to AX-9, AX-5 and AX-19, "Drive Shaft" and "Wheel Hub".
2. Remove the sensor rotor using suitable puller, drift and bearing replacer.

Sensor Rotor (Cont'd)

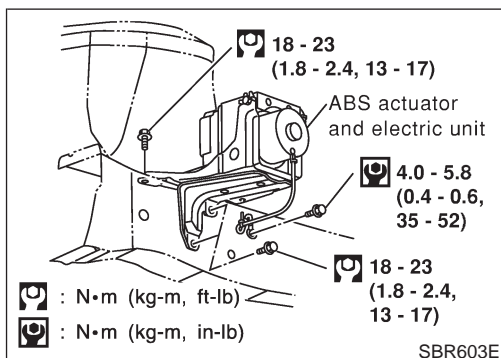
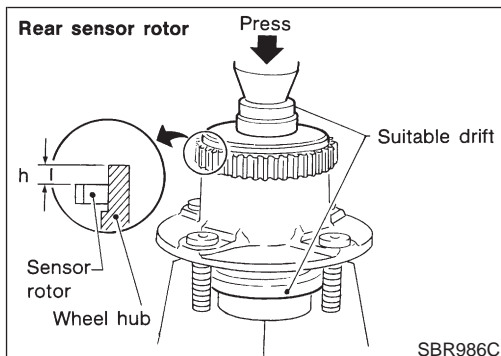
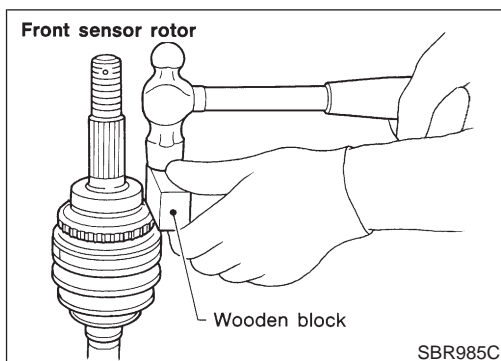

INSTALLATION

NFBR0164S0202

Install the sensor rotor. For front sensor rotor, use hammer and wooden block. For rear sensor rotor, use suitable drift and press.

- Always replace sensor rotor with new one.

- Pay attention to the dimension of rear sensor rotor as show in figure.

h: 12.5 - 13.5 mm (0.492 - 0.531 in)

Actuator

NFBR0164S04

REMOVAL

NFBR0164S0401

1. Disconnect battery cable.
2. Drain brake fluid. Refer to "Changing Brake Fluid" (BR-7).
3. Remove air cleaner and duct.
4. Apply different colored paint to each pipe connector and actuator to prevent incorrect connection.
5. Disconnect harness connectors, brake pipes and remove fixing nuts and actuator ground cable.

INSTALLATION

NFBR0164S0402

CAUTION:

- After installation, refill brake fluid. Then bleed air. Refer to "Bleeding Brake System" (BR-8).

1. Temporarily install actuator on the bracket.
2. Tighten actuator ground cable.
3. Connect brake pipes temporarily.
4. Tighten fixing nuts.
5. Tighten brake pipes.
6. Connect harness connectors and battery cable.
7. Install air cleaner and duct.

SERVICE DATA AND SPECIFICATIONS (SDS)

General Specifications

General Specifications

NFBR0165
Unit: mm (in)

Front brake	Brake model		CL28VF disc brake
	Cylinder bore diameter		42.8 (1.685) × 2
	Pad Length × width × thickness		127 × 56 × 9.5 (5.00 × 2.20 × 0.374)
	Rotor outer diameter × thickness		280 × 28 (11.02 × 1.10)
Rear brake	Brake model		CL11HB disc brake
	Cylinder bore diameter		38.18 (1.5031)
	Pad Length × width × thickness		75 × 40 × 8 (2.95 × 1.57 × 0.31)
	Rotor outer diameter × thickness		278 × 9 (10.94 × 0.35)
Master cylinder	Cylinder bore diameter		25.4 (1)
Control valve*	Valve model		Dual proportioning valve
Brake booster	Booster model		M215T
	Diaphragm diameter	Primary	230 (9.06)
		Secondary	205 (8.07)
Recommended brake fluid			DOT 3 or DOT 4

*: Applied model

- Models with ABS (Standard)
- Models with ABS (Optional)
- Models applicable to Chinese Law

Disc Brake

NFBR0166
Unit: mm (in)

Brake model		CL28VF	CL11HB
Pad wear limit	Minimum thickness	2.0 (0.079)	2.0 (0.079)
	Maximum runout	0.07 (0.0028)	0.07 (0.0028)
Rotor repair limit	Minimum thickness	26.0 (1.024)	8 (0.31)

Brake Pedal

NFBR0167
Unit: mm (in)

Steering position	LHD		RHD	
	M/T	A/T	M/T	A/T
Transmission				
Free height "H"	158 - 165 (6.22 - 6.50)	167 - 174 (6.57 - 6.85)	167 - 175 (6.57 - 6.89)	176 - 184 (6.93 - 7.24)
Clearance "C" between pedal stopper and threaded end of stop lamp switch or ASCD switch	0.74 - 1.96 (0.0291 - 0.0772)			

*: Measured from surface of metal panel to surface of pedal pad

Parking Brake

NFBR0168

Number of notches [under force of 196 N (20 kg, 44 lb)]	10 - 11
Number of notches when warning lamp switch comes on	1

SERVICE DATA AND SPECIFICATIONS (SDS)

Control Valve

Control Valve

NFBR0169
Unit: kPa (bar, kg/cm², psi)

Applied pressure (front)	7,355 (73.6, 75, 1,067)
Output pressure (rear)	5,100 - 5,492 (51.0 - 54.9, 52 - 56, 739 - 796)

Brake Booster

NFBR0170
Unit: mm (in)

Steering position	LHD	RHD
Output rod length	10.275 - 10.525 (0.4045 - 0.4144)	1.275 - 1.525 (0.0502 - 0.0600)
Clevis length	Approx. 130 (5.12)	

ABS Wheel Sensor

NFBR0171

Clearance	Front	0.273 - 0.925 mm (0.0107 - 0.0364 in)
	Rear	0.385 - 0.973 mm (0.0152 - 0.0383 in)
Resistance	Front	0.8 - 1.85Ω
	Rear	0.8 - 1.85Ω
Dimension of rear sensor rotor		12.5 - 13.5 mm (0.4921 - 0.5315 in)