

# MANUAL TRANSAXLE

## SECTION **MT**

### CONTENTS

<b>PREPARATION</b> .....	3	Shift Control Components .....	34
Special Service Tools .....	3	INSPECTION.....	34
Commercial Service Tools .....	5	Case Components .....	35
<b>NOISE, VIBRATION AND HARSHNESS (NVH)</b>		REMOVAL AND INSTALLATION.....	35
<b>TROUBLESHOOTING</b> .....	6	<b>ADJUSTMENT</b> .....	36
NVH Troubleshooting Chart.....	6	Input Shaft End Play and Differential Side	
MANUAL TRANSAXLE .....	6	Bearing Preload.....	36
<b>DESCRIPTION</b> .....	7	DIFFERENTIAL SIDE .....	36
Cross-sectional View .....	7	INPUT SHAFT SIDE.....	37
RS5F50A AND 50V .....	7	Mainshaft Bearing Preload .....	37
<b>ON-VEHICLE SERVICE</b> .....	8	<b>ASSEMBLY</b> .....	39
Replacing Oil Seal .....	8	<b>SERVICE DATA AND SPECIFICATIONS (SDS)</b> .....	43
DIFFERENTIAL OIL SEAL .....	8	General Specifications.....	43
STRIKING ROD OIL SEAL .....	8	TRANSAXLE .....	43
Position Switch Check.....	9	FINAL GEAR .....	43
BACK-UP LAMP SWITCH AND PARK/NEUTRAL		Gear End Play .....	43
POSITION SWITCH .....	9	Clearance Between Baulk Ring and Gear .....	43
Viscous Coupling Check.....	9	3RD, 4TH & 5TH.....	43
<b>REMOVAL AND INSTALLATION</b> .....	10	1ST AND 2ND DOUBLE BAULK RING .....	44
Removal.....	10	REVERSE BAULK RING .....	44
Installation.....	10	Available Snap Rings .....	44
<b>OVERHAUL</b> .....	12	1ST & 2ND SYNCHRONIZER HUB (AT	
Transaxle Gear Control .....	12	MAINSHAFT).....	44
Case Components .....	13	3RD & 4TH SYNCHRONIZER HUB (AT INPUT	
Gear Components .....	14	SHAFT).....	44
Shift Control Components .....	15	5TH MAIN GEAR (AT MAINSHAFT).....	45
<b>DISASSEMBLY</b> .....	16	Available Thrust Washer.....	45
<b>REPAIR FOR COMPONENT PARTS</b> .....	19	4TH INPUT GEAR (AT INPUT SHAFT).....	45
Input Shaft and Gears .....	19	DIFFERENTIAL SIDE GEAR THRUST WASHER.....	45
DISASSEMBLY.....	19	Available Shims .....	45
INSPECTION.....	20	BEARING PRELOAD AND END PLAY .....	45
ASSEMBLY .....	21	TOTAL TURNING TORQUE (NEW BEARING) .....	46
Mainshaft and Gears .....	24	MAINSHAFT BEARING ADJUSTING SHIM .....	46
DISASSEMBLY.....	24	TABLE FOR SELECTING MAINSHAFT BEARING	
INSPECTION.....	25	ADJUSTING SHIM .....	46
ASSEMBLY .....	27	INPUT SHAFT BEARING ADJUSTING SHIM .....	47
Final Drive.....	28	TABLE FOR SELECTING INPUT SHAFT BEARING	
DISASSEMBLY.....	28	ADJUSTING SHIM(S).....	47
INSPECTION.....	30	DIFFERENTIAL SIDE BEARING ADJUSTING	
ASSEMBLY .....	30	SHIM .....	47

# CONTENTS (Cont'd)

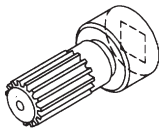
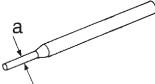
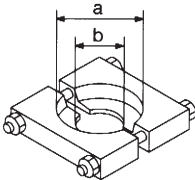
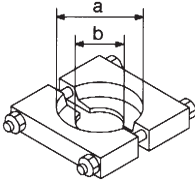
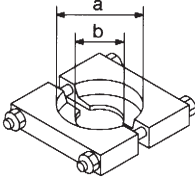
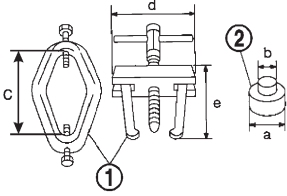

TABLE FOR SELECTING DIFFERENTIAL SIDE BEARING ADJUSTING SHIM.....	48
--	----

# PREPARATION

Special Service Tools

## Special Service Tools

NFMT0001

Tool number Tool name	Description
KV38105210 Preload adapter	 <p>Measuring turning torque of final drive assembly Measuring total turning torque</p> <p>NT075</p>
KV32101000 Pin punch	 <p>Removing and installing retaining pin <b>a: 4 mm (0.16 in) dia.</b></p> <p>NT410</p>
ST22730000 Puller	 <p>Removing mainshaft front and rear bearing inner race <b>a: 82 mm (3.23 in) dia.</b> <b>b: 30 mm (1.18 in) dia.</b></p> <p>NT411</p>
ST30031000 Puller	 <p>Removing input shaft front and rear bearing Removing 4th &amp; 5th main gear <b>a: 90 mm (3.54 in) dia.</b> <b>b: 50 mm (1.97 in) dia.</b></p> <p>NT411</p>
ST30021000 Puller	 <p>Removing 5th synchronizer Removing 3rd &amp; 4th synchronizer Removing 2nd &amp; 3rd main gear <b>a: 110 mm (4.33 in) dia.</b> <b>b: 68 mm (2.68 in) dia.</b></p> <p>NT411</p>
ST3306S001 Differential side bearing puller set 1: ST33051001 Puller 2: ST33061000 Adapter	 <p>Removing differential side bearing inner race <b>a: 38 mm (1.50 in) dia.</b> <b>b: 28.5 mm (1.122 in) dia.</b> <b>c: 130 mm (5.12 in)</b> <b>d: 135 mm (5.31 in)</b> <b>e: 100 mm (3.94 in)</b></p> <p>NT675</p>
ST33290001 Puller	 <p>Removing differential oil seal Removing mainshaft rear bearing outer race Removing differential side bearing outer race <b>a: 250 mm (9.84 in)</b> <b>b: 160 mm (6.30 in)</b></p> <p>NT414</p>

## PREPARATION

### Special Service Tools (Cont'd)

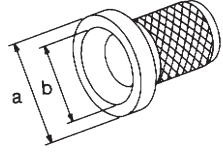
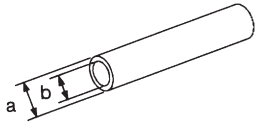
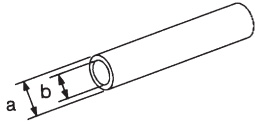
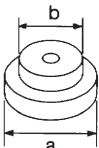
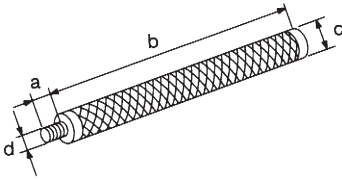
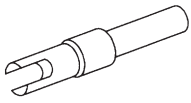
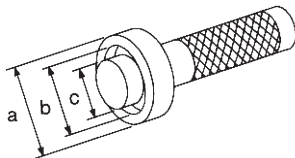
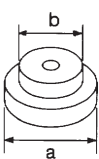
Tool number Tool name	Description
ST33400001 Drift	 <p>Installing differential oil seal (50A and 50V right side)  <b>a: 60 mm (2.36 in) dia.</b>  <b>b: 47 mm (1.85 in) dia.</b></p>
NT086	
ST30600000 Drift	 <p>Installing input shaft front bearing  <b>a: 36 mm (1.42 in) dia.</b>  <b>b: 31 mm (1.22 in) dia.</b></p>
NT065	
ST22452000 Drift	 <p>Installing 3rd, 4th and 5th main gear  <b>a: 45 mm (1.77 in) dia.</b>  <b>b: 36 mm (1.42 in) dia.</b></p>
NT065	
ST30621000 Drift	 <p>Installing mainshaft rear bearing outer race            (Use with ST30611000.)  <b>a: 79 mm (3.11 in) dia.</b>  <b>b: 59 mm (2.32 in) dia.</b></p>
NT073	
ST30611000	 <p>(Use with ST30621000.)  <b>a: 15 mm (0.59 in)</b>  <b>b: 335 mm (13.19 in)</b>  <b>c: 25 mm (0.98 in) dia.</b>  <b>d: M12 x 1.5P</b></p>
NT419	
KV38106500 Preload adapter	 <p>Measuring side gear clearance</p>
NT087	
KV38100300 ( — ) Drift	 <p>Installing differential side bearing  <b>a: 54 mm (2.13 in) dia.</b>  <b>b: 46 mm (1.81 in) dia.</b>  <b>c: 32 mm (1.26 in) dia.</b></p>
NT085	
ST30613000 ( — ) Drift	 <p>Installing differential side bearing  <b>a: 72 mm (2.83 in) dia.</b>  <b>b: 48 mm (1.89 in) dia.</b></p>
NT073	

# PREPARATION

Commercial Service Tools

## Commercial Service Tools

NFMT0002

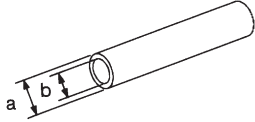
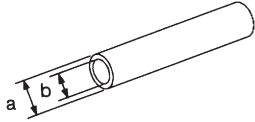
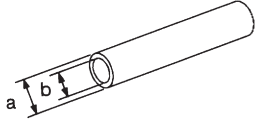
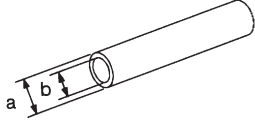
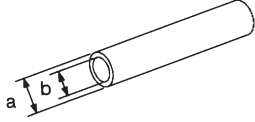
Tool name	Description
Drift	 <p>Installing differential side bearing inner race <b>a: 45 mm (1.77 in) dia.</b> <b>b: 41 mm (1.61 in) dia.</b></p> <p>NT065</p>
Drift	 <p>Installing differential side bearing outer race <b>a: 69 mm (2.72 in) dia.</b> <b>b: 64 mm (2.52 in) dia.</b></p> <p>NT065</p>
Drift	 <p>Installing striking rod oil seal <b>a: 38 mm (1.50 in) dia.</b> <b>b: 20 mm (0.79 in) dia.</b></p> <p>NT065</p>
Drift	 <p>Installing differential oil seal (50V left side) <b>a: 92 mm (3.62 in) dia.</b> <b>b: 72 mm (2.83 in) dia.</b></p> <p>NT065</p>
Drift	 <p>Installing differential side bearing outer race (50V) <b>a: 99 mm (3.90 in) dia.</b> <b>b: 94 mm (3.70 in) dia.</b></p> <p>NT065</p>

# NOISE, VIBRATION AND HARSHNESS (NVH) TROUBLESHOOTING

NVH Troubleshooting Chart

## NVH Troubleshooting Chart

NFMT0003S01

Use the chart below to help you find the cause of the symptom. The numbers indicate the order of the inspection. If necessary, repair or replace these parts.

### MANUAL TRANSAXLE

NFMT0003S0101

		Refer to MA-25, "Checking M/T Oil".											
Reference page													
SUSPECTED PARTS (Possible cause)	(Oil level is low.)	(Wrong oil)	(Oil level is high.)	GASKET (Damaged)	OIL SEAL (Worn or damaged)	O-RING (Worn or damaged)	SHIFT CONTROL ROD (Worn)	CHECK PLUG RETURN SPRING AND CHECK BALL (Worn or damaged)	SHIFT FORK (Worn)	GEAR (Worn or damaged)	BEARING (Worn or damaged)	BAULK RING (Worn or damaged)	INSERT SPRING (Damaged)
Symptoms	Noise	1	2							3	3		
	Oil leakage		3	1	2	2							
	Hard to shift or will not shift		1	1			2					3	3
	Jumps out of gear						1	2	3	3			

# DESCRIPTION

NFMT0004

Cross-sectional View

## Cross-sectional View

### RS5F50A AND 50V

NFMT0004S01

NFMT0004S0101

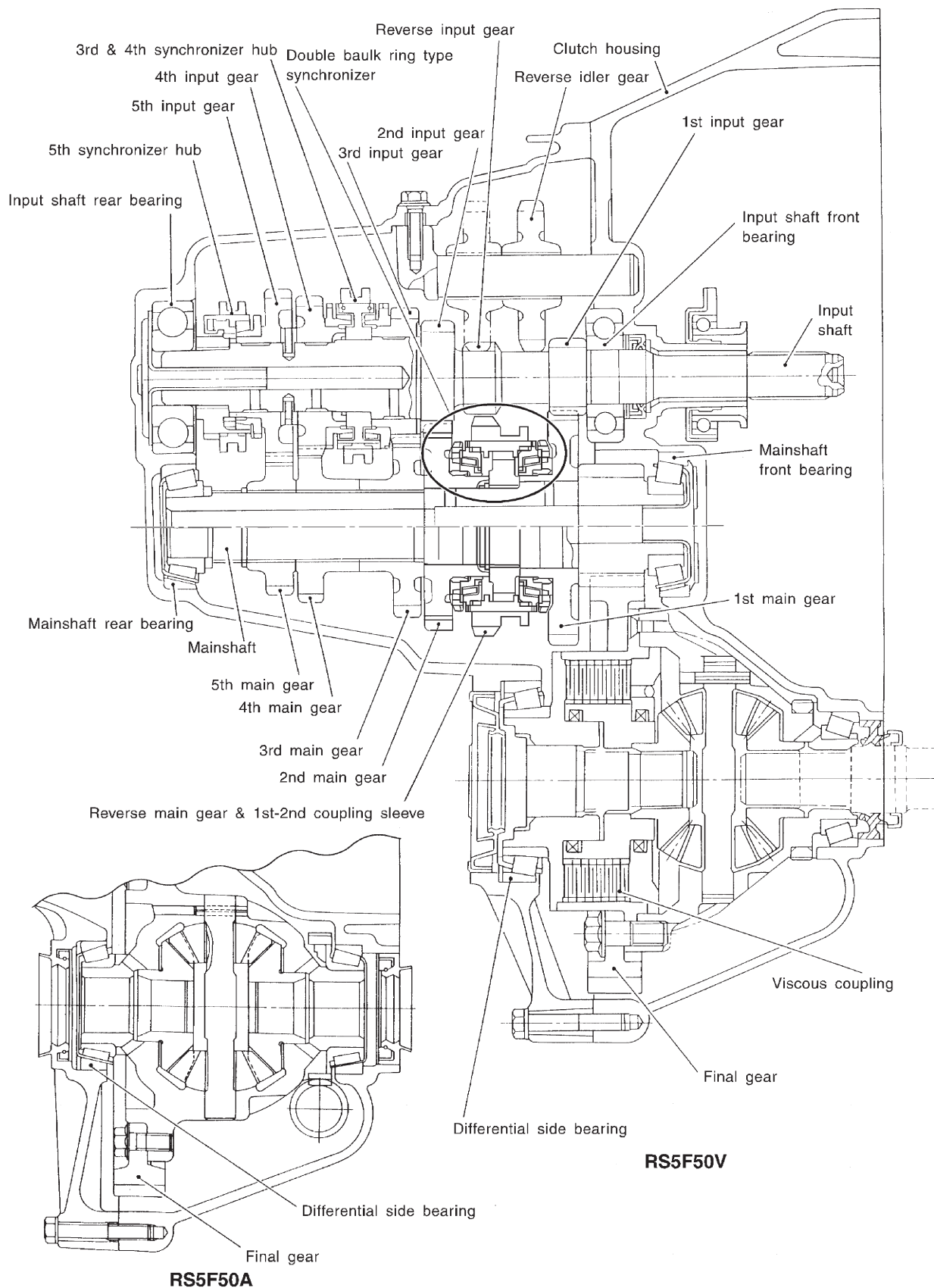

SMT873D

## ON-VEHICLE SERVICE

### Replacing Oil Seal

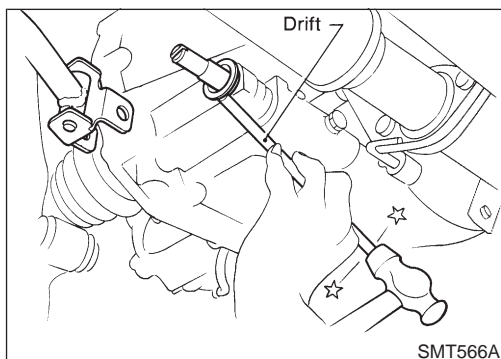
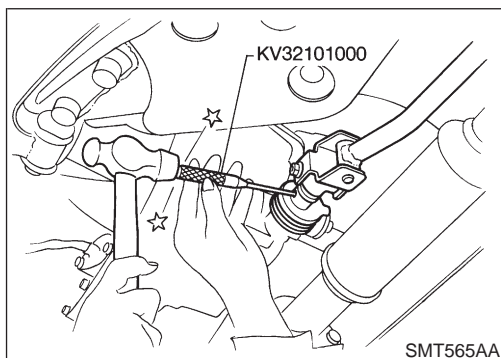
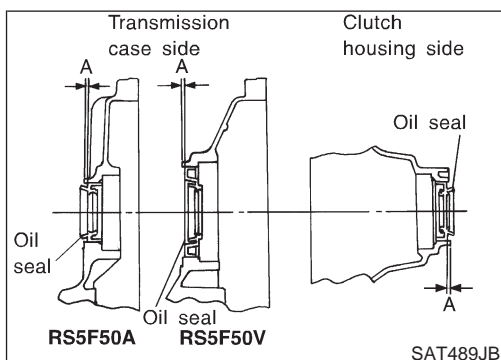
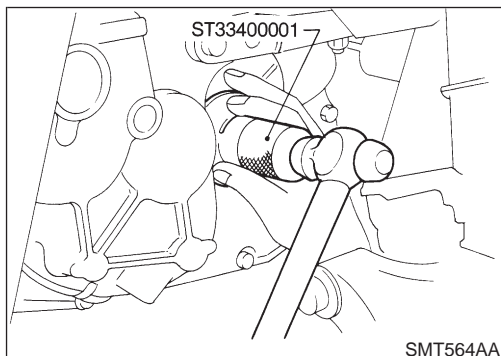
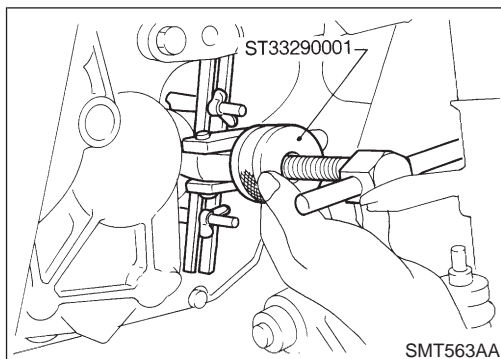

### Replacing Oil Seal

#### DIFFERENTIAL OIL SEAL

NFMT0005

NFMT0005S01

1. Drain gear oil from transaxle.
2. Remove drive shafts. Refer to AX-10, "Drive Shaft".
3. Remove differential oil seals.
4. Install differential oil seals.
  - Apply multi-purpose grease to seal lip of oil seal before installing.
5. Install drive shafts. Refer to AX-10, "Drive Shaft".

- Install oil seals so that dimension "A" is within specifications.

#### Dimension "A":

-0.5 mm (-0.020 in) to 0.5 mm (0.020 in)

### STRIKING ROD OIL SEAL

NFMT0005S02

1. Remove transaxle control rod from yoke.
2. Remove retaining pin.
  - Be careful not to damage boot.

3. Remove striking rod oil seal.



## ON-VEHICLE SERVICE

*Replacing Oil Seal (Cont'd)*

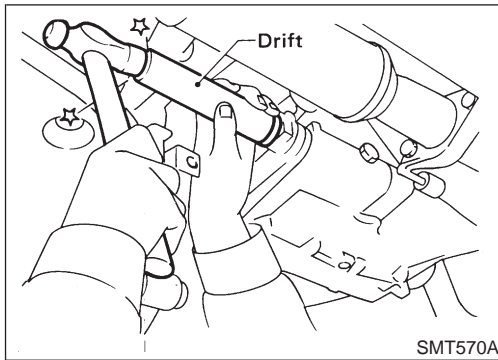

4. Install striking rod oil seal.
  - **Apply multi-purpose grease to seal lip of oil seal before installing.**

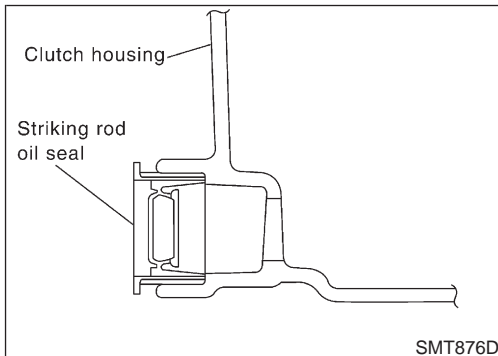

- **Drive it in as far as it will go.**

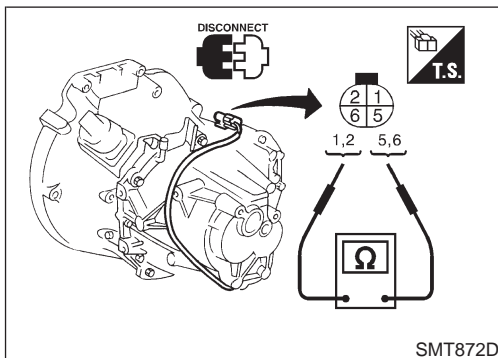

### Position Switch Check BACK-UP LAMP SWITCH AND PARK/NEUTRAL POSITION SWITCH

NFMT0006

NFMT0006S01

- Check continuity.

Gear position	Continuity
Reverse	1 - 5
Neutral	2 - 6
Except reverse and neutral	No

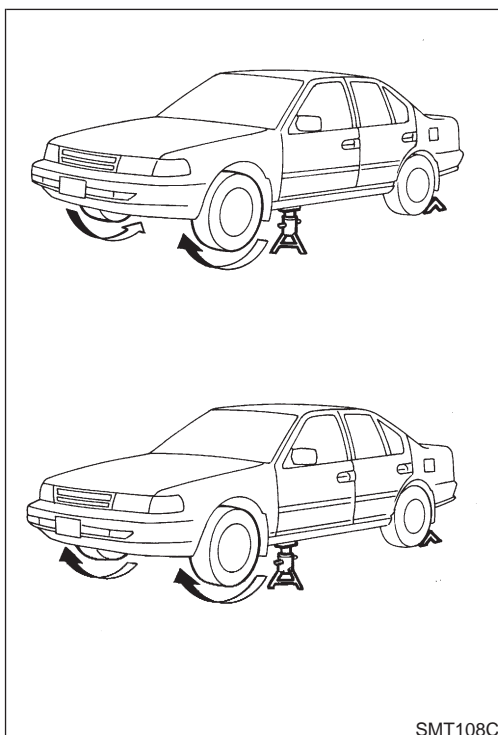

### Viscous Coupling Check

NFMT0030

1. Apply parking brake firmly and place shift lever in the neutral position.
2. Jack up front wheels.
3. Rotate one front wheel and check turning direction of the other front wheel.

**Turning direction of the two wheels is opposite:**

The viscous coupling is not functioning normally.

**Turning direction of the two wheels is the same:**

If differential side gear and pinion mate gear thrust washers are OK, viscous coupling is functioning normally.

## REMOVAL AND INSTALLATION

### Removal

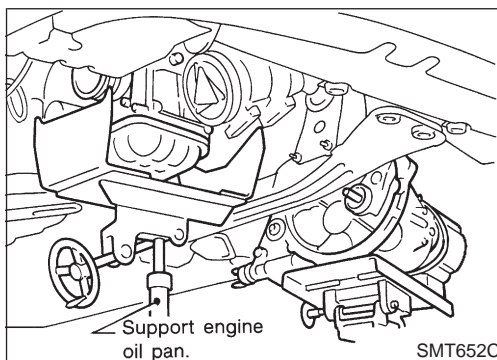
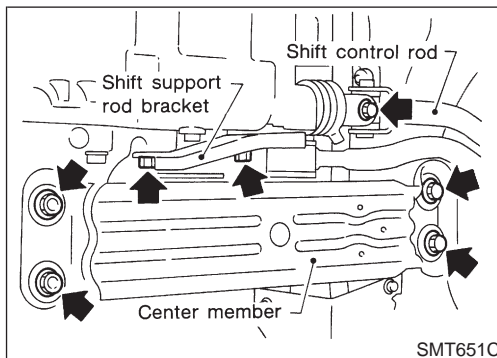
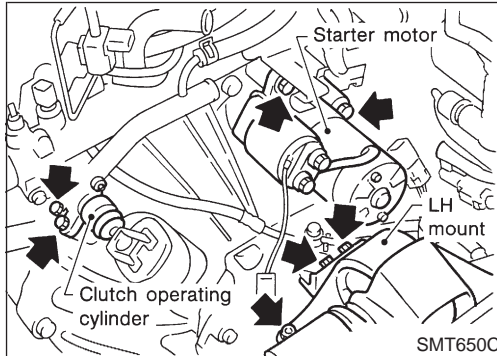
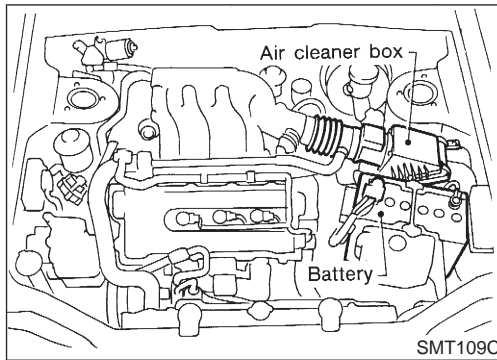

### Removal

NFMT0008S01

#### CAUTION:

Remove the crankshaft position sensor (POS) from transaxle assembly before separating transaxle from engine. Be careful not to damage sensor edge.

1. Remove battery and its bracket.
2. Remove air cleaner box with mass air flow sensor.
3. Remove clutch operating cylinder from transaxle.
4. Remove clutch hose clamp.
5. Disconnect speedometer pinion, PNP switch and ground harness connectors.
6. Remove starter motor from transaxle.
7. Remove crankshaft position sensor (POS) from transaxle front side.
8. Remove shift control rod and support rod bracket from transaxle.
9. Drain gear oil from transaxle.
10. Draw out drive shafts from transaxle. Refer to AX-10, "Drive Shaft".
11. Support engine of transaxle by placing a jack under oil pan.
12. Remove bolts securing center member.
13. Remove LH mount.
14. Remove bolts securing transaxle.
15. Lower transaxle while supporting it with a jack.

#### CAUTION:

Do not place jack under oil pan drain plug.

### Installation

NFMT0008S02

- Tighten LH mount and center member bolts. Refer to EM-56, "Installation".
- Tighten clutch operating cylinder bolts. Refer to CL-5, "Components".
- Install drive shafts. Refer to AX-10, "Drive Shaft".
- Tighten all transaxle bolts and any part removed.

# REMOVAL AND INSTALLATION

Installation (Cont'd)

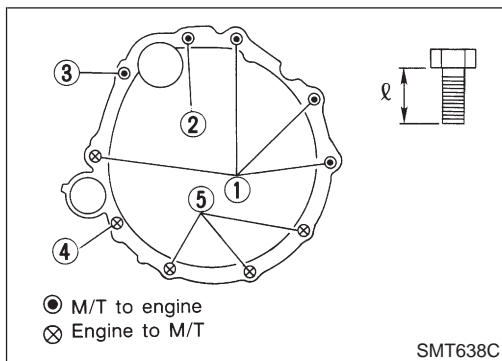

Bolt No.	Tightening torque N·m (kg·m, ft·lb)	"ℓ" mm (in)
1	70 - 79 (7.1 - 8.1, 52 - 58)	52 (2.05)
2	70 - 79 (7.1 - 8.1, 52 - 58)	65 (2.56)
3	70 - 79 (7.1 - 8.1, 52 - 58)	124 (4.88)
4	36 - 47 (3.58 - 4.80, 26 - 34)	40 (1.57)
5	36 - 47 (3.58 - 4.80, 26 - 34)	40 (1.57)

3 with starter

4 with support rod bracket

# OVERHAUL

Transaxle Gear Control

## Transaxle Gear Control

NFMT0009S01

### SEC. 341

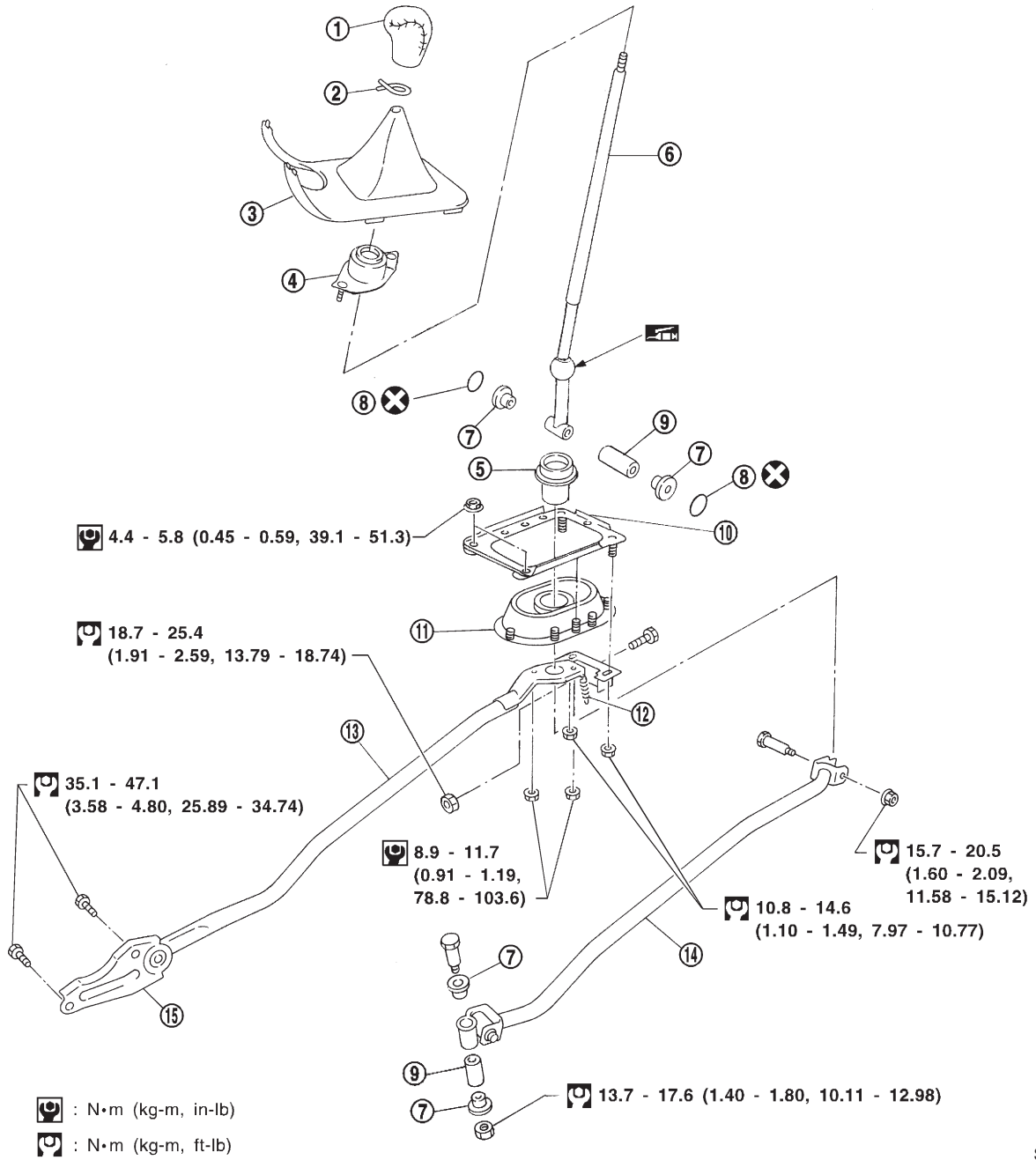

SMT860C

- |                       |                |                               |
|-----------------------|----------------|-------------------------------|
| 1. Shift lever knob   | 6. Shift lever | 11. Transaxle hole cover      |
| 2. Boot retainer      | 7. Bushing     | 12. Return spring             |
| 3. Boot               | 8. O-ring      | 13. Support rod               |
| 4. Shift lever socket | 9. Collar      | 14. Shift control rod         |
| 5. Seat-bearing set   | 10. Plate bolt | 15. Shift support rod bracket |

## Case Components

NFMT0009S02

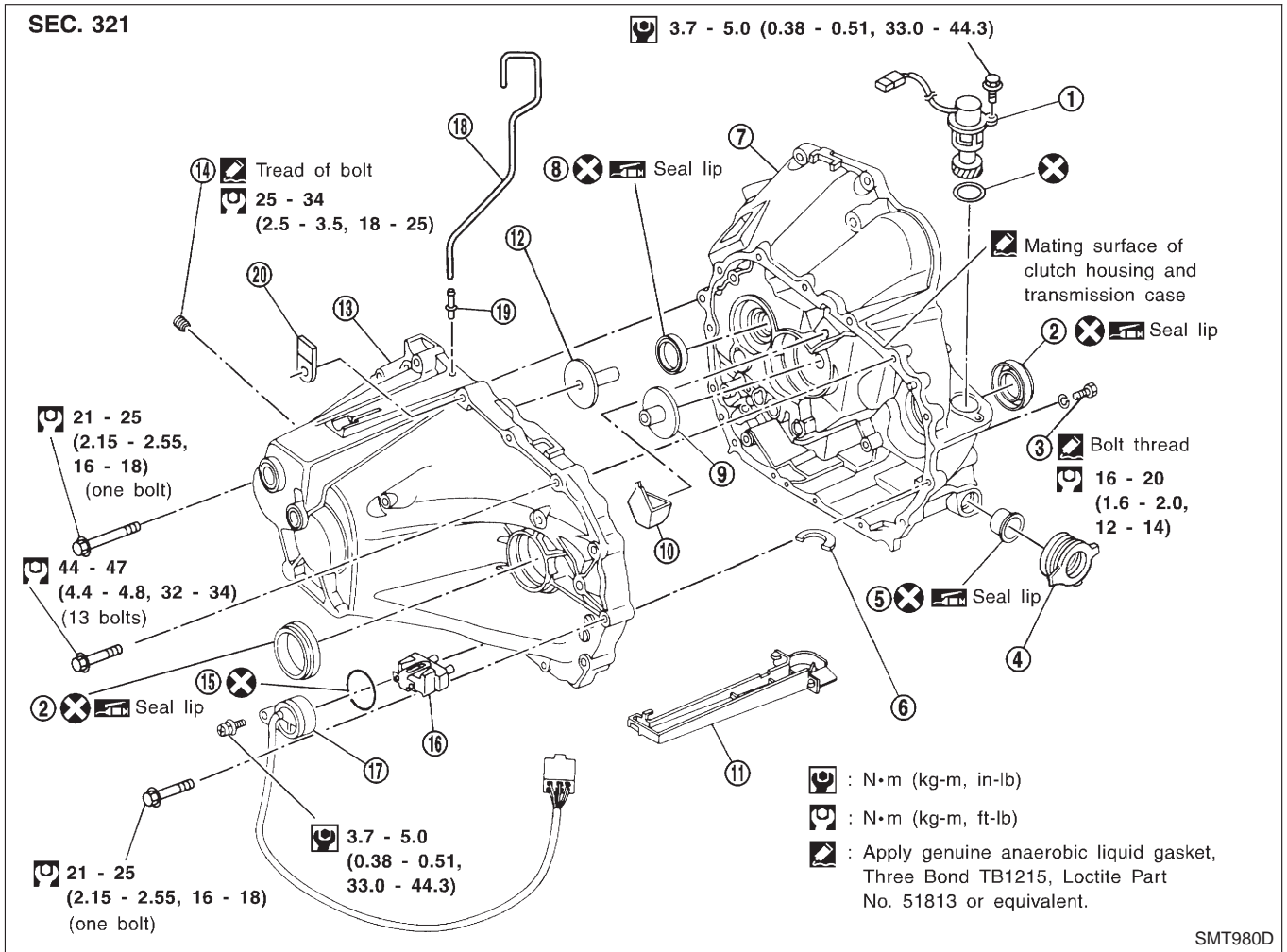

- |                          |                               |                            |
|--------------------------|-------------------------------|----------------------------|
| 1. Speedometer pinion    | 8. Input shaft oil seal       | 15. O-ring                 |
| 2. Differential oil seal | 9. Oil channel (Mainshaft)    | 16. Movable plate assembly |
| 3. Drain plug            | 10. Oil pocket                | 17. PNP switch             |
| 4. Boot                  | 11. Oil gutter                | 18. Breather hose          |
| 5. Striking rod oil seal | 12. Oil channel (Input shaft) | 19. Breather pipe          |
| 6. Magnet                | 13. Transmission case         | 20. Clip                   |
| 7. Clutch housing        | 14. Filler plug               |                            |

# OVERHAUL

## Gear Components

NFMT0009S05

SEC. 322

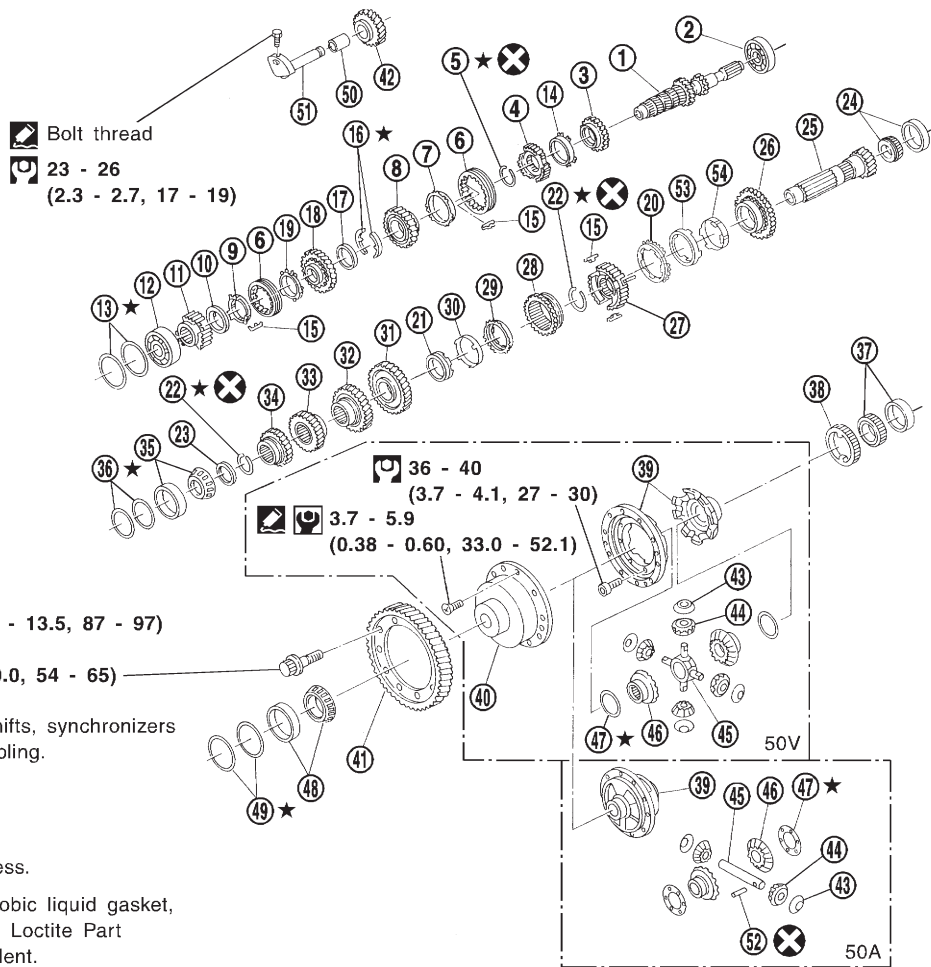

SMT875DA

- |  |   |  |
|--|---|--|
| 1. Input shaft                         | 20. 1st outer baulk ring                        | 38. Speedometer drive gear                   |
| 2. Input shaft front bearing           | 21. 2nd inner baulk ring                        | 39. Differential case                        |
| 3. 3rd input gear                      | 22. Snap ring                                   | 40. Viscous coupling                         |
| 4. 3rd & 4th synchronizer hub          | 23. Mainshaft bearing spacer                    | 41. Final gear                               |
| 5. Snap ring                           | 24. Mainshaft front bearing                     | 42. Reverse idler gear                       |
| 6. Coupling sleeve                     | 25. Mainshaft                                   | 43. Pinion mate gear thrust washer           |
| 7. 4th baulk ring                      | 26. 1st main gear                               | 44. Pinion mate gear                         |
| 8. 4th input gear                      | 27. 1st & 2nd synchronizer hub                  | 45. Pinion mate shaft                        |
| 9. Reverse baulk ring                  | 28. Reverse main gear & 1st-2nd coupling sleeve | 46. Side gear                                |
| 10. Reverse synchronizer cone          | 29. 2nd outer baulk ring                        | 47. Side gear thrust washer                  |
| 11. 5th synchronizer hub               | 30. 2nd gear synchronizer cone                  | 48. Differential side bearing                |
| 12. Input shaft rear bearing           | 31. 2nd main gear                               | 49. Differential side bearing adjusting shim |
| 13. Input shaft bearing adjusting shim | 32. 3rd main gear                               | 50. Bushing                                  |
| 14. 3rd baulk ring                     | 33. 4th main gear                               | 51. Reverse idler shaft                      |
| 15. Insert spring                      | 34. 5th main gear                               | 52. Retaining pin                            |
| 16. 4th input gear thrust washer       | 35. Mainshaft rear bearing                      | 53. 1st gear synchronizer cone               |
| 17. Thrust washer ring                 | 36. Mainshaft bearing adjusting shim            | 54. 1st inner baulk ring                     |
| 18. 5th input gear                     | 37. Differential side bearing                   |  |
| 19. 5th baulk ring                     |   |  |





## DISASSEMBLY

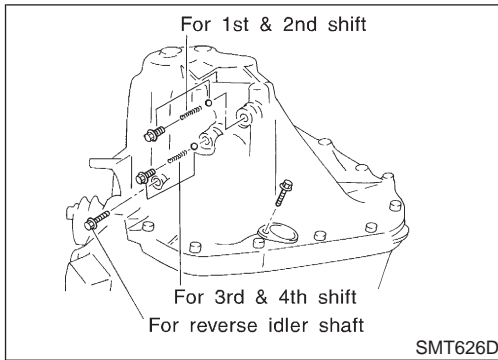

1. Before removing transmission case, remove bolts, check plugs, springs and check balls as shown left.
  - **Be careful not to lose check balls.**
2. Remove transmission case.

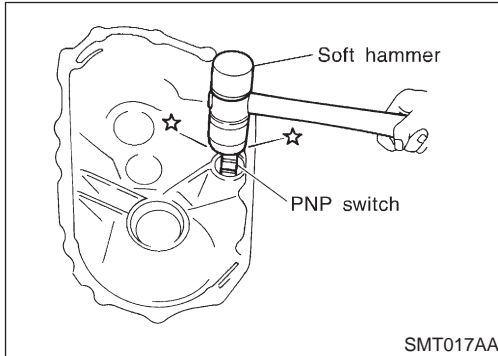

3. Remove PNP switch.

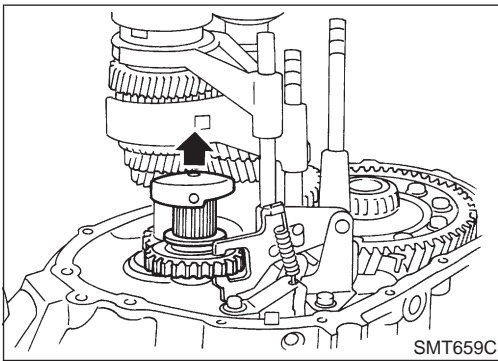

4. Mesh 4th gear, and then remove reverse idler shaft and reverse idler gear.

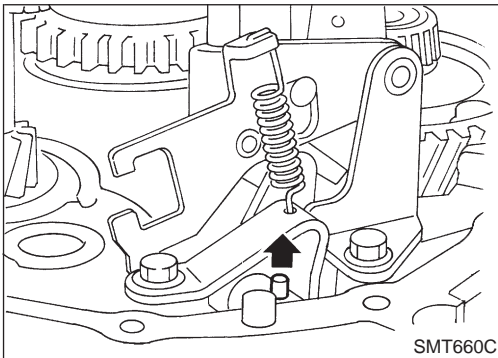

5. Pull out retaining pin.

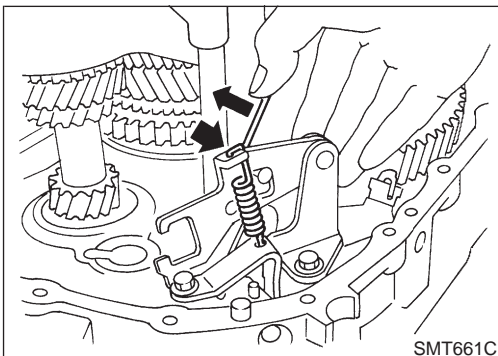

6. Remove reverse lever spring and reverse lock spring from reverse lever assembly.



## DISASSEMBLY

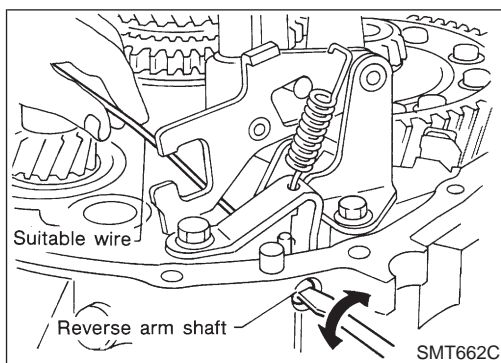

7. Remove reverse arm shaft while rotating it.

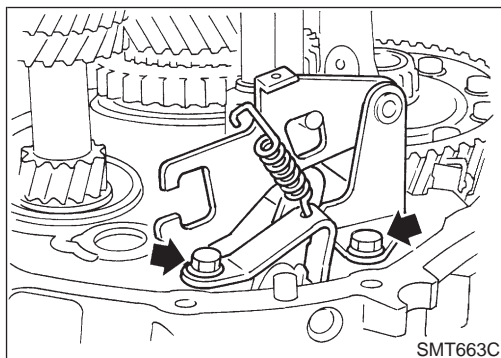

8. Remove reverse lever assembly and check ball.

- **Be careful not to lose check ball.**

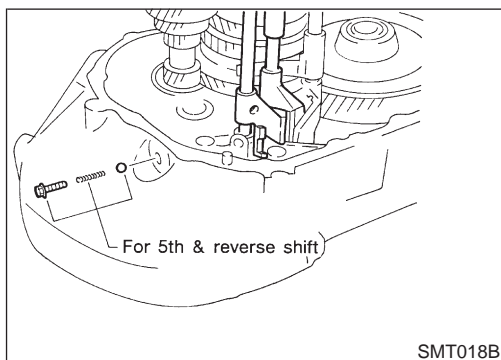

9. Remove 5th & reverse check plug, spring and ball.

- **Be careful not to lose check ball.**

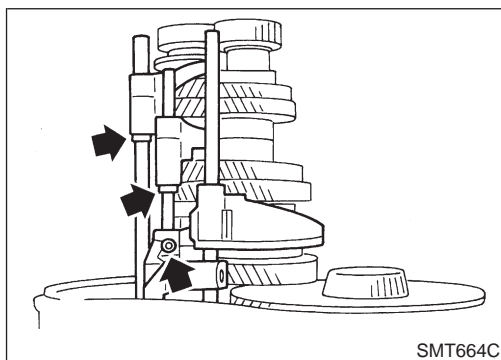

10. Remove stopper rings and retaining pins from 5th and 3rd & 4th fork rods.

11. Remove 5th and 3rd & 4th fork rods. Then remove forks and brackets.

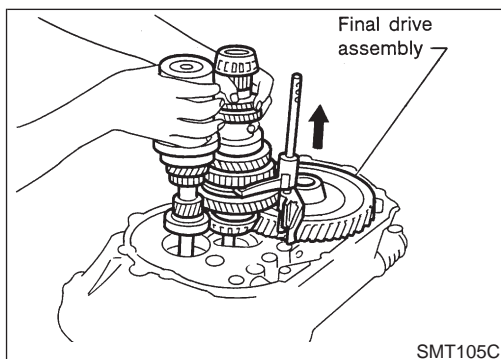

12. Remove both input and mainshafts with 1st & 2nd fork and fork rod as a set.

13. Remove final drive assembly.

- **Always withdraw mainshaft straight out. Failure to do so can damage resin oil channel on clutch housing side.**

## DISASSEMBLY

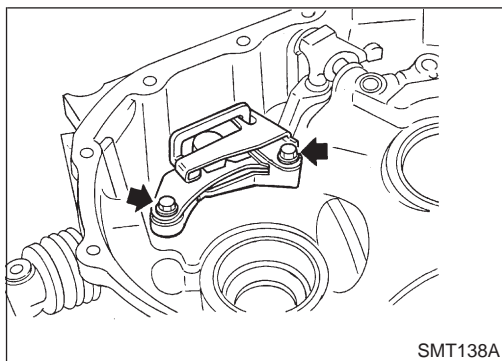

14. Remove reverse check assembly and check ball.
- **Be careful not to lose check ball.**

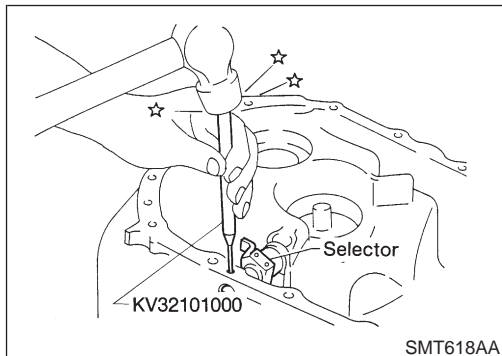

15. Remove retaining pin and detach the selector.

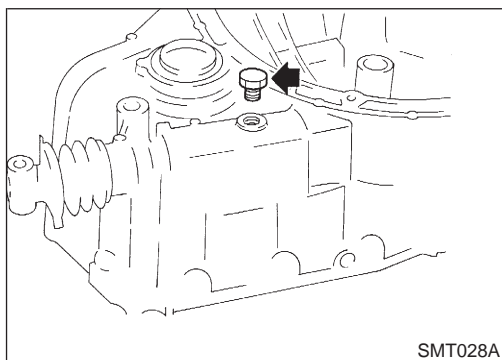
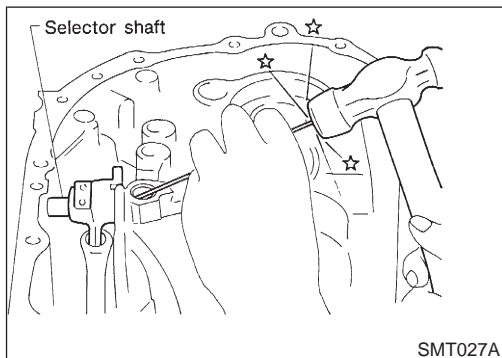

16. Remove drain plug for convenience in removing retaining pin which holds striking lever to striking rod.

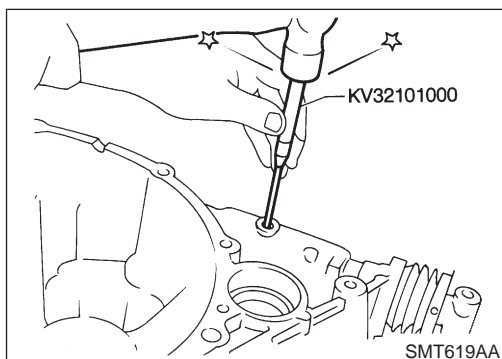

17. Remove retaining pin and then withdraw striking lever and striking rod.

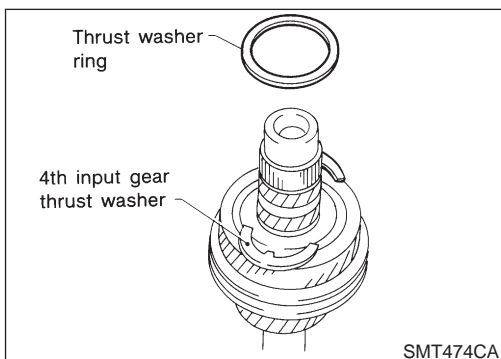
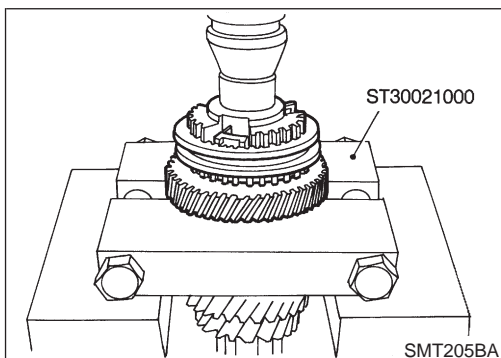
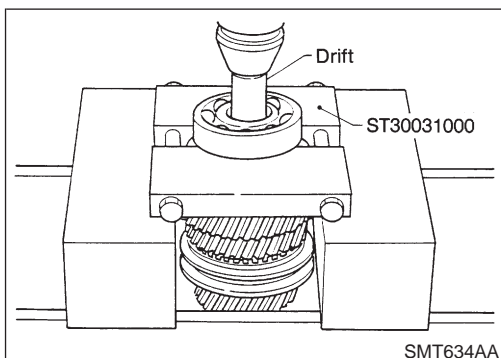
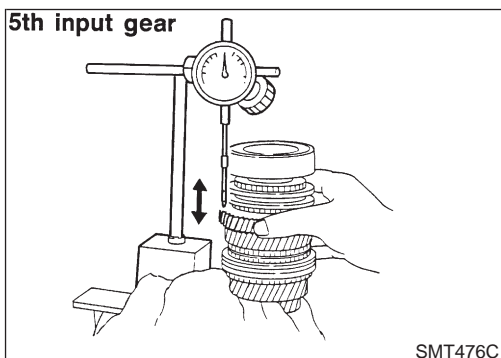
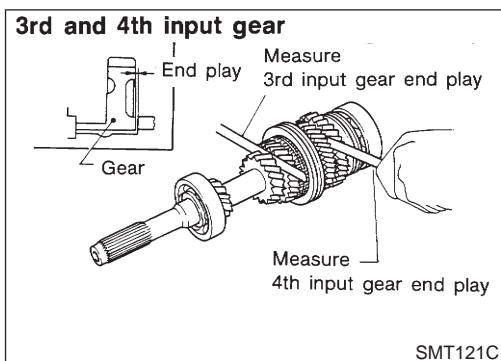

## Input Shaft and Gears DISASSEMBLY

NFMT0011

1. Before disassembly, check 3rd, 4th and 5th input gear end plays.

**Gear end play:**  
**Refer to SDS, MT-43.**

- If not within specification, disassemble and check contact surface of gear, shaft and hub. Check clearance of snap ring groove. Refer to "ASSEMBLY", MT-21.

2. Remove input shaft rear bearing.

3. Remove 5th & reverse synchronizer and 5th input gear.

4. Remove thrust washer ring, 4th input gear thrust washers and 4th input gear.

## REPAIR FOR COMPONENT PARTS

### Input Shaft and Gears (Cont'd)

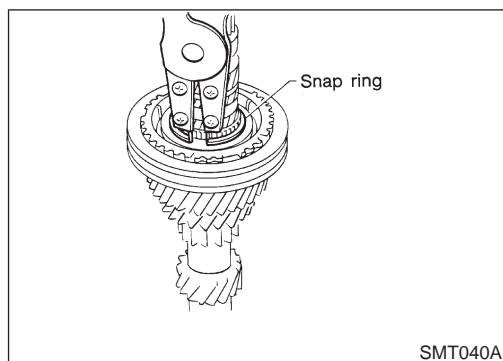

5. Remove snap ring.

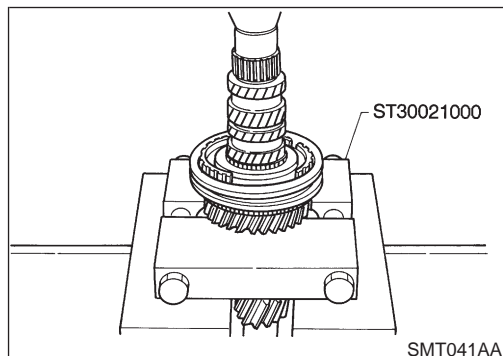

6. Remove 3rd & 4th synchronizer and 3rd input gear.

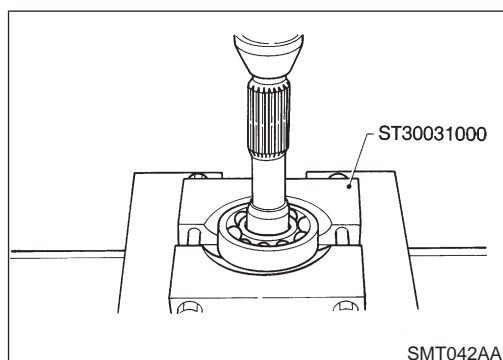

7. Remove input shaft front bearing.

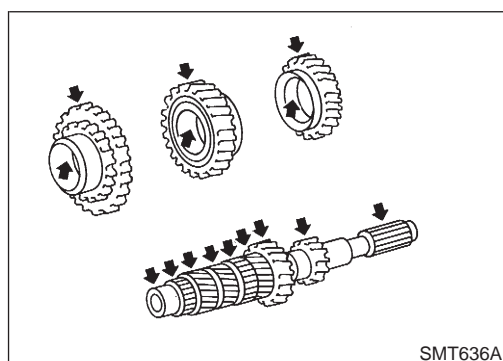

### INSPECTION

#### Input shaft and Gears

- Check input shaft for cracks, wear or bending.
- Check gears for excessive wear, chips or cracks.

NFMT0012

NFMT0012S01

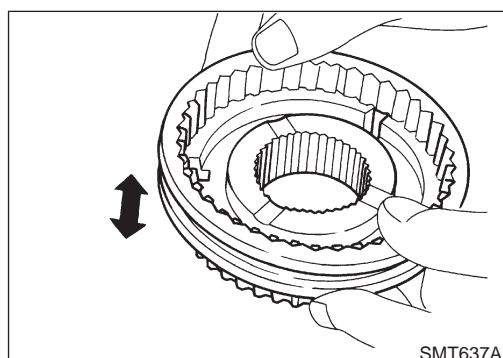

#### Synchronizer

- Check spline portion of coupling sleeves, hubs and gears for wear or cracks.
- Check baulk rings for cracks or deformation.
- Check insert springs for wear or deformation.

NFMT0012S02

## REPAIR FOR COMPONENT PARTS

*Input Shaft and Gears (Cont'd)*

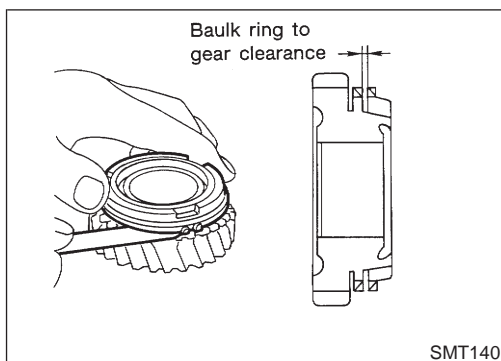

- Measure clearance between baulk ring and gear (3rd, 4th and 5th).

### Clearance between baulk ring and gear:

#### Standard

1.0 - 1.35 mm (0.0394 - 0.0531 in)

#### Wear limit

0.7 mm (0.028 in)

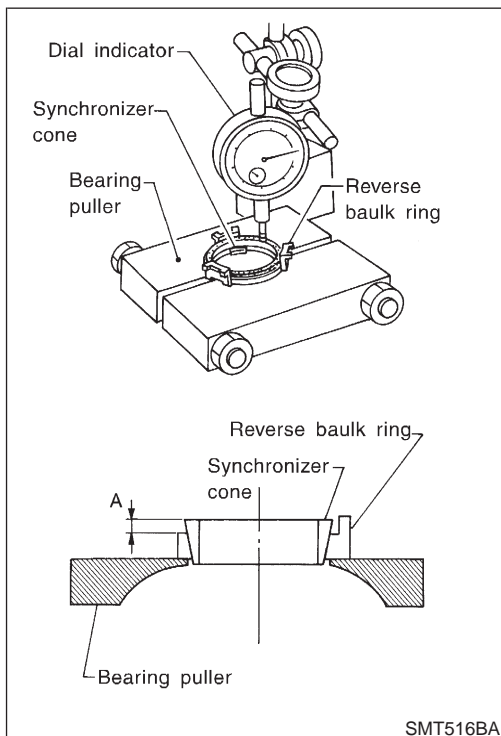

- **Measure wear of reverse baulk ring.**

1. Place reverse baulk ring on suitable bearing puller and then place reverse synchronizer cone on reverse baulk ring.

- **Make sure projection of synchronizer cone is positioned over the recess on Tool.**

2. While holding reverse synchronizer cone against reverse baulk ring as firmly as possible, measure dimension "A" with dial indicator.

#### Wear limit:

Dimension "A" 1.2 mm (0.047 in)

3. If dimension "A" is smaller than the wear limit, replace baulk ring.

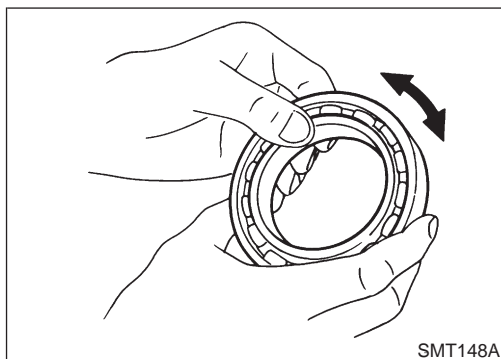

### Bearing

- Make sure bearings roll freely and are free from noise, cracks, pitting or wear. NFMT0012S03

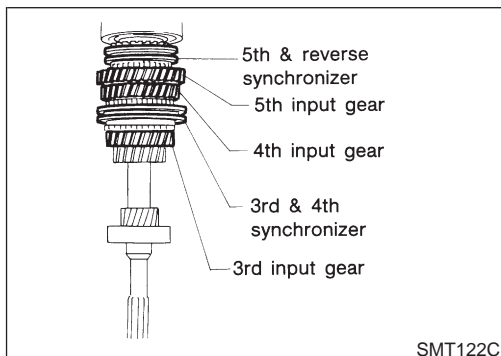

### ASSEMBLY

NFMT0013

## REPAIR FOR COMPONENT PARTS

### Input Shaft and Gears (Cont'd)

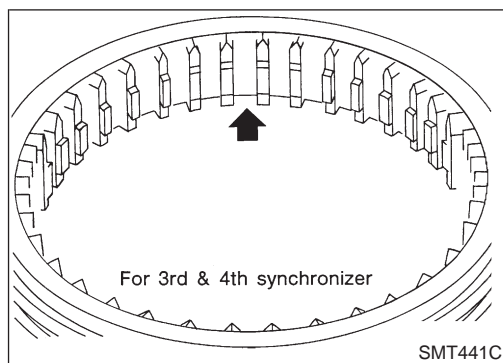

1. Place inserts in three grooves on coupling sleeve (3rd & 4th synchronizer).

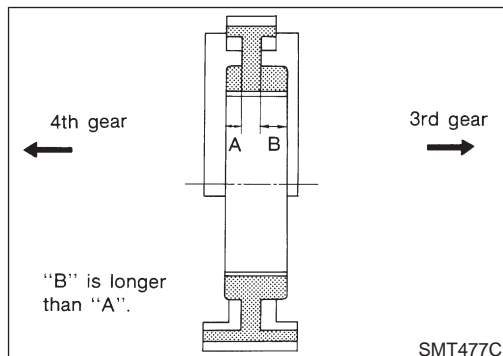

2. Install 3rd input gear and 3rd baulk ring.
3. Press on 3rd & 4th synchronizer hub.
  - **Pay attention to its direction.**
4. Select proper snap ring of 3rd & 4th synchronizer hub to minimize clearance of groove, and then install it.

**Allowable clearance of groove:**

**0 - 0.1 mm (0 - 0.004 in)**

**Snap ring of 3rd & 4th synchronizer hub:**

**Refer to SDS, MT-44.**

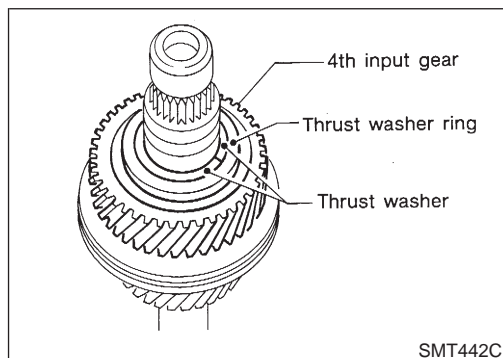
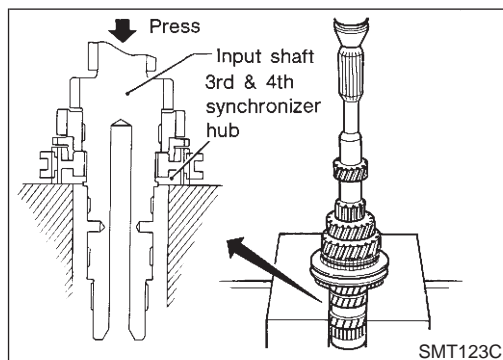

5. Install 4th input gear.
6. Select proper thrust washers to minimize clearance of groove. Then install them and thrust washer ring.

**Allowable clearance of groove:**

**0 - 0.06 mm (0 - 0.0024 in)**

**4th input gear thrust washer:**

**Refer to SDS, MT-45.**

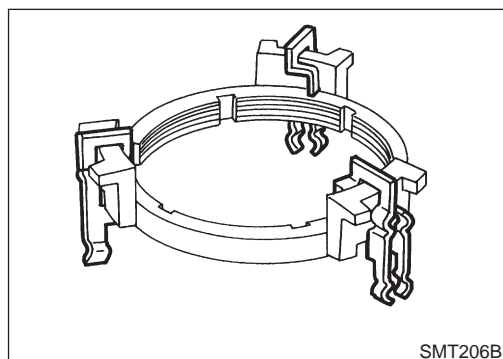

7. Install 5th & reverse synchronizer assembly.
  - a. Hook insert springs on reverse baulk ring.

## REPAIR FOR COMPONENT PARTS

*Input Shaft and Gears (Cont'd)*

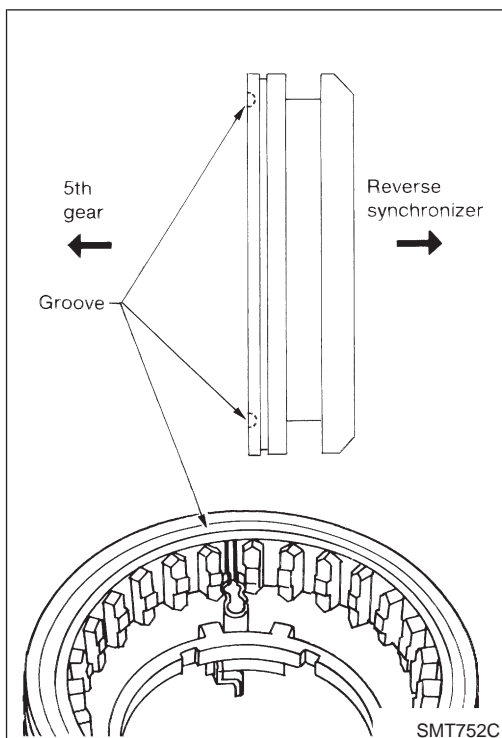

- b. Install insert springs with reverse baulk ring onto coupling sleeve.
  - **Pay attention to position of insert springs.**
- c. Place 5th baulk ring on 5th input gear.
- d. Install reverse synchronizer cone on reverse baulk ring.

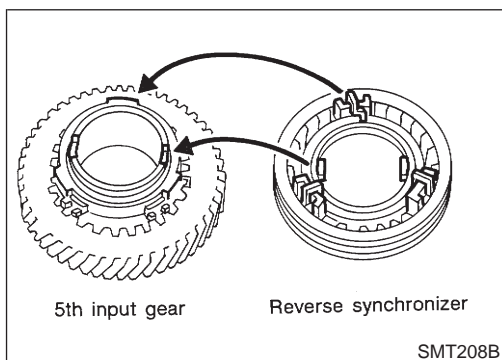

- e. Place reverse synchronizer assembly on 5th input gear.
  - **Mesh recesses of 5th input gear with projections of reverse synchronizer cone.**
  - **Put insert spring mounts on reverse baulk ring upon those on 5th baulk ring.**

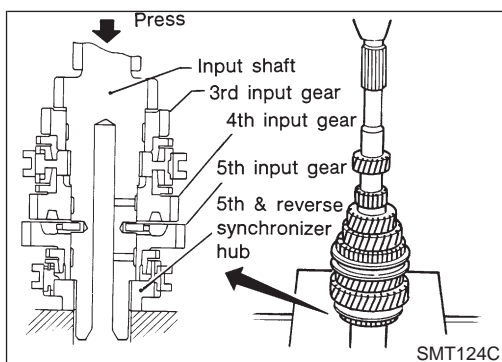

- f. Press on 5th & reverse synchronizer assembly with 5th input gear.

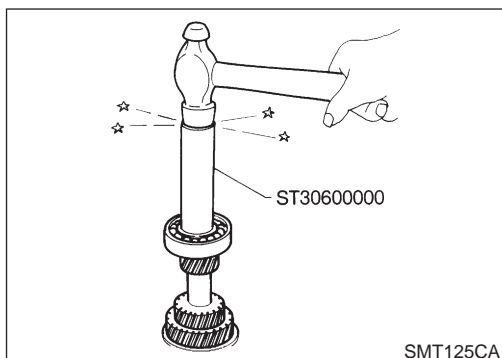

8. Install input shaft front bearing.

## REPAIR FOR COMPONENT PARTS

### Input Shaft and Gears (Cont'd)

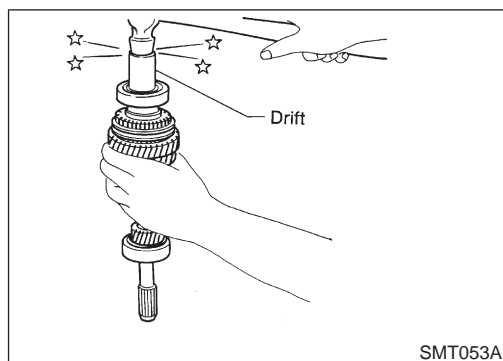

9. Install input shaft rear bearing.
10. Measure gear end play as a final check. Refer to "DISASSEMBLY", MT-19.

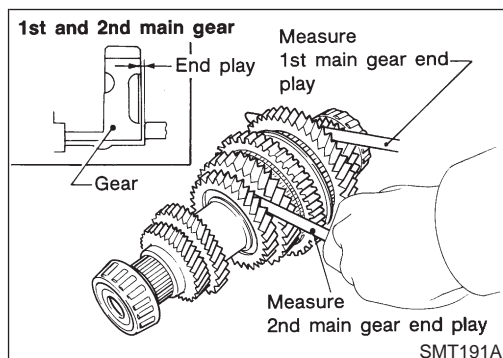

### Mainshaft and Gears DISASSEMBLY

1. Before disassembly, check 1st and 2nd main gear end plays. NFMT0014

**Gear end play:**  
**Refer to SDS, MT-43.**

If not within specification, disassemble and check contact surface of gear, shaft and hub. Check clearance of snap ring groove. Refer to "ASSEMBLY", MT-27.

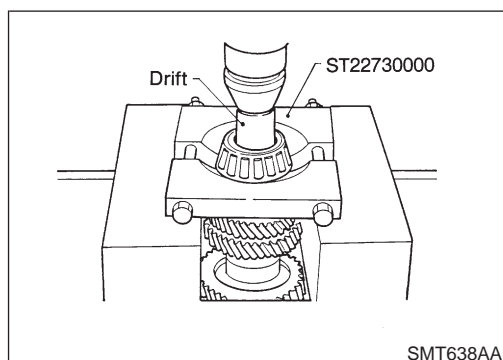

2. Press out mainshaft rear bearing.

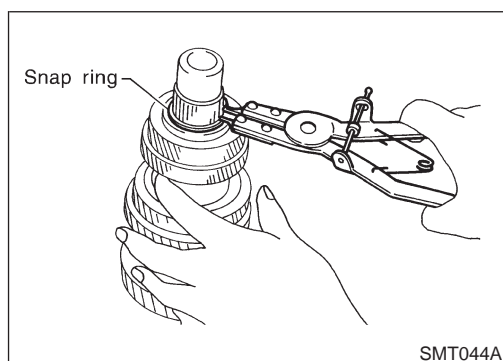

3. Remove thrust washer and snap ring.

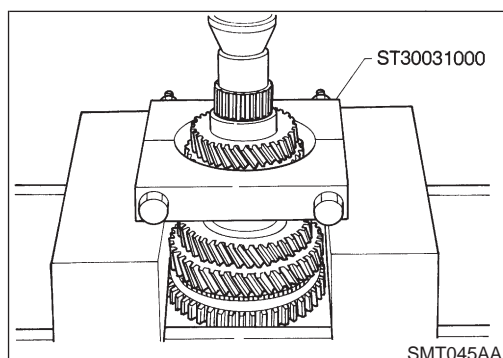

4. Press out 5th main gear and 4th main gear.



## REPAIR FOR COMPONENT PARTS

Mainshaft and Gears (Cont'd)

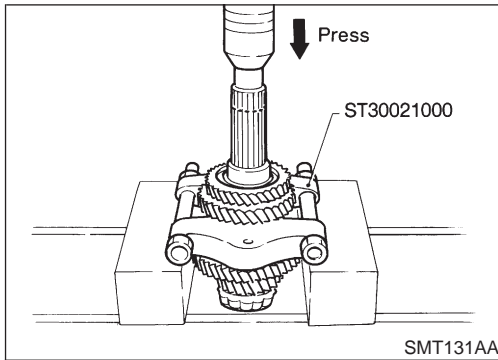

5. Press out 3rd main gear and 2nd main gear.

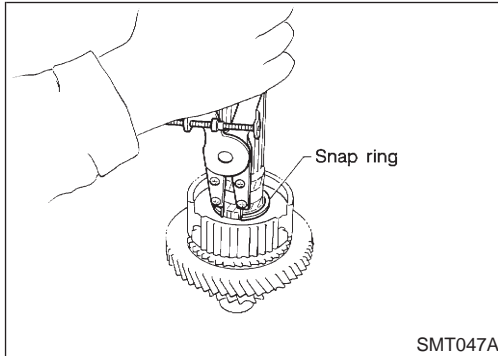

6. Remove snap ring.

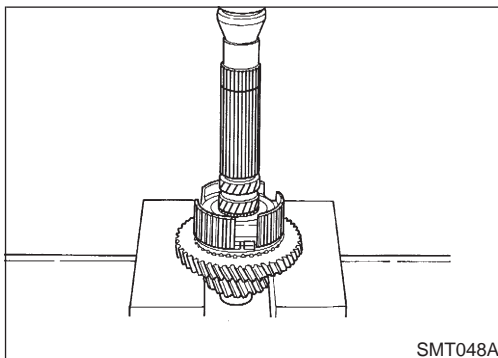

7. Remove 1st & 2nd synchronizer hub and 1st main gear.

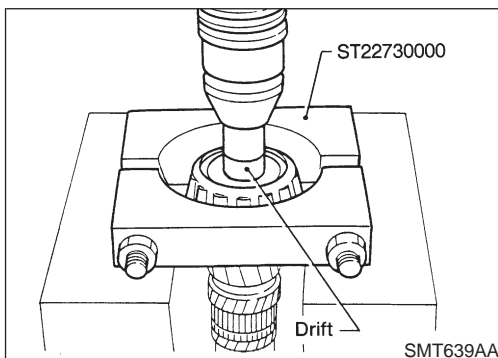

8. Remove mainshaft front bearing.

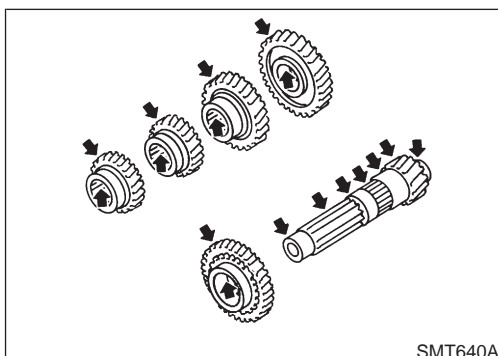

### INSPECTION Mainshaft and Gears

- Check mainshaft for cracks, wear or bending.
- Check gears for excessive wear, chips or cracks.

NFMT0015

NFMT0015S01

## REPAIR FOR COMPONENT PARTS

Mainshaft and Gears (Cont'd)

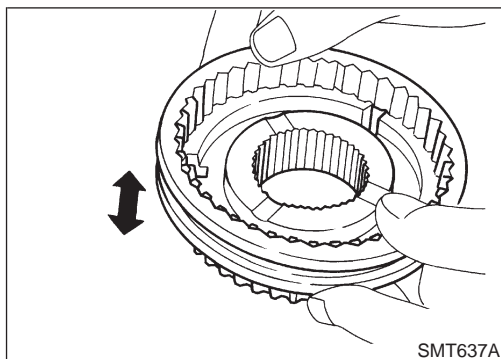

### Synchronizer

NFMT0015S02

- Check spline portion of coupling sleeves, hubs and gears for wear or cracks.
- Check baulk rings for cracks or deformation.
- Check insert springs for deformation.

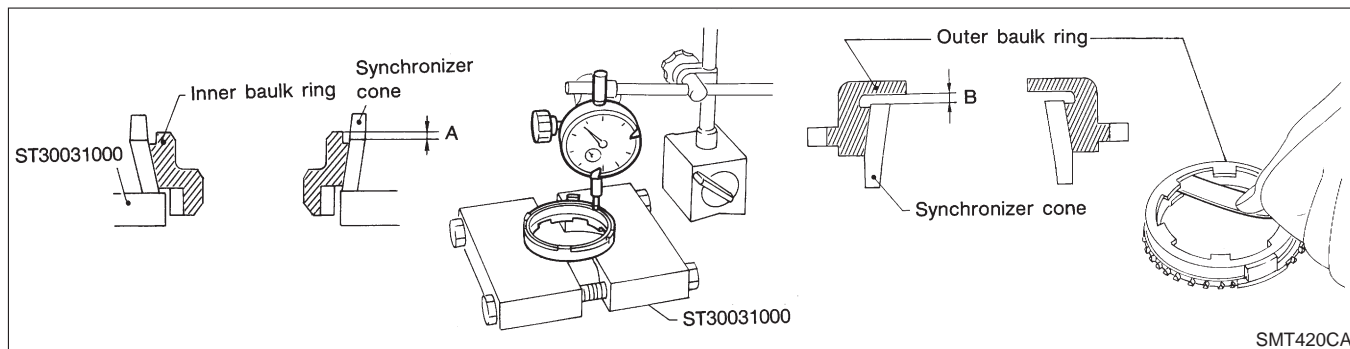

- Measure wear of 1st and 2nd double baulk rings.
- a) Place baulk rings in position on synchronizer cone.
- b) While holding baulk ring against synchronizer cone as far as it will go, measure dimensions "A" and "B".

#### Standard:

**A 0.6 - 0.8 mm (0.024 - 0.031 in)**

**B 0.6 - 1.1 mm (0.024 - 0.043 in)**

#### Wear limit:

**0.2 mm (0.008 in)**

- c) If dimension "A" or "B" is smaller than the wear limit, replace outer baulk ring, inner baulk ring and synchronizer cone as a set.

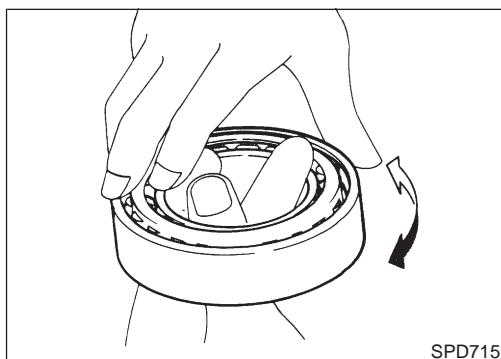

### Bearing

NFMT0015S03

- Make sure bearings roll freely and are free from noise, cracks, pitting or wear.
- **When replacing tapered roller bearing, replace outer and inner race as a set.**

# REPAIR FOR COMPONENT PARTS

Mainshaft and Gears (Cont'd)

NFMT0016

## ASSEMBLY

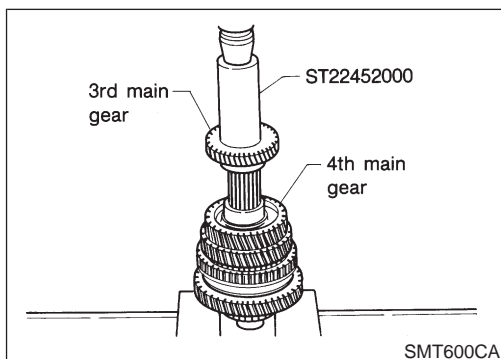
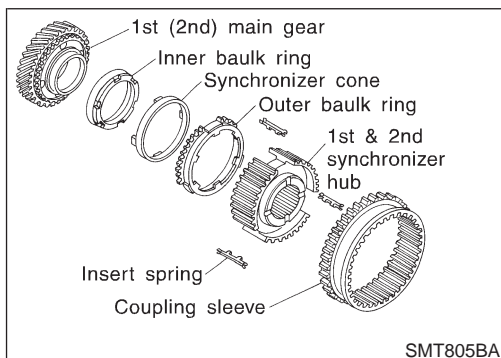
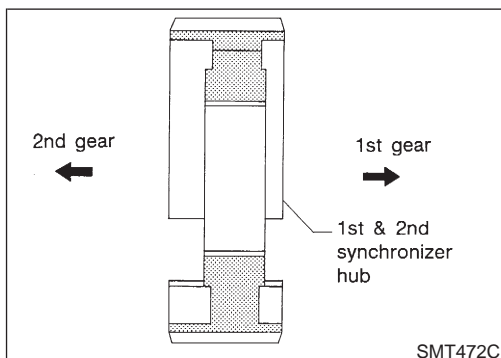
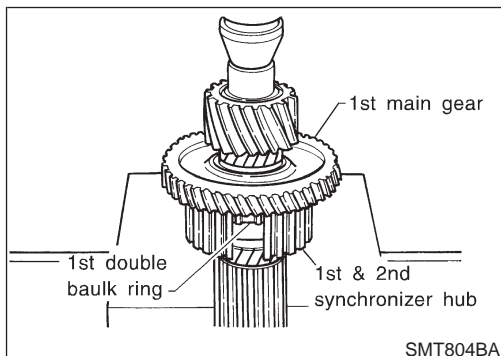
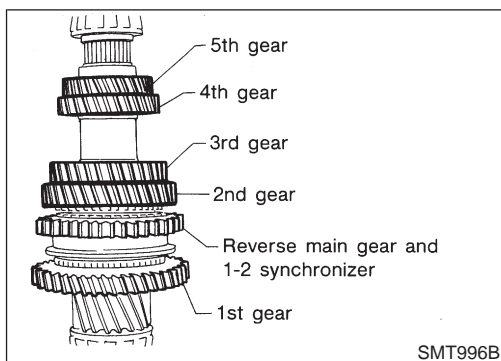

1. Press on 1st main gear, 1st synchronizer cone, inner & outer baulk rings and 1st & 2nd synchronizer hub. Refer to the illustration for step 3.

- **Pay attention to direction of 1st & 2nd synchronizer hub.**
2. Select proper snap ring of 1st & 2nd synchronizer hub to minimize clearance of groove and then install it.

**Allowable clearance of groove:**

**0 - 0.1 mm (0 - 0.004 in)**

**Snap ring of 1st & 2nd synchronizer hub:**

**Refer to SDS, MT-44.**

3. Install 1st (2nd) synchronizer cone, inner & outer baulk rings. Insert springs and 1st & 2nd coupling sleeve.

4. Install 2nd main gear.

- Ensure four protrusions of 1st (2nd) synchronizer cone are set in holes of 1st (2nd) main gear.

5. Press on 3rd main gear.

6. Press on 4th main gear.

## REPAIR FOR COMPONENT PARTS

### Mainshaft and Gears (Cont'd)

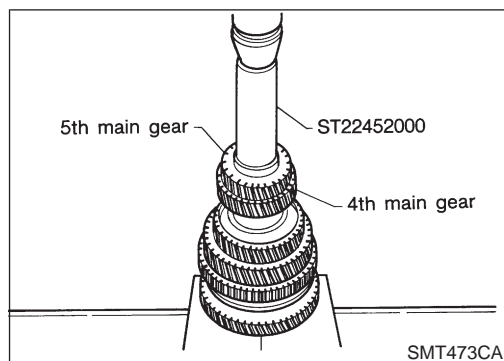

7. Press on 5th main gear.
8. Select proper snap ring of 5th main gear to minimize clearance of groove and then install it.

**Allowable clearance of groove:**

**0 - 0.15 mm (0 - 0.0059 in)**

**Snap ring of 5th main gear:**

**Refer to SDS, MT-45.**

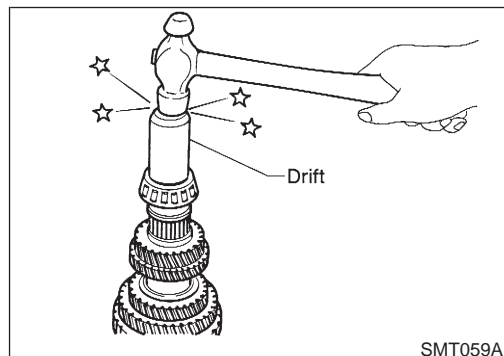

9. Press on thrust washer and press on mainshaft rear bearing.
10. Press on mainshaft front bearing.
11. Measure gear end play as a final check. Refer to "DISASSEMBLY", MT-24.

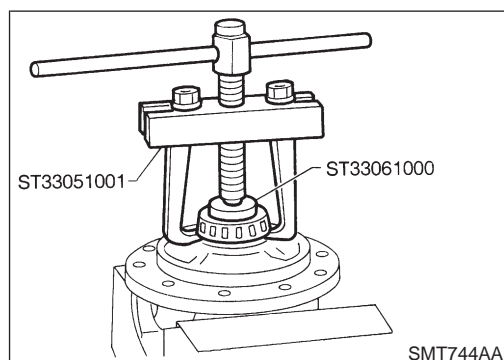

### Final Drive DISASSEMBLY — RS5F50A —

NFMT0017  
NFMT0017S03

1. Remove final gear.
2. Remove speedometer drive gear by cutting it.
3. Press out differential side bearings.
- **Be careful not to mix up the right and left bearings.**

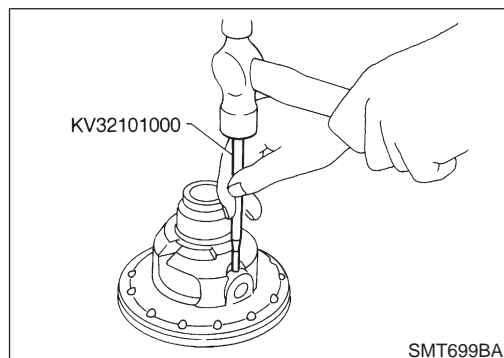

4. Drive out retaining pin and draw out pinion mate shaft.
5. Remove pinion mate gears and side gears.

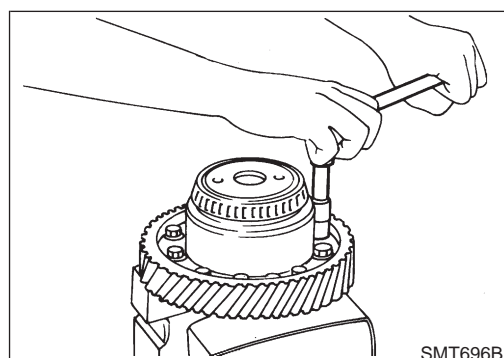

### — RS5F50V —

NFMT0017S04

1. Remove final gear.

## REPAIR FOR COMPONENT PARTS

Final Drive (Cont'd)

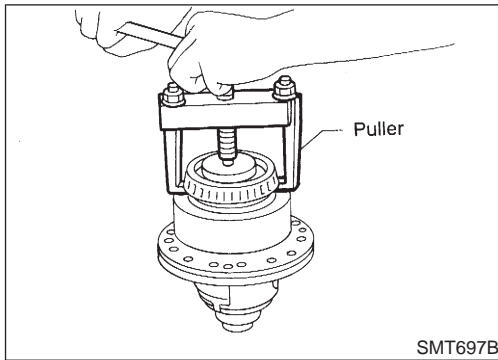

2. Press out differential side bearings.

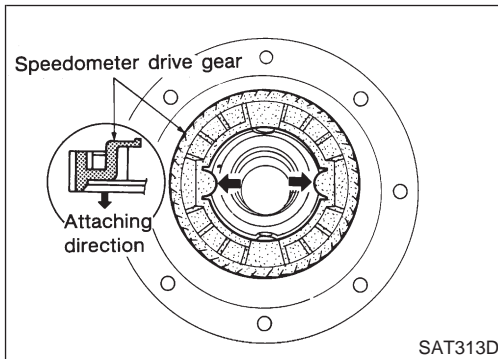

3. Remove speedometer drive gear.

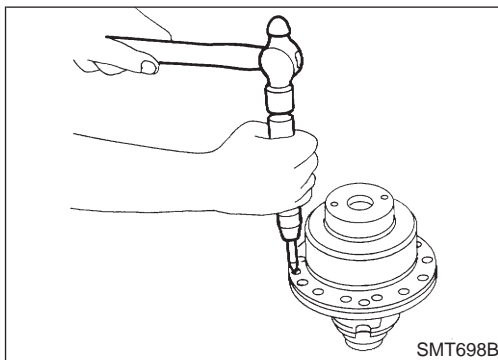

4. Remove viscous coupling.

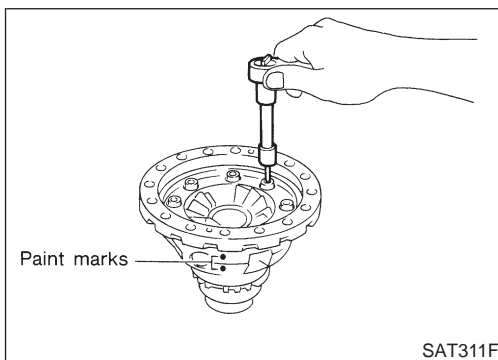

5. Separate differential cases. Make paint marks to identify their original positions.

6. Remove pinion mate shaft with gears.

## REPAIR FOR COMPONENT PARTS

Final Drive (Cont'd)

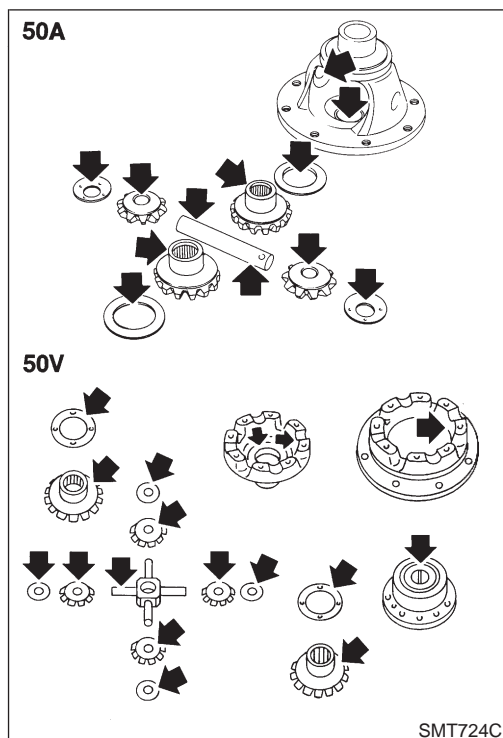

### INSPECTION

#### Gear, Washer, Shaft and Case

NFMT0031

NFMT0031S01

- Check mating surfaces of differential case, viscous coupling, side gears and pinion mate gears.
- Check washers for wear.

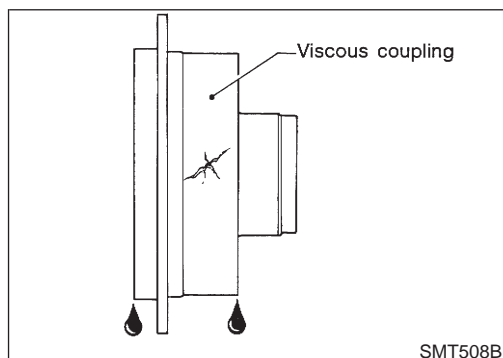

#### Viscous Coupling

NFMT0031S02

- Check case for cracks.
- Check silicone oil for leakage.

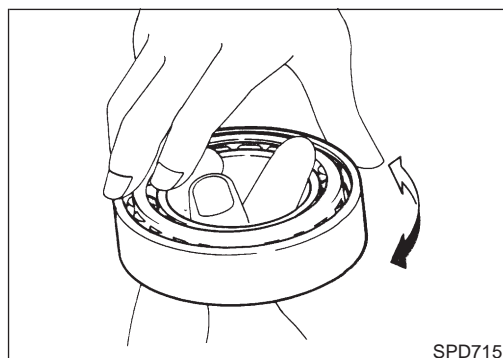

#### Bearings

NFMT0031S03

- Make sure bearings roll freely and are free from noise, cracks, pitting or wear.
- **When replacing taper roller bearing, replace outer and inner race as a set.**

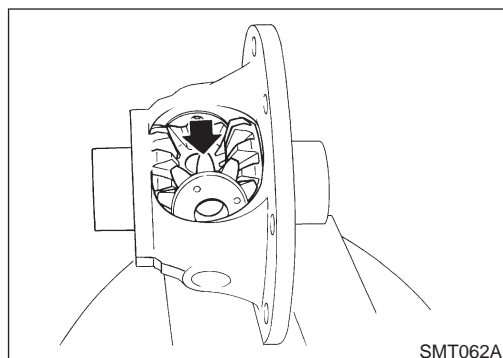

### ASSEMBLY

#### — RS5F50A —

NFMT0019

NFMT0019S03

1. Attach side gear thrust washers to side gears, then install pinion mate washers and pinion mate gears in place.

## REPAIR FOR COMPONENT PARTS

Final Drive (Cont'd)

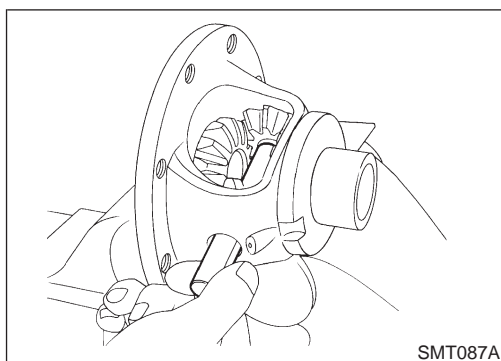

2. Insert pinion mate shaft.
  - **When inserting, be careful not to damage pinion mate thrust washers.**

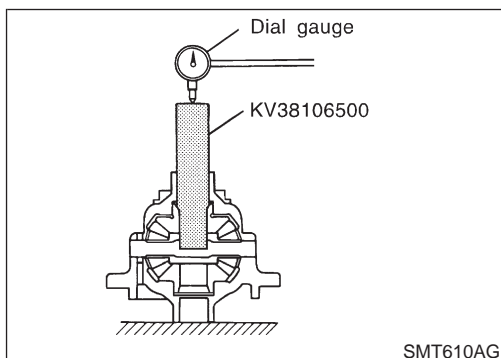

3. Measure clearance between side gear and differential case with washers following the procedure below:
  - a. Set Tool and dial indicator on side gear.
  - b. Move side gear up and down to measure dial indicator deflection. Always measure indicator deflection on both side gears.

**Clearance between side gear and differential case with washers:**

**0.1 - 0.2 mm (0.004 - 0.008 in)**

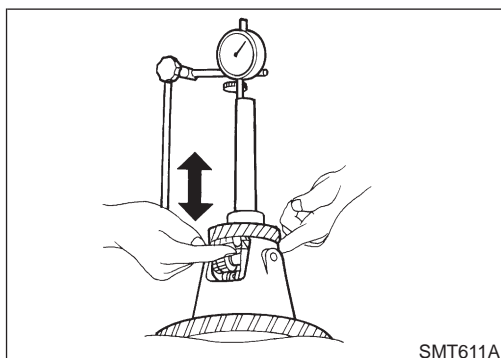

- c. If not within specification, adjust clearance by changing thickness of side gear thrust washers.

**Differential side gear thrust washer:**

**Refer to SDS, MT-45.**

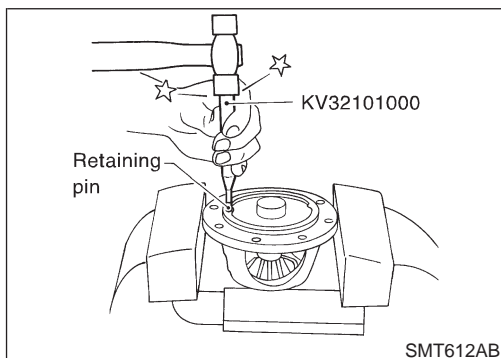

4. Install retaining pin.
  - **Make sure that retaining pin is flush with case.**

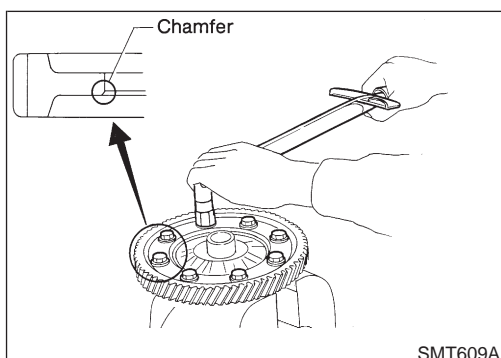

5. Install final gear.
6. Install speedometer drive gear.

## REPAIR FOR COMPONENT PARTS

Final Drive (Cont'd)

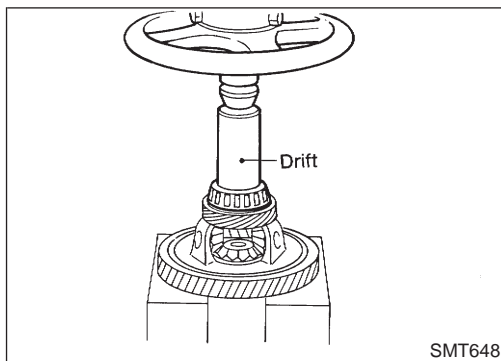

7. Press on differential side bearings.

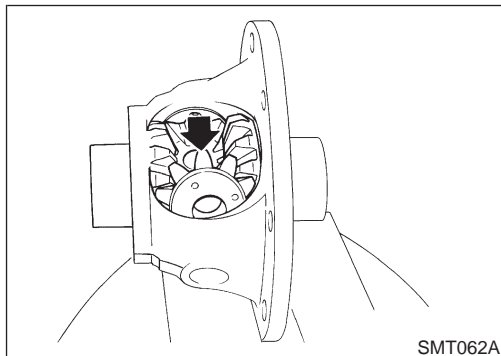

### — RS5F50V —

1. Attach side gear thrust washers to side gears, then install pinion mate washers and pinion mate gears in place. NFMT0019S04

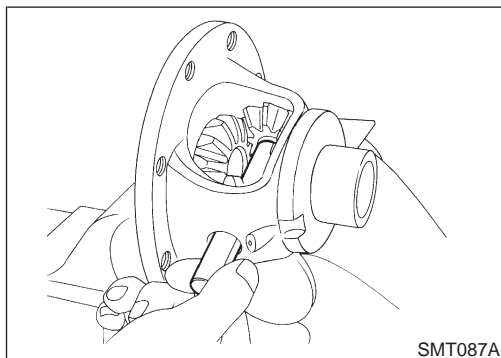

2. Insert pinion mate shaft.  
 ● **When inserting, be careful not to damage pinion mate thrust washers.**

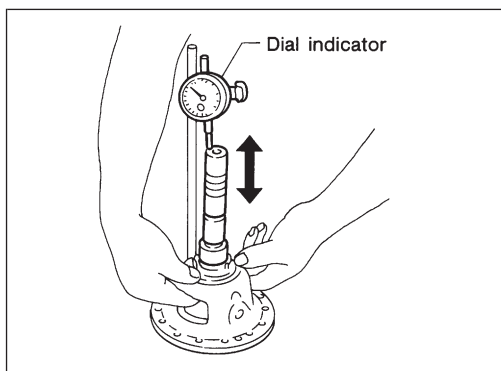

3. Measure clearance between side gear and differential case & viscous coupling with washers using the following procedure:

#### Differential case side

- 1) Set Tool and dial indicator on side gear. NFMT0019S0401
- 2) Move side gear up and down to measure dial indicator deflection.

**Clearance between side gear and differential case with washers:**

**0.1 - 0.2 mm (0.004 - 0.008 in)**

- 3) If not within specification adjust clearance by changing thickness of side gear thrust washer.

**Side gear thrust washers for differential case side:  
 Refer to SDS, MT-45.**

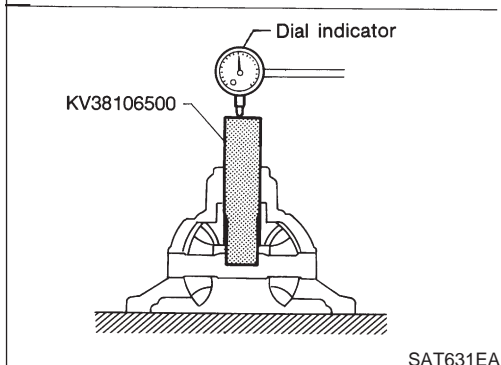



# REPAIR FOR COMPONENT PARTS

Final Drive (Cont'd)

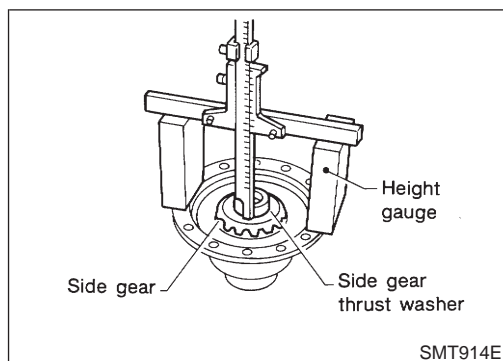

## Viscous coupling side

NFMT0019S0402

- 1) Place side gear and thrust washer on pinion mate gears installed on differential case.

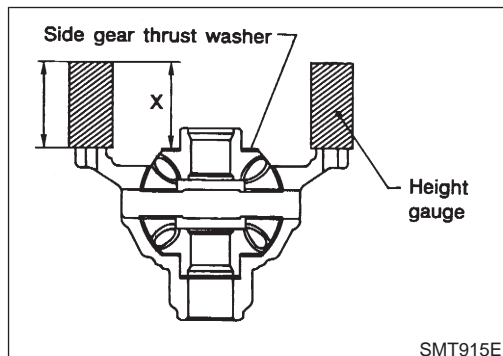

- 2) Measure dimension X.
  - Measure dimension X in at least four places.

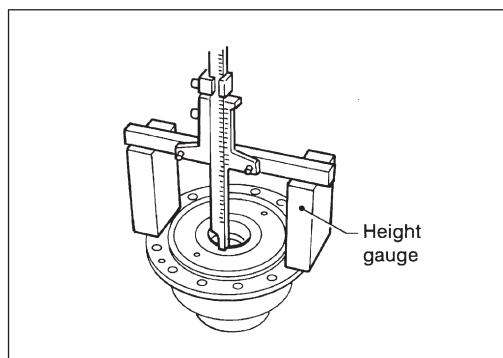

- 3) Measure dimension Y.
  - Measure dimension Y in at least four places.
    - Clearance between side gear and viscous coupling =  $X + Y - 2A$ : 0.1 - 0.2 mm (0.004 - 0.008 in)
    - A: Height of gauge
- 4) If not within specification, adjust clearance by changing thickness of side gear thrust washer.

Side gear thrust washers for viscous coupling side:  
Refer to SDS, MT-45.

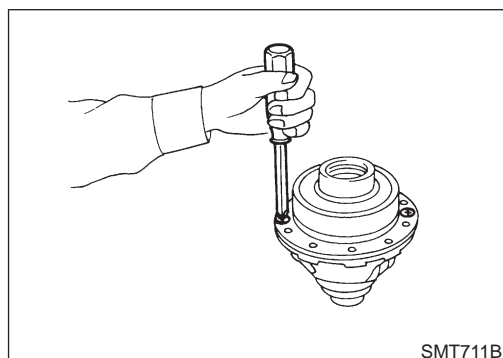
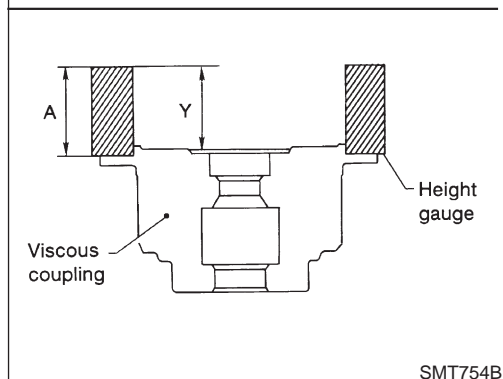

4. Install viscous coupling.

## REPAIR FOR COMPONENT PARTS

### Final Drive (Cont'd)

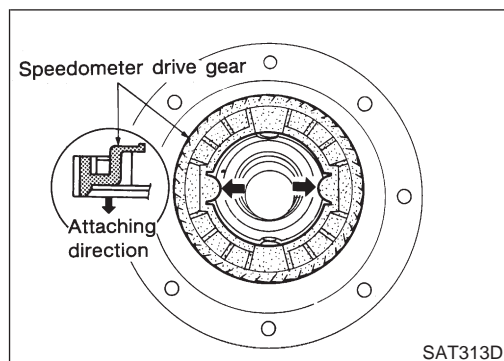

5. Install speedometer drive gear on differential case.
  - **Align the projection of speedometer drive gear with the groove of differential case.**

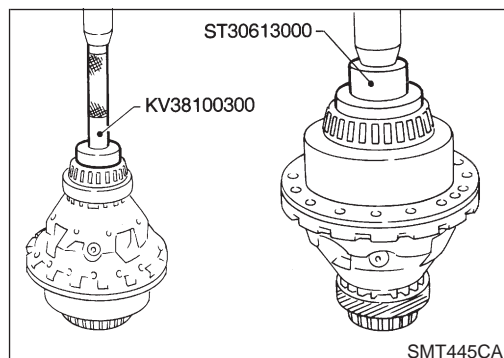

6. Press differential side bearings on differential case.

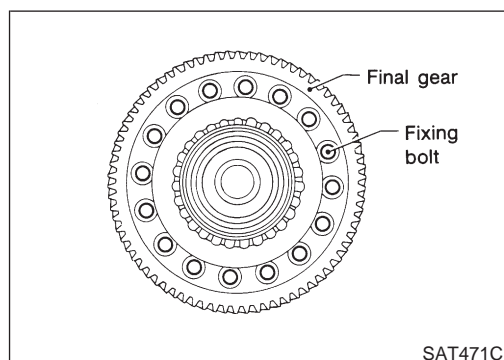

7. Install final gear and tighten fixing bolts in a crisscross pattern.

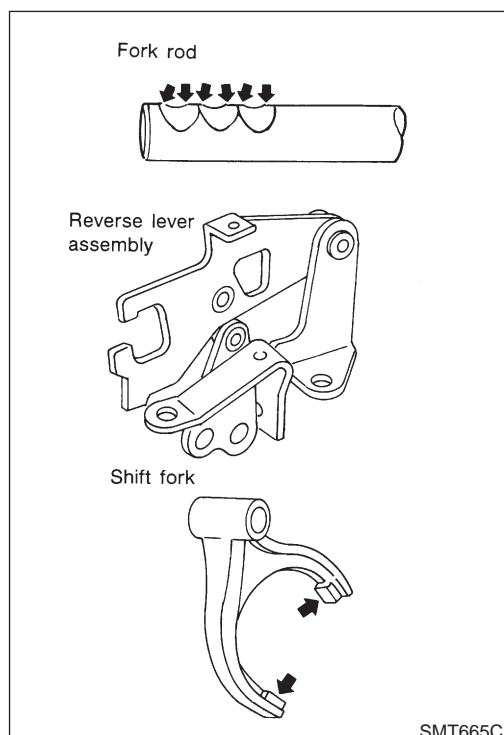

### Shift Control Components INSPECTION

- Check contact surface and sliding surface for wear, scratches, projections or other damage.

NFMT0020

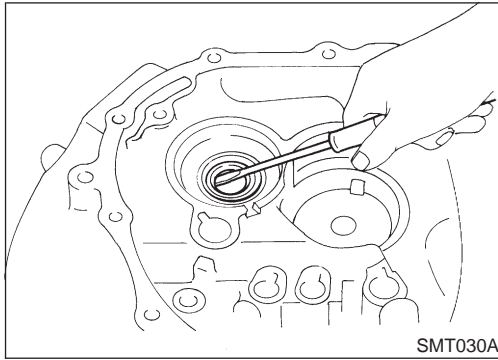

## Case Components REMOVAL AND INSTALLATION Input Shaft Oil Seal

NFMT0021

NFMT0021S01

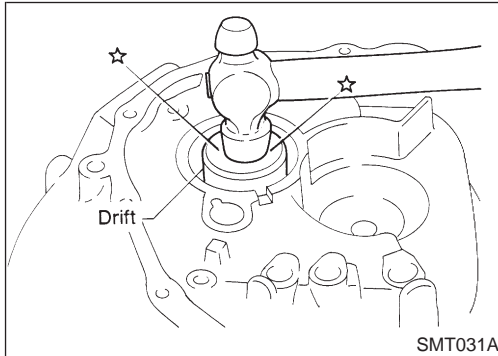

- Apply multi-purpose grease to seal lip of oil seal before installing.

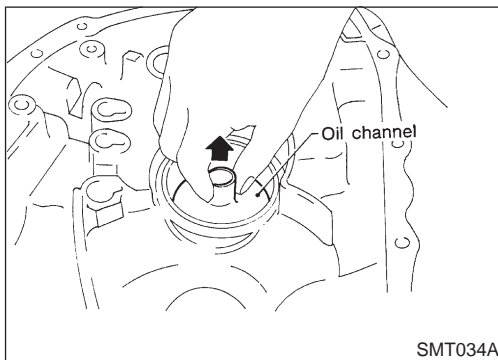

## Mainshaft Front Bearing Outer Race

NFMT0021S02

- Extract the oil channel and remove the mainshaft front bearing outer race.

## Mainshaft Rear Bearing Outer Race

NFMT0021S03

Refer to “Mainshaft Bearing Preload”, MT-37.

## Differential Side Bearing Outer Race

NFMT0021S04

Refer to “Input Shaft End Play and Differential Side Bearing Preload”, MT-36.

## ADJUSTMENT

### Input Shaft End Play and Differential Side Bearing Preload

#### Input Shaft End Play and Differential Side Bearing Preload

NFMT0022S01

If any of the following parts are replaced, adjust input shaft end play.

- Input shaft
- Input shaft bearing
- Clutch housing
- Transmission case

If any of the following parts are replaced, adjust differential side bearing preload.

- Differential case
- Differential side bearing
- Clutch housing
- Transmission case

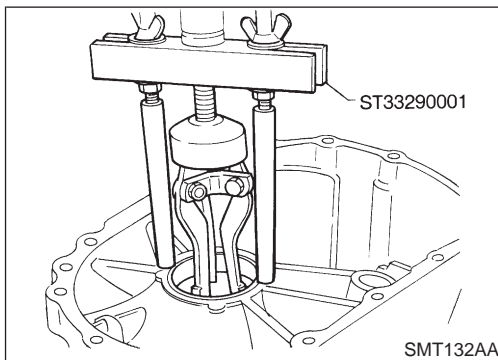

1. Remove differential side bearing outer race (transmission case side) and shim(s).

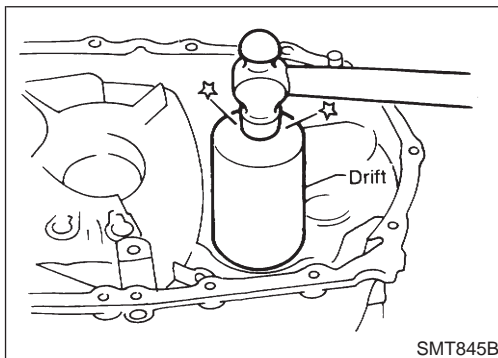

2. Reinstall differential side bearing outer race without shim(s).
3. Install input shaft and final drive assembly on clutch housing.
4. Install transmission case without input shaft bearing shim(s). Then tighten it to the specified torque. Refer to "Case Components", MT-13.

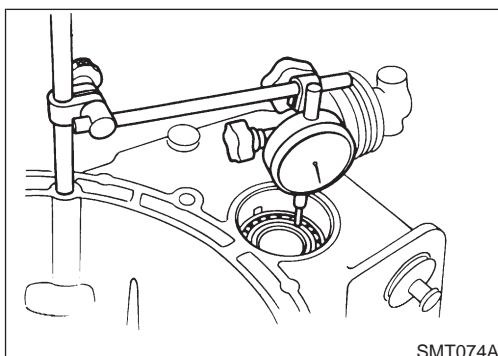

5. Using the following procedures, measure clearance between bearings and transmission case.

#### DIFFERENTIAL SIDE

NFMT0022S0101

1. Attach dial indicator. If clamp diameter of dial indicator is too small or too large, attach dial indicator using a magnetic stand.

## ADJUSTMENT

### Input Shaft End Play and Differential Side Bearing Preload (Cont'd)

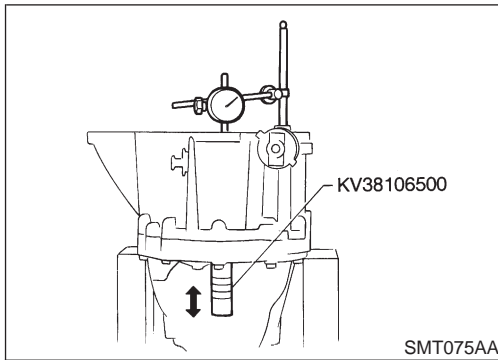

2. Insert preload adapter all the way into differential side gear. Move preload adapter up and down and measure dial indicator deflection.
3. Select differential side bearing adjusting shims with proper thickness with SDS table as a guide. Refer to SDS, MT-47, MT-48.

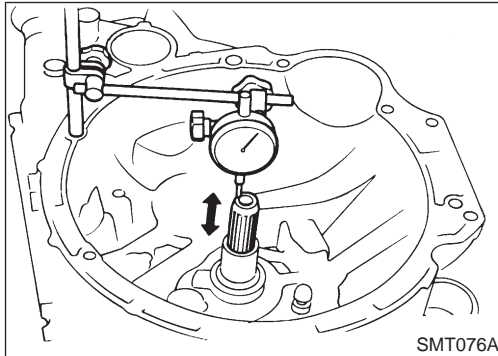

### INPUT SHAFT SIDE

NFMT0022S0102

1. Set dial indicator on end of input shaft.
2. Move input shaft up and down and measure dial indicator deflection.
3. Select input shaft bearing adjusting shims with proper thickness with SDS table as a guide. Refer to SDS, MT-47.
4. Install selected differential side bearing adjusting shim and differential side bearing outer race.

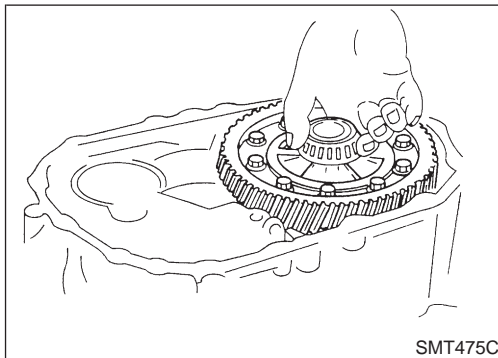

5. Check differential side bearing turning torque.
  - a. Install final drive assembly on clutch housing.
  - b. Install transmission case on clutch housing.
- **Tighten transmission case fixing bolts to the specified torque. Refer to "Case Components", MT-13.**

### Mainshaft Bearing Preload

NFMT0022S02

If any of the following parts are replaced, adjust mainshaft bearing preload.

- Mainshaft
- Mainshaft bearings
- Clutch housing
- Transmission case

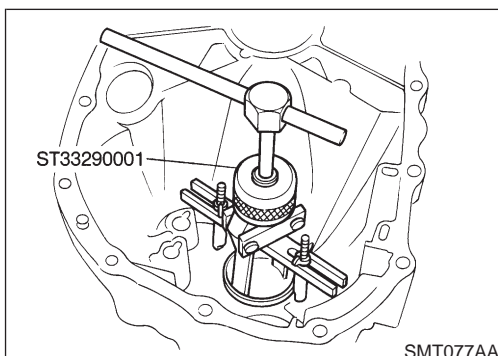

1. Remove mainshaft rear bearing outer race and shim(s).

## ADJUSTMENT

### Mainshaft Bearing Preload (Cont'd)

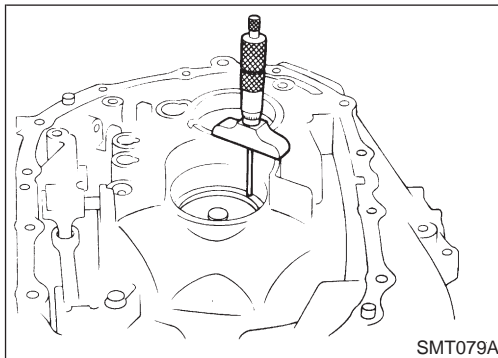
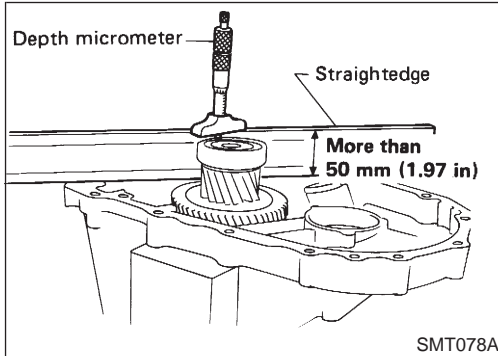
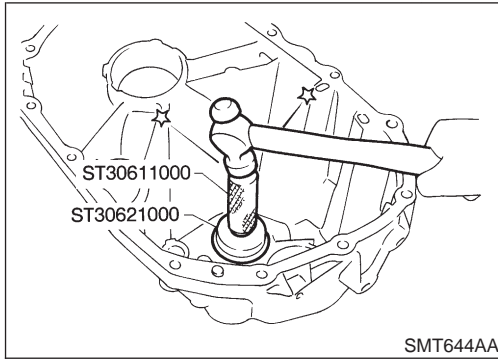

2. Reinstall mainshaft rear bearing outer race without shims.
3. Clean mating surfaces of clutch housing and transmission case with solvent.
4. Install mainshaft and mainshaft front bearing outer race into transmission case. Turn mainshaft while holding bearing outer race so that bearings are properly seated.
5. Put straightedge [width must be more than 50 mm (1.97 in)] on transmission case, and measure the distance from upper surface of straightedge to surface of the bearing outer race using a depth micrometer.
  - Measure at three places on bearing outer race, and take the average.
6. Determine dimension A to be used by the following equation.  
**Dimension A = Width of straightedge – measured distance**
7. Measure the distance from mating surface of clutch housing to portion with which mainshaft front bearing outer race is to be mated.
  - Measure at three places on the portion, and take the average.  
**Dimension B = Measured distance**
8. Determine dimension C to be used by the following equation.  
**Dimension "C" = B – A**
9. Determine total thickness of mainshaft bearing adjusting shims with SDS table as a guide. Refer to SDS, MT-46.
10. Install selected mainshaft bearing adjusting shim and mainshaft bearing outer race.
11. Check total turning torque after assembly. Refer to "ASSEMBLY", MT-39.

# ASSEMBLY

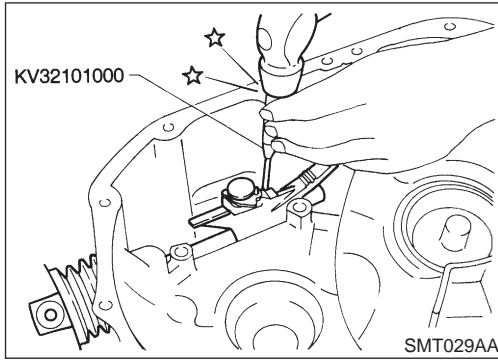

1. Install striking lever and striking rod.

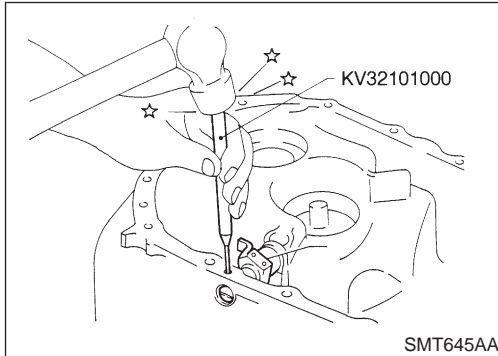

2. Install selector and retaining pin.

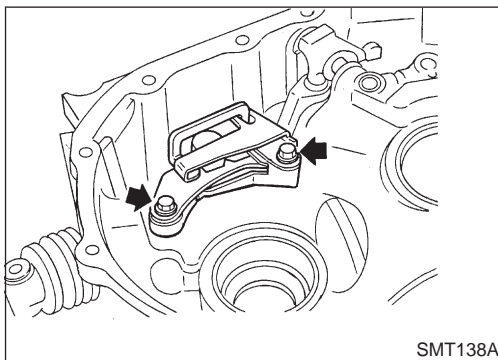

3. Install check ball and reverse check assembly.

- **Before installation, rotate striking rod as shown in the figure to avoid interference.**

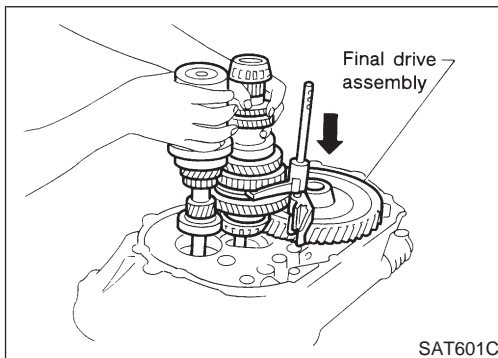

4. Install final drive assembly.

5. Install input shaft and mainshaft with 1st & 2nd shift fork assembly.

- **Be careful not to damage input shaft oil seal.**

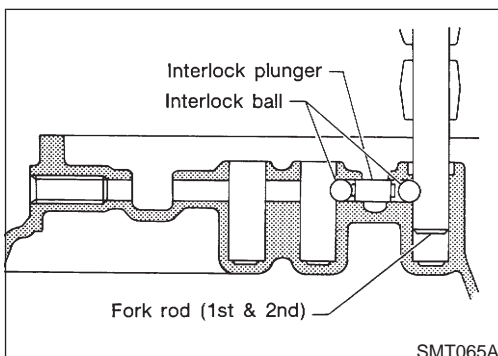

6. Install interlock balls and plunger.

## ASSEMBLY

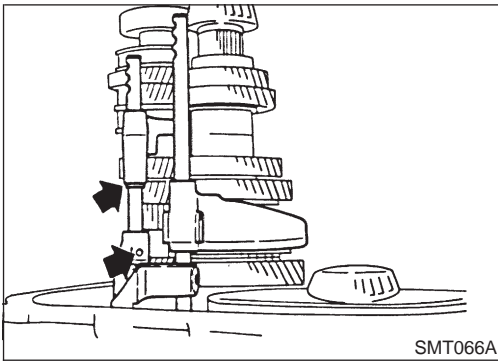

7. Install 3rd & 4th shift fork and bracket, then install 3rd & 4th fork rod, stopper ring and retaining pin.

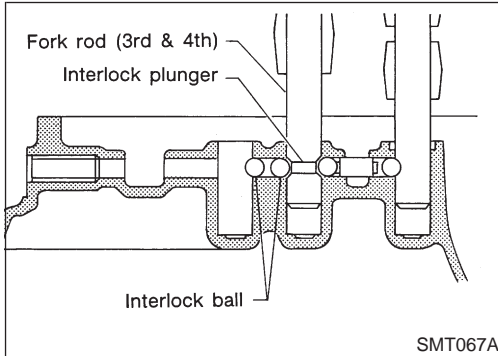

8. Install interlock balls and plunger.

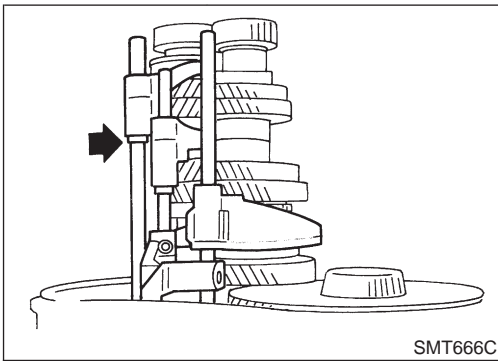

9. Install 5th shift fork, then install fork rod, stopper ring and retaining pin.

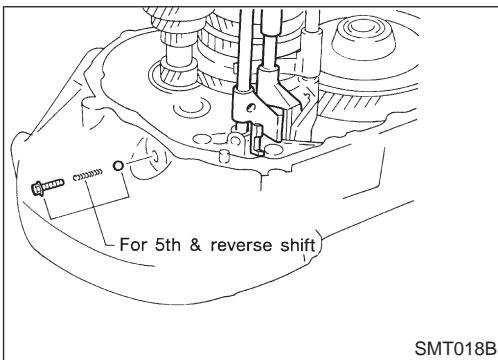

10. Install 5th & reverse check plug, spring and ball.
  - Apply sealant to bolt threads. Refer to "Shift Control Components", MT-15.

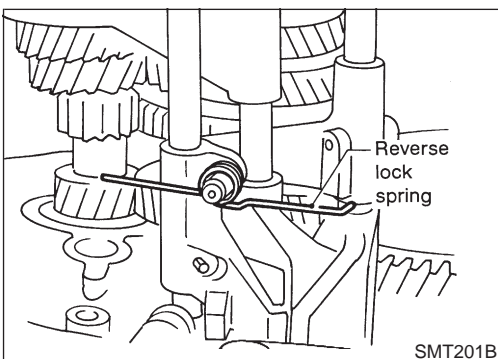

11. Install reverse lock spring on 5th & reverse bracket.
  - Pay attention to its direction.



## ASSEMBLY

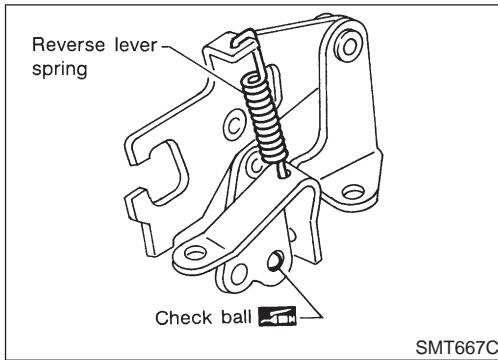

12. Install check ball and reverse lever spring on reverse lever assembly.
  - Apply multi-purpose grease to check ball.
  - Pay attention to direction of reverse lever spring.

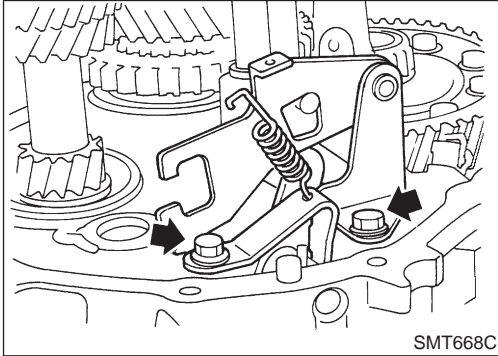

13. Install reverse lever assembly on clutch housing.

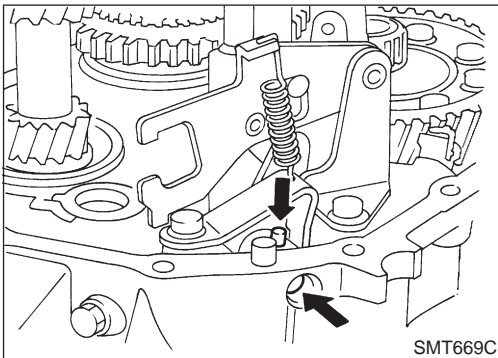

14. Install reverse arm shaft and retaining pin.

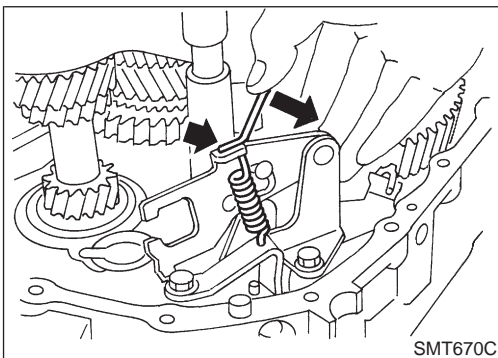

15. Hook reverse lock spring and reverse lever spring on reverse lever assembly.

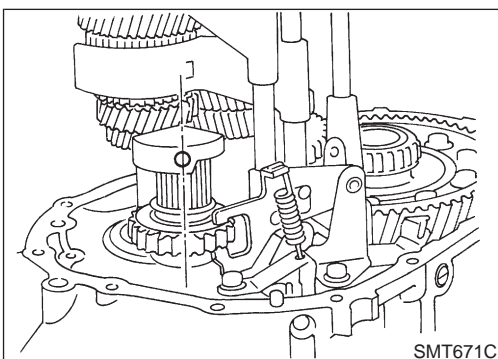

16. Mesh 4th gear, then install reverse idler gear and shaft.
  - Pay attention to direction of tapped hole.

## ASSEMBLY

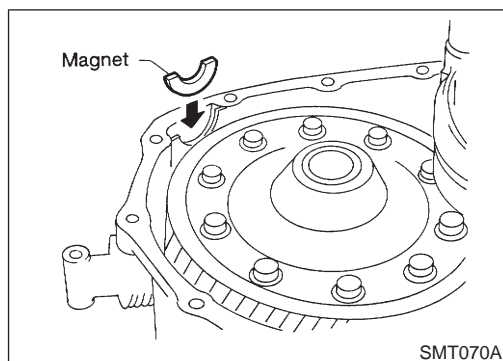

17. Place magnet on clutch housing.

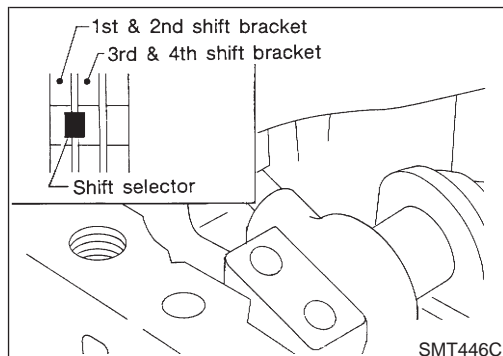

18. If bearing preload of mainshaft was adjusted, install selected shim(s) into transmission case.

- To aid in installation of transmission case, place shift selector in the 1st and 2nd shift bracket or between 1st and 2nd bracket and 3rd and 4th bracket.

19. Apply sealant to mating surface of transmission case and install it. Refer to "Case Components", MT-13.

20. Install PNP switch.

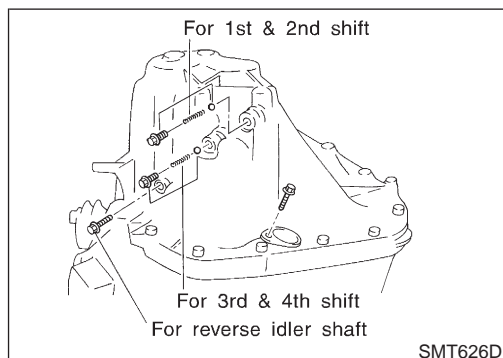

21. Apply sealant to threads of check plugs. Install balls, springs and plugs. Refer to "Shift Control Components", MT-15.

22. After assembly, check that you can shift into each gear smoothly.

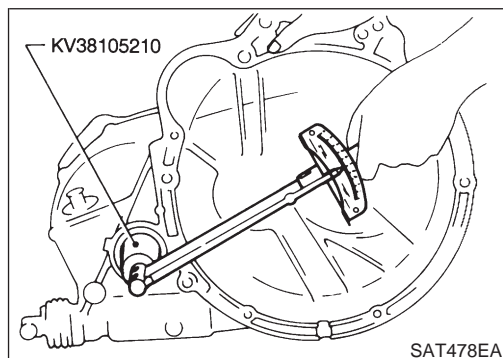

23. Measure total turning torque.

**Total turning torque (New bearing):**

**8.8 - 21.6 N·m (90 - 220 kg·cm, 78 - 191 in·lb)**

- When old bearing is used again, preload will be slightly less than the above. Make sure torque is close to the specified range.

# SERVICE DATA AND SPECIFICATIONS (SDS)

General Specifications

## General Specifications

NFMT0024

### TRANSAXLE

NFMT0024S01

Engine	VQ20DE	VQ30DE
Transaxle model	RS5F50A	RS5F50V
Number of speeds	5	
Synchromesh type	Warner	
Shift pattern		
Shift position	Gear ratio	Number of teeth
		Input gear      Main gear
1st	3.285	14      46
2nd	1.850	20      37
3rd	1.272	33      42
4th	0.954	44      42
5th	0.795	49      39
Rev.	3.428	14      48
Reverse idler gear	29	
Gear oil*	Level mm (in)	16 - 25 (0.63 - 0.98)
	Capacity liter (Imp pt)	4.5 - 4.8 (7-7/8 - 8-1/2)      4.25 - 4.55 (7-1/2 - 8)
Remarks	Double baulk ring type synchronizer	1st & 2nd synchronizer

\*1: Refer to MT-9, "Fluids and Lubricants".

### FINAL GEAR

NFMT0024S02

Engine	VQ20DE	VQ30DE
Transaxle model	RS5F50A	RS5F50V
Final gear ratio	4.471	3.823
Number of teeth	Final gear/Pinion	76/17      65/17
	Side gear/Pinion	14/10      16/10

### Gear End Play

NFMT0025  
Unit: mm (in)

Gear	End play
1st main gear	0.23 - 0.43 (0.0091 - 0.0169)
2nd main gear	0.23 - 0.58 (0.0091 - 0.0228)
3rd input gear	0.23 - 0.43 (0.0091 - 0.0169)
4th input gear	0.25 - 0.55 (0.0098 - 0.0217)
5th input gear	0.23 - 0.48 (0.0091 - 0.0189)

### Clearance Between Baulk Ring and Gear

NFMT0026

#### 3RD, 4TH & 5TH

NFMT0026S01  
Unit: mm (in)

Gear	Standard	Wear limit
3rd, 4th & 5th	1.0 - 1.35 (0.0394 - 0.0531)	0.7 (0.028)

## SERVICE DATA AND SPECIFICATIONS (SDS)

Clearance Between Baulk Ring and Gear (Cont'd)

### 1ST AND 2ND DOUBLE BAULK RING

NFMT0026S02  
Unit: mm (in)

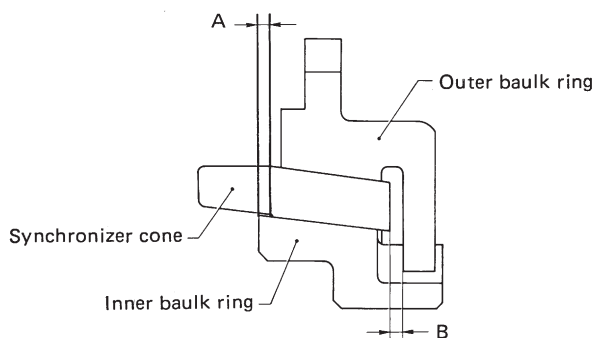

SMT806B

Dimension	Standard	Wear limit
A	0.6 - 0.8 (0.024 - 0.031)	0.2 (0.008)
B	0.6 - 1.1 (0.024 - 0.043)	

### REVERSE BAULK RING

NFMT0026S03

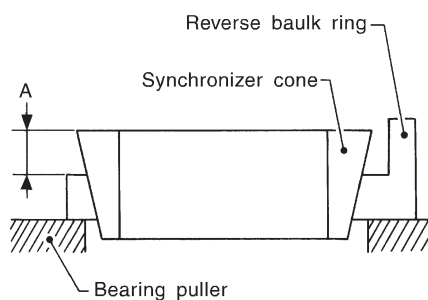

SMT581BA

Dimension	Wear limit
A	1.2 mm (0.047 in)

## Available Snap Rings

### 1ST & 2ND SYNCHRONIZER HUB (AT MAINSHAFT)

NFMT0027  
NFMT0027S01

Allowable clearance	0 - 0.1 mm (0 - 0.004 in)
Thickness mm (in)	Part number*
1.95 (0.0768)	32269-03E03
2.00 (0.0787)	32269-03E00
2.05 (0.0807)	32269-03E01
2.10 (0.0827)	32269-03E02

\*: Always check with the Parts Department for the latest parts information.

### 3RD & 4TH SYNCHRONIZER HUB (AT INPUT SHAFT)

NFMT0027S02

Allowable clearance	0 - 0.1 mm (0 - 0.004 in)
Thickness mm (in)	Part number*
1.95 (0.0768)	32269-03E03
2.00 (0.0787)	32269-03E00
2.05 (0.0807)	32269-03E01
2.10 (0.0827)	32269-03E02

\*: Always check with the Parts Department for the latest parts information.

## SERVICE DATA AND SPECIFICATIONS (SDS)

Available Snap Rings (Cont'd)

### 5TH MAIN GEAR (AT MAINSHAFT)

NFMT0027S03

Allowable clearance	0 - 0.15 mm (0 - 0.0059 in)
Thickness mm (in)	Part number*
1.95 (0.0768)	32348-05E00
2.05 (0.0807)	32348-05E01
2.15 (0.0846)	32348-05E02
2.25 (0.0886)	32348-05E03

\*: Always check with the Parts Department for the latest parts information.

### Available Thrust Washer

### 4TH INPUT GEAR (AT INPUT SHAFT)

NFMT0032

NFMT0032S01

Allowable clearance	0 - 0.06 mm (0 - 0.0024 in)
Thickness mm (in)	Part number*
4.500 (0.1772)	32278-03E01
4.525 (0.1781)	32278-03E02
4.550 (0.1791)	32278-03E03
4.575 (0.1801)	32278-03E04

\*: Always check with the Parts Department for the latest parts information.

### DIFFERENTIAL SIDE GEAR THRUST WASHER

NFMT0032S02

### RS5F50A

NFMT0032S0201

Allowable clearance between side gear and differential case with washer	0.1 - 0.2 mm (0.004 - 0.008 in)
Thickness mm (in)	Part number*
0.75 - 0.80 (0.0295 - 0.0315)	38424-E3020
0.80 - 0.85 (0.0315 - 0.0335)	38424-E3021
0.85 - 0.90 (0.0335 - 0.0354)	38424-E3022
0.90 - 0.95 (0.0354 - 0.0374)	38424-E3023

\*: Always check with the Parts Department for the latest parts information.

### RS5F50V

NFMT0032S0202

Allowable clearance between side gear and (differential case or viscous coupling) with washer	0.1 - 0.2 mm (0.004 - 0.008 in)	
	Thickness mm (in)	Part number*
Differential case side	0.75 - 0.80 (0.0295 - 0.0315)	38424-E3000
	0.80 - 0.85 (0.0315 - 0.0335)	38424-E3001
	0.85 - 0.90 (0.0335 - 0.0354)	38424-E3002
	0.90 - 0.95 (0.0354 - 0.0374)	38424-E3003
Viscous coupling side	0.43 - 0.45 (0.0169 - 0.0177)	38424-51E10
	0.52 - 0.54 (0.0205 - 0.0213)	38424-51E11
	0.61 - 0.63 (0.0240 - 0.0248)	38424-51E12
	0.70 - 0.72 (0.0276 - 0.0283)	38424-51E13
	0.79 - 0.81 (0.0311 - 0.0319)	38424-51E14

\*: Always check with the Parts Department for the latest parts information.

### Available Shims

### — INPUT SHAFT END PLAY AND MAINSHAFT AND DIFFERENTIAL SIDE BEARING PRELOAD AND ADJUSTING SHIM

NFMT0033

### BEARING PRELOAD AND END PLAY

NFMT0033S01  
Unit: mm (in)

Mainshaft bearing preload	0.06 - 0.11 (0.0024 - 0.0043)
Input shaft end play	0 - 0.05 (0 - 0.0020)
Differential side bearing preload	0.40 - 0.45 (0.0157 - 0.0177)

## SERVICE DATA AND SPECIFICATIONS (SDS)

Available Shims (Cont'd)

### TOTAL TURNING TORQUE (NEW BEARING)

NFMT0033S02  
Unit: N·m (kg·cm, in·lb)

Total turning torque (new bearing)	8.8 - 21.6 (90 - 220, 78 - 191)
------------------------------------	---------------------------------

### MAINSHAFT BEARING ADJUSTING SHIM

NFMT0033S03

Thickness mm (in)	Part number*
0.40 (0.0157)	32139-03E11
0.44 (0.0173)	32139-03E00
0.48 (0.0189)	32139-03E01
0.52 (0.0205)	32139-03E12
0.56 (0.0220)	32139-03E02
0.60 (0.0236)	32139-03E03
0.64 (0.0252)	32139-03E04
0.68 (0.0268)	32139-03E05
0.72 (0.0283)	32139-03E06
0.76 (0.0299)	32139-03E07
0.80 (0.0315)	32139-03E08
1.20 (0.0472)	32139-03E13

\*: Always check with the Parts Department for the latest parts information.

### TABLE FOR SELECTING MAINSHAFT BEARING ADJUSTING SHIM

NFMT0033S04  
Unit: mm (in)

Dimension "C"	Suitable shim(s)
0.30 - 0.34 (0.0118 - 0.0134)	0.40 (0.0157)
0.34 - 0.38 (0.0134 - 0.0150)	0.44 (0.0173)
0.38 - 0.42 (0.0150 - 0.0165)	0.48 (0.0189)
0.42 - 0.46 (0.0165 - 0.0181)	0.52 (0.0205)
0.46 - 0.50 (0.0181 - 0.0197)	0.56 (0.0220)
0.50 - 0.54 (0.0197 - 0.0213)	0.60 (0.0236)
0.54 - 0.58 (0.0213 - 0.0228)	0.64 (0.0252)
0.58 - 0.62 (0.0228 - 0.0244)	0.68 (0.0268)
0.62 - 0.66 (0.0244 - 0.0260)	0.72 (0.0283)
0.66 - 0.70 (0.0260 - 0.0276)	0.76 (0.0299)
0.70 - 0.74 (0.0276 - 0.0291)	0.80 (0.0315)
0.74 - 0.78 (0.0291 - 0.0307)	0.40 + 0.44 (0.0157 + 0.0173)
0.78 - 0.82 (0.0307 - 0.0323)	0.44 + 0.44 (0.0173 + 0.0173)
0.82 - 0.86 (0.0323 - 0.0339)	0.44 + 0.48 (0.0173 + 0.0189)
0.86 - 0.90 (0.0339 - 0.0354)	0.48 + 0.48 (0.0189 + 0.0189)
0.90 - 0.94 (0.0354 - 0.0370)	0.48 + 0.52 (0.0189 + 0.0205)
0.94 - 0.98 (0.0370 - 0.0386)	0.52 + 0.52 (0.0205 + 0.0205)
0.98 - 1.02 (0.0386 - 0.0402)	0.52 + 0.56 (0.0205 + 0.0220)
1.02 - 1.06 (0.0402 - 0.0417)	0.56 + 0.56 (0.0220 + 0.0220)
1.06 - 1.10 (0.0417 - 0.0433)	0.56 + 0.60 (0.0220 + 0.0236)
1.10 - 1.14 (0.0433 - 0.0449)	0.60 + 0.60 (0.0236 + 0.0236)
1.14 - 1.18 (0.0449 - 0.0465)	0.60 + 0.64 (0.0236 + 0.0252)
1.18 - 1.22 (0.0465 - 0.0480)	0.64 + 0.64 (0.0252 + 0.0252)
1.22 - 1.26 (0.0480 - 0.0496)	0.64 + 0.68 (0.0252 + 0.0268)
1.26 - 1.30 (0.0496 - 0.0512)	0.68 + 0.68 (0.0268 + 0.0268)
1.30 - 1.34 (0.0512 - 0.0528)	0.68 + 0.72 (0.0268 + 0.0283)
1.34 - 1.38 (0.0528 - 0.0543)	0.72 + 0.72 (0.0283 + 0.0283)
1.38 - 1.42 (0.0543 - 0.0559)	0.72 + 0.76 (0.0283 + 0.0299)
1.42 - 1.46 (0.0559 - 0.0575)	0.76 + 0.76 (0.0299 + 0.0299)
1.46 - 1.50 (0.0575 - 0.0591)	0.76 + 0.80 (0.0299 + 0.0315)

## SERVICE DATA AND SPECIFICATIONS (SDS)

Available Shims (Cont'd)

### INPUT SHAFT BEARING ADJUSTING SHIM

NFMT0033S05

Thickness mm (in)	Part number*
0.40 (0.0157)	32225-08E00
0.44 (0.0173)	32225-08E01
0.48 (0.0189)	32225-08E02
0.52 (0.0205)	32225-08E03
0.56 (0.0220)	32225-08E04
0.60 (0.0236)	32225-08E05
0.64 (0.0252)	32225-08E06
0.68 (0.0268)	32225-08E07
0.72 (0.0283)	32225-08E08
0.76 (0.0299)	32225-08E09
0.80 (0.0315)	32225-08E10
1.20 (0.0472)	32225-08E11

\*: Always check with the Parts Department for the latest parts information.

### TABLE FOR SELECTING INPUT SHAFT BEARING ADJUSTING SHIM(S)

NFMT0033S06  
Unit: mm (in)

Dial indicator indication	Suitable shim(s)
0.65 - 0.69 (0.0256 - 0.0272)	0.64 (0.0252)
0.69 - 0.73 (0.0272 - 0.0287)	0.68 (0.0268)
0.73 - 0.77 (0.0287 - 0.0303)	0.72 (0.0283)
0.77 - 0.81 (0.0303 - 0.0319)	0.76 (0.0299)
0.81 - 0.85 (0.0319 - 0.0335)	0.80 (0.0315)
0.85 - 0.89 (0.0335 - 0.0350)	0.40 + 0.44 (0.0157 + 0.0173)
0.89 - 0.93 (0.0350 - 0.0366)	0.44 + 0.44 (0.0173 + 0.0173)
0.93 - 0.97 (0.0366 - 0.0382)	0.44 + 0.48 (0.0173 + 0.0189)
0.97 - 1.01 (0.0382 - 0.0398)	0.48 + 0.48 (0.0189 + 0.0189)
1.01 - 1.05 (0.0398 - 0.0413)	0.48 + 0.52 (0.0189 + 0.0205)
1.05 - 1.09 (0.0413 - 0.0429)	0.52 + 0.52 (0.0205 + 0.0205)
1.09 - 1.13 (0.0429 - 0.0445)	0.52 + 0.56 (0.0205 + 0.0220)
1.13 - 1.17 (0.0445 - 0.0461)	0.56 + 0.56 (0.0220 + 0.0220)
1.17 - 1.21 (0.0461 - 0.0476)	0.56 + 0.60 (0.0220 + 0.0236)
1.21 - 1.25 (0.0476 - 0.0492)	0.60 + 0.60 (0.0236 + 0.0236)
1.25 - 1.29 (0.0492 - 0.0508)	0.60 + 0.64 (0.0236 + 0.0252)
1.29 - 1.33 (0.0508 - 0.0524)	0.64 + 0.64 (0.0252 + 0.0252)
1.33 - 1.37 (0.0524 - 0.0539)	0.64 + 0.68 (0.0252 + 0.0268)
1.37 - 1.41 (0.0539 - 0.0555)	0.68 + 0.68 (0.0268 + 0.0268)
1.41 - 1.45 (0.0555 - 0.0571)	0.68 + 0.72 (0.0268 + 0.0283)
1.45 - 1.49 (0.0571 - 0.0587)	0.72 + 0.72 (0.0283 + 0.0283)
1.49 - 1.53 (0.0587 - 0.0602)	0.72 + 0.76 (0.0283 + 0.0299)
1.53 - 1.57 (0.0602 - 0.0618)	0.76 + 0.76 (0.0299 + 0.0299)
1.57 - 1.61 (0.0618 - 0.0634)	0.76 + 0.80 (0.0299 + 0.0315)
1.61 - 1.65 (0.0634 - 0.0650)	0.80 + 0.80 (0.0315 + 0.0315)
1.65 - 1.69 (0.0650 - 0.0665)	0.44 + 1.20 (0.0173 + 0.0472)

### DIFFERENTIAL SIDE BEARING ADJUSTING SHIM RS5F50A

NFMT0033S07

NFMT0033S0701

Thickness mm (in)	Part number*
0.40 (0.0157)	38453-96E00
0.44 (0.0173)	38453-96E01
0.48 (0.0189)	38453-96E02
0.52 (0.0205)	38453-96E03
0.56 (0.0220)	38453-96E04
0.60 (0.0236)	38453-96E05
0.64 (0.0252)	38453-96E06
0.68 (0.0268)	38453-96E07
0.72 (0.0283)	38453-96E08
0.76 (0.0299)	38453-96E09
0.80 (0.0315)	38453-96E10
0.84 (0.0331)	38453-96E11
0.88 (0.0346)	38453-96E12
1.20 (0.0472)	38453-96E13

\*: Always check with the Parts Department for the latest parts information.

## SERVICE DATA AND SPECIFICATIONS (SDS)

Available Shims (Cont'd)

### RS5F50V

NFMT0033S0702

Thickness mm (in)	Part number*
0.36 (0.0142)	38753-56E00
0.40 (0.0157)	38753-56E01
0.44 (0.0173)	38753-56E02
0.48 (0.0189)	38753-56E03
0.52 (0.0205)	38753-56E04
0.56 (0.0220)	38753-56E05
0.60 (0.0236)	38753-56E06
0.64 (0.0252)	38753-56E07
0.68 (0.0268)	38753-56E08
0.72 (0.0283)	38753-56E09
0.76 (0.0299)	38753-56E10
0.80 (0.0315)	38753-56E11
0.84 (0.0331)	38753-56E12
0.88 (0.0346)	38753-56E13
0.92 (0.0362)	38753-56E14

\*: Always check with the Parts Department for the latest parts information.

### TABLE FOR SELECTING DIFFERENTIAL SIDE BEARING ADJUSTING SHIM RS5F50A

NFMT0033S08

NFMT0033S0801  
Unit: mm (in)

Dial indicator deflection	Suitable shim(s)
0.47 - 0.51 (0.0185 - 0.0201)	0.44 + 0.48 (0.0173 + 0.0189)
0.51 - 0.55 (0.0201 - 0.0217)	0.48 + 0.48 (0.0189 + 0.0189)
0.55 - 0.59 (0.0217 - 0.0232)	0.48 + 0.52 (0.0189 + 0.0205)
0.59 - 0.63 (0.0232 - 0.0248)	0.52 + 0.52 (0.0205 + 0.0205)
0.63 - 0.67 (0.0248 - 0.0264)	0.52 + 0.56 (0.0205 + 0.0220)
0.67 - 0.71 (0.0264 - 0.0280)	0.56 + 0.56 (0.0220 + 0.0220)
0.71 - 0.75 (0.0280 - 0.0295)	0.56 + 0.60 (0.0220 + 0.0236)
0.75 - 0.79 (0.0295 - 0.0311)	0.60 + 0.60 (0.0236 + 0.0236)
0.79 - 0.83 (0.0311 - 0.0327)	0.60 + 0.64 (0.0236 + 0.0252)
0.83 - 0.87 (0.0327 - 0.0343)	0.64 + 0.64 (0.0252 + 0.0252)
0.87 - 0.91 (0.0343 - 0.0358)	0.64 + 0.68 (0.0252 + 0.0268)
0.91 - 0.95 (0.0358 - 0.0374)	0.68 + 0.68 (0.0268 + 0.0268)
0.95 - 0.99 (0.0374 - 0.0390)	0.68 + 0.72 (0.0268 + 0.0283)
0.99 - 1.03 (0.0390 - 0.0406)	0.72 + 0.72 (0.0283 + 0.0283)
1.03 - 1.07 (0.0406 - 0.0421)	0.72 + 0.76 (0.0283 + 0.0299)
1.07 - 1.11 (0.0421 - 0.0437)	0.76 + 0.76 (0.0299 + 0.0299)
1.11 - 1.15 (0.0437 - 0.0453)	0.76 + 0.80 (0.0299 + 0.0315)
1.15 - 1.19 (0.0453 - 0.0469)	0.80 + 0.80 (0.0315 + 0.0315)
1.19 - 1.23 (0.0469 - 0.0484)	0.44 + 1.20 (0.0173 + 0.0472)
1.23 - 1.27 (0.0484 - 0.0500)	0.48 + 1.20 (0.0189 + 0.0472)
1.27 - 1.31 (0.0500 - 0.0516)	0.52 + 1.20 (0.0205 + 0.0472)



## SERVICE DATA AND SPECIFICATIONS (SDS)

Available Shims (Cont'd)

**RS5F50V**

NFMT0033S0802  
Unit: mm (in)

Dial indicator deflection	Suitable shim(s)
0.47 - 0.51 (0.0185 - 0.0201)	0.44 + 0.48 (0.0173 + 0.0189)
0.51 - 0.55 (0.0201 - 0.0217)	0.48 + 0.48 (0.0189 + 0.0189)
0.55 - 0.59 (0.0217 - 0.0232)	0.48 + 0.52 (0.0189 + 0.0205)
0.59 - 0.63 (0.0232 - 0.0248)	0.52 + 0.52 (0.0205 + 0.0205)
0.63 - 0.67 (0.0248 - 0.0264)	0.52 + 0.56 (0.0205 + 0.0220)
0.67 - 0.71 (0.0264 - 0.0280)	0.56 + 0.56 (0.0220 + 0.0220)
0.71 - 0.75 (0.0280 - 0.0295)	0.56 + 0.60 (0.0220 + 0.0236)
0.75 - 0.79 (0.0295 - 0.0311)	0.60 + 0.60 (0.0236 + 0.0236)
0.79 - 0.83 (0.0311 - 0.0327)	0.60 + 0.64 (0.0236 + 0.0252)
0.83 - 0.87 (0.0327 - 0.0343)	0.64 + 0.64 (0.0252 + 0.0252)
0.87 - 0.91 (0.0343 - 0.0358)	0.64 + 0.68 (0.0252 + 0.0268)
0.91 - 0.95 (0.0358 - 0.0374)	0.68 + 0.68 (0.0268 + 0.0268)
0.95 - 0.99 (0.0374 - 0.0390)	0.68 + 0.72 (0.0268 + 0.0283)
0.99 - 1.03 (0.0390 - 0.0406)	0.72 + 0.72 (0.0283 + 0.0283)
1.03 - 1.07 (0.0406 - 0.0421)	0.72 + 0.76 (0.0283 + 0.0299)
1.07 - 1.11 (0.0421 - 0.0437)	0.76 + 0.76 (0.0299 + 0.0299)
1.11 - 1.15 (0.0437 - 0.0453)	0.76 + 0.80 (0.0299 + 0.0315)
1.15 - 1.19 (0.0453 - 0.0469)	0.80 + 0.80 (0.0315 + 0.0315)
1.19 - 1.23 (0.0469 - 0.0484)	0.72 + 0.92 (0.0283 + 0.0362)
1.23 - 1.27 (0.0484 - 0.0500)	0.76 + 0.92 (0.0299 + 0.0362)
1.27 - 1.31 (0.0500 - 0.0516)	0.80 + 0.92 (0.0315 + 0.0362)

**SERVICE DATA AND SPECIFICATIONS (SDS)**

*Available Shims (Cont'd)*

---