

# SECTION **CL**

## CONTENTS

<p><b>PRECAUTIONS</b> .....2</p> <p style="padding-left: 20px;">Precautions .....2</p> <p><b>PREPARATION</b> .....3</p> <p style="padding-left: 20px;">Special Service Tools .....3</p> <p style="padding-left: 20px;">Commercial Service Tools .....3</p> <p><b>NOISE, VIBRATION AND HARSHNESS (NVH)</b></p> <p><b>TROUBLESHOOTING</b> .....4</p> <p style="padding-left: 20px;">NVH Troubleshooting Chart.....4</p> <p style="padding-left: 40px;">CLUTCH .....4</p> <p><b>CLUTCH SYSTEM</b>.....5</p> <p style="padding-left: 20px;">Components.....5</p> <p style="padding-left: 20px;">Inspection and Adjustment .....6</p> <p style="padding-left: 40px;">ON-VEHICLE INSPECTION AND ADJUSTMENT.....6</p> <p style="padding-left: 40px;">AIR BLEEDING PROCEDURE .....6</p> <p><b>CLUTCH MASTER CYLINDER</b>.....8</p> <p style="padding-left: 20px;">Components.....8</p> <p style="padding-left: 20px;">Removal.....8</p> <p style="padding-left: 20px;">Installation.....8</p> <p style="padding-left: 20px;">Disassembly.....9</p> <p style="padding-left: 20px;">Inspection.....9</p> <p style="padding-left: 20px;">Assembly .....9</p> <p><b>OPERATING CYLINDER</b>.....10</p> <p style="padding-left: 20px;">Components.....10</p> <p style="padding-left: 20px;">Removal.....10</p> <p style="padding-left: 20px;">Disassembly.....10</p> <p style="padding-left: 20px;">Inspection.....11</p>	<p style="padding-left: 20px;">Assembly .....11</p> <p style="padding-left: 20px;">Installation.....11</p> <p><b>PIPING</b> .....12</p> <p style="padding-left: 20px;">Removal.....12</p> <p style="padding-left: 20px;">Installation.....12</p> <p><b>CLUTCH RELEASE MECHANISM</b> .....13</p> <p style="padding-left: 20px;">Components.....13</p> <p style="padding-left: 20px;">Removal.....13</p> <p style="padding-left: 20px;">Inspection.....13</p> <p style="padding-left: 20px;">Installation.....13</p> <p><b>CLUTCH DISC, CLUTCH COVER AND FLYWHEEL</b>.....15</p> <p style="padding-left: 20px;">Components.....15</p> <p style="padding-left: 20px;">Inspection and Adjustment .....15</p> <p style="padding-left: 40px;">CLUTCH DISC.....15</p> <p style="padding-left: 40px;">CLUTCH COVER .....15</p> <p style="padding-left: 40px;">FLYWHEEL .....16</p> <p style="padding-left: 20px;">Installation.....16</p> <p><b>SERVICE DATA AND SPECIFICATIONS (SDS)</b> .....17</p> <p style="padding-left: 20px;">Clutch Control System.....17</p> <p style="padding-left: 20px;">Clutch Master Cylinder .....17</p> <p style="padding-left: 20px;">Clutch Operating Cylinder .....17</p> <p style="padding-left: 20px;">Clutch Disc.....17</p> <p style="padding-left: 20px;">Clutch Cover .....17</p> <p style="padding-left: 20px;">Clutch Pedal .....17</p>
---	--

# PRECAUTIONS

## Precautions

NFCL0001

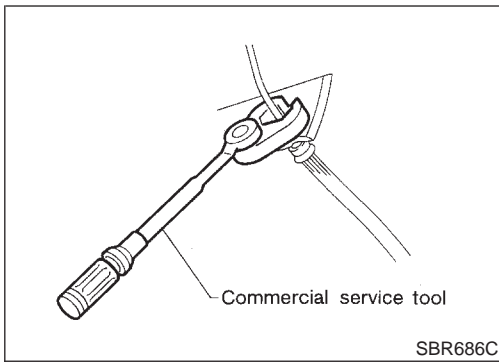

## Precautions

- Recommended fluid is brake fluid “DOT 3”.
- Never reuse drained brake fluid.
- Be careful not to splash brake fluid on painted areas.
- When removing and installing clutch piping, use Tool.
- Use new brake fluid to clean or wash all parts of master cylinder and operating cylinder.
- Never use mineral oils such as gasoline or kerosene. It will ruin the rubber parts of the hydraulic system.

### **WARNING:**

After cleaning clutch disc, wipe it with a dust collector. Do not use compressed air.

# PREPARATION

Special Service Tools

## Special Service Tools

NFCL0002

The actual shapes of Kent-Moore tools may differ from those of special service tools illustrated here.

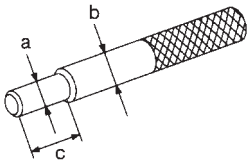
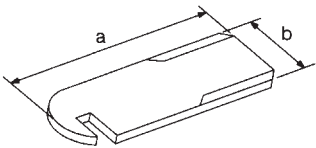
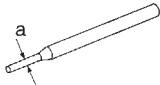
Tool number (Kent-Moore No.) Tool name	Description	
ST20630000 (J26366) Clutch aligning bar	 <p>NT405</p>	Installing clutch cover and clutch disc <b>a: 15.8 mm (0.622 in) dia.</b> <b>b: 22.9 mm (0.902 in) dia.</b> <b>c: 45.0 mm (1.772 in)</b>
ST20050240 ( — ) Diaphragm spring adjusting wrench	 <p>NT404</p>	Adjusting unevenness of diaphragm spring of clutch cover <b>a: 150 mm (5.91 in)</b> <b>b: 25 mm (0.98 in)</b>
KV32101000 (J25689-A) Pin punch	 <p>NT410</p>	Removing and installing spring pin <b>a: 4 mm (0.16 in) dia.</b>

## Commercial Service Tools

NFCL0003

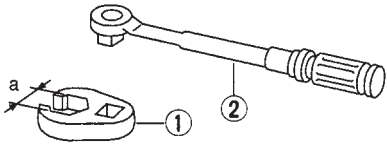
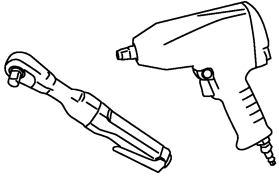
Tool name	Description	
1 Flare nut crowfoot 2 Torque wrench	 <p>NT360</p>	Removing and installing clutch piping <b>a: 10 mm (0.39 in)</b>
Power tool	 <p>PBIC0190E</p>	Loosening bolts and nuts

GI  
MA  
EM  
LC  
EC  
FE  
CL  
MT  
AT  
AX  
SU  
BR  
ST  
RS  
BT  
HA  
SC  
EL  
IDX

# NOISE, VIBRATION AND HARSHNESS (NVH) TROUBLESHOOTING

NFCL0004

NVH Troubleshooting Chart

## NVH Troubleshooting Chart

NFCL0004S07

Use the chart below to help you find the cause of the symptom. The numbers indicate the order of the inspection. If necessary, repair or replace these parts.

### CLUTCH

NFCL0004S07/01

Reference page	SUSPECTED PARTS (Possible cause)			
	Clutch grabs/chatters	Clutch pedal spongy	Clutch noisy	Clutch slips
CL-6				1
CL-6		1		2
CL-8		2		3
CL-10		2		4
Refer to EM-69, "Removal and Installation".	1			
CL-13			1	
CL-15				5
CL-15		2		5
CL-15				5
CL-15				5
CL-15		2		5
CL-15		2		5
CL-15		2		5
CL-15				5
CL-15				6
CL-15		2		6
CL-15				7
CL-16				5

# CLUTCH SYSTEM

Components

## Components

NFCL0005

SEC. 300•305•306•465

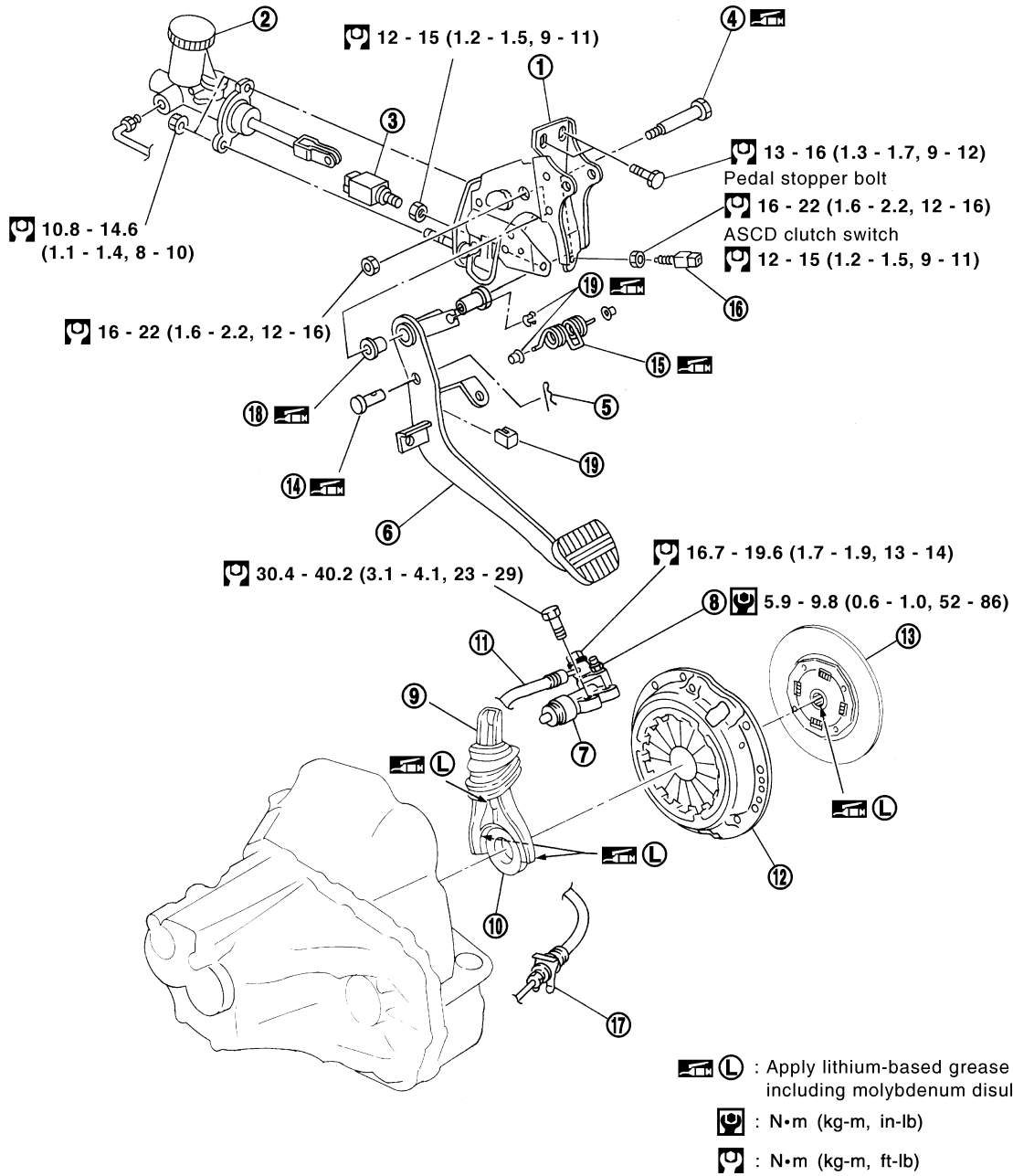

SCL912

- |                            |                      |                        |
|----------------------------|----------------------|------------------------|
| 1. Pedal bracket           | 8. Air bleeder valve | 14. Clevis pin         |
| 2. Clutch master cylinder  | 9. Withdrawal lever  | 15. Assist spring      |
| 3. Clutch interlock switch | 10. Release bearing  | 16. ASCD clutch switch |
| 4. Fulcrum pin             | 11. Clutch hose      | 17. Lock plate         |
| 5. Snap pin                | 12. Clutch cover     | 18. Bushing rubber     |
| 6. Clutch pedal            | 13. Clutch disc      | 19. Stopper rubber     |
| 7. Operating cylinder      |                      |                        |

GI  
MA  
EM  
LC  
EC  
FE  
**CL**  
MT  
AT  
AX  
SU  
BR  
ST  
RS  
BT  
HA  
SC  
EL  
IDX

# CLUTCH SYSTEM

## Inspection and Adjustment

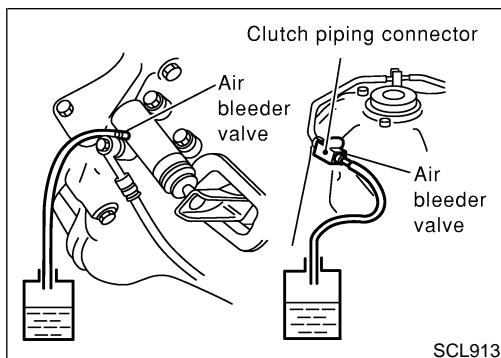
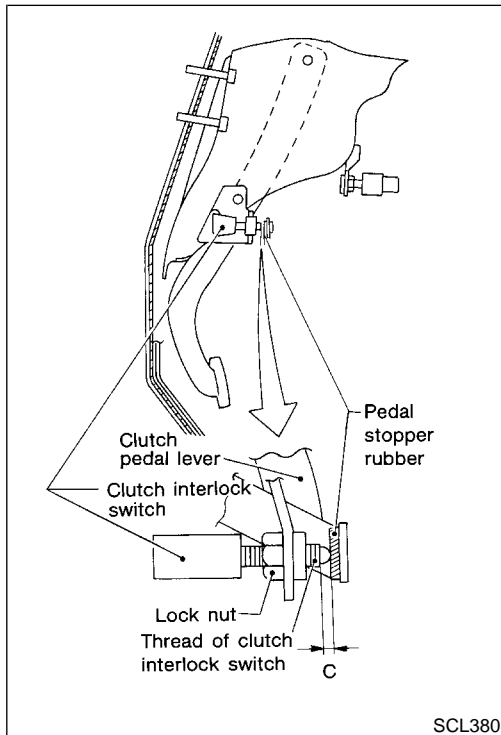
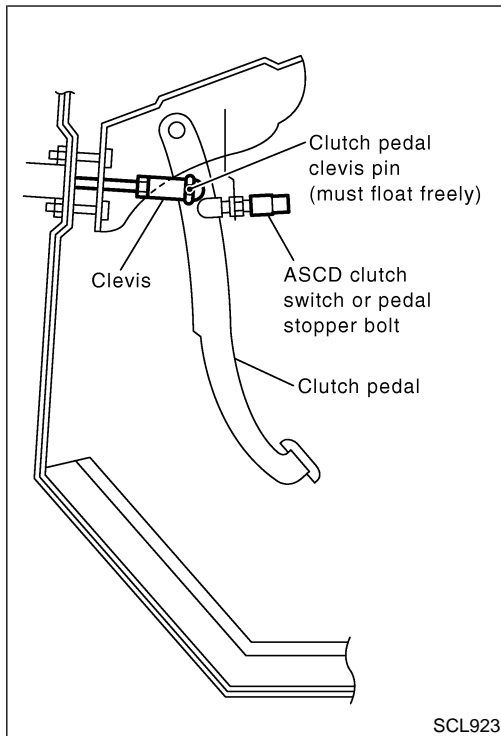

## Inspection and Adjustment

### ON-VEHICLE INSPECTION AND ADJUSTMENT

NFCL0006

NFCL0006S01

1. Check to see if the clutch pedal clevis pin floats freely in the bore of the clutch pedal. It should not be bound by the clevis or clutch pedal.
  - a. If the pin is not free, check that the ASCD switch is not applying pressure to the clutch pedal causing the pin to bind. To adjust, loosen ASCD switch lock nut and turn ASCD switch.
  - b. Tighten the lock nut.
  - c. Verify that the clutch pedal clevis pin floats in the bore of the clutch pedal. It should not be bound by the clutch pedal.
  - d. If the pin is still not free, remove the pin and check for deformation or damage. Replace pin if necessary. Leave pin removed for step 2.
2. Check clutch pedal stroke for free range of movement.
  - a. With the clutch pedal clevis pin removed, manually move the pedal up and down to determine if it moves freely.
  - b. If any sticking is noted, replace the related parts (clutch pedal bracket, assist spring, bushing, etc.) Reassemble the pedal and re-verify that the clevis pin floats freely in the bore of the pedal.
3. Adjust clearance "C" while depressing clutch pedal fully. (With clutch interlock switch)  
**Clearance C: 0.1 - 1.5 mm (0.004 - 0.059 in)**
4. Check clutch hydraulic and system components (clutch master cylinder, clutch operating cylinder, clutch withdrawal lever, clutch release bearing, etc.) for sticking or binding.
  - a. If any sticking or binding noted, repair or replace related parts as necessary.
  - b. If hydraulic system repair was necessary, bleed the clutch hydraulic system. Refer to CL-6, "AIR BLEEDING PROCEDURE".

#### NOTE:

Do not use a vacuum assist or any other type of power bleeder on this system. Use of a vacuum assist or power bleeder will not purge all the air from the system.

### AIR BLEEDING PROCEDURE

NFCL0006S02

1. Bleed air from clutch piping connector and operating cylinder according to the following procedure.
  - **Carefully monitor fluid level at master cylinder during air bleeding operation.**
  - **Be careful not to splash brake fluid on painted areas; it may cause paint damage. If brake fluid is splashed on painted areas, wash it away with water immediately.**
- a. Top up reservoir of master cylinder with recommended brake fluid.
- b. Connect a transparent vinyl tube to air bleeder valve.

# CLUTCH SYSTEM

*Inspection and Adjustment (Cont'd)*

- c. Slowly depress clutch pedal to its full stroke and release it completely. Repeat this operation several times at 2 to 3 second intervals. GI
- d. Holding clutch pedal depressed, open air bleeder valve to release air. MA
- e. Close air bleeder valve. EM
- f. Release clutch pedal and wait at least 5 seconds. EM
- g. Repeat steps c through f above until brake fluid flows from air bleeder valve without air bubbles. EM
2. Bleed air from clutch operating cylinder according to the above same procedure. LC
3. Repeat the above air bleeding procedures 1 and 2 several times. EC

**Tightening torque of air bleeder valve:**

 : 5.9 - 9.8 N·m (0.6 - 1.0 kg-m, 52 - 86 in-lb)

FE

**CL**

MT

AT

AX

SU

BR

ST

RS

BT

HA

SC

EL

IDX

# CLUTCH MASTER CYLINDER

Components

## Components

NFCL0007

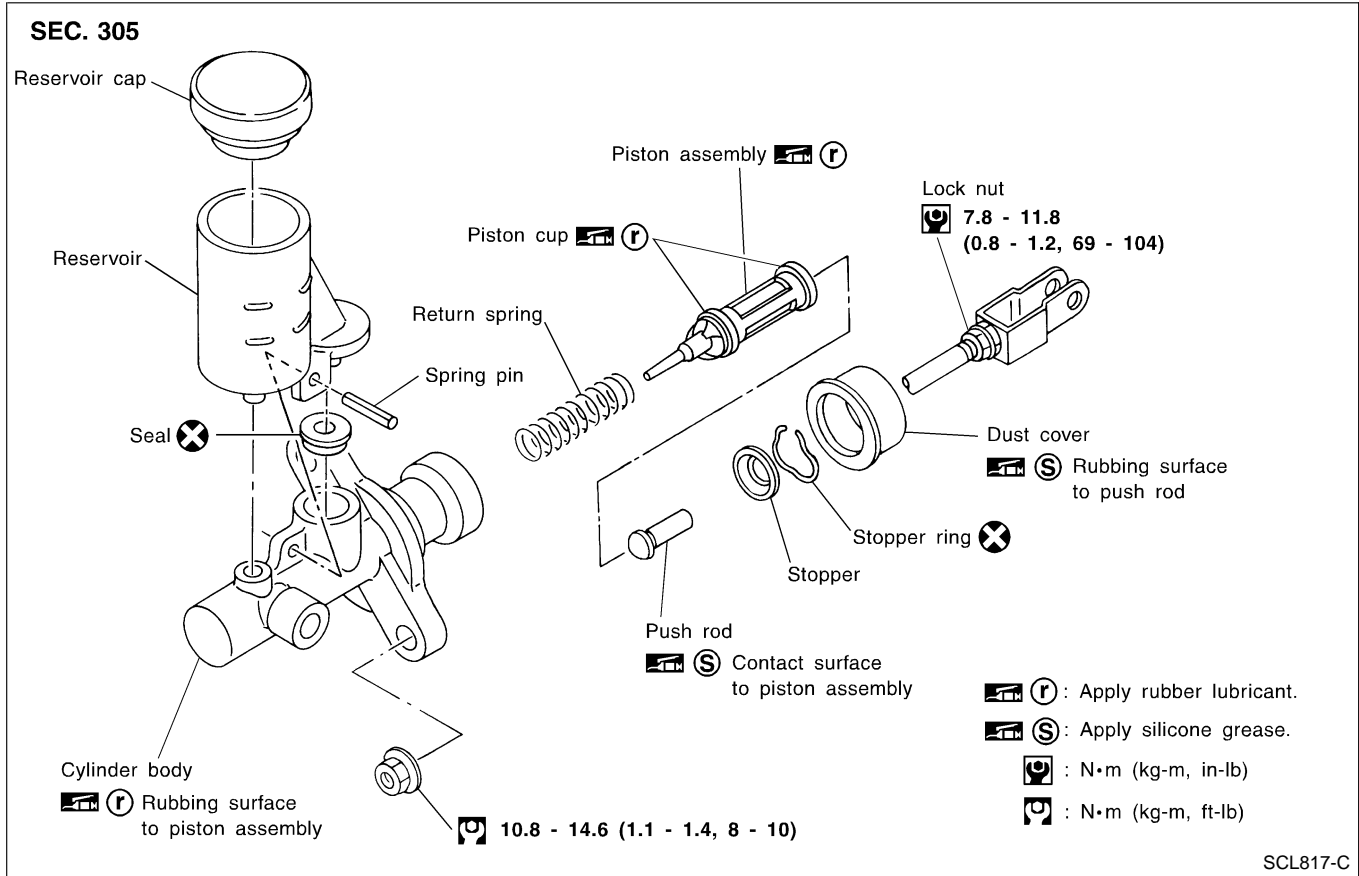

## Removal

NFCL0008

1. Drain brake fluid.

### CAUTION:

**Be careful not to splash brake fluid on painted areas; it may cause paint damage. If brake fluid is splashed on painted areas, wash it away with water immediately.**

2. Remove clutch tube using a flare nut wrench.
3. Remove snap pin between clutch pedal and push rod, and remove clevis pin.
4. Unscrew master cylinder assembly mounting nuts and remove master cylinder assembly from vehicle.

## Installation

NFCL0009

1. Connect clutch tube to master cylinder assembly, and hand-tighten flare nut.
2. Install master cylinder assembly to vehicle, and tighten mounting nuts to the specified torque.  
Ⓢ : 10.8 - 14.6 N·m (1.1 - 1.4 kg-m, 8 - 10 ft-lb)
3. Tighten clutch tube flare nut using a flare nut torque wrench.  
Ⓢ : 15 - 17 N·m (1.5 - 1.7 kg-m, 11 - 12 ft-lb)
4. After installing clevis pin, install snap pin to connect clutch pedal to push rod.

CL-8



5. After finishing the operation, bleed air from clutch piping connector and operating cylinder. (Refer to "Air Bleeding Procedure", CL-6.)

GI

MA

EM

LC

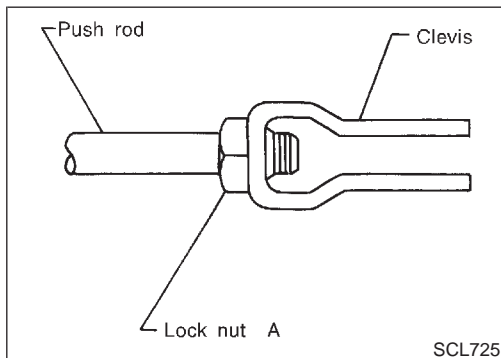

## Disassembly

1. Loosen push rod lock nut A to remove clevis and lock nut A. <sup>NFCL0010</sup>
2. Remove dust cover.
3. Remove stopper ring and stopper, and remove push rod from cylinder body. During removal, keep push rod depressed, to prevent piston inside master cylinder from popping out.
4. Remove piston assembly from cylinder body.

EC

FE

CL

MT

## Inspection

Check the following items, and replace if necessary.

- Rubbing surface of cylinder and piston, for uneven wear, rust or damage
- Piston with piston cup, for wear or damage
- Return spring, for wear or damage
- Dust cover, for cracks, deformation or damage
- Reservoir, for deformation or damage

<sup>NFCL0011</sup>

AT

AX

SU

BR

## Assembly

1. Apply rubber lubricant to the sliding part of piston assembly, and insert piston assembly.
2. After installing stopper to push rod, install stopper ring while keeping piston assembly depressed by hand, so that piston assembly will not pop out.

<sup>NFCL0012</sup>

ST

RS

BT

### CAUTION:

**Stopper ring cannot be reused. Always use a new stopper ring for assembly.**

HA

3. Install dust cover.
4. Install clevis to push rod, and tighten lock nut A to the specified torque.

SC

 : 7.8 - 11.8 N·m (0.8 - 1.2 kg·m, 69 - 104 in·lb)

5. Install spring pin using a pin punch.

EL

IDX

# OPERATING CYLINDER

Components

## Components

NFCL0019

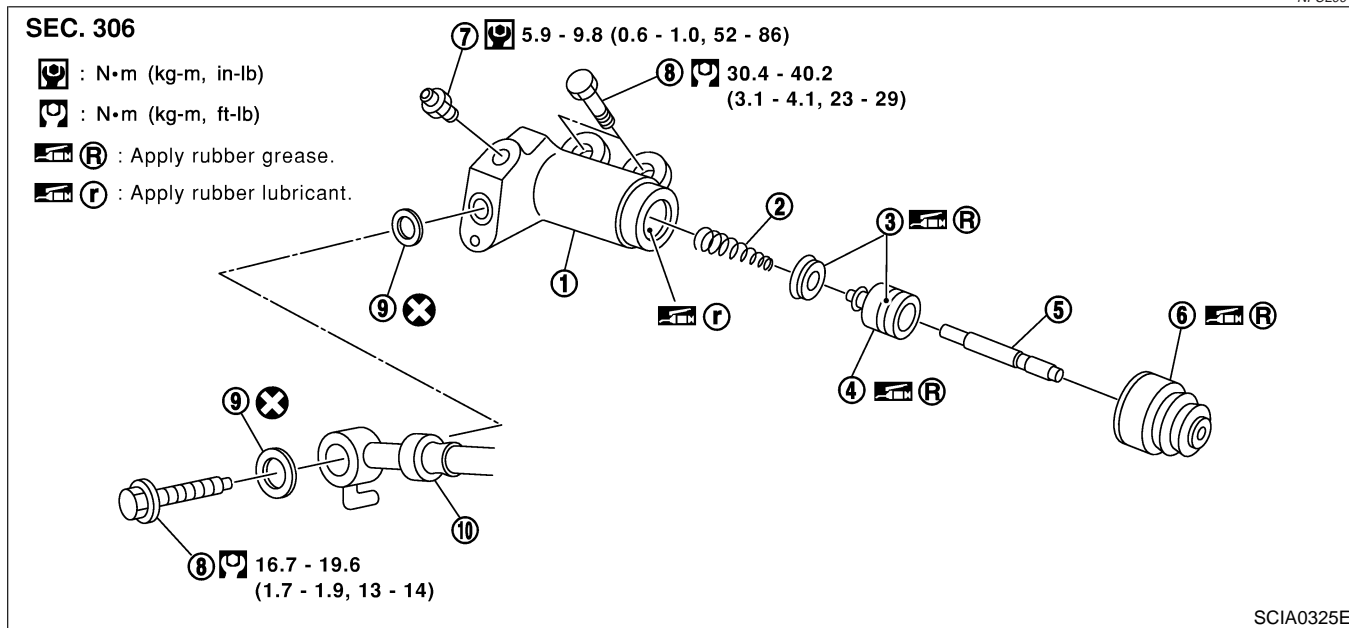

1. Cylinder body
2. Piston spring
3. Piston cup
4. Piston assembly

5. Push rod
6. Dust cover
7. Air bleeder valve

8. Union bolt
9. Copper washer
10. Clutch hose

## Removal

NFCL0020

1. Drain brake fluid.

### CAUTION:

Be careful not to splash brake fluid on painted areas; it may cause paint damage. If brake fluid is splashed on painted areas, wash it away with water immediately.

2. Remove union bolt and clutch hose from operating cylinder.
3. Remove operating cylinder mounting bolts, and remove cylinder from vehicle.

## Disassembly

NFCL0021

Remove dust cover, push rod, remove piston assembly and piston spring from cylinder body.

## Inspection

NFCL0022

Inspect for following, and replace parts if necessary.

- Damage, foreign material, wear, rust, and pinholes on the cylinder inner surface, piston, and sliding part of piston cup
- Weak spring
- Crack and deformation of dust cover

GI

MA

EM

LC

## Assembly

NFCL0023

1. Install piston spring.
2. Apply recommended rubber grease to piston cup and piston, and insert piston assembly.
3. Install push rod.
4. Install dust cover.

EC

FE

CL

MT

## Installation

NFCL0024

Install the components in the reverse order of removal. Adhere to the operations described below.

### CAUTION:

Install the hose without twisting it.

- The copper washer of the union bolt should not be reused. Always use a new copper washer for installation.
- After finishing the operation, bleed air from the clutch piping connector and operating cylinder. Refer to “Air Bleeding Procedure”, CL-6.

AT

AX

SU

BR

ST

RS

BT

HA

SC

EL

IDX

# PIPING

## Removal

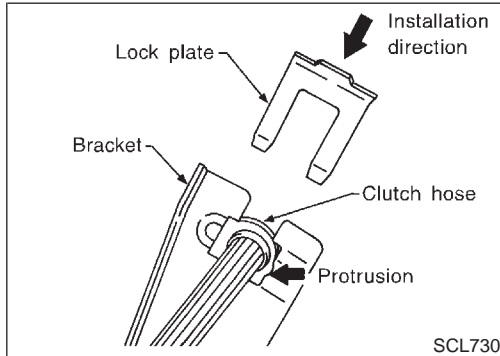
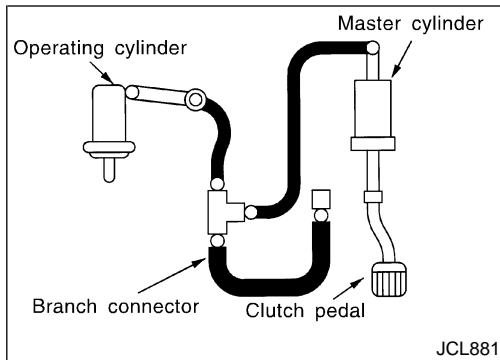

## Removal

NFCL0025

1. Remove air cleaner and air duct.
2. Drain brake fluid.

### CAUTION:

Be careful not to splash brake fluid on painted areas; it may cause paint damage. If brake fluid is splashed on painted areas, wash it away with water immediately.

3. Remove flare nut using a flare nut wrench.
4. Remove clutch hose and clutch tube.

## Installation

NFCL0026

1. When installing clutch hose to bracket, face lock plate in the correct direction as shown to secure clutch hose.

### CAUTION:

Install clutch hose without twisting or bending it.

2. Tighten flare nut to the specified torque, using a flare nut wrench.

 : 15 - 17 N·m (1.5 - 1.7 kg-m, 11 - 12 ft-lb)

### CAUTION:

Be careful not to damage flare nut and clutch tube.

3. Install clutch hose to operating cylinder, and tighten mounting bolts to the specified torque.

 : 16.7 - 19.6 N·m (1.7 - 1.9 kg-m, 13 - 14 ft-lb)

4. After finishing the operation, bleed air from the clutch piping connector and operating cylinder. Refer to "Air Bleeding Procedure", CL-6.

## Components

NFCL0027

SEC. 321

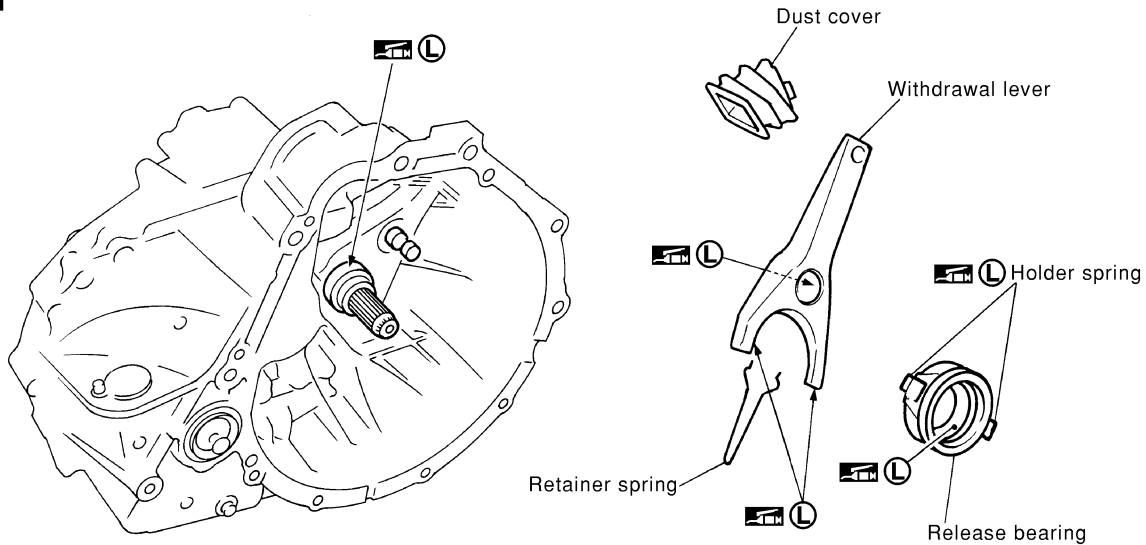

L : Apply lithium-based grease including molybdenum disulphide.

SCL914

GI  
MA  
EM  
LC  
EC  
FE  
**CL**

## Removal

1. Remove manual transaxle from vehicle. Refer to MT-14, "Removal".
2. Move withdrawal lever enough to remove release bearing, and remove release bearing from clutch withdrawal lever.
3. Remove dust cover.
4. Remove retainer spring from withdrawal lever.

NFCL0028

AT  
AX  
SU  
BR

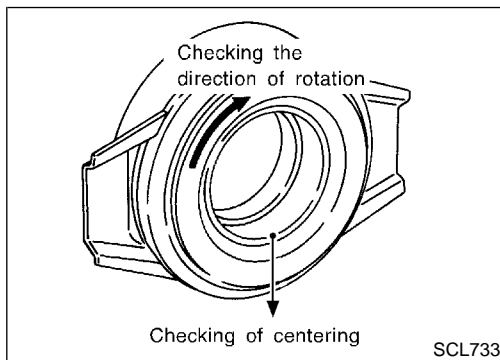

SCL733

## Inspection

- Replace the release bearing if it is seized, damaged, faulty in rotation direction, or has poor aligning function.
- Replace the withdrawal lever if its contact surface is worn abnormally.
- Replace the dust cover if it is deformed or cracked.

NFCL0029

ST  
RS  
BT  
HA

## Installation

1. Apply a coat of grease to parts as instructed in the following cautions and notes before installation.

NFCL0030

### CAUTION:

- Be sure to apply grease to the clutch components. Otherwise, abnormal noise, poor clutch disengagement, or clutch damage may occur. Wipe the excess grease off completely, because it may cause the clutch components to slip and shudder.
- Keep the clutch disc facing, pressure plate, and flywheel free of oil and grease.

SC  
EL  
IDX

## CLUTCH RELEASE MECHANISM

Installation (Cont'd)

- Clean old grease and abrasive materials off the grease application area.

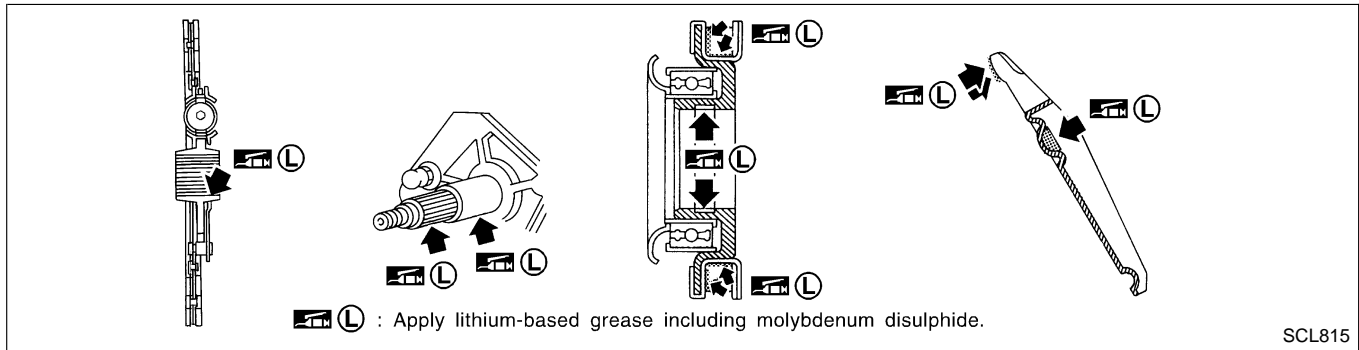

SCL815

### NOTE:

- Equally apply a coat [approximately 1 mm (0.04 in) thick] of clutch sleeve grease to withdrawal lever and holder spring frictional surfaces.
  - Apply a coat of clutch sleeve grease to the grooves on contact surfaces of the withdrawal lever ball pin and inner surface of release bearing so that grease application, make sure that grease is flush with grooves.
  - Equally apply a thin coat of clutch sleeve grease to release bearing frictional surface. After grease application, install release bearing. Wipe off excess grease forced out during bearing installation. Remove release bearing.
2. Installation is in the reverse order of removal.

## Components

NFCL0031

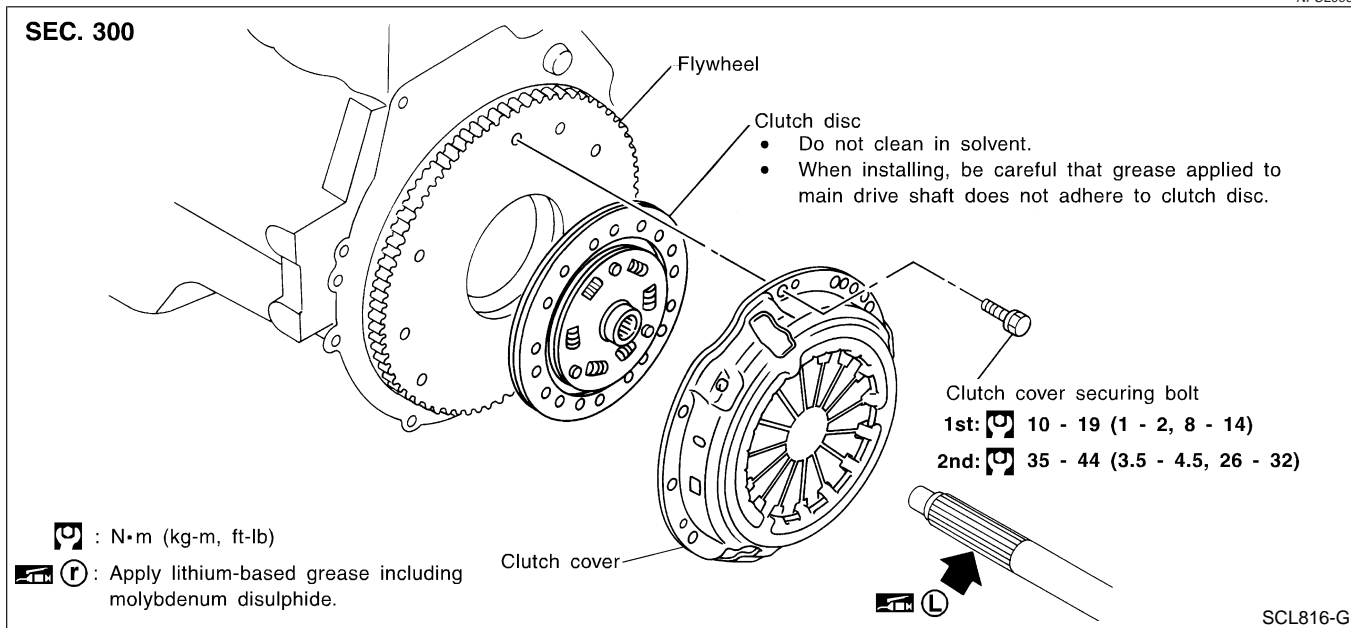

GI

MA

EM

LC

EC

FE

CL

MT

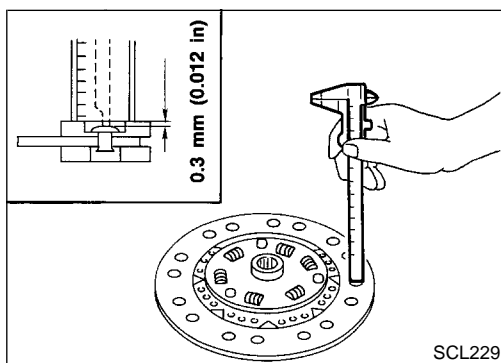

## Inspection and Adjustment

### CLUTCH DISC

NFCL0032

NFCL0032S01

- Check clutch disc for wear of facing.  
**Wear limit of facing surface to rivet head:**  
**0.3 mm (0.012 in)**

AT

AX

SU

BR

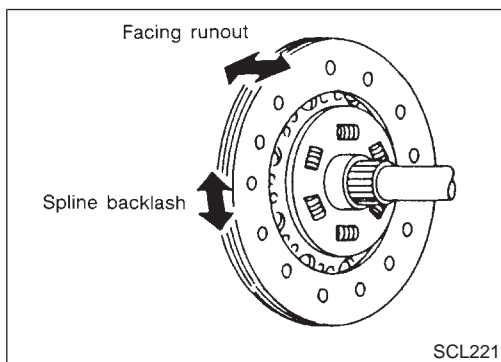

- Check clutch disc for backlash of spline and runout of facing.  
**Maximum spline backlash (at outer edge of disc):**  
**1.0 mm (0.039 in)**  
**Runout limit:**  
**1.0 mm (0.039 in)**  
**Distance of runout check point (from hub center):**  
**120 mm (4.72 in)**
- Check clutch disc for burns, discoloration or oil or grease leakage. Replace if necessary.

ST

RS

BT

HA

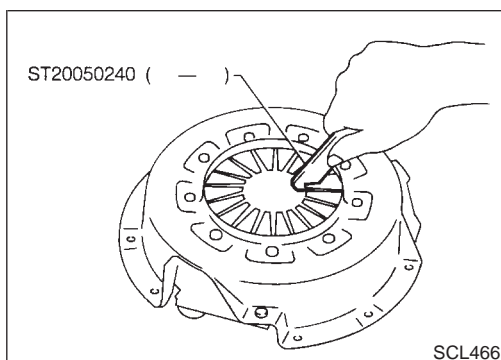

### CLUTCH COVER

NFCL0032S02

- Check clutch cover installed on vehicle for unevenness of diaphragm spring toe height.  
**Uneven limit:**  
**0.5 mm (0.020 in)**
- If out of limit, adjust the height with Tool.

SC

EL

IDX

# CLUTCH DISC, CLUTCH COVER AND FLYWHEEL

Inspection and Adjustment (Cont'd)

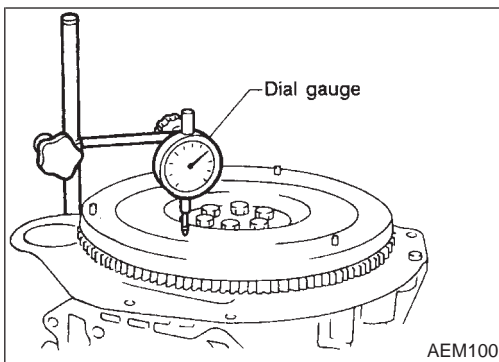

## FLYWHEEL

- Check contact surface of flywheel for slight burns or discoloration. Repair flywheel with emery paper. NFCL0032S03
- Check flywheel runout.

**Maximum allowable runout:**

**Refer to EM-82, "Flywheel/drive plate runout".**

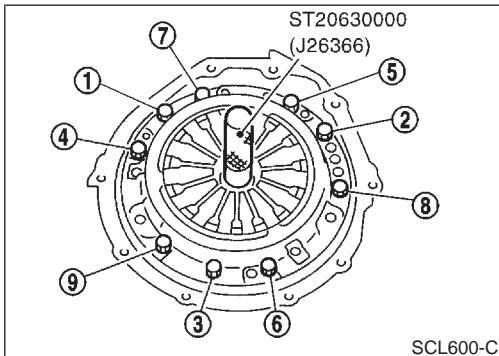

## Installation

- Insert Tool into clutch disc hub when installing clutch cover and disc. NFCL0033
- **Be careful not to allow grease to contaminate clutch facing.**
- Tighten bolts in numerical order.

**First step:**

 : 10 - 19 N·m (1 - 2 kg·m, 8 - 14 ft·lb)

**Final step:**

 : 35 - 44 N·m (3.5 - 4.5 kg·m, 26 - 32 ft·lb)



# SERVICE DATA AND SPECIFICATIONS (SDS)

Clutch Control System

<b>Clutch Control System</b>		<small>NFCL0034</small>
Type of clutch control	Hydraulic	GI
<b>Clutch Master Cylinder</b>		<small>NFCL0035</small>
		Unit: mm (in)
Inner diameter	15.87 (5/8)	MA
<b>Clutch Operating Cylinder</b>		<small>NFCL0036</small>
		Unit: mm (in)
Inner diameter	19.05 (3/4)	EM
<b>Clutch Disc</b>		<small>NFCL0038</small>
Model	250	EC
Facing size (Outer dia. × inner dia. × thickness)	250 mm × 160 mm × 3.5 mm (9.84 in × 6.30 in × 0.138 in)	FE
Thickness of disc assembly With load	8.1 - 8.5 mm (0.319 - 0.335 in) with 4,903 N (500 kg, 1,102 lb)	<b>CL</b>
Wear limit of facing surface to rivet head	0.3 mm (0.012 in)	MT
Facing runout limit	1.0 mm (0.039 in)	AT
Distance of runout check point (from the hub center)	120 mm (4.72 in)	
Maximum spline backlash (at outer edge of disc)	1.0 mm (0.039 in)	
<b>Clutch Cover</b>		<small>NFCL0039</small>
Model	250	AX
Set load	7,355 N (750 kg, 1,653 lb)	SU
Uneven limit of diaphragm spring toe height	0.5 mm (0.020 in)	
<b>Clutch Pedal</b>		<small>NFCL0040</small>
		Unit: mm (in)
Clearance "C" between pedal stopper rubber and clutch interlock switch threaded end while clutch pedal is fully depressed.	0.1 - 1.5 (0.004 - 0.059)	BR
		ST
		RS
		BT
		HA
		SC
		EL
		IDX

## NOTES