

SECTION IP
INSTRUMENT PANEL

A
B
C
D
E
F
G
H
IP
J
K
L
M

CONTENTS

PRECAUTIONS	2	INSTALLATION	12
Precautions for Supplemental Restraint System (SRS) "AIR BAG" and "SEAT BELT PRE-TENSIONER"	2	Cluster Lid D	13
PREPARATION	3	REMOVAL	13
Special Service Tools	3	INSTALLATION	13
Commercial Service Tools	3	Center Stack Assembly	13
SQUEAK AND RATTLE TROUBLE DIAGNOSIS	4	REMOVAL AND INSTALLATION	13
Work Flow	4	DISASSEMBLY AND ASSEMBLY	14
CUSTOMER INTERVIEW	4	Lower Driver Instrument Panel	15
DUPLICATE THE NOISE AND TEST DRIVE	5	REMOVAL	15
CHECK RELATED SERVICE BULLETINS	5	INSTALLATION	15
LOCATE THE NOISE AND IDENTIFY THE ROOT CAUSE	5	Glove Box Assembly and Housing	16
REPAIR THE CAUSE	5	REMOVAL AND INSTALLATION	16
CONFIRM THE REPAIR	6	DISASSEMBLY AND ASSEMBLY	16
Generic Squeak and Rattle Troubleshooting	6	CENTER CONSOLE ASSEMBLY	17
INSTRUMENT PANEL	6	Front Center Console	17
CENTER CONSOLE	6	REMOVAL AND INSTALLATION	17
DOORS	6	INSTALLATION	17
TRUNK	7	Disassembly and Assembly	17
SUNROOF/HEADLINING	7	DISASSEMBLY	18
OVERHEAD CONSOLE (FRONT AND REAR).....	7	ASSEMBLY	18
SEATS	7	A/T Finisher	18
UNDERHOOD	7	REMOVAL AND INSTALLATION	18
Diagnostic Worksheet	8	INSTALLATION	18
INSTRUMENT PANEL ASSEMBLY	10	M/T Finisher	18
Instrument Panel	10	REMOVAL AND INSTALLATION	18
REMOVAL	10	INSTALLATION	18
INSTALLATION	11	Rear Center Console	18
Cluster Lid C	12	REMOVAL AND INSTALLATION	18
REMOVAL	12	Rear Center Console	19
		DISASSEMBLY AND ASSEMBLY	19
		ASSEMBLY	20

PRECAUTIONS

PRECAUTIONS

PFP:00001

Precautions for Supplemental Restraint System (SRS) “AIR BAG” and “SEAT BELT PRE-TENSIONER”

EIS003WR

The Supplemental Restraint System such as “AIR BAG” and “SEAT BELT PRE-TENSIONER”, used along with a front seat belt, helps to reduce the risk or severity of injury to the driver and front passenger for certain types of collision. This system includes seat belt switch inputs and dual stage front air bag modules. The SRS system uses the seat belt switches to determine the front air bag deployment, and may only deploy one front air bag, depending on the severity of a collision and whether the front occupants are belted or unbelted. Information necessary to service the system safely is included in the SRS and SB section of this Service Manual.

WARNING:

- To avoid rendering the SRS inoperative, which could increase the risk of personal injury or death in the event of a collision which would result in air bag inflation, all maintenance must be performed by an authorized NISSAN/INFINITI dealer.
- Improper maintenance, including incorrect removal and installation of the SRS, can lead to personal injury caused by unintentional activation of the system. For removal of Spiral Cable and Air Bag Module, see the SRS section.
- Do not use electrical test equipment on any circuit related to the SRS unless instructed to in this Service Manual. SRS wiring harnesses can be identified by yellow and/or orange harnesses or harness connectors.

PREPARATION

PREPARATION

PFP:00002

Special Service Tools

EIS003WS

The actual shapes of Kent-Moore tools may differ from those of special service tools illustrated here.

Tool number (Kent-Moore No.) Tool name	Description
— (J-39570) Chassis ear	Locating the noise
— (J-43980) NISSAN Squeak and Rattle kit	Repairing the cause of noise

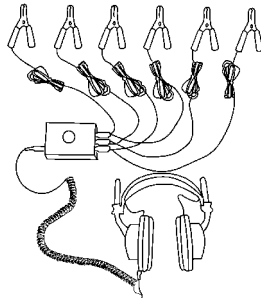

SBT839

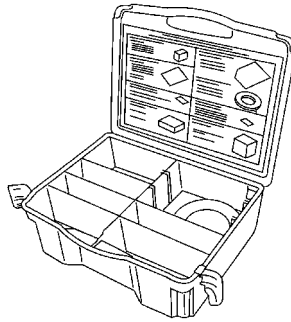

SBT840

Commercial Service Tools

EIS003WT

(Kent-Moore No.) Tool name	Description
(J-39565) Engine ear	Locating the noise
Power Tool	Loosening bolts and nuts

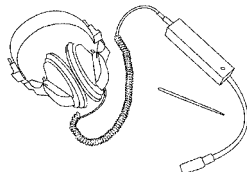

SIIA0995E

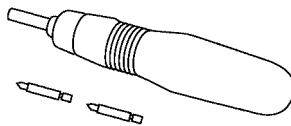

PBIC0191E

SQUEAK AND RATTLE TROUBLE DIAGNOSIS

SQUEAK AND RATTLE TROUBLE DIAGNOSIS

PF0:0000

Work Flow

EIS003WU

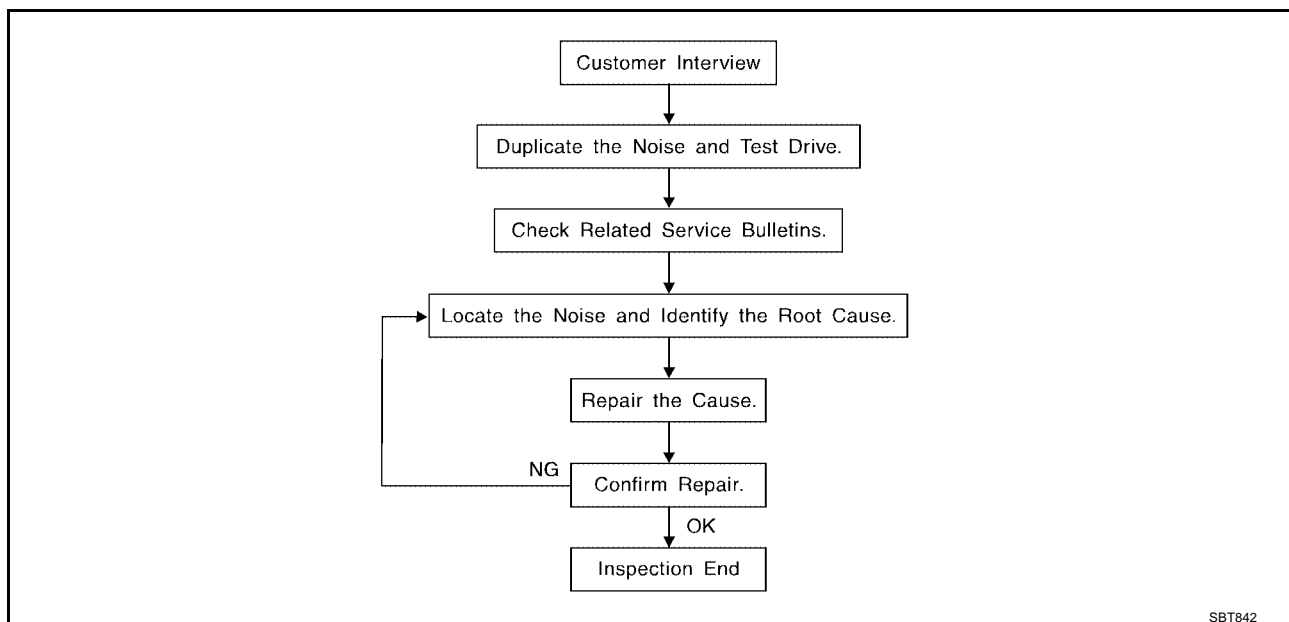

CUSTOMER INTERVIEW

Interview the customer, if possible, to determine the conditions that exist when the noise occurs. Use the Diagnostic Worksheet during the interview to document the facts and conditions when the noise occurs and any customer's comments; refer to [IP-8, "Diagnostic Worksheet"](#). This information is necessary to duplicate the conditions that exist when the noise occurs.

- The customer may not be able to provide a detailed description or the location of the noise. Attempt to obtain all the facts and conditions that exist when the noise occurs (or does not occur).
- If there is more than one noise in the vehicle, be sure to diagnose and repair the noise that the customer is concerned about. This can be accomplished by test driving the vehicle with the customer.
- After identifying the type of noise, isolate the noise in terms of its characteristics. The noise characteristics are provided so the customer, service adviser and technician are all speaking the same language when defining the noise.
- Squeak — (Like tennis shoes on a clean floor)
Squeak characteristics include the light contact/fast movement/brought on by road conditions/hard surfaces = higher pitch noise/softer surfaces = lower pitch noises/edge to surface = chirping.
- Creak — (Like walking on an old wooden floor)
Creak characteristics include firm contact/slow movement/twisting with a rotational movement/pitch dependent on materials/often brought on by activity.
- Rattle — (Like shaking a baby rattle)
Rattle characteristics include the fast repeated contact/vibration or similar movement/loose parts/missing clip or fastener/incorrect clearance.
- Knock — (Like a knock on a door)
Knock characteristics include hollow sounding/sometimes repeating/often brought on by driver action.
- Tick — (Like a clock second hand)
Tick characteristics include gentle contacting of light materials/loose components/can be caused by driver action or road conditions.
- Thump — (Heavy, muffled knock noise)
Thump characteristics include softer knock/dead sound often brought on by activity.
- Buzz — (Like a bumblebee)
Buzz characteristics include high frequency rattle/firm contact.
- Often the degree of acceptable noise level will vary depending upon the person. A noise that you may judge as acceptable may be very irritating to the customer.
- Weather conditions, especially humidity and temperature, may have a great effect on noise level.

SQUEAK AND RATTLE TROUBLE DIAGNOSIS

DUPLICATE THE NOISE AND TEST DRIVE

If possible, drive the vehicle with the customer until the noise is duplicated. Note any additional information on the Diagnostic Worksheet regarding the conditions or location of the noise. This information can be used to duplicate the same conditions when you confirm the repair.

If the noise can be duplicated easily during the test drive, to help identify the source of the noise, try to duplicate the noise with the vehicle stopped by doing one or all of the following:

1. Close a door.
 2. Tap or push/pull around the area where the noise appears to be coming from.
 3. Rev the engine.
 4. Use a floor jack to recreate vehicle "twist".
 5. At idle, apply engine load (electrical load, half-clutch on M/T model, drive position on A/T model).
 6. Raise the vehicle on a hoist and hit a tire with a rubber hammer.
- Drive the vehicle and attempt to duplicate the conditions the customer states exist when the noise occurs.
 - If it is difficult to duplicate the noise, drive the vehicle slowly on an undulating or rough road to stress the vehicle body.

CHECK RELATED SERVICE BULLETINS

After verifying the customer concern or symptom, check ASIST for Technical Service Bulletins (TSBs) related to that concern or symptom.

If a TSB relates to the symptom, follow the procedure to repair the noise.

LOCATE THE NOISE AND IDENTIFY THE ROOT CAUSE

1. Narrow down the noise to a general area. To help pinpoint the source of the noise, use a listening tool (Chassis Ear: J-39570, Engine Ear: J-39565 and mechanics stethoscope).
2. Narrow down the noise to a more specific area and identify the cause of the noise by:
 - Removing the components in the area that you suspect the noise is coming from.
Do not use too much force when removing clips and fasteners, otherwise clips and fasteners can be broken or lost during the repair, resulting in the creation of new noise.
 - Tapping or pushing/pulling the component that you suspect is causing the noise.
Do not tap or push/pull the component with excessive force, otherwise the noise will be eliminated only temporarily.
 - Feeling for a vibration with your hand by touching the component(s) that you suspect is (are) causing the noise.
 - Placing a piece of paper between components that you suspect are causing the noise.
 - Looking for loose components and contact marks.

Refer to [IP-6, "Generic Squeak and Rattle Troubleshooting"](#).

REPAIR THE CAUSE

- If the cause is a loose component, tighten the component securely.
- If the cause is insufficient clearance between components:
 - Separate components by repositioning or loosening and retightening the component, if possible.
 - Insulate components with a suitable insulator such as urethane pads, foam blocks, felt cloth tape or urethane tape. A NISSAN Squeak and Rattle Kit (J-43980) is available through your authorized NISSAN Parts Department.

CAUTION:

Do not use excessive force as many components are constructed of plastic and may be damaged.

Always check with the Parts Department for the latest parts information.

The following materials are contained in the NISSAN Squeak and Rattle Kit (J-43980). Each item can be ordered separately as needed.

URETHANE PADS [1.5 mm (0.059 in) thick]

Insulates connectors, harness, etc.

76268-9E005: 100 x 135 mm (3.94 x 5.31 in)/76884-71L01: 60 x 85 mm (2.36 x 3.35 in)/76884-71L02: 15 x 25 mm (0.59 x 0.98 in)

INSULATOR (Foam blocks)

Insulates components from contact. Can be used to fill space behind a panel.

SQUEAK AND RATTLE TROUBLE DIAGNOSIS

73982-9E000: 45 mm (1.77 in) thick, 50 x 50 mm (1.97 x 1.97 in)/73982-50Y00: 10 mm (0.39 in) thick, 50 x 50 mm (1.97 x 1.97 in)

INSULATOR (Light foam block)

80845-71L00: 30 mm (1.18 in) thick, 30 x 50 mm (1.18 x 1.97 in)

FELT CLOTH TAPE

Used to insulate where movement does not occur. Ideal for instrument panel applications.

68370-4B000: 15 x 25 mm (0.59 x 0.98 in) pad/68239-13E00: 5 mm (0.20 in) wide tape roll

The following materials, not found in the kit, can also be used to repair squeaks and rattles.

UHMW (TEFLON) TAPE

Insulates where slight movement is present. Ideal for instrument panel applications.

SILICONE GREASE

Used in place of UHMW tape that will be visible or not fit.

Note: Will only last a few months.

SILICONE SPRAY

Use when grease cannot be applied.

DUCT TAPE

Use to eliminate movement.

CONFIRM THE REPAIR

Confirm that the cause of a noise is repaired by test driving the vehicle. Operate the vehicle under the same conditions as when the noise originally occurred. Refer to the notes on the Diagnostic Worksheet.

Generic Squeak and Rattle Troubleshooting

EIS0048H

Refer to Table of Contents for specific component removal and installation information.

INSTRUMENT PANEL

Most incidents are caused by contact and movement between:

1. The cluster lid A and instrument panel
2. Acrylic lens and combination meter housing
3. Instrument panel to front pillar garnish
4. Instrument panel to windshield
5. Instrument panel mounting pins
6. Wiring harnesses behind the combination meter
7. A/C defroster duct and duct joint

These incidents can usually be located by tapping or moving the components to duplicate the noise or by pressing on the components while driving to stop the noise. Most of these incidents can be repaired by applying felt cloth tape or silicone spray (in hard to reach areas). Urethane pads can be used to insulate wiring harness.

CAUTION:

Do not use silicone spray to isolate a squeak or rattle. If you saturate the area with silicone, you will not be able to recheck the repair.

CENTER CONSOLE

Components to pay attention to include:

1. Shifter assembly cover to finisher
2. A/C control unit and cluster lid C
3. Wiring harnesses behind audio and A/C control unit

The instrument panel repair and isolation procedures also apply to the center console.

DOORS

Pay attention to the:

1. Finisher and inner panel making a slapping noise
2. Inside handle escutcheon to door finisher
3. Wiring harnesses tapping
4. Door striker out of alignment causing a popping noise on starts and stops

SQUEAK AND RATTLE TROUBLE DIAGNOSIS

Tapping or moving the components or pressing on them while driving to duplicate the conditions can isolate many of these incidents. You can usually insulate the areas with felt cloth tape or insulator foam blocks from the NISSAN Squeak and Rattle Kit (J-43980) to repair the noise.

A

TRUNK

Trunk noises are often caused by a loose jack or loose items put into the trunk by the owner.

B

In addition look for:

1. Trunk lid bumpers out of adjustment
2. Trunk lid striker out of adjustment
3. The trunk lid torsion bars knocking together
4. A loose license plate or bracket

C

Most of these incidents can be repaired by adjusting, securing or insulating the item(s) or component(s) causing the noise.

D

SUNROOF/HEADLINING

Noises in the sunroof/headlining area can often be traced to one of the following:

1. Sunroof lid, rail, linkage or seals making a rattle or light knocking noise
2. Sun visor shaft shaking in the holder
3. Front or rear windshield touching headliner and squeaking

E

Again, pressing on the components to stop the noise while duplicating the conditions can isolate most of these incidents. Repairs usually consist of insulating with felt cloth tape.

F

G

OVERHEAD CONSOLE (FRONT AND REAR)

Overhead console noises are often caused by the console panel clips not being engaged correctly. Most of these incidents are repaired by pushing up on the console at the clip locations until the clips engage.

H

In addition look for:

1. Loose harness or harness connectors.
2. Front console map/reading lamp lens loose.
3. Loose screws at console attachment points.

IP

SEATS

When isolating seat noise it's important to note the position the seat is in and the load placed on the seat when the noise is present. These conditions should be duplicated when verifying and isolating the cause of the noise.

J

Cause of seat noise include:

1. Headrest rods and holder
2. A squeak between the seat pad cushion and frame
3. The rear seatback lock and bracket

K

These noises can be isolated by moving or pressing on the suspected components while duplicating the conditions under which the noise occurs. Most of these incidents can be repaired by repositioning the component or applying urethane tape to the contact area.

L

M

UNDERHOOD

Some interior noise may be caused by components under the hood or on the engine wall. The noise is then transmitted into the passenger compartment.

Causes of transmitted underhood noise include:

1. Any component mounted to the engine wall
2. Components that pass through the engine wall
3. Engine wall mounts and connectors
4. Loose radiator mounting pins
5. Hood bumpers out of adjustment
6. Hood striker out of adjustment

These noises can be difficult to isolate since they cannot be reached from the interior of the vehicle. The best method is to secure, move or insulate one component at a time and test drive the vehicle. Also, engine RPM or load can be changed to isolate the noise. Repairs can usually be made by moving, adjusting, securing, or insulating the component causing the noise.

SQUEAK AND RATTLE TROUBLE DIAGNOSIS

Diagnostic Worksheet

EIS003WW

Dear Customer:

We are concerned about your satisfaction with your vehicle. Repairing a squeak or rattle sometimes can be very difficult. To help us fix your vehicle right the first time, please take a moment to note the area of the vehicle where the squeak or rattle occurs and under what conditions. You may be asked to take a test drive with a service advisor or technician to ensure we confirm the noise you are hearing.

SQUEAK & RATTLE DIAGNOSTIC WORKSHEET

I. WHERE DOES THE NOISE COME FROM? (circle the area of the vehicle)

The illustrations are for reference only, and may not reflect the actual configuration of your vehicle.

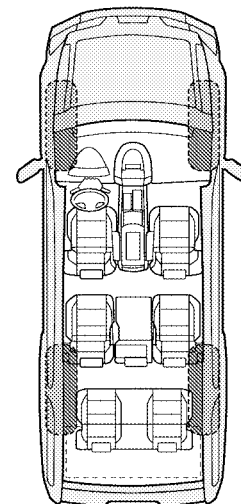
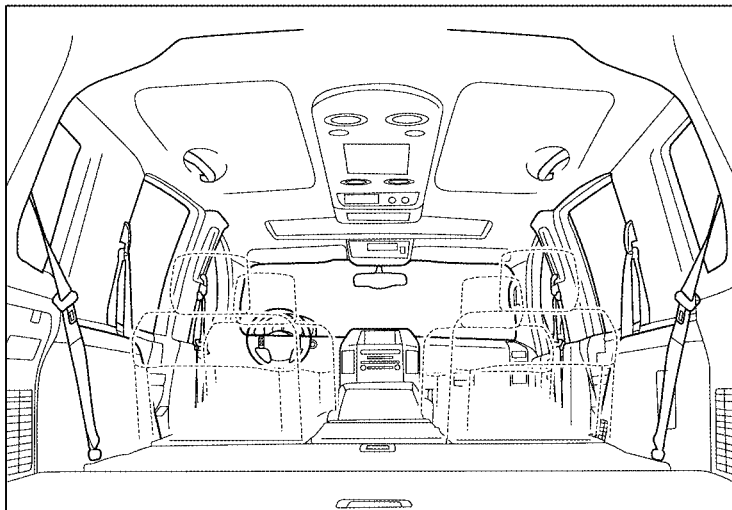
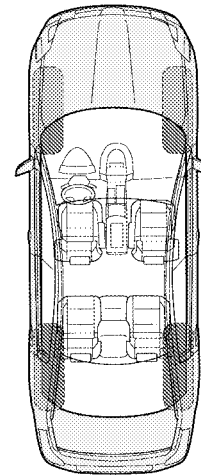
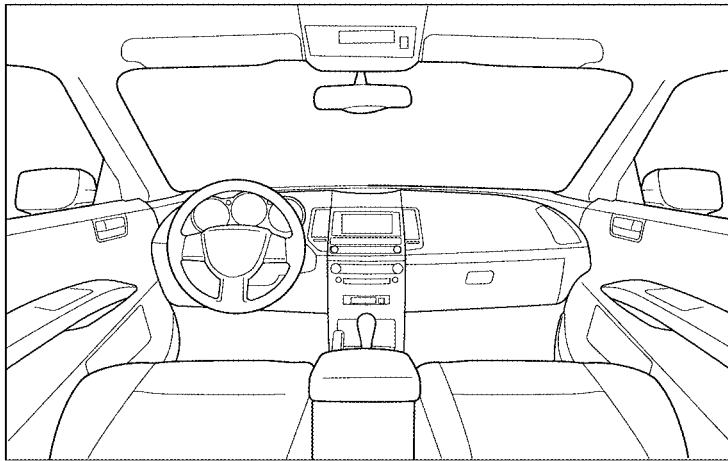

Continue to page 2 of the worksheet and briefly describe the location of the noise or rattle. In addition, please indicate the conditions which are present when the noise occurs.

SQUEAK AND RATTLE TROUBLE DIAGNOSIS

SQUEAK & RATTLE DIAGNOSTIC WORKSHEET - page 2

Briefly describe the location where the noise occurs:

II. WHEN DOES IT OCCUR? (please check the boxes that apply)

- | | |
|---|--|
| <input type="checkbox"/> Anytime | <input type="checkbox"/> After sitting out in the rain |
| <input type="checkbox"/> 1st time in the morning | <input type="checkbox"/> When it is raining or wet |
| <input type="checkbox"/> Only when it is cold outside | <input type="checkbox"/> Dry or dusty conditions |
| <input type="checkbox"/> Only when it is hot outside | <input type="checkbox"/> Other: |

III. WHEN DRIVING:

- Through driveways
- Over rough roads
- Over speed bumps
- Only about ____ mph
- On acceleration
- Coming to a stop
- On turns: left, right or either (circle)
- With passengers or cargo
- Other: _____
- After driving ____ miles or ____ minutes

IV. WHAT TYPE OF NOISE

- Squeak (like tennis shoes on a clean floor)
- Creak (like walking on an old wooden floor)
- Rattle (like shaking a baby rattle)
- Knock (like a knock at the door)
- Tick (like a clock second hand)
- Thump (heavy muffled knock noise)
- Buzz (like a bumble bee)

TO BE COMPLETED BY DEALERSHIP PERSONNEL

Test Drive Notes:

	YES	NO	Initials of person performing
Vehicle test driven with customer	<input type="checkbox"/>	<input type="checkbox"/>	_____
- Noise verified on test drive	<input type="checkbox"/>	<input type="checkbox"/>	_____
- Noise source located and repaired	<input type="checkbox"/>	<input type="checkbox"/>	_____
- Follow up test drive performed to confirm repair	<input type="checkbox"/>	<input type="checkbox"/>	_____

VIN: _____ Customer Name _____

W.O.# _____ Date: _____

This form must be attached to Work Order

LAIA0071E

INSTRUMENT PANEL ASSEMBLY

PFP:68200

EIS007N8

INSTRUMENT PANEL ASSEMBLY

Instrument Panel REMOVAL

SEC. 680

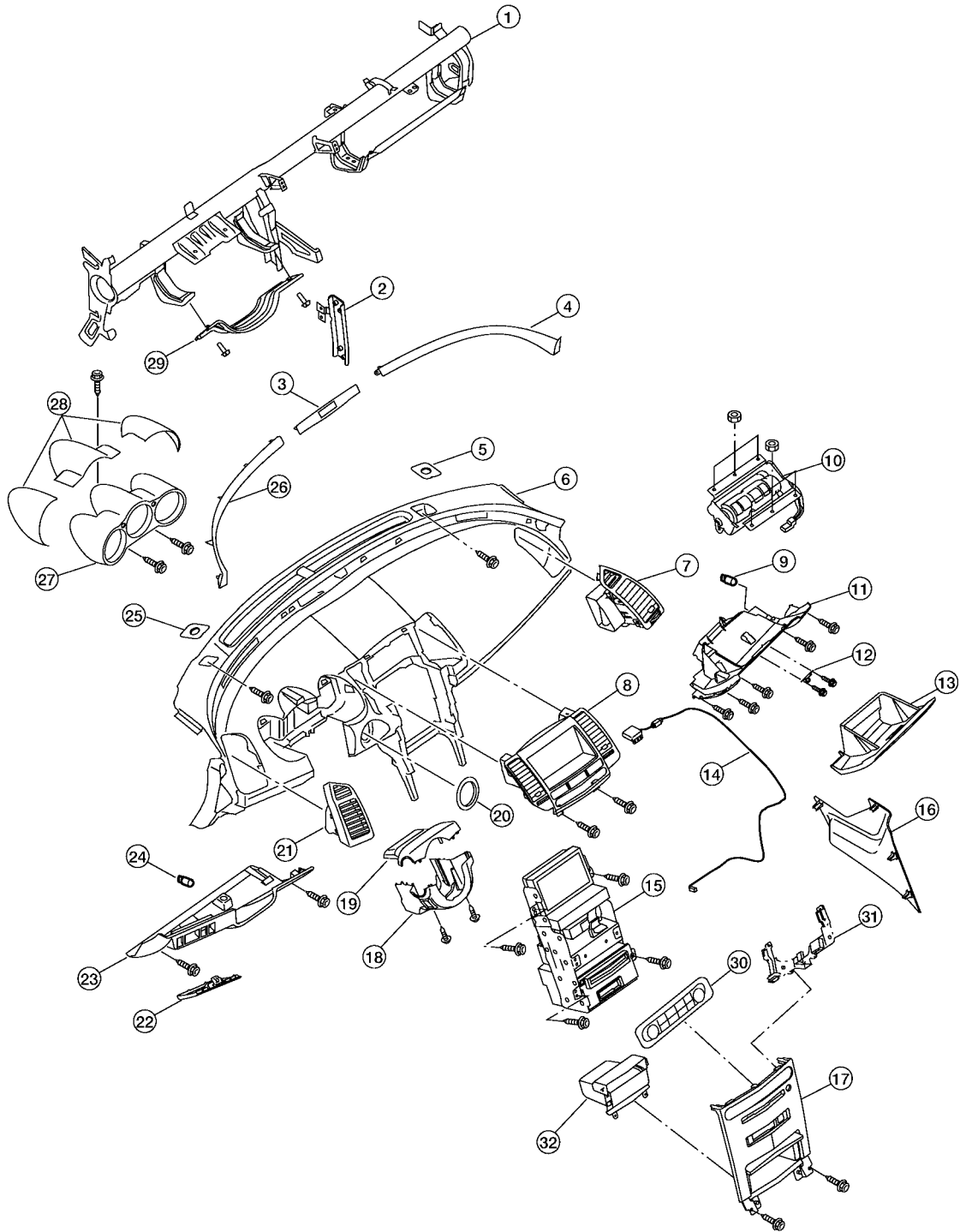

WI1A1367E

INSTRUMENT PANEL ASSEMBLY

- | | | | |
|--|-----------------------------------|--|---|
| 1. Steering member assembly | 2. Instrument stay, driver | 3. Security light finisher/Passenger air bag off indicator | A |
| 4. Instrument panel finisher, RH | 5. Instrument mask RH, sun sensor | 6. Instrument panel | |
| 7. Side ventilator assembly, RH | 8. Cluster lid D | 9. Glove box bulb | B |
| 10. Front passenger air bag module | 11. Glove box housing | 12. Glove box striker | |
| 13. Glove box assembly | 14. GPS antenna assembly | 15. Center stack | C |
| 16. Instrument lower cover, RH | 17. Cluster lid C | 18. Steering column cover, lower | |
| 19. Steering column cover, upper | 20. Steering lock escutcheon | 21. Side ventilator assembly, LH | D |
| 22. Fuse block cover | 23. Lower driver instrument panel | 24. Lower driver instrument panel bulb | |
| 25. Instrument mask LH, optical sensor | 26. Instrument panel finisher, LH | 27. Combination meter assembly | E |
| 28. Combination meter covers | 29. Lower knee protector, LH | 30. Display control unit | |
| 31. Cassette bracket | 32. Cluster lid C bin | | |

1. Disconnect battery negative terminal.
2. Disconnect battery positive terminal.
3. Remove lower driver instrument panel. Refer to [IP-15, "Lower Driver Instrument Panel"](#).
4. Remove instrument lower cover RH.
5. Remove glove box housing. Refer to [IP-16, "Glove Box Assembly and Housing"](#).
6. Remove rear center console. Refer to [IP-18, "Rear Center Console"](#).
7. Remove center stack assembly. Refer to [IP-13, "Center Stack Assembly"](#).
8. Remove and disconnect the security light flasher/ passenger air bag off indicator.
9. Disconnect the GPS antenna.
10. Remove and disconnect instrument mask RH, sun sensor.
11. Remove and disconnect instrument mask LH, optical sensor.
12. Partially remove and place the front door welts aside.
13. Remove instrument panel finisher LH.
14. Remove instrument panel finisher RH.
15. Remove front pillar garnish LH and front pillar garnish RH. Refer to [EI-33, "BODY SIDE TRIM"](#).
16. Remove kicking plate. Refer to [EI-33, "BODY SIDE TRIM"](#).
17. Remove lower dash side trim RH and lower dash side trim LH. Refer to [EI-33, "BODY SIDE TRIM"](#).
18. Remove passenger air bag to steering member assembly bolt.
19. Disconnect passenger side air bag electrical connector.
20. Disconnect tilt motor and telescopic motor. Refer to [PS-13, "TILT & TELESCOPIC SYSTEM"](#).
21. Remove the steering lock escutcheon.
22. Remove the steering column. Refer to [PS-15, "STEERING COLUMN"](#).

CAUTION:

- The rotation of the spiral cable (SRS air bag component part) is limited. If the steering gear must be removed, set the front wheels in the straight-ahead direction. Do not rotate the steering column while the steering gear is removed.
- Remove the steering wheel before disconnecting the coupling joint to avoid damaging the spiral cable.

23. Remove instrument panel.

INSTALLATION

Installation is in the reverse order of removal.

CAUTION:

When installing the steering column, finger-tighten all of the lower bracket and joint retaining bolts; then tighten them to specification. Do not apply undue stress to the steering column.

INSTRUMENT PANEL ASSEMBLY

EIS007N9

Cluster Lid C REMOVAL

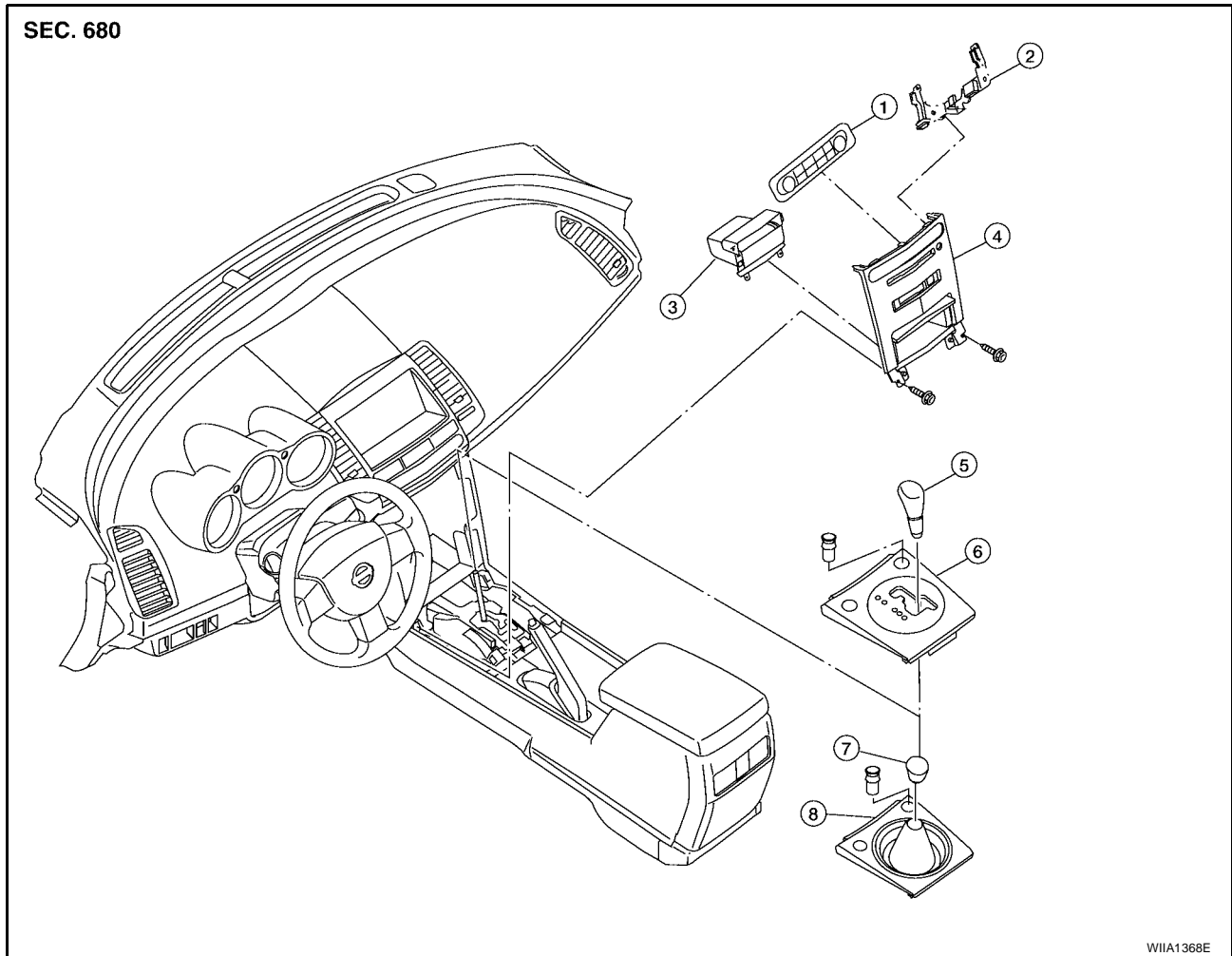

- | | | |
|-------------------------|---------------------|----------------------|
| 1. Display control unit | 2. Cassette bracket | 3. Cluster lid C bin |
| 4. Cluster lid C | 5. A/T shift knob | 6. A/T finisher |
| 7. M/T shift knob | 8. M/T finisher | |

CAUTION:

When removing and installing, place shop cloths onto surrounding parts to protect A/T or M/T finisher and center console from damage.

1. Disconnect battery negative terminal.
2. Remove A/T or M/T finisher. Refer to [IP-18, "A/T Finisher"](#) or [IP-18, "M/T Finisher"](#).
3. Remove cluster lid C screws, using power tool.
4. Pull cluster lid C towards rear of vehicle to release clips.
5. Disconnect cluster lid C component electrical connectors.
6. Remove the display control unit from the top of cluster lid C.
7. Remove the cassette bracket from the center of cluster lid C.
8. Remove the cluster lid C bin from the bottom of cluster lid C.

INSTALLATION

Installation is in the reverse order of removal.

INSTRUMENT PANEL ASSEMBLY

Cluster Lid D REMOVAL

EIS007NA

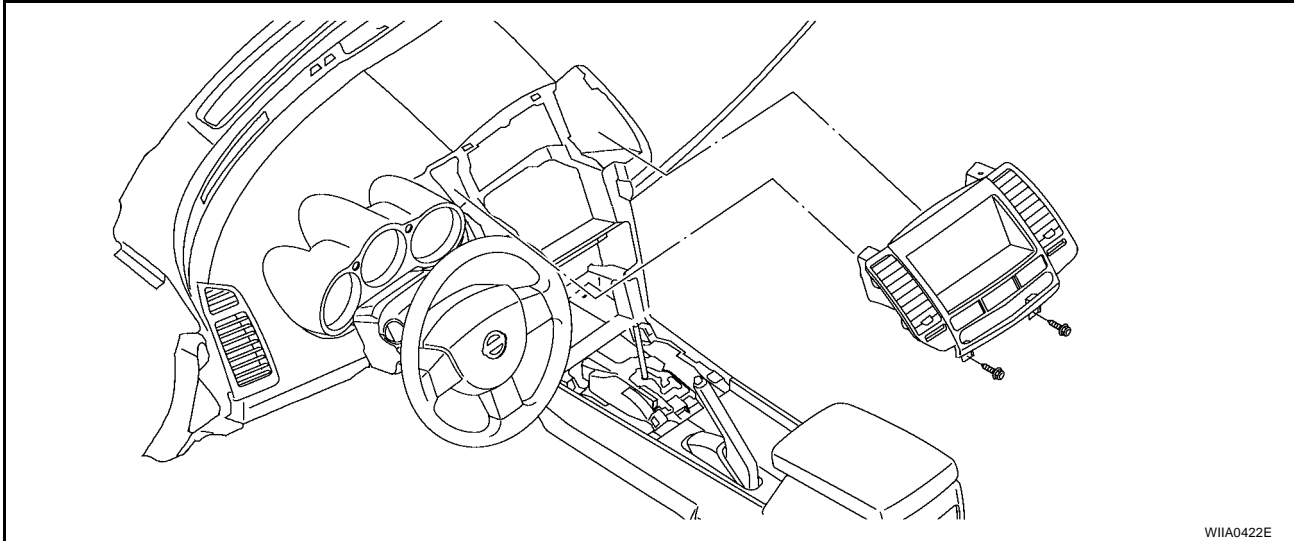

W1IA0422E

1. Disconnect battery negative terminal.
2. Remove cluster lid C. Refer to [IP-12, "Cluster Lid C"](#).
3. Remove cluster lid D screws using power tool.
4. Pull cluster lid D toward rear of vehicle to release clips.
5. Disconnect cluster lid D electrical connectors.

INSTALLATION

Installation is in the reverse order of removal.

Center Stack Assembly REMOVAL AND INSTALLATION

EIS007NB

Removal

CAUTION:

- To avoid damage, eject map DVD-ROM disk before removing the NAVI control unit.
- Cover NAVI control unit with a cloth and avoid contact of NAVI control unit with brackets that may cause scratches or damage to NAVI control unit.

1. Disconnect battery negative terminal.
2. Remove the front center console. Refer to [IP-17, "Front Center Console"](#).
3. Remove cluster lid D. Refer to [IP-13, "Cluster Lid D"](#).
4. Remove screws from the NAVI control unit.

NOTE:

NAVI control unit only on vehicles with navigation system.

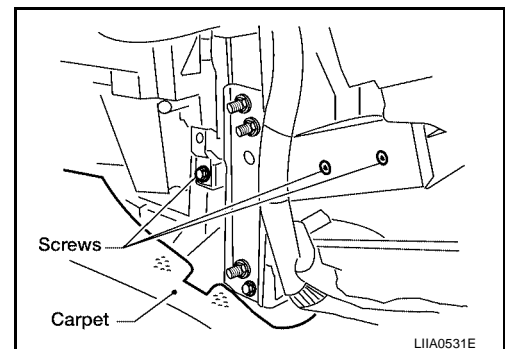

L1IA0531E

5. Disconnect NAVI control unit connectors.
6. Remove NAVI control unit.

INSTRUMENT PANEL ASSEMBLY

7. Remove screws and remove center stack.
8. Disconnect center stack electrical harness connectors and GPS antenna.

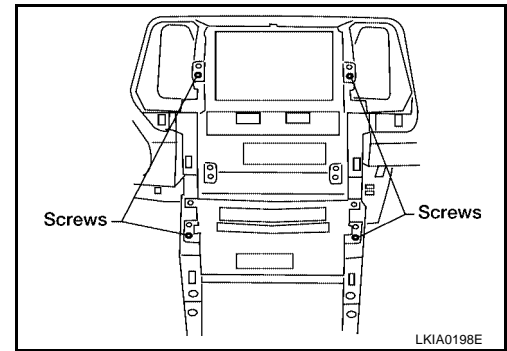

Installation

Installation is in the reverse order of removal.

DISASSEMBLY AND ASSEMBLY

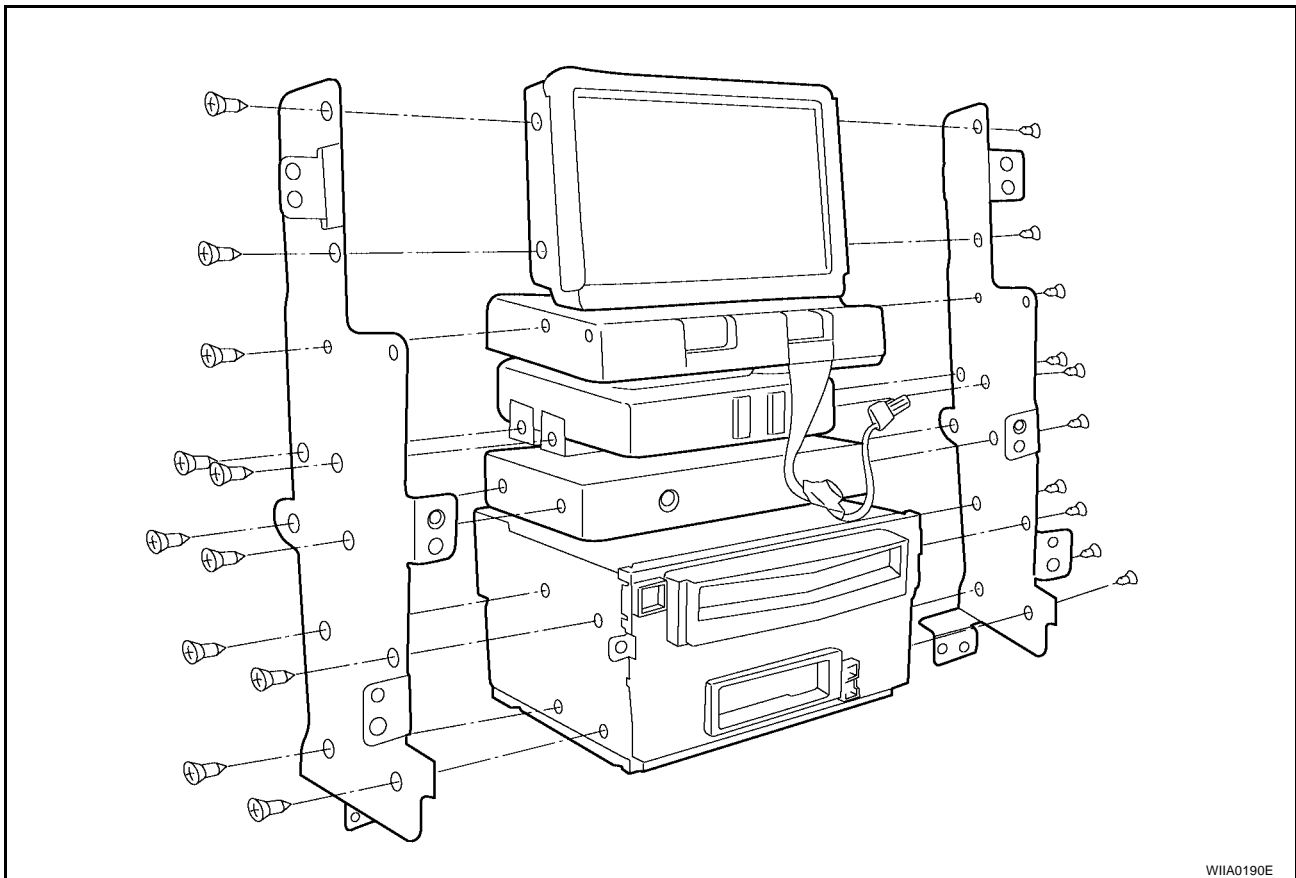

Disassembly

CAUTION:

Keep track of appropriate screws used for each component, the screws for audio unit are different from those used for unified meter and A/C amp.

1. Remove display unit screws using power tool and remove display unit from brackets.
2. Remove unified meter and A/C amp. screws using power tool and remove unified meter and A/C amp. Refer to [DI-35, "Unified Meter and A/C Amp."](#)
3. Remove automatic drive positioner control unit screws using power tool and remove automatic drive positioner control unit from brackets.
4. Remove display control unit screws using power tool and remove the display control unit from brackets.

NOTE:

Display control unit only on vehicles with navigation system.

5. Remove audio unit screws using power tool and remove audio unit from brackets.

INSTRUMENT PANEL ASSEMBLY

Assembly

CAUTION:

- Use appropriate screws for each component, the screws for audio unit are different from those used for unified meter and A/C amp.
- Cover NAVI control unit with a cloth and avoid contact with brackets that may cause scratches or damage to control unit.

Assembly is in the reverse order of disassembly

Lower Driver Instrument Panel REMOVAL

1. Remove fuse block cover.

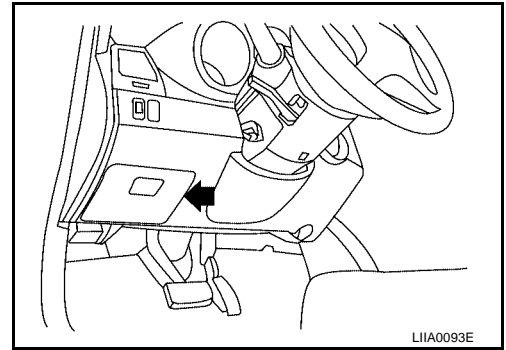

2. Remove lower driver instrument panel screws using power tool.
3. Remove lower driver instrument panel.
4. Disconnect aspirator tube and in vehicle temperature sensor.
5. Disconnect electrical harness connectors.

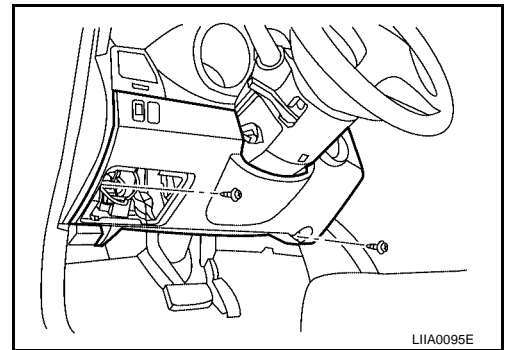

INSTALLATION

Installation is in the reverse order of removal.

A
B
C
D
E
F
G
H
IP
J
K
L
M

INSTRUMENT PANEL ASSEMBLY

EIS007NF

Glove Box Assembly and Housing REMOVAL AND INSTALLATION

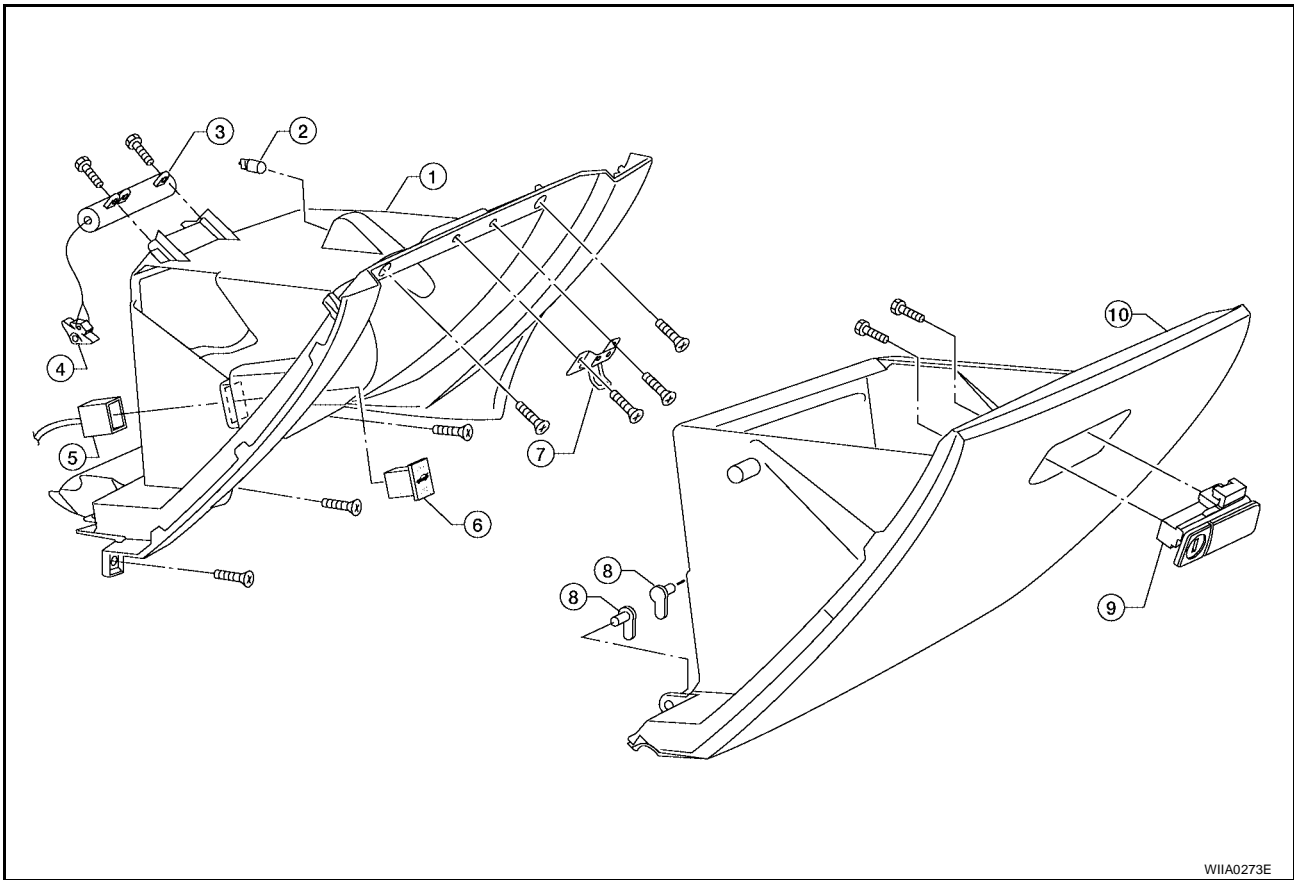

W11A0273E

- | | | |
|----------------------|--------------------------------|------------------------|
| 1. Glove box housing | 2. Glove box lamp | 3. Glove box damper |
| 4. Damper clip | 5. Trunk cancel switch harness | 6. Trunk cancel switch |
| 7. Glove box striker | 8. Glove box pin | 9. Glove box latch |
| 10. Glove box door | | |

Removal

1. Remove glove box pins and remove glove box door.
2. Remove glove box housing screws using power tool.
3. Disconnect trunk cancel switch harness.
4. Remove glove box lamp and harness from glove box housing.
5. Remove glove box housing.

Installation

Installation is in the reverse order of removal.

DISASSEMBLY AND ASSEMBLY

Disassembly

1. Remove glove box latch screws using power tool and remove glove box latch.
2. Remove trunk cancel switch.
3. Remove glove box striker.
4. Remove damper clip and remove glove box damper.

Assembly

Assembly is in the reverse order of disassembly.

CENTER CONSOLE ASSEMBLY

PF9:96910

CENTER CONSOLE ASSEMBLY

Front Center Console REMOVAL AND INSTALLATION

EIS007N6

Removal

1. Disconnect battery negative terminal.
2. If equipped, remove rear center console. Refer to [IP-18, "REMOVAL AND INSTALLATION"](#).
3. Remove glove box housing. Refer to [IP-16, "Glove Box Assembly and Housing"](#).
4. Remove lower driver instrument panel. Refer to [IP-15, "Lower Driver Instrument Panel"](#).
5. Remove instrument lower cover, RH.
6. Remove glove box assembly. Refer to [IP-16, "Glove Box Assembly and Housing"](#).
7. Remove control device. Refer to A/T [AT-239, "Control Device"](#) or M/T [MT-13, "Removal and Installation of Control Device and Cable"](#).
8. Remove cluster lid C. Refer to [IP-12, "Cluster Lid C"](#).
9. Pull up parking brake lever and remove parking brake lever finisher.
10. Disconnect harnesses.
11. Move front seats forward and remove center console assembly.

INSTALLATION

Installation is in the reverse order of removal.

Disassembly and Assembly

EIS007X3

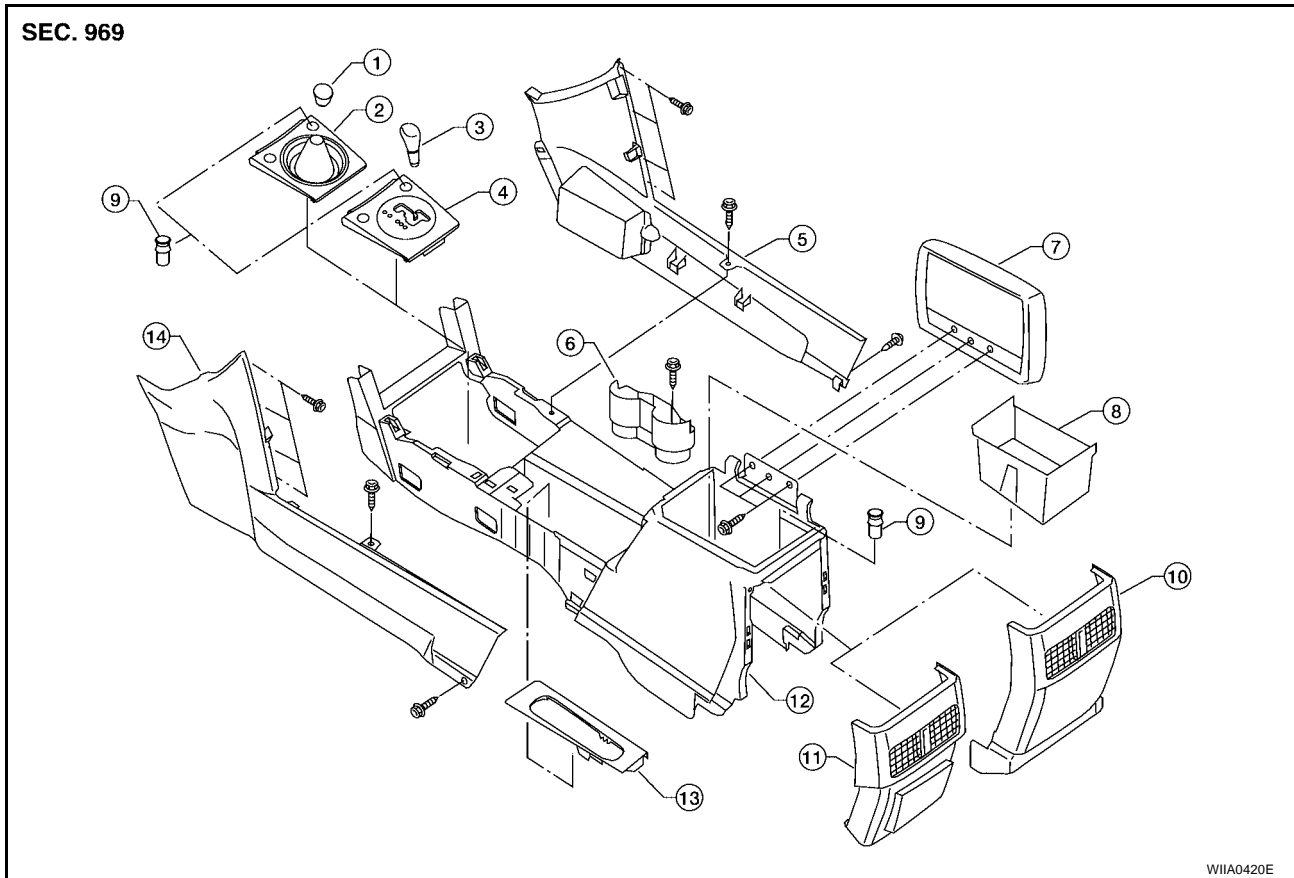

- | | | |
|--|--|--------------------------|
| 1. M/T shift knob | 2. M/t finisher | 3. A/T shift knob |
| 4. A/T finisher | 5. Console cover, RH | 6. Cup holder insert |
| 7. Console lid assembly | 8. Console rear pocket | 9. Power socket assembly |
| 10. Rear finisher assembly, 5 seat model | 11. Rear finisher assembly, 4 seat model | 12. Front center console |
| 13. Parking brake lever finisher | 14. Console cover, LH | |

CENTER CONSOLE ASSEMBLY

DISASSEMBLY

1. Disconnect the battery negative cable.
2. Remove front center console. Refer to [IP-17, "REMOVAL AND INSTALLATION"](#).
3. Remove cup holder insert from cup holder assembly.
4. Disconnect clips, remove screw on each side and remove RH and LH console covers.
5. Remove console rear pocket.
6. Remove power point assembly.
7. Remove screws from hinge plate and remove console lid assembly.
8. Release clips and remove rear finisher assembly.

ASSEMBLY

Assembly is in the reverse order of disassembly.

A/T Finisher

REMOVAL AND INSTALLATION

EIS007NG

Removal

1. Remove shift knob (1).
2. Pull up to release clips and remove A/T finisher (2).
3. Disconnect harnesses.
4. Remove the hazard switch.
5. Remove the power socket.

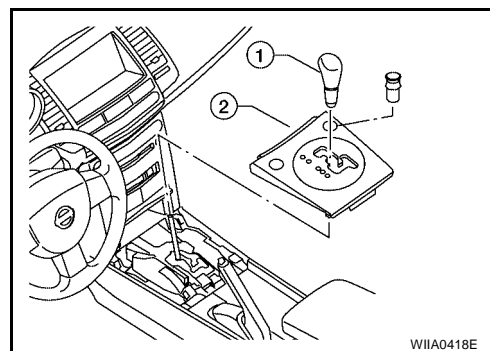

INSTALLATION

Installation is in the reverse order of removal.

M/T Finisher

REMOVAL AND INSTALLATION

EIS007NH

Removal

1. Remove shift knob (1).
2. Pull up to release clips and remove M/T finisher.
3. Disconnect harnesses.
4. Remove the hazard switch (2).
5. Remove the power socket.

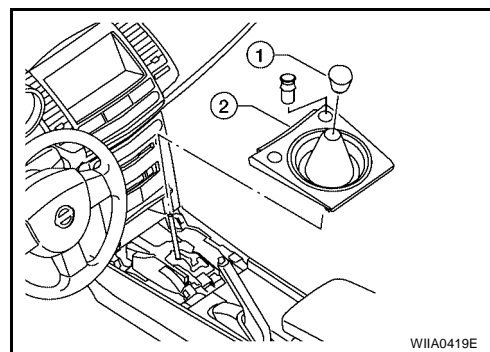

INSTALLATION

Installation is in the reverse order of removal.

Rear Center Console

REMOVAL AND INSTALLATION

EIS007N7

Removal

1. Remove both rear seat cushions and both rear seatbacks. Refer to [SE-106, "REAR SEAT"](#).
2. Remove screws and pass through assembly.
3. Release clips and remove lower side cover RH and lower side cover LH.
4. Remove screws, disconnect harness and remove rear console assembly.

CENTER CONSOLE ASSEMBLY

Installation

Installation is in the reverse order of removal.

Rear Center Console DISASSEMBLY AND ASSEMBLY

EIS007X4

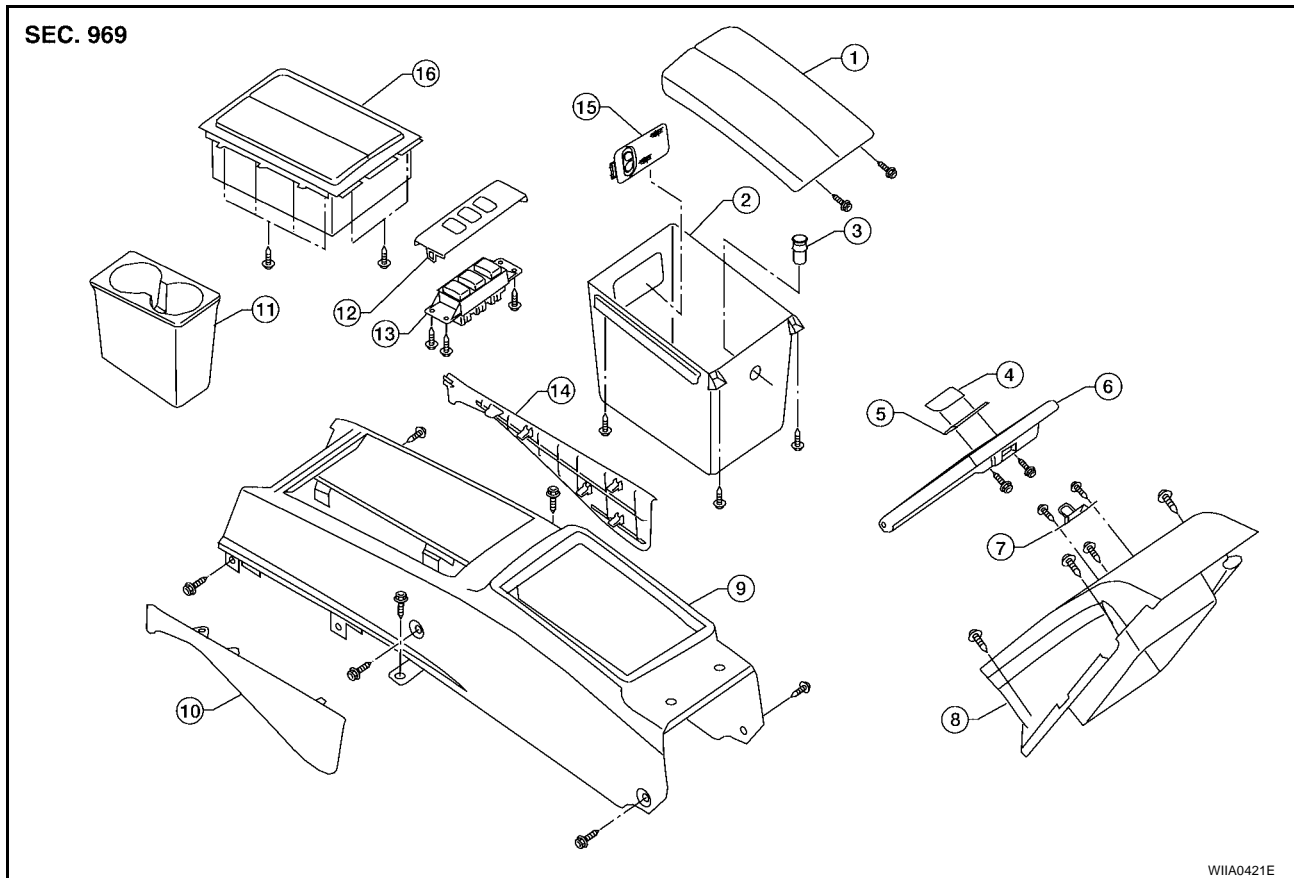

- | | | |
|------------------------------|--------------------------|-------------------------------------|
| 1. Rear console lid assembly | 2. Rear console tray | 3. Power point assembly |
| 4. Lock assembly | 5. Key cylinder | 6. Rear pass through lid assembly |
| 7. Striker | 8. Pass through assembly | 9. Rear center console |
| 10. Lower side cover, LH | 11. Cup holder assembly | 12. Switch finisher |
| 13. Switch assembly | 14. Lower side cover, RH | 15. Rear console lamp (if equipped) |
| 16. Front lid assembly | | |

Disassembly

1. Remove rear center console. Refer to [IP-18, "REMOVAL AND INSTALLATION"](#).
2. Remove cup holder assembly.
3. Remove screws and rear console lid assembly.
4. Disconnect harnesses and remove switch finisher and switch assembly.
 - Remove screws to separate switch finisher and switch assembly.
5. Remove screws and rear console tray.
 - Disconnect harnesses.
 - Remove power point assembly.
 - Remove rear console lamp (if equipped).
6. Remove screws and front lid assembly.
7. Remove screws and striker from rear pass through assembly.
8. Remove rear pass through lid assembly.
9. Remove screws, lock assembly and key cylinder.

CENTER CONSOLE ASSEMBLY

ASSEMBLY

Assembly is in the reverse order of disassembly.