

A
B
MT
D
E
F
G
H
I
J
K
L
M

SECTION **MT**

MANUAL TRANSAXLE

CONTENTS

PRECAUTIONS	3	CASE AND HOUSING COMPONENTS	19
Precautions for Supplemental Restraint System (SRS) "AIR BAG" and "SEAT BELT PRE-TENSIONER"	3	GEAR COMPONENTS	20
Caution	3	SHIFT CONTROL COMPONENTS	22
PREPARATION	4	FINAL DRIVE COMPONENTS	23
Special Service Tools	4	Disassembly and Assembly	23
Commercial Service Tools	6	DISASSEMBLY	23
NOISE, VIBRATION, AND HARSHNESS (NVH)		ASSEMBLY	27
TROUBLESHOOTING	7	Adjustment	34
NVH Troubleshooting Chart	7	INPUT SHAFT END PLAY	34
DESCRIPTION	8	DIFFERENTIAL SIDE BEARING PRELOAD	35
Cross-sectional View	8	MAINSHAFT END PLAY	36
DOUBLE-CONE SYNCHRONIZER	9	REVERSE IDLER GEAR END PLAY	37
TRIPLE-CONE SYNCHRONIZER	9	INPUT SHAFT AND GEARS	39
REVERSE GEAR	9	Disassembly and Assembly	39
M/T OIL	10	DISASSEMBLY	39
Replacement	10	INSPECTION AFTER DISASSEMBLY	40
DRAINING	10	ASSEMBLY	42
FILLING	10	MAINSHAFT AND GEARS	47
Checking	10	Disassembly and Assembly	47
OIL LEAKAGE AND OIL LEVEL	10	DISASSEMBLY	47
SIDE OIL SEAL	11	INSPECTION AFTER DISASSEMBLY	48
Removal and Installation	11	ASSEMBLY	50
REMOVAL	11	REVERSE IDLER SHAFT AND GEARS	56
INSTALLATION	11	Disassembly and Assembly	56
POSITION SWITCH	12	DISASSEMBLY	56
Checking	12	INSPECTION AFTER DISASSEMBLY	56
BACK-UP LAMP SWITCH	12	ASSEMBLY	57
PARK/NEUTRAL POSITION SWITCH	12	FINAL DRIVE	58
CONTROL LINKAGE	13	Disassembly and Assembly	58
Removal and Installation of Control Device and Cable	13	PRE-INSPECTION	58
AIR BREATHER HOSE	15	DISASSEMBLY	58
Removal and Installation	15	INSPECTION AFTER DISASSEMBLY	59
TRANSAXLE ASSEMBLY	16	ASSEMBLY	59
Removal and Installation	16	SHIFT CONTROL	62
REMOVAL	16	Inspection	62
INSTALLATION	18	SHIFT FORK	62
Component Parts	19	SERVICE DATA AND SPECIFICATIONS (SDS)	63
		General Specifications	63
		TRANSAXLE	63
		FINAL GEAR	64

Gear End Play	64	MAINSHAFT ADJUSTING SHIM	66
Clearance Between Baulk Ring and Gear	64	INPUT SHAFT REAR BEARING ADJUSTING SHIM	66
4TH, 5TH, 6TH & REVERSE BAULK RING	64	MAINSHAFT REAR BEARING ADJUSTING SHIM	67
1ST, 2ND AND 3RD BAULK RING	65	REVERSE IDLER GEAR ADJUSTING SHIM	67
Available Snap Rings	65	6TH MAIN GEAR ADJUSTING SHIM	67
6TH BUSHING	65	Available Shims	67
Available C-rings	65	BEARING PRELOAD	67
MAINSHAFT C-RING	65	DIFFERENTIAL SIDE BEARING ADJUSTING SHIM(S)	67
Available Thrust Washers	66		
INPUT SHAFT THRUST WASHER	66		
Available Adjusting Shims	66		

PRECAUTIONS

PRECAUTIONS

PFP:00001

Precautions for Supplemental Restraint System (SRS) “AIR BAG” and “SEAT BELT PRE-TENSIONER”

ECS001Z1

The Supplemental Restraint System such as “AIR BAG” and “SEAT BELT PRE-TENSIONER”, used along with a front seat belt, helps to reduce the risk or severity of injury to the driver and front passenger for certain types of collision. This system includes seat belt switch inputs and dual stage front air bag modules. The SRS system uses the seat belt switches to determine the front air bag deployment, and may only deploy one front air bag, depending on the severity of a collision and whether the front occupants are belted or unbelted. Information necessary to service the system safely is included in the SRS and SB section of this Service Manual.

WARNING:

- To avoid rendering the SRS inoperative, which could increase the risk of personal injury or death in the event of a collision which would result in air bag inflation, all maintenance must be performed by an authorized NISSAN/INFINITI dealer.
- Improper maintenance, including incorrect removal and installation of the SRS, can lead to personal injury caused by unintentional activation of the system. For removal of Spiral Cable and Air Bag Module, see the SRS section.
- Do not use electrical test equipment on any circuit related to the SRS unless instructed to in this Service Manual. SRS wiring harnesses can be identified by yellow and/or orange harnesses or harness connectors.

Caution

ECS00EN0

- Do not reuse transaxle oil.
- Drain, fill and check transaxle oil with the vehicle on level ground.
- During removal and installation, keep inside of transaxle clean of dust and dirt.
- Check for the correct installation orientation prior to removal or disassembly. If mating marks are required, be certain they do not interfere with the function of the parts they are applied to.
- In principle, tighten bolts or nuts gradually in several steps working diagonally and from inside to outside as applicable. If a tightening sequence is specified, follow it.
- Be careful not to damage the sliding surfaces and mating surfaces of parts.

PREPARATION

PFP:00002

ECS00EN1

PREPARATION

Special Service Tools

The actual shapes of Kent-Moore tools may differ from those of special tools illustrated here.

Tool number (Kent-Moore No.) Tool name	Description
KV381054S0 (J-34286) Puller	Removing side bearing outer race Removing mainshaft front bearing
ST35321000 (—) Drift	Installing input shaft oil seal Installing reverse main gear Installing 1st bushing Installing 1st-2nd synchronizer hub Installing 2nd bushing Installing 3rd main gear a: 49 mm (1.93 in) dia. b: 41 mm (1.61 in) dia.
ST30720000 (J-25405) Drift	Installing differential oil seal Installing differential side bearing outer race Installing mainshaft rear bearing Installing differential side bearing a: 77 mm (3.03 in) dia. b: 55.5 mm (2.185 in) dia.
ST33200000 (J-26082) Drift	Installing mainshaft front bearing Installing 6th bushing Installing 4th main gear Installing 5th main gear Installing 6th main gear a: 60 mm (2.36 in) dia. b: 44.5 mm (1.752 in) dia.
ST33061000 (J-8107-2) Drift	Installing bore plug Removing differential side bearing a: 38 mm (1.50 in) dia. b: 28.5 mm (1.122 in) dia.
ST33052000 (—) Drift	Installing welch plug Removing input shaft rear bearing Removing 5th bushing, thrust washer, 4th input gear, 4th gear bushing, 3rd-4th synchronizer hub and 3rd input gear Installing input shaft front bearing Removing 6th input gear and 6th bushing Removing mainshaft rear bearing Removing 4th main gear and 5th main gear Removing 6th main gear a: 22 mm (0.87 in) dia. b: 28 mm (1.10 in) dia.

PREPARATION

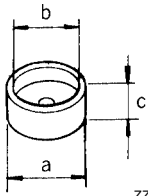
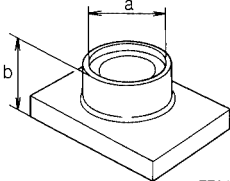
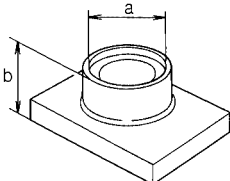
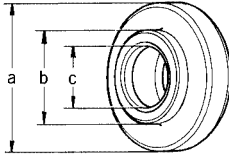
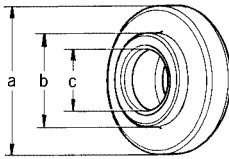
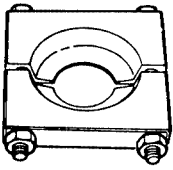
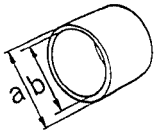

Tool number (Kent-Moore No.) Tool name	Description	
KV40105020 (—) Drift	 <p style="text-align: center;">ZZA1133D</p>	A B MT
KV40105710 (—) Press stand	 <p style="text-align: center;">ZZA1058D</p>	D E F
ST38220000 (—) Press stand	 <p style="text-align: center;">ZZA1058D</p>	G H
ST30032000 (J-26010-01) Drift	 <p style="text-align: center;">ZZA0978D</p>	I J
ST30901000 (J-26010-01) Drift	 <p style="text-align: center;">ZZA0978D</p>	K L
ST30031000 (J-22912-01) Puller	 <p style="text-align: center;">ZZA0537D</p>	M
KV40101630 (J-35870) Drift	 <p style="text-align: center;">ZZA1003D</p>	

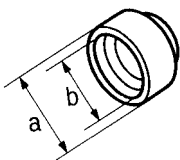
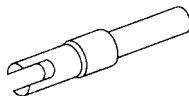
PREPARATION

Tool number (Kent-Moore No.) Tool name	Description
KV38102510 (J-35870) Drift  ZZA0838D	Installing 1st bushing Installing 1st-2nd synchronizer hub Installing differential side bearing a: 71 mm (2.80 in) dia. b: 65 mm (2.56 in) dia.
— (J-39713) Drift  NT087	Measuring end play of side gear

Commercial Service Tools

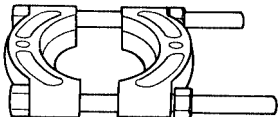
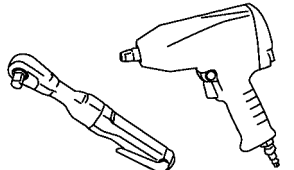
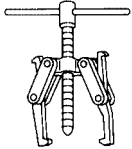
ECS00EN2

Tool name	Description
Puller  ZZB0823D	Removing each bearing gear and bushing
Power tool  PBIC0190E	Loosening bolts and nuts
Puller  NT077	Removing each bearing gear and bushing
Pin punch  ZZA0815D	Removing and installing each retaining pin Tip: 4.5 mm (0.177 in) dia.

NOISE, VIBRATION, AND HARSHNESS (NVH) TROUBLESHOOTING

NOISE, VIBRATION, AND HARSHNESS (NVH) TROUBLESHOOTING

PF0:00003

NVH Troubleshooting Chart

ECS00EN3

Use the chart below to help you find the cause of the symptom. The numbers indicate the order of the inspection. If necessary, repair or replace these parts.

Reference page		MT-10	MT-10	MT-10	MT-11			MT-13	MT-23		MT-19			
Suspected parts (possible cause)		(oil level is low)	(wrong oil)	(oil level is high)	Gasket (damaged)	Oil seal (worn or damaged)	O-Ring (worn or damaged)	Control device and cable (worn)	Check plug return spring and check ball (worn or damaged)	Shift fork (worn)	Gear (worn or damaged)	Bearing (worn or damaged)	Baulk ring (worn or damaged)	Insert spring, shifting insert (damaged)
Symptom	Noise	1	2								3	3		
	Oil leakage		3	1	2	2	2							
	Hard to shift or will not shift		1	1				2					3	3
	Jumps out of gear							1	2	3	3			

A
B
MT
D
E
F
G
H
I
J
K
L
M

DESCRIPTION

DESCRIPTION

PFP:00000

Cross-sectional View

ECS00EN4

RS6F51A

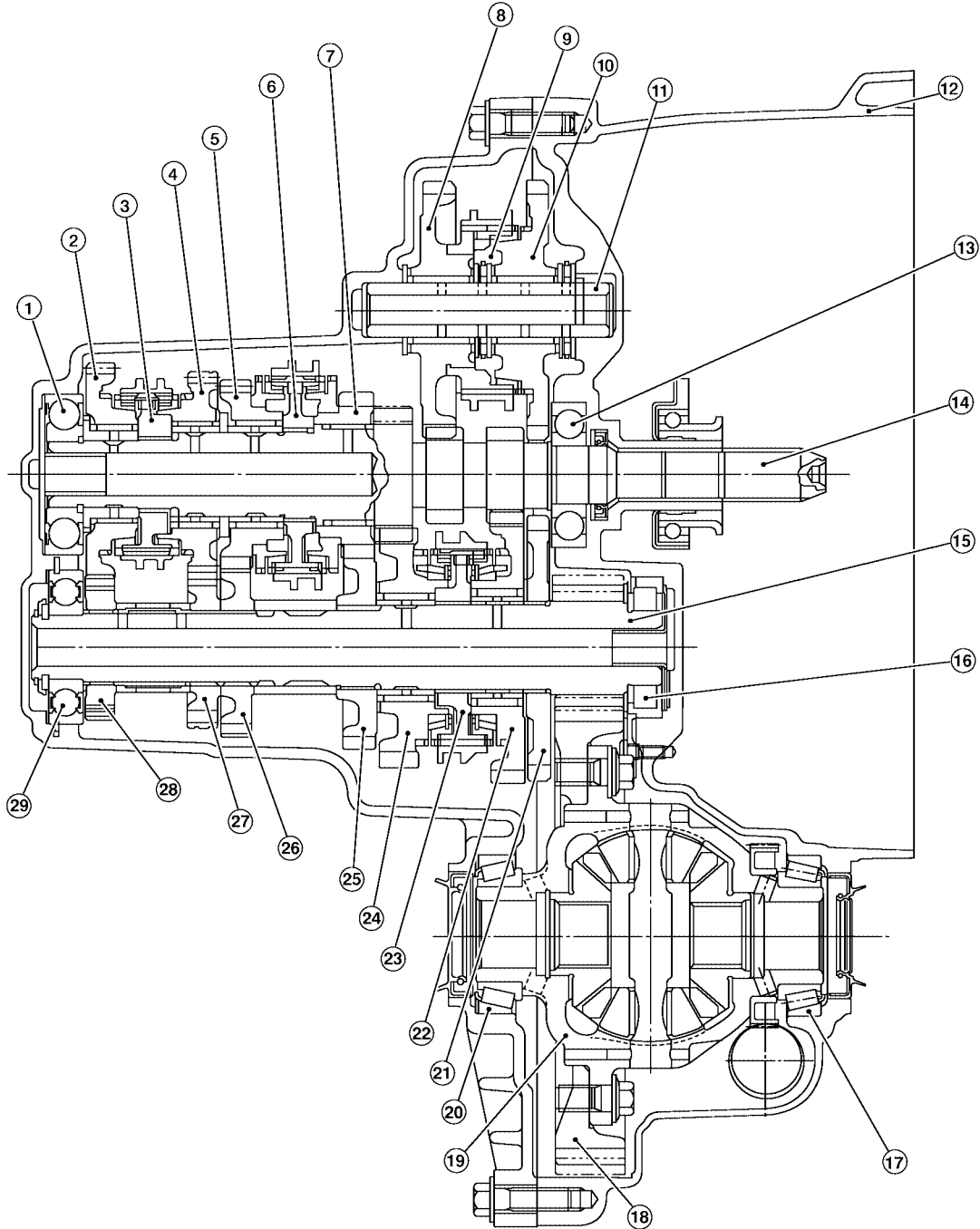

WCIA0263E

DESCRIPTION

- | | | |
|--------------------------------|---------------------------------------|---------------------------|
| 1. Input shaft rear bearing | 2. 6th input gear | 3. 5th & 6th synchronizer |
| 4. 5th input gear | 5. 4th input gear | 6. 3rd & 4th synchronizer |
| 7. 3rd input gear | 8. Reverse idler gear (rear) | 9. Reverse synchronizer |
| 10. Reverse idler gear (front) | 11. Reverse idler shaft | 12. Clutch housing |
| 13. Input shaft front bearing | 14. Input shaft | 15. Mainshaft |
| 16. Mainshaft front bearing | 17. Differential side bearing (front) | 18. Final gear |
| 19. Differential case | 20. Differential side bearing (rear) | 21. Reverse main gear |
| 22. 1st main gear | 23. 1st & 2nd synchronizer | 24. 2nd main gear |
| 25. 3rd main gear | 26. 4th main gear | 27. 5th main gear |
| 28. 6th main gear | 29. Mainshaft rear bearing | |

A
B
MT
D
E
F
G
H
I
J
K
L
M

DOUBLE-CONE SYNCHRONIZER

The 3rd gear is equipped with a double-cone synchronizer to reduce the operating force of the shift lever as shown.

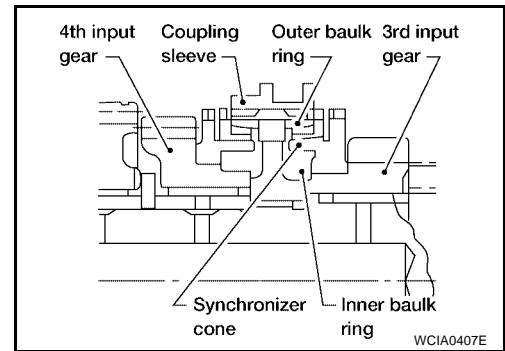

TRIPLE-CONE SYNCHRONIZER

The 1st and 2nd gears are equipped with a triple-cone synchronizer to reduce the operating force of the control lever as shown.

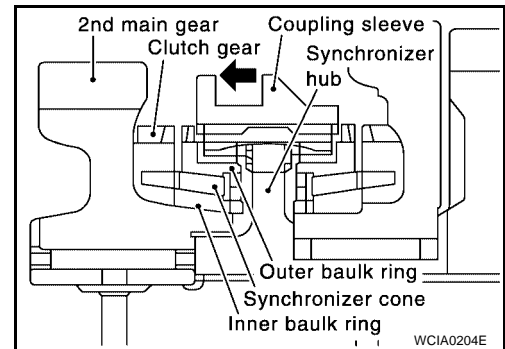

REVERSE GEAR

Description of reverse gear components is as shown.

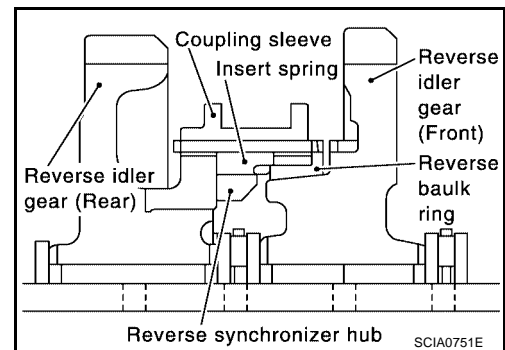

M/T OIL

Replacement DRAINING

1. Start the engine and let it run to warm up the transaxle oil.
2. Stop the engine. Drain the oil by removing the drain plug.
3. Install a new gasket on the drain plug and install the drain plug in the transaxle case.

Drain plug : 34.5 N·m (3.5 kg·m, 25 ft·lb)

CAUTION:
Do not reuse gasket.

FILLING

1. Remove the speedometer pinion gear and fill the transaxle with new gear oil through the opening for the speedometer pinion gear.

Oil grade and capacity : Refer to [MA-9, "Fluids and Lubricants"](#) .

2. Check the oil level using a suitable gauge as shown. Check that the oil level is at specification "L". Add oil as necessary through the opening for the speedometer pinion gear.

Oil level "L" : 49 - 55 mm (1.93 - 2.17 in)

CAUTION:
Never start the engine while checking the oil level.

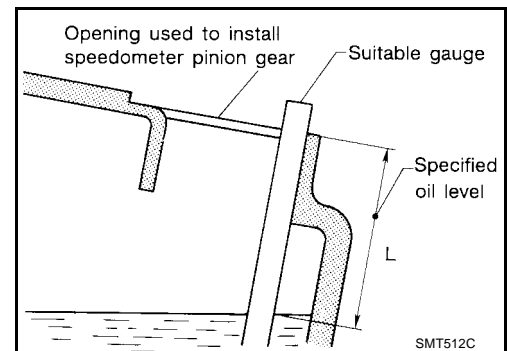

3. Install a new O-ring on the speedometer pinion gear, and install the speedometer pinion gear in to the transaxle case.

Speedometer pinion gear : 5.6 N·m (0.6 kg·m, 50 in·lb)

CAUTION:
Do not reuse the O-ring.

Checking

OIL LEAKAGE AND OIL LEVEL

1. Check the transaxle for any oil leaks.
2. Remove the speedometer pinion gear.
3. Measure the oil level using a suitable gauge as shown. Check that the oil level is at specification "L". Add oil as necessary through the opening for the speedometer pinion gear.

Oil level "L" : 49 - 55 mm (1.93 - 2.17 in)

CAUTION:
Never start the engine while checking the oil level.

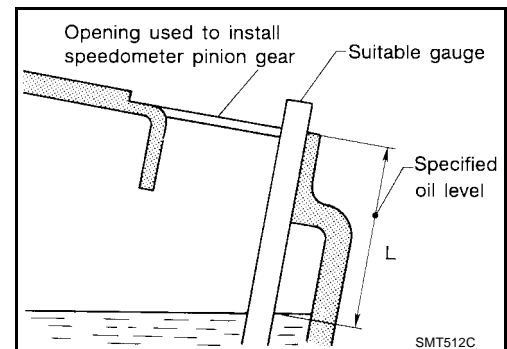

4. Install a new O-ring on the speedometer pinion gear, and install the speedometer pinion gear in the transaxle case.

Speedometer pinion gear : 5.6 N·m (0.6 kg·m, 50 in·lb)

CAUTION:
Do not reuse the O-ring.

SIDE OIL SEAL

SIDE OIL SEAL

PF3:32113

Removal and Installation

ECS00EN7

REMOVAL

1. Remove the drive shaft from the transaxle case. Refer to [FAX-11, "Removal and Installation"](#).
2. Remove the oil seal using a suitable tool as shown.

CAUTION:

Be careful not to damage the transaxle case surface when removing the oil seal.

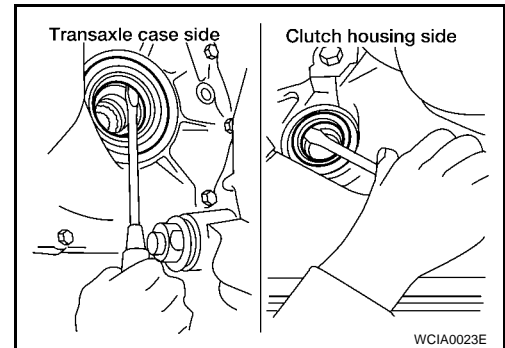

INSTALLATION

Installation is in the reverse order of removal.

- Drive the oil seal straight in until it protrudes from the transaxle case end equal to dimension "A" using Tool, as shown.

Dimension "A" : Within 0.5 mm (0.02 in) or flush with the case.

Tool number : ST30720000 (J-25405)

CAUTION:

- Before installing oil seal, apply multi-purpose grease to oil seal lips.
 - Do not reuse oil seal.
- Check the transaxle oil level after installation. Refer to [MT-10, "Checking"](#).

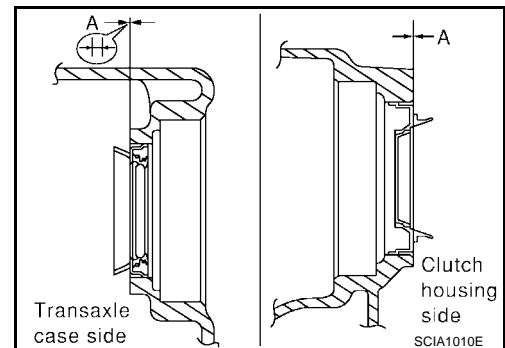

POSITION SWITCH

PFP:32005

ECS00EN8

POSITION SWITCH

Checking

NOTE:

For removal and installation of the switches. Refer to [MT-19, "CASE AND HOUSING COMPONENTS"](#).

BACK-UP LAMP SWITCH

- Check continuity.

Gear position	Continuity
Reverse	Yes
Except reverse	No

PARK/NEUTRAL POSITION SWITCH

- Check continuity.

Gear position	Continuity
Neutral	Yes
Except neutral	No

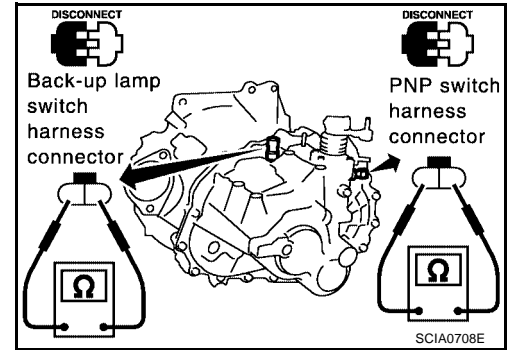

CONTROL LINKAGE

PF3:34103

ECS00EN9

CONTROL LINKAGE

Removal and Installation of Control Device and Cable

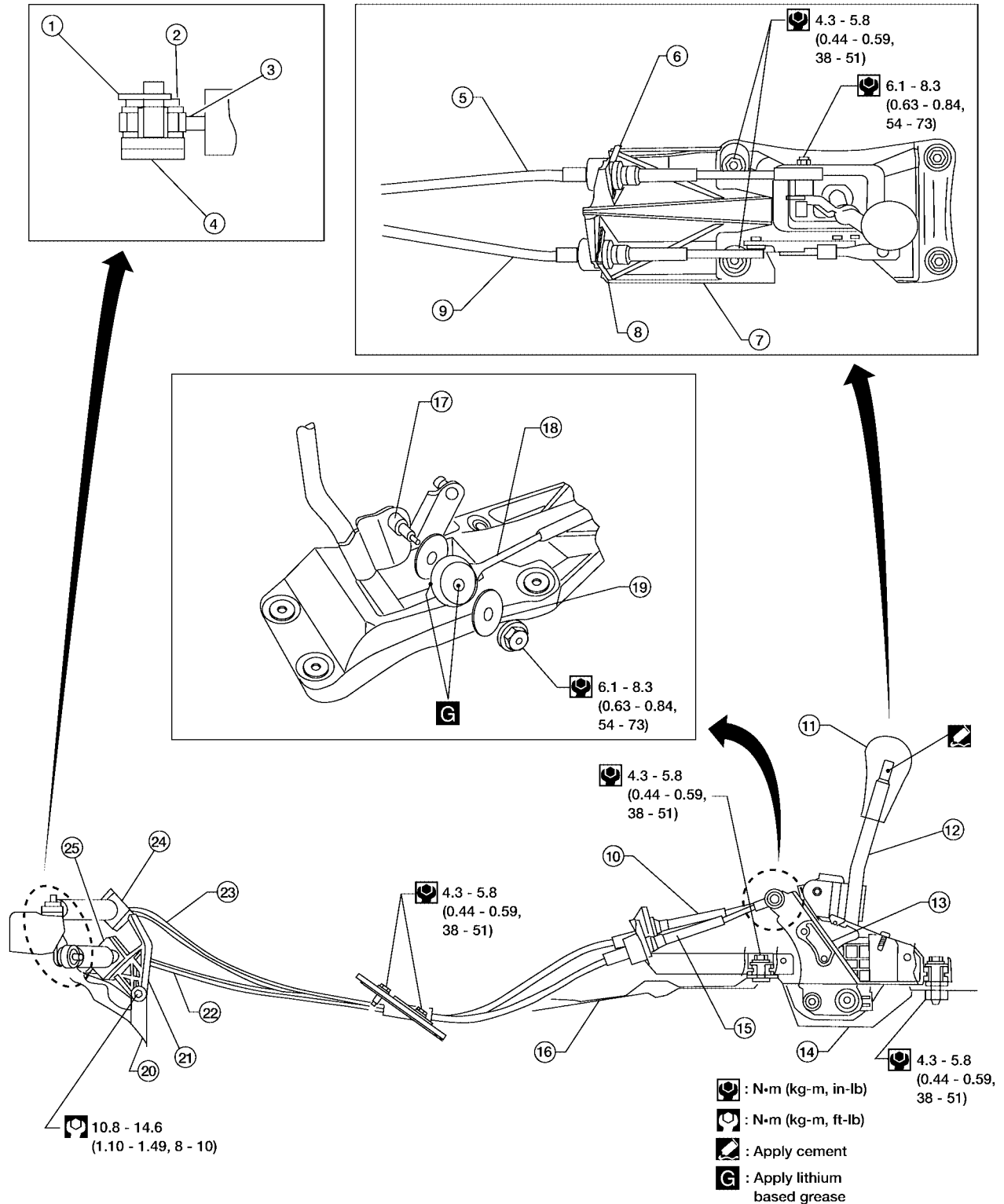

- 1. Snap pin
- 2. Washer
- 3. Cable
- 4. Manual lever
- 5. Shift cable
- 6. Lock plate
- 7. Control device assembly
- 8. Lock plate
- 9. Select cable
- 10. Shift cable
- 11. Control lever knob
- 12. Control lever

- 13. Control lever
- 14. Control lever knob
- 15. Control lever knob
- 16. Control lever knob
- 17. Control lever knob
- 18. Control lever knob
- 19. Control lever knob
- 20. Control lever knob
- 21. Control lever knob
- 22. Control lever knob
- 23. Control lever knob
- 24. Control lever knob
- 25. Control lever knob

- 26. Control lever knob
- 27. Control lever knob
- 28. Control lever knob
- 29. Control lever knob
- 30. Control lever knob
- 31. Control lever knob
- 32. Control lever knob
- 33. Control lever knob
- 34. Control lever knob
- 35. Control lever knob
- 36. Control lever knob
- 37. Control lever knob
- 38. Control lever knob
- 39. Control lever knob
- 40. Control lever knob

WCIA0203E

CONTROL LINKAGE

- | | | |
|-----------------------------|--------------------|----------------------------|
| 13. Control device assembly | 14. Cover | 15. Select cable |
| 16. Floor | 17. Pin | 18. Shift cable |
| 19. Washer | 20. Clutch housing | 21. Cable mounting bracket |
| 22. Select cable | 23. Shift cable | 24. Lock plate |
| 25. Lock plate | | |

CAUTION:

- **Note that the select side lock plate for securing the control cable is different from the one on the shift side.**
- **After assembly, make sure selector lever automatically returns to Neutral when it is moved to 1st, 2nd, or Reverse.**

AIR BREATHER HOSE

PF3:31098

ECS00ENA

AIR BREATHER HOSE Removal and Installation

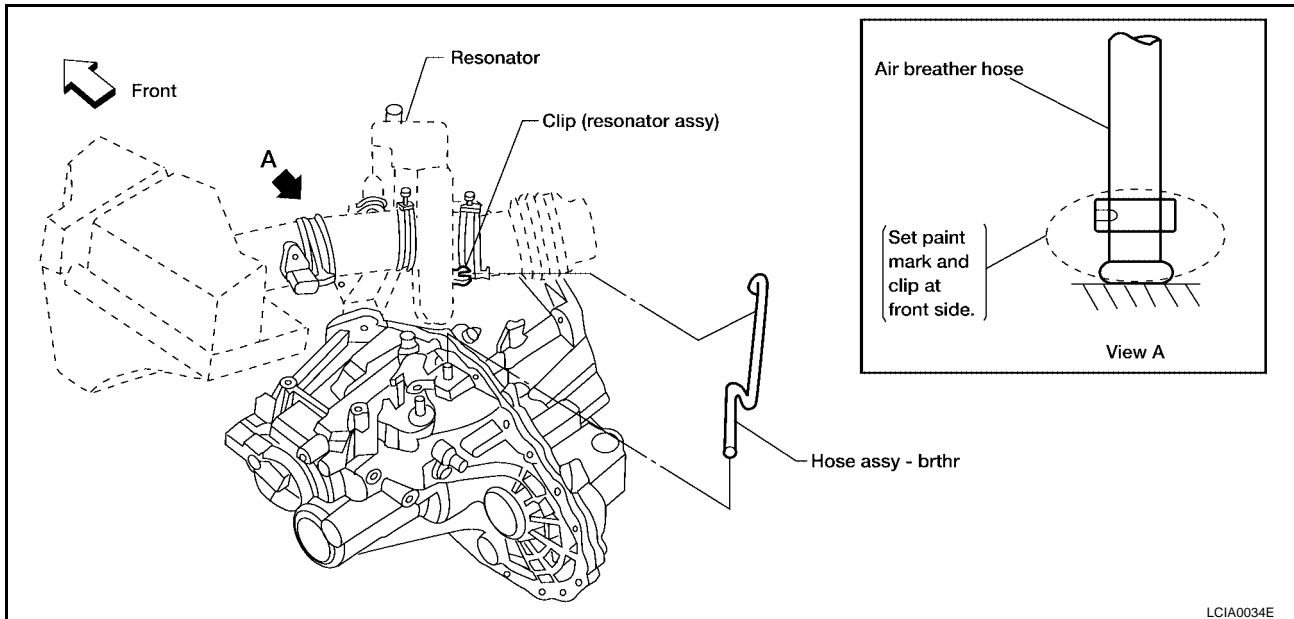

CAUTION:

- Make sure there are no pinched or restricted areas on the air breather hose caused by bending or winding when installing it.
- Insert the air breather hose into the transaxle tube until the overlap area reaches the spool.

A
B
MT
D
E
F
G
H
I
J
K
L
M

TRANSAXLE ASSEMBLY

PFP:32010

TRANSAXLE ASSEMBLY

Removal and Installation

ECS00ENB

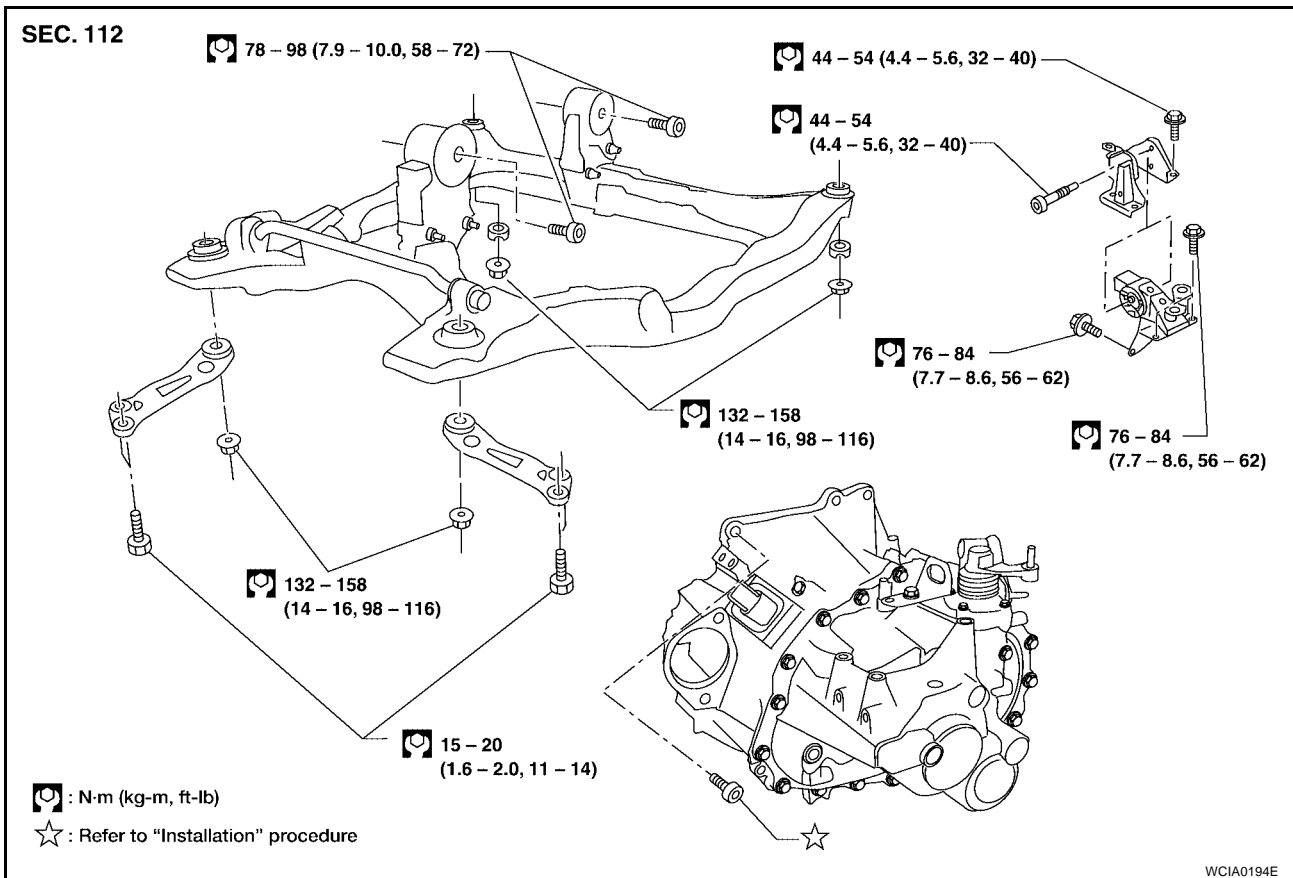

REMOVAL

1. Remove the air cleaner and air duct. Refer to [EM-14, "Removal and Installation"](#).
2. Remove the battery tray and battery.
3. Remove air breather hose from the transaxle.
4. Remove the clutch operating cylinder and position it aside without disconnecting the hydraulic lines. Refer to [CL-11, "Removal and Installation"](#).

CAUTION:

Do not depress clutch pedal during removal procedure.

5. Remove the two shift cables from the transaxle. Refer to [MT-13, "Removal and Installation of Control Device and Cable"](#).
6. Disconnect and remove the harnesses for the back-up lamp switch and ground straps.
7. Remove the starter motor using power tool. Refer to [SC-14, "Removal and Installation"](#).
8. Raise vehicle and remove the engine undercover and splash shields using power tool.
9. Drain the gear oil from the transaxle. Refer to [MT-10, "DRAINING"](#).
10. Disconnect and remove the harnesses for:
 - Vehicle speed sensor
 - PNP switch
 - Crankshaft position sensor
11. Remove the bolt and heated oxygen sensor harness clamp bracket, then remove the crankshaft position sensor.
12. Remove the exhaust front tube using power tool. Refer to [EX-3, "Removal and Installation"](#).
13. Remove the drive shafts using power tool. Refer to [FAX-11, "Removal and Installation"](#).

TRANSAXLE ASSEMBLY

14. Lower vehicle, then install suitable engine slinger on the front of the left bank cylinder head, and the rear of the right bank cylinder head as shown.

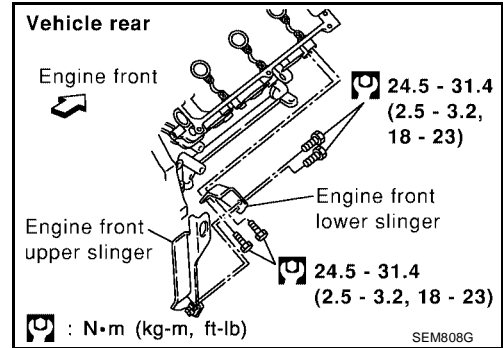
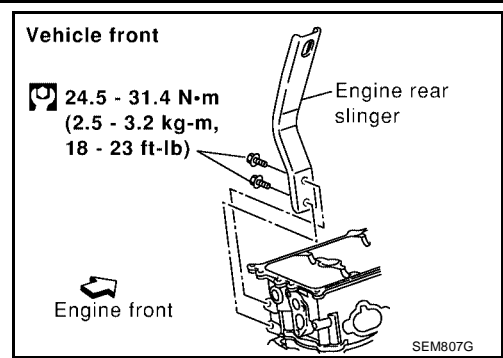

15. Support the engine using an engine support fixture or suitable tool.
16. Remove the five upper bolts that mount the transaxle to the engine using power tool.
17. Disconnect the LH transaxle mounting insulator using power tool.
18. Raise vehicle, then remove front suspension member, LH engine insulator, and LH engine mount bracket. Refer to [EM-119, "REMOVAL"](#).
19. Place a suitable jack support under the transaxle.

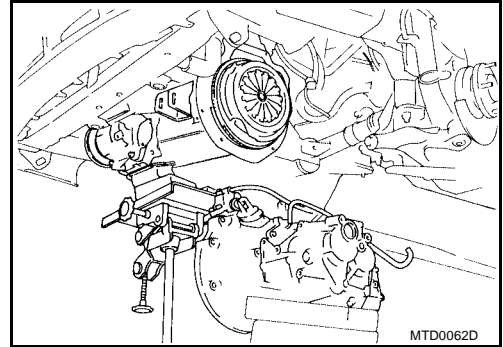

CAUTION:

When setting the jack, be careful not to bring it into contact with the switches.

20. Remove the five lower bolts that mount the transaxle to the engine using power tool.
21. Remove the transaxle from the vehicle.

TRANSAXLE ASSEMBLY

INSTALLATION

Installation is in the reverse order of removal.

- When installing the transaxle to the engine, use the specified torque in the numerical sequence shown below:

CAUTION:

When installing the transaxle, do not allow the transaxle input shaft to make contact with the clutch cover.

Bolt No.	1	2	3	4	5	6	7	8	9	10
Bolt length "ℓ" mm (in)	40 (1.57)	82 (3.23)	47 (1.85)	47 (1.85)	52 (2.05)	40 (1.57)	40 (1.57)	40 (1.57)	30 (1.18)	30 (1.18)
Tranaxle to engine bolt torque N·m (kg·m, ft·lb)	30 - 40 (3.1 - 4.1, 22 - 29)	70 - 80 (7.1 - 8.1, 52 - 59)				30 - 40 (3.1 - 4.1, 22 - 29)				

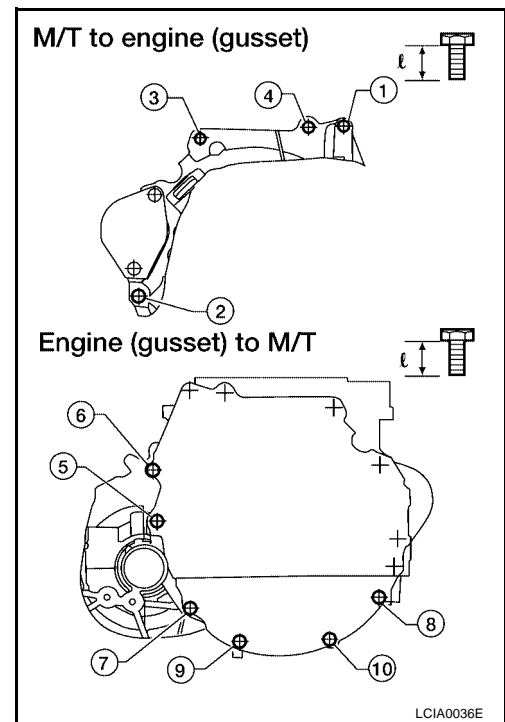

TRANSAXLE ASSEMBLY

ECS00ENC

Component Parts CASE AND HOUSING COMPONENTS

SEC. 321

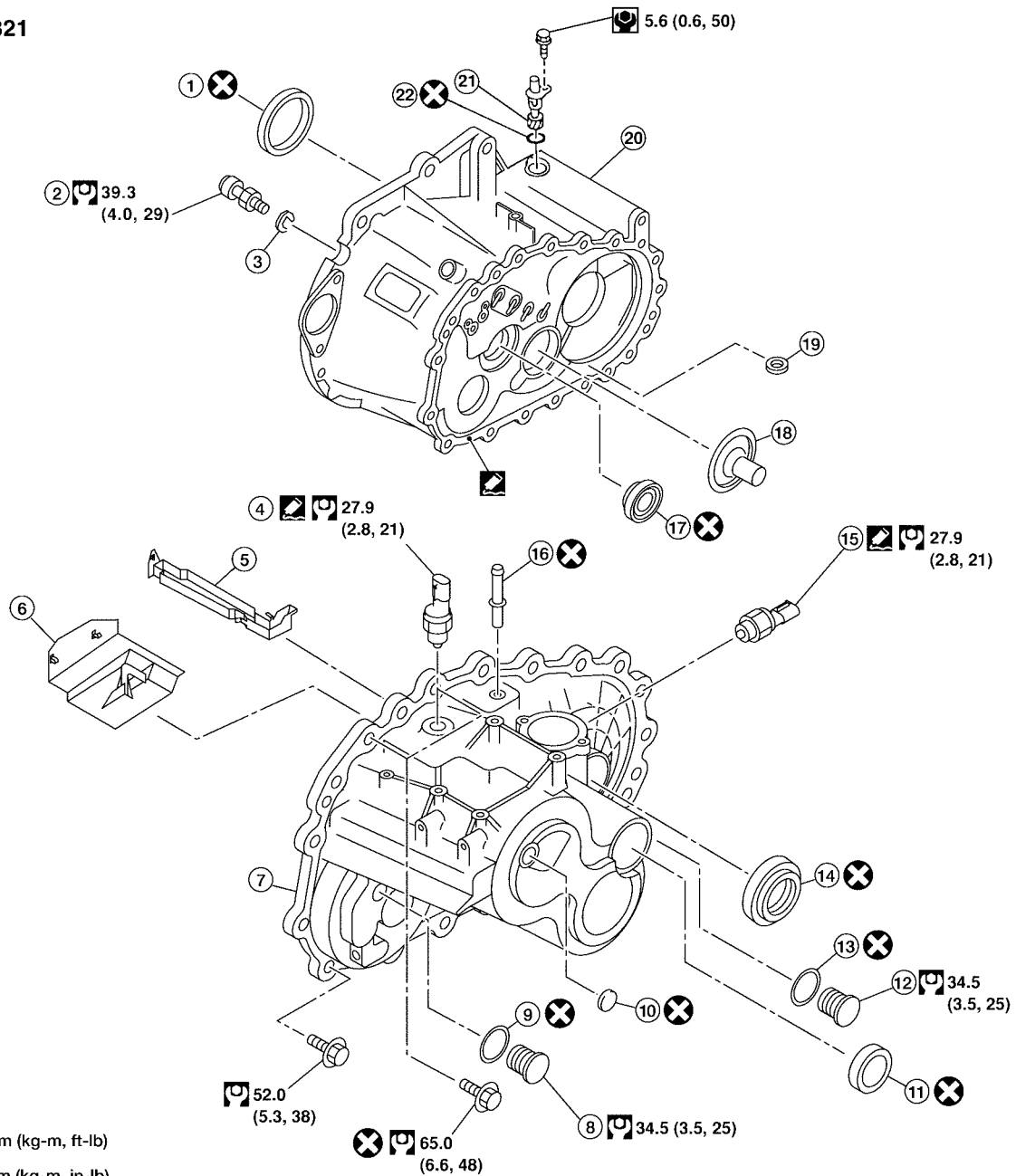

: N·m (kg·m, ft·lb)

: N·m (kg·m, in·lb)

: Apply Genuine Silicone RTV or equivalent. Refer to GI section.

: Always replace after every disassembly.

- | | | |
|--------------------------|---------------------------|----------------------------------|
| 1. Differential oil seal | 2. Ball pin | 3. Washer |
| 4. Back-up lamp switch | 5. Oil gutter | 6. Baffle plate |
| 7. Transaxle case | 8. Filler plug | 9. Gasket |
| 10. Welch plug | 11. Bore plug | 12. Drain plug |
| 13. Gasket | 14. Differential oil seal | 15. Park/Neutral position switch |
| 16. Air breather tube | 17. Input shaft oil seal | 18. Oil channel |
| 19. Magnet | 20. Clutch housing | 21. Speedometer pinion gear |
| 22. O-ring | | |

WCIA0432E

TRANSAXLE ASSEMBLY

GEAR COMPONENTS

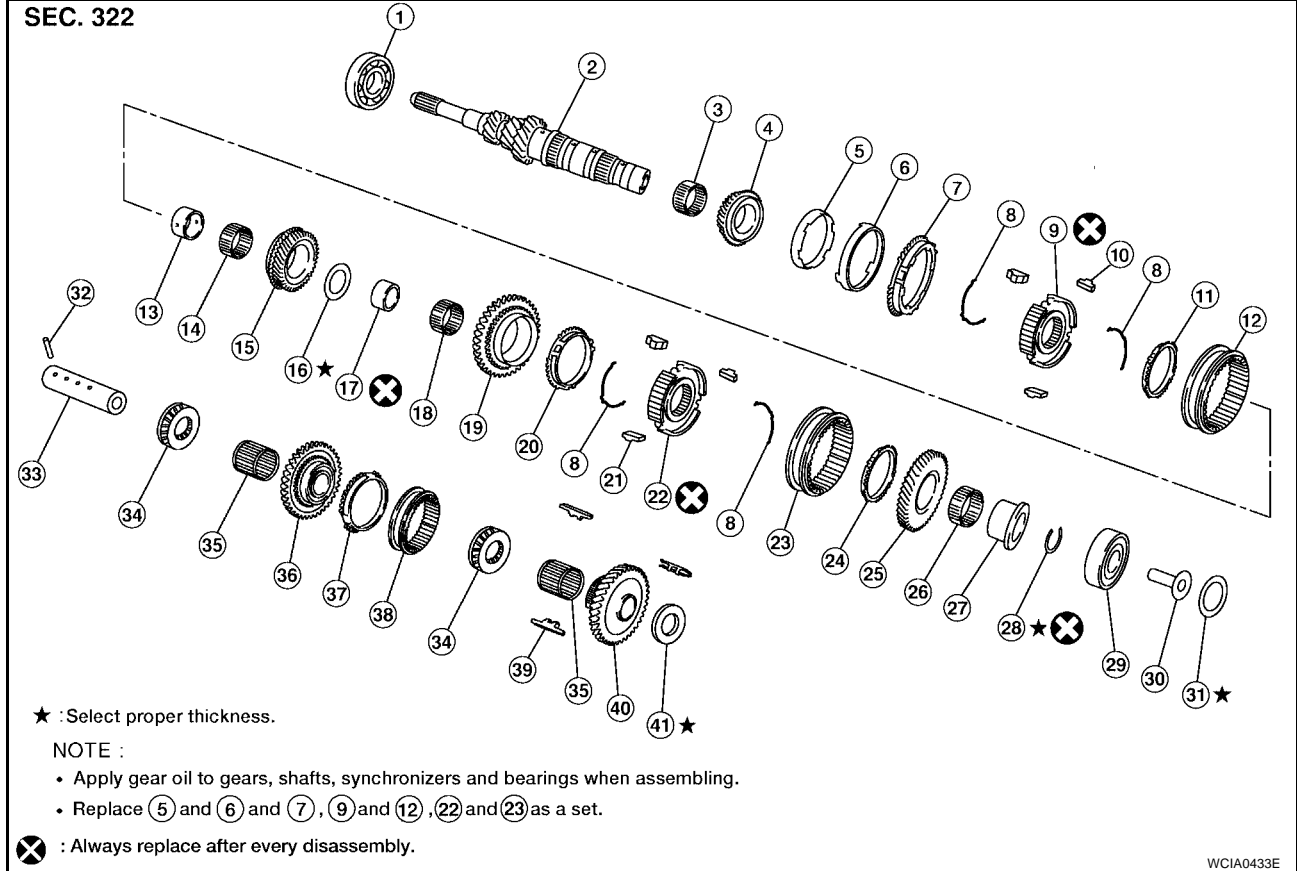

- | | | |
|---|---------------------------------------|--------------------------------|
| 1. Input shaft front bearing | 2. Input shaft | 3. Needle bearing |
| 4. 3rd input gear | 5. 3rd inner baulk ring | 6. 3rd gear synchronizer cone |
| 7. 3rd outer baulk ring | 8. Spread spring | 9. 3rd & 4th synchronizer hub |
| 10. 3rd & 4th shifting insert | 11. 4th baulk ring | 12. 3rd & 4th coupling sleeve |
| 13. Bushing | 14. Needle bearing | 15. 4th input gear |
| 16. Thrust washer | 17. Bushing | 18. Needle bearing |
| 19. 5th input gear | 20. 5th baulk ring | 21. 5th & 6th shifting insert |
| 22. 5th & 6th synchronizer hub | 23. 5th & 6th coupling sleeve | 24. Baulk ring |
| 25. 6th input gear | 26. Needle bearing | 27. Bushing |
| 28. Snap ring | 29. Input shaft rear bearing | 30. Oil channel |
| 31. Input shaft rear bearing adjusting shim | 32. Retaining pin | 33. Reverse idler shaft |
| 34. Thrust bearing | 35. Needle bearing | 36. Reverse idler gear (Front) |
| 37. Reverse baulk ring | 38. Reverse coupling sleeve | 39. Insert spring |
| 40. Reverse idler gear (Rear) | 41. Reverse idler gear adjusting shim | |

TRANSAXLE ASSEMBLY

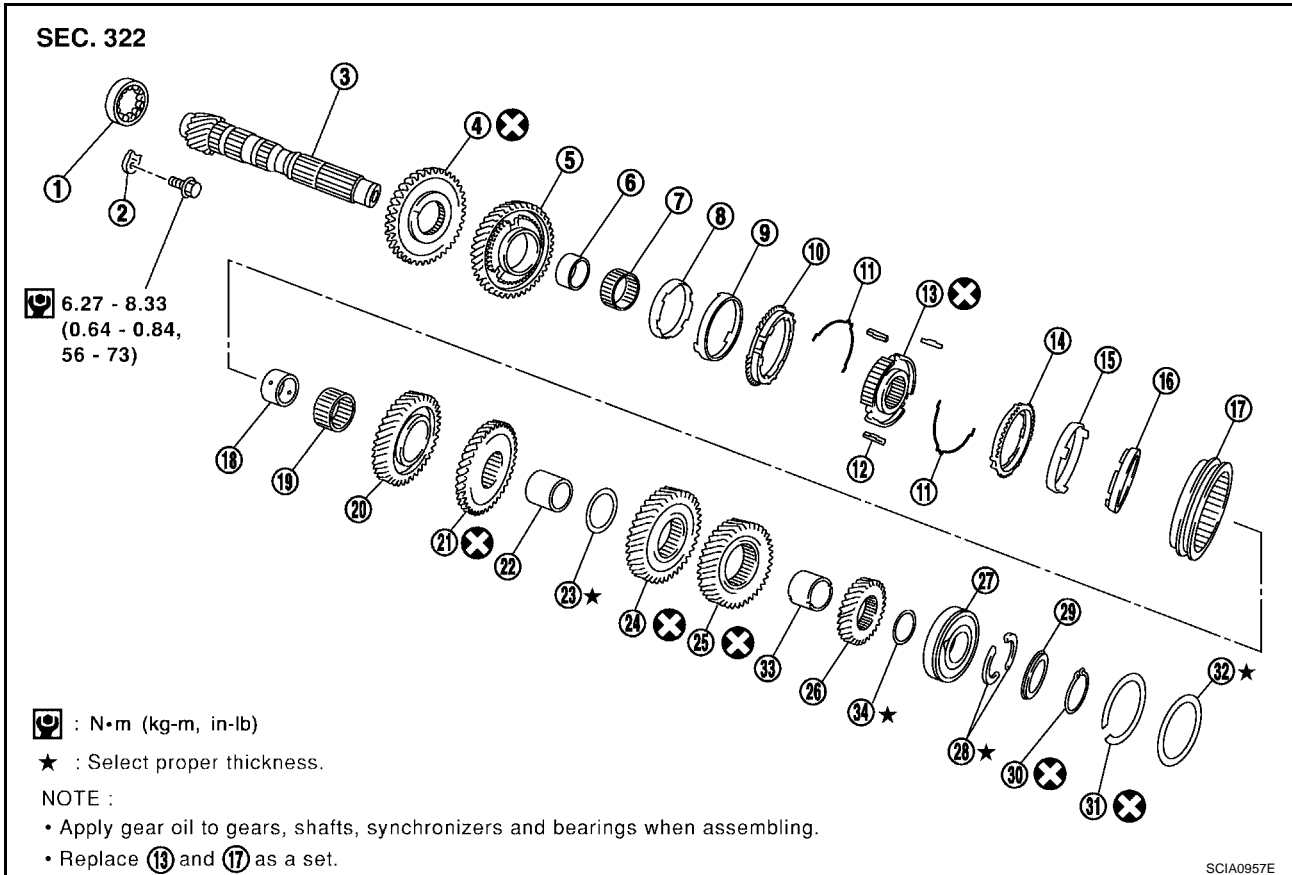

- | | | |
|--------------------------------|---|--------------------------------|
| 1. Mainshaft front bearing | 2. Mainshaft bearing retainer | 3. Mainshaft |
| 4. Reverse main gear | 5. 1st main gear | 6. Bushing |
| 7. Needle bearing | 8. 1st inner baulk ring | 9. 1st gear synchronizer cone |
| 10. 1st outer baulk ring | 11. Spread spring | 12. 1st & 2nd shifting insert |
| 13. 1st & 2nd synchronizer hub | 14. 2nd outer baulk ring | 15. 2nd gear synchronizer cone |
| 16. 2nd inner baulk ring | 17. 1st & 2nd coupling sleeve | 18. Bushing |
| 19. Needle bearing | 20. 2nd main gear | 21. 3rd main gear |
| 22. 3rd & 4th mainshaft spacer | 23. 4th main adjusting shim | 24. 4th main gear |
| 25. 5th main gear | 26. 6th main gear | 27. Mainshaft rear bearing |
| 28. Mainshaft C-ring | 29. C-ring holder | 30. Snap ring |
| 31. Snap ring | 32. Mainshaft rear bearing adjusting shim | 33. 5th & 6th mainshaft spacer |
| 34. 6th main adjusting shim | | |

TRANSAXLE ASSEMBLY

SHIFT CONTROL COMPONENTS

SEC. 328

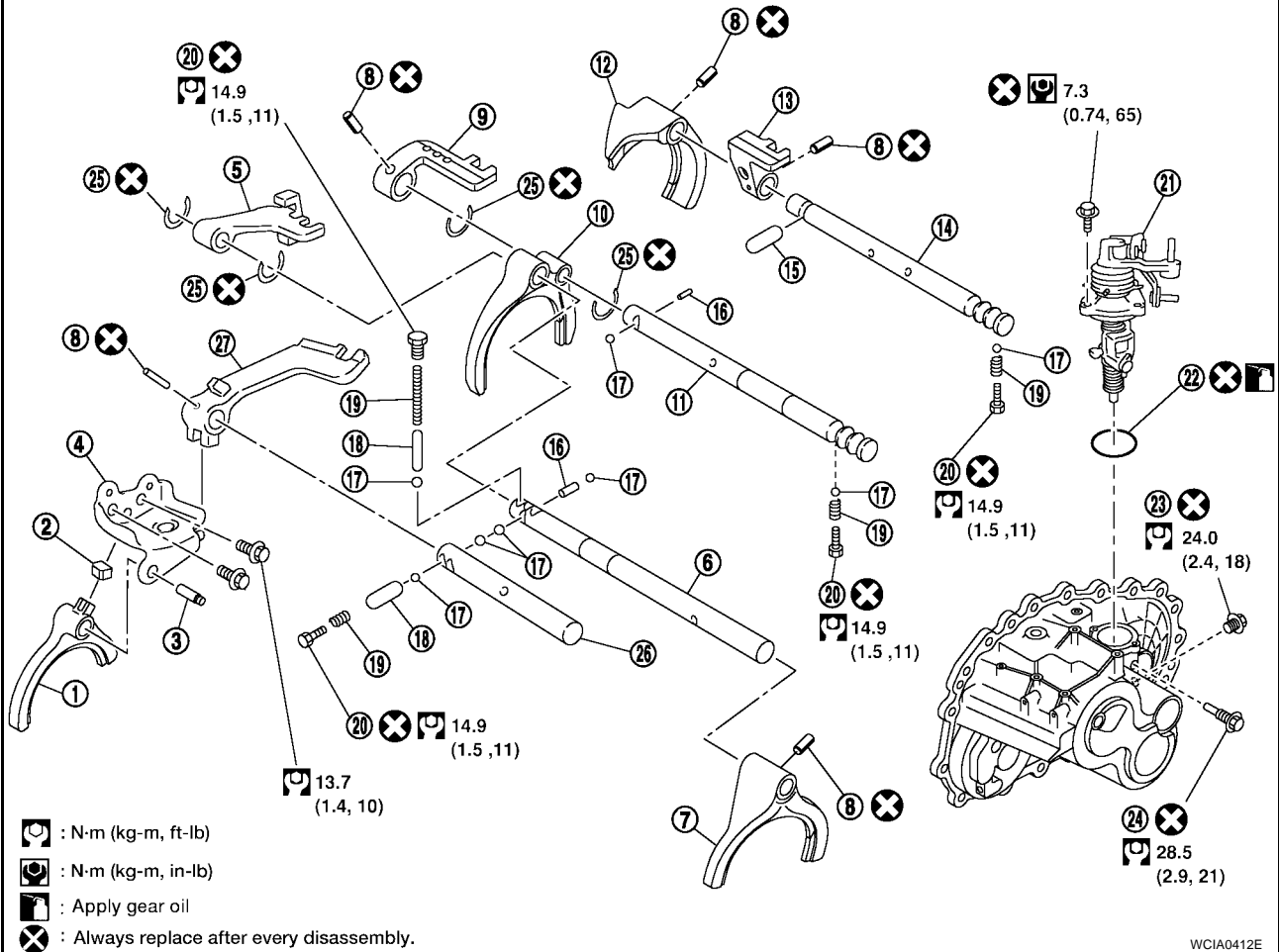

WCIA0412E

- | | | |
|---------------------------|------------------------------|--------------------------|
| 1. Reverse shift fork | 2. Shifter cap | 3. Reverse fork rod |
| 4. Reverse lever assembly | 5. 5th & 6th bracket | 6. 5th & 6th fork rod |
| 7. 5th & 6th shift fork | 8. Retaining pin | 9. 3rd & 4th bracket |
| 10. 3rd & 4th shift fork | 11. 3rd & 4th fork rod | 12. 1st & 2nd shift fork |
| 13. 1st & 2nd bracket | 14. 1st & 2nd fork rod | 15. Shift check sleeve |
| 16. Inter lock pin | 17. Check ball | 18. Shift check sleeve |
| 19. Check spring | 20. Check plug | 21. Control assembly |
| 22. O-ring | 23. Shift check | 24. Stopper bolt |
| 25. Stopper ring | 26. Reverse bracket fork rod | 27. Reverse bracket |

TRANSAXLE ASSEMBLY

FINAL DRIVE COMPONENTS

SEC. 381

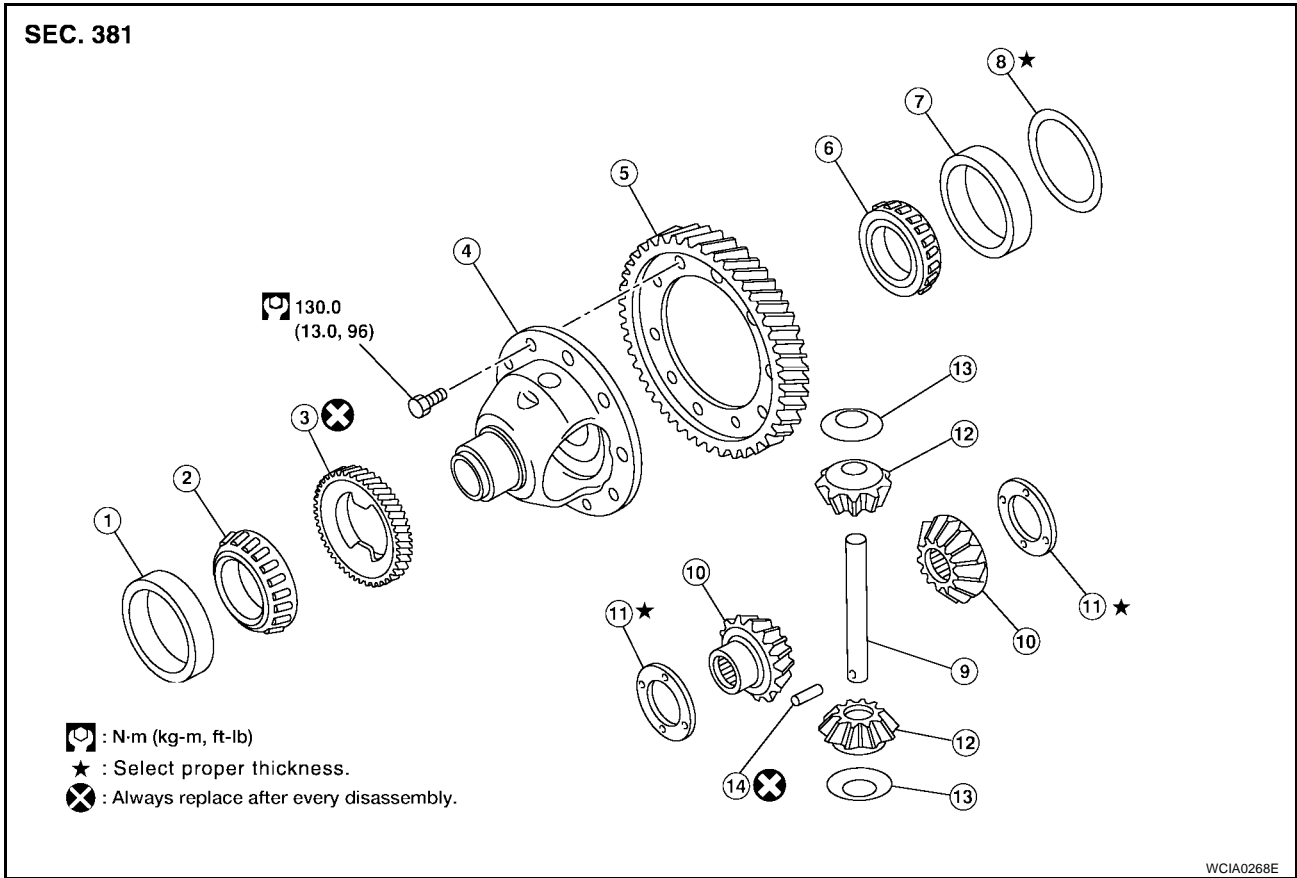

- | | | |
|---|---|------------------------------|
| 1. Differential side bearing outer race | 2. Differential side bearing | 3. Speedometer drive gear |
| 4. Differential case | 5. Final gear | 6. Differential side bearing |
| 7. Differential side bearing outer race | 8. Differential side bearing adjusting shim | 9. Pinion mate shaft |
| 10. Side gear | 11. Side gear thrust washer | 12. Pinion mate gear |
| 13. Pinion mate thrust washer | 14. Lock pin | |

Disassembly and Assembly

DISASSEMBLY

1. Remove the drain plug and filler plug.
2. Remove the park/neutral position switch and back-up lamp switch.
3. After removing the shift check and stopper bolt, remove the control assembly.

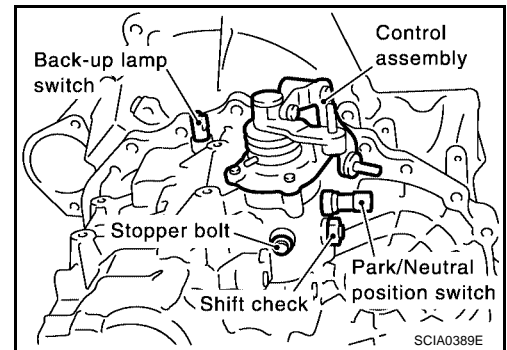

TRANSAXLE ASSEMBLY

- Remove the 2 check ball plugs, 2 check springs, 2 check balls as shown. Discard the check ball plugs.

CAUTION:

Check ball plugs are not reusable.

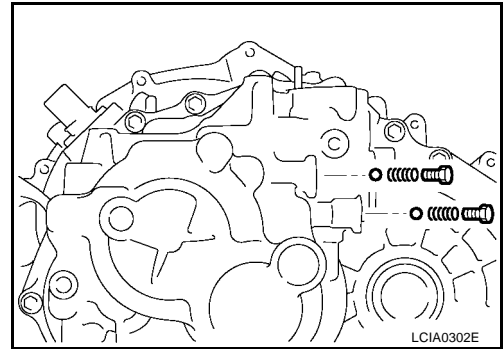

- Remove the transaxle case fixing bolts as shown.

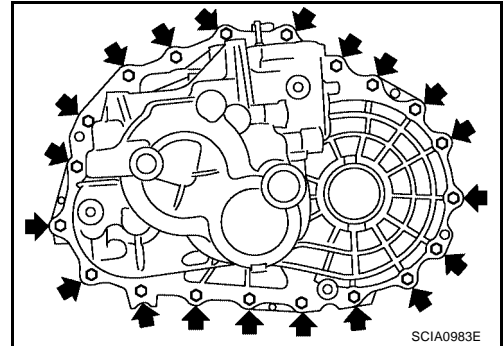

- Remove the bore plug.

CAUTION:

Be careful not to damage transaxle case.

- While spreading the snap ring of the mainshaft rear bearing located at bore plug hole, remove the transaxle case.
- Remove the oil gutter and baffle plate.
- Remove the snap ring, mainshaft rear bearing adjusting shim, and input shaft rear bearing adjusting shim from the transaxle case.
- Remove the differential side bearing outer race (transaxle case side) using Tool as shown, and then remove the adjusting shim.

Tool number : KV381054S0 (J-34286)

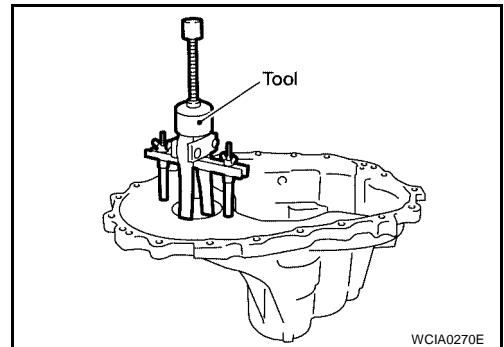

- Remove the welch plug with a suitable tools as shown.

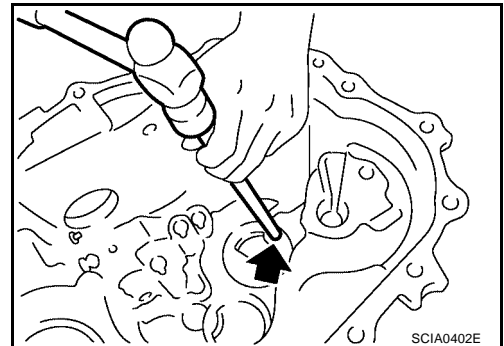

TRANSAXLE ASSEMBLY

12. Remove the differential oil seal with a suitable tool as shown.

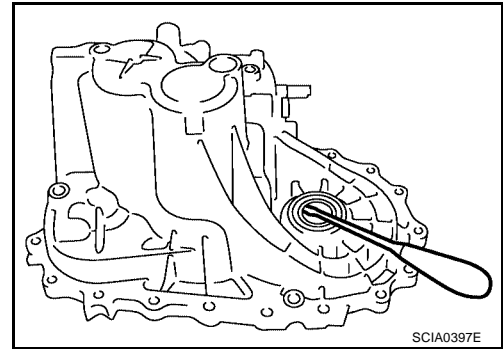

A
B
MT

13. Remove the magnet from the clutch housing.

14. Remove the reverse check ball plug, reverse check spring, reverse shift check sleeve, and check ball. Discard the check ball.

CAUTION:

- Do not reuse the check ball plug.
- Do not drop the check ball.

15. With the shift lever in 5th position, remove the bracket bolts from the reverse lever assembly as shown. Lift the reverse lever assembly to remove.

CAUTION:

Retain the shifter cap for installation.

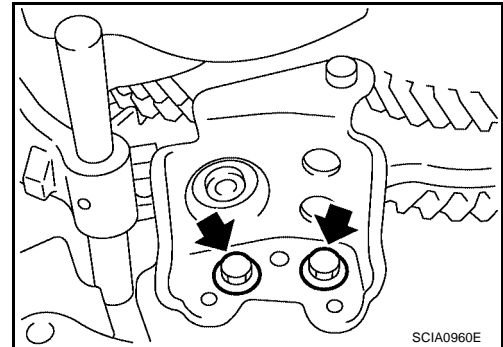

D
E
F
G
H
I

16. Pull out the reverse fork rod then remove the reverse shift fork.

17. Remove the retaining pin of the reverse bracket.

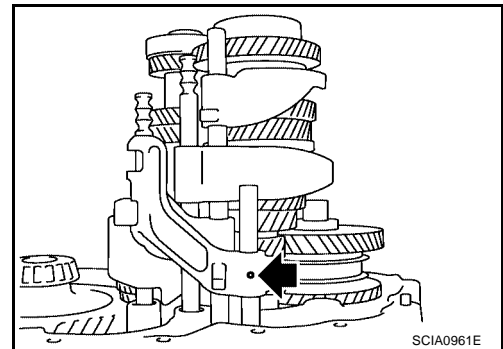

J
K
L
M

18. Pull out the reverse lever and the reverse bracket fork rod.

19. Remove the check ball (2 pieces) and the interlock pin.

20. Shift the 3rd-4th fork rod to the 3rd position. Remove the retaining pin of the 5th-6th shift fork using a pin punch.

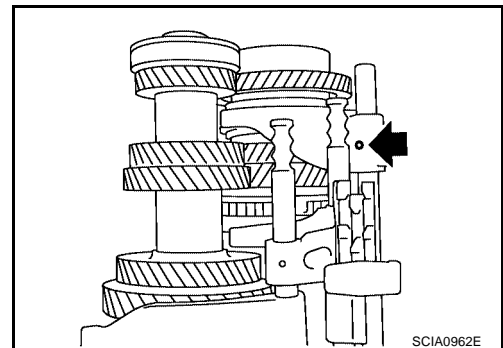

TRANSAXLE ASSEMBLY

21. Remove the stopper rings for the 5th-6th bracket.

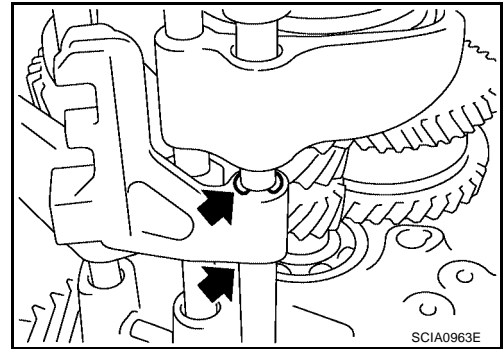

22. Pull out the 5th-6th fork rod and remove the 5th-6th shift fork and the 5th-6th bracket.

23. Remove the check balls (2 pieces) and interlock pin.

24. Remove the retaining pin of 3rd-4th bracket using pin punch.

25. Remove the stopper rings for 3rd-4th shift fork.

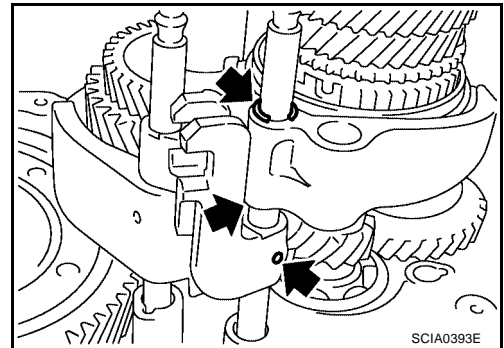

26. Pull out the 3rd-4th fork rod and remove 3rd-4th shift fork and bracket.

27. Remove the shift check sleeve from the clutch housing.

28. Remove the retaining pin of 1st-2nd shift fork using a suitable pin punch.

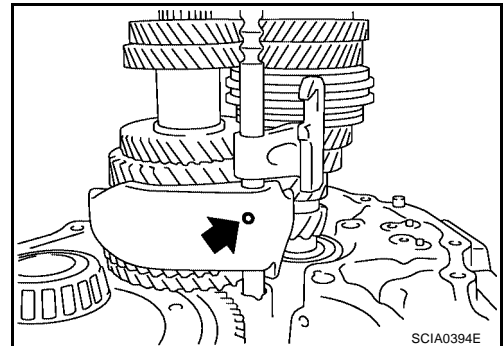

29. Pull out the 1st-2nd fork rod with bracket.

30. Remove the 1st-2nd shift fork.

31. Remove the retaining pin of 1st-2nd bracket using a suitable tool and separate the fork rod and bracket.

32. Remove the gear components from the clutch housing.

a. While tapping the input shaft with a plastic hammer, remove the input shaft assembly, mainshaft assembly, and reverse idler gear assembly as a set.

CAUTION:

Always withdraw the mainshaft straight out. Failure to do so can damage the resin oil channel on the clutch housing side.

b. Remove the final drive assembly.

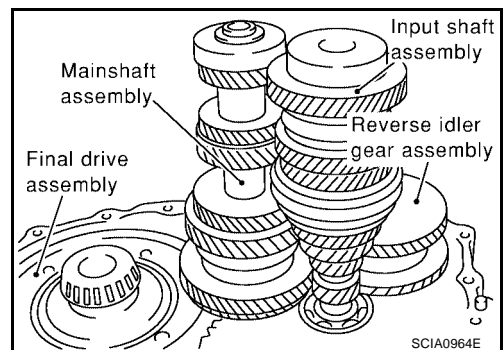

TRANSAXLE ASSEMBLY

33. Remove the bearing retainer and then the mainshaft front bearing as shown.
34. Remove the oil channel on the mainshaft side.

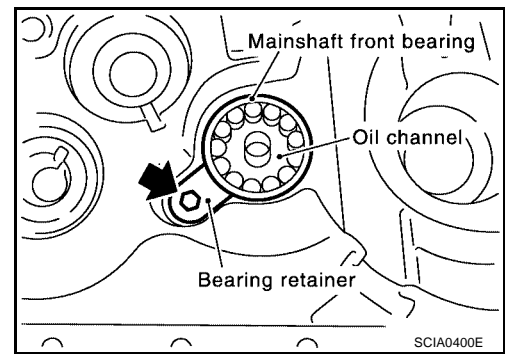

35. Remove the differential oil seal (clutch housing side).
36. Remove the differential side bearing outer race (clutch housing side) using Tool as shown.

Tool number : KV381054S0 (J-34286)

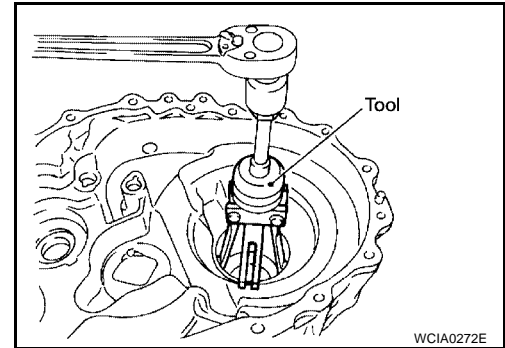

37. Remove the input shaft oil seal using a suitable tool as shown.

CAUTION:
Do not damage the clutch housing sealing surface.

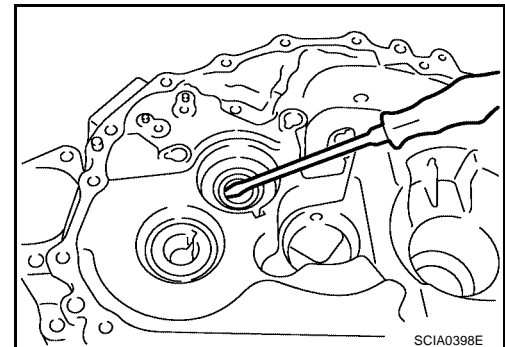

ASSEMBLY

1. Install a new input shaft oil seal from the clutch housing end of the side, to the depth of 1.8 - 2.8 mm (0.071 - 0.110 in) using Tool as shown.

Tool number : ST35321000 (—)

CAUTION:
Oil seals are not reusable.

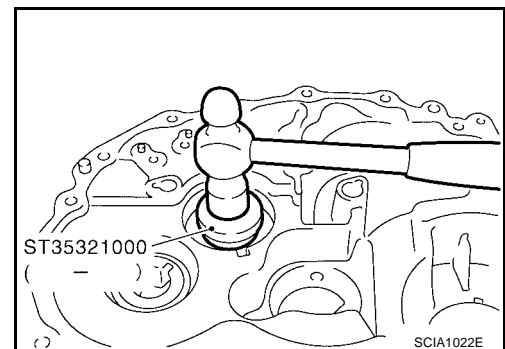

TRANSAXLE ASSEMBLY

2. Install a new differential oil seal using Tool as shown.

Tool number : ST30720000 (J-25405)

CAUTION:
Oil seals are not reusable.

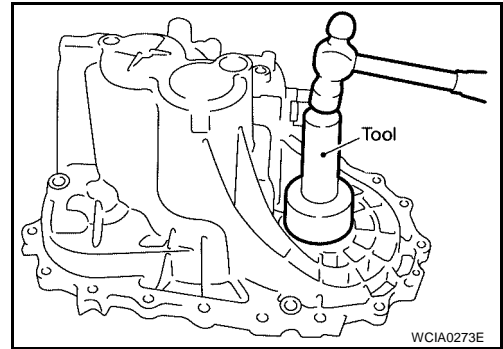

3. Install the oil channel on the mainshaft side as shown.

CAUTION:
Position the oil channel with the orientation as shown, for installation.

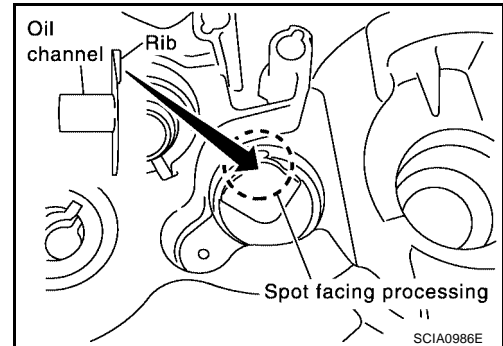

4. Install the mainshaft front bearing using Tool as shown.

Tool number : ST33200000 (J-26082)

CAUTION:
Position the mainshaft front bearing with the orientation as shown, for installation.

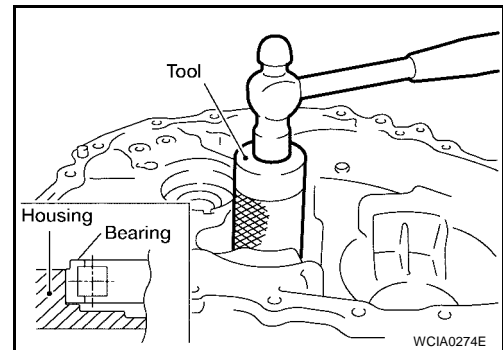

5. Install the mainshaft front bearing retainer.

CAUTION:
Install the bearing retainer with the punched surface facing up.

Retainer bolt : 6.27 - 8.33 N·m (0.64 - 0.84 kg·m,
56 - 73 in·lb)

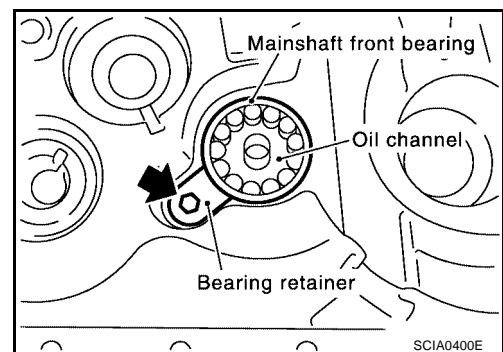

6. Install the differential side bearing outer race using Tool as shown.

Tool number : ST30720000 (J-25405)

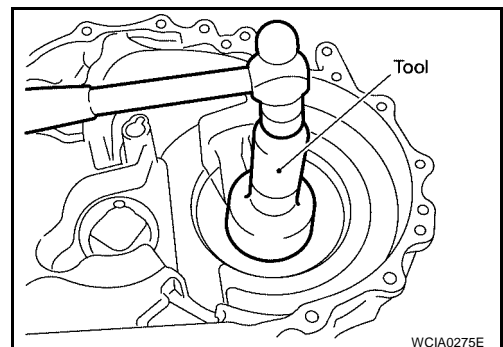

TRANSAXLE ASSEMBLY

7. Install the final drive assembly into the clutch housing.

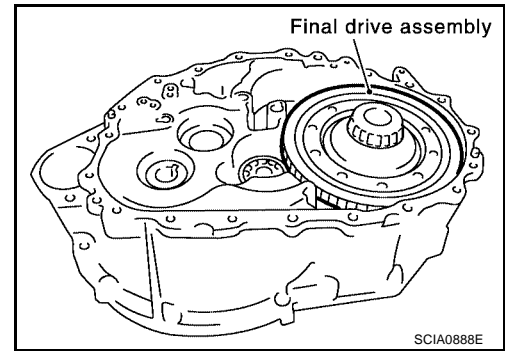

8. Install the input shaft assembly, mainshaft assembly, and reverse idler gear assembly into the clutch housing.

CAUTION:
Do not damage the input shaft oil seal.

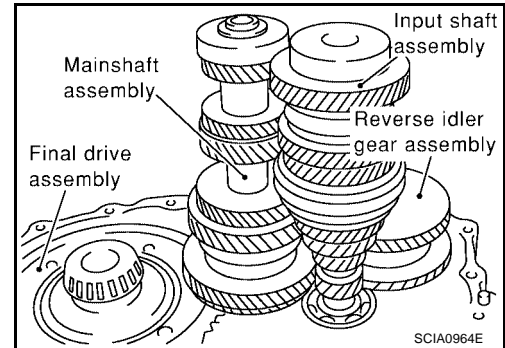

9. Install the 1st-2nd fork rod bracket onto the 1st-2nd fork rod, and then install a new retaining pin as shown.

CAUTION:
Retaining pins are not reusable.

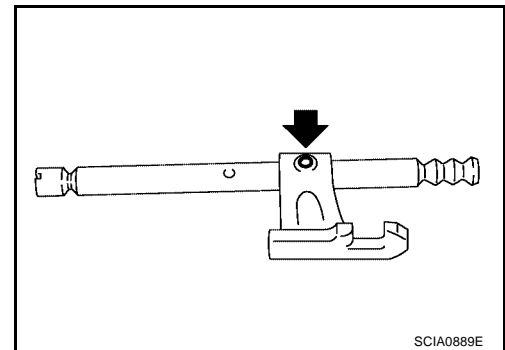

10. Install the 1st-2nd fork rod and the 1st-2nd shift fork, and then install a new retaining pin.

CAUTION:
Retaining pins are not reusable.

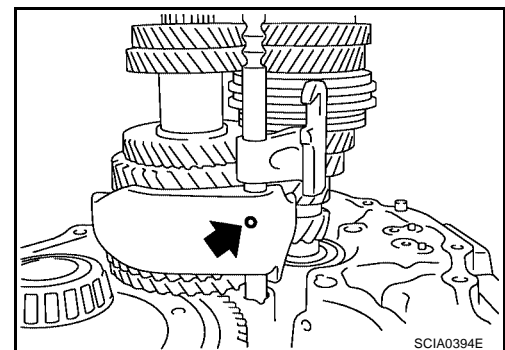

11. Install the shift check sleeve.

12. Install the 3rd-4th bracket, 3rd-4th shift fork, and 3rd-4th fork rod with the interlock pin.

A
B
MT
D
E
F
G
H
I
J
K
L
M

TRANSAXLE ASSEMBLY

13. Install the new stopper rings onto the 3rd-4th shift fork.

CAUTION:
Stopper rings are not reusable.

14. Install a new retaining pin onto the 3rd-4th bracket.

CAUTION:
Retaining pins are not reusable.

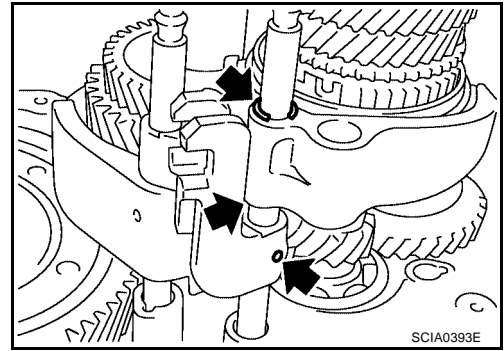

15. Install the 2 check balls.
16. Install the 5th-6th bracket, 5th-6th shift fork, and 5th-6th fork rod.
17. Install new stopper rings onto the 5th-6th bracket with interlock pin.

CAUTION:
Stopper rings are not reusable.

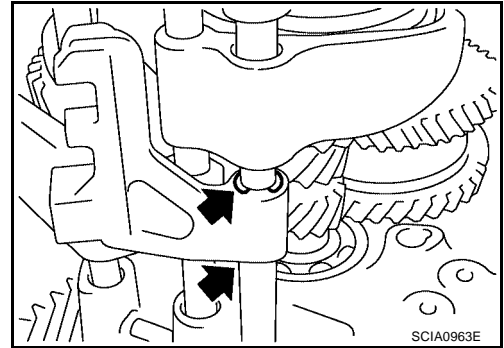

18. Install a new retaining pin onto the 5th-6th shift fork.

CAUTION:
Retaining pins are not reusable.

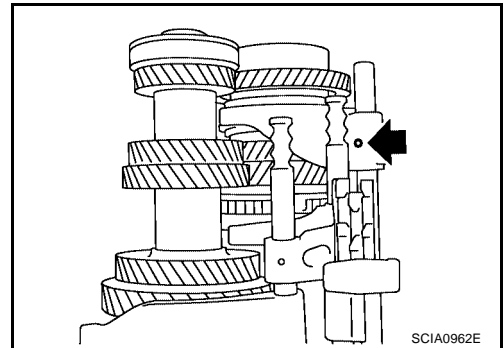

19. Install the two check balls.
20. Install the 5th-6th check ball, 5th-6th shift check sleeve, 5th-6th check spring, and the 5th-6th check ball plug.

CAUTION:

- Do not reuse the check ball plug.
- Do not drop the check ball.

21. Install the reverse bracket fork rod and reverse lever bracket.
22. Install a new retaining pin onto the reverse bracket.

CAUTION:
Retaining pins are not reusable.

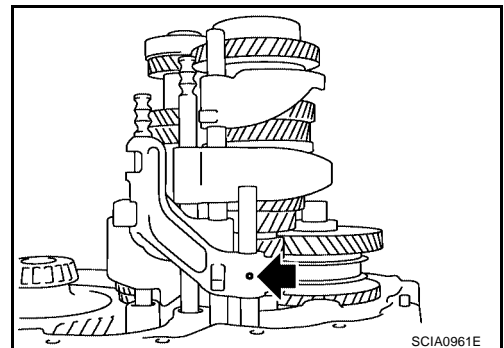

23. Install the reverse shift fork and reverse fork rod.

TRANSAXLE ASSEMBLY

24. Install the reverse lever assembly using the following steps:

- a. Install the shifter cap onto the reverse lever assembly cam, and then install them onto the reverse shift fork.

CAUTION:

Do not drop the shifter cap.

- b. While lifting the reverse shift fork, align the cam with the reverse bracket.

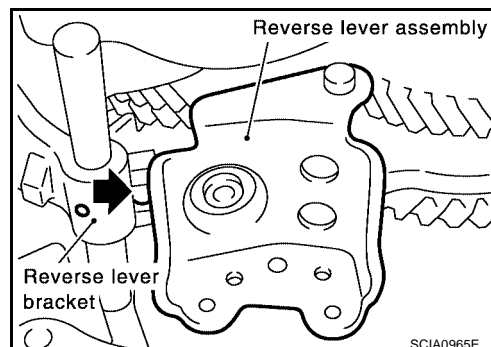

- c. Tighten the bracket bolts to specification, and install the reverse lever assembly.

Bracket bolts : 13.7 N·m (1.4 kg·m, 10 ft·lb)

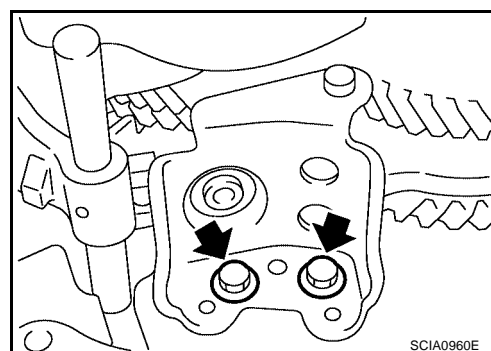

25. Install the check ball, reverse shift check sleeve, reverse check spring, and the reverse check ball plug.

CAUTION:

● **Do not reuse the check ball plug.**

● **Do not drop the check ball.**

26. Install the magnet onto the clutch housing.

27. Install the selected input shaft adjusting shim onto the input shaft. Refer to [MT-34, "INPUT SHAFT END PLAY"](#).

28. Install selected differential side bearing adjusting shim and differential side bearing outer race. Refer to [MT-35, "DIFFERENTIAL SIDE BEARING PRELOAD"](#).

29. Install the baffle plate and oil gutter.

30. Install the transaxle case using the following steps:

a. Install the selected mainshaft rear bearing adjusting shim into the transaxle case. Refer to [MT-36, "MAIN-SHAFT END PLAY"](#).

b. Temporarily install the snap ring of the mainshaft rear bearing into the transaxle case.

CAUTION:

Do not reuse the snap ring.

c. Apply sealant to the mating surfaces of the transaxle case and clutch housing as shown. Use Genuine Silicone RTV or equivalent. Refer to [GI-45, "Recommended Chemical Products and Sealants"](#).

CAUTION:

Remove any old sealant adhering to the mounting surfaces. Also remove any moisture, oil, or foreign material adhering to the sealant application and mounting surfaces.

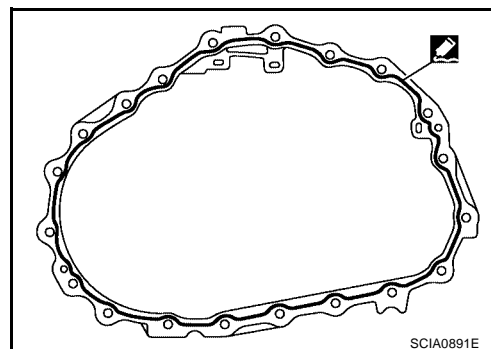

TRANSAXLE ASSEMBLY

- d. Using a snap ring of the mainshaft rear bearing temporarily, install the transaxle case over the clutch housing as shown.

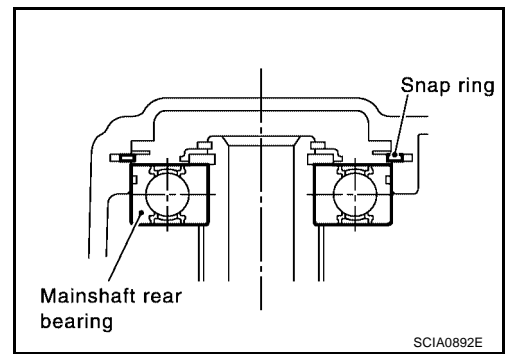

- e. Through the bore plug mounting hole, with the snap ring stretched, lift up the mainshaft assembly from the control assembly mounting hole.
- f. Securely install the snap ring onto the mainshaft rear bearing as shown.

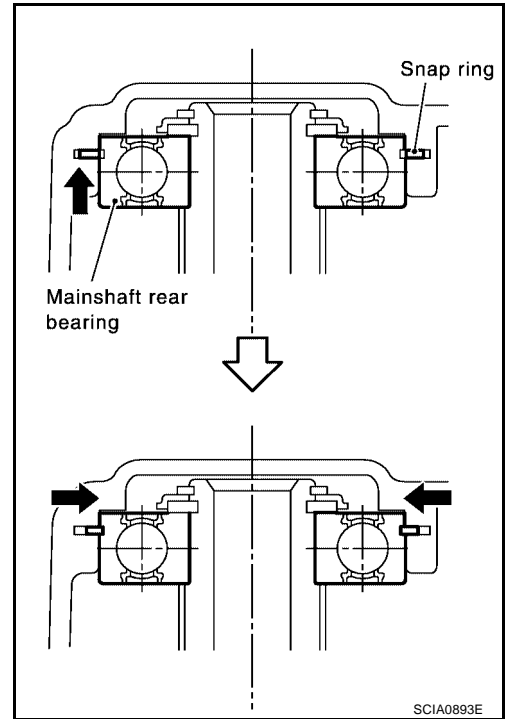

- g. Tighten the "A" bolts (gold) and new "B" bolts (black) to specification.

"A" Bolt : 52.0 N-m (5.3 kg-m, 38 ft-lb)

"B" Bolt : 65.0 N-m (6.6 kg-m, 48 ft-lb)

CAUTION:

Always replace the "B" bolts as they are self-sealing bolts.

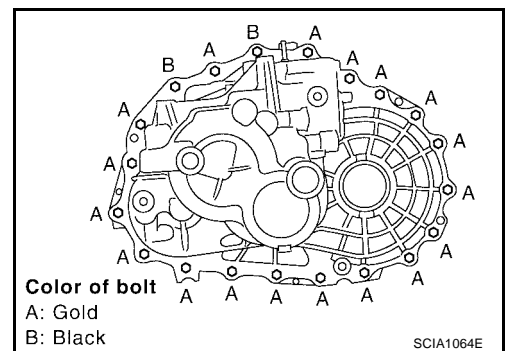

- h. Apply gear oil to the O-ring and install it to the control assembly. Then install control assembly to transaxle case. Tighten bolts to the specified torque. Refer to [MT-22, "SHIFT CONTROL COMPONENTS"](#).

CAUTION:

Do not reuse the O-ring.

- i. Install a new shift check and a new stopper bolt.

CAUTION:

Shift check and stopper bolt are not reusable.

TRANSAXLE ASSEMBLY

31. Install a new bore plug using Tool as shown.

Tool number : ST33061000 (J-8107-2)

CAUTION:
Bore plugs are not reusable.

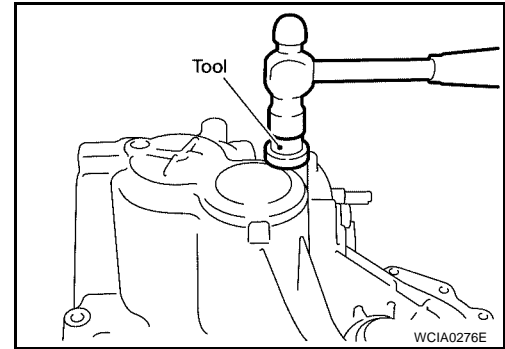

32. Install the new welch plug using Tool as shown.

Tool number : ST33052000 (—)

CAUTION:
Do not reuse the welch plug.

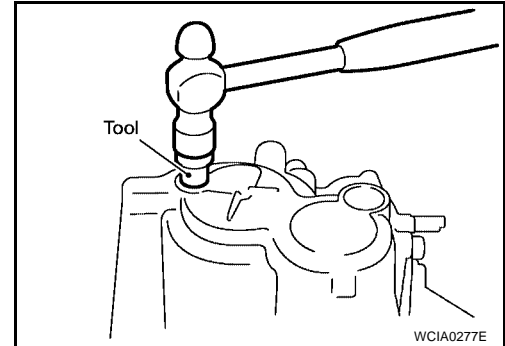

33. Install the 2 check balls, 2 check springs, and the 2 new check ball plugs.

CAUTION:
Check ball plugs are not reusable.

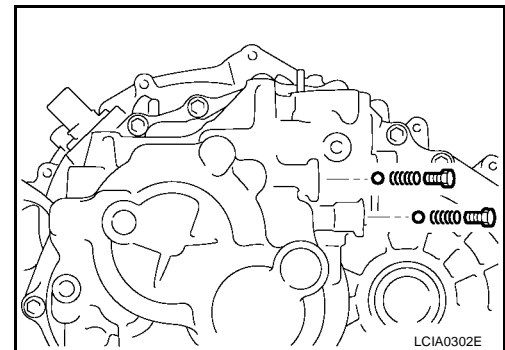

34. Apply sealant to the threads of the park/neutral position switch and back-up lamp switch. Then install them into the transaxle case. Refer to [MT-19, "CASE AND HOUSING COMPONENTS"](#) . Use Genuine Silicone RTV or equivalent. Refer to [GI-45, "Recommended Chemical Products and Sealants"](#) .

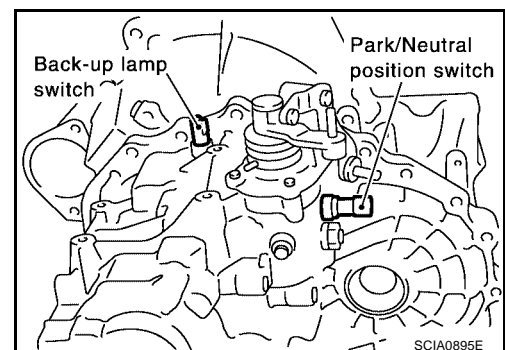

35. Install new gaskets onto the drain plug and filler plug, and then install them into the transaxle case.

CAUTION:

- Gaskets are not reusable.
- After oil is filled, tighten filler plug to specification. Refer to [MT-19, "CASE AND HOUSING COMPONENTS"](#) .

TRANSAXLE ASSEMBLY

ECS00ENE

Adjustment INPUT SHAFT END PLAY

- When adjusting the input shaft end play, select the adjusting shim for the input shaft bearing. To select the correct thickness for the adjusting shim, measure the clearance between the transaxle case and input shaft rear bearing.
- Calculate the dimension “O” (thickness of adjusting shim) using the following steps to adjust the input shaft rear bearing for the specified end play.

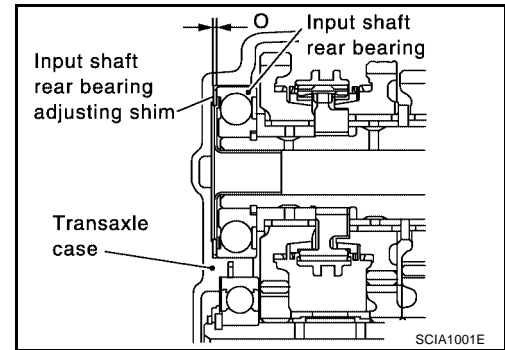

CAUTION:

Only 1 adjusting shim can be selected.

End play : 0 - 0.06 mm (0 - 0.0024 in)

Dimension “O” = (O₁ - O₂) - End play

“O” : Thickness of adjusting shim

“O₁” : Distance between transaxle case end face and mounting face of adjusting shim

“O₂” : Distance between clutch housing case end face and end face of input shaft rear bearing

Adjusting Shims

Shim thickness	Part number	Shim thickness	Part number	Shim thickness	Part number
0.40 mm (0.0157 in)	32225 8H500	0.88 mm (0.0346 in)	32225 8H512	1.36 mm (0.0535 in)	32225 8H524
0.44 mm (0.0173 in)	32225 8H501	0.92 mm (0.0362 in)	32225 8H513	1.40 mm (0.0551 in)	32225 8H560
0.48 mm (0.0189 in)	32225 8H502	0.96 mm (0.0378 in)	32225 8H514	1.44 mm (0.0567 in)	32225 8H561
0.52 mm (0.0205 in)	32225 8H503	1.00 mm (0.0394 in)	32225 8H515	1.48 mm (0.0583 in)	32225 8H562
0.56 mm (0.0220 in)	32225 8H504	1.04 mm (0.0409 in)	32225 8H516	1.52 mm (0.0598 in)	32225 8H563
0.60 mm (0.0236 in)	32225 8H505	1.08 mm (0.0425 in)	32225 8H517	1.56 mm (0.0614 in)	32225 8H564
0.64 mm (0.0252 in)	32225 8H506	1.12 mm (0.0441 in)	32225 8H518	1.60 mm (0.0630 in)	32225 8H565
0.68 mm (0.0268 in)	32225 8H507	1.16 mm (0.0457 in)	32225 8H519	1.64 mm (0.0646 in)	32225 8H566
0.72 mm (0.0283 in)	32225 8H508	1.20 mm (0.0472 in)	32225 8H520		
0.76 mm (0.0299 in)	32225 8H509	1.24 mm (0.0488 in)	32225 8H521		
0.80 mm (0.0315 in)	32225 8H510	1.28 mm (0.0504 in)	32225 8H522		
0.84 mm (0.0331 in)	32225 8H511	1.32 mm (0.0520 in)	32225 8H523		

1. Using a depth micrometer and straight edge, measure the dimension “O₁” between the transaxle case end face and mounting face of the adjusting shim as shown.

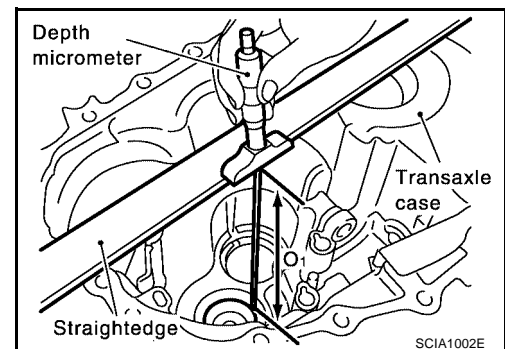

TRANSAXLE ASSEMBLY

- Using a depth micrometer and straight edge, measure the dimension "O₂" between the clutch housing case end face and end face of the input shaft rear bearing as shown.

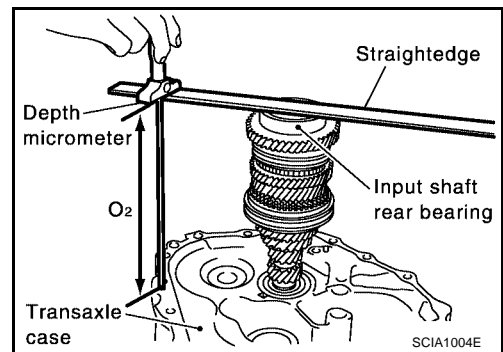

- Install the selected input shaft rear bearing adjusting shim onto the input shaft.

DIFFERENTIAL SIDE BEARING PRELOAD

- When adjusting differential side bearing preload, select adjusting shim for differential side bearing. To select adjusting shim, measure clearance "L" between transaxle case and differential side bearing outer race.
- Calculate dimension "L" (thickness of adjusting shim) using the following procedure to meet specification of preload for differential side bearing.

Preload : 0.15 - 0.21 mm (0.0059 - 0.0083 in)

Dimension "L" = ("L₁" - "L₂") + Preload

"L" : Thickness of adjusting shim

"L₁" : Distance between transaxle case end face and mounting face of adjusting shim

"L₂" : Distance between differential side bearing and clutch housing end face

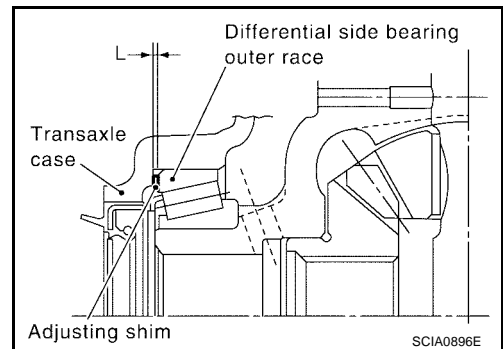

CAUTION:

Up to only 2 adjusting shims can be selected.

Adjusting Shim

Shim thickness	Part number
0.48 mm (0.0189 in)	31438 80X00
0.52 mm (0.0205 in)	31438 80X01
0.56 mm (0.0220 in)	31438 80X02
0.60 mm (0.0236 in)	31438 80X03
0.64 mm (0.0252 in)	31438 80X04
0.68 mm (0.0268 in)	31438 80X05
0.72 mm (0.0283 in)	31438 80X06
0.76 mm (0.0299 in)	31438 80X07
0.80 mm (0.0315 in)	31438 80X08
0.84 mm (0.0331 in)	31438 80X09
0.88 mm (0.0346 in)	31438 80X10
0.92 mm (0.0362 in)	31438 80X11

- Using a depth micrometer and straight edge, measure the dimension "L₁" between the transaxle case end face and mounting face of the adjusting shim as shown.

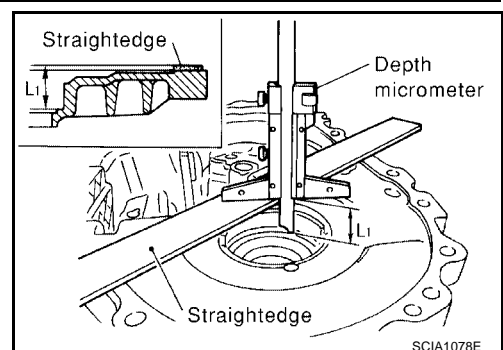

TRANSAXLE ASSEMBLY

2. Install the outer race onto the differential side bearing on the final gear side. Holding the outer race horizontally by hand, rotate the final gear five times or more (for smooth movement of the bearing roller).
3. Using a depth micrometer and straight edge, measure the dimension "L2" between the differential side bearing outer race and clutch housing end face as shown.

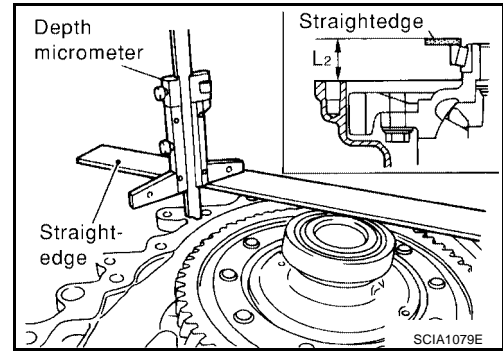

4. Install the selected adjusting shim and then the differential side bearing outer race using Tool as shown.

Tool number : ST30720000 (J-25405)

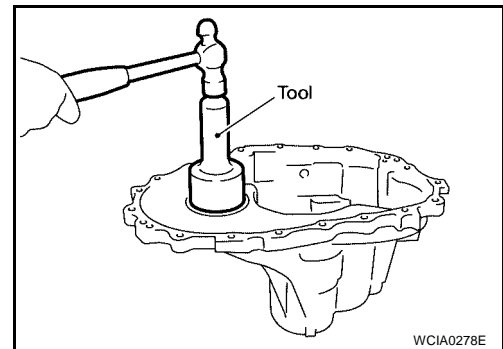

MAINSHAFT END PLAY

- When adjusting the mainshaft end play, select the adjusting shim for the mainshaft rear bearing. To select the adjusting shim, measure clearance "M" between the transaxle case and mainshaft rear bearing.
- Calculate the dimension "P" (thickness of adjusting shim) using the following procedure to meet specification of end play for mainshaft rear bearing.

End play : 0 - 0.06 mm (0 - 0.0024 in)

Dimension "P" = "M" - End play

"P" : Thickness of adjusting shim

"M" : Distance between mainshaft rear bearing and transaxle case

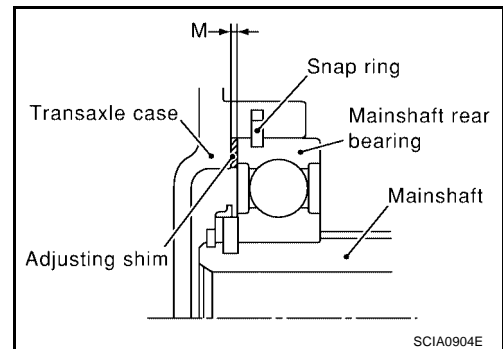

CAUTION:

Only 1 adjusting shim can be selected.

TRANSAXLE ASSEMBLY

Adjusting Shim

Shim thickness	Part number
0.44 mm (0.0173 in)	32238 8H510
0.48 mm (0.0189 in)	32238 8H511
0.52 mm (0.0205 in)	32238 8H512
0.56 mm (0.0220 in)	32238 8H513
0.60 mm (0.0236 in)	32238 8H514
0.64 mm (0.0252 in)	32238 8H515
0.68 mm (0.0268 in)	32238 8H516
0.72 mm (0.0283 in)	32238 8H517
0.76 mm (0.0299 in)	32238 8H518
0.80 mm (0.0315 in)	32238 8H519
0.84 mm (0.0331 in)	32238 8H520
0.88 mm (0.0346 in)	32238 8H521
0.92 mm (0.0362 in)	32238 8H522
0.96 mm (0.0378 in)	32238 8H523
1.00 mm (0.0394 in)	32238 8H524
1.04 mm (0.0409 in)	32238 8H560
1.08 mm (0.0425 in)	32238 8H561

1. Install the mainshaft assembly to the clutch housing.
2. Install the snap ring to the transaxle case.
3. Install the transaxle case to clutch housing, and temporarily assemble them with bolts. Temporarily install the snap ring to the mainshaft rear bearing.
4. Install the dial gauge to the snap ring access hole, and expand the snap ring as shown. Lift the mainshaft assembly through the control assembly installation hole, and push it against the transaxle case. This state shall be defined as base. Moving the distance of the mainshaft assembly, with the snap ring installed on the main bearing, becomes "M".

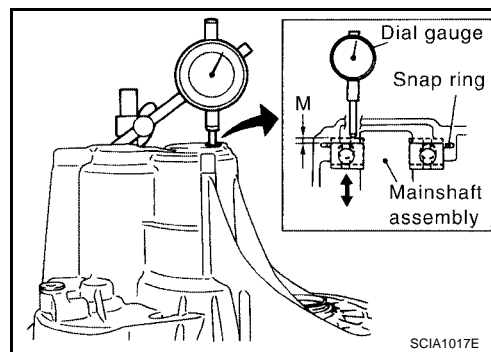

REVERSE IDLER GEAR END PLAY

- When adjusting the reverse idler gear end play, select the adjusting shim for the reverse idler gear. To select the correct thickness of adjusting shim, measure the clearance between the transaxle case and reverse idler gear.
- Calculate the dimension "Q" (thickness of adjusting shim) using the following steps to adjust the end play of the reverse idler gear to specification.

End play : 0.04 - 0.10 mm (0.0016 - 0.0039 in)

Dimension "Q" = ("Q1" - "Q2") - End play

"Q" : Thickness of adjusting shim

"Q1" : Distance between transaxle case end face and mounting face of adjusting shim

"Q2" : Distance between clutch housing case end face and end face of reverse idler gear

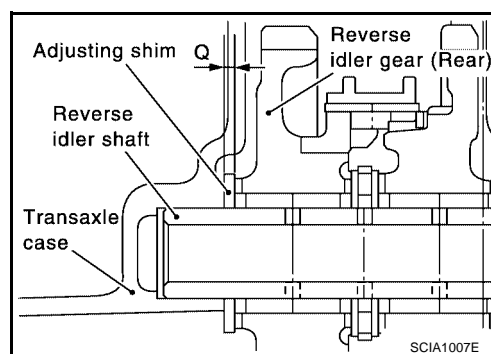

CAUTION:

Only 1 adjusting shim can be selected.

TRANSAXLE ASSEMBLY

Adjusting Shim

Shim thickness mm (in)	Part number	Shim thickness mm (in)	Part number
1.76 (0.0693)	32237 8H800	2.24 (0.0882)	32237 8H812
1.80 (0.0709)	32237 8H801	2.28 (0.0898)	32237 8H813
1.84 (0.0724)	32237 8H802	2.32 (0.0913)	32237 8H814
1.88 (0.0740)	32237 8H803	2.36 (0.0929)	32237 8H815
1.92 (0.0756)	32237 8H804	2.40 (0.0945)	32237 8H816
1.96 (0.0772)	32237 8H805	2.44 (0.0961)	32237 8H817
2.00 (0.0787)	32237 8H806	2.48 (0.0976)	32237 8H818
2.04 (0.0803)	32237 8H807	2.52 (0.0992)	32237 8H819
2.08 (0.0819)	32237 8H808	2.56 (0.1008)	32237 8H820
2.12 (0.0835)	32237 8H809	2.60 (0.1024)	32237 8H821
2.16 (0.0850)	32237 8H810	2.64 (0.1039)	32237 8H822
2.20 (0.0866)	32237 8H811		

CAUTION:

Only 1 adjusting shim can be selected.

- Using a depth micrometer and straight edge, measure the dimension "Q1" between the transaxle case end face and the mounting face of the adjusting shim as shown.

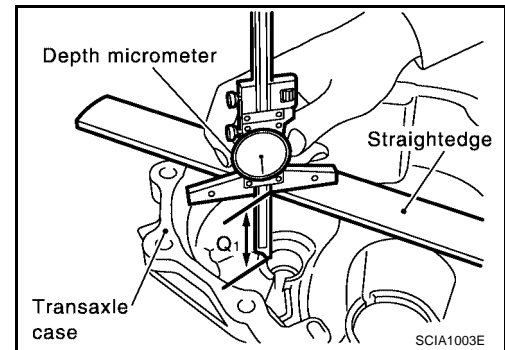

- Using a depth micrometer and straight edge, measure the dimension "Q2" between the clutch housing case end face and the end face of reverse idler gear as shown.

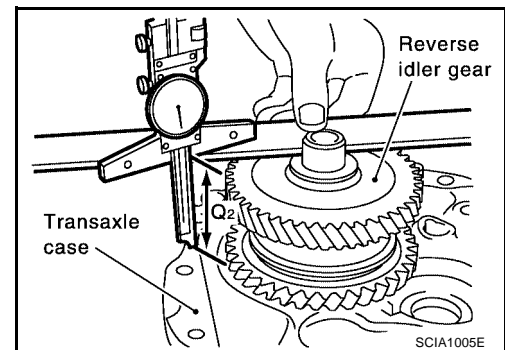

- Install the selected reverse idler gear adjusting shim onto the reverse idler gear.

INPUT SHAFT AND GEARS

PF3:32200

ECS00ENF

INPUT SHAFT AND GEARS

Disassembly and Assembly DISASSEMBLY

1. Before disassembling, measure the end play for the 3rd, 4th, 5th, and 6th input gears.

End play standard values

3rd gear : 0.18 - 0.31 mm (0.0071 - 0.0122 in)

4th gear : 0.20 - 0.30 mm (0.0079 - 0.0118 in)

5th gear : 0.06 - 0.16 mm (0.0024 - 0.0063 in)

6th gear : 0.06 - 0.16 mm (0.0024 - 0.0063 in)

CAUTION:

If the measurement is outside the standard value, disassemble to check the contact surfaces of the gear, shaft, and hub. Adjust using the correct size snap ring for assembly.

2. Remove the oil channel.
3. Remove the input shaft rear bearing using Tools as shown.

Tool number **A: Commercial service tool**
 B: ST33052000 (—)

4. Remove the snap ring.

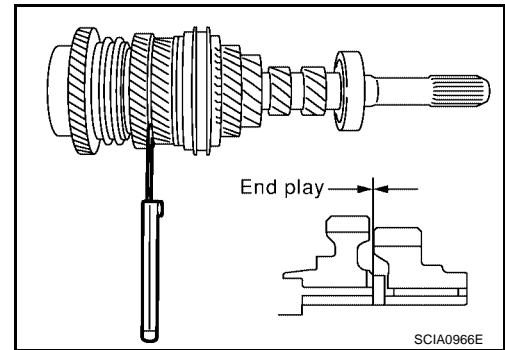

5. Remove the 6th input gear, 6th bushing, and 6th needle bearing using Tools as shown.

Tool number **A: Commercial service tool**
 B: ST33052000 (—)

6. Remove the 6th baulk ring, 5th-6th coupling sleeve, and shifting insert.

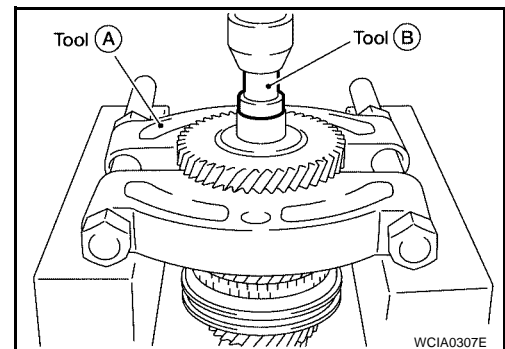
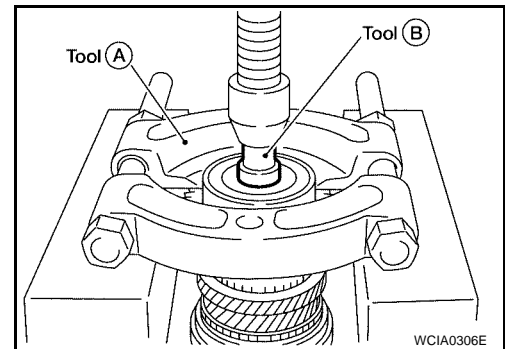

7. Remove the 5th input gear and synchronizer hub assembly simultaneously using Tools as shown.

Tool number **A: KV40105020 (—)**
 B: Commercial service tool

8. Remove the 5th needle bearing.

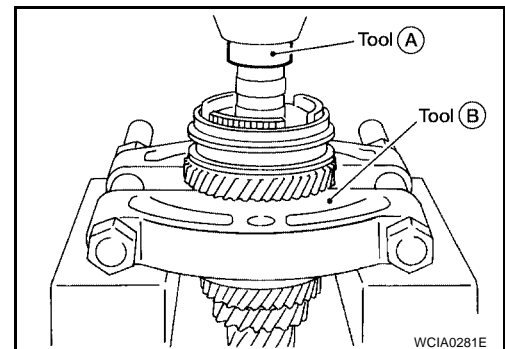

A
B
MT
D
E
F
G
H
I
J
K
L
M

INPUT SHAFT AND GEARS

9. Remove the 5th bushing, thrust washer, 4th input gear, 4th needle bearing, 4th bushing, 4th baulk ring, 3rd-4th synchronizer hub assembly, 3rd baulk ring, and 3rd input gear simultaneously using Tools as shown.

Tool number **A: ST33052000 (—)**
 B: Commercial service tool

10. Remove the 3rd needle bearing.

11. Remove the input shaft front bearing using suitable puller as shown.

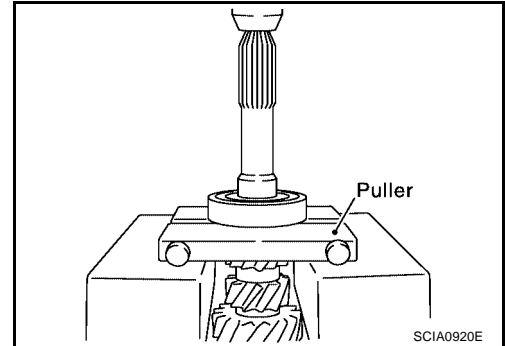
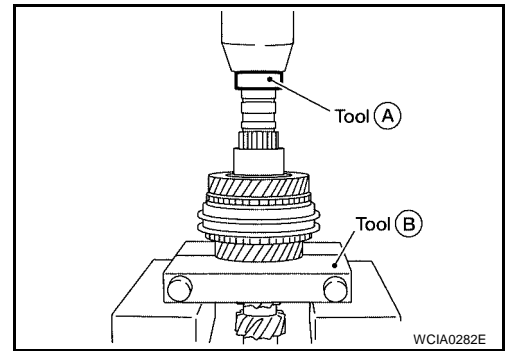

INSPECTION AFTER DISASSEMBLY

Input Shaft and Gear

Check the items listed. If necessary, replace them with new ones.

- Damage, peeling, dent, uneven wear, or bending of the input shaft.
- Excessive wear, damage, or peeling of the input gears.

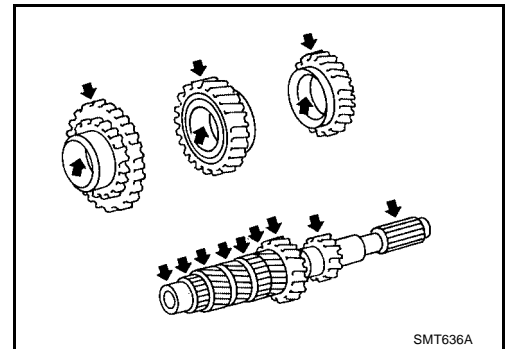

Synchronizer

Check the items listed. If necessary, replace them with new ones.

- Damage and excessive wear of the contact surfaces of coupling sleeve, synchronizer hub, and shifting insert.
- Coupling sleeve and synchronizer hub must move smoothly as shown.

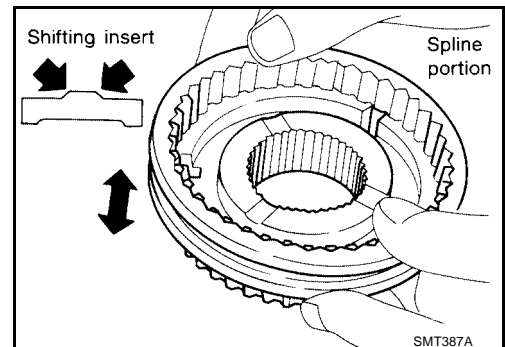

INPUT SHAFT AND GEARS

- If any cracks, damage, or excessive wear is found on the cam face of baulk ring or working face of the insert as shown, replace it.

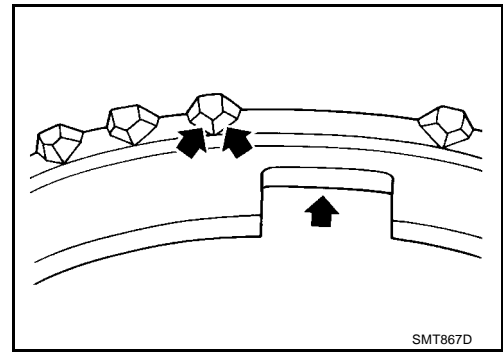

Baulk Ring Clearance for Single Cone Synchronizer (4th, 5th and 6th)

- Press the baulk ring against cone, and measure clearance between baulk ring and cone. If measurement is below limit, replace it with a new one.

Clearance - standard

4th : 0.9 - 1.45 mm (0.035 - 0.0571 in)

5th and 6th : 0.95 - 1.4 mm (0.0374 - 0.055 in)

Limit : 0.7 mm (0.028 in)

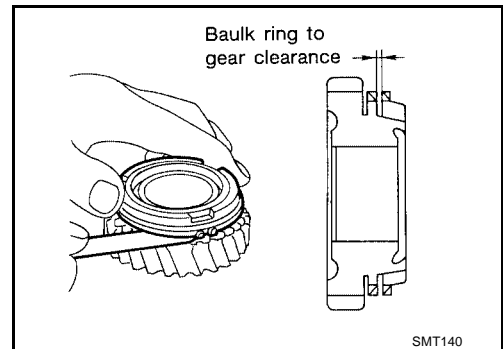

Baulk Ring Clearance for Double-cone Synchronizer (3rd)

- Follow the instructions below and inspect the clearance of the outer baulk ring, synchronizer cone, and inner baulk ring.

CAUTION:

Outer baulk ring, synchronizer cone, and inner baulk ring act as a set to control the clearances "A" and "B". If the measurement exceeds the service limit value, replace all of them as a set.

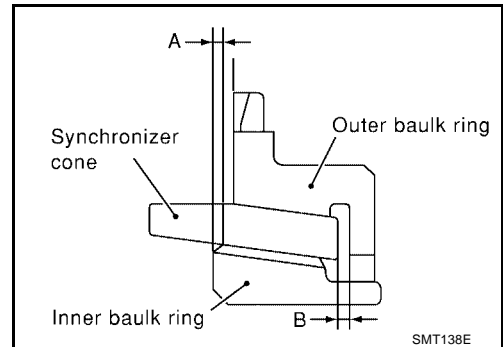

1. Using a dial gauge and Tool, measure clearance "A" at two or more points diagonally opposite, and calculate mean value.

Tool number : ST30031000 (J-22912-01)

Clearance "A"

Standard : 0.6 - 0.8 mm (0.024 - 0.031 in)

Limit value : 0.2 mm (0.008 in)

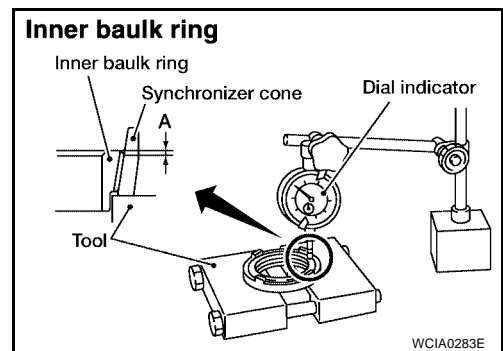

INPUT SHAFT AND GEARS

- Using a feeler gauge, measure clearance "B" at two or more points diagonally opposite, and calculate mean value as shown.

Clearance "B"

Standard : 0.6 - 1.1 mm (0.024 - 0.043 in)

Limit value : 0.2 mm (0.008 in)

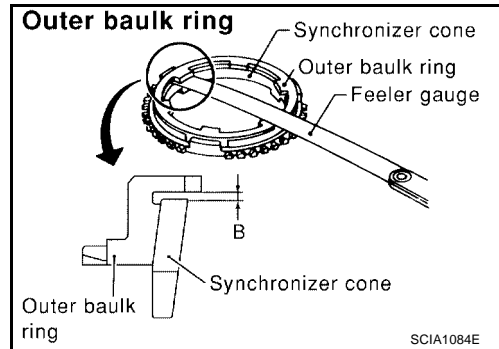

Bearing

Check the item listed. If necessary, replace it with a new one.

- Damage and rough rotation of the bearing as shown.

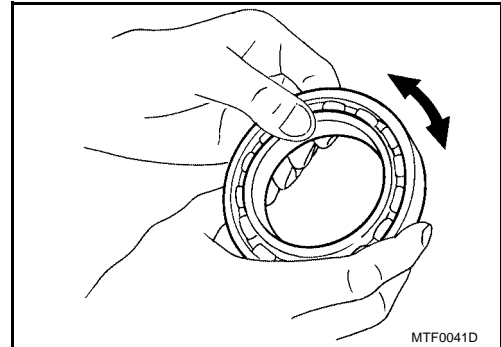

ASSEMBLY

- Install the 3rd needle bearing.
- Install the 3rd input gear and 3rd baulk ring.
- Install the spread spring, shifting insert, and a new 3rd-4th synchronizer hub onto the 3rd-4th coupling sleeve.

CAUTION:

- Install with the orientation of the new synchronizer hub as shown.
- Do not reuse the 3rd-4th synchronizer hub.

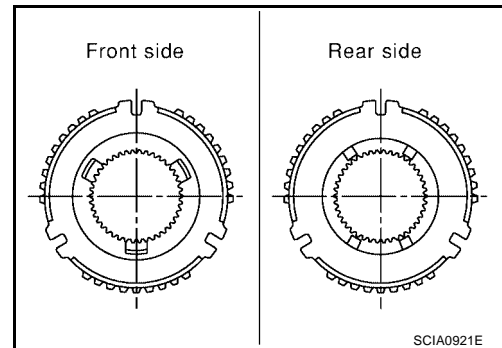

- Install with the orientation of the coupling sleeve as shown.

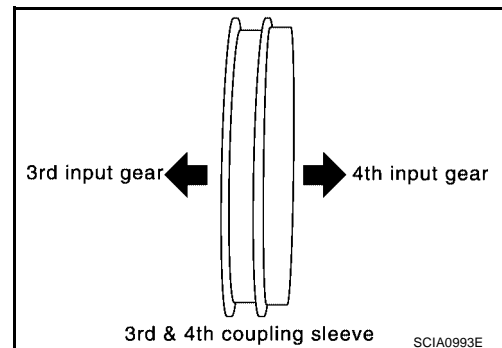

INPUT SHAFT AND GEARS

- Do not hook the ends of the two spread springs (front and back have two each) on the same shifting insert.

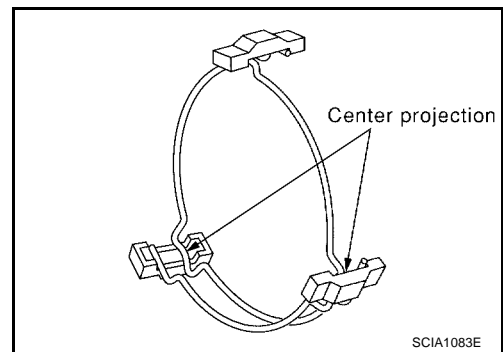

4. Install the 3rd-4th synchronizer assembly using Tool as shown.

Tool number : KV40105710 (—)

CAUTION:

Align grooves of the shifting insert and 3rd baulk ring.

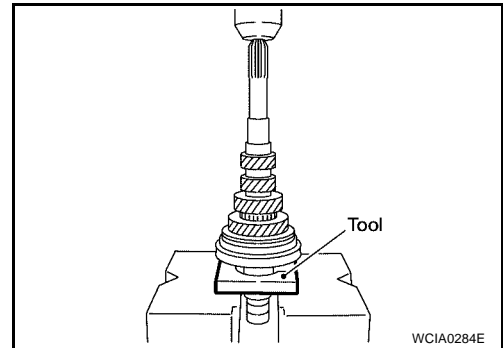

5. Install the 4th bushing using Tool as shown.

Tool number : KV40105710 (—)

6. Install the 4th baulk ring.

7. Install the 4th input gear and 4th needle bearing.

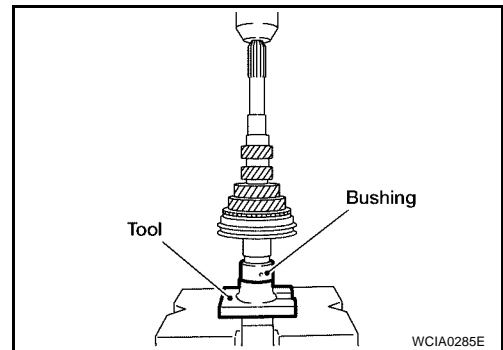

8. Measure the dimension "C2" as shown. Select a suitable thrust washer so that dimension "C2" satisfies the standard dimension specification. Then install the thrust washer onto the input shaft.

Standard for : 154.7 - 154.8 mm (6.091 - 6.094 in)
dimension "C2"

CAUTION:

Only 1 thrust washer can be selected.

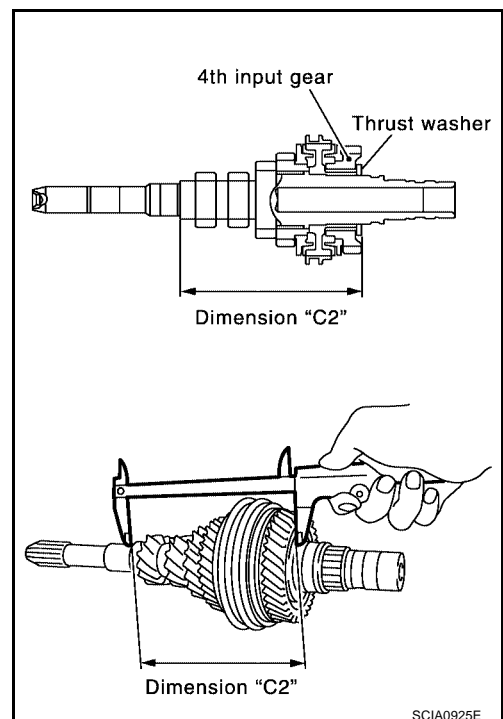

A
B
MT
D
E
F
G
H
I
J
K
L
M

INPUT SHAFT AND GEARS

Thrust Washer

Thickness	Part number	Thickness	Part number
3.84 mm (0.1512 in)	32347 8H500	4.02 mm (0.1583 in)	32347 8H503
3.90 mm (0.1535 in)	32347 8H501	4.08 mm (0.1606 in)	32347 8H504
3.96 mm (0.1559 in)	32347 8H502	4.14 mm (0.1630 in)	32347 8H505

9. Install the 5th bushing using Tool as shown.

Tool number : KV40105710 (—)

10. Install the 5th needle bearing and 5th input gear.

11. Install the 5th baulk ring.

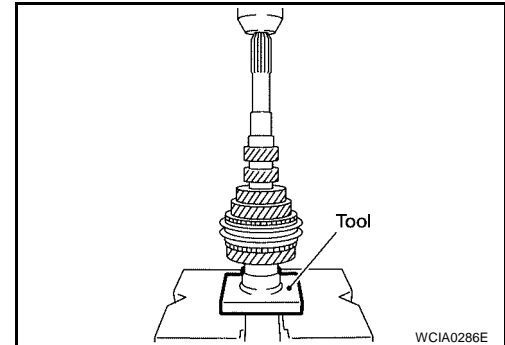

12. Install the synchronizer assembly onto a new 5th-6th synchronizer hub.

CAUTION:

- Install with the orientation of the new synchronizer hub as shown.
- Do not reuse the 5th-6th synchronizer hub.

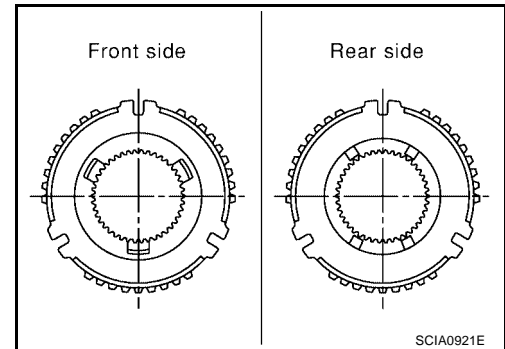

- Do not to hook the ends of the 2 spread springs (front and back have two each) on the same shifting insert.

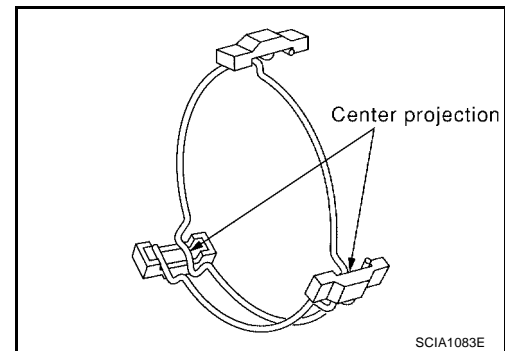

13. Install the 5th-6th synchronizer hub assembly using Tool as shown.

Tool number : KV40105710 (—)

CAUTION:

Align the grooves of the 5th-6th shifting insert and the 5th-6th baulk ring.

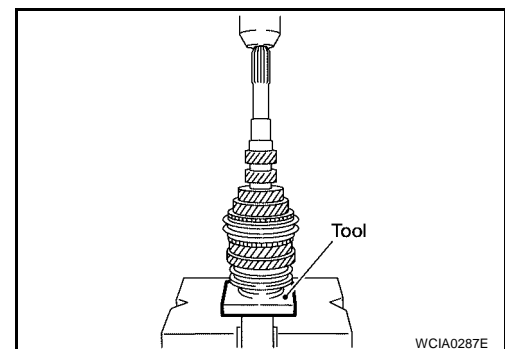

INPUT SHAFT AND GEARS

14. Install the needle bearing, 6th input gear and then 6th bushing using Tool as shown.

Tool number : ST33200000 (J-26082)

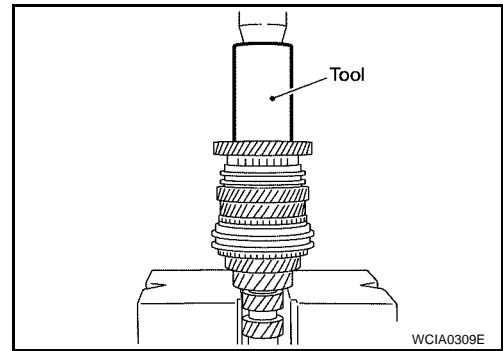

15. Install the snap ring onto the input shaft, and measure to check that end play (gap between snap ring and groove) of the 6th bushing is within specification.

End play standard value : 0 - 0.1 mm (0 - 0.004 in)

- If the measurement is outside the standard value, select the appropriate size snap ring.

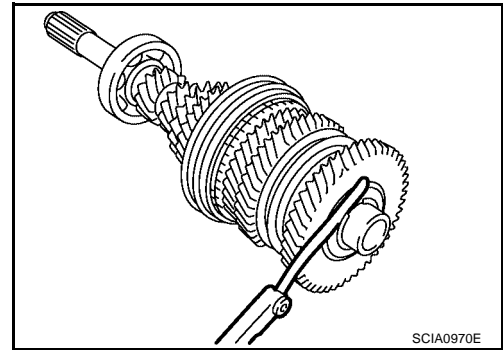

Snap Rings

Thickness	Part number	Thickness	Part number
1.76 mm (0.0693 in)	32204 8H511	2.01 mm (0.0791 in)	32204 8H516
1.81 mm (0.0713 in)	32204 8H512	2.06 mm (0.0811 in)	32204 8H517
1.86 mm (0.0732 in)	32204 8H513	2.11 mm (0.0831 in)	32204 8H518
1.91 mm (0.0752 in)	32204 8H514	2.16 mm (0.0850 in)	32204 8H519
1.96 mm (0.0772 in)	32204 8H515	2.21 mm (0.0871 in)	32204 8H520

16. Install the input shaft rear bearing using Tool as shown.

Tool number : ST30901000 (J-26010-01)

CAUTION:

Install input shaft rear bearing with its brown surface facing the input gear side.

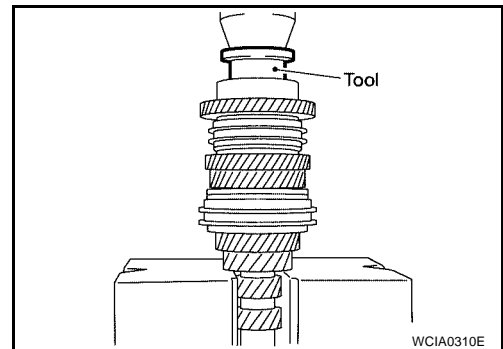

17. Install the input shaft front bearing using Tools as shown.

Tool number A: ST33052000 (—)
B: ST30032000 (J-26010-01)

18. Install the oil channel onto the input shaft.

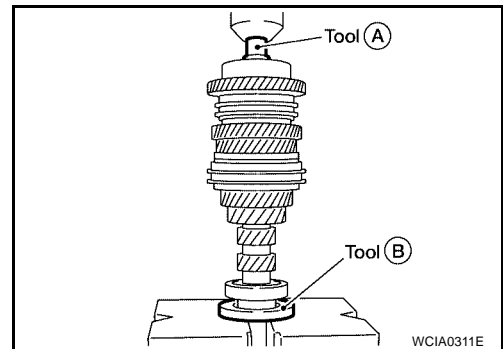

INPUT SHAFT AND GEARS

19. Check the end play of the 3rd, 4th, 5th and 6th input gears as shown.

End play standard values

3rd gear : 0.18 - 0.31 mm (0.0071 - 0.0122 in)

4th gear : 0.20 - 0.30 mm (0.0079 - 0.0118 in)

5th gear : 0.06 - 0.16 mm (0.0024 - 0.0063 in)

6th gear : 0.06 - 0.16 mm (0.0024 - 0.0063 in)

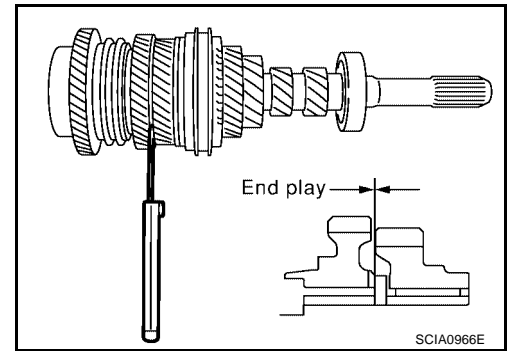

MAINSHAFT AND GEARS

PFP:32241

EC500ENG

MAINSHAFT AND GEARS

Disassembly and Assembly DISASSEMBLY

1. Before disassembling, measure the end play of the 1st and 2nd main gears as shown.

End play standard values

1st gear : 0.20 - 0.30 mm (0.0079 - 0.0118 in)

2nd gear : 0.06 - 0.16 mm (0.0024 - 0.0063 in)

CAUTION:

If the measurement is outside the standard value, disassemble to check the contact surfaces of the gear, shaft, and hub. Adjust with the snap ring at assembly.

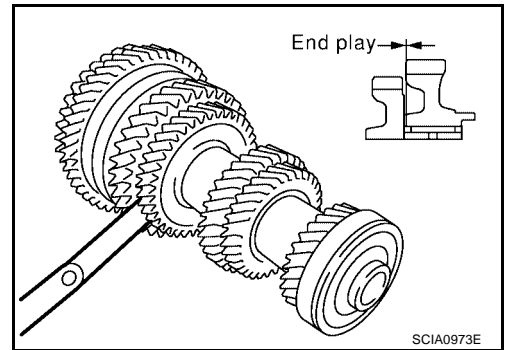

2. Remove the snap ring.
3. Remove the C-ring holder, and then mainshaft C-ring as shown.

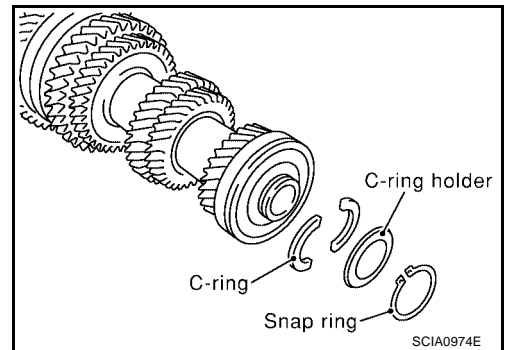

4. Remove the mainshaft rear bearing, adjust shim, and 6th main gear using Tools as shown.

Tool number A: Commercial service tool
B: ST33052000 (—)

5. Remove the 5th-6th mainshaft spacer.

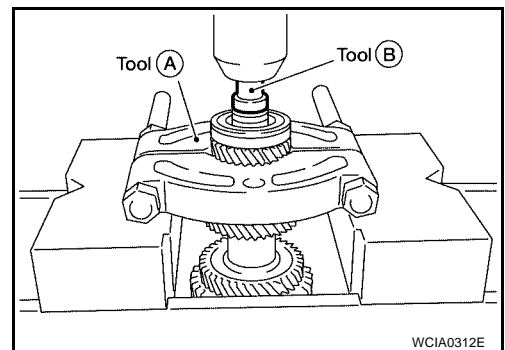

6. Remove the 4th main gear and 5th main gear simultaneously using Tools as shown.

Tool number A: ST33052000 (—)
B: Commercial service tool

7. Remove the adjusting shim.
8. Remove the 3rd-4th mainshaft spacer.

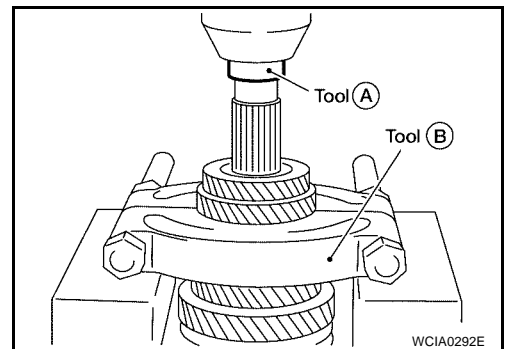

A
B
MT
D
E
F
G
H
I
J
K
L
M

MAINSHAFT AND GEARS

9. Remove the 3rd main gear, 2nd main gear, 2nd gear needle bearing, 2nd bushing, 1st-2nd synchronizer assembly, 1st main gear, reverse main gear, 1st gear needle bearing, and 1st bushing simultaneously using Tool as shown.

Tool number : KV40105020 (—)

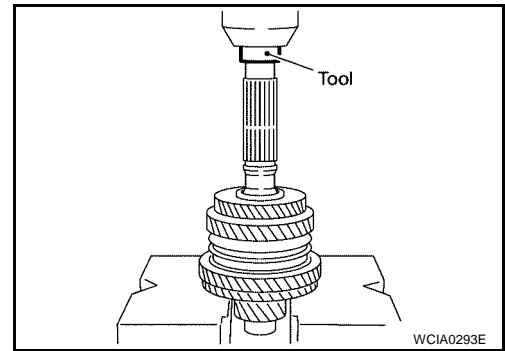

INSPECTION AFTER DISASSEMBLY

Mainshaft and Gears

Check the items listed as shown. If necessary, replace them with new ones.

- Damage, peeling, dent, uneven wear, and bending of the mainshaft.
- Excessive wear, damage and peeling of the mainshaft gears.

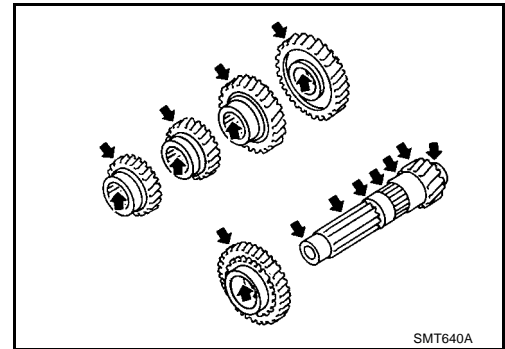

Synchronizer

Check the items listed as shown. If necessary, replace them with new ones.

- Damage, excessive wear on contact surfaces of the coupling sleeve, synchronizer hub, and shifting insert.
- Coupling sleeve and synchronizer hub must move smoothly as shown.

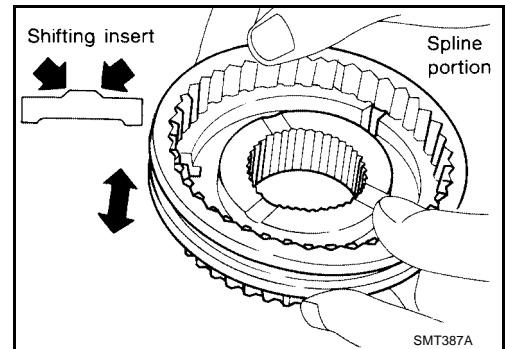

- If any cracks, damage, or excessive wear is found on the cam face of baulk ring or working face of the insert as shown, replace it.

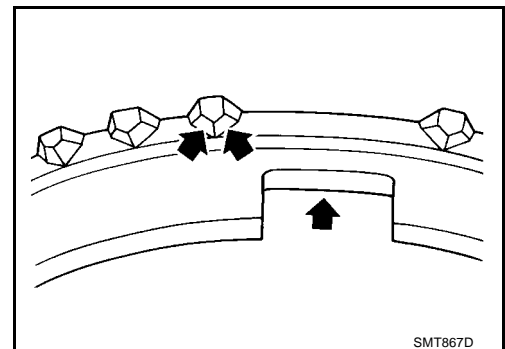

MAINSHAFT AND GEARS

Triple Cone Synchronizer (1st and 2nd)

- Check the clearance of the outer baulk ring, synchronizer cone, and inner baulk ring of the 1st and 2nd triple cone synchronizers, using the following procedure.

CAUTION:

The outer baulk ring, synchronizer cone, and inner baulk ring operate as a set to control the clearances "A", "B", and "C". If the measured clearances exceed the service limit value, replace the components as a set.

NOTE:

To calculate the mean value of two or more measured values, add the highest and lowest measured values and divide by two.

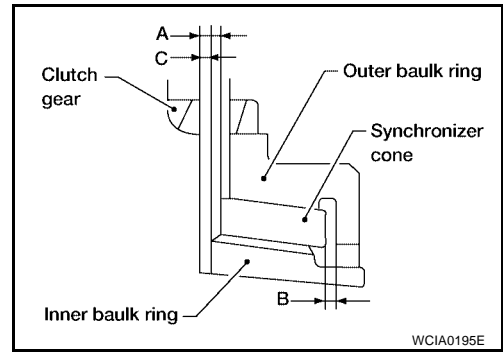

- Press the baulk ring on to the clutch gear taper cone by hand, then measure the clearance "A" at two or more points diagonally opposite with a feeler gauge, and then calculate the mean value.

Clearance "A"

Standard : 0.6 - 1.2 mm (0.024 - 0.047 in)

Limit : 0.3 mm (0.012 in)

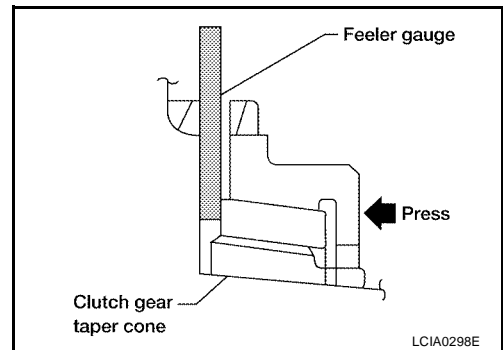

- Measure clearances "B" at two or more points diagonally opposite with a feeler gauge, and then calculate the mean value.

Clearance "B"

Standard : 0.6 - 1.1 mm (0.024 - 0.043 in)

Limit : 0.2 mm (0.008 in)

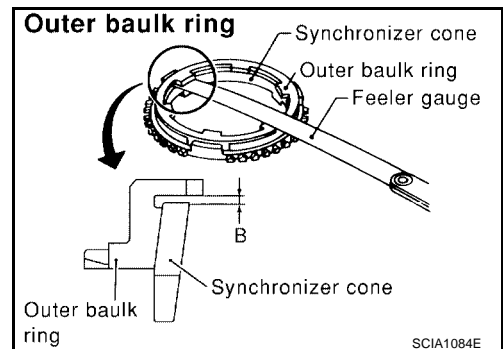

- Press the baulk ring on to the clutch gear taper cone by hand, then measure the clearance "C" at two or more points diagonally opposite with a feeler gauge, and then calculate the mean value.

Clearance "C"

Standard : 0.7 - 1.1 mm (0.028 - 0.043 in)

Limit : 0.3 mm (0.012 in)

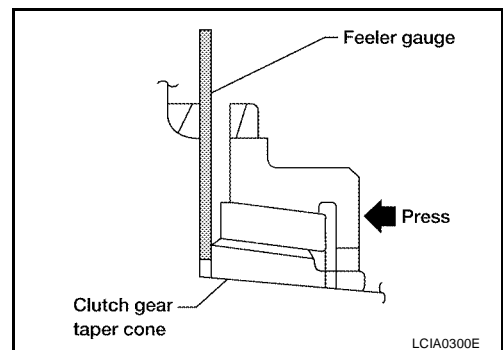

MAINSHAFT AND GEARS

Bearing

Check the item listed. If necessary, replace it with a new one.

- Damage and rough rotation of the bearing as shown.

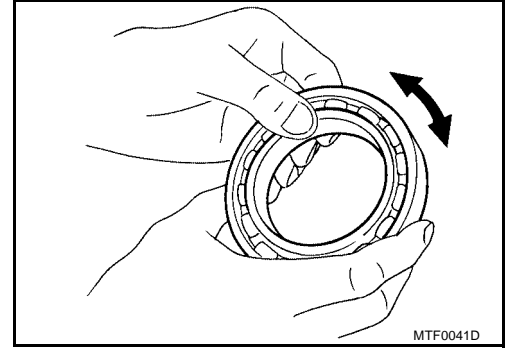

ASSEMBLY

1. Install the reverse main gear using Tools as shown.

Tool number **A: ST35321000 (—)**
 B: KV40101630 (J-35870)
 C: ST38220000 (—)

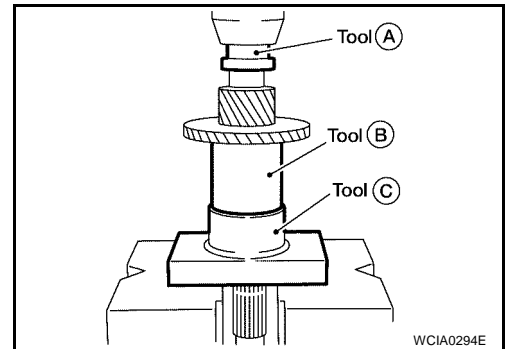

CAUTION:

Install with the orientation of reverse main gear as shown.

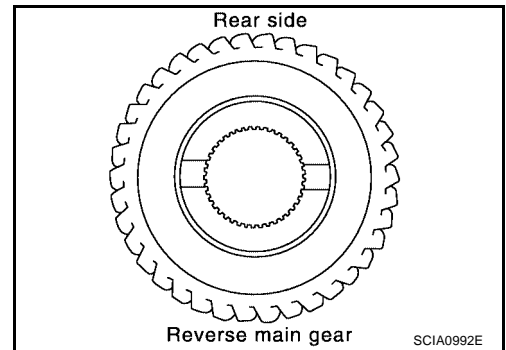

2. Install the 1st bushing using Tools as shown.

Tool number **A: ST35321000 (—)**
 B: KV38102510 (J-35870)
 C: ST38220000 (—)

3. Install the needle bearing, and then the 1st main gear.

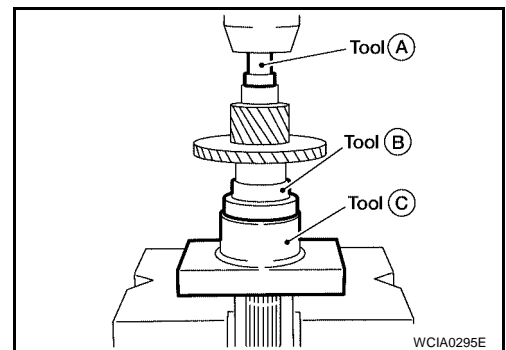

4. Install the spread spring, shifting insert, and a new 1st-2nd synchronizer hub onto the 1st-2nd coupling sleeve.

MAINSHAFT AND GEARS

CAUTION:

- Install with the orientation of the new synchronizer hub as shown.
- Do not reuse 1st-2nd synchronizer hub

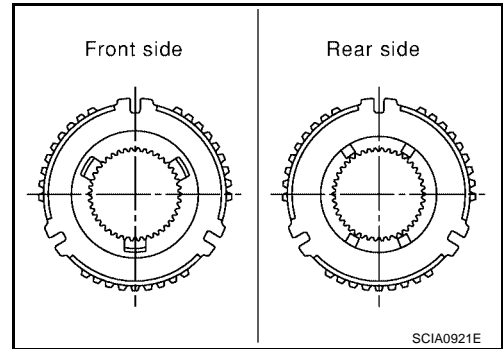

- Install with the orientation of coupling sleeve as shown.

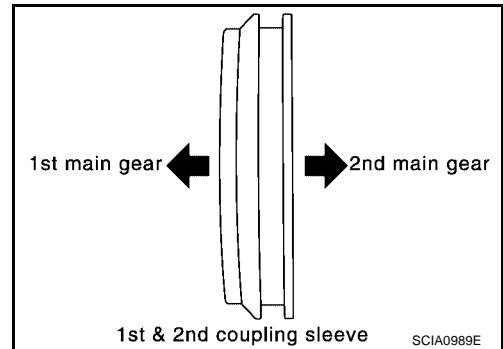

- Do not hook the ends of the two spread springs (front and back have two each) on the same shifting insert.

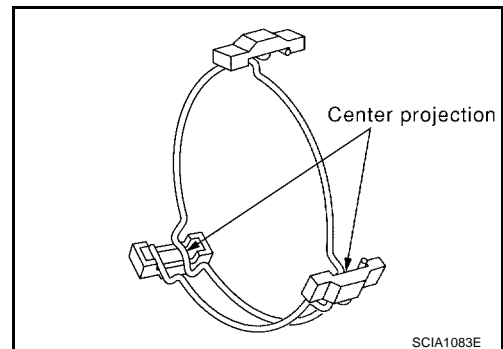

5. Install the 1st gear synchronizer assembly onto the mainshaft, and the synchronizer hub assembly onto the mainshaft using Tools as shown.

Tool number A: ST35321000 (—)
 B: KV38102510 (J-35870)
 C: ST38220000 (—)

CAUTION:

- Outer baulk ring, synchronizer cone, and inner baulk ring on the 2nd gear-side must have been removed.
- Install the coupling sleeve with the proper orientation.

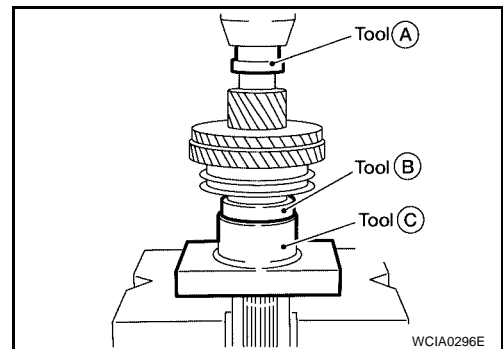

MAINSHAFT AND GEARS

6. Install the 2nd bushing using Tools as shown.

Tool number **A: ST35321000 (—)**
 B: KV40105710 (—)

7. Install the outer baulk ring, synchronizer cone, and inner baulk ring on 2nd gear-side.

8. Install the 2nd needle bearing and 2nd gear.

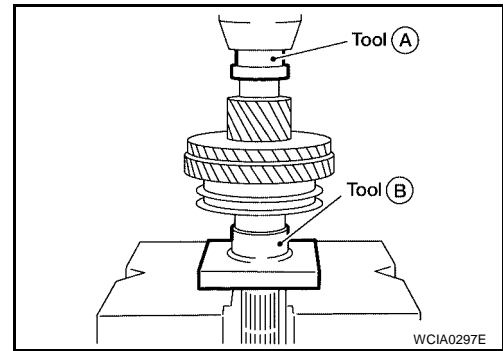

9. Install the 3rd main gear using Tools.

Tool number **A: ST35321000 (—)**
 B: KV40105710 (—)

CAUTION:
Install the 3rd main gear with the orientation as shown.

10. Install the 3rd-4th mainshaft spacer.

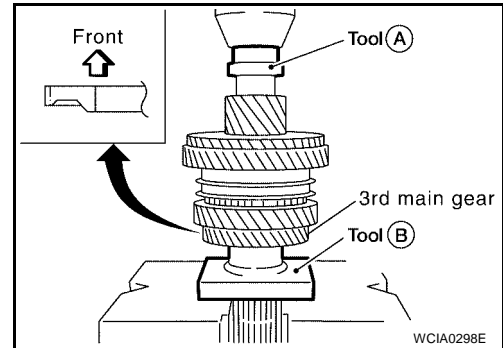

11. Measure the dimension "C1" . Select a suitable adjusting shim so that the dimension "C1 " satisfies the standard dimension specification, and install it onto the mainshaft.

Standard for **: 173.85 - 173.95 mm (6.844 - 6.848 in)**
dimension "C1"

CAUTION:
Only 1 adjusting shim can be selected.

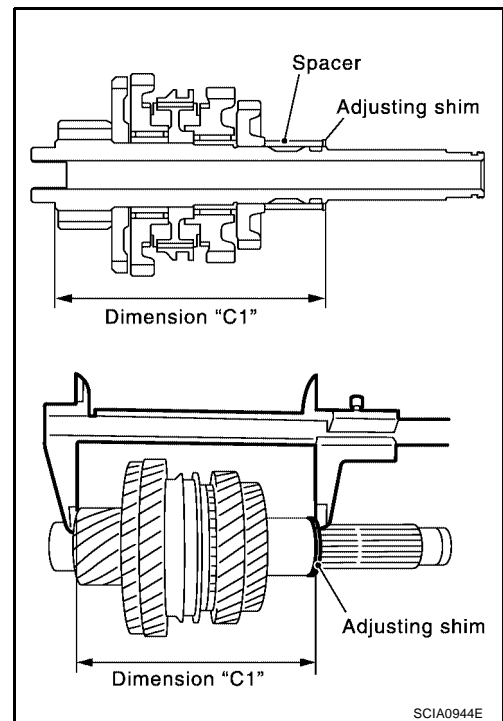

Adjusting Shim

Thickness	Part number	Thickness	Part number
0.52 mm (0.0205 in)	32238 8H500	0.84 mm (0.0331 in)	32238 8H504
0.60 mm (0.0236 in)	32238 8H501	0.92 mm (0.0362 in)	32238 8H505
0.68 mm (0.0268 in)	32238 8H502	1.00 mm (0.0394 in)	32238 8H506
0.76 mm (0.0299 in)	32238 8H503	1.08 mm (0.0425 in)	32238 8H507

MAINSHAFT AND GEARS

12. Install the 4th main gear with the specified orientation, using Tools as shown.

Tool number **A: ST33200000 (J-26082)**
 B: ST30901000 (J-26010-01)

CAUTION:
Install the 4th main gear with the orientation as shown.

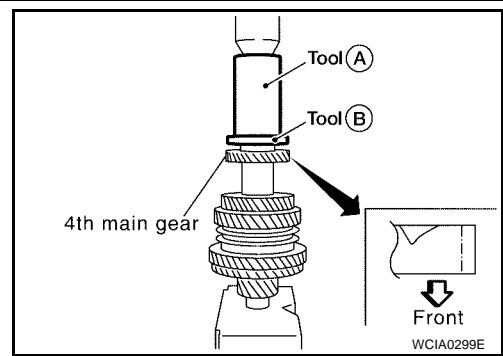

13. Install the 5th main gear with the specified orientation, using Tools as shown.

Tool number **A: ST33200000 (J-26082)**
 B: ST30901000 (J-26010-01)

CAUTION:
Install the 5th main gear with the orientation as shown.

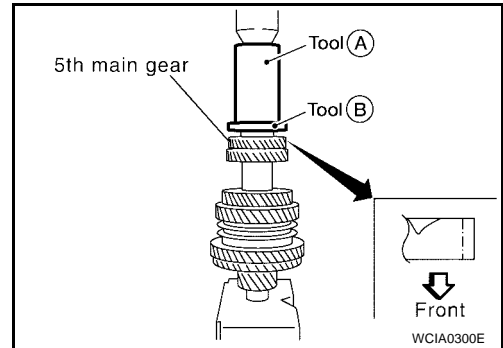

14. Install the 5th-6th mainshaft spacer.

15. Install the 6th main gear using Tools as shown.

Tool number **A: ST33200000 (J-26082)**
 B: ST30901000 (J-26010-01)

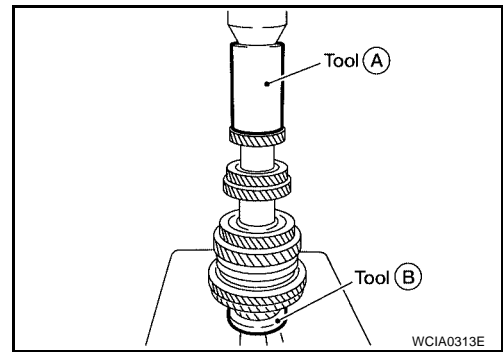

16. Select the 6th main adjusting shim and then install it onto the mainshaft.

- Calculate thickness "S" of 6th main adjusting shim by procedure below so that end play dimension between 6th main gear and mainshaft rear bearing becomes the dimension specified.

End play : 0 - 0.1 mm (0 - 0.004 in)

Dimension "S" = ("S₁" - "S₂") - End play

"S" : Thickness of adjusting shim

"S₁" : Dimension from mainshaft standard face to mainshaft rear bearing press-fit end face

"S₂" : Dimension from mainshaft standard face to 6th main gear end face

CAUTION:
Only 1 adjusting shim can be selected.

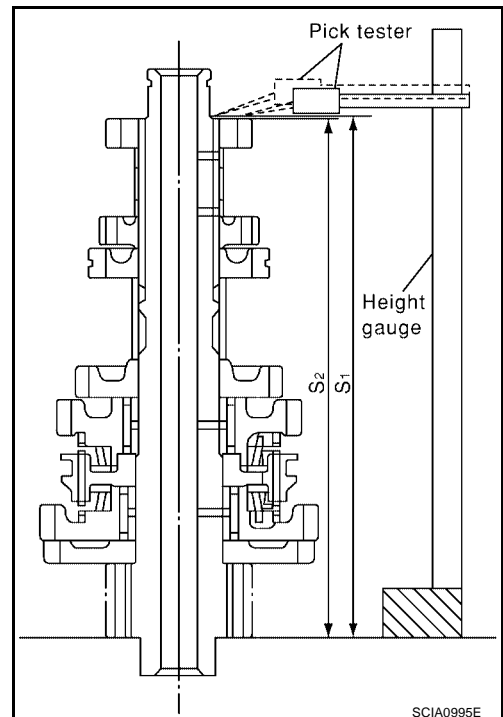

A
 B
 MT
 D
 E
 F
 G
 H
 I
 J
 K
 L
 M

MAINSHAFT AND GEARS

Adjusting Shim

Thickness	Part number	Thickness	Part number
0.88 mm (0.0346 in)	32237 8H560	1.20 mm (0.0472 in)	32237 8H564
0.96 mm (0.0378 in)	32237 8H561	1.28 mm (0.0504 in)	32237 8H565
1.04 mm (0.0409 in)	32237 8H562	1.36 mm (0.0535 in)	32237 8H566
1.12 mm (0.0441 in)	32237 8H563		

- a. Using a height gauge, measure the dimension “S1 ” and “S2 ” as shown.
 - b. Install the selected 6th main adjusting shim to the mainshaft.
17. Install the mainshaft rear bearing using Tools as shown.

Tool number A: ST30720000 (J-25405)
B: ST30901000 (J-26010-01)

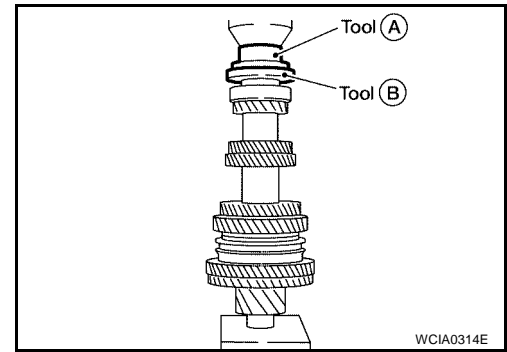

18. Install the C-ring onto the mainshaft, and check that the end play of mainshaft rear bearing meets specifications.

End play standard value : 0 - 0.06 mm (0 - 0.0024 in)

- If the measurement is outside the specified standard value, reselect a new C-ring.

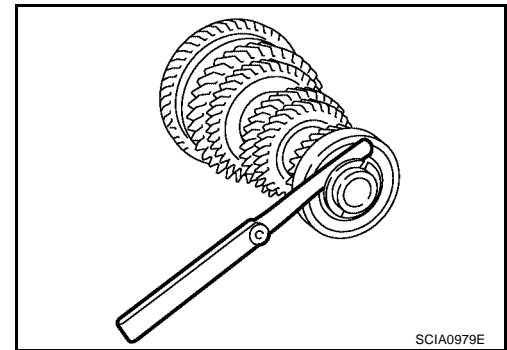

C-Ring

Thickness	Part number	Thickness	Part number
2.535 mm (0.0998 in)	32348 8H800	2.835 mm (0.1116 in)	32348 8H810
2.565 mm (0.1010 in)	32348 8H801	2.865 mm (0.1128 in)	32348 8H811
2.595 mm (0.1022 in)	32348 8H802	2.895 mm (0.1140 in)	32348 8H812
2.625 mm (0.1033 in)	32348 8H803	2.925 mm (0.1152 in)	32348 8H813
2.655 mm (0.1045 in)	32348 8H804	2.955 mm (0.1163 in)	32348 8H814
2.685 mm (0.1057 in)	32348 8H805	2.985 mm (0.1175 in)	32348 8H815
2.715 mm (0.1069 in)	32348 8H806	3.015 mm (0.1187 in)	32348 8H816
2.745 mm (0.1081 in)	32348 8H807	3.045 mm (0.1199 in)	32348 8H817
2.775 mm (0.1093 in)	32348 8H808	3.075 mm (0.1211 in)	32348 8H818
2.805 mm (0.1104 in)	32348 8H809		

19. Fit the C-ring holder, and install the snap ring as shown.

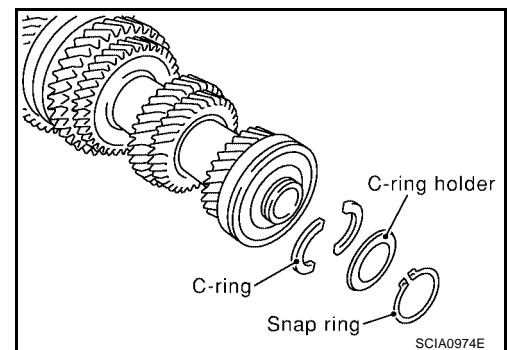

MAINSHAFT AND GEARS

20. Check the end play of the 1st and 2nd main gears as shown.

End play standard values

1st gear : 0.20 - 0.30 mm (0.0079 - 0.0118 in)

2nd gear : 0.06 - 0.16 mm (0.0024 - 0.0063 in)

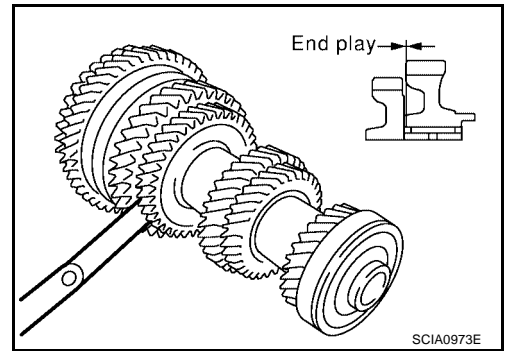

A
B
MT

D
E
F
G
H
I
J
K
L
M

REVERSE IDLER SHAFT AND GEARS

PFP:32281

ECS00ENH

REVERSE IDLER SHAFT AND GEARS

Disassembly and Assembly DISASSEMBLY

1. Remove the reverse idler gear adjusting shim.
2. Remove the reverse idler gear (rear), reverse coupling sleeve and insert spring simultaneously.
3. Remove the reverse idler gear needle bearing.
4. Remove the thrust needle bearing.
5. Remove the reverse baulk ring.
6. Remove the reverse idler gear (front).
7. Remove the reverse idler gear needle bearing.
8. Remove the thrust needle bearing.
9. Pull off the locking pin from the reverse idler shaft.

INSPECTION AFTER DISASSEMBLY

Reverse Idler Shaft and Gears

Check the items listed. If necessary, replace them with new ones.

- Damage, peeling, dent, uneven wear and bending of the reverse idler shaft.
- Excessive wear, damage and peeling, of the reverse idler gears.

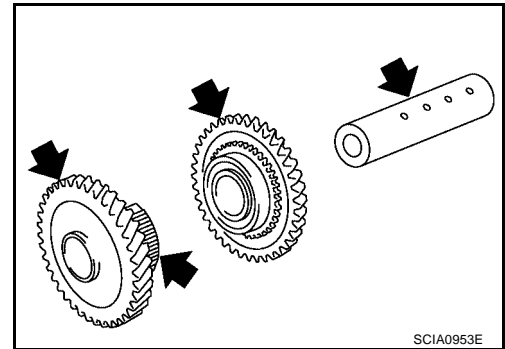

Synchronizer

Check the items listed. If necessary, replace them with new ones.

- Damage and excessive wear on contact surfaces of coupling sleeve, synchronizer hub, and insert spring.
- Coupling sleeve and synchronizer hub must move smoothly as shown.

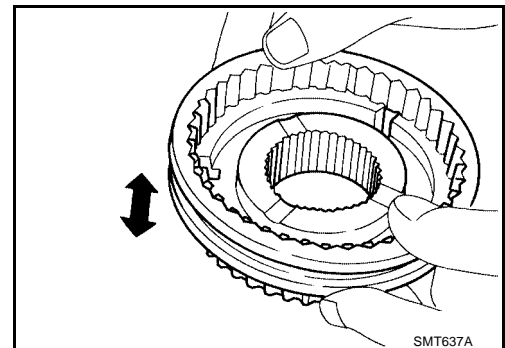

- If any crack, damage, or excessive wear is found on the cam face of the baulk ring or working face of the insert as shown, replace it.

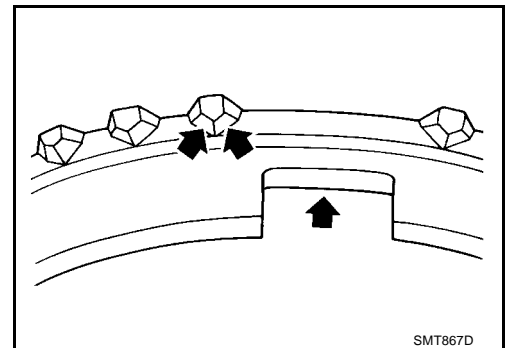

REVERSE IDLER SHAFT AND GEARS

Baulk ring clearance

- Press the baulk ring against the cone, and measure the clearance between the baulk ring and cone as shown. If the measurement is below the specified limit, replace it with a new one.

Baulk ring to gear clearance

Standard : 0.95 - 1.4 mm (0.0374 - 0.055 in)

Limit value : 0.7 mm (0.028 in)

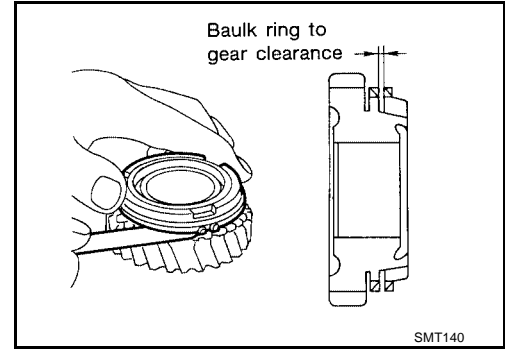

Bearing

Check the item listed. If necessary, replace it with a new one.

- Damage and rough rotation of the bearing.

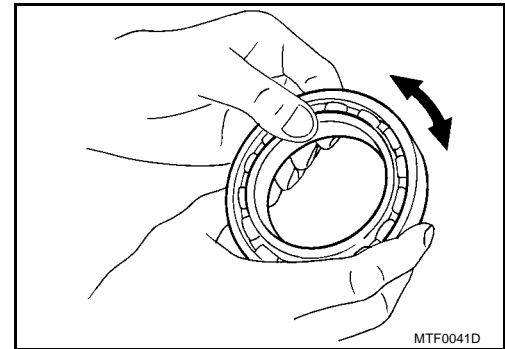

ASSEMBLY

Assembly is in the reverse order of disassembly.

CAUTION:

- Install the insert spring with the orientation as shown.

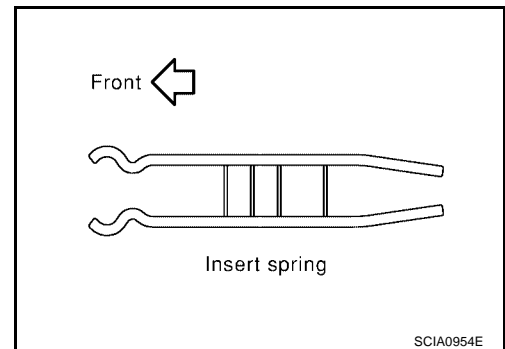

A
B
MT
D
E
F
G
H
I
J
K
L
M

FINAL DRIVE

FINAL DRIVE

PFP:38411

Disassembly and Assembly PRE-INSPECTION

ECS00ENR

1. Clean final drive assembly sufficiently to prevent side gear thrust washer, differential case, side gear, and other parts from sticking by gear oil.
2. Upright the differential case so that the side gear to be measured faces upward.
3. Place final drive adapter and dial indicator onto side gears using Tool as shown.

Tool number : — (J-39713)

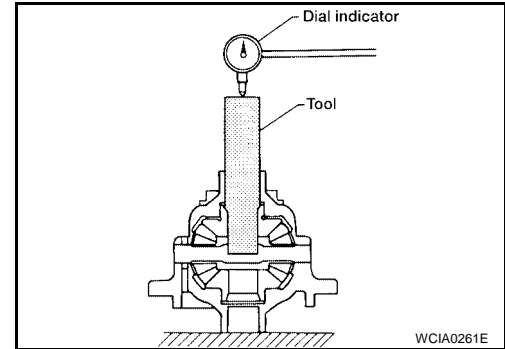

4. Move side gears up and down, and measure the clearance as shown.

Clearance between side gear and differential case : 0.1 - 0.2 mm
(0.004 - 0.008 in)

CAUTION:

There must be no resistance and the gears must rotate freely.

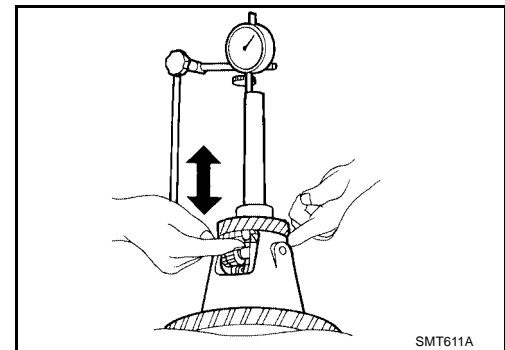

5. If the clearance measured is not within specification, adjust the clearance by changing the thrust washer thickness.
6. Turn the differential case upside down, and measure the clearance between the side gear and differential case on the other side to the same specifications, adjust using a thrust washer as necessary.

DISASSEMBLY

1. Remove the bolts and then separate the final gear from the differential case.
2. Remove speedometer drive gear.
3. Remove the differential side bearing (clutch housing side) using tool and puller as shown.

Tool number : ST33061000 (J-8107-2)

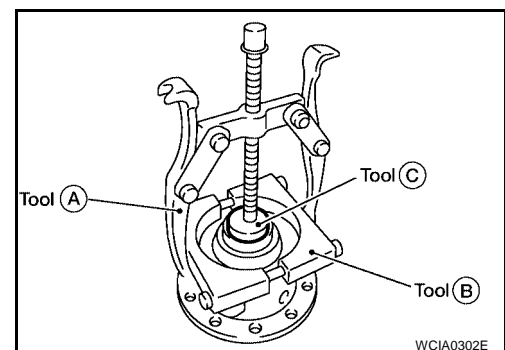

FINAL DRIVE

4. Remove the differential side bearing (transaxle case side) using tool and puller as shown.

Tool number : ST33061000 (J-8107-2)

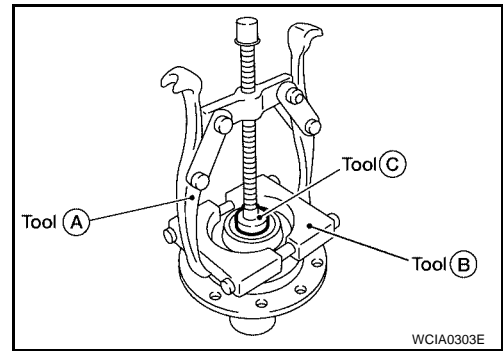

5. Pull out lock pin and pinion mate shaft as shown. using suitable pin punch.

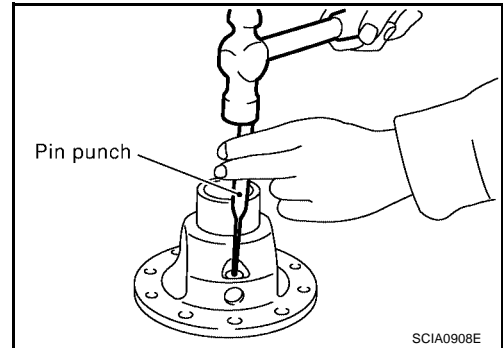

6. Rotate pinion mate gears, and remove pinion mate gears, pinion mate thrust washers, side gears, and side gear thrust washers from differential case.

INSPECTION AFTER DISASSEMBLY

Gear, Washer, Shaft and Case

Check side gears, side gear thrust washers, pinion mate shaft, pinion mate gears, pinion mate thrust washers and differential case as shown. If necessary, replace with new parts.

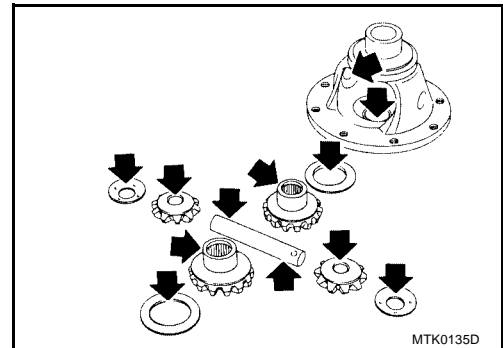

Bearing

Check for bearing damage and rough rotation as shown. If necessary, replace with new parts.

CAUTION:

When replacing the tapered roller bearing, replace the outer and inner races as a set.

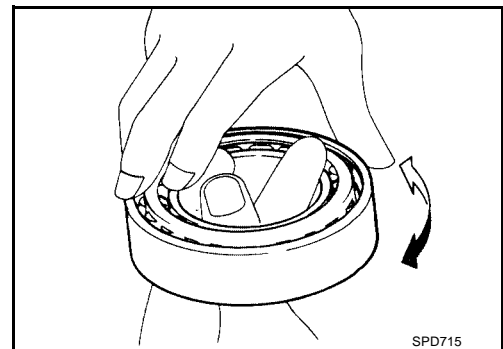

ASSEMBLY

1. Apply gear oil to sliding area of differential case, each gear, and thrust washer.

A
B
MT
D
E
F
G
H
I
J
K
L
M

FINAL DRIVE

2. Install side gear thrust washers and side gears into differential case as shown.

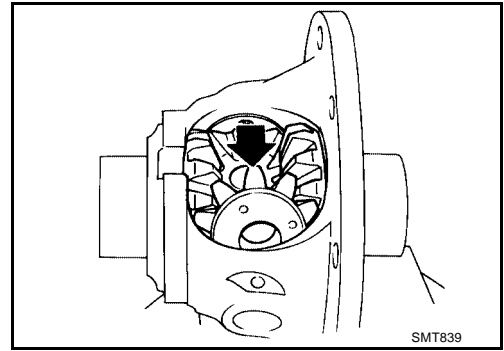

3. While rotating pinion mate thrust washers and pinion mate gears, and aligning them diagonally, install them into differential case.

4. Insert pinion mate shaft into differential case as shown.

CAUTION:
Be sure not to damage pinion mate thrust washers.

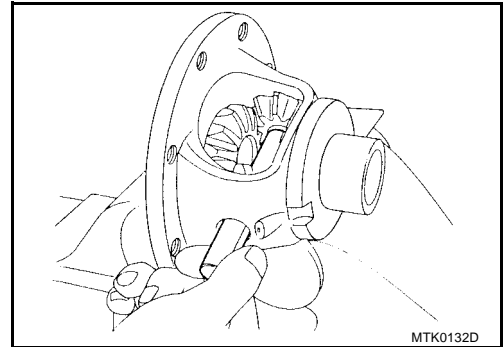

5. Measure end play of side gears, using the procedure below. Then select side gear thrust washer.

- a. Upright the differential case so that the side gear to be measured faces upward.
- b. Place final drive adapter and dial indicator onto side gears using tool as shown.

Tool number : — (J-39713)

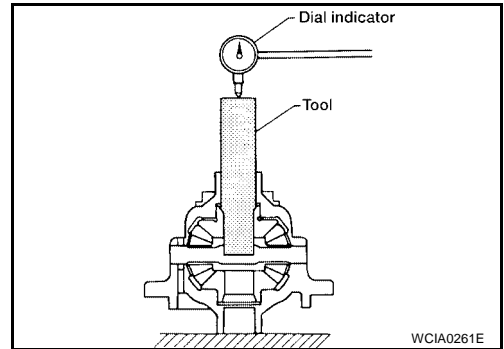

- c. Move side gears up and down to measure end play, and select thrust washer so that it meets specification.

End play standard value : 0.1 - 0.2 mm (0.004 - 0.008 in)

CAUTION:

- There must be no resistance and the gears must rotate freely.
- Place differential case upside down. Measure the end play for opposite side-gears using the same procedure.
- Only one thrust washer can be selected.

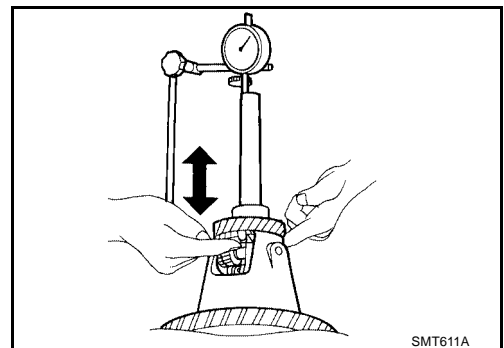

Thrust washers

Thickness	Part number
0.75 mm (0.0295 in)	38424 81X00
0.80 mm (0.0315 in)	38424 81X01
0.85 mm (0.0335 in)	38424 81X02
0.90 mm (0.0354 in)	38424 81X03
0.95 mm (0.0374 in)	38424 81X04

FINAL DRIVE

6. Drive a new lock pin into the pinion mate shaft using a suitable pin punch as shown.

CAUTION:

Do not reuse the lock pin.

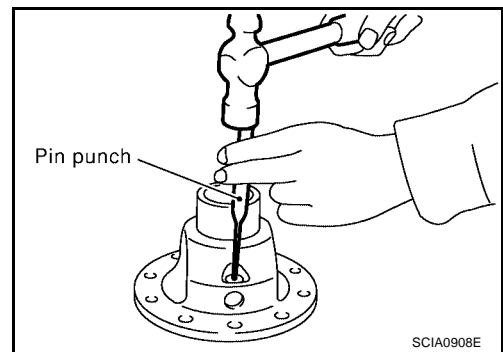

7. Install differential side bearing (transaxle case side) using Tools as shown.

Tool number **A: ST30720000 (J-25405)**
 B: KV38102510 (J-35870)

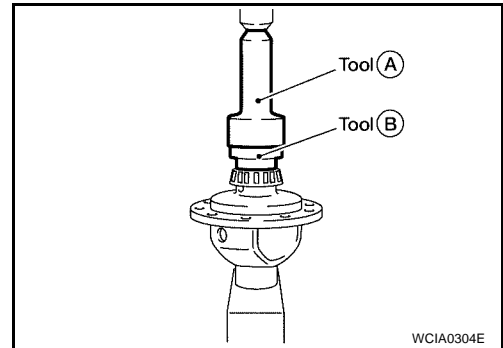

8. Align and install the speedometer drive gear onto the differential case as shown.

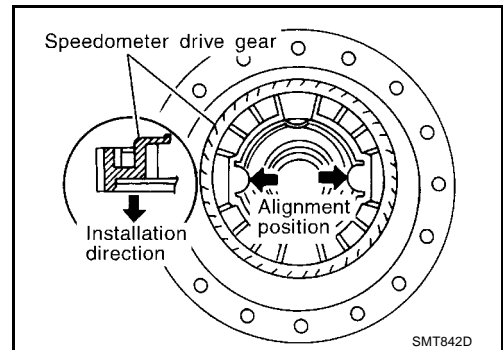

9. Install differential side bearing (clutch housing side) using Tools as shown.

Tool number **A: ST30720000 (J-25405)**
 B: KV38102510 (J-35870)

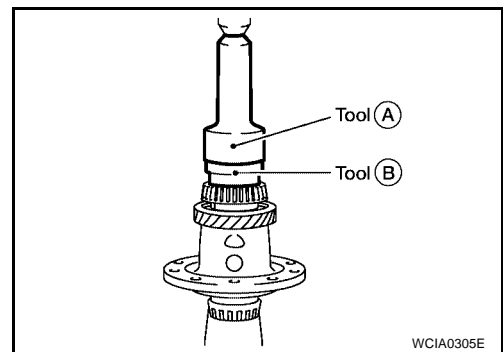

10. Install the final gear into the differential case, and tighten the final gear bolts to specification.

Final gear bolts **: 122.5 - 137.5 N·m (13 - 14 kg·m,**
 91 - 101 ft·lb)

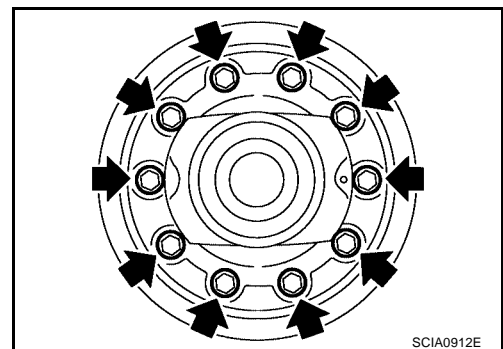

A
B
MT
D
E
F
G
H
I
J
K
L
M

SHIFT CONTROL

PFP:32982

SHIFT CONTROL

ECS00ENI

Inspection

- Check the contact surfaces and sliding area for wear, damage, or bending as shown. If necessary, replace the parts.

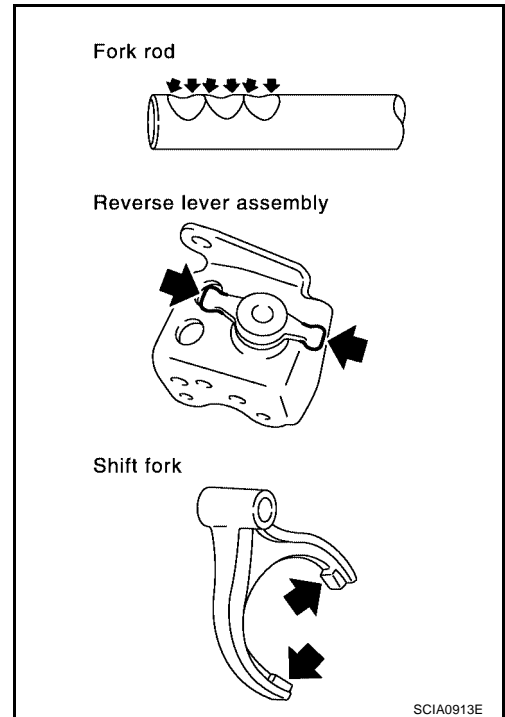

SHIFT FORK

- Check if the width of the shift fork hook (sliding area with coupling sleeve) is within specification, as shown.

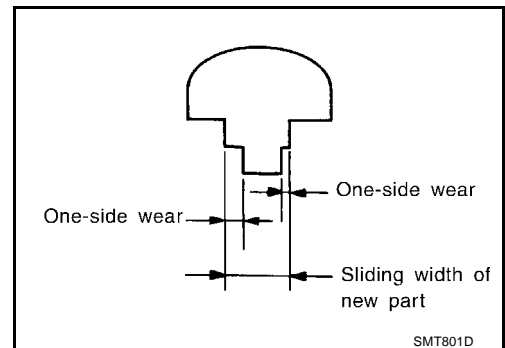

Shift Fork

Item	One-side wear specification	Sliding width of new part
1st & 2nd	0.2 mm (0.008 in)	7.80 - 7.93 mm (0.3071 - 0.3122 in)
3rd & 4th	0.2 mm (0.008 in)	7.80 - 7.93 mm (0.3071 - 0.3122 in)
5th & 6th	0.2 mm (0.008 in)	6.10 - 6.23 mm (0.2402 - 0.2453 in)
Reverse	0.2 mm (0.008 in)	12.80 - 12.93 mm (0.5039 - 0.5091 in)

SERVICE DATA AND SPECIFICATIONS (SDS)

SERVICE DATA AND SPECIFICATIONS (SDS)

PF0:00030

General Specifications TRANSAXLE

ECS00ENJ

Engine		VQ35DE	
Transaxle model		RS6F51A	
Model code number		7Y466	
Number of speeds		6	
Synchromesh type		Warner	
Shift pattern		<p style="text-align: center;">SCIA0955E</p>	
Gear ratio	1st	3.153	
	2nd	1.944	
	3rd	1.392	
	4th	1.055	
	5th	0.809	
	6th	0.630	
	Reverse	3.002	
Number of teeth	Input gear	1st	13
		2nd	18
		3rd	28
		4th	36
		5th	42
		6th	46
		Reverse	13
	Main gear	1st	41
		2nd	35
		3rd	39
		4th	38
		5th	34
		6th	29
		Reverse	38
Reverse idler gear	Front	37	
	Rear	38	
Oil capacity (Reference)		2.2 ℓ (2 3/8 US qt, 2 Imp qt)	
Oil Level		49 - 55 mm (1.93 - 2.17 in)	
Oil type		Genuine NISSAN Manual Transmission Fluid (MTF) HQ Multi 75W-85 or API GL-4, Viscosity SAE 75W-85	
Remarks	Reverse synchronizer	Installed	
	Double cone synchronizer	3rd	
	Triple cone synchronizer	1st and 2nd	

SERVICE DATA AND SPECIFICATIONS (SDS)

FINAL GEAR

Engine		VQ35DE
Transaxle model		RS6F51A
Model code number		7Y466
Final gear ratio		4.133
Number of teeth	Final gear/Pinion	62/15
	Side gear/Pinion mate gear	—

Gear End Play

ECS00ENK

Unit: mm (in)

Gear	End play
1st main gear	0.20 - 0.30 (0.0079 - 0.0118)
2nd main gear	0.06 - 0.16 (0.0024 - 0.0063)
3rd input gear	0.18 - 0.31 (0.0071 - 0.0122)
4th input gear	0.20 - 0.30 (0.0079 - 0.0118)
5th input gear	0.06 - 0.16 (0.0024 - 0.0063)
6th input gear	0.06 - 0.16 (0.0024 - 0.0063)

Clearance Between Baulk Ring and Gear 4TH, 5TH, 6TH & REVERSE BAULK RING

ECS00ENL

Unit: mm (in)

Baulk ring	Standard	Wear limit
4th	0.9 - 1.45 (0.035 - 0.0571)	0.7 (0.028)
5th	0.95 - 1.4 (0.0374 - 0.055)	0.7 (0.028)
6th	0.95 - 1.4 (0.0374 - 0.055)	0.7 (0.028)
Reverse	0.95 - 1.4 (0.0374 - 0.055)	0.7 (0.028)

SERVICE DATA AND SPECIFICATIONS (SDS)

1ST, 2ND AND 3RD BAULK RING

Unit: mm (in)

1st, 2nd and 3rd Double Bulk Ring

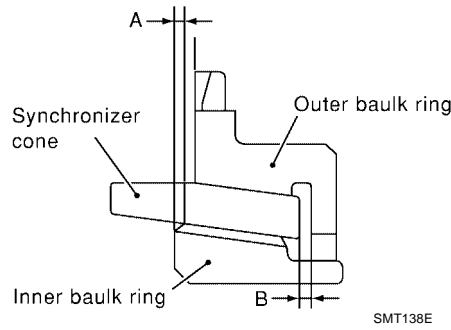

1st and 2nd Triple Bulk Ring

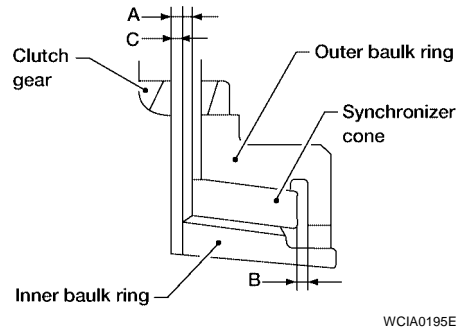

Dimension	Standard	Wear limit		
		Double baulk ring	Triple baulk ring	Double baulk ring
A	0.6 - 0.8 (0.024 - 0.031)	0.6 - 1.2 (0.024 - 0.047)	0.2 (0.008)	0.3 (0.012)
B	0.6 - 1.1 (0.024 - 0.043)	0.6 - 1.1 (0.024 - 0.043)	0.2 (0.008)	0.2 (0.008)
C	—	0.7 - 1.1 (0.028 - 0.043)	—	0.3 (0.012)

Available Snap Rings 6TH BUSHING

ECS00ENM

End play		0 - 0.1 mm (0 - 0.004 in)	
Thickness mm (in)	Part number*	Thickness mm (in)	Part number*
1.76 (0.0693)	32204 8H511	2.01 (0.0791)	32204 8H516
1.81 (0.0713)	32204 8H512	2.06 (0.0811)	32204 8H517
1.86 (0.0732)	32204 8H513	2.11 (0.0831)	32204 8H518
1.91 (0.0752)	32204 8H514	2.16 (0.0850)	32204 8H519
1.96 (0.0772)	32204 8H515	2.21 (0.0871)	32204 8H520

*: Always check with the Parts Department for the latest parts information.

Available C-rings MAINSHAFT C-RING

ECS00ENN

End play		0 - 0.06 mm (0 - 0.0024 in)	
Thickness mm (in)	Part number*	Thickness mm (in)	Part number*
2.535 (0.0998)	32348 8H800	2.835 (0.1116)	32348 8H810
2.565 (0.1010)	32348 8H801	2.865 (0.1128)	32348 8H811
2.595 (0.1022)	32348 8H802	2.895 (0.1140)	32348 8H812
2.625 (0.1033)	32348 8H803	2.925 (0.1152)	32348 8H813
2.655 (0.1045)	32348 8H804	2.955 (0.1163)	32348 8H814
2.685 (0.1057)	32348 8H805	2.985 (0.1175)	32348 8H815
2.715 (0.1069)	32348 8H806	3.015 (0.1187)	32348 8H816
2.745 (0.1081)	32348 8H807	3.045 (0.1199)	32348 8H817
2.775 (0.1093)	32348 8H808	3.075 (0.1211)	32348 8H818
2.805 (0.1104)	32348 8H809		

*: Always check with the Parts Department for the latest parts information.

SERVICE DATA AND SPECIFICATIONS (SDS)

Available Thrust Washers INPUT SHAFT THRUST WASHER

ECS00ENO

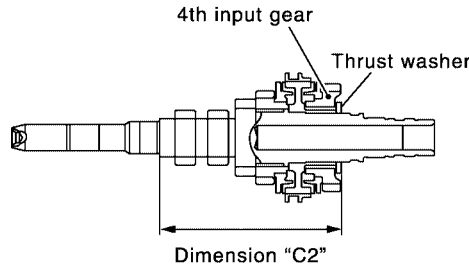

SCIA1008E

Standard length "C2"		154.7 - 154.8 mm (6.091 - 6.094in)	
Thickness mm (in)	Part number*	Thickness mm (in)	Part number*
3.84 (0.1512)	32347 8H500	4.02 (0.1583)	32347 8H503
3.90 (0.1535)	32347 8H501	4.08 (0.1606)	32347 8H504
3.96 (0.1559)	32347 8H502	4.14 (0.1630)	32347 8H505

*: Always check with the Parts Department for the latest parts information.

Available Adjusting Shims MAINSHAFT ADJUSTING SHIM

ECS00ENP

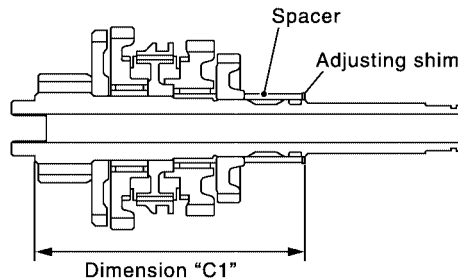

SCIA1009E

Standard length "C1"		173.85 - 173.95 mm (6.844 - 6.848in)	
Thickness mm (in)	Part number*	Thickness mm (in)	Part number*
0.52 (0.0205)	32238 8H500	0.84 (0.0331)	32238 8H504
0.60 (0.0236)	32238 8H501	0.92 (0.0362)	32238 8H505
0.68 (0.0268)	32238 8H502	1.00 (0.0394)	32238 8H506
0.76 (0.0299)	32238 8H503	1.08 (0.0425)	32238 8H507

*: Always check with the Parts Department for the latest parts information.

INPUT SHAFT REAR BEARING ADJUSTING SHIM

End play			0 - 0.06 mm (0 - 0.0024 in)		
Thickness mm (in)	Part number*	Thickness mm (in)	Part number*	Thickness mm (in)	Part number*
0.40 (0.0157)	32225 8H500	0.88 (0.0346)	32225 8H512	1.36 (0.0535)	32225 8H524
0.44 (0.0173)	32225 8H501	0.92 (0.0362)	32225 8H513	1.40 (0.0551)	32225 8H560
0.48 (0.0189)	32225 8H502	0.96 (0.0378)	32225 8H514	1.44 (0.0567)	32225 8H561
0.52 (0.0205)	32225 8H503	1.00 (0.0394)	32225 8H515	1.48 (0.0583)	32225 8H562
0.56 (0.0220)	32225 8H504	1.04 (0.0409)	32225 8H516	1.52 (0.0598)	32225 8H563
0.60 (0.0236)	32225 8H505	1.08 (0.0425)	32225 8H517	1.56 (0.0614)	32225 8H564
0.64 (0.0252)	32225 8H506	1.12 (0.0441)	32225 8H518	1.60 (0.0630)	32225 8H565
0.68 (0.0268)	32225 8H507	1.16 (0.0457)	32225 8H519	1.64 (0.0646)	32225 8H566
0.72 (0.0283)	32225 8H508	1.20 (0.0472)	32225 8H520		
0.76 (0.0299)	32225 8H509	1.24 (0.0488)	32225 8H521		
0.80 (0.0315)	32225 8H510	1.28 (0.0504)	32225 8H522		
0.84 (0.0331)	32225 8H511	1.32 (0.0520)	32225 8H523		

SERVICE DATA AND SPECIFICATIONS (SDS)

*: Always check with the Parts Department for the latest parts information.

MAINSHAFT REAR BEARING ADJUSTING SHIM

End play		0 - 0.06 mm (0 - 0.0024 in)	
Thickness mm (in)	Part number*	Thickness mm (in)	Part number*
0.44 (0.0173)	32238 8H510	0.80 (0.0315)	32238 8H519
0.48 (0.0189)	32238 8H511	0.84 (0.0331)	32238 8H520
0.52 (0.0205)	32238 8H512	0.88 (0.0346)	32238 8H521
0.56 (0.0220)	32238 8H513	0.92 (0.0362)	32238 8H522
0.60 (0.0236)	32238 8H514	0.96 (0.0378)	32238 8H523
0.64 (0.0252)	32238 8H515	1.00 (0.0394)	32238 8H524
0.68 (0.0268)	32238 8H516	1.04 (0.0409)	32238 8H560
0.72 (0.0283)	32238 8H517	1.08 (0.0425)	32238 8H561
0.76 (0.0299)	32238 8H518		

*: Always check with the Parts Department for the latest parts information.

REVERSE IDLER GEAR ADJUSTING SHIM

End play		0.04 - 0.10 mm (0.0016 - 0.0039 in)	
Thickness mm (in)	Part number*	Thickness mm (in)	Part number*
1.76 (0.0693)	32237 8H800	2.24 (0.0882)	32237 8H812
1.80 (0.0709)	32237 8H801	2.28 (0.0898)	32237 8H813
1.84 (0.0724)	32237 8H802	2.32 (0.0913)	32237 8H814
1.88 (0.0740)	32237 8H803	2.36 (0.0929)	32237 8H815
1.92 (0.0756)	32237 8H804	2.40 (0.0945)	32237 8H816
1.96 (0.0772)	32237 8H805	2.44 (0.0961)	32237 8H817
2.00 (0.0787)	32237 8H806	2.48 (0.0976)	32237 8H818
2.04 (0.0803)	32237 8H807	2.52 (0.0992)	32237 8H819
2.08 (0.0819)	32237 8H808	2.56 (0.1008)	32237 8H820
2.12 (0.0835)	32237 8H809	2.60 (0.1024)	32237 8H821
2.16 (0.0850)	32237 8H810	2.64 (0.1039)	32237 8H822
2.20 (0.0866)	32237 8H811		

*: Always check with the Parts Department for the latest parts information.

6TH MAIN GEAR ADJUSTING SHIM

End play		0 - 0.1 mm (0 - 0.004 in)	
Thickness mm (in)	Part number*	Thickness mm (in)	Part number*
0.88 (0.0346)	32237 8H560	1.20 (0.0472)	32237 8H564
0.96 (0.0378)	32237 8H561	1.28 (0.0504)	32237 8H565
1.04 (0.0409)	32237 8H562	1.36 (0.0535)	32237 8H566
1.12 (0.0441)	32237 8H563		

*: Always check with the Parts Department for the latest parts information.

Available Shims

ECS00ENG

— Differential Side Bearing Preload and Adjusting Shim —

BEARING PRELOAD

Differential side bearing preload: L*	0.15 - 0.21 mm (0.0059 - 0.0083 in)
---------------------------------------	-------------------------------------

*: Install shims which are "deflection of differential case" + "L" in thickness.

DIFFERENTIAL SIDE BEARING ADJUSTING SHIM(S)

End play		0.1 - 0.2 mm (0.004 - 0.008 in)	
Thickness mm (in)	Part number*	Thickness mm (in)	Part number*
0.48 (0.0189)	31438 80X00	0.72 (0.0283)	31438 80X06
0.52 (0.0205)	31438 80X01	0.76 (0.0299)	31438 80X07
0.56 (0.0220)	31438 80X02	0.80 (0.0315)	31438 80X08
0.60 (0.0236)	31438 80X03	0.84 (0.0331)	31438 80X09
0.64 (0.0252)	31438 80X04	0.88 (0.0346)	31438 80X10
0.68 (0.0268)	31438 80X05	0.92 (0.0362)	31438 80X11

*: Always check with the Parts Department for the latest parts information.

SERVICE DATA AND SPECIFICATIONS (SDS)
