

SECTION **BRC**

BRAKE CONTROL SYSTEM

A
B
C
D
E

CONTENTS

TCS/ABS	
PRECAUTIONS	3
Precautions for Supplemental Restraint System (SRS) "AIR BAG" and "SEAT BELT PRE-TENSIONER"	3
Precautions for Brake System	3
Precautions When Using CONSULT-II	3
CHECK POINTS FOR USING CONSULT-II	3
Precautions for Brake Control	4
Precautions for CAN System	4
PREPARATION	5
Special Service Tool	5
Commercial Service Tools	5
SYSTEM DESCRIPTION	6
System Diagram	6
ABS Function	6
EBD Function	6
TCS Function	6
Wheel Sensors	7
Fail-Safe Function	7
ABS/EBD SYSTEM	7
TCS SYSTEM	7
Hydraulic Circuit Diagram	8
CAN COMMUNICATION	9
System Description	9
TROUBLE DIAGNOSIS	10
How to Perform Trouble Diagnoses for Quick and Accurate Repair	10
INTRODUCTION	10
WORK FLOW	11
CLARIFY CONCERN	12
EXAMPLE OF DIAGNOSIS SHEET	12
Component Parts and Harness Connector Location	13
Schematic	15
Wiring Diagram — TCS —	16
Basic Inspection	20
BRAKE FLUID LEVEL, FLUID LEAK, AND BRAKE PAD INSPECTION	20
POWER SYSTEM TERMINAL LOOSENESS AND BATTERY INSPECTION	20
ABS WARNING LAMP AND SLIP INDICATOR LAMP INSPECTION	20
Warning Lamp and Indicator Timing	20
Control Unit Input/Output Signal Standard	21
REFERENCE VALUE FROM CONSULT-II	21
CONSULT-II Function (ABS)	23
CONSULT-II START PROCEDURE	23
SELF-DIAGNOSIS	23
DATA MONITOR	25
ACTIVE TEST	27
TROUBLE DIAGNOSIS FOR SELF-DIAGNOSTIC ITEMS	29
Wheel Sensor System Inspection	29
Engine System Inspection	30
ABS/TCS Control Unit Inspection	31
Solenoid Valve System Inspection	31
Actuator Motor, Motor Relay, and Circuit Inspection	32
Stop Lamp Switch System Inspection	33
ABS/TCS Control Unit Power and Ground Systems Inspection	34
CAN Communication System Inspection	35
Component Inspection	35
TCS OFF SWITCH	35
TROUBLE DIAGNOSES FOR SYMPTOMS	36
ABS Works Frequently	36
Unexpected Pedal Action	37
Long Stopping Distance	38
ABS Does Not Work	38
Pedal Vibration or ABS Operation Noise	38
ABS Warning Lamp Does Not Come On When Ignition Switch Is Turned On	39
ABS Warning Lamp Stays On When Ignition Switch Is Turned On	39
Vehicle Jerks During TCS Activation	40
WHEEL SENSORS	41
Removal and Installation	41
REMOVAL	41
INSTALLATION	41

BRC

G
H
I
J
K
L
M

SENSOR ROTOR	42	REFERENCE VALUE FROM CONSULT-II	67
Removal and Installation	42	CONSULT-II Function (ABS)	70
REMOVAL	42	CONSULT-II START PROCEDURE	70
INSTALLATION	42	SELF-DIAGNOSIS	70
ACTUATOR AND ELECTRIC UNIT (ASSEMBLY)...	43	DATA MONITOR	73
Removal and Installation	43	ACTIVE TEST	75
REMOVAL	43		
INSTALLATION	43		
VDC/TCS/ABS			
PRECAUTIONS	45	TROUBLE DIAGNOSIS FOR SELF-DIAGNOSTIC	ITEMS
Precautions for Supplemental Restraint System (SRS) "AIR BAG" and "SEAT BELT PRE-TENSIONER"	45	Wheel Sensor System Inspection	77
Precautions for Brake System	45	Engine System Inspection	78
Precautions When Using CONSULT-II	45	ABS/TCS/VDC Control Unit Inspection	79
CHECK POINTS FOR USING CONSULT-II	45	Steering Angle Sensor System Inspection	79
Precautions for Brake Control	46	Yaw Rate/Side/Decel G Sensor System Inspection..	81
Precautions for CAN System	46	Solenoid and VDC Change-Over Valve System Inspection	82
PREPARATION	48	Actuator Motor, Motor Relay, and Circuit Inspection..	83
Special Service Tool	48	Stop Lamp Switch System Inspection	84
Commercial Service Tools	48	ABS/TCS/VDC Control Unit Power and Ground Systems Inspection	85
SYSTEM DESCRIPTION	49	Brake Fluid Level Switch System Inspection	86
System Components	49	CAN Communication System Inspection	87
ABS Function	49	Component Inspection	87
EBD Function	49	VDC OFF SWITCH	87
TCS Function	50	TROUBLE DIAGNOSES FOR SYMPTOMS	88
VDC Function	50	ABS Works Frequently	88
Wheel Sensors	51	Unexpected Pedal Action	89
Fail-Safe Function	51	Long Stopping Distance	90
ABS/EBD SYSTEM	51	ABS Does Not Work	90
VDC/TCS SYSTEM	51	Pedal Vibration or ABS Operation Noise	90
Hydraulic Circuit Diagram	52	ABS Warning Lamp Does Not Come On When Ignition Switch Is Turned On	91
CAN COMMUNICATION	53	ABS Warning Lamp Stays On When Ignition Switch Is Turned On	91
System Description	53	Vehicle Jerks During TCS/VDC Activation	92
TROUBLE DIAGNOSIS	54	ON-VEHICLE SERVICE	93
How to Perform Trouble Diagnoses for Quick and Accurate Repair	54	Adjustment of Steering Angle Sensor Neutral Position	93
INTRODUCTION	54	WHEEL SENSORS	94
WORK FLOW	55	Removal and Installation	94
CLARIFY CONCERN	56	REMOVAL	94
EXAMPLE OF DIAGNOSIS SHEET	56	INSTALLATION	94
Component Parts and Harness Connector Location..	57	SENSOR ROTOR	95
Schematic	59	Removal and Installation	95
Wiring Diagram — VDC —	60	REMOVAL	95
Basic Inspection	66	INSTALLATION	95
BRAKE FLUID LEVEL, FLUID LEAK, AND BRAKE PAD INSPECTION	66	ACTUATOR AND ELECTRIC UNIT (ASSEMBLY)...	96
POWER SYSTEM TERMINAL LOOSENESS AND BATTERY INSPECTION	66	Removal and Installation	96
ABS WARNING LAMP, SLIP INDICATOR LAMP AND VDC OFF INDICATOR LAMP INSPECTION..	66	REMOVAL	96
Warning Lamp and Indicator Timing	67	INSTALLATION	96
Control Unit Input/Output Signal Standard	67	STEERING ANGLE SENSOR	98
		Removal and Installation	98
		G SENSOR	99
		Removal and Installation	99
		REMOVAL	99
		INSTALLATION	99

PRECAUTIONS

PFP:00001

Precautions for Supplemental Restraint System (SRS) “AIR BAG” and “SEAT BELT PRE-TENSIONER”

EFS00637

The Supplemental Restraint System such as “AIR BAG” and “SEAT BELT PRE-TENSIONER”, used along with a front seat belt, helps to reduce the risk or severity of injury to the driver and front passenger for certain types of collision. This system includes seat belt switch inputs and dual stage front air bag modules. The SRS system uses the seat belt switches to determine the front air bag deployment, and may only deploy one front air bag, depending on the severity of a collision and whether the front occupants are belted or unbelted. Information necessary to service the system safely is included in the SRS and SB section of this Service Manual.

WARNING:

- To avoid rendering the SRS inoperative, which could increase the risk of personal injury or death in the event of a collision which would result in air bag inflation, all maintenance must be performed by an authorized NISSAN/INFINITI dealer.
- Improper maintenance, including incorrect removal and installation of the SRS, can lead to personal injury caused by unintentional activation of the system. For removal of Spiral Cable and Air Bag Module, see the SRS section.
- Do not use electrical test equipment on any circuit related to the SRS unless instructed to in this Service Manual. SRS wiring harnesses can be identified by yellow and/or orange harnesses or harness connectors.

Precautions for Brake System

EFS004FC

CAUTION:

- Refer to [MA-9, "RECOMMENDED FLUIDS AND LUBRICANTS"](#) for recommended brake fluid.
- Never reuse drained brake fluid.
- Be careful not to splash brake fluid on painted areas; it may cause paint damage. If brake fluid is splashed on painted areas, wash it away with water immediately.
- To clean or wash all parts of master cylinder and disc brake caliper, use clean brake fluid.
- Never use mineral oils such as gasoline or kerosene. They will ruin rubber parts of the hydraulic system.
- Use flare nut wrench when removing and installing brake tube.
- If a brake fluid leak is found, the part must be disassembled without fail. Then it has to be replaced with a new one if a defect exists.
- Turn the ignition switch OFF and remove the connector of the ABS actuator and electric unit (control unit) or the battery terminal before performing the work.
- Always torque brake lines when installing.
- Burnish the brake contact surfaces after refinishing or replacing rotors, after replacing pads, or if a soft pedal occurs at very low mileage.

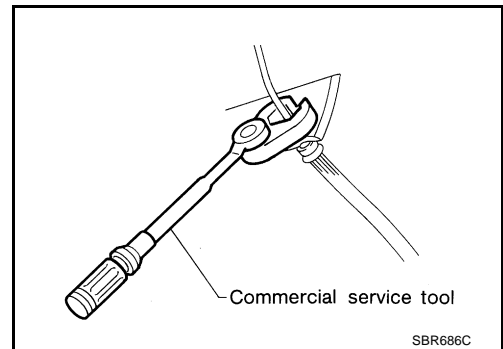

Refer to [BR-28, "Brake Burnishing"](#) (front disc brakes) or [BR-35, "Brake Burnishing"](#) (rear disc brakes).

WARNING:

- Clean brake pads and shoes with a waste cloth, then wipe with a dust collector.

Precautions When Using CONSULT-II

EFS004FD

When connecting CONSULT-II to data link connector, connect them through CONSULT-II CONVERTER.

CAUTION:

If CONSULT-II is used with no connection of CONSULT-II CONVERTER, malfunctions might be detected in self-diagnosis depending on control unit which carries out CAN communication.

CHECK POINTS FOR USING CONSULT-II

1. Has CONSULT-II been used without connecting CONSULT-II CONVERTER on this vehicle?
 - If YES, GO TO 2.

A
B
C
D
E
BRC
G
H
I
J
K
L
M

PRECAUTIONS

[TCS/ABS]

- If NO, GO TO 5.
- 2. Is there any indication other than indications relating to CAN communication system in the self-diagnosis results?
 - If YES, GO TO 3.
 - If NO, GO TO 4.
- 3. Based on self-diagnosis results unrelated to CAN communication, carry out the inspection.
- 4. Malfunctions may be detected in self-diagnosis depending on control units carrying out CAN communication. Therefore, erase the self-diagnosis results.
- 5. Diagnose CAN communication system. Refer to [LAN-44, "TROUBLE DIAGNOSIS"](#) .

Precautions for Brake Control

EFS004FE

- During ABS operation, the brake pedal may vibrate lightly and a mechanical noise may be heard. This is normal.
- Just after starting vehicle, the brake pedal may vibrate or a motor operating noise may be heard from engine compartment. This is a normal status of operation check.
- Stopping distance may be longer than that of vehicles without ABS when vehicle drives on rough, gravel, or snow-covered (fresh, deep snow) roads.
- When an error is indicated by ABS or another warning lamp, collect all necessary information from customer (what symptoms are present under what conditions) and check for simple causes before starting diagnosis. Besides electrical system inspection, check booster operation, brake fluid level, and fluid leaks.
- If incorrect tire sizes or types are installed on the vehicle or brake pads are not Genuine NISSAN parts, stopping distance or steering stability may deteriorate.
- If there is a radio, antenna or related wiring near control module, ABS function may have a malfunction or error.
- If aftermarket parts (car stereo, CD player, etc.) have been installed, check for incidents such as harness pinches, open circuits or improper wiring.

Precautions for CAN System

EFS004FF

- Do not apply voltage of 7.0V or higher to terminal to be measured.
- Maximum open terminal voltage of tester in use must be less than 7.0V.
- Before checking harnesses, turn ignition switch OFF and disconnect battery negative cable.
- Area to be repaired must be soldered and wrapped with tape. Make sure that fraying of twisted wire is within 110 mm (4.33 in).

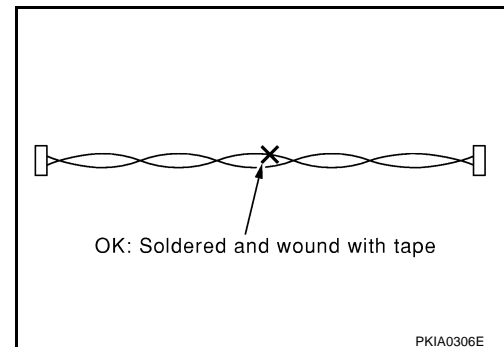

- Do not make a bypass connection to repaired area. (If the circuit is bypassed, characteristics of twisted wire will be lost.)

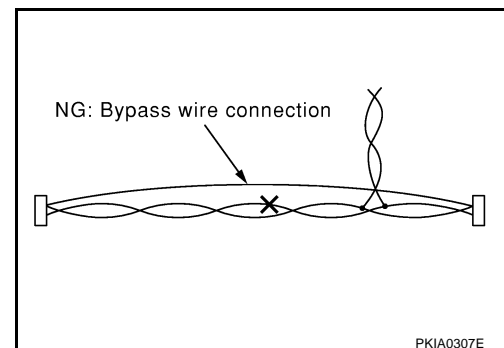

PREPARATION

[TCS/ABS]

PREPARATION

PF0:00002

Special Service Tool

EFS00632

The actual shapes of Kent-Moore tools may differ from those of special service tools illustrated here.

Tool number (Kent-Moore No.) Tool name	Description
(J-45741) ABS active wheel sensor tester	Checking operation of ABS active wheel sensor

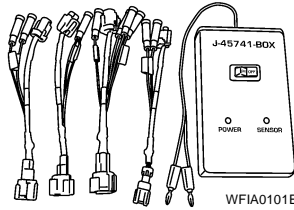

Commercial Service Tools

EFS00633

Tool name	Description
1. Flare nut crowfoot 2. Torque wrench	Removing and installing brake piping a: 10mm (0.39 in)/12mm (0.47 in)

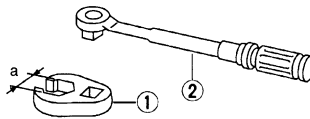

S-NT360

A
B
C
D
E
BRC
G
H
I
J
K
L
M

SYSTEM DESCRIPTION

PFP:00000

System Diagram

EFS004FJ

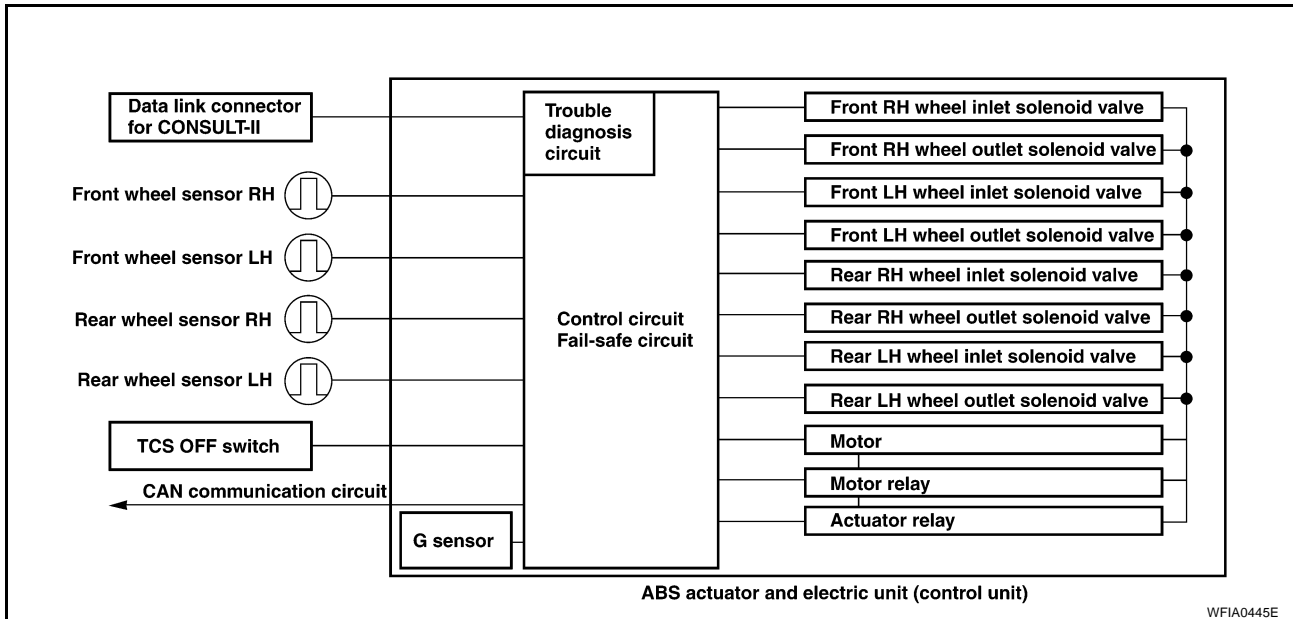

WFIA0445E

ABS Function

EFS004FK

- The Anti-Lock Brake System detects wheel revolution while braking and improves handling stability during sudden braking by electrically preventing wheel lockup. Maneuverability is also improved for avoiding obstacles.
- If the electrical system malfunctions, the Fail-Safe function is activated, the ABS becomes inoperative and the ABS warning lamp turns on.
- The electrical system can be diagnosed using CONSULT-II.
- During ABS operation, the brake pedal may vibrate lightly and a mechanical noise may be heard. This is normal.
- Just after starting the vehicle, the brake pedal may vibrate or a motor operating noise may be heard from engine compartment. This is a normal status of operation check.
- Stopping distance may be longer than that of vehicles without ABS when vehicle drives on rough, gravel, or snow-covered (fresh, deep snow) roads.

EBD Function

EFS004FL

- Electronic Brake Distribution is a function that detects subtle slippages between the front and rear wheels during braking, and it improves handling stability by electronically controlling the brake fluid pressure which results in reduced rear wheel slippage.
- If the electrical system malfunctions, the Fail-Safe function is activated, the EBD and ABS become inoperative, and the ABS warning lamp and BRAKE warning lamp are turned on.
- The electrical system can be diagnosed using CONSULT-II.
- During EBD operation, the brake pedal may vibrate lightly and a mechanical noise may be heard. This is normal.
- Just after starting the vehicle, the brake pedal may vibrate or a motor operating noise may be heard from engine compartment. This is a normal status of operation check.
- Stopping distance may be longer than that of vehicles without EBD when vehicle drives on rough, gravel, or snow-covered (fresh, deep snow) roads.

TCS Function

EFS004FM

- Spinning of the drive wheels is detected by the ABS/TCS control unit using inputs from the wheel speed sensors. If wheel spin occurs, the drive wheel right and left brake fluid pressure control and engine fuel cut are conducted while the throttle value is restricted to reduce the engine torque and decrease the amount of wheel spin. In addition, the throttle opening is controlled to achieve the optimum engine torque.

- Depending on road condition, the vehicle may have a sluggish feel. This is normal, because optimum traction has the highest priority during TCS operation.
- TCS may be activated during sudden vehicle acceleration, wide open throttle acceleration, sudden transmission shifts or when the vehicle is driven on a road with a varying surface friction coefficient.
- The SLIP indicator lamp flashes to inform the driver of TCS operation.

Wheel Sensors

EFS004FN

The front sensor units consist of a gear-shaped sensor rotor and a sensor element. The element contains a magnet around which a coil is wound. The front wheel sensors are installed on the front of the wheel knuckles. As the wheel rotates, the sensor generates a square-wave signal. The frequency increases as the wheel speed increases.

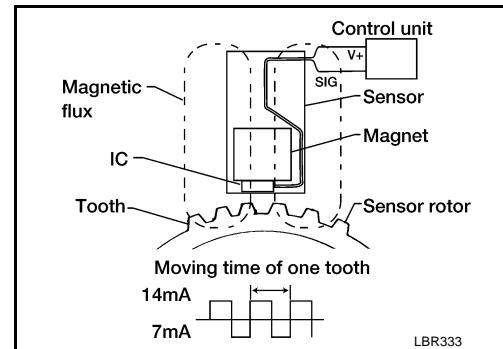

The rear sensor units consist of wheel hubs with a series of internal magnets and a sensor element. The rear wheel sensors are installed on the inner side of the wheel knuckles. As the wheel rotates, the sensor generates a square-wave signal. The frequency increases as the wheel speed increases.

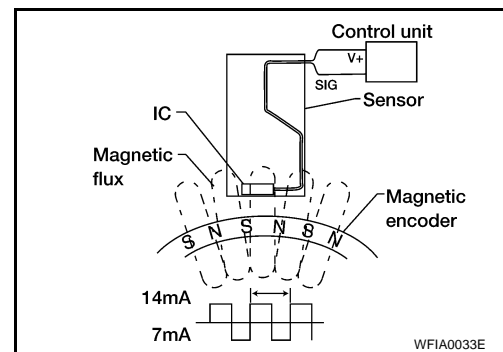

Fail-Safe Function

EFS004FO

CAUTION:

If the Fail-Safe function is activated, perform the Self Diagnosis for ABS/TCS system.

ABS/EBD SYSTEM

In case of an electrical malfunction with the ABS, the ABS warning lamp and SLIP indicator lamp will turn on. In case of an electrical malfunction with the EBD system, the BRAKE warning lamp, ABS warning lamp and SLIP indicator lamp will turn on.

The system will revert to one of the following conditions of the Fail-Safe function.

1. For ABS malfunction, only the EBD is operative and the condition of the vehicle is the same condition of vehicles without ABS/TCS system.
2. For EBD malfunction, the EBD and ABS become inoperative, and the condition of the vehicle is the same as the condition of vehicles without ABS/TCS or EBD system.

TCS SYSTEM

In case of TCS system malfunction, the SLIP indicator lamp is turned on and the condition of the vehicle is the same as the condition of vehicles without TCS system. In case of an electrical malfunction with the TCS system, the ABS control continues to operate normally without TCS control.

SYSTEM DESCRIPTION

[TCS/ABS]

Hydraulic Circuit Diagram

EFS004FP

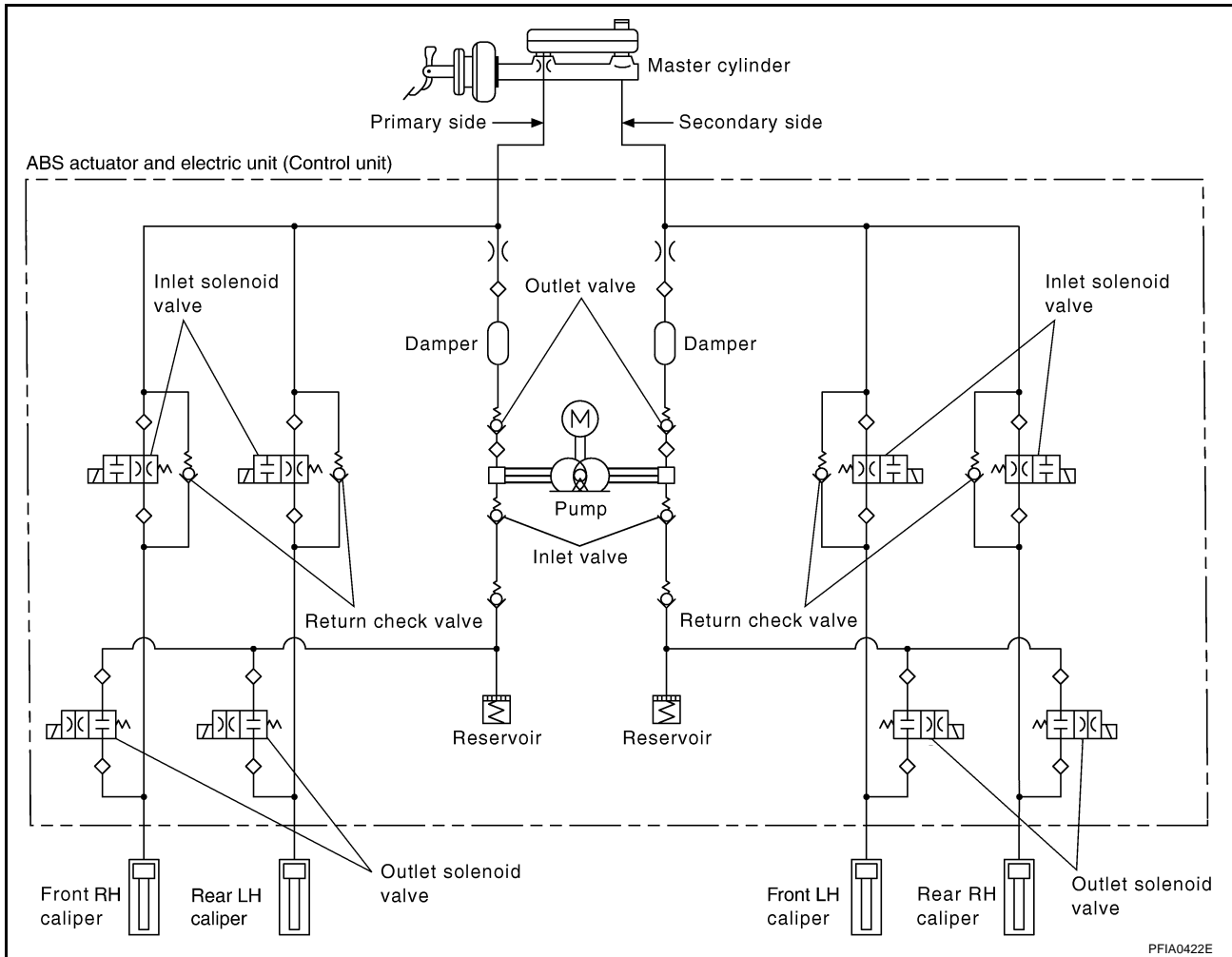

PFIA0422E

CAN COMMUNICATION

PFP:23710

System Description

EFS004FQ

Refer to [LAN-4, "SYSTEM DESCRIPTION"](#) .

A

B

C

D

E

BRC

G

H

I

J

K

L

M

TROUBLE DIAGNOSIS

How to Perform Trouble Diagnoses for Quick and Accurate Repair

INTRODUCTION

The ABS/TCS system has an electronic control unit to control major functions. The control unit accepts input signals from sensors and controls actuator operation. It is also important to check for conventional malfunctions such as air leaks in the booster or lines, lack of brake fluid, or other malfunctions with the brake system.

It is much more difficult to diagnose a malfunction that occurs intermittently rather than continuously. Most intermittent malfunctions are caused by poor electrical connections or wiring. In this case, careful checking of suspicious circuits may help prevent the replacement of good parts.

A visual check only may not find the cause of the malfunction, so a road test should be performed.

Before undertaking actual checks, take just a few minutes to talk with a customer who approaches with an ABS/TCS complaint. The customer is a very good source of information, especially for intermittent malfunctions. Through the talks with the customer, find out what symptoms are present and under what conditions they occur.

Start your diagnosis by looking for "conventional" malfunctions first. This is one of the best ways to troubleshoot brake malfunctions on an ABS/TCS equipped vehicle. Also check related Service Bulletins for information.

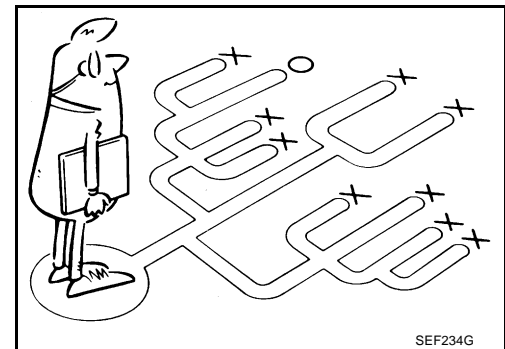
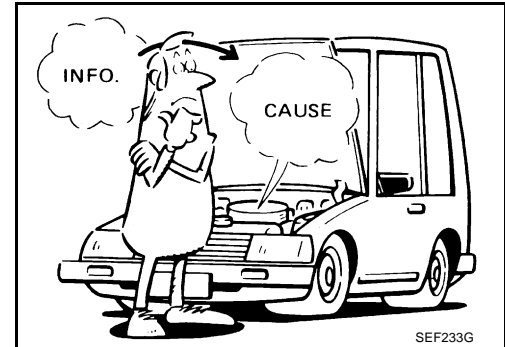

TROUBLE DIAGNOSIS

[TCS/ABS]

WORK FLOW

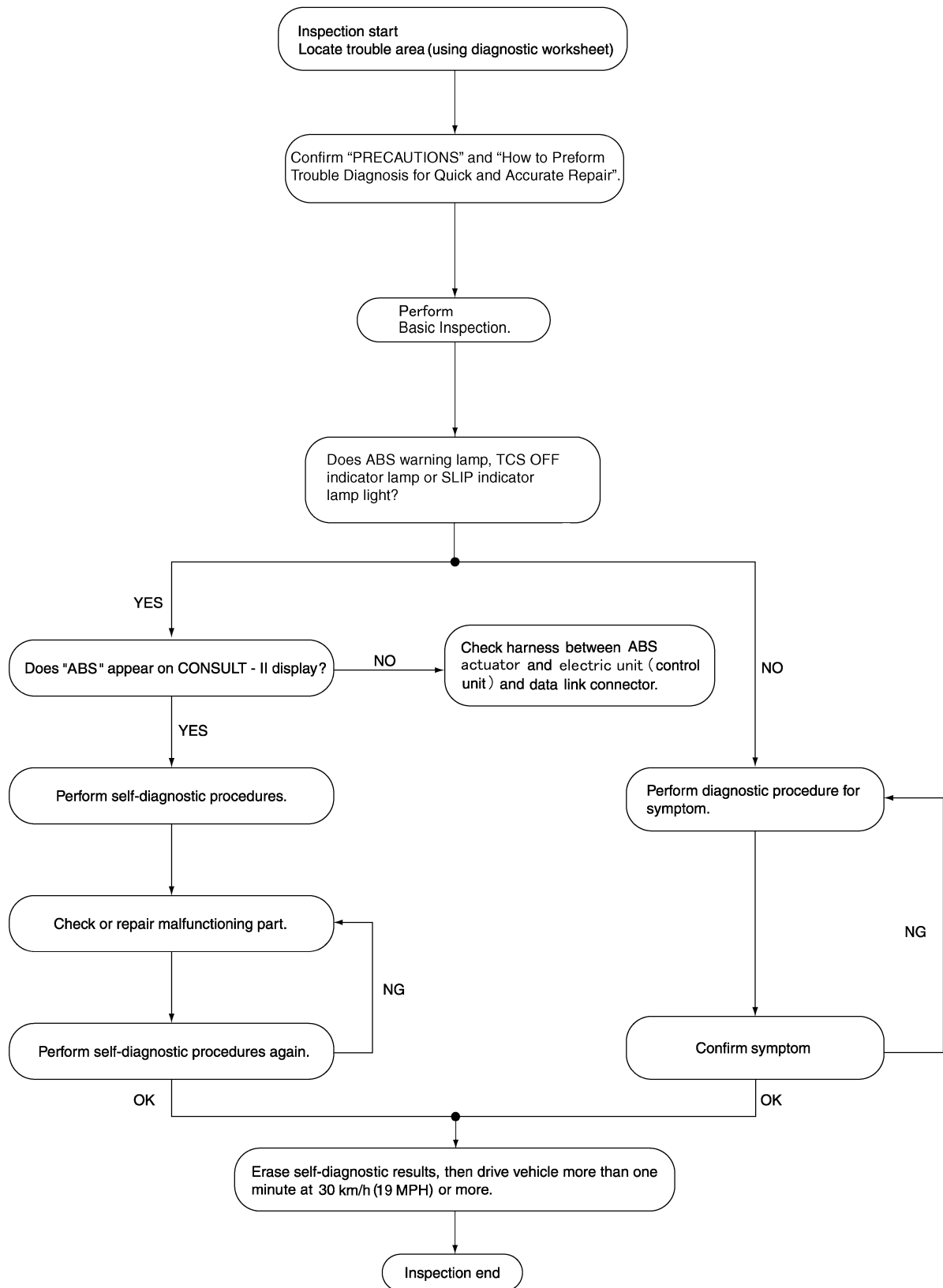

A
B
C
D
E
BRC
G
H
I
J
K
L
M

WFIA0532E

TROUBLE DIAGNOSIS

[TCS/ABS]

CLARIFY CONCERN

- A customer's description of a vehicle concern may vary depending on the individual. It is important to clarify the customer's concern.
- Ask the customer about what symptoms are present under what conditions. Use this information to reproduce the symptom while driving.
- It is also important to use the diagnosis sheet to understand what type of trouble the customer is having.

KEY POINTS

WHAT Vehicle model
WHEN Date, Frequencies
WHERE Road conditions
HOW Operating conditions,
 Weather conditions,
 Symptoms

SBR339B

EXAMPLE OF DIAGNOSIS SHEET

Customer name	Model & Year	VIN	
Engine #	Trans.	Mileage	
Incident Date	Manuf. Date	In Service Date	
Symptoms	<input type="checkbox"/> Noise and vibration (from engine compartment)	<input type="checkbox"/> ABS warning lamp activates	<input type="checkbox"/> Pedal operation
	<input type="checkbox"/> Noise and vibration (from axle)	<input type="checkbox"/> SLIP warning lamp activates	<input type="checkbox"/> Large stroke pedal operation
	<input type="checkbox"/> TCS does not work (drive wheels slip when accelerating)	<input type="checkbox"/> ABS does not work (wheels slip when braking)	<input type="checkbox"/> Firm pedal
	<input type="checkbox"/> Lack of sense of acceleration		
Engine conditions	<input type="checkbox"/> When starting <input type="checkbox"/> After starting		
Road conditions	<input type="checkbox"/> Low friction road (<input type="checkbox"/> Snow <input type="checkbox"/> Gravel <input type="checkbox"/> Other) <input type="checkbox"/> Bumps/potholes		
Driving conditions	<input type="checkbox"/> Full-acceleration <input type="checkbox"/> High speed cornering <input type="checkbox"/> Vehicle speed: Greater than 10 km/h (6 MPH) <input type="checkbox"/> Vehicle speed: 10 km/h (6 MPH) or less <input type="checkbox"/> Vehicle is stopped		
Applying brake conditions	<input type="checkbox"/> Suddenly <input type="checkbox"/> Gradually		
Other conditions	<input type="checkbox"/> Operation of electrical equipment <input type="checkbox"/> Shift change <input type="checkbox"/> Other descriptions		

WFIA0097E

Component Parts and Harness Connector Location

EFS004FS

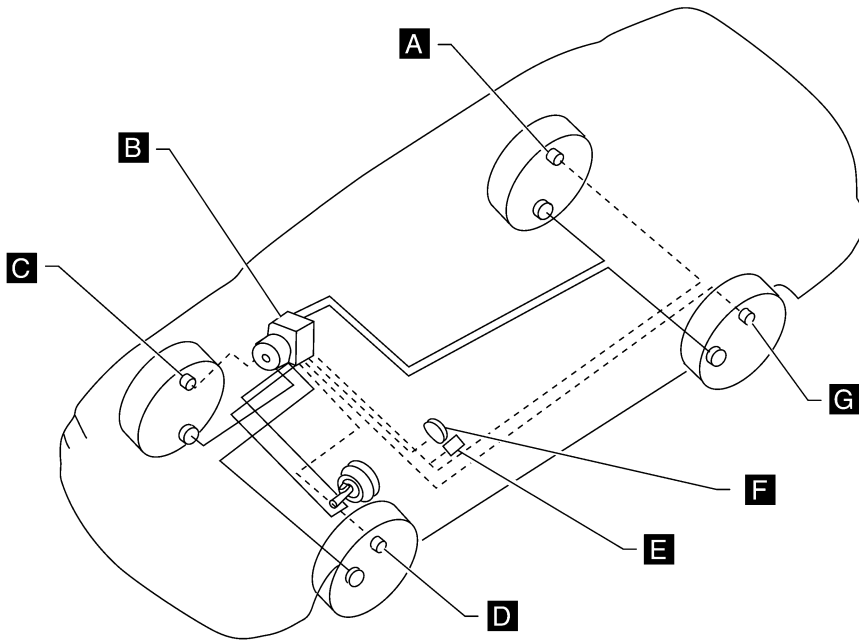

A
B
C
D
E
BRC

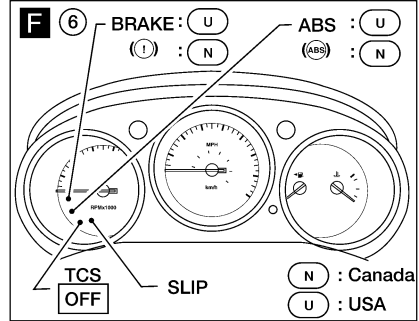
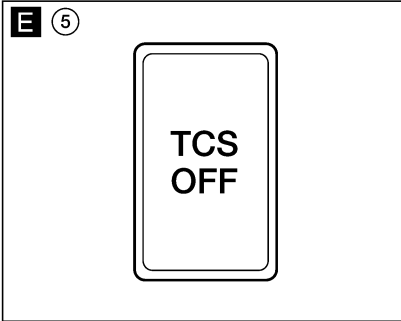
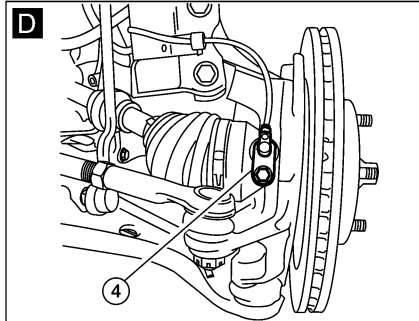
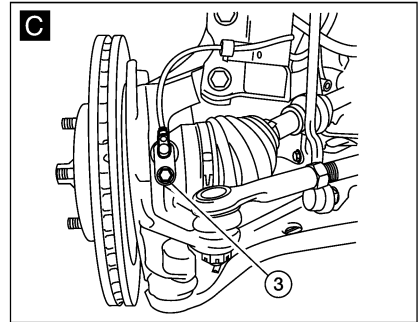
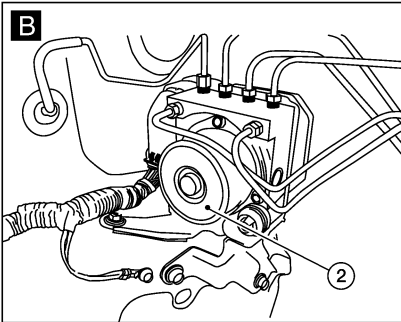
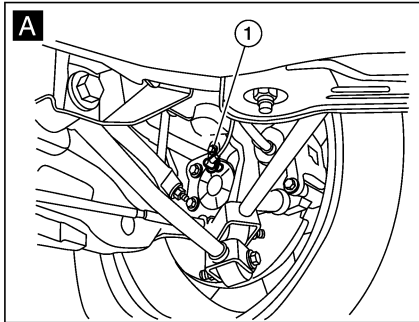

G
H
I
J
K
L
M

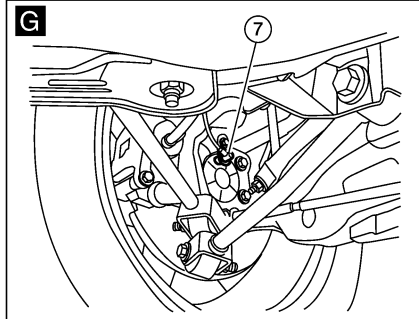

WFIA0487E

TROUBLE DIAGNOSIS

[TCS/ABS]

-
1. Rear wheel sensor RH B122
 2. ABS actuator and electric unit (control unit) E125 (engine removed for clarity)
 3. Front wheel sensor RH E117
 4. Front wheel sensor LH E18
 5. TCS OFF switch M6
 6. Combination meter M24
 7. Rear wheel sensor LH B123

Schematic

EFS004FT

A
B
C
D
E
BRC
G
H
I
J
K
L
M

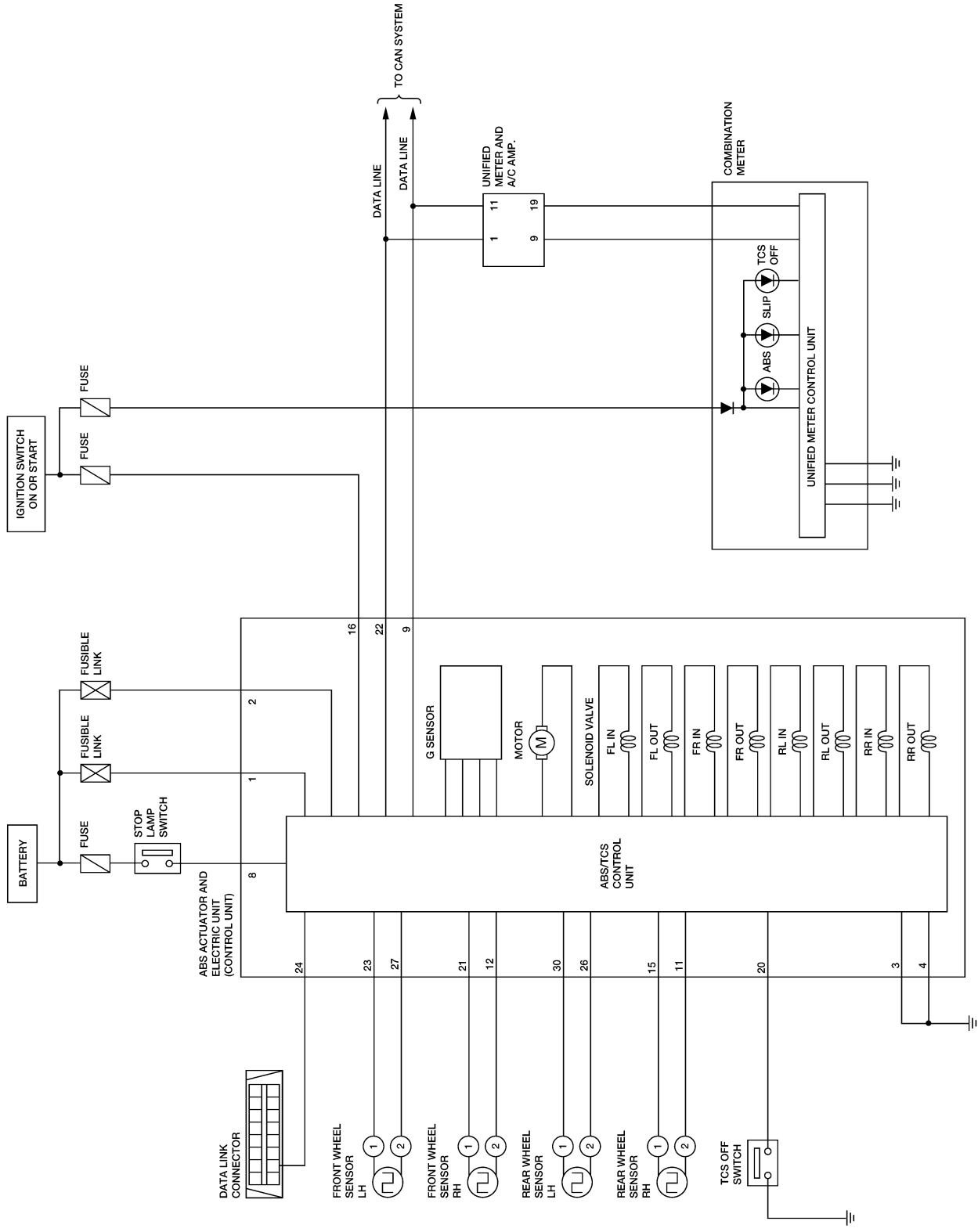

WFWA0423E

TROUBLE DIAGNOSIS

[TCS/ABS]

Wiring Diagram — TCS —

EFS004FU

BRC-TCS-01

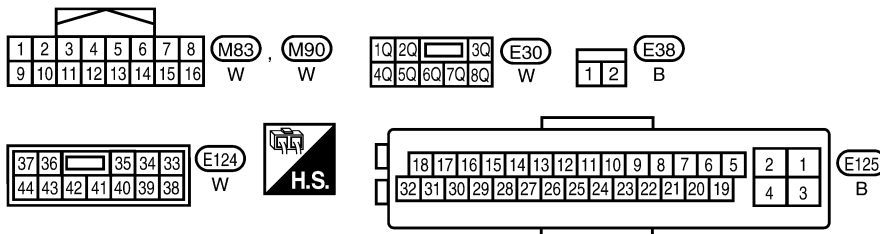
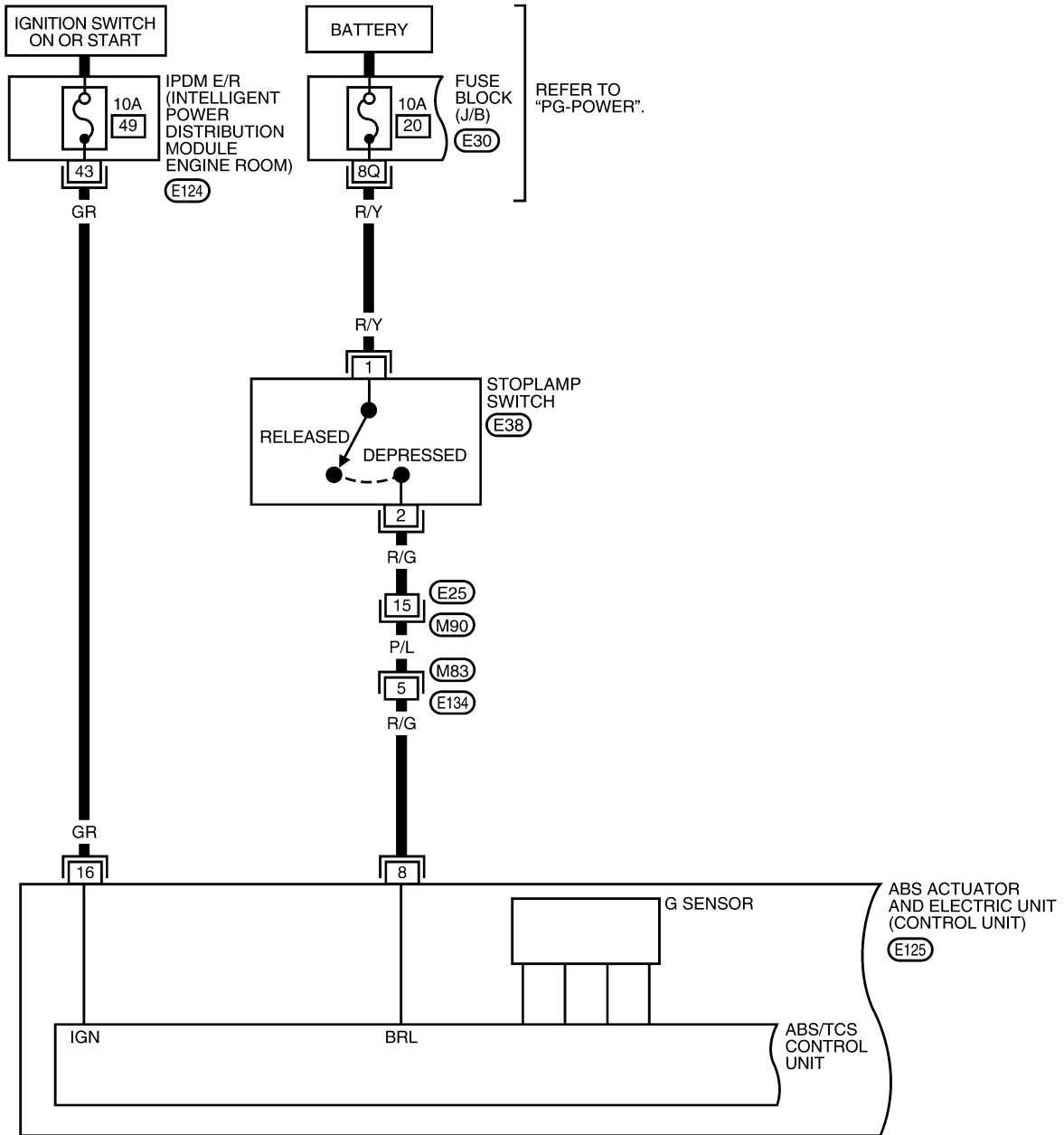

WFWA0424E

TROUBLE DIAGNOSIS

[TCS/ABS]

BRC-TCS-02

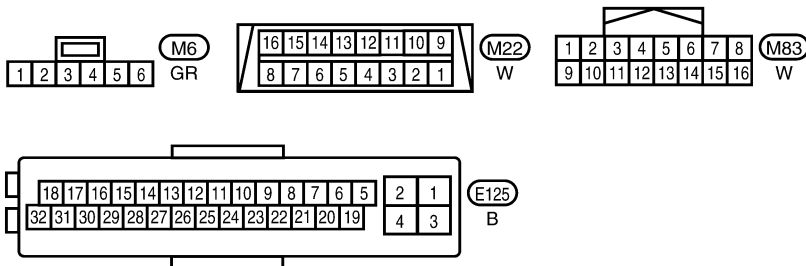
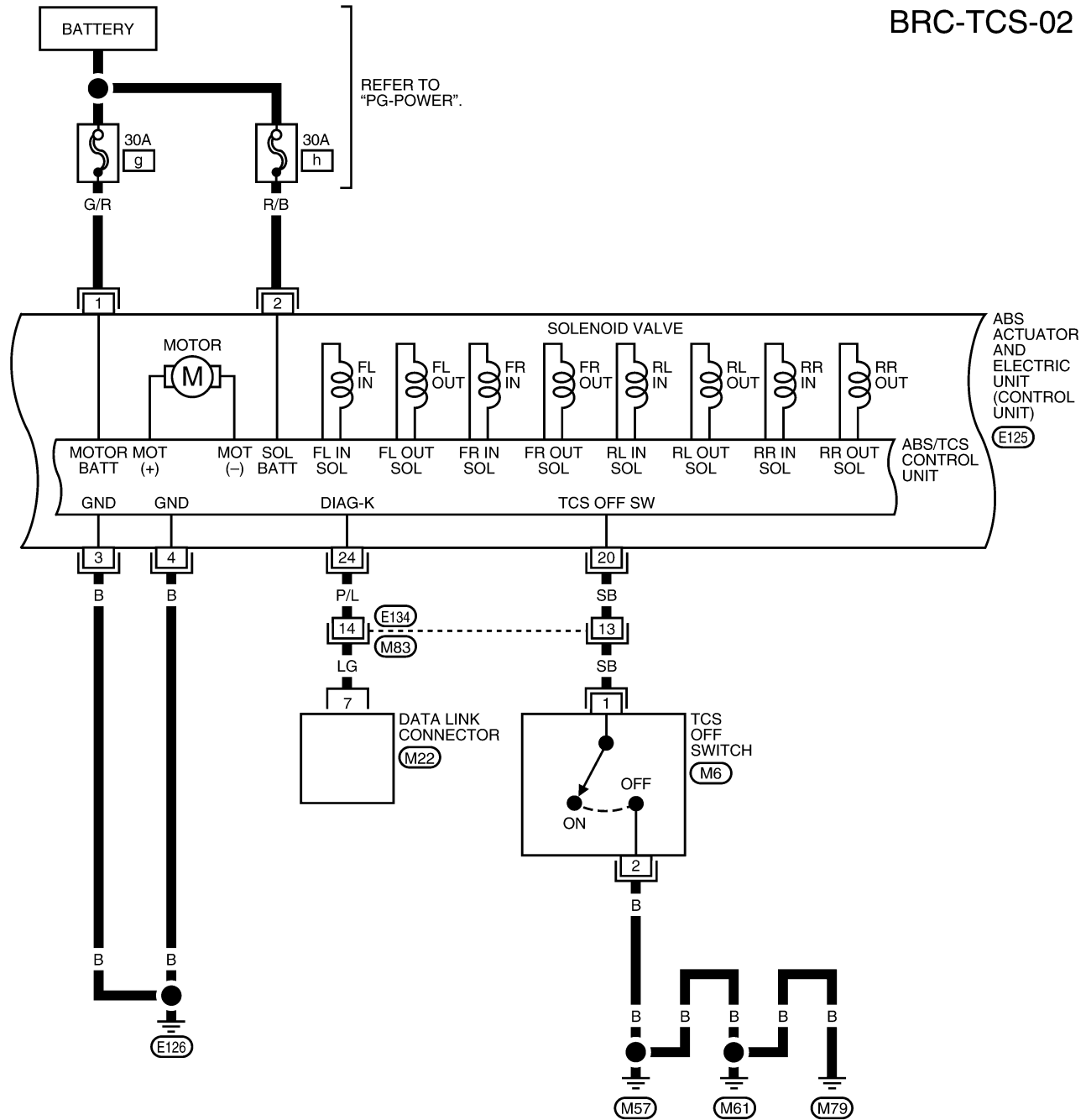

WFWA0425E

TROUBLE DIAGNOSIS

[TCS/ABS]

BRC-TCS-03

▬ : DATA LINE

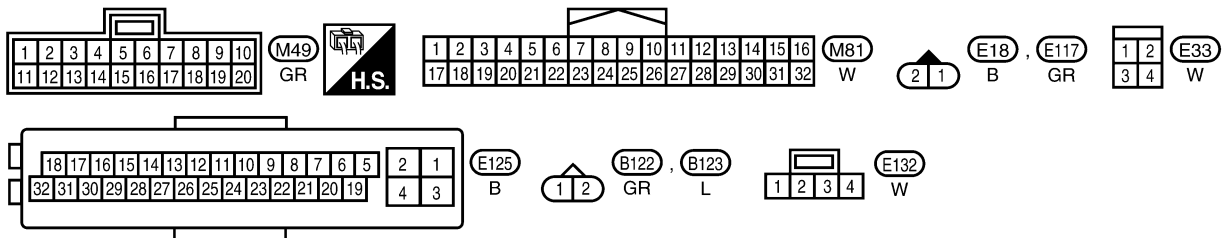
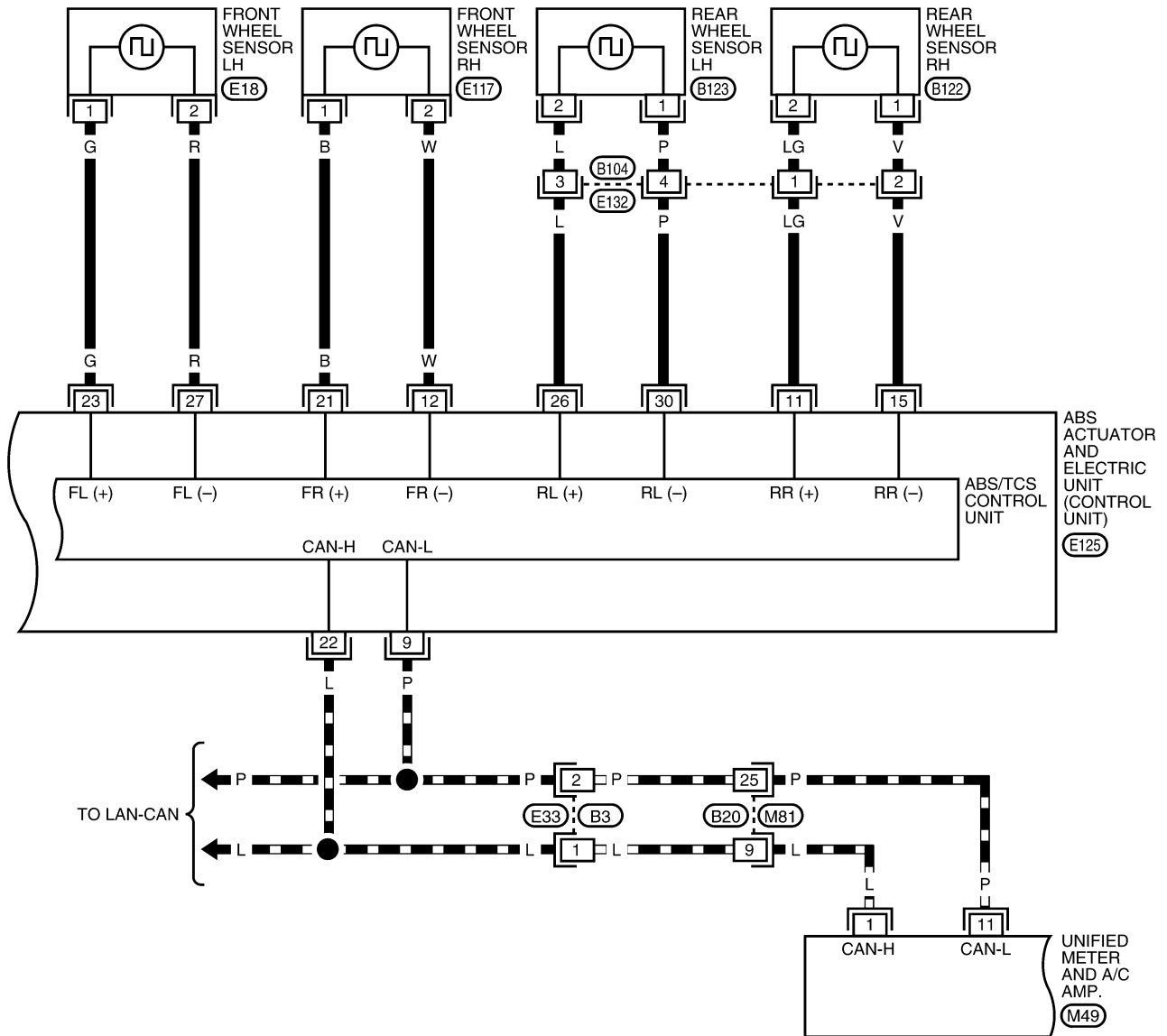

WFWA0426E

TROUBLE DIAGNOSIS

[TCS/ABS]

BRC-TCS-04

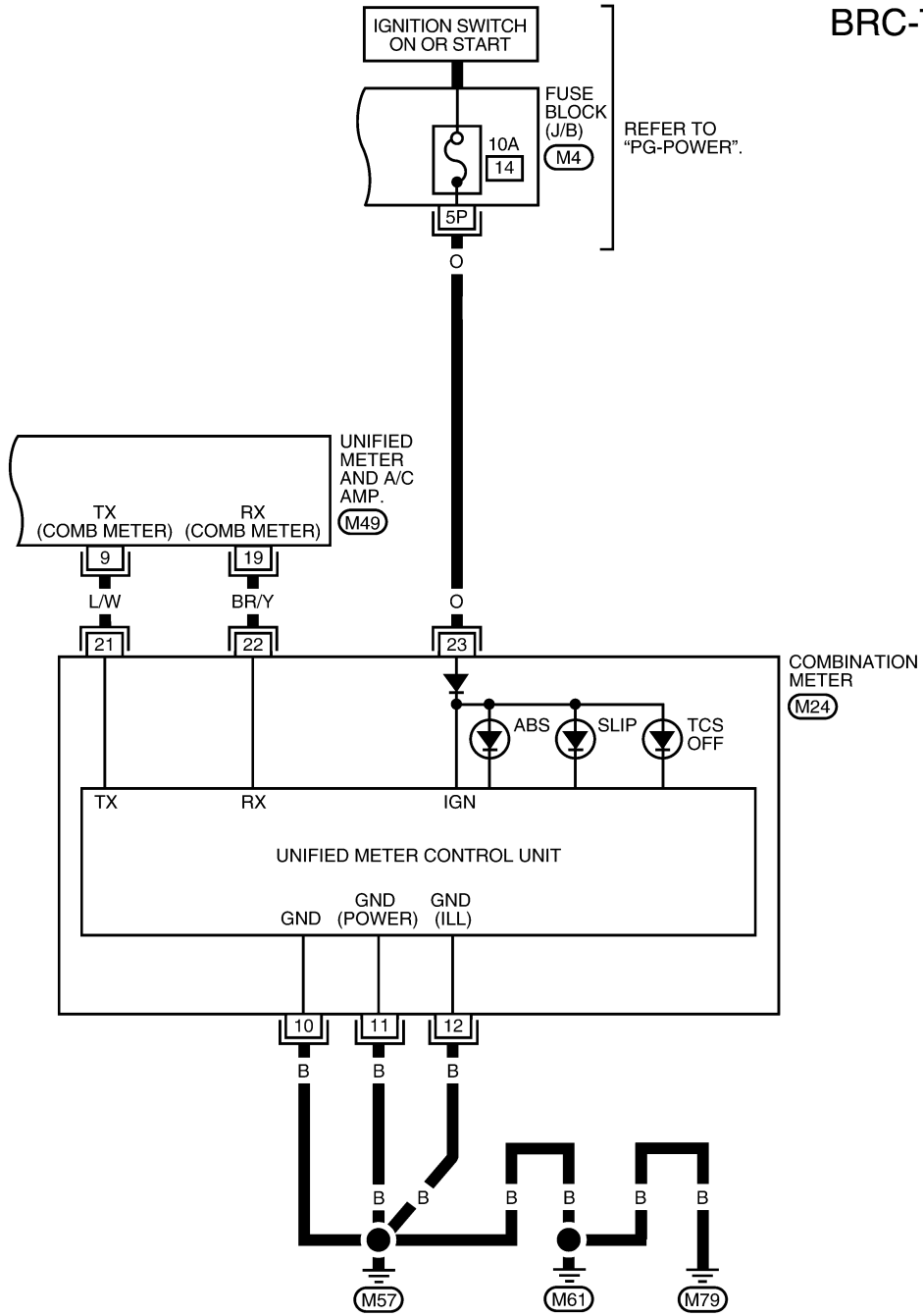

A
B
C
D
E
BRC
G
H
I
J
K
L
M

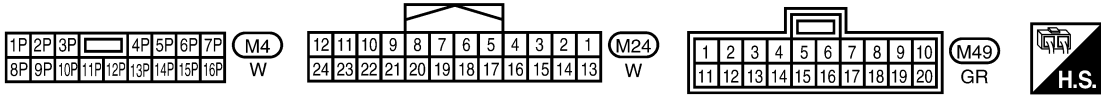

WFWA0427E

Basic Inspection

BRAKE FLUID LEVEL, FLUID LEAK, AND BRAKE PAD INSPECTION

1. Check fluid level in the brake fluid reservoir. If fluid level is low, add fluid.
2. Check the brake piping and around the ABS actuator and electric unit (control unit) for leaks. If there is leaking or seeping fluid, check the following items.
 - If ABS actuator and electric unit (control unit) connection is loose, tighten the piping to the specified torque and recheck for leaks.
 - If there is damage to the connection flare nut or ABS actuator and electric unit (control unit) screw, replace the damaged part and recheck for leaks.
 - When there is fluid leaking or seeping from a fluid connection, use a clean cloth to wipe off the fluid and recheck for leaks. If fluid is still seeping out, replace the damaged part. If the fluid is leaking at the ABS actuator and electric unit (control unit), replace the ABS actuator and electric unit (control unit) assembly.

CAUTION:

The ABS actuator and electric unit (control unit) cannot be disassembled and must be replaced as an assembly.

3. Check the brake pads for excessive wear.

POWER SYSTEM TERMINAL LOOSENESS AND BATTERY INSPECTION

Make sure the battery positive cable, negative cable and ground connection are not loose. In addition, make sure the battery is sufficiently charged.

ABS WARNING LAMP AND SLIP INDICATOR LAMP INSPECTION

1. Make sure ABS warning lamp and SLIP indicator lamp turn on for approximately 2 seconds when the ignition switch is turned ON. Check CAN communications. If there are no errors with the CAN communication system, check combination meter. Refer to [DI-5, "COMBINATION METERS"](#).
2. Make sure the lamps turn off approximately 2 seconds after the ignition switch is turned ON. If the lamp does not turn off, conduct self-diagnosis.
3. Make sure ABS warning lamp and SLIP indicator lamp turn off approximately 2 seconds after the engine is started. If ABS warning lamp and SLIP indicator lamp have not turned off 10 seconds after the engine has been started, conduct self-diagnosis of the ABS actuator and electric unit (control unit).
4. After conducting the self-diagnosis, be sure to erase the error memory. Refer to [BRC-23, "CONSULT-II Function \(ABS\)"](#).

Warning Lamp and Indicator Timing

x: ON -: OFF

Condition	ABS warning lamp	TCS OFF indicator lamp	SLIP indicator lamp	Remarks
When the ignition switch is OFF	-	-	-	-
After the ignition switch is turned ON For approx. 2 seconds	x	x	x	-
Ignition switch ON Approx. 2 seconds later	-	-	-	-
When the TCS OFF switch turns ON (TCS function OFF).	-	x	-	-
TCS/ABS malfunction	x	x	x	-
	x	x	-	When the TCS/ABS control unit is malfunctioning (power supply or ground malfunction).
When the TCS is malfunctioning.	-	x	x	-

TROUBLE DIAGNOSIS

[TCS/ABS]

EFS004FX

Control Unit Input/Output Signal Standard REFERENCE VALUE FROM CONSULT-II

CAUTION:

The display shows the control unit calculation data, so a normal value might be displayed even in the event the output circuit (harness) is open or short circuited.

Monitor item	Display content	Data monitor		Note: Error inspection checklist
		Condition	Reference value in normal operation	
FR RH SENSOR FR LH SENSOR RR RH SENSOR RR LH SENSOR	Wheel speed	Vehicle stopped	0 [km/h (MPH)]	BRC-29, "Wheel Sensor System Inspection"
		Vehicle running (Note 1)	Almost in accordance with speedometer display (within ±10%)	
ACCEL POS SIG	Open/close condition of throttle valve (linked with accelerator pedal).	Accelerator pedal not depressed (ignition switch is ON)	0%	BRC-35, "CAN Communication System Inspection"
		Depress accelerator pedal (ignition switch is ON)	0 to 100%	
ENGINE SPEED	With engine running	With engine stopped	0 rpm	BRC-30, "Engine System Inspection"
		Engine running	Almost in accordance with tachometer display	
BATTERY VOLT	Battery voltage supplied to ABS actuator and electric unit (control unit)	Ignition switch ON	10 to 16V	BRC-34, "ABS/TCS Control Unit Power and Ground Systems Inspection"
STOP LAMP SW	Brake pedal operation	Brake pedal depressed	ON	BRC-33, "Stop Lamp Switch System Inspection"
		Brake pedal not depressed	OFF	
ABS WARN LAMP	ABS warning lamp ON condition (Note 2)	ABS warning lamp ON	ON	BRC-39, "ABS Warning Lamp Does Not Come On When Ignition Switch Is Turned On"
		ABS warning lamp OFF	OFF	
MOTOR RELAY	Operation status of motor and motor relay	Ignition switch ON or engine running (ABS not operated)	OFF	BRC-32, "Actuator Motor, Motor Relay, and Circuit Inspection"
		Ignition switch ON or engine running (ABS operated)	ON	
ACTUATOR RLY	Actuator relay operation status	Vehicle stopped (Ignition switch ON)	OFF	BRC-32, "Actuator Motor, Motor Relay, and Circuit Inspection"
		Vehicle stopped (Engine running)	ON	
SLIP LAMP	SLIP indicator lamp status (Note 4)	When SLIP indicator lamp is ON	ON	DI-8, "Arrangement of Combination Meter"
		When SLIP indicator lamp is OFF	OFF	
FR LH IN SOL FR LH OUT SOL FR RH IN SOL FR RH OUT SOL RR RH IN SOL RR RH OUT SOL RR LH IN SOL RR LH OUT SOL	Solenoid valve operation	Actuator (solenoid) is active ("ACTIVE TEST" with CONSULT-II) or actuator relay is inactive (in fail-safe mode).	ON	—
		When actuator (solenoid) is not active and actuator relay is active (ignition switch ON).	OFF	
TCS FAIL SIG ABS FAIL SIG EBD FAIL SIG	Fail signal status	TCS fail ABS fail EBD fail	OFF	TCS system ABS system EBD system

Note 1: Confirm tire pressure is normal.

A
B
C
D
E
BRC
G
H
I
J
K
L
M

TROUBLE DIAGNOSIS

[TCS/ABS]

Note 2: ON/OFF timing of ABS warning lamp

ON: For approximately 2 seconds after ignition switch is turned ON, or when a malfunction is detected.

OFF: Approximately 2 seconds after ignition switch is turned ON (when system is in normal operation) and TCS function is not activated.

Note 4: SLIP indicator lamp ON/OFF timing

ON: For approximately 2 seconds after ignition switch is turned ON, or when a malfunction is detected and TCS function is activated while driving.

OFF: Approximately 2 seconds after ignition switch is turned ON (when system is in normal operation) and TCS function is not activated.

Flashing: TCS function is active during driving

CONSULT-II Function (ABS)

CONSULT-II can display each diagnostic item using the diagnostic test modes shown following.

ABS diagnostic mode	Description
WORK SUPPORT	Supports inspection and adjustments. Commands are transmitted to the ABS actuator and electric unit (control unit) for setting the status suitable for required operation, input/output signals are received from the ABS actuator and electric unit (control unit) and received data is displayed.
SELF-DIAG RESULTS	Displays ABS actuator and electric unit (control unit) self-diagnosis results.
DATA MONITOR	Displays ABS actuator and electric unit (control unit) input/output data in real time.
CAN DIAG SUPPORT MNTR	The result of transmit/receive diagnosis of CAN communication can be read.
ACTIVE TEST	Operation of electrical loads can be checked by sending drive signal to them.
FUNCTION TEST	Conducted by CONSULT-II instead of a technician to determine whether each system is "OK" or "NG".
ECU PART NUMBER	ABS actuator and electric unit (control unit) part number can be read.

CONSULT-II START PROCEDURE

Refer to [GI-37, "CONSULT-II Start Procedure"](#).

SELF-DIAGNOSIS**Description**

If an error is detected in the system, the ABS warning lamp will turn on. In this case, perform self-diagnosis as follows:

Operation Procedure

- Turn ignition switch OFF.
- Connect CONSULT-II and CONSULT-II CONVERTER to the data link connector.

CAUTION:
If CONSULT-II is used with no connection of CONSULT-II CONVERTER, malfunctions might be detected in self-diagnosis depending on control unit which carries out CAN communication.
- Turn ignition switch ON.
- Start engine and drive at approximately 30 km/h (19 MPH) for approximately 1 minute.
- After stopping the vehicle, with the engine running, touch "START (NISSAN BASED VHCL)", "ABS", "SELF-DIAG RESULTS" in order on the CONSULT-II screen.

CAUTION:
If "START (NISSAN BASED VHCL)" is touched immediately after starting the engine or turning on the ignition switch, "ABS" might not be displayed in the SELECT SYSTEM screen. In this case, repeat the operation from step 1.
- The self-diagnostic results are displayed. (If necessary, the self-diagnostic results can be printed out by touching "COPY".)
 - When "NO DTC IS DETECTED" is displayed, check the ABS warning lamp and SLIP indicator lamp.
- Conduct the appropriate inspection from the display item list, and repair or replace the malfunctioning component.
- Start engine and drive at approximately 30 km/h (19 MPH) for approximately 1 minute.

CAUTION:
● When a wheel sensor "short-circuit" is detected, if the vehicle is not driven at 30 km/h (19 MPH) for at least 1 minute, the ABS warning lamp will not turn off even if the malfunction is repaired.
- Turn ignition switch OFF to prepare for erasing the memory.
- Start the engine and touch "START (NISSAN BASED VHCL)", "ABS", "SELF-DIAG RESULTS", "ERASE" in order on the CONSULT-II screen to erase the error memory.
If "ABS" is not indicated, go to [GI-39, "CONSULT-II Data Link Connector \(DLC\) Circuit"](#).

CAUTION:
If the error memory is not erased, re-conduct the operation from step 5.
- For the final inspection, drive at approximately 30 km/h (19 MPH) for approximately 1 minute and confirm that the ABS warning lamp and SLIP indicator lamp are off.

TROUBLE DIAGNOSIS

[TCS/ABS]

Display Item List

Self-diagnostic item	Malfunction detecting condition	Check system	
FR LH SENSOR 1 [C1104]	Circuit of front LH wheel sensor is open.	BRC-29. "Wheel Sensor System Inspection" (Note 1)	
RR RH SENSOR 1 [C1101]	Circuit of rear RH wheel sensor is open.		
FR RH SENSOR 1 [C1103]	Circuit of front RH wheel sensor is open.		
RR LH SENSOR 1 [C1102]	Circuit of rear LH wheel sensor is open.		
FR LH SENSOR 2 [C1108]	Circuit of front LH wheel sensor is shorted, or sensor power voltage is unusual. ABS actuator and electric unit (control unit) cannot identify sensor pulses, because of large gap between wheel sensor and sensor rotor.		
RR RH SENSOR 2 [C1105]	Circuit of rear RH wheel sensor is shorted, or sensor power voltage is unusual. ABS actuator and electric unit (control unit) cannot identify sensor pulses, because of large gap between wheel sensor and sensor rotor.		
FR RH SENSOR 2 [C1107]	Circuit of front RH wheel sensor is shorted, or sensor power voltage is unusual. ABS actuator and electric unit (control unit) cannot identify sensor pulses, because of large gap between wheel sensor and sensor rotor.		
RR LH SENSOR 2 [C1106]	Circuit of rear LH wheel sensor is shorted, or sensor power voltage is unusual. ABS actuator and electric unit (control unit) cannot identify sensor pulses, because of large gap between wheel sensor and sensor rotor.		
STOP LAMP SW 1 [C1116]	Stop lamp switch or circuit malfunction.		BRC-33. "Stop Lamp Switch System Inspection"
FR LH IN ABS SOL [C1120]	Circuit of front LH IN ABS solenoid is open or shorted, or control line is open or shorted to power supply or ground.		BRC-31. "Solenoid Valve System Inspection"
FR LH OUT ABS SOL [C1121]	Circuit of front LH OUT ABS solenoid is open or shorted, or control line is open or shorted to power supply or ground.		
RR RH IN ABS SOL [C1126]	Circuit of rear RH IN ABS solenoid is open or shorted, or control line is open or shorted to power supply or ground.		
RR RH OUT ABS SOL [C1127]	Circuit of rear RH OUT ABS solenoid is open or shorted, or control line is open or shorted to power supply or ground.		
FR RH IN ABS SOL [C1122]	Circuit of front RH IN ABS solenoid is open or shorted, or control line is open or shorted to power supply or ground.		
FR RH OUT ABS SOL [C1123]	Circuit of front RH OUT ABS solenoid is open or shorted, or control line is open or shorted to power supply or ground.		
RR LH IN ABS SOL [C1124]	Circuit of rear LH IN ABS solenoid is open or shorted, or control line is open or shorted to power supply or ground.		
RR LH OUT ABS SOL [C1125]	Circuit of rear LH OUT ABS solenoid is open or shorted, or control line is open or shorted to power supply or ground.		
PUMP MOTOR (Note 3) [C1111]	During actuator motor operation with ON, when actuator motor turns OFF or when control line for actuator motor relay is open. During actuator motor operation with OFF, when actuator motor turns ON or when control line for relay is shorted to ground.	BRC-32. "Actuator Motor, Motor Relay, and Circuit Inspection"	
BATTERY VOLTAGE [ABNORMAL] [C1109]	ABS actuator and electric unit (control unit) power voltage is too low.	BRC-34. "ABS/TCS Control Unit Power and Ground Systems Inspection"	
CONTROLLER FAILURE [C1110]	Internal malfunction of ABS actuator and electric unit (control unit) or wheel speed signal malfunction.	BRC-31. "ABS/TCS Control Unit Inspection"	

TROUBLE DIAGNOSIS

[TCS/ABS]

Self-diagnostic item	Malfunction detecting condition	Check system
CAN COMM CIRCUIT [U1000]	<ul style="list-style-type: none"> ● CAN communication line is open or shorted. ● ABS actuator and electric unit (control unit) internal malfunction ● Battery voltage for ECM is suddenly interrupted for approximately 0.5 seconds or more. 	BRC-35. "CAN Communication System Inspection" (Note 2)
BR FLUID LEVEL LOW [C1155]	Brake fluid level drops or circuit between ABS actuator and electric unit (control unit) and brake fluid level switch is open or shorted.	DI-39. "WARNING LAMPS"
ENGINE SIGNAL 1 [C1130]	ECM judges the communication between ABS/TCS control unit and ECM is abnormal.	BRC-30. "Engine System Inspection"
ACTUATOR RLY [C1140]	ABS actuator or relay circuit malfunction.	BRC-32. "Actuator Motor, Motor Relay, and Circuit Inspection"
STOP LAMP SW 2 [C1176]	ASCD brake switch or circuit malfunction.	EC-524. "DTC P1572 ASCD BRAKE SWITCH"

Note 1. If wheel sensor 2 for each wheel is indicated, check ABS actuator and electric unit (control unit) power supply voltage in addition to wheel sensor circuit check.

Note 2. If multiple malfunctions are detected including CAN communication line [U1000], perform diagnosis for CAN communication line first.

DATA MONITOR

Operation Procedure

- After turning OFF the ignition switch, connect CONSULT-II and CONSULT-II CONVERTER to the data link connector.

CAUTION:

If CONSULT-II is used with no connection of CONSULT-II CONVERTER, malfunctions might be detected in self-diagnosis depending on control unit which carries out CAN communication.

- Touch "START (NISSAN BASED VHCL)", "ABS", "DATA MONITOR" in order on the CONSULT-II screen. If "ABS" is not indicated, go to [GI-39. "CONSULT-II Data Link Connector \(DLC\) Circuit"](#).

CAUTION:

When "START (NISSAN BASED VHCL)" is touched immediately after starting the engine or turning on the ignition switch, "ABS" might not be displayed in the SELECT SYSTEM screen. In this case, repeat the operation from step 2.

- Return to the SELECT MONITOR ITEM screen, and touch "ECU INPUT SIGNALS", "MAIN SIGNALS" or "SELECTION FROM MENU". Refer to the following information.
- When "START" is touched, the data monitor screen is displayed.

Display Item List

Item (Unit)	Data monitor item selection			Remarks
	ECU INPUT SIGNALS	MAIN SIGNALS	SELECTION FROM MENU	
GEAR	×	×	×	This item is not used for this model. "1" is always displayed.
FR RH SENSOR (km/h, MPH)	×	×	×	Wheel speed calculated by front RH wheel sensor signal is displayed.
FR LH SENSOR (km/h, MPH)	×	×	×	Wheel speed calculated by front LH wheel sensor signal is displayed.
RR RH SENSOR (km/h, MPH)	×	×	×	Wheel speed calculated by rear RH wheel sensor signal is displayed.
RR LH SENSOR (km/h, MPH)	×	×	×	Wheel speed calculated by rear LH wheel sensor signal is displayed.
BATTERY VOLT (V)	×	×	×	Voltage supplied to ABS actuator and electric unit (control unit) is displayed.

TROUBLE DIAGNOSIS

[TCS/ABS]

Item (Unit)	Data monitor item selection			Remarks
	ECU INPUT SIGNALS	MAIN SIGNALS	SELECTION FROM MENU	
ACCEL POS SIG (%)	×	-	×	Throttle valve open/close status judged by LAN communication signal is displayed.
ENGINE SPEED (rpm)	×	×	×	Engine speed judged by LAN communication signal is displayed.
STOP LAMP SW (ON/OFF)	×	×	×	Stop lamp switch (ON/OFF) status is displayed.
ABS WARN LAMP (ON/OFF)	-	×	×	ABS warning lamp (ON/OFF) status is displayed.
EBD WARN LAMP (ON/OFF)	-	-	×	BRAKE warning lamp (ON/OFF) status is displayed.
SLIP LAMP (ON/OFF)	-	×	×	SLIP indicator lamp (ON/OFF) status is displayed.
FR LH IN SOL (ON/OFF)	-	×	×	Front LH IN ABS solenoid (ON/OFF) status is displayed.
FR LH OUT SOL (ON/OFF)	-	×	×	Front LH OUT ABS solenoid (ON/OFF) status is displayed.
RR RH IN SOL (ON/OFF)	-	×	×	Rear RH IN ABS solenoid (ON/OFF) status is displayed.
RR RH OUT SOL (ON/OFF)	-	×	×	Rear RH OUT ABS solenoid (ON/OFF) status is displayed.
FR RH IN SOL (ON/OFF)	-	×	×	Front RH IN ABS solenoid (ON/OFF) status is displayed.
FR RH OUT SOL (ON/OFF)	-	×	×	Front RH OUT ABS solenoid (ON/OFF) status is displayed.
RR LH IN SOL (ON/OFF)	-	×	×	Rear LH IN ABS solenoid (ON/OFF) status is displayed.
RR LH OUT SOL (ON/OFF)	-	×	×	Rear LH OUT ABS solenoid (ON/OFF) status is displayed.
OFF LAMP (ON/OFF)	-	×	×	OFF Lamp (ON/OFF) status is displayed.
OFF SW (ON/OFF)	×	×	×	TCS OFF switch (ON/OFF) status is displayed.
MOTOR RELAY (ON/OFF)	-	×	×	ABS motor relay signal (ON/OFF) status is displayed.
ACTUATOR RLY (ON/OFF)	-	×	×	ABS actuator relay signal (ON/OFF) status is displayed.
TCS FAIL SIG (ON/OFF)	-	-	×	TCS fail signal (ON/OFF) status is displayed.
ABS FAIL SIG (ON/OFF)	-	-	×	ABS fail signal (ON/OFF) status is displayed.
EBD FAIL SIG (ON/OFF)	-	-	×	EBD fail signal (ON/OFF) status is displayed.
EBD SIGNAL (ON/OFF)	-	-	×	EBD operation (ON/OFF) status is displayed.
ABS SIGNAL (ON/OFF)	-	-	×	ABS operation (ON/OFF) status is displayed.
TCS SIGNAL (ON/OFF)	-	-	×	TCS operation (ON/OFF) status is displayed.

TROUBLE DIAGNOSIS

[TCS/ABS]

Item (Unit)	Data monitor item selection			Remarks
	ECU INPUT SIGNALS	MAIN SIGNALS	SELECTION FROM MENU	
ASCD SIGNAL	–	–	×	ASCD (ON/OFF) status is displayed.
CRANKING SIG	–	–	×	Ignition switch START position signal input status is displayed.

×: Applicable
–: Not applicable

ACTIVE TEST

CAUTION:

- Do not perform active test while driving.
- Make sure to completely bleed air from the brake system.
- The ABS and BRAKE warning lamps turn on during the active test.

Operation Procedure

1. Connect the CONSULT-II and CONSULT-II CONVERTER to the data link connector and start the engine.

CAUTION:

If CONSULT-II is used with no connection of CONSULT-II CONVERTER, malfunctions might be detected in self-diagnosis depending on control unit which carries out CAN communication.

2. Touch "START (NISSAN BASED VHCL)" on the display screen.
3. Touch "ABS".
If "ABS" is not indicated, go to [GI-39, "CONSULT-II Data Link Connector \(DLC\) Circuit"](#).
4. Touch "ACTIVE TEST".
5. The SELECT TEST ITEM screen is displayed.
6. Touch necessary test item.

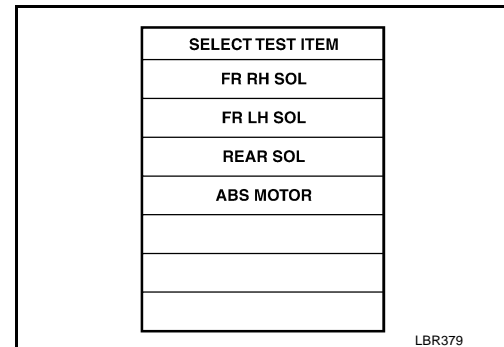

7. With the "MAIN SIGNALS" display selected, touch "START".
8. The Active Test screen will be displayed, so conduct the following test.

Solenoid Valve Operation Chart

Operation		ABS solenoid valve			ABS solenoid valve (ACT)		
		UP	KEEP	DOWN	UP	ACTUA-TOR UP	ACTUA-TOR KEEP
FR RH SOL FR RH ABS SOLE- NOID (ACT)	FR RH IN SOL	OFF	ON	ON	OFF	OFF	OFF
	FR RH OUT SOL	OFF	OFF	ON*	OFF	OFF	OFF
FR LH SOL FR LH ABS SOLE- NOID (ACT)	FR LH IN SOL	OFF	ON	ON	OFF	OFF	OFF
	FR LH OUT SOL	OFF	OFF	ON*	OFF	OFF	OFF
RR RH SOL RR RH ABS SOLE- NOID (ACT)	RR RH IN SOL	OFF	ON	ON	OFF	OFF	OFF
	RR RH OUT SOL	OFF	OFF	ON*	OFF	OFF	OFF
RR LH SOL RR LH ABS SOLE- NOID (ACT)	RR LH IN SOL	OFF	ON	ON	OFF	OFF	OFF
	RR LH OUT SOL	OFF	OFF	ON*	OFF	OFF	OFF

*: ON for 1 to 2 seconds after the touch, and then OFF

TROUBLE DIAGNOSIS

[TCS/ABS]

NOTE:

- If active test is performed with brake pedal depressed, pedal stroke may change. This is normal.
- "TEST IS STOPPED" is displayed approximately 10 seconds after operation starts.
- After "TEST IS STOPPED" is displayed, to perform test again, repeat Step 6.

ABS Motor

Touch "ON" and "OFF" on the screen. Check that ABS motor relay operates as shown in table below.

Operation	ON	OFF
ABS actuator relay	ON	ON
ABS motor relay	ON	OFF

NOTE:

- If active test is performed with brake pedal depressed, pedal stroke may change. This is normal.
- "TEST IS STOPPED" is displayed approximately 10 seconds after operation starts.

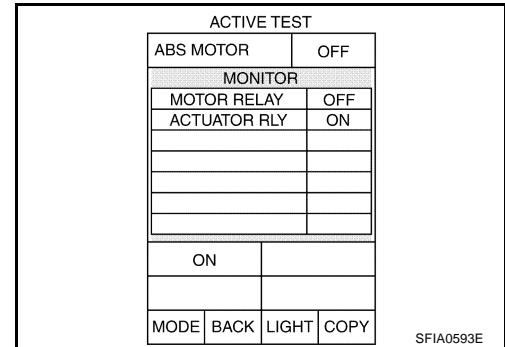

TROUBLE DIAGNOSIS FOR SELF-DIAGNOSTIC ITEMS

PFP:00000

Wheel Sensor System Inspection

EFS004FZ

INSPECTION PROCEDURE

1. CONNECTOR INSPECTION

Disconnect the ABS actuator and electric unit connector E125 and wheel sensor of malfunctioning code. Check the terminals for deformation, disconnection, looseness or damage.

OK or NG

OK >> GO TO 2.

NG >> Repair or replace as necessary.

2. CHECK WHEEL SENSOR OUTPUT SIGNAL

1. Disconnect connectors from wheel sensor of malfunction code No.
2. Connect ABS active wheel sensor tester (J-45741) to wheel sensor using appropriate adapter.
3. Turn on the ABS active wheel sensor tester power switch.

NOTE:

The green POWER indicator should illuminate. If the POWER indicator does not illuminate, replace the battery in the ABS active wheel sensor tester before proceeding.

4. Spin the wheel of the vehicle by hand and observe the red SENSOR indicator on the ABS active wheel sensor tester. The red SENSOR indicator should flash on and off to indicate an output signal.

NOTE:

If the red SENSOR indicator illuminates but does not flash, reverse the polarity of the tester leads and retest.

Does the ABS active wheel sensor tester detect a signal?

YES >> GO TO 3.

NO >> GO TO 6.

3. CHECK TIRES

Check for inflation pressure, wear and size of each tire.

Are tire pressure and size correct and is tire wear within specifications?

YES >> GO TO 4.

NO >> Adjust tire pressure or replace tire(s).

4. CHECK WHEEL BEARINGS

Check wheel bearing axial end play. Refer to [FAX-5, "FRONT WHEEL BEARING"](#) or [RAX-5, "REAR WHEEL BEARING"](#).

OK or NG

OK >> GO TO 5.

NG >> Repair as necessary. Refer to [FAX-5, "FRONT WHEEL BEARING"](#) or [RAX-5, "REAR WHEEL BEARING"](#).

5. CHECK SENSOR ROTORS

Check sensor rotors for tooth damage.

OK or NG

OK >> GO TO 6.

NG >> Replace sensor rotor. Refer to [BRC-42, "Removal and Installation"](#).

6. CHECK WIRING HARNESS FOR SHORT CIRCUIT

1. Disconnect ABS actuator and electric unit (control unit) connector and wheel sensor connector of malfunction code No.
2. Check continuity between harness connector terminal and ground.

Continuity should not exist.

OK or NG

- OK >> GO TO 7.
- NG >> Repair the circuit.

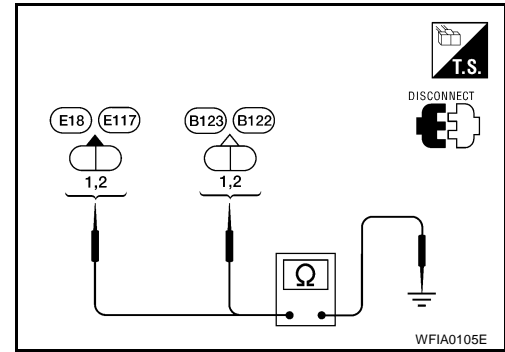

7. CHECK WIRING HARNESS FOR OPEN CIRCUIT

1. Disconnect ABS actuator and electric unit (control unit) connector and wheel sensor connector of malfunction code No.
2. Check continuity between both wiring harness ends.

Sensor	ABS actuator and electric unit (control unit)		Wheel sensor		Continuity
	Connector	Terminal	Connector	Terminal	
Front LH	E125	23	E18	1	Yes
		27		2	
Front RH		21	E117	1	
		12		2	
Rear LH		30	B123	1	
		26		2	
Rear RH		15	B122	1	
		11		2	

OK or NG

- OK >> Replace the ABS actuator and electric unit (control unit). Refer to [BRC-43, "Removal and Installation"](#).
- NG >> Repair the circuit.

Engine System Inspection

EFS004G0

INSPECTION PROCEDURE

1. SELF-DIAGNOSIS RESULT CHECK

Check self-diagnosis results.

Self-diagnosis results
ENGINE SIGNAL 1

Is the above displayed in the self-diagnosis display items?

- YES >> GO TO 2.
- NO >> Inspection End.

2. ENGINE SYSTEM INSPECTION

1. Perform ECM self-diagnosis and repair as necessary.
2. Perform ABS actuator and electric unit (control unit) self-diagnosis again.

OK or NG

- OK >> Inspection End.
- NG >> Repair as necessary.

ABS/TCS Control Unit Inspection

EFS004G1

INSPECTION PROCEDURE

1. SELF-DIAGNOSIS RESULT CHECK

Check self-diagnosis results.

Self-diagnosis results
CONTROLLER FAILURE

Is the above displayed in the self-diagnosis display items?

- YES >> GO TO 2.
- NO >> Inspection End.

2. CHECK WHEEL SENSORS

Check all wheel sensors. Refer to [BRC-29, "Wheel Sensor System Inspection"](#) .

OK or NG

- OK >> Replace ABS actuator and electric unit (control unit). Refer to [BRC-43, "Removal and Installation"](#)
- NG >> Repair or replace as necessary.

Solenoid Valve System Inspection

EFS006B7

INSPECTION PROCEDURE

1. SELF-DIAGNOSIS RESULT CHECK

Check self-diagnosis results.

Self-diagnosis results
FR LH IN ABS SOL
FR LH OUT ABS SOL
RR RH IN ABS SOL
RR RH OUT ABS SOL
FR RH IN ABS SOL
FR RH OUT ABS SOL
RR LH IN ABS SOL
RR LH OUT ABS SOL

Is the above displayed in the self-diagnosis display items?

- YES >> GO TO 2.
- NO >> Inspection End.

2. CONNECTOR INSPECTION

1. Disconnect ABS actuator and electric unit (control unit) connector E125.
2. Check the terminals for deformation, disconnection, looseness or damage.

OK or NG

- OK >> GO TO 3.
- NG >> Repair or replace as necessary.

A
B
C
D
E
BRC
G
H
I
J
K
L
M

3. CHECKING SOLENOID POWER AND GROUND

1. Disconnect ABS actuator and electric unit (control unit) connector E125.
2. Check voltage between ABS actuator and electric unit (control unit) connector E125 and ground.

ABS actuator and electric unit (control unit) connector E125	Body ground	Measured value (Approx.)
2	—	12V

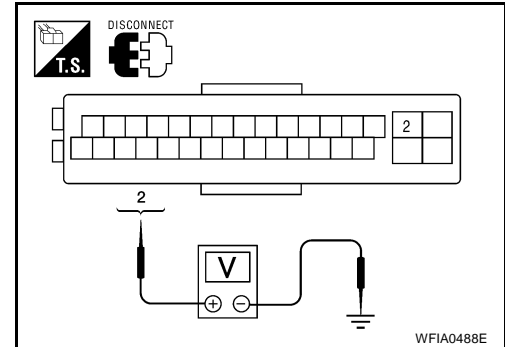

3. Check resistance between ABS actuator and electric unit (control unit) connector E125 and body ground.

ABS actuator and electric unit (control unit) connector E125	Body ground	Measured value Ω (Approx.)
3	—	0 Ω
4		

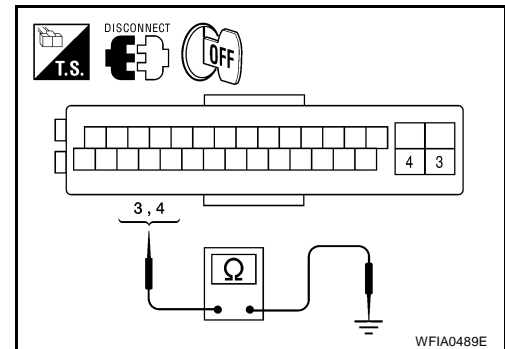

OK or NG

- OK >> Perform self-diagnosis again. If the same results appear, replace ABS actuator and electric unit (control unit). Refer to [BRC-96, "Removal and Installation"](#).
- NG >> Repair the circuit.

Actuator Motor, Motor Relay, and Circuit Inspection

EFS004G2

INSPECTION PROCEDURE

1. CHECKING SELF-DIAGNOSIS RESULTS

Check self-diagnosis results.

Self-diagnosis results
PUMP MOTOR
ACTUATOR RLY

Is the above displayed in the self-diagnosis display items?

- YES >> GO TO 2.
- NO >> Inspection End.

2. CONNECTOR INSPECTION

Disconnect the ABS actuator and electric unit (control unit) connector E125. Check the terminals for deformation, disconnection, looseness or damage.

OK or NG

- OK >> GO TO 3.
- NG >> Repair or replace as necessary.

3. CHECKING ABS MOTOR AND MOTOR RELAY POWER SYSTEM

1. Check voltage between ABS actuator and electric unit (control unit) connector E125 and body ground.

ABS actuator and electric unit (control unit) connector E125	Body ground	Measured value (Approx.)
1	—	12V

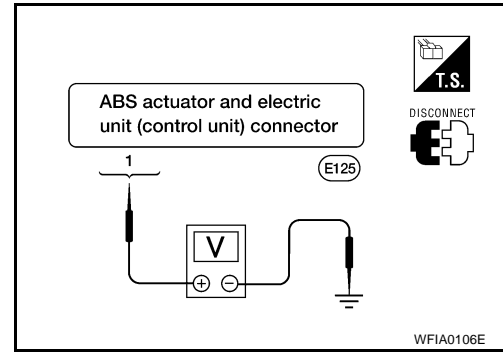

2. Check resistance between ABS actuator and electric unit (control unit) connector E125 and ground.

ABS actuator and electric unit (control unit) connector E125	Body ground	Measured value (Approx.)
4	—	0Ω

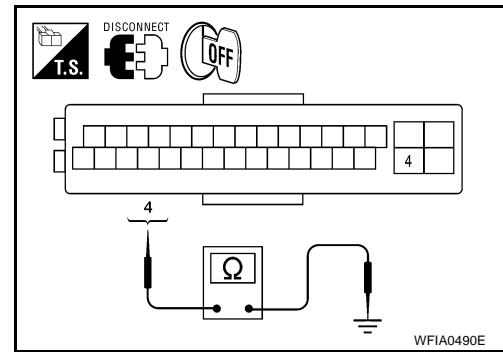

OK or NG

- OK >> Perform self-diagnosis again. If the same result appears, replace ABS actuator and electric unit (control unit). Refer to [BRC-43, "Removal and Installation"](#).
- NG >> Repair the circuit.

Stop Lamp Switch System Inspection

EFS004G3

INSPECTION PROCEDURE

1. SELF-DIAGNOSIS RESULT CHECK

Check self-diagnosis results.

Self-diagnosis results
STOP LAMP SW 1

Is the above displayed in the self-diagnosis display items?

- YES >> GO TO 2.
- NO >> Inspection End.

2. CONNECTOR INSPECTION

1. Disconnect the ABS actuator and electric unit (control unit) connector E125 and stop lamp switch connector E38.
2. Check the terminals for deformation, disconnection, looseness or damage.

OK or NG

- OK >> GO TO 3.
- NG >> Repair or replace as necessary.

A
B
C
D
E
BRC
G
H
I
J
K
L
M

3. STOP LAMP SWITCH INSPECTION

Turn the ignition switch ON and check the voltage between the ABS actuator and electric unit (control unit) connector E125 terminal 8 and ground.

8 - Ground

Brake pedal depressed : Battery voltage (approx. 12V)

Brake pedal not depressed : Approx. 0V

OK or NG

OK >> Connect the connectors and conduct ABS actuator and electric unit (control unit) self-diagnosis. Refer to [BRC-23, "SELF-DIAGNOSIS"](#).

NG >> Repair the circuit.

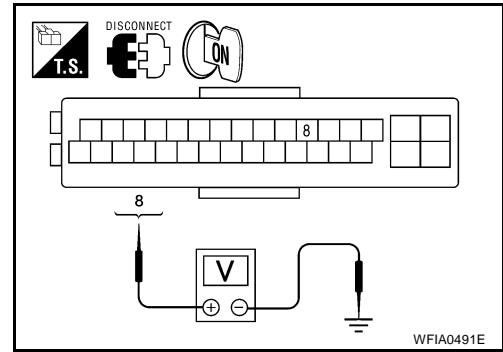

ABS/TCS Control Unit Power and Ground Systems Inspection

EFS004G4

INSPECTION PROCEDURE

1. SELF-DIAGNOSIS RESULT CHECK

Check self-diagnosis results.

Self-diagnosis results
BATTERY VOLTAGE

Is the above displayed in the self-diagnosis item?

YES >> GO TO 2.

NO >> Inspection End.

2. CONNECTOR INSPECTION

1. Turn the ignition switch OFF and disconnect the ABS actuator and electric unit (control unit) connector E125.
2. Check the terminals for deformation, disconnection, looseness or damage.

OK or NG

OK >> GO TO 3.

NG >> Repair or replace as necessary.

3. ABS/TCS CONTROL UNIT POWER AND GROUND CIRCUIT INSPECTION

Measure the voltage and continuity between the ABS actuator and electric unit (control unit) connector E125 and ground.

Signal name	ABS actuator and electric unit (control unit) connector E125	Ground	Measured value
Power supply	16	—	Battery voltage (Approx. 12V)
Ground	3		Continuity should exist.
	4		

OK or NG

OK >> Check the battery for loose terminals, low voltage, etc. Repair as necessary.

NG >> Repair the circuit.

CAN Communication System Inspection

EFS004G5

INSPECTION PROCEDURE

1. CHECK CONNECTOR

1. Turn ignition switch OFF, disconnect the ABS actuator and electric unit (control unit) connector, and check the terminals for deformation, disconnection, looseness, and so on. If there is a malfunction, repair or replace the terminal.
2. Reconnect connector to perform self-diagnosis.

Is "CAN COMM CIRCUIT" displayed in the self-diagnosis display items?

- YES >> Print out the self-diagnosis results, and refer to [LAN-44, "TROUBLE DIAGNOSIS"](#) .
 NO >> Connector terminal connection is loose, damaged, open, or shorted.

Component Inspection**TCS OFF SWITCH**

EFS004M5

Check the continuity between terminals 1 and 2.

- 1 -2 : Continuity should exist when pushing the switch.
 Continuity should not exist when releasing the switch.**

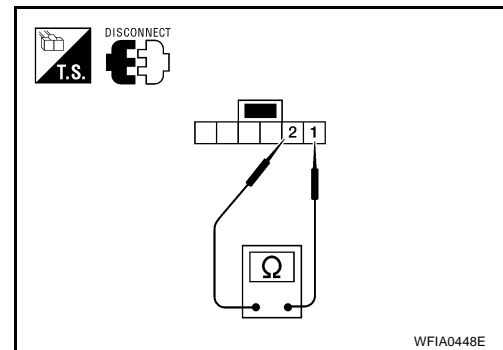

A

B

C

D

E

BRC

G

H

I

J

K

L

M

TROUBLE DIAGNOSES FOR SYMPTOMS**ABS Works Frequently**

1. CHECK WARNING LAMP ACTIVATION

Make sure warning lamp remains off while driving.

OK or NG

OK >> GO TO 2.

NG >> Carry out self-diagnosis. Refer to [BRC-23, "SELF-DIAGNOSIS"](#) .

2. CHECK WHEEL SENSORS

Check the following.

- Wheel sensor mounting for looseness
- Wheel sensors for physical damage
- Wheel sensor connectors for terminal damage or loose connections

OK or NG

OK >> GO TO 3.

NG >> Repair as necessary.

3. CHECK WHEEL BEARINGS

Check wheel bearing axial end play. Refer to [FAX-5, "FRONT WHEEL BEARING"](#) or [RAX-5, "REAR WHEEL BEARING"](#) .

OK or NG

OK >> GO TO 4.

NG >> Repair as necessary.

4. CHECK BRAKE FLUID PRESSURE

Check brake fluid pressure distribution.

Refer to [BR-36, "Inspection"](#) .

Is brake fluid pressure distribution normal?

YES >> Inspection End.

NO >> Perform Basic Inspection. Refer to [BRC-20, "Basic Inspection"](#) .

Unexpected Pedal Action**1. CHECK WARNING LAMP ACTIVATION**

Make sure warning lamp remains off while driving.

OK or NG

OK >> GO TO 2.

NG >> Carry out self-diagnosis. Refer to [BRC-23, "SELF-DIAGNOSIS"](#) .

2. CHECK BRAKE PEDAL STROKE

Check brake pedal stroke.

Is pedal stroke excessive?

YES >> Perform Basic Inspection. Refer to [BRC-20, "Basic Inspection"](#) .

NO >> GO TO 3.

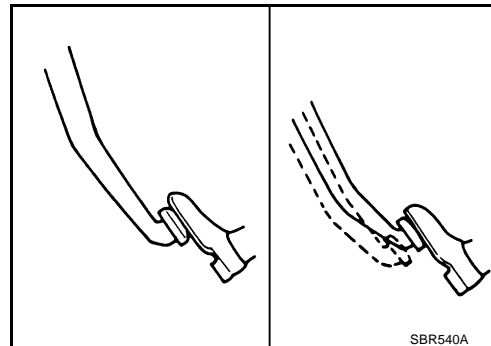
**3. CHECK CONNECTOR AND BRAKING PERFORMANCE**

1. Disconnect ABS actuator and electric unit (control unit) connector.

2. Check brake effectiveness.

NOTE:

Driving the vehicle with the ABS actuator and electric unit (control unit) disconnected may induce DTCs in electrical control units using CAN communication. After the inspection, clear all DTCs. Refer to [LAN-4, "SYSTEM DESCRIPTION"](#) .

OK or NG

OK >> GO TO 4.

NG >> Perform Basic Inspection. Refer to [BRC-20, "Basic Inspection"](#) .

4. CHECK WHEEL SENSORS

Check the following.

- Wheel sensor mounting for looseness
- Wheel sensors for physical damage
- Wheel sensor connectors for terminal damage or loose connections

OK or NG

OK >> Check ABS actuator and electric unit (control unit) pin terminals for damage and the connection of harness connector. Reconnect ABS actuator and electric unit (control unit) harness connector. Then retest.

NG >> Repair as necessary.

Long Stopping Distance

EFS004G8

1. CHECK BASE BRAKING SYSTEM PERFORMANCE

1. Disable ABS by disconnecting ABS actuator and electric unit (control unit) connector.
2. Drive vehicle and check to see if stopping distance is still long.

NOTE:

Driving the vehicle with the ABS actuator and electric unit (control unit) disconnected may induce DTCs in electrical control units using CAN communication. After the inspection, clear all DTCs. Refer to [LAN-4, "SYSTEM DESCRIPTION"](#).

OK or NG

- OK >> Go to [BRC-36, "ABS Works Frequently"](#).
- NG >> Perform Basic Inspection. Refer to [BRC-20, "Basic Inspection"](#).

NOTE:

Stopping distance may be longer than vehicles without ABS when road condition is slippery.

ABS Does Not Work

EFS004G9

CAUTION:

The ABS does not operate when the vehicle speed is 10 km/h (6 MPH) or less.

1. CHECK WARNING LAMP ACTIVATION

Turn ignition switch ON and check for warning lamp activation.

- Warning lamp should activate for approximately 2 seconds after turning the ignition switch ON.

OK or NG

- OK >> Carry out self-diagnosis. Refer to [BRC-23, "SELF-DIAGNOSIS"](#).
- NG >> Go to [BRC-39, "ABS Warning Lamp Does Not Come On When Ignition Switch Is Turned On"](#).

Pedal Vibration or ABS Operation Noise

EFS004GA

NOTE:

During ABS activation, pedal vibration may be felt and a noise may be heard. This is normal and does not indicate a malfunction.

1. CHECK SYMPTOM

1. Apply brake.
2. Start engine.

Does the symptom occur only when engine is started?

- YES >> Carry out self-diagnosis. Refer to [BRC-23, "SELF-DIAGNOSIS"](#).
- NO >> GO TO 2.

2. RECHECK SYMPTOM

Does the symptom occur only when electrical equipment switches (such as headlamp) are turned on?

- YES >> Check for radio, antenna or related wiring that is routed too close to the ABS actuator and electric unit (control unit) and reroute as necessary.
- NO >> Go to [BRC-36, "ABS Works Frequently"](#).

ABS Warning Lamp Does Not Come On When Ignition Switch Is Turned On EF5004GB

1. CHECK ABS ACTUATOR AND ELECTRIC UNIT (CONTROL UNIT) FUSES

Check 30A fusible link **g** and 30A fusible link **h** for ABS actuator and electric unit (control unit). For fusible link layout, refer to [PG-4, "POWER SUPPLY ROUTING CIRCUIT"](#).

OK or NG

- OK >> GO TO 2.
- NG >> If fusible link is blown, be sure to eliminate cause of problem before replacing.

2. CHECK ABS ACTUATOR AND ELECTRIC UNIT (CONTROL UNIT) POWER SUPPLY CIRCUITS

1. Disconnect ABS actuator and electric unit (control unit) connector.
2. Check voltage between ABS actuator and electric unit (control unit) connector terminal 1 and ground and terminal 2 and ground.

Does battery voltage exist?

- YES >> GO TO 3.
- NO >> Repair harness or connectors between fusible link and ABS actuator and electric unit (control unit).

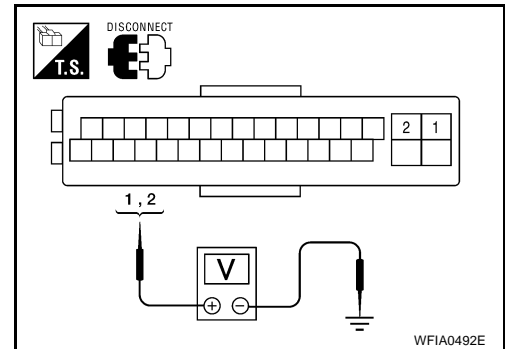

3. CHECK ABS ACTUATOR AND ELECTRIC UNIT (CONTROL UNIT) GROUND CIRCUIT

Check continuity between ABS actuator and electric unit (control unit) connector terminal 3 and ground and terminal 4 and ground.

Does continuity exist?

- YES >> Replace ABS actuator and electric unit (control unit). Refer to [BRC-43, "Removal and Installation"](#).
- NO >> Repair harness or connectors between ABS actuator and electric unit (control unit) and ground.

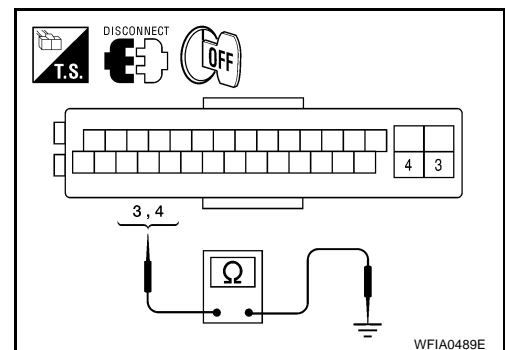

ABS Warning Lamp Stays On When Ignition Switch Is Turned On EF5004GC

1. CARRY OUT SELF-DIAGNOSIS

Carry out self-diagnosis. Refer to [BRC-23, "SELF-DIAGNOSIS"](#).

Are malfunctions detected in self-diagnosis?

- YES >> Refer to [BRC-24, "Display Item List"](#).
- NO >> Refer to [DI-39, "WARNING LAMPS"](#).

Vehicle Jerks During TCS Activation**1. ABS ACTUATOR AND ELECTRIC UNIT (CONTROL UNIT) SELF-DIAGNOSIS**

Perform ABS actuator and electric unit (control unit) self-diagnosis. Refer to [BRC-23, "SELF-DIAGNOSIS"](#) .

Are self-diagnosis result items displayed?

- YES >> After checking and repairing the applicable item, perform the ABS actuator and electric unit (control unit) self-diagnosis again.
NO >> GO TO 2.

2. ENGINE SPEED SIGNAL INSPECTION

Perform data monitor with CONSULT-II for the ABS actuator and electric unit (control unit).

Is the engine speed at idle 400 rpm or higher?

- YES >> GO TO 4.
NO >> GO TO 3.

3. ECM SELF-DIAGNOSIS

Perform ECM self-diagnosis.

Are self-diagnosis result items displayed?

- YES >> After checking and repairing the applicable item, perform the ECM self-diagnosis again.
NO >> GO TO 4.

4. TCM SELF-DIAGNOSIS

Perform TCM self-diagnosis.

Are self-diagnosis result items displayed?

- YES >> After checking and repairing the applicable item, perform the TCM self-diagnosis again.
NO >> GO TO 5.

5. CONNECTOR INSPECTION

Disconnect the ABS actuator and electric unit (control unit) connector and the ECM connectors and check the terminals for deformation, disconnection, looseness or damage.

OK or NG

- OK >> GO TO 6.
NG >> Repair or replace the connector terminal.

6. CAN COMMUNICATION INSPECTION

Check the CAN communication system. Refer to [BRC-35, "CAN Communication System Inspection"](#) .

OK or NG

- OK >> Inspection End.
NG >> Reconnect the connectors, and perform ABS actuator and electric unit (control unit) self-diagnosis.

WHEEL SENSORS

Removal and Installation

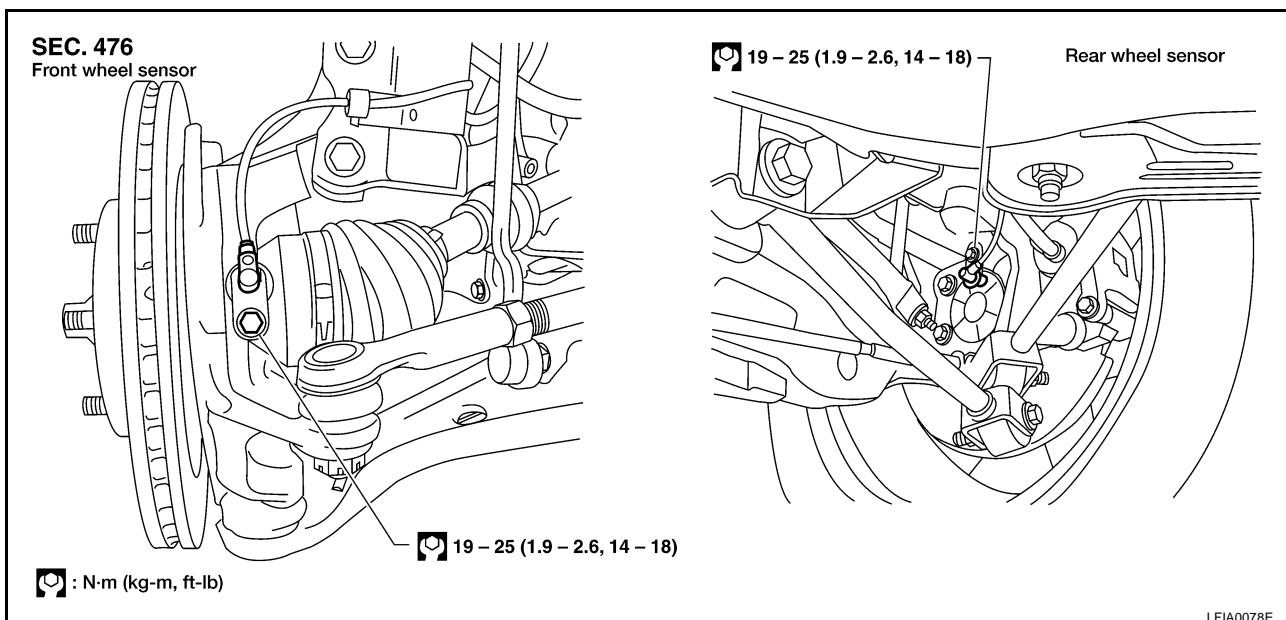
**CAUTION:**

- Be careful not to damage wheel sensor edge and sensor rotor teeth.
- When removing the front or rear wheel hub assembly, first remove the wheel sensor from the assembly. Failure to do so may result in damage to the wheel sensor wires making the sensor inoperative.

CAUTION:

- Pull out the wheel sensor, being careful to turn it as little as possible. Do not pull on the wheel sensor harness.
- Installation should be performed while paying attention to the following, and then tighten mounting bolts and nuts to the specified torque.
- Check if foreign objects such as iron fragments are adhered to the pick-up part of the sensor or to the inside of the hole for the wheel sensor, or if a foreign object is caught in the mating surface of the sensor rotor. If something wrong is found, fix it and then install the wheel sensor.

REMOVAL

1. Remove wheel and tire using power tool.
2. Disconnect wheel sensor harness connector and remove harness wire from attachment points.
3. Remove wheel sensor bolt and wheel sensor.

INSTALLATION

Installation is in the reverse order of removal.

- When installing wheel and tire, refer to [WT-7, "Tire Rotation"](#).

SENSOR ROTOR

Removal and Installation

REMOVAL

Front

1. Remove the front wheel hub. Refer to [FAX-6, "Removal and Installation"](#) .
2. Remove the sensor rotor from the drive shaft using a suitable tool as shown.

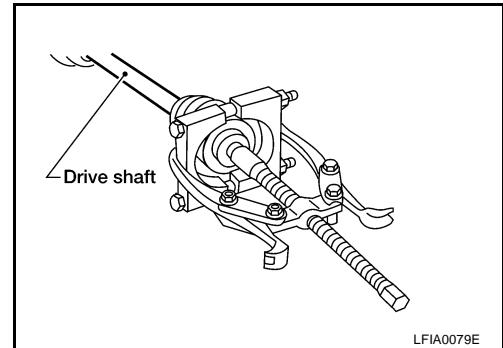

Rear

The rear wheel sensor rotor is built into the rear wheel hub. For removal and installation procedure, refer to [RAX-6, "Removal and Installation"](#) .

INSTALLATION

Front

Installation is in the reverse order of removal.

- Install the sensor rotor using a wooden block and suitable tool as shown.
- Always replace sensor rotor with new one.

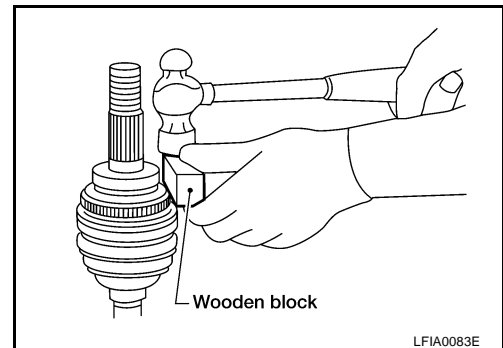

Rear

The rear wheel sensor rotor is built into the rear wheel hub. For removal and installation procedure, refer to [RAX-6, "Removal and Installation"](#) .

ACTUATOR AND ELECTRIC UNIT (ASSEMBLY)

PF0:47660

Removal and Installation

EFS004GG

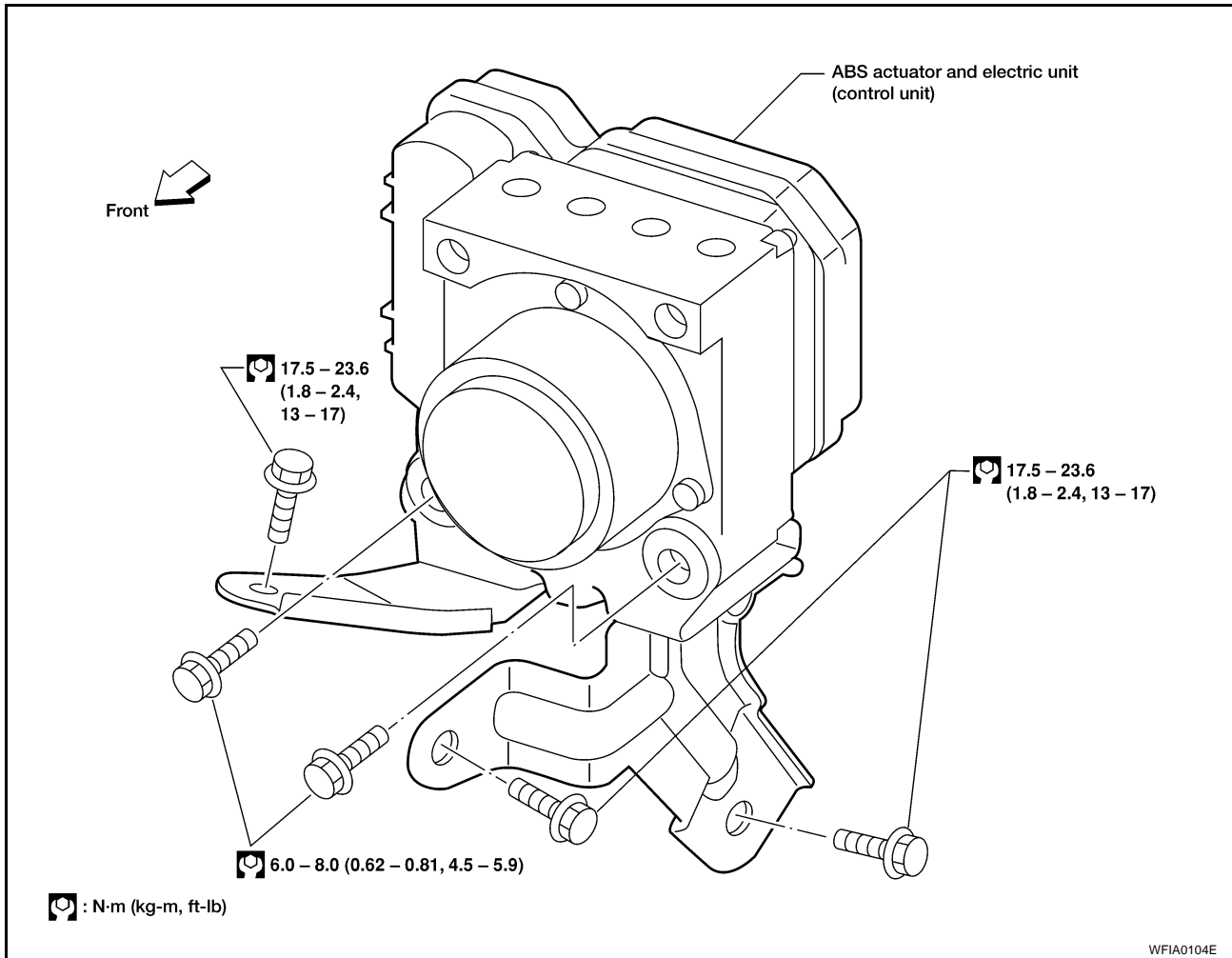

A

B

C

D

E

BRC

G

H

I

J

K

REMOVAL

1. Disconnect the battery negative terminal.
2. Remove windshield wiper and linkage assembly. Refer to [WW-21, "Removal"](#) .
3. Drain brake fluid. Refer to [BR-8, "Changing Brake Fluid"](#) .
4. Discharge the A/C refrigerant. Refer to [ATC-130, "HFC-134a \(R-134a\) Service Procedure"](#) .
5. Disconnect and remove high-pressure and low-pressure A/C pipes to allow access to ABS actuator and electric unit (control unit). Refer to [ATC-132, "Components"](#) .
6. Disconnect harness connectors from ABS actuator and electric unit (control unit).
7. Disconnect brake pipes, noting their location for installation.
8. Remove bolts and ABS actuator and electric unit (control unit).

INSTALLATION

CAUTION:

After installation of ABS actuator and electric unit (control unit), refill brake fluid. Then bleed air from system. Refer to [BR-8, "Bleeding Brake System"](#) .

1. Position ABS actuator and electric unit (control unit) in vehicle.
2. Connect brake pipes and bolts temporarily.
3. Tighten bolts and brake pipes to specification. Refer to [BR-9, "Hydraulic Circuit"](#) .
4. Connect ABS actuator and electric unit (control unit) harness connectors.
5. Install and connect high-pressure and low-pressure A/C pipes. Refer to [ATC-132, "Components"](#) .
6. Install windshield wiper and linkage assembly. Refer to [WW-21, "Installation"](#) .

ACTUATOR AND ELECTRIC UNIT (ASSEMBLY)

[TCS/ABS]

7. Connect battery negative terminal.
8. Evacuate and recharge the A/C system. Refer to [ATC-130, "HFC-134a \(R-134a\) Service Procedure"](#) .

PRECAUTIONS

PFP:00001

Precautions for Supplemental Restraint System (SRS) “AIR BAG” and “SEAT BELT PRE-TENSIONER”

EFS00638

The Supplemental Restraint System such as “AIR BAG” and “SEAT BELT PRE-TENSIONER”, used along with a front seat belt, helps to reduce the risk or severity of injury to the driver and front passenger for certain types of collision. This system includes seat belt switch inputs and dual stage front air bag modules. The SRS system uses the seat belt switches to determine the front air bag deployment, and may only deploy one front air bag, depending on the severity of a collision and whether the front occupants are belted or unbelted. Information necessary to service the system safely is included in the SRS and SB section of this Service Manual.

WARNING:

- To avoid rendering the SRS inoperative, which could increase the risk of personal injury or death in the event of a collision which would result in air bag inflation, all maintenance must be performed by an authorized NISSAN/INFINITI dealer.
- Improper maintenance, including incorrect removal and installation of the SRS, can lead to personal injury caused by unintentional activation of the system. For removal of Spiral Cable and Air Bag Module, see the SRS section.
- Do not use electrical test equipment on any circuit related to the SRS unless instructed to in this Service Manual. SRS wiring harnesses can be identified by yellow and/or orange harnesses or harness connectors.

Precautions for Brake System

EFS004GI

CAUTION:

- Refer to [MA-9, "RECOMMENDED FLUIDS AND LUBRICANTS"](#) for recommended brake fluid.
- Never reuse drained brake fluid.
- Be careful not to splash brake fluid on painted areas; it may cause paint damage. If brake fluid is splashed on painted areas, wash it away with water immediately.
- To clean or wash all parts of master cylinder and disc brake caliper, use clean brake fluid.
- Never use mineral oils such as gasoline or kerosene. They will ruin rubber parts of the hydraulic system.
- Use flare nut wrench when removing and installing brake tube.
- If a brake fluid leak is found, the part must be disassembled without fail. Then it has to be replaced with a new one if a defect exists.
- Turn the ignition switch OFF and remove the connector of the ABS actuator and electric unit (control unit) or the battery terminal before performing the work.
- Always torque brake lines when installing.
- Burnish the brake contact surfaces after refinishing or replacing rotors, after replacing pads, or if a soft pedal occurs at very low mileage.

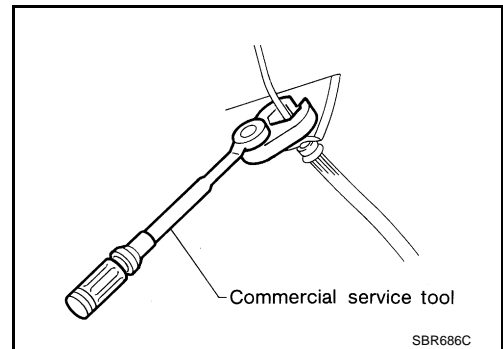

Refer to [BR-28, "Brake Burnishing"](#) (front disc brake) or [BR-35, "Brake Burnishing"](#) (rear disc brake).

WARNING:

- Clean brake pads and shoes with a waste cloth, then wipe with a dust collector.

Precautions When Using CONSULT-II

EFS004GJ

When connecting CONSULT-II to data link connector, connect them through CONSULT-II CONVERTER.

CAUTION:

If CONSULT-II is used with no connection of CONSULT-II CONVERTER, malfunctions might be detected in self-diagnosis depending on control unit which carries out CAN communication.

CHECK POINTS FOR USING CONSULT-II

1. Has CONSULT-II been used without connecting CONSULT-II CONVERTER on this vehicle?
 - If YES, GO TO 2.

A
B
C
D
E
BRC
G
H
I
J
K
L
M

- If NO, GO TO 5.
2. Is there any indication other than indications relating to CAN communication system in the self-diagnosis results?
 - If YES, GO TO 3.
 - If NO, GO TO 4.
3. Based on self-diagnosis results unrelated to CAN communication, carry out the inspection.
4. Malfunctions may be detected in self-diagnosis depending on control units carrying out CAN communication. Therefore, erase the self-diagnosis results.
5. Diagnose CAN communication system. Refer to [LAN-44, "TROUBLE DIAGNOSIS"](#) .

Precautions for Brake Control

EFS004GK

- During ABS operation, the brake pedal may vibrate lightly and a mechanical noise may be heard. This is normal.
- Just after starting vehicle, the brake pedal may vibrate or a motor operating noise may be heard from engine compartment. This is a normal status of operation check.
- Stopping distance may be longer than that of vehicles without ABS when vehicle drives on rough, gravel, or snow-covered (fresh, deep snow) roads.
- When an error is indicated by ABS or another warning lamp, collect all necessary information from customer (what symptoms are present under what conditions) and check for simple causes before starting diagnosis. Besides electrical system inspection, check booster operation, brake fluid level, and fluid leaks.
- If incorrect tire sizes or types are installed on the vehicle or brake pads are not Genuine NISSAN parts, stopping distance or steering stability may deteriorate.
- If there is a radio, antenna or related wiring near control module, ABS function may have a malfunction or error.
- If aftermarket parts (car stereo, CD player, etc.) have been installed, check for incidents such as harness pinches, open circuits or improper wiring.
- If the following components are replaced with non-genuine components or modified, the VDC OFF indicator lamp and SLIP indicator lamp may turn on or the VDC system may not operate properly. Components related to suspension (shock absorbers, struts, springs, bushings, etc.), tires, wheels (exclude specified size), components related to brake system (pads, rotors, calipers, etc.), components related to engine (muffler, ECM, etc.), components related to body reinforcement (roll bar, tower bar, etc.).
- Driving with broken or excessively worn suspension components, tires or brake system components may cause the VDC OFF indicator lamp and the SLIP indicator lamp to turn on, and the VDC system may not operate properly.
- When the TCS or VDC is activated by sudden acceleration or sudden turn, some noise may occur. The noise is a result of the normal operation of the TCS and VDC.
- When driving on roads which have extreme slopes (such as mountainous roads) or high banks (such as sharp curves on a freeway), the VDC may not operate normally, or the VDC warning lamp and the SLIP indicator lamp may turn on. This is not a problem if normal operation can be resumed after restarting the engine.
- Sudden turns (such as spin turns, acceleration turns), drifting, etc. with VDC turned off may cause the yaw rate/side/decel G sensor to indicate a problem. This is not a problem if normal operation can be resumed after restarting the engine.

Precautions for CAN System

EFS004GL

- Do not apply voltage of 7.0V or higher to terminal to be measured.
- Maximum open terminal voltage of tester in use must be less than 7.0V.
- Before checking harnesses, turn ignition switch OFF and disconnect battery negative cable.

PRECAUTIONS

[VDC/TCS/ABS]

- Area to be repaired must be soldered and wrapped with tape. Make sure that fraying of twisted wire is within 110 mm (4.33 in).

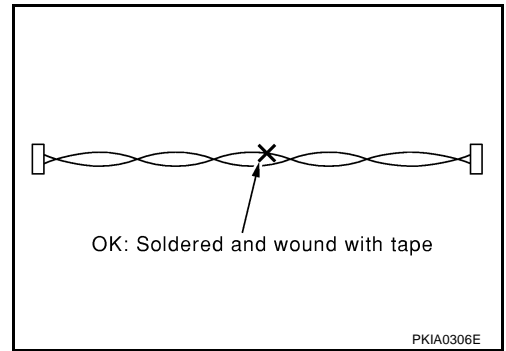

- Do not make a bypass connection to repaired area. (If the circuit is bypassed, characteristics of twisted wire will be lost.)

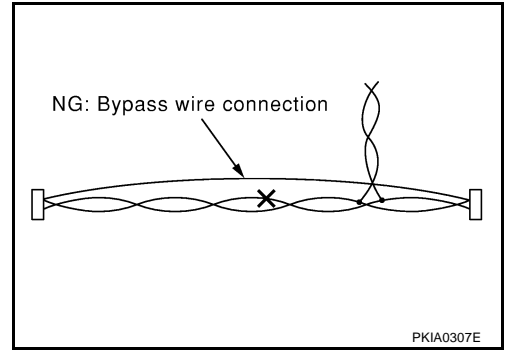

A
B
C
D
E
BRC
G
H
I
J
K
L
M

PREPARATION

[VDC/TCS/ABS]

PREPARATION

PFP:00002

Special Service Tool

EFS00634

The actual shapes of Kent-Moore tools may differ from those of special service tools illustrated here.

Tool number (Kent-Moore No.) Tool name	Description
(J-45741) ABS active wheel sensor tester	Checking operation of ABS active wheel sensor

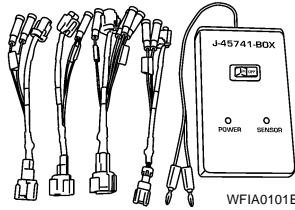

Commercial Service Tools

EFS00635

Tool name	Description
1. Flare nut crowfoot 2. Torque wrench	Removing and installing brake piping a: 10mm (0.39 in)/12mm (0.47 in)

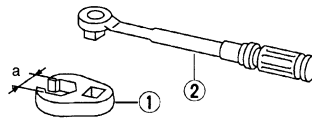

S-NT360

SYSTEM DESCRIPTION

System Components

EFS004GP

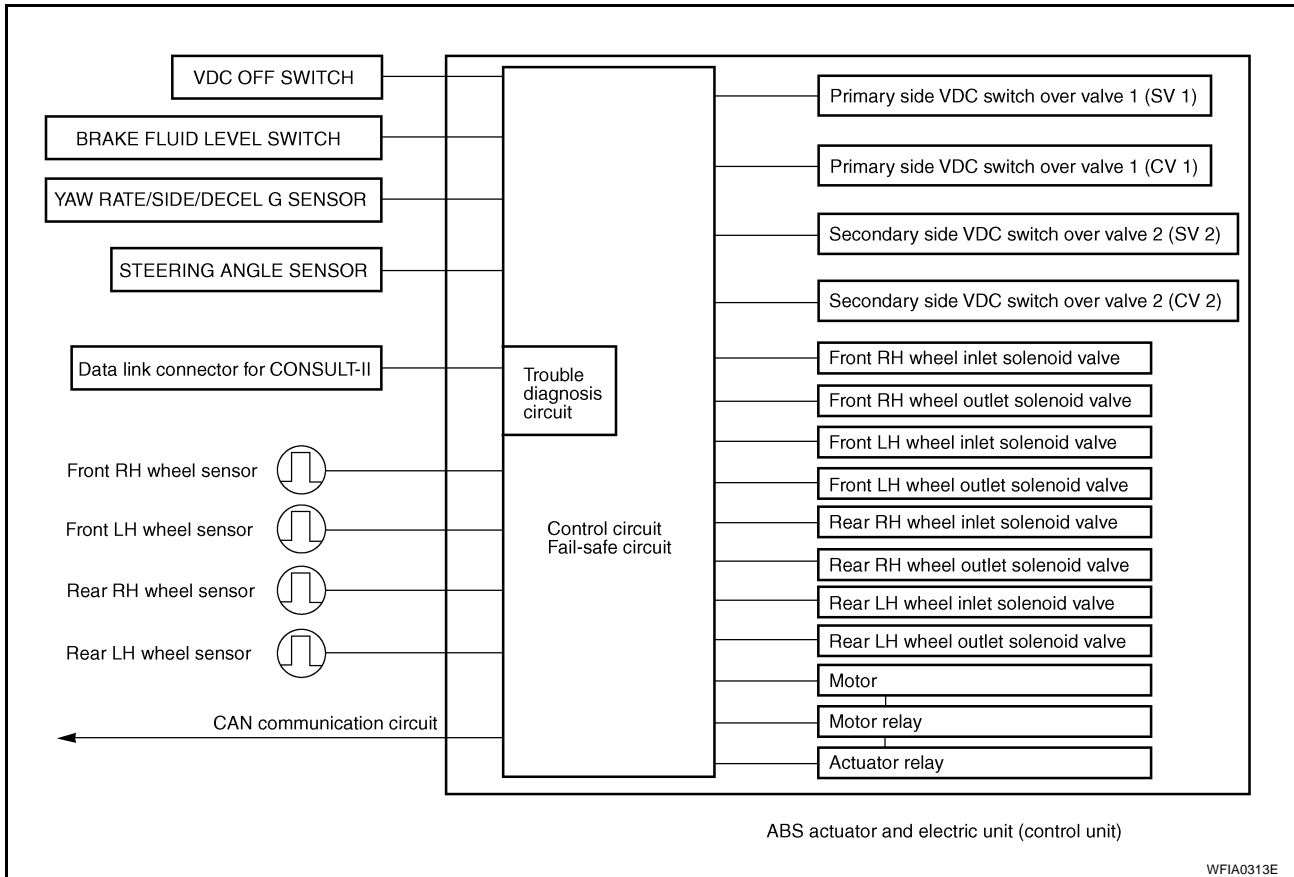

A

B

C

D

E

BRC

G

H

I

ABS Function

EFS004GQ

- The Anti-Lock Brake System detects wheel revolution while braking and improves handling stability during sudden braking by electrically preventing wheel lockup. Maneuverability is also improved for avoiding obstacles.
- If the electrical system malfunctions, the Fail-Safe function is activated, the ABS becomes inoperative and the ABS warning lamp turns on.
- The electrical system can be diagnosed using CONSULT-II.
- During ABS operation, the brake pedal may vibrate lightly and a mechanical noise may be heard. This is normal.
- Just after starting the vehicle, the brake pedal may vibrate or a motor operating noise may be heard from engine compartment. This is a normal status of operation check.
- Stopping distance may be longer than that of vehicles without ABS when vehicle drives on rough, gravel, or snow-covered (fresh, deep snow) roads.

EBD Function

EFS004GR

- Electronic Brake Distribution is a function that detects subtle slippages between the front and rear wheels during braking, and it improves handling stability by electronically controlling the brake fluid pressure which results in reduced rear wheel slippage.
- If the electrical system malfunctions, the Fail-Safe function is activated, the EBD and ABS become inoperative, and the ABS warning lamp and BRAKE warning lamp are turned on.
- The electrical system can be diagnosed using CONSULT-II.
- During EBD operation, the brake pedal may vibrate lightly and a mechanical noise may be heard. This is normal.
- Just after starting the vehicle, the brake pedal may vibrate or a motor operating noise may be heard from engine compartment. This is a normal status of operation check.

- Stopping distance may be longer than that of vehicles without EBD when vehicle drives on rough, gravel, or snow-covered (fresh, deep snow) roads.

TCS Function

EFS004GS

- Spinning of the drive wheels is detected by the ABS/TCS/VDC control unit using inputs from the wheel speed sensors. If wheel spin occurs, the drive wheel right and left brake fluid pressure control and engine fuel cut are conducted while the throttle value is restricted to reduce the engine torque and decrease the amount of wheel spin. In addition, the throttle opening is controlled to achieve the optimum engine torque.
- Depending on road condition, the vehicle may have a sluggish feel. This is normal, because optimum traction has the highest priority during TCS operation.
- TCS may be activated during sudden vehicle acceleration, wide open throttle acceleration, sudden transmission shifts or when the vehicle is driven on a road with a varying surface friction coefficient.
- The SLIP indicator lamp flashes to inform the driver of TCS operation.

VDC Function

EFS004GT

- In addition to the ABS/TCS function, the driver steering amount and brake operation amount are detected from the steering angle sensor, and the vehicle's driving status (amount of under steering/over steering) is determined using inputs from the yaw rate/side/decel G sensor, wheel speed sensors, etc. and this information is used to improve vehicle stability by controlling the braking and engine torque application to the wheels.
- The SLIP indicator lamp flashes to inform the driver of VDC operation.
- During VDC operation, the vehicle body and brake pedal may vibrate lightly and a mechanical noise may be heard. This is normal.
- The ABS warning lamp, VDC OFF indicator lamp and SLIP indicator lamp may turn on when the vehicle is subject to strong shaking or large vibration, such as when the vehicle is on a turn table or a ship while the engine is running or steep slope. In this case, restart the engine on a normal road and if the ABS warning lamp, VDC OFF indicator lamp and SLIP indicator lamp turn off, there is no problem.

Wheel Sensors

EFS004GU

The front sensor units consist of a gear-shaped sensor rotor and a sensor element. The element contains a magnet around which a coil is wound. The front wheel sensors are installed on the front of the wheel knuckles. As the wheel rotates, the sensor generates a square-wave signal. The frequency increases as the wheel speed increases.

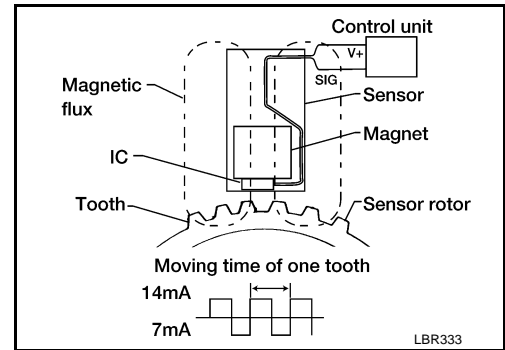

The rear sensor units consist of wheel hubs with a series of internal magnets and a sensor element. The rear wheel sensors are installed on the inner side of the wheel knuckles. As the wheel rotates, the sensor generates a square-wave signal. The frequency increases as the wheel speed increases.

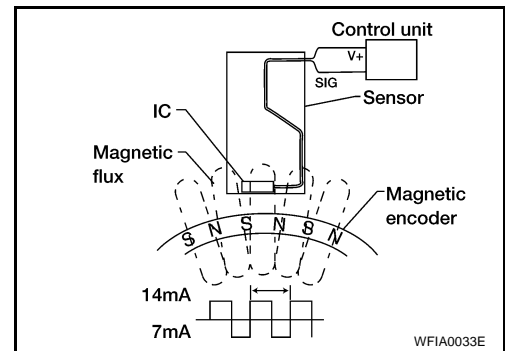

EFS004GV

**Fail-Safe Function
ABS/EBD SYSTEM**

In case of an electrical malfunction with the ABS, the ABS warning lamp, VDC OFF indicator lamp and SLIP indicator lamp will turn on. In case of an electrical malfunction with the EBD system, the BRAKE warning lamp, ABS warning lamp, VDC OFF indicator lamp and SLIP indicator lamp will turn on.

The system will revert to one of the following conditions of the Fail-Safe function.

1. For ABS malfunction, only the EBD is operative and the condition of the vehicle is the same condition of vehicles without ABS/TCS/VDC system.
2. For EBD malfunction, the EBD and ABS become inoperative, and the condition of the vehicle is the same as the condition of vehicles without ABS/TCS/VDC or EBD system.

VDC/TCS SYSTEM

In case of TCS/VDC system malfunction, the VDC OFF indicator lamp and SLIP indicator lamp are turned on and the condition of the vehicle is the same as the condition of vehicles without TCS/VDC system. In case of an electrical malfunction with the TCS/VDC system, the ABS control continues to operate normally without TCS/VDC control.

CAUTION:

If the Fail-Safe function is activated, perform the Self Diagnosis for ABS/TCS/VDC system.

A
B
C
D
E
BRC
G
H
I
J
K
L
M

SYSTEM DESCRIPTION

[VDC/TCS/ABS]

Hydraulic Circuit Diagram

EFS004GW

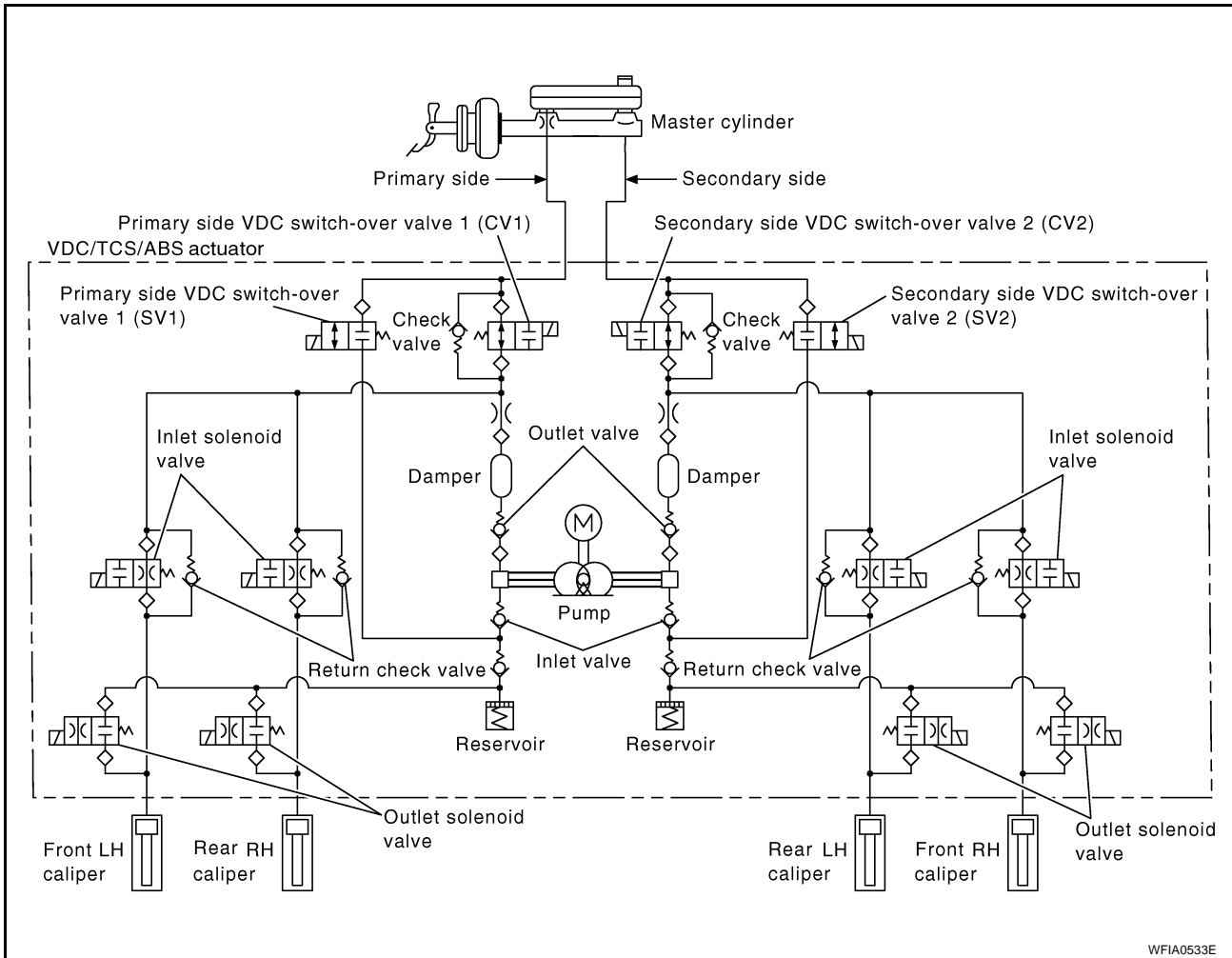

WFIA0533E

CAN COMMUNICATION

PFP:23710

System Description

EFS004GX

Refer to [LAN-4, "SYSTEM DESCRIPTION"](#) .

A

B

C

D

E

BRC

G

H

I

J

K

L

M

TROUBLE DIAGNOSIS

How to Perform Trouble Diagnoses for Quick and Accurate Repair INTRODUCTION

The ABS/TCS/VDC system has an electronic control unit to control major functions. The control unit accepts input signals from sensors and controls actuator operation. It is also important to check for conventional malfunctions such as air leaks in the booster or lines, lack of brake fluid, or other malfunctions with the brake system.

It is much more difficult to diagnose a malfunction that occurs intermittently rather than continuously. Most intermittent malfunctions are caused by poor electrical connections or wiring. In this case, careful checking of suspicious circuits may help prevent the replacement of good parts.

A visual check only may not find the cause of the malfunction, so a road test should be performed.

Before undertaking actual checks, take just a few minutes to talk with a customer who approaches with an ABS/TCS/VDC complaint. The customer is a very good source of information, especially for intermittent malfunctions. Through the talks with the customer, find out what symptoms are present and under what conditions they occur. Start your diagnosis by looking for "conventional" malfunctions first. This is one of the best ways to troubleshoot brake malfunctions on an ABS/TCS/VDC equipped vehicle. Also check related Service Bulletins for information.

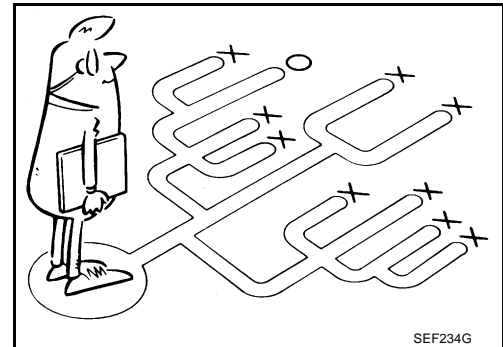
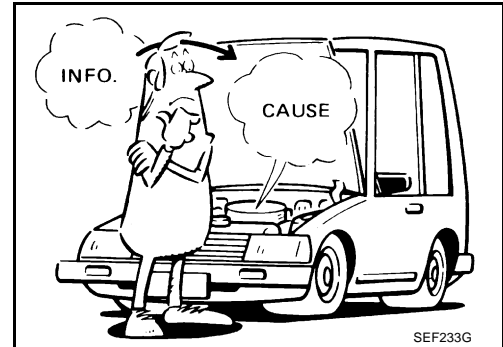

TROUBLE DIAGNOSIS

[VDC/TCS/ABS]

WORK FLOW

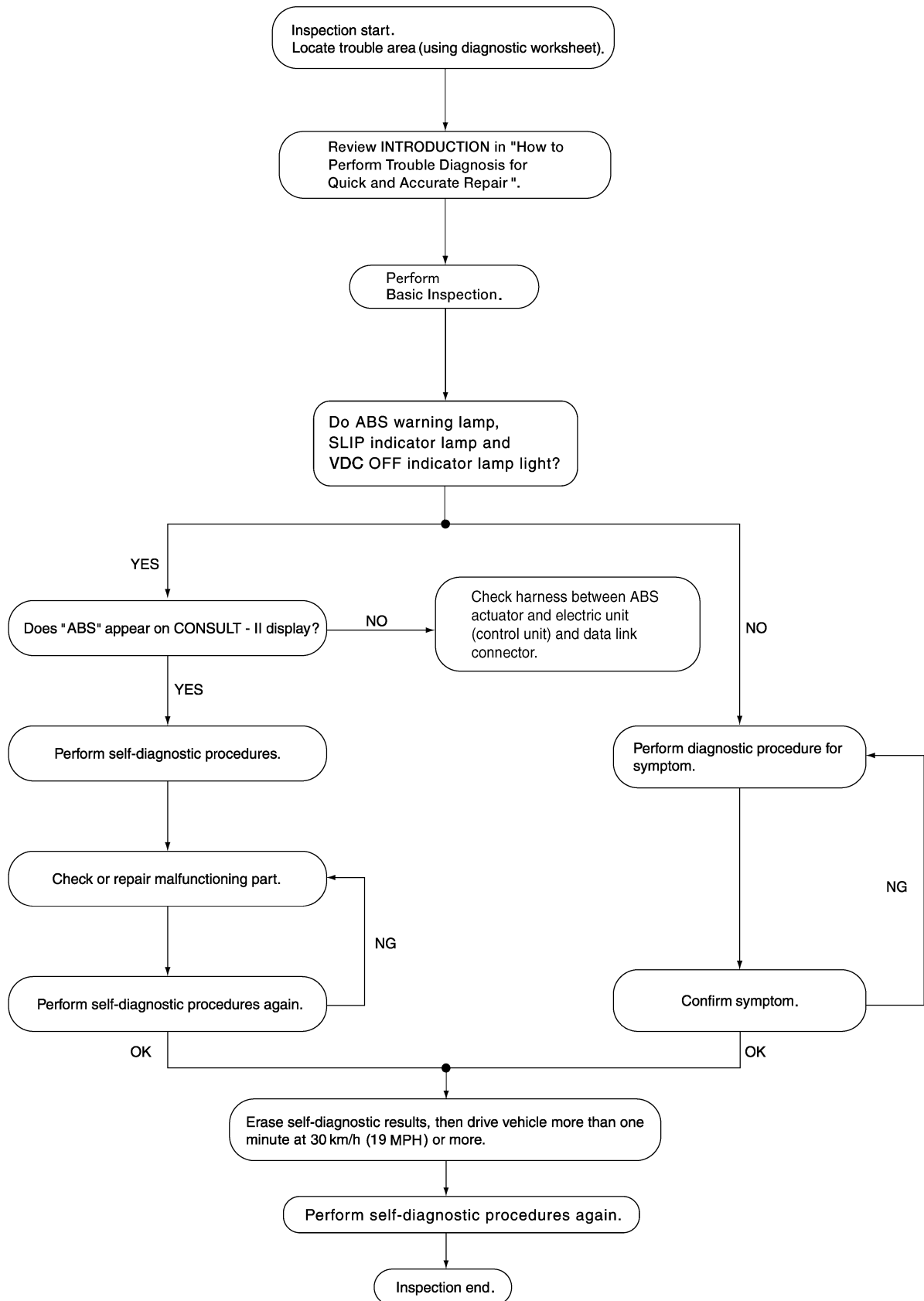

A
B
C
D
E
BRC
G
H
I
J
K
L
M

WFIA0534E

TROUBLE DIAGNOSIS

[VDC/TCS/ABS]

CLARIFY CONCERN

- A customer's description of a vehicle concern may vary depending on the individual. It is important to clarify the customer's concern.
- Ask the customer about what symptoms are present under what conditions. Use this information to reproduce the symptom while driving.
- It is also important to use the diagnosis sheet to understand what type of trouble the customer is having.

KEY POINTS

WHAT Vehicle model
WHEN Date, Frequencies
WHERE Road conditions
HOW Operating conditions,
 Weather conditions,
 Symptoms

SBR339B

EXAMPLE OF DIAGNOSIS SHEET

Customer name	Model & Year	VIN	
Engine #	Trans.	Mileage	
Incident Date	Manuf. Date	In Service Date	
Symptoms	<input type="checkbox"/> Noise and vibration (from engine compartment)	<input type="checkbox"/> ABS warning lamp activates	<input type="checkbox"/> Pedal operation
	<input type="checkbox"/> Noise and vibration (from axle)	<input type="checkbox"/> SLIP warning lamp activates	<input type="checkbox"/> Large stroke pedal operation
	<input type="checkbox"/> TCS does not work (drive wheels slip when accelerating)	<input type="checkbox"/> ABS does not work (wheels slip when braking)	<input type="checkbox"/> Firm pedal
	<input type="checkbox"/> Lack of sense of acceleration		
Engine conditions	<input type="checkbox"/> When starting <input type="checkbox"/> After starting		
Road conditions	<input type="checkbox"/> Low friction road (<input type="checkbox"/> Snow <input type="checkbox"/> Gravel <input type="checkbox"/> Other) <input type="checkbox"/> Bumps/potholes		
Driving conditions	<input type="checkbox"/> Full-acceleration <input type="checkbox"/> High speed cornering <input type="checkbox"/> Vehicle speed: Greater than 10 km/h (6 MPH) <input type="checkbox"/> Vehicle speed: 10 km/h (6 MPH) or less <input type="checkbox"/> Vehicle is stopped		
Applying brake conditions	<input type="checkbox"/> Suddenly <input type="checkbox"/> Gradually		
Other conditions	<input type="checkbox"/> Operation of electrical equipment <input type="checkbox"/> Shift change <input type="checkbox"/> Other descriptions		

WFIA0097E

TROUBLE DIAGNOSIS

[VDC/TCS/ABS]

Component Parts and Harness Connector Location

EFS004GZ

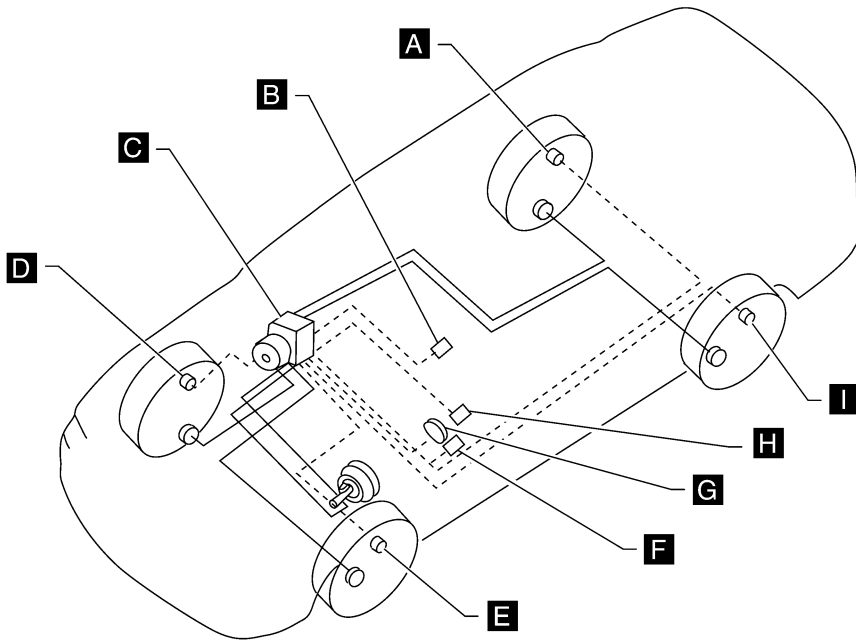

A
B
C
D
E
BRC
G
H
I
J
K
L
M

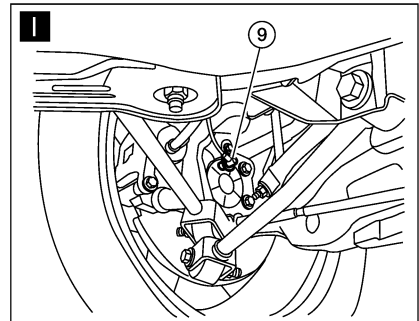
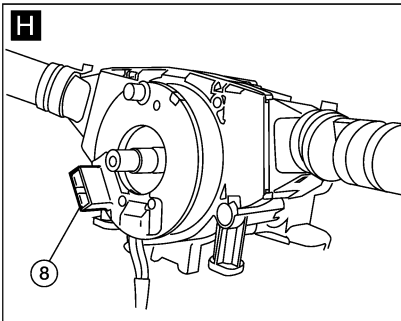
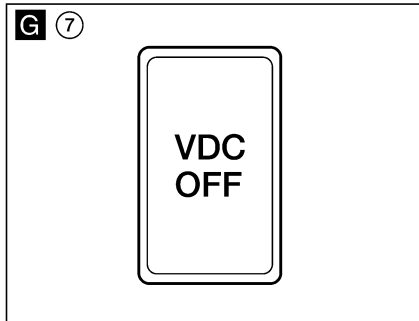
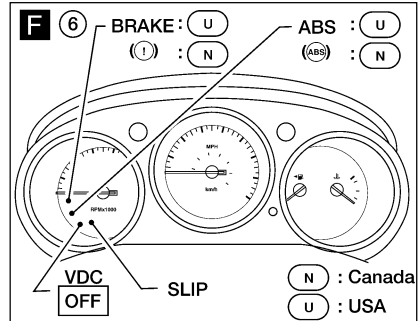
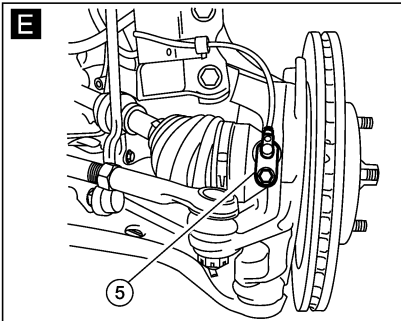
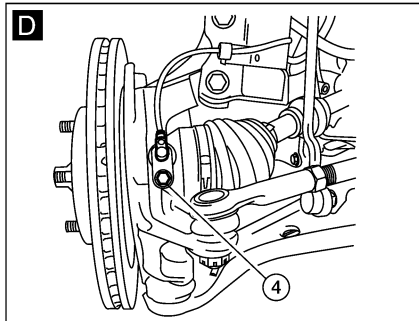
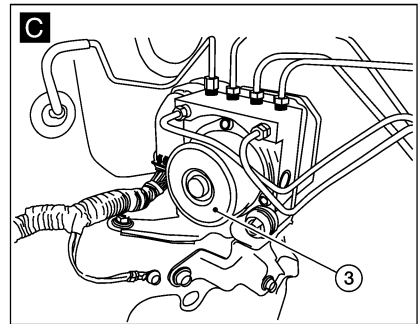
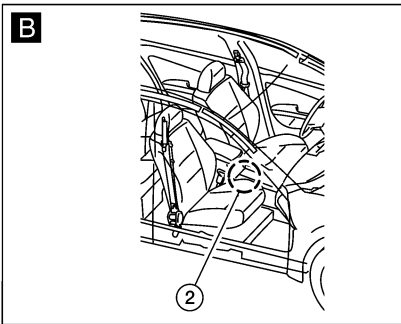
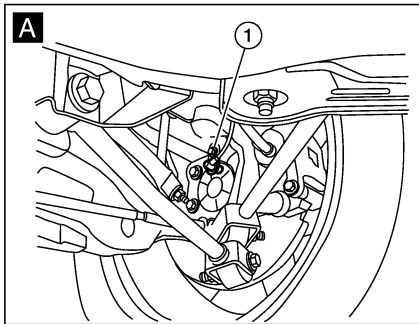

WFIA0493E

TROUBLE DIAGNOSIS

[VDC/TCS/ABS]

-
- | | | |
|-------------------------------|---|--|
| 1. Rear wheel sensor RH B122 | 2. Yaw rate/side/decel G sensor M46 | 3. ABS actuator and electric unit (control unit) E125 (engine removed for clarity) |
| 4. Front wheel sensor RH E117 | 5. Front wheel sensor LH E18 | 6. Combination meter M24 |
| 7. VDC OFF switch M6 | 8. Steering angle sensor M47 (steering wheel removed for clarity) | 9. Rear wheel sensor LH B123 |

Schematic

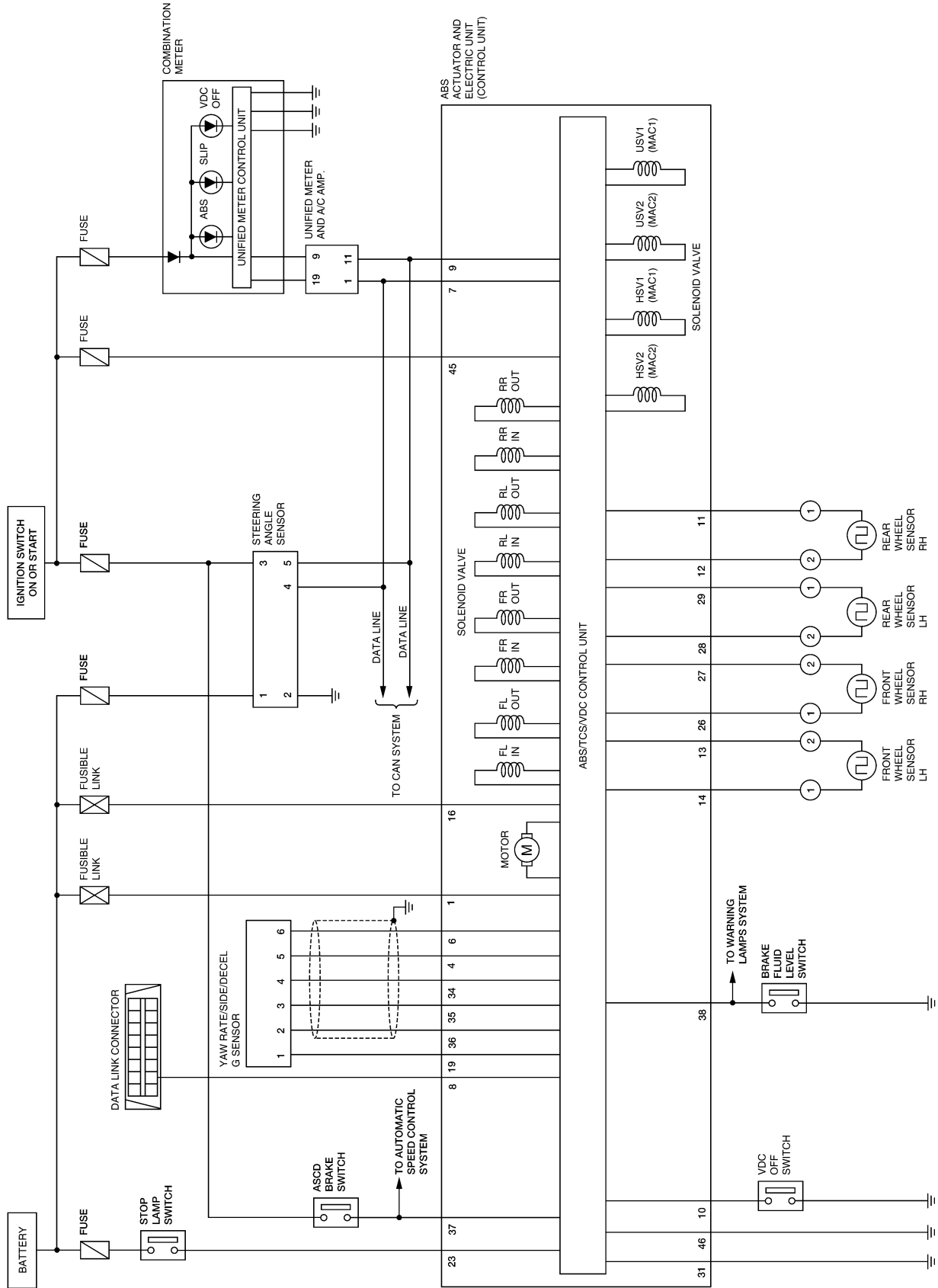

A
B
C
D
E
BRC
G
H
I
J
K
L
M

TROUBLE DIAGNOSIS

[VDC/TCS/ABS]

EFS004H1

Wiring Diagram — VDC —

BRC-VDC-01

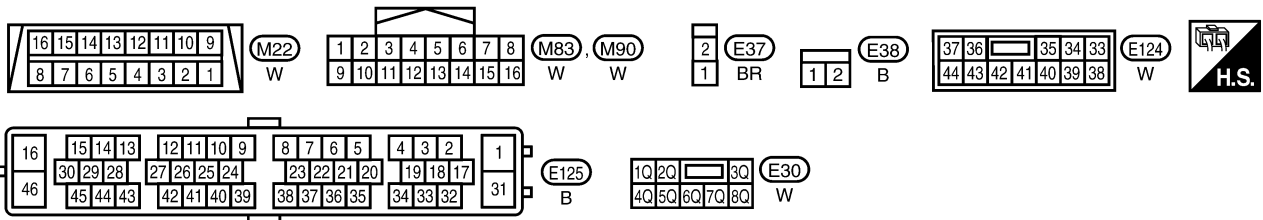
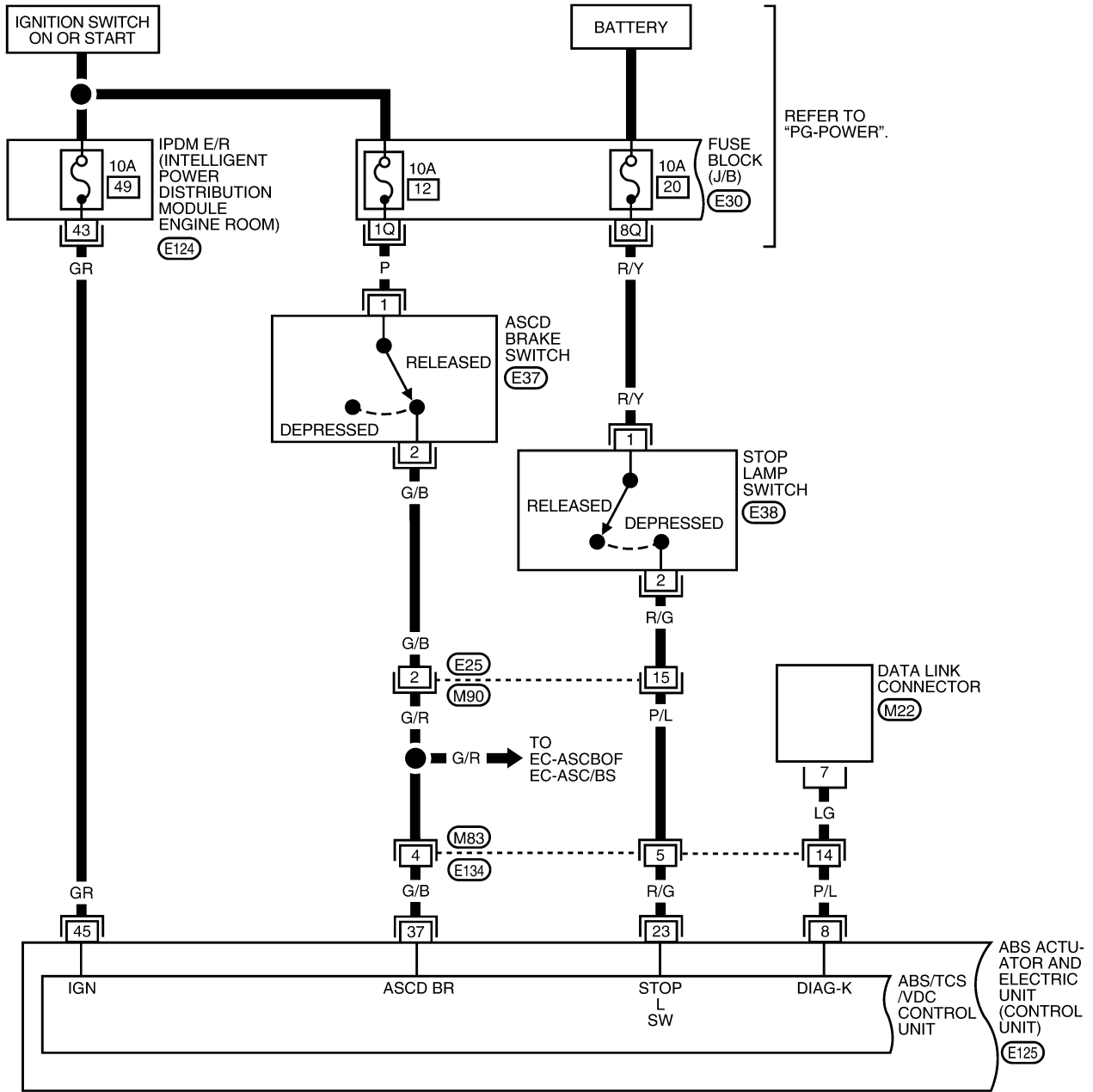

WFWA0429E

TROUBLE DIAGNOSIS

[VDC/TCS/ABS]

BRC-VDC-02

A
B
C
D
E
BRC
G
H
I
J
K
L
M

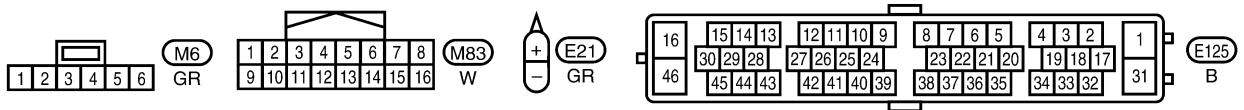
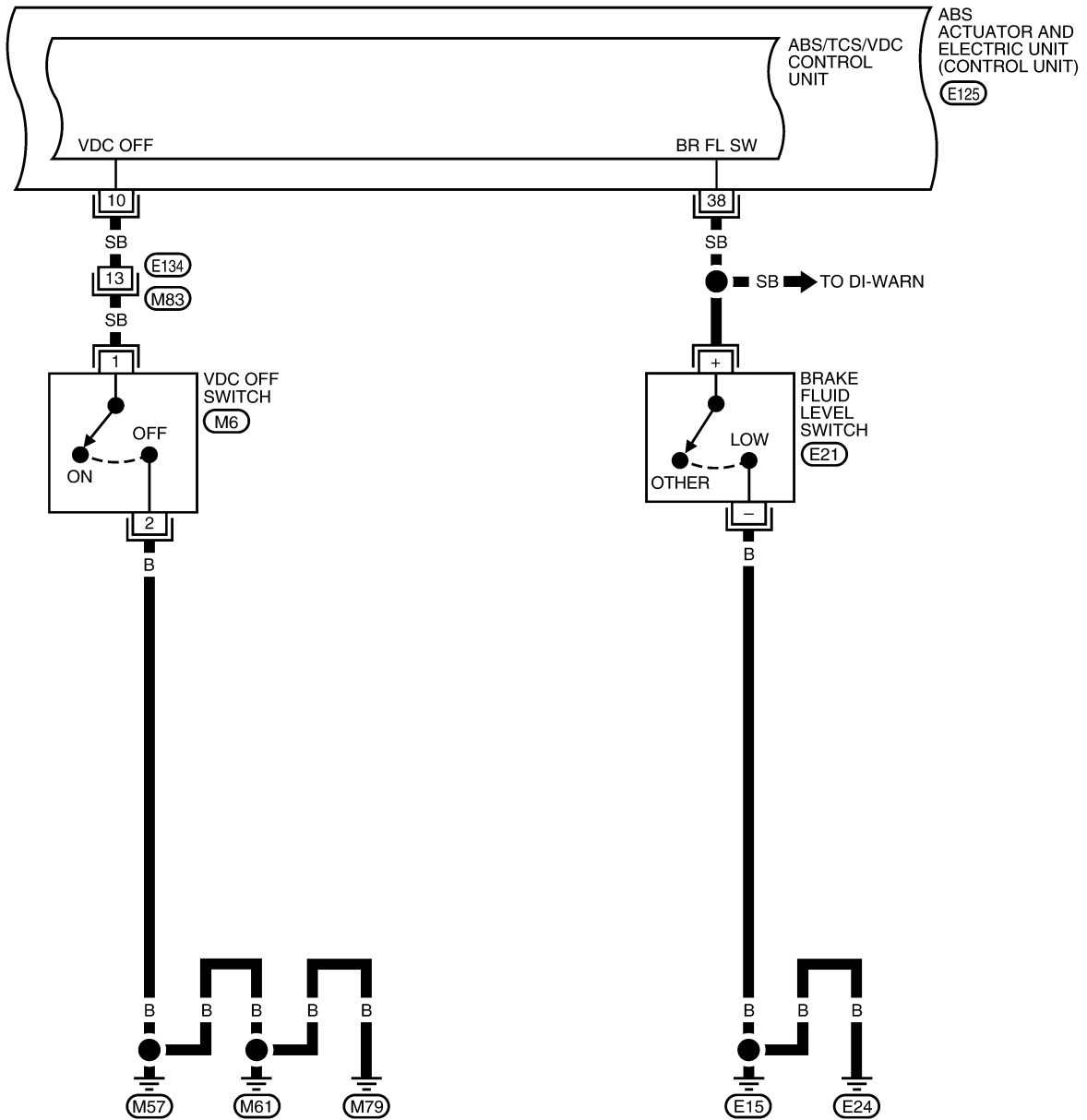

WFWA0430E

TROUBLE DIAGNOSIS

[VDC/TCS/ABS]

BRC-VDC-03

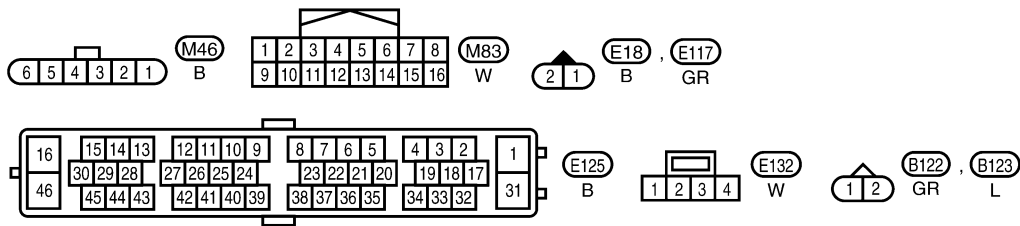
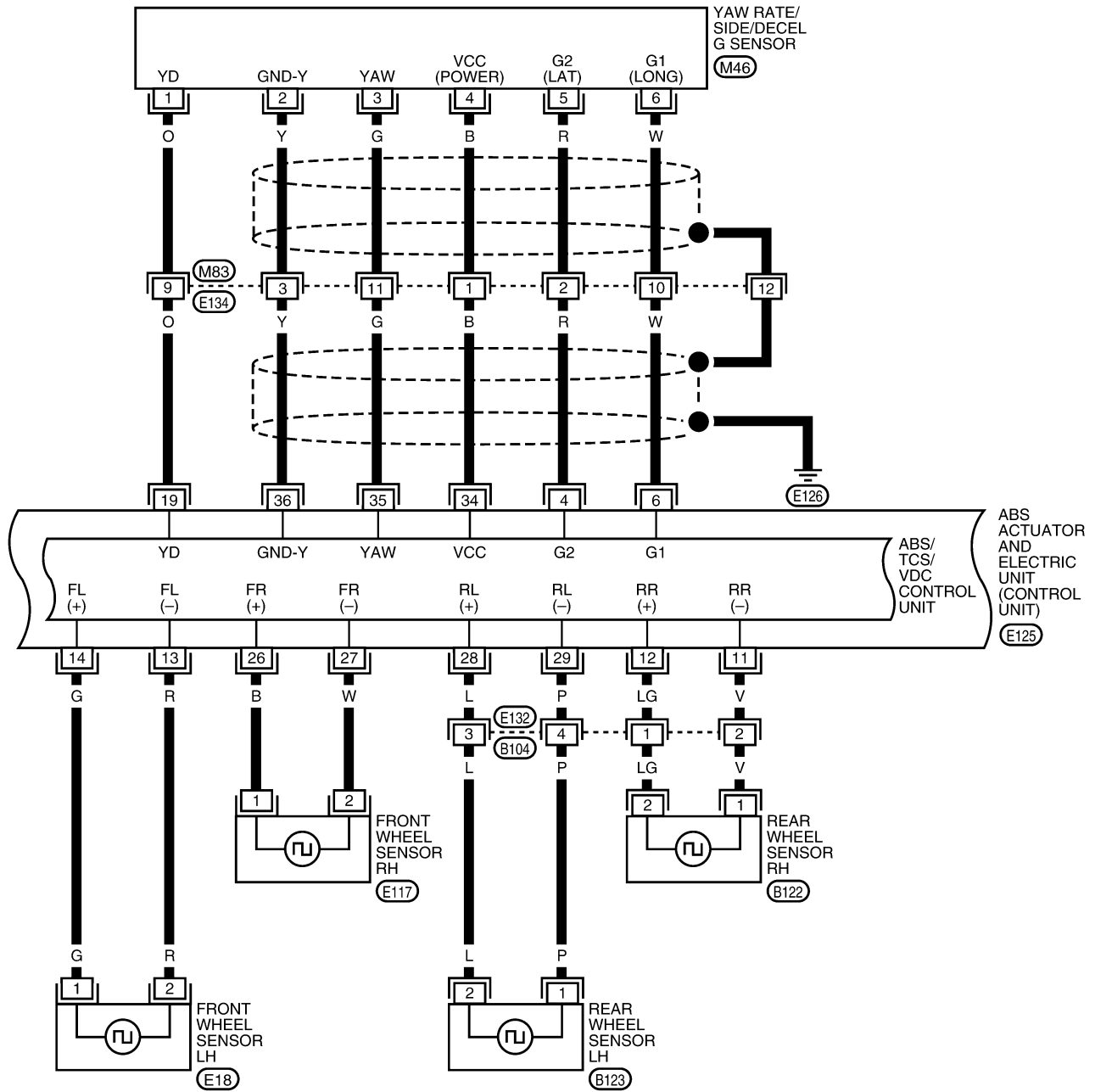

WFWA0431E

TROUBLE DIAGNOSIS

[VDC/TCS/ABS]

BRC-VDC-04

A
B
C
D
E
BRC
G
H
I
J
K
L
M

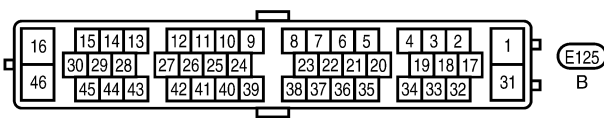
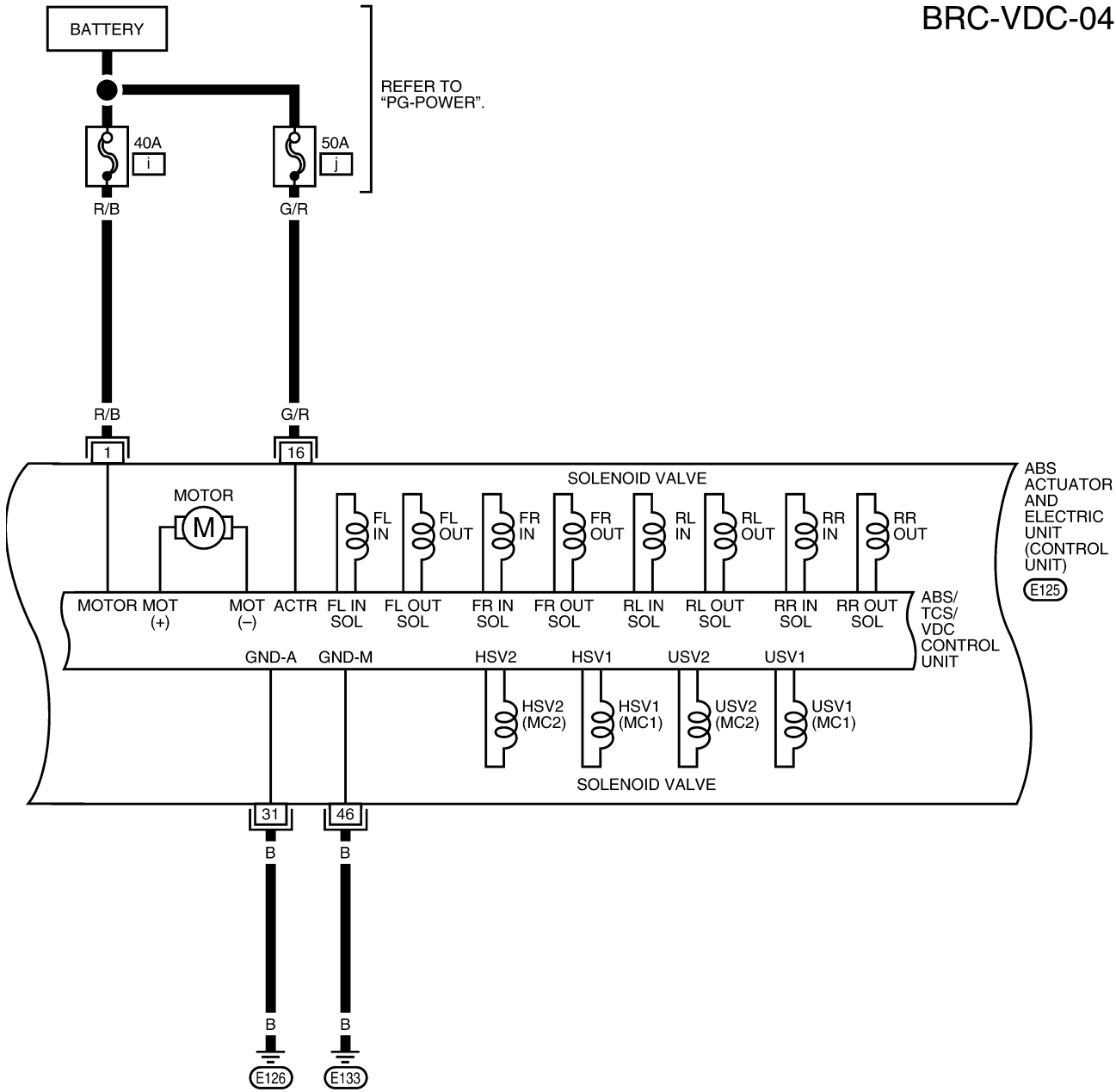

WFWA0432E

TROUBLE DIAGNOSIS

[VDC/TCS/ABS]

BRC-VDC-05

▬ : DATA LINE

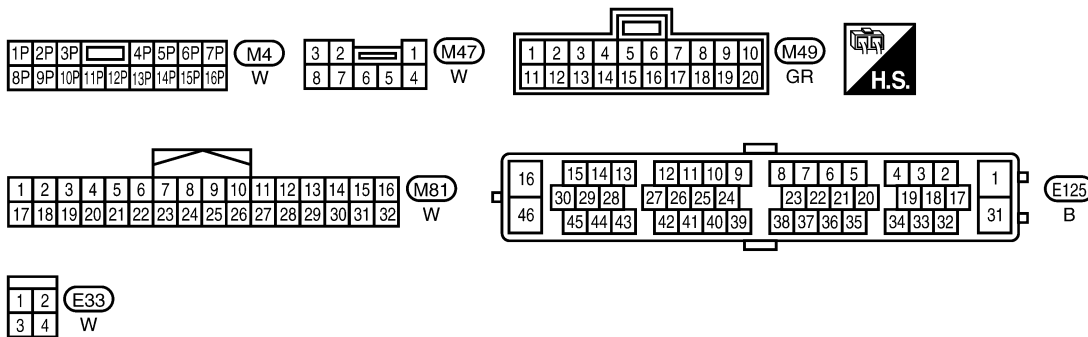
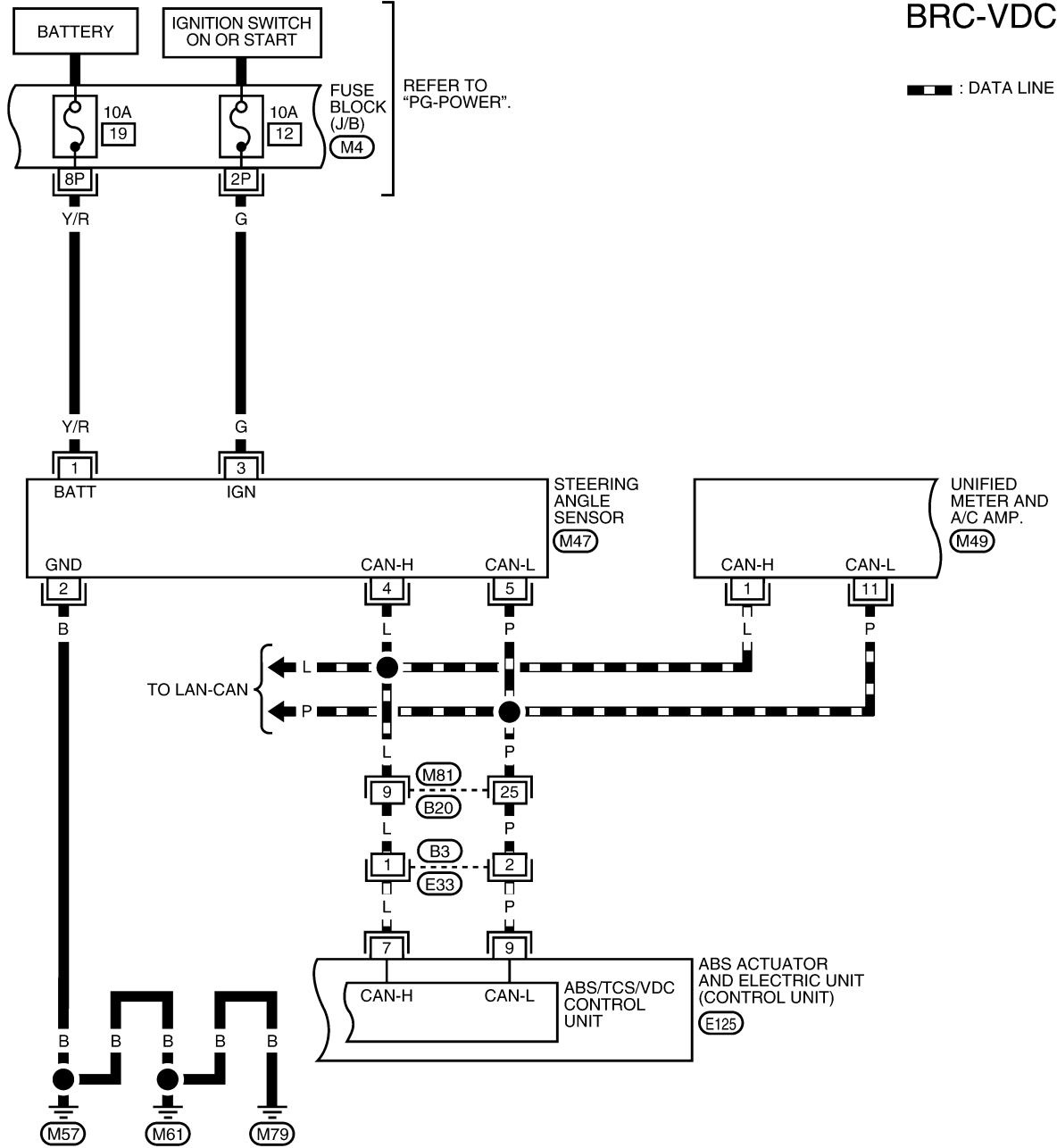

WFWA0433E

TROUBLE DIAGNOSIS

[VDC/TCS/ABS]

BRC-VDC-06

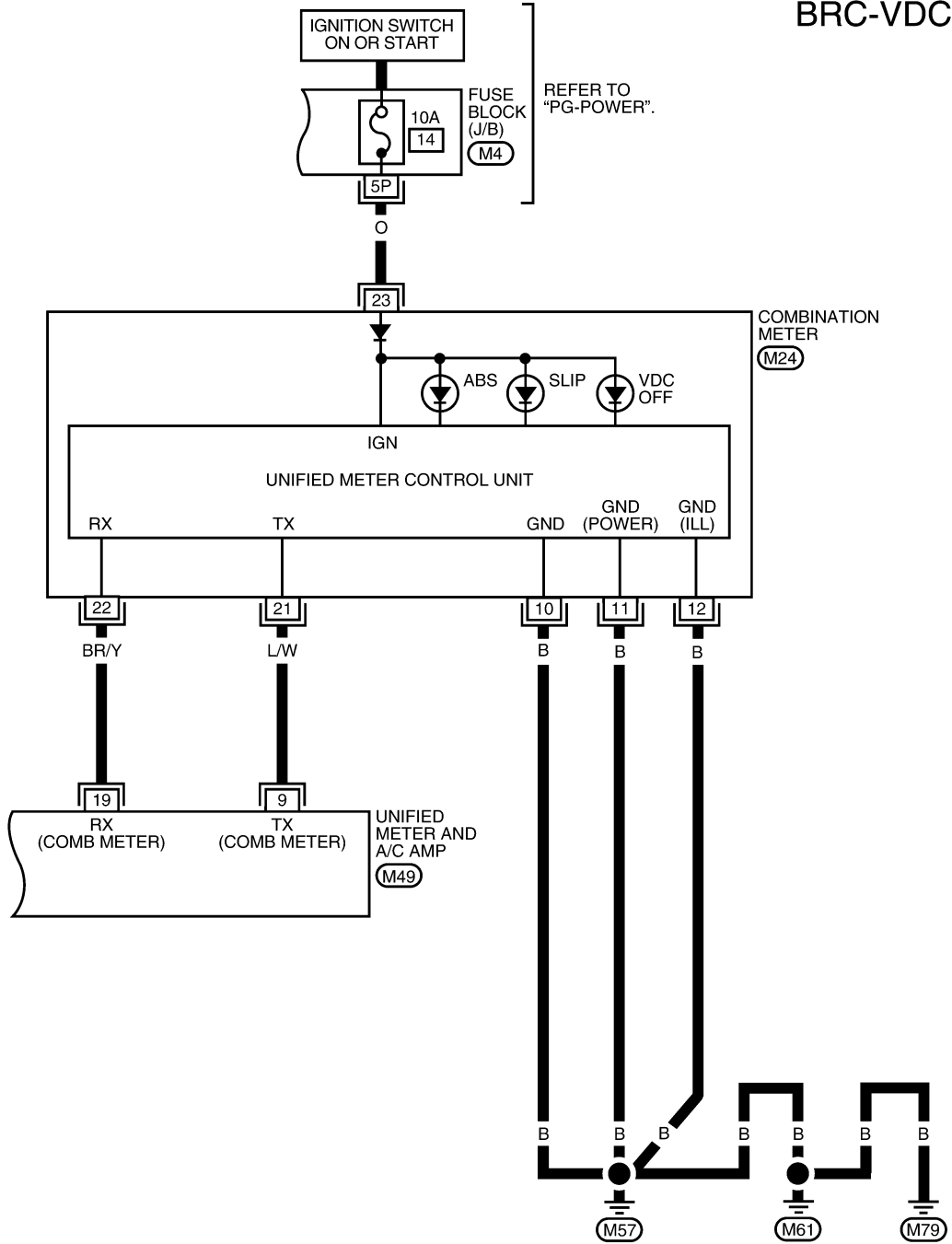

A
B
C
D
E
BRC
G
H
I
J
K
L
M

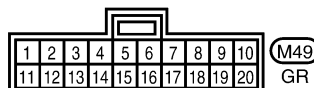
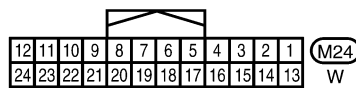
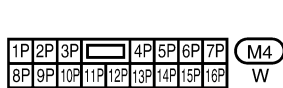

WFWA0434E

Basic Inspection**BRAKE FLUID LEVEL, FLUID LEAK, AND BRAKE PAD INSPECTION**

1. Check fluid level in the brake fluid reservoir. If fluid level is low, add fluid.
2. Check the brake piping and around the ABS actuator and electric unit (control unit) for leaks. If there is leaking or seeping fluid, check the following items.
 - If ABS actuator and electric unit (control unit) connection is loose, tighten the piping to the specified torque and recheck for leaks.
 - If there is damage to the connection flare nut or ABS actuator and electric unit (control unit) screw, replace the damaged part and recheck for leaks.
 - When there is fluid leaking or seeping from a fluid connection, use a clean cloth to wipe off the fluid and recheck for leaks. If fluid is still seeping out, replace the damaged part. If the fluid is leaking at the ABS actuator and electric unit (control unit), replace the ABS actuator and electric unit (control unit) assembly.

CAUTION:

The ABS actuator and electric unit (control unit) cannot be disassembled and must be replaced as an assembly.

3. Check the brake pads for excessive wear.

POWER SYSTEM TERMINAL LOOSENESS AND BATTERY INSPECTION

Make sure the battery positive cable, negative cable and ground connection are not loose. In addition, make sure the battery is sufficiently charged.

ABS WARNING LAMP, SLIP INDICATOR LAMP AND VDC OFF INDICATOR LAMP INSPECTION

1. Make sure ABS warning lamp, SLIP indicator lamp and VDC OFF indicator lamp (when VDC OFF switch is off), turn on for approximately 2 seconds when the ignition switch is turned ON. If they do not, check the VDC OFF indicator lamp and then VDC OFF switch. Refer to [BRC-87, "VDC OFF SWITCH"](#) . Check CAN communications. If there are no errors with VDC OFF switch and CAN communication system, check combination meter. Refer to [DI-5, "COMBINATION METERS"](#) .
2. Make sure the lamps turn off approximately 2 seconds after the ignition switch is turned ON. If the lamp does not turn off, conduct self-diagnosis.
3. With the engine running, make sure VDC OFF indicator lamp turns on and off when VDC OFF switch is turned on and off. If the indicator lamp status does not correspond to switch operation, check the VDC OFF switch system. Refer to [BRC-87, "VDC OFF SWITCH"](#) .
4. Make sure ABS warning lamp, SLIP indicator lamp and VDC OFF indicator lamp turn off approximately 2 seconds after the engine is started. If ABS warning lamp, SLIP indicator lamp or VDC OFF indicator lamp have not turned off 10 seconds after the engine has been started, conduct self-diagnosis of the ABS actuator and electric unit (control unit).
5. After conducting the self-diagnosis, be sure to erase the error memory. Refer to [BRC-70, "CONSULT-II Function \(ABS\)"](#) .

TROUBLE DIAGNOSIS

[VDC/TCS/ABS]

Warning Lamp and Indicator Timing

EFS004H3

×: ON –: OFF

Condition	ABS warning lamp	VDC OFF indicator lamp	SLIP indicator lamp	Remarks
When the ignition switch is OFF	–	–	–	–
After the ignition switch is turned ON For approx. 2 seconds	×	×	×	–
Ignition switch ON Approx. 2 seconds later	–	–	–	–
When the VDC OFF switch turns ON (VDC function OFF).	–	×	–	–
ABS/TCS/VDC malfunction	×	×	×	When the ABS/TCS/VDC control unit is malfunctioning (power supply or ground malfunction).
	×	×	–	
When the VDC is malfunctioning.	–	×	×	–

Control Unit Input/Output Signal Standard REFERENCE VALUE FROM CONSULT-II

EFS004H4

CAUTION:

The display shows the control unit calculation data, so a normal value might be displayed even in the event the output circuit (harness) is open or short circuited.

Monitor item	Display content	Data monitor		Note: Error inspection checklist
		Condition	Reference value in normal operation	
FR RH SENSOR FR LH SENSOR RR RH SENSOR RR LH SENSOR	Wheel speed	Vehicle stopped	0 [km/h (MPH)]	BRC-77. "Wheel Sensor System Inspection"
		Vehicle running (Note 1)	Almost in accordance with speedometer display (within ±10%)	
ACCEL POS SIG	Open/close condition of throttle valve (linked with accelerator pedal).	Accelerator pedal not depressed (ignition switch is ON)	0%	BRC-87. "CAN Communication System Inspection"
		Depress accelerator pedal (ignition switch is ON)	0 to 100%	
ENGINE SPEED	With engine running	With engine stopped	0 rpm	BRC-78. "Engine System Inspection"
		Engine running	Almost in accordance with tachometer display	
STR ANGLE SIG	Steering angle detected by steering angle sensor	Straight-ahead	Approx. 0 deg	BRC-79. "Steering Angle Sensor System Inspection"
		Steering wheel turned	–756 to 756 deg	
YAW RATE SEN	Yaw rate detected by yaw rate sensor	Vehicle stopped	Approx. 0 d/s	BRC-81. "Yaw Rate/Side/Decel G Sensor System Inspection"
		Vehicle running	–100 to 100 d/s	
SIDE G-SENSOR	Transverse G detected by side G-sensor	Vehicle stopped	Approx. 0 m/s ²	BRC-81. "Yaw Rate/Side/Decel G Sensor System Inspection"
		Vehicle running	–16.7 to 16.7 m/s ²	
BATTERY VOLT	Battery voltage supplied to ABS actuator and electric unit (control unit)	Ignition switch ON	10 to 16V	BRC-85. "ABS/TCS/VDC Control Unit Power and Ground Systems Inspection"
STOP LAMP SW	Brake pedal operation	Brake pedal depressed	ON	BRC-84. "Stop Lamp Switch System Inspection"
		Brake pedal not depressed	OFF	

TROUBLE DIAGNOSIS

[VDC/TCS/ABS]

Monitor item	Display content	Data monitor		Note: Error inspection checklist
		Condition	Reference value in normal operation	
OFF SW	VDC OFF switch ON/OFF status	VDC OFF switch ON (When VDC OFF indicator lamp is ON)	ON	BRC-87, "VDC OFF SWITCH"
		VDC OFF switch OFF (When VDC OFF indicator lamp is OFF)	OFF	
ABS WARN LAMP	ABS warning lamp ON condition (Note 2)	ABS warning lamp ON	ON	BRC-91, "ABS Warning Lamp Does Not Come On When Ignition Switch Is Turned On"
		ABS warning lamp OFF	OFF	
MOTOR RELAY	Operation status of motor and motor relay	Ignition switch ON or engine running (ABS not operated)	OFF	BRC-83, "Actuator Motor, Motor Relay, and Circuit Inspection"
		Ignition switch ON or engine running (ABS operated)	ON	
ACTUATOR RLY	Actuator relay operation status	Vehicle stopped (Ignition switch ON)	OFF	BRC-83, "Actuator Motor, Motor Relay, and Circuit Inspection"
		Vehicle stopped (Engine running)	ON	
OFF LAMP	VDC OFF indicator lamp status (Note 3)	When VDC OFF indicator lamp is ON	ON	BRC-87, "CAN Communication System Inspection"
		When VDC OFF indicator lamp is OFF	OFF	
SLIP LAMP	SLIP indicator lamp status (Note 4)	When SLIP indicator lamp is ON	ON	BRC-87, "CAN Communication System Inspection"
		When SLIP indicator lamp is OFF	OFF	
FR LH IN SOL FR LH OUT SOL FR RH IN SOL FR RH OUT SOL RR RH IN SOL RR RH OUT SOL RR LH IN SOL RR LH OUT SOL	Solenoid valve operation	Actuator (solenoid) is active ("ACTIVE TEST" with CONSULT-II) or actuator relay is inactive (in fail-safe mode).	ON	BRC-82, "Solenoid and VDC Change-Over Valve System Inspection"
		When actuator (solenoid) is not active and actuator relay is active (ignition switch ON).	OFF	
CV1 CV2 SV1 SV2	VDC switch-over valve status	When actuator (switch-over valve) is active ("ACTIVE TEST" with CONSULT-II) or actuator relay is inactive (when in fail-safe mode).	ON	BRC-82, "Solenoid and VDC Change-Over Valve System Inspection"
		When actuator (switch-over valve) is not active and actuator relay is active (ignition switch ON).	OFF	
DECEL G-SEN	Longitudinal acceleration detected by Decel G-Sensor	Vehicle stopped	ON	BRC-81, "Yaw Rate/Side/Decel G Sensor System Inspection"
		Vehicle running	OFF	
FLUID LEV SW	ON/OFF status of brake fluid level switch	When brake fluid level switch ON	ON	DI-39, "WARNING LAMPS"
		When brake fluid level switch OFF	OFF	
VDC FAIL SIG TCS FAIL SIG ABS FAIL SIG EBD FAIL SIG	Fail signal status	VDC fail TCS fail ABS fail EBD fail	OFF	VDC system TCS system ABS system EBD system

Note 1: Confirm tire pressure is normal.

TROUBLE DIAGNOSIS

[VDC/TCS/ABS]

Note 2: ON/OFF timing of ABS warning lamp

ON: For approximately 2 seconds after ignition switch is turned ON, or when a malfunction is detected.

OFF: Approximately 2 seconds after ignition switch is turned ON (when system is in normal operation) and TCS/VDC function is not activated.

Note 3: ON/OFF timing of VDC OFF indicator lamp

ON: For approximately 2 seconds after ignition switch is turned ON, or when a malfunction is detected and VDC OFF switch is ON.

OFF: Approximately 2 seconds after ignition switch is turned ON (when system is in normal operation.) And when VDC OFF switch is OFF.

Note 4: SLIP indicator lamp ON/OFF timing

ON: For approximately 2 seconds after ignition switch is turned ON, or when a malfunction is detected and TCS/VDC function is activated while driving.

OFF: Approximately 2 seconds after ignition switch is turned ON (when system is in normal operation) and TCS/VDC function is not activated.

Flashing: TCS/VDC function is active during driving

A

B

C

D

E

BRC

G

H

I

J

K

L

M

CONSULT-II Function (ABS)

CONSULT-II can display each diagnostic item using the diagnostic test modes shown following.

ABS diagnostic mode	Description
WORK SUPPORT	Supports inspection and adjustments. Commands are transmitted to the ABS actuator and electric unit (control unit) for setting the status suitable for required operation, input/output signals are received from the ABS actuator and electric unit (control unit) and received data is displayed.
SELF-DIAG RESULTS	Displays ABS actuator and electric unit (control unit) self-diagnosis results.
DATA MONITOR	Displays ABS actuator and electric unit (control unit) input/output data in real time.
CAN DIAG SUPPORT MNTR	The result of transmit/receive diagnosis of CAN communication can be read.
ACTIVE TEST	Operation of electrical loads can be checked by sending drive signal to them.
FUNCTION TEST	Conducted by CONSULT-II instead of a technician to determine whether each system is "OK" or "NG".
ECU PART NUMBER	ABS actuator and electric unit (control unit) part number can be read.

CONSULT-II START PROCEDURE

Refer to [GI-37, "CONSULT-II Start Procedure"](#) .

SELF-DIAGNOSIS**Description**

If an error is detected in the system, the ABS warning lamp will turn on. In this case, perform self-diagnosis as follows:

Operation Procedure

1. Turn ignition switch OFF.
2. Connect CONSULT-II and CONSULT-II CONVERTER to the data link connector.

CAUTION:

If CONSULT-II is used with no connection of CONSULT-II CONVERTER, malfunctions might be detected in self-diagnosis depending on control unit which carries out CAN communication.

3. Turn ignition switch ON.
4. Start engine and drive at approximately 30 km/h (19 MPH) for approximately 1 minute.
5. After stopping the vehicle, with the engine running, touch "START (NISSAN BASED VHCL)", "ABS", "SELF-DIAG RESULTS" in order on the CONSULT-II screen.

CAUTION:

If "START (NISSAN BASED VHCL)" is touched immediately after starting the engine or turning on the ignition switch, "ABS" might not be displayed in the SELECT SYSTEM screen. In this case, repeat the operation from step 1.

6. The self-diagnostic results are displayed. (If necessary, the self-diagnostic results can be printed out by touching "COPY".)
 - When "NO DTC IS DETECTED" is displayed, check the ABS warning lamp, SLIP indicator lamp and VDC OFF indicator lamp.
7. Conduct the appropriate inspection from the display item list, and repair or replace the malfunctioning component.
8. Start engine and drive at approximately 30 km/h (19 MPH) for approximately 1 minute.

CAUTION:

● When a wheel sensor "short-circuit" is detected, if the vehicle is not driven at 30 km/h (19 MPH) for at least 1 minute, the ABS warning lamp will not turn off even if the malfunction is repaired.

9. Turn ignition switch OFF to prepare for erasing the memory.
10. Start the engine and touch "START (NISSAN BASED VHCL)", "ABS", "SELF-DIAG RESULTS", "ERASE" in order on the CONSULT-II screen to erase the error memory.

If "ABS" is not indicated, go to [GI-39, "CONSULT-II Data Link Connector \(DLC\) Circuit"](#) .

CAUTION:

If the error memory is not erased, re-conduct the operation from step 5.

TROUBLE DIAGNOSIS

[VDC/TCS/ABS]

11. For the final inspection, drive at approximately 30 km/h (19 MPH) for approximately 1 minute and confirm that the ABS warning lamp, SLIP indicator lamp, and VDC OFF indicator lamp are off.

Display Item List

Self-diagnostic item	Malfunction detecting condition	Check system	
FR LH SENSOR 1 [C1104]	Circuit of front LH wheel sensor is open.	BRC-77. "Wheel Sensor System Inspection" (Note 1)	
RR RH SENSOR 1 [C1101]	Circuit of rear RH wheel sensor is open.		
FR RH SENSOR 1 [C1103]	Circuit of front RH wheel sensor is open.		
RR LH SENSOR 1 [C1102]	Circuit of rear LH wheel sensor is open.		
FR LH SENSOR 2 [C1108]	Circuit of front LH wheel sensor is shorted, or sensor power voltage is unusual. ABS actuator and electric unit (control unit) cannot identify sensor pulses, because of large gap between wheel sensor and sensor rotor.		
RR RH SENSOR 2 [C1105]	Circuit of rear RH wheel sensor is shorted, or sensor power voltage is unusual. ABS actuator and electric unit (control unit) cannot identify sensor pulses, because of large gap between wheel sensor and sensor rotor.		
FR RH SENSOR 2 [C1107]	Circuit of front RH wheel sensor is shorted, or sensor power voltage is unusual. ABS actuator and electric unit (control unit) cannot identify sensor pulses, because of large gap between wheel sensor and sensor rotor.		
RR LH SENSOR 2 [C1106]	Circuit of rear LH wheel sensor is shorted, or sensor power voltage is unusual. ABS actuator and electric unit (control unit) cannot identify sensor pulses, because of large gap between wheel sensor and sensor rotor.		
STOP LAMP SW 1 [C1116]	Stop lamp switch or circuit malfunction.		BRC-84. "Stop Lamp Switch System Inspection"
ST ANGLE SEN CIRCUIT [C1143, C1163]	Neutral position of steering angle sensor is dislocated, or steering angle sensor is malfunctioning.		BRC-79. "Steering Angle Sensor System Inspection"
YAW RATE SENSOR [C1145]	Yaw rate sensor has generated an error, or yaw rate sensor signal line is open or shorted.	BRC-81. "Yaw Rate/Side/Decel G Sensor System Inspection"	

A
B
C
D
E
BRC
G
H
I
J
K
L
M

TROUBLE DIAGNOSIS

[VDC/TCS/ABS]

Self-diagnostic item	Malfunction detecting condition	Check system	
FR LH IN ABS SOL [C1120]	Circuit of front LH IN ABS solenoid is open or shorted, or control line is open or shorted to power supply or ground.	BRC-82. "Solenoid and VDC Change-Over Valve System Inspection"	
FR LH OUT ABS SOL [C1121]	Circuit of front LH OUT ABS solenoid is open or shorted, or control line is open or shorted to power supply or ground.		
RR RH IN ABS SOL [C1126]	Circuit of rear RH IN ABS solenoid is open or shorted, or control line is open or shorted to power supply or ground.		
RR RH OUT ABS SOL [C1127]	Circuit of rear RH OUT ABS solenoid is open or shorted, or control line is open or shorted to power supply or ground.		
FR RH IN ABS SOL [C1122]	Circuit of front RH IN ABS solenoid is open or shorted, or control line is open or shorted to power supply or ground.		
FR RH OUT ABS SOL [C1123]	Circuit of front RH OUT ABS solenoid is open or shorted, or control line is open or shorted to power supply or ground.		
RR LH IN ABS SOL [C1124]	Circuit of rear LH IN ABS solenoid is open or shorted, or control line is open or shorted to power supply or ground.		
RR LH OUT ABS SOL [C1125]	Circuit of rear LH OUT ABS solenoid is open or shorted, or control line is open or shorted to power supply or ground.		
CV1 [C1164]	Front side VDC switch-over solenoid valve (cut valve) is open or shorted, or control line is open or shorted to power supply or ground.		
CV2 [C1165]	Rear side VDC switch-over solenoid valve (cut valve) is open or shorted, or control line is open or shorted to power supply or ground.		
SV1 [C1166]	Front side VDC switch-over solenoid valve (suction valve) is open or shorted, or control line is open or shorted to power supply or ground.		
SV2 [C1167]	Rear side VDC switch-over solenoid valve (suction valve) is open or shorted, or control line is open or shorted to power supply or ground.		
PUMP MOTOR (Note 3) [C1111]	During actuator motor operation with ON, when actuator motor turns OFF or when control line for actuator motor relay is open.		BRC-83. "Actuator Motor, Motor Relay, and Circuit Inspection"
	During actuator motor operation with OFF, when actuator motor turns ON or when control line for relay is shorted to ground.		
BATTERY VOLTAGE [ABNORMAL] [C1109]	ABS actuator and electric unit (control unit) power voltage is too low.	BRC-85. "ABS/TCS/VDC Control Unit Power and Ground Systems Inspection"	
ST ANGLE SEN SIGNAL [C1144]	Neutral position correction of steering angle sensor is not finished.	BRC-79. "Steering Angle Sensor System Inspection"	
ST ANG SEN COM CIR [C1156]	CAN communication line or steering angle sensor has generated an error.		
LONGITUDINAL G-SENSOR [C1113]	Longitudinal G-sensor is malfunctioning, or signal line of longitudinal G-sensor is open or shorted.	BRC-81. "Yaw Rate/Side/Decel G Sensor System Inspection"	
CONTROLLER FAILURE [C1110]	Internal malfunction of ABS actuator and electric unit (control unit) or wheel speed signal malfunction.	BRC-79. "ABS/TCS/VDC Control Unit Inspection"	
CAN COMM CIRCUIT [U1000]	<ul style="list-style-type: none"> ● CAN communication line is open or shorted. ● ABS actuator and electric unit (control unit) internal malfunction ● Battery voltage for ECM is suddenly interrupted for approximately 0.5 seconds or more. 	BRC-87. "CAN Communication System Inspection" (Note 2)	
LATERAL G-SENSOR [C1146]	Lateral G-sensor is malfunctioning, or signal line of lateral G-sensor is open or shorted.	BRC-81. "Yaw Rate/Side/Decel G Sensor System Inspection"	

TROUBLE DIAGNOSIS

[VDC/TCS/ABS]

Self-diagnostic item	Malfunction detecting condition	Check system
BR FLUID LEVEL LOW [C1155]	Brake fluid level drops or circuit between ABS actuator and electric unit (control unit) and brake fluid level switch is open or shorted.	BRC-86. "Brake Fluid Level Switch System Inspection"
ENGINE SIGNAL 1 [C1130]	ECM judges the communication between ABS/TCS/VDC control unit and ECM is abnormal.	BRC-78. "Engine System Inspection"
ENGINE SIGNAL 2 [C1131]	ECM judges the communication between ABS/TCS/VDC control unit and ECM is abnormal.	
ENGINE SIGNAL 3 [C1132]	ECM judges the communication between ABS/TCS/VDC control unit and ECM is abnormal.	
ENGINE SIGNAL 4 [C1133]	ECM judges the communication between ABS/TCS/VDC control unit and ECM is abnormal.	
ENGINE SIGNAL 5 [C1134]	ECM judges the communication between ABS/TCS/VDC control unit and ECM is abnormal.	
ENGINE SIGNAL 6 [C1136]	ECM judges the communication between ABS/TCS/VDC control unit and ECM is abnormal.	
ACTUATOR RLY [C1140]	ABS actuator or relay circuit malfunction.	BRC-83. "Actuator Motor, Motor Relay, and Circuit Inspection"
STOP LAMP SW 2 [C1176]	ASCD brake switch or circuit malfunction.	EC-524. "DTC P1572 ASCD BRAKE SWITCH"

Note 1. If wheel sensor 2 for each wheel is indicated, check ABS actuator and electric unit (control unit) power supply voltage in addition to wheel sensor circuit check.

Note 2. If multiple malfunctions are detected including CAN communication line [U1000], perform diagnosis for CAN communication line first.

DATA MONITOR

Operation Procedure

- After turning OFF the ignition switch, connect CONSULT-II and CONSULT-II CONVERTER to the data link connector.

CAUTION:

If CONSULT-II is used with no connection of CONSULT-II CONVERTER, malfunctions might be detected in self-diagnosis depending on control unit which carries out CAN communication.

- Touch "START (NISSAN BASED VHCL)", "ABS", "DATA MONITOR" in order on the CONSULT-II screen. If "ABS" is not indicated, go to [GI-39. "CONSULT-II Data Link Connector \(DLC\) Circuit"](#).

CAUTION:

When "START (NISSAN BASED VHCL)" is touched immediately after starting the engine or turning on the ignition switch, "ABS" might not be displayed in the SELECT SYSTEM screen. In this case, repeat the operation from step 2.

- Return to the SELECT MONITOR ITEM screen, and touch "ECU INPUT SIGNALS", "MAIN SIGNALS" or "SELECTION FROM MENU". Refer to the following information.
- When "START" is touched, the data monitor screen is displayed.

Display Item List

Item (Unit)	Data monitor item selection			Remarks
	ECU INPUT SIGNALS	MAIN SIGNALS	SELECTION FROM MENU	
GEAR	×	×	×	This item is not used for this model. "1" is always displayed.
FR RH SENSOR (km/h, MPH)	×	×	×	Wheel speed calculated by front RH wheel sensor signal is displayed.
FR LH SENSOR (km/h, MPH)	×	×	×	Wheel speed calculated by front LH wheel sensor signal is displayed.

TROUBLE DIAGNOSIS

[VDC/TCS/ABS]

Item (Unit)	Data monitor item selection			Remarks
	ECU INPUT SIGNALS	MAIN SIGNALS	SELECTION FROM MENU	
RR RH SENSOR (km/h, MPH)	×	×	×	Wheel speed calculated by rear RH wheel sensor signal is displayed.
RR LH SENSOR (km/h, MPH)	×	×	×	Wheel speed calculated by rear LH wheel sensor signal is displayed.
BATTERY VOLT (V)	×	×	×	Voltage supplied to ABS actuator and electric unit (control unit) is displayed.
ACCEL POS SIG (%)	×	-	×	Throttle valve open/close status judged by LAN communication signal is displayed.
ENGINE SPEED (rpm)	×	×	×	Engine speed judged by LAN communication signal is displayed.
STR ANGLE SIG (deg)	×	-	×	Steering angle detected by steering angle sensor is displayed.
YAW RATE SEN (d/s)	×	×	×	Yaw rate detected by yaw rate sensor is displayed.
DECEL G-SEN (d/s)	×	×	×	Longitudinal acceleration detected by Decel G-sensor is displayed.
SIDE G-SENSOR (m/s ²)	×	-	×	Transverse acceleration detected by side G-sensor is displayed.
STOP LAMP SW (ON/OFF)	×	×	×	Stop lamp switch (ON/OFF) status is displayed.
OFF SW (ON/OFF)	×	×	×	VDC OFF switch (ON/OFF) status is displayed.
ABS WARN LAMP (ON/OFF)	-	×	×	ABS warning lamp (ON/OFF) status is displayed.
SLIP LAMP (ON/OFF)	-	×	×	SLIP indicator lamp (ON/OFF) status is displayed.
FR LH IN SOL (ON/OFF)	-	×	×	Front LH IN ABS solenoid (ON/OFF) status is displayed.
FR LH OUT SOL (ON/OFF)	-	×	×	Front LH OUT ABS solenoid (ON/OFF) status is displayed.
RR RH IN SOL (ON/OFF)	-	×	×	Rear RH IN ABS solenoid (ON/OFF) status is displayed.
RR RH OUT SOL (ON/OFF)	-	×	×	Rear RH OUT ABS solenoid (ON/OFF) status is displayed.
FR RH IN SOL (ON/OFF)	-	×	×	Front RH IN ABS solenoid (ON/OFF) status is displayed.
FR RH OUT SOL (ON/OFF)	-	×	×	Front RH OUT ABS solenoid (ON/OFF) status is displayed.
RR LH IN SOL (ON/OFF)	-	×	×	Rear LH IN ABS solenoid (ON/OFF) status is displayed.
RR LH OUT SOL (ON/OFF)	-	×	×	Rear LH OUT ABS solenoid (ON/OFF) status is displayed.
OFF LAMP (ON/OFF)	-	×	×	OFF Lamp (ON/OFF) status is displayed.
MOTOR RELAY (ON/OFF)	-	×	×	ABS motor relay signal (ON/OFF) status is displayed.
ACTUATOR RLY (ON/OFF)	-	×	×	ABS actuator relay signal (ON/OFF) status is displayed.

TROUBLE DIAGNOSIS

[VDC/TCS/ABS]

Item (Unit)	Data monitor item selection			Remarks
	ECU INPUT SIGNALS	MAIN SIGNALS	SELECTION FROM MENU	
EBD WARN LAMP (ON/OFF)	-	-	×	Brake warning lamp (ON/OFF) status is displayed.
P POSI SIG (ON/OFF)	-	-	×	Shift position judged by PNP switch signal.
N POSI SIG (ON/OFF)	-	-	×	Shift position judged by PNP switch signal.
CRANKING SIG (ON/OFF)	-	-	×	Ignition switch START position signal input status is displayed.
CV1 (ON/OFF)	-	-	×	Front side switch-over solenoid valve (cut valve) (ON/OFF) status is displayed.
CV2 (ON/OFF)	-	-	×	Rear side switch-over solenoid valve (cut-valve) (ON/OFF) status is displayed.
SV1 (ON/OFF)	-	-	×	Front side switch-over solenoid valve (suction valve) (ON/OFF) status is displayed.
SV2 (ON/OFF)	-	-	×	Rear side switch-over solenoid valve (suction valve) (ON/OFF) status is displayed.
VDC FAIL SIG (ON/OFF)	-	-	×	VDC fail signal (ON/OFF) status is displayed.
TCS FAIL SIG (ON/OFF)	-	-	×	TCS fail signal (ON/OFF) status is displayed.
ABS FAIL SIG (ON/OFF)	-	-	×	ABS fail signal (ON/OFF) status is displayed.
EBD FAIL SIG (ON/OFF)	-	-	×	EBD fail signal (ON/OFF) status is displayed.
FLUID LEV SW (ON/OFF)	×	-	×	Brake fluid level switch (ON/OFF) status is displayed.
EBD SIGNAL (ON/OFF)	-	-	×	EBD operation (ON/OFF) status is displayed.
ABS SIGNAL (ON/OFF)	-	-	×	ABS operation (ON/OFF) status is displayed.
TCS SIGNAL (ON/OFF)	-	-	×	TCS operation (ON/OFF) status is displayed.
VDC SIGNAL (ON/OFF)	-	-	×	VDC operation (ON/OFF) status is displayed.
STOP LAMP SW2	-	-	×	ASCD (ON/OFF) status is displayed.

×: Applicable

-: Not applicable

ACTIVE TEST

CAUTION:

- Do not perform active test while driving.
- Make sure to completely bleed air from the brake system.
- The ABS and BRAKE warning lamps turn on during the active test.

Operation Procedure

1. Connect the CONSULT-II and CONSULT-II CONVERTER to the data link connector and start the engine.

CAUTION:

If CONSULT-II is used with no connection of CONSULT-II CONVERTER, malfunctions might be detected in self-diagnosis depending on control unit which carries out CAN communication.

2. Touch "START (NISSAN BASED VHCL)" on the display screen.
3. Touch "ABS".
If "ABS" is not indicated, go to [GI-39, "CONSULT-II Data Link Connector \(DLC\) Circuit"](#).
4. Touch "ACTIVE TEST".
5. The "SELECT TEST ITEM" screen is displayed.
6. Touch necessary test item.

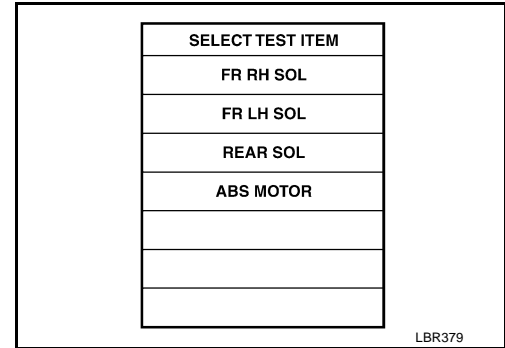

7. With the "MAIN SIGNALS" display selected, touch "START".
8. The Active Test screen will be displayed, so conduct the following test.

Solenoid Valve Operation Chart

Operation		ABS solenoid valve			ABS solenoid valve (ACT)		
		UP	KEEP	DOWN	UP	ACTUA-TOR UP	ACTUA-TOR KEEP
FR RH SOL FR RH ABS SOLE- NOID (ACT)	FR RH IN SOL	OFF	ON	ON	OFF	OFF	OFF
	FR RH OUT SOL	OFF	OFF	ON*	OFF	OFF	OFF
FR LH SOL FR LH ABS SOLE- NOID (ACT)	FR LH IN SOL	OFF	ON	ON	OFF	OFF	OFF
	FR LH OUT SOL	OFF	OFF	ON*	OFF	OFF	OFF
RR RH SOL RR RH ABS SOLE- NOID (ACT)	RR RH IN SOL	OFF	ON	ON	OFF	OFF	OFF
	RR RH OUT SOL	OFF	OFF	ON*	OFF	OFF	OFF
RR LH SOL RR LH ABS SOLE- NOID (ACT)	RR LH IN SOL	OFF	ON	ON	OFF	OFF	OFF
	RR LH OUT SOL	OFF	OFF	ON*	OFF	OFF	OFF

*: ON for 1 to 2 seconds after the touch, and then OFF

NOTE:

- If active test is performed with brake pedal depressed, pedal stroke may change. This is normal.
- "TEST IS STOPPED" is displayed approximately 10 seconds after operation starts.
- After "TEST IS STOPPED" is displayed, to perform test again, repeat Step 6.

ABS Motor

Touch "ON" and "OFF" on the screen. Check that ABS motor relay operates as shown in table below.

Operation	ON	OFF
ABS actuator relay	ON	ON
ABS motor relay	ON	OFF

NOTE:

- If active test is performed with brake pedal depressed, pedal stroke may change. This is normal.
- "TEST IS STOPPED" is displayed approximately 10 seconds after operation starts.

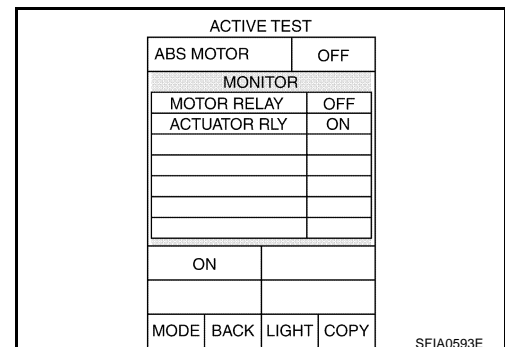

TROUBLE DIAGNOSIS FOR SELF-DIAGNOSTIC ITEMS

PFP:00000

Wheel Sensor System Inspection

EFS004H6

INSPECTION PROCEDURE

1. CONNECTOR INSPECTION

Disconnect the ABS actuator and electric unit (control unit) connector E125 and wheel sensor of malfunctioning code.

Check the terminals for deformation, disconnection, looseness or damage.

OK or NG

OK >> GO TO 2.

NG >> Repair or replace as necessary.

2. CHECK WHEEL SENSOR OUTPUT SIGNAL

1. Disconnect connector from wheel sensor of malfunction code No.

2. Connect ABS active wheel sensor tester (J-45741) to wheel sensor using appropriate adapter.

3. Turn on the ABS active wheel sensor tester power switch.

NOTE:

The green POWER indicator should illuminate. If the POWER indicator does not illuminate, replace the battery in the ABS active wheel sensor tester before proceeding.

4. Spin the wheel of the vehicle by hand and observe the red SENSOR indicator on the ABS active wheel sensor tester. The red SENSOR indicator should flash on and off to indicate an output signal.

NOTE:

If the red SENSOR indicator illuminates but does not flash, reverse the polarity of the tester leads and retest.

Does the ABS active wheel sensor tester detect a signal?

YES >> GO TO 3.

NO >> GO TO 6.

3. CHECK TIRES

Check for inflation pressure, wear and size of each tire.

Are tire pressure and size correct and is tire wear within specifications?

YES >> GO TO 4.

NO >> Adjust tire pressure or replace tire(s).

4. CHECK WHEEL BEARINGS

Check wheel bearing axial end play. Refer to [FAX-5, "FRONT WHEEL BEARING"](#) or [RAX-5, "REAR WHEEL BEARING"](#).

OK or NG

OK >> GO TO 5.

NG >> Repair as necessary. Refer to [FAX-5, "FRONT WHEEL BEARING"](#) or [RAX-5, "REAR WHEEL BEARING"](#).

5. CHECK SENSOR ROTORS

Check sensor rotors for tooth damage.

OK or NG

OK >> GO TO 6.

NG >> Replace sensor rotor. Refer to [BRC-95, "Removal and Installation"](#).

6. CHECK WIRING HARNESS FOR SHORT CIRCUIT

1. Disconnect ABS actuator and electric unit (control unit) connector and wheel sensor connector of malfunction code No.
2. Check continuity between harness connector terminal and ground.

Continuity should not exist.

OK or NG

- OK >> GO TO 7.
- NG >> Repair the circuit.

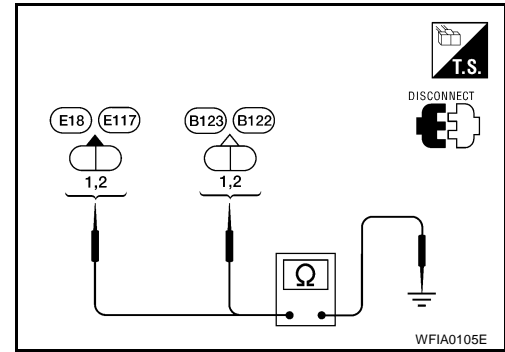

7. CHECK WIRING HARNESS FOR OPEN CIRCUIT

1. Disconnect ABS actuator and electric unit (control unit) connector and wheel sensor connector of malfunction code No.
2. Check continuity between both wiring harness ends.

Sensor	ABS actuator and electric unit (control unit)		Wheel sensor		Continuity
	Connector	Terminals	Connector	Terminals	
Front LH	E125	14	E18	1	Yes
		13		2	
Front RH		26	E117	1	
		27		2	
Rear LH		29	B123	1	
		28		2	
Rear RH		11	B122	1	
		12		2	

OK or NG

- OK >> Replace the ABS actuator and electric unit (control unit). Refer to [BRC-43, "Removal and Installation"](#).
- NG >> Repair the circuit.

Engine System Inspection

EFS004H7

INSPECTION PROCEDURE

1. SELF-DIAGNOSIS RESULT CHECK

Check self-diagnosis results.

Self-diagnosis results
ENGINE SIGNAL 1
ENGINE SIGNAL 2
ENGINE SIGNAL 3
ENGINE SIGNAL 4
ENGINE SIGNAL 5
ENGINE SIGNAL 6

Is the above displayed in the self-diagnosis display items?

- YES >> GO TO 2.
- NO >> Inspection End.

2. ENGINE SYSTEM INSPECTION

1. Perform ECM self-diagnosis and repair as necessary.
2. Perform ABS actuator and electric unit (control unit) self-diagnosis again.

OK or NG

- OK >> Inspection End.
 NG >> Repair as necessary.

ABS/TCS/VDC Control Unit Inspection

EFS004H8

INSPECTION PROCEDURE

1. SELF-DIAGNOSIS RESULT CHECK

Check self-diagnosis results.

Self-diagnosis results
CONTROLLER FAILURE

Is the above displayed in the self-diagnosis display items?

- YES >> GO TO 2.
 NO >> Inspection End.

2. CHECK WHEEL SENSORS

Check all wheel sensors. Refer to [BRC-77, "Wheel Sensor System Inspection"](#) .

OK or NG

- OK >> Replace ABS actuator and electric unit (control unit). Refer to [BRC-96, "Removal and Installation"](#)
 NG >> Repair or replace as necessary.

Steering Angle Sensor System Inspection

EFS004H9

INSPECTION PROCEDURE

1. SELF-DIAGNOSIS RESULT CHECK

Check self-diagnosis results.

Self-diagnosis results
ST ANGLE SEN CIRCUIT
ST ANGLE SEN SIGNAL
ST ANG SEN COM CIR

Is the above displayed in the self-diagnosis display items?

- YES >> GO TO 3.
 NO >> GO TO 2.

2. DATA MONITOR CHECK

Conduct "DATA MONITOR" of the "STR ANGLE SIG" to check if the status is normal.

Steering condition	Data monitor
Straight-ahead	-5deg - +5deg
Turn wheel 90° to the right.	Approx. +90°
Turn wheel 90° to the left.	Approx. -90°

OK or NG

- OK >> Inspection End.
 NG >> GO TO 3.

3. CONNECTOR INSPECTION

1. Disconnect the ABS actuator and electric unit (control unit) connector E125 and steering angle sensor M47.
2. Check the terminals for deformation, disconnection, looseness or damage.

OK or NG

- OK >> GO TO 4.
 NG >> Repair or replace as necessary.

4. CHECKING STEERING ANGLE SENSOR POWER AND GROUND

1. Turn the ignition switch ON.
2. Check voltage between steering angle sensor connector M47 and ground.

Terminals			Measured value (Approx.)
(+)		(-)	
Steering angle sensor connector	Terminal		
M47	1	Ground	12V
	3		12V

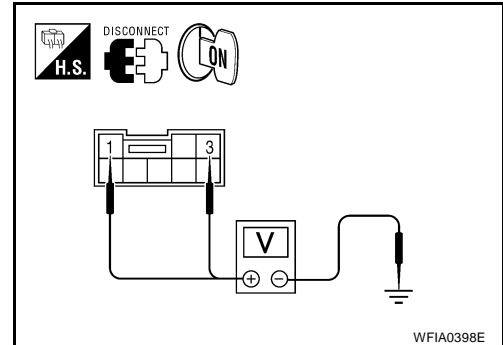

3. Check resistance between steering angle sensor connector M47 and ground.

Terminals			Measured value Ω (Approx.)
(+)		(-)	
Steering angle sensor connector	Terminal		
M47	2	Ground	0Ω

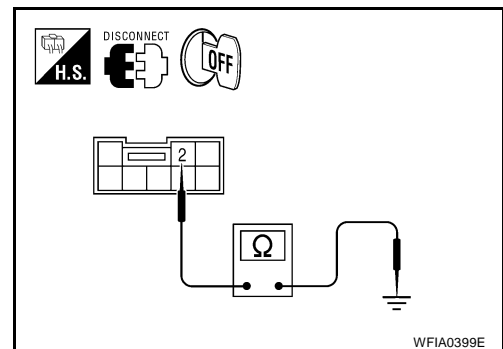

OK or NG

- OK >> Check the CAN communication system. Refer to [BRC-87, "CAN Communication System Inspection"](#). If the CAN communication system is OK, replace spiral cable (steering angle sensor) and adjust neutral position of steering angle sensor. Refer to [BRC-93, "Adjustment of Steering Angle Sensor Neutral Position"](#).
- NG >> Repair the circuit.

TROUBLE DIAGNOSIS FOR SELF-DIAGNOSTIC ITEMS

[VDC/TCS/ABS]

EFS004HA

Yaw Rate/Side/Decel G Sensor System Inspection

CAUTION:

Sudden turns (such as spin turns, acceleration turns), drifting, etc. When VDC function is OFF may cause the yaw rate/side/decels G sensor system to indicate a problem. However this is not a problem if normal operation can be resumed after restarting the engine.

INSPECTION PROCEDURE

1. SELF-DIAGNOSIS RESULT CHECK

Check self-diagnosis results.

Self-diagnosis results
YAW RATE SENSOR
LONGITUDINAL G-SENSOR
LATERAL G-SENSOR

CAUTION:

When on a turntable, such as at a parking structure entrance, or when on a moving object with the engine running, the VDC OFF indicator lamp might turn on and the self-diagnosis using the CONSULT-II the yaw rate sensor system might be displayed, but in this case there is no problem with the yaw rate sensor system. As soon as the vehicle leaves the turntable or moving object, restart the engine to return the system to normal.

Is the above displayed in the self-diagnosis display items?

- YES >> GO TO 2.
- NO >> Inspection End.

2. CONNECTOR INSPECTION

Disconnect the ABS actuator and electric unit (control unit) connector E125 and yaw rate/side/decels G sensor connector M46.

Check the terminals for deformation, disconnection, looseness or damage.

OK or NG

- OK >> GO TO 3.
- NG >> Repair or replace as necessary.

3. YAW RATE/SIDE/DECCEL G SENSOR HARNESS INSPECTION

1. Turn the ignition switch OFF.
2. Check the continuity between the ABS actuator and electric unit (control unit) connector E125 and the yaw rate/side/decels G sensor connector M46.

ABS actuator and electric unit (control unit) connector E125	Yaw rate/side/decels G sensor connector M46	Continuity
19	1	Continuity should exist.
36	2	
35	3	
34	4	
4	5	
6	6	

OK or NG

- OK >> GO TO 4.
- NG >> Repair or replace as necessary.

TROUBLE DIAGNOSIS FOR SELF-DIAGNOSTIC ITEMS

[VDC/TCS/ABS]

4. YAW RATE/SIDE/DECEL G SENSOR INSPECTION

1. Connect the yaw rate/side/decel G sensor connector M46 and ABS actuator and electric unit (control unit) connector E125.
2. Use "DATA MONITOR" to check the yaw rate/side/decel G sensor.

Vehicle status	YAW RATE SEN (Data monitor standard)	SIDE G-SENSOR (Data monitor standard)
When stopped	-4 to +4 deg/s	-1.1 to +1.1 m/s ²
Right hand turn	Negative value	Negative value
Left turn	Positive value	Positive value

OK or NG

OK >> Inspection End.

NG >> Replace the yaw rate/side/decel G sensor. Refer to [BRC-99, "Removal and Installation"](#) .

Solenoid and VDC Change-Over Valve System Inspection

EFS004HB

INSPECTION PROCEDURE

1. SELF-DIAGNOSIS RESULT CHECK

Check self-diagnosis results.

Self-diagnosis results
FR LH IN ABS SOL
FR LH OUT ABS SOL
RR RH IN ABS SOL
RR RH OUT ABS SOL
FR RH IN ABS SOL
FR RH OUT ABS SOL
RR LH IN ABS SOL
RR LH OUT ABS SOL
CV 1
CV 2
SV 1
SV 2

Is the above displayed in the self-diagnosis display items?

YES >> GO TO 2.

NO >> Inspection End.

2. CONNECTOR INSPECTION

1. Disconnect ABS actuator and electric unit (control unit) connector E125.
2. Check the terminals for deformation, disconnection, looseness or damage.

OK or NG

OK >> GO TO 3.

NG >> Repair or replace as necessary.

3. CHECKING SOLENOID POWER AND GROUND

1. Disconnect ABS actuator and electric unit (control unit) connector E125.
2. Check voltage between ABS actuator and electric unit (control unit) connector E125 and ground.

ABS actuator and electric unit (control unit) connector E125	Body ground	Measured value (Approx.)
16	—	12V

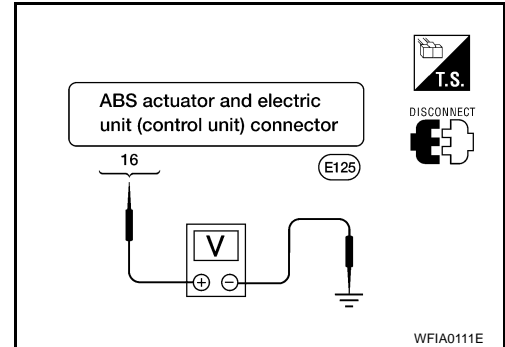

3. Check resistance between ABS actuator and electric unit (control unit) connector E125 and body ground.

ABS actuator and electric unit (control unit) connector E125	Body ground	Measured value Ω (Approx.)
31	—	0Ω
46		

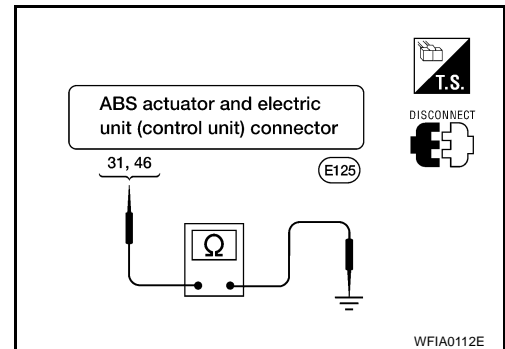

OK or NG

- OK >> Perform self-diagnosis again. If the same results appear, replace ABS actuator and electric unit (control unit). Refer to [BRC-96, "Removal and Installation"](#).
- NG >> Repair the circuit.

Actuator Motor, Motor Relay, and Circuit Inspection

EFS004HC

INSPECTION PROCEDURE

1. CHECKING SELF-DIAGNOSIS RESULTS

Check self-diagnosis results.

Self-diagnosis results
ACTUATOR RLY
PUMP MOTOR

Is the above displayed in the self-diagnosis display items?

- YES >> GO TO 2.
- NO >> Inspection End.

2. CONNECTOR INSPECTION

Disconnect the ABS actuator and electric unit (control unit) connector E125. Check the terminals for deformation, disconnection, looseness or damage.

OK or NG

- OK >> GO TO 3.
- NG >> Repair or replace as necessary.

A
B
C
D
E
BRC
G
H
I
J
K
L
M

3. CHECKING ABS MOTOR AND MOTOR RELAY POWER SYSTEM

1. Check voltage between ABS actuator and electric unit (control unit) connector E125 and body ground.

ABS actuator and electric unit (control unit) connector E125	Body ground	Measured value (Approx.)
1	—	12V

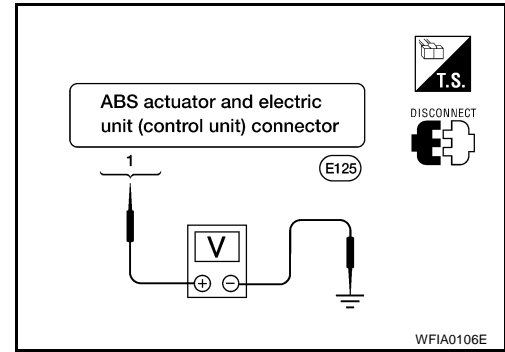

2. Check resistance between ABS actuator and electric unit (control unit) connector E125 and ground.

ABS actuator and electric unit (control unit) connector E125	Body ground	Measured value (Approx.)
46	—	0Ω

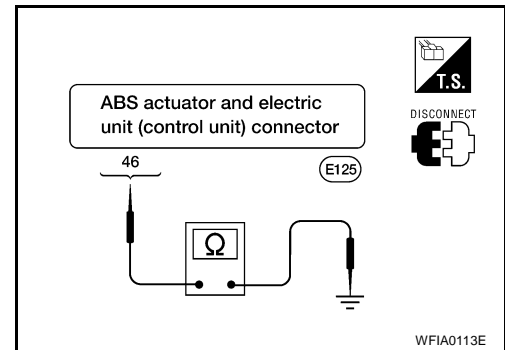

OK or NG

- OK >> Perform self-diagnosis again. If the same result appears, replace ABS actuator and electric unit (control unit). Refer to [BRC-43, "Removal and Installation"](#).
- NG >> Repair the circuit.

Stop Lamp Switch System Inspection

EFS004HD

INSPECTION PROCEDURE

1. SELF-DIAGNOSIS RESULT CHECK

Check self-diagnosis results.

Self-diagnosis results
STOP LAMP SW 1

Is the above displayed in the self-diagnosis display items?

- YES >> GO TO 2.
 NO >> Inspection End.

2. CONNECTOR INSPECTION

- Turn the ignition switch OFF and disconnect the ABS actuator and electric unit (control unit) connector E125 and stop lamp switch connector E38.
- Check the terminals for deformation, disconnection, looseness or damage.

OK or NG

- OK >> GO TO 3.
 NG >> Repair or replace as necessary.

3. STOP LAMP SWITCH INSPECTION

Check the voltage between the ABS actuator and electric unit (control unit) connector E125 terminal 23 and ground.

23 - Ground

Brake pedal depressed : Battery voltage (approx. 12V)

Brake pedal not depressed : Approx. 0V

OK or NG

OK >> Connect the connectors and conduct ABS actuator and electric unit (control unit) self-diagnosis.

NG >> Repair the circuit.

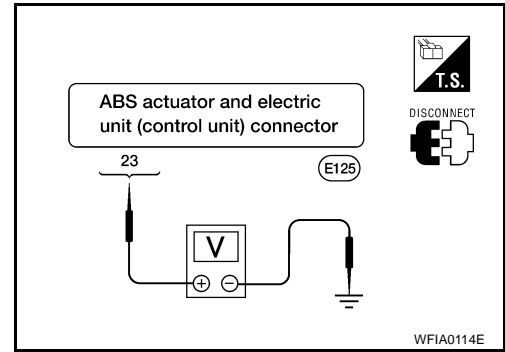

ABS/TCS/VDC Control Unit Power and Ground Systems Inspection

EFS004HE

INSPECTION PROCEDURE

1. SELF-DIAGNOSIS RESULT CHECK

Check self-diagnosis results.

Self-diagnosis results
BATTERY VOLTAGE

Is the above displayed in the self-diagnosis display items?

YES >> GO TO 2.

NO >> Inspection End.

2. CONNECTOR INSPECTION

1. Turn the ignition switch OFF and disconnect the ABS actuator and electric unit (control unit) connector E125.

2. Check the terminals for deformation, disconnection, looseness or damage.

OK or NG

OK >> GO TO 3.

NG >> Repair or replace as necessary.

3. ABS/TCS/VDC CONTROL UNIT POWER AND GROUND CIRCUIT INSPECTION

Measure the voltage and continuity between the ABS actuator and electric unit (control unit) connector E125 and ground.

Signal name	ABS actuator and electric unit (control unit) connector E125	Ground	Measured value
Power supply	45	—	Battery voltage (Approx. 12V)
Ground	31		Continuity should exist.
	46		

OK or NG

OK >> Check the battery for loose terminals, low voltage, etc. Repair as necessary.

NG >> Repair the circuit.

Brake Fluid Level Switch System Inspection

INSPECTION PROCEDURE

1. SELF-DIAGNOSIS RESULT CHECK

1. Check the brake reservoir tank fluid level. If the level is low, add brake fluid.
2. Erase the self-diagnosis results and check the self-diagnosis results.

 Self-diagnosis results

 BR FLUID LEVEL LOW

Is the above displayed in the self-diagnosis display items?

- YES >> GO TO 2.
 NO >> Inspection End.

2. CONNECTOR INSPECTION

1. Turn the ignition switch OFF and disconnect the ABS actuator and electric unit (control unit) connector E125 and brake fluid level switch connector E21.
2. Check the terminals for deformation, disconnection, looseness or damage.

OK or NG

- OK >> GO TO 3.
 NG >> Repair or replace as necessary.

3. CHECK THE HARNESS BETWEEN THE BRAKE FLUID LEVEL SWITCH AND THE ABS ACTUATOR AND ELECTRIC UNIT (CONTROL UNIT)

Check the continuity between the brake fluid level switch connector E21 and the ABS actuator and electric unit (control unit) connector E125.

ABS actuator and electric unit (control unit) connector E125	Brake fluid level switch connector E21	Continuity
38	+	Continuity should exist.
38	Ground	Continuity should not exist.
Ground	-	Continuity should exist.

OK or NG

- OK >> GO TO 4.
 NG >> Repair the circuit.

4. CHECK BRAKE FLUID LEVEL SWITCH

Check continuity between brake fluid level switch terminals + and -.

Continuity should not exist.

OK or NG

- OK >> Perform self-diagnosis again. If the same results appear, replace ABS actuator and electric unit (control unit). Refer to [BRC-96, "Removal and Installation"](#) .
 NG >> Replace brake fluid level switch.

TROUBLE DIAGNOSIS FOR SELF-DIAGNOSTIC ITEMS

[VDC/TCS/ABS]

CAN Communication System Inspection

EFS004HG

INSPECTION PROCEDURE

1. CHECK CONNECTOR

1. Turn ignition switch OFF, disconnect the ABS actuator and electric unit (control unit) connector, and check the terminals for deformation, disconnection, looseness, and so on. If there is a malfunction, repair or replace the terminal.
2. Reconnect connector to perform self-diagnosis.

Is "CAN COMM CIRCUIT" displayed in the self-diagnosis display items?

- YES >> Print out the self-diagnosis results, and refer to [LAN-44, "TROUBLE DIAGNOSIS"](#) .
NO >> Connector terminal connection is loose, damaged, open, or shorted.

Component Inspection

VDC OFF SWITCH

EFS004HH

Check the continuity between terminals 1 and 2.

- 1 -2 : Continuity should exist when pushing the switch.
Continuity should not exist when releasing the switch.**

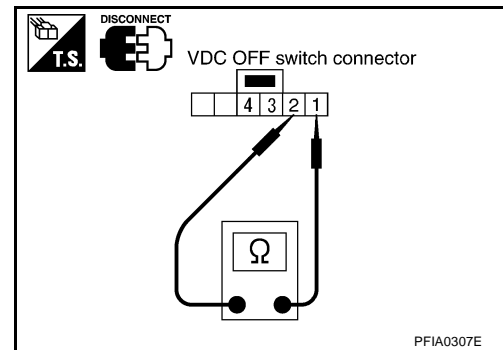

TROUBLE DIAGNOSES FOR SYMPTOMS**ABS Works Frequently**

1. CHECK WARNING LAMP ACTIVATION

Make sure warning lamp remains off while driving.

OK or NG

OK >> GO TO 2.

NG >> Carry out self-diagnosis. Refer to [BRC-70, "SELF-DIAGNOSIS"](#) .

2. CHECK WHEEL SENSORS

Check the following.

- Wheel sensor mounting for looseness
- Wheel sensors for physical damage
- Wheel sensor connectors for terminal damage or loose connections

OK or NG

OK >> GO TO 3.

NG >> Repair as necessary.

3. CHECK WHEEL BEARINGS

Check wheel bearing axial end play. Refer to [FAX-5, "FRONT WHEEL BEARING"](#) or [RAX-5, "REAR WHEEL BEARING"](#) .

OK or NG

OK >> GO TO 4.

NG >> Repair as necessary.

4. CHECK BRAKE FLUID PRESSURE

Check brake fluid pressure distribution.

Refer to [BR-36, "Inspection"](#) .

Is brake fluid pressure distribution normal?

YES >> Inspection End.

NO >> Perform Basic Inspection. Refer to [BRC-66, "Basic Inspection"](#) .

Unexpected Pedal Action

EFS004HJ

1. CHECK WARNING LAMP ACTIVATION

Make sure warning lamp remains off while driving.

OK or NG

OK >> GO TO 2.

NG >> Carry out self-diagnosis. Refer to [BRC-70, "SELF-DIAGNOSIS"](#) .

2. CHECK BRAKE PEDAL STROKE

Check brake pedal stroke.

Is pedal stroke excessive?

YES >> Perform Basic Inspection. Refer to [BRC-66, "Basic Inspection"](#) .

NO >> GO TO 3.

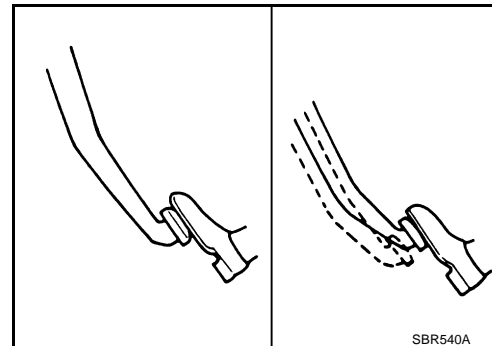
**3. CHECK CONNECTOR AND BRAKING PERFORMANCE**

1. Disconnect ABS actuator and electric unit (control unit) connector.

2. Check brake effectiveness.

NOTE:

Driving the vehicle with the ABS actuator and electric unit (control unit) disconnected may induce DTCs in electrical control units using CAN communication. After the inspection, clear all DTCs. Refer to [LAN-4, "SYSTEM DESCRIPTION"](#) .

OK or NG

OK >> GO TO 4.

NG >> Perform Basic Inspection. Refer to [BRC-66, "Basic Inspection"](#) .

4. CHECK WHEEL SENSORS

Check the following.

- Wheel sensor mounting for looseness
- Wheel sensors for physical damage
- Wheel sensor connectors for terminal damage or loose connections

OK or NG

OK >> Check ABS actuator and electric unit (control unit) pin terminals for damage and the connection of harness connector. Reconnect ABS actuator and electric unit (control unit) harness connector. Then retest.

NG >> Repair as necessary.

Long Stopping Distance

1. CHECK BASE BRAKING SYSTEM PERFORMANCE

1. Disable ABS by disconnecting ABS actuator and electric unit (control unit) connector.
2. Drive vehicle and check to see if stopping distance is still long.

NOTE:

Driving the vehicle with the ABS actuator and electric unit (control unit) disconnected may induce DTCs in electrical control units using CAN communication. After the inspection, clear all DTCs. Refer to [LAN-4, "SYSTEM DESCRIPTION"](#).

OK or NG

- OK >> Go to [BRC-88, "ABS Works Frequently"](#).
- NG >> Perform Basic Inspection. Refer to [BRC-66, "Basic Inspection"](#).

NOTE:

Stopping distance may be longer than vehicles without ABS when road condition is slippery.

ABS Does Not Work

CAUTION:

The ABS does not operate when the vehicle speed is 10 km/h (6 MPH) or less.

1. CHECK WARNING LAMP ACTIVATION

Turn ignition switch ON and check for warning lamp activation.

- Warning lamp should activate for approximately 2 seconds after turning the ignition switch ON.

OK or NG

- OK >> Carry out self-diagnosis. Refer to [BRC-70, "SELF-DIAGNOSIS"](#).
- NG >> Go to [BRC-91, "ABS Warning Lamp Does Not Come On When Ignition Switch Is Turned On"](#).

Pedal Vibration or ABS Operation Noise

NOTE:

During ABS activation, pedal vibration may be felt and a noise may be heard. This is normal and does not indicate a malfunction.

1. CHECK SYMPTOM

1. Apply brake.
2. Start engine.

Does the symptom occur only when engine is started?

- YES >> Carry out self-diagnosis. Refer to [BRC-70, "SELF-DIAGNOSIS"](#).
- NO >> GO TO 2.

2. RECHECK SYMPTOM

Does the symptom occur only when electrical equipment switches (such as headlamp) are turned on?

- YES >> Check for radio, antenna or related wiring that is routed too close to the ABS actuator and electric unit (control unit) and reroute as necessary.
- NO >> Go to [BRC-88, "ABS Works Frequently"](#).

ABS Warning Lamp Does Not Come On When Ignition Switch Is Turned On EFS004HN**1. CHECK ABS ACTUATOR AND ELECTRIC UNIT (CONTROL UNIT) FUSES**

Check 40A fusible link i and 50A fusible link j for ABS actuator and electric unit (control unit). For fusible link layout, refer to [PG-4, "POWER SUPPLY ROUTING CIRCUIT"](#).

OK or NG

OK >> GO TO 2.

NG >> If fusible link is blown, be sure to eliminate cause of problem before replacing.

2. CHECK ABS ACTUATOR AND ELECTRIC UNIT (CONTROL UNIT) POWER SUPPLY CIRCUITS

1. Disconnect ABS actuator and electric unit (control unit) connector.
2. Check voltage between ABS actuator and electric unit (control unit) connector terminal 1 and ground and terminal 16 and ground.

Does battery voltage exist?

YES >> GO TO 3.

NO >> Repair harness or connectors between fusible link and ABS actuator and electric unit (control unit).

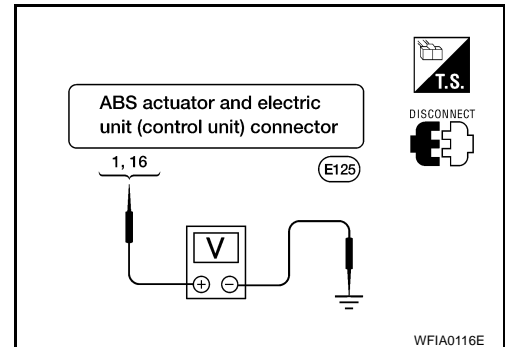
**3. CHECK ABS ACTUATOR AND ELECTRIC UNIT (CONTROL UNIT) GROUND CIRCUIT**

Check continuity between ABS actuator and electric unit (control unit) connector E125 terminal 31 and ground and terminal 46 and ground.

Does continuity exist?

YES >> Replace ABS actuator and electric unit (control unit). Refer to [BRC-96, "Removal and Installation"](#).

NO >> Repair harness or connectors between ABS actuator and electric unit (control unit) and ground.

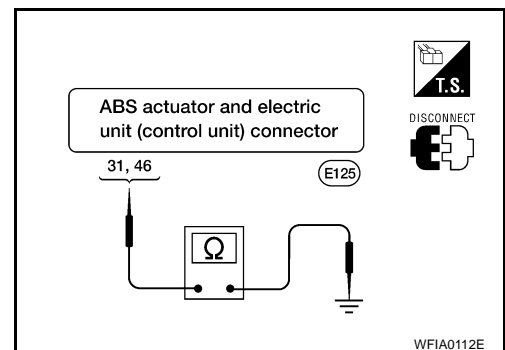
**ABS Warning Lamp Stays On When Ignition Switch Is Turned On** EFS004HO**1. CARRY OUT SELF-DIAGNOSIS**

Carry out self-diagnosis. Refer to [BRC-70, "SELF-DIAGNOSIS"](#).

Are malfunctions detected in self-diagnosis?

YES >> Refer to [BRC-71, "Display Item List"](#).

NO >> Refer to [DI-39, "WARNING LAMPS"](#).

Vehicle Jerks During TCS/VDC Activation

1. ABS ACTUATOR AND ELECTRIC UNIT (CONTROL UNIT) SELF-DIAGNOSIS

Perform ABS actuator and electric unit (control unit) self-diagnosis.

Are self-diagnosis result items displayed?

- YES >> After checking and repairing the applicable item, perform the ABS actuator and electric unit (control unit) self-diagnosis again.
- NO >> GO TO 2.

2. ENGINE SPEED SIGNAL INSPECTION

Perform data monitor with CONSULT-II for the ABS actuator and electric unit (control unit).

Is the engine speed at idle 400 rpm or higher?

- YES >> GO TO 4.
- NO >> GO TO 3.

3. ECM SELF-DIAGNOSIS

Perform ECM self-diagnosis.

Are self-diagnosis result items displayed?

- YES >> After checking and repairing the applicable item, perform the ECM self-diagnosis again.
- NO >> GO TO 4.

4. TCM SELF-DIAGNOSIS

Perform TCM self-diagnosis.

Are self-diagnosis result items displayed?

- YES >> After checking and repairing the applicable item, perform the TCM self-diagnosis again.
- NO >> GO TO 5.

5. CONNECTOR INSPECTION

Disconnect the ABS actuator and electric unit (control unit) connector and the ECM connectors and check the terminals for deformation, disconnection, looseness or damage.

OK or NG

- OK >> GO TO 6.
- NG >> Repair or replace the connector terminal.

6. CAN COMMUNICATION INSPECTION

Check the CAN communication system. Refer to [BRC-87, "CAN Communication System Inspection"](#) .

OK or NG

- OK >> Inspection End.
- NG >> Reconnect the connectors, and perform ABS actuator and electric unit (control unit) self-diagnosis.

ON-VEHICLE SERVICE

Adjustment of Steering Angle Sensor Neutral Position

EFS004HQ

After removing/installing or replacing ABS actuator and electric unit (control unit), steering angle sensor, steering and suspension components which affect wheel alignment or after adjusting wheel alignment, be sure to adjust neutral position of steering angle sensor before running vehicle.

NOTE:

Adjustment of steering angle sensor neutral position requires CONSULT-II.

1. Stop vehicle with front wheels in straight-ahead position.
2. Connect CONSULT-II and CONSULT-II CONVERTER to data link connector on vehicle, and turn ignition switch ON (do not start engine).
3. Touch "START (NISSAN BASED VHCL)", "ABS", "WORK SUPPORT" and "ST ANGLE SENSOR ADJUSTMENT" on CONSULT-II screen in this order.

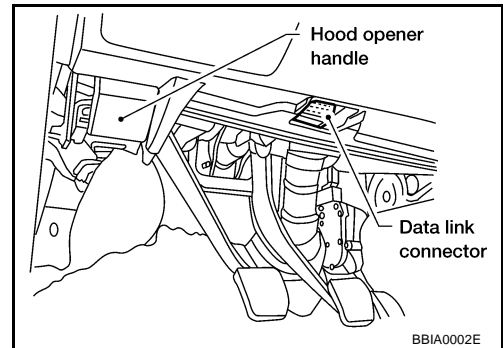

4. Touch "START".

CAUTION:

Do not touch steering wheel while adjusting steering angle sensor.

5. After approximately 10 seconds, touch "END". (After approximately 60 seconds, it ends automatically.)
6. Turn ignition switch OFF, then turn it ON again.
7. Run vehicle with front wheels in straight-ahead position, then stop.
8. Select "DATA MONITOR", "SELECTION FROM MENU", and "STR ANGLE SIG" on CONSULT-II screen. Then check that "STR ANGLE SIG" is within 0 ± 2.5 deg. If value is more than specification, repeat steps 1 to 5.
9. Erase memory of ABS actuator and electric unit (control unit) and ECM.
10. Turn ignition switch to OFF.

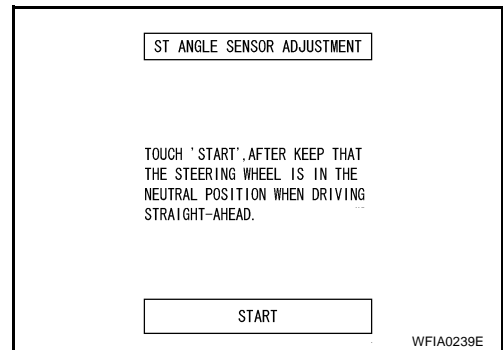

A
B
C
D
E
BRC
G
H
I
J
K
L
M

WHEEL SENSORS

Removal and Installation

EFS00682

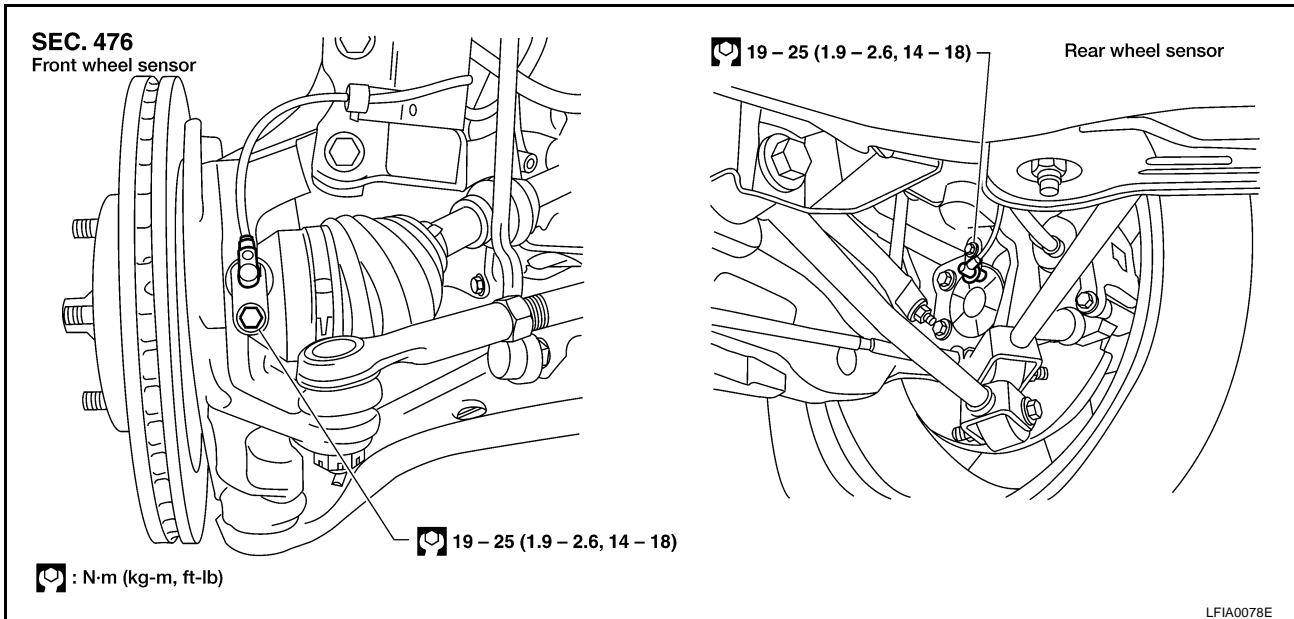

CAUTION:

- Be careful not to damage wheel sensor edge and sensor rotor teeth.
- When removing the front or rear wheel hub assembly, first remove the wheel sensor from the assembly. Failure to do so may result in damage to the wheel sensor wires making the sensor inoperative.

CAUTION:

- Pull out the wheel sensor, being careful to turn it as little as possible. Do not pull on the wheel sensor harness.
- Installation should be performed while paying attention to the following, and then tighten mounting bolts and nuts to the specified torque.
- Check if foreign objects such as iron fragments are adhered to the pick-up part of the sensor or to the inside of the hole for the wheel sensor, or if a foreign object is caught in the mating surface of the sensor rotor. If something wrong is found, fix it and then install the wheel sensor.

REMOVAL

1. Remove wheel and tire using power tool.
2. Disconnect wheel sensor harness connector and remove harness wire from attachment points.
3. Remove wheel sensor bolt and wheel sensor.

INSTALLATION

Installation is in the reverse order of removal.

- When installing wheel and tire, refer to [WT-7, "Tire Rotation"](#) .

SENSOR ROTOR

Removal and Installation

REMOVAL

Front

1. Remove the front wheel hub. Refer to [FAX-6, "Removal and Installation"](#) .
2. Remove the sensor rotor from the drive shaft using a suitable tool as shown.

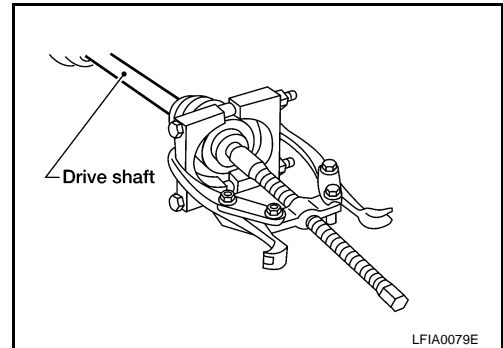

Rear

The rear wheel sensor rotor is built into the rear wheel hub. For removal and installation procedure, refer to [RAX-6, "Removal and Installation"](#) .

INSTALLATION

Front

Installation is in the reverse order of removal.

- Install the sensor rotor using a wooden block and suitable tool as shown.
- Always replace sensor rotor with new one.

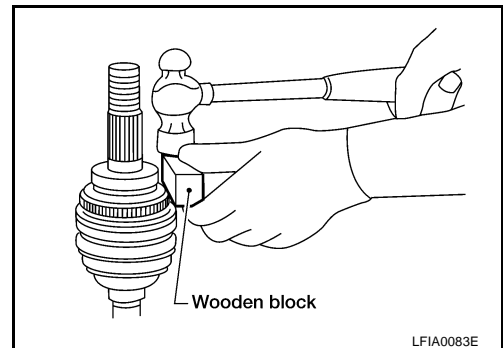

Rear

The rear wheel sensor rotor is built into the rear wheel hub. For removal and installation procedure, refer to [RAX-6, "Removal and Installation"](#) .

A
B
C
D
E
BRC
G
H
I
J
K
L
M

ACTUATOR AND ELECTRIC UNIT (ASSEMBLY)

PF:47660

Removal and Installation

EFS004HT

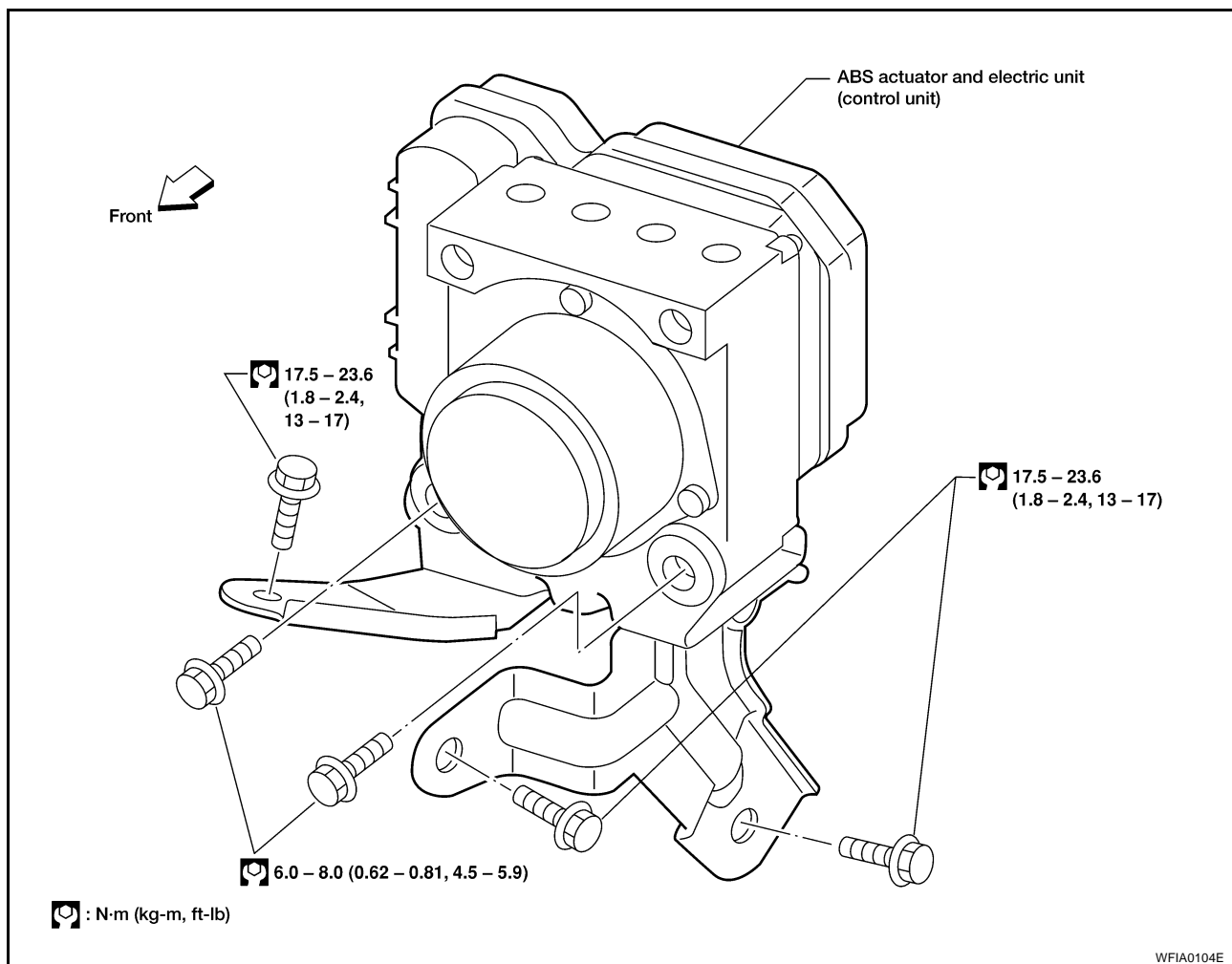

REMOVAL

1. Disconnect battery negative terminal.
2. Remove windshield wiper and linkage assembly. Refer to [WW-21, "Removal"](#).
3. Drain brake fluid. Refer to [BR-8, "Changing Brake Fluid"](#).
4. Discharge the A/C refrigerant. Refer to [ATC-130, "HFC-134a \(R-134a\) Service Procedure"](#).
5. Disconnect and remove high-pressure and low-pressure A/C pipes to allow access to ABS actuator and electric unit (control unit). Refer to [ATC-132, "Components"](#).
6. Disconnect harness connectors from ABS actuator and electric unit (control unit).
7. Disconnect brake pipes, noting their location for installation.
8. Remove bolts and ABS actuator and electric unit (control unit).

INSTALLATION

CAUTION:

After installation of ABS actuator and electric unit (control unit), refill brake fluid. Then bleed air from system. Refer to [BR-8, "Bleeding Brake System"](#).

1. Position ABS actuator and electric unit (control unit) in vehicle.
2. Connect brake pipes and bolts temporarily.
3. Tighten bolts and brake pipes to specification. Refer to [BR-9, "Hydraulic Circuit"](#).
4. Connect ABS actuator and electric unit (control unit) harness connectors.
5. Install and connect high-pressure and low-pressure A/C pipes. Refer to [ATC-132, "Components"](#).
6. Install windshield wiper and linkage assembly. Refer to [WW-21, "Installation"](#).

ACTUATOR AND ELECTRIC UNIT (ASSEMBLY)

[VDC/TCS/ABS]

7. Connect battery negative terminal.
8. Evacuate and recharge the A/C system. Refer to [ATC-130, "HFC-134a \(R-134a\) Service Procedure"](#) .
9. Adjust the steering angle sensor. Refer to [BRC-93, "Adjustment of Steering Angle Sensor Neutral Position"](#) .

A

B

C

D

E

BRC

G

H

I

J

K

L

M

STEERING ANGLE SENSOR

PF:25554

Removal and Installation

EF004HU

The steering angle sensor is built into the spiral cable. For removal and installation procedure, refer to [SRS-43, "Removal and Installation"](#).

G SENSOR**Removal and Installation****REMOVAL**

1. Remove center console. Refer to [IP-17, "Front Center Console"](#).
2. Disconnect harness connector.
3. Remove attaching nuts and remove yaw rate/side/decel G sensor.

CAUTION:

- Do not drop or strike the yaw rate/side/decel G sensor.
- Do not use power tools to remove or install yaw rate/side/decel G sensor.

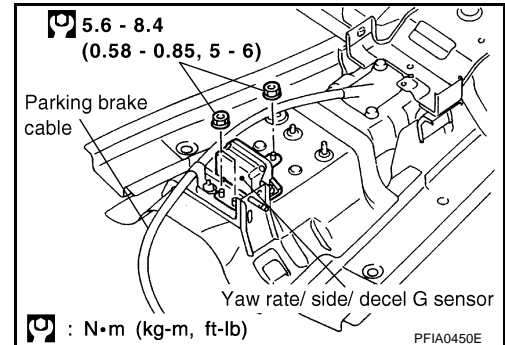
**INSTALLATION**

Installation is in the reverse order of removal.

CAUTION:

- Do not drop or strike the yaw rate/side/decel G sensor.

A
B
C
D
E

BRC

G
H
I
J
K
L
M

