

A  
EM  
C  
D  
E  
F  
G  
H  
I  
J  
K  
L  
M  
N  
O  
P

# SECTION **EM**

## ENGINE MECHANICAL

### CONTENTS

<b>PRECAUTION</b> .....	3	<b>Removal and Installation of Drive Belt Auto-tensioner</b> .....	15
<b>PRECAUTIONS</b> .....	3	<b>AIR CLEANER FILTER</b> .....	16
Precaution for Supplemental Restraint System (SRS) "AIR BAG" and "SEAT BELT PRE-TENSIONER" .....	3	Removal and Installation .....	16
Precautions Necessary for Steering Wheel Rotation after Battery Disconnect .....	3	<b>CAMSHAFT VALVE CLEARANCE</b> .....	17
Precaution for Drain Coolant .....	3	Valve Clearance .....	17
Precaution for Disconnecting Fuel Piping .....	4	<b>COMPRESSION PRESSURE</b> .....	21
Precaution for Removal and Disassembly .....	4	On-Vehicle Service .....	21
Precaution for Inspection, Repair and Replacement .....	4	<b>ON-VEHICLE REPAIR</b> .....	22
Precaution for Assembly and Installation .....	4	<b>ENGINE COVER</b> .....	22
Parts Requiring Angular Tightening .....	4	Removal and Installation .....	22
Precaution for Liquid Gasket .....	4	<b>AIR CLEANER AND AIR DUCT</b> .....	23
<b>PREPARATION</b> .....	6	Removal and Installation .....	23
<b>PREPARATION</b> .....	6	<b>INTAKE MANIFOLD COLLECTOR</b> .....	24
Special Service Tool .....	6	Removal and Installation .....	24
Commercial Service Tool .....	8	<b>INTAKE MANIFOLD</b> .....	27
<b>FUNCTION DIAGNOSIS</b> .....	10	Removal and Installation .....	27
<b>NOISE, VIBRATION, AND HARSHNESS (NVH) TROUBLESHOOTING</b> .....	10	<b>EXHAUST MANIFOLD AND THREE WAY CATALYST</b> .....	30
NVH Troubleshooting - Engine Noise .....	10	Removal and Installation .....	30
Use the Chart Below to Help You Find the Cause of the Symptom .....	11	<b>OIL PAN AND OIL STRAINER</b> .....	33
<b>ON-VEHICLE MAINTENANCE</b> .....	12	Removal and Installation .....	33
<b>SPARK PLUG</b> .....	12	<b>IGNITION COIL</b> .....	39
Exploded View .....	12	Exploded View .....	39
Removal and Installation .....	12	Removal and Installation LH .....	39
<b>DRIVE BELTS</b> .....	14	Removal and Installation RH .....	39
Checking Drive Belts .....	14	<b>FUEL INJECTOR AND FUEL TUBE</b> .....	40
Tension Adjustment .....	14	Exploded View .....	40
Removal and Installation .....	14	Removal and Installation .....	40
		Inspection .....	44

<b>ROCKER COVER</b> .....	<b>45</b>	<b>REMOVAL AND INSTALLATION</b> .....	<b>96</b>
Exploded View .....	45	<b>ENGINE ASSEMBLY</b> .....	<b>96</b>
Removal and Installation LH .....	45	Removal and Installation .....	96
Removal and Installation RH .....	46	<b>DISASSEMBLY AND ASSEMBLY</b> .....	<b>100</b>
<b>FRONT TIMING CHAIN CASE</b> .....	<b>49</b>	<b>CYLINDER BLOCK</b> .....	<b>100</b>
Removal and Installation .....	49	Disassembly and Assembly .....	100
<b>TIMING CHAIN</b> .....	<b>57</b>	Inspection .....	109
Component .....	57	Dowel Pin Alignment .....	119
Removal .....	57	<b>SERVICE DATA AND SPECIFICATIONS</b>	
Inspection .....	60	<b>(SDS)</b> .....	<b>121</b>
Installation .....	60	<b>SERVICE DATA AND SPECIFICATIONS</b>	
<b>REAR TIMING CHAIN CASE</b> .....	<b>66</b>	<b>(SDS)</b> .....	<b>121</b>
Component .....	66	General Specification .....	121
Removal and Installation .....	66	Drive Belt .....	121
<b>CAMSHAFT</b> .....	<b>71</b>	Spark Plug .....	122
Removal and Installation .....	71	Intake Manifold .....	122
Inspection after Installation .....	79	Exhaust Manifold .....	122
<b>OIL SEAL</b> .....	<b>81</b>	Camshaft .....	122
Removal and Installation of Valve Oil Seal .....	81	Cylinder Head .....	124
Removal and Installation of Front Oil Seal .....	81	Cylinder Block .....	127
Removal and Installation of Rear Oil Seal .....	83	Main Bearing .....	130
<b>CYLINDER HEAD</b> .....	<b>85</b>	Connecting Rod Bearing .....	131
Removal and Installation .....	85	Drive Plate .....	132
Disassembly and Assembly .....	89		
Inspection After Disassembly .....	91		

# PRECAUTIONS

< PRECAUTION >

## PRECAUTION

### PRECAUTIONS

#### Precaution for Supplemental Restraint System (SRS) "AIR BAG" and "SEAT BELT PRE-TENSIONER"

INFOID:000000004173747

The Supplemental Restraint System such as "AIR BAG" and "SEAT BELT PRE-TENSIONER", used along with a front seat belt, helps to reduce the risk or severity of injury to the driver and front passenger for certain types of collision. This system includes seat belt switch inputs and dual stage front air bag modules. The SRS system uses the seat belt switches to determine the front air bag deployment, and may only deploy one front air bag, depending on the severity of a collision and whether the front occupants are belted or unbelted. Information necessary to service the system safely is included in the SR and SB section of this Service Manual.

#### **WARNING:**

- To avoid rendering the SRS inoperative, which could increase the risk of personal injury or death in the event of a collision which would result in air bag inflation, all maintenance must be performed by an authorized NISSAN/INFINITI dealer.
- Improper maintenance, including incorrect removal and installation of the SRS, can lead to personal injury caused by unintentional activation of the system. For removal of Spiral Cable and Air Bag Module, see the SR section.
- Do not use electrical test equipment on any circuit related to the SRS unless instructed to in this Service Manual. SRS wiring harnesses can be identified by yellow and/or orange harnesses or harness connectors.

#### Precautions Necessary for Steering Wheel Rotation after Battery Disconnect

INFOID:000000004394023

#### **NOTE:**

- Before removing and installing any control units, first turn the push-button ignition switch to the LOCK position, then disconnect both battery cables.
- After finishing work, confirm that all control unit connectors are connected properly, then re-connect both battery cables.
- Always use CONSULT-III to perform self-diagnosis as a part of each function inspection after finishing work. If a DTC is detected, perform trouble diagnosis according to self-diagnosis results.

This vehicle is equipped with a push-button ignition switch and a steering lock unit.

If the battery is disconnected or discharged, the steering wheel will lock and cannot be turned.

If turning the steering wheel is required with the battery disconnected or discharged, follow the procedure below before starting the repair operation.

#### OPERATION PROCEDURE

1. Connect both battery cables.

#### **NOTE:**

Supply power using jumper cables if battery is discharged.

2. Carry the Intelligent Key or insert it to the key slot and turn the push-button ignition switch to ACC position. (At this time, the steering lock will be released.)
3. Disconnect both battery cables. The steering lock will remain released with both battery cables disconnected and the steering wheel can be turned.
4. Perform the necessary repair operation.
5. When the repair work is completed, re-connect both battery cables. With the brake pedal released, turn the push-button ignition switch from ACC position to ON position, then to LOCK position. (The steering wheel will lock when the push-button ignition switch is turned to LOCK position.)
6. Perform self-diagnosis check of all control units using CONSULT-III.

#### Precaution for Drain Coolant

INFOID:000000004173748

- Drain coolant when engine is cooled.

# PRECAUTIONS

## < PRECAUTION >

### Precaution for Disconnecting Fuel Piping

INFOID:000000004173749

- Before starting work, make sure no fire or spark producing items are in the work area.
- Release fuel pressure before disassembly.
- After disconnecting pipes, plug openings to stop fuel leakage.

### Precaution for Removal and Disassembly

INFOID:000000004173750

- When instructed to use special service tools, use the specified tools. Always be careful to work safely, avoid forceful or uninstructed operations.
- Exercise maximum care to avoid damage to mating or sliding surfaces.
- Cover openings of engine system with tape or the equivalent, if necessary, to seal out foreign materials.
- Mark and arrange disassembly parts in an organized way for easy troubleshooting and assembly.
- When loosening nuts and bolts, as a basic rule, start with the one furthest outside, then the one diagonally opposite, and so on. If the order of loosening is specified, do exactly as specified. Power tools may be used where noted in the step.

### Precaution for Inspection, Repair and Replacement

INFOID:000000004173751

- Before repairing or replacing, thoroughly inspect parts. Inspect new replacement parts in the same way, and replace if necessary.

### Precaution for Assembly and Installation

INFOID:000000004173752

- Use torque wrench to tighten bolts or nuts to specification.
- When tightening nuts and bolts, as a basic rule, equally tighten in several different steps starting with the ones in center, then ones on inside and outside diagonally in this order. If the order of tightening is specified, do exactly as specified.
- Replace with new gasket, packing, oil seal or O-ring.
- Thoroughly wash, clean, and air-blow each part. Carefully check oil or coolant passages for any restriction and blockage.
- Avoid damaging sliding or mating surfaces. Completely remove foreign materials such as cloth lint or dust. Before assembly, oil sliding surfaces well.
- Release air within route after draining coolant.
- Before starting engine, apply fuel pressure to fuel lines with turning ignition switch ON (with engine stopped). Then make sure that there are no leaks at fuel line connections.
- After repairing, start engine and increase engine speed to check coolant, fuel, oil, and exhaust systems for leakage.

### Parts Requiring Angular Tightening

INFOID:000000004173753

- Use an angle wrench for the final tightening of the following engine parts:
  - Cylinder head bolts
  - Main bearing cap bolts
  - Connecting rod cap nuts
  - Crankshaft pulley bolt (No angle wrench is required as the bolt flange is provided with notches for angular tightening)
- Do not use a torque value for final tightening.
- The torque value for these parts are for a preliminary step.
- Ensure thread and seat surfaces are clean and coated with engine oil.

### Precaution for Liquid Gasket

INFOID:000000004173754

## REMOVAL OF LIQUID GASKET SEALING

# PRECAUTIONS

## < PRECAUTION >

- After removing the bolts and nuts, separate the mating surface and remove the sealant using Tool.

**Tool number : KV10111100 (J-37228)**

### CAUTION:

**Be careful not to damage the mating surfaces.**

- In areas where the cutter is difficult to use, use a plastic hammer to lightly tap (1) the cutter where the RTV Silicone Sealant is applied. Use a plastic hammer to slide the cutter (2) by tapping on the side.

### CAUTION:

**If for some unavoidable reason a tool such as a flat-bladed screwdriver is used, be careful not to damage the mating surfaces.**

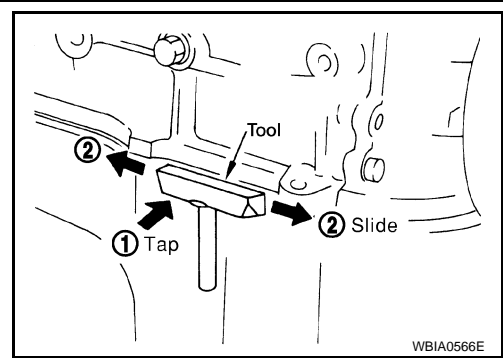

## LIQUID GASKET APPLICATION PROCEDURE

1. Using a scraper, remove the old Silicone RTV Sealant adhering to the gasket application surface and the mating surface.
  - Remove the sealant completely from the groove of the gasket application surface, bolts, and bolt holes.
2. Thoroughly clean the gasket application surface and the mating surface and remove adhering moisture, grease and foreign materials.
3. Attach the sealant tube to the tube presser.  
**Use Genuine Silicone RTV Sealant or equivalent. Refer to [GI-15, "Recommended Chemical Products and Sealants"](#).**

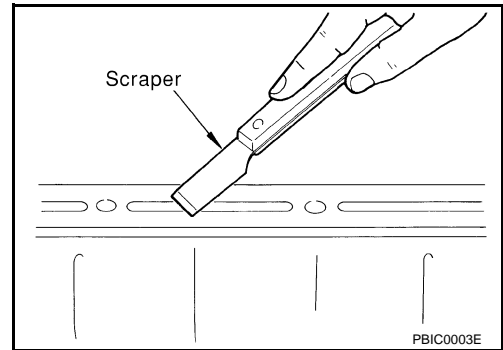

4. Apply the sealant using Tool without breaks to the specified location.

**Tube presser WS39930000 ( - )**

- If there is a groove for the sealant application, apply the sealant to the groove.

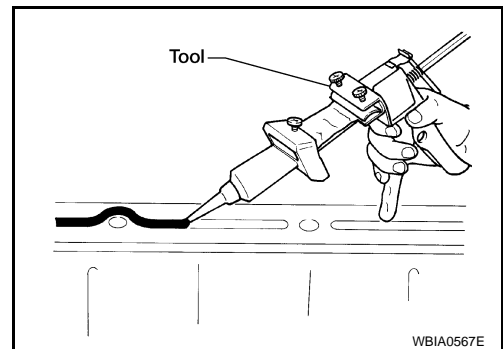

- As for the bolt holes, normally apply the sealant inside the holes. If specified, it should be applied outside the holes. Make sure to read the text of this manual.
- Within five minutes of the sealant application, install the mating component.
- If the sealant protrudes, wipe it off immediately.
- Do not retighten after the installation.
- After 30 minutes or more have passed from the installation, fill the engine with the specified oil and coolant. Refer to [MA-17, "FOR NORTH AMERICA : Fluids and Lubricants"](#) (United States and Canada) or [MA-18, "FOR MEXICO : Fluids and Lubricants"](#) (Mexico).

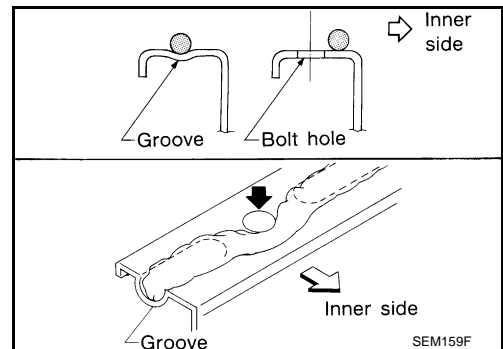

### CAUTION:

**Follow all specific instructions in this manual.**

# PREPARATION

< PREPARATION >

## PREPARATION

### PREPARATION

#### Special Service Tool

INFOID:000000004173755

The actual shapes of Kent-Moore tools may differ from those of special service tools illustrated here.

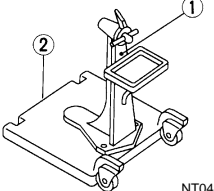
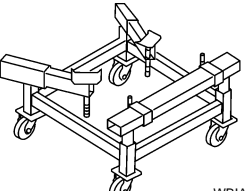
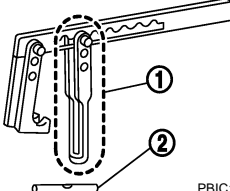
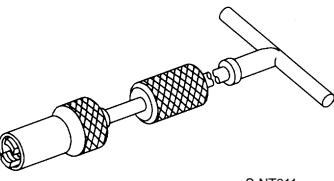
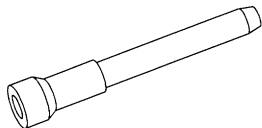
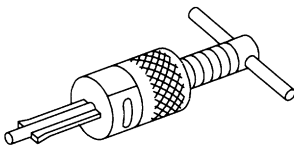
Tool number (Kent-Moore No.) Tool name	Description
ST0501S000 ( — ) Engine stand assembly 1 ST05011000 ( — ) Engine stand 2 ST05012000 ( — ) Base	 Disassembling and assembling NT042
KV101J0010 (J-47242) Engine support table	 Removal engine and transmission assembly WBIA0658E
KV10116200 (J-26336-A) Valve spring compressor 1. KV10115900 (J-26336-20) Attachment 2. KV10109220 ( — ) Adapter	 Disassembling valve mechanism Part (1) is a component of KV10116200 (J-26336-A), but part (2) is not. PBIC1650E
KV10107902 (J-38959) Valve oil seal puller	 Removing valve oil seal S-NT011
— (J-39386) Valve oil seal drift	 Installing valve oil seal NT024
ST16610001 (J-23907) Pilot bushing puller	 Removing crankshaft pilot bushing NT045

# PREPARATION

## < PREPARATION >



Tool number (Kent-Moore No.) Tool name	Description	
KV10111100 (J-37228) Seal cutter	Removing steel oil pan and rear timing chain case	EM
WS39930000 ( — ) Tube presser	Pressing the tube of liquid gasket	
KV10112100 (BT-8653-A) Angle wrench	Tightening bolts for bearing cap, cylinder head, etc.	
— (J-44626) Air fuel sensor Socket	Loosening or tightening air fuel ratio A/F sensor <b>a: 22 mm (0.87 in)</b>	
KV10114400 (J-38365) Heated oxygen sensor wrench	Loosening or tightening rear heated oxygen sensor <b>a: 22 mm (0.87 in)</b>	
KV10117700 (J-44716) Ring gear stopper	Removing and installing crankshaft pulley	
KV10109300 ( — ) Pulley holder	Holding pulley position <b>a: 68 mm (2.68 in)</b> <b>b: 8 mm (0.31 in)</b>	

# PREPARATION

< PREPARATION >

## Commercial Service Tool

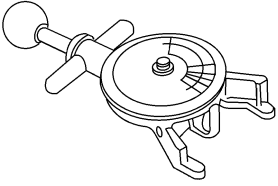
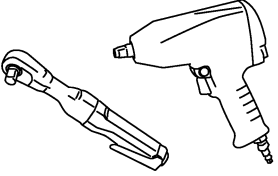
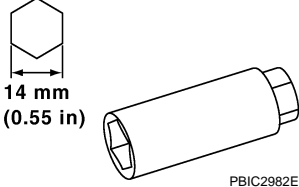

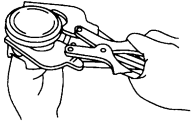
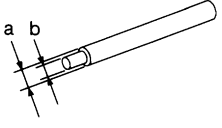
INFOID:000000004173756

(Kent-Moore No.) Tool name	Description
(BT-3373-F) Belt tension gauge   AMA126	Checking drive belt tension
Power tool   PBIC0190E	Loosening bolts and nuts
Spark plug wrench   PBIC2982E	Removing and installing spark plug
Valve seat cutter set   NT048	Finishing valve seat dimensions
Piston ring expander   NT030	Removing and installing piston ring
Valve guide drift   NT015	Removing and installing valve guide <b>Intake &amp; Exhaust:</b> <b>a: 9.5 mm (0.374 in) dia.</b> <b>b: 5.5 mm (0.217 in) dia.</b>

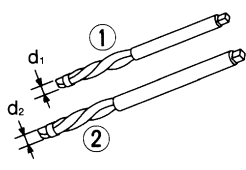
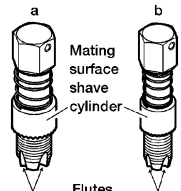

# PREPARATION

## < PREPARATION >

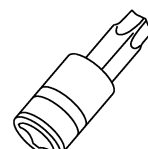
(Kent-Moore No.) Tool name	Description
Valve guide reamer  	Reaming valve guide 1 or hole for oversize valve guide 2 <b>Intake &amp; Exhaust:</b> <b>d1: 6.0 mm (0.236 in) dia.</b> <b>d2: 10.2 mm (0.402 in) dia.</b>
(J-43897-18) (J-43897-12) Oxygen sensor thread cleaner  	Reconditioning the exhaust system threads before installing a new oxygen sensor (Use with anti-seize lubricant shown below.) <b>a: J-43897-18 (18 mm dia.) for zirconia oxygen sensor</b> <b>b: J-43897-12 (12 mm dia.) for titania oxygen sensor</b>
Anti-seize lubricant (Permatex 133AR or equivalent meeting MIL specification MIL-A-907)  	Lubricating oxygen sensor thread cleaning tool when reconditioning exhaust system threads
T55 Torx® Plus Bit  	Removing and installing M/T flywheel bolts

A

EM

C

D

E

F

G

H

I

J

K

L

M

N

O

P

# NOISE, VIBRATION, AND HARSHNESS (NVH) TROUBLESHOOTING

< FUNCTION DIAGNOSIS >

## FUNCTION DIAGNOSIS

### NOISE, VIBRATION, AND HARSHNESS (NVH) TROUBLESHOOTING

#### NVH Troubleshooting - Engine Noise

INFOID:000000004173757

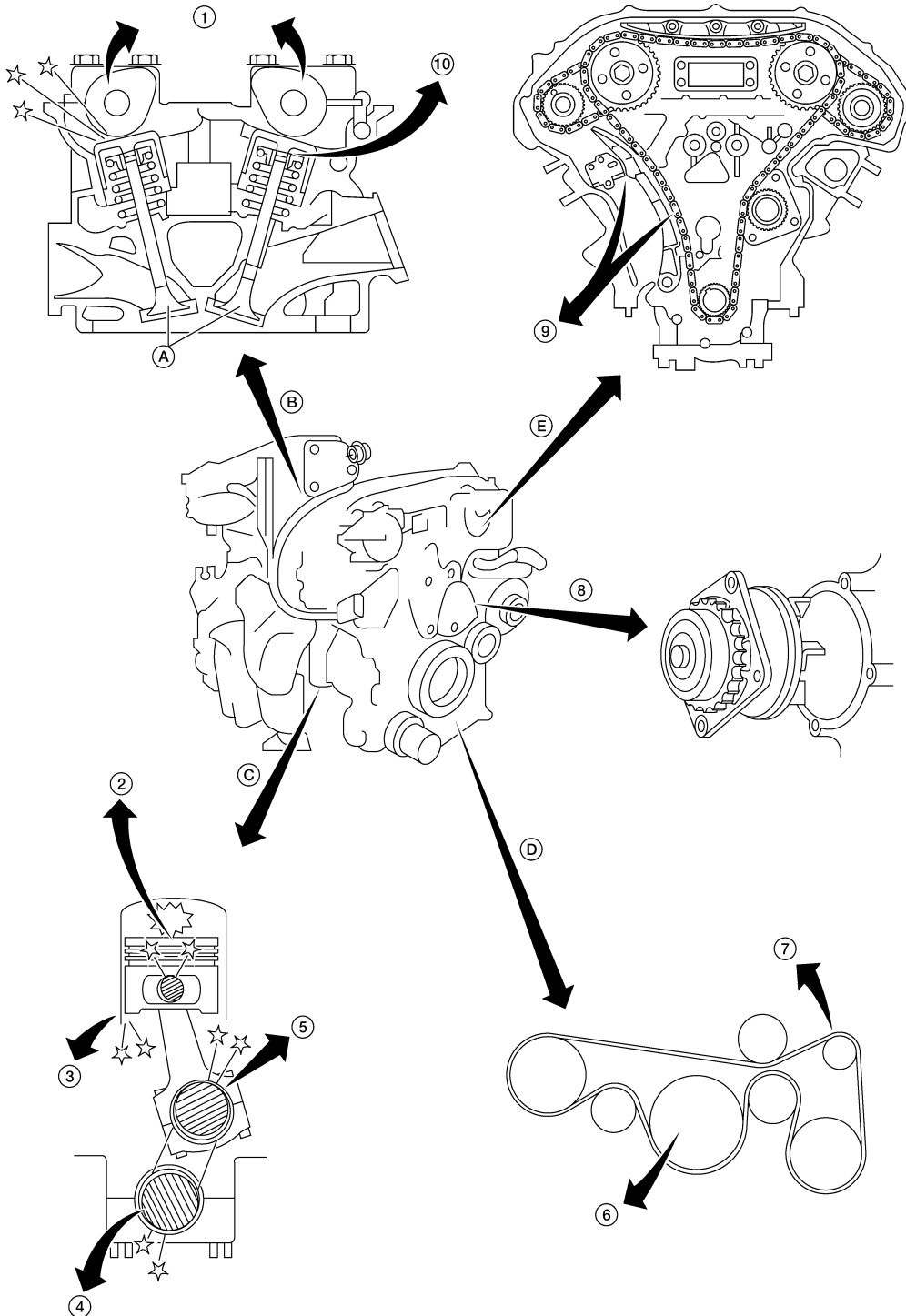

AWBIA002ZZZ

- |                                |                                 |   |
|--------------------------------|---------------------------------|---|
| 1. Camshaft bearing noise      | 2. Piston pin noise             | 3. Piston slap noise                      |
| 4. Main bearing noise          | 5. Connecting rod bearing noise | 6. Drive belt noise (Sticking/Slipping)   |
| 7. Drive belt noise (Slipping) | 8. Water pump noise             | 9. Timing chain and chain tensioner noise |

# NOISE, VIBRATION, AND HARSHNESS (NVH) TROUBLESHOOTING

## < FUNCTION DIAGNOSIS >

10. Tappet noise                      A. Valve                                      B. Valve mechanism  
 C. Rotation mechanism            D. Drive belt                              E. Timing chain

A

### Use the Chart Below to Help You Find the Cause of the Symptom

INFOID:000000004173758

EM

1. Locate the area where noise occurs.
2. Confirm the type of noise.
3. Specify the operating condition of engine.
4. Check specified noise source. Repair or replace the identified part as necessary.

C

Location of noise	Type of noise	Operating condition of engine						Source of noise	Check item	Reference page
		Before warm-up	After warm-up	When starting	When idling	When racing	While driving			
Top of engine Rocker cover Cylinder head	Ticking or clicking	C	A	—	A	B	—	Tappet noise	Valve clearance	<a href="#">EM-17</a>
	Rattle	C	A	—	A	B	C	Camshaft bearing noise	Camshaft journal clearance Camshaft runout	<a href="#">EM-71</a>
Crankshaft pulley Cylinder block (Side of engine) Oil pan	Slap or knock	—	A	—	B	B	—	Piston pin noise	Piston and piston pin clearance Connecting rod bushing clearance	<a href="#">EM-21</a>
	Slap or rap	A	—	—	B	B	A	Piston slap noise	Piston-to-bore clearance Piston ring side clearance Piston ring end gap Connecting rod bend and torsion	<a href="#">EM-100</a>
	Knock	A	B	C	B	B	B	Connecting rod bearing noise	Connecting rod bushing clearance (Small end) Connecting rod bearing clearance (Big end)	<a href="#">EM-100</a>
	Knock	A	B	—	A	B	C	Main bearing noise	Main bearing oil clearance Crankshaft runout	<a href="#">EM-100</a>
Front of engine Timing chain cover	Tapping or ticking	A	A	—	B	B	B	Timing chain and chain tensioner noise	Timing chain cracks and wear Timing chain tensioner operation	<a href="#">EM-57</a>
Front of engine	Squeaking or fizzing	A	B	—	B	—	C	Drive belts (Sticking or slipping)	Drive belts deflection	<a href="#">EM-14</a>
	Creaking	A	B	A	B	A	B	Drive belts (Slipping)	Idler pulley bearing operation	
	Squall Creak	A	B	—	B	A	B	Water pump noise	Water pump operation	<a href="#">CO-17</a>

D

E

F

G

H

I

J

K

L

M

N

O

P

A: Closely related    B: Related    C: Sometimes related    —: Not related

# SPARK PLUG

< ON-VEHICLE MAINTENANCE >

## ON-VEHICLE MAINTENANCE

### SPARK PLUG

Exploded View

INFOID:000000004335581

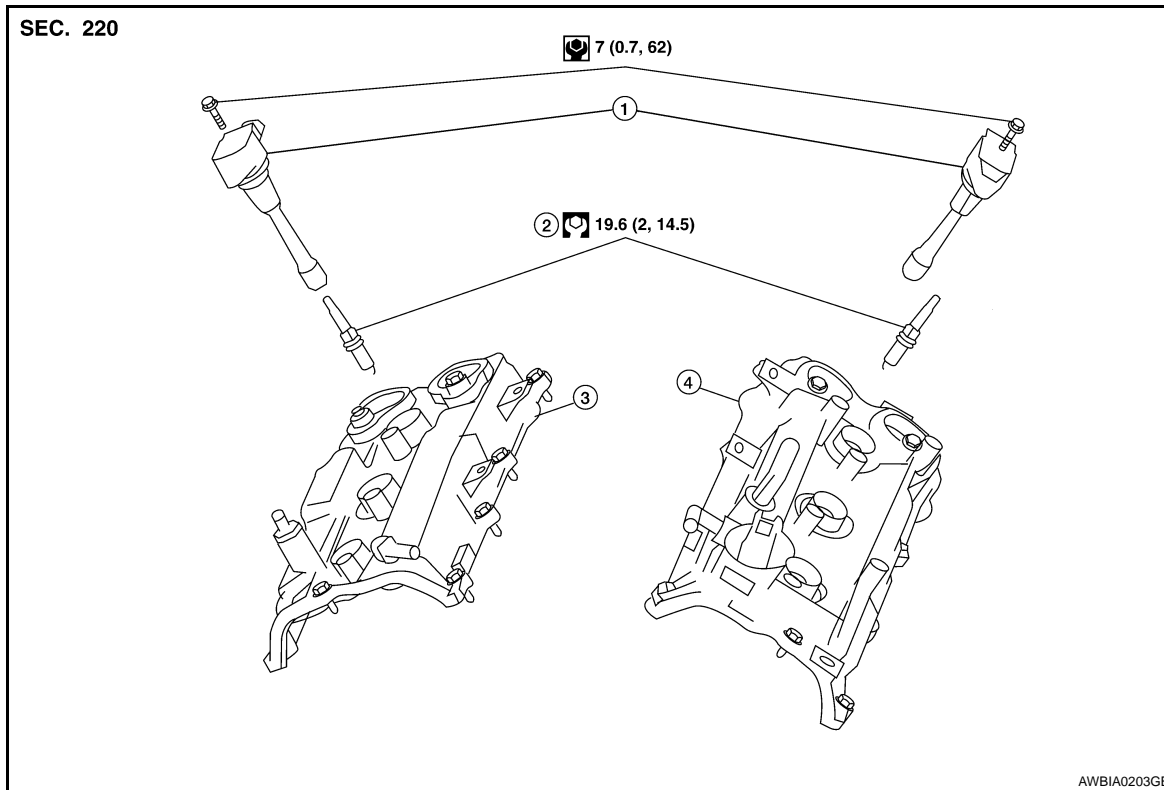

- 1. Ignition coil
- 2. Spark plug
- 3. Rocker cover RH
- 4. Rocker cover LH

### Removal and Installation

INFOID:000000004399675

#### REMOVAL

1. Remove the ignition coil. Refer to [EM-39, "Removal and Installation LH"](#) and [EM-39, "Removal and Installation RH"](#).
2. Remove the spark plug with a suitable spark plug wrench.

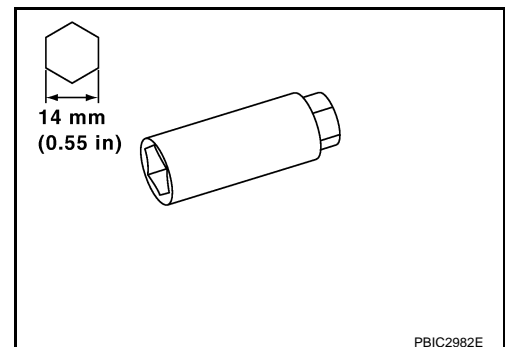

#### INSPECTION AFTER REMOVAL

# SPARK PLUG

## < ON-VEHICLE MAINTENANCE >

- Do not use a wire brush for cleaning the spark plugs. Replace as necessary.

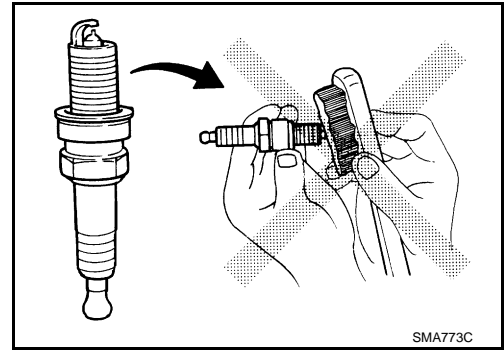

- If plug is covered with carbon, a spark plug cleaner may be used.

**Cleaner air pressure : less than 588 kPa (6 kg/cm<sup>2</sup>, 85 psi)**

**Cleaning time : less than 20 seconds**

- Checking and adjusting plug gap is not required between change intervals. If the gap is out of specification, replace the spark plug.

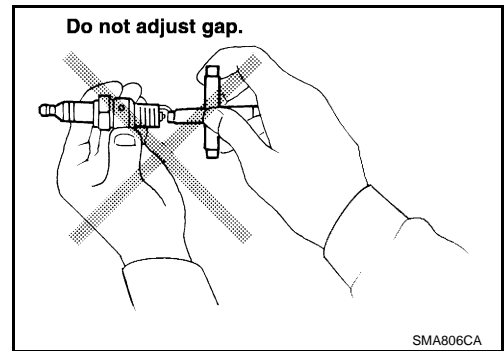

## INSTALLATION

Installation is in the reverse order of removal.

Make	DENSO
Standard type	FXE22HR11
Gap (nominal)	1.1 mm (0.043 in)

A  
EM  
C  
D  
E  
F  
G  
H  
I  
J  
K  
L  
M  
N  
O  
P

# DRIVE BELTS

< ON-VEHICLE MAINTENANCE >

## DRIVE BELTS

### Checking Drive Belts

INFOID:000000004173760

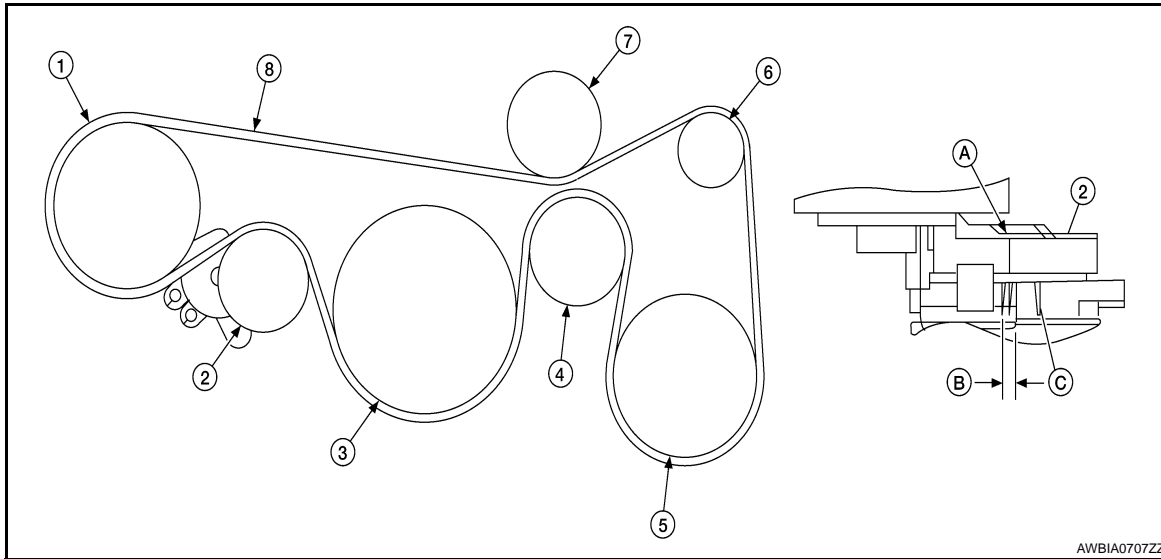

AWBIA0707ZZ

- |                                      |                              |                     |
|--------------------------------------|------------------------------|---------------------|
| 1. Power steering pump               | 2. Drive belt auto-tensioner | 3. Crankshaft       |
| 4. Idler pulley                      | 5. A/C compressor pulley     | 6. Generator pulley |
| 7. Idler pulley                      | 8. Drive belt                | A. Indicator        |
| B. Possible use range (for new belt) | C. Belt replacement          |                     |

### **WARNING:**

**Inspect and check the drive belts with the engine off.**

1. Inspect belt for cracks, fraying, wear or oil adhesion. If necessary, replace with a new one.
2. Rotate the crankshaft pulley two times then check the belt tension using Tool.

**Tool Number** : — (BT-3373-F)

### **NOTE:**

- Inspect drive belt tension when engine is cold.

### Tension Adjustment

INFOID:000000004173761

- Belt tension is not manually adjustable, it is automatically adjusted by the drive belt auto-tensioner.

### Removal and Installation

INFOID:000000004173762

#### REMOVAL

1. Remove the front RH side cover.
2. While securely holding the hexagonal part in pulley center of drive belt auto-tensioner, move in the direction of arrow (loosening direction of tensioner) using suitable tool.

### **WARNING:**

- Avoid placing hand in a location where pinching may occur if the holding tool accidentally comes off.

### **CAUTION:**

- Do not loosen the auto-tensioner pulley bolt. (Do not turn it counterclockwise. If turned counterclockwise, the complete auto-tensioner must be replaced as a unit, including pulley.)

3. Insert a rod approximately 6 mm (0.24 in) in diameter through the rear of tensioner into retaining boss to lock tensioner pulley.
  - Leave tensioner pulley arm locked until belt is installed again.

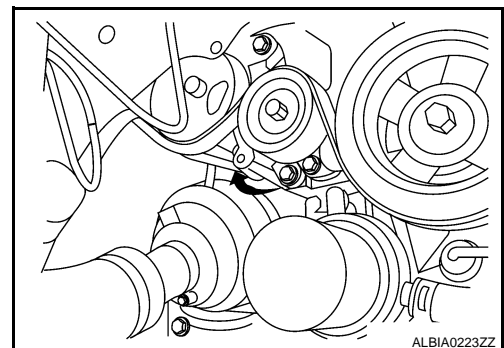

ALBIA0223ZZ

# DRIVE BELTS

## < ON-VEHICLE MAINTENANCE >

4. Loosen auxiliary drive belt from water pump pulley and then remove it from the other pulleys.

### INSTALLATION

1. Install the drive belt onto all of the pulleys.

#### **CAUTION:**

**Confirm belts are completely set on the pulleys.**

2. Release tensioner, and apply tensions to belt.

#### **WARNING:**

- Avoid placing hand in a location where pinching may occur if the holding tool accidentally comes off.

#### **CAUTION:**

- Do not loosen the auto-tensioner pulley bolt. (Don't turn it counterclockwise. If turned counterclockwise, the complete auto-tensioner must be replaced as a unit, including pulley.)

3. Turn crankshaft pulley clockwise several times to equalize tension between each pulley.
4. Confirm tensions of belt at indicator is within the allowable use range. Refer to [EM-14, "Checking Drive Belts"](#).

### Removal and Installation of Drive Belt Auto-tensioner

INFOID:000000004173763

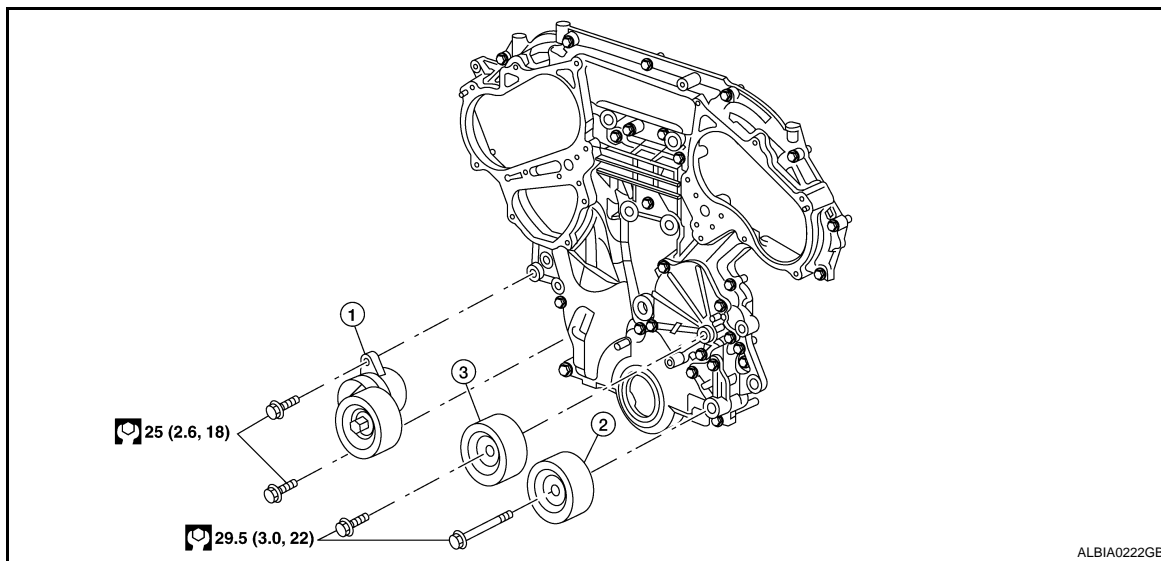

1. Drive belt auto-tensioner

2. Idler pulley

3. A/C idler pulley

### REMOVAL

#### **CAUTION:**

**The complete auto-tensioner must be replaced as a unit, including the pulley.**

1. Remove the front RH side cover.
2. Remove the drive belt. Refer to [EM-14, "Removal and Installation"](#).
  - Insert a rod approximately 6 mm (0.24 in) in diameter through the rear of tensioner into the retaining boss to lock tensioner pulley.
3. Remove the drive belt auto-tensioner, with power tool.

#### **CAUTION:**

**Do not loosen the auto-tensioner pulley bolt. (Don't turn it counterclockwise. If turned counterclockwise, the complete auto-tensioner must be replaced as a unit, including pulley).**

### INSTALLATION

Installation is in the reverse order of removal.

#### **CAUTION:**

- If there is damage greater than peeled paint, replace drive belt auto-tensioner units.
- Do not swap the pulley between the new and old auto-tensioner units.

# AIR CLEANER FILTER

< ON-VEHICLE MAINTENANCE >

## AIR CLEANER FILTER

### Removal and Installation

INFOID:000000004173764

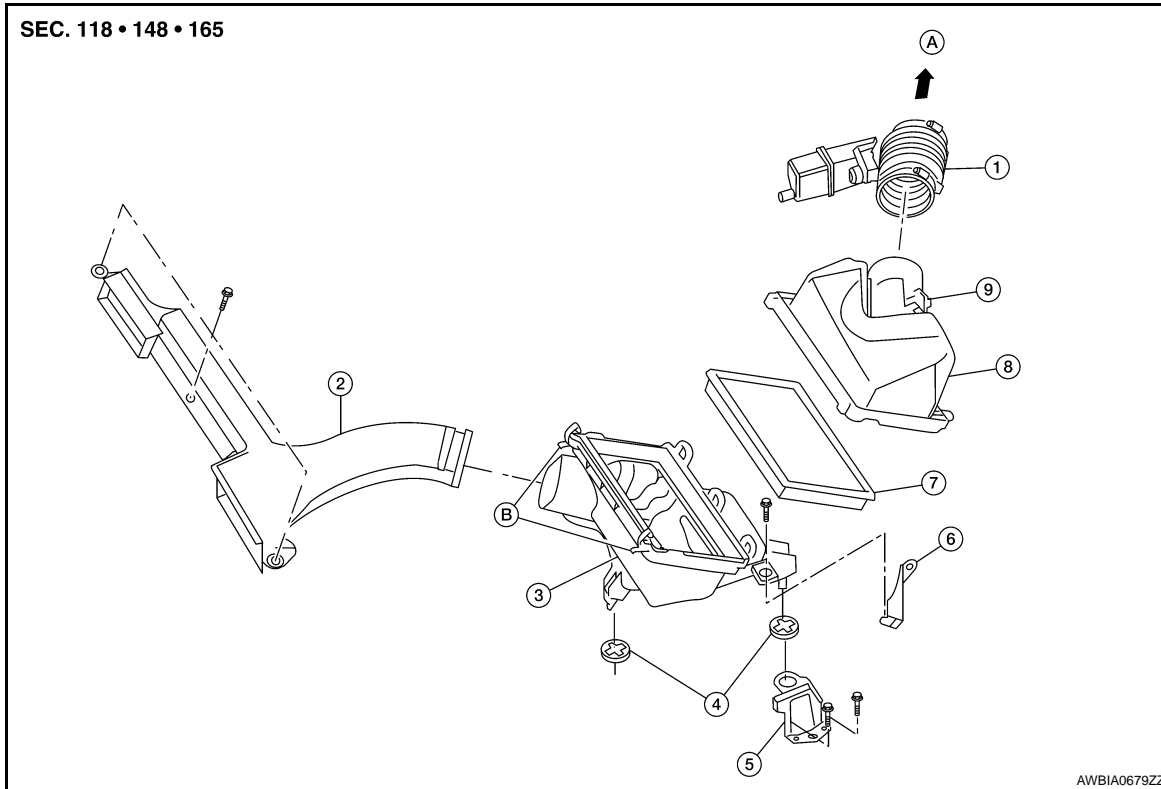

- |  |                                      |                             |
|--|--------------------------------------|-----------------------------|
| 1. Air duct hose                           | 2. Front air duct                    | 3. Air cleaner case (lower) |
| 4. Grommets                                | 5. Air cleaner case mounting bracket | 6. Bracket                  |
| 7. Air cleaner filter                      | 8. Air cleaner case (upper)          | 9. Mass air flow sensor     |
| A. To electronic throttle control actuator | B. Air cleaner case side clips       |                             |

### CHANGING THE AIR CLEANER FILTER

**CAUTION:**

**It is not necessary to remove the front air duct to replace the air cleaner filter.**

1. Unhook the air cleaner case side clips.
2. Remove the air cleaner filter.
3. Install a new air cleaner filter.
4. Lock the air cleaner case side clips.



# CAMSHAFT VALVE CLEARANCE

< ON-VEHICLE MAINTENANCE >

## CAMSHAFT VALVE CLEARANCE

### Valve Clearance

INFOID:000000004173765

#### CHECKING

- Perform inspection as follows after removal, installation or replacement of camshaft or valve related parts, or if there are unusual engine conditions regarding valve clearance.

#### Check valve clearance while engine is cold and not running.

1. Remove the air duct with air cleaner case, collectors, hoses, wires, harnesses, and connectors.
  2. Remove the intake manifold collectors.
  3. Remove the ignition coils and spark plugs.
  4. Remove the rocker covers.
- 
5. Set No.1 cylinder at TDC on its compression stroke.
    - Align pointer with TDC mark on crankshaft pulley.

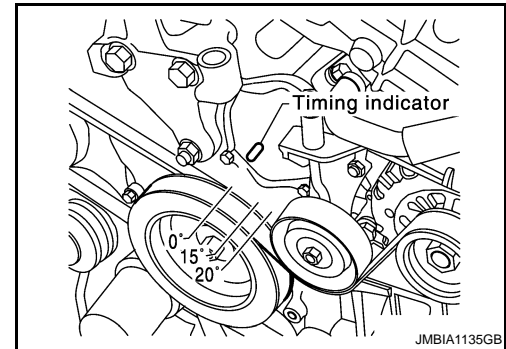
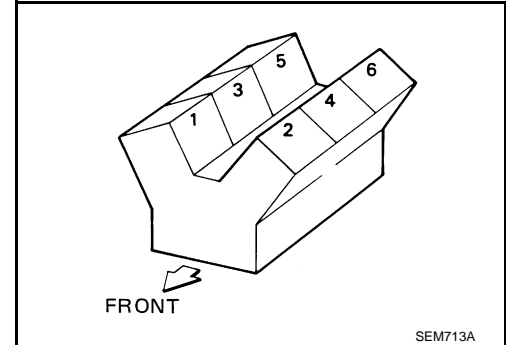

- Check that the valve lifters on No.1 cylinder are loose and valve lifters on No.4 are tight. If not, turn the crankshaft one full revolution (360°) and align as shown.

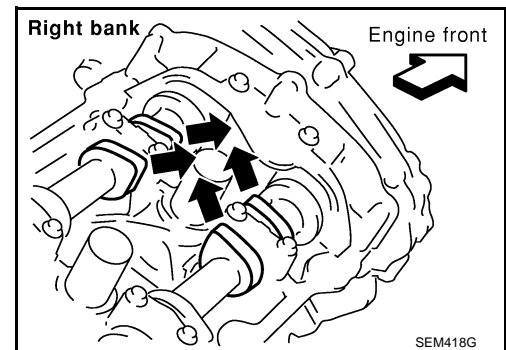

A

EM

C

D

E

F

G

H

I

J

K

L

M

N

O

P

# CAMSHAFT VALVE CLEARANCE

## < ON-VEHICLE MAINTENANCE >

6. Check only the valves as shown.

Crank Position	Valve No. 1	Valve No. 2	Valve No. 3	Valve No. 6
No. 1 TDC	Intake	Exhaust	Exhaust	Intake

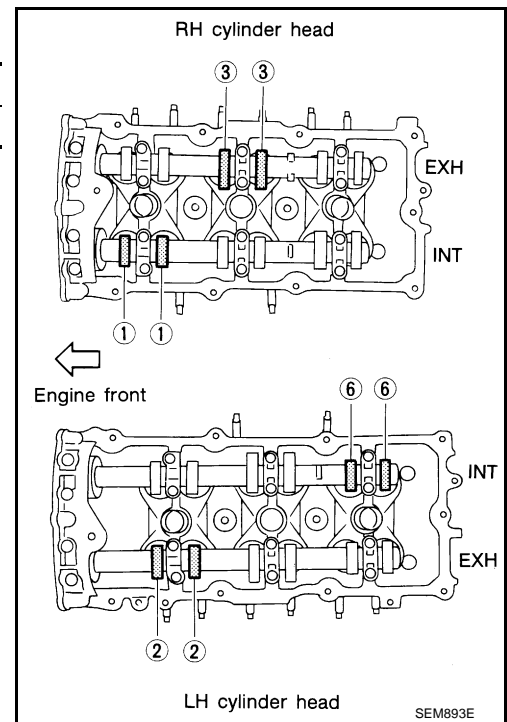

- Using a feeler gauge, measure the clearance between the valve lifter and camshaft.
- Record any valve clearance measurements which are out of specification. They will be used later to determine the required replacement lifter size.

### Valve Clearance for Checking (cold)

**Intake** : 0.26 - 0.34 mm (0.010 - 0.013 in)

**Exhaust** : 0.29 - 0.37 mm (0.011 - 0.015 in)

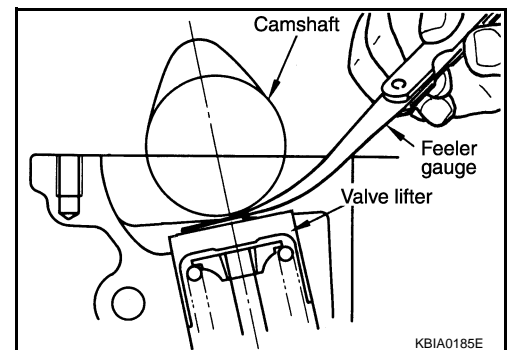
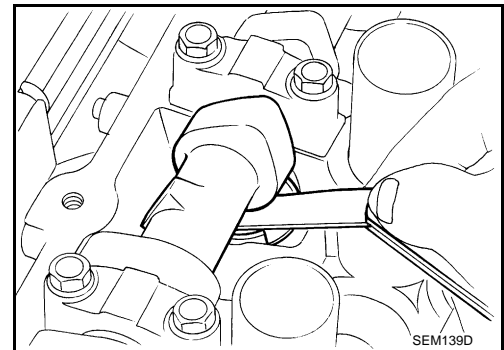

7. Turn crankshaft 240°.
8. Set No.3 cylinder at TDC on its compression stroke.

# CAMSHAFT VALVE CLEARANCE

## < ON-VEHICLE MAINTENANCE >

9. Check only those valves as shown.

Crank Position	Valve No. 2	Valve No. 3	Valve No. 4	Valve No. 5
No. 3 TDC	Intake	Intake	Exhaust	Exhaust

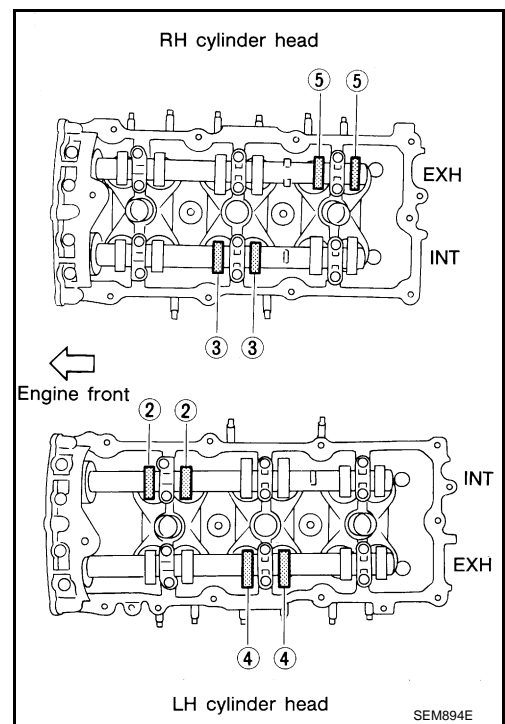

10. Turn the crankshaft 240° and align as above.

11. Set No.5 cylinder at TDC on its compression stroke.

12. Check only those valves as shown.

Crank Position	Valve No. 1	Valve No. 4	Valve No. 5	Valve No. 6
No. 5 TDC	Exhaust	Intake	Intake	Exhaust

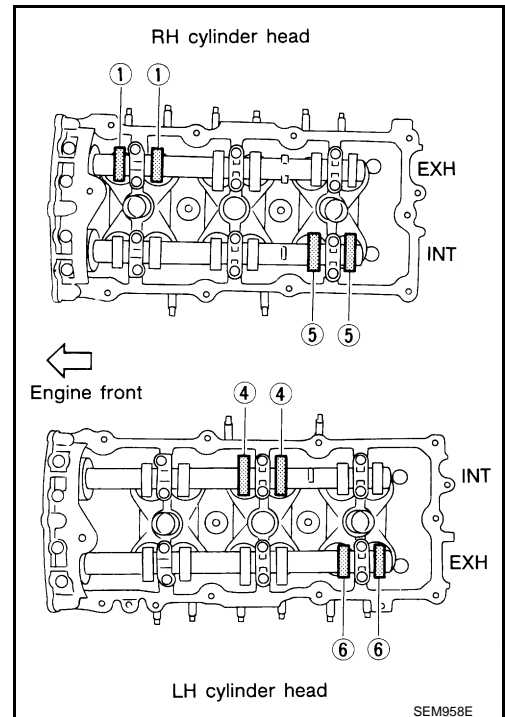

13. If all valve clearances are within specification, install the following components. If the valve clearances are out of specification, adjust the valve clearances.

- Intake manifold collectors
- Rocker covers
- All spark plugs
- All ignition coils

VALVE ADJUSTING

# CAMSHAFT VALVE CLEARANCE

## < ON-VEHICLE MAINTENANCE >

### CAUTION:

Adjust valve clearance while engine is cold.

### NOTE:

- Perform adjustment by selecting the correct head thickness of the valve lifter (adjusting shims are not used).
- The specified valve lifter thickness is the dimension at normal temperatures. Ignore dimensional differences caused by temperature. Use specifications for hot engine condition to confirm valve clearances.

1. Remove the camshaft.
2. Remove the valve lifter that was measured as being outside the standard specifications.
3. Measure the center thickness of the removed lifter with a micrometer, as shown.

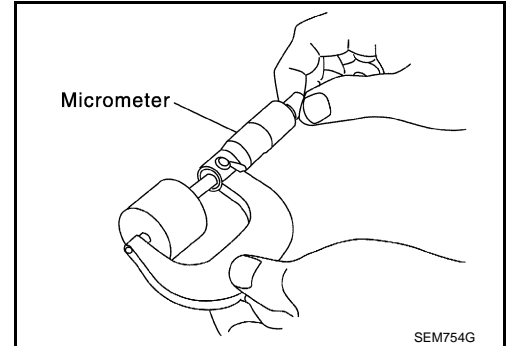

4. Use the equation below to calculate the replacement valve lifter thickness.

Valve lifter thickness calculation equation:  $t = t_1 + (C_1 - C_2)$

t = thickness of the replacement lifter

t<sub>1</sub> = thickness of the removed lifter

C<sub>1</sub> = measured valve clearance

C<sub>2</sub> = standard valve clearance

- The thickness of the new valve lifter can be identified by the stamp mark on the reverse side (inside the lifter).
- Available thickness of the valve lifter (factory setting):  
7.88 - 8.40 mm (0.3102 - 0.3307 in), in 0.02 mm (0.0008 in) increments, in 27 sizes (intake/exhaust). Refer to [EM-124, "Cylinder Head"](#).

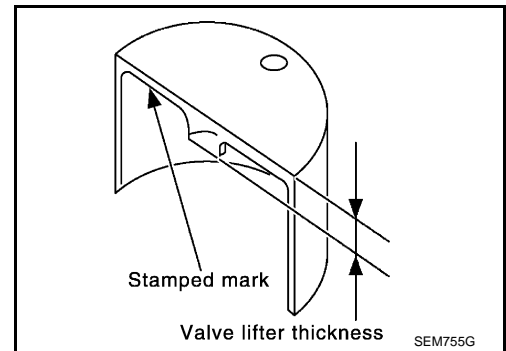

5. Install the selected replacement valve lifter.
6. Install the camshaft.
7. Rotate the crankshaft a few turns by hand.
8. Confirm that the valve clearances are within specification.
9. After the engine has been run to full operating temperature, confirm that the valve clearances are within specification.

Standard Valve Clearance	Cold	Hot* (reference data)
Intake	0.26 - 0.34 mm (0.010 - 0.013 in)	0.304 - 0.416 mm (0.012 - 0.016 in)
Exhaust	0.29 - 0.37 mm (0.011 - 0.015 in)	0.308 - 0.432 mm (0.012 - 0.017 in)

\* Approximately 80°C (176°F)

# COMPRESSION PRESSURE

< ON-VEHICLE MAINTENANCE >

## COMPRESSION PRESSURE

### On-Vehicle Service

INFOID:000000004173766

#### CHECKING COMPRESSION PRESSURE

1. Run the engine until it reaches normal operating temperature.
2. Turn the ignition switch to OFF.
3. Release fuel pressure and leave the fuel pump electrically disconnected.  
Refer to [EC-559, "Inspection"](#).
4. Remove all six spark plugs.  
Refer to [EM-12, "Removal and Installation"](#).
5. Attach a compression tester to No. 1 cylinder.
6. Depress accelerator pedal fully to keep the electric throttle control actuator butterfly-valve wide open to maximize air intake flow.
7. Crank the engine and record the highest gauge indication.
8. Repeat the measurement on each cylinder (steps 5 - 7).
  - **Always use a fully-charged battery to obtain specified engine speed.**

Unit: kPa (kg/cm<sup>2</sup>, psi)/rpm

Standard	Minimum	Difference limit between cylinders
1,275 (13.0, 185)/300	981 (10.0, 142)/300	98 (1.0, 14)/300

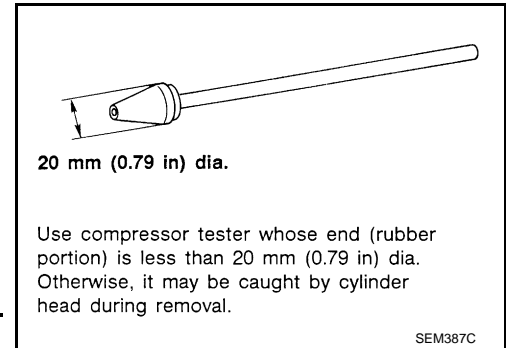

9. If compression in one or more cylinders is low:
  - a. Pour a small amount of engine oil into cylinders through the spark plug holes.
  - b. Retest compression (steps 5 - 8).
  - **If adding oil helps raise compression pressure, then the piston rings may be worn or damaged. If so, replace piston rings after checking piston.**
  - **If the pressure stays low, a valve may be sticking or is seating improperly. Inspect and repair the valve and/or valve seat. Refer to [EM-124, "Cylinder Head"](#). If the valve and/or valve seat is damaged excessively, replace as necessary.**
  - **If compression stays low in two or more cylinders that are next to each other:**
    - The cylinder head gasket may be leaking.
    - Both cylinders may have valve component damage. Inspect and repair as necessary.

# ENGINE COVER

< ON-VEHICLE REPAIR >

## ON-VEHICLE REPAIR

### ENGINE COVER

#### Removal and Installation

INFOID:000000004393999

#### REMOVAL

- Remove the engine room cover bolts and engine room cover.

**CAUTION:**

**Do not damage or scratch engine room cover when installing or removing.**

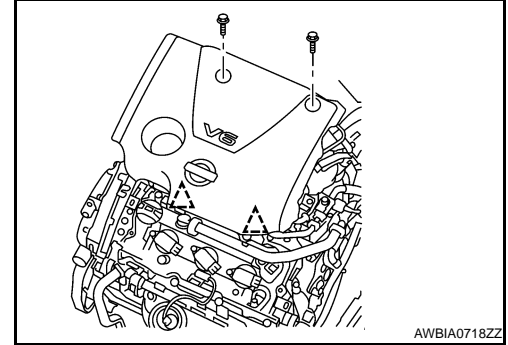

#### INSTALLATION

Installation is in the reverse order of removal.

# AIR CLEANER AND AIR DUCT

< ON-VEHICLE REPAIR >

## AIR CLEANER AND AIR DUCT

### Removal and Installation

INFOID:000000004173767

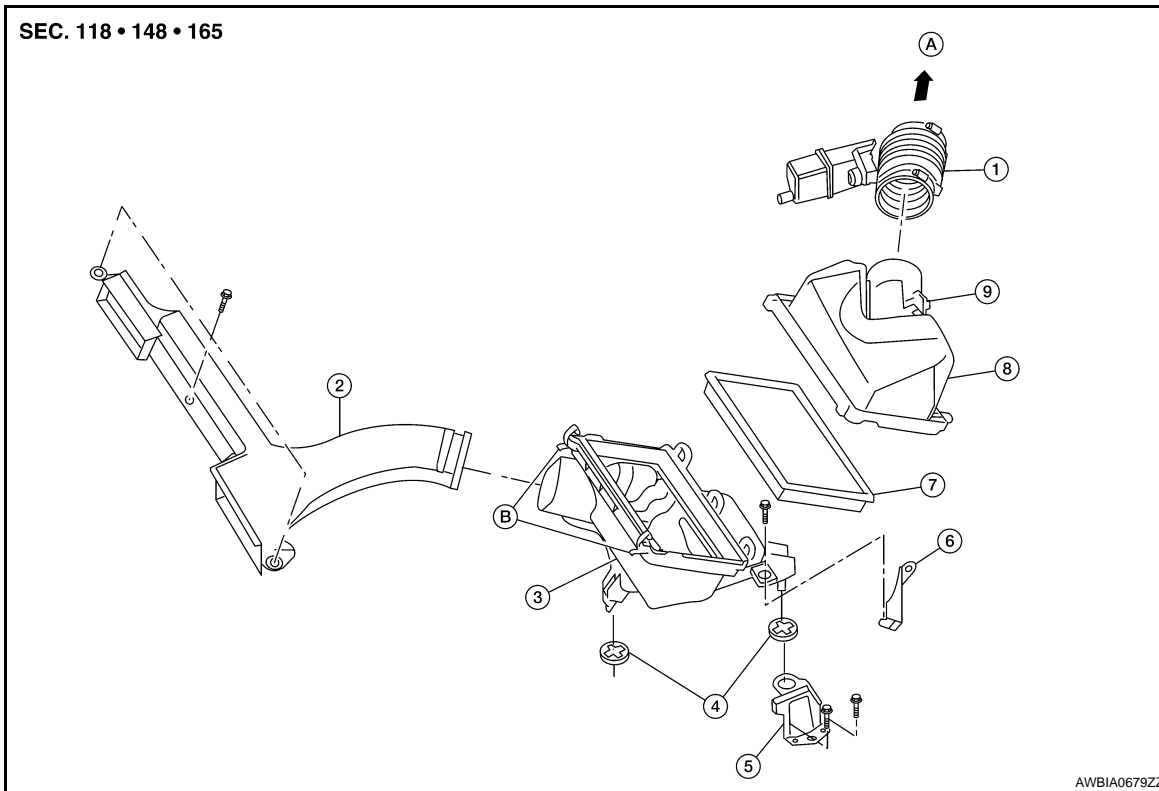

- |  |                                      |                             |
|--|--------------------------------------|-----------------------------|
| 1. Air duct hose                           | 2. Front air duct                    | 3. Air cleaner case (lower) |
| 4. Grommets                                | 5. Air cleaner case mounting bracket | 6. Bracket                  |
| 7. Air cleaner filter                      | 8. Air cleaner case (upper)          | 9. Mass air flow sensor     |
| A. To electronic throttle control actuator | B. Air cleaner case side clips       |                             |

### REMOVAL

1. Remove front air duct.
2. Disconnect the tube clamp at the electronic throttle control actuator and at the air duct hose.
3. Remove air duct hose.
4. Disconnect mass air flow sensor.
5. Remove mass air flow sensor from air cleaner assembly, as necessary.

#### **CAUTION:**

**Handle mass air flow sensor with care.**

- Do not shock it.
- Do not disassemble it.
- Do not touch its sensor.

6. Remove air cleaner assembly.

### INSTALLATION

Installation is in the reverse order of removal.

# INTAKE MANIFOLD COLLECTOR

< ON-VEHICLE REPAIR >

## INTAKE MANIFOLD COLLECTOR

### Removal and Installation

INFOID:000000004173768

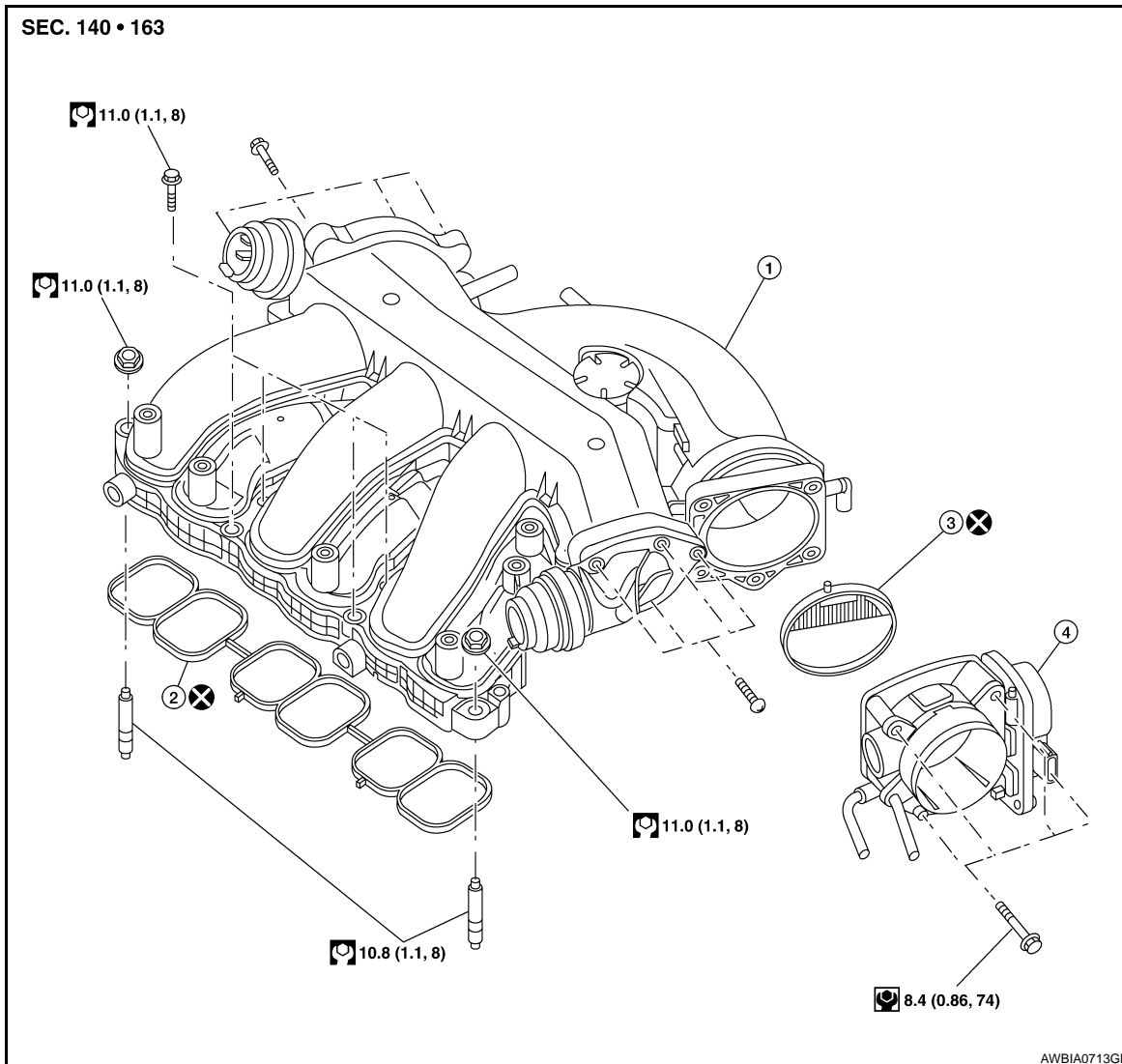

1. Intake manifold collector

2. Gasket

3. Electric throttle control actuator

#### NOTE:

Do not remove power valves.

#### REMOVAL

#### WARNING:

- To avoid the danger of being scalded, never drain the coolant when the engine is hot.
- The gasket for intake manifold collector (upper) is secured together with intake manifold collector (lower) bolt. Thus, when replacing only the upper gasket the lower gasket must also be replaced.

1. Remove the cowl top. Refer to [EXT-18, "Removal and Installation"](#).
2. Remove the engine cover, using power tool.
3. Remove air cleaner assembly and fresh air intake tube as an assembly. Refer to [EM-23, "Removal and Installation"](#).



# INTAKE MANIFOLD COLLECTOR

## < ON-VEHICLE REPAIR >

- Remove the electric throttle control actuator bolts in the reverse order as shown and remove the electric throttle control actuator.

**CAUTION:**

- Handle carefully to avoid any shock to the electric throttle control actuator.
- Do not disassemble.

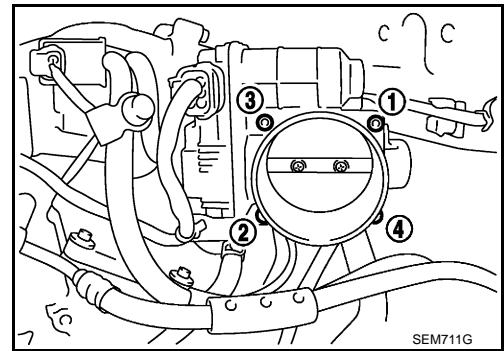

- Disconnect the following:
  - Power brake booster vacuum hose
  - Fuel injector electrical connectors
  - PCV hose
  - Electric throttle control actuator electrical connector
  - EVAP canister purge hose

**CAUTION:**

- Cover any engine openings to avoid the entry of any foreign material.

- Remove the EVAP canister purge volume solenoid valve bracket bolt. Position the valve aside.
- Loosen the intake manifold collector bolts in the order as shown using power tool, and remove the intake manifold collector and gasket.

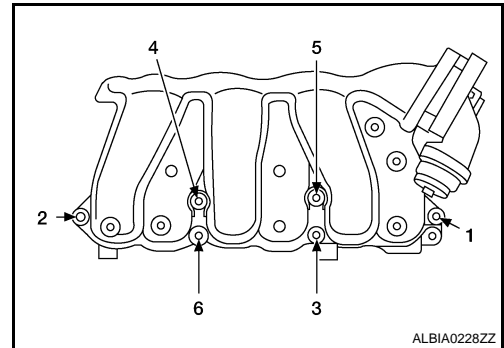

- If necessary remove the following components:
  - VIAS control solenoid valve
  - EVAP canister purge volume control solenoid valve

## INSTALLATION

Installation is in the reverse order of removal.

- Tighten intake manifold collector bolts in the order as shown.

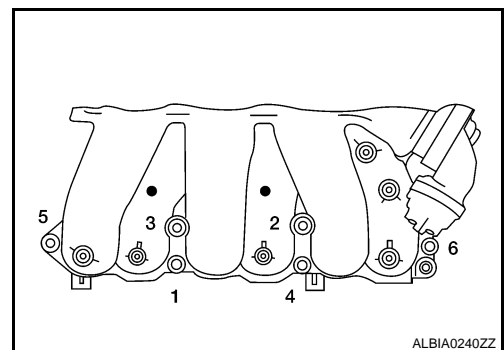

A

EM

C

D

E

F

G

H

I

J

K

L

M

N

O

P

## INTAKE MANIFOLD COLLECTOR

### < ON-VEHICLE REPAIR >

- Tighten electric throttle control actuator bolts in the order shown.

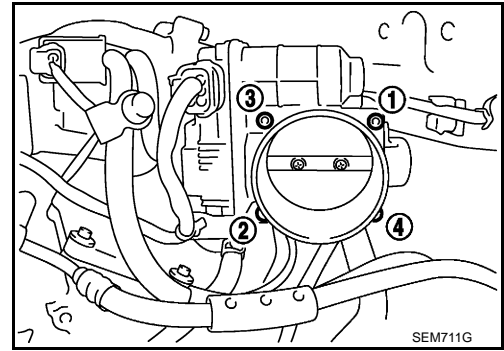

### NOTE:

After installation, it is necessary to re-calibrate the electric throttle control actuator as follows:

1. Perform the "Throttle Valve Closed Position Learning" when harness connector of the electric throttle control actuator is disconnected. Refer to [EC-18. "THROTTLE VALVE CLOSED POSITION LEARNING : Special Repair Requirement"](#).
2. Perform the "Idle Air Volume Learning" when the electric throttle control actuator is replaced. Refer to [EC-19. "IDLE AIR VOLUME LEARNING : Special Repair Requirement"](#).

# INTAKE MANIFOLD

< ON-VEHICLE REPAIR >

## INTAKE MANIFOLD

### Removal and Installation

INFOID:000000004173769

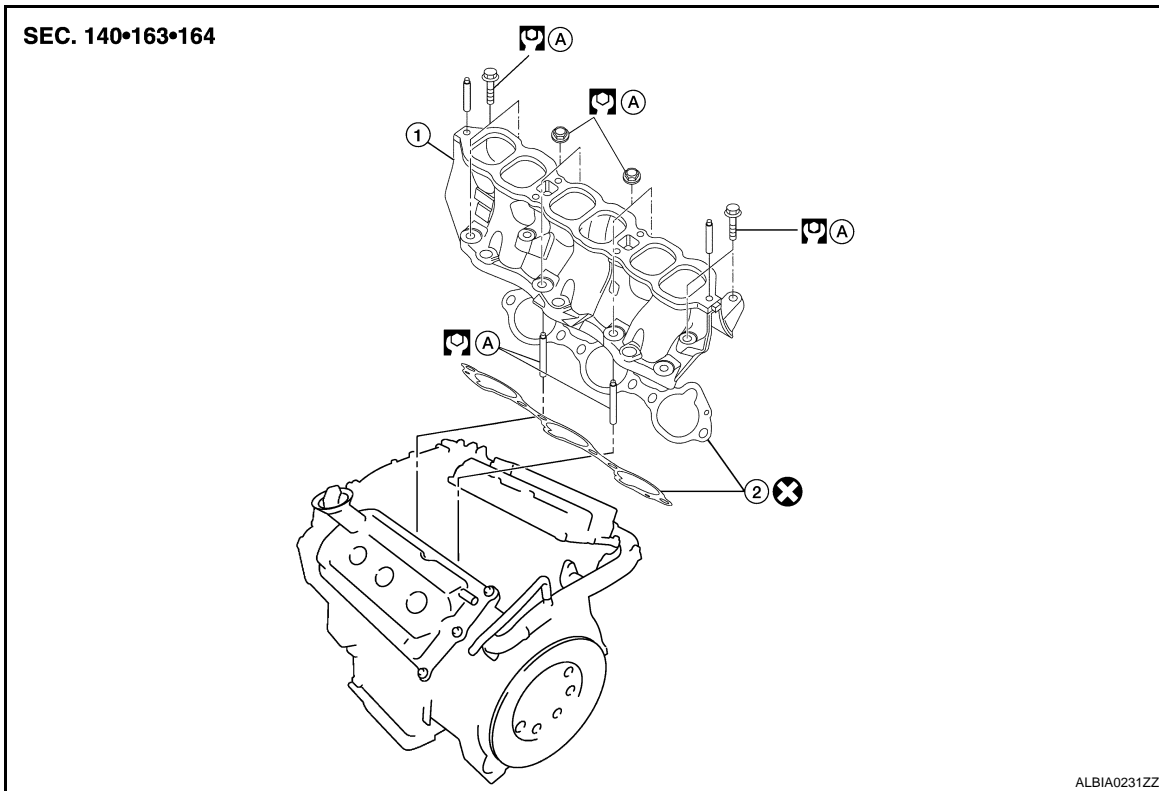

1. Intake manifold

2. Gasket

A. Follow installation procedure

### REMOVAL

#### **WARNING:**

**To avoid the danger of being scalded, never drain the coolant when the engine is hot.**

1. Remove the engine cover with power tool.
2. Release the fuel pressure. Refer to [EC-559, "Inspection"](#).
3. Remove intake manifold collector. Refer to [EM-24, "Removal and Installation"](#).
4. Disconnect fuel tube quick connector at vehicle piping side.
5. To remove the quick connector cap, hold the sides of the connector, push in the tabs and pull out the tube.

#### **CAUTION:**

- The tube can be removed when the tabs are completely depressed. Do not twist it more than necessary.
- Do not use any tools to remove the quick connector.
- Keep the resin tube away from heat. Be especially careful when welding near the tube.
- Prevent acid liquids such as battery electrolyte, etc. from getting on the resin tube.
- Do not bend or twist the tube during removal or installation.
- Do not remove the remaining retainer on the tube.
- When the tube is replaced, also replace the retainer with a new one.

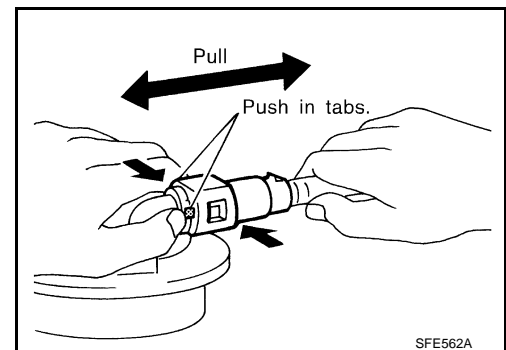

# INTAKE MANIFOLD

## < ON-VEHICLE REPAIR >

- To keep the connecting portion clean and to avoid damage and foreign materials entering, cover the ends of the fuel tubes with plastic bags or something similar.

### NOTE:

If the connector and the tube are stuck together, push and pull several times until they start to move. Then disconnect them by pulling.

6. Remove the fuel rail with the fuel injectors attached, from the intake manifold. Remove the fuel injector O-rings and use new O-rings for installation.
7. Loosen the bolts in the order as shown, and remove the intake manifold with power tool.

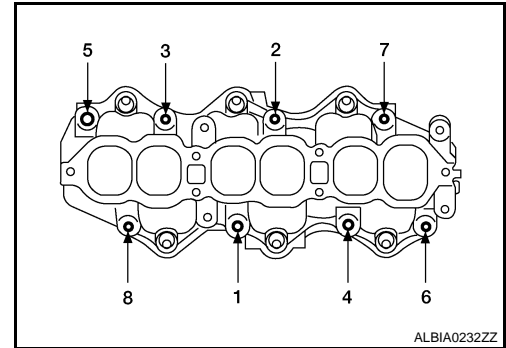
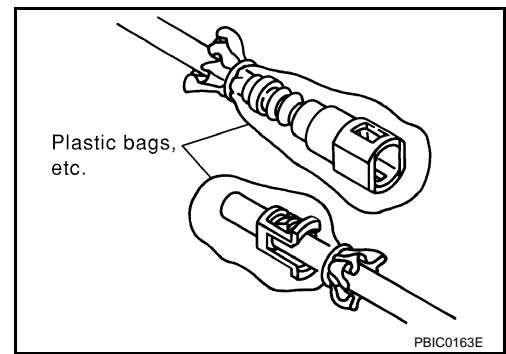

## INSPECTION AFTER REMOVAL

### Surface Distortion

- Using straightedge and feeler gauge, inspect the surface distortion of the intake manifold. Inspect the surface distortion of the intake manifold collector. Refer to [EM-24, "Removal and Installation"](#).

**Standard : 0.1 mm (0.004 in)**

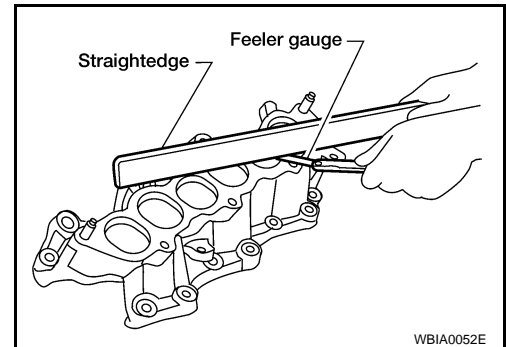

## INSTALLATION

Installation is in the reverse order of removal. Follow the procedure below for specific tightening sequences and procedures.

- Install intake manifold bolts in two steps in the numerical order as shown.

**Step 1 : 7.3 N·m (0.74 kg-m, 65 in-lb)**

**Step 2 : 25 N·m (2.6 kg-m, 19 ft-lb)**

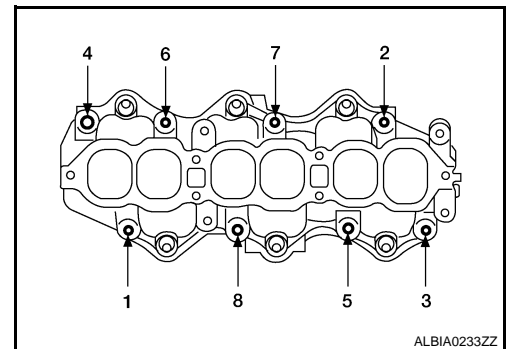

### NOTE:

After installation, it is necessary to re-calibrate the electric throttle control actuator as follows:

1. Perform the "Throttle Valve Closed Position Learning" when harness connector of the electric throttle control actuator is disconnected. Refer to [EC-18, "THROTTLE VALVE CLOSED POSITION LEARNING : Special Repair Requirement"](#).
2. Perform the "Idle Air Volume Learning" when the electric throttle control actuator is replaced. Refer to [EC-19, "IDLE AIR VOLUME LEARNING : Special Repair Requirement"](#).

# INTAKE MANIFOLD

## < ON-VEHICLE REPAIR >

- Install the quick connector as follows:
- Make sure no foreign substances are deposited in and around the fuel tube and quick connector and that there is no damage.
- Align the center to insert the quick connector straight onto the fuel tube.
- Insert the fuel tube until a click is heard.
- Install the quick connector cap on the quick connector joint. Align the arrow mark on the quick connector cap to the upper side.
- Install the fuel hose into the hose clamp.

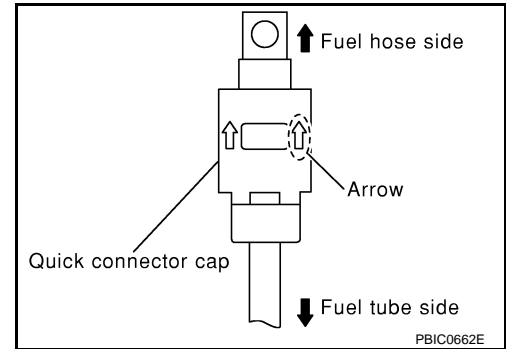

## INSPECTION AFTER INSTALLATION

Make sure there is no fuel leakage at connections as follows:

1. Apply fuel pressure to fuel lines by turning ignition switch ON (with engine stopped). Then check for fuel leaks at connections.
2. Start the engine and rev it up and check for fuel leaks at connections.

### **CAUTION:**

**Do not touch engine immediately after stopping as engine is extremely hot.**

### **NOTE:**

Use mirrors for checking on connections out of the direct line of sight.

# EXHAUST MANIFOLD AND THREE WAY CATALYST

< ON-VEHICLE REPAIR >

## EXHAUST MANIFOLD AND THREE WAY CATALYST

### Removal and Installation

INFOID:000000004173770

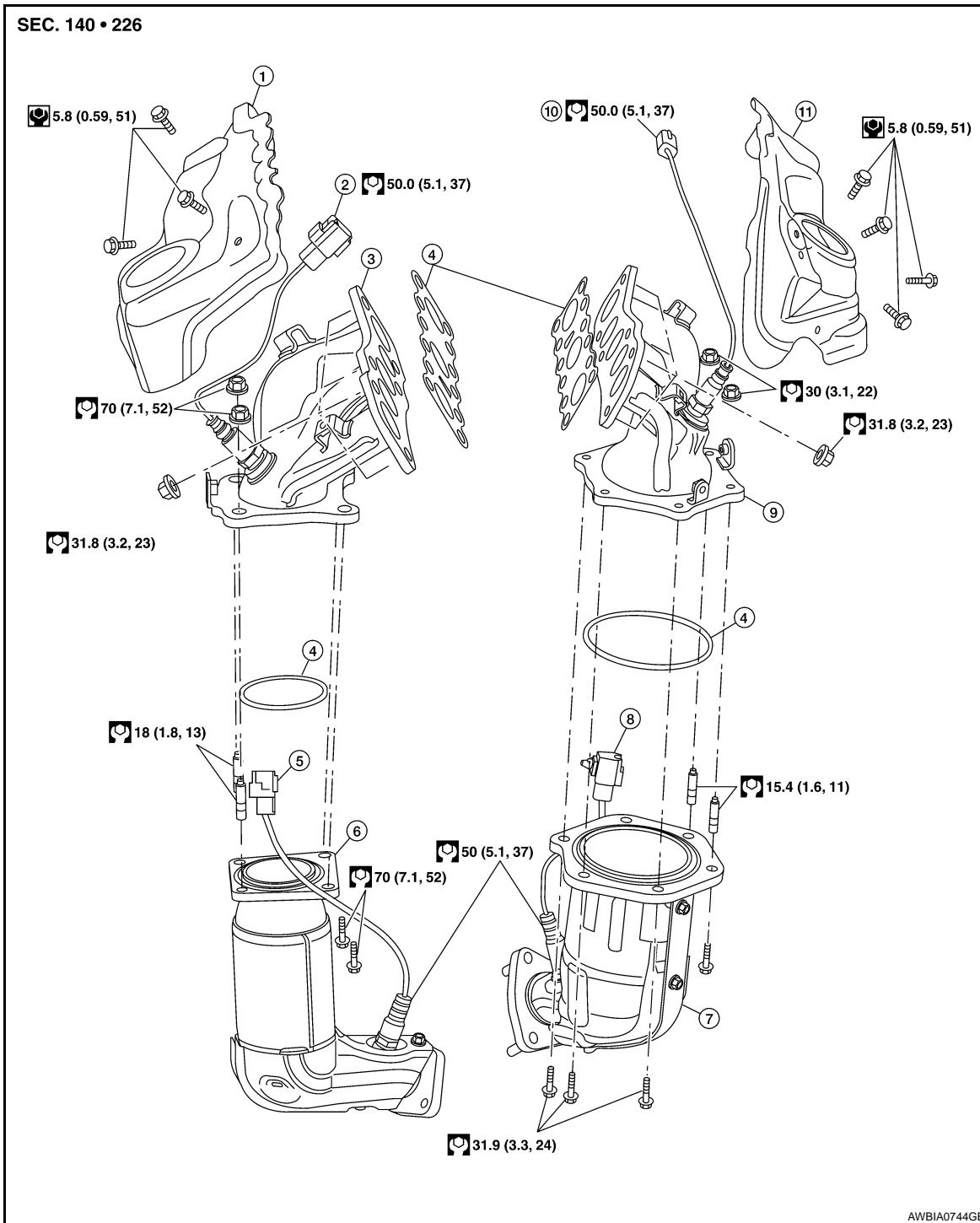

- |  |   |   |
|--|---|---|
| 1. Exhaust manifold heat shield (RH)       | 2. Air fuel ratio (A/F) sensor 1 (bank 1) | 3. Exhaust manifold (RH)                  |
| 4. Gaskets                                 | 5. Heated oxygen sensor 2 (bank 1)        | 6. Three way catalyst (manifold) (bank 1) |
| 7. Three way catalyst (manifold) (bank 2)  | 8. Heated oxygen sensor 2 (bank 2)        | 9. Exhaust manifold (LH)                  |
| 10. Air fuel ratio (A/F) sensor 1 (bank 2) | 11. Exhaust manifold heat shield (LH)     |   |

### REMOVAL

**WARNING:**

# EXHAUST MANIFOLD AND THREE WAY CATALYST

< ON-VEHICLE REPAIR >

- Perform the work when the exhaust and cooling system have completely cooled down.
  - When removing the front and rear engine mounting through bolts and nuts, lift the engine up slightly for safety. For engine slingers, refer to [EM-96, "Removal and Installation"](#).
1. Remove engine and CVT assembly. Refer to [EM-96, "Removal and Installation"](#).
  2. Remove the RH and LH three way catalyst supports.
  3. Remove heated oxygen sensor 2 (bank 1), heated oxygen sensor 2 (bank 2), air fuel ratio (A/F) sensor 1 (bank 1) and air fuel ratio (A/F) sensor 1 (bank 2).
    - a. Remove harness connector of each sensor, and disconnect the harness from the bracket and middle clamp.
    - b. Remove both heated oxygen sensors and air fuel ratio (A/F) sensors using Tool.

**Tool numbers** : KV10114400 (J-38365)  
: — (J-44626)

## CAUTION:

- Be careful not to damage heated oxygen sensors or air fuel ratio (A/F) sensors.
  - Discard any heated oxygen sensor which has been dropped from a height of more than 0.5 m (19.7 in) onto a hard surface such as a concrete floor; replace with a new sensor.
4. Remove exhaust manifold and three way catalyst heat shields with power tool.
  5. Remove the three way catalyst (manifold) (bank 1) and three way catalyst (manifold) (bank 2) by loosening the bolts first and then removing the nuts and through bolts.
  6. Remove the exhaust manifolds RH (A) and LH (B). Loosen the exhaust manifold nuts in the order as shown.

← : Front

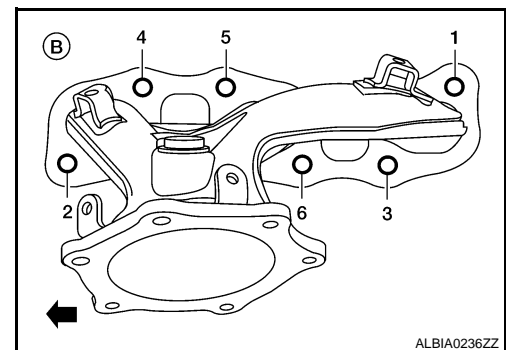
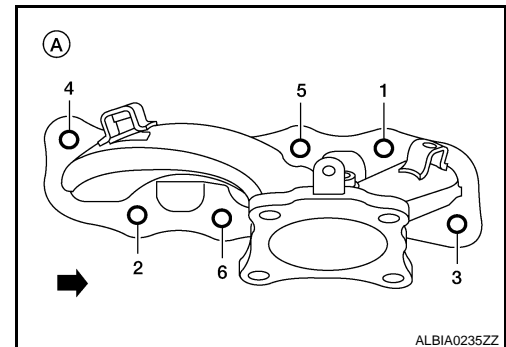

## INSPECTION AFTER REMOVAL

### Surface Distortion

- Use a reliable straightedge and feeler gauge to check the flatness of the exhaust manifold mating surfaces.

**Limit** : 0.3 mm (0.012 in)

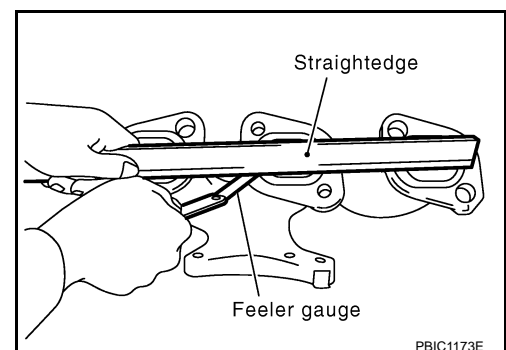

# EXHAUST MANIFOLD AND THREE WAY CATALYST

< ON-VEHICLE REPAIR >

## INSTALLATION

Installation is in the reverse order of removal.

- Install the exhaust manifold nuts in the order as shown RH (A) and LH (B).

← : **Front**

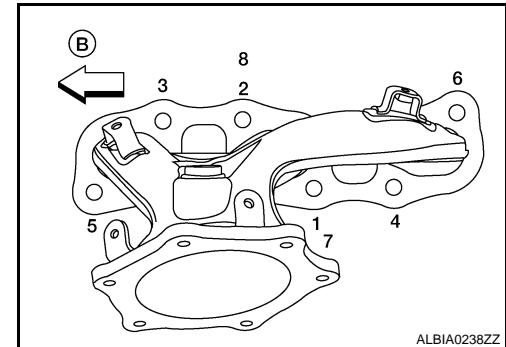
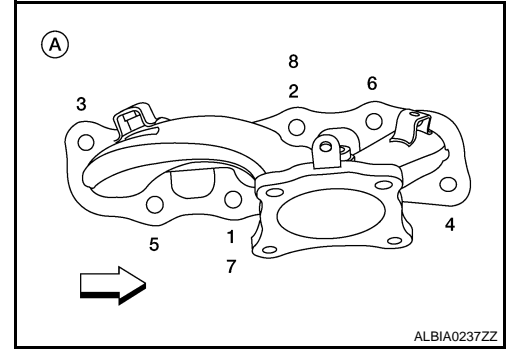

### CAUTION:

- Before installing a heated oxygen sensor or air fuel ratio (A/F) sensor, clean the exhaust manifold threads using the oxygen sensor thread cleaner tool, and apply anti-seize lubricant.

**Tool numbers** : — (J-43897-18)  
: — (J-43897-12)

- Do not over-tighten the air fuel ratio (A/F) sensor or heated oxygen sensors. Doing so may cause damage.

**Tool numbers** : KV10114400 (J-38365)  
: — (J-44626)



# OIL PAN AND OIL STRAINER

< ON-VEHICLE REPAIR >

## OIL PAN AND OIL STRAINER

### Removal and Installation

INFOID:000000004173771

SEC. 110.150.221.251

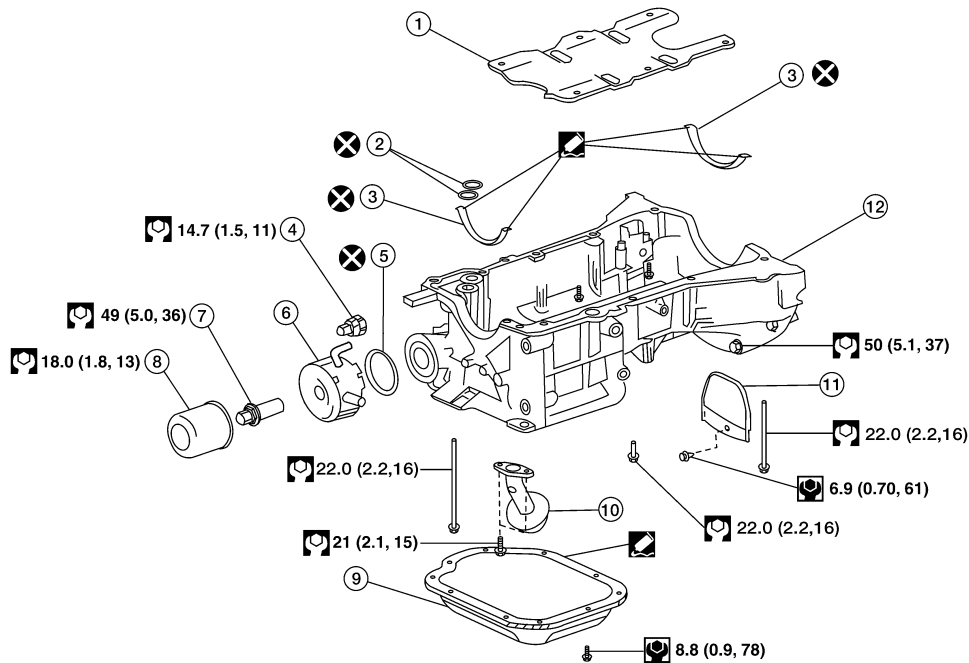

AWBIA0577GB

- |                          |                      |                   |
|--------------------------|----------------------|-------------------|
| 1. Oil pan baffle        | 2. O-ring            | 3. Gasket         |
| 4. Oil pressure switch   | 5. Oil cooler gasket | 6. Oil cooler     |
| 7. Oil cooler connection | 8. Oil filter        | 9. Lower oil pan  |
| 10. Oil strainer         | 11. Rear plate cover | 12. Upper oil pan |

### REMOVAL

#### **WARNING:**

- You should not remove the oil pan until the exhaust system and cooling system have completely cooled off.
- When removing the front and rear engine through bolts and nuts, lift the engine up slightly for safety. For engine slingers, refer to [EM-96. "Removal and Installation"](#).

#### **CAUTION:**

When removing the upper oil pan from the engine, first remove the crankshaft position sensor (POS). Be careful not to damage sensor edges or signal plate teeth.

1. Remove the front RH wheel and tire using power tool.
2. Disconnect the battery negative terminal.
3. Remove the oil dipstick.
4. Drain the engine coolant. Refer to [CO-10. "Changing Engine Coolant"](#).
5. Remove the engine undercover.
6. Remove the RH inner fender splash shield.
7. Remove the drive belt. Refer to [EM-14. "Removal and Installation"](#).
8. Remove the front exhaust tube. Refer to [EX-5. "Removal and Installation"](#).
9. Remove coolant pipe bolts.
10. Remove the A/C compressor with piping attached, and position it out of the way securely with wire.  
**CAUTION:**  
Do not pull on or crimp the A/C lines and hoses.
11. Disconnect the coolant lines from the engine oil cooler and plug them to prevent coolant loss.

# OIL PAN AND OIL STRAINER

## < ON-VEHICLE REPAIR >

12. Remove the oil filter and engine oil cooler from the upper oil pan.
13. Remove the oil pressure switch/sensor, and the crankshaft position sensor (POS) from the upper oil pan.
14. Remove the front drive shaft (RH). Refer to [FAX-11, "Removal and Installation \(Right Side\)"](#).
15. Disconnect the heated oxygen sensors and air flow ratio (A/F) sensors and remove the two catalytic converters from the exhaust manifolds using power tool. Refer to [EM-30, "Removal and Installation"](#).
16. Remove the rear cover plate from the upper oil pan.

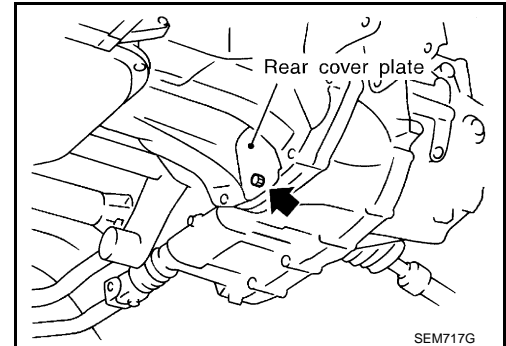

17. Loosen the lower oil pan bolts using power tool in order as shown. Remove the lower oil pan.

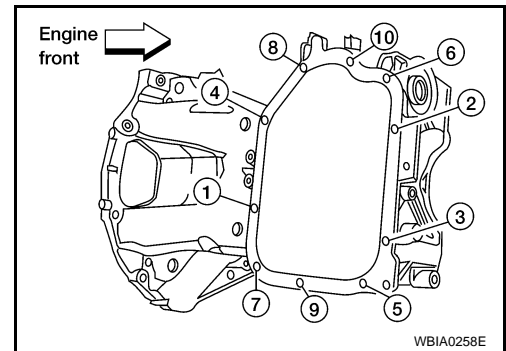

- a. Insert Tool between the lower oil pan and the upper oil pan.

**Tool number : KV10111100 (J-37228)**

- Be careful not to damage the mating surface.
  - Do not insert a screwdriver, this will damage the mating surfaces.
- b. Slide (2) the Tool by tapping (1) its side with a hammer to remove the lower oil pan from the upper oil pan.

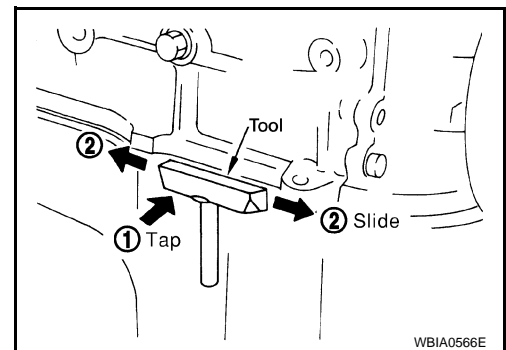

18. Remove the four upper oil pan to transaxle bolts.

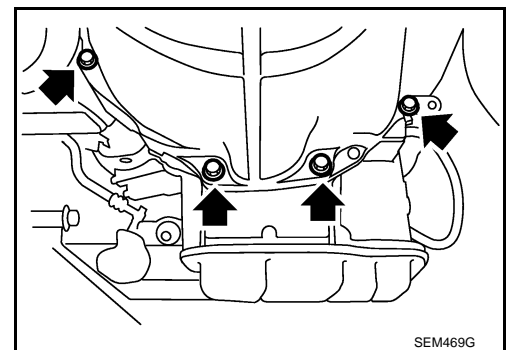

## OIL PAN AND OIL STRAINER

### < ON-VEHICLE REPAIR >

19. Remove the upper oil pan.

a. Loosen the bolts in the order as shown, using power tool.

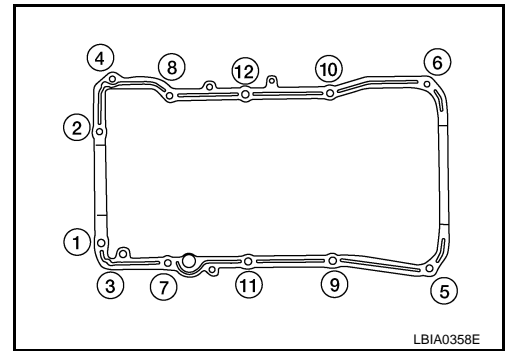

b. Insert an appropriate size tool into the notch (1) of the upper oil pan as shown.

c. Pry off the upper oil pan by moving the tool up and down (2) as shown.

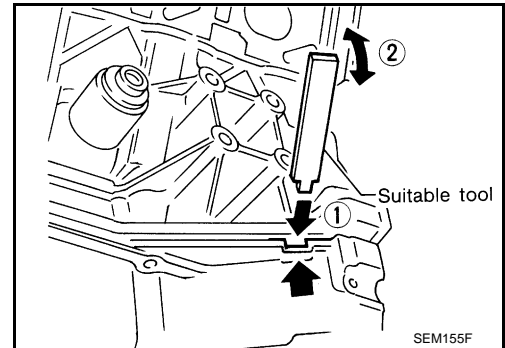

20. Remove the O-ring seals from the bottom of the cylinder block and oil pump housing. Use new O-rings for installation.

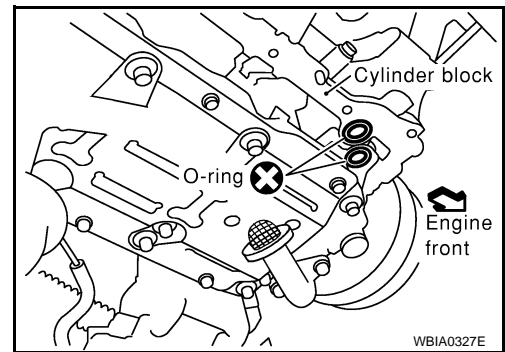

21. Remove front cover gasket and rear oil seal retainer gasket.

22. Remove the oil strainer.

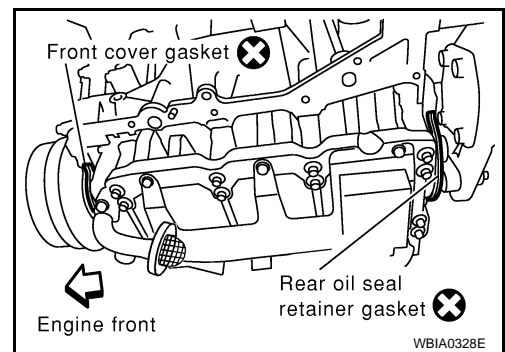

A

EM

C

D

E

F

G

H

I

J

K

L

M

N

O

P

# OIL PAN AND OIL STRAINER

## < ON-VEHICLE REPAIR >

23. If re-installing the original oil pan, remove the old sealant from the mating surfaces using a scraper.
- Also remove the old sealant from mating surface of the cylinder block.
  - Remove the old sealant from the bolt holes and threads.

**CAUTION:**

**Do not scratch or damage the mating surfaces when cleaning off the old sealant.**

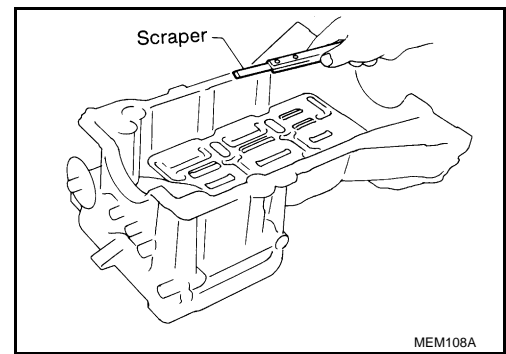

## INSPECTION AFTER REMOVAL

Clean oil strainer if any object is attached.

## INSTALLATION

**CAUTION:**

**Wait at least 30 minutes before refilling the engine with oil.**

1. Install oil strainer and tighten bolt to specified torque. Refer to [EM-33, "Removal and Installation"](#).

2. Apply Genuine Silicone RTV Sealant or equivalent, to the front cover gasket and the rear oil seal retainer gasket as shown. Refer to [GI-15, "Recommended Chemical Products and Sealants"](#).

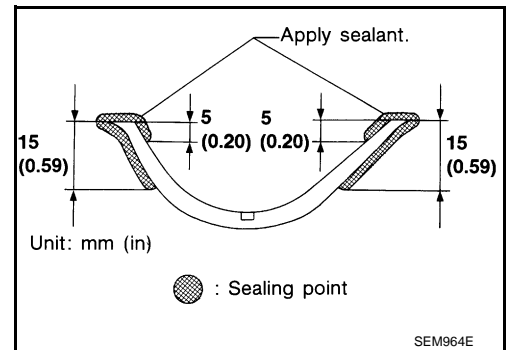

3. Install the front cover gasket and rear oil seal retainer gasket as shown.

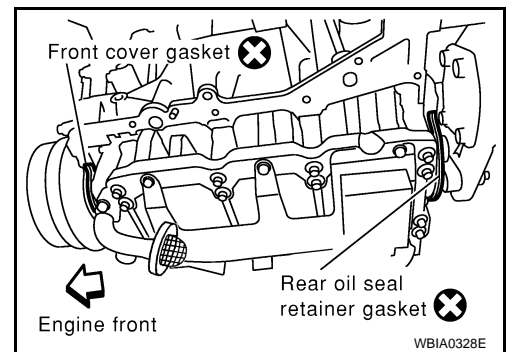

4. Apply a bead of sealant to the cylinder block mating surface of the upper oil pan to a limited portion as shown.

- Use Genuine Silicone RTV Sealant, or equivalent. Refer to [GI-15, "Recommended Chemical Products and Sealants"](#).
- Be sure the sealant is applied to a limited portion as shown, and the sealant is 4.0 - 5.0 mm (0.157 - 0.197 in) or 4.5 - 5.5 mm (0.177 - 0.217 in) wide.
- Attaching should be done within 5 minutes after coating.

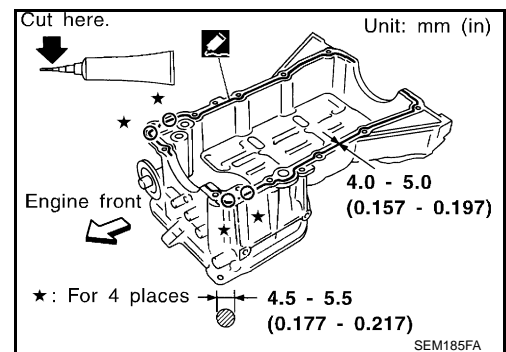

# OIL PAN AND OIL STRAINER

< ON-VEHICLE REPAIR >

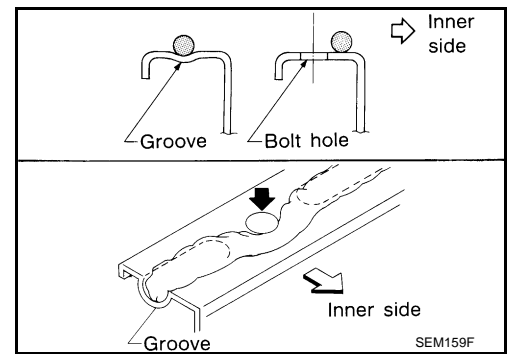

5. Install new O-rings on the cylinder block and oil pump body.

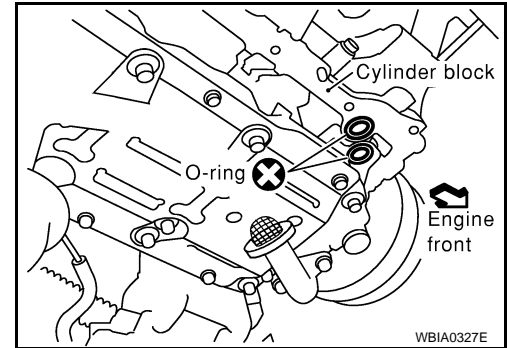

6. Install the upper oil pan.  
 • Tighten upper oil pan bolts in the order as shown.  
 • Wait at least 30 minutes before refilling the engine with oil.

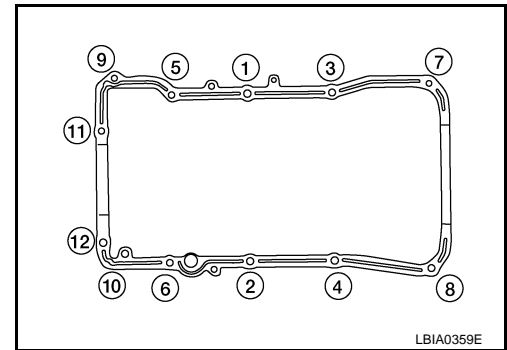

7. Install the four upper oil pan to transaxle bolts.

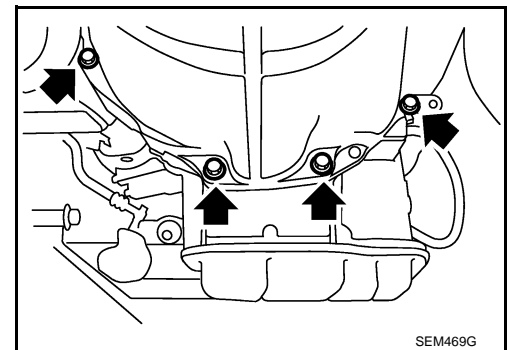

8. Apply a continuous bead of sealant to the lower oil pan.  
 • Use Genuine Silicone RTV Sealant, or equivalent. Refer to [GL-15. "Recommended Chemical Products and Sealants"](#).  
 • Be sure the sealant is 4.5 - 5.5 mm (0.177 - 0.217 in) wide.  
 • Installation must be done within 5 minutes after applying sealant.

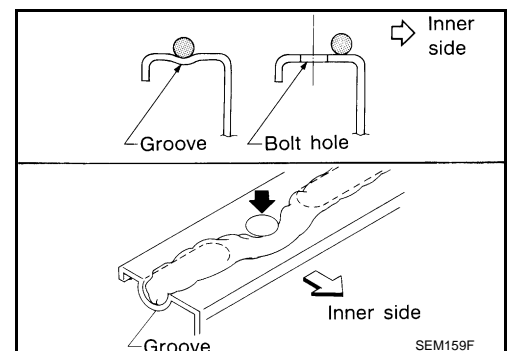

A  
EM  
C  
D  
E  
F  
G  
H  
I  
J  
K  
L  
M  
N  
O  
P

## OIL PAN AND OIL STRAINER

### < ON-VEHICLE REPAIR >

9. Install the lower oil pan. Tighten the lower oil pan bolts in order as shown.
- Wait at least 30 minutes before refilling the engine with oil.

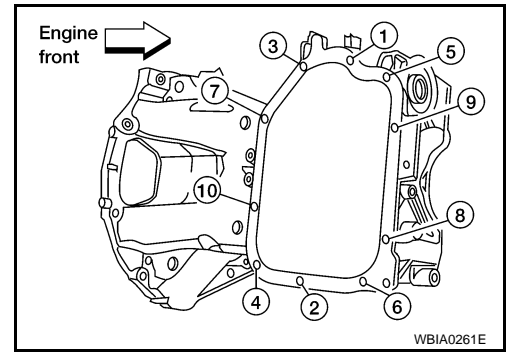

10. Install rear cover plate.

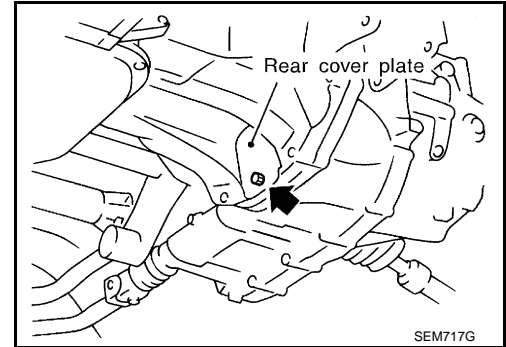

11. Installation of the remaining components is in the reverse order of removal.

### INSPECTION AFTER INSTALLATION

- Start the engine and check for leaks. Refer to [LU-7, "Inspection"](#).
- Inspect the engine oil level. Refer to [LU-7, "Inspection"](#).

# IGNITION COIL

< ON-VEHICLE REPAIR >

## IGNITION COIL

### Exploded View

INFOID:000000004335586

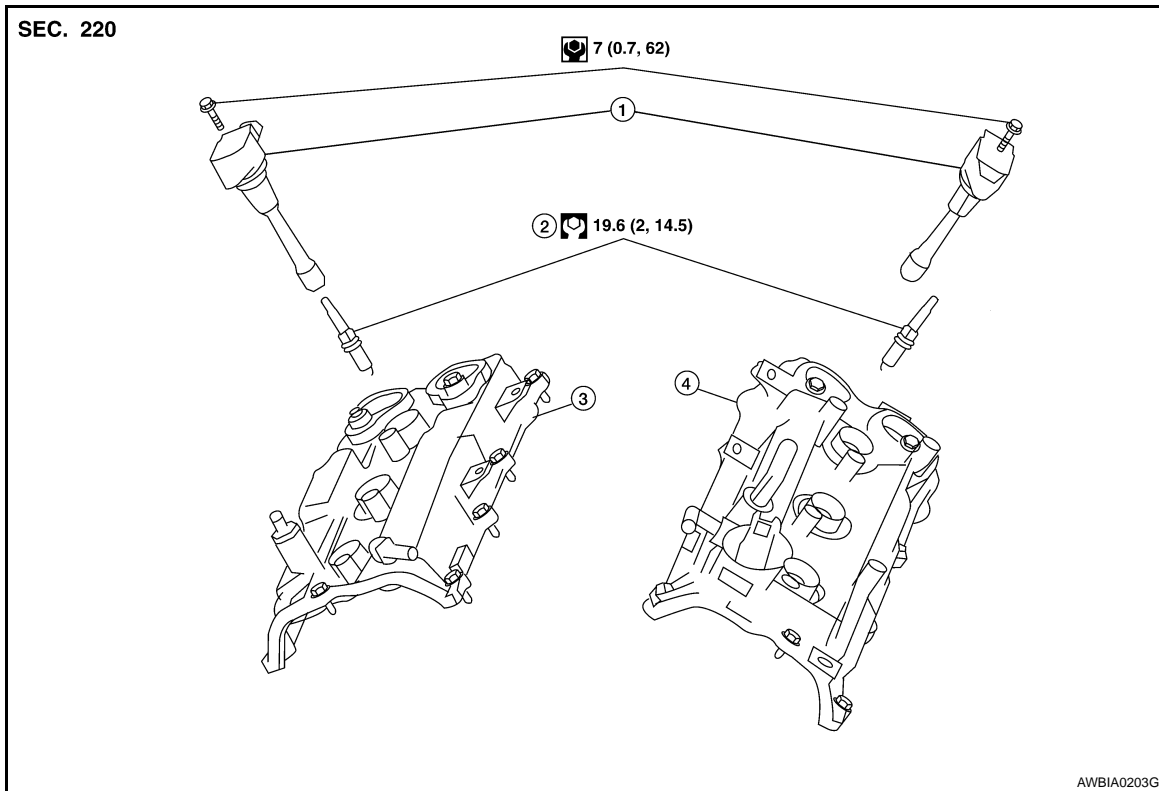

- 1. Ignition coil
- 2. Spark plug
- 3. Rocker cover (RH)
- 4. Rocker cover (LH)

### Removal and Installation LH

INFOID:000000004173772

#### REMOVAL

1. Remove engine room cover.
2. Disconnect ignition coil connector.
3. Remove the ignition coil.

**CAUTION:**  
Never shock ignition coil.

#### INSTALLATION

Installation is in the reverse order of removal.

### Removal and Installation RH

INFOID:000000004335585

#### REMOVAL

1. Remove the intake manifold collector. Refer to [EM-24, "Removal and Installation"](#).
2. Disconnect ignition coil connector.
3. Remove the ignition coil.

**CAUTION:**  
Never shock ignition coil.

#### INSTALLATION

Installation is in the reverse order of removal.

# FUEL INJECTOR AND FUEL TUBE

< ON-VEHICLE REPAIR >

## FUEL INJECTOR AND FUEL TUBE

Exploded View

INFOID:000000004363698

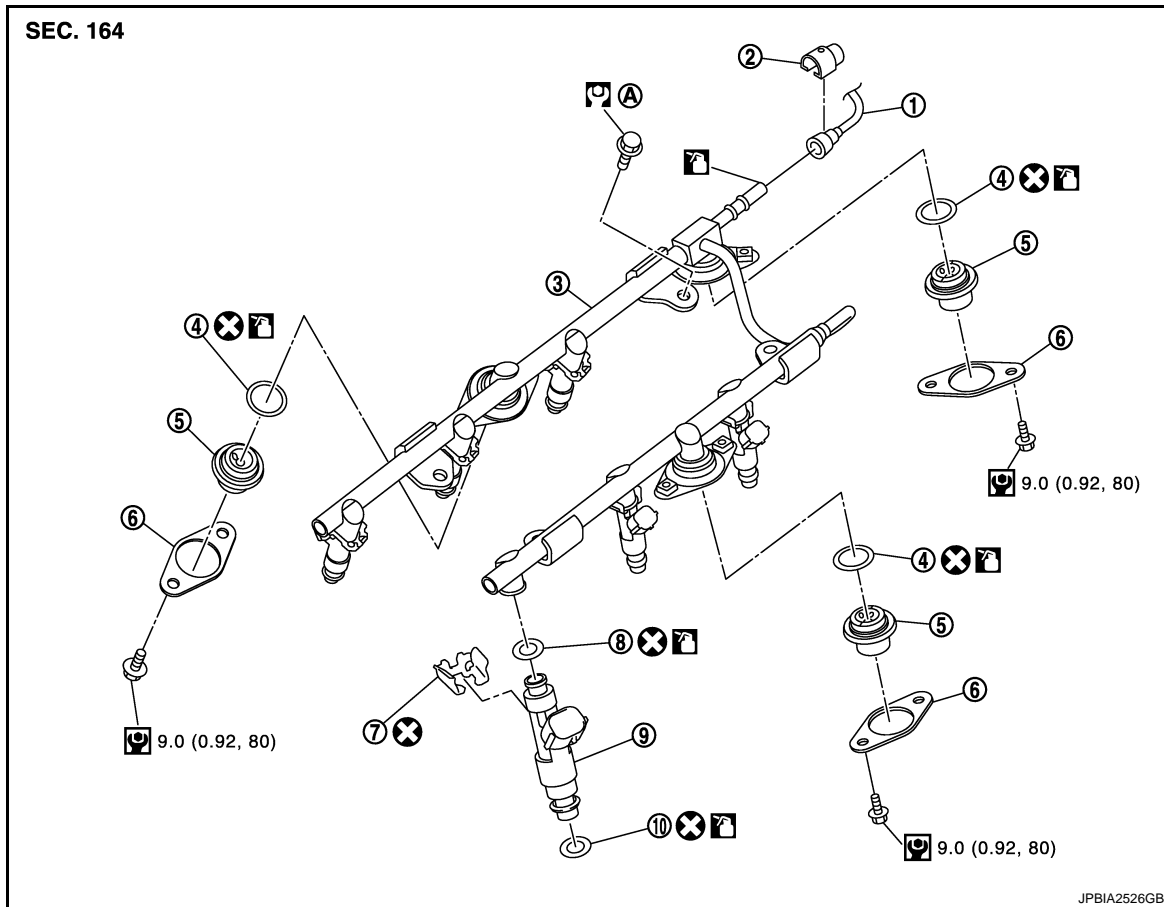

- |                          |                        |                    |
|--------------------------|------------------------|--------------------|
| 1. Fuel feed hose        | 2. Quick connector cap | 3. Fuel tube       |
| 4. O-ring                | 5. Fuel damper         | 6. Fuel damper cap |
| 7. Clip                  | 8. O-ring (black)      | 9. Fuel injector   |
| 10. O-ring (green)       |                        |                    |
| A. Refer to installation |                        |                    |

### CAUTION:

Never remove or disassemble parts unless instructed.

### Removal and Installation

INFOID:000000004363699

#### REMOVAL

#### WARNING:

- Put a "CAUTION: FLAMMABLE" sign in the workshop.
- Be sure to work in a well ventilated area and furnish workshop with a CO2 fire extinguisher.
- Never smoke while servicing fuel system. Keep open flames and sparks away from the work area.
- To avoid the danger of being scalded, never drain engine coolant when engine is hot.

1. Remove engine cover.
2. Release the fuel pressure. Refer to [EC-559, "Inspection"](#).
3. Remove front wiper arm and extension cowl top. Refer to [WW-92, "Exploded View"](#) and [EXT-17, "Exploded View"](#).



## FUEL INJECTOR AND FUEL TUBE

### < ON-VEHICLE REPAIR >

4. Remove the electric throttle control actuator bolts in the reverse order as shown and remove the electric throttle control actuator.

**CAUTION:**

- Handle carefully to avoid any shock to the electric throttle control actuator.
- Do not disassemble.

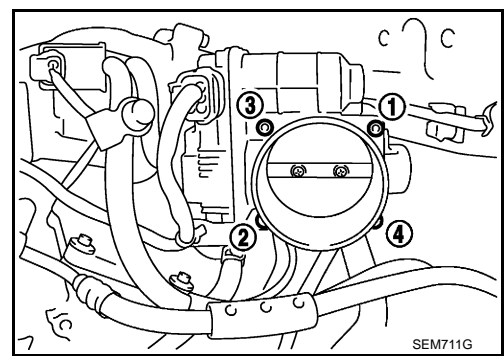

5. Remove intake manifold collector. Refer to [EM-24, "Removal and Installation"](#).
6. When separating fuel feed hose and fuel tube connection, disconnect quick connector as follows:

- a. Remove quick connector cap from quick connector.
- b. Disconnect quick connector from fuel tube as follows:

**CAUTION:**

**Disconnect quick connector by using the quick connector release (commercial service tool: J-45488), not by picking out retainer tabs.**

- i. With the sleeve side of quick connector release facing to quick connector, install the quick connector release onto fuel tube.
- ii. Insert the quick connector release (A) into quick connector (2) until sleeve (B) contacts and goes no further. Hold quick connector release on that position.

C : Insert and retain

**CAUTION:**

**Inserting quick connector release hard will not disconnect quick connector. Hold quick connector release where it contacts and goes no further.**

- iii. Draw and pull out quick connector straight from fuel tube (1).

**CAUTION:**

- Pull quick connector (E) holding position (D) as shown in the figure.
- Never pull with lateral force applied. O-ring inside quick connector may be damaged.
- Prepare container and cloth beforehand as fuel will leakage out.
- Avoid fire and sparks.
- Keep parts away from heat source. Especially, be careful when welding is performed around them.
- Never expose parts to battery electrolyte or other acids.
- Never bend or twist connection between quick connector and fuel feed hose (with damper) during installation/removal.
- To keep clean the connecting portion and to avoid damage and foreign materials, cover them completely with plastic bags, etc. (A) or something similar.

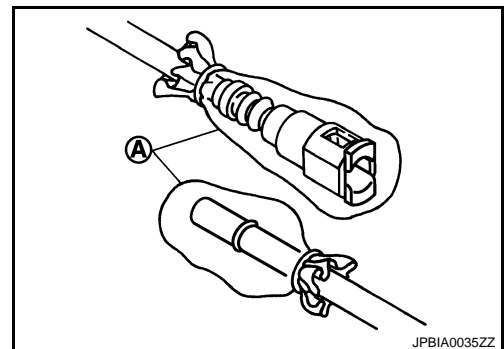
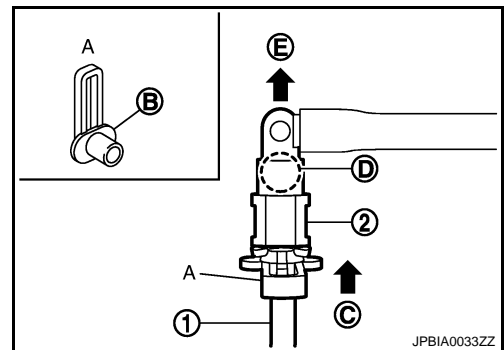

7. Disconnect harness connector from fuel injector.

# FUEL INJECTOR AND FUEL TUBE

## < ON-VEHICLE REPAIR >

8. Loosen bolts in reverse order as shown, and remove fuel tube and fuel injector assembly.

← : Engine front

### CAUTION:

Never tilt fuel tube, or remaining fuel in pipes may flow out from pipes.

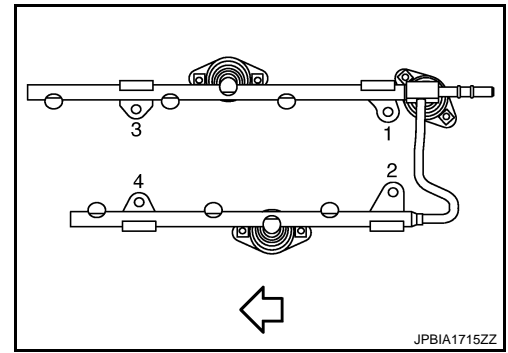

JPBIA1715ZZ

9. Remove fuel injector from fuel tube as follows:

- a. Open and remove clip (1).

3 : O-ring (green)

4 : O-ring (black)

A : Installed condition

B : Clip groove

- b. Remove fuel injector (2) from fuel tube (5) by pulling straight.

### CAUTION:

- Be careful with remaining fuel that may go out from fuel tube.
- Be careful not to damage injector nozzle during removal.
- Never bump or drop fuel injector.
- Never disassemble fuel injector.

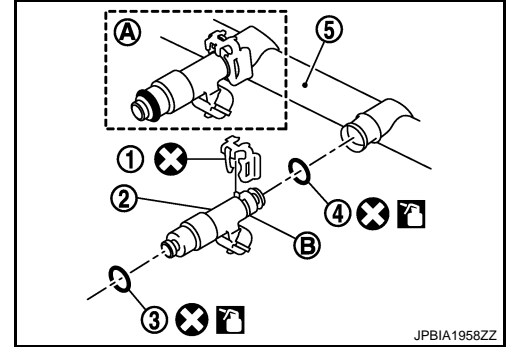

JPBIA1958ZZ

10. Remove fuel damper from fuel tube.

## INSTALLATION

1. Install fuel damper as follows:

- a. Install new O-ring (2) to fuel tube (1) as shown. When handling new O-ring, be careful of the following caution:

### CAUTION:

- Handle O-ring with bare hands. Never wear gloves.
- Lubricate O-ring with new engine oil.
- Never clean O-ring with solvent.
- Check that O-ring and its mating part are free of foreign material.
- When installing O-ring, be careful not to scratch it with tool or fingernails. Also be careful not to twist or stretch O-ring. If O-ring was stretched while it was being attached, never insert it quickly into fuel tube.
- Insert new O-ring straight into fuel tube. Never twist it.

- b. Install spacer (3) to fuel damper (4).

- c. Insert fuel damper straight into fuel tube.

### CAUTION:

- Insert straight, checking that the axis is lined up.
- Never pressure-fit with excessive force.

Reference value : 130 N (13.3 kg, 29.2 lb)

- Insert fuel damper until (B) is touching (A) of fuel tube.

- d. Tighten bolts evenly in turn.

- After tightening bolts, check that there is no gap between fuel damper cap (5) and fuel tube.

2. Install new O-rings to fuel injector paying attention to the following.

### CAUTION:

- Upper and lower O-ring are different. Be careful not to confuse them.

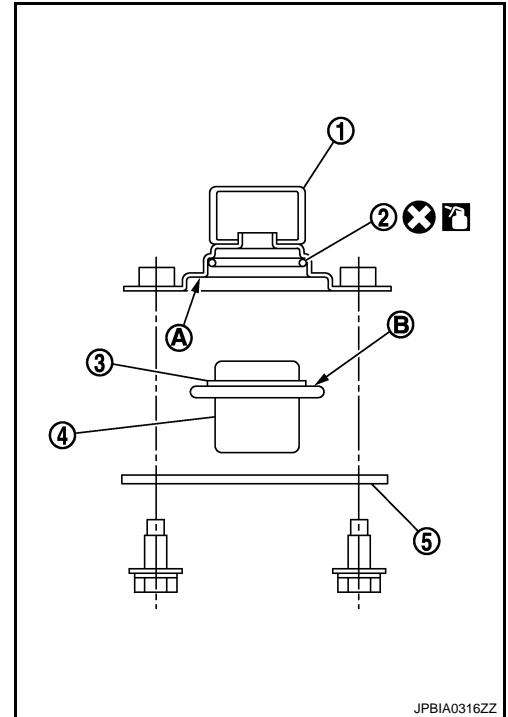

JPBIA0316ZZ

# FUEL INJECTOR AND FUEL TUBE

< ON-VEHICLE REPAIR >

Fuel tube side : Black

Nozzle side : Green

- Handle O-ring with bare hands. Never wear gloves.
- Lubricate O-ring with new engine oil.
- Never clean O-ring with solvent.
- Check that O-ring and its mating part are free of foreign material.
- When installing O-ring, be careful not to scratch it with tool or fingernails. Also be careful not to twist or stretch O-ring. If O-ring was stretched while it was being attached, never insert it quickly into fuel tube.
- Insert O-ring straight into fuel injector. Never decenter or twist it.

3. Install fuel injector to fuel tube as follows:

a. Insert clip (3) into clip groove (F) on fuel injector (5).

2 : O-ring (black)

4 : O-ring (green)

- Insert clip so that protrusion (E) of fuel injector matches cutout (C) of clip.

**CAUTION:**

- Never reuse clip. Replace it with new one.
- Be careful to keep clip from interfering with O-ring. If interference occurs, replace O-ring.

b. Insert fuel injector into fuel tube (1) with clip attached.

- Insert it while matching it to the axial center.
- Insert fuel injector so that protrusion (A) of fuel tube matches cutout (B) of clip.
- Check that fuel tube flange (G) is securely fixed in flange fixing groove (D) on clip.

c. Check that installation is complete by checking that fuel injector does not rotate or come off.

- Check that protrusions of fuel injectors and fuel tubes are aligned with cutouts of clips after installation.

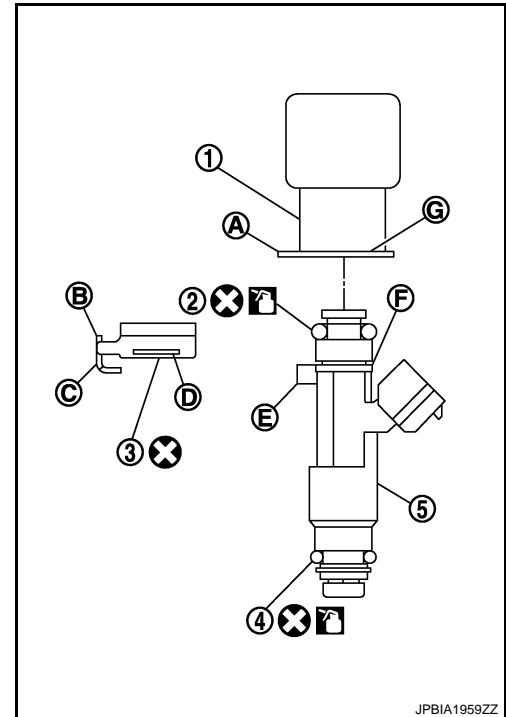

JPBIA1959ZZ

4. Install fuel tube and fuel injector assembly to intake manifold.

**CAUTION:**

Be careful not to let tip of injector nozzle come in contact with other parts.

- Tighten bolts in two steps in numerical order as shown in the figure.

← : Engine front

1st step : 10.1 N·m (1.0 kg·m, 7 ft·lb)

2nd step : 22.0 N·m (2.2 kg·m, 16 ft·lb)

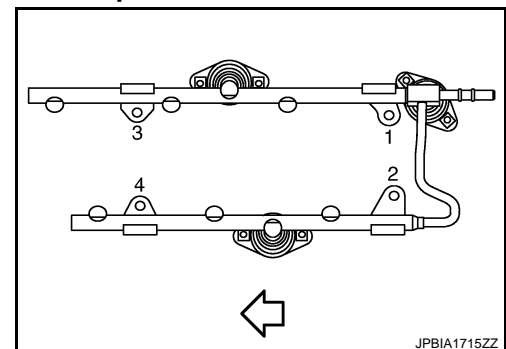

JPBIA1715ZZ

5. Connect fuel injector harness.

6. Install intake manifold collector. Refer to [EM-24, "Removal and Installation"](#).

7. Connect quick connector between fuel feed hose and fuel tube connection with the following procedure:

- Check no foreign substances are deposited in and around fuel tube and quick connector, and no damage on them.
- Thinly apply new engine oil around fuel tube from tip end to spool end.
- Align center to insert quick connector straightly into fuel tube.

# FUEL INJECTOR AND FUEL TUBE

## < ON-VEHICLE REPAIR >

- Insert quick connector (1) to fuel tube until top spool (2) is completely inside quick connector, and 2nd level spool (3) exposes right below quick connector.

B : Fitted condition

⇐ : Upright insertion

### CAUTION:

- Hold (A) position as shown in the figure when inserting fuel tube into quick connector.
  - Carefully align center to avoid inclined insertion to prevent damage to O-ring inside quick connector.
  - Insert until you hear a “click” sound and actually feel the engagement.
  - To avoid misidentification of engagement with a similar sound, be sure to perform the next step.
- d. Pull quick connector by hand holding position. Check it is completely engaged (connected) so that it does not come out from fuel tube.
- e. Install quick connector cap (3) to quick connector.

1 : Fuel feed hose

2 : Fuel tube

B : Upper view

- Install quick connector cap with arrow (A) on surface facing in direction of quick connector (fuel feed hose side).

### CAUTION:

**If quick connector cap cannot be installed smoothly, quick connector may have not been installed correctly. Check connection again.**

- f. Secure fuel feed hose to clamp of quick connector cap.
8. Installation is in the reverse order of removal.

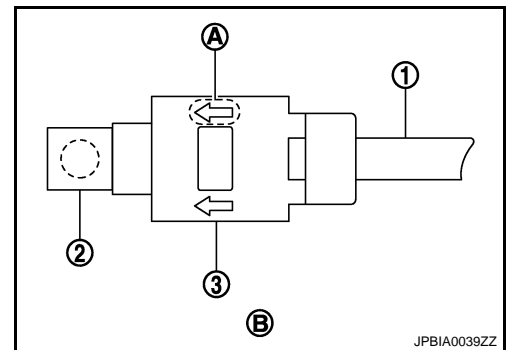
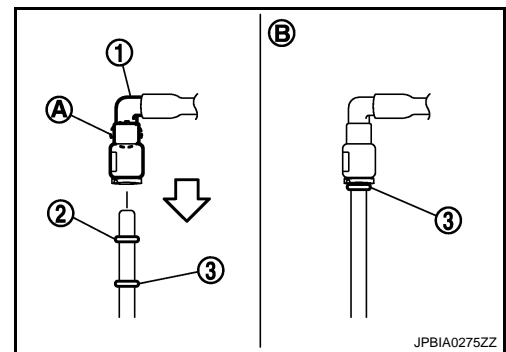

## Inspection

INFOID:000000004363700

## INSPECTION AFTER INSTALLATION

### Check on Fuel Leakage

1. Turn ignition switch “ON” (with the engine stopped). With fuel pressure applied to fuel piping, check there are no fuel leakage at connection points.

### NOTE:

Use mirrors for checking at points out of clear sight.

2. Start the engine. With engine speed increased, check again that there are no fuel leakage at connection points.

### CAUTION:

**Never touch the engine immediately after stopped, as the engine becomes extremely hot.**

# ROCKER COVER

< ON-VEHICLE REPAIR >

## ROCKER COVER

### Exploded View

INFOID:000000004335631

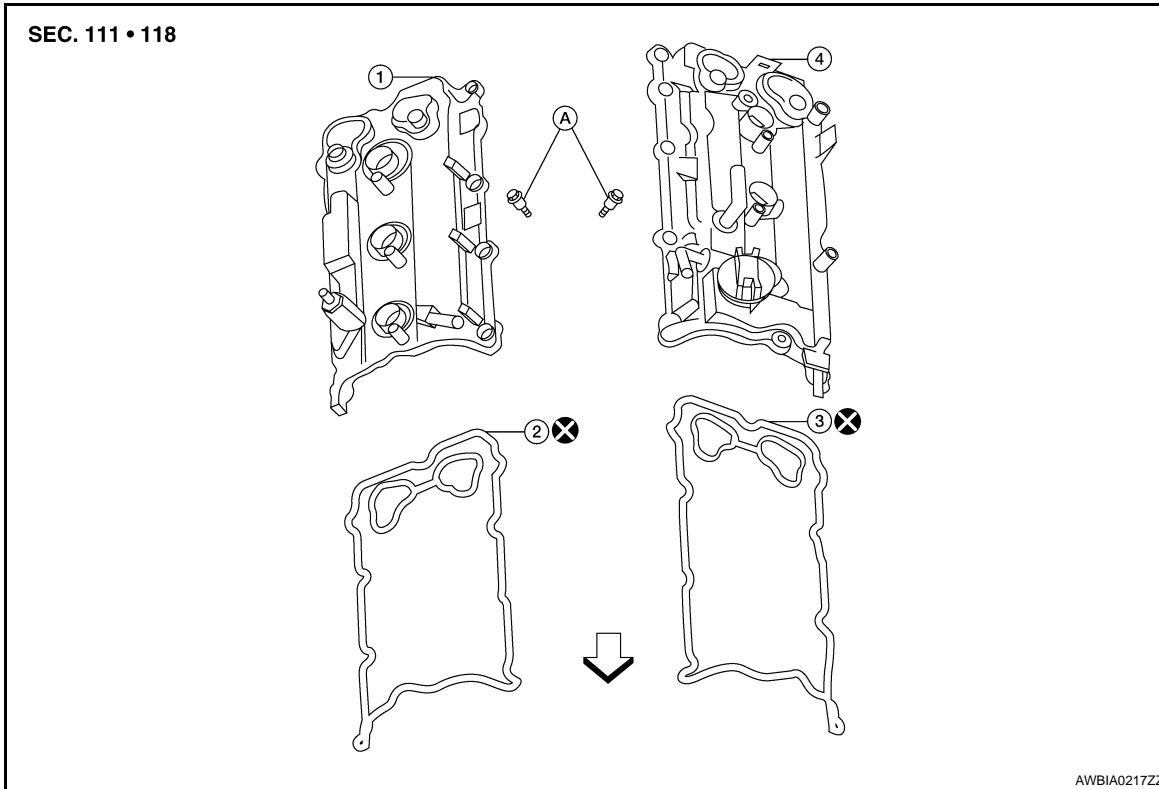

- |                      |                                  |                             |
|----------------------|----------------------------------|-----------------------------|
| 1. Rocker cover (RH) | 2. Rocker cover gasket (RH)      | 3. Rocker cover gasket (LH) |
| 4. Rocker cover (LH) | A. Follow installation procedure | ← Front                     |

### Removal and Installation LH

INFOID:000000004173774

#### REMOVAL

1. Remove the engine cover, using power tool.
2. Remove front air duct.
3. Remove blow by hose from rocker cover.
4. Remove camshaft position sensor.

#### CAUTION:

- Handle carefully to avoid dropping and shocks.
- Do not disassemble.
- Do not allow metal powder to adhere to magnetic part at sensor tip (A).
- Do not place sensors in a location where they are exposed to magnetism.

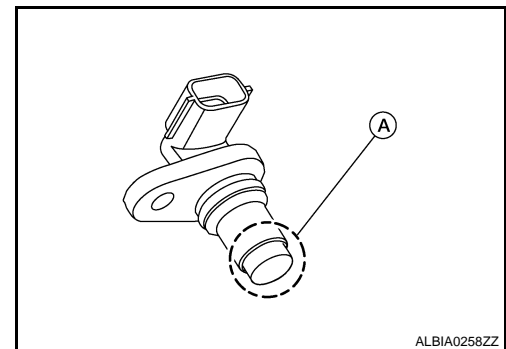

5. Disconnect the ignition coil connectors.
6. Remove the ignition coils. Refer to [EM-39, "Removal and Installation LH"](#).

#### CAUTION:

Never shock ignition coils.

# ROCKER COVER

## < ON-VEHICLE REPAIR >

7. Remove LH rocker cover bolts from cylinder head as shown.

← : Front

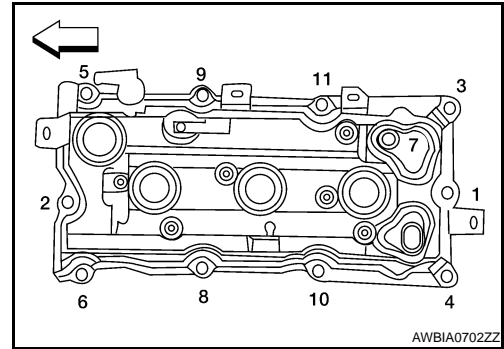

## INSTALLATION

Installation is in the reverse order of removal.

- Apply sealant to the areas on the front corners using Tool.
- Use Genuine Silicone RTV Sealant or equivalent. Refer to [GI-15, "Recommended Chemical Products and Sealants"](#).

Tool number : WS39930000 ( — )

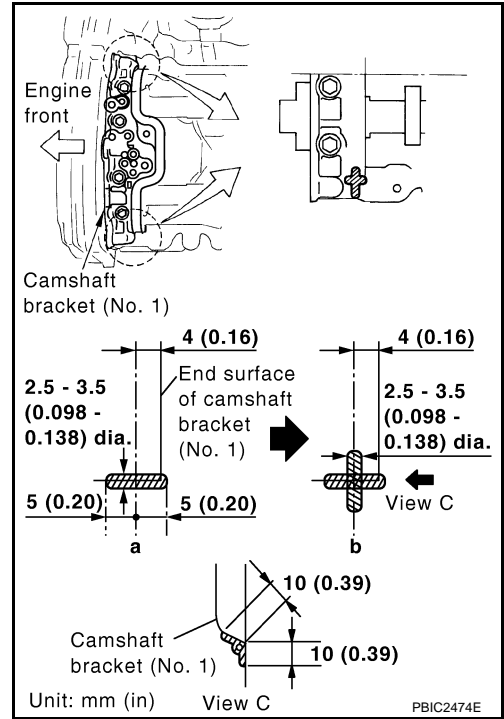

- Tighten the rocker cover bolts in two steps in the order as shown.

← : Front

### Rocker cover bolts

Step 1 : 1.96 N·m (0.20 kg·m, 17 in·lb)

Step 2 : 8.33 N·m (0.85 kg·m, 74 in·lb)

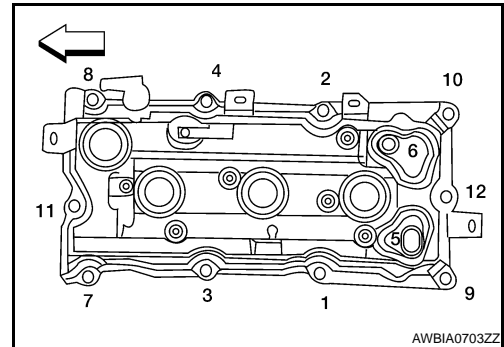

## Removal and Installation RH

INFOID:000000004335632

### REMOVAL

1. Remove the engine cover, using power tool.
2. Disconnect the mass air flow sensor electrical connector and remove the air cleaner assembly and air intake tubes. Refer to [EM-23, "Removal and Installation"](#).
3. Remove the intake manifold collector using power tool. Remove gasket and the electric throttle control actuator. Refer to [EM-27, "Removal and Installation"](#).

# ROCKER COVER

## < ON-VEHICLE REPAIR >

- Remove ignition coils. Refer to [EM-39, "Removal and Installation RH"](#).

**CAUTION:**

**Never shock ignition coils.**

- Remove camshaft position sensor.

**CAUTION:**

- Handle carefully to avoid dropping and shocks.
- Do not disassemble.
- Do not allow metal powder to adhere to magnetic part at sensor tip (A).
- Do not place sensors in a location where they are exposed to magnetism.

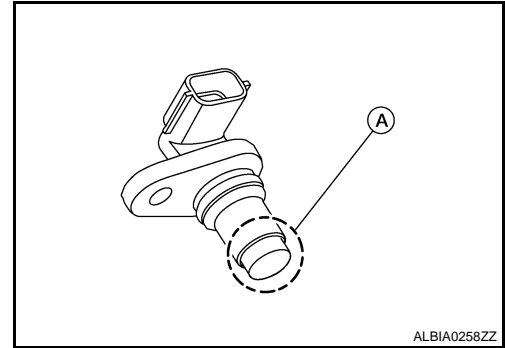

- Remove RH rocker cover bolts from cylinder head as shown.

← : Front

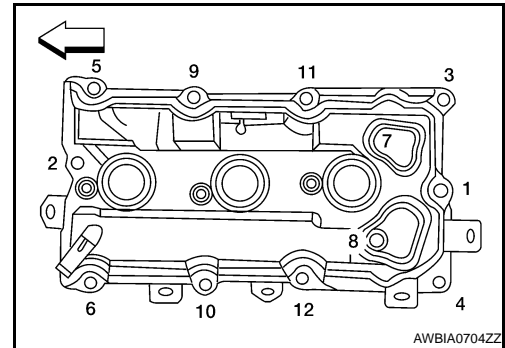

## INSTALLATION

Installation is in the reverse order of removal.

- Apply sealant to the areas on the front corners using Tool.
- Use Genuine Silicone RTV Sealant or equivalent. Refer to [GI-15, "Recommended Chemical Products and Sealants"](#).

Tool number : WS39930000 ( — )

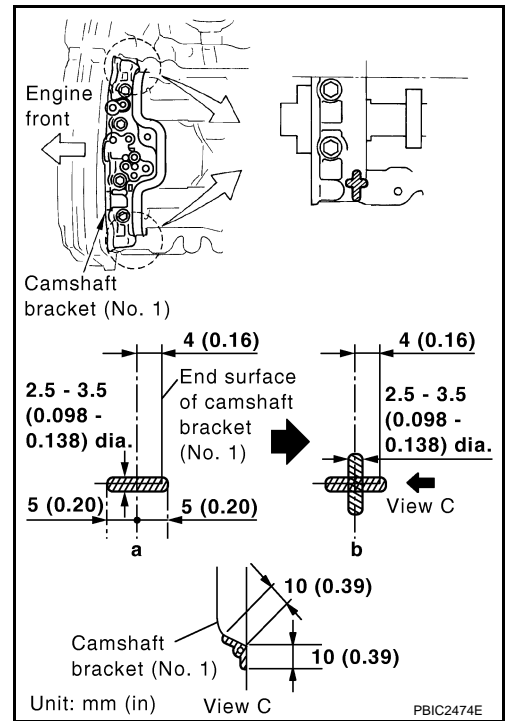

- Tighten the rocker cover bolts in two steps in the order as shown.

# ROCKER COVER

< ON-VEHICLE REPAIR >

← : Front

## Rocker cover bolts

Step 1 : 1.96 N·m (0.20 kg-m, 17 in-lb)

Step 2 : 8.33 N·m (0.85 kg-m, 74 in-lb)

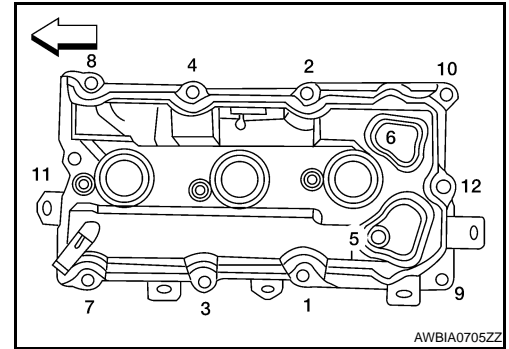



# FRONT TIMING CHAIN CASE

< ON-VEHICLE REPAIR >

## FRONT TIMING CHAIN CASE

### Removal and Installation

INFOID:000000004173775

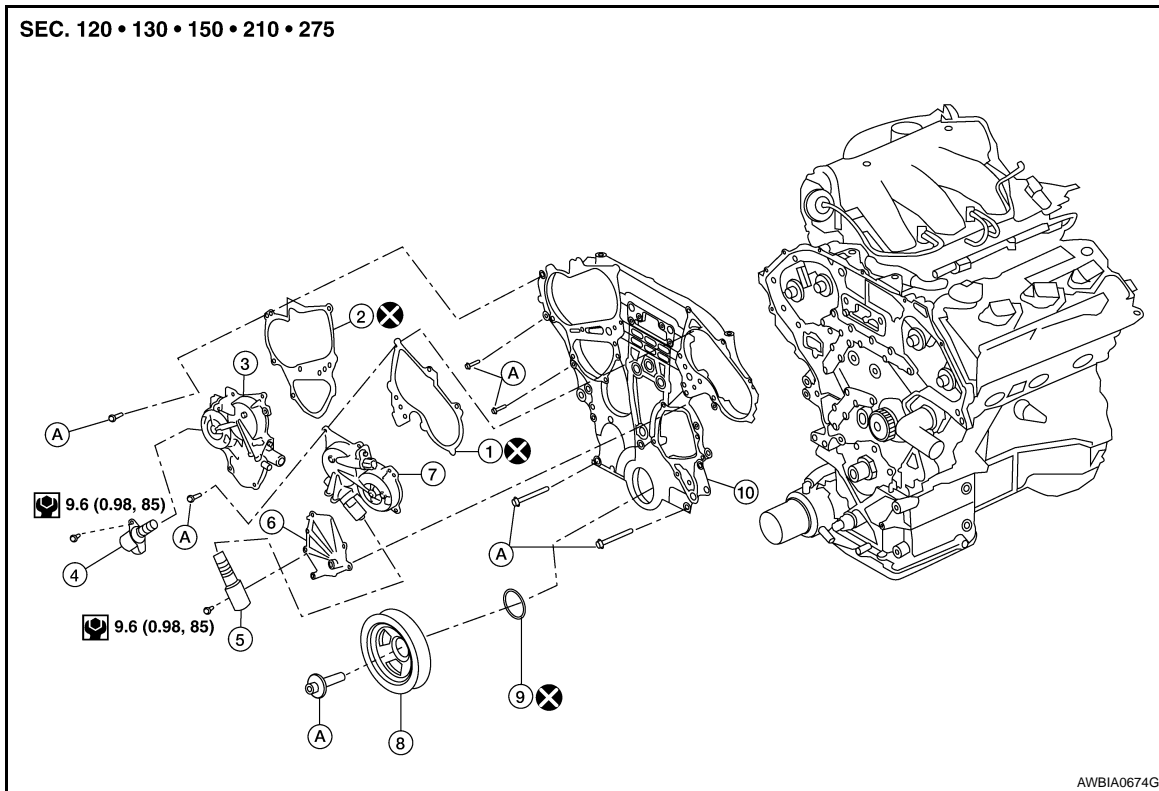

- |  |                                  |  |
|--|----------------------------------|--|
| 1. Gasket LH                           | 2. Gasket RH                     | 3. IVT control valve cover RH (bank 1) |
| 4. IVT valve RH                        | 5. IVT valve LH                  | 6. Water pump cover                    |
| 7. IVT control valve cover LH (bank 2) | 8. Crankshaft pulley             | 9. Front oil seal                      |
| 10. Front timing chain case            | A. Follow installation procedure |  |

#### NOTE:

- This section describes procedures for removal/installation procedure of the front timing chain case and timing chain related parts without removing the oil pan (upper) from the vehicle.
- When oil pan (upper) needs to be removed or installed, or when rear timing chain case is removed or installed, remove oil pans (upper and lower) first. Then remove front timing chain case, timing chain related parts, and rear timing chain case in this order, and install in reverse order of removal. Refer to [EM-57](#).
- Refer to [EM-57](#) for component parts location.

#### REMOVAL

1. Remove engine cover using power tool.
2. Release fuel pressure. Refer to [EC-559, "Inspection"](#).
3. Remove the air cleaner case, mass air flow sensor and air cleaner to electric throttle control actuator tube. Refer to [EM-23, "Removal and Installation"](#).
4. Remove the engine coolant reservoir. Refer to [CO-13, "Removal and Installation"](#).
5. Remove the cowl top and cowl top extension. Refer to [EXT-18, "Removal and Installation"](#).
6. Remove the front RH wheel and tire using power tool.
7. Remove the engine undercover.
8. Remove the RH inner fender splash shield.
9. Remove the drive belt, idler pulley and drive belt auto-tensioner. Refer to [EM-14, "Removal and Installation"](#) and [EM-15, "Removal and Installation of Drive Belt Auto-tensioner"](#).

## FRONT TIMING CHAIN CASE

### < ON-VEHICLE REPAIR >

10. Recover the A/C system R134a and remove the A/C compressor. Refer to [HA-34, "Collection and Charge"](#).
11. Remove engine oil cooler pipe bolts.
12. Remove the power steering oil pump and reservoir tank with lines attached and position them aside. Refer to [ST-25, "Removal and Installation"](#).
13. Remove the generator. Refer to [CHG-21, "Removal and Installation"](#).
14. Disconnect the engine harness and position aside.
15. Remove the A/C low-pressure flexible hose. Refer to [HA-48, "LOW-PRESSURE FLEXIBLE HOSE : Removal and Installation for Low-Pressure Flexible Hose"](#).
16. Support the engine and remove the RH engine insulator, mount and bracket. Refer to [EM-96, "Removal and Installation"](#).
17. Remove the water pump cover, using Tool.

**Tool number** : KV10111100 (J-37228)

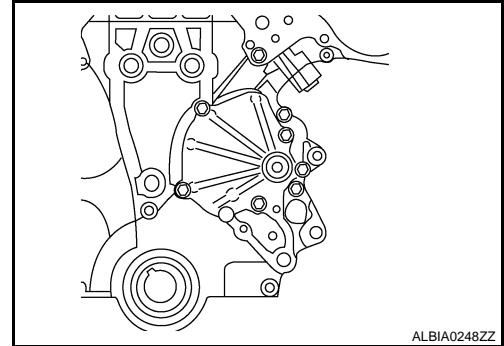

18. Remove the starter motor. Refer to [STR-15, "Removal and Installation"](#).
  19. Disconnect valve timing control harness connector.
  20. Remove the intake manifold collector. Refer to [EM-24, "Removal and Installation"](#).
  21. Remove the Bank 1 (RH) (A) and Bank 2 (LH) (B) IVT covers.
- a. Loosen the IVT cover bolts in the reverse order as shown.

**CAUTION:**

The shaft in the cover is inserted into the center hole of the intake camshaft sprocket. Remove the cover by pulling straight out until the cover disengages from the camshaft sprocket.

- A: Bank 1 (Conventional RH bank)
- B: Bank 2 (Conventional LH bank)
- C: Dowel pin hole

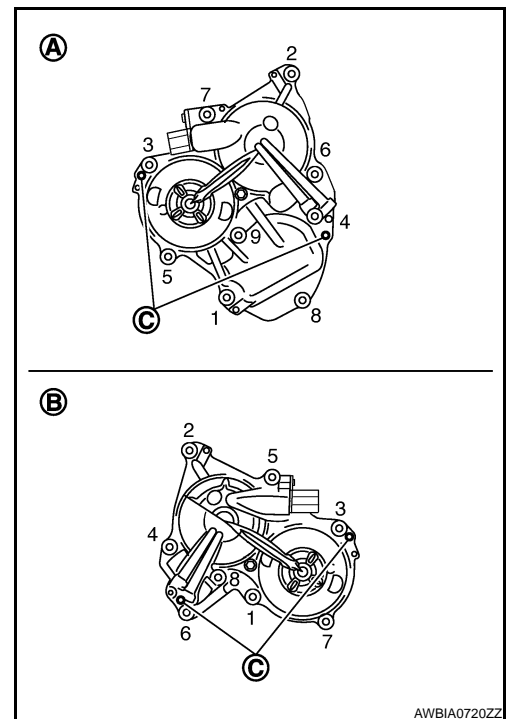

- b. Shaft is engaged with intake side camshaft sprocket center hole on inside. Pull straight out so as not to tilt until the joint is disengaged.

# FRONT TIMING CHAIN CASE

## < ON-VEHICLE REPAIR >

- The mating surface of magnet retarder (2) may be fitted with the exhaust side camshaft sprocket via engine oil. Open valve timing control cover (1) carefully.
- If the mating surface of the magnet retarder is fitted with the camshaft sprocket, open the cover within the range that the load is not applied to the harness. Remove it so as to prevent magnet retarder from dropping.

### CAUTION:

- **Be careful not to damage magnet retarder.**
- **When carrying valve timing control cover, face the magnet retarder side up to prevent the cover from falling from magnet retarder.**
- **Never remove magnet retarder from valve timing control cover. (Disassembly prohibited)**

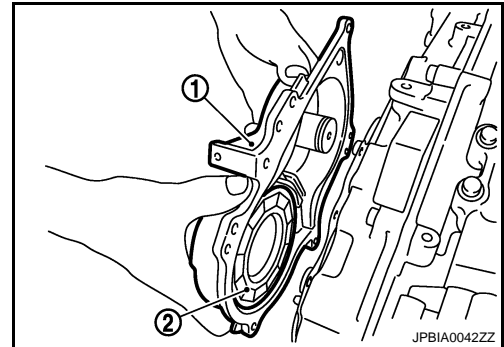

22. Remove the rocker covers as necessary. Refer to [EM-45, "Removal and Installation LH"](#) or [EM-46, "Removal and Installation RH"](#).

### NOTE:

Necessary only when removing secondary timing chains.

23. Obtain compression TDC of No. 1 cylinder as follows:

- a. Rotate crankshaft pulley clockwise to align timing mark (grooved line without color) with timing indicator.

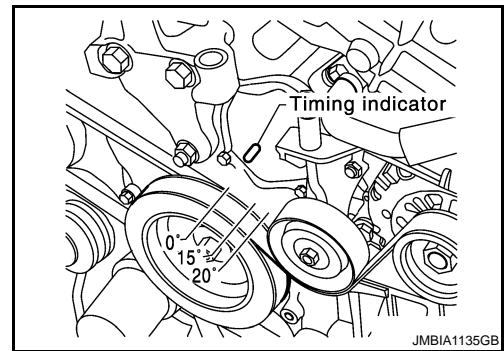

- b. Check that intake and exhaust camshaft lobes on No. 1 cylinder (right bank of engine) are located as shown.

- If not, turn the crankshaft one revolution (360°) and align as shown.

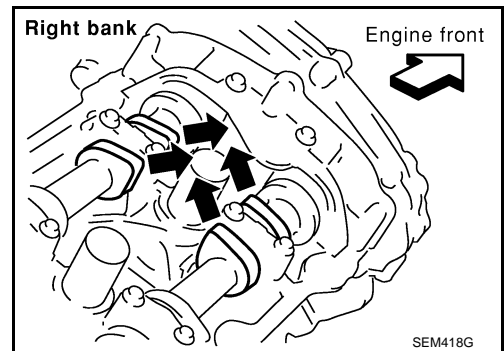

24. Lock the drive plate (CVT), using Tool attached to the starter bolt hole.

**Tool number : KV10117700 (J-44716)**

### CAUTION:

**Do not damage the ring gear teeth, or the signal plate teeth behind the ring gear, when setting the Tool.**

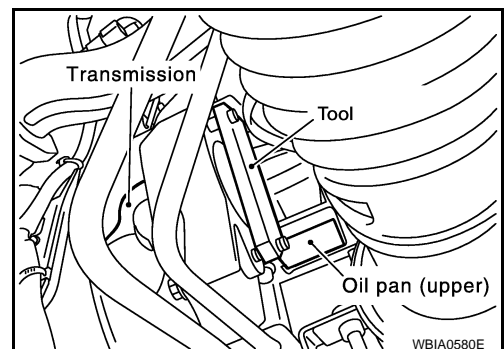

## FRONT TIMING CHAIN CASE

### < ON-VEHICLE REPAIR >

25. Remove the crankshaft pulley as follows:

- a. Loosen crankshaft pulley bolt using Tool and locate bolt seating surface at 10 mm (0.39 in) from its original position.

**Tool number : KV10109300**

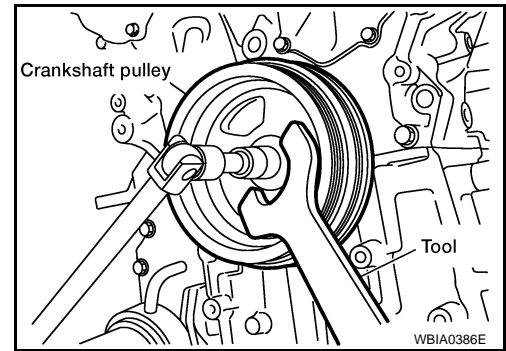

- b. Position a pulley puller at recess hole of crankshaft pulley to remove crankshaft pulley.

**CAUTION:**

**Do not use a puller claw on crankshaft pulley periphery.**

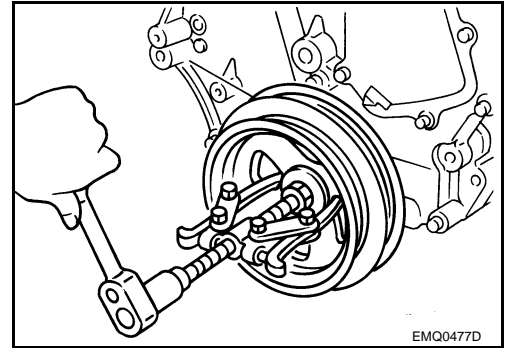

26. Remove the lower oil pan. Loosen the lower oil pan bolts using power tool in order as shown.

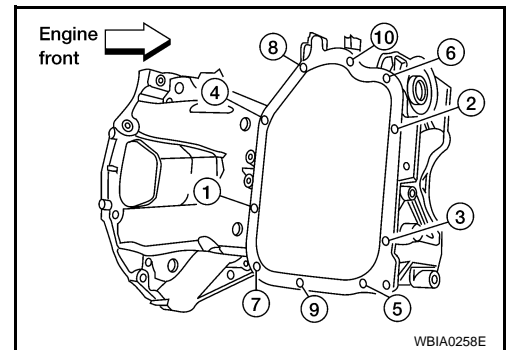

- a. Insert Tool between the lower oil pan and the upper oil pan.

**Tool number : KV10111100 (J-37228)**

- Be careful not to damage the mating surface.
- Do not insert a screwdriver, this will damage the mating surfaces.

- b. Slide (2) the Tool by tapping (1) its side with a hammer to remove the lower oil pan from the upper oil pan.

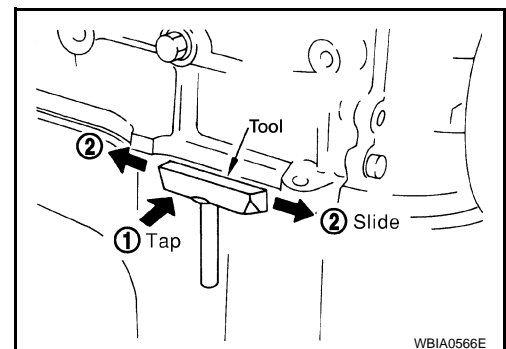

27. Remove upper oil pan bolts as shown.

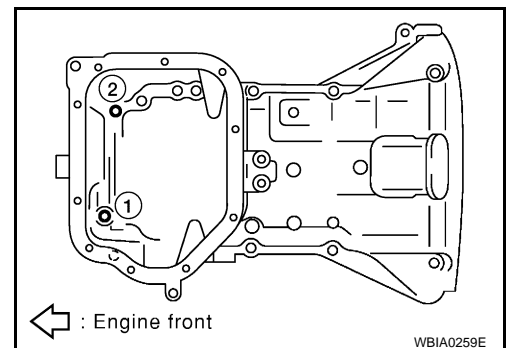

# FRONT TIMING CHAIN CASE

## < ON-VEHICLE REPAIR >

28. Temporarily install lower oil pan.
29. Support front of engine with a suitable jack.
30. Remove the front timing chain case.
  - a. Loosen the front timing chain case bolts in the order as shown.

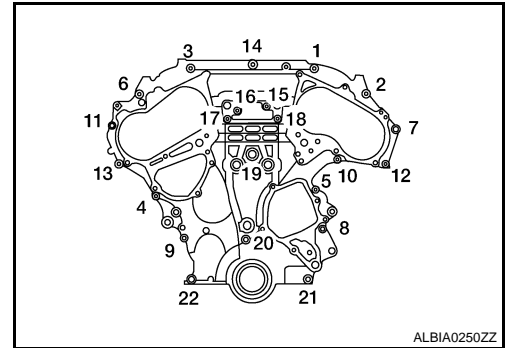

- b. Insert the appropriate size tool into the notch (A) at the top of the front timing chain case as shown.
      - c. Pry off the case by moving the suitable tool (B) as shown.
        - Cut liquid gasket for removal using Tool.
- CAUTION:**
- Do not use a screwdriver or similar tool.
  - After removal, handle carefully so it does not bend, or warp under a load.

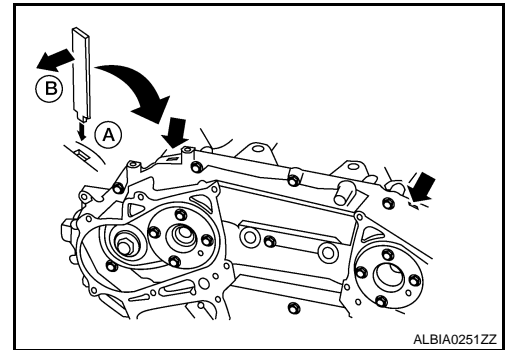

31. Remove the front oil seal from the front timing chain case using a suitable tool.

**CAUTION:**  
Do not damage the front cover.

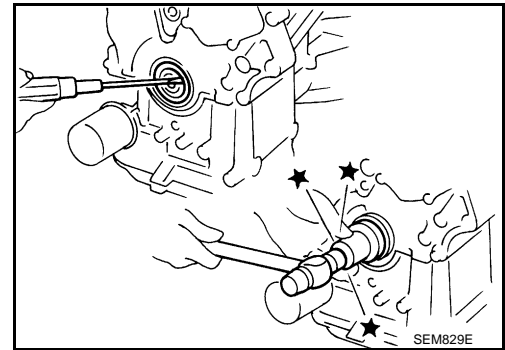

32. Use a scraper to remove all of the old Silicone RTV Sealant from the front timing chain case and opposite mating surfaces.

**CAUTION:**  
Do not damage the mating surfaces.

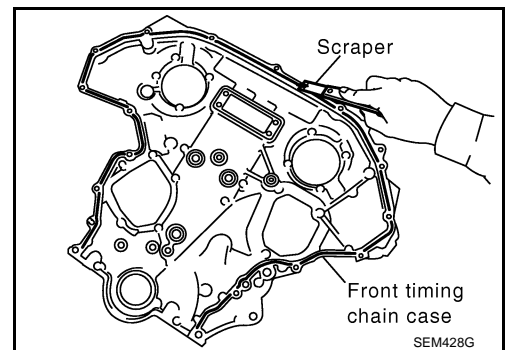

## INSTALLATION

A  
EM  
C  
D  
E  
F  
G  
H  
I  
J  
K  
L  
M  
N  
O  
P

# FRONT TIMING CHAIN CASE

## < ON-VEHICLE REPAIR >

1. Install dowel pins (right and left) into front timing chain case up to a point close to taper in order to shorten protrusion length.

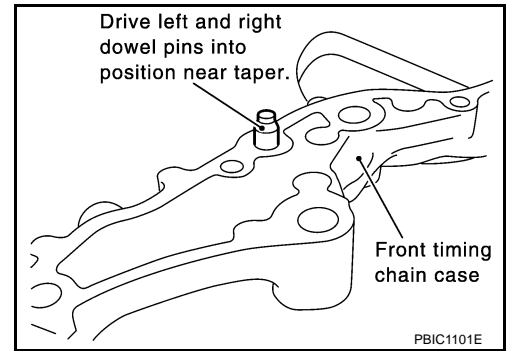

2. Install the new front oil seal on the front timing chain case. Apply new engine oil to the oil seal edges.

**NOTE:**

Install it so that each seal lip is oriented as shown.

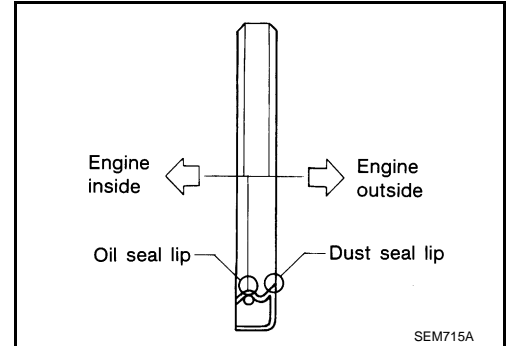

- a. Install the new front oil seal so that it becomes flush with the face with front timing chain case using suitable drift.

**CAUTION:**

**Press fit straight and avoid causing burrs or tilting the oil seal.**

**NOTE:**

Make sure the garter spring is in position and seal lip is not inverted.

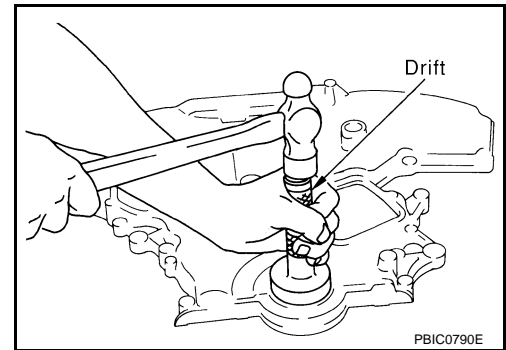

3. Apply Silicone RTV Sealant to front timing chain case as shown.
  - Use Genuine Silicone RTV Sealant, or equivalent. Refer to [GI-15, "Recommended Chemical Products and Sealants"](#).
  - Before installation, wipe off the protruding sealant.
  - C: 2.6 - 3.6 mm (0.102 - 0.142 in) dia.

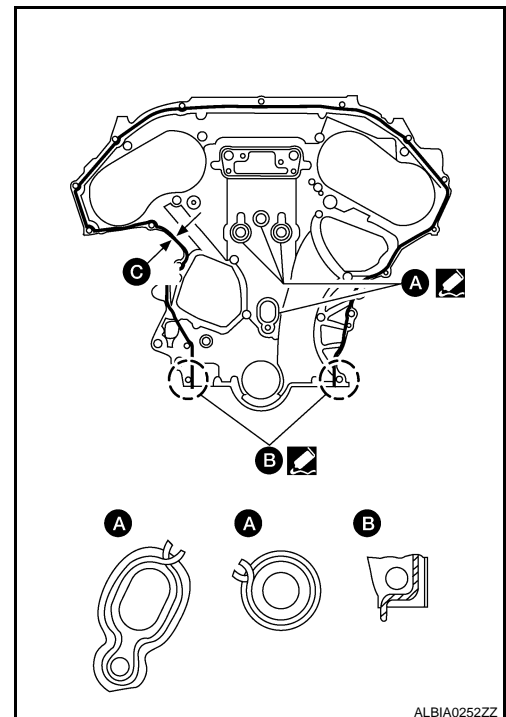

# FRONT TIMING CHAIN CASE

## < ON-VEHICLE REPAIR >

4. Install dowel pin on the rear timing chain case into dowel pin hole in front timing chain case.
5. Loosely install the front timing chain case bolts.

Bolt position	Bolt diameter
1, 2	: 8 mm (0.31 in)
3 – 22	: 6 mm (0.24 in)

6. Tighten the front timing chain case bolts in the order as shown.
  - Retighten the front timing chain case bolts in the order as shown.

Bolt position	Tightening specification
1, 2	: 28.5 N·m (2.9 kg-m, 21 ft-lb)
3 – 22	: 12.8 N·m (1.3 kg-m, 9 ft-lb)

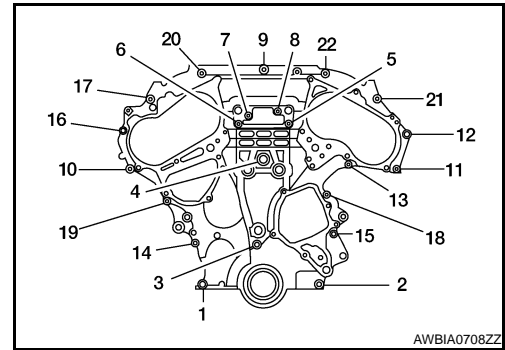

7. Remove lower oil pan.
8. Install upper oil pan bolts. Refer to [EM-33, "Removal and Installation"](#).
9. Install lower oil pan. Refer to [EM-33, "Removal and Installation"](#).
10. Install IVT control valve covers.

- a. Install new seal rings (1) in shaft grooves.

**CAUTION:**

When replacing seal rings, replace all rings with new ones on both RH and LH IVT control valve covers.

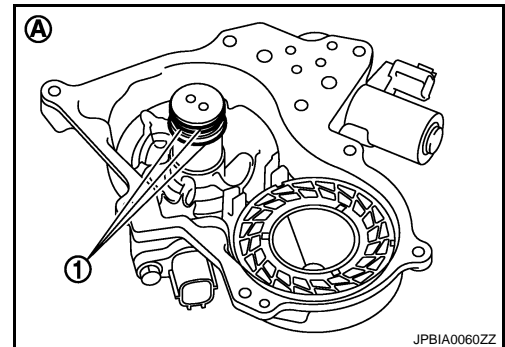

- b. To check the joint between dowel pins and dowel pin holes, check the looseness in the axle direction by pushing the circumferential looseness (between dowel pins and dowel holes) by twisting in the circumferential direction.

- A :Mating surface of magnet retarded
- B :Moves slightly
- C :Not shaken

**CAUTION:**

Always perform this procedure when removing because the gap between dowel pins and dowel pin holes may not be caused on purpose.

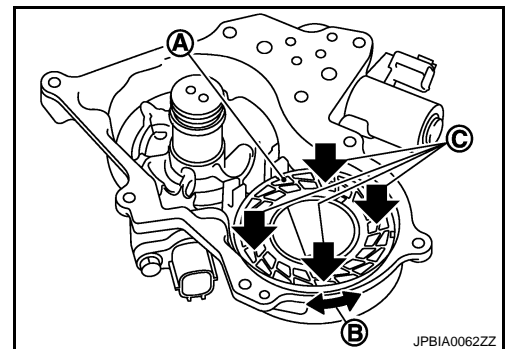

- c. Install IVT covers with a new gasket to front timing chain case.

- 1: Valve timing control cover
- 2: Magnet retarder

**CAUTION:**

- Never face magnet retarder side down to prevent magnet retarder from dropping.
- Check the mating surface of the magnet retarder and the drum of the exhaust side camshaft sprocket for foreign materials.
- Align center of both shaft holes of the shaft and the intake side of the intake camshaft sprocket, and then insert them.
- Be careful not to drop the seal ring from the shaft groove.

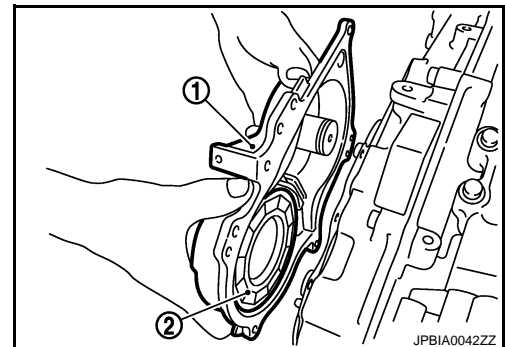

A  
EM  
C  
D  
E  
F  
G  
H  
I  
J  
K  
L  
M  
N  
O  
P

# FRONT TIMING CHAIN CASE

## < ON-VEHICLE REPAIR >

- When setting the valve timing control cover in position by hand, if valve timing control cover is not centered with the valve timing case, the dowel pin of the magnet retarder may not be aligned with the dowel pin holes of the cover. In this case, return to step "b".

- Being careful not to move seal ring from the installation groove, align the dowel pins on the front timing chain case with the holes to install valve timing control covers.
- Tighten bolts in the numerical order as shown.

### IVT cover torque 11.3 N-m (1.2 kg-m, 8 ft-lb)

- A: Bank 1 (Conventional RH bank)
- B: Bank 2 (Conventional LH bank)
- C: Dowel pin hole

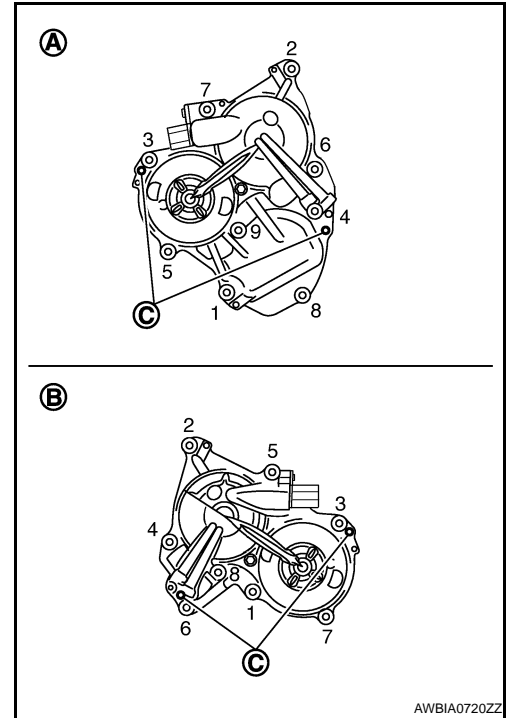

- Apply liquid gasket and install the water pump cover.
  - Use Genuine Silicone RTV Sealant or equivalent. Refer to [GI-15. "Recommended Chemical Products and Sealants"](#).

- Install crankshaft pulley and tighten the bolt in two steps.
  - Lubricate thread and seat surface of the bolt with new engine oil.
  - Apply a paint mark for the second step of angle tightening.

- Step 1 : 44 N-m (4.5 kg-m, 32 ft-lb)**  
**Step 2 : 84° - 90° degrees clockwise**

**Tool Number : KV10112100 (BT-8653-A)**

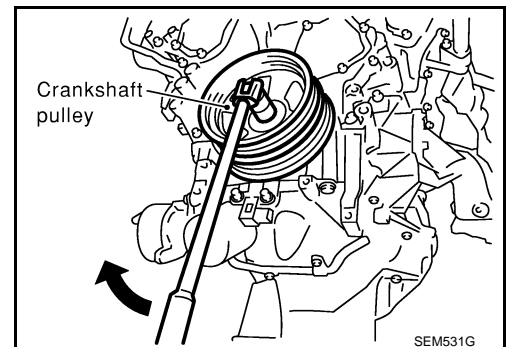

- Rotate crankshaft pulley in normal direction (clockwise when viewed from front) to confirm it turns smoothly.
- Installation of the remaining components is in reverse order of removal.



# TIMING CHAIN

< ON-VEHICLE REPAIR >

## TIMING CHAIN

### Component

INFOID:000000004173776

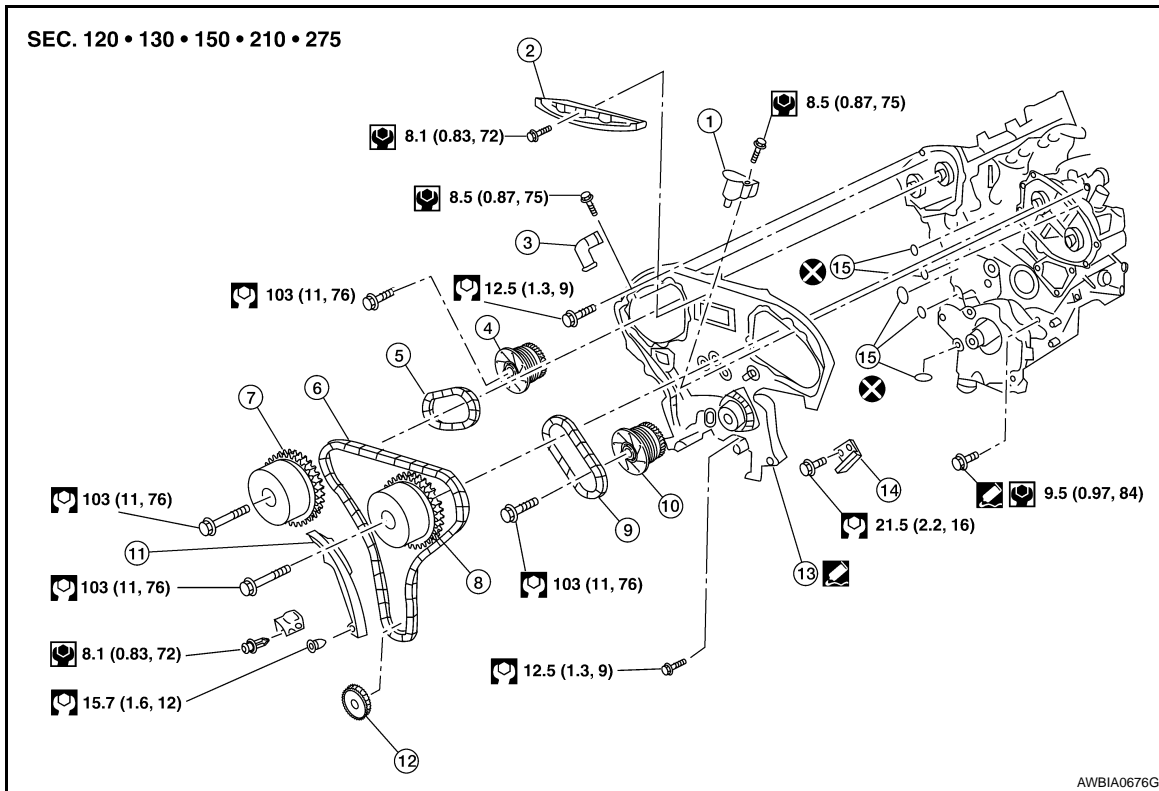

- |                             |                             |                             |
|-----------------------------|-----------------------------|-----------------------------|
| 1. Timing chain tensioner   | 2. Internal chain guide     | 3. Timing chain tensioner   |
| 4. Camshaft sprocket (EXH)  | 5. Timing chain (secondary) | 6. Timing chain (primary)   |
| 7. Camshaft sprocket (INT)  | 8. Camshaft sprocket (INT)  | 9. Timing chain (secondary) |
| 10. Camshaft sprocket (EXH) | 11. Slack guide             | 12. Crankshaft sprocket     |
| 13. Rear timing chain case  | 14. Tension guide           | 15. O-ring                  |

- Refer to [EM-4. "Precaution for Liquid Gasket"](#).
- Before installation, wipe off any protruding sealant.

#### CAUTION:

- After removing timing chain, do not turn the crankshaft and camshaft separately, or the valves will strike the pistons.
- When installing camshafts, chain tensioners, oil seals, or other sliding parts, lubricate contacting surfaces with new engine oil.
- Apply new engine oil to bolt threads and seat surfaces when installing camshaft sprockets, camshaft brackets, and crankshaft pulley.
- Before disconnecting fuel hose, release fuel pressure. Refer to [EC-559. "Inspection"](#).
- Before removing the upper oil pan, remove the crankshaft position sensor (POS).
- Be careful not to damage sensor edges.
- Do not spill engine oil or coolant on drive belts.

### Removal

INFOID:000000004173777

1. Remove front timing chain cover. Refer to [EM-49. "Removal and Installation"](#).
2. Disconnect the power brake booster vacuum hose.
3. Disconnect the electric throttle control actuator.
4. Disconnect the coolant hoses at the electric throttle control actuator.
5. Disconnect the PCV hose.
6. Disconnect the EVAP canister purge volume control solenoid vacuum hose.

# TIMING CHAIN

## < ON-VEHICLE REPAIR >

7. Remove the engine oil dipstick.
8. Remove the rocker covers. Refer to [EM-45, "Removal and Installation LH"](#).
9. Place paint marks on the timing chain and sprockets to indicate the correct position of the components for installation.
10. Remove the internal chain guide (1), and slack guide (2).

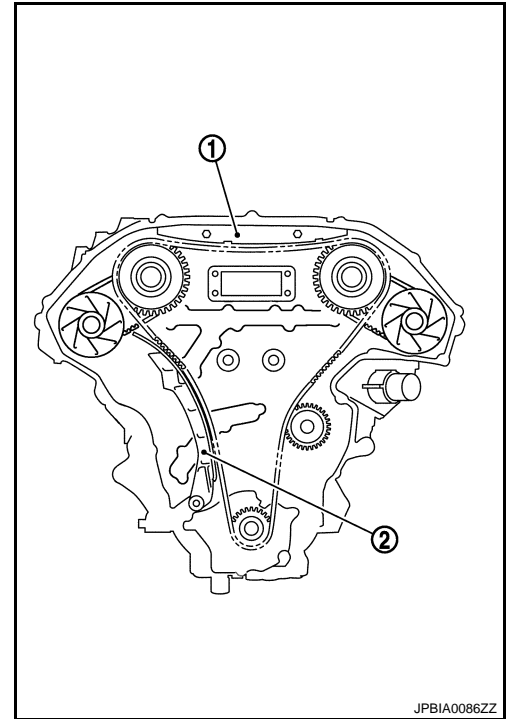

11. Remove the timing chain tensioner.
  - a. Pull lever down and release plunger stopper tab. Plunger stopper tab can be pushed up to release (coaxial structure with lever).
  - b. Insert stopper pin into tensioner body hole to hold lever, and keep the tab released. An Allen wrench [1.2 mm (0.047 in)] is used for a stopper pin as an example.
  - c. Insert plunger into tensioner body by pressing the slack side chain guide.
  - d. Keep the slack side chain guide pressed and hold it by pushing the stopper pin through the lever hole and body hole.
  - e. Remove the bolts and remove the timing chain tensioner.
12. Remove primary timing chain and crankshaft sprocket.

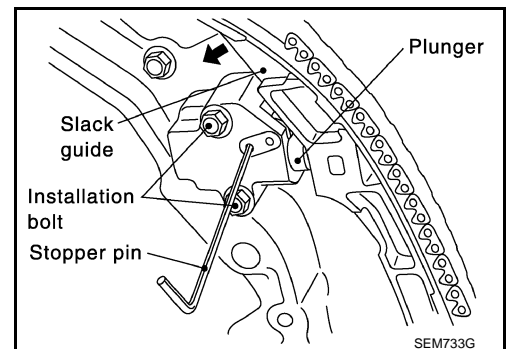
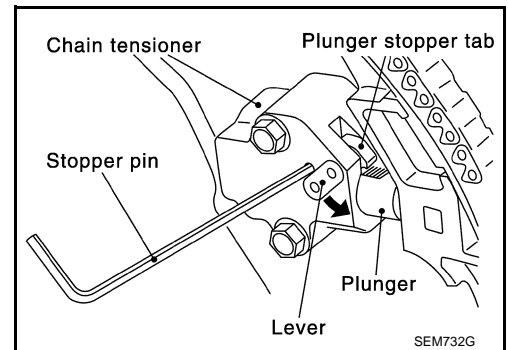

**CAUTION:**

**After removing timing chain, do not turn the crankshaft and camshaft separately, or the valves will strike the pistons.**

# TIMING CHAIN

## < ON-VEHICLE REPAIR >

13. Attach a suitable stopper pin (2) to the right and left camshaft chain tensioners (1) (for secondary timing chains).
  - A: Bank 1
  - B: Bank 2

- a. Insert metal or resin plate [0.5 mm (0.020 in)] into guide between timing chain and chain tensioner plunger. Remove cam sprocket and secondary timing chain with timing chain removed from guide groove.

**CAUTION:**

**Chain tensioner plunger can move while stopper pin is inserted in tensioner. Plunger can come out of tensioner when timing chain is removed. Use caution during removal.**

- Handle the camshaft sprockets as assemblies.

14. Remove the intake and exhaust camshaft sprocket bolts.
  - Apply paint to the timing chain and camshaft sprockets for alignment during installation.
  - Secure the hexagonal portion of the camshaft using a wrench to loosen the bolts.

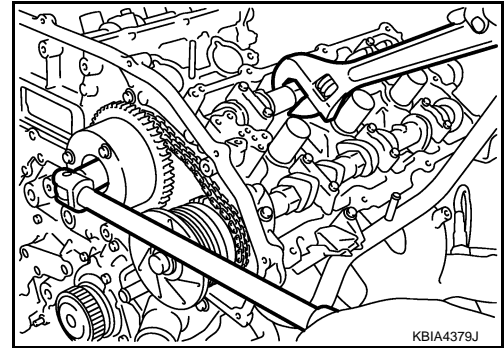
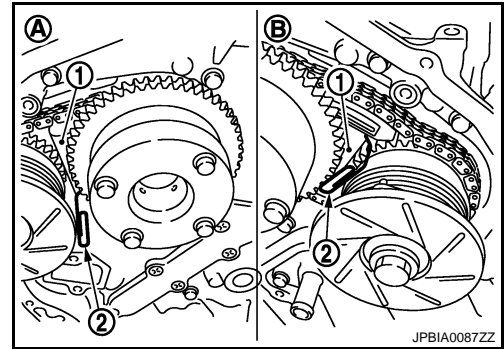

**CAUTION:**

- Avoid impact or dropping the camshaft sprockets. Do not disassemble the camshaft sprockets (never loosen bolts (A) and (B) as shown).

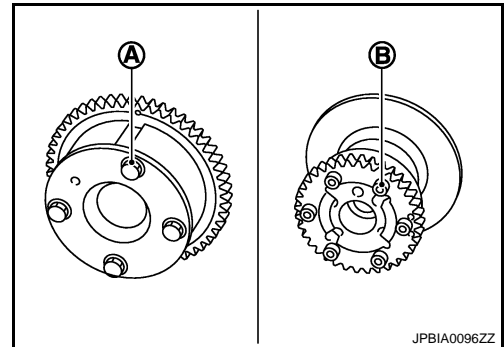

15. Remove the chain tension guide.
16. Remove the rear timing chain case, if necessary. Refer to [EM-66. "Removal and Installation"](#).
17. Use a scraper to remove all of the old Silicone RTV Sealant from the front timing chain case and opposite mating surfaces.

**CAUTION:**

**Do not damage the mating surfaces.**

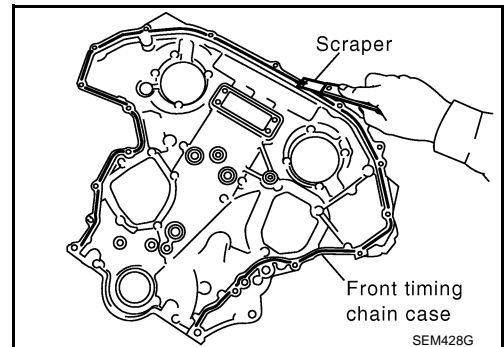

# TIMING CHAIN

## < ON-VEHICLE REPAIR >

18. Remove all old Silicone RTV Sealant from all the bolt holes and bolts.

**CAUTION:**  
Do not damage the threads or mating surfaces.

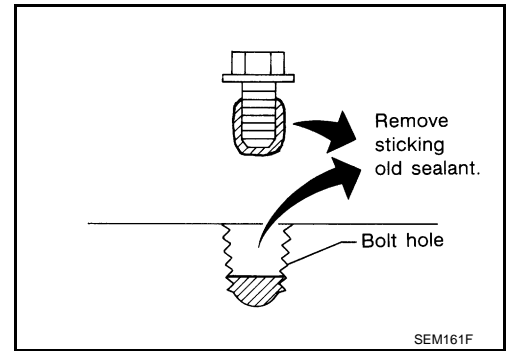

19. Remove the front oil seal from the front timing chain case using a suitable tool.

**CAUTION:**  
Do not damage the front cover.

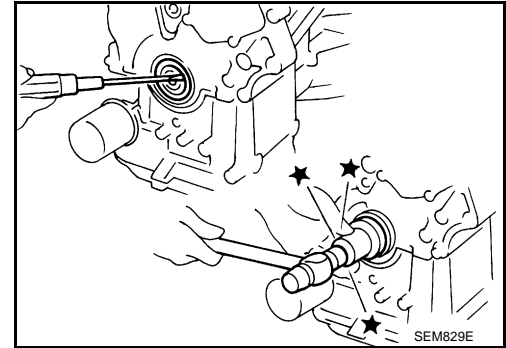

## Inspection

INFOID:000000004173778

Check for cracks and any excessive wear of the timing chain. Replace the timing chain as necessary.

## Installation

INFOID:000000004173779

### NOTE:

The figure shows the relationship between the mating mark on each timing chain and that on the corresponding sprocket, the components installed.

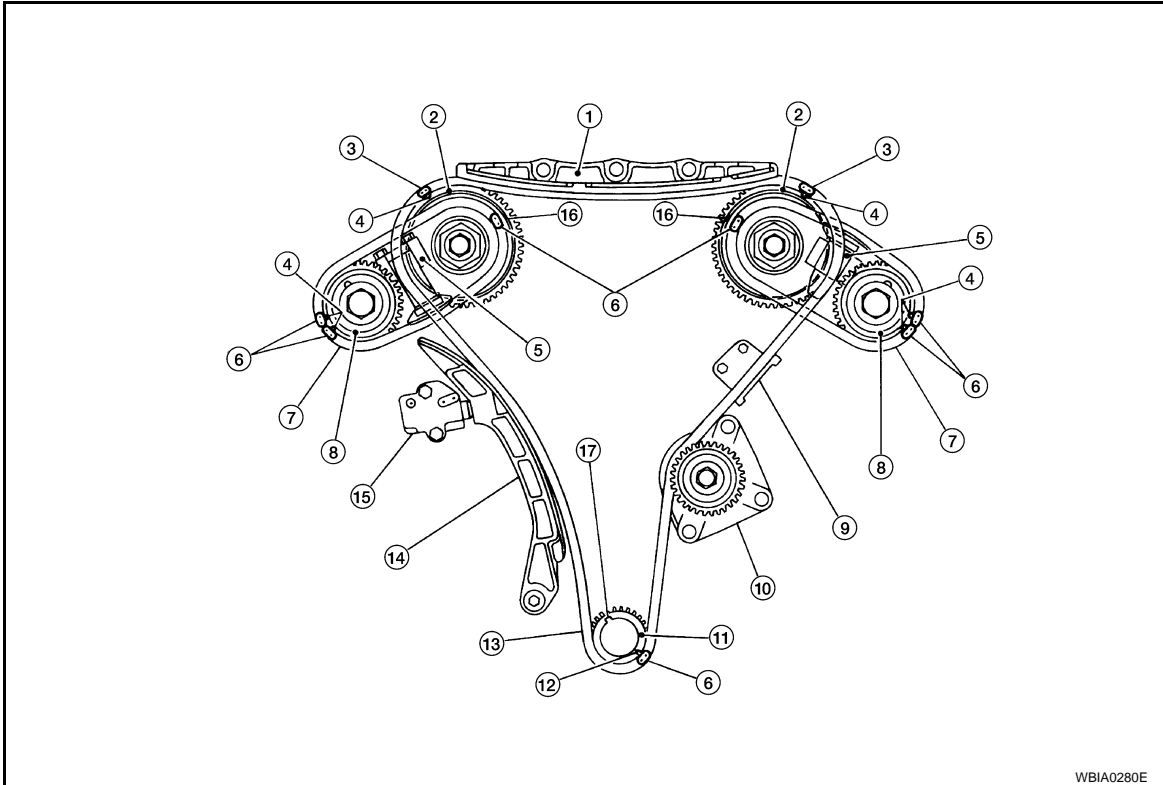

# TIMING CHAIN

## < ON-VEHICLE REPAIR >

- |                             |                                     |                                    |
|-----------------------------|-------------------------------------|------------------------------------|
| 1. Internal chain guide     | 2. Camshaft sprocket (intake)       | 3. Mating mark (pink link)         |
| 4. Mating mark (punched)    | 5. Secondary timing chain tensioner | 6. Mating mark (orange link)       |
| 7. Secondary timing chain   | 8. Camshaft sprocket (exhaust)      | 9. Tension guide                   |
| 10. Water pump              | 11. Crankshaft sprocket             | 12. Mating mark (notched)          |
| 13. Primary timing chain    | 14. Slack guide                     | 15. Primary timing chain tensioner |
| 16. Mating mark (back side) | 17. Crankshaft key                  |                                    |

1. Install the rear timing chain case, if removed. Refer to [EM-66, "Removal and Installation"](#).
2. Install the timing chain tension guide.
3. Position the crankshaft so No. 1 piston is set at TDC on the compression stroke.

- Make sure that the dowel pin hole, dowel pin and crankshaft key are located as shown.

Camshaft dowel pin hole (intake side): at cylinder head upper face side in each bank.

Camshaft dowel pin (exhaust side): at cylinder head upper face side in each bank.

Crankshaft key: at cylinder head side of RH bank.

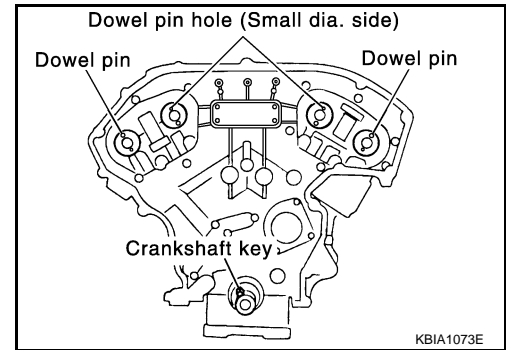

### **CAUTION:**

Hole on small diameter side must be used for intake camshaft sprocket dowel pin. Do not misidentify (ignore big diameter side).

4. Install the secondary timing chains and camshaft sprockets.

### **CAUTION:**

Matching marks between the timing chain and sprockets slip easily. Confirm all matching mark positions repeatedly during the installation process.

- Push the sleeve of the secondary chain tensioner and keep it pressed in with a stopper pin.

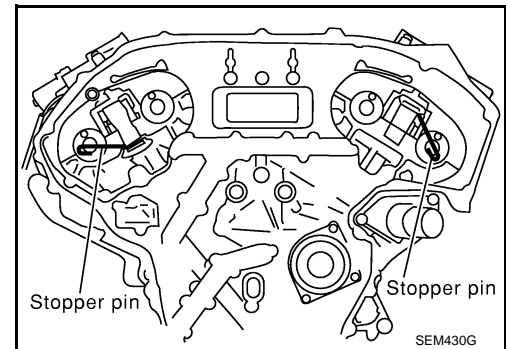

# TIMING CHAIN

## < ON-VEHICLE REPAIR >

- a. Align the matching marks (4), (5), (7) and (10) on the secondary timing chain (8) (orange link) with the ones on the intake and exhaust sprockets (stamped), and install them.
  - Matching marks for the intake sprocket are on the back side of the secondary sprocket.
  - There are two types of matching marks, round (7) and (10) oval (4) and (5) types. They should be used for the RH and LH banks, respectively.  
RH bank: use round type (7) and (10).  
LH (6) bank: use oval type (4) and (5).
- b. Align the dowel pin (3) with and pin hole on the camshaft sprocket INT side (1), and dowel pin groove (11) with the dowel pin on the camshaft EXH side, and install them.
  - On the intake side, align the pin hole on the small diameter side of the camshaft front end with the dowel pin (3) on the back side of the camshaft sprocket (1), and install them.
  - On the exhaust side, align the dowel pin on the camshaft front end with the dowel pin groove (11) on the camshaft sprocket (9), and install them.
  - Camshaft sprocket bolts must be tightened in the next step. Tightening them by hand is enough to prevent the dislocation of the dowel pins (3) and dowel pin grooves (11).

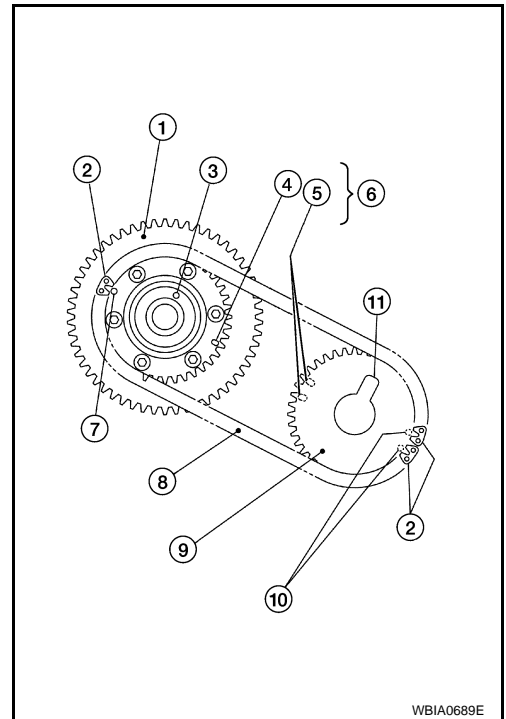

WBIA0689E

- Check mating mark (punched) (D) on each camshaft sprocket are positioned on the mating marks (orange link) (C) on timing chain (secondary).
- A: Intake side
- B: Exhaust side

**NOTE:**

Mating mark (punched) in the figure is for checking loose at this step.

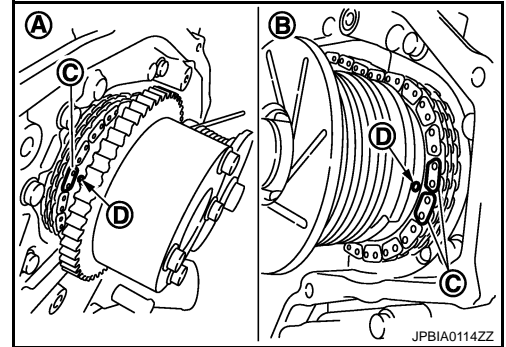

JPBIA0114ZZ

5. After confirming the mating marks are aligned, tighten the camshaft sprocket bolts.
  - Secure the camshaft using a wrench at the hexagonal portion to tighten the bolts.

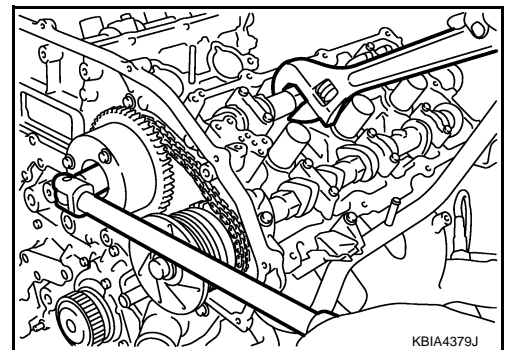

KBIA4379J

# TIMING CHAIN

## < ON-VEHICLE REPAIR >

6. Pull the stopper pins (2) out from the secondary timing chain tensioners (secondary) (1).

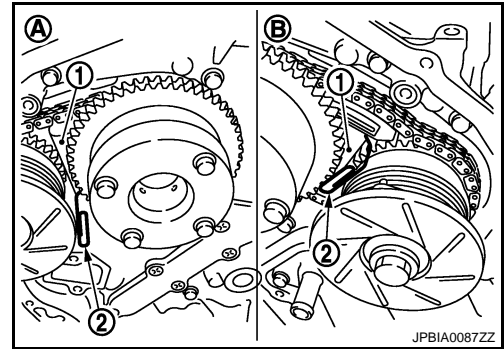

7. Install the crankshaft sprocket on the crankshaft.
- Make sure the mating marks on the crankshaft sprocket face the front of the engine.

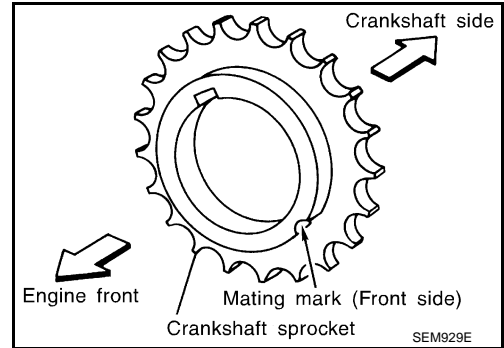

8. Install the primary timing chain.
- Install primary timing chain so the mating mark (punched) (B) on camshaft sprocket (C) is aligned with the pink link (A) on the timing chain, while the mating mark (notched) (E) on the crankshaft sprocket (D) is aligned with the orange one (F) on the timing chain, as shown.
  - When it is difficult to align mating marks of the primary timing chain with each sprocket, gradually turn the camshaft using a wrench on the hexagonal portion to align it with the mating marks.
  - During alignment, be careful to prevent dislocation of mating mark alignments of the secondary timing chains.
- (G): Water pump

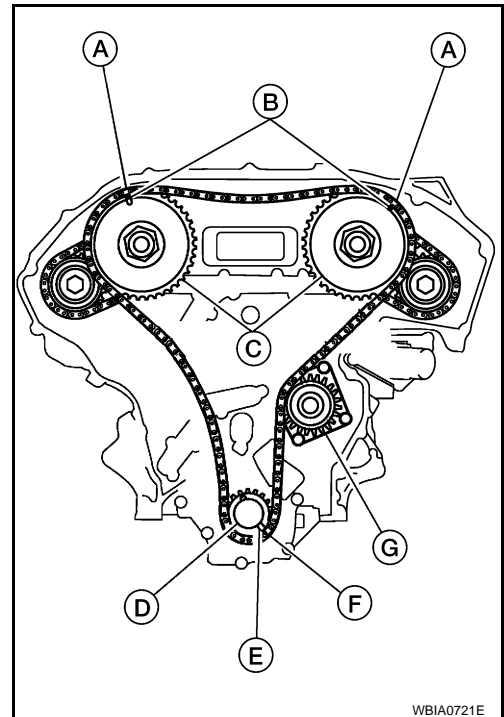

# TIMING CHAIN

## < ON-VEHICLE REPAIR >

9. Install the internal chain guide (1), slack guide (2) and timing chain (primary).

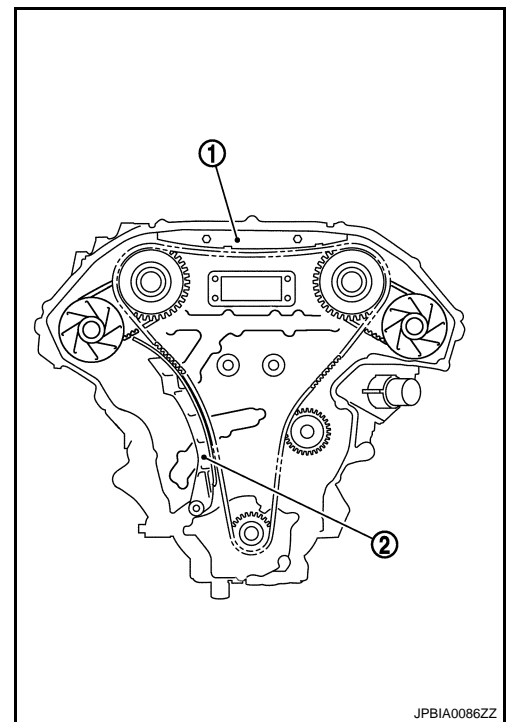

### CAUTION:

Do not overtighten the slack guide bolts. It is normal for a gap to exist under the bolt seats when the bolts are tightened to specification.

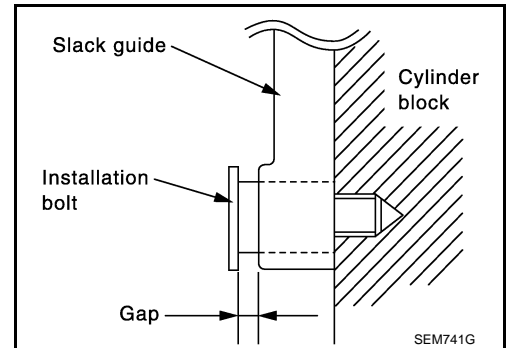

10. Install the timing chain tensioner for the slack guide.
- When installing the chain tensioner, push in the sleeve and keep it pressed in with the stopper pin.
  - Remove any dirt and foreign materials completely from the back and the mounting surfaces of the chain tensioner.
  - After installation, pull out the stopper pin while pressing the slack guide.
11. Reconfirm that the matching marks on the sprockets and the timing chain have not slipped out of alignment.

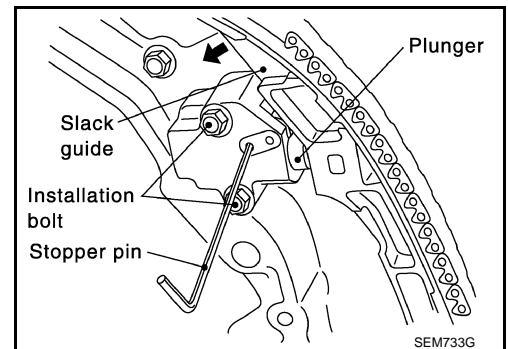



## TIMING CHAIN

### < ON-VEHICLE REPAIR >

12. Install new O-rings (A) on the rear timing chain case.

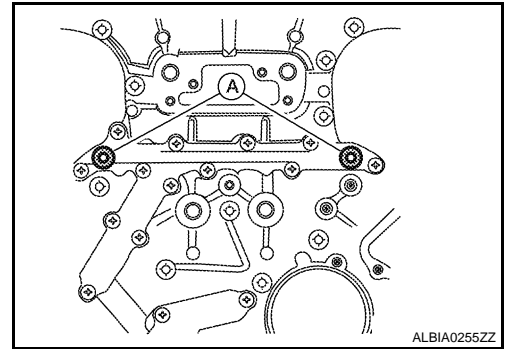

13. Install the front timing chain case. Refer to [EM-49. "Removal and Installation"](#).
14. Activate the fuel system. Check for any leaks when the system is repressurized and correct as necessary.
15. Start the engine and check all systems for leaks or improper operation. Correct as necessary.
  - **After starting engine, keep idling for three minutes. Then rev engine up to 3,000 rpm under no load to purge air from the high-pressure oil chamber of the chain tensioners. The engine may produce a rattling noise. This indicates that air still remains in the chamber and is not a matter of concern.**

A

EM

C

D

E

F

G

H

I

J

K

L

M

N

O

P

# REAR TIMING CHAIN CASE

< ON-VEHICLE REPAIR >

## REAR TIMING CHAIN CASE

Component

INFOID:000000004173780

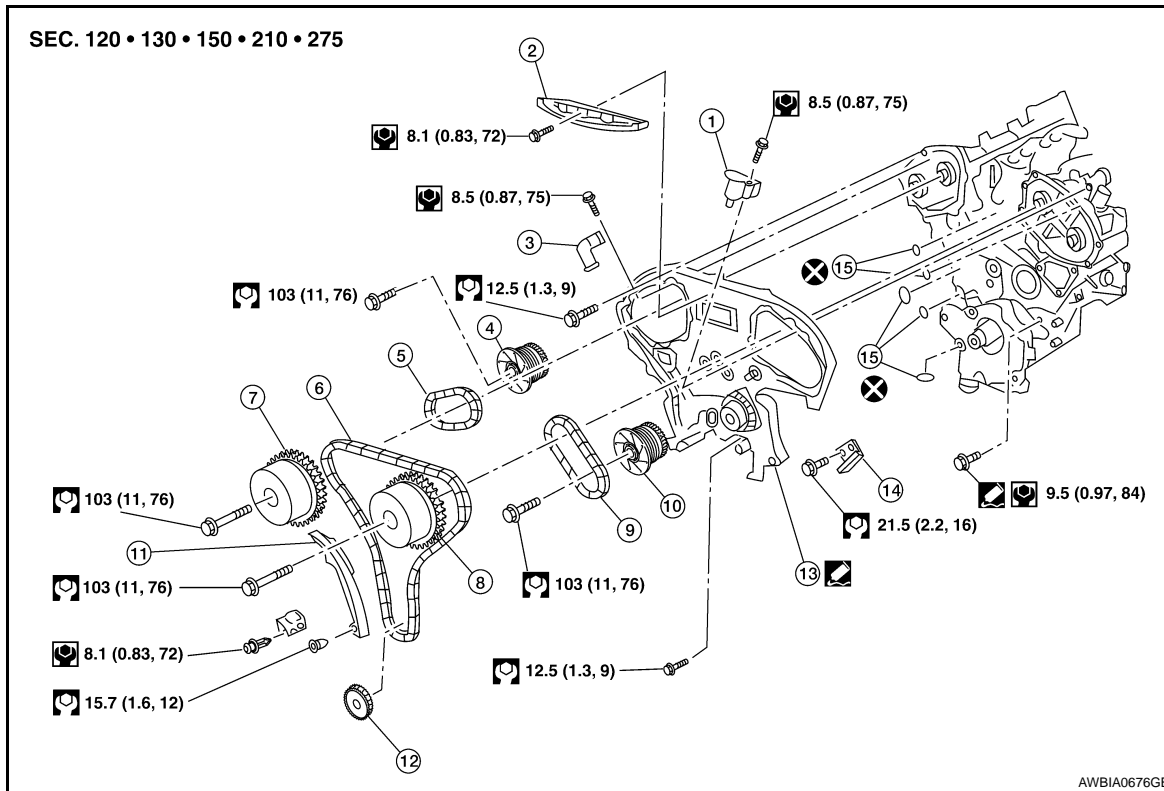

- |                             |                             |                             |
|-----------------------------|-----------------------------|-----------------------------|
| 1. Timing chain tensioner   | 2. Internal chain guide     | 3. Timing chain tensioner   |
| 4. Camshaft sprocket (EXH)  | 5. Timing chain (secondary) | 6. Timing chain (primary)   |
| 7. Camshaft sprocket (INT)  | 8. Camshaft sprocket (INT)  | 9. Timing chain (secondary) |
| 10. Camshaft sprocket (EXH) | 11. Slack guide             | 12. Crankshaft sprocket     |
| 13. Rear timing chain case  | 14. Tension guide           | 15. O-ring                  |

- Refer to [EM-4. "Precaution for Liquid Gasket"](#).
- Before installation, wipe off any protruding sealant.

### CAUTION:

- After removing timing chain, do not turn the crankshaft and camshaft separately, or the valves will strike the pistons.
- When installing camshafts, chain tensioners, oil seals, or other sliding parts, lubricate contacting surfaces with new engine oil.
- Apply new engine oil to bolt threads and seat surfaces when installing camshaft sprockets, camshaft brackets, and crankshaft pulley.
- Before disconnecting fuel hose, release fuel pressure. Refer to [EC-559. "Inspection"](#).
- Before removing the upper oil pan, remove the crankshaft position sensor (POS).
- Be careful not to damage sensor edges.
- Do not spill engine oil or coolant on drive belts.

## Removal and Installation

INFOID:000000004173781

### REMOVAL

1. Remove the engine assembly. Refer to [EM-96. "Removal and Installation"](#).
2. Remove the primary and secondary timing chains. Refer to [EM-57. "Removal"](#).

# REAR TIMING CHAIN CASE

## < ON-VEHICLE REPAIR >

3. Remove the rear timing chain case.

**CAUTION:**

- Do not remove the plate metal cover for the oil passage.
- After removing the chain case, do not apply any load to the case that might bend it.

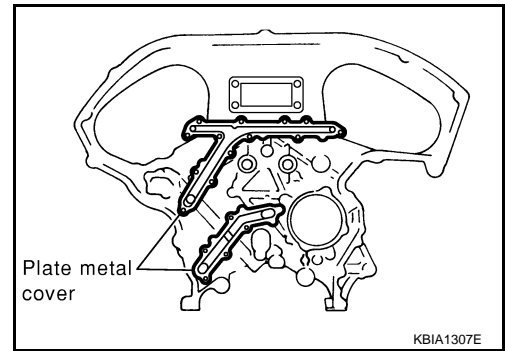

a. Loosen and remove the rear timing chain case bolts in the order as shown.

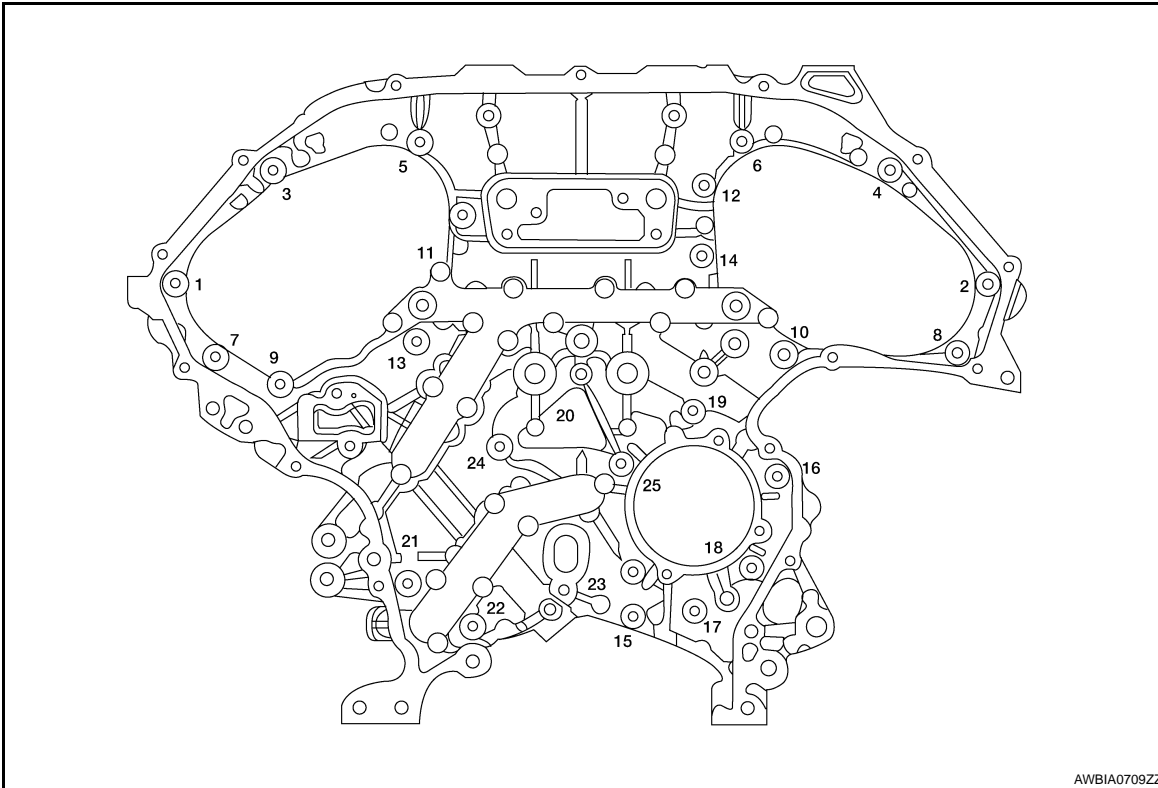

b. Cut the sealant with an appropriate tool and remove the rear timing chain case.

4. Remove O-rings to timing chain case and cylinder block.

5. Use a scraper to remove all of the old Silicone RTV Sealant from the front and rear timing chain case and opposite mating surfaces.

**CAUTION:**

**Do not damage the mating surfaces.**

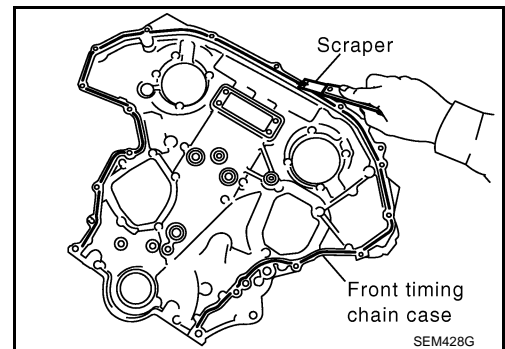

A  
EM  
C  
D  
E  
F  
G  
H  
I  
J  
K  
L  
M  
N  
O  
P

## REAR TIMING CHAIN CASE

### < ON-VEHICLE REPAIR >

6. Remove all old Silicone RTV Sealant from all the bolt holes and bolts.

**CAUTION:**

**Do not damage the threads or mating surfaces.**

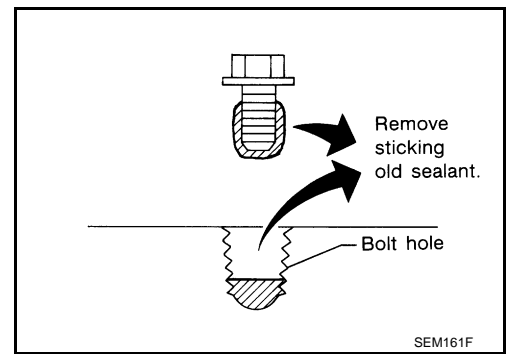

### INSTALLATION

1. Install O-rings on cylinder block.

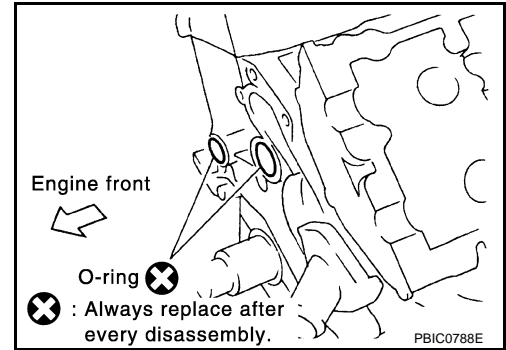

2. Apply Genuine Silicone RTV Sealant or equivalent, to the rear timing chain case using Tool as shown. Refer to [GI-15, "Recommended Chemical Products and Sealants"](#).

**Tool number** : **WS39930000 ( — )**

**CAUTION:**

- For "a", completely wipe out liquid gasket extended on a portion touching at engine coolant.
- Apply liquid gasket on installation position of water pump and cylinder completely.

# REAR TIMING CHAIN CASE

< ON-VEHICLE REPAIR >

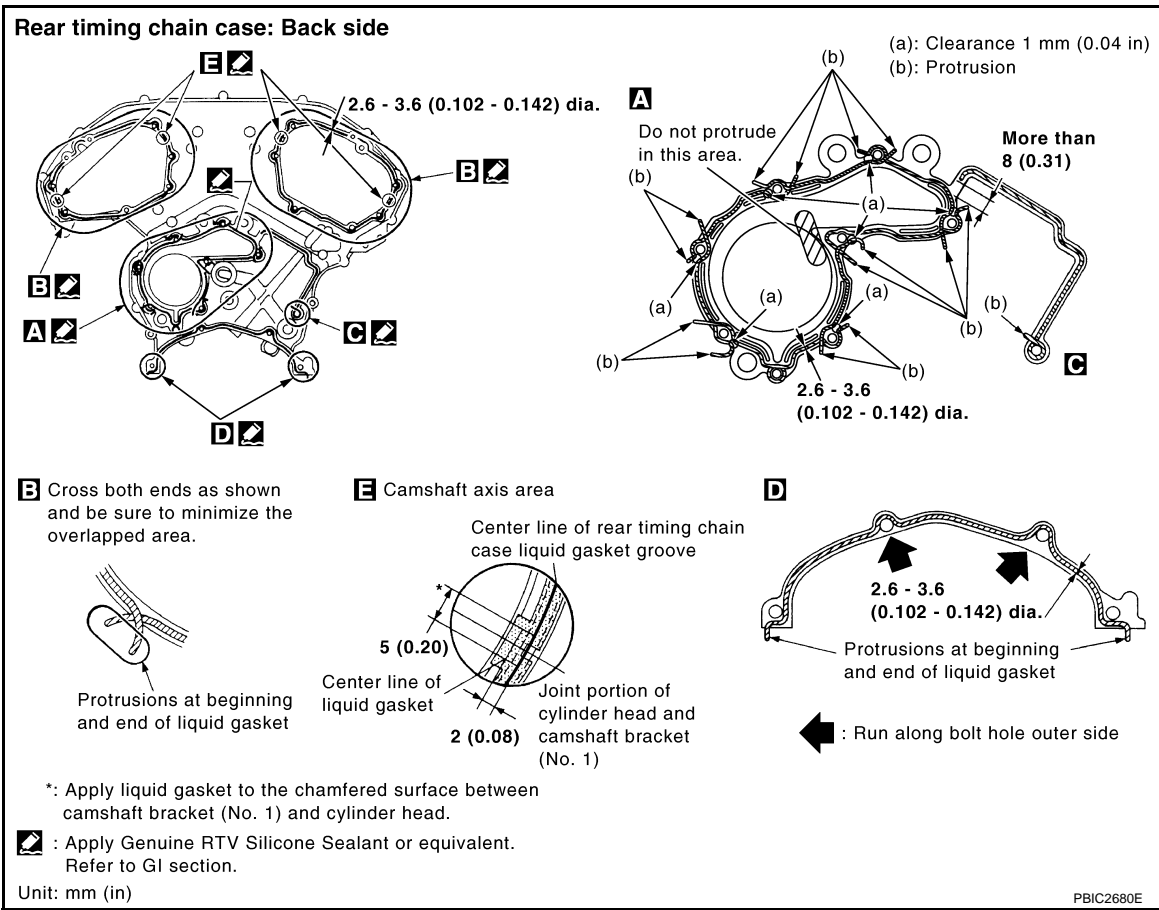

3. Align the rear timing chain case and water pump assembly with the dowel pins (RH and LH) on the cylinder block and install the case. Make sure the O-rings stay in place during installation.
  - a. Tighten the bolts in the numerical order as shown. There are two bolt lengths used. Follow the chart below for proper bolt length specifications.

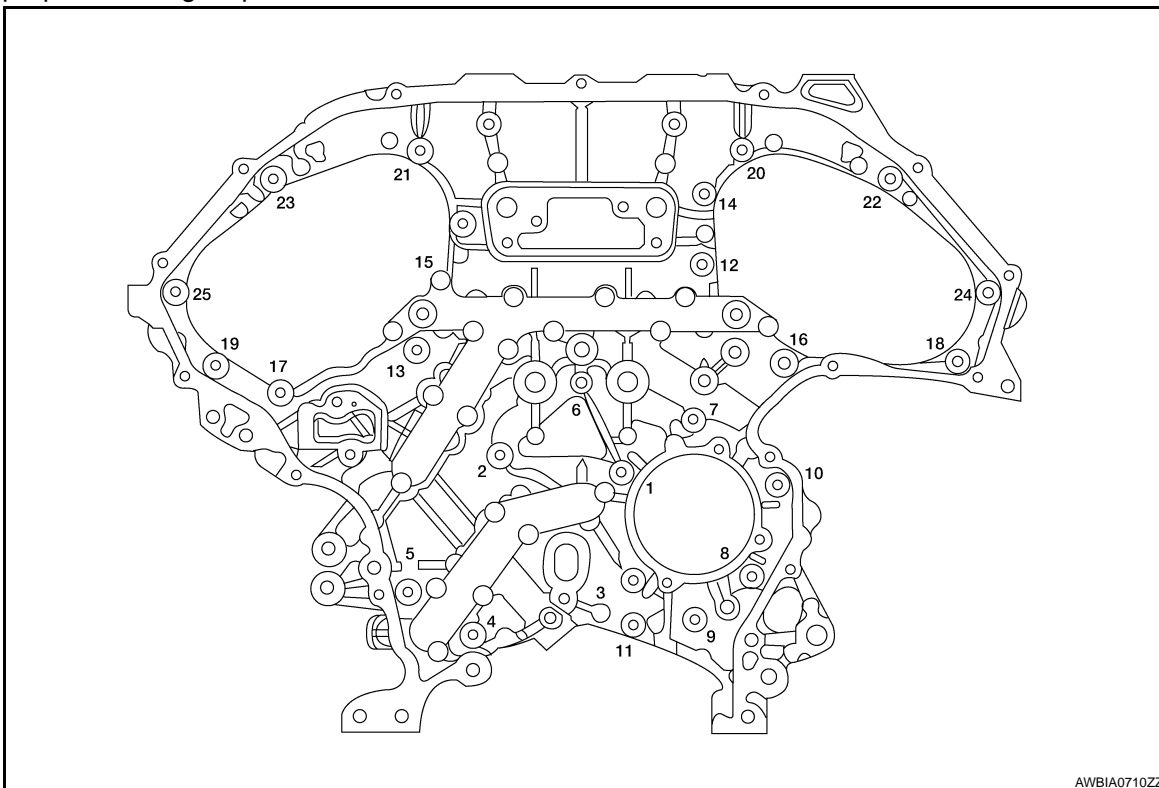

## REAR TIMING CHAIN CASE

< ON-VEHICLE REPAIR >

---

Bolt length	Bolt position	Torque specification
20 mm (0.79 in)	1, 2, 3, 6, 7, 8, 9, 10	12.7 N·m (1.3 kg-m, 9 ft-lb)
16 mm (0.63 in)	4, 5, 11	12.7 N·m (1.3 kg-m, 9 ft-lb)
16 mm (0.63 in)	12 - 25	14.0 N·m (1.4 kg-m, 10 ft-lb)

- b. After all bolts are initially tightened, retighten them to the specification in the numerical order as shown.
4. Install the primary and secondary timing chains. Refer to [EM-60, "Installation"](#).
5. Install the engine assembly. Refer to [EM-96, "Removal and Installation"](#).

# CAMSHAFT

< ON-VEHICLE REPAIR >

## CAMSHAFT

### Removal and Installation

INFOID:000000004173782

SEC. 111•130•221

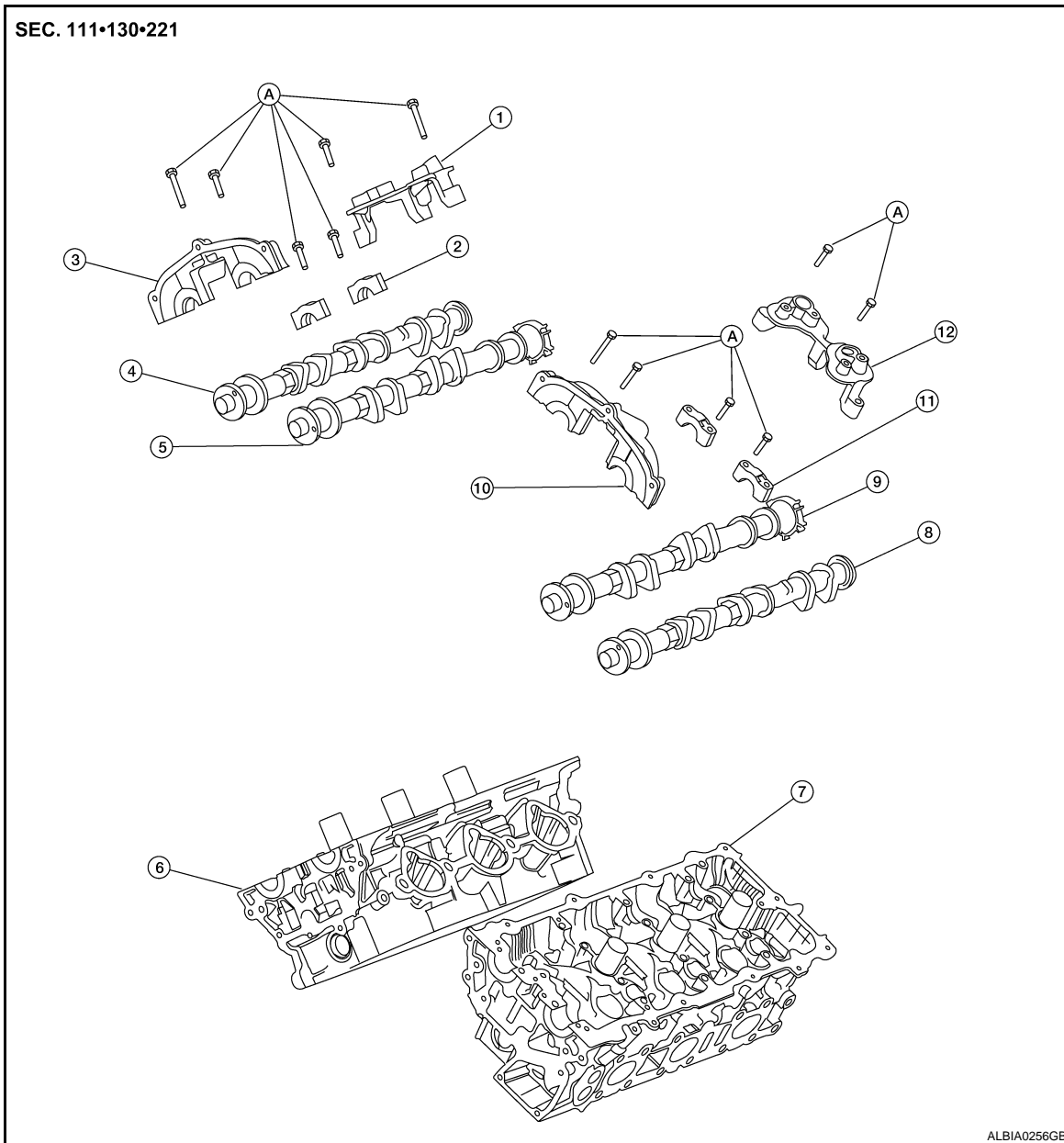

- |  |                       |   |
|--|-----------------------|---|
| 1. Camshaft position sensor bracket (RH) | 2. Camshaft brackets  | 3. No. 1 camshaft bracket (RH)            |
| 4. Camshaft (EXH) RH                     | 5. Camshaft (INT) RH  | 6. Cylinder head (RH)                     |
| 7. Cylinder head (LH)                    | 8. Camshaft (EXH) LH  | 9. Camshaft (INT) LH                      |
| 10. No. 1 camshaft bracket (LH)          | 11. Camshaft brackets | 12. Camshaft position sensor bracket (LH) |
| A. Follow installation procedure         |                       |   |

#### CAUTION:

Apply new engine oil to parts marked in illustration before installation.

#### REMOVAL

1. Remove the timing chains. Refer to [EM-57. "Removal"](#).
2. Remove the fuel rail and injectors. Refer to [EM-40. "Removal and Installation"](#).

# CAMSHAFT

## < ON-VEHICLE REPAIR >

3. Remove camshaft position brackets (RH shown, LH similar).

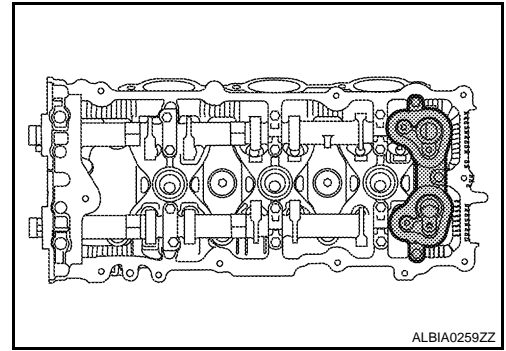

4. Remove the intake and exhaust camshaft brackets and the camshafts.

- Mark the camshafts, camshaft brackets, and bolts so they are placed in the same position and direction for installation.
- Equally loosen the camshaft bracket bolts in several steps in the numerical order as shown.

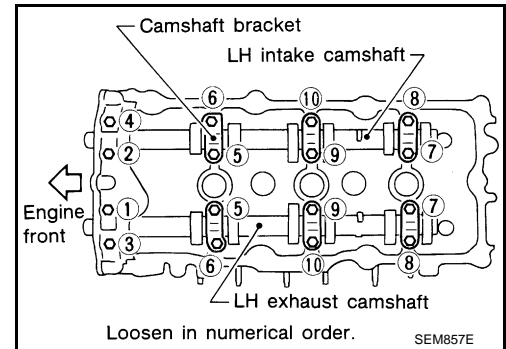
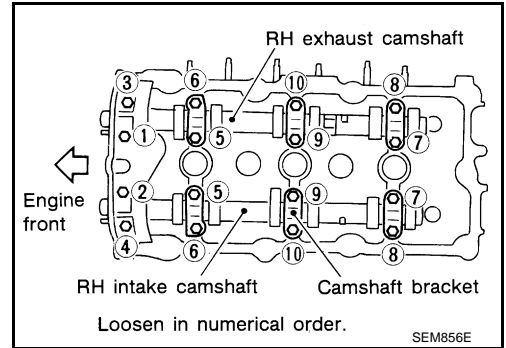

5. Remove valve lifters.

**NOTE:**

Identify installation positions to ensure proper installation.

6. Remove secondary timing chain tensioner from cylinder head

- Remove secondary tensioner with its stopper pin attached.

**NOTE:**

Stopper pin was attached when secondary timing chain was removed.

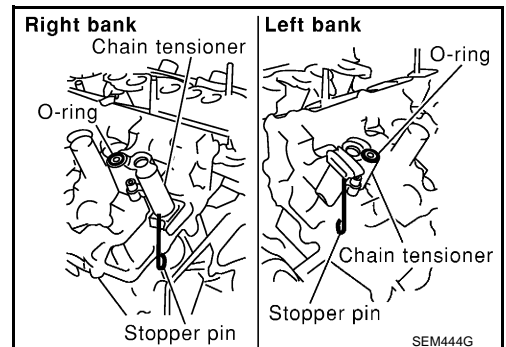

## INSTALLATION



# CAMSHAFT

## < ON-VEHICLE REPAIR >

1. Before installation, remove any old Silicone RTV Sealant from component mating surfaces using a scraper.
  - Remove the old Silicone RTV Sealant from the bolt holes and threads.
  - Do not scratch or damage the mating surfaces.

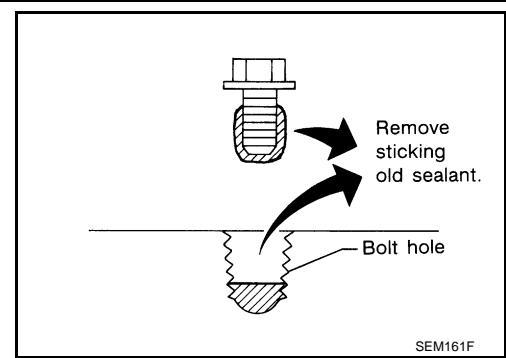

2. Before installing the front cam bracket, remove the old Silicone RTV Sealant from the mating surface using a scraper.
  - Do not scratch or damage the mating surface.

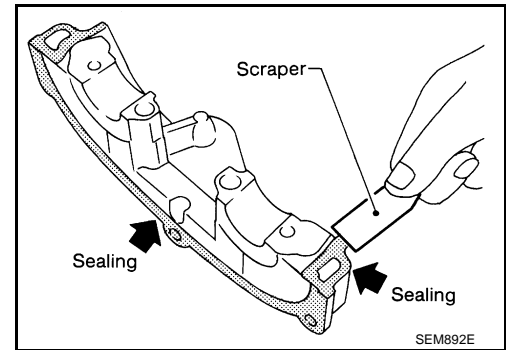

3. Turn the crankshaft until No. 1 piston is set at TDC on the compression stroke.
  - The crankshaft key should line up with the right bank cylinder center line as shown.

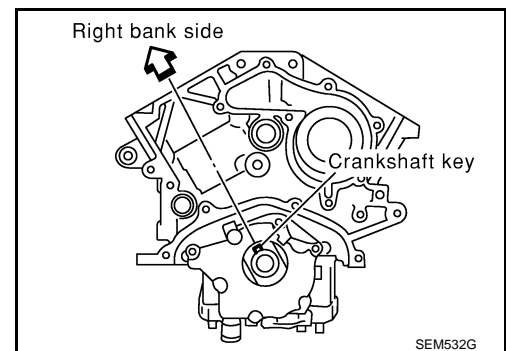

4. Install camshaft chain tensioners on both sides of cylinder head. Refer to [EM-49, "Removal and Installation"](#).

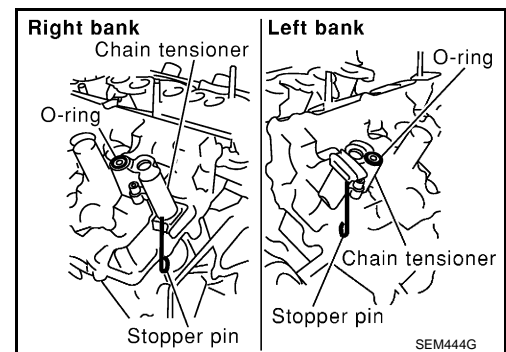

5. Install valve lifters.

**NOTE:**

Install them in original positions.

# CAMSHAFT

## < ON-VEHICLE REPAIR >

6. Install exhaust and intake camshafts and camshaft brackets.
  - Intake camshaft has a drill mark on camshaft sprocket mounting flange.

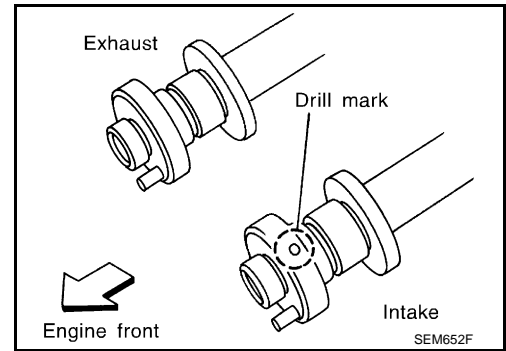

- Follow your identification marks made during removal, or follow the identification marks that are present on the new camshafts components for proper placement and direction of the components.

Bank	INT/EXH	ID mark	Drill mark	Paint marks	
				M1	M2
RH	INT	1A	Yes	Blue	No
	EXH	1C	No	No	Blue
LH	INT	1B	Yes	Blue	No
	EXH	1D	No	No	Blue

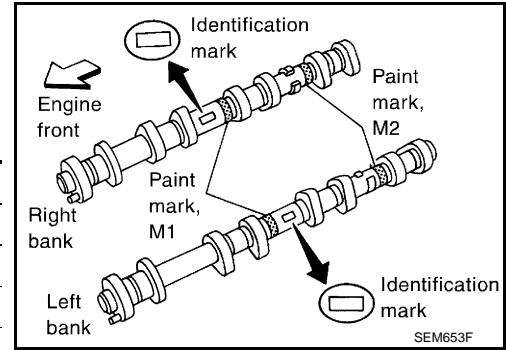

- Position the camshafts:  
 RH exhaust camshaft dowel pin at about 10 o'clock.  
 LH exhaust camshaft dowel pin at about 2 o'clock.

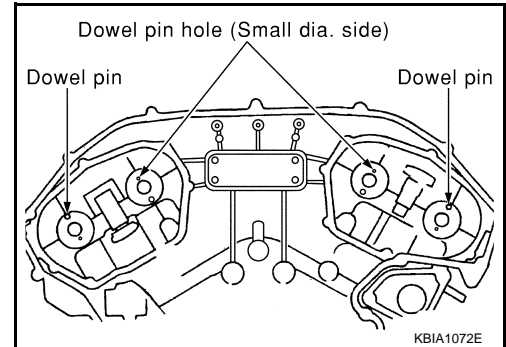

# CAMSHAFT

## < ON-VEHICLE REPAIR >

- Before installing camshaft brackets, apply sealant to mating surface of No. 1 camshaft bracket.
  - Use **Genuine Silicone RTV Sealant, or equivalent. Refer to [GI-15, "Recommended Chemical Products and Sealants"](#).**

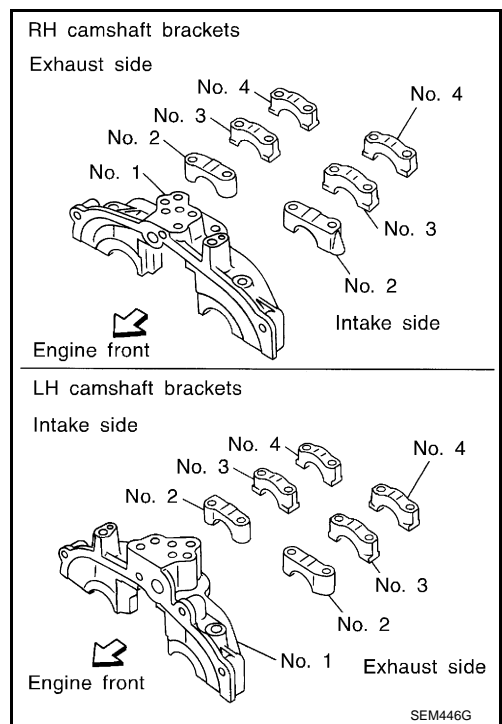

- Before installation, wipe off any protruding sealant.
- Refer to [EM-4, "Precaution for Liquid Gasket"](#).

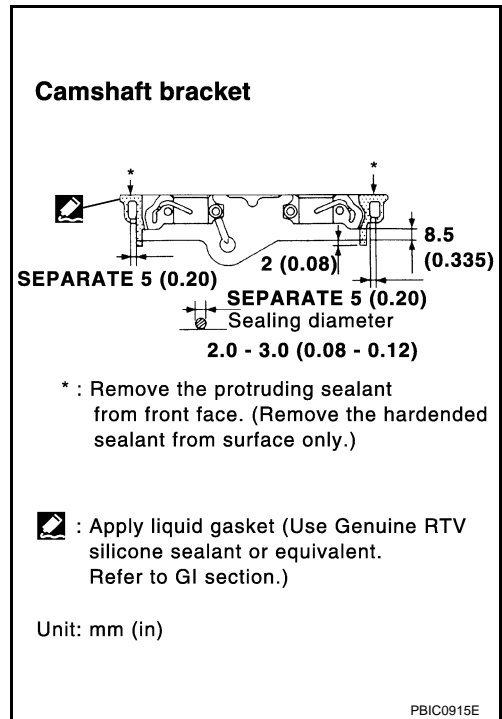

- Install camshaft brackets in their original positions and direction. Align the stamp marks as shown.
- If checking and adjusting any part of valve assembly or camshaft, check valve clearance according to the reference data. Refer to [EM-17, "Valve Clearance"](#).

Valve clearance (cold) Intake	: 0.26 - 0.34 mm (0.010 - 0.013 in)
Valve clearance (cold) Exhaust	: 0.29 - 0.37 mm (0.011 - 0.015 in)

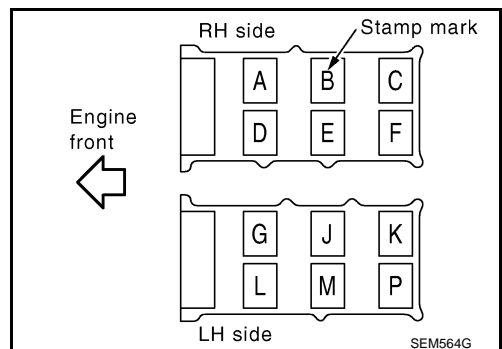

# CAMSHAFT

## < ON-VEHICLE REPAIR >

- Tighten the camshaft brackets in the three steps, in numerical order as shown.

1	1.96 N·m (0.2 kg-m, 17 in-lb)	Tighten No.s 7 - 10, then tighten 1 - 6 in numerical order as shown.
2	5.88 N·m (0.6 kg-m, 52 in-lb)	Tighten in numerical order as shown.
3	10.41 N·m (1.10 kg-m, 8 ft-lb)	Tighten No. 1 - 6 in the numerical order as shown.

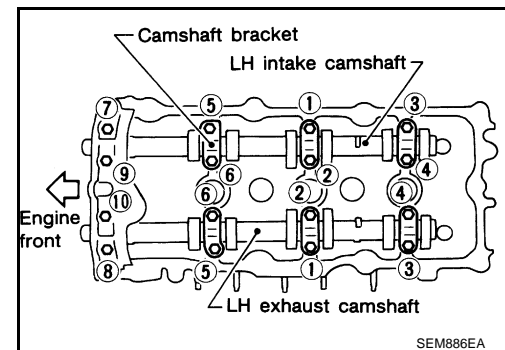
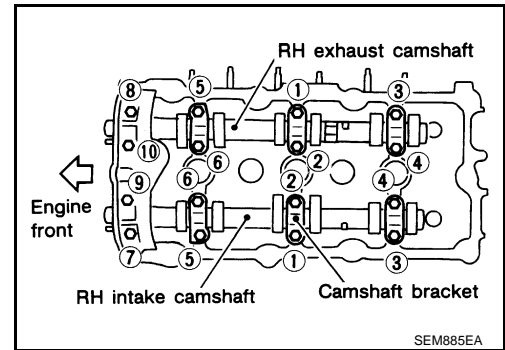

8. Measure difference in levels between front end faces of No. 1 camshaft bracket and cylinder head.

**Standard : - 0.14 mm (- 0.0055 in)**

- If measurement is outside the specified range, re-install camshaft and camshaft bracket.

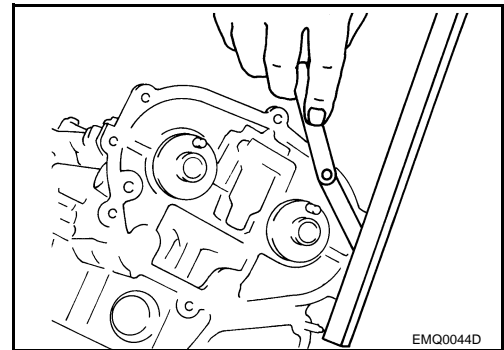

9. Install the IVT control solenoid valves with new gaskets. Refer to [EM-49. "Removal and Installation"](#).

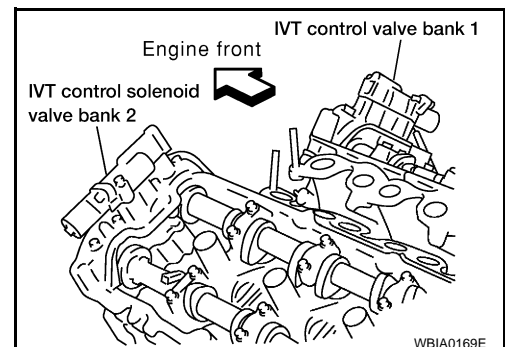

10. If necessary, install camshaft position sensor (PHASE) (RH and LH bank.)  
 11. Install the fuel rail and injectors. Refer to [EM-40. "Removal and Installation"](#).  
 12. Install the timing chains. Refer to [EM-60. "Installation"](#).

## INSPECTION AFTER REMOVAL

### Camshaft Visual Check

Check camshaft for scratches, seizure and wear. Replace if necessary.

### Camshaft Runout

# CAMSHAFT

## < ON-VEHICLE REPAIR >

1. Put V-block on precise flat bed and support No. 2 and No. 4 journal of camshaft as shown.
2. Set dial gauges vertically to No. 3 journal as shown.
3. Turn camshaft in one direction slowly by hand, measure the camshaft runout on the dial gauges.
  - Runout is the largest indicator reading after one full revolution.

### Camshaft Runout

<b>Standard</b>	<b>: Less than 0.02 mm (0.0008 in)</b>
<b>Limit</b>	<b>: 0.05 mm (0.0020 in)</b>

4. If actual runout exceeds the limit, replace the camshaft.

### Camshaft Cam Lobe Height

1. Measure camshaft cam lobe height as shown. Refer to [EM-122, "Camshaft"](#).
2. If wear has reduced the lobe height below specifications, replace the camshaft.

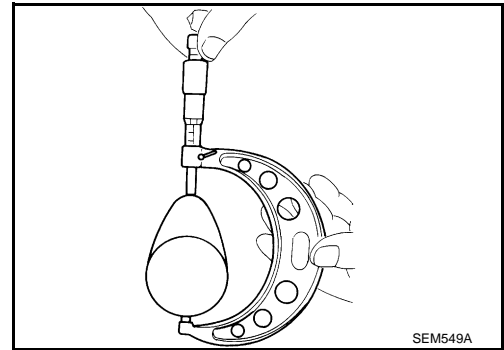
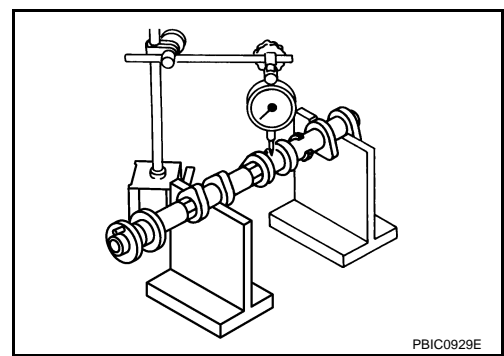

### Camshaft Journal Clearance

#### Outer Diameter of Camshaft Journal

- Measure outer diameter of camshaft journal as shown.

<b>Standard outer diameter No.1</b>	<b>: 25.935 - 25.955 mm (1.0211 - 1.0218 in)</b>
<b>Standard outer diameter No.2, 3, 4</b>	<b>: 23.445 - 23.465 mm (0.9230 - 0.9238 in)</b>

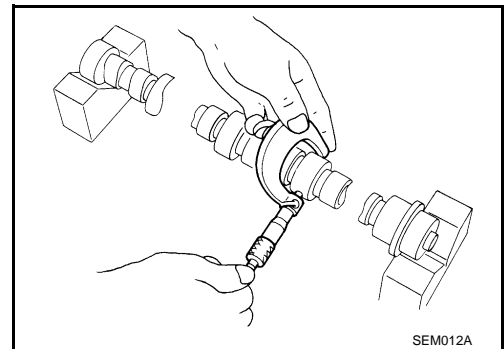

#### Inner Diameter of Camshaft Bracket

1. Tighten camshaft bracket bolt with specified torque.
2. Using inside micrometer, measure inner diameter "A" of camshaft bearing.

<b>Standard inner diameter No.1</b>	<b>: 26.000 - 26.021 mm (1.0236 - 1.0244 in)</b>
<b>Standard inner diameter No.2, 3, 4</b>	<b>: 23.500 - 23.521 mm (0.9252 - 0.9260 in)</b>

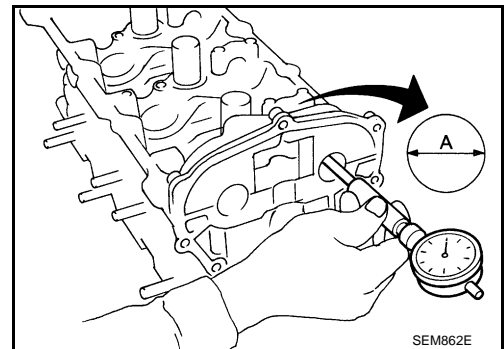

#### Calculation of Camshaft Journal Clearance

(Journal clearance) = (inner diameter of camshaft bracket) – (outer diameter of camshaft journal)

A  
EM  
C  
D  
E  
F  
G  
H  
I  
J  
K  
L  
M  
N  
O  
P

# CAMSHAFT

## < ON-VEHICLE REPAIR >

**Standard No.1** : 0.045 - 0.086 mm (0.0018 - 0.0034 in)

**Standard No.2, 3, 4** : 0.035 - 0.076 mm (0.0014 - 0.0030 in)

**Limit** : 0.15 mm (0.0059 in)

- When out of the specified range, replace either or both camshaft and cylinder head.

### NOTICE:

Inner diameter of camshaft bracket is manufactured together with cylinder head. Replace the whole cylinder head assembly.

### Camshaft End Play

1. Install the camshaft in the cylinder head.
2. Install dial gauge in thrust direction on front end of camshaft. Measure end play when camshaft is moved forward/backward (in direction to axis) as shown.

**Standard** : 0.115 - 0.188 mm (0.0045 - 0.0074 in)

**Limit** : 0.24 mm (0.0094 in)

- If out of the specified range, replace with new camshaft and measure again.
- If out of the specified range again, replace with new cylinder head.

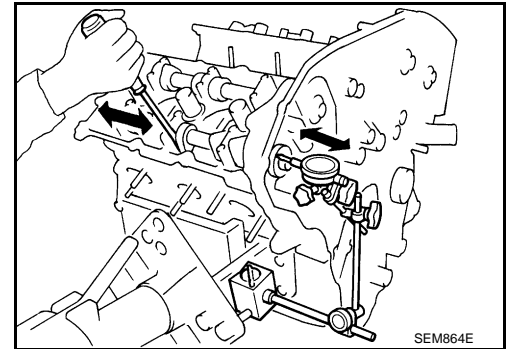

### Camshaft Sprocket Runout

1. Put V-block on precise flat bed and support No. 2 and No. 4 journal of camshaft as shown.
2. Install camshaft sprocket on camshaft.
3. Measure camshaft sprocket runout.

**Runout** : Less than 0.15 mm (0.0059 in)

4. If sprocket runout exceeds the limit, replace camshaft sprocket.

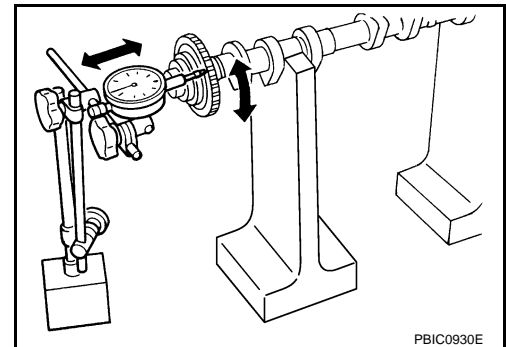

### Valve Lifter

- Check if the surface of the valve lifter has any excessive wear or cracks, replace as necessary.

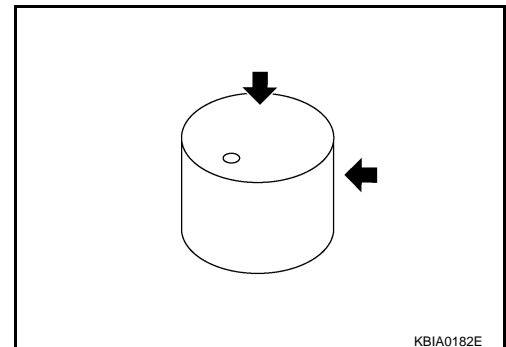

### Valve Lifter Clearance

#### Outer Diameter of Valve Lifter

# CAMSHAFT

## < ON-VEHICLE REPAIR >

- Measure the outer diameter of the valve lifter. Refer to [EM-124, "Cylinder Head"](#).
- If out of the specified range, replace the valve lifter.

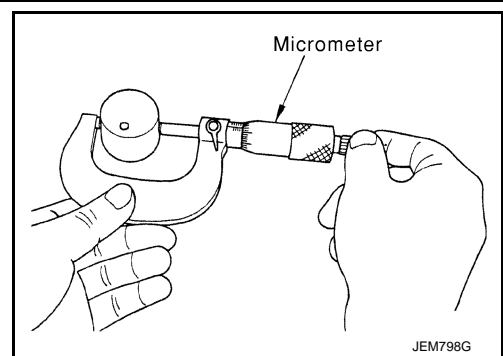

### Valve Lifter Bore Diameter

- Using inside micrometer, measure diameter of valve lifter bore of cylinder head. Refer to [EM-124, "Cylinder Head"](#).
- If out of the specified range, replace the cylinder head assembly.

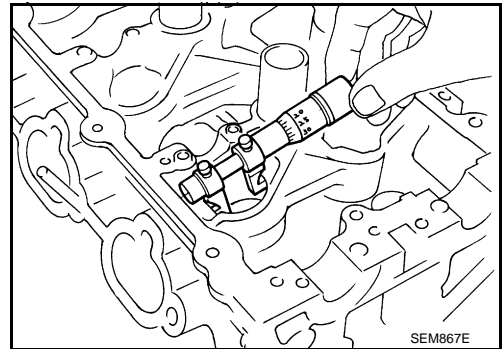

### Calculation of Valve Lifter Clearance

- (Valve lifter clearance) = (hole diameter for valve lifter) – (outer diameter of valve lifter) Refer to [EM-124, "Cylinder Head"](#).
- If out of specified range, replace either or both valve lifter and cylinder head assembly.

## Inspection after Installation

INFOID:000000004173783

### INSPECTION OF CAMSHAFT SPROCKET (INT) OIL GROOVE

#### CAUTION:

- Perform this inspection only when DTC P0011 is detected in self-diagnostic results of CONSULT III and it is directed according to inspection procedure of EC section. Refer to [EC-150, "Diagnosis Procedure"](#).
  - Check when engine is cold so as to prevent burns from any splashing engine oil.
1. Check engine oil level. Refer to [LU-7, "Inspection"](#).
  2. Perform the following procedure so as to prevent the engine from being unintentionally started while checking.
    - a. Release fuel pressure. Refer to [EC-559, "Inspection"](#).
    - b. Disconnect ignition coil and injector harness connectors if practical.
  3. Remove IVT control solenoid valve.
  4. Crank engine, and then make sure that engine oil comes out from IVT control cover oil hole. End cranking after checking.

#### WARNING:

Be careful not to touch rotating parts (drive belts, idler pulley, and crankshaft pulley, etc.).

#### CAUTION:

- Engine oil may squirt from IVT control solenoid valve installation hole during cranking. Use a shop cloth to prevent engine oil from splashing on worker, engine components and vehicle.
- Do not allow engine oil to get on rubber components such as drive belts or engine mount insulators. Immediately wipe off any splashed engine oil.

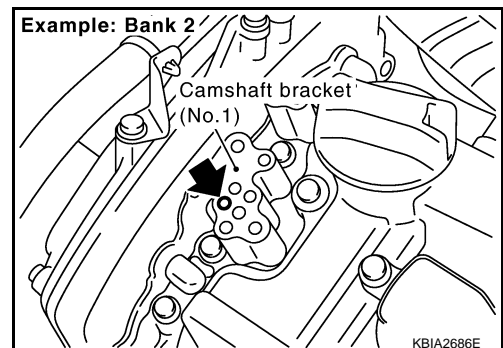

## CAMSHAFT

### < ON-VEHICLE REPAIR >

---

5. Clean oil groove between oil strainer and IVT control solenoid valve if engine oil does not come out from IVT control cover oil hole.
6. Remove components between IVT control solenoid valve and camshaft sprocket (INT), and then check each oil groove for clogging.
  - Clean oil groove if necessary.
7. After inspection, installation of the remaining components is in the reverse order of removal.



# OIL SEAL

< ON-VEHICLE REPAIR >

## OIL SEAL

### Removal and Installation of Valve Oil Seal

INFOID:000000004173784

#### REMOVAL

1. Turn crankshaft until the cylinder requiring new oil seals is at TDC. This will prevent valve from dropping into cylinder.

#### CAUTION:

When rotating crankshaft, be careful to avoid scarring the front cover with the timing chain.

2. Remove camshaft relating to valve oil seal to be removed. Refer to [EM-71, "Removal and Installation"](#).
3. Remove valve lifters. Refer to [EM-71, "Removal and Installation"](#).
4. Remove valve collet, valve spring retainer and valve spring using Tool.

#### CAUTION:

When working, take care not to damage valve lifter holes.

**Tool numbers** : KV10116200 (J-26336-A)  
: KV10115900 (J-26336-20)  
: KV10109220 ( — )

- Compress valve spring using Tool attachment, adapter. Remove valve collet with magnet hand.

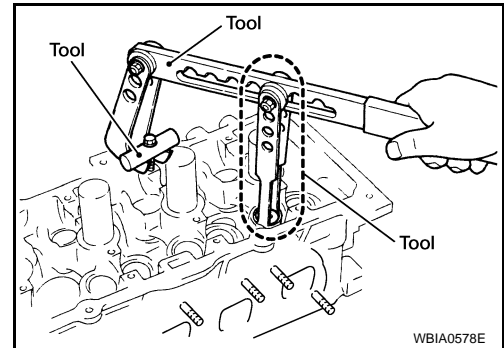

5. Remove valve oil seal using Tool.

**Tool number** : KV10107902 (J-38959)

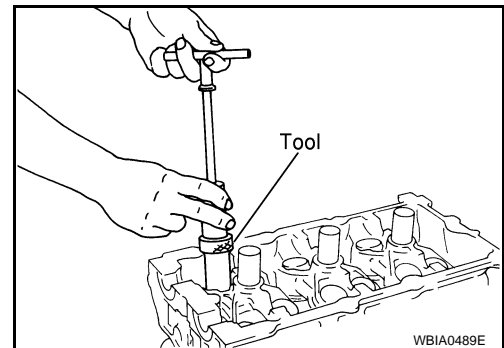

#### INSTALLATION

1. Apply new engine oil to new valve oil seal joint surface and seal lip.
2. Press in valve oil seal to height "H" using Tool to specified height.

**Tool number** : — (J-39386)

#### NOTE:

Dimension "H": height measured before valve spring seat installation.

**Intake and exhaust** : 14.3 - 14.9 mm (0.563 - 0.587 in)

3. Installation of the remaining components is in the reverse order of removal.

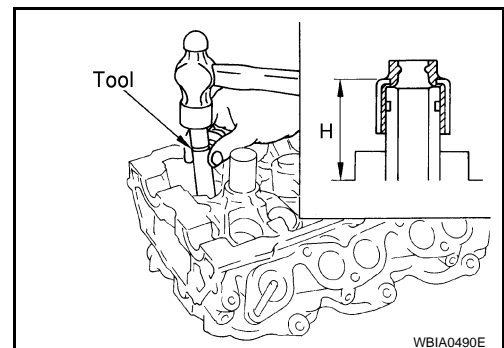

### Removal and Installation of Front Oil Seal

INFOID:000000004173785

#### REMOVAL

1. Remove the following parts:
  - Engine undercover.
  - Drive belts. Refer to [EM-14, "Removal and Installation"](#).

A

EM

C

D

E

F

G

H

I

J

K

L

M

N

O

P

# OIL SEAL

## < ON-VEHICLE REPAIR >

- Radiator fan. Refer to [CO-15. "Removal and Installation"](#).
2. Remove the crankshaft pulley as follows:
    - a. Remove the starter motor. Refer to [STR-15. "Removal and Installation"](#).
    - b. Lock the ring gear using Tool attached to the starter bolt hole.

**Tool number** : KV10117700 (J-44716)

**CAUTION:**

**Do not damage the ring gear teeth, or the signal plate teeth behind the ring gear when setting the stopper.**

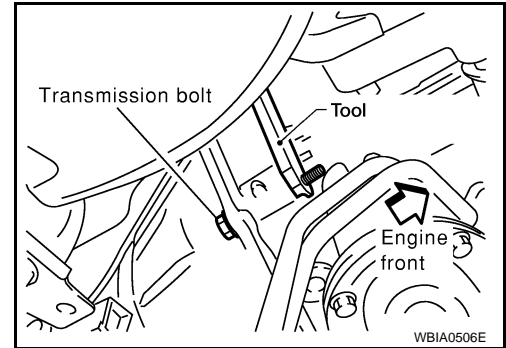

- c. Loosen crankshaft pulley bolt using Tool and locate bolt seating surface at 10 mm (0.39 in) from its original position.

**Tool number** : KV10109300 ( — )

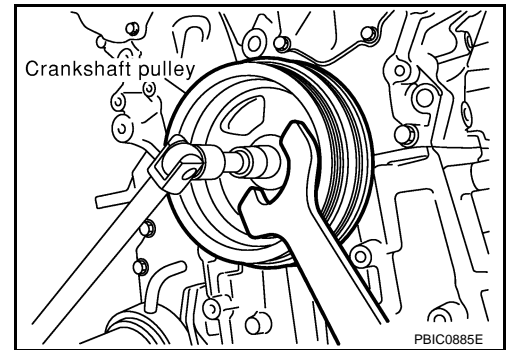

- d. Position a pulley puller at recess hole of crankshaft pulley to remove crankshaft pulley.

**CAUTION:**

**Do not use a puller claw on crankshaft pulley periphery.**

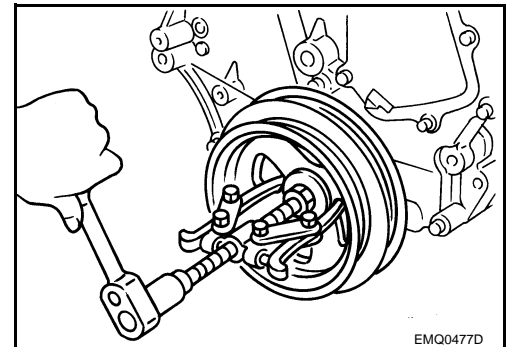

3. Remove front oil seal from front cover.

**CAUTION:**

**Be careful not to damage front cover or crankshaft.**

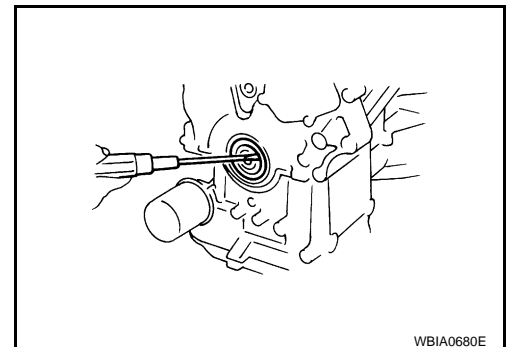

## INSTALLATION

# OIL SEAL

## < ON-VEHICLE REPAIR >

1. Apply new engine oil to new oil seal and install.
  - Install new oil seal in the direction as shown.

**CAUTION:**

**Press fit straight and avoid causing burrs or tilting the oil seal.**

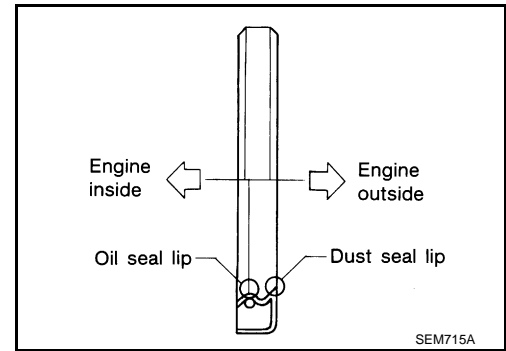

- Press-fit oil seal until it becomes flush with the timing chain case end face, using suitable tool.
- Make sure the garter spring in the oil seal is in position and seal lip is not inverted.

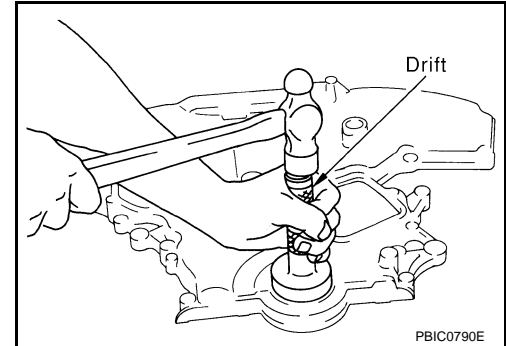

2. Install crankshaft pulley and tighten the bolt in two steps.
  - Lubricate thread and seat surface of the bolt with new engine oil.
  - For the second step angle tighten using Tool.

**Step 1 : 44 N·m (4.5 kg-m, 32 ft-lb)**

**Step 2 : 84° - 90° degrees clockwise**

**Tool number : KV10112100 (BT-8653-A)**

3. Remove Tool attached to the starter bolt hole.

**Tool number : KV10117700 (J-44716)**

4. Installation of the remaining components is in reverse order of removal.

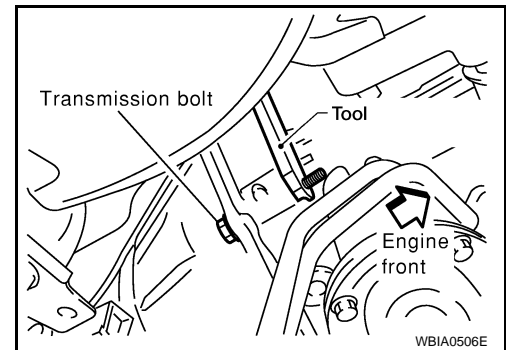

## Removal and Installation of Rear Oil Seal

INFOID:000000004173786

### REMOVAL

1. Remove engine and CVT assembly. Refer to [EM-96, "Removal and Installation"](#).
2. Separate the CVT from the engine assembly. Refer to [TM-180, "Removal and Installation"](#).
3. Remove drive plate. Refer to [EM-119, "Dowel Pin Alignment"](#).
4. Remove rear oil seal retainer using Tool.

# OIL SEAL

< ON-VEHICLE REPAIR >

**Tool Number : KV10111100 (J-37228)**

**CAUTION:**

- Be careful not to damage mating surface.
- If rear oil retainer is removed, replace it with a new one

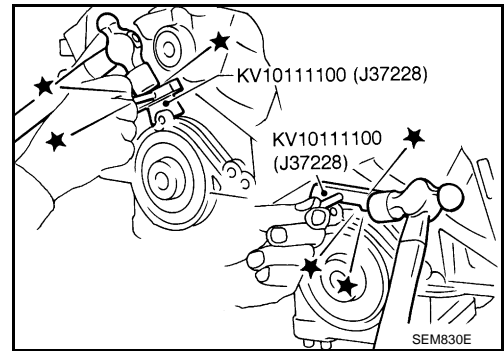

## INSTALLATION

1. Remove old liquid gasket material from mating surface of cylinder block and oil pan using a suitable scraper.
2. Apply liquid gasket to the new rear oil seal retainer using suitable tool.
  - Use Genuine Silicone RTV Sealant or equivalent. Refer to [GI-15, "Recommended Chemical Products and Sealants"](#).
  - Assembly should be completed within 5 minutes after coating.

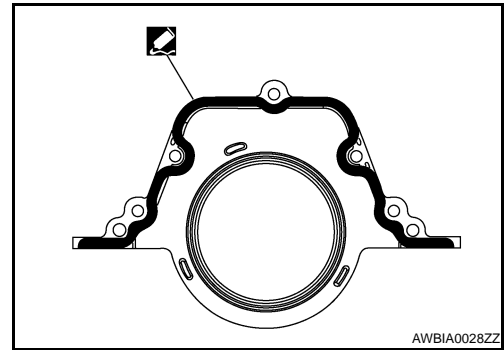

3. Installation is in the reverse order of removal.

**CAUTION:**

- When replacing an engine or transmission you must make sure the dowels are installed correctly during re-assembly.
- Improper alignment caused by missing dowels may cause vibration, oil leaks or breakage of drivetrain components.

# CYLINDER HEAD

< ON-VEHICLE REPAIR >

## CYLINDER HEAD

### Removal and Installation

INFOID:000000004173787

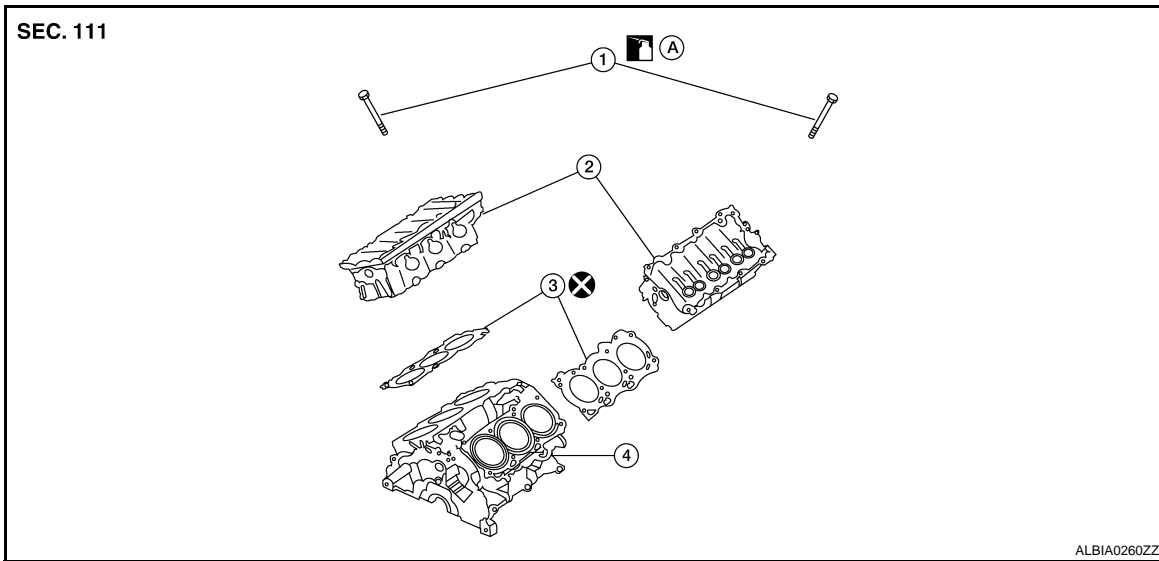

- |                       |                                  |                         |
|-----------------------|----------------------------------|-------------------------|
| 1. Cylinder head bolt | 2. Cylinder head                 | 3. Cylinder head gasket |
| 4. Engine block       | A. Follow installation procedure |                         |

### REMOVAL

1. Remove the intake and exhaust camshafts. Refer to [EM-71, "Removal and Installation"](#).
2. Remove the coolant outlet housing. Refer to [CO-23, "Removal and Installation"](#).
3. Remove the RH and LH cylinder head bolts, with power tool.
  - The bolts should be loosened gradually in three stages.
  - Loosen the bolts in the numerical order as shown.

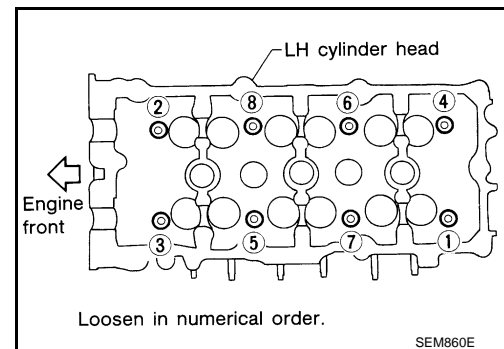
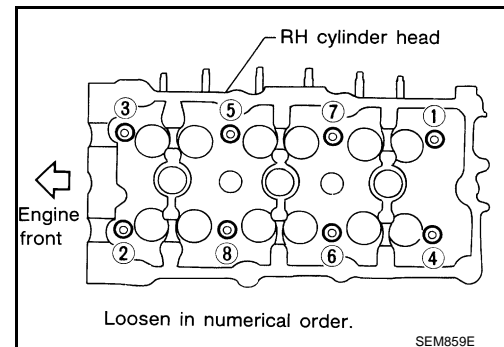

# CYLINDER HEAD

## < ON-VEHICLE REPAIR >

4. Remove cylinder heads and gaskets.
  - Discard the cylinder head gaskets and use new gaskets for installation.

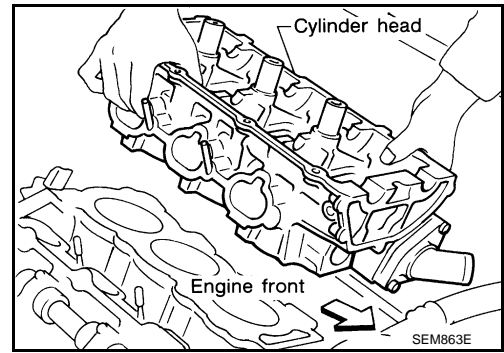

## INSTALLATION

1. Before installing the rear timing chain case, remove the old Silicone RTV Sealant from mating surface using a scraper.
  - Also remove old sealant from mating surface of cylinder block.

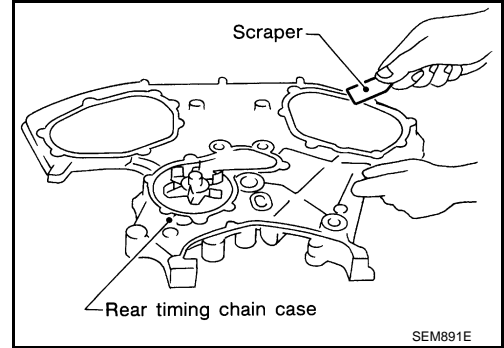

- Remove the old Silicone RTV Sealant from the bolt hole and thread.

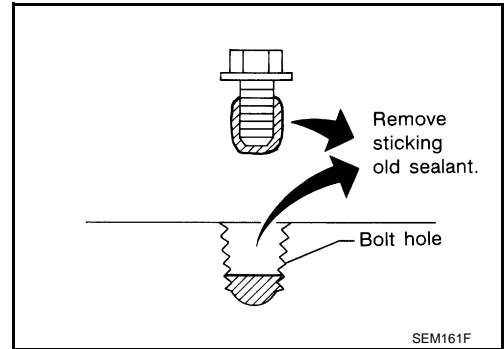

2. Before installing the front cam bracket, remove the old RTV Silicone Sealant from the mating surface using a scraper.
  - Do not scratch the mating surface.

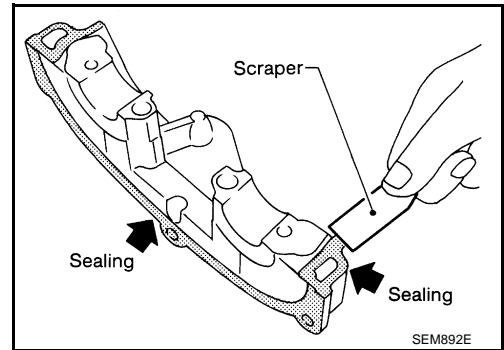

# CYLINDER HEAD

## < ON-VEHICLE REPAIR >

3. Turn the crankshaft until No. 1 piston is set at TDC on the compression stroke.
  - The crankshaft key should line up with the right bank cylinder center line as shown.

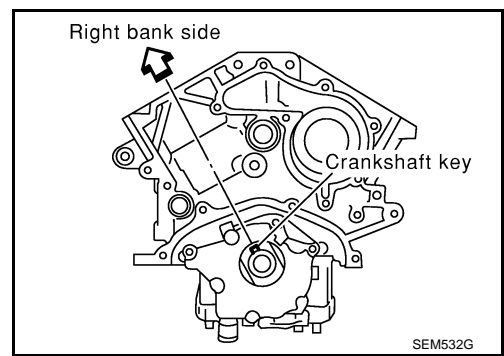

4. Install new gaskets on the cylinder heads.

**CAUTION:**

**Do not rotate crankshaft and camshaft separately or valves will strike piston heads.**

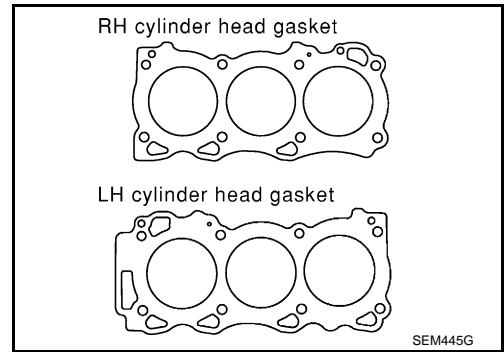

5. Inspect the cylinder head bolts before installing the cylinder heads.

**CAUTION:**

**Cylinder head bolts are tightened by degree rotation tightening method. Whenever the size difference between d1 and d2 exceeds the limit, replace the bolts with new ones.**

**Limit (d1 - d2) : 0.11 mm (0.0043 in)**

- Lubricate threads and seat surfaces of the bolts with new engine oil.

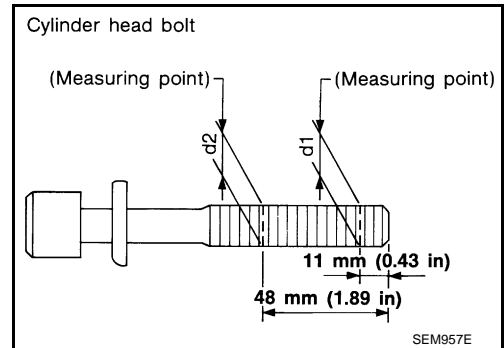

6. Install the cylinder heads on the cylinder block. Tighten the cylinder head bolts in the five steps in the numerical order as shown using Tool.

**Tool Number : KV10112100 (BT-8653-A)**

- Tightening procedure:

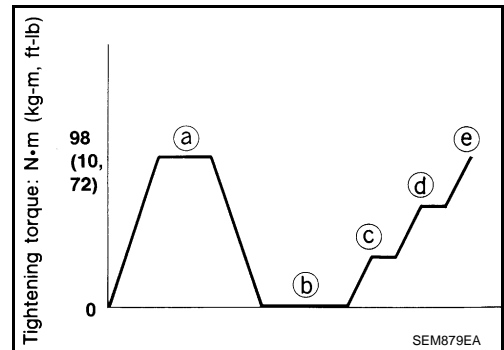

# CYLINDER HEAD

< ON-VEHICLE REPAIR >

## Cylinder head bolts

**Step a** : 98.1 N·m (10 kg-m, 72 ft-lb)

**Step b** : Loosen in the reverse order of tightening

**Step c** : 32.9 N·m (4.0 kg-m, 29 ft-lb)

**Step d** : 103° degrees rotation clockwise

**Step e** : 103° degrees rotation clockwise

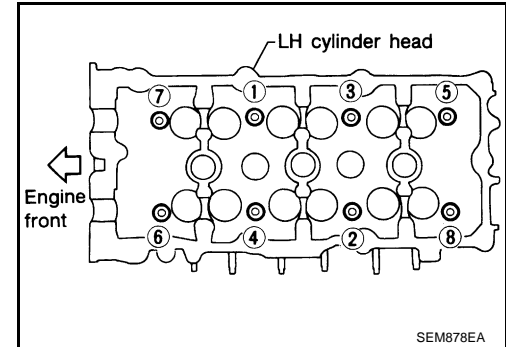
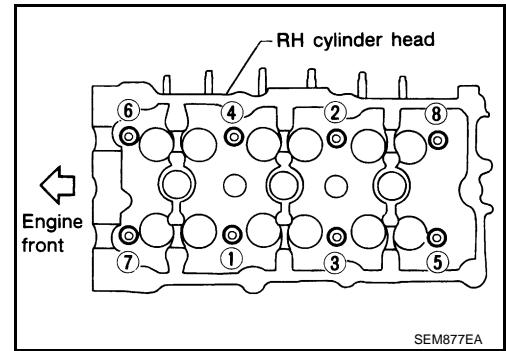

7. Installation of the remaining components is in the reverse order of removal.



# CYLINDER HEAD

< ON-VEHICLE REPAIR >

## Disassembly and Assembly

INFOID:000000004173788

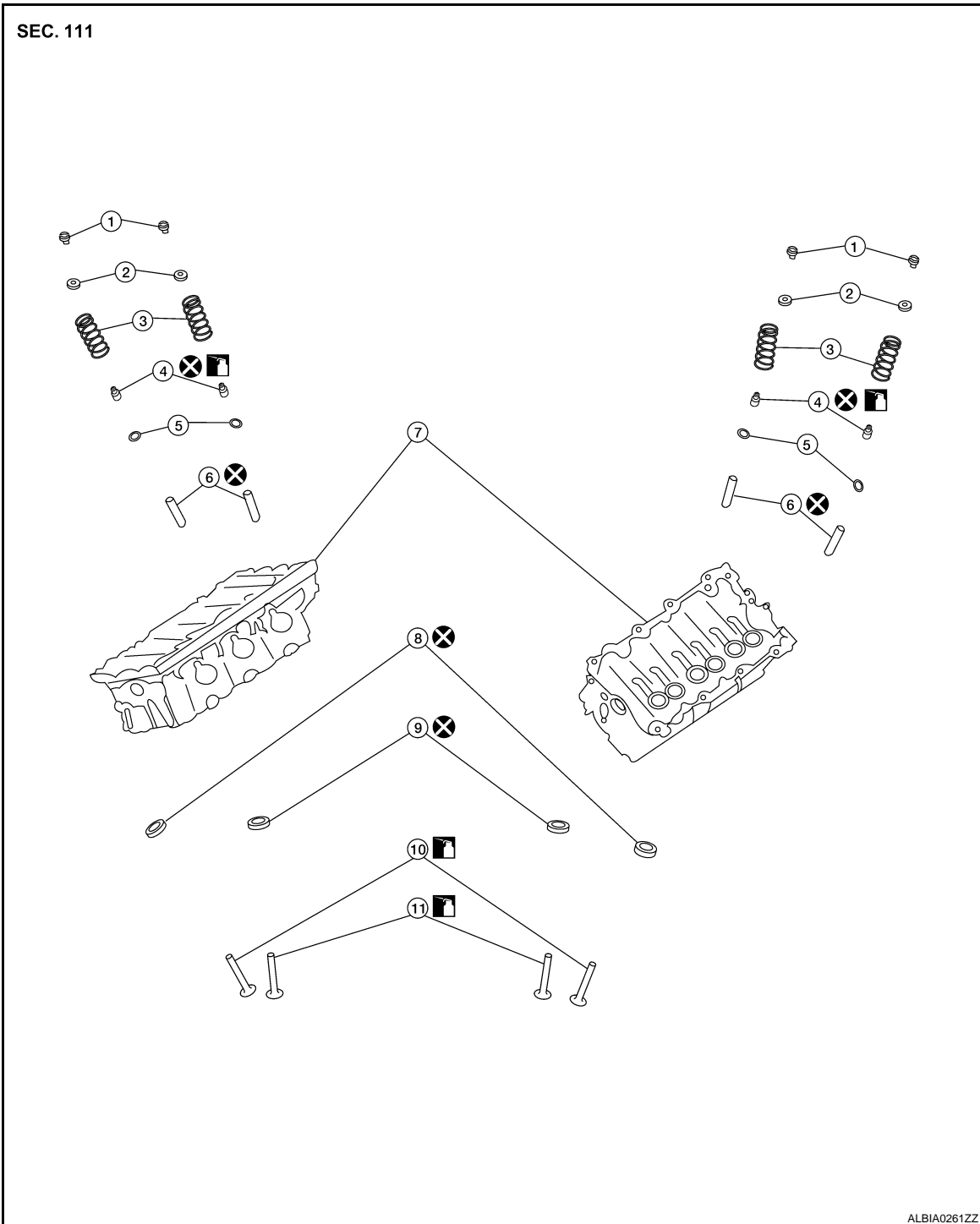

- |                   |                          |                     |
|-------------------|--------------------------|---------------------|
| 1. Valve collet   | 2. Valve spring retainer | 3. Valve spring     |
| 4. Valve oil seal | 5. Valve spring seat     | 6. Valve guide      |
| 7. Cylinder head  | 8. Valve seat (EXH)      | 9. Valve seat (INT) |
| 10. Valve (EXH)   | 11. Valve (INT)          |                     |

### CAUTION:

- When installing camshafts, chain tensioners, oil seals, or other sliding parts, lubricate contacting surfaces with new engine oil.
- Apply new engine oil to threads and seat surface when installing cylinder head, camshaft sprocket, crankshaft pulley, and camshaft bracket.
- Attach tags to valve lifters so as not to mix them up.

A  
EM  
C  
D  
E  
F  
G  
H  
I  
J  
K  
L  
M  
N  
O  
P

# CYLINDER HEAD

< ON-VEHICLE REPAIR >

## DISASSEMBLY

1. Remove spark plug.
2. Remove valve lifter.
  - Identify installation positions, and store them without mixing them up.
3. Remove valve collet.
  - Compress valve spring and remove valve collet with magnet hand using Tool.

**CAUTION:**

**When working, take care not to damage valve lifter holes.**

**Tool numbers** : KV10109220 ( — )  
: KV10116200 (J-26336-A)  
: KV10115900 (J-26336-20)

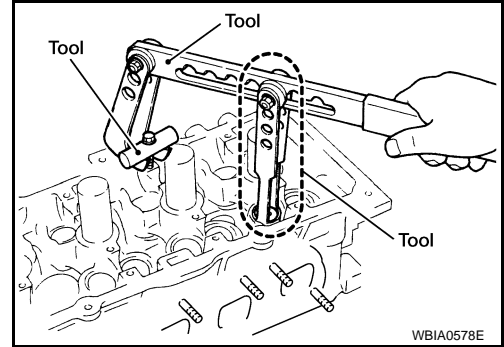

4. Remove valve spring retainer, valve spring and valve spring seat.
5. Push valve stem to combustion chamber side, and remove valve.
  - Identify installation positions, and store them without mixing them up.
6. Remove valve oil seals using Tool.

**Tool number** : KV10107902 (J-38959)

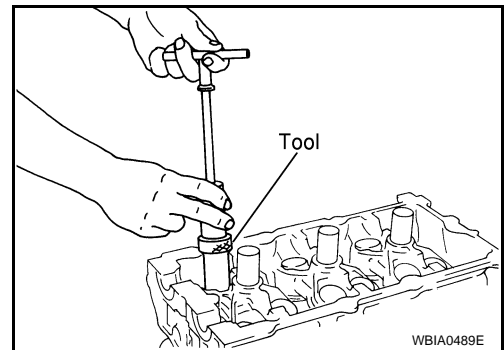

7. If valve seat must be replaced, refer to [EM-91, "Inspection After Disassembly"](#).
8. If valve guide must be replaced, refer to [EM-91, "Inspection After Disassembly"](#).
9. Remove spark plug tube, as necessary.

- Using pair of pliers, pull spark plug tube out of cylinder head.

**CAUTION:**

- Take care not to damage cylinder head.
- Once removed, spark plug tube will be deformed and cannot be reused. Do not remove it unless absolutely necessary.

## ASSEMBLY

1. When valve guide is removed, install it. Refer to [EM-91, "Inspection After Disassembly"](#).
2. When valve seat is removed, install it. Refer to [EM-91, "Inspection After Disassembly"](#).
3. Install valve oil seals using Tool.

**Tool number** : — (J-39386)

**Height "H" (Without valve spring seat installed)**

**Intake and exhaust** : 14.3 - 14.9 mm (0.563 - 0.587 in)

4. Install valve spring seat.
5. Install valves.
  - Install it in the original position.

**NOTE:**

Larger diameter valves are for intake side.

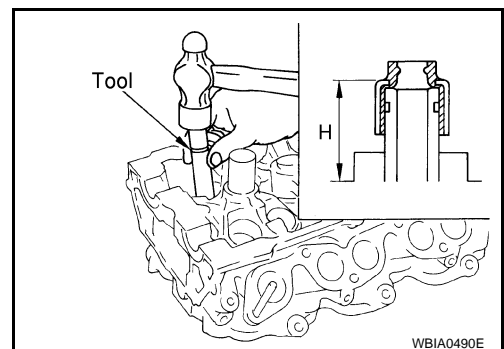

# CYLINDER HEAD

## < ON-VEHICLE REPAIR >

6. Install valve spring (uneven pitch type) with narrow pitch end (paint mark) to cylinder head side (valve spring seat side).

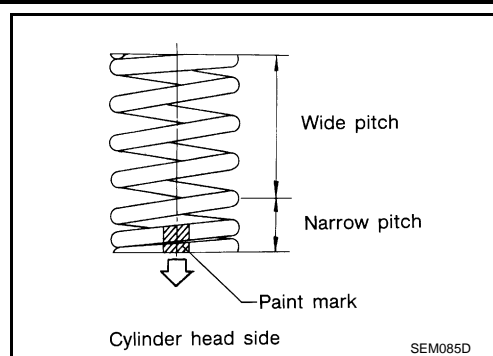

7. Install valve spring retainer.  
8. Install valve collet.  
• Compress valve spring with valve spring compressor, attachment and adapter using Tool. Install valve collet with magnet hand.  
**CAUTION:**  
**When working, take care not to damage valve lifter holes.**  
• Tap valve stem edge lightly with plastic hammer after installation to check its installed condition.

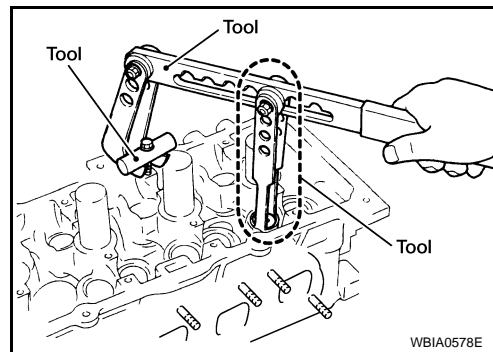

**Tool numbers** : KV10109220 ( — )  
: KV10116200 (J-26336-A)  
: KV10115900 (J-26336-20)

9. Install valve lifter.  
• Install it in the original position.  
10. Install spark plug tube.  
• Press-fit spark plug tube as follows:  
a. Remove old liquid gasket adhering to cylinder head mounting hole.  
b. Apply sealant to area within approximately 12 mm (0.47 in) from edge of spark plug tube press-fit side.  
**Use Genuine High Strength Locking Sealant or equivalent. Refer to [GI-15, "Recommended Chemical Products and Sealants"](#).**  
c. Press-fit spark plug tube so that its height "H" is as specified in using suitable drift.

**Press-fit height "H"** : 37.7 - 38.7 mm (1.484 - 1.529 in)

### **CAUTION:**

- **When press-fitting, take care not to deform spark plug tube.**
  - **After press-fitting, wipe off liquid gasket protruding onto cylinder-head upper face.**
11. Install spark plug.

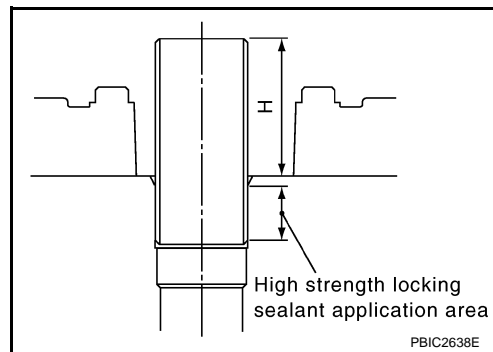

INFOID:000000004173789

## Inspection After Disassembly

### CYLINDER HEAD DISTORTION

Clean the surface of the cylinder head. Use a reliable straightedge and feeler gauge to check the flatness of cylinder head surface.

# CYLINDER HEAD

## < ON-VEHICLE REPAIR >

Check along six positions as shown.

### Head surface distortion

Limit	: 0.1 mm (0.004 in)
Standard	: Less than 0.03 mm (0.0012 in)

If beyond the specified limit, resurface or replace it.

**The limit for cylinder head resurfacing is determined by the cylinder block resurfacing.**

### Resurfacing Limit

Amount of cylinder head resurfacing is "A".

Amount of cylinder block resurfacing is "B".

The maximum limit :  $A + B = 0.2 \text{ mm (0.008 in)}$

After resurfacing cylinder head, check that camshaft rotates freely by hand. If resistance is felt, cylinder head must be replaced.

**Nominal cylinder head height : 126.3 - 126.5 mm (4.972 - 4.980 in)**

## VALVE GUIDE CLEARANCE

1. Measure valve deflection as shown. (Valve and valve guide mostly wear in this direction.)

### Valve deflection limit (dial gauge reading)

Intake	: 0.24 mm (0.0094 in)
Exhaust	: 0.28 mm (0.0110 in)

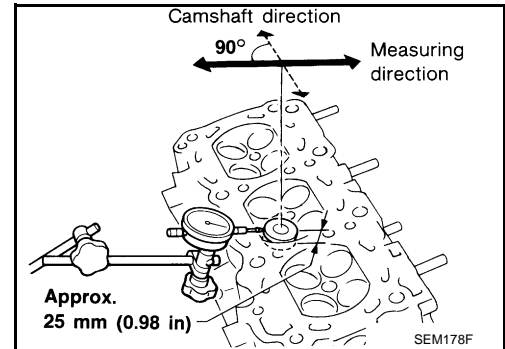

2. If it exceeds the limit, check valve to valve guide clearance.
  - a. Measure valve stem diameter and valve guide inner diameter. Refer to [EM-124, "Cylinder Head"](#).
  - b. Check that clearance is within specification.  
(Valve guide clearance) = (Valve guide inner diameter) - (Valve stem diameter)

### Valve to valve guide clearance standard

Intake	: 0.020 - 0.053 mm (0.0008 - 0.0021 in)
Exhaust	: 0.040 - 0.073 mm (0.0016 - 0.0029 in)

### Valve to valve guide clearance limit

Intake	: 0.08 mm (0.0031 in)
Exhaust	: 0.1 mm (0.004 in)

- c. If it exceeds the limit, replace valve or valve guide.

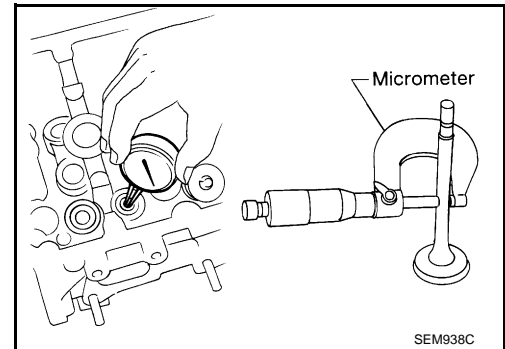

## VALVE GUIDE REPLACEMENT

When valve guide is removed, replace with oversized [0.2 mm (0.008 in)] valve guide.

# CYLINDER HEAD

## < ON-VEHICLE REPAIR >

1. To remove valve guide, heat cylinder head to 110° to 130°C (230° to 266°F) by soaking in heated oil.

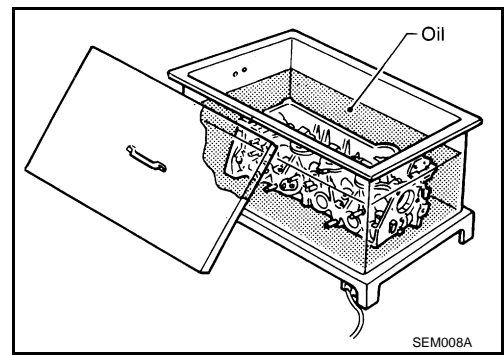

2. Drive out the valve guide with a press [under a 20 kN (2.2 US ton) pressure] or hammer and suitable tool.

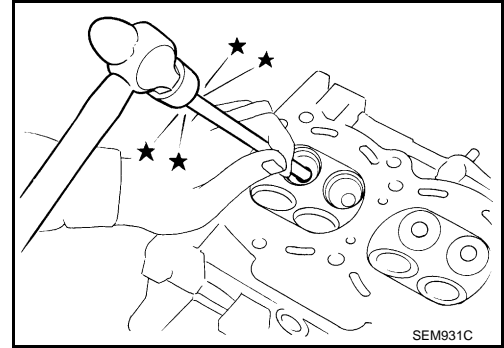

3. Ream cylinder head valve guide hole.

**Valve guide hole diameter : 10.175 - 10.196 mm  
(for service parts), intake (0.4006 - 0.4014 in)  
and exhaust**

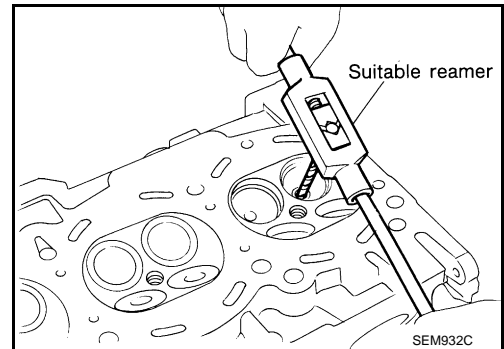

4. Heat cylinder head to 110° to 130°C (230° to 266°F) by soaking in heated oil and press new valve guide from camshaft side into the cylinder head to the dimensions as shown.

**Projection "L" : 12.6 - 12.8 mm (0.496 - 0.504 in)**

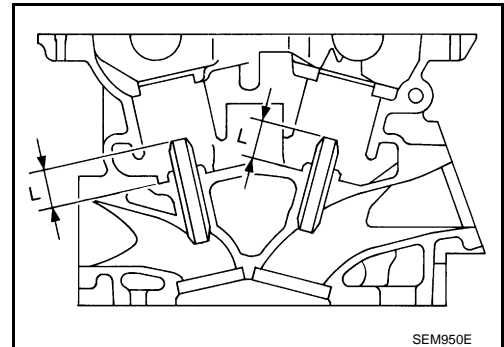

A  
EM  
C  
D  
E  
F  
G  
H  
I  
J  
K  
L  
M  
N  
O  
P

# CYLINDER HEAD

## < ON-VEHICLE REPAIR >

- Using a valve guide reamer, apply a reamer finish to the valve guide.

**Intake and exhaust finished size : 6.000 - 6.018 mm (0.2362 - 0.2369 in)**

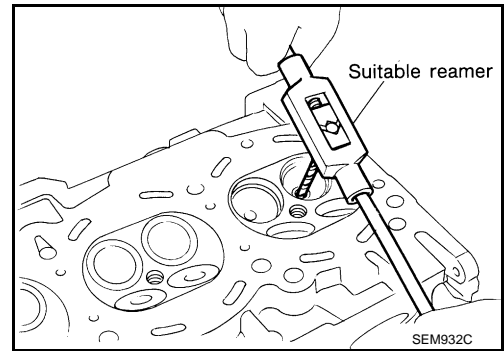

## VALVE SEAT CONTACT

- After confirming that the dimensions of valve guides and valves are within specifications, perform this procedure.
- Apply prussian blue onto contacting surface of valve seat to check the condition of the valve contact on the surface.
- Check if the contact area band is continuous all around the circumference.
- If not, grind to adjust valve fitting and check again. If the contacting surface still has N.G conditions even after the re-check, replace valve seat.

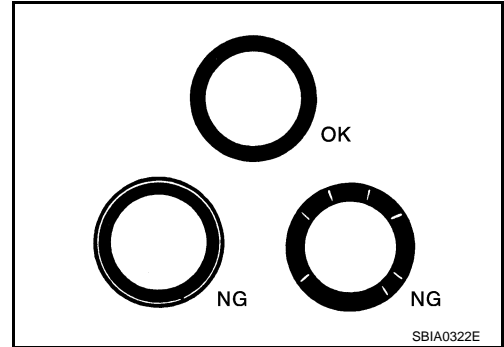

## VALVE SEAT REPLACEMENT

- Bore out old seat until it collapses. Boring should not continue beyond the bottom face of the seat recess in cylinder head. Set the machine depth stop to ensure this.
- Ream cylinder head recess for service valve seat.

**Oversize : 0.5 mm (0.020 in)**  
**Intake : 38.500 - 38.516 mm (1.5157 - 1.5164 in)**  
**Exhaust : 32.100 - 32.116 mm (1.2638 - 1.2644 in)**

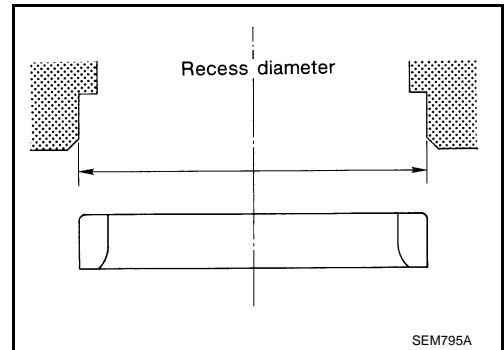

**Be sure to ream in circles concentric to the valve guide center.**

**This will enable valve seat to fit correctly.**

- Heat cylinder head to 110° to 130°C (230° to 266°F) by soaking in heated oil.
- Press fit valve seat until it seats on the bottom.
- Cut or grind valve seat using suitable tool to the specified dimensions. Refer to [EM-124. "Cylinder Head"](#).
- After cutting, lap valve seat with abrasive compound.
- Check valve seating condition.

**Seat face angle "α" : 45° 15' - 45° 45' degrees/minutes**  
**Contacting width "W" for intake : 1.18 - 1.22 mm (0.0465 - 0.0480 in)**  
**Contacting width "W" for exhaust : 1.38 - 1.42 mm (0.0543 - 0.0559 in)**

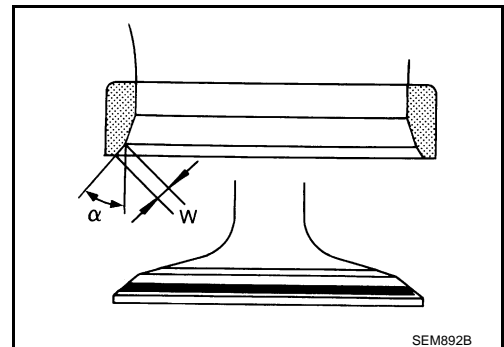

# CYLINDER HEAD

## < ON-VEHICLE REPAIR >

8. Use a depth gauge to measure the distance between the mounting surface of the cylinder head spring seat and the valve stem end. If the distance is shorter than specified, repeat step 5 to adjust it. If it is longer, replace the valve seat with a new one.

<b>Valve seat resurface limit "L" intake</b>	<b>: 41.16 - 41.76 mm (1.6205 - 1.6441 in)</b>
<b>Valve seat resurface limit "L" exhaust</b>	<b>: 41.09 - 41.69 mm (1.6177 - 1.6413 in)</b>

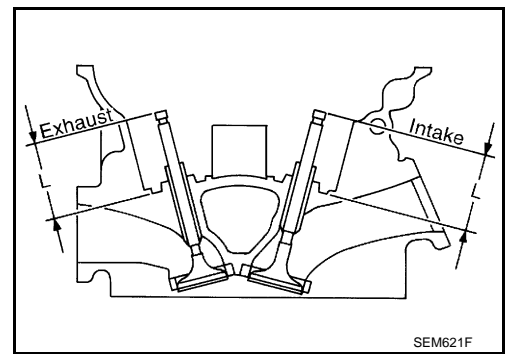

## VALVE SPRING SQUARENESS

Set try square along the side of valve spring and rotate the spring. Measure the maximum clearance between the top face of spring and try square.

<b>Out-of-square limit</b>	<b>: Less than 2.0 mm (0.079 in)</b>
----------------------------	--------------------------------------

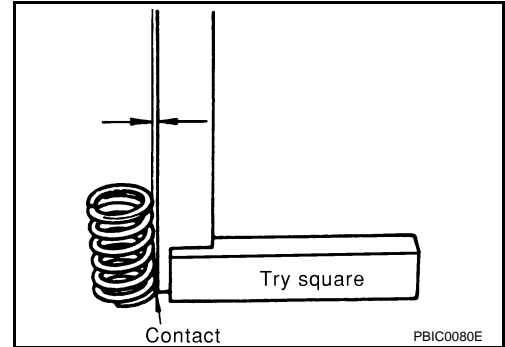

## VALVE SPRING DIMENSIONS AND VALVE SPRING PRESSURE LOAD

Check valve spring pressure at specified spring height.

<b>Standard</b>	<b>: 166 - 188 N (16.9 - 19.2 kg, 37.3 - 42.3 lb) at height 37.0 mm (1.457 in)</b>
<b>Limit</b>	<b>: 373 - 421 N (38.0 - 42.9 kg, 84 - 95 lb) at height 27.2 mm (1.071 in)</b>

If it is not within specifications, replace the spring.

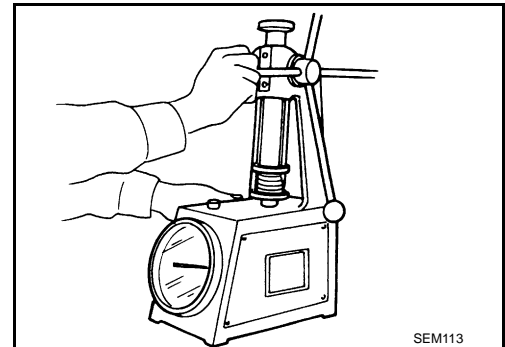

A  
EM  
C  
D  
E  
F  
G  
H  
I  
J  
K  
L  
M  
N  
O  
P

# ENGINE ASSEMBLY

< REMOVAL AND INSTALLATION >

## REMOVAL AND INSTALLATION

### ENGINE ASSEMBLY

#### Removal and Installation

INFOID:000000004173790

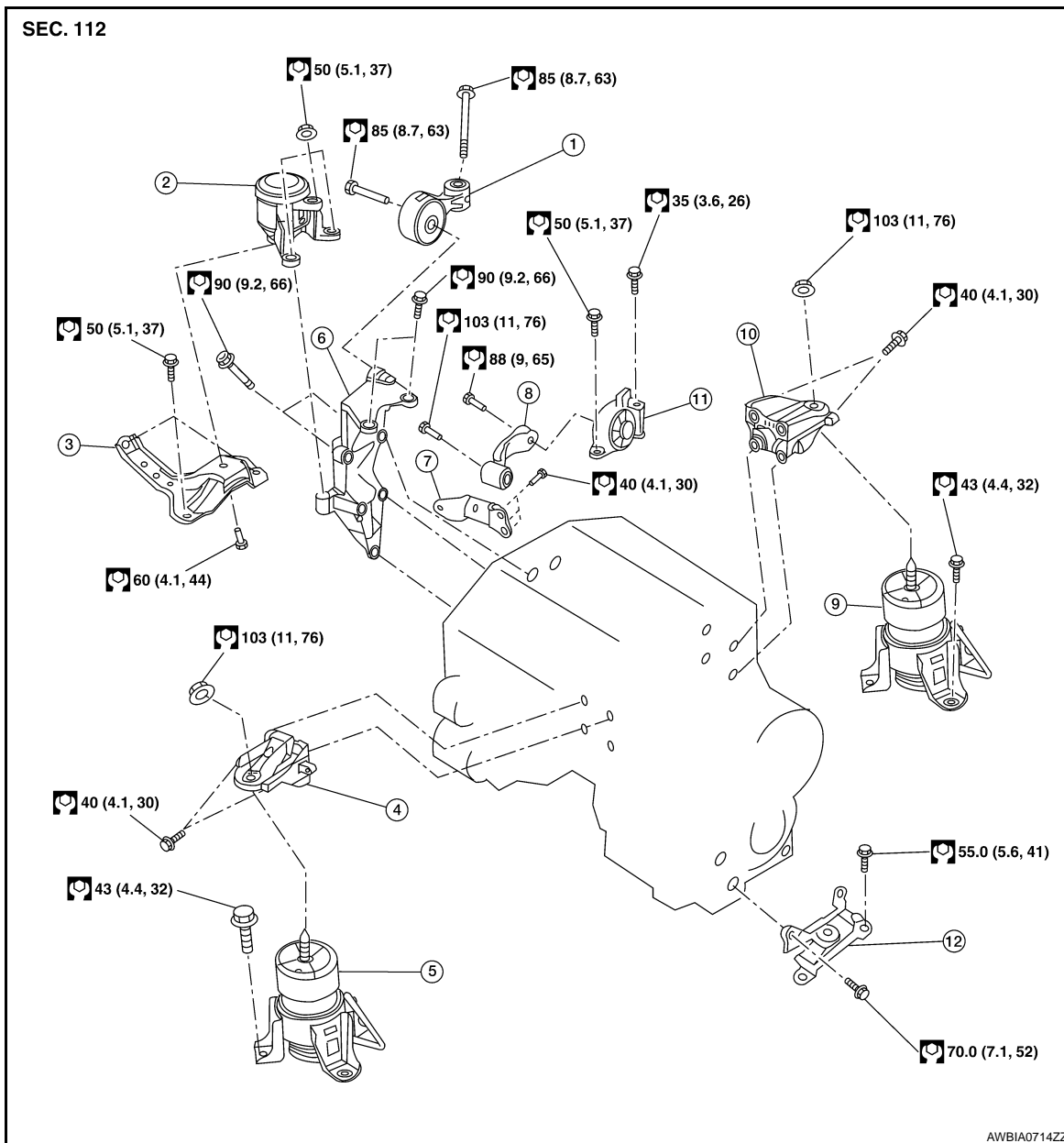

- |                               |                                 |                                  |
|-------------------------------|---------------------------------|----------------------------------|
| 1. Torque rod                 | 2. RH engine mount insulator    | 3. RH engine mount support       |
| 4. Front engine mount bracket | 5. Front engine mount insulator | 6. RH engine mount bracket       |
| 7. Lower torque rod bracket   | 8. Lower torque rod             | 9. Rear engine mount insulator   |
| 10. Rear engine mount bracket | 11. Rear lower insulator        | 12. LH transaxle mount insulator |

#### WARNING:

- Place chocks at front and back of rear wheels.
- For engines not equipped with engine slingers, attach proper slingers and bolts as described in the NISSAN Parts Catalog.

#### CAUTION:

- Do not start working until exhaust system and coolant are cool.
- If items or work required are not covered by the engine main body section, follow the applicable procedures.



# ENGINE ASSEMBLY

## < REMOVAL AND INSTALLATION >

- Use the correct supporting points for lifting and jacking. Refer to [GI-30, "Garage Jack and Safety Stand"](#).
- In removing the drive shafts, be careful not to damage any transaxle grease seals.
- Before separating the engine and transaxle, remove the crankshaft position sensor (POS).
- Do not damage the edge of the crankshaft position sensor (POS) or the ring gear teeth.

### REMOVAL

1. Release fuel pressure. Refer to [EC-559, "Inspection"](#).
2. Drain coolant. Refer to [CO-10, "Changing Engine Coolant"](#).
3. Drain power steering fluid. Refer to [ST-13, "Draining"](#).
4. Drain transaxle fluid. Refer to [TM-153, "Changing"](#).
5. Remove the engine cover, and the engine undercover using power tool.
6. Remove front air inlet duct.
7. Remove air intake duct and air cleaner case assembly with mass air flow sensor.
8. Remove battery. Refer to [PG-66, "Removal and Installation \(Battery\)"](#).
9. Remove ECM.
10. Remove transmission control module.
11. Remove battery ground cable with current sensor.
12. Remove battery tray and bracket. Refer to [PG-67, "Removal and Installation \(Battery Tray\)"](#).
13. Remove strut bar using power tools.
14. Remove cowl top extension. Refer to [EXT-18, "Removal and Installation"](#).
15. Remove IPDM E/R.
16. Remove upper radiator hose.
17. Disconnect CVT cooler hoses.
18. Disconnect fuel hose quick connection at vehicle piping side. Refer to [EM-40, "Removal and Installation"](#).
19. Disconnect evap vacuum hose.
20. Disconnect heater hoses (engine side).
21. Remove coolant reservoir tank.
22. Disconnect transaxle shift control cables.
23. Remove lower radiator hose.
24. Disconnect brake booster vacuum hose.
25. Remove power steering reservoir.
26. Remove engine mount stay.
27. Remove RH upper engine mount insulator.
28. Remove LH insulator nut.
29. Remove the cooling fan assembly. Refer to [CO-15, "Removal and Installation"](#).
30. Discharge and recover the R134a refrigerant. Refer to [HA-34, "Collection and Charge"](#).
31. Remove the front drive shafts. Refer to [FAX-10, "Removal and Installation \(Left Side\)"](#) and [FAX-11, "Removal and Installation \(Right Side\)"](#).
32. Remove the front exhaust tube using power tools. Refer to [EX-5, "Removal and Installation"](#).
33. Remove the A/C compressor using power tools. Refer to [HA-44, "Removal and Installation for Compressor"](#).

# ENGINE ASSEMBLY

## < REMOVAL AND INSTALLATION >

34. Install engine slingers into front of LH cylinder head and rear of RH cylinder head.

- (A): RH cylinder head

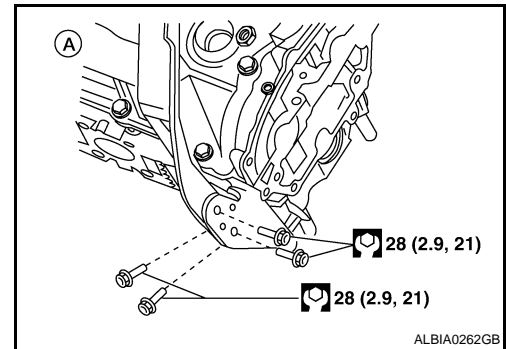

- (B): LH cylinder head

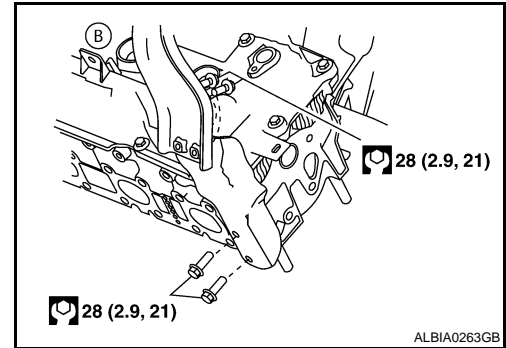

35. Remove rear cover plate.

36. Remove the torque converter bolts.

37. Disconnect engine mount vacuum hoses.

38. Position a suitable support table under suspension member and engine assembly.

39. Disconnect the LH transaxle mount and the RH engine mount.

40. For additional safety, secure the engine in position with suitable tool.

41. Remove suspension member bolts. Refer to [FSU-14. "Removal and Installation"](#).

42. Carefully lower the engine, transaxle assembly and suspension member using Tool, avoiding interference with the vehicle body.

### **CAUTION:**

- **Before and during this procedure, always check if any harnesses are left connected.**
- **Avoid any damage to, or any oil/grease smearing or spills onto the engine mount insulators.**

**Tool number** : KV101J0010 (J-47242)

43. Remove the starter motor. Refer to [STR-15. "Removal and Installation"](#).

44. Remove the crankshaft position sensor (POS).

45. Remove engine and transaxle harness.

46. Separate the engine and transaxle and mount the engine on a suitable engine stand.

47. Drain engine oil. Refer to [LU-8. "Changing Engine Oil"](#).

## INSTALLATION

Installation is in the reverse order of removal.

### **NOTE:**

Tighten transmission bolts to specification. Refer to [TM-180. "Removal and Installation"](#).

## INSPECTION AFTER INSTALLATION

- Before starting engine, check the levels of engine coolant, engine oil and working fluid. If less than required quantity, fill to the specified level.
- Use procedure below to check for fuel leakage.
- Turn ignition switch ON (with engine stopped). With fuel pressure applied to fuel piping, check for fuel leakage at connection points.
- Start engine. With engine speed increased, check again for fuel leakage at connection points.

# ENGINE ASSEMBLY

## < REMOVAL AND INSTALLATION >

- Run engine to check for unusual noise and vibration.
- Warm up engine thoroughly to make sure there is no leakage of engine coolant, engine oil, working fluid, fuel and exhaust gas.
- Bleed air from passages in pipes and tubes of applicable lines, such as in cooling system.
- After cooling down engine, again check amounts of engine coolant, engine oil and working fluid. Refill to specified level, if necessary.
- Summary of the inspection items:

Item	Before starting engine	Engine running	After engine stopped
Engine coolant	Level	Leakage	Level
Engine oil	Level	Leakage	Level
Working fluid	Level	Leakage	Level
Fuel	Leakage	Leakage	Leakage
Exhaust gas	—	Leakage	—

\*Transmission/transaxle/CVT fluid, power steering fluid, brake fluid, etc.

A

EM

C

D

E

F

G

H

I

J

K

L

M

N

O

P

# CYLINDER BLOCK

< DISASSEMBLY AND ASSEMBLY >

## DISASSEMBLY AND ASSEMBLY

### CYLINDER BLOCK

Disassembly and Assembly

INFOID:000000004173791

SEC. 110 • 120 • 226

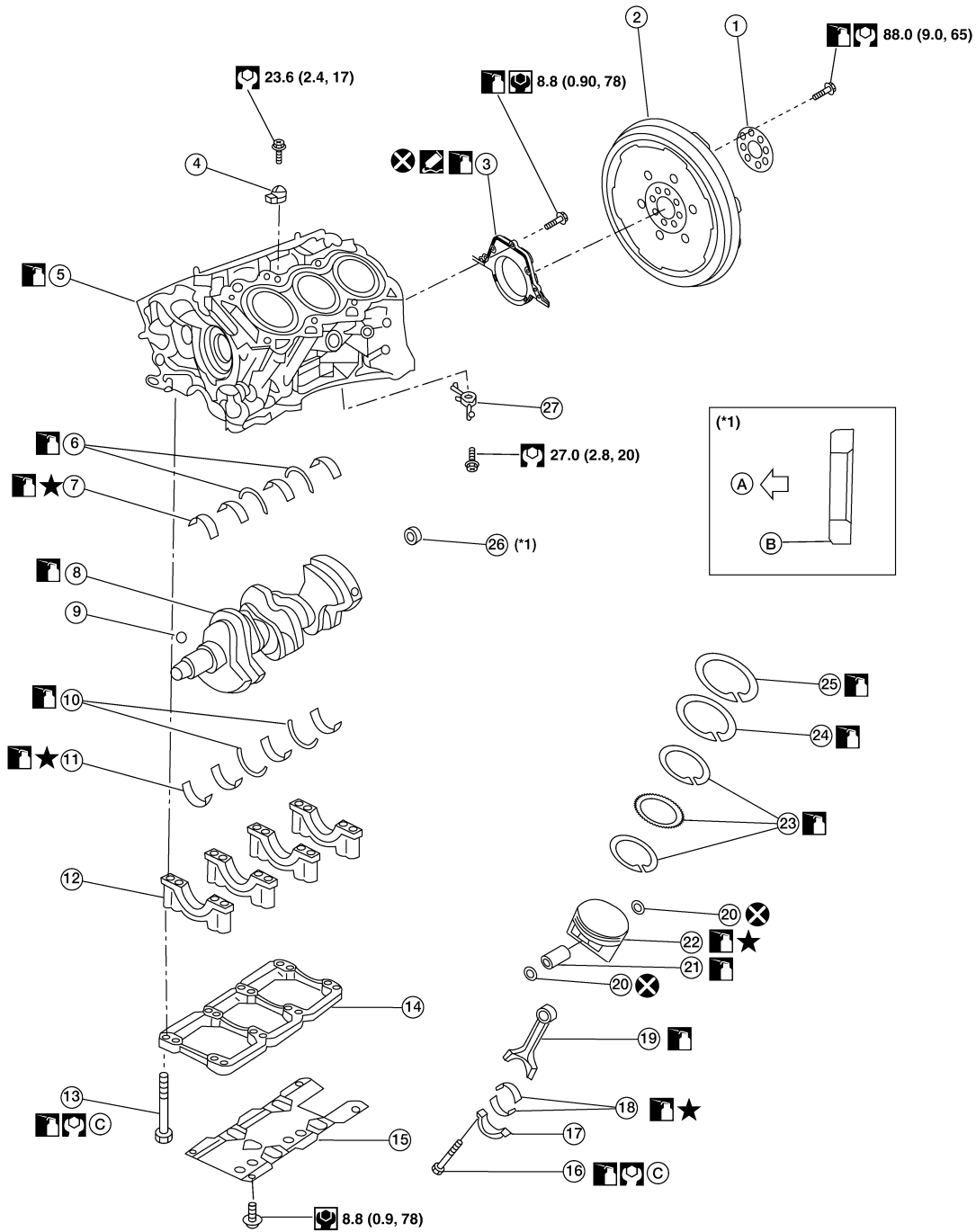

- |                                    |                   |                           |
|------------------------------------|-------------------|---------------------------|
| 1. Drive plate reinforcement       | 2. Drive plate    | 3. Rear oil seal retainer |
| 4. Knock sensor upper main bearing | 5. Cylinder block | 6. Thrust bearing (upper) |
| 7. Main bearing (upper)            | 8. Crankshaft     | 9. Crankshaft key         |

EM-100

AWBIA0220GB

# CYLINDER BLOCK

## < DISASSEMBLY AND ASSEMBLY >

- |                            |                                |                                  |
|----------------------------|--------------------------------|----------------------------------|
| 10. Thrust bearing (lower) | 11. Main bearing (lower)       | 12. Main bearing cap             |
| 13. Main bearing cap bolt  | 14. Main bearing beam          | 15. Baffle plate                 |
| 16. Connecting rod bolt    | 17. Connecting rod bearing cap | 18. Connecting rod bearing       |
| 19. Connecting rod         | 20. Snap ring                  | 21. Piston pin                   |
| 22. Piston                 | 23. Oil ring                   | 24. Second ring                  |
| 25. Top ring               | 26. Pilot converter            | 27. Oil jet                      |
| A. Crankshaft side         | B. Chamfered                   | C. Follow installation procedure |

### CAUTION:

- Apply new engine oil to parts as marked in illustrations before installation.
- Place removed parts such as bearings and bearing caps in their proper order and direction.
- When installing the connecting rod nuts, and main bearing cap bolts, apply new engine oil to the threads and mating surfaces
- Do not allow any magnetic materials to contact the signal plate teeth on the drive plate.

### DISASSEMBLY

1. Remove the engine assembly. Refer to [EM-96, "Removal and Installation"](#).
2. Install the engine on engine stand.
3. Remove the knock sensor.

### CAUTION:

Carefully handle sensor avoiding shocking it.

4. Drain the engine of all coolant and oil.
5. Remove the oil pan. Refer to [EM-33, "Removal and Installation"](#).
6. Remove the timing chain. Refer to [EM-57, "Removal"](#).
7. Remove the cylinder head. Refer to [EM-85, "Removal and Installation"](#).
8. Remove drive plate. Refer to [EM-119, "Dowel Pin Alignment"](#).
9. Remove pilot converter.

**Tool number** : ST16610001 (J-23907)

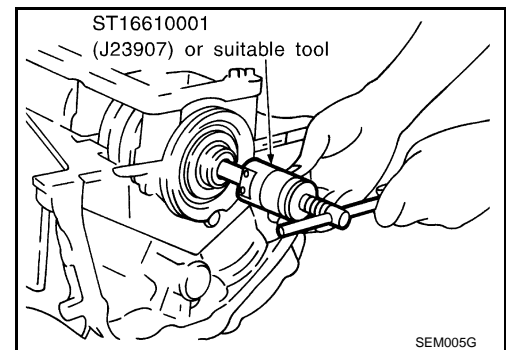

10. Cut away liquid gasket and remove rear oil seal retainer using Tool. Refer to [EM-4, "Precaution for Liquid Gasket"](#).

**Tool number** : KV10111100 (J-37228)

### CAUTION:

- Be careful not to damage mounting surface.
- If rear oil seal retainer is removed, replace it with a new one.

### NOTE:

Rear oil seal and retainer form a single part and are handled as an assembly.

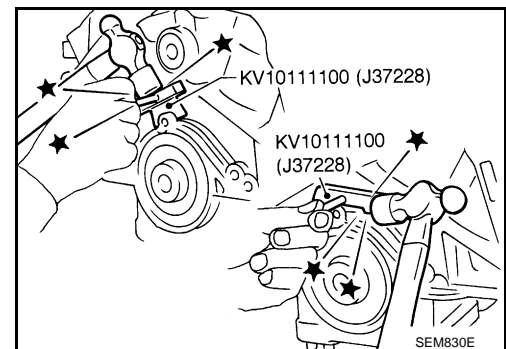

## CYLINDER BLOCK

### < DISASSEMBLY AND ASSEMBLY >

11. Remove the piston and connecting rod assemblies.
  - a. Position the crankshaft pin corresponding to the connecting rod to be removed onto the bottom dead center.
  - b. Remove the connecting rod cap.
  - c. Using a hammer handle or similar tool, push the piston and connecting rod assembly out to the cylinder head side.
    - Before removing the piston and connecting rod assembly, check the connecting rod side clearance. Refer to [EM-131, "Connecting Rod Bearing"](#).

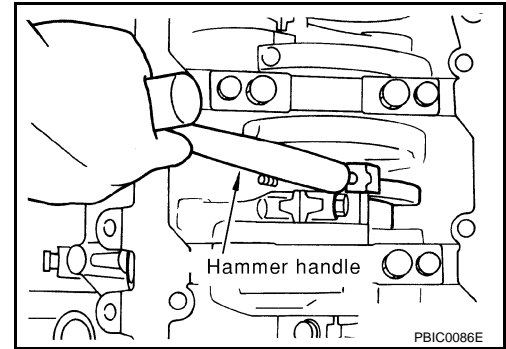

12. Remove the connecting rod bearings.

**CAUTION:**

- When removing the connecting rod side bearings, note the installation position. Keep them in the correct order.

13. Remove the piston rings from the piston.

- Use a piston ring expander.

**CAUTION:**

- When removing the piston rings, be careful not to damage the piston. Do not expand the rings excessively.
  - Be careful to mark the rings if they are to be reused so they are installed in their original position.
- Before removing the piston rings, check the piston ring side clearance. Refer to [EM-109, "Inspection"](#).

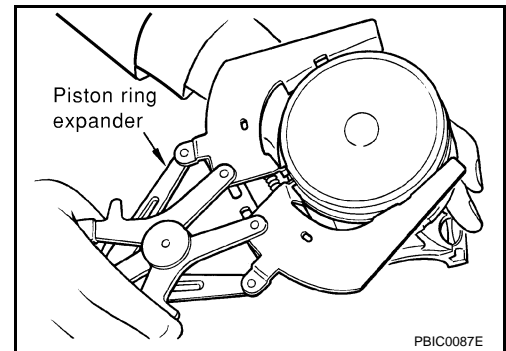

14. Remove the piston from the connecting rod as follows.

- a. Using a snap ring pliers, remove the snap ring.

**CAUTION:**

- Do not reuse snap rings, always replace with new ones.**

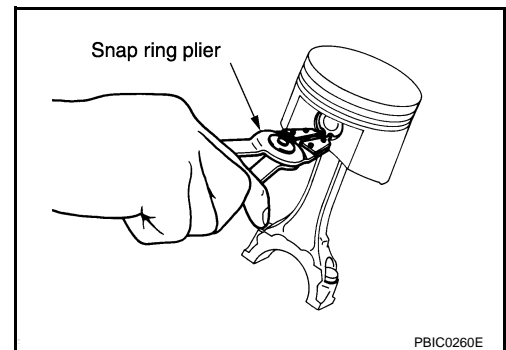

- b. Heat the pistons to 60° - 70°C (140° - 158°F).

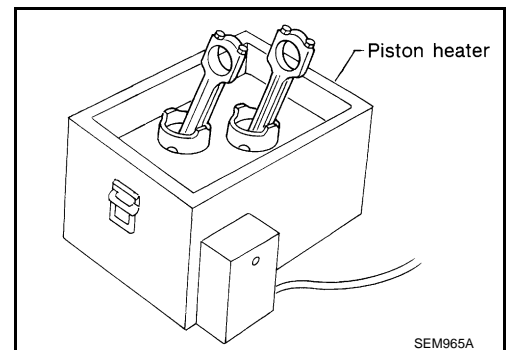

# CYLINDER BLOCK

## < DISASSEMBLY AND ASSEMBLY >

- c. Push out the piston pin with a suitable tool, with an outer diameter approximately 20 mm (0.8 in).

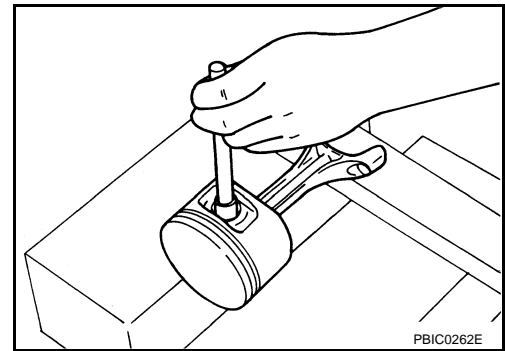

15. Remove the rear oil seal retainer from the cylinder block.
- Insert a screwdriver or similar tool between the rear end of the crankshaft counter weight and rear oil seal retainer, and separate the liquid gasket to remove.

**CAUTION:**

**Be careful not to damage the mating surface.**

**NOTE:**

When replacing the rear oil seal during on-vehicle service, it is necessary to remove the oil pan. Refer to [EM-33, "Removal and Installation"](#).

16. Remove the baffle plate from the main bearing beam.
17. Loosen the bolts in the numerical order as shown and remove the main bearing beam, bearing caps and crankshaft.
- Before loosening the main bearing cap bolts, measure the crankshaft side clearance. Refer to [EM-109, "Inspection"](#).

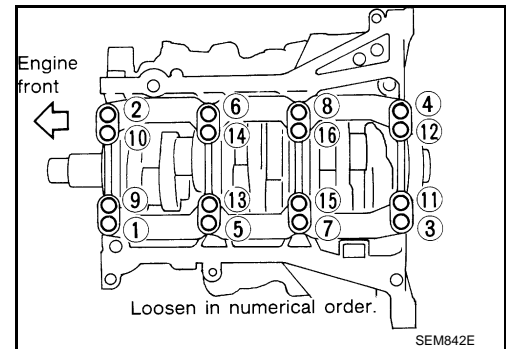

18. Remove the oil jets and dowel pins.
19. Remove the main bearings and thrust bearings from the cylinder block and main bearing caps.
- When removing them, note the direction and position. Keep them in the correct order for installation.

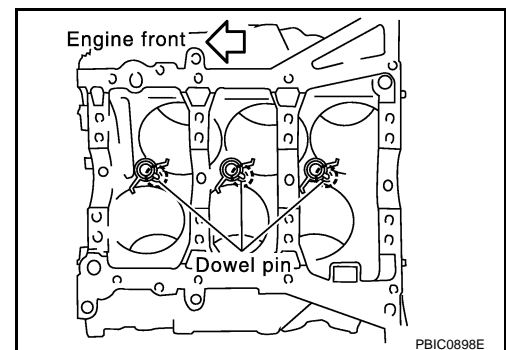

## ASSEMBLY

1. Blow out the coolant and oil passages and cylinder bore to remove any foreign materials.
- CAUTION:**
- Use goggles to protect your eyes.**
2. Apply liquid gasket and install each plug into the cylinder block.
- Use Genuine Silicone RTV Sealant or equivalent. Refer to [GI-15, "Recommended Chemical Products and Sealants"](#).

# CYLINDER BLOCK

## < DISASSEMBLY AND ASSEMBLY >

3. Install the oil jets.
  - Insert the oil jet dowel pin into the cylinder block dowel pin hole, and tighten the bolts.

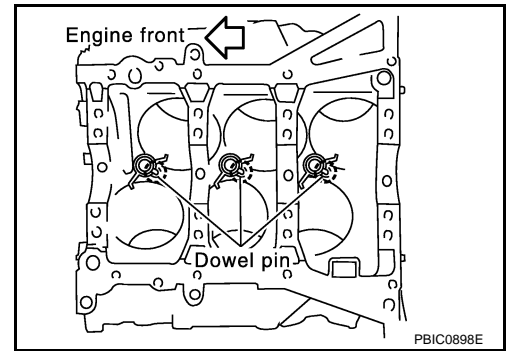

4. Install the main bearings and the thrust bearings.
  - a. Remove dust, dirt, and oil on the bearing mating surfaces of the cylinder block and the main bearing cap.
  - b. Install the thrust bearings to both sides of the No. 3 journal housing on the cylinder block and the main bearing cap.
    - Install the thrust bearings with the oil groove facing the crankshaft arm (outside).
    - Install bearing with a projection on one end on cylinder block and bearing with a projection at center on cap. Align each projection with mating notch.

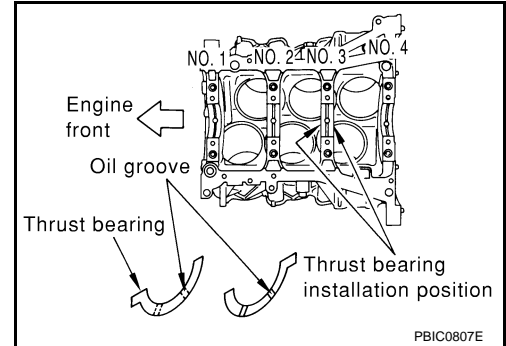

5. Set the upper main bearings in their proper positions on the cylinder block.
  - Confirm the correct main bearings are used. Refer to [EM-109](#), "[Inspection](#)".

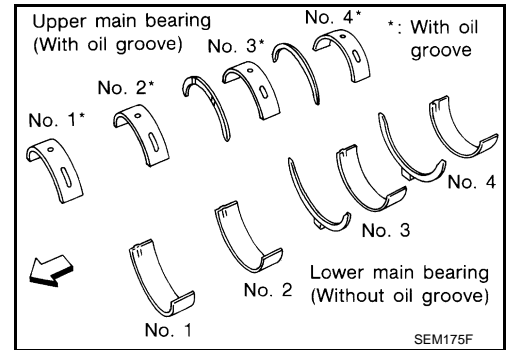

6. Instructions for the re-use of the main bearing cap bolts.
  - A plastic zone tightening method is used for tightening the main bearing cap bolts. Measure  $d_1$  and  $d_2$  as shown.
  - For  $d_2$ , select the minimum diameter in the measuring area.
  - If the difference between  $d_1$  and  $d_2$  exceeds the limit, replace the bolts for assembly.

**Limit ( $d_1 - d_2$ ) : 0.11 mm (0.0043 in)**

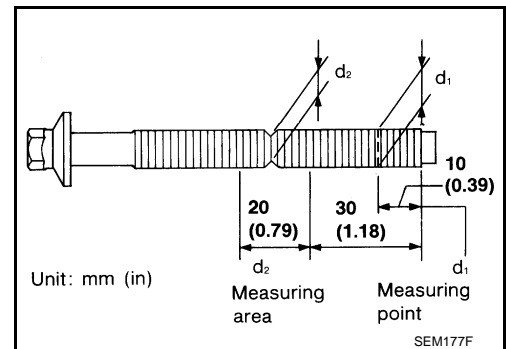



# CYLINDER BLOCK

## < DISASSEMBLY AND ASSEMBLY >

7. After installing the crankshaft, lower main bearings, main bearing caps, main bearing beam, and bearing cap bolts. Tighten the bearing cap bolts in the numerical order as shown.

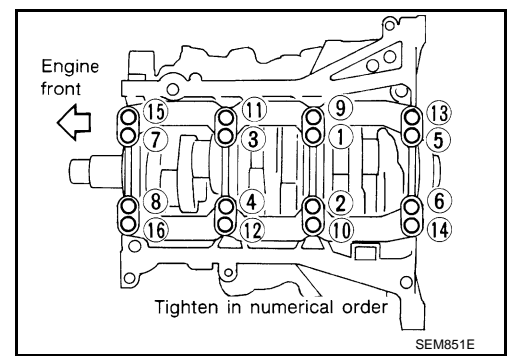

- Make sure that the front marks on the main bearing beam faces the front of the engine.
- Prior to tightening all the bearing cap bolts, place the bearing beam in its proper position by shifting the crankshaft in the axial position.
- After tightening the bearing cap bolts, make sure the crankshaft turns smoothly.
- Lubricate the threads and seat surfaces of the bolts with new engine oil.
- Tighten the bolts in two stages:

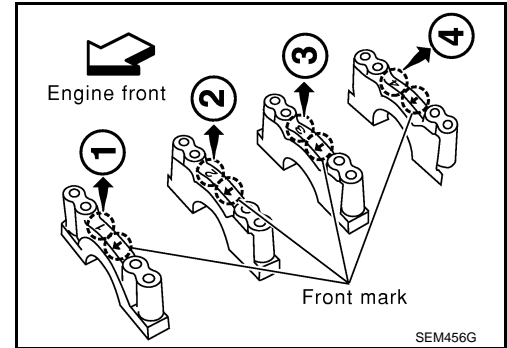

### CAUTION:

Measure the tighten angle in stage 2 using Tool. Do not measure visually.

**Stage 1** : 32.3 - 38.3 N·m (3.3 - 3.9 kg·m, 24 - 28 ft·lb)

**Stage 2** : 90° - 95° degrees clockwise

**Tool number** : KV10112100 (BT-8653-A)

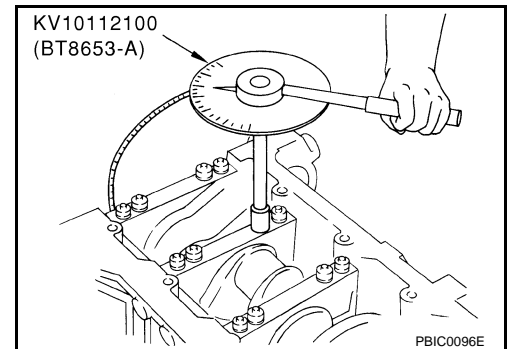

8. Measure crankshaft end play.
- If beyond the limit, replace the bearing with a new one.

**Standard** : 0.10 - 0.25 mm (0.0039 - 0.0098 in)

**Limit** : 0.30 mm (0.0118 in)

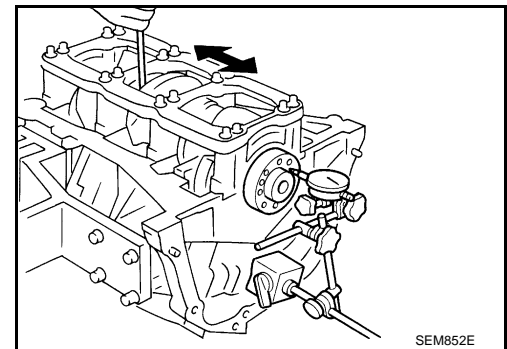

A  
EM  
C  
D  
E  
F  
G  
H  
I  
J  
K  
L  
M  
N  
O  
P

# CYLINDER BLOCK

## < DISASSEMBLY AND ASSEMBLY >

9. Install the rear oil seal retainer.

- Apply sealant to rear oil seal retainer as shown.

**Use Genuine Silicone RTV Sealant, or equivalent. Refer to [GI-15, "Recommended Chemical Products and Sealants"](#).**

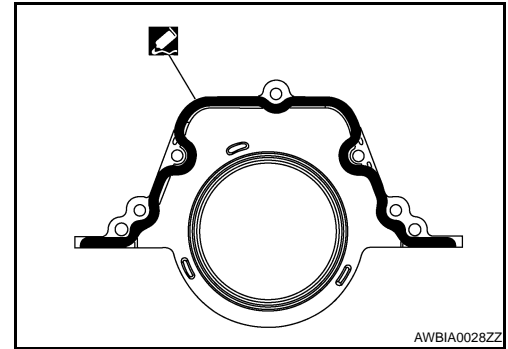

10. Install the piston to the connecting rod.

a. Using suitable snap ring pliers, install the snap ring fully into the pin-groove of the piston rear side.

- Piston front mark (A)
- Oil hole (B)
- Connecting rod front mark (C)
- Cylinder No. (D)

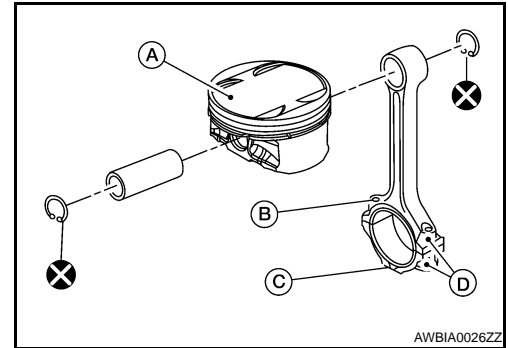

b. Install the piston to the connecting rod.

- Heat the piston until the piston pin can be pushed in by hand without excess force [approx. 60° - 70°C (140° to 158°F)]. From the front to the rear, insert the piston pin into the piston and through the connecting rod.

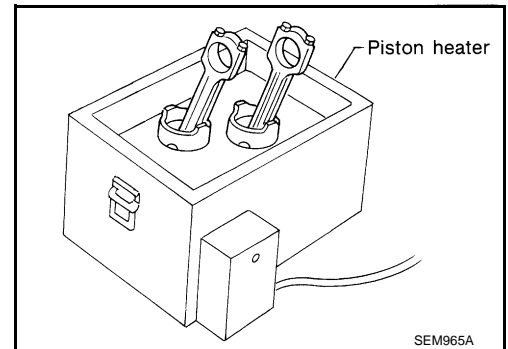

- Assemble so that the piston front mark (B) on the crown and the oil hole (C), connecting rod front mark (D) and Cylinder No. (E) on the are positioned as shown.

- ←: Front
- Piston grade number (A)
- Pin grade number (F)

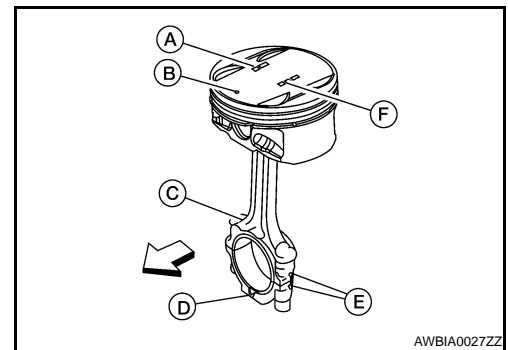

# CYLINDER BLOCK

## < DISASSEMBLY AND ASSEMBLY >

- c. Install the snap ring into the front of the piston pin-groove.
- After installing, check that the connecting rod pivots smoothly on the pin.
- CAUTION:**  
Do not reuse snap rings, always replace with new ones.

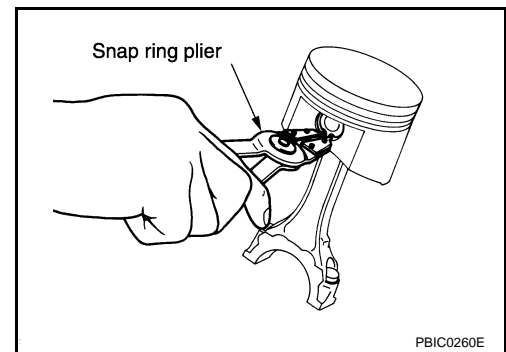

11. Using a piston ring expander, install the piston rings.

**CAUTION:**

- Be careful not to damage the piston.
- When the piston rings are not replaced, remount the rings in their original positions.
- When replacing the piston rings, those without stamped surface (A) can be mounted either side up.
- Install the second ring with the stamped surface (B) facing upward. If the ring is not stamped it can face in either direction.

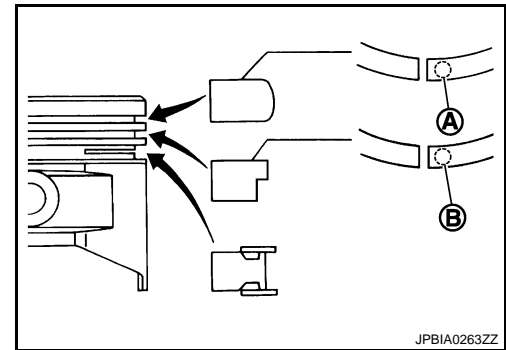

Top ring (A) : —

Second ring (B) : 2A

- Position each ring with the gap as shown, referring to the piston front mark.

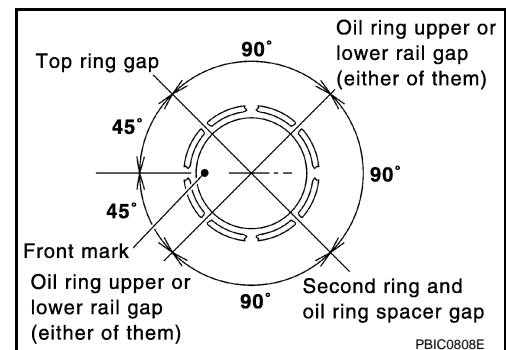

12. Install the connecting rod bearings to the connecting rod and the connecting rod cap.
- When installing the connecting rod bearings, apply engine oil to the bearing surface (crankshaft side). Do not apply oil to the back surface (connecting rod and cap side), but thoroughly clean it.
  - When installing, align the connecting rod bearing protrusion with the notch of the connecting rod to install.
  - Check that the oil holes on the connecting rod and on the corresponding bearing are aligned.

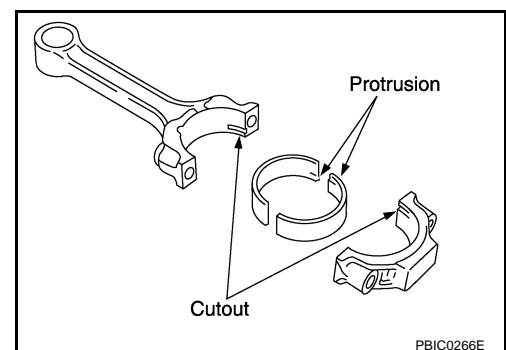

# CYLINDER BLOCK

## < DISASSEMBLY AND ASSEMBLY >

13. Install the piston and connecting rod assembly into the corresponding cylinder.
- Position the crankshaft pin corresponding to the connecting rod to be installed onto the bottom dead center.
  - Apply engine oil sufficiently to the cylinder bore, piston, and crankshaft pin.
  - Match the cylinder position with the cylinder No. (B) on the connecting rod to install.
  - Install the piston with the piston front mark (A) on the crown facing the front of the engine (↔) using a suitable tool.
  - Oil hole (C)

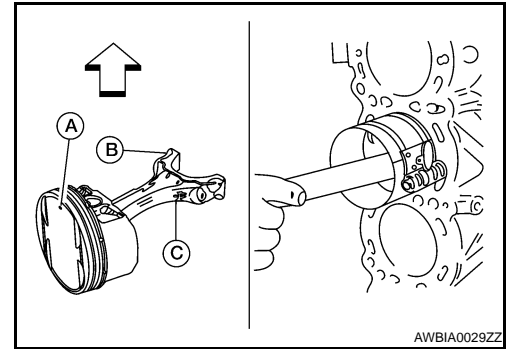

### CAUTION:

**Be careful not to damage the crankshaft pin and cylinder wall, resulting from interference of the connecting rod big end.**

14. Install the connecting rod cap.
- Match the stamped cylinder number marks on the connecting rod with those on the cylinder cap for installation.
  - Install the piston connecting rod assembly and cap so that the front mark on the cap and piston are facing the front of the engine.
  - **Lubricate the threads and seat surfaces with new engine oil.**

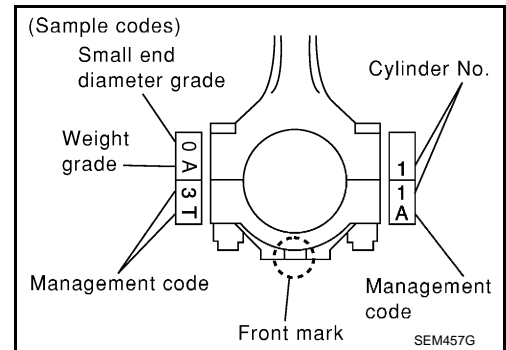

15. Check the connecting rod cap bolts before reusing, then install in their original position in the connecting rod. The bolts should screw in smoothly by hand.
- Measure the outer diameter of the connecting rod cap bolt as shown.

### Outer diameter "d" of the connecting rod bolt

**Standard : 7.90 - 8.00 mm (0.3110 - 0.3150 in)**

**Limit : 7.75 mm (0.3051 in)**

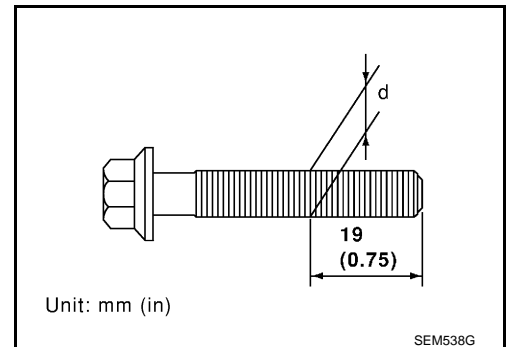

16. Tighten the connecting rod nuts in two stages using Tool:

**Stage 1 : 19 - 21 N·m (1.9 - 2.1 kg-m, 14 - 15 ft-lb)**

**Stage 2 : 90° - 95° degrees clockwise**

### CAUTION:

**Always use either an angle wrench or protractor. Avoid tightening based on visual check alone.**

**Tool number : KV10112100 (BT-8653-A)**

- Apply engine oil to the threads and seats of the connecting rod bolts and nuts.
- After tightening the nuts, make sure that the crankshaft rotates smoothly.
- Check the connecting rod side clearance. If beyond the limit, replace the connecting rod and/or crankshaft.

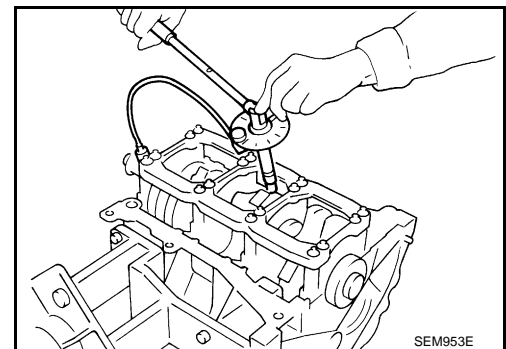

### Connecting rod side clearance:

**Standard : 0.20 - 0.35 mm (0.0079 - 0.0138 in)**

**Limit : 0.40 mm (0.0157 in)**

# CYLINDER BLOCK

## < DISASSEMBLY AND ASSEMBLY >

17. Install the baffle plate to the main bearing beam.
18. Install the knock sensor.
  - Make sure that there is no foreign material on the cylinder block mating surface and the back surface of the knock sensor.
  - Install the knock sensor with the connector facing the rear of the engine.
  - Do not tighten the bolts while holding the connector.
  - Make sure that the knock sensor does not interfere with other parts.

**CAUTION:**

**If any impact by dropping occurs to the knock sensor, replace it with new one.**

19. Install the pilot converter with its chamfer facing crankshaft as shown.
  - ←: Crankshaft side

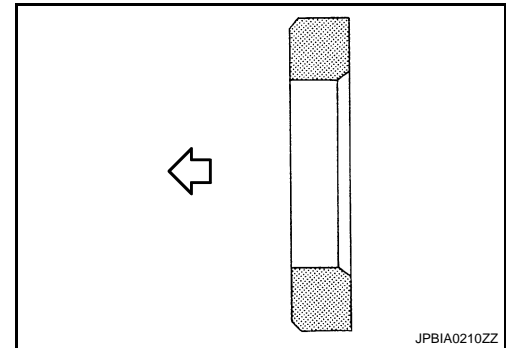
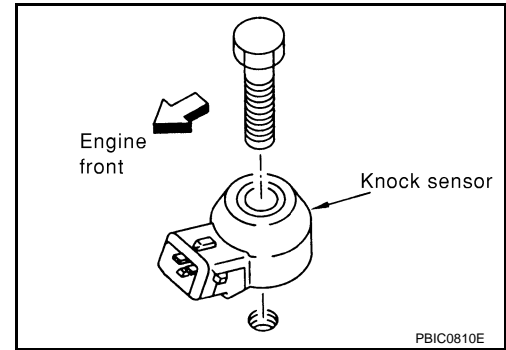

20. Install the drive plate.
  - Install the drive plate and reinforce plate in the direction as shown.
  - Align dowel pins of crankshaft rear and drive plate with pin holes of each part.
  - Secure the crankshaft using a ring gear stopper.
  - Tighten the drive plate bolts in one or two steps.

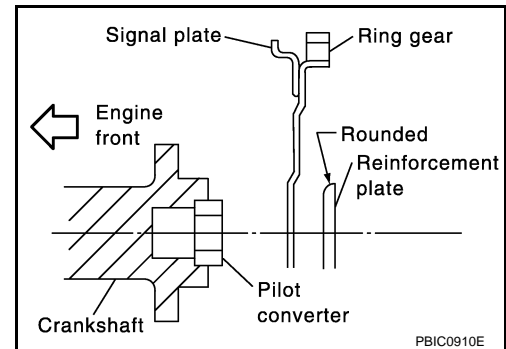

21. Install the cylinder head. Refer to [EM-85, "Removal and Installation"](#).
22. Install the timing chain. Refer to [EM-60, "Installation"](#).
23. Install the oil pan. Refer to [EM-33, "Removal and Installation"](#).
24. Remove the engine from the stand and install the engine assembly into the vehicle. Refer to [EM-96, "Removal and Installation"](#).
25. Assembly of the remaining parts is in the reverse order of disassembly.
26. Fill the engine with the specified oil and coolant. Refer to [MA-17, "FOR NORTH AMERICA : Fluids and Lubricants"](#) (United State or Canada) [MA-18, "FOR MEXICO : Fluids and Lubricants"](#) (Mexico).

**CAUTION:**

**Wait at least 30 minutes for the sealant to set-up before filling the engine with fluids and running it.**

## Inspection

INFOID:000000004173792

## PISTON AND PISTON PIN CLEARANCE

Inner Diameter of Piston Pin Hole

# CYLINDER BLOCK

## < DISASSEMBLY AND ASSEMBLY >

- Measure the inner diameter of piston pin hole "dp".

### Standard diameter "dp"

**Grade No. 0 : 21.993 – 21.999 mm (0.8659 – 0.8661 in)**

**Grade No. 1 : 21.999 – 22.005 mm (0.8661 – 0.8663 in)**

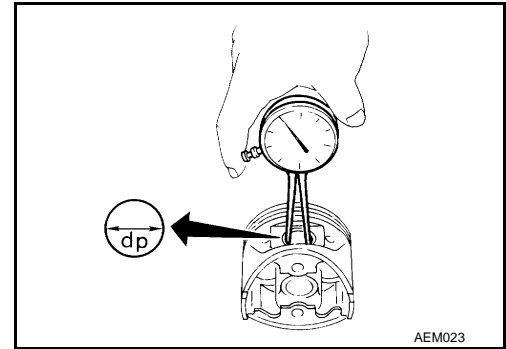

### Outer Diameter of Piston Pin

- Measure outer diameter of piston pin "Dp".

### Standard diameter "Dp"

**Grade No. 0 : 21.989 – 21.995 mm (0.8657 – 0.8659 in)**

**Grade No. 1 : 21.995 – 22.001 mm (0.8659 – 0.8662 in)**

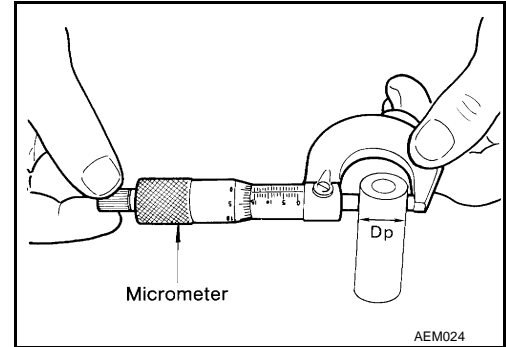

- ←: Front
- Piston Grade No. (A)
- Piston front mark (B)
- Oil hole (C)
- Connecting rod front mark (D)
- Cylinder No. (E)
- Pin Grade No. (F)

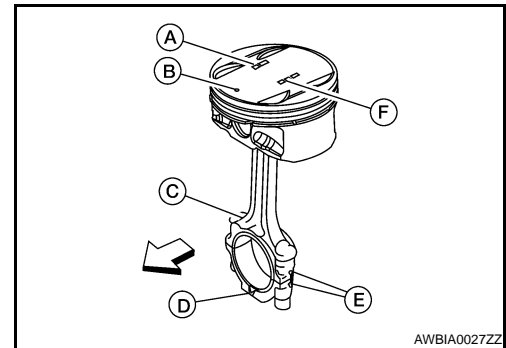

### Piston and Piston Pin Interference Fit

Standard Interference Fit = "Dp" – "dp"

**Standard : 0.002 – 0.010 mm (0.0001 – 0.0004 in)**

- If clearance exceeds specification, replace either or both of piston/piston pin assembly and connecting rod assembly with reference to specification of each part.

### PISTON RING SIDE CLEARANCE

- Measure side clearance of piston ring and piston ring groove with feeler gauge.

### Standard Side Clearance

**Top ring : 0.045 - 0.080 mm (0.0018 - 0.0031 in)**

**2nd ring : 0.030 - 0.070 mm (0.0012 - 0.0028 in)**

**Oil ring : 0.045 - 0.125 mm (0.0018 - 0.0049 in)**

### Maximum Limit

**Top ring : 0.11 mm (0.0043 in)**

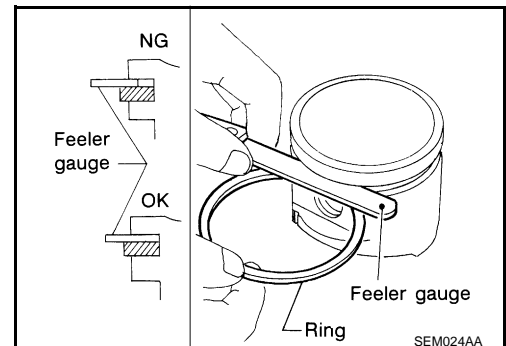

# CYLINDER BLOCK

## < DISASSEMBLY AND ASSEMBLY >

**2nd ring** : 0.1 mm (0.004 in)  
**Oil ring** : —

- If out of specification, replace piston ring assembly. If clearance exceeds maximum limit with new rings, replace piston

### PISTON RING END GAP

- Insert piston ring until it is in the middle of the cylinder bore and measure the end gap.

#### Standard

**Top ring** : 0.23 - 0.28 mm (0.0091 - 0.0110 in)  
**2nd ring** : 0.33 - 0.43 mm (0.0130 - 0.0169 in)  
**Oil ring** : 0.20 - 0.45 mm (0.0079 - 0.0177 in)

#### Limit:

**Top ring** : 0.50 mm (0.0197 in)  
**2nd ring** : 0.62 mm (0.0244 in)  
**Oil ring** : 0.80 mm (0.0315 in)

- If out of specification, replace piston ring.

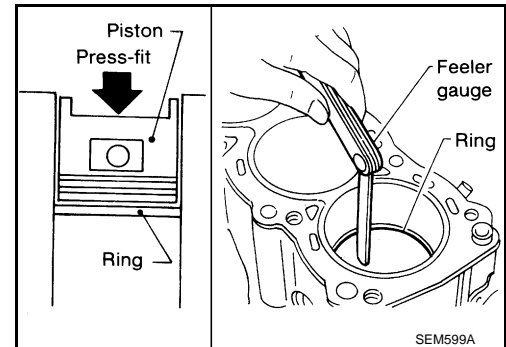

### CONNECTING ROD BEND AND TORSION

**Bend** : Limit 0.15 mm (0.0059 in) per 100 mm (3.94 in) length  
**Torsion** : Limit 0.30 mm (0.0118 in) per 100 mm (3.94 in) length

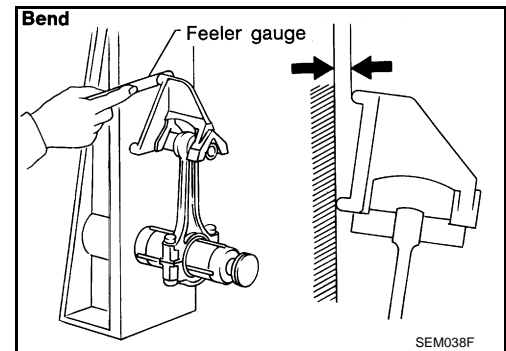

- If it exceeds the limit, replace connecting rod assembly.

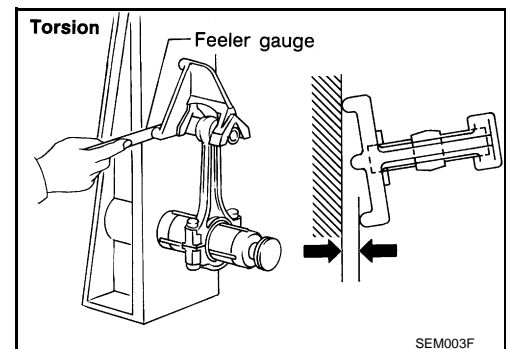

### CONNECTING ROD BEARING HOUSING DIAMETER (BIG END)

# CYLINDER BLOCK

## < DISASSEMBLY AND ASSEMBLY >

- Install the connecting rod cap without the connecting rod bearing installed. After tightening the connecting rod nut to the specified torque, measure the connecting rod bearing housing big end inner diameter using an inside micrometer.

**Standard : 55.000 - 55.013 mm (2.1654 - 2.1659 in)**

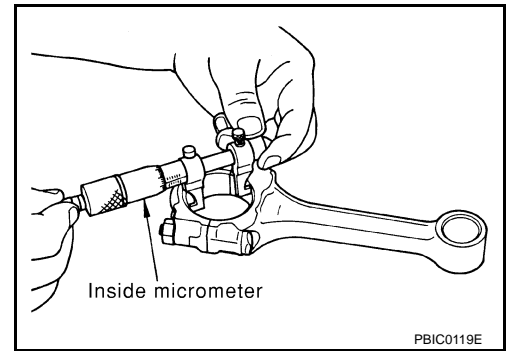

## CONNECTING ROD BUSHING OIL CLEARANCE (SMALL END)

Inner Diameter of Connecting Rod (Small End)

- Measure inner diameter of piston pin bushing.

**Standard Grade No. 0 : 22.000 - 22.006 mm (0.8661 - 0.8664 in)**  
**Grade No. 1 : 22.006 - 22.012 mm (0.8664 - 0.8666 in)**

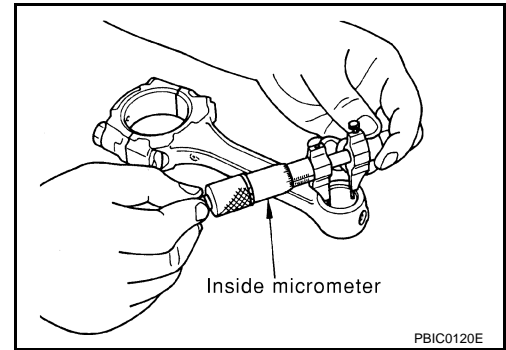

Outer Diameter of Piston Pin

- Measure outer diameter of piston pin.

**Standard Grade No. 0 : 21.989 - 21.995 mm (0.8657 - 0.8659 in)**  
**Grade No. 1 : 21.995 - 22.001 mm (0.8659 - 0.8662 in)**

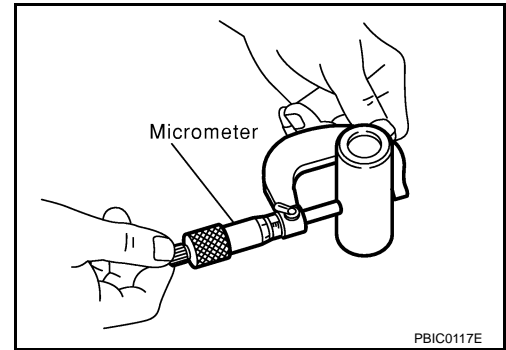

Connecting Rod Bushing Oil Clearance (Small End)

(Connecting rod small end oil clearance) = (Inner diameter of connecting rod small end) – (Outer diameter of piston pin)

**Standard : 0.005 - 0.017 mm (0.0002 - 0.0007 in)**  
**Limit : 0.030 mm (0.0012 in)**

- If the measured value exceeds the standard, replace the connecting rod assembly and/or piston and piston pin assembly.
- If replacing the piston and piston pin assembly, use the Table for Selective Fitting for Piston to select the piston corresponding to the applicable bore grade of the cylinder block to be used. Follow the "PISTON-TO-CYLINDER BORE CLEARANCE" procedure.

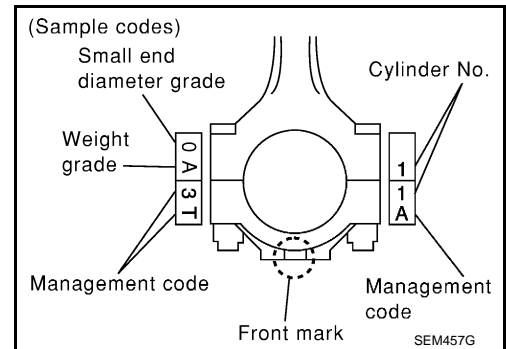

**Factory installed parts grading:**



# CYLINDER BLOCK

## < DISASSEMBLY AND ASSEMBLY >

- ←: Front
- Piston Grade No. (A)
- Piston front mark (B)
- Oil hole (C)
- Connecting rod front mark (D)
- Cylinder No. (E)
- Pin Grade No. (F)

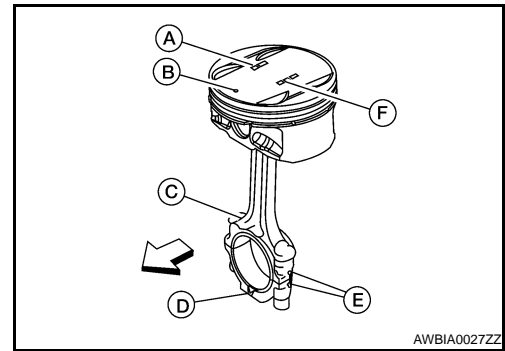

Service parts apply only to grade 0.

Unit: mm (in)

Grade	0	1
Connecting rod small end inner diameter	22.000 - 22.006 (0.8661 - 0.8664)	22.006 - 22.012 (0.8664 - 0.8666)
Piston pin outer diameter	21.989 - 21.995 (0.8657 - 0.8659)	21.995 - 22.001 (0.8659 - 0.8662)
Piston pin hole diameter	21.993 - 21.999 (0.8659 - 0.8661)	21.999 - 22.005 (0.8661 - 0.8663)

## CYLINDER BLOCK DISTORTION

- Using a scraper, remove any old gasket material on the cylinder block surface, and remove any oil, scale, carbon, or other contamination.

### CAUTION:

**Be careful not to allow gasket flakes to enter the oil or coolant passages.**

- Measure the distortion on the block upper face at different points in six directions.

**Distortion limit : 0.10 mm (0.0039 in)**

- If out of specification, resurface the cylinder block. The allowable amount of resurfacing is dependent on the amount of any cylinder head resurfacing. The resurfacing limit is [amount of cylinder head resurfacing] + [amount of cylinder head resurfacing] = 0.2 mm (0.008 in).

**Cylinder block height : 214.95 - 215.05 mm  
(8.4626 - 8.4665 in)**

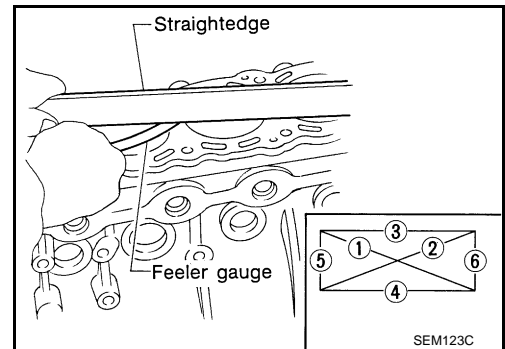

## INNER DIAMETER OF MAIN BEARING HOUSING

- Install the main bearing caps with the main bearings removed, and tighten the bolts to the specified torque.
- Using a bore gauge, measure the inner diameter of the main bearing housing "A".

**Standard : 63.993 - 64.017 mm (2.5194 - 2.5203 in)**

- If out of the standard, replace the cylinder block and main bearing caps as an assembly.

### NOTE:

These components cannot be replaced as a single unit, because they were processed together.

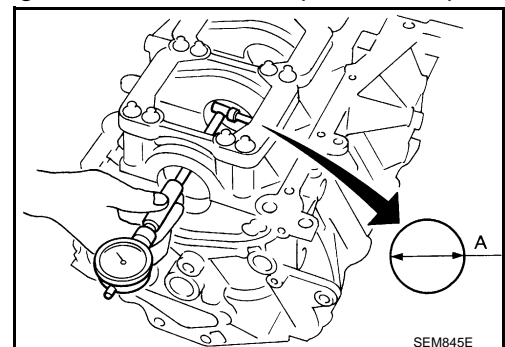

## PISTON-TO-CYLINDER BORE CLEARANCE

1. Using a bore gauge, measure cylinder bore for wear, out-of-round and taper at (A), (B) and (C). The X axis is in the longitudinal direction of the engine.

# CYLINDER BLOCK

## < DISASSEMBLY AND ASSEMBLY >

Cylinder bore inner diameter

Grade No.	Standard inner diameter	Wear limit
No. 1	95.500 - 95.510 mm (3.7598 - 3.7602 in)	0.20 mm (0.0079 in)
No. 2	95.510 - 95.520 mm (3.7602 - 3.7606 in)	
No. 3	95.520 - 95.530 mm (3.7606 - 3.7610 in)	

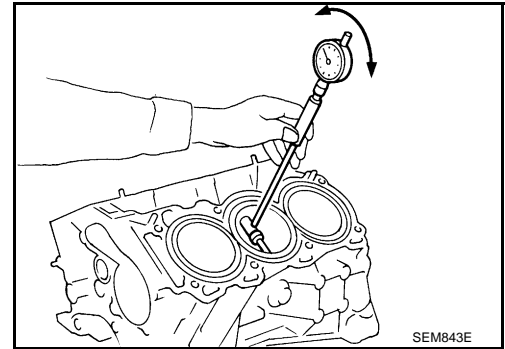

If it exceeds the limit, rebore all cylinders. Replace cylinder block if necessary.

**Out-of-round (Difference between X and Y)** : limit 0.015 mm (0.0006 in)

**Taper (Difference between A and C)** : limit 0.010 mm (0.0004 in)

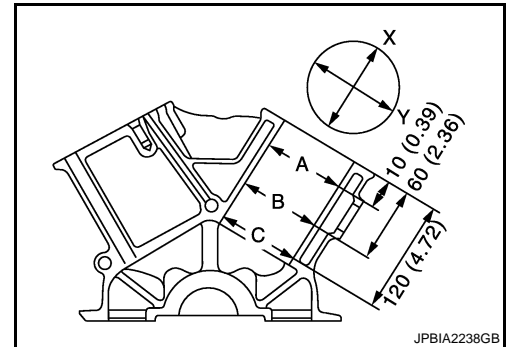

- Check for scratches and seizure. If seizure is found, hone it.
  - If both cylinder block and piston are replaced with new ones, select piston of the same grade number punched on cylinder block rear position. These numbers are punched in either Arabic or Roman numerals.

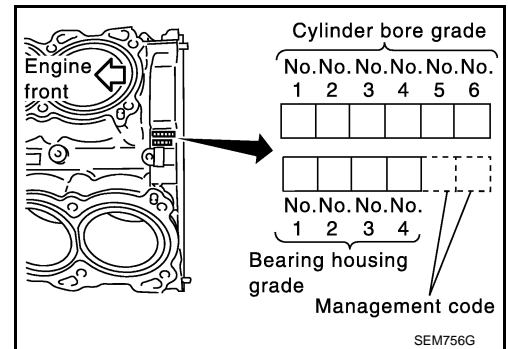

- Measure piston skirt diameter.

**Piston diameter "A"** : Refer to [EM-127, "Cylinder Block"](#).

**Measuring point "a"** : 38.0 mm (1.496 in)  
(Distance from the top)

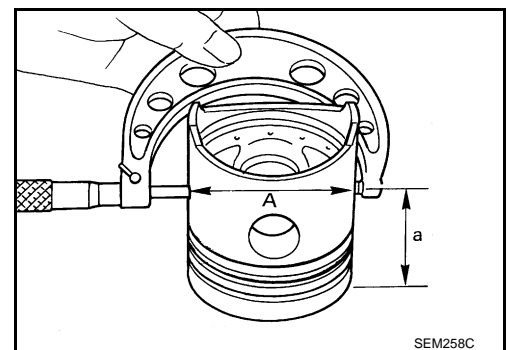

- Check that piston-to-bore clearance is within specification.

**Piston-to-bore clearance at "B"** : 0.010 - 0.030 mm (0.0004 - 0.0012 in)

- The piston-to-bore clearance is measured at the "B" level in the cylinder as shown.

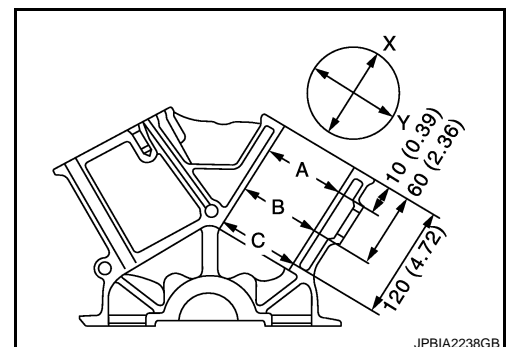

# CYLINDER BLOCK

## < DISASSEMBLY AND ASSEMBLY >

5. Cylinder bore size is determined by adding piston-to-bore clearance to piston diameter "A".

**Rebored size calculation** :  $D = A + B - C$

where,

- D** : Bored diameter  
**A** : Piston diameter as measured  
**B** : Piston-to-bore clearance  
**C** : Honing allowance 0.02 mm (0.0008 in)

6. Install main bearing caps, and tighten to the specified torque. Otherwise, cylinder bores may be distorted after boring.
7. Cut cylinder bores.
- **When any cylinder needs boring, all other cylinders must also be bored.**
  - **Do not cut too much out of cylinder bore at a time. Cut only 0.05 mm (0.0020 in) or so in diameter at a time.**
8. Hone cylinders to obtain specified piston-to-bore clearance.
9. Measure finished cylinder bore for out-of-round and taper.
- **Measurement should be done after cylinder bore cools down.**

## CRANKSHAFT

1. Check the crankshaft main and pin journals for scoring, wear, or cracks.
2. Measure the journals for taper and out-of-round.

**Standard**

**Out-of-round (X - Y)** : 0.002 mm (0.0001 in)

**Taper (A - B)** : 0.002 mm (0.0001 in)

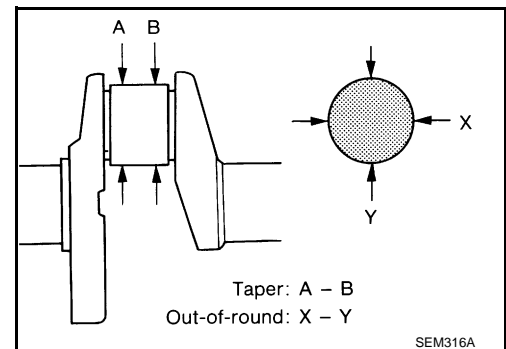

3. Measure crankshaft runout.
- a. Place a V-block on a precise flat table to support the journals on the both ends of the crankshaft.
- b. Place a dial gauge straight up on the No. 3 journal.
- c. While rotating the crankshaft, read the movement of the pointer on the dial gauge.

**Runout limit (total indicator reading)** : 0.10 mm (0.0039 in)

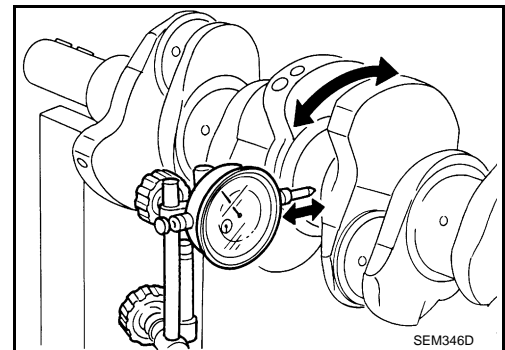

## BEARING CLEARANCE

- Use either of the following two methods, however method "A" gives more reliable results and so is the preferred method.

### Method A (Using Bore Gauge and Micrometer)

#### Main Bearing

# CYLINDER BLOCK

## < DISASSEMBLY AND ASSEMBLY >

1. Set the main bearings in their proper positions on the cylinder block and the main bearing cap.
2. Install the main bearing caps and bearing beam to the cylinder block. Tighten all bolts in the numerical order as specified. Refer to [EM-100, "Disassembly and Assembly"](#).

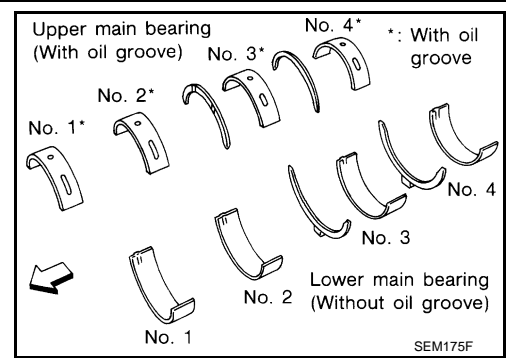

3. Measure the inner diameters "A" of each main bearing as shown.

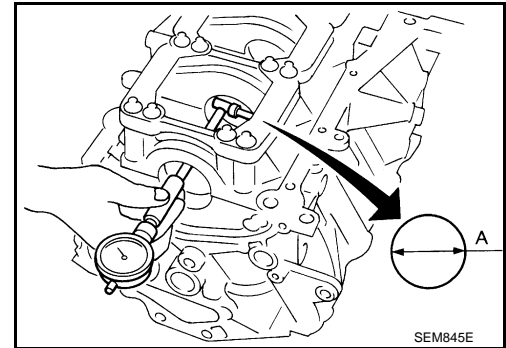

4. Measure the outer diameters "Dm" of each crankshaft main journal as shown.
5. Calculate the main bearing clearance.  
**Main bearing clearance = "A" - "Dm"**

**Standard : 0.035 - 0.045 mm (0.0014 - 0.0018 in)**

**Limit : 0.065 mm (0.0026 in)**

- If it exceeds the limit, replace the bearing.
- If clearance cannot be adjusted using any standard bearing grade, grind crankshaft journal and use an undersized bearing.

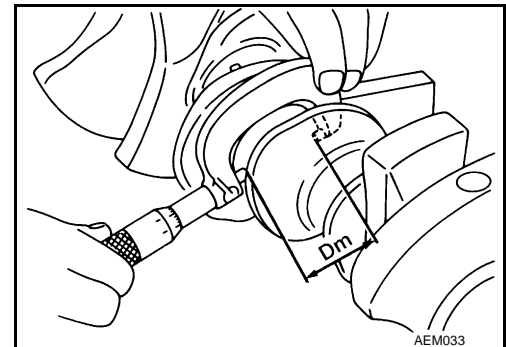

- When grinding the crankshaft journal, confirm that the "L" dimension in the fillet role is more than the specified limit.

**"L" : 0.10 mm (0.0039 in)**

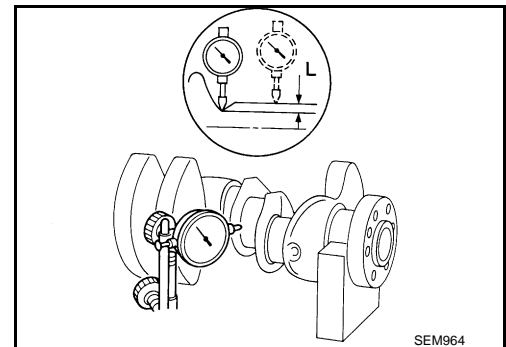

6. If the crankshaft or the cylinder block is replaced with a new one, select thickness of the main bearings as follows:

# CYLINDER BLOCK

## < DISASSEMBLY AND ASSEMBLY >

- a. The grade number of each cylinder block main journal is punched on the respective cylinder block. These numbers are punched in either Arabic or Roman numerals. If measured diameter is out of the grade punched, decide suitable grade from available main bearings.

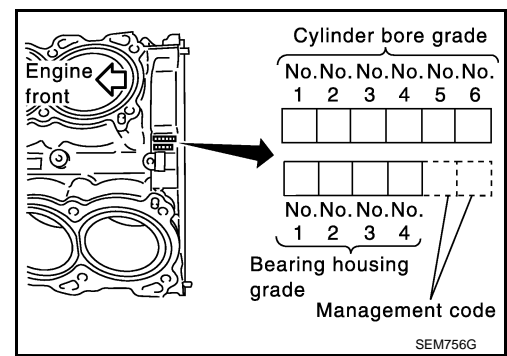

- b. The grade number of each crankshaft main journal is punched on the crankshaft end. These numbers are punched in either Arabic or Roman numerals. If measured diameter is out of grade punched, decide the suitable grade from available main bearings.

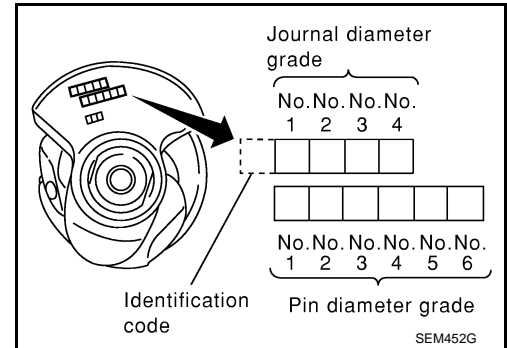

- c. Select the main bearing suitable thickness according to the following table:

Mark	Axle diameter	Cylinder block bearing housing inner diameter Unit: mm (in)																							
		Hole diameter																							
		A	B	C	D	E	F	G	H	J	K	L	M	N	P	R	S	T	U	V	W	X	Y	4	7
A	59.975 - 59.974 (2.3612 - 2.3612)	0	0	0	0	0	1	1	1	1	1	1	1	1	1	1	1	1	1	1	1	1	1	1	1
B	59.974 - 59.973 (2.3612 - 2.3611)	0	0	0	1	1	1	1	1	1	1	1	1	1	1	1	1	1	1	1	1	1	1	1	1
C	59.973 - 59.972 (2.3611 - 2.3611)	0	0	1	1	1	1	1	1	1	1	1	1	1	1	1	1	1	1	1	1	1	1	1	1
D	59.972 - 59.971 (2.3611 - 2.3611)	0	1	1	1	1	1	1	1	1	1	1	1	1	1	1	1	1	1	1	1	1	1	1	1
E	59.971 - 59.970 (2.3611 - 2.3610)	0	1	1	1	1	1	1	1	1	1	1	1	1	1	1	1	1	1	1	1	1	1	1	1
F	59.970 - 59.969 (2.3610 - 2.3610)	0	1	1	1	1	1	1	1	1	1	1	1	1	1	1	1	1	1	1	1	1	1	1	1
G	59.969 - 59.968 (2.3610 - 2.3609)	1	1	1	1	1	1	1	1	1	1	1	1	1	1	1	1	1	1	1	1	1	1	1	1
H	59.968 - 59.967 (2.3609 - 2.3609)	1	1	1	1	1	1	1	1	1	1	1	1	1	1	1	1	1	1	1	1	1	1	1	1
J	59.967 - 59.966 (2.3609 - 2.3609)	1	1	1	1	1	1	1	1	1	1	1	1	1	1	1	1	1	1	1	1	1	1	1	1
K	59.966 - 59.965 (2.3608 - 2.3608)	1	1	1	1	1	1	1	1	1	1	1	1	1	1	1	1	1	1	1	1	1	1	1	1
L	59.965 - 59.964 (2.3608 - 2.3608)	1	1	1	1	1	1	1	1	1	1	1	1	1	1	1	1	1	1	1	1	1	1	1	1
M	59.964 - 59.963 (2.3608 - 2.3607)	1	1	1	1	1	1	1	1	1	1	1	1	1	1	1	1	1	1	1	1	1	1	1	1
N	59.963 - 59.962 (2.3607 - 2.3607)	1	1	1	1	1	1	1	1	1	1	1	1	1	1	1	1	1	1	1	1	1	1	1	1
P	59.962 - 59.961 (2.3607 - 2.3607)	1	1	1	1	1	1	1	1	1	1	1	1	1	1	1	1	1	1	1	1	1	1	1	1
R	59.961 - 59.960 (2.3607 - 2.3606)	1	1	1	1	1	1	1	1	1	1	1	1	1	1	1	1	1	1	1	1	1	1	1	1
S	59.960 - 59.959 (2.3606 - 2.3606)	1	1	1	1	1	1	1	1	1	1	1	1	1	1	1	1	1	1	1	1	1	1	1	1
T	59.959 - 59.958 (2.3606 - 2.3605)	1	1	1	1	1	1	1	1	1	1	1	1	1	1	1	1	1	1	1	1	1	1	1	1
U	59.958 - 59.957 (2.3605 - 2.3605)	1	1	1	1	1	1	1	1	1	1	1	1	1	1	1	1	1	1	1	1	1	1	1	1
V	59.957 - 59.956 (2.3605 - 2.3605)	1	1	1	1	1	1	1	1	1	1	1	1	1	1	1	1	1	1	1	1	1	1	1	1
W	59.956 - 59.955 (2.3605 - 2.3604)	1	1	1	1	1	1	1	1	1	1	1	1	1	1	1	1	1	1	1	1	1	1	1	1
X	59.955 - 59.954 (2.3604 - 2.3604)	1	1	1	1	1	1	1	1	1	1	1	1	1	1	1	1	1	1	1	1	1	1	1	1
Y	59.954 - 59.953 (2.3604 - 2.3603)	1	1	1	1	1	1	1	1	1	1	1	1	1	1	1	1	1	1	1	1	1	1	1	1
4	59.953 - 59.952 (2.3603 - 2.3603)	1	1	1	1	1	1	1	1	1	1	1	1	1	1	1	1	1	1	1	1	1	1	1	1
7	59.952 - 59.951 (2.3603 - 2.3603)	1	1	1	1	1	1	1	1	1	1	1	1	1	1	1	1	1	1	1	1	1	1	1	1

PBIC0814E

# CYLINDER BLOCK

## < DISASSEMBLY AND ASSEMBLY >

### Connecting Rod Bearing (Big End)

1. Install the connecting rod bearing to the connecting rod and cap.
2. Install the connecting rod cap to the connecting rod. Tighten to specification. Refer to [EM-100, "Disassembly and Assembly"](#).
3. Measure the inner diameter "C" of each connecting rod (big end) as shown.

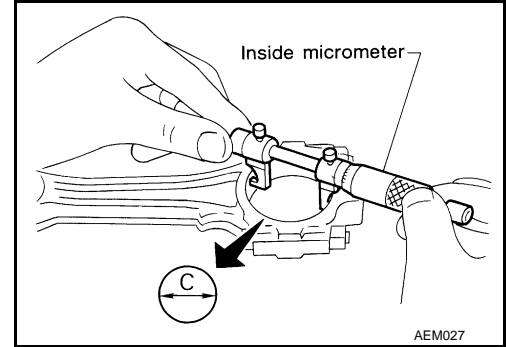

4. Measure the outer diameter "Dp" of each crankshaft pin journal.
5. Calculate the connecting rod bearing clearance.  
**Connecting rod bearing clearance = C - Dp**

**Standard : 0.020 - 0.045 mm (0.0008 - 0.0018 in)**

**Limit : 0.070 mm (0.0028 in)**

6. If the calculated clearance exceeds the specified limit, replace the bearings.
7. If the clearance cannot be adjusted within the standard of any bearing, grind the crankshaft journal and use undersized bearings.

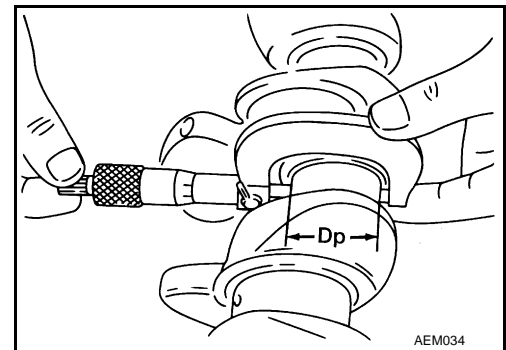

8. If the crankshaft is replaced with a new one, select the connecting rod bearings according to the following table:  
**Connecting Rod Bearing Grade Number (Identification Color)**

Crankshaft pin journal grade number	Connecting rod bearing grade number
0	0 (black)
1	1 (brown)
2	2 (green)

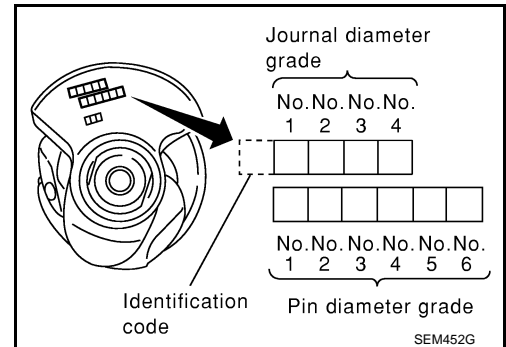

These numbers are punched in either Arabic or Roman numerals.

### Method B (Using Plastigage)

- Remove oil and dust on the crankshaft pin and the surfaces of each bearing completely.
- Cut a Plastigage slightly shorter than the bearing width, and place it in crankshaft axial direction, avoiding oil holes.
- Install the connecting rod bearings to the connecting rod cap, and tighten the connecting rod nuts to the specified torque.

#### **CAUTION:**

**Never rotate the crankshaft.**

- Remove the connecting rod cap and bearings, and using the scale on the Plastigage bag, measure the Plastigage width.

#### **NOTE:**

The procedure when the measured value exceeds the repair limit is same as that described in "Method A (Using Bore Gauge and Micrometer)".

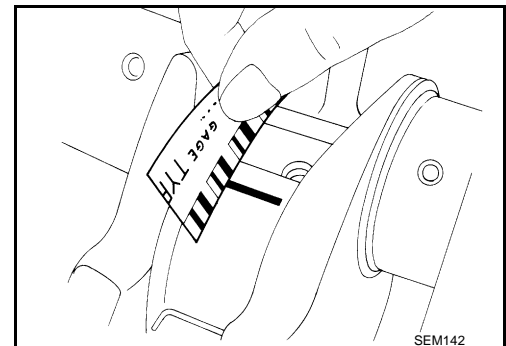

## DRIVE PLATE RUNOUT (CVT)

# CYLINDER BLOCK

< DISASSEMBLY AND ASSEMBLY >

## Runout (Total Indicator Reading):

- Drive plate (CVT)  
torque converter sur- : less than 0.35 mm (.0138 in)  
face
- Ring gear : less than 0.5 mm (.0197 in)

### CAUTION:

- The signal plate is built into the drive assembly. Be careful not to damage the signal plate, particularly the teeth.
- Check the drive plate and signal plate for deformation or cracks.
- Keep any magnetized objects away from the signal plate, particularly the teeth.

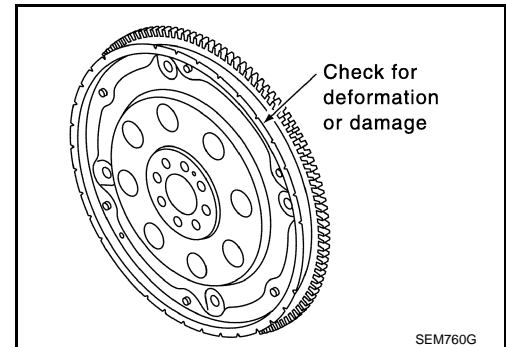
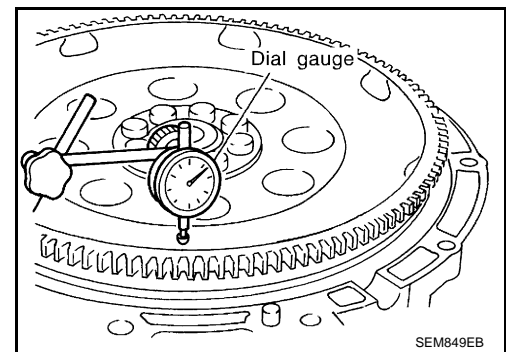

## OIL JET

- Check nozzle for deformation and damage.
- Blow compressed air from nozzle, and check for clogs.
- If it is not satisfied, replace oil jet.

## OIL JET RELIEF VALVE

- Using a clean plastic stick, press check valve in oil jet relief valve. Make sure that valve moves smoothly with proper reaction force.
- If it is not satisfied, replace oil jet relief valve.

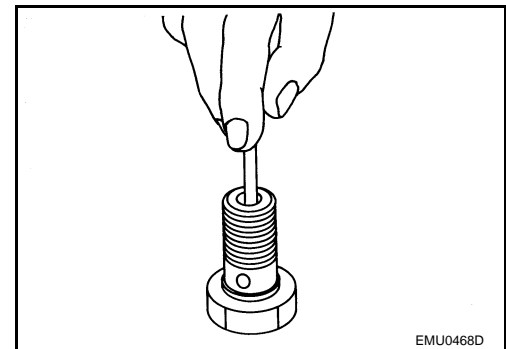

## Dowel Pin Alignment

INFOID:000000004173793

## REMOVAL

1. Use Tool to lock the drive plate and match mark (A) the drive plate before removing the bolts.

Tool number : KV10117700 (J-48716)

### CAUTION:

Do not damage the ring gear teeth, or the signal plate teeth behind the ring gear, when setting Tool.

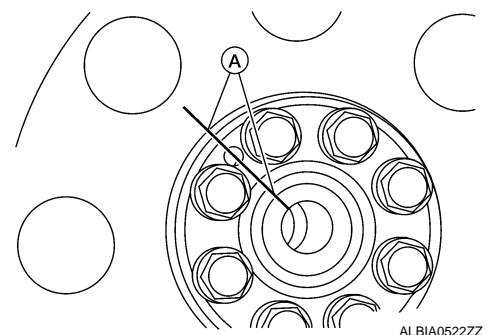

# CYLINDER BLOCK

## < DISASSEMBLY AND ASSEMBLY >

- Remove drive plate.
  - Loosen the drive plate in a diagonal order.
  - CAUTION:**
    - Never place drive plate with signal plate facing down.
    - When handling the signal plate, take care not to damage or scratch it.
    - Handle the signal plate in a manner that prevents it from becoming magnetized.

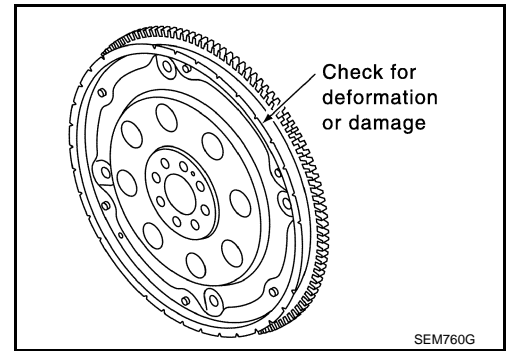

## INSTALLATION

- Installation is in the reverse order of removal after the following:
  - When installing the drive plate to the crankshaft, use the match mark (A) as shown to correctly align the crankshaft side dowel pin to the drive plate side dowel pin hole.

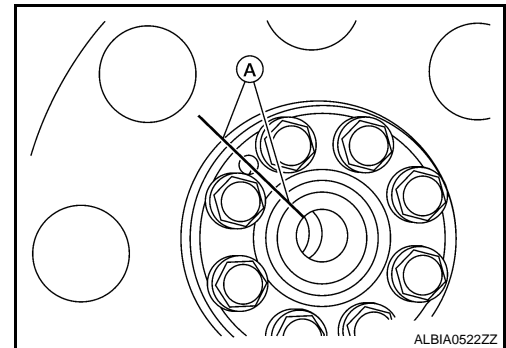

- Install the drive plate and the reinforcement plate in the direction as shown.

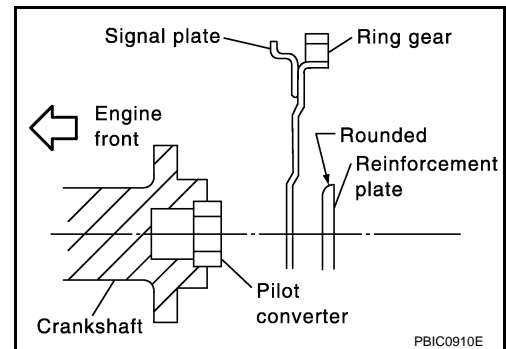

- Tighten the drive plate bolts in a diagonal pattern in two steps. Refer to [EM-100, "Disassembly and Assembly"](#).



# SERVICE DATA AND SPECIFICATIONS (SDS)

< SERVICE DATA AND SPECIFICATIONS (SDS)

## SERVICE DATA AND SPECIFICATIONS (SDS)

### SERVICE DATA AND SPECIFICATIONS (SDS)

#### General Specification

INFOID:000000004348985

A

EM

#### GENERAL SPECIFICATIONS

Cylinder arrangement		V-6
Displacement cm <sup>3</sup> (cu in)		3,498 (213.45)
Bore and stroke mm (in)		95.5 x 81.4 (3.760 x 3.205)
Valve arrangement		DOHC
Firing order		1-2-3-4-5-6
Number of piston rings	Compression	2
	Oil	1
Number of main bearings		4
Compression ratio		10.6:1
Compression pressure kPa (kg/cm <sup>2</sup> , psi)/300 rpm	Standard	1,275 (13.0, 185)
	Minimum	981 (10.0, 142)
	Differential limit between cylinders	98 (1.0, 14)

C

D

E

F

G

H

I

J

K

L

M

N

O

P

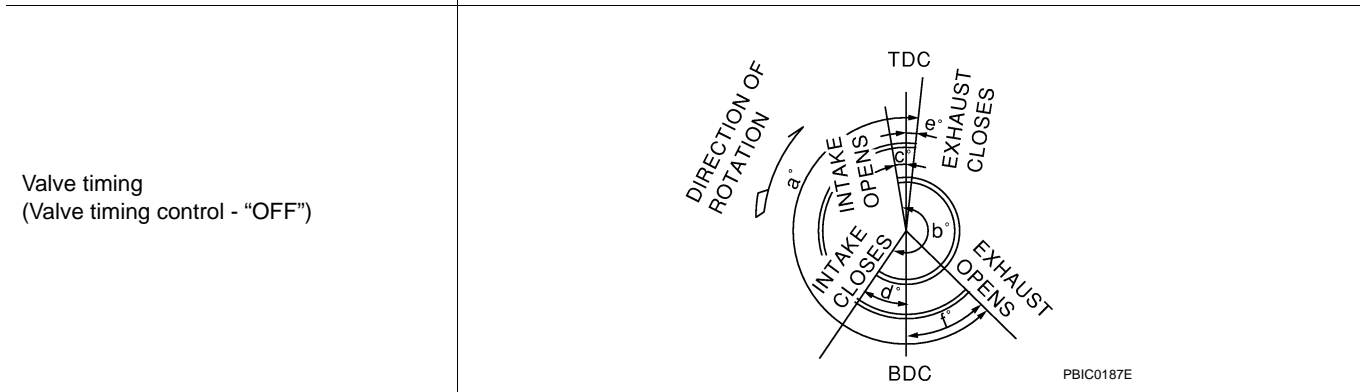
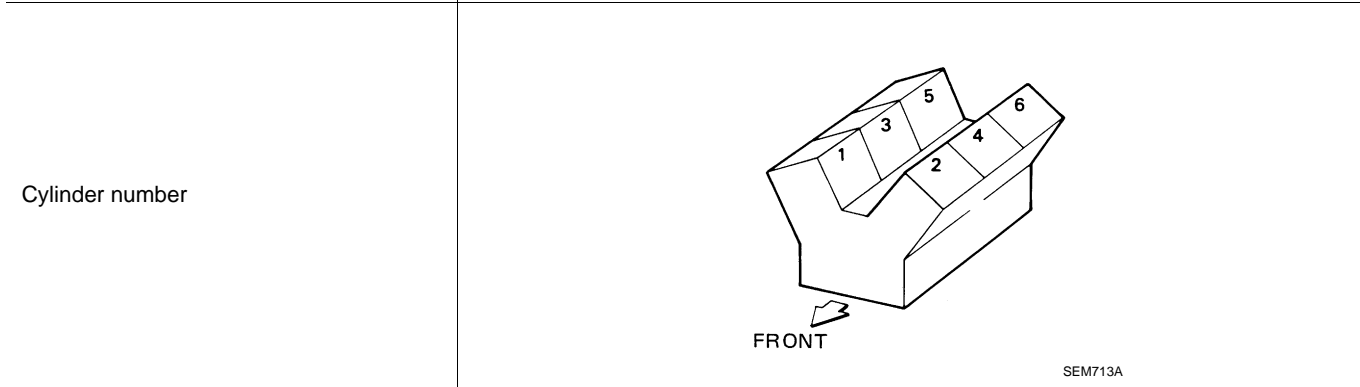

Unit: degree

a	b	c	d	e	f
240	240	-10	70	10	50

#### Drive Belt

INFOID:000000004348986

#### DRIVE BELT

Tension of drive belt	Belt tension is not necessary, as it is automatically adjusted by drive belt auto-tensioner.
-----------------------	--

# SERVICE DATA AND SPECIFICATIONS (SDS)

## < SERVICE DATA AND SPECIFICATIONS (SDS)

### Spark Plug

INFOID:000000004348987

#### SPARK PLUG

Unit: mm (in)

Make	DENSO	
Standard type	FXE22HR11	
Gap	Standard	1.1 (0.043)
	Limit	1.4 (0.055)

### Intake Manifold

INFOID:000000004348988

#### INTAKE MANIFOLD

Unit: mm (in)

Items		Limit
Surface distortion	Intake manifold collector	0.1 (0.004)
	Intake manifold	0.1 (0.004)

### Exhaust Manifold

INFOID:000000004348989

#### EXHAUST MANIFOLD

Unit: mm (in)

Items		Limit
Surface distortion	Exhaust manifold	0.3 (0.012)

### Camshaft

INFOID:000000004348990

#### CAMSHAFT

Unit: mm (in)

Items		Standard	Limit
Camshaft journal oil clearance	No. 1	0.045 - 0.086 (0.0018 - 0.0034)	0.15 (0.0059)
	No. 2, 3, 4	0.035 - 0.076 (0.0014 - 0.0030)	
Camshaft bracket inner diameter	No. 1	26.000 - 26.021 (1.0236 - 1.0244)	—
	No. 2, 3, 4	23.500 - 23.521 (0.9252 - 0.9260)	—
Camshaft journal diameter	No. 1	25.935 - 25.955 (1.0211 - 1.0218)	—
	No. 2, 3, 4	23.445 - 23.465 (0.9230 - 0.9238)	—
Camshaft end play		0.115 - 0.188 (0.0045 - 0.0074)	0.24 (0.0094)
Camshaft cam height "A"	Intake	45.475 - 45.665 (1.7904 - 1.7978)	0.2 (0.008)* <sup>1</sup>
	Exhaust	45.485 - 45.675 (1.7907 - 1.7982)	0.2 (0.008)* <sup>1</sup>
Camshaft runout [TIR* <sup>2</sup> ]		Less than 0.02 mm (0.0008)	0.05 (0.0020)
Camshaft sprocket runout [TIR* <sup>2</sup> ]		Less than 0.15 (0.0059)	—

# SERVICE DATA AND SPECIFICATIONS (SDS)

## < SERVICE DATA AND SPECIFICATIONS (SDS)

Difference in level between front end faces of No. 1 camshaft bracket and cylinder head	-0.14 (-0.0055)	—
---	-----------------	---

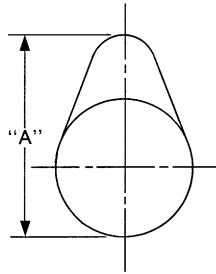

SEM671

\*1: Cam wear limit

\*2: Total indicator reading

### VALVE LIFTER

Unit: mm (in)

Items	Standard
Valve lifter outer diameter	33.977 - 33.987 (1.3377 - 1.3381)
Valve lifter hole diameter	34.000 - 34.016 (1.3386 - 1.3392)
Valve lifter clearance	0.013 - 0.039 (0.0005 - 0.0015)

### VALVE CLEARANCE

Unit: mm (in)

Items	Cold	Hot* (reference data)
Intake	0.26 - 0.34 (0.010 - 0.013)	0.304 - 0.416 (0.012 - 0.016)
Exhaust	0.29 - 0.37 (0.011 - 0.015)	0.308 - 0.432 (0.012 - 0.017)

\*: Approximately 80°C (176°F)

### AVAILABLE VALVE LIFTER

Unit: mm (in)

Identification (stamped) mark	Thickness
788C	7.88 (0.3102)
790C	7.90 (0.3110)
792C	7.92 (0.3118)
794C	7.94 (0.3126)
796C	7.96 (0.3134)
798C	7.98 (0.3142)
800C	8.00 (0.3150)
802C	8.02 (0.3157)
804C	8.04 (0.3165)
806C	8.06 (0.3173)
808C	8.08 (0.3181)
810C	8.10 (0.3189)
812C	8.12 (0.3197)
814C	8.14 (0.3205)
816C	8.16 (0.3213)
818C	8.18 (0.3220)

# SERVICE DATA AND SPECIFICATIONS (SDS)

## < SERVICE DATA AND SPECIFICATIONS (SDS)

Identification (stamped) mark	Thickness
820C	8.20 (0.3228)
822C	8.22 (0.3236)
824C	8.24 (0.3244)
826C	8.26 (0.3252)
828C	8.28 (0.3260)
830C	8.30 (0.3268)
832C	8.32 (0.3276)
834C	8.34 (0.3283)
836C	8.36 (0.3291)
838C	8.38 (0.3299)
840C	8.40 (0.3307)

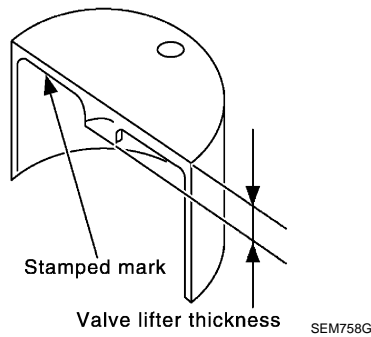

## Cylinder Head

INFOID:000000004348991

### CYLINDER HEAD

Unit: mm (in)

Items	Standard	Limit
Head surface distortion	Less than 0.03 (0.0012)	0.1 (0.004)
Normal cylinder head height "H"	126.3 - 126.5 (4.97 - 4.98)	—
Spark plug tube installation height	37.7 - 38.7 (1.484 - 1.529)	—

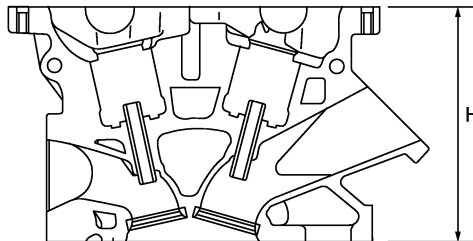

PBIC0924E

## VALVE DIMENSIONS

# SERVICE DATA AND SPECIFICATIONS (SDS)

## < SERVICE DATA AND SPECIFICATIONS (SDS)

Unit: mm (in)

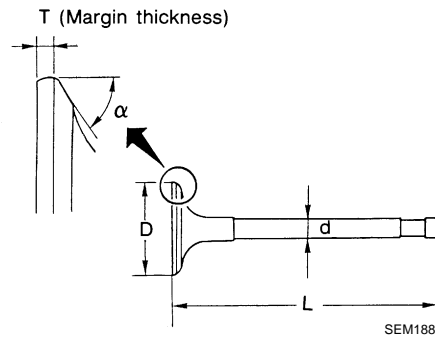

Valve head diameter "D"	Intake	36.6 - 36.9 (1.441 - 1.453)
	Exhaust	30.2 - 30.5 (1.189 - 1.201)
Valve length "L"	Intake	97.13 (3.8240)
	Exhaust	94.67 (3.7272)
Valve stem diameter "d"	Intake	5.965 - 5.980 (0.2348 - 0.2354)
	Exhaust	5.955 - 5.970 (0.2344 - 0.2350)
Valve seat angle "α"	Intake	45°15' - 45°45'
	Exhaust	
Valve margin "T"	Intake	1.15 - 1.45 (0.0453 - 0.0571)
	Exhaust	1.45 - 1.75 (0.0571 - 0.0689)
Valve margin "T" limit		More than 0.5 (0.020)
Valve stem end surface grinding limit		Less than 0.2 (0.008)

### VALVE OIL SEAL

Unit: mm (in)

Description	Standard
Valve oil seal instalation height	14.3 - 14.9 (0.563 - 0.587)

### VALVE GUIDE

Unit: mm (in)

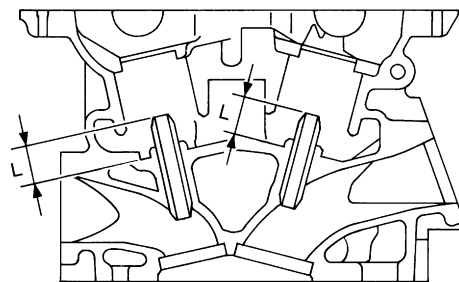

SEM950E

Items		Standard	Oversize (Service) [0.2 (0.008)]
Valve guide	Outer diameter	10.023 - 10.034 (0.3946 - 0.3950)	10.223 - 10.234 (0.4025 - 0.4029)
	Inner diameter (Finished size)	6.000 - 6.018 (0.2362 - 0.2369)	
Cylinder head valve guide hole diameter		9.975 - 9.996 (0.3927 - 0.3935)	10.175 - 10.196 (0.4006 - 0.4014)
Interference fit of valve guide		0.027 - 0.059 (0.0011 - 0.0023)	
Items		Standard	Limit

# SERVICE DATA AND SPECIFICATIONS (SDS)

## < SERVICE DATA AND SPECIFICATIONS (SDS)

Valve guide clearance	Intake	0.020 - 0.053 (0.0008 - 0.0021)	0.08 (0.0031)
	Exhaust	0.040 - 0.073 (0.0016 - 0.0029)	0.01 (0.004)
Valve deflection	Intake	—	0.24 (0.0094)
	Exhaust	—	0.28 (0.0110)
Projection length "L"		12.6 - 12.8 (0.496 - 0.504)	

## VALVE SEAT

Unit: mm (in)

Items	Standard	Oversize (Service) [0.5 (0.02)]
-------	----------	---------------------------------

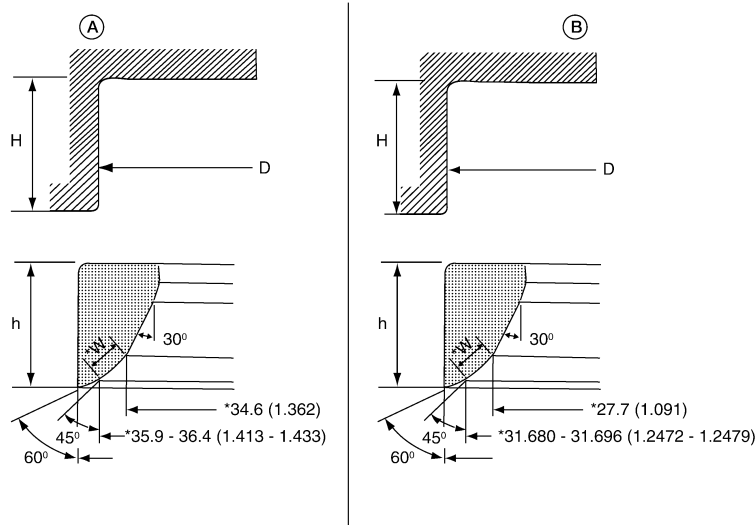

AWBIA0033GB

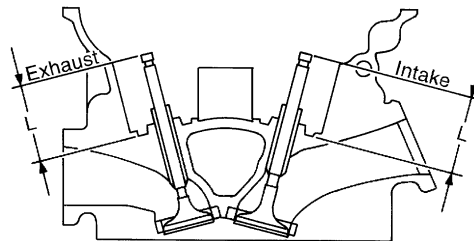

SEM621F

Cylinder head seat recess diameter "D"	Intake (A)	38.000 - 38.016 (1.4961 - 1.4967)	38.500 - 38.516 (1.5157 - 1.5164)
	Exhaust (B)	31.600 - 31.616 (1.2441 - 1.2447)	32.100 - 32.116 (1.2638 - 1.2644)
Valve seat outer diameter	Intake	38.097 - 38.113 (1.4999 - 1.5005)	38.597 - 38.613 (1.5196 - 1.5202)
	Exhaust	31.680 - 31.696 (1.2472 - 1.2479)	32.180 - 32.196 (1.2669 - 1.2676)
Valve seat interference fit	Intake	0.081 - 0.113 (0.0032 - 0.0044)	
	Exhaust	0.064 - 0.096 (0.0025 - 0.0038)	
Height "h"	Intake (A)	5.9 - 6.0 (0.232 - 0.236)	5.0 - 5.1 (0.197 - 0.201)
	Exhaust (B)	5.9 - 6.0 (0.232 - 0.236)	4.9 - 5.0 (0.193 - 0.197)
Contacting width "W"*	Intake (A)	1.18 - 1.22 (0.0465 - 0.0480)	
	Exhaust (B)	1.38 - 1.42 (0.0543 - 0.0559)	
Cylindr head seat recess depth (H)		6.0 (0.236)	
Depth "L"	Intake (A)	41.16 - 41.76 (1.6205 - 1.6441)	
	Exhaust (B)	41.09 - 41.69 (1.6177 - 1.6413)	

\*:Machining data

# SERVICE DATA AND SPECIFICATIONS (SDS)

## < SERVICE DATA AND SPECIFICATIONS (SDS)

### VALVE SPRING

Items	Standard
Free height	47.07 mm (1.8531 in)
Installation height	37.00 mm (1.4567 in)
Installation load	166 - 188 N (16.9 - 19.2 kg, 37 - 42 lb)
Height during valve open	27.20 mm (1.0709 in)
Load with valve open	373 - 421 N (38.0 - 42.9 kg, 84 - 95 lb)

Unit: mm (in)

Items	Limit
Squareness	2.0 (0.079)

### Cylinder Block

INFOID:000000004348992

### CYLINDER BLOCK

Unit: mm (in)

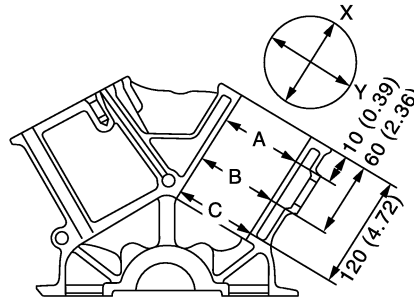

JPBIA2238GB

Surface distortion		Standard		Less than 0.03 (0.0012)
		Limit		0.10 (0.0039)
Main bearing housing inner diameter		Standard		63.993 - 64.017 (2.5194 - 2.5203)
Cylinder bore	Inner diameter	Standard	Grade No. 1	95.500 - 95.510 (3.7598 - 3.7602)
			Grade No. 2	95.510 - 95.520 (3.7602 - 3.7606)
			Grade No. 3	95.520 - 95.530 (3.7606 - 3.7610)
		Wear limit		0.20 (0.0079)
Out-of-round		Limit		0.015 (0.0006)
Taper (Difference between A and C)				0.015 (0.0006)

# SERVICE DATA AND SPECIFICATIONS (SDS)

## < SERVICE DATA AND SPECIFICATIONS (SDS)

Main bearing housing inner diameter grade (Without bearing)	Grade No. A	63.993 - 63.994 (2.5194 - 2.5194)
	Grade No. B	63.994 - 63.995 (2.5194 - 2.5195)
	Grade No. C	63.995 - 63.996 (2.5195 - 2.5195)
	Grade No. D	63.996 - 63.997 (2.5195 - 2.5196)
	Grade No. E	63.997 - 63.998 (2.5196 - 2.5196)
	Grade No. F	63.998 - 63.999 (2.5196 - 2.5196)
	Grade No. G	63.999 - 64.000 (2.5196 - 2.5197)
	Grade No. H	64.000 - 64.001 (2.5197 - 2.5197)
	Grade No. J	64.001 - 64.002 (2.5197 - 2.5198)
	Grade No. K	64.002 - 64.003 (2.5198 - 2.5198)
	Grade No. L	64.003 - 64.004 (2.5198 - 2.5198)
	Grade No. M	64.004 - 64.005 (2.5198 - 2.5199)
	Grade No. N	64.005 - 64.006 (2.5199 - 2.5199)
	Grade No. P	64.006 - 64.007 (2.5199 - 2.5200)
	Grade No. R	64.007 - 64.008 (2.5200 - 2.5200)
	Grade No. S	64.008 - 64.009 (2.5200 - 2.5200)
	Grade No. T	64.009 - 64.010 (2.5200 - 2.5201)
	Grade No. U	64.010 - 64.011 (2.5201 - 2.5201)
	Grade No. V	64.011 - 64.012 (2.5201 - 2.5202)
Grade No. W	64.012 - 64.013 (2.5202 - 2.5202)	
Grade No. X	64.013 - 64.014 (2.5202 - 2.5202)	
Grade No. Y	64.014 - 64.015 (2.5202 - 2.5203)	
Grade No. 4	64.015 - 64.016 (2.5203 - 2.5203)	
Grade No. 7	64.016 - 64.017 (2.5203 - 2.5203)	
Difference in inner diameter between cylinders	Standard	Less than 0.03 (0.0012)

## AVAILABLE PISTON

Unit: mm (in)

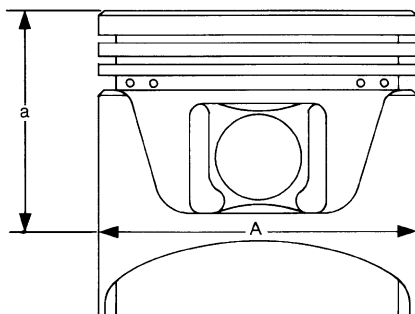

SEM882E

Items	Standard	
Piston skirt diameter "A"	Grade No. 1	95.480 - 95.490 (3.7590 - 3.7594)
	Grade No. 2	95.490 - 95.500 (3.7594 - 3.7598)
	Grade No. 3	95.500 - 95.510 (3.7598 - 3.7602)
"a" dimension	38.0 (1.496)	
Piston pin hole diameter	Grade No. 0	21.993 - 21.999 (0.8659 - 0.8661)
	Grade No. 1	21.999 - 22.005 (0.8661 - 0.8663)
Piston to cylinder bore clearance	0.010 - 0.030 (0.0004 - 0.0012)	

## PISTON RING

Unit: mm (in)

Items	Standard	Limit	
Side clearance	Top	0.045 - 0.080 (0.0018 - 0.0031)	0.11 (0.0043)
	2nd	0.030 - 0.070 (0.0012 - 0.0028)	0.1 (0.004)
	Oil ring	0.065 - 0.125 (0.0018 - 0.0049)	—



# SERVICE DATA AND SPECIFICATIONS (SDS)

## < SERVICE DATA AND SPECIFICATIONS (SDS)

End gap	Top	0.23 - 0.28 (0.0091 - 0.0110)	0.50 (0.0197)
	2nd	0.33 - 0.43 (0.0130 - 0.0169)	0.62 (0.0244)
	Oil (rail ring)	0.20 - 0.45 (0.0079 - 0.0177)	0.80 (0.0315)

### PISTON PIN

Unit: mm (in)

Items		Standard	Limit
Piston pin outer diameter	Grade No. 0	21.989 - 21.995 (0.8657 - 0.8659)	—
	Grade No. 1	21.995 - 22.001 (0.8659 - 0.8662)	—
Piston to piston pin oil clearance		0.002 - 0.010 (0.0001 - 0.0004)	—
Connecting rod bushing oil clearance		0.005 - 0.017 (0.0002 - 0.0007)	0.030 (0.0012)

### CONNECTING ROD

Unit: mm (in)

Items		Standard	Limit
Center distance		144.15 - 144.25 (5.68 - 5.68)	—
Bend [per 100 (3.94)]		—	0.15 (0.0059)
Torsion [per 100 (3.94)]		—	0.30 (0.0118)
Connecting rod small end inner diameter		23.980 - 24.000 (0.9441 - (0.9449)	—
Connecting rod bushing inner diameter*	Grade No. 0	22.000 - 22.006 (0.8661 - 0.8664)	—
	Grade No. 1	22.006 - 22.012 (0.8664 - 0.8666)	—
Connecting rod big end diameter (Without bearing)		55.000 - 55.013 (2.1654 - 2.1659)	—
Side clearance		0.20 - 0.35 (0.0079 - 0.0138)	0.40 (0.0157)

\*: After installing in connecting rod

### CRANKSHAFT

# SERVICE DATA AND SPECIFICATIONS (SDS)

## < SERVICE DATA AND SPECIFICATIONS (SDS)

Unit: mm (in)

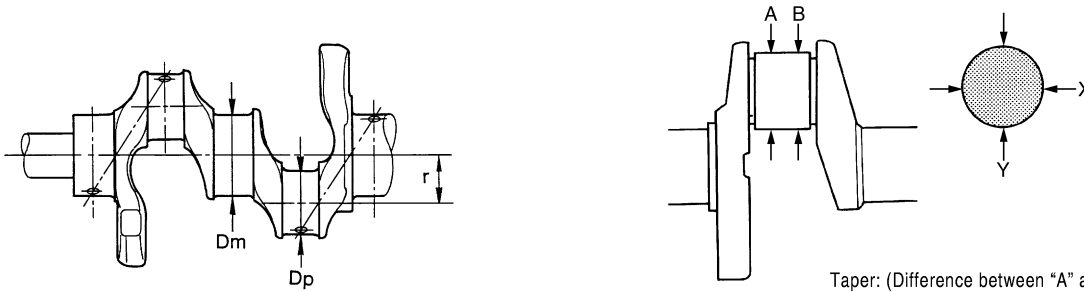

SEM645

SBIA0535E

Taper: (Difference between "A" and "B")  
Out-of-round: (Difference between "X" and "Y")

Main journal diameter. "Dm" grade	Standard	Grade No. A	59.975 - 59.974 (2.3612 - 2.3612)
		Grade No. B	59.974 - 59.973 (2.3612 - 2.3611)
		Grade No. C	59.973 - 59.972 (2.3611 - 2.3611)
		Grade No. D	59.972 - 59.971 (2.3611 - 2.3611)
		Grade No. E	59.971 - 59.970 (2.3611 - 2.3610)
		Grade No. F	59.970 - 59.969 (2.3610 - 2.3610)
		Grade No. G	59.969 - 59.968 (2.3610 - 2.3609)
		Grade No. H	59.968 - 59.967 (2.3609 - 2.3609)
		Grade No. J	59.967 - 59.966 (2.3609 - 2.3609)
		Grade No. K	59.966 - 59.965 (2.3609 - 2.3608)
		Grade No. L	59.965 - 59.964 (2.3608 - 2.3608)
		Grade No. M	59.964 - 59.963 (2.3608 - 2.3607)
		Grade No. N	59.963 - 59.962 (2.3607 - 2.3607)
		Grade No. P	59.962 - 59.961 (2.3607 - 2.3607)
		Grade No. R	59.961 - 59.960 (2.3607 - 2.3606)
		Grade No. S	59.960 - 59.959 (2.3606 - 2.3606)
		Grade No. T	59.959 - 59.958 (2.3606 - 2.3605)
		Grade No. U	59.958 - 59.957 (2.3605 - 2.3605)
		Grade No. V	59.957 - 59.956 (2.3605 - 2.3605)
Grade No. W	59.956 - 59.955 (2.3605 - 2.3604)		
Grade No. X	59.955 - 59.954 (2.3604 - 2.3604)		
Grade No. Y	59.954 - 59.953 (2.3604 - 2.3603)		
Grade No. 4	59.953 - 59.952 (2.3603 - 2.3603)		
Grade No. 7	59.952 - 59.951 (2.3603 - 2.3603)		
Pin journal diameter. "Dp" grade	Standard	Grade No. 0	51.968 - 51.974 (2.0460 - 2.0462)
		Grade No. 1	51.962 - 51.968 (2.0457 - 2.0460)
		Grade No. 2	51.956 - 51.962 (2.0445 - 2.0457)
Center distance "r"			40.66 - 40.74 (1.6008 - 1.6039)
Taper (Difference between "A" and "B")	Limit		Less than 0.002 (0.0001)
Out-of-round (Difference between "X" and "Y")			Less than 0.002 (0.0001)
Crankshaft runout [TIR*]	Standard		Less than 0.05 (0.0020)
	Limit		0.10 (0.0039)
Crankshaft end play	Standard		0.10 - 0.25 (0.0039 - 0.0098)
	Limit		0.30 (0.0118)
Fillet role of crankshaft journal	Standard		More than 0.10 (0.0039)

\*: Total indicator reading

## Main Bearing

INFOID:000000004348993

## MAIN BEARING

# SERVICE DATA AND SPECIFICATIONS (SDS)

## < SERVICE DATA AND SPECIFICATIONS (SDS)

Unit: mm (in)

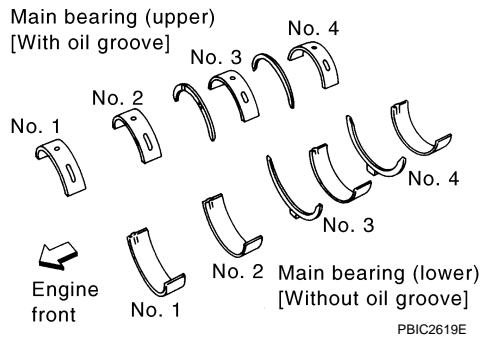

Grade number		Thickness	Width	Identification color	Remarks
0		2.000 - 2.003 (0.0787 - 0.0789)	19.9 - 20.1 (0.783 - 0.791)	Black	Grade is the same for upper and lower bearings.
1		2.003 - 2.006 (0.0789 - 0.0790)		Brown	
2		2.006 - 2.009 (0.0790 - 0.0791)		Green	
3		2.009 - 2.012 (0.0791 - 0.0792)		Yellow	
4		2.012 - 2.015 (0.0792 - 0.0793)		Blue	
5		2.015 - 2.018 (0.0793 - 0.0794)		Pink	
6		2.018 - 2.021 (0.0794 - 0.0796)		Purple	
7		2.021 - 2.024 (0.0796 - 0.0797)		White	
01	UPR	2.003 - 2.006 (0.0789 - 0.0790)	19.9 - 20.1 (0.783 - 0.791)	Brown	Grade and color are different for upper and lower bearings.
	LWR	2.000 - 2.003 (0.0787 - 0.0789)		Black	
12	UPR	2.006 - 2.009 (0.0790 - 0.0791)		Green	
	LWR	2.003 - 2.006 (0.0789 - 0.0790)		Brown	
23	UPR	2.009 - 2.012 (0.0791 - 0.0792)		Yellow	
	LWR	2.006 - 2.009 (0.0790 - 0.0791)		Green	
34	UPR	2.012 - 2.015 (0.0792 - 0.0793)		Blue	
	LWR	2.009 - 2.012 (0.0791 - 0.0792)		Yellow	
45	UPR	2.015 - 2.018 (0.0793 - 0.0794)		Pink	
	LWR	2.012 - 2.015 (0.0792 - 0.0793)		Blue	
56	UPR	2.018 - 2.021 (0.0794 - 0.0796)		Purple	
	LWR	2.015 - 2.018 (0.0793 - 0.0794)		Pink	
67	UPR	2.021 - 2.024 (0.0796 - 0.0797)		White	
	LWR	2.018 - 2.021 (0.0794 - 0.0796)		Purple	

### UNDERSIZE

Unit: mm (in)

Items	Thickness	Main journal diameter
0.25 (0.0098)	2.132 - 2.140 (0.0839 - 0.0843)	Grind so that bearing clearance is the specified value.

### MAIN BEARING OIL CLEARANCE

Unit: mm (in)

Items	Standard	Limit
Main bearing oil clearance	0.035 - 0.045 (0.0014 - 0.0018)*	0.065 (0.0026)

\*: Actual clearance

## Connecting Rod Bearing

INFOID:000000004348994

## CONNECTING ROD BEARING

# SERVICE DATA AND SPECIFICATIONS (SDS)

## < SERVICE DATA AND SPECIFICATIONS (SDS)

Unit: mm (in)

Grade number	Thickness	Identification color (mark)
0	1.500 - 1.503 (0.0591 - 0.0592)	Black
1	1.503 - 1.506 (0.0592 - 0.0593)	Brown
2	1.506 - 1.509 (0.0593 - 0.0594)	Green

## UNDERSIZE

Unit: mm (in)

Items	Thickness	Crank pin journal diameter "Dp"
0.25 (0.0098)	1.626 - 1.634 (0.0640 - 0.0643)	Grind so that bearing clearance is the specified value.

## CONNECTING ROD BEARING OIL CLEARANCE

Unit: mm (in)

Items	Standard	Limit
Connecting rod bearing oil clearance	0.020 - 0.045 (0.0008 - 0.0018)*	0.070 (0.0028)

\*: Actual clearance

## Drive Plate

INFOID:000000004348984

Unit: mm (in)

Drive plate runout [TIR]* - on torque converter mounting surface	Less than 0.35 (0.0138)
Drive plate runout [TIR]* - on ring gear	0.5 (0.0197)