

SECTION **PWC**

POWER WINDOW CONTROL SYSTEM

A
B
C

CONTENTS

LH&RH FRONT WINDOW ANTI-PINCH	POWER SUPPLY AND GROUND CIRCUIT18	F
BASIC INSPECTION 6	BCM18	
DIAGNOSIS AND REPAIR WORKFLOW 6	BCM : Diagnosis Procedure18	G
Work Flow6	BCM : Special Repair Requirement19	
INSPECTION AND ADJUSTMENT 9	POWER WINDOW MAIN SWITCH19	H
ADDITIONAL SERVICE WHEN REMOVING BATTERY NEGATIVE TERMINAL9	POWER WINDOW MAIN SWITCH : Diagnosis Procedure19	
ADDITIONAL SERVICE WHEN REMOVING BATTERY NEGATIVE TERMINAL : Description9	POWER WINDOW MAIN SWITCH : Special Repair Requirement20	I
ADDITIONAL SERVICE WHEN REMOVING BATTERY NEGATIVE TERMINAL : Special Repair Requirement9	FRONT POWER WINDOW SWITCH20	
ADDITIONAL SERVICE WHEN REPLACING CONTROL UNIT9	FRONT POWER WINDOW SWITCH : Diagnosis Procedure20	J
ADDITIONAL SERVICE WHEN REPLACING CONTROL UNIT : Description9	FRONT POWER WINDOW SWITCH : Special Repair Requirement21	
ADDITIONAL SERVICE WHEN REPLACING CONTROL UNIT : Special Repair Requirement9	REAR POWER WINDOW SWITCH21	PWC
FUNCTION DIAGNOSIS11	REAR POWER WINDOW SWITCH : Diagnosis Procedure21	L
POWER WINDOW SYSTEM11	REAR POWER WINDOW SWITCH : Special Repair Requirement22	
System Diagram 11	REAR POWER WINDOW SWITCH24	M
System Description 11	Description24	
Component Parts Location 14	Component Function Check24	N
Component Description 15	Diagnosis Procedure24	
DIAGNOSIS SYSTEM (BCM)16	Component Inspection25	O
COMMON ITEM 16	Special Repair Requirement26	
COMMON ITEM : Diagnosis Description 16	POWER WINDOW MOTOR27	P
COMMON ITEM : CONSULT-III Function 16	DRIVER SIDE27	
RETAINED PWR16	DRIVER SIDE : Description27	
RETAINED PWR : CONSULT-III Function (BCM - RETAINED PWR) 17	DRIVER SIDE : Component Function Check27	
COMPONENT DIAGNOSIS18	DRIVER SIDE : Diagnosis Procedure27	
	DRIVER SIDE : Component Inspection28	
	DRIVER SIDE : Special Repair Requirement28	
	PASSENGER SIDE28	
	PASSENGER SIDE : Description29	

PASSENGER SIDE : Component Function Check	FRONT POWER WINDOW SWITCH : Diagnosis
..... 29	Procedure 48
PASSENGER SIDE : Diagnosis Procedure 29	FRONT POWER WINDOW SWITCH : Special
PASSENGER SIDE : Component Inspection 30	Repair Requirement 48
PASSENGER SIDE : Special Repair Requirement	
..... 30	POWER WINDOW LOCK SWITCH 50
REAR LH 30	Component Function Check 50
REAR LH : Description 30	Component Inspection 50
REAR LH : Component Function Check 30	Special Repair Requirement 50
REAR LH : Diagnosis Procedure 31	
REAR LH : Component Inspection 32	ECU DIAGNOSIS 52
REAR RH 32	BCM (BODY CONTROL MODULE) 52
REAR RH : Description 32	Reference Value 52
REAR RH : Component Function Check 32	Terminal Layout 57
REAR RH : Diagnosis Procedure 32	Physical Values 57
REAR RH : Component Inspection 33	
ENCODER 34	POWER WINDOW MAIN SWITCH 76
DRIVER SIDE 34	Reference Value 76
DRIVER SIDE : Description 34	Wiring Diagram 78
DRIVER SIDE : Component Function Check 34	Fail Safe 85
DRIVER SIDE : Diagnosis Procedure 34	
DRIVER SIDE : Special Repair Requirement 36	FRONT POWER WINDOW SWITCH 87
PASSENGER SIDE 36	Reference Value 87
PASSENGER SIDE : Description 37	Wiring Diagram 89
PASSENGER SIDE : Component Function Check	Fail Safe 96
..... 37	
PASSENGER SIDE : Diagnosis Procedure 37	SYMPTOM DIAGNOSIS 98
PASSENGER SIDE : Special Repair Requirement	NONE OF THE POWER WINDOWS CAN BE
..... 39	OPERATED USING ANY SWITCH 98
DOOR SWITCH 40	Diagnosis Procedure 98
Description 40	
Component Function Check 40	DRIVER SIDE POWER WINDOW ALONE
Diagnosis Procedure 40	DOES NOT OPERATE 99
Component Inspection 42	Diagnosis Procedure 99
DOOR KEY CYLINDER SWITCH 43	
Description 43	FRONT PASSENGER SIDE POWER WIN-
Component Function Check 43	DOW ALONE DOES NOT OPERATE 100
Diagnosis Procedure 43	Diagnosis Procedure 100
Component Inspection 44	
Special Repair Requirement 45	REAR LH SIDE POWER WINDOW ALONE
POWER WINDOW SERIAL LINK 46	DOES NOT OPERATE 101
POWER WINDOW MAIN SWITCH 46	Diagnosis Procedure 101
POWER WINDOW MAIN SWITCH : Description ... 46	
POWER WINDOW MAIN SWITCH : Component	REAR RH SIDE POWER WINDOW ALONE
Function Check 46	DOES NOT OPERATE 102
POWER WINDOW MAIN SWITCH : Diagnosis	Diagnosis Procedure 102
Procedure 46	
POWER WINDOW MAIN SWITCH : Special Re-	ANTI-PINCH SYSTEM DOES NOT OPERATE
pair Requirement 47	NORMALLY (DRIVER SIDE) 103
FRONT POWER WINDOW SWITCH 47	Diagnosis Procedure 103
FRONT POWER WINDOW SWITCH : Descrip-	
tion 47	ANTI-PINCH SYSTEM DOES NOT OPERATE
	NORMALLY (PASSENGER SIDE) 104
	Diagnosis Procedure 104
	AUTO OPERATION DOES NOT OPERATE
	BUT MANUAL OPERATE NORMALLY
	(DRIVER SIDE) 105
	Diagnosis Procedure 105

AUTO OPERATION DOES NOT OPERATE BUT MANUAL OPERATE NORMALLY (PASSENGER SIDE)	106	ADDITIONAL SERVICE WHEN REPLACING CONTROL UNIT	119	A
Diagnosis Procedure	106	ADDITIONAL SERVICE WHEN REPLACING CONTROL UNIT : Description	119	
POWER WINDOW RETAINED POWER OPERATION DOES NOT OPERATE PROPERLY	107	ADDITIONAL SERVICE WHEN REPLACING CONTROL UNIT : Special Repair Requirement ...	119	B
Diagnosis Procedure	107	FUNCTION DIAGNOSIS	121	C
DOES NOT OPERATE BY KEY CYLINDER SWITCH	108	POWER WINDOW SYSTEM	121	
Diagnosis Procedure	108	System Diagram	121	D
KEYLESS POWER WINDOW DOWN DOES NOT OPERATE	109	System Description	121	
Diagnosis Procedure	109	Component Parts Location	124	
POWER WINDOW LOCK SWITCH DOES NOT FUNCTION	110	Component Description	125	
Diagnosis Procedure	110	DIAGNOSIS SYSTEM (BCM)	126	E
PRECAUTION	111	COMMON ITEM	126	
PRECAUTIONS	111	COMMON ITEM : Diagnosis Description	126	F
Precaution for Supplemental Restraint System (SRS) "AIR BAG" and "SEAT BELT PRE-TENSIONER"	111	COMMON ITEM : CONSULT-III Function	126	
Precautions Necessary for Steering Wheel Rotation after Battery Disconnect	111	RETAINED PWR	126	
ON-VEHICLE MAINTENANCE	112	RETAINED PWR : CONSULT-III Function (BCM - RETAINED PWR)	127	G
PRE-INSPECTION FOR DIAGNOSTIC	112	COMPONENT DIAGNOSIS	128	H
Basic Inspection	112	POWER SUPPLY AND GROUND CIRCUIT ..	128	
ON-VEHICLE REPAIR	113	BCM	128	I
POWER WINDOW MAIN SWITCH	113	BCM : Diagnosis Procedure	128	
Removal and Installation	113	BCM : Special Repair Requirement	129	J
FRONT POWER WINDOW SWITCH	114	POWER WINDOW MAIN SWITCH	129	
Removal and Installation	114	POWER WINDOW MAIN SWITCH : Diagnosis Procedure	129	
REAR POWER WINDOW SWITCH	115	POWER WINDOW MAIN SWITCH : Special Repair Requirement	130	PWC
Removal and Installation	115	FRONT POWER WINDOW SWITCH	130	
FRONT & REAR WINDOW ANTI-PINCH		FRONT POWER WINDOW SWITCH : Diagnosis Procedure	130	L
BASIC INSPECTION	116	FRONT POWER WINDOW SWITCH : Special Repair Requirement	131	M
DIAGNOSIS AND REPAIR WORKFLOW	116	REAR POWER WINDOW SWITCH	131	
Work Flow	116	REAR POWER WINDOW SWITCH : Diagnosis Procedure	131	N
INSPECTION AND ADJUSTMENT	119	REAR POWER WINDOW SWITCH : Special Repair Requirement	132	
ADDITIONAL SERVICE WHEN REMOVING BATTERY NEGATIVE TERMINAL	119	POWER WINDOW MOTOR	134	O
ADDITIONAL SERVICE WHEN REMOVING BATTERY NEGATIVE TERMINAL : Description ..	119	DRIVER SIDE	134	
ADDITIONAL SERVICE WHEN REMOVING BATTERY NEGATIVE TERMINAL : Special Repair Requirement	119	DRIVER SIDE : Description	134	P
		DRIVER SIDE : Component Function Check	134	
		DRIVER SIDE : Diagnosis Procedure	134	
		DRIVER SIDE : Component Inspection	135	
		DRIVER SIDE : Special Repair Requirement	135	
		PASSENGER SIDE	135	
		PASSENGER SIDE : Description	136	

PASSENGER SIDE : Component Function Check ..136	POWER WINDOW SERIAL LINK 160
PASSENGER SIDE : Diagnosis Procedure136	POWER WINDOW MAIN SWITCH 160
PASSENGER SIDE : Component Inspection137	POWER WINDOW MAIN SWITCH : Description . 160
PASSENGER SIDE : Special Repair Requirement ..137	POWER WINDOW MAIN SWITCH : Component Function Check
REAR LH 137	160
REAR LH : Description	POWER WINDOW MAIN SWITCH : Diagnosis Procedure
REAR LH : Component Function Check	160
REAR LH : Diagnosis Procedure	POWER WINDOW MAIN SWITCH : Special Repair Requirement
REAR LH : Component Inspection	161
REAR LH : Special Repair Requirement	FRONT POWER WINDOW SWITCH 161
REAR RH 139	FRONT POWER WINDOW SWITCH : Description
REAR RH : Description	161
REAR RH : Component Function Check	FRONT POWER WINDOW SWITCH : Diagnosis Procedure
REAR RH : Diagnosis Procedure	162
REAR RH : Component Inspection	FRONT POWER WINDOW SWITCH : Special Repair Requirement
REAR RH : Special Repair Requirement	162
ENCODER 142	REAR LH 163
DRIVER SIDE 142	REAR LH : Description
DRIVER SIDE : Description	163
DRIVER SIDE : Component Function Check	REAR LH : Diagnosis Procedure
DRIVER SIDE : Diagnosis Procedure	163
DRIVER SIDE : Special Repair Requirement	REAR LH : Special Repair Requirement
144	164
PASSENGER SIDE 144	REAR RH 164
PASSENGER SIDE : Description	REAR RH : Description
PASSENGER SIDE : Component Function Check	164
..145	REAR RH : Diagnosis Procedure
PASSENGER SIDE : Diagnosis Procedure	164
PASSENGER SIDE : Special Repair Requirement	REAR RH : Special Repair Requirement
..147	165
REAR LH 147	POWER WINDOW LOCK SWITCH 167
REAR LH : Description	Component Function Check
REAR LH : Component Function Check	167
REAR LH : Diagnosis Procedure	Special Repair Requirement
REAR LH : Special Repair Requirement	167
150	ECU DIAGNOSIS 168
REAR RH 150	BCM (BODY CONTROL MODULE) 168
REAR RH : Description	Reference Value
REAR RH : Component Function Check	168
REAR RH : Diagnosis Procedure	Terminal Layout
REAR RH : Special Repair Requirement	173
152	Physical Values
DOOR SWITCH 154	173
Description	POWER WINDOW MAIN SWITCH 192
Component Function Check	Reference Value
Diagnosis Procedure	192
Component Inspection	Wiring Diagram
156	194
DOOR KEY CYLINDER SWITCH 157	Fail Safe
Description	201
Component Function Check	FRONT POWER WINDOW SWITCH 203
Diagnosis Procedure	Reference Value
Component Inspection	203
159	Wiring Diagram
REAR POWER WINDOW SWITCH 214	205
Reference Value	Fail Safe
214	212
Wiring Diagram	REAR POWER WINDOW SWITCH 214
216	Reference Value
Fail Safe	214
223	Wiring Diagram
SYMPTOM DIAGNOSIS 225	216
NONE OF THE POWER WINDOWS CAN BE OPERATED USING ANY SWITCH 225	Fail Safe
Diagnosis Procedure	223
225	SYMPTOM DIAGNOSIS 225

DRIVER SIDE POWER WINDOW ALONE DOES NOT OPERATE	226	AUTO OPERATION DOES NOT OPERATE BUT MANUAL OPERATES NORMALLY (REAR RH SIDE)	237	A
Diagnosis Procedure	226	Diagnosis Procedure	237	
FRONT PASSENGER SIDE POWER WINDOW ALONE DOES NOT OPERATE	227	POWER WINDOW RETAINED POWER OPERATION DOES NOT OPERATE PROPERLY	238	B
Diagnosis Procedure	227	Diagnosis Procedure	238	
REAR LH SIDE POWER WINDOW ALONE DOES NOT OPERATE	228	DOES NOT OPERATE BY KEY CYLINDER SWITCH	239	C
Diagnosis Procedure	228	Diagnosis Procedure	239	
REAR RH SIDE POWER WINDOW ALONE DOES NOT OPERATE	229	KEYLESS POWER WINDOW DOWN DOES NOT OPERATE	240	E
Diagnosis Procedure	229	Diagnosis Procedure	240	
ANTI-PINCH SYSTEM DOES NOT OPERATE NORMALLY (DRIVER SIDE)	230	POWER WINDOW LOCK SWITCH DOES NOT FUNCTION	241	F
Diagnosis Procedure	230	Diagnosis Procedure	241	
ANTI-PINCH SYSTEM DOES NOT OPERATE NORMALLY (PASSENGER SIDE)	231	PRECAUTION	242	G
Diagnosis Procedure	231	PRECAUTIONS	242	
ANTI-PINCH SYSTEM DOES NOT OPERATE NORMALLY (REAR LH SIDE)	232	Precaution for Supplemental Restraint System (SRS) "AIR BAG" and "SEAT BELT PRE-TENSIONER"	242	H
Diagnosis Procedure	232	Precautions Necessary for Steering Wheel Rotation after Battery Disconnect	242	
ANTI-PINCH SYSTEM DOES NOT OPERATE NORMALLY (REAR RH SIDE)	233	ON-VEHICLE MAINTENANCE	243	J
Diagnosis Procedure	233	PRE-INSPECTION FOR DIAGNOSTIC	243	
AUTO OPERATION DOES NOT OPERATE BUT MANUAL OPERATE NORMALLY (DRIVER SIDE)	234	Basic Inspection	243	
Diagnosis Procedure	234	ON-VEHICLE REPAIR	244	
AUTO OPERATION DOES NOT OPERATE BUT MANUAL OPERATE NORMALLY (PASSENGER SIDE)	235	POWER WINDOW MAIN SWITCH	244	L
Diagnosis Procedure	235	Removal and Installation	244	
AUTO OPERATION DOES NOT OPERATE BUT MANUAL OPERATES NORMALLY (REAR LH SIDE)	236	FRONT POWER WINDOW SWITCH	245	M
Diagnosis Procedure	236	Removal and Installation	245	
		REAR POWER WINDOW SWITCH	246	N
		Removal and Installation	246	

PWC

DIAGNOSIS AND REPAIR WORKFLOW

< BASIC INSPECTION >

[LH&RH FRONT WINDOW ANTI-PINCH]

BASIC INSPECTION

DIAGNOSIS AND REPAIR WORKFLOW

Work Flow

INFOID:000000003898164

OVERALL SEQUENCE

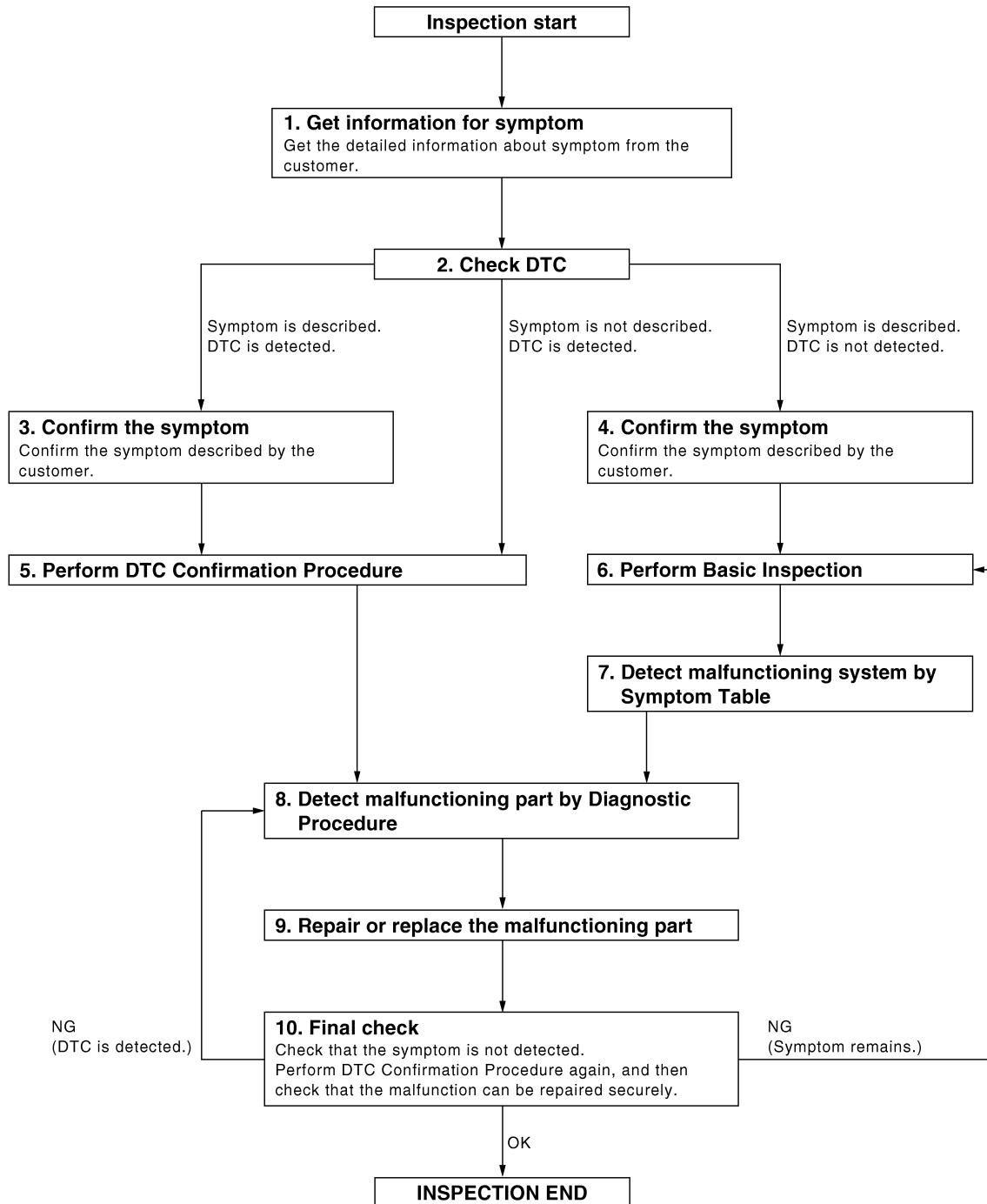

DETAILED FLOW

JMKIA0101GB

DIAGNOSIS AND REPAIR WORKFLOW

< BASIC INSPECTION >

[LH&RH FRONT WINDOW ANTI-PINCH]

1. GET INFORMATION FOR SYMPTOM

Get the detailed information from the customer about the symptom (the condition and the environment when the incident/malfunction occurred).

>> GO TO 2

2. CHECK DTC

1. Check DTC.
2. Perform the following procedure if DTC is displayed.
 - Record DTC and freeze frame data (Print them out with CONSULT-III.)
 - Erase DTC.
 - Study the relationship between the cause detected by DTC and the symptom described by the customer.
3. Check related service bulletins for information.

Is any symptom described and any DTC detected?

Symptom is described, DTC is displayed>>GO TO 3

Symptom is described, DTC is not displayed>>GO TO 4

Symptom is not described, DTC is displayed>>GO TO 5

3. CONFIRM THE SYMPTOM

Confirm the symptom described by the customer.

Connect CONSULT-III to the vehicle in "DATA MONITOR" mode and check real time diagnosis results. Verify relation between the symptom and the condition when the symptom is detected.

>> GO TO 5

4. CONFIRM THE SYMPTOM

Confirm the symptom described by the customer.

Connect CONSULT-III to the vehicle in "DATA MONITOR" mode and check real time diagnosis results. Verify relation between the symptom and the condition when the symptom is detected.

>> GO TO 6

5. PERFORM DTC CONFIRMATION PROCEDURE

Perform DTC Confirmation Procedure for the displayed DTC, and then check that DTC is detected again. At this time, always connect CONSULT-III to the vehicle, and check diagnostic results in real time.

If two or more DTCs are detected, refer to [BCS-81. "DTC Inspection Priority Chart"](#) and determine trouble diagnosis order.

NOTE:

- Freeze frame data is useful if the DTC is not detected.
- Perform Component Function Check if DTC Confirmation Procedure is not included in Service Manual. This simplified check procedure is an effective alternative though DTC cannot be detected during this check. If the result of Component Function Check is NG, it is the same as the detection of DTC by DTC Confirmation Procedure.

Is DTC detected?

YES >> GO TO 8

NO >> Refer to [GI-39. "Intermittent Incident"](#).

6. PERFORM BASIC INSPECTION

Perform [PWC-6. "Work Flow"](#).

Inspection End>>GO TO 7

7. DETECT MALFUNCTIONING SYSTEM BY SYMPTOM TABLE

Detect malfunctioning system based on the confirmed symptom in step 4, and determine the trouble diagnosis order based on possible causes and symptom.

>> GO TO 8

A
B
C
D
E
F
G
H
I
J
L
M
N
O
P

PWC

DIAGNOSIS AND REPAIR WORKFLOW

< BASIC INSPECTION >

[LH&RH FRONT WINDOW ANTI-PINCH]

8. DETECT MALFUNCTIONING PART BY DIAGNOSTIC PROCEDURE

Inspect according to Diagnostic Procedure of the system.

NOTE:

The Diagnostic Procedure described based on open circuit inspection. A short circuit inspection is also required for the circuit check in the Diagnostic Procedure.

Is malfunctioning part detected?

YES >> GO TO 9

NO >> Check voltage of related BCM terminals using CONSULT-III.

9. REPAIR OR REPLACE THE MALFUNCTIONING PART

1. Repair or replace the malfunctioning part.
2. Reconnect parts or connectors disconnected during Diagnostic Procedure again after repair and replacement.
3. Check DTC. If DTC is displayed, erase it.

>> GO TO 10

10. FINAL CHECK

When DTC was detected in step 2, perform DTC Confirmation Procedure or Component Function Check again, and then check that the malfunction has been repaired securely.

When symptom was described from the customer, refer to confirmed symptom in step 3 or 4, and check that the symptom is not detected.

Does the symptom reappear?

YES (DTC is detected)>>GO TO 8

YES (Symptom remains)>>GO TO 6

NO >> Inspection End.

INSPECTION AND ADJUSTMENT

< BASIC INSPECTION >

[LH&RH FRONT WINDOW ANTI-PINCH]

INSPECTION AND ADJUSTMENT

ADDITIONAL SERVICE WHEN REMOVING BATTERY NEGATIVE TERMINAL

ADDITIONAL SERVICE WHEN REMOVING BATTERY NEGATIVE TERMINAL : Description

INFOID:000000003898165

Initial setting is necessary when battery terminal is removed.

CAUTION:

The following specified operations are not performed under the non-initialized condition.

- Auto-up operation
- Anti-pinch function
- Retained power operation

ADDITIONAL SERVICE WHEN REMOVING BATTERY NEGATIVE TERMINAL : Special Repair Requirement

INFOID:000000003898166

INITIALIZATION PROCEDURE

1. Disconnect battery negative terminal or power window main switch connector. Reconnect it after a minute or more.
2. Turn ignition switch ON.
3. Operate power window switch to fully open the window. (This operation is unnecessary if the window is already fully open)
4. Continue pulling the power window switch UP (AUTO-UP operation). Even after glass stops at fully closed position, keep pulling the switch for 4 seconds or more.
5. Inspect anti-pinch function.

CHECK ANTI-PINCH FUNCTION

1. Fully open the door window.
 2. Place a piece of wood near fully closed position.
 3. Close door glass completely with AUTO-UP.
- Check that glass lowers for approximately 150 mm (5.91 in) or 2 seconds without pinching piece of wood and stops.
 - Check that glass does not rise when operating the power window main switch while lowering.

CAUTION:

- Do not check with hands and other parts of the body because they may be pinched. Do not get pinched.
- Check that AUTO-UP operates before inspection when system initialization is performed.
- It may switch to fail-safe mode if open/close operation is performed continuously. Perform initial setting in that situation. Refer to [PWC-85, "Fail Safe"](#).
- Perform initial setting when auto-up operation or anti-pinch function does not operate normally.
- Finish initial setting. Otherwise, next operation cannot be done.

1. Auto-up operation
2. Anti-pinch function
3. Retained power operation when ignition switch is OFF.

ADDITIONAL SERVICE WHEN REPLACING CONTROL UNIT

ADDITIONAL SERVICE WHEN REPLACING CONTROL UNIT : Description

INFOID:000000003898167

Initial setting is necessary when replacing power window main switch.

CAUTION:

The following specified operations are not performed under the non-initialized condition.

- Auto-up operation
- Anti-pinch function
- Retained power operation

ADDITIONAL SERVICE WHEN REPLACING CONTROL UNIT : Special Repair Requirement

INFOID:000000003898168

INITIALIZATION PROCEDURE

A
B
C
D
E
F
G
H
I
J
L
M
N
O
P

PWC

INSPECTION AND ADJUSTMENT

< BASIC INSPECTION >

[LH&RH FRONT WINDOW ANTI-PINCH]

1. Disconnect battery negative terminal or power window main switch connector. Reconnect it after a minute or more.
2. Turn ignition switch ON.
3. Operate power window switch to fully open the window. (This operation is unnecessary if the window is already fully open)
4. Continue pulling the power window switch UP (AUTO-UP operation). Even after glass stops at fully closed position, keep pulling the switch for 4 seconds or more.
5. Inspect anti-pinch function.

CHECK ANTI-PINCH FUNCTION

1. Fully open the door window.
2. Place a piece of wood near fully closed position.
3. Close door glass completely with AUTO-UP.
 - Check that glass lowers for approximately 150 mm (5.91 in) or 2 seconds without pinching piece of wood and stops.
 - Check that glass does not rise when operating the power window main switch while lowering.

CAUTION:

- Do not check with hands and other parts of the body because they may be pinched. Do not get pinched.
 - Check that AUTO-UP operates before inspection when system initialization is performed.
 - It may switch to fail-safe mode if open/close operation is performed continuously. Perform initial setting in that situation. Refer to [PWC-85, "Fail Safe"](#).
 - Perform initial setting when auto-up operation or anti-pinch function does not operate normally.
 - Finish initial setting. Otherwise, next operation cannot be done.
1. Auto-up operation
 2. Anti-pinch function
 3. Retained power operation when ignition switch is OFF.

POWER WINDOW SYSTEM

< FUNCTION DIAGNOSIS >

[LH&RH FRONT WINDOW ANTI-PINCH]

FUNCTION DIAGNOSIS

POWER WINDOW SYSTEM

System Diagram

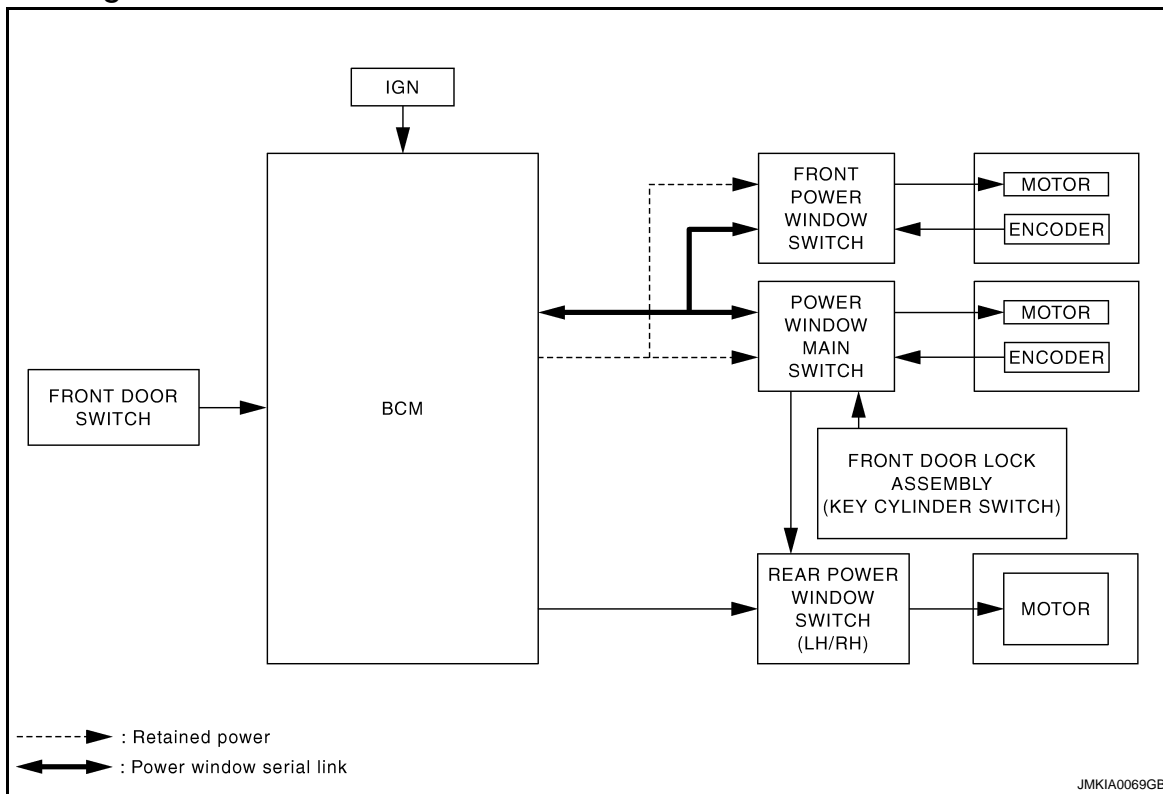

System Description

INFOID:000000004392477

POWER WINDOW MAIN SWITCH INPUT/OUTPUT SIGNAL CHART

PWC

Item	Input signal to power window main switch	Power window main switch function	Actuator
Key cylinder switch	LOCK/UNLOCK signal (more than 1.5 seconds over)	Power window control	Front power window motor
Encoder	Encoder pulse signal		
Power window main switch	Front power window motor (driver side) UP/DOWN signal		
Front power window switch (passenger side)	Front power window motor (passenger side) UP/DOWN signal		
BCM	RAP signal		
Rear power window switch	Rear power window motor UP/DOWN signal		Rear power window motor

FRONT POWER WINDOW SWITCH INPUT/OUTPUT SIGNAL CHART

POWER WINDOW SYSTEM

< FUNCTION DIAGNOSIS >

[LH&RH FRONT WINDOW ANTI-PINCH]

Item	Input signal to front power window switch	Front power window switch function	Actuator
Front power window switch (passenger side)	Front power window motor (passenger side) UP/DOWN signal	Power window control	Front power window motor (passenger side)
Encoder	Encoder pulse signal		
BCM	RAP signal		

POWER WINDOW OPERATION

- Power window system is operable during the retained power operation timer after turning ignition switch ON and OFF.
- Power window main switch (driver side) can open/close all windows.
- Front & rear power window switch can open/close the corresponding windows.

POWER WINDOW AUTO-OPERATION (FRONT DRIVER SIDE & PASSENGER SIDE)

- AUTO UP/DOWN operation can be performed when power window main switch & front power window switch (passenger side) turns to AUTO.
- Encoder continues detecting the movement of power window motor and transmits to power window switch as the encoder pulse signal while power window motor is operating.
- Power window switch reads the changes of encoder signal and stops AUTO operation when door glass is at fully opened/closed position.
- Power window motor is operable in case encoder is malfunctioning.

RETAINED POWER OPERATION

- Retained power operation is an additional power supply function that enables power window system to operate during the 45 seconds even when ignition switch is turned OFF.

Retained power function cancel conditions

- Front door CLOSE (door switch OFF)→OPEN (door switch ON).
- When ignition switch is ON.
- When timer time passes. (45 seconds)

POWER WINDOW LOCK

Ground circuit inside power window main switch shuts off when power window lock switch is ON. This inhibits power window switch operation except with the power window switch.

ANTI-PINCH OPERATION (FRONT DRIVER SIDE & PASSENGER SIDE)

- Pinch foreign material in the door glass during AUTO-UP operation, and it is the anti-pinch function that lowers the door glass 150 mm (5.91 in) or 2 seconds when detected.
- Encoder continues detecting the movement of power window motor and transmits to power window switch as the encoder pulse signal while power window motor is operating.
- Resistance is applied to the power window motor rotation that changes the frequency of encoder pulse signal if foreign material is trapped in the door glass.
- Power window switch controls to lower the window glass for 150 mm or 2 seconds after it detects encoder pulse signal frequency change.

OPERATION CONDITION

- When all door glass AUTO-UP operation is performed (anti-pinch function does not operate just before the door glass closes and is fully closed).

NOTE:

Depending on environment and driving conditions, if a similar impact or load is applied to the door glass, it may lower.

KEY CYLINDER SWITCH OPERATION

Hold the door key cylinder to the LOCK or UNLOCK direction for 1.5 seconds or more to OPEN or CLOSE all power windows when ignition switch is OFF. In addition, it stops when key position is moved to NEUTRAL when operating.

OPERATION CONDITION

- Ignition switch OFF.
- Hold door key cylinder to LOCK position for 1.5 seconds or more to perform CLOSE operation of the door glass.

POWER WINDOW SYSTEM

< FUNCTION DIAGNOSIS >

[LH&RH FRONT WINDOW ANTI-PINCH]

- Hold door key cylinder to UNLOCK position for 1.5 seconds or more to perform OPEN operation of the door glass.

KEYLESS POWER WINDOW DOWN OPERATION (FRONT DRIVER SIDE & PASSENGER SIDE)

All power windows open when the unlock button on Intelligent Key is activated and kept pressed for more than 3 seconds^{NOTE} with the ignition switch OFF. The windows keep opening if the unlock button is continuously pressed.

The power window opening stops when the following operations are performed:

- When the unlock button is kept pressed more than 15 seconds.
- When the ignition switch is turned ON while the power window opening is operated.
- When the unlock button is released.

While retained power operation is active, keyless power window down function cannot be operated.

Keyless power window down operation mode can be changed by "PW DOWN SET" mode in "WORK SUPPORT". Refer to [DLK-50. "INTELLIGENT KEY : CONSULT-III Function \(BCM - INTELLIGENT KEY\)".](#)

NOTE:

Use CONSULT-III to change settings.

MODE 1 (3 sec) / MODE 2 (OFF) / MODE 3 (5 sec)

A
B
C
D
E
F
G
H
I
J
L
M
N
O
P

PWC

POWER WINDOW SYSTEM

< FUNCTION DIAGNOSIS >

[LH&RH FRONT WINDOW ANTI-PINCH]

Component Parts Location

INFOID:000000004392478

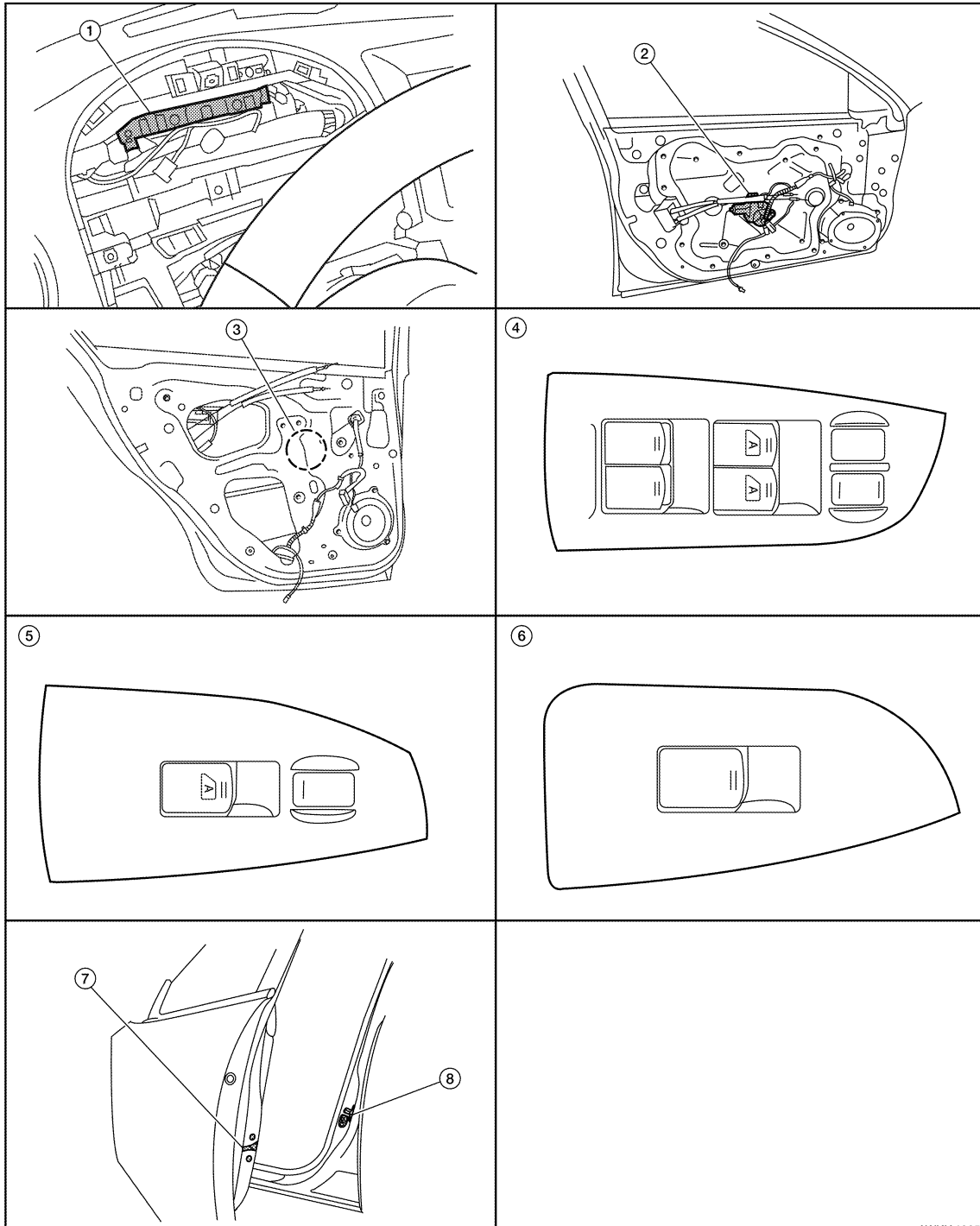

AWKIA1395ZZ

- | | | |
|---|---|---|
| 1. BCM M16, M17, M18, M19 (view with combination meter removed) | 2. Front power window motor LH D9
Front power window motor RH D104 | 3. Rear power window motor LH D204
Rear power window motor RH D304 |
| 4. Main power window and door lock/unlock switch D7, D8 | 5. Power window and door lock/unlock switch RH D105 | 6. Rear power window switch LH D203
Rear power window switch RH D303 |
| 7. Front door lock assembly LH (key cylinder switch) D10 | 8. Front door switch LH B8
Front door switch RH B108 | |

POWER WINDOW SYSTEM

[LH&RH FRONT WINDOW ANTI-PINCH]

< FUNCTION DIAGNOSIS >

INFOID:000000004392479

Component Description

Component	Function
BCM	<ul style="list-style-type: none"> Supplies power supply to power window switch. Controls retained power.
Power window main switch	<ul style="list-style-type: none"> Directly controls all power window motor of all doors. Controls anti-pinch operation of power window.
Front power window switch	<ul style="list-style-type: none"> Controls power window motor of passenger door. Controls anti-pinch operation of power window.
Rear power window switch	<ul style="list-style-type: none"> Controls power window motor of rear right and left doors.
Front power window motor	<ul style="list-style-type: none"> Integrates the ENCODER POWER and WINDOW MOTOR. Starts operating with signals from power window main switch & front power window switch (passenger side). Transmits power window motor rotation as a pulse signal to power window switch.
Rear power window motor	Starts operating with signals from power window main switch & rear power window switch.
Front door lock assembly (key cylinder switch)	Transmits operation condition of key cylinder switch to power window main switch.
Front door switch	Detects door open/close condition and transmits to BCM.

A
B
C
D
E
F
G
H
I
J
L
M
N
O
P

PWC

DIAGNOSIS SYSTEM (BCM)

< FUNCTION DIAGNOSIS >

[LH&RH FRONT WINDOW ANTI-PINCH]

DIAGNOSIS SYSTEM (BCM)

COMMON ITEM

COMMON ITEM : Diagnosis Description

INFOID:000000004363686

BCM CONSULT-III FUNCTION

CONSULT-III performs the following functions via CAN communication with BCM.

Diagnosis mode	Function Description
WORK SUPPORT	Changes the setting for each system function.
SELF-DIAG RESULTS	Displays the diagnosis results judged by BCM.
CAN DIAG SUPPORT MNTR	Monitors the reception status of CAN communication viewed from BCM.
DATA MONITOR	The BCM input/output signals are displayed.
ACTIVE TEST	The signals used to activate each device are forcibly supplied from BCM.
ECU IDENTIFICATION	The BCM part number is displayed.
CONFIGURATION	This function is not used even though it is displayed.

SYSTEM APPLICATION

BCM can perform the following functions for each system.

NOTE:

It can perform the diagnosis modes except the following for all sub system selection items.

System	Sub system selection item	Diagnosis mode		
		WORK SUPPORT	DATA MONITOR	ACTIVE TEST
Door lock	DOOR LOCK	×	×	×
Rear window defogger	REAR DEFOGGER		×	×
Warning chime	BUZZER		×	×
Interior room lamp timer	INT LAMP	×	×	×
Exterior lamp	HEADLAMP	×	×	×
Wiper and washer	WIPER	×	×	×
Turn signal and hazard warning lamps	FLASHER	×	×	×
Air conditioner	AIR CONDITONER		×	
Intelligent Key system	INTELLIGENT KEY	×	×	×
Combination switch	COMB SW		×	
BCM	BCM	×		
Immobilizer	IMMU		×	×
Interior room lamp battery saver	BATTERY SAVER	×	×	×
Trunk open	TRUNK		×	
Vehicle security system	THEFT ALM	×	×	×
RAP system	RETAINED PWR		×	
Signal buffer system	SIGNAL BUFFER		×	×
TPMS	AIR PRESSURE MONITOR	×	×	

COMMON ITEM : CONSULT-III Function

INFOID:000000004363687

ECU IDENTIFICATION

Displays the BCM part No.

SELF-DIAG RESULT

Refer to [BCS-82, "DTC Index"](#).

RETAINED PWR

DIAGNOSIS SYSTEM (BCM)

< FUNCTION DIAGNOSIS >

[LH&RH FRONT WINDOW ANTI-PINCH]

RETAINED PWR : CONSULT-III Function (BCM - RETAINED PWR)

INFOID:000000004363688

Data monitor

Monitor Item [Unit]	Description
DOOR SW-DR [ON/OFF]	Indicates condition of front door switch LH.
DOOR SW-AS [ON/OFF]	Indicates condition of front door switch RH.

A

B

C

D

E

F

G

H

I

J

PWC

L

M

N

O

P

POWER SUPPLY AND GROUND CIRCUIT

< COMPONENT DIAGNOSIS >

[LH&RH FRONT WINDOW ANTI-PINCH]

COMPONENT DIAGNOSIS

POWER SUPPLY AND GROUND CIRCUIT

BCM

BCM : Diagnosis Procedure

INFOID:000000004364410

1. CHECK FUSE AND FUSIBLE LINK

Check if the following BCM fuses or fusible link are blown.

Terminal No.	Signal name	Fuse and fusible link No.
1	Battery power supply	H
11		10
24		7

Is the fuse or fusible link blown?

- YES >> Replace the blown fuse or fusible link after repairing the affected circuit.
 NO >> GO TO 2

2. CHECK POWER SUPPLY CIRCUIT

- Turn ignition switch OFF.
- Disconnect BCM.
- Check voltage between BCM harness connector and ground.

Terminals		Voltage (Approx.)
(+)	(-)	
BCM		Ground
Connector	Terminal	
M16 (A)	1	
M17 (B)	11	
M18 (C)	24	Battery voltage

Is the measurement normal?

- YES >> GO TO 3
 NO >> Repair or replace harness.

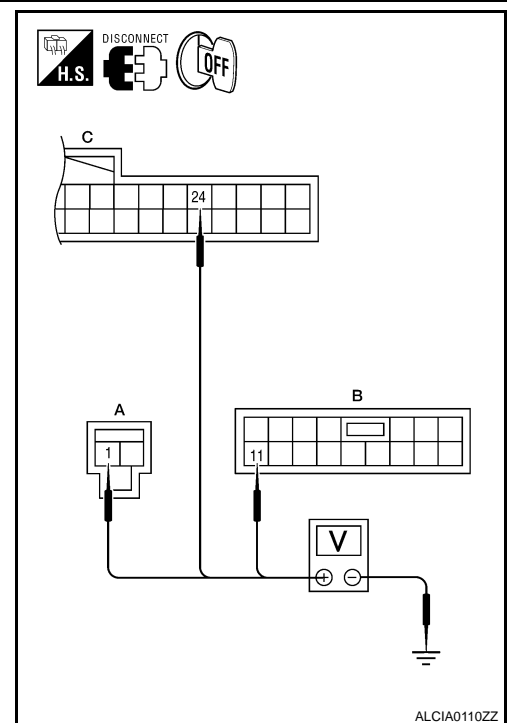

3. CHECK GROUND CIRCUIT

Check continuity between BCM harness connector and ground.

BCM		Ground	Continuity
Connector	Terminal		
M17	13		Yes

Does continuity exist?

- YES >> Inspection End.
 NO >> Repair or replace harness.

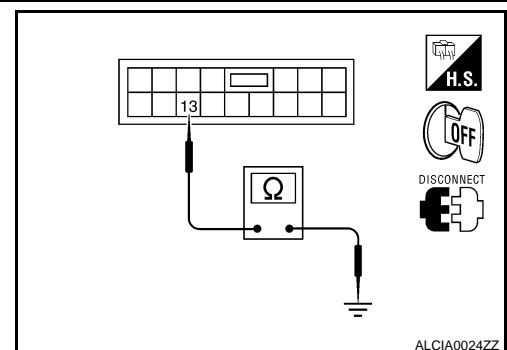

POWER SUPPLY AND GROUND CIRCUIT

[LH&RH FRONT WINDOW ANTI-PINCH]

< COMPONENT DIAGNOSIS >

INFOID:000000004375791

BCM : Special Repair Requirement

1. REQUIRED WORK WHEN REPLACING BCM

Initialize control unit. Refer to [BCS-6, "CONFIGURATION \(BCM\) : Special Repair Requirement"](#).

>> Work End.

POWER WINDOW MAIN SWITCH

POWER WINDOW MAIN SWITCH : Diagnosis Procedure

INFOID:000000003898177

1. CHECK POWER SUPPLY CIRCUIT

1. Turn ignition switch ON.
2. Check voltage between main power window and door lock/unlock switch connectors D7 (A) terminal 10 and D8 (B) terminal 19 and ground.

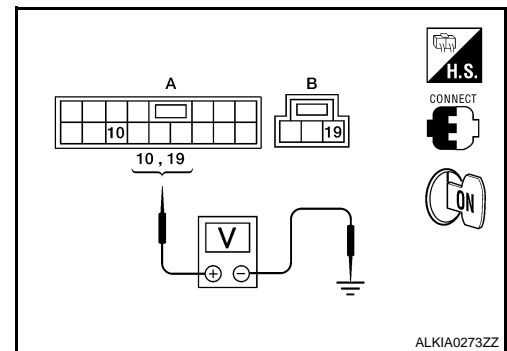

Terminal (+)		Terminal (-)	Voltage (V) (Approx.)
Main power window and door lock/unlock switch connector	Terminal		
D7 (A)	10	Ground	Battery voltage
D8 (B)	19		

Is the inspection result normal?

- YES >> GO TO 3
NO >> GO TO 2

2. CHECK HARNESS CONTINUITY

1. Turn ignition switch OFF.
2. Disconnect BCM connector M16 and main power window and door lock/unlock switch connectors.
3. Check continuity between BCM connector M16 (A) terminals 2 and 3 and main power window and door lock/unlock switch connectors D7 (B) terminal 10 and D8 (C) terminal 19.

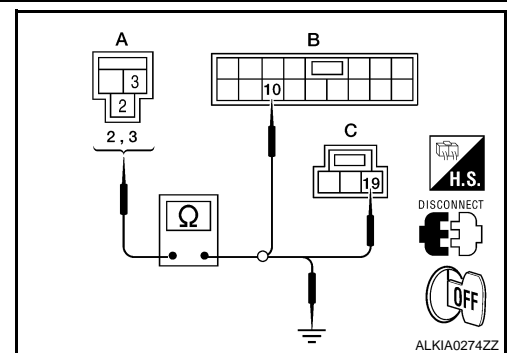

BCM connector	Terminal	Main power window and door lock/unlock switch connector	Terminal	Continuity
M16 (A)	3	D7 (B)	10	Yes
	2	D8 (C)	19	

4. Check continuity between BCM connector M16 (A) terminals 2 and 3 and ground.

BCM connector	Terminal	Ground	Continuity
M16 (A)	3		Ground
	2		

Is the inspection result normal?

- YES >> Replace BCM. Refer to [BCS-87, "Removal and Installation"](#).
NO >> Repair or replace harness or connectors.

3. CHECK GROUND CIRCUIT

POWER SUPPLY AND GROUND CIRCUIT

< COMPONENT DIAGNOSIS >

[LH&RH FRONT WINDOW ANTI-PINCH]

1. Turn ignition switch OFF.
2. Disconnect main power window and door lock/unlock switch connector D8.
3. Check continuity between main power window and door lock/unlock switch connector D8 terminal 17 and ground.

Main power window and door lock/unlock switch connector	Terminal	Ground	Continuity
D8	17		Yes

Is the inspection result normal?

- YES >> Inspection End.
 NO >> Repair or replace harness or connectors.

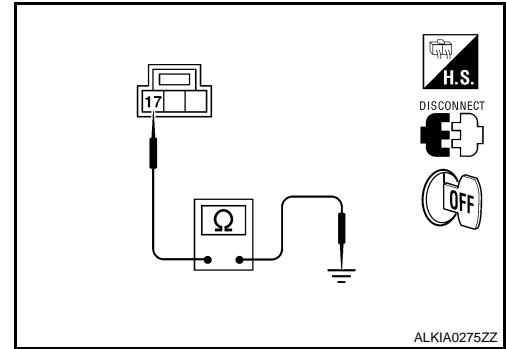

POWER WINDOW MAIN SWITCH : Special Repair Requirement

INFOID:000000004375764

1. PERFORM INITIALIZATION PROCEDURE

Perform initialization procedure. Refer to [PWC-9, "ADDITIONAL SERVICE WHEN REMOVING BATTERY NEGATIVE TERMINAL : Special Repair Requirement"](#) and [PWC-9, "ADDITIONAL SERVICE WHEN REPLACING CONTROL UNIT : Special Repair Requirement"](#).

>> GO TO 2

2. CHECK ANTI-PINCH OPERATION

Check anti-pinch operation. Refer to [PWC-9, "ADDITIONAL SERVICE WHEN REMOVING BATTERY NEGATIVE TERMINAL : Special Repair Requirement"](#) and [PWC-9, "ADDITIONAL SERVICE WHEN REPLACING CONTROL UNIT : Special Repair Requirement"](#).

>> End.

FRONT POWER WINDOW SWITCH

FRONT POWER WINDOW SWITCH : Diagnosis Procedure

INFOID:000000003898182

1. CHECK POWER SUPPLY CIRCUIT

Check voltage between power window and door lock/unlock switch RH connector D105 terminal 10 and ground.

Terminal		Terminal	Voltage (V) (Approx.)
(+)	(-)		
Power window and door lock/unlock switch RH connector			
D105	10	Ground	Battery voltage

Is the inspection result normal?

- YES >> GO TO 3
 NO >> GO TO 2

2. CHECK HARNESS CONTINUITY

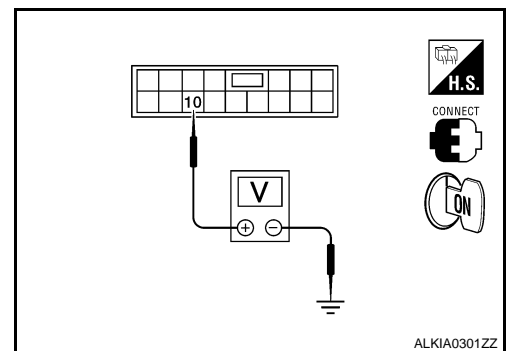

POWER SUPPLY AND GROUND CIRCUIT

< COMPONENT DIAGNOSIS >

[LH&RH FRONT WINDOW ANTI-PINCH]

1. Turn ignition switch OFF.
2. Disconnect BCM connector M16 and power window and door lock/unlock switch RH connector.
3. Check continuity between BCM connector M16 (A) terminal 2 and power window and door lock/unlock switch RH connector D105 (B) terminal 10.

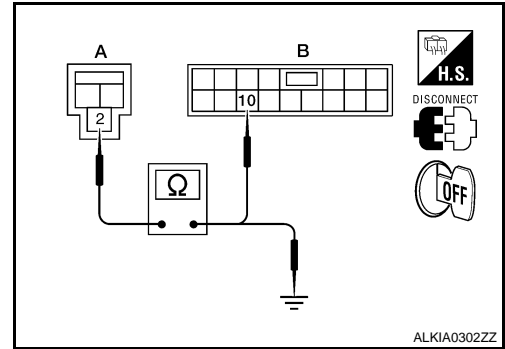

BCM connector	Terminal	Power window and door lock/unlock switch RH connector	Terminal	Continuity
M16 (A)	2	D105 (B)	10	Yes

4. Check continuity between BCM connector M16 (A) terminal 2 and ground.

BCM connector	Terminal	Ground	Continuity
M16 (A)	2		No

Is the inspection result normal?

- YES >> Replace BCM. Refer to [BCS-87, "Removal and Installation"](#).
 NO >> Repair or replace harness or connectors.

3. CHECK GROUND CIRCUIT

1. Turn ignition switch OFF.
2. Disconnect power window and door lock/unlock switch RH.
3. Check continuity between power window and door lock/unlock switch RH connector D105 terminal 11 and ground.

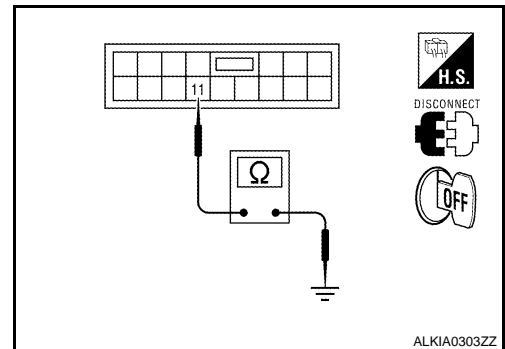

Power window and door lock/unlock switch RH	Terminal	Ground	Continuity
D105	11		Yes

Is the inspection result normal?

- YES >> Inspection End.
 NO >> Repair or replace harness or connectors.

FRONT POWER WINDOW SWITCH : Special Repair Requirement

INFOID:000000004375782

1. PERFORM INITIALIZATION PROCEDURE

Perform initialization procedure. Refer to [PWC-9, "ADDITIONAL SERVICE WHEN REMOVING BATTERY NEGATIVE TERMINAL : Special Repair Requirement"](#) and [PWC-9, "ADDITIONAL SERVICE WHEN REPLACING CONTROL UNIT : Special Repair Requirement"](#).

>> GO TO 2

2. CHECK ANTI-PINCH OPERATION

Check anti-pinch operation. Refer to [PWC-9, "ADDITIONAL SERVICE WHEN REMOVING BATTERY NEGATIVE TERMINAL : Special Repair Requirement"](#) and [PWC-9, "ADDITIONAL SERVICE WHEN REPLACING CONTROL UNIT : Special Repair Requirement"](#).

>> End.

REAR POWER WINDOW SWITCH

REAR POWER WINDOW SWITCH : Diagnosis Procedure

INFOID:000000003898186

1. CHECK POWER SUPPLY CIRCUIT

POWER SUPPLY AND GROUND CIRCUIT

[LH&RH FRONT WINDOW ANTI-PINCH]

< COMPONENT DIAGNOSIS >

Check voltage between rear power window switch connector terminal 1 and ground.

Terminal		Condition	Voltage (V) (Approx.)
(+)	(-)		
Rear power window switch connector	Terminal	Ignition switch ON	Battery voltage
LH	D203		
RH	D303		

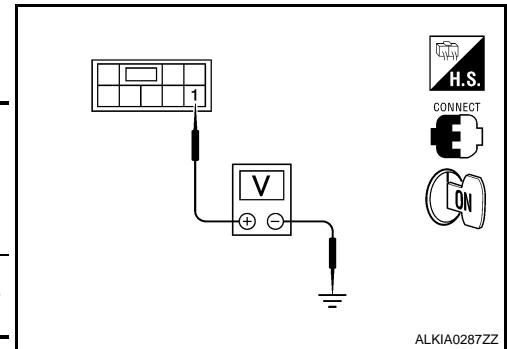

Is the inspection result normal?

YES >> GO TO 3

NO >> GO TO 2

2. CHECK HARNESS CONTINUITY

1. Disconnect BCM connector M16 and rear power window switch connector.
2. Check continuity between BCM connector M16 (A) terminal 3 and rear power window switch connector (B) terminal 1.

BCM connector	Terminal	Rear power window switch connector		Terminal	Continuity
M16 (A)	3	LH	D203 (B)	1	Yes
		RH	D303 (B)		

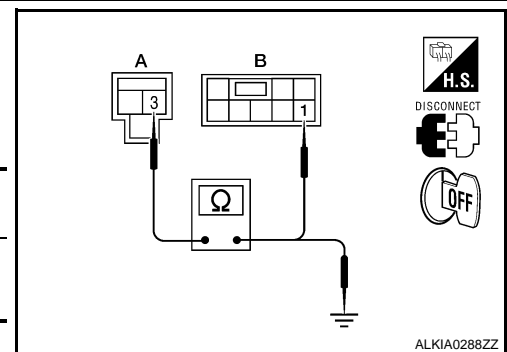

3. Check continuity between BCM connector M16 (A) terminal 3 and ground.

BCM connector	Terminal	Ground	Continuity
M16 (A)	3		No

Is the inspection result normal?

YES >> Replace BCM. Refer to [BCS-87, "Removal and Installation"](#).

NO >> Repair or replace harness or connectors.

3. CHECK GROUND CIRCUIT

1. Disconnect rear power window switch connector.
2. Check continuity between rear power window switch connector terminal 7 and ground.

Rear power window switch connector	Terminal	Ground	Continuity
D203	7		No
D303			

Is the inspection result normal?

YES >> Inspection End.

NO >> Repair or replace harness or connectors.

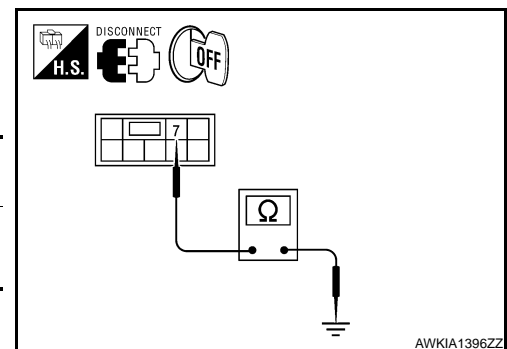

REAR POWER WINDOW SWITCH : Special Repair Requirement

INFOID:000000004375783

1. PERFORM INITIALIZATION PROCEDURE

Perform initialization procedure. Refer to [PWC-9, "ADDITIONAL SERVICE WHEN REMOVING BATTERY NEGATIVE TERMINAL : Special Repair Requirement"](#) and [PWC-9, "ADDITIONAL SERVICE WHEN REPLACING CONTROL UNIT : Special Repair Requirement"](#).

POWER SUPPLY AND GROUND CIRCUIT

< COMPONENT DIAGNOSIS >

[LH&RH FRONT WINDOW ANTI-PINCH]

>> GO TO 2

2. CHECK ANTI-PINCH OPERATION

Check anti-pinch operation. Refer to [PWC-9, "ADDITIONAL SERVICE WHEN REMOVING BATTERY NEGATIVE TERMINAL : Special Repair Requirement"](#) and [PWC-9, "ADDITIONAL SERVICE WHEN REPLACING CONTROL UNIT : Special Repair Requirement"](#).

>> End.

A
B
C
D
E
F
G
H
I
J
L
M
N
O
P

PWC

REAR POWER WINDOW SWITCH

< COMPONENT DIAGNOSIS >

[LH&RH FRONT WINDOW ANTI-PINCH]

REAR POWER WINDOW SWITCH

Description

INFOID:000000004375769

- BCM supplies power.
- Rear power window motor operates when rear power window switch is activated.

Component Function Check

INFOID:000000004375770

Rear Power Window Switch

1. CHECK REAR POWER WINDOW MOTOR FUNCTION

Check that rear power window motor operates from rear power window switch.

Is the inspection result normal?

- YES >> Rear power window switch is OK.
 NO >> Refer to [PWC-24, "Diagnosis Procedure"](#).

Diagnosis Procedure

INFOID:000000004375771

1. CHECK REAR POWER WINDOW SWITCH

Check rear power window switch. Refer to [PWC-25, "Component Inspection"](#).

Is the inspection result normal?

- YES >> GO TO 2
 NO >> Replace rear power window switch. Refer to [PWC-115, "Removal and Installation"](#).

2. CHECK REAR POWER WINDOW SWITCH INPUT SIGNAL

1. Turn ignition switch OFF.
2. Disconnect rear power window switch connector.
3. Turn ignition switch ON.
4. Check voltage between rear power window switch connector and ground.

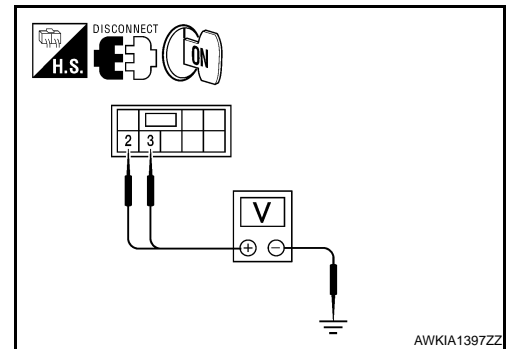

Rear power window switch		Condition	Voltage (V) (Approx.)	
Connector	Terminal			
D203	2	Power window main switch : LH	UP	Battery voltage
			DOWN	0V
	3	Ground	UP	0V
			DOWN	Battery voltage
D303	2	Power window main switch : RH	UP	Battery voltage
			DOWN	0V
	3	Ground	UP	0V
			DOWN	Battery voltage

Is the inspection result normal?

- YES >> Check intermittent incident. Refer to [GI-39, "Intermittent Incident"](#).
 NO >> • For rear power window switch LH, GO TO 3
 • For rear power window switch RH, GO TO 4

3. CHECK HARNESS CONTINUITY (REAR POWER WINDOW SWITCH LH)

REAR POWER WINDOW SWITCH

[LH&RH FRONT WINDOW ANTI-PINCH]

< COMPONENT DIAGNOSIS >

1. Turn ignition switch OFF.
2. Disconnect main power window and door lock/unlock switch connector D7 and rear power window switch LH connector.
3. Check continuity between main power window and door lock/unlock switch connector D7 (A) terminals 1, 3 and rear power window switch LH connector D203 (B) terminals 2, 3.

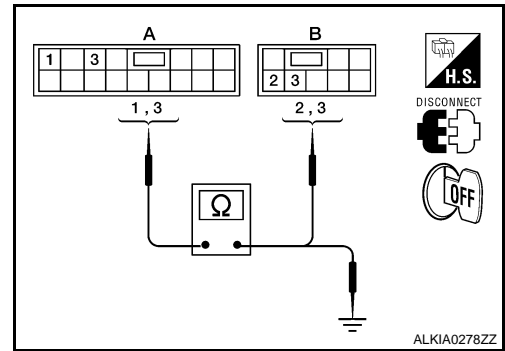

Main power window and door lock/unlock switch connector	Terminal	Rear power window switch LH connector	Terminal	Continuity
D7 (A)	1	D203 (B)	2	Yes
	3		3	

4. Check continuity between main power window and door lock/unlock switch connector D7 (A) terminals 1, 3 and ground.

Main power window and door lock/unlock switch connector	Terminal	Ground	Continuity
D7 (A)	1	Ground	No
	3		

Is the inspection result normal?

YES >> Replace main power window and door lock/unlock switch. Refer to [PWC-113. "Removal and Installation"](#).

NO >> Repair or replace harness or connectors.

4. CHECK HARNESS CONTINUITY (REAR POWER WINDOW SWITCH RH)

1. Turn ignition switch OFF.
2. Disconnect main power window and door lock/unlock switch connector D7 and rear power window switch RH connector.
3. Check continuity between main power window and door lock/unlock switch connector D7 (A) terminals 5, 7 and rear power window switch RH connector D303 (B) terminals 2, 3.

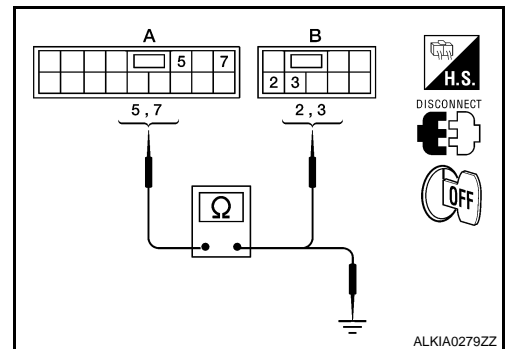

Main power window and door lock/unlock switch connector	Terminal	Rear power window switch RH connector	Terminal	Continuity
D7 (A)	5	D303 (B)	3	Yes
	7		2	

4. Check continuity between main power window and door lock/unlock switch connector D7 (A) terminals 5, 7 and ground.

Main power window and door lock/unlock switch connector	Terminal	Ground	Continuity
D7 (A)	5	Ground	No
	7		

Is the inspection result normal?

YES >> Replace main power window and door lock/unlock switch. Refer to [PWC-113. "Removal and Installation"](#).

NO >> Repair or replace harness or connectors.

Component Inspection

INFOID:000000004375772

COMPONENT INSPECTION

REAR POWER WINDOW SWITCH

< COMPONENT DIAGNOSIS >

[LH&RH FRONT WINDOW ANTI-PINCH]

1. CHECK REAR POWER WINDOW SWITCH

Check rear power window switch.

Terminal		Power window switch condition	Continuity
1	5	DOWN	Yes
3	4		
3	4	NEUTRAL	
5	2		
1	4	UP	
5	2		

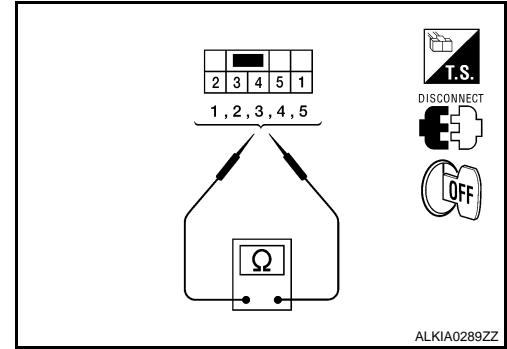

Is the inspection result normal?

YES >> Rear power window switch is OK.

NO >> Replace rear power window switch. Refer to [PWC-115. "Removal and Installation"](#).

Special Repair Requirement

INFOID:000000004375781

1. PERFORM INITIALIZATION PROCEDURE

Perform initialization procedure. Refer to [PWC-9. "ADDITIONAL SERVICE WHEN REMOVING BATTERY NEGATIVE TERMINAL : Special Repair Requirement"](#) and [PWC-9. "ADDITIONAL SERVICE WHEN REPLACING CONTROL UNIT : Special Repair Requirement"](#).

>> GO TO 2

2. CHECK ANTI-PINCH OPERATION

Check anti-pinch operation. Refer to [PWC-9. "ADDITIONAL SERVICE WHEN REMOVING BATTERY NEGATIVE TERMINAL : Special Repair Requirement"](#) and [PWC-9. "ADDITIONAL SERVICE WHEN REPLACING CONTROL UNIT : Special Repair Requirement"](#).

>> End.

POWER WINDOW MOTOR

[LH&RH FRONT WINDOW ANTI-PINCH]

< COMPONENT DIAGNOSIS >

POWER WINDOW MOTOR DRIVER SIDE

DRIVER SIDE : Description

INFOID:000000003898188

Door glass moves UP/DOWN by receiving the signal from main power window and door lock/unlock switch.

DRIVER SIDE : Component Function Check

INFOID:000000003898189

1. CHECK POWER WINDOW MOTOR

Check that front power window motor LH operates with main power window and door lock/unlock switch.

Is the inspection result normal?

- YES >> Front power window motor LH is OK.
- NO >> Refer to [PWC-27. "DRIVER SIDE : Diagnosis Procedure"](#).

DRIVER SIDE : Diagnosis Procedure

INFOID:000000003898190

1. CHECK POWER WINDOW MOTOR

Check front power window motor LH. Refer to [PWC-28. "DRIVER SIDE : Component Inspection"](#).

Is the inspection result normal?

- YES >> GO TO 2
- NO >> Replace power window motor LH. Refer to [GW-19. "Removal and Installation"](#).

2. CHECK MAIN POWER WINDOW AND DOOR LOCK/UNLOCK SWITCH OUTPUT SIGNAL

1. Disconnect front power window motor LH connector.
2. Turn ignition switch ON.
3. Check voltage between front power window motor LH connector D9 terminals 1, 2 and ground.

Terminal (+)		Terminal (-)	Main power window and door lock/unlock switch condition	Voltage (V) (Approx.)
Power window motor LH connector	Terminal			
D9	2	Ground	UP	Battery voltage
			DOWN	0
	1		UP	0
			DOWN	Battery voltage

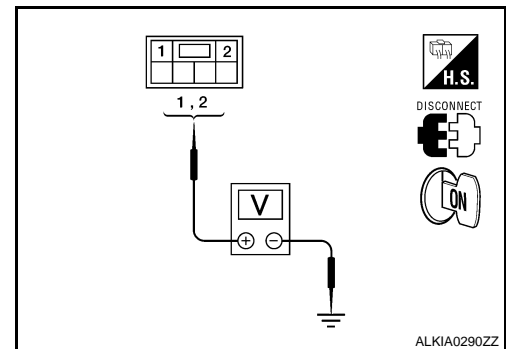

Is the inspection result normal?

- YES >> Check intermittent incident. Refer to [GI-39. "Intermittent Incident"](#).
- NO >> GO TO 3

3. CHECK HARNESS CONTINUITY

1. Turn ignition switch OFF.
2. Disconnect main power window and door lock/unlock switch connector D7.
3. Check continuity between main power window and door lock/unlock switch connector D7 (A) terminals 8, 11 and front power window motor connector LH D9 (B) terminals 1, 2.

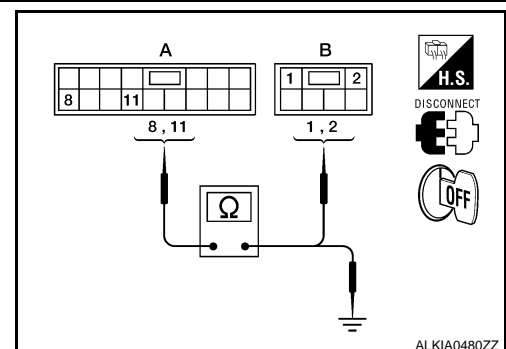

POWER WINDOW MOTOR

[LH&RH FRONT WINDOW ANTI-PINCH]

< COMPONENT DIAGNOSIS >

Main power window and door lock/unlock switch connector	Terminal	Front power window motor LH connector	Terminal	Continuity
D7 (A)	8	D9 (B)	2	Yes
	11		1	

4. Check continuity between main power window and door lock/unlock switch connector D7 (A) terminals 8, 11 and ground.

Main power window and door lock/unlock switch connector	Terminal	Ground	Continuity
D7 (A)	8	Ground	No
	11		

Is the inspection result normal?

YES >> Replace main power window and door lock/unlock switch. Refer to [PWC-113, "Removal and Installation"](#).

NO >> Repair or replace harness or connectors.

DRIVER SIDE : Component Inspection

INFOID:000000003898191

COMPONENT INSPECTION

1. CHECK FRONT POWER WINDOW MOTOR LH

1. Disconnect front power window motor LH.
2. Check motor operation by connecting battery voltage directly to front power window motor LH.

Terminal		Motor condition
(+)	(-)	
1	2	DOWN
2	1	UP

Is the inspection result normal?

YES >> Inspection End.

NO >> Replace front power window motor LH. Refer to [GW-19, "Removal and Installation"](#).

DRIVER SIDE : Special Repair Requirement

INFOID:000000004375784

1. PERFORM INITIALIZATION PROCEDURE

Perform initialization procedure. Refer to [PWC-9, "ADDITIONAL SERVICE WHEN REMOVING BATTERY NEGATIVE TERMINAL : Special Repair Requirement"](#) and [PWC-9, "ADDITIONAL SERVICE WHEN REPLACING CONTROL UNIT : Special Repair Requirement"](#).

>> GO TO 2

2. CHECK ANTI-PINCH OPERATION

Check anti-pinch operation. Refer to [PWC-9, "ADDITIONAL SERVICE WHEN REMOVING BATTERY NEGATIVE TERMINAL : Special Repair Requirement"](#) and [PWC-9, "ADDITIONAL SERVICE WHEN REPLACING CONTROL UNIT : Special Repair Requirement"](#).

>> End.

PASSENGER SIDE

POWER WINDOW MOTOR

[LH&RH FRONT WINDOW ANTI-PINCH]

< COMPONENT DIAGNOSIS >

PASSENGER SIDE : Description

INFOID:000000003898193

Door glass moves UP/DOWN by receiving the signal from main power window and door lock/unlock switch or power window and door lock/unlock switch RH.

PASSENGER SIDE : Component Function Check

INFOID:000000003898194

1. CHECK POWER WINDOW MOTOR CIRCUIT

Check that front power window motor RH operates with main power window and door lock/unlock switch or power window and door lock/unlock switch RH.

Is the inspection result normal?

- YES >> Front power window motor RH is OK.
- NO >> Refer to [PWC-29. "PASSENGER SIDE : Diagnosis Procedure"](#).

PASSENGER SIDE : Diagnosis Procedure

INFOID:000000003898195

1. CHECK FRONT POWER WINDOW MOTOR RH

Check front power window motor RH. Refer to [PWC-30. "PASSENGER SIDE : Component Inspection"](#).

Is the inspection result normal?

- YES >> GO TO 2
- NO >> Replace front power window motor RH. Refer to [GW-19. "Removal and Installation"](#).

2. CHECK FRONT POWER WINDOW SWITCH RH OUTPUT SIGNAL

1. Disconnect front power window motor RH connector.
2. Turn ignition switch ON.
3. Check voltage between front power window motor RH connector D104 terminals 1, 2 and ground.

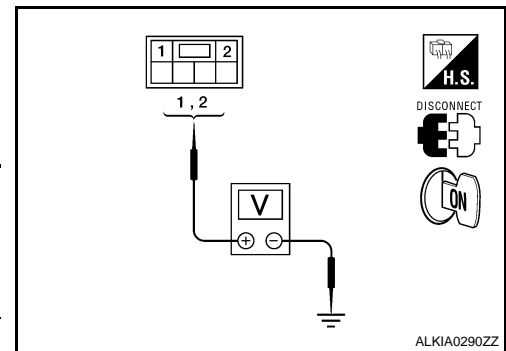

Terminal (+)		Terminal (-)	Front power window motor RH condition	Voltage (V) (Approx.)
Front power window motor RH connector	Terminal			
D104	2	Ground	UP	Battery voltage
			DOWN	0
	1		UP	0
			DOWN	Battery voltage

Is the inspection result normal?

- YES >> Check intermittent incident. Refer to [GI-39. "Intermittent Incident"](#).
- NO >> GO TO 3

3. CHECK HARNESS CONTINUITY

1. Turn ignition switch OFF.
2. Disconnect power window and door lock/unlock switch RH connector.
3. Check continuity between power window and door lock/unlock switch RH connector D105 (A) terminals 8, 9 and front power window motor RH connector D104 (B) terminals 1, 2.

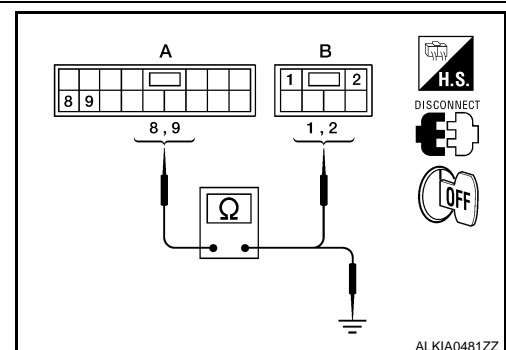

Power window and door lock/unlock switch RH connector	Terminal	Front power window motor RH connector	Terminal	Continuity
D105 (A)	8	D104 (B)	2	Yes
	9		1	

POWER WINDOW MOTOR

[LH&RH FRONT WINDOW ANTI-PINCH]

< COMPONENT DIAGNOSIS >

4. Check continuity between power window and door lock/unlock switch RH connector D105 (A) terminals 8, 9 and ground.

Power window and door lock/unlock switch RH connector	Terminal	Ground	Continuity
D105 (A)	8		No
	9		

Is the inspection result normal?

YES >> Replace power window and door lock/unlock switch RH. Refer to [PWC-114, "Removal and Installation"](#).

NO >> Repair or replace harness or connectors.

PASSENGER SIDE : Component Inspection

INFOID:000000003898196

COMPONENT INSPECTION

1. CHECK FRONT POWER WINDOW MOTOR RH

1. Disconnect front power window motor RH.
2. Check motor operation by connecting battery voltage directly to front power window motor RH.

Terminal		Motor condition
(+)	(-)	
1	2	DOWN
2	1	UP

Is the inspection result normal?

YES >> Inspection End.

NO >> Replace front power window motor RH. Refer to [GW-19, "Removal and Installation"](#).

PASSENGER SIDE : Special Repair Requirement

INFOID:000000004375785

1. PERFORM INITIALIZATION PROCEDURE

Perform initialization procedure. Refer to [PWC-9, "ADDITIONAL SERVICE WHEN REMOVING BATTERY NEGATIVE TERMINAL : Special Repair Requirement"](#) and [PWC-9, "ADDITIONAL SERVICE WHEN REPLACING CONTROL UNIT : Special Repair Requirement"](#).

>> GO TO 2

2. CHECK ANTI-PINCH OPERATION

Check anti-pinch operation. Refer to [PWC-9, "ADDITIONAL SERVICE WHEN REMOVING BATTERY NEGATIVE TERMINAL : Special Repair Requirement"](#) and [PWC-9, "ADDITIONAL SERVICE WHEN REPLACING CONTROL UNIT : Special Repair Requirement"](#).

>> End.

REAR LH

REAR LH : Description

INFOID:000000003898198

Door glass moves UP/DOWN by receiving the signal from main power window and door lock/unlock switch or rear power window switch LH.

REAR LH : Component Function Check

INFOID:000000003898199

1. CHECK REAR POWER WINDOW MOTOR LH CIRCUIT

Check that rear power window motor LH operates with main power window and door lock/unlock switch or rear power window switch LH.

POWER WINDOW MOTOR

[LH&RH FRONT WINDOW ANTI-PINCH]

< COMPONENT DIAGNOSIS >

Is the inspection result normal?

- YES >> Rear power window motor LH is OK.
- NO >> Refer to [PWC-31, "REAR LH : Diagnosis Procedure"](#)

REAR LH : Diagnosis Procedure

INFOID:000000003898200

1. CHECK REAR POWER WINDOW MOTOR LH

Check rear power window motor LH. Refer to [PWC-32, "REAR LH : Component Inspection"](#).

Is the inspection result normal?

- YES >> GO TO 2
- NO >> Replace rear power window motor LH. Refer to [GW-24, "Rear Door Glass Regulator"](#).

2. CHECK REAR POWER WINDOW SWITCH OUTPUT SIGNAL

1. Disconnect rear power window motor LH connector.
2. Turn ignition switch ON.
3. Check voltage between rear power window motor LH connector D204 terminal 1, 3 and ground.

Terminal (+)		Terminal (-)	Window condition	Voltage (V) (Approx.)
Rear power window motor LH connector	Terminal			
D204	3	Ground	UP	Battery voltage
			DOWN	0
	1		UP	0
			DOWN	Battery voltage

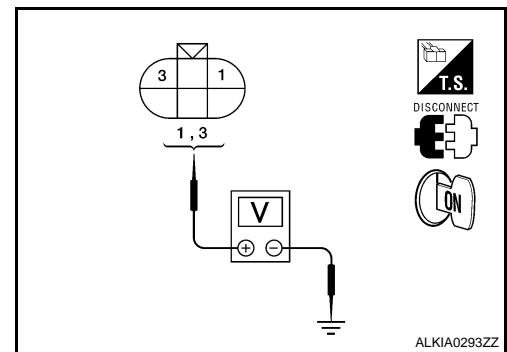

Is the inspection result normal?

- YES >> Check intermittent incident. Refer to [GI-39, "Intermittent Incident"](#).
- NO >> GO TO 3

3. CHECK HARNESS CONTINUITY

1. Turn ignition switch OFF.
2. Disconnect rear power window switch LH connector.
3. Check continuity between rear power window switch LH connector D203 (A) terminals 4, 5 and rear power window motor LH connector D204 (B) terminals 1, 3.

Rear power window switch LH connector	Terminal	Rear power window motor LH connector	Terminal	Continuity
D203 (A)	5	D204 (B)	1	Yes
	4		3	

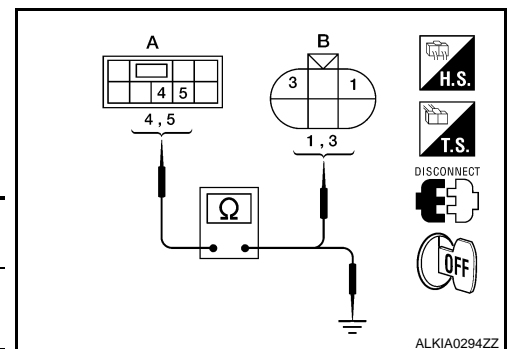

4. Check continuity between rear power window switch LH connector D203 (A) terminals 4, 5 and ground.

Rear power window switch LH connector	Terminal	Ground	Continuity
D203 (A)	5	Ground	No
	4		

Is the inspection result normal?

- YES >> Check rear power window switch LH. Refer to [PWC-24, "Diagnosis Procedure"](#).
- NO >> Repair or replace harness or connectors.

POWER WINDOW MOTOR

[LH&RH FRONT WINDOW ANTI-PINCH]

< COMPONENT DIAGNOSIS >

REAR LH : Component Inspection

INFOID:000000003898201

COMPONENT INSPECTION

1. CHECK REAR POWER WINDOW MOTOR LH

1. Disconnect rear power window motor LH.
2. Check motor operation by connecting battery voltage directly to rear power window motor LH.

Terminal		Motor condition
(+)	(-)	
3	1	UP
1	3	DOWN

Is the inspection result normal?

- YES >> Inspection End.
 NO >> Replace rear power window motor LH. Refer to [GW-24, "Rear Door Glass Regulator"](#).

REAR RH

REAR RH : Description

INFOID:000000003898202

Door glass moves UP/DOWN by receiving the signal from main power window and door lock/unlock switch or rear power window switch RH.

REAR RH : Component Function Check

INFOID:000000003898203

1. CHECK REAR POWER WINDOW MOTOR RH CIRCUIT

Check that rear power window motor RH operates with main power window and door lock/unlock switch or rear power window switch RH.

Is the inspection result normal?

- YES >> Rear power window motor RH is OK.
 NO >> Refer to [PWC-32, "REAR RH : Diagnosis Procedure"](#).

REAR RH : Diagnosis Procedure

INFOID:000000003898204

1. CHECK REAR POWER WINDOW MOTOR RH

Check rear power window motor RH. Refer to [PWC-33, "REAR RH : Component Inspection"](#).

Is the inspection result normal?

- YES >> GO TO 2
 NO >> Replace rear power window motor RH. Refer to [GW-14, "Removal and Installation"](#).

2. CHECK REAR POWER WINDOW SWITCH RH OUTPUT SIGNAL

1. Disconnect rear power window motor RH connector.
2. Turn ignition switch ON.
3. Check voltage between rear power window motor RH connector D304 terminal 1, 3 and ground.

Terminal		Rear power window switch RH condition	Voltage (V) (Approx.)
(+)	(-)		
Rear power window motor RH connector D304	Terminal 3	UP	Battery voltage
	Ground	DOWN	0
		UP	0
	Terminal 1	DOWN	Battery voltage

Is the inspection result normal?

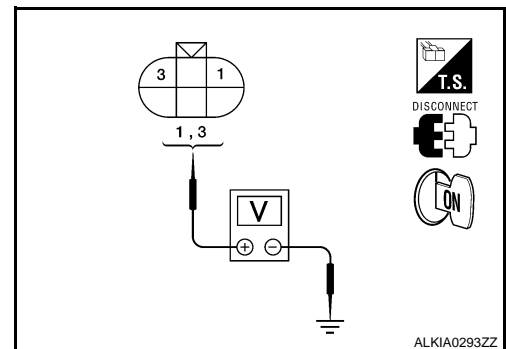

POWER WINDOW MOTOR

[LH&RH FRONT WINDOW ANTI-PINCH]

< COMPONENT DIAGNOSIS >

- YES >> Check intermittent incident. Refer to [GI-39. "Intermittent Incident"](#).
 NO >> GO TO 3

3. CHECK HARNESS CONTINUITY

- Turn ignition switch OFF.
- Disconnect rear power window switch RH connector.
- Check continuity between rear power window switch RH connector D303 (A) terminals 4, 5 and rear power window motor RH connector D304 (B) terminals 1, 3.

Rear power window switch RH connector	Terminal	Rear power window motor RH connector	Terminal	Continuity
D303 (A)	5	D304 (B)	1	Yes
	4		3	

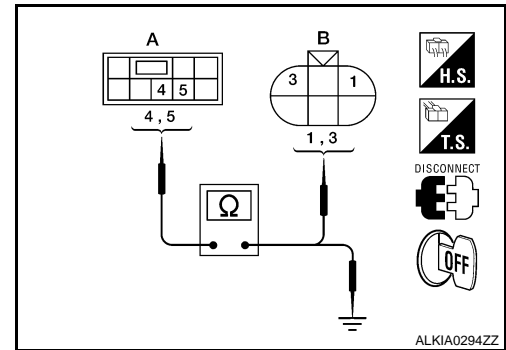

- Check continuity between rear power window switch RH connector D303 (A) terminals 4, 5 and ground.

Rear power window switch RH connector	Terminal	Ground	Continuity
D303 (A)	5	Ground	No
	4		

Is the inspection result normal?

- YES >> Check rear power window switch RH. Refer to [PWC-24. "Diagnosis Procedure"](#).
 NO >> Repair or replace harness or connectors.

REAR RH : Component Inspection

INFOID:000000003898205

COMPONENT INSPECTION

1. CHECK REAR POWER WINDOW MOTOR RH

- Disconnect rear power window motor RH.
- Check motor operation by connecting battery voltage directly to rear power window motor RH.

Terminal		Motor condition
(+)	(-)	
3	1	UP
1	3	DOWN

Is the inspection result normal?

- YES >> Inspection End.
 NO >> Replace rear power window motor RH. Refer to [GW-24. "Rear Door Glass Regulator"](#).

A
B
C
D
E
F
G
H
I
J
L
M
N
O
P

PWC

ENCODER

< COMPONENT DIAGNOSIS >

[LH&RH FRONT WINDOW ANTI-PINCH]

ENCODER DRIVER SIDE

DRIVER SIDE : Description

INFOID:000000003898206

Detects condition of the front power window motor LH operation and transmits to main power window and door lock/unlock switch as pulse signal.

DRIVER SIDE : Component Function Check

INFOID:000000003898207

1. CHECK ENCODER OPERATION

Check that front door glass LH performs AUTO open/close operation normally when operating main power window and door lock/unlock switch.

Is the inspection result normal?

YES >> Encoder operation is OK.

NO >> Refer to [PWC-34, "DRIVER SIDE : Diagnosis Procedure"](#).

DRIVER SIDE : Diagnosis Procedure

INFOID:000000003898208

Encoder Circuit Check

1. CHECK ENCODER OPERATION

1. Turn ignition switch ON.
2. Check signal between main power window and door lock/unlock switch connector D7 terminals 9, 13 and ground with oscilloscope.

Terminals		Signal (Reference value)
(+)	(-)	
Main power window and door lock/unlock switch connector	Terminal	Ground
D7	9 13	
		Refer to following signal

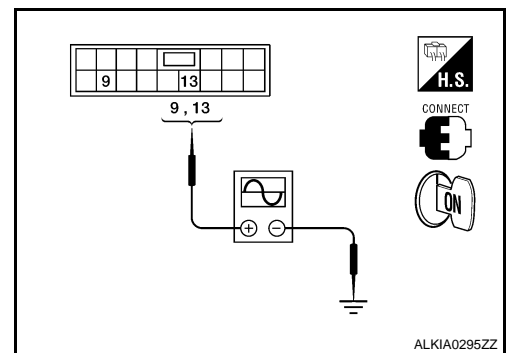

ALKIA0295ZZ

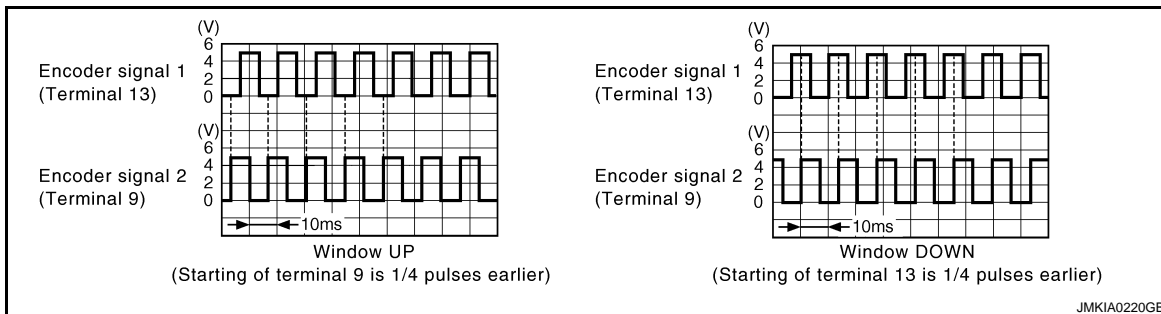

JMKIA0220GB

Is the inspection result normal?

YES >> Check intermittent incident. Refer to [GI-39, "Intermittent Incident"](#).

NO >> GO TO 2

2. CHECK ENCODER POWER SUPPLY

ENCODER

< COMPONENT DIAGNOSIS >

[LH&RH FRONT WINDOW ANTI-PINCH]

Check voltage between front power window motor LH connector D9 terminal 4 and ground.

Terminal (+)		Terminal (-)	Voltage (V) (Approx.)
Front power window motor LH connector	Terminal		
D9	4	Ground	10

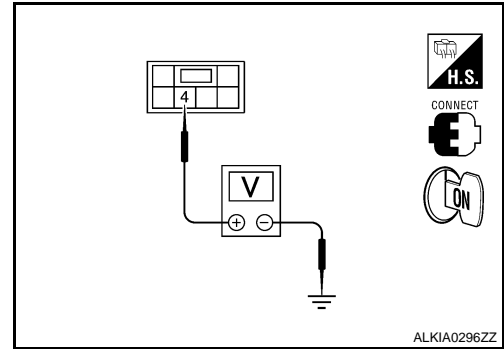

Is the inspection result normal?

- YES >> GO TO 4
- NO >> GO TO 3

3. CHECK HARNESS CONTINUITY 1

- Turn ignition switch OFF.
- Disconnect main power window and door lock/unlock switch connector D7 and front power window motor LH connector.
- Check continuity between main power window and door lock/unlock switch connector D7 (A) terminal 15 and front power window motor LH connector D9 (B) terminal 4.

Main power window and door lock/unlock switch connector	Terminal	Front power window motor LH connector	Terminal	Continuity
D7 (A)	15	D9 (B)	4	Yes

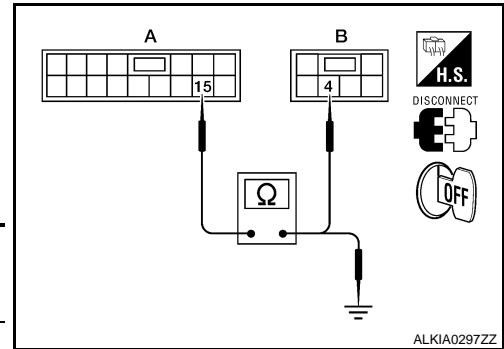

- Check continuity between main power window and door lock/unlock switch connector D7 (A) terminal 15 and ground.

Main power window and door lock/unlock switch connector	Terminal	Ground	Continuity
D7 (A)	15		No

Is the inspection result normal?

- YES >> Replace main power window and door lock/unlock switch. Refer to [PWC-113, "Removal and Installation"](#).
- NO >> Repair or replace harness or connectors.

4. CHECK ENCODER GROUND CIRCUIT

- Turn ignition switch OFF.
- Disconnect front power window motor LH connector.
- Check continuity between front power window motor LH connector D9 terminal 6 and ground.

Front power window motor LH connector	Terminal	Ground	Continuity
D9	6		Yes

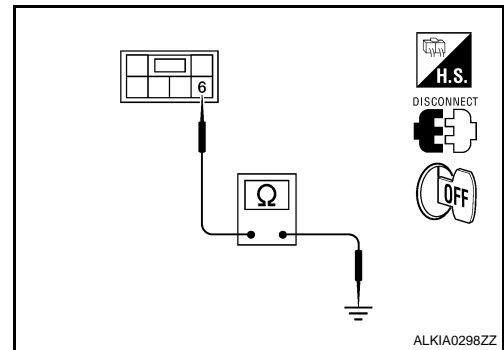

Is the inspection result normal?

- YES >> GO TO 6
- NO >> GO TO 5

5. CHECK HARNESS CONTINUITY 2

A
B
C
D
E
F
G
H
I
J
L
M
N
O
P

PWC

ENCODER

[LH&RH FRONT WINDOW ANTI-PINCH]

< COMPONENT DIAGNOSIS >

1. Disconnect main power window and door lock/unlock switch connector D7.
2. Check continuity between main power window and door lock/unlock switch connector D7 (A) terminal 2 and front power window motor LH connector D9 (B) terminal 6.

Main power window and door lock/unlock switch connector	Terminal	Front power window motor LH connector	Terminal	Continuity
D7 (A)	2	D9 (B)	6	Yes

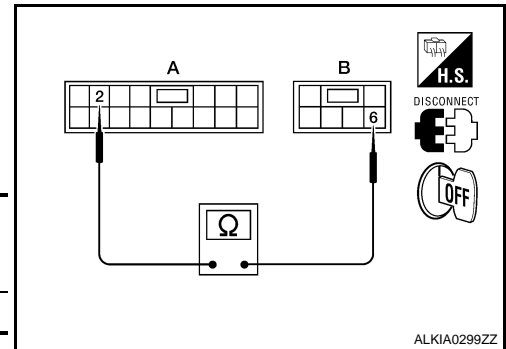

Is the inspection result normal?

YES >> Replace main power window and door lock/unlock switch. Refer to [PWC-113, "Removal and Installation"](#).

NO >> Repair or replace harness or connectors.

6. CHECK HARNESS CONTINUITY 3

1. Disconnect main power window and door lock/unlock switch connector D7.
2. Check continuity between main power window and door lock/unlock switch connector D7 (A) terminals 9, 13 and front power window motor LH connector D9 (B) terminals 3, 5.

Main power window and door lock/unlock switch connector	Terminal	Front power window motor LH connector	Terminal	Continuity
D7 (A)	9	D9 (B)	5	Yes
	13		3	

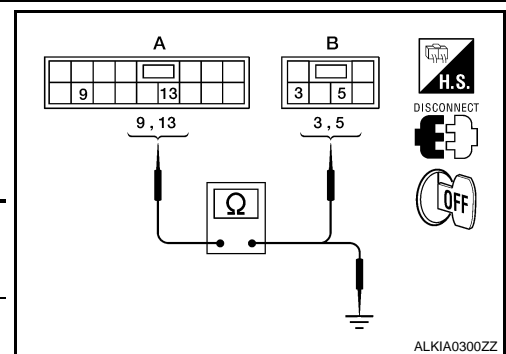

3. Check continuity between main power window and door lock/unlock switch connector D7 (A) terminals 9, 13 and ground.

Main power window and door lock/unlock switch connector	Terminal	Ground	Continuity
D7 (A)	9	Ground	No
	13		

Is the inspection result normal?

YES >> Replace front power window motor LH. Refer to [GW-19, "Removal and Installation"](#).

NO >> Repair or replace harness or connectors.

DRIVER SIDE : Special Repair Requirement

INFOID:000000004375786

1. PERFORM INITIALIZATION PROCEDURE

Perform initialization procedure. Refer to [PWC-9, "ADDITIONAL SERVICE WHEN REMOVING BATTERY NEGATIVE TERMINAL : Special Repair Requirement"](#) and [PWC-9, "ADDITIONAL SERVICE WHEN REPLACING CONTROL UNIT : Special Repair Requirement"](#).

>> GO TO 2

2. CHECK ANTI-PINCH OPERATION

Check anti-pinch operation. Refer to [PWC-9, "ADDITIONAL SERVICE WHEN REMOVING BATTERY NEGATIVE TERMINAL : Special Repair Requirement"](#) and [PWC-9, "ADDITIONAL SERVICE WHEN REPLACING CONTROL UNIT : Special Repair Requirement"](#).

>> End.

PASSENGER SIDE

ENCODER

< COMPONENT DIAGNOSIS >

[LH&RH FRONT WINDOW ANTI-PINCH]

PASSENGER SIDE : Description

INFOID:000000003898209

Detects condition of the front power window motor RH operation and transmits to power window and door lock/unlock switch RH as pulse signal.

PASSENGER SIDE : Component Function Check

INFOID:000000003898210

1. CHECK ENCODER OPERATION

Check that front door glass RH performs AUTO open/close operation normally when operating power window and door lock/unlock switch RH.

Is the inspection result normal?

- YES >> Encoder operation is OK.
- NO >> Refer to [PWC-37, "PASSENGER SIDE : Diagnosis Procedure"](#).

PASSENGER SIDE : Diagnosis Procedure

INFOID:000000003898211

1. CHECK ENCODER SIGNAL

1. Turn ignition switch ON.
2. Check signal between power window and door lock/unlock switch RH connector D105 terminal 12, 15 and ground with oscilloscope.

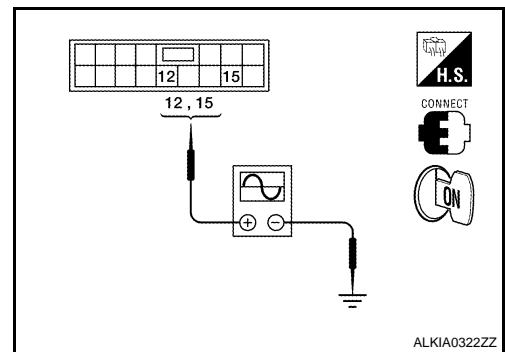

Terminals		Signal (Reference value)
(+)	(-)	
Power window and door lock/unlock switch RH connector	Terminal	Ground
D105	12 15	
		Refer to following signal

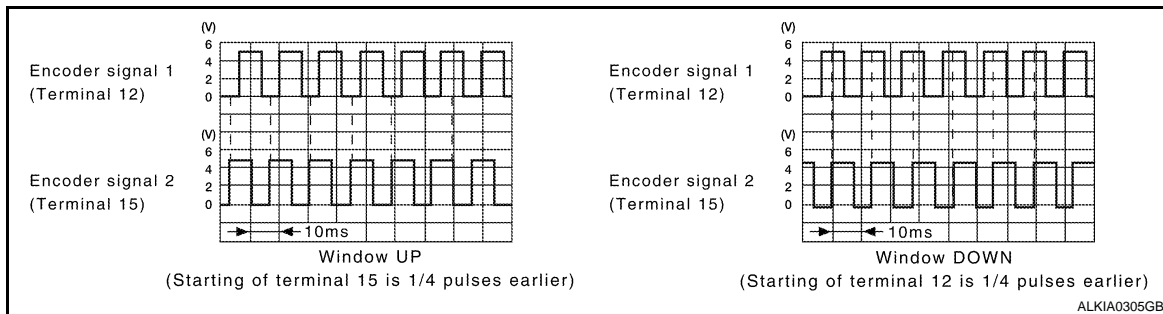

Is the inspection result normal?

- YES >> Check intermittent incident. Refer to [GI-39, "Intermittent Incident"](#).
- NO >> GO TO 2

2. CHECK ENCODER POWER SUPPLY

Check voltage between front power window motor RH connector D104 terminal 4 and ground.

Terminal		Voltage (V) (Approx.)
(+)	(-)	
Front power window motor RH connector	Terminal	10
D104	4	
		Ground

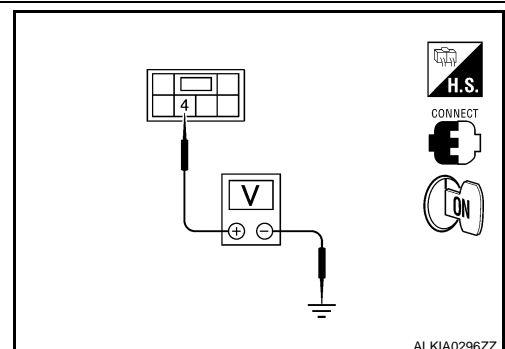

Is the inspection result normal?

- YES >> GO TO 4

A
B
C
D
E
F
G
H
I
J
L
M
N
O
P

PWC

ENCODER

[LH&RH FRONT WINDOW ANTI-PINCH]

< COMPONENT DIAGNOSIS >

NO >> GO TO 3

3. CHECK HARNESS CONTINUITY 1

1. Turn ignition switch OFF.
2. Disconnect power window and door lock/unlock switch RH and front power window motor RH connectors.
3. Check continuity between power window and door lock/unlock switch RH connector D105 (A) terminal 4 and front power window motor RH connector D104 (B) terminal 4.

Power window and door lock/unlock switch RH connector	Terminal	Front power window motor RH connector	Terminal	Continuity
D105 (A)	4	D104 (B)	4	Yes

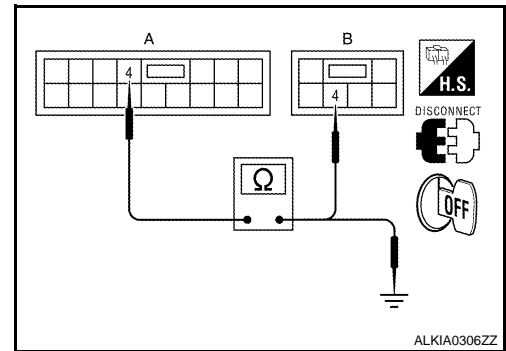

4. Check continuity between power window and door lock/unlock switch RH connector D105 (A) terminal 4 and ground.

Power window and door lock/unlock switch RH connector	Terminal	Ground	Continuity
D105 (A)	4		No

Is the inspection result normal?

YES >> Replace power window and door lock/unlock switch RH. Refer to [PWC-114. "Removal and Installation"](#).

NO >> Repair or replace harness or connectors.

4. CHECK ENCODER GROUND CIRCUIT

1. Turn ignition switch OFF.
2. Disconnect front power window motor RH connector.
3. Check continuity between front power window motor RH connector D104 terminal 6 and ground.

Front power window motor RH connector	Terminal	Ground	Continuity
D104	6		Yes

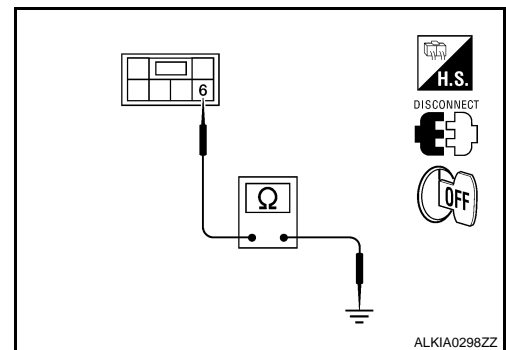

Is the inspection result normal?

YES >> GO TO 6

NO >> GO TO 5

5. CHECK HARNESS CONTINUITY 2

1. Disconnect power window and door lock/unlock switch RH connector.
2. Check continuity between power window and door lock/unlock switch RH connector D105 (A) terminal 3 and front power window motor RH connector D104 (B) terminal 6.

Power window and door lock/unlock switch RH connector	Terminal	Front power window motor RH connector	Terminal	Continuity
D105 (A)	3	D104 (B)	6	Yes

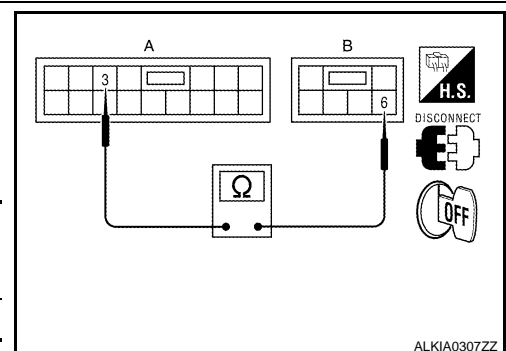

Is the inspection result normal?

YES >> Replace power window and door lock/unlock switch RH. Refer to [PWC-114. "Removal and Installation"](#).

NO >> Repair or replace harness or connectors.

6. CHECK HARNESS CONTINUITY 3

ENCODER

[LH&RH FRONT WINDOW ANTI-PINCH]

< COMPONENT DIAGNOSIS >

1. Disconnect power window and door lock/unlock switch RH connector.
2. Check continuity between power window and door lock/unlock switch RH connector D105 (A) terminals 12, 15 and front power window motor RH connector D104 (B) terminals 3, 5.

Power window and door lock/unlock switch RH connector	Terminal	Front power window motor RH connector	Terminal	Continuity
D105 (A)	12	D104 (B)	3	Yes
	15		5	

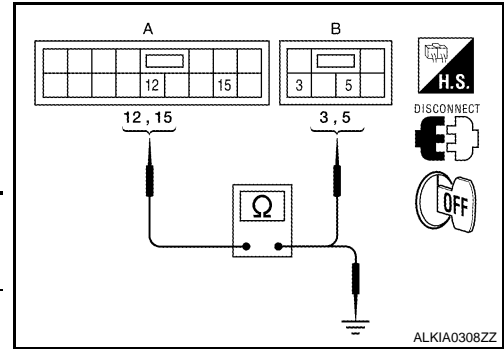

3. Check continuity between power window and door lock/unlock switch RH connector D105 (A) terminals 12, 15 and ground.

Power window and door lock/unlock switch RH connector	Terminal	Ground	Continuity
D105 (A)	12	Ground	No
	15		

Is the inspection result normal?

- YES >> Replace front power window motor RH. Refer to [GW-19, "Removal and Installation"](#).
 NO >> Repair or replace harness or connectors.

PASSENGER SIDE : Special Repair Requirement

INFOID:000000004375787

1. PERFORM INITIALIZATION PROCEDURE

Perform initialization procedure. Refer to [PWC-9, "ADDITIONAL SERVICE WHEN REMOVING BATTERY NEGATIVE TERMINAL : Special Repair Requirement"](#) and [PWC-9, "ADDITIONAL SERVICE WHEN REPLACING CONTROL UNIT : Special Repair Requirement"](#).

>> GO TO 2

2. CHECK ANTI-PINCH OPERATION

Check anti-pinch operation. Refer to [PWC-9, "ADDITIONAL SERVICE WHEN REMOVING BATTERY NEGATIVE TERMINAL : Special Repair Requirement"](#) and [PWC-9, "ADDITIONAL SERVICE WHEN REPLACING CONTROL UNIT : Special Repair Requirement"](#).

>> End.

A
B
C
D
E
F
G
H
I
J
L
M
N
O
P

PWC

DOOR SWITCH

< COMPONENT DIAGNOSIS >

[LH&RH FRONT WINDOW ANTI-PINCH]

DOOR SWITCH

Description

INFOID:000000004391468

Detects door open/close condition.

Component Function Check

INFOID:000000004391469

1.CHECK FUNCTION

With CONSULT-III

Check door switches DOOR SW-DR, DOOR SW-AS, DOOR SW-RL, DOOR SW-RR in Data Monitor mode with CONSULT-III.

Monitor item	Condition
DOOR SW-DR	CLOSE → OPEN: OFF → ON
DOOR SW-AS	

Is the inspection result normal?

YES >> Door switch is OK.

NO >> Refer to [PWC-40. "Diagnosis Procedure"](#).

Diagnosis Procedure

INFOID:000000004391470

1.CHECK DOOR SWITCH INPUT SIGNAL

1. Turn ignition switch OFF.
2. Check signal between BCM connector and ground with oscilloscope.

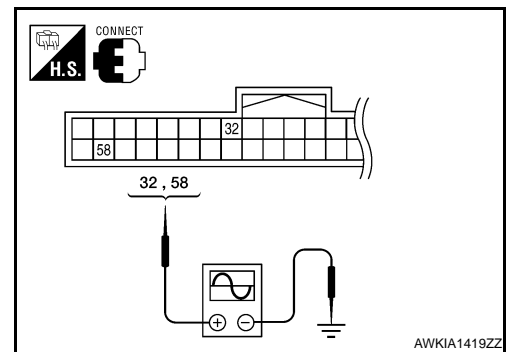

DOOR SWITCH

< COMPONENT DIAGNOSIS >

[LH&RH FRONT WINDOW ANTI-PINCH]

Terminals		(-)	Door condition		Voltage (V) (Approx.)
(+)					
BCM connector	Terminal				
A: M18	58	Ground	Driver side	OPEN	0
				CLOSE	<p style="text-align: right;">JPMIA0011GB</p>
	32		Passenger side	OPEN	0
				CLOSE	<p style="text-align: right;">JPMIA0011GB</p>

Is the inspection result normal?

- YES >> GO TO 4
- NO >> GO TO 2

2. CHECK DOOR SWITCH CIRCUIT

1. Disconnect BCM connector.
2. Check continuity between BCM connector and door switch connector.

BCM connector	Terminal	Door switch connector	Terminal	Continuity
M18	58	B8 (Driver side)	2	Yes
	32	B108 (Passenger side)		

3. Check continuity between BCM connector and ground.

BCM connector	Terminal	Ground	Continuity
M18	58		
	32		

Is the inspection result normal?

- YES >> GO TO 3
- NO >> Repair or replace harness between BCM and door switch.

3. CHECK DOOR SWITCH

Refer to [PWC-42, "Component Inspection"](#).

Is the inspection result normal?

- YES >> GO TO 4
- NO >> Replace malfunctioning door switch.

4. CHECK INTERMITTENT INCIDENT

Refer to [GI-39, "Intermittent Incident"](#).

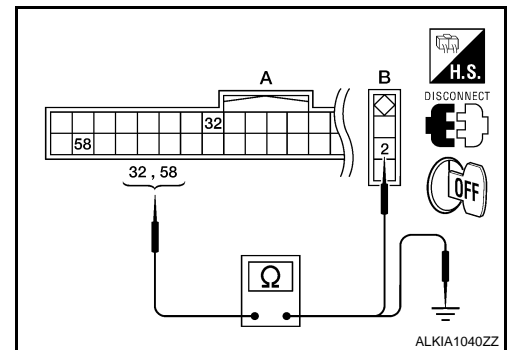

A
B
C
D
E
F
G
H
I
J
L
M
N
O
P

PWC

DOOR SWITCH

< COMPONENT DIAGNOSIS >

[LH&RH FRONT WINDOW ANTI-PINCH]

>> Inspection End.

Component Inspection

INFOID:000000004391471

1. CHECK DOOR SWITCH

1. Turn ignition switch OFF.
2. Disconnect door switch connector.
3. Check door switch.

Terminal		Door switch condition	Continuity
Door switch			
2	Ground part of door switch	Pressed	No
		Released	Yes

Is the inspection result normal?

- YES >> Inspection End.
NO >> Replace malfunctioning door switch.

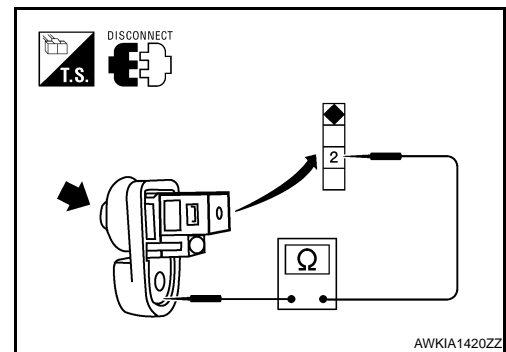

DOOR KEY CYLINDER SWITCH

< COMPONENT DIAGNOSIS >

[LH&RH FRONT WINDOW ANTI-PINCH]

DOOR KEY CYLINDER SWITCH

Description

INFOID:000000004394071

The main power window and door lock/unlock switch detects condition of the door key cylinder switch and transmits to BCM as the LOCK or UNLOCK signal.

Component Function Check

INFOID:000000004394072

1. CHECK DOOR KEY CYLINDER SWITCH INPUT SIGNAL

Check KEY CYL UN-SW, KEY CYL UN-SW in "DATA MONITOR" mode for "POWER DOOR LOCK SYSTEM" with CONSULT-III. Refer to [DLK-50, "DOOR LOCK : CONSULT-III Function \(BCM - DOOR LOCK\)"](#).

Monitor item	Condition
KEY CYL LK-SW	Lock : ON
	Neutral / Unlock : OFF
KEY CYL UN-SW	Unlock : ON
	Neutral / Lock : OFF

Is the inspection result normal?

- YES >> Key cylinder switch is OK.
- NO >> Refer to [PWC-157, "Diagnosis Procedure"](#).

Diagnosis Procedure

INFOID:000000004394073

1. CHECK DOOR KEY CYLINDER SWITCH INPUT SIGNAL

1. Turn ignition switch ON.
2. Check voltage between main power window and door lock/unlock switch connector and ground.

Terminals		Key position	Voltage (V) (Approx.)
(+)	(-)		
Main power window and door lock/unlock switch connector D7	Terminal 4	Lock	0
		Neutral / Unlock	5
	Terminal 6	Unlock	0
		Neutral / Lock	5

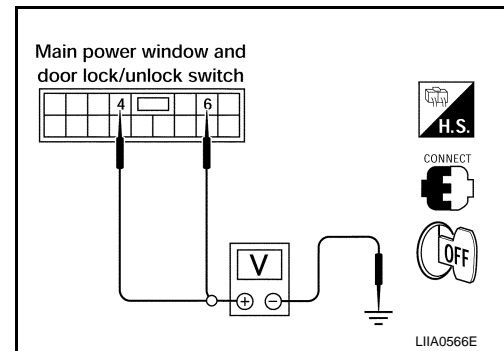

Is the inspection result normal?

- YES >> Replace main power window and door lock/unlock switch. Refer to [PWC-113, "Removal and Installation"](#). After that, refer to [PWC-9, "ADDITIONAL SERVICE WHEN REPLACING CONTROL UNIT : Special Repair Requirement"](#).
- NO >> GO TO 2

2. CHECK DOOR KEY CYLINDER SIGNAL CIRCUIT

1. Turn ignition switch OFF.
2. Disconnect main power window and door lock/unlock switch connector and front door lock assembly LH (key cylinder switch) connector.

DOOR KEY CYLINDER SWITCH

[LH&RH FRONT WINDOW ANTI-PINCH]

< COMPONENT DIAGNOSIS >

3. Check continuity between main power window and door lock/unlock switch connector and front door lock assembly LH (key cylinder switch) connector.

Main power window and door lock/unlock switch connector	Terminal	Front door lock assembly LH (key cylinder switch) connector	Terminal	Continuity
A: D7	4	B: D10	6	Yes
	6		5	

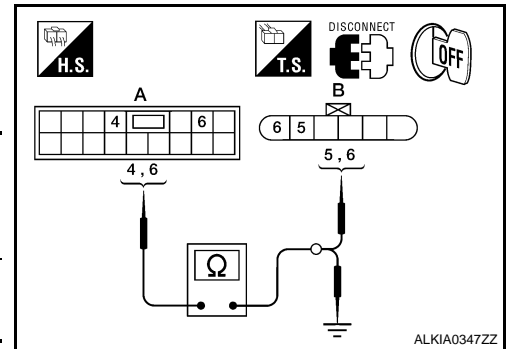

4. Check continuity between main power window and door lock/unlock switch connector and ground.

Power window main switch connector	Terminal	Ground	Continuity
A: D7	4	Ground	No
	6		

Is the inspection result normal?

YES >> GO TO 3

NO >> Repair or replace harness.

3. CHECK DOOR KEY CYLINDER SWITCH GROUND CIRCUIT

Check continuity between front door lock assembly LH connector and ground.

Front door lock assembly LH connector	Terminal	Ground	Continuity
D10	4	Ground	Yes

Is the inspection result normal?

YES >> GO TO 4

NO >> Repair or replace harness.

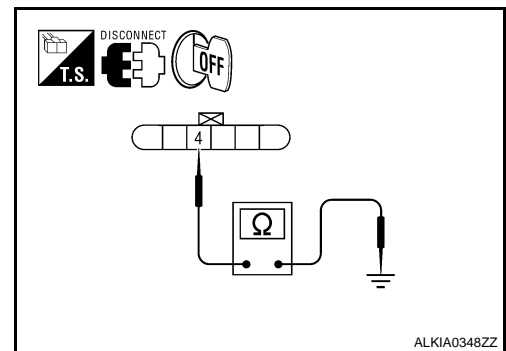

4. CHECK DOOR KEY CYLINDER SWITCH

Check door key cylinder switch.

Refer to [PWC-158, "Component Inspection"](#).

Is the inspection result normal?

YES >> Check intermittent incident. Refer to [GI-39, "Intermittent Incident"](#).

NO >> Replace front door lock assembly LH (key cylinder switch). Refer to [DLK-224, "FRONT DOOR LOCK : Removal and Installation"](#). After that, Refer to [PWC-9, "ADDITIONAL SERVICE WHEN REPLACING CONTROL UNIT : Special Repair Requirement"](#).

Component Inspection

INFOID:000000004394074

COMPONENT INSPECTION

1. CHECK DOOR KEY CYLINDER SWITCH

DOOR KEY CYLINDER SWITCH

[LH&RH FRONT WINDOW ANTI-PINCH]

< COMPONENT DIAGNOSIS >

Check front door lock assembly LH (key cylinder switch).

Terminal		Key position	Continuity
Front door lock assembly LH (key cylinder switch) connector			
5	4	Unlock	Yes
		Neutral / Lock	No
6		Lock	Yes
		Neutral / Unlock	No

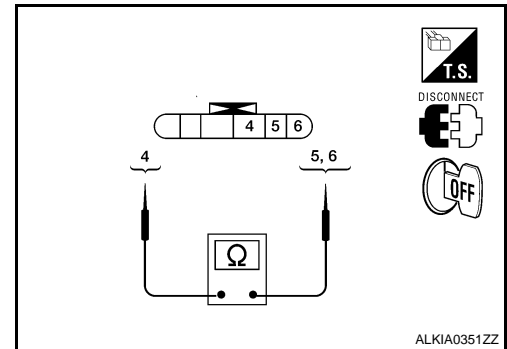

Is the inspection result normal?

YES >> Key cylinder switch is OK.

NO >> Replace front door lock assembly LH (key cylinder switch). Refer to [DLK-224, "FRONT DOOR LOCK : Removal and Installation"](#). After that, refer to [PWC-159, "Special Repair Requirement"](#).

Special Repair Requirement

INFOID:000000004394075

1.PERFORM INITIALIZATION PROCEDURE

Perform initialization procedure.

Refer to [DLK-8, "ADDITIONAL SERVICE WHEN REPLACING CONTROL UNIT : Special Repair Requirement"](#).

Is the inspection result normal?

YES >> Inspection End.

NO >> Check intermittent incident. Refer to [GI-39, "Intermittent Incident"](#).

A
B
C
D
E
F
G
H
I
J
L
M
N
O
P

PWC

POWER WINDOW SERIAL LINK

< COMPONENT DIAGNOSIS >

[LH&RH FRONT WINDOW ANTI-PINCH]

POWER WINDOW SERIAL LINK

POWER WINDOW MAIN SWITCH

POWER WINDOW MAIN SWITCH : Description

INFOID:000000003898221

- Main power window and door lock/unlock switch, power window and door lock/unlock switch RH and BCM communicate via the power window serial link.
- The keyless power window down signal is transmitted from BCM to main power window and door lock/unlock switch and power window and door lock/unlock switch RH.
- The following signals are transmitted from main power window and door lock/unlock switch to power window and door lock/unlock switch RH:
 - Front door window RH operation
 - Power window control by key cylinder switch
 - Power window lock switch
 - Retained accessory power operation

POWER WINDOW MAIN SWITCH : Component Function Check

INFOID:000000003898222

1. CHECK POWER WINDOW SWITCH OUTPUT SIGNAL

Check ("CDL LOCK SW ", "CDL UNLOCK SW") in "DATA MONITOR" mode for "POWER DOOR LOCK SYSTEM" with CONSULT-III. Refer to [DLK-50, "DOOR LOCK : CONSULT-III Function \(BCM - DOOR LOCK\)"](#).

Monitor item	Condition	
CDL LOCK SW	LOCK	: ON
	UNLOCK	: OFF
CDL UNLOCK SW	LOCK	: OFF
	UNLOCK	: ON

Is the inspection result normal?

YES >> Power window serial link is OK.

NO >> Refer to [PWC-46, "POWER WINDOW MAIN SWITCH : Diagnosis Procedure"](#).

POWER WINDOW MAIN SWITCH : Diagnosis Procedure

INFOID:000000003898223

Power Window Serial Link Check

1. CHECK POWER WINDOW SWITCH OUTPUT SIGNAL

1. Remove Intelligent Key, and close front door LH and RH.
2. Check signal between BCM connector M18 terminal 40 and ground with oscilloscope when door lock and unlock switch (key cylinder switch) is turned to "LOCK" or "UNLOCK".
3. Check that signals which are shown in the figure below can be detected during 10 seconds just after door lock and unlock switch (key cylinder switch) is turned to "LOCK" or "UNLOCK".

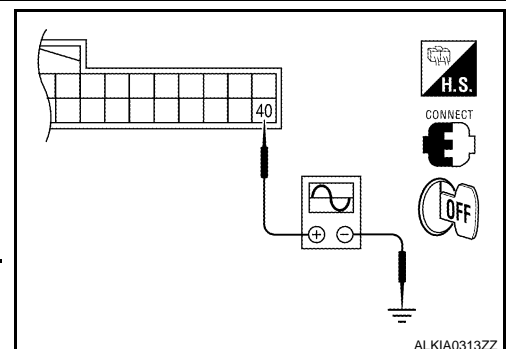

Terminal		Signal (Reference value)
(+)	(-)	
BCM connector	Terminal	
M18	40	Ground

PIIA1297E

POWER WINDOW SERIAL LINK

[LH&RH FRONT WINDOW ANTI-PINCH]

< COMPONENT DIAGNOSIS >

Is the inspection result normal?

- YES >> Power window serial link is OK.
- NO >> GO TO 2

2. CHECK POWER WINDOW SERIAL LINK CIRCUIT

1. Turn ignition switch OFF.
2. Disconnect BCM connector M18 and main power window and door lock/unlock switch connector D7.
3. Check continuity between BCM connector M18 (A) terminal 40 and main power window and door lock/unlock switch connector D7 (B) terminal 14.

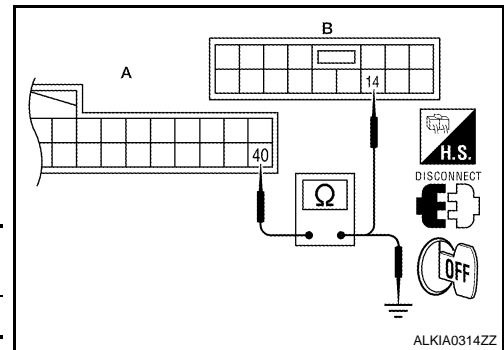

BCM connector	Terminal	Main power window and door lock/unlock switch connector	Terminal	Continuity
M18 (A)	40	D7 (B)	14	Yes

4. Check continuity between BCM connector M18 (A) terminal 40 and ground.

BCM connector	Terminal	Ground	Continuity
M18 (A)	40		No

Is the inspection result normal?

- YES >> Replace main power window and door lock/unlock switch. Refer to [PWC-113, "Removal and Installation"](#).
- NO >> Repair or replace harness or connectors.

POWER WINDOW MAIN SWITCH : Special Repair Requirement

INFOID:000000004375788

1. PERFORM INITIALIZATION PROCEDURE

Perform initialization procedure. Refer to [PWC-9, "ADDITIONAL SERVICE WHEN REMOVING BATTERY NEGATIVE TERMINAL : Special Repair Requirement"](#) and [PWC-9, "ADDITIONAL SERVICE WHEN REPLACING CONTROL UNIT : Special Repair Requirement"](#).

>> GO TO 2

2. CHECK ANTI-PINCH OPERATION

Check anti-pinch operation. Refer to [PWC-9, "ADDITIONAL SERVICE WHEN REMOVING BATTERY NEGATIVE TERMINAL : Special Repair Requirement"](#) and [PWC-9, "ADDITIONAL SERVICE WHEN REPLACING CONTROL UNIT : Special Repair Requirement"](#).

>> End.

FRONT POWER WINDOW SWITCH

FRONT POWER WINDOW SWITCH : Description

INFOID:000000004391472

- Main power window and door lock/unlock switch, power window and door lock/unlock switch RH and BCM communicate via the power window serial link.
- The keyless power window down signal is transmitted from BCM to main power window and door lock/unlock switch and power window and door lock/unlock switch RH.
- The following signals are transmitted from main power window and door lock/unlock switch to power window and door lock/unlock switch RH:
 - Front door window RH operation
 - Power window control by key cylinder switch
 - Power window lock switch
 - Retained accessory power operation

POWER WINDOW SERIAL LINK

[LH&RH FRONT WINDOW ANTI-PINCH]

< COMPONENT DIAGNOSIS >

FRONT POWER WINDOW SWITCH : Diagnosis Procedure

INFOID:000000003898226

Power Window Serial Link Check

1. CHECK POWER WINDOW AND DOOR LOCK/UNLOCK SWITCH RH

1. Remove Intelligent Key, and close the front door LH and RH.
2. Check signal between BCM connector M18 terminal 40 and ground with oscilloscope when door lock and unlock switch (key cylinder switch) is turned to "LOCK" or "UNLOCK".
3. Check that signals which are shown in the figure below can be detected during 10 seconds just after door lock and unlock switch (key cylinder switch) is turned to "LOCK" or "UNLOCK".

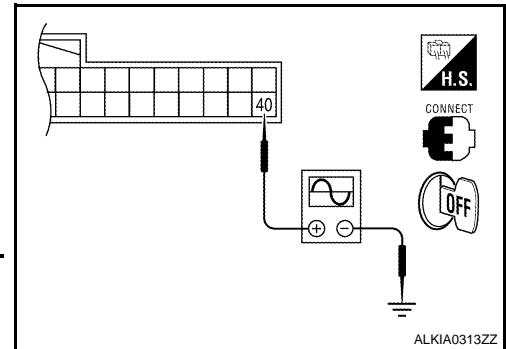

Terminal (+)		Terminal (-)	Signal (Reference value)
BCM connector	Terminal		
M18	40	Ground	<p>PIIA1297E</p>

Is the inspection result normal?

YES >> Power window serial link is OK.

NO >> GO TO 2

2. CHECK POWER WINDOW SERIAL LINK CIRCUIT

1. Turn ignition switch OFF.
2. Disconnect BCM connector M18 and power window and door lock/unlock switch RH connector.
3. Check continuity between BCM connector M18 (A) terminal 40 and power window and door lock/unlock switch RH connector D105 (B) terminal 16.

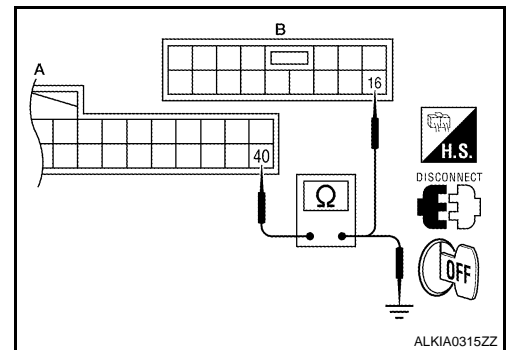

BCM connector	Terminal	Power window and door lock/unlock switch RH connector	Terminal	Continuity
M18 (A)	40	D105 (B)	16	Yes

4. Check continuity between BCM connector M18 (A) terminal 40 and ground.

BCM connector	Terminal	Ground	Continuity
M18 (A)	40	Ground	No

Is the inspection result normal?

YES >> Replace main power window and door lock/unlock switch. Refer to [PWC-113, "Removal and Installation"](#).

NO >> Repair or replace harness or connectors.

FRONT POWER WINDOW SWITCH : Special Repair Requirement

INFOID:000000004375789

1. PERFORM INITIALIZATION PROCEDURE

Perform initialization procedure. Refer to [PWC-9, "ADDITIONAL SERVICE WHEN REMOVING BATTERY NEGATIVE TERMINAL : Special Repair Requirement"](#) and [PWC-9, "ADDITIONAL SERVICE WHEN REPLACING CONTROL UNIT : Special Repair Requirement"](#).

POWER WINDOW SERIAL LINK

< COMPONENT DIAGNOSIS >

[LH&RH FRONT WINDOW ANTI-PINCH]

>> GO TO 2

2. CHECK ANTI-PINCH OPERATION

Check anti-pinch operation. Refer to [PWC-9. "ADDITIONAL SERVICE WHEN REMOVING BATTERY NEGATIVE TERMINAL : Special Repair Requirement"](#) and [PWC-9. "ADDITIONAL SERVICE WHEN REPLACING CONTROL UNIT : Special Repair Requirement"](#).

>> End.

A

B

C

D

E

F

G

H

I

J

PWC

L

M

N

O

P

POWER WINDOW LOCK SWITCH

< COMPONENT DIAGNOSIS >

[LH&RH FRONT WINDOW ANTI-PINCH]

POWER WINDOW LOCK SWITCH

Component Function Check

INFOID:0000000043898228

1. CHECK POWER WINDOW LOCK

Activate the power window lock switch and verify that the front power window RH, rear power window LH and rear power window RH are inoperative.

Is the inspection result normal?

- YES >> Power window lock switch is OK.
- NO >> Refer to [PWC-50, "Component Inspection"](#).

Component Inspection

INFOID:000000004375763

1. CHECK POWER WINDOW LOCK SWITCH

1. Disconnect main power window and door lock/unlock switch connectors.
2. Check continuity between main power window and door lock/unlock switch (lock operation).

Terminal	Main power window and door lock/unlock switch condition	Continuity
3	Rear LH	UP
5	Rear RH	
1	Rear LH	NEUTRAL
3	Rear RH	
5	Rear LH	DOWN
7	Rear RH	

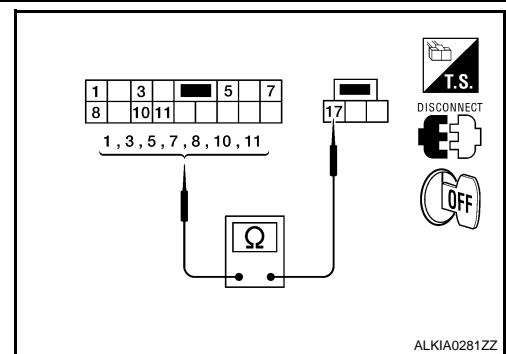

3. Check continuity between main power window and door lock/unlock switch (unlock operation).

Terminal	Main power window and door lock/unlock switch condition	Continuity
3	Rear LH	UP
5	Rear RH	
1	Rear LH	NEUTRAL
3	Rear RH	
5	Rear LH	DOWN
7	Rear RH	

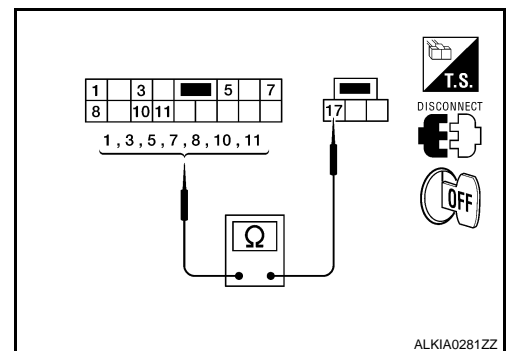

Is the inspection result normal?

- YES >> Inspection End.
- NO >> Replace main power window and door lock/unlock switch. Refer to [PWC-113, "Removal and Installation"](#).

Special Repair Requirement

INFOID:000000004375790

1. PERFORM INITIALIZATION PROCEDURE

POWER WINDOW LOCK SWITCH

< COMPONENT DIAGNOSIS >

[LH&RH FRONT WINDOW ANTI-PINCH]

Perform initialization procedure. Refer to [PWC-9, "ADDITIONAL SERVICE WHEN REMOVING BATTERY NEGATIVE TERMINAL : Special Repair Requirement"](#) and [PWC-9, "ADDITIONAL SERVICE WHEN REPLACING CONTROL UNIT : Special Repair Requirement"](#).

>> GO TO 2

2. CHECK ANTI-PINCH OPERATION

Check anti-pinch operation. Refer to [PWC-9, "ADDITIONAL SERVICE WHEN REMOVING BATTERY NEGATIVE TERMINAL : Special Repair Requirement"](#) and [PWC-9, "ADDITIONAL SERVICE WHEN REPLACING CONTROL UNIT : Special Repair Requirement"](#).

>> End.

A
B
C
D
E
F
G
H
I
J
L
M
N
O
P

PWC

BCM (BODY CONTROL MODULE)

[LH&RH FRONT WINDOW ANTI-PINCH]

< ECU DIAGNOSIS >

ECU DIAGNOSIS

BCM (BODY CONTROL MODULE)

Reference Value

INFOID:000000004363692

VALUES ON THE DIAGNOSIS TOOL

Monitor Item	Condition	Value/Status
FR WIPER HI	Other than front wiper switch HI	OFF
	Front wiper switch HI	ON
FR WIPER LOW	Other than front wiper switch LO	OFF
	Front wiper switch LO	ON
FR WASHER SW	Front washer switch OFF	OFF
	Front washer switch ON	ON
FR WIPER INT	Other than front wiper switch INT	OFF
	Front wiper switch INT	ON
FR WIPER STOP	Front wiper is not in STOP position	OFF
	Front wiper is in STOP position	ON
INT VOLUME	Wiper intermittent dial is in a dial position 1 - 7	Wiper intermittent dial position
TURN SIGNAL R	Other than turn signal switch RH	OFF
	Turn signal switch RH	ON
TURN SIGNAL L	Other than turn signal switch LH	OFF
	Turn signal switch LH	ON
TAIL LAMP SW	Other than lighting switch 1ST and 2ND	OFF
	Lighting switch 1ST or 2ND	ON
HI BEAM SW	Other than lighting switch HI	OFF
	Lighting switch HI	ON
HEAD LAMP SW 1	Other than lighting switch 2ND	OFF
	Lighting switch 2ND	ON
HEAD LAMP SW 2	Other than lighting switch 2ND	OFF
	Lighting switch 2ND	ON
PASSING SW	Other than lighting switch PASS	OFF
	Lighting switch PASS	ON
AUTO LIGHT SW	Other than lighting switch AUTO	OFF
	Lighting switch AUTO	ON
FR FOG SW	Front fog lamp switch OFF	OFF
	Front fog lamp switch ON	ON
DOOR SW-DR	Driver door closed	OFF
	Driver door opened	ON
DOOR SW-AS	Passenger door closed	OFF
	Passenger door opened	ON
DOOR SW-RR	Rear door RH closed	OFF
	Rear door RH opened	ON
DOOR SW-RL	Rear door LH closed	OFF
	Rear door LH opened	ON

BCM (BODY CONTROL MODULE)

[LH&RH FRONT WINDOW ANTI-PINCH]

< ECU DIAGNOSIS >

Monitor Item	Condition	Value/Status	
DOOR SW-BK	NOTE: This item is displayed, but cannot be monitored.	OFF	A
CDL LOCK SW	Other than power door lock switch LOCK	OFF	B
	Power door lock switch LOCK	ON	
CDL UNLOCK SW	Other than power door lock switch UNLOCK	OFF	C
	Power door lock switch UNLOCK	ON	
KEY CYL LK-SW	Other than driver door key cylinder LOCK position	OFF	D
	Driver door key cylinder LOCK position	ON	
KEY CYL UN-SW	Other than driver door key cylinder UNLOCK position	OFF	E
	Driver door key cylinder UNLOCK position	ON	
KEY CYL SW-TR	NOTE: This item is displayed, but cannot be monitored.	OFF	E
HAZARD SW	When hazard switch is not pressed	OFF	F
	When hazard switch is pressed	ON	
REAR DEF SW	When rear window defogger switch is pressed	ON	
TR CANCEL SW	Trunk lid opener cancel switch OFF	OFF	G
	Trunk lid opener cancel switch ON	ON	
TR/BD OPEN SW	Trunk lid opener switch OFF	OFF	H
	While the trunk lid opener switch is turned ON	ON	
TRNK/HAT MNTR	Trunk lid closed	OFF	I
	Trunk lid opened	ON	
RKE-LOCK	When LOCK button of Intelligent Key is not pressed	OFF	J
	When LOCK button of Intelligent Key is pressed	ON	
RKE-UNLOCK	When UNLOCK button of Intelligent Key is not pressed	OFF	J
	When UNLOCK button of Intelligent Key is pressed	ON	
RKE-TR/BD	When TRUNK OPEN button of Intelligent Key is not pressed	OFF	PWC
	When TRUNK OPEN button of Intelligent Key is pressed	ON	
RKE-PANIC	When PANIC button of Intelligent Key is not pressed	OFF	L
	When PANIC button of Intelligent Key is pressed	ON	
RKE-P/W OPEN	When UNLOCK button of Intelligent Key is not pressed and held	OFF	M
	When UNLOCK button of Intelligent Key is pressed and held	ON	
RKE-MODE CHG	When LOCK/UNLOCK button of Intelligent Key is not pressed and held simultaneously	OFF	N
	When LOCK/UNLOCK button of Intelligent Key is pressed and held simultaneously	ON	
OPTICAL SENSOR	When outside of the vehicle is bright	Close to 5 V	O
	When outside of the vehicle is dark	Close to 0 V	
REQ SW-DR	When front door request switch is not pressed (driver side)	OFF	P
	When front door request switch is pressed (driver side)	ON	
REQ SW-AS	When front door request switch is not pressed (passenger side)	OFF	P
	When front door request switch is pressed (passenger side)	ON	
REQ SW-RL	When rear door request switch is not pressed (driver side)	OFF	
	When rear door request switch is pressed (driver side)	ON	
REQ SW-RR	When rear door request switch is not pressed (passenger side)	OFF	
	When rear door request switch is pressed (passenger side)	ON	

BCM (BODY CONTROL MODULE)

< ECU DIAGNOSIS >

[LH&RH FRONT WINDOW ANTI-PINCH]

Monitor Item	Condition	Value/Status
REQ SW-BD/TR	When trunk request switch is not pressed	OFF
	When trunk request switch is pressed	ON
PUSH SW	When engine switch (push switch) is not pressed	OFF
	When engine switch (push switch) is pressed	ON
IGN RLY 2-F/B	Ignition switch OFF or ACC	OFF
	Ignition switch ON	ON
ACC RLY-F/B	Ignition switch OFF	OFF
	Ignition switch ACC or ON	ON
CLUTCH SW	NOTE: This item is displayed, but cannot be monitored.	OFF
BRAKE SW 1	When the brake pedal is not depressed	ON
	When the brake pedal is depressed	OFF
DETE/CANCL SW	When selector lever is in P position	OFF
	When selector lever is in any position other than P	ON
SFT PN/N SW	When selector lever is in any position other than P or N	OFF
	When selector lever is in P or N position	ON
S/L-LOCK	Electronic steering column lock LOCK status	OFF
	Electronic steering column lock UNLOCK status	ON
S/L-UNLOCK	Electronic steering column lock UNLOCK status	OFF
	Electronic steering column lock LOCK status	ON
S/L RELAY-F/B	Ignition switch OFF or ACC	OFF
	Ignition switch ON	ON
UNLK SEN-DR	Driver door UNLOCK status	OFF
	Driver door LOCK status	ON
PUSH SW-IPDM	When engine switch (push switch) is not pressed	OFF
	When engine switch (push switch) is pressed	ON
IGN RLY1 F/B	Ignition switch OFF or ACC	OFF
	Ignition switch ON	ON
DETE SW -IPDM	When selector lever is in P position	OFF
	When selector lever is in any position other than P	ON
SFT PN -IPDM	When selector lever is in any position other than P or N	OFF
	When selector lever is in P or N position	ON
SFT P-MET	When selector lever is in any position other than P	OFF
	When selector lever is in P position	ON
SFT N-MET	When selector lever is in any position other than N	OFF
	When selector lever is in N position	ON
ENGINE STATE	Engine stopped	STOP
	While the engine stalls	STALL
	At engine cranking	CRANK
	Engine running	RUN
S/L LOCK-IPDM	Electronic steering column lock LOCK status	OFF
	Electronic steering column lock UNLOCK status	ON
S/L UNLCK-IPDM	Electronic steering column lock UNLOCK status	OFF
	Electronic steering column lock LOCK status	ON

BCM (BODY CONTROL MODULE)

[LH&RH FRONT WINDOW ANTI-PINCH]

< ECU DIAGNOSIS >

Monitor Item	Condition	Value/Status	
S/L RELAY-REQ	Ignition switch OFF or ACC	OFF	A
	Ignition switch ON	ON	
VEH SPEED 1	While driving	Equivalent to speedometer reading	B
VEH SPEED 2	While driving	Equivalent to speedometer reading	
DOOR STAT-DR	Driver door LOCK status	LOCK	C
	Wait with selective UNLOCK operation (5 seconds)	READY	
	Driver door UNLOCK status	UNLK	
DOOR STAT-AS	Passenger door LOCK status	LOCK	D
	Wait with selective UNLOCK operation (5 seconds)	READY	
	Passenger door UNLOCK status	UNLK	
ID OK FLAG	Ignition switch ACC or ON	RESET	E
	Ignition switch OFF	SET	
PRMT ENG STAT	When the engine start is prohibited	RESET	F
	When the engine start is permitted	SET	
PRMT RKE STAT	NOTE: This item is displayed, but cannot be monitored.	RESET	G
KEY SW -SLOT	When Intelligent Key is not inserted into key slot	OFF	H
	When Intelligent Key is inserted into key slot	ON	
RKE OPE COUN1	During the operation of Intelligent Key	Operation frequency of Intelligent Key	
RKE OPE COUN2	NOTE: This item is displayed, but cannot be monitored.	Operation frequency of Intelligent Key	I
CONFIRM ID ALL	The key ID that the key slot receives does not accord with any key ID registered to BCM.	YES	J
	The key ID that the key slot receives accords with any key ID registered to BCM.	DONE	
CONFIRM ID4	The key ID that the key slot receives does not accord with the fourth key ID registered to BCM.	YES	PWC
	The key ID that the key slot receives accords with the fourth key ID registered to BCM.	DONE	
CONFIRM ID3	The key ID that the key slot receives does not accord with the third key ID registered to BCM.	YES	L
	The key ID that the key slot receives accords with the third key ID registered to BCM.	DONE	
CONFIRM ID2	The key ID that the key slot receives does not accord with the second key ID registered to BCM.	YES	M
	The key ID that the key slot receives accords with the second key ID registered to BCM.	DONE	N
CONFIRM ID1	The key ID that the key slot receives does not accord with the first key ID registered to BCM.	YES	O
	The key ID that the key slot receives accords with the first key ID registered to BCM.	DONE	
TP 4	The ID of fourth key is not registered to BCM	YES	P
	The ID of fourth key is registered to BCM	DONE	
TP 3	The ID of third key is not registered to BCM	YES	
	The ID of third key is registered to BCM	DONE	
TP 2	The ID of second key is not registered to BCM	YES	
	The ID of second key is registered to BCM	DONE	

BCM (BODY CONTROL MODULE)

< ECU DIAGNOSIS >

[LH&RH FRONT WINDOW ANTI-PINCH]

Monitor Item	Condition	Value/Status
TP 1	The ID of first key is not registered to BCM	YET
	The ID of first key is registered to BCM	DONE
AIR PRESS FL	Ignition switch ON (only when the signal from the transmitter is received)	Air pressure of front LH tire
AIR PRESS FR	Ignition switch ON (only when the signal from the transmitter is received)	Air pressure of front RH tire
AIR PRESS RR	Ignition switch ON (only when the signal from the transmitter is received)	Air pressure of rear RH tire
AIR PRESS RL	Ignition switch ON (only when the signal from the transmitter is received)	Air pressure of rear LH tire
ID REGST FL1	When ID of front LH tire transmitter is registered	DONE
	When ID of front LH tire transmitter is not registered	YET
ID REGST FR1	When ID of front RH tire transmitter is registered	DONE
	When ID of front RH tire transmitter is not registered	YET
ID REGST RR1	When ID of rear RH tire transmitter is registered	DONE
	When ID of rear RH tire transmitter is not registered	YET
ID REGST RL1	When ID of rear LH tire transmitter is registered	DONE
	When ID of rear LH tire transmitter is not registered	YET
WARNING LAMP	Tire pressure indicator OFF	OFF
	Tire pressure indicator ON	ON
BUZZER	Tire pressure warning alarm is not sounding	OFF
	Tire pressure warning alarm is sounding	ON

BCM (BODY CONTROL MODULE)

[LH&RH FRONT WINDOW ANTI-PINCH]

< ECU DIAGNOSIS >

Terminal Layout

INFOID:000000004363693

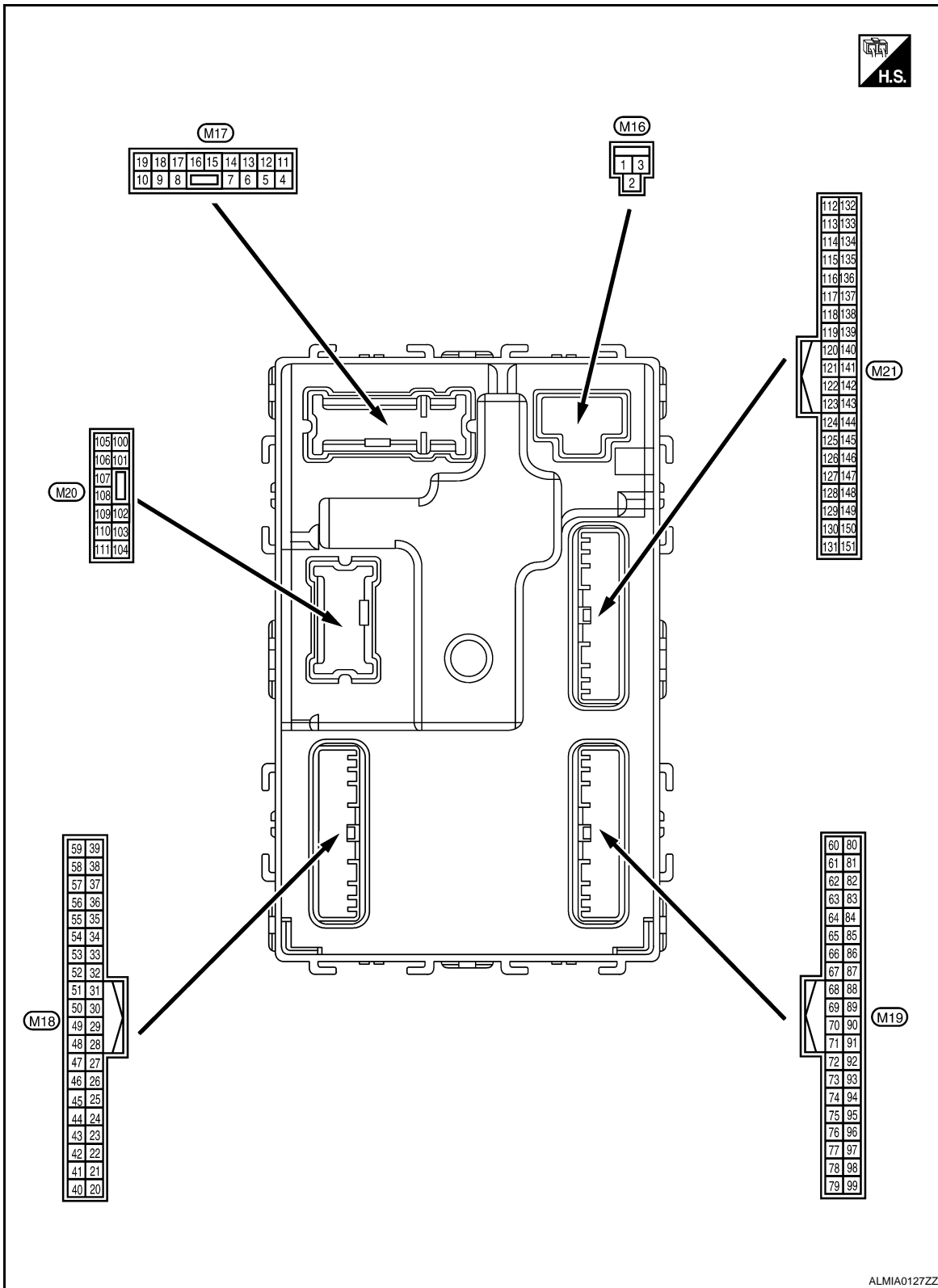

Physical Values

INFOID:000000004363694

A
B
C
D
E
F
G
H
I
J
L
M
N
O
P

PWC

BCM (BODY CONTROL MODULE)

[LH&RH FRONT WINDOW ANTI-PINCH]

< ECU DIAGNOSIS >

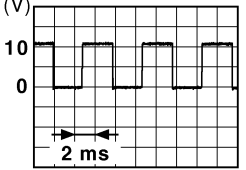
Terminal No. (Wire color)		Description		Condition		Value (Approx.)
		Signal name	Input/ Output			
(+)	(-)					
1 (W/B)	Ground	Battery power supply	Input	Ignition switch OFF		Battery voltage
2 (R/Y)	Ground	Battery power supply output	Output	Ignition switch OFF		Battery voltage
3 (L/W)	Ground	Ignition power supply output	Output	Ignition switch ON		Battery voltage
4 (P/W)	Ground	Interior room lamp power supply	Output	After passing the interior room lamp battery saver operation time		0V
				Any other time after passing the interior room lamp battery saver operation time		Battery voltage
5 (G)	Ground	Front door RH UN-LOCK	Output	Front door RH	UNLOCK (actuator is activated)	Battery voltage
					Other than UNLOCK (actuator is not activated)	0V
7 (R/W)	Ground	Step lamp	Output	Step lamp	ON	0V
					OFF	Battery voltage
8 (V)	Ground	All doors LOCK	Output	All doors	LOCK (actuator is activated)	Battery voltage
					Other than LOCK (actuator is not activated)	0V
9 (L)	Ground	Front door LH UN-LOCK	Output	Front door LH	UNLOCK (actuator is activated)	Battery voltage
					Other than UNLOCK (actuator is not activated)	0V
10 (G)	Ground	Rear door RH and rear door LH UN-LOCK	Output	Rear door RH and rear door LH	UNLOCK (actuator is activated)	Battery voltage
					Other than UNLOCK (actuator is not activated)	0V
11 (Y/R)	Ground	Battery power supply	Input	Ignition switch OFF		Battery voltage
13 (B)	Ground	Ground	—	Ignition switch ON		0V
14 (GR/W)	Ground	Engine switch (push switch) illumination ground	Input	Tail lamp	OFF	NOTE: When the illumination brightening/dimming level is in the neutral position 
					ON	
15 (Y/L)	Ground	ACC indicator lamp	Output	Ignition switch	OFF	Battery voltage
					ACC or ON	0V

JSNIA0010GB

BCM (BODY CONTROL MODULE)

[LH&RH FRONT WINDOW ANTI-PINCH]

< ECU DIAGNOSIS >

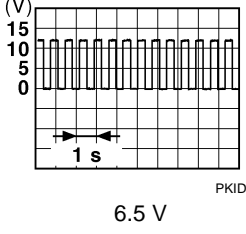
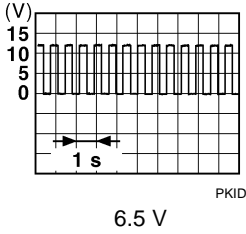
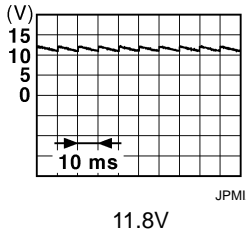
Terminal No. (Wire color)		Description		Condition		Value (Approx.)
(+)	(-)	Signal name	Input/ Output			
17 (G/B)	Ground	Turn signal (RH)	Output	Ignition switch ON	Turn signal switch OFF	0V
					Turn signal switch RH	
18 (G/Y)	Ground	Turn signal (LH)	Output	Ignition switch ON	Turn signal switch OFF	0V
					Turn signal switch LH	
19 (Y)	Ground	Room lamp timer control	Output	Interior room lamp	OFF	Battery voltage
					ON	0V
21 (P/B)	Ground	Optical sensor signal	Input	Ignition switch ON	When outside of the vehi- cle is bright	Close to 5V
					When outside of the vehi- cle is dark	Close to 0V
24 (R/W)	Ground	Stop lamp switch 1	Input	—	Battery voltage	
26 (O/L)	Ground	Stop lamp switch 2	Input	Stop lamp switch	OFF (brake pedal is not de- pressed)	0V
					ON (brake pedal is de- pressed)	Battery voltage
27 (O)	Ground	Front door lock as- sembly LH (unlock sensor)	Input	Front door LH	LOCK status	
					UNLOCK status	0V
29 (Y)	Ground	Key slot switch	Input	When Intelligent Key is inserted into key slot	Battery voltage	
				When Intelligent Key is not inserted into key slot	0V	
30 (V/Y)	Ground	ACC feedback signal	Input	Ignition switch	OFF	0
				ACC or ON	Battery voltage	
31 (G)	Ground	Rear window defog- ger feedback signal	Input	Rear window de- fogger switch	OFF	0V
				ON	Battery voltage	



A
B
C
D
E
F
G
H
I
J
L
M
N
O
P

PWC

BCM (BODY CONTROL MODULE)

[LH&RH FRONT WINDOW ANTI-PINCH]

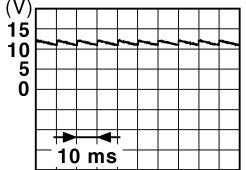
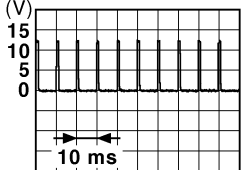
< ECU DIAGNOSIS >

Terminal No. (Wire color)		Description		Condition		Value (Approx.)
(+)	(-)	Signal name	Input/ Output			
32 (R/B)	Ground	Front door RH switch	Input	Front door RH switch	OFF (when front door RH closes)	 <p style="text-align: right; font-size: small;">JPMIA0011GB</p> <p style="text-align: center;">11.8 V</p>
					ON (when front door RH opens)	0V
37 (O)	Ground	Trunk lid opener cancel switch	Input	Trunk lid opener cancel switch	CANCEL	 <p style="text-align: right; font-size: small;">JPMIA0012GB</p> <p style="text-align: center;">1.1V</p>
					ON	0V
38 (GR/W)	Ground	Rear window defogger ON signal	Input	Rear window defogger switch	OFF	5V
					ON	0V
40 (Y/G)	Ground	Power window serial link	Input/ Output	Ignition switch ON	 <p style="text-align: right; font-size: small;">JPMIA0013GB</p> <p style="text-align: center;">10.2V</p>	
				Ignition switch OFF or ACC	0V	
41 (W)	Ground	Engine switch (push switch) illumination	Output	Engine switch (push switch) illumination	ON	5.5V
					OFF	0V
42 (R)	Ground	LOCK indicator lamp	Output	LOCK indicator lamp	ON	0V
					OFF	Battery voltage
45 (P)	Ground	Receiver & sensor ground	Input	Ignition switch ON		0V
46 (V/W)	Ground	Receiver & sensor power supply output	Output	Ignition switch	OFF	0V
					ACC or ON	5.0V

BCM (BODY CONTROL MODULE)

[LH&RH FRONT WINDOW ANTI-PINCH]

< ECU DIAGNOSIS >

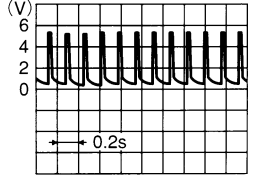
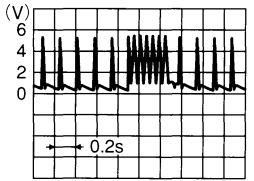
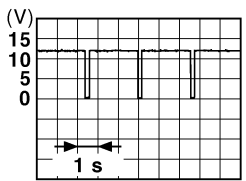
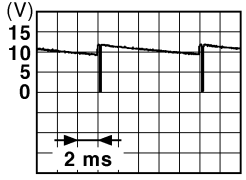
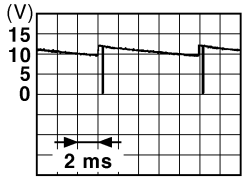
Terminal No. (Wire color)		Description		Condition	Value (Approx.)
		Signal name	Input/ Output		
(+)	(-)				
47 (G/O)	Ground	Tire pressure receiver signal	Input/ Output	Ignition switch ON	Standby state  OCC3881D
					When receiving the signal from the transmitter  OCC3880D
48 (R/G)	Ground	Selector lever P/N position signal	Input	Selector lever	P or N position 12.0V
					Except P and N positions 0V
49 (L/O)	Ground	Security indicator signal	Output	Security indicator	ON 0V
					Blinking  11.3V JPMIA0014GB
50 (LG/B)	Ground	Combination switch OUTPUT 5	Output	Combination switch (Wiper intermittent dial 4)	All switch OFF 0V
					Lighting switch 1ST
					Lighting switch high-beam
					Lighting switch 2ND
Turn signal switch RH  10.7V JPMIA0031GB					
51 (L/W)	Ground	Combination switch OUTPUT 1	Output	Combination switch	All switch OFF (Wiper intermittent dial 4) 0V
					Front wiper switch HI (Wiper intermittent dial 4)
					Any of the conditions below with all switch OFF <ul style="list-style-type: none"> • Wiper intermittent dial 1 • Wiper intermittent dial 2 • Wiper intermittent dial 3 • Wiper intermittent dial 6 • Wiper intermittent dial 7  10.7V JPMIA0032GB

A
B
C
D
E
F
G
H
I
J
L
M
N
O
P

PWC

BCM (BODY CONTROL MODULE)

[LH&RH FRONT WINDOW ANTI-PINCH]

< ECU DIAGNOSIS >

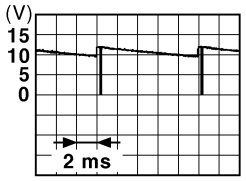
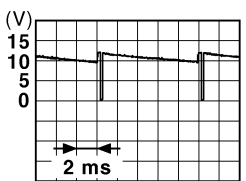
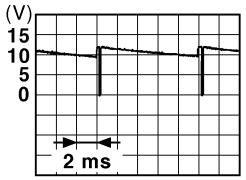
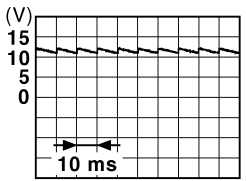
Terminal No. (Wire color)		Description		Condition	Value (Approx.)
(+)	(-)	Signal name	Input/ Output		
52 (G/B)	Ground	Combination switch OUTPUT 2	Output	Combination switch	0V
				All switch OFF (Wiper intermittent dial 4)	 <p style="text-align: right; font-size: small;">JPMIA0033GB</p>
				Front washer switch ON (Wiper intermittent dial 4)	
				Any of the conditions below with all switch OFF	
				<ul style="list-style-type: none"> • Wiper intermittent dial 1 • Wiper intermittent dial 5 • Wiper intermittent dial 6 	10.7V
53 (LG/ R)	Ground	Combination switch OUTPUT 3	Output	Combination switch (Wiper intermittent dial 4)	0V
				All switch OFF	 <p style="text-align: right; font-size: small;">JPMIA0034GB</p>
				Front wiper switch INT	
				Front wiper switch LO	
				Lighting switch AUTO	10.7V
54 (G/Y)	Ground	Combination switch OUTPUT 4	Output	Combination switch (Wiper intermittent dial 4)	0V
				All switch OFF	 <p style="text-align: right; font-size: small;">JPMIA0035GB</p>
				Front fog lamp switch ON	
				Lighting switch 2ND	
				Lighting switch flash-to-pass	
				Turn signal switch LH	10.7V
57 (W)	Ground	Tire pressure warning check switch	Input	—	5V
58 (SB)	Ground	Front door LH switch	Input	Front door LH switch	 <p style="text-align: right; font-size: small;">JPMIA0011GB</p>
				OFF (front door LH CLOSE)	11.8V
				ON (front door LH OPEN)	0V
59 (G/R)	Ground	Rear window defogger relay	Output	Rear window defogger	Battery voltage
				Active	
				Not activated	0V

BCM (BODY CONTROL MODULE)

[LH&RH FRONT WINDOW ANTI-PINCH]

< ECU DIAGNOSIS >

Terminal No. (Wire color)		Description		Condition	Value (Approx.)
(+)	(-)	Signal name	Input/ Output		
60 (B/R)	Ground	Front console antenna 2 (-)	Output	Ignition switch OFF	<p>JMKIA0062GB</p>
				When Intelligent Key is not in the passenger compartment	<p>JMKIA0063GB</p>
61 (W/R)	Ground	Center console antenna 2 (+)	Output	Ignition switch OFF	<p>JMKIA0062GB</p>
				When Intelligent Key is not in the passenger compartment	<p>JMKIA0063GB</p>
62 (V)	Ground	Front outside handle RH antenna (-)	Output	When the front door RH request switch is operated with ignition switch OFF	<p>JMKIA0062GB</p>
				When Intelligent Key is not in the antenna detection area	<p>JMKIA0063GB</p>

A
B
C
D
E
F
G
H
I
J
L
M
N
O
P

PWC

BCM (BODY CONTROL MODULE)

[LH&RH FRONT WINDOW ANTI-PINCH]

< ECU DIAGNOSIS >

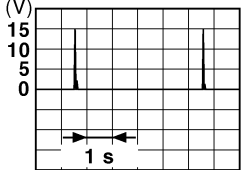
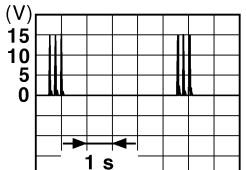
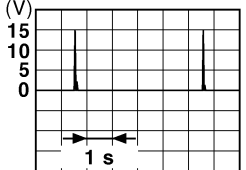
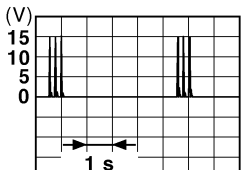
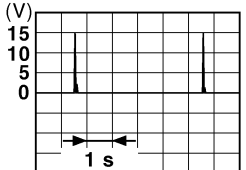
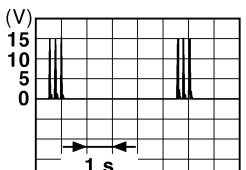
Terminal No. (Wire color)		Description		Condition	Value (Approx.)
(+)	(-)	Signal name	Input/ Output		
63 (P)	Ground	Front outside handle RH antenna (+)	Output	When the front door RH request switch is operat- ed with ignition switch OFF	 <p style="text-align: right; font-size: small;">JMKIA0062GB</p>
				When Intelligent Key is not in the antenna detection area	 <p style="text-align: right; font-size: small;">JMKIA0063GB</p>
64 (V)	Ground	Front outside handle LH antenna (-)	Output	When the front door LH request switch is operat- ed with ignition switch OFF	 <p style="text-align: right; font-size: small;">JMKIA0062GB</p>
				When Intelligent Key is not in the antenna detection area	 <p style="text-align: right; font-size: small;">JMKIA0063GB</p>
65 (P)	Ground	Front outside handle LH antenna (+)	Output	When the front door LH request switch is operat- ed with ignition switch OFF	 <p style="text-align: right; font-size: small;">JMKIA0062GB</p>
				When Intelligent Key is not in the antenna detection area	 <p style="text-align: right; font-size: small;">JMKIA0063GB</p>

BCM (BODY CONTROL MODULE)

[LH&RH FRONT WINDOW ANTI-PINCH]

< ECU DIAGNOSIS >

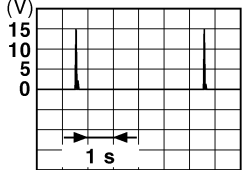
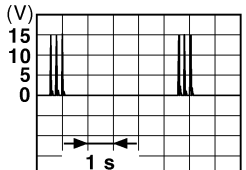
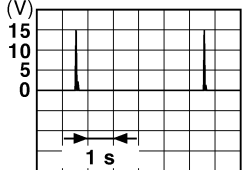
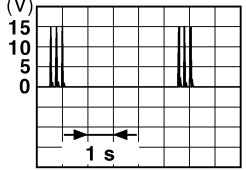
Terminal No. (Wire color)		Description		Condition	Value (Approx.)
(+)	(-)	Signal name	Input/ Output		
66 (R)	Ground	Instrument panel antenna (-)	Output	When Intelligent Key is in the passenger compartment	 <p style="text-align: right; font-size: small;">JMKIA0062GB</p>
				When Intelligent Key is not in the passenger compartment	 <p style="text-align: right; font-size: small;">JMKIA0063GB</p>
67 (G)	Ground	Instrument panel antenna (+)	Output	When Intelligent Key is in the passenger compartment	 <p style="text-align: right; font-size: small;">JMKIA0062GB</p>
				When Intelligent Key is not in the passenger compartment	 <p style="text-align: right; font-size: small;">JMKIA0063GB</p>
68 (G/O)	Ground	NATS antenna amp (built in key slot)	Input/ Output	During waiting	Ignition switch is pressed while inserting the Intelligent Key into the key slot.
					Just after pressing ignition switch. Pointer of tester should move.
69 (O)	Ground	NATS antenna amp (built in key slot)	Input/ Output	During waiting	Ignition switch is pressed while inserting the Intelligent Key into the key slot.
					Just after pressing ignition switch. Pointer of tester should move.
70 (R/B)	Ground	Ignition relay-2 control	Output	Ignition switch	OFF or ACC
				ON	Battery voltage





A
B
C
D
E
F
G
H
I
J
L
M
N
O
P

PWC

BCM (BODY CONTROL MODULE)

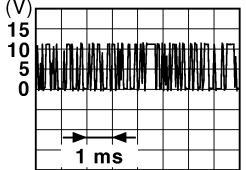
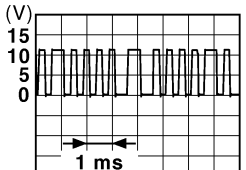
[LH&RH FRONT WINDOW ANTI-PINCH]

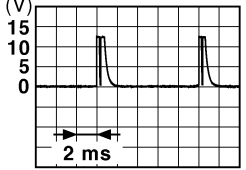

< ECU DIAGNOSIS >

Terminal No. (Wire color)		Description		Condition	Value (Approx.)
(+)	(-)	Signal name	Input/ Output		
71 (L/O)	Ground	Remote keyless entry receiver signal	Input/ Output	During waiting	 <p style="text-align: right; font-size: small;">JMKIA0064GB</p>
				When operating either button on Intelligent Key	 <p style="text-align: right; font-size: small;">JMKIA0065GB</p>
75 (R/Y)	Ground	Combination switch INPUT 5	Input	All switch OFF (Wiper intermittent dial 4)	 <p style="text-align: right; font-size: small;">JPMIA0041GB</p> <p style="text-align: center;">1.4V</p>
				Combination switch Front fog lamp switch ON (Wiper intermittent dial 4)	 <p style="text-align: right; font-size: small;">JPMIA0037GB</p> <p style="text-align: center;">1.3V</p>
				Any of the conditions below with all switch OFF	<ul style="list-style-type: none"> • Wiper intermittent dial 1 • Wiper intermittent dial 2 • Wiper intermittent dial 6 • Wiper intermittent dial 7  <p style="text-align: right; font-size: small;">JPMIA0040GB</p> <p style="text-align: center;">1.3V</p>

BCM (BODY CONTROL MODULE)

[LH&RH FRONT WINDOW ANTI-PINCH]

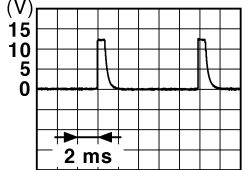
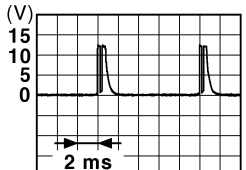
< ECU DIAGNOSIS >

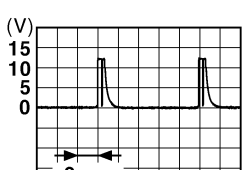
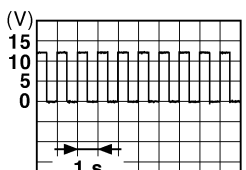
Terminal No. (Wire color)		Description		Condition	Value (Approx.)
(+)	(-)	Signal name	Input/ Output		
76 (R/G)	Ground	Combination switch INPUT 3	Input	Combination switch	All switch OFF (Wiper intermittent dial 4)  JPMIA0041GB 1.4V
					Lighting switch high-beam (Wiper intermittent dial 4)  JPMIA0036GB 1.3V
					Lighting switch 2ND (Wiper intermittent dial 4)  JPMIA0037GB 1.3V
					Any of the conditions below with all switch OFF • Wiper intermittent dial 1 • Wiper intermittent dial 2 • Wiper intermittent dial 3  JPMIA0040GB 1.3V
77 (BR)	Ground	Engine switch (push switch)	Input	Engine switch (push switch)	Pressed 0V Not pressed Battery voltage
				78 (P)	Ground
79 (L)	Ground	CAN-H	Input/ Output	—	—
80 (R/L)	Ground	Key slot illumination	Output	Key slot illumina- tion	OFF 0V
					Blinking  JPMIA0015GB 6.5V
					ON Battery voltage

A
B
C
D
E
F
G
H
I
J
L
M
N
O
P

PWC

BCM (BODY CONTROL MODULE)

[LH&RH FRONT WINDOW ANTI-PINCH]



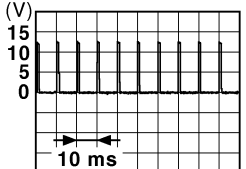
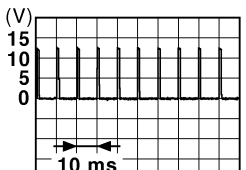

< ECU DIAGNOSIS >

Terminal No. (Wire color)		Description		Condition		Value (Approx.)
		Signal name	Input/ Output			
(+)	(-)					
81 (Y/L)	Ground	ON indicator lamp	Output	Ignition switch	OFF or ACC	0V
					ON	Battery voltage
83 (L)	Ground	ACC relay control	Output	Ignition switch	OFF	0V
					ACC or ON	Battery voltage
84 (Y/R)	Ground	A/T device	Output	—		Battery voltage
85 (L/O)	Ground	Electronic steering column lock condition No. 1	Input	Electronic steering column lock	Lock status	0V
					Unlock status	Battery voltage
86 (G/R)	Ground	Electronic steering column lock condition No. 2	Input	Electronic steering column lock	Lock status	Battery voltage
					Unlock status	0V
87 (G/B)	Ground	Selector lever P position switch	Input	Selector lever	P position	0V
					Any position other than P	Battery voltage
88 (R)	Ground	Front door RH request switch	Input	Front door RH request switch	ON (pressed)	0V
					OFF (not pressed)	 <p style="text-align: right; margin-right: 50px;">JPMIA0016GB 1.0V</p>
89 (R)	Ground	Front door LH request switch	Input	Front door LH request switch	ON (pressed)	0V
					OFF (not pressed)	 <p style="text-align: right; margin-right: 50px;">JPMIA0016GB 1.0V</p>
90 (Y)	Ground	Blower fan motor relay control	Output	Ignition switch	OFF or ACC	0V
					ON	Battery voltage
91 (L/R)	Ground	Remote keyless entry receiver power supply	Output	Ignition switch OFF		Battery voltage
94 (G/Y)	Ground	Steering wheel lock unit power supply	Output	Ignition switch	OFF or ACC	Battery voltage
					ON	0V

BCM (BODY CONTROL MODULE)

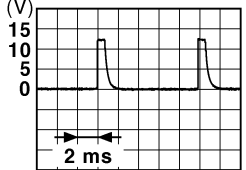
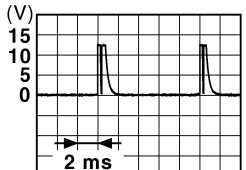
[LH&RH FRONT WINDOW ANTI-PINCH]

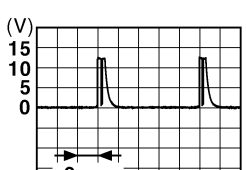
< ECU DIAGNOSIS >

Terminal No. (Wire color)		Description		Condition	Value (Approx.)
(+)	(-)	Signal name	Input/ Output		
95 (R/W)	Ground	Combination switch INPUT 1	Input	All switch OFF	 1.4V
				Turn signal switch LH	 1.3V
				Turn signal switch RH	 1.3V
				Front wiper switch LO	 1.3V
				Front washer switch ON	 1.3V

A
B
C
D
E
F
G
H
I
J
L
M
N
O
P

PWC

BCM (BODY CONTROL MODULE)

[LH&RH FRONT WINDOW ANTI-PINCH]



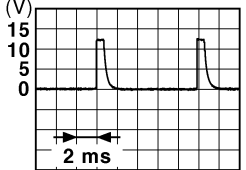
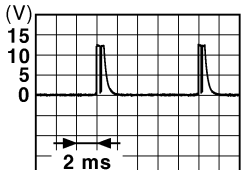
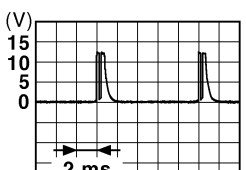
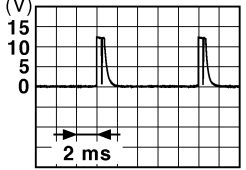

< ECU DIAGNOSIS >

Terminal No. (Wire color)		Description		Condition	Value (Approx.)
(+)	(-)	Signal name	Input/ Output		
96 (P/B)	Ground	Combination switch INPUT 4	Input	Combination switch	<p>All switch OFF (Wiper intermittent dial 4)</p>  <p style="text-align: right; font-size: small;">JPMIA0041GB</p> <p style="text-align: center;">1.4V</p>
				Lighting switch AUTO (Wiper intermittent dial 4)	 <p style="text-align: right; font-size: small;">JPMIA0038GB</p> <p style="text-align: center;">1.3V</p>
				Lighting switch 1ST (Wiper intermittent dial 4)	 <p style="text-align: right; font-size: small;">JPMIA0036GB</p> <p style="text-align: center;">1.3V</p>
				Any of the conditions below with all switch OFF	<ul style="list-style-type: none"> • Wiper intermittent dial 1 • Wiper intermittent dial 5 • Wiper intermittent dial 6  <p style="text-align: right; font-size: small;">JPMIA0039GB</p> <p style="text-align: center;">1.3V</p>

BCM (BODY CONTROL MODULE)

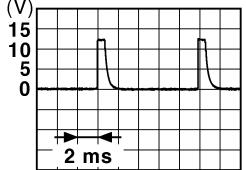
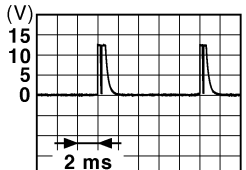
[LH&RH FRONT WINDOW ANTI-PINCH]

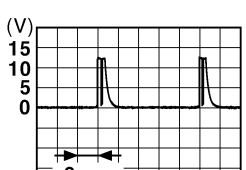
< ECU DIAGNOSIS >

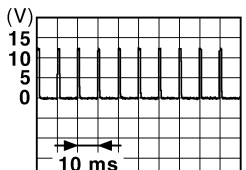
Terminal No. (Wire color)		Description		Condition	Value (Approx.)	
(+)	(-)	Signal name	Input/ Output			
97 (R/B)	Ground	Combination switch INPUT 2	Input	Combination switch (Wiper intermittent dial 4)	All switch OFF	 <small>JPMIA0041GB</small> 1.4V
					Lighting switch flash-to-pass	 <small>JPMIA0037GB</small> 1.3V
					Lighting switch 2ND	 <small>JPMIA0036GB</small> 1.3V
					Front wiper switch INT	 <small>JPMIA0038GB</small> 1.3V
					Front wiper switch HI	 <small>JPMIA0040GB</small> 1.3V
					Pressed	0 V
98 (G/O)	Ground	Hazard switch	Input	Hazard switch	Not pressed  <small>JPMIA0012GB</small> 1.1V	

A
B
C
D
E
F
G
H
I
J
L
M
N
O
P

PWC

BCM (BODY CONTROL MODULE)

[LH&RH FRONT WINDOW ANTI-PINCH]

< ECU DIAGNOSIS >

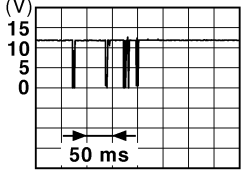
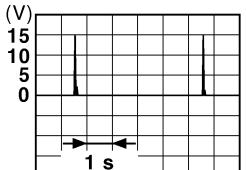
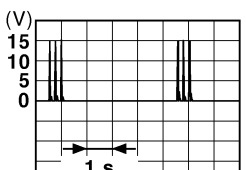
Terminal No. (Wire color)		Description		Condition	Value (Approx.)	
(+)	(-)	Signal name	Input/ Output			
99 (L/Y)	Ground	Electronic steering column lock unit com- munication	Input/ Output	Electronic steer- ing column lock	LOCK status	Battery voltage
					LOCK or UNLOCK	 <small>JMKIA0066GB</small>
					For 15 seconds after UN- LOCK	Battery voltage
					15 seconds or later after UNLOCK	0V
103 (V)	Ground	Trunk lid opening.	Output	Trunk lid	Open (trunk lid opener ac- tuator is activated)	Battery voltage
					Close (trunk lid opener ac- tuator is not activated)	0V
110 (V/W)	Ground	Trunk room lamp	Output	Trunk room lamp	ON	0V
					OFF	Battery voltage
114 (B)	Ground	Trunk room antenna 1 (-)	Output	Ignition switch OFF	When Intelligent Key is in the passenger compart- ment	 <small>JMKIA0062GB</small>
					When Intelligent Key is not in the passenger compart- ment	 <small>JMKIA0063GB</small>

BCM (BODY CONTROL MODULE)

[LH&RH FRONT WINDOW ANTI-PINCH]

< ECU DIAGNOSIS >

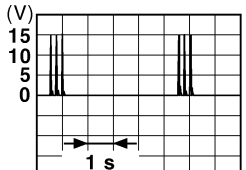
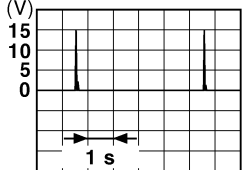
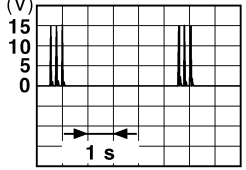
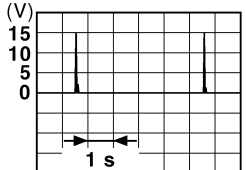
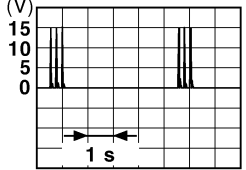
Terminal No. (Wire color)		Description		Condition	Value (Approx.)
(+)	(-)	Signal name	Input/ Output		
115 (W)	Ground	Trunk room antenna 1 (+)	Output		
				When Intelligent Key is not in the passenger compart- ment	 <p style="text-align: right; font-size: small;">JMKIA0063GB</p>
118 (L/O)	Ground	Rear bumper anten- na (-)	Output	When the trunk lid request switch is operated with ignition switch OFF	 <p style="text-align: right; font-size: small;">JMKIA0062GB</p>
				When Intelligent Key is not in the antenna detection area	 <p style="text-align: right; font-size: small;">JMKIA0063GB</p>
119 (BR/ W)	Ground	Rear bumper anten- na (+)	Output	When the trunk lid request switch is operated with ignition switch OFF	 <p style="text-align: right; font-size: small;">JMKIA0062GB</p>
				When Intelligent Key is not in the antenna detection area	 <p style="text-align: right; font-size: small;">JMKIA0063GB</p>

A
B
C
D
E
F
G
H
I
J
L
M
N
O
P

PWC

BCM (BODY CONTROL MODULE)

[LH&RH FRONT WINDOW ANTI-PINCH]

< ECU DIAGNOSIS >

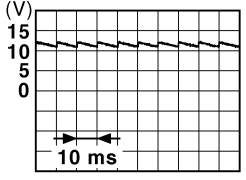
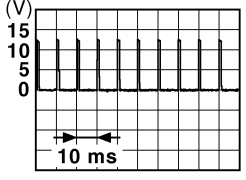
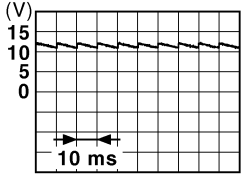
Terminal No. (Wire color)		Description		Condition	Value (Approx.)	
		Signal name	Input/ Output			
(+)	(-)					
127 (BR/ W)	Ground	Ignition relay (IPDM E/R) control	Output	Ignition switch	OFF or ACC	Battery voltage
					ON	0V
130 (W)	Ground	Trunk room lamp switch	Input	Trunk room lamp switch	OFF (trunk is closed)	 <p style="text-align: right; margin-right: 50px;">11.8V</p>
					ON (trunk is open)	0V
132 (R)	Ground	Starter motor relay control	Output	Ignition switch OFF (M/T vehi- cle)	When the clutch pedal is depressed	Battery voltage
					When the clutch pedal is not depressed	0V
				Ignition switch ON (other than M/ T vehicle)	When selector lever is in P or N position and the brake is depressed	Battery voltage
					When selector lever is in P or N position and the brake is not depressed	0V
141 (BR)	Ground	Trunk request switch	Input	Trunk request switch	ON (pressed)	0V
					OFF (not pressed)	 <p style="text-align: right; margin-right: 50px;">1.0V</p>
144 (GR)	Ground	Request switch buzzer	Output	Request switch buzzer	Sounding	0V
					Not sounding	Battery voltage
147 (L/R)	Ground	Trunk lid opener switch	Input	Trunk lid opener switch	Pressed	0V
					Not pressed	Battery voltage
148 (R/W)	Ground	Rear door RH switch	Input	Rear door RH switch	OFF (when rear door RH closes)	 <p style="text-align: right; margin-right: 50px;">11.8V</p>
					ON (when rear door RH opens)	0V

BCM (BODY CONTROL MODULE)

[LH&RH FRONT WINDOW ANTI-PINCH]

< ECU DIAGNOSIS >

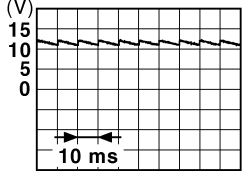
Terminal No. (Wire color)		Description		Condition	Value (Approx.)
(+)	(-)	Signal name	Input/ Output		
149 (R/B)	Ground	Rear door LH switch	Input	Rear door LH switch	 <p>11.8V</p> <p>JPMIA0011GB</p>
				OFF (when rear door LH closes)	ON (when rear door LH opens)

A
B
C
D
E
F
G
H
I
J
L
M
N
O
P

PWC

POWER WINDOW MAIN SWITCH

< ECU DIAGNOSIS >

[LH&RH FRONT WINDOW ANTI-PINCH]

POWER WINDOW MAIN SWITCH

Reference Value

INFOID:000000003898231

TERMINAL LAYOUT

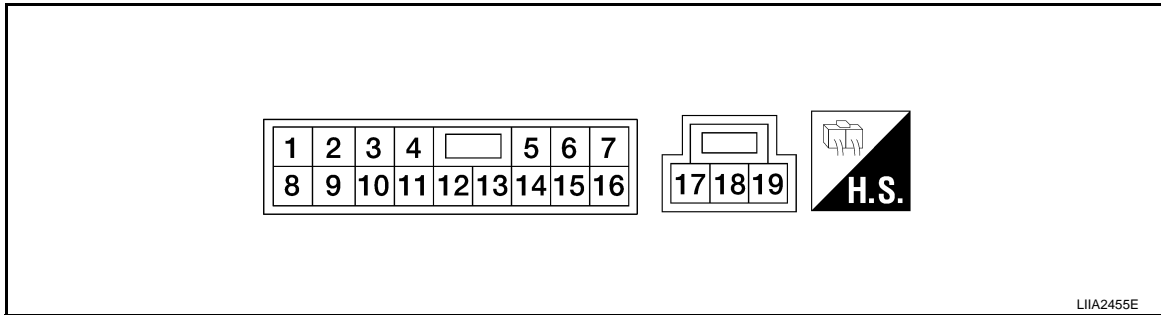

PHYSICAL VALUES

MAIN POWER WINDOW AND DOOR LOCK/UNLOCK SWITCH

Terminal No.		Description		Condition	Voltage [V] (Approx.)
+	-	Signal name	Input/ Output		
1 (W)	Ground	Rear power window motor LH UP signal	Output	When rear LH switch in power window main switch is operated UP.	Battery voltage
2 (GR)	Ground	Encoder ground	—	—	0
3 (Y)	Ground	Rear power window motor LH DOWN signal	Output	When rear LH switch in power window main switch is operated DOWN.	Battery voltage
4 (L)	Ground	Door key cylinder switch LH LOCK signal	Input	Key position (Neutral → Locked)	5 → 0
5 (SB)	Ground	Rear power window motor RH DOWN signal	Output	When rear RH switch in power window main switch is operated DOWN.	Battery voltage
6 (R)	Ground	Door key cylinder switch LH UNLOCK signal	Input	Key position (Neutral → Unlocked)	5 → 0
7 (P)	Ground	Rear power window motor RH UP signal	Output	When rear RH switch in power window main switch is operated UP.	Battery voltage
8 (L)	11	Front door power window motor LH UP signal	Output	When front LH switch in power window main switch is operated UP.	Battery voltage
9 (Y)	2	Encoder pulse signal 2	Input	When power window motor operates.	

JMKIA0070GB

POWER WINDOW MAIN SWITCH

[LH&RH FRONT WINDOW ANTI-PINCH]

< ECU DIAGNOSIS >

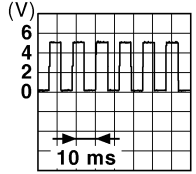
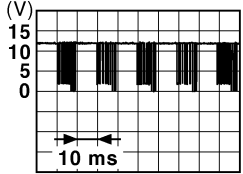
Terminal No.		Description		Condition	Voltage [V] (Approx.)
+	-	Signal name	Input/ Output		
10 (V)	Ground	RAP signal	Input	IGN SW ON	Battery voltage
				Within 45 seconds after ignition switch is turned to OFF.	Battery voltage
				When front LH or RH door is opened during retained power operation.	0
11 (LG)	8	Front door power window motor LH DOWN signal	Output	When front LH switch in power window main switch is operated DOWN.	Battery voltage
13 (G)	2	Encoder pulse signal 1	Input	When power window motor operates.	 <small>JMKIA0070GB</small>
14 (O)	Ground	Power window serial link	Input/ Output	IGN SW ON or power window timer operating.	 <small>JPMIA0013GB</small>
15 (BR)	Ground	Encoder power supply	Output	When ignition switch ON or power window timer operates.	10
17 (B)	Ground	Ground	—	—	0
19 (R)		Battery power supply	Input	—	Battery voltage

A
B
C
D
E
F
G
H
I
J
L
M
N
O
P

PWC

POWER WINDOW MAIN SWITCH

[LH&RH FRONT WINDOW ANTI-PINCH]

< ECU DIAGNOSIS >

Wiring Diagram

INFOID:000000003898232

POWER WINDOW SYSTEM - WITH FRONT LEFT AND RIGHT POWER WINDOW ANTI-PINCH SYSTEM

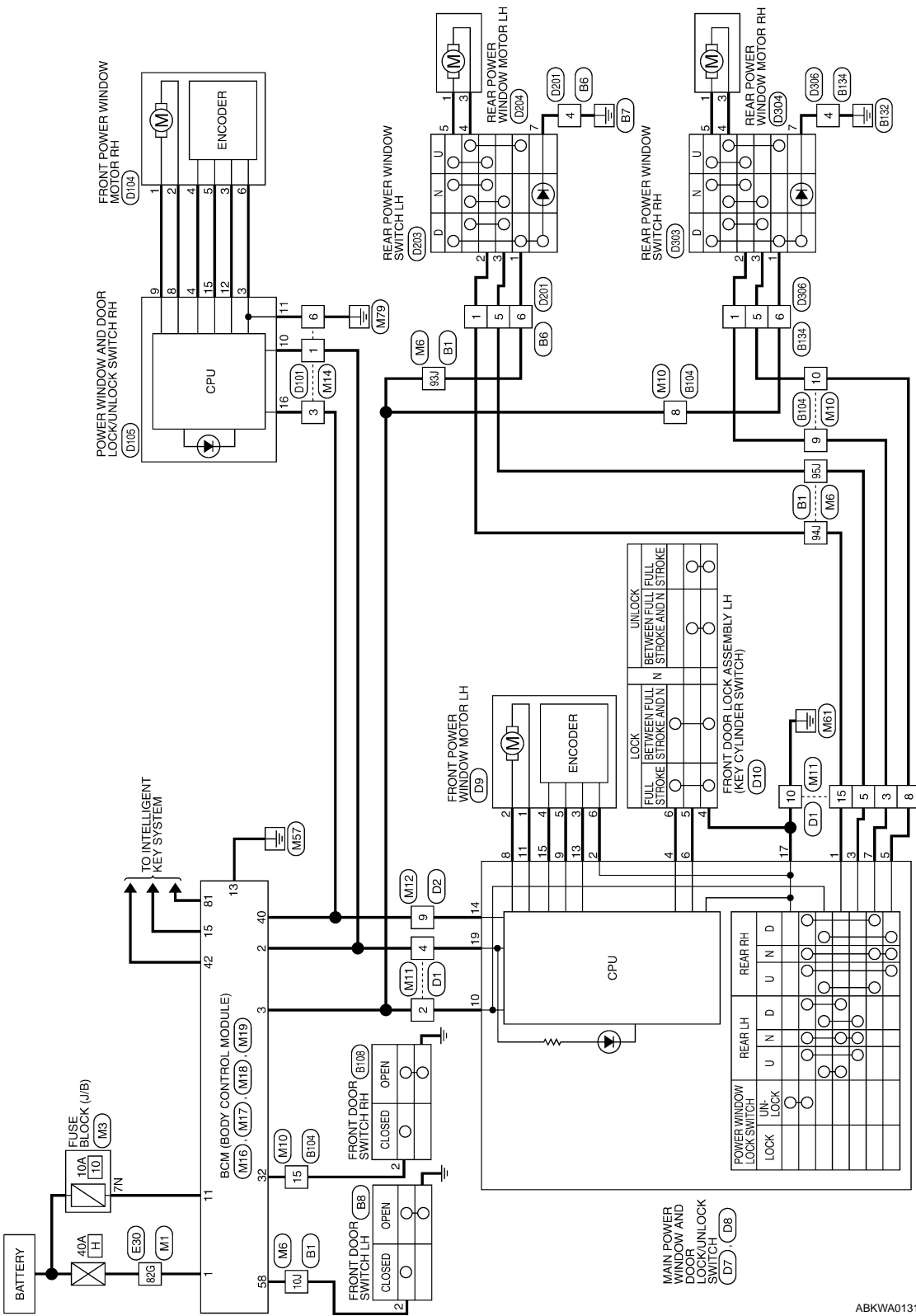

ABKWA0131GE

POWER WINDOW MAIN SWITCH

[LH&RH FRONT WINDOW ANTI-PINCH]

POWER WINDOW SYSTEM CONNECTORS-WITH FRONT LEFT AND RIGHT POWER WINDOW ANTI-PINCH SYSTEM

Connector No.	M1
Connector Name	WIRE TO WIRE
Connector Color	WHITE

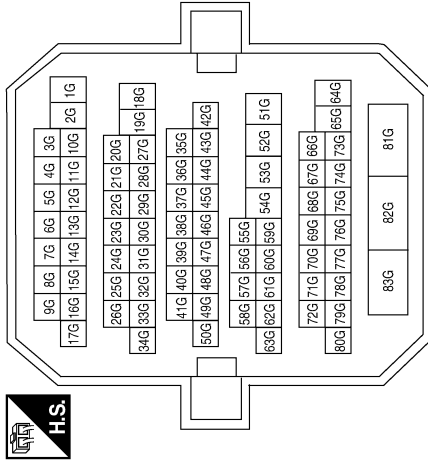

Terminal No.	Color of Wire	Signal Name
82G	W/B	-

Connector No.	M3
Connector Name	FUSE BLOCK (J/B)
Connector Color	WHITE

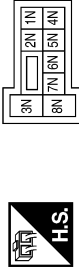

Terminal No.	Color of Wire	Signal Name
7N	Y/R	-

Connector No.	M6
Connector Name	WIRE TO WIRE
Connector Color	WHITE

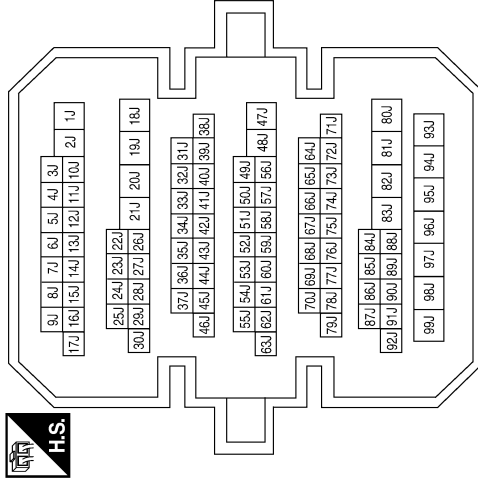

Terminal No.	Color of Wire	Signal Name
10J	SB	-
93J	L/W	- (WITH FRONT LEFT AND RIGHT POWER WINDOW ANTI-PINCH SYSTEM)
94J	BR	-
95J	Y/G	-

A
B
C
D
E
F
G
H
I
J
L
M
N
O
P

PWC

POWER WINDOW MAIN SWITCH

[LH&RH FRONT WINDOW ANTI-PINCH]

< ECU DIAGNOSIS >

Connector No.	M12
Connector Name	WIRE TO WIRE
Connector Color	WHITE

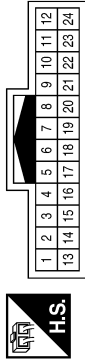

Terminal No.	Color of Wire	Signal Name
9	Y/G	-

Connector No.	M11
Connector Name	WIRE TO WIRE
Connector Color	WHITE

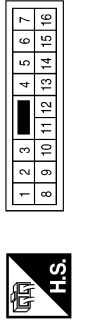

Terminal No.	Color of Wire	Signal Name
2	L/W	-
3	G	-
4	R/Y	-
5	Y/G	-
8	Y/G	-
10	B	-
15	BR	-

Connector No.	M10
Connector Name	WIRE TO WIRE
Connector Color	WHITE

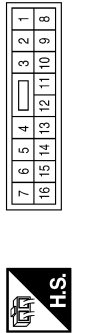

Terminal No.	Color of Wire	Signal Name
8	L/W	- (WITH FRONT LEFT AND RIGHT POWER WINDOW ANTI-PINCH SYSTEM)
9	G	-
10	Y/G	-
15	R/B	-

Connector No.	M17
Connector Name	BCM (BODY CONTROL MODULE)
Connector Color	WHITE



Terminal No.	Color of Wire	Signal Name
11	Y/R	BAT BCM FUSE
13	B	GND1
15	Y/L	ACC LED

Connector No.	M16
Connector Name	BCM (BODY CONTROL MODULE)
Connector Color	BLACK



Terminal No.	Color of Wire	Signal Name
1	W/B	BAT POWER F/L
2	R/Y	P/W POWER SUPPLY PERM
3	L/W	P/W POWER SUPPLY IGN

Connector No.	M14
Connector Name	WIRE TO WIRE
Connector Color	WHITE

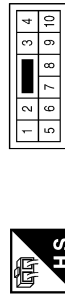

Terminal No.	Color of Wire	Signal Name
1	R/Y	-
3	Y/G	-
6	B	-

ABKIA0431GB

POWER WINDOW MAIN SWITCH

[LH&RH FRONT WINDOW ANTI-PINCH]

< ECU DIAGNOSIS >

Connector No.	M18
Connector Name	BCM (BODY CONTROL MODULE)
Connector Color	GREEN

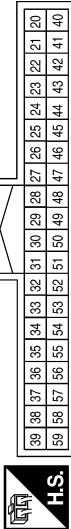

Connector No.	M19
Connector Name	BCM (BODY CONTROL MODULE)
Connector Color	BLACK

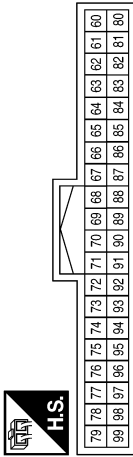

Connector No.	E30
Connector Name	WIRE TO WIRE
Connector Color	WHITE

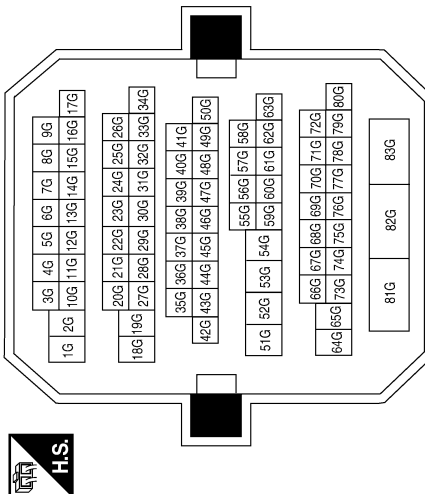

Connector No.	B1
Connector Name	WIRE TO WIRE
Connector Color	WHITE

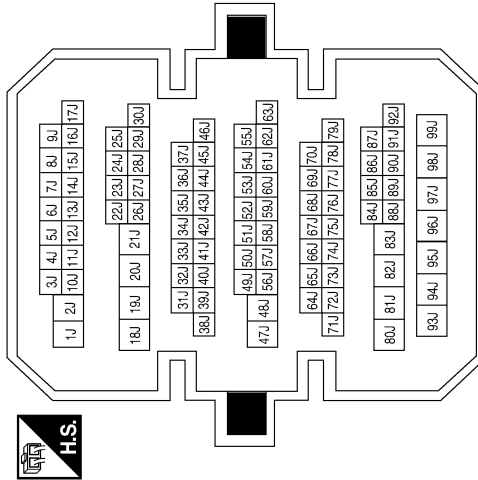

Terminal No.	Color of Wire	Signal Name
10J	SB	-
93J	R	-
94J	P	-
95J	SB	-

ABKIA0432GB

A
B
C
D
E
F
G
H
I
J
L
M
N
O
P

POWER WINDOW MAIN SWITCH

[LH&RH FRONT WINDOW ANTI-PINCH]

< ECU DIAGNOSIS >

Connector No.	B104
Connector Name	WIRE TO WIRE
Connector Color	WHITE



1	2	3	4	5	6	7
8	9	10	11	12	13	14
15	16					

Terminal No.	Color of Wire	Signal Name
8	R	-
9	P	-
10	SB	-
15	GR	-

Connector No.	B8
Connector Name	FRONT DOOR SWITCH LH
Connector Color	WHITE



1	2	3
---	---	---

Terminal No.	Color of Wire	Signal Name
2	SB	-

Connector No.	B6
Connector Name	WIRE TO WIRE
Connector Color	WHITE



1	2	3	4
5	6	7	8
9	10		

Terminal No.	Color of Wire	Signal Name
1	P	-
4	B	-
5	SB	-
6	R	-

Connector No.	D1
Connector Name	WIRE TO WIRE
Connector Color	WHITE



7	6	5	4	3	2	1
16	15	14	13	12	11	10
9	8					

Terminal No.	Color of Wire	Signal Name
2	V	-
3	P	-
4	R	-
5	Y	-
8	SB	-
10	B	-
15	W	-

Connector No.	B134
Connector Name	WIRE TO WIRE
Connector Color	WHITE



1	2	3	4
5	6	7	8
9	10		

Terminal No.	Color of Wire	Signal Name
1	P	-
4	B	-
5	SB	-
6	R	-

Connector No.	B108
Connector Name	FRONT DOOR SWITCH RH
Connector Color	WHITE



1	2	3
---	---	---

Terminal No.	Color of Wire	Signal Name
2	GR	-

ABKIA0433GB

POWER WINDOW MAIN SWITCH

[LH&RH FRONT WINDOW ANTI-PINCH]

< ECU DIAGNOSIS >

Connector No.	D2
Connector Name	WIRE TO WIRE
Connector Color	WHITE

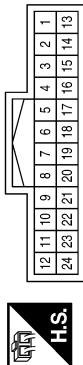

Terminal No.	Color of Wire	Signal Name
9	O	-

Connector No.	D7
Connector Name	MAIN POWER WINDOW AND DOOR LOCK/UNLOCK SWITCH
Connector Color	WHITE

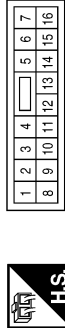

Terminal No.	Color of Wire	Signal Name
1	W	RL UP
2	GR	ENCODER GND
3	Y	RL DOWN
4	L	LOCK

Terminal No.	Color of Wire	Signal Name
5	SB	RR DOWN
6	R	UNLOCK
7	P	RR UP
8	L	AS UP
9	Y	ENCODER SIG1
10	V	IGN
11	LG	AS DOWN
13	G	ENCODER SIG2
14	O	COM
15	BR	ENCODER POWER

Connector No.	D8
Connector Name	MAIN POWER WINDOW AND DOOR LOCK/UNLOCK SWITCH
Connector Color	WHITE



Terminal No.	Color of Wire	Signal Name
17	B	GND
19	R	BAT

Connector No.	D9
Connector Name	FRONT POWER WINDOW MOTOR LH
Connector Color	WHITE



Terminal No.	Color of Wire	Signal Name
1	LG	-
2	L	-
3	G	-
4	BR	-
5	Y	-
6	GR	-

Connector No.	D10
Connector Name	FRONT DOOR LOCK ASSEMBLY LH
Connector Color	GRAY



Terminal No.	Color of Wire	Signal Name
4	B	-
5	R	-
6	L	-

ABKIA0434GB

A B C D E F G H I J L M N O P

POWER WINDOW MAIN SWITCH

[LH&RH FRONT WINDOW ANTI-PINCH]

< ECU DIAGNOSIS >

Connector No.	D105
Connector Name	POWER WINDOW AND DOOR LOCK/JUNLOCK SWITCH RH
Connector Color	WHITE

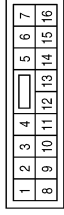

Terminal No.	Color of Wire	Signal Name
3	W	GND
4	BR	ENCODER POWER
8	L	UP
9	LG	DOWN
10	P	BAT
11	B	GND
12	G	ENCODER SIG2
15	Y	ENCODER SIG1
16	R	COM

Connector No.	D104
Connector Name	FRONT POWER WINDOW MOTOR RH
Connector Color	WHITE



Terminal No.	Color of Wire	Signal Name
1	LG	-
2	L	-
3	G	-
4	BR	-
5	Y	-
6	W	-

Connector No.	D101
Connector Name	WIRE TO WIRE
Connector Color	WHITE

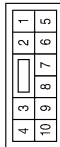

Terminal No.	Color of Wire	Signal Name
1	P	-
3	R	-
6	B	-

Connector No.	D204
Connector Name	REAR POWER WINDOW MOTOR LH (WITH FRONT LEFT AND RIGHT POWER WINDOW ANTI-PINCH SYSTEM)
Connector Color	GREEN

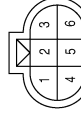

Terminal No.	Color of Wire	Signal Name
1	L	-
3	LG	-

Connector No.	D203
Connector Name	REAR POWER WINDOW SWITCH LH (WITH FRONT LEFT AND RIGHT POWER WINDOW ANTI-PINCH SYSTEM)
Connector Color	WHITE

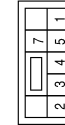

Terminal No.	Color of Wire	Signal Name
1	R	-
2	P	-
3	SB	-
4	LG	-
5	L	-
7	B	-

Connector No.	D201
Connector Name	WIRE TO WIRE
Connector Color	WHITE



Terminal No.	Color of Wire	Signal Name
1	P	-
4	B	-
5	SB	-
6	R	-

ABKIA0435GB

POWER WINDOW MAIN SWITCH

[LH&RH FRONT WINDOW ANTI-PINCH]

< ECU DIAGNOSIS >

Connector No.	D306
Connector Name	WIRE TO WIRE
Connector Color	WHITE

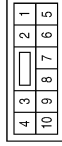

Terminal No.	Color of Wire	Signal Name
1	P	-
4	B	-
5	SB	-
6	R	-

Connector No.	D304
Connector Name	REAR POWER WINDOW MOTOR RH (WITH FRONT LEFT AND RIGHT POWER WINDOW ANTI-PINCH SYSTEM)
Connector Color	GREEN

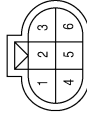

Terminal No.	Color of Wire	Signal Name
1	L	-
3	LG	-

Connector No.	D303
Connector Name	REAR POWER WINDOW SWITCH RH (WITH FRONT LEFT AND RIGHT POWER WINDOW ANTI-PINCH SYSTEM)
Connector Color	WHITE

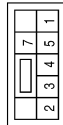

Terminal No.	Color of Wire	Signal Name
1	R	-
2	P	-
3	SB	-
4	LG	-
5	L	-
7	B	-

Fail Safe

FAIL-SAFE CONTROL

Switches to fail-safe control when malfunction is detected in encoder signal that detects up/down speed and direction of door glass. Switches to fail-safe control when error beyond regulation value is detected between the fully closed position and the actual position of the glass.

ABKIA0436GB

INFOID:0000000003898233

A
B
C
D
E
F
G
H
I
J
L
M
N
O
P

PWC

POWER WINDOW MAIN SWITCH

[LH&RH FRONT WINDOW ANTI-PINCH]

< ECU DIAGNOSIS >

Error	Error condition
Pulse sensor malfunction	When only one side of pulse signal is being detected for more than the specified value.
Both pulse sensors malfunction	When both pulse signals have not been detected for more than the specified value during glass open/close operation.
Pulse direction malfunction	When the pulse signal that is detected during glass open/close operation detects the opposite condition of power window motor operating direction.
Glass recognition position malfunction 1	When it detects the error between glass fully closed position in power window switch memory and actual fully closed position during glass open/close operation is more than the specified value.
Glass recognition position malfunction 2	When it detects pulse count more than the value of glass full stroke during glass open/close operation.
Malfunction of not yet updated closed position of glass	When glass open/close operation is continuously performed without fully closing more than the specified value (approximately 10 strokes).

It changes to condition before initialization and the following functions do not operate when switched to fail-safe control:

- Auto-up operation
- Anti-pinch function
- Retained power function

Perform initial operation to recover when switched to fail-safe mode. However, it switches back to fail-safe control when malfunction is found in power window switch or in motor.

FRONT POWER WINDOW SWITCH

< ECU DIAGNOSIS >

[LH&RH FRONT WINDOW ANTI-PINCH]

FRONT POWER WINDOW SWITCH

Reference Value

INFOID:000000003898234

TERMINAL LAYOUT

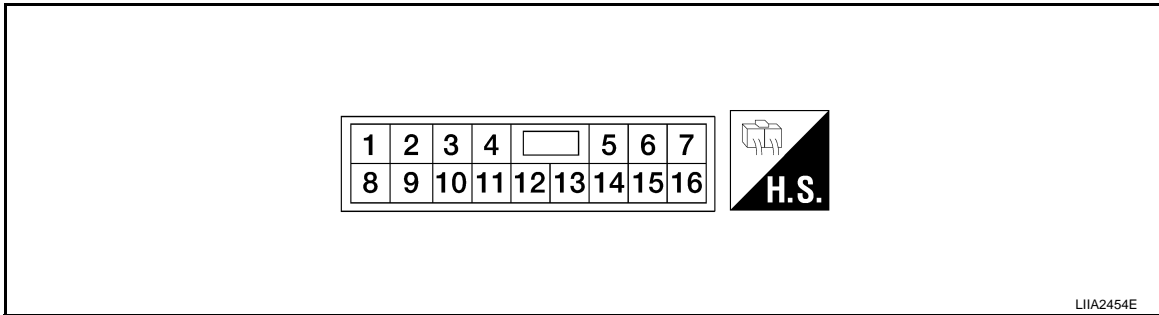

PHYSICAL VALUES

POWER WINDOW AND DOOR LOCK/UNLOCK SWITCH RH

Terminal No.		Description		Condition	Voltage [V] (Approx.)
+	-	Signal name	Input/ Output		
3 (W)	Ground	Encoder ground	—	—	0
4 (BR)	Ground	Encoder power supply	Output	When ignition switch ON or power window timer operates.	10
8 (L)	9	Power window motor UP signal	Output	When power window motor is operated UP.	Battery voltage
9 (L/G)	8	Power window motor DOWN signal	Output	When power window motor is operated DOWN.	Battery voltage
10 (P)	Ground	Battery power supply	Input	—	Battery voltage
11 (B)	Ground	Ground	—	—	0
12 (G)	3	Encoder pulse signal 1	Input	When power window motor operates.	<p>The timing diagram shows a square wave signal. The vertical axis is labeled (V) and ranges from 0 to 6. The horizontal axis is labeled 10 ms. The signal is a square wave with a period of 10 ms and a peak voltage of approximately 5V.</p>

JMKIA0070GB

A
B
C
D
E
F
G
H
I
J
L
M
N
O
P

PWC

FRONT POWER WINDOW SWITCH

[LH&RH FRONT WINDOW ANTI-PINCH]

< ECU DIAGNOSIS >

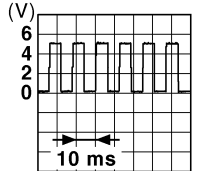
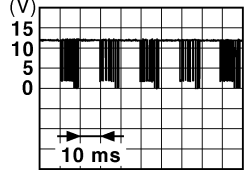
Terminal No.		Description		Condition	Voltage [V] (Approx.)
+	-	Signal name	Input/ Output		
15 (Y)	3	Encoder pulse signal 2	Input	When power window motor operates.	 <p style="text-align: right; font-size: small;">JMKIA0070GB</p>
16 (R)	Ground	Power window serial link	Input/ Output	IGN SW ON or power window timer operating.	 <p style="text-align: right; font-size: small;">JPMIA0013GB</p>

FRONT POWER WINDOW SWITCH

[LH&RH FRONT WINDOW ANTI-PINCH]

< ECU DIAGNOSIS >

Wiring Diagram

INFOID:000000003898235

POWER WINDOW SYSTEM - WITH FRONT LEFT AND RIGHT POWER WINDOW ANTI-PINCH SYSTEM

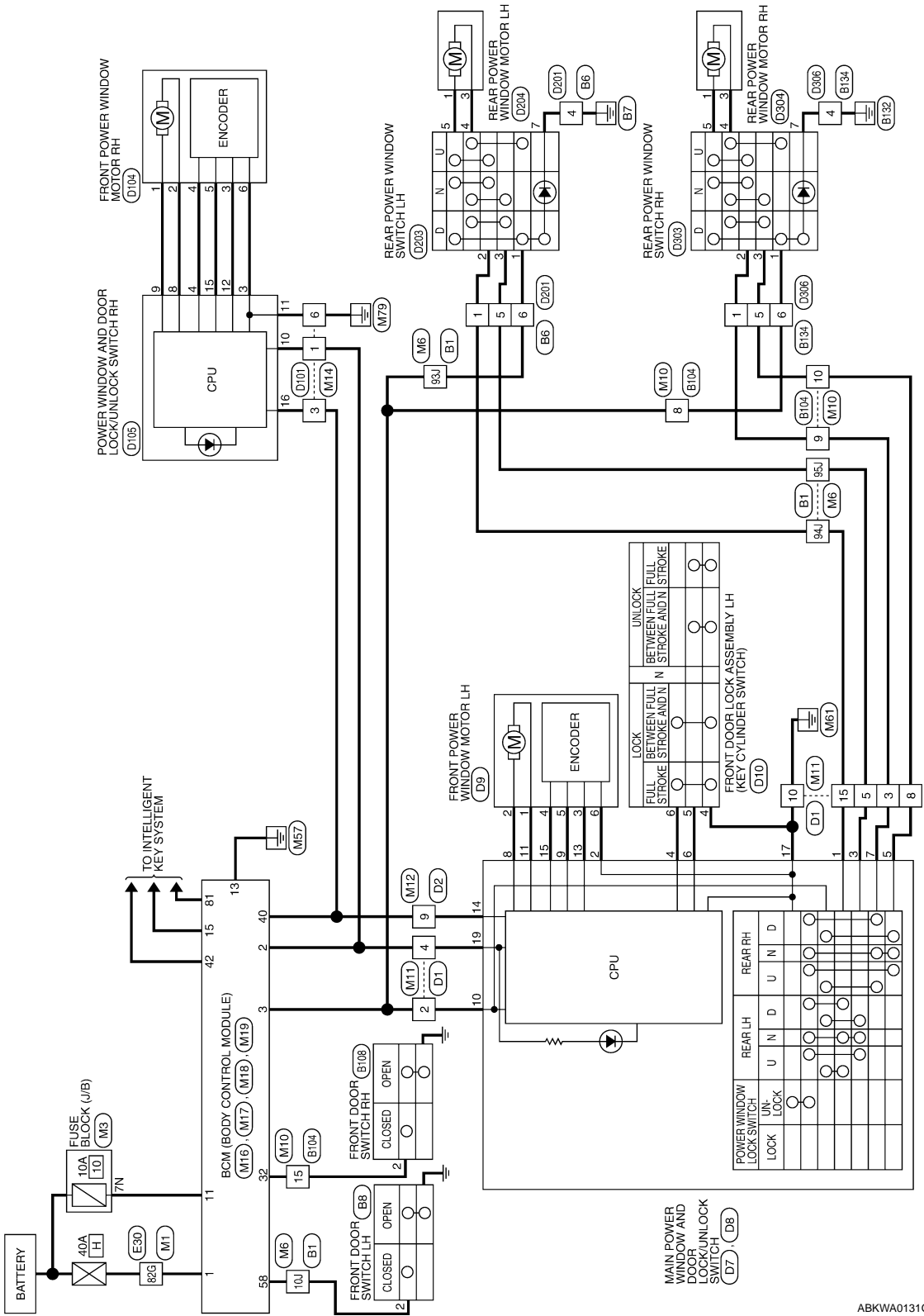

ABKWA0131GE

A
B
C
D
E
F
G
H
I
J
L
M
N
O
P

PWC

FRONT POWER WINDOW SWITCH

[LH&RH FRONT WINDOW ANTI-PINCH]

< ECU DIAGNOSIS >

POWER WINDOW SYSTEM CONNECTORS-WITH FRONT LEFT AND RIGHT POWER WINDOW ANTI-PINCH SYSTEM

Connector No.	M1
Connector Name	WIRE TO WIRE
Connector Color	WHITE

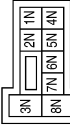
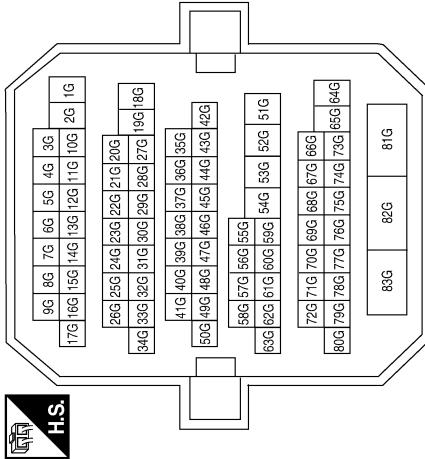

Terminal No.	7N	Color of Wire	Y/R	Signal Name	-
--------------	----	---------------	-----	-------------	---

Connector No.	M3
Connector Name	FUSE BLOCK (J/B)
Connector Color	WHITE

Connector No.	M6
Connector Name	WIRE TO WIRE
Connector Color	WHITE

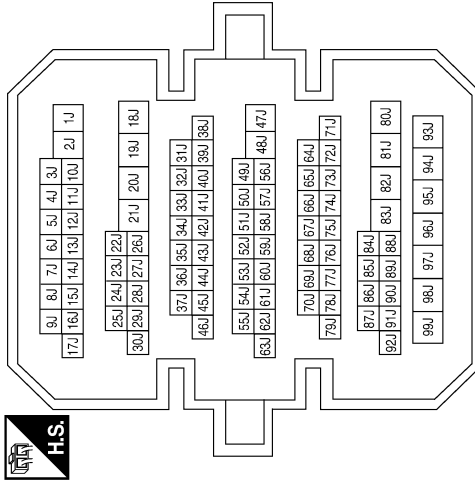

Terminal No.	82G	Color of Wire	W/B	Signal Name	-
--------------	-----	---------------	-----	-------------	---

Terminal No.	Color of Wire	Signal Name
10J	SB	-
93J	L/W	-(WITH FRONT LEFT AND RIGHT POWER WINDOW ANTI-PINCH SYSTEM)
94J	BR	-
95J	Y/G	-

ABKIA0430GB

FRONT POWER WINDOW SWITCH

[LH&RH FRONT WINDOW ANTI-PINCH]

< ECU DIAGNOSIS >

Connector No.	M10
Connector Name	WIRE TO WIRE
Connector Color	WHITE

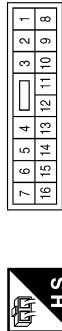

Terminal No.	Color of Wire	Signal Name
8	L/W	-(WITH FRONT LEFT AND RIGHT POWER WINDOW ANTI-PINCH SYSTEM)
9	G	-
10	Y/G	-
15	R/B	-

Connector No.	M11
Connector Name	WIRE TO WIRE
Connector Color	WHITE

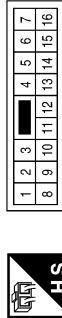

Terminal No.	Color of Wire	Signal Name
2	L/W	-
3	G	-
4	R/Y	-
5	Y/G	-
8	Y/G	-
10	B	-
15	BR	-

Connector No.	M12
Connector Name	WIRE TO WIRE
Connector Color	WHITE

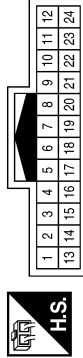

Terminal No.	Color of Wire	Signal Name
9	Y/G	-

Connector No.	M14
Connector Name	WIRE TO WIRE
Connector Color	WHITE

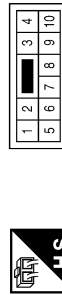

Terminal No.	Color of Wire	Signal Name
1	R/Y	-
3	Y/G	-
6	B	-

Connector No.	M16
Connector Name	BCM (BODY CONTROL MODULE)
Connector Color	BLACK



Terminal No.	Color of Wire	Signal Name
1	W/B	BAT POWER F/L
2	R/Y	P/W POWER SUPPLY PERM
3	L/W	P/W POWER SUPPLY IGN

Connector No.	M17
Connector Name	BCM (BODY CONTROL MODULE)
Connector Color	WHITE

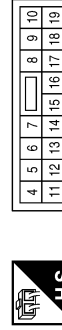

Terminal No.	Color of Wire	Signal Name
11	Y/R	BAT BCM FUSE
13	B	GND1
15	Y/L	ACC LED

A
B
C
D
E
F
G
H
I
J
K
L
M
N
O
P

PWC

FRONT POWER WINDOW SWITCH

[LH&RH FRONT WINDOW ANTI-PINCH]

< ECU DIAGNOSIS >

Connector No.	M18
Connector Name	BCM (BODY CONTROL MODULE)
Connector Color	GREEN



39	38	37	36	35	34	33	32	31	30	29	28	27	26	25	24	23	22	21	20
59	58	57	56	55	54	53	52	51	50	49	48	47	46	45	44	43	42	41	40

Terminal No.	Color of Wire	Signal Name
32	R/B	AS DOOR SW
40	Y/G	PW K-LINE
42	R	S/L LOCK LED
58	SB	DR DOOR SW

Connector No.	M19
Connector Name	BCM (BODY CONTROL MODULE)
Connector Color	BLACK



79	78	77	76	75	74	73	72	71	70	69	68	67	66	65	64	63	62	61	60
99	98	97	96	95	94	93	92	91	90	89	88	87	86	85	84	83	82	81	80

Terminal No.	Color of Wire	Signal Name
81	LG	IGN ON LED

Connector No.	E30
Connector Name	WIRE TO WIRE
Connector Color	WHITE

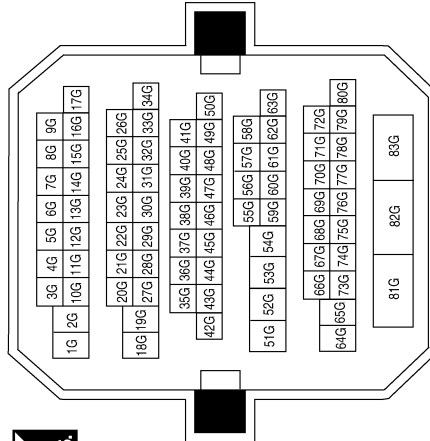

Terminal No.	Color of Wire	Signal Name
82G	LG	-

Connector No.	B1
Connector Name	WIRE TO WIRE
Connector Color	WHITE

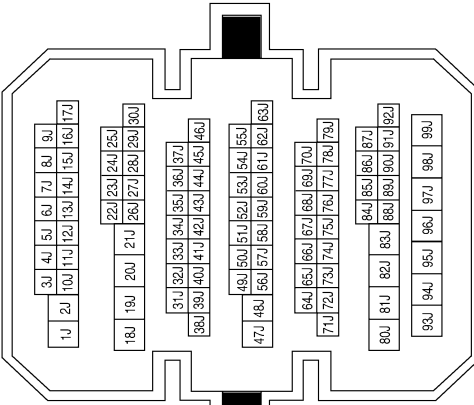

Terminal No.	Color of Wire	Signal Name
10J	SB	-
93J	R	-
94J	P	-
95J	SB	-

FRONT POWER WINDOW SWITCH

[LH&RH FRONT WINDOW ANTI-PINCH]

< ECU DIAGNOSIS >

Connector No.	B104
Connector Name	WIRE TO WIRE
Connector Color	WHITE



1	2	3	4	5	6	7		
8	9	10	11	12	13	14	15	16

Terminal No.	Color of Wire	Signal Name
8	R	-
9	P	-
10	SB	-
15	GR	-

Connector No.	B8
Connector Name	FRONT DOOR SWITCH LH
Connector Color	WHITE



1	2	3
---	---	---

Terminal No.	Color of Wire	Signal Name
2	SB	-

Connector No.	B6
Connector Name	WIRE TO WIRE
Connector Color	WHITE



1	2	3	4		
5	6	7	8	9	10

Terminal No.	Color of Wire	Signal Name
1	P	-
4	B	-
5	SB	-
6	R	-

Connector No.	D1
Connector Name	WIRE TO WIRE
Connector Color	WHITE



7	6	5	4	3	2	1		
16	15	14	13	12	11	10	9	8

Terminal No.	Color of Wire	Signal Name
2	V	-
3	P	-
4	R	-
5	Y	-
8	SB	-
10	B	-
15	W	-

Connector No.	B134
Connector Name	WIRE TO WIRE
Connector Color	WHITE



1	2	3	4		
5	6	7	8	9	10

Terminal No.	Color of Wire	Signal Name
1	P	-
4	B	-
5	SB	-
6	R	-

Connector No.	B108
Connector Name	FRONT DOOR SWITCH RH
Connector Color	WHITE



1	2	3
---	---	---

Terminal No.	Color of Wire	Signal Name
2	GR	-

ABKIA0433GB

A
B
C
D
E
F
G
H
I
J
L
M
N
O
P

FRONT POWER WINDOW SWITCH

[LH&RH FRONT WINDOW ANTI-PINCH]

< ECU DIAGNOSIS >

Connector No.	D2
Connector Name	WIRE TO WIRE
Connector Color	WHITE

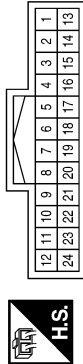

Terminal No.	Color of Wire	Signal Name
9	O	-

Connector No.	D7
Connector Name	MAIN POWER WINDOW AND DOOR LOCK/UNLOCK SWITCH
Connector Color	WHITE

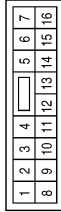

Terminal No.	Color of Wire	Signal Name
1	W	RL UP
2	GR	ENCODER GND
3	Y	RL DOWN
4	L	LOCK

Terminal No.	Color of Wire	Signal Name
5	SB	RR DOWN
6	R	UNLOCK
7	P	RR UP
8	L	AS UP
9	Y	ENCODER SIG1
10	V	IGN
11	LG	AS DOWN
13	G	ENCODER SIG2
14	O	COM
15	BR	ENCODER POWER

Connector No.	D8
Connector Name	MAIN POWER WINDOW AND DOOR LOCK/UNLOCK SWITCH
Connector Color	WHITE

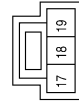

Terminal No.	Color of Wire	Signal Name
17	B	GND
19	R	BAT

Connector No.	D9
Connector Name	FRONT POWER WINDOW MOTOR LH
Connector Color	WHITE



Terminal No.	Color of Wire	Signal Name
1	LG	-
2	L	-
3	G	-
4	BR	-
5	Y	-
6	GR	-

Connector No.	D10
Connector Name	FRONT DOOR LOCK ASSEMBLY LH
Connector Color	GRAY

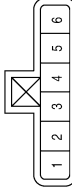

Terminal No.	Color of Wire	Signal Name
4	B	-
5	R	-
6	L	-

ABKIA0434GB

FRONT POWER WINDOW SWITCH

[LH&RH FRONT WINDOW ANTI-PINCH]

< ECU DIAGNOSIS >

Connector No.	D105
Connector Name	POWER WINDOW AND DOOR LOCK/UNLOCK SWITCH RH
Connector Color	WHITE

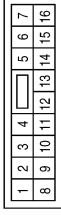

Terminal No.	Color of Wire	Signal Name
3	W	GND
4	BR	ENCODER POWER
8	L	UP
9	LG	DOWN
10	P	BAT
11	B	GND
12	G	ENCODER SIG2
15	Y	ENCODER SIG1
16	R	COM

Connector No.	D104
Connector Name	FRONT POWER WINDOW MOTOR RH
Connector Color	WHITE

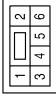

Terminal No.	Color of Wire	Signal Name
1	LG	-
2	L	-
3	G	-
4	BR	-
5	Y	-
6	W	-

Connector No.	D101
Connector Name	WIRE TO WIRE
Connector Color	WHITE

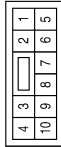

Terminal No.	Color of Wire	Signal Name
1	P	-
3	R	-
6	B	-

Connector No.	D204
Connector Name	REAR POWER WINDOW MOTOR LH (WITH FRONT LEFT AND RIGHT POWER WINDOW ANTI-PINCH SYSTEM)
Connector Color	GREEN

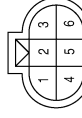

Terminal No.	Color of Wire	Signal Name
1	L	-
3	LG	-

Connector No.	D203
Connector Name	REAR POWER WINDOW SWITCH LH (WITH FRONT LEFT AND RIGHT POWER WINDOW ANTI-PINCH SYSTEM)
Connector Color	WHITE



Terminal No.	Color of Wire	Signal Name
1	R	-
2	P	-
3	SB	-
4	LG	-
5	L	-
7	B	-

Connector No.	D201
Connector Name	WIRE TO WIRE
Connector Color	WHITE



Terminal No.	Color of Wire	Signal Name
1	P	-
4	B	-
5	SB	-
6	R	-

ABKIA0435GB

A B C D E F G H I J L M N O P

PWC

FRONT POWER WINDOW SWITCH

[LH&RH FRONT WINDOW ANTI-PINCH]

< ECU DIAGNOSIS >

Connector No.	D306
Connector Name	WIRE TO WIRE
Connector Color	WHITE

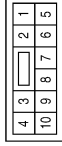

Terminal No.	Color of Wire	Signal Name
1	P	-
4	B	-
5	SB	-
6	R	-

Connector No.	D304
Connector Name	REAR POWER WINDOW MOTOR RH (WITH FRONT LEFT AND RIGHT POWER WINDOW ANTI-PINCH SYSTEM)
Connector Color	GREEN

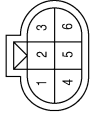

Terminal No.	Color of Wire	Signal Name
1	L	-
3	LG	-

Connector No.	D303
Connector Name	REAR POWER WINDOW SWITCH RH (WITH FRONT LEFT AND RIGHT POWER WINDOW ANTI-PINCH SYSTEM)
Connector Color	WHITE

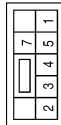

Terminal No.	Color of Wire	Signal Name
1	R	-
2	P	-
3	SB	-
4	LG	-
5	L	-
7	B	-

Fail Safe

ABKIA0436GB

INFOID:000000003898236

FAIL-SAFE CONTROL

Switches to fail-safe control when malfunction is detected in encoder signal that detects up/down speed and direction of door glass. Switches to fail-safe control when error beyond regulation value is detected between the fully closed position and the actual position of the glass.

FRONT POWER WINDOW SWITCH

[LH&RH FRONT WINDOW ANTI-PINCH]

< ECU DIAGNOSIS >

Error	Error condition
Pulse sensor malfunction	When only one side of pulse signal is being detected for more than the specified value.
Both pulse sensors malfunction	When both pulse signals have not been detected for more than the specified value during glass open/close operation.
Pulse direction malfunction	When the pulse signal that is detected during glass open/close operation detects the opposite condition of power window motor operating direction.
Glass recognition position malfunction 1	When it detects the error between glass fully closed position in power window switch memory and actual fully closed position during glass open/close operation is more than the specified value.
Glass recognition position malfunction 2	When it detects pulse count more than the value of glass full stroke during glass open/close operation.
Malfunction of not yet updated closed position of glass	When glass open/close operation is continuously performed without fully closing more than the specified value (approximately 10 strokes).

It changes to condition before initialization and the following functions do not operate when switched to fail-safe control:

- Auto-up operation
- Anti-pinch function
- Retained power function

Perform initial operation to recover when switched to fail-safe mode. However, it switches back to fail-safe control when malfunction is found in power window switch or in motor.

A
B
C
D
E
F
G
H
I
J
L
M
N
O
P

PWC

SYMPTOM DIAGNOSIS

NONE OF THE POWER WINDOWS CAN BE OPERATED USING ANY SWITCH

Diagnosis Procedure

INFOID:000000003898237

1. CHECK BCM POWER SUPPLY AND GROUND CIRCUIT

Check BCM power supply and ground circuit. Refer to [PWC-18. "BCM : Diagnosis Procedure"](#).

Is the inspection result normal?

YES >> GO TO 2

NO >> Repair or replace the malfunctioning parts.

2. CHECK MAIN POWER WINDOW AND DOOR LOCK/UNLOCK SWITCH POWER SUPPLY AND GROUND CIRCUIT

Check main power window and door lock/unlock switch power supply and ground circuit. Refer to [PWC-19. "POWER WINDOW MAIN SWITCH : Diagnosis Procedure"](#).

Is the inspection result normal?

YES >> Check intermittent incident. Refer to [GI-39. "Intermittent Incident"](#).

NO >> Repair or replace the malfunctioning parts.

DRIVER SIDE POWER WINDOW ALONE DOES NOT OPERATE

< SYMPTOM DIAGNOSIS >

[LH&RH FRONT WINDOW ANTI-PINCH]

DRIVER SIDE POWER WINDOW ALONE DOES NOT OPERATE

Diagnosis Procedure

INFOID:000000003898238

1. CHECK FRONT POWER WINDOW MOTOR LH

Check front power window motor LH. Refer to [PWC-27, "DRIVER SIDE : Component Function Check"](#).

Is the inspection result normal?

YES >> Inspection End.

NO >> Check intermittent incident. Refer to [GI-39, "Intermittent Incident"](#).

A
B
C
D
E
F
G
H
I
J
L
M
N
O
P

PWC

FRONT PASSENGER SIDE POWER WINDOW ALONE DOES NOT OPERATE
< SYMPTOM DIAGNOSIS > **[LH&RH FRONT WINDOW ANTI-PINCH]**

FRONT PASSENGER SIDE POWER WINDOW ALONE DOES NOT OPERATE

Diagnosis Procedure

INFOID:000000003898239

1. CHECK FRONT POWER WINDOW MOTOR RH CIRCUIT

Check front power window motor RH circuit. Refer to [PWC-29, "PASSENGER SIDE : Component Function Check"](#).

Is the inspection result normal?

YES >> Inspection End.

NO >> Check intermittent incident. Refer to [GI-39, "Intermittent Incident"](#).

REAR LH SIDE POWER WINDOW ALONE DOES NOT OPERATE

< SYMPTOM DIAGNOSIS >

[LH&RH FRONT WINDOW ANTI-PINCH]

REAR LH SIDE POWER WINDOW ALONE DOES NOT OPERATE

Diagnosis Procedure

INFOID:000000003898240

1. CHECK REAR POWER WINDOW MOTOR LH

Check rear power window motor LH. Refer to [PWC-30, "REAR LH : Component Function Check"](#).

Is the inspection result normal?

YES >> Inspection End.

NO >> Check intermittent incident. Refer to [GI-39, "Intermittent Incident"](#).

A
B
C
D
E
F
G
H
I
J
L
M
N
O
P

PWC

REAR RH SIDE POWER WINDOW ALONE DOES NOT OPERATE

< SYMPTOM DIAGNOSIS >

[LH&RH FRONT WINDOW ANTI-PINCH]

REAR RH SIDE POWER WINDOW ALONE DOES NOT OPERATE

Diagnosis Procedure

INFOID:000000003898241

1. CHECK REAR POWER WINDOW MOTOR RH

Check rear power window motor RH. Refer to [PWC-32, "REAR RH : Component Function Check"](#).

Is the inspection result normal?

YES >> Inspection End.

NO >> Check intermittent incident. Refer to [GI-39, "Intermittent Incident"](#).

ANTI-PINCH SYSTEM DOES NOT OPERATE NORMALLY (DRIVER SIDE)

< SYMPTOM DIAGNOSIS >

[LH&RH FRONT WINDOW ANTI-PINCH]

ANTI-PINCH SYSTEM DOES NOT OPERATE NORMALLY (DRIVER SIDE)

Diagnosis Procedure

INFOID:000000003898242

1. PERFORM INITIALIZATION PROCEDURE

Perform initialization procedure. Refer to [PWC-9, "ADDITIONAL SERVICE WHEN REPLACING CONTROL UNIT : Special Repair Requirement"](#).

Is the inspection result normal?

YES >> Inspection End.

NO >> GO TO 2

2. CHECK ENCODER CIRCUIT

Check encoder circuit. Refer to [PWC-34, "DRIVER SIDE : Component Function Check"](#).

Is the inspection result normal?

YES >> Check intermittent incident. Refer to [GI-39, "Intermittent Incident"](#).

NO >> Repair or replace malfunctioning parts.

A
B
C
D
E
F
G
H
I
J
L
M
N
O
P

PWC

ANTI-PINCH SYSTEM DOES NOT OPERATE NORMALLY (PASSENGER SIDE)
< SYMPTOM DIAGNOSIS > **[LH&RH FRONT WINDOW ANTI-PINCH]**

ANTI-PINCH SYSTEM DOES NOT OPERATE NORMALLY (PASSENGER SIDE)

Diagnosis Procedure

INFOID:000000003898243

1. PERFORM INITIALIZATION PROCEDURE

Perform initialization procedure. Refer to [PWC-9, "ADDITIONAL SERVICE WHEN REPLACING CONTROL UNIT : Special Repair Requirement"](#).

Is the inspection result normal?

- YES >> Inspection End.
- NO >> GO TO 2

2. CHECK ENCODER CIRCUIT

Check encoder circuit. Refer to [PWC-37, "PASSENGER SIDE : Component Function Check"](#).

Is the inspection result normal?

- YES >> Check intermittent incident. Refer to [GI-39, "Intermittent Incident"](#).
- NO >> Repair or replace the malfunctioning parts.

AUTO OPERATION DOES NOT OPERATE BUT MANUAL OPERATE NORMALLY (DRIVER SIDE)

< SYMPTOM DIAGNOSIS >

[LH&RH FRONT WINDOW ANTI-PINCH]

AUTO OPERATION DOES NOT OPERATE BUT MANUAL OPERATE NORMALLY (DRIVER SIDE)

Diagnosis Procedure

INFOID:000000003898244

1. PERFORM INITIALIZATION PROCEDURE

Perform initialization procedure. Refer to [PWC-9, "ADDITIONAL SERVICE WHEN REPLACING CONTROL UNIT : Special Repair Requirement"](#).

Is the inspection result normal?

YES >> Inspection End.

NO >> GO TO 2

2. CHECK ENCODER

Check encoder. Refer to [PWC-34, "DRIVER SIDE : Component Function Check"](#).

Is the inspection result normal?

YES >> Check intermittent incident. Refer to [GI-39, "Intermittent Incident"](#).

NO >> Repair or replace the malfunctioning parts.

A
B
C
D
E
F
G
H
I
J
L
M
N
O
P

PWC

AUTO OPERATION DOES NOT OPERATE BUT MANUAL OPERATE NORMALLY (PASSENGER SIDE)

< SYMPTOM DIAGNOSIS >

[LH&RH FRONT WINDOW ANTI-PINCH]

AUTO OPERATION DOES NOT OPERATE BUT MANUAL OPERATE NORMALLY (PASSENGER SIDE)

Diagnosis Procedure

INFOID:000000003898245

1. PERFORM INITIALIZATION PROCEDURE

Perform initialization procedure. Refer to [PWC-9, "ADDITIONAL SERVICE WHEN REPLACING CONTROL UNIT : Special Repair Requirement"](#).

Is the inspection result normal?

YES >> Inspection End.

NO >> GO TO 2

2. CHECK ENCODER

Check encoder. Refer to [PWC-37, "PASSENGER SIDE : Component Function Check"](#).

Is the inspection result normal?

YES >> Check intermittent incident. Refer to [GI-39, "Intermittent Incident"](#).

NO >> Repair or replace the malfunctioning parts.

POWER WINDOW RETAINED POWER OPERATION DOES NOT OPERATE PROPERLY

< SYMPTOM DIAGNOSIS >

[LH&RH FRONT WINDOW ANTI-PINCH]

POWER WINDOW RETAINED POWER OPERATION DOES NOT OPERATE PROPERLY

Diagnosis Procedure

INFOID:000000003898246

1. CHECK FRONT DOOR SWITCH

Check front door switch. Refer to [PWC-40, "Component Function Check"](#).

Is the inspection result normal?

- YES >> Check intermittent incident. Refer to [GI-39, "Intermittent Incident"](#).
- NO >> Repair or replace malfunctioning parts.

A
B
C
D
E
F
G
H
I
J
L
M
N
O
P

PWC

DOES NOT OPERATE BY KEY CYLINDER SWITCH

< SYMPTOM DIAGNOSIS >

[LH&RH FRONT WINDOW ANTI-PINCH]

DOES NOT OPERATE BY KEY CYLINDER SWITCH

Diagnosis Procedure

INFOID:000000003898247

1. CHECK FRONT DOOR LOCK ASSEMBLY LH (KEY CYLINDER SWITCH)

Check front door lock assembly LH (key cylinder switch). Refer to [PWC-43, "Diagnosis Procedure"](#).

Is the inspection result normal?

- YES >> Check intermittent incident. Refer to [GI-39, "Intermittent Incident"](#).
- NO >> Repair or replace malfunctioning parts.

KEYLESS POWER WINDOW DOWN DOES NOT OPERATE

< SYMPTOM DIAGNOSIS >

[LH&RH FRONT WINDOW ANTI-PINCH]

KEYLESS POWER WINDOW DOWN DOES NOT OPERATE

Diagnosis Procedure

INFOID:000000003898248

1. CHECK INTELLIGENT KEY FUNCTION

Check Intelligent Key function. Refer to [DLK-112, "Component Function Check"](#).

Is the inspection result normal?

YES >> Check intermittent incident. Refer to [GI-39, "Intermittent Incident"](#).

NO >> Replace BCM. Refer to [BCS-87, "Removal and Installation"](#).

A
B
C
D
E
F
G
H
I
J
L
M
N
O
P

PWC

POWER WINDOW LOCK SWITCH DOES NOT FUNCTION

< SYMPTOM DIAGNOSIS >

[LH&RH FRONT WINDOW ANTI-PINCH]

POWER WINDOW LOCK SWITCH DOES NOT FUNCTION

Diagnosis Procedure

INFOID:000000003898249

1. CHECK POWER WINDOW LOCK SWITCH

Check power window lock switch. Refer to [PWC-50, "Component Function Check"](#).

Is the inspection result normal?

- YES >> Check intermittent incident. Refer to [GI-39, "Intermittent Incident"](#).
- NO >> Repair or replace malfunctioning parts.

PRECAUTION

PRECAUTIONS

Precaution for Supplemental Restraint System (SRS) "AIR BAG" and "SEAT BELT PRE-TENSIONER"

INFOID:000000003898250

The Supplemental Restraint System such as "AIR BAG" and "SEAT BELT PRE-TENSIONER", used along with a front seat belt, helps to reduce the risk or severity of injury to the driver and front passenger for certain types of collision. This system includes seat belt switch inputs and dual stage front air bag modules. The SRS system uses the seat belt switches to determine the front air bag deployment, and may only deploy one front air bag, depending on the severity of a collision and whether the front occupants are belted or unbelted. Information necessary to service the system safely is included in the SR and SB section of this Service Manual.

WARNING:

- To avoid rendering the SRS inoperative, which could increase the risk of personal injury or death in the event of a collision which would result in air bag inflation, all maintenance must be performed by an authorized NISSAN/INFINITI dealer.
- Improper maintenance, including incorrect removal and installation of the SRS, can lead to personal injury caused by unintentional activation of the system. For removal of Spiral Cable and Air Bag Module, see the SR section.
- Do not use electrical test equipment on any circuit related to the SRS unless instructed to in this Service Manual. SRS wiring harnesses can be identified by yellow and/or orange harnesses or harness connectors.

Precautions Necessary for Steering Wheel Rotation after Battery Disconnect

INFOID:000000004394044

NOTE:

- Before removing and installing any control units, first turn the push-button ignition switch to the LOCK position, then disconnect both battery cables.
- After finishing work, confirm that all control unit connectors are connected properly, then re-connect both battery cables.
- Always use CONSULT-III to perform self-diagnosis as a part of each function inspection after finishing work. If a DTC is detected, perform trouble diagnosis according to self-diagnosis results.

This vehicle is equipped with a push-button ignition switch and a steering lock unit.

If the battery is disconnected or discharged, the steering wheel will lock and cannot be turned.

If turning the steering wheel is required with the battery disconnected or discharged, follow the procedure below before starting the repair operation.

OPERATION PROCEDURE

1. Connect both battery cables.
 - NOTE:**
Supply power using jumper cables if battery is discharged.
2. Carry the Intelligent Key or insert it to the key slot and turn the push-button ignition switch to ACC position. (At this time, the steering lock will be released.)
3. Disconnect both battery cables. The steering lock will remain released with both battery cables disconnected and the steering wheel can be turned.
4. Perform the necessary repair operation.
5. When the repair work is completed, re-connect both battery cables. With the brake pedal released, turn the push-button ignition switch from ACC position to ON position, then to LOCK position. (The steering wheel will lock when the push-button ignition switch is turned to LOCK position.)
6. Perform self-diagnosis check of all control units using CONSULT-III.

A
B
C
D
E
F
G
H
I
J
L
M
N
O
P

PWC

PRE-INSPECTION FOR DIAGNOSTIC

< ON-VEHICLE MAINTENANCE >

[LH&RH FRONT WINDOW ANTI-PINCH]

ON-VEHICLE MAINTENANCE

PRE-INSPECTION FOR DIAGNOSTIC

Basic Inspection

INFOID:000000003898251

BASIC INSPECTION

1.INSPECTION START

1. Check the service history.
2. Check the following parts.
 - Fuse/circuit breaker blown.
 - Poor connection, open or short circuit of harness connector.
 - Battery voltage.

Is the inspection result normal?

- YES >> Inspection End.
NO >> Repair or replace the malfunctioning parts.

POWER WINDOW MAIN SWITCH

< ON-VEHICLE REPAIR >

[LH&RH FRONT WINDOW ANTI-PINCH]

ON-VEHICLE REPAIR

POWER WINDOW MAIN SWITCH

Removal and Installation

INFOID:000000003898252

REMOVAL

1. Disconnect the negative battery terminal.
2. Using a suitable tool, remove the front door grip cover. Refer to [INT-18. "Exploded View"](#).
CAUTION:
Wrap a cloth around suitable tools to protect components from damage.
3. Remove the power window main switch locking clip (A).

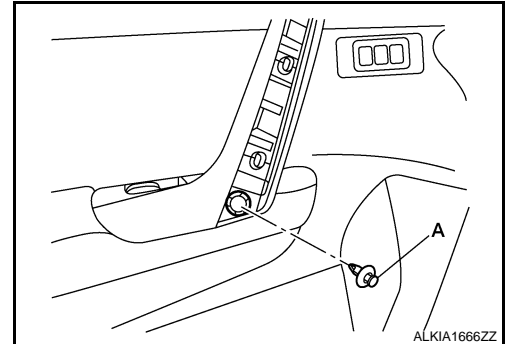

4. Release the metal clip, then lift the power window main switch and finisher as an assembly upward to remove it from the front door finisher.

□: Metal clip

○: Pawl

5. Disconnect the harness connector.
6. Release the tabs on each side, then separate the switch finisher (1) from the power window main switch (2) and remove.

CAUTION:

Do not fold the pawl of power window main switch finisher.

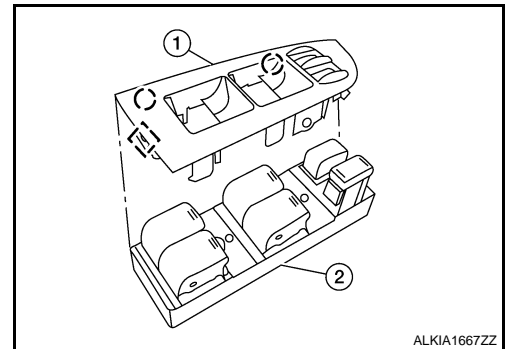

INSTALLATION

Installation is in the reverse order of removal.

NOTE:

After every switch harness disconnection, it is necessary to perform the initialization procedure. Refer to [PWC-9. "ADDITIONAL SERVICE WHEN REPLACING CONTROL UNIT : Special Repair Requirement"](#).

A
B
C
D
E
F
G
H
I
J
L
M
N
O
P

PWC

FRONT POWER WINDOW SWITCH

< ON-VEHICLE REPAIR >

[LH&RH FRONT WINDOW ANTI-PINCH]

FRONT POWER WINDOW SWITCH

Removal and Installation

INFOID:000000004362909

REMOVAL

1. Disconnect the negative battery terminal.
2. Using a suitable tool, remove the front door grip cover. Refer to [INT-18, "Exploded View"](#).

CAUTION:

Do not fold the pawl of front power window switch finisher.

3. Remove the front power window switch locking clip (A).

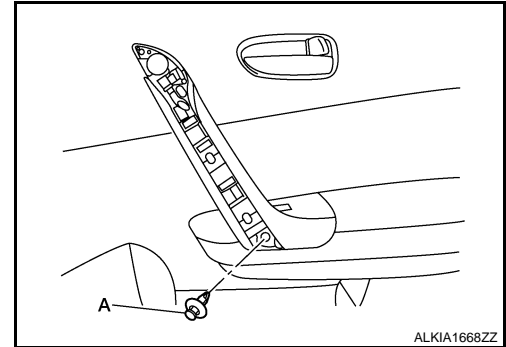

4. Release the metal clip, then lift the front power window switch and finisher as an assembly upward to remove it from the front door finisher.

☐: Metal clip

○: Pawl

CAUTION:

Wrap a cloth around suitable tools to protect components from damage.

5. Disconnect the harness connector.
6. Release the tabs on each side, then separate the switch finisher (1) from the front power window switch (2) and remove.

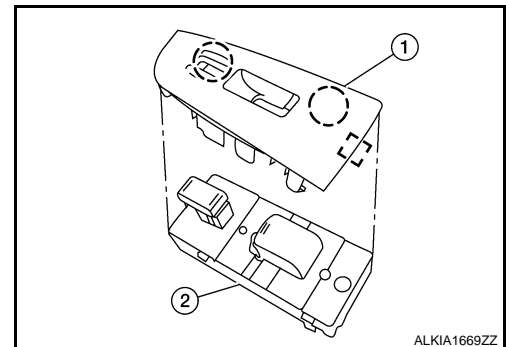

INSTALLATION

Installation is in the reverse order of removal.

NOTE:

After every switch harness disconnection, it is necessary to perform the initialization procedure. Refer to [PWC-9, "ADDITIONAL SERVICE WHEN REPLACING CONTROL UNIT : Special Repair Requirement"](#).

REAR POWER WINDOW SWITCH

< ON-VEHICLE REPAIR >

[LH&RH FRONT WINDOW ANTI-PINCH]

REAR POWER WINDOW SWITCH

Removal and Installation

INFOID:000000004362910

REMOVAL

1. Disconnect the negative battery terminal.
2. Using a suitable tool, remove the rear door arm rest finisher (1), then disconnect the harness connector. Refer to [INT-21, "Exploded View"](#).

CAUTION:

Wrap a cloth around suitable tools to protect components from damage.

3. Release the tabs on each side with suitable tool (A), then separate the rear power window switch (2) from the finisher (1) and remove.

⊖: Pawl

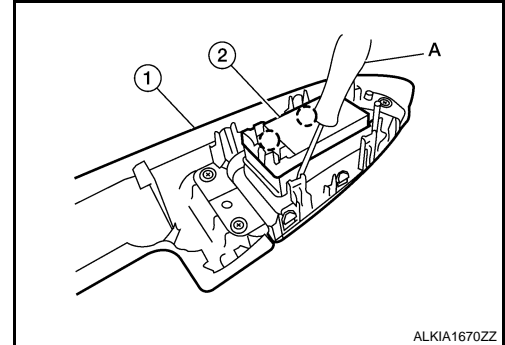

INSTALLATION

Installation is in the reverse order of removal.

NOTE:

After every switch harness disconnection, it is necessary to perform the initialization procedure. Refer to [PWC-9, "ADDITIONAL SERVICE WHEN REPLACING CONTROL UNIT : Special Repair Requirement"](#).

A
B
C
D
E
F
G
H
I
J
L
M
N
O
P

PWC

DIAGNOSIS AND REPAIR WORKFLOW

< BASIC INSPECTION >

[FRONT & REAR WINDOW ANTI-PINCH]

BASIC INSPECTION

DIAGNOSIS AND REPAIR WORKFLOW

Work Flow

INFOID:000000004362919

OVERALL SEQUENCE

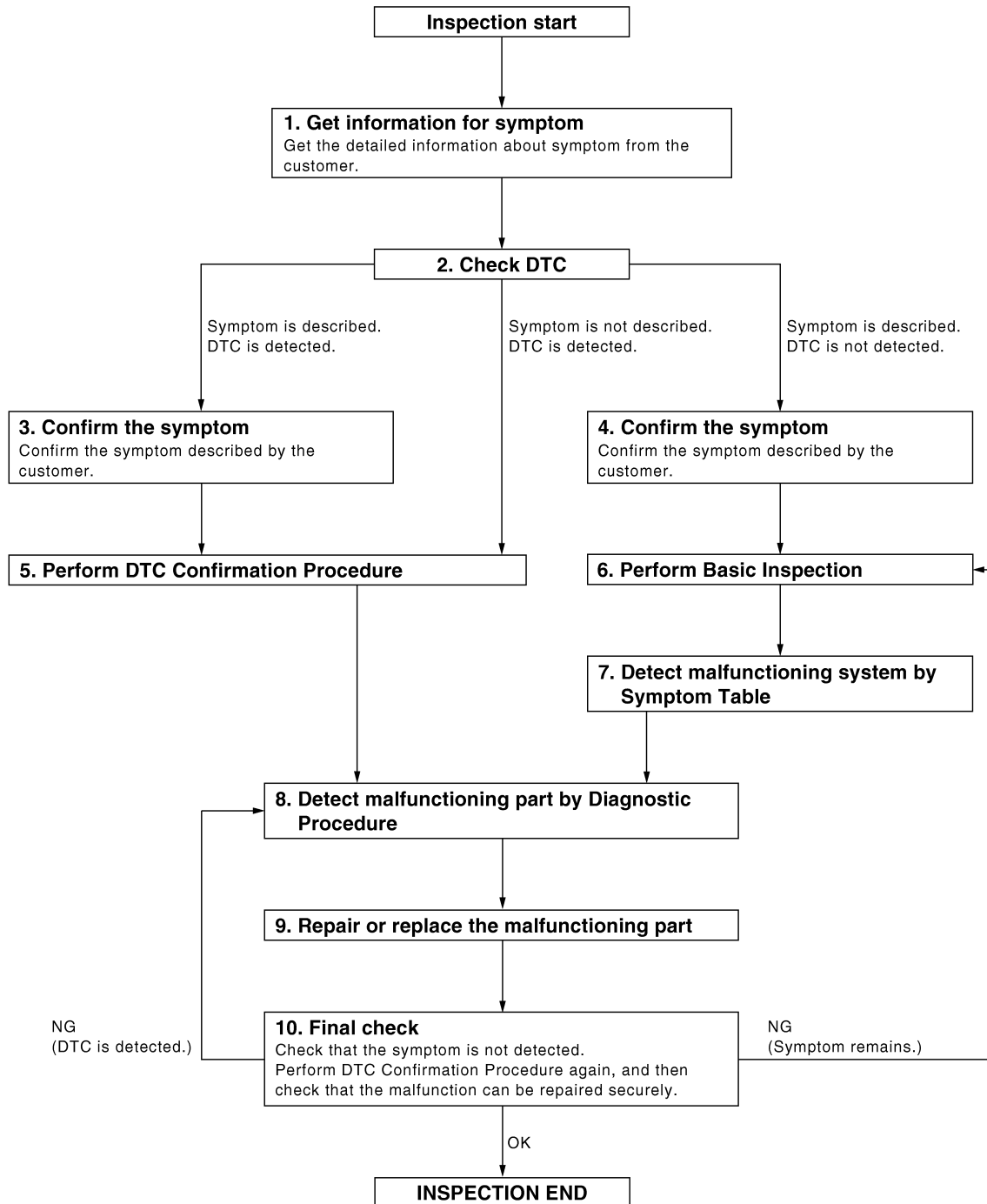

DETAILED FLOW

JMKIA0101GB

DIAGNOSIS AND REPAIR WORKFLOW

< BASIC INSPECTION >

[FRONT & REAR WINDOW ANTI-PINCH]

1. GET INFORMATION FOR SYMPTOM

Get the detailed information from the customer about the symptom (the condition and the environment when the incident/malfunction occurred).

>> GO TO 2

2. CHECK DTC

1. Check DTC.
2. Perform the following procedure if DTC is displayed.
 - Record DTC and freeze frame data (Print them out with CONSULT-III.)
 - Erase DTC.
 - Study the relationship between the cause detected by DTC and the symptom described by the customer.
3. Check related service bulletins for information.

Is any symptom described and any DTC detected?

- Symptom is described, DTC is displayed>>GO TO 3
- Symptom is described, DTC is not displayed>>GO TO 4
- Symptom is not described, DTC is displayed>>GO TO 5

3. CONFIRM THE SYMPTOM

Confirm the symptom described by the customer.
Connect CONSULT-III to the vehicle in "DATA MONITOR" mode and check real time diagnosis results.
Verify relation between the symptom and the condition when the symptom is detected.

>> GO TO 5

4. CONFIRM THE SYMPTOM

Confirm the symptom described by the customer.
Connect CONSULT-III to the vehicle in "DATA MONITOR" mode and check real time diagnosis results.
Verify relation between the symptom and the condition when the symptom is detected.

>> GO TO 6

5. PERFORM DTC CONFIRMATION PROCEDURE

Perform DTC Confirmation Procedure for the displayed DTC, and then check that DTC is detected again.
At this time, always connect CONSULT-III to the vehicle, and check diagnostic results in real time.
If two or more DTCs are detected, refer to [BCS-81. "DTC Inspection Priority Chart"](#) and determine trouble diagnosis order.

NOTE:

- Freeze frame data is useful if the DTC is not detected.
- Perform Component Function Check if DTC Confirmation Procedure is not included in Service Manual. This simplified check procedure is an effective alternative though DTC cannot be detected during this check.
If the result of Component Function Check is NG, it is the same as the detection of DTC by DTC Confirmation Procedure.

Is DTC detected?

- YES >> GO TO 8
- NO >> Refer to [GI-39. "Intermittent Incident"](#).

6. PERFORM BASIC INSPECTION

Perform [PWC-116. "Work Flow"](#).

Inspection End>>GO TO 7

7. DETECT MALFUNCTIONING SYSTEM BY SYMPTOM TABLE

Detect malfunctioning system based on the confirmed symptom in step 4, and determine the trouble diagnosis order based on possible causes and symptom.

>> GO TO 8

A
B
C
D
E
F
G
H
I
J
L
M
N
O
P

PWC

DIAGNOSIS AND REPAIR WORKFLOW

< BASIC INSPECTION >

[FRONT & REAR WINDOW ANTI-PINCH]

8. DETECT MALFUNCTIONING PART BY DIAGNOSTIC PROCEDURE

Inspect according to Diagnostic Procedure of the system.

NOTE:

The Diagnostic Procedure described based on open circuit inspection. A short circuit inspection is also required for the circuit check in the Diagnostic Procedure.

Is malfunctioning part detected?

YES >> GO TO 9

NO >> Check voltage of related BCM terminals using CONSULT-III.

9. REPAIR OR REPLACE THE MALFUNCTIONING PART

1. Repair or replace the malfunctioning part.
2. Reconnect parts or connectors disconnected during Diagnostic Procedure again after repair and replacement.
3. Check DTC. If DTC is displayed, erase it.

>> GO TO 10

10. FINAL CHECK

When DTC was detected in step 2, perform DTC Confirmation Procedure or Component Function Check again, and then check that the malfunction has been repaired securely.

When symptom was described from the customer, refer to confirmed symptom in step 3 or 4, and check that the symptom is not detected.

Does the symptom reappear?

YES (DTC is detected)>>GO TO 8

YES (Symptom remains)>>GO TO 6

NO >> Inspection End.

INSPECTION AND ADJUSTMENT

< BASIC INSPECTION >

[FRONT & REAR WINDOW ANTI-PINCH]

INSPECTION AND ADJUSTMENT

ADDITIONAL SERVICE WHEN REMOVING BATTERY NEGATIVE TERMINAL

ADDITIONAL SERVICE WHEN REMOVING BATTERY NEGATIVE TERMINAL : Description

INFOID:000000004362920

Initial setting is necessary when battery terminal is disconnected.

CAUTION:

The following specified operations are not performed under the non-initialized condition.

- Auto-up operation
- Anti-pinch function
- Retained power operation

ADDITIONAL SERVICE WHEN REMOVING BATTERY NEGATIVE TERMINAL : Special Repair Requirement

INFOID:000000004362921

INITIALIZATION PROCEDURE

1. Disconnect battery negative terminal or main power window and door lock/unlock switch. Reconnect it after a minute or more.
2. Turn ignition switch ON.
3. Operate power window switch to fully open the window. (This operation is unnecessary if the window is already fully open)
4. Continue pulling the power window switch UP (AUTO-UP operation). Even after glass stops at fully closed position, keep pulling the switch for 4 seconds or more.
5. Inspect anti-pinch function.

CHECK ANTI-PINCH FUNCTION

1. Fully open the door window.
 2. Place a piece of wood near fully closed position.
 3. Close door glass completely with AUTO-UP.
- Check that glass lowers for approximately 150 mm (5.91 in) or 2 seconds without pinching piece of wood and stops.
 - Check that glass does not rise when operating the power window main switch while lowering.

CAUTION:

- Do not check with hands and other parts of the body because they may be pinched. Do not get pinched.
- Check that AUTO-UP operates before inspection when system initialization is performed.
- It may switch to fail-safe mode if open/close operation is performed continuously. Perform initial setting in that situation. Refer to [PWC-201, "Fail Safe"](#), [PWC-212, "Fail Safe"](#) or [PWC-223, "Fail Safe"](#).
- Perform initial setting when auto-up operation or anti-pinch function does not operate normally.
- Finish initial setting. Otherwise, next operation cannot be done.

1. Auto-up operation
2. Anti-pinch function
3. Retained power operation when ignition switch is OFF.

ADDITIONAL SERVICE WHEN REPLACING CONTROL UNIT

ADDITIONAL SERVICE WHEN REPLACING CONTROL UNIT : Description

INFOID:000000004362922

Initial setting is necessary when replacing main power window and door lock/unlock switch.

CAUTION:

The following specified operations are not performed under the non-initialized condition.

- Auto-up operation
- Anti-pinch function
- Retained power operation

ADDITIONAL SERVICE WHEN REPLACING CONTROL UNIT : Special Repair Requirement

INFOID:000000004362923

INITIALIZATION PROCEDURE

A
B
C
D
E
F
G
H
I
J
L
M
N
O
P

PWC

INSPECTION AND ADJUSTMENT

< BASIC INSPECTION >

[FRONT & REAR WINDOW ANTI-PINCH]

1. Disconnect battery negative terminal or main power window and door lock/unlock switch. Reconnect it after a minute or more.
2. Turn ignition switch ON.
3. Operate power window switch to fully open the window. (This operation is unnecessary if the window is already fully open)
4. Continue pulling the power window switch UP (AUTO-UP operation). Even after glass stops at fully closed position, keep pulling the switch for 4 seconds or more.
5. Inspect anti-pinch function.

CHECK ANTI-PINCH FUNCTION

1. Fully open the door window.
2. Place a piece of wood near fully closed position.
3. Close door glass completely with AUTO-UP.
 - Check that glass lowers for approximately 150 mm (5.91 in) or 2 seconds without pinching piece of wood and stops.
 - Check that glass does not rise when operating the main power window and door lock/unlock switch while lowering.

CAUTION:

- Do not check with hands and other parts of the body because they may be pinched. Do not get pinched.
 - Check that AUTO-UP operates before inspection when system initialization is performed.
 - It may switch to fail-safe mode if open/close operation is performed continuously. Perform initial setting in that situation. Refer to [PWC-201, "Fail Safe"](#), [PWC-212, "Fail Safe"](#) or [PWC-223, "Fail Safe"](#).
 - Perform initial setting when auto-up operation or anti-pinch function does not operate normally.
 - Finish initial setting. Otherwise, next operation cannot be done.
1. Auto-up operation
 2. Anti-pinch function
 3. Retained power operation when ignition switch is OFF.

POWER WINDOW SYSTEM

< FUNCTION DIAGNOSIS >

[FRONT & REAR WINDOW ANTI-PINCH]

FUNCTION DIAGNOSIS

POWER WINDOW SYSTEM

System Diagram

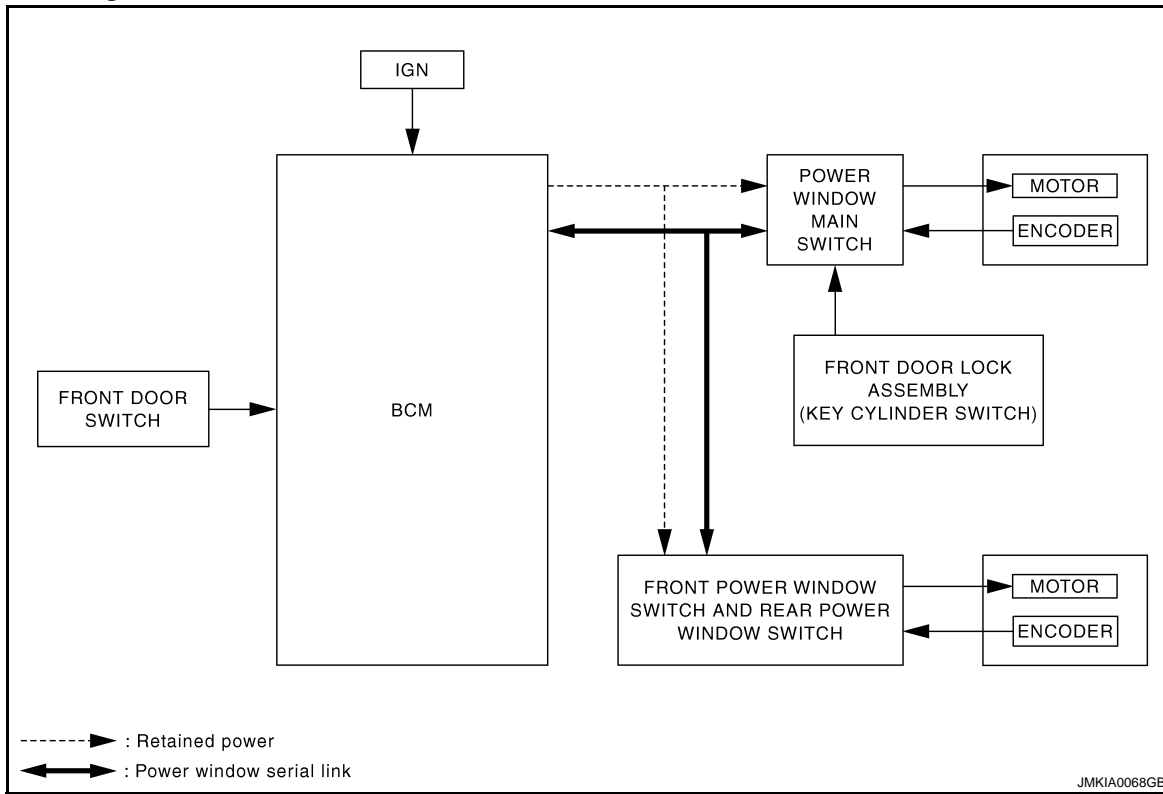

System Description

INFOID:000000004392473

POWER WINDOW MAIN SWITCH INPUT/OUTPUT SIGNAL CHART

PWC

Item	Input signal to power window main switch	Power window main switch function	Actuator
Key cylinder switch	LOCK/UNLOCK signal (more than 1.5 seconds over)	Power window control	Each power window motor
Encoder	Encoder pulse signal		
Power window main switch	Front power window motor (driver side) UP/DOWN signal		
Front power window switch (passenger side)	Front power window motor (passenger side) UP/DOWN signal		
Rear power window switch	Rear power window motor UP/DOWN signal		
BCM	RAP signal		

FRONT POWER WINDOW & REAR POWER WINDOW SWITCH INPUT/OUTPUT SIGNAL CHART

POWER WINDOW SYSTEM

< FUNCTION DIAGNOSIS >

[FRONT & REAR WINDOW ANTI-PINCH]

Item	Input signal to front power window & rear power window switch	Front power window & rear power window switch function	Actuator
Encoder	Encoder pulse signal	Power window control	Front power window motor (passenger side) & rear power window motor
BCM	RAP signal		
Front power window switch (passenger side) & rear power window switch	Front power window motor (passenger side) & rear power window motor UP/DOWN signal		

POWER WINDOW OPERATION

- Power window system is operable during the retained power operation timer after turning ignition switch ON and OFF.
- Power window main switch (driver side) can open/close all windows.
- Front & rear power window switch can open/close the corresponding windows.

POWER WINDOW AUTO-OPERATION

- AUTO UP/DOWN operation can be performed when each power window motor turns to AUTO.
- Encoder continues detecting the movement of power window motor and transmits to power window switch as the encoder pulse signal while power window motor is operating.
- Power window switch reads the changes of encoder signal and stops AUTO operation when door glass is at fully opened/closed position.
- Power window motor is operable in case encoder is malfunctioning.

RETAINED POWER OPERATION

- Retained power operation is an additional power supply function that enables power window system to operate during the 45 seconds even when ignition switch is turned OFF.

Retained power function cancel conditions

- Front door CLOSE (door switch OFF)→OPEN (door switch ON).
- When ignition switch is ON again.
- When timer time passes. (45 seconds)

POWER WINDOW LOCK

Ground circuit inside power window main switch shuts off when power window lock switch is ON. This inhibits power window switch operation except with the power window switch.

ANTI-PINCH OPERATION

- Pinch foreign material in the door glass during AUTO-UP operation, and it is the anti-pinch function that lowers the door glass 150 mm (5.91 in) or 2 seconds when detected.
- Encoder continues detecting the movement of power window motor and transmits to power window switch as the encoder pulse signal while power window motor is operating.
- Resistance is applied to the power window motor rotation that changes the frequency of encoder pulse signal if foreign material is trapped in the door glass.
- Power window switch controls to lower the window glass for 150 mm or 2 seconds after it detects encoder pulse signal frequency change.

OPERATION CONDITION

- When all door glass AUTO-UP operation is performed (anti-pinch function does not operate just before the door glass closes and is fully closed)

NOTE:

Depending on environment and driving conditions, if a similar impact or load is applied to the door glass, it may lower.

KEY CYLINDER SWITCH OPERATION

Hold the door key cylinder to the LOCK or UNLOCK direction for 1.5 seconds or more to OPEN or CLOSE all power windows when ignition switch is OFF. In addition, it stops when key position is moved to NEUTRAL when operating.

OPERATION CONDITION

- Ignition switch OFF.
- Hold door key cylinder to LOCK position for 1.5 seconds or more to perform CLOSE operation of the door glass.

POWER WINDOW SYSTEM

< FUNCTION DIAGNOSIS >

[FRONT & REAR WINDOW ANTI-PINCH]

- Hold door key cylinder to UNLOCK position for 1.5 seconds or more to perform OPEN operation of the door glass.

KEYLESS POWER WINDOW DOWN FUNCTION

All power windows open when the unlock button on Intelligent Key is activated and kept pressed for more than 3 seconds^{NOTE} with the ignition switch OFF. The windows keep opening if the unlock button is continuously pressed.

The power window opening stops when the following operations are performed.

- When the unlock button is kept pressed more than 15 seconds.
- When the ignition switch is turned ON while the power window opening is operated.
- When the unlock button is released.

While retained power operation is active, keyless power window down function cannot be operated.

Keyless power window down operation mode can be changed by "PW DOWN SET" mode in "WORK SUPPORT". Refer to [DLK-50. "INTELLIGENT KEY : CONSULT-III Function \(BCM - INTELLIGENT KEY\)"](#).

NOTE:

Use CONSULT-III to change settings.

MODE 1 (3 sec) / MODE 2 (OFF) / MODE 3 (5 sec)

A
B
C
D
E
F
G
H
I
J
L
M
N
O
P

PWC

POWER WINDOW SYSTEM

< FUNCTION DIAGNOSIS >

[FRONT & REAR WINDOW ANTI-PINCH]

Component Parts Location

INFOID:000000004392474

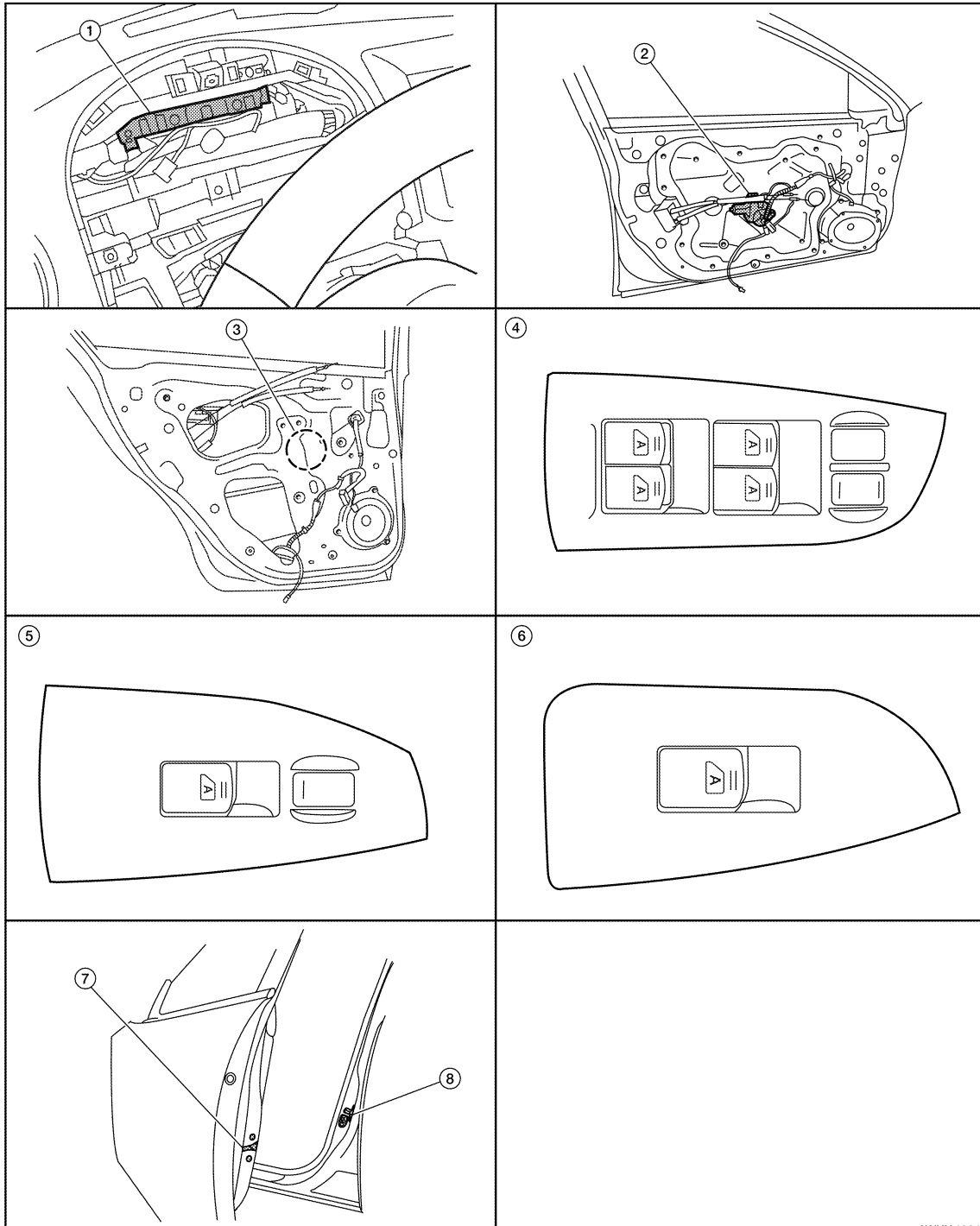

AWKIA1394ZZ

- | | | |
|---|---|---|
| 1. BCM M16, M17, M18, M19 (view with combination meter removed) | 2. Front power window motor LH D9
Front power window motor RH D104 | 3. Rear power window motor LH D208
Rear power window motor RH D304 |
| 4. Main power window and door lock/unlock switch D7, D8 | 5. Power window and door lock/unlock switch RH D105 | 6. Rear power window switch LH D207
Rear power window switch RH D307 |
| 7. Front door lock assembly LH (key cylinder switch) D10 | 8. Front door switch LH B8
Front door switch RH B108 | |

POWER WINDOW SYSTEM

[FRONT & REAR WINDOW ANTI-PINCH]

< FUNCTION DIAGNOSIS >

Component Description

INFOID:000000004392475

Component	Function
BCM	<ul style="list-style-type: none"> Supplies power supply to power window switch. Controls retained power.
Power window main switch	<ul style="list-style-type: none"> Directly controls all power window motor of all doors. Controls anti-pinch operation of power window.
Front power window switch	<ul style="list-style-type: none"> Controls anti-pinch operation of power window. Controls power window motor of passenger door.
Rear power window switch	<ul style="list-style-type: none"> Controls anti-pinch operation of power window. Controls power window motor of rear right and left doors.
Power window motor	<ul style="list-style-type: none"> Integrates the ENCODER and WINDOW MOTOR. Starts operating with signals from each power window switch. Transmits power window motor rotation as a pulse signal to power window switch.
Front door lock assembly (key cylinder switch)	Transmits operation condition of key cylinder switch to power window main switch.
Front door switch	Detects door open/close condition and transmits to BCM.

A
B
C
D
E
F
G
H
I
J
L
M
N
O
P

PWC

DIAGNOSIS SYSTEM (BCM)

[FRONT & REAR WINDOW ANTI-PINCH]

< FUNCTION DIAGNOSIS >

DIAGNOSIS SYSTEM (BCM)

COMMON ITEM

COMMON ITEM : Diagnosis Description

INFOID:000000004391478

BCM CONSULT-III FUNCTION

CONSULT-III performs the following functions via CAN communication with BCM.

Diagnosis mode	Function Description
WORK SUPPORT	Changes the setting for each system function.
SELF-DIAG RESULTS	Displays the diagnosis results judged by BCM.
CAN DIAG SUPPORT MNTR	Monitors the reception status of CAN communication viewed from BCM.
DATA MONITOR	The BCM input/output signals are displayed.
ACTIVE TEST	The signals used to activate each device are forcibly supplied from BCM.
ECU IDENTIFICATION	The BCM part number is displayed.
CONFIGURATION	This function is not used even though it is displayed.

SYSTEM APPLICATION

BCM can perform the following functions for each system.

NOTE:

It can perform the diagnosis modes except the following for all sub system selection items.

System	Sub system selection item	Diagnosis mode		
		WORK SUPPORT	DATA MONITOR	ACTIVE TEST
Door lock	DOOR LOCK	×	×	×
Rear window defogger	REAR DEFOGGER		×	×
Warning chime	BUZZER		×	×
Interior room lamp timer	INT LAMP	×	×	×
Exterior lamp	HEADLAMP	×	×	×
Wiper and washer	WIPER	×	×	×
Turn signal and hazard warning lamps	FLASHER	×	×	×
Air conditioner	AIR CONDITONER		×	
Intelligent Key system	INTELLIGENT KEY	×	×	×
Combination switch	COMB SW		×	
BCM	BCM	×		
Immobilizer	IMMU		×	×
Interior room lamp battery saver	BATTERY SAVER	×	×	×
Trunk open	TRUNK		×	
Vehicle security system	THEFT ALM	×	×	×
RAP system	RETAINED PWR		×	
Signal buffer system	SIGNAL BUFFER		×	×
TPMS	AIR PRESSURE MONITOR	×	×	

COMMON ITEM : CONSULT-III Function

INFOID:000000004391479

ECU IDENTIFICATION

Displays the BCM part No.

SELF-DIAG RESULT

Refer to [BCS-82, "DTC Index"](#).

RETAINED PWR

DIAGNOSIS SYSTEM (BCM)

< FUNCTION DIAGNOSIS >

[FRONT & REAR WINDOW ANTI-PINCH]

RETAINED PWR : CONSULT-III Function (BCM - RETAINED PWR)

INFOID:000000004391480

Data monitor

Monitor Item [Unit]	Description
DOOR SW-DR [ON/OFF]	Indicates condition of front door switch LH.
DOOR SW-AS [ON/OFF]	Indicates condition of front door switch RH.

A
B
C
D
E
F
G
H
I
J
L
M
N
O
P

PWC

POWER SUPPLY AND GROUND CIRCUIT

< COMPONENT DIAGNOSIS >

[FRONT & REAR WINDOW ANTI-PINCH]

COMPONENT DIAGNOSIS

POWER SUPPLY AND GROUND CIRCUIT

BCM

BCM : Diagnosis Procedure

INFOID:000000004391546

1. CHECK FUSE AND FUSIBLE LINK

Check if the following BCM fuses or fusible link are blown.

Terminal No.	Signal name	Fuse and fusible link No.
1	Battery power supply	H
11		10
24		7

Is the fuse or fusible link blown?

- YES >> Replace the blown fuse or fusible link after repairing the affected circuit.
 NO >> GO TO 2

2. CHECK POWER SUPPLY CIRCUIT

1. Turn ignition switch OFF.
2. Disconnect BCM.
3. Check voltage between BCM harness connector and ground.

Terminals		Voltage (Approx.)
(+)	(-)	
BCM		Ground
Connector	Terminal	
M16 (A)	1	
M17 (B)	11	
M18 (C)	24	Battery voltage

Is the measurement normal?

- YES >> GO TO 3
 NO >> Repair or replace harness.

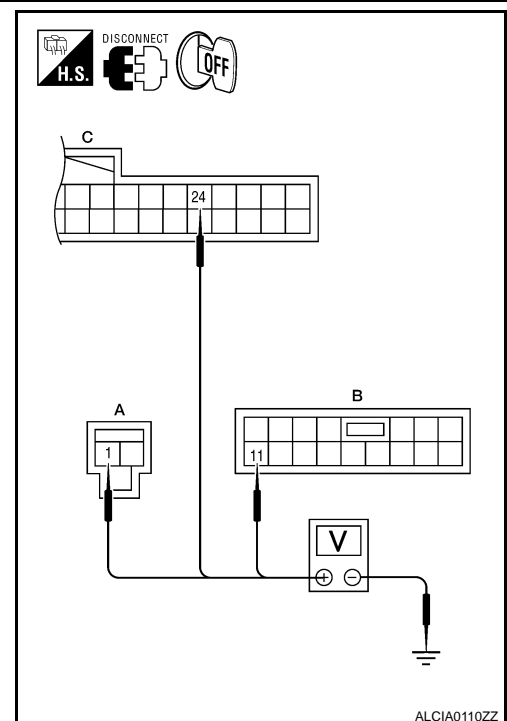

ALCIA0110ZZ

3. CHECK GROUND CIRCUIT

Check continuity between BCM harness connector and ground.

BCM		Ground	Continuity
Connector	Terminal		
M17	13		Yes

Does continuity exist?

- YES >> Inspection End.
 NO >> Repair or replace harness.

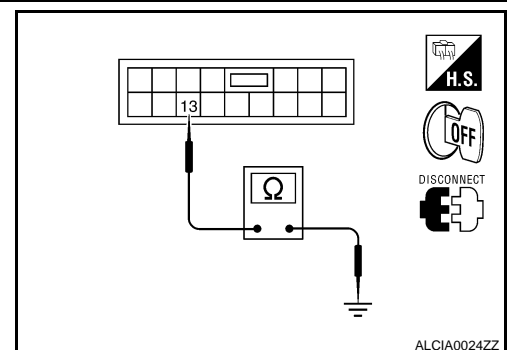

ALCIA0024ZZ

POWER SUPPLY AND GROUND CIRCUIT

< COMPONENT DIAGNOSIS >

[FRONT & REAR WINDOW ANTI-PINCH]

BCM : Special Repair Requirement

INFOID:000000004391547

1. REQUIRED WORK WHEN REPLACING BCM

Initialize control unit. Refer to [BCS-6, "CONFIGURATION \(BCM\) : Special Repair Requirement"](#).

>> Work End.

POWER WINDOW MAIN SWITCH

POWER WINDOW MAIN SWITCH : Diagnosis Procedure

INFOID:000000004391485

1. CHECK POWER SUPPLY CIRCUIT

1. Turn ignition switch ON.
2. Check voltage between main power window and door lock/unlock switch connectors D7 (A) terminal 10 and D8 (B) terminal 19 and ground.

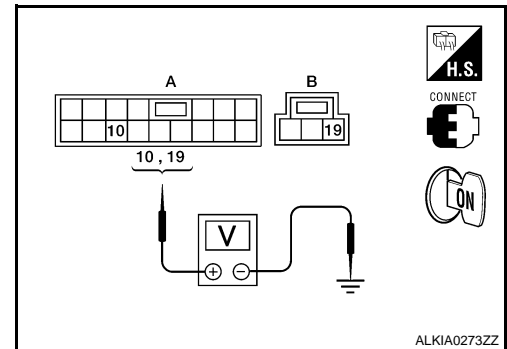

Terminal (+)		Terminal (-)	Voltage (V) (Approx.)
Main power window and door lock/unlock switch connector	Terminal		
D7 (A)	10	Ground	Battery voltage
D8 (B)	19		

Is the inspection result normal?

- YES >> GO TO 3
NO >> GO TO 2

2. CHECK HARNESS CONTINUITY

1. Turn ignition switch OFF.
2. Disconnect BCM connector M16 and main power window and door lock/unlock switch connectors.
3. Check continuity between BCM connector M16 (A) terminals 2 and 3 and main power window and door lock/unlock switch connectors D7 (B) terminal 10 and D8 (C) terminal 19.

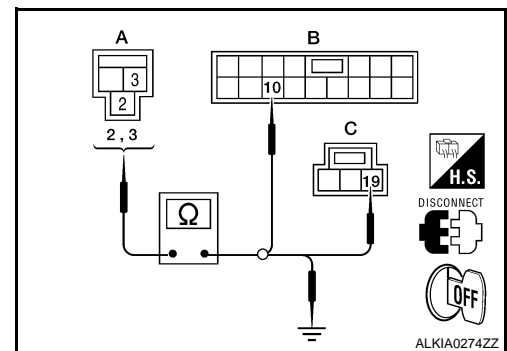

BCM connector	Terminal	Main power window and door lock/unlock switch connector	Terminal	Continuity
M16 (A)	3	D7 (B)	10	Yes
	2	D8 (C)	19	

4. Check continuity between BCM connector M16 (A) terminals 2 and 3 and ground.

BCM connector	Terminal	Ground	Continuity
M16 (A)	3		Ground
	2		

Is the inspection result normal?

- YES >> Replace BCM. Refer to [BCS-87, "Removal and Installation"](#).
NO >> Repair or replace harness or connectors.

3. CHECK GROUND CIRCUIT

POWER SUPPLY AND GROUND CIRCUIT

< COMPONENT DIAGNOSIS >

[FRONT & REAR WINDOW ANTI-PINCH]

1. Turn ignition switch OFF.
2. Disconnect main power window and door lock/unlock switch connector D8.
3. Check continuity between main power window and door lock/unlock switch connector D8 terminal 17 and ground.

Main power window and door lock/ unlock switch connector	Terminal	Ground	Continuity
D8	17		Yes

Is the inspection result normal?

- YES >> Inspection End.
NO >> Repair or replace harness or connectors.

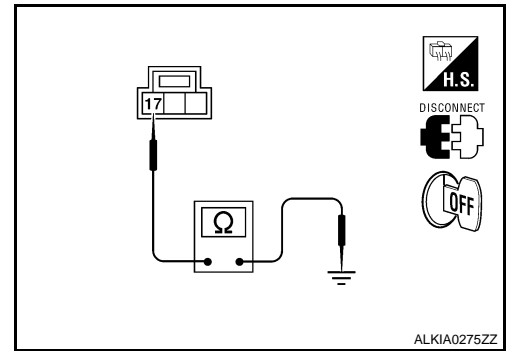

POWER WINDOW MAIN SWITCH : Special Repair Requirement

INFOID:000000004391488

1. PERFORM INITIALIZATION PROCEDURE

Perform initialization procedure. Refer to [PWC-119, "ADDITIONAL SERVICE WHEN REMOVING BATTERY NEGATIVE TERMINAL : Special Repair Requirement"](#) and [PWC-119, "ADDITIONAL SERVICE WHEN REPLACING CONTROL UNIT : Special Repair Requirement"](#).

>> GO TO 2

2. CHECK ANTI-PINCH OPERATION

Check anti-pinch operation. Refer to [PWC-119, "ADDITIONAL SERVICE WHEN REMOVING BATTERY NEGATIVE TERMINAL : Special Repair Requirement"](#) and [PWC-119, "ADDITIONAL SERVICE WHEN REPLACING CONTROL UNIT : Special Repair Requirement"](#).

>> End.

FRONT POWER WINDOW SWITCH

FRONT POWER WINDOW SWITCH : Diagnosis Procedure

INFOID:000000004391491

1. CHECK POWER SUPPLY CIRCUIT

Check voltage between power window and door lock/unlock switch RH connector D105 terminal 10 and ground.

Terminal		Terminal	Voltage (V) (Approx.)
(+)	(-)		
Power window and door lock/ unlock switch RH connector			
D105	10	Ground	Battery voltage

Is the inspection result normal?

- YES >> GO TO 3
NO >> GO TO 2

2. CHECK HARNESS CONTINUITY

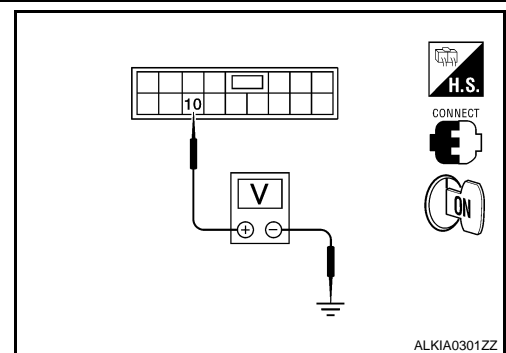

POWER SUPPLY AND GROUND CIRCUIT

< COMPONENT DIAGNOSIS >

[FRONT & REAR WINDOW ANTI-PINCH]

1. Turn ignition switch OFF.
2. Disconnect BCM connector M16 and power window and door lock/unlock switch RH connector.
3. Check continuity between BCM connector M16 (A) terminal 2 and power window and door lock/unlock switch RH connector D105 (B) terminal 10.

BCM connector	Terminal	Power window and door lock/unlock switch RH connector	Terminal	Continuity
M16 (A)	2	D105 (B)	10	Yes

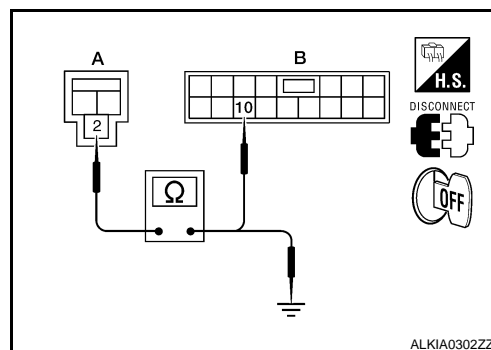

4. Check continuity between BCM connector M16 (A) terminal 2 and ground.

BCM connector	Terminal	Ground	Continuity
M16 (A)	2		No

Is the inspection result normal?

YES >> Replace BCM. Refer to [BCS-87, "Removal and Installation"](#).

NO >> Repair or replace harness or connectors.

3. CHECK GROUND CIRCUIT

1. Turn ignition switch OFF.
2. Disconnect power window and door lock/unlock switch RH.
3. Check continuity between power window and door lock/unlock switch RH connector D105 terminal 11 and ground.

Power window and door lock/unlock switch RH	Terminal	Ground	Continuity
D105	11		Yes

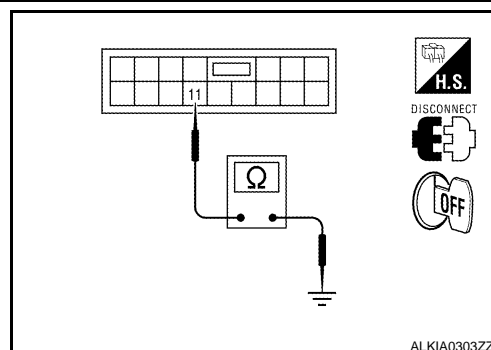

Is the inspection result normal?

YES >> Inspection End.

NO >> Repair or replace harness or connectors.

FRONT POWER WINDOW SWITCH : Special Repair Requirement

INFOID:000000004392456

1. PERFORM INITIALIZATION PROCEDURE

Perform initialization procedure. Refer to [PWC-119, "ADDITIONAL SERVICE WHEN REMOVING BATTERY NEGATIVE TERMINAL : Special Repair Requirement"](#) and [PWC-119, "ADDITIONAL SERVICE WHEN REPLACING CONTROL UNIT : Special Repair Requirement"](#).

>> GO TO 2

2. CHECK ANTI-PINCH OPERATION

Check anti-pinch operation. Refer to [PWC-119, "ADDITIONAL SERVICE WHEN REMOVING BATTERY NEGATIVE TERMINAL : Special Repair Requirement"](#) and [PWC-119, "ADDITIONAL SERVICE WHEN REPLACING CONTROL UNIT : Special Repair Requirement"](#).

>> End.

REAR POWER WINDOW SWITCH

REAR POWER WINDOW SWITCH : Diagnosis Procedure

INFOID:000000004391550

1. CHECK POWER SUPPLY CIRCUIT

POWER SUPPLY AND GROUND CIRCUIT

[FRONT & REAR WINDOW ANTI-PINCH]

< COMPONENT DIAGNOSIS >

Check voltage between rear power window switch connector terminal 10 and ground.

(+)		(-)	Voltage (V) (Approx.)
Rear power window switch			
Connector	Terminal		
D207 (LH)	10	Ground	Battery voltage
D307 (RH)			

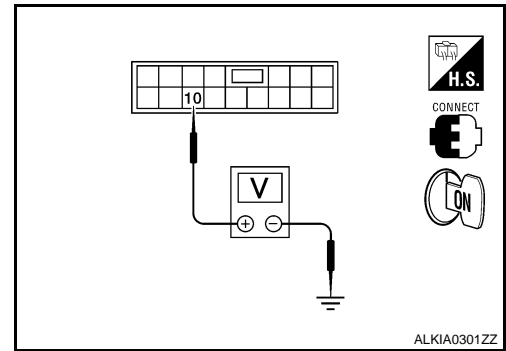

Is the inspection result normal?

- YES >> GO TO 3
- NO >> GO TO 2

2. CHECK HARNESS CONTINUITY

1. Turn ignition switch OFF.
2. Disconnect BCM connector M16 and rear power window switch connector.
3. Check continuity between BCM connector M16 (A) terminal 2 and rear power window switch connector (B) terminal 10.

BCM connector	Terminal	Rear power window switch connector	Terminal	Continuity
M16 (A)	2	D207 (LH) (B)	10	Yes
		D307 (RH) (B)		

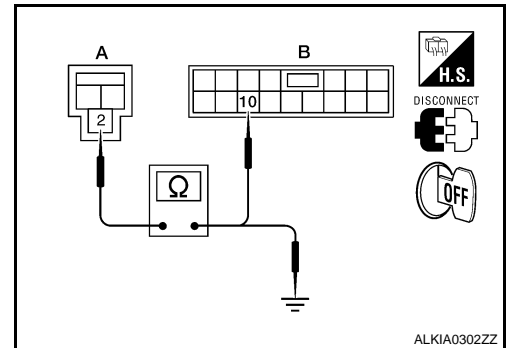

4. Check continuity between BCM connector M16 (A) terminal 2 and ground.

BCM connector	Terminal	Ground	Continuity
M16 (A)	2		No

Is the inspection result normal?

- YES >> Replace BCM. Refer to [BCS-87, "Removal and Installation"](#).
- NO >> Repair or replace harness or connectors.

3. CHECK GROUND CIRCUIT

1. Turn ignition switch OFF.
2. Disconnect rear power window switch connector.
3. Check continuity between rear power window switch connector terminal 11 and ground.

Rear power window switch connector	Terminal	Ground	Continuity
D207 (LH)	11	Ground	Yes
D307 (RH)			

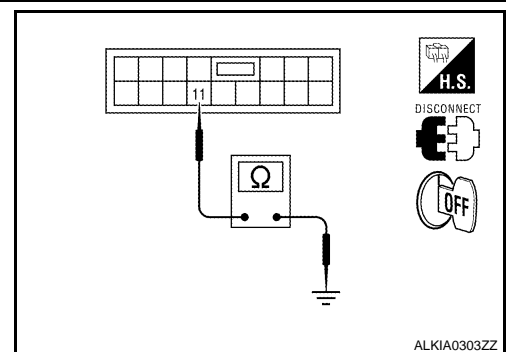

Is the inspection result normal?

- YES >> Inspection End.
- NO >> Repair or replace harness or connectors.

REAR POWER WINDOW SWITCH : Special Repair Requirement

INFOID:000000004392457

1. PERFORM INITIALIZATION PROCEDURE

Perform initialization procedure. Refer to [PWC-119, "ADDITIONAL SERVICE WHEN REMOVING BATTERY NEGATIVE TERMINAL : Special Repair Requirement"](#) and [PWC-119, "ADDITIONAL SERVICE WHEN REPLACING CONTROL UNIT : Special Repair Requirement"](#).

POWER SUPPLY AND GROUND CIRCUIT

< COMPONENT DIAGNOSIS >

[FRONT & REAR WINDOW ANTI-PINCH]

>> GO TO 2

2. CHECK ANTI-PINCH OPERATION

Check anti-pinch operation. Refer to [PWC-119, "ADDITIONAL SERVICE WHEN REMOVING BATTERY NEGATIVE TERMINAL : Special Repair Requirement"](#) and [PWC-119, "ADDITIONAL SERVICE WHEN REPLACING CONTROL UNIT : Special Repair Requirement"](#).

>> End.

A
B
C
D
E
F
G
H
I
J
L
M
N
O
P

PWC

POWER WINDOW MOTOR

[FRONT & REAR WINDOW ANTI-PINCH]

< COMPONENT DIAGNOSIS >

POWER WINDOW MOTOR DRIVER SIDE

DRIVER SIDE : Description

INFOID:000000004391494

Door glass moves UP/DOWN by receiving the signal from main power window and door lock/unlock switch.

DRIVER SIDE : Component Function Check

INFOID:000000004391495

1. CHECK POWER WINDOW MOTOR

Check that front power window motor LH operates with main power window and door lock/unlock switch.

Is the inspection result normal?

YES >> Front power window motor LH is OK.

NO >> Refer to [PWC-134. "DRIVER SIDE : Diagnosis Procedure"](#).

DRIVER SIDE : Diagnosis Procedure

INFOID:000000004391496

1. CHECK POWER WINDOW MOTOR

Check front power window motor LH. Refer to [PWC-135. "DRIVER SIDE : Component Inspection"](#).

Is the inspection result normal?

YES >> GO TO 2

NO >> Replace power window motor LH. Refer to [GW-19. "Removal and Installation"](#).

2. CHECK MAIN POWER WINDOW AND DOOR LOCK/UNLOCK SWITCH OUTPUT SIGNAL

1. Disconnect front power window motor LH connector.
2. Turn ignition switch ON.
3. Check voltage between front power window motor LH connector D9 terminals 1, 2 and ground.

Terminal (+)		Terminal (-)	Main power window and door lock/unlock switch condition	Voltage (V) (Approx.)
Power window motor LH connector	Terminal			
D9	2	Ground	UP	Battery voltage
			DOWN	0
	1		UP	0
			DOWN	Battery voltage

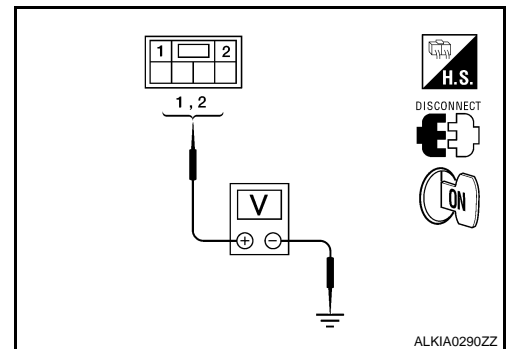

Is the inspection result normal?

YES >> Check intermittent incident. Refer to [GI-39. "Intermittent Incident"](#).

NO >> GO TO 3

3. CHECK HARNESS CONTINUITY

1. Turn ignition switch OFF.
2. Disconnect main power window and door lock/unlock switch connector D7.
3. Check continuity between main power window and door lock/unlock switch connector D7 (A) terminals 8, 11 and front power window motor connector LH D9 (B) terminals 1, 2.

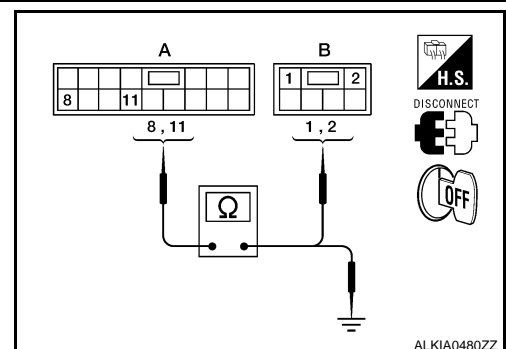

POWER WINDOW MOTOR

[FRONT & REAR WINDOW ANTI-PINCH]

< COMPONENT DIAGNOSIS >

Main power window and door lock/unlock switch connector	Terminal	Front power window motor LH connector	Terminal	Continuity
D7 (A)	8	D9 (B)	2	Yes
	11		1	

4. Check continuity between main power window and door lock/unlock switch connector D7 (A) terminals 8, 11 and ground.

Main power window and door lock/unlock switch connector	Terminal	Ground	Continuity
D7 (A)	8	Ground	No
	11		

Is the inspection result normal?

- YES >> Replace main power window and door lock/unlock switch. Refer to [PWC-113, "Removal and Installation"](#).
 NO >> Repair or replace harness or connectors.

DRIVER SIDE : Component Inspection

INFOID:000000004391497

COMPONENT INSPECTION

1. CHECK FRONT POWER WINDOW MOTOR LH

1. Disconnect front power window motor LH.
2. Check motor operation by connecting battery voltage directly to front power window motor LH.

Terminal		Motor condition
(+)	(-)	
1	2	DOWN
2	1	UP

Is the inspection result normal?

- YES >> Inspection End.
 NO >> Replace front power window motor LH. Refer to [GW-19, "Removal and Installation"](#).

DRIVER SIDE : Special Repair Requirement

INFOID:000000004392458

1. PERFORM INITIALIZATION PROCEDURE

Perform initialization procedure. Refer to [PWC-119, "ADDITIONAL SERVICE WHEN REMOVING BATTERY NEGATIVE TERMINAL : Special Repair Requirement"](#) and [PWC-119, "ADDITIONAL SERVICE WHEN REPLACING CONTROL UNIT : Special Repair Requirement"](#).

>> GO TO 2

2. CHECK ANTI-PINCH OPERATION

Check anti-pinch operation. Refer to [PWC-119, "ADDITIONAL SERVICE WHEN REMOVING BATTERY NEGATIVE TERMINAL : Special Repair Requirement"](#) and [PWC-119, "ADDITIONAL SERVICE WHEN REPLACING CONTROL UNIT : Special Repair Requirement"](#).

>> End.

PASSENGER SIDE

POWER WINDOW MOTOR

[FRONT & REAR WINDOW ANTI-PINCH]

< COMPONENT DIAGNOSIS >

PASSENGER SIDE : Description

INFOID:000000004391500

Door glass moves UP/DOWN by receiving the signal from main power window and door lock/unlock switch or power window and door lock/unlock switch RH.

PASSENGER SIDE : Component Function Check

INFOID:000000004391501

1. CHECK POWER WINDOW MOTOR CIRCUIT

Check that front power window motor RH operates with main power window and door lock/unlock switch or power window and door lock/unlock switch RH.

Is the inspection result normal?

YES >> Front power window motor RH is OK.

NO >> Refer to [PWC-136. "PASSENGER SIDE : Diagnosis Procedure"](#).

PASSENGER SIDE : Diagnosis Procedure

INFOID:000000004391502

1. CHECK FRONT POWER WINDOW MOTOR RH

Check front power window motor RH. Refer to [PWC-137. "PASSENGER SIDE : Component Inspection"](#).

Is the inspection result normal?

YES >> GO TO 2

NO >> Replace front power window motor RH. Refer to [GW-19. "Removal and Installation"](#).

2. CHECK FRONT POWER WINDOW SWITCH RH OUTPUT SIGNAL

1. Disconnect front power window motor RH connector.
2. Turn ignition switch ON.
3. Check voltage between front power window motor RH connector D104 terminals 1, 2 and ground.

Terminal (+)		Terminal (-)	Front power window motor RH condition	Voltage (V) (Approx.)
Front power window motor RH connector	Terminal			
D104	2	Ground	UP	Battery voltage
			DOWN	0
	1		UP	0
			DOWN	Battery voltage

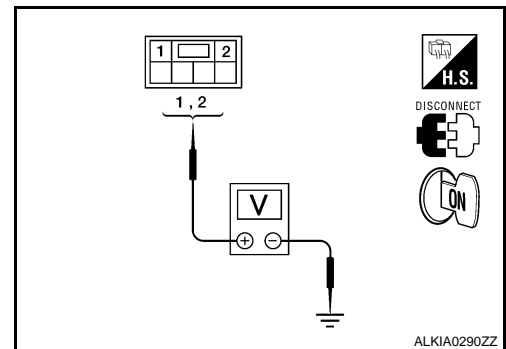

Is the inspection result normal?

YES >> Check intermittent incident. Refer to [GI-39. "Intermittent Incident"](#).

NO >> GO TO 3

3. CHECK HARNESS CONTINUITY

1. Turn ignition switch OFF.
2. Disconnect power window and door lock/unlock switch RH connector.
3. Check continuity between power window and door lock/unlock switch RH connector D105 (A) terminals 8, 9 and front power window motor RH connector D104 (B) terminals 1, 2.

Power window and door lock/unlock switch RH connector	Terminal	Front power window motor RH connector	Terminal	Continuity
D105 (A)	8	D104 (B)	2	Yes
	9		1	

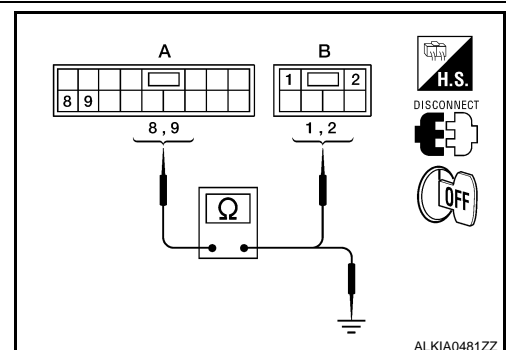

POWER WINDOW MOTOR

[FRONT & REAR WINDOW ANTI-PINCH]

< COMPONENT DIAGNOSIS >

4. Check continuity between power window and door lock/unlock switch RH connector D105 (A) terminals 8, 9 and ground.

Power window and door lock/unlock switch RH connector	Terminal	Ground	Continuity
D105 (A)	8		No
	9		

Is the inspection result normal?

YES >> Replace power window and door lock/unlock switch RH. Refer to [PWC-114, "Removal and Installation"](#).

NO >> Repair or replace harness or connectors.

PASSENGER SIDE : Component Inspection

INFOID:000000004391503

COMPONENT INSPECTION

1. CHECK FRONT POWER WINDOW MOTOR RH

1. Disconnect front power window motor RH.
2. Check motor operation by connecting battery voltage directly to front power window motor RH.

Terminal		Motor condition
(+)	(-)	
1	2	DOWN
2	1	UP

Is the inspection result normal?

YES >> Inspection End.

NO >> Replace front power window motor RH. Refer to [GW-19, "Removal and Installation"](#).

PASSENGER SIDE : Special Repair Requirement

INFOID:000000004392459

1. PERFORM INITIALIZATION PROCEDURE

Perform initialization procedure. Refer to [PWC-119, "ADDITIONAL SERVICE WHEN REMOVING BATTERY NEGATIVE TERMINAL : Special Repair Requirement"](#) and [PWC-119, "ADDITIONAL SERVICE WHEN REPLACING CONTROL UNIT : Special Repair Requirement"](#).

>> GO TO 2

2. CHECK ANTI-PINCH OPERATION

Check anti-pinch operation. Refer to [PWC-119, "ADDITIONAL SERVICE WHEN REMOVING BATTERY NEGATIVE TERMINAL : Special Repair Requirement"](#) and [PWC-119, "ADDITIONAL SERVICE WHEN REPLACING CONTROL UNIT : Special Repair Requirement"](#).

>> End.

REAR LH

REAR LH : Description

INFOID:000000004391551

Door glass moves UP/DOWN by receiving the signal from main power window and door lock/unlock switch or rear power window switch LH.

REAR LH : Component Function Check

INFOID:000000004391552

1. CHECK POWER WINDOW MOTOR CIRCUIT

Check that rear power window motor LH operates with main power window and door lock/unlock switch or rear power window switch LH.

POWER WINDOW MOTOR

[FRONT & REAR WINDOW ANTI-PINCH]

< COMPONENT DIAGNOSIS >

Is the inspection result normal?

- YES >> Rear power window motor LH is OK.
- NO >> Refer to [PWC-138, "REAR LH : Diagnosis Procedure"](#).

REAR LH : Diagnosis Procedure

INFOID:000000004391553

1. CHECK REAR POWER WINDOW MOTOR LH

Check rear power window motor LH. Refer to [PWC-139, "REAR LH : Component Inspection"](#).

Is the inspection result normal?

- YES >> GO TO 2
- NO >> Replace rear power window motor LH. Refer to [GW-24, "Rear Door Glass Regulator"](#).

2. CHECK REAR POWER WINDOW SWITCH LH OUTPUT SIGNAL

1. Disconnect rear power window motor LH connector.
2. Turn ignition switch ON.
3. Check voltage between rear power window motor LH connector D208 terminals 1, 3 and ground.

Terminal (+)		Terminal (-)	Condition	Voltage (V) (Approx.)
Rear power window motor LH connector	Terminal			
D208	1	Ground	UP	Battery voltage
			DOWN	0
	3		UP	0
			DOWN	Battery voltage

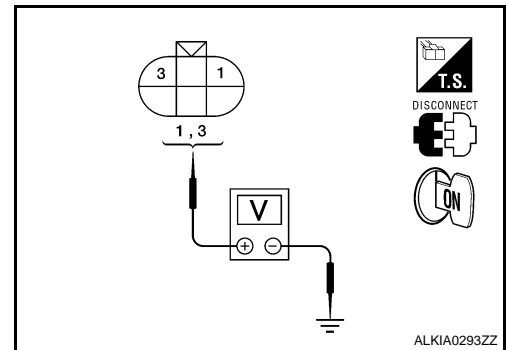

Is the inspection result normal?

- YES >> Check intermittent incident. Refer to [GI-39, "Intermittent Incident"](#).
- NO >> GO TO 3

3. CHECK HARNESS CONTINUITY

1. Turn ignition switch OFF.
2. Disconnect rear power window switch LH connector.
3. Check continuity between rear power window switch LH connector D207 (A) terminals 8, 9 and rear power window motor LH connector D208 (B) terminals 1, 3.

Rear power window switch LH connector	Terminal	Rear power window motor LH connector	Terminal	Continuity
D207 (A)	8	D208 (B)	1	Yes
	9		3	

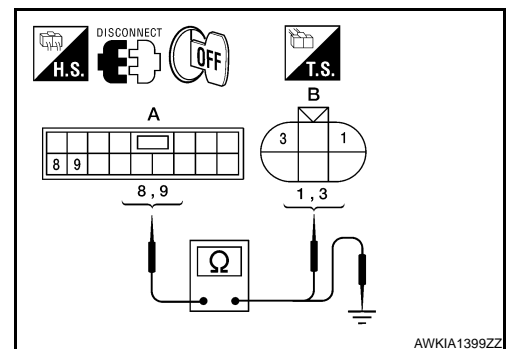

4. Check continuity between rear power window switch LH connector D207 (A) terminals 8, 9 and ground.

Rear power window switch LH connector	Terminal	Ground	Continuity
D207 (A)	8		
	9		

Is the inspection result normal?

- YES >> Replace rear power window switch LH. Refer to [PWC-114, "Removal and Installation"](#).
- NO >> Repair or replace harness or connectors.

POWER WINDOW MOTOR

[FRONT & REAR WINDOW ANTI-PINCH]

< COMPONENT DIAGNOSIS >

REAR LH : Component Inspection

INFOID:000000004391554

COMPONENT INSPECTION

1. CHECK REAR POWER WINDOW MOTOR LH

1. Disconnect rear power window motor LH.
2. Check motor operation by connecting battery voltage directly to rear power window motor LH.

Terminal		Motor condition
(+)	(-)	
3	1	DOWN
1	3	UP

Is the inspection result normal?

- YES >> Inspection End.
NO >> Replace rear power window motor LH. Refer to [GW-19, "Removal and Installation"](#).

REAR LH : Special Repair Requirement

INFOID:000000004392460

1. PERFORM INITIALIZATION PROCEDURE

Perform initialization procedure. Refer to [PWC-119, "ADDITIONAL SERVICE WHEN REMOVING BATTERY NEGATIVE TERMINAL : Special Repair Requirement"](#) and [PWC-119, "ADDITIONAL SERVICE WHEN REPLACING CONTROL UNIT : Special Repair Requirement"](#).

>> GO TO 2

2. CHECK ANTI-PINCH OPERATION

Check anti-pinch operation. Refer to [PWC-119, "ADDITIONAL SERVICE WHEN REMOVING BATTERY NEGATIVE TERMINAL : Special Repair Requirement"](#) and [PWC-119, "ADDITIONAL SERVICE WHEN REPLACING CONTROL UNIT : Special Repair Requirement"](#).

>> End.

REAR RH

PWC

REAR RH : Description

INFOID:000000004392443

Door glass moves UP/DOWN by receiving the signal from main power window and door lock/unlock switch or rear power window switch RH.

REAR RH : Component Function Check

INFOID:000000004392444

1. CHECK POWER WINDOW MOTOR CIRCUIT

Check that rear power window motor RH operates with main power window and door lock/unlock switch or rear power window switch RH.

Is the inspection result normal?

- YES >> Rear power window motor RH is OK.
NO >> Refer to [PWC-139, "REAR RH : Diagnosis Procedure"](#).

REAR RH : Diagnosis Procedure

INFOID:000000004392445

1. CHECK REAR POWER WINDOW MOTOR RH

Check rear power window motor RH. Refer to [PWC-140, "REAR RH : Component Inspection"](#).

Is the inspection result normal?

- YES >> GO TO 2
NO >> Replace rear power window motor RH. Refer to [GW-24, "Rear Door Glass Regulator"](#).

2. CHECK REAR POWER WINDOW SWITCH RH OUTPUT SIGNAL

POWER WINDOW MOTOR

[FRONT & REAR WINDOW ANTI-PINCH]

< COMPONENT DIAGNOSIS >

1. Disconnect rear power window motor RH connector.
2. Turn ignition switch ON.
3. Check voltage between rear power window motor RH connector D304 terminals 1, 3 and ground.

Terminal		Condition	Voltage (V) (Approx.)
(+)	(-)		
Rear power window motor RH connector	Terminal		
D304	1	UP	Battery voltage
		DOWN	0
	3	UP	0
		DOWN	Battery voltage

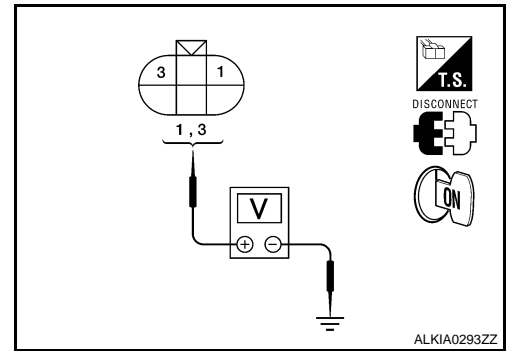

Is the inspection result normal?

- YES >> Check intermittent incident. Refer to [GI-39. "Intermittent Incident"](#).
 NO >> GO TO 3

3. CHECK HARNESS CONTINUITY

1. Turn ignition switch OFF.
2. Disconnect rear power window switch RH connector.
3. Check continuity between rear power window switch RH connector D307 (A) terminals 8, 9 and rear power window motor RH connector D304 (B) terminals 1, 3.

Rear power window switch RH connector	Terminal	Rear power window motor RH connector	Terminal	Continuity
D307 (A)	8	D304 (B)	1	Yes
	9		3	

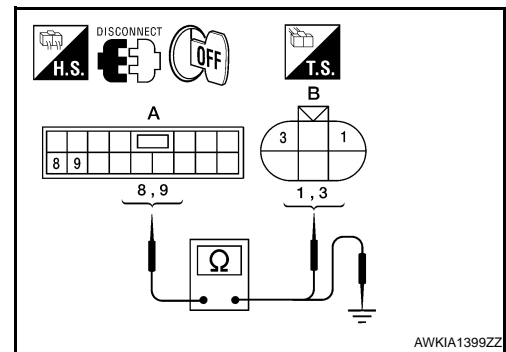

4. Check continuity between rear power window switch RH connector D307 (A) terminals 8, 9 and ground.

Rear power window switch RH connector	Terminal	Ground	Continuity
D307 (A)	8	Ground	No
	9		

Is the inspection result normal?

- YES >> Replace rear power window switch RH. Refer to [PWC-114. "Removal and Installation"](#).
 NO >> Repair or replace harness or connectors.

REAR RH : Component Inspection

INFOID:000000004392446

COMPONENT INSPECTION

1. CHECK REAR POWER WINDOW MOTOR RH

1. Disconnect rear power window motor RH.
2. Check motor operation by connecting battery voltage directly to rear power window motor RH.

Terminal		Motor condition
(+)	(-)	
3	1	DOWN
1	3	UP

Is the inspection result normal?

- YES >> Inspection End.

POWER WINDOW MOTOR

[FRONT & REAR WINDOW ANTI-PINCH]

< COMPONENT DIAGNOSIS >

NO >> Replace rear power window motor RH. Refer to [GW-19. "Removal and Installation"](#).

REAR RH : Special Repair Requirement

INFOID:000000004392461

1. PERFORM INITIALIZATION PROCEDURE

Perform initialization procedure. Refer to [PWC-119. "ADDITIONAL SERVICE WHEN REMOVING BATTERY NEGATIVE TERMINAL : Special Repair Requirement"](#) and [PWC-119. "ADDITIONAL SERVICE WHEN REPLACING CONTROL UNIT : Special Repair Requirement"](#).

>> GO TO 2

2. CHECK ANTI-PINCH OPERATION

Check anti-pinch operation. Refer to [PWC-119. "ADDITIONAL SERVICE WHEN REMOVING BATTERY NEGATIVE TERMINAL : Special Repair Requirement"](#) and [PWC-119. "ADDITIONAL SERVICE WHEN REPLACING CONTROL UNIT : Special Repair Requirement"](#).

>> End.

A
B
C
D
E
F
G
H
I
J
L
M
N
O
P

PWC

ENCODER

< COMPONENT DIAGNOSIS >

[FRONT & REAR WINDOW ANTI-PINCH]

ENCODER DRIVER SIDE

DRIVER SIDE : Description

INFOID:000000004391506

Detects condition of the front power window motor LH operation and transmits to main power window and door lock/unlock switch as pulse signal.

DRIVER SIDE : Component Function Check

INFOID:000000004391507

1. CHECK ENCODER OPERATION

Check that front door glass LH performs AUTO open/close operation normally when operating main power window and door lock/unlock switch.

Is the inspection result normal?

YES >> Encoder operation is OK.

NO >> Refer to [PWC-142, "DRIVER SIDE : Diagnosis Procedure"](#).

DRIVER SIDE : Diagnosis Procedure

INFOID:000000004391508

Encoder Circuit Check

1. CHECK ENCODER OPERATION

1. Turn ignition switch ON.
2. Check signal between main power window and door lock/unlock switch connector D7 terminals 9, 13 and ground with oscilloscope.

Terminals		Signal (Reference value)
(+)	(-)	
Main power window and door lock/unlock switch connector	Terminal	Ground
D7	9 13	
		Refer to following signal

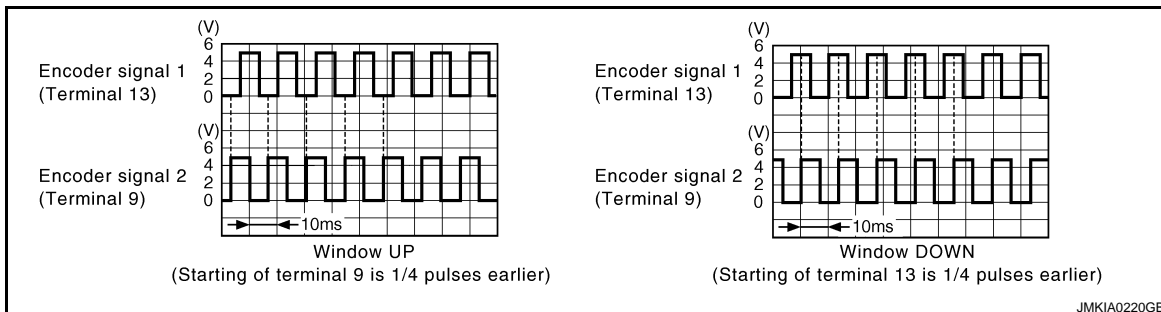
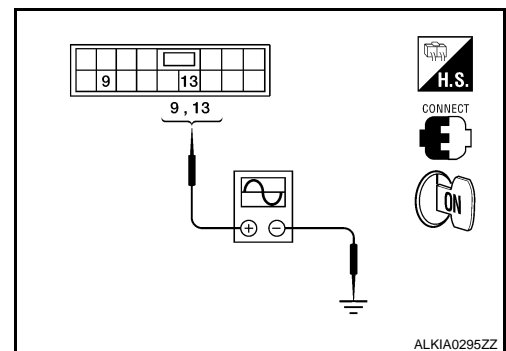

Is the inspection result normal?

YES >> Check intermittent incident. Refer to [GI-39, "Intermittent Incident"](#).

NO >> GO TO 2

2. CHECK ENCODER POWER SUPPLY

ENCODER

< COMPONENT DIAGNOSIS >

[FRONT & REAR WINDOW ANTI-PINCH]

Check voltage between front power window motor LH connector D9 terminal 4 and ground.

Terminal (+)		Terminal (-)	Voltage (V) (Approx.)
Front power window motor LH connector	Terminal		
D9	4	Ground	10

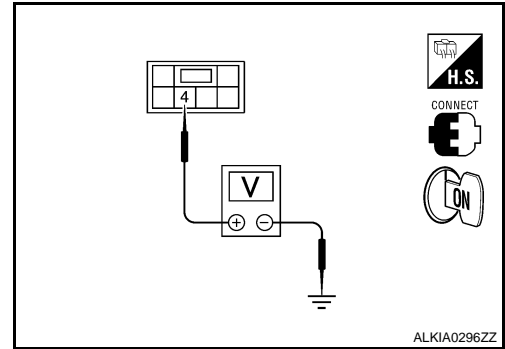

Is the inspection result normal?

- YES >> GO TO 4
- NO >> GO TO 3

3. CHECK HARNESS CONTINUITY 1

- Turn ignition switch OFF.
- Disconnect main power window and door lock/unlock switch connector D7 and front power window motor LH connector.
- Check continuity between main power window and door lock/unlock switch connector D7 (A) terminal 15 and front power window motor LH connector D9 (B) terminal 4.

Main power window and door lock/unlock switch connector	Terminal	Front power window motor LH connector	Terminal	Continuity
D7 (A)	15	D9 (B)	4	Yes

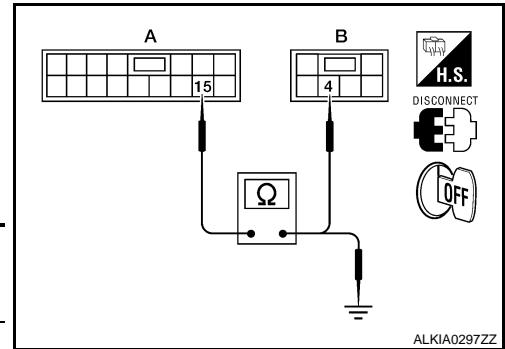

- Check continuity between main power window and door lock/unlock switch connector D7 (A) terminal 15 and ground.

Main power window and door lock/unlock switch connector	Terminal	Ground	Continuity
D7 (A)	15		No

Is the inspection result normal?

- YES >> Replace main power window and door lock/unlock switch. Refer to [PWC-113, "Removal and Installation"](#).
- NO >> Repair or replace harness or connectors.

4. CHECK ENCODER GROUND CIRCUIT

- Turn ignition switch OFF.
- Disconnect front power window motor LH connector.
- Check continuity between front power window motor LH connector D9 terminal 6 and ground.

Front power window motor LH connector	Terminal	Ground	Continuity
D9	6		Yes

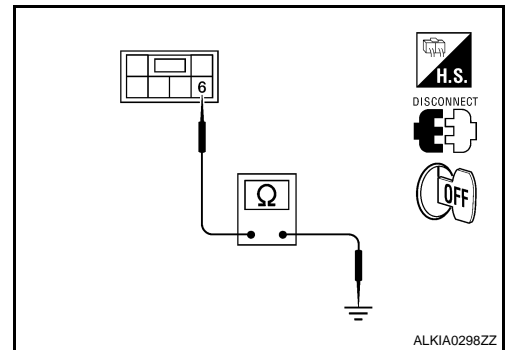

Is the inspection result normal?

- YES >> GO TO 6
- NO >> GO TO 5

5. CHECK HARNESS CONTINUITY 2

A
B
C
D
E
F
G
H
I
J
L
M
N
O
P

ENCODER

< COMPONENT DIAGNOSIS >

[FRONT & REAR WINDOW ANTI-PINCH]

1. Disconnect main power window and door lock/unlock switch connector D7.
2. Check continuity between main power window and door lock/unlock switch connector D7 (A) terminal 2 and front power window motor LH connector D9 (B) terminal 6.

Main power window and door lock/unlock switch connector	Terminal	Front power window motor LH connector	Terminal	Continuity
D7 (A)	2	D9 (B)	6	Yes

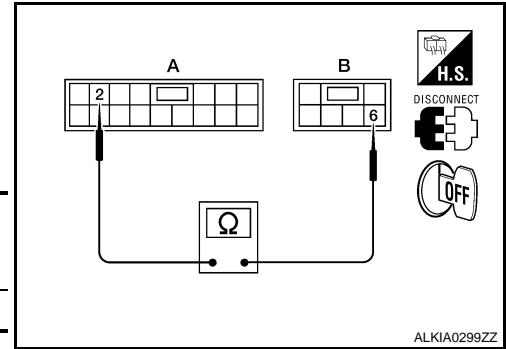

Is the inspection result normal?

YES >> Replace main power window and door lock/unlock switch. Refer to [PWC-113, "Removal and Installation"](#).

NO >> Repair or replace harness or connectors.

6. CHECK HARNESS CONTINUITY 3

1. Disconnect main power window and door lock/unlock switch connector D7.
2. Check continuity between main power window and door lock/unlock switch connector D7 (A) terminals 9, 13 and front power window motor LH connector D9 (B) terminals 3, 5.

Main power window and door lock/unlock switch connector	Terminal	Front power window motor LH connector	Terminal	Continuity
D7 (A)	9	D9 (B)	5	Yes
	13		3	

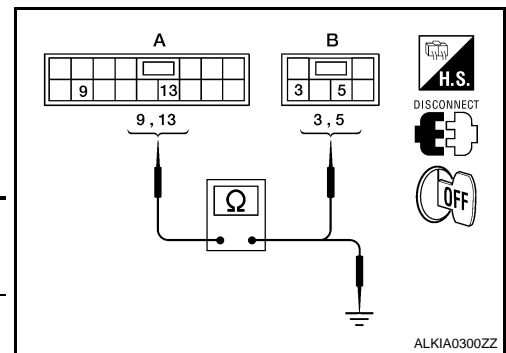

3. Check continuity between main power window and door lock/unlock switch connector D7 (A) terminals 9, 13 and ground.

Main power window and door lock/unlock switch connector	Terminal	Ground	Continuity
D7 (A)	9	Ground	No
	13		

Is the inspection result normal?

YES >> Replace front power window motor LH. Refer to [GW-19, "Removal and Installation"](#).

NO >> Repair or replace harness or connectors.

DRIVER SIDE : Special Repair Requirement

INFOID:000000004392462

1. PERFORM INITIALIZATION PROCEDURE

Perform initialization procedure. Refer to [PWC-119, "ADDITIONAL SERVICE WHEN REMOVING BATTERY NEGATIVE TERMINAL : Special Repair Requirement"](#) and [PWC-119, "ADDITIONAL SERVICE WHEN REPLACING CONTROL UNIT : Special Repair Requirement"](#).

>> GO TO 2

2. CHECK ANTI-PINCH OPERATION

Check anti-pinch operation. Refer to [PWC-119, "ADDITIONAL SERVICE WHEN REMOVING BATTERY NEGATIVE TERMINAL : Special Repair Requirement"](#) and [PWC-119, "ADDITIONAL SERVICE WHEN REPLACING CONTROL UNIT : Special Repair Requirement"](#).

>> End.

PASSENGER SIDE

ENCODER

< COMPONENT DIAGNOSIS >

[FRONT & REAR WINDOW ANTI-PINCH]

PASSENGER SIDE : Description

INFOID:000000004391510

Detects condition of the front power window motor RH operation and transmits to power window and door lock/unlock switch RH as pulse signal.

PASSENGER SIDE : Component Function Check

INFOID:000000004391511

1. CHECK ENCODER OPERATION

Check that front door glass RH performs AUTO open/close operation normally when operating power window and door lock/unlock switch RH.

Is the inspection result normal?

- YES >> Encoder operation is OK.
- NO >> Refer to [PWC-145, "PASSENGER SIDE : Diagnosis Procedure"](#).

PASSENGER SIDE : Diagnosis Procedure

INFOID:000000004391512

1. CHECK ENCODER SIGNAL

1. Turn ignition switch ON.
2. Check signal between power window and door lock/unlock switch RH connector D105 terminal 12, 15 and ground with oscilloscope.

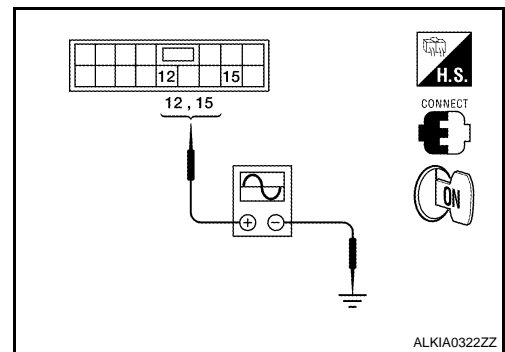

Terminals		Signal (Reference value)
(+)	(-)	
Power window and door lock/unlock switch RH connector	Terminal	Ground
D105	12 15	

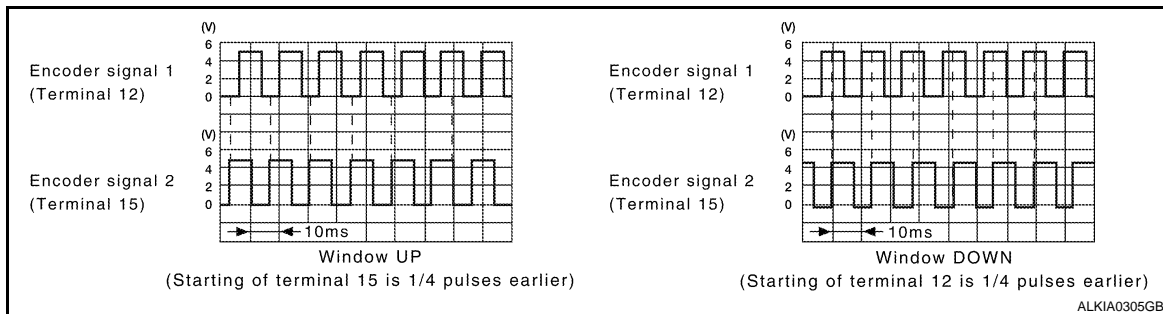

Is the inspection result normal?

- YES >> Check intermittent incident. Refer to [GI-39, "Intermittent Incident"](#).
- NO >> GO TO 2

2. CHECK ENCODER POWER SUPPLY

Check voltage between front power window motor RH connector D104 terminal 4 and ground.

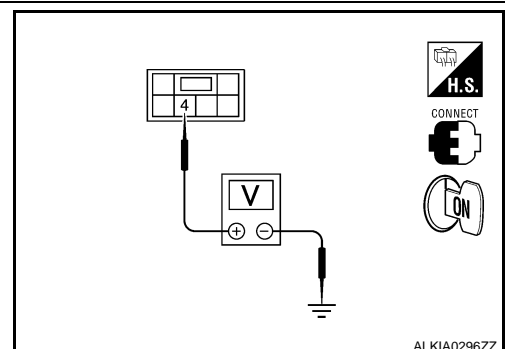

Terminal		Voltage (V) (Approx.)
(+)	(-)	
Front power window motor RH connector	Terminal	10
D104	4	

Is the inspection result normal?

- YES >> GO TO 4

A
B
C
D
E
F
G
H
I
J
L
M
N
O
P

PWC

ENCODER

< COMPONENT DIAGNOSIS >

[FRONT & REAR WINDOW ANTI-PINCH]

NO >> GO TO 3

3. CHECK HARNESS CONTINUITY 1

1. Turn ignition switch OFF.
2. Disconnect power window and door lock/unlock switch RH and front power window motor RH connectors.
3. Check continuity between power window and door lock/unlock switch RH connector D105 (A) terminal 4 and front power window motor RH connector D104 (B) terminal 4.

Power window and door lock/unlock switch RH connector	Terminal	Front power window motor RH connector	Terminal	Continuity
D105 (A)	4	D104 (B)	4	Yes

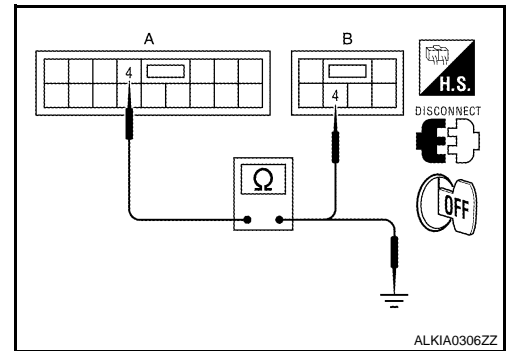

4. Check continuity between power window and door lock/unlock switch RH connector D105 (A) terminal 4 and ground.

Power window and door lock/unlock switch RH connector	Terminal	Ground	Continuity
D105 (A)	4		No

Is the inspection result normal?

YES >> Replace power window and door lock/unlock switch RH. Refer to [PWC-114. "Removal and Installation"](#).

NO >> Repair or replace harness or connectors.

4. CHECK ENCODER GROUND CIRCUIT

1. Turn ignition switch OFF.
2. Disconnect front power window motor RH connector.
3. Check continuity between front power window motor RH connector D104 terminal 6 and ground.

Front power window motor RH connector	Terminal	Ground	Continuity
D104	6		Yes

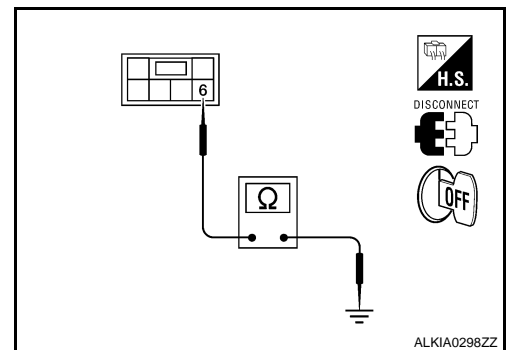

Is the inspection result normal?

YES >> GO TO 6

NO >> GO TO 5

5. CHECK HARNESS CONTINUITY 2

1. Disconnect power window and door lock/unlock switch RH connector.
2. Check continuity between power window and door lock/unlock switch RH connector D105 (A) terminal 3 and front power window motor RH connector D104 (B) terminal 6.

Power window and door lock/unlock switch RH connector	Terminal	Front power window motor RH connector	Terminal	Continuity
D105 (A)	3	D104 (B)	6	Yes

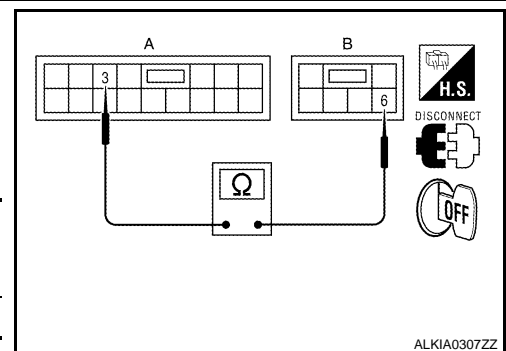

Is the inspection result normal?

YES >> Replace power window and door lock/unlock switch RH. Refer to [PWC-114. "Removal and Installation"](#).

NO >> Repair or replace harness or connectors.

6. CHECK HARNESS CONTINUITY 3

ENCODER

< COMPONENT DIAGNOSIS >

[FRONT & REAR WINDOW ANTI-PINCH]

1. Disconnect power window and door lock/unlock switch RH connector.
2. Check continuity between power window and door lock/unlock switch RH connector D105 (A) terminals 12, 15 and front power window motor RH connector D104 (B) terminals 3, 5.

Power window and door lock/unlock switch RH connector	Terminal	Front power window motor RH connector	Terminal	Continuity
D105 (A)	12	D104 (B)	3	Yes
	15		5	

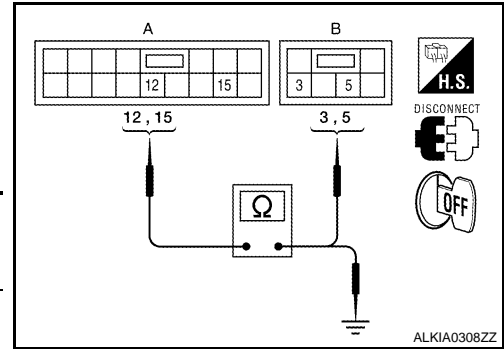

3. Check continuity between power window and door lock/unlock switch RH connector D105 (A) terminals 12, 15 and ground.

Power window and door lock/unlock switch RH connector	Terminal	Ground	Continuity
D105 (A)	12	Ground	No
	15		

Is the inspection result normal?

- YES >> Replace front power window motor RH. Refer to [GW-19, "Removal and Installation"](#).
 NO >> Repair or replace harness or connectors.

PASSENGER SIDE : Special Repair Requirement

INFOID:000000004392463

1. PERFORM INITIALIZATION PROCEDURE

Perform initialization procedure. Refer to [PWC-119, "ADDITIONAL SERVICE WHEN REMOVING BATTERY NEGATIVE TERMINAL : Special Repair Requirement"](#) and [PWC-119, "ADDITIONAL SERVICE WHEN REPLACING CONTROL UNIT : Special Repair Requirement"](#).

>> GO TO 2

2. CHECK ANTI-PINCH OPERATION

Check anti-pinch operation. Refer to [PWC-119, "ADDITIONAL SERVICE WHEN REMOVING BATTERY NEGATIVE TERMINAL : Special Repair Requirement"](#) and [PWC-119, "ADDITIONAL SERVICE WHEN REPLACING CONTROL UNIT : Special Repair Requirement"](#).

>> End.

REAR LH

REAR LH : Description

INFOID:000000004391555

Detects condition of the rear power window motor LH operation and transmits to rear power window switch LH as pulse signal.

REAR LH : Component Function Check

INFOID:000000004391556

1. CHECK ENCODER OPERATION

Check that rear door window motor LH performs AUTO open/close operation normally when operating rear power window switch LH.

Is the inspection result normal?

- YES >> Encoder operation is OK.
 NO >> Refer to [PWC-148, "REAR LH : Diagnosis Procedure"](#).

ENCODER

< COMPONENT DIAGNOSIS >

[FRONT & REAR WINDOW ANTI-PINCH]

INFOID:00000004391577

REAR LH : Diagnosis Procedure

1. CHECK ENCODER SIGNAL

1. Turn ignition switch ON.
2. Check signal between rear power window switch LH connector D207 terminal 12, 15 and ground with oscilloscope.

Terminals		Signal (Reference value)
(+)	(-)	
Rear power window switch LH connector	Terminal	Ground
D207	12	
	15	Refer to following signal

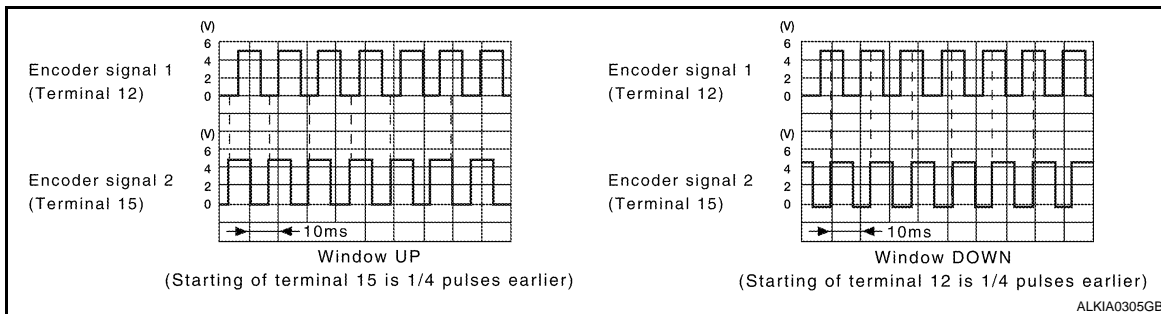
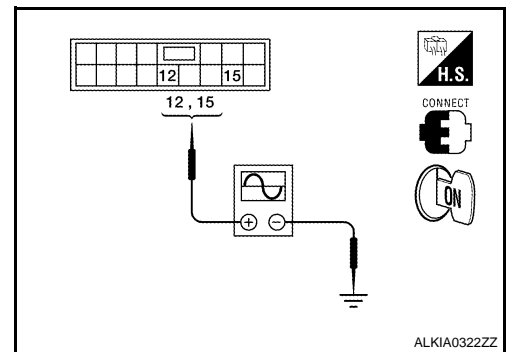

Is the inspection result normal?

- YES >> Check intermittent incident. Refer to [GI-39. "Intermittent Incident"](#).
 NO >> GO TO 2

2. CHECK ENCODER POWER SUPPLY

Check voltage between rear power window motor LH connector D208 terminal 2 and ground.

Terminal		Voltage (V) (Approx.)
(+)	(-)	
Rear power window motor LH connector	Terminal	10
D208	2	

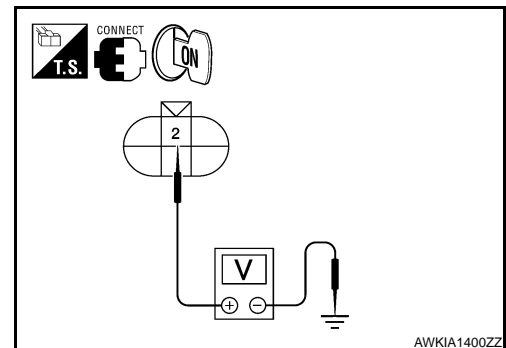

Is the inspection result normal?

- YES >> GO TO 4
 NO >> GO TO 3

3. CHECK HARNESS CONTINUITY 1

1. Turn ignition switch OFF.
2. Disconnect rear power window switch LH and rear power window motor LH connectors.
3. Check continuity between rear power window switch LH connector D207 (A) terminal 4 and rear power window motor LH connector D208 (B) terminal 2.

Rear power window switch LH connector	Terminal	Rear power window motor LH connector	Terminal	Continuity
D207 (A)	4	D208 (B)	2	Yes

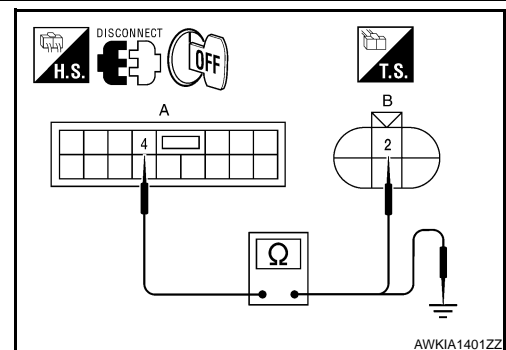

4. Check continuity between rear power window switch LH connector D207 (A) terminal 4 and ground.

ENCODER

< COMPONENT DIAGNOSIS >

[FRONT & REAR WINDOW ANTI-PINCH]

Rear power window switch LH connector	Terminal	Ground	Continuity
D207 (A)	4		No

Is the inspection result normal?

- YES >> Replace rear power window switch LH. Refer to [PWC-114, "Removal and Installation"](#).
 NO >> Repair or replace harness or connectors.

4. CHECK ENCODER GROUND CIRCUIT

- Turn ignition switch OFF.
- Disconnect rear power window motor LH connector.
- Check continuity between rear power window motor LH connector D208 terminal 4 and ground.

Rear power window motor LH connector	Terminal	Ground	Continuity
D208	4		Yes

Is the inspection result normal?

- YES >> GO TO 6
 NO >> GO TO 5

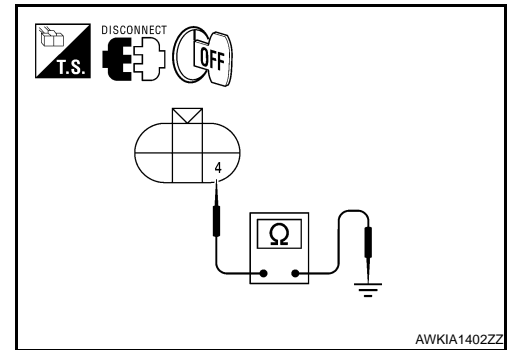

5. CHECK HARNESS CONTINUITY 2

- Disconnect rear power window switch LH connector.
- Check continuity between rear power window switch LH connector D207 (A) terminal 3 and rear power window motor LH connector D208 (B) terminal 4.

Rear power window switch LH connector	Terminal	Rear power window motor LH connector	Terminal	Continuity
D207 (A)	3	D208 (B)	4	Yes

Is the inspection result normal?

- YES >> Replace rear power window switch LH. Refer to [PWC-114, "Removal and Installation"](#).
 NO >> Repair or replace harness or connectors.

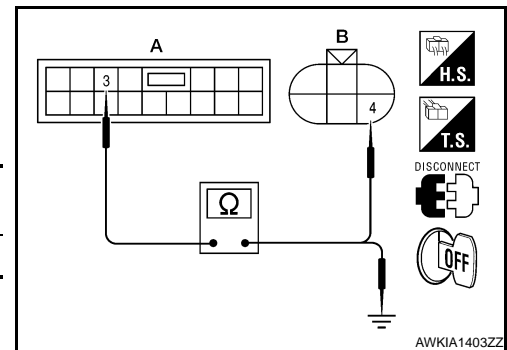

6. CHECK HARNESS CONTINUITY 3

- Disconnect rear power window switch LH connector.
- Check continuity between rear power window switch LH connector D207 (A) terminals 12, 15 and rear power window motor LH connector D208 (B) terminals 5, 6.

Rear power window switch LH connector	Terminal	Rear power window motor LH connector	Terminal	Continuity
D207 (A)	12	D208 (B)	5	Yes
	15		6	

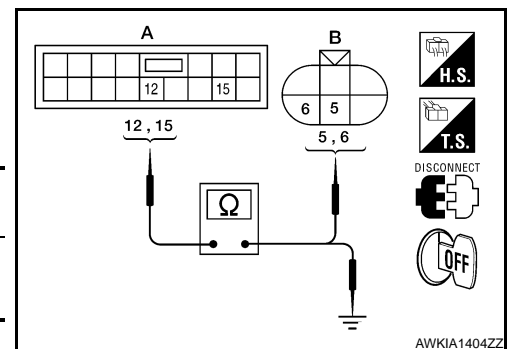

- Check continuity between rear power window switch LH connector D207 (A) terminals 12, 15 and ground.

Rear power window switch LH connector	Terminal	Ground	Continuity
D207 (A)	12		No
	15		

Is the inspection result normal?

ENCODER

< COMPONENT DIAGNOSIS >

[FRONT & REAR WINDOW ANTI-PINCH]

- YES >> Replace rear power window motor LH. Refer to [GW-19, "Removal and Installation"](#).
NO >> Repair or replace harness or connectors.

REAR LH : Special Repair Requirement

INFOID:000000004392464

1. PERFORM INITIALIZATION PROCEDURE

Perform initialization procedure. Refer to [PWC-119, "ADDITIONAL SERVICE WHEN REMOVING BATTERY NEGATIVE TERMINAL : Special Repair Requirement"](#) and [PWC-119, "ADDITIONAL SERVICE WHEN REPLACING CONTROL UNIT : Special Repair Requirement"](#).

>> GO TO 2

2. CHECK ANTI-PINCH OPERATION

Check anti-pinch operation. Refer to [PWC-119, "ADDITIONAL SERVICE WHEN REMOVING BATTERY NEGATIVE TERMINAL : Special Repair Requirement"](#) and [PWC-119, "ADDITIONAL SERVICE WHEN REPLACING CONTROL UNIT : Special Repair Requirement"](#).

>> End.

REAR RH

REAR RH : Description

INFOID:000000004392447

Detects condition of the rear power window motor RH operation and transmits to rear power window switch RH as pulse signal.

REAR RH : Component Function Check

INFOID:000000004392448

1. CHECK ENCODER OPERATION

Check that rear door window motor RH performs AUTO open/close operation normally when operating rear power window switch RH.

Is the inspection result normal?

- YES >> Encoder operation is OK.
NO >> Refer to [PWC-150, "REAR RH : Diagnosis Procedure"](#).

REAR RH : Diagnosis Procedure

INFOID:000000004392449

1. CHECK ENCODER SIGNAL

- Turn ignition switch ON.
- Check signal between rear power window switch RH connector D307 terminal 12, 15 and ground with oscilloscope.

Terminals		Signal (Reference value)
(+)	(-)	
Rear power window switch RH connector	Terminal	Ground
D307	12	
	15	

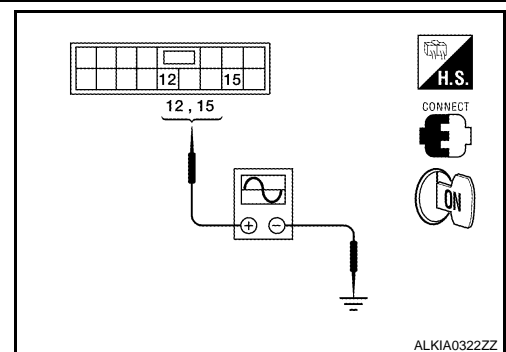

ENCODER

< COMPONENT DIAGNOSIS >

[FRONT & REAR WINDOW ANTI-PINCH]

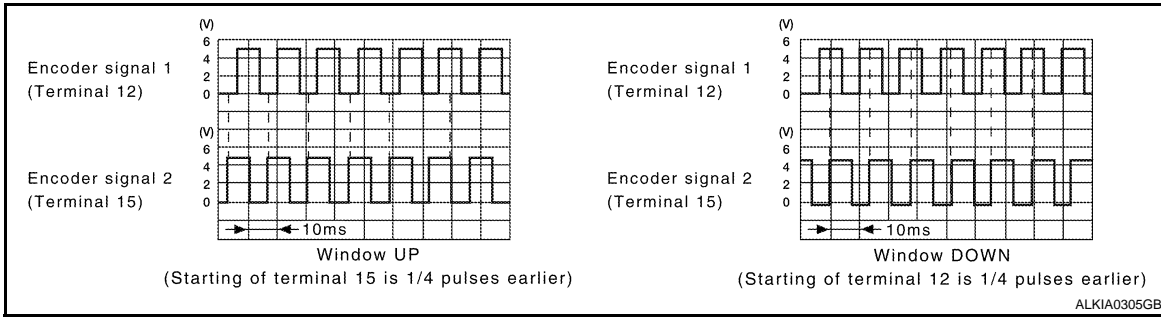

Is the inspection result normal?

- YES >> Check intermittent incident. Refer to [GI-39, "Intermittent Incident"](#).
- NO >> GO TO 2

2. CHECK ENCODER POWER SUPPLY

Check voltage between rear power window motor RH connector D304 terminal 2 and ground.

Terminal (+)		Terminal (-)	Voltage (V) (Approx.)
Rear power window motor RH connector	Terminal		
D304	2	Ground	10

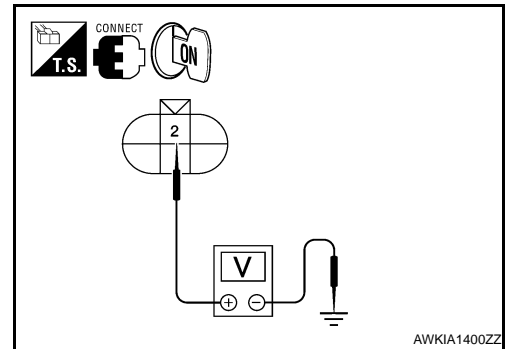

Is the inspection result normal?

- YES >> GO TO 4
- NO >> GO TO 3

3. CHECK HARNESS CONTINUITY 1

1. Turn ignition switch OFF.
2. Disconnect rear power window switch RH and rear power window motor RH connectors.
3. Check continuity between rear power window switch RH connector D307 (A) terminal 4 and rear power window motor RH connector D304 (B) terminal 2.

Rear power window switch RH connector	Terminal	Rear power window motor RH connector	Terminal	Continuity
D307 (A)	4	D304 (B)	2	Yes

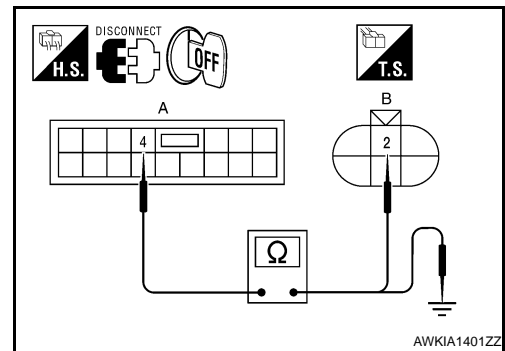

4. Check continuity between rear power window switch RH connector D307 (A) terminal 4 and ground.

Rear power window switch RH connector	Terminal	Ground	Continuity
D307 (A)	4		No

Is the inspection result normal?

- YES >> Replace rear power window switch RH. Refer to [PWC-114, "Removal and Installation"](#).
- NO >> Repair or replace harness or connectors.

4. CHECK ENCODER GROUND CIRCUIT

A
B
C
D
E
F
G
H
I
J
PWC
L
M
N
O
P

ENCODER

< COMPONENT DIAGNOSIS >

[FRONT & REAR WINDOW ANTI-PINCH]

1. Turn ignition switch OFF.
2. Disconnect rear power window motor RH connector.
3. Check continuity between rear power window motor RH connector D304 terminal 4 and ground.

Rear power window motor RH connector	Terminal	Ground	Continuity
D304	4		Yes

Is the inspection result normal?

- YES >> GO TO 6
NO >> GO TO 5

5. CHECK HARNESS CONTINUITY 2

1. Disconnect rear power window switch RH connector.
2. Check continuity between rear power window switch RH connector D307 (A) terminal 3 and rear power window motor RH connector D304 (B) terminal 4.

Rear power window switch RH connector	Terminal	Rear power window motor RH connector	Terminal	Continuity
D307 (A)	3	D304 (B)	4	Yes

Is the inspection result normal?

- YES >> Replace rear power window switch RH. Refer to [PWC-114, "Removal and Installation"](#).
NO >> Repair or replace harness or connectors.

6. CHECK HARNESS CONTINUITY 3

1. Disconnect rear power window switch RH connector.
2. Check continuity between rear power window switch RH connector D307 (A) terminals 12, 15 and rear power window motor RH connector D304 (B) terminals 5, 6.

Rear power window switch RH connector	Terminal	Rear power window motor RH connector	Terminal	Continuity
D307 (A)	12	D304 (B)	5	Yes
	15		6	

3. Check continuity between rear power window switch RH connector D307 (A) terminals 12, 15 and ground.

Rear power window switch RH connector	Terminal	Ground	Continuity
D307 (A)	12		No
	15		

Is the inspection result normal?

- YES >> Replace rear power window motor RH. Refer to [GW-19, "Removal and Installation"](#).
NO >> Repair or replace harness or connectors.

REAR RH : Special Repair Requirement

1. PERFORM INITIALIZATION PROCEDURE

Perform initialization procedure. Refer to [PWC-119, "ADDITIONAL SERVICE WHEN REMOVING BATTERY NEGATIVE TERMINAL : Special Repair Requirement"](#) and [PWC-119, "ADDITIONAL SERVICE WHEN REPLACING CONTROL UNIT : Special Repair Requirement"](#).

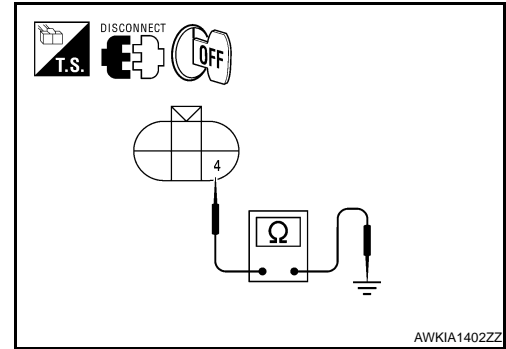

AWKIA1402ZZ

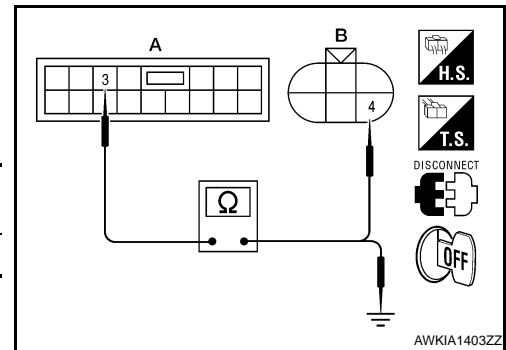

AWKIA1403ZZ

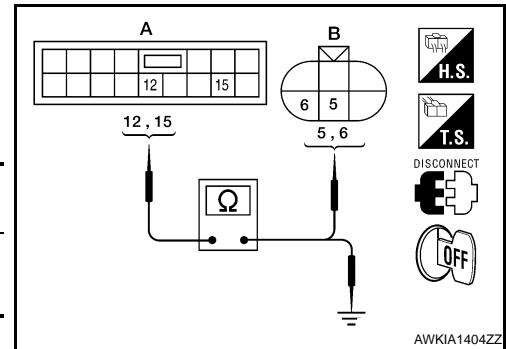

AWKIA1404ZZ

INFOID:000000004392465

ENCODER

< COMPONENT DIAGNOSIS >

[FRONT & REAR WINDOW ANTI-PINCH]

>> GO TO 2

2. CHECK ANTI-PINCH OPERATION

Check anti-pinch operation. Refer to [PWC-119, "ADDITIONAL SERVICE WHEN REMOVING BATTERY NEGATIVE TERMINAL : Special Repair Requirement"](#) and [PWC-119, "ADDITIONAL SERVICE WHEN REPLACING CONTROL UNIT : Special Repair Requirement"](#).

>> End.

A
B
C
D
E
F
G
H
I
J
L
M
N
O
P

PWC

DOOR SWITCH

< COMPONENT DIAGNOSIS >

[FRONT & REAR WINDOW ANTI-PINCH]

DOOR SWITCH

Description

INFOID:000000004394067

Detects door open/close condition.

Component Function Check

INFOID:000000004394068

1.CHECK FUNCTION

With CONSULT-III

Check door switches DOOR SW-DR, DOOR SW-AS, DOOR SW-RL, DOOR SW-RR in Data Monitor mode with CONSULT-III.

Monitor item	Condition
DOOR SW-DR	CLOSE → OPEN: OFF → ON
DOOR SW-AS	
DOOR SW-RL	
DOOR SW-RR	

Is the inspection result normal?

YES >> Door switch is OK.

NO >> Refer to [PWC-154, "Diagnosis Procedure"](#).

Diagnosis Procedure

INFOID:000000004394069

1.CHECK DOOR SWITCH INPUT SIGNAL

1. Turn ignition switch OFF.
2. Check signal between BCM connector and ground with oscilloscope.

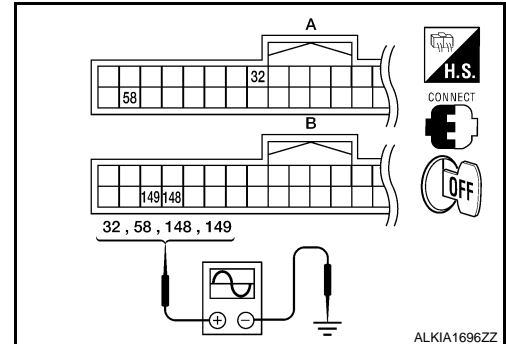

DOOR SWITCH

< COMPONENT DIAGNOSIS >

[FRONT & REAR WINDOW ANTI-PINCH]

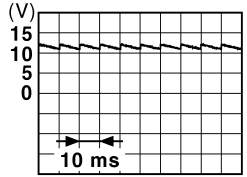
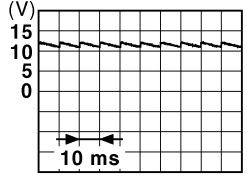
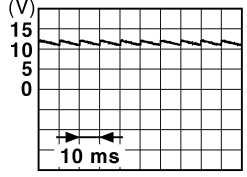
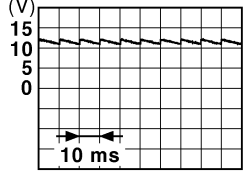
Terminals		(-)	Door condition		Voltage (V) (Approx.)
(+)					
BCM connector	Terminal				
A: M18	58	Ground	Driver side	OPEN	0
			Driver side	CLOSE	 <small>JPMIA0011GB</small>
	32		Passenger side	OPEN	0
			Passenger side	CLOSE	 <small>JPMIA0011GB</small>
B: M21	148	Ground	Rear RH	OPEN	0
			Rear RH	CLOSE	 <small>JPMIA0011GB</small>
	149		Rear LH	OPEN	0
			Rear LH	CLOSE	 <small>JPMIA0011GB</small>

Is the inspection result normal?

- YES >> GO TO 4
- NO >> GO TO 2

2. CHECK DOOR SWITCH CIRCUIT

1. Disconnect BCM connector.

A
B
C
D
E
F
G
H
I
J
L
M
N
O
P

PWC

DOOR SWITCH

< COMPONENT DIAGNOSIS >

[FRONT & REAR WINDOW ANTI-PINCH]

- Check continuity between BCM connector and door switch connector.

BCM connector	Terminal	Door switch connector	Terminal	Continuity
A: M18	58	C: B8 (Driver side)	2	Yes
	32	C: B108 (Passenger side)		
B: M21	148	C: B116 (Rear RH)		
	149	C: B18 (Rear LH)		

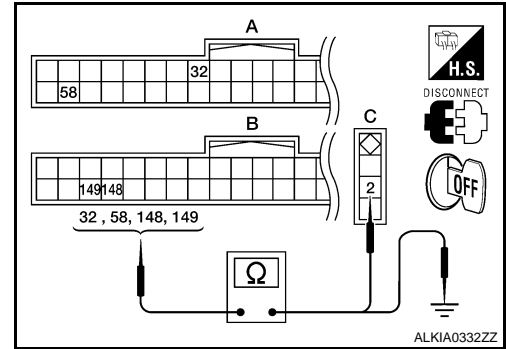

- Check continuity between BCM connector and ground.

BCM connector	Terminal	Continuity
A: M18	58	No
	32	
B: M21	148	
	149	

Is the inspection result normal?

YES >> GO TO 3

NO >> Repair or replace harness between BCM and door switch.

3.CHECK DOOR SWITCH

Refer to [PWC-156](#). "Component Inspection".

Is the inspection result normal?

YES >> GO TO 4

NO >> Replace malfunctioning door switch.

4.CHECK INTERMITTENT INCIDENT

Refer to [GI-39](#). "Intermittent Incident".

>> Inspection End.

Component Inspection

INFOID:000000004394070

1.CHECK DOOR SWITCH

- Turn ignition switch OFF.
- Disconnect door switch connector.
- Check door switch.

Terminal	Door switch condition	Continuity
2	Pressed	No
	Released	Yes

Is the inspection result normal?

YES >> Inspection End.

NO >> Replace malfunctioning door switch.

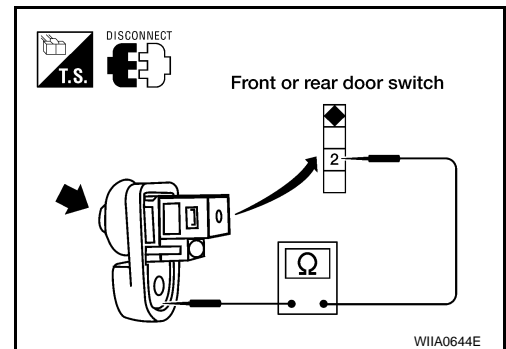

DOOR KEY CYLINDER SWITCH

< COMPONENT DIAGNOSIS >

[FRONT & REAR WINDOW ANTI-PINCH]

DOOR KEY CYLINDER SWITCH

Description

INFOID:000000004394076

The main power window and door lock/unlock switch detects condition of the door key cylinder switch and transmits to BCM as the LOCK or UNLOCK signal.

Component Function Check

INFOID:000000004394077

1. CHECK DOOR KEY CYLINDER SWITCH INPUT SIGNAL

Check KEY CYL UN-SW, KEY CYL UN-SW in "DATA MONITOR" mode for "POWER DOOR LOCK SYSTEM" with CONSULT-III. Refer to [DLK-50, "DOOR LOCK : CONSULT-III Function \(BCM - DOOR LOCK\)"](#).

Monitor item	Condition
KEY CYL LK-SW	Lock : ON
	Neutral / Unlock : OFF
KEY CYL UN-SW	Unlock : ON
	Neutral / Lock : OFF

Is the inspection result normal?

- YES >> Key cylinder switch is OK.
- NO >> Refer to [PWC-157, "Diagnosis Procedure"](#).

Diagnosis Procedure

INFOID:000000004394078

1. CHECK DOOR KEY CYLINDER SWITCH INPUT SIGNAL

1. Turn ignition switch ON.
2. Check voltage between main power window and door lock/unlock switch connector and ground.

Terminals		Key position	Voltage (V) (Approx.)
(+)	(-)		
Main power window and door lock/unlock switch connector	Terminal		
	D7	Ground	
	4	Lock	0
		Neutral / Unlock	5
	6	Unlock	0
		Neutral / Lock	5

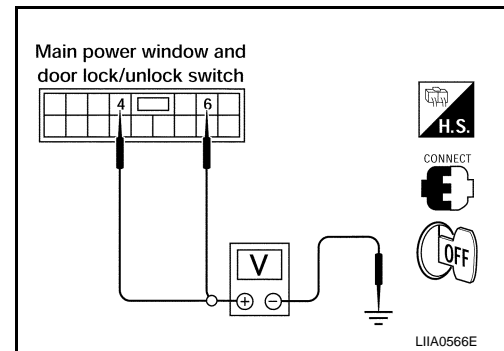

Is the inspection result normal?

- YES >> Replace main power window and door lock/unlock switch. Refer to [PWC-113, "Removal and Installation"](#). After that, refer to [PWC-9, "ADDITIONAL SERVICE WHEN REPLACING CONTROL UNIT : Special Repair Requirement"](#).
- NO >> GO TO 2

2. CHECK DOOR KEY CYLINDER SIGNAL CIRCUIT

1. Turn ignition switch OFF.
2. Disconnect main power window and door lock/unlock switch connector and front door lock assembly LH (key cylinder switch) connector.

DOOR KEY CYLINDER SWITCH

[FRONT & REAR WINDOW ANTI-PINCH]

< COMPONENT DIAGNOSIS >

3. Check continuity between main power window and door lock/unlock switch connector and front door lock assembly LH (key cylinder switch) connector.

Main power window and door lock/unlock switch connector	Terminal	Front door lock assembly LH (key cylinder switch) connector	Terminal	Continuity
A: D7	4	B: D10	6	Yes
	6		5	

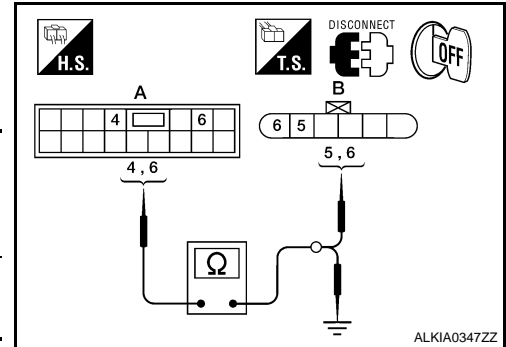

4. Check continuity between main power window and door lock/unlock switch connector and ground.

Power window main switch connector	Terminal	Ground	Continuity
A: D7	4	Ground	No
	6		

Is the inspection result normal?

YES >> GO TO 3

NO >> Repair or replace harness.

3. CHECK DOOR KEY CYLINDER SWITCH GROUND CIRCUIT

Check continuity between front door lock assembly LH connector and ground.

Front door lock assembly LH connector	Terminal	Ground	Continuity
D10	4	Ground	Yes

Is the inspection result normal?

YES >> GO TO 4

NO >> Repair or replace harness.

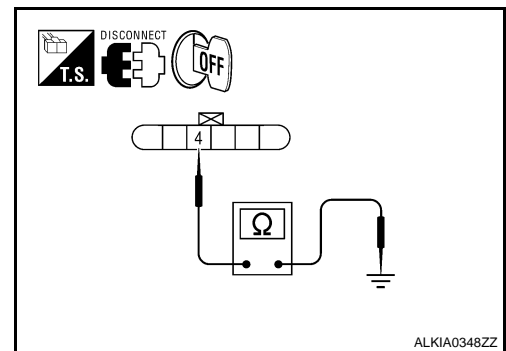

4. CHECK DOOR KEY CYLINDER SWITCH

Check door key cylinder switch.

Refer to [PWC-158, "Component Inspection"](#).

Is the inspection result normal?

YES >> Check intermittent incident. Refer to [GI-39, "Intermittent Incident"](#).

NO >> Replace front door lock assembly LH (key cylinder switch). Refer to [DLK-224, "FRONT DOOR LOCK : Removal and Installation"](#). After that, Refer to [PWC-9, "ADDITIONAL SERVICE WHEN REPLACING CONTROL UNIT : Special Repair Requirement"](#).

Component Inspection

INFOID:000000004394079

COMPONENT INSPECTION

1. CHECK DOOR KEY CYLINDER SWITCH

DOOR KEY CYLINDER SWITCH

< COMPONENT DIAGNOSIS >

[FRONT & REAR WINDOW ANTI-PINCH]

Check front door lock assembly LH (key cylinder switch).

Terminal		Key position	Continuity
Front door lock assembly LH (key cylinder switch) connector			
5	4	Unlock	Yes
		Neutral / Lock	No
6		Lock	Yes
		Neutral / Unlock	No

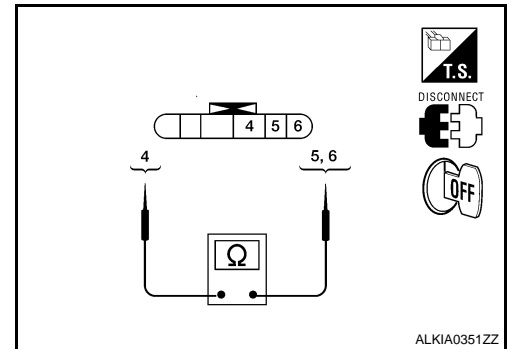

Is the inspection result normal?

YES >> Key cylinder switch is OK.

NO >> Replace front door lock assembly LH (key cylinder switch). Refer to [DLK-224, "FRONT DOOR LOCK : Removal and Installation"](#). After that, refer to [PWC-159, "Special Repair Requirement"](#).

Special Repair Requirement

INFOID:000000004394080

1.PERFORM INITIALIZATION PROCEDURE

Perform initialization procedure.

Refer to [DLK-8, "ADDITIONAL SERVICE WHEN REPLACING CONTROL UNIT : Special Repair Requirement"](#).

Is the inspection result normal?

YES >> Inspection End.

NO >> Check intermittent incident. Refer to [GI-39, "Intermittent Incident"](#).

A
B
C
D
E
F
G
H
I
J
L
M
N
O
P

PWC

POWER WINDOW SERIAL LINK

[FRONT & REAR WINDOW ANTI-PINCH]

< COMPONENT DIAGNOSIS >

POWER WINDOW SERIAL LINK

POWER WINDOW MAIN SWITCH

POWER WINDOW MAIN SWITCH : Description

INFOID:000000004391524

- Main power window and door lock/unlock switch, power window and door lock/unlock switch RH and BCM communicate via the power window serial link.
- The keyless power window down signal is transmitted from BCM to main power window and door lock/unlock switch and power window and door lock/unlock switch RH.
- The following signals are transmitted from main power window and door lock/unlock switch to power window and door lock/unlock switch RH:
 - Front door window RH operation
 - Power window control by key cylinder switch
 - Power window lock switch
 - Retained accessory power operation

POWER WINDOW MAIN SWITCH : Component Function Check

INFOID:000000004391525

1. CHECK POWER WINDOW SWITCH OUTPUT SIGNAL

Check ("CDL LOCK SW ", "CDL UNLOCK SW") in "DATA MONITOR" mode for "POWER DOOR LOCK SYSTEM" with CONSULT-III. Refer to [DLK-50, "DOOR LOCK : CONSULT-III Function \(BCM - DOOR LOCK\)"](#).

Monitor item	Condition
CDL LOCK SW	LOCK : ON
	UNLOCK : OFF
CDL UNLOCK SW	LOCK : OFF
	UNLOCK : ON

Is the inspection result normal?

YES >> Power window serial link is OK.

NO >> Refer to [PWC-160, "POWER WINDOW MAIN SWITCH : Diagnosis Procedure"](#).

POWER WINDOW MAIN SWITCH : Diagnosis Procedure

INFOID:000000004391526

Power Window Serial Link Check

1. CHECK POWER WINDOW SWITCH OUTPUT SIGNAL

1. Remove Intelligent Key, and close front door LH and RH.
2. Check signal between BCM connector M18 terminal 40 and ground with oscilloscope when door lock and unlock switch (key cylinder switch) is turned to "LOCK" or "UNLOCK".
3. Check that signals which are shown in the figure below can be detected during 10 seconds just after door lock and unlock switch (key cylinder switch) is turned to "LOCK" or "UNLOCK".

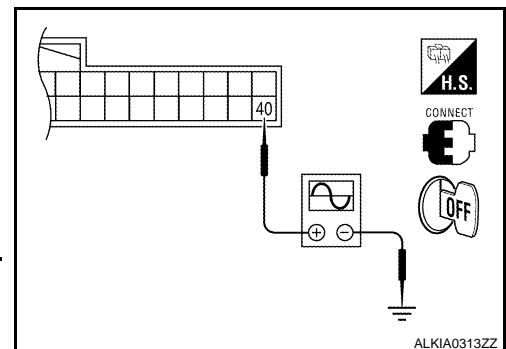

Terminal		Signal (Reference value)
(+)	(-)	
BCM connector	Terminal	
M18	40	Ground

PIIA1297E

POWER WINDOW SERIAL LINK

[FRONT & REAR WINDOW ANTI-PINCH]

< COMPONENT DIAGNOSIS >

Is the inspection result normal?

YES >> Power window serial link is OK.

NO >> GO TO 2

2. CHECK POWER WINDOW SERIAL LINK CIRCUIT

1. Turn ignition switch OFF.
2. Disconnect BCM connector M18 and main power window and door lock/unlock switch connector D7.
3. Check continuity between BCM connector M18 (A) terminal 40 and main power window and door lock/unlock switch connector D7 (B) terminal 14.

BCM connector	Terminal	Main power window and door lock/unlock switch connector	Terminal	Continuity
M18 (A)	40	D7 (B)	14	Yes

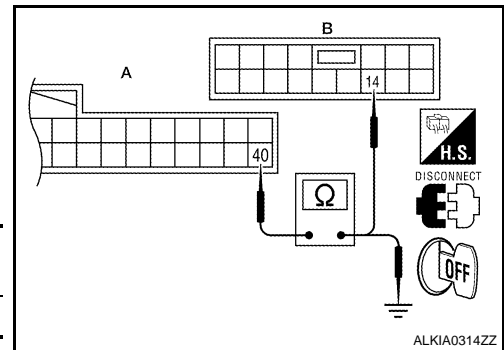

4. Check continuity between BCM connector M18 (A) terminal 40 and ground.

BCM connector	Terminal	Ground	Continuity
M18 (A)	40		No

Is the inspection result normal?

YES >> Replace main power window and door lock/unlock switch. Refer to [PWC-113, "Removal and Installation"](#).

NO >> Repair or replace harness or connectors.

POWER WINDOW MAIN SWITCH : Special Repair Requirement

INFOID:000000004392466

1. PERFORM INITIALIZATION PROCEDURE

Perform initialization procedure. Refer to [PWC-119, "ADDITIONAL SERVICE WHEN REMOVING BATTERY NEGATIVE TERMINAL : Special Repair Requirement"](#) and [PWC-119, "ADDITIONAL SERVICE WHEN REPLACING CONTROL UNIT : Special Repair Requirement"](#).

>> GO TO 2

2. CHECK ANTI-PINCH OPERATION

Check anti-pinch operation. Refer to [PWC-119, "ADDITIONAL SERVICE WHEN REMOVING BATTERY NEGATIVE TERMINAL : Special Repair Requirement"](#) and [PWC-119, "ADDITIONAL SERVICE WHEN REPLACING CONTROL UNIT : Special Repair Requirement"](#).

>> End.

FRONT POWER WINDOW SWITCH

FRONT POWER WINDOW SWITCH : Description

INFOID:000000004391530

- Main power window and door lock/unlock switch, power window and door lock/unlock switch RH and BCM communicate via the power window serial link.
- The keyless power window down signal is transmitted from BCM to main power window and door lock/unlock switch and power window and door lock/unlock switch RH.
- The following signals are transmitted from main power window and door lock/unlock switch to power window and door lock/unlock switch RH:
 - Front door window RH operation
 - Power window control by key cylinder switch
 - Power window lock switch
 - Retained accessory power operation

POWER WINDOW SERIAL LINK

[FRONT & REAR WINDOW ANTI-PINCH]

< COMPONENT DIAGNOSIS >

FRONT POWER WINDOW SWITCH : Diagnosis Procedure

INFOID:000000004391531

Power Window Serial Link Check

1. CHECK POWER WINDOW AND DOOR LOCK/UNLOCK SWITCH RH

1. Remove Intelligent Key, and close the front door LH and RH.
2. Check signal between BCM connector M18 terminal 40 and ground with oscilloscope when door lock and unlock switch (key cylinder switch) is turned to "LOCK" or "UNLOCK".
3. Check that signals which are shown in the figure below can be detected during 10 seconds just after door lock and unlock switch (key cylinder switch) is turned to "LOCK" or "UNLOCK".

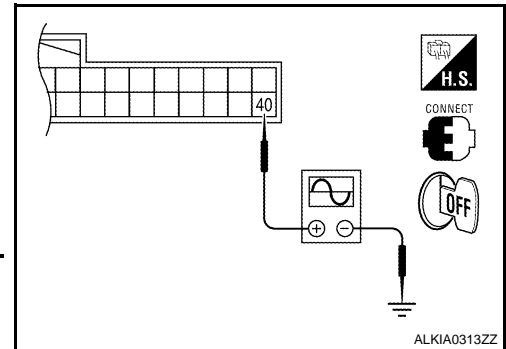

Terminal (+)		Terminal (-)	Signal (Reference value)
BCM connector	Terminal		
M18	40	Ground	<p>PIIA1297E</p>

Is the inspection result normal?

YES >> Power window serial link is OK.

NO >> GO TO 2

2. CHECK POWER WINDOW SERIAL LINK CIRCUIT

1. Turn ignition switch OFF.
2. Disconnect BCM connector M18 and power window and door lock/unlock switch RH connector.
3. Check continuity between BCM connector M18 (A) terminal 40 and power window and door lock/unlock switch RH connector D105 (B) terminal 16.

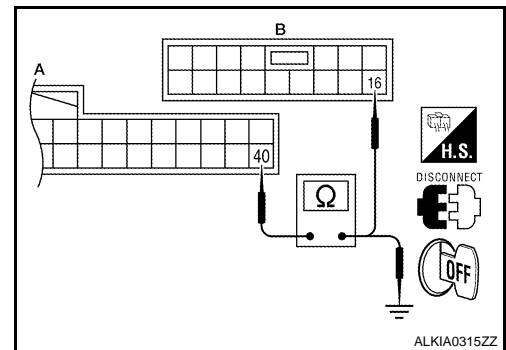

BCM connector	Terminal	Power window and door lock/unlock switch RH connector	Terminal	Continuity
M18 (A)	40	D105 (B)	16	Yes

4. Check continuity between BCM connector M18 (A) terminal 40 and ground.

BCM connector	Terminal	Ground	Continuity
M18 (A)	40	Ground	No

Is the inspection result normal?

YES >> Replace main power window and door lock/unlock switch. Refer to [PWC-113, "Removal and Installation"](#).

NO >> Repair or replace harness or connectors.

FRONT POWER WINDOW SWITCH : Special Repair Requirement

INFOID:000000004392467

1. PERFORM INITIALIZATION PROCEDURE

Perform initialization procedure. Refer to [PWC-119, "ADDITIONAL SERVICE WHEN REMOVING BATTERY NEGATIVE TERMINAL : Special Repair Requirement"](#) and [PWC-119, "ADDITIONAL SERVICE WHEN REPLACING CONTROL UNIT : Special Repair Requirement"](#).

POWER WINDOW SERIAL LINK

[FRONT & REAR WINDOW ANTI-PINCH]

< COMPONENT DIAGNOSIS >

>> GO TO 2

2. CHECK ANTI-PINCH OPERATION

Check anti-pinch operation. Refer to [PWC-119, "ADDITIONAL SERVICE WHEN REMOVING BATTERY NEGATIVE TERMINAL : Special Repair Requirement"](#) and [PWC-119, "ADDITIONAL SERVICE WHEN REPLACING CONTROL UNIT : Special Repair Requirement"](#).

>> End.

REAR LH

REAR LH : Description

INFOID:000000004391558

- Main power window and door lock/unlock switch, power window and door lock/unlock switch RH, rear power window switch LH, rear power window switch RH and BCM communicate via the power window serial link.
- The keyless power window down signal is transmitted from BCM to main power window and door lock/unlock switch and power window and door lock/unlock switch RH, rear power window switch LH and rear power window switch RH.
- The following signals are transmitted from main power window and door lock/unlock switch to power window and door lock/unlock switch RH, rear power window switch LH, rear power window switch RH:
 - Front door window RH operation
 - Rear door window LH operation
 - Rear door window RH operation
 - Power window control by key cylinder switch
 - Power window lock switch
 - Retained accessory power operation

REAR LH : Diagnosis Procedure

INFOID:000000004391559

1. CHECK REAR POWER WINDOW SWITCH LH

1. Remove Intelligent Key, and close all doors.
2. Check signal between BCM connector M18 terminal 40 and ground with oscilloscope when door lock and unlock switch (key cylinder switch) is turned to "LOCK" or "UNLOCK".
3. Check that signals which are shown in the figure below can be detected during 10 seconds just after door lock and unlock switch (key cylinder switch) is turned to "LOCK" or "UNLOCK".

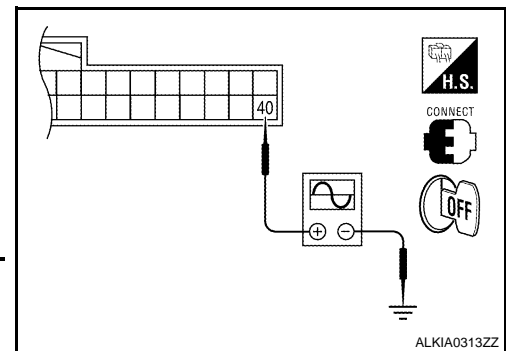

Terminal (+)		Terminal (-)	Signal (Reference value)
BCM connector	Terminal		
M18	40	Ground	<p>PIIA1297E</p>

Is the inspection result normal?

- YES >> Power window serial link is OK.
 NO >> GO TO 2

2. CHECK POWER WINDOW SERIAL LINK CIRCUIT

POWER WINDOW SERIAL LINK

[FRONT & REAR WINDOW ANTI-PINCH]

< COMPONENT DIAGNOSIS >

1. Turn ignition switch OFF.
2. Disconnect BCM connector M18 and rear power window switch LH connector.
3. Check continuity between BCM connector M18 (A) terminal 40 and rear power window switch LH connector D207 (B) terminal 16.

BCM connector	Terminal	Rear power window switch LH connector	Terminal	Continuity
M18 (A)	40	D207 (B)	16	Yes

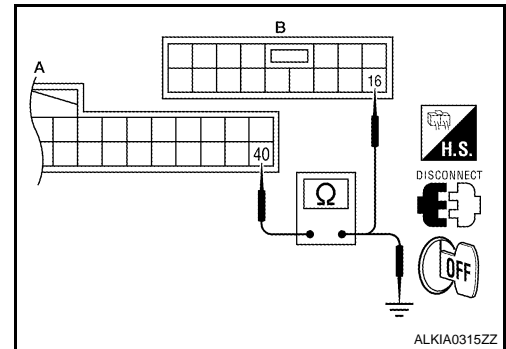

4. Check continuity between BCM connector M18 (A) terminal 40 and ground.

BCM connector	Terminal	Ground	Continuity
M18 (A)	40		No

Is the inspection result normal?

- YES >> Replace rear power window switch LH. Refer to [PWC-113, "Removal and Installation"](#).
 NO >> Repair or replace harness or connectors.

REAR LH : Special Repair Requirement

INFOID:000000004392468

1. PERFORM INITIALIZATION PROCEDURE

Perform initialization procedure. Refer to [PWC-119, "ADDITIONAL SERVICE WHEN REMOVING BATTERY NEGATIVE TERMINAL : Special Repair Requirement"](#) and [PWC-119, "ADDITIONAL SERVICE WHEN REPLACING CONTROL UNIT : Special Repair Requirement"](#).

>> GO TO 2

2. CHECK ANTI-PINCH OPERATION

Check anti-pinch operation. Refer to [PWC-119, "ADDITIONAL SERVICE WHEN REMOVING BATTERY NEGATIVE TERMINAL : Special Repair Requirement"](#) and [PWC-119, "ADDITIONAL SERVICE WHEN REPLACING CONTROL UNIT : Special Repair Requirement"](#).

>> End.

REAR RH

REAR RH : Description

INFOID:000000004392450

- Main power window and door lock/unlock switch, power window and door lock/unlock switch RH, rear power window switch LH, rear power window switch RH and BCM communicate via the power window serial link.
- The keyless power window down signal is transmitted from BCM to main power window and door lock/unlock switch and power window and door lock/unlock switch RH, rear power window switch LH and rear power window switch RH.
- The following signals are transmitted from main power window and door lock/unlock switch to power window and door lock/unlock switch RH, rear power window switch LH, rear power window switch RH:
 - Front door window RH operation
 - Rear door window LH operation
 - Rear door window RH operation
 - Power window control by key cylinder switch
 - Power window lock switch
 - Retained accessory power operation

REAR RH : Diagnosis Procedure

INFOID:000000004392451

1. CHECK REAR POWER WINDOW SWITCH RH

POWER WINDOW SERIAL LINK

[FRONT & REAR WINDOW ANTI-PINCH]

< COMPONENT DIAGNOSIS >

1. Remove Intelligent Key, and close all doors.
2. Check signal between BCM connector M18 terminal 40 and ground with oscilloscope when door lock and unlock switch (key cylinder switch) is turned to "LOCK" or "UNLOCK".
3. Check that signals which are shown in the figure below can be detected during 10 seconds just after door lock and unlock switch (key cylinder switch) is turned to "LOCK" or "UNLOCK".

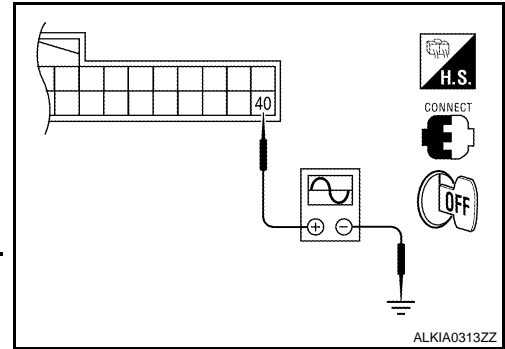

Terminal (+)		Terminal (-)	Signal (Reference value)
BCM connector	Terminal		
M18	40	Ground	

Is the inspection result normal?

- YES >> Power window serial link is OK.
 NO >> GO TO 2

2. CHECK POWER WINDOW SERIAL LINK CIRCUIT

1. Turn ignition switch OFF.
2. Disconnect BCM connector M18 and rear power window switch RH connector.
3. Check continuity between BCM connector M18 (A) terminal 40 and rear power window switch RH connector D307 (B) terminal 16.

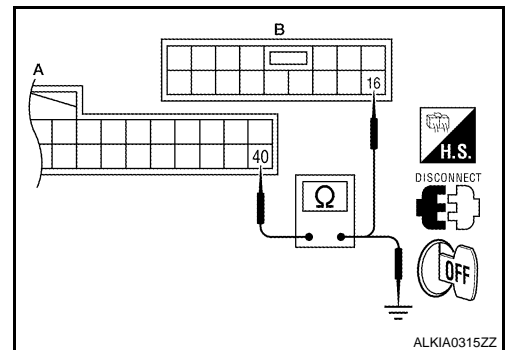

BCM connector	Terminal	Rear power window switch RH connector	Terminal	Continuity
M18 (A)	40	D307 (B)	16	Yes

4. Check continuity between BCM connector M18 (A) terminal 40 and ground.

BCM connector	Terminal	Ground	Continuity
M18 (A)	40		No

Is the inspection result normal?

- YES >> Replace rear power window switch RH. Refer to [PWC-113, "Removal and Installation"](#).
 NO >> Repair or replace harness or connectors.

REAR RH : Special Repair Requirement

INFOID:000000004392469

1. PERFORM INITIALIZATION PROCEDURE

Perform initialization procedure. Refer to [PWC-119, "ADDITIONAL SERVICE WHEN REMOVING BATTERY NEGATIVE TERMINAL : Special Repair Requirement"](#) and [PWC-119, "ADDITIONAL SERVICE WHEN REPLACING CONTROL UNIT : Special Repair Requirement"](#).

>> GO TO 2

2. CHECK ANTI-PINCH OPERATION

POWER WINDOW SERIAL LINK

< COMPONENT DIAGNOSIS >

[FRONT & REAR WINDOW ANTI-PINCH]

Check anti-pinch operation. Refer to [PWC-119, "ADDITIONAL SERVICE WHEN REMOVING BATTERY NEGATIVE TERMINAL : Special Repair Requirement"](#) and [PWC-119, "ADDITIONAL SERVICE WHEN REPLACING CONTROL UNIT : Special Repair Requirement"](#).

>> End.

POWER WINDOW LOCK SWITCH

< COMPONENT DIAGNOSIS >

[FRONT & REAR WINDOW ANTI-PINCH]

POWER WINDOW LOCK SWITCH

Component Function Check

INFOID:000000004392440

1. CHECK POWER WINDOW LOCK

Activate the power window lock switch and verify that the front power window RH, rear power window LH and rear power window RH are inoperative.

Is the inspection result normal?

YES >> Power window lock switch is OK.

NO >> Replace the main power window and door lock/unlock switch. Refer to [PWC-244. "Removal and Installation"](#).

Special Repair Requirement

INFOID:000000004392470

1. PERFORM INITIALIZATION PROCEDURE

Perform initialization procedure. Refer to [PWC-119. "ADDITIONAL SERVICE WHEN REMOVING BATTERY NEGATIVE TERMINAL : Special Repair Requirement"](#) and [PWC-119. "ADDITIONAL SERVICE WHEN REPLACING CONTROL UNIT : Special Repair Requirement"](#).

>> GO TO 2

2. CHECK ANTI-PINCH OPERATION

Check anti-pinch operation. Refer to [PWC-119. "ADDITIONAL SERVICE WHEN REMOVING BATTERY NEGATIVE TERMINAL : Special Repair Requirement"](#) and [PWC-119. "ADDITIONAL SERVICE WHEN REPLACING CONTROL UNIT : Special Repair Requirement"](#).

>> End.

A
B
C
D
E
F
G
H
I
J
L
M
N
O
P

PWC

BCM (BODY CONTROL MODULE)

[FRONT & REAR WINDOW ANTI-PINCH]

< ECU DIAGNOSIS >

ECU DIAGNOSIS

BCM (BODY CONTROL MODULE)

Reference Value

INFOID:000000004363695

VALUES ON THE DIAGNOSIS TOOL

Monitor Item	Condition	Value/Status
FR WIPER HI	Other than front wiper switch HI	OFF
	Front wiper switch HI	ON
FR WIPER LOW	Other than front wiper switch LO	OFF
	Front wiper switch LO	ON
FR WASHER SW	Front washer switch OFF	OFF
	Front washer switch ON	ON
FR WIPER INT	Other than front wiper switch INT	OFF
	Front wiper switch INT	ON
FR WIPER STOP	Front wiper is not in STOP position	OFF
	Front wiper is in STOP position	ON
INT VOLUME	Wiper intermittent dial is in a dial position 1 - 7	Wiper intermittent dial position
TURN SIGNAL R	Other than turn signal switch RH	OFF
	Turn signal switch RH	ON
TURN SIGNAL L	Other than turn signal switch LH	OFF
	Turn signal switch LH	ON
TAIL LAMP SW	Other than lighting switch 1ST and 2ND	OFF
	Lighting switch 1ST or 2ND	ON
HI BEAM SW	Other than lighting switch HI	OFF
	Lighting switch HI	ON
HEAD LAMP SW 1	Other than lighting switch 2ND	OFF
	Lighting switch 2ND	ON
HEAD LAMP SW 2	Other than lighting switch 2ND	OFF
	Lighting switch 2ND	ON
PASSING SW	Other than lighting switch PASS	OFF
	Lighting switch PASS	ON
AUTO LIGHT SW	Other than lighting switch AUTO	OFF
	Lighting switch AUTO	ON
FR FOG SW	Front fog lamp switch OFF	OFF
	Front fog lamp switch ON	ON
DOOR SW-DR	Driver door closed	OFF
	Driver door opened	ON
DOOR SW-AS	Passenger door closed	OFF
	Passenger door opened	ON
DOOR SW-RR	Rear door RH closed	OFF
	Rear door RH opened	ON
DOOR SW-RL	Rear door LH closed	OFF
	Rear door LH opened	ON

BCM (BODY CONTROL MODULE)

[FRONT & REAR WINDOW ANTI-PINCH]

< ECU DIAGNOSIS >

Monitor Item	Condition	Value/Status	
DOOR SW-BK	NOTE: This item is displayed, but cannot be monitored.	OFF	A
CDL LOCK SW	Other than power door lock switch LOCK	OFF	B
	Power door lock switch LOCK	ON	
CDL UNLOCK SW	Other than power door lock switch UNLOCK	OFF	C
	Power door lock switch UNLOCK	ON	
KEY CYL LK-SW	Other than driver door key cylinder LOCK position	OFF	D
	Driver door key cylinder LOCK position	ON	
KEY CYL UN-SW	Other than driver door key cylinder UNLOCK position	OFF	E
	Driver door key cylinder UNLOCK position	ON	
KEY CYL SW-TR	NOTE: This item is displayed, but cannot be monitored.	OFF	E
HAZARD SW	When hazard switch is not pressed	OFF	F
	When hazard switch is pressed	ON	
REAR DEF SW	When rear window defogger switch is pressed	ON	
TR CANCEL SW	Trunk lid opener cancel switch OFF	OFF	G
	Trunk lid opener cancel switch ON	ON	
TR/BD OPEN SW	Trunk lid opener switch OFF	OFF	H
	While the trunk lid opener switch is turned ON	ON	
TRNK/HAT MNTR	Trunk lid closed	OFF	I
	Trunk lid opened	ON	
RKE-LOCK	When LOCK button of Intelligent Key is not pressed	OFF	J
	When LOCK button of Intelligent Key is pressed	ON	
RKE-UNLOCK	When UNLOCK button of Intelligent Key is not pressed	OFF	J
	When UNLOCK button of Intelligent Key is pressed	ON	
RKE-TR/BD	When TRUNK OPEN button of Intelligent Key is not pressed	OFF	PWC
	When TRUNK OPEN button of Intelligent Key is pressed	ON	
RKE-PANIC	When PANIC button of Intelligent Key is not pressed	OFF	L
	When PANIC button of Intelligent Key is pressed	ON	
RKE-P/W OPEN	When UNLOCK button of Intelligent Key is not pressed and held	OFF	M
	When UNLOCK button of Intelligent Key is pressed and held	ON	
RKE-MODE CHG	When LOCK/UNLOCK button of Intelligent Key is not pressed and held simultaneously	OFF	N
	When LOCK/UNLOCK button of Intelligent Key is pressed and held simultaneously	ON	
OPTICAL SENSOR	When outside of the vehicle is bright	Close to 5 V	O
	When outside of the vehicle is dark	Close to 0 V	
REQ SW-DR	When front door request switch is not pressed (driver side)	OFF	P
	When front door request switch is pressed (driver side)	ON	
REQ SW-AS	When front door request switch is not pressed (passenger side)	OFF	P
	When front door request switch is pressed (passenger side)	ON	
REQ SW-RL	When rear door request switch is not pressed (driver side)	OFF	
	When rear door request switch is pressed (driver side)	ON	
REQ SW-RR	When rear door request switch is not pressed (passenger side)	OFF	
	When rear door request switch is pressed (passenger side)	ON	

BCM (BODY CONTROL MODULE)

[FRONT & REAR WINDOW ANTI-PINCH]

< ECU DIAGNOSIS >

Monitor Item	Condition	Value/Status
REQ SW-BD/TR	When trunk request switch is not pressed	OFF
	When trunk request switch is pressed	ON
PUSH SW	When engine switch (push switch) is not pressed	OFF
	When engine switch (push switch) is pressed	ON
IGN RLY 2-F/B	Ignition switch OFF or ACC	OFF
	Ignition switch ON	ON
ACC RLY-F/B	Ignition switch OFF	OFF
	Ignition switch ACC or ON	ON
CLUTCH SW	NOTE: This item is displayed, but cannot be monitored.	OFF
BRAKE SW 1	When the brake pedal is not depressed	ON
	When the brake pedal is depressed	OFF
DETE/CANCL SW	When selector lever is in P position	OFF
	When selector lever is in any position other than P	ON
SFT PN/N SW	When selector lever is in any position other than P or N	OFF
	When selector lever is in P or N position	ON
S/L-LOCK	Electronic steering column lock LOCK status	OFF
	Electronic steering column lock UNLOCK status	ON
S/L-UNLOCK	Electronic steering column lock UNLOCK status	OFF
	Electronic steering column lock LOCK status	ON
S/L RELAY-F/B	Ignition switch OFF or ACC	OFF
	Ignition switch ON	ON
UNLK SEN-DR	Driver door UNLOCK status	OFF
	Driver door LOCK status	ON
PUSH SW-IPDM	When engine switch (push switch) is not pressed	OFF
	When engine switch (push switch) is pressed	ON
IGN RLY1 F/B	Ignition switch OFF or ACC	OFF
	Ignition switch ON	ON
DETE SW -IPDM	When selector lever is in P position	OFF
	When selector lever is in any position other than P	ON
SFT PN -IPDM	When selector lever is in any position other than P or N	OFF
	When selector lever is in P or N position	ON
SFT P-MET	When selector lever is in any position other than P	OFF
	When selector lever is in P position	ON
SFT N-MET	When selector lever is in any position other than N	OFF
	When selector lever is in N position	ON
ENGINE STATE	Engine stopped	STOP
	While the engine stalls	STALL
	At engine cranking	CRANK
	Engine running	RUN
S/L LOCK-IPDM	Electronic steering column lock LOCK status	OFF
	Electronic steering column lock UNLOCK status	ON
S/L UNLCK-IPDM	Electronic steering column lock UNLOCK status	OFF
	Electronic steering column lock LOCK status	ON

BCM (BODY CONTROL MODULE)

[FRONT & REAR WINDOW ANTI-PINCH]

< ECU DIAGNOSIS >

Monitor Item	Condition	Value/Status	
S/L RELAY-REQ	Ignition switch OFF or ACC	OFF	A
	Ignition switch ON	ON	
VEH SPEED 1	While driving	Equivalent to speedometer reading	B
VEH SPEED 2	While driving	Equivalent to speedometer reading	
DOOR STAT-DR	Driver door LOCK status	LOCK	C
	Wait with selective UNLOCK operation (5 seconds)	READY	
	Driver door UNLOCK status	UNLK	
DOOR STAT-AS	Passenger door LOCK status	LOCK	D
	Wait with selective UNLOCK operation (5 seconds)	READY	
	Passenger door UNLOCK status	UNLK	
ID OK FLAG	Ignition switch ACC or ON	RESET	E
	Ignition switch OFF	SET	
PRMT ENG STAT	When the engine start is prohibited	RESET	F
	When the engine start is permitted	SET	
PRMT RKE STAT	NOTE: This item is displayed, but cannot be monitored.	RESET	G
KEY SW -SLOT	When Intelligent Key is not inserted into key slot	OFF	H
	When Intelligent Key is inserted into key slot	ON	
RKE OPE COUN1	During the operation of Intelligent Key	Operation frequency of Intelligent Key	
RKE OPE COUN2	NOTE: This item is displayed, but cannot be monitored.	Operation frequency of Intelligent Key	I
CONFIRM ID ALL	The key ID that the key slot receives does not accord with any key ID registered to BCM.	YES	J
	The key ID that the key slot receives accords with any key ID registered to BCM.	DONE	
CONFIRM ID4	The key ID that the key slot receives does not accord with the fourth key ID registered to BCM.	YES	PWC
	The key ID that the key slot receives accords with the fourth key ID registered to BCM.	DONE	
CONFIRM ID3	The key ID that the key slot receives does not accord with the third key ID registered to BCM.	YES	L
	The key ID that the key slot receives accords with the third key ID registered to BCM.	DONE	
CONFIRM ID2	The key ID that the key slot receives does not accord with the second key ID registered to BCM.	YES	M
	The key ID that the key slot receives accords with the second key ID registered to BCM.	DONE	N
CONFIRM ID1	The key ID that the key slot receives does not accord with the first key ID registered to BCM.	YES	O
	The key ID that the key slot receives accords with the first key ID registered to BCM.	DONE	
TP 4	The ID of fourth key is not registered to BCM	YES	P
	The ID of fourth key is registered to BCM	DONE	
TP 3	The ID of third key is not registered to BCM	YES	
	The ID of third key is registered to BCM	DONE	
TP 2	The ID of second key is not registered to BCM	YES	
	The ID of second key is registered to BCM	DONE	

BCM (BODY CONTROL MODULE)

[FRONT & REAR WINDOW ANTI-PINCH]

< ECU DIAGNOSIS >

Monitor Item	Condition	Value/Status
TP 1	The ID of first key is not registered to BCM	YET
	The ID of first key is registered to BCM	DONE
AIR PRESS FL	Ignition switch ON (only when the signal from the transmitter is received)	Air pressure of front LH tire
AIR PRESS FR	Ignition switch ON (only when the signal from the transmitter is received)	Air pressure of front RH tire
AIR PRESS RR	Ignition switch ON (only when the signal from the transmitter is received)	Air pressure of rear RH tire
AIR PRESS RL	Ignition switch ON (only when the signal from the transmitter is received)	Air pressure of rear LH tire
ID REGST FL1	When ID of front LH tire transmitter is registered	DONE
	When ID of front LH tire transmitter is not registered	YET
ID REGST FR1	When ID of front RH tire transmitter is registered	DONE
	When ID of front RH tire transmitter is not registered	YET
ID REGST RR1	When ID of rear RH tire transmitter is registered	DONE
	When ID of rear RH tire transmitter is not registered	YET
ID REGST RL1	When ID of rear LH tire transmitter is registered	DONE
	When ID of rear LH tire transmitter is not registered	YET
WARNING LAMP	Tire pressure indicator OFF	OFF
	Tire pressure indicator ON	ON
BUZZER	Tire pressure warning alarm is not sounding	OFF
	Tire pressure warning alarm is sounding	ON

BCM (BODY CONTROL MODULE)

[FRONT & REAR WINDOW ANTI-PINCH]

< ECU DIAGNOSIS >

Terminal Layout

INFOID:000000004363696

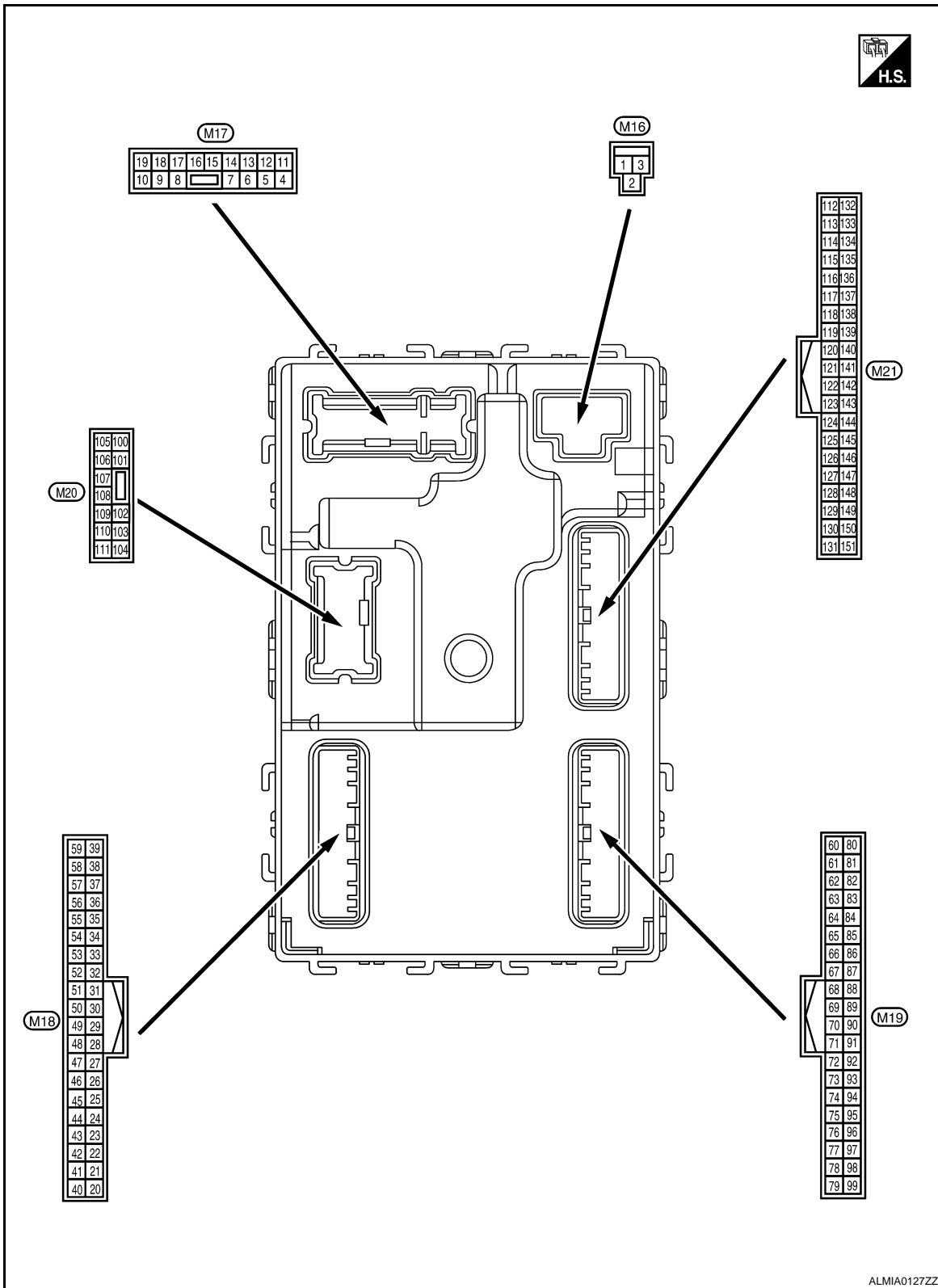

Physical Values

INFOID:000000004363697

A
B
C
D
E
F
G
H
I
J
PWC
L
M
N
O
P

BCM (BODY CONTROL MODULE)

< ECU DIAGNOSIS >

[FRONT & REAR WINDOW ANTI-PINCH]

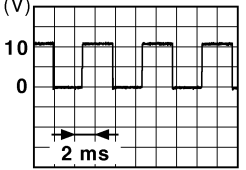
Terminal No. (Wire color)		Description		Condition		Value (Approx.)
		Signal name	Input/ Output			
(+)	(-)					
1 (W/B)	Ground	Battery power supply	Input	Ignition switch OFF		Battery voltage
2 (R/Y)	Ground	Battery power supply output	Output	Ignition switch OFF		Battery voltage
3 (L/W)	Ground	Ignition power supply output	Output	Ignition switch ON		Battery voltage
4 (P/W)	Ground	Interior room lamp power supply	Output	After passing the interior room lamp battery saver operation time		0V
				Any other time after passing the interior room lamp battery saver operation time		Battery voltage
5 (G)	Ground	Front door RH UN-LOCK	Output	Front door RH	UNLOCK (actuator is activated)	Battery voltage
					Other than UNLOCK (actuator is not activated)	0V
7 (R/W)	Ground	Step lamp	Output	Step lamp	ON	0V
					OFF	Battery voltage
8 (V)	Ground	All doors LOCK	Output	All doors	LOCK (actuator is activated)	Battery voltage
					Other than LOCK (actuator is not activated)	0V
9 (L)	Ground	Front door LH UN-LOCK	Output	Front door LH	UNLOCK (actuator is activated)	Battery voltage
					Other than UNLOCK (actuator is not activated)	0V
10 (G)	Ground	Rear door RH and rear door LH UN-LOCK	Output	Rear door RH and rear door LH	UNLOCK (actuator is activated)	Battery voltage
					Other than UNLOCK (actuator is not activated)	0V
11 (Y/R)	Ground	Battery power supply	Input	Ignition switch OFF		Battery voltage
13 (B)	Ground	Ground	—	Ignition switch ON		0V
14 (GR/W)	Ground	Engine switch (push switch) illumination ground	Input	Tail lamp	OFF	NOTE: When the illumination brightening/dimming level is in the neutral position 
					ON	
15 (Y/L)	Ground	ACC indicator lamp	Output	Ignition switch	OFF	Battery voltage
					ACC or ON	0V

JSNIA0010GB

BCM (BODY CONTROL MODULE)

[FRONT & REAR WINDOW ANTI-PINCH]

< ECU DIAGNOSIS >

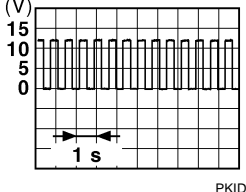
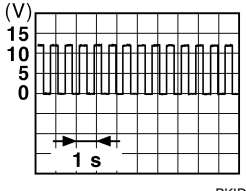
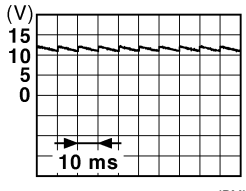
Terminal No. (Wire color)		Description		Condition		Value (Approx.)
(+)	(-)	Signal name	Input/ Output			
17 (G/B)	Ground	Turn signal (RH)	Output	Ignition switch ON	Turn signal switch OFF	0V
					Turn signal switch RH	 <p style="text-align: center;">6.5 V</p>
18 (G/Y)	Ground	Turn signal (LH)	Output	Ignition switch ON	Turn signal switch OFF	0V
					Turn signal switch LH	 <p style="text-align: center;">6.5 V</p>
19 (Y)	Ground	Room lamp timer control	Output	Interior room lamp	OFF	Battery voltage
					ON	0V
21 (P/B)	Ground	Optical sensor signal	Input	Ignition switch ON	When outside of the vehi- cle is bright	Close to 5V
					When outside of the vehi- cle is dark	Close to 0V
24 (R/W)	Ground	Stop lamp switch 1	Input	—	Battery voltage	
26 (O/L)	Ground	Stop lamp switch 2	Input	Stop lamp switch	OFF (brake pedal is not de- pressed)	0V
					ON (brake pedal is de- pressed)	Battery voltage
27 (O)	Ground	Front door lock as- sembly LH (unlock sensor)	Input	Front door LH	LOCK status	 <p style="text-align: center;">11.8V</p>
					UNLOCK status	0V
29 (Y)	Ground	Key slot switch	Input	When Intelligent Key is inserted into key slot	Battery voltage	
				When Intelligent Key is not inserted into key slot	0V	
30 (V/Y)	Ground	ACC feedback signal	Input	Ignition switch	OFF	0
				ACC or ON	Battery voltage	
31 (G)	Ground	Rear window defog- ger feedback signal	Input	Rear window de- fogger switch	OFF	0V
				ON	Battery voltage	



A
B
C
D
E
F
G
H
I
J
L
M
N
O
P

PWC

BCM (BODY CONTROL MODULE)

[FRONT & REAR WINDOW ANTI-PINCH]

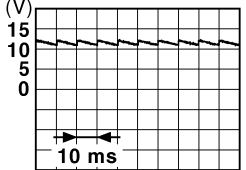
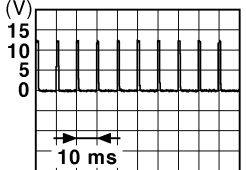



< ECU DIAGNOSIS >

Terminal No. (Wire color)		Description		Condition		Value (Approx.)
(+)	(-)	Signal name	Input/ Output			
32 (R/B)	Ground	Front door RH switch	Input	Front door RH switch	OFF (when front door RH closes)	 <p style="text-align: right; font-size: small;">JPMIA0011GB</p> <p style="text-align: center;">11.8 V</p>
					ON (when front door RH opens)	0V
37 (O)	Ground	Trunk lid opener cancel switch	Input	Trunk lid opener cancel switch	CANCEL	 <p style="text-align: right; font-size: small;">JPMIA0012GB</p> <p style="text-align: center;">1.1V</p>
					ON	0V
38 (GR/W)	Ground	Rear window defogger ON signal	Input	Rear window defogger switch	OFF	5V
					ON	0V
40 (Y/G)	Ground	Power window serial link	Input/ Output	Ignition switch ON	 <p style="text-align: right; font-size: small;">JPMIA0013GB</p> <p style="text-align: center;">10.2V</p>	
				Ignition switch OFF or ACC	0V	
41 (W)	Ground	Engine switch (push switch) illumination	Output	Engine switch (push switch) illumination	ON	5.5V
					OFF	0V
42 (R)	Ground	LOCK indicator lamp	Output	LOCK indicator lamp	ON	0V
					OFF	Battery voltage
45 (P)	Ground	Receiver & sensor ground	Input	Ignition switch ON		0V
46 (V/W)	Ground	Receiver & sensor power supply output	Output	Ignition switch	OFF	0V
					ACC or ON	5.0V

BCM (BODY CONTROL MODULE)

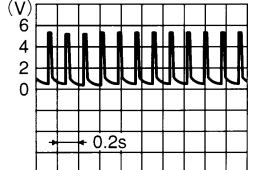
[FRONT & REAR WINDOW ANTI-PINCH]

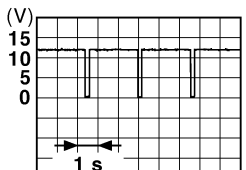
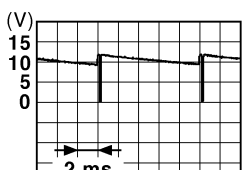
< ECU DIAGNOSIS >

Terminal No. (Wire color)		Description		Condition	Value (Approx.)
		Signal name	Input/ Output		
(+)	(-)				
47 (G/O)	Ground	Tire pressure receiver signal	Input/ Output	Ignition switch ON	Standby state  OCC3881D
					When receiving the signal from the transmitter  OCC3880D
48 (R/G)	Ground	Selector lever P/N position signal	Input	Selector lever	P or N position 12.0V
					Except P and N positions 0V
49 (L/O)	Ground	Security indicator signal	Output	Security indicator	ON 0V
					Blinking  11.3V JPMIA0014GB
50 (LG/B)	Ground	Combination switch OUTPUT 5	Output	Combination switch (Wiper intermittent dial 4)	All switch OFF 0V
					Lighting switch 1ST  10.7V JPMIA0031GB
					Lighting switch high-beam
					Lighting switch 2ND
Turn signal switch RH					
51 (L/W)	Ground	Combination switch OUTPUT 1	Output	Combination switch	All switch OFF (Wiper intermittent dial 4) 0V
					Front wiper switch HI (Wiper intermittent dial 4)  10.7V JPMIA0032GB
					Any of the conditions below with all switch OFF <ul style="list-style-type: none"> • Wiper intermittent dial 1 • Wiper intermittent dial 2 • Wiper intermittent dial 3 • Wiper intermittent dial 6 • Wiper intermittent dial 7

A
B
C
D
E
F
G
H
I
J
L
M
N
O
P

PWC

BCM (BODY CONTROL MODULE)

[FRONT & REAR WINDOW ANTI-PINCH]

< ECU DIAGNOSIS >

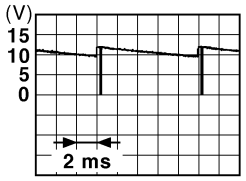
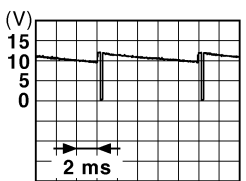
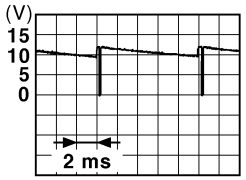
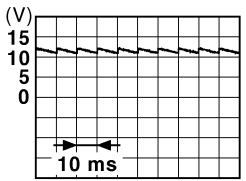
Terminal No. (Wire color)		Description		Condition	Value (Approx.)	
(+)	(-)	Signal name	Input/ Output			
52 (G/B)	Ground	Combination switch OUTPUT 2	Output	Combination switch	All switch OFF (Wiper intermittent dial 4)	0V
					Front washer switch ON (Wiper intermittent dial 4)	 <p style="text-align: right; font-size: small;">JPMIA0033GB</p>
					Any of the conditions below with all switch OFF	
					<ul style="list-style-type: none"> • Wiper intermittent dial 1 • Wiper intermittent dial 5 • Wiper intermittent dial 6 	
					10.7V	
53 (LG/ R)	Ground	Combination switch OUTPUT 3	Output	Combination switch (Wiper intermit- tent dial 4)	All switch OFF	0V
					Front wiper switch INT	 <p style="text-align: right; font-size: small;">JPMIA0034GB</p>
					Front wiper switch LO	
					Lighting switch AUTO	
					10.7V	
54 (G/Y)	Ground	Combination switch OUTPUT 4	Output	Combination switch (Wiper intermit- tent dial 4)	All switch OFF	0V
					Front fog lamp switch ON	 <p style="text-align: right; font-size: small;">JPMIA0035GB</p>
					Lighting switch 2ND	
					Lighting switch flash-to- pass	
					10.7V	
57 (W)	Ground	Tire pressure warn- ing check switch	Input	—	5V	
58 (SB)	Ground	Front door LH switch	Input	Front door LH switch	OFF (front door LH CLOSE)	 <p style="text-align: right; font-size: small;">JPMIA0011GB</p>
					ON (front door LH OPEN)	
59 (G/R)	Ground	Rear window defog- ger relay	Output	Rear window de- fogger	Active	Battery voltage
				Not activated	0V	

BCM (BODY CONTROL MODULE)

[FRONT & REAR WINDOW ANTI-PINCH]

< ECU DIAGNOSIS >

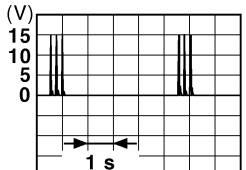
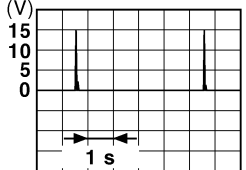
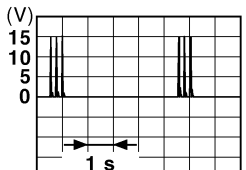
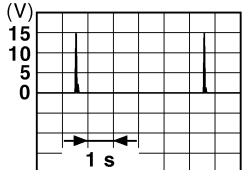
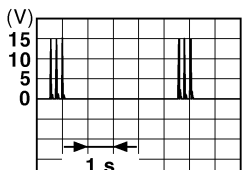
Terminal No. (Wire color)		Description		Condition	Value (Approx.)
(+)	(-)	Signal name	Input/ Output		
60 (B/R)	Ground	Front console antenna 2 (-)	Output		
				When Intelligent Key is not in the passenger compartment	 <p style="text-align: right; font-size: small;">JMKIA0063GB</p>
61 (W/R)	Ground	Center console antenna 2 (+)	Output	Ignition switch OFF	 <p style="text-align: right; font-size: small;">JMKIA0062GB</p>
				When Intelligent Key is not in the passenger compartment	 <p style="text-align: right; font-size: small;">JMKIA0063GB</p>
62 (V)	Ground	Front outside handle RH antenna (-)	Output	When the front door RH request switch is operated with ignition switch OFF	 <p style="text-align: right; font-size: small;">JMKIA0062GB</p>
				When Intelligent Key is not in the antenna detection area	 <p style="text-align: right; font-size: small;">JMKIA0063GB</p>

A
B
C
D
E
F
G
H
I
J
L
M
N
O
P

PWC

BCM (BODY CONTROL MODULE)

[FRONT & REAR WINDOW ANTI-PINCH]

< ECU DIAGNOSIS >

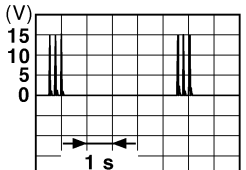
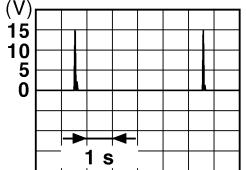
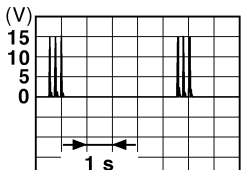
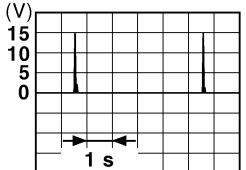
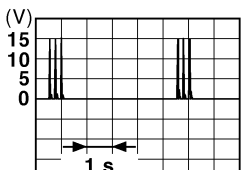
Terminal No. (Wire color)		Description		Condition	Value (Approx.)
(+)	(-)	Signal name	Input/ Output		
63 (P)	Ground	Front outside handle RH antenna (+)	Output		
				When the front door RH request switch is operat- ed with ignition switch OFF	 <small>JMKIA0063GB</small>
64 (V)	Ground	Front outside handle LH antenna (-)	Output	When Intelligent Key is in the antenna detection area	 <small>JMKIA0062GB</small>
				When the front door LH request switch is operat- ed with ignition switch OFF	 <small>JMKIA0063GB</small>
65 (P)	Ground	Front outside handle LH antenna (+)	Output	When Intelligent Key is in the antenna detection area	 <small>JMKIA0062GB</small>
				When the front door LH request switch is operat- ed with ignition switch OFF	 <small>JMKIA0063GB</small>

BCM (BODY CONTROL MODULE)

[FRONT & REAR WINDOW ANTI-PINCH]

< ECU DIAGNOSIS >

Terminal No. (Wire color)		Description		Condition	Value (Approx.)
(+)	(-)	Signal name	Input/ Output		
66 (R)	Ground	Instrument panel antenna (-)	Output	Ignition switch OFF	<p>JMKIA0062GB</p>
				When Intelligent Key is not in the passenger compartment	<p>JMKIA0063GB</p>
67 (G)	Ground	Instrument panel antenna (+)	Output	Ignition switch OFF	<p>JMKIA0062GB</p>
				When Intelligent Key is not in the passenger compartment	<p>JMKIA0063GB</p>
68 (G/O)	Ground	NATS antenna amp (built in key slot)	Input/ Output	During waiting	Just after pressing ignition switch. Pointer of tester should move.
69 (O)	Ground	NATS antenna amp (built in key slot)	Input/ Output	During waiting	Just after pressing ignition switch. Pointer of tester should move.
70 (R/B)	Ground	Ignition relay-2 control	Output	Ignition switch OFF or ACC	0V
				ON	Battery voltage





A
B
C
D
E
F
G
H
I
J
L
M
N
O
P

PWC

BCM (BODY CONTROL MODULE)

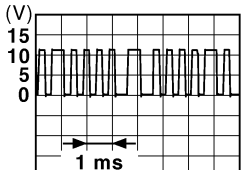
[FRONT & REAR WINDOW ANTI-PINCH]

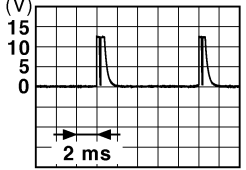

< ECU DIAGNOSIS >

Terminal No. (Wire color)		Description		Condition	Value (Approx.)
(+)	(-)	Signal name	Input/ Output		
71 (L/O)	Ground	Remote keyless entry receiver signal	Input/ Output		
				When operating either button on Intelligent Key	 <p style="text-align: right; font-size: small;">JMKIA0065GB</p>
75 (R/Y)	Ground	Combination switch INPUT 5	Input	All switch OFF (Wiper intermittent dial 4)	 <p style="text-align: right; font-size: small;">JPMIA0041GB</p> <p style="text-align: center;">1.4V</p>
				Combination switch Front fog lamp switch ON (Wiper intermittent dial 4)	 <p style="text-align: right; font-size: small;">JPMIA0037GB</p> <p style="text-align: center;">1.3V</p>
				Any of the conditions below with all switch OFF	<ul style="list-style-type: none"> • Wiper intermittent dial 1 • Wiper intermittent dial 2 • Wiper intermittent dial 6 • Wiper intermittent dial 7  <p style="text-align: right; font-size: small;">JPMIA0040GB</p> <p style="text-align: center;">1.3V</p>

BCM (BODY CONTROL MODULE)

[FRONT & REAR WINDOW ANTI-PINCH]

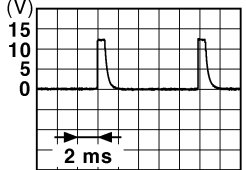
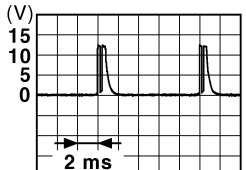
< ECU DIAGNOSIS >

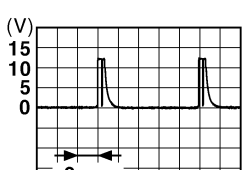
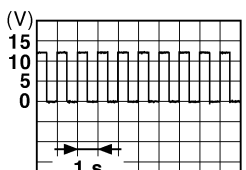
Terminal No. (Wire color)		Description		Condition	Value (Approx.)	
(+)	(-)	Signal name	Input/ Output			
76 (R/G)	Ground	Combination switch INPUT 3	Input	Combination switch	All switch OFF (Wiper intermittent dial 4)	 <small>JPMIA0041GB</small> 1.4V
					Lighting switch high-beam (Wiper intermittent dial 4)	 <small>JPMIA0036GB</small> 1.3V
					Lighting switch 2ND (Wiper intermittent dial 4)	 <small>JPMIA0037GB</small> 1.3V
					Any of the conditions below with all switch OFF <ul style="list-style-type: none"> • Wiper intermittent dial 1 • Wiper intermittent dial 2 • Wiper intermittent dial 3 	 <small>JPMIA0040GB</small> 1.3V
77 (BR)	Ground	Engine switch (push switch)	Input	Engine switch (push switch)	Pressed 0V Not pressed Battery voltage	
78 (P)	Ground	CAN-L	Input/ Output	—	—	
79 (L)	Ground	CAN-H	Input/ Output	—	—	
80 (R/L)	Ground	Key slot illumination	Output	Key slot illumina- tion	OFF	0V
					Blinking	 <small>JPMIA0015GB</small> 6.5V
					ON	Battery voltage

A
B
C
D
E
F
G
H
I
J
L
M
N
O
P

PWC

BCM (BODY CONTROL MODULE)

[FRONT & REAR WINDOW ANTI-PINCH]



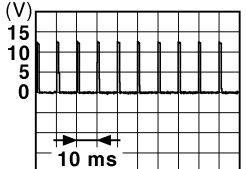
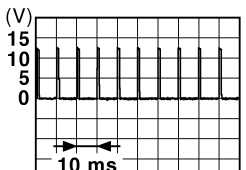

< ECU DIAGNOSIS >

Terminal No. (Wire color)		Description		Condition		Value (Approx.)
		Signal name	Input/ Output			
(+)	(-)					
81 (Y/L)	Ground	ON indicator lamp	Output	Ignition switch	OFF or ACC	0V
					ON	Battery voltage
83 (L)	Ground	ACC relay control	Output	Ignition switch	OFF	0V
					ACC or ON	Battery voltage
84 (Y/R)	Ground	A/T device	Output	—		Battery voltage
85 (L/O)	Ground	Electronic steering column lock condition No. 1	Input	Electronic steer- ing column lock	Lock status	0V
					Unlock status	Battery voltage
86 (G/R)	Ground	Electronic steering column lock condition No. 2	Input	Electronic steer- ing column lock	Lock status	Battery voltage
					Unlock status	0V
87 (G/B)	Ground	Selector lever P posi- tion switch	Input	Selector lever	P position	0V
					Any position other than P	Battery voltage
88 (R)	Ground	Front door RH re- quest switch	Input	Front door RH re- quest switch	ON (pressed)	0V
					OFF (not pressed)	 <p style="text-align: right; margin-right: 50px;">1.0V</p>
89 (R)	Ground	Front door LH re- quest switch	Input	Front door LH re- quest switch	ON (pressed)	0V
					OFF (not pressed)	 <p style="text-align: right; margin-right: 50px;">1.0V</p>
90 (Y)	Ground	Blower fan motor re- lay control	Output	Ignition switch	OFF or ACC	0V
					ON	Battery voltage
91 (L/R)	Ground	Remote keyless entry receiver power sup- ply	Output	Ignition switch OFF		Battery voltage
94 (G/Y)	Ground	Steering wheel lock unit power supply	Output	Ignition switch	OFF or ACC	Battery voltage
					ON	0V

BCM (BODY CONTROL MODULE)

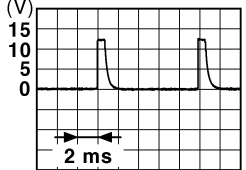
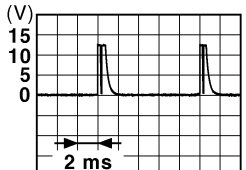
[FRONT & REAR WINDOW ANTI-PINCH]

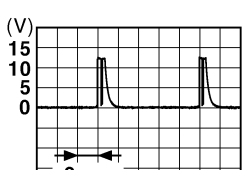
< ECU DIAGNOSIS >

Terminal No. (Wire color)		Description		Condition	Value (Approx.)
(+)	(-)	Signal name	Input/ Output		
95 (R/W)	Ground	Combination switch INPUT 1	Input	Combination switch (Wiper intermittent dial 4)	All switch OFF <div style="text-align: right;">  <p>1.4V</p> </div>
					Turn signal switch LH <div style="text-align: right;">  <p>1.3V</p> </div>
					Turn signal switch RH <div style="text-align: right;">  <p>1.3V</p> </div>
					Front wiper switch LO <div style="text-align: right;">  <p>1.3V</p> </div>
					Front washer switch ON <div style="text-align: right;">  <p>1.3V</p> </div>

A
B
C
D
E
F
G
H
I
J
L
M
N
O
P

PWC

BCM (BODY CONTROL MODULE)

[FRONT & REAR WINDOW ANTI-PINCH]



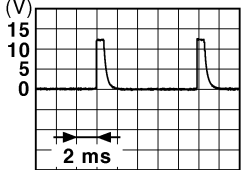
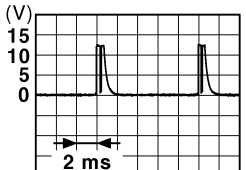
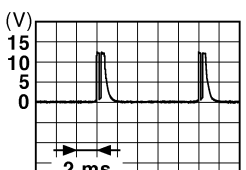
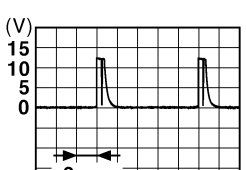

< ECU DIAGNOSIS >

Terminal No. (Wire color)		Description		Condition	Value (Approx.)
(+)	(-)	Signal name	Input/ Output		
96 (P/B)	Ground	Combination switch INPUT 4	Input	Combination switch	All switch OFF (Wiper intermittent dial 4) <div style="text-align: right;">  <p style="font-size: small; margin: 0;">JPMIA0041GB</p> <p style="margin: 0;">1.4V</p> </div>
				Lighting switch AUTO	Lighting switch AUTO (Wiper intermittent dial 4) <div style="text-align: right;">  <p style="font-size: small; margin: 0;">JPMIA0038GB</p> <p style="margin: 0;">1.3V</p> </div>
				Lighting switch 1ST	Lighting switch 1ST (Wiper intermittent dial 4) <div style="text-align: right;">  <p style="font-size: small; margin: 0;">JPMIA0036GB</p> <p style="margin: 0;">1.3V</p> </div>
				Any of the conditions below with all switch OFF	<ul style="list-style-type: none"> • Wiper intermittent dial 1 • Wiper intermittent dial 5 • Wiper intermittent dial 6 <div style="text-align: right;">  <p style="font-size: small; margin: 0;">JPMIA0039GB</p> <p style="margin: 0;">1.3V</p> </div>

BCM (BODY CONTROL MODULE)

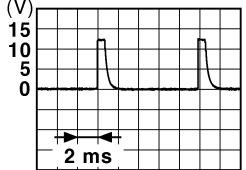
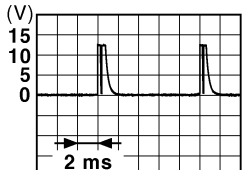
[FRONT & REAR WINDOW ANTI-PINCH]

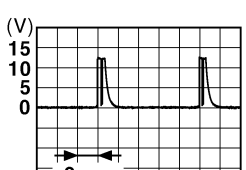
< ECU DIAGNOSIS >

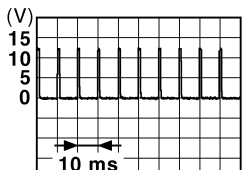
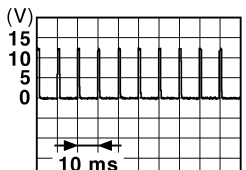
Terminal No. (Wire color)		Description		Condition	Value (Approx.)	
(+)	(-)	Signal name	Input/ Output			
97 (R/B)	Ground	Combination switch INPUT 2	Input	Combination switch (Wiper intermittent dial 4)	All switch OFF	 1.4V
					Lighting switch flash-to-pass	 1.3V
					Lighting switch 2ND	 1.3V
					Front wiper switch INT	 1.3V
					Front wiper switch HI	 1.3V
					Pressed	0 V
98 (G/O)	Ground	Hazard switch	Input	Hazard switch	 1.1V	
				Not pressed	 1.1V	

A
B
C
D
E
F
G
H
I
J
L
M
N
O
P

PWC

BCM (BODY CONTROL MODULE)

[FRONT & REAR WINDOW ANTI-PINCH]

< ECU DIAGNOSIS >

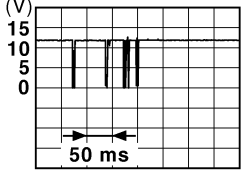
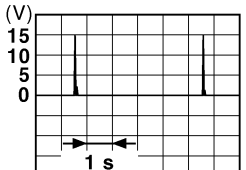
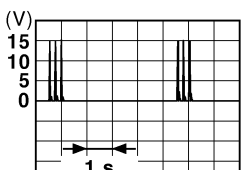
Terminal No. (Wire color)		Description		Condition	Value (Approx.)	
(+)	(-)	Signal name	Input/ Output			
99 (L/Y)	Ground	Electronic steering column lock unit com- munication	Input/ Output	Electronic steer- ing column lock	LOCK status	Battery voltage
					LOCK or UNLOCK	 <p style="text-align: right; font-size: small;">JMkia0066GB</p>
					For 15 seconds after UN- LOCK	Battery voltage
					15 seconds or later after UNLOCK	0V
103 (V)	Ground	Trunk lid opening.	Output	Trunk lid	Open (trunk lid opener ac- tuator is activated)	Battery voltage
					Close (trunk lid opener ac- tuator is not activated)	0V
110 (V/W)	Ground	Trunk room lamp	Output	Trunk room lamp	ON	0V
					OFF	Battery voltage
114 (B)	Ground	Trunk room antenna 1 (-)	Output	Ignition switch OFF	When Intelligent Key is in the passenger compart- ment	 <p style="text-align: right; font-size: small;">JMkia0062GB</p>
					When Intelligent Key is not in the passenger compart- ment	 <p style="text-align: right; font-size: small;">JMkia0063GB</p>

BCM (BODY CONTROL MODULE)

[FRONT & REAR WINDOW ANTI-PINCH]

< ECU DIAGNOSIS >

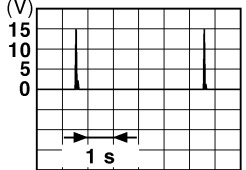
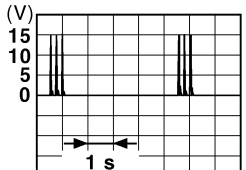
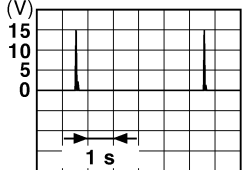
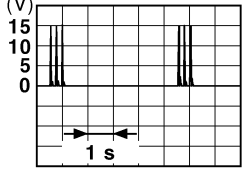
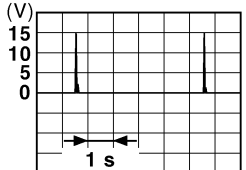
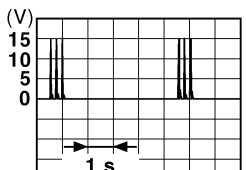
Terminal No. (Wire color)		Description		Condition	Value (Approx.)
(+)	(-)	Signal name	Input/ Output		
115 (W)	Ground	Trunk room antenna 1 (+)	Output	Ignition switch OFF	 <p style="text-align: right; font-size: small;">JMKIA0062GB</p>
				When Intelligent Key is not in the passenger compart- ment	 <p style="text-align: right; font-size: small;">JMKIA0063GB</p>
118 (L/O)	Ground	Rear bumper anten- na (-)	Output	When the trunk lid request switch is operated with ignition switch OFF	 <p style="text-align: right; font-size: small;">JMKIA0062GB</p>
				When Intelligent Key is not in the antenna detection area	 <p style="text-align: right; font-size: small;">JMKIA0063GB</p>
119 (BR/ W)	Ground	Rear bumper anten- na (+)	Output	When the trunk lid request switch is operated with ignition switch OFF	 <p style="text-align: right; font-size: small;">JMKIA0062GB</p>
				When Intelligent Key is not in the antenna detection area	 <p style="text-align: right; font-size: small;">JMKIA0063GB</p>

A
B
C
D
E
F
G
H
I
J
L
M
N
O
P

PWC

BCM (BODY CONTROL MODULE)

[FRONT & REAR WINDOW ANTI-PINCH]

< ECU DIAGNOSIS >

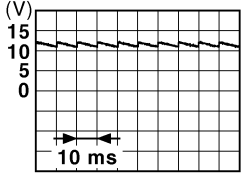
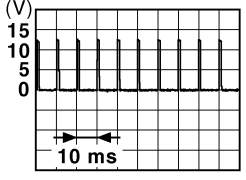
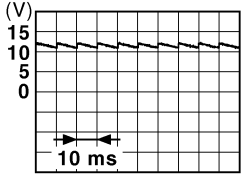
Terminal No. (Wire color)		Description		Condition	Value (Approx.)	
(+)	(-)	Signal name	Input/ Output			
127 (BR/ W)	Ground	Ignition relay (IPDM E/R) control	Output	Ignition switch	OFF or ACC	Battery voltage
					ON	0V
130 (W)	Ground	Trunk room lamp switch	Input	Trunk room lamp switch	OFF (trunk is closed)	 <p style="text-align: right; margin-right: 50px;">11.8V</p>
					ON (trunk is open)	0V
132 (R)	Ground	Starter motor relay control	Output	Ignition switch OFF (M/T vehi- cle)	When the clutch pedal is depressed	Battery voltage
					When the clutch pedal is not depressed	0V
				Ignition switch ON (other than M/ T vehicle)	When selector lever is in P or N position and the brake is depressed	Battery voltage
					When selector lever is in P or N position and the brake is not depressed	0V
141 (BR)	Ground	Trunk request switch	Input	Trunk request switch	ON (pressed)	0V
					OFF (not pressed)	 <p style="text-align: right; margin-right: 50px;">1.0V</p>
144 (GR)	Ground	Request switch buzz- er	Output	Request switch buzzer	Sounding	0V
					Not sounding	Battery voltage
147 (L/R)	Ground	Trunk lid opener switch	Input	Trunk lid opener switch	Pressed	0V
					Not pressed	Battery voltage
148 (R/W)	Ground	Rear door RH switch	Input	Rear door RH switch	OFF (when rear door RH closes)	 <p style="text-align: right; margin-right: 50px;">11.8V</p>
					ON (when rear door RH opens)	0V

BCM (BODY CONTROL MODULE)

[FRONT & REAR WINDOW ANTI-PINCH]

< ECU DIAGNOSIS >

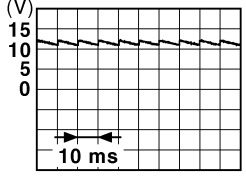
Terminal No. (Wire color)		Description		Condition	Value (Approx.)	
		Signal name	Input/ Output			
(+)	(-)					
149 (R/B)	Ground	Rear door LH switch	Input	Rear door LH switch	OFF (when rear door LH closes)	 <p style="text-align: center;">11.8V</p> <p style="text-align: right; font-size: small;">JPMIA0011GB</p>
				ON (when rear door LH opens)	0V	

A
B
C
D
E
F
G
H
I
J
L
M
N
O
P

PWC

POWER WINDOW MAIN SWITCH

[FRONT & REAR WINDOW ANTI-PINCH]

< ECU DIAGNOSIS >

POWER WINDOW MAIN SWITCH

Reference Value

INFOID:000000004362960

TERMINAL LAYOUT

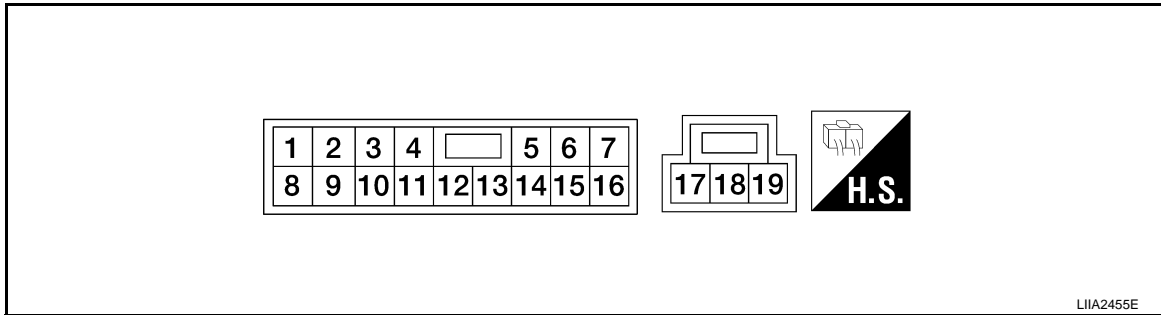

LIA2455E

PHYSICAL VALUES

MAIN POWER WINDOW AND DOOR LOCK/UNLOCK SWITCH

Terminal No.		Description		Condition	Voltage [V] (Approx.)
+	-	Signal name	Input/ Output		
2 (GR)	Ground	Encoder ground	—	—	0
4 (L)	Ground	Door key cylinder switch LH LOCK signal	Input	Key position (Neutral → Locked)	5 → 0
6 (R)	Ground	Door key cylinder switch LH UNLOCK signal	Input	Key position (Neutral → Unlocked)	5 → 0
8 (L)	11	Front door power window mo- tor LH UP signal	Output	When front LH switch in power window main switch is operated UP.	Battery voltage
9 (Y)	2	Encoder pulse signal 2	Input	When power window mo- tor operates.	
10 (V)	Ground	RAP signal	Input	IGN SW ON	Battery voltage
				Within 45 second after ig- nition switch is turned to OFF.	Battery voltage
				When front LH or RH door is opened during retained power operation.	0
11 (LG)	8	Front door power window mo- tor LH DOWN signal	Output	When front LH switch in power window main switch is operated DOWN.	Battery voltage

JMKIA0070GB

POWER WINDOW MAIN SWITCH

[FRONT & REAR WINDOW ANTI-PINCH]

< ECU DIAGNOSIS >

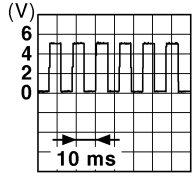
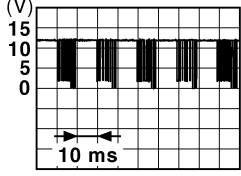
Terminal No.		Description		Condition	Voltage [V] (Approx.)
+	-	Signal name	Input/ Output		
13 (G)	2	Encoder pulse signal 1	Input	When power window motor operates.	 <p style="text-align: right; font-size: small;">JMKIA0070GB</p>
14 (O)	Ground	Power window serial link	Input/ Output	IGN SW ON or power window timer operating.	 <p style="text-align: right; font-size: small;">JPMIA0013GB</p>
15 (BR)	Ground	Encoder power supply	Output	When ignition switch ON or power window timer operates.	10

A
B
C
D
E
F
G
H
I
J
L
M
N
O
P

PWC

POWER WINDOW MAIN SWITCH

[FRONT & REAR WINDOW ANTI-PINCH]

< ECU DIAGNOSIS >

Wiring Diagram

INFOID:000000004362961

POWER WINDOW SYSTEM - WITH FRONT AND REAR POWER WINDOW ANTI-PINCH SYSTEM

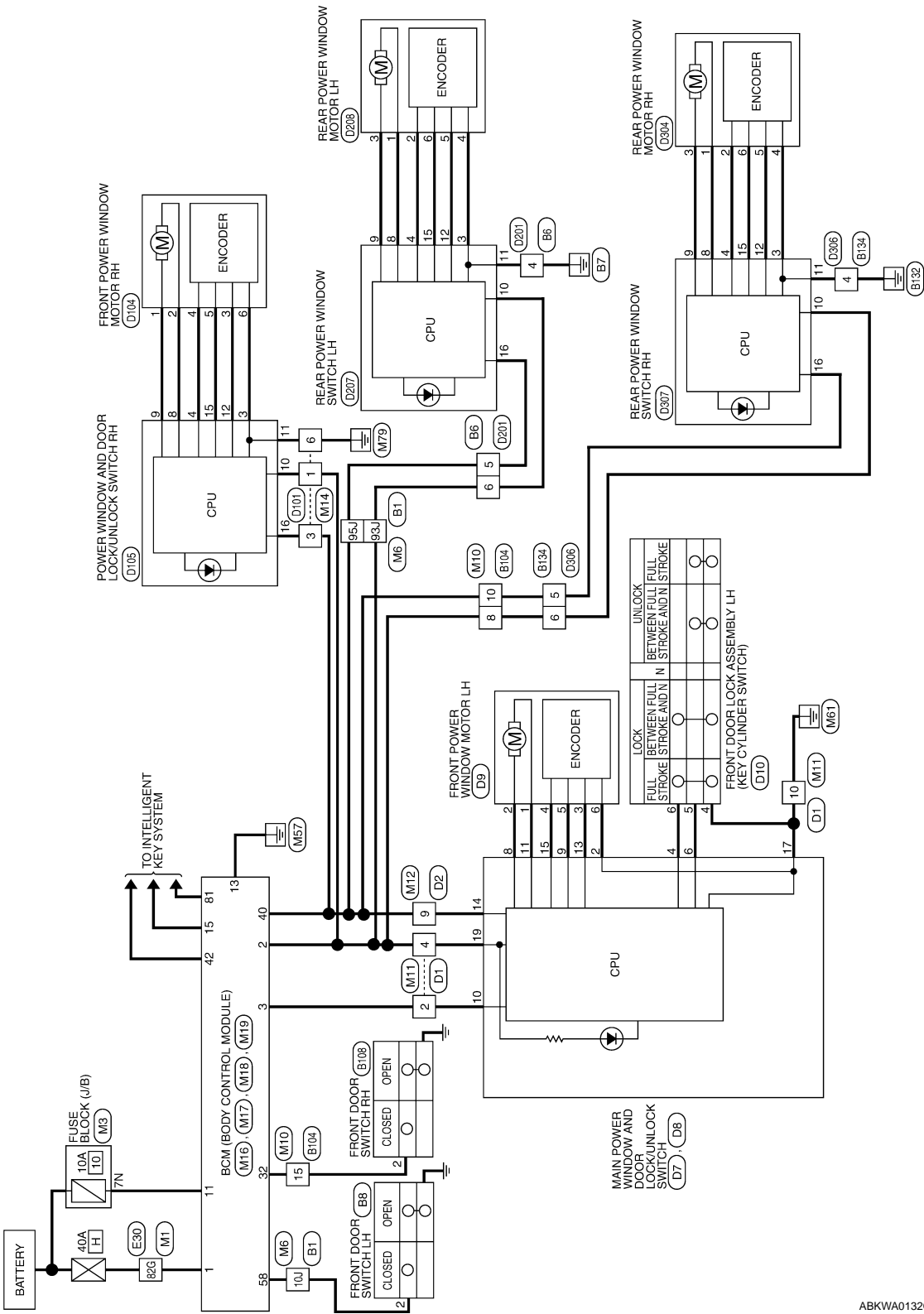

ABKWA0132GE

POWER WINDOW MAIN SWITCH

[FRONT & REAR WINDOW ANTI-PINCH]

< ECU DIAGNOSIS >

POWER WINDOW SYSTEM CONNECTORS -WITH FRONT AND REAR POWER WINDOW ANTI-PINCH SYSTEM

Connector No.	M1
Connector Name	WIRE TO WIRE
Connector Color	WHITE

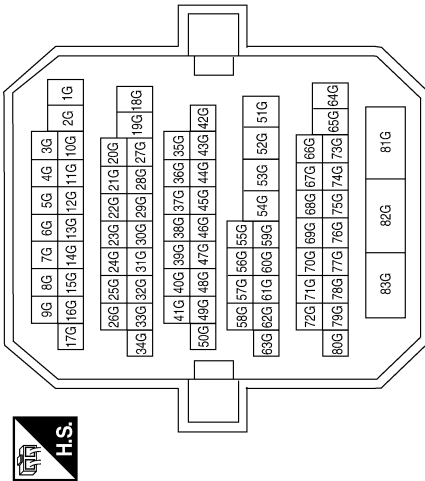

Terminal No.	Color of Wire	Signal Name
82G	W/B	-

Connector No.	M3
Connector Name	FUSE BLOCK (J/B)
Connector Color	WHITE

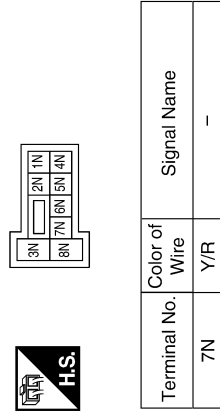

Connector No.	M6
Connector Name	WIRE TO WIRE
Connector Color	WHITE

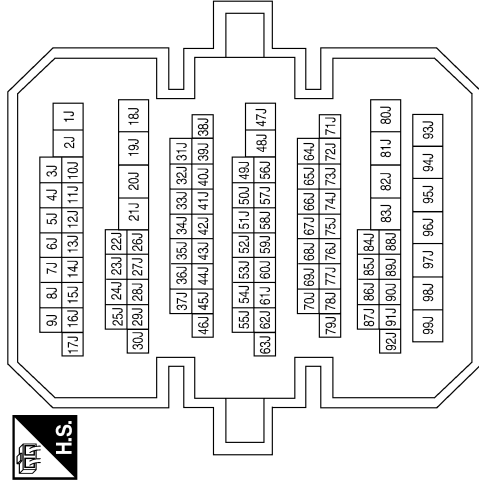

Terminal No.	Color of Wire	Signal Name
10J	SB	-
93J	R/Y	-(WITH FRONT AND REAR POWER WINDOW ANTI-PINCH SYSTEM)
95J	Y/G	-

A
B
C
D
E
F
G
H
I
J
L
M
N
O
P

PWC

ABKIA0437GB

POWER WINDOW MAIN SWITCH

[FRONT & REAR WINDOW ANTI-PINCH]

< ECU DIAGNOSIS >

Connector No.	M12
Connector Name	WIRE TO WIRE
Connector Color	WHITE

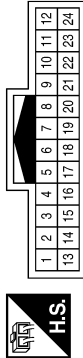

Terminal No.	Color of Wire	Signal Name
9	Y/G	-

Connector No.	M11
Connector Name	WIRE TO WIRE
Connector Color	WHITE

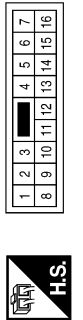

Terminal No.	Color of Wire	Signal Name
2	L/W	-
4	R/Y	-
10	B	-

Connector No.	M10
Connector Name	WIRE TO WIRE
Connector Color	WHITE

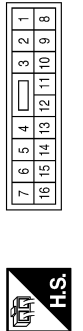

Terminal No.	Color of Wire	Signal Name
8	R/Y	- (WITH FRONT AND REAR POWER WINDOW ANTI-PINCH SYSTEM)
10	Y/G	-
15	R/B	-

Connector No.	M17
Connector Name	BCM (BODY CONTROL MODULE)
Connector Color	WHITE



Terminal No.	Color of Wire	Signal Name
11	Y/R	BAT BCM FUSE
13	B	GND1
15	Y/L	ACC LED

Connector No.	M16
Connector Name	BCM (BODY CONTROL MODULE)
Connector Color	BLACK



Terminal No.	Color of Wire	Signal Name
1	W/B	BAT POWER F/L
2	R/Y	P/W POWER SUPPLY PERM
3	L/W	P/W POWER SUPPLY IGN

Connector No.	M14
Connector Name	WIRE TO WIRE
Connector Color	WHITE

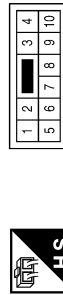

Terminal No.	Color of Wire	Signal Name
1	R/Y	-
3	Y/G	-
6	B	-

ABKIA0438GB

POWER WINDOW MAIN SWITCH

[FRONT & REAR WINDOW ANTI-PINCH]

< ECU DIAGNOSIS >

Connector No.	M18
Connector Name	BCM (BODY CONTROL MODULE)
Connector Color	GREEN

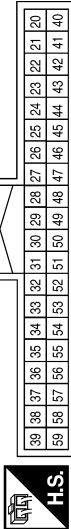

Terminal No.	Color of Wire	Signal Name
32	R/B	AS DOOR SW
40	Y/G	PW K LINE
42	R	S/L LOCK LED
58	SB	DR DOOR SW

Connector No.	M19
Connector Name	BCM (BODY CONTROL MODULE)
Connector Color	BLACK

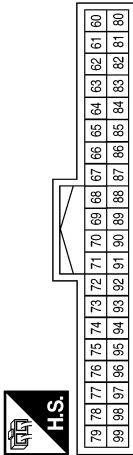

Terminal No.	Color of Wire	Signal Name
81	LG	IGN ON LED

Connector No.	E30
Connector Name	WIRE TO WIRE
Connector Color	WHITE

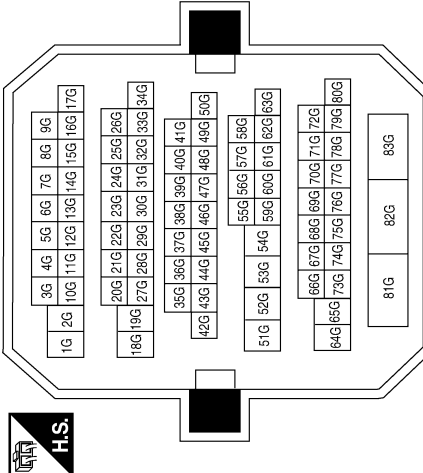

Terminal No.	Color of Wire	Signal Name
82G	LG	-

Connector No.	B1
Connector Name	WIRE TO WIRE
Connector Color	WHITE

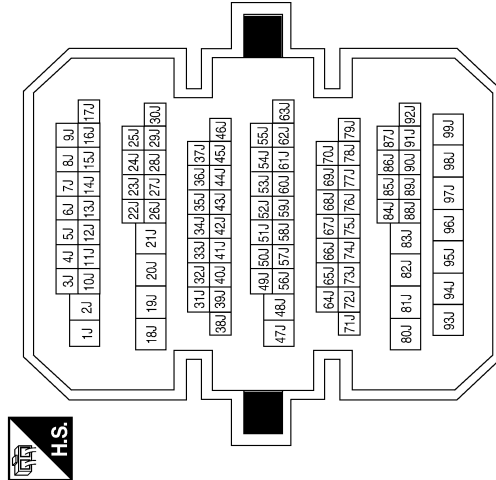

Terminal No.	Color of Wire	Signal Name
10J	SB	-
93J	R	-
95J	SB	-

A
B
C
D
E
F
G
H
I
J
PWC
L
M
N
O
P

POWER WINDOW MAIN SWITCH

[FRONT & REAR WINDOW ANTI-PINCH]

< ECU DIAGNOSIS >

Connector No.	B104
Connector Name	WIRE TO WIRE
Connector Color	WHITE

1	2	3	4	5	6	7		
8	9	10	11	12	13	14	15	16



Terminal No.	Color of Wire	Signal Name
8	R	-
10	SB	-
15	GR	-

Connector No.	B8
Connector Name	FRONT DOOR SWITCH LH
Connector Color	WHITE

1	2	3
---	---	---



Terminal No.	Color of Wire	Signal Name
2	SB	-

Connector No.	B6
Connector Name	WIRE TO WIRE
Connector Color	WHITE

1	2	3	4		
5	6	7	8	9	10



Terminal No.	Color of Wire	Signal Name
4	B	-
5	SB	-
6	R	-

Connector No.	D1
Connector Name	WIRE TO WIRE
Connector Color	WHITE

7	6	5	4	3	2	1		
16	15	14	13	12	11	10	9	8



Terminal No.	Color of Wire	Signal Name
2	V	-
4	R	-
10	B	-

Connector No.	B134
Connector Name	WIRE TO WIRE
Connector Color	WHITE

1	2	3	4		
5	6	7	8	9	10



Terminal No.	Color of Wire	Signal Name
4	B	-
5	SB	-
6	R	-

Connector No.	B108
Connector Name	FRONT DOOR SWITCH RH
Connector Color	WHITE

1	2	3
---	---	---



Terminal No.	Color of Wire	Signal Name
2	GR	-

ABKIA0440GB

POWER WINDOW MAIN SWITCH

[FRONT & REAR WINDOW ANTI-PINCH]

< ECU DIAGNOSIS >

Connector No.	D2
Connector Name	WIRE TO WIRE
Connector Color	WHITE

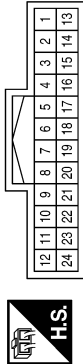

Terminal No.	Color of Wire	Signal Name
9	O	-

Connector No.	D7
Connector Name	MAIN POWER WINDOW AND DOOR LOCK/UNLOCK SWITCH
Connector Color	WHITE

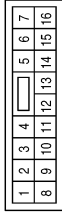

Terminal No.	Color of Wire	Signal Name
2	GR	ENCODER GND
4	L	LOCK

Terminal No.	Color of Wire	Signal Name
6	R	UNLOCK
8	L	AS UP
9	Y	ENCODER SIG1
10	V	IGN
11	LG	AS DOWN
13	G	ENCODER SIG2
14	O	COM
15	BR	ENCODER POWER

Connector No.	D8
Connector Name	MAIN POWER WINDOW AND DOOR LOCK/UNLOCK SWITCH
Connector Color	WHITE



Terminal No.	Color of Wire	Signal Name
17	B	GND
19	R	BAT

Connector No.	D9
Connector Name	FRONT POWER WINDOW MOTOR LH
Connector Color	WHITE



Terminal No.	Color of Wire	Signal Name
1	LG	-
2	L	-
3	G	-
4	BR	-
5	Y	-
6	GR	-

Connector No.	D10
Connector Name	FRONT DOOR LOCK ASSEMBLY LH
Connector Color	GRAY

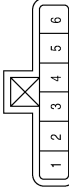

Terminal No.	Color of Wire	Signal Name
4	B	-
5	R	-
6	L	-

ABKIA0441GB

A
B
C
D
E
F
G
H
I
J
L
M
N
O
P

POWER WINDOW MAIN SWITCH

[FRONT & REAR WINDOW ANTI-PINCH]

< ECU DIAGNOSIS >

Connector No.	D105
Connector Name	POWER WINDOW AND DOOR LOCK/UNLOCK SWITCH RH
Connector Color	WHITE

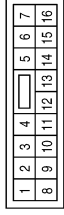

Terminal No.	Color of Wire	Signal Name
3	W	GND
4	BR	ENCODER POWER
8	L	UP
9	LG	DOWN
10	P	BAT
11	B	GND
12	G	ENCODER SIG2
15	Y	ENCODER SIG1
16	R	COM

Connector No.	D104
Connector Name	FRONT POWER WINDOW MOTOR RH
Connector Color	WHITE



Terminal No.	Color of Wire	Signal Name
1	LG	-
2	L	-
3	G	-
4	BR	-
5	Y	-
6	W	-

Connector No.	D101
Connector Name	WIRE TO WIRE
Connector Color	WHITE

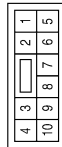

Terminal No.	Color of Wire	Signal Name
1	P	-
3	R	-
6	B	-

Terminal No.	Color of Wire	Signal Name
10	R	-
11	B	-
12	P	-
15	V	-
16	SB	-

Connector No.	D207
Connector Name	REAR POWER WINDOW SWITCH LH (WITH FRONT AND REAR POWER WINDOW ANTI-PINCH SYSTEM)
Connector Color	WHITE

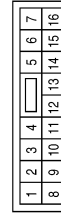

Terminal No.	Color of Wire	Signal Name
3	W	-
4	G	-
8	L	-
9	LG	-

Connector No.	D201
Connector Name	WIRE TO WIRE
Connector Color	WHITE



Terminal No.	Color of Wire	Signal Name
4	B	-
5	SB	-
6	R	-

ABKIA0442GB

POWER WINDOW MAIN SWITCH

[FRONT & REAR WINDOW ANTI-PINCH]

< ECU DIAGNOSIS >

Connector No.	D307
Connector Name	REAR POWER WINDOW SWITCH RH (WITH FRONT AND REAR POWER WINDOW ANTI-PINCH SYSTEM)
Connector Color	WHITE

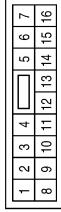

Terminal No.	Color of Wire	Signal Name
3	W	-
4	G	-
8	L	-
9	LG	-
10	R	-
11	B	-
15	V	-
16	SB	-

Connector No.	D306
Connector Name	WIRE TO WIRE
Connector Color	WHITE

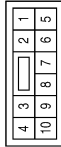

Terminal No.	Color of Wire	Signal Name
4	B	-
5	SB	-
6	R	-

Connector No.	D208
Connector Name	REAR POWER WINDOW MOTOR LH (WITH FRONT AND REAR POWER WINDOW ANTI-PINCH SYSTEM)
Connector Color	GREEN

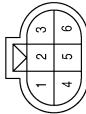

Terminal No.	Color of Wire	Signal Name
1	L	-
2	G	VCC
3	LG	-
4	W	GND
5	P	OUTPUT1
6	V	OUTPUT2

Terminal No.	Color of Wire	Signal Name
1	L	-
2	G	VCC
3	LG	-
4	W	GND
5	P	OUTPUT1
6	V	OUTPUT2

Connector No.	D308
Connector Name	REAR POWER WINDOW MOTOR RH (WITH FRONT AND REAR POWER WINDOW ANTI-PINCH SYSTEM)
Connector Color	GREEN

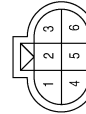

Fail Safe

FAIL-SAFE CONTROL

Switches to fail-safe control when malfunction is detected in encoder signal that detects up/down speed and direction of door glass. Switches to fail-safe control when error beyond regulation value is detected between the fully closed position and the actual position of the glass.

ABKIA0443GB

INFOID:000000004362962

A
B
C
D
E
F
G
H
I
J
PWC
L
M
N
O
P

POWER WINDOW MAIN SWITCH

[FRONT & REAR WINDOW ANTI-PINCH]

< ECU DIAGNOSIS >

Error	Error condition
Pulse sensor malfunction	When only one side of pulse signal is being detected for more than the specified value.
Both pulse sensors malfunction	When both pulse signals have not been detected for more than the specified value during glass open/close operation.
Pulse direction malfunction	When the pulse signal that is detected during glass open/close operation detects the opposite condition of power window motor operating direction.
Glass recognition position malfunction 1	When it detects the error between glass fully closed position in power window switch memory and actual fully closed position during glass open/close operation is more than the specified value.
Glass recognition position malfunction 2	When it detects pulse count more than the value of glass full stroke during glass open/close operation.
Malfunction of not yet updated closed position of glass	When glass open/close operation is continuously performed without fully closing more than the specified value (approximately 10 strokes).

It changes to condition before initialization and the following functions do not operate when switched to fail-safe control:

- Auto-up operation
- Anti-pinch function
- Retained power function

Perform initial operation to recover when switched to fail-safe mode. However, it switches back to fail-safe control when malfunction is found in power window switch or in motor.

FRONT POWER WINDOW SWITCH

[FRONT & REAR WINDOW ANTI-PINCH]

< ECU DIAGNOSIS >

FRONT POWER WINDOW SWITCH

Reference Value

INFOID:000000004392503

TERMINAL LAYOUT

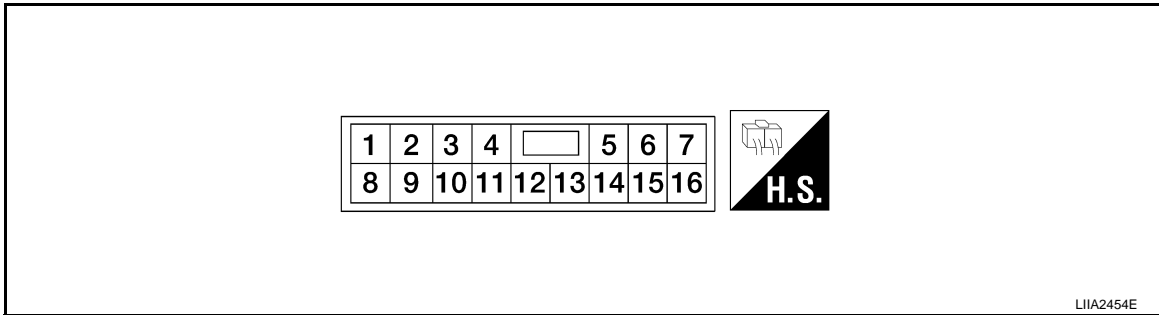

PHYSICAL VALUES

POWER WINDOW AND DOOR LOCK/UNLOCK SWITCH RH

Terminal No.		Description		Condition	Voltage [V] (Approx.)
+	-	Signal name	Input/ Output		
3 (W)	Ground	Encoder ground	—	—	0
4 (BR)	Ground	Encoder power supply	Output	When ignition switch ON or power window timer operates.	10
8 (L)	9	Power window motor UP signal	Output	When power window motor is operated UP.	Battery voltage
9 (L/G)	8	Power window motor DOWN signal	Output	When power window motor is operated DOWN.	Battery voltage
10 (P)	Ground	Battery power supply	Input	—	Battery voltage
11 (B)	Ground	Ground	—	—	0
12 (G)	3	Encoder pulse signal 1	Input	When power window motor operates.	<p>The timing diagram shows a square wave signal. The vertical axis is labeled (V) with values 0, 2, 4, 6. The horizontal axis is labeled 10 ms. The signal is a square wave with a period of 10 ms and a high level of approximately 5V.</p>

JMKIA0070GB

A
B
C
D
E
F
G
H
I
J
L
M
N
O
P

PWC

FRONT POWER WINDOW SWITCH

[FRONT & REAR WINDOW ANTI-PINCH]

< ECU DIAGNOSIS >

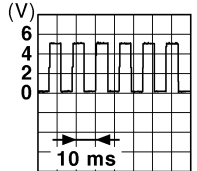
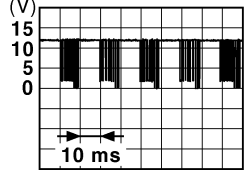
Terminal No.		Description		Condition	Voltage [V] (Approx.)
+	-	Signal name	Input/ Output		
15 (Y)	3	Encoder pulse signal 2	Input	When power window motor operates.	 <p style="text-align: right; font-size: small;">JMKIA0070GB</p>
16 (R)	Ground	Power window serial link	Input/ Output	IGN SW ON or power window timer operating.	 <p style="text-align: right; font-size: small;">JPMIA0013GB</p>

FRONT POWER WINDOW SWITCH

[FRONT & REAR WINDOW ANTI-PINCH]

< ECU DIAGNOSIS >

Wiring Diagram

INFOID:000000004375793

POWER WINDOW SYSTEM - WITH FRONT AND REAR POWER WINDOW ANTI-PINCH SYSTEM

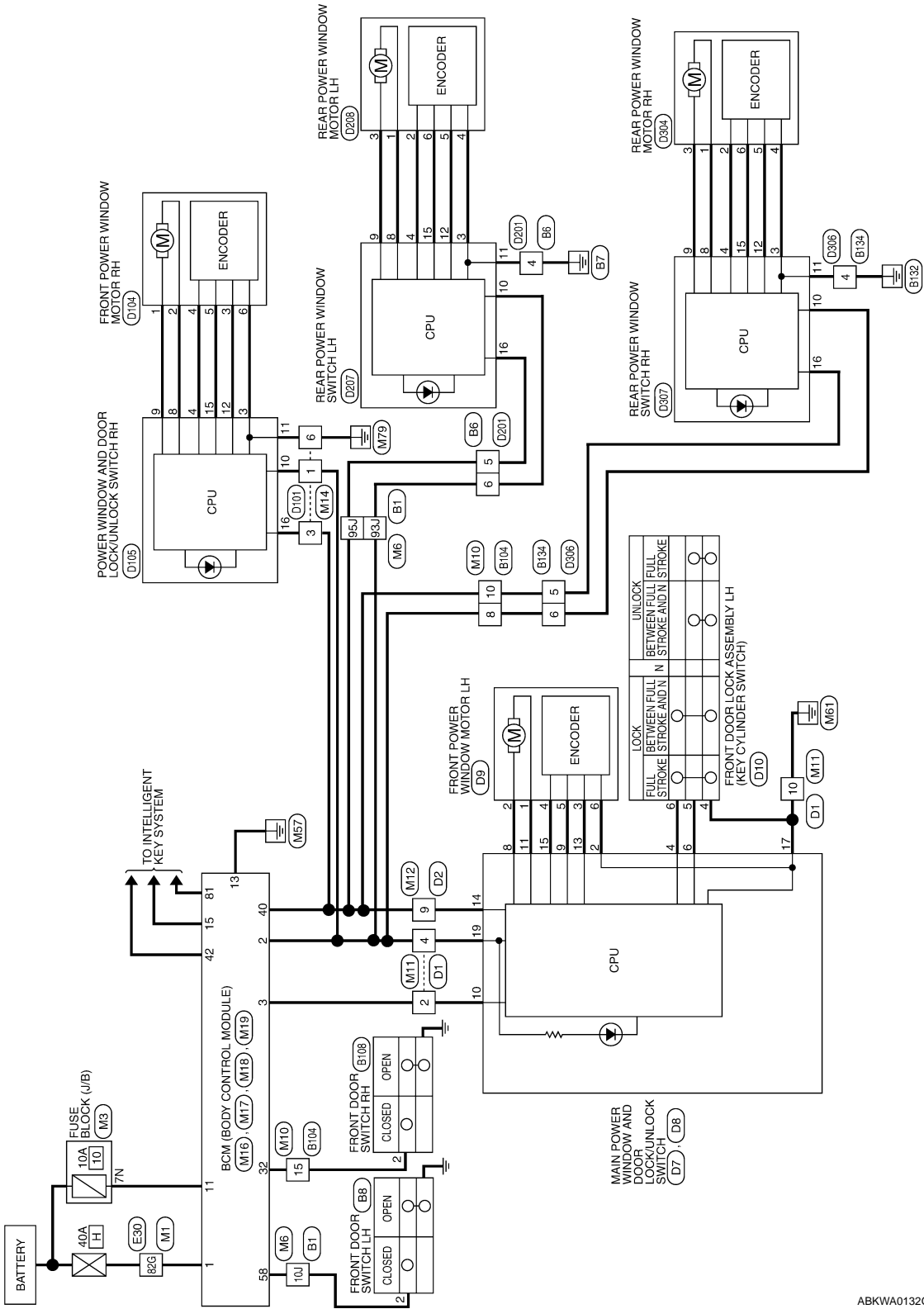

ABKWA0132GE

A
B
C
D
E
F
G
H
I
J
L
M
N
O
P

PWC

FRONT POWER WINDOW SWITCH

[FRONT & REAR WINDOW ANTI-PINCH]

< ECU DIAGNOSIS >

POWER WINDOW SYSTEM CONNECTORS -WITH FRONT AND REAR POWER WINDOW ANTI-PINCH SYSTEM

Connector No.	M1
Connector Name	WIRE TO WIRE
Connector Color	WHITE

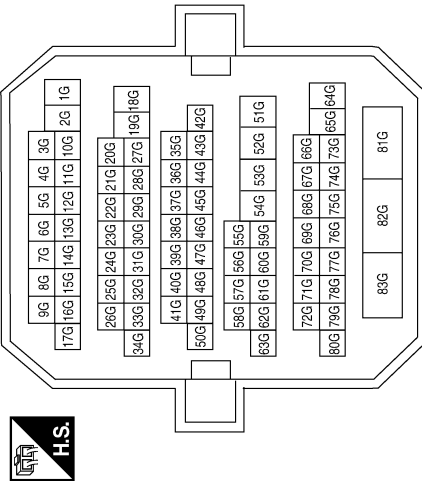

Terminal No.	Color of Wire	Signal Name
82G	W/B	-

Connector No.	M3
Connector Name	FUSE BLOCK (J/B)
Connector Color	WHITE

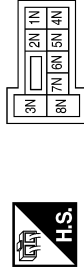

Terminal No.	Color of Wire	Signal Name
7N	Y/R	-

Connector No.	M6
Connector Name	WIRE TO WIRE
Connector Color	WHITE

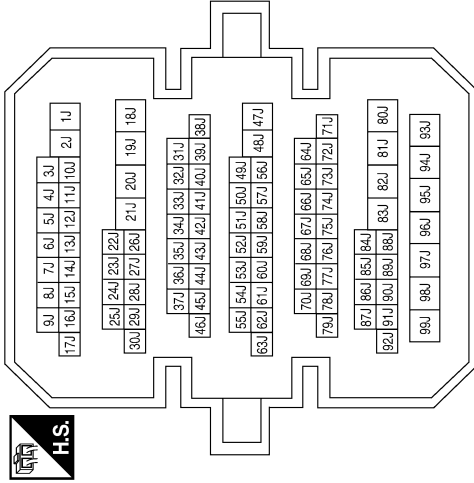

Terminal No.	Color of Wire	Signal Name
10J	SB	-
93J	R/Y	-(WITH FRONT AND REAR POWER WINDOW ANTI-PINCH SYSTEM)
95J	Y/G	-

ABKIA0437GB

FRONT POWER WINDOW SWITCH

[FRONT & REAR WINDOW ANTI-PINCH]

< ECU DIAGNOSIS >

Connector No.	M12
Connector Name	WIRE TO WIRE
Connector Color	WHITE

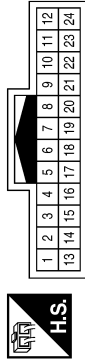

Terminal No.	Color of Wire	Signal Name
9	Y/G	-

Connector No.	M11
Connector Name	WIRE TO WIRE
Connector Color	WHITE

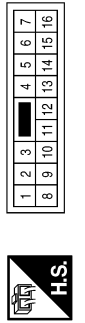

Terminal No.	Color of Wire	Signal Name
2	L/W	-
4	R/Y	-
10	B	-

Connector No.	M10
Connector Name	WIRE TO WIRE
Connector Color	WHITE

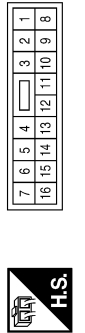

Terminal No.	Color of Wire	Signal Name
8	R/Y	- (WITH FRONT AND REAR POWER WINDOW ANTI-PINCH SYSTEM)
10	Y/G	-
15	R/B	-

Connector No.	M17
Connector Name	BCM (BODY CONTROL MODULE)
Connector Color	WHITE



Terminal No.	Color of Wire	Signal Name
11	Y/R	BAT BCM FUSE
13	B	GND1
15	Y/L	ACC LED

Connector No.	M16
Connector Name	BCM (BODY CONTROL MODULE)
Connector Color	BLACK



Terminal No.	Color of Wire	Signal Name
1	W/B	BAT POWER F/L
2	R/Y	P/W POWER SUPPLY PERM
3	L/W	P/W POWER SUPPLY IGN

Connector No.	M14
Connector Name	WIRE TO WIRE
Connector Color	WHITE

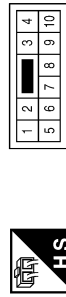

Terminal No.	Color of Wire	Signal Name
1	R/Y	-
3	Y/G	-
6	B	-

ABKIA0438GB

A
B
C
D
E
F
G
H
I
J
K
L
M
N
O
P

PWC

FRONT POWER WINDOW SWITCH

[FRONT & REAR WINDOW ANTI-PINCH]

< ECU DIAGNOSIS >

Connector No.	M18
Connector Name	BCM (BODY CONTROL MODULE)
Connector Color	GREEN

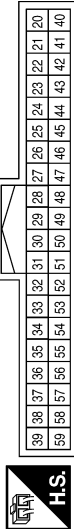

Terminal No.	Color of Wire	Signal Name
32	R/B	AS DOOR SW
40	Y/G	PW K LINE
42	R	S/L LOCK LED
58	SB	DR DOOR SW

Connector No.	M19
Connector Name	BCM (BODY CONTROL MODULE)
Connector Color	BLACK

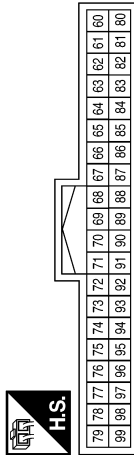

Terminal No.	Color of Wire	Signal Name
81	LG	IGN ON LED

Connector No.	E30
Connector Name	WIRE TO WIRE
Connector Color	WHITE

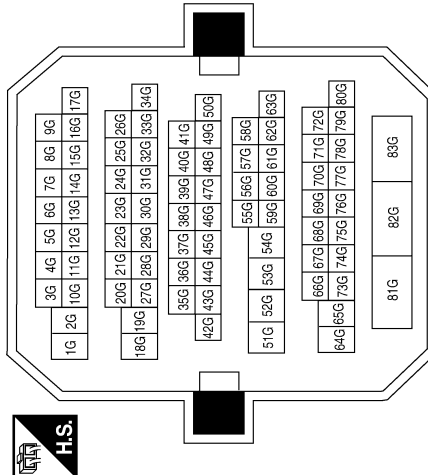

Terminal No.	Color of Wire	Signal Name
82G	LG	-

Connector No.	B1
Connector Name	WIRE TO WIRE
Connector Color	WHITE

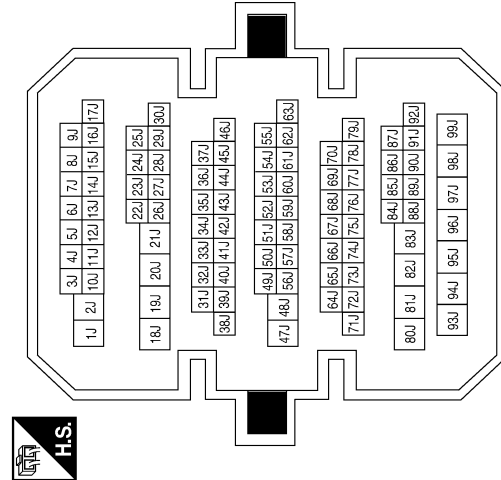

Terminal No.	Color of Wire	Signal Name
10J	SB	-
93J	R	-
95J	SB	-

ABKIA0439GB

FRONT POWER WINDOW SWITCH

[FRONT & REAR WINDOW ANTI-PINCH]

< ECU DIAGNOSIS >

Connector No.	B104
Connector Name	WIRE TO WIRE
Connector Color	WHITE



1	2	3	4	5	6	7
8	9	10	11	12	13	14
15	16					

Terminal No.	Color of Wire	Signal Name
8	R	-
10	SB	-
15	GR	-

Connector No.	B8
Connector Name	FRONT DOOR SWITCH LH
Connector Color	WHITE



1	2	3
---	---	---

Terminal No.	Color of Wire	Signal Name
2	SB	-

Connector No.	B6
Connector Name	WIRE TO WIRE
Connector Color	WHITE



1	2	3	4
5	6	7	8
9	10		

Terminal No.	Color of Wire	Signal Name
4	B	-
5	SB	-
6	R	-

Connector No.	D1
Connector Name	WIRE TO WIRE
Connector Color	WHITE



7	6	5	4	3	2	1
16	15	14	13	12	11	10
9	8					

Terminal No.	Color of Wire	Signal Name
2	V	-
4	R	-
10	B	-

Connector No.	B134
Connector Name	WIRE TO WIRE
Connector Color	WHITE



1	2	3	4
5	6	7	8
9	10		

Terminal No.	Color of Wire	Signal Name
4	B	-
5	SB	-
6	R	-

Connector No.	B108
Connector Name	FRONT DOOR SWITCH RH
Connector Color	WHITE



1	2	3
---	---	---

Terminal No.	Color of Wire	Signal Name
2	GR	-

ABKIA0440GB

A
B
C
D
E
F
G
H
I
J
L
M
N
O
P

FRONT POWER WINDOW SWITCH

[FRONT & REAR WINDOW ANTI-PINCH]

< ECU DIAGNOSIS >

Connector No.	D2
Connector Name	WIRE TO WIRE
Connector Color	WHITE

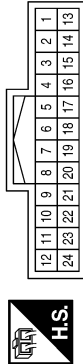

Terminal No.	Color of Wire	Signal Name
9	O	-

Connector No.	D7
Connector Name	MAIN POWER WINDOW AND DOOR LOCK/UNLOCK SWITCH
Connector Color	WHITE

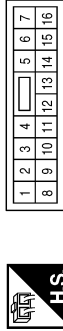

Terminal No.	Color of Wire	Signal Name
2	GR	ENCODER GND
4	L	LOCK

Terminal No.	Color of Wire	Signal Name
6	R	UNLOCK
8	L	AS UP
9	Y	ENCODER SIG1
10	V	IGN
11	LG	AS DOWN
13	G	ENCODER SIG2
14	O	COM
15	BR	ENCODER POWER

Connector No.	D8
Connector Name	MAIN POWER WINDOW AND DOOR LOCK/UNLOCK SWITCH
Connector Color	WHITE



Terminal No.	Color of Wire	Signal Name
17	B	GND
19	R	BAT

Connector No.	D9
Connector Name	FRONT POWER WINDOW MOTOR LH
Connector Color	WHITE



Terminal No.	Color of Wire	Signal Name
1	LG	-
2	L	-
3	G	-
4	BR	-
5	Y	-
6	GR	-

Connector No.	D10
Connector Name	FRONT DOOR LOCK ASSEMBLY LH
Connector Color	GRAY



Terminal No.	Color of Wire	Signal Name
4	B	-
5	R	-
6	L	-

ABKIA0441GB

FRONT POWER WINDOW SWITCH

[FRONT & REAR WINDOW ANTI-PINCH]

< ECU DIAGNOSIS >

Connector No.	D105
Connector Name	POWER WINDOW AND DOOR LOCK/UNLOCK SWITCH RH
Connector Color	WHITE

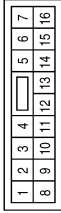

Terminal No.	Color of Wire	Signal Name
3	W	GND
4	BR	ENCODER POWER
8	L	UP
9	LG	DOWN
10	P	BAT
11	B	GND
12	G	ENCODER SIG2
15	Y	ENCODER SIG1
16	R	COM

Connector No.	D104
Connector Name	FRONT POWER WINDOW MOTOR RH
Connector Color	WHITE



Terminal No.	Color of Wire	Signal Name
1	LG	-
2	L	-
3	G	-
4	BR	-
5	Y	-
6	W	-

Connector No.	D101
Connector Name	WIRE TO WIRE
Connector Color	WHITE

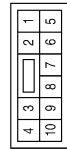

Terminal No.	Color of Wire	Signal Name
1	P	-
3	R	-
6	B	-

Terminal No.	Color of Wire	Signal Name
10	R	-
11	B	-
12	P	-
15	V	-
16	SB	-

Connector No.	D207
Connector Name	REAR POWER WINDOW SWITCH LH (WITH FRONT AND REAR POWER WINDOW ANTI-PINCH SYSTEM)
Connector Color	WHITE

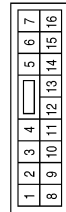

Terminal No.	Color of Wire	Signal Name
3	W	-
4	G	-
8	L	-
9	LG	-

Connector No.	D201
Connector Name	WIRE TO WIRE
Connector Color	WHITE

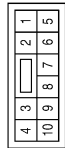

Terminal No.	Color of Wire	Signal Name
4	B	-
5	SB	-
6	R	-

ABKIA0442GB

A
B
C
D
E
F
G
H
I
J
K
L
M
N
O
P

PWC

FRONT POWER WINDOW SWITCH

[FRONT & REAR WINDOW ANTI-PINCH]

< ECU DIAGNOSIS >

Connector No.	D307
Connector Name	REAR POWER WINDOW SWITCH RH (WITH FRONT AND REAR POWER WINDOW ANTI-PINCH SYSTEM)
Connector Color	WHITE

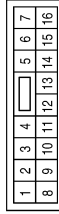

Terminal No.	Color of Wire	Signal Name
3	W	-
4	G	-
8	L	-
9	LG	-
10	R	-
11	B	-
15	V	-
16	SB	-

Connector No.	D306
Connector Name	WIRE TO WIRE
Connector Color	WHITE

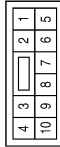

Terminal No.	Color of Wire	Signal Name
4	B	-
5	SB	-
6	R	-

Connector No.	D208
Connector Name	REAR POWER WINDOW MOTOR LH (WITH FRONT AND REAR POWER WINDOW ANTI-PINCH SYSTEM)
Connector Color	GREEN

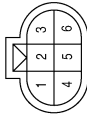

Terminal No.	Color of Wire	Signal Name
1	L	-
2	G	VCC
3	LG	-
4	W	GND
5	P	OUTPUT1
6	V	OUTPUT2

Terminal No.	Color of Wire	Signal Name
1	L	-
2	G	VCC
3	LG	-
4	W	GND
5	P	OUTPUT1
6	V	OUTPUT2

Connector No.	D308
Connector Name	REAR POWER WINDOW MOTOR RH (WITH FRONT AND REAR POWER WINDOW ANTI-PINCH SYSTEM)
Connector Color	GREEN



Fail Safe

FAIL-SAFE CONTROL

Switches to fail-safe control when malfunction is detected in encoder signal that detects up/down speed and direction of door glass. Switches to fail-safe control when error beyond regulation value is detected between the fully closed position and the actual position of the glass.

ABKIA0443GB

INFOID:000000004392505

FRONT POWER WINDOW SWITCH

[FRONT & REAR WINDOW ANTI-PINCH]

< ECU DIAGNOSIS >

Error	Error condition
Pulse sensor malfunction	When only one side of pulse signal is being detected for more than the specified value.
Both pulse sensors malfunction	When both pulse signals have not been detected for more than the specified value during glass open/close operation.
Pulse direction malfunction	When the pulse signal that is detected during glass open/close operation detects the opposite condition of power window motor operating direction.
Glass recognition position malfunction 1	When it detects the error between glass fully closed position in power window switch memory and actual fully closed position during glass open/close operation is more than the specified value.
Glass recognition position malfunction 2	When it detects pulse count more than the value of glass full stroke during glass open/close operation.
Malfunction of not yet updated closed position of glass	When glass open/close operation is continuously performed without fully closing more than the specified value (approximately 10 strokes).

It changes to condition before initialization and the following functions do not operate when switched to fail-safe control:

- Auto-up operation
- Anti-pinch function
- Retained power function

Perform initial operation to recover when switched to fail-safe mode. However, it switches back to fail-safe control when malfunction is found in power window switch or in motor.

A
B
C
D
E
F
G
H
I
J
L
M
N
O
P

PWC

REAR POWER WINDOW SWITCH

[FRONT & REAR WINDOW ANTI-PINCH]

< ECU DIAGNOSIS >

REAR POWER WINDOW SWITCH

Reference Value

INFOID:000000004392504

TERMINAL LAYOUT

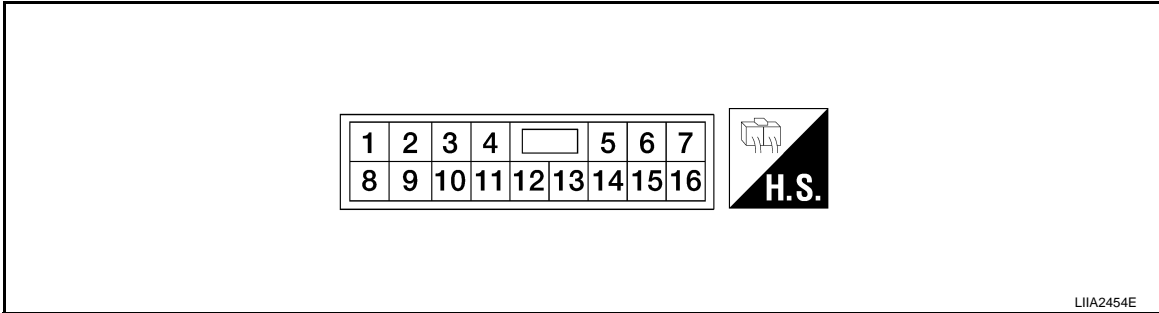

PHYSICAL VALUES

REAR POWER WINDOW SWITCH

Terminal No.		Description		Condition	Voltage [V] (Approx.)
+	-	Signal name	Input/ Output		
3 (W)	Ground	Encoder ground	—	—	0
4 (G)	Ground	Encoder power supply	Output	When ignition switch ON or power window timer operates.	10
8 (L)	9	Power window motor UP signal	Output	When power window motor is operated UP.	Battery voltage
9 (LG)	8	Power window motor DOWN signal	Output	When power window motor is operated DOWN.	Battery voltage
10 (R)	Ground	Battery power supply	Input	—	Battery voltage
11 (B)	Ground	Ground	—	—	0
12 (P)	3	Encoder pulse signal 1	Input	When power window motor operates.	<p>The diagram shows a square wave pulse on a grid. The vertical axis is labeled (V) with values 0, 2, 4, 6. The horizontal axis is labeled 10 ms. The pulse has a period of 10 ms and a peak voltage of approximately 5V.</p>

JMKIA0070GB

REAR POWER WINDOW SWITCH

[FRONT & REAR WINDOW ANTI-PINCH]

< ECU DIAGNOSIS >

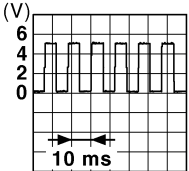
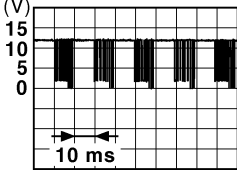
Terminal No.		Description		Condition	Voltage [V] (Approx.)
+	-	Signal name	Input/ Output		
15 (V)	3	Encoder pulse signal 2	Input	When power window motor operates.	 <p style="text-align: right; font-size: small;">JMKIA0070GB</p>
16 (SB)	Ground	Power window serial link	Input/ Output	IGN SW ON or power window timer operating.	 <p style="text-align: right; font-size: small;">JPMIA0013GB</p>

A
B
C
D
E
F
G
H
I
J
L
M
N
O
P

PWC

REAR POWER WINDOW SWITCH

[FRONT & REAR WINDOW ANTI-PINCH]

< ECU DIAGNOSIS >

POWER WINDOW SYSTEM CONNECTORS -WITH FRONT AND REAR POWER WINDOW ANTI-PINCH SYSTEM

Connector No.	M1
Connector Name	WIRE TO WIRE
Connector Color	WHITE

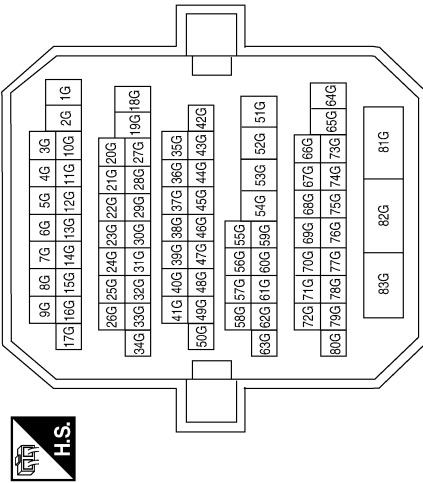

Terminal No.	Color of Wire	Signal Name
82G	W/B	-

Connector No.	M3
Connector Name	FUSE BLOCK (J/B)
Connector Color	WHITE

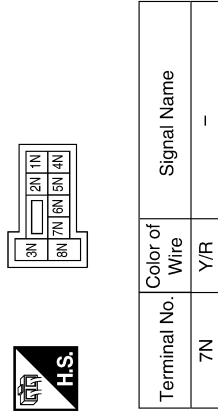

Connector No.	M6
Connector Name	WIRE TO WIRE
Connector Color	WHITE

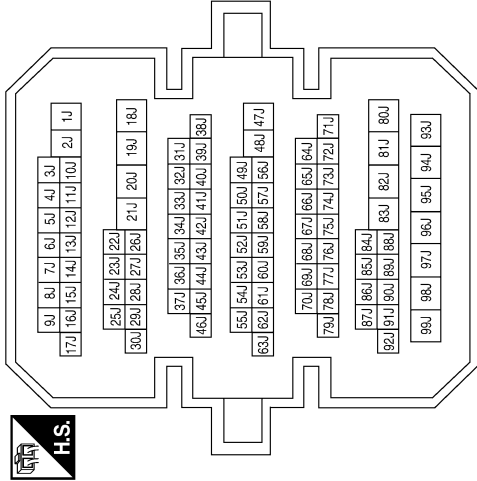

Terminal No.	Color of Wire	Signal Name
10J	SB	-
93J	R/Y	-(WITH FRONT AND REAR POWER WINDOW ANTI-PINCH SYSTEM)
95J	Y/G	-

A
B
C
D
E
F
G
H
I
J
L
M
N
O
P

PWC

ABKIA0437GB

REAR POWER WINDOW SWITCH

[FRONT & REAR WINDOW ANTI-PINCH]

< ECU DIAGNOSIS >

Connector No.	M12
Connector Name	WIRE TO WIRE
Connector Color	WHITE

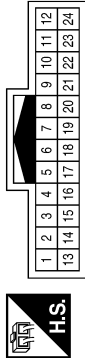

Terminal No.	Color of Wire	Signal Name
9	Y/G	-

Connector No.	M11
Connector Name	WIRE TO WIRE
Connector Color	WHITE

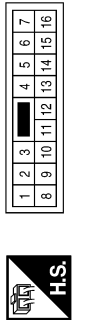

Terminal No.	Color of Wire	Signal Name
2	L/W	-
4	R/Y	-
10	B	-

Connector No.	M10
Connector Name	WIRE TO WIRE
Connector Color	WHITE

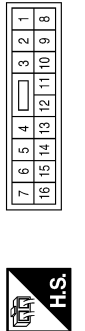

Terminal No.	Color of Wire	Signal Name
8	R/Y	- (WITH FRONT AND REAR POWER WINDOW ANTI-PINCH SYSTEM)
10	Y/G	-
15	R/B	-

Connector No.	M17
Connector Name	BCM (BODY CONTROL MODULE)
Connector Color	WHITE



Terminal No.	Color of Wire	Signal Name
11	Y/R	BAT BCM FUSE
13	B	GND1
15	Y/L	ACC LED

Connector No.	M16
Connector Name	BCM (BODY CONTROL MODULE)
Connector Color	BLACK



Terminal No.	Color of Wire	Signal Name
1	W/B	BAT POWER F/L
2	R/Y	P/W POWER SUPPLY PERM
3	L/W	P/W POWER SUPPLY IGN

Connector No.	M14
Connector Name	WIRE TO WIRE
Connector Color	WHITE

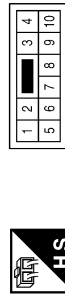

Terminal No.	Color of Wire	Signal Name
1	R/Y	-
3	Y/G	-
6	B	-

ABKIA0438GB

REAR POWER WINDOW SWITCH

[FRONT & REAR WINDOW ANTI-PINCH]

< ECU DIAGNOSIS >

Connector No.	M18
Connector Name	BCM (BODY CONTROL MODULE)
Connector Color	GREEN

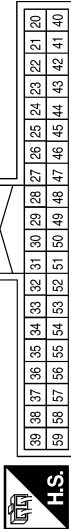

Connector No.	M19
Connector Name	BCM (BODY CONTROL MODULE)
Connector Color	BLACK

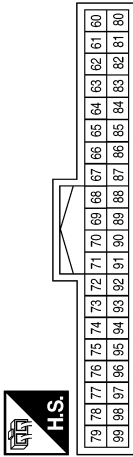

Connector No.	E30
Connector Name	WIRE TO WIRE
Connector Color	WHITE

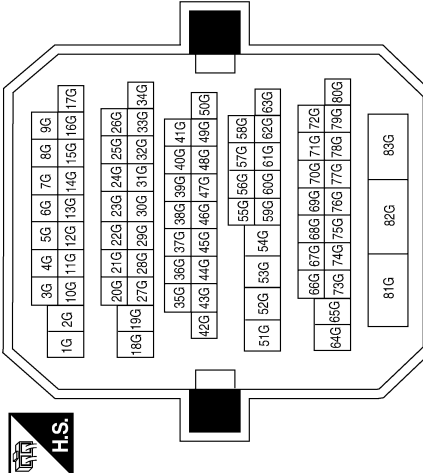

Connector No.	B1
Connector Name	WIRE TO WIRE
Connector Color	WHITE

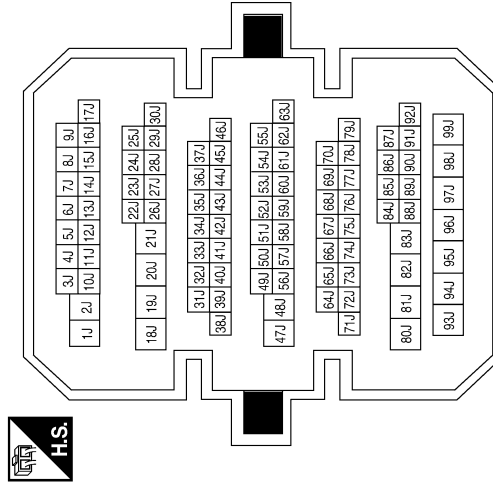

Terminal No.	Color of Wire	Signal Name
10J	SB	-
93J	R	-
95J	SB	-

ABKIA0439GB

A
B
C
D
E
F
G
H
I
J
K
L
M
N
O
P

REAR POWER WINDOW SWITCH

[FRONT & REAR WINDOW ANTI-PINCH]

< ECU DIAGNOSIS >

Connector No.	B104
Connector Name	WIRE TO WIRE
Connector Color	WHITE

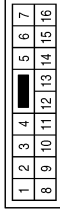

Terminal No.	Color of Wire	Signal Name
8	R	-
10	SB	-
15	GR	-

Connector No.	B8
Connector Name	FRONT DOOR SWITCH LH
Connector Color	WHITE

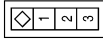

Terminal No.	Color of Wire	Signal Name
2	SB	-

Connector No.	B6
Connector Name	WIRE TO WIRE
Connector Color	WHITE

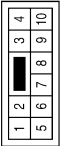

Terminal No.	Color of Wire	Signal Name
4	B	-
5	SB	-
6	R	-

Connector No.	D1
Connector Name	WIRE TO WIRE
Connector Color	WHITE

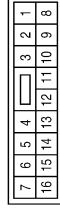

Terminal No.	Color of Wire	Signal Name
2	V	-
4	R	-
10	B	-

Connector No.	B134
Connector Name	WIRE TO WIRE
Connector Color	WHITE



Terminal No.	Color of Wire	Signal Name
4	B	-
5	SB	-
6	R	-

Connector No.	B108
Connector Name	FRONT DOOR SWITCH RH
Connector Color	WHITE

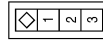

Terminal No.	Color of Wire	Signal Name
2	GR	-

ABKIA0440GB

REAR POWER WINDOW SWITCH

[FRONT & REAR WINDOW ANTI-PINCH]

< ECU DIAGNOSIS >

Connector No.	D2
Connector Name	WIRE TO WIRE
Connector Color	WHITE

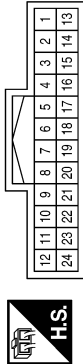

Terminal No.	Color of Wire	Signal Name
9	O	-

Connector No.	D7
Connector Name	MAIN POWER WINDOW AND DOOR LOCK/UNLOCK SWITCH
Connector Color	WHITE

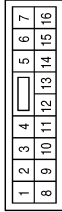

Terminal No.	Color of Wire	Signal Name
2	GR	ENCODER GND
4	L	LOCK

Terminal No.	Color of Wire	Signal Name
6	R	UNLOCK
8	L	AS UP
9	Y	ENCODER SIG1
10	V	IGN
11	LG	AS DOWN
13	G	ENCODER SIG2
14	O	COM
15	BR	ENCODER POWER

Connector No.	D8
Connector Name	MAIN POWER WINDOW AND DOOR LOCK/UNLOCK SWITCH
Connector Color	WHITE

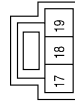

Terminal No.	Color of Wire	Signal Name
17	B	GND
19	R	BAT

Connector No.	D9
Connector Name	FRONT POWER WINDOW MOTOR LH
Connector Color	WHITE



Terminal No.	Color of Wire	Signal Name
1	LG	-
2	L	-
3	G	-
4	BR	-
5	Y	-
6	GR	-

Connector No.	D10
Connector Name	FRONT DOOR LOCK ASSEMBLY LH
Connector Color	GRAY

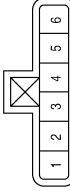

Terminal No.	Color of Wire	Signal Name
4	B	-
5	R	-
6	L	-

ABKIA0441GB

A
B
C
D
E
F
G
H
I
J
L
M
N
O
P

REAR POWER WINDOW SWITCH

[FRONT & REAR WINDOW ANTI-PINCH]

< ECU DIAGNOSIS >

Connector No.	D105
Connector Name	POWER WINDOW AND DOOR LOCK/UNLOCK SWITCH RH
Connector Color	WHITE

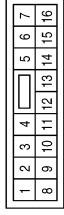

Terminal No.	Color of Wire	Signal Name
3	W	GND
4	BR	ENCODER POWER
8	L	UP
9	LG	DOWN
10	P	BAT
11	B	GND
12	G	ENCODER SIG2
15	Y	ENCODER SIG1
16	R	COM

Connector No.	D104
Connector Name	FRONT POWER WINDOW MOTOR RH
Connector Color	WHITE



Terminal No.	Color of Wire	Signal Name
1	LG	-
2	L	-
3	G	-
4	BR	-
5	Y	-
6	W	-

Connector No.	D101
Connector Name	WIRE TO WIRE
Connector Color	WHITE

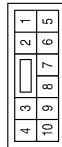

Terminal No.	Color of Wire	Signal Name
1	P	-
3	R	-
6	B	-

Terminal No.	Color of Wire	Signal Name
10	R	-
11	B	-
12	P	-
15	V	-
16	SB	-

Connector No.	D207
Connector Name	REAR POWER WINDOW SWITCH LH (WITH FRONT AND REAR POWER WINDOW ANTI-PINCH SYSTEM)
Connector Color	WHITE

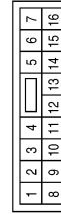

Terminal No.	Color of Wire	Signal Name
3	W	-
4	G	-
8	L	-
9	LG	-

Connector No.	D201
Connector Name	WIRE TO WIRE
Connector Color	WHITE



Terminal No.	Color of Wire	Signal Name
4	B	-
5	SB	-
6	R	-

ABKIA0442GB

REAR POWER WINDOW SWITCH

[FRONT & REAR WINDOW ANTI-PINCH]

< ECU DIAGNOSIS >

Connector No.	D307
Connector Name	REAR POWER WINDOW SWITCH RH (WITH FRONT AND REAR POWER WINDOW ANTI-PINCH SYSTEM)
Connector Color	WHITE

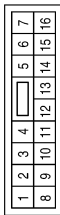

Terminal No.	Color of Wire	Signal Name
3	W	-
4	G	-
8	L	-
9	LG	-
10	R	-
11	B	-
15	V	-
16	SB	-

Connector No.	D306
Connector Name	WIRE TO WIRE
Connector Color	WHITE

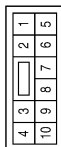

Terminal No.	Color of Wire	Signal Name
4	B	-
5	SB	-
6	R	-

Connector No.	D208
Connector Name	REAR POWER WINDOW MOTOR LH (WITH FRONT AND REAR POWER WINDOW ANTI-PINCH SYSTEM)
Connector Color	GREEN

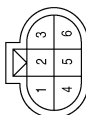

Terminal No.	Color of Wire	Signal Name
1	L	-
2	G	VCC
3	LG	-
4	W	GND
5	P	OUTPUT1
6	V	OUTPUT2

Terminal No.	Color of Wire	Signal Name
1	L	-
2	G	VCC
3	LG	-
4	W	GND
5	P	OUTPUT1
6	V	OUTPUT2

Connector No.	D308
Connector Name	REAR POWER WINDOW MOTOR RH (WITH FRONT AND REAR POWER WINDOW ANTI-PINCH SYSTEM)
Connector Color	GREEN

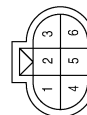

Fail Safe

FAIL-SAFE CONTROL

Switches to fail-safe control when malfunction is detected in encoder signal that detects up/down speed and direction of door glass. Switches to fail-safe control when error beyond regulation value is detected between the fully closed position and the actual position of the glass.

ABKIA0443GB

INFOID:000000004392506

A
B
C
D
E
F
G
H
I
J
K
L
M
N
O
P

PWC

REAR POWER WINDOW SWITCH

[FRONT & REAR WINDOW ANTI-PINCH]

< ECU DIAGNOSIS >

Error	Error condition
Pulse sensor malfunction	When only one side of pulse signal is being detected for more than the specified value.
Both pulse sensors malfunction	When both pulse signals have not been detected for more than the specified value during glass open/close operation.
Pulse direction malfunction	When the pulse signal that is detected during glass open/close operation detects the opposite condition of power window motor operating direction.
Glass recognition position malfunction 1	When it detects the error between glass fully closed position in power window switch memory and actual fully closed position during glass open/close operation is more than the specified value.
Glass recognition position malfunction 2	When it detects pulse count more than the value of glass full stroke during glass open/close operation.
Malfunction of not yet updated closed position of glass	When glass open/close operation is continuously performed without fully closing more than the specified value (approximately 10 strokes).

It changes to condition before initialization and the following functions do not operate when switched to fail-safe control:

- Auto-up operation
- Anti-pinch function
- Retained power function

Perform initial operation to recover when switched to fail-safe mode. However, it switches back to fail-safe control when malfunction is found in power window switch or in motor.

SYMPTOM DIAGNOSIS

NONE OF THE POWER WINDOWS CAN BE OPERATED USING ANY SWITCH

Diagnosis Procedure

INFOID:000000004391533

1. CHECK BCM POWER SUPPLY AND GROUND CIRCUIT

Check BCM power supply and ground circuit. Refer to [PWC-128, "BCM : Diagnosis Procedure"](#).

Is the inspection result normal?

YES >> GO TO 2

NO >> Repair or replace the malfunctioning parts.

2. CHECK MAIN POWER WINDOW AND DOOR LOCK/UNLOCK SWITCH POWER SUPPLY AND GROUND CIRCUIT

Check main power window and door lock/unlock switch power supply and ground circuit. Refer to [PWC-129, "POWER WINDOW MAIN SWITCH : Diagnosis Procedure"](#).

Is the inspection result normal?

YES >> Check intermittent incident. Refer to [GI-39, "Intermittent Incident"](#).

NO >> Repair or replace the malfunctioning parts.

A
B
C
D
E
F
G
H
I
J
L
M
N
O
P

PWC

DRIVER SIDE POWER WINDOW ALONE DOES NOT OPERATE

< SYMPTOM DIAGNOSIS >

[FRONT & REAR WINDOW ANTI-PINCH]

DRIVER SIDE POWER WINDOW ALONE DOES NOT OPERATE

Diagnosis Procedure

INFOID:000000004391534

1. CHECK FRONT POWER WINDOW MOTOR LH

Check front power window motor LH. Refer to [PWC-134, "DRIVER SIDE : Component Function Check"](#).

Is the inspection result normal?

YES >> Inspection End.

NO >> Check intermittent incident. Refer to [GI-39, "Intermittent Incident"](#).

FRONT PASSENGER SIDE POWER WINDOW ALONE DOES NOT OPERATE

< SYMPTOM DIAGNOSIS >

[FRONT & REAR WINDOW ANTI-PINCH]

FRONT PASSENGER SIDE POWER WINDOW ALONE DOES NOT OPERATE

Diagnosis Procedure

INFOID:000000004391535

1. CHECK FRONT POWER WINDOW MOTOR RH CIRCUIT

Check front power window motor RH circuit. Refer to [PWC-136, "PASSENGER SIDE : Component Function Check"](#).

Is the inspection result normal?

YES >> Inspection End.

NO >> Check intermittent incident. Refer to [GI-39, "Intermittent Incident"](#).

A
B
C
D
E
F
G
H
I
J
L
M
N
O
P

PWC

REAR LH SIDE POWER WINDOW ALONE DOES NOT OPERATE

< SYMPTOM DIAGNOSIS >

[FRONT & REAR WINDOW ANTI-PINCH]

REAR LH SIDE POWER WINDOW ALONE DOES NOT OPERATE

Diagnosis Procedure

INFOID:000000004391536

1. CHECK REAR POWER WINDOW MOTOR LH

Check rear power window motor LH. Refer to [PWC-30, "REAR LH : Component Function Check"](#).

Is the inspection result normal?

YES >> Inspection End.

NO >> Check intermittent incident. Refer to [GI-39, "Intermittent Incident"](#).

REAR RH SIDE POWER WINDOW ALONE DOES NOT OPERATE

< SYMPTOM DIAGNOSIS >

[FRONT & REAR WINDOW ANTI-PINCH]

REAR RH SIDE POWER WINDOW ALONE DOES NOT OPERATE

Diagnosis Procedure

INFOID:000000004391537

1. CHECK REAR POWER WINDOW MOTOR RH

Check rear power window motor RH. Refer to [PWC-32, "REAR RH : Component Function Check"](#).

Is the inspection result normal?

YES >> Inspection End.

NO >> Check intermittent incident. Refer to [GI-39, "Intermittent Incident"](#).

A
B
C
D
E
F
G
H
I
J
L
M
N
O
P

PWC

ANTI-PINCH SYSTEM DOES NOT OPERATE NORMALLY (DRIVER SIDE)

< SYMPTOM DIAGNOSIS >

[FRONT & REAR WINDOW ANTI-PINCH]

ANTI-PINCH SYSTEM DOES NOT OPERATE NORMALLY (DRIVER SIDE)

Diagnosis Procedure

INFOID:000000004391538

1. PERFORM INITIALIZATION PROCEDURE

Perform initialization procedure. Refer to [PWC-9, "ADDITIONAL SERVICE WHEN REPLACING CONTROL UNIT : Special Repair Requirement"](#).

Is the inspection result normal?

YES >> Inspection End.

NO >> GO TO 2

2. CHECK ENCODER CIRCUIT

Check encoder circuit. Refer to [PWC-142, "DRIVER SIDE : Component Function Check"](#).

Is the inspection result normal?

YES >> Check intermittent incident. Refer to [GI-39, "Intermittent Incident"](#).

NO >> Repair or replace malfunctioning parts.

ANTI-PINCH SYSTEM DOES NOT OPERATE NORMALLY (PASSENGER SIDE)
< SYMPTOM DIAGNOSIS > **[FRONT & REAR WINDOW ANTI-PINCH]**

ANTI-PINCH SYSTEM DOES NOT OPERATE NORMALLY (PASSENGER SIDE)

Diagnosis Procedure

INFOID:000000004391539

1. PERFORM INITIALIZATION PROCEDURE

Perform initialization procedure. Refer to [PWC-9, "ADDITIONAL SERVICE WHEN REPLACING CONTROL UNIT : Special Repair Requirement"](#).

Is the inspection result normal?

YES >> Inspection End.

NO >> GO TO 2

2. CHECK ENCODER CIRCUIT

Check encoder circuit. Refer to [PWC-145, "PASSENGER SIDE : Component Function Check"](#).

Is the inspection result normal?

YES >> Check intermittent incident. Refer to [GI-39, "Intermittent Incident"](#).

NO >> Repair or replace the malfunctioning parts.

A
B
C
D
E
F
G
H
I
J
L
M
N
O
P

PWC

ANTI-PINCH SYSTEM DOES NOT OPERATE NORMALLY (REAR LH SIDE)

< SYMPTOM DIAGNOSIS >

[FRONT & REAR WINDOW ANTI-PINCH]

ANTI-PINCH SYSTEM DOES NOT OPERATE NORMALLY (REAR LH SIDE)

Diagnosis Procedure

INFOID:000000004392453

1. PERFORM INITIALIZATION PROCEDURE

Perform initialization procedure. Refer to [PWC-119, "ADDITIONAL SERVICE WHEN REPLACING CONTROL UNIT : Special Repair Requirement"](#).

Is the inspection result normal?

YES >> Inspection End.

NO >> GO TO 2

2. CHECK ENCODER CIRCUIT

Check encoder circuit. Refer to [PWC-147, "REAR LH : Component Function Check"](#).

Is the inspection result normal?

YES >> Check intermittent incident. Refer to [GI-39, "Intermittent Incident"](#).

NO >> Repair or replace the malfunctioning parts.

ANTI-PINCH SYSTEM DOES NOT OPERATE NORMALLY (REAR RH SIDE)

< SYMPTOM DIAGNOSIS >

[FRONT & REAR WINDOW ANTI-PINCH]

ANTI-PINCH SYSTEM DOES NOT OPERATE NORMALLY (REAR RH SIDE)

Diagnosis Procedure

INFOID:000000004392452

1. PERFORM INITIALIZATION PROCEDURE

Perform initialization procedure. Refer to [PWC-119, "ADDITIONAL SERVICE WHEN REPLACING CONTROL UNIT : Special Repair Requirement"](#).

Is the inspection result normal?

YES >> Inspection End.

NO >> GO TO 2

2. CHECK ENCODER CIRCUIT

Check encoder circuit. Refer to [PWC-150, "REAR RH : Component Function Check"](#).

Is the inspection result normal?

YES >> Check intermittent incident. Refer to [GI-39, "Intermittent Incident"](#).

NO >> Repair or replace the malfunctioning parts.

A
B
C
D
E
F
G
H
I
J
L
M
N
O
P

PWC

AUTO OPERATION DOES NOT OPERATE BUT MANUAL OPERATE NORMALLY (DRIVER SIDE)

< SYMPTOM DIAGNOSIS >

[FRONT & REAR WINDOW ANTI-PINCH]

AUTO OPERATION DOES NOT OPERATE BUT MANUAL OPERATE NORMALLY (DRIVER SIDE)

Diagnosis Procedure

INFOID:000000004391540

1. PERFORM INITIALIZATION PROCEDURE

Perform initialization procedure. Refer to [PWC-9, "ADDITIONAL SERVICE WHEN REPLACING CONTROL UNIT : Special Repair Requirement"](#).

Is the inspection result normal?

YES >> Inspection End.

NO >> GO TO 2

2. CHECK ENCODER

Check encoder. Refer to [PWC-142, "DRIVER SIDE : Component Function Check"](#).

Is the inspection result normal?

YES >> Check intermittent incident. Refer to [GI-39, "Intermittent Incident"](#).

NO >> Repair or replace the malfunctioning parts.

AUTO OPERATION DOES NOT OPERATE BUT MANUAL OPERATE NORMALLY (PASSENGER SIDE)

< SYMPTOM DIAGNOSIS >

[FRONT & REAR WINDOW ANTI-PINCH]

AUTO OPERATION DOES NOT OPERATE BUT MANUAL OPERATE NORMALLY (PASSENGER SIDE)

Diagnosis Procedure

INFOID:000000004391541

1. PERFORM INITIALIZATION PROCEDURE

Perform initialization procedure. Refer to [PWC-9, "ADDITIONAL SERVICE WHEN REPLACING CONTROL UNIT : Special Repair Requirement"](#).

Is the inspection result normal?

YES >> Inspection End.

NO >> GO TO 2

2. CHECK ENCODER

Check encoder. Refer to [PWC-145, "PASSENGER SIDE : Component Function Check"](#).

Is the inspection result normal?

YES >> Check intermittent incident. Refer to [GI-39, "Intermittent Incident"](#).

NO >> Repair or replace the malfunctioning parts.

A
B
C
D
E
F
G
H
I
J
L
M
N
O
P

PWC

AUTO OPERATION DOES NOT OPERATE BUT MANUAL OPERATES NORMALLY (REAR LH SIDE)

< SYMPTOM DIAGNOSIS >

[FRONT & REAR WINDOW ANTI-PINCH]

AUTO OPERATION DOES NOT OPERATE BUT MANUAL OPERATES NORMALLY (REAR LH SIDE)

Diagnosis Procedure

INFOID:000000004392455

1. PERFORM INITIALIZATION PROCEDURE

Perform initialization procedure. Refer to [PWC-119, "ADDITIONAL SERVICE WHEN REPLACING CONTROL UNIT : Special Repair Requirement"](#).

Is the inspection result normal?

YES >> Inspection End.

NO >> GO TO 2

2. CHECK ENCODER

Check encoder. Refer to [PWC-147, "REAR LH : Component Function Check"](#).

Is the inspection result normal?

YES >> Check intermittent incident. Refer to [GI-39, "Intermittent Incident"](#).

NO >> Repair or replace the malfunctioning parts.

AUTO OPERATION DOES NOT OPERATE BUT MANUAL OPERATES NORMALLY (REAR RH SIDE)

< SYMPTOM DIAGNOSIS >

[FRONT & REAR WINDOW ANTI-PINCH]

AUTO OPERATION DOES NOT OPERATE BUT MANUAL OPERATES NORMALLY (REAR RH SIDE)

Diagnosis Procedure

INFOID:000000004392454

1. PERFORM INITIALIZATION PROCEDURE

Perform initialization procedure. Refer to [PWC-119, "ADDITIONAL SERVICE WHEN REPLACING CONTROL UNIT : Special Repair Requirement"](#).

Is the inspection result normal?

YES >> Inspection End.

NO >> GO TO 2

2. CHECK ENCODER

Check encoder. Refer to [PWC-150, "REAR RH : Component Function Check"](#).

Is the inspection result normal?

YES >> Check intermittent incident. Refer to [GI-39, "Intermittent Incident"](#).

NO >> Repair or replace the malfunctioning parts.

A
B
C
D
E
F
G
H
I
J
L
M
N
O
P

PWC

POWER WINDOW RETAINED POWER OPERATION DOES NOT OPERATE PROPERLY

< SYMPTOM DIAGNOSIS >

[FRONT & REAR WINDOW ANTI-PINCH]

POWER WINDOW RETAINED POWER OPERATION DOES NOT OPERATE PROPERLY

Diagnosis Procedure

INFOID:000000004391542

1. CHECK FRONT DOOR SWITCH

Check front door switch. Refer to [PWC-40, "Component Function Check"](#).

Is the inspection result normal?

- YES >> Check intermittent incident. Refer to [GI-39, "Intermittent Incident"](#).
- NO >> Repair or replace malfunctioning parts.

DOES NOT OPERATE BY KEY CYLINDER SWITCH

< SYMPTOM DIAGNOSIS >

[FRONT & REAR WINDOW ANTI-PINCH]

DOES NOT OPERATE BY KEY CYLINDER SWITCH

Diagnosis Procedure

INFOID:000000004391543

1. CHECK FRONT DOOR LOCK ASSEMBLY LH (KEY CYLINDER SWITCH)

Check front door lock assembly LH (key cylinder switch). Refer to [PWC-157, "Diagnosis Procedure"](#).

Is the inspection result normal?

- YES >> Check intermittent incident. Refer to [GI-39, "Intermittent Incident"](#).
- NO >> Repair or replace malfunctioning parts.

A
B
C
D
E
F
G
H
I
J
L
M
N
O
P

PWC

KEYLESS POWER WINDOW DOWN DOES NOT OPERATE

< SYMPTOM DIAGNOSIS >

[FRONT & REAR WINDOW ANTI-PINCH]

KEYLESS POWER WINDOW DOWN DOES NOT OPERATE

Diagnosis Procedure

INFOID:000000004391544

1. CHECK INTELLIGENT KEY FUNCTION

Check Intelligent Key function. Refer to [DLK-112, "Component Function Check"](#).

Is the inspection result normal?

YES >> Check intermittent incident. Refer to [GI-39, "Intermittent Incident"](#).

NO >> Replace BCM. Refer to [BCS-87, "Removal and Installation"](#).

POWER WINDOW LOCK SWITCH DOES NOT FUNCTION

< SYMPTOM DIAGNOSIS >

[FRONT & REAR WINDOW ANTI-PINCH]

POWER WINDOW LOCK SWITCH DOES NOT FUNCTION

Diagnosis Procedure

INFOID:000000004391545

1. CHECK POWER WINDOW LOCK SWITCH

Check power window lock switch. Refer to [PWC-50, "Component Function Check"](#).

Is the inspection result normal?

- YES >> Check intermittent incident. Refer to [GI-39, "Intermittent Incident"](#).
- NO >> Repair or replace malfunctioning parts.

A
B
C
D
E
F
G
H
I
J
L
M
N
O
P

PWC

PRECAUTION

PRECAUTIONS

Precaution for Supplemental Restraint System (SRS) "AIR BAG" and "SEAT BELT PRE-TENSIONER"

INFOID:000000004362970

The Supplemental Restraint System such as "AIR BAG" and "SEAT BELT PRE-TENSIONER", used along with a front seat belt, helps to reduce the risk or severity of injury to the driver and front passenger for certain types of collision. This system includes seat belt switch inputs and dual stage front air bag modules. The SRS system uses the seat belt switches to determine the front air bag deployment, and may only deploy one front air bag, depending on the severity of a collision and whether the front occupants are belted or unbelted. Information necessary to service the system safely is included in the SR and SB section of this Service Manual.

WARNING:

- To avoid rendering the SRS inoperative, which could increase the risk of personal injury or death in the event of a collision which would result in air bag inflation, all maintenance must be performed by an authorized NISSAN/INFINITI dealer.
- Improper maintenance, including incorrect removal and installation of the SRS, can lead to personal injury caused by unintentional activation of the system. For removal of Spiral Cable and Air Bag Module, see the SR section.
- Do not use electrical test equipment on any circuit related to the SRS unless instructed to in this Service Manual. SRS wiring harnesses can be identified by yellow and/or orange harnesses or harness connectors.

Precautions Necessary for Steering Wheel Rotation after Battery Disconnect

INFOID:000000004394046

NOTE:

- Before removing and installing any control units, first turn the push-button ignition switch to the LOCK position, then disconnect both battery cables.
- After finishing work, confirm that all control unit connectors are connected properly, then re-connect both battery cables.
- Always use CONSULT-III to perform self-diagnosis as a part of each function inspection after finishing work. If a DTC is detected, perform trouble diagnosis according to self-diagnosis results.

This vehicle is equipped with a push-button ignition switch and a steering lock unit.

If the battery is disconnected or discharged, the steering wheel will lock and cannot be turned.

If turning the steering wheel is required with the battery disconnected or discharged, follow the procedure below before starting the repair operation.

OPERATION PROCEDURE

1. Connect both battery cables.

NOTE:

Supply power using jumper cables if battery is discharged.

2. Carry the Intelligent Key or insert it to the key slot and turn the push-button ignition switch to ACC position. (At this time, the steering lock will be released.)
3. Disconnect both battery cables. The steering lock will remain released with both battery cables disconnected and the steering wheel can be turned.
4. Perform the necessary repair operation.
5. When the repair work is completed, re-connect both battery cables. With the brake pedal released, turn the push-button ignition switch from ACC position to ON position, then to LOCK position. (The steering wheel will lock when the push-button ignition switch is turned to LOCK position.)
6. Perform self-diagnosis check of all control units using CONSULT-III.

PRE-INSPECTION FOR DIAGNOSTIC

< ON-VEHICLE MAINTENANCE >

[FRONT & REAR WINDOW ANTI-PINCH]

ON-VEHICLE MAINTENANCE

PRE-INSPECTION FOR DIAGNOSTIC

Basic Inspection

INFOID:000000004362971

BASIC INSPECTION

1.INSPECTION START

1. Check the service history.
2. Check the following parts.
 - Fuse/circuit breaker blown.
 - Poor connection, open or short circuit of harness connector.
 - Battery voltage.

Is the inspection result normal?

- YES >> Inspection End.
NO >> Repair or replace the malfunctioning parts.

A
B
C
D
E
F
G
H
I
J
L
M
N
O
P

PWC

POWER WINDOW MAIN SWITCH

< ON-VEHICLE REPAIR >

[FRONT & REAR WINDOW ANTI-PINCH]

ON-VEHICLE REPAIR

POWER WINDOW MAIN SWITCH

Removal and Installation

INFOID:000000004399673

REMOVAL

1. Disconnect the negative battery terminal.
2. Using a suitable tool, remove the front door grip cover. Refer to [INT-18, "Exploded View"](#).
CAUTION:
Wrap a cloth around suitable tools to protect components from damage.
3. Remove the power window main switch locking clip (A).

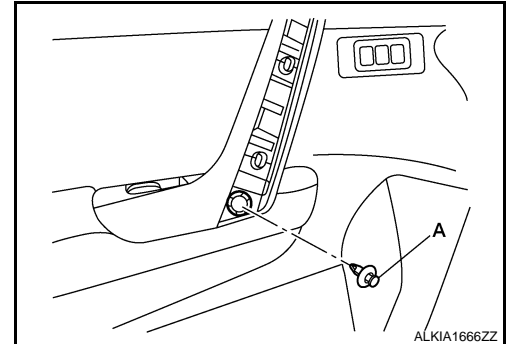

4. Release the metal clip, then lift the power window main switch and finisher as an assembly upward to remove it from the front door finisher.

□: Metal clip

○: Pawl

5. Disconnect the harness connector.
6. Release the tabs on each side, then separate the switch finisher (1) from the power window main switch (2) and remove.

CAUTION:

Do not fold the pawl of power window main switch finisher.

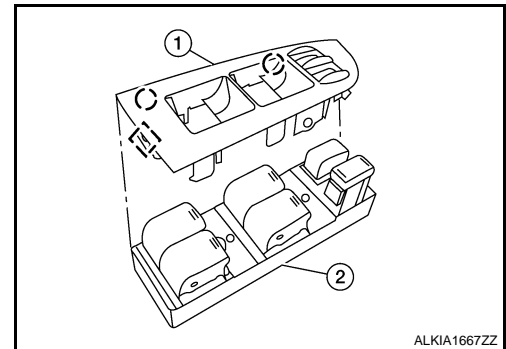

INSTALLATION

Installation is in the reverse order of removal.

NOTE:

After every switch harness disconnection, it is necessary to perform the initialization procedure. Refer to [PWC-119, "ADDITIONAL SERVICE WHEN REPLACING CONTROL UNIT : Special Repair Requirement"](#).

FRONT POWER WINDOW SWITCH

< ON-VEHICLE REPAIR >

[FRONT & REAR WINDOW ANTI-PINCH]

FRONT POWER WINDOW SWITCH

Removal and Installation

INFOID:000000004392595

REMOVAL

1. Disconnect the negative battery terminal.
2. Using a suitable tool, remove the front door grip cover. Refer to [INT-18, "Exploded View"](#).
CAUTION:
Do not fold the pawl of front power window switch finisher.
3. Remove the front power window switch locking clip (A).

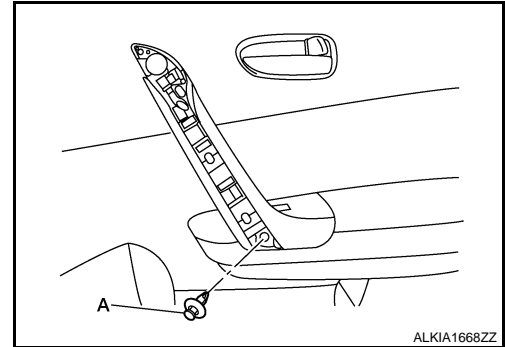

4. Release the metal clip, then lift the front power window switch and finisher as an assembly upward to remove it from the front door finisher.

□: Metal clip

○: Pawl

CAUTION:

Wrap a cloth around suitable tools to protect components from damage.

5. Disconnect the harness connector.
6. Release the tabs on each side, then separate the switch finisher (1) from the front power window switch (2) and remove.

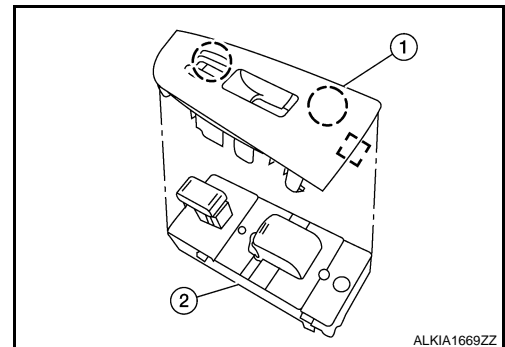

INSTALLATION

Installation is in the reverse order of removal.

NOTE:

After every switch harness disconnection, it is necessary to perform the initialization procedure Refer to [PWC-119, "ADDITIONAL SERVICE WHEN REPLACING CONTROL UNIT : Special Repair Requirement"](#).

A
B
C
D
E
F
G
H
I
J
L
M
N
O
P

PWC

REAR POWER WINDOW SWITCH

< ON-VEHICLE REPAIR >

[FRONT & REAR WINDOW ANTI-PINCH]

REAR POWER WINDOW SWITCH

Removal and Installation

INFOID:000000004392596

REMOVAL

1. Disconnect the negative battery terminal.
2. Using a suitable tool, remove the rear door arm rest finisher (1), then disconnect the harness connector. Refer to [INT-21, "Exploded View"](#).

CAUTION:

Wrap a cloth around suitable tools to protect components from damage.

3. Release the tabs on each side with suitable tool (A), then separate the rear power window switch (2) from the finisher (1) and remove.

⊖: Pawl

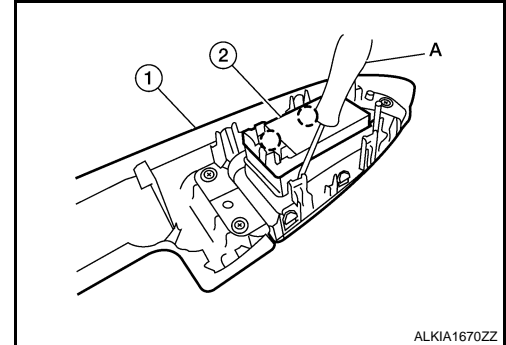

INSTALLATION

Installation is in the reverse order of removal.

NOTE:

After every switch harness disconnection, it is necessary to perform the initialization procedure. Refer to [PWC-119, "ADDITIONAL SERVICE WHEN REPLACING CONTROL UNIT : Special Repair Requirement"](#).