

A
CO
C
D
E
F
G
H
I
J
K
L
M

SECTION CO

ENGINE COOLING SYSTEM

CONTENTS

<p>PRECAUTIONS 2</p> <p style="padding-left: 20px;">Precautions for Supplemental Restraint System (SRS) "AIR BAG" and "SEAT BELT PRE-TENSIONER" 2</p> <p style="padding-left: 20px;">Precautions for Liquid Gasket 2</p> <p style="padding-left: 40px;">REMOVAL OF LIQUID GASKET SEALING 2</p> <p style="padding-left: 40px;">LIQUID GASKET APPLICATION PROCEDURE... 2</p> <p>PREPARATION 4</p> <p style="padding-left: 20px;">Special Service Tools 4</p> <p style="padding-left: 20px;">Commercial Service Tools 4</p> <p>OVERHEATING CAUSE ANALYSIS 6</p> <p style="padding-left: 20px;">Troubleshooting Chart 6</p> <p>COOLING SYSTEM 8</p> <p style="padding-left: 20px;">Cooling Circuit 8</p> <p style="padding-left: 20px;">System Drawing 9</p> <p>ENGINE COOLANT 10</p> <p style="padding-left: 20px;">Inspection 10</p> <p style="padding-left: 40px;">LEVEL CHECK 10</p> <p style="padding-left: 40px;">CHECKING COOLING SYSTEM FOR LEAKS... 10</p> <p style="padding-left: 40px;">CHECKING RESERVOIR CAP 10</p> <p style="padding-left: 40px;">CHECKING RADIATOR CAP 10</p> <p style="padding-left: 20px;">Changing Engine Coolant 10</p> <p style="padding-left: 40px;">DRAINING ENGINE COOLANT 10</p> <p style="padding-left: 40px;">REFILLING ENGINE COOLANT 11</p> <p style="padding-left: 40px;">FLUSHING COOLING SYSTEM 11</p> <p>RADIATOR 12</p> <p style="padding-left: 20px;">Removal and Installation 12</p> <p style="padding-left: 40px;">REMOVAL 12</p> <p style="padding-left: 40px;">INSTALLATION 14</p>	<p style="padding-left: 40px;">INSPECTION AFTER INSTALLATION 14</p> <p style="padding-left: 40px;">Checking Radiator 14</p> <p>ENGINE COOLING FAN 15</p> <p style="padding-left: 20px;">Removal and Installation (Crankshaft driven type).. 15</p> <p style="padding-left: 40px;">REMOVAL 15</p> <p style="padding-left: 40px;">INSPECTION AFTER REMOVAL 15</p> <p style="padding-left: 40px;">INSTALLATION 15</p> <p style="padding-left: 40px;">INSPECTION AFTER INSTALLATION 15</p> <p style="padding-left: 20px;">Removal and Installation (Motor driven type) 16</p> <p style="padding-left: 40px;">REMOVAL 16</p> <p style="padding-left: 40px;">INSTALLATION 16</p> <p>WATER PUMP 17</p> <p style="padding-left: 20px;">Removal and Installation 17</p> <p style="padding-left: 40px;">REMOVAL 17</p> <p style="padding-left: 40px;">INSPECTION AFTER REMOVAL 17</p> <p style="padding-left: 40px;">INSTALLATION 17</p> <p style="padding-left: 40px;">INSPECTION AFTER INSTALLATION 18</p> <p>THERMOSTAT AND WATER PIPING 19</p> <p style="padding-left: 20px;">Removal and Installation 19</p> <p style="padding-left: 40px;">REMOVAL 19</p> <p style="padding-left: 40px;">INSPECTION AFTER REMOVAL 20</p> <p style="padding-left: 40px;">INSTALLATION 20</p> <p style="padding-left: 40px;">INSPECTION AFTER INSTALLATION 20</p> <p>SERVICE DATA AND SPECIFICATIONS (SDS) 21</p> <p style="padding-left: 20px;">Standard and Limit 21</p> <p style="padding-left: 40px;">ENGINE COOLANT CAPACITY (APPROXIMATE) 21</p> <p style="padding-left: 40px;">THERMOSTAT 21</p> <p style="padding-left: 40px;">RADIATOR 21</p>
--------------------------------------------------------------------------------------------------------------------------------------------------------------------------------------------------------------------------------------------------------------------------------------------------------------------------------------------------------------------------------------------------------------------------------------------------------------------------------------------------------------------------------------------------------------------------------------------------------------------------------------------------------------------------------------------------------------------------------------------------------------------------------------------------------------------------------------------------------------------------------------------------------------------------------------------------------------------------------------------------------------------------------------------------------------------------------------------------------------------------------------------------------------------------------------------------------------------------------------------------------------------------------------------------------------------------------------------------------------------------------------------------------------------------------------------------------------------------------------------------------------------------------------------------------------------------------------------------------------------------------------------------------------------------------------------------------------------------------------	--------------------------------------------------------------------------------------------------------------------------------------------------------------------------------------------------------------------------------------------------------------------------------------------------------------------------------------------------------------------------------------------------------------------------------------------------------------------------------------------------------------------------------------------------------------------------------------------------------------------------------------------------------------------------------------------------------------------------------------------------------------------------------------------------------------------------------------------------------------------------------------------------------------------------------------------------------------------------------------------------------------------------------------------------------------------------------------------------------------------------------------------------------------------------------------------------------------------------------------------------------------------------------------------------------------------------------------------------------------------------------------------------------------------------------------------------------------------------------------------------------------------------------------------------------------------------------------------------------------------------------------------------------------------------------------------------------------------------------------------------------------------------------------------------------------------------------

PRECAUTIONS

PRECAUTIONS

PF0:0001

Precautions for Supplemental Restraint System (SRS) “AIR BAG” and “SEAT BELT PRE-TENSIONER”

EBS00KNE

The Supplemental Restraint System such as “AIR BAG” and “SEAT BELT PRE-TENSIONER”, used along with a front seat belt, helps to reduce the risk or severity of injury to the driver and front passenger for certain types of collision. This system includes seat belt switch inputs and dual stage front air bag modules. The SRS system uses the seat belt switches to determine the front air bag deployment, and may only deploy one front air bag, depending on the severity of a collision and whether the front occupants are belted or unbelted. Information necessary to service the system safely is included in the SRS and SB section of this Service Manual.

WARNING:

- To avoid rendering the SRS inoperative, which could increase the risk of personal injury or death in the event of a collision which would result in air bag inflation, all maintenance must be performed by an authorized NISSAN/INFINITI dealer.
- Improper maintenance, including incorrect removal and installation of the SRS, can lead to personal injury caused by unintentional activation of the system. For removal of Spiral Cable and Air Bag Module, see the SRS section.
- Do not use electrical test equipment on any circuit related to the SRS unless instructed to in this Service Manual. SRS wiring harnesses can be identified by yellow and/or orange harnesses or harness connectors.

Precautions for Liquid Gasket REMOVAL OF LIQUID GASKET SEALING

EBS00NIL

- After removing the bolts and nuts, separate the mating surface and remove the old liquid gasket sealing using Tool.

Tool number : KV10111100 (J-37228)

CAUTION:

Do not damage the mating surfaces.

- Tap the seal cutter to insert it.
- In areas where the Tool is difficult to use, lightly tap to slide it.

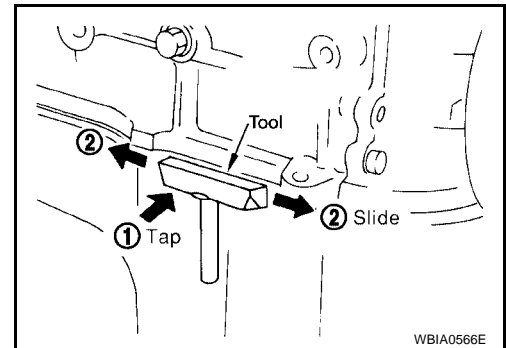

WBIA0566E

LIQUID GASKET APPLICATION PROCEDURE

1. Remove the old liquid gasket adhering to the gasket application surface and the mating surface using suitable tool.
 - Remove the liquid gasket completely from the groove of the liquid gasket application surface, bolts, and bolt holes.
2. Thoroughly clean the mating surfaces and remove adhering moisture, grease and foreign material.

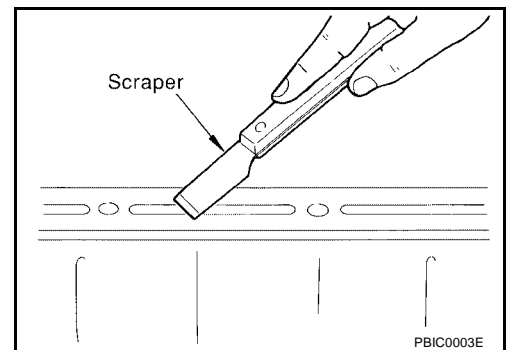

PBIC0003E

PRECAUTIONS

3. Attach the liquid gasket tube to the Tool.

Tool number : WS39930000 (—)

Use Genuine RTV Silicone Sealant or equivalent. Refer to GI-45, "Recommended Chemical Products and Sealants" .

4. Apply the liquid gasket without breaks to the specified location with the specified dimensions.

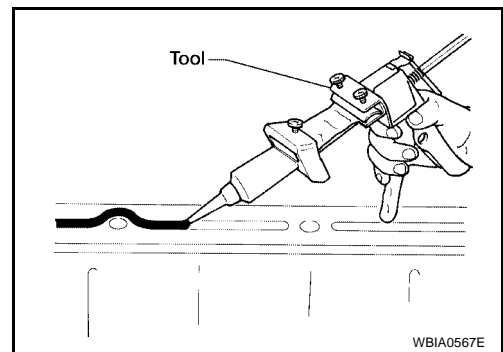

- If there is a groove for the liquid gasket application, apply the liquid gasket to the groove.
- As for the bolt holes, normally apply the liquid gasket inside the holes. If specified in the procedure, it should also be applied outside the holes.
- Within five minutes of liquid gasket application, install the mating component.
- If the liquid gasket protrudes, wipe it off immediately.
- Do not retighten after the installation.
- Wait 30 minutes or more after installation before refilling the engine with engine oil and engine coolant.

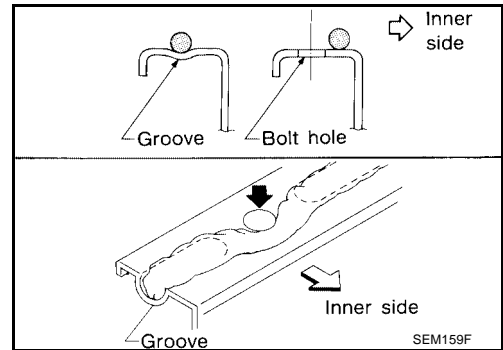

CAUTION:

If there are specific instructions in this manual, observe them.

A
CO
C
D
E
F
G
H
I
J
K
L
M

PREPARATION

PREPARATION

PF0:0002

Special Service Tools

EBS00KNG

The actual shapes of Kent-Moore tools may differ from those of special service tools illustrated here.

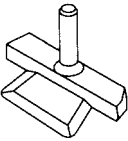
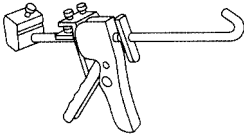
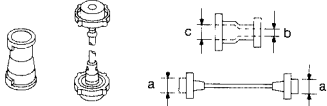
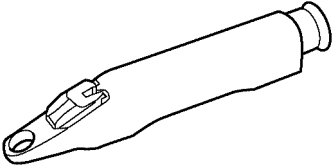
Tool number (Kent-Moore No.) Tool name	Description
KV10111100 (J-37228) Seal cutter	Removing steel oil pan and rear timing chain case  NT046
WS39930000 (—) Tube pressure	Pressing the tube of liquid gasket  S-NT052
EG17650301 (J-33984-A) Radiator cap tester adapter	Adapting radiator cap tester to radiator cap and radiator filler neck a: 28 (1.10) dia. b: 31.4 (1.236) dia. c: 41.3 (1.626) dia. Unit: mm (in)  S-NT564
— (J-23688) Engine coolant refractometer	Checking concentration of ethylene glycol in engine coolant  WBIA0539E

Commercial Service Tools

EBS00KNH

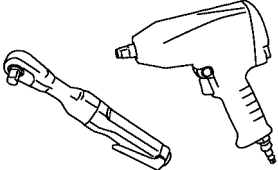
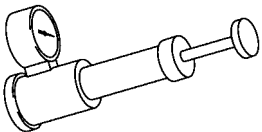
Tool name	Description
Power tool	Loosening bolts and nuts  PBIC0190E
Radiator cap tester	Checking radiator and radiator cap  PBIC1982E

PREPARATION

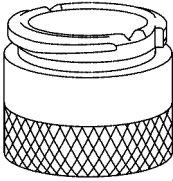
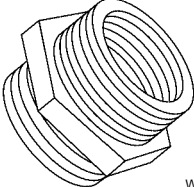
Tool name	Description
Coolant system tester adapter  <small>WBIA0408E</small>	Adapting radiator cap tester to reservoir filler neck
Coolant system tester adapter  <small>WBIA0409E</small>	Adapting radiator cap tester to reservoir cap

A

CO

C

D

E

F

G

H

I

J

K

L

M

OVERHEATING CAUSE ANALYSIS

OVERHEATING CAUSE ANALYSIS

PPF:00012

Troubleshooting Chart

EBS00KNI

		Symptom	Check items	
Cooling system parts malfunction	Poor heat transfer	Water pump malfunction	Worn or loose drive belt	—
		Thermostat stuck closed	—	
		Damaged fins	Dust contamination or paper clogging	
			Physical damage	
		Clogged radiator cooling tube	Excess foreign material (rust, dirt, sand, etc.)	
	Water cut valve malfunction	Excess foreign material (rust, dirt, sand, etc.), physical damage		
	Reduced air flow	Cooling fan does not operate	Fan assembly	—
		High resistance to fan rotation		
		Damaged fan blades		
	Damaged radiator shroud	—	—	—
	Improper engine coolant mixture ratio	—	—	—
	Poor engine coolant quality	—	Engine coolant density	—
	Insufficient engine coolant	Engine coolant leaks	Cooling hose	Loose clamp
				Cracked hose
			Water pump	Poor sealing
Radiator cap			Loose	
		Poor sealing		
Radiator		O-ring for damage, deterioration or improper fitting		
		Cracked radiator tank		
	Cracked radiator core			
Reservoir tank	Cracked reservoir tank			
Overflowing reservoir tank	Exhaust gas leaks into cooling system	Cylinder head deterioration		
		Cylinder head gasket deterioration		

OVERHEATING CAUSE ANALYSIS

	Symptom		Check items			
Except cooling system parts malfunction	—	Overload on engine	Abusive driving	High engine rpm under no load	A	
				Driving in low gear for extended time	CO	
				Driving at extremely high speed		
				Powertrain system malfunction		C
				Installed improper size wheels and tires	—	D
				Dragging brakes		
		Improper ignition timing		E		
	Blocked or restricted air flow	Blocked bumper	—			
		Blocked radiator grille	Installed car brassiere			
			Mud contamination or paper clogging	—	F	
		Blocked radiator	—			
		Blocked condenser	Blocked air flow		G	
Installed large fog lamp						

A
CO
C
D
E
F
G
H
I
J
K
L
M

COOLING SYSTEM

COOLING SYSTEM

PF2:21020

Cooling Circuit

EBS00KNJ

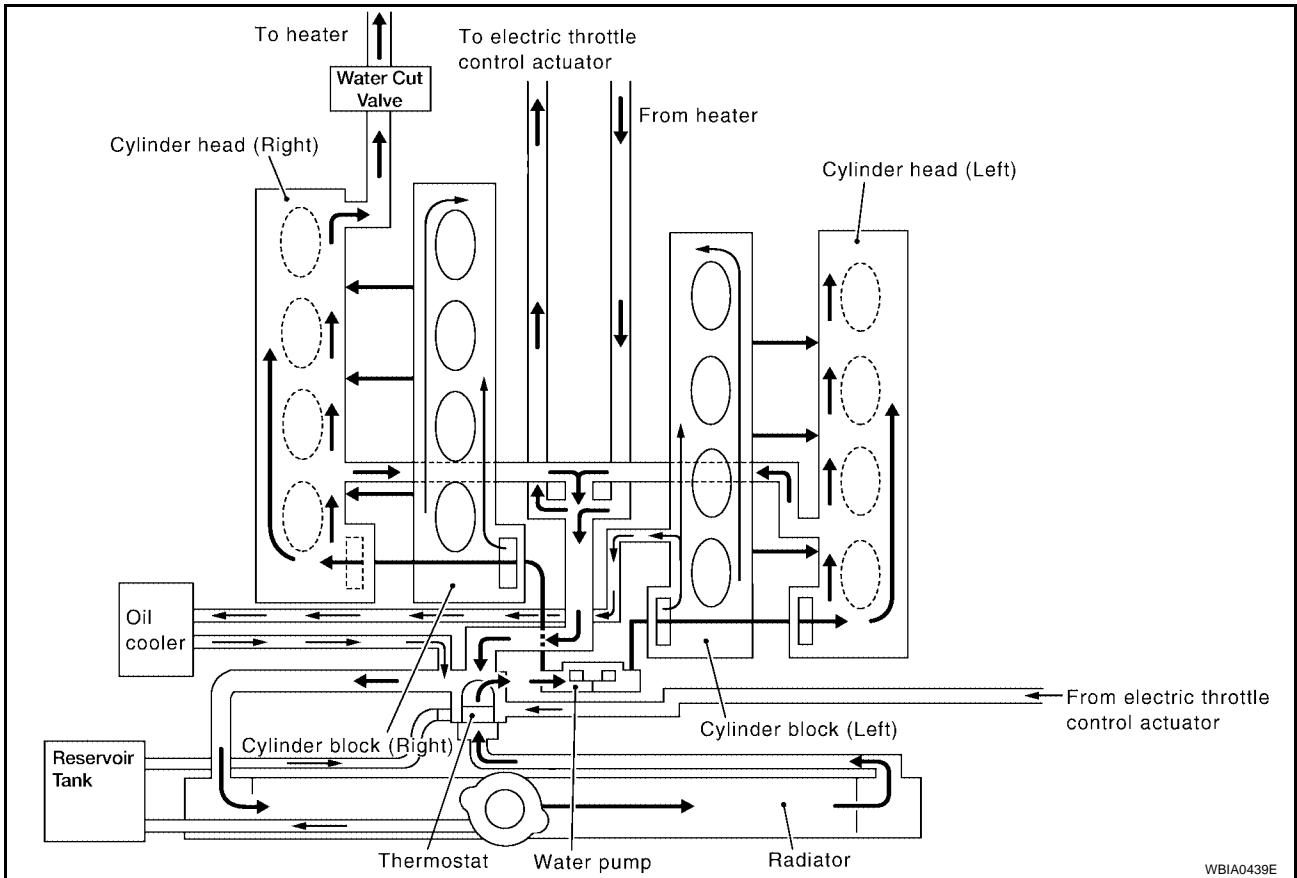

COOLING SYSTEM

System Drawing

EBS00KNK

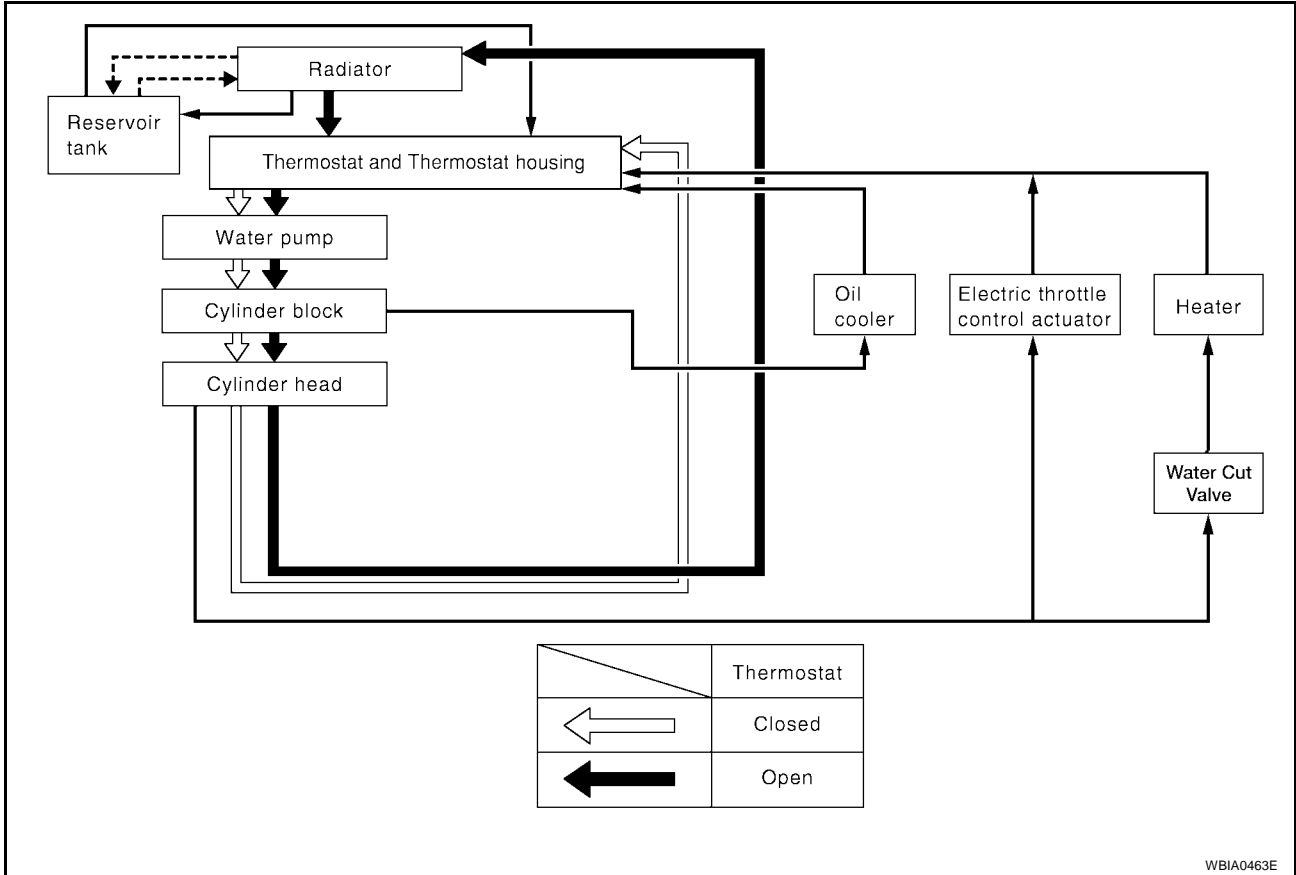

A
CO
C
D
E
F
G
H
I
J
K
L
M

ENGINE COOLANT

PFP:KQ100

EBS00KNL

ENGINE COOLANT

Inspection LEVEL CHECK

- Check if the engine coolant reservoir tank level is within MIN to MAX level when engine is cool.
- Adjust engine coolant level as necessary.

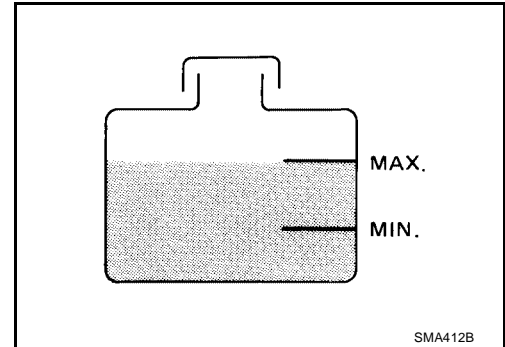

CHECKING COOLING SYSTEM FOR LEAKS

WARNING:

Never remove the radiator or reservoir cap when the engine is hot. Serious burns could occur from high-pressure engine coolant escaping from the radiator or reservoir.

- To check for leakage, apply pressure to the cooling system at the reservoir filler neck using suitable tool and Tool.

Tool number : EG17650301 (J-33984-A)

Leakage test pressure : 137 kPa (1.4 kg/cm, 20 psi)

CAUTION:

Higher pressure than specified may cause radiator damage.

NOTE:

In case that engine coolant decreases, replenish cooling system with engine coolant.

- If any concerns are found, repair or replace damaged parts.

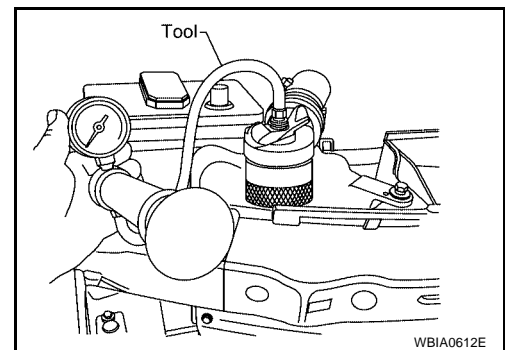

CHECKING RESERVOIR CAP

- Check reservoir cap relief pressure using suitable tool and Tool.

Tool number : EG17650301 (J-33984-A)

Standard : 95 - 125 kPa (0.97 - 1.28 kg/cm² , 14 - 18 psi)

NOTE:

Apply engine coolant to the cap seal.

- Replace the reservoir cap if there is any damage in the negative-pressure valve, or if the open-valve pressure is outside of the limit.

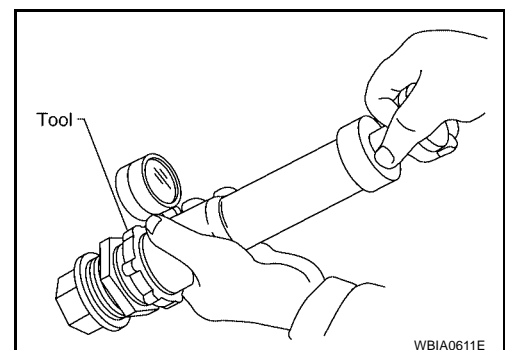

CHECKING RADIATOR CAP

Inspect the radiator cap.

NOTE:

Thoroughly wipe out the radiator filler neck to remove any waxy residue or foreign material.

- Replace the cap if the metal plunger cannot be seen around the edge of the black rubber gasket.
- Replace the cap if deposits of waxy residue or other foreign material are on the black rubber gasket or the metal retainer.

Changing Engine Coolant

Refer to [MA-13, "Changing Engine Coolant"](#) .

DRAINING ENGINE COOLANT

Refer to [MA-13, "DRAINING ENGINE COOLANT"](#) .

EBS00KNM

ENGINE COOLANT

REFILLING ENGINE COOLANT

Refer to [MA-14, "REFILLING ENGINE COOLANT"](#) .

FLUSHING COOLING SYSTEM

Refer to [MA-15, "FLUSHING COOLING SYSTEM"](#) .

A

CO

C

D

E

F

G

H

I

J

K

L

M

RADIATOR

PF21400

RADIATOR

Removal and Installation

EBS00KNN

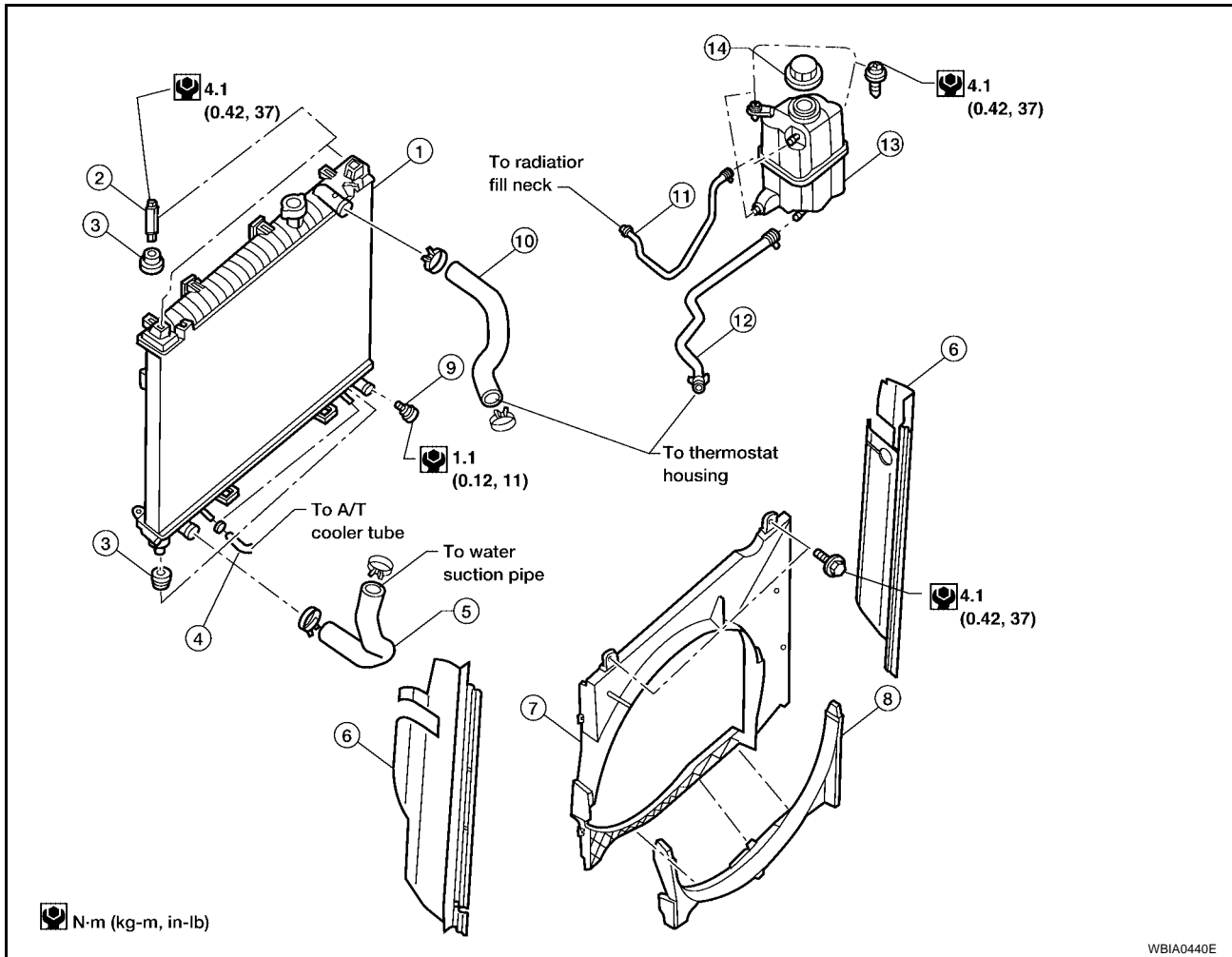

- | | | |
|----------------------------|----------------------------|--------------------|
| 1. Radiator | 2. Bolt | 3. Mounting rubber |
| 4. A/T fluid cooler hose | 5. Radiator hose (lower) | 6. Flaps |
| 7. Radiator shroud (upper) | 8. Radiator shroud (lower) | 9. Drain plug |
| 10. Radiator hose (upper) | 11. Reservoir tank hose | 12. By-pass hose |
| 13. Reservoir tank | 14. Reservoir tank cap | |

WARNING:

Never remove the radiator cap when the engine is hot. Serious burns could occur from high-pressure engine coolant escaping from the radiator.

REMOVAL

CAUTION:

Perform when the engine is cold.

1. Drain engine coolant from the radiator. Refer to [MA-13, "DRAINING ENGINE COOLANT"](#).
2. Remove air cleaner and air duct assembly. Refer to [EM-14, "REMOVAL"](#).
3. Disconnect A/T fluid cooler hoses.
 - Install blind plug to avoid leakage of A/T fluid.
4. Disconnect radiator upper and lower hoses from radiator.

CAUTION:

Do not allow coolant to contact drive belts.

RADIATOR

5. Remove the lower radiator shroud.

- Release the tabs, pull lower radiator shroud rearwards and down to remove.

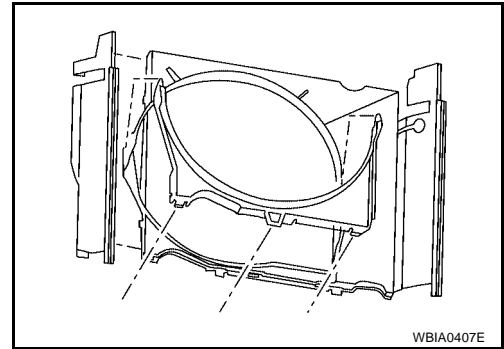

6. Remove the radiator shroud upper bolts and remove the radiator shroud upper.

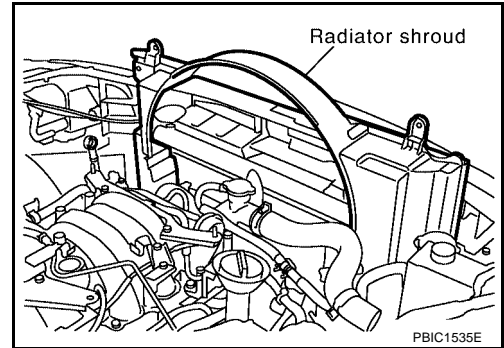

7. Remove the A/C condenser bolts and brackets.

- NOTE:**
Lift A/C condenser up and forward to remove from radiator.

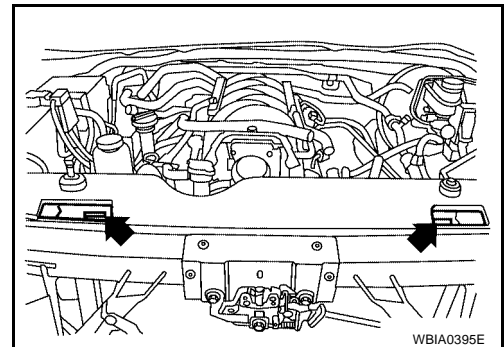

8. Remove A/T oil cooler bolts and oil cooler from radiator and position aside.

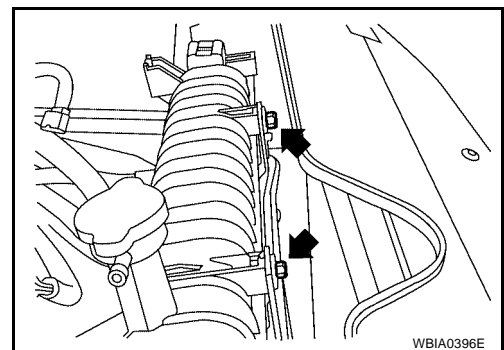

A

CO

C

D

E

F

G

H

I

J

K

L

M

RADIATOR

9. Lift up and remove the radiator.

CAUTION:

Do not damage or scratch air conditioner condenser and radiator core when removing.

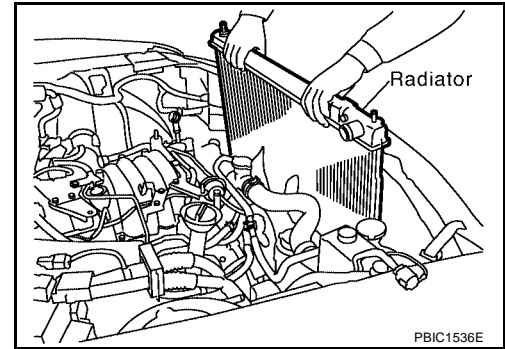

INSTALLATION

Installation is in the reverse order of removal.

INSPECTION AFTER INSTALLATION

- Check for leaks of engine coolant. Refer to [CO-10, "CHECKING COOLING SYSTEM FOR LEAKS"](#).
- Start and warm up the engine. Visually check for leaks of the engine coolant and A/T fluid.

Checking Radiator

EBS00KNP

Check radiator for mud or clogging. If necessary, clean radiator as follows.

CAUTION:

- **Be careful not to bend or damage the radiator fins.**
 - **When radiator is cleaned without removal, remove all surrounding parts such as cooling fan, radiator shroud and horns. Then tape the harness and electrical connectors to prevent water from entering.**
1. Apply water by hose to the back side of the radiator core vertically downward.
 2. Apply water again to all radiator core surfaces.
 3. Stop washing when dirt and debris no longer flow out from the radiator.
 4. Blow air into the back side of radiator core vertically downward.
 - Use compressed air lower than 490 kPa (5 kg/cm², 71 psi) and keep distance more than 30 cm (11.8 in).
 5. Blow air again into all the radiator core surfaces until no water sprays out.

ENGINE COOLING FAN

PFP:21140

ENGINE COOLING FAN

Removal and Installation (Crankshaft driven type)

EBS00KNQ

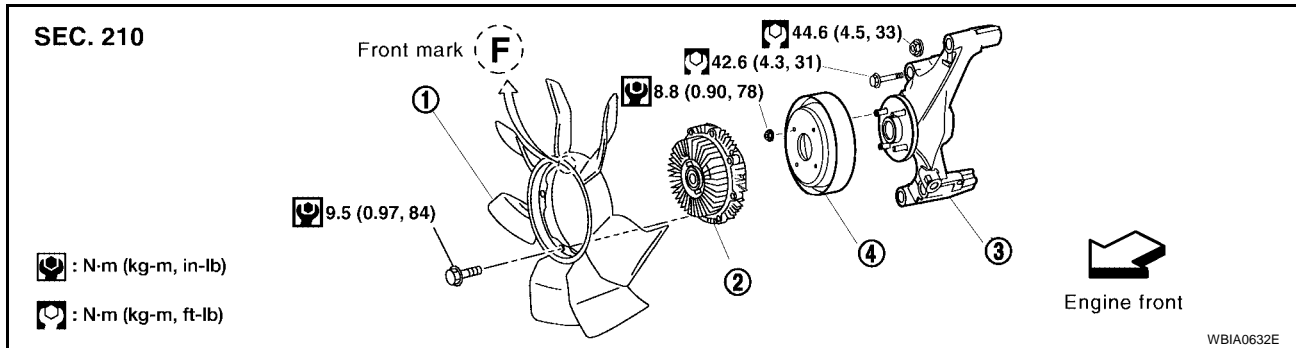

1. Cooling fan
2. Fan coupling
3. Fan bracket
4. Cooling fan pulley

REMOVAL

1. Remove the air duct and resonator assembly. Refer to [EM-14, "Removal and Installation"](#).
2. Remove the engine front undercover using power tool.
3. Remove the lower radiator shroud. Refer to [CO-12, "Removal and Installation"](#).
4. Remove the drive belt. Refer to [EM-12, "Removal and Installation"](#).
5. Remove the cooling fan.

INSPECTION AFTER REMOVAL

Fan Coupling

Inspect fan coupling for oil leakage and bimetal conditions.

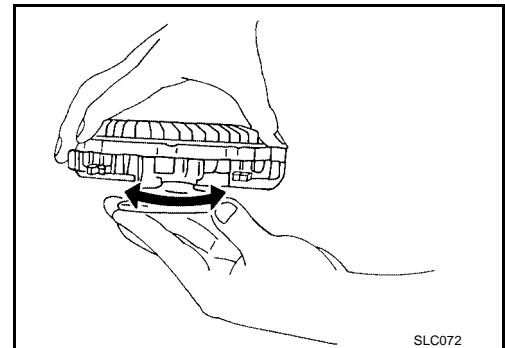

Fan Bracket

- Visually check that there is no significant looseness in the fan bracket shaft, and that it turns smoothly by hand.
- If there are any unusual concerns, replace the cooling fan pulley.

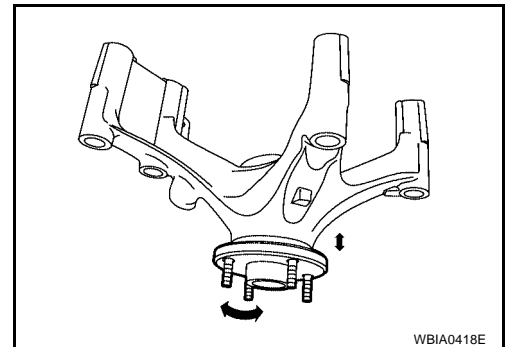

INSTALLATION

Installation is in the reverse order of removal.

- Install cooling fan with its front mark "F" facing front of engine. Refer to [CO-15, "Removal and Installation \(Crankshaft driven type\)"](#).

INSPECTION AFTER INSTALLATION

- Check for leaks of the engine coolant. Refer to [CO-10, "CHECKING COOLING SYSTEM FOR LEAKS"](#).

ENGINE COOLING FAN

- Start and warm up the engine. Visually make sure that there are no leaks of the engine coolant.

Removal and Installation (Motor driven type)

EBS00KNR

REMOVAL

1. Remove front grille. Refer to [EI-20, "Removal and Installation"](#) .
2. Disconnect harness connector from fan motor.
3. Remove the bolt and remove the fan grille and motor assembly.

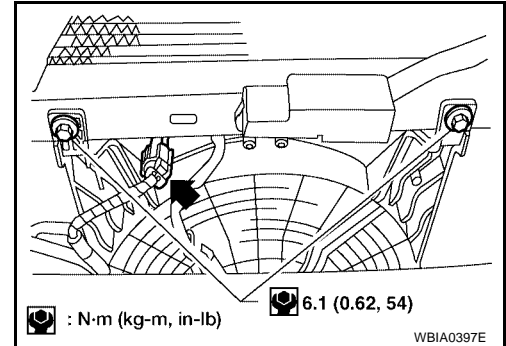

INSTALLATION

Installation is in the reverse order of removal.

- Cooling fan is controlled by ECM. For details, refer to [EC-436, "Cooling Fan Operation"](#) .

WATER PUMP

PF21020

WATER PUMP

Removal and Installation

EBS00KNS

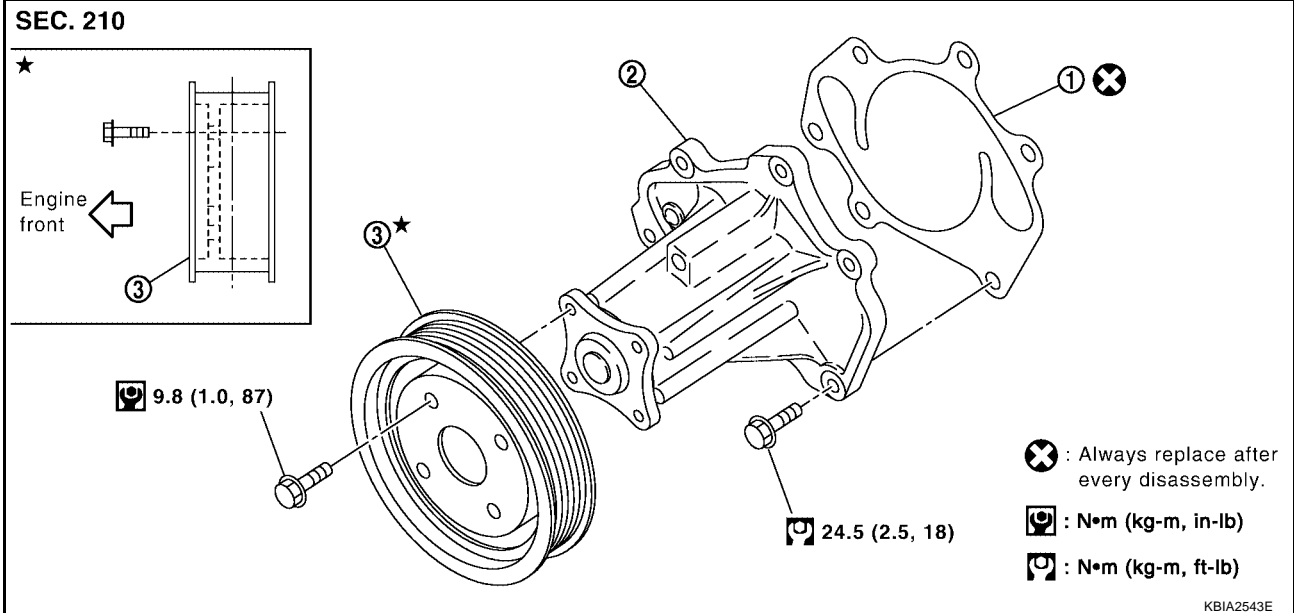

1. Gasket

2. Water pump

3. Water pump pulley

CAUTION:

- When removing water pump, be careful not to get engine coolant on drive belt.
- Water pump cannot be disassembled and should be replaced as a unit.

REMOVAL

1. Drain engine coolant so that no engine coolant comes out from water pump fitting hole. Refer to [MA-13, "DRAINING ENGINE COOLANT"](#).

CAUTION:

Perform when the engine is cold.

2. Remove the engine front undercover using power tool.
3. Remove the air duct and resonator assembly. Refer to [EM-14, "Removal and Installation"](#).
4. Remove the drive belt. Refer to [EM-12, "Removal and Installation"](#).
5. Remove the water pump pulley.
6. Remove the water pump.
 - Engine coolant will leak from the cylinder block, so have a receptacle ready below.

CAUTION:

Handle water pump vane so that it does not contact any other parts.

INSPECTION AFTER REMOVAL

- Visually check that there is no significant dirt or rust on the water pump body and vane.
- Make sure there is no looseness in the vane shaft, and that it turns smoothly when rotated by hand.
- Replace the water pump assembly, if necessary.

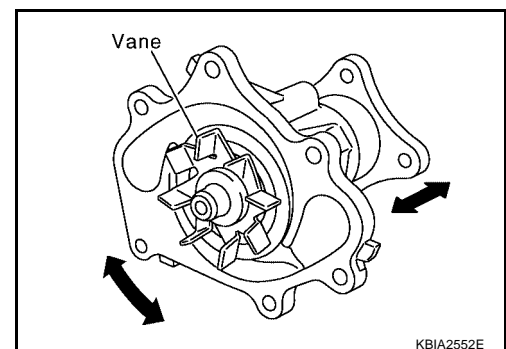

INSTALLATION

Installation is in the reverse order of removal.

WATER PUMP

- After installation bleed the air from the cooling system. Refer to [MA-14, "REFILLING ENGINE COOLANT"](#)

INSPECTION AFTER INSTALLATION

- Check for leaks of engine coolant. Refer to [CO-10, "CHECKING COOLING SYSTEM FOR LEAKS"](#) .
- Start and warm up engine. Visually check for leaks of the engine coolant.

THERMOSTAT AND WATER PIPING

Removal and Installation

SEC. 210•211•214•278

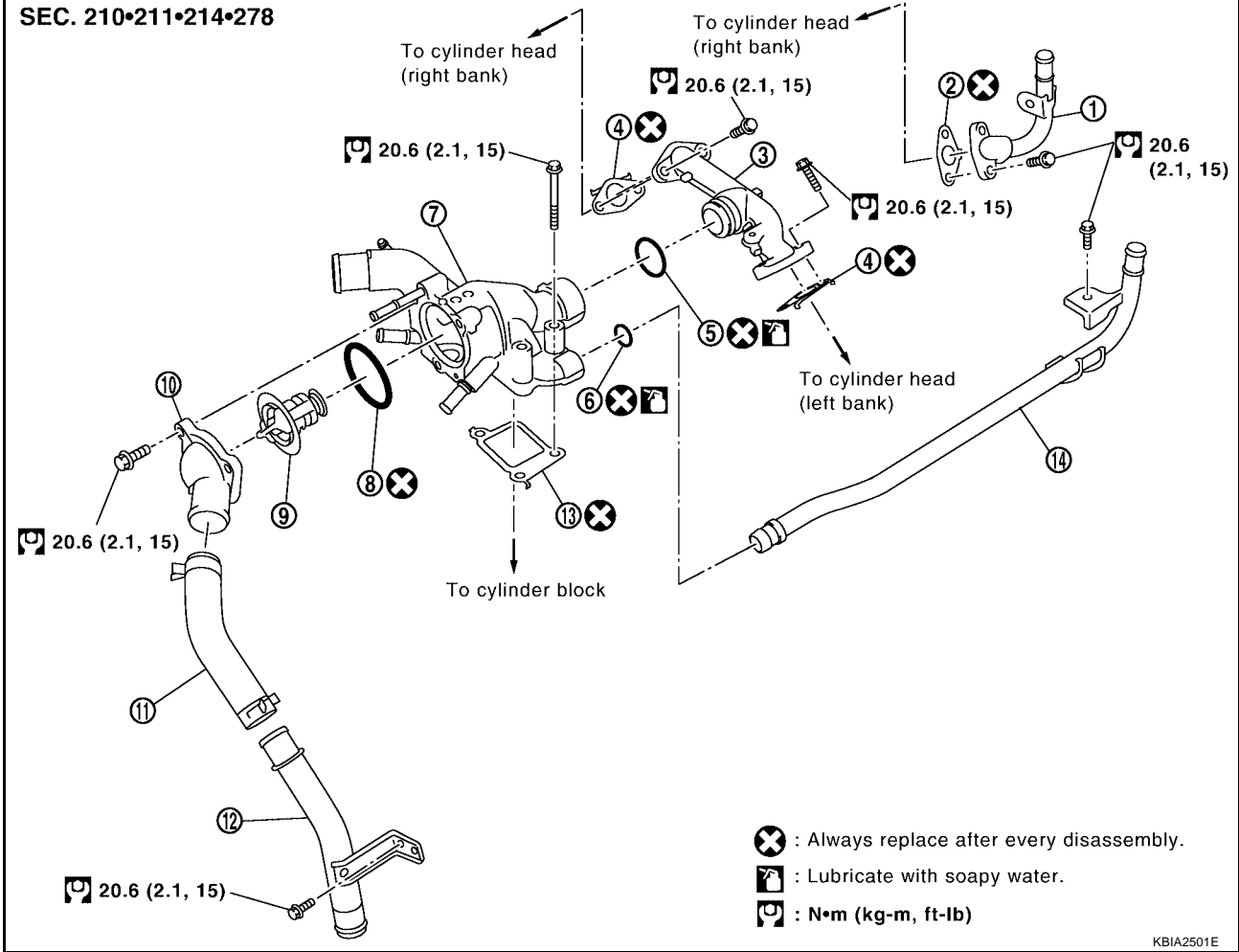

- | | | |
|-----------------------|------------------------|------------------------|
| 1. Heater pipe | 2. Gasket | 3. Water outlet |
| 4. Gasket | 5. O-ring | 6. O-ring |
| 7. Thermostat housing | 8. Rubber ring | 9. Thermostat |
| 10. Water inlet | 11. Water suction hose | 12. Water suction pipe |
| 13. Gasket | 14. Heater pipe | |

REMOVAL

Removal of Thermostat

1. Drain engine coolant from the radiator. Refer to [MA-13, "DRAINING ENGINE COOLANT"](#) .

CAUTION:

Perform when engine is cold.

2. Remove the air duct and resonator assembly. Refer to [EM-14, "REMOVAL"](#) .
3. Remove the engine room cover using power tools.
4. Disconnect the water suction hose from the water inlet.
5. Remove the water inlet and thermostat.

Removal of Thermostat Housing, Water Outlet and Heater Pipe

1. Remove the intake manifold. Refer to [EM-15, "REMOVAL"](#) .
2. Remove the thermostat housing, water outlet and heater pipe.

THERMOSTAT AND WATER PIPING

Removal of Water Cut Valve

1. Drain the engine coolant from the radiator. Refer to [MA-13, "DRAINING ENGINE COOLANT"](#) .

CAUTION:

Perform when the engine is cold.

2. Disconnect the heater hoses.
3. Disconnect the water valve electrical connector.
4. Remove the water cut valve.

Installation of Water Cut Valve

Installation is in the reverse order of removal.

- Check for leaks of the engine coolant using suitable tool. Refer to [CO-10, "CHECKING COOLING SYSTEM FOR LEAKS"](#) .
- Start and warm up the engine. Visually make sure that there is no leaks of the engine coolant.

INSPECTION AFTER REMOVAL

- Place a thread so that it is caught in the valve of the thermostat. Immerse fully in a container filled with water. Heat while stirring.
- The valve opening temperature is the temperature at which the valve opens and falls from the thread.
- Continue heating. Check the full-open lift amount.
- After checking the full-open lift amount, lower the water temperature and check the valve closing temperature.

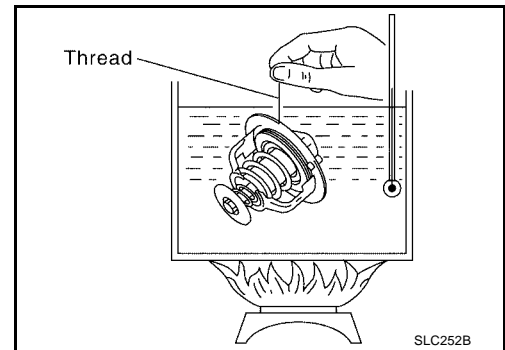

Standard values:

	Thermostat
Valve opening temperature	80 - 84°C (176 - 183° F)
Full-open lift amount	More than 10 mm/ 95°C (0.39 in/ 203°F)
Valve closing temperature	77°C (171°F) or lower

INSTALLATION

Installation is in the reverse order of removal.

Installation of Thermostat

- Install the thermostat with the whole circumference of each flange part fit securely inside the rubber ring as shown.
- Install the thermostat with the jiggle valve facing upwards.

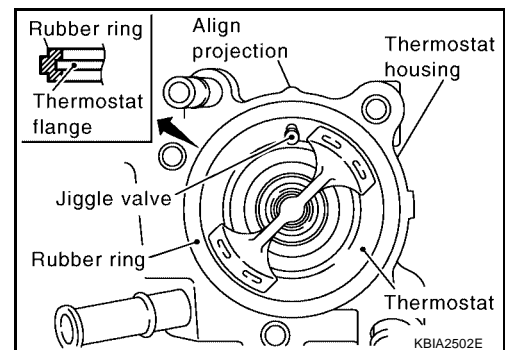

Installation of Water Outlet Pipe and Heater Pipe

First apply a neutral detergent to the O-rings, then quickly insert the insertion parts of the water outlet pipe and heater pipe into the installation holes.

INSPECTION AFTER INSTALLATION

- Check for leaks of the engine coolant. Refer to [CO-10, "CHECKING COOLING SYSTEM FOR LEAKS"](#) .
- Start and warm up the engine. Visually check for leaks of the engine coolant.

SERVICE DATA AND SPECIFICATIONS (SDS)

SERVICE DATA AND SPECIFICATIONS (SDS)

PFP:00030

Standard and Limit

EBS00KNU

ENGINE COOLANT CAPACITY (APPROXIMATE)

Unit: ℓ (US gal, Imp gal)

Engine coolant capacity with reservoir ("MAX" level)	12.2 (3 1/4, 2 5/8)
------------------------------------------------------	---------------------

THERMOSTAT

Valve opening temperature	80° - 84°C (176° - 183°F)
Maximum valve lift	More than 10 mm at 95°C (0.39 in at 203°F)
Valve closing temperature	77°C (171°F) or lower

RADIATOR

Unit: kPa (kg/cm², psi)

Reservoir cap relief pressure	Standard	95 - 125 (0.97- 1.28, 14 - 18)
Leakage test pressure		137 (1.4, 20)

A

CO

C

D

E

F

G

H

I

J

K

L

M

SERVICE DATA AND SPECIFICATIONS (SDS)
