

SECTION **FL**
FUEL SYSTEM

CONTENTS

PREPARATION	2	FUEL TANK	10	F
Special Service Tools	2	Removal and Installation	10	
Commercial Service Tool	2	REMOVAL	11	
FUEL SYSTEM	3	INSTALLATION	13	G
Checking Fuel Lines	3	INSPECTION AFTER INSTALLATION	14	
General Precautions	3	SERVICE DATA AND SPECIFICATIONS (SDS)	15	H
FUEL LEVEL SENSOR UNIT, FUEL FILTER AND		Standard and Limit	15	
FUEL PUMP ASSEMBLY	5			
Removal and Installation	5			
REMOVAL	6			I
INSTALLATION	8			
INSPECTION AFTER INSTALLATION	8			J

PREPARATION

PREPARATION

PPF:00002

Special Service Tools

EBS00L3E

The actual shapes of the Kent-Moore tools may differ from those of the special tools illustrated here.

Tool number (Kent-Moore No.) Tool name	Description
— (J-46536) Fuel tank lock ring tool	Removing and installing fuel tank lock ring

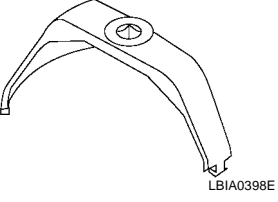

Commercial Service Tool

EBS00L3F

Tool name	Description
Power tool	Loosening bolts and nuts

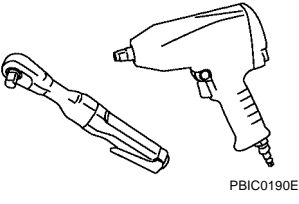

FUEL SYSTEM

Checking Fuel Lines

Inspect fuel lines, fuel filler cap and fuel tank for improper attachment, leaks, cracks, damage, loose connections, chafing or deterioration.

If necessary, repair or replace damaged parts.

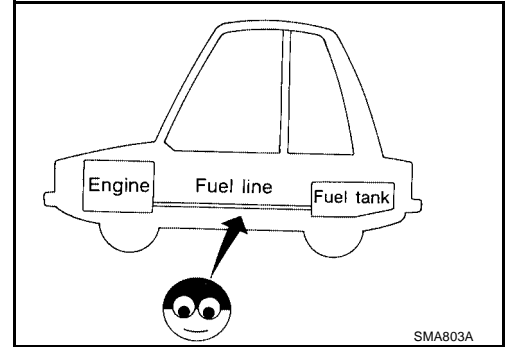

General Precautions

WARNING:

When replacing fuel line parts, be sure to observe the following.

- Put a “CAUTION: INFLAMMABLE” sign in the workshop.
- Be sure to work in a well ventilated area and furnish workshop with a CO₂ fire extinguisher.
- Do not smoke while servicing fuel system. Keep open flames and sparks away from the work area.

CAUTION:

- Before removing fuel line parts, carry out the following procedures:

- Put drained fuel in an explosion-proof container and put the lid on securely. Keep the container in safe area.
- Release fuel pressure from the fuel lines. Refer to [EC-92, "FUEL PRESSURE RELEASE"](#).
- Disconnect the battery negative terminal.

- Always replace O-rings and clamps with new ones.
- Do not kink or twist hoses when they are being installed.
- Do not tighten hose clamps excessively to avoid damaging hoses.

Tighten high-pressure rubber hose clamp so that clamp end is 3 mm (0.12 in) from hose end.

Tightening torque specifications are the same for all rubber hose clamps.

Ensure that screw does not contact adjacent parts.

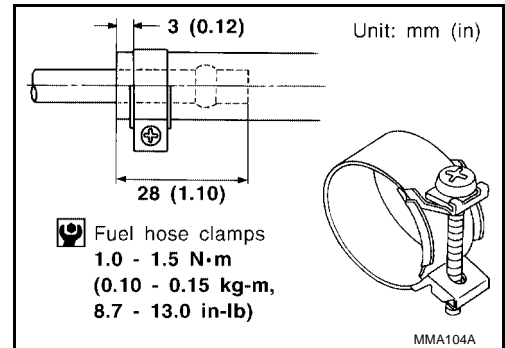

FUEL SYSTEM

- After connecting the fuel tube quick connectors, make sure the quick connectors are secure. Ensure that the connector and resin tube do not contact any adjacent parts.
- After installing tubes, make sure there is no fuel leakage at connections in the following steps.
- Apply fuel pressure to fuel lines with turning ignition switch ON (with engine stopped). Then check for fuel leaks at connections.
- Start the engine and rev it up and check for fuel leaks at connections.
- Use only a Genuine NISSAN fuel filler cap as a replacement. If an incorrect fuel filler cap is used, the MIL may come on.
- For servicing "Evaporative Emission System" parts, refer to [EC-32, "EVAPORATIVE EMISSION SYSTEM"](#) .
- For servicing "On Board Refueling Vapor Recovery (ORVR)" parts, refer to [EC-39, "ON BOARD REFUELING VAPOR RECOVERY \(ORVR\)"](#) .

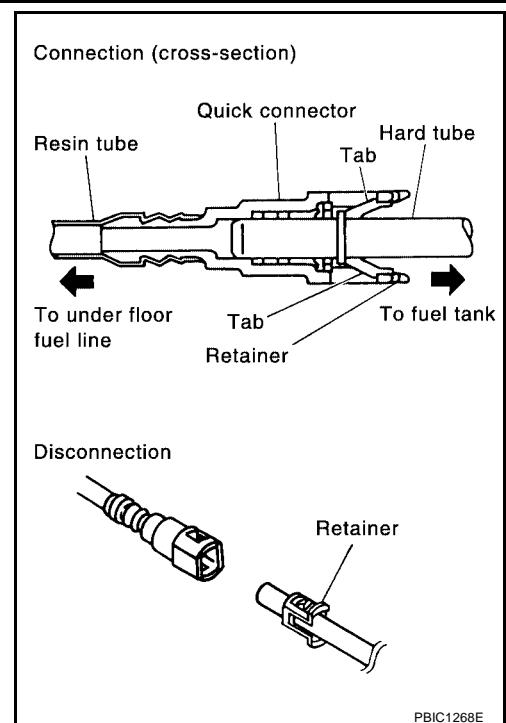

FUEL LEVEL SENSOR UNIT, FUEL FILTER AND FUEL PUMP ASSEMBLY

FUEL LEVEL SENSOR UNIT, FUEL FILTER AND FUEL PUMP ASSEMBLY PFP:17042

Removal and Installation

EBS00L3I

SEC. 172 • 747

A

FL

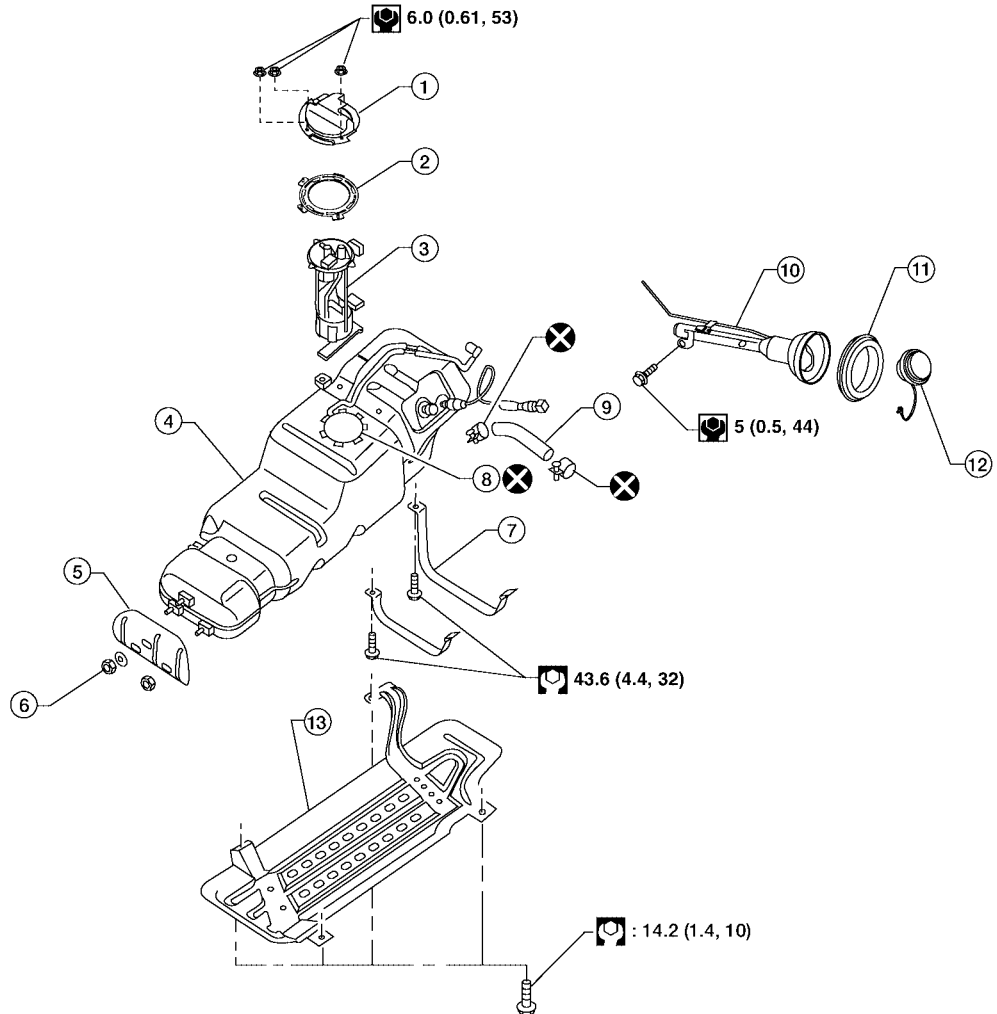

C

D

E

F

G

H

I

J

K

L

M

: N·m (kg-m, ft-lb)

: N·m (kg-m, in-lb)

: Always replace after every disassembly

LBIA0420E

- | | | |
|-----------------------------|--|---|
| 1. Fuel line pump protector | 2. Lock ring | 3. Fuel level sensor, fuel filter, and fuel pump assembly |
| 4. Fuel tank | 5. Fuel tank protector | 6. Fuel tank protector clips |
| 7. Fuel tank straps | 8. Fuel level sensor, fuel filter, and fuel pump assembly O-ring | 9. Fuel filler hose |
| 10. Fuel filler pipe | 11. Fuel filler hose grommet | 12. Fuel filler cap |
| 13. Fuel tank shield | | |

FUEL LEVEL SENSOR UNIT, FUEL FILTER AND FUEL PUMP ASSEMBLY

REMOVAL

WARNING:

Follow the "General Precautions" before working on the fuel system. Refer to [FL-3, "General Precautions"](#).

1. Remove the fuel filler cap to release the pressure from inside the fuel tank.
2. Check the fuel level on level gauge. If the fuel gauge indicates more than the level as shown (full or almost full), drain the fuel from the fuel tank until the fuel gauge indicates the level as shown, or less.
 - If the fuel pump does not operate, use the following procedure to drain the fuel to the specified level.
- a. Insert a suitable hose of less than 15 mm (0.59 in) diameter into the fuel filler pipe through the fuel filler opening to drain the fuel from fuel filler pipe.
- b. Remove the LH rear wheel and tire. Refer to [WT-6, "Rotation"](#).
- c. Remove the fuel filler pipe shield.

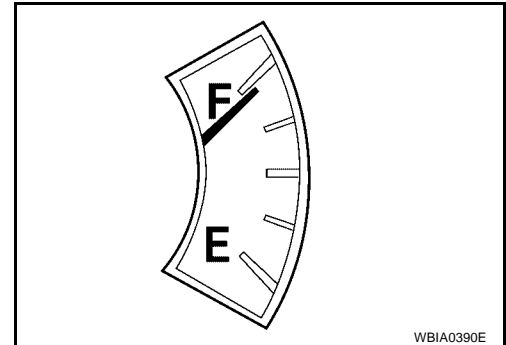

- d. Disconnect the fuel filler hose from the fuel filler pipe and disconnect the vent hose quick connector.
- e. Insert a suitable hose into the fuel tank through the fuel filler hose to drain the fuel from the fuel tank.
 - As a guide, the fuel level reaches the fuel gauge position as shown, or less, when approximately 14 liters (3 3/4 US gal, 3 1/8 Imp gal) of fuel are drained from the fuel tank when it is full.

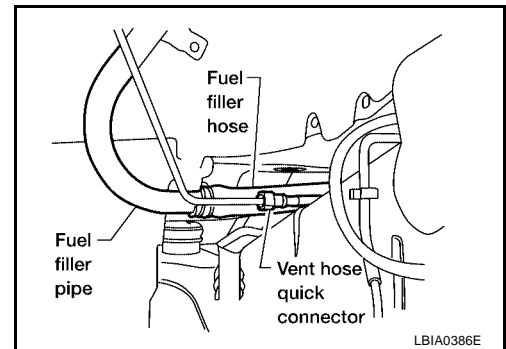
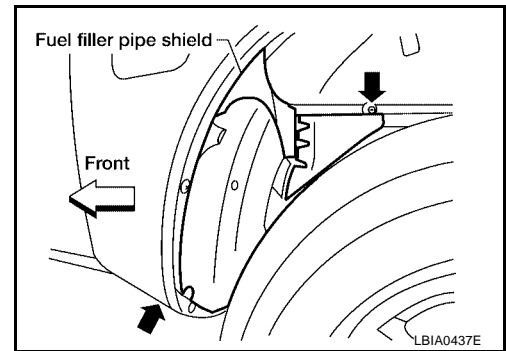

3. Release the fuel pressure from the fuel lines. Refer to [EC-92, "FUEL PRESSURE RELEASE"](#).
4. Remove the three nuts and remove fuel line pump protector.
5. Disconnect the EVAP hose at the EVAP canister.

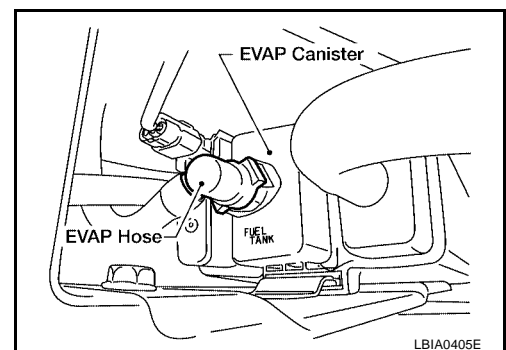

FUEL LEVEL SENSOR UNIT, FUEL FILTER AND FUEL PUMP ASSEMBLY

6. Disconnect the fuel level sensor, fuel filter, and fuel pump assembly electrical connector and the fuel feed hose.

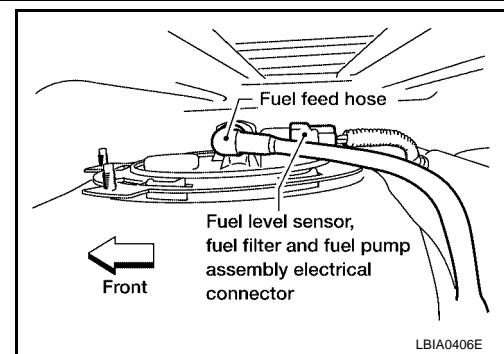

Disconnect the quick connector as follows:

- Hold the sides of the connector, push in tabs and pull out the tube.
- If the connector and the tube are stuck together, push and pull several times until they start to move. Then disconnect them by pulling.

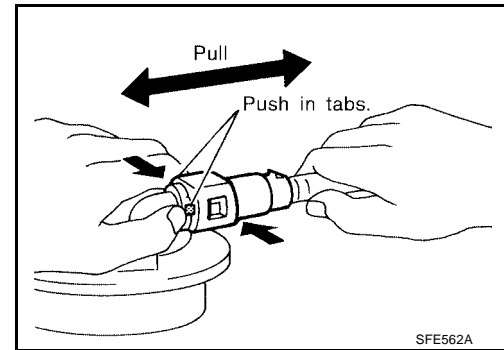

CAUTION:

- The quick connector can be disconnected when the tabs are completely depressed. Do not twist the quick connector more than necessary.
- Do not use any tools to disconnect the quick connector.
- Keep the resin tube away from heat. Be especially careful when welding near the tube.
- Prevent any acid liquids such as battery electrolyte, from getting on the resin tube.
- Do not bend or twist the resin tube during connection.
- Do not remove the remaining retainer on the hard tube (or the equivalent) except when the resin tube or the retainer is replaced.
- When the resin tube or hard tube, or the equivalent, is replaced, also replace the retainer with a new one (white colored retainer).

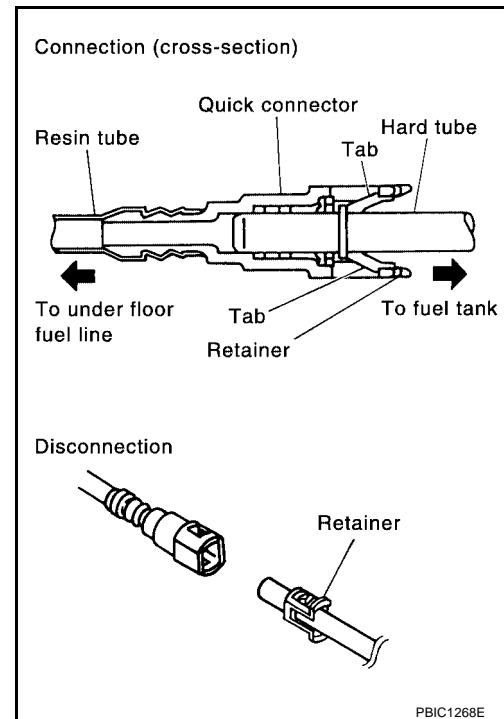

FUEL LEVEL SENSOR UNIT, FUEL FILTER AND FUEL PUMP ASSEMBLY

- To keep the quick connector clean and to avoid damage and contamination from foreign materials, cover the quick connector with plastic bags or suitable material as shown.

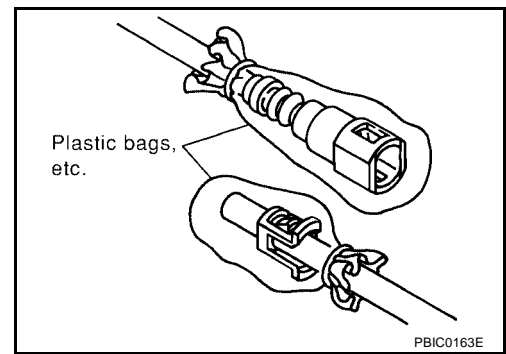

7. Remove the fuel tank strap bolts while supporting the fuel tank with a suitable lift jack.
8. Lower the fuel tank using a suitable lift jack and remove it from the vehicle to access the fuel level sensor, fuel filter, and fuel pump assembly.

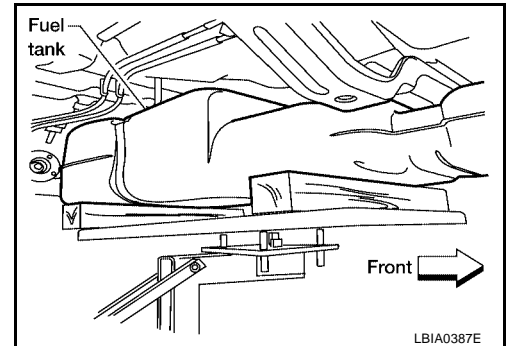

9. Remove the lock ring using Tool as shown.

Tool number : — (J-46536)

10. Remove the fuel level sensor, fuel filter, and fuel pump assembly. Remove and discard the fuel level sensor, fuel filter, and fuel pump assembly O-ring.

CAUTION:

- Do not bend the float arm during removal.
- Avoid impacts such as dropping when handling the components.

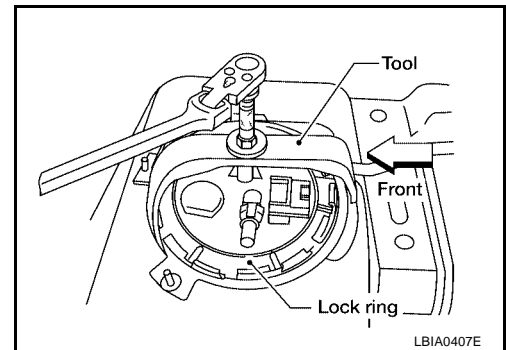

INSTALLATION

Installation is in the reverse order of removal.

- For installation, use a new fuel level sensor, fuel filter, and fuel pump assembly O-ring.
- Connect the quick connector as follows:
 - Check the connection for any damage or foreign materials.
 - Align the connector with the pipe, then insert the connector straight into the pipe until a click is heard.
 - After connecting the quick connector, make sure that the connection is secure by checking as follows:
 - Pull the tube and the connector to make sure they are securely connected.
 - Visually inspect the connector to make sure the two retainer tabs are securely connected.

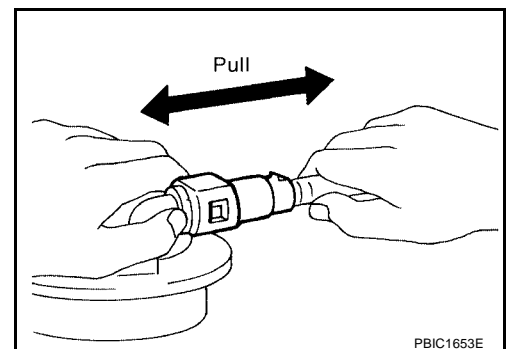

INSPECTION AFTER INSTALLATION

1. Turn the ignition switch ON but do not start engine, then check the fuel pipes and hose connections for leaks while applying fuel pressure to the system.

FUEL LEVEL SENSOR UNIT, FUEL FILTER AND FUEL PUMP ASSEMBLY

2. Start the engine and rev it above idle speed, then check that there are no fuel leaks at any of the fuel pipe and hose connections.

A

FL

C

D

E

F

G

H

I

J

K

L

M

FUEL TANK

FUEL TANK Removal and Installation

PPF:17202

EBS00L3J

SEC. 172 • 747

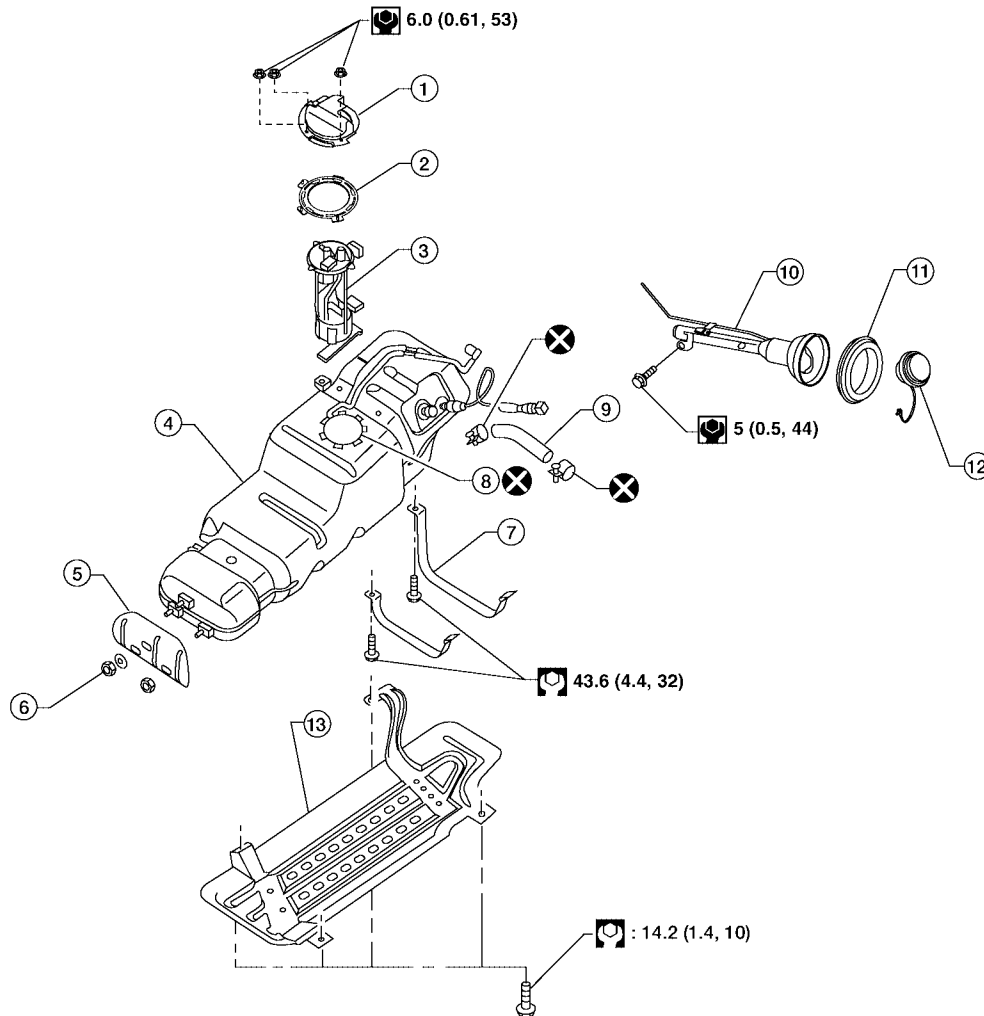

: N·m (kg·m, ft·lb)

: N·m (kg·m, in·lb)

: Always replace after every disassembly

LBI/A0420E

- | | | |
|-----------------------------|--|---|
| 1. Fuel line pump protector | 2. Lock ring | 3. Fuel level sensor, fuel filter, and fuel pump assembly |
| 4. Fuel tank | 5. Fuel tank protector | 6. Fuel tank protector clips |
| 7. Fuel tank straps | 8. Fuel level sensor, fuel filter, and fuel pump assembly O-ring | 9. Fuel filler hose |
| 10. Fuel filler pipe | 11. Fuel filler hose grommet | 12. Fuel filler cap |
| 13. Fuel tank shield | | |

FUEL TANK

REMOVAL

WARNING:

Follow the "General Precautions" before working on the fuel system. Refer to [FL-3, "General Precautions"](#).

1. Remove the fuel filler cap to release the pressure from inside the fuel tank.
2. Check the fuel level on level gauge. If the fuel gauge indicates more than the level as shown (full or almost full), drain the fuel from the fuel tank until the fuel gauge indicates the level as shown, or less.
 - If the fuel pump does not operate, use the following procedure to drain the fuel to the specified level.
- a. Insert a suitable hose of less than 15 mm (0.59 in) diameter into the fuel filler pipe through the fuel filler opening to drain the fuel from fuel filler pipe.
- b. Remove the LH rear wheel and tire. Refer to [WT-6, "Rotation"](#).
- c. Remove the fuel filler pipe shield.

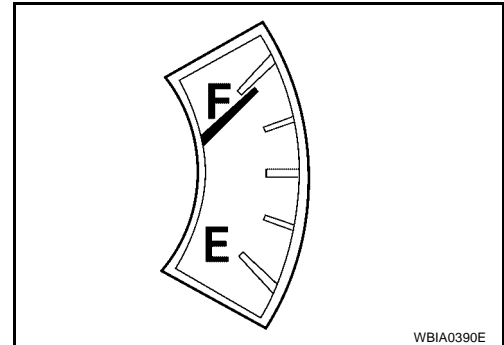

- d. Disconnect the fuel filler hose from the fuel filler pipe and disconnect the vent hose quick connector.
- e. Insert a suitable hose into the fuel tank through the fuel filler hose to drain the fuel from the fuel tank.

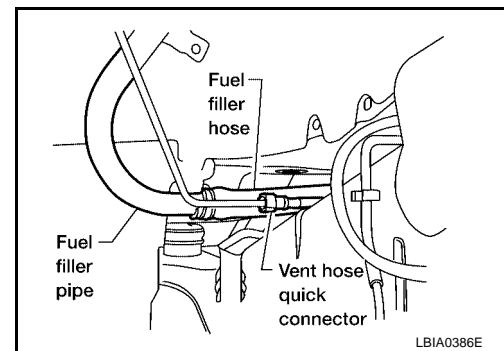
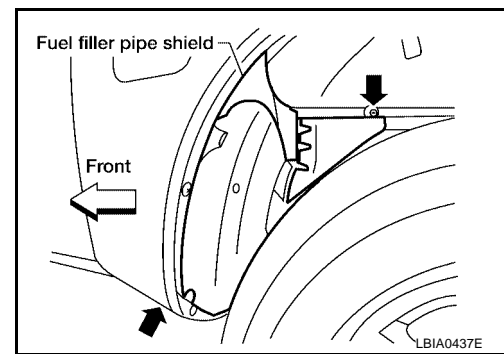

3. Release the fuel pressure from the fuel lines. Refer to [EC-92, "FUEL PRESSURE RELEASE"](#).
4. Remove the three nuts and remove fuel line pump protector.
5. Disconnect the EVAP hose at the EVAP canister.

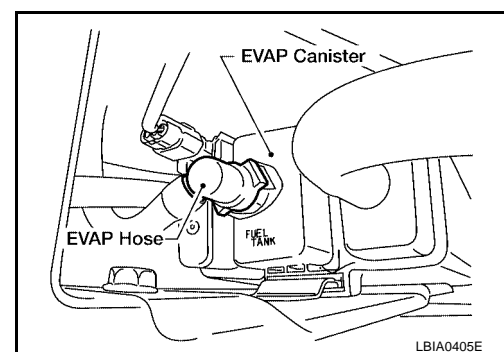

FUEL TANK

6. Disconnect the fuel level sensor, fuel filter, and fuel pump assembly electrical connector, and the fuel feed hose.

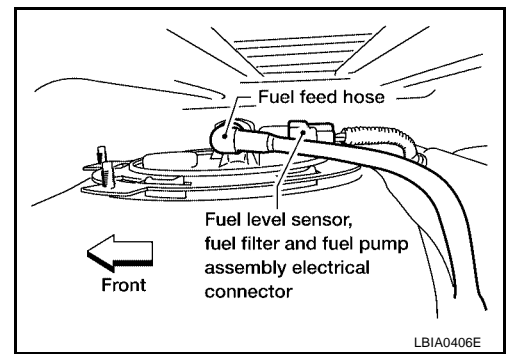

Disconnect the quick connector as follows:

- Hold the sides of the connector, push in tabs and pull out the tube.
- If the connector and the tube are stuck together, push and pull several times until they start to move. Then disconnect them by pulling.

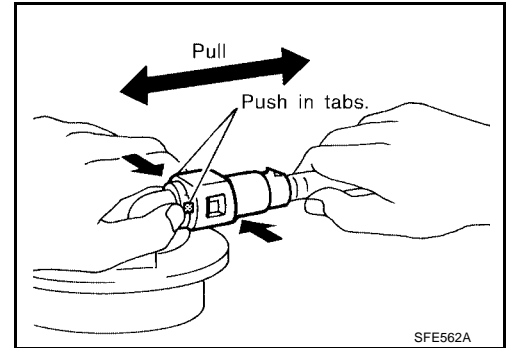

CAUTION:

- The quick connector can be disconnected when the tabs are completely depressed. Do not twist the quick connector more than necessary.
- Do not use any tools to disconnect the quick connector.
- Keep the resin tube away from heat. Be especially careful when welding near the tube.
- Prevent any acid liquids such as battery electrolyte, from getting on the resin tube.
- Do not bend or twist the resin tube during connection.
- Do not remove the remaining retainer on the hard tube (or the equivalent) except when the resin tube or the retainer is replaced.
- When the resin tube or hard tube, or the equivalent, is replaced, also replace the retainer with a new one (white colored retainer).

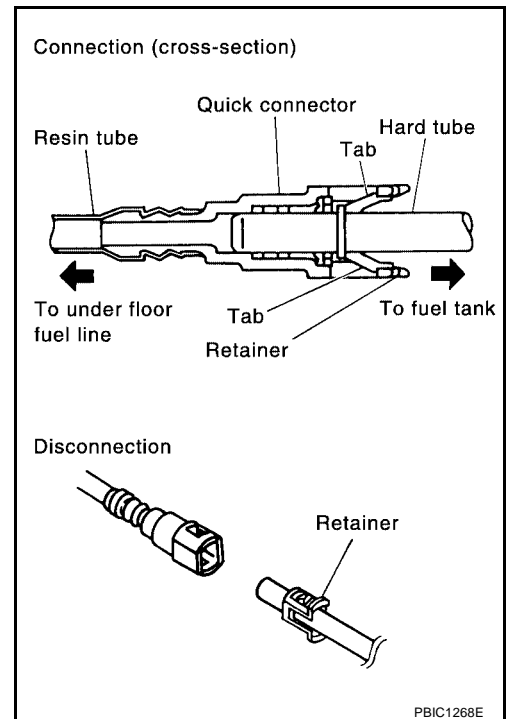

FUEL TANK

- To keep the quick connector clean and to avoid damage and contamination from foreign materials, cover the quick connector with plastic bags or suitable material as shown.

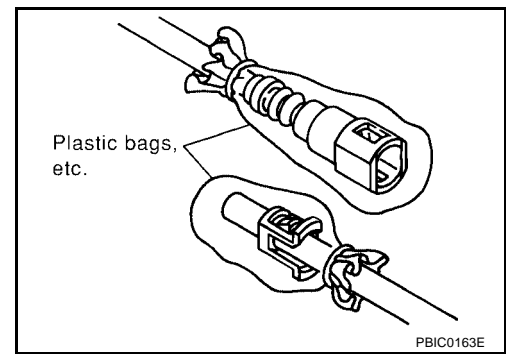

7. Remove the four bolts and remove the fuel tank shield using power tool.
8. Remove the three clips and remove the fuel tank protector at the front of the fuel tank as necessary to transfer to the new fuel tank.

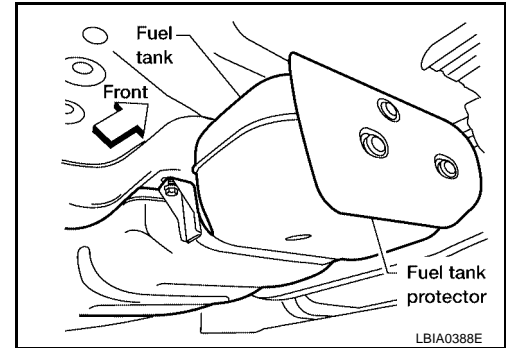

9. Disconnect fuel filler hose at the fuel tank side.
10. Remove the fuel tank strap bolts while supporting the fuel tank with a suitable lift jack.
11. Lower the fuel tank using a suitable lift jack and remove it from the vehicle.

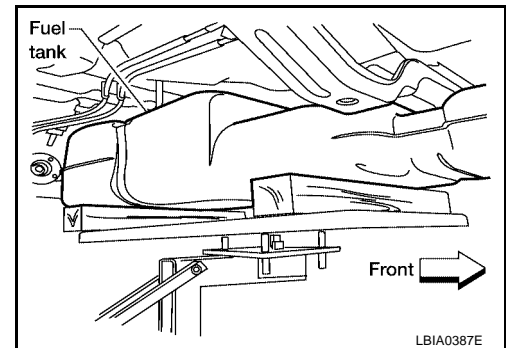

12. If necessary, remove the lock ring using Tool as shown.

Tool number : — (J-46536)

13. If necessary, remove the fuel level sensor, fuel filter, and fuel pump assembly. Discard the fuel level sensor, fuel filter, and fuel pump assembly O-ring.

CAUTION:

- Do not bend the float arm during removal.
- Avoid impacts such as dropping when handling the components.

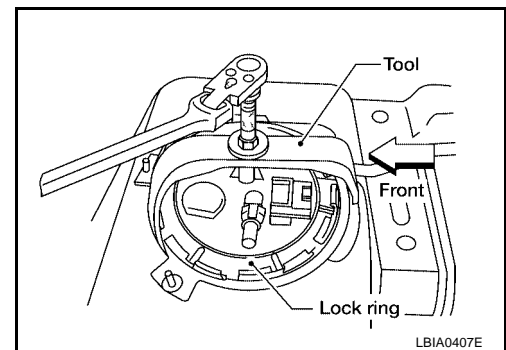

INSTALLATION

Installation is in the reverse order of removal.

- For installation, use a new fuel level sensor, fuel filter, and fuel pump assembly O-ring.
- Connect the quick connector as follows:
 - Check the connection for any damage or foreign materials.
 - Align the connector with the pipe, then insert the connector straight into the pipe until a click is heard.

FUEL TANK

- After connecting the quick connector, make sure that the connection is secure by checking as follows:
- Pull the tube and the connector to make sure they are securely connected.
- Visually inspect the connector to make sure the two retainer tabs are securely connected.

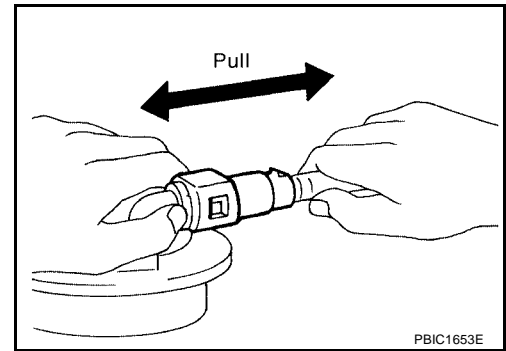

INSPECTION AFTER INSTALLATION

1. Turn the ignition switch ON but do not start engine, then check the fuel pipe and hose connections for leaks while applying fuel pressure.
2. Start the engine and rev it above idle, then check that there are no fuel leaks at any of the fuel pipe and hose connections.

SERVICE DATA AND SPECIFICATIONS (SDS)

SERVICE DATA AND SPECIFICATIONS (SDS)

PF0:00030

Standard and Limit

EBS00L3K

Fuel tank capacity	105.8 ℓ (28 US gal, 23 1/4 Imp gal)
--------------------	-------------------------------------

A

FL

C

D

E

F

G

H

I

J

K

L

M

SERVICE DATA AND SPECIFICATIONS (SDS)
