

SECTION **AP**
ADJUSTABLE PEDAL

A
B
C
D
E
F
G
H
I
AP
K
L
M
N
O
P

CONTENTS

BASIC INSPECTION	2	Pedal Adjusting Motor Circuit Inspection	6
DIAGNOSIS AND REPAIR WORKFLOW	2	Wiring Diagram	8
Repair Work Flow	2	SYMPTOM DIAGNOSIS	11
INSPECTION AND ADJUSTMENT	4	ADJUSTABLE PEDAL SYSTEM	11
Preliminary Check	4	Symptom Table	11
FUNCTION DIAGNOSIS	5	PRECAUTION	12
ADJUSTABLE PEDAL SYSTEM	5	PRECAUTIONS	12
Automatic Drive Positioner Interlocking Adjustable Pedal	5	Precaution for Supplemental Restraint System (SRS) "AIR BAG" and "SEAT BELT PRE-TENSIONER"	12
Component Parts Location	5	Precaution for Work	12
Component Description	5	ON-VEHICLE REPAIR	13
COMPONENT DIAGNOSIS	6	ADJUSTABLE PEDAL SYSTEM	13
ADJUSTABLE PEDAL SYSTEM	6	Removal and Installation	13
Pedal Adjusting Switch Power Supply and Ground Circuit Inspection	6		

DIAGNOSIS AND REPAIR WORKFLOW

< BASIC INSPECTION >

BASIC INSPECTION

DIAGNOSIS AND REPAIR WORKFLOW

Repair Work Flow

INFOID:000000004109533

WORK FLOW

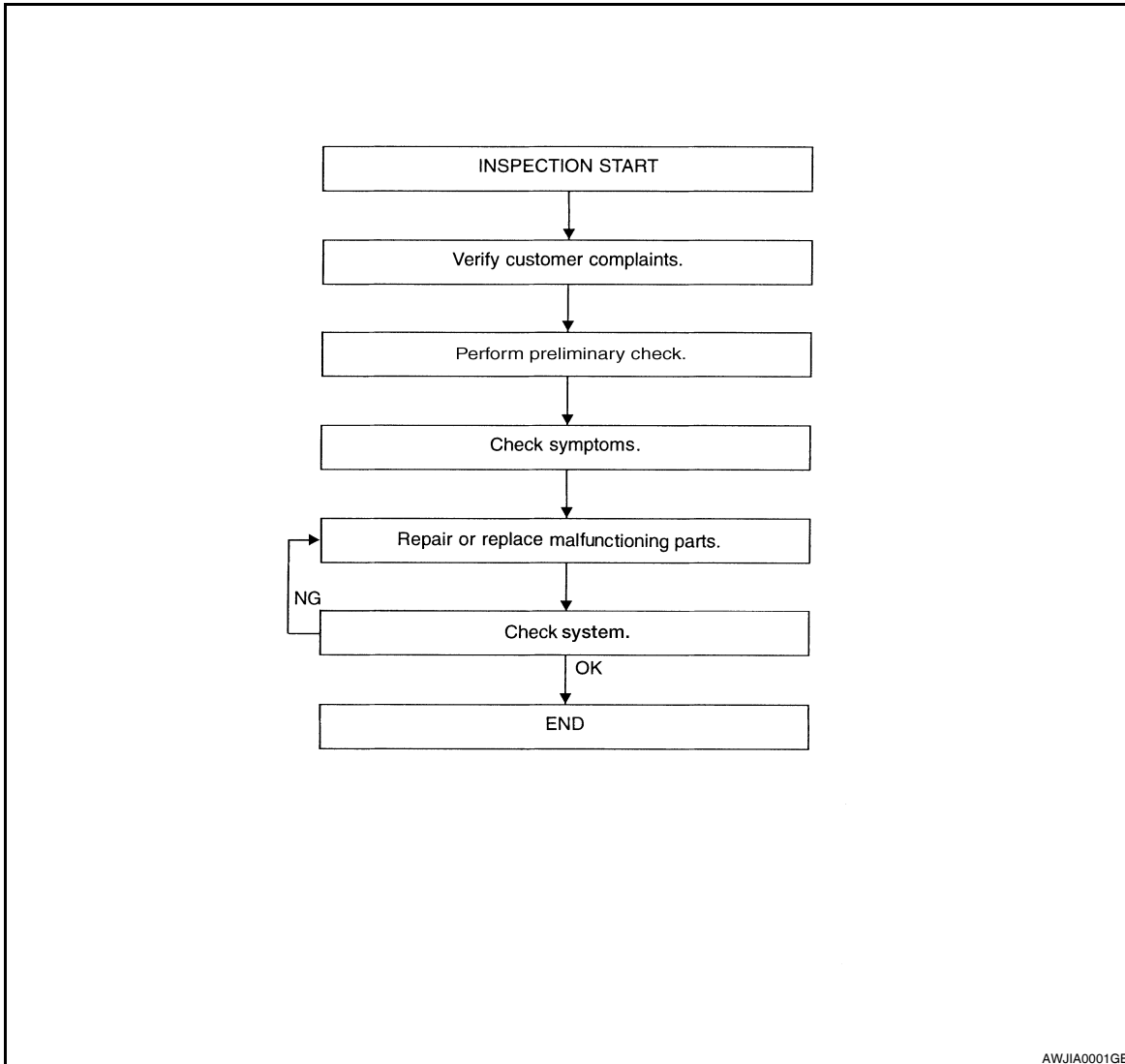

DETAILED FLOW

1. CUSTOMER INFORMATION

Talk to the customer to obtain detailed information about the symptom.

>> GO TO 2

2. PRELIMINARY CHECK

Perform preliminary check. Refer to [AP-4, "Preliminary Check"](#).

>> GO TO 3

3. SYMPTOM

Check for symptoms. Refer to [AP-11, "Symptom Table"](#).

DIAGNOSIS AND REPAIR WORKFLOW

< BASIC INSPECTION >

>> GO TO 4

4. MALFUNCTIONING PARTS

Repair or replace the applicable parts.

>> GO TO 5

5. SYSTEM CHECK

Operate the pedal adjusting switch to ensure that the pedals move completely forward and backward.

Does the system operate normally?

YES >> Inspection End.

NO >> Refer to [GI-38. "Intermittent Incident"](#).

A

B

C

D

E

F

G

H

I

AP

K

L

M

N

O

P

INSPECTION AND ADJUSTMENT

< BASIC INSPECTION >

INSPECTION AND ADJUSTMENT

Preliminary Check

INFOID:000000004109534

1. FOREIGN OBJECTS

Check the following:

- objects on or behind the pedals that could cause binding

Are there any foreign objects that could be causing interference with the pedals?

YES >> Remove objects.

NO >> GO TO 2

2. WIRING CONNECTIONS

1. Disconnect pedal adjusting motor.
2. Check terminals for damage or loose connections.
3. Reconnect harness connector.

Are any connectors damaged or loose?

YES >> Repair or replace damaged parts.

NO >> GO TO 3

3. POWER AND GROUND

Check power supply and ground circuits for pedal adjusting switch. Refer to [AP-6. "Pedal Adjusting Switch Power Supply and Ground Circuit Inspection"](#).

Is the inspection result normal?

YES >> Refer to [AP-11. "Symptom Table"](#).

NO >> Repair or replace as necessary.

ADJUSTABLE PEDAL SYSTEM

< FUNCTION DIAGNOSIS >

FUNCTION DIAGNOSIS

ADJUSTABLE PEDAL SYSTEM

Automatic Drive Positioner Interlocking Adjustable Pedal

INFOID:000000004109535

Automatic drive positioner interlocking adjustable pedal. Refer to [ADP-11, "AUTOMATIC DRIVE POSITIONER SYSTEM : System Description"](#).

Component Parts Location

INFOID:000000004109536

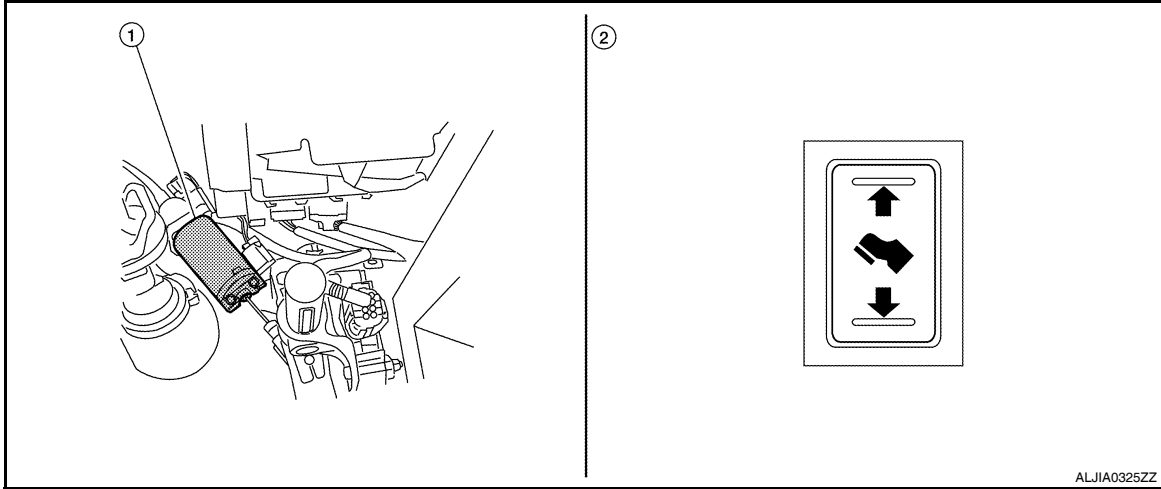

1. Pedal adjusting motor E167

2. Pedal adjusting switch M83

Component Description

INFOID:000000004109537

Component	Function
Pedal adjusting switch	Provide move forward/backward signals to pedal adjusting motor
Pedal adjusting motor	Move pedal assembly forward and backward

A
B
C
D
E
F
G
H
I
K
L
M
N
O
P

AP

ADJUSTABLE PEDAL SYSTEM

< COMPONENT DIAGNOSIS >

COMPONENT DIAGNOSIS

ADJUSTABLE PEDAL SYSTEM

Pedal Adjusting Switch Power Supply and Ground Circuit Inspection

INFOID:000000004109538

1. CHECK PEDAL ADJUSTING SWITCH POWER SUPPLY

1. Turn ignition switch OFF.
2. Disconnect pedal adjusting switch.
3. Check voltage between pedal adjusting switch connector M83 terminal 1 and ground.

1 - Ground : Battery voltage.

Is inspection result normal?

- YES >> GO TO 2
NO >> Repair or replace harness.

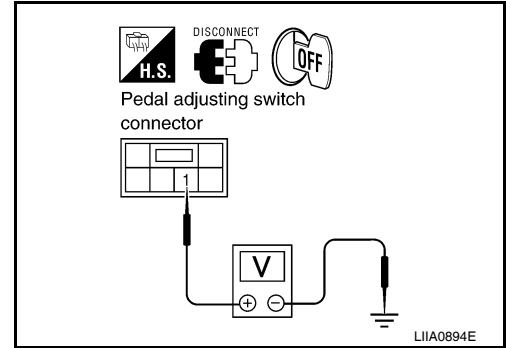

2. CHECK PEDAL ADJUSTING SWITCH GROUND CIRCUIT

Check continuity between pedal adjusting switch connector M83 terminal 4 and ground.

4 - Ground : Continuity should exist.

Is inspection result normal?

- YES >> Pedal adjusting switch power supply and ground circuit is OK.
NO >> Repair or replace harness.

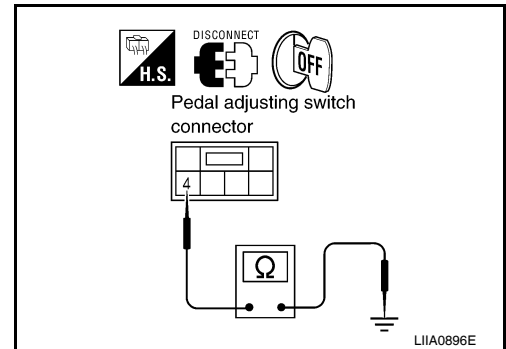

Pedal Adjusting Motor Circuit Inspection

INFOID:000000004109539

1. CHECK PEDAL ADJUSTING SWITCH

1. Turn ignition switch OFF.
2. Disconnect pedal adjusting switch.
3. Check continuity between pedal adjusting switch terminals as follows.

Terminals	Condition	Continuity	
3	1	Pedal adjusting switch forward.	Continuity should exist.
		Pedal adjusting switch neutral.	Continuity should not exist.
	4	Pedal adjusting switch backward.	Continuity should exist.
		Pedal adjusting switch neutral.	Continuity should not exist.
2	1	Pedal adjusting switch backward.	Continuity should exist.
		Pedal adjusting switch neutral.	Continuity should not exist.
	4	Pedal adjusting switch forward.	Continuity should exist.
		Pedal adjusting switch neutral.	Continuity should not exist.

Is inspection result normal?

- YES >> GO TO 2
NO >> Replace pedal adjusting switch. Refer to [IP-10. "Exploded View"](#).

2. CHECK PEDAL ADJUSTING MOTOR HARNESS

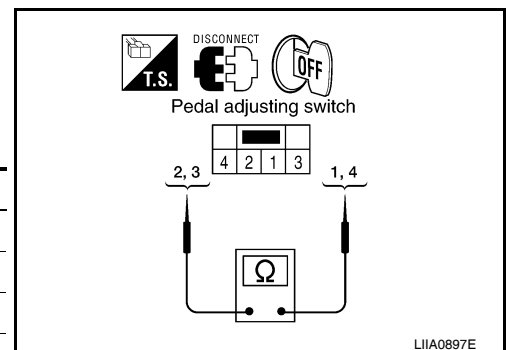

ADJUSTABLE PEDAL SYSTEM

< COMPONENT DIAGNOSIS >

1. Disconnect pedal adjusting motor.
2. Check continuity between pedal adjusting switch connector M83 (A) terminals 2, 3 and pedal adjusting motor connector E167 (B) terminals 1, 2.

2 - 2 : Continuity should exist.

3 - 1 : Continuity should exist.

3. Check continuity between pedal adjusting switch connector M83 (A) terminals 2, 3 and ground.

2 - Ground : Continuity should not exist.

3 - Ground : Continuity should not exist.

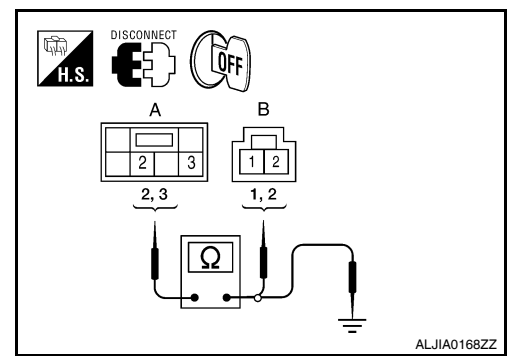

Is inspection result normal?

YES >> GO TO 3

NO >> Repair or replace harness.

3. CHECK PEDAL ADJUSTING MOTOR POWER SUPPLY

1. Connect pedal adjusting switch.
2. Check voltage between pedal adjusting motor connector E167 and ground.

Connector	Terminals		Condition	Voltage (V) (Approx.)
	(+)	(-)		
E167	1	Ground	Pedal adjusting switch forward	Battery voltage
			Other than above	0
	2		Pedal adjusting switch back-ward	Battery voltage
			Other than above	0

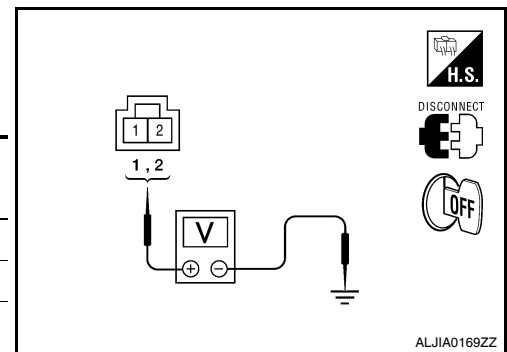

Is inspection result normal?

YES >> Replace pedal adjusting motor. Refer to [AP-13, "Removal and Installation"](#).

NO >> Repair or replace harness.

ADJUSTABLE PEDAL SYSTEM

< COMPONENT DIAGNOSIS >

Wiring Diagram

INFOID:000000004109540

ADJUSTABLE PEDAL SYSTEM

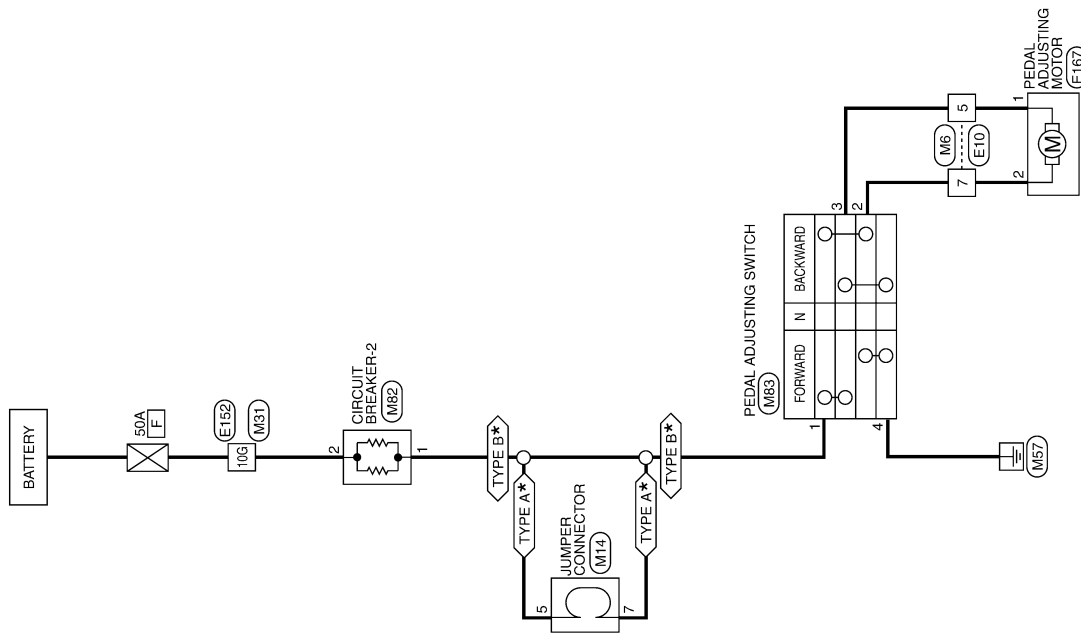

: REFER TO HARNESS LAYOUT OF PG SECTION FOR DEFINITION OF TYPE A AND TYPE B.

ABJWA0026GE

ADJUSTABLE PEDAL SYSTEM

< COMPONENT DIAGNOSIS >

ADJUSTABLE PEDAL SYSTEM CONNECTORS

Connector No.	M6
Connector Name	WIRE TO WIRE
Connector Color	WHITE



Terminal No.	Color of Wire	Signal Name
5	V	-
7	SB	-

Connector No.	M14
Connector Name	JUMPER CONNECTOR
Connector Color	WHITE

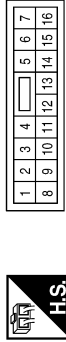

Terminal No.	Color of Wire	Signal Name
5	L/B	-
7	W/R	-

Connector No.	M31
Connector Name	WIRE TO WIRE
Connector Color	WHITE

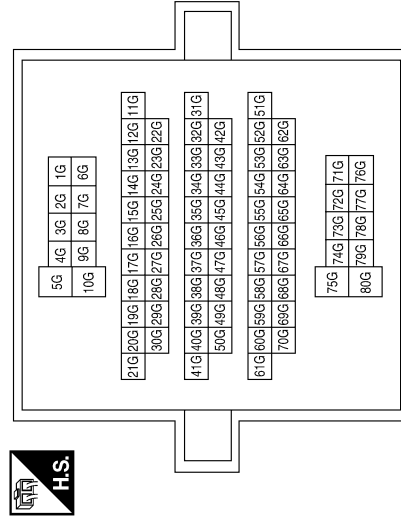

Terminal No.	Color of Wire	Signal Name
10G	W/B	-

Connector No.	M82
Connector Name	CIRCUIT BREAKER-2 (WITH POWER SEATS)
Connector Color	WHITE



Terminal No.	Color of Wire	Signal Name
1	L/B	-
2	W/B	-

Connector No.	M83
Connector Name	PEDAL ADJUSTING SWITCH (WITHOUT AUTOMATIC DRIVE POSITIONER)
Connector Color	BROWN



Terminal No.	Color of Wire	Signal Name
1	L/B	-
2	SB	-
3	V	-
4	B	-
5	-	-
6	-	-

ABJIA0070GB

A
B
C
D
E
F
G
H
I
AP
K
L
M
N
O
P

ADJUSTABLE PEDAL SYSTEM

< COMPONENT DIAGNOSIS >

Connector No.	E167
Connector Name	PEDAL ADJUSTING MOTOR
Connector Color	GRAY



Terminal No.	Color of Wire	Signal Name
1	G	-
2	R	-

Connector No.	E152
Connector Name	WIRE TO WIRE
Connector Color	WHITE

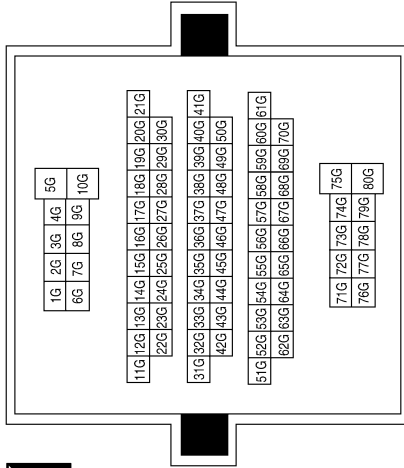

Terminal No.	Color of Wire	Signal Name
10G	W/B	-

Connector No.	E10
Connector Name	WIRE TO WIRE
Connector Color	WHITE



Terminal No.	Color of Wire	Signal Name
5	G	-
7	R	-

ABJIA0071GB

ADJUSTABLE PEDAL SYSTEM

< SYMPTOM DIAGNOSIS >

SYMPTOM DIAGNOSIS

ADJUSTABLE PEDAL SYSTEM

Symptom Table

INFOID:000000004109541

NOTE:

Always check the WORK FLOW before troubleshooting. Refer to [AP-2, "Repair Work Flow"](#).

Symptom	Diagnosis/Service procedure	Reference page
Adjustable pedal system does not operate.	1. Pedal adjusting switch power supply and ground circuit inspection.	AP-6
	2. Pedal adjusting motor circuit inspection.	AP-6

A
B
C
D
E
F
G
H
I
K
L
M
N
O
P

AP

PRECAUTIONS

< PRECAUTION >

PRECAUTION

PRECAUTIONS

Precaution for Supplemental Restraint System (SRS) "AIR BAG" and "SEAT BELT PRE-TENSIONER"

INFOID:000000003788185

The Supplemental Restraint System such as "AIR BAG" and "SEAT BELT PRE-TENSIONER", used along with a front seat belt, helps to reduce the risk or severity of injury to the driver and front passenger for certain types of collision. This system includes seat belt switch inputs and dual stage front air bag modules. The SRS system uses the seat belt switches to determine the front air bag deployment, and may only deploy one front air bag, depending on the severity of a collision and whether the front occupants are belted or unbelted. Information necessary to service the system safely is included in the SR and SB section of this Service Manual.

WARNING:

- **To avoid rendering the SRS inoperative, which could increase the risk of personal injury or death in the event of a collision which would result in air bag inflation, all maintenance must be performed by an authorized NISSAN/INFINITI dealer.**
- **Improper maintenance, including incorrect removal and installation of the SRS, can lead to personal injury caused by unintentional activation of the system. For removal of Spiral Cable and Air Bag Module, see the SR section.**
- **Do not use electrical test equipment on any circuit related to the SRS unless instructed to in this Service Manual. SRS wiring harnesses can be identified by yellow and/or orange harnesses or harness connectors.**

Precaution for Work

INFOID:000000003788186

- When removing or disassembling each component, be careful not to damage or deform it. If a component may be subject to interference, be sure to protect it with a shop cloth.
- When removing (disengaging) components with a screwdriver or similar tool, be sure to wrap the component with a shop cloth or vinyl tape to protect it.
- Protect the removed parts with a shop cloth and keep them.
- Replace a deformed or damaged clip.
- If a part is specified as a non-reusable part, always replace it with new one.
- Be sure to tighten bolts and nuts securely to the specified torque.
- After re-installation is completed, be sure to check that each part works normally.
- Follow the steps below to clean components.
 - Water soluble foul: Dip a soft cloth into lukewarm water, and wring the water out of the cloth to wipe the fouled area.
Then rub with a soft and dry cloth.
 - Oily foul: Dip a soft cloth into lukewarm water with mild detergent (concentration: within 2 to 3%), and wipe the fouled area.
Then dip a cloth into fresh water, and wring the water out of the cloth to wipe the detergent off. Then rub with a soft and dry cloth.
- Do not use organic solvent such as thinner, benzene, alcohol, or gasoline.
- For genuine leather seats, use a genuine leather seat cleaner.

ADJUSTABLE PEDAL SYSTEM

< ON-VEHICLE REPAIR >

ON-VEHICLE REPAIR

ADJUSTABLE PEDAL SYSTEM

Removal and Installation

INFOID:000000003788187

Refer to [BR-20, "Removal and Installation"](#) and [ACC-3, "Removal and Installation"](#).

A
B
C
D
E
F
G
H
I
K
L
M
N
O
P

AP