

SECTION **PG**

POWER SUPPLY, GROUND & CIRCUIT ELEMENTS

CONTENTS

PRECAUTION	2	GROUND	28
PRECAUTIONS	2	Ground Distribution	28
Precaution for Supplemental Restraint System (SRS) "AIR BAG" and "SEAT BELT PRE-TENSIONER"	2	HARNESS	38
Precaution for Power Generation Variable Voltage Control System	2	Harness Layout	38
PREPARATION	3	ELECTRICAL UNITS LOCATION	65
PREPARATION	3	Electrical Units Location	65
Special Service Tool	3	HARNESS CONNECTOR	68
Commercial Service Tool	3	Description	68
BASIC INSPECTION	4	STANDARDIZED RELAY	71
BATTERY	4	Description	71
How to Handle Battery	4	FUSE BLOCK - JUNCTION BOX (J/B)	73
Work Flow	6	Terminal Arrangement	73
Special Repair Requirement	6	FUSE, FUSIBLE LINK AND RELAY BOX	74
COMPONENT DIAGNOSIS	7	Terminal Arrangement	74
POWER SUPPLY ROUTING CIRCUIT	7	ON-VEHICLE REPAIR	76
Wiring Diagram — Battery Power Supply —	7	BATTERY	76
Wiring Diagram — Accessory Power Supply —	16	Removal and Installation	76
Wiring Diagram — Ignition Power Supply —	20	SERVICE DATA AND SPECIFICATIONS	
Fuse	27	(SDS)	77
Fusible Link	27	SERVICE DATA AND SPECIFICATIONS	
Circuit Breaker (PTC)	27	(SDS)	77
		Battery	77

A
B
C
D
E
F
G
H
I
J
K
L
PG
N
O
P

PRECAUTIONS

< PRECAUTION >

PRECAUTION

PRECAUTIONS

Precaution for Supplemental Restraint System (SRS) "AIR BAG" and "SEAT BELT PRE-TENSIONER"

INFOID:000000003789659

The Supplemental Restraint System such as "AIR BAG" and "SEAT BELT PRE-TENSIONER", used along with a front seat belt, helps to reduce the risk or severity of injury to the driver and front passenger for certain types of collision. This system includes seat belt switch inputs and dual stage front air bag modules. The SRS system uses the seat belt switches to determine the front air bag deployment, and may only deploy one front air bag, depending on the severity of a collision and whether the front occupants are belted or unbelted. Information necessary to service the system safely is included in the SR and SB section of this Service Manual.

WARNING:

- To avoid rendering the SRS inoperative, which could increase the risk of personal injury or death in the event of a collision which would result in air bag inflation, all maintenance must be performed by an authorized NISSAN/INFINITI dealer.
- Improper maintenance, including incorrect removal and installation of the SRS, can lead to personal injury caused by unintentional activation of the system. For removal of Spiral Cable and Air Bag Module, see the SR section.
- Do not use electrical test equipment on any circuit related to the SRS unless instructed to in this Service Manual. SRS wiring harnesses can be identified by yellow and/or orange harnesses or harness connectors.

Precaution for Power Generation Variable Voltage Control System

INFOID:000000003789660

CAUTION:

For this model, the battery current sensor that is installed to the negative battery cable measures the charging/discharging current of the battery and performs various engine controls. If an electrical component is connected directly to the negative battery terminal, the current flowing through that component will not be measured by the battery current sensor. This condition may cause a malfunction of the engine control system and battery discharge may occur. Do not connect an electrical component or ground wire directly to the battery terminal.

PREPARATION

< PREPARATION >

PREPARATION

PREPARATION

Special Service Tool

INFOID:000000004688015

Tool number (Kent-Moore No.) Tool name	Description
<p>— (—) Model GR-8 Multitasking Battery Diagnostic Station</p>  <p style="text-align: right;">AWIIA1239ZZ</p>	<p>Tests batteries, starting and charging systems. For operating instructions, refer to diagnostic station instruction manual.</p>

Commercial Service Tool

INFOID:0000000003789662

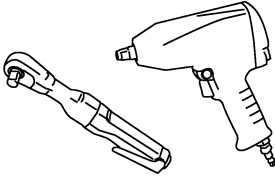
Tool name	Description
<p>Power tool</p>  <p style="text-align: right;">PBIC0190E</p>	<p>Loosening bolts and nuts</p>

A
B
C
D
E
F
G
H
I
J
K
L
PG
N
O
P

BATTERY

< BASIC INSPECTION >

BASIC INSPECTION

BATTERY

How to Handle Battery

INFOID:000000003789663

CAUTION:

- If it becomes necessary to start the engine with a booster battery and jumper cables, use a 12-volt booster battery.
- After connecting battery cables, ensure that they are tightly clamped to battery terminals for good contact.
- Never add distilled water through the hole used to check specific gravity.

METHODS OF PREVENTING OVER-DISCHARGE

The following precautions must be taken to prevent over-discharging a battery.

- The battery surface (particularly its top) should always be kept clean and dry.
- The terminal connections should be clean and tight.
- At every routine maintenance, check the electrolyte level. This also applies to batteries designated as "low maintenance" and "maintenance-free".

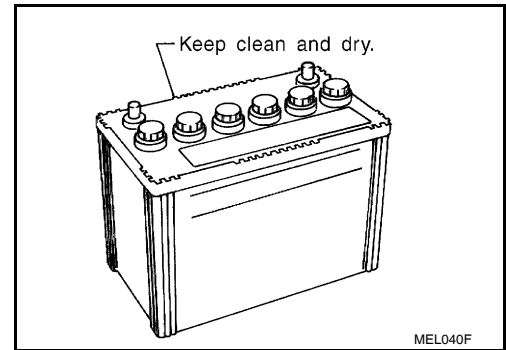

- When the vehicle is not going to be used over a long period of time, disconnect the battery cable from the negative terminal. (If the vehicle has an extended storage switch, turn it off.)

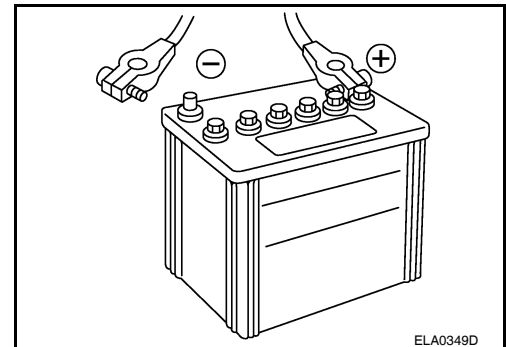

- Check the charge condition of the battery. Periodically check the specific gravity of the electrolyte. Keep a close check on charge condition to prevent over-discharge.

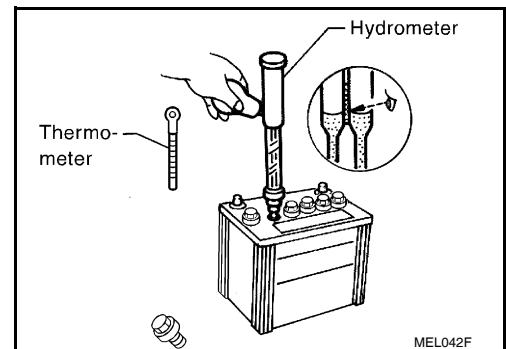

CHECKING ELECTROLYTE LEVEL

WARNING:

Never allow battery fluid to come in contact with skin, eyes, fabrics, or painted surfaces. After touching a battery, never touch or rub your eyes until you have thoroughly washed your hands. If acid contacts eyes, skin or clothing, immediately flush with water for 15 minutes and seek medical attention.

BATTERY

< BASIC INSPECTION >

- Remove the cell plug using a suitable tool.
- Add distilled water up to the MAX level.

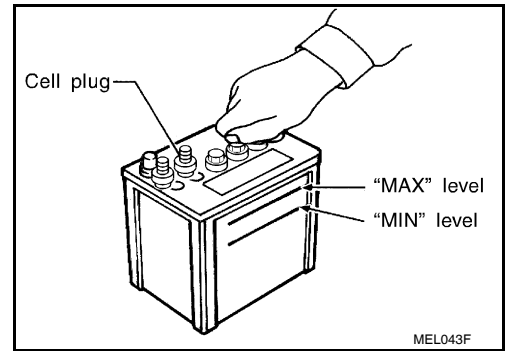

Sulphation

A battery will be completely discharged if it is left unattended for a long time and the specific gravity will become less than 1.100. This may result in sulphation on the cell plates.

To determine if a battery has been “sulphated”, note its voltage and current when charging it. As shown in the figure, less current and higher voltage are observed in the initial stage of charging sulphated batteries.

A sulphated battery may sometimes be brought back into service by means of a long, slow charge, 12 hours or more, followed by a battery capacity test.

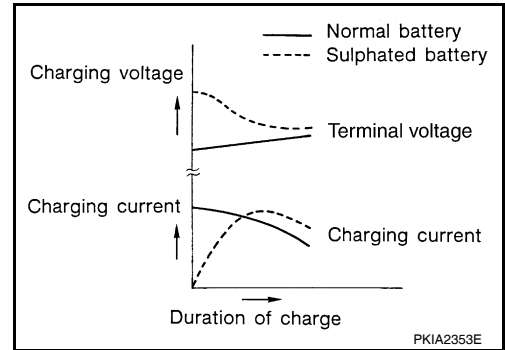

SPECIFIC GRAVITY CHECK

1. Read hydrometer and thermometer indications at eye level.
2. Use the chart below to correct your hydrometer reading according to electrolyte temperature.

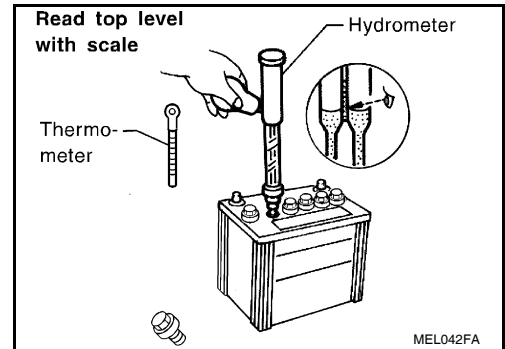

Hydrometer Temperature Correction

Battery electrolyte temperature [°C (°F)]	Add to specific gravity reading
71 (160)	0.032
66 (150)	0.028
60 (140)	0.024
54 (130)	0.020
49 (120)	0.016
43 (110)	0.012
38 (100)	0.008
32 (90)	0.004
27 (80)	0
21 (70)	-0.004
16 (60)	-0.008
10 (50)	-0.012
4 (40)	-0.016
-1 (30)	-0.020
-7 (20)	-0.024

A
B
C
D
E
F
G
H
I
J
K
L
N
O
P

BATTERY

< BASIC INSPECTION >

Battery electrolyte temperature [°C (°F)]	Add to specific gravity reading
-12 (10)	-0.028
-18 (0)	-0.032

Corrected specific gravity	Approximate charge condition
1.260 - 1.280	Fully charged
1.230 - 1.250	3/4 charged
1.200 - 1.220	1/2 charged
1.170 - 1.190	1/4 charged
1.140 - 1.160	Almost discharged
1.110 - 1.130	Completely discharged

CHARGING THE BATTERY

CAUTION:

- Never “quick charge” a fully discharged battery.
- Keep the battery away from open flame while it is being charged.
- When connecting the charger, connect the leads first, then turn on the charger. Never turn on the charger first, as this may cause a spark.
- If battery electrolyte temperature rises above 55 °C (131 °F), stop charging. Always charge battery at a temperature below 55 °C (131 °F).

Charging Rates

Amps	Time
50	1 hour
25	2 hours
10	5 hours
5	10 hours

Do not charge at more than 50 ampere rate.

NOTE:

The ammeter reading on your battery charger will automatically decrease as the battery charges. This indicates that the voltage of the battery is increasing normally as the state of charge improves. The charging amps indicated above refer to initial charge rate.

- If, after charging, the specific gravity of any two cells varies more than 0.050, the battery should be replaced.

Work Flow

INFOID:000000004688016

TROUBLE DIAGNOSIS WITH MULTITASKING BATTERY DIAGNOSTIC STATION

Refer to diagnostic station instruction manual.

Special Repair Requirement

INFOID:000000003789665

Required Procedure After Battery Disconnection

System	Item	Reference
Brake Control	Steering Angle Sensor Neutral Position	Refer to BRC-149 .
Roof	Sunroof Memory Reset/Initialization	Refer to RF-5 .
Seats	Automatic Drive Positioner System Initialization	Refer to Owner's Manual.
Audio-Visual System	Audio (Radio Preset)	Refer to Owner's Manual.
	Navigation System	Refer to Owner's Manual.

POWER SUPPLY ROUTING CIRCUIT

< COMPONENT DIAGNOSIS >

COMPONENT DIAGNOSIS

POWER SUPPLY ROUTING CIRCUIT

Wiring Diagram —Battery Power Supply—

INFOID:000000003789666

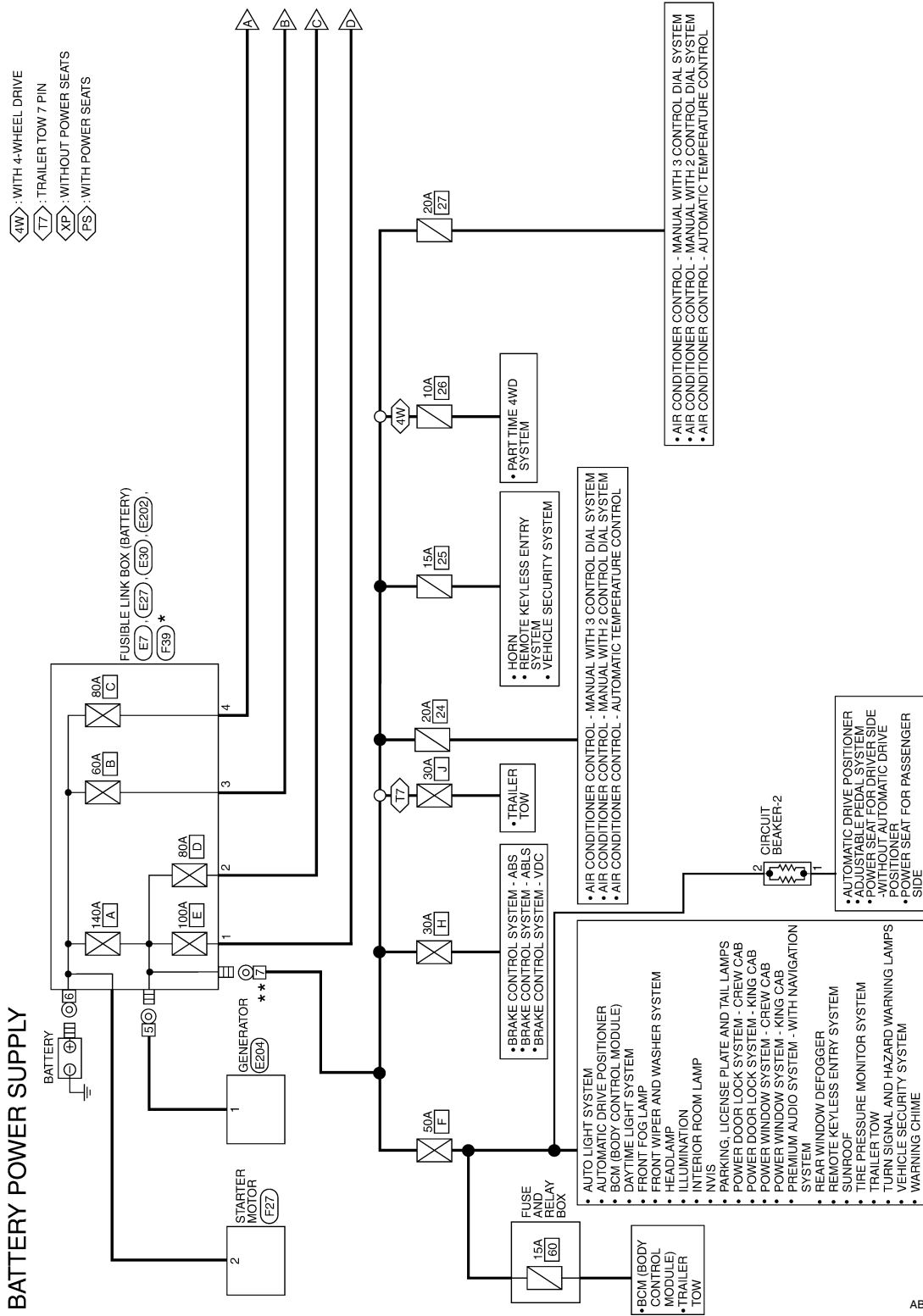

* : (F39) IS AN INTEGRAL PART OF FUSIBLE LINK BOX (BATTERY) ASSEMBLY.
 ** : FUSIBLE LINK

ABMWA0051GI

A
B
C
D
E
F
G
H
I
J
K
L
M
N
O
P
PG

POWER SUPPLY ROUTING CIRCUIT

< COMPONENT DIAGNOSIS >

- ◁AB▷ : WITH ABS
- ◁AV▷ : WITH ABL S OR VDC
- ◁T7▷ : TRAILER TOW 7PIN

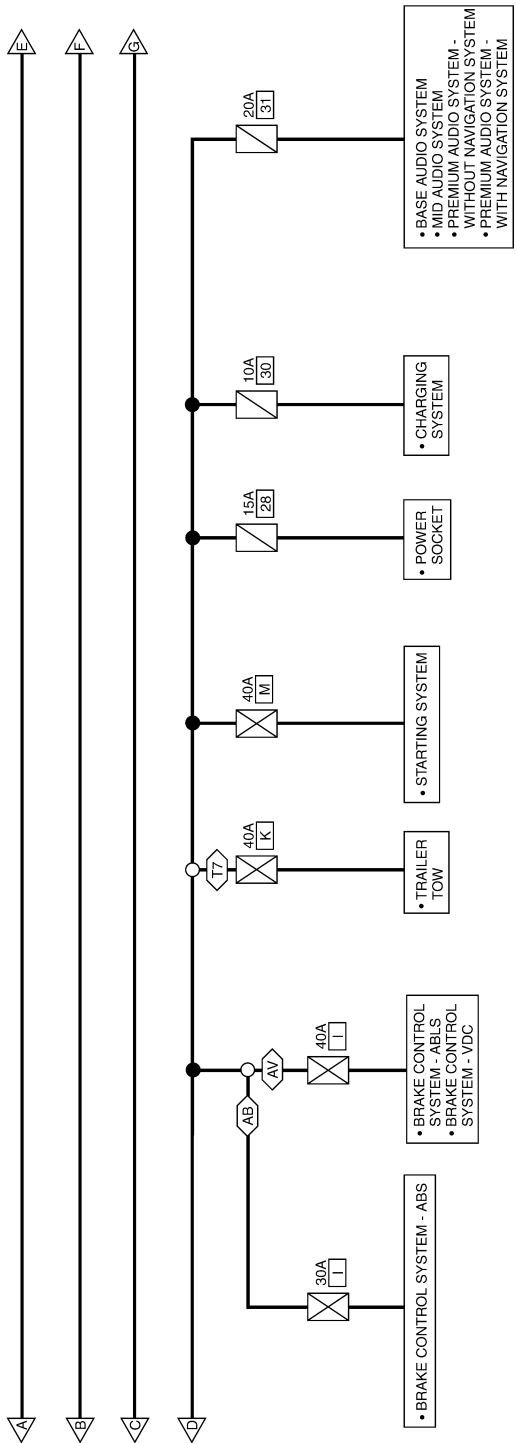

ABMWA0052GI

POWER SUPPLY ROUTING CIRCUIT

< COMPONENT DIAGNOSIS >

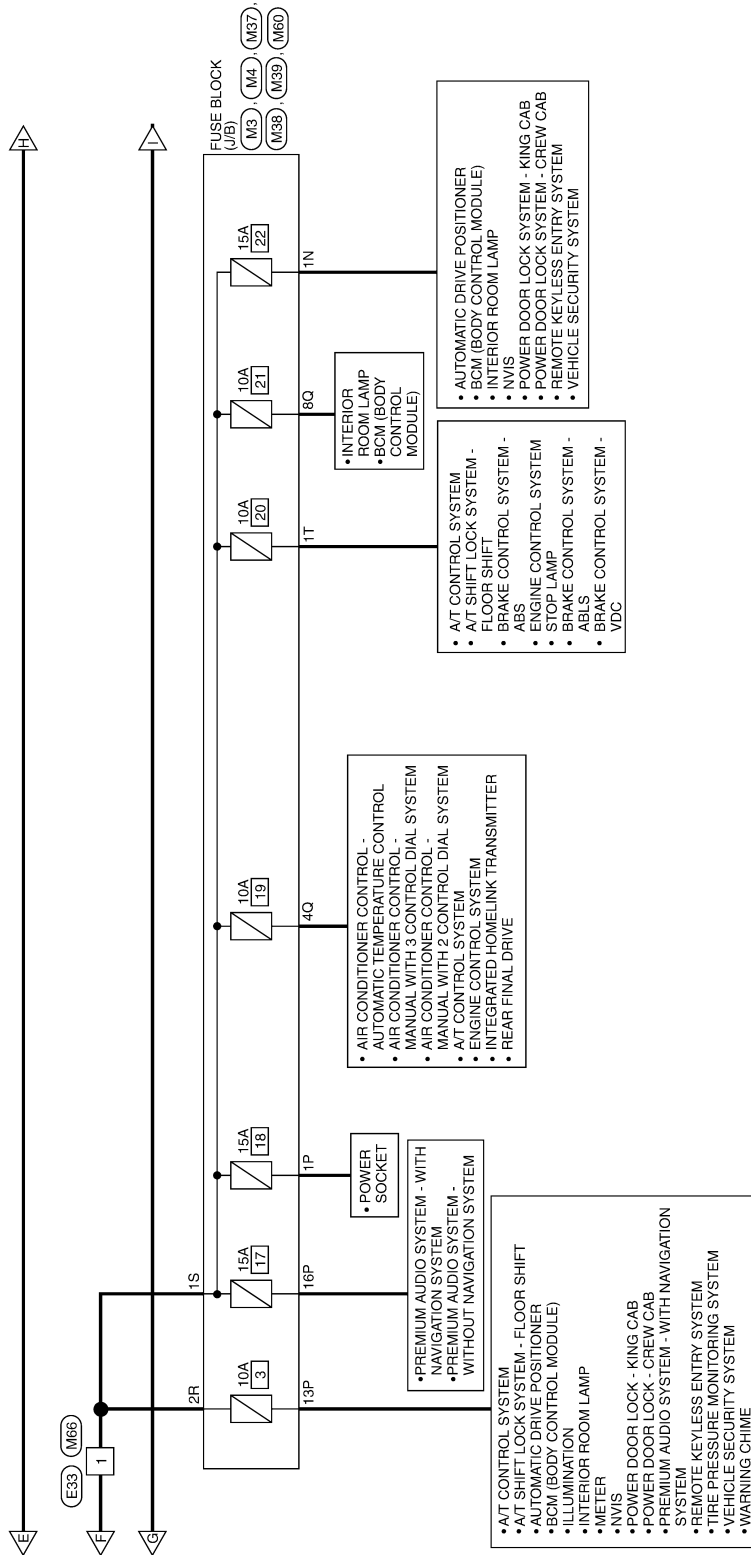

ABMWA0053GI

A
B
C
D
E
F
G
H
I
J
K
L
PG
N
O
P

POWER SUPPLY ROUTING CIRCUIT

< COMPONENT DIAGNOSIS >

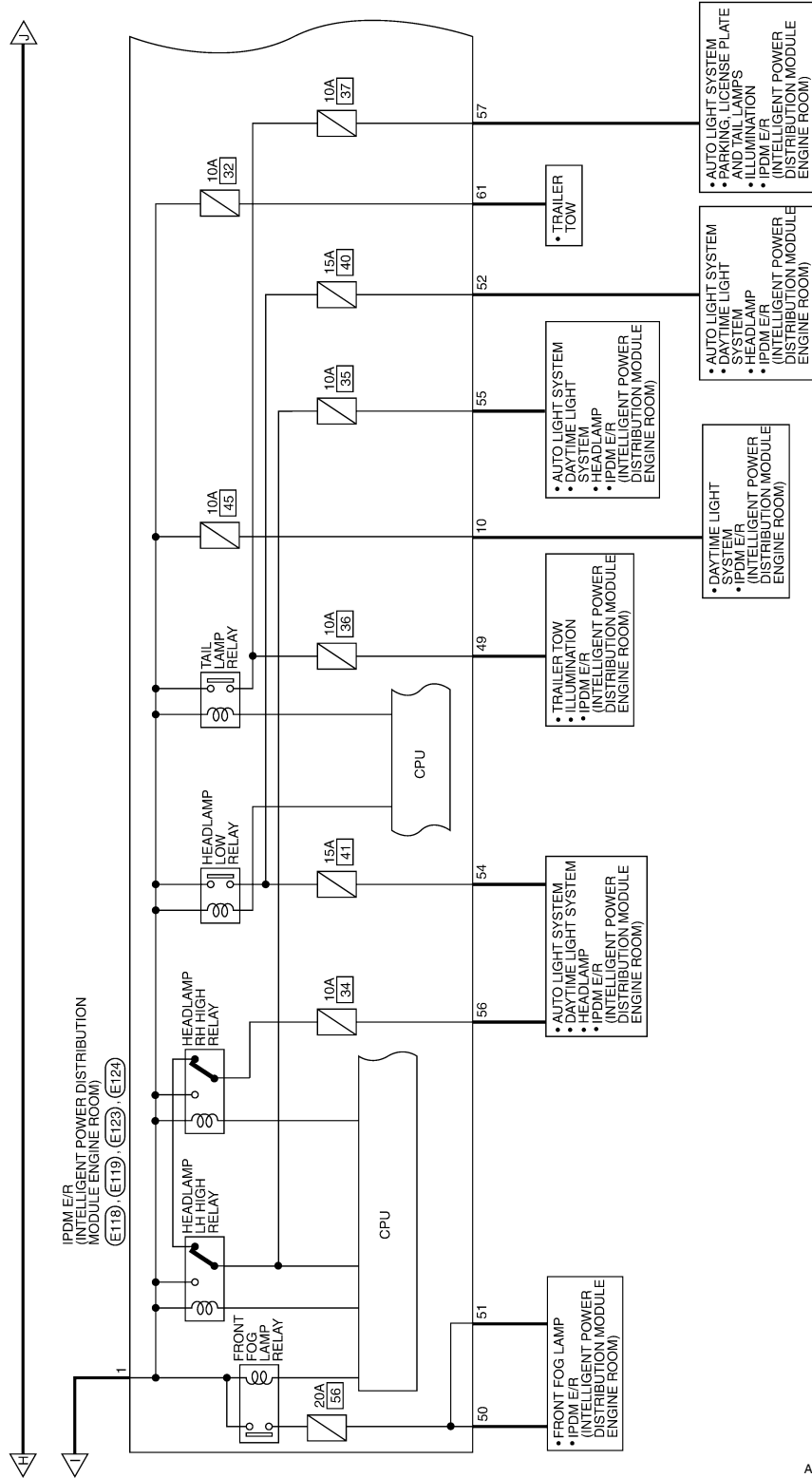

ABMWA0054GI

POWER SUPPLY ROUTING CIRCUIT

< COMPONENT DIAGNOSIS >

— : DATA LINE

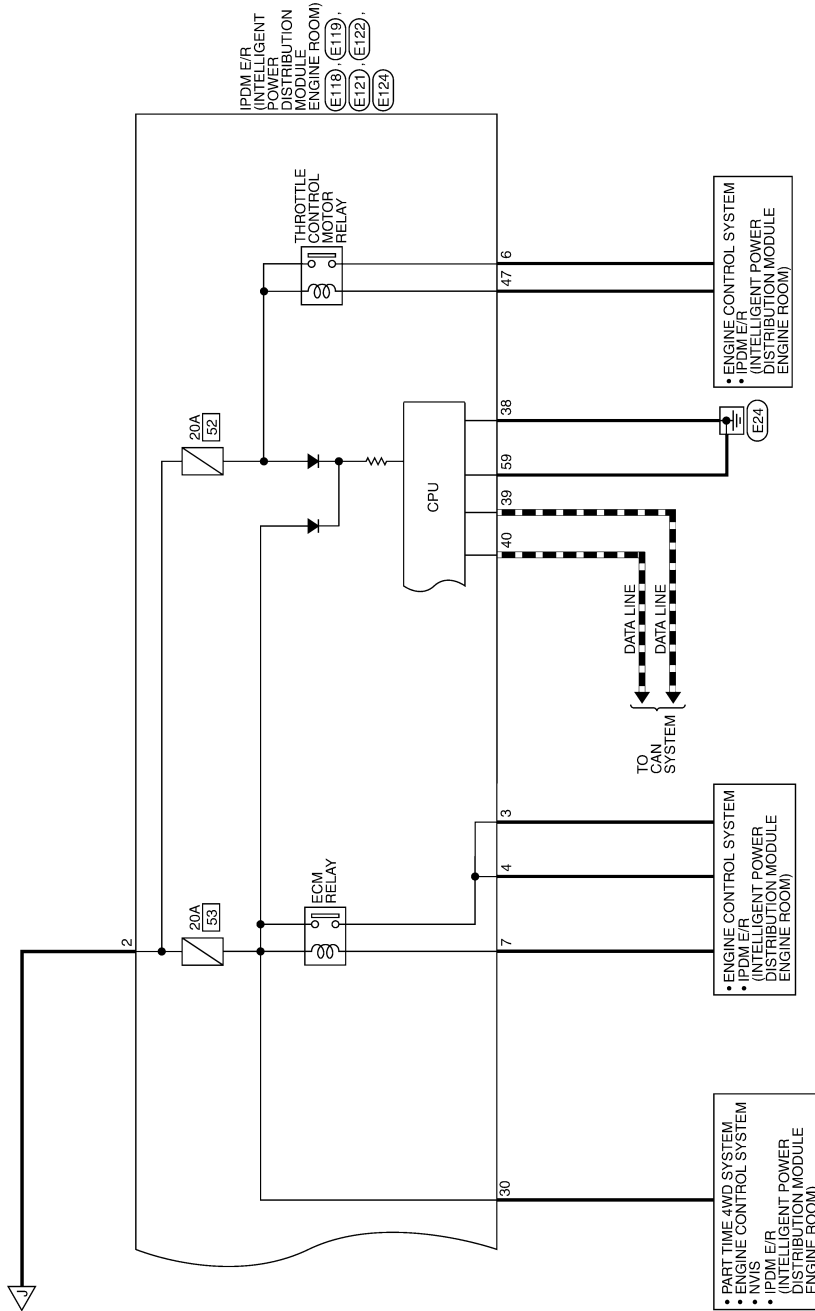

A
B
C
D
E
F
G
H
I
J
K
L
N
O
P

PG

ABMWA0073GI

POWER SUPPLY ROUTING CIRCUIT

< COMPONENT DIAGNOSIS >

BATTERY POWER SUPPLY CONNECTORS

Connector No.	M3
Connector Name	FUSE BLOCK (J/B)
Connector Color	WHITE

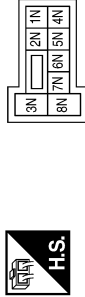

Terminal No.	Color of Wire	Signal Name
1N	Y/R	-

Connector No.	M4
Connector Name	FUSE BLOCK (J/B)
Connector Color	WHITE

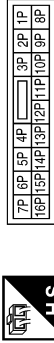

Terminal No.	Color of Wire	Signal Name
1P	G	-
13P	P	-
16P	R	-
16P	Y/G	-

Connector No.	M31
Connector Name	WIRE TO WIRE
Connector Color	WHITE

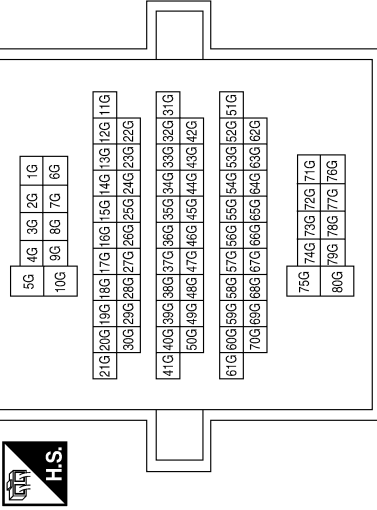

Terminal No.	Color of Wire	Signal Name
10G	W/B	-

Connector No.	M37
Connector Name	FUSE BLOCK (J/B)
Connector Color	BLACK



Terminal No.	Color of Wire	Signal Name
1S	W	B

Connector No.	M38
Connector Name	FUSE BLOCK (J/B)
Connector Color	BLACK



Terminal No.	Color of Wire	Signal Name
2R	W	B

Connector No.	M39
Connector Name	FUSE BLOCK (J/B)
Connector Color	WHITE



Terminal No.	Color of Wire	Signal Name
4Q	Y/R	-

POWER SUPPLY ROUTING CIRCUIT

< COMPONENT DIAGNOSIS >

Connector No.	M82
Connector Name	CIRCUIT BREAKER-2 (WITH POWER SEATS)
Connector Color	WHITE



Terminal No.	Color of Wire	Signal Name
1	L/B	-
2	W/B	-

Connector No.	M66
Connector Name	WIRE TO WIRE
Connector Color	BLACK



Terminal No.	Color of Wire	Signal Name
1	W	-

Connector No.	M60
Connector Name	FUSE BLOCK (J/B)
Connector Color	WHITE

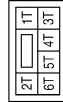

Terminal No.	Color of Wire	Signal Name
1T	R/Y	-

Connector No.	E27
Connector Name	FUSIBLE LINK BOX (BATTERY)
Connector Color	BROWN



Terminal No.	Color of Wire	Signal Name
1	B/R	-
2	B/Y	-

Connector No.	E7
Connector Name	FUSIBLE LINK BOX (BATTERY)
Connector Color	GRAY



Terminal No.	Color of Wire	Signal Name
3	W	-
4	R	-

Connector No.	M88
Connector Name	CIRCUIT BREAKER-2 (WITHOUT POWER SEATS)
Connector Color	WHITE



Terminal No.	Color of Wire	Signal Name
1	L/B	-
2	W/B	-

ABMIA0101GB

A
B
C
D
E
F
G
H
I
J
K
L
PG
N
O
P

POWER SUPPLY ROUTING CIRCUIT

< COMPONENT DIAGNOSIS >

Connector No.	E118
Connector Name	IPDM E/R (INTELLIGENT POWER DISTRIBUTION MODULE ENGINE ROOM)
Connector Color	BLACK



Terminal No.	Color of Wire	Signal Name
1	B/Y	F/L USM
2	R	F/L MAIN

Connector No.	E33
Connector Name	WIRE TO WIRE
Connector Color	BLACK



Terminal No.	Color of Wire	Signal Name
1	W	-

Connector No.	E30
Connector Name	FUSIBLE LINK BOX (BATTERY)
Connector Color	-



Terminal No.	Color of Wire	Signal Name
7	W	-

Connector No.	E122
Connector Name	IPDM E/R (INTELLIGENT POWER DISTRIBUTION MODULE ENGINE ROOM)
Connector Color	WHITE

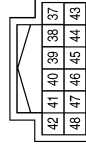

Terminal No.	Color of Wire	Signal Name
38	B	GND (SIGNAL)
39	L	CAN-H
40	P	CAN-L
47	O	ETC RLY CONT

Connector No.	E121
Connector Name	IPDM E/R (INTELLIGENT POWER DISTRIBUTION MODULE ENGINE ROOM)
Connector Color	BROWN



Terminal No.	Color of Wire	Signal Name
30	W	ECM BAT

Connector No.	E119
Connector Name	IPDM E/R (INTELLIGENT POWER DISTRIBUTION MODULE ENGINE ROOM)
Connector Color	WHITE

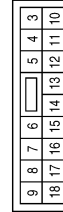

Terminal No.	Color of Wire	Signal Name
3	BR	IGN COIL
4	W/L	ECM
6	L	ETC
7	W/B	ECM RLY CONT
10	G	DTRL RLY SUPPLY

ABMIA0102GB

POWER SUPPLY ROUTING CIRCUIT

< COMPONENT DIAGNOSIS >

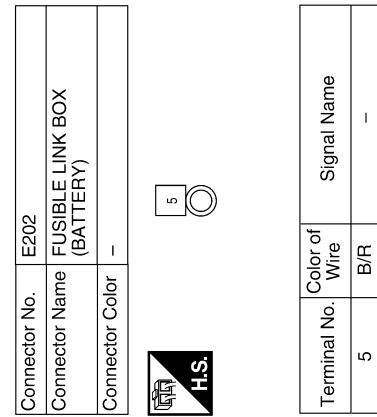
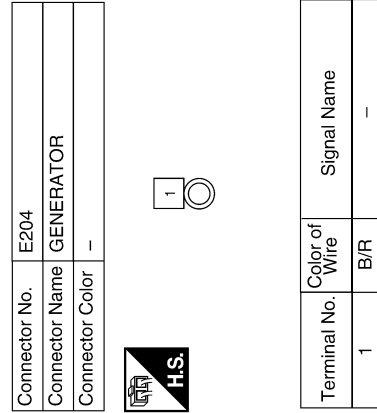
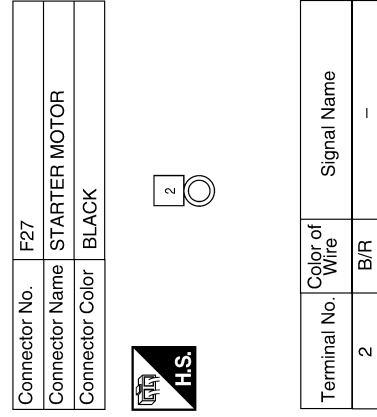
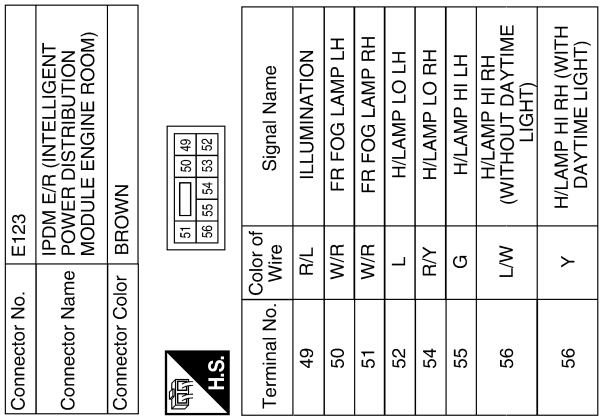
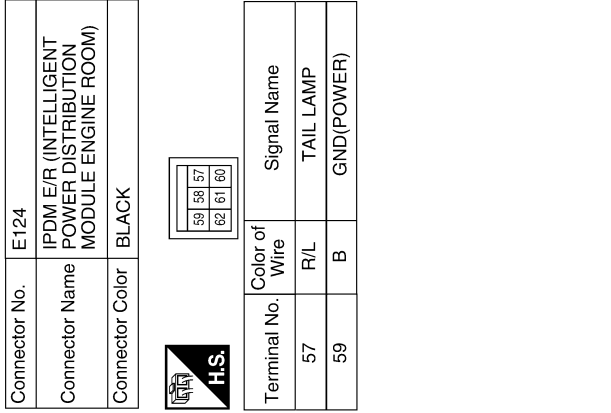
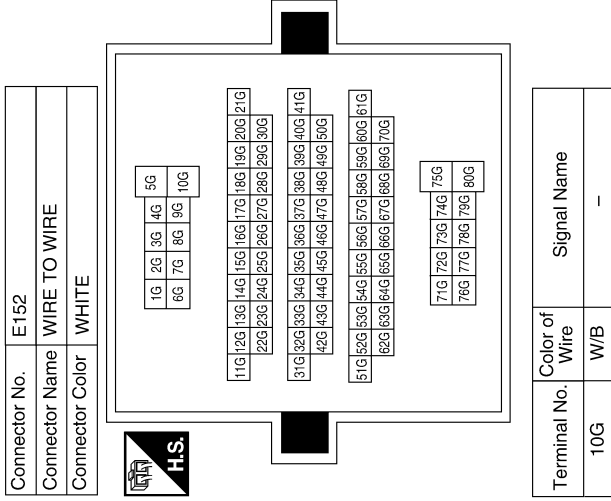

ABMIA0167GB

A
B
C
D
E
F
G
H
I
J
K
L
N
O
P

POWER SUPPLY ROUTING CIRCUIT

< COMPONENT DIAGNOSIS >

Wiring Diagram —Accessory Power Supply—

INFOID:000000003789667

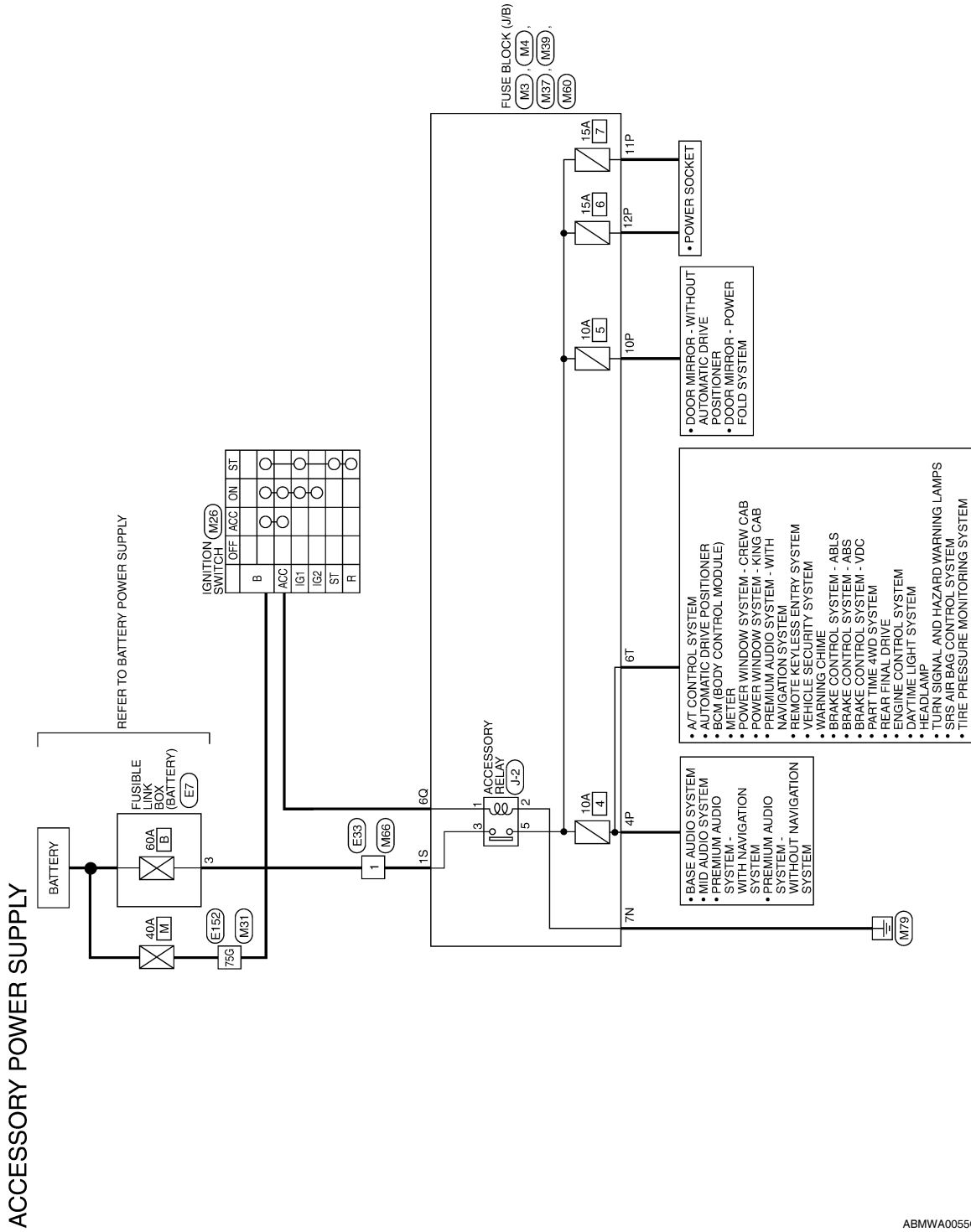

ACCESSORY POWER SUPPLY CONNECTORS

Connector No.	M3
Connector Name	FUSE BLOCK (J/B)
Connector Color	WHITE

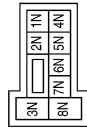

Terminal No.	Color of Wire	Signal Name
7N	B	-

Connector No.	M4
Connector Name	FUSE BLOCK (J/B)
Connector Color	WHITE



Terminal No.	Color of Wire	Signal Name
4P	V	-
10P	O	-(WITH AUTOMATIC DRIVE POSITIONER)
10P	GR	-(WITHOUT AUTOMATIC DRIVE POSITIONER)
11P	G/W	-
12P	L/W	-

Connector No.	M26
Connector Name	IGNITION SWITCH
Connector Color	WHITE



Terminal No.	Color of Wire	Signal Name
B	G	-
ACC	V	-

Connector No.	M31
Connector Name	WIRE TO WIRE
Connector Color	WHITE

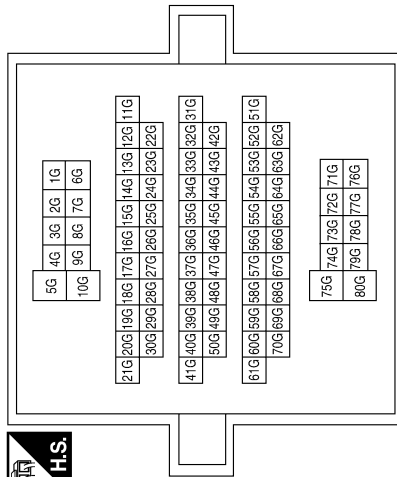

Terminal No.	Color of Wire	Signal Name
75G	G	-

Connector No.	M37
Connector Name	FUSE BLOCK (J/B)
Connector Color	BLACK



Terminal No.	Color of Wire	Signal Name
1S	W	B

ABMIA0103GB

POWER SUPPLY ROUTING CIRCUIT

< COMPONENT DIAGNOSIS >

Connector No.	M66
Connector Name	WIRE TO WIRE
Connector Color	BLACK



Terminal No.	1	Color of Wire	W	Signal Name	-
--------------	---	---------------	---	-------------	---

Connector No.	M60
Connector Name	FUSE BLOCK (J/B)
Connector Color	WHITE

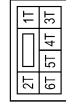

Terminal No.	6T	Color of Wire	O	Signal Name	-
--------------	----	---------------	---	-------------	---

Connector No.	M39
Connector Name	FUSE BLOCK (J/B)
Connector Color	WHITE

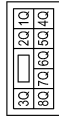

Terminal No.	6Q	Color of Wire	V	Signal Name	ACC
--------------	----	---------------	---	-------------	-----

Connector No.	E33
Connector Name	WIRE TO WIRE
Connector Color	BLACK



Terminal No.	1	Color of Wire	W	Signal Name	-
--------------	---	---------------	---	-------------	---

Connector No.	E7
Connector Name	FUSIBLE LINK BOX (BATTERY)
Connector Color	GRAY



Terminal No.	3	Color of Wire	W	Signal Name	-
--------------	---	---------------	---	-------------	---

AWMIA0839GB

POWER SUPPLY ROUTING CIRCUIT

< COMPONENT DIAGNOSIS >

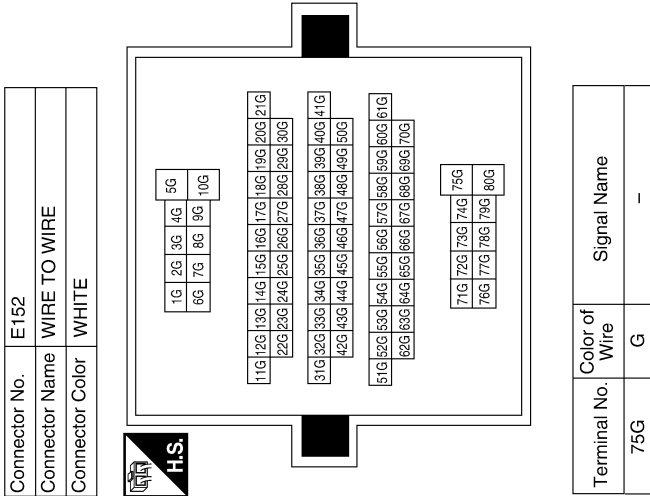
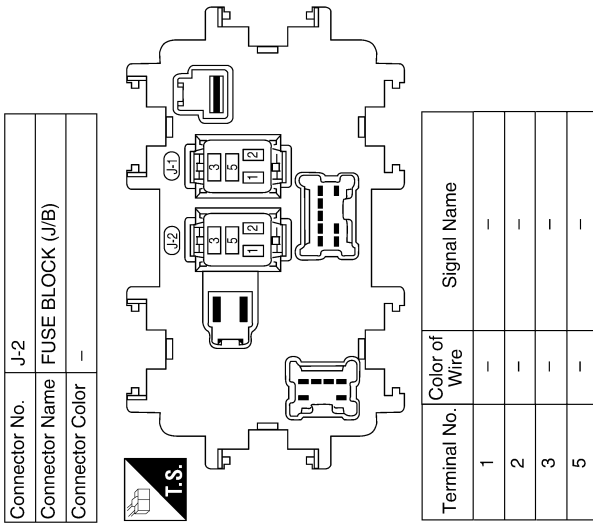

Connector No.	E152
Connector Name	WIRE TO WIRE
Connector Color	WHITE

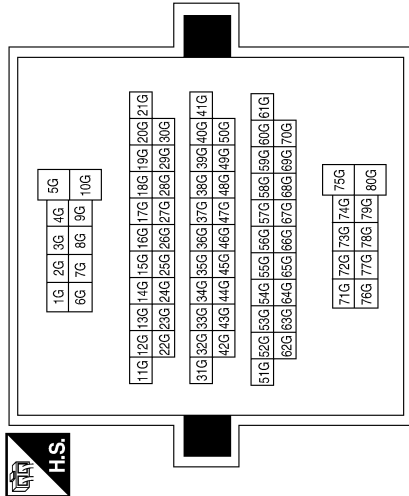

Terminal No.	75G
Color of Wire	G
Signal Name	-

A
B
C
D
E
F
G
H
I
J
K
L
N
O
P

PG

ABMIA0104GB

POWER SUPPLY ROUTING CIRCUIT

< COMPONENT DIAGNOSIS >

Wiring Diagram — Ignition Power Supply —

INFOID:000000003789668

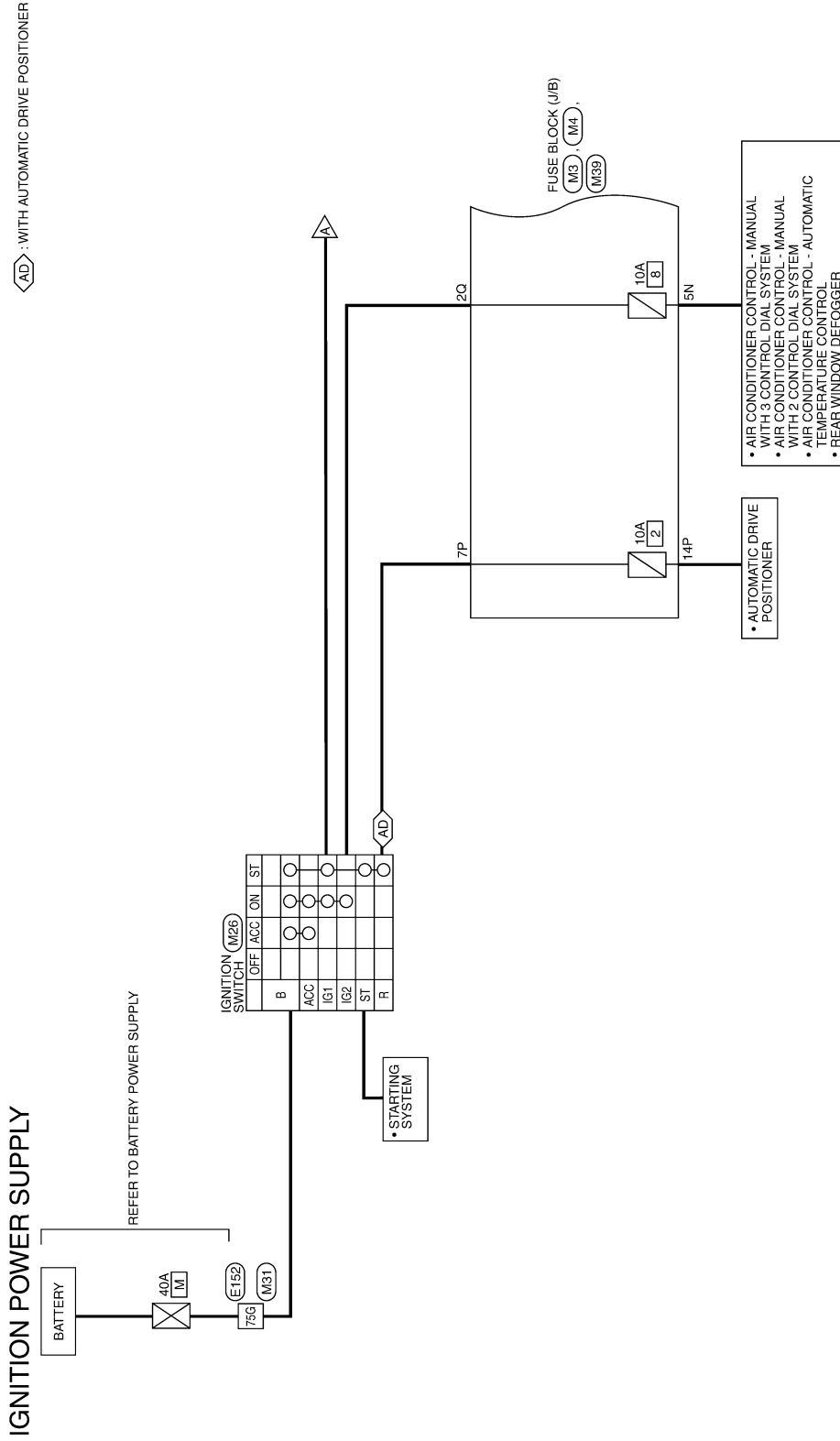

ABMWA0056GI

POWER SUPPLY ROUTING CIRCUIT

< COMPONENT DIAGNOSIS >

HS : WITH HEATED SEATS
 ■ : DATA LINE

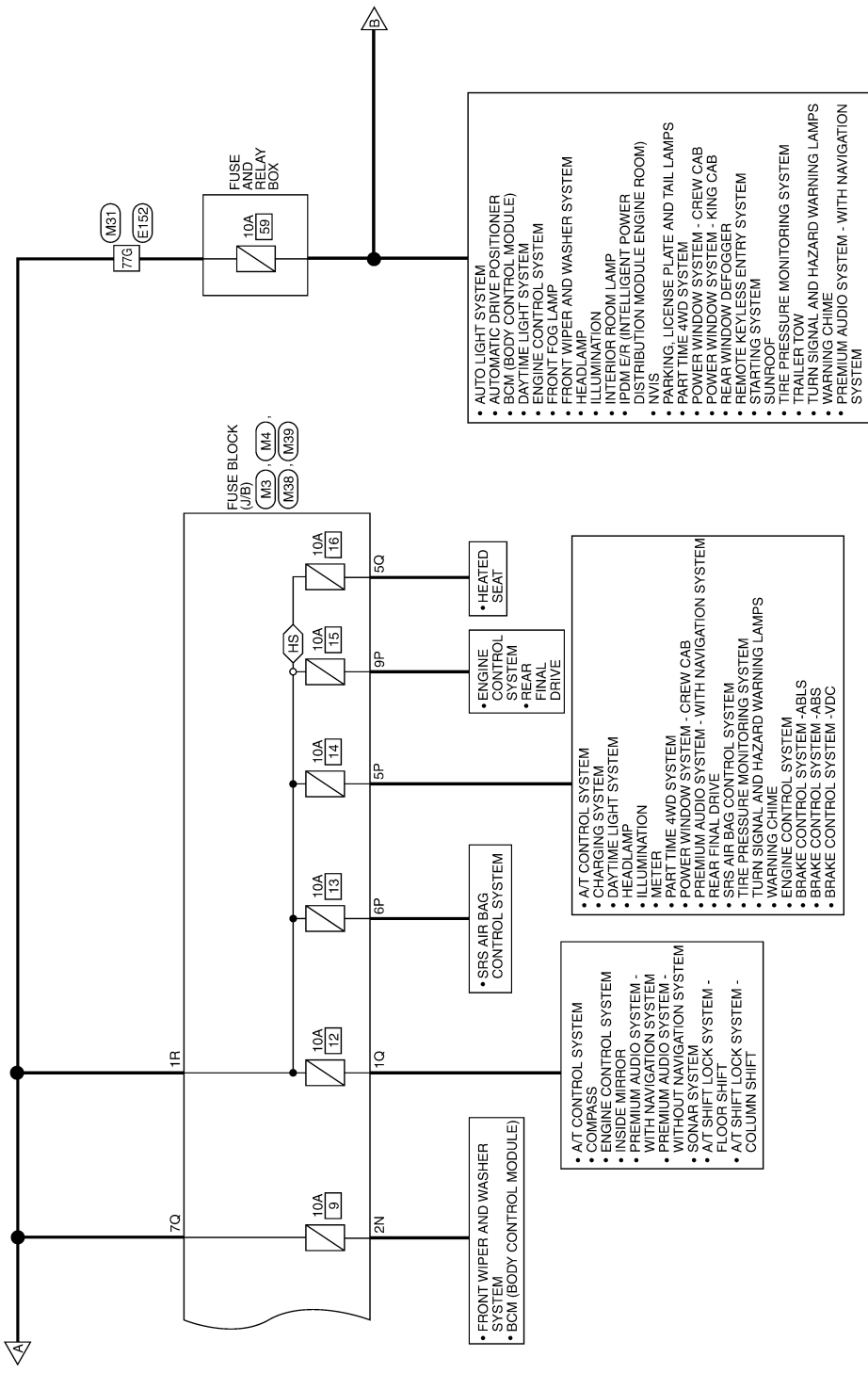

A
B
C
D
E
F
G
H
I
J
K
L
N
O
P

PG

ABMWA0057GI

POWER SUPPLY ROUTING CIRCUIT

< COMPONENT DIAGNOSIS >

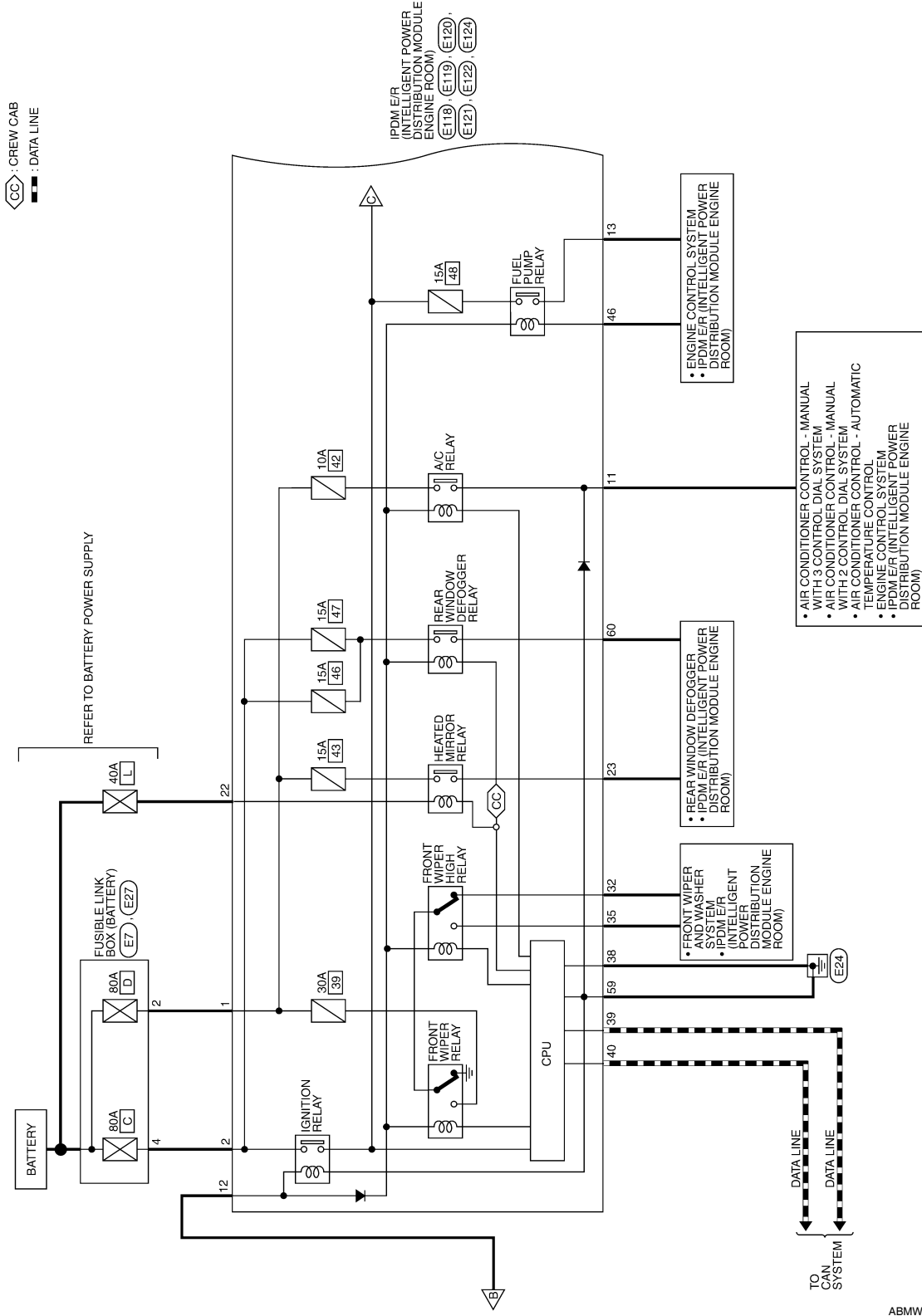

ABMWA0058GI

POWER SUPPLY ROUTING CIRCUIT

< COMPONENT DIAGNOSIS >

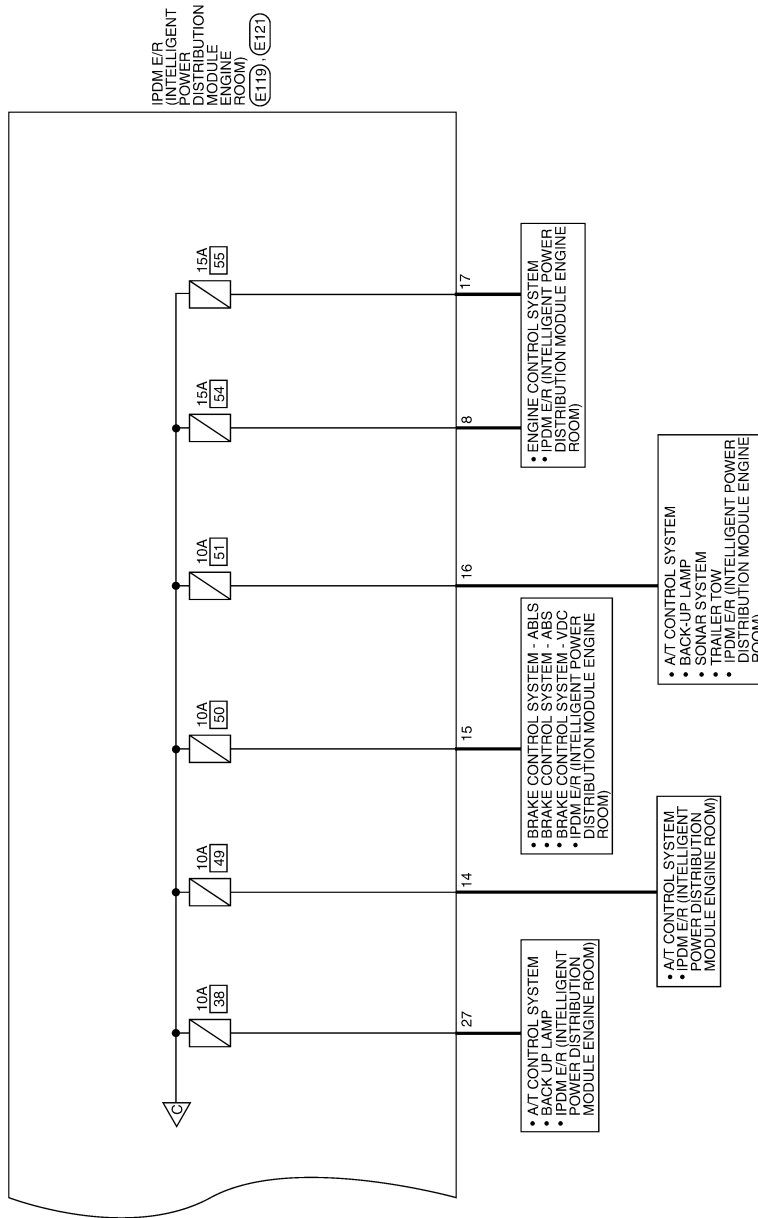

A
B
C
D
E
F
G
H
I
J
K
L
N
O
P

PG

ABMWA0059GI

POWER SUPPLY ROUTING CIRCUIT

< COMPONENT DIAGNOSIS >

IGNITION POWER SUPPLY CONNECTORS

Connector No.	M3
Connector Name	FUSE BLOCK (J/B)
Connector Color	WHITE

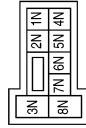

Terminal No.	Color of Wire	Signal Name
2N	W/R	WASH
5N	Y/G	-

Connector No.	M4
Connector Name	FUSE BLOCK (J/B)
Connector Color	WHITE



Terminal No.	Color of Wire	Signal Name
5P	O/L	-
6P	W/L	-
7P	LG	ST-R
9P	R/B	-
14P	O	AUTO DRFO

Connector No.	M26
Connector Name	IGNITION SWITCH
Connector Color	WHITE



Terminal No.	Color of Wire	Signal Name
B	G	-
ST	BR	-
IG1	B/R	-
R	LG	-
IG2	R	-

Connector No.	M31
Connector Name	WIRE TO WIRE
Connector Color	WHITE

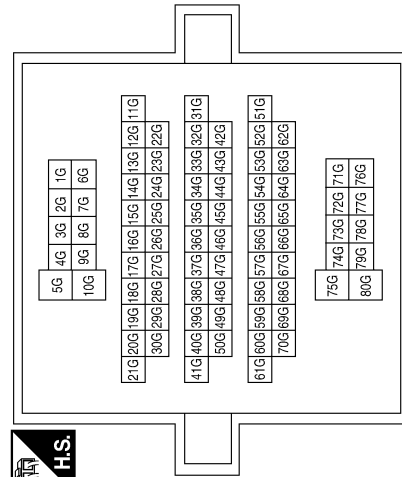

Terminal No.	Color of Wire	Signal Name
75G	G	-
77G	B/R	-

Connector No.	M38
Connector Name	FUSE BLOCK (J/B)
Connector Color	BLACK



Terminal No.	Color of Wire	Signal Name
1R	B/R	IGN

ABMIA0105GB

POWER SUPPLY ROUTING CIRCUIT

< COMPONENT DIAGNOSIS >

Connector No.	E27
Connector Name	FUSIBLE LINK BOX (BATTERY)
Connector Color	BROWN



Terminal No.	Color of Wire	Signal Name
2	B/Y	-

Connector No.	E7
Connector Name	FUSIBLE LINK BOX (BATTERY)
Connector Color	GRAY



Terminal No.	Color of Wire	Signal Name
4	R	-

Connector No.	M39
Connector Name	FUSE BLOCK (J/B)
Connector Color	WHITE



Terminal No.	Color of Wire	Signal Name
1Q	G/R	-
2Q	R	IGN N
5Q	G	-
7Q	B/R	IGN

Connector No.	E120
Connector Name	IPDM E/R (INTELLIGENT POWER DISTRIBUTION MODULE ENGINE ROOM)
Connector Color	WHITE

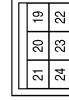

Terminal No.	Color of Wire	Signal Name
22	G	F/L MOTOR FAN
23	GR/W	HEATED MIRROR

Connector No.	E119
Connector Name	IPDM E/R (INTELLIGENT POWER DISTRIBUTION MODULE ENGINE ROOM)
Connector Color	WHITE

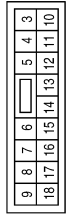

Terminal No.	Color of Wire	Signal Name
8	R/B	02 SENSOR
11	Y/B	A/C COMPRESSOR
12	L/W	IGN SW (IG)
13	B/Y	FUEL PUMP
14	Y/R	A/T CU IGN SUPPLY
15	GR	ABS IGN SUPPLY (WITH ABS)
15	G/R	ABS IGN SUPPLY (WITH ABL)
15	LG/B	ABS IGN SUPPLY (WITH VDC)
16	G	REVERSE LAMP
17	W	INJECTOR

Connector No.	E118
Connector Name	IPDM E/R (INTELLIGENT POWER DISTRIBUTION MODULE ENGINE ROOM)
Connector Color	BLACK



Terminal No.	Color of Wire	Signal Name
1	B/Y	F/L USM
2	R	F/L MAIN

ABMIA106GB

A
B
C
D
E
F
G
H
I
J
K
L
M
N
O
P

POWER SUPPLY ROUTING CIRCUIT

< COMPONENT DIAGNOSIS >

Connector No.	E124
Connector Name	IPDM E/R (INTELLIGENT POWER DISTRIBUTION MODULE ENGINE ROOM)
Connector Color	BLACK



59	56	57
62	61	60

Terminal No.	Color of Wire	Signal Name
59	B	GND (POWER)
60	B/W	RR DEF

Connector No.	E122
Connector Name	IPDM E/R (INTELLIGENT POWER DISTRIBUTION MODULE ENGINE ROOM)
Connector Color	WHITE



42	41	40	39	38	37
48	47	46	45	44	43

Terminal No.	Color of Wire	Signal Name
38	B	GND (SIGNAL)
39	L	CAN-H
40	P	CAN-L
46	GR	FUEL PUMP RLY CONT

Connector No.	E121
Connector Name	IPDM E/R (INTELLIGENT POWER DISTRIBUTION MODULE ENGINE ROOM)
Connector Color	BROWN



29	28	27	26	25
36	35	34	33	32
31	30			

Terminal No.	Color of Wire	Signal Name
27	W/B	T TOW REV LAMP
32	L	FR WIPER LO
35	L/B	FR WIPER HI

Terminal No.	Color of Wire	Signal Name
75G	G	-
77G	B/R	-

Connector No.	E152
Connector Name	WIRE TO WIRE
Connector Color	WHITE

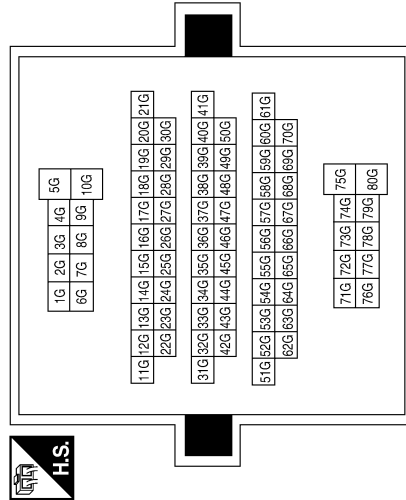

ABMIA0107GB

POWER SUPPLY ROUTING CIRCUIT

< COMPONENT DIAGNOSIS >

Fuse

INFOID:000000003789669

- If fuse is blown, be sure to eliminate cause of malfunction before installing new fuse.
- Use fuse of specified rating. Never use fuse of more than specified rating.
- Do not partially install fuse; always insert it into fuse holder properly.
- Remove fuse for "ELECTRICAL PARTS (BAT)" if vehicle is not used for a long period of time.

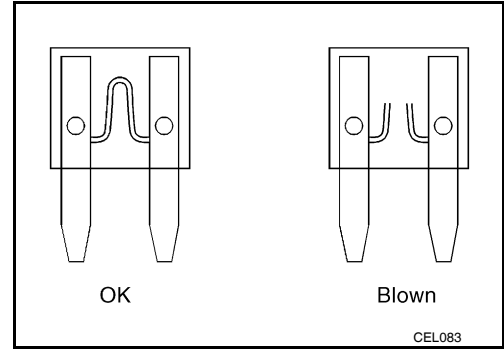

Fusible Link

INFOID:000000003789670

A melted fusible link can be detected either by visual inspection or by feeling with finger tip. If its condition is questionable, use circuit tester or test lamp.

1 : Fusible link

CAUTION:

- If fusible link should melt, it is possible that critical circuit (power supply or large current carrying circuit) is shorted. In such a case, carefully check and eliminate cause of malfunction.
- Never wrap outside of fusible link with vinyl tape. Important: Never let fusible link touch any other wiring harness, vinyl or rubber parts.

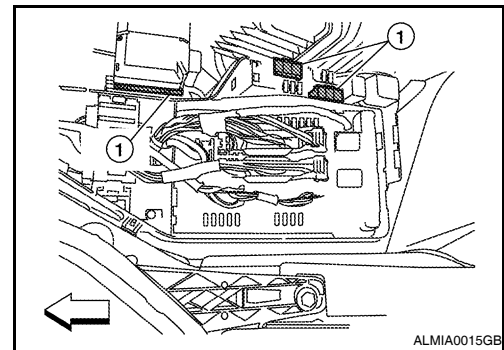

Circuit Breaker (PTC)

INFOID:000000004333519

The PTC thermistor generates heat in response to current flow. The temperature (and resistance) of the thermistor element varies with current flow. Excessive current flow will cause the element's temperature to rise. When the temperature reaches a specified level, the electrical resistance will rise sharply to reduce the circuit current. This reduced current flow will cause the element to cool lowering the resistance accordingly. Once resistance falls to a specified level normal circuit current flow is allowed to resume.

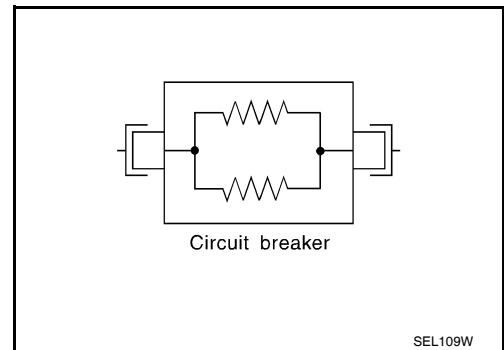

A
B
C
D
E
F
G
H
I
J
K
L
PG
N
O
P

GROUND

< COMPONENT DIAGNOSIS >

GROUND

Ground Distribution

INFOID:000000003789671

MAIN HARNESS

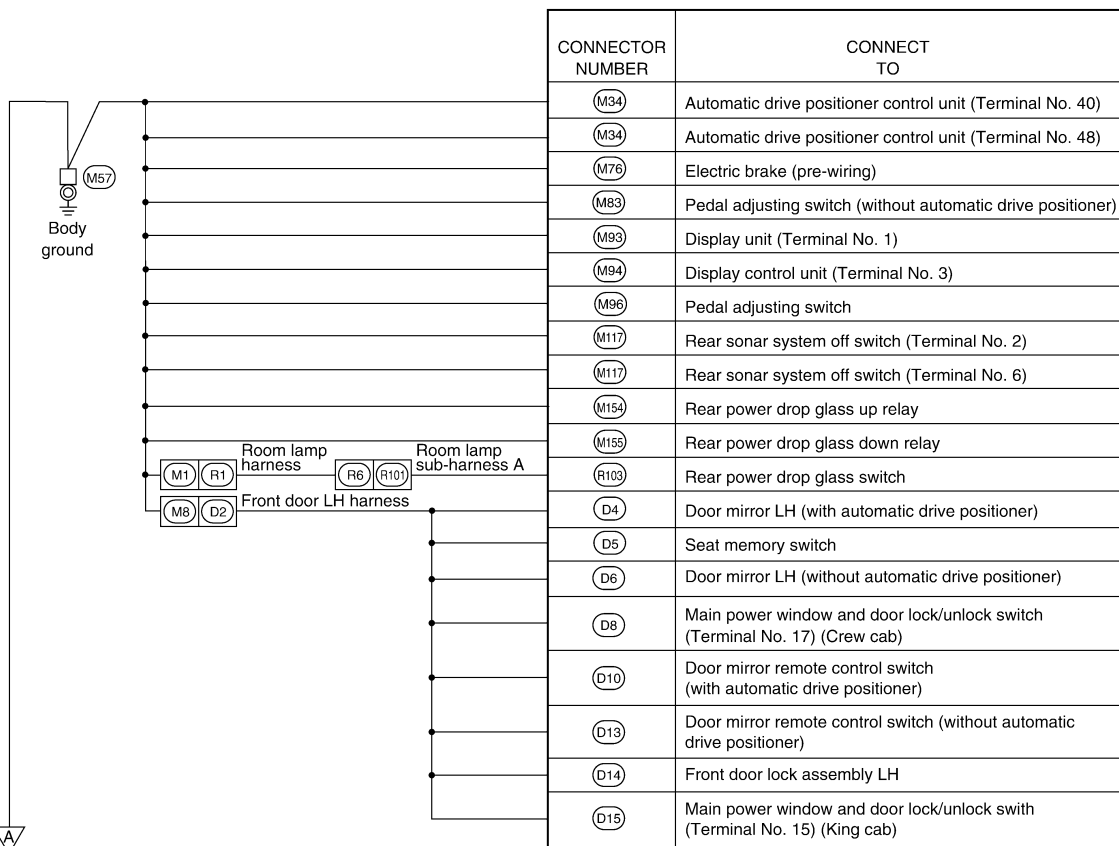
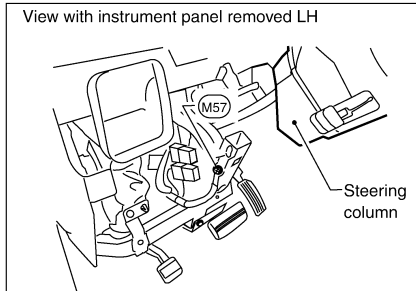

Next page

ABMIA0133GB

GROUND

< COMPONENT DIAGNOSIS >

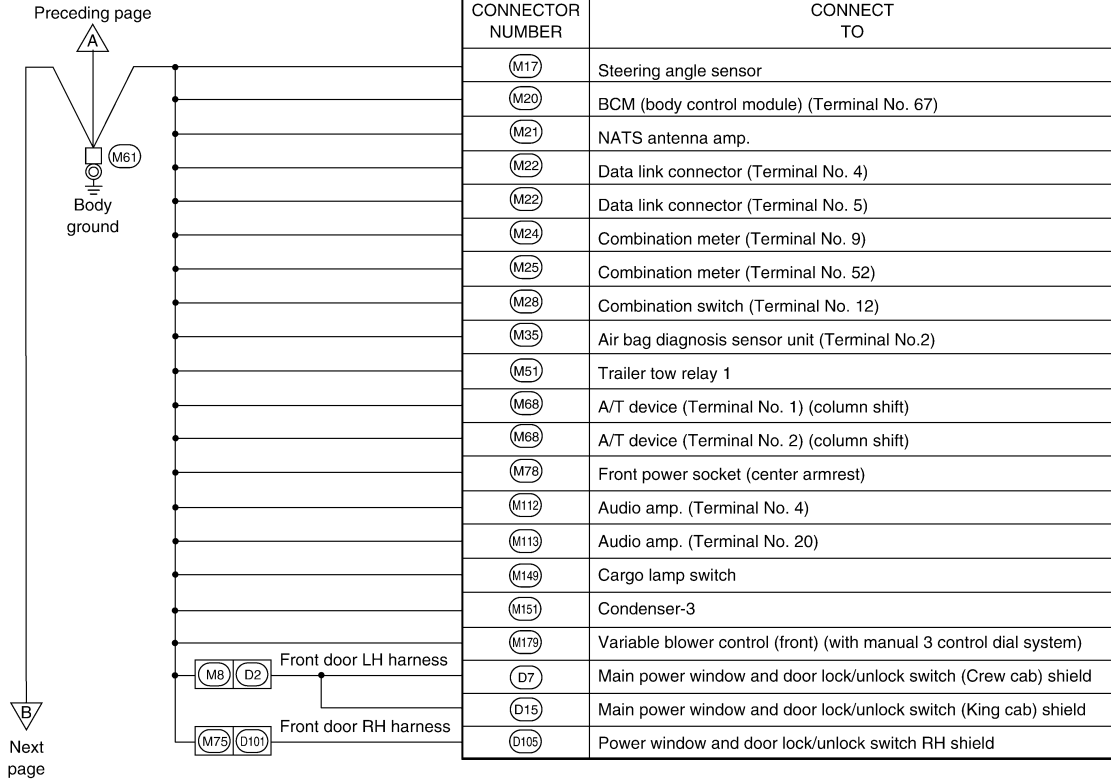
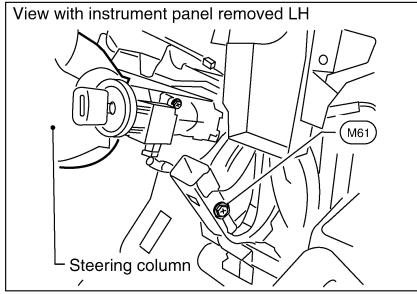

ABMIA0108GB

A
B
C
D
E
F
G
H
I
J
K
L
N
O
P

PG

GROUND

< COMPONENT DIAGNOSIS >

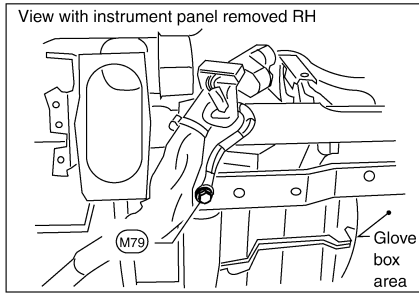

Preceding page

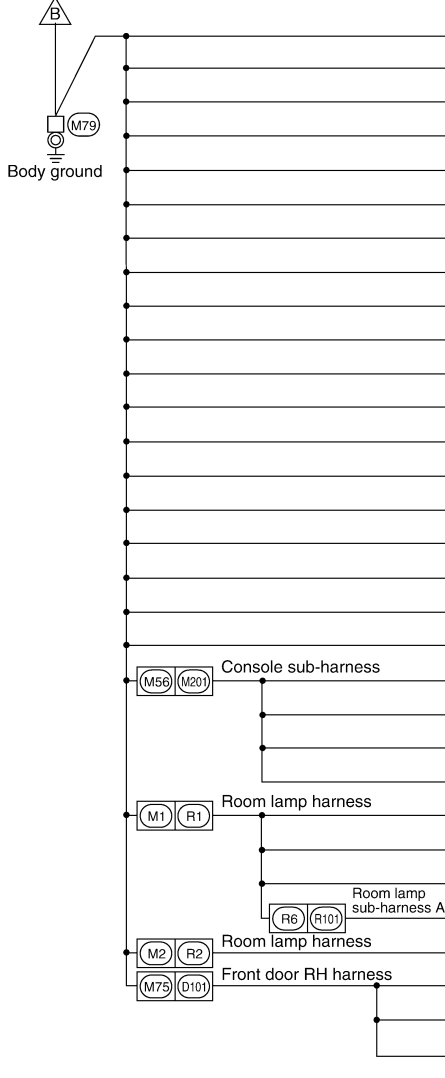

CONNECTOR NUMBER	CONNECT TO
M3	Fuse block J/B (Terminal No. 7N)
M13	Front passenger air bag off indicator
M32	In-vehicle sensor
M47	Hazard switch (Terminal No. 5) (with 2 control dial system)
M50	Front air control (Terminal No. 35) (with automatic temperature control)
M53	Front power socket LH
M54	Front power socket RH
M55	Hazard switch (Terminal No. 5) (with 3 control dial system)
M67	Tow mode switch (Terminal No. 2)
M67	Tow mode switch (Terminal No. 6)
M81	Shift lock control unit (Terminal No. 8)
M98	AV switch
M107	Front blower relay
M122	Variable blower control (front)
M148	VDC OFF switch
M159	Front heated seat switch LH
M160	Front heated seat switch RH
M178	Front air control (Terminal No. 1)(with manual 3 control dial system)
M181	Front air control (Terminal No. 35)(with manual 2 control dial system)
M203	A/T device (floor shift) (Terminal No. 2)
M203	A/T device (floor shift) (Terminal No. 8)
M206	DVD player (Terminal No. 22)
M207	Console power socket
R3	Vanity lamp LH
R7	Auto anti-dazzling inside mirror
R8	Vanity lamp RH
R102	Front room/map lamp assembly
R4	Sunroof motor assembly
D105	Power window and door lock/unlock switch RH
D106	Door mirror RH (without automatic drive positioner)
D107	Door mirror RH (with automatic drive positioner)

ABMIA0109GB

GROUND

< COMPONENT DIAGNOSIS >

ENGINE ROOM HARNESS

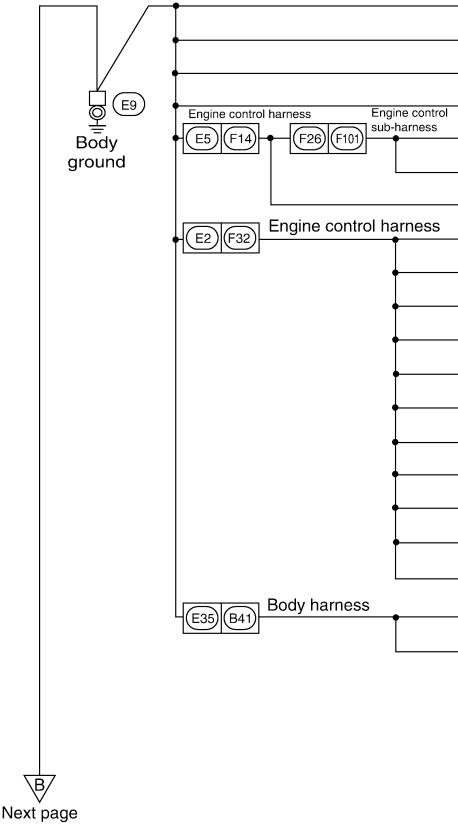
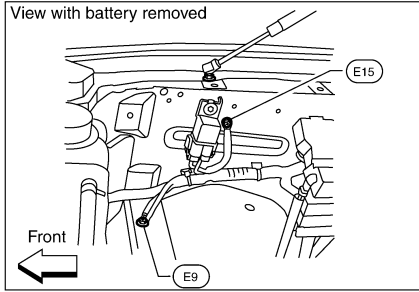

CONNECTOR NUMBER	CONNECT TO
(E16)	ECM (Terminal No. 115)
(E16)	ECM (Terminal No. 116)
(E142)	Transfer control unit (Terminal No. 6)
(E142)	Transfer control unit (Terminal No. 18)
(F102)	Knock sensor (bank 1) shield
(F104)	Knock sensor (bank 2) shield
(F5)	Air fuel ratio (A/F) sensor 1 (bank 2) (shield)
(F9)	A/T assembly (TCM) (Terminal No. 10) (floor shift)
(F9)	A/T assembly (TCM) (Terminal No. 5) (floor shift)
(F11)	Crankshaft position sensor (POS)
(F17)	A/T assembly (TCM) (Terminal No.10) (column shift)
(F17)	A/T assembly (TCM) (Terminal No.5) (column shift)
(F23)	Camshaft position sensor (PHASE)
(F50)	Electric throttle control actuator (throttle position sensor shield)
(F54)	ECM (Terminal No. 1)
(F62)	Intake valve timing control position sensor (bank 1)
(F64)	Intake valve timing control position sensor (bank 2)
(F65)	Air fuel ratio (A/F) sensor 1 (bank 1) (shield)
(B77)	Differential lock control unit (Terminal No. 3)
(B77)	Differential lock control unit (Terminal No. 10)

Next page

A
B
C
D
E
F
G
H
I
J
K
L
N
O
P

PG

ABMIA0110GB

GROUND

< COMPONENT DIAGNOSIS >

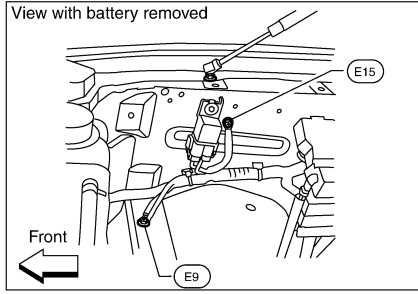

Preceding page

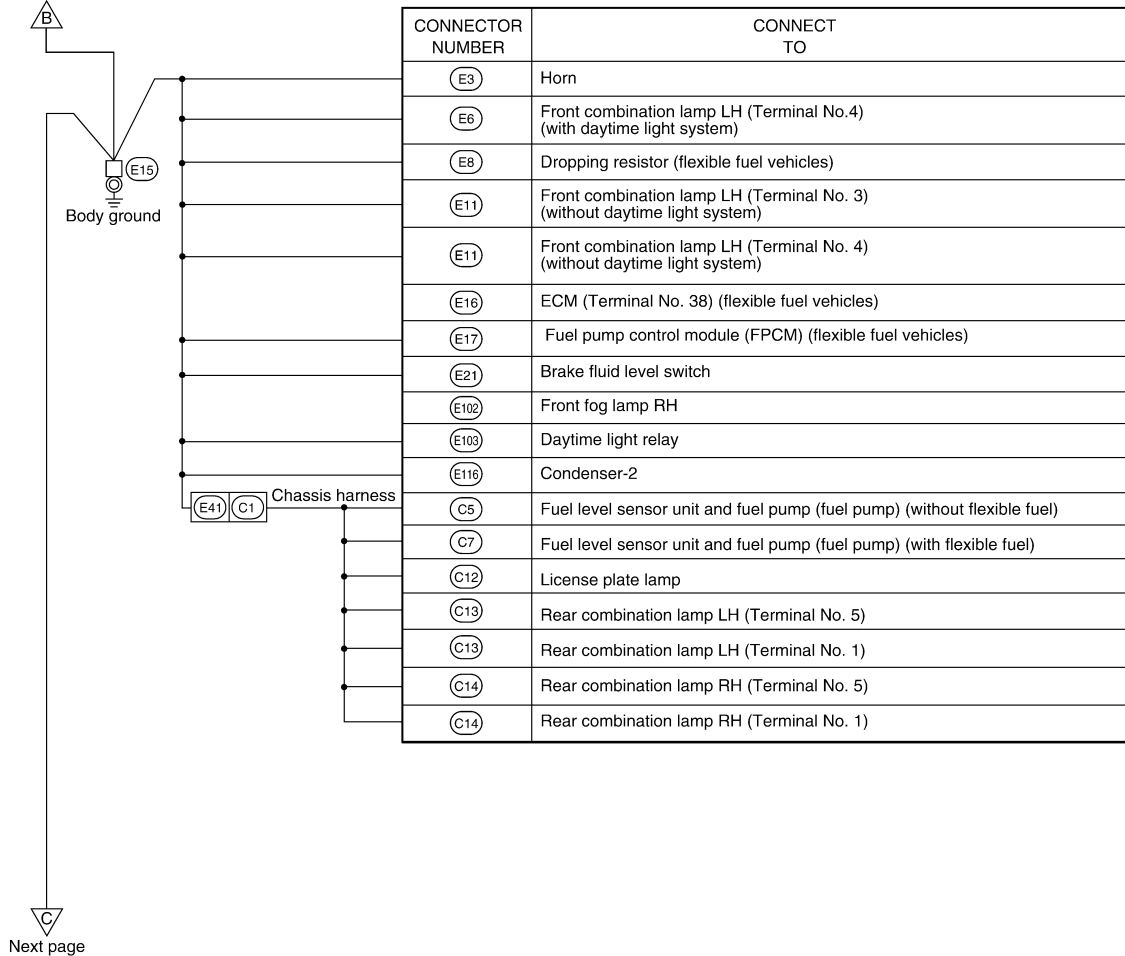

ABMIA0160GB

GROUND

< COMPONENT DIAGNOSIS >

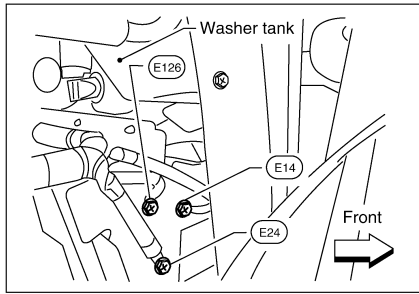

Preceding page

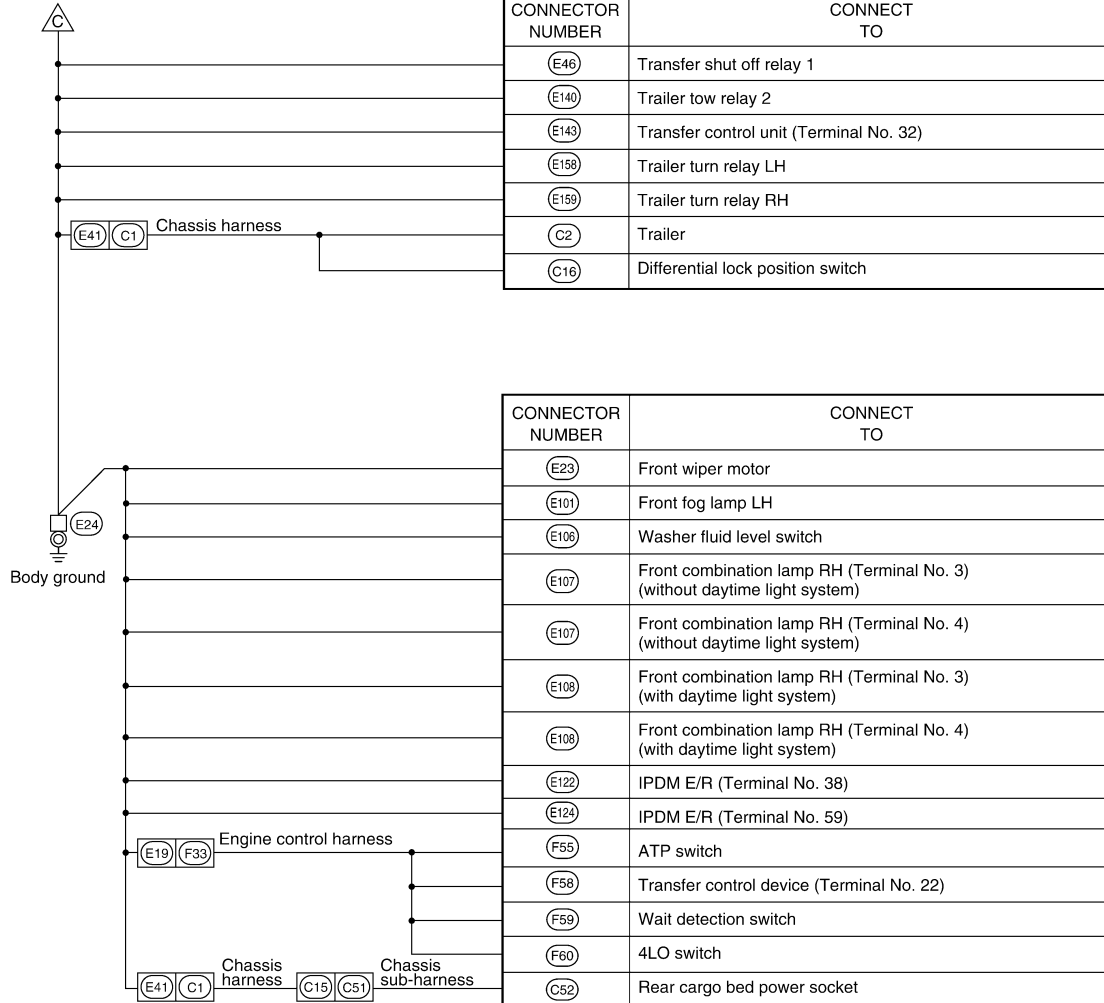

ABMIA0111GB

A
B
C
D
E
F
G
H
I
J
K
L
PG
N
O
P

GROUND

< COMPONENT DIAGNOSIS >

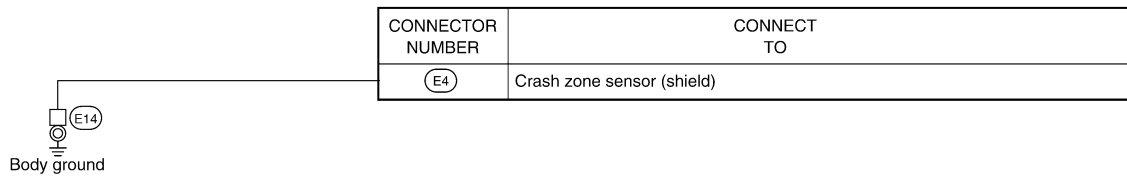
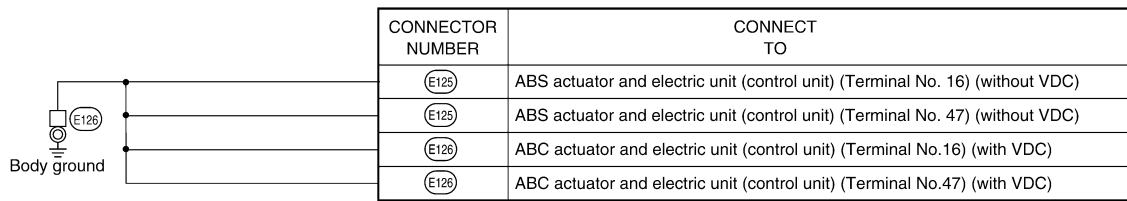
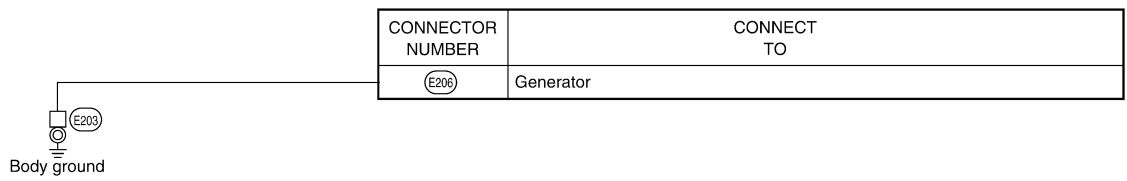
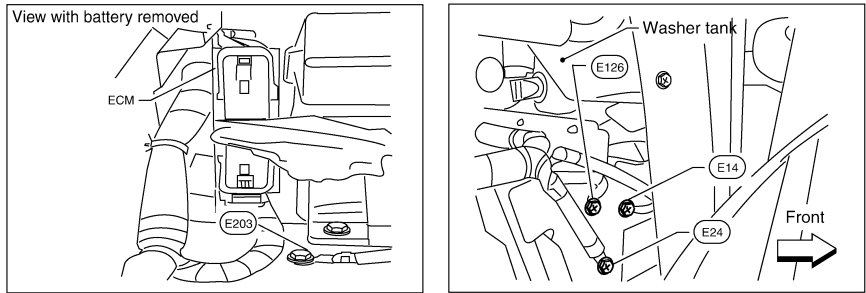

ABMIA0112GB

GROUND

< COMPONENT DIAGNOSIS > ENGINE CONTROL HARNESS

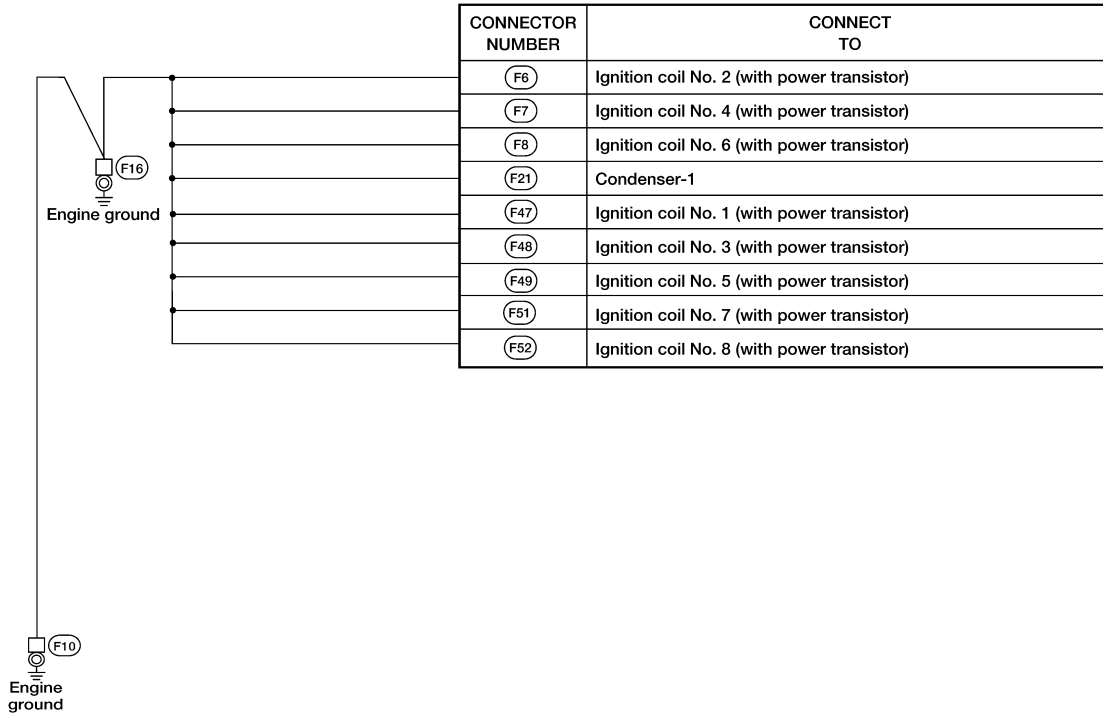
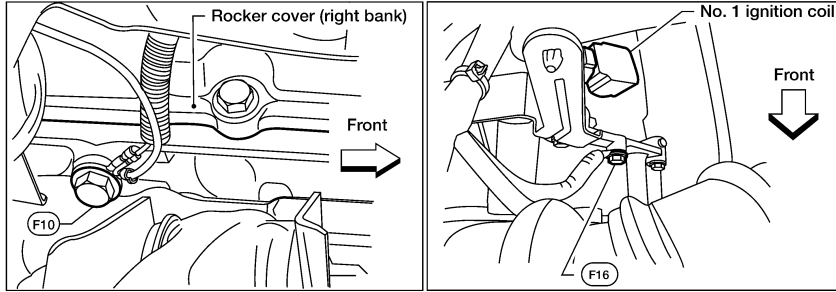

A
B
C
D
E
F
G
H
I
J
K
L
PG
N
O
P

WKIA3853E

GROUND

< COMPONENT DIAGNOSIS >

BODY HARNESS

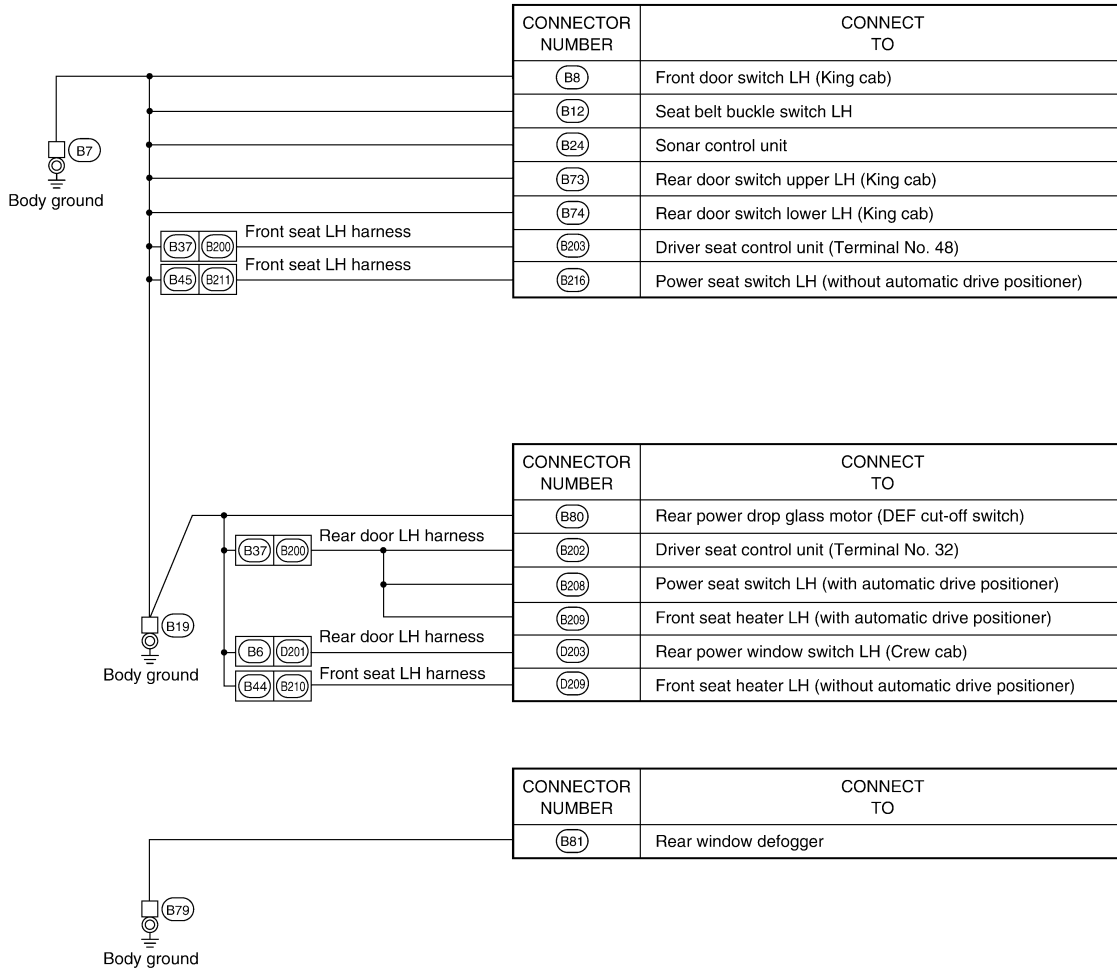
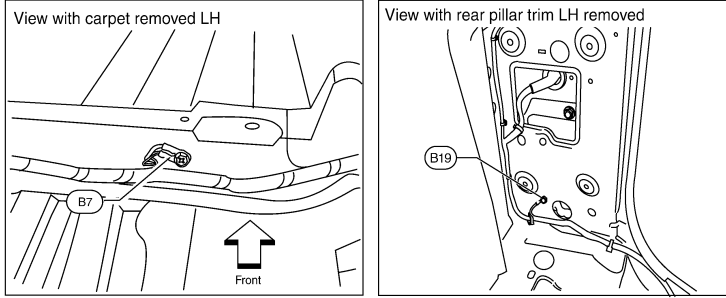

ABMIA0113GB

GROUND

< COMPONENT DIAGNOSIS >

BODY NO. 2 HARNESS

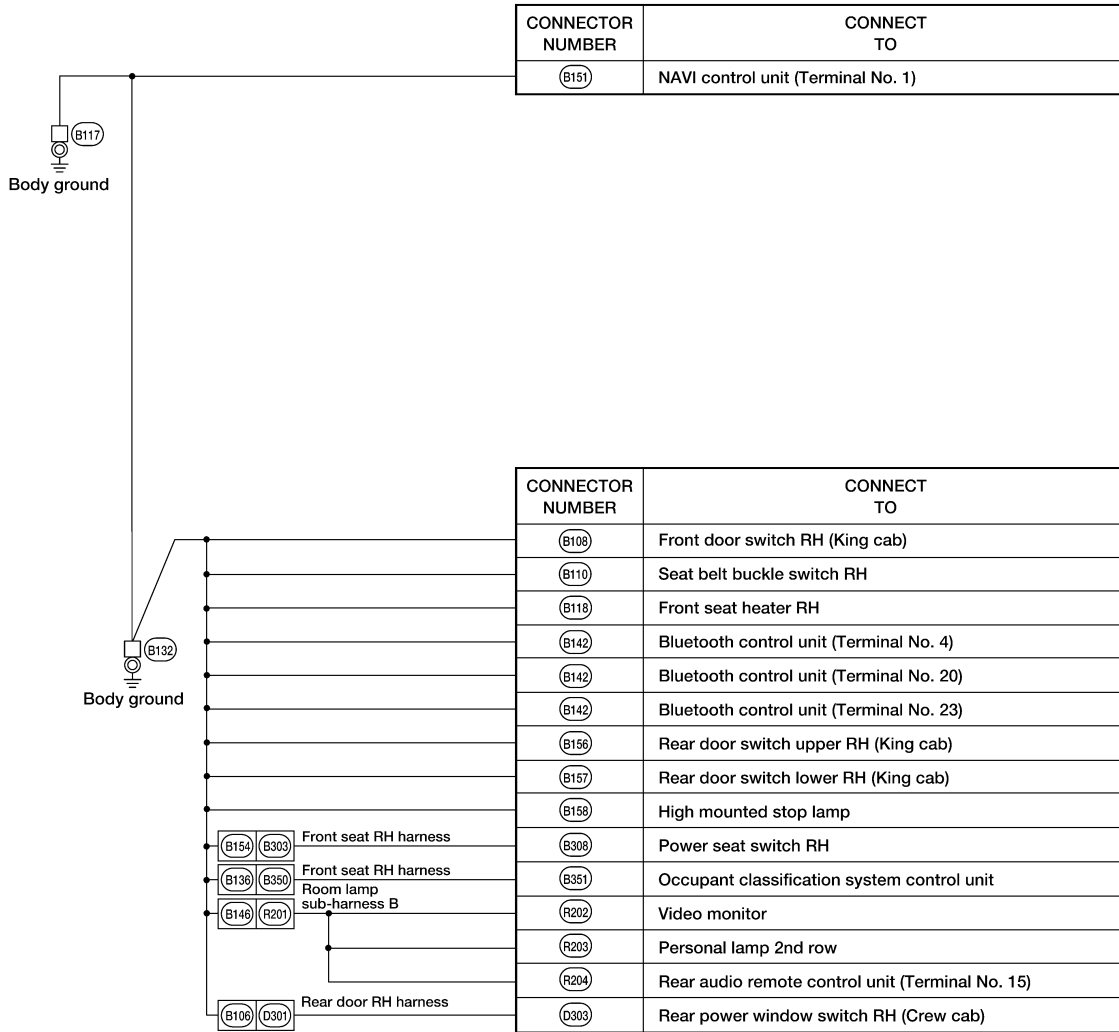
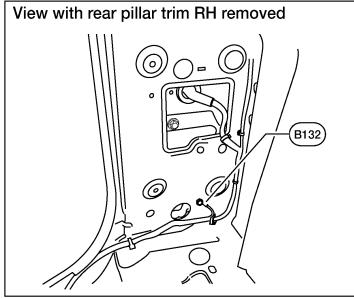
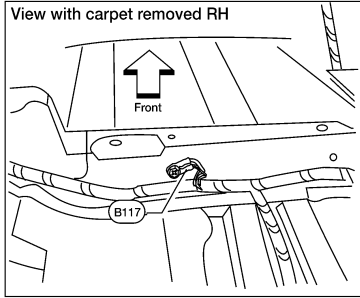

ABMIA0114GB

A
B
C
D
E
F
G
H
I
J
K
L
M
N
O
P

PG

HARNESS

< COMPONENT DIAGNOSIS >

HARNESS

Harness Layout

INFOID:000000003789672

HOW TO IDENTIFY TYPE A AND TYPE B MAIN HARNESSSES

The differences between Type A and type B harnesses are minimal and mainly consist of differences in the circuit connections to the fuse block (J/B) and adjustable pedal control.

For vehicles equipped with floor shift, determine type of harness by locating the Nissan Name Plate on the main harness. This can be found on the main harness near SMJ M31 connector above the right hand lower side dash finisher. Find the six digit number on Nissan Name Plate. If the number ends in 103, it is a Type A harness, any other number indicates a Type B harness.

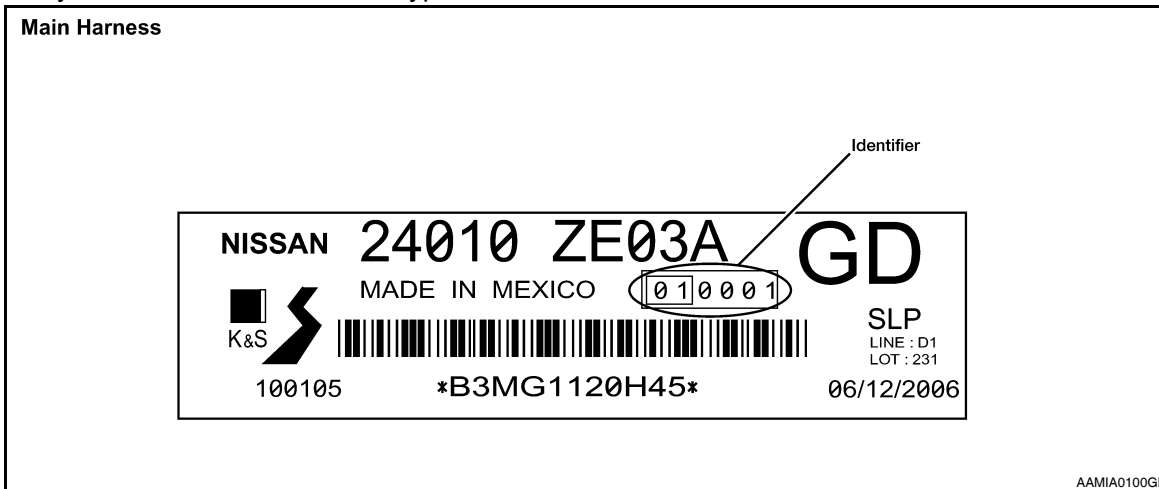

For vehicles equipped with column shift, determine type of harness by locating green tape on the harness near M4 connector of fuse block (J/B). If green tape is present on this harness branch it is a Type A harness. If no green tape is present on this harness branch it is a Type B harness.

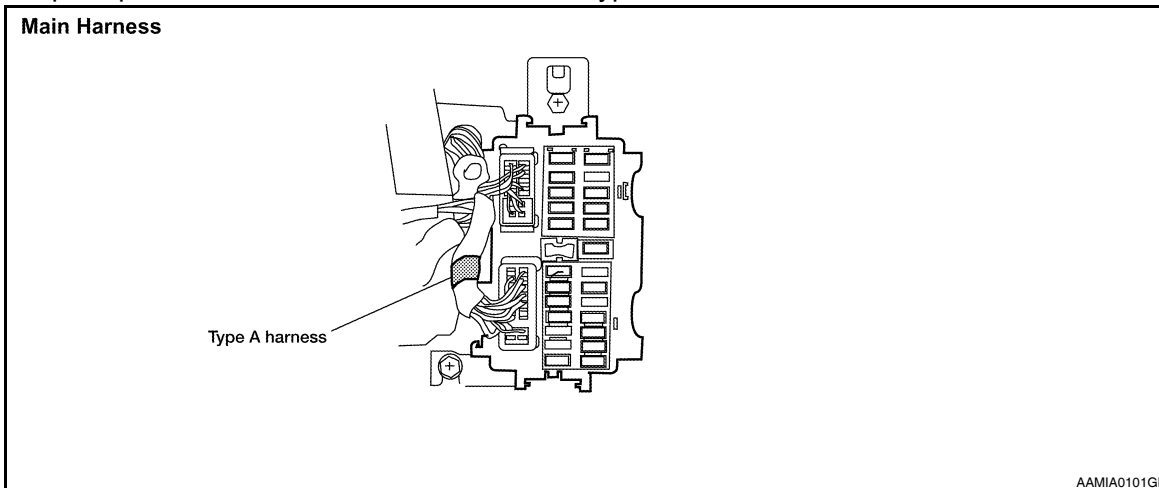

HOW TO READ HARNESS LAYOUT

The following Harness Layouts use a map style grid to help locate connectors on the drawings:

- Main Harness, Console Sub-harness, Console Switch Sub-harness and Optical Sensor Sub-harness
- Engine Room Harness and Engine Room Sub-harness
- Engine Room Harness (Passenger Compartment)
- Engine Control Harness and Knock Sensor Sub-harness
- Chassis Harness, Rear Sonar Sensor Sub-harness and Rear Power Socket Sub-harness
- Body Harness (King Cab Models) and Left Front Seat Harness
- Body Harness (Crew Cab Models) and Left Front Seat Harness
- Body No. 2 Harness (King Cab Models) and Right Front Seat Harness

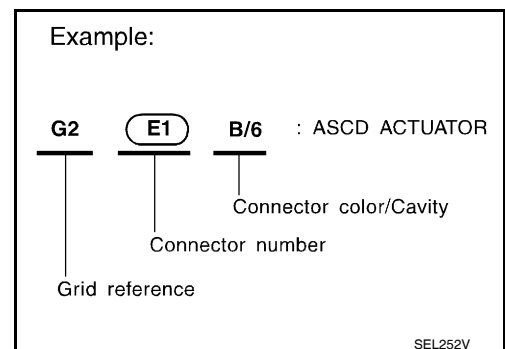

HARNESS

< COMPONENT DIAGNOSIS >

- Body No. 2 Harness (Crew Cab Models) and Right Front Seat Harness
- Room Lamp Harness, Room Lamp Sub-harness A and Room Lamp Sub-harness B

To use the grid reference

1. Find the desired connector number on the connector list.
2. Find the grid reference.
3. On the drawing, find the crossing of the grid reference letter column and number row.
4. Find the connector number in the crossing zone.
5. Follow the line (if used) to the connector.

OUTLINE (CREW CAB MODELS)

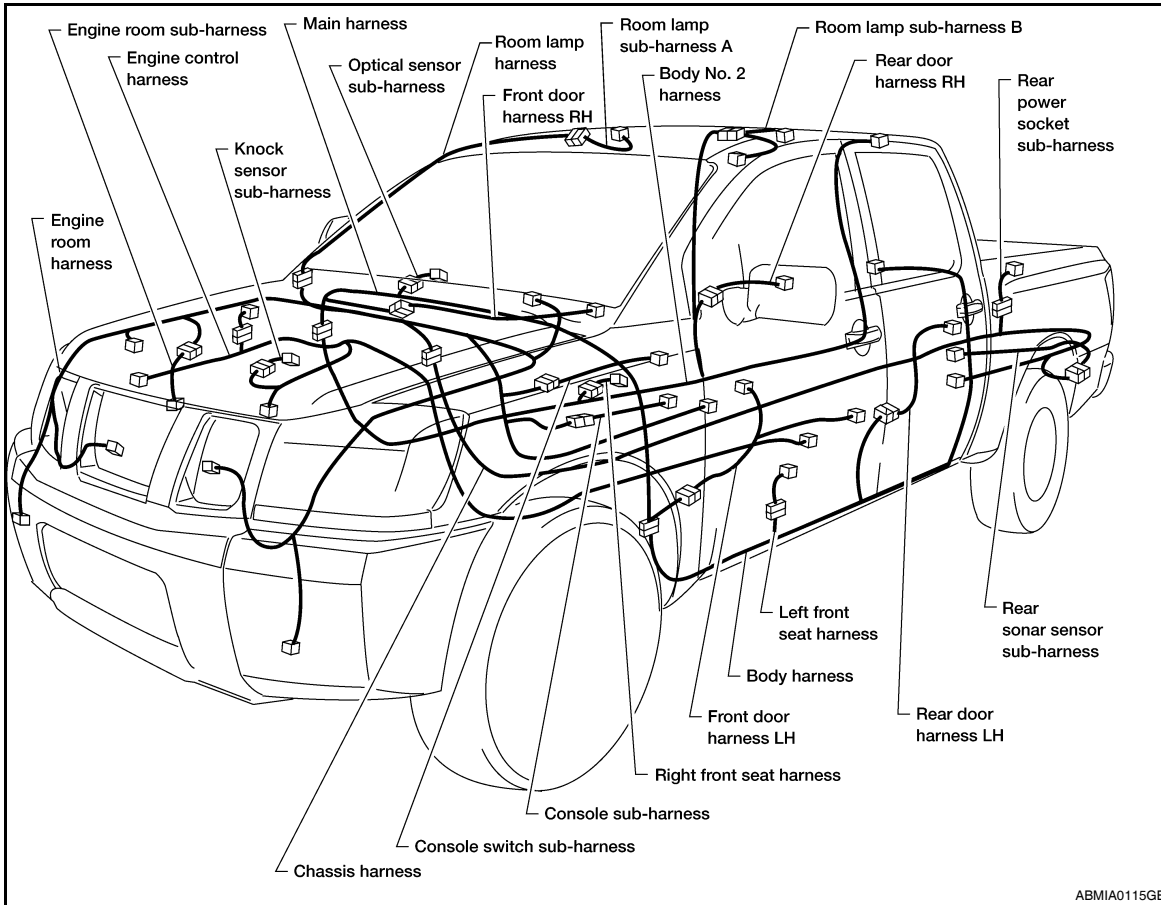

A
B
C
D
E
F
G
H
I
J
K
L

PG

N
O
P

HARNESS

< COMPONENT DIAGNOSIS >

OUTLINE (KING CAB MODELS)

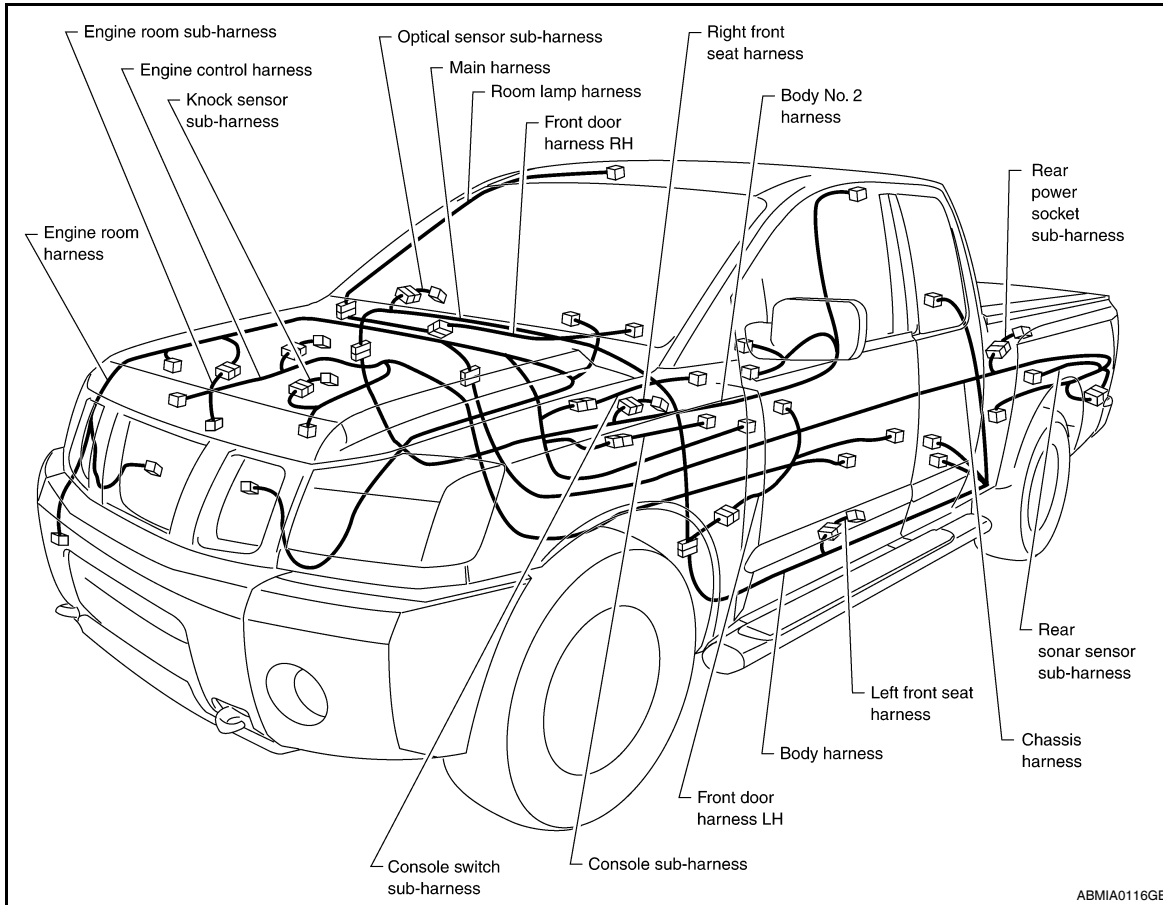

HARNESS

< COMPONENT DIAGNOSIS >

MAIN HARNESS

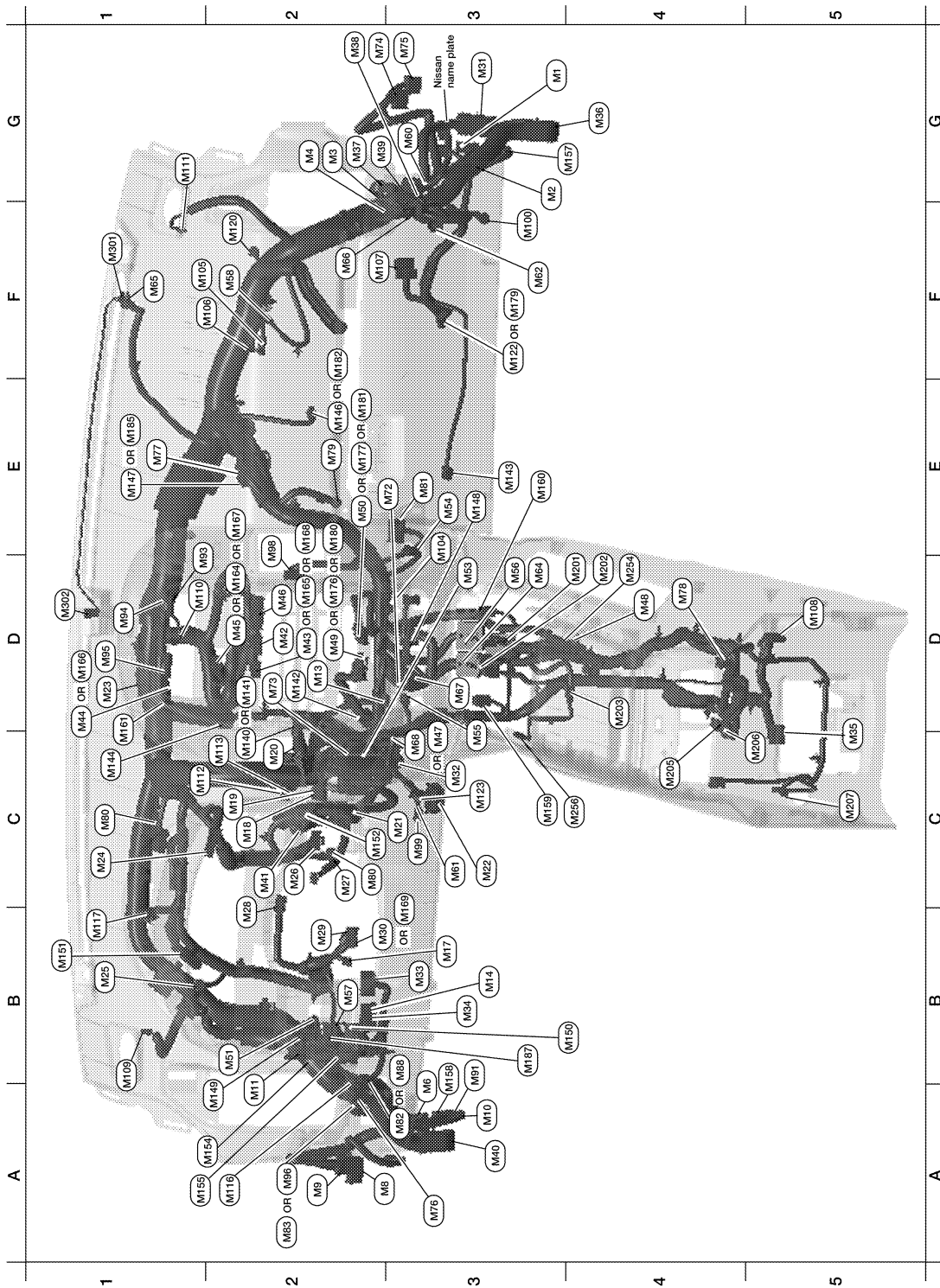

ABMIA0117GB

G3	M1	W/16	: To R1	A2	M96	BR/6	: Pedal adjusting switch (with automatic drive positioner)
G3	M2	W/12	: To R2	D2	M98	W/24	: AV switch
G2	M3	W/8	: Fuse block (J/B)	C3	M99	BR/2	: Foot lamp LH
G2	M4	W/16	: Fuse block (J/B)	F3	M100	BR/2	: Foot lamp RH

HARNESS

< COMPONENT DIAGNOSIS >

A3	M6	W/10	: To E10	E3	M104	W/4	: Aux jack
A3	M8	W/16	: To D2	F1	M105	Y/2	: Front passenger air bag module
A2	M9	BR/24	: To D1	F1	M106	O/2	: Front passenger air bag module
A3	M10	Y/4	: To E29	F3	M107	B/5	: Front blower relay
A2	M11	B/1	: Parking brake switch	D5	M108	B/6	: Yaw rate/ side/ decel G sensor
D2	M13	BR/3	: Front passenger air bag OFF indicator	B1	M109	BR/2	: Front tweeter LH
B3	M14	W/16	: Jumper connector (Type A harness)	D1	M110	BR/2	: Center speaker
D2	M17	W/8	: Steering angle sensor	G1	M111	BR/2	: Front tweeter RH
C2	M18	W/40	: BCM (body control module)	C1	M112	W/8	: Audio amp.
C2	M19	W/15	: BCM (body control module)	C2	M113	W/24	: Audio amp.
C2	M20	B/15	: BCM (body control module)	A2	M116	B/2	: Rear sonar buzzer
C3	M21	W/4	: NATS antenna amp.	B1	M117	GR/8	: Rear sonar system OFF switch
C3	M22	W/16	: Data link connector	F2	M120	W/4	: Remote keyless entry receiver
D1	M23	W/2	: Diode-1	F3	M122	W/4	: Variable blower control (front) (2 control dial system or auto A/C)
C1	M24	W/40	: Combination meter	C3	M123	W/2	: Tire pressure warning check connector
B1	M25	W/12	: Combination meter	C2	M140	GR/8	: 4WD shift switch (2 control dial system or auto A/C)
C2	M26	W/6	: Ignition switch	C2	M141	W/8	: 4WD shift switch (3 control dial system without auto A/C)
C2	M27	W/4	: Key switch and key lock solenoid	D2	M142	B/6	: Mode door motor
B2	M28	W/16	: Combination switch	E3	M143	B/6	: Air mix door motor (passenger)
B2	M29	Y/6	: Combination switch (spiral cable)	C1	M144	B/6	: Defroster door motor
B3	M30	GR/8	: Combination switch (spiral cable) (with BLUETOOTH)	E2	M146	GR/2	: Intake sensor (2 control dial system or auto A/C)
G3	M31	SMJ	: To E152	E1	M147	B/6	: Air mix door motor (front)
C3	M32	W/4	: In-vehicle sensor	E3	M148	GR/6	: VDC OFF switch
B3	M33	W/32	: Automatic drive positioner control unit	A1	M149	W/6	: Cargo lamp switch
B3	M34	W/16	: Automatic drive positioner control unit	B3	M150	L/4	: Cargo lamp relay
C5	M35	Y/28	: Air bag diagnosis sensor unit	B1	M151	W/2	: Condenser-3
G4	M36	SMJ	: To B149	C2	M152	W/2	: Ignition keyhole illumination
G2	M37	B/1	: Fuse block (J/B)	A1	M154	B/5	: Rear power drop glass up relay
G2	M38	B/2	: Fuse block (J/B)	A1	M155	B/5	: Rear power drop glass down relay
G2	M39	W/8	: Fuse block (J/B)	G3	M157	W/20	: To B161
A3	M40	SMJ	: To B69	B3	M158	W/10	: To D3
C2	M41	W/16	: Satellite radio tuner or pre-wiring for satellite radio tuner	C3	M159	W/6	: Front heated seat switch LH
D2	M42	W/12	: Audio unit (with premium audio system)	E3	M160	BR/6	: Front heated seat switch RH
D2	M43	W/10	: Audio unit (with premium audio system)	C1	M161	W/2	: Diode-3
D1	M44	W/6	: Audio unit (with premium audio system)	D2	M164	W/16	: Audio unit (with premium audio system-without NAVI)
D1	M45	W/16	: Audio unit (with premium audio system-with NAVI)	D2	M165	W/10	: Audio unit (with mid audio system)
D2	M46	W/20	: Audio unit (with premium audio system)	D1	M166	W/6	: Audio unit (with mid audio system)
D3	M47	W/4	: Hazard switch (2 control dial system or auto A/C)	D2	M167	W/16	: Audio unit (with mid audio system)
D4	M48	BR/2	: To M254	D2	M168	W/20	: Audio unit (with base audio system)

HARNESS

< COMPONENT DIAGNOSIS >

D2	M49	B/26	: Front air control (with automatic temperature control)	B3	M169	GR/8	: Combination switch (spiral cable) (without BLUETOOTH)	A
D2	M50	L/18	: Front air control (with automatic temperature control)	D2	M176	B/26	: Front air control (3 control dial system without auto A/C)	B
B2	M51	L/4	: Trailer tow relay 1	D2	M177	L/18	: Front air control (3 control dial system without auto A/C)	C
D3	M53	B/3	: Front power socket LH	F3	M179	W/4	: Variable blower control (front) (3 control dial system without auto A/C)	D
E3	M54	B/3	: Front power socket RH (for cigarette lighter)	D2	M180	B/26	: Front air control (2 control dial system or auto A/C)	E
C3	M55	W/8	: Hazard switch (3 control dial system without auto A/C)	D2	M181	L/18	: Front air control (2 control dial system or auto A/C)	F
D3	M56	W/16	: To M201	E2	M182	GR/2	: Intake sensor (3 control dial system without auto A/C)	G
B2	M57	—	: Body ground	E1	M185	B/6	: Air mix door motor (driver)	H
F2	M58	B/6	: Intake door motor	B3	M187	L/4	: Rear window defogger cut-off relay	I
G3	M60	W/6	: Fuse block (J/B)	Console sub-harness				F
C3	M61	—	: Body ground	D4	M201	W/16	: To M56	G
F3	M62	B/2	: Front blower motor	D4	M202	BR/24	: To M64	H
D3	M64	BR/24	: To M202	D4	M203	W/12	: A/T device (floor shift)	I
F1	M65	W/4	: To M301	G4	M205	GR/16	: DVD player	J
F2	M66	B/1	: To E33	C5	M206	L/16	: DVD player	K
C3	M67	GR/8	: Tow mode switch	C5	M207	B/3	: Console power socket	L
C3	M68	W/8	: A/T device (column shift)	Console switch sub-harness				M
E2	M72	W/6	: Differential lock mode switch	D4	M254	BR/2	: To M48	N
D2	M73	BR/6	: Back-up lamp relay	C4	M256	B/2	: A/T device	O
G2	M74	BR/20	: To D102	Optical sensor sub-harness				P
G3	M75	W/10	: To D101	F1	M301	W/4	: To M65	
A3	M76	W/6	: Electric brake (pre-wiring)	D1	M302	B/4	: Optical sensor	
E1	M77	Y/4	: Front passenger air bag module (service replacement)					
D4	M78	W/2	: Front power socket (center arm rest)					
E2	M79	—	: Body ground					
C2	M80	W/2	: Key switch					
E3	M81	GR/10	: Shift lock control unit					PG
A3	M82	W/2	: Circuit breaker-2 (with power seats)					
A2	M83	BR/6	: Pedal adjusting switch (without automatic drive positioner)					N
B3	M88	W/2	: Circuit breaker-2 (without power seats)					O
B3	M91	W/16	: To E26					P
D1	M93	W/24	: Display unit					
D1	M94	W/24	: Display control unit					
D1	M95	W/32	: Display control unit					

HARNESS

< COMPONENT DIAGNOSIS >

ENGINE ROOM HARNESS

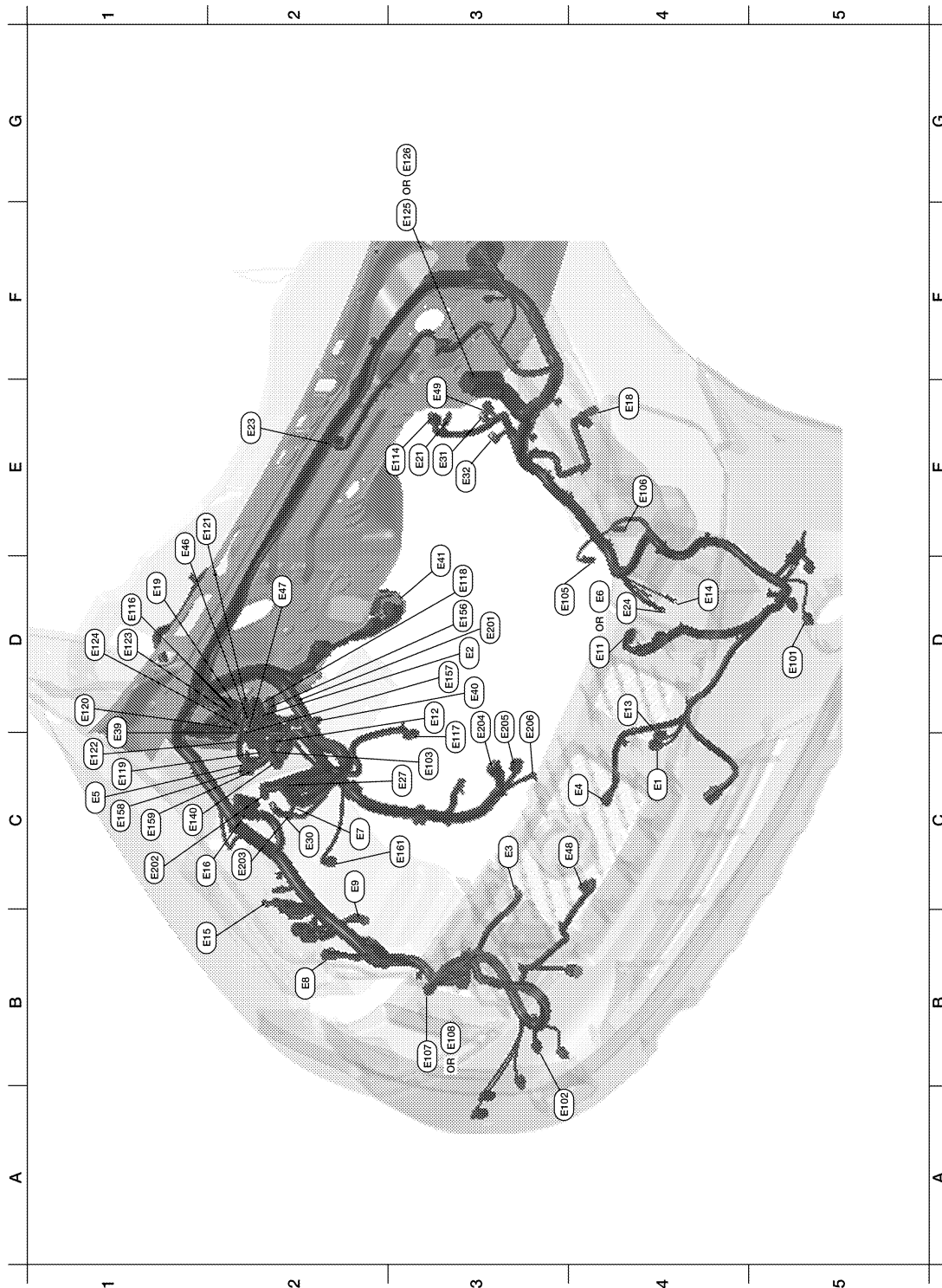

ABMIA0118GB

C4	E1	GR/2	: Ambient sensor	C1	E119	W/16	: IPDM E/R (intelligent power distribution module engine room)
D3	E2	W/16	: To F32	D1	E120	W/6	: IPDM E/R (intelligent power distribution module engine room)
C3	E3	B/2	: Horn	E1	E121	BR/12	: IPDM E/R (intelligent power distribution module engine room)

HARNESS

< COMPONENT DIAGNOSIS >

C4	E4	Y/2	: Crash zone sensor	C1	E122	W/12	: IPDM E/R (intelligent power distribution module engine room)	A	
C1	E5	W/24	: To F14	D1	E123	BR/8	: IPDM E/R (intelligent power distribution module engine room)	B	
D4	E6	B/6	: Front combination lamp LH (with daytime light system)	D1	E124	B/6	: IPDM E/R (intelligent power distribution module engine room)	B	
C2	E7	GR/2	: Fusible link box (battery)	F3	E125	B/47	: ABS actuator and electric unit (control unit) (without VDC)	C	
B2	E8	GR/2	: Dropping resistor	G3	E126	B/47	: ABS actuator and electric unit (control unit) (with VDC)	C	
C2	E9	—	: Body ground	C1	E140	BR/6	: Trailer tow relay-2	D	
D4	E11	B/6	: Front combination lamp LH (without daytime light system)	C2	E150	—	: Engine ground	E	
D3	E12	B/5	: Stop lamp relay	C2	E151	—	: Negative battery cable	E	
D4	E13	GR/2	: Ambient sensor 2	D3	E156	B/5	: Transfer shift high relay	F	
D4	E14	—	: Body ground	D3	E157	B/5	: Transfer shift low relay	F	
B1	E15	—	: Body ground	C1	E158	L/4	: Trailer tow relay LH	F	
C1	E16	B/40	: ECM	C1	E159	L/4	: Trailer tow relay RH	F	
E4	E18	GR/2	: Front wheel sensor LH	C3	E161	B/3	: Battery current sensor	G	
D1	E19	W/16	: To F33	Engine room sub-harness					
E3	E21	GR/2	: Brake fluid level switch	D3	E201	B/3	: To E40	H	
E2	E23	GR/6	: Front wiper motor	C1	E202	/1	: Fusible link box (battery)	H	
D4	E24	—	: Body ground	C2	E203	—	: Engine ground	I	
C3	E27	BR/2	: Fusible link box (battery)	D3	E204	/1	: Generator	I	
C2	E30	/1	: Fusible link box (battery)	D3	E205	B/3	: Generator	J	
E3	E31	GR/3	: Front pressure sensor	D3	E206	/1	: Generator	J	
E3	E32	GR/3	: Rear pressure sensor					J	
D1	E39	W/2	: To F34					K	
D3	E40	B/3	: To E201					K	
D3	E41	SMJ	: To C1					L	
E1	E46	L/4	: Transfer SHUT OFF relay 1					L	
D2	E47	L/4	: Transfer SHUT OFF relay 2					L	
C4	E48	B/3	: Refrigerant pressure sensor					L	
E3	E49	B/6	: Active booster					PG	
D5	E101	B/2	: Front fog lamp LH					PG	
A3	E102	B/2	: Front fog lamp RH					PG	
C3	E103	B/5	: Daytime light relay					N	
D4	E105	BR/2	: Front washer motor					N	
E4	E106	BR/2	: Washer fluid level switch					O	
B3	E107	B/6	: Front combination lamp RH (without daytime light system)					O	
B3	E108	B/6	: Front combination lamp RH (with daytime light system)					P	
E3	E114	B/6	: Delta stroke motor					P	
D1	E116	W/2	: Condenser-2					P	
D3	E117	GR/2	: Front wheel sensor RH					P	
D3	E118	B/2	: IPDM E/R (intelligent power distribution module engine room)					P	

HARNESS

< COMPONENT DIAGNOSIS >

ENGINE ROOM HARNESS (PASSENGER COMPARTMENT)

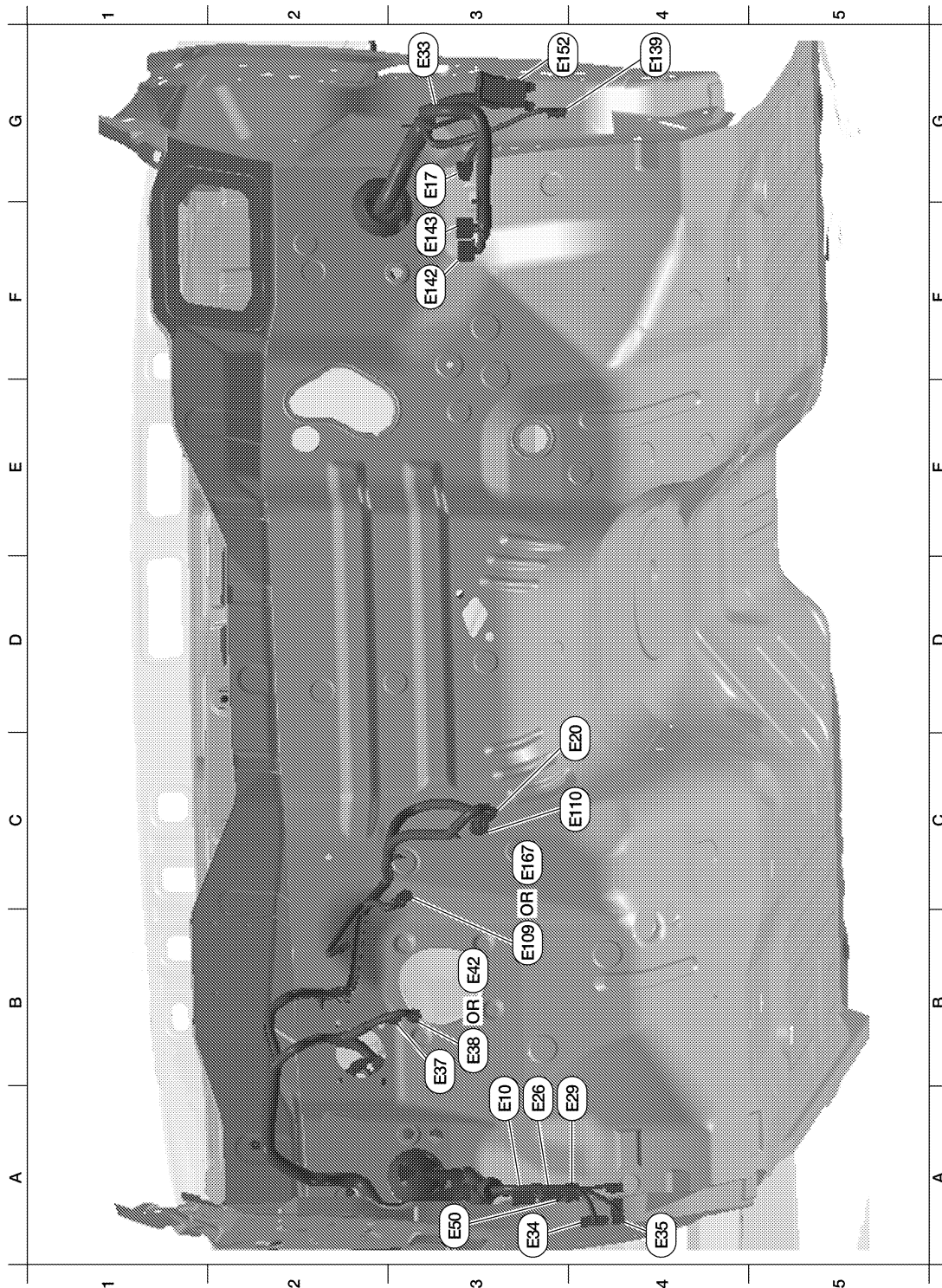

ABMIA0119GB

A3	E10	W/10	: To M6			
G3	E17	W/4	: Fuel pump control module (FPCM)			
C4	E20	B/8	: Accelerator pedal position (APP) sensor			
A3	E26	W/16	: To M91			
A3	E29	Y/4	: To M10			

HARNESS

< COMPONENT DIAGNOSIS >

G3	E33	B/1	: To M66					A
A3	E34	W/24	: To B40					
A4	E35	W/12	: To B41					
B3	E37	BR/2	: ASCD brake switch					B
B3	E38	W/4	: Stop lamp switch (column shift)					
B3	E42	B/2	: Stop lamp switch (floor shift)					
A3	E50	BR/2	: To B75					C
B3	E109	GR/2	: Pedal adjusting motor assembly					
C4	E110	GR/3	: Pedal adjusting motor assembly					D
G4	E139	W/8	: To B107					
F3	E142	W/26	: Transfer control unit					
F3	E143	W/24	: Transfer control unit					E
G3	E152	SMJ	: To M31					
C3	E167	GR/2	: Pedal adjusting motor					F

PG

N

O

P

HARNESS

< COMPONENT DIAGNOSIS > ENGINE CONTROL HARNESS

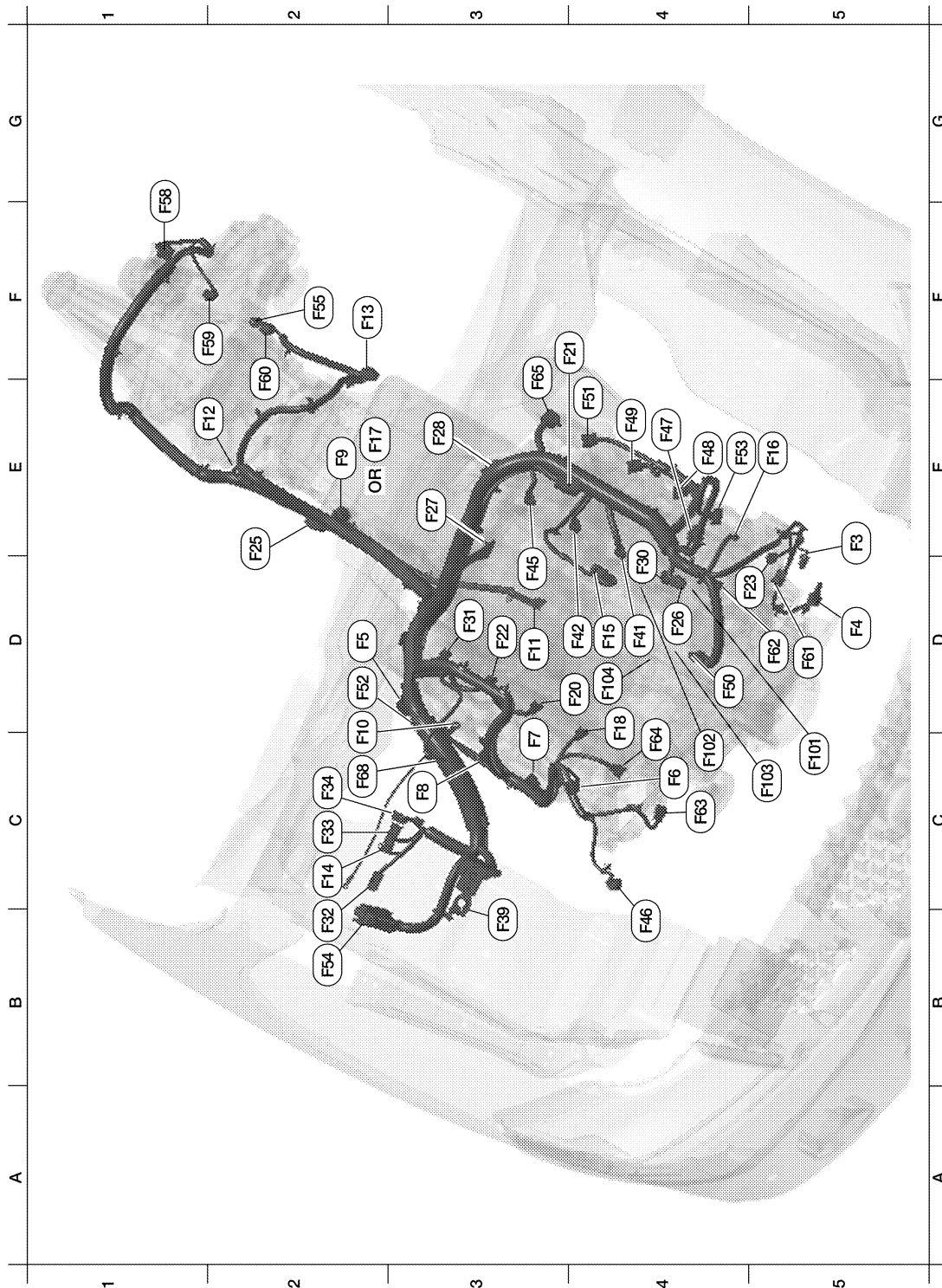

ABMIA0120GB

E5	F3	B/1	: A/C Compressor	F1	F58	B/8	: Transfer control device
D5	F4	GR/1	: Oil pressure switch	F2	F59	GR/2	: Wait detection switch
D2	F5	GR/4	: Air fuel ratio (A/F) sensor 1 (bank 2)	F2	F60	GR/2	: 4LO switch
C4	F6	GR/3	: Ignition coil No. 2 (with power transistor)	D5	F61	G/2	: Intake valve timing control solenoid valve (bank 1)

HARNESS

< COMPONENT DIAGNOSIS >

C3	F7	GR/3	: Ignition coil No. 4 (with power transistor)	D4	F62	B/2	: Intake valve timing control position sensor (bank 1)	A
C3	F8	GR/3	: Ignition coil No. 6 (with power transistor)	C4	F63	G/2	: Intake valve timing control solenoid valve (bank 2)	B
E2	F9	G/10	: A/T assembly (floor shift)	C4	F64	B/3	: Intake valve timing control position sensor (bank 2)	B
C2	F10	—	: Engine ground	F3	F65	GR/4	: Air fuel ratio (A/F) sensor 1 (bank 1)	C
D3	F11	B/3	: Crankshaft position sensor (POS)	C2	F68	GR/2	: Water valve	C
E1	F12	G/4	: Heated oxygen sensor 2 (bank 2)	Knock sensor sub-harness				
F2	F13	G/4	: Heated oxygen sensor 2 (bank 1)	C5	F101	B/6	: To F26	D
C2	F14	W/24	: To E5	C4	F102	B/2	: Knock sensor (bank 1)	D
D4	F15	GR/2	: EVAP canister purge volume control solenoid valve	C5	F103	GR/2	: Engine coolant temperature sensor	E
E5	F16	—	: Engine ground	D4	F104	B/2	: Knock sensor (bank 2)	E
E2	F17	G/10	: A/T assembly (column shift)					F
C4	F18	GR/2	: Fuel injector No. 2					F
D4	F20	GR/2	: Fuel injector No. 4					G
F4	F21	GR/2	: Condenser-1					G
D3	F22	GR/2	: Fuel injector No. 6					H
D4	F23	B/3	: Camshaft position sensor (phase)					H
D2	F25	W/2	: Diode-2					I
D4	F26	B/6	: To F101					I
E3	F27	B/1	: Starter motor					J
E3	F28	GR/1	: Starter motor					J
D4	F30	GR/2	: Fuel injector No. 1					K
D3	F31	GR/2	: Fuel injector No. 8					K
B2	F32	W/16	: To E2					L
C2	F33	W/16	: To E19					L
C2	F34	W/2	: To E39					M
B3	F39	—	: Fusible link (battery)					N
D4	F41	GR/2	: Fuel injector No. 3					N
D4	F42	GR/2	: Fuel injector No. 5					O
D3	F45	GR/2	: Fuel injector No. 7					O
B4	F46	B/3	: Power steering pressure sensor					P
E4	F47	GR/3	: Ignition coil No. 1 (with power transistor)					P
E4	F48	GR/3	: Ignition coil No. 3 (with power transistor)					Q
E4	F49	GR/3	: Ignition coil No. 5 (with power transistor)					Q
D4	F50	W/6	: Electric throttle control actuator					R
E4	F51	GR/3	: Ignition coil No. 7 (with power transistor)					R
D2	F52	GR/3	: Ignition coil No. 8 (with power transistor)					S
E5	F53	B/6	: Mass air flow sensor					S
B2	F54	B/81	: ECM					T
F2	F55	B/2	: ATP switch					T

HARNESS

< COMPONENT DIAGNOSIS >

CHASIS HARNESS

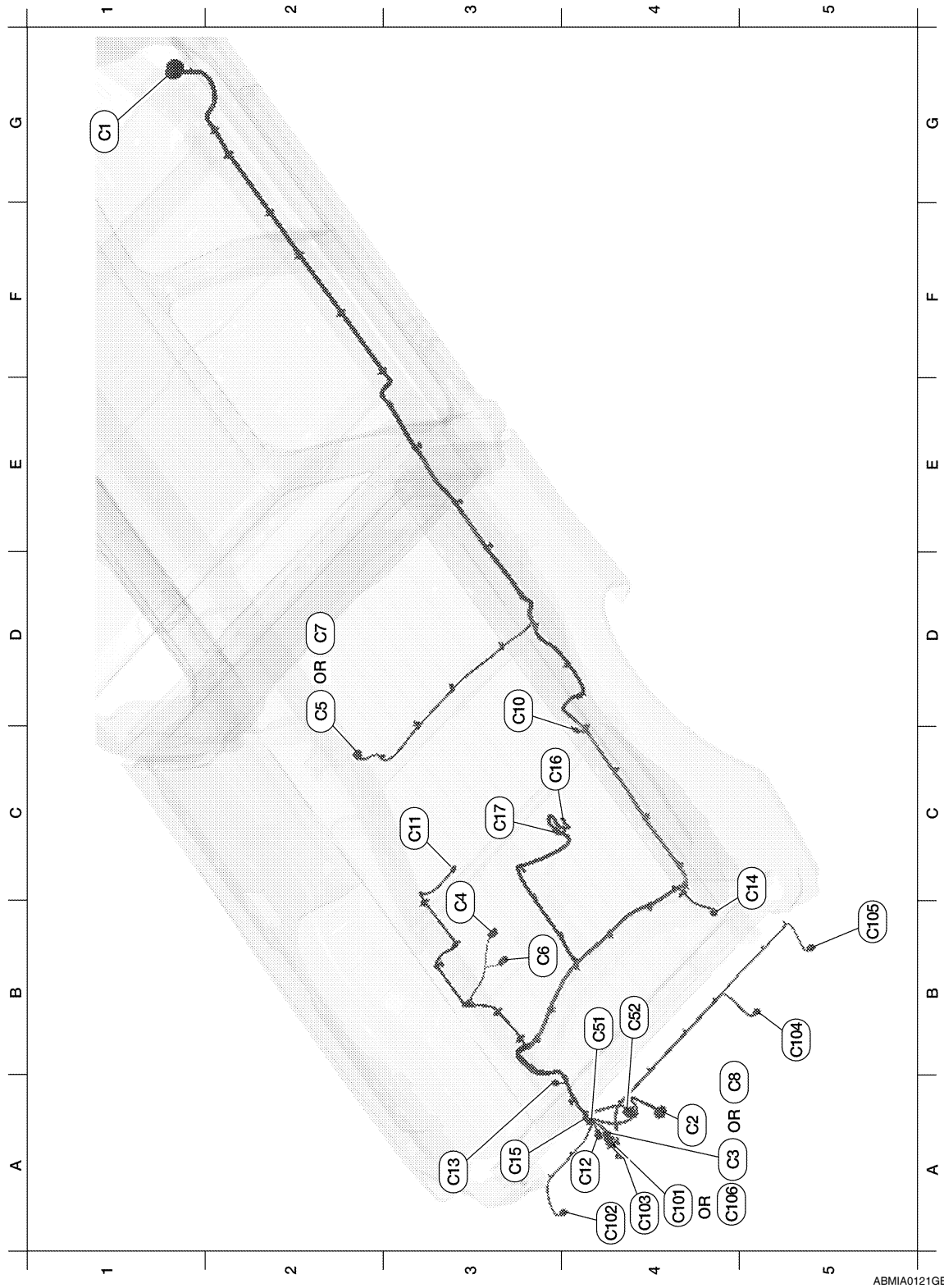

ABMIA0121GB

G1	C1	SMJ	: To E41			
A4	C2	B/7	: Trailer			
A4	C3	GR/6	: To C106 (short bed)			
C3	C4	GR/3	: Evap control system pressure sensor			

HARNESS

< COMPONENT DIAGNOSIS >

D2	C5	GR/5	: Fuel level sensor unit and fuel pump (without flexible fuel)					A
B3	C6	B/2	: Evap canister vent control valve					
D2	C7	GR/5	: Fuel level sensor unit and fuel pump (with flexible fuel)					B
B4	C8	GR/6	: To C101 (long bed)					
D3	C10	GR/2	: Rear wheel sensor RH					C
C3	C11	BR/2	: Rear wheel sensor LH					
A4	C12	W/2	: License plate lamps					
A3	C13	GR/8	: Rear combination lamp LH					D
C5	C14	GR/8	: Rear combination lamp LH					
A3	C15	GR/2	: To C51					E
C3	C16	GR/2	: Differential lock position switch					
C3	C17	B/2	: Differential lock solenoid					
Rear power socket sub-harness								F
B4	C51	GR/2	: To C15					
B4	C52	BR/2	: Rear cargo power socket (cargo bed)					G
Rear sonar sensor sub-harness								
A4	C101	GR/6	: To C8 (long bed)					H
A4	C102	B/3	: Rear sonar sensor LH outer					
A4	C103	B/3	: Rear sonar sensor LH inner					
B5	C104	B/3	: Rear sonar sensor RH inner					I
B5	C105	B/3	: Rear sonar sensor RH outer					
A4	C106	GR/6	: To C3 (short bed)					J

PG

N

O

P

HARNESS

< COMPONENT DIAGNOSIS >

BODY HARNESS (KING CAB MODELS)

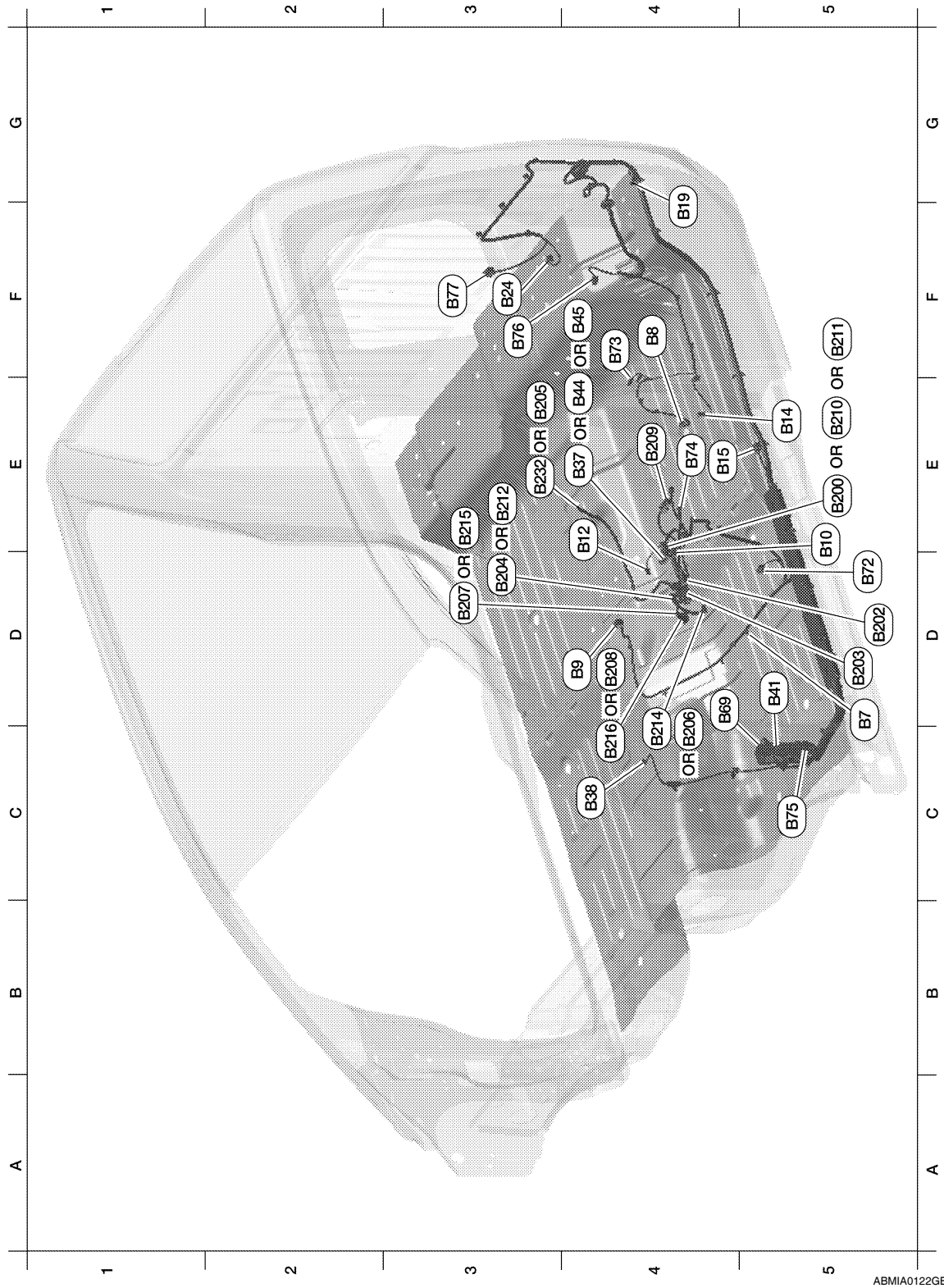

ABMIA0122GB

D5	B7	—	: Body ground	Driver seat harness		
F4	B8	W/3	: Front door switch LH	E5	B200	W/16 : To B37 (with automatic drive positioner)
D4	B9	Y/12	: Air bag diagnosis sensor unit	D5	B202	W/32 : Driver seat control unit
E5	B10	Y/2	: Front LH side air bag module	D4	B203	W/16 : Driver seat control unit

HARNESS

< COMPONENT DIAGNOSIS >

E4	B12	W/3	: Seat belt buckle switch LH	D3	B204	GR/5	: Sliding motor LH (with automatic drive positioner)	A
E5	B14	Y/2	: Front LH seat belt pre-tensioner	E3	B205	W/4	: Reclining motor LH (with automatic drive positioner)	B
E4	B15	Y/2	: LH side air bag (satellite) sensor	D4	B206	GR/5	: Lifting motor (front) (with automatic drive positioner)	B
E4	B18	W/3	: Rear door switch LH	D3	B207	GR/5	: Lifting motor (rear) (with automatic drive positioner)	C
F4	B19	—	: Body ground	D4	B208	W/10	: Power seat switch LH (with automatic drive positioner)	C
F3	B24	W/16	: Sonar control unit	E4	B209	W/3	: Front seat heater LH	D
E4	B37	W/16	: To B200 (with automatic drive positioner)	E5	B210	W/3	: To B44 (without automatic drive positioner)(with heated seats)	D
C4	B38	Y/2	: LH side curtain air bag module	F5	B211	W/2	: To B45 (without automatic drive positioner)(without heated seats)	E
D5	B41	W/12	: To E35	E3	B212	B/2	: Sliding motor LH (without automatic drive positioner)	F
E4	B44	W/3	: To B210 (without automatic drive positioner)(with heated seats)	D4	B214	GR/2	: Lifting motor (front) (without automatic drive positioner)	F
E4	B45	W/2	: To B211 (without automatic drive positioner)(without heated seats)	E3	B215	GR/2	: Lifting motor (rear) (without automatic drive positioner)	G
B3	B69	SMJ	: To M40	D4	B216	W/10	: Power seat switch LH (without automatic drive positioner)	H
D5	B72	W/4	: Subwoofer	E3	B232	W/2	: Reclining motor LH (without automatic drive positioner)	H
F4	B73	B/2	: Rear door switch upper LH					I
E4	B74	B/2	: Rear door switch lower LH					I
C5	B75	BR/2	: To E50					J
F3	B76	W/2	: Rear door speaker LH					J
F3	B77	W/26	: Differential lock control unit					K

PG

N

O

P

HARNESS

< COMPONENT DIAGNOSIS >

BODY HARNESS (CREW CAB MODELS)

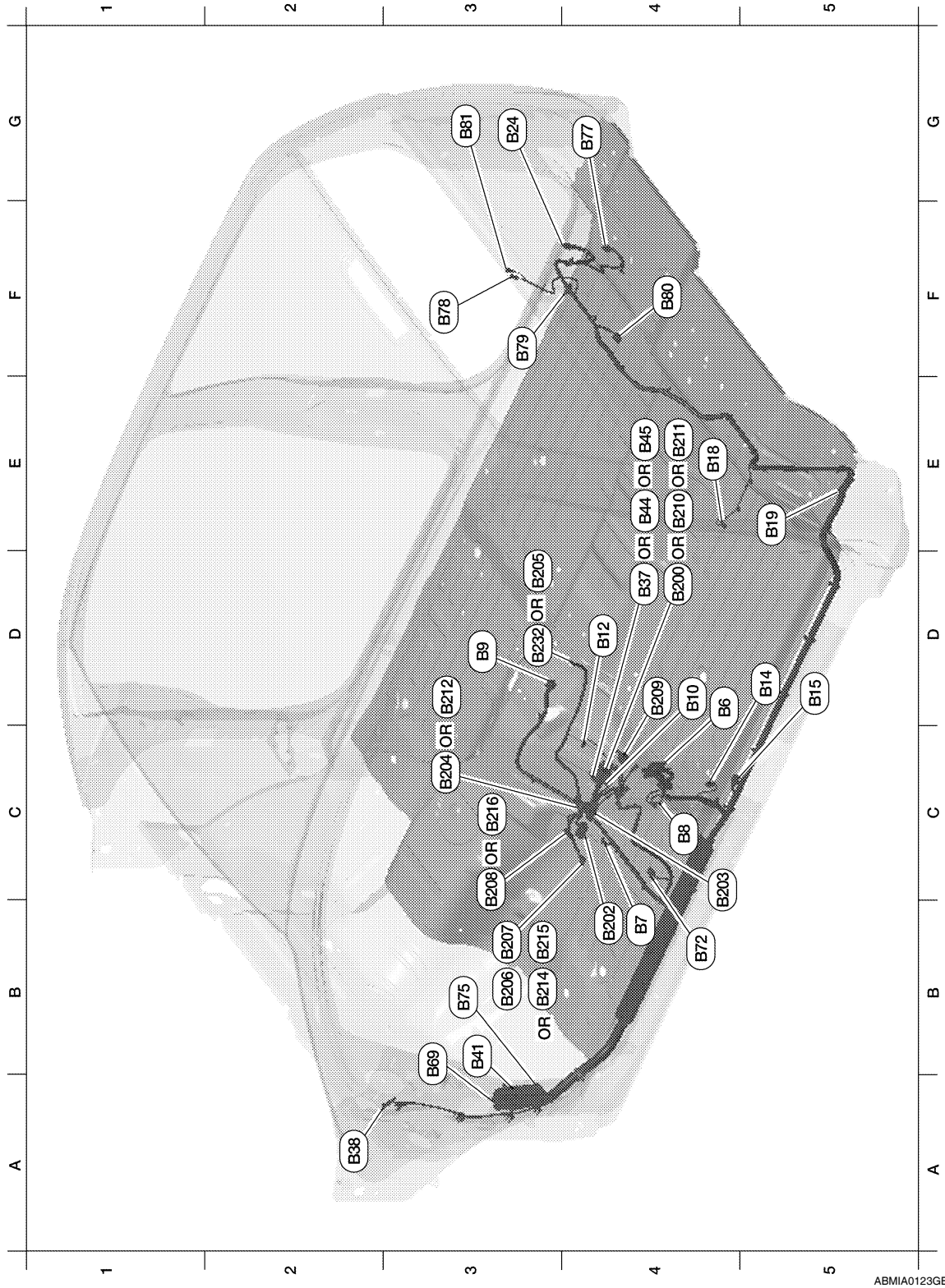

D4	B6	W/18	: To D201	Driver seat harness		
B4	B7	—	: Body ground	D4	B200	W/16 : To B37 (with automatic drive positioner)
C4	B8	W/3	: Front door switch LH	C4	B202	W/32 : Driver seat control unit
D3	B9	Y/12	: Air bag diagnosis sensor unit	B4	B203	W/16 : Driver seat control unit

HARNES

< COMPONENT DIAGNOSIS >

D4	B10	Y/2	: Front LH side air bag module	C3	B204	GR/5	: Sliding motor LH (with automatic drive positioner)	A
D4	B12	W/3	: Seat belt buckle switch LH	E3	B205	W/4	: Reclining motor LH (with automatic drive positioner)	B
D5	B14	Y/2	: Front LH seat belt pre-tensioner	B3	B206	GR/5	: Lifting motor (front) (with automatic drive positioner)	B
D5	B15	Y/2	: LH side air bag (satellite) sensor	B3	B207	GR/5	: Lifting motor (rear) (with automatic drive positioner)	C
E4	B18	W/3	: Rear door switch LH	C3	B208	W/10	: Power seat switch LH (with automatic drive positioner)	D
E5	B19	—	: Body ground	D4	B209	W/3	: Front seat heater LH	D
G3	B24	W/16	: Sonar control unit	E4	B210	W/3	: To B44 (without automatic drive positioner)(with heated seats)	E
D4	B37	W/16	: To B200 (with automatic drive positioner)	E4	B211	W/2	: To B45 (without automatic drive positioner)(without heated seats)	E
A2	B38	Y/2	: LH side curtain air bag module	D3	B212	B/2	: Sliding motor LH (without automatic drive positioner)	F
B3	B41	W/12	: To E35	B3	B214	GR/2	: Lifting motor (front) (without automatic drive positioner)	G
E4	B44	W/3	: To B210 (without automatic drive positioner)(with heated seats)	B3	B215	GR/2	: Lifting motor (rear) (without automatic drive positioner)	G
E4	B45	W/2	: To B211 (without automatic drive positioner)(without heated seats)	C3	B216	W/10	: Power seat switch LH (without automatic drive positioner)	H
B3	B69	SMJ	: To M40	D3	B232	W/2	: Reclining motor LH (without automatic drive positioner)	I
B4	B72	W/4	: Subwoofer					I
E4	B75	BR/2	: To E50					J
G4	B77	W/26	: Differential lock control unit					J
F3	B78	B/1	: Rear window defogger					K
F3	B79	—	: Body ground					K
F4	B80	GR/4	: Rear power drop glass motor					L
G3	B81	B/1	: Rear window defogger					L

PG

N

O

P

HARNESS

< COMPONENT DIAGNOSIS >

BODY NO. 2 HARNESS (KING CAB MODELS)

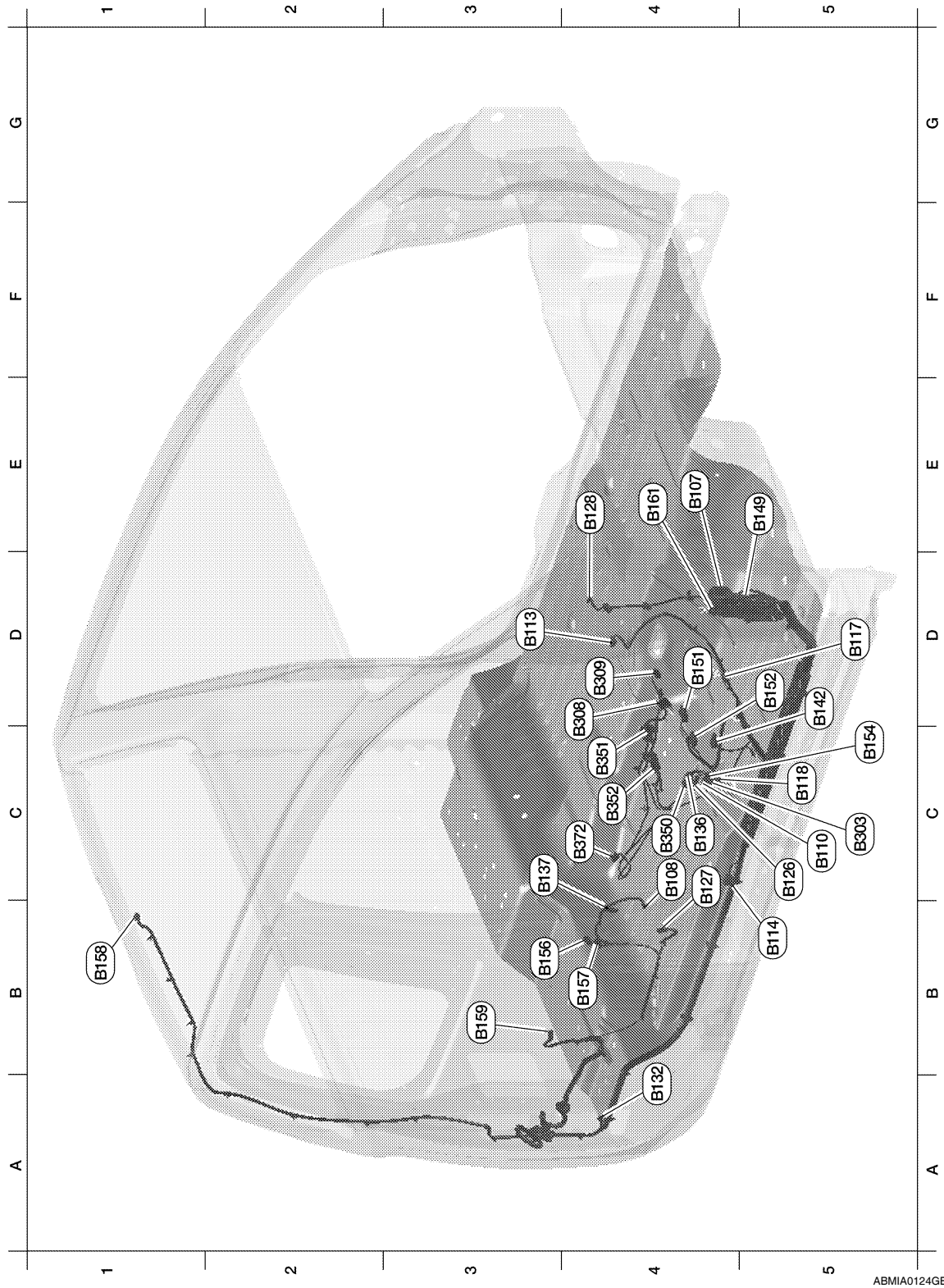

ABMIA0124GB

E4	B107	W/8	: To E139	Passenger side seat harness		
C4	B108	W/3	: Front door switch RH	C5	B303	W/2 : To B154
C5	B110	W/3	: Seat belt buckle switch RH	D4	B308	W/6 : Power seat switch RH
D3	B113	Y/12	: Air bag diagnosis sensor unit	D4	B309	GR/2 : Sliding motor RH
B5	B114	Y/2	: RH side air bag (satellite) sensor	C4	B350	Y/8 : To B136

HARNESS

< COMPONENT DIAGNOSIS >

D5	B117	—	: Body ground	C4	B351	B/18	: Occupant classification control unit
C5	B118	W/3	: Front seat heater RH	C4	B352	B/3	: Occupant classification system sensor
C5	B126	Y/2	: Front RH side air bag module	C2	B372	W/2	: Reclining motor RH
C4	B127	Y/2	: Front RH seat belt pre-tensioner				
E4	B128	Y/2	: RH side curtain air bag module				
B4	B132	—	: Body ground				
C4	B136	W/8	: To B350				
C3	B137	W/3	: Belt tension sensor				
C5	B142	W/32	: Bluetooth control unit				
E5	B149	SMJ	: To M36				
D4	B151	W/40	: NAVI control unit				
D5	B152	W/40	: NAVI control unit				
C5	B154	W/2	: To B303				
B3	B156	B/2	: Rear door switch upper RH				
B4	B157	B/2	: Rear door switch lower RH				
B1	B158	W/3	: High mounted stop lamp				
B3	B159	W/2	: Rear door speaker RH				
E4	B161	W/20	: To M157				

A

B

C

D

E

F

G

H

I

J

K

L

PG

N

O

P

HARNESS

< COMPONENT DIAGNOSIS >

BODY NO. 2 HARNESS (CREW CAB MODELS)

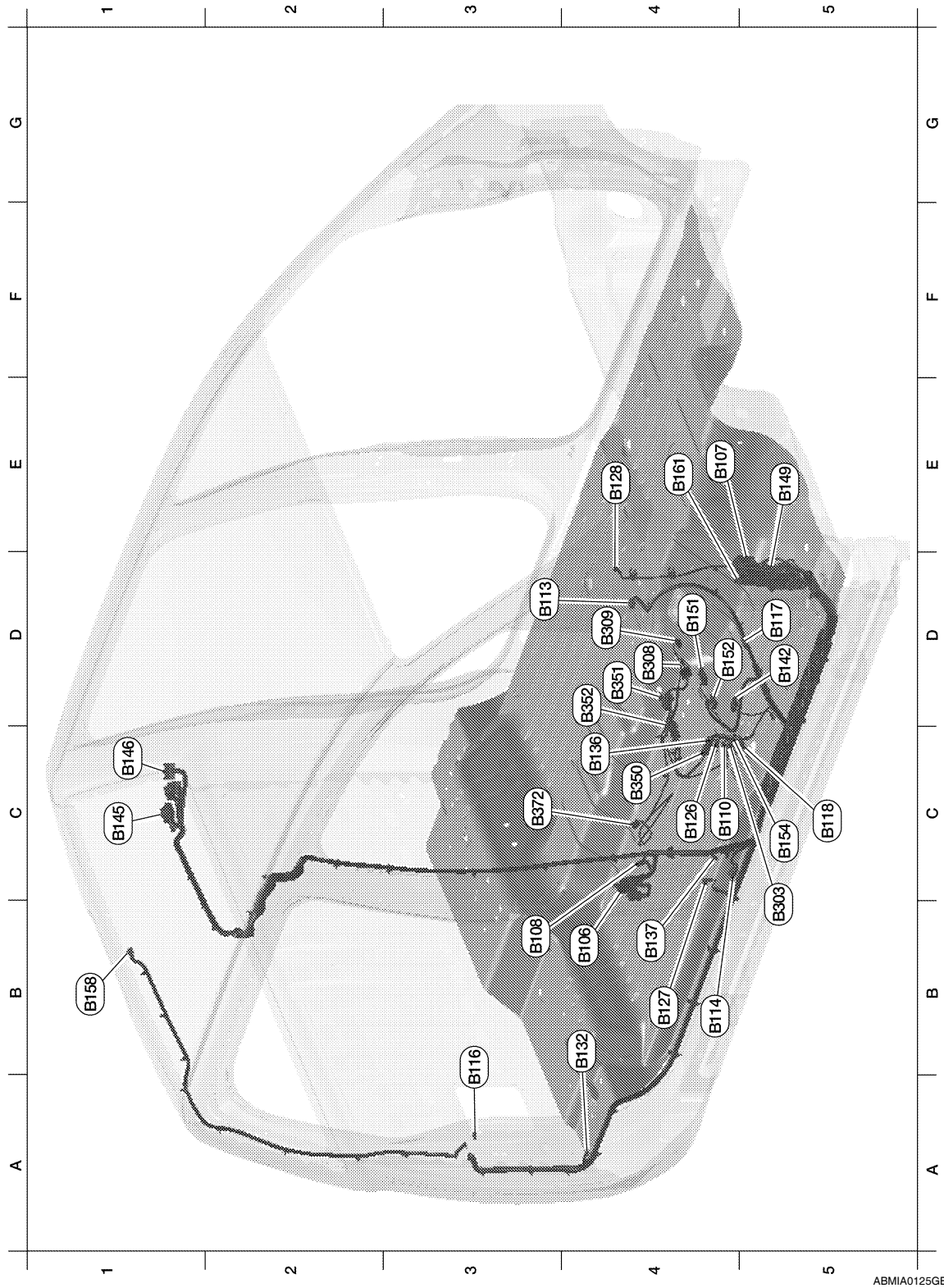

ABMIA0125GB

B4	B106	W/18	: To D301	Passenger side seat harness			
E5	B107	W/8	: To E139	C5	B303	W/2	: To B154
B3	B108	W/3	: Front door switch RH	D4	B308	W/6	: Power seat switch RH
C4	B110	W/3	: Seat belt buckle switch RH	D4	B309	GR/2	: Sliding motor RH
D3	B113	Y/12	: Air bag diagnosis sensor unit	C4	B350	Y/8	: To B136

HARNES

< COMPONENT DIAGNOSIS >

B4	B114	Y/2	: RH side air bag (satellite) sensor	D4	B351	B/18	: Occupant classification control unit
B3	B116	W/3	: Rear door switch RH	D4	B352	B/3	: Occupant classification system sensor
D5	B117	—	: Body ground	C3	B372	W/2	: Reclining motor RH
C5	B118	W/3	: Front seat heater RH				
C4	B126	Y/2	: Front RH side air bag module				
B4	B127	Y/2	: Front RH seat belt pre-tensioner				
E4	B128	Y/2	: RH side curtain air bag module				
B4	B132	—	: Body ground				
C4	B136	W/8	: To B350				
B4	B137	W/3	: Belt tension sensor				
D5	B142	W/32	: Bluetooth control unit				
C1	B145	W/16	: To R200				
C1	B146	BR/24	: To R201				
E5	B149	SMJ	: To M36				
D4	B151	W/40	: NAVI control unit				
D4	B152	W/40	: NAVI control unit				
C5	B154	W/2	: To B303				
B1	B158	W/3	: High mounted stop lamp				
E4	B161	W/20	: To M157				

A
B
C
D
E
F
G
H
I
J
K
L

PG

N
O
P

HARNESS

< COMPONENT DIAGNOSIS >

ROOM LAMP HARNESS

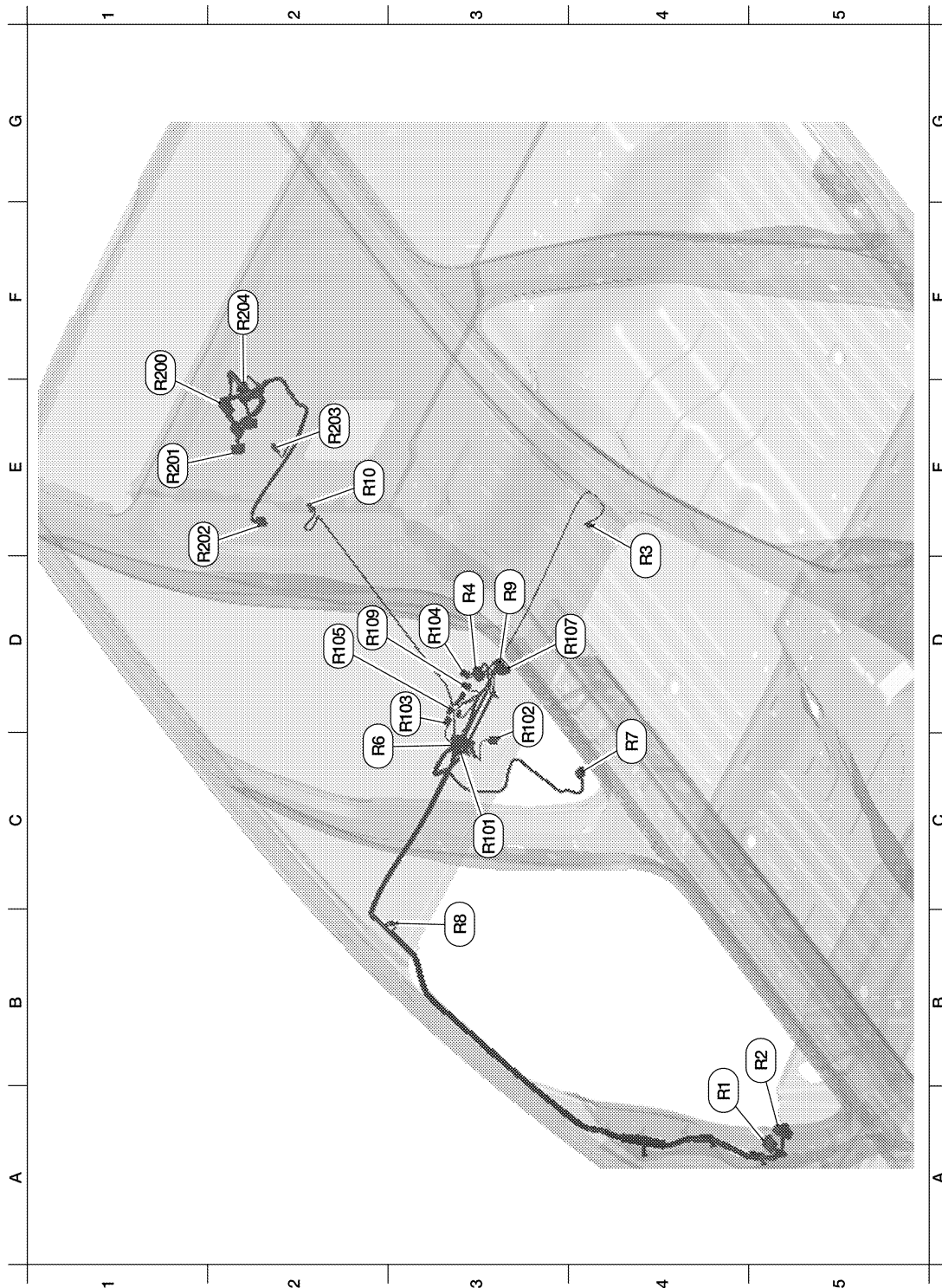

ABMIA0126GB

A4	R1	W/16	: To M1	D3	R103	W/6	: Rear power drop glass switch
B5	R2	W/12	: To M2	D3	R104	GR/6	: Sunroof switch
E4	R3	W/2	: Vanity lamp LH	D2	R105	W/4	: Bluetooth ON indicator
D3	R4	W/10	: Sunroof motor assembly	D3	R107	W/8	: To R9
C2	R6	W/16	: To R101	D2	R109	W/4	: Microphone

HARNESS

< COMPONENT DIAGNOSIS >

C4	R7	GR/10	: Auto anti-dazzling inside mirror	Room lamp sub-harness B			
B3	R8	W/2	: Vanity lamp RH	F1	R200	W/16	: To B145
D3	R9	W/8	: To R107	E1	R201	BR/24	: To B146
E2	R10	W/2	: Room lamp	E1	R202	W/12	: Video monitor
Room lamp sub-harness A				E2	R203	W/3	: Personal lamp 2ND row
C3	R101	W/16	: To R6	F2	R204	W/16	: Rear audio remote control unit
D3	R102	GR/8	: Front room/map lamp assembly				

FRONT DOOR LH HARNESS

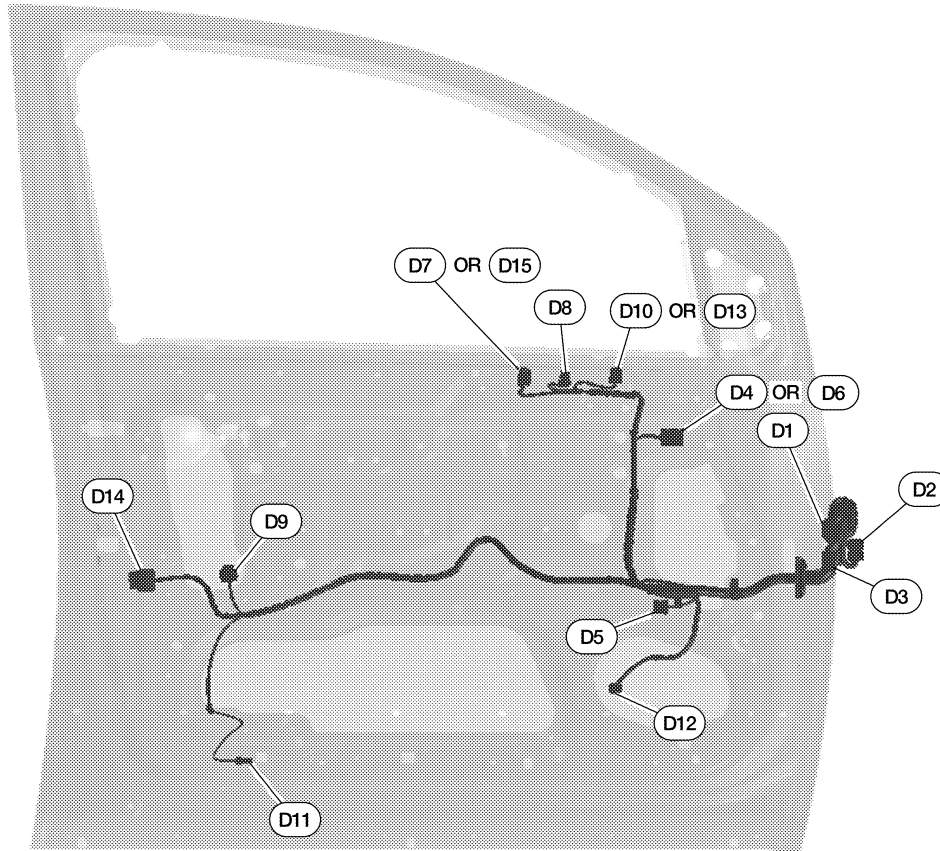

ABMIA0127GB

D1	BR/24	: To M9	D9	GR/6	: Front power window motor LH
D2	W/16	: To M8	D10	BR/16	: Door mirror remote control switch (with automatic drive positioner)
D3	W/10	: To M158	D11	W/2	: Front step lamp LH
D4	W/16	: Door mirror LH (with automatic drive positioner)	D12	W/2	: Front door speaker LH
D5	W/8	: Seat memory switch	D13	W/16	: Door mirror remote control switch (without automatic drive positioner)
D6	W/6	: Door mirror LH (without automatic drive positioner)	D14	B/6	: Front door lock assembly LH
D7	W/16	: Main power window and door lock/unlock switch (crew cab)	D15	W/16	: Main power window and door lock/unlock switch (king cab)
D8	W/3	: Main power window and door lock/unlock switch (with left and right front power window anti-pinch system) (crew cab)			

HARNESS

< COMPONENT DIAGNOSIS >

FRONT DOOR RH HARNESS

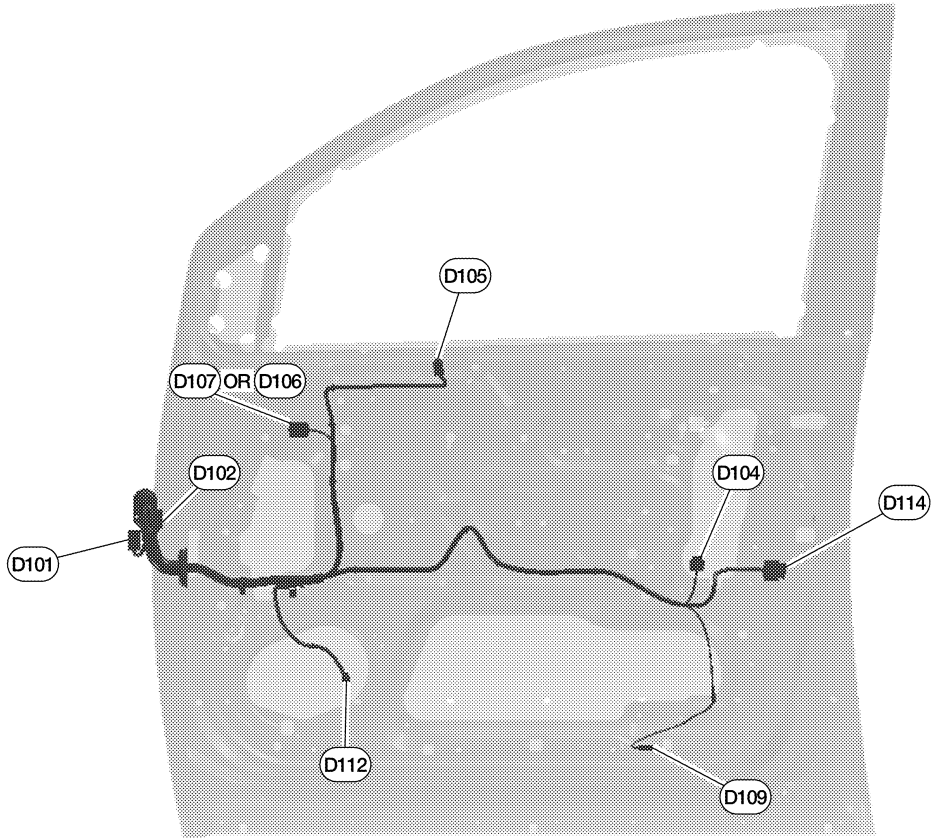

ABMIA0128GB

D101	W/10	: To M75	D107	W/16	: Door mirror RH (with automatic drive positioner)
D102	BR/20	: To M74	D109	W/2	: Front step lamp RH
D104	GR/6	: Front power window motor RH	D112	W/2	: Front door speaker RH
D105	W/16	: Power window and door lock/unlock switch RH	D114	B/6	: Front door lock actuator RH
D106	W/6	: Door mirror RH (without automatic drive positioner)			

HARNESS

< COMPONENT DIAGNOSIS >

REAR DOOR LH HARNESS (CREW CAB MODELS)

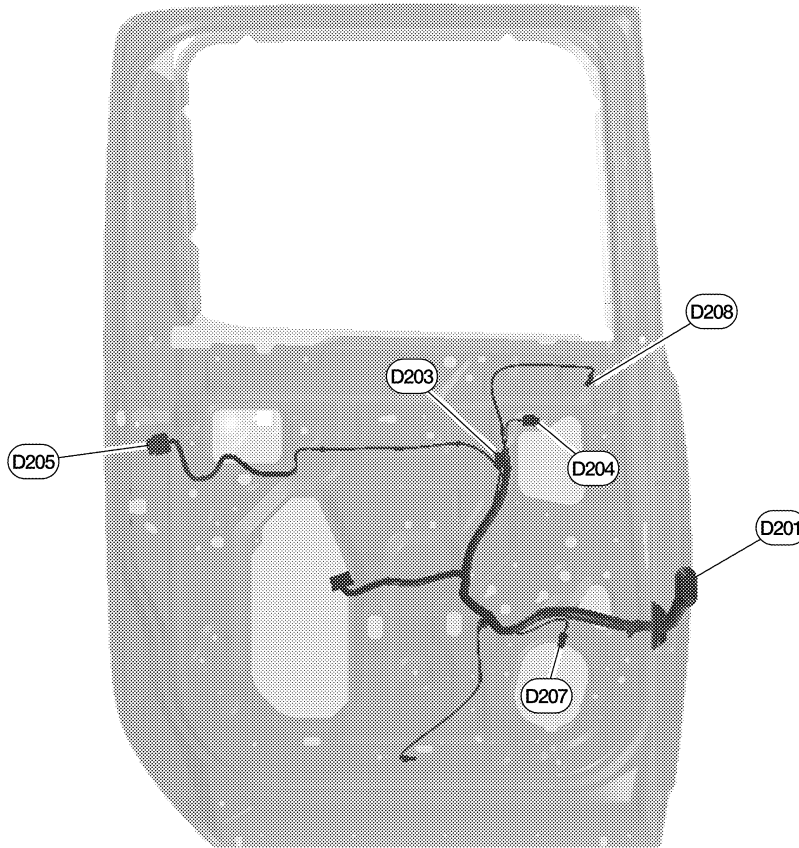

ABMIA0129GB

D201	W/18	: To B6			
D203	W/8	: Rear power window switch LH			
D204	GR/2	: Rear power window motor LH			
D205	B/6	: Rear door lock actuator LH			
D207	W/2	: Rear door speaker LH			
D208	BR/2	: Rear door tweeter LH			

A
B
C
D
E
F
G
H
I
J
K
L

PG

N
O
P

HARNESS

< COMPONENT DIAGNOSIS >

REAR DOOR RH HARNESS (CREW CAB MODELS)

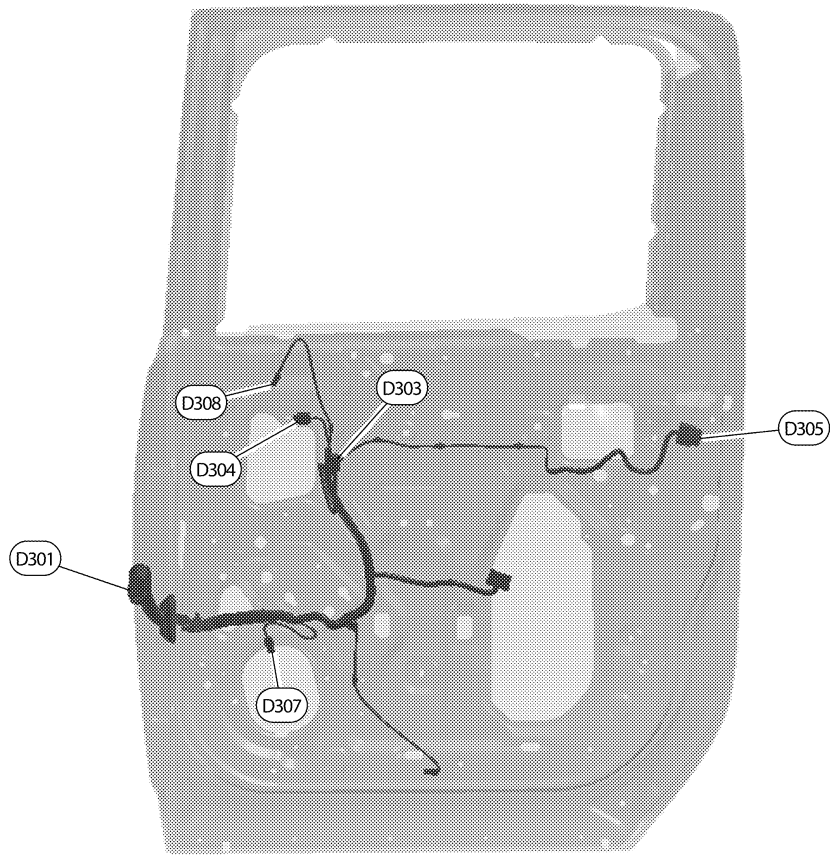

ABMIA0130GB

D301	W/18	: To B106			
D303	W/8	: Rear power window switch RH			
D304	GR/2	: Rear power window motor RH			
D305	B/6	: Rear door lock actuator RH			
D307	W/2	: Rear door speaker RH			
D308	BR/2	: Rear door tweeter RH			

ELECTRICAL UNITS LOCATION

< COMPONENT DIAGNOSIS >

ELECTRICAL UNITS LOCATION

Electrical Units Location

INFOID:000000003789673

ENGINE COMPARTMENT

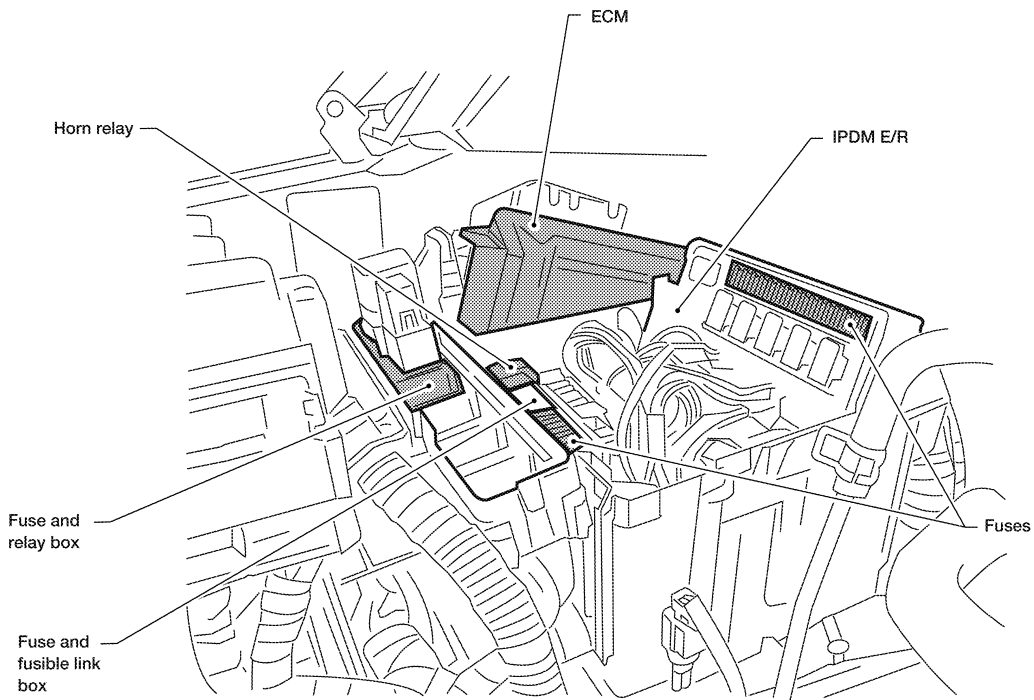
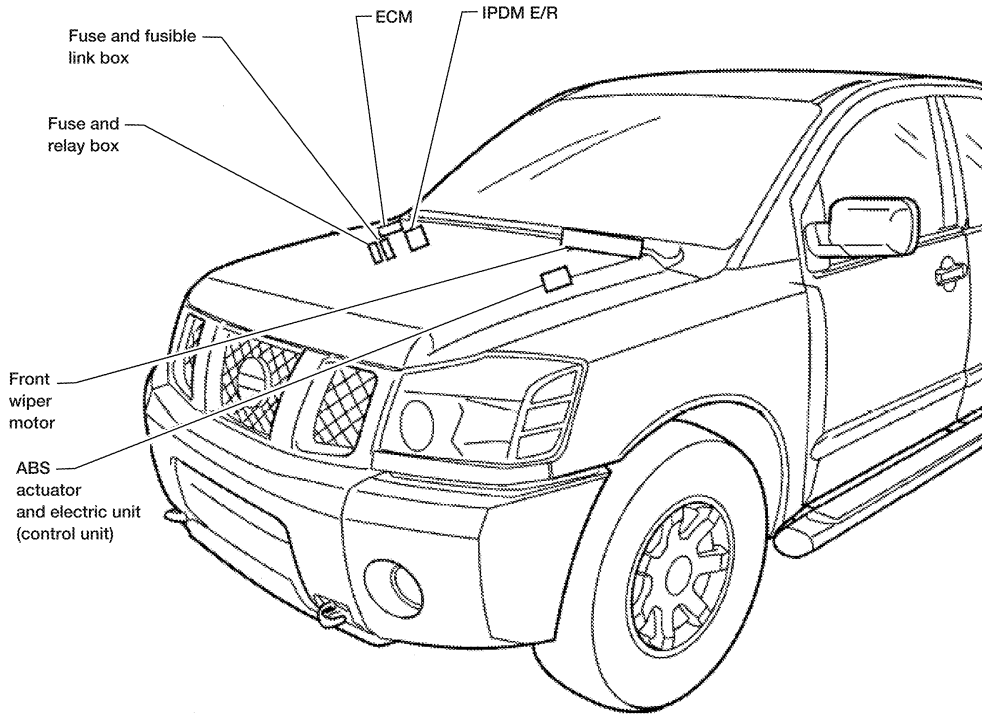

A
B
C
D
E
F
G
H
I
J
K
L
PG
N
O
P

ALMIA0303GB

ELECTRICAL UNITS LOCATION

< COMPONENT DIAGNOSIS > PASSENGER COMPARTMENT

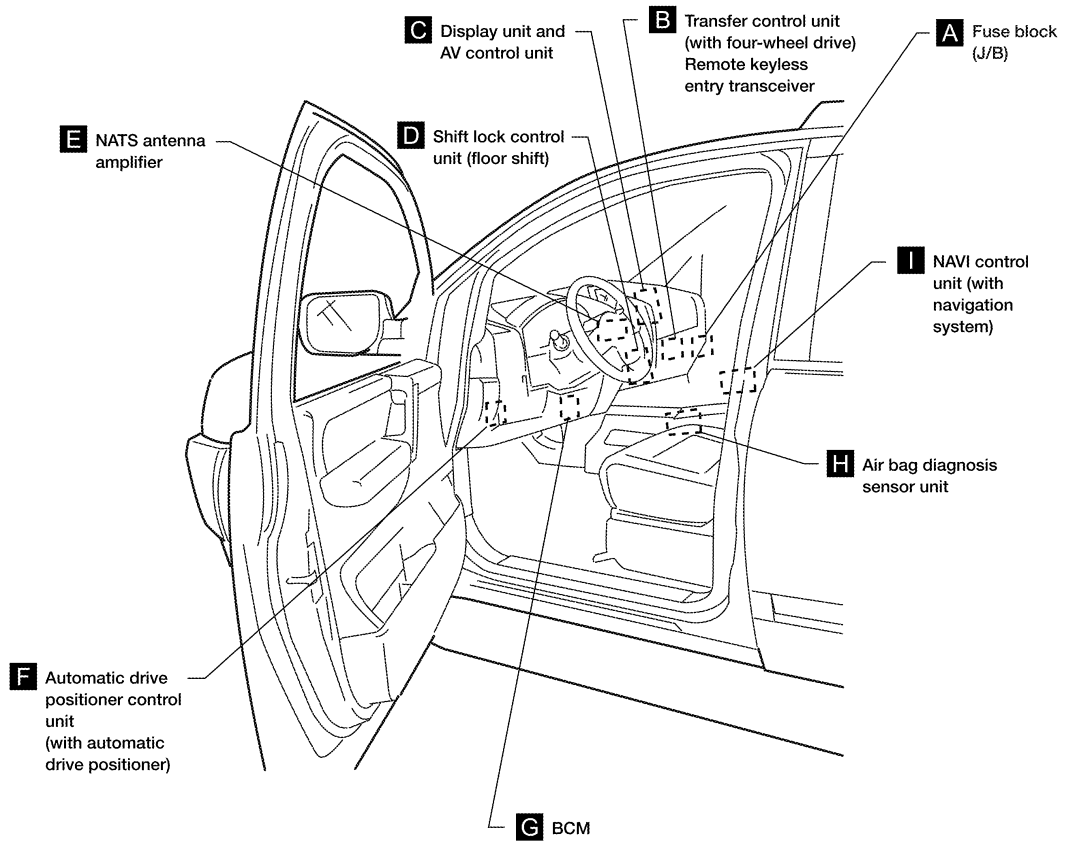

A Instrument panel side RH

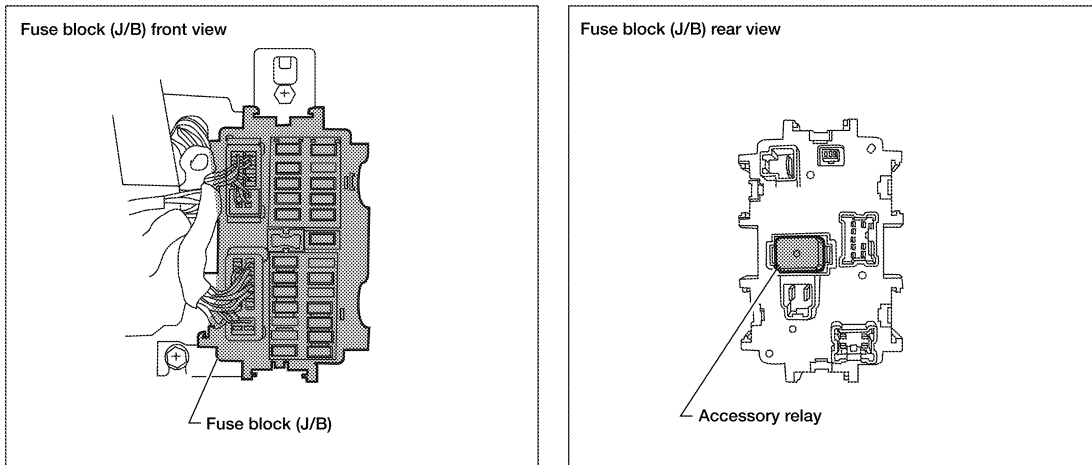

ABMIA0168GB

ELECTRICAL UNITS LOCATION

< COMPONENT DIAGNOSIS >

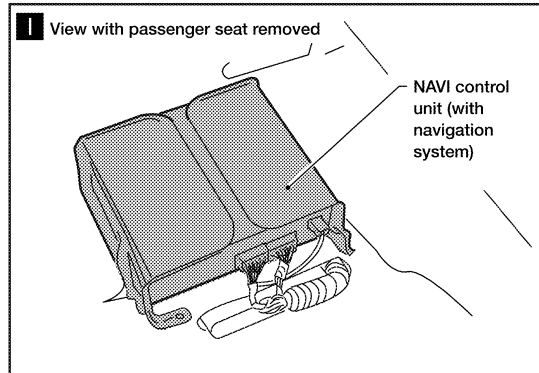
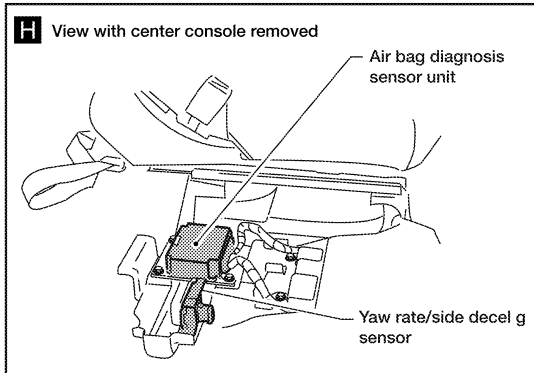
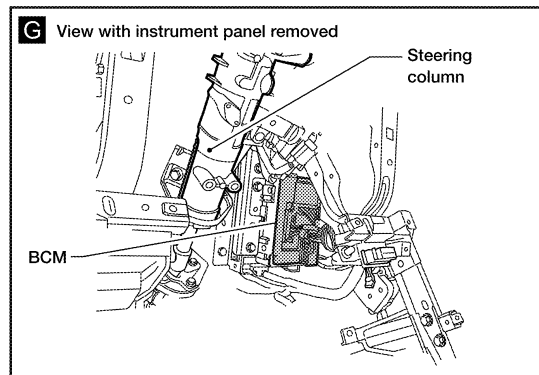
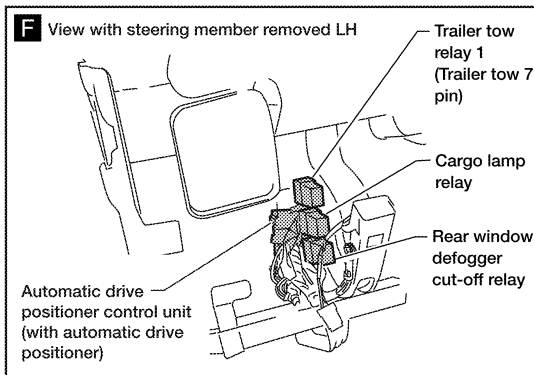
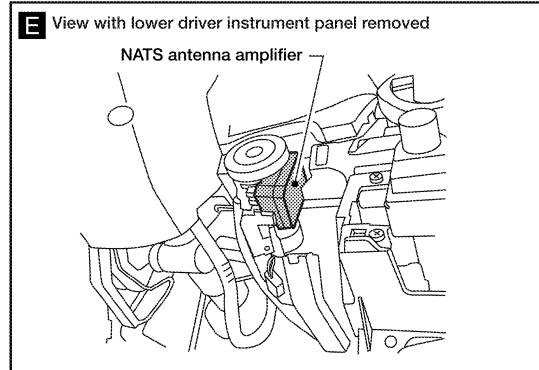
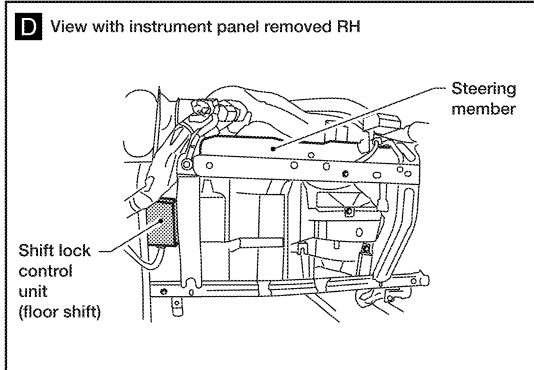
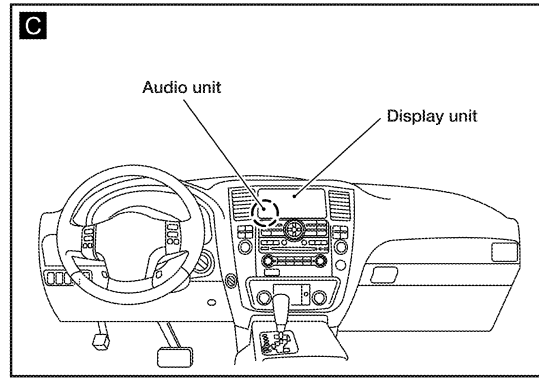
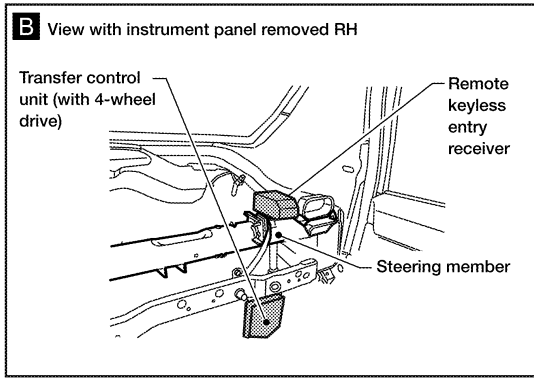

ABMIA0131GB

A
B
C
D
E
F
G
H
I
J
K
L
PG
N
O
P

HARNESS CONNECTOR

< COMPONENT DIAGNOSIS >

HARNESS CONNECTOR

Description

INFOID:000000003789674

HARNESS CONNECTOR (TAB-LOCKING TYPE)

- The tab-locking type connectors help prevent accidental looseness or disconnection.
- The tab-locking type connectors are disconnected by pushing or lifting the locking tab(s). Refer to the figure below.

Refer to the next page for description of the slide-locking type connector.

CAUTION:

Do not pull the harness or wires when disconnecting the connector.

[Example]

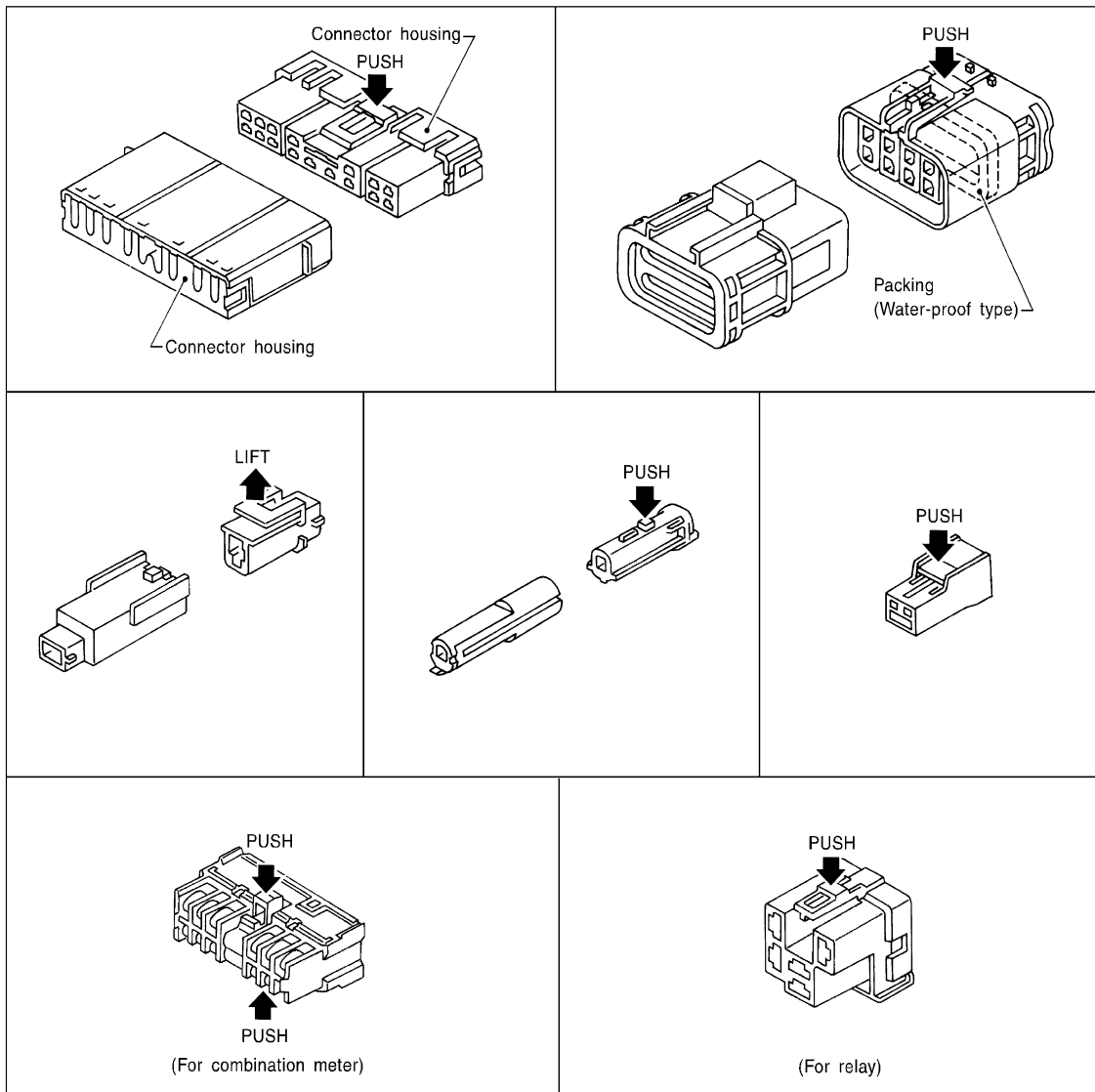

SEL769DA

HARNESS CONNECTOR (SLIDE-LOCKING TYPE)

- A new style slide-locking type connector is used on certain systems and components, especially those related to OBD.
- The slide-locking type connectors help prevent incomplete locking and accidental looseness or disconnection.

HARNESS CONNECTOR

< COMPONENT DIAGNOSIS >

- The slide-locking type connectors are disconnected by pushing or pulling the slider. Refer to the figure below.

CAUTION:

- Do not pull the harness or wires when disconnecting the connector.
- Be careful not to damage the connector support bracket when disconnecting the connector.

[Example]

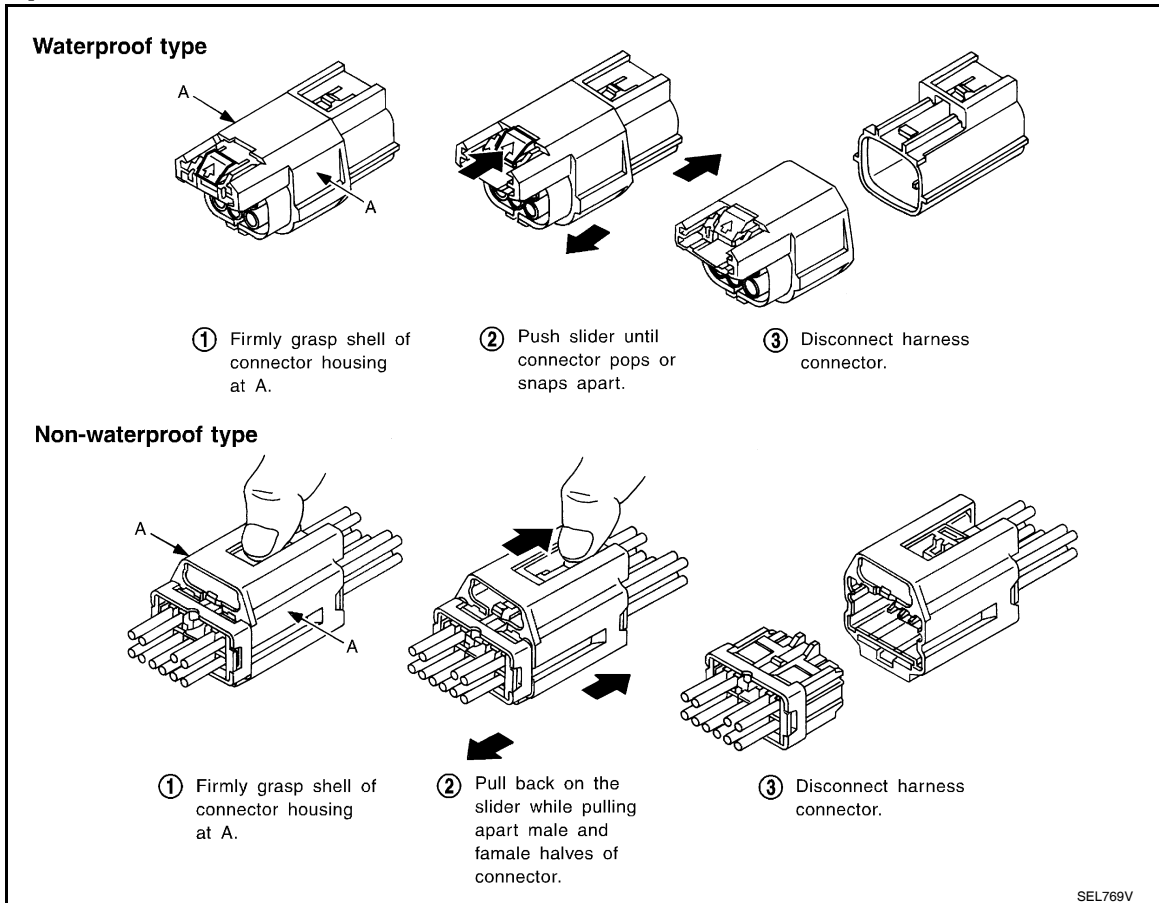

HARNESS CONNECTOR (LEVER LOCKING TYPE)

- Lever locking type harness connectors are used on certain control units and control modules such as ECM, ABS actuator and electric unit (control unit), etc.
- Lever locking type harness connectors are also used on super multiple junction (SMJ) connectors.
- Always confirm the lever is fully locked in place by moving the lever as far as it will go to ensure full connection.

CAUTION:

HARNES CONNECTOR

< COMPONENT DIAGNOSIS >

- Always confirm the lever is fully released (loosened) before attempting to disconnect or connect these connectors to avoid damage to the connector housing or terminals.

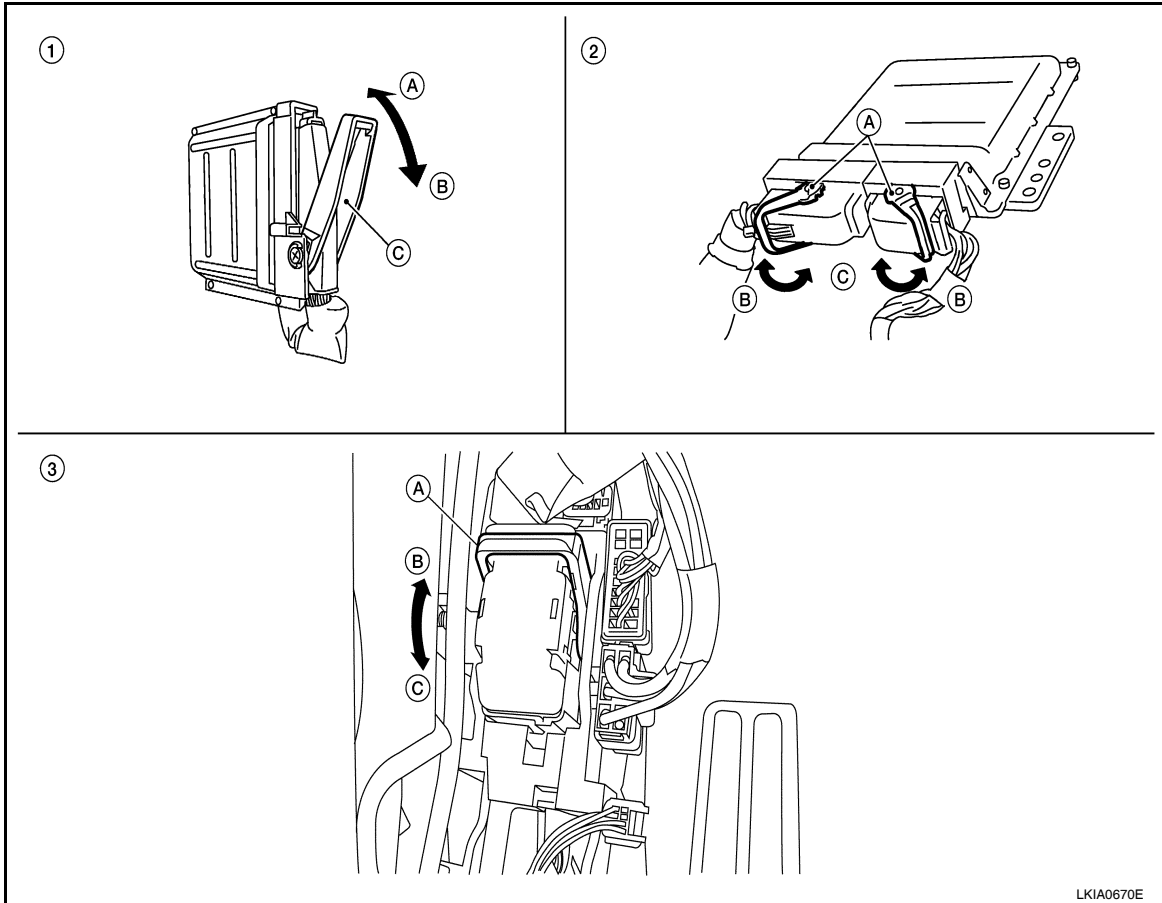

LKIA0670E

- | | | |
|-----------------------------------|---------------------------------|------------------|
| 1. Control unit with single lever | 2. Control unit with dual lever | 3. SMJ connector |
| A. Fasten | A. Fasten | A. Fasten |
| B. Loosen | B. Loosen | B. Loosen |
| C. Lever | C. Lever | C. Lever |

HARNES CONNECTOR (DIRECT-CONNECT SRS COMPONENT TYPE)

- SRS direct-connect type harness connectors are used on certain SRS components such as air bag modules and seat belt pre-tensioners.
- Always pull up to release black locking tab prior to removing connector from SRS components.
- Always push down to lock black locking tab after installing connector to SRS components. When locked, the black locking tab is level with the connector housing.

CAUTION:

- Do not pull the harness or wires when removing connectors from SRS components.

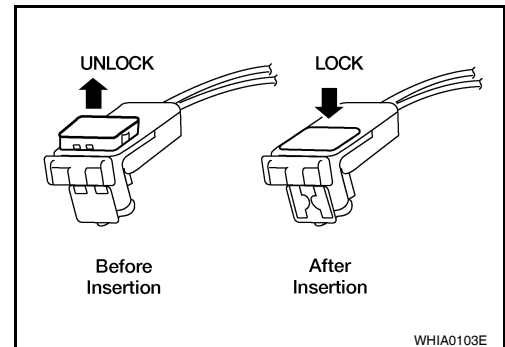

WHIA0103E

STANDARDIZED RELAY

< COMPONENT DIAGNOSIS >

STANDARDIZED RELAY

Description

INFOID:000000003789675

NORMAL OPEN, NORMAL CLOSED AND MIXED TYPE RELAYS

Relays can mainly be divided into three types: normal open, normal closed and mixed type relays.

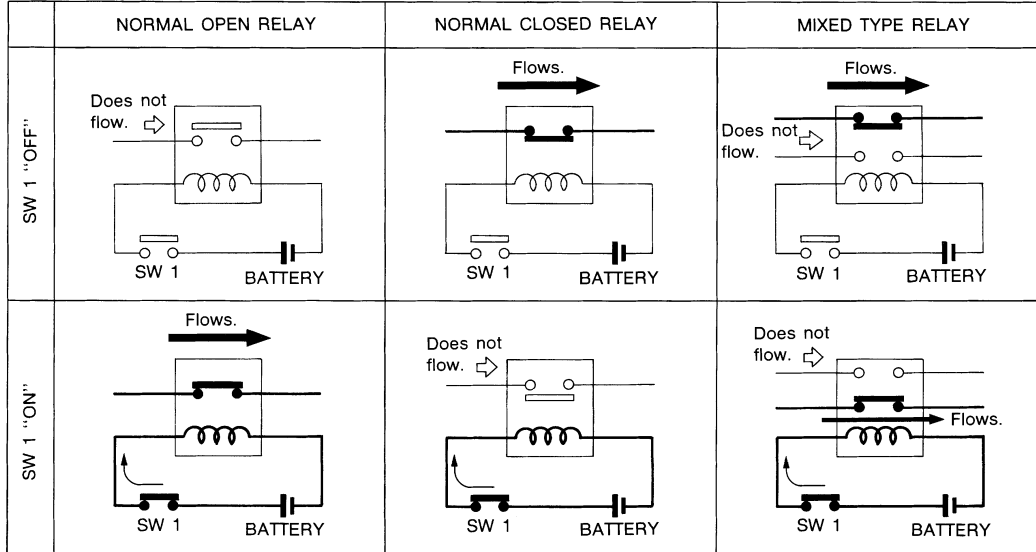

SEL881H

TYPE OF STANDARDIZED RELAYS

- 1M 1 Make
- 2M 2 Make
- 1T 1 Transfer
- 1M-1B 1 Make 1 Break

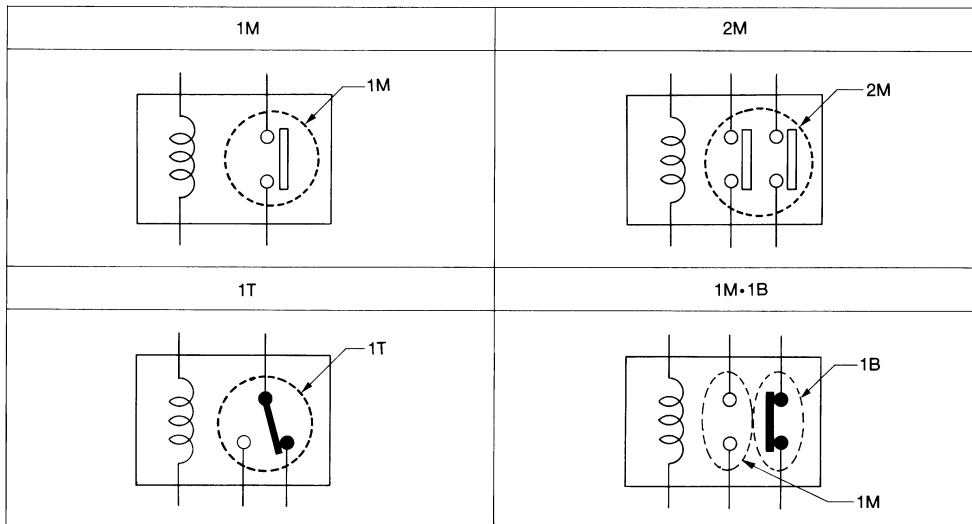

SEL882H

STANDARDIZED RELAY

< COMPONENT DIAGNOSIS >

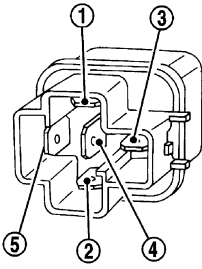
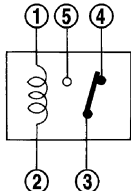
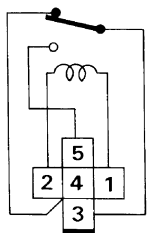
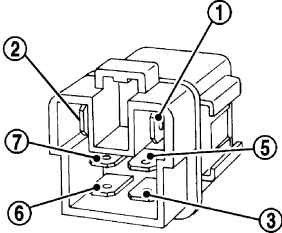
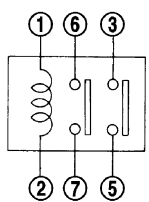
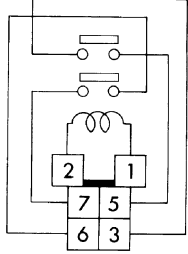
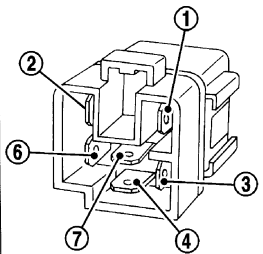
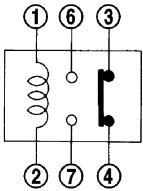
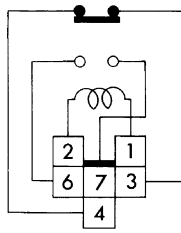
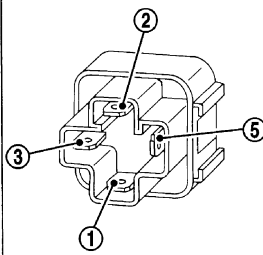
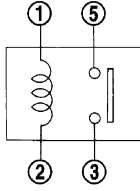
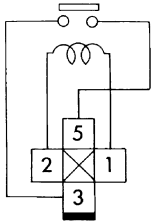
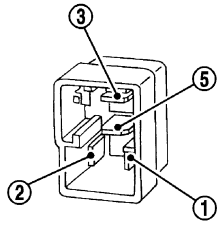
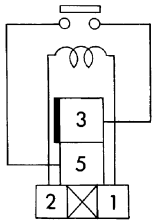
Type	Outer view	Circuit	Connector symbol and connection	Case color
1T				BLACK
2M				BROWN
1M•1B				GRAY
1M				BLUE
				

The arrangement of terminal numbers on the actual relays may differ from those shown above.

SEL188W

FUSE BLOCK - JUNCTION BOX (J/B)

< COMPONENT DIAGNOSIS >

FUSE BLOCK - JUNCTION BOX (J/B)

Terminal Arrangement

INFOID:000000003789676

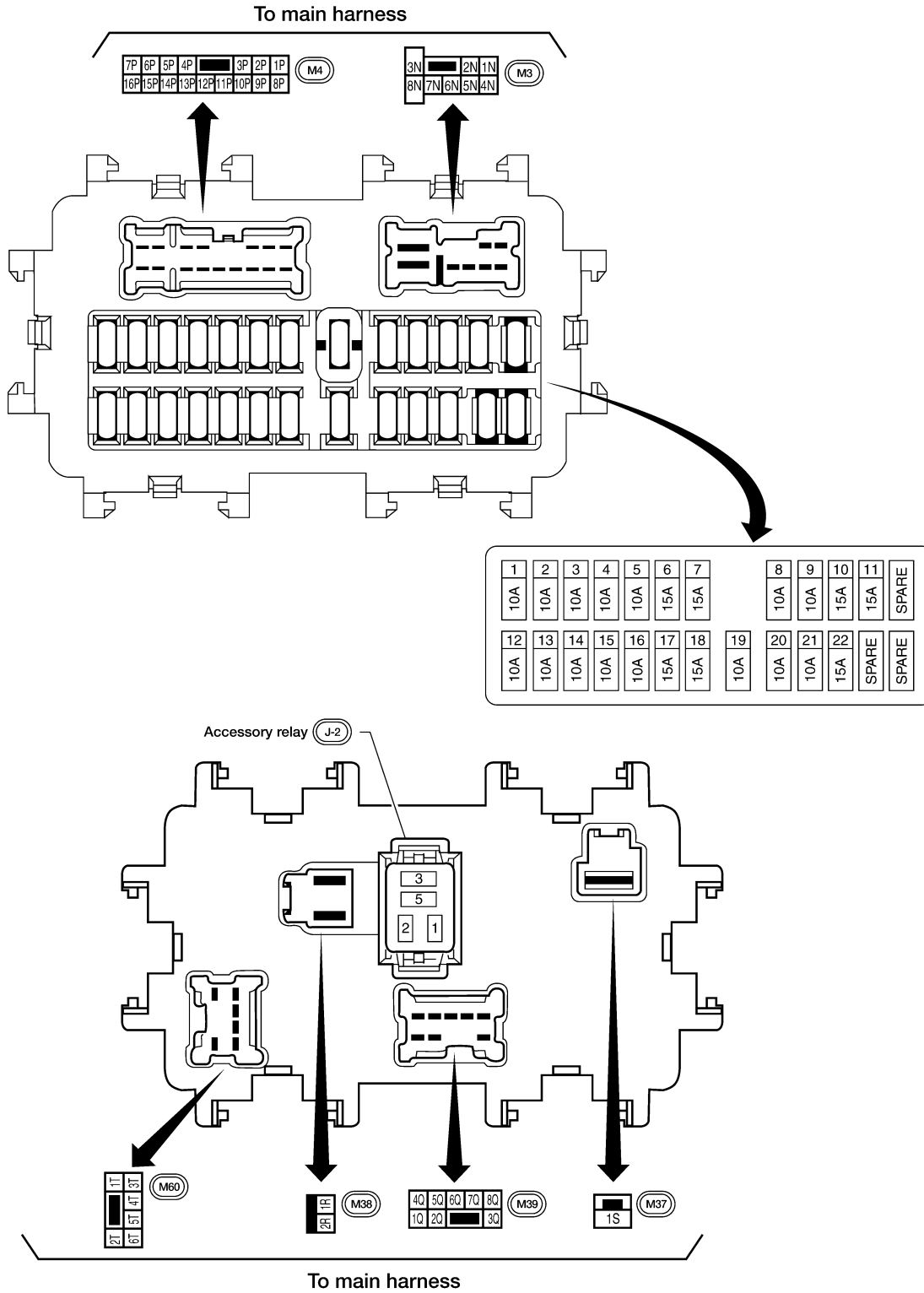

A
B
C
D
E
F
G
H
I
J
K
L
PG
N
O
P

WKIA4734E

FUSE, FUSIBLE LINK AND RELAY BOX

< COMPONENT DIAGNOSIS >

FUSE, FUSIBLE LINK AND RELAY BOX

Terminal Arrangement

INFOID:000000003789677

FUSE AND FUSIBLE LINK BOX

FUSIBLE LINK BOX (BATTERY)

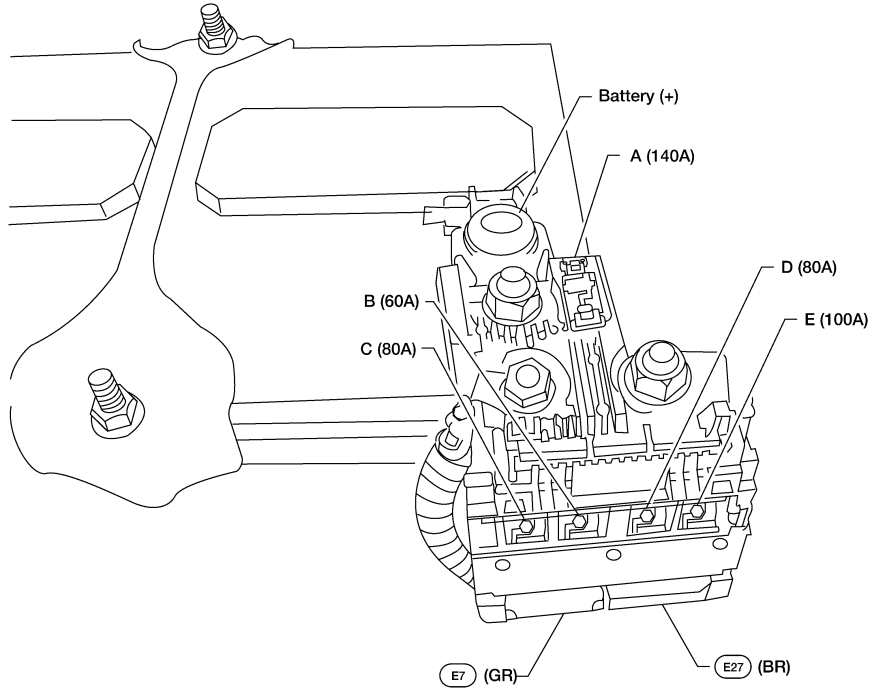

FUSE AND FUSIBLE LINK BOX

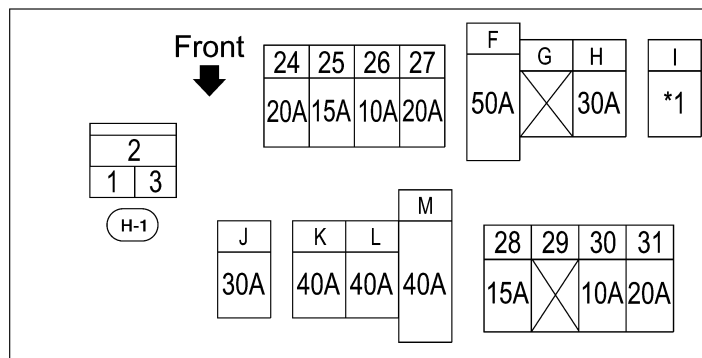

24 - 31 : FUSE F - M : FUSIBLE LINK

*1 40A WITH ABLs OR VDC
30A WITH ABS

ABMIA0132GB

FUSE, FUSIBLE LINK AND RELAY BOX

< COMPONENT DIAGNOSIS >

FUSE AND RELAY BOX

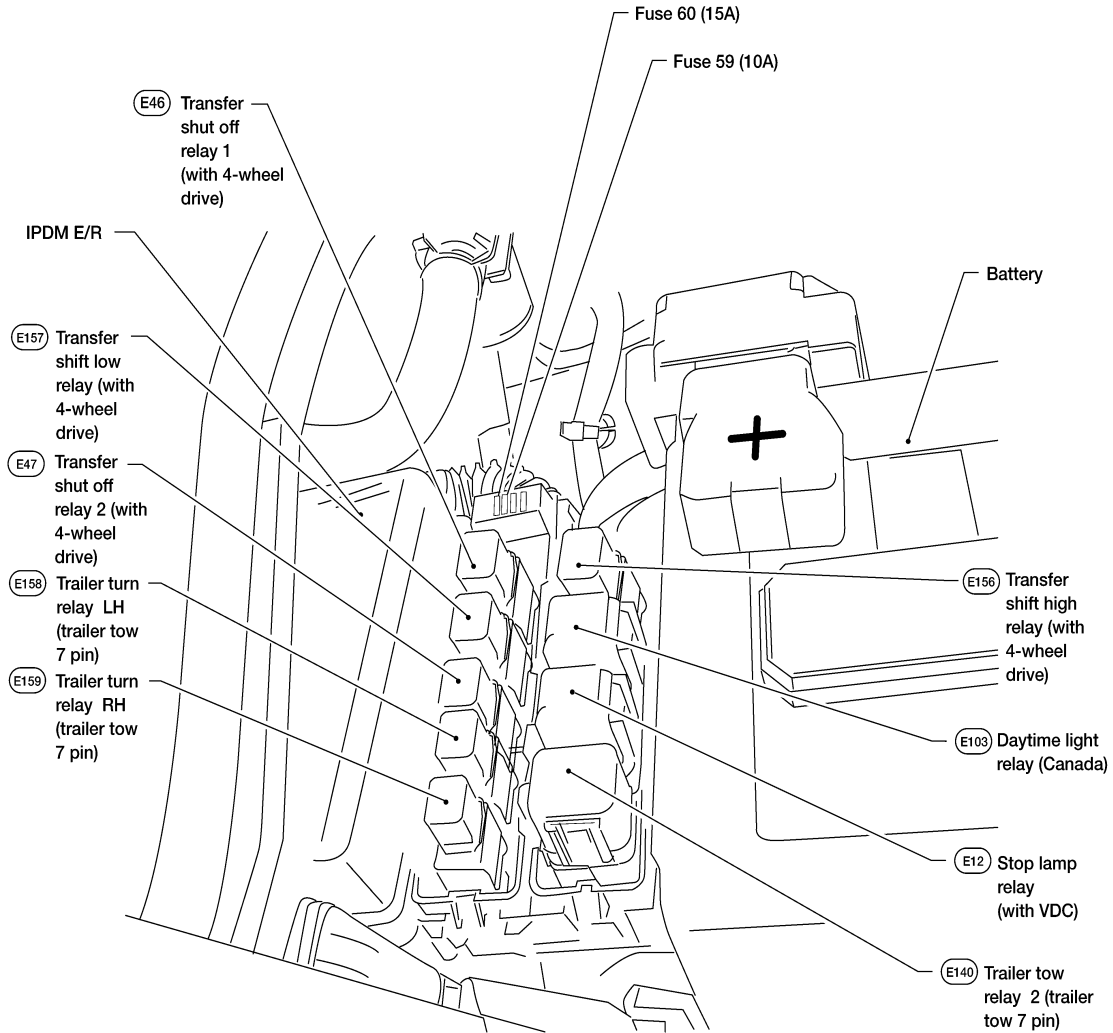

A

B

C

D

E

F

G

H

I

J

K

L

PG

N

O

P

ABMIA0134GB

BATTERY

< ON-VEHICLE REPAIR >

ON-VEHICLE REPAIR

BATTERY

Removal and Installation

INFOID:000000003789678

REMOVAL

1. Disconnect the negative battery terminal (1) and positive battery terminal (2).

CAUTION:

Remove negative battery terminal first.

⇐ : Front

2. Remove the battery cover.
3. Remove the battery clamp bolt (3) and battery clamp.
4. Remove the battery.

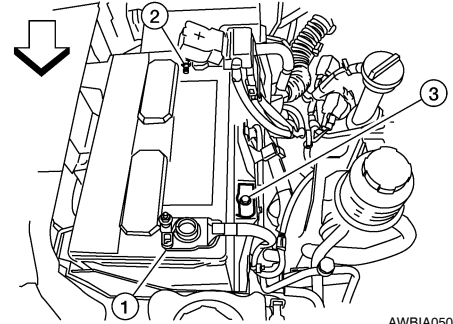

AWBIA0504ZZ

INSTALLATION

Installation is in the reverse order of removal.

CAUTION:

When installing, install the positive battery terminal first.

Battery clamp bolt : 14.7 N·m (1.5 kg-m, 11 ft-lb)

Battery terminal nut : 3.5 N·m (0.36 kg-m, 31 in-lb)

Reset electronic systems as necessary. Refer to [PG-6. "Special Repair Requirement"](#).

SERVICE DATA AND SPECIFICATIONS (SDS)

< SERVICE DATA AND SPECIFICATIONS (SDS)

SERVICE DATA AND SPECIFICATIONS (SDS)

SERVICE DATA AND SPECIFICATIONS (SDS)

Battery

INFOID:000000003789679

	Standard battery	Heavy duty battery (with towing package and FFV equipped vehicles)
Type	Gr. 24	Gr. 27
Capacity (20 HR) minimum V-AH	72	80
Cold cranking current A (For reference value)	650	710

A

B

C

D

E

F

G

H

I

J

K

L

PG

N

O

P