

SECTION MA

GI

MA

EM

LC

EC

FE

CL

MT

AT

FA

RA

BR

ST

RS

BT

HA

FL

IDX

CONTENTS

PRECAUTIONS AND PREPARATION	2
Supplemental Restraint System (SRS) "AIR BAG"	2
Special Service Tools.....	2
GENERAL MAINTENANCE	3
PERIODIC MAINTENANCE	5
Schedule 1	6
Schedule 2.....	7
RECOMMENDED FLUIDS AND LUBRICANTS	8
Fluids and Lubricants.....	8
SAE Viscosity Number.....	8
Antifreeze Coolant Mixture Ratio.....	9

SR

ENGINE MAINTENANCE	10
Checking Drive Belts	10
Changing Engine Coolant.....	11
Checking Fuel Lines	13
Changing Fuel Filter	13
Changing Air Cleaner Filter	14
Changing Engine Oil.....	14
Changing Oil Filter.....	15
Changing Spark Plugs (Platinum-tipped type)	15
Changing Spark Plugs (Conventional type)	17
Checking EVAP Vapor Purge Lines.....	17

GA

ENGINE MAINTENANCE	18
Checking Drive Belts	18
Changing Engine Coolant.....	19

Checking Fuel Lines	21
Changing Fuel Filter	22
Changing Air Cleaner Filter	22
Changing Engine Oil.....	23
Changing Oil Filter.....	23
Changing Spark Plugs	24
Checking EVAP Vapor Purge Lines.....	25

SR & GA

CHASSIS AND BODY MAINTENANCE	26
Checking Exhaust System.....	26
Checking Clutch System.....	26
Checking M/T Oil	26
Changing M/T Oil.....	26
Checking A/T Fluid.....	27
Changing A/T Fluid.....	28
Checking Brake Fluid Level and Leaks.....	28
Checking Brake Lines and Cables	28
Checking Disc Brake	28
Checking Drum Brake.....	29
Balancing Wheels	30
Tire Rotation.....	30
Checking Steering Gear and Linkage	30
Checking Power Steering Fluid and Lines	30
Lubricating Locks, Hinges and Hood Latches.....	31
Checking Seat Belts, Buckles, Retractors, Anchors and Adjusters.....	31
SERVICE DATA AND SPECIFICATIONS (SDS)	32
Engine Maintenance (SR).....	32
Engine Maintenance (GA)	32
Chassis and Body Maintenance	32

PRECAUTIONS AND PREPARATION



Supplemental Restraint System (SRS) "AIR BAG"

The Supplemental Restraint System "Air Bag" used along with a seat belt, helps to reduce the risk or severity of injury to the driver and front passenger in a frontal collision. The Supplemental Restraint System consists of air bag modules (located in the center of the steering wheel and on the instrument panel on the passenger side), a diagnosis sensor unit, warning lamp, wiring harness and spiral cable. Information necessary to service the system safely is included in the **RS section** of this Service Manual.

WARNING:

- To avoid rendering the SRS inoperative, which could increase the risk of personal injury or death in the event of a collision which would result in air bag inflation, all maintenance must be performed by an authorized NISSAN dealer.
- Improper maintenance, including incorrect removal and installation of the SRS, can lead to personal injury caused by unintentional activation of the system.
- Do not use electrical test equipment on any circuit related to the SRS unless instructed to in this Service Manual. SRS wiring harnesses are covered with yellow insulation either just before the harness connectors or for the complete harness, for easy identification.

Special Service Tools

The actual shapes of Kent-Moore tools may differ from those of special service tools illustrated here.

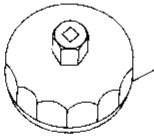
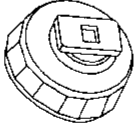
Tool number (Kent-Moore No.) Tool name	Description	Engine application		
		SR20DE	GA16DE	
KV10115801 (J38956) Oil filter wrench	 NT362	Removing oil filter	X	—
KV10105900 (J34274) Oil filter wrench	 NT005	Removing oil filter 80 mm (3.15 in) dia.	—	X

GENERAL MAINTENANCE

General maintenance includes those items which should be checked during the normal day-to-day operation of the vehicle. They are essential if the vehicle is to continue operating properly. The owners can perform checks and inspections themselves or have their NISSAN dealers do them.

Item	Reference page	GI
OUTSIDE THE VEHICLE		
The maintenance items listed here should be performed from time to time, unless otherwise specified.		
Tires Check the pressure, including the spare, with a gauge periodically when at a service station and adjust to the specified pressure if necessary. Check carefully for damage, cuts and excessive wear.	—	EM
Wheel nuts When checking the tires, make sure no nuts are missing, and check for any loose nuts. Tighten if necessary.	MA-30	LC
Tire rotation Tires should be rotated every 12,000 km (7,500 miles).	MA-30	EC
Wheel alignment and balance If the vehicle pulls to either side while driving on a straight and level road, or if you detect uneven or abnormal tire wear, there may be a need for wheel alignment. If the steering wheel or seat vibrates at normal highway speeds, wheel balancing may be needed.	MA-30, FA-6	FE
Windshield wiper blades Check for cracks and wear if they do not wipe properly.	—	CL
Doors and engine hood Check that all doors, engine hood and trunk lid operate smoothly. Also make sure that all latches lock securely. Lubricate hinges, latches, rollers and links if necessary. Make sure that the secondary latch keeps the hood from opening when the primary latch is released. When driving in areas using road salt or other corrosive materials, check lubrication frequently.	MA-31	MT
Lamps Make sure that the headlamps, stop lamps, tail lamps, turn signal lamps, and other lamps are all operating properly and installed securely. Also check headlamp aim.	—	AT
INSIDE THE VEHICLE		
The maintenance items listed here should be checked on a regular basis, such as when performing periodic maintenance, cleaning the vehicle, etc.		
Warning lamps and buzzers/chimes Make sure that all warning lamps and buzzers/chimes are operating properly.	—	PA
Windshield wiper and washer Check that the wipers and washer operate properly and that the wipers do not streak.	—	BR
Windshield defroster Check that the air comes out of the defroster outlets properly and in sufficient quantity when operating the heater or air conditioner.	—	SI
Steering wheel Check that it has the specified play. Be sure to check for changes in the steering condition, such as excessive play, hard steering or strange noises. Free play: Less than 35 mm (1.38 in)	—	RS
Seats Check seat position controls such as seat adjusters, seatback recliner, etc. to make sure they operate smoothly and that all latches lock securely in every position. Check that the head restraints move up and down smoothly and that the locks (if equipped) hold securely in all latched positions. Check that the latches lock securely for folding-down rear seatbacks.	—	BT
Seat belts Check that all parts of the seat belt system (e.g., buckles, anchors, adjusters and retractors) operate properly and smoothly and are installed securely. Check the belt webbing for cuts, fraying, wear and damage.	MA-31	HA
Clutch pedal Make sure the pedal operates smoothly and check that it has the proper free play.	CL-4	EL
Brakes Check that the brake does not pull the vehicle to one side when applied.	—	ID
Brake pedal and booster Check the pedal for smooth operation and make sure it has the proper distance under it when depressed fully. Check the brake booster function. Be sure to keep the floor mats away from the pedal.	BR-10, 16	ID
Parking brake Check that the lever has the proper travel and make sure that the vehicle is held securely on a fairly steep hill when only the parking brake is applied.	BR-34	ID

GENERAL MAINTENANCE

Item	Reference page
Automatic transaxle "Park position" mechanism Check that the lock release button on the selector lever operates properly and smoothly. On a fairly steep hill, check that the vehicle is held securely with the selector lever in the "P" position without applying any brakes.	—
UNDER THE HOOD AND VEHICLE	
The maintenance items listed here should be checked periodically (e.g., each time you check the engine oil or refuel).	
Windshield washer fluid Check that there is adequate fluid in the tank.	—
Engine coolant level Check the coolant level when the engine is cold.	MA-11, 19
Radiator and hoses Check the front of the radiator and clean off any dirt, insects, leaves, etc., that may have accumulated. Make sure the hoses have no cracks, deformation, deterioration or loose connections.	—
Brake fluid level Make sure that the brake fluid level is between the "MAX" and "MIN" lines on the reservoir.	MA-28
Battery Check the fluid level in each cell. It should be between the "MAX" and "MIN" lines.	—
Engine drive belts Make sure that no belt is frayed, worn, cracked or oily.	MA-10, 18
Engine oil level Check the level on the dipstick after parking the vehicle on a level spot and turning off the engine.	MA-14, 23
Power steering fluid level and lines Check the level in the reservoir tank with the engine off. Check the lines for improper attachment, leaks, cracks, etc.	MA-30
Automatic transaxle fluid level Check the level on the dipstick after putting the selector lever in "P" with the engine idling.	MA-27
Exhaust system Make sure there are no loose supports, cracks or holes. If the sound of the exhaust seems unusual or there is a smell of exhaust fumes, immediately locate the trouble and correct it.	MA-26
Underbody The underbody is frequently exposed to corrosive substances such as those used on icy roads or to control dust. It is very important to remove these substances, otherwise rust will form on the floor pan, frame, fuel lines and around the exhaust system. At the end of winter, the underbody should be thoroughly flushed with plain water, being careful to clean those areas where mud and dirt can easily accumulate.	—
Fluid leaks Check under the vehicle for fuel, oil, water and other fluid leaks after the vehicle has been parked for a while. Water dripping from the air conditioner after use is normal. If any leaks or gasoline fumes are evident, check for the cause and correct it immediately.	—

PERIODIC MAINTENANCE

Two different maintenance schedules are provided, and should be used, depending upon the conditions in which the vehicle is usually operated. **After 60,000 miles (96,000 km) or 48 months, continue the periodic maintenance at the same mileage/time intervals.**

GI

SCHEDULE 1

Follow Periodic Maintenance Schedule 1 if your driving habits frequently includes one or more of the following driving conditions:

MA

- Repeated short trips of less than 5 miles (8 km).
- Repeated short trips of less than 10 miles (16 km) with outside temperatures remaining below freezing.
- Operating in hot weather in stop-and-go “rush hour” traffic.
- Extensive idling and/or low speed driving for long distances, such as police, taxi or door-to-door delivery use.
- Driving in dusty conditions.
- Driving on rough, muddy, or salted roads.
- Towing a trailer, using a camper or a car-top carrier.

EM

LC

EC

SCHEDULE 2

Follow Periodic Maintenance Schedule 2 if none of the driving conditions shown in Schedule 1 apply to your driving habits.

FE

CL

MT

AT

FA

RA

BR

ST

RS

BT

HA

EL

DX

Schedule 1

Abbreviations: R = Replace. I = Inspect. Correct or replace if necessary. []: At the mileage intervals only

MAINTENANCE OPERATION	MAINTENANCE INTERVAL												Reference page			
	Miles x 1,000 (km x 1,000) Months	3.75 (6) 3	7.5 (12) 6	11.25 (18) 9	15 (24) 12	18.75 (30) 15	22.5 (36) 18	26.25 (42) 21	30 (48) 24	33.75 (54) 27	37.5 (60) 30	41.25 (66) 33		45 (72) 36	48.75 (78) 39	52.5 (84) 42

Emission control system maintenance

															SR series	GA series	
Drive belts	See NOTE (1).														I*	MA-10	MA-18
Air cleaner filter	See NOTE (2).														[R]	MA-14	MA-22
Vapor lines															I*	MA-17	MA-25
Fuel lines															I*	MA-13	MA-21
Fuel filter	See NOTE (3)*.														I*	MA-13	MA-22
Engine coolant	See NOTE (4).																
Engine oil		R	R	R	R	R	R	R	R	R	R	R	R	R	R*	MA-11	MA-19
Engine oil filter (Use part No. 15208-H8903 for GA16DE engine and 15208-65F00 for SR20DE engine.)		R	R	R	R	R	R	R	R	R	R	R	R	R	R	MA-14	MA-23
Spark plugs GA16DE engine															[R]		MA-15
	SR20DE engine (Use PLATINUM-TIPPED type.) See NOTE (5).														[R]		MA-24
Idle rpm (GA16DE engine)															[R]	MA-15	
Intake & exhaust valve clearance (GA16DE engine)	See NOTE (6)*.														I*	EC-27	EC-256

Chassis and body maintenance

Brake lines & cables																	
Brake pads, rotors, drums & linings																	MA-28
Manual transaxle oil & automatic transmission fluid	See NOTE (7).																MA-28, 29
Steering gear & linkage, axle & suspension parts																	MA-26, 27, 28
Steering linkage ball joints & front suspension ball joints																	MA-30, FA-5, RA-4
Exhaust system																	MA-30, FA-5
Drive shaft boots																	MA-26
Air bag system	See NOTE (8).																FA-7

- NOTE:** (1) After 60,000 miles (96,000 km) or 48 months, inspect every 15,000 miles (24,000 km) or 12 months.
 (2) If vehicle is usually operated in dusty conditions, more frequent maintenance may be required.
 (3) If vehicle is operated under extremely adverse weather conditions or in areas where ambient temperatures are either extremely low or extremely high, the filters might become clogged. In such an event, replace them immediately.
 (4) After 60,000 miles (96,000 km) or 48 months, replace every 30,000 miles (48,000 km) or 24 months.
 (5) Original equipment platinum-tipped plugs should be replaced at 60,000 miles (96,000 km) intervals. Conventional spark plugs can be used but should be replaced at 30,000 mile (48,000 km) intervals.
 (6) If valve noise increases, inspect valve clearance.
 (7) If towing a trailer, using a camper or a car-top carrier, or driving on rough or muddy roads, change (not just inspect) oil at every 30,000 miles (48,000 km) or 24 months.
 (8) Inspect the air bag system 10 years after the date of manufacture noted on the FMVSS certification label.
 * Maintenance items and intervals with "S" are recommended by NISSAN for reliable vehicle operation. The owner need not perform such maintenance in order to maintain the emission warranty or manufacturer recall liability. Other maintenance items and intervals are required.

Schedule 2

Abbreviations: R = Replace. I = Inspect. Correct or replace if necessary. [] : At the mileage intervals only

MAINTENANCE OPERATION

Perform at number of miles, kilometers or months, whichever comes first.	MAINTENANCE INTERVAL						Reference page		
	Miles x 1,000 (km x 1,000)	7.5 (12)	15 (24)	22.5 (36)	30 (48)	37.5 (60)		45 (72)	52.5 (84)
Months	6	12	18	24	30	36	42	48	

Emission control system maintenance

	SR series	GA series
Drive belts	I* MA-10	MA-18
Air cleaner filter	[R]	MA-22
Vapor lines	I*	MA-17 MA-25
Fuel lines	I*	MA-13 MA-21
Fuel filter	See NOTE (2)*	MA-13 MA-22
Engine coolant	See NOTE (3)	MA-11 MA-19
Engine oil	R R R R R R R R R R R R R R R R R R R R	MA-14 MA-23 MA-23
Engine oil filter (Use Part No. 15208-H8903 for GA16DE engine and 15208-65F00 for SR20DE engine.)	R R R R R R R R R R R R R R R R R R R R	MA-15 MA-23
Spark plugs	GA16DE engine [R] SR20DE engine (Use PLATINUM-TIPPED type.) See NOTE (4).	MA-24
Idle rpm (GA16DE engine)	[R]	MA-15
Intake & exhaust valve clearance (GA16DE engine)	I*	EC-27 EC-256
	See NOTE (5)*	EM-90

Chassis and body maintenance

Brake lines & cables	I	I	I	I	I	I	I	I	MA-28
Brake pads, rotors, drums & linings	I	I	I	I	I	I	I	I	MA-28, 29
Manual transaxle oil & automatic transaxle fluid	I	I	I	I	I	I	I	I	MA-26, 27, 28
Steering gear linkage, axle & suspension parts	I	I	I	I	I	I	I	I	MA-30, FA-5, RA-4, ST-29
Exhaust system	I	I	I	I	I	I	I	I	MA-26
Drive shaft boots	I	I	I	I	I	I	I	I	FA-7
Air bag system	See NOTE (6).								RS-10

- NOTE: (1)** After 60,000 miles (96,000 km) or 48 months, inspect every 15,000 miles (24,000 km) or 12 months.
(2) If vehicle is operated under extremely adverse weather conditions or in areas where ambient temperatures are either extremely low or extremely high, the filters might become clogged. In such an event, replace them immediately.
(3) After 60,000 miles (96,000 km) or 48 months, replace every 30,000 miles (48,000 km) or 24 months.
(4) Original equipment platinum-tipped plugs should be replaced at 60,000 miles (96,000 km) intervals.
(5) If valve noise increases, inspect valve clearance.
(6) Inspect the air bag system 10 years after the date of manufacture noted on the FMVSS certification label.

* Maintenance items and intervals with "*" are recommended by NISSAN for reliable vehicle operation. The owner need not perform such maintenance in order to maintain the emission warranty or manufacturer recall liability. Other maintenance items and intervals are required.



RECOMMENDED FLUIDS AND LUBRICANTS

Fluids and Lubricants

			Capacity (Approximate)			Recommended fluids and lubricants
			US measure	Imp measure	Liter	
Engine oil (Refill)	With oil filter	SR20DE	3-5/8 qt	3 qt	3.4	<ul style="list-style-type: none"> ● API SG or SH and Energy Conserving II *2 ● API Certification Mark *2
		GA16DE	3-3/8 qt	2-7/8 qt	3.2	
	Without oil filter	SR20DE	3-3/8 qt	2-7/8 qt	3.2	
		GA16DE	3 qt	2-1/2 qt	2.8	
Cooling system (with reservoir tank)	M/T	SR20DE	6-1/2 qt	5-1/2 qt	6.2	Antifreeze coolant (Ethylene glycol base)
		GA16DE	5-1/2 qt	4-5/8 qt	5.2	
	A/T	SR20DE	6-1/2 qt	5-1/2 qt	6.2	
		GA16DE	6 qt	5 qt	5.7	
Manual transaxle gear oil	RS5F31A	6-1/8 - 6-3/4 pt	5-1/8 - 5-5/8 pt	2.9 - 3.2	API GL-4*2	
	RS5F32V	7-7/8 - 8-1/4 pt	6-1/2 - 6-7/8 pt	3.7 - 3.9		
Automatic transaxle fluid	RL4F03A RE4F03V	7-3/8 qt	6-1/8 qt	7.0	Nissan Matic 'D' (Continental U.S. and Alaska) or Genuine Automatic Transmission Fluid (Canada). *1	
Power steering fluid		—	—	—	Type DEXRON™ IIE, DEXRON™ III or equivalent	
Brake fluid		—	—	—	Genuine Nissan Brake Fluid*3 or equivalent DOT 3 (US FMVSS No. 116)	
Multi-purpose grease		—	—	—	NLGI No. 2 (Lithium soap base)	

*1: Dexron® III/Mercon® or equivalent may also be used. Outside the continental United States and Alaska contact a Nissan dealership for more information regarding suitable fluids, including recommended brand(s) of Dexron® III/Mercon® or Dexron® IIE/Mercon® Automatic Transmission Fluid.

*2: For further details, see "SAE Viscosity Number".

*3: Available in mainland USA through your NISSAN dealer

SAE Viscosity Number

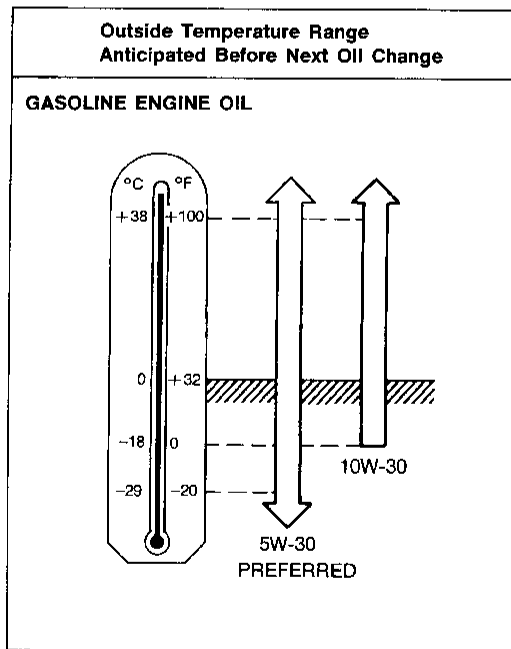

SAE 5W-30 viscosity oil is preferred for all ambient temperatures. SAE 10W-30 viscosity oil may be used if the ambient temperature is above -18°C (0°F).

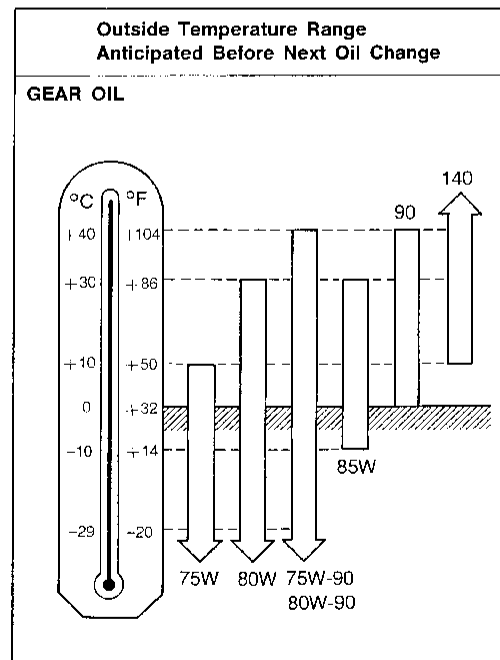

80W-90 is preferable if the ambient temperature is below 40°C (104°F).

RECOMMENDED FLUIDS AND LUBRICANTS

Antifreeze Coolant Mixture Ratio

The engine cooling system is filled at the factory with a high-quality, year-round, antifreeze coolant solution. The antifreeze solution contains rust and corrosion inhibitors. Additional cooling system additives are not necessary.

CAUTION:

When adding or replacing coolant, be sure to use only an ethylene glycol antifreeze with a mixture ratio of 50% antifreeze, 50% soft water.

Outside temperature down to		Anti-freeze	Soft water
°C	°F		
-35	-30	50%	50%

Other types of coolant solutions may damage the cooling system.

GI

MA

EM

LC

EC

FE

CL

MT

AT

FA

RA

BR

ST

RS

BT

HA

EL

IDX

Checking Drive Belts

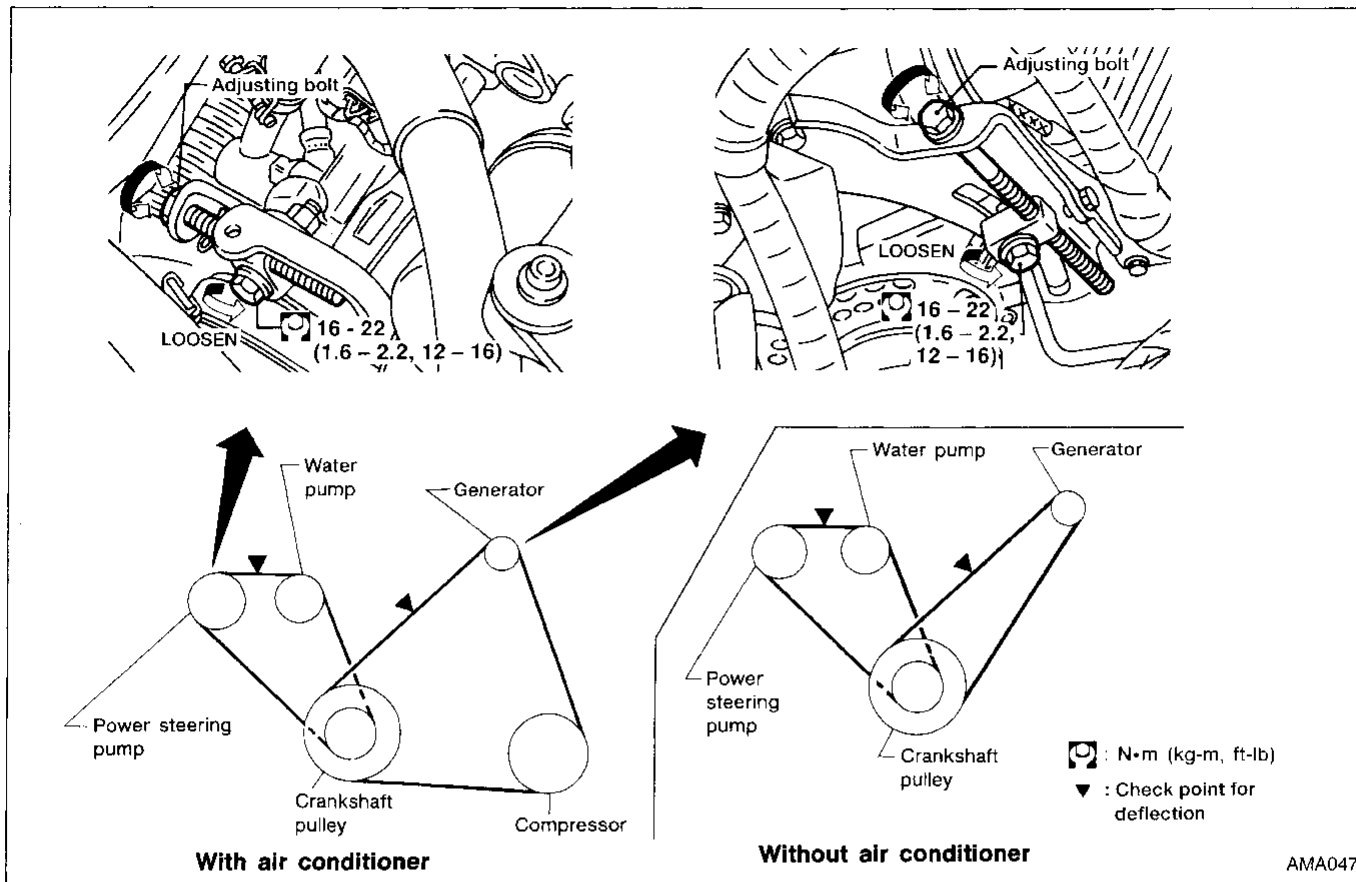

AMA047

1. Inspect for cracks, fraying, wear or oil. If necessary, replace with a new one.
2. Inspect drive belt deflections by pushing midway between pulleys.

Inspect drive belt deflections when engine is cold.

Adjust if belt deflections exceed the limit.

Belt deflection:

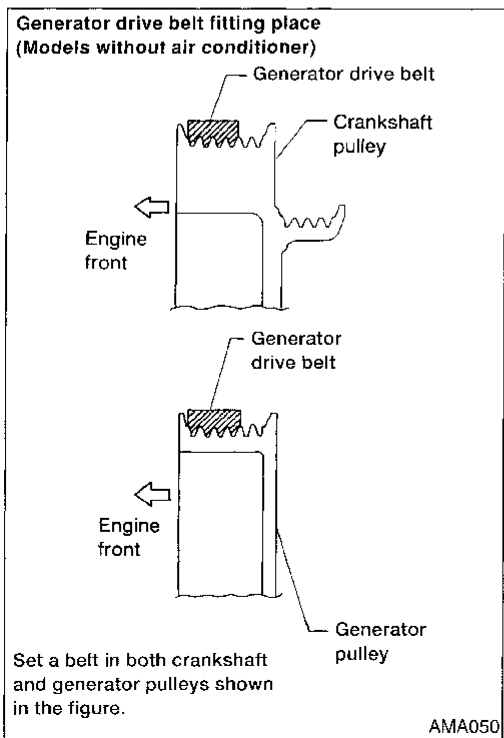

AMA050

Unit: mm (in)

	Used belt deflection		Deflection of new belt
	Limit	Deflection after adjustment	
Generator			
With air conditioner compressor	11.5 - 12.5 (0.453 - 0.492)	7 - 8 (0.28 - 0.31)	6.5 - 7.5 (0.256 - 0.295)
Without air conditioner compressor	12 - 13 (0.47 - 0.51)	8 - 9 (0.31 - 0.35)	7 - 8 (0.28 - 0.31)
Power steering pump	6 - 7 (0.24 - 0.28)	4 - 5 (0.16 - 0.20)	3.5 - 4.5 (0.138 - 0.177)
Applied pushing force	98 N (10 kg, 22 lb)		

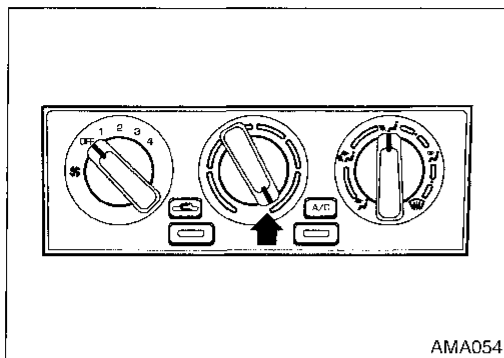

Changing Engine Coolant

WARNING:

To avoid being scalded, never change the coolant when the engine is hot.

-DRAINING ENGINE COOLANT-

1. Move heater temperature control lever all the way to WARM.
 - Make sure air conditioner switch is OFF.
2. Open radiator drain plug at the bottom of radiator, and remove radiator filler cap.
3. Remove reservoir tank, drain coolant, then clean reservoir tank. Install it temporarily.
 - Be careful not to allow coolant to contact drive belts.

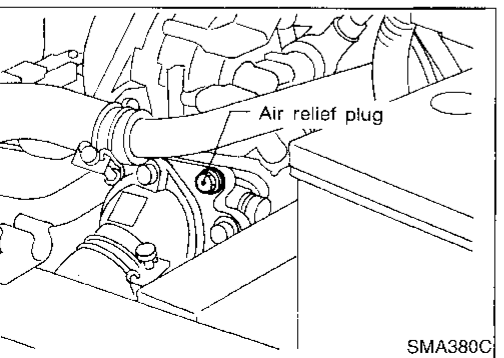
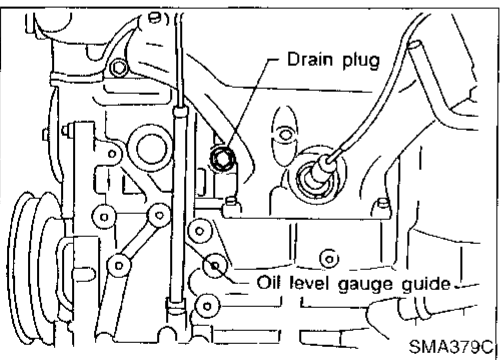
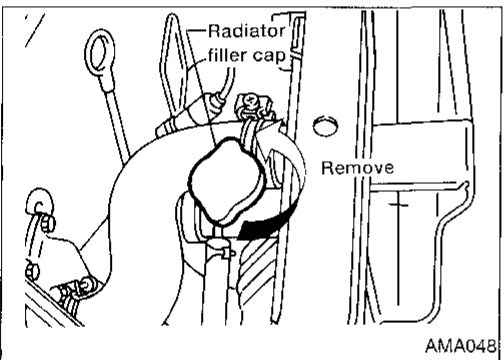
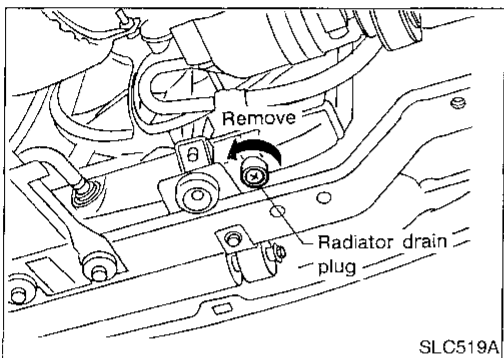

4. Remove cylinder block drain plug and air relief plug.

-FLUSHING COOLING SYSTEM-

5. Install radiator drain plug and cylinder block drain plug securely.
6. Fill radiator with water until water spills from the air relief hole, then install air relief plug. Fill radiator and reservoir tank with water and install radiator filler cap.

Air relief plug:

: 7.2 - 9.8 N·m (0.73 - 1.0 kg-m, 63 - 87 in-lb)

7. Warm up engine until cooling fan operates, then rev engine 2 or 3 times under no-load.
8. Stop engine and wait until it cools down.
9. Drain water.
10. Repeat steps 2 through 9 until clear water begins to drain from radiator.

-REFILLING ENGINE COOLANT-

11. Install reservoir tank, radiator drain plug and cylinder block drain plug.
 - Apply sealant to the thread of cylinder block drain plug.
 - : 8 - 12 N·m (0.8 - 1.2 kg-m, 69 - 104 in-lb)

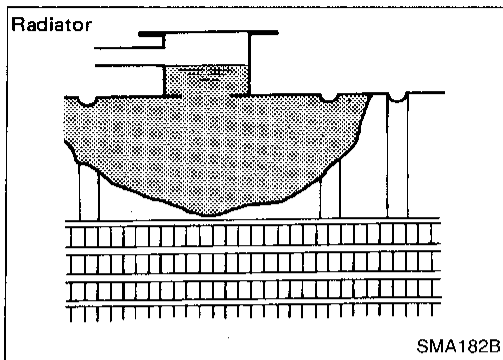

Changing Engine Coolant (Cont'd)

12. Fill radiator until coolant spills from the air relief hole, then install air relief plug.
13. Fill radiator and reservoir tank to specified level and install radiator filler cap.

Air relief plug:

🔧: 7.2 - 9.8 N·m (0.73 - 1.0 kg-m, 63 - 87 in-lb)

For coolant mixture ratio, refer to MA-9.

Coolant capacity (With reservoir tank):

Unit: ℓ (US qt, Imp qt)

M/T	6.2 (6-1/2, 5-1/2)
A/T	6.2 (6-1/2, 5-1/2)

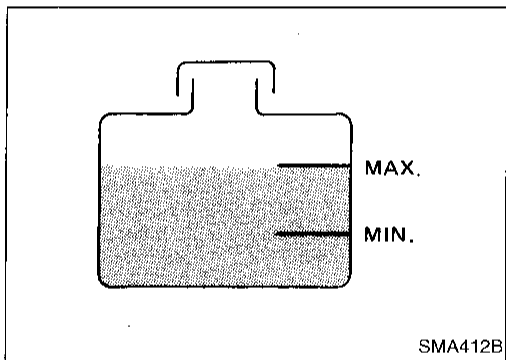

Reservoir tank capacity (for MAX level):

0.7 ℓ (3/4 US qt, 5/8 Imp qt).

Pour coolant through coolant filler neck slowly to allow air in system to escape.

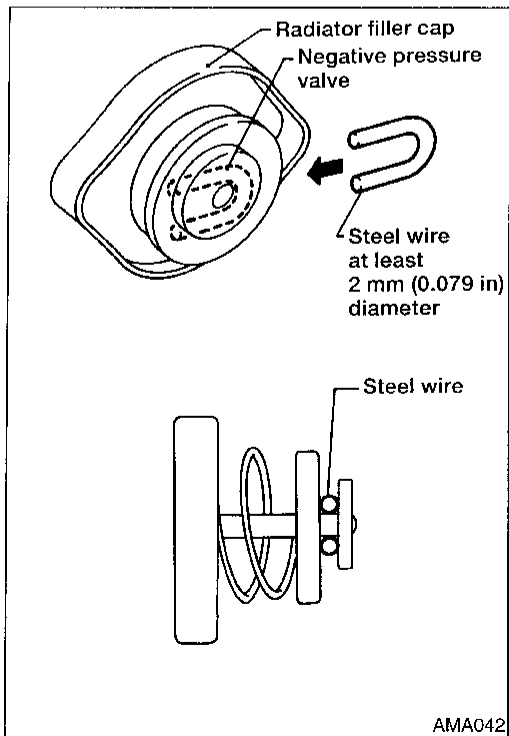

14. Install a wire under radiator filler cap negative pressure valve to allow air and coolant in cooling system to be directed into reservoir tank regardless of pressure.

- Install a suitable steel wire between negative pressure valve and its seat as shown in the picture.

15. Warm up engine to normal operating temperature.
16. Run engine at 2,500 rpm for 10 seconds and return to idle speed.
- Repeat 2 or 3 times.

Watch coolant temperature gauge so as not to overheat the engine.

17. Stop engine and cool it down.
 - Cool down using a fan to reduce the time.
18. Remove the radiator filler cap and check coolant level.
 - If necessary, refill radiator up to filler neck.
19. Refill reservoir tank to MAX level line.
20. Repeat steps 16 through 19 two or more times.

Changing Engine Coolant (Cont'd)

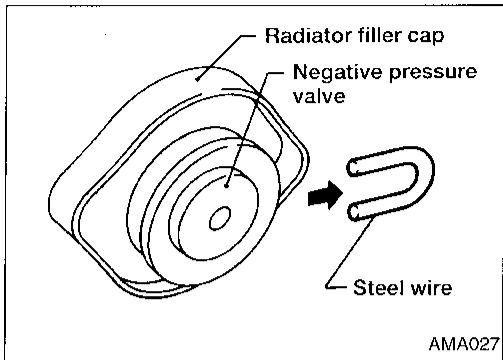

21. Remove wire and reinstall radiator filler cap.
22. Warm up engine, and check for sound of coolant flow while running engine from idle up to 4,000 rpm with heater temperature control lever set at several positions between COOL and WARM.
 - Sound may be noticeable at heater water cock.
23. If sound is heard, bleed air from cooling system by repeating steps 14 through 19 until coolant level no longer drops.
 - **Clean excess coolant from engine.**

GI
MA
EM

Checking Fuel Lines

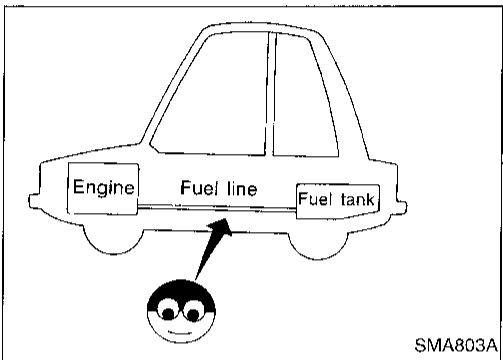

Inspect fuel lines and tank for improper attachment, leaks, cracks, damage, chafing and deterioration. If necessary, repair or replace.

LC
EC

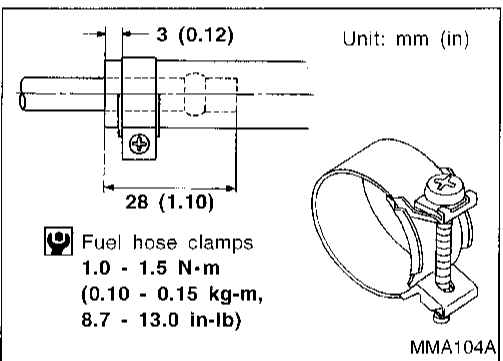

CAUTION:
Tighten high-pressure rubber hose clamp so that clamp end is 3 mm (0.12 in) from hose end. Tightening torque specifications are the same for all rubber hose clamps. Ensure that screw does not contact adjacent parts.

FE
CL
MT
AT
FA

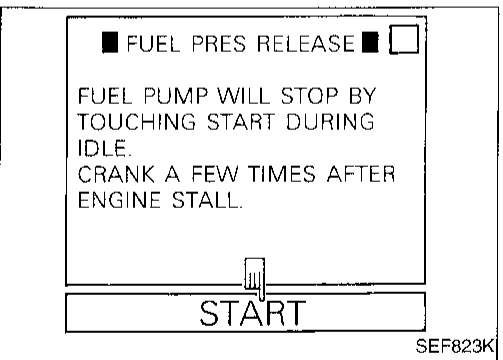

Changing Fuel Filter

WARNING:
Before removing fuel filter, release fuel pressure from fuel line.

1. Release fuel pressure using the following procedure.
 - a. Turn ignition switch ON.
 - b. Perform FUEL PRESSURE RELEASE in WORK SUPPORT mode and release fuel pressure to zero.
 - c. Start engine.
 - d. After engine stalls, crank engine two or three times to make sure that fuel pressure is released.
 - e. Turn ignition switch OFF.
2. Remove fuse for fuel pump.
 - a. Start engine.
 - b. After engine stalls, crank engine two or three times to make sure that fuel pressure is released.
 - c. Turn ignition switch OFF and install fuse for fuel pump.

ST
RS
BT
HA
EL
IDX

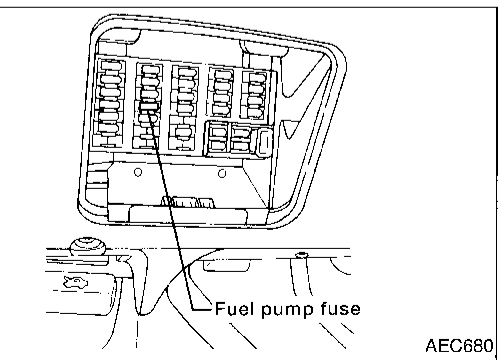

Changing Fuel Filter (Cont'd)

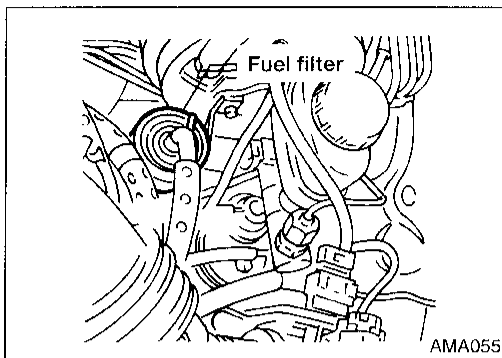

WARNING:

Use rubber gloves to prevent fuel from contacting skin when removing fuel hoses and filter.

2. Loosen fuel hose clamps.
 3. Replace fuel filter.
- Be careful not to spill fuel over engine compartment. Place a shop towel to absorb fuel.
 - Use a high-pressure type fuel filter. Do not use a synthetic resinous fuel filter.
 - When tightening fuel hose clamps, refer to "Checking Fuel Lines", MA-13.

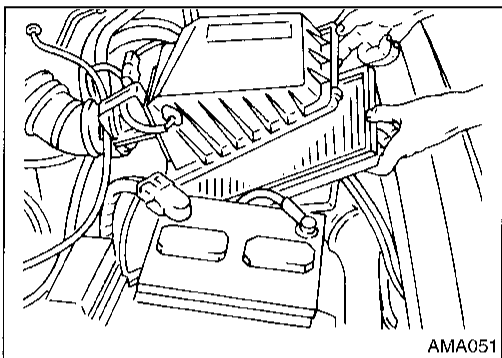

Changing Air Cleaner Filter

Unfasten clamps to change air cleaner filter. The viscous paper type filter does not need cleaning between replacement intervals.

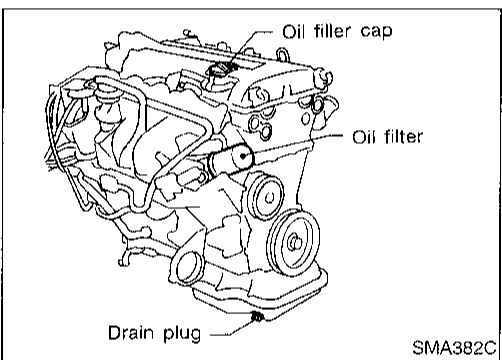

Changing Engine Oil

WARNING:

- Be careful not to burn yourself, as the engine oil is hot.
- Prolonged and repeated contact with used engine oil may cause skin cancer; try to avoid direct skin contact with used oil. If skin contact is made, wash thoroughly with soap or hand cleaner as soon as possible.

1. Warm up engine, and check for oil leakage from engine components.
2. Stop engine and wait for more than five minutes.
3. Remove drain plug and oil filler cap.
4. Drain oil and refill with new engine oil.

Oil Specification and Viscosity:

- API SG or SH and Energy Conserving II
- API Certification Mark
- See "RECOMMENDED FLUIDS AND LUBRICANTS", MA-8.

Refill oil capacity (Approximately):

	Unit: l (US qt, Imp qt)
With oil filter change	3.4 (3-5/8, 3)
Without oil filter change	3.2 (3-3/8, 2-7/8)

CAUTION:

- Be sure to clean drain plug and install with new washer.
 Drain plug:
 ⚙️: 29 - 39 N·m (3.0 - 4.0 kg·m, 22 - 29 ft·lb)
- The refill capacity depends on the oil temperature and drain time; use the "Refill oil capacity" values as a reference and be certain to check oil level with the dipstick when changing the oil.

Changing Engine Oil (Cont'd)

5. Warm up engine and check area around drain plug and oil filter for oil leakage.
6. Stop engine and wait for more than five minutes.
7. Check oil level.

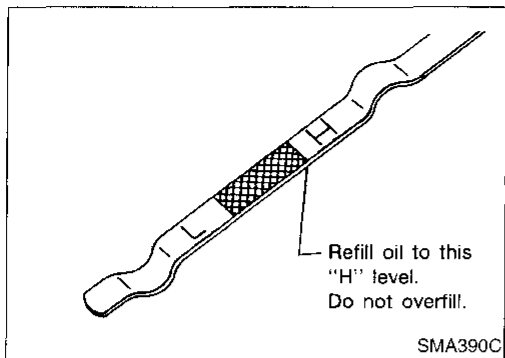

Changing Oil Filter

1. Remove oil filter with Tool.

WARNING:

Be careful not to burn yourself, as the engine and the engine oil are hot.

The filter is a full-flow cartridge type and is provided with a relief valve.

Refer to LC section ("Oil Filter", "ENGINE LUBRICATION SYSTEM").

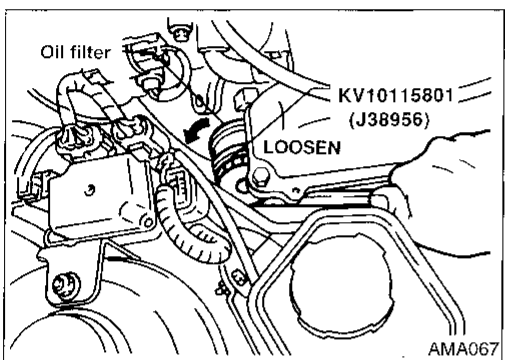

2. Clean oil filter mounting surface on cylinder block. Coat rubber seal of new oil filter with engine oil.

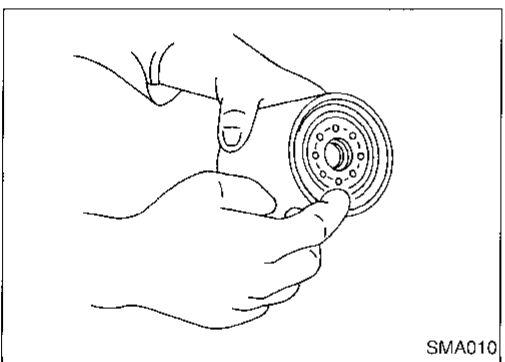

3. Screw in the oil filter until a slight resistance is felt, then tighten additionally more than 2/3 of a turn.
4. Add engine oil.

Refer to "Changing Engine Oil", MA-14.

- Clean excess oil from engine.

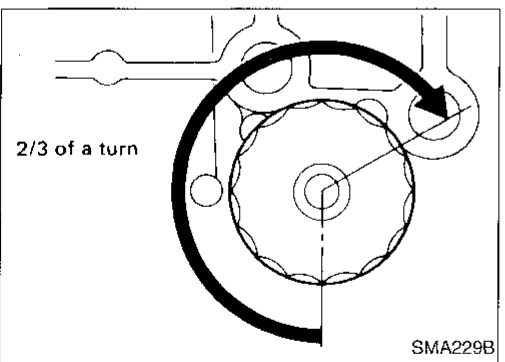

Changing Spark Plugs (Platinum-tipped type)

1. Disconnect ignition wires from spark plugs at boot. Do not pull on the wire.

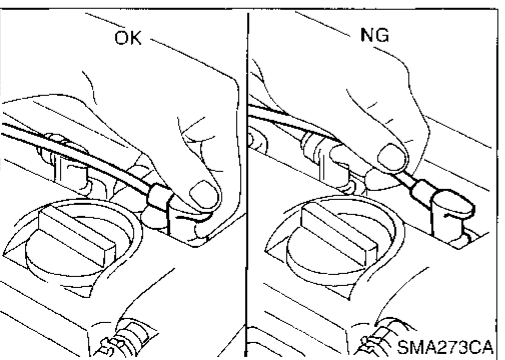

GI

MA

EM

LC

EC

FE

CL

WT

AT

FA

RA

BR

ST

RS

BT

HA

EL

ICX

Changing Spark Plugs (Platinum-tipped type) (Cont'd)

2. Remove spark plugs with spark plug socket.

Spark plug:

Standard type	PFR5B-11
Cold type	PFR6B-11 PFR7B-11

Use standard type spark plug for normal condition.

The hot type spark plug is suitable when fouling occurs with the standard type spark plug under conditions such as:

- frequent engine starts
- low ambient temperatures

The cold type spark plug is suitable when spark knock occurs with the standard type spark plug under conditions such as:

- extended highway driving
- frequent high engine revolution

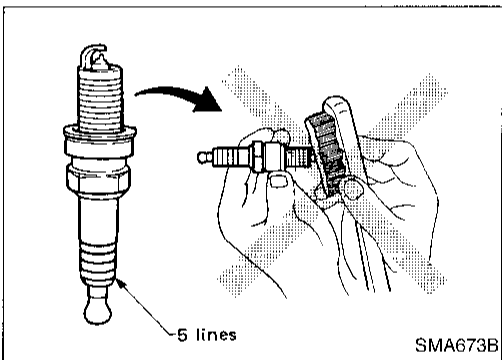
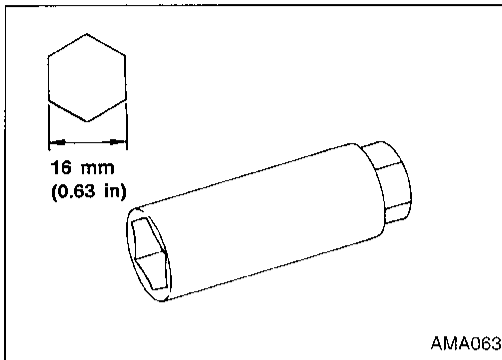

- Do not use a wire brush for cleaning.
- If plug tip is covered with carbon, spark plug cleaner may be used.

Cleaner air pressure:

Less than 588 kPa (6 kg/cm², 85 psi)

Cleaning time:

Less than 20 seconds

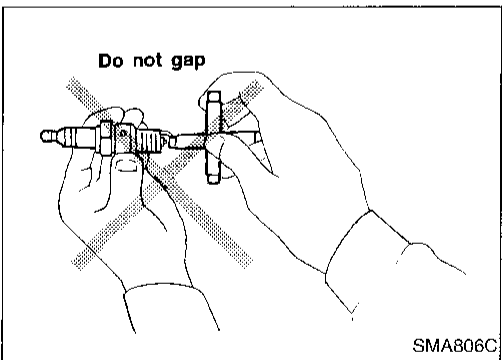

- Checking and adjusting plug gap is not required between change intervals.

3. Install spark plugs. Reconnect ignition wires according to numbers indicated on them.

Spark plug:

: 20 - 29 N·m (2.0 - 3.0 kg·m, 14 - 22 ft·lb)

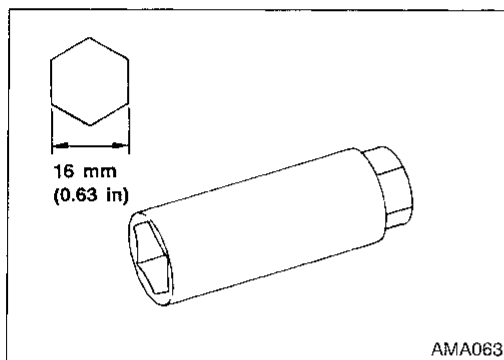
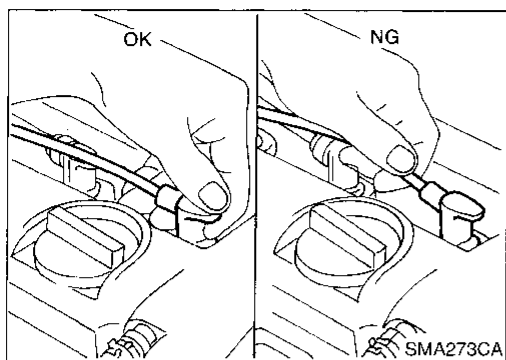

Changing Spark Plugs (Conventional type)

1. Disconnect ignition wires from spark plugs at boot. Do not pull on the wire.

2. Remove spark plugs with spark plug socket.

Spark plug:

Standard type	BKR6E
Hot type	BKR5E
Cold type	BKR7E

Use standard type spark plug for normal condition.

The hot type spark plug is suitable when fouling occurs with the standard type spark plug under conditions such as:

- frequent engine starts
- low ambient temperatures

The cold type spark plug is suitable when spark knock occurs with the standard type spark plug under conditions such as:

- extended highway driving
- frequent high engine revolution

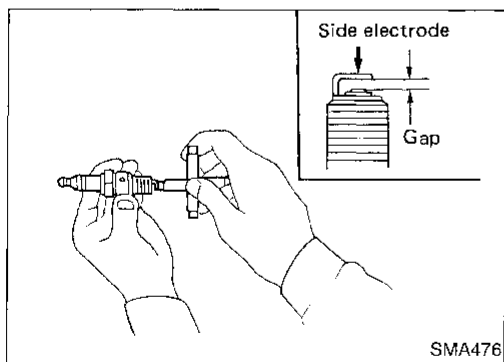

3. Check plug gap of each new spark plug.

Gap: 0.8 - 0.9 mm (0.031 - 0.035 in)

- Use a wire brush for cleaning, if necessary.

4. Install spark plugs. Reconnect ignition wires according to numbers indicated on them.

Spark plug:

Ⓜ: 20 - 29 N·m (2.0 - 3.0 kg·m, 14 - 22 ft·lb)

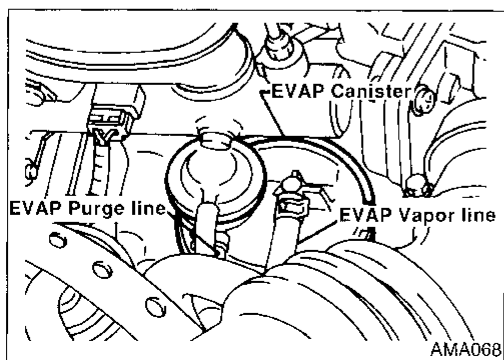

Checking EVAP Vapor Purge Lines

1. Visually inspect EVAP vapor purge lines for improper attachment, cracks, damage, loose connections, chafing and deterioration.
2. Inspect vacuum relief valve of fuel tank filler cap for clogging, sticking, etc.

Refer to EC section ("EVAPORATIVE EMISSION SYSTEM").

Checking Drive Belts

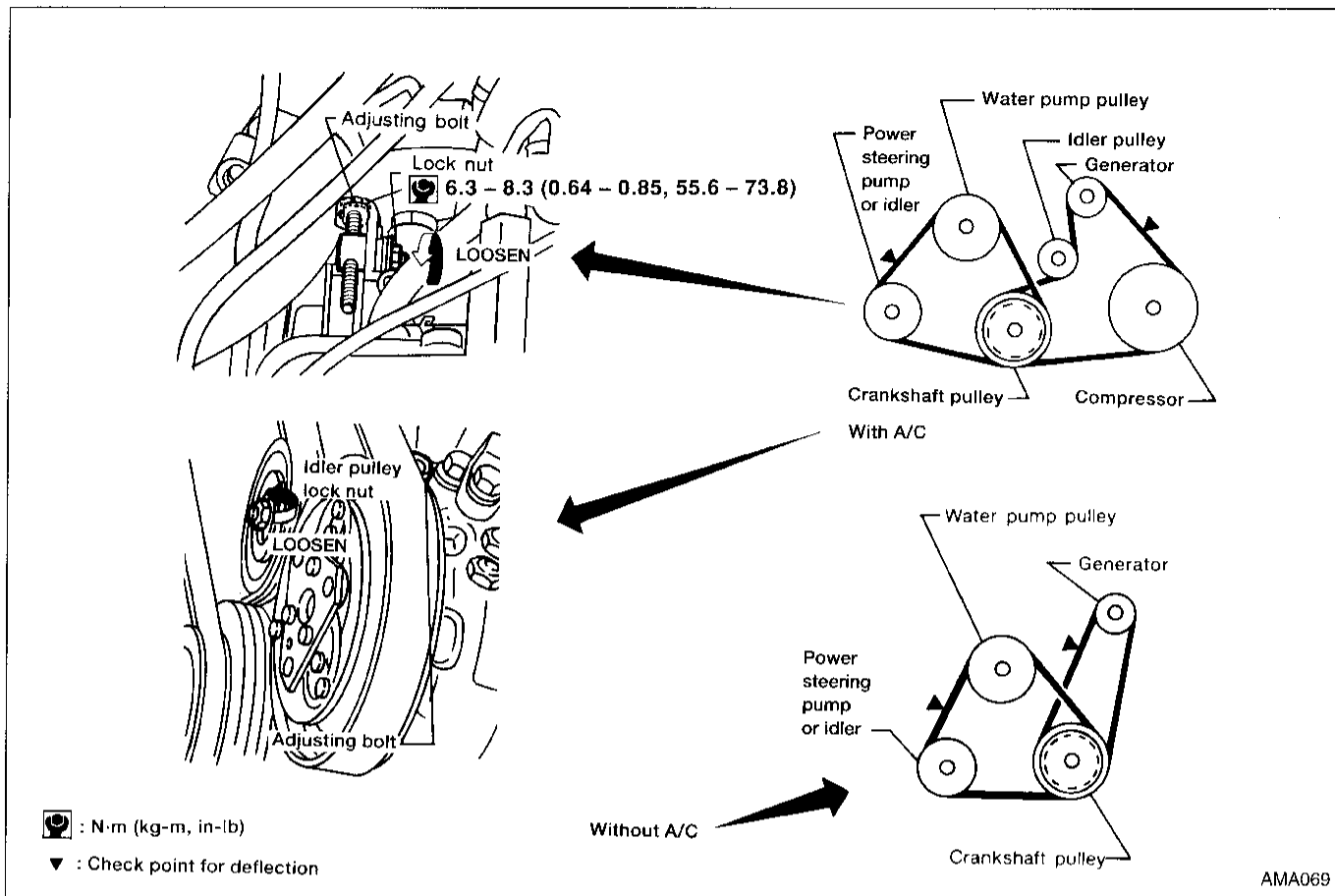

1. Inspect for cracks, fraying, wear or oil. If necessary, replace with a new one.
2. Inspect drive belt deflections by pushing midway between pulleys.

Inspect drive belt deflections when engine is cold.

Adjust if belt deflections exceed the limit.

Belt deflection:

Unit: mm (in)

	Used belt deflection		Deflection of new belt
	Limit	Deflection after adjustment	
Generator			
With A/C compressor	9.5 (0.374)	6 - 6.5 (0.24 - 0.256)	5 - 6 (0.20 - 0.24)
Without A/C compressor	11.5 (0.453)	7.5 - 8 (0.295 - 0.315)	6.5 - 7 (0.256 - 0.28)
Water pump			
With power steering pump	7.5 (0.295)	4 - 6 (0.16 - 0.24)	3 - 5 (0.12 - 0.20)
Without power steering pump	6 (0.24)	3 - 4.5 (0.12 - 0.177)	3 - 4 (0.12 - 0.16)
Applied pushing force	98 N (10 kg, 22 lb)		

Changing Engine Coolant

WARNING:

To avoid being scalded, never change the coolant when the engine is hot.

-DRAINING ENGINE COOLANT-

1. Move heater temperature control lever all the way to WARM.
 - Make sure blower fan switch is OFF.
2. Open radiator drain plug at the bottom of radiator and remove radiator filler cap.
3. Remove reservoir tank, drain coolant, then clean reservoir tank. Install it temporarily.
 - Be careful not to allow coolant to contact drive belts.

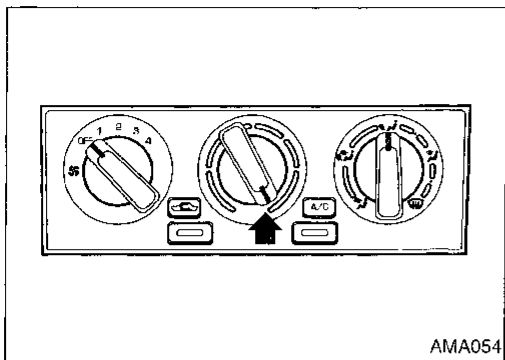

AMA054

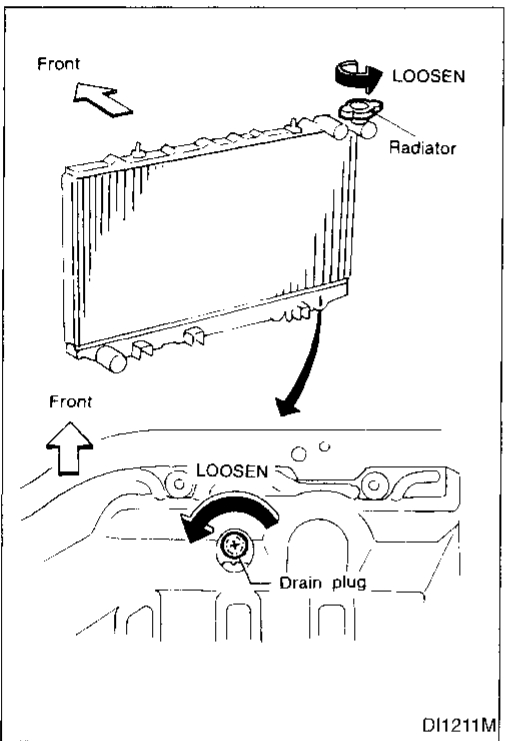

DI1211M

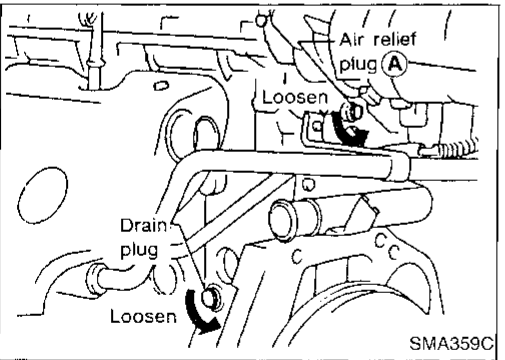

SMA359C

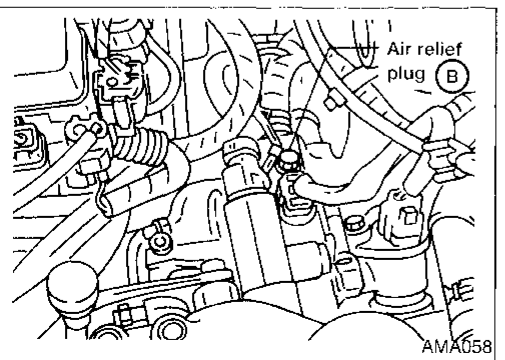

AMA058

4. Remove cylinder block drain plug and air relief plugs (A) and (B).
5. Close radiator drain plug.

-FLUSHING COOLING SYSTEM-

6. Fill radiator with water until coolant spills from cylinder block drain plug hole during refill, then reinstall drain plug securely.
7. Fill radiator with water again until coolant spills from the air relief hole during refill, then reinstall air relief plugs (A) and (B). Then fill radiator and reservoir tank with water.

Air relief plug:

: 7 - 8 N·m (0.7 - 0.8 kg·m, 61 - 69 in·lb)

8. Reinstall radiator filler cap.
9. Warm up engine until cooling fan operates, then rev engine 2 or 3 times under no-load.
10. Stop engine and wait until it cools down.
11. Repeat steps 2 through 10 until clear water begins to drain from radiator.
12. Drain water.

GI

MA

EM

LC

EC

FE

CL

MT

AT

EA

BA

BR

ST

FS

BT

HA

EL

IDX

Changing Engine Coolant (Cont'd)

- Apply sealant to the thread of drain plug on cylinder block.
 - \square : 34.3 - 44.1 N·m
(3.50 - 4.50 kg·m, 25.30 - 32.53 ft·lb)
13. Reinstall reservoir tank.

-REFILLING ENGINE COOLANT-

14. Fill radiator with coolant at the speed of less than 2ℓ (2-1/8 US qt, 1-3/4 Imp qt)/min.
- If coolant spills from air relief hole, install the air relief plug and then add coolant again.
 - After filling radiator, fill reservoir tank to MAX level line.
15. Install radiator filler cap and air relief plug. Then, start engine and warm up to thermostat opening temperature.
- If coolant level becomes low, refill reservoir tank until coolant level does not change.
16. Run engine at 2,500 rpm for 10 seconds and return to idle speed.
- Repeat 2 or 3 times.

Watch coolant temperature gauge so as not to overheat the engine.

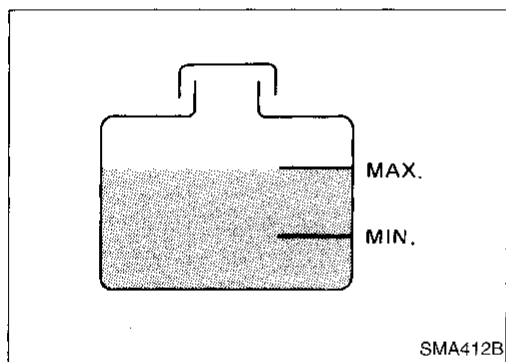
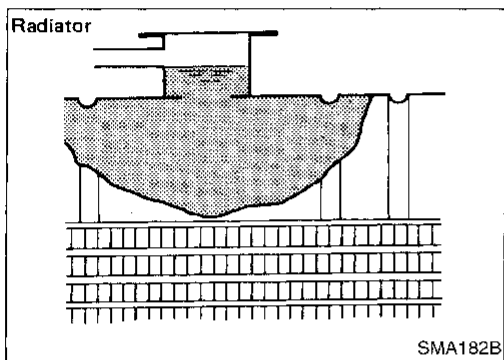

17. Stop engine and cool it down.
- Cool down using a fan to reduce the time.
18. Remove radiator filler cap and check coolant level.
- If coolant level becomes low, repeat step 14 through step 17 until coolant level does not change.
19. Refill reservoir tank to MAX level line.
20. Warm up engine, and check for sound of coolant flow while running engine from idle up to 3,000 rpm with heater temperature control lever set at several positions between COOL and WARM.
- Sound may be noticeable at heater water cock.

For models without air bleeder on heater inlet hose

21. If the sound is heard, repeat step 15 through step 16 until coolant level does not change.

For models with air bleeder on heater inlet hose

21. If the sound is heard, bleed air from cooling system according to the following steps.

- 1) Stop engine and cool it down. Then, remove air bleeder cap on heater inlet hose.

- 2) Attach a suitable transparent hose at air bleeder pipe and put the opposite end of the hose into coolant of reservoir tank.

- Check that coolant level of reservoir tank is not beyond MAX level line.

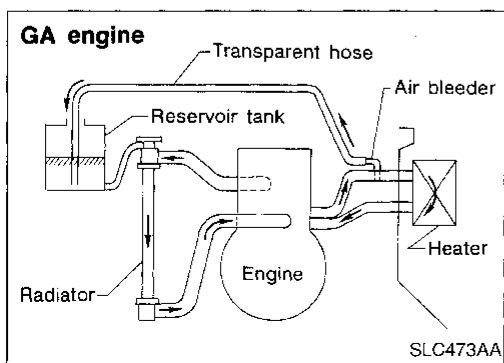

Changing Engine Coolant (Cont'd)

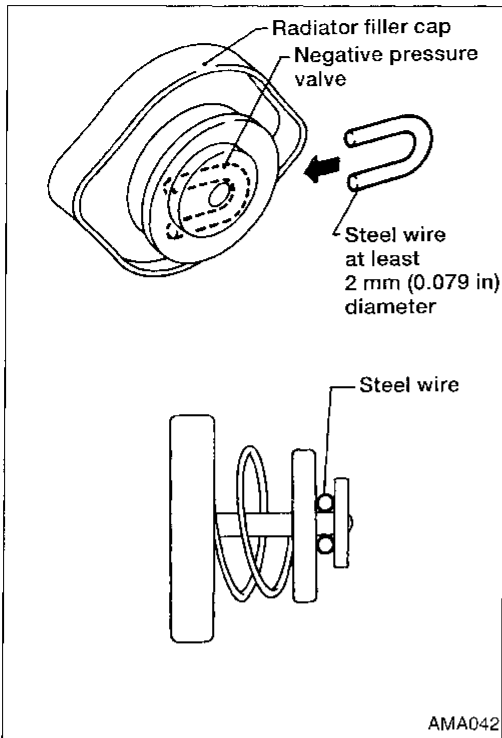

- 3) Install a wire under radiator filler cap negative pressure valve to allow air and coolant in cooling system to be directed into reservoir tank regardless of pressure.
 - Install a suitable steel wire between negative pressure valve and its seat as shown in the picture.
- 4) Start engine and check for bubbles in reservoir tank.
- 5) Set heater temperature control lever to max COOL position in order to bypass coolant through the transparent hose.
- 6) Run engine at 2,300 rpm until bubbles disappear in the transparent hose.

Do not run engine over 2,300 rpm because engine may be damaged due to reduced coolant flow.

- 7) After removing bubbles, set heater temperature control lever to max WARM position and check for sound of coolant flow.
- 8) If sound is heard, repeat step 5 through step 6.
22. Stop engine and cool it down.

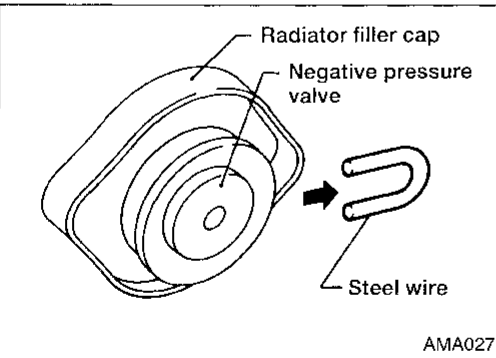

23. Remove wire, reinstall radiator cap.
 - Remove the steel wire from between the negative pressure valve and its seat as shown in the figure.
24. Remove the transparent hose and install air bleeder cap.
25. Check any removed parts for secure reinstallation.

Checking Fuel Lines

Inspect fuel lines and tank for improper attachment, leaks, cracks, damage, chafing and deterioration. If necessary, repair or replace.

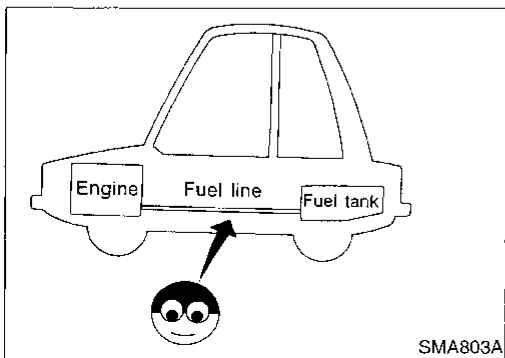

GI
MA
EM
LC
EC
FE
CL
MT
AT
FA
RA
BR
ST
RS
BT
HA
EL
DX

Checking Fuel Lines (Cont'd)

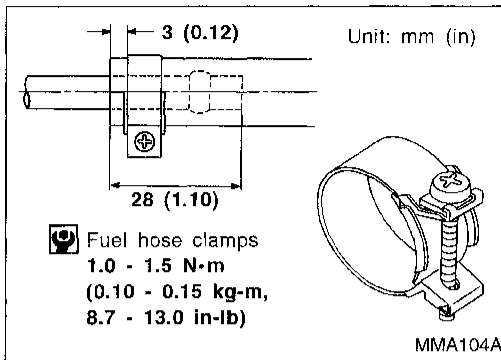

CAUTION:

Tighten high-pressure rubber hose clamp so that clamp end is 3 mm (0.12 in) from hose end.

Tightening torque specifications are the same for all rubber hose clamps.

Ensure that screw does not contact adjacent parts.

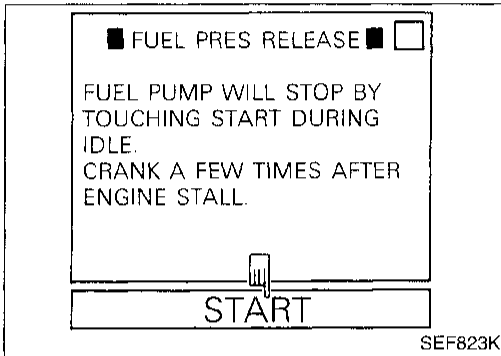

Changing Fuel Filter

WARNING:

Before removing fuel filter, release fuel pressure from fuel line.

1. Release fuel pressure using the following procedure.

- a. Turn ignition switch ON.
 - b. Perform FUEL PRESSURE RELEASE in WORK SUPPORT mode and release fuel pressure to zero.
 - c. Start engine.
 - d. After engine stalls, crank engine two or three times to make sure that fuel pressure is released.
 - e. Turn ignition switch OFF.
- a. Remove fuse for fuel pump.
 - b. Start engine.
 - c. After engine stalls, crank engine two or three times to make sure that fuel pressure is released.
 - d. Turn ignition switch OFF and install fuse for fuel pump.

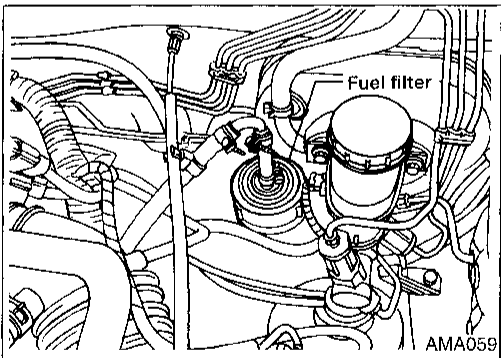
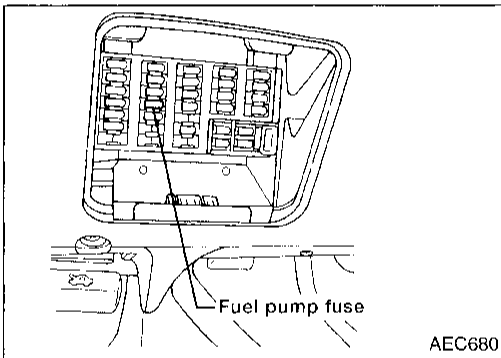

WARNING:

Use rubber gloves to prevent fuel from contacting skin when removing fuel hoses and filter.

2. Loosen fuel hose clamps.
 3. Replace fuel filter.
- Be careful not to spill fuel over engine compartment. Place a shop towel to absorb fuel.
 - Use a high-pressure type fuel filter. Do not use a synthetic resinous fuel filter.
 - When tightening fuel hose clamps, refer to "Checking Fuel Lines", MA-21.

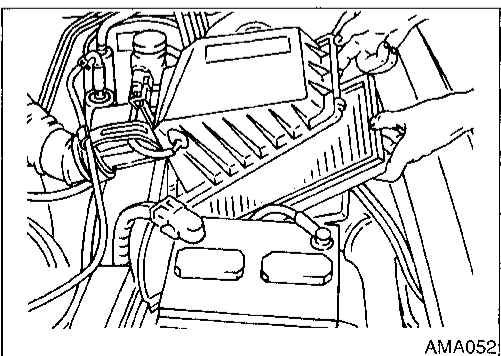

Changing Air Cleaner Filter

Unfasten clamps to change air cleaner filter.

The viscous paper type filter does not need cleaning between replacement intervals.

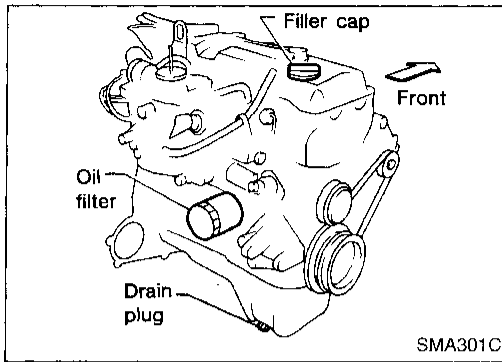

Changing Engine Oil

WARNING:

- Be careful not to burn yourself, as the engine oil is hot.
- Prolonged and repeated contact with used engine oil may cause skin cancer; try to avoid direct skin contact with used oil. If skin contact is made, wash thoroughly with soap or hand cleaner as soon as possible.

1. Warm up engine, and check for oil leakage from engine components.
2. Stop engine and wait for more than five minutes.
3. Remove drain plug and oil filler cap.
4. Drain oil and refill with new engine oil.

Oil specification and viscosity:

- API SG or SH and Energy Conserving II
- API Certification Mark
- See "RECOMMENDED FLUIDS AND LUBRICANTS", MA-8.

Refill oil capacity (Approximately):

	Unit: l (US qt, Imp qt)
With oil filter change	3.2 (3-3/8, 2-7/8)
Without oil filter change	2.8 (3, 2-1/2)

CAUTION:

- Be sure to clean drain plug and install with new washer.
Drain plug:
 □: 29 - 39 N·m
 (3.0 - 4.0 kg-m, 22 - 29 ft-lb)
- The refill capacity depends on the oil temperature and drain time. Use the "Refill oil capacity" values as a reference and be certain to check with the dipstick when changing the oil.

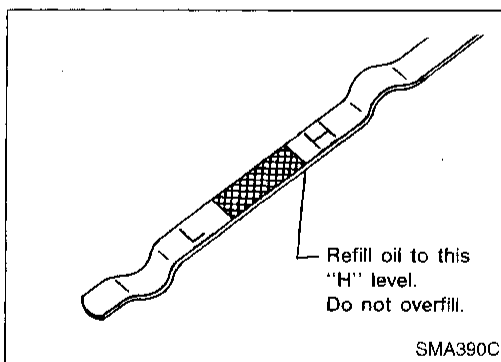

5. Warm up engine and check area around drain plug and oil filter for oil leakage.
6. Stop engine and wait for more than five minutes.
7. Check oil level.

Changing Oil Filter

1. Remove oil filter with Tool.

WARNING:

Be careful not to burn yourself, as the engine and the engine oil are hot.

Changing Oil Filter (Cont'd)

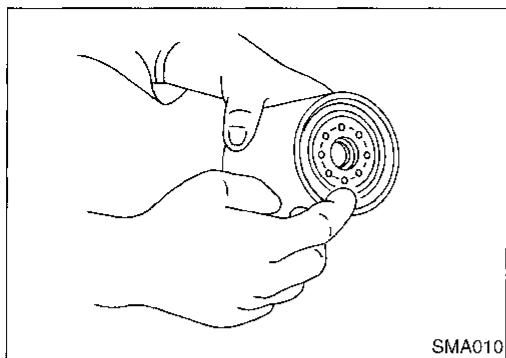

2. Clean oil filter mounting surface on cylinder block. Coat the rubber seal of new oil filter with engine oil.

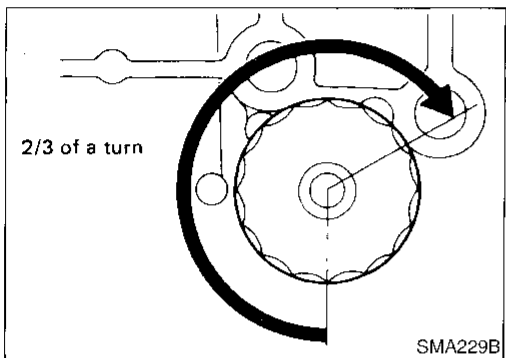

3. Screw in the oil filter until a slight resistance is felt, then tighten additionally more than 2/3 of a turn.
4. Add engine oil.

Refer to "Changing Engine Oil", MA-23.

- Clean excess oil from engine.

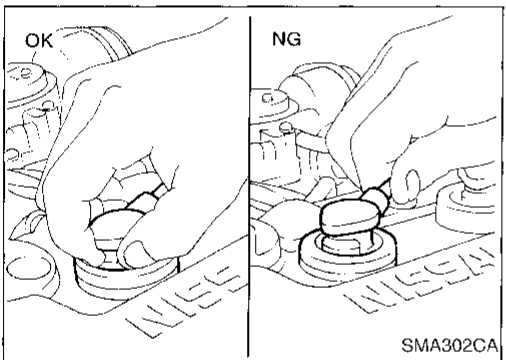

Changing Spark Plugs

1. Disconnect ignition wires from spark plugs at boot. Do not pull on the wire.

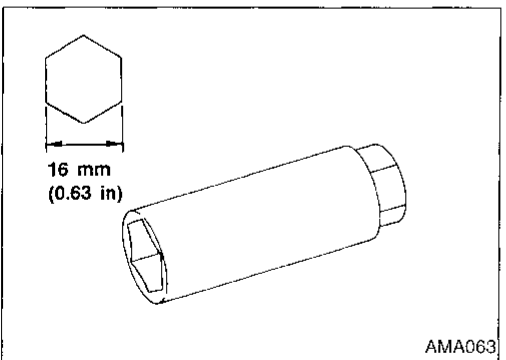

2. Remove spark plugs with spark plug socket.

Spark plug:

Standard type	BKR5E-11
Hot type	BKR4E-11
Cold type	BKR6E-11
	BKR7E-11

Use standard type spark plug for normal condition.

The hot type spark plug is suitable when fouling occurs with the standard type spark plug under conditions such as:

- frequent engine starts
- low ambient temperatures

The cold type spark plug is suitable when spark knock occurs with the standard type spark plug under conditions such as:

- extended highway driving
- frequent high engine revolution

Changing Spark Plugs (Cont'd)

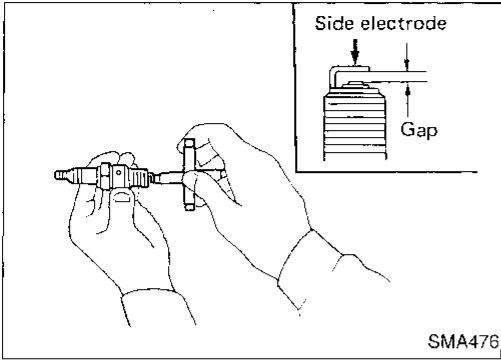

3. Check gap of each new spark plug.
 Gap: 1.0 - 1.1 mm (0.039 - 0.043 in)
 - Use a wire brush for cleaning, if necessary.
4. Install spark plugs. Reconnect ignition wires according to numbers indicated on them.

Spark plug:
 ⚙️: 20 - 29 N·m
 (2.0 - 3.0 kg-m, 14 - 22 ft-lb)

GI

MA

EM

LC

Checking EVAP Vapor Purge Lines

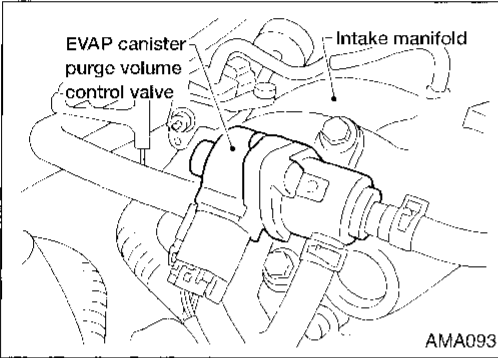

1. Visually inspect EVAP vapor purge lines for improper attachment, cracks, damage, chafing and deterioration.
2. Inspect vacuum relief valve of fuel tank filler cap for clogging, sticking, etc.

Refer to EC section ("Inspection", EVAPORATIVE EMISSION SYSTEM").

EC

FE

CL

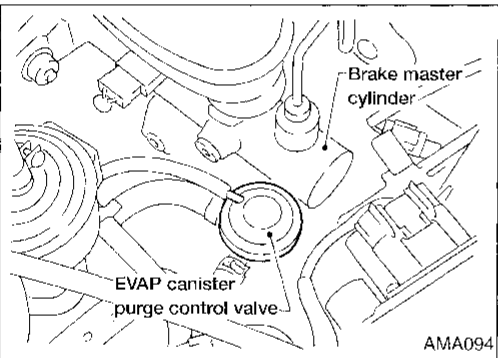

MT

AT

FA

RA

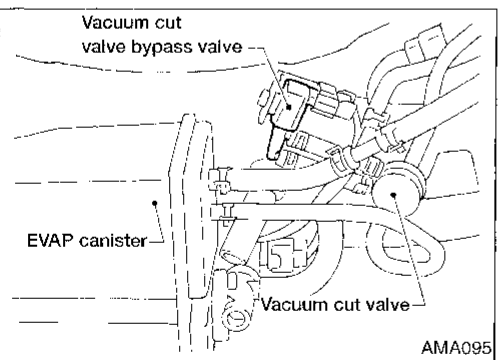

BR

ST

RS

BT

HA

HL

IDX

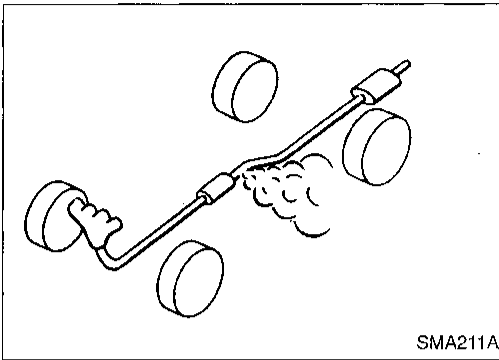

Checking Exhaust System

Check exhaust pipes, muffler and mounting for improper attachment, leaks, cracks, damage, chafing and deterioration.

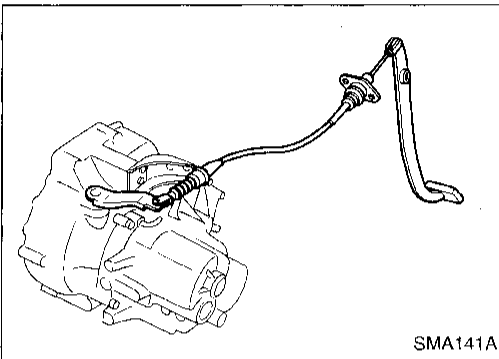

Checking Clutch System

Check cable and lever for improper attachment, chafing, wear and deterioration.

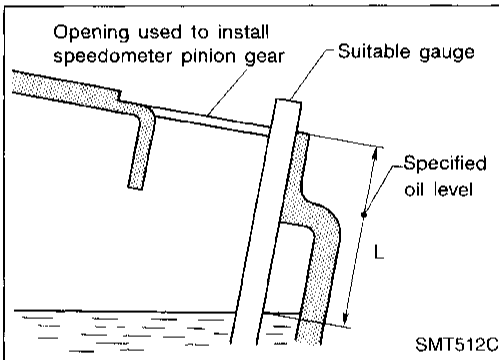

Checking M/T Oil

- Check that oil is not leaking from transaxle or around it.
- Remove speedometer pinion and check that the oil level L at vehicle rear side is within specification.

Oil level "L":

RS5F31A (GA engine model)

57 - 66 mm (2.24 - 2.60 in)

RS5F32V (SR engine model)

34 - 40 mm (1.34 - 1.57 in)

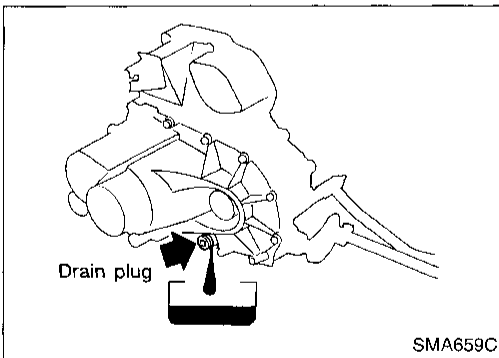

Changing M/T Oil

1. Drain oil from drain plug and refill with new gear oil.
2. Check oil level. Refer to "Checking M/T Oil".

Oil grade: API GL-4

Viscosity: Refer to MA-8.

Capacity:

RS5F31A (GA engine model)

2.9 - 3.2 liters (6-1/8 - 6-3/4 US pt, 5-1/8 - 5-5/8 Imp pt)

RS5F32V (SR engine model)

3.7 - 3.9 liters (7-7/8 - 8-1/4 US pt, 6-1/2 - 6-7/8 Imp pt)

Drain plug:

⌘: 25 - 34 N·m (2.5 - 3.5 kg·m, 18 - 25 ft·lb)

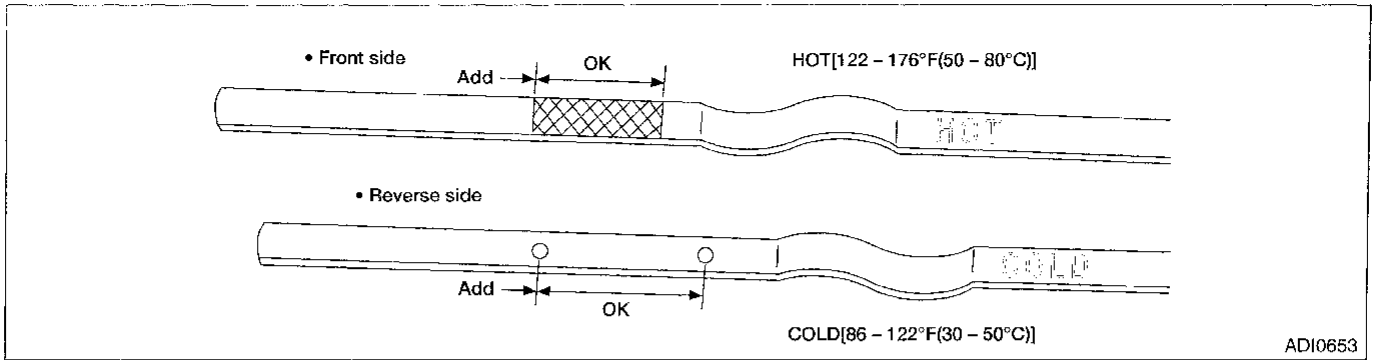

Checking A/T Fluid

1. Warm up engine.
2. Check for fluid leakage.
3. Before driving, fluid level can be checked at fluid temperatures of 30 to 50°C (86 to 122°F) using COLD range on dipstick.
 - a. Park vehicle on level surface and set parking brake.
 - b. Start engine and move selector lever through each gear position. Leave selector lever in "P" position.
 - c. Check fluid level with engine idling.
 - d. Remove dipstick and wipe clean with lint-free paper.
 - e. Reinsert dipstick into charging pipe as far as it will go.
 - f. Remove dipstick and note reading. If reading is at low side of range, add fluid to the charging pipe.
4. Drive vehicle for approximately 5 minutes in urban areas.
5. Recheck fluid level at fluid temperatures of 50 to 80°C (122 to 176°F) using HOT range on dipstick.

Do not overfill.

6. Check fluid condition.
 - If fluid is very dark or smells burned, refer to A/T section for checking operation of A/T. Flush engine cooling system after repair of A/T.
 - If A/T fluid contains frictional material (clutches, bands, etc.), replace radiator and flush cooler line using cleaning solvent and compressed air after repair of A/T. Refer to LC section ("Radiator", "ENGINE COOLING SYSTEM").

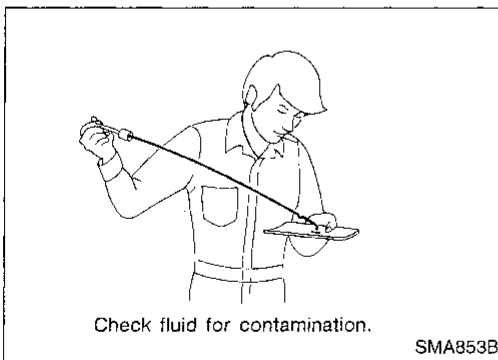

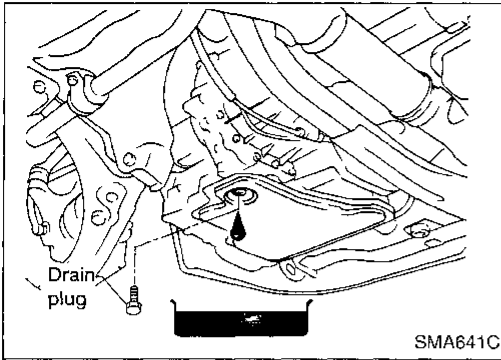

Changing A/T Fluid

1. Warm up A/T fluid.
2. Stop engine.
3. Drain A/T fluid from drain plug and refill with new A/T fluid. Measure amount of fluid drained and refill with equal amount of new fluid.

Fluid grade:

**Nissan Matic "D" (Continental U.S. and Alaska)
or Genuine Nissan Automatic Transmission
Fluid (Canada)**

**Refer to "RECOMMENDED FLUIDS AND
LUBRICANTS", MA-8.**

**Fluid capacity (With torque converter):
7.0 liters (7-3/8 US qt, 6-1/8 Imp qt)**

Drain plug:

⊗: 29 - 39 N·m (3.0 - 4.0 kg·m, 22 - 29 ft·lb)

4. Run engine at idle speed for five minutes.
5. Check fluid level and condition. Refer to "Checking A/T Fluid".
If fluid is still dirty, repeat steps 2. through 5.

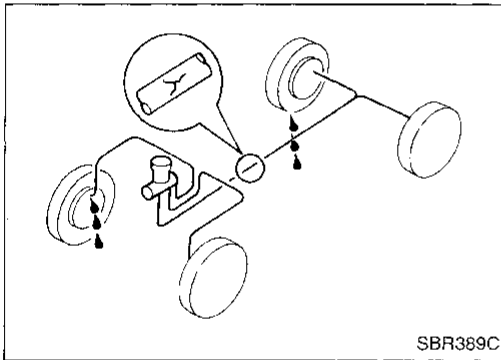

Checking Brake Fluid Level and Leaks

If fluid level is extremely low, check brake system for leaks.

Checking Brake Lines and Cables

Check brake fluid lines and parking brake cables for improper attachment, leaks, chafing, abrasions and deterioration.

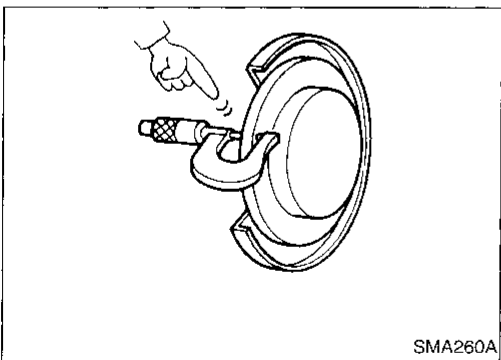

Checking Disc Brake

ROTOR

Check condition and thickness.

Thickness:

Unit: mm (in)

	CL22VD, CL22VE	CL7HB
Standard	18 (0.71)	7 (0.28)
Minimum	16.0 (0.630)	6.0 (0.236)

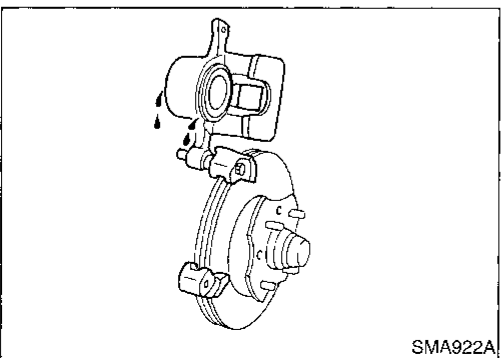

CALIPER

Check operation and for leakage.

CHASSIS AND BODY MAINTENANCE

Checking Disc Brake (Cont'd)

PAD

Measure wear and check for damage.

Thickness:

Unit: mm (in)

	CL22VD, CL22VE	CL7HB
Standard	11 (0.43)	10 (0.39)
Minimum	2.0 (0.079)	1.5 (0.059)

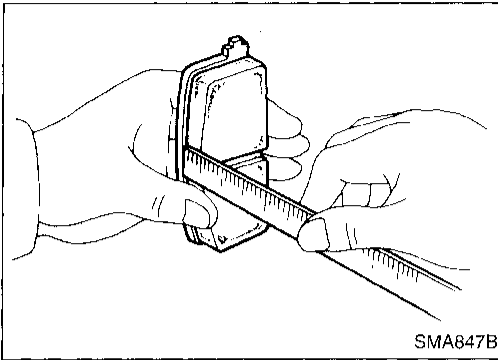

Checking Drum Brake

WHEEL CYLINDER

Check operation and for leakage.

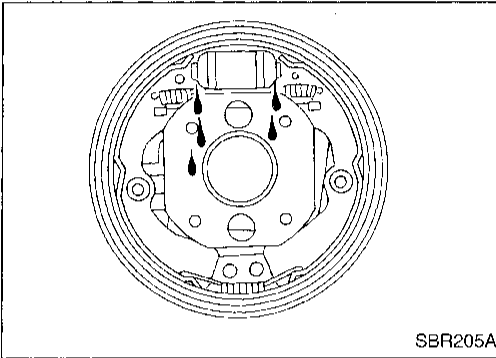

DRUM

Check condition of inner surface.

Standard diameter:

180 mm (7.09 in)

Drum repair limit (Inner diameter):

181 mm (7.13 in)

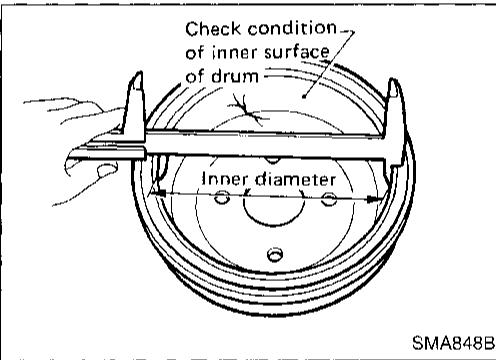

LINING

Measure wear and check for damage.

Standard thickness:

4 mm (0.16 in)

Lining wear limit (Minimum thickness):

1.5 mm (0.059 in)

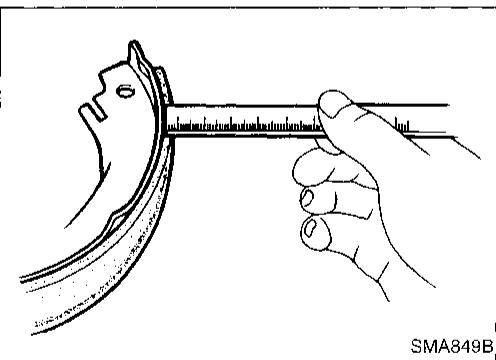

TEMPORARY METHOD FOR CHECKING LINING WEAR

Remove inspection hole plug and check for lining wear.

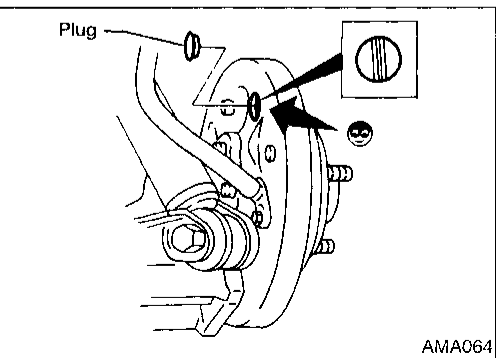

GI

MA

EM

LC

EC

FE

CL

MT

AT

FA

RA

BR

ST

RS

BT

HA

EL

IDX

Balancing Wheels

Adjust wheel balance using road wheel center.

Wheel balance (Maximum allowable unbalance):
Refer to SDS, MA-32.

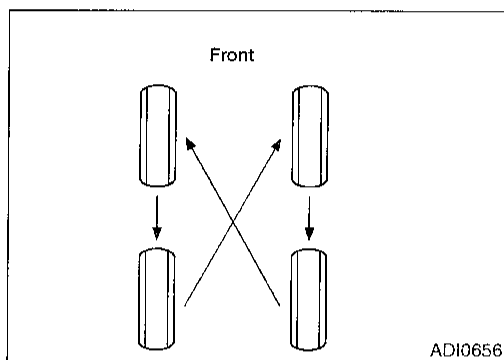

Tire Rotation

Do not include the T-type spare tire when rotating the tires.

Wheel nuts:

: 98 - 118 N·m (10.0 - 12.0 kg-m, 72 - 87 ft-lb)

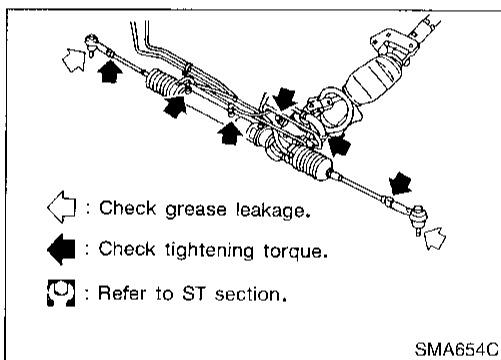

Checking Steering Gear and Linkage

STEERING GEAR

- Check gear housing and boots for looseness, damage and grease leakage.
- Check connection with steering column for looseness.

STEERING LINKAGE

Check ball joint, dust cover and other component parts for looseness, wear, damage and grease leakage.

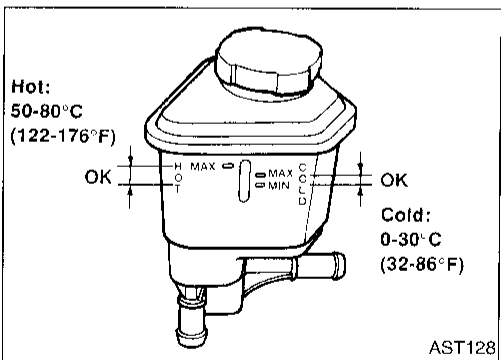

Checking Power Steering Fluid and Lines

Check fluid level with engine off. Check fluid level in reservoir. Use HOT range at fluid temperatures of 50 to 80°C (122 to 176°F). Use COLD range at fluid temperatures of 0 to 30°C (32 to 86°F).

CAUTION:

- Do not overfill.
- Recommended fluid is type DEXRONTMIIE, DEXRONTMIII or equivalent.
- Check lines for improper attachment, leaks, cracks, damage, loose connections, chafing and deterioration.
- Check rack boots for accumulation of power steering fluid.

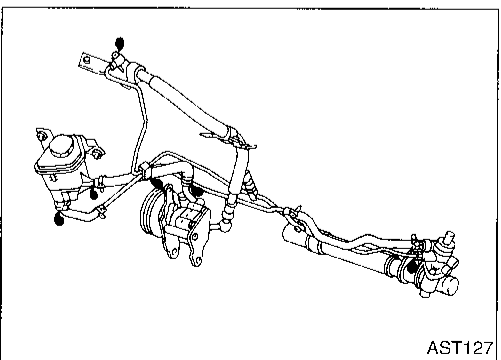

Lubricating Locks, Hinges and Hood Latches

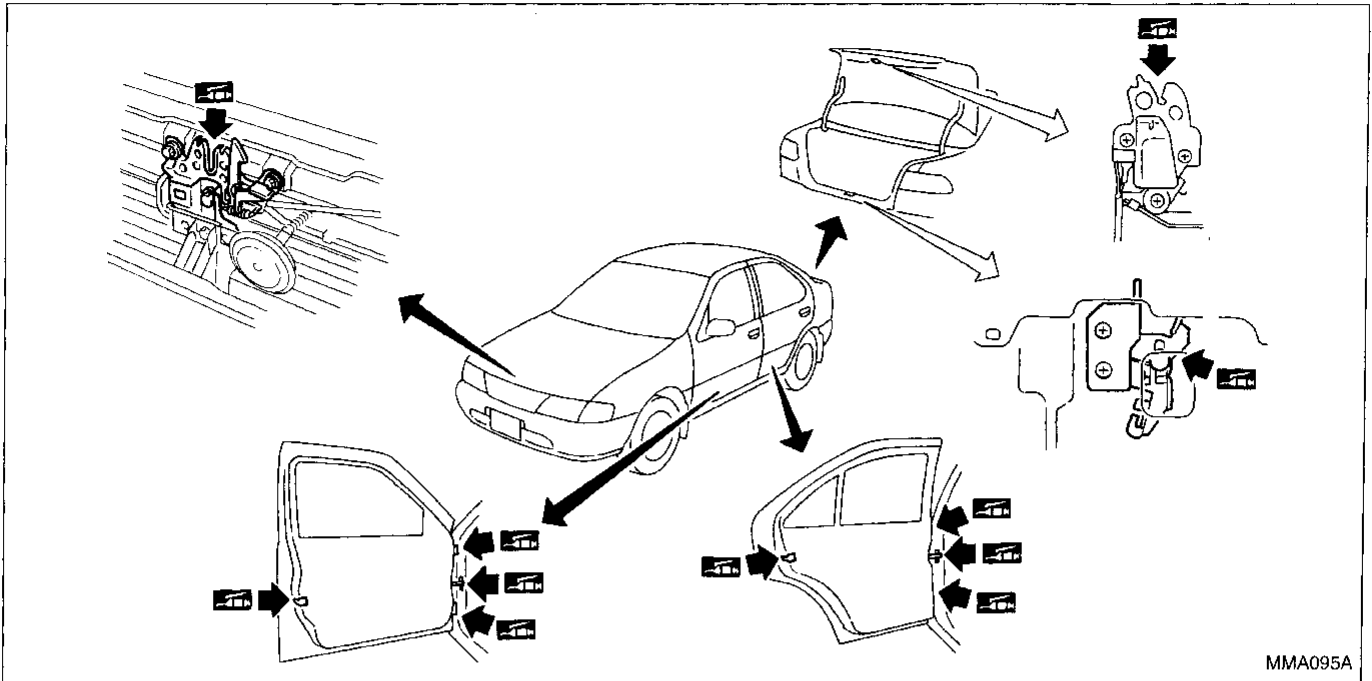

Checking Seat Belts, Buckles, Retractors, Anchors and Adjusters

CAUTION:

- After any collision, inspect all seat belt assemblies, including retractors and other attached hardware (i.e. guide rail set). Nissan recommends to replace all seat belt assemblies in use during a collision, unless not damaged and properly operating after minor collision. Also inspect seat belt assemblies not in use during a collision, and replace if damaged or improperly operating.
- If any component of seat belt assembly is questionable, do not repair. Replace as seat belt assembly.
- If webbing is cut, frayed, or damaged, replace belt assembly.
- Do not spill drinks, oil etc. on inner lap belt buckle. Never oil tongue and buckle.
- Use a NISSAN genuine seat belt assembly.

 Anchor bolt
43 - 55 N·m
(4.4 - 5.6 kg-m,
32 - 41 ft-lb)

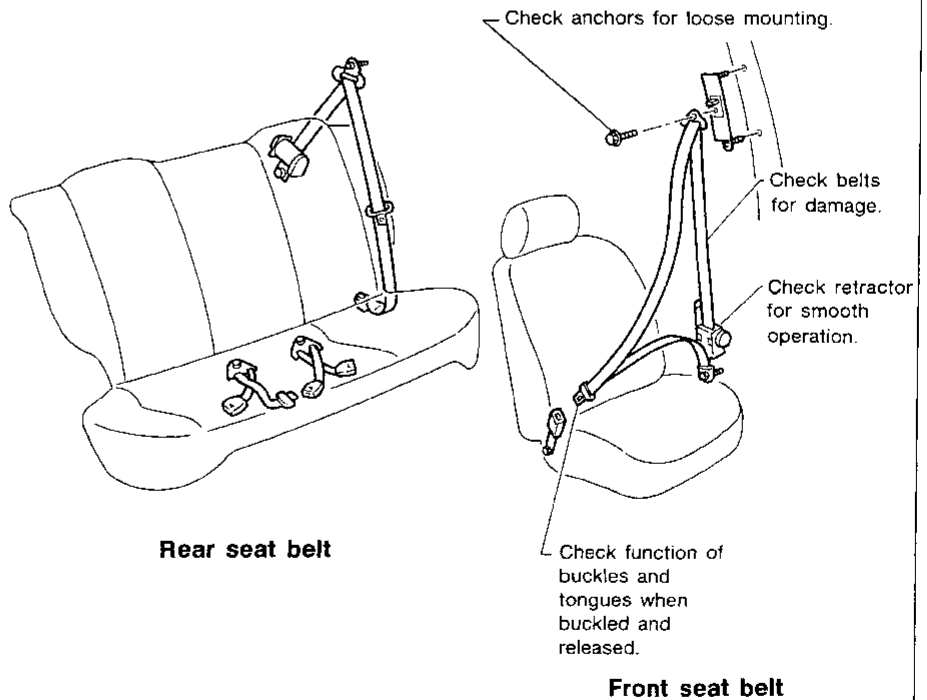

MMA096AA

SERVICE DATA AND SPECIFICATIONS (SDS)

Engine Maintenance (SR)

INSPECTION AND ADJUSTMENT

Drive belt deflection

Unit: mm (in)

	Used belt deflection		Deflection of new belt
	Limit	Deflection after adjustment	
Generator			
With air conditioner compressor	11.5 - 12.5 (0.453 - 0.492)	7 - 8 (0.28 - 0.31)	6.5 - 7.5 (0.256 - 0.295)
Without air conditioner compressor	12 - 13 (0.47 - 0.51)	8 - 9 (0.31 - 0.35)	7 - 8 (0.28 - 0.31)
Power steering pump	6 - 7 (0.24 - 0.28)	4 - 5 (0.16 - 0.20)	3.5 - 4.5 (0.138 - 0.177)
Applied pushing force	98 N (10 kg, 22 lb)		

Spark plug

		Platinum-tipped type	Conventional type
Type			
Standard		PFR5B-11	BKR6E
Hot		—	BKR5E
Cold		PFR6B-11 PFR7B-11	BKR7E
Plug gap	mm (in)	—	0.8 - 0.9 (0.031 - 0.035)

Engine Maintenance (GA)

INSPECTION AND ADJUSTMENT

Drive belt deflection

Unit: mm (in)

	Used belt deflection		Deflection of new belt
	Limit	Deflection after adjustment	
Generator			
With A/C compressor	9.5 (0.374)	6 - 6.5 (0.24 - 0.256)	5 - 6 (0.20 - 0.24)
Without A/C compressor	11.5 (0.453)	7.5 - 8 (0.295 - 0.315)	6.5 - 7 (0.256 - 0.28)
Water pump			
With power steering pump	7.5 (0.295)	4 - 6 (0.16 - 0.24)	3 - 5 (0.12 - 0.20)
Without power steering pump	6 (0.24)	3 - 4.5 (0.12 - 0.177)	3 - 4 (0.12 - 0.16)
Applied pushing force	98 N (10 kg, 22 lb)		

Spark plug

Type		
Standard		BKR5E-11
Hot		BKR4E-11
Cold		BKR6E-11 BKR7E-11
Plug gap	mm (in)	1.0 - 1.1 (0.039 - 0.043)

Chassis and Body Maintenance

INSPECTION AND ADJUSTMENT

Wheel balance

Maximum allowable unbalance	Dynamic (at rim flange) g (oz)	10 (0.35) (One side)
	Static g (oz)	20 (0.71)