

# ACCELERATOR CONTROL, FUEL & EXHAUST SYSTEMS

## SECTION FE

GI  
MA  
EM  
LC  
EC  
**FE**  
CL  
MT  
AT  
FA  
RA  
BR  
ST  
RS  
BT  
HA  
EL  
IDX

## CONTENTS

<b>ACCELERATOR CONTROL SYSTEM</b> .....	2	Fuel Pump and Gauge .....	5
Accelerator Control System .....	2	Removal.....	5
Adjusting Accelerator Wire.....	2	Installation.....	5
<b>FUEL SYSTEM</b> .....	3	<b>EXHAUST SYSTEM</b> .....	6
Fuel Tank .....	3		

# ACCELERATOR CONTROL SYSTEM

## Accelerator Control System

### CAUTION:

- When removing accelerator wire, mark lock nut's initial position.
- Check that throttle valve opens fully when accelerator pedal is fully depressed. Check that throttle valve returns to idle position when accelerator pedal is released.
- Check accelerator control parts for improper contact with any adjacent parts.
- When connecting accelerator wire, do not twist or scratch inner wire.
- For adjustment of A/T throttle wire, refer to AT section ("Throttle Wire Adjustment", "ON-VEHICLE SERVICE").

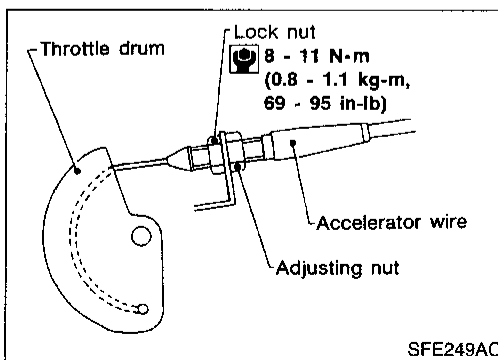
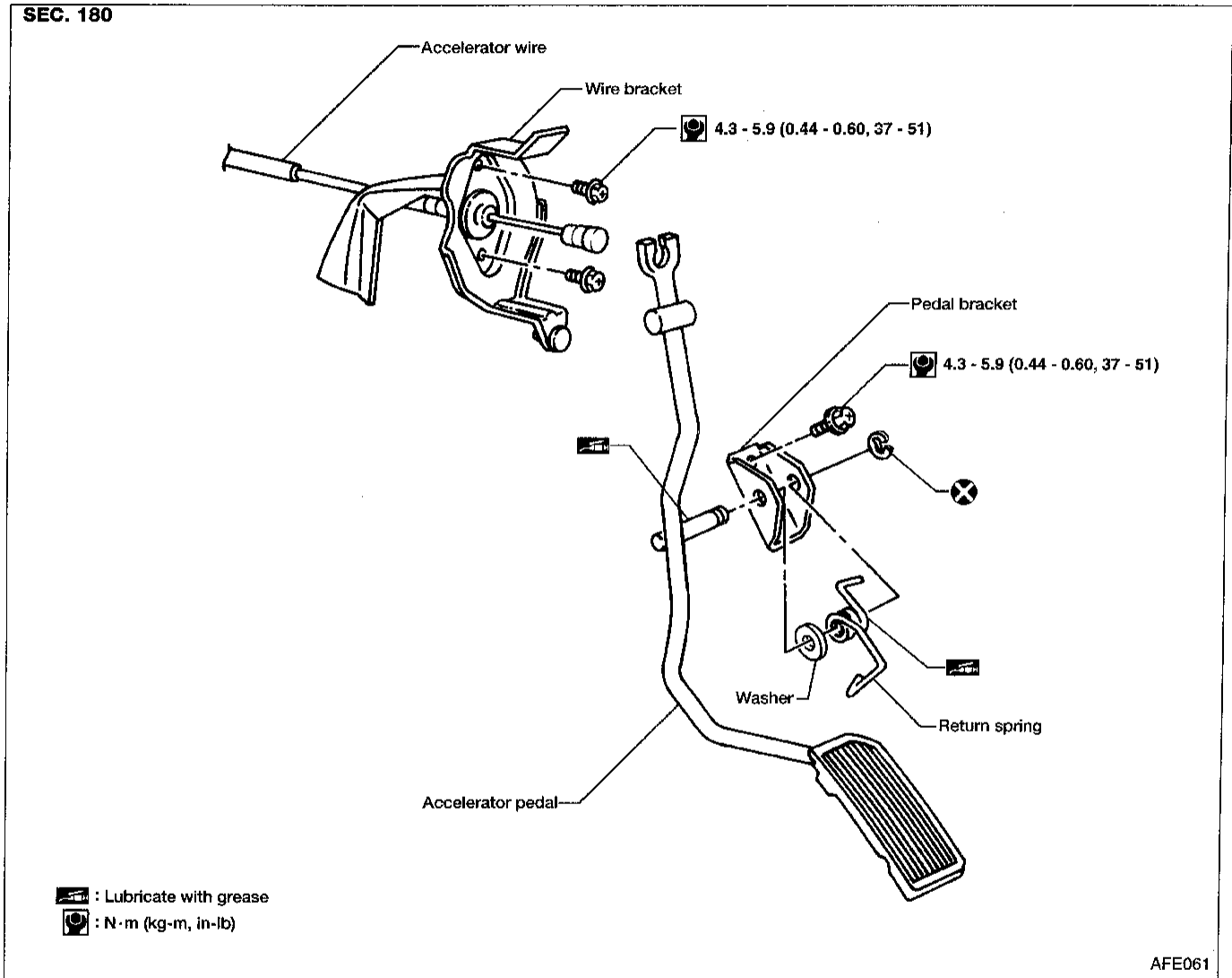

### Adjusting Accelerator Wire

#### CAUTION:

- Make sure the ASCD wire is not pulling the throttle drum.
  - For ASCD wire adjustment, refer to EL section ["AUTOMATIC SPEED CONTROL DEVICE (ASCD)"].
1. Loosen lock nut, then tighten adjusting nut until throttle drum starts to move.
  2. From that position, turn back adjusting nut 1.5 to 2 turns, then tighten lock nut.

## Fuel Tank

### WARNING:

When replacing fuel line parts, be sure to observe the following:

- Put a “CAUTION: FLAMMABLE” sign in workshop.
- Do not smoke while servicing fuel system. Keep open flames and sparks away from work area.
- Be sure to furnish workshop with a CO<sub>2</sub> fire extinguisher.

### CAUTION:

- Before removing fuel line parts, carry out the following procedures:
  - a. Put drained fuel in an explosion-proof container and put the lid on securely.
  - b. Release fuel pressure. Refer to EC section (“Fuel Pressure Release”, “BASIC SERVICE PROCEDURE”).
  - c. Disconnect battery ground cable.
- When installing fuel check valve, be careful of its designated direction. Refer to EC section (“EVAPORATIVE EMISSION SYSTEM”).
- Always replace O-ring and clamps with new ones.
- Do not kink or twist tubes when they are being installed.
- Do not overtighten hose clamps to avoid damaging hoses.
- After installing tubes, run engine and check for fuel leaks at connections.
- Use only a genuine fuel filler cap as a replacement. If an incorrect fuel filler cap is used, the MIL may come on.

GI

MA

EM

LC

EC

FE

CL

MT

AT

FA

RA

BR

ST

RS

BT

HA

EL

IDX

# FUEL SYSTEM

## Fuel Tank (Cont'd)

SEC. 172

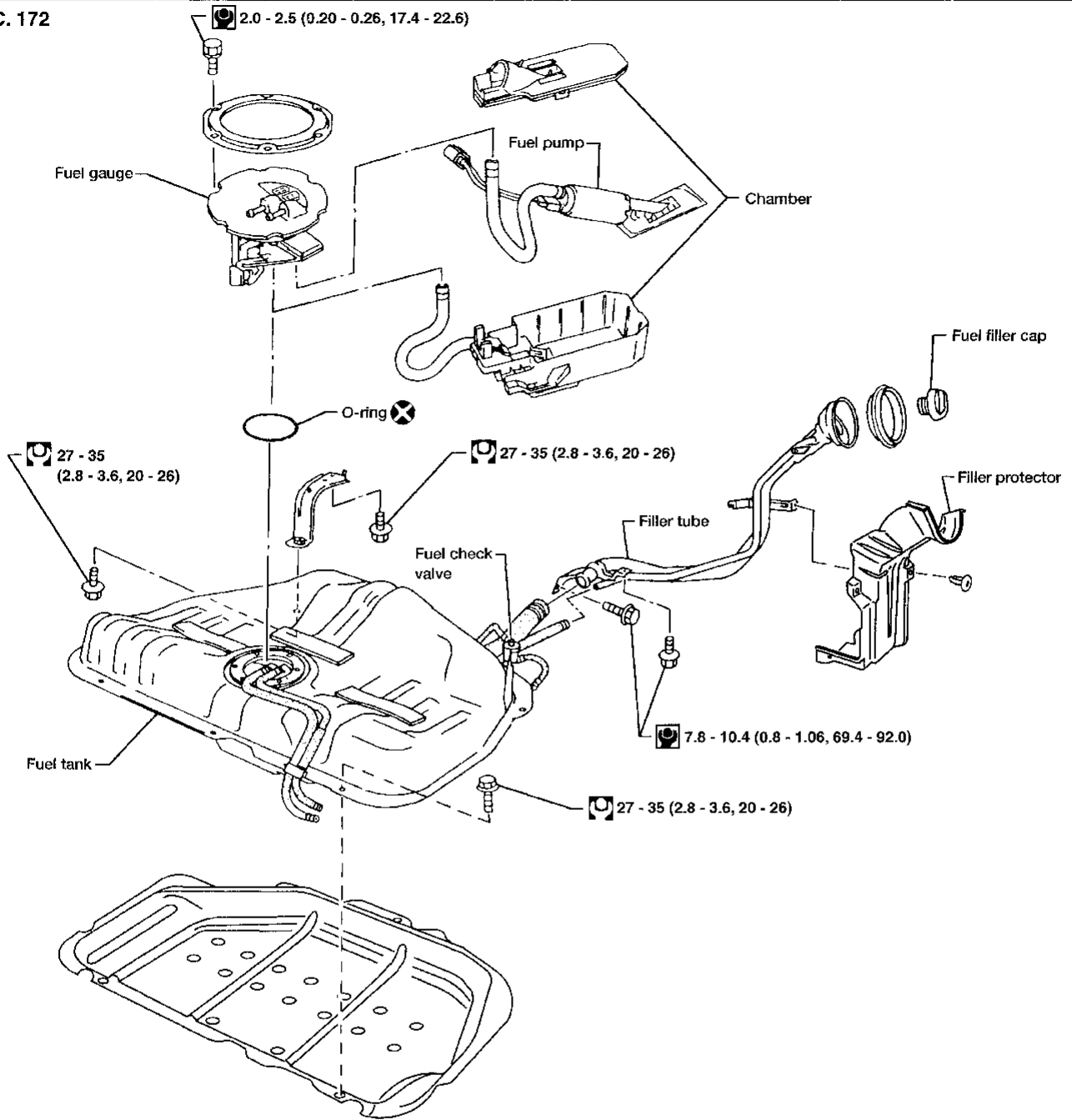

: N·m (kg-m, in-lb)

: N·m (kg-m, ft-lb)

AFE063

# FUEL SYSTEM

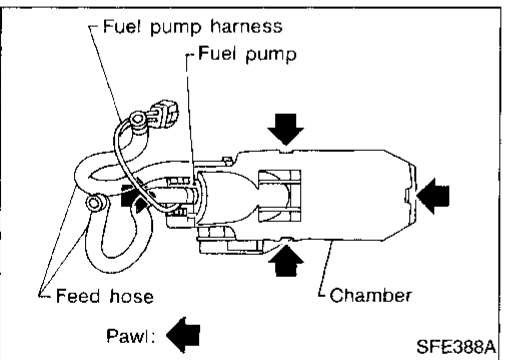
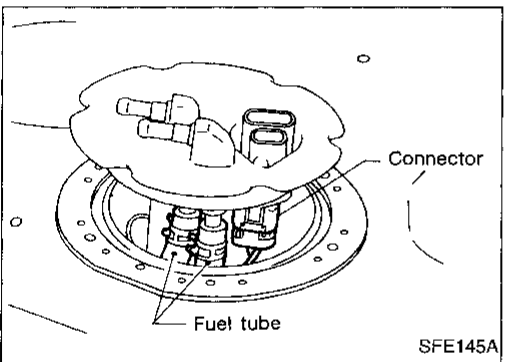
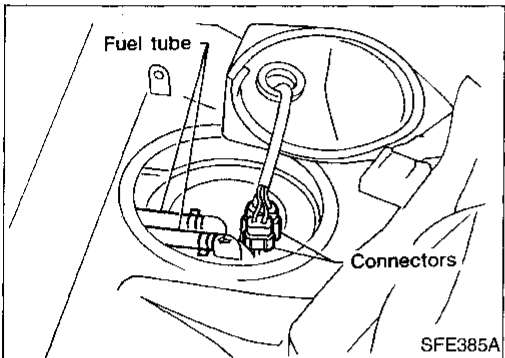
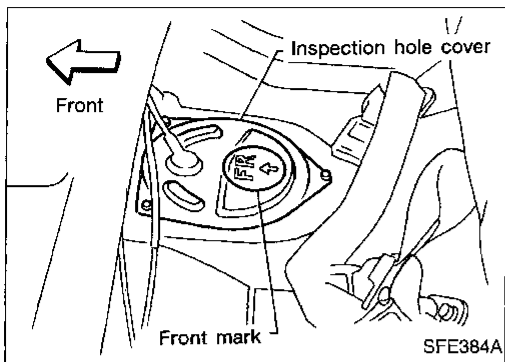

## Fuel Pump and Gauge

### REMOVAL

1. Release fuel pressure.  
Refer to EC section ("Fuel Pressure Release", "BASIC SERVICE PROCEDURE").
2. Remove rear seat back and bottom. Refer to BT section.
3. Remove inspection hole cover located under the rear seat.
4. Disconnect fuel tubes and electrical connectors.
5. Remove the six screws.
6. Disconnect fuel tubes and connector, then remove fuel gauge assembly.
7. Remove fuel pump with chamber.
  - a. Pull up the front of the chamber.
  - b. Slide chamber forward.
8. Remove fuel pump from chamber.

### INSTALLATION

To install, reverse the removal procedure.

#### CAUTION:

- Tighten bolts to specified torque.  
Ⓜ: 2.0 - 2.5 N·m (0.20 - 0.26 kg-m, 17.4 - 22.6 in-lb)
- Always replace O-ring with a new one.
- After installation, run engine and check for leaks at connections.

GI

MA

EM

LC

EC

FE

CL

MT

AT

FA

RA

BR

ST

RS

BT

HA

EL

IDX

# EXHAUST SYSTEM

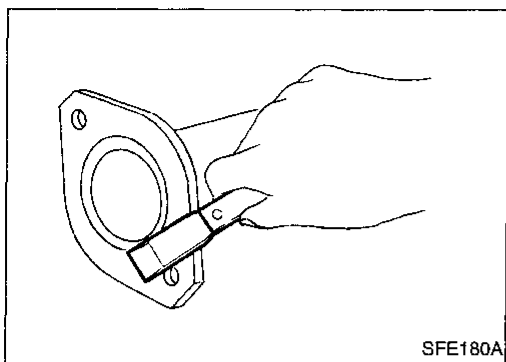

## CAUTION:

- Always replace exhaust gaskets with new ones when reassembling.  
If gasket remains on the flange surface, scrape off completely as shown at left.
- With engine running, check all tube connections for exhaust gas leaks and entire system for unusual noises.
- Ensure that mounting brackets and mounting insulators are installed properly and free from undue stress. Improper installation could result in excessive noise or vibration.
- Discard any oxygen sensor which has been dropped from a height of more than 0.5 m (19.7 in) onto a hard surface such as a concrete floor; use a new one.

(Except California emission)  
SEC. 200

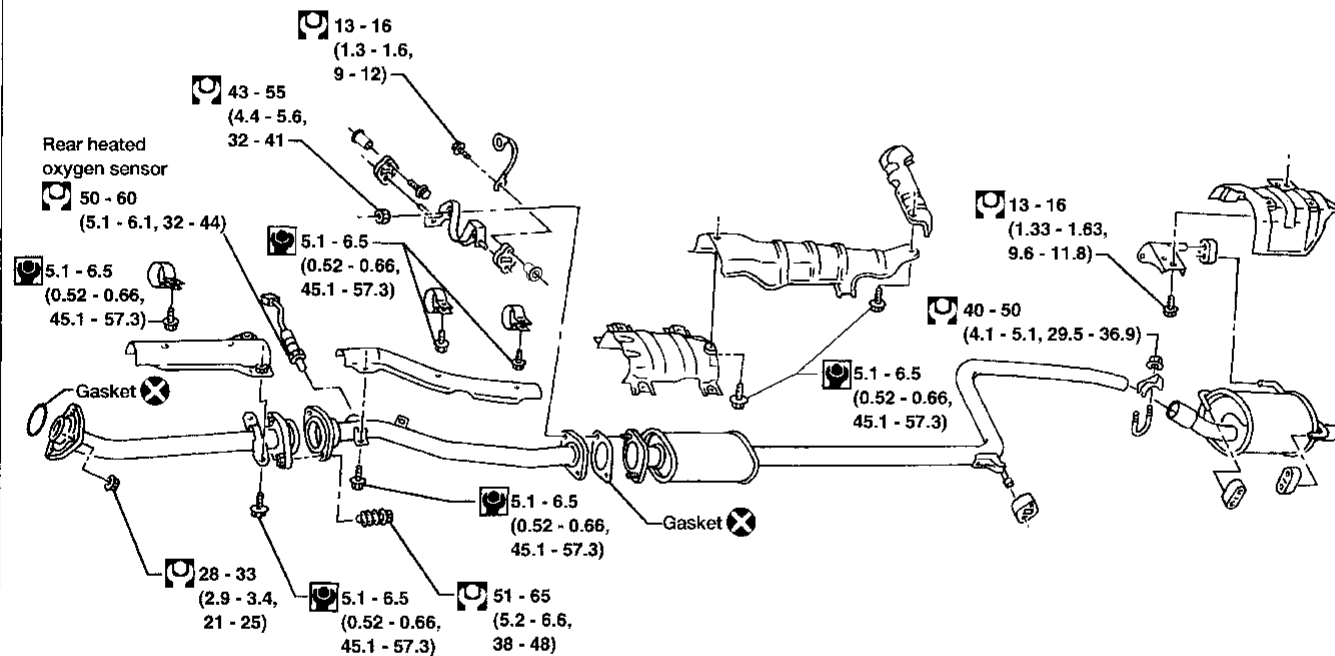

⊙ : N·m (kg-m, in-lb)  
⊚ : N·m (kg-m, ft-lb)

AFE072

# EXHAUST SYSTEM

(California emission)  
SEC. 200

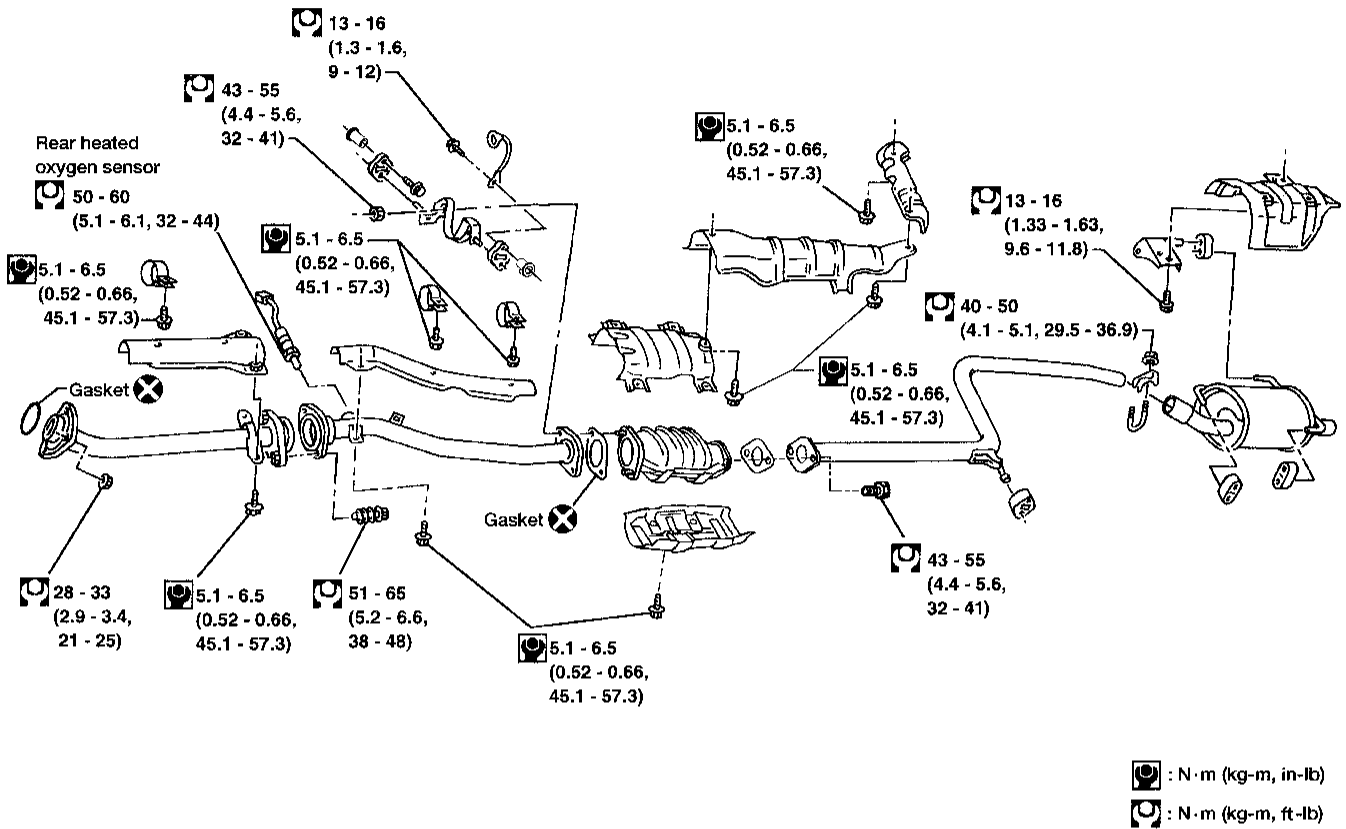

AFE073

GI  
MA  
EM  
LC  
EC  
**FE**  
CL  
MT  
AT  
FA  
RA  
BR  
ST  
RS  
BT  
HA  
EL  
IDX